

ENGINE LUBRICATION & COOLING SYSTEMS

SECTION **LC**

GI

MA

EM

LC

EC

FE

CL

MT

AT

FA

RA

BR

ST

BF

HA

EL

IDX

CONTENTS

PRECAUTION	2	Cooling Circuit	8
Supplemental Restraint System "AIR BAG" and "SEAT BELT PRE-TENSIONER"	2	System Check.....	8
Liquid Gasket Application Procedure	2	Cooling System Inspection.....	8
PREPARATION	3	Water Pump.....	9
Special Service Tools.....	3	Thermostat	10
ENGINE LUBRICATION SYSTEM	4	Water Outlet	11
Lubrication Circuit.....	4	Radiator	11
Oil Pressure Check.....	4	Refilling Engine Coolant.....	12
Oil Pump.....	5	SERVICE DATA AND SPECIFICATIONS (SDS)	14
ENGINE COOLING SYSTEM	8	Engine Lubrication System.....	14
		Engine Cooling System	14

PRECAUTION

Supplemental Restraint System "AIR BAG" and "SEAT BELT PRE-TENSIONER"

The Supplemental Restraint System "Air Bag" and "Seat Belt Pre-tensioner", used along with a seat belt, help to reduce the risk or severity of injury to the driver and front passenger in a frontal collision. The Supplemental Restraint System consists of air bags (located in the center of the steering wheel and on the instrument panel on the passenger side), seat belt pre-tensioners, sensors, a diagnosis unit, warning lamp, wiring harness and spiral cable. Information necessary to service the system safely is included in the **BF section** of this Service Manual.

WARNING:

- To avoid rendering the SRS inoperative, which could lead to personal injury or death in the event of a severe frontal collision, all maintenance must be performed by an authorized INFINITI dealer.
- Improper maintenance, including incorrect removal and installation of the SRS, can lead to personal injury caused by unintentional activation of the system.
- All SRS air bag electrical wiring harnesses and connectors are covered with yellow outer insulation. Do not use electrical test equipment on any circuit related to the SRS SYSTEM.

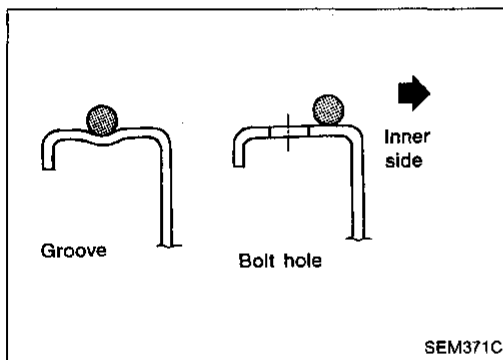

Liquid Gasket Application Procedure

- Remove all traces of old liquid gasket from mating surface and grooves using a scraper. Then completely clean any oil stains from these portions.
- Apply a continuous bead of liquid gasket to mating surfaces. (Use Genuine Liquid Gasket or equivalent.)
 - Be sure liquid gasket is 3.5 to 4.5 mm (0.138 to 0.177 in) wide (for oil pan).
 - Be sure liquid gasket is 2.0 to 3.0 mm (0.079 to 0.118 in) wide (in areas except oil pan).
- Apply liquid gasket to inner surface around hole perimeter area. (Assembly should be done within 5 minutes after coating.)
- Wait at least 30 minutes before refilling engine oil and engine coolant.

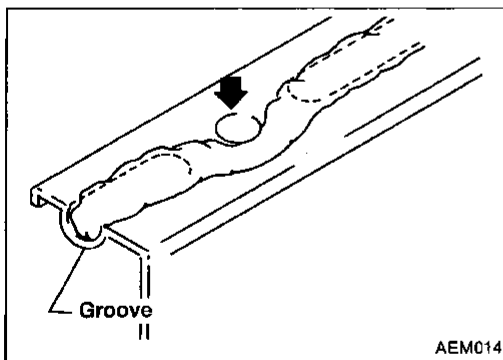

PREPARATION

Special Service Tools

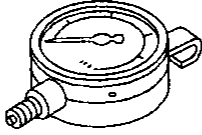
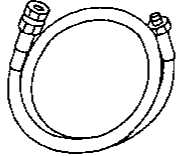
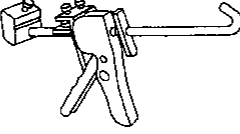
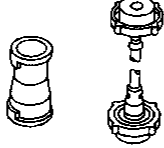
Tool number (Kent-Moore No.) Tool name	Description	
ST25051001 (J25695-1) Oil pressure gauge	 NT050	GI MA EM
ST25052000 (J25695-2) Hose	 NT051	Adapting oil pressure gauge to cylinder block EC LC
WS39930000 (—) Tube presser	 NT052	Pressing the tube of liquid gasket FE CL
EG17650301 (—) Radiator cap tester adapter	 NT053	Adapting radiator cap tester to radiator filler neck MT AT

FA

 RA

 BR

 ST

 BF

 HA

 EL

 IDX

ENGINE LUBRICATION SYSTEM

Lubrication Circuit

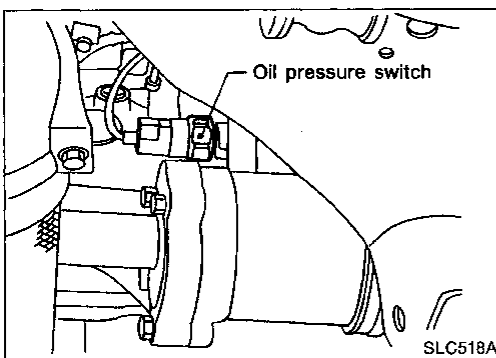
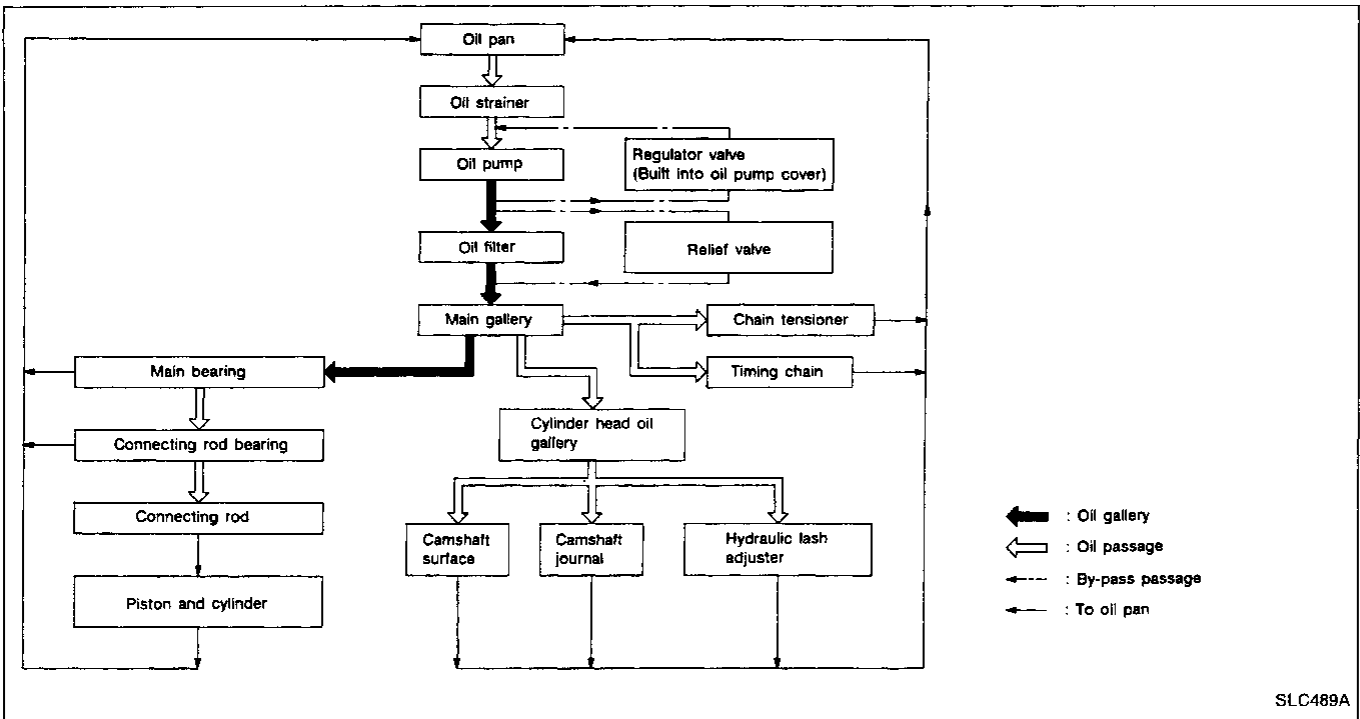
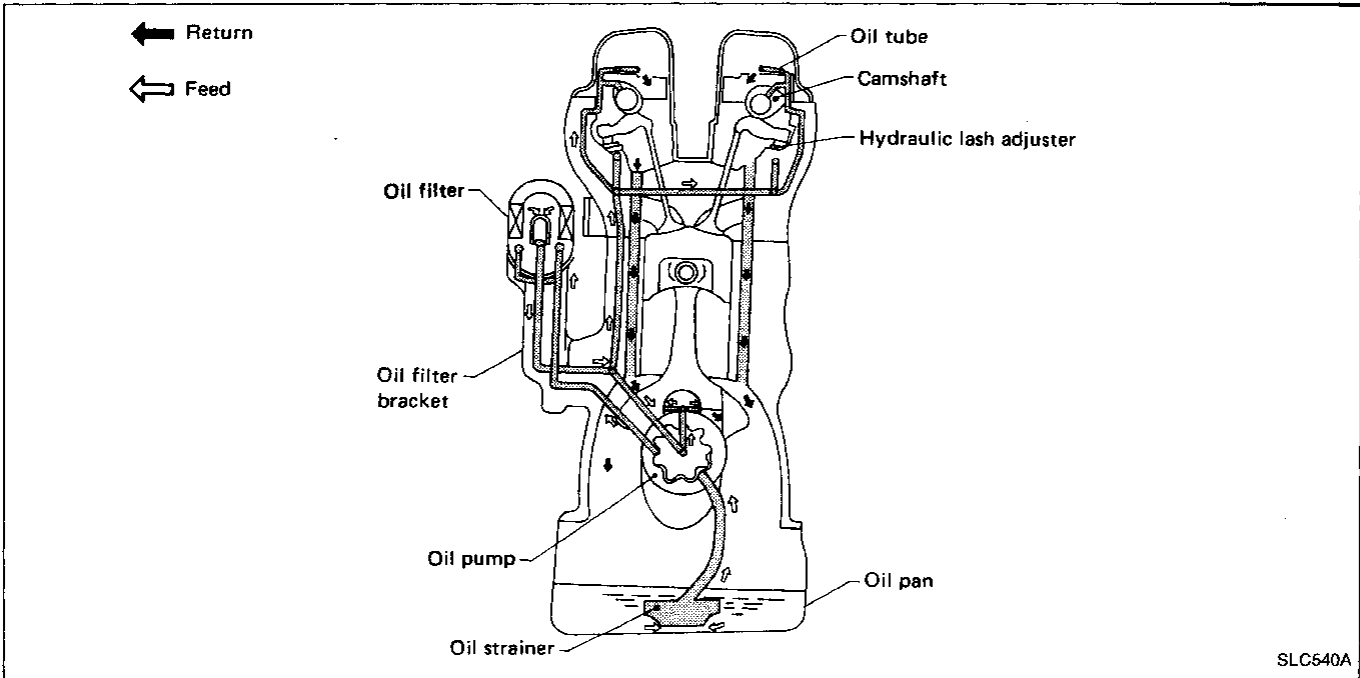

Oil Pressure Check

WARNING:

- Be careful not to burn yourself, as the engine and oil may be hot.
 - Oil pressure check should be done in "Neutral position".
1. Check oil level.
 2. Remove oil pressure switch.

ENGINE LUBRICATION SYSTEM

Oil Pressure Check (Cont'd)

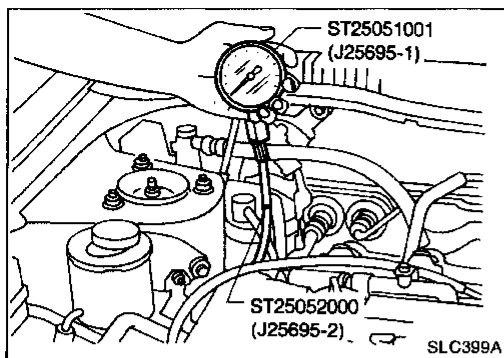

3. Install pressure gauge.
4. Start engine and warm it up to normal operating temperature.
5. Check oil pressure with engine running under no-load.

Engine speed rpm	Approximate discharge pressure kPa (kg/cm ² , psi)
Idle speed	More than 78 (0.8, 11)
3,200	314 - 392 (3.2 - 4.0, 46 - 57)

If difference is extreme, check oil passage and oil pump for oil leaks.

6. Install oil pressure switch with sealant.

Oil Pump

REMOVAL

1. Remove drive belts.
2. Remove cylinder head. (Refer to EM section.)
3. Remove oil pans. (Refer to EM section.)
4. Remove oil strainer and baffle plate.
5. Remove front cover assembly.

DISASSEMBLY AND ASSEMBLY

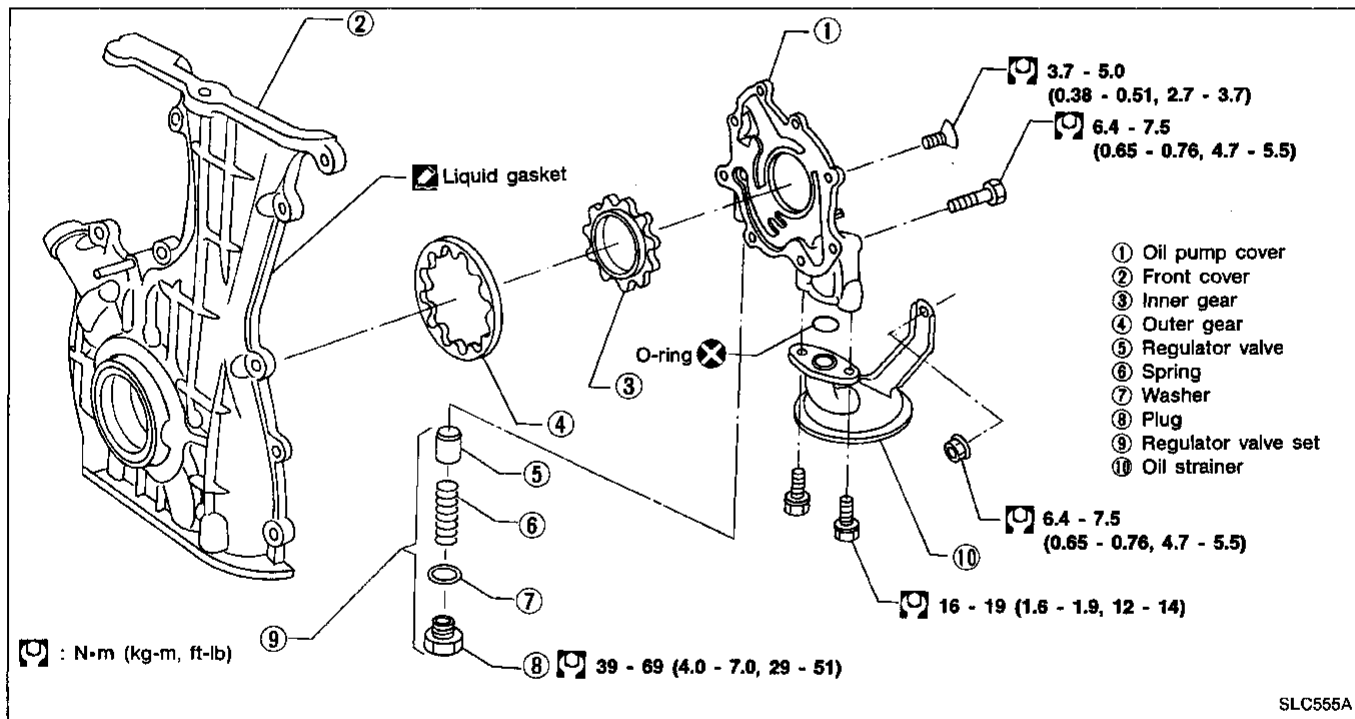

- Always replace oil seal and O-ring with new ones.
- When installing oil pump, apply engine oil to inner and outer gears.
- Be sure that O-rings are properly fitted.

ENGINE LUBRICATION SYSTEM

Oil Pump (Cont'd)

INSTALLATION

- Before installing front cover assembly, remove all traces of liquid gasket from mating surface using a scraper.
- Also remove traces of liquid gasket from mating surface of cylinder block.

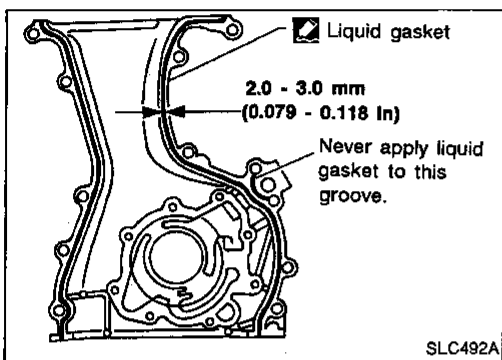
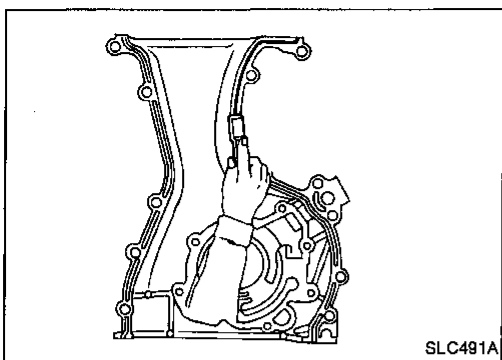

1. Apply a continuous bead of liquid gasket to mating surface of front cover assembly.
- Use Genuine Liquid Gasket or equivalent.
2. Installation is the reverse order of removal.

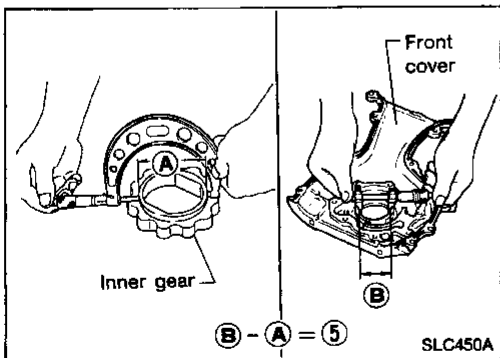
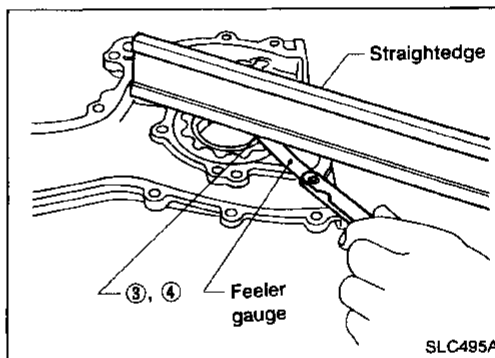
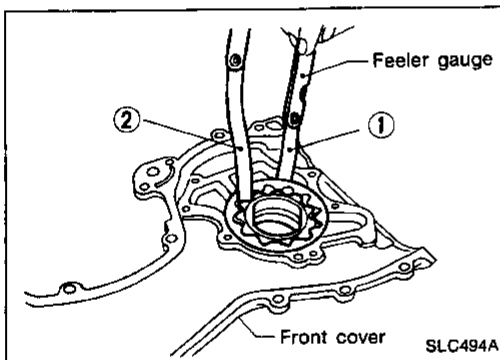

SLC860A

ENGINE LUBRICATION SYSTEM

Oil Pump (Cont'd)

INSPECTION

Using a feeler gauge, check the following clearances:

Unit: mm (in)

Body to outer gear clearance ①	0.114 - 0.200 (0.0045 - 0.0079)
Inner gear to outer gear tip clearance ②	Below 0.18 (0.0071)
Body to inner gear clearance ③	0.05 - 0.09 (0.0020 - 0.0035)
Body to outer gear clearance ④	0.05 - 0.11 (0.0020 - 0.0043)
Inner gear to brazed portion of housing clearance ⑤	0.045 - 0.091 (0.0018 - 0.0036)

- If the tip clearance (②) exceeds the limit, replace gear set.
- If body to gear clearances (①, ③, ④, ⑤) exceed the limit, replace front cover assembly.

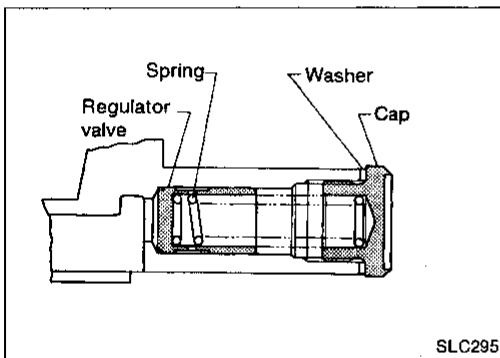

REGULATOR VALVE INSPECTION

1. Visually inspect components for wear and damage.
2. Check oil pressure regulator valve sliding surface and valve spring.
3. Coat regulator valve with engine oil. Check that it falls smoothly into the valve hole by its own weight.

If damaged, replace regulator valve set or oil pump cover.

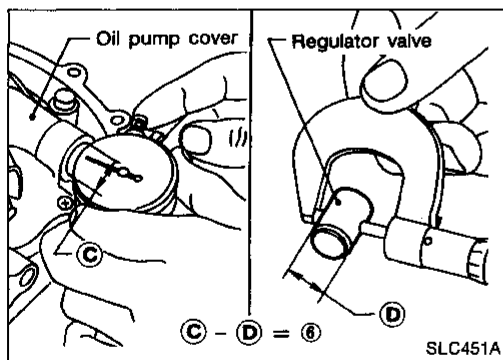

4. Check regulator valve to oil pump cover clearance.

Clearance:

⑥ : 0.040 - 0.097 mm (0.0016 - 0.0038 in)

If it exceeds the limit, replace oil pump cover.

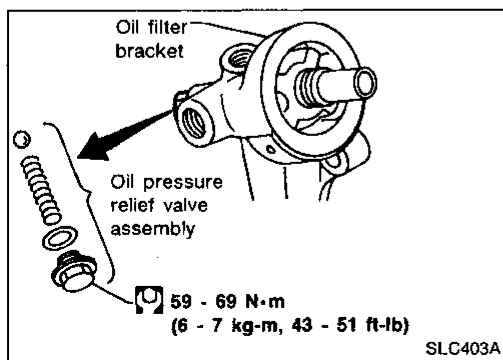

OIL PRESSURE RELIEF VALVE INSPECTION

Inspect oil pressure relief valve for movement, cracks and breaks. If damaged, replace oil filter bracket assembly.

ENGINE COOLING SYSTEM

Cooling Circuit

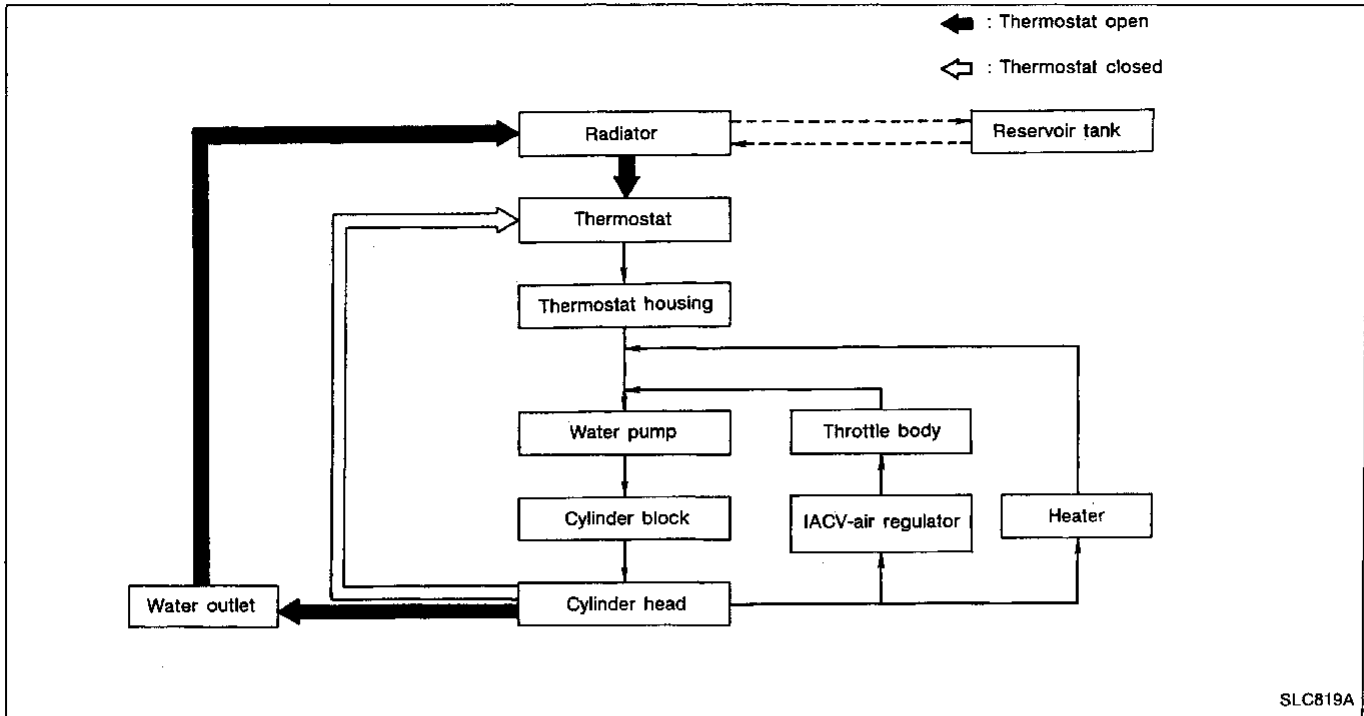

System Check

WARNING:

Never remove the radiator cap when the engine is hot; serious burns could be caused by high pressure fluid escaping from the radiator.

Wrap a thick cloth around the cap and carefully remove it by turning it a quarter turn to allow built-up pressure to escape and then turn the cap all the way off.

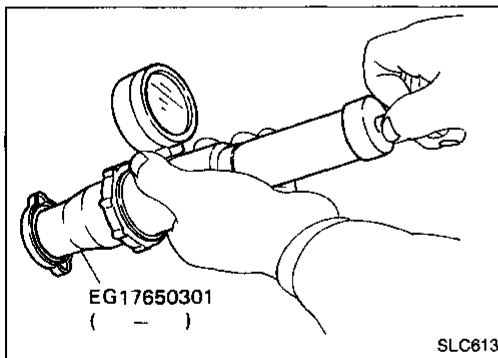

Cooling System Inspection

CHECKING HOSES

Check water hoses for proper attachment, leaks, cracks, damage, loose connections, chafing and deterioration.

CHECKING RADIATOR CAP

To check radiator cap, apply pressure to cap with a tester.

Radiator cap relief pressure:

78 - 98 kPa

(0.8 - 1.0 kg/cm², 11 - 14 psi)

Pull the negative pressure valve to open it.

Check that it closes completely when released.

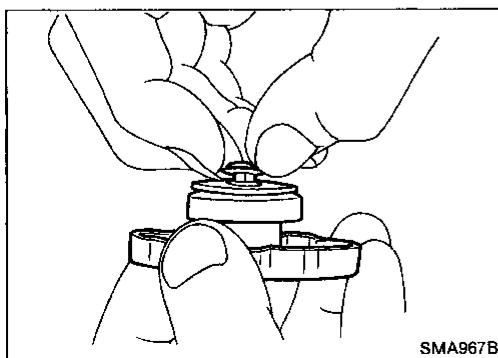

ENGINE COOLING SYSTEM

Cooling System Inspection (Cont'd)

CHECKING COOLING SYSTEM FOR LEAKS

To check for leakage, apply pressure to the cooling system with a tester.

Testing pressure:

157 kPa (1.6 kg/cm², 23 psi)

CAUTION:

Higher than the specified pressure may cause radiator damage.

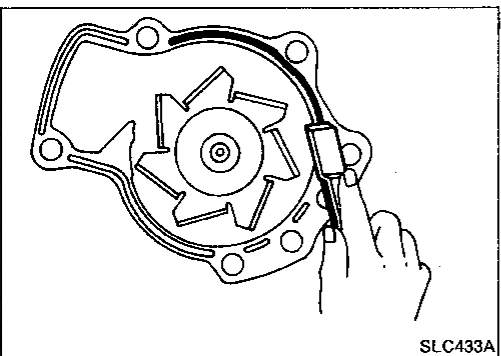
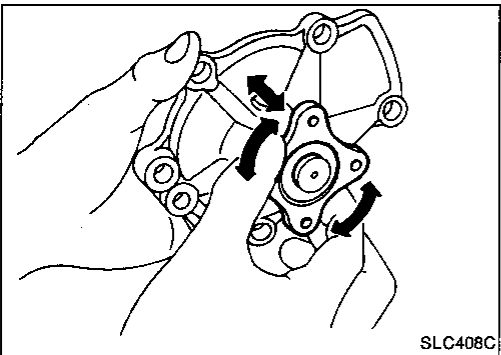
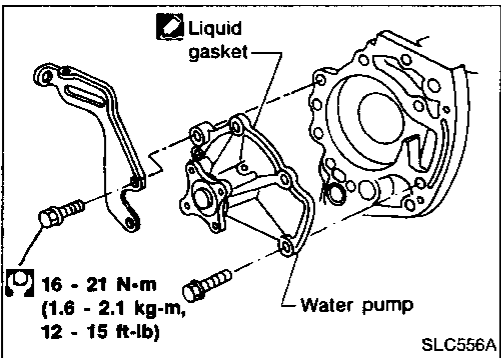
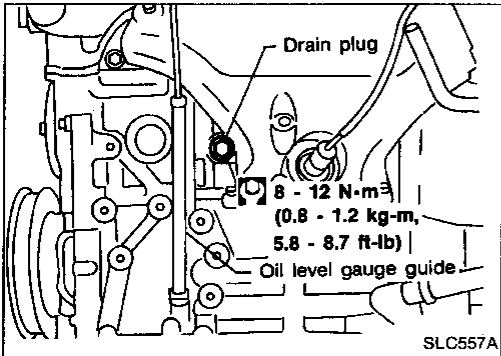
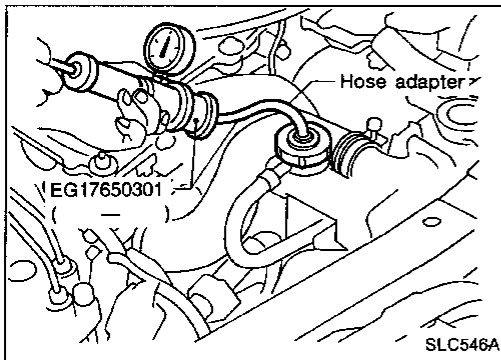

Water Pump

REMOVAL

1. Drain coolant from radiator.
2. Remove cylinder block drain plug located at left front of cylinder block and drain coolant.
3. Remove front RH wheel and engine side cover.
4. Remove drive belts.
5. Remove front engine mounting.

6. Remove water pump.

CAUTION:

- When removing water pump assembly, be careful not to get coolant on drive belt.
- Water pump cannot be disassembled and should be replaced as a unit.
- After installing water pump, connect hose and clamp securely, then check for leaks using radiator cap tester.

INSPECTION

1. Check for badly rusted or corroded body assembly.
2. Check for rough operation due to excessive end play.

INSTALLATION

1. Before installing, remove all traces of liquid gasket from mating surface of water pump using a scraper.
- Also remove traces of liquid gasket from mating surface of cylinder block .

GI

MA

EM

LC

EC

FE

CL

MT

AT

FA

RA

BR

ST

BF

HA

EL

IDX

ENGINE COOLING SYSTEM

Water Pump (Cont'd)

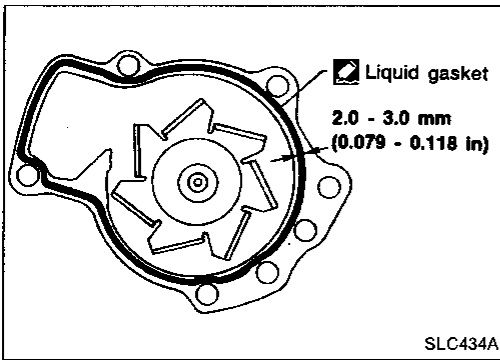

2. Apply a continuous bead of liquid gasket to mating surface of water pump.
- Use Genuine Liquid Gasket or equivalent.

Thermostat

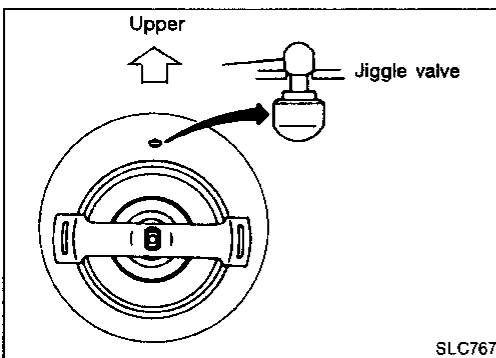
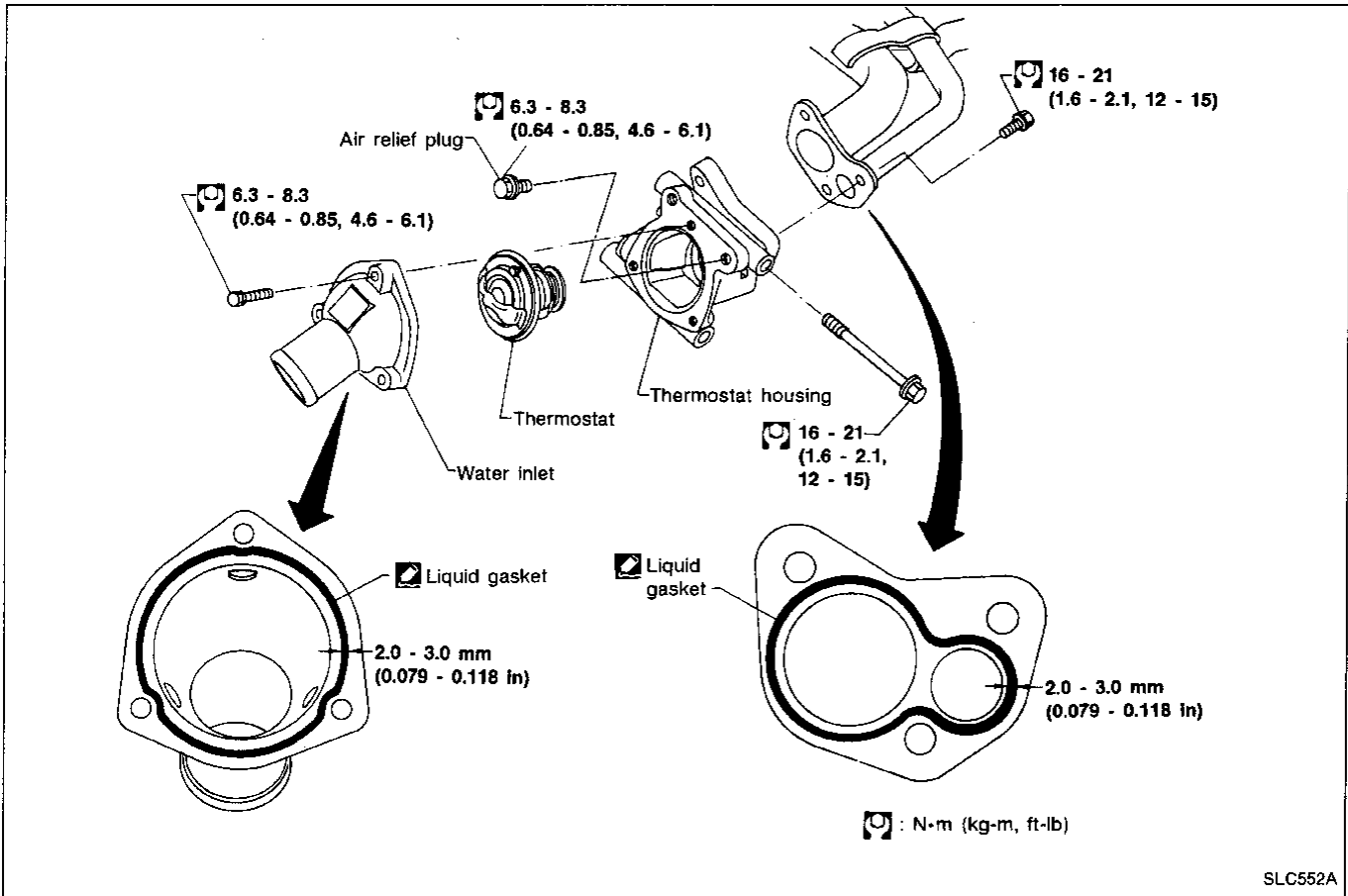

REMOVAL AND INSTALLATION

1. Drain engine coolant.
 2. Remove lower radiator hose.
 3. Remove water inlet, then take out thermostat.
 4. Install thermostat with jiggle valve or air bleeder facing upward.
- After installation, run engine for a few minutes, and check for leaks.
 - Be careful not to spill coolant over engine compartment. Use a rag to absorb coolant.

ENGINE COOLING SYSTEM

Thermostat (Cont'd)

INSPECTION

1. Check for valve seating condition at ordinary temperatures. It should seat tightly.
2. Check valve opening temperature and maximum valve lift.

Valve opening temperature	°C (°F)	76.5 (170)
Max. valve lift	mm/°C (in/°F)	8/90 (0.31/194)

3. Then check if valve closes at 5°C (9°F) below valve opening temperature.

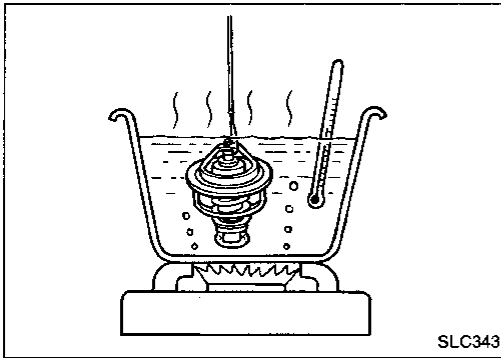

Water Outlet

INSPECTION

Visually inspect for water leaks. If there is leakage, apply liquid gasket.

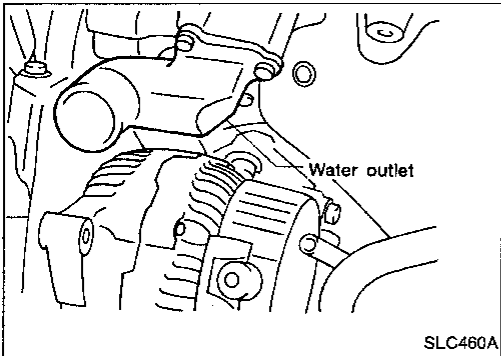

INSTALLATION

1. Before installing, remove all traces of liquid gasket from mating surface of water outlet using a scraper.
 - Also remove traces of liquid gasket from mating surface of cylinder head.
2. Apply a continuous bead of liquid gasket to mating surface of water outlet.
 - Use Genuine Liquid Gasket or equivalent.

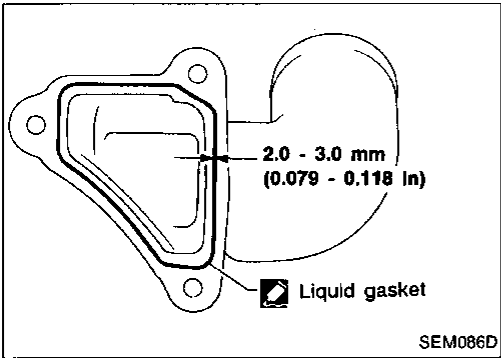

Radiator

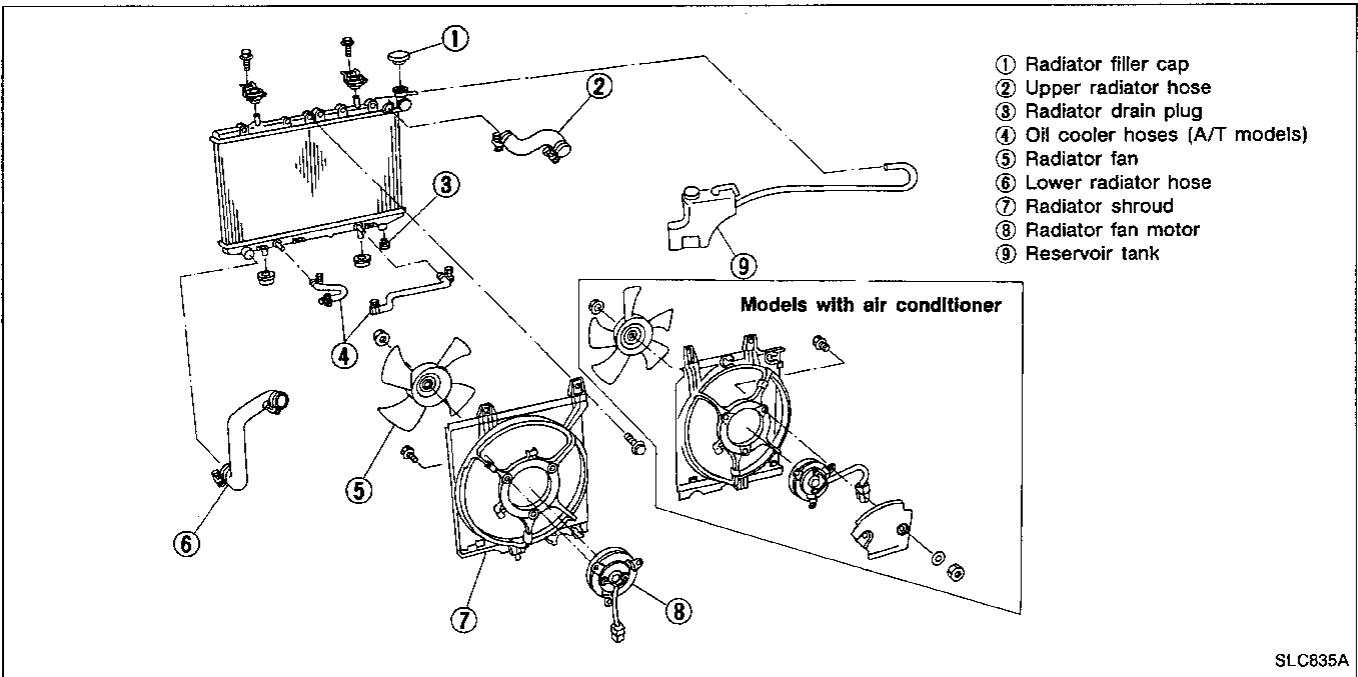

ENGINE COOLING SYSTEM

Refilling Engine Coolant

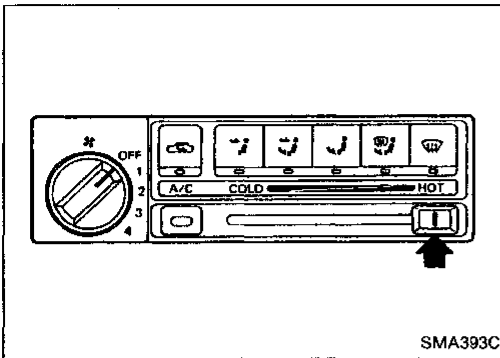

1. Set heater temperature control lever to Maximum Hot position.

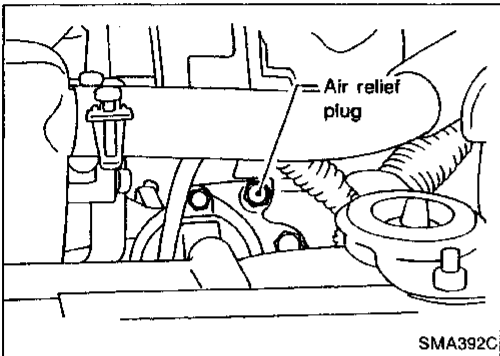

2. Remove radiator filler cap and air relief plug.
 3. Fill radiator with coolant and fill reservoir tank to Max line with coolant.
- Air relief plug is reinstalled once coolant spills from the air relief hole during refill. Then fill radiator and reservoir tank with coolant.

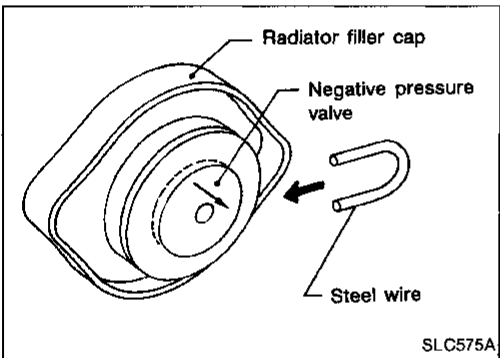

4. Install a temporary radiator filler cap. This allows air and coolant in cooling system to be directed into reservoir tank regardless of pressure.
- Install a suitable steel wire between negative pressure valve and its seat as shown in the picture.
5. Warm up engine to normal operating temperature.
 6. Run engine at 2,500 rpm for 10 seconds and return to idle speed.
- Repeat 2 or 3 times

Watch coolant temperature gauge so as not to overheat the engine.

7. Stop engine and cool it down.
- Cool down using a fan to reduce the time.
8. Remove the temporary radiator filler cap and check coolant level.
- If necessary, refill radiator up to filler neck with coolant.
 9. Refill reservoir tank to Max line with coolant.
 10. Repeat step 7 through step 9 two or more times.

ENGINE COOLING SYSTEM

Refilling Engine Coolant (Cont'd)

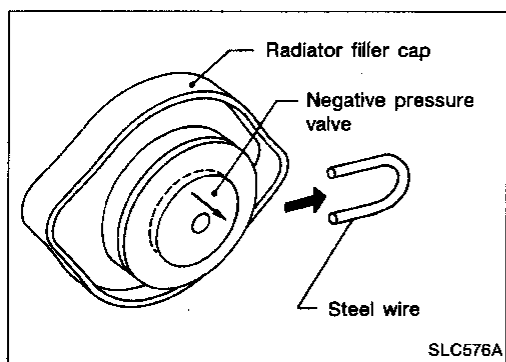

11. Install a proper radiator filler cap. (Original radiator filler cap)
12. Warm up engine, and check for sound of coolant flow under the following conditions. Sound may be noticeable at heater water cock.
 - Engine running from idle up to 4,000 rpm.
 - Heater temperature control lever set at several positions between COOL and HOT.
13. If sound is heard, bleed air from cooling system by repeating steps 4 through 9 until coolant level no longer drops.
14. Stop engine and cool it down.
15. Install a proper radiator filler cap. (Original radiator filler cap)
16. Check any removed parts for secure reinstallation.

GI

MA

EM

LC

EC

FE

CL

MT

AT

FA

RA

BR

ST

BF

HA

EL

IDX

SERVICE DATA AND SPECIFICATIONS (SDS)

Engine Lubrication System

Oil pressure check

Engine speed rpm	Approximate discharge pressure kPa (kg/cm ² , psi)
Idle speed	More than 78 (0.8, 11)
3,200	314 - 392 (3.2 - 4.0, 46 - 57)

Regulator valve inspection

Unit: mm (in)

Regulator valve to oil pump cover clearance	0.040 - 0.097 (0.0016 - 0.0038)
--	---------------------------------

Oil pump inspection

Unit: mm (in)

Body to outer gear clearance	0.114 - 0.200 (0.0045 - 0.0079)
Inner gear to outer gear tip clearance	Below 0.18 (0.0071)
Body to inner gear clearance	0.05 - 0.09 (0.0020 - 0.0035)
Body to outer gear clearance	0.05 - 0.11 (0.0020 - 0.0043)
Inner gear to brazed portion of housing clearance	0.045 - 0.091 (0.0018 - 0.0036)

Engine Cooling System

Cooling system inspection

Radiator cap relief pressure kPa (kg/cm ² , psi)	78 - 98 (0.8 - 1.0, 11 - 14)
Testing pressure for leaks kPa (kg/cm ² , psi)	157 (1.6, 23)

Thermostat

Valve opening temperature	°C (°F)	76.5 (170)
Max. valve lift	mm/°C (in/°F)	8/90 (0.31/194)