

ENGINE LUBRICATION & COOLING SYSTEMS

GI

MA

EM

LC

EC

FE

CL

MT

AT

AX

SU

BR

ST

RS

BT

HA

SC

EL

IDX

SECTION LC

CONTENTS

ENGINE LUBRICATION SYSTEM2	System Check.....9	CL
Precautions2	CHECKING COOLING SYSTEM HOSES9	
LIQUID GASKET APPLICATION PROCEDURE.....2	CHECKING COOLING SYSTEM FOR LEAKS.....9	MT
Preparation2	CHECKING RADIATOR.....10	
SPECIAL SERVICE TOOLS2	CHECKING RADIATOR CAP10	
Lubrication Circuit.....3	Water Pump.....10	AT
Oil Pressure Check.....4	REMOVAL.....10	
Oil Pump.....4	INSPECTION.....11	
REMOVAL.....4	INSTALLATION.....11	AX
DISASSEMBLY AND ASSEMBLY.....5	Thermostat.....12	
INSPECTION.....5	REMOVAL AND INSTALLATION.....12	
REGULATOR VALVE INSPECTION6	INSPECTION.....13	SU
INSTALLATION.....7	Water Outlet.....13	
Oil Filter7	INSPECTION.....13	
Service Data and Specifications (SDS).....7	INSTALLATION.....13	BR
OIL PRESSURE CHECK7	Radiator14	
REGULATOR VALVE INSPECTION7	COMPONENTS14	
OIL PUMP INSPECTION7	Cooling Fan Control System14	ST
ENGINE COOLING SYSTEM8	Refilling Engine Coolant15	
Precautions8	Overheating Cause Analysis15	RS
LIQUID GASKET APPLICATION PROCEDURE.....8	Service Data and Specifications (SDS).....16	
Preparation8	THERMOSTAT16	
SPECIAL SERVICE TOOL8	RADIATOR.....16	BT
Cooling Circuit9		

ENGINE LUBRICATION SYSTEM

Precautions

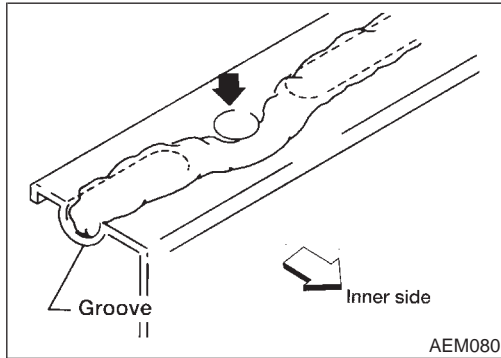
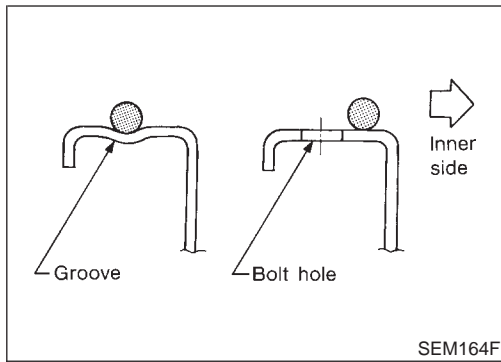

Precautions

LIQUID GASKET APPLICATION PROCEDURE

NCLC0001

1. Use a scraper to remove all traces of old liquid gasket from mating surfaces and grooves. Also, completely clean any oil from these areas.
2. Apply a continuous bead of liquid gasket to mating surfaces. **(Use Genuine RTV silicone sealant part No. 999MP-A7007 or equivalent.)**
 - For oil pan, be sure liquid gasket diameter is 4.0 to 5.0 mm (0.157 to 0.197 in).
 - For areas except oil pan, be sure liquid gasket diameter is 2.0 to 3.0 mm (0.079 to 0.118 in).
3. Apply liquid gasket around the inner side of bolt holes (unless otherwise specified).
4. Assembly should be done within 5 minutes after coating.
5. Wait at least 30 minutes before refilling engine oil and engine coolant.

Preparation

SPECIAL SERVICE TOOLS

NCLC0002

The actual shapes of Kent-Moore tools may differ from those of special service tools illustrated here.

Tool number (Kent-Moore No.) Tool name	Description
(J34301-C) Oil pressure gauge set 1 (J34301-1) Oil Pressure gauge 2 (J34301-2) Hoses 3 (J34298) Adapter 4 (J34282-1) Adapter 5 (790-301-1230-A) 60° adapter 6 (J34301-15) Square socket	<p>Measuring oil pressure Maximum measuring range: 1,379 kPa (14 kg/cm², 200 psi)</p> <p>AAT896</p>
ST25052000 (J25695-2) Hose	<p>Adapting oil pressure gauge to cylinder block</p> <p>NT559</p>
KV10115801 (J38956) Oil filter wrench	<p>Removing oil filter</p> <p>14 faces, Inner span: 64.3 mm (2.531 in) (Face to opposite face)</p> <p>NT362</p>

ENGINE LUBRICATION SYSTEM

Preparation (Cont'd)

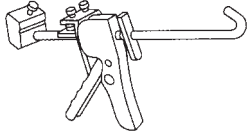
Tool number (Kent-Moore No.) Tool name	Description
WS39930000 (—) Tube presser	 <p>Pressing the tube of liquid gasket</p> <p>NT052</p>

GI
MA
EM

LC

Lubrication Circuit

NCLC0003

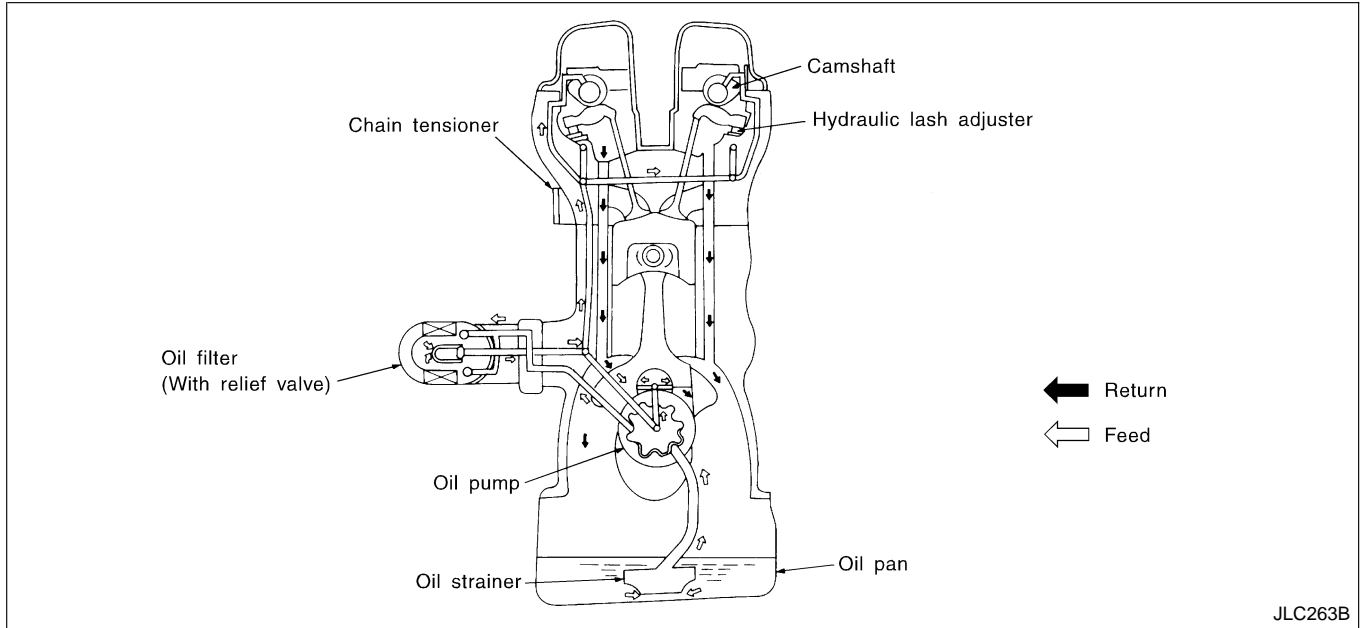

EC
FE
CL
MT
AT
AX
SU
BR

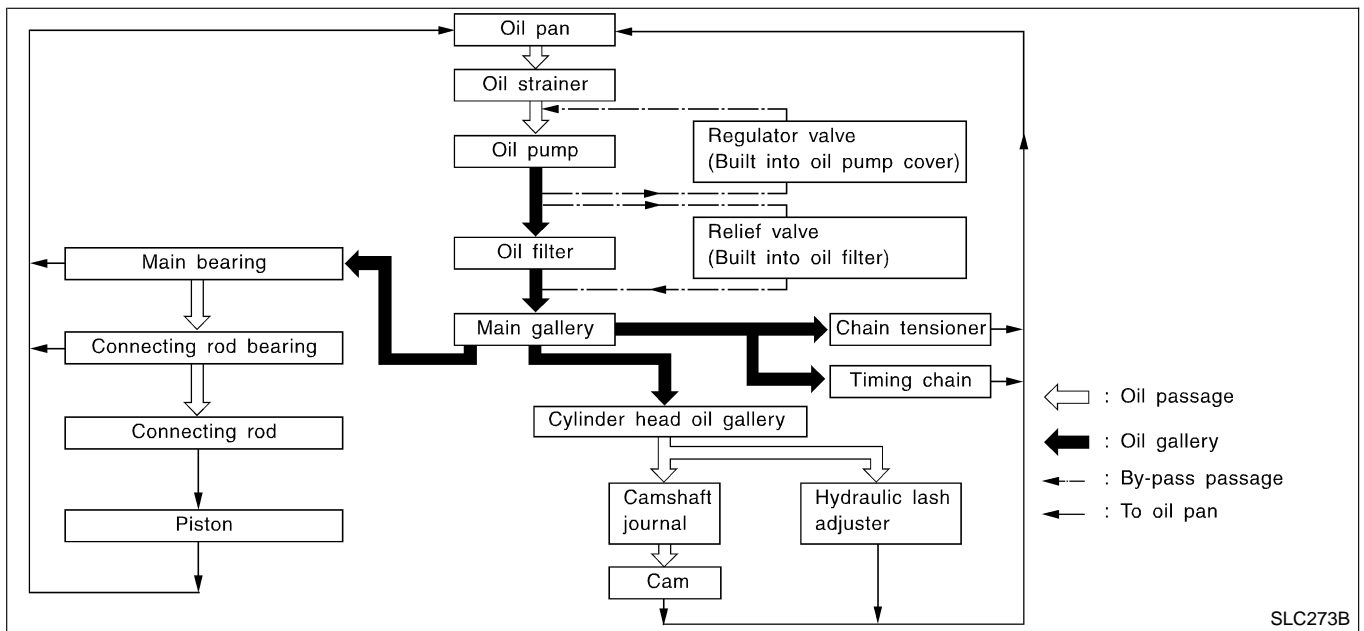

ST
RS
BT
HA
SC
EL
IDX

ENGINE LUBRICATION SYSTEM

Oil Pressure Check

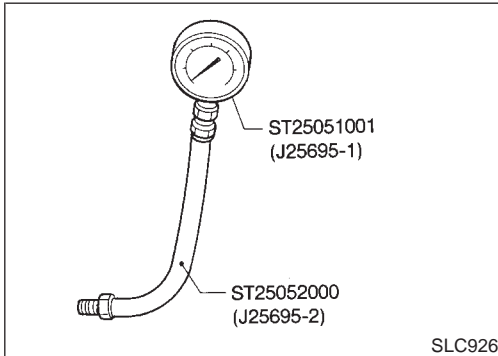
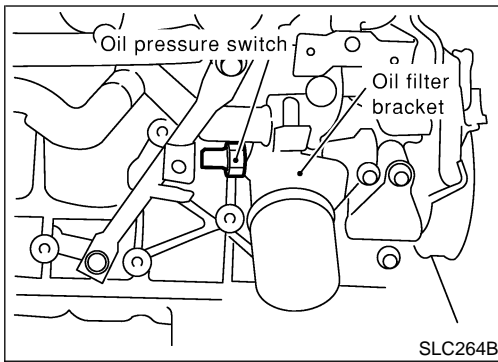

Oil Pressure Check

NCLC0004

WARNING:

- Be careful not to burn yourself, as the engine and oil may be hot.
- For M/T models, put gearshift lever in Neutral “N” position. For A/T models, put selector lever in Park “P” position.

1. Check oil level.
2. Remove oil pressure switch.
3. Install pressure gauge.
4. Start engine and warm it up to normal operating temperature.
5. Check oil pressure with engine running under no-load.

Engine speed rpm	Approximate discharge pressure kPa (kg/cm ² , psi)
Idle speed	More than 80 (0.82, 11.7)
3,200	314 - 392 (3.2 - 4.0, 46 - 57)

- If difference is extreme, check oil passage and oil pump for oil leaks.
6. Install oil pressure switch with sealant.

Oil Pump REMOVAL

NCLC0005

1. Remove drive belts.
2. Remove cylinder head. Refer to EM-31, “Removal”.
3. Remove oil pans. Refer to EM-14, “Removal”.
4. Remove oil strainer and baffle plate.
5. Remove front cover assembly.

DISASSEMBLY AND ASSEMBLY

NCLC0006

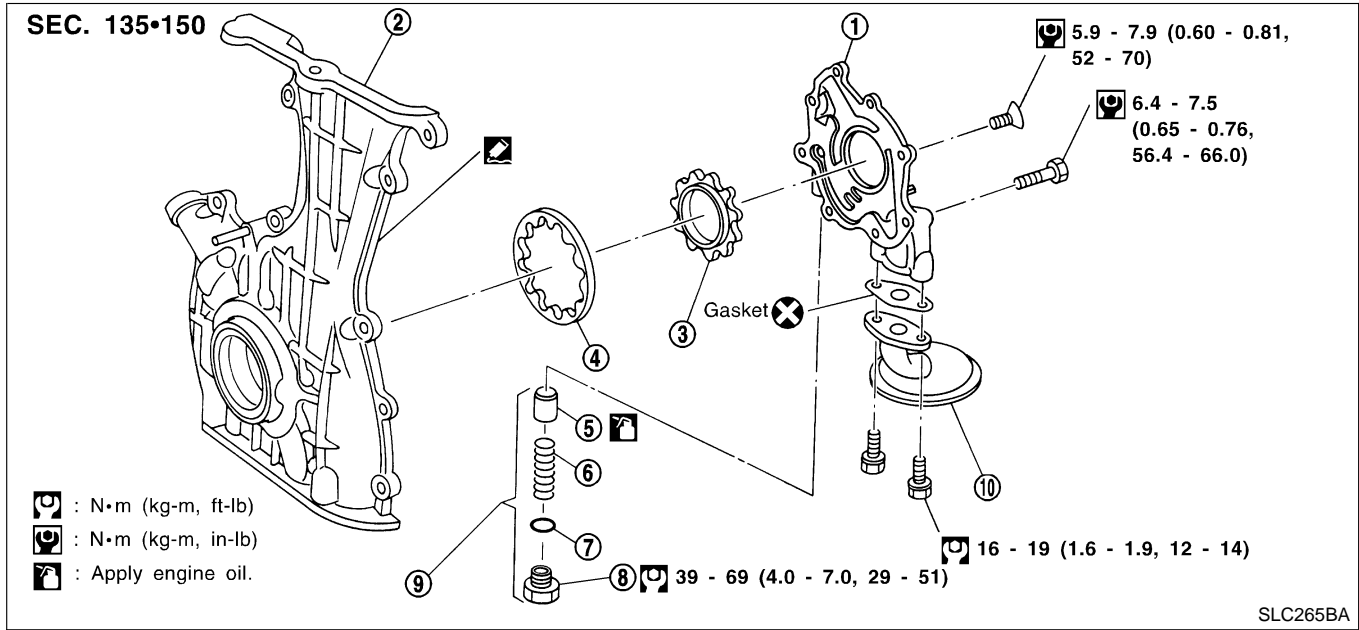

- | | | |
|-------------------|--------------------|-----------------------------|
| 1. Oil pump cover | 5. Regulator valve | 8. Plug |
| 2. Front cover | 6. Spring | 9. Regulator valve assembly |
| 3. Inner gear | 7. Shim | 10. Oil strainer |
| 4. Outer gear | | |

INSPECTION

NCLC0007

Using a feeler gauge, check the following clearances:
Standard clearance:

Unit: mm (in)

Body to outer gear radial clearance 1	0.114 - 0.200 (0.0045 - 0.0079)
Inner gear to outer gear tip clearance 2	Below 0.18 (0.0071)
Body to inner gear clearance 3	0.05 - 0.09 (0.0020 - 0.0035)
Body to outer gear axial clearance 4	0.05 - 0.11 (0.0020 - 0.0043)
Inner gear to brazed portion of housing clearance 5	0.045 - 0.091 (0.0018 - 0.0036)

- If the tip clearance (2) exceeds the limit, replace gear set.
- If body to gear clearances (1, 3, 4, 5) exceed the limit, replace front cover assembly.

ENGINE LUBRICATION SYSTEM

Oil Pump (Cont'd)

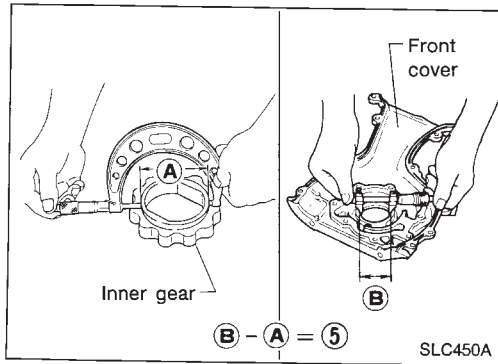
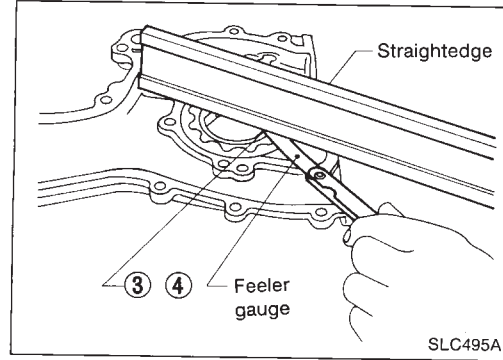
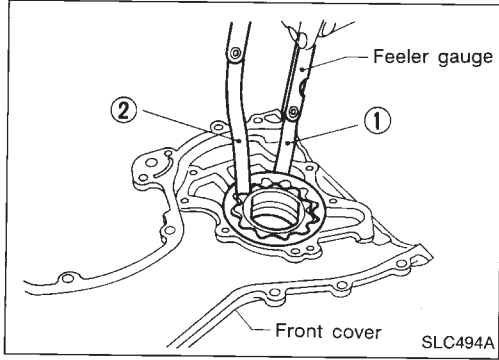

SLC854A

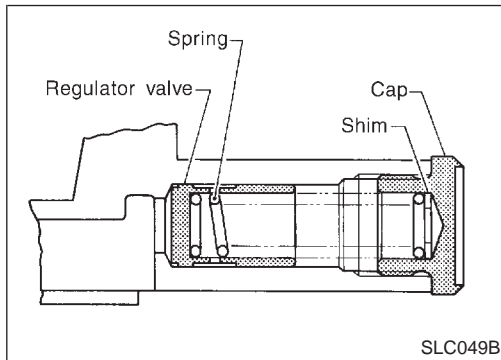

REGULATOR VALVE INSPECTION

NCLC0008

1. Visually inspect components for wear and damage.
2. Check oil pressure regulator valve sliding surface and valve spring.
3. Coat regulator valve with engine oil. Check that it falls smoothly into the valve hole by its own weight.
 - If damaged, replace regulator valve set or oil pump assembly.

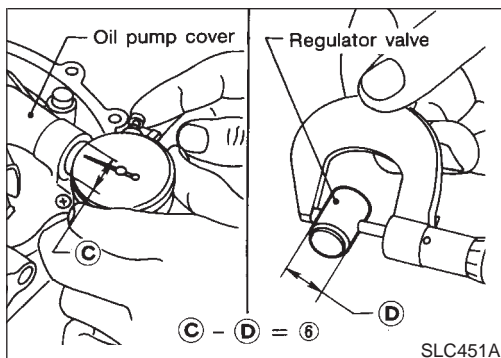

4. Check regulator valve to oil pump cover clearance.

Clearance:

6: 0.040 - 0.097 mm (0.0016 - 0.0038 in)

- If it exceeds the limit, replace oil pump cover.

ENGINE LUBRICATION SYSTEM

Oil Pump (Cont'd)

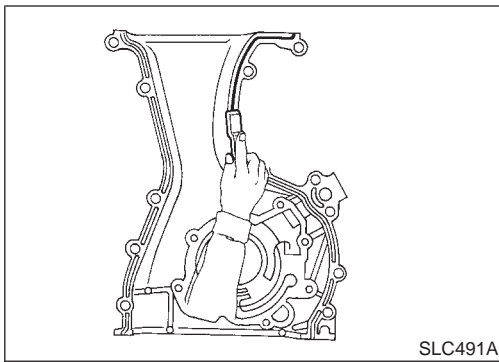

INSTALLATION

NCLC0009

- Always replace oil seal and O-ring with new ones. Refer to EM-28, "OIL SEAL REPLACEMENT".
- When installing oil pump, apply engine oil to gears.
- Be sure that O-rings are properly fitted.
- Use a scraper to remove old liquid gasket from mating surface of front cover.
- Also remove traces of liquid gasket from mating surface of cylinder block.

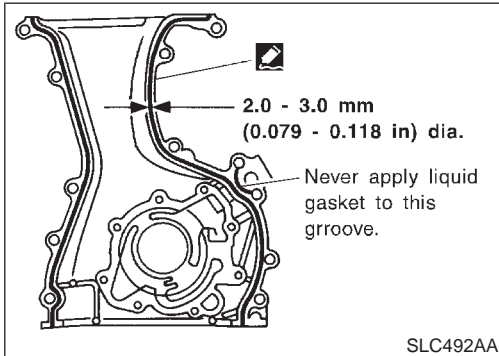

1. Apply a continuous bead of liquid gasket to mating surface of front cover assembly.
- Use **Genuine RTV silicone sealant part No. 999MP-A7007 or equivalent.**
2. Installation is in the reverse order of removal.

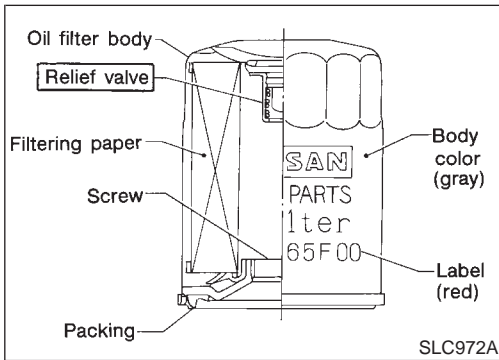

Oil Filter

NCLC0010

The oil filter is a small, full-flow cartridge type and is provided with a relief valve.

- Use **Tool KV10115801 (J38956)** for removing oil filter.

Service Data and Specifications (SDS)

OIL PRESSURE CHECK

NCLC0011

Engine speed rpm	Approximate discharge pressure kPa (kg/cm ² , psi)
Idle speed	More than 80 (0.82, 11.7)
3,200	314 - 392 (3.2 - 4.0, 46 - 57)

REGULATOR VALVE INSPECTION

NCLC0012

Unit: mm (in)

Regulator valve to oil pump cover clearance	0.040 - 0.097 (0.0016 - 0.0038)
---	---------------------------------

OIL PUMP INSPECTION

NCLC0013

Unit: mm (in)

Body to outer gear radial clearance	0.114 - 0.200 (0.0045 - 0.0079)
Inner gear to outer gear tip clearance	Below 0.18 (0.0071)
Body to inner gear clearance	0.05 - 0.09 (0.0020 - 0.0035)
Body to outer gear axial clearance	0.05 - 0.11 (0.0020 - 0.0043)
Inner gear to brazed portion of housing clearance	0.045 - 0.091 (0.0018 - 0.0036)

GI

MA

EM

LC

EC

FE

CL

MT

AT

AX

SU

BR

ST

RS

BT

HA

SC

EL

IDX

ENGINE COOLING SYSTEM

Precautions

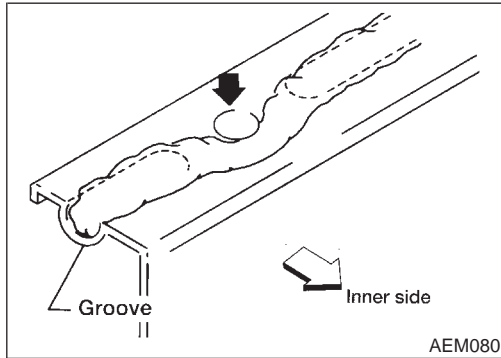
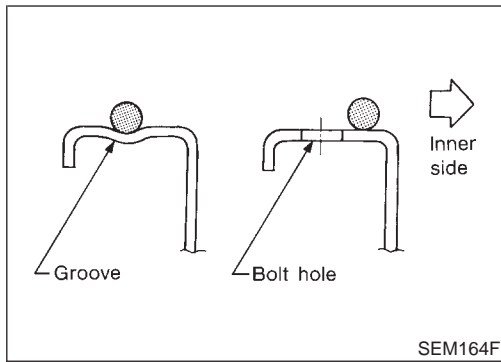

Precautions

LIQUID GASKET APPLICATION PROCEDURE

NCLC0014

1. Use a scraper to remove all traces of old liquid gasket from mating surfaces and grooves. Also, completely clean any oil from these areas.
2. Apply a continuous bead of liquid gasket to mating surfaces. **(Use Genuine RTV silicone sealant part No. 999MP-A7007 or equivalent.)**
 - For oil pan, be sure liquid gasket diameter is 4.0 to 5.0 mm (0.157 to 0.197 in).
 - For areas except oil pan, be sure liquid gasket diameter is 2.0 to 3.0 mm (0.079 to 0.118 in).
3. Apply liquid gasket around the inner side of bolt holes (unless otherwise specified).
4. Assembly should be done within 5 minutes after coating.
5. Wait at least 30 minutes before refilling engine oil and engine coolant.

Preparation

SPECIAL SERVICE TOOL

NCLC0015

The actual shapes of Kent-Moore tools may differ from those of special service tools illustrated here.

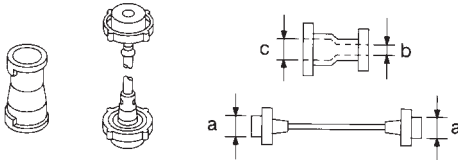
Tool number (Kent-Moore No.) Tool name	Description
EG17650301 (J33984-A) Radiator cap tester adapter	 <p>Adapting radiator cap tester to radiator filler neck a: 28 (1.10) dia. b: 31.4 (1.236) dia. c: 41.3 (1.626) dia. Unit: mm (in)</p> <p>NT564</p>

Cooling Circuit

NCLC0016

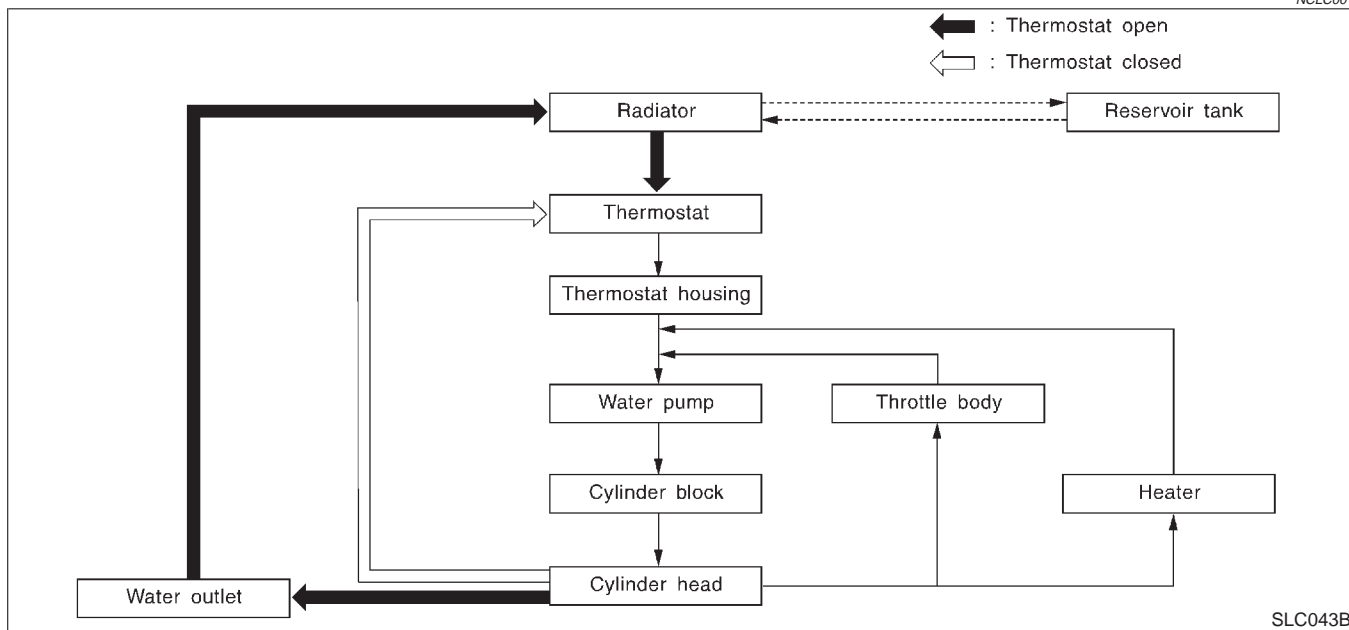

GI

MA

EM

LC

EC

FE

CL

MT

System Check

NCLC0017

WARNING:

Never remove the radiator cap when the engine is hot. Serious burns could occur from high pressure coolant escaping from the radiator.

Wrap a thick cloth around the cap. Slowly turn it a quarter turn to allow built-up pressure to escape. Carefully remove the cap by turning it all the way.

AT

AX

SU

CHECKING COOLING SYSTEM HOSES

NCLC0017S01

Check hoses for the following:

- Improper attachment
- Leaks
- Cracks
- Damage
- Chafing
- Deterioration

BR

ST

RS

BT

HA

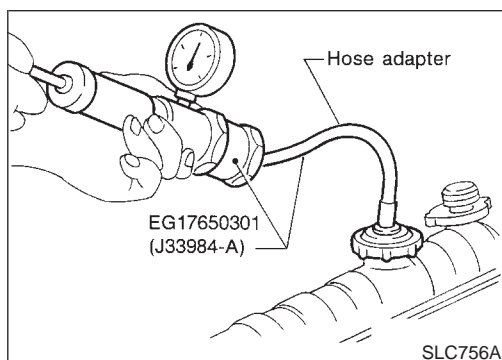

CHECKING COOLING SYSTEM FOR LEAKS

NCLC0017S02

To check for leakage, apply pressure to the cooling system with a tester.

Testing pressure:

157 kPa (1.6 kg/cm², 23 psi)

CAUTION:

Higher pressure than specified may cause radiator damage.

SC

EL

IDX

ENGINE COOLING SYSTEM

System Check (Cont'd)

CHECKING RADIATOR

NCLC0017S04

Check radiator for mud or clogging. If necessary, clean radiator as follows.

- Be careful not to bend or damage the radiator fins.
 - When radiator is cleaned without removal, remove all surrounding parts such as cooling fan, radiator shroud and horns. Then tape the harness and connectors to prevent water from entering.
1. Apply water by hose to the back side of the radiator core vertically download.
 2. Apply water again to all radiator core surfaces once per minute.
 3. Stop washing if any stains no longer flow out from the radiator.
 4. Blow air into the back side of radiator core vertically download.
 - Use compressed air lower than 490 kPa (5 kg/cm², 71 psi) and keep distance more than 30 cm (11.8 in).
 5. Blow air again into all the radiator core surfaces once per minute until no water sprays out.

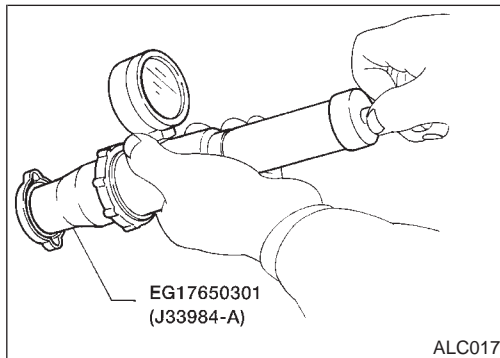

CHECKING RADIATOR CAP

NCLC0017S03

To check radiator cap, apply pressure to cap with a tester.

Radiator cap relief pressure:

Standard

78 - 98 kPa (0.8 - 1.0 kg/cm², 11 - 14 psi)

Limit

59 - 98 kPa (0.6 - 1.0 kg/cm², 9 - 14 psi)

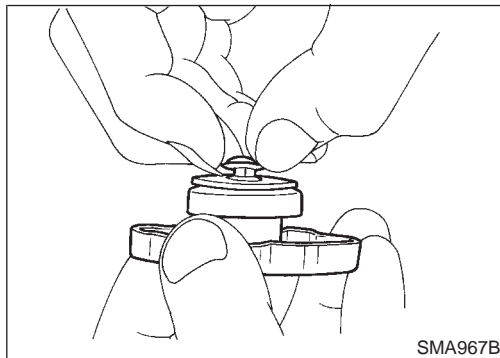

Pull the negative pressure valve to open it.
Check that it closes completely when released.

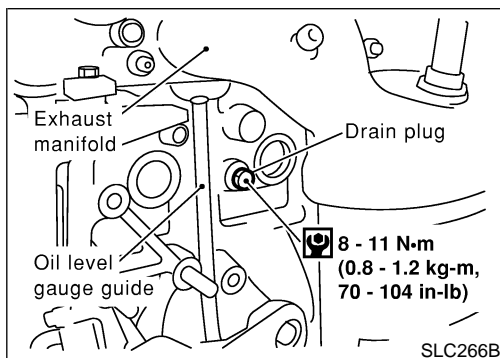

Water Pump

REMOVAL

NCLC0018

1. Drain coolant from radiator.
2. Remove cylinder block drain plug located at left front of cylinder block and drain coolant.
3. Remove front RH wheel and engine side cover.
4. Remove drive belts. Refer to MA-13, "Checking Drive Belts".
5. Remove RH engine mounting. Refer to EM-56, "ENGINE REMOVAL".

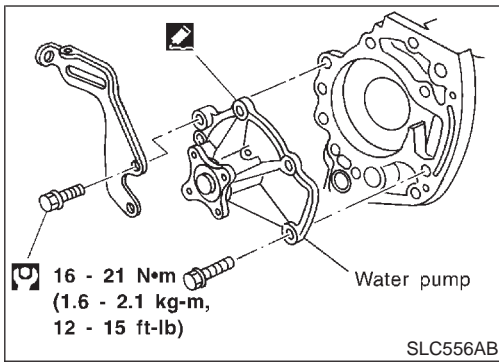

6. Remove water pump.

CAUTION:

- When removing water pump assembly, be careful not to get coolant on drive belt.
- Water pump cannot be disassembled and should be replaced as a unit.
- After installing water pump, connect hose and clamp securely, then check for leaks using radiator cap tester.

GI
MA
EM

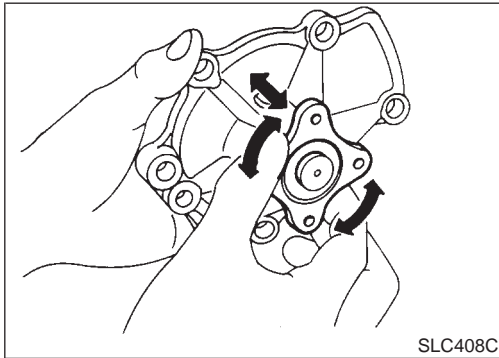

INSPECTION

- Check body assembly for rust or corrosion.
- Check for rough operation due to excessive end play.

NCLC0019

LC

EC

FE

CL

MT

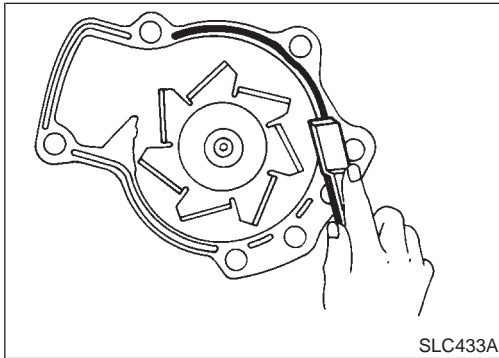

INSTALLATION

1. Use a scraper to remove liquid gasket from water pump.
 - Also remove traces of liquid gasket from mating surface of cylinder block.

NCLC0020

AT

AX

SU

BR

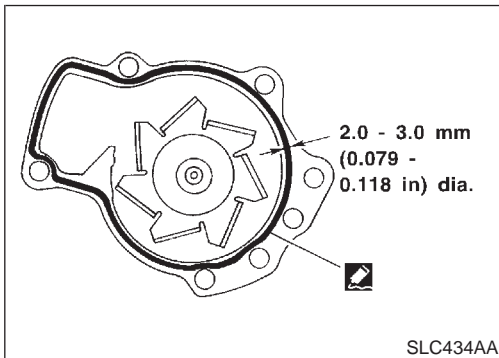

2. Apply a continuous bead of liquid gasket to mating surface of water pump.
 - Use Genuine RTV silicone sealant part No. 999MP-A7007 or equivalent.

ST

RS

When filling radiator with coolant, refer to MA-14, "Changing Engine Coolant".

When installing drive belts, refer to MA-13, "Checking Drive Belts".

BT

HA

SC

EL

IDX

Thermostat REMOVAL AND INSTALLATION

NCLC0021

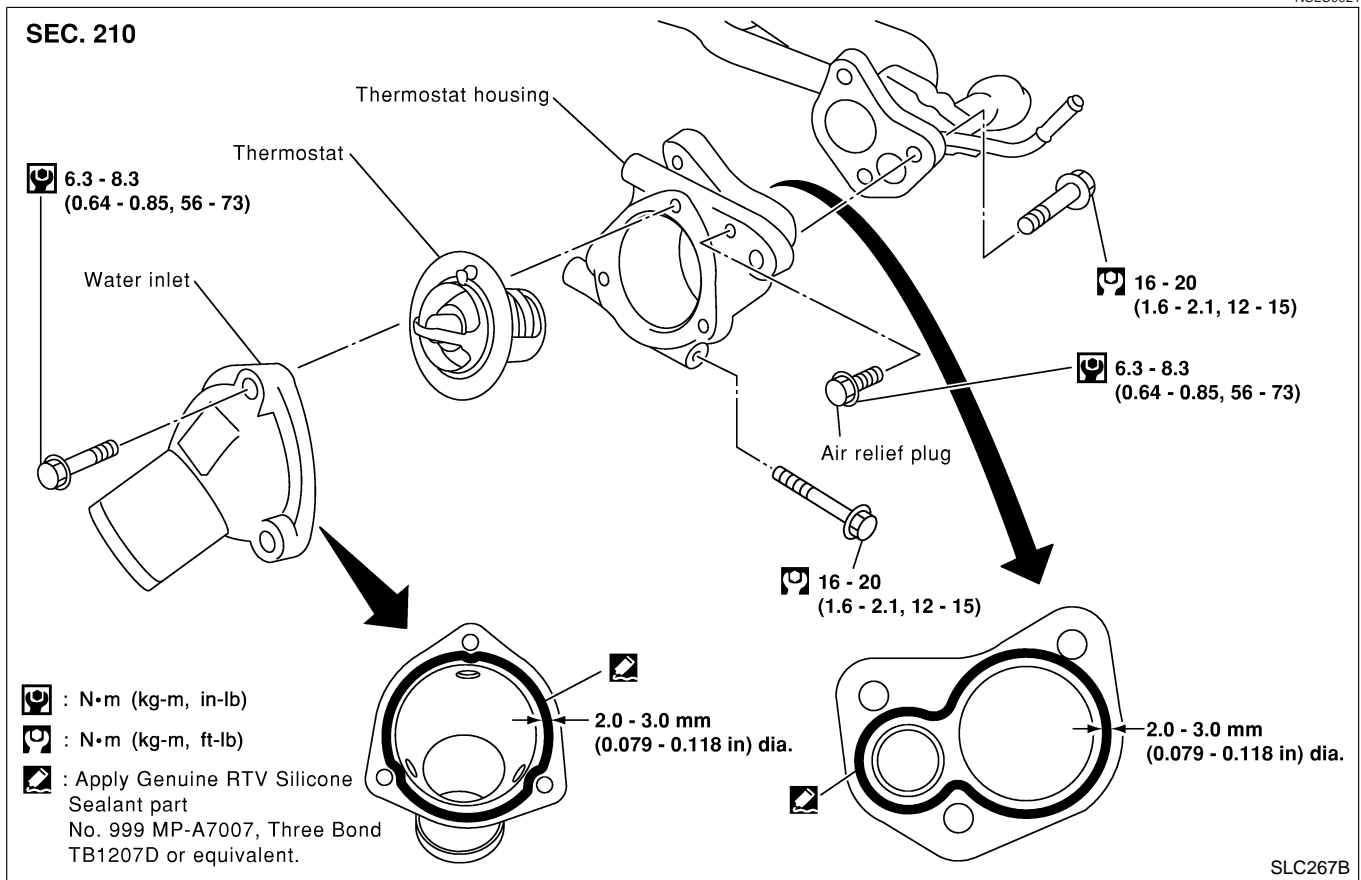

Be careful not to spill coolant over engine compartment. Use a rag to absorb coolant.

1. Drain engine coolant.
2. Remove lower radiator hose.
3. Remove water inlet, then take out thermostat.

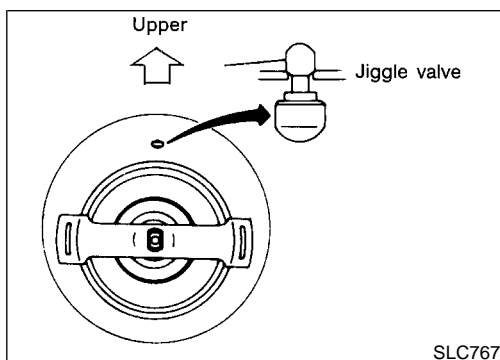

4. Install thermostat with jiggle valve or air bleeder at upper side.
 - Apply a continuous bead of liquid gasket to mating surface of water inlet.
 - After installation, run engine for a few minutes, and check for leaks.

ENGINE COOLING SYSTEM

Thermostat (Cont'd)

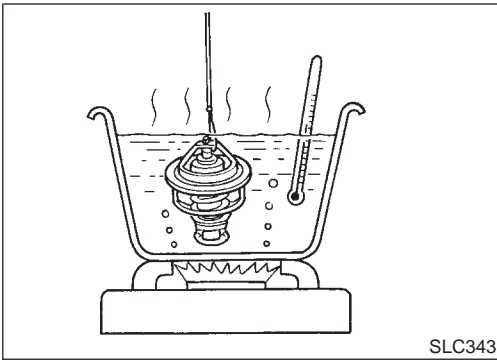

INSPECTION

1. Check for valve seating condition at normal room temperature. It should seat tightly. NCLC0022
2. Check valve opening temperature and valve lift.

Valve opening temperature °C (°F)	82 (180)
Valve lift mm/°C (in/°F)	More than 8/95 (0.31/203)

3. Then check if valve closes at 5°C (9°F) below valve opening temperature.

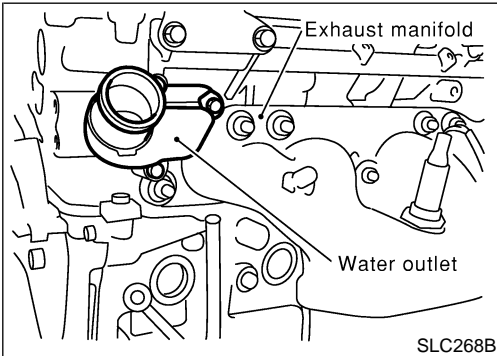

Water Outlet

INSPECTION

Visually inspect for water leaks. If there is leakage, apply liquid gasket. NCLC0023

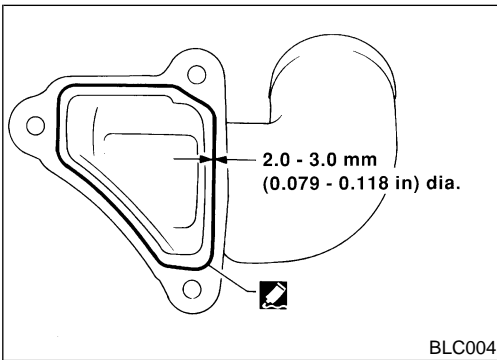

INSTALLATION

1. Use a scraper to remove old liquid gasket from water outlet.
 - Also remove traces of liquid gasket from mating surface of cylinder head.
2. Apply a continuous bead of liquid gasket to mating surface of water outlet.
 - Use Genuine RTV silicone sealant part No. 999MP-A7007 or equivalent.
 - When installing, tighten water outlet bolts to the specified torque.

: 6.3 - 8.3 N-m (0.64 - 0.85 kg-m, 55.6 - 73.8 in-lb)

GI
MA
EM
LC
EC
FE
CL
MT
AT
AX
SU
BR
ST
RS
BT
HA
SC
EL
IDX

ENGINE COOLING SYSTEM

Radiator

Radiator COMPONENTS

NCLC0025

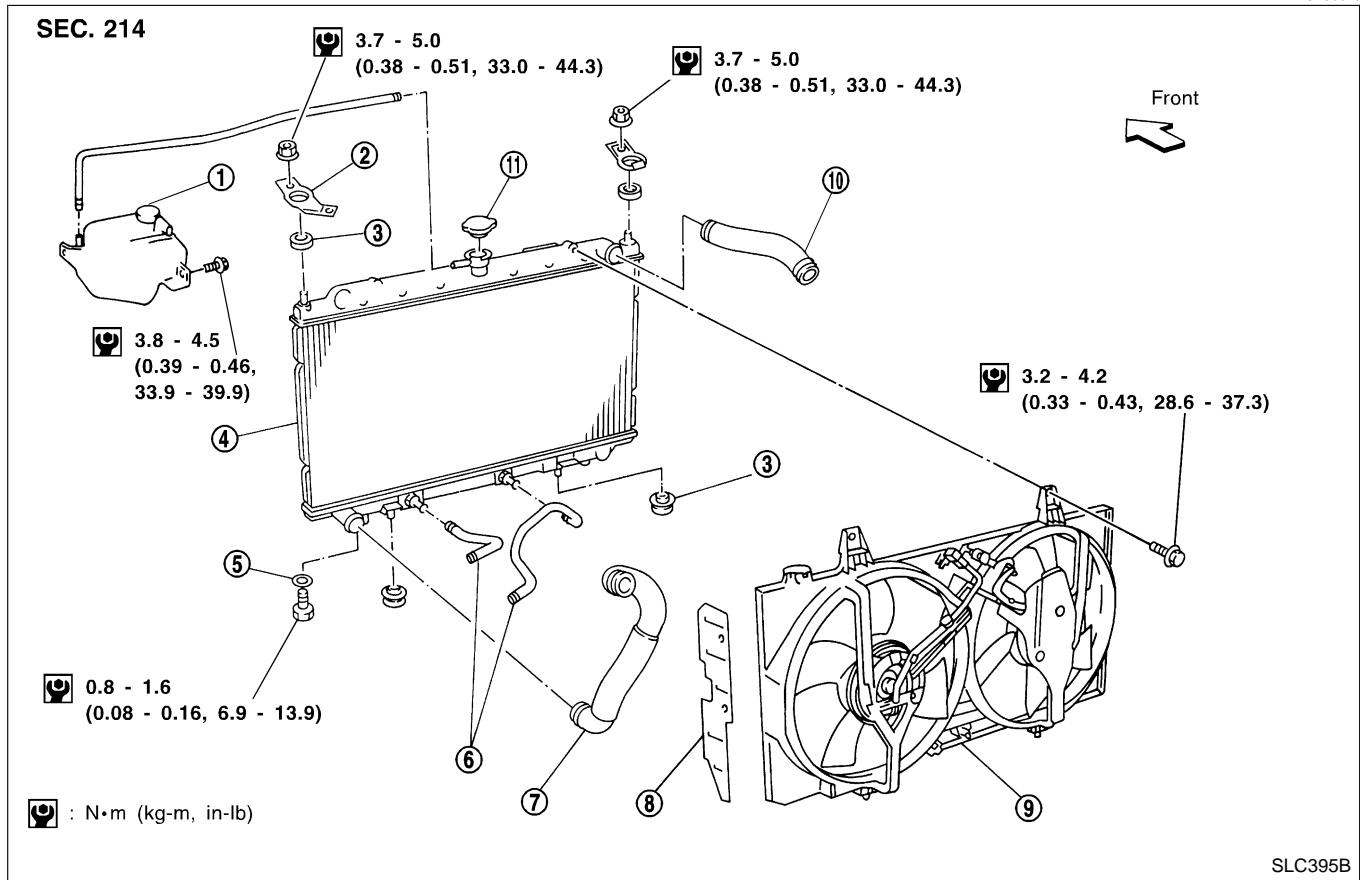

- | | | |
|---------------------|---------------------------------|-------------------------|
| 1. Reservoir tank | 5. Washer | 9. Cooling fan assembly |
| 2. Mounting bracket | 6. Oil cooler hose (A/T models) | 10. Upper hose |
| 3. Mounting rubber | 7. Lower hose | 11. Radiator cap |
| 4. Radiator | 8. Air guide plate | |

Cooling Fan Control System

Cooling fans are controlled by the ECM. For details, refer to EC-409, "Cooling Fan".

NCLC0026

Refilling Engine Coolant

For details on refilling engine coolant, refer to MA-14, "Changing Engine Coolant".

NCLC0027

GI

MA

EM

LC

Overheating Cause Analysis

NCLC0028

		Symptom		Check items				
Cooling system parts malfunction	Poor heat transfer	Water pump malfunction	Worn or loose drive belt	—	—	EC		
		Thermostat stuck closed	—			FE		
		Damaged fins	Dust contamination or paper clogging			—	—	CL
			Mechanical damage					MT
	Reduced air flow	Clogged radiator cooling tube	Excess foreign material (rust, dirt, sand, etc.)	—	—	AT		
		Cooling fan does not operate	High resistance to fan rotation			—	AX	
			Damaged fan blades			—	SU	
	Damaged radiator shroud	—	—	—	—	BR		
	Improper coolant mixture ratio	—	—	—	—	ST		
	Poor coolant quality	—	—	—	—	RS		
	Insufficient coolant	Coolant leaks	Cooling hose	Loose clamp	—	—	BT	
				Cracked hose			HA	
			Water pump	Poor sealing	—	—	SC	
				Radiator cap			Loose	EL
		Radiator	Poor sealing	—	—	EL		
O-ring for damage, deterioration or improper fitting			HA					
Cracked radiator tank	SC							
Reservoir tank	Cracked reservoir tank	—	—	—	EL			
Overflowing reservoir tank	Exhaust gas leaks into cooling system	Cylinder head deterioration	—	—	—	EL		
		Cylinder head gasket deterioration				IDX		

ENGINE COOLING SYSTEM

Overheating Cause Analysis (Cont'd)

		Symptom		Check items	
Except cooling system parts malfunction	—	Overload on engine	Abusive driving	High engine rpm under no load	—
				Driving in low gear for extended time	
				Driving at extremely high speed	
			Powertrain system malfunction		
			Installed improper size wheels and tires		
				Dragging brakes	
				Improper ignition timing	
	Blocked or restricted air flow	Blocked bumper	—		—
		Blocked radiator grille	Installed car brassiere		
			Mud contamination or paper clogging		
Blocked radiator		—			
Blocked condenser		—			
	Installed large fog lamp	—			

Service Data and Specifications (SDS)

THERMOSTAT

NCLC0029

Valve opening temperature °C (°F)	82 (180)
Valve lift mm/°C (in/°F)	More than 8/95 (0.31/203)

RADIATOR

Unit: kPa (kg/cm², psi) ^{NCLC0030}

Cap relief pressure	Standard	78 - 98 (0.8 - 1.0, 11 - 14)
	Limit	59 - 98 (0.6 - 1.0, 9 - 14)
Leakage test pressure		157 (1.6, 23)