

ENGINE MECHANICAL

SECTION **EM**

GI

MA

EM

LC

EC

FE

CL

MT

AT

AX

SU

BR

ST

RS

BT

HA

SC

EL

IDX

CONTENTS

| | | | |
|---|----|--|----|
| PRECAUTIONS | 3 | VALVE SEATS..... | 39 |
| Parts Requiring Angular Tightening..... | 3 | REPLACING VALVE SEAT FOR SERVICE PARTS | 40 |
| Liquid Gasket Application Procedure | 3 | VALVE DIMENSIONS..... | 41 |
| PREPARATION | 4 | VALVE SPRING..... | 41 |
| Special Service Tools | 4 | HYDRAULIC LASH ADJUSTER | 41 |
| Commercial Service Tools | 6 | ROCKER ARM, SHIM AND ROCKER ARM GUIDE.... | 42 |
| NOISE, VIBRATION AND HARSHNESS (NVH) | | Assembly | 42 |
| TROUBLESHOOTING | 8 | Installation..... | 46 |
| NVH Troubleshooting - Engine Noise | 9 | ENGINE ASSEMBLY | 55 |
| OUTER COMPONENT PARTS | 10 | Removal and Installation | 55 |
| Removal and Installation | 10 | REMOVAL..... | 56 |
| MEASUREMENT OF COMPRESSION PRESSURE | 13 | INSTALLATION..... | 57 |
| OIL PAN | 14 | CYLINDER BLOCK | 58 |
| Components..... | 14 | Components..... | 58 |
| Removal..... | 14 | Removal and Installation | 59 |
| Installation..... | 16 | Disassembly..... | 59 |
| TIMING CHAIN | 19 | PISTON AND CRANKSHAFT..... | 59 |
| Components..... | 19 | Inspection..... | 59 |
| Removal..... | 20 | PISTON AND PISTON PIN CLEARANCE | 59 |
| Inspection..... | 23 | PISTON RING SIDE CLEARANCE | 60 |
| Installation..... | 23 | PISTON RING END GAP..... | 61 |
| OIL SEAL | 28 | CONNECTING ROD BEND AND TORSION | 61 |
| Replacement..... | 28 | CYLINDER BLOCK DISTORTION AND WEAR..... | 61 |
| VALVE OIL SEAL..... | 28 | PISTON-TO-BORE CLEARANCE | 62 |
| FRONT OIL SEAL..... | 28 | CRANKSHAFT..... | 63 |
| REAR OIL SEAL | 29 | BEARING CLEARANCE | 63 |
| CYLINDER HEAD | 30 | CONNECTING ROD BUSHING CLEARANCE | |
| Components..... | 30 | (SMALL END)..... | 66 |
| Removal..... | 31 | REPLACEMENT OF CONNECTING ROD | |
| Disassembly..... | 34 | BUSHING (SMALL END) | 66 |
| Inspection..... | 36 | REPLACEMENT OF PILOT BUSHING (M/T) OR | |
| CYLINDER HEAD DISTORTION | 36 | PILOT CONVERTER (A/T)..... | 66 |
| CAMSHAFT VISUAL CHECK..... | 36 | FLYWHEEL/DRIVE PLATE RUNOUT | 67 |
| CAMSHAFT RUNOUT..... | 36 | Assembly | 67 |
| CAMSHAFT CAM HEIGHT | 36 | PISTON | 67 |
| CAMSHAFT JOURNAL CLEARANCE | 37 | CRANKSHAFT..... | 68 |
| CAMSHAFT END PLAY..... | 37 | SERVICE DATA AND SPECIFICATIONS (SDS) | 71 |
| CAMSHAFT SPROCKET RUNOUT | 38 | General Specifications..... | 71 |
| VALVE GUIDE CLEARANCE | 38 | Compression Pressure | 71 |
| VALVE GUIDE REPLACEMENT | 38 | Cylinder Head | 71 |
| | | Valve | 72 |

CONTENTS (Cont'd)

| | | | |
|--|----|--------------------------------|----|
| VALVE | 72 | PISTON PIN | 78 |
| VALVE SPRING | 72 | Connecting Rod | 79 |
| HYDRAULIC LASH ADJUSTER (HLA) | 72 | Crankshaft | 80 |
| VALVE GUIDE | 73 | Main Bearing | 81 |
| VALVE SHIM CLEARANCE ADJUSTMENT | 73 | STANDARD | 81 |
| AVAILABLE SHIM | 74 | UNDERSIZE | 81 |
| VALVE SEAT | 75 | Connecting Rod Bearing | 81 |
| VALVE SEAT RESURFACE LIMIT | 76 | STANDARD SIZE | 81 |
| Camshaft and Camshaft Bearing | 76 | UNDERSIZE | 81 |
| Cylinder Block | 77 | Bearing Clearance | 82 |
| Piston, Piston Ring and Piston pin | 78 | Miscellaneous Components | 82 |
| PISTON | 78 | | |
| PISTON RING | 78 | | |

PRECAUTIONS

Parts Requiring Angular Tightening

Parts Requiring Angular Tightening

NCEM0001

- Use an angle wrench for the final tightening of the following engine parts:
 - a) Cylinder head bolts
 - b) Main bearing cap bolts
 - c) Connecting rod cap nuts
- Do not use a torque value for final tightening.
- The torque value for these parts are for a preliminary step.
- Ensure thread and seat surfaces are clean and coated with engine oil.

GI

MA

EM

LC

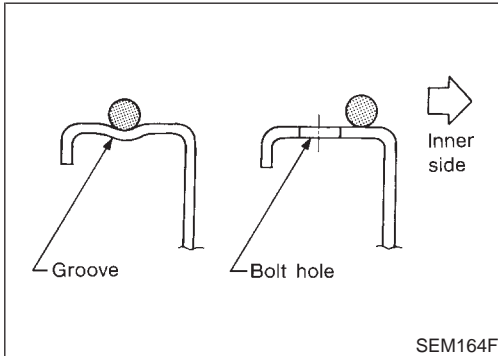

SEM164F

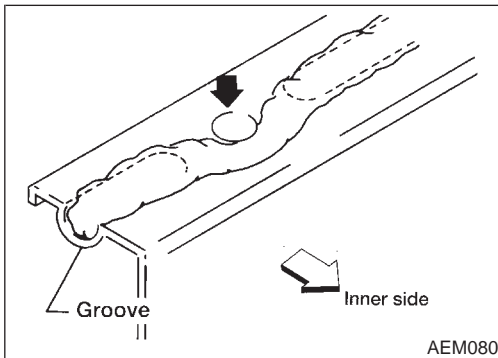

AEM080

Liquid Gasket Application Procedure

NCEM0002

1. Use a scraper to remove old liquid gasket from mating surfaces and grooves. Also, completely clean any oil from these areas.
2. Apply a continuous bead of liquid gasket to mating surfaces. (Use Genuine RTV silicone sealant part No. 999MP-A7007 or equivalent.)
 - For oil pan, be sure liquid gasket diameter is 4.0 to 5.0 mm (0.157 to 0.197 in).
 - For areas except oil pan, be sure liquid gasket diameter is 2.0 to 3.0 mm (0.079 to 0.118 in).
3. Apply liquid gasket around the inner side of bolt holes (unless otherwise specified).
4. Assembly should be done within 5 minutes after coating.
5. Wait at least 30 minutes before refilling engine oil and engine coolant.

EC

FE

CL

MT

AT

AX

SU

BR

ST

RS

BT

HA

SC

EL

IDX

PREPARATION

Special Service Tools

Special Service Tools

NCEM0003

The actual shapes of Kent-Moore tools may differ from those of special service tools illustrated here.

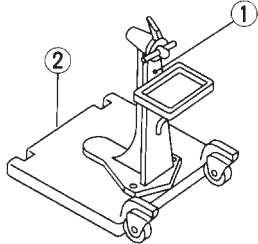
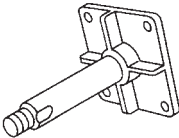
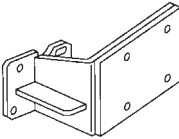
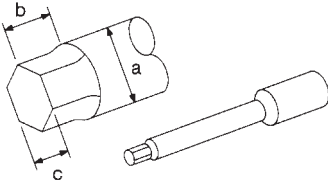
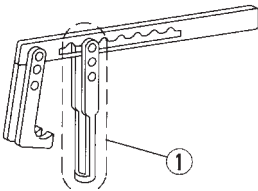
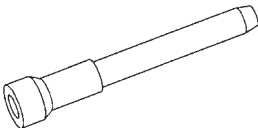
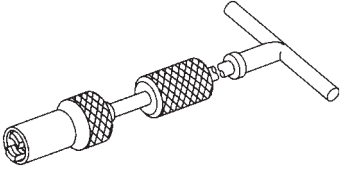
| Tool number (Kent-Moore No.) Tool name | Description | |
|--|--|--|
| ST0501S000 (—) Engine stand assembly 1 ST05011000 (—) Engine stand 2 ST05012000 (—) Base |  <p>NT042</p> | Disassembling and assembling |
| KV10106500 (—) Engine stand shaft |  <p>NT028</p> | |
| KV10115300 (—) Engine sub-attachment |  <p>NT008</p> | |
| ST10120000 (J24239-01) Cylinder head bolt wrench |  <p>NT583</p> | Loosening and tightening cylinder head bolt a: 13 (0.51) dia. b: 12 (0.47) c: 10 (0.39) Unit: mm (in) |
| KV10116200 (J26336-B) Valve spring compressor 1 KV10115900 (J26336-20) Attachment |  <p>NT022</p> | Disassembling valve mechanism |
| KV10115600 (J38958) Valve oil seal drift |  <p>NT024</p> | Installing valve oil seal |
| KV10107902 (J38959) Valve oil seal puller |  <p>NT011</p> | Displacement valve lip seal |

PREPARATION

Special Service Tools (Cont'd)

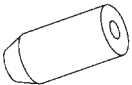
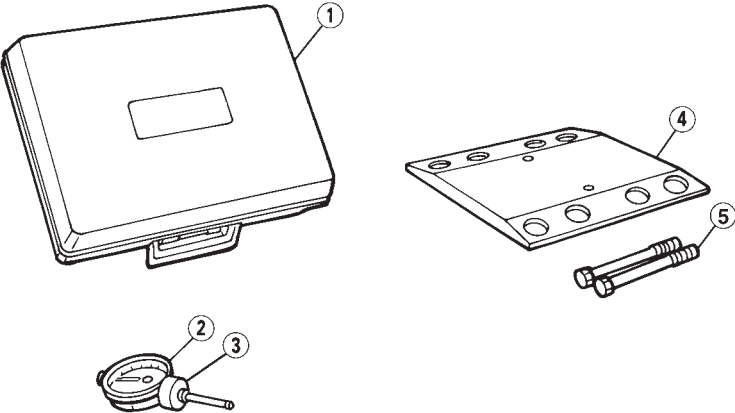
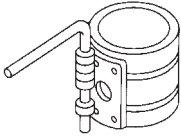
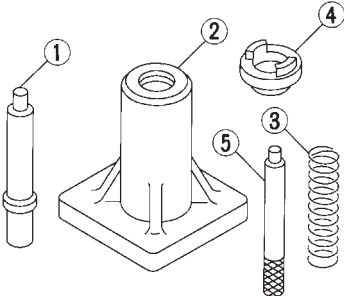
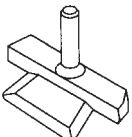
| Tool number (Kent-Moore No.) Tool name | Description | |
|---|--|---|
| KV10115700 (J38957) Dial gauge stand |  <p>Adjusting shims</p> <p>NT012</p> | GI MA |
| (J38957-N) Valve shim gauge plate kit 1 — (J35772) Plastic case 2 — (J38957-8) Dial indicator 3 — (J38957-2) Collar 4 — (J38957-1) Plate 5 — (—) Hex bolts |  <p>Measuring valve shims</p> <p>AEM274</p> | EM LC EC FE CL MT AT |
| EM03470000 (J8037) Piston ring compressor |  <p>Installing piston assembly into cylinder bore</p> <p>NT044</p> | AX SU |
| KV10107400 (J26365-12, J26365) Piston pin press stand 1 KV10107310 (—) Center shaft 2 ST13040020 (—) Stand 3 ST13040030 (—) Spring 4 KV10107320 (—) Cap 5 ST13040050 (—) Drift |  <p>Disassembling and assembling piston pin</p> <p>NT013</p> | BR ST RS BT HA SC |
| KV10111100 (J37228) Seal cutter |  <p>Removing oil pan</p> <p>NT046</p> | EL IDX |

PREPARATION

Special Service Tools (Cont'd)

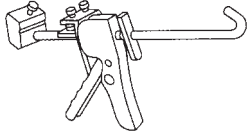
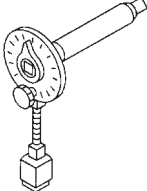
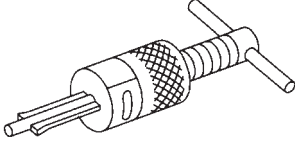
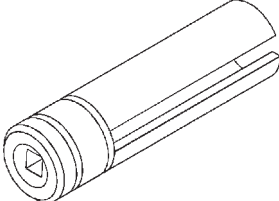
| Tool number (Kent-Moore No.) Tool name | Description | |
|--|--|---|
| WS39930000 (—) Tube presser |  | Pressing the tube of liquid gasket |
| KV10112100 (BT-8653-A) Angle wrench |  | Tightening bolts for bearing cap, cylinder head, etc. |
| ST16610001 (J23907) Pilot bushing puller |  | Removing pilot bushing |
| (J36471-A) Front (heated) oxygen sensor wrench |  | Loosening or tightening front (heated) oxygen sensor |

Commercial Service Tools

NCEM0004

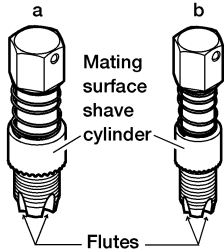
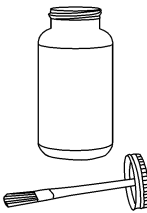
| Tool number (Kent-Moore No.) Tool name | Description | |
|--|---|---|
| (J-43897-18) (J-43897-12) Oxygen sensor thread cleaner |  | Reconditioning the exhaust system threads before installing a new oxygen sensor (Use with anti-seize lubricant shown below.) a: J-43897-18 [18 mm (0.71 in) dia.] for zirconia oxygen sensor b: J-43897-12 [12 mm (0.47 in) dia.] for titania oxygen sensor |
| Anti-seize lubricant (Permatex 133AR or equivalent meeting MIL specification MIL-A-907) |  | Lubricating oxygen sensor thread cleaning tool when reconditioning exhaust system threads |

PREPARATION

Commercial Service Tools (Cont'd)

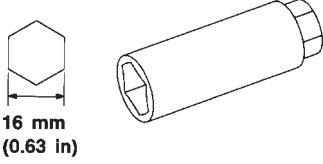
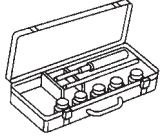
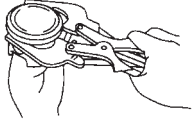
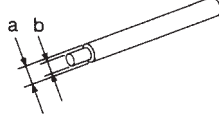
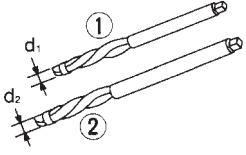
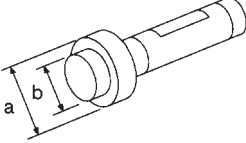
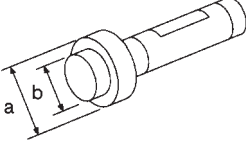
| Tool number (Kent-Moore No.) Tool name | Description | |
|--|---|--------------------------------------|
| Spark plug wrench |  <p>16 mm (0.63 in)</p> <p>NT047</p> | <p>GI</p> <p>MA</p> <p>EM</p> |
| Valve seat cutter set |  <p>NT048</p> | <p>LC</p> <p>EC</p> <p>FE</p> |
| Piston ring expander |  <p>NT030</p> | <p>CL</p> <p>MT</p> |
| Valve guide drift |  <p>NT015</p> | <p>AT</p> <p>AX</p> |
| Valve guide reamer |  <p>NT016</p> | <p>SU</p> <p>BR</p> |
| Front oil seal drift |  <p>NT049</p> | <p>ST</p> <p>RS</p> |
| Rear oil seal drift |  <p>NT049</p> | <p>BT</p> <p>HA</p> <p>SC</p> |

NOISE, VIBRATION AND HARSHNESS (NVH) TROUBLESHOOTING

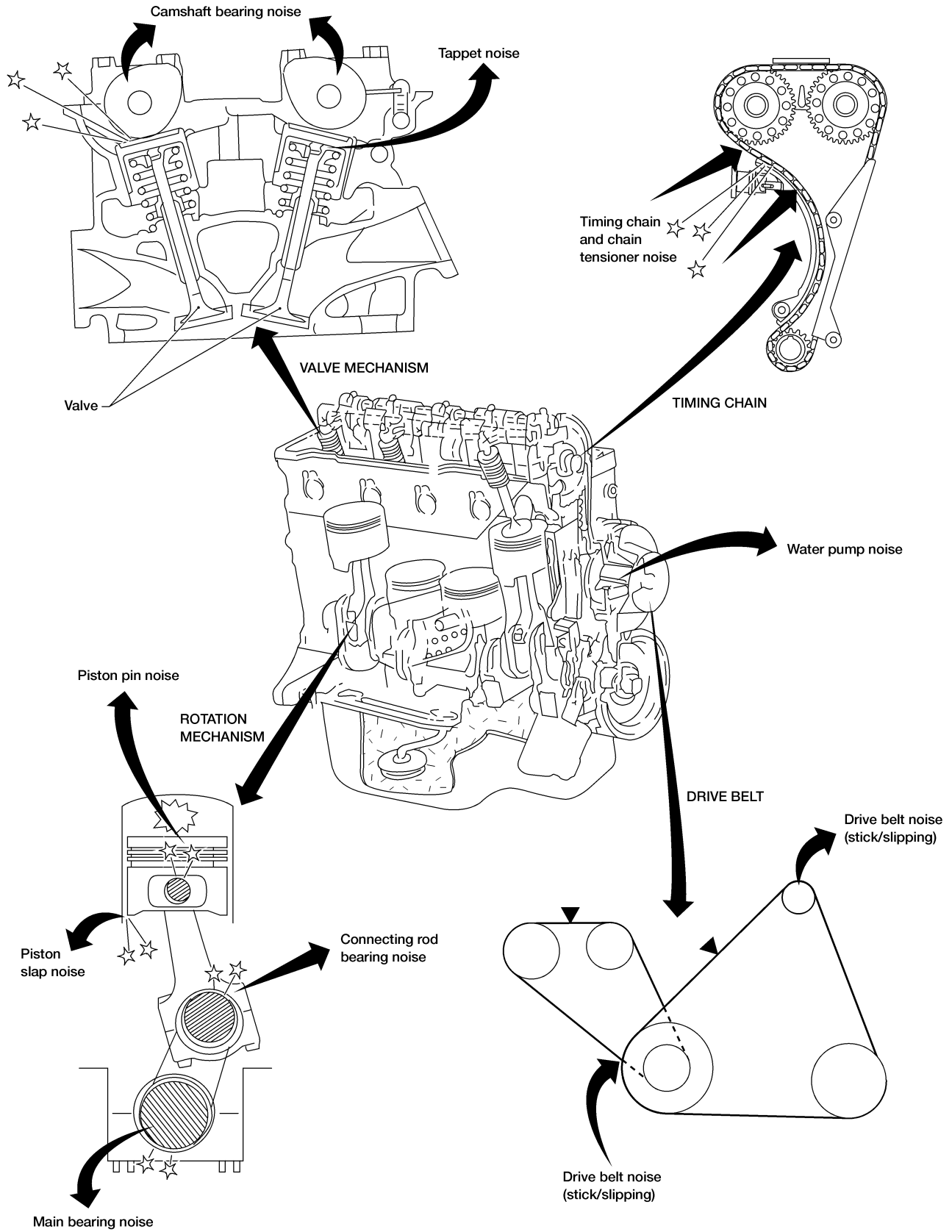

NOISE, VIBRATION AND HARSHNESS (NVH) TROUBLESHOOTING

Use the table below to help you find the cause of the symptom.

1. Locate the area where noise occurs.
2. Confirm the type of noise.
3. Specify the operating condition of the engine.
4. Check the specified noise source.

If necessary, repair or replace these parts.

NVH Troubleshooting — Engine Noise

NCEM0005S01

| Location of noise | Type of noise | Operating condition of engine | | | | | | Source of noise | Check item | Reference page |
|---|----------------------|-------------------------------|---------------|---------------|-------------|-------------|---------------|--|--|-----------------------------------|
| | | Before warm-up | After warm-up | When starting | When idling | When racing | While driving | | | |
| Top of engine Rocker cover Cylinder head | Ticking or clicking | C | A | — | A | B | — | Tappet noise | Hydraulic lash adjuster | EM-41 |
| | Rattle | C | A | — | A | B | C | Camshaft bearing noise | Camshaft journal clearance Camshaft runout | EM-36, 37 |
| Crankshaft pulley Cylinder block (Side of engine) Oil pan | Slap or knock | — | A | — | B | B | — | Piston pin noise | Piston and piston pin clearance Connecting rod bushing clearance | EM-59, 66 |
| | Slap or rap | A | — | — | B | B | A | Piston slap noise | Piston-to-bore clearance Piston ring side clearance Piston ring end gap Connecting rod bend and torsion | EM-62, 60 |
| | Knock | A | B | C | B | B | B | Connecting rod bearing noise | Connecting rod bushing clearance (Small end) Connecting rod bearing clearance (Big end) | EM-65, 66 |
| | Knock | A | B | — | A | B | C | Main bearing noise | Main bearing oil clearance Crankshaft runout | EM-63, 63 |
| Front of engine Timing chain cover | Tapping or ticking | A | A | — | B | B | B | Timing chain and chain tensioner noise | Timing chain cracks and wear | EM-23 |
| Front of engine | Squeaking or fizzing | A | B | — | B | — | C | Other drive belts (Sticking or slipping) | Drive belt deflection | MA-13, "Checking Drive Belts" |
| | Creaking | A | B | A | B | A | B | Other drive belts (Slipping) | Idler pulley bearing operation | |
| | Squall Creak | A | B | — | B | A | B | Water pump noise | Water pump operation | LC-11, "Water Pump Inspection" |

A: Closely related B: Related C: Sometimes related —: Not related

OUTER COMPONENT PARTS

Removal and Installation (Cont'd)

SEC. 140•146•147•148•163•164•210•226

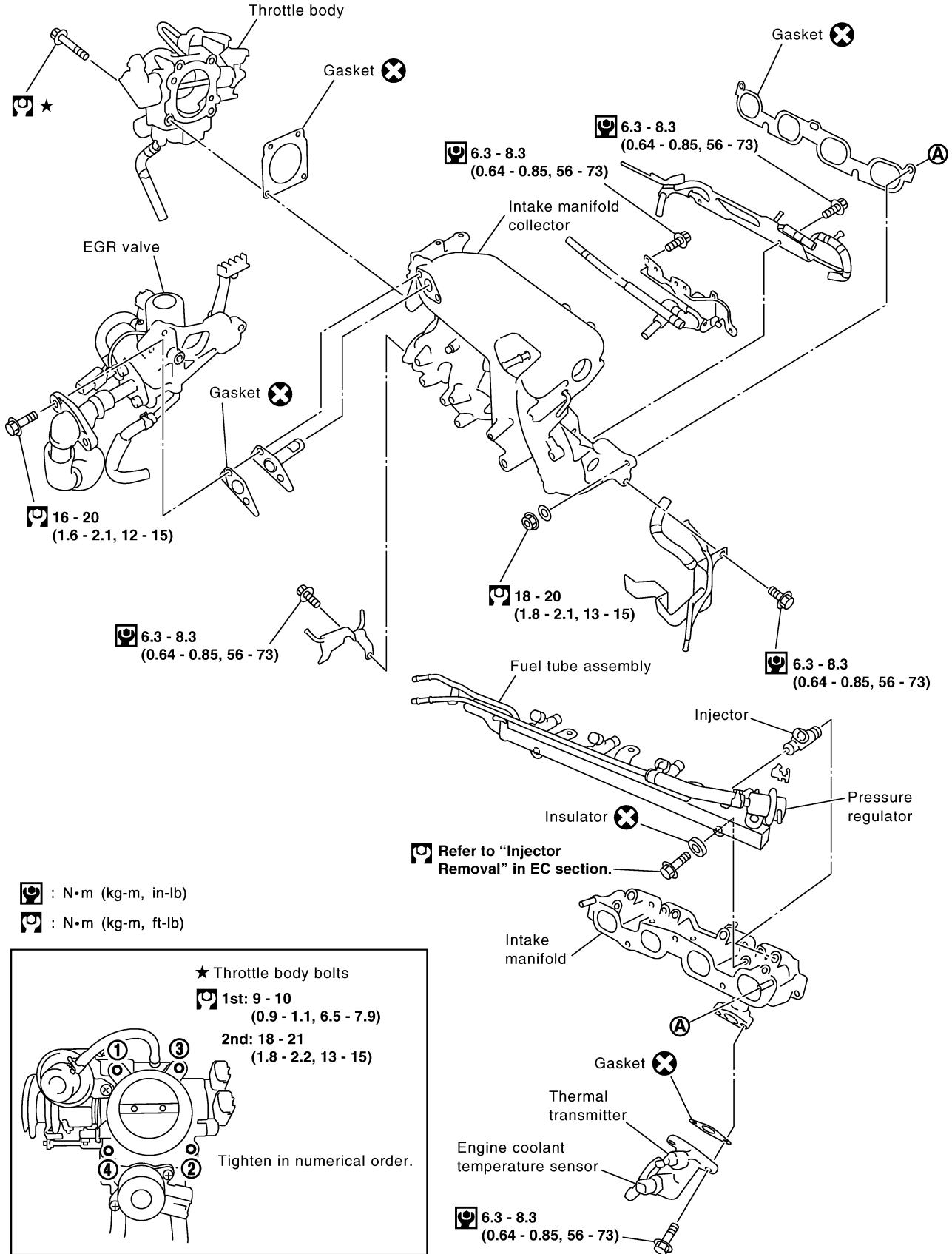

\star : N·m (kg-m, in-lb)

\square : N·m (kg-m, ft-lb)

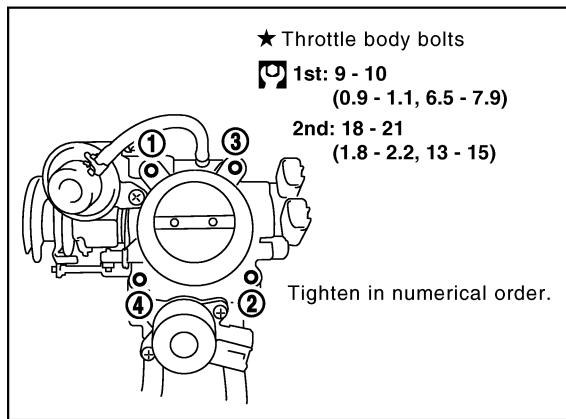

GI

MA

EM

LC

EC

FE

CL

MT

AT

AX

SU

BR

ST

RS

BT

HA

SC

EL

IDX

SEM018G

OUTER COMPONENT PARTS

Removal and Installation (Cont'd)

SEC. 140•230•275

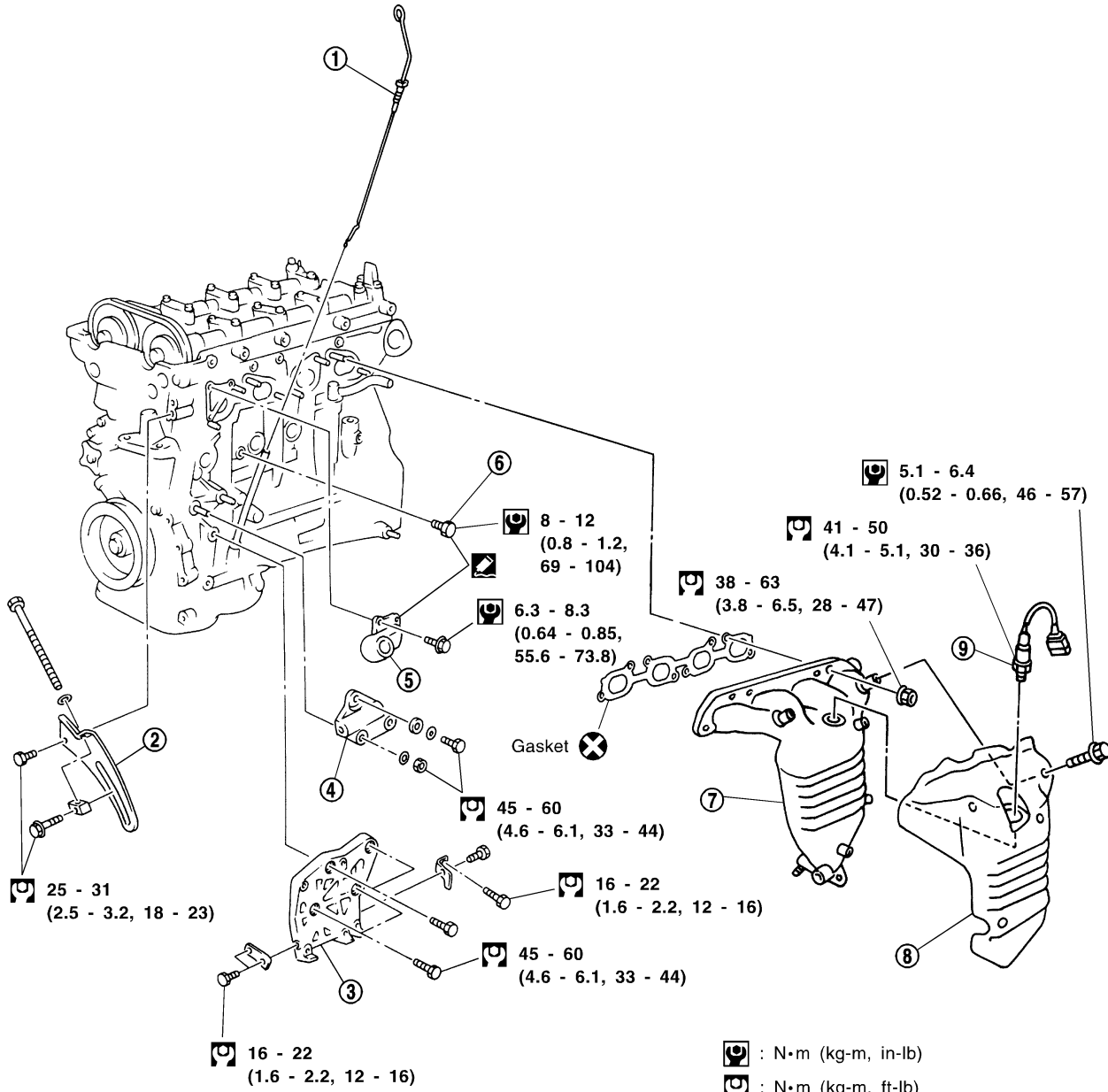

SEM019GA

- | | | |
|----------------------------|------------------------------|---|
| 1. Oil level gauge | 4. Generator bracket | 7. Exhaust manifold (With three way catalyst) |
| 2. Generator adjusting bar | 5. Water outlet | 8. Exhaust manifold cover |
| 3. A/C compressor bracket | 6. Cylinder block drain plug | 9. Heated oxygen sensor |

MEASUREMENT OF COMPRESSION PRESSURE

1. Warm up engine.
2. Turn ignition switch OFF.
3. Release fuel pressure.
Refer to EC-50, "Fuel Pressure Release".
4. Remove all spark plugs.
5. Disconnect distributor coil connector.

GI

MA

EM

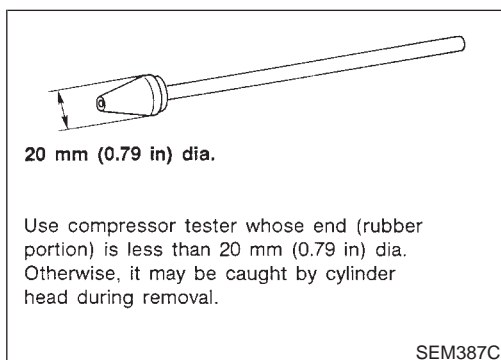
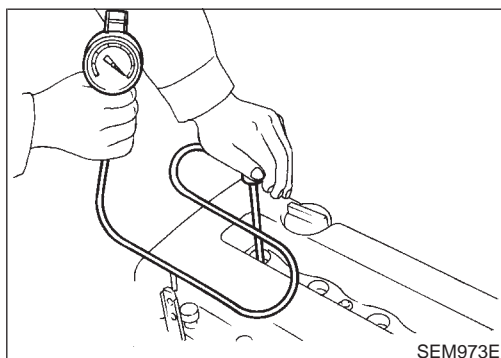

6. Attach a compression tester to No. 1 cylinder.
7. Depress accelerator pedal fully to keep throttle valve wide open.
8. Crank engine and record highest gauge indication.
9. Repeat the measurement on each cylinder.
- **Always use a fully-charged battery to obtain specified engine speed.**

Compression pressure: kPa (kg/cm², psi)/rpm
Standard

1,275 (13.0, 185)/300

Minimum

1,079 (11.0, 156)/300

Difference limit between cylinders

98 (1.0, 14)/300

10. If compression in one or more cylinders is low:
 - a. Pour a small amount of engine oil into cylinders through spark plug holes.
 - b. Retest compression.
- **If adding oil helps compression, piston rings may be worn or damaged. If so, replace piston rings after checking piston.**
- **If pressure stays low, a valve may be sticking or seating improperly. Inspect and repair valve and valve seat. Refer to SDS, EM-75. If valve or valve seat is damaged excessively, replace them.**
- **If compression stays low in two cylinders that are next to each other:**
 - a) **The cylinder head gasket may be leaking, or**
 - b) **Both cylinders may have valve component damage. Inspect and repair as necessary.**

LC

EC

FE

CL

MT

AT

AX

SU

BR

ST

RS

BT

HA

SC

EL

IDX

OIL PAN

Components

Components

NCEM0008

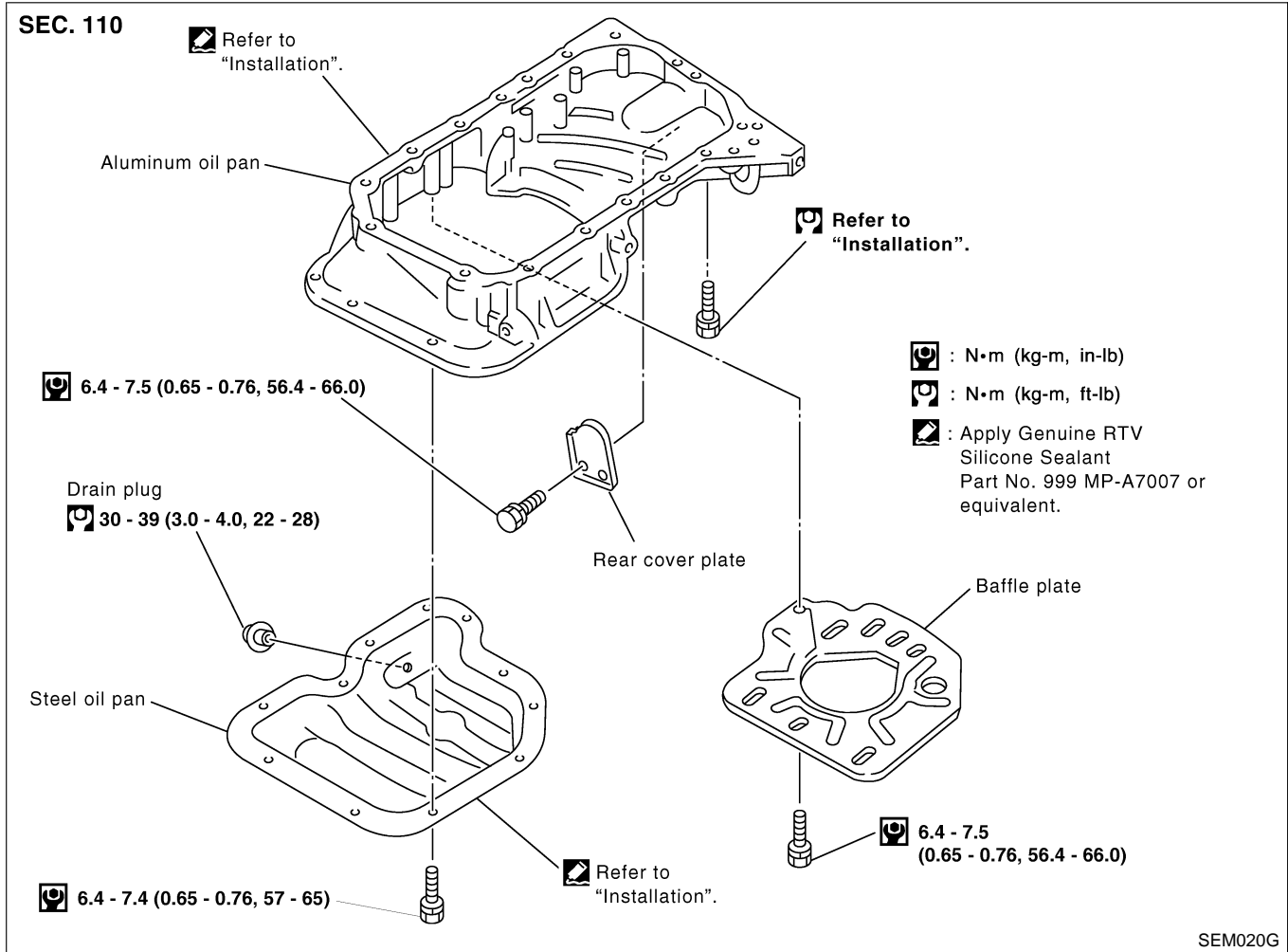

Removal

NCEM0009

1. Remove engine side cover.
2. Drain engine oil.

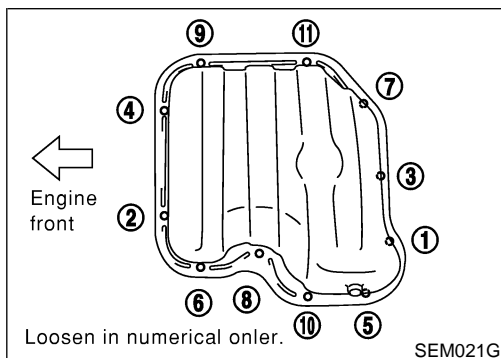

3. Remove steel oil pan bolts in numerical order.

OIL PAN

Removal (Cont'd)

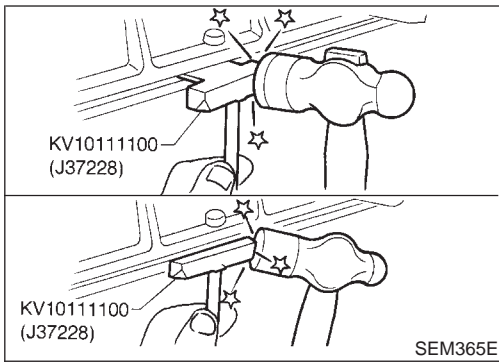

4. Remove steel oil pan.
 - a. Insert Tool between aluminum oil pan and steel oil pan.
 - **Be careful not to damage aluminum mating surface.**
 - **Do not insert screwdriver, or oil pan flange will be damaged.**
 - b. Slide Tool by tapping on the side of the Tool with a hammer.
 - c. Remove steel oil pan.

GI

MA

EM

LC

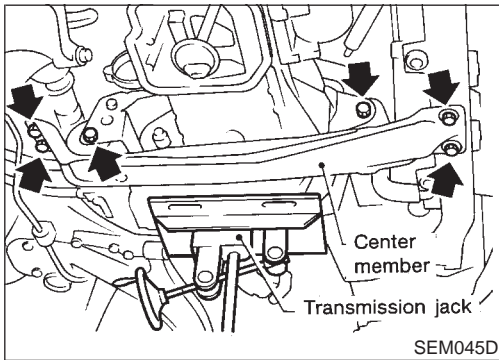

5. Remove front exhaust tube. Refer to FE-8, "EXHAUST SYSTEM".
6. Set a suitable transmission jack under transaxle and lift engine with engine slinger.
7. Remove center member.
8. Remove A/T control cable. (A/T only)

EC

FE

CL

MT

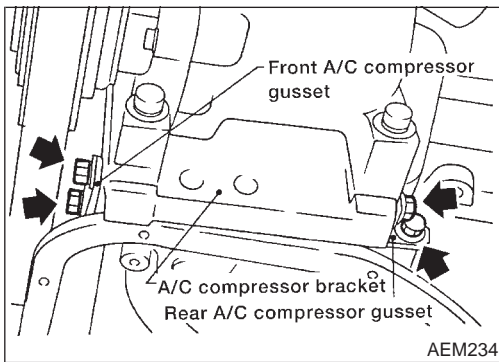

9. Remove A/C compressor gussets.

AT

AX

SU

BR

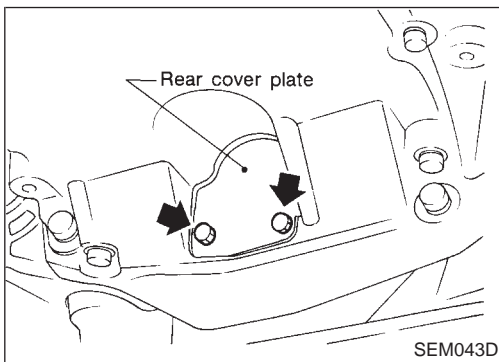

10. Remove rear cover plate.

ST

RS

BT

HA

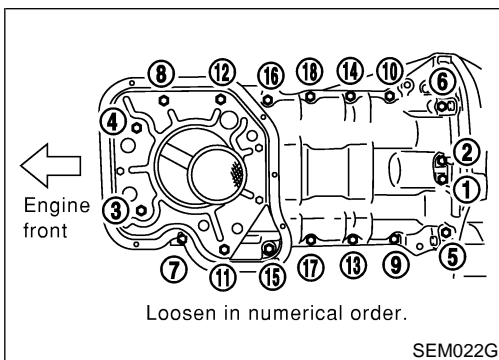

11. Remove aluminum oil pan bolts in numerical order.

SC

EL

IDX

OIL PAN

Removal (Cont'd)

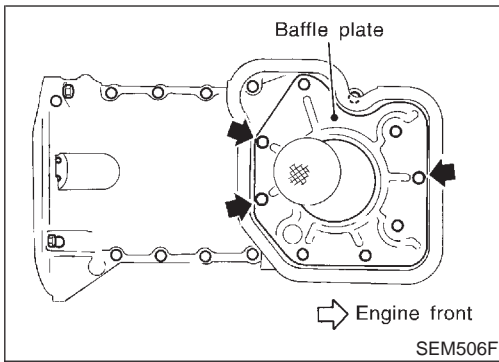

12. Remove baffle plate.

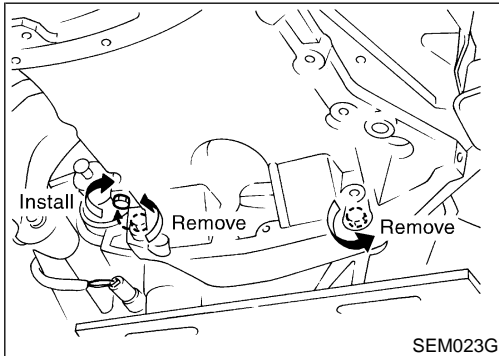

13. Remove two engine-to-transaxle bolts and install one of them into open bolt hole as shown. Tighten installed bolt to separate aluminum oil pan from cylinder block.

14. Remove aluminum oil pan.

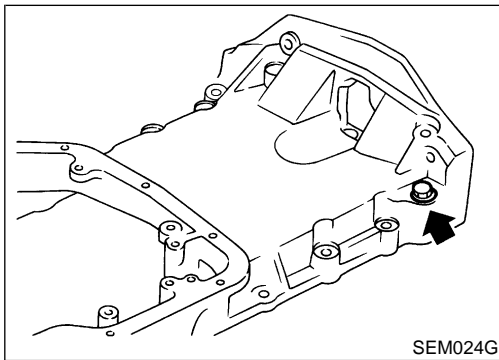

15. Remove the engine-to-transaxle bolts previously installed in aluminum oil pan.

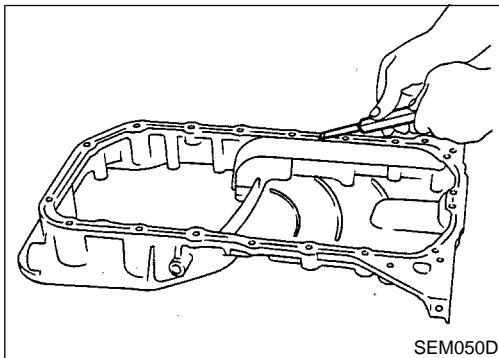

Installation

NCEM0010

1. Install aluminum oil pan.

a. Use a scraper to remove old liquid gasket from mating surfaces.

- Also remove old liquid gasket from mating surfaces of cylinder block and front cover.

b. Apply a continuous bead of liquid gasket to mating surface of aluminum oil pan.

- Use Genuine RTV silicone sealant part No. 999MP-A7007 or equivalent.

- Apply to groove on mating surface.

- Allow 7 mm (0.28 in) clearance around bolt holes.

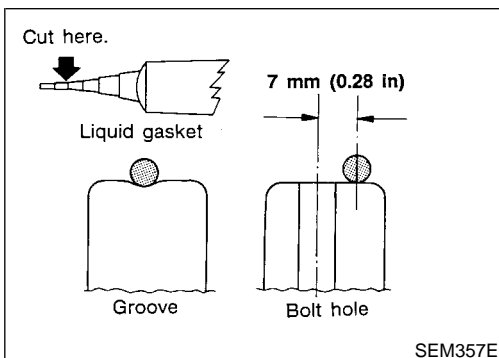

OIL PAN

Installation (Cont'd)

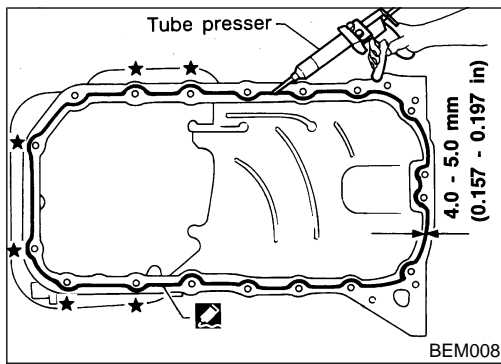

- For areas marked with “★”, apply liquid gasket around the outer side of the bolt hole as shown.
- Be sure liquid gasket diameter is 4.0 to 5.0 mm (0.157 to 0.197 in).
- Attaching should be done within 5 minutes after coating.

GI
MA
EM

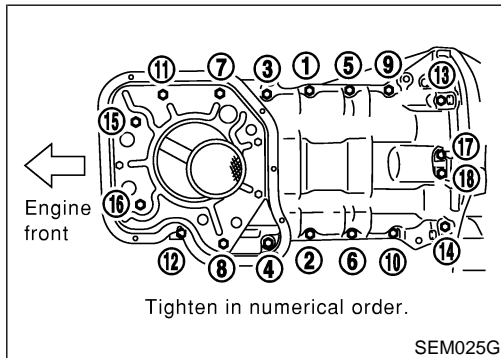

c. Tighten nuts and bolts in numerical order.

Bolts 1 - 16:

☞ : 16 - 19 N·m (1.6 - 1.9 kg·m, 12 - 14 ft·lb)

Bolts 17, 18:

☞ : 6.4 - 7.5 N·m (0.65 - 0.76 kg·m, 56.4 - 66.0 in·lb)

LC
EC
FE
CL
MT

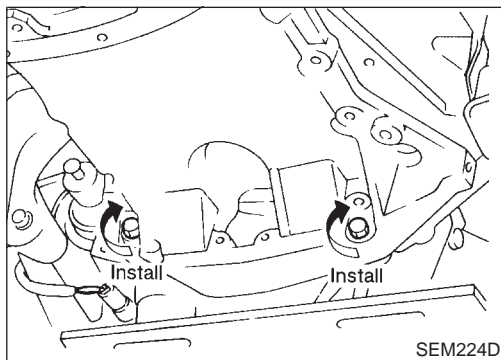

2. Install the two engine-to-transaxle bolts.
For tightening torque, refer to MT-12 or AT-283, “REMOVAL AND INSTALLATION”.
3. Install rear cover plate.

AT
AX
SU
BR

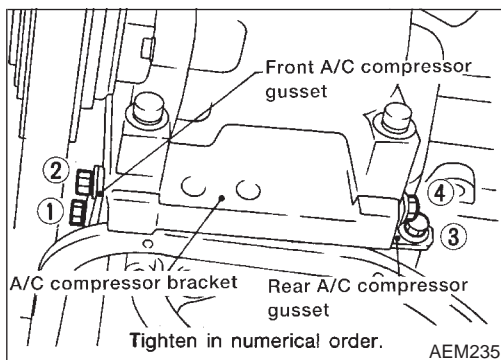

4. Install A/C compressor gussets.
5. Install A/T control cable. (A/T only)
6. Install center member.
7. Install front exhaust tube.
8. Install baffle plate.

ST
RS
BT
HA

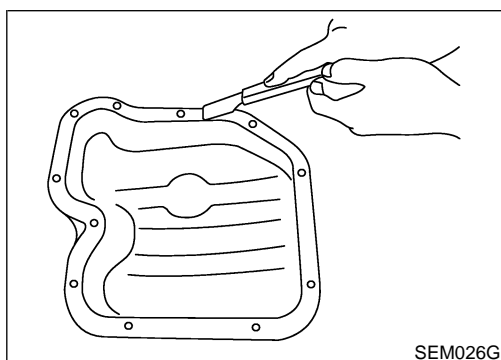

9. Install steel oil pan.
 - a. Use a scraper to remove old liquid gasket from mating surface of steel oil pan.
- Also remove old liquid gasket from mating surface of aluminum oil pan.

SC
EL
IDX

OIL PAN

Installation (Cont'd)

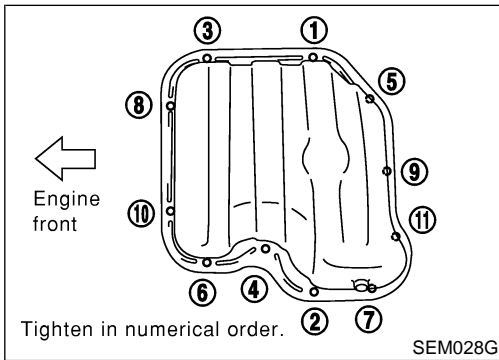
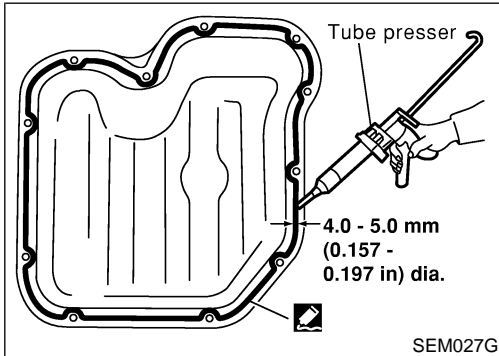
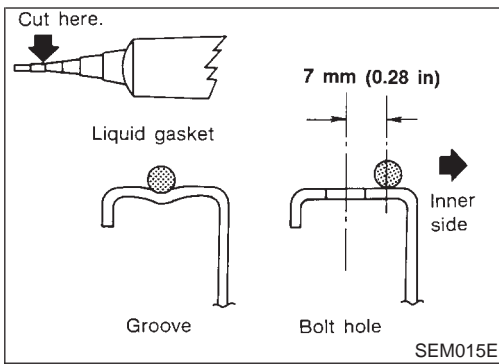

- b. Apply a continuous bead of liquid gasket to mating surface of steel oil pan.
- Use Genuine RTV silicone sealant part No. 999MP-A7007 or equivalent.
 - Apply to groove on mating surface.
 - Allow 7 mm (0.28 in) clearance around bolt hole.
- Be sure liquid gasket diameter is 4.0 to 5.0 mm (0.157 to 0.197 in).
- Attaching should be done within 5 minutes after coating.
- c. Tighten bolts in numerical order as shown.
- Wait at least 30 minutes before refilling engine oil.

TIMING CHAIN

Components

Components

NCEM0011

CAUTION:

- After removing timing chain, do not turn crankshaft and camshaft separately, or valves will strike piston heads.
- When installing rocker arms, camshafts, chain tensioner, oil seals, or other sliding parts, lubricate contacting surfaces with new engine oil.
- Apply new engine oil to bolt threads and seat surfaces when installing, camshaft sprockets, crankshaft pulley, and camshaft brackets.

SEC. 120•130•135

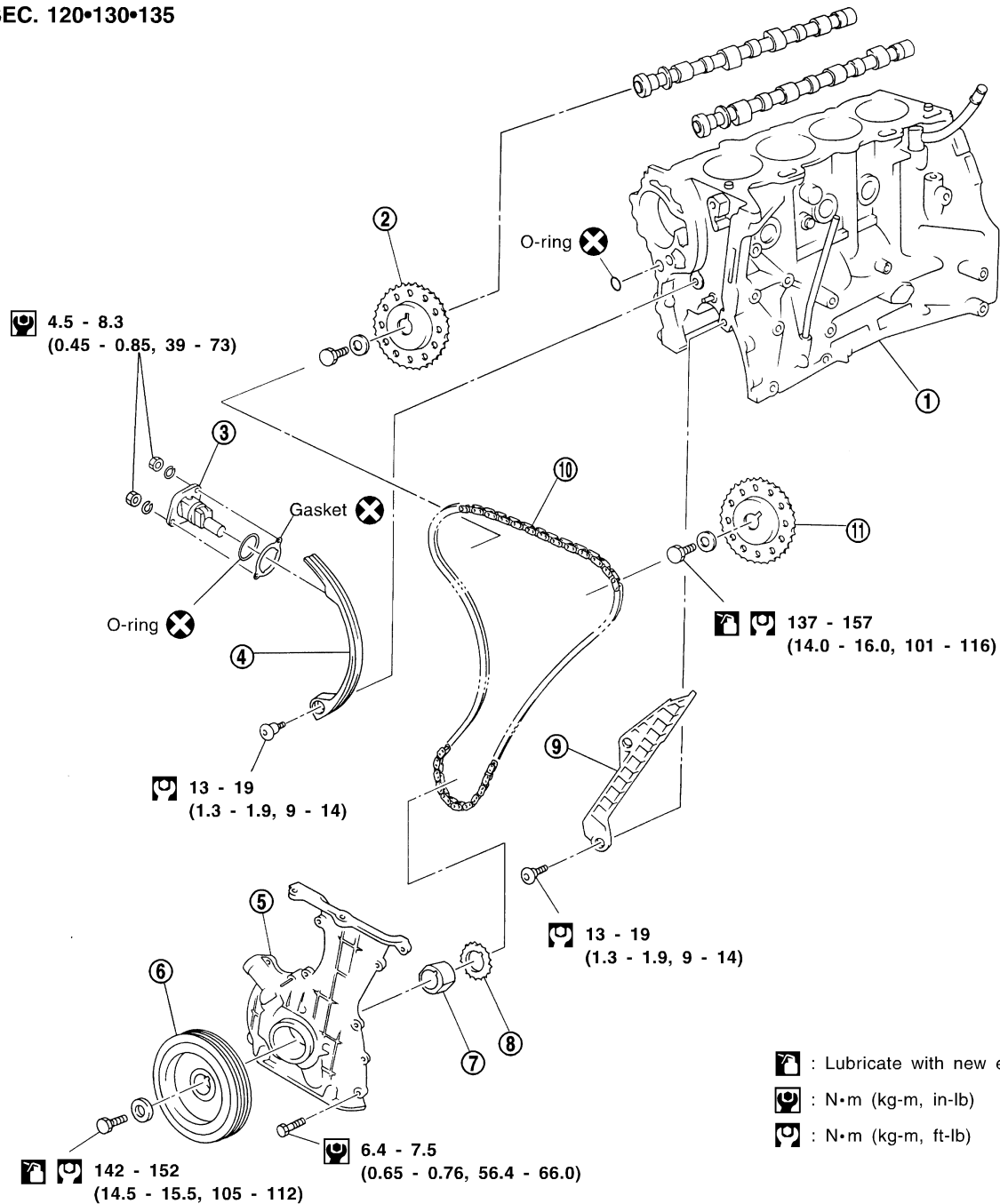

1. Cylinder block
2. RH camshaft sprocket
3. Chain tensioner
4. Chain guide

5. Front cover
6. Crankshaft pulley
7. Oil pump drive spacer
8. Crankshaft sprocket

9. Chain guide
10. Timing chain
11. LH camshaft sprocket

GI
MA
EM
LC
EC
FE
CL
MT
AT
AX
SU
BR
ST
RS
BT
HA
SC
EL
IDX

TIMING CHAIN

Removal

NCEM0012

Removal

1. Remove engine under cover.
2. Remove front RH wheel and engine side cover.
3. Remove drive belts and water pump pulley.
4. Disconnect the following parts:
 - Vacuum hoses
 - Wires
 - Harness
 - Connectors
5. Remove rocker cover bolts in numerical order.
6. Remove rocker cover.

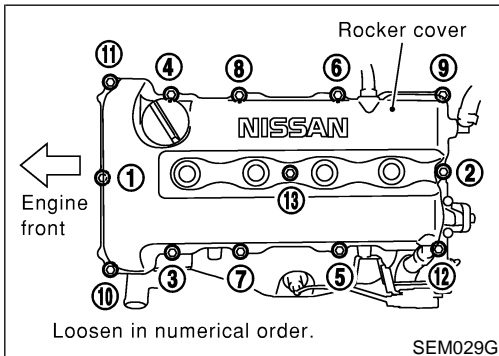

7. Remove cylinder head outside bolts.

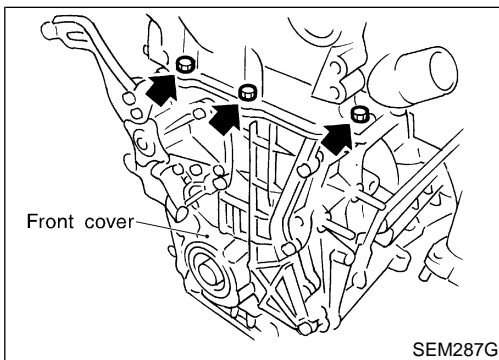

8. Set No. 1 piston at TDC of its compression stroke.

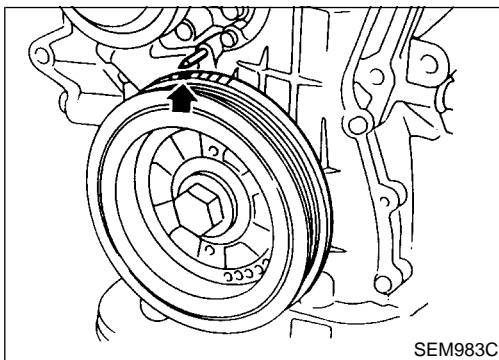

- Rotate crankshaft until mating mark on camshaft sprocket is set at position indicated in figure.

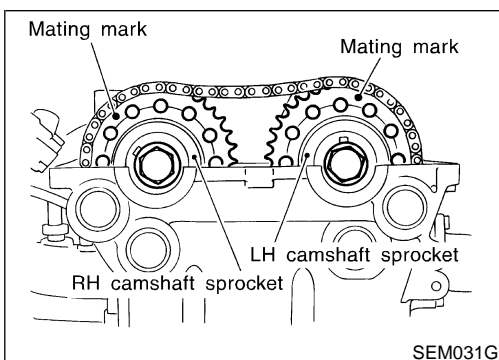

TIMING CHAIN

Removal (Cont'd)

9. Remove oil pans.
Refer to EM-14.

GI

MA

EM

LC

10. Remove oil strainer.
11. Temporarily install center member to support engine.

EC

FE

CL

MT

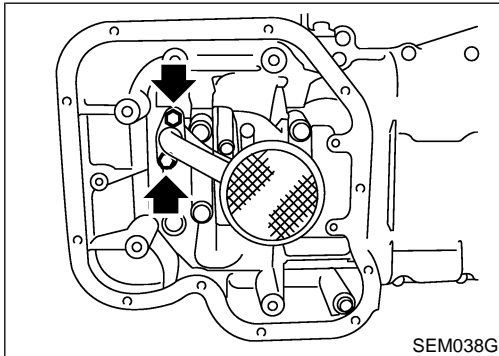

12. Remove crankshaft pulley.
13. Remove generator.
14. Remove A/C compressor and position it to the side.
15. Remove A/C bracket.
16. Remove generator bracket.

AT

AX

SU

BR

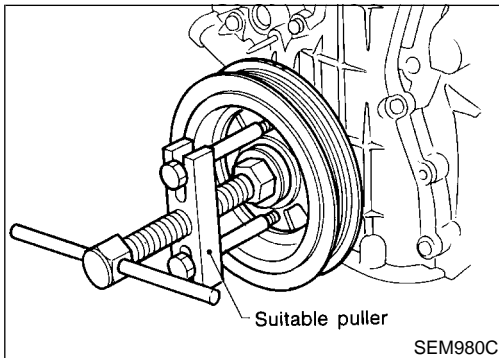

17. Set a suitable transmission jack under main bearing beam.

ST

RS

BT

HA

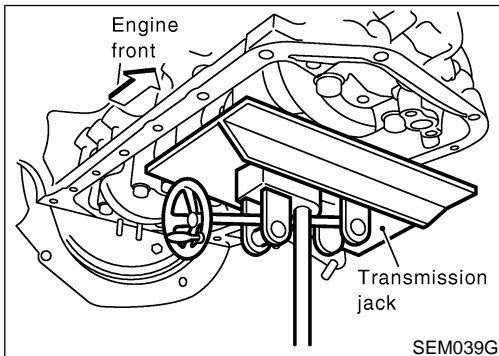

18. Remove RH engine mounting.

SC

EL

IDX

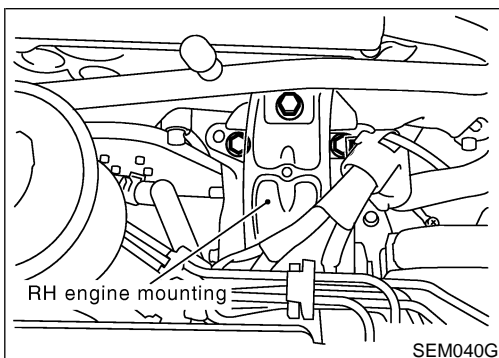

TIMING CHAIN

Removal (Cont'd)

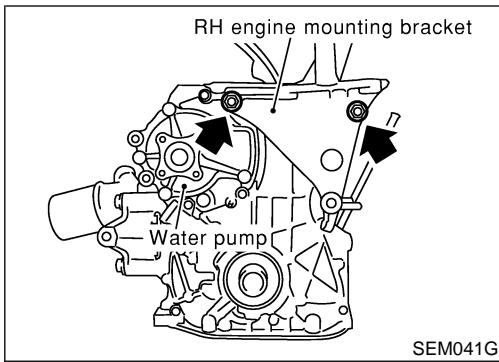

19. Remove RH engine mounting bracket.

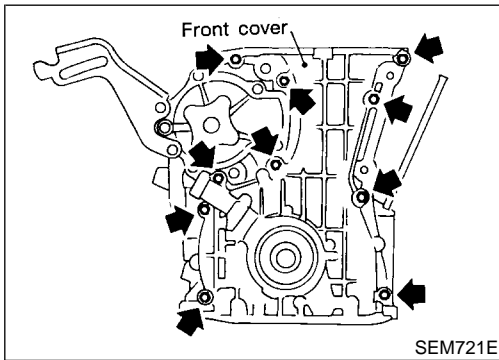

20. Remove oil pump drive spacer.

CAUTION:

Be careful not to damage oil pump drive spacer and front oil seal.

21. Remove front cover.

CAUTION:

- Be careful not to rear or damage the cylinder gasket.
- Inspect for oil leakage at front oil seal. Replace seal if oil leak is present.

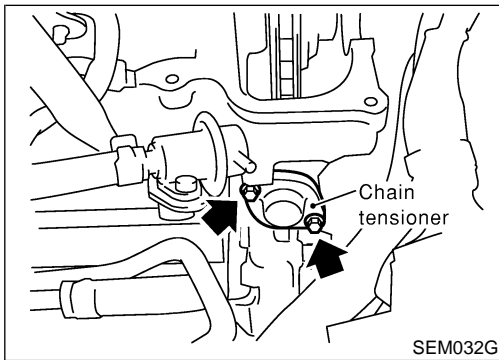

22. Remove chain tensioner.

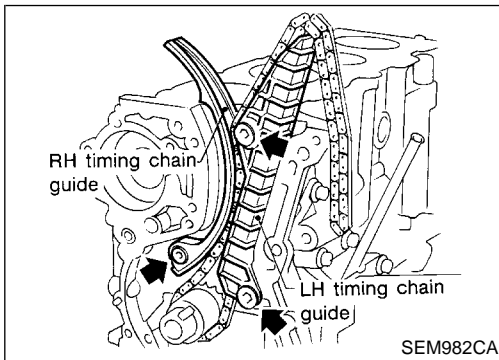

23. Remove timing chain guides.

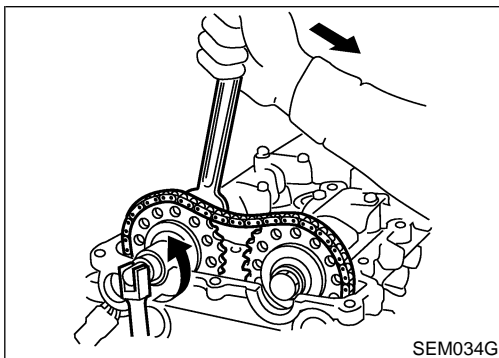

24. Remove camshaft sprockets.

- For retiming in cylinder head removal, apply paint mark to timing chain matched with mating marks of camshaft sprockets.

25. Remove timing chain and crankshaft sprocket.

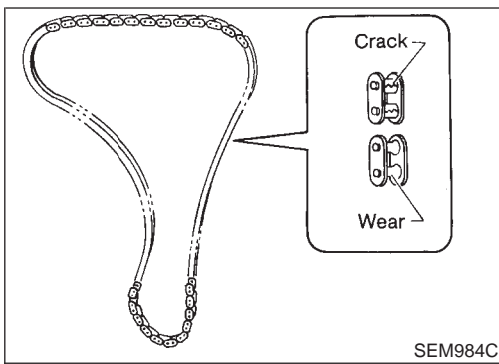

Inspection

Check for cracks and excessive wear at roller links. Replace chain if necessary.

NCEM0013

GI

MA

EM

LC

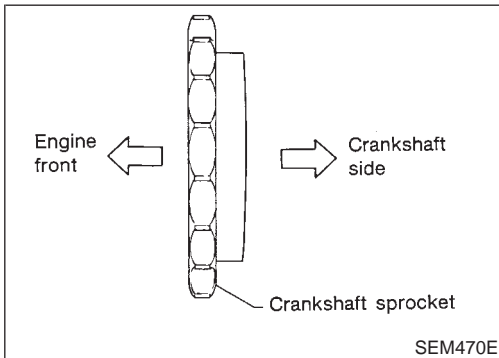

Installation

NCEM0014

1. Install crankshaft sprocket on crankshaft.
 - Make sure that mating marks on crankshaft sprocket face front of engine.

EC

FE

CL

MT

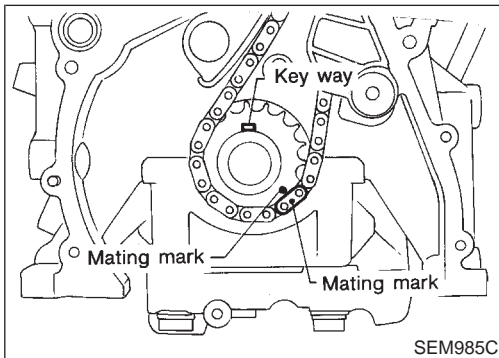

2. Position crankshaft so that No. 1 piston is set at TDC and key way is at 12 o'clock. Fit timing chain on crankshaft sprocket, aligning the mating marks.

AT

AX

SU

BR

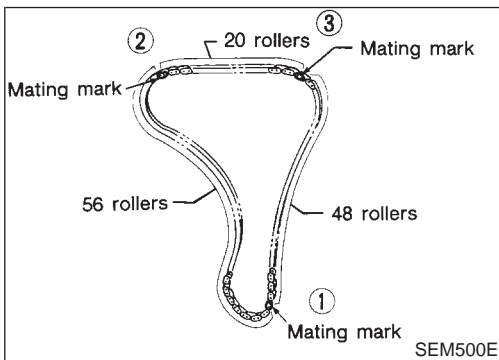

- Mating mark color on timing chain.
 - 1: Yellow
 - 2, 3: Blue

ST

RS

BT

HA

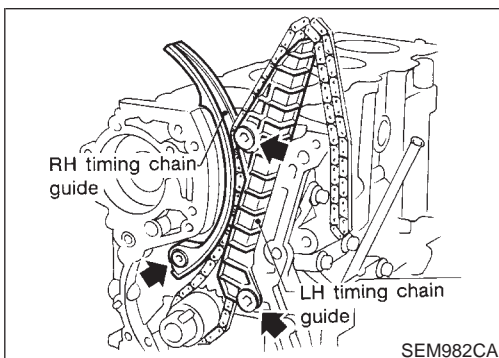

3. Install timing chain and timing chain guides.

SC

EL

IDX

TIMING CHAIN

Installation (Cont'd)

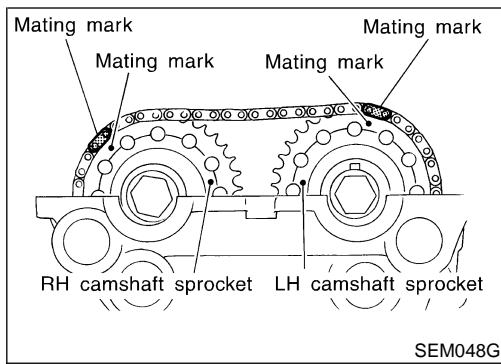

4. Install camshaft sprockets and timing chain on them.
Line up mating marks on timing chain with mating marks on camshaft sprockets.

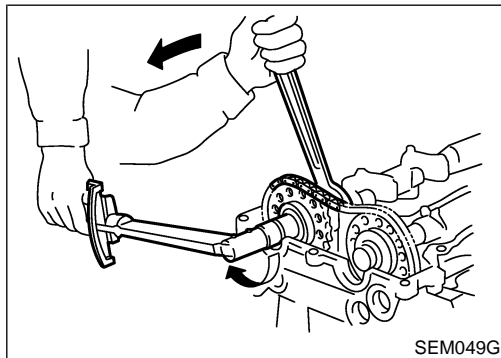

- Lock camshafts as shown in figure and tighten to specified torque.

 : 137 - 157 N·m (14.0 - 16.0 kg-m, 101 - 116 ft-lb)

Apply new engine oil to threads and seating surfaces of camshaft sprocket bolts before installing them.

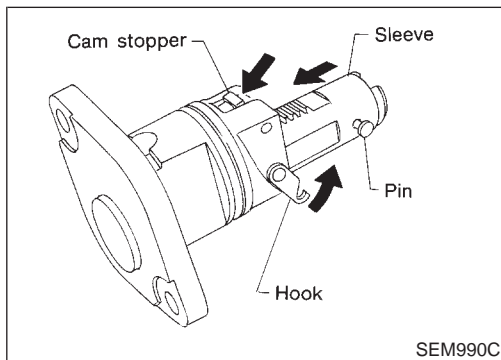

5. Install chain tensioner.

Make sure the camshaft sprockets are tightened completely. Press cam stopper down and “press-in” sleeve until hook can be engaged on pin. When tensioner is bolted in position the hook will release automatically. Make sure arrow “A” points toward engine front.

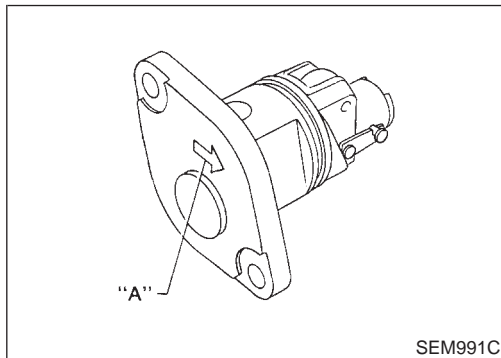

6. Use a scraper to remove old liquid gasket from mating surface of front cover.
- **Also remove old liquid gasket from mating surface of cylinder block.**

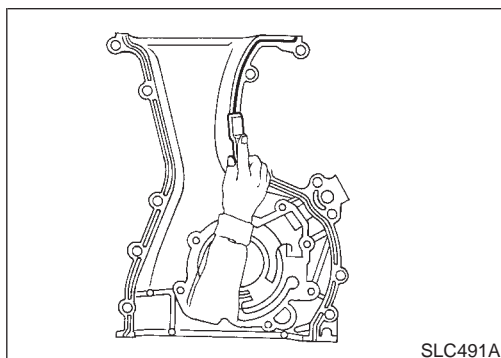

TIMING CHAIN

Installation (Cont'd)

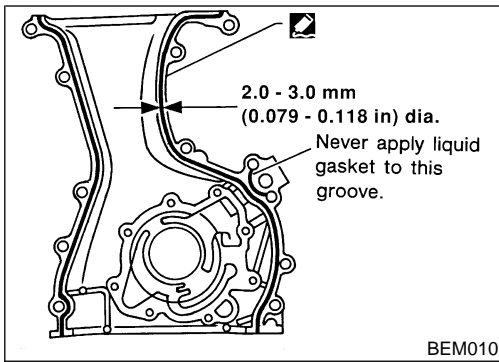

7. Apply a continuous bead of liquid gasket to front cover. Also apply liquid gasket to matching surface to cylinder head gasket.
- Use Genuine RTV silicone sealant part No. 999MP-A7007 or equivalent.
Be sure to install new front oil seal in the right direction. Refer to "OIL SEAL", EM-28.

GI

MA

EM

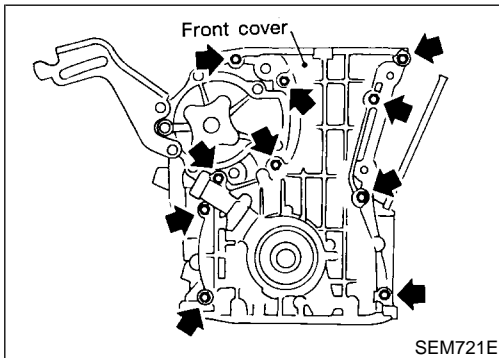

8. Install oil pump drive spacer.
9. Install front cover.

LC

EC

FE

CL

MT

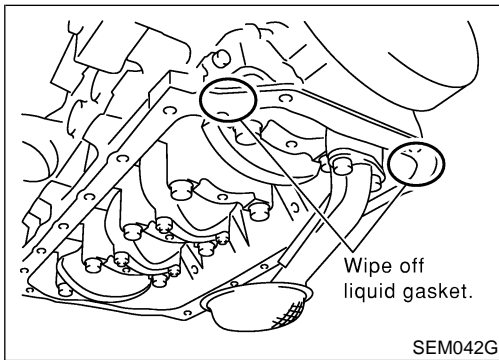

- Wipe off excessive liquid gasket.

AT

AX

SU

BR

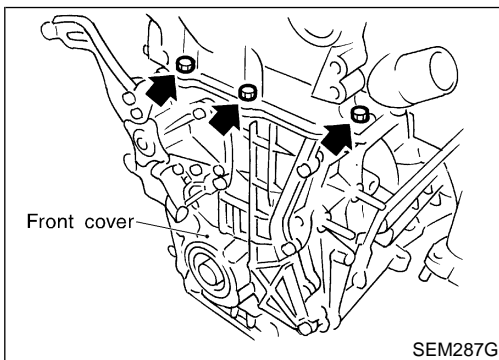

10. Install cylinder head outside bolts.

ST

RS

BT

HA

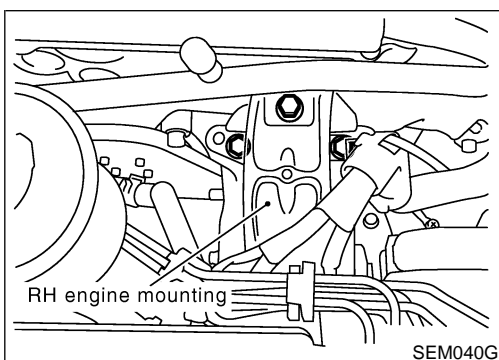

11. Install RH engine mounting and bracket.
12. Install generator bracket and generator.
13. Install A/C compressor bracket and compressor.

SC

EL

IDX

TIMING CHAIN

Installation (Cont'd)

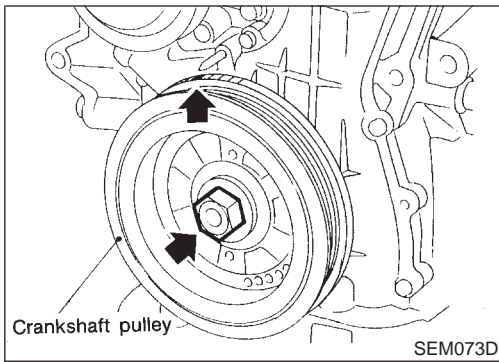

14. Install crankshaft pulley.
15. Set No. 1 piston at TDC of its compression stroke.

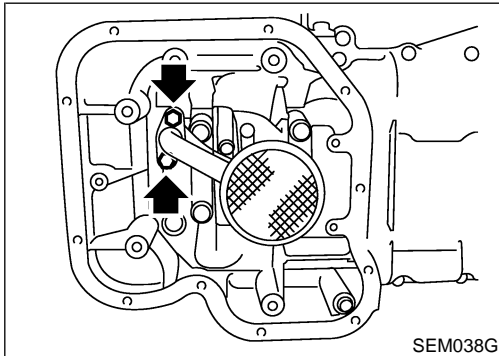

16. Install oil strainer.
17. Install oil pans.
Refer to EM-16.

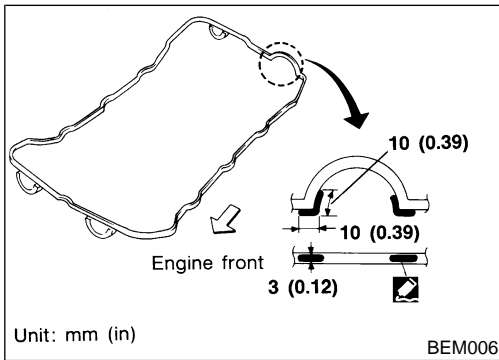

18. Remove old liquid gasket from mating surfaces of rocker cover and cylinder head.
19. Apply a continuous bead of liquid gasket to rocker cover gasket and cylinder head as shown in the illustrations.

- Use Genuine RTV silicone sealant Part No. 999MP-A7007 or equivalent.

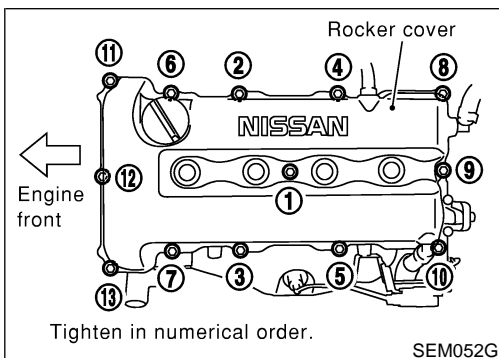
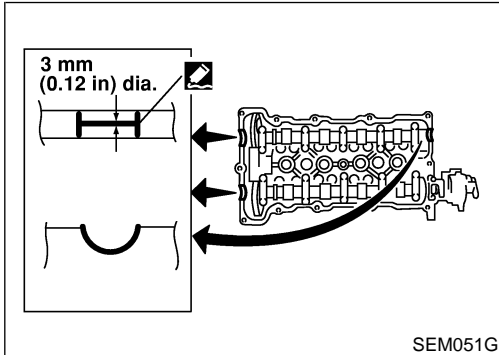

20. Install rocker cover and oil separator.

- Be sure to install washers between bolts and rocker cover.
- Tightening procedure
STEP 1: Tighten bolts 1 - 10 - 11 - 13 - 8 in that order.
STEP 2: Tighten bolts 1 - 13 in that order.
⚙️ : 8 - 10 N·m (0.8 - 1.0 kg·m, 69 - 87 in·lb)

21. Install the following parts:

- Spark plugs and leads
- Water pump pulley and drive belts.

TIMING CHAIN

Installation (Cont'd)

For adjusting drive belt deflection, refer to MA-13, "Checking Drive Belts".

- Front RH wheel
 - Engine under cover
22. Connect the following:
- Vacuum hoses
 - Wire harnesses and connectors

GI

MA

EM

LC

EC

FE

CL

MT

AT

AX

SU

BR

ST

RS

BT

HA

SC

EL

IDX

OIL SEAL

Replacement

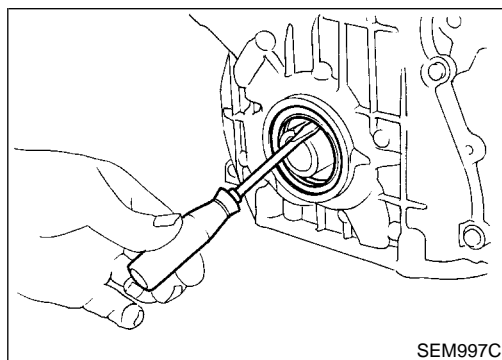
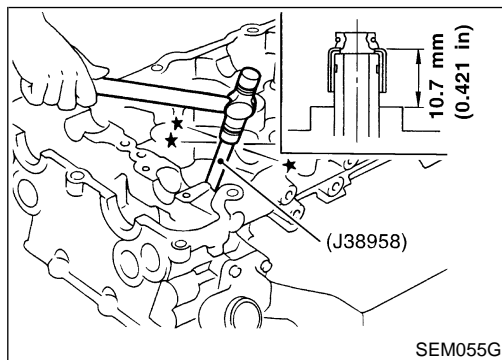
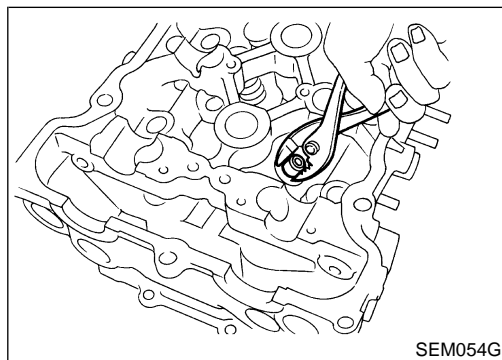
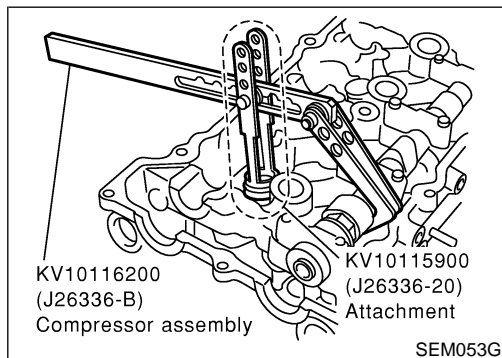
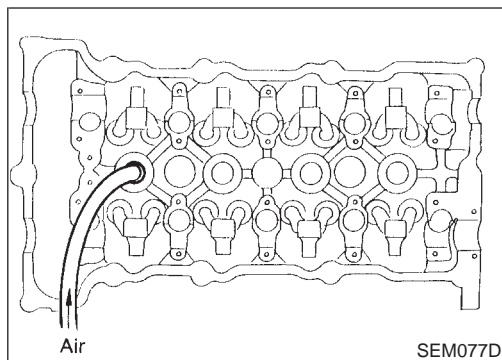

Replacement VALVE OIL SEAL

NCEM0015

NCEM0015S01

1. Remove accelerator wire.
2. Remove rocker cover.
3. Remove camshafts and sprockets. Refer to EM-20.
4. Remove spark plugs.
5. Install air hose adapter into spark plug hole and apply air pressure to hold valves in place. Apply a pressure of 490 kPa (5 kg/cm², 71 psi).
6. Remove rocker arm, rocker arm guide and shim.
7. Remove valve spring with Tool. Temporarily install camshaft as shown.

Piston concerned should be set at TDC to prevent valve from falling.

8. Remove valve oil seal with a suitable tool.

9. Apply new engine oil to new valve oil seal and install it with Tool.

FRONT OIL SEAL

NCEM0015S02

1. Remove the following parts:
 - Engine under cover
 - Front RH wheel and engine side cover
 - Drive belts
 - Crankshaft pulley
2. Remove front oil seal.

Be careful not to scratch front cover.

OIL SEAL

Replacement (Cont'd)

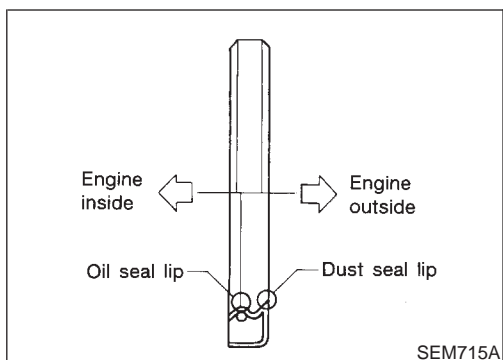

3. Apply new engine oil to new oil seal and install it using a suitable tool.
- **Install new oil seal in the direction shown.**

GI

MA

EM

LC

EC

FE

CL

MT

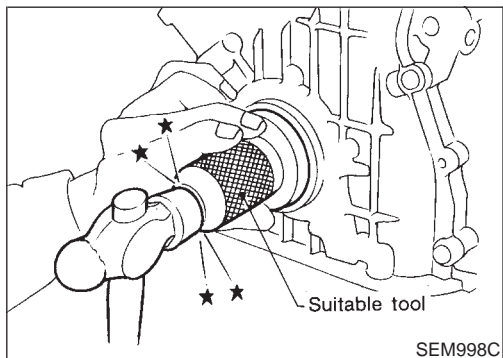

REAR OIL SEAL

NCEM0015S03

1. Remove transaxle. (Refer to MT or AT section.)
2. Remove flywheel or drive plate.
3. Remove rear oil seal.

AT

AX

- **Be careful not to scratch rear oil seal retainer.**

SU

BR

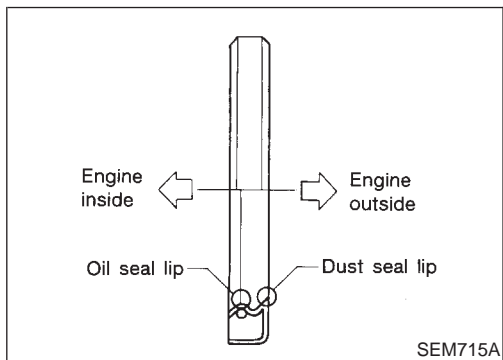
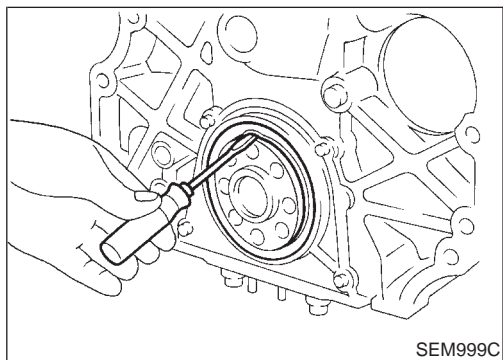

4. Apply new engine oil to new oil seal and install it using a suitable tool.
- **Install new oil seal in the direction shown.**

ST

RS

BT

HA

SC

EL

IDX

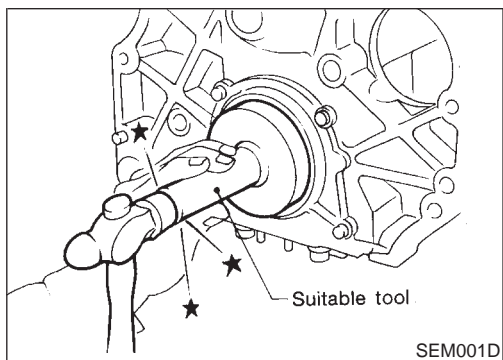

Removal

NCEM0017

1. Release fuel pressure.
Refer to "Releasing Fuel Pressure" in EC-50.
2. Remove engine under covers.
3. Remove front RH wheel and engine side cover.
4. Drain coolant by removing cylinder block drain plug and lower radiator hose.
5. Remove radiator.
6. Remove air duct to intake manifold.
7. Remove drive belts and water pump pulley.
8. Remove alternator and power steering oil pump.
9. Remove vacuum hoses, fuel hoses, wires, and harness connectors.
10. Remove all spark plugs.

GI

MA

EM

LC

EC

FE

CL

MT

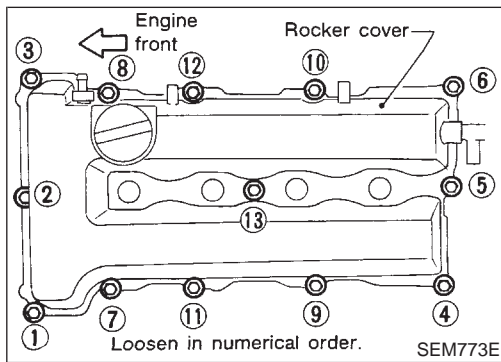

11. Remove rocker cover, loosen bolts in numerical order.
12. Remove front exhaust tube. Refer to FE-8 ("Exhaust System").
13. Remove the lower intake manifold supports.

AT

AX

SU

BR

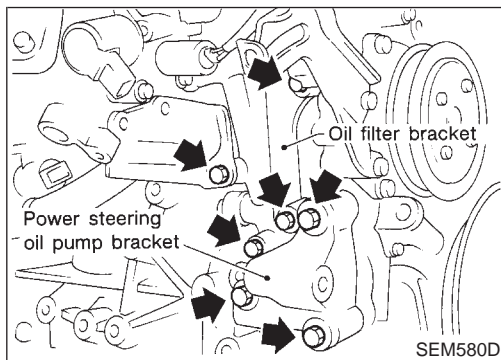

14. Remove oil filter bracket and power steering oil pump bracket.

ST

RS

BT

HA

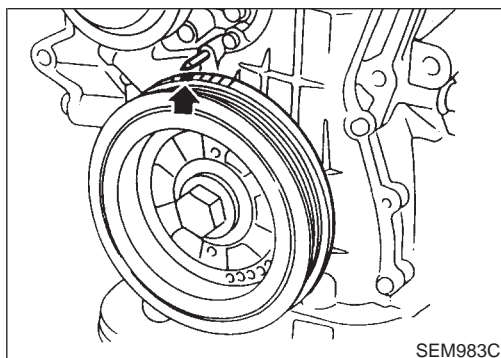

15. Set No. 1 piston at TDC on the compression stroke by rotating crankshaft.

SC

EL

IDX

CYLINDER HEAD

Removal (Cont'd)

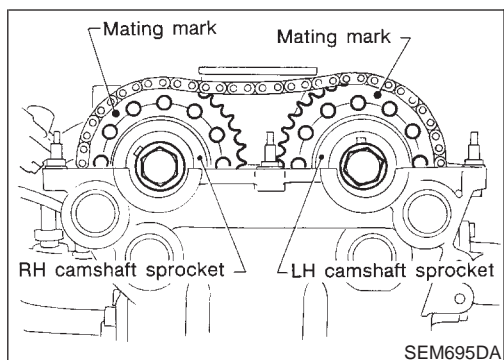

- Rotate crankshaft until mating mark on camshaft sprocket is set at position indicated in figure at left.
- Apply paint to timing chain and camshaft sprockets for alignment during installation.

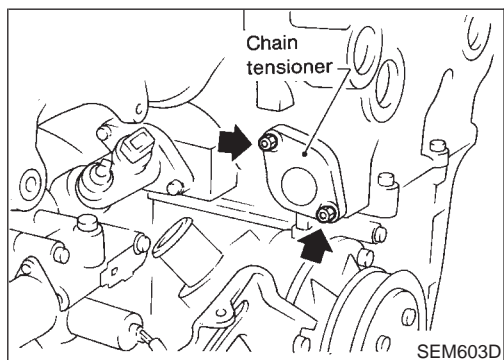

16. Remove chain tensioner.

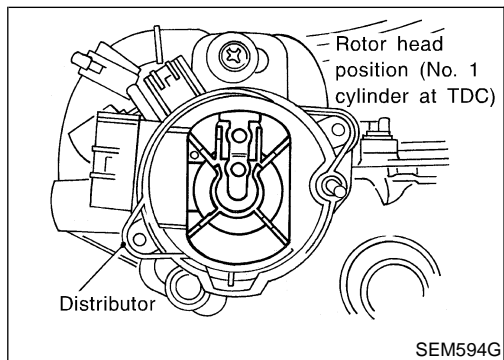

17. Remove distributor.
Do not turn rotor with distributor removed.

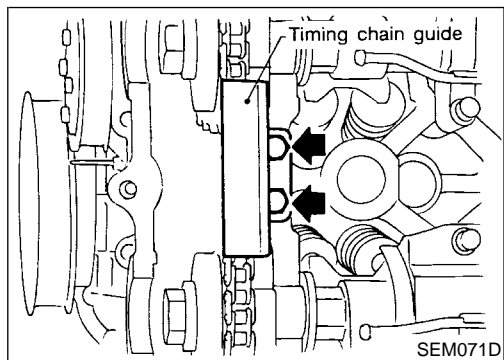

18. Remove timing chain guide.

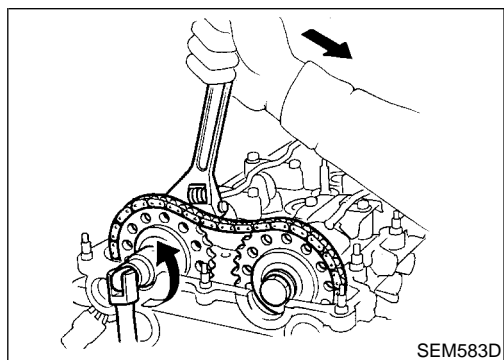

19. Remove camshaft sprockets.

CYLINDER HEAD

Removal (Cont'd)

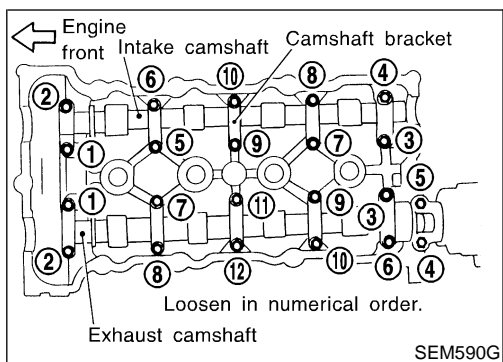

20. Remove camshafts and camshaft brackets.

GI

MA

EM

LC

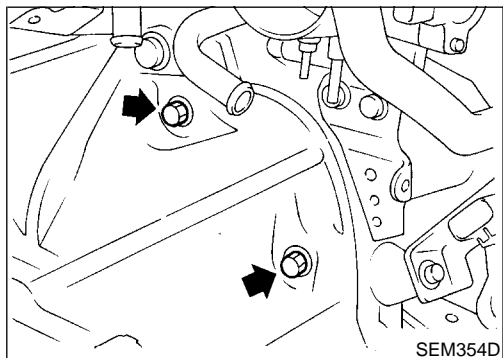

21. Remove starter motor.

EC

FE

CL

MT

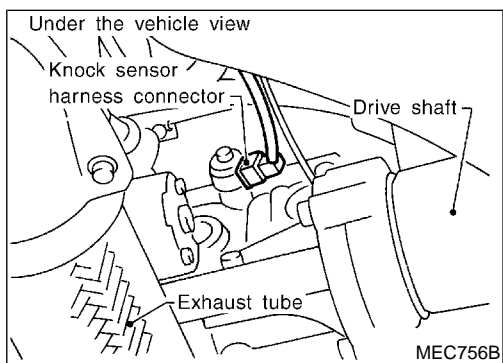

22. Remove the following water hoses:

- Water hose to water pump.
- Water hoses for heater.

AT

23. Remove knock sensor harness connector.

AX

SU

BR

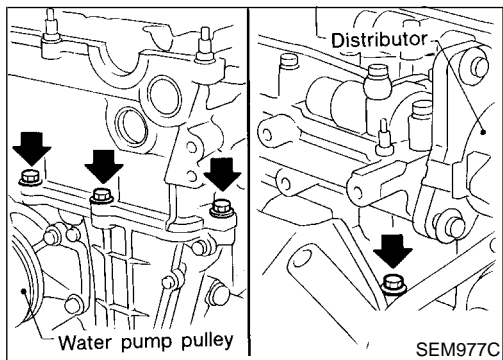

24. Remove cylinder head outside bolts.

ST

RS

BT

HA

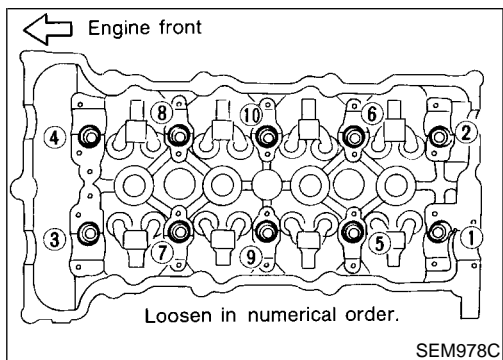

25. Remove cylinder head bolts.

- **Bolts should be loosened in two or three steps.**

SC

26. Remove cylinder head completely with intake and exhaust manifolds.

EL

IDX

CYLINDER HEAD

Disassembly

NCEM0018

CAUTION:

- When installing rocker arms, camshaft and oil seal, lubricate contacting surfaces with new engine oil.
- When tightening cylinder head bolts, camshaft sprocket bolts and camshaft bracket bolts, lubricate bolt threads and seat surfaces with new engine oil.

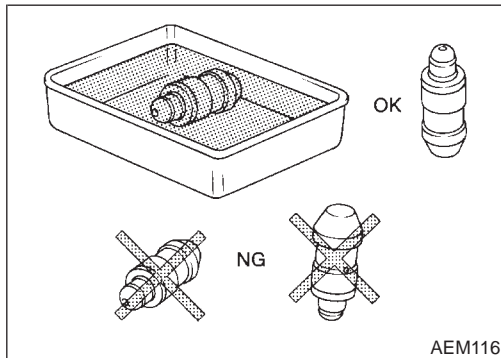

- If a hydraulic lash adjuster is kept on its side, there is a risk of air entering it. When hydraulic lash adjusters are removed, stand them straight up or soak them in new engine oil.
- Do not disassemble hydraulic lash adjusters.
- Attach tags to lash adjusters so as not to mix them up.

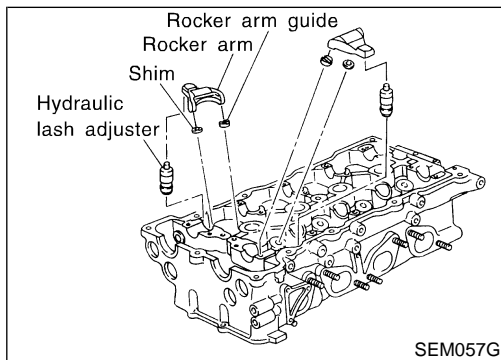

1. Remove rocker arms, shims, rocker arm guides and hydraulic lash adjusters from cylinder head.

CAUTION:

Keep parts in order so they can be installed in their original positions during assembly.

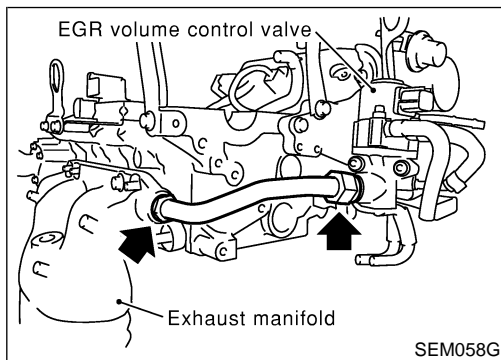

2. Remove exhaust manifold cover.
3. Remove EGR tube.

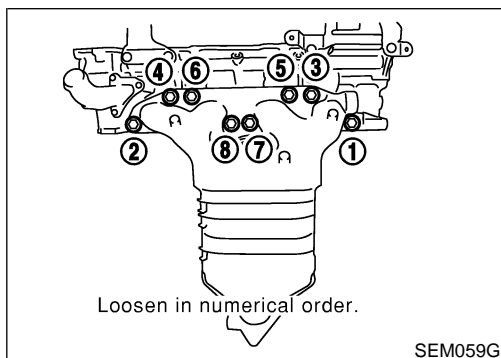

4. Remove exhaust manifold as shown.

CYLINDER HEAD

Disassembly (Cont'd)

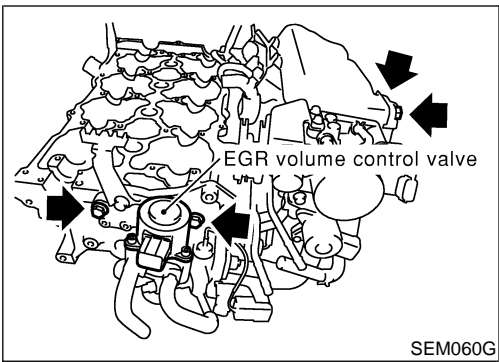

5. Remove EGR volume control valve assembly.

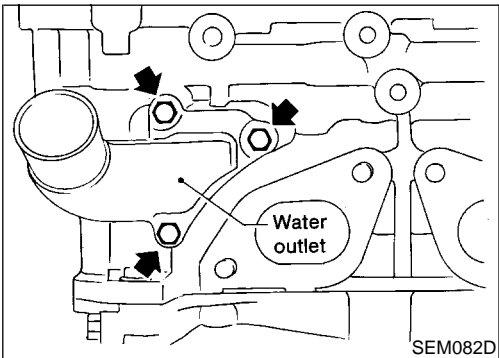

6. Remove water outlet.

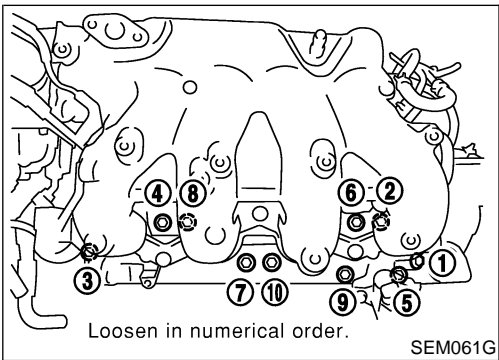

7. Remove intake manifold with intake manifold collector as shown.

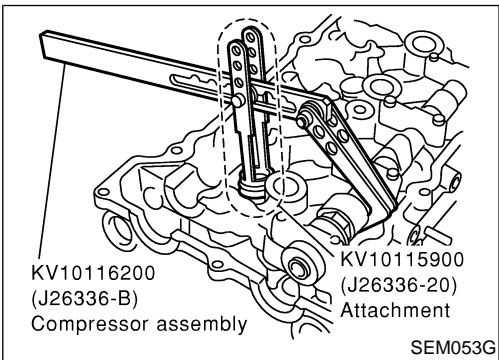

8. Remove valve components with Tool. Install camshaft temporarily.

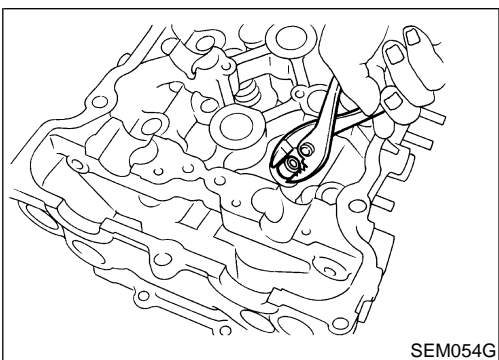

9. Remove valve oil seal with a suitable tool.

GI

MA

EM

LC

EC

FE

CL

MT

AT

AX

SU

BR

ST

RS

BT

HA

SC

EL

IDX

CYLINDER HEAD

Inspection

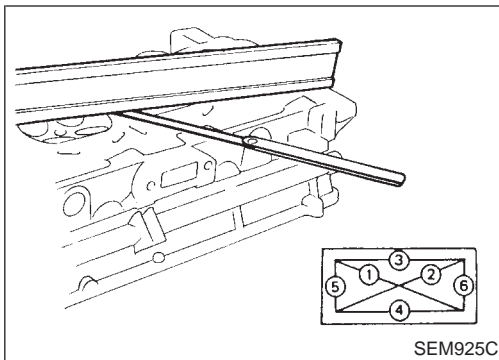

Inspection

CYLINDER HEAD DISTORTION

NCEM0019

NCEM0019S01

- Clean mating surface of cylinder head.
- Use a reliable straightedge and feeler gauge to check the flatness of cylinder head mating surface.
- Check along six positions shown in figure.

Head surface flatness:

Standard: Less than 0.03 mm (0.0012 in)

Limit: 0.1 mm (0.004 in)

If beyond the specified limit, replace or resurface it.

Resurfacing limit:

The limit for cylinder head resurfacing is determined by the amount of cylinder block resurfacing.

Amount of cylinder head resurfacing is "A".

Amount of cylinder block resurfacing is "B".

The maximum limit is as follows:

A + B = 0.2 mm (0.008 in)

After resurfacing cylinder head, check that camshaft rotates freely by hand. If resistance is felt, cylinder head must be replaced.

Nominal cylinder head height:

136.9 - 137.1 mm (5.390 - 5.398 in)

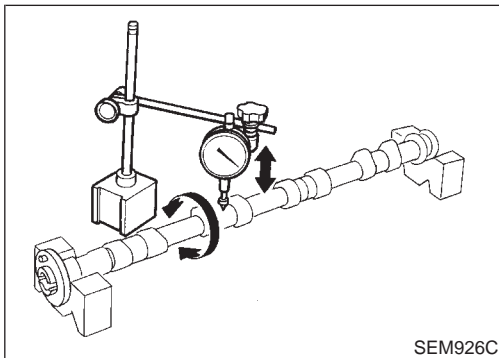

CAMSHAFT VISUAL CHECK

Check camshaft for scratches, seizure and wear.

NCEM0019S02

CAMSHAFT RUNOUT

1. Measure camshaft runout at the center journal.

NCEM0019S03

Runout (Total indicator reading):

Standard

Less than 0.02 mm (0.0008 in)

Limit

0.1 mm (0.004 in)

2. If it exceeds the limit, replace camshaft.

CAMSHAFT CAM HEIGHT

1. Measure camshaft cam height.

NCEM0019S04

Standard cam height:

Intake

37.550 - 37.740 mm (1.4783 - 1.4858 in)

Exhaust

37.920 - 38.110 mm (1.4929 - 1.5004 in)

Cam height wear limit:

Intake & Exhaust

0.2 mm (0.008 in)

2. If wear is beyond the limit, replace camshaft.

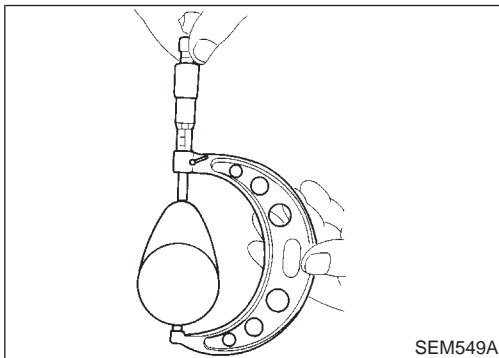

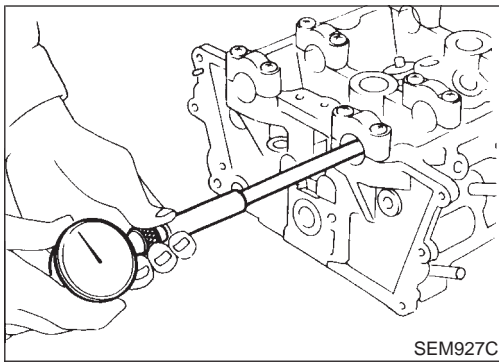

SEM927C

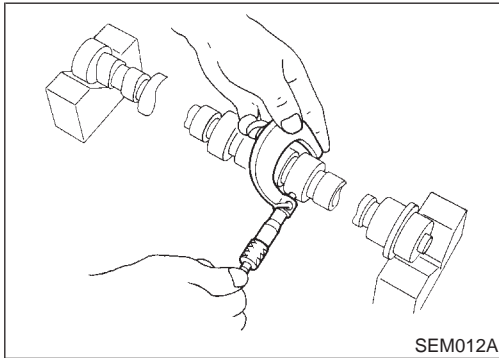

SEM012A

CAMSHAFT JOURNAL CLEARANCE

NCEM0019S05

1. Install camshaft bracket and tighten bolts. Refer to EM-23.
2. Measure inner diameter of camshaft bearing.

Standard inner diameter:

28.000 - 28.021 mm (1.1024 - 1.1032 in)

3. Measure outer diameter of camshaft journal.

Standard outer diameter:

27.935 - 27.955 mm (1.0998 - 1.1006 in)

4. Calculate camshaft journal clearance.

**Camshaft journal clearance = standard inner diameter
– standard outer diameter:**

Standard

0.030 - 0.071 mm (0.0012 - 0.0028 in)

Limit

0.15 mm (0.0059 in)

5. If clearance exceeds the limit, replace camshaft and remeasure camshaft journal clearance.

- If clearance still exceeds the limit after replacing camshaft, replace cylinder head.

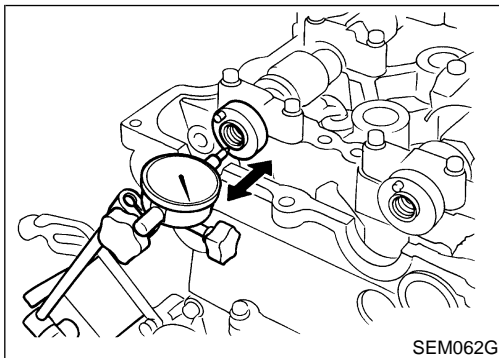

SEM062G

CAMSHAFT END PLAY

NCEM0019S06

1. Install camshaft in cylinder head. Refer to EM-23.
2. Measure camshaft end play.

Camshaft end play:

Standard

0.055 - 0.139 mm (0.0022 - 0.0055 in)

Limit

0.20 mm (0.0079 in)

3. If end play exceeds the limit, replace camshaft and remeasure camshaft end play.

- If end play still exceeds the limit after replacing camshaft, replace cylinder head.

CYLINDER HEAD

Inspection (Cont'd)

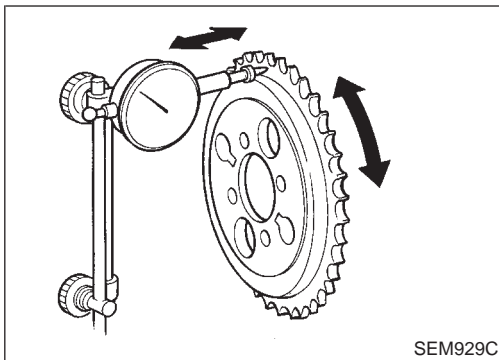

CAMSHAFT SPROCKET RUNOUT

NCEM0019S07

1. Install sprocket on camshaft.
2. Measure camshaft sprocket runout.
**Runout (Total indicator reading):
Limit 0.25 mm (0.0098 in)**
3. If it exceeds the limit, replace camshaft sprocket.

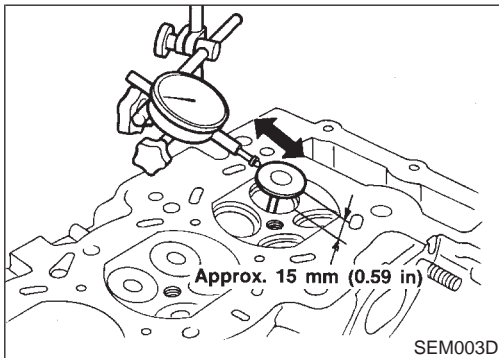

VALVE GUIDE CLEARANCE

NCEM0019S08

1. Measure valve deflection as shown in illustration. (Valve and valve guide mostly wear in this direction.)

**Valve deflection limit (Dial gauge reading):
Intake & Exhaust
0.2 mm (0.008 in)**

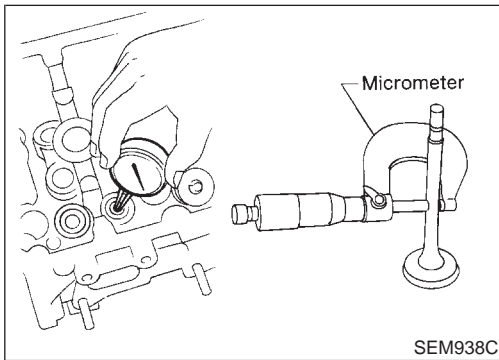

2. If it exceeds the limit, check valve to valve guide clearance.
 - a. Measure valve stem diameter and valve guide inner diameter.
 - b. Calculate valve to valve guide clearance.

Valve to valve guide clearance = valve guide inner diameter - valve stem diameter:

Standard

Intake 0.020 - 0.053 mm (0.0008 - 0.0021 in)

Exhaust 0.040 - 0.073 mm (0.0016 - 0.0029 in)

Limit

Intake 0.08 mm (0.0031 in)

Exhaust 0.1 mm (0.004 in)

- c. If it exceeds the limit, replace valve and remeasure clearance.
 - If clearance still exceeds the limit after replacing valve, replace valve guide.

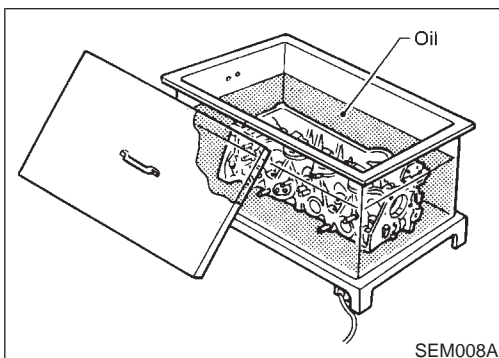

VALVE GUIDE REPLACEMENT

NCEM0019S09

1. To remove valve guide, heat cylinder head to 110 to 130°C (230 to 266°F).

CYLINDER HEAD

Inspection (Cont'd)

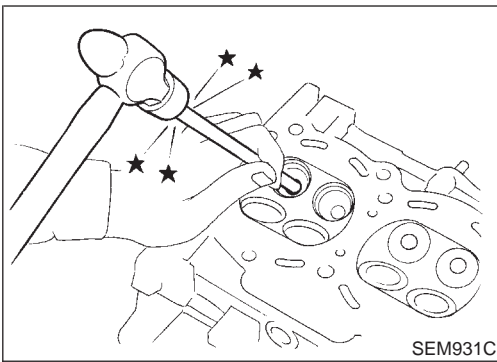

2. Drive out valve guide with a press (under a 20 kN [2 ton, 2.2 US ton, 2.0 Imp ton] pressure) or hammer and suitable tool.

GI

MA

EM

LC

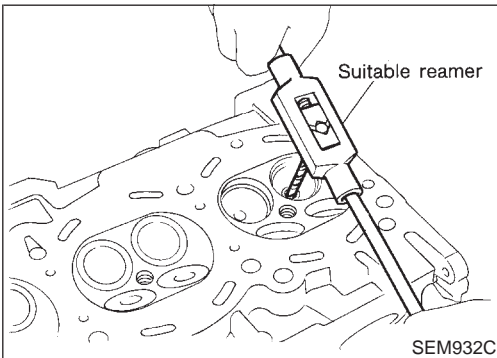

3. Ream cylinder head valve guide hole.

Valve guide hole diameter

(for service parts):

Intake & Exhaust

10.175 - 10.196 mm (0.4006 - 0.4014 in)

EC

FE

CL

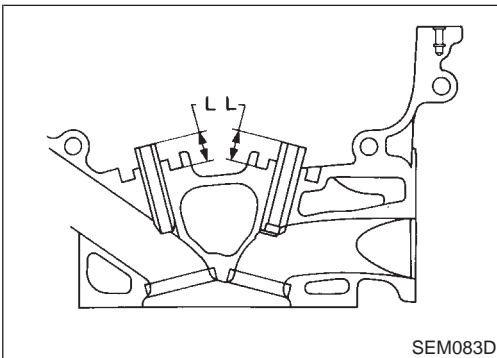

4. Heat cylinder head to 110 to 130°C (230 to 266°F) and press service valve guide into cylinder head.

Projection "L":

14.0 - 14.2 mm (0.551 - 0.559 in)

AT

AX

SU

BR

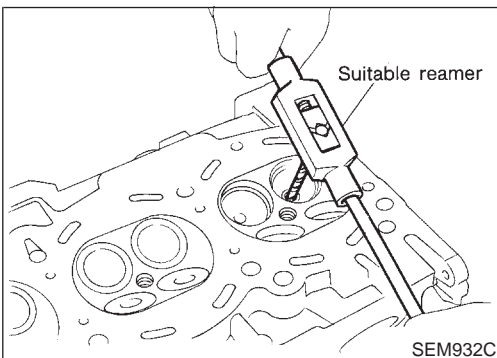

5. Ream valve guide.

Finished size:

Intake & Exhaust

6.000 - 6.018 mm (0.2362 - 0.2369 in)

ST

RS

BT

HA

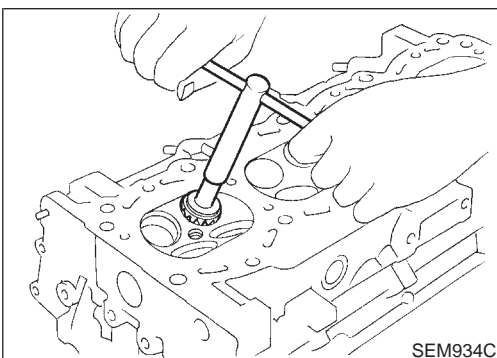

VALVE SEATS

Check valve seats for pitting at contact surface. Resurface or replace if excessively worn.

- Before repairing valve seats, check valve and valve guide for wear. If they are worn, replace them. Then correct valve seat.
- Use both hands to cut uniformly.

NCEM0019S10

SC

EL

IDX

CYLINDER HEAD

Inspection (Cont'd)

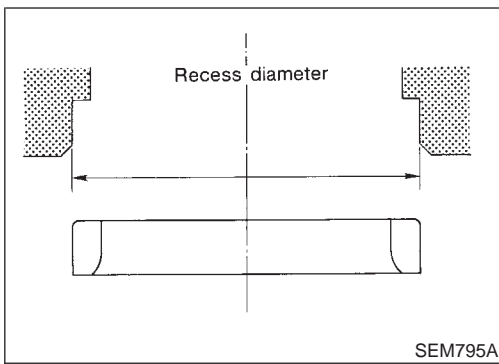

REPLACING VALVE SEAT FOR SERVICE PARTS

NCEM0019S11

1. Bore out old seat until it collapses. Set machine depth stop so that boring cannot contact bottom face of seat recess in cylinder head.
2. Ream cylinder head recess.

Reaming bore for service valve seat

Oversize [0.5 mm (0.020 in)]:

Intake 35.500 - 35.516 mm (1.3976 - 1.3983 in)

Exhaust 31.500 - 31.516 mm (1.2402 - 1.2408 in)

Use the valve guide center for reaming to ensure valve seat will have the correct fit.

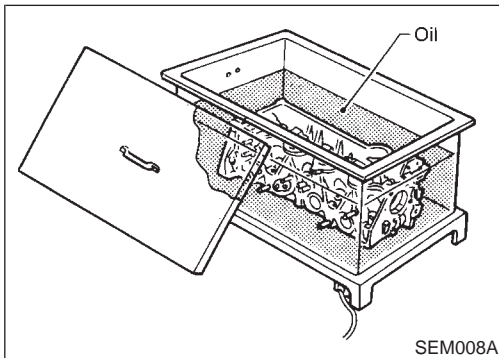

3. Heat cylinder head to 110 to 130°C (230 to 266°F).
4. Press fit valve seat until it seats on the bottom.

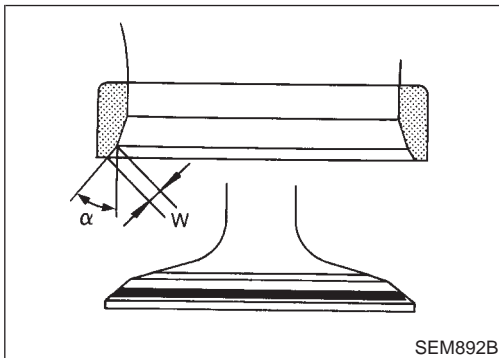

5. Cut or grind valve seat to the specified dimensions using a suitable tool. Refer to SDS, EM-75.
6. After cutting, lap valve seat with abrasive compound.
7. Check valve seating condition.

Seat face angle " α ":

44°53' - 45°07'

Contacting width "W":

Intake

1.05 - 1.35 mm (0.0413 - 0.0531 in)

Exhaust

1.25 - 1.55 mm (0.0492 - 0.0610 in)

CYLINDER HEAD

Inspection (Cont'd)

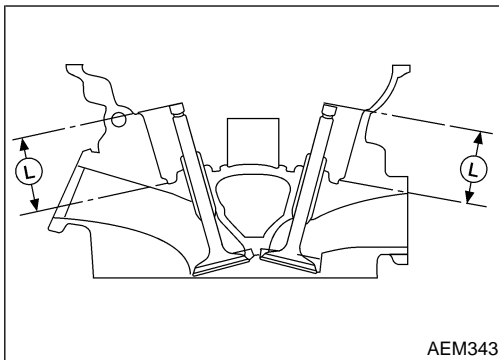

AEM343

Use a depth gauge to measure the distance between the mounting surface of the cylinder head spring seat and the valve stem end. If the distance is shorter than the specified valve, repeat step 5 above to adjust it.

If it is longer, replace the valve seat with a new one.

Valve seat resurface limit:

42.74 - 43.26 mm (1.6827 - 1.7031 in)

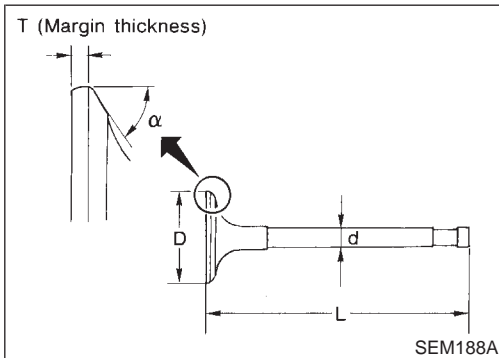

SEM188A

VALVE DIMENSIONS

Check dimensions of each valve. Refer to SDS, EM-72.

NCEM0019S12

When valve head has been worn down to 0.5 mm (0.020 in) in margin thickness, replace valve.

Grinding allowance for valve stem tip is 0.2 mm (0.008 in) or less.

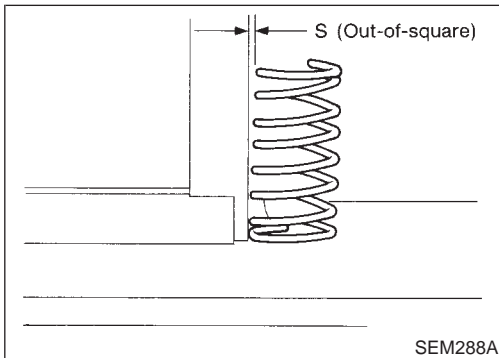

SEM288A

VALVE SPRING

Squareness

1. Measure dimension "S".

Out-of-square "S":

Less than 2.1 mm (0.083 in)

2. If it exceeds the limit, replace spring.

NCEM0019S13

NCEM0019S1301

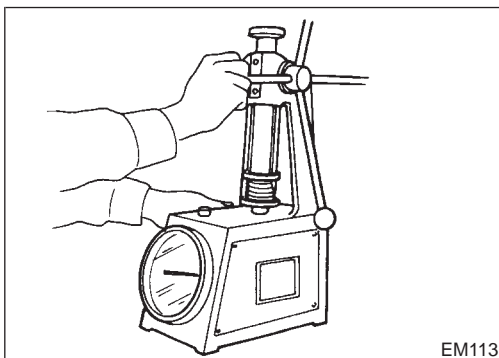

EM113

Pressure

Check valve spring pressure at specified spring height.

NCEM0019S1302

Pressure:

Standard

519 - 571 N (52.9 - 58.2 kg, 116.7 - 128.4 lb) at 27.0 mm (1.063 in)

Limit

More than 491.8 N (50.16 kg, 110.56 lb) at 27.0 mm (1.063 in)

If it exceeds the limit, replace spring.

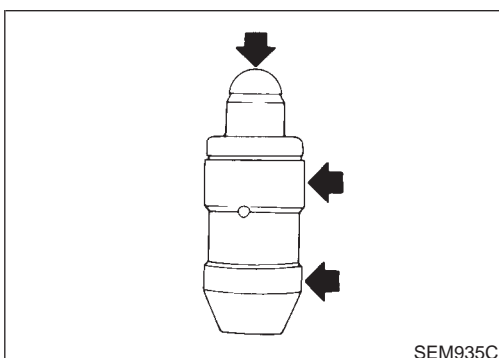

SEM935C

HYDRAULIC LASH ADJUSTER

1. Check contact and sliding surfaces for wear or score.

NCEM0019S14

GI

MA

EM

LC

EC

FE

CL

MT

AT

AX

SU

BR

ST

RS

BT

HA

SC

EL

IDX

CYLINDER HEAD

Inspection (Cont'd)

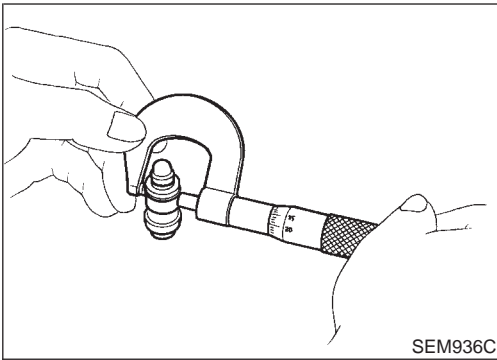

2. Check diameter of lash adjuster.

Outer diameter:

16.980 - 16.993 mm (0.6685 - 0.6690 in)

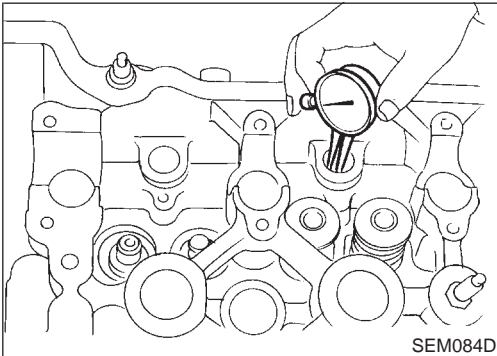

3. Check lash adjuster guide hole diameter.

Inner diameter:

17.000 - 17.020 mm (0.6693 - 0.6701 in)

Standard clearance between lash adjuster and adjuster guide hole:

0.007 - 0.040 mm (0.0003 - 0.0016 in)

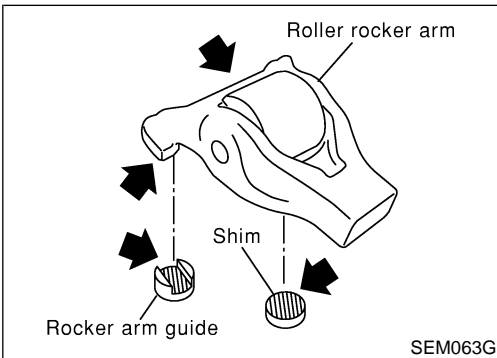

ROCKER ARM, SHIM AND ROCKER ARM GUIDE

NCEM0019S15

Check contact and sliding surfaces of rocker arms, shims and rocker arm guides for wear or score.

Assembly

NCEM0020

CAUTION:

- When installing rocker arms, camshaft and oil seal, lubricate contacting surfaces with new engine oil.
- When tightening cylinder head bolts, camshaft sprocket bolts and camshaft bracket bolts, lubricate bolt threads and seat surfaces with new engine oil.

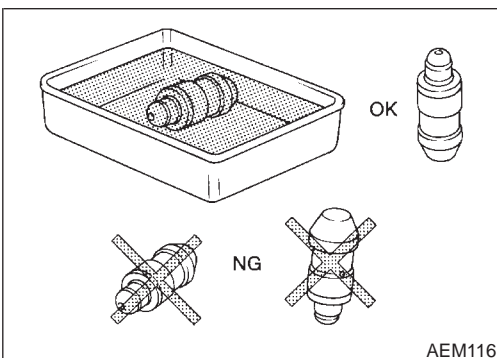

- If a hydraulic lash adjuster is kept on its side, there is a risk of air entering it. When hydraulic lash adjusters are removed, stand them straight up or soak them in new engine oil.
- Do not disassemble hydraulic lash adjusters.
- Attach tags to lash adjusters so as not to mix them up.

CYLINDER HEAD

Assembly (Cont'd)

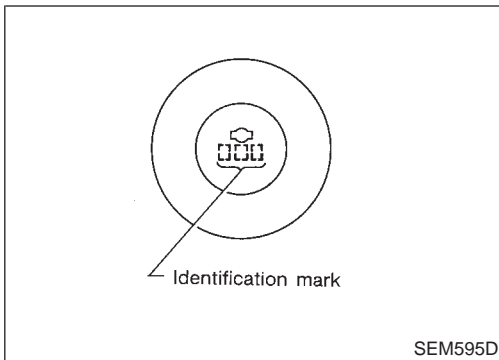

1. Install valve component parts.
 - Install valves, noting their identification marks as indicated in the table below.

| | Identification mark |
|---------------|---------------------|
| Intake valve | 2J3 |
| Exhaust valve | J21 |

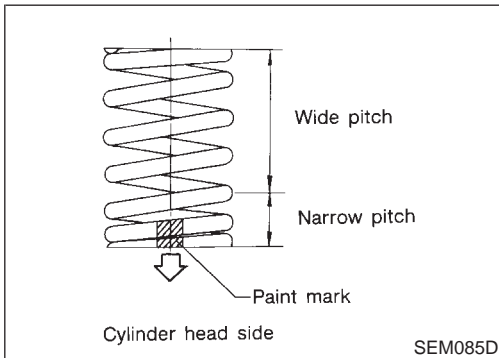

- Always use new valve oil seal. Refer to EM-28.
- Before installing valve oil seal, install valve spring seat.
- Install valve spring (uneven pitch type) with its narrow pitched side (paint mark) toward cylinder head side.
- After installing valve components, use plastic hammer to lightly tap valve stem tip to assure a proper fit.

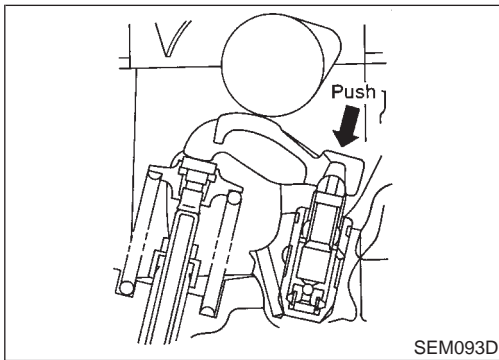

2. Check hydraulic lash adjusters.
 - a. Push on the rocker arm above the hydraulic lash adjuster. If it moves 1 mm (0.04 in) or more, there is air in the high pressure chamber of hydraulic lash adjuster. Noise will be emitted from hydraulic lash adjuster if engine is started without bleeding air.

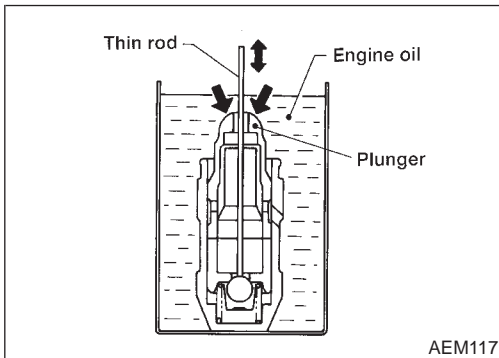

- b. Remove hydraulic lash adjuster and dip in a container filled with new engine oil. While pushing plunger as shown in figure, lightly push check ball using a thin rod. Air is completely bled when plunger no longer moves.

Air cannot be bled from this type of lash adjuster by running engine.

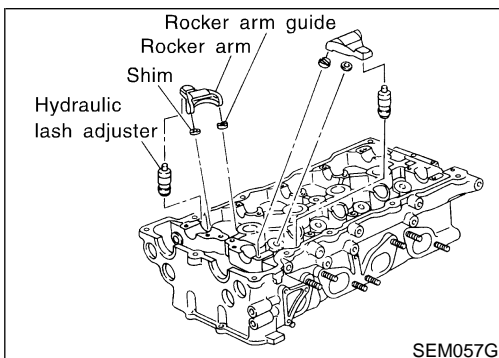

3. Remove camshafts, rocker arms and shims. For future reference, identify each shim with the cylinder it was removed from. Since the shims are reusable, it may not be necessary to replace all of the existing shims.

GI

MA

EM

LC

EC

FE

CL

MT

AT

AX

SU

BR

ST

RS

BT

HA

SC

EL

IDX

CYLINDER HEAD

Assembly (Cont'd)

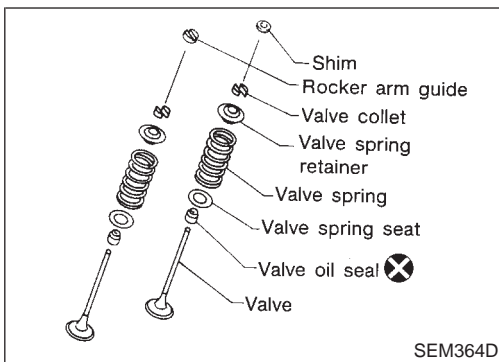

4. Before attempting any measurement, make sure the valve, valve spring, collet, retainer and rocker arm guide are properly installed in the head.

- **Always replace rocker arm guide with a new one.**

CAUTION:
Install parts in their original positions.

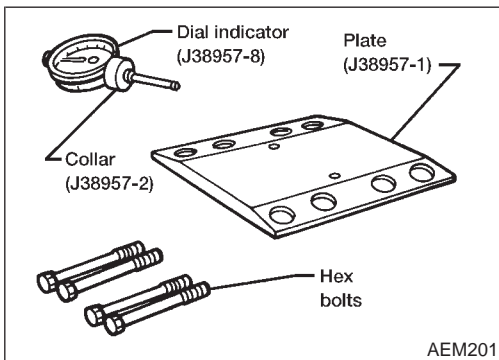

5. Install the J38957-1 gauge plate into the tapped holes at the cam journals and secure it to the head using two of the hex bolts supplied with the kit. (The two remaining bolts are spares.)

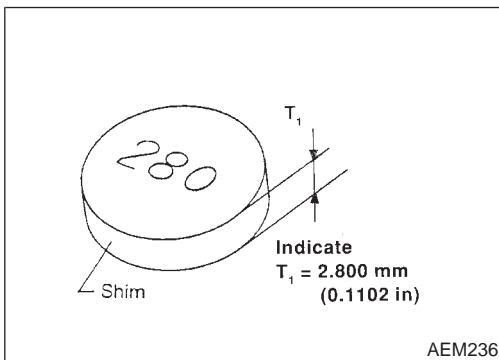
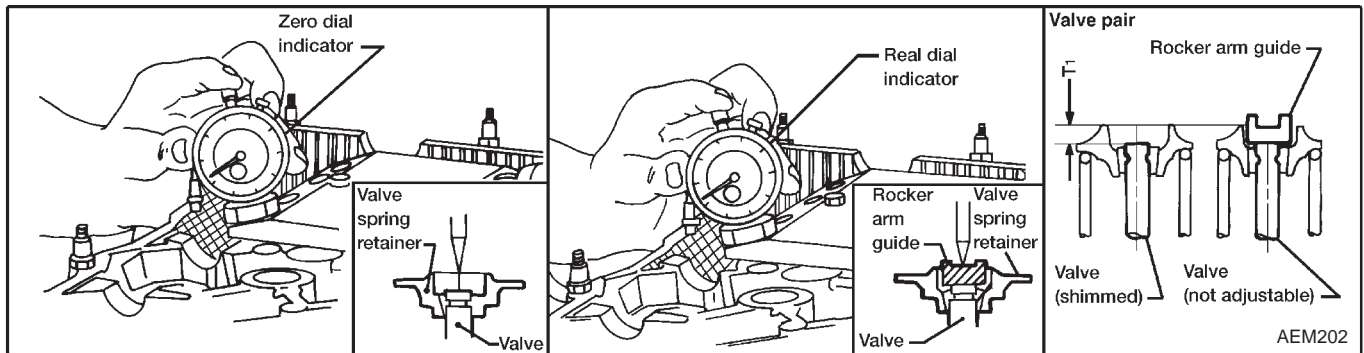

6. Place the J38957-2 collar on the J38957-8 dial indicator. Make sure the dished side of the collar is facing "up" (toward the dial indicator). Secure the collar to the dial indicator by tightening the set screw in the collar.

7. Place the indicator and collar over #1 cylinder intake valve shim side. Slide the tip of the dial indicator through the access hole and place it on the end of the valve stem. While resting the dial indicator collar on the gauge plate, "zero" the dial indicator.

8. Move the dial indicator and collar to the adjacent hole in the gauge plate and place the tip of the indicator in the center of the rocker arm guide. Write down the dial indicator reading. This measured distance between the valve stem end and the contact surface of the rocker arm guide is the "T₁" dimension.

9. Match the measured "T₁" dimension (in inches) to the available shim chart (in millimeters). Refer to SDS, EM-74. (The "T₁" dimension is equivalent to the thickness and size designation of the valve shim.) Select the closest size shim to the measured "T₁" dimension. For example, if the measured "T₁" dimension is 0.1152 in, use a 2.925 mm (0.1152 in) shim. Shims are available in 17 different thicknesses ranging from 2.800 mm (0.1102 in) to 3.200 mm (0.1260 in) and increase in increments of 0.025 mm (0.0010 in).

CYLINDER HEAD

Assembly (Cont'd)

10. Repeat this procedure on the remaining cylinders.

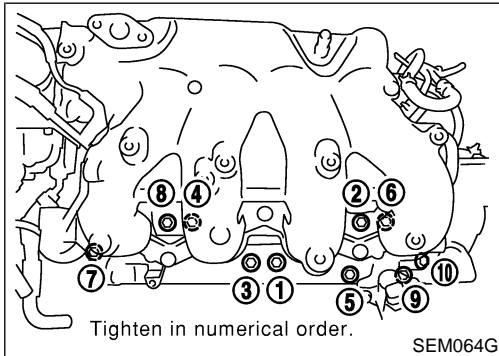

11. Install intake manifold with intake manifold collector as shown.

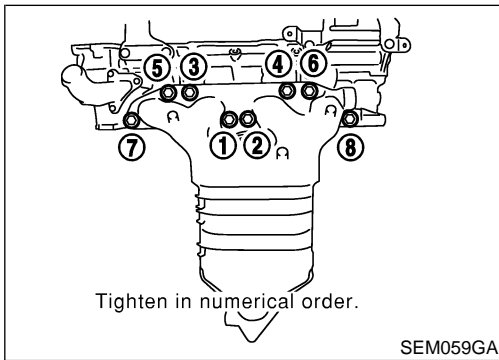

12. Install exhaust manifold.

- Tighten exhaust manifold bolts in numerical order.

Exhaust manifold:

: 37.8 - 48.1 N-m (3.8 - 4.9 kg-m, 28 - 35 ft-lb)

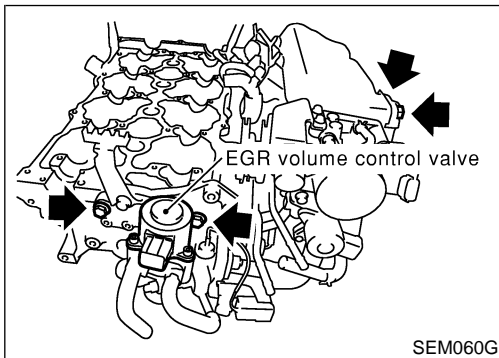

13. Install EGR volume control valve assembly.

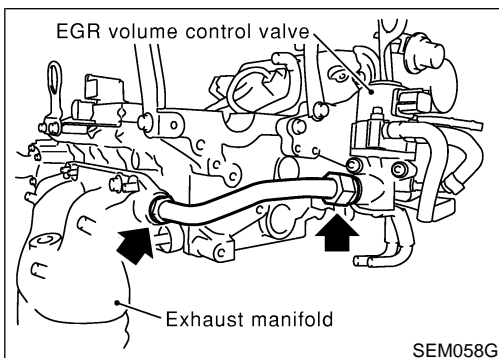

14. Install EGR tube.

15. Install exhaust manifold cover.

GI

MA

EM

LC

EC

FE

CL

MT

AT

AX

SU

BR

ST

RS

BT

HA

SC

EL

IDX

CYLINDER HEAD

Assembly (Cont'd)

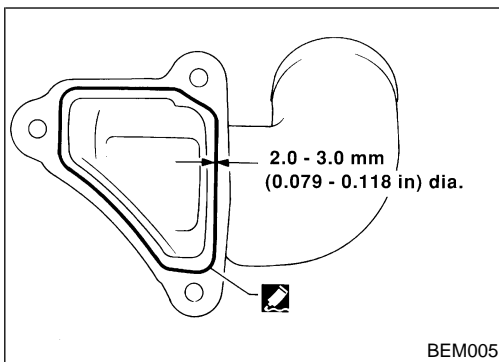

16. Install water outlet.
 - a. Remove old liquid gasket from mating surface of water outlet.
 - **Also remove old liquid gasket from mating surface of cylinder head.**
 - b. Apply a continuous bead of liquid gasket to mating surface of water outlet.
 - **Use Genuine RTV silicone sealant part No. 999MP-A7007 or equivalent.**

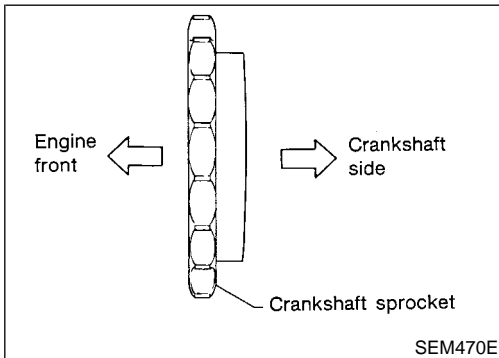

Installation

NCEM0041

1. Install crankshaft sprocket on crankshaft.
 - **Make sure that mating marks on crankshaft sprocket face front of engine.**

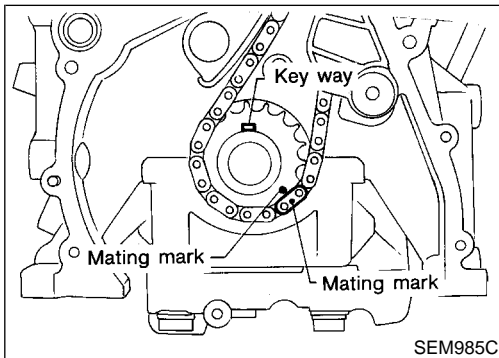

2. Position crankshaft so that No. 1 piston is set at TDC and key way is at 12 o'clock. Fit timing chain on crankshaft sprocket, aligning the mating marks.

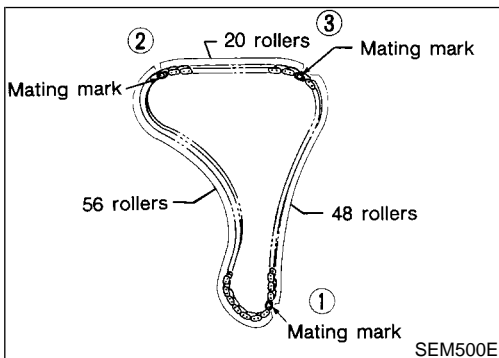

- Mating mark color on timing chain.
 - 1: Copper**
 - 2, 3: Silver**

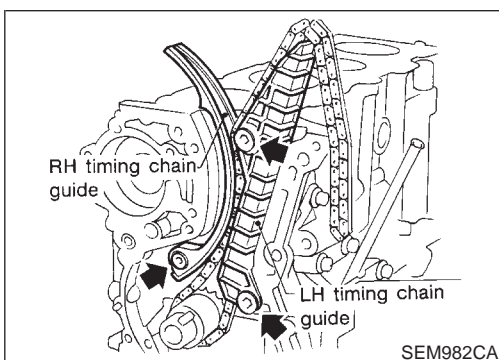

3. Install timing chain and timing chain guides.

CYLINDER HEAD

Installation (Cont'd)

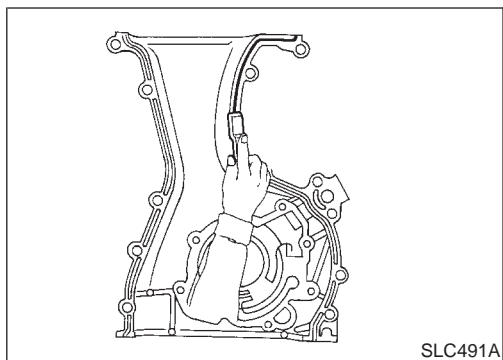

4. Before installing front cover, remove all traces of liquid gasket from mating surface using a scraper.

 - Also remove traces of liquid gasket from mating surface of

GI

MA

EM

LC

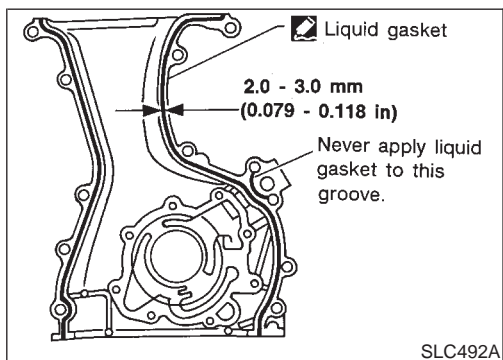

5. Apply a continuous bead of liquid gasket to mating surface of front cover.

 - Use Genuine Liquid Gasket or equivalent.
 - Be sure to install new front oil seal in the right direction. Refer to EM-28.

EC

FE

CL

MT

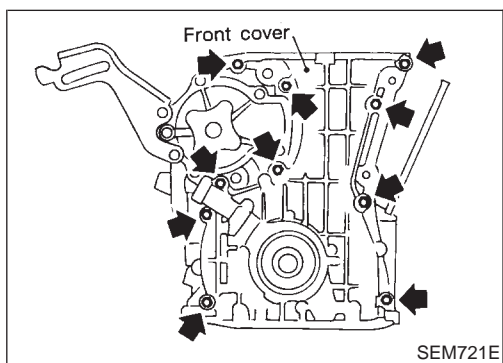

6. Install oil pump drive spacer and front cover.

AT

AX

SU

BR

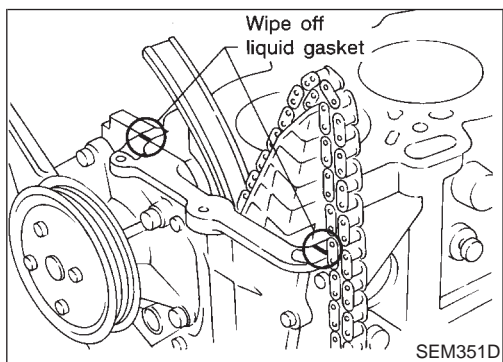

- Wipe off excessive liquid gasket.

ST

RS

BT

HA

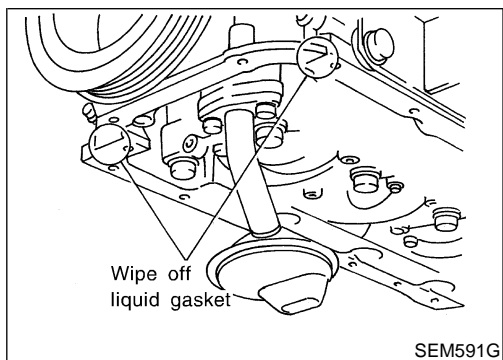

SC

EL

IDX

CYLINDER HEAD

Installation (Cont'd)

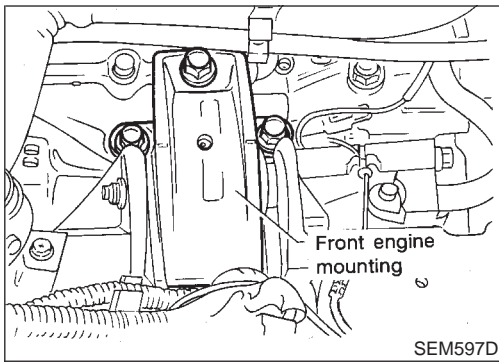

7. Install front engine mounting.

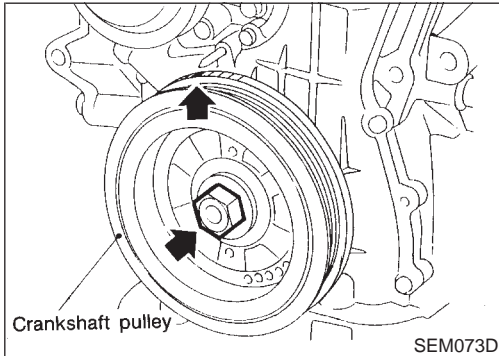

8. Install crankshaft pulley.

9. Set No. 1 piston at TDC on its compression stroke.

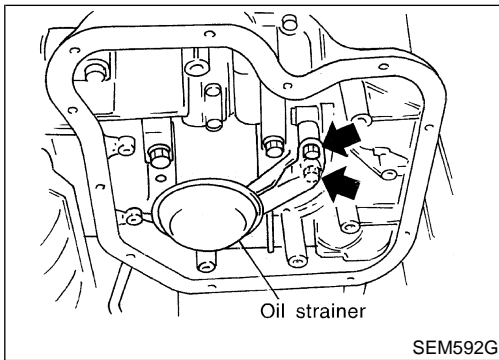

10. Install oil strainer.

11. Install oil pan.

Refer to "Installation" in "OIL PAN" (EM-16).

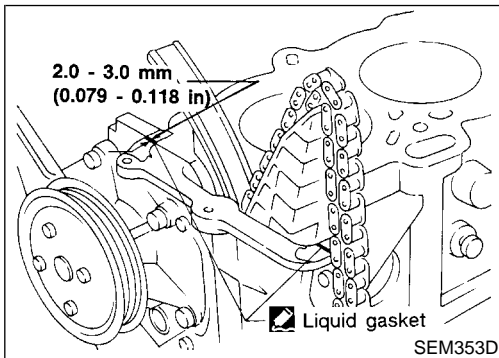

12. Before installing cylinder head gasket, apply a continuous bead of liquid gasket to mating surface of cylinder block.

CYLINDER HEAD

Installation (Cont'd)

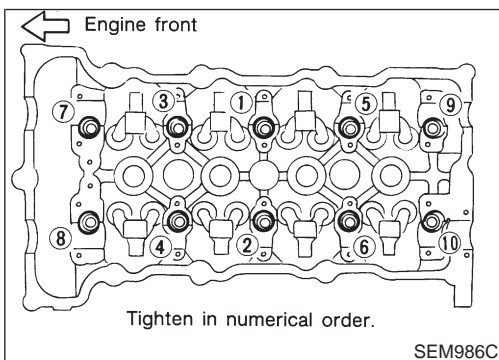
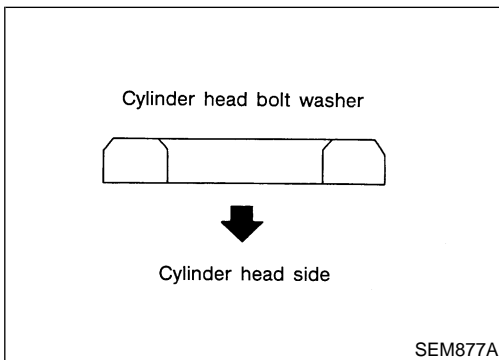
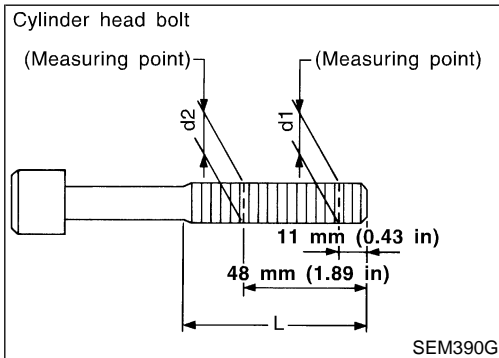
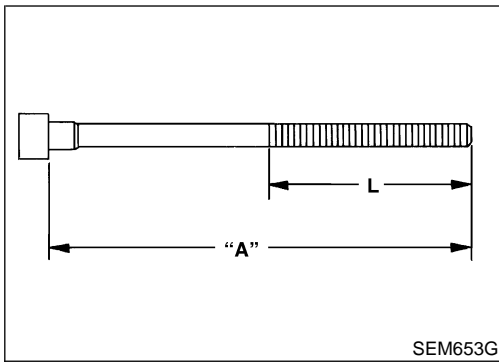

13. Install cylinder head completely with intake and exhaust manifolds.

- Apply engine oil to threads and seating surfaces of cylinder head bolts before installing them.
- Be sure to install washers between bolts and cylinder head.

CAUTION:

Old specification (Production before August 2000):
The cylinder head bolts can be reused providing dimension "A" is not exceeded.

Dimension "A":

158.2 mm (6.228 in)

- Bolt identification, old specification:

L: 75 mm (2.95 in)

CAUTION:

New specification (production from September, 2000):
Cylinder head bolts are tightened by plastic zone tightening method. Whenever the size difference between d1 and d2 exceeds the limit, replace them with new ones.

Limit (d1 - d2):

0.15 mm (0.0059 in)

- If reduction of outer diameter appears in a position other than d2, use it as d2 point.

- Bolt identification, new specification:

L: 55 mm (2.17 in)

- **Tightening procedure:**

- Tighten all bolts to 39.2 N·m (4.0 kg·m, 29 ft·lb).
- Tighten all bolts to 78.5 N·m (8.0 kg·m, 58 ft·lb).
- Loosen all bolts completely.
- Tighten all bolts to 39.2 N·m (4.0 kg·m, 29 ft·lb).

GI
MA
EM
LC
EC
FE
CL
MT
AT
AX
SU
BR
ST
RS
BT
HA
SC
EL
IDX

CYLINDER HEAD

Installation (Cont'd)

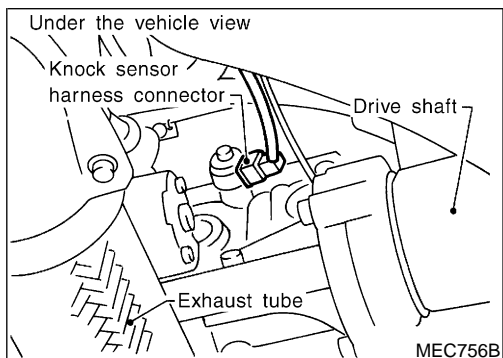
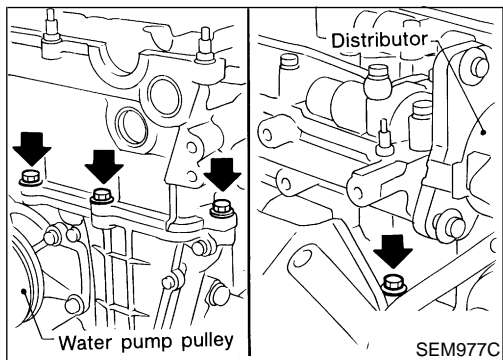
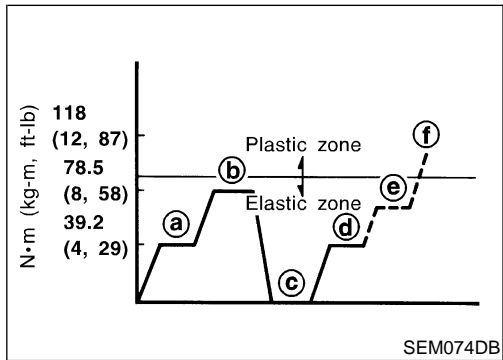
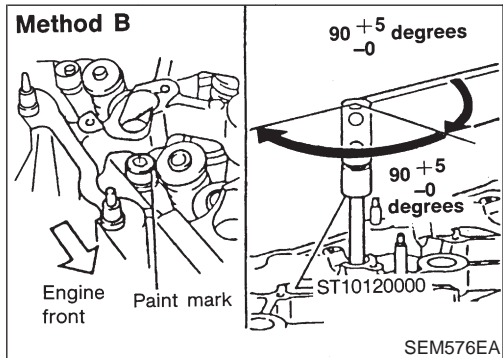
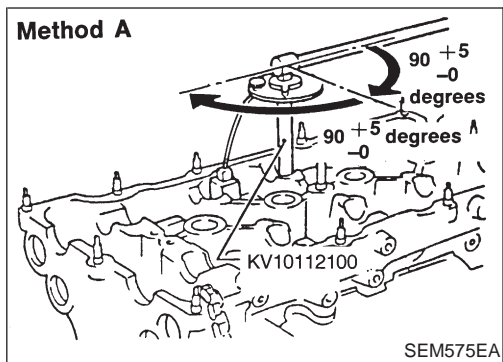

- e) **Method A:**
Turn all bolts 90 to 95 degrees clockwise with Tool or suitable angle wrench.
Method B:
If angle wrench is not available, do the following. Mark the side of all bolts with paint marks facing the front of the engine. Then turn them 90 to 95 degrees clockwise.
- f) Turn all bolts 90 to 95 degrees clockwise.
- g) Ensure that paint mark on each bolt faces the rear of the engine. (Method B only)
- Do not turn any bolt 180 to 190 degrees clockwise all at once.

| | Tightening torque N-m (kg-m, ft-lb) |
|---|---------------------------------------|
| a | 39.2 (4.0, 29) |
| b | 78.5 (8.0, 58) |
| c | 0 (0, 0) |
| d | 39.2 (4.0, 27) |
| e | 90 - 95 degrees (90 degree preferred) |
| f | 90 - 95 degrees (90 degree preferred) |

14. Install cylinder head outside bolts.
15. Install the following water hoses.
- Water hose for cylinder block.
 - Water hoses for heater.

16. Install knock sensor harness connector.

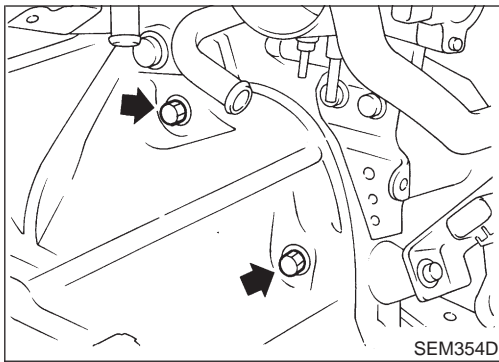

17. Install starter motor.

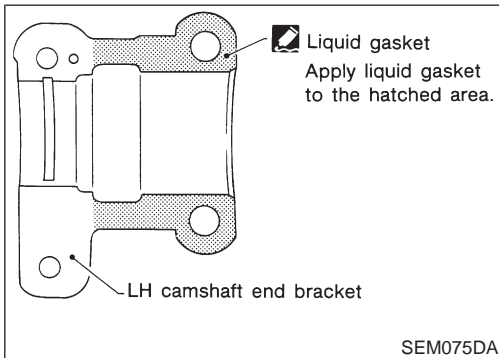

18. Remove all traces of liquid gasket from mating surface of LH camshaft end bracket.

- Also remove traces of liquid gasket from mating surface of cylinder head.

19. Apply liquid gasket to mating surface of LH camshaft end bracket as shown in illustration.

- Use Genuine Liquid Gasket or equivalent.

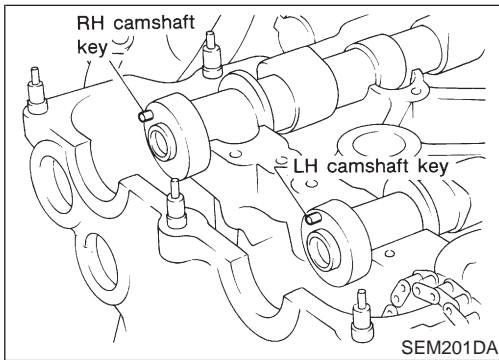

20. Install camshafts and camshaft brackets.

- Position camshaft.

- Exhaust camshaft key at about 12 o'clock

- Intake camshaft key at about 10 o'clock

Apply engine oil to bearings and cam surfaces of camshafts before installing them.

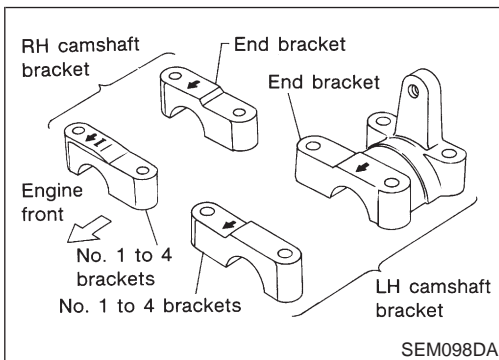

- Position camshaft brackets as shown in illustration.

Apply engine oil to threads and seating surfaces of camshaft bracket bolts before installing them.

GI

MA

EM

LC

EC

FE

CL

MT

AT

AX

SU

BR

ST

RS

BT

HA

SC

EL

IDX

CYLINDER HEAD

Installation (Cont'd)

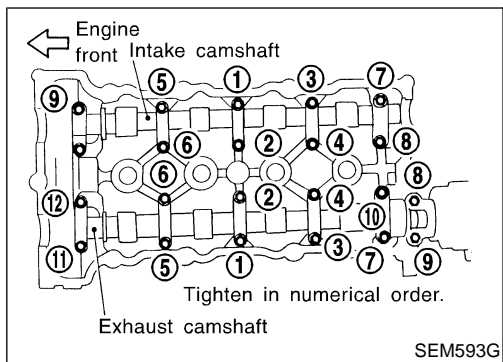

● Tightening procedure

STEP 1:

Intake camshaft

Tighten bolts 9 - 10 in that order then tighten bolts 1 - 8 in numerical order.

: 2 N·m (0.2 kg-m, 1.4 ft-lb)

Exhaust camshaft

Tighten bolts 11 - 12 in that order then tighten bolts 1 - 10 in numerical order.

: 2 N·m (0.2 kg-m, 1.4 ft-lb)

STEP 2:

Tighten bolts in the specified order.

: 6 N·m (0.6 kg-m, 4.3 ft-lb)

STEP 3:

Tighten bolts in the specified order.

Bolt type A B

: 10 - 12 N·m (1.0 - 1.2 kg-m, 7.2 - 8.7 ft-lb)

Bolt type C

: 18 - 25 N·m (1.8 - 2.6 kg-m, 13 - 19 ft-lb)

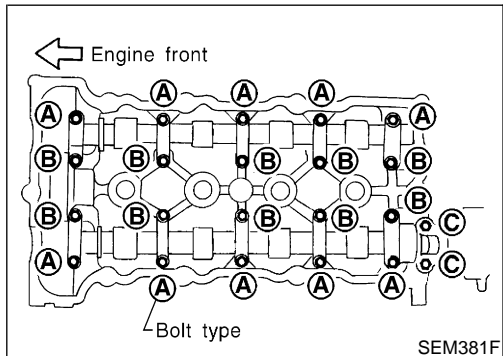

21. Install camshaft sprockets.

Line up mating marks on timing chain with mating marks on camshaft sprockets.

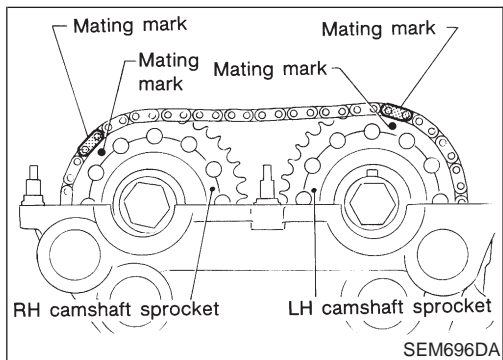

● Lock camshafts as shown in figure and tighten to specified torque.

: 137 - 157 N·m (14.0 - 16.0 kg-m, 101 - 116 ft-lb)

Apply engine oil to threads and seating surfaces of camshaft sprocket bolts before installing them.

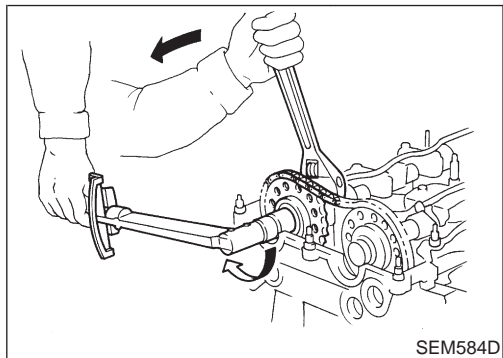

22. Install timing chain guide.

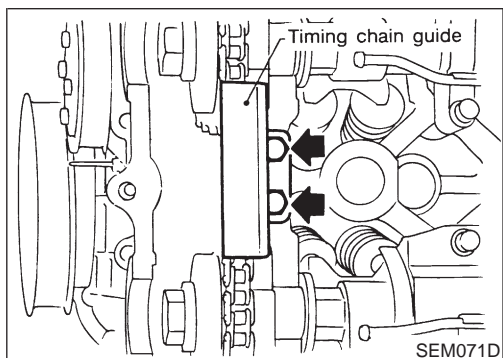

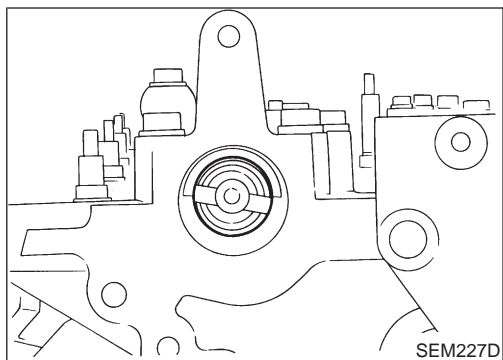

23. Install distributor.

- Make sure that position of camshaft is as shown in figure.

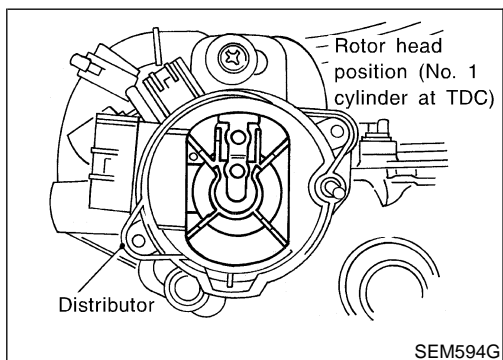

- Make sure that No. 1 piston is set at TDC and that distributor is set at No. 1 cylinder spark position.

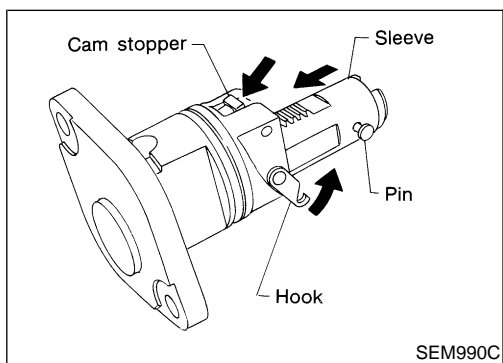

24. Install chain tensioner.

- Make sure the camshaft sprockets are tightened completely. Press cam stopper down and “press-in” sleeve until hook can be engaged on pin. When tensioner is bolted in position the hook will release automatically.

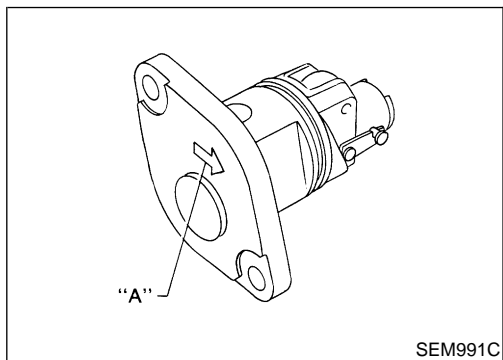

- Make sure arrow “A” points toward engine front.

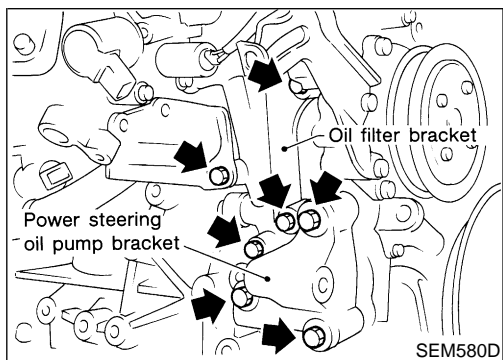

25. Install oil filter bracket (SR20DE engine only) and power steering oil pump bracket.

26. Install intake manifold supports.

GI

MA

EM

LC

EC

FE

CL

MT

AT

AX

SU

BR

ST

RS

BT

HA

SC

EL

IDX

CYLINDER HEAD

Installation (Cont'd)

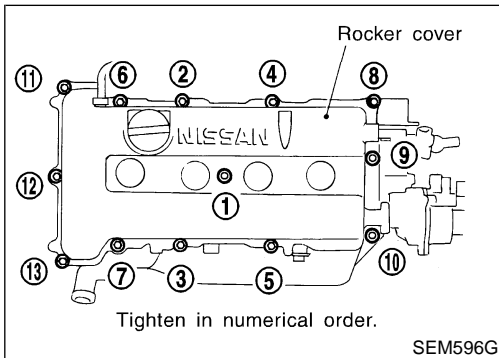
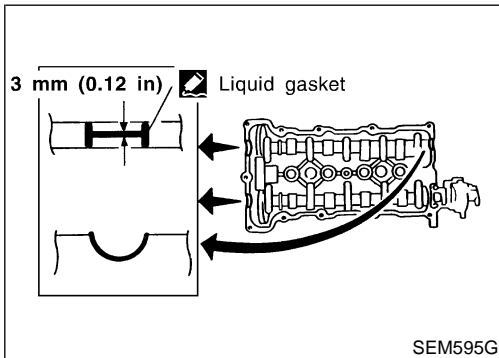
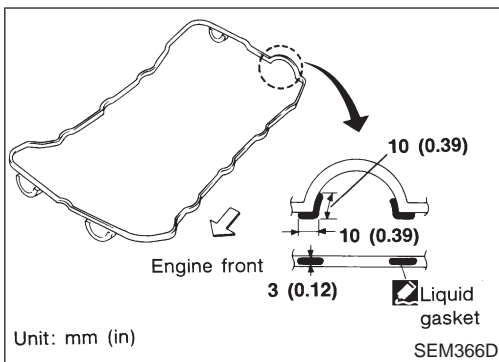

27. Remove all old liquid gasket from mating surfaces of rocker cover and cylinder head.
 28. Apply a continuous bead of liquid gasket to mating surfaces of rocker cover gasket and cylinder head.
- **Use Genuine Liquid Gasket or equivalent.**

29. Install rocker cover.
 - 1) **Tighten bolts 1 - 10 - 11 - 13 - 8 in that order to 8 to 10 N-m (0.8 to 1.0 kg-m, 69 to 89 in-lb).**
 - 2) **Tighten bolts 1 through 13 in numerical order to 8 to 10 N-m (0.8 to 1.0 kg-m, 70 to 89 in-lb).**
30. Refit spark plugs and leads.
31. Install vacuum hoses, fuel hoses, wires, harness, connectors and so on.
32. Install power steering oil pump and alternator.
33. Install water pump pulley and drive belts.
34. Install intake manifold collector and brackets.
35. Refit air duct to intake manifold.
36. Install radiator.
37. Refit hoses and refill with coolant. (Refer to MA-15.)
38. Install engine side cover and front RH wheel.
39. Install engine under covers.

Removal and Installation

NCEM0022

SEC. 112

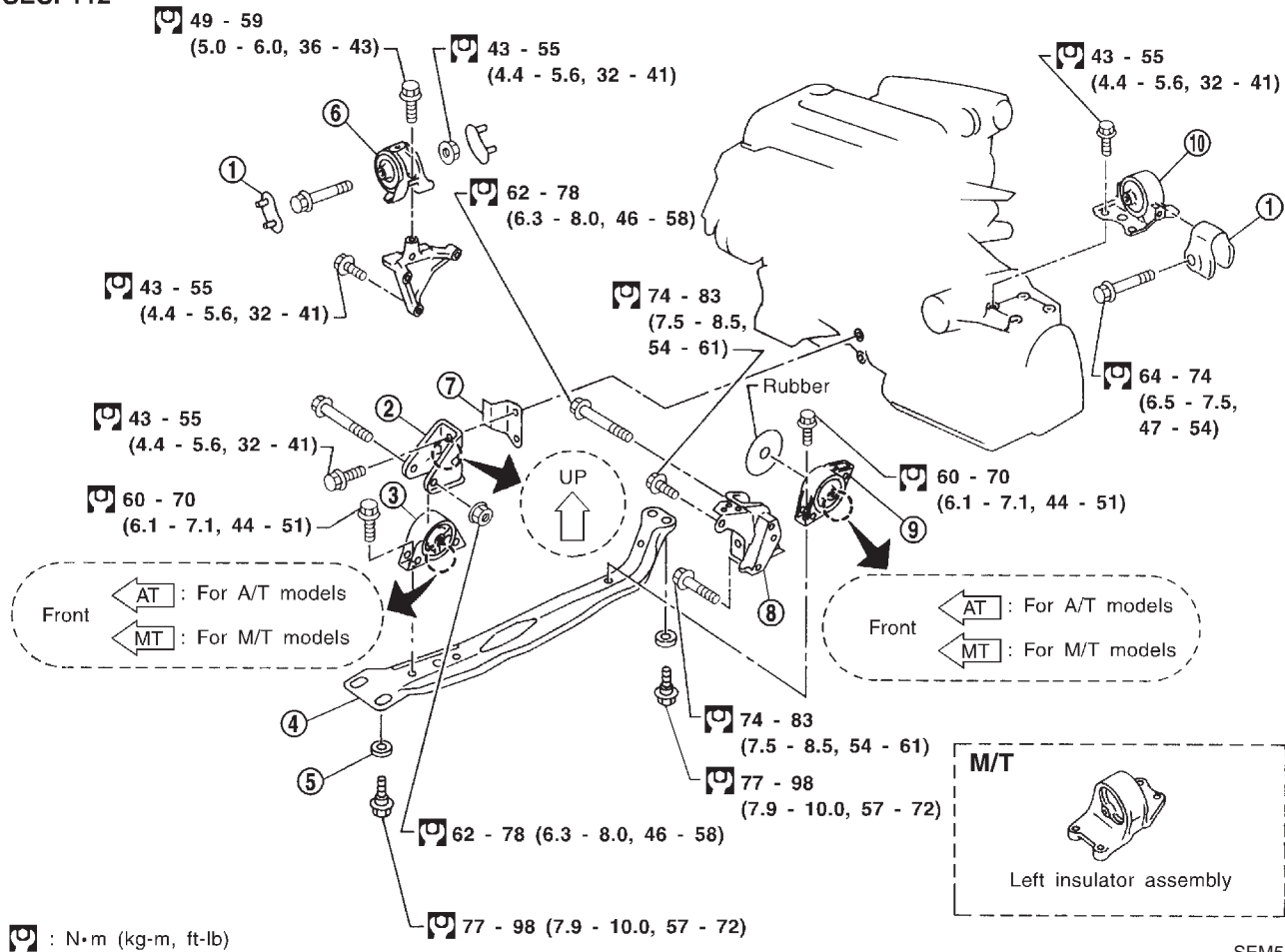

: N·m (kg-m, ft-lb)

SEM518F

- | | | |
|-----------------------------|-----------------------------|-----------------------------------|
| 1. Stopper | 5. Pad | 8. Bracket |
| 2. Bracket | 6. Right insulator assembly | 9. Rear insulator assembly |
| 3. Front insulator assembly | 7. Exhaust bracket | 10. Left insulator assembly (A/T) |
| 4. Center member | | |

WARNING:

- Position vehicle on a flat and solid surface.
- Place chocks at front and back of rear wheels.
- Do not remove engine until exhaust system has completely cooled off, otherwise you may burn yourself and/or fire may break out in fuel line.
- Before disconnecting fuel hose, release pressure. Refer to EC-50, "Fuel Pressure Release".
- Before removing front axle from transaxle, place safety stands under designated front supporting points. Refer to GI-47, "Garage Jack and Safety Stand".
- Be sure to lift engine and transaxle in a safe manner.
- For engines not equipped with engine slingers, attach proper slingers and bolts described in PARTS CATALOG.

CAUTION:

- When lifting engine, be sure to clear surrounding parts. Use special care near accelerator wire casing, brake lines and brake master cylinder.

GI
MA
EM
LC
EC
FE
CL
MT
AT
AX
SU
BR
ST
RS
BT
HA
SC
EL
IDX

ENGINE ASSEMBLY

Removal and Installation (Cont'd)

- In lifting the engine, always use engine slingers in a safe manner.
- In removing drive shaft, be careful not to damage grease seal of transaxle.
- Before separating engine and transaxle, remove the crankshaft position sensor (OBD) from the assembly.
- Always be extra careful not to damage edge of crankshaft position sensor (OBD) or ring gear teeth.

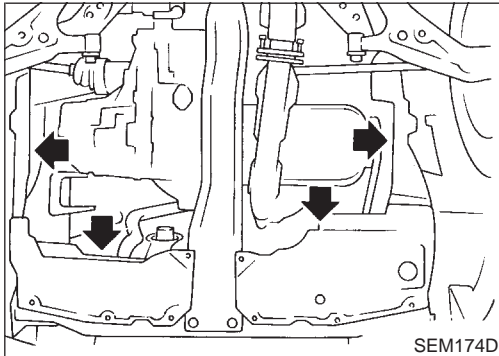

REMOVAL

NCEM0022S01

1. Remove engine under covers and engine side cover.
2. Drain coolant from both cylinder block and radiator. Refer to MA-14, "Changing Engine Coolant".
3. Drain engine oil.
4. Remove air cleaner assembly and duct.
5. Remove the battery and battery tray.
6. Disconnect the following:
 - Vacuum hoses
 - Heater hoses
 - A/T cooler hoses
 - Power steering hoses
 - Fuel lines
 - Wires
 - Harnesses and connectors
 - Throttle cable
 - ASCD cable
 - A/T control cable
7. Remove the cooling fans, radiator and recovery tank.
8. Remove front LH and RH wheels and drive shafts. Refer to AX-10, "Drive Shaft".
9. Remove front exhaust pipe.
10. Remove starter and intake manifold support.
11. Remove the drive belts.
12. Remove power steering oil pump and A/C compressor.
13. Set a suitable transmission jack under transaxle. Lift engine with engine slinger.

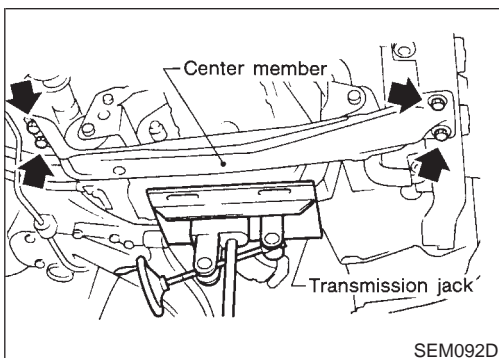

14. Remove center member.
15. Remove generator and adjusting bracket.

ENGINE ASSEMBLY

Removal and Installation (Cont'd)

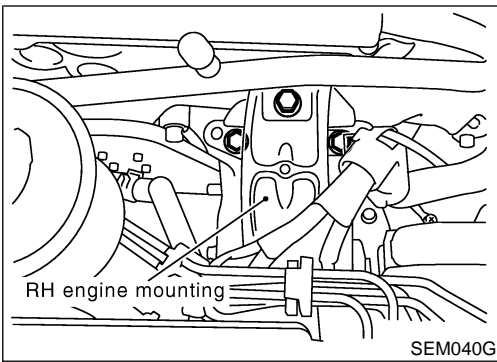

16. Remove engine mounting bolts from both sides, then slowly lower transmission jack.

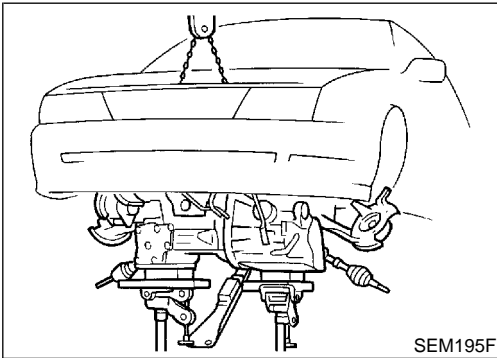

17. Remove engine with transaxle as shown.

INSTALLATION

1. Install in the reverse order of removal.

NCEM0022S02

GI

MA

EM

LC

EC

FE

CL

MT

AT

AX

SU

BR

ST

RS

BT

HA

SC

EL

IDX

Removal and Installation

NCEM0024

CAUTION:

- When installing sliding parts (bearings, pistons, etc.), lubricate contacting surfaces with new engine oil.
- Place removed parts such as bearings and bearing caps in their proper order and direction.
- When installing connecting rod nuts and main bearing cap bolts, apply new engine oil to threads and seating surfaces.
- Do not allow any magnetic materials to contact the ring gear teeth of flywheel or drive plate.

GI

MA

EM

LC

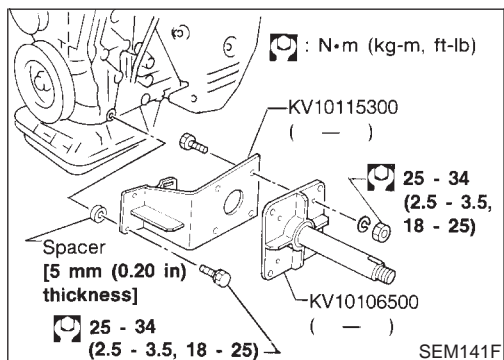

SEM141F

Disassembly

PISTON AND CRANKSHAFT

NCEM0025

NCEM0025S01

1. Place engine on engine stand (ST0501S000).
2. Remove cylinder head and timing chain. Refer to EM-20.
3. Remove oil pan. Refer to EM-14.

EC

FE

CL

MT

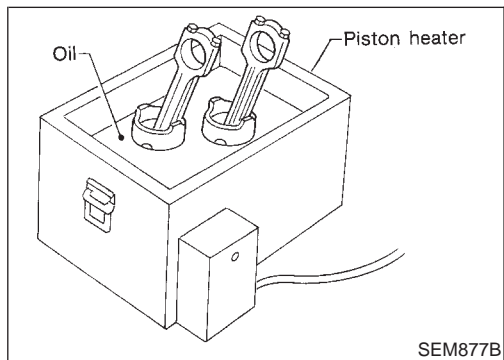

SEM877B

4. Remove pistons with connecting rods.
 - To disassemble piston and connecting rod, first remove snap rings. Heat piston to 60 to 70°C (140 to 158°F) then use piston pin press to remove pin.
 - When piston rings are not replaced, make sure that piston rings are mounted in their original positions.
 - When replacing piston rings, if there is no punchmark, install with either side up.
5. Remove rear oil seal retainer.

AT

AX

SU

BR

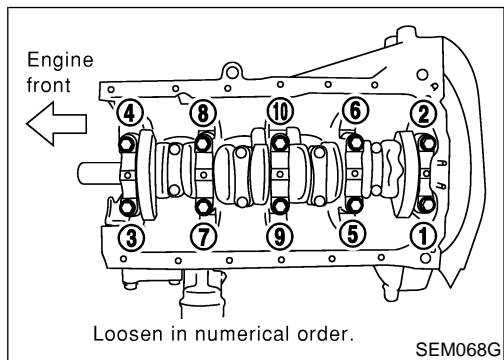

SEM068G

6. Remove main bearing cap and crankshaft as shown.
 - Bolts should be loosened in two or three steps.

ST

RS

BT

HA

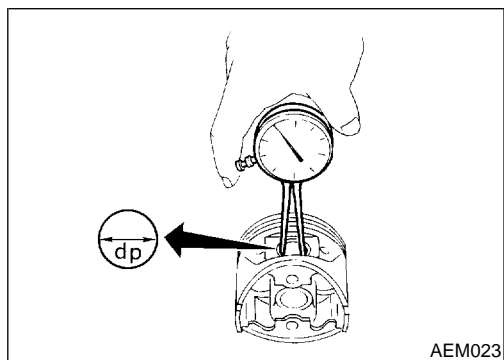

AEM023

Inspection

PISTON AND PISTON PIN CLEARANCE

NCEM0026

NCEM0026S01

1. Measure inner diameter of piston pin hole "dp".
 - Standard diameter "dp":
21.993 - 22.005 mm (0.8659 - 0.8663 in)

EL

IDX

CYLINDER BLOCK

Inspection (Cont'd)

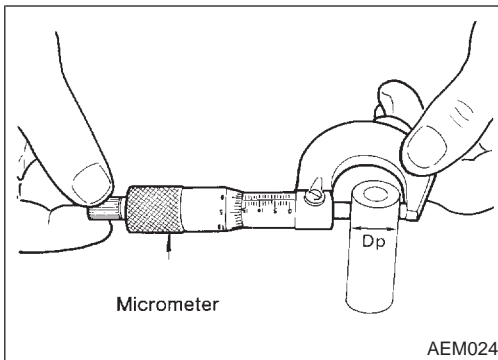

2. Measure outer diameter of piston pin "Dp".

Standard diameter "Dp":

21.989 - 22.001 mm (0.8657 - 0.8622 in)

3. Calculate interference fit of piston pin to piston.

Dp - dp: 0.005 - 0.017 mm (0.0002 - 0.0007 in)

If it exceeds the above value, replace piston assembly with pin.

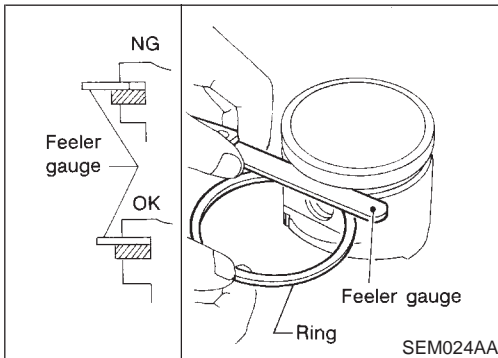

PISTON RING SIDE CLEARANCE

NCEM0026S02

Side clearance:

Top ring

0.040 - 0.080 mm (0.0016 - 0.0031 in)

2nd ring

0.030 - 0.070 mm (0.0012 - 0.0028 in)

Max. limit of side clearance:

Top and 2nd ring

0.1 mm (0.004 in)

If out of specification, replace piston ring. If clearance exceeds maximum limit with new ring, replace piston.

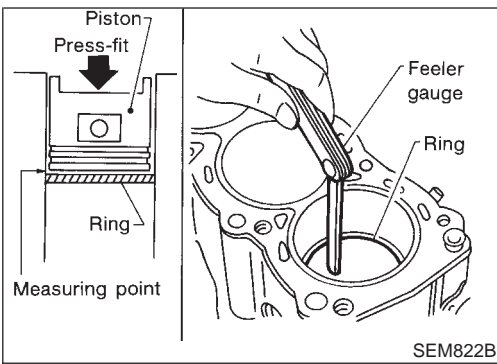

PISTON RING END GAP

NCEM0026S03

End gap:

Top ring 0.20 - 0.39 mm (0.0079 - 0.0154 in)

2nd ring 0.35 - 0.59 mm (0.0138 - 0.0232 in)

Oil ring 0.20 - 0.69 mm (0.0079 - 0.0272 in)

Max. limit of ring gap:

Top ring 0.53 mm (0.0209 in)

2nd ring 0.7 mm (0.028 in)

Oil ring 0.95 mm (0.374 in)

If out of specification, replace piston ring. If gap exceeds maximum limit with a new ring, rebore cylinder and use oversized piston and piston rings. Refer to SDS, EM-78.

- When replacing the piston, check cylinder block surface for scratches or seizure. If scratches or seizure are found, hone or replace the cylinder block.

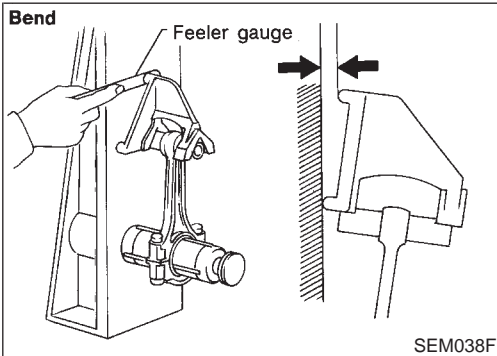

CONNECTING ROD BEND AND TORSION

NCEM0026S04

Bend:

Limit 0.15 mm (0.0059 in)

per 100 mm (3.94 in) length

Torsion:

Limit 0.30 mm (0.0118 in)

per 100 mm (3.94 in) length

If it exceeds the limit, replace connecting rod assembly.

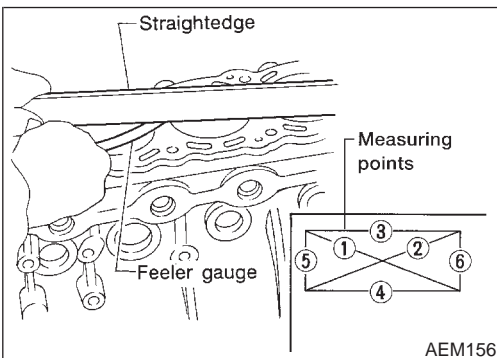
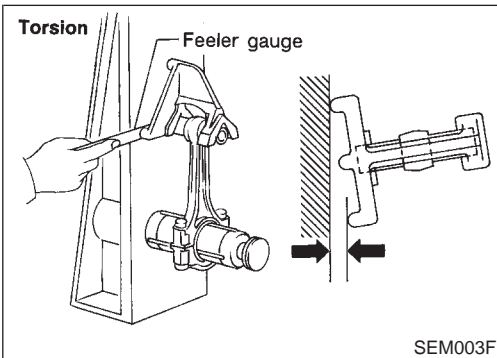

CYLINDER BLOCK DISTORTION AND WEAR

NCEM0026S05

Clean upper surface of cylinder block.

Use a reliable straightedge and feeler gauge to check the flatness of cylinder block surface. Check along six positions shown in figure.

Block surface flatness:

Standard Less than 0.03 mm (0.0012 in)

Limit 0.10 mm (0.0039 in)

If out of specification, resurface it.

The limit for cylinder block resurfacing is determined by the amount of cylinder head resurfacing.

Amount of cylinder head resurfacing is "A".

Amount of cylinder block resurfacing is "B".

The maximum limit is as follows:

A + B = 0.2 mm (0.008 in)

Nominal cylinder block height

from crankshaft center:

211.25 - 211.35 mm (8.3169 - 8.3208 in)

If necessary, replace cylinder block.

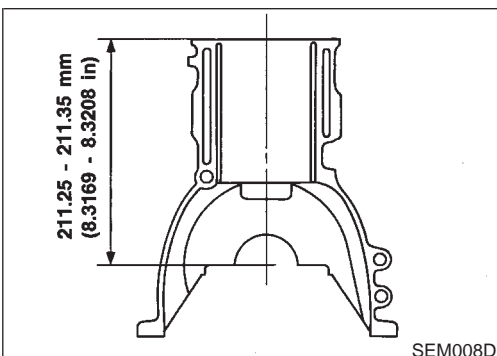

GI
MA
EM
LC
EC
FE
CL
MT
AT
AX
SU
BR
ST
RS
BT
HA
SC
EL
IDX

CYLINDER BLOCK

Inspection (Cont'd)

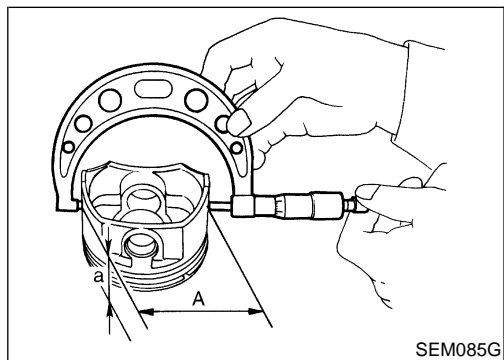
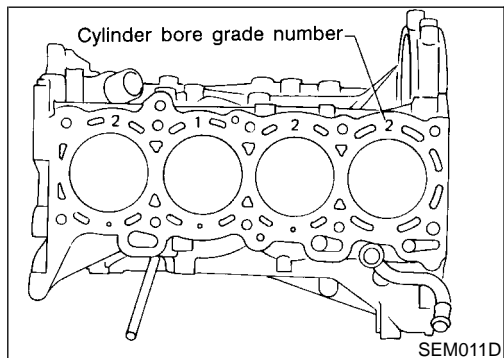
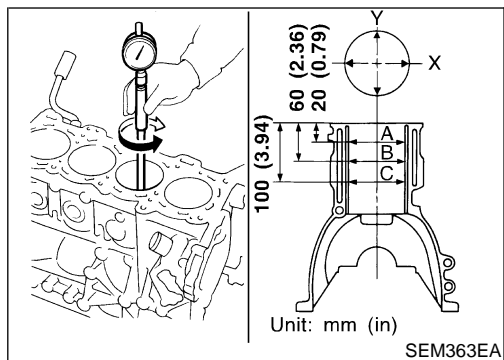

PISTON-TO-BORE CLEARANCE

NCEM0026S06

- Using a bore gauge, measure cylinder bore for wear, out-of-round and taper.

Standard inner diameter:

86.000 - 86.030 mm (3.3858 - 3.3870 in)

Wear limit:

0.20 mm (0.0079 in)

Out-of-round (X – Y) standard:

0.015 mm (0.0006 in)

Taper (A – B and A – C) standard:

0.010 mm (0.0004 in)

If it exceeds the limit, rebores all cylinders. Replace cylinder block if necessary.

- Check for score and seizure. If seizure is found, hone it.
 - If cylinder block and piston are replaced, match piston grade with grade number on cylinder block upper surface.

- Measure piston skirt diameter.

Piston diameter "A": Refer to SDS, EM-78.

Measuring point "a" (Distance from the top):

45.0 mm (1.772 in)

- Check that piston-to-bore clearance is within specification.

Piston-to-bore clearance = bore measurement "C" – Piston diameter "A":

0.010 - 0.030 mm (0.0004 - 0.0012 in)

- Determine piston oversize according to amount of cylinder wear.

Oversize pistons are available for service. Refer to SDS, EM-78.

- Cylinder bore size is determined by adding piston-to-bore clearance to piston diameter "A".

Rebored size calculation:

$$D = A + B - C$$

where,

D: Bored diameter

A: Piston diameter as measured

B: Piston-to-bore clearance

C: Honing allowance 0.02 mm (0.0008 in)

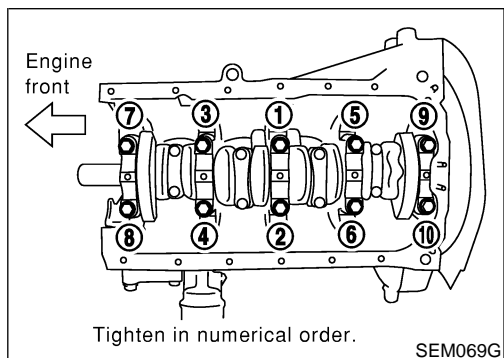

- Install main bearing caps and tighten to the specified torque. This will prevent distortion of cylinder bores, otherwise cylinder bores may be distorted in final assembly.

- Cut cylinder bores.

- When any cylinder needs boring, all other cylinders must also be bored.

- Do not cut too much out of cylinder bore at a time. Cut only 0.05 mm (0.0020 in) or so at a time.

- Hone cylinders to obtain specified piston-to-bore clearance.

- Measure finished cylinder bore for out-of-round and taper.

- Measurement should be done after cylinder bore cools down.

GI

MA

EM

LC

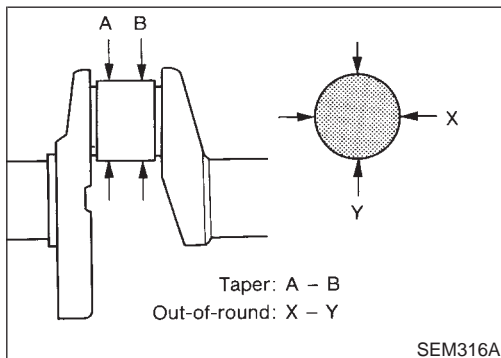

CRANKSHAFT

NCEM0026S07

1. Check crankshaft main and pin journals for score, wear or cracks.
2. With a micrometer, measure journals for taper and out-of-round.

EC

FE

Out-of-round (X - Y):

Taper (A - B):

Main journal: Less than 0.005 mm (0.0002 in)

Pin journal: Less than 0.003 mm (0.0001 in)

CL

MT

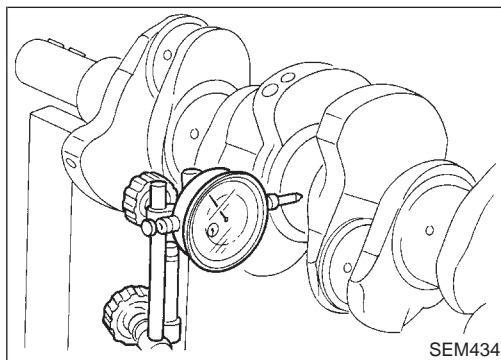

3. Measure crankshaft runout.

Runout (Total indicator reading):

Less than 0.05 mm (0.0020 in)

AT

AX

SU

BR

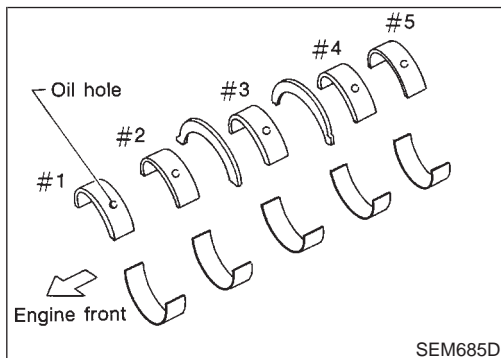

BEARING CLEARANCE

NCEM0026S08

- Use Method A or Method B. Method A is preferred because it is more accurate.

ST

Method A (Using bore gauge and micrometer)

RS

Main bearing

NCEM0026S0801

1. Set main bearings in their proper positions on cylinder block and main bearing cap.
2. Install main bearing cap and main bearing beam to cylinder block.

BT

HA

Tighten all bolts in correct order in two or three stages. Refer to EM-68.

SC

3. Measure inner diameter "A" of each main bearing.

EL

IDX

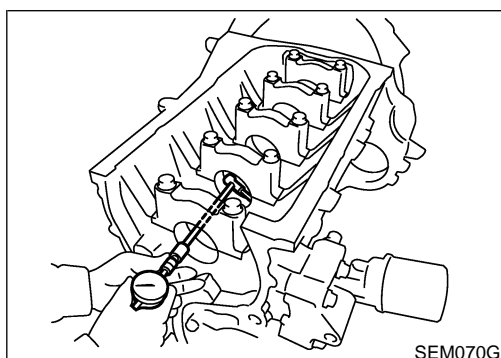

CYLINDER BLOCK

Inspection (Cont'd)

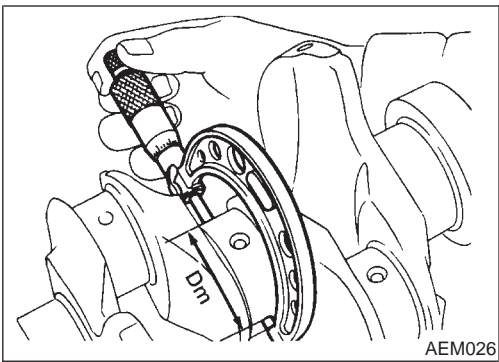

4. Measure outer diameter "Dm" of each crankshaft main journal.
5. Calculate main bearing clearance.

$$\text{Main bearing clearance} = A - Dm$$

Standard: 0.004 - 0.022 mm (0.0002 - 0.0009 in)

Limit: 0.050 mm (0.0020 in)

If it exceeds the limit, replace bearing.

- If clearance cannot be adjusted within the standard of any bearing, grind crankshaft main journal and use undersized bearing.

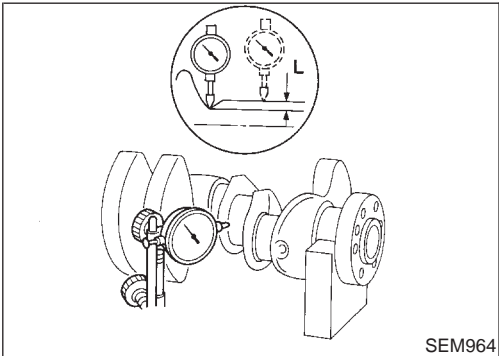

- **When grinding crankshaft journal, confirm that "L" dimension in fillet roll is more than the specified limit.**

"L": 0.05 mm (0.0020 in)

- Refer to SDS, EM-80 for grinding crankshaft and available service parts.

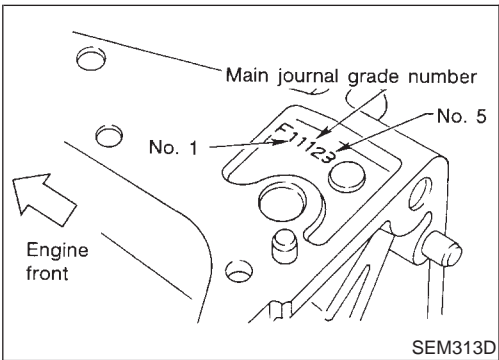

- If crankshaft is replaced, select thickness of main bearings as follows:

- a. Grade number of each cylinder block main journal is punched on the respective cylinder block. These numbers are punched in either Arabic or Roman numerals.

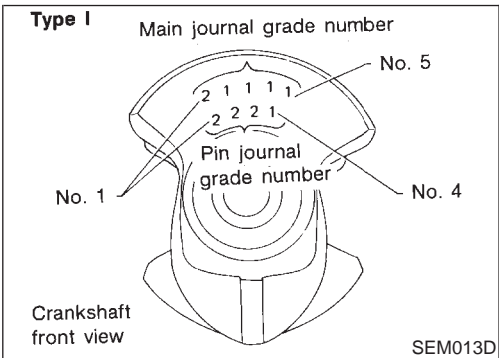

- b. Grade number of each crankshaft main journal is punched on the respective crankshaft. These numbers are punched in either Arabic or Roman numerals.

- c. Select main bearing with suitable thickness according to the following table.

How to Select Main Bearings (Identification mark and color)

NCEM0026S0803

| Crankshaft main journal grade number | Cylinder block main journal grade number | | | |
|--------------------------------------|--|------------------|------------------|--------------------|
| | 0 | 1 | 2 | 3 |
| 0 | 0 (A, Black) | 1 (B, Brown) | 2 (C, Green) | 3 (D, Yellow) |
| 1 | 1 (B, Brown) | 2 (C, Green) | 3 (D, Yellow) | 4 (E, Blue) |
| 2 | 2 (C, Green) | 3 (D, Yellow) | 4 (E, Blue) | 5 (F, Pink) |
| 3 | 3 (D, Yellow) | 4 (E, Blue) | 5 (F, Pink) | 6 (G, No color) |

For example:

Cylinder block main journal grade number: 1

EM-64

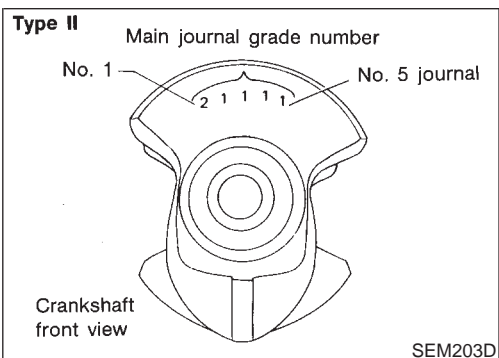

Crankshaft main journal grade number: 2
Main bearing grade number = 1 + 2
= 3 (D, Yellow)

GI

MA

EM

LC

EC

FE

CL

MT

AT

AX

SU

BR

ST

RS

BT

HA

SC

EL

IDX

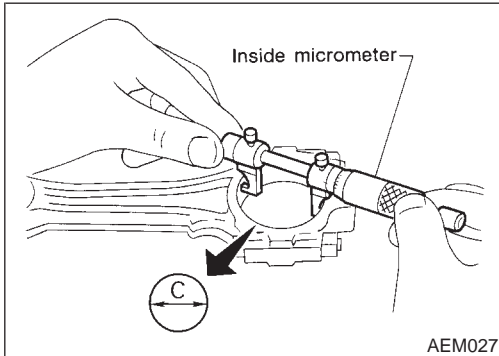

AEM027

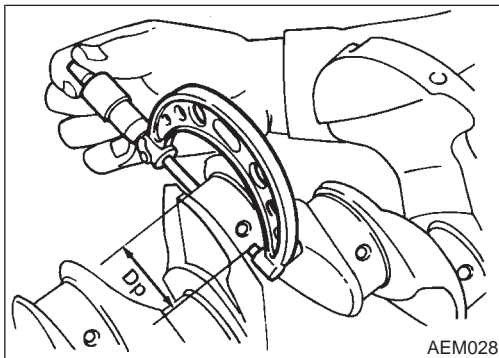

AEM028

Connecting Rod Bearing (Big end)

NCEM0026S0802

1. Install connecting rod bearing to connecting rod and cap.
2. Install connecting rod cap to connecting rod.

Tighten bolts to the specified torque. Refer to EM-68.

3. Measure inner diameter "C" of each bearing.

4. Measure outer diameter "Dp" of corresponding crankshaft pin journal.
5. Calculate connecting rod bearing clearance.

Connecting rod bearing clearance = C - Dp

Standard: 0.020 - 0.045 mm (0.0008 - 0.0018 in)

Limit: 0.065 mm (0.0026 in)

If it exceeds the limit, replace bearing.

- If clearance cannot be adjusted within the standard of any bearing, grind crankshaft journal and use undersized bearing. Refer to EM-63 for fillet roll remarks, grinding crankshaft and available service parts.
- If crankshaft is replaced with a new one, select connecting rod bearing according to the following table.

Connecting rod bearing grade number:

These numbers are punched in either Arabic or Roman numerals.

| Crank pin grade number | Connecting rod bearing grade number |
|------------------------|-------------------------------------|
| 0 | 0 |
| 1 | 1 |
| 2 | 2 |

Identification color:

Grade 0; No color

Grade 1; Black

Grade 2; Brown

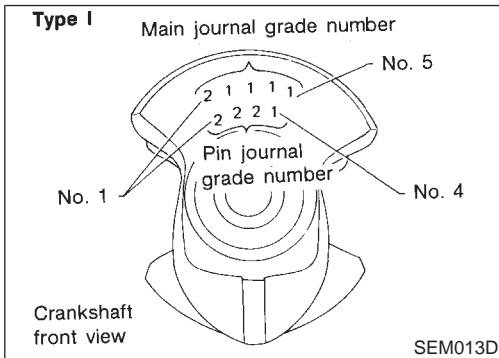

SEM013D

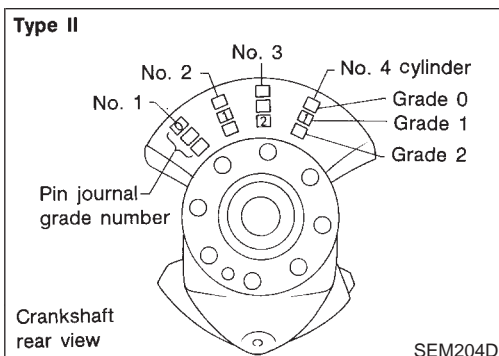

SEM204D

CYLINDER BLOCK

Inspection (Cont'd)

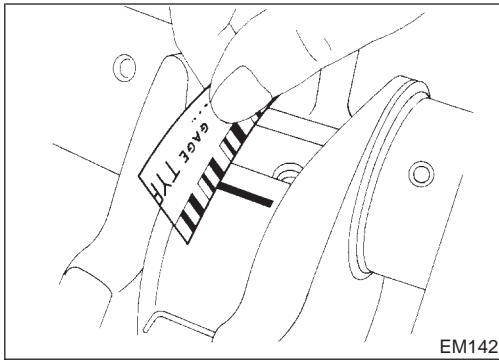

Method B (Using Plastigage)

CAUTION:

- Do not turn crankshaft or connecting rod while Plastigage is being inserted.
- If incorrect bearing clearance exists, use a thicker or undersized main bearing to ensure specified clearance.

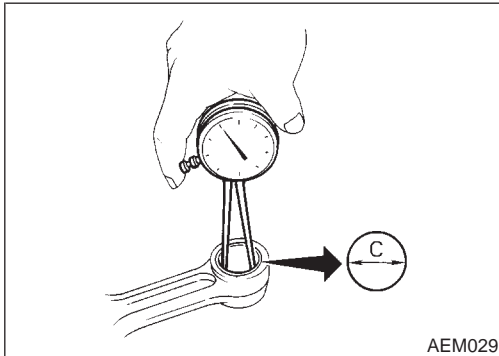

CONNECTING ROD BUSHING CLEARANCE (SMALL END)

NCEM0026S09

1. Measure inner diameter "C" of bushing.

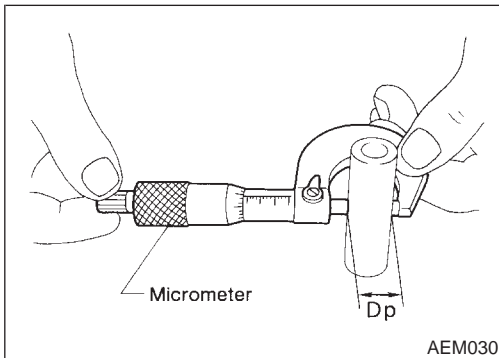

2. Measure outer diameter "Dp" of piston pin.
3. Calculate connecting rod bushing clearance.
Connecting rod bushing clearance = C - Dp

Standard:

0.005 - 0.017 mm (0.0002 - 0.0007 in)

Limit:

0.023 mm (0.0009 in)

If it exceeds the limit, replace connecting rod assembly or connecting rod bushing and/or piston set with pin.

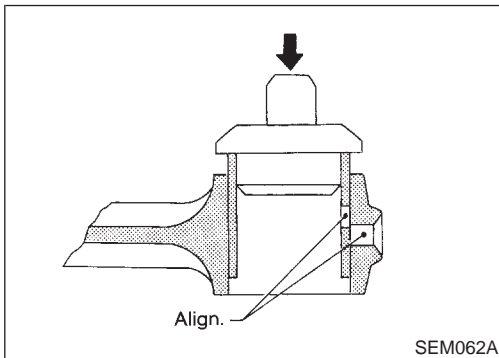

REPLACEMENT OF CONNECTING ROD BUSHING (SMALL END)

NCEM0026S10

1. Drive in small end bushing until it is flush with end surface of rod.

Be sure to align the oil holes.

2. Ream the bushing so that clearance with piston pin is within specification.

Clearance between connecting rod bushing and piston pin:

0.005 - 0.017 mm (0.0002 - 0.0007 in)

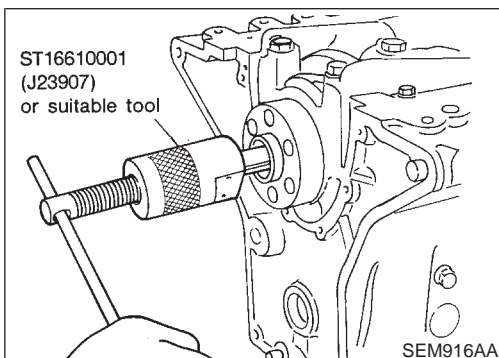

REPLACEMENT OF PILOT BUSHING (M/T) OR PILOT CONVERTER (A/T)

NCEM0026S11

1. Remove pilot bushing or pilot converter using Tool or suitable tool.

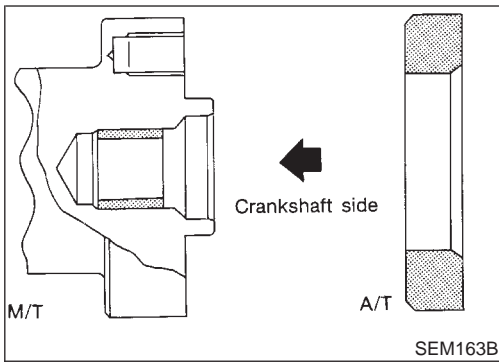

2. Install pilot bushing or pilot converter as shown.

GI

MA

EM

LC

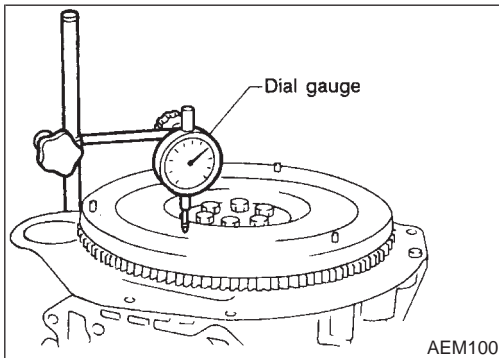

FLYWHEEL/DRIVE PLATE RUNOUT

NCEM0026S12

Runout (Total indicator reading):

Flywheel (M/T model)

Less than 0.15 mm (0.0059 in)

Drive plate (A/T model)

Less than 0.20 mm (0.0079 in)

EC

FE

CAUTION:

- Be careful not to damage the ring gear teeth.
- Check the drive plate for deformation or cracks.
- Do not allow any magnetic materials to contact the ring gear teeth.
- Do not resurface flywheel. Replace as necessary.

CL

MT

AT

AX

SU

BR

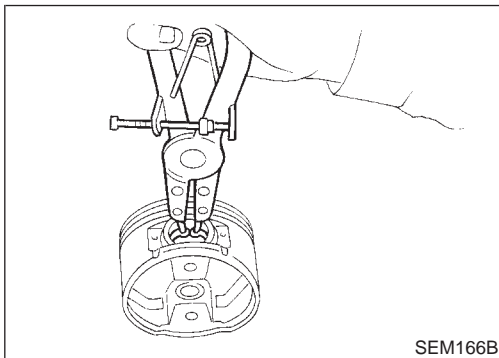

Assembly PISTON

NCEM0027

NCEM0027S01

1. Install new snap ring on one side of piston pin hole.

ST

RS

BT

HA

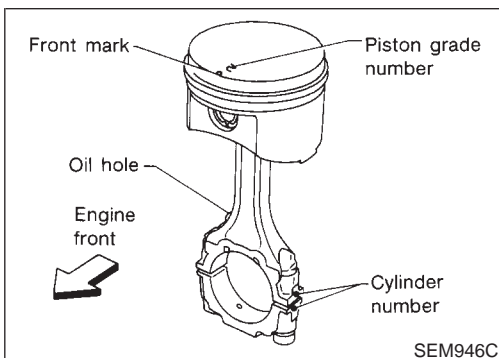

2. Heat piston to 60 to 70°C (140 to 158°F) and assemble piston, piston pin, connecting rod and new snap ring.

- Align the direction of piston and connecting rod.
- Numbers stamped on connecting rod and cap correspond to each cylinder.
- After assembly, make sure connecting rod swings smoothly.

SC

EL

IDX

CYLINDER BLOCK

Assembly (Cont'd)

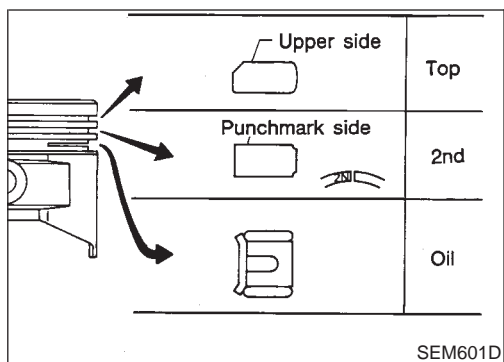

3. Set piston rings as shown.

CAUTION:

- When piston rings are not replaced, make sure that piston rings are mounted in their original positions.
- Install new piston rings either side up if there is no punch mark.

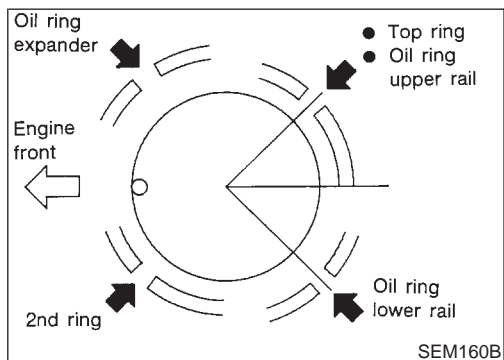

- Align piston rings so that end gaps are positioned as shown.

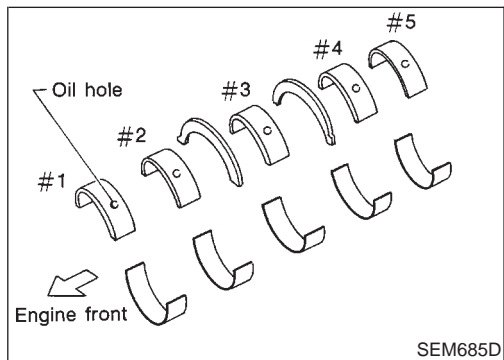

CRANKSHAFT

NCEM0027S02

1. Set main bearings in their proper positions on cylinder block and main bearing cap.

- Confirm that correct main bearings are selected by using Method A or Method B. Refer to EM-63.
- Apply new engine oil to bearing surfaces.

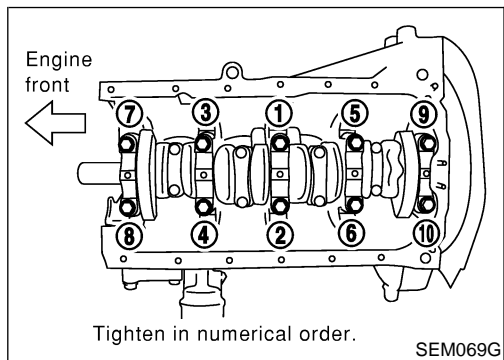

2. Install crankshaft and main bearing caps, then tighten bolts to the specified torque.

- Prior to tightening bearing cap bolts, shift crankshaft back and forth to properly seat the bearing cap.
- Apply new engine oil to threads and seating surfaces of bearing cap bolts before installing them.
- Tightening procedure:
 - a. Tighten all bolts to 7 to 12 N-m (0.7 to 1.3 kg-m, 61 to 112 ft-lb).

CYLINDER BLOCK

Assembly (Cont'd)

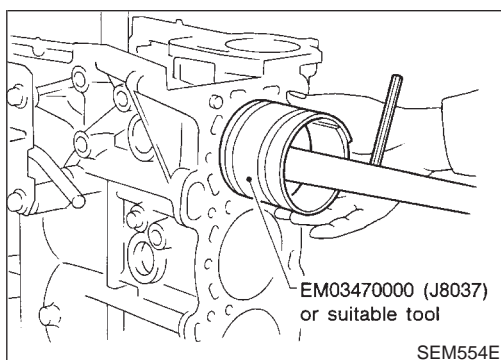
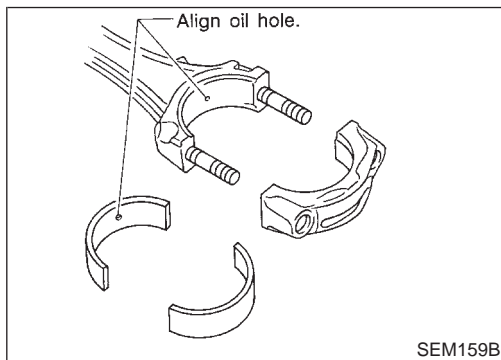
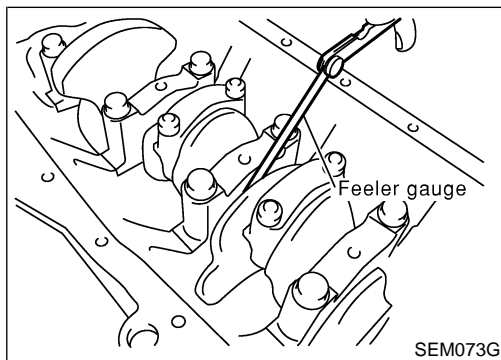
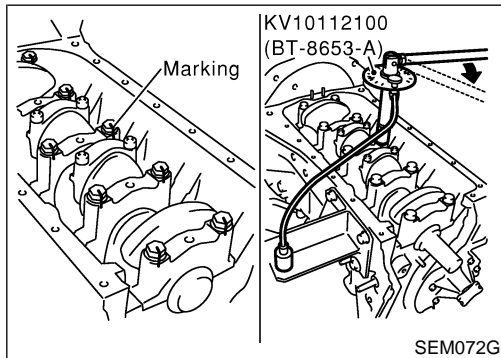
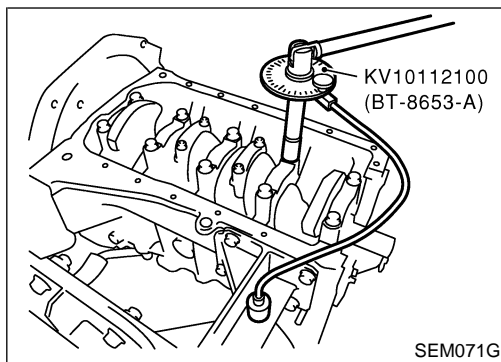

- b. Turn all bolts 70 to 80 degrees clockwise with Tool or suitable angle wrench.
- c. Loosen all bolts completely.
- d. Tighten all bolts to 33 to 38 N-m (3.3 to 3.9 kg-m, 24 to 28 ft-lb).
- e. Turn all bolts 30 to 35 degrees clockwise with Tool or suitable angle wrench.
 - If an angle wrench is not available, mark all bearing cap bolts on the side facing engine rear. Then, turn each bolt specified degrees clockwise. Confirm angle of degrees with a graduator, not by eye measurement.
 - After securing bearing cap bolts, make sure crankshaft turns smoothly by hand.

3. Measure crankshaft end play.

Crankshaft end play:

Standard

0.10 - 0.26 mm (0.0039 - 0.0102 in)

Limit

0.30 mm (0.0118 in)

If beyond the limit, replace thrust bearing with new one.

4. Install connecting rod bearings in connecting rods and connecting rod caps.

- Confirm that correct bearings are used. Refer to EM-64.
- Install bearings so that oil hole in connecting rod aligns with oil hole of bearing.
- Apply new engine oil to bolt threads and bearing surfaces.

5. Install pistons with connecting rods.

- a. Install them into corresponding cylinders with Tool.
 - Make sure connecting rod does not scratch cylinder wall.
 - Make sure connecting rod bolts do not scratch crankshaft pin journals.
 - Arrange so that front mark on piston head faces engine front.
 - Apply new engine oil to piston rings and sliding surface of piston.

GI

MA

EM

LC

EC

FE

CL

MT

AT

AX

SU

BR

ST

RS

BT

HA

SC

EL

IDX

CYLINDER BLOCK

Assembly (Cont'd)

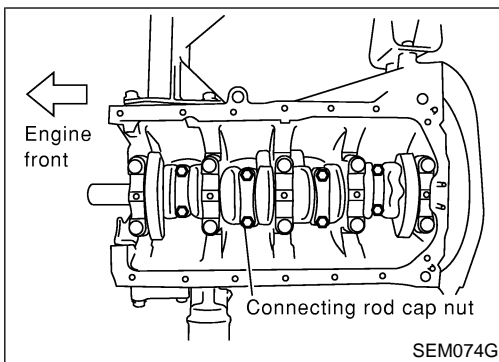

- b. Install connecting rod caps.
 - **Apply new engine oil to threads and seat surfaces.** Tighten connecting rod cap nuts using the following procedure:
 - a) **Tighten nuts to 13.7 to 15.7 N-m (1.4 to 1.6 kg-m, 10 to 12 ft-lb).**
 - b) **Turn all nuts 60 to 65 degrees clockwise. If an angle wrench is not available, tighten nuts to 38 to 44 N-m (3.9 to 4.5 kg-m, 28 to 33 ft-lb).**

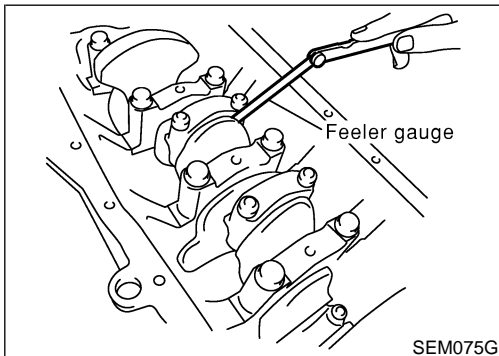

6. Measure connecting rod side clearance.

Connecting rod side clearance:

Standard

0.20 - 0.35 mm (0.0079 - 0.0138 in)

Limit

0.40 mm (0.0157 in)

If beyond the limit, replace connecting rod and/or crankshaft.

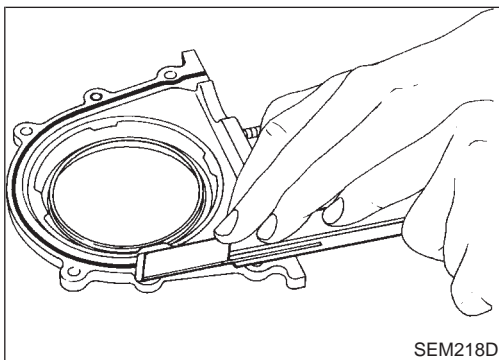

7. Install rear oil seal retainer.

- a. Before installing rear oil seal retainer, remove old liquid gasket from mating surface.
 - Also remove old liquid gasket from mating surface of cylinder block.

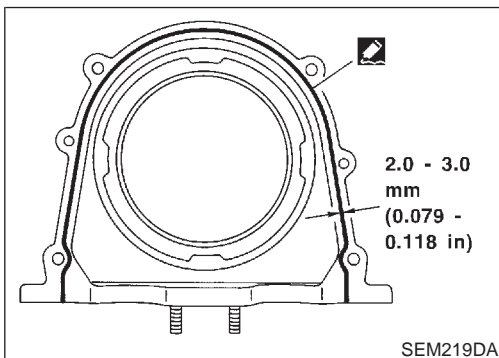

- b. Apply a continuous bead of liquid gasket to mating surface of rear oil seal retainer.
 - **Use Genuine RTV silicone sealant part No. 999MP-A7007 or equivalent.**
 - **Apply around inner side of bolt holes.**

SERVICE DATA AND SPECIFICATIONS (SDS)

General Specifications

General Specifications

NCEM0028

| | | | |
|--------------------------------------|-------------|-----------------------|----|
| Cylinder arrangement | | In-line 4 | GI |
| Displacement cm ³ (cu in) | | 1,998 (121.92) | MA |
| Bore and stroke mm (in) | | 86 x 86 (3.39 x 3.39) | MA |
| Valve arrangement | | DOHC | EM |
| Firing order | | 1-3-4-2 | EM |
| Number of piston rings | Compression | 2 | LC |
| | Oil | 1 | LC |
| Number of main bearings | | 5 | EC |
| Compression ratio | | 9.5 | EC |

| | | | | | | | |
|------------------------------|------|------|----|-----|----|-----|-------|
| Valve timing Unit: degree | | | | | | | EM120 |
| | a | b | c | d | e | f | |
| | 240° | 232° | 5° | 47° | 3° | 57° | |

Compression Pressure

Unit: kPa (kg/cm², psi)/300 rpm NCEM0029

| | | | |
|----------------------|--------------------------------------|-----------------|----|
| Compression pressure | Standard | 1,275 (13, 185) | BR |
| | Minimum | 1,079 (11, 156) | BR |
| | Differential limit between cylinders | 98 (1.0, 14) | ST |

Cylinder Head

Unit: mm (in) NCEM0030

| | | | | |
|----------------|----------------------------------|-------------------------------|-------------|----|
| <p>SEM043F</p> | | Standard | Limit | BT |
| | Head surface distortion | Less than 0.03 (0.0012) | 0.1 (0.004) | HA |
| | Nominal cylinder head height "H" | 136.9 - 137.1 (5.390 - 5.398) | | SC |
| | Resurfacing limit | 0.2 (0.008)* | | EL |

*Total amount of cylinder head resurfacing plus cylinder block resurfacing

GI
MA
EM
LC
EC
FE
CL
MT
AT
AX
SU
BR
ST
RS
BT
HA
SC
EL
IDX

SERVICE DATA AND SPECIFICATIONS (SDS)

Valve

Valve

NCEM0031

VALVE

NCEM0031S01
Unit: mm (in)

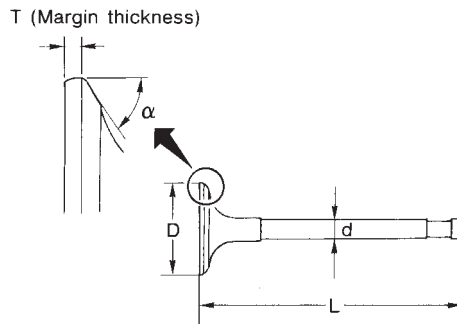

SEM188A

| | | |
|---------------------------------------|---------|---------------------------------|
| Valve head diameter "D" | Intake | 34.0 - 34.3 (1.339 - 1.350) |
| | Exhaust | 30.0 - 30.3 (1.181 - 1.193) |
| Valve length "L" | Intake | 97.04 - 97.16 (3.8205 - 3.8252) |
| | Exhaust | 97.66 - 97.78 (3.8449 - 3.8496) |
| Valve stem diameter "d" | Intake | 5.965 - 5.980 (0.2348 - 0.2354) |
| | Exhaust | 5.945 - 5.960 (0.2341 - 0.2346) |
| Valve seat angle "α" | Intake | 45°15' - 45°45' |
| | Exhaust | |
| Valve margin "T" | Intake | 1.1 (0.043) |
| | Exhaust | 1.3 (0.051) |
| Valve margin "T" limit | | More than 0.5 (0.020) |
| Valve stem end surface grinding limit | | Less than 0.2 (0.008) |

VALVE SPRING

NCEM0031S02

| | | |
|--|----------|---|
| Free height mm (in) | | 47.53 (1.8713) |
| Pressure N (kg, lb) at height mm (in) | Standard | 519 - 571 (53.0 - 58.2, 117 - 128) at 27.0 (1.063) |
| | Limit | 491.8 (50.16, 110.6) at 27.0 (1.063) |
| Out-of-square mm (in) | | Less than 2.1 (0.083) |

HYDRAULIC LASH ADJUSTER (HLA)

NCEM0031S03
Unit: mm (in)

| | |
|--|-----------------------------------|
| HLA outer diameter | 16.980 - 16.993 (0.6685 - 0.6690) |
| HLA guide hole diameter | 17.000 - 17.020 (0.6693 - 0.6701) |
| Clearance between HLA and HLA guide hole | 0.007 - 0.040 (0.0003 - 0.0016) |

SERVICE DATA AND SPECIFICATIONS (SDS)

Valve (Cont'd)

VALVE GUIDE

NCEM0031S04
Unit: mm (in)

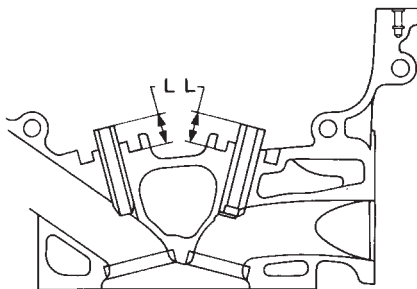

SEM083D

| | | Standard | Service |
|---|---------|-----------------------------------|-----------------------------------|
| Valve guide Outer diameter | Intake | 10.023 - 10.034 (0.3946 - 0.3950) | 10.223 - 10.234 (0.4025 - 0.4029) |
| | Exhaust | 10.023 - 10.034 (0.3946 - 0.3950) | 10.223 - 10.234 (0.4025 - 0.4029) |
| Valve guide Inner diameter (Finished size) | Intake | 6.000 - 6.018 (0.2362 - 0.2369) | |
| | Exhaust | 6.000 - 6.018 (0.2362 - 0.2369) | |
| Cylinder head valve guide hole diameter | Intake | 9.975 - 9.996 (0.3927 - 0.3935) | 10.175 - 10.196 (0.4006 - 0.4014) |
| | Exhaust | 9.975 - 9.996 (0.3927 - 0.3935) | 10.175 - 10.196 (0.4006 - 0.4014) |
| Interference fit of valve guide | | 0.027 - 0.059 (0.0011 - 0.0023) | |
| | | Standard | Limit |
| Stem to guide clearance | Intake | 0.020 - 0.053 (0.0008 - 0.0021) | 0.08 (0.0031) |
| | Exhaust | 0.040 - 0.073 (0.0016 - 0.0029) | 0.1 (0.004) |
| Valve deflection limit | | 0.2 (0.008) | |
| Projection length "L" | | 14.0 - 14.2 (0.551 - 0.559) | |

VALVE SHIM CLEARANCE ADJUSTMENT

NCEM0031S06
Unit: mm (in)

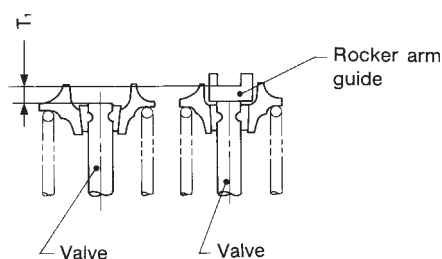

SEM095D

| | |
|---|--------------------------------|
| Valve shim clearance (cold) Intake & Exhaust | Less than 0.025 (0.001) |
| Shim thickness "T ₁ " | T ₁ ± 0.025 (0.001) |

SERVICE DATA AND SPECIFICATIONS (SDS)

Valve (Cont'd)

AVAILABLE SHIM

NCEM0031S07

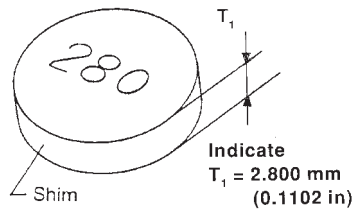

AEM236

| Thickness mm (in) | Identification mark |
|-------------------|---------------------|
| 2.800 (0.1102) | 28 00 |
| 2.825 (0.1112) | 28 25 |
| 2.850 (0.1122) | 28 50 |
| 2.875 (0.1132) | 28 75 |
| 2.900 (0.1142) | 29 00 |
| 2.925 (0.1152) | 29 25 |
| 2.950 (0.1161) | 29 50 |
| 2.975 (0.1171) | 29 75 |
| 3.000 (0.1181) | 30 00 |
| 3.025 (0.1191) | 30 25 |
| 3.050 (0.1201) | 30 50 |
| 3.075 (0.1211) | 30 75 |
| 3.100 (0.1220) | 31 00 |
| 3.125 (0.1230) | 31 25 |
| 3.150 (0.1240) | 31 50 |
| 3.175 (0.1250) | 31 75 |
| 3.200 (0.1260) | 32 00 |

SERVICE DATA AND SPECIFICATIONS (SDS)

Valve (Cont'd)

VALVE SEAT

NCEM0031S05
Unit: mm (in)

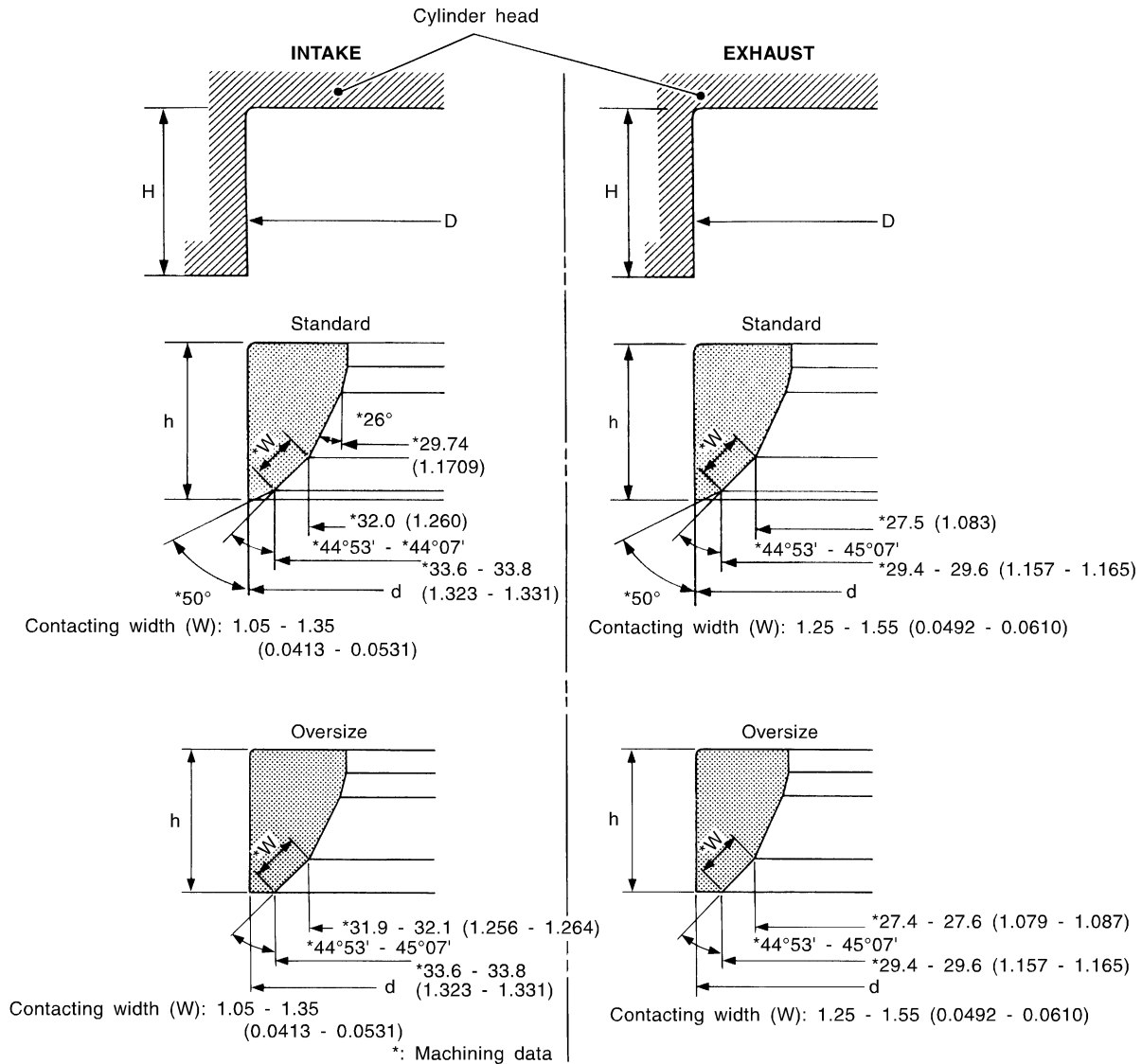

SEM651DE

| | | Standard | Service |
|--|-----|-----------------------------------|-----------------------------------|
| Cylinder head seat recess diameter (D) | In. | 35.000 - 35.016 (1.3780 - 1.3786) | 35.500 - 35.516 (1.3976 - 1.3983) |
| | Ex. | 31.000 - 31.016 (1.2205 - 1.2211) | 31.500 - 31.516 (1.2402 - 1.2408) |
| Valve seat interference fit | In. | 0.064 - 0.096 (0.0025 - 0.0038) | |
| | Ex. | 0.064 - 0.096 (0.0025 - 0.0038) | |
| Valve seat outer diameter (d) | In. | 35.080 - 35.096 (1.3811 - 1.3817) | 35.580 - 35.596 (1.4008 - 1.4014) |
| | Ex. | 31.080 - 31.096 (1.2236 - 1.2242) | 31.580 - 31.596 (1.2433 - 1.2439) |
| Depth (H) | In. | 6.25 (0.2461) | |
| | Ex. | 6.25 (0.2461) | |
| Height (h) | | 6.2 - 6.3 (0.244 - 0.248) | 5.4 - 5.5 (0.213 - 0.217) |

GI
MA
EM
LC
EC
FE
CL
MT
AT
AX
SU
BR
ST
RS
BT
HA
SC
EL
IDX

SERVICE DATA AND SPECIFICATIONS (SDS)

Valve (Cont'd)

VALVE SEAT RESURFACE LIMIT

NCEM0031S08
Unit: mm (in)

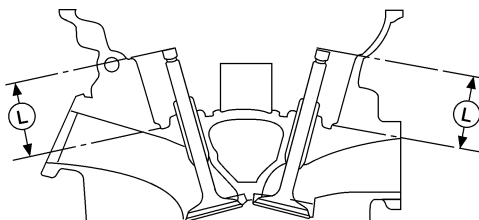

AEM343

| | |
|-----------|---------------------------------|
| Depth (L) | 42.74 - 43.26 (1.6827 - 1.7031) |
|-----------|---------------------------------|

Camshaft and Camshaft Bearing

NCEM0032
Unit: mm (in)

| | Standard | Limit |
|---------------------------------------|-----------------------------------|---------------|
| Camshaft journal to bearing clearance | 0.030 - 0.071 (0.0012 - 0.0028) | 0.15 (0.0059) |
| Inner diameter of camshaft bearing | 28.000 - 28.021 (1.1024 - 1.1032) | — |
| Outer diameter of camshaft journal | 27.935 - 27.955 (1.0998 - 1.1006) | — |
| Camshaft runout [TIR*] | Less than 0.02 (0.0008) | 0.1 (0.004) |
| Camshaft sprocket runout [TIR*] | Less than 0.25 (0.0098) | — |
| Camshaft end play | 0.055 - 0.139 (0.0022 - 0.0055) | 0.20 (0.0079) |

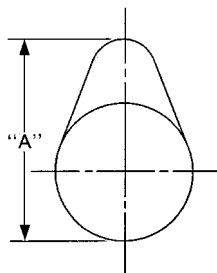

EM671

| | | |
|--------------------------|---------|-----------------------------------|
| Cam height "A" | Intake | 37.550 - 37.740 (1.4783 - 1.4858) |
| | Exhaust | 37.920 - 38.110 (1.4929 - 1.5004) |
| Wear limit of cam height | | 0.2 (0.008) |
| Valve lift | Intake | 9.4 (0.370) |
| | Exhaust | 8.8 (0.346) |

*Total indicator reading

SERVICE DATA AND SPECIFICATIONS (SDS)

Cylinder Block

Cylinder Block

Unit: mm (in) ^{NCEM0033}

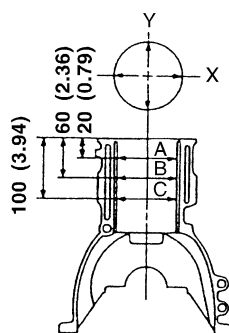
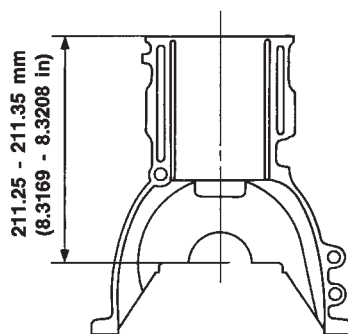

SEM008D

SEM686DB

| | | | |
|--|-------------|-------------|-----------------------------------|
| Surface flatness | Standard | | Less than 0.03 (0.0012) |
| | Limit | | 0.10 (0.0039) |
| Cylinder bore Inner diameter | Standard | Grade No. 1 | 86.000 - 86.010 (3.3858 - 3.3862) |
| | | Grade No. 2 | 86.010 - 86.020 (3.3862 - 3.3866) |
| | | Grade No. 3 | 86.020 - 86.030 (3.3866 - 3.3870) |
| | Wear limit | | 0.20 (0.0079) |
| Out-of-round (X - Y) | | | Less than 0.015 (0.0006) |
| Taper (A - B and A - C) | | | Less than 0.010 (0.0004) |
| Difference in inner diameter between cylinders | Limit | | Less than 0.05 (0.0020) |
| Main journal inner diameter | Grade No. 0 | | 58.944 - 58.950 (2.3206 - 2.3209) |
| | Grade No. 1 | | 58.950 - 58.956 (2.3209 - 2.3211) |
| | Grade No. 2 | | 58.956 - 58.962 (2.3211 - 2.3213) |
| | Grade No. 3 | | 58.962 - 58.968 (2.3213 - 2.3216) |

GI

MA

EM

LC

EC

FE

CL

MT

AT

AX

SU

BR

ST

RS

BT

HA

SC

EL

IDX

SERVICE DATA AND SPECIFICATIONS (SDS)

Piston, Piston Ring and Piston pin

Piston, Piston Ring and Piston pin

NCEM0034

PISTON

NCEM0034S01
Unit: mm (in)

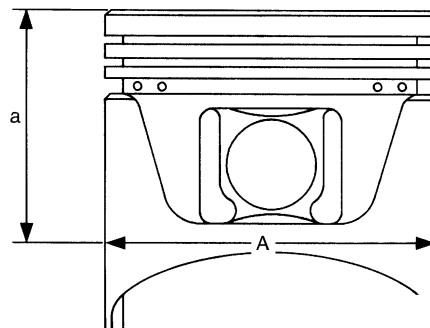

SEM086G

| | | |
|---------------------------------------|----------------------------------|-----------------------------------|
| Piston skirt diameter "A" Standard | Grade No. 1 | 85.980 - 85.990 (3.3850 - 3.3854) |
| | Grade No. 2 | 85.990 - 86.000 (3.3854 - 3.3858) |
| | Grade No. 3 | 86.000 - 86.010 (3.3858 - 3.3862) |
| | 0.20 (0.0079) oversize (Service) | 86.180 - 86.210 (3.3929 - 3.3941) |
| "a" dimension | | 45.0 (1.772) |
| Piston clearance to cylinder block | | 0.010 - 0.030 (0.0004 - 0.0012) |
| Piston pin hole diameter | | 21.993 - 22.005 (0.8659 - 0.8663) |

PISTON RING

NCEM0034S02
Unit: mm (in)

| | | | |
|----------------|-----|----------|---------------------------------|
| Side clearance | Top | Standard | 0.04 - 0.08 (0.0016 - 0.0031) |
| | | Limit | 0.1 (0.004) |
| | 2nd | Standard | 0.03 - 0.07 (0.0012 - 0.0028) |
| | | Limit | 0.1 (0.004) |
| | Oil | Standard | 0.065 - 0.135 (0.0026 - 0.0053) |
| | | Limit | — |
| Ring end gap | Top | Standard | 0.20 - 0.39 (0.0079 - 0.0154) |
| | | Limit | 0.53 (0.0209) |
| | 2nd | Standard | 0.35 - 0.59 (0.0138 - 0.0232) |
| | | Limit | 0.7 (0.028) |
| | Oil | Standard | 0.20 - 0.69 (0.0079 - 0.0272) |
| | | Limit | 0.95 (0.0374) |

PISTON PIN

NCEM0034S03
Unit: mm (in)

| | | |
|--|----------|-----------------------------------|
| Piston pin outer diameter | | 21.989 - 22.001 (0.8657 - 0.8622) |
| Interference fit of piston pin to piston | | 0.002 - 0.006 (0.0001 - 0.0002) |
| Piston pin to connecting rod bushing clearance | Standard | 0.005 - 0.017 (0.0002 - 0.0007) |
| | Limit | 0.023 (0.0009) |

* Values measured at ambient temperature of 20°C (68°F)

SERVICE DATA AND SPECIFICATIONS (SDS)

Connecting Rod

Connecting Rod

NCEM0035
Unit: mm (in)

| | | | |
|---|----------|-----------------------------------|-----------|
| Center distance | | 136.25 - 136.35 (5.3642 - 5.3681) | GI |
| Bend [per 100 (3.94)] | Limit | 0.15 (0.0059) | MA |
| Torsion [per 100 (3.94)] | Limit | 0.30 (0.0118) | |
| Connecting rod small end inner diameter | | 24.980 - 25.000 (0.9835 - 0.9843) | EM |
| Piston pin bushing inner diameter* | | 22.000 - 22.012 (0.8661 - 0.8666) | |
| Connecting rod big end inner diameter | | 51.000 - 51.013 (2.0079 - 2.0084) | LC |
| Side clearance | Standard | 0.20 - 0.35 (0.0079 - 0.0138) | |
| | Limit | 0.5 (0.020) | EC |

*After installing in connecting rod

GI

MA

EM

LC

EC

FE

CL

MT

AT

AX

SU

BR

ST

RS

BT

HA

SC

EL

IDX

SERVICE DATA AND SPECIFICATIONS (SDS)

Crankshaft

Crankshaft

NCEM0036
Unit: mm (in)

| | | |
|----------------------------------|--------------|-----------------------------------|
| Main journal dia. "Dm" | Grade No. 0 | 54.974 - 54.980 (2.1643 - 2.1646) |
| | Grade No. 1 | 54.968 - 54.974 (2.1641 - 2.1643) |
| | Grade No. 2 | 54.962 - 54.968 (2.1639 - 2.1641) |
| | Grade No. 3 | 54.956 - 54.962 (2.1636 - 2.1639) |
| Pin journal dia. "Dp" | Grade No. 0 | 47.968 - 47.974 (1.8885 - 1.8887) |
| | Grade No. 1 | 47.962 - 47.968 (1.8883 - 1.8885) |
| | Grade No. 2 | 47.956 - 47.962 (1.8880 - 1.8883) |
| Center distance "r" | | 42.96 - 43.04 (1.6913 - 1.6945) |
| Out-of-round (X - Y) Standard | Main journal | Less than 0.005 (0.0002) |
| | Pin journal | Less than 0.003 (0.0001) |
| Taper (A - B) Standard | Main journal | Less than 0.005 (0.0002) |
| | Pin journal | Less than 0.0025 (0.0001) |
| Runout [TIR] | Standard | Less than 0.025 (0.0010) |
| | Limit | Less than 0.05 (0.0020) |
| Free end play | Standard | 0.10 - 0.26 (0.0039 - 0.0102) |
| | Limit | 0.30 (0.0118) |

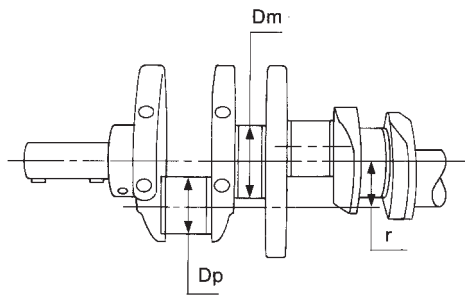

SEM954C

Out-of-round $\text{X} - \text{Y}$
Taper $\text{A} - \text{B}$

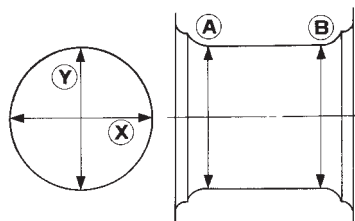

EM715

SERVICE DATA AND SPECIFICATIONS (SDS)

Main Bearing

Main Bearing

NCEM0037

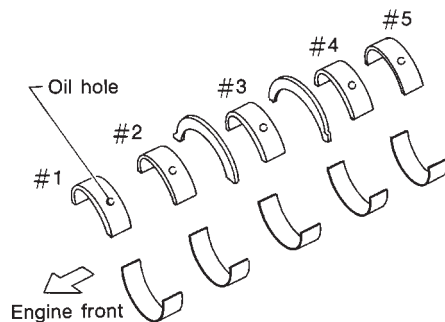

SEM685D

STANDARD

NCEM0037S01
Unit: mm (in)

| Grade number | Thickness "T" | Width "W" | Identification color (mark) |
|--------------|---------------------------------|-----------------------------|-----------------------------|
| 0 | 1.977 - 1.980 (0.0778 - 0.0780) | 18.9 - 19.1 (0.744 - 0.752) | Black (A) |
| 1 | 1.980 - 1.983 (0.0780 - 0.0781) | | Brown (B) |
| 2 | 1.983 - 1.986 (0.0781 - 0.0782) | | Green (C) |
| 3 | 1.986 - 1.989 (0.0782 - 0.0783) | | Yellow (D) |
| 4 | 1.989 - 1.992 (0.0783 - 0.0784) | | Blue (E) |
| 5 | 1.992 - 1.995 (0.0784 - 0.0785) | | Pink (F) |
| 6 | 1.995 - 1.998 (0.0785 - 0.0787) | | No color (G) |

UNDERSIZE

NCEM0037S02
Unit: mm (in)

| Undersize | Thickness "T" | Main journal diameter "Dm" |
|---------------|---------------------------------|---|
| 0.25 (0.0098) | 2.109 - 2.117 (0.0830 - 0.0833) | Grind so that bearing clearance is the specified value. |

Connecting Rod Bearing

NCEM0038

STANDARD SIZE

NCEM0038S01
Unit: mm (in)

| Grade number | Thickness "T" | Width "W" | Identification color (mark) |
|--------------|---------------------------------|-----------------------------|-----------------------------|
| 0 | 1.500 - 1.503 (0.0591 - 0.0592) | 16.9 - 17.1 (0.665 - 0.673) | No color (A) |
| 1 | 1.503 - 1.506 (0.0592 - 0.0593) | | Black (B) |
| 2 | 1.506 - 1.509 (0.0593 - 0.0594) | | Brown (C) |

UNDERSIZE

NCEM0038S02
Unit: mm (in)

| Undersize | Thickness "T" | Crank pin journal diameter "Dp" |
|---------------|---------------------------------|---|
| 0.08 (0.0031) | 1.541 - 1.549 (0.0607 - 0.0610) | Grind so that bearing clearance is the specified value. |
| 0.12 (0.0047) | 1.561 - 1.569 (0.0615 - 0.0618) | |
| 0.25 (0.0098) | 1.626 - 1.634 (0.0640 - 0.0643) | |

SERVICE DATA AND SPECIFICATIONS (SDS)

Bearing Clearance

Bearing Clearance

^{NCEM0039}
Unit: mm (in)

| | | |
|----------------------------------|----------|---------------------------------|
| Main bearing clearance | Standard | 0.004 - 0.022 (0.0002 - 0.0009) |
| | Limit | 0.05 (0.0020) |
| Connecting rod bearing clearance | Standard | 0.020 - 0.045 (0.0008 - 0.0018) |
| | Limit | 0.065 (0.0026) |

Miscellaneous Components

^{NCEM0040}
Unit: mm (in)

| | |
|--------------------------------------|---------------|
| Camshaft sprocket runout limit [TIR] | 0.25 (0.0098) |
| Flywheel runout limit [TIR] | 0.15 (0.0059) |
| Drive plate runout limit [TIR] | 0.2 (0.008) |