

SECTION **CL**
CLUTCH

A
B
CL
D
E
F
G
H
I
J
K
L
M

CONTENTS

PRECAUTIONS	2	Removal and Installation	11
Caution	2	REMOVAL	11
Precautions for Battery Service	2	INSTALLATION	11
PREPARATION	3	Disassembly and Assembly	11
Special Service Tools	3	DISASSEMBLY	11
Commercial Service Tools	3	INSPECTION AFTER DISASSEMBLY	11
NOISE, VIBRATION AND HARSHNESS (NVH)		ASSEMBLY	11
TROUBLESHOOTING	4	CLUTCH PIPING	12
NVH Troubleshooting Chart	4	Removal and Installation	12
CLUTCH	4	CLUTCH RELEASE MECHANISM	13
CLUTCH PEDAL	5	Removal and Installation	13
On-Vehicle Inspection and Adjustment	5	REMOVAL	13
Removal and Installation	6	INSPECTION AFTER REMOVAL	13
REMOVAL	6	INSTALLATION	14
INSPECTION AFTER REMOVAL	6	CLUTCH DISC, CLUTCH COVER	15
INSTALLATION	6	Removal and Installation	15
CLUTCH FLUID	7	REMOVAL	15
Bleeding	7	INSPECTION AND ADJUSTMENT AFTER	
CLUTCH MASTER CYLINDER	8	REMOVAL	15
Removal and Installation	8	INSTALLATION	16
REMOVAL	8	SERVICE DATA AND SPECIFICATIONS (SDS)	17
INSTALLATION	9	Clutch Control System	17
Disassembly and Assembly	9	Clutch Master Cylinder	17
DISASSEMBLY	9	Clutch Operating Cylinder	17
INSPECTION AFTER DISASSEMBLY	10	Clutch Disc	17
ASSEMBLY	10	Clutch Cover	17
OPERATING CYLINDER	11	Clutch Pedal	17

PRECAUTIONS

PRECAUTIONS

PFP:00001

Caution

ACS004NY

- Recommended fluid is brake fluid “DOT 3”.
- Never reuse drained brake fluid.
- Be careful not to splash brake fluid on painted areas.
- When removing and installing clutch piping, use Tool.
- Use new brake fluid to clean or wash all parts of master cylinder and operating cylinder.
- Never use mineral oils such as gasoline or kerosene. It will ruin the rubber parts of the hydraulic system.

WARNING:

After cleaning clutch disc, wipe it with a dust collector. Do not use compressed air.

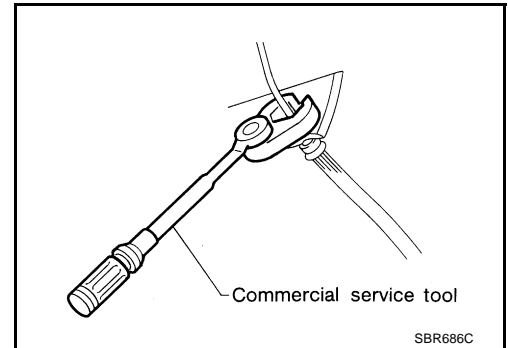

Precautions for Battery Service

ACS006DZ

Before disconnecting the battery, lower both the driver and passenger windows. This will prevent any interference between the window edge and the vehicle when the door is opened/closed. During normal operation, the window slightly raises and lowers automatically to prevent any window to vehicle interference. The automatic window function will not work with the battery disconnected.

PREPARATION

PREPARATION

PFP:00002

Special Service Tools

ACS004NZ

The actual shapes of Kent-Moore tools may differ from those of special service tools illustrated here.

Tool number (Kent-Moore No.) Tool name	Description
KV30101400 (—) Drift a: 51 mm (2.01 in) dia. b: 44 mm (1.73 in) dia.	Installing release bearing
ST20050240 (—) Diaphragm adjusting wrench	Adjusting unevenness of diaphragm spring of clutch cover
ST20670000 (—) Clutch aligning bar a: 15 mm (0.59 in) dia. b: 23 mm (0.91 in) dia.	Installing clutch disc

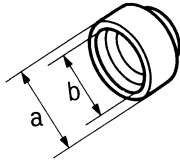

ZZA0838D



ZZA0508D

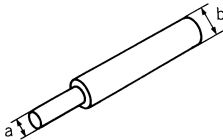

ZZA1178D

Commercial Service Tools

ACS00400

Tool name	Description
Pin punch Tip diameter: 4.5 mm (0.177 in) dia.	Removing and installing master cylinder spring pin
1. Flare nut crowfoot 2. Torque wrench a: 10 mm (0.39 in)	Removing and installing clutch piping
Power tool	Loosening bolts and nuts



ZZA0515D

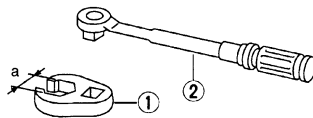

S-NT360

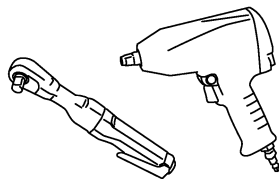

PBIC0190E

NOISE, VIBRATION AND HARSHNESS (NVH) TROUBLESHOOTING

NOISE, VIBRATION AND HARSHNESS (NVH) TROUBLESHOOTING

PF0:00003

NVH Troubleshooting Chart

ACS00401

Use the chart below to help you find the cause of the symptom. The numbers indicate the order of the inspection. If necessary, repair or replace these parts.

CLUTCH

Reference page		CL-5	CL-7	CL-9	CL-11	EM-102	CL-13	CL-15	CL-15	CL-15	CL-15	CL-15	CL-15	CL-15	CL-15	CL-15	CL-15	EM-135	
SUSPECTED PARTS (Possible cause)		CLUTCH PEDAL (Inspection and adjustment)	CLUTCH LINE (Air in line)	MASTER CYLINDER PISTON CUP (Damaged)	OPERATING CYLINDER PISTON CUP (Damaged)	ENGINE MOUNTING (Loose)	RELEASE BEARING (Worn, dirty or damaged)	CLUTCH DISC (Out of true)	CLUTCH DISC (Runout is excessive)	CLUTCH DISC (Lining broken)	CLUTCH DISC (Dirty or burned)	CLUTCH DISC (Oily)	CLUTCH DISC (Worn out)	CLUTCH DISC (Hardened)	CLUTCH DISC (Lack of spline grease)	DIAPHRAGM SPRING (Damaged)	DIAPHRAGM SPRING (Out of tip alignment)	PRESSURE PLATE (Distortion)	FLYWHEEL (Distortion)
Symptom	Clutch grabs/chatters					1			2			2	2	2			2		
	Clutch pedal spongy		1	2	2														
	Clutch noisy						1												
	Clutch slips	1										2	2			3		4	5
	Clutch does not disengage	1	2	3	4			5	5	5	5	5			5	6	6	7	

CLUTCH PEDAL

CLUTCH PEDAL

PF4:46540

On-Vehicle Inspection and Adjustment

ACS00402

1. Check to see if clevis pin floats freely in the bore of clutch pedal. It should not be bound by clevis or clutch pedal.
 - a. If clevis pin is not free, check that ASCD clutch switch is not applying pressure to clutch pedal causing clevis pin to bind. To adjust, loosen lock nut and turn ASCD clutch switch.
 - b. Tighten lock nut.
 - c. Verify that clevis pin floats in the bore of clutch pedal. It should not be bound by clutch pedal.
 - d. If clevis pin is still not free, remove clevis pin and check for deformation or damage. Replace clevis pin if necessary. Leave pin removed for step 2.
2. Check clutch pedal stroke for free range of movement.
 - a. With clevis pin removed, manually move clutch pedal up and down to determine if it moves freely.
 - b. If any sticking is noted, replace the related parts (clutch pedal bracket, assist spring, bushing etc.) Re-assemble clutch pedal and re-verify that clevis pin floats freely in the bore of clutch pedal.
3. Adjust clearance "C" while depressing clutch pedal fully.(With clutch interlock switch)

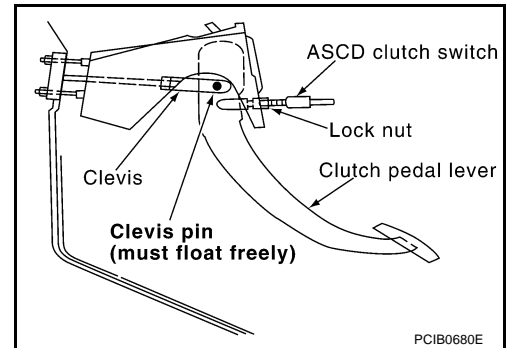

Clearance C : 0.1 - 1.0mm (0.004 - 0.039 in)

4. Check clutch hydraulic and system components (clutch master cylinder, clutch operating cylinder, clutch withdrawal lever, clutch release bearing, etc.) for sticking or binding.
 - a. If any sticking or binding noted, repair or replace related parts as necessary.
 - b. If hydraulic system repair was necessary, bleed the clutch hydraulic system. Refer to [CL-7, "Bleeding"](#) .

NOTE:

Do not use a vacuum assist or any other type of power bleeder on this system. Use of a vacuum assist or power bleeder will not purge all the air from the system.

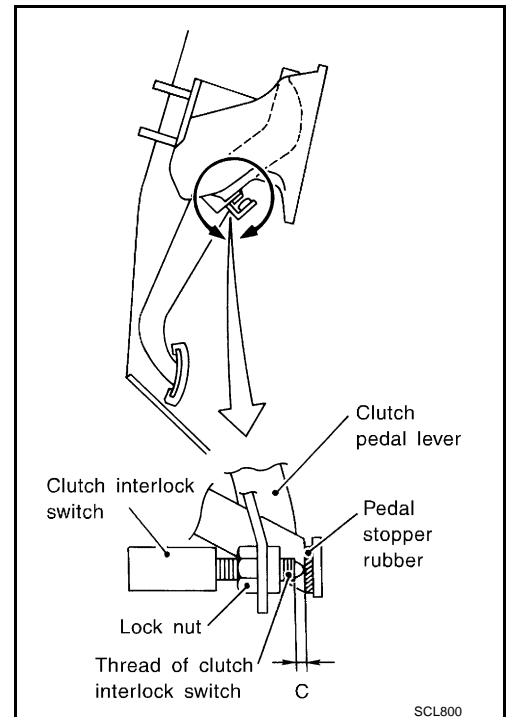

CLUTCH PEDAL

ACS00403

Removal and Installation

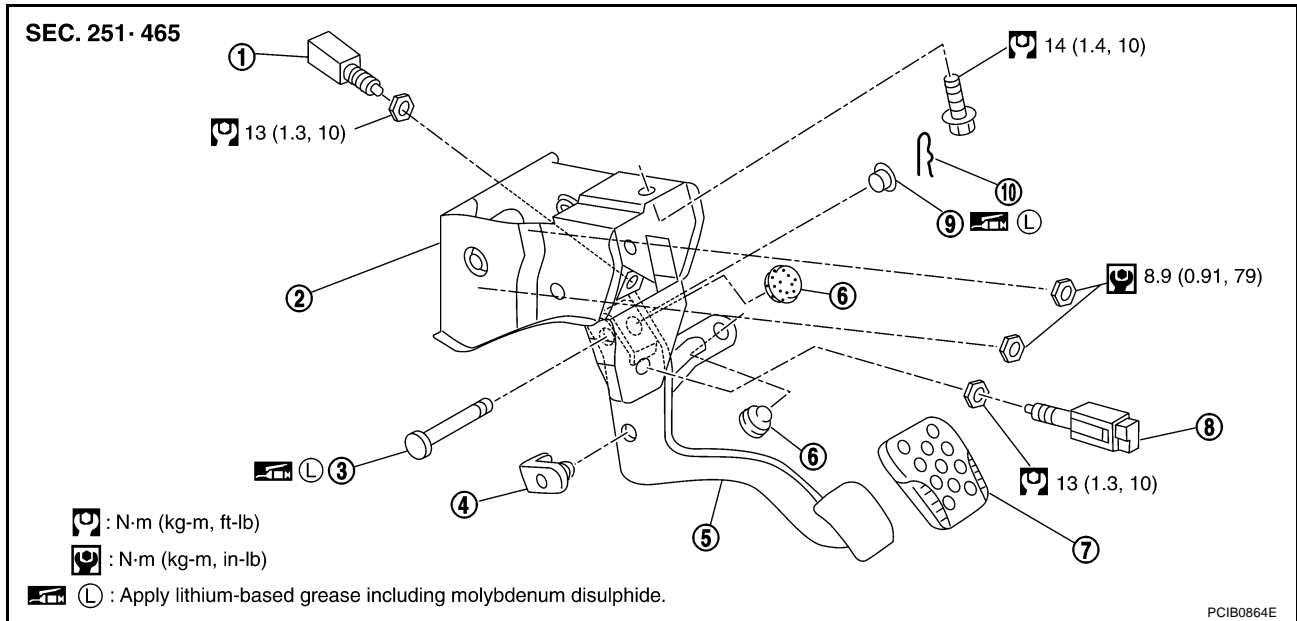

- | | | |
|----------------------------|-----------------------|-------------------|
| 1. Clutch interlock switch | 2. Bracket | 3. Clevis pin |
| 4. Pedal stopper rubber | 5. Clutch pedal | 6. Stopper rubber |
| 7. Pedal pad | 8. ASCD clutch switch | 9. Bushing |
| 10. Snap pin | | |

REMOVAL

1. Remove kicking plate. Refer to [EI-32, "Removal and Installation"](#) .
2. Remove foot-rest. Refer to [EI-35, "Removal and Installation"](#) .
3. Remove dash side finisher. Refer to [EI-32, "Removal and Installation"](#) .
4. Remove instrument lower driver panel. Refer to [IP-11, "Removal and Installation"](#) .
5. Remove VDC/TCS/ABS control unit. (VDC/TCS/ABS model) Refer to [BRC-62, "Removal and Installation"](#) .
6. Remove clutch interlock switch and ASCD clutch switch connector and harness.
7. Remove snap pin and clevis pin.
8. Remove pedal bracket mounting bolt and nuts and then remove clutch pedal assembly.

INSPECTION AFTER REMOVAL

- Check clutch pedal for bend, damage, or a cracked weld. If bend, damage, or a cracked weld is found, replace clutch pedal assembly.

INSTALLATION

To install, reverse the removal procedure, following the cautions below:

- Install clutch pedal assembly and adjust the pedal height. Tighten ASCD clutch switch lock nut to the specified torque.
- After installing clutch interlock switch, adjust the switch position.

NOTE:

Tighten ASCD clutch switch lock nut to the specified torque after installing clutch pedal assembly in vehicle and adjusting the pedal height.

CLUTCH FLUID

CLUTCH FLUID

PFP:00017

Bleeding

ACS00404

CAUTION:

- Monitor fluid level in reservoir tank to make sure it does not empty.
- Do not spill clutch fluid onto painted surfaces. If it spills, wipe up immediately and wash the affected area with water.

NOTE:

Do not use a vacuum assist or any other type of power bleeder on this system. Use of vacuum assist or power bleeder will not purge all the air from the system.

1. Fill master cylinder reservoir tank with new clutch fluid.
2. Connect a transparent vinyl hose to air bleeder.
3. Depress clutch pedal quickly and fully a few times and hold it.
4. With clutch pedal depressed, open air bleeder.
5. Close air bleeder.
6. Release clutch pedal and wait for 5 seconds.
7. Repeat steps 3 to 6 until no bubbles can be observed in brake fluid.
8. Tighten air bleeder to the specified torque. Refer to [CL-11, "Removal and Installation"](#).

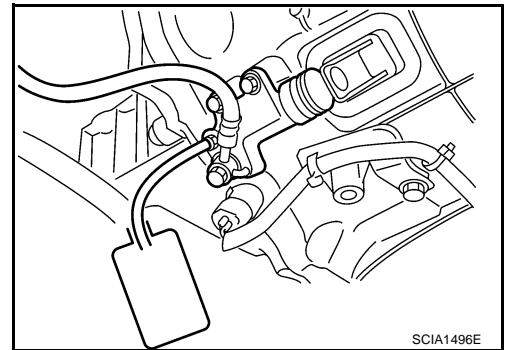

CLUTCH MASTER CYLINDER

PFP:30610

ACS00405

CLUTCH MASTER CYLINDER

Removal and Installation

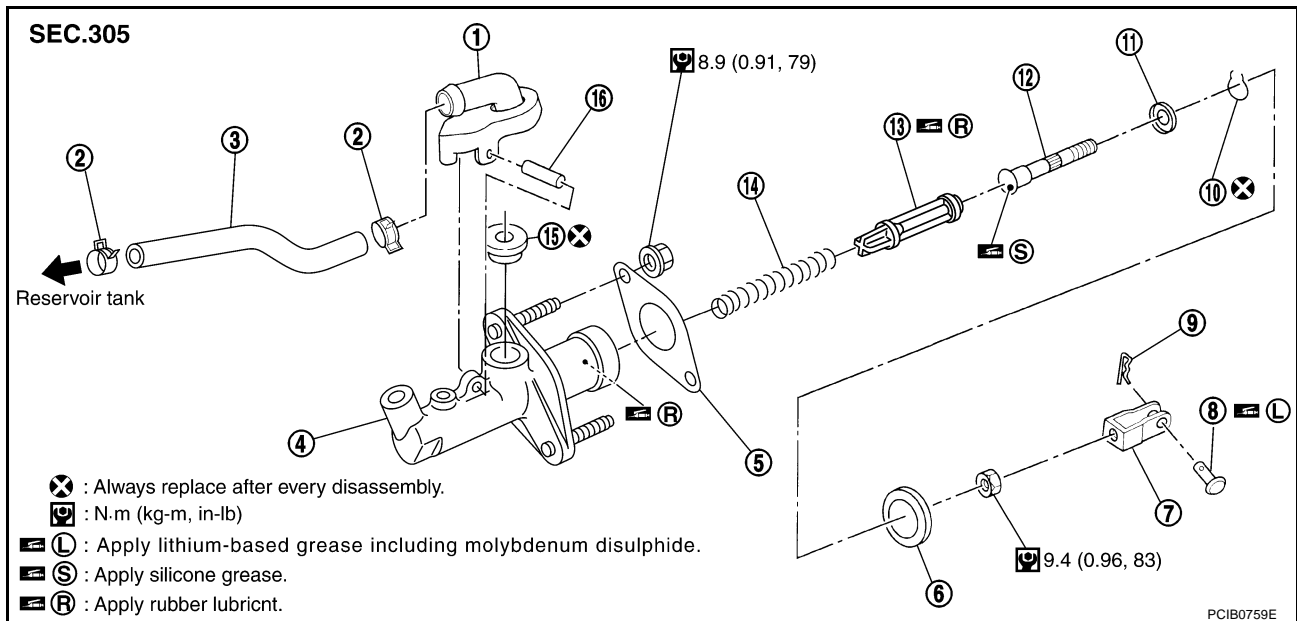

- | | | |
|---------------------|-------------------|--------------------|
| 1. Nipple | 2. Clamp | 3. Reservoir hose |
| 4. Cylinder body | 5. Packing | 6. Seat |
| 7. Clevis | 8. Clevis pin | 9. Snap pin |
| 10. Stopper ring | 11. Stopper | 12. Push rod |
| 13. Piston assembly | 14. Return spring | 15. Reservoir seal |
| 16. Spring pin | | |

REMOVAL

- Remove kicking plate. Refer to [EI-32, "Removal and Installation"](#).
- Remove foot-rest. Refer to [EI-35, "Removal and Installation"](#).
- Remove dash side finisher. Refer to [EI-32, "Removal and Installation"](#).
- Remove instrument lower driver panel. Refer to [IP-11, "Removal and Installation"](#).
- Remove VDC/TCS/ABS control unit. (VDC/TCS/ABS model) Refer to [BRC-62, "Removal and Installation"](#).
- Remove snap pin and clevis pin from clevis, and separate it from clutch pedal.
- Remove hoodledge cover.
- Drain clutch fluid in reservoir tank and remove reservoir hose.

CAUTION:

Do not spill clutch fluid onto painted surfaces. If it spills, wipe up immediately and wash the affected area with water.

- Remove reservoir tank.
- Remove clutch tube using a flare nut wrench. Refer to [CL-12, "Removal and Installation"](#).
- Remove master cylinder assembly.

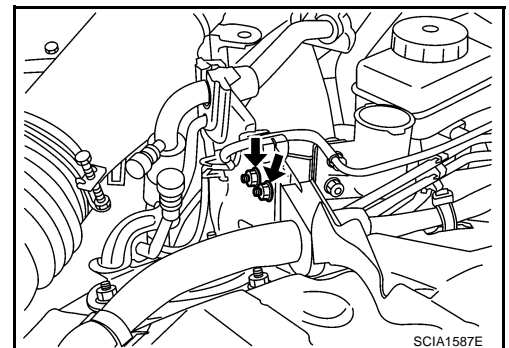

CLUTCH MASTER CYLINDER

INSTALLATION

1. Connect clutch tube to master cylinder assembly and temporarily tighten flare nut.
2. Install master cylinder assembly and tighten mounting nuts to the specified torque. Refer to [CL-8, "Removal and Installation"](#).
3. Tighten clutch tube flare nut to the specified torque using a flare nut torque wrench. Refer to [CL-12, "Removal and Installation"](#).
4. Install clevis to clutch pedal, and fix clevis with clevis pin.
5. Install snap pin to clevis pin.
6. Install reservoir hose to nipple. Install reservoir tank to vehicle, and then tighten mounting nuts to the specified torque.

: 5.8 N·m (0.59 Kg-m, 51 in-lb)

7. After completing this procedure, inspect and bleed clutch tube. Refer to [CL-5, "On-Vehicle Inspection and Adjustment"](#) and [CL-7, "Bleeding"](#).
8. Install hoodledge cover.
9. Install VDC/TCS/ABS control unit. (VDC/TCS/ABS model) Refer to [BRC-62, "Removal and Installation"](#).
10. Install instrument lower driver panel. Refer to [IP-11, "Removal and Installation"](#).
11. Install dash side finisher. Refer to [EI-32, "Removal and Installation"](#).
12. Install foot-rest. Refer to [EI-35, "Removal and Installation"](#).
13. Install kicking plate. Refer to [EI-32, "Removal and Installation"](#).

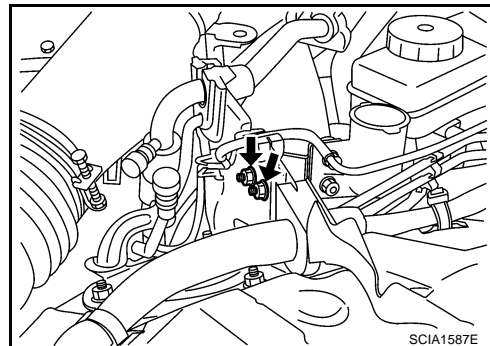

Disassembly and Assembly

DISASSEMBLY

1. Remove spring pin, nipple and reservoir seal from cylinder body using a pin punch.
2. Loosen push rod lock nut. Remove clevis and lock nut.
3. Remove seat from cylinder body.
4. Remove stopper ring and stopper, then remove push rod, piston assembly, and return spring from cylinder body.

CAUTION:

Restrain push rod while doing this because there is a danger piston assembly will fly out of cylinder body.

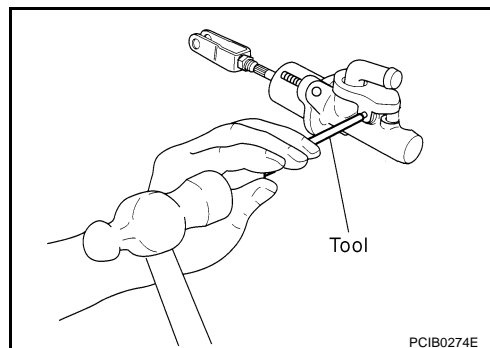

CLUTCH MASTER CYLINDER

INSPECTION AFTER DISASSEMBLY

Check for any of the conditions shown below. If any malfunction is found, replace the part concerned.

- Damaged cylinder internal wall, foreign matter, wear, corrosion, or pin hole
- Damaged or deformed nipple or reservoir tank
- Settling of the spring
- Cracked and deformed seat

ASSEMBLY

1. Apply rubber lubricant to internal surface of cylinder body, sliding surface of piston assembly, and piston cup. Insert return spring and piston assembly to cylinder body.
2. Apply silicone grease to push rod and install stopper before installing stopper ring.

CAUTION:

Restrain push rod while doing this because there is a danger piston assembly will fly out of master cylinder.

3. Install seat to cylinder body.
4. Install clevis to push rod and tighten lock nut to the specified torque. Refer to [CL-8, "Removal and Installation"](#).
5. Install reservoir seal and nipple to cylinder body. Install spring pin using a pin punch.

CLUTCH PIPING

CLUTCH PIPING

PFP:30650

Removal and Installation

ACS00409

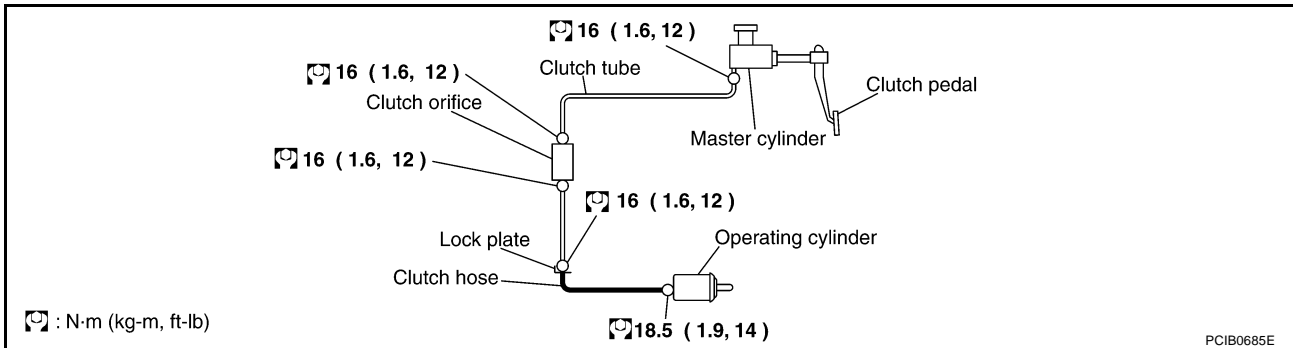

Carefully observe the following steps during clutch tube removal and installation.

- Do not spill clutch fluid onto painted surfaces. If it spills, wipe up immediately and wash the affected area with water.
- When fixing clutch hose to bracket, align clutch hose metal fittings with bracket positioning emboss and lock plate to secure. At this time, prevent twisting or damage of clutch hose. In addition, be careful not to damage clutch hose.
- Tighten clutch tube flare nut to the specified torque.
CAUTION:
Be careful not to damage flare nut and clutch tube.
- Tighten union bolt to the specified torque. Refer to [CL-11, "Removal and Installation"](#).
- **CAUTION:**
Do not reuse copper washer.
- After installation, bleed clutch tube. Refer to [CL-7, "Bleeding"](#).

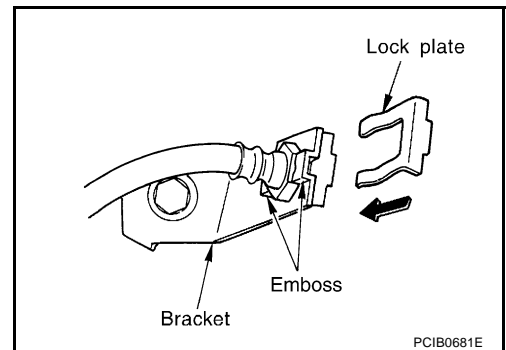

CLUTCH RELEASE MECHANISM

CLUTCH RELEASE MECHANISM

PF3:30502

Removal and Installation

ACS0040A

A
B
CL
D
E
F
G
H
I
J
K
L
M

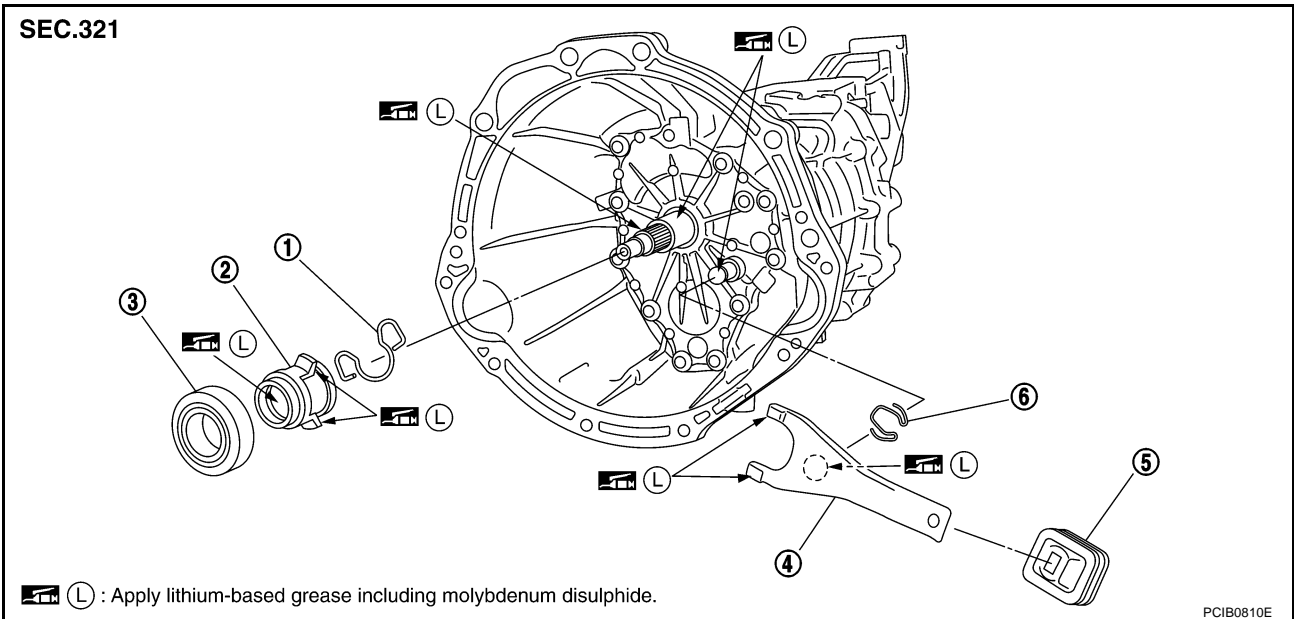

(L) : Apply lithium-based grease including molybdenum disulphide.

- | | | |
|---------------------|---------------------------|--------------------|
| 1. Holder spring | 2. Release bearing sleeve | 3. Release bearing |
| 4. Withdrawal lever | 5. Dust cover | 6. Snap spring |

REMOVAL

1. Remove manual transmission from vehicle. Refer to [MT-19, "Removal and Installation from Vehicle"](#).
2. Remove release bearing sleeve assembly, holder spring, and withdrawal lever from inside clutch housing.
3. Remove dust cover.
4. Remove snap spring from withdrawal lever.
5. Remove release bearing from release bearing sleeve using a puller.

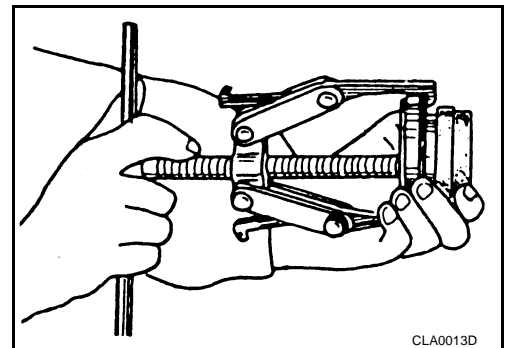

INSPECTION AFTER REMOVAL

- If release bearing is seized, damaged, not properly centered or does not rotate smoothly, replace it.
- If contact surface of withdrawal lever is excessively worn out, replace it.
- If dust cover is cracked or deformed, replace it.

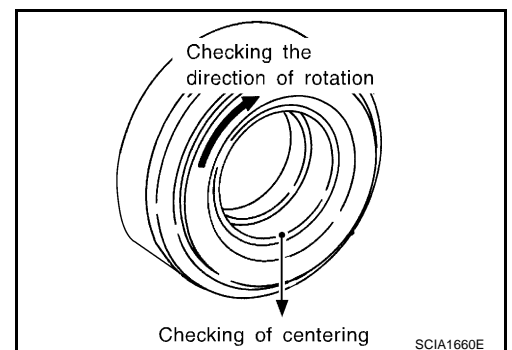

CLUTCH RELEASE MECHANISM

INSTALLATION

CAUTION:

- Be sure to apply grease to the points specified. Otherwise, noise, poor disengagement, or damage to the clutch may result. Excessive grease may cause slip or quiver. Wipe off any grease oozing from the parts.
 - Be careful not to bring any grease into contact with clutch disc facing, pressure plate surface, or flywheel surface.
1. Install release bearing to release bearing sleeve using the drift.

Tool number : KV 30101400 (-)

CAUTION:

Press bearing inner race by pushing with the drift.

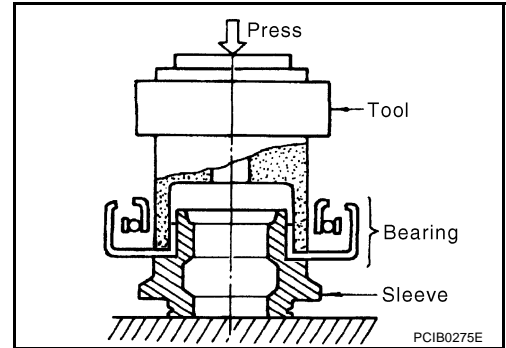

2. Following the instructions below, apply grease to the specified points.

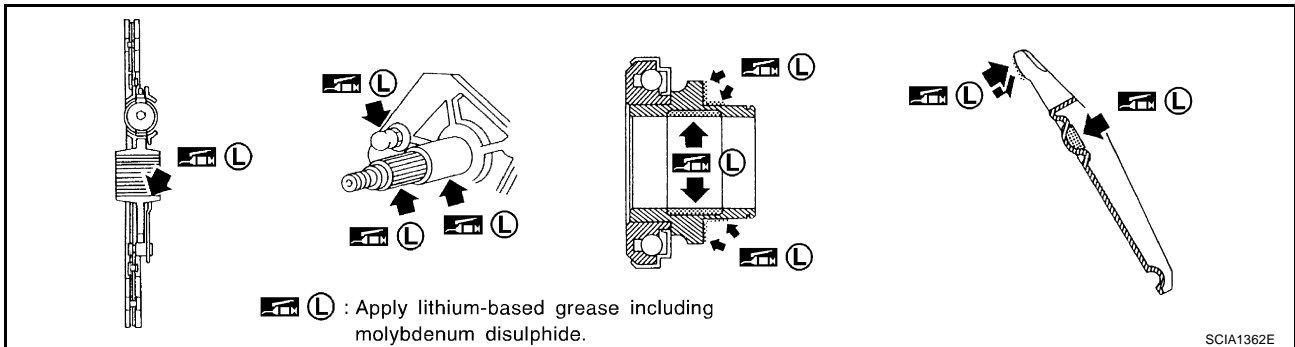

CAUTION:

Wipe off any old grease, debris, or powdery residue left on the surfaces.

- Evenly apply a 1 mm thick coating of recommended grease to withdrawal lever and release bearing sleeve or holder spring sliding surface.
 - Apply recommended grease to ball pin contact surface of withdrawal lever and inner slots of release bearing. The grease surface should be level with the surrounding area.
 - Evenly apply a thin coat of recommended grease to release bearing sliding surface. Install release bearing. Wipe off any excess grease that oozes from the parts and then remove release bearing.
3. To install, reverse the removal procedure, following the cautions below.

CAUTION:

- Before installing manual transmission to vehicle, check that each sliding surface slides smoothly by operating withdrawal lever.
- When assembling, make sure that both ends of snap spring touch the end face of withdrawal lever.
- Be careful with the orientation of installation.

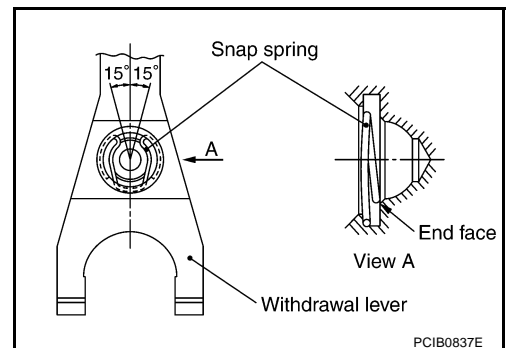

CLUTCH DISC, CLUTCH COVER

CLUTCH DISC, CLUTCH COVER

PFP:30100

Removal and Installation

ACS0040B

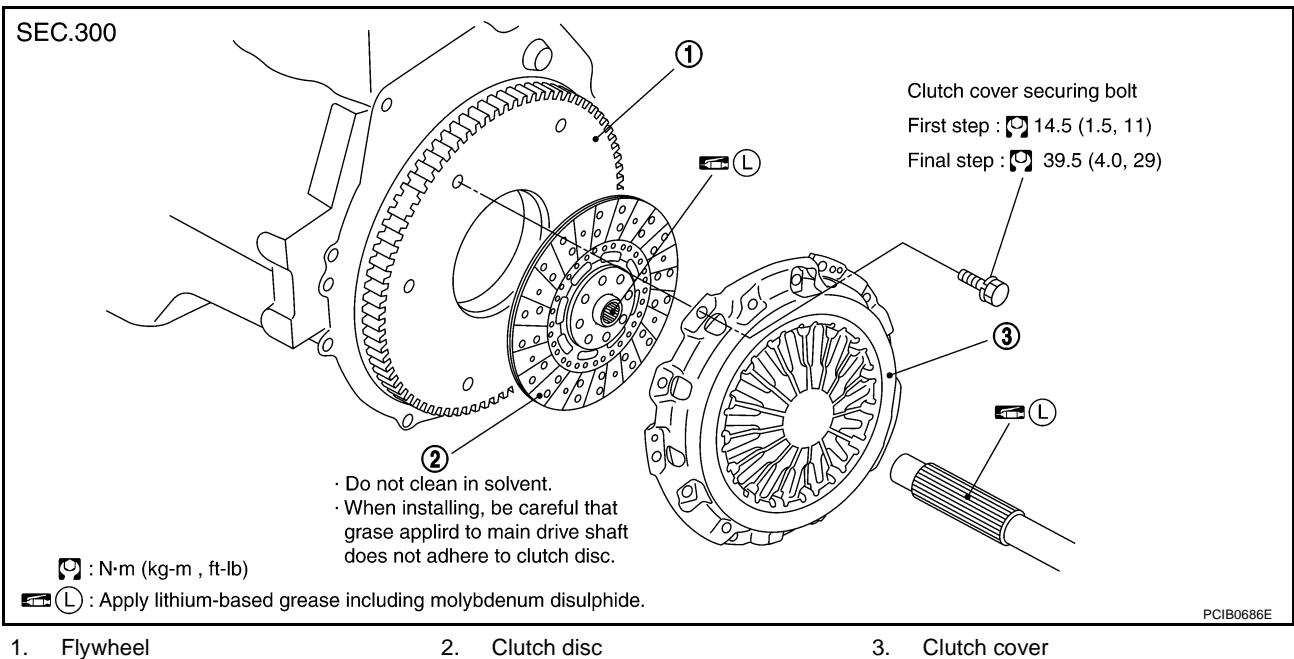

CAUTION:

Be careful not to bring any grease into contact with clutch disc facing, pressure plate surface, or flywheel surface.

REMOVAL

1. Remove manual transmission from vehicle. Refer to [MT-19, "Removal and Installation from Vehicle"](#).
2. Loosen clutch cover mounting bolts with power tool. Remove clutch cover and clutch disc.

INSPECTION AND ADJUSTMENT AFTER REMOVAL

Clutch Disc

- Measure circumference runout relative to clutch disc center spline. If it is outside the specification, replace clutch disc.

Runout limit/diameter of the area to be measured:
0.7 mm (0.028 in) / 240 mm (9.45 in) dia.

- Measure backlash for clutch disc spline and main drive shaft spline at the circumference of clutch disc. If it is outside the specified range, replace clutch disc.

Maximum backlash of spline:
1.0 mm (0.039 in)

- Measure the depth to clutch disc facing rivet heads using calipers. If it exceeds the allowable wear limit, replace clutch disc.

Facing wear limit (depth to the rivet head):
0.3 mm (0.012 in)

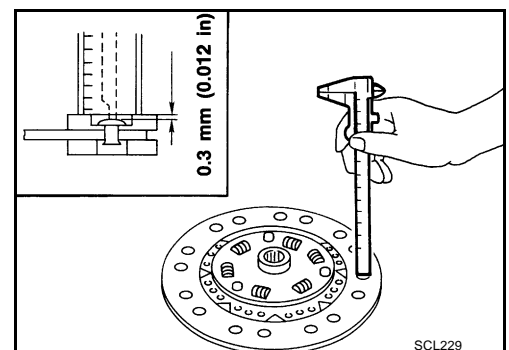
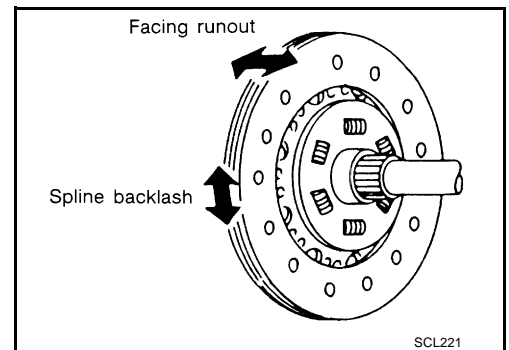

CLUTCH DISC, CLUTCH COVER

Clutch Cover

Check diaphragm spring lever claws for unevenness with the lever still on vehicle. If they exceed the tolerance, adjust lever height using the diaphragm adjusting wrench.

**Tolerance for diaphragm spring lever unevenness:
0.5 mm (0.02 in)**

Tool number : ST 20050240 (-)

- Check clutch cover thrust ring for wear or breakage. If wear or breakage is found, replace clutch cover.

NOTE:

- Worn thrust ring will generate a beating noise when tapped at the rivet with a hammer.
- Broken thrust ring will make a clinking sound when cover is shaken up and down.
- If a trace of burn or discoloration is found on clutch cover pressure plate to clutch disc contact surface, repair the surface with sandpaper. If surface is damaged or distorted, replace clutch cover.

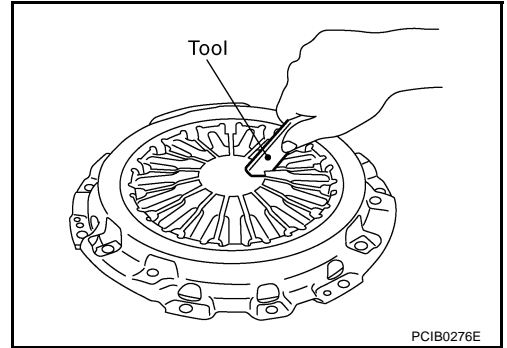

INSTALLATION

1. Apply recommended grease to clutch disc and main drive shaft spline.

CAUTION:

Be sure to apply grease to the points specified. Otherwise, noise, poor disengagement, or damage to the clutch may result. Excessive grease may cause slip or quiver. Wipe off any grease oozing from the parts.

2. Install clutch disc and clutch cover. Pre-tighten mounting bolts and install clutch aligning bar.

Tool number : ST20670000 (-)

3. Tighten clutch cover mounting bolts evenly in two steps in the order shown in the figure. Refer to [CL-15, "Removal and Installation"](#).
4. Install manual transmission. Refer to [MT-19, "Removal and Installation from Vehicle"](#).

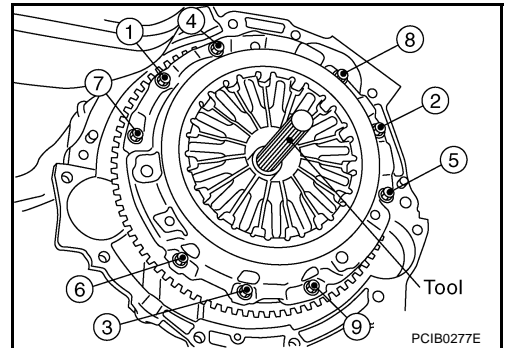

SERVICE DATA AND SPECIFICATIONS (SDS)

SERVICE DATA AND SPECIFICATIONS (SDS)

PPF:00030

Clutch Control System

ACS0040C

Type of clutch control	Hydraulic
------------------------	-----------

Clutch Master Cylinder

ACS0040D

Unit: mm (in)

Inner diameter	15.87 (5/8)
----------------	-------------

Clutch Operating Cylinder

ACS0040E

Unit: mm (in)

Inner diameter	19.05 (3/4)
----------------	-------------

Clutch Disc

ACS0040F

Unit: mm (in)

Engine model	VQ35DE
Model	250
Facing size (Outer dia. × inner dia. × thickness)	250 × 170 × 3.2 (9.84 × 6.69 × 0.126)
Wear limit (depth to the rivet head)	0.3 (0.012)
Runout limit/diameter of the area to be measured	0.7 (0.028) / 240 (9.45) dia.
Maximum backlash of spline (at outer edge disc)	1.0 (0.039)

Clutch Cover

ACS0040G

Unit: mm (in)

Engine model	VQ35DE
Model	250
Set-load	8,630 N (880 kg)
Diaphragm spring lever height	39.5 - 41.5 (1.555 - 1.634)
Uneven limit of diaphragm spring toe height	0.5 (0.02)

Clutch Pedal

ACS0040H

Unit: mm (in)

Clearance "C" between pedal stopper rubber and clutch interlock switch threaded while clutch pedal is fully depressed.	0.1 - 1.0 (0.004 - 0.039)
--	---------------------------

SERVICE DATA AND SPECIFICATIONS (SDS)
