

A
B
C
D
E

SECTION **PB**

PARKING BRAKE SYSTEM

CONTENTS

<p>PRECAUTIONS 2</p> <p> Precautions for Supplemental Restraint System (SRS) "AIR BAG" and "SEAT BELT PRE-TENSIONER" 2</p> <p> Precautions for Battery Service 2</p> <p>PARKING BRAKE SYSTEM 3</p> <p> On-Vehicle Service (Foot Lever Type) 3</p> <p> INSPECTION 3</p> <p> ADJUSTMENT 3</p> <p> On-Vehicle Service (Hand Lever Type) 4</p> <p> INSPECTION 4</p> <p> ADJUSTMENT 4</p> <p>PARKING BRAKE CONTROL 5</p> <p> Components 5</p>	<p> Removal and Installation 6</p> <p> REMOVAL 6</p> <p> INSTALLATION 6</p> <p> Inspection 6</p> <p>PARKING BRAKE SHOE 7</p> <p> Components 7</p> <p> Removal and Installation 7</p> <p> REMOVAL 7</p> <p> INSPECTION AFTER REMOVAL 8</p> <p> INSTALLATION 8</p> <p> BREAKING IN DRUM AND LINING 9</p> <p>SERVICE DATA AND SPECIFICATIONS (SDS) 10</p> <p> Parking Drum Brake 10</p> <p> Parking Brake Control 10</p>
--	---

PB

G

H

I

J

K

L

M

PRECAUTIONS

PRECAUTIONS

PF0:00001

Precautions for Supplemental Restraint System (SRS) “AIR BAG” and “SEAT BELT PRE-TENSIONER”

AFS00277

The Supplemental Restraint System such as “AIR BAG” and “SEAT BELT PRE-TENSIONER”, used along with a front seat belt, helps to reduce the risk or severity of injury to the driver and front passenger for certain types of collision. This system includes seat belt switch inputs and dual stage front air bag modules. The SRS system uses the seat belt switches to determine the front air bag deployment, and may only deploy one front air bag, depending on the severity of a collision and whether the front occupants are belted or unbelted. Information necessary to service the system safely is included in the SRS and SB section of this Service Manual.

WARNING:

- **To avoid rendering the SRS inoperative, which could increase the risk of personal injury or death in the event of a collision which would result in air bag inflation, all maintenance must be performed by an authorized NISSAN/INFINITI dealer.**
- **Improper maintenance, including incorrect removal and installation of the SRS, can lead to personal injury caused by unintentional activation of the system. For removal of Spiral Cable and Air Bag Module, see the SRS section.**
- **Do not use electrical test equipment on any circuit related to the SRS unless instructed to in this Service Manual. SRS wiring harnesses can be identified by yellow and/or orange harnesses or harness connectors.**

Precautions for Battery Service

AFS002A2

Before disconnecting the battery, lower both the driver and passenger windows. This will prevent any interference between the window edge and the vehicle when the door is opened/closed. During normal operation, the window slightly raises and lowers automatically to prevent any window to vehicle interference. The automatic window function will not work with the battery disconnected.

PARKING BRAKE SYSTEM

PARKING BRAKE SYSTEM

PFP:36010

On-Vehicle Service (Foot Lever Type) INSPECTION

AFS00130

- While depressing the parking brake pedal to the specified amount of force. Check that the pedal stroke is within the range of the specified stroke amount.

Number of notches : 2 - 3

- Check that warning lamp comes on when parking brake pedal is depressed within one notch.

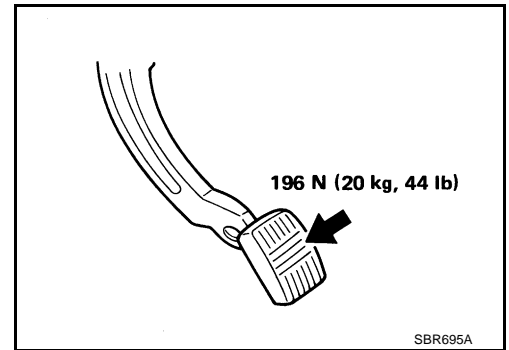

ADJUSTMENT

- To perform adjustment operations, remove tire from the vehicle with power tool. Using a wheel nut, fix the disc to the hub preventing it from tilting.

1. Insert a deep-well socket wrench to rotate the self-locking nut to loosen the cable sufficiently. Then, after returning the pedal completely, adjust the clearance of the rear shoes.

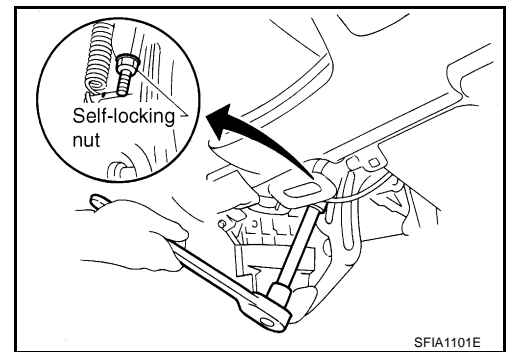

2. Remove the adjuster hole plug installed on the disc. Using a flat-bladed screwdriver, turn the disc clockwise as shown in the figure until the disc is locked. After locking, turn the adjuster in the opposite direction by 5 or 6 notches.

3. Rotate the disc to make sure that there is no drag. Then install the adjuster hole plug.

4. After adjusting the clearance of the rear shoes, with no drag on the rear brake, adjust the cable as follows:

- a. Operate the pedal 10 times or more with the force of 294 N (30 kg, 66 lb).

- b. Depress the pedal until the deep-well socket can be inserted. Insert the deep-well socket, and rotate the self-locking nut to adjust the pedal stroke.

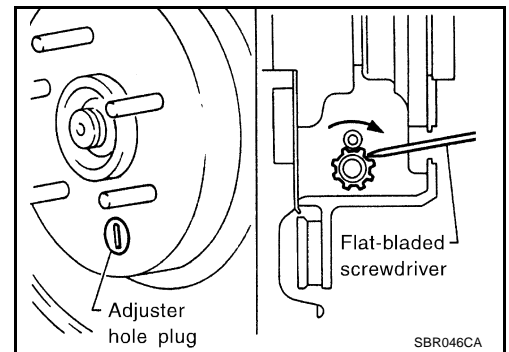

CAUTION:

Do not reuse the self-locking nut after removing it.

- c. After operating the pedal 3 or 4 times with the force of 196 N (20 kg, 44 lb), make sure that the pedal stroke is within the specified value.

- d. With the pedal completely returned, make sure that there is no drag on the rear brake.

PARKING BRAKE SYSTEM

AFS0014R

On-Vehicle Service (Hand Lever Type) INSPECTION

- While depressing the parking brake lever to the specified amount of force. Check that the lever stroke is within the range of the specified stroke amount.

Number of notches : 6 - 7

- Check that warning lamp comes on when parking brake lever is depressed within one notch.

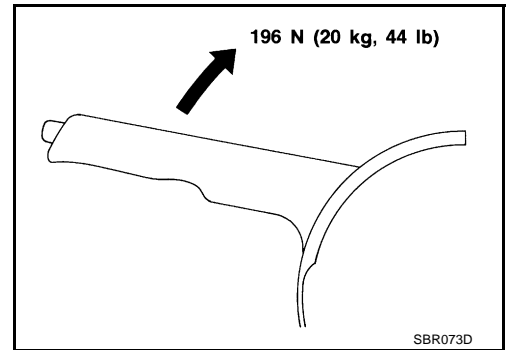

ADJUSTMENT

- To perform adjustment operations, remove tire from the vehicle with power tool. Using a wheel nut, fix the disc to the hub preventing it from tilting.

1. Insert a deep-well socket wrench to rotate the self-locking nut to loosen the cable sufficiently. Then, after returning the lever completely, adjust the clearance of the rear shoes.

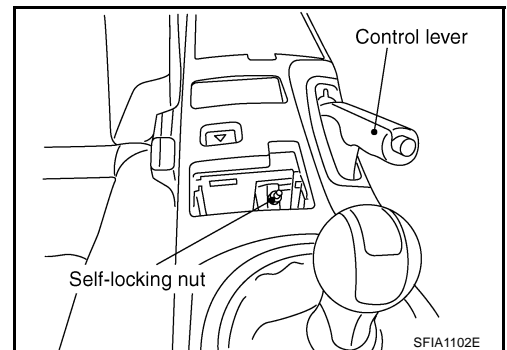

2. Remove the adjuster hole plug installed on the disc. Using a flat-bladed screwdriver, turn the disc clockwise as shown in the figure until the disc is locked. After locking, turn the adjuster to the opposite direction by 5 or 6 notches.
3. Rotate the disc to make sure that there is no drag. Then install the adjuster hole plug.

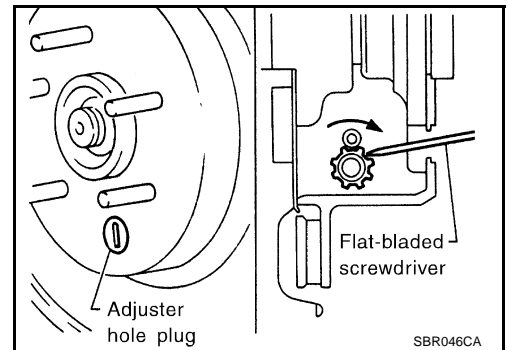

4. After adjusting the clearance of the rear shoes, with no drag on the rear brake, adjust the cable as follows:

- a. Operate the lever 10 times or more with the force of 294 N (30 kg, 66 lb).

- b. Depress the lever until a deep-well socket can be inserted. Insert the deep-well socket, and rotate the self-locking nut to adjust the lever stroke.

CAUTION:

Do not reuse the self-locking nut after removing it.

- c. After operating the lever 3 or 4 times with the force of 196 N (20 kg, 44 lb), make sure that the lever stroke is within the specified value.
- d. With the lever completely returned, make sure that there is no drag on the rear brake.

PARKING BRAKE CONTROL

PPF:36010

AFS00131

PARKING BRAKE CONTROL

Components

Foot lever type

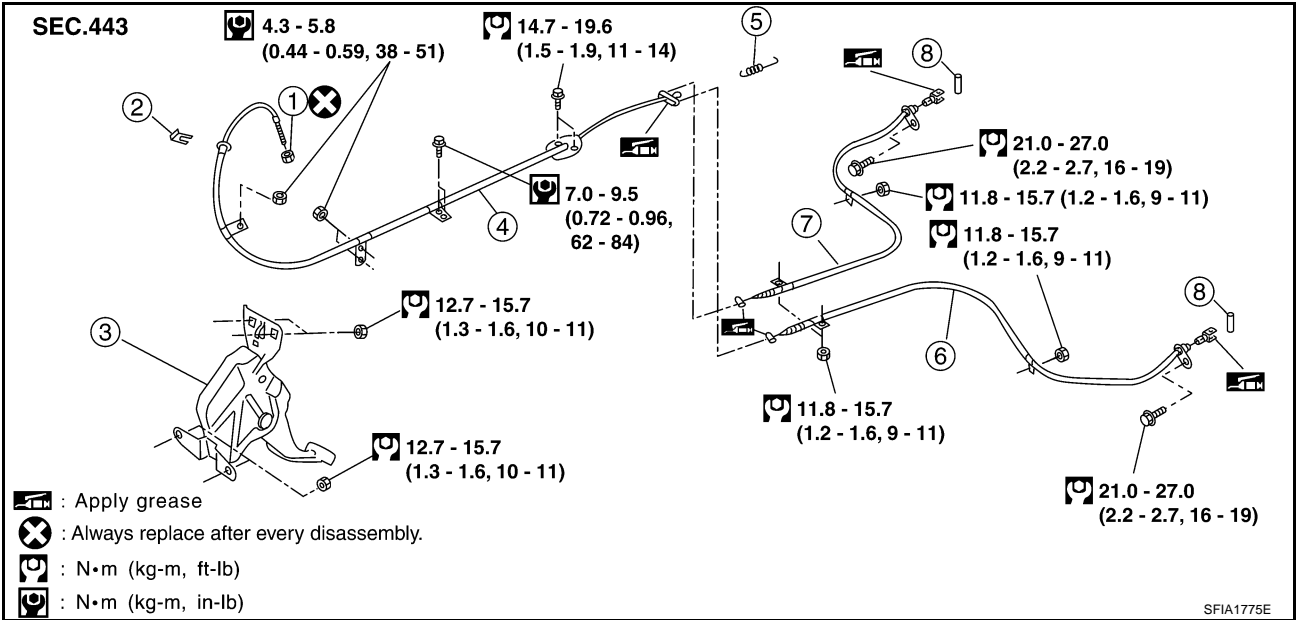

- | | | |
|---------------------|------------------|--------------------|
| 1. Self-locking nut | 2. Lock plate | 3. Device assembly |
| 4. Front cable | 5. Return spring | 6. LH rear cable |
| 7. RH rear cable | 8. Pin | |

Hand lever type

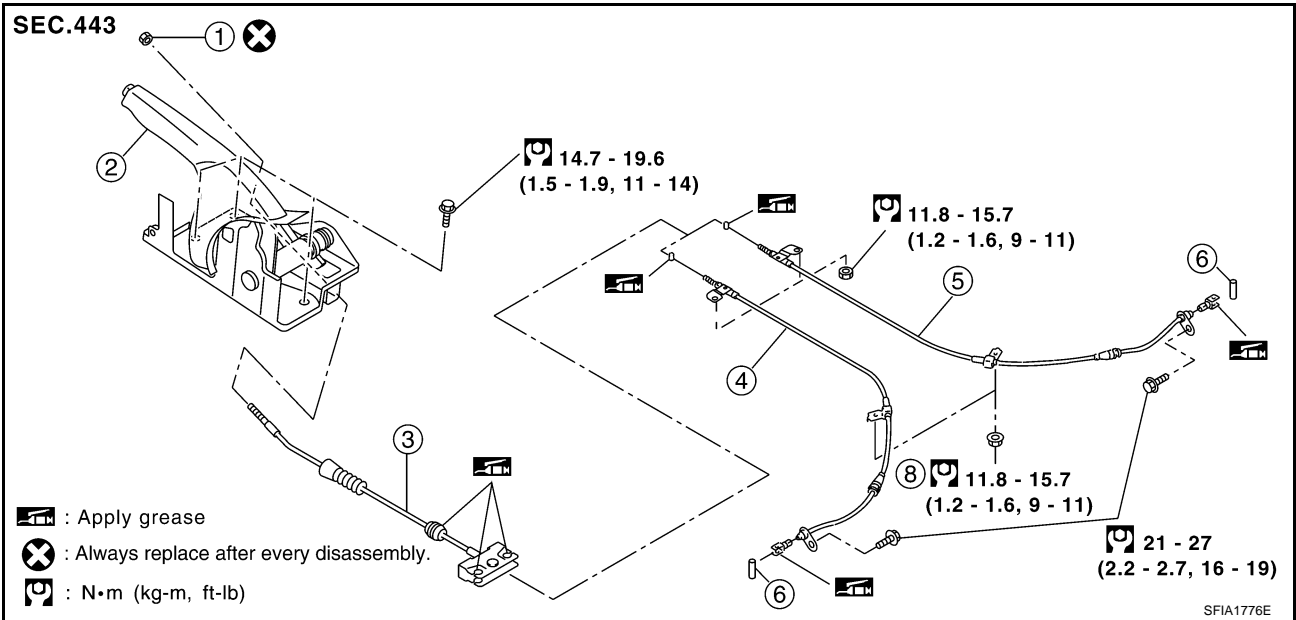

- | | | |
|---------------------|--------------------|----------------|
| 1. Self-locking nut | 2. Device assembly | 3. Front cable |
| 4. LH rear cable | 5. RH rear cable | 6. Pin |

PARKING BRAKE CONTROL

AFS00132

Removal and Installation

REMOVAL

1. Remove instrument lower driver panel (foot lever type). Refer to [IP-10, "INSTRUMENT PANEL ASSEMBLY"](#) .
2. Remove console. Refer to [IP-10, "INSTRUMENT PANEL ASSEMBLY"](#) .
3. Remove self-locking nut from device assembly.
4. Remove the tire.
5. Remove rear disc caliper and disc rotor. Refer to [BR-37, "REAR DISC BRAKE \(AD14VE TYPE\)"](#) , [BR-43, "REAR DISC BRAKE \(OPB13VB TYPE\)"](#) .
6. Remove parking brake shoe, and remove rear cable from toggle lever. Refer to [PB-7, "PARKING BRAKE SHOE"](#) .
7. Remove cable mounting nuts and bolts.
8. Remove right and left rear cables from the vehicle.
9. Remove air bag sensor unit with the sensor mount bracket. Refer to [SRS-50, "DIAGNOSIS SENSOR UNIT"](#) .
10. Remove front cable mounting nuts and bolts (foot lever type), and remove front cable from the vehicle.
11. Remove mounting bolts of the device assembly, and remove device assembly from the vehicle.

INSTALLATION

1. Install in the reverse order of removal. Tighten the mounting bolts and nuts to the specified torque.
CAUTION:
Do not reuse the self-locking nut of the parking cable.
2. Adjust clearance of parking brake shoes. Refer to [PB-3, "On-Vehicle Service \(Foot Lever Type\)"](#) , [PB-4, "On-Vehicle Service \(Hand Lever Type\)"](#) .

Inspection

AFS00133

- Check the device assembly for bend, damage, and cracks. Replace if necessary.
- Check the cable for wear and damage.
- Check the warning lamp switch. Replace if necessary.
- Check each part for deformation, or damage by contact with other parts. Replace if necessary.

PARKING BRAKE SHOE

PARKING BRAKE SHOE

PF0:44060

Components

AFS00134

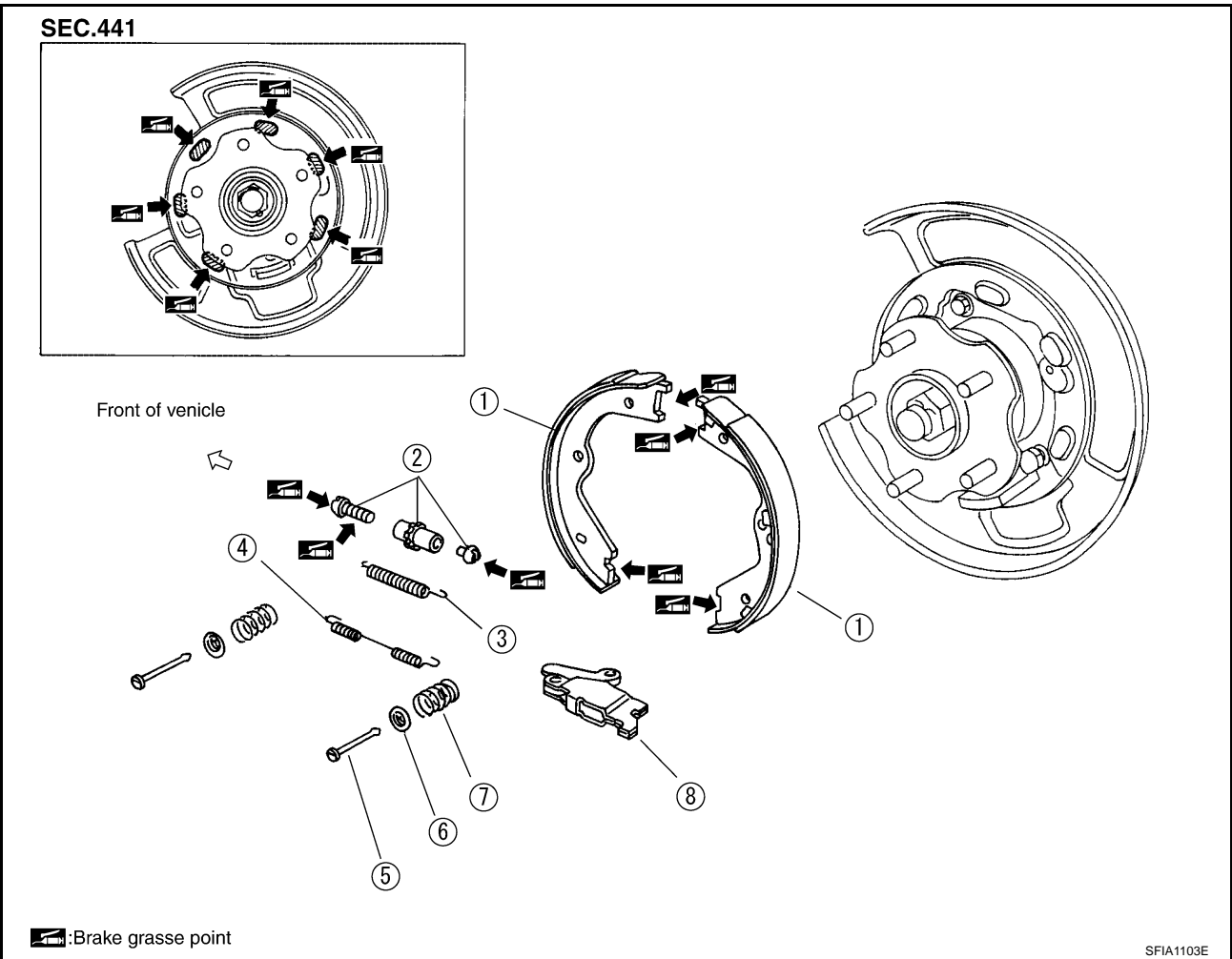

- | | | |
|-----------------------|----------------------|--------------------|
| 1. Shoe | 2. Adjuster assembly | 3. Adjuster spring |
| 4. Return spring | 5. Anti-rattle pin | 6. Retainer |
| 7. Anti-rattle spring | 8. Toggle lever | |

Removal and Installation

REMOVAL

AFS00135

CAUTION:

Clean brakes with a vacuum dust collector to minimize the hazard of airborne particles or other materials.

Be careful of the following:

- Remove the wheel, and remove the disc rotor with the parking pedal completely returned.
- If the disc rotor cannot be removed, remove as follows.
 1. Fix the disc rotor with the wheel nut.
 2. Remove plug.
 3. Insert flat-bladed screwdriver through plug. Turn adjuster to make clearance between brake shoe and drum.

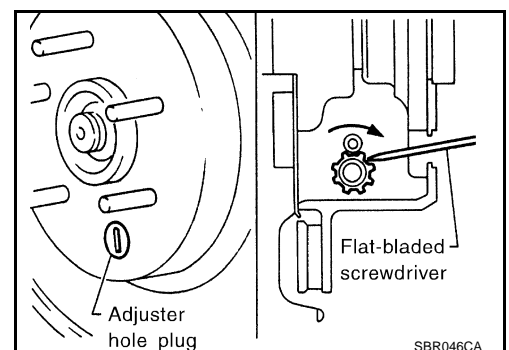

PARKING BRAKE SHOE

INSPECTION AFTER REMOVAL

Lining Thickness Inspection

- Visually check the lining for malfunction, wear, damage, and peeling.
- Using a scale, check the thickness of the lining.

Standard lining thickness : 3.2 mm (0.126 in)

lining wear limit (A) : 1.5 mm (0.059 in)

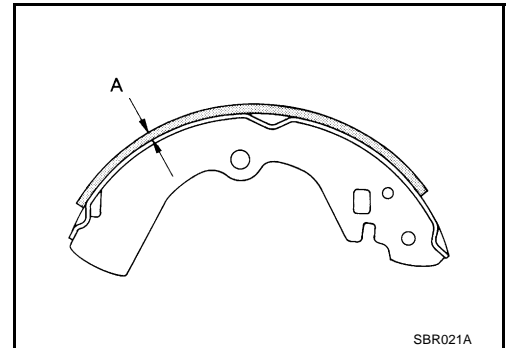

Drum Inner Diameter Inspection

- Check the inner diameter of the drum.

Standard inner diameter : 172.0 mm (6.77 in)

Maximum inner diameter : 173.0 mm (6.81 in)

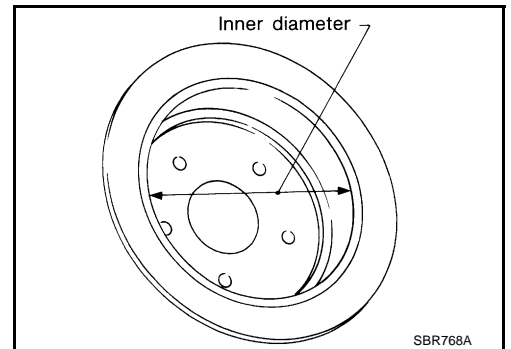

Other Inspections

- Check the shoe sliding surface for abnormal wear and damage.
- Check the anchor pin for abnormal wear and corrosion.
- Check the return spring for sagging.
- Check the adjuster for rough operation.
- Visually check the inside of the drum for abnormal wear, damage, and cracks. Using a pair of vernier calipers, check the inside of the drum.

INSTALLATION

Install all parts in reverse order while taking care of the following.

- Apply brake grease to the contact areas shown in the figure.

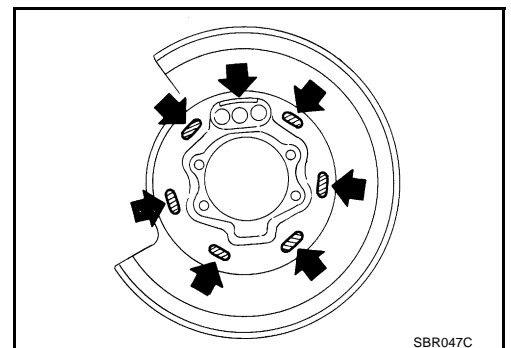

PARKING BRAKE SHOE

- The orientation of the adjuster is different from left to right. Assemble the adjuster so that the threaded part is expanded when rotating it to the direction shown by the arrow. Contract the adjuster to assemble. When disassembling the adjuster, apply brake grease to the thread.
- Adjust the parking brake pedal or lever stroke to the specified amount.
- After replacing the shoe or disc rotor, or if the brake does not function well, carry out the break-in operation as follows.

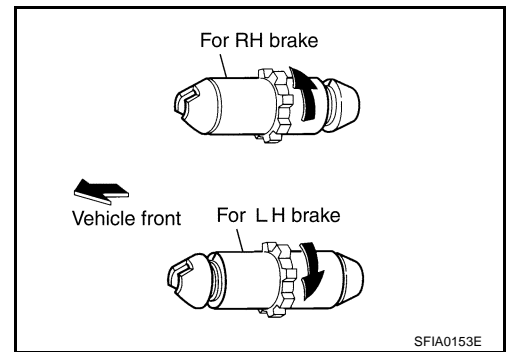

BREAKING IN DRUM AND LINING

CAUTION:

Do not carry out the break-in procedure excessively, because it may cause uneven wear or premature wear of the lining.

When a new rotor/parking brake shoe is installed, or when braking performance is poor, perform the following break-in procedure.

1. Drive the unloaded vehicle on a safe, level and dry road.
2. Depress parking brake pedal or lever with a force of 147 N (15 kg, 33 lb).
3. While depressing the pedal or pulling the lever, continue to drive the vehicle forward 100 m (328 ft) at approximately 35 km/h (22 MPH).
4. Cool down parking brake for approx. five minutes.
5. After releasing the pedal or lever, drive the vehicle under the normal conditions for two minutes to cool down the parking drum brake.
6. Repeat steps 1 through 5 three times and then repeat only step 5 one more time.
7. After the break-in procedure, check the pedal or lever stroke of the parking brake. If it is out of the specification, adjust again.

SERVICE DATA AND SPECIFICATIONS (SDS)

SERVICE DATA AND SPECIFICATIONS (SDS)

PFP:00030

Parking Drum Brake

AFS00137

Type		DS17HF
Brake lining	Standard thickness (new)	3.2 mm (0.126 in)
	Wear limit thickness	1.5 mm (0.059 in)

Parking Brake Control

AFS00138

Control type	Foot lever / Hand lever
Number of notches (under force of 196 N (20 kg,44lb))	2 - 3 (foot lever type)
	6 - 7 (hand lever type)
Number of notches when warning lamp switch comes on	1