

SECTION **PR**
PROPELLER SHAFT

A
B
C

PR

CONTENTS

E

PREPARATION	2	REMOVAL	5	F
Special Service Tools	2	INSTALLATION	5	
Commercial Service Tools	2	INSPECTION	6	
NOISE, VIBRATION AND HARSHNESS (NVH)		Disassembly and Assembly	7	G
TROUBLESHOOTING	3	DISASSEMBLY	7	
NVH Troubleshooting Chart	3	ASSEMBLY	8	
REAR PROPELLER SHAFT	4	SERVICE DATA	9	H
On-Vehicle Service	4	General Specifications	9	
PROPELLER SHAFT VIBRATION	4	Journal Axial Play	9	
APPEARANCE CHECKING	4	Propeller Shaft Runout Limit	9	I
Removal and Installation	4			

J

K

L

M

PREPARATION

PREPARATION

PFP:00002

Special Service Tools

ADS000CY

The actual shapes of Kent-Moore tools may differ from those of special service tools illustrated here.

Tool name Tool number (Kent-Moore No.)	Description
ST38060002 (J34311) Companion flange wrench	Removing and installing propeller shaft lock nut
Drift pinion rear inner race puller set 1. ST30031000 (J22912-01) puller 2. ST30901000 (-) Base Equivalent tool (J26010-01) Base a : 90mm (3.54in) dia. b : 80mm (3.15in) dia. c : 50mm (1.97in) dia. d : 79mm (3.11in) dia. e : 45mm (1.77in) dia. f : 35mm (1.33in) dia.	Remove center bearing

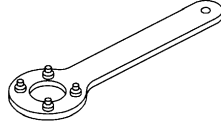

NT113

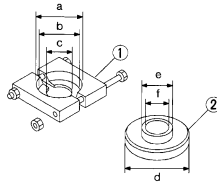

S-NT640

Commercial Service Tools

ADS000CZ

Tool name	Description
Power tool	Loosening bolts and nuts

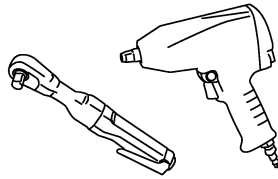

PBIC0190E

NOISE, VIBRATION AND HARSHNESS (NVH) TROUBLESHOOTING

NOISE, VIBRATION AND HARSHNESS (NVH) TROUBLESHOOTING

PF0:00003

NVH Troubleshooting Chart

ADS000D0

Use the chart below to help you find the cause of the symptom. If necessary, repair or replace these parts.

Symptom		PROPELLER SHAFT	Possible cause and SUSPECTED PARTS													
			Uneven rotation torque	Center bearing improper installation	Excessive center bearing axial end play	Center bearing mounting (insulator) cracks, damage or deterioration	Excessive joint angle	Rotation imbalance	Excessive runout	DIFFERENTIAL	AXLE AND SUSPENSION	TIRES	ROAD WHEEL	DRIVE SHAFT	BRAKES	STEERING
Noise	PROPELLER SHAFT		×	×	×	×	×	×	×	×	×	×	×	×	×	×
		Shake		×			×				×	×	×	×	×	×
		Vibration	×	×	×	×	×	×	×	×	×		×		×	×
Reference page			—	—	—	—	—	—	—	—	—	—	—	—	—	—

×: Applicable

A
B
C
PR
E
F
G
H
I
J
K
L
M

REAR PROPELLER SHAFT

PFP:37000

ADS000F2

REAR PROPELLER SHAFT

On-Vehicle Service PROPELLER SHAFT VIBRATION

If vibration is present at high speed, inspect propeller shaft runout first.

1. Measure propeller shaft runout at several points by rotating final drive companion flange with hands.

Runout limit : 0.6 mm (0.024 in) or less

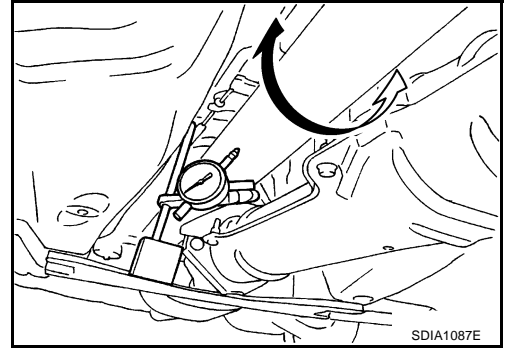

Propeller shaft runout measuring points:

Unit: mm (in)

Distance	A	B	C
	192 (7.56)	172 (6.77)	170 (6.69)

2. If runout still exceeds specifications, disconnect propeller shaft at final drive companion flange; then rotate companion flange 90, 180, 270 degrees and reconnect propeller shaft.
3. Check runout again. If runout still exceeds specifications, replace propeller shaft assembly.

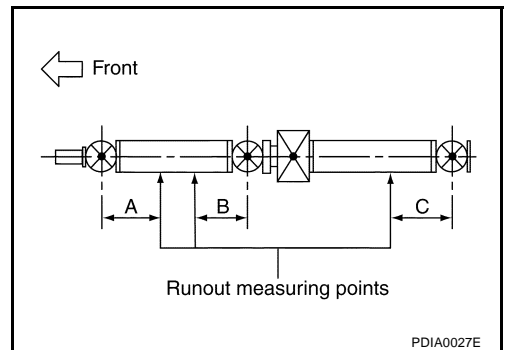

APPEARANCE CHECKING

- Inspect propeller shaft tube surface for dents or cracks. If damaged, replace propeller shaft assembly.
- If center bearing is noisy or damaged, replace it.

Removal and Installation

ADS000D2

SEC.370
Apply a coat of multi-purpose lithium grease containing molybdenum disulfide to the end face of the center bearing and both sides of the washer.

M/T model

A/T model

⊗ ⑧
⊗ 294 (30, 217)
Refer to ASSEMBLY.

⊗ 95 (9.7, 70)

⊗ 44.5 (4.5, 33)

⊗ 9.35 (0.95, 83)

⊗ 73.5 (7.5, 54)

⊗ : Always replace after evry dissembly.

- | | | |
|--|--|---------------------|
| 1. 1st shaft | 2. Center bearing mounting bracket (lower) | 3. Floor rain force |
| 4. Center bearing | 5. 2nd shaft | 6. Clip |
| 7. Center bearing mounting bracket (upper) | 8. Lock nut | |

REAR PROPELLER SHAFT

REMOVAL

1. Move A/T select lever to N range position, set M/T shift lever to neutral position.
2. Release parking brake.
3. Put matchmarks on flanges and separate propeller shaft from final drive.
4. Remove exhaust tube with power tool.
5. Remove floor reinforcement.
6. Remove propeller shaft.

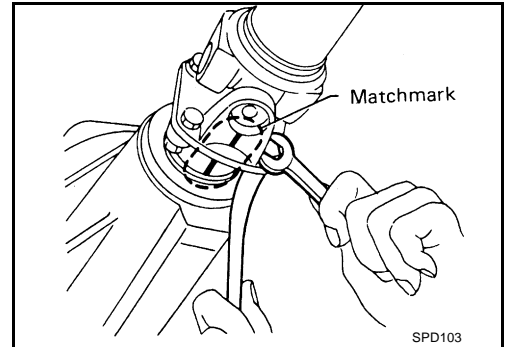

INSTALLATION

Companion Flange Installation

If companion flange has been removed, put new alignment marks B and C on it. Then, reassemble using the following procedure. (Perform step 4 when final drive and propeller shaft are separated from each other. Also perform step 4 when either of these parts is replaced with a new one.)

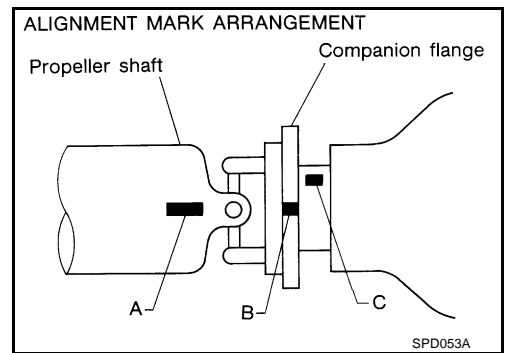

1. Erase original marks B and C from companion flange with suitable solvent.
2. Put mark B on flange perimeter.
 - a. Measure companion flange vertical runout.
 - b. Determine the position where maximum runout is read on dial gauge. Put mark (shown by B in figure) on flange perimeter corresponding to maximum runout position.

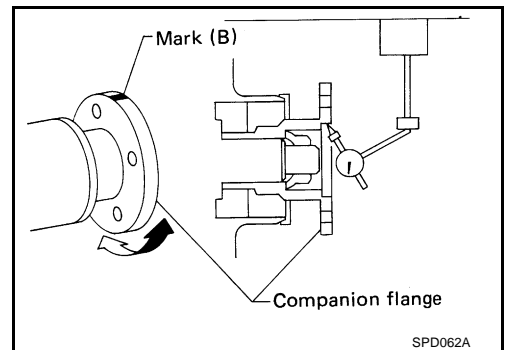

3. Put mark C on flange perimeter.
 - a. Measure companion flange surface runout.
 - b. Determine the position where maximum runout is read on dial gauge. Put mark (shown by C in figure) on flange perimeter corresponding to maximum runout position.

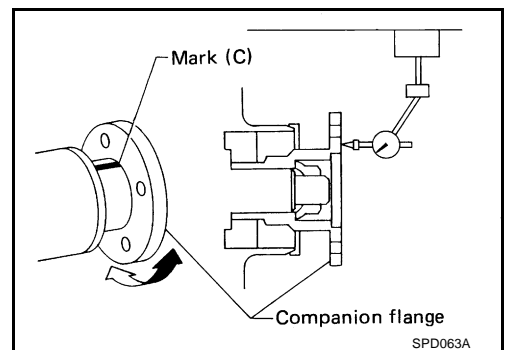

REAR PROPELLER SHAFT

4. Position companion flange and propeller shaft using alignment marks A and B. Set the marks A and B as close to each other as possible. Temporarily attach bolts and nuts.
5. Press down propeller shaft with alignment mark C facing upward. Then tighten the lower nut to specified torque.
6. Tighten remaining nuts to specified torque.

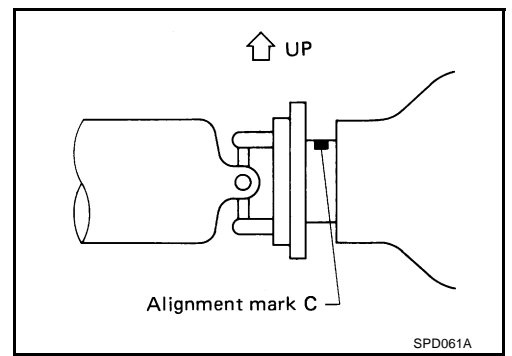

Center Bearing Bracket Installation

- Position the bearing cushion overlap as illustrated.

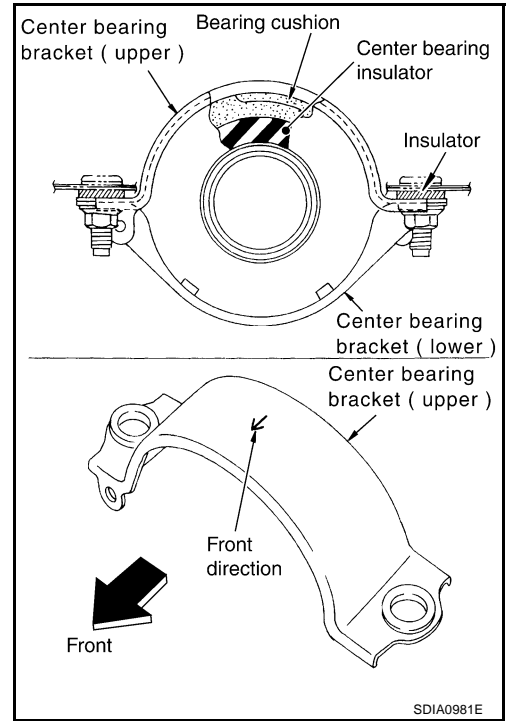

INSPECTION

- Inspect propeller shaft runout. If runout exceeds specifications, replace propeller shaft assembly.

Runout limit: 0.6 mm (0.024 in) or less

- Propeller shaft runout measuring points

Distance	Unit: mm (in)		
	A	B	C
	192 (7.56)	172 (6.77)	170 (6.69)

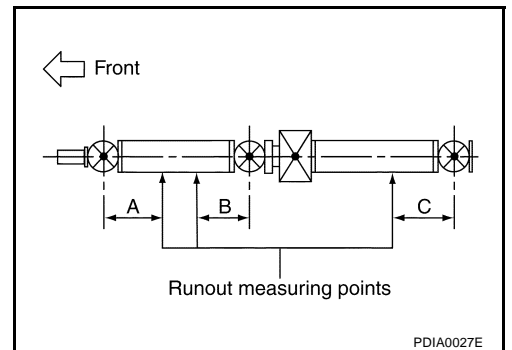

- If runout still exceeds specifications, replace propeller shaft assembly.

REAR PROPELLER SHAFT

- Inspect journal axial play. If the play exceeds specifications, replace propeller shaft assembly.

Journal axial play: **0 mm (0 in)**

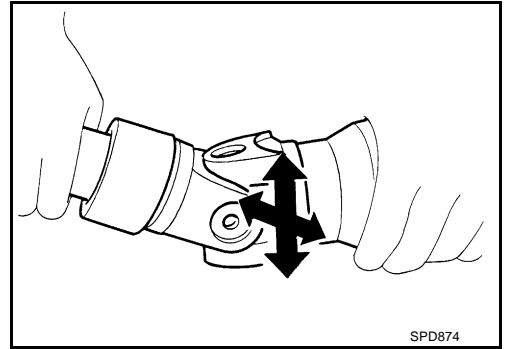

A
B
C

PR

Disassembly and Assembly DISASSEMBLY

ADS000D3

Center Bearing

1. Put matchmarks on flanges, and separate 2nd tube from 1st tube.
2. Put matchmarks on the flange and shaft.

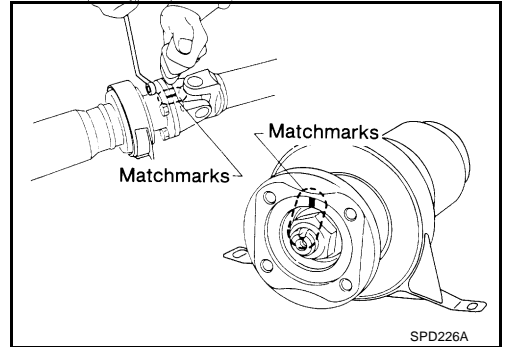

E
F
G
H

3. Remove locking nut with Tool.

Tool number **:ST38060002 (J34311)**

4. Remove companion flange with puller.

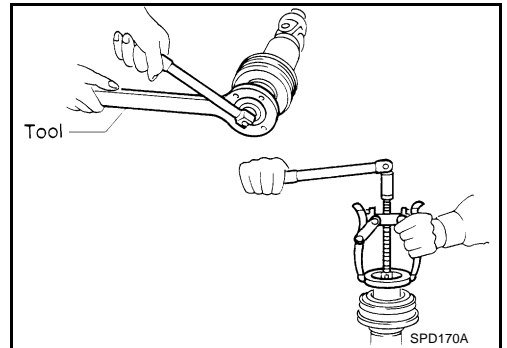

I
J
K
L

5. Remove center bearing with Tool and press.

Tool number **:ST30031000 (J22912-01)**

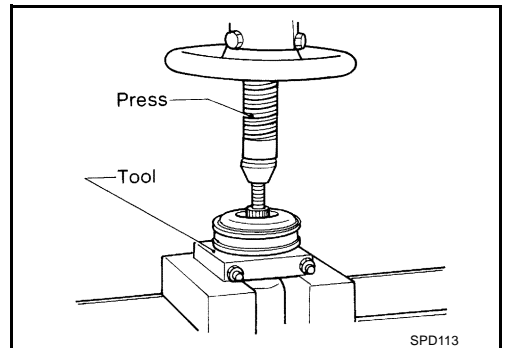

M

REAR PROPELLER SHAFT

ASSEMBLY

Center bearing

1. When installing center bearing, position the "F" mark on center bearing toward rear of vehicle.
2. Apply a coat of multi-purpose lithium grease containing molybdenum disulfide to the end face of the center bearing and both sides of the washer.

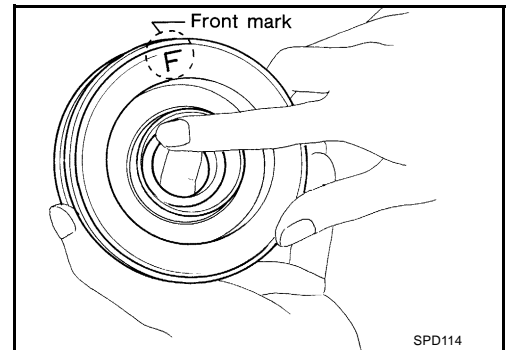

3. The lock nut is tightened according to the following.
 - a. Using a suitable torque wrench and tighten lock nut.
 - b. Loosen lock nut and tighten specified torque again.

 :294N·m (30.0kg-m,217ft-lb)

 :82.9N·m (8.5kg-m,61ft-lb)

4. Stake the nut. Always use new one.
5. Align matchmarks when assembling tubes.

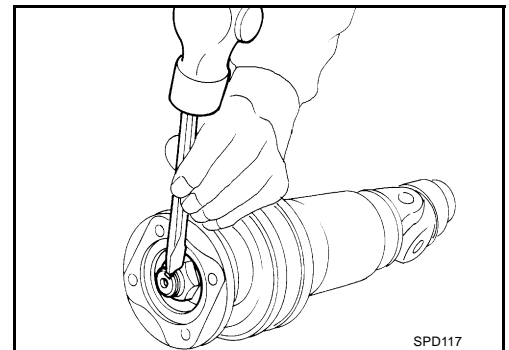

SERVICE DATA

SERVICE DATA

PFP:00030

General Specifications

ADS000D4

Unit: mm (in)

Applied model		VQ35DE	
		M/T	A/T
Propeller shaft model		3S80A	
Number of joints		3	
Coupling method with transmission		Sleeve type	
Type of journal bearings		Shell type (Non-disassembly type)	
Shaft length (Spider to spider)	1st	619 (24.37)	581 (22.87)
	2nd	902 (35.51)	
Shaft outer diameter	1st	82.6 (3.25)	
	2nd	82.6 (3.25)	

Journal Axial Play

ADS000E3

Unit: mm (in)

Model	3S80A
Journal axial play	0 (0)

Propeller Shaft Runout Limit

ADS000D6

Unit: mm (in)

Model	3S80A
Propeller shaft runout limit	0.6 (0.024) or less

SERVICE DATA
