

SECTION **FSU**
FRONT SUSPENSION

A
B
C
D

FSU

CONTENTS

PRECAUTIONS	2	TRANSVERSE LINK	12	F
Precautions	2	Removal and Installation	12	
PREPARATION	3	REMOVAL	12	G
Special Service Tools	3	INSPECTION AFTER REMOVAL	12	
Commercial Service Tools	3	INSTALLATION	12	H
NOISE, VIBRATION AND HARSHNESS (NVH)		STABILIZER BAR	13	
TROUBLESHOOTING	5	Removal and Installation	13	I
NVH Troubleshooting Chart	5	REMOVAL	13	
FRONT SUSPENSION ASSEMBLY	6	INSPECTION AFTER REMOVAL	13	J
Components	6	INSTALLATION	13	
On-Vehicle Inspection and Service	7	FRONT SUSPENSION MEMBER	14	K
LOOSENESS, BACKLASH AND DAMAGE OF		Removal and Installation	14	
MOUNTING PARTS AND CONNECTIONS	7	REMOVAL	14	L
Wheel Alignment Inspection	7	INSTALLATION	14	
DESCRIPTION	7	UPPER LINK	15	M
PRELIMINARY INSPECTION	7	Removal and Installation	15	
INSPECTION OF CAMBER, CASTER AND		REMOVAL	15	
KINGPIN INCLINATION ANGLES.	7	INSPECTION AFTER REMOVAL	15	
COIL SPRING AND SHOCK ABSORBER	9	INSTALLATION	15	
Removal and Installation	9	COMPRESSION ROD	16	
REMOVAL	9	Removal and Installation	16	
INSTALLATION	9	REMOVAL	16	
Disassembly and Assembly	9	INSPECTION AFTER REMOVAL	16	
DISASSEMBLY	9	INSTALLATION	16	
INSPECTION AFTER DISASSEMBLY	9	SERVICE DATA	17	
ASSEMBLY	10	Wheel Alignment (Unladen)	17	
		Ball Joint	17	
		Wheelarch Height (Unladen*)	17	

PRECAUTIONS

PRECAUTIONS

PFP:00001

Precautions

AES00001

- When installing rubber parts, final tightening must be carried out under unladen condition*: with tires on ground.
Oil will shorten the life of rubber bushes. Be sure to wipe off any spilled oil.
*: Fuel, radiator coolant and engine oil full. Spare tire, jack, hand tools and mats in designated positions.
- After installing removed suspension parts, check wheel alignment and adjust if necessary.
- Lock nuts are un reusable parts; always use new ones. When replacing, do not wipe oil off the new lock nut before tightening.
- Use flare nut wrench when removing or installing brake tubes.
- Always torque brake lines when installing.

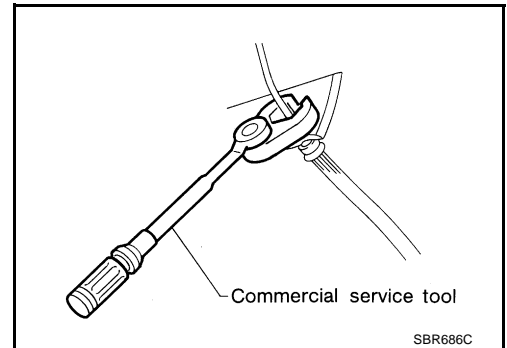

PREPARATION

PREPARATION

PFP:00002

Special Service Tools

AES00002

The actual shapes of Kent-Moore tools may differ from those of special service tools illustrated here.

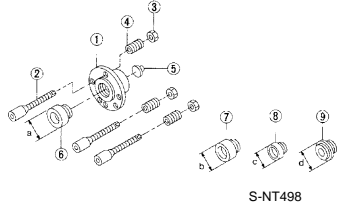
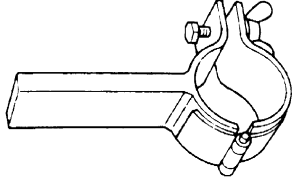
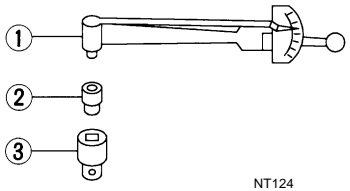
Tool number (Kent-Moore No.) Tool name	Description
KV991040S0 (—) CCK gauge 1. Plate 2. Guide bolts 3. Nuts 4. Springs 5. Center plate 6. KV9910 4030 Adapter A a: 72 mm (2.83 in) dia. 7. KV9910 4030 Adapter B b: 65 mm (2.56 in) dia. 8. KV9910 4040 Adapter C c: 57 mm (2.24 in) dia. 9. KV9910 4050 Adapter D d: 53.4 mm (2.102 in) dia.	 <p>Measuring wheel alignment</p>
ST35652000 (—) Strut attachment	 <p>Strut disassembly/re-assembly</p>
ST3127S000 (See J25742-1) Preload Gauge 1. GG91030000 Torque wrench (J25765) 2. HT62940000 (—) Socket adapter (1/2") 3. HT62900000 (—) Socket adapter (3/8")	 <p>Measuring sliding torque of ball joint</p>

Commercial Service Tools

AES00003

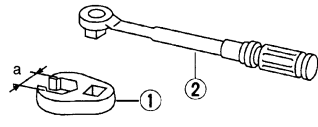
Tool name	Description
1. Flare nut crowfoot a: 10 mm (0.39 in) 2. Torque wrench	 <p>Removing and installing each brake piping</p>

PREPARATION

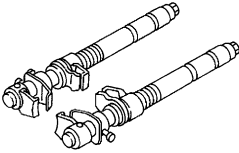
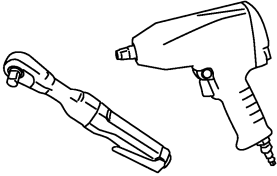
<p>Spring compressor</p>  <p>S-NT717</p>	<p>Removing coil spring</p>
<p>Power tool</p>  <p>PBIC0190E</p>	<ul style="list-style-type: none">● Removing wheel nuts● Removing engine under cover● Removing stabilizer assembly

NOISE, VIBRATION AND HARSHNESS (NVH) TROUBLESHOOTING

NOISE, VIBRATION AND HARSHNESS (NVH) TROUBLESHOOTING

PF0:00003

NVH Troubleshooting Chart

AES00004

Use chart below to help you find the cause of the symptom. If necessary, repair or replace these parts.

		Reference page	Possible cause and SUSPECTED PARTS														
		Refer to FSU-6 .	Refer to FSU-9 .	—	—	—	Refer to FSU-6 .	Refer to FSU-7 .	Refer to FSU-13 .	NVH in PR section	NVH in RFD section.	NVH in RAX and RSU section.	NVH in WT section.	NVH in WT section.	NVH in RAX section.	NVH in BR section.	NVH in PS section.
Symptom	FRONT SUSPENSION	Noise	x	x	x	x	x	x		x	x	x	x	x	x	x	x
		Shake	x	x	x	x		x		x		x	x	x	x	x	x
		Vibration	x	x	x	x	x			x		x	x		x		x
		Shimmy	x	x	x	x			x			x	x	x		x	x
		Judder	x	x	x							x	x	x		x	x
		Poor quality ride or handling	x	x	x	x	x		x	x			x	x	x		

x: Applicable

A
B
C
D
E
FSU
F
G
H
I
J
K
L
M

FRONT SUSPENSION ASSEMBLY

PF5:54010

FRONT SUSPENSION ASSEMBLY

Components

AES0001H

SEC.400·401·406

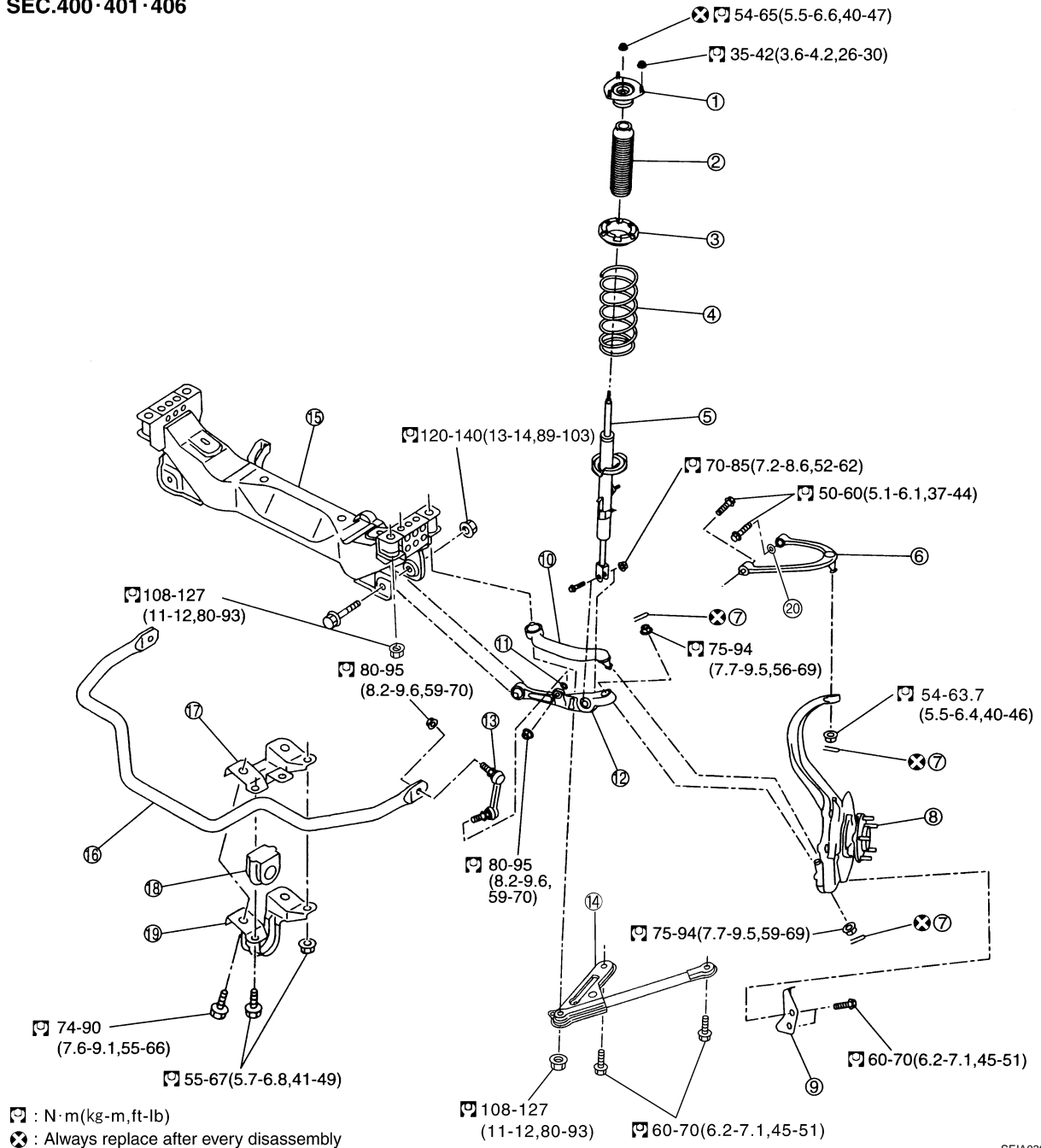

SEIA0393E

- | | | |
|-------------------------------|------------------------------|-----------------------------|
| 1. Mounting insulator | 2. Bound bumper | 3. Spring rubber seat |
| 4. Coil spring | 5. Shock absorber | 6. Upper link |
| 7. Cotter pin | 8. Front axle | 9. Steering stopper bracket |
| 10. Compression rod | 11. Washer | 12. Transverse link |
| 13. Stabilizer connecting rod | 14. Compression rod stay | 15. Front suspension member |
| 16. Stabilizer bar | 17. Stabilizer clamp bracket | 18. Stabilizer bushing |
| 19. Stabilizer clamp | 20. Stopper rubber | |

FRONT SUSPENSION ASSEMBLY

On-Vehicle Inspection and Service

AES0001J

LOOSENESS, BACKLASH AND DAMAGE OF MOUNTING PARTS AND CONNECTIONS

Lift vehicle and inspect the following:

- Check mounting point of each component for looseness, backlash and damage.
- Check lower ball joint end play.
 1. Attach a dial gauge so that the contact rests on the brake caliper.
 2. Set front wheels in a straight-ahead position. Do not depress brake pedal.
 3. Measure axial end play by placing an iron pry bar or something similar between transverse link and steering knuckle.

Axial end play : 0 mm (0 in)

CAUTION:

Be careful not to damage ball joint boot.

4. If axial end play is outside the standard, remove transverse link and check lower ball joint.

Wheel Alignment Inspection DESCRIPTION

AES0001J

- Measure wheel alignment under unladen conditions. "Unladen conditions" means that fuel, coolant, and lubricant are full. Spare tire, jack, hand tools and mats in designated positions.

PRELIMINARY INSPECTION

1. Check tires for improper air pressure and wear.
2. Check road wheels for runout.
3. Check wheel bearing axial end play.
4. Check suspension lower ball joint axial endplay.
5. Check shock absorber operation.
6. Check each mounting point of axle and suspension for looseness and deformation.
7. Check each link and arm for cracks, deformation, and other damage.
8. Check vehicle posture.

INSPECTION OF CAMBER, CASTER AND KINGPIN INCLINATION ANGLES.

- Camber, caster, kingpin inclination angles cannot be adjusted.
- Before inspection, mount front wheels onto turning radius gauge. Mount rear wheels onto a stand that has same height so vehicle will remain horizontal.

Using a CCK Gauge

1. Remove wheel nuts (2), and install a guide bolt (special service tool) to hub bolt.
2. Screw adapter (special service tool) into plate body (special service tool) until it contacts body tightly.
3. Screw center plate (special service tool) into plate body (special service tool).
4. Insert plate (special service tool) on guide bolt (special service tool). Put spring in, and then evenly screw in guide bolt nut (special service tool). When fastening guide bolt nut, do not completely compress spring.

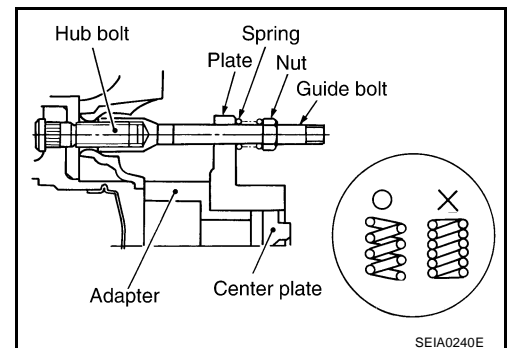

FRONT SUSPENSION ASSEMBLY

5. Place the dent of alignment gauge onto the projection of center plate (special service tool) and tightly contact them to measure.

Camber, caster, king inclination angles:

Refer to [FSU-17, "SERVICE DATA"](#)

CAUTION:

- If camber, caster, is outside the standard, check front suspension parts for wear and damage, and replace suspect parts if necessary.
- King pin inclination angles is reference value, no inspection is required. (Due to the type of suspension, the king-pin inclination angle cannot be measured correctly using a normal alignment tester.)

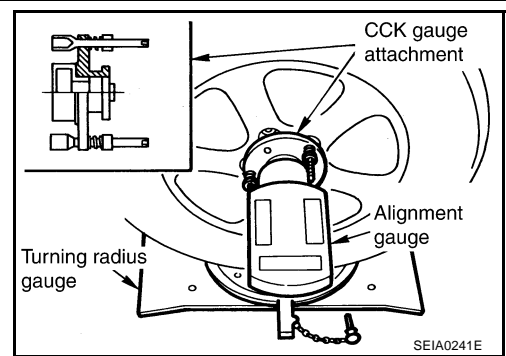

Toe-In Inspection

Measure toe-in using the following procedure.

WARNING:

- Always perform the following procedure on a flat surface.
 - Make sure that no person is in front of vehicle before pushing it.
1. Bounce front of vehicle up and down to stabilize the posture.
 2. Push vehicle straight ahead about 5 m (16 ft).
 3. Put a mark on base line of tread (rear side) of both tires at the same height as hub center. These are measuring points.

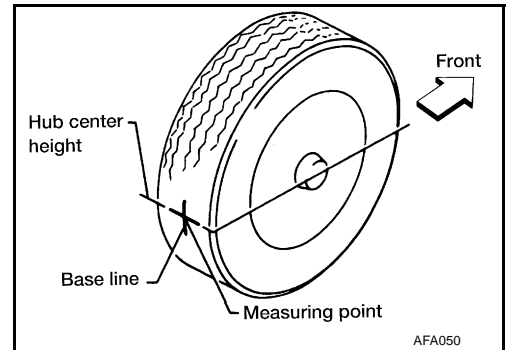

4. Measure distance "A" (rear side).
5. Push vehicle slowly ahead to rotate wheels 180 degrees (1/2 turn).

If wheels have rotated more than 180 degrees (1/2 turn), try the above procedure again from the beginning. Never push vehicle backward.

6. Measure distance "B" (front side).

Total toe-in :Refer to [FSU-17, "SERVICE DATA"](#)

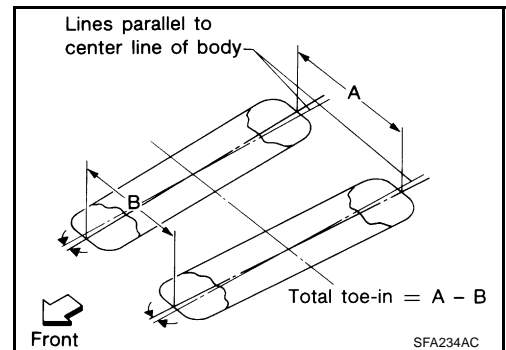

COIL SPRING AND SHOCK ABSORBER

COIL SPRING AND SHOCK ABSORBER

PFP:54302

Removal and Installation

AES0001K

REMOVAL

1. Remove tire with power tool.
2. Remove engine under cover with power tool.
3. Remove electrical wires of ABS wheel sensor from shock absorber.
4. Remove mounting nuts of brake hose.
5. Remove mounting bolts and nuts shock absorber and transverse link.
6. Remove mounting nuts on mounting insulator and remove shock absorber from vehicle.

INSTALLATION

- Refer to [FSU-6, "Components"](#) in "Front Suspension Assembly" for tightening torque. Install in the reverse order of removal.

CAUTION:

Refer to component parts location and do not reuse non-reusable parts.

- Perform final tightening of shock absorber lower side (rubber bushing) under unladen condition with tires on level ground. Check wheel alignment. Refer to [FSU-7, "Wheel Alignment Inspection"](#).

Disassembly and Assembly

AES0001L

DISASSEMBLY

CAUTION:

Make sure piston rod on shock absorber is not damaged when removing components from shock absorber.

1. Install strut attachment (special service tool) to shock absorber and fix it in a vise.

CAUTION:

When installing strut attachment (special service tool) to shock absorber, wrap a shop cloth around shock absorber to protect it from damage.

2. Using a spring compressor (commercial service tool), compress coil spring between spring upper seat and spring lower seat (on shock absorber) until coil spring is free.

CAUTION:

Be sure spring compressor (commercial service tool) is securely attached to coil spring. Compress coil spring.

3. Check that coil spring between spring upper seat and spring lower seat is free and then secure piston rod does not turn, and remove piston rod lock nut.
4. Remove mounting insulator, bound bumper, spring upper seat. Then remove coil spring from shock absorber.
5. Gradually release spring compressor (commercial service tool), and remove coil spring.

CAUTION:

Loosen while making sure coil spring attachment position does not move.

6. Remove strut attachment (special service tool) from shock absorber.

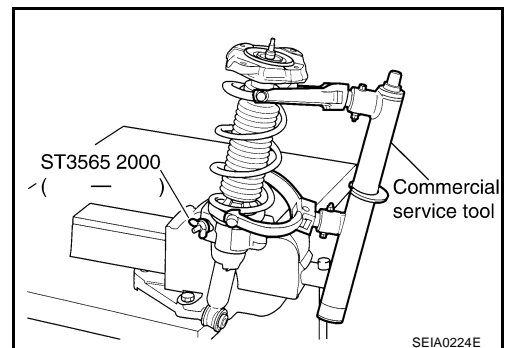

INSPECTION AFTER DISASSEMBLY

Shock Absorber Inspection

- Check shock absorber for deformation, cracks, damage, and replace if necessary.
- Check piston rod for damage, uneven wear, distortion, and replace if necessary.
- Check welded and sealed areas for oil leakage, and replace if necessary.

Mounting Insulator and Rubber Parts Inspection

Check mounting insulator for cracks and rubber parts for wear. Replace them if necessary.

Coil Spring Inspection

Check coil spring for cracks, wear, damage, and replace if necessary.

COIL SPRING AND SHOCK ABSORBER

ASSEMBLY

CAUTION:

Make sure piston rod on shock absorber is not damaged when attaching components to shock absorber.

1. Install strut attachment (special service tool) to shock absorber and fix it in a vise.

CAUTION:

When installing strut attachment (special service tool) to shock absorber, wrap a shop cloth around shock absorber to protect it from damage.

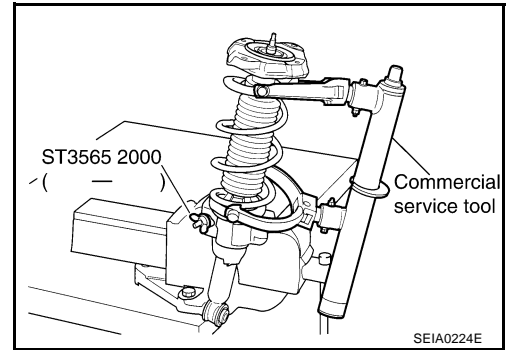

2. Compress coil spring using a spring compressor (commercial service tool), and install it onto shock absorber.

CAUTION:

- Install coil spring as shown in the figure with large diameter side [100 mm (3.94 in)] up and small diameter side 90 mm (3.54 in) down.
- Be sure spring compressor (commercial service tool) is securely attached to coil spring. Compress coil spring.

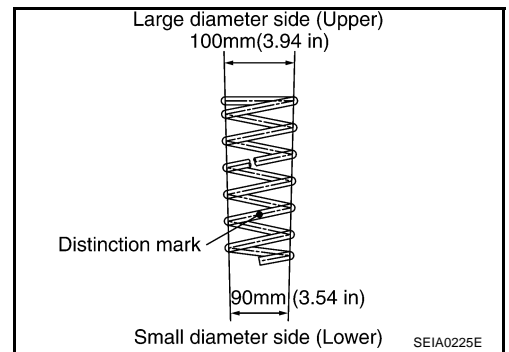

3. Apply soapy water to bound bumper and insert into mounting insulator.

CAUTION:

Do not use machine oil.

4. Attach spring upper seat and mounting insulator as shown in the figure.

CAUTION:

- Make sure coil spring is securely seated in spring mounting groove of spring upper seat.
- The bottom part of spring should be at the position of A point of spring seat.

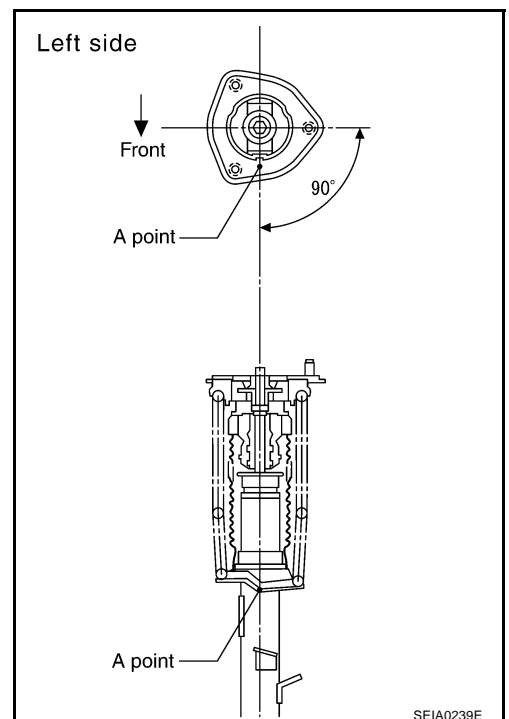

COIL SPRING AND SHOCK ABSORBER

-
5. Secure piston rod tip so that piston rod does not turn, and tighten the specified torque on piston rod lock nut. A
 6. Gradually release spring compressor (commercial service tool), and remove coil spring.
CAUTION:
Loosen while making sure coil spring attachment position does not move. B
 7. Remove strut attachment (special service tool) from shock absorber. C
- D

FSU

F

G

H

I

J

K

L

M

TRANSVERSE LINK

TRANSVERSE LINK

PFP:54500

Removal and Installation

AES0001M

REMOVAL

1. Remove tire with power tool.
2. Remove engine under cover with power tool.
3. Remove mounting nut between steering knuckle and transverse link. Refer to [FAX-5, "FRONT WHEEL HUB AND KNUCKLE"](#) .
4. Remove mounting nuts and washers on lower portion of stabilizer connecting rod with power tool.
5. Remove mounting nut between transverse link and shock absorber.
6. Remove transverse link mounting bolts and nuts, and remove transverse link from suspension member.

INSPECTION AFTER REMOVAL

Visual Inspection

Check transverse link and bushing for deformation, cracks, and other damage. Replace the entire transverse link assembly if cracks, deformation or any other damage is found.

INSTALLATION

- Refer to [FSU-6, "Components"](#) for tightening torque. Install in the reverse order of removal.
CAUTION:
Refer to component parts location and do not reuse non-reusable parts.
- Tighten transverse link mounting bolts with vehicle unladen and all four tires on flat, level ground.
- After installation, check wheel alignment. Refer to [FSU-7, "Wheel Alignment Inspection"](#) .

STABILIZER BAR

STABILIZER BAR

PF:54611

Removal and Installation

AES0002M

REMOVAL

1. Remove tire with power tool.
2. Remove engine under cover with power tool.
3. Remove mounting nuts on upper portion of stabilizer connecting rod with power tool.
4. Remove stabilizer clamp mounting bolts and nuts with power tool.
5. Remove stabilizer bar from vehicle.

INSPECTION AFTER REMOVAL

Check stabilizer bar, connecting rod, bushing and clamp for deformation, cracks and damage, and replace if necessary.

INSTALLATION

- Refer to [FSU-6, "Components"](#) in "Front Suspension Assembly" for tightening torque. Follow the steps below to install.

CAUTION:

Refer to component parts location and do not reuse non-reusable parts.

- Tighten each bolt and nut as shown for tightening stabilizer bracket and clamp. Tightening order is as follows. 1 (fully tighten) → 2 (temporarily tighten) → 3 (temporarily tighten) → 2 (fully tighten) → 3 (fully tighten) → 4, 5 (temporarily tighten) → 4, 5 (fully tighten).

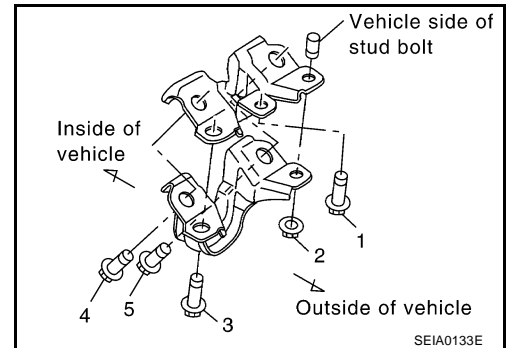

- Stabilizer bar uses pillow ball type connecting rod. Position ball joint with case on pillow ball head parallel to stabilizer bar.

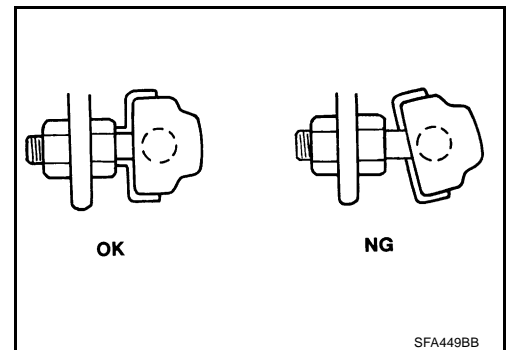

A
B
C
D
FSU
F
G
H
I
J
K
L
M

FRONT SUSPENSION MEMBER

FRONT SUSPENSION MEMBER

PFP:54401

Removal and Installation

AES00010

REMOVAL

1. Remove tire with power tool.
2. Remove engine undercover with power tool.
3. Remove steering tube bracket from suspension member.
4. Remove steering gear mounting bolts from suspension member. Refer to [PS-13, "POWER STEERING GEAR AND LINKAGE"](#) .
5. Remove transverse link from suspension member. Refer to [FSU-12, "TRANSVERSE LINK"](#) .
6. Support engine with a transmission jack.
7. Remove fixing nuts between engine mounting insulator and front suspension member. Refer to [EM-98, "ENGINE ASSEMBLY"](#) .
8. Remove mounting nuts suspension member and body.
9. Slowly lower transmission jack to remove suspension member from vehicle.

INSTALLATION

- Refer to [FSU-6, "Components"](#) for tightening torque in the reverse order of removal.

CAUTION:

Refer to component parts location and do not reuse non-reusable parts.

- After installation, perform final tightening of each part with vehicle in unladen condition and tires on ground. Check wheel alignment and bleed air from steering gear hydraulic pipes. Refer to [FSU-7, "Wheel Alignment Inspection"](#) , [PS-6, "POWER STEERING FLUID"](#) .

UPPER LINK

UPPER LINK

PFP:54524

Removal and Installation

REMOVAL

1. Remove tire with power tool.
2. Remove under cover with power tool.
3. Remove shock absorber.
4. Remove mounting nut and cotter pin between steering knuckle and upper link.
5. Remove upper link from vehicle.

INSPECTION AFTER REMOVAL

Visual Inspection

Check upper link for deformation, cracks, or damage. If any non-standard condition is found, replace it.

Ball Joint Inspection

CAUTION:

Before measurement, move ball joint by hand ten times or more to check for smooth operation of ball joint.

Oscillating Torque Inspection

- Fix upper link, and hook spring scale onto cotter pin mounting hole. Check that spring scale value when ball stud begins moving is within the specified range.

Oscillating torque:

Less than 2.0 N-m (0.20 kg-m, 18 in-lb)

Measured value of spring scale:

Less than 34.8 N (3.5 kg, 7.8 lb)

- If it is outside the specified range, replace upper link.

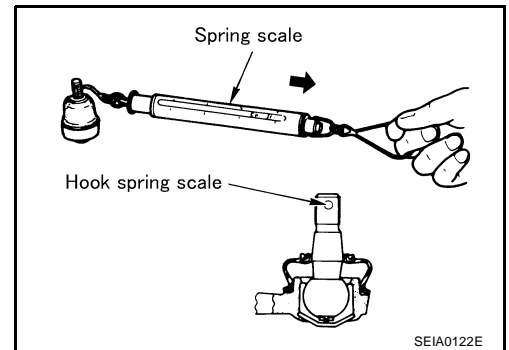

Sliding Torque Inspection

- Temporarily tighten mounting nut to ball joint. Using a preload gauge (special service tool), check that the sliding torque is within the specified range.

Sliding torque:

Less than 2.0 N-m (0.20 kg-m, 18 in-lb)

- If it is outside the specified range, replace upper link.

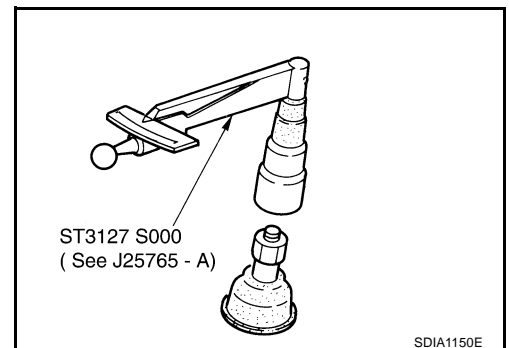

Axial End Play Inspection

- Move tip of ball joint in axial direction to check for looseness.

Axial end play : 0 mm (0 in)

INSTALLATION

- Refer to [FSU-6, "Components"](#) for tightening torque. Install in the reverse order of removal.

CAUTION:

Refer to component parts location and do not reuse non-reusable parts.

- Perform final tightening of front suspension member installation position (rubber bushing) under unladen condition with tires on level ground. Check wheel alignment. Refer to [FSU-7, "Wheel Alignment Inspection"](#).

COMPRESSION ROD

PFP:54468

COMPRESSION ROD

Removal and Installation REMOVAL

AES0002D

1. Remove tires with power tool.
2. Remove engine under cover with power tool.
3. Remove mounting nut and cotter pin between compression rod and steering knuckle assembly.
4. Remove mounting nut between compression rod and body.
5. Remove compression rod and compression rod stay from vehicle.

INSPECTION AFTER REMOVAL

Visual Inspection

Check compression rod for deformation, cracks, or damage. If any non-standard condition is found, replace it.

Ball Joint Inspection

CAUTION:

Before measurement, move ball joint by hand ten times or more to check for smooth operation of ball joint.

Oscillating Torque Inspection

- Fix compression rod, and hook spring scale onto cotter pin mounting hole. Check that spring scale value when ball stud begins moving is within the specified range.

Oscillating torque:

0.147 - 2.45 N·m (0.02 - 0.24 kg·m, 2 - 21 in·lb)

Measured value of spring scale:

2.37 - 39.5 N (0.24 - 4.03 kg, 0.53 - 8.88 lb)

- If it is outside the specified range, replace compression rod.

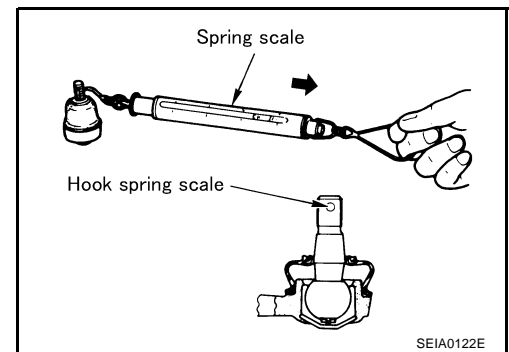

Sliding Torque Inspection

- Temporarily tighten mounting nut to ball joint. Using a preload gauge (special service tool), check that the sliding torque is within the specified range.

Sliding torque:

0.147 - 2.45 N·m (0.02 - 0.24 kg·m, 2 - 21 in·lb)

- If it is outside the specified range, replace compression rod.

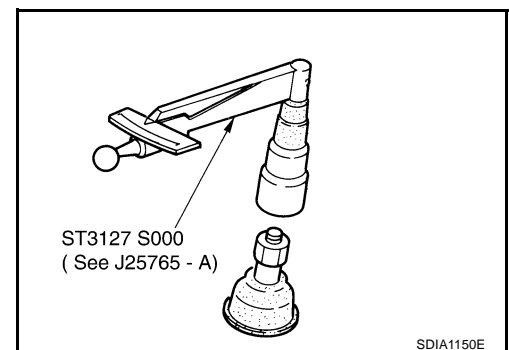

Axial End Play Inspection

- Move tip of ball joint in axial direction to check for looseness.

Axial end play : 0 mm (0 in)

INSTALLATION

- Refer to [FSU-6, "Components"](#) for tightening torque. Install in the reverse order of removal.

CAUTION:

Refer to component parts location and do not reuse non-reusable parts.

- Perform final tightening of front suspension member installation position (rubber bushing) under unladen condition with tires on level ground. Check wheel alignment. Refer to [FSU-7, "Wheel Alignment Inspection"](#).

SERVICE DATA

SERVICE DATA

PFP:00030

Wheel Alignment (Unladen)

AES00009

Camber Degree minute (Decimal degree)	Minimum	- 0°50' (- 0.83°)
	Nominal	- 0°05' (- 0.08°)
	Maximum	0°40' (0.67°)
	Left and right difference	45' (0.75°)
Caster Degree minute (Decimal degree)	Minimum	7°00' (7.00°)
	Nominal	7°45' (7.75°)
	Maximum	8°30' (8.50°)
	Left and right difference	45' (0.75°)
Kingpin offset Degree minute (Decimal degree)	Minimum	3°45' (3.75°)
	Nominal	4°30' (4.50°)
	Maximum	5°15' (5.25°)
Total toe-in Distance (A - B)	Minimum	0 mm (0 in)
	Nominal	1 mm (0.04 in)
	Maximum	2 mm (0.08 in)

Ball Joint

AES0000A

Oscillating torque	Less than 2.0 N·m (0.20 kg·m, 18 in·lb) (Upper link) 0.147 - 2.45 N·m (0.02 - 0.24 kg·m, 2 - 21 in·lb) (Compression rod)
Measurement on spring balance (cotter pinhole position)	Less than 34.8 N (3.5 kg, 7.8 lb) (Upper link) 2.37 - 39.5 N (0.24 - 4.03 kg, 0.53 - 8.88 lb) (Compression rod)
Sliding torque	Less than 2.0 N·m (0.20 kg·m, 18 in·lb) (Upper link) 0.147 - 2.45 N·m (0.02 - 0.24 kg·m, 2 - 21 in·lb) (Compression rod)
Axial end play	0 mm (0 in)

Wheelarch Height (Unladen*)

AES0000B

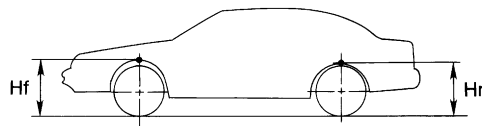

SFA818A

Applied model	205/65R16	215/55R17
Front (Hf)	711 mm (27.99 in)	711 mm (27.99 in)
Rear (Hr)	703 mm (27.68 in)	704 mm (27.72 in)

*: Fuel, radiator coolant and engine oil full. Spare tire, jack, hand tools and mats in designated positions.

SERVICE DATA
