

A
B
C
D
E
F
G
H
I
J
L
M

WW

SECTION

WIPER, WASHER & HORN

CONTENTS

<p>PRECAUTION 3</p> <p>Precautions for Supplemental Restraint System (SRS) "AIR BAG" and "SEAT BELT PRE-TENSIONER" 3</p> <p>Wiring Diagrams and Trouble Diagnosis 3</p> <p>FRONT WIPER AND WASHER SYSTEM 4</p> <p>Components Parts and Harness Connector Location 4</p> <p>System Description 4</p> <p> LOW SPEED WIPER OPERATION 4</p> <p> HI SPEED WIPER OPERATION 5</p> <p> INTERMITTENT OPERATION 5</p> <p> AUTO STOP OPERATION 6</p> <p> WASHER OPERATION 6</p> <p> MIST OPERATION 6</p> <p> FAIL-SAFE FUNCTION 6</p> <p> BCM WIPER SWITCH READING FUNCTION 7</p> <p>CAN Communication System Description 10</p> <p>CAN Communication Unit 10</p> <p> TYPE 1/TYPE 3 10</p> <p> TYPE 2 12</p> <p>Schematic 14</p> <p>Wiring Diagram — WIPER — 15</p> <p>Terminals and Reference Values for BCM 18</p> <p>Terminals and Reference Values for IPDM E/R 18</p> <p>How to Proceed With Trouble Diagnosis 18</p> <p>Preliminary Inspection 19</p> <p> CHECK POWER SUPPLY AND GROUND CIRCUIT 19</p> <p>CONSULT-II Functions 20</p> <p> CONSULT-II OPERATION 20</p> <p> DATA MONITOR 21</p> <p> ACTIVE TEST 21</p> <p>Front Wiper Does Not Operate 21</p> <p>Front Wiper Stop Position Is Incorrect 23</p> <p>Only Front Wiper Low Does Not Operate 24</p> <p>Only Front Wiper Hi Does Not Operate 26</p> <p>Only Front Wiper Intermittent Does Not Operate ... 27</p> <p>Front Wiper Intermittent Operation Switch Position</p>	<p>Cannot Be Adjusted 27</p> <p>Wipers Do Not Wipe When Front Washer Operates.. 28</p> <p>Removal and Installation for Front Wiper Arms, Adjustment for Wiper Arms Stop Location 29</p> <p> REMOVAL 29</p> <p> INSTALLATION 29</p> <p> ADJUSTMENT 29</p> <p>Removal and Installation of Front Wiper Motor Assembly 29</p> <p> REMOVAL 29</p> <p> INSTALLATION 29</p> <p>Disassembly and Assembly Front Wiper Motor Assembly 30</p> <p> DISASSEMBLY 30</p> <p> ASSEMBLY 30</p> <p>Washer Nozzle Adjustment 31</p> <p>Washer Tube Layout 32</p> <p>Removal and Installation for Front Washer Nozzle.. 32</p> <p>Removal and Installation for Front Washer Joint ... 32</p> <p>Inspection for Washer Nozzle 32</p> <p> CHECK VALVE INSPECTION 32</p> <p>Removal and Installation for Front Wiper and Washer Switch 32</p> <p>Removal and Installation for Washer Tank 33</p> <p> REMOVAL 33</p> <p> INSTALLATION 33</p> <p>Removal and Installation for Washer Pump 33</p> <p> REMOVAL 33</p> <p> INSTALLATION 34</p> <p>CIGARETTE LIGHTER 35</p> <p> Wiring Diagram — CIGAR — 35</p> <p> Removal and Installation 36</p> <p>POWER SOCKET 37</p> <p> Wiring Diagram — P/SCKT — 37</p> <p> Removal and Installation for Console Power Socket.. 38</p> <p> REMOVAL 38</p> <p> INSTALLTION 38</p> <p>HORN 39</p>
---	--

Wiring Diagram — HORN —	39
Removal and Installation	40
REMOVAL	40
INSTALLATION	40

PRECAUTION

PRECAUTION

PPF:00011

Precautions for Supplemental Restraint System (SRS) “AIR BAG” and “SEAT BELT PRE-TENSIONER”

AKS008YI

The Supplemental Restraint System such as “AIR BAG” and “SEAT BELT PRE-TENSIONER”, used along with a front seat belt, helps to reduce the risk or severity of injury to the driver and front passenger for certain types of collision. This system includes seat belt switch inputs and dual stage front air bag modules. The SRS system uses the seat belt switches to determine the front air bag deployment, and may only deploy one front air bag, depending on the severity of a collision and whether the front occupants are belted or unbelted. Information necessary to service the system safely is included in the SRS and SB section of this Service Manual.

WARNING:

- To avoid rendering the SRS inoperative, which could increase the risk of personal injury or death in the event of a collision which would result in air bag inflation, all maintenance must be performed by an authorized NISSAN/INFINITI dealer.
- Improper maintenance, including incorrect removal and installation of the SRS, can lead to personal injury caused by unintentional activation of the system. For removal of Spiral Cable and Air Bag Module, see the SRS section.
- Do not use electrical test equipment on any circuit related to the SRS unless instructed to in this Service Manual. SRS wiring harnesses can be identified by yellow and/or orange harnesses or harness connectors.

Wiring Diagrams and Trouble Diagnosis

AKS000AG

When You Read Wiring Diagrams, Refer to the Following:

- Refer to [GI-14, "How to Read Wiring Diagrams"](#) .
- Refer to [PG-3, "POWER SUPPLY ROUTING CIRCUIT"](#) for power distribution circuit.

When You Perform Trouble Diagnosis, Refer to the Following:

- Refer to [GI-10, "How to Follow Trouble Diagnoses"](#) .
- Refer to [GI-26, "How to Perform Efficient Diagnosis for an Electrical Incident"](#) .

A
B
C
D
E
F
G
H
I
J
L
M

WW

FRONT WIPER AND WASHER SYSTEM

FRONT WIPER AND WASHER SYSTEM

PFP:28810

Components Parts and Harness Connector Location

AKS004T5

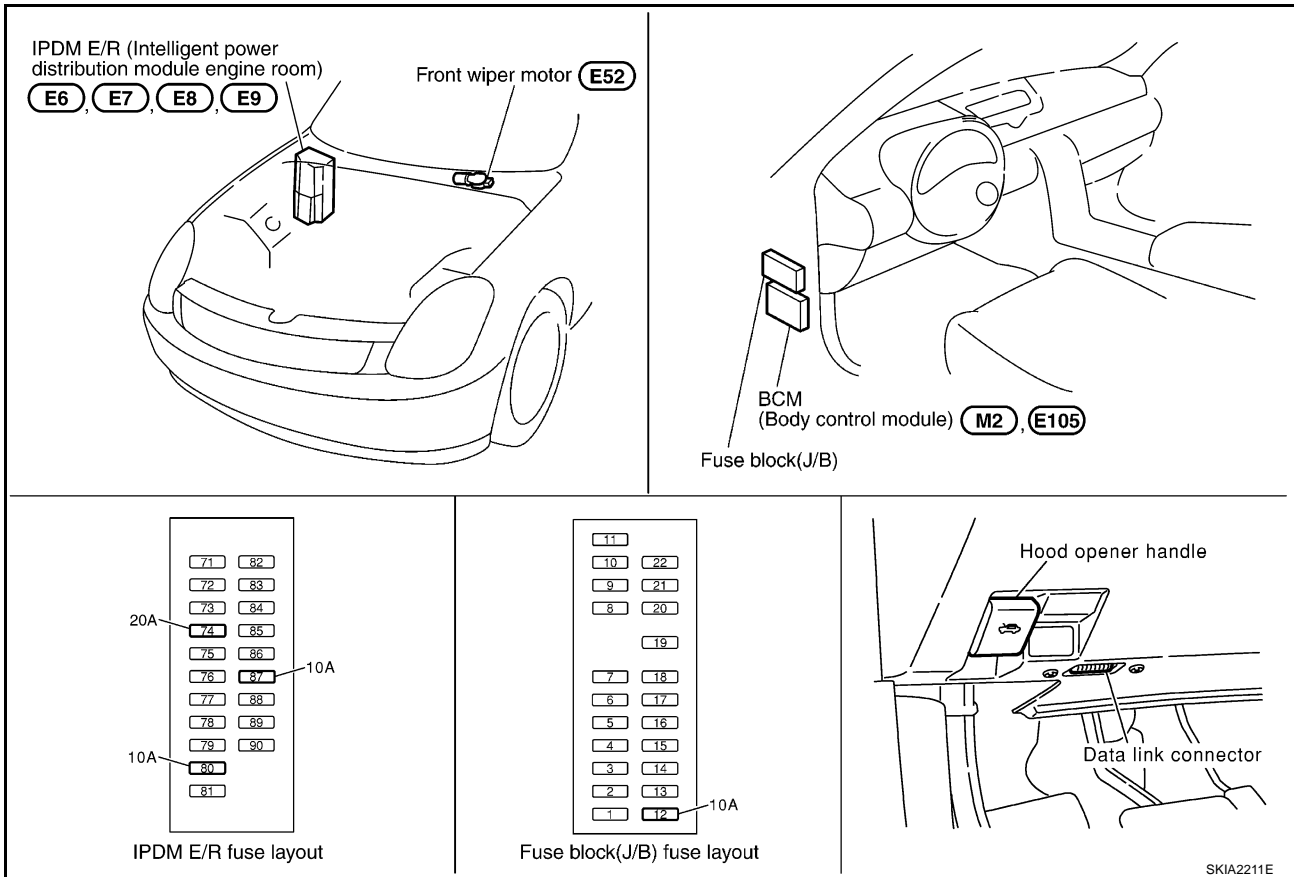

System Description

AKS004T6

- All front wiper relays (HI, LO) are included in IPDM E/R (intelligent power distribution module engine room).
- Wiper switch (combination switch) is composed of a combination of 5 output terminals and 5 input terminals. Terminal combination status is read by BCM (body control module) when switch is turned ON.
- BCM (body control module) controls front wiper LO, HI, and INT (intermittent) operation.
- IPDM E/R (intelligent power distribution module engine room) operates wiper motor according to CAN communication signals from BCM.

LOW SPEED WIPER OPERATION

Power is supplied at all times

- from BCM (input 1) terminal 48
- to combination switch terminal 17
- to 20A fuse (No. 74, located in IPDM E/R) and
- through IPDM E/R terminal 42
- to wiper motor terminal 4.

When the ignition switch is in the ON or START position, and front wiper switch is turned to LO position, front wiper LO contact in combination switch comes ON, and Power is supplied

- through combination switch terminal 10
- to BCM (output 3) terminal 41.

When BCM determines that wiper switch is in LO position, it uses CAN communications and Front wiper request signal (LO) is sent

- from BCM terminals 70 and 71
- to IPDM E/R terminals 48 and 49.

FRONT WIPER AND WASHER SYSTEM

When IPDM E/R receives front wiper request signal (LO), it turns ON front wiper LO relay (in IPDM E/R).
Ground is supplied

- from wiper motor terminal 3,
- through IPDM E/R terminal 31 and front wiper HI and LO relays
- to IPDM E/R terminal 14
- through grounds E17 and E43.

With power and ground supplied, the front wiper motor operates at low speed.

HI SPEED WIPER OPERATION

Power is supplied at all times

- from BCM (input 2) terminal 49
- to combination switch terminal 2
- to 20A fuse (No. 74, located in IPDM E/R) and
- through IPDM E/R terminal 42
- to wiper motor terminal 4.

When the ignition switch is the ON or START position, and the front wiper switch is turned to HI position, front wiper HI contact in combination switch comes ON, and

Power is supplied

- through combination switch terminal 6
- to BCM (output 1) terminal 47.

When BCM determines that wiper switch is in HI position, it uses CAN communications and Front wiper request signal (HI) is sent to IPDM E/R

- from BCM terminals 70 and 71
- to IPDM E/R terminals 48 and 49.

When the IPDM E/R receives front wiper request signal (HI), it turns ON front wiper LO relay and front wiper HI relay. (in IPDM E/R),

Ground is supplied

- to front wiper motor terminal 2
- through IPDM E/R terminal 30 and front wiper HI relay and front wiper LO relay
- to IPDM E/R terminal 14
- through grounds E17 and E43.

With power and ground supplied, the front wiper motor operates at high speed.

INTERMITTENT OPERATION

Power is supplied at all times

- from BCM (input 2) terminal 49
- to combination switch terminal 2.

When the ignition switch is in ON or START position, and the front wiper switch is turned to INT position, the front wiper INT contact in the combination switch comes ON, and power is supplied

- from combination switch terminal 10
- to BCM (output 3) terminal 41.

When BCM determines that combination switch status is front wiper INT ON, it performs the following operations.

- When BCM detects ON/OFF status of intermittent operation dial positions 1, 2, and 3 (in same way as wiper INT), it determines wiper dial position status.
- BCM calculates operation interval from wiper dial position and vehicle speed signal received from combination meter through CAN communications.
- BCM sends front wiper request signal (INT) to IPDM E/R at calculated operation interval.

When IPDM E/R receives front wiper request signal (INT), it turns ON internal front wiper relay. It then sends auto-stop signal to BCM, and conducts intermittent front wiper motor operation.

A

B

C

D

E

F

G

H

I

J

WW

L

M

FRONT WIPER AND WASHER SYSTEM

AUTO STOP OPERATION

With wiper switch turned OFF, wiper motor will continue to operate until wiper arms reach windshield base. When wiper arms are not located at base of windshield with wiper switch OFF, ground is provided

- from IPDM E/R terminal 31
- to front wiper motor terminal 3, in order to continue wiper motor operation at low speed.

Ground is also supplied

- through IPDM E/R terminal 38
- to front wiper motor terminal 1
- through front wiper motor terminal 5, and
- through grounds E17 and E43.

When wiper arms reach base of windshield, front wiper motor terminals 1 and 4 are connected instead of terminals 1 and 5.

Then the IPDM E/R sends auto stop operation signal to BCM with CAN communication line.

When BCM receives auto-stop operation signal, BCM sends wiper stop signal to IPDM E/R with CAN communication line.

IPDM E/R stops wiper motor. Wiper motor will then stop wiper arms at the STOP position.

WASHER OPERATION

When the ignition switch is in ON or START position, power is supplied

- from BCM (input 1) terminal 48
- to combination switch terminal 1
- through 10A fuse (No. 87 located in IPDM E/R)
- through IPDM E/R terminal 18
- to washer motor terminal 2.

When front wiper switch is turned to washer position,

Ground is supplied

- to washer motor terminal 1
- through combination switch terminal 11
- through combination switch terminal 12
- from grounds M30 and M66.

With ground supplied, the front washer motor is operated, and at the same time,

Power is supplied

- through combination switch terminal 7
- to BCM (output 2) terminal 40.

When BCM detects that front washer motor has operated for 0.4 seconds or longer, BCM uses CAN communication and sends wiper request signal to IPDM E/R for low speed operation of wipers.

When BCM detects that washer switch is OFF, low speed operation cycles approximately 3 times and then stops.

MIST OPERATION

When the wiper switch is turned to the mist position, wiper low speed operation cycles once and then stops.

For additional information about wiper operation under this condition, refer to [WW-4, "LOW SPEED WIPER OPERATION"](#).

If the switch is held in the mist position, low speed operation continues.

FAIL-SAFE FUNCTION

IPDM E/R includes a fail-safe function to prevent malfunction of electrical components controlled by CAN communications in CAN communications occurs.

When fail-safe status is initiated, IPDM E/R remains in steady unit signals are received.

FRONT WIPER AND WASHER SYSTEM

BCM WIPER SWITCH READING FUNCTION

BCM reads combination switch (wiper switch) status, and controls front wipers based on the results. BCM is a combination of 5 output terminals (OUTPUT 1 - 5) and 5 input terminals (INPUT 1 - 5). It reads 20 types of switch data and 5 types of diagnosis data.

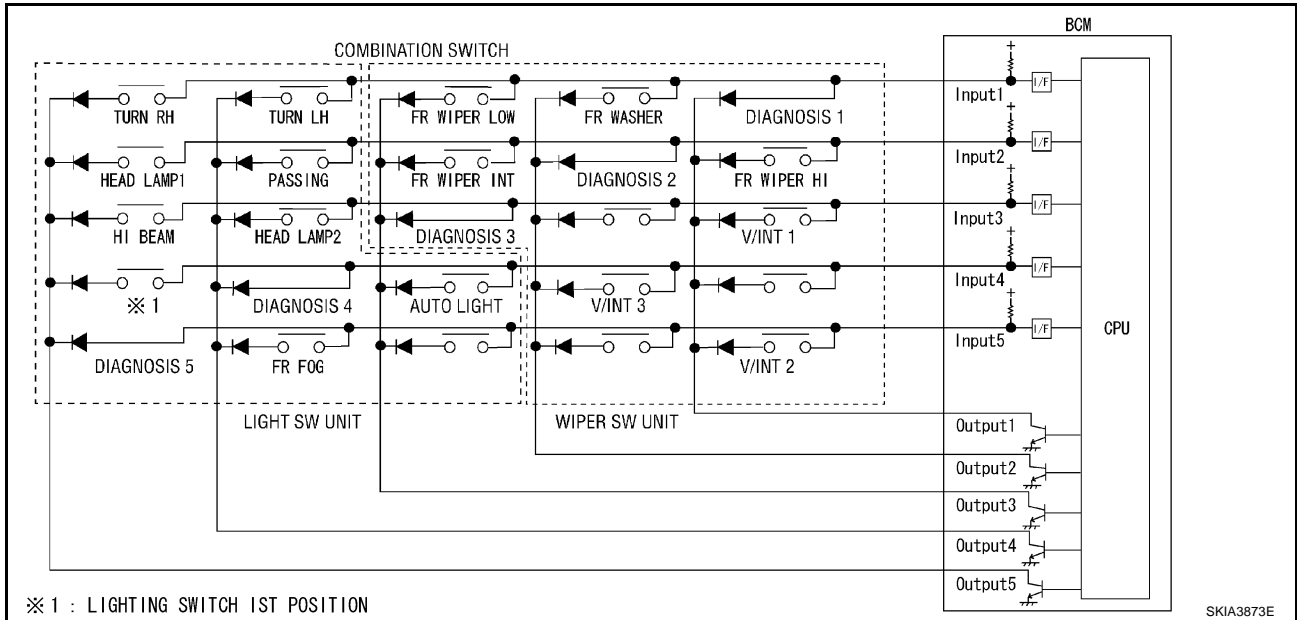

OPERATION DESCRIPTION

BCM continuously outputs power voltage from input terminals (INPUT 1 - 5). At this time, output terminals (OUTPUT 1 - 5) operate transistors in sequence and carry current. If any switch (or switches) becomes ON at this time, the input terminal corresponding to that switch detects current flowing, and BCM determines that the switch is ON.

TABLE OF BCM - COMBINATION SWITCH OPERATIONS

BCM reads operation status of combination switch using combinations shown in table below.

	COMB SW INPUT 1		COMB SW INPUT 2		COMB SW INPUT 3		COMB SW INPUT 4		COMB SW INPUT 5	
	ON	OFF	ON	OFF	ON	OFF	ON	OFF	ON	OFF
COMB SW OUTPUT 1	DIAGNOSIS 1 OK	DIAGNOSIS 1 NG	FR WIPER HI ON	FR WIPER HI OFF	V/INT 1 ON	V/INT 1 OFF	—	—	V/INT 2 ON	V/INT 2 OFF
COMB SW OUTPUT 2	FR WASHER ON	FR WASHER OFF	DIAGNOSIS 2 OK	DIAGNOSIS 2 NG	—	—	V/INT 3 ON	V/INT 3 OFF	—	—
COMB SW OUTPUT 3	FR WIPER LOW ON	FR WIPER LOW OFF	FR WIPER INT ON	FR WIPER INT OFF	DIAGNOSIS 3 OK	DIAGNOSIS 3 NG	AUTO LIGHT ON	AUTO LIGHT OFF	—	—
COMB SW OUTPUT 4	TURN LH ON	TURN LH OFF	PASSING ON	PASSING OFF	HEAD LAMP 2 ON	HEAD LAMP 2 OFF	DIAGNOSIS 4 OK	DIAGNOSIS 4 NG	FR FOG ON	FR FOG OFF
COMB SW OUTPUT 5	TURN RH ON	TURN RH OFF	HEAD LAMP ON	HEAD LAMP OFF	HI BEAM ON	HI BEAM OFF	LIGHTING SWITCH 1ST POSITION ON	LIGHTING SWITCH 1ST POSITION OFF	DIAGNOSIS 5 OK	DIAGNOSIS 5 NG

SKIA2101E

FRONT WIPER AND WASHER SYSTEM

SAMPLE OPERATION: (WIPER SWITCH TURNED TO LO POSITION)

- When wiper switch is turned to LO position, front wiper LO contact inside combination switch becomes ON. At this time, OUTPUT 3 transistor operates and BCM detects flow of current at INPUT 1.
- When OUTPUT 3 transistor is ON and BCM detects current flowing at INPUT 1, BCM determines that wiper switch is at LO. BCM uses CAN communication and sends front wiper signals to IPDM E/R.
- When OUTPUT 3 transistor operates again and BCM again detects current flowing at INPUT 1, it confirms that front wiper LO operation is continuing.

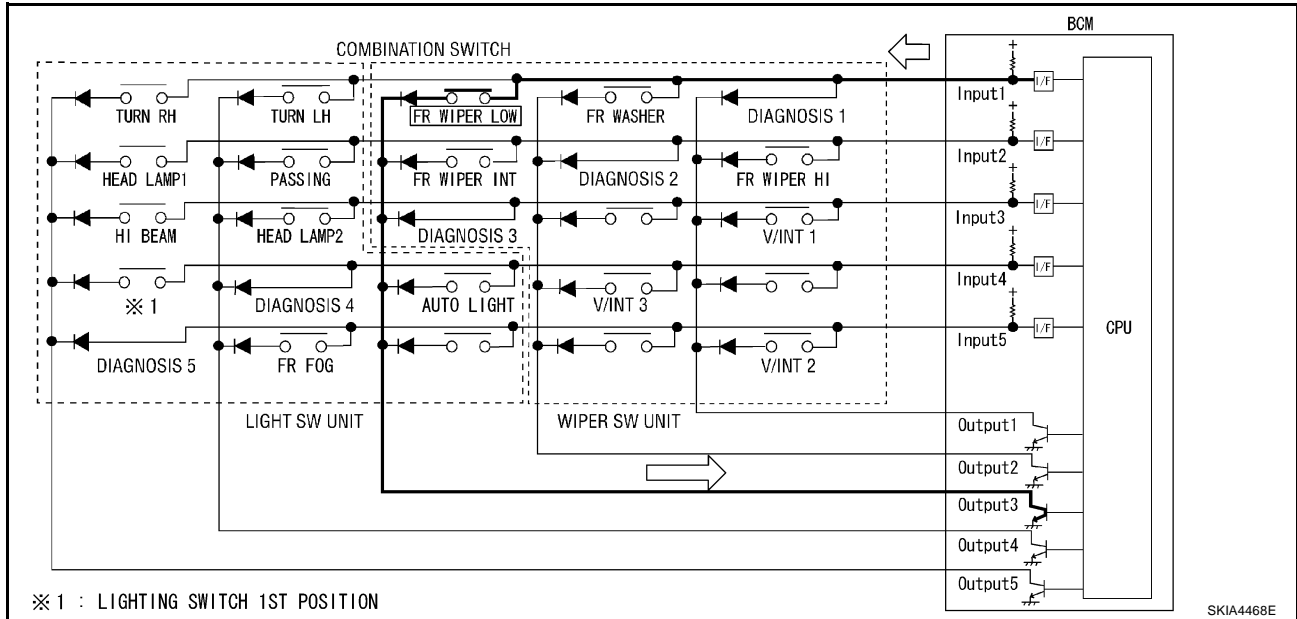

NOTE:

Each OUTPUT terminal transistor operates at 10 ms intervals. Therefore, a delay occurs between the switch becoming ON and operation of the electric load. However, this delay is so small it is undetectable.

OPERATING MODES

The following operation modes exist for combination switch reading function.

Normal Status

When BCM is not in sleep status, OUTPUT terminals (1 - 5) each turn ON-OFF every 10 ms.

Sleep Status

When BCM is in sleep status, output from OUTPUT 1 and 2 transistors stops, with BCM entering a power-saving mode. OUTPUT (3 - 5) turns ON-OFF every 60 ms, and only input from lighting switch system is accepted.

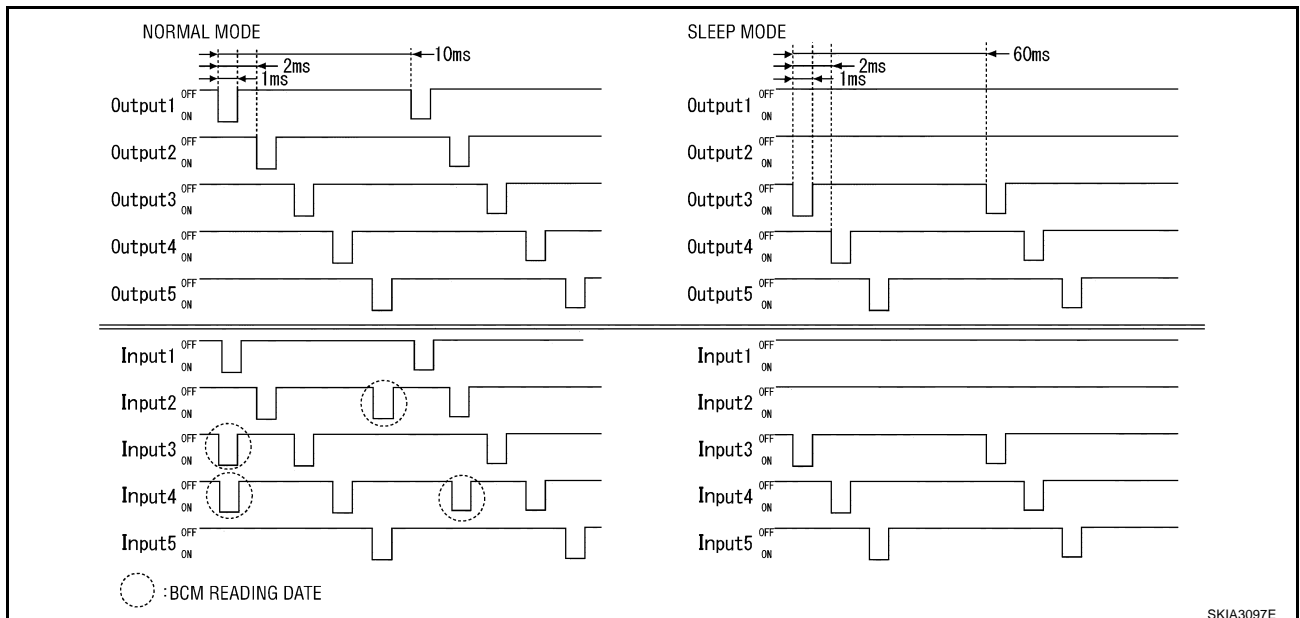

FRONT WIPER AND WASHER SYSTEM

INTERMITTENT OPERATION

Wiper intermittent operation delay interval is determined from a combination of 3 switches (intermittent operation dial position 1, intermittent operation dial position 2, and intermittent operation dial position 3) and vehicle speed signal.

During each intermittent operation delay interval, BCM sends front wiper request signal to IPDM E/R.

Wiper Dial Position Setting

Wiper dial position	Intermittent operation interval	Combination switch		
		Intermittent operation dial position 1	Intermittent operation dial position 2	Intermittent operation dial position 3
Wiper dial position 1	Small	ON	ON	ON
Wiper dial position 2		ON	ON	OFF
Wiper dial position 3		ON	OFF	OFF
Wiper dial position 4	↓	OFF	OFF	OFF
Wiper dial position 5		OFF	OFF	ON
Wiper dial position 6		OFF	ON	ON
Wiper dial position 7		Large	OFF	ON

Example: For wiper dial position 1...

Using combination switch reading function, BCM detects ON/OFF status of intermittent operation dial positions 1, 2, and 3.

When combination switch status is as listed below, BCM determines that it is wiper dial position 1.

- Intermittent operation dial position 1: ON (input 3 and output 1 are conducting.)
- Intermittent operation dial position 2: ON (input 5 and output 1 are conducting.)
- Intermittent operation dial position 3: ON (input 4 and output 2 are conducting.)

BCM determines front wiper intermittent operation delay interval from wiper dial position 1 and vehicle speed, and sends wiper request signal (INT) to IPDM E/R.

A

B

C

D

E

F

G

H

I

J

WW

L

M

FRONT WIPER AND WASHER SYSTEM

CAN Communication System Description

AKS005L7

CAN (Controller Area Network) is a serial communication line for real time application. It is an on-vehicle multiplex communication line with high data communication speed and excellent error detection ability. Many electronic control units are equipped onto a vehicle, and each control unit shares information and links with other control units during operation (not independent). In CAN communication, control units are connected with 2 communication lines (CAN H line, CAN L line) allowing a high rate of information transmission with less wiring. Each control unit transmits/receives data but selectively reads required data only.

CAN Communication Unit

AKS0093Q

Body type	Sedan	
Axle	2WD	
Engine	VQ35DE	
Transmission	A/T	
	Up to serial 329287*	From serial 329288*
Brake control	M/T	
CAN communication unit		
ECM	×	×
TCM	×	
Data link connector	×	×
Combination meter	×	×
BCM	×	×
Steering angle sensor	×	×
VDC/TCS/ABS control unit	×	×
IPDM E/R	×	×
CAN communication type	WW-10. "TYPE 1/TYPE 3"	WW-12. "TYPE 2"

×: Applicable

*:For further information, refer to [GI-47. "IDENTIFICATION NUMBER"](#) .

TYPE 1/TYPE 3

System Diagram

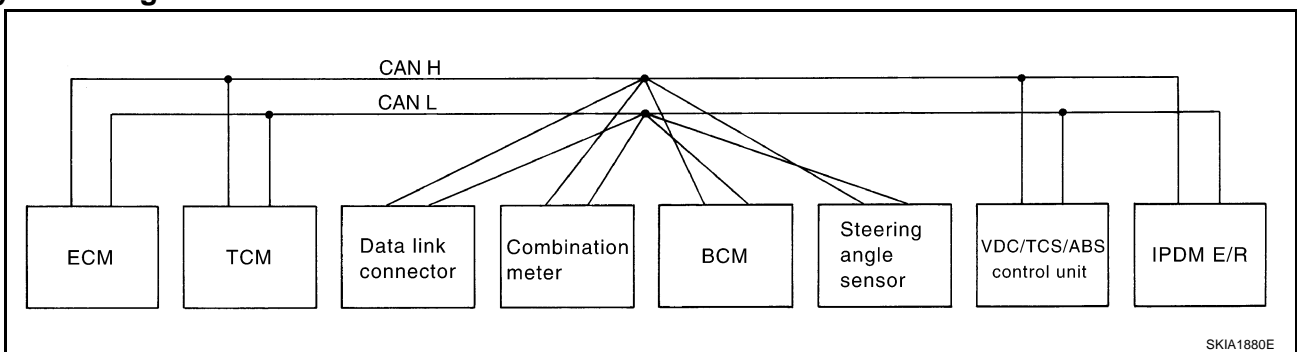

SKIA1880E

Input/Output Signal Chart

T: Transmit R: Receive

Signals	ECM	TCM	Combina- tion meter	BCM	Steering angle sensor	VDC/TCS/ ABS con- trol unit	IPDM E/R
Engine torque signal	T	R					
Engine speed signal	T	R	R			R	
Engine coolant temperature signal	T	R	R				
Accelerator pedal position signal	T	R				R	
Closed throttle position signal	T	R					

FRONT WIPER AND WASHER SYSTEM

Signals	ECM	TCM	Combina- tion meter	BCM	Steering angle sensor	VDC/TCS/ ABS con- trol unit	IPDM E/R	A
Wide open throttle position signal	T	R						B
Battery voltage signal	T	R						C
Stop lamp switch signal		R	T					D
Fuel consumption monitor signal	T		R					E
A/T self-diagnosis signal	R	T						F
A/T CHECK indicator lamp signal		T	R					G
A/T position indicator signal		T	R			R		H
ABS operation signal		R				T		I
A/T shift schedule change demand signal		R				T		J
A/C switch signal	R			T				
A/C compressor request signal	T						R	
A/C compressor feedback signal	T		R					
Blower fan motor switch signal	R			T				
Cooling fan motor operation signal	T						R	
Position lights request signal			R	T			R	
Low beam request signal				T			R	
Low beam status signal	R						T	
High beam request signal			R	T			R	
High beam status signal	R						T	
Front fog lights request signal				T			R	
Vehicle speed signal	R	R	R	R		T		
Sleep request 1 signal			R	T				
Sleep request 2 signal				T			R	
Wake up request 1 signal			R	T			R	
Wake up request 2 signal			R	T			R	
Door switch signal (without naviga- tion system)			R	T			R	
Door switch signal (with navigation system)			T	R				
Turn indicator signal			R	T				
Seat belt buckle switch signal			T	R				
Oil pressure switch signal			R				T	
Buzzer output signal			R	T				
ASCD SET lamp signal	T		R					
ASCD CRUISE lamp signal	T		R					
ASCD OD cancel request signal	T	R						
ASCD operation signal	T	R						
Output shaft revolution signal	R	T						
Front wiper request signal				T			R	
Front wiper stop position signal				R			T	
Rear window defogger switch signal				T			R	

FRONT WIPER AND WASHER SYSTEM

Signals	ECM	TCM	Combina- tion meter	BCM	Steering angle sensor	VDC/TCS/ ABS con- trol unit	IPDM E/R
Rear window defogger control signal	R						T
Manual mode signal		R	T				
Not manual mode signal		R	T				
Manual mode shift up signal		R	T				
Manual mode shift down signal		R	T				
Manual mode indicator signal		T	R				
Hood switch signal				R			T
Theft warning horn request signal				T			R
Horn chirp signal				T			R
Steering angle sensor signal					T	R	
Malfunction indicator lamp signal (Type 3 only: From serial 329288*)	T		R				
Fuel level sensor signal (Type 3 only: From serial 329288*)	R		T				
Turbine revolution signal (Type 3 only: From serial 329288*)	R	T					

*:For further information, refer to [GI-47, "IDENTIFICATION NUMBER"](#).

TYPE 2

System Diagram

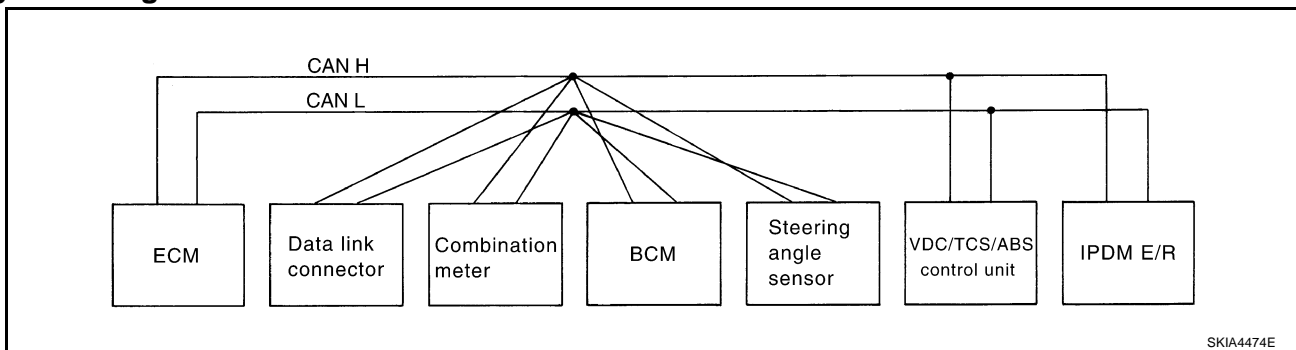

Input/Output Signal Chart

T: Transmit R: Receive

Signals	ECM	Combina- tion meter	BCM	Steering angle sen- sor	VDC/TCS/ ABS con- trol unit	IPDM E/R
Engine speed signal	T	R			R	
Engine coolant temperature signal	T	R				
Accelerator pedal position signal	T				R	
Fuel consumption monitor signal	T	R				
A/C switch signal	R		T			
A/C compressor request signal	T					R
A/C compressor feedback signal	T	R				
Blower fan motor switch signal	R		T			
Cooling fan motor operation signal	T					R
Position lights request signal		R	T			R
Low beam request signal			T			R
Low beam status signal	R		R			T

FRONT WIPER AND WASHER SYSTEM

Signals	ECM	Combina- tion meter	BCM	Steering angle sen- sor	VDC/TCS/ ABS con- trol unit	IPDM E/R	
High beam request signal		R	T			R	A
High beam status signal	R		R			T	B
Front fog lights request signal			T			R	
Vehicle speed signal		R			T		C
	R	T	R				
Sleep request 1 signal		R	T				
Sleep request 2 signal			T			R	D
Wake up request 1 signal		R	T				
Wake up request 2 signal		R	T				
Door switch signal (without navigation system)		R	T			R	E
Door switch signal (with navigation system)		T	R				
Turn indicator signal		R	T				F
Seat belt buckle switch signal		T	R				
Oil pressure switch signal		R				T	
Buzzer output signal		R	T				G
Malfunction indicator lamp signal	T	R					
ASCD SET lamp signal	T	R					H
ASCD CRUISE lamp signal	T	R					
Fuel level sensor signal	R	T					
Front wiper request signal			T			R	I
Front wiper stop position signal			R			T	
Rear window defogger switch signal			T			R	J
Rear window defogger control signal	R		R			T	
Hood switch signal			R			T	
Theft warning horn request signal			T			R	WW
Horn chirp signal			T			R	
Steering angle sensor signal				T	R		L

A
B
C
D
E
F
G
H
I
J
L
M

WW

FRONT WIPER AND WASHER SYSTEM

Schematic

AKS004T8

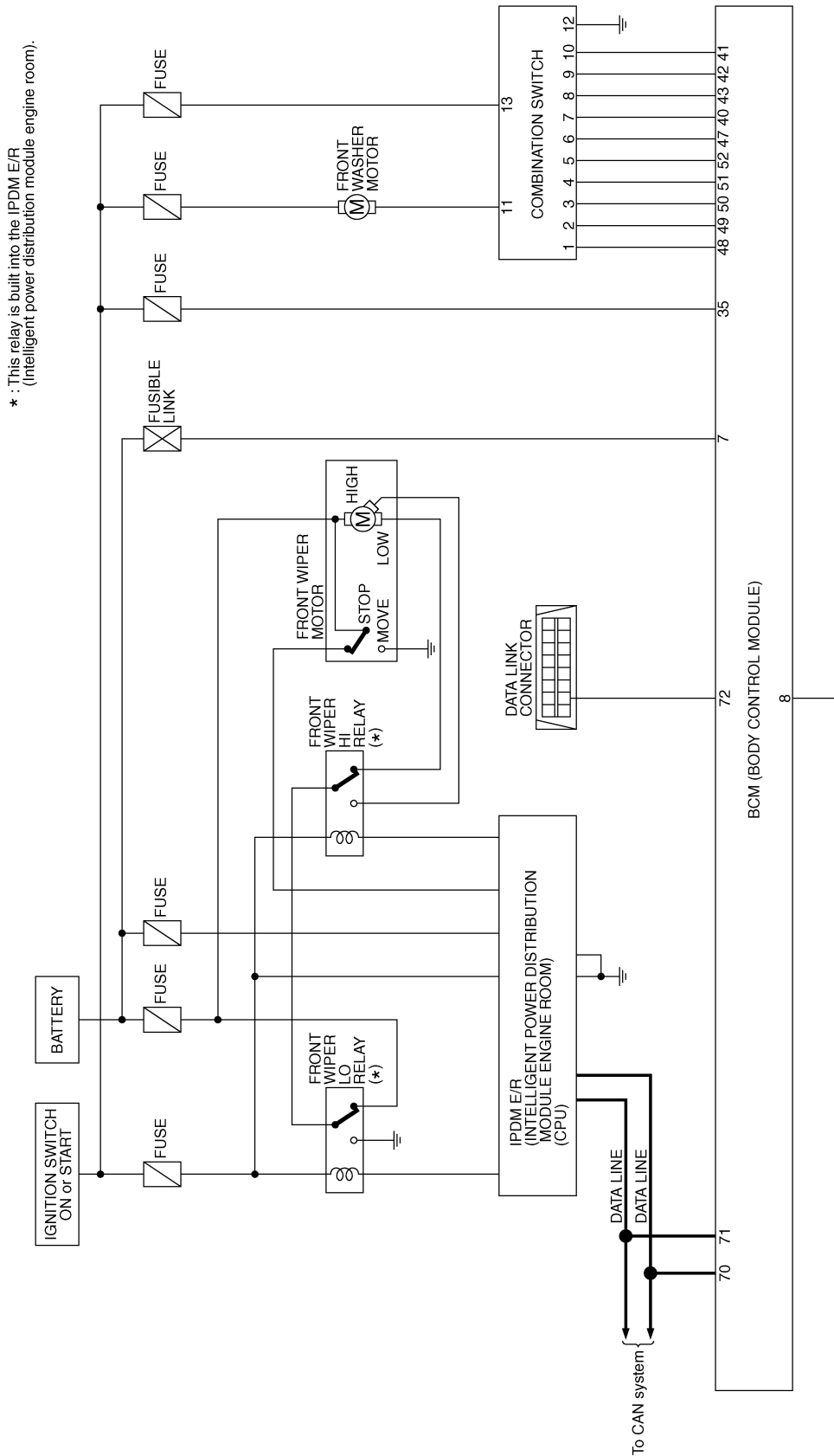

TKWT0265E

FRONT WIPER AND WASHER SYSTEM

Wiring Diagram — WIPER —

AKS004T9

WW-WIPER-01

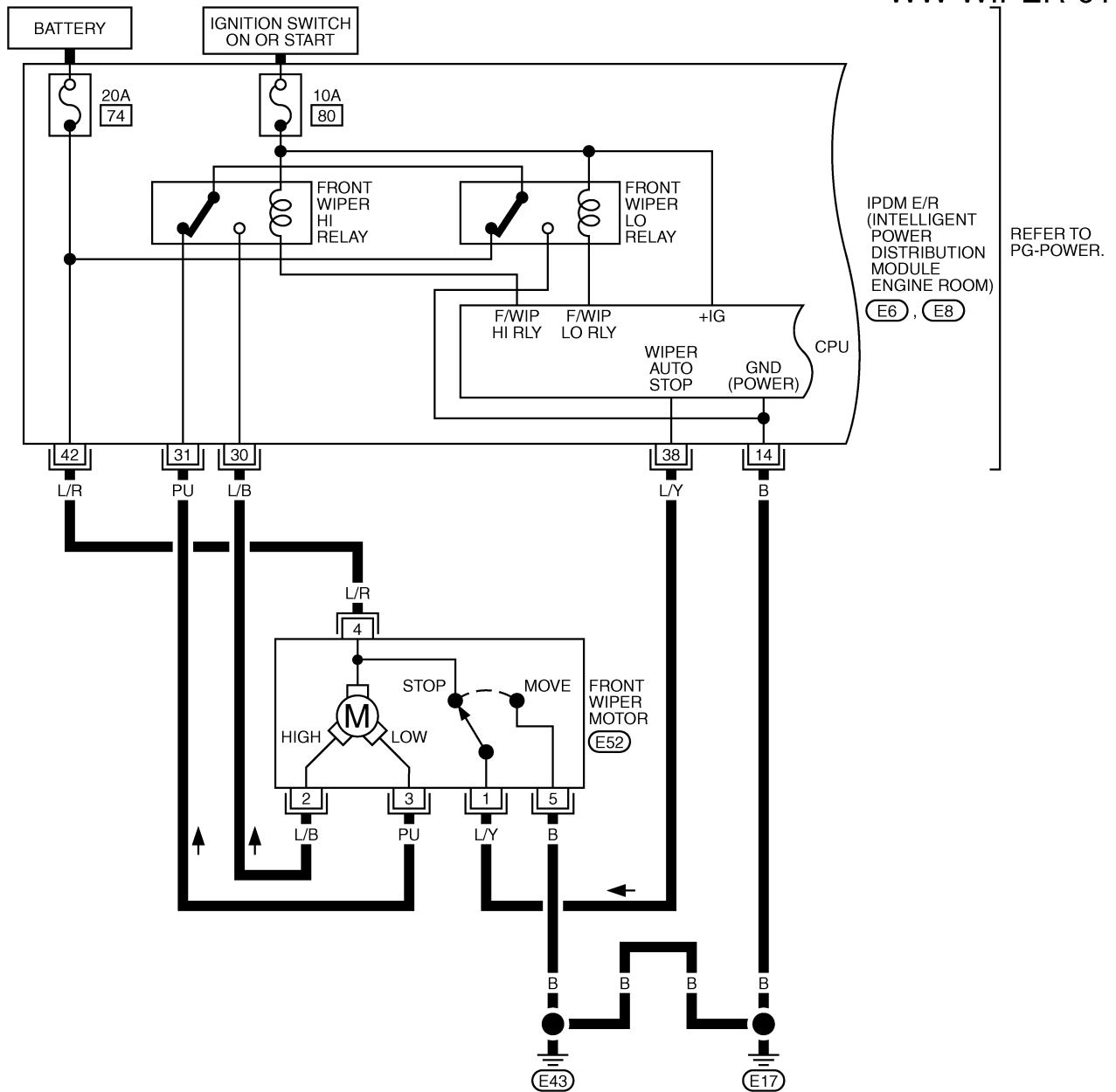

A
B
C
D
E
F
G
H
I
J
K
L
M

WW

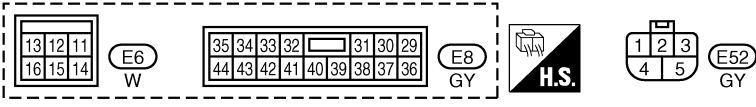

TKWT0266E

FRONT WIPER AND WASHER SYSTEM

WW-WIPER-02

▬ : DATA LINE

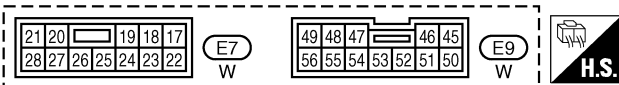
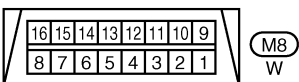
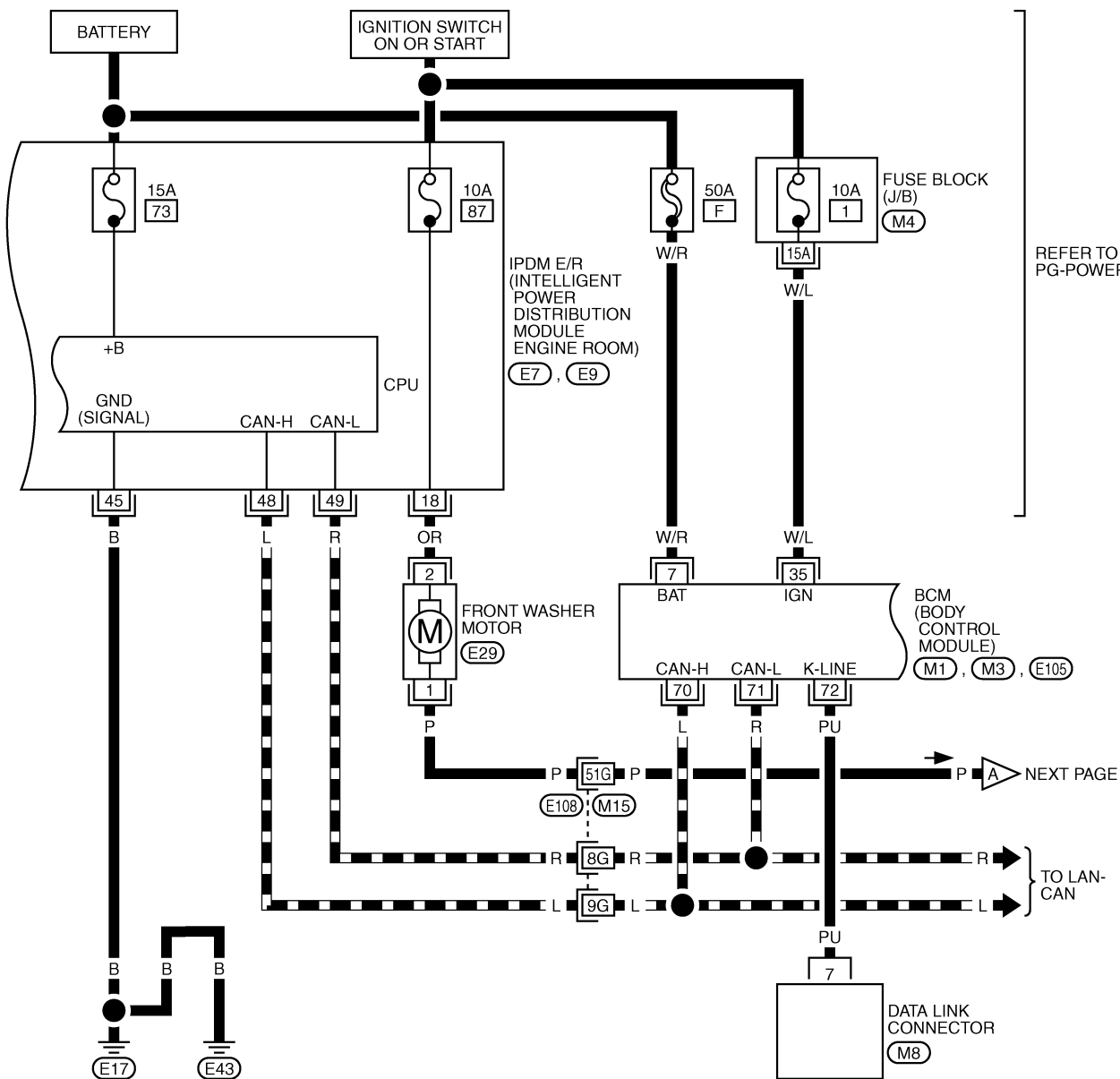

REFER TO THE FOLLOWING.

- (E108) -SUPER MULTIPLE JUNCTION (SMJ)
- (M4) -FUSE BLOCK-JUNCTION BOX (J/B)
- (M1), (M3), (E105) -ELECTRICAL UNITS

TKWT0724E

FRONT WIPER AND WASHER SYSTEM

WW-WIPER-03

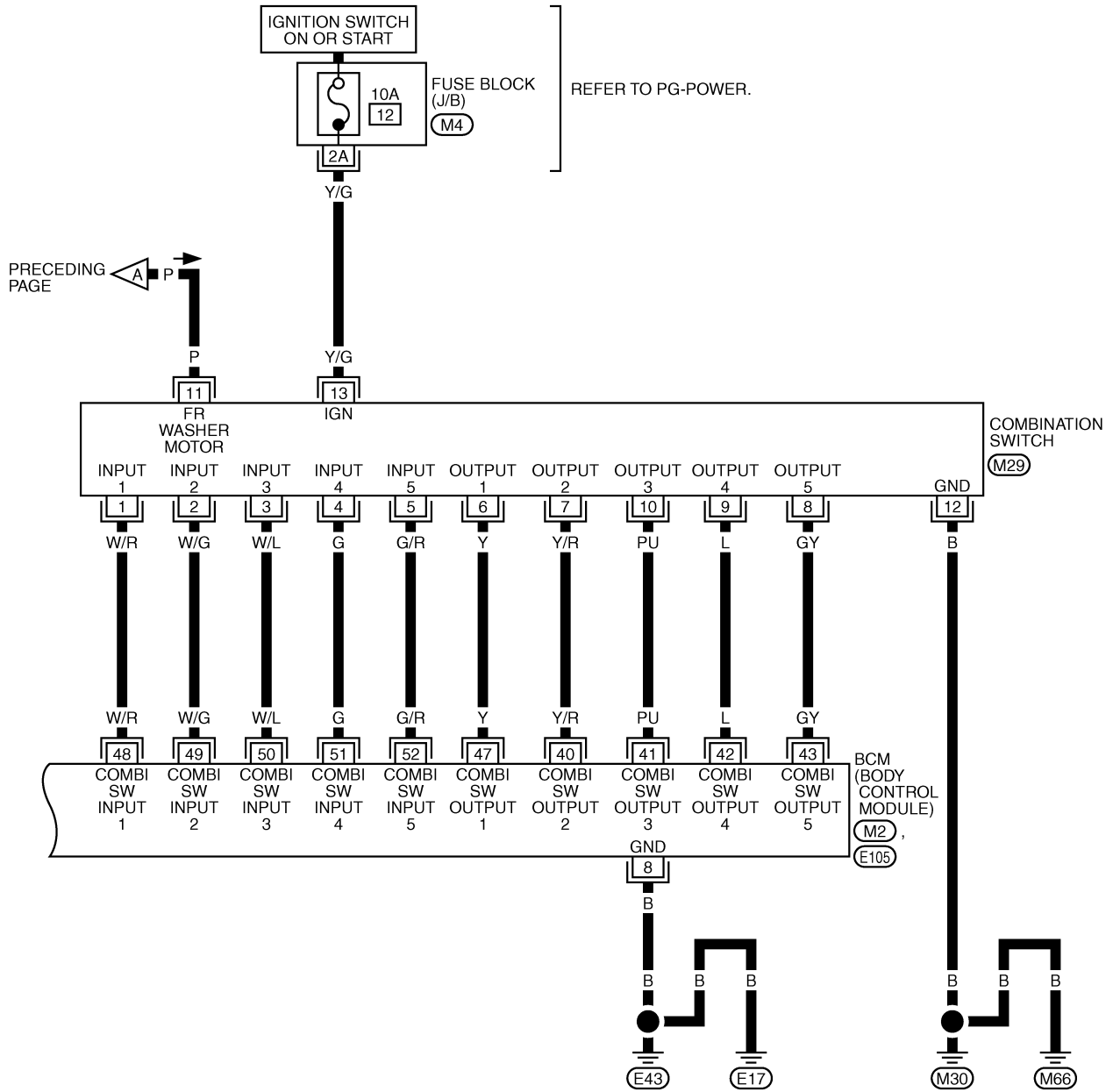

7	8	9	10	12
6	5	4	3	2
1	11	13	(M29)	W

REFER TO THE FOLLOWING.

(M4) -FUSE BLOCK-JUNCTION BOX (J/B)

(M2), (E105) -ELECTRICAL UNITS

TKWT0725E

FRONT WIPER AND WASHER SYSTEM

Terminals and Reference Values for BCM

AKS004TA

Terminal No. (Wire color)	Signal name	Measuring condition		Reference value
		Ignition switch	Operation or condition	
7 (W/R)	Battery power supply	ON	—	Battery voltage
8 (B)	Ground	ON	—	Approx. 0V
35 (W/L)	Ignition switch (ON)	ON	—	Battery voltage
40 (Y/R)	Combination switch output 2	ON	Lighting switch and wiper switch OFF	
41 (PU)	Combination switch output 3			
42 (L)	Combination switch output 4			
43 (GY)	Combination switch output 5			
47 (Y)	Combination switch output 1			
48 (W/R)	Combination switch input 1	ON	Lighting switch and wiper switch OFF	4.5V or more
49 (W/G)	Combination switch input 2	ON		
50 (W/L)	Combination switch input 3	ON		
51 (G)	Combination switch input 4	ON		
52 (G/R)	Combination switch input 5	ON		
70 (L)	CAN- H	—	—	—
71 (R)	CAN- L	—	—	—
72 (PU)	K-LINE	—	—	—

SKIA1119J

Terminals and Reference Values for IPDM E/R

AKS004TY

Terminal No. (Wire color)	Signal name	Measuring condition		Reference value	
		Ignition switch	Operation or condition		
14 (B)	Ground	ON	—	Approx. 0V	
18 (OR)	Washer motor power	ON	Wiper switch	OFF	Battery voltage
				LO	Approx. 0V
30 (L/B)	High speed signal	ON	Wiper switch	OFF	Battery voltage
				HI	Approx. 0V
31 (PU)	Low speed signal	ON	Wiper switch	OFF	Battery voltage
				LO	Approx. 0V
38 (L/Y)	Wiper auto stop signal	ON	Wiper operating		Approx. 0V
			Wiper stopped		Battery voltage
42 (L/R)	Wiper motor power source	—	—	Battery voltage	
45 (B)	Ground	—	—	Approx. 0V	
48 (L)	CAN- H	—	—	—	
49 (R)	CAN- L	—	—	—	

How to Proceed With Trouble Diagnosis

AKS004TC

1. Confirm the symptoms and customer complaint.
2. Understand operation description and function description. Refer to [WW-4, "System Description"](#).
3. Carry out the Preliminary Inspection. Refer to [WW-19, "Preliminary Inspection"](#).
4. Check symptom and repair or replace the cause of malfunction.
5. Does the warning chime operate normally? If YES: GO TO 6. If NO: GO TO 4.
6. INSPECTION END

FRONT WIPER AND WASHER SYSTEM

AKS004TD

Preliminary Inspection

CHECK POWER SUPPLY AND GROUND CIRCUIT

Inspection Procedure

1. CHECK FUSE

- Check if wiper and washer fuse is blown.

Unit	Power source	Fuse No.
Front washer motor	Ignition ON or START position	87
Front wiper motor, front wiper relay, front wiper high relay	Battery	74
Front wiper relay, front wiper high relay	Ignition ON or START position	80
Combination switch	Ignition ON or START position	12

Refer to [WW-15, "Wiring Diagram — WIPER —"](#)

OK or NG

OK >> GO TO 2.

NG >> If fuse is blown, be sure to eliminate cause of malfunction before installing new fuse. Refer to [PG-3, "POWER SUPPLY ROUTING CIRCUIT"](#).

2. CHECK POWER SUPPLY CIRCUIT

1. Turn ignition switch OFF.
2. Disconnect BCM connector.
3. Check voltage between BCM harness connector and ground.

Terminals		Ignition switch position	
(+)		(-)	
Connector	Terminal (Wire color)	OFF	ON
E105	7 (W/R)	Battery voltage	Battery voltage
M1	35 (W/L)	0V	Battery voltage

OK or NG

OK >> GO TO 3.

NG >> Check harness for open or short between BCM and fuse.

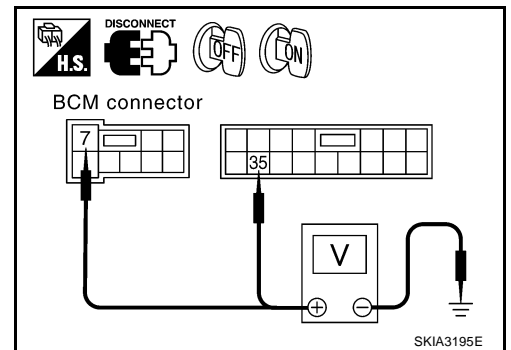

3. CHECK GROUND CIRCUIT

Check continuity between BCM harness connector and ground.

Terminals		Continuity
Connector	Terminal (Wire color)	
E105	8 (B)	Ground
		Yes

OK or NG

OK >> INSPECTION END

NG >> Check harness ground circuit.

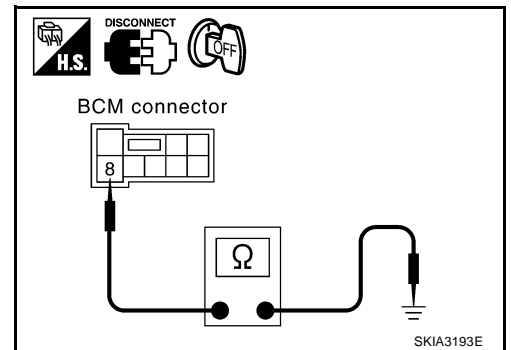

FRONT WIPER AND WASHER SYSTEM

CONSULT-II Functions

AKS004TE

CONSULT-II performs the following functions communicating with BCM.

BCM diagnosis position	Check item, Diagnosis mode	Description
Wiper	DATA MONITOR	Displays BCM input data in real time.
	ACTIVE TEST	Device operation can be checked by applying a drive signal to device.
BCM C/U	CAN DIAG SUPPORT MNTR	The result of transmit/receive diagnosis of CAN communication can be read.

CONSULT-II OPERATION

- With the ignition switch OFF, connect CONSULT-II and CONSULT-II CONVERTER to the data link connector, then turn ignition switch ON.

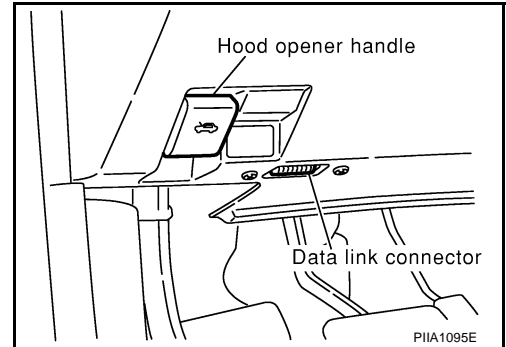

- Touch "START (NISSAN BASED VHCL)".

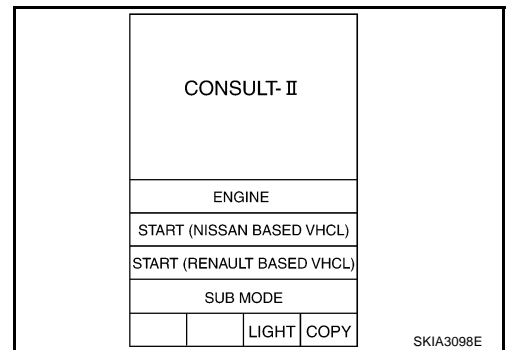

- Touch "BCM" on "SELECT SYSTEM" screen. If "BCM" is not indicated, refer to [GI-38, "CONSULT-II Data Link Connector \(DLC\) Circuit"](#).

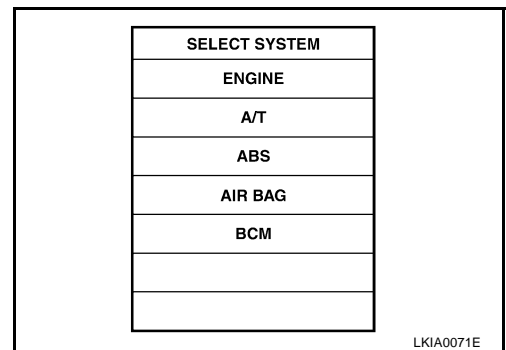

- Touch "WIPER".

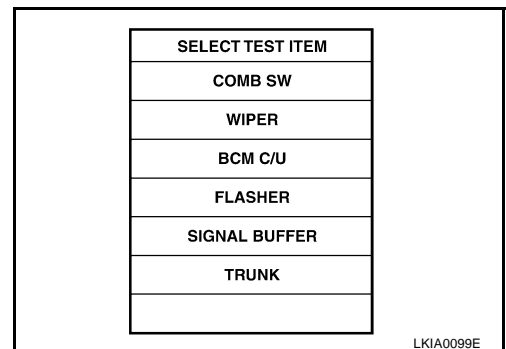

FRONT WIPER AND WASHER SYSTEM

DATA MONITOR

Operation Procedure

1. Touch "WIPER" on "SELECT TEST ITEM" screen.
2. Touch "DATA MONITOR" on "SELECT DIAG MODE" screen.
3. Touch either "ALL SIGNALS" or "SELECTION FROM MENU" on "DATA MONITOR" screen.

All signals	Monitors all the items.
Selection from menu	Selects and monitors the individual item selected.

4. Touch "START".
5. When "SELECTION FROM MENU" is selected, touch items to be monitored. When "ALL SIGNALS" is selected, all the items will be monitored.
6. Touch "RECORD" while monitoring, then the status of the monitored item can be recorded. To stop recording, touch "STOP".

Display Item List

Monitor item name "operation or unit"	Contents
IGN ON SW "ON/OFF"	Displays "IGN Position (ON)/OFF, ACC Position (OFF)" status as judged from ignition switch signal.
FR WIPER INT "ON/OFF"	Displays "Front Wiper INT (ON)/Other (OFF)" status as judged from wiper switch signal.
FR WIPER LOW "ON/OFF"	Displays "Front Wiper LOW (ON)/Other (OFF)" status as judged from wiper switch signal.
FR WIPER HI "ON/OFF"	Displays "Front Wiper HI (ON)/Other (OFF)" status as judged from wiper switch signal.
FR WASHER SW "ON/OFF"	Displays "Front Washer Switch (ON)/Other (OFF)" status as judged from wiper switch signal.
INT VOLUME (1 - 7)	Displays intermittent operation dial position setting (1 - 7) as judged from wiper switch signal.
VHCL SPEED SEN "ON/OFF"	Displays "Driving (ON)/Stopped (OFF)" status as judged from vehicle speed signal.
FR WIPER STOP "ON/OFF"	Displays "Stopped (ON)/Operating (OFF)" status as judged from the auto-stop signal.

ACTIVE TEST

Operation Procedure

1. Touch "WIPERS" on the "SELECT TEST ITEM" screen.
2. Touch "ACTIVE TEST" on the "SELECT DIAG MODE" screen.
3. Touch item to be tested and check operation of the selected item.
4. During the operation check, touching "BACK" deactivates the operation.

Display Item List

Test item	Display on CONSULT-II screen	Description
Front wiper HI output	FR WIPER (HI)	Front wiper HI can be operated by any ON-OFF operation.
Front wiper LO output	FR WIPER (LO)	Front wiper LO can be operated by any ON-OFF operation.
Front wiper INT output	FR WIPER (INT)	Front wiper INT can be operated by any ON-OFF operation.

Front Wiper Does Not Operate

AKS004TF

1. INSPECTION 1: IPDM E/R TO FRONT WIPERS (1) INSPECTION

1. Turn on front wipers using active test. Refer to [WW-21, "ACTIVE TEST"](#).
2. Confirm front wiper operation.

OK or NG

- OK >> GO TO 4.
NG >> GO TO 2.

FRONT WIPER AND WASHER SYSTEM

2. INSPECTION: IPDM E/R TO FRONT WIPERS

1. Turn ignition switch OFF.
2. Disconnect IPDM E/R connector and front wiper motor connector.
3. Check continuity between harness connector of IPDM E/R and harness connector of front wiper motor.

Terminals				Continuity
IPDM E/R		Front wiper motor		
Connector	Terminal (Wire color)	Connector	Terminal (Wire color)	
E8	30 (L/B)	E52	2 (L/B)	Yes
	31 (PU)		3 (PU)	
	42 (L/R)		4 (L/R)	

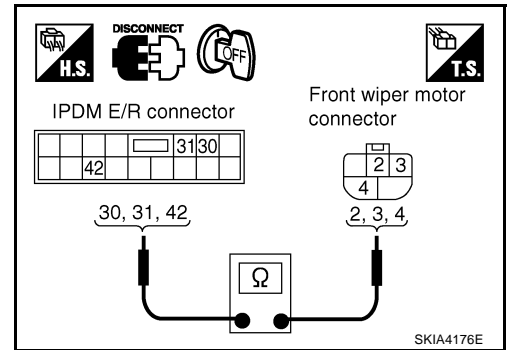

4. Check continuity between IPDM E/R harness connector terminal and ground.

Terminals			Continuity
IPDM E/R		Ground	
Connector	Terminal (Wire color)		
E6	14 (B)		Yes

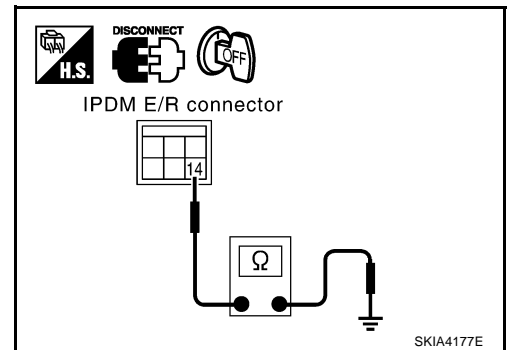

OK or NG

OK >> GO TO 3.

NG >> ● Check for short circuit or open circuit in harness between IPDM E/R and front wiper motor.

- Check for open circuit in harness between IPDM E/R and ground.

3. CHECK IPDM E/R

1. Connect IPDM E/R connector and front wiper motor connector.
2. Select "FR WIPER HI" during active test. Refer to [WW-21, "ACTIVE TEST"](#). When front wiper relay, and front wiper HI relay are operating, check voltage between harness connector of IPDM E/R and ground.

Terminals				Voltage
IPDM E/R (+)		(-)	Condition	
Connector	Terminal (Wire color)			
E8	31 (PU)	Ground	Stopped	Battery voltage
			LO operation	Approx. 0V
	30 (L/B)		Stopped	Battery voltage
			HI operation	Approx. 0V
42 (L/R)	—	Battery voltage		

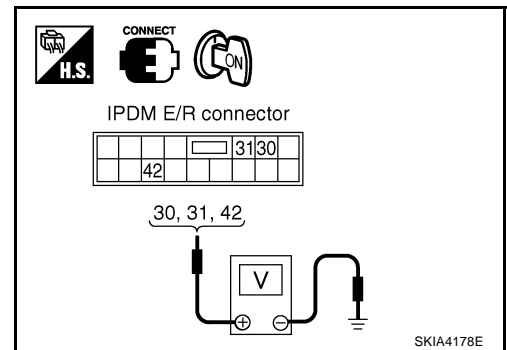

OK or NG

OK >> Replace front wiper motor.

NG >> Replace IPDM E/R.

FRONT WIPER AND WASHER SYSTEM

4. INSPECTION1: COMBINATION SWITCH TO BCM

Select "BCM" on CONSULT-II. Carry out self-diagnosis of "BCM C/U".

Displayed self-diagnosis results

No malfunction detected>>GO TO 5.

CAN communications or CAN system>>Inspect the BCM CAN communications system. Go to [BCS-16, "CAN Communication Inspection Using CONSULT-II \(Self-Diagnosis\)"](#)

OPEN DETECT 1 - 5>>Combination switch system malfunction. Go to [LT-125, "Combination Switch Inspection According to Self-Diagnostic Results"](#) .

SELF-DIAG RESULTS	
DTC RESULTS	TIME
NO DTC IS DETECTED. FURTHER TESTING MAY BE REQUIRED	

LKIA0073E

5. INSPECTION 2: COMBINATION SWITCH TO BCM

Select "BCM" on CONSULT-II. With "WIPER" data monitor, make sure "FR WIPER INT", "FR WIPER LOW" and "FR WIPER HI" turn ON-OFF according to operation of wiper switch.

OK or NG

OK >> Replace BCM. Refer to [BCS-23, "Removal and Installation of BCM"](#) .

NG >> Replace wiper switch.

DATA MONITOR	
MONITOR	
IGN ON SW	ON
FR WIPER INT	OFF
FR WIPER LOW	OFF
FR WIPER HI	OFF
FR WASHER SW	OFF
INT VOLUME	5
VHCL SPEED SEN	OFF
FR WIPER STOP	ON

LKIA0102E

Front Wiper Stop Position Is Incorrect

1. INSPECTION: IPDM E/R TO WIPER MOTOR

Select "BCM" on CONSULT-II. With "WIPER" data monitor, make sure "FR WIPER STOP" turns ON-OFF according to wiper operation.

OK or NG

OK >> Replace IPDM E/R.

NG >> GO TO 2.

DATA MONITOR	
MONITOR	
IGN ON SW	ON
FR WIPER INT	OFF
FR WIPER LOW	OFF
FR WIPER HI	OFF
FR WASHER SW	OFF
INT VOLUME	5
VHCL SPEED SEN	OFF
FR WIPER STOP	ON

LKIA0102E

A
B
C
D
E
F
G
H
I
J
L
M

WW

FRONT WIPER AND WASHER SYSTEM

2. INSPECTION: IPDM E/R AND WIPER MOTOR

1. Turn ignition switch OFF.
2. Disconnect IPDM E/R connector and front wiper motor connector.
3. Check continuity between harness connector of IPDM E/R and harness connector of front wiper motor.

Terminals				Continuity
IPDM E/R		Front wiper motor		
Connector	Terminal (Wire color)	Connector	Terminal (Wire color)	
E8	38 (L/Y)	E52	1 (L/Y)	Yes

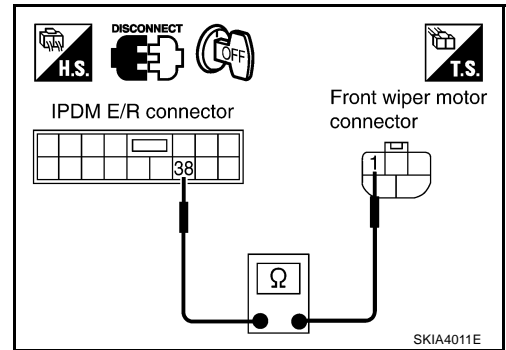

4. Check continuity between front wiper motor harness connector terminal and ground.

Terminals			Continuity
Front wiper motor		Ground	
Connector	Terminal (Wire color)		
E52	5 (B)		Yes

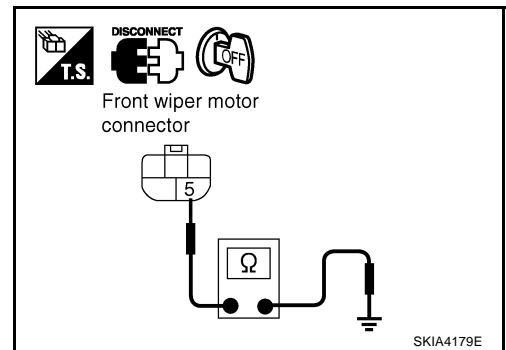

OK or NG

OK >> GO TO 3.

NG >> ● Check for short circuit or open circuit in harness between IPDM E/R and front wiper motor.

- Check for open circuit in harness between front wiper motor and ground.

3. CHECK IPDM E/R

While front wiper motor is stopped and while operating, measure voltage between IPDM E/R harness connector terminal and ground.

Terminals				Voltage
IPDM E/R (+)		(-)	Condition	
Connector	Terminal (Wire color)			
E8	38 (L/Y)	Ground	Wiper operating	Approx. 0V
			Wiper stopped	Battery voltage

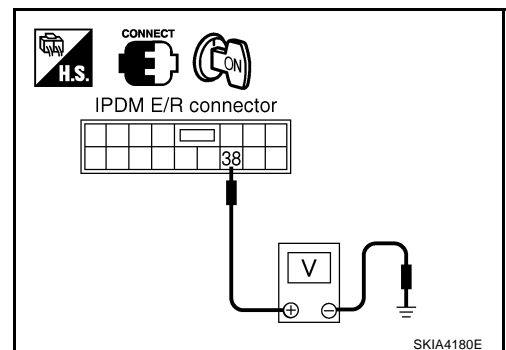

OK or NG

OK >> Replace IPDM E/R.

NG >> Replace front wiper motor.

Only Front Wiper Low Does Not Operate

1. INSPECTION 1: IPDM E/R TO FRONT WIPERS

1. Select "FR WIPER LOW" during active test. Refer to [WW-21, "ACTIVE TEST"](#).
2. Make sure front wipers operate in LOW operation mode.

OK or NG

OK >> GO TO 4.

NG >> GO TO 2.

AKS004TH

FRONT WIPER AND WASHER SYSTEM

2. INSPECTION 2: IPDM E/R TO FRONT WIPERS

1. Turn ignition switch OFF.
2. Disconnect IPDM E/R connector and front wiper motor connector.
3. Check continuity between harness connector of IPDM E/R and harness connector of front wiper motor.

Terminals				Continuity
IPDM E/R		Front wiper motor		
Connector	Terminal (Wire color)	Connector	Terminal (Wire color)	
E8	31 (PU)	E52	3 (PU)	Yes

OK or NG

- OK >> GO TO 3.
 NG >> Repair harness or connector.

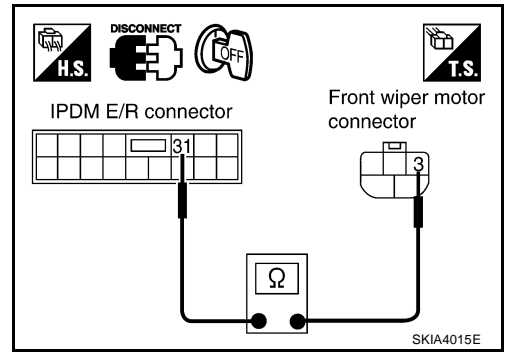

3. CHECK IPDM E/R

1. Connect IPDM E/R connector and front wiper motor connector.
2. Select "FR WIPER LOW" during active test. Refer to [WW-21, "ACTIVE TEST"](#). When front wiper relay are operating, check voltage between harness connector of IPDM E/R and ground.

Terminals				Voltage
IPDM E/R (+)		(-)	Condition	
Connector	Terminal (Wire color)			
E8	31 (PU)	Ground	Stopped	Battery voltage
			LO operation	Approx. 0V

OK or NG

- OK >> Replace front wiper motor.
 NG >> Replace IPDM E/R.

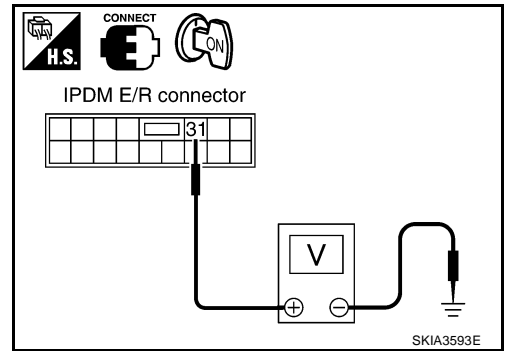

4. INSPECTION 1: COMBINATION SWITCH TO BCM

Select "BCM" on CONSULT-II. Carry out self-diagnosis of "BCM C/U".

Displayed self-diagnosis results

- No malfunction detected >> GO TO 5.
 CAN communications or CAN system >> Inspect the BCM CAN communications system. Go to [BCS-16, "CAN Communication Inspection Using CONSULT-II \(Self-Diagnosis\)"](#).
- OPEN DETECT 1 - 5 >> Combination switch system malfunction. Go to [LT-125, "Combination Switch Inspection According to Self-Diagnostic Results"](#).

SELF-DIAG RESULTS	
DTC RESULTS	TIME
NO DTC IS DETECTED. FURTHER TESTING MAY BE REQUIRED	

LKIA0073E

FRONT WIPER AND WASHER SYSTEM

5. INSPECTION 2: COMBINATION SWITCH TO BCM

Select "BCM" on CONSULT-II. With "WIPER" data monitor, make sure "FR WIPER LOW" turns ON-OFF according to operation of wiper switch.

OK or NG

- OK >> Replace BCM. Refer to [BCS-23, "Removal and Installation of BCM"](#).
- NG >> Replace wiper switch.

DATA MONITOR	
MONITOR	
IGN ON SW	ON
FR WIPER INT	OFF
FR WIPER LOW	OFF
FR WIPER HI	OFF
FR WASHER SW	OFF
INT VOLUME	5
VHCL SPEED SEN	OFF
FR WIPER STOP	ON

LKIA0102E

Only Front Wiper Hi Does Not Operate

AKS0047I

1. INSPECTION 1: IPDM E/R TO FRONT WIPERS

- Select "FR WIPER HI" during active test. Refer to [WW-21, "ACTIVE TEST"](#).
- make sure front wipers operate in HI operation mode.

OK or NG

- OK >> GO TO 4.
- NG >> GO TO 2.

2. INSPECTION 2: IPDM E/R TO FRONT WIPERS

- Turn ignition switch OFF.
- Disconnect IPDM E/R connector and front wiper motor connector.
- Check continuity between harness connector of IPDM E/R and harness connector of front wiper motor.

Terminals				Continuity
IPDM E/R		Front wiper motor		
Connector	Terminal (Wire color)	Connector	Terminal (Wire color)	
E8	30 (L/B)	E52	2 (L/B)	Yes

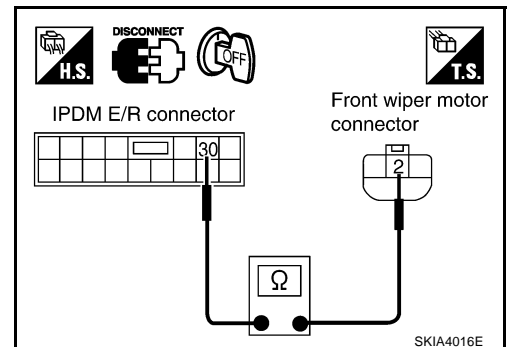

OK or NG

- OK >> GO TO 3.
- NG >> Repair harness or connector.

3. CHECK IPDM E/R

- Connect IPDM E/R connector and front wiper motor connector.
- Select "FR WIPER HI" during active test. Refer to [WW-21, "ACTIVE TEST"](#). When front wiper relay, and front wiper HI relay are operating, check voltage between harness connector of IPDM E/R and ground.

Terminals				Voltage
IPDM E/R (+)		(-)	Condition	
Connector	Terminal (Wire color)			
E8	30 (L/B)	Ground	Stopped	Battery voltage
			HI operation	Approx. 0V

OK or NG

- OK >> Replace front wiper motor.
- NG >> Replace IPDM E/R.

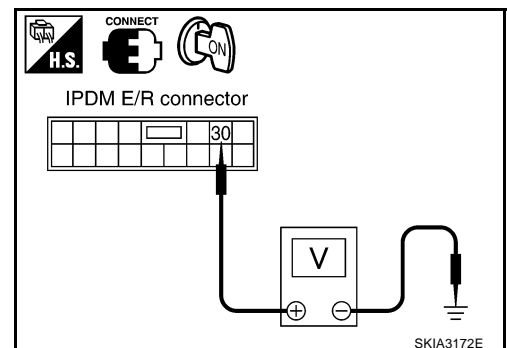

FRONT WIPER AND WASHER SYSTEM

4. INSPECTION 1: COMBINATION SWITCH TO BCM

Select "BCM" on CONSULT-II. Carry out self-diagnosis of "BCM C/U".

Displayed self-diagnosis results

No malfunction detected>>GO TO 5.

CAN communications or CAN system>>Inspect the BCM CAN communications system. Go to [BCS-16, "CAN Communication Inspection Using CONSULT-II \(Self-Diagnosis\)"](#)

OPEN DETECT 1 - 5>>Combination switch system malfunction. Go to [LT-125, "Combination Switch Inspection According to Self-Diagnostic Results"](#).

SELF-DIAG RESULTS	
DTC RESULTS	TIME
NO DTC IS DETECTED. FURTHER TESTING MAY BE REQUIRED	

LKIA0073E

5. INSPECTION 2: COMBINATION SWITCH TO BCM

Select "BCM" on CONSULT-II. With "WIPER" data monitor, make sure "FR WIPER HI" turns ON-OFF according to operation of wiper switch.

OK or NG

OK >> Replace BCM. Refer to [BCS-23, "Removal and Installation of BCM"](#).

NG >> Replace wiper switch.

DATA MONITOR	
MONITOR	
IGN ON SW	ON
FR WIPER INT	OFF
FR WIPER LOW	OFF
FR WIPER HI	OFF
FR WASHER SW	OFF
INT VOLUME	5
VHCL SPEED SEN	OFF
FR WIPER STOP	ON

LKIA0102E

Only Front Wiper Intermittent Does Not Operate

1. INSPECTION: COMBINATION SWITCH TO BCM

Select "BCM" on CONSULT-II. With "WIPER" data monitor, make sure "FR WIPER INT" turns ON-OFF according to operation of wiper switch.

OK or NG

OK >> Replace BCM. Refer to [BCS-23, "Removal and Installation of BCM"](#).

NG >> Replace wiper switch.

DATA MONITOR	
MONITOR	
IGN ON SW	ON
FR WIPER INT	OFF
FR WIPER LOW	OFF
FR WIPER HI	OFF
FR WASHER SW	OFF
INT VOLUME	5
VHCL SPEED SEN	OFF
FR WIPER STOP	ON

LKIA0102E

Front Wiper Intermittent Operation Switch Position Cannot Be Adjusted

1. INSPECTION: COMBINATION SWITCH TO BCM

Select "BCM" on CONSULT-II. With "WIPER" data monitor, make sure "INT VOLUME" changes in order from 1 to 7 according to operation of the intermittent switch dial position.

OK or NG

OK >> Replace BCM. Refer to [BCS-23, "Removal and Installation of BCM"](#).

NG >> Replace wiper switch.

DATA MONITOR	
MONITOR	
IGN ON SW	ON
FR WIPER INT	OFF
FR WIPER LOW	OFF
FR WIPER HI	OFF
FR WASHER SW	OFF
INT VOLUME	5
VHCL SPEED SEN	OFF
FR WIPER STOP	ON

LKIA0102E

FRONT WIPER AND WASHER SYSTEM

Wipers Do Not Wipe When Front Washer Operates

AKS004TL

1. INSPECTION: COMBINATION SWITCH TO BCM

Select "BCM" on CONSULT-II. With "WIPER" data monitor, make sure "FR WASHER SW" turns ON-OFF according to operation of front washer switch.

OK or NG

- OK >> Replace BCM. Refer to [BCS-23, "Removal and Installation of BCM"](#).
- NG >> Replace wiper switch.

DATA MONITOR	
MONITOR	
IGN ON SW	ON
FR WIPER INT	OFF
FR WIPER LOW	OFF
FR WIPER HI	OFF
FR WASHER SW	OFF
INT VOLUME	5
VHCL SPEED SEN	OFF
FR WIPER STOP	ON

LKIA0102E

FRONT WIPER AND WASHER SYSTEM

Removal and Installation for Front Wiper Arms, Adjustment for Wiper Arms Stop Location

AKS004TZ

REMOVAL

1. Operate wiper motor, and stop it at the auto stop position.
2. Remove washer tube from washer tube joint.
3. Remove wiper arm mounting nuts and wiper arm from vehicle.

INSTALLATION

1. Clean up the pivot area as illustrated. This will reduce possibility of wiper arm looseness.

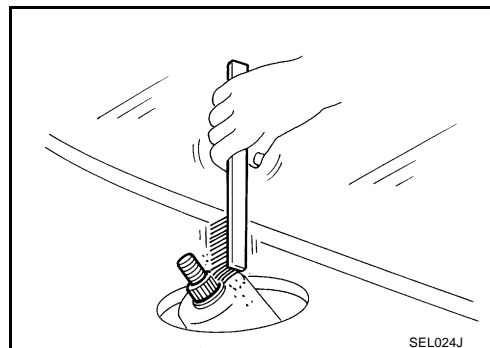

2. Prior to wiper arm installation, turn on wiper switch to operate wiper motor and then turn it "OFF" (Auto Stop).
3. Push wiper arm onto pivot shaft, paying attention to blind spline.
4. Attach washer tube to washer tube joint.
5. Lift the blade up and then set it down onto glass surface to set the blade center to clearance "L1" & "L2" immediately before tightening nut.
6. Eject washer fluid. Turn on wiper switch to operate wiper motor and then turn it "OFF".
7. Ensure that wiper blades stop within clearance "L1" & "L2".

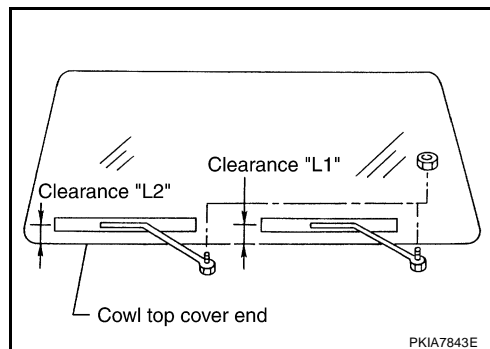

Clearance "L1" : 56.5 - 71.5 mm (2.22 - 2.82 in)

Clearance "L2" : 25 - 38 mm (0.98 - 1.50 in)

- Tighten wiper arm nuts to specified torque.

Front wiper arm nuts  : 23.6 N-m (2.4 kg-m, 17 ft-lb)

CAUTION:

Don't operate the front wiper when engine hood is being open.

ADJUSTMENT

Refer to [WW-29, "INSTALLATION"](#)

Removal and Installation of Front Wiper Motor Assembly

AKS004U0

REMOVAL

1. Remove wiper arm. Refer to [WW-29, "REMOVAL"](#).
2. Remove cowl top cover. Refer to [EI-21, "COWL TOP"](#) in "EI" section.
3. Remove washer tube.
4. Disconnect wiper motor connector.
5. Remove wiper motor assembly screws, and remove wiper motor assembly.

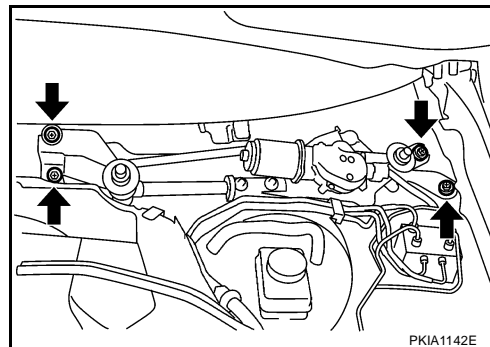

INSTALLATION

1. Install wiper motor assembly to the vehicle.

FRONT WIPER AND WASHER SYSTEM

2. Connect wiper motor assembly to the connector. Turn wiper switch ON to operate wiper motor, then turn wiper switch OFF (auto stop).
3. Attach washer tube to connector joint.
4. Install cowl top cover. Refer to [EI-21, "COWL TOP"](#) in "EI" section.
5. Install wiper arms. Refer to [WW-29, "Removal and Installation for Front Wiper Arms, Adjustment for Wiper Arms Stop Location"](#).
6. Attach wiper arm washer tube.

Wiper motor assembly bolts  : 5.5 N-m (0.56 kg-m, 49 in-lb)

CAUTION:

- Do not drop the wiper motor or cause it to contact other parts.
- Check grease conditions of the motor arm and wiper link joint (at retainer). Apply grease if necessary.

Disassembly and Assembly Front Wiper Motor Assembly

AKS004U1

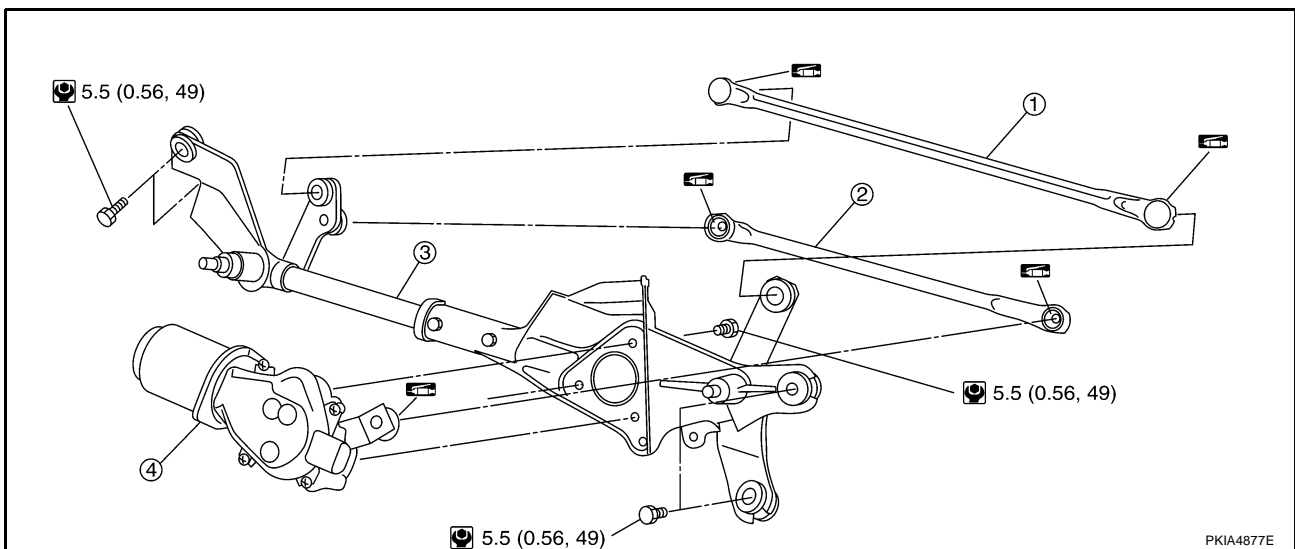

1. Wiper link
4. Wiper motor

2. Wiper link

3. Wiper frame

DISASSEMBLY

1. Remove wiper link from wiper frame and the motor arm.
2. Remove wiper motor bolts, and remove wiper motor from wiper frame.

ASSEMBLY

Paying attention to the work listed below, assemble in reverse order of disassembly.

Wiper motor bolts  : 5.5 N-m (0.56 kg-m, 49 in-lb)

FRONT WIPER AND WASHER SYSTEM

AKS004U2

Washer Nozzle Adjustment

1. When wiper blade position is in auto stop condition, remove wiper motor connector to ensure wiper arms do not move.
2. Adjust each nozzle position (A, B, E, F, and G) so that spray positions are in the range of shaded parts.

CAUTION:

Only washer nozzles (A, B, E, F, and G) can be adjusted. Washer nozzles (C, D, H, I, and J) cannot be adjusted because of fixed nozzles.

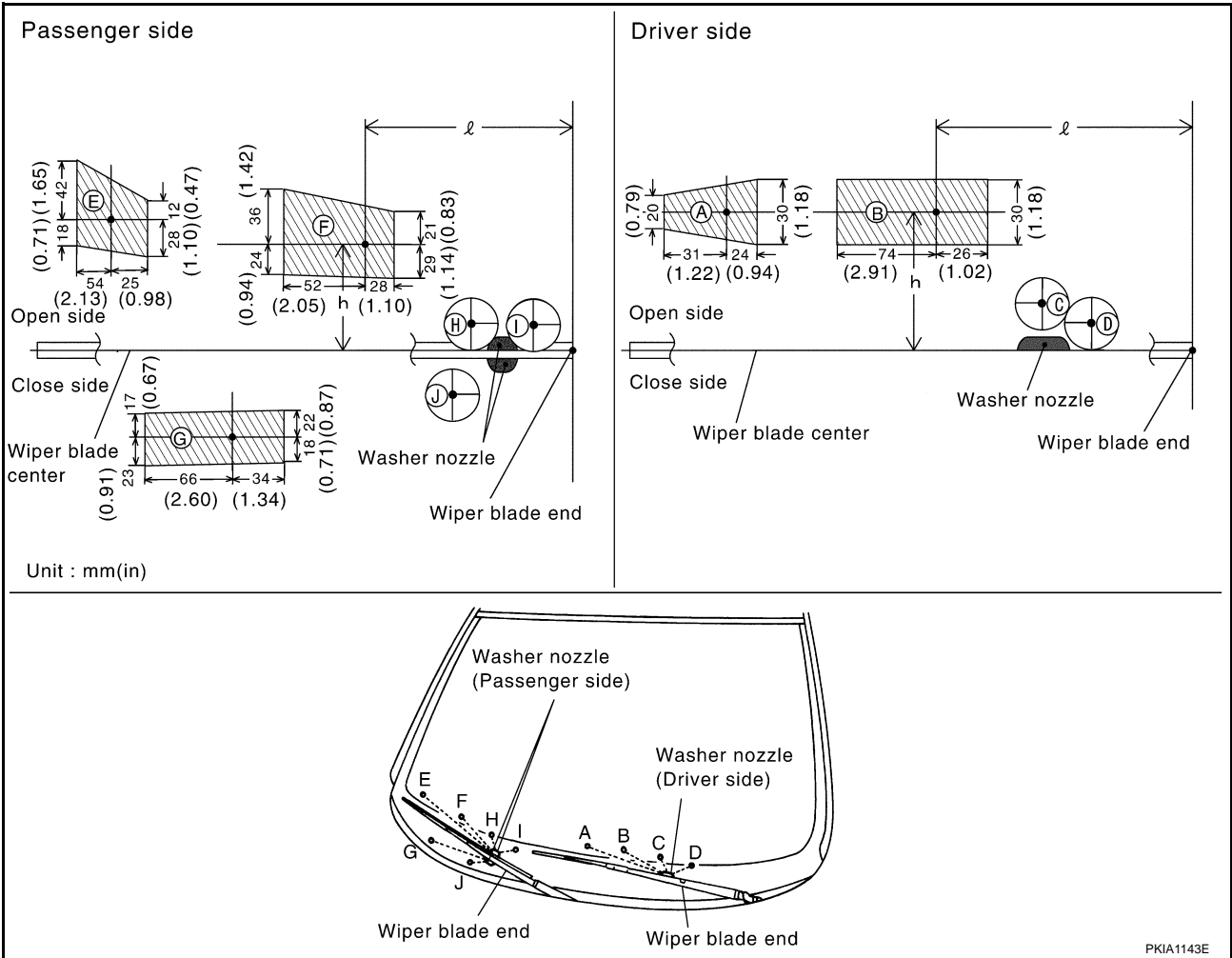

Unit: mm (in)

Spray position	h (height)	ℓ (width)
A	25 (0.98)	339 (13.35)
B	25 (0.98)	176 (6.93)
(C)	—	—
(D)	—	—
E	53 (2.09)	306 (12.05)
F	39 (1.54)	158 (6.22)
G	-32 (-1.26)	244 (9.61)
(H)	—	—
(I)	—	—
(J)	—	—

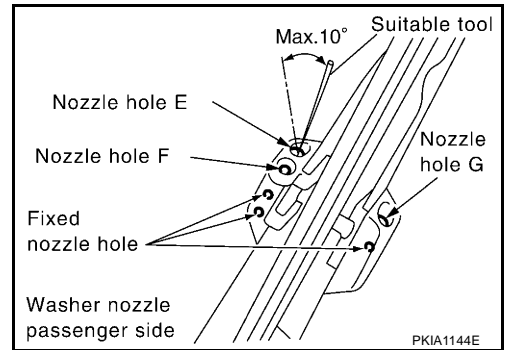

FRONT WIPER AND WASHER SYSTEM

Washer Tube Layout

AKS004U3

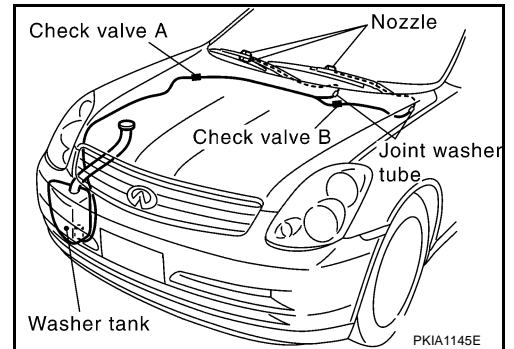

Removal and Installation for Front Washer Nozzle

AKS004U4

Replace wiper arm assembly. Refer to [WW-29, "Removal and Installation for Front Wiper Arms, Adjustment for Wiper Arms Stop Location"](#).

CAUTION:

Removal/installation of the washer nozzle as a unit must not be done.

Removal and Installation for Front Washer Joint

AKS004U5

1. Remove upwards while pressing the tab on reverse side.
2. Remove washer tube.

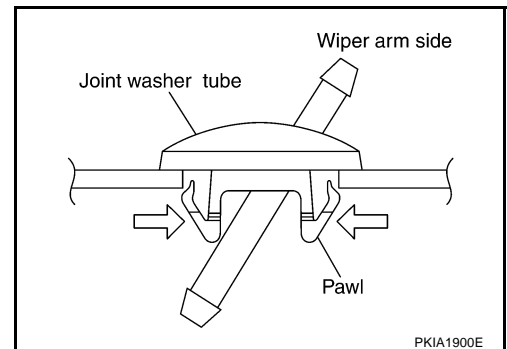

Inspection for Washer Nozzle

CHECK VALVE INSPECTION

Blow air in the injection direction, and check that air flows only one way. Make sure that the reverse direction (inhale) is not possible.

AKS004U6

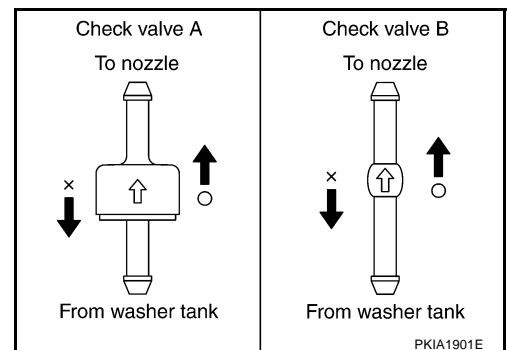

Removal and Installation for Front Wiper and Washer Switch

AKS004U7

1. Remove steering column cover. Refer to [IP-10, "INSTRUMENT PANEL ASSEMBLY"](#) in "IP" section.
2. Remove mounting bolts of clusterlid A and combination meter. Refer to [IP-10, "INSTRUMENT PANEL ASSEMBLY"](#) in "IP" section.
3. Pull wiper and washer switch toward the passenger door while pressing pawls in direction shown by the arrow in the figure, and remove it from the base.
4. Remove wiper and washer switch connector.

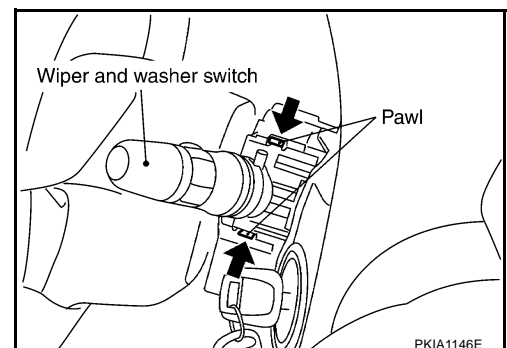

FRONT WIPER AND WASHER SYSTEM

Removal and Installation for Washer Tank

AKS004U8

REMOVAL

1. Pull out washer tank inlet.

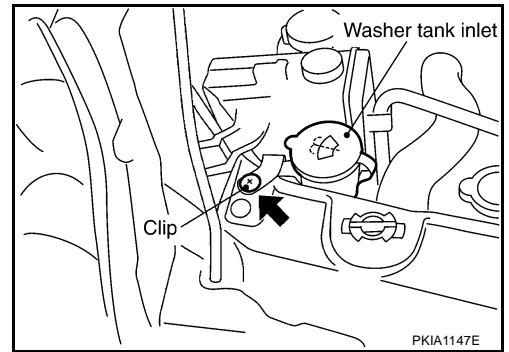

2. Remove fender protector in the right side. Refer to [EI-22](#), "[FENDER PROTECTOR](#)" in "EI" section.
3. Remove right half of front bumper fascia. Refer to [EI-14](#), "[FRONT BUMPER](#)" in "EI" section.
4. Remove washer pump connector.
5. Remove washer tank installation screw and nuts.

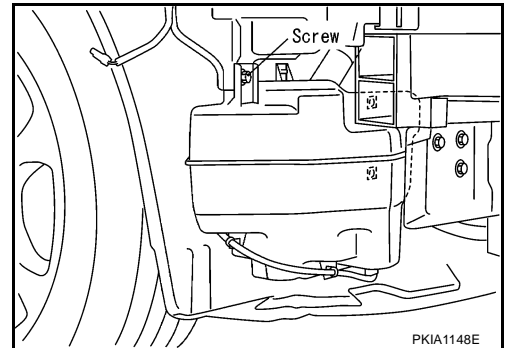

6. Remove washer tube, and remove washer tank from the vehicle.

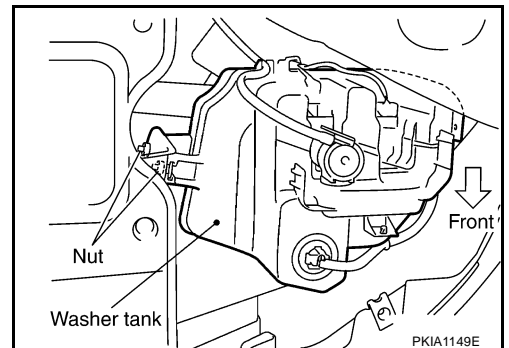

INSTALLATION

Note the following, and install in reverse order of removal.

CAUTION:

After installation, add water up to the upper level of the washer tank inlet, and check for water leaks.
Washer tank installation screw

Tightening torque  : 5.5 N·m (0.56 kg·m, 49 in·lb)

Removal and Installation for Washer Pump

AKS004U9

REMOVAL

1. Remove fender protector in the right side. Refer to [EI-22](#), "[FENDER PROTECTOR](#)" in "EI" section.
2. Remove washer pump connector and tube.
3. Pull out washer pump in direction shown by the arrow in the figure. Remove washer pump from washer tank.

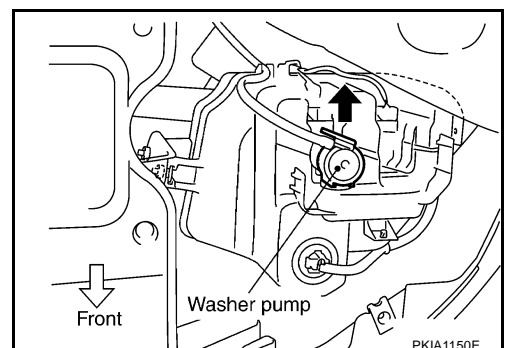

FRONT WIPER AND WASHER SYSTEM

INSTALLATION

Paying attention to the following, install in reverse order of removal.

CAUTION:

When installing washer pump, there should be no packing twists, etc.

CIGARETTE LIGHTER

CIGARETTE LIGHTER

Wiring Diagram — CIGAR —

PPF:35330

AKS000AZ

WW-CIGAR-01

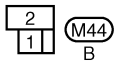
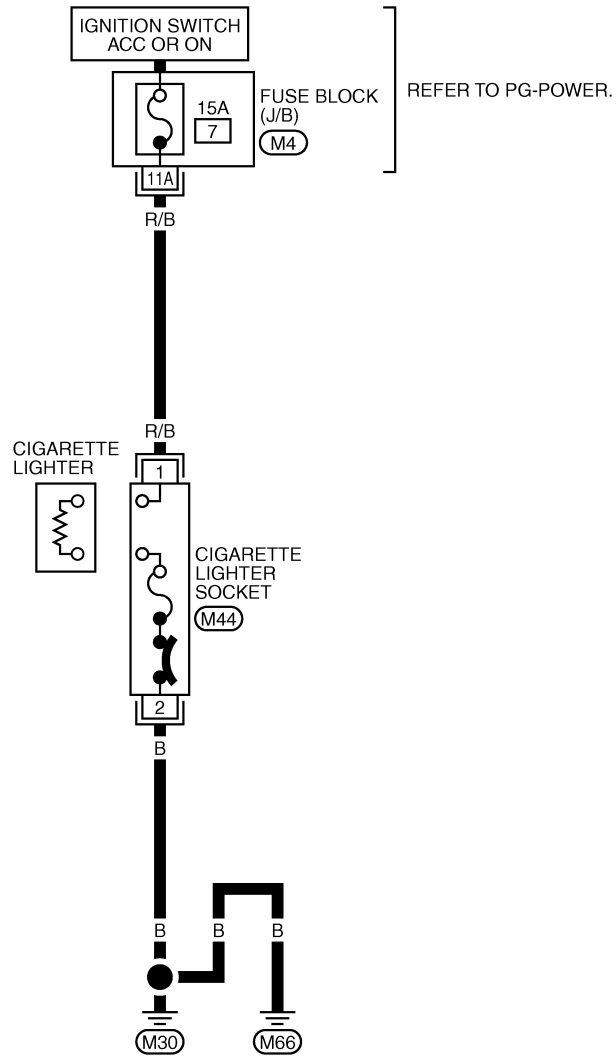

REFER TO THE FOLLOWING.

M4 - FUSE BLOCK-
JUNCTION BOX (J/B)

TKWT0726E

CIGARETTE LIGHTER

Removal and Installation

AKS000B0

1. Remove the instrument side panel. Refer to [IP-10, "INSTRUMENT PANEL ASSEMBLY"](#) "IP" section.
2. Pull out the cigarette lighter.
3. Remove socket.
4. Press out ring from the back of instrument side panel.

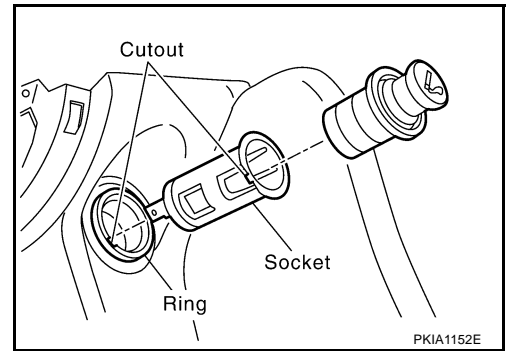

POWER SOCKET

POWER SOCKET

PFP:253A2

Wiring Diagram — P/SCKT —

AKS005L5

WW-P/SCKT-01

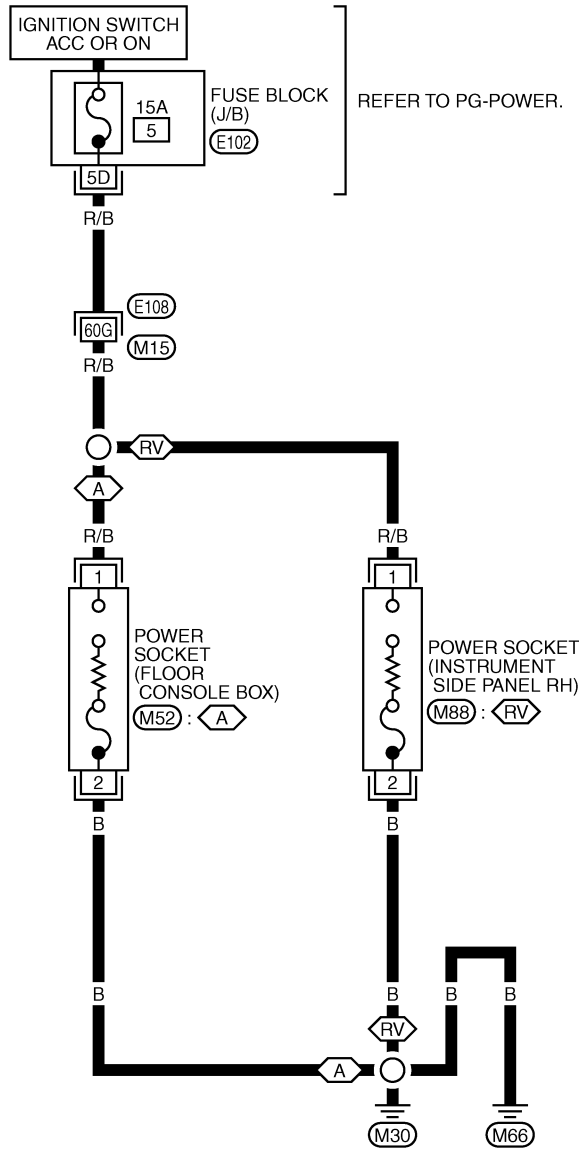

A : WITH A/T
RV : EXCEPT UP TO
SERIAL 099999

A
B
C
D
E
F
G
H
I
J
L
M

WW

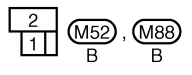

REFER TO THE FOLLOWING.
E108 -SUPER MULTIPLE
JUNCTION (SMJ)
E102 -FUSE BLOCK-
JUNCTION BOX (J/B)

TKWT0951E

POWER SOCKET

Removal and Installation for Console Power Socket

AKS005QP

REMOVAL

1. Remove console box assembly. Refer to [IP-10, "INSTRUMENT PANEL ASSEMBLY"](#) in "IP" section.
2. Disconnect power socket connector.
3. Remove inner socket from the ring, while pressing the hook on the ring out from square hole.
4. Remove ring from console box while pressing pawls.

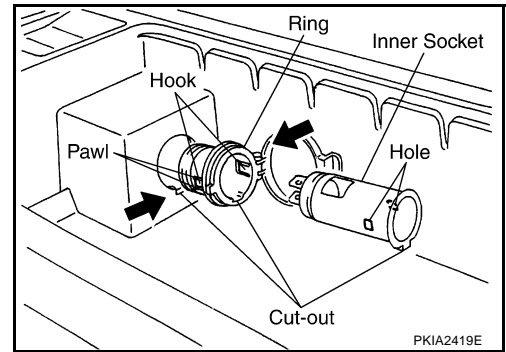

INSTALLTION

Install in the reverse order of removal.

HORN

HORN

PPF:25610

Wiring Diagram — HORN —

AKS000B3

WW-HORN-01

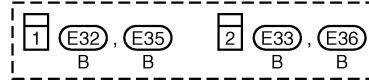
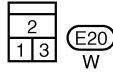
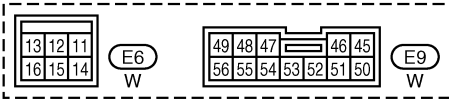
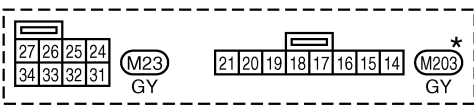
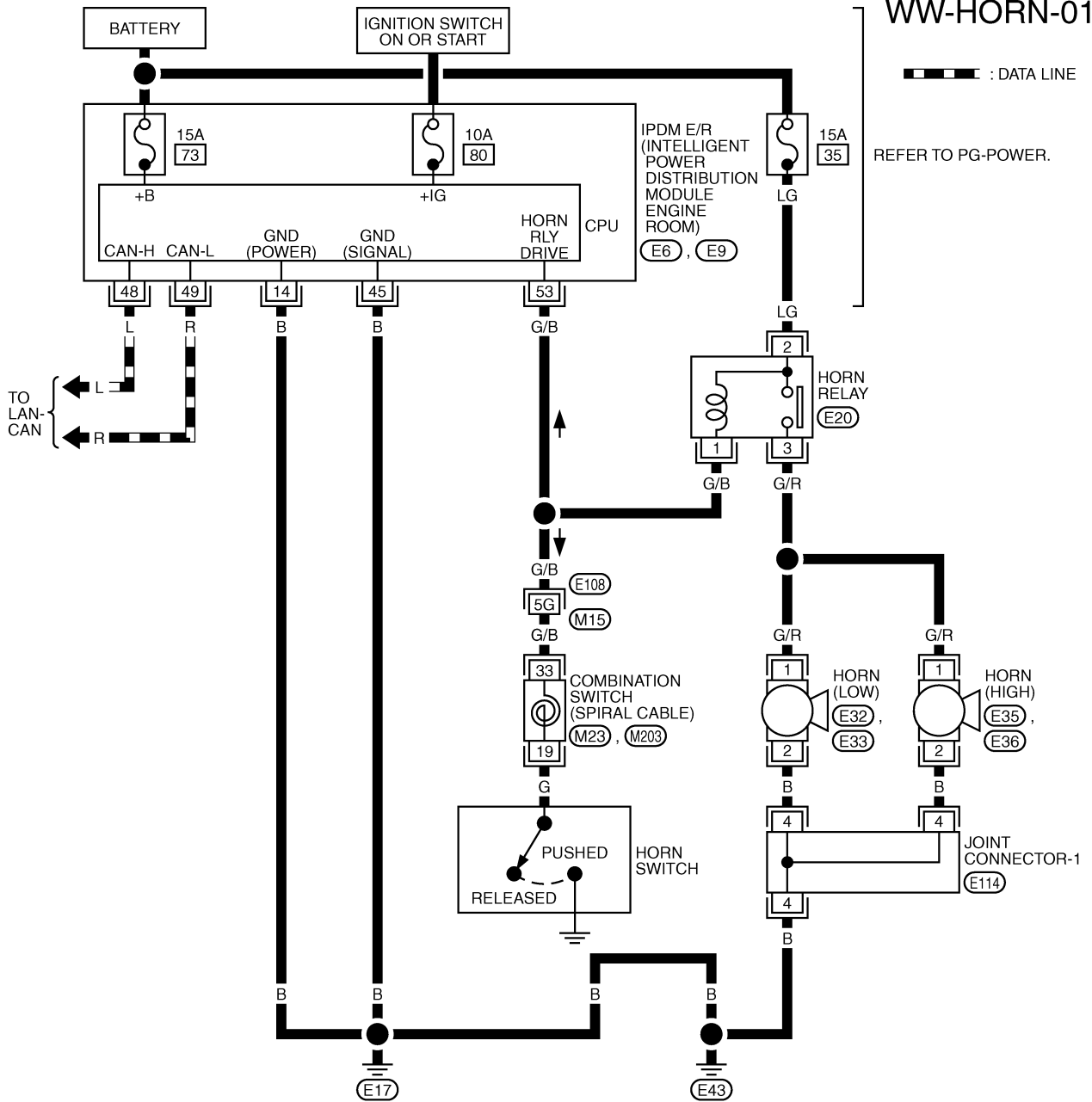

REFER TO THE FOLLOWING.

E108 -SUPER MULTIPLE JUNCTION (SMJ)

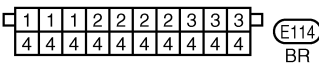

*: THIS CONNECTOR IS NOT SHOWN IN "HARNESS LAYOUT", PG SECTION.

TKWT0270E

HORN

Removal and Installation

AKS000B4

REMOVAL

1. Remove front grille. Refer to [EI-20, "FRONT GRILLE"](#) in "EI" section.
2. Disconnect all horn connectors.
3. Remove horn bolt and remove horn from vehicle.

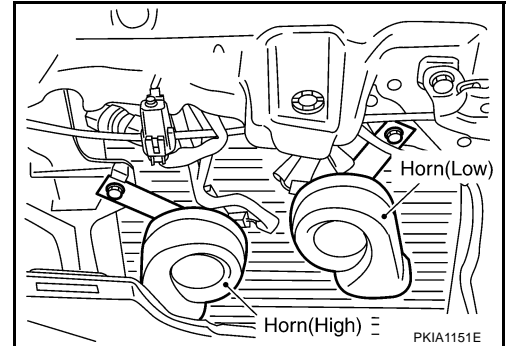

INSTALLATION

Tighten horn bolt to specified torque.

Horn bolt  : 17.1 N·m (1.7 kg·m, 13 ft·lb)