

# SECTION **ATC**

## AUTOMATIC AIR CONDITIONER

A  
B  
C  
D  
E  
F  
G  
H  
I  
J  
K  
L  
M

### CONTENTS

<p><b>PRECAUTIONS ..... 5</b></p> <p>Precautions for Supplemental Restraint System (SRS) "AIR BAG" and "SEAT BELT PRE-TENSIONER" ..... 5</p> <p>Precautions for Working with HFC-134a (R-134a)..... 5</p> <p style="padding-left: 20px;">CONTAMINATED REFRIGERANT ..... 6</p> <p>General Refrigerant Precautions ..... 6</p> <p>Lubricant Precautions ..... 6</p> <p>Precautions for Refrigerant Connection ..... 7</p> <p style="padding-left: 20px;">ABOUT ONE-TOUCH JOINT ..... 7</p> <p style="padding-left: 20px;">FEATURES OF NEW TYPE REFRIGERANT CONNECTION ..... 10</p> <p style="padding-left: 20px;">O-RING AND REFRIGERANT CONNECTION... 10</p> <p>Precautions for Servicing Compressor ..... 12</p> <p>Precautions for Service Equipment ..... 12</p> <p style="padding-left: 20px;">RECOVERY/RECYCLING EQUIPMENT ..... 12</p> <p style="padding-left: 20px;">ELECTRONIC LEAK DETECTOR ..... 12</p> <p style="padding-left: 20px;">VACUUM PUMP ..... 13</p> <p style="padding-left: 20px;">MANIFOLD GAUGE SET ..... 13</p> <p style="padding-left: 20px;">SERVICE HOSES ..... 13</p> <p style="padding-left: 20px;">SERVICE COUPLERS ..... 14</p> <p style="padding-left: 20px;">REFRIGERANT WEIGHT SCALE ..... 14</p> <p style="padding-left: 20px;">CHARGING CYLINDER ..... 14</p> <p>Precautions for Leak Detection Dye ..... 15</p> <p style="padding-left: 20px;">IDENTIFICATION ..... 15</p> <p style="padding-left: 20px;">IDENTIFICATION LABEL FOR VEHICLE ..... 15</p> <p>Wiring Diagrams and Trouble Diagnosis ..... 15</p> <p><b>PREPARATION ..... 16</b></p> <p>Special Service Tools ..... 16</p> <p>HFC-134a (R-134a) Service Tools and Equipment.. 17</p> <p>Commercial Service Tools ..... 19</p> <p><b>REFRIGERATION SYSTEM ..... 20</b></p> <p>Refrigerant Cycle ..... 20</p> <p style="padding-left: 20px;">REFRIGERANT FLOW ..... 20</p> <p style="padding-left: 20px;">FREEZE PROTECTION ..... 20</p> <p>Refrigerant System Protection ..... 20</p> <p style="padding-left: 20px;">REFRIGERANT PRESSURE SENSOR ..... 20</p> <p style="padding-left: 20px;">PRESSURE RELIEF VALVE ..... 20</p> <p>V-6 Variable Displacement Compressor ..... 21</p> <p style="padding-left: 20px;">GENERAL INFORMATION ..... 21</p>	<p>DESCRIPTION ..... 22</p> <p>Component Layout ..... 25</p> <p><b>LUBRICANT ..... 26</b></p> <p>Maintenance of Lubricant Quantity in Compressor.. 26</p> <p style="padding-left: 20px;">LUBRICANT ..... 26</p> <p style="padding-left: 20px;">LUBRICANT RETURN OPERATION ..... 26</p> <p style="padding-left: 20px;">LUBRICANT ADJUSTING PROCEDURE FOR COMPONENTS REPLACEMENT EXCEPT COMPRESSOR ..... 27</p> <p style="padding-left: 20px;">LUBRICANT ADJUSTING PROCEDURE FOR COMPRESSOR REPLACEMENT ..... 27</p> <p><b>AIR CONDITIONER CONTROL ..... 29</b></p> <p>Description of Air Conditioner LAN Control System.. 29</p> <p>System Construction ..... 29</p> <p style="padding-left: 20px;">OPERATION ..... 30</p> <p style="padding-left: 20px;">TRANSMISSION DATA AND TRANSMISSION ORDER ..... 30</p> <p style="padding-left: 20px;">AIR MIX DOOR CONTROL (AUTOMATIC TEMPERATURE CONTROL) ..... 31</p> <p style="padding-left: 20px;">FAN SPEED CONTROL ..... 31</p> <p style="padding-left: 20px;">INTAKE DOOR CONTROL ..... 31</p> <p style="padding-left: 20px;">OUTLET DOOR CONTROL ..... 31</p> <p style="padding-left: 20px;">MAGNET CLUTCH CONTROL ..... 32</p> <p style="padding-left: 20px;">SELF-DIAGNOSTIC SYSTEM ..... 32</p> <p>Description of Control System ..... 33</p> <p>Control Operation ..... 33</p> <p style="padding-left: 20px;">DISPLAY SCREEN ..... 34</p> <p style="padding-left: 20px;">AUTO.ECON SWITCH ..... 34</p> <p style="padding-left: 20px;">TEMPERATURE CONTROL DIAL (POTENTIAL TEMPERATURE CONTROL) ..... 34</p> <p style="padding-left: 20px;">RECIRCULATION (REC) SWITCH ..... 34</p> <p style="padding-left: 20px;">FRESH (FRE) SWITCH ..... 34</p> <p style="padding-left: 20px;">DEFROSTER (DEF) SWITCH ..... 34</p> <p style="padding-left: 20px;">REAR WINDOW DEFOGGER SWITCH ..... 34</p> <p style="padding-left: 20px;">OFF SWITCH ..... 34</p> <p style="padding-left: 20px;">A/C SWITCH ..... 34</p> <p style="padding-left: 20px;">MODE SWITCH ..... 34</p> <p style="padding-left: 20px;">FAN SWITCHES ..... 34</p> <p style="padding-left: 20px;">DUAL SWITCH (WITH LEFT AND RIGHT VENTILATION TEMPERATURE SEPARATELY</p>
--	--

ATC

CONTROL SYSTEM) .....	34	DOOR .....	76
Fail-Safe Function .....	35	Air Mix Door Motor PBR Circuit .....	76
Discharge Air Flow .....	36	DIAGNOSTIC PROCEDURE FOR AIR MIX	
System Description .....	37	DOOR PBR .....	76
SWITCHES AND THEIR CONTROL FUNCTION..	37	Intake Door Motor Circuit .....	77
CAN Communication System Description .....	38	INSPECTION FLOW .....	77
<b>TROUBLE DIAGNOSIS .....</b>	<b>39</b>	SYSTEM DESCRIPTION .....	78
CONSULT-II Function (BCM) .....	39	COMPONENT DESCRIPTION .....	79
CONSULT-II BASIC OPERATION .....	39	DIAGNOSTIC PROCEDURE FOR INTAKE	
DATA MONITOR .....	40	DOOR MOTOR .....	79
How to Perform Trouble Diagnosis for Quick and		Blower Motor Circuit .....	80
Accurate Repair .....	41	INSPECTION FLOW .....	80
WORK FLOW .....	41	SYSTEM DESCRIPTION .....	81
SYMPTOM TABLE .....	41	COMPONENT DESCRIPTION .....	82
Component Parts and Harness Connector Location..	42	DIAGNOSTIC PROCEDURE FOR BLOWER	
ENGINE COMPARTMENT .....	42	MOTOR .....	82
PASSENGER COMPARTMENT .....	43	COMPONENT INSPECTION .....	85
Schematic .....	44	Magnet Clutch Circuit .....	86
Wiring Diagram —A/C— .....	45	INSPECTION FLOW .....	86
Auto Amp. Terminals and Reference Value .....	50	SYSTEM DESCRIPTION .....	87
PIN CONNECTOR TERMINAL LAYOUT .....	50	DIAGNOSTIC PROCEDURE FOR MAGNET	
TERMINALS AND REFERENCE VALUE FOR		CLUTCH .....	87
DISPLAY AND A/C AUTO AMP. ....	50	COMPONENT INSPECTION .....	92
Self-Diagnosis Function .....	53	Insufficient Cooling .....	93
DESCRIPTION .....	53	INSPECTION FLOW .....	93
FUNCTION CONFIRMATION PROCEDURE .....	54	PERFORMANCE TEST DIAGNOSIS .....	95
AUXILIARY MECHANISM: TEMPERATURE		PERFORMANCE CHART .....	97
SETTING TRIMMER .....	60	TROUBLE DIAGNOSIS FOR UNUSUAL PRES-	
AUXILIARY MECHANISM: FOOT POSITION		SURE .....	99
SETTING TRIMMER .....	61	DIAGNOSTIC PROCEDURE FOR INSUFFI-	
AUXILIARY MECHANISM: INLET PORT MEM-		CIENT COOLING .....	101
ORY FUNCTION .....	61	Insufficient Heating .....	103
Operational Check .....	62	INSPECTION FLOW .....	103
CHECKING MEMORY FUNCTION .....	62	Noise .....	104
CHECKING BLOWER .....	62	INSPECTION FLOW .....	104
CHECKING DISCHARGE AIR .....	62	Self-Diagnosis .....	105
CHECKING RECIRCULATION .....	63	INSPECTION FLOW .....	105
CHECKING TEMPERATURE DECREASE .....	63	Memory Function .....	106
CHECKING TEMPERATURE INCREASE .....	63	INSPECTION FLOW .....	106
CHECK A/C SWITCH .....	63	Ambient Sensor Circuit .....	106
CHECKING AUTO. ECON MODE .....	64	COMPONENT DESCRIPTION .....	106
Power Supply and Ground Circuit for Auto Amp. ....	64	AMBIENT TEMPERATURE INPUT PROCESS..	107
INSPECTION FLOW .....	64	DIAGNOSTIC PROCEDURE FOR AMBIENT	
COMPONENT DESCRIPTION .....	65	SENSOR .....	107
DIAGNOSTIC PROCEDURE FOR A/C SYSTEM..	65	COMPONENT INSPECTION .....	108
LAN System Circuit .....	67	In-Vehicle Sensor Circuit .....	109
DIAGNOSTIC PROCEDURE FOR LAN CIR-		COMPONENT DESCRIPTION .....	109
CUIT .....	67	DIAGNOSTIC PROCEDURE FOR IN-VEHICLE	
Mode Door Motor Circuit .....	71	SENSOR .....	110
INSPECTION FLOW .....	71	COMPONENT INSPECTION .....	111
SYSTEM DESCRIPTION .....	72	Sunload Sensor Circuit .....	112
COMPONENT DESCRIPTION .....	73	COMPONENT DESCRIPTION .....	112
DIAGNOSTIC PROCEDURE FOR MODE		SUNLOAD INPUT PROCESS .....	112
DOOR MOTOR .....	73	DIAGNOSTIC PROCEDURE FOR SUNLOAD	
Air Mix Door Motor Circuit .....	74	SENSOR .....	112
INSPECTION FLOW .....	74	COMPONENT INSPECTION .....	114
SYSTEM DESCRIPTION .....	75	Intake Sensor Circuit .....	115
COMPONENT DESCRIPTION .....	76	COMPONENT DESCRIPTION .....	115
DIAGNOSTIC PROCEDURE FOR AIR MIX		DIAGNOSTIC PROCEDURE FOR INTAKE SEN-	

SOR .....	115	<b>AIR MIX DOOR MOTOR .....</b>	<b>135</b>	
COMPONENT INSPECTION .....	116	Removal and Installation .....	135	A
Multiplex Communication Circuit .....	117	REMOVAL .....	135	
DIAGNOSTIC PROCEDURE FOR MULTIPLEX		INSTALLATION .....	135	
COMMUNICATION .....	117	<b>DUCTS AND GRILLES .....</b>	<b>136</b>	B
<b>A/C AND AUDIO CONTROLLER .....</b>	<b>119</b>	Removal and Installation .....	136	
Removal and Installation .....	119	REMOVAL .....	136	
REMOVAL .....	119	INSTALLATION .....	139	
INSTALLATION .....	119	<b>REFRIGERANT LINES .....</b>	<b>140</b>	C
<b>AUTO AMP .....</b>	<b>120</b>	HFC-134a (R-134a) Service Procedure .....	140	
Removal and Installation of Display and A/C Auto		SETTING OF SERVICE TOOLS AND EQUIP-		D
Amp. ....	120	MENT .....	140	
REMOVAL .....	120	Components .....	142	
INSTALLATION .....	120	Removal and Installation of Compressor .....	142	
<b>AMBIENT SENSOR .....</b>	<b>121</b>	REMOVAL .....	142	E
Removal and Installation .....	121	INSTALLATION .....	144	
REMOVAL .....	121	Removal and Installation of Compressor Clutch ..	144	
INSTALLATION .....	121	REMOVAL .....	144	
<b>IN-VEHICLE SENSOR .....</b>	<b>122</b>	INSTALLATION .....	146	F
Removal and Installation .....	122	Removal and Installation of Low-pressure Flexible		
REMOVAL .....	122	Hose .....	147	
INSTALLATION .....	122	REMOVAL .....	147	G
<b>SUNLOAD SENSOR .....</b>	<b>123</b>	INSTALLATION .....	148	
Removal and Installation .....	123	Removal and Installation of High-Pressure Flexible		
REMOVAL .....	123	Hose .....	148	H
INSTALLATION .....	123	REMOVAL .....	148	
<b>INTAKE SENSOR .....</b>	<b>124</b>	INSTALLATION .....	149	I
Removal and Installation .....	124	Removal and Installation of Low-Pressure Pipe 1		
REMOVAL .....	124	(Engine Compartment) .....	149	
INSTALLATION .....	124	REMOVAL .....	149	
<b>BLOWER UNIT .....</b>	<b>125</b>	INSTALLATION .....	150	ATC
Removal and Installation .....	125	Removal and Installation of High-Pressure Pipe 1		
REMOVAL .....	125	(Engine Compartment) .....	150	
INSTALLATION .....	125	REMOVAL .....	150	
Disassembly and Assembly .....	126	INSTALLATION .....	151	K
<b>BLOWER MOTOR .....</b>	<b>127</b>	Removal and Installation of Low-Pressure Pipe 2		
Removal and Installation .....	127	and High-pressure Pipe 2 .....	151	
REMOVAL .....	127	REMOVAL .....	151	L
INSTALLATION .....	127	INSTALLATION .....	152	
<b>INTAKE DOOR MOTOR .....</b>	<b>128</b>	Removal and Installation of Liquid Tank .....	153	
Removal and Installation .....	128	REMOVAL .....	153	M
REMOVAL .....	128	INSTALLATION .....	153	
INSTALLATION .....	128	Removal and Installation of Condenser .....	154	
<b>IN-CABIN MICROFILTER .....</b>	<b>129</b>	REMOVAL .....	154	
Removal and Installation .....	129	INSTALLATION .....	155	
FUNCTION .....	129	Removal and Installation of Refrigerant Pressure		
REPLACEMENT TIMING .....	129	Sensor .....	155	
REPLACEMENT PROCEDURES .....	129	REMOVAL .....	155	
<b>HEATER &amp; COOLING UNIT ASSEMBLY .....</b>	<b>130</b>	INSTALLATION .....	155	
Removal and Installation .....	130	Removal and Installation of Evaporator .....	156	
REMOVAL .....	130	REMOVAL .....	156	
INSTALLATION .....	131	INSTALLATION .....	156	
Disassembly and Assembly .....	132	Removal and Installation of Expansion Valve .....	157	
<b>MODE DOOR MOTOR .....</b>	<b>134</b>	REMOVAL .....	157	
Removal and Installation .....	134	INSTALLATION .....	157	
REMOVAL .....	134	Checking for Refrigerant Leaks .....	158	
INSTALLATION .....	134	Checking System for Leaks Using the Fluorescent		
		Leak Detector .....	158	

---

Dye Injection .....	158	Compressor .....	162
Electronic Refrigerant Leak Detector .....	159	Lubricant .....	162
PRECAUTIONS FOR HANDLING LEAK		Refrigerant .....	162
DETECTOR .....	159	Engine Idling Speed .....	162
CHECKING PROCEDURE .....	160	Belt Tension .....	162
<b>SERVICE DATA AND SPECIFICATIONS (SDS) ...</b>	<b>162</b>		

# PRECAUTIONS

## PRECAUTIONS

PFP:00001

### Precautions for Supplemental Restraint System (SRS) “AIR BAG” and “SEAT BELT PRE-TENSIONER”

AJS001P0

The Supplemental Restraint System such as “AIR BAG” and “SEAT BELT PRE-TENSIONER”, used along with a front seat belt, helps to reduce the risk or severity of injury to the driver and front passenger for certain types of collision. This system includes seat belt switch inputs and dual stage front air bag modules. The SRS system uses the seat belt switches to determine the front air bag deployment, and may only deploy one front air bag, depending on the severity of a collision and whether the front occupants are belted or unbelted. Information necessary to service the system safely is included in the SRS and SB section of this Service Manual.

#### **WARNING:**

- To avoid rendering the SRS inoperative, which could increase the risk of personal injury or death in the event of a collision which would result in air bag inflation, all maintenance must be performed by an authorized NISSAN/INFINITI dealer.
- Improper maintenance, including incorrect removal and installation of the SRS, can lead to personal injury caused by unintentional activation of the system. For removal of Spiral Cable and Air Bag Module, see the SRS section.
- Do not use electrical test equipment on any circuit related to the SRS unless instructed to in this Service Manual. SRS wiring harnesses can be identified by yellow and/or orange harnesses or harness connectors.

### Precautions for Working with HFC-134a (R-134a)

AJS00118

#### **WARNING:**

- CFC-12 (R-12) refrigerant and HFC-134a (R-134a) refrigerant are not compatible. If the refrigerants are mixed and compressor malfunction is likely to occur, refer to “CONTAMINATED REFRIGERANT” below. To determine the purity of HFC-134a (R-134a) in the vehicle and recovery tank, use Refrigerant Recovery/Recycling Recharging equipment and Refrigerant Identifier.
- Use only specified lubricant for the HFC-134a (R-134a) A/C system and HFC-134a (R-134a) components. If lubricant other than that specified is used, compressor malfunction is likely to occur.
- The specified HFC-134a (R-134a) lubricant rapidly absorbs moisture from the atmosphere. The following handling precautions must be observed:
  - When removing refrigerant components from a vehicle, immediately cap (seal) the component to minimize the entry of moisture from the atmosphere.
  - When installing refrigerant components to a vehicle, do not remove the caps (unseal) until just before connecting the components. Connect all refrigerant loop components as quickly as possible to minimize the entry of moisture into system.
  - Only use the specified lubricant from a sealed container. Immediately reseal containers of lubricant. Without proper sealing, lubricant will become moisture saturated and should not be used.
  - Avoid breathing A/C refrigerant and lubricant vapor or mist. Exposure may irritate eyes, nose and throat. Remove HFC-134a (R-134a) from the A/C system, using certified service equipment meeting requirements of SAE J-2210 [HFC-134a (R-134a) recycling equipment], or J-2209 [HFC-134a (R-134a) recovery equipment]. If accidental system discharge occurs, ventilate work area before resuming service. Additional health and safety information may be obtained from refrigerant and lubricant manufacturers.
  - Do not allow lubricant (Nissan A/C System Oil Type S) to come in contact with styrofoam parts. Damage may result.

# PRECAUTIONS

## CONTAMINATED REFRIGERANT

If a refrigerant other than pure HFC-134a (R-134a) is identified in a vehicle, your options are:

- Explain to the customer that environmental regulations prohibit the release of contaminated refrigerant into the atmosphere.
- Explain that recovery of the contaminated refrigerant could damage your service equipment and refrigerant supply.
- Suggest the customer return the vehicle to the location of previous service where the contamination may have occurred.
- If you choose to perform the repair, recover the refrigerant using only **dedicated equipment and containers. Do not recover contaminated refrigerant into your existing service equipment.** If your facility does not have dedicated recovery equipment, you may contact a local refrigerant product retailer for available service. This refrigerant must be disposed of in accordance with all federal and local regulations. In addition, replacement of all refrigerant system components on the vehicle is recommended.
- If the vehicle is within the warranty period, the air conditioner warranty is void. Please contact Nissan Customer Affairs for further assistance.

## General Refrigerant Precautions

AJS00119

### WARNING:

- **Do not release refrigerant into the air. Use approved recovery/recycling equipment to capture the refrigerant every time an air conditioning system is discharged.**
- **Always wear eye and hand protection (goggles and gloves) when working with any refrigerant or air conditioning system.**
- **Do not store or heat refrigerant containers above 52°C (125°F).**
- **Do not heat a refrigerant container with an open flame; if container warming is required, place the bottom of the container in a warm pail of water.**
- **Do not intentionally drop, puncture, or incinerate refrigerant containers.**
- **Keep refrigerant away from open flames: poisonous gas will be produced if refrigerant burns.**
- **Refrigerant will displace oxygen, therefore be certain to work in well ventilated areas to prevent suffocation.**
- **Do not pressure test or leak test HFC-134a (R-134a) service equipment and/or vehicle air conditioning systems with compressed air during repair. Some mixtures of air and HFC-134a (R-134a) have been shown to be combustible at elevated pressures. These mixtures, if ignited, may cause injury or property damage. Additional health and safety information may be obtained from refrigerant manufacturers.**

## Lubricant Precautions

AJS0011A

- Use only specified lubricant for the HFC-134a (R-134a) A/C system and HFC-134a (R-134a) components. If lubricant other than that specified is used, compressor malfunction is likely to occur.
- The specified HFC-134a (R-134a) lubricant rapidly absorbs moisture from the atmosphere. The following handling precautions must be observed:
  - When removing refrigerant components from a vehicle, immediately cap (seal) the component to minimize the entry of moisture from the atmosphere.
  - When installing refrigerant components to a vehicle, do not remove the caps (unseal) until just before connecting the components. Connect all refrigerant loop components as quickly as possible to minimize the entry of moisture into system.
  - Only use the specified lubricant from a sealed container. Immediately reseal containers of lubricant. Without proper sealing, lubricant will become moisture saturated and should not be used.
- Avoid breathing A/C refrigerant and lubricant vapor or mist. Exposure may irritate eyes, nose and throat. Remove HFC-134a (R-134a) from the A/C system, using certified service equipment meeting requirements of SAE J-2210 [HFC-134a (R-134a) recycling equipment], or J-2209 [HFC-134a (R-134a) recovery equipment]. If accidental system discharge occurs, ventilate work area before resuming service. Additional health and safety information may be obtained from refrigerant and lubricant manufacturers.
- Do not allow lubricant (Nissan A/C System Oil Type S) to come in contact with styrofoam parts. Damage may result.

# PRECAUTIONS

AJS0011B

## Precautions for Refrigerant Connection

A new type refrigerant connection has been introduced to all refrigerant lines except the following location.

- Expansion valve to evaporator
- Refrigerant pressure sensor to condenser

### ABOUT ONE-TOUCH JOINT

#### Description

- One-touch joints are pipe joints which do not require tools during piping connection.
- Unlike conventional connection methods using union nuts and flanges, controlling tightening torque at connection point is not necessary.
- When removing a pipe joint, use a disconnecter.

#### COMPONENT PARTS

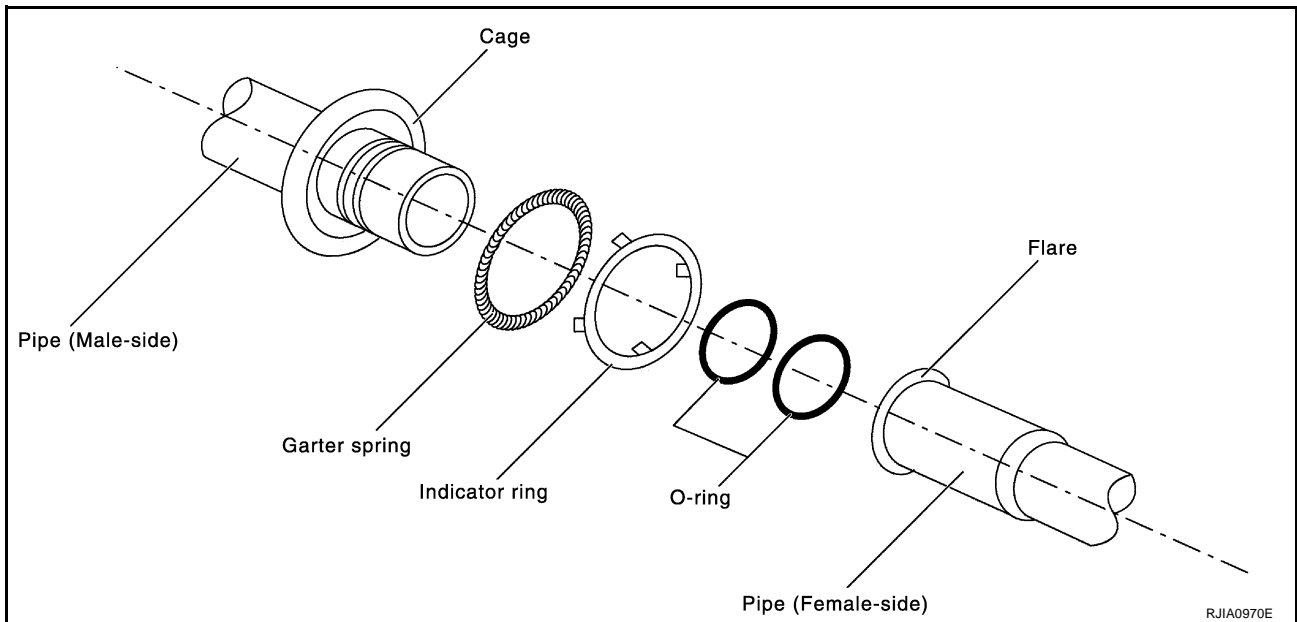

#### FUNCTIONS OF COMPONENT PARTS

Pipe (Male side)	<ul style="list-style-type: none"> <li>● Retains O-rings.</li> <li>● Retains garter spring in cage.</li> </ul>
Garter spring	Anchors female side piping.
Indicator ring	When connection is made properly, this is ejected from male-side piping. (This part is no longer necessary after connection.)
O-ring	Seals connection point. (Not reusable)
Pipe (Female side)	<ul style="list-style-type: none"> <li>● Seals connection by compressing O-rings.</li> <li>● Anchors piping connection using flare and garter spring.</li> </ul>

#### NOTE:

- Garter spring cannot be removed from cage of male-side piping.
- Indicator ring remains near piping connection point, however, this is not a malfunction. (This is to check piping connection during factory assembly.)

A  
B  
C  
D  
E  
F  
G  
H  
I  
K  
L  
M

ATC

# PRECAUTIONS

## REMOVAL

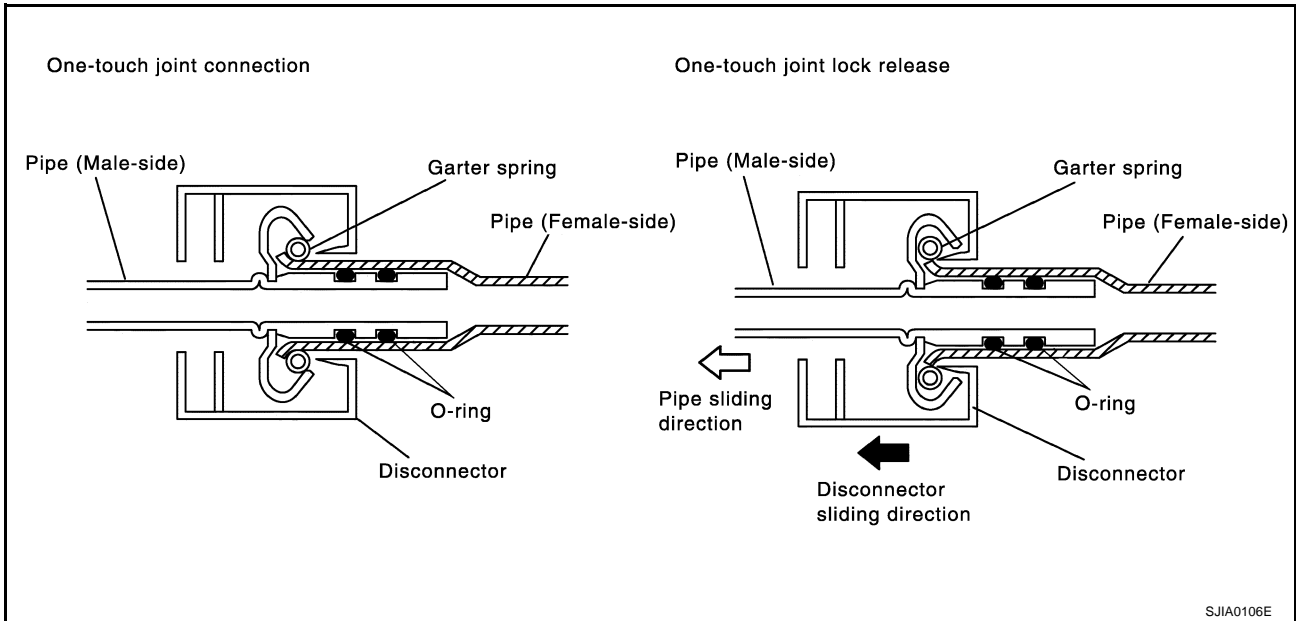

1. Clean piping connection point, and set a disconnecter.
2. Slide disconnecter in axial direction of piping, and stretch garter spring with tapered point of disconnecter.
3. Slide disconnecter farther so that inside diameter of garter spring becomes larger than outside diameter of female-side piping flare. Then male-side piping can be disconnected.

## INSTALLATION

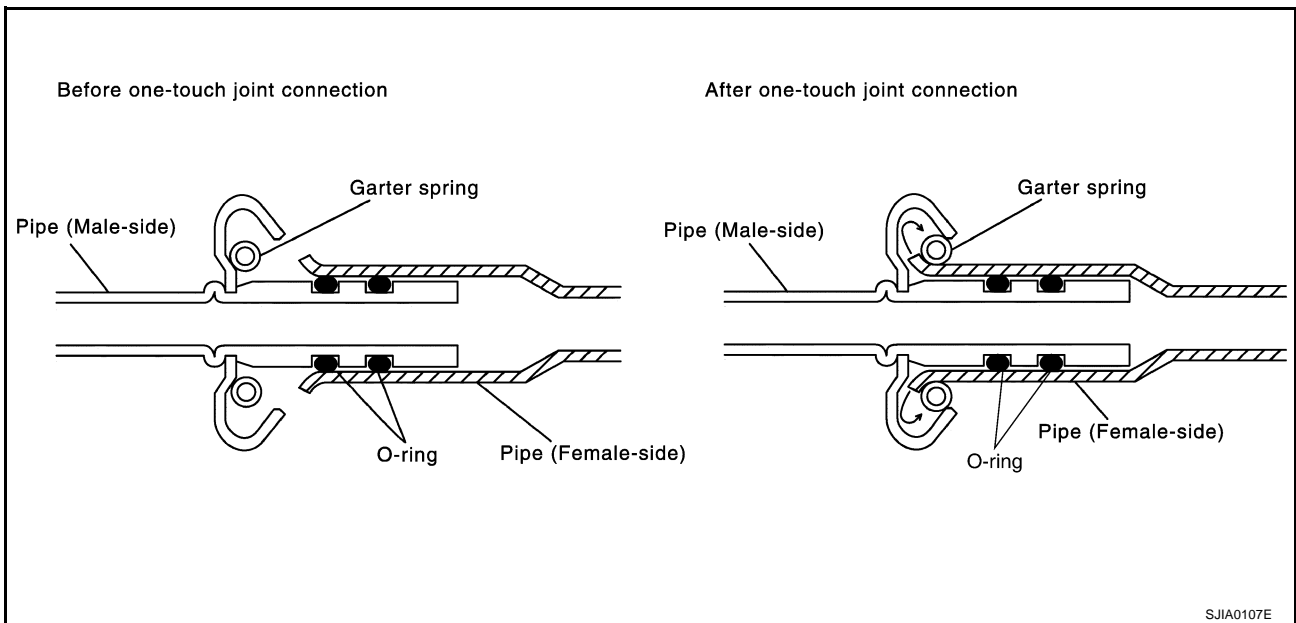

1. Clean piping connection points, and insert male-side piping into female-side piping.
2. Push inserted male-side piping harder so that female-side piping flare stretches garter spring.
3. If inside diameter of garter spring becomes larger than outside diameter of female-side piping flare, garter spring seats on flare. Then, it fits in between male-side piping cage and female-side piping flare to anchor piping connection point.

### NOTICE:

When garter spring seats on flare, and fits in between male-side piping cage and female-side piping flare, it clicks.

### CAUTION:

- Female-side piping connection point is thin. So, when inserting male-side piping, take care not to deform female-side piping. Slowly insert it in axial direction.
- Insert piping securely until a click is heard.



## PRECAUTIONS

- 
- After piping connection is completed, pull male-side piping by hand to make sure that connection does not come loose.

**NOTE:**

One-touch joint connection is used in points below.

- Low-pressure flexible hose to low-pressure pipe 1 (O-ring size: 16)
- Low-pressure pipe 1 to low-pressure pipe 2 (O-ring size: 16)
- High-pressure flexible hose to condenser (O-ring size: 12)
- High-pressure pipe 1 to evaporator (O-ring size: 8)
- High-pressure pipe 1 to condenser (O-ring size: 8)

A

B

C

D

E

F

G

H

I

ATC

K

L

M

# PRECAUTIONS

## FEATURES OF NEW TYPE REFRIGERANT CONNECTION

- The O-ring has been relocated. It has also been provided with a groove for proper installation. This eliminates the chance of the O-ring being caught in, or damaged by, the mating part. The sealing direction of the O-ring is now set vertically in relation to the contacting surface of the mating part to improve sealing characteristics.
- The reaction force of the O-ring will not occur in the direction that causes the joint to pull out, thereby facilitating piping connections.

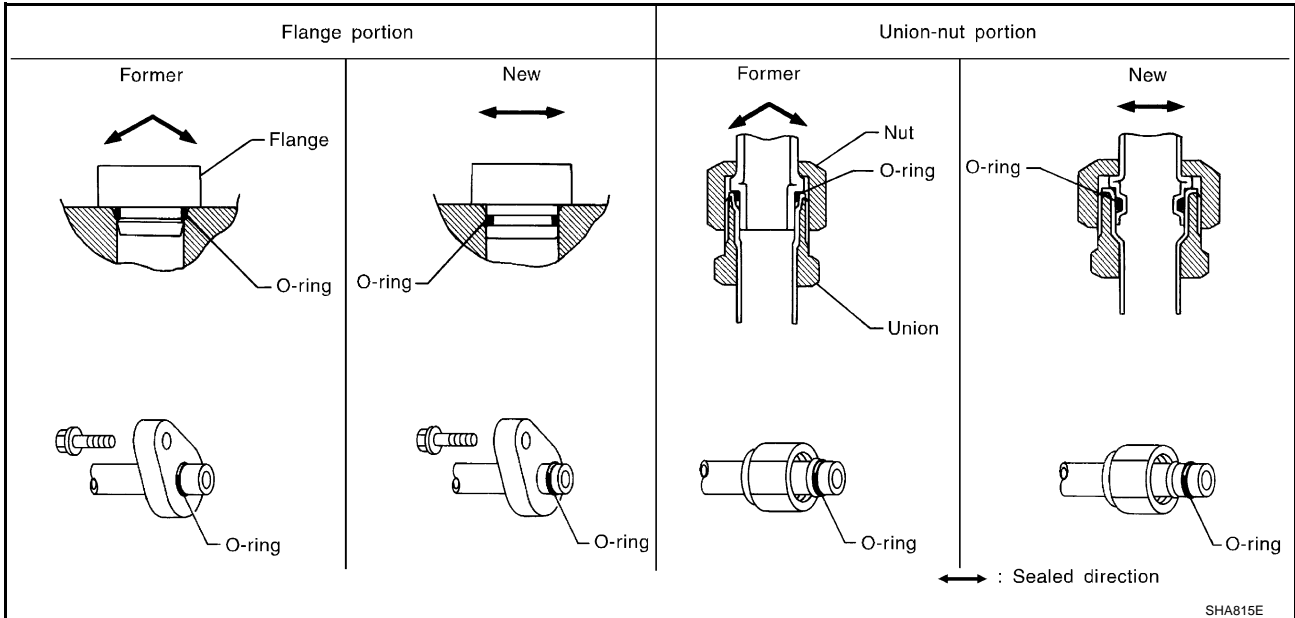

## O-RING AND REFRIGERANT CONNECTION

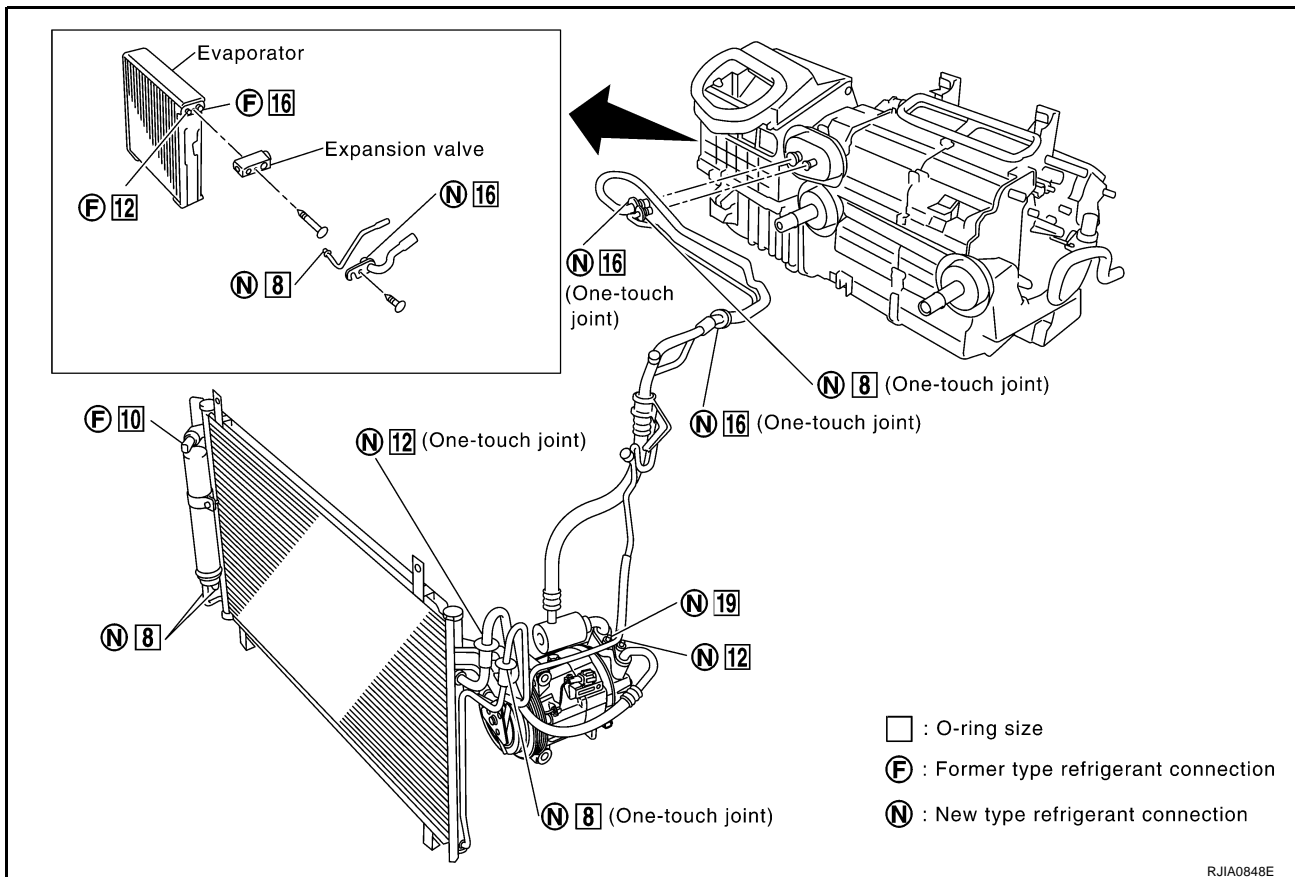

# PRECAUTIONS

## CAUTION:

The new and former refrigerant connections use different O-ring configurations. Do not confuse O-rings since they are not interchangeable. If a wrong O-ring is installed, refrigerant will leak at, or around, the connection.

## O-Ring Part Numbers and Specifications

Connection type	Piping connection point		Part number	QTY	O-ring size	
New	Low-pressure flexible hose to low-pressure pipe 1 (One-touch joint)		92473 N8221	2	16	
	Low-pressure pipe 1 to low-pressure pipe 2 (One-touch joint)		92473 N8221	2	16	
	High-pressure pipe 1 to high-pressure pipe 2 (One-touch joint)		92471 N8221	2	8	
	Condenser to high-pressure flexible hose (One-touch joint)		92472 N8221	2	12	
	Condenser to high-pressure pipe 1 (One-touch joint)		92471 N8221	2	8	
	Low-pressure pipe 2 to expansion valve		92473 N8210	1	16	
	High-pressure pipe 2 to expansion valve		92471 N8210	1	8	
	Compressor to low-pressure flexible hose		92474 N8210	1	19	
	Compressor to high-pressure flexible hose		92472 N8210	1	12	
	Liquid tank to condenser pipe		Inlet	92471 N8210	1	8
Outlet			1			
Former	Refrigerant pressure sensor to condenser		J2476 89956	1	10	
	Expansion valve to evaporator		Inlet	92475 71L00	1	12
			Outlet	92475 72L00	1	16

## WARNING:

Make sure all refrigerant is discharged into the recycling equipment and the pressure in the system is less than atmospheric pressure. Then gradually loosen the discharge side hose fitting and remove it.

## CAUTION:

When replacing or cleaning refrigerant cycle components, observe the following.

- When the compressor is removed, store it in the same position as it is when mounted on the car. Malfunction to do so will cause lubricant to enter the low-pressure chamber.
- When connecting tubes, always use a torque wrench and a back-up wrench.
- After disconnecting tubes, immediately plug all openings to prevent entry of dirt and moisture.
- When installing an air conditioner in the vehicle, connect the pipes as the final stage of the operation. Do not remove the seal caps of pipes and other components until just before required for connection.
- Allow components stored in cool areas to warm to working area temperature before removing seal caps. This prevents condensation from forming inside A/C components.
- Thoroughly remove moisture from the refrigeration system before charging the refrigerant.
- Always replace used O-rings.
- When connecting tube, apply lubricant to circle of the O-rings shown in illustration. Be careful not to apply lubricant to threaded portion.

**Lubricant name** : Nissan A/C System Oil Type S

**Part number** : KLH00-PAGS0

- O-ring must be closely attached to dented portion of tube.
- When replacing the O-ring, be careful not to damage O-ring and tube.
- Connect tube until you hear it click, then tighten the nut or bolt by hand until snug. Make sure that the O-ring is installed to tube correctly.

## PRECAUTIONS

- After connecting line, perform leak test and make sure that there is no leakage from connections. When the refrigerant leaking point is found, disconnect that line and replace the O-ring. Then tighten connections of seal seat to the specified torque.

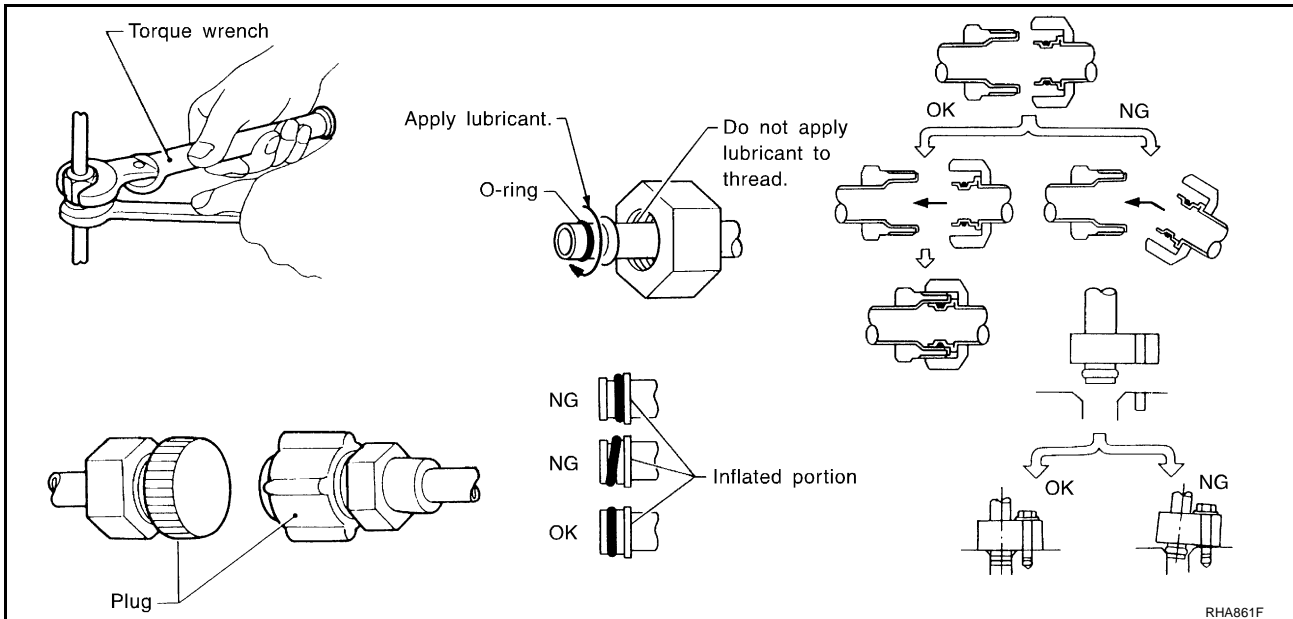

### Precautions for Servicing Compressor

AJS0011C

- Plug all openings to prevent moisture and foreign matter from entering.
- When the compressor is removed, store it in the same position as it is when mounted on the car.
- When replacing or repairing compressor, follow "Maintenance of Lubricant Quantity in Compressor" exactly. Refer to [ATC-26, "Maintenance of Lubricant Quantity in Compressor"](#).
- Keep friction surfaces between clutch and pulley clean. If the surface is contaminated, with lubricant, wipe it off by using a clean waste cloth moistened with thinner.
- After compressor service operation, turn the compressor shaft by hand more than five turns in both directions. This will equally distribute lubricant inside the compressor. After the compressor is installed, let the engine idle and operate the compressor for one hour.
- After replacing the compressor magnet clutch, apply voltage to the new one and check for usual operation.

### Precautions for Service Equipment RECOVERY/RECYCLING EQUIPMENT

AJS0011D

Be certain to follow the manufacturer's instructions for machine operation and machine maintenance. Never introduce any refrigerant other than that specified into the machine.

### ELECTRONIC LEAK DETECTOR

Be certain to follow the manufacturer's instructions for tester operation and tester maintenance.

# PRECAUTIONS

## VACUUM PUMP

The lubricant contained inside the vacuum pump is not compatible with the specified lubricant for HFC-134a (R-134a) A/C systems. The vent side of the vacuum pump is exposed to atmospheric pressure. So the vacuum pump lubricant may migrate out of the pump into the service hose. This is possible when the pump is switched off after evacuation (vacuuming) and hose is connected to it.

To prevent this migration, use a manual valve placed near the hose-to-pump connection, as follows.

- Usually vacuum pumps have a manual isolator valve as part of the pump. Close this valve to isolate the service hose from the pump.
- For pumps without an isolator, use a hose equipped with a manual shut-off valve near the pump end. Close the valve to isolate the hose from the pump.
- If the hose has an automatic shut-off valve, disconnect the hose from the pump. As long as the hose is connected, the valve is open and lubricating oil may migrate.

Some one-way valves open when vacuum is applied and close under a no vacuum condition. Such valves may restrict the pump's ability to pull a deep vacuum and are not recommended.

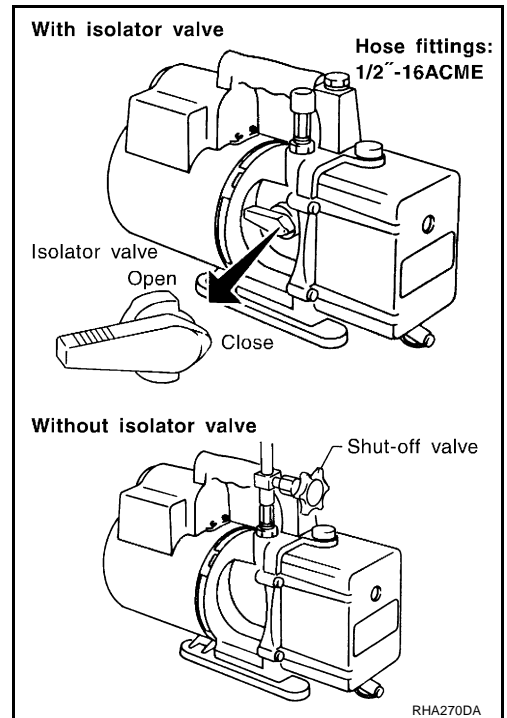

## MANIFOLD GAUGE SET

Be certain that the gauge face indicates HFC-134a or R-134a. Be sure the gauge set has 1/2"-16 ACME threaded connections for service hoses. Confirm the set has been used only with refrigerant HFC-134a (R-134a) and specified lubricants.

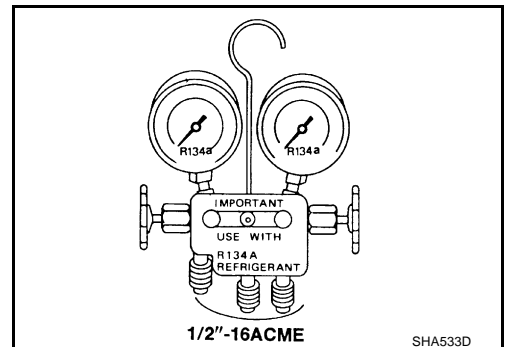

## SERVICE HOSES

Be certain that the service hoses display the markings described (colored hose with black stripe). All hoses must include positive shut-off devices (either manual or automatic) near the end of the hoses opposite the manifold gauge.

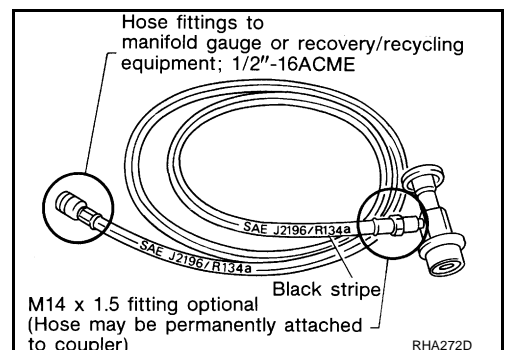

A  
B  
C  
D  
E  
F  
G  
H  
I  
K  
L  
M

ATC

# PRECAUTIONS

## SERVICE COUPLERS

Never attempt to connect HFC-134a (R-134a) service couplers to a CFC-12 (R-12) A/C system. The HFC-134a (R-134a) couplers will not properly connect to the CFC-12 (R-12) system. However, if an improper connection is attempted, discharging and contamination may occur.

Shut-off valve rotation	A/C service valve
Clockwise	Open
Counterclockwise	Close

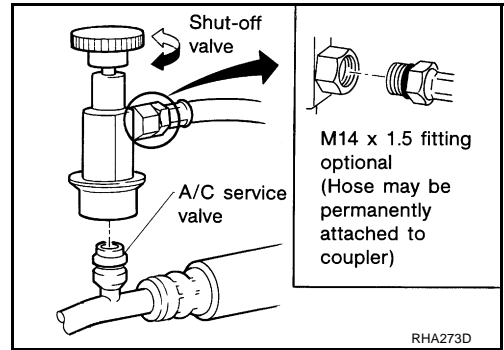

## REFRIGERANT WEIGHT SCALE

Verify that no refrigerant other than HFC-134a (R-134a) and specified lubricants have been used with the scale. If the scale controls refrigerant flow electronically, the hose fitting must be 1/2"-16 ACME.

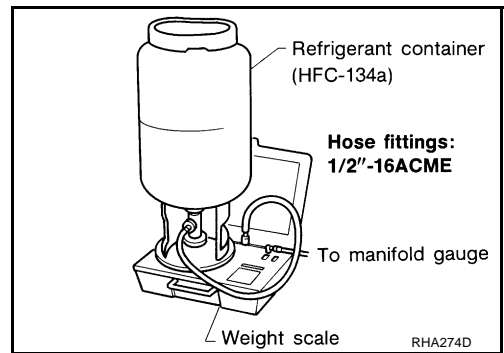

## CHARGING CYLINDER

Using a charging cylinder is not recommended. Refrigerant may be vented into air from cylinder's top valve when filling the cylinder with refrigerant. Also, the accuracy of the cylinder is generally less than that of an electronic scale or of quality recycle/recharge equipment.

# PRECAUTIONS

AJS0011E

## Precautions for Leak Detection Dye

- The A/C system contains a fluorescent leak detection dye used for locating refrigerant leaks. An ultraviolet (UV) lamp is required to illuminate the dye when inspecting for leaks.
- Always wear fluorescence enhancing UV safety goggles to protect your eyes and enhance the visibility of the fluorescent dye.
- The fluorescent dye leak detector is not a replacement for an electronic refrigerant leak detector. The fluorescent dye leak detector should be used in conjunction with an electronic refrigerant leak detector (J-41995) to pin-point refrigerant leaks.
- For your safety and your customer's satisfaction, read and follow all manufacturer's operating instructions and precautions prior to performing the work.
- A compressor shaft seal should not be repaired because of dye seepage. The compressor shaft seal should only be repaired after confirming the leak with an electronic refrigerant leak detector (J-41995).
- Always remove any remaining dye from the leak area after repairs are complete to avoid a misdiagnosis during a future service.
- Do not allow dye to come into contact with painted body panels or interior components. If dye is spilled, clean immediately with the approved dye cleaner. Fluorescent dye left on a surface for an extended period of time cannot be removed.
- Do not spray the fluorescent dye cleaning agent on hot surfaces (engine exhaust manifold, etc.).
- Do not use more than one refrigerant dye bottle (1/4 ounce /7.4 cc) per A/C system.
- Leak detection dyes for HFC-134a (R-134a) and CFC-12 (R-12) A/C systems are different. Do not use HFC-134a (R-134a) leak detection dye in CFC-12 (R-12) A/C system or CFC-12 (R-12) leak detector dye in HFC-134a (R-134a) A/C system or A/C system damage may result.
- The fluorescent properties of the dye will remain for over three (3) years unless a compressor malfunction occurs.

## IDENTIFICATION

### NOTE:

Vehicles with factory installed fluorescent dye have a green label.  
Vehicles without factory installed fluorescent dye have a blue label.

## IDENTIFICATION LABEL FOR VEHICLE

Vehicles with factory installed fluorescent dye have this identification label on the front side of hood.

AIR CONDITIONER <small>NISSAN</small>		
	REFRIGERANT	COMPRESSOR LUBRICANT
TYPE (PART NO.)	HFC134a (R134a)	Nissan UV Luminous Oil Type S [KLHOO-PAGSO]
AMOUNT		

**CAUTION PRECAUTION**

- REFRIGERANT UNDER HIGH PRESSURE.
- SYSTEM TO BE SERVICED BY QUALIFIED PERSONNEL.
- IMPROPER SERVICE METHODS MAY CAUSE PERSONAL INJURY.
- CONSULT SERVICE MANUAL.
- THIS AIR CONDITIONER SYSTEM COMPLIES WITH SAE J-639.

Nissan Motor Co., Ltd., TOKYO, Japan

27090 6P102

SHA436FA

## Wiring Diagrams and Trouble Diagnosis

AJS0011F

When you read wiring diagrams, refer to the following:

- [GI-14, "How to Read Wiring Diagrams"](#) in GI section.
- [PG-4, "Wiring Diagram - POWER -"](#) in PG section.

When you perform trouble diagnosis, refer to the following:

- [GI-10, "How to Follow Trouble Diagnoses"](#) in GI section.
- [GI-26, "How to Perform Efficient Diagnosis for an Electrical Incident"](#) in GI section.

# PREPARATION

## PREPARATION

PFP:00002

### Special Service Tools

AJS0011G

The actual shapes of Kent-Moore tools may differ from those of special service tools illustrated here.

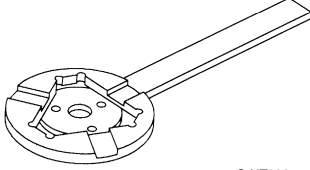
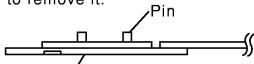
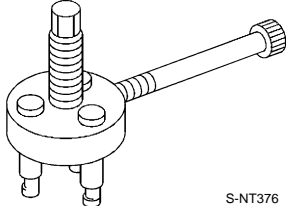
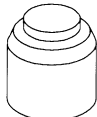
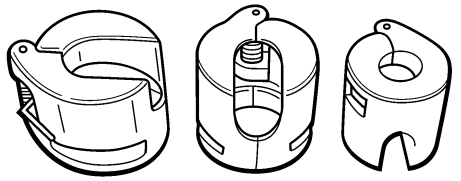
Tool number (Kent-Moore No.) Tool name	Description
<p>KV99106100 (J-41260) Clutch disc wrench</p>  <p style="text-align: right;">S-NT232</p> <p>When replacing the magnetic clutch in the above compressor, use a clutch disc wrench with the pin side on the clutch disc to remove it.</p>  <p style="text-align: right;">RJIA0194E</p>	<p>Removing shaft nut and clutch disc</p>
<p>KV99232340 (J-38874) Clutch disc puller</p>  <p style="text-align: right;">S-NT376</p>	<p>Removing clutch disc</p>
<p>KV99106200 (J-41261) Pulley installer</p>  <p style="text-align: right;">S-NT235</p>	<p>Installing pulley</p>
<p>92530 89908 (for high-pressure pipe 1) (-) 92530 89912 (for high-pressure flexible hose) (-) 92530 89916 (for low-pressure pipe 1 and low-pressure flexible hose) (-) Disconnecter tool set (J-45815)</p>  <p style="text-align: center;">             92530 89916 (16 mm)    92530 89912 (12 mm)    92530 89908 (8 mm)         </p> <p style="text-align: center;">Disconnecter tool set : J-45815</p> <p style="text-align: right;">SJIA0285E</p>	<p>Disconnect one-touch joint connection</p>



# PREPARATION

## HFC-134a (R-134a) Service Tools and Equipment



AJS0011H

Never mix HFC-134a (R-134a) refrigerant and/or its specified lubricant with CFC-12 (R-12) refrigerant and/or its lubricant.

Separate and non-interchangeable service equipment must be used for handling each type of refrigerant/lubricant.

Refrigerant container fittings, service hose fittings and service equipment fittings (equipment which handles refrigerant and/or lubricant) are different between CFC-12 (R-12) and HFC-134a (R-134a). This is to avoid mixed use of the refrigerants/lubricant.

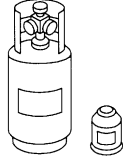

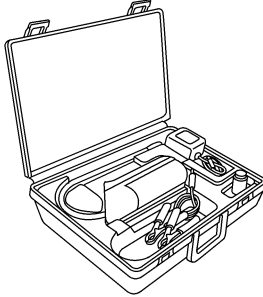

Adapters that convert one size fitting to another must never be used: refrigerant/lubricant contamination will occur and compressor malfunction will result.

Tool number (Kent-Moore No.) Tool name	Description
<p>HFC-134a (R-134a) refrigerant</p>  <p style="text-align: center;">S-NT196</p>	<p>Container color: Light blue Container marking: HFC-134a (R-134a) Fitting size: Thread size</p> <ul style="list-style-type: none"> <li>● Large container 1/2" -16 ACME</li> </ul>
<p>KLH00-PAGS0 (-) Nissan A/C System Oil Type S (DH-PS)</p>  <p style="text-align: center;">S-NT197</p>	<p>Type: Polyalkylene glycol oil (PAG), type S (DH-PS) Application: HFC-134a (R-134a) wobble (swash) plate compressors (Nissan only) Lubricity: 40 m ℓ (1.4 US fl oz., 1.4 Imp fl oz.)</p>
<p>(J-43600) Recovery/Recycling/ Recharging equipment (ACR2000)</p>  <p style="text-align: center;">WJIA0293E</p>	<p>Function: Refrigerant recovery and recycling and recharging</p>
<p>(J-41995) Electrical leak detector</p>  <p style="text-align: center;">AHA281A</p>	<p>Power supply: DC 12V (Battery terminal)</p>

A  
B  
C  
D  
E  
F  
G  
H  
I  
K  
L  
M

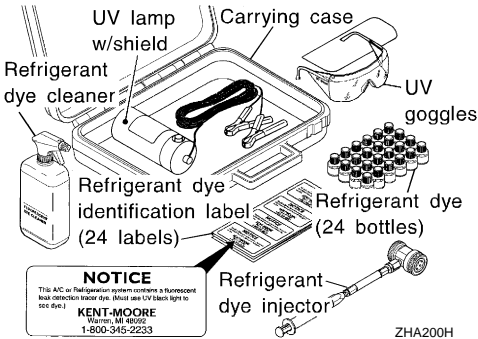
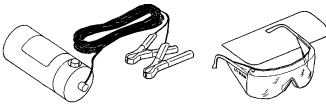
ATC

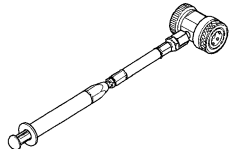
# PREPARATION

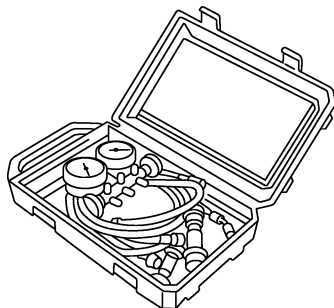
Tool number (Kent-Moore No.) Tool name	Description
(J-43926) Refrigerant dye leak detection kit Kit includes: (J-42220) UV lamp and UV safety goggles (J-41459) HFC-134a (R-134a) dye injector Use with J-41447, 1/4 ounce bottle (J-41447) HFC-134a (R-134a) fluorescent leak detection dye (Box of 24, 1/4 ounce bottles) (J-43872) Refrigerant dye cleaner	 <p>Power supply: DC 12V (Battery terminal)</p>
(J-42220) UV lamp and UV safety goggles	 <p>Power supply: DC 12V (Battery terminal)                      For checking refrigerant leak when fluorescent dye is installed in A/C system                      Includes: UV lamp and UV safety goggles</p>
(J-41447) HFC-134a (R-134a) fluorescent leak detection dye (Box of 24, 1/4 ounce bottles)	 <p>Application: For HFC-134a (R-134a) PAG oil                      Container: 1/4 ounce (7.4 cc) bottle                      (Includes self-adhesive dye identification labels for affixing to vehicle after charging system with dye.)</p>
(J-41459) HFC-134a (R-134a) dye injector Use with J-41447, 1/4 ounce bottle	 <p>For injecting 1/4 ounce of fluorescent leak detection dye into A/C system</p>
(J-43872) Refrigerant dye cleaner	 <p>For cleaning dye spills</p>
(J-39183) Manifold gauge set (with hoses and couplers)	 <p>Identification:</p> <ul style="list-style-type: none"> <li>● The gauge face indicates HFC-134a (R-134a).</li> </ul> <p>Fitting size: Thread size</p> <ul style="list-style-type: none"> <li>● 1/2" -16 ACME</li> </ul>

# PREPARATION

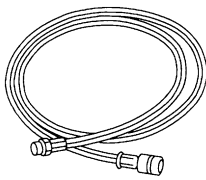
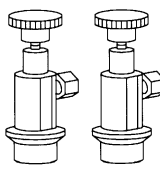
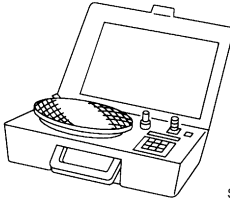
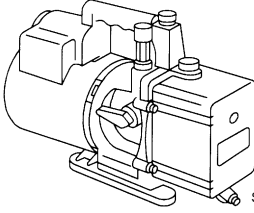
Tool number (Kent-Moore No.) Tool name	Description		
Service hoses <ul style="list-style-type: none"> <li>● High-pressure side hose (J-39501-72)</li> <li>● Low-pressure side hose (J-39502-72)</li> <li>● Utility hose (J-39476-72)</li> </ul>	 <p style="text-align: right; margin-right: 50px;">S-NT201</p>	Hose color: <ul style="list-style-type: none"> <li>● Low hose: Blue with black stripe</li> <li>● High hose: Red with black stripe</li> <li>● Utility hose: Yellow with black stripe or green with black stripe</li> </ul> Hose fitting to gauge: <ul style="list-style-type: none"> <li>● 1/2" -16 ACME</li> </ul>	A B C D
Service couplers <ul style="list-style-type: none"> <li>● High-pressure side coupler (J-39500-20)</li> <li>● Low-pressure side coupler (J-39500-24)</li> </ul>	 <p style="text-align: right; margin-right: 50px;">S-NT202</p>	Hose fitting to service hose: <ul style="list-style-type: none"> <li>● M14 x 1.5 fitting is optional or permanently attached.</li> </ul>	E F
(J-39650) Refrigerant weight scale	 <p style="text-align: right; margin-right: 50px;">S-NT200</p>	For measuring of refrigerant Fitting size: Thread size <ul style="list-style-type: none"> <li>● 1/2" -16 ACME</li> </ul>	G H
(J-39649) Vacuum pump (Including the isolator valve)	 <p style="text-align: right; margin-right: 50px;">S-NT203</p>	Capacity: <ul style="list-style-type: none"> <li>● Air displacement: 4 CFM</li> <li>● Micron rating: 20 microns</li> <li>● Oil capacity: 482 g (17 oz.)</li> </ul> Fitting size: Thread size <ul style="list-style-type: none"> <li>● 1/2" -16 ACME</li> </ul>	I <b>ATC</b>

## Commercial Service Tools

AJS00111

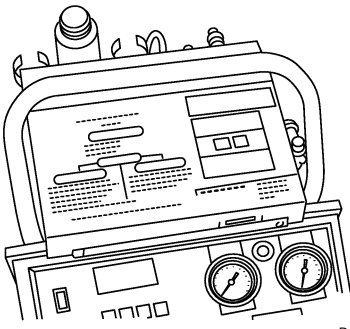
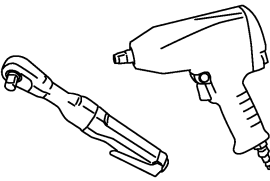
Tool name	Description		
Refrigerant identifier equipment	 <p style="text-align: right; margin-right: 50px;">RJIA0197E</p>	Checking for refrigerant purity and system contamination	K L M
Power tool	 <p style="text-align: right; margin-right: 50px;">PBIC0190E</p>	For loosening bolts and nuts	

# REFRIGERATION SYSTEM

## REFRIGERATION SYSTEM

PFP:KA990

### Refrigerant Cycle REFRIGERANT FLOW

AJS0011J

The refrigerant flows in the standard pattern, that is, through the compressor, the condenser with liquid tank, through the evaporator, and back to the compressor. The refrigerant evaporation through the evaporator is controlled by an externally equalized expansion valve, located inside the evaporator case.

### FREEZE PROTECTION

Under usual operating conditions, when the A/C is switched ON, the compressor runs continuously, and the evaporator pressure, and therefore, temperature is controlled by the compressor to prevent freeze up.

### Refrigerant System Protection REFRIGERANT PRESSURE SENSOR

AJS0011K

The refrigerant system is protected against excessively high- or low-pressures by the refrigerant pressure sensor, located on the condenser. If the system pressure rises above, or falls below the specifications, the refrigerant pressure sensor detects the pressure inside the refrigerant line and sends the voltage signal to the ECM. ECM makes the A/C relay go OFF and stops the compressor when pressure on the high-pressure side detected by refrigerant pressure sensor is over about 3,119 kPa (31.8 kg/cm<sup>2</sup>, 452 psi), or below about 118 kPa (1.2 kg/cm<sup>2</sup>, 17 psi).

### PRESSURE RELIEF VALVE

The refrigerant system is also protected by a pressure relief valve, located in the rear head of the compressor. When the pressure of refrigerant in the system increases to an unusual level [more than 3,727 kPa (38 kg/cm<sup>2</sup>, 540 psi)], the release port on the pressure relief valve automatically opens and releases refrigerant into the atmosphere.

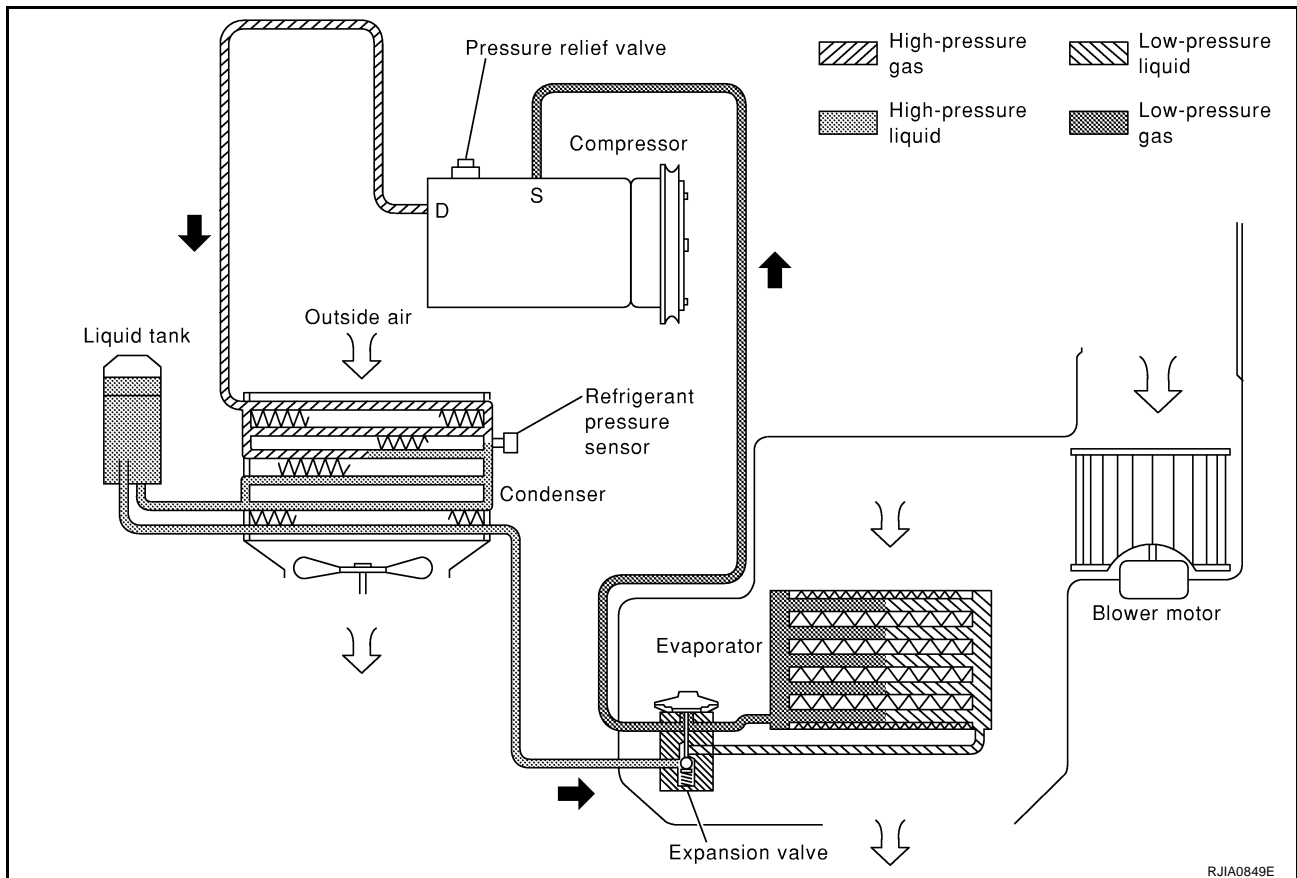

# REFRIGERATION SYSTEM

## V-6 Variable Displacement Compressor

AJS0011L

### GENERAL INFORMATION

1. The V-6 variable compressor differs from previous units. The vent temperatures of the V-6 variable compressor do not drop too far below 5°C (41°F) when:  
Evaporator intake air temperature is less than 20°C (68°F).  
Engine is running at speeds less than 1,500 rpm.  
This is because the V-6 compressor provides a means of “capacity” control.
2. The V-6 variable compressor provides refrigerant control under varying conditions. During cold winters, it may not produce high refrigerant pressure discharge (compared to previous units) when used with air conditioning systems.
3. A “clanking” sound may occasionally be heard during refrigerant charge. The sound indicates that the tilt angle of the wobble (swash) plate has changed and is not a malfunction.
4. For air conditioning systems with the V-6 compressor, the clutch remains engaged unless: the system main switch, fan switch or ignition switch is turned OFF. When ambient (outside) temperatures are low or when the amount of refrigerant is insufficient, the clutch is disengaged to protect the compressor.

A

B

C

D

E

F

G

H

I

ATC

K

L

M

# REFRIGERATION SYSTEM

## DESCRIPTION

### General

The variable compressor is basically a swash plate type that changes piston stroke in response to the required cooling capacity.

The tilt of the wobble (swash) plate allows the piston's stroke to change so that refrigerant discharge can be continuously changed from 14.5 to 184 cm<sup>3</sup> (0.885 to 11.228 cu. in).

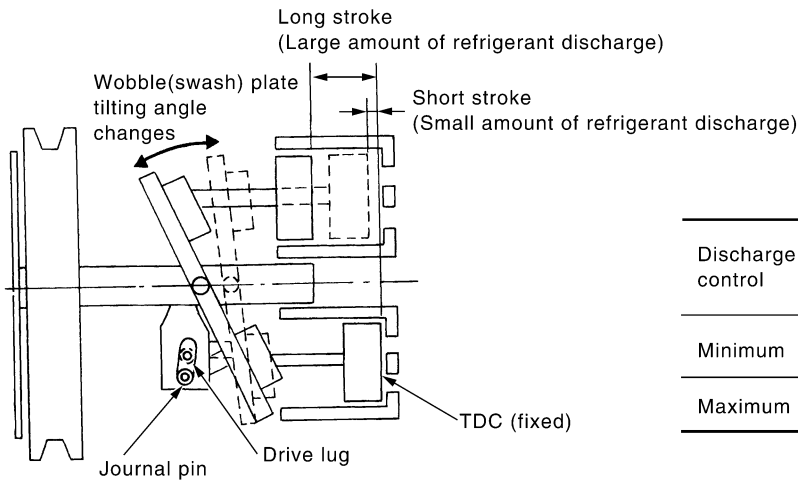
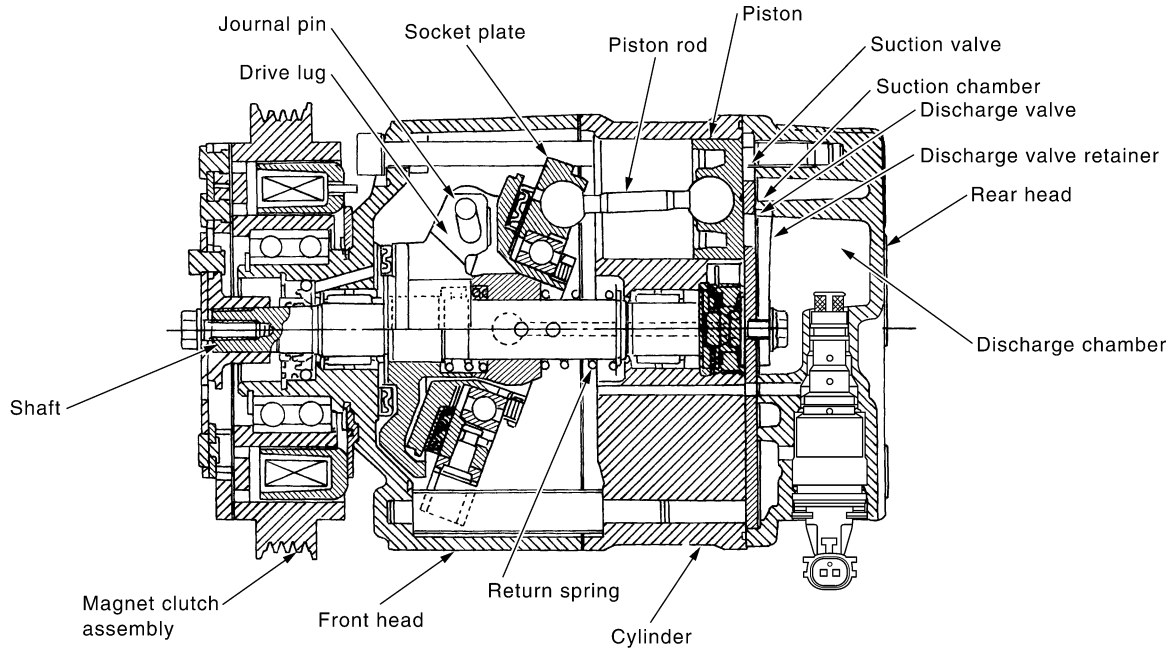

Discharge control	Discharge capacity cm <sup>3</sup> (cu in)/rev.	Piston stroke length mm (in)
Minimum	14.5 (0.885)	2.3 (0.091)
Maximum	184 (11.228)	28.6 (1.126)

RJIA1260E

# REFRIGERATION SYSTEM

## Operation

1. Control Valve
  - By changing high-pressure valve lift amount, built-in compressor control valve executes the following:
    - Controls high-pressure valve discharge amount.
    - Changes crankcase pressure in compressor.
    - Changes angle of wobble (swash) plate.
  - Amount of high-pressure valve lift is determined by factors below.
    - Low pressure applied to diaphragm
    - Spring load of set spring
    - Balance of magnetic force generated in magnet coil
  - Electronic control valve (ECV) magnet coil receives electric signal (duty control) from display and A/C auto amp. Then, magnetic force generated by electric current is changed to control high-pressure valve lift amount.
2. Maximum Cooling

High-pressure valve is closed by magnetic force generated by electric signal sent from display and A/C auto amp. At this time, cylinder moves full stroke due to pressure balance between inside crankcase ( $P_c$ ) and suction line ( $P_s$ ).  
Under this condition, the wobble (swash) plate is set to the maximum stroke position.

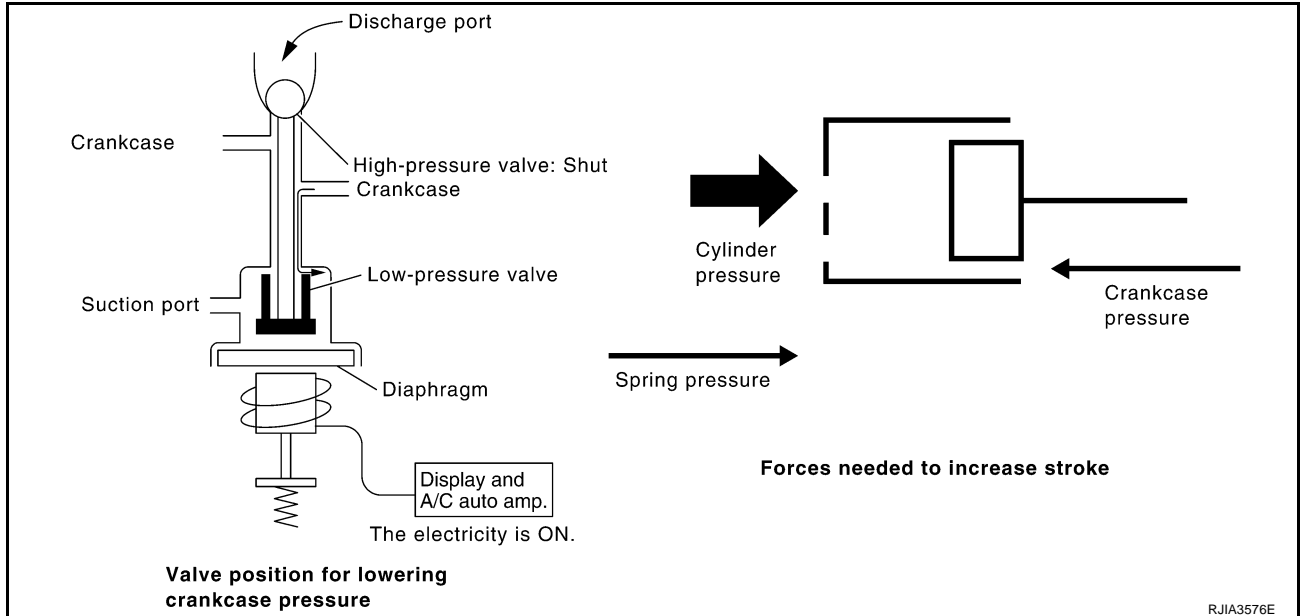

3. Capacity Control

When no electric signal is sent from display and A/C auto amp. (current: OFF), high-pressure valve is opened by spring force. Since suction pressure is low, it makes the suction port close and the discharge port open. Thus, crankcase pressure becomes high as high-pressure enters the crankcase.

  - The force acts around the journal pin near the wobble (swash) plate, and is generated by the pressure difference before and behind the piston.
  - The drive lug and journal pin are located where the piston generates the highest pressure. Piston pressure is between suction pressure  $P_s$  and discharge pressure  $P_d$ , which is near suction pressure  $P_s$ . If crankcase pressure  $P_c$  rises due to capacity control, the force around the journal pin makes the wobble (swash) plate angle decrease and also the piston stroke decrease. In other words, crankcase pressure

# REFRIGERATION SYSTEM

increase triggers pressure difference between the piston and the crankcase. The pressure difference changes the angle of the wobble (swash) plate.

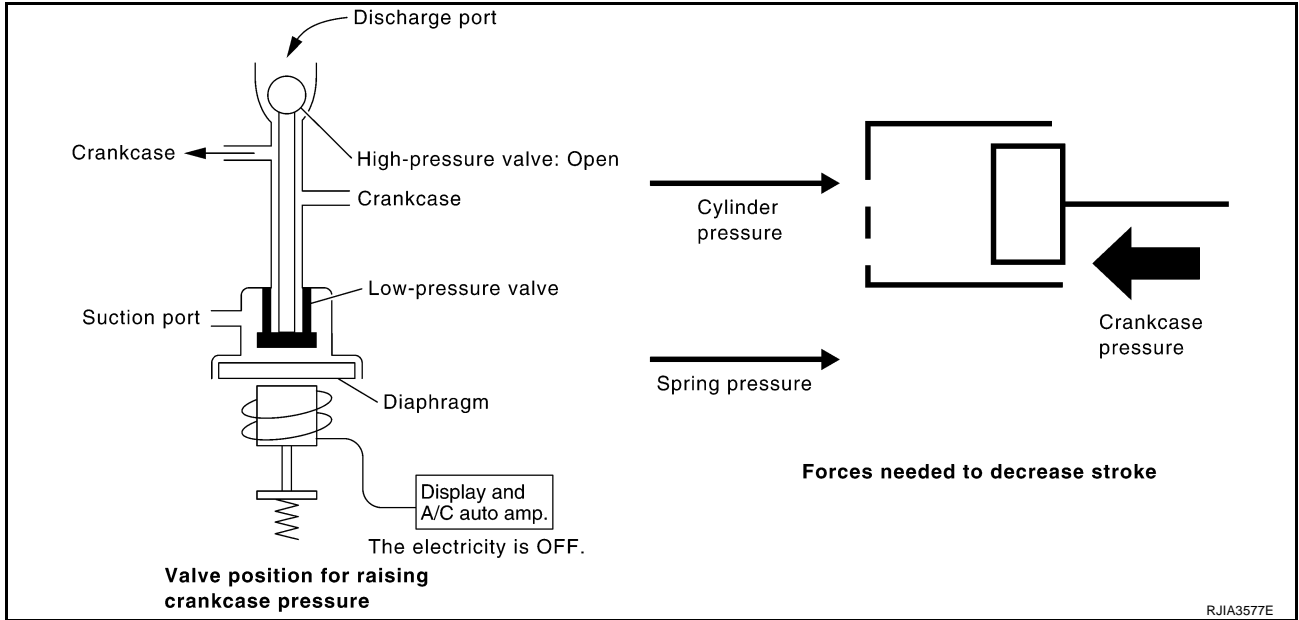



# REFRIGERATION SYSTEM

## Component Layout

AJS0011M

A  
B  
C  
D  
E  
F  
G  
H  
I  
ATC  
K  
L  
M

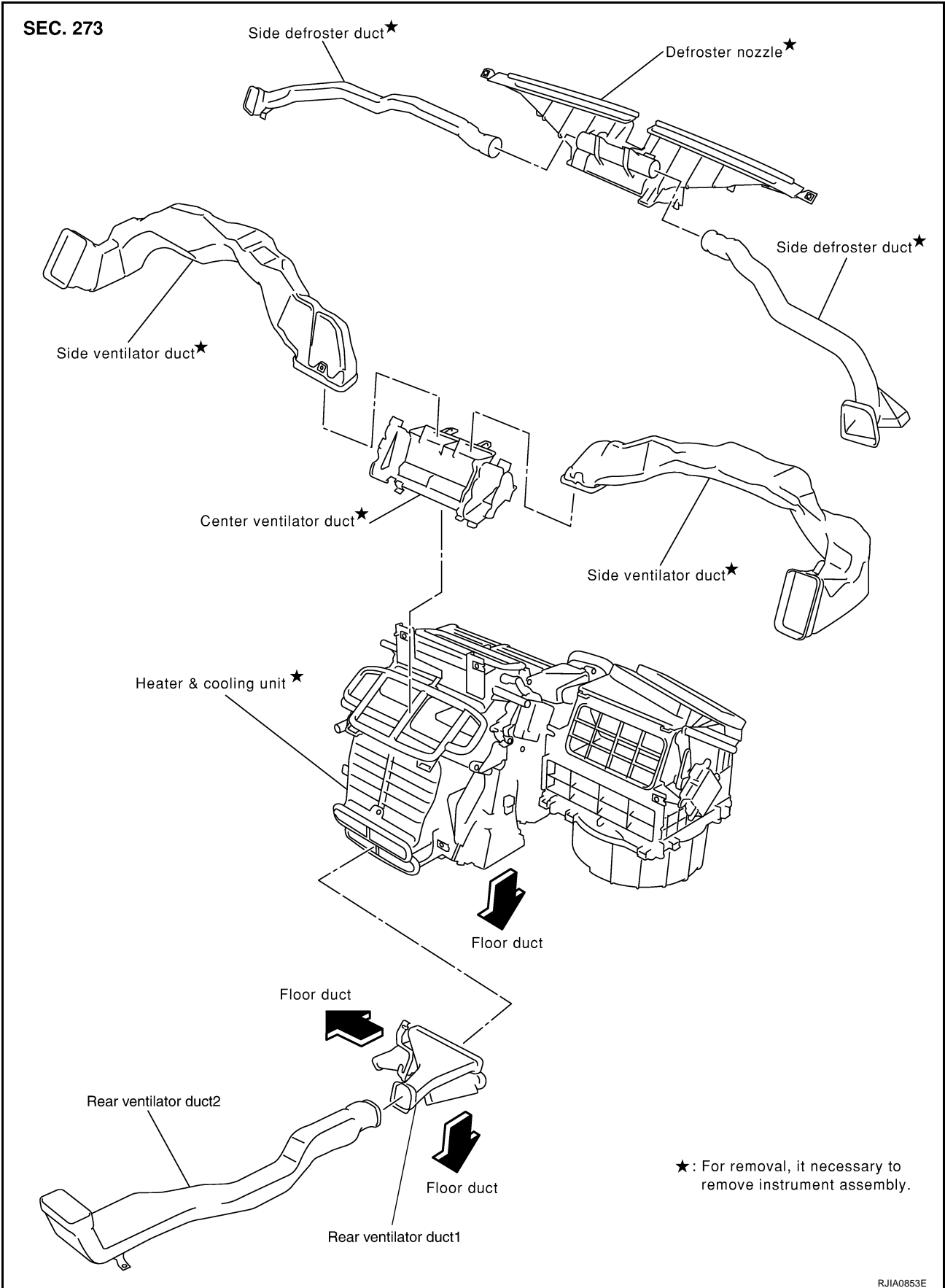

## LUBRICANT

PFP:KLG00

### Maintenance of Lubricant Quantity in Compressor

AJS0011N

The lubricant in the compressor circulates through the system with the refrigerant. Add lubricant to compressor when replacing any component or after a large refrigerant leakage occurred. It is important to maintain the specified amount.

If lubricant quantity is not maintained properly, the following malfunctions may result:

- Lack of lubricant: May lead to a seized compressor.
- Excessive lubricant: Inadequate cooling (thermal exchange interference)

## LUBRICANT

**Name** : Nissan A/C System Oil Type S  
**Part number** : KLH00-PAGS0

### LUBRICANT RETURN OPERATION

Adjust the lubricant quantity according to the test group shown below.

#### 1. CHECK LUBRICANT RETURN OPERATION

---

Can lubricant return operation be performed?

- A/C system works properly.
- There is no evidence of a large amount of lubricant leakage.

**CAUTION:**

**If excessive lubricant leakage is noted, do not perform the lubricant return operation.**

OK or NG

- OK >> GO TO 2.  
NG >> GO TO 3.

#### 2. PERFORM LUBRICANT RETURN OPERATION, PROCEEDING AS FOLLOWS

---

1. Start engine, and set the following conditions:
  - Test condition
  - Engine speed: Idling to 1,200 rpm
  - A/C switch: ON
  - Blower speed: Max. position
  - Temp. control: Optional [Set so that intake air temperature is 25 to 30°C (77 to 86°F).]
  - Intake position: Recirculation (REC)
2. Perform lubricant return operation for about 10 minutes.
3. Stop engine.

>> GO TO 3.

#### 3. CHECK REPLACEMENT PART

---

Should the compressor be replaced?

- YES >> GO TO [ATC-27, "LUBRICANT ADJUSTING PROCEDURE FOR COMPRESSOR REPLACEMENT"](#).
- NO >> GO TO [ATC-27, "LUBRICANT ADJUSTING PROCEDURE FOR COMPONENTS REPLACEMENT EXCEPT COMPRESSOR"](#).

# LUBRICANT

## LUBRICANT ADJUSTING PROCEDURE FOR COMPONENTS REPLACEMENT EXCEPT COMPRESSOR

After replacing any of the following major components, add the correct amount of lubricant to the system.

Amount of lubricant to be added

Part replaced	Lubricant to be added to system	Remarks
	Amount of lubricant m ℓ (US fl oz., Imp fl oz.)	
Evaporator	75 (2.5, 2.6)	-
Condenser	35 (1.2, 1.2)	-
Liquid tank	10 (0.3, 0.4)	-
In case of refrigerant leak	30 (1.0, 1.1)	Large leak
	-	Small leak <sup>*1</sup>

\*1: If refrigerant leak is small, no addition of lubricant is needed.

## LUBRICANT ADJUSTING PROCEDURE FOR COMPRESSOR REPLACEMENT

1. Before connecting recovery/recycling recharging equipment to vehicle, check recovery/recycling recharging equipment gauges. No refrigerant pressure should be displayed. If NG, recover refrigerant from equipment lines.
2. Connect recovery/recycling recharging equipment to vehicle. Confirm refrigerant purity in supply tank using recovery/recycling recharging equipment and refrigerant identifier. If NG, refer to [ATC-6, "CONTAMINATED REFRIGERANT"](#).
3. Confirm refrigerant purity in vehicle A/C system using recovery/recycling recharging equipment and refrigerant identifier. If NG, refer to [ATC-6, "CONTAMINATED REFRIGERANT"](#).
4. Discharge refrigerant into the refrigerant recovery/recycling equipment. Measure lubricant discharged into the recovery/recycling equipment.
5. Drain the lubricant from the old (removed) compressor into a graduated container and recover the amount of lubricant drained.
6. Drain the lubricant from the new compressor into a separate, clean container.
7. Measure an amount of new lubricant installed equal to amount drained from old compressor. Add this lubricant to new compressor through the suction port opening.
8. Measure an amount of new lubricant equal to the amount recovered during discharging. Add this lubricant to new compressor through the suction port opening.
9. If the liquid tank also needs to be replaced, add another 5 m ℓ (0.2 US fl oz., 0.2 Imp fl oz.) of lubricant at this time.  
Do not add this 5 m ℓ (0.2 US fl oz., 0.2 Imp fl oz.) of lubricant only when replaces the compressor.

# LUBRICANT

## Lubricant adjusting procedure for compressor replacement

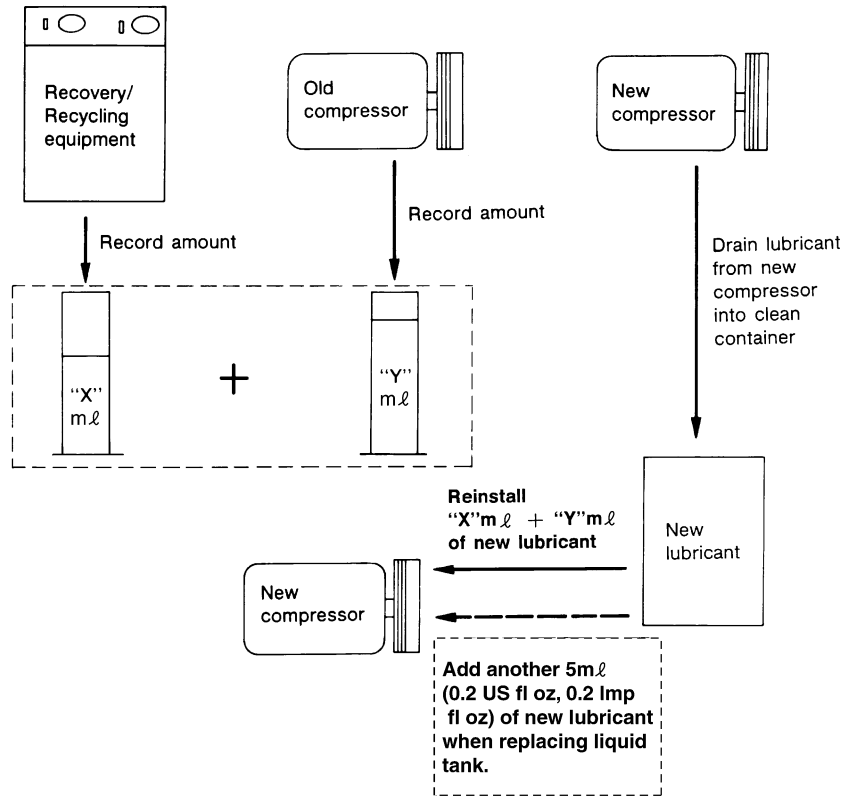

RJIA3578E

## AIR CONDITIONER CONTROL

PFP:27500

### Description of Air Conditioner LAN Control System

AJS00110

The LAN (Local Area Network) system consists of display and A/C auto amp., mode door motor, air mix door motor and intake door motor.

A configuration of these components is shown in the diagram below.

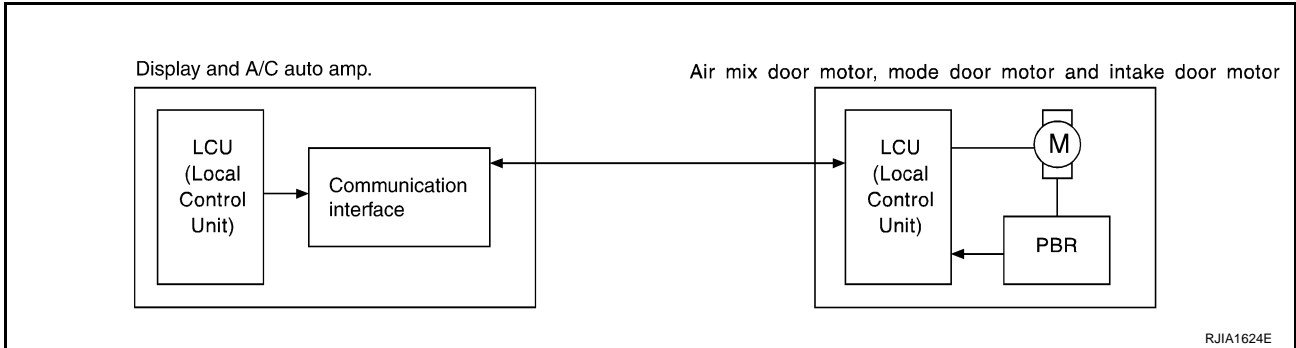

### System Construction

AJS0011P

A small network is constructed between the display and A/C auto amp., air mix door motor, mode door motor and intake door motor. The display and A/C auto amp. and motors are connected by data transmission lines and motor power supply lines. The LAN network is built through the ground circuits of each door motor.

Addresses, motor opening angle signals, motor stop signals and error checking messages are all transmitted through the data transmission lines connecting the display and A/C auto amp. and each door motor.

The following functions are contained in LCUs built into the air mix door motor, the mode door motor and the intake door motor.

- Address
- Motor opening angle signals
- Data transmission
- Motor stop and drive decision
- Opening angle sensor (PBR function)
- Comparison
- Decision (Display and A/C auto amp. indicated value and motor opening angle comparison)

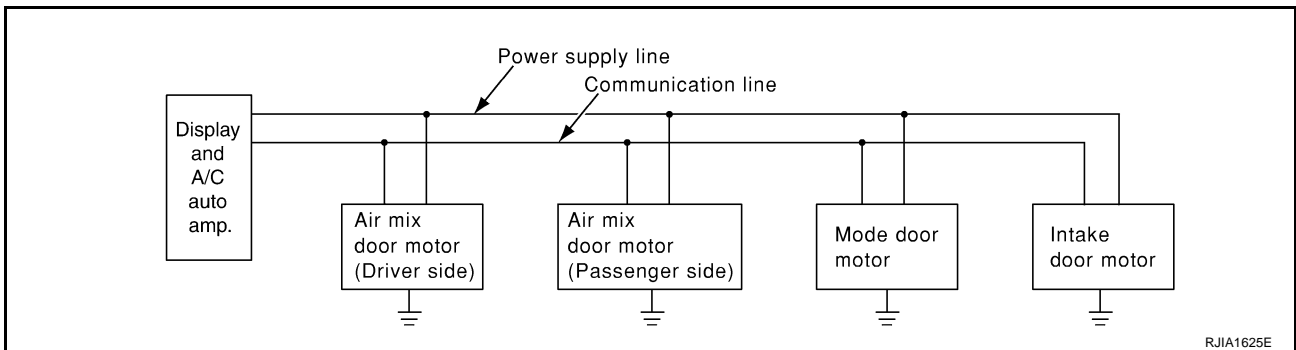

# AIR CONDITIONER CONTROL

## OPERATION

The display and A/C auto amp. receives data from each of the sensors. The display and A/C auto amp. sends mode door, air mix door and intake door opening angle data to the mode door motor LCU, air mix door motor LCU and intake door motor LCU.

The mode door motor, air mix door motor and intake door motor read their respective signals according to the address signal. Opening angle indication signals received from the display and A/C auto amp. and each of the motor position sensors is compared by the LCUs in each door motor with the existing decision and opening angles. Subsequently, HOT/COLD, DEFROST/VENT or FRESH/RECIRCULATION operation is selected. The new selection data is returned to the display and A/C auto amp.

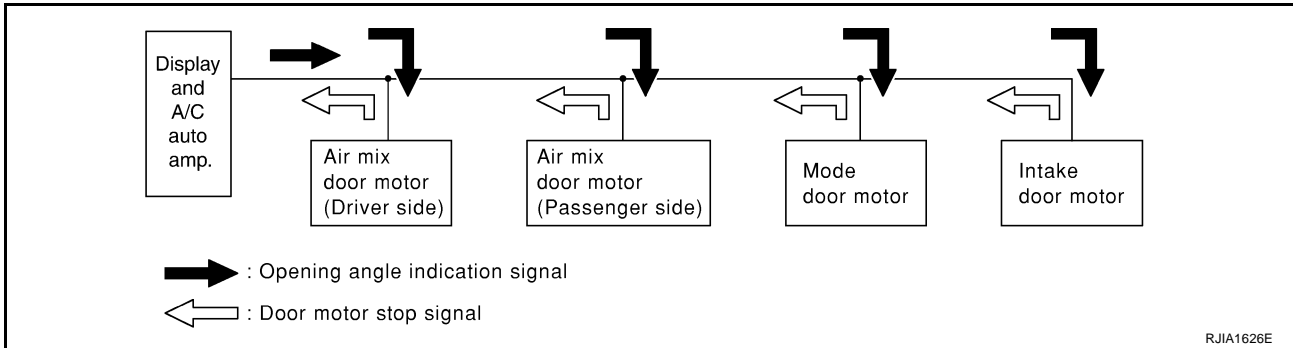

## TRANSMISSION DATA AND TRANSMISSION ORDER

Display and A/C auto amp. data is transmitted consecutively to each of the door motors following the form shown in figure below.

### Start:

Initial compulsory signal sent to each of the door motors.

### Address:

Data sent from the display and A/C auto amp. is selected according to data-based decisions made by the air mix door motor, mode door motor and intake door motor.

If the addresses are identical, the opening angle data and error check signals are received by the door motor LCUs. The LCUs then make the appropriate error decision. If the opening angle data is usual, door control begins.

If an error exists, the received data is rejected and corrected data received. Finally, door control is based upon the corrected opening angle data.

### Opening angle:

Data that shows the indicated door opening angle of each door motor.

### Error Check:

Procedure by which sent and received data is checked for errors. Error data is then compiled. The error check prevents corrupted data from being used by the air mix door motor, mode door motor and intake door motor. Error data can be related to the following symptoms.

- Malfunction electrical frequency
- Poor electrical connections
- Signal leakage from transmission lines
- Signal level fluctuation

# AIR CONDITIONER CONTROL

## Stop signal:

At the end of each transmission, a stop operation, in-operation, or internal error message is delivered to the display and A/C amp. This completes one data transmission and control cycle.

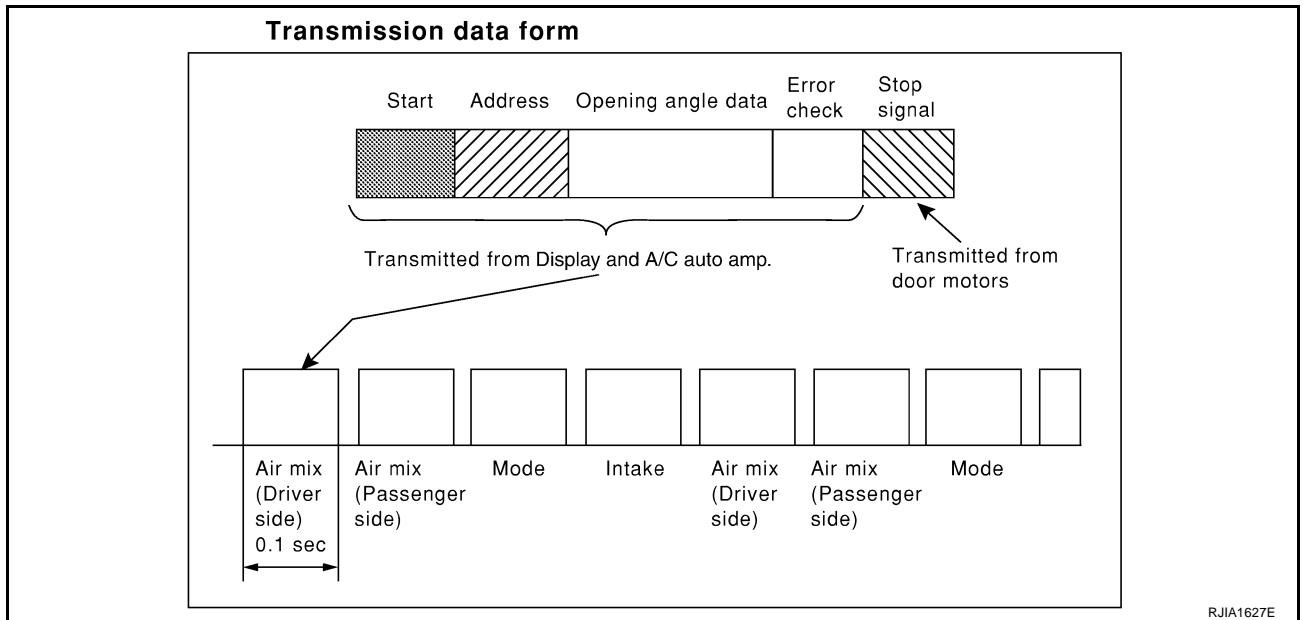

## AIR MIX DOOR CONTROL (AUTOMATIC TEMPERATURE CONTROL)

The air mix door is automatically controlled so that in-vehicle temperature is maintained at a predetermined value by the temperature setting, ambient temperature, in-vehicle temperature and amount of sunload.

## FAN SPEED CONTROL

Blower speed is automatically controlled by the temperature setting, ambient temperature, in-vehicle temperature, intake temperature, amount of sunload and air mix door position.

With FAN switch set to AUTO, the blower motor starts to gradually increase air flow volume.

When engine coolant temperature is low, the blower motor operation is delayed to prevent cool air from flowing.

## INTAKE DOOR CONTROL

The intake doors are automatically controlled by the temperature setting, ambient temperature, in-vehicle temperature, intake temperature, amount of sunload and ON-OFF operation of the compressor.

## OUTLET DOOR CONTROL

The outlet door is automatically controlled by the temperature setting, ambient temperature, in-vehicle temperature, intake temperature and amount of sunload.

# AIR CONDITIONER CONTROL

## MAGNET CLUTCH CONTROL

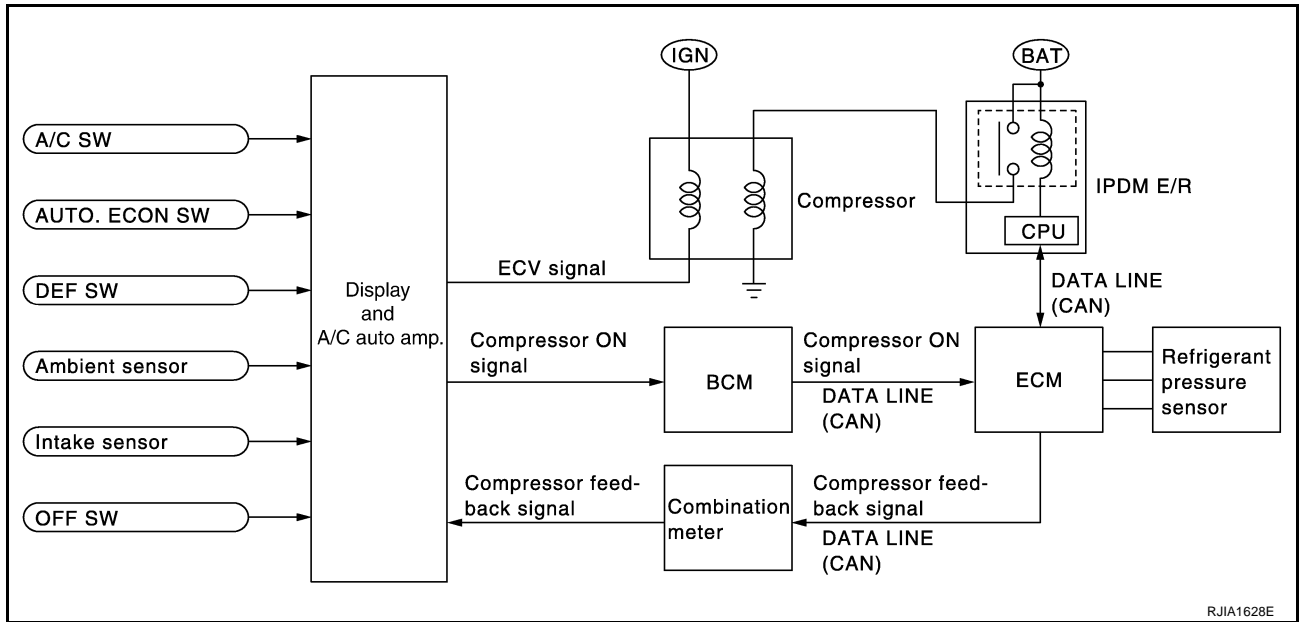

RJIA1628E

When A/C switch, AUTO.ECON switch or DEF switch is pressed, display and A/C auto amp. inputs compressor ON signal to BCM.

BCM sends compressor ON signal to ECM, via CAN communication line.

ECM judges whether compressor can be turned ON, based on each sensor status (refrigerant-pressure sensor signal, throttle angle, etc.). If it judges compressor can be turned ON, it sends compressor ON signal to IPDM E/R, via CAN communication line.

Upon receipt of compressor ON signal from ECM, IPDM E/R turns air conditioner relay ON to operate compressor.

When sending compressor ON signal to IPDM E/R via CAN communication line, ECM simultaneously sends compressor feedback signal to meter control unit via CAN communication line.

Meter control unit sends compressor feedback signal to display and A/C auto amp., then, uses input compressor feedback signal to control air inlet.

## SELF-DIAGNOSTIC SYSTEM

The self-diagnostic system is built into the display and A/C auto amp. to quickly locate the cause of symptoms.



# AIR CONDITIONER CONTROL

AJS0011Q

## Description of Control System

The control system consists of input sensors, switches, the display and A/C auto amp. (microcomputer) and outputs.

The relationship of these components is shown in the figure below:

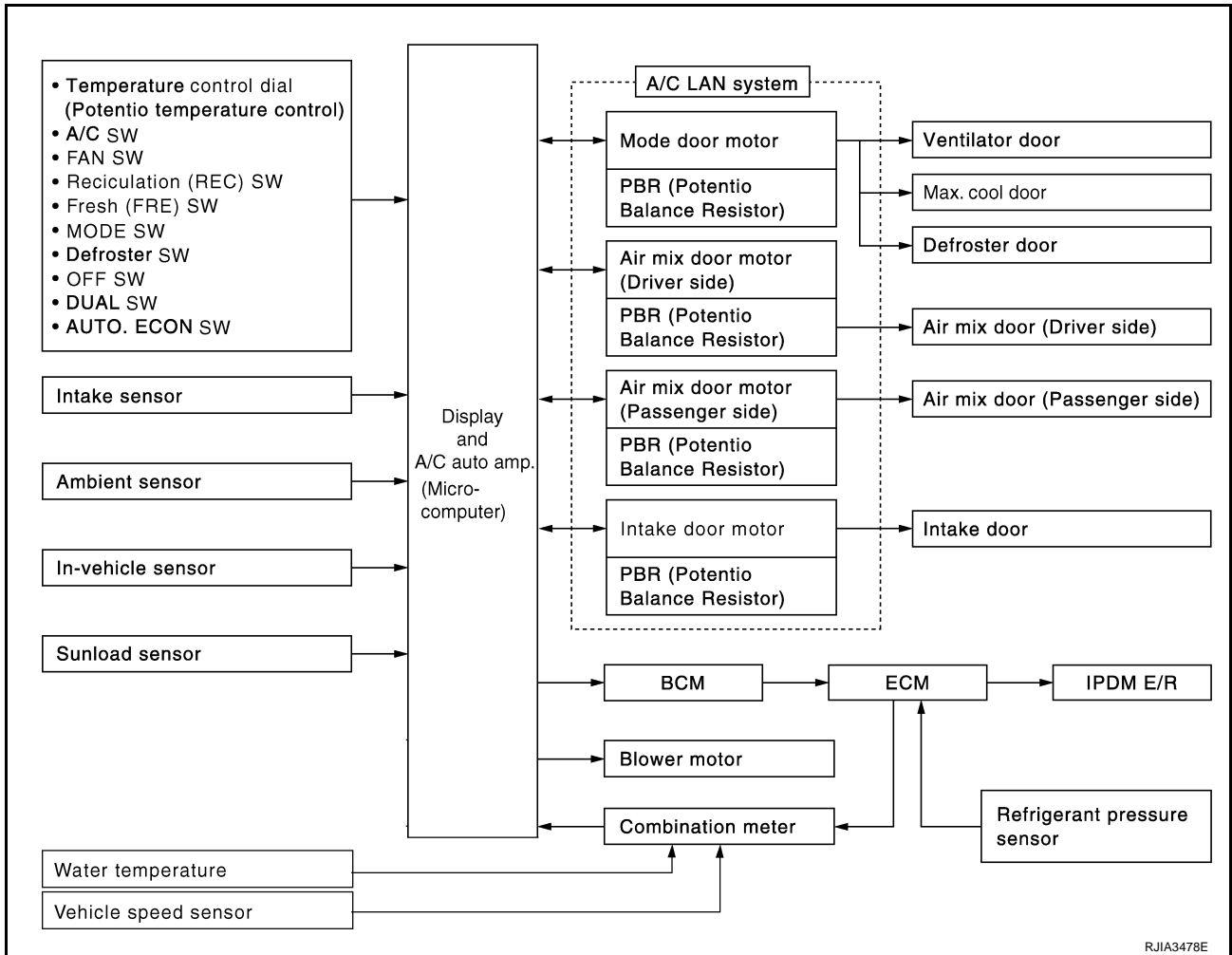

## Control Operation

AJS0011R

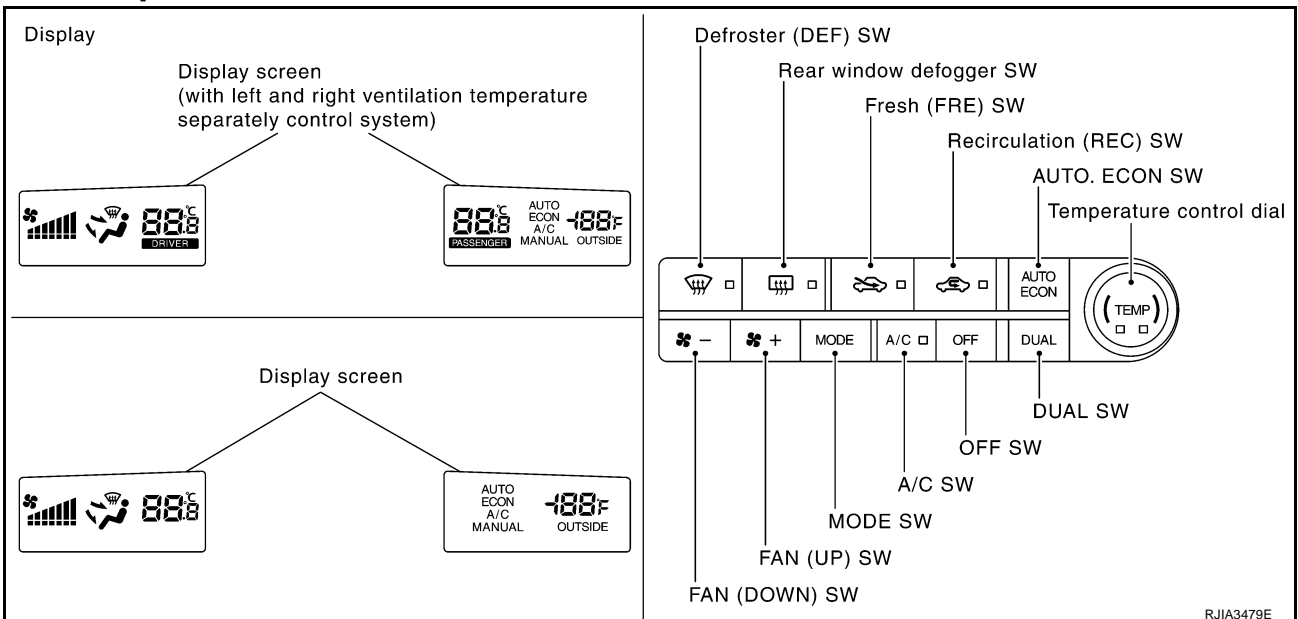

# AIR CONDITIONER CONTROL

---

## DISPLAY SCREEN

Displays the operational status of the system.

## AUTO.ECON SWITCH

- The compressor, intake doors, air mix doors, outlet doors and blower speed are automatically controlled so that the in-vehicle temperature will reach, and be maintained at the set temperature selected by the operator.
- When pressing AUTO.ECON switch, air inlet, air outlet, fan speed, and discharge air temperature are automatically controlled. (Inlet is automatically controlled only when FRE or REC switch is OFF.)
- Press AUTO.ECON switch again. "ECON" appears on display and control is switched to economy control.

## TEMPERATURE CONTROL DIAL (POTENTIO TEMPERATURE CONTROL)

Increases or decreases the set temperature.

## RECIRCULATION (REC) SWITCH

- When REC switch is ON, REC switch indicator turns ON, air inlet is fixed to REC, and compressor will turn ON.
- When REC switch is ON and is pressed for approximately 1.5 seconds or longer, REC and FRE switch indicators blink twice. Then, automatic control mode is entered. Inlet status is displayed even during automatically controlled.
- When FRE switch is turned ON, air outlet switches to D/F or DEF position, or when compressor is turned from ON to OFF, REC switch is automatically turned OFF (fixed to FRE mode).

## FRESH (FRE) SWITCH

- When FRE switch is ON, FRE switch indicator turns ON, and air inlet is fixed to FRE.
- When FRE switch is ON and is pressed for approximately 1.5 seconds or longer, REC and FRE switch indicators blink twice. Then, automatic control mode is entered. Inlet status is displayed even during automatically controlled.
- When REC switch is turned ON, FRE switch is automatically turned OFF (fixed to REC mode). FRE mode can be re-entered by pressing FRE switch again.

## DEFROSTER (DEF) SWITCH

Positions the air outlet doors to the defrost position. Also positions the intake doors to the outside air position, and compressor will turn ON.

## REAR WINDOW DEFOGGER SWITCH

When illumination is ON, rear window is defogged.

## OFF SWITCH

The compressor and blower are OFF, the intake doors are set to the outside air position, and the air outlet doors are set to the foot (75% foot and 25% defrost) position.

## A/C SWITCH

The compressor is ON or OFF.

(Pressing the A/C switch when the A/C switch is ON will turn off the A/C switch and compressor.)

## MODE SWITCH

Controls the air discharge outlets.

When air outlet switches to D/F position, compressor will turn ON and fixed to REC mode.

## FAN SWITCHES

Manually control the blower speed. Seven speeds are available for manual control (as shown on the display screen).

## DUAL SWITCH (WITH LEFT AND RIGHT VENTILATION TEMPERATURE SEPARATELY CONTROL SYSTEM)

- When air conditioner system is operating and DUAL switch is pressed, only underlined portion of driver's seat set temperature indication on display (left-hand side) turns ON (and display shows "DRIVER"). Then, changing set temperature for driver's seat is possible using temperature control dial.

# AIR CONDITIONER CONTROL

- When DUAL switch is pressed again, only underlined portion of passenger's seat set temperature indication on display (right-hand side) turns ON (and display shows "PASSENGER"). Then, changing set temperature for passenger's seat is possible using temperature control dial. A
- When DUAL switch is pressed again, underlined portions of both seats set temperature indications turn ON (and display shows "DRIVER" and "PASSENGER"). Set temperatures for left and right can be set equal to temperature for driver's seat, with temperature control dial. B

## Fail-Safe Function

AJS0011S

- If a communication error exists between display and A/C auto amp. and A/C and audio controller for 30 seconds or longer, air conditioner is controlled under following conditions: C
  - Compressor: ON D
  - Air outlet: AUTO
  - Air inlet: FRE (Fresh)
  - Blower fan speed: AUTO E
  - Set temperature: Setting before communication error occurs F

ATC

K

L

M

# AIR CONDITIONER CONTROL

## Discharge Air Flow

AJS0011T

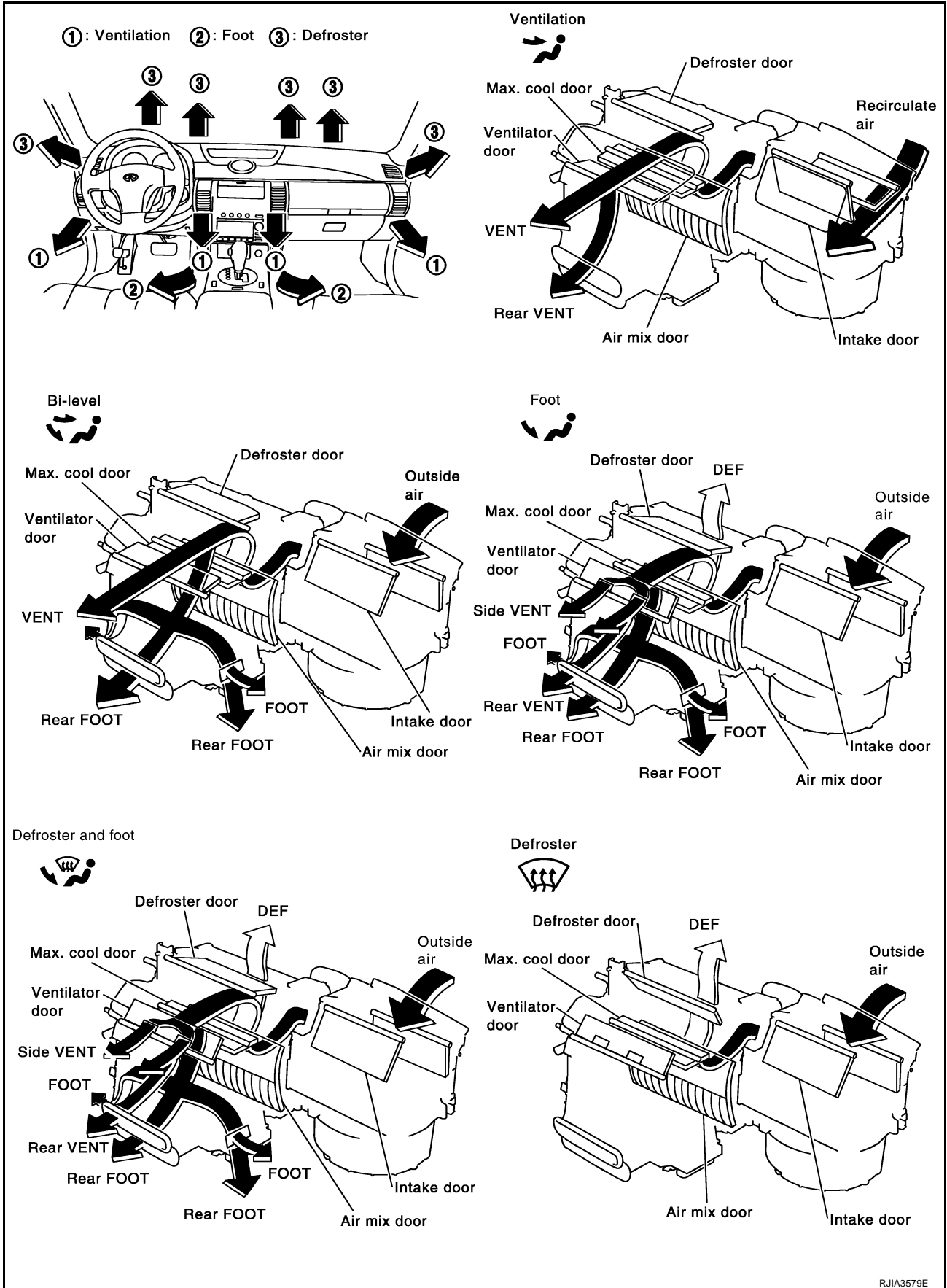

# AIR CONDITIONER CONTROL

AJS0011U

## System Description SWITCHES AND THEIR CONTROL FUNCTION

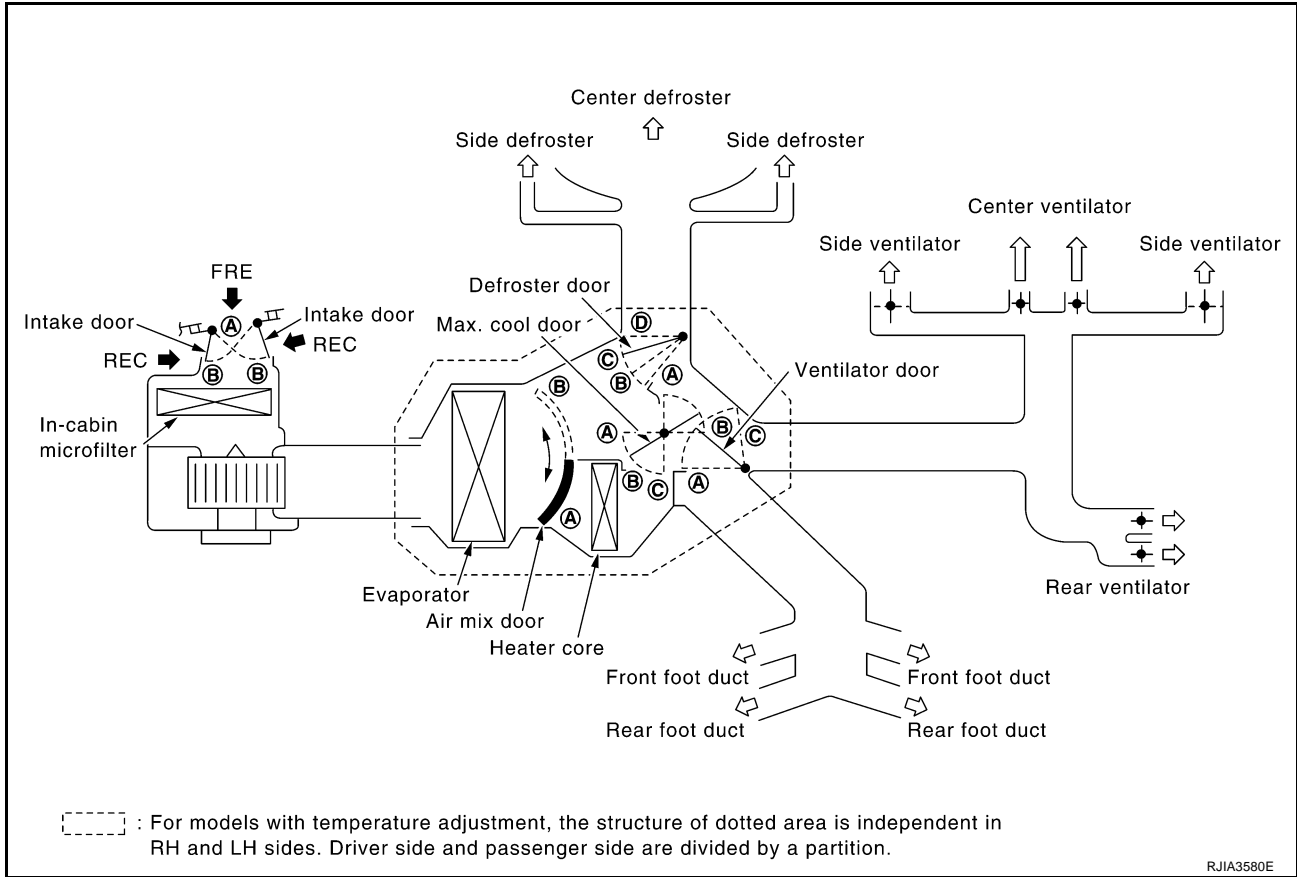

A  
B  
C  
D  
E  
F  
G  
H  
I

ATC

K  
L  
M

Position or switch	MODE SW				DEF SW		AUTO ECON SW	REC SW	FRE SW	Temperature control dial			OFF SW
	VENT	B/L	FOOT	D/F	ON	OFF				(TEMP)	18°C (60°F)	~	
Door							AUTO ECON						OFF
Ventilator door	(A)	(B)	(B~C)	(B~C)	(C)								(C)
Max. cool door	(A)	(B)	(B)	(B)	(C)								(B)
Defroster door	(D)	(D)	(D <sup>*1</sup> or C)	(B)	(A)								(C)
Intake door				(B)	(B)			(A) <sup>*2</sup>	(B) <sup>*2</sup>				(B)
Air mix door							AUTO			(A)	AUTO	(B)	

\*1: This position is selected only when the mode door is automatically controlled.

\*2: Inlet status is displayed even during automatic control.

RJA3480E

---

## CAN Communication System Description

AJS0011V

CAN (Controller Area Network) is a serial communication line for real time application. It is an on-vehicle multiplex communication line with high data communication speed and excellent error detection ability. Many electronic control units are equipped onto a vehicle, and each control unit shares information and links with other control units during operation (not independent). In CAN communication, control units are connected with 2 communication lines (CAN H line, CAN L line) allowing a high rate of information transmission with less wiring. Each control unit transmits/receives data but selectively reads required data only. For details, refer to [LAN-21, "CAN Communication Unit"](#) .

# TROUBLE DIAGNOSIS

## TROUBLE DIAGNOSIS

PF0:00004

### CONSULT-II Function (BCM)

AJS0011X

CONSULT-II can display diagnostic item using the diagnostic test modes shown following.

System part	Check item, diagnosis mode	Description
BCM	Data monitor	Displays BCM input data in real time.

### CONSULT-II BASIC OPERATION

#### CAUTION:

If CONSULT-II is used with no connection of CONSULT-II CONVERTER, malfunctions might be detected in self-diagnosis depending on control unit which carry out CAN communication.

1. With the ignition switch OFF, connect CONSULT-II and "CONSULT-II CONVERTER" to the data link connector, and turn the ignition switch ON.

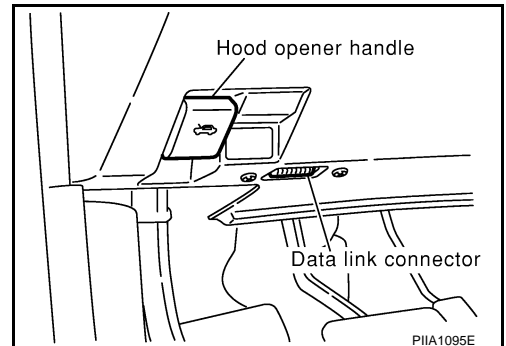

2. Touch "START (NISSAN BASED VHCL)".

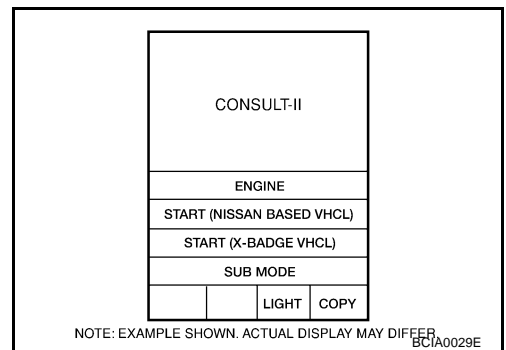

3. Touch "BCM" on "SELECT SYSTEM" screen. If "BCM" is not indicated, go to [GI-38, "CONSULT-II Data Link Connector \(DLC\) Circuit"](#).

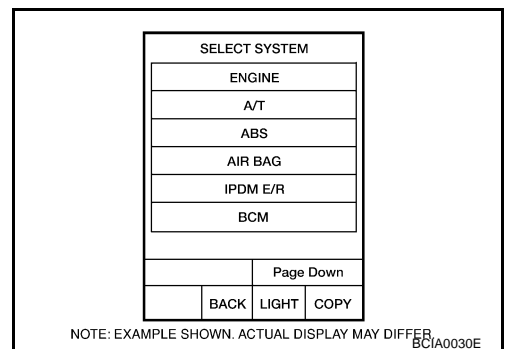

A  
B  
C  
D  
E  
F  
G  
H  
I  
K  
L  
M

ATC

# TROUBLE DIAGNOSIS

## DATA MONITOR

### Operation Procedure

1. Touch "AIR CONDITIONER" on "SELECT TEST ITEM" screen.

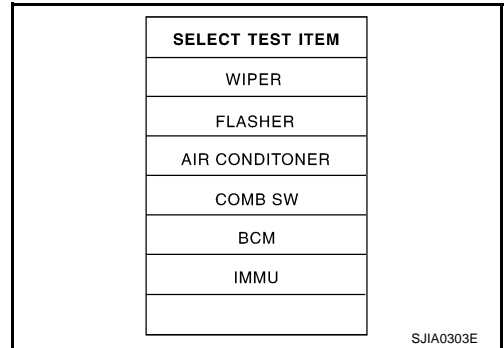

2. Touch "DATA MONITOR" on "SELECT DIAG MODE" screen.

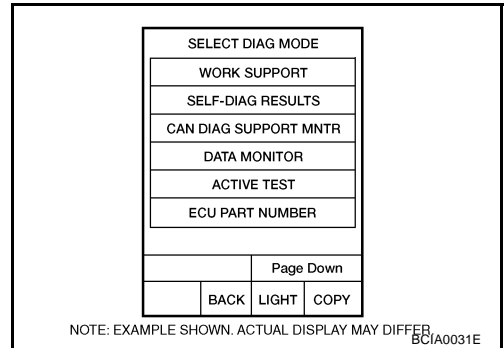

3. Touch either "ALL SIGNALS" or "SELECTION FROM MENU" on "DATA MONITOR" screen.

All signals	Monitors all the items.
Selection from menu	Selects and monitors the individual item selected.

4. When "SELECTION FROM MENU" is selected, touch items to be monitored. When "ALL SIGNALS" is selected, all the items will be monitored.

5. Touch "START".

6. Touch "RECORD" while monitoring, then the status of the monitored item can be recorded. To stop recording, touch "STOP".

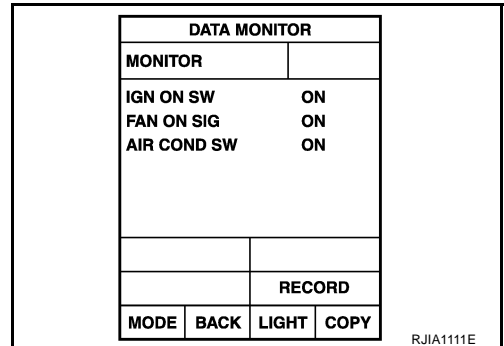

### Display Item List

Monitor item name "operation or unit"	Contents
IGN ON SW "ON/OFF"	Displays "IGN Position (ON)/OFF, ACC Position (OFF)" status as judged from ignition switch signal.
FAN ON SIG "ON/OFF"	Displays "FAN (ON)/FAN (OFF)" status as judged from blower fan motor switch signal.
AIR COND SW "ON/OFF"	Displays "COMP (ON)/COMP (OFF)" status as judged from air conditioner switch signal.



# TROUBLE DIAGNOSIS

## How to Perform Trouble Diagnosis for Quick and Accurate Repair

AJS0011Y

### WORK FLOW

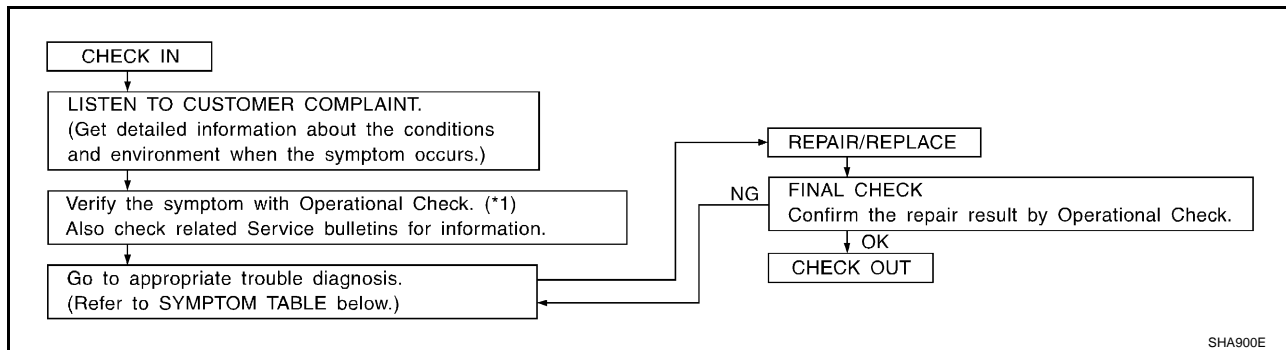

SHA900E

\*1 [ATC-62. "Operational Check"](#).

### SYMPTOM TABLE

Symptom	Reference Page	
A/C system does not come on.	Go to Trouble Diagnosis Procedure for A/C System.	<a href="#">ATC-64. "Power Supply and Ground Circuit for Auto Amp."</a>
A/C system cannot be controlled.	Go to Trouble Diagnosis Procedure for Multiplex Communication Circuit.	<a href="#">ATC-117. "Multiplex Communication Circuit"</a>
Air outlet does not change.	Go to Trouble Diagnosis Procedure for Mode Door Motor. (LAN)	<a href="#">ATC-71. "Mode Door Motor Circuit"</a>
Mode door motor does not operate normally.		
Discharge air temperature does not change.	Go to Trouble Diagnosis Procedure for Air Mix Door Motor. (LAN)	<a href="#">ATC-74. "Air Mix Door Motor Circuit"</a>
Air mix door motor does not operate normally.		
Intake door does not change.	Go to Trouble Diagnosis Procedure for Intake Door Motor. (LAN)	<a href="#">ATC-77. "Intake Door Motor Circuit"</a>
Intake door motor does not operate normally.		
Blower motor operation is malfunctioning.	Go to Trouble Diagnosis Procedure for Blower Motor.	<a href="#">ATC-80. "Blower Motor Circuit"</a>
Blower motor operation is malfunctioning under out of starting fan speed control.		
Magnet clutch does not engage.	Go to Trouble Diagnosis Procedure for Magnet Clutch.	<a href="#">ATC-86. "Magnet Clutch Circuit"</a>
Insufficient cooling	Go to Trouble Diagnosis Procedure for Insufficient Cooling.	<a href="#">ATC-93. "Insufficient Cooling"</a>
	Go to Trouble Diagnosis Procedure for Insufficient Cooling.	<a href="#">ATC-93. "Insufficient Cooling"</a>
Insufficient heating	Go to Trouble Diagnosis Procedure for Insufficient Heating.	<a href="#">ATC-103. "Insufficient Heating"</a>
Noise	Go to Trouble Diagnosis Procedure for Noise.	<a href="#">ATC-104. "Noise"</a>
Self-diagnosis cannot be performed.	Go to Trouble Diagnosis Procedure for Self-diagnosis.	<a href="#">ATC-105. "Self-Diagnosis"</a>
Memory function does not operate.	Go to Trouble Diagnosis Procedure for Memory Function.	<a href="#">ATC-106. "Memory Function"</a>

# TROUBLE DIAGNOSIS

## Component Parts and Harness Connector Location ENGINE COMPARTMENT

AJS0011Z

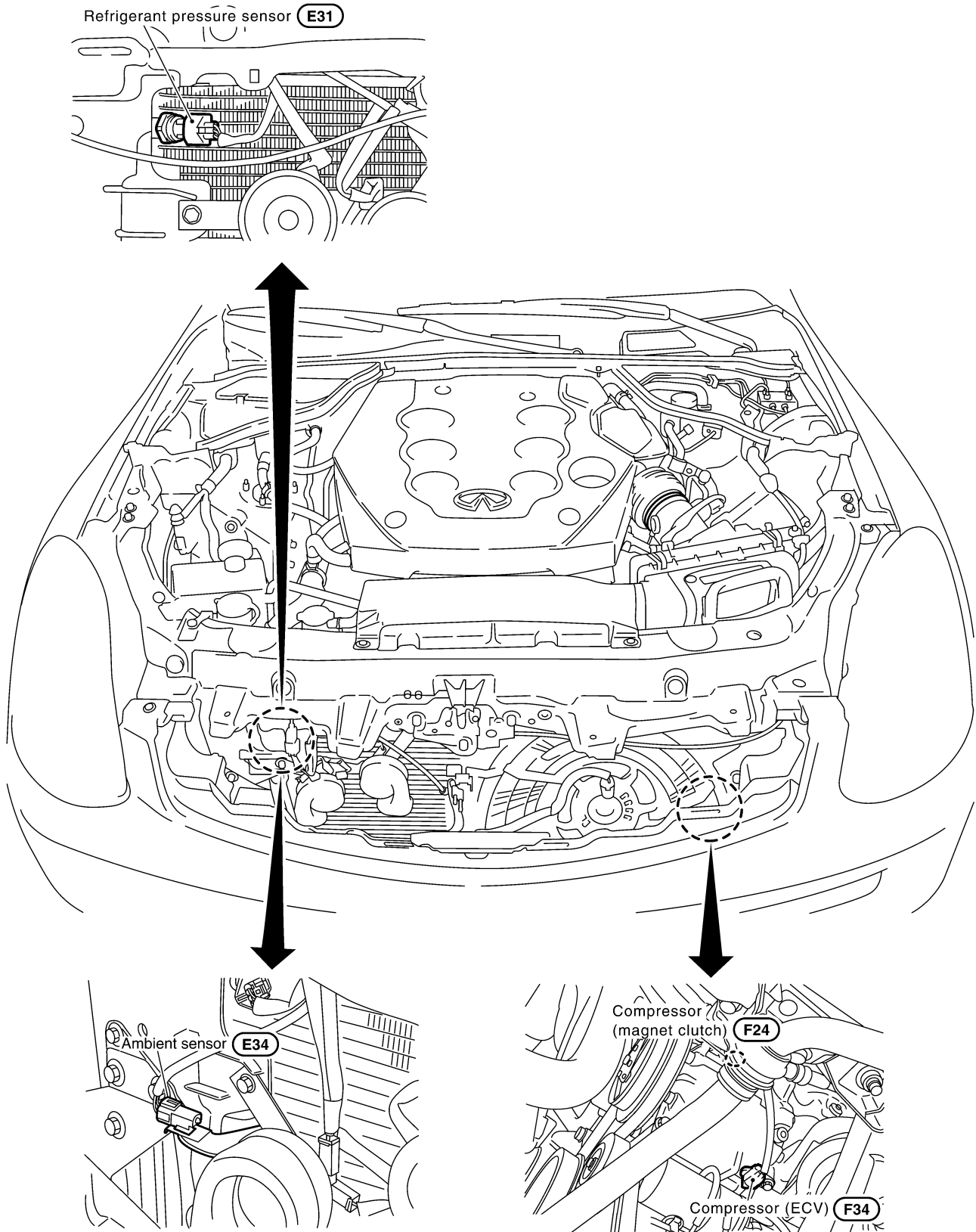

RJIA1866E

# TROUBLE DIAGNOSIS

## PASSENGER COMPARTMENT

A  
B  
C  
D  
E  
F  
G  
H  
I  
K  
L  
M

ATC

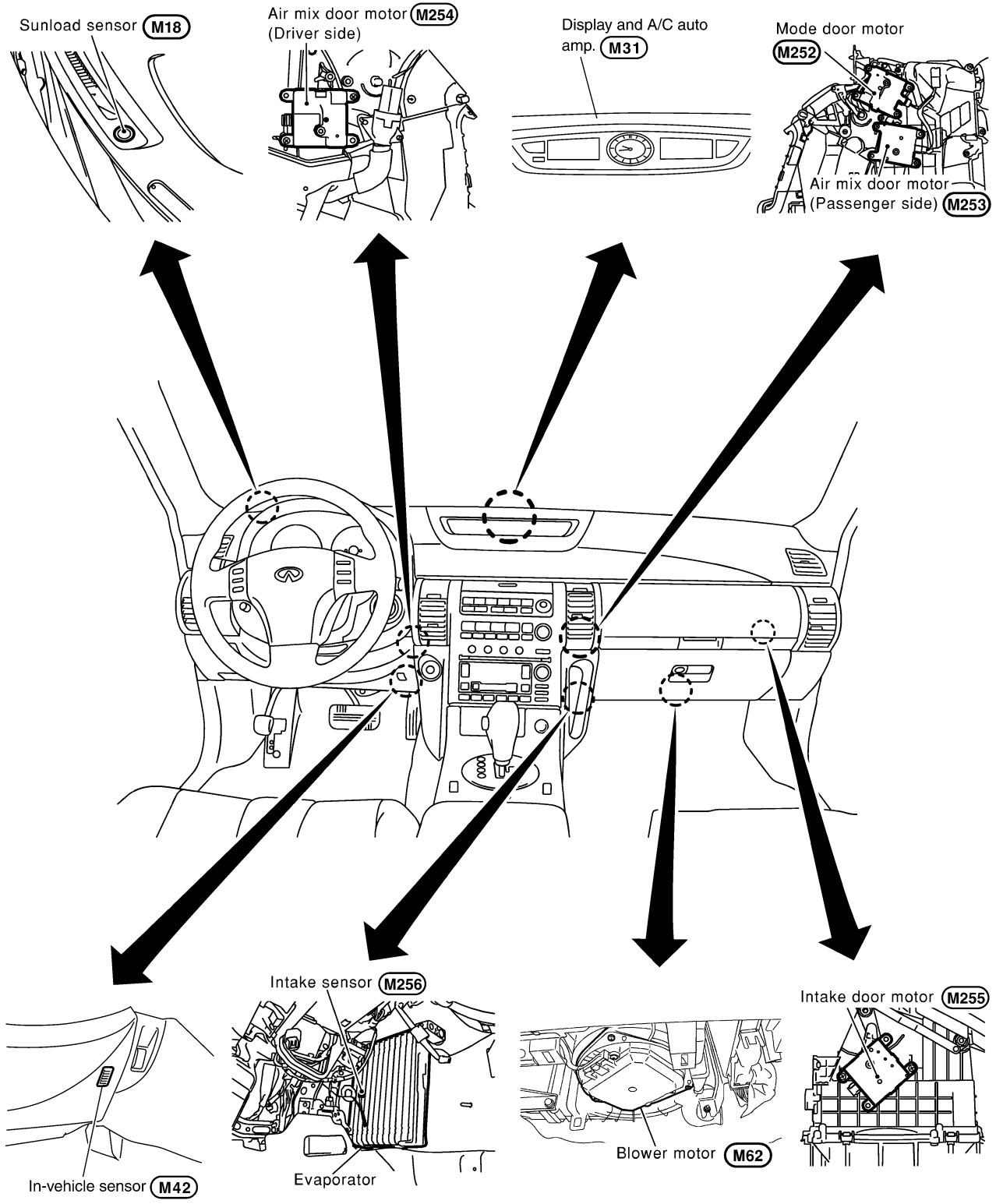

RJIA3581E

# TROUBLE DIAGNOSIS

## Schematic

AJS00120

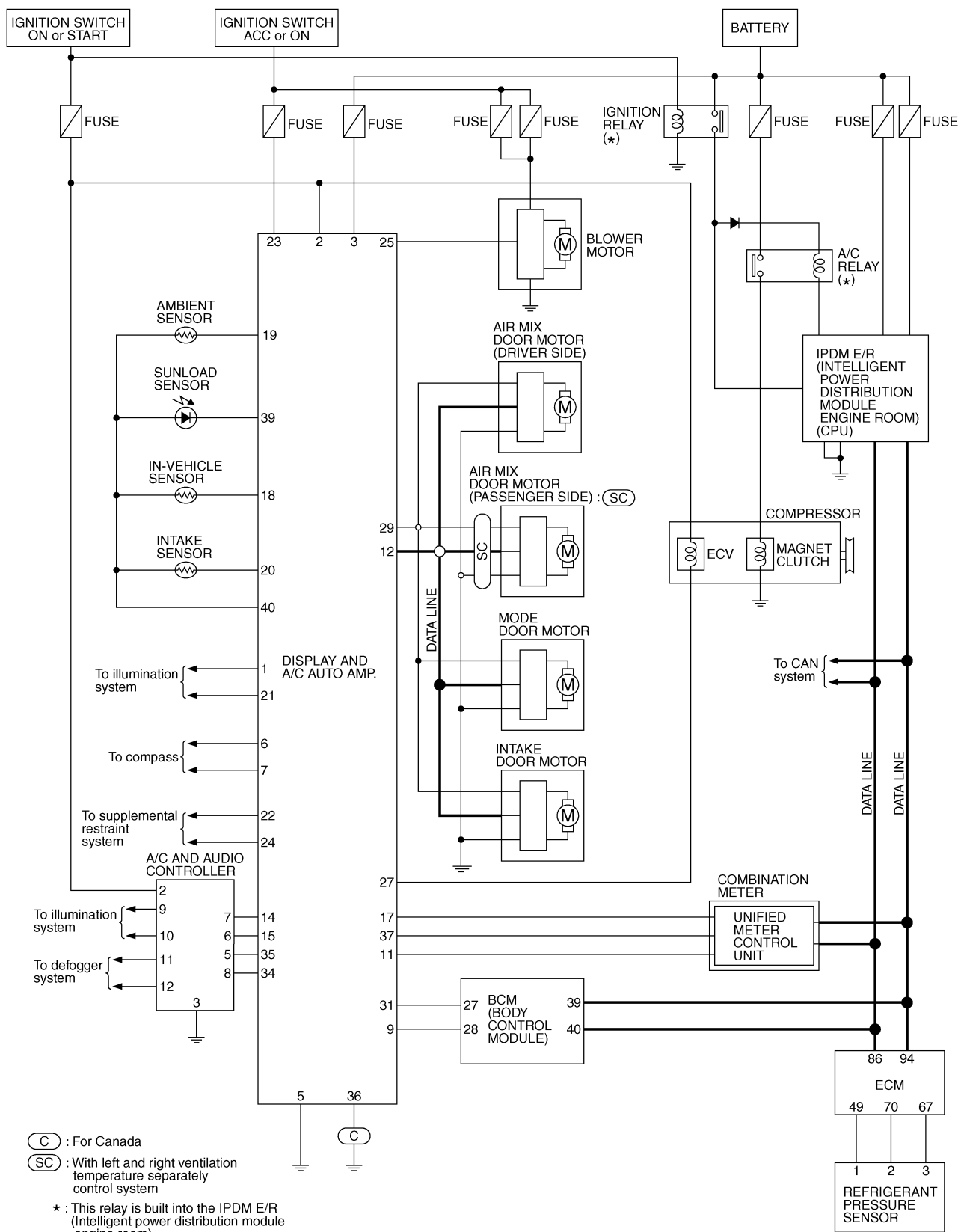

TJWM0139E

# TROUBLE DIAGNOSIS

## Wiring Diagram —A/C—

AJS001F9

### ATC-A/C-01

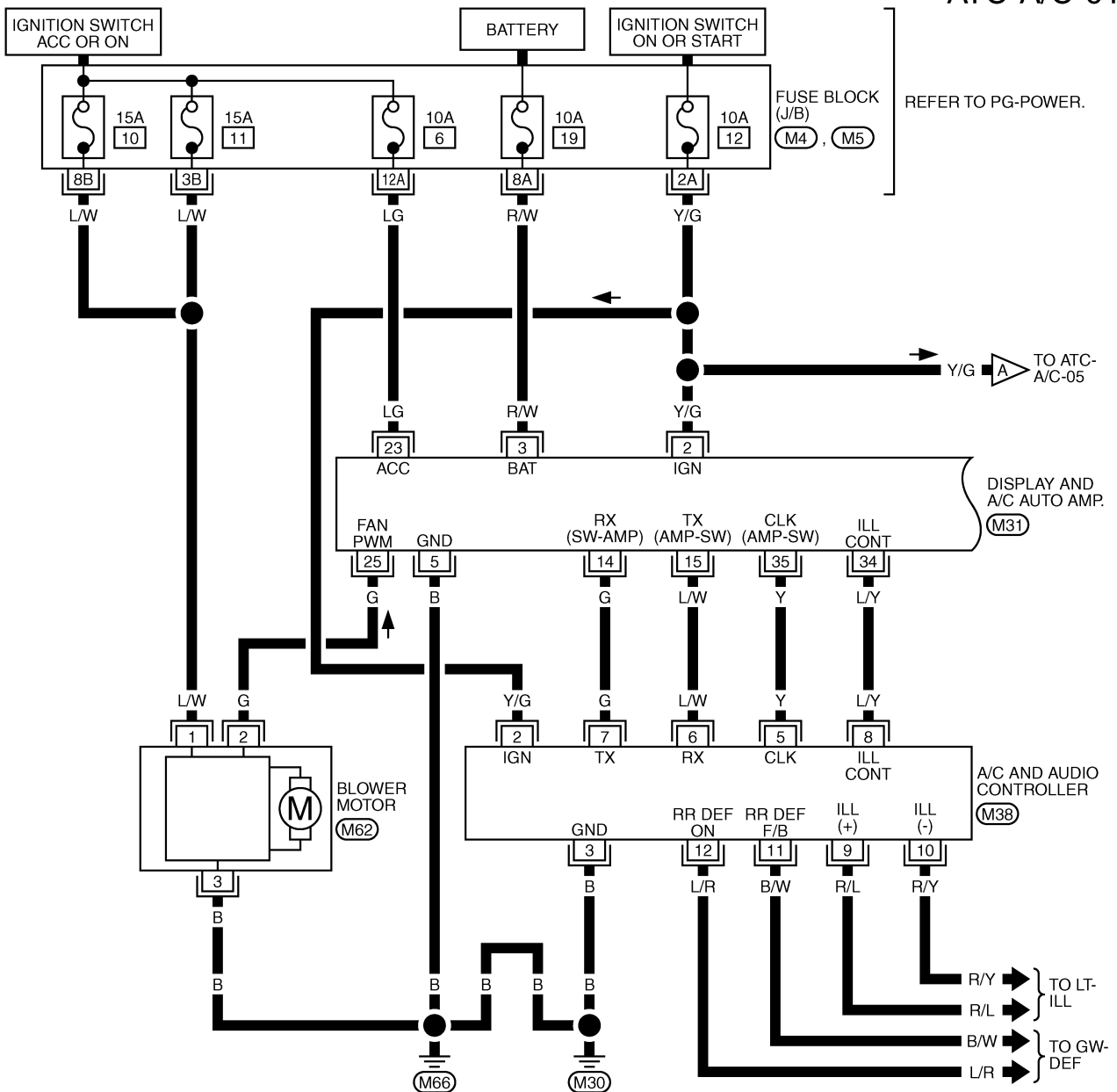

A  
B  
C  
D  
E  
F  
G  
H  
I  
J  
K  
L  
M

ATC

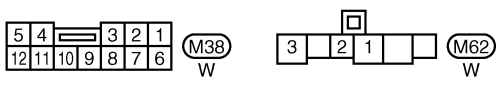
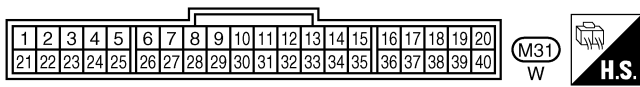

REFER TO THE FOLLOWING.  
 (M4) (M5) - FUSE BLOCK-JUNCTION BOX (J/B)

TJWM0140E

# TROUBLE DIAGNOSIS

ATC-A/C-02

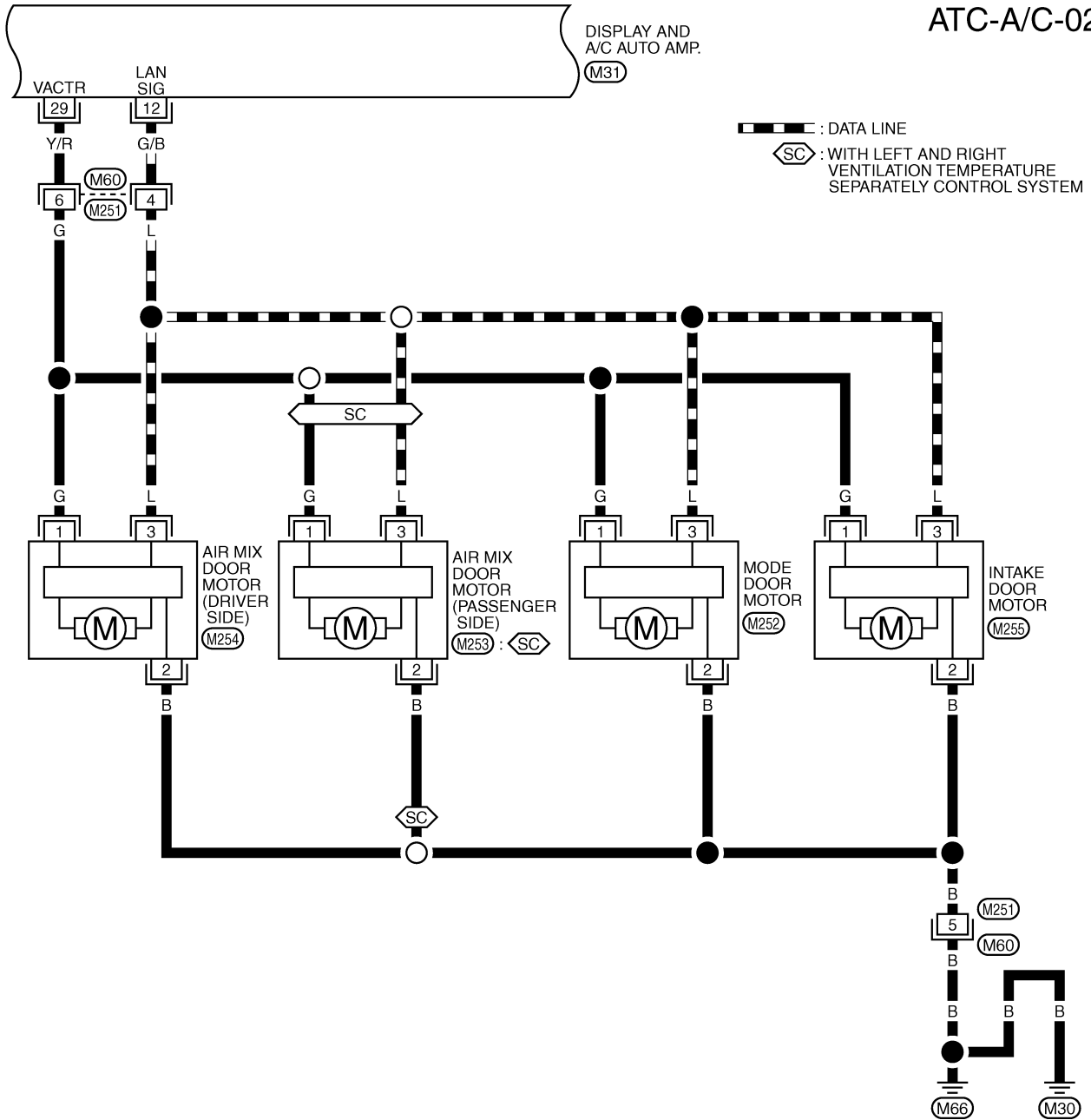

1	2	3	4	5	6	7	8	9	10	11	12	13	14	15	16	17	18	19	20
21	22	23	24	25	26	27	28	29	30	31	32	33	34	35	36	37	38	39	40

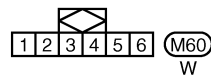

1				
2	M252	M253	M254	M255
3	W	W	W	W

\*: THIS CONNECTOR IS NOT SHOWN IN "HARNESS LAYOUT", PG SECTION.

TJWM0141E

# TROUBLE DIAGNOSIS

ATC-A/C-03

▬ : DATA LINE  
 ◊ : FOR CANADA

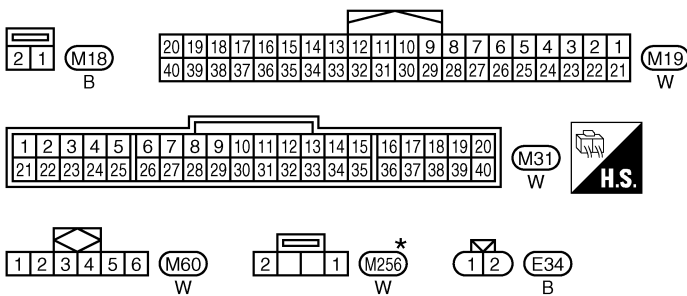
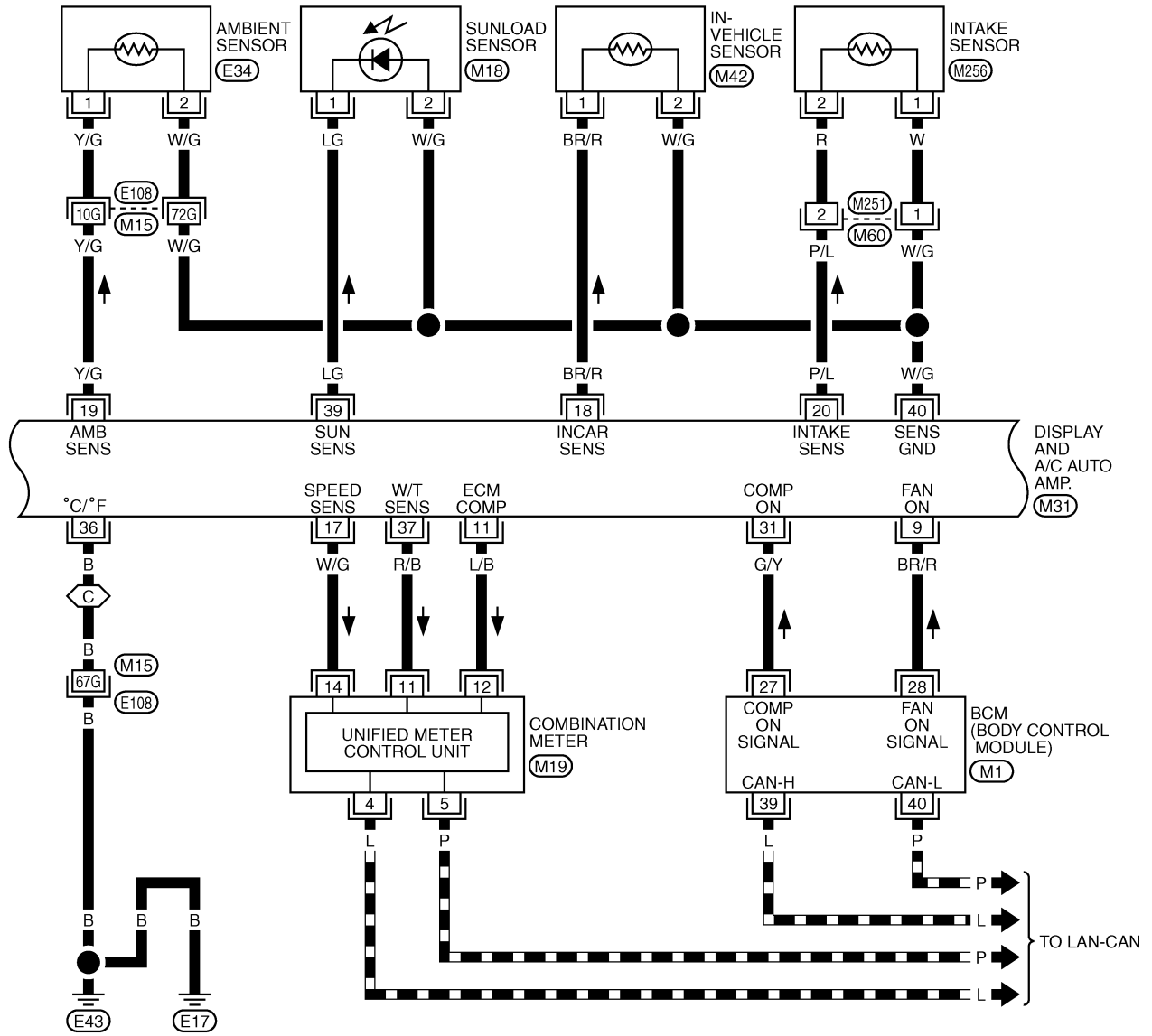

\*: THIS CONNECTOR IS NOT SHOWN IN "HARNESS LAYOUT", PG SECTION.

REFER TO THE FOLLOWING.

- (E108) -SUPER MULTIPLE JUNCTION (SMJ)
- (M1) -ELECTRICAL UNITS

TJWM0142E

# TROUBLE DIAGNOSIS

ATC-A/C-04

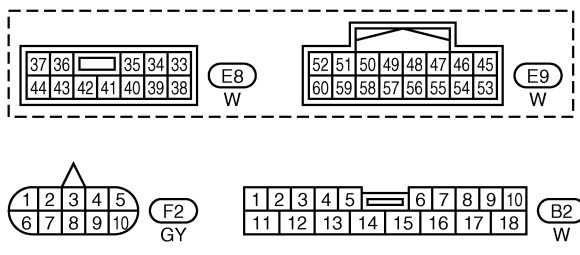
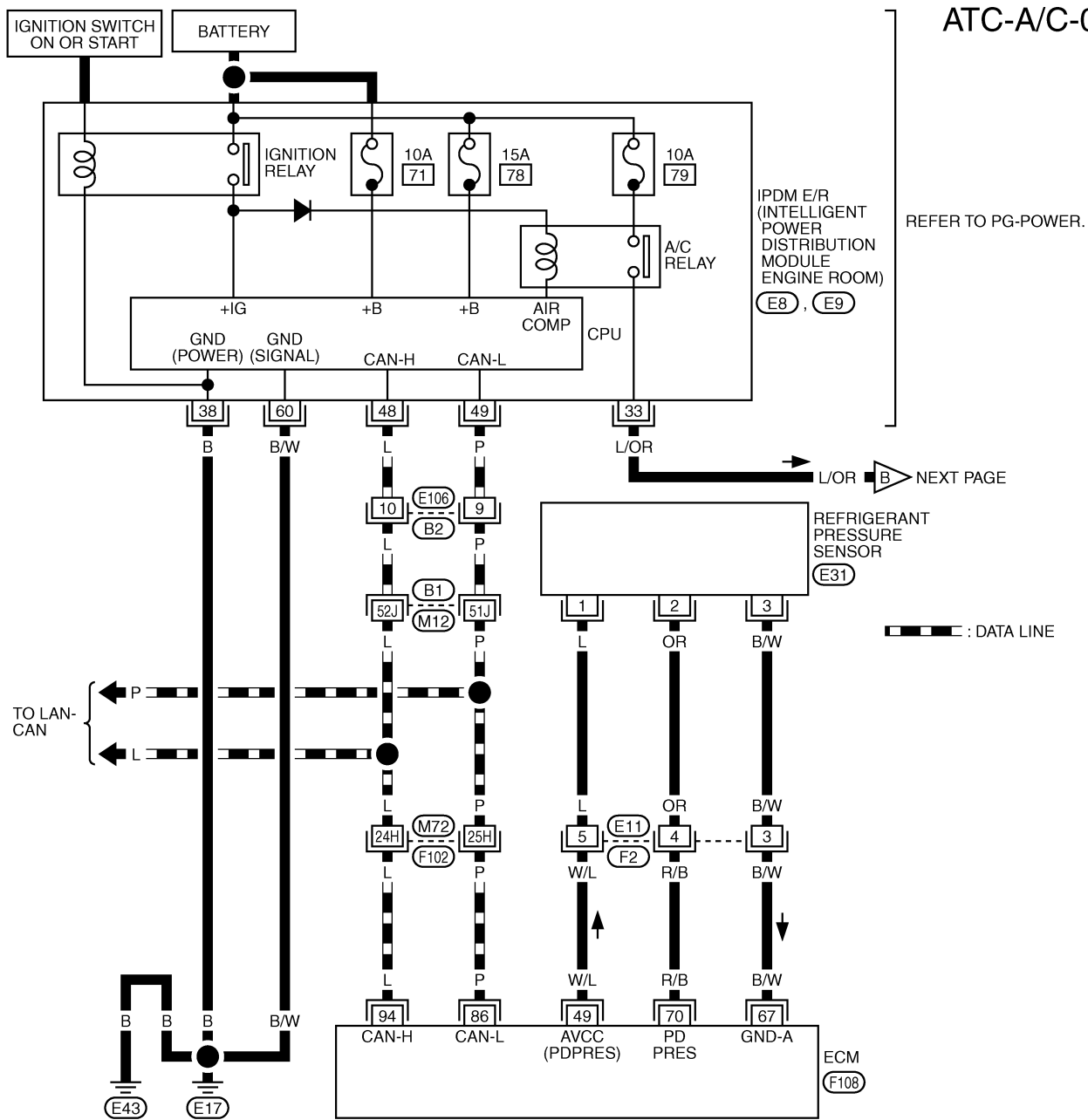

REFER TO THE FOLLOWING.

(F102), (B1) -SUPER MULTIPLE JUNCTION (SMJ)

(F108) -ELECTRICAL UNITS

TJWM0143E



# TROUBLE DIAGNOSIS

ATC-A/C-05

A  
B  
C  
D  
E  
F  
G  
H  
I  
K  
L  
M

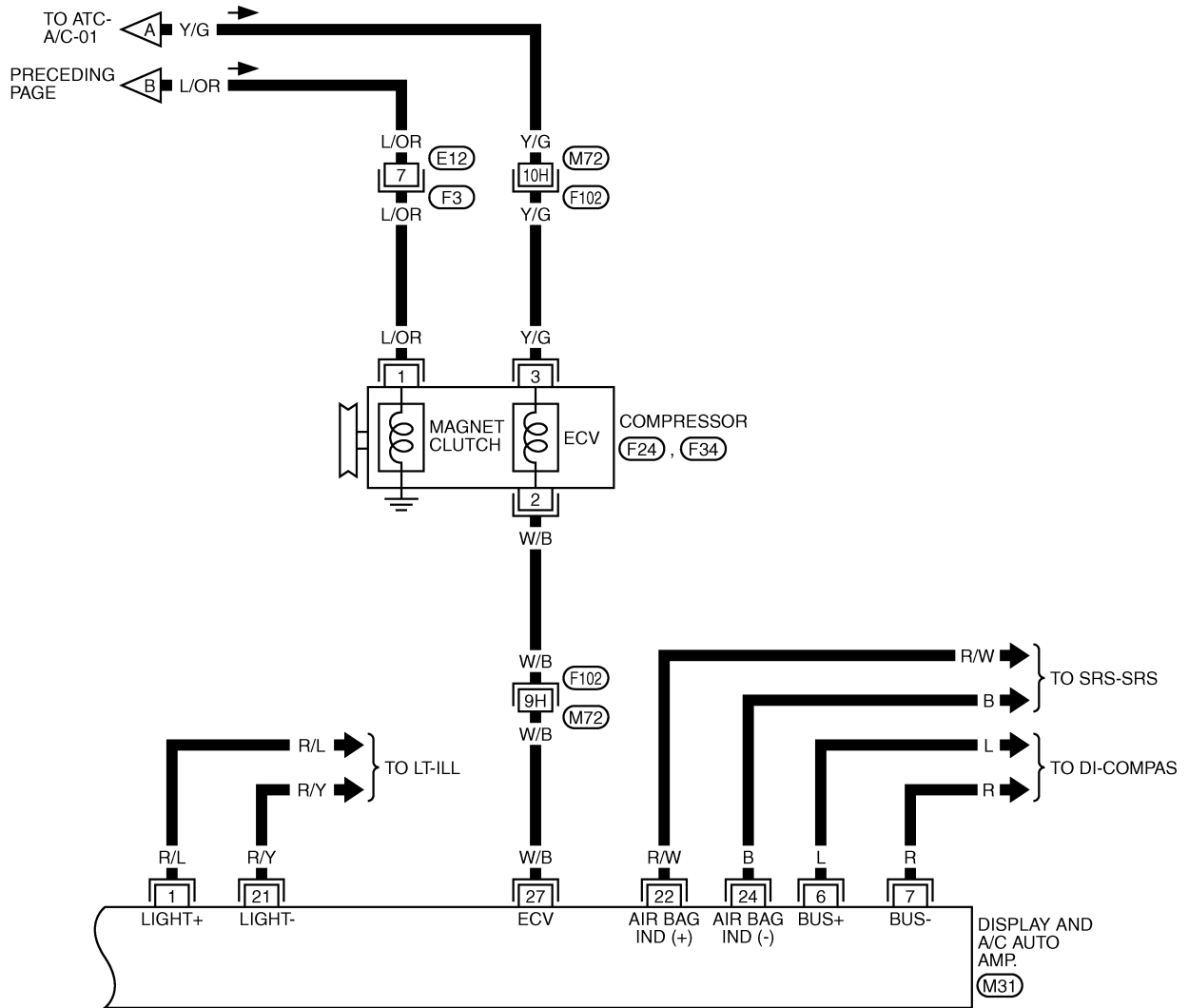

ATC

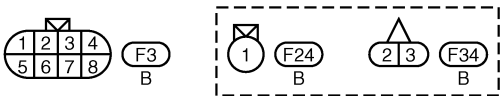
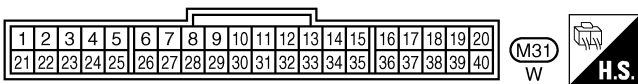

REFER TO THE FOLLOWING.

F102 -SUPER MULTIPLE JUNCTION (SMJ)

TJWM0144E

# TROUBLE DIAGNOSIS

AJS00122

## Auto Amp. Terminals and Reference Value

Measure voltage between each terminal and ground by following terminals and reference value for display and A/C auto amp.

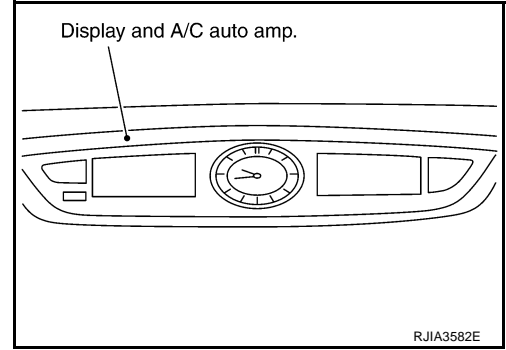

## PIN CONNECTOR TERMINAL LAYOUT

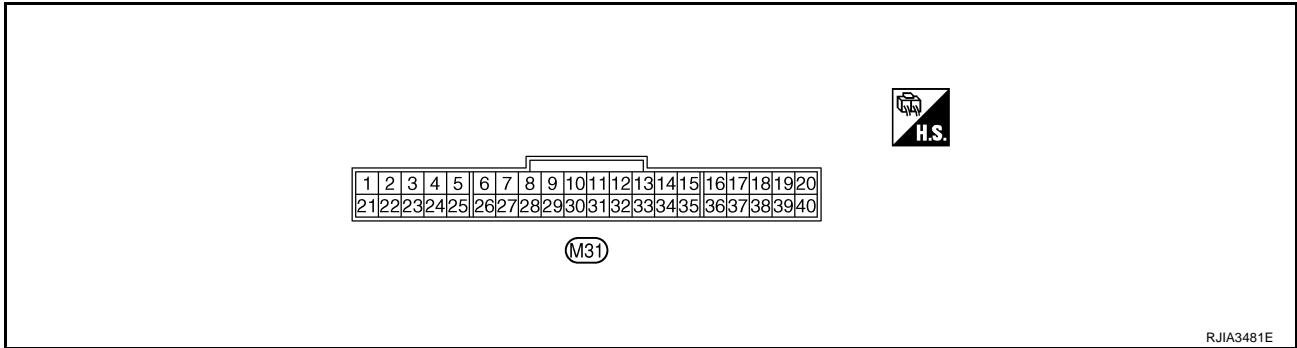

## TERMINALS AND REFERENCE VALUE FOR DISPLAY AND A/C AUTO AMP.

Terminal No.	Wire color	Item	Ignition switch	Condition	Voltage (V)
1	R/L	Power supply for illumination	ON	Light switch: ON	Approx. 12
				Light switch: OFF	Approx. 0
2	Y/G	Power supply for IGN	ON	-	Battery voltage
3	R/W	Power supply for BAT	OFF	-	Battery voltage
5	B	Ground	ON	-	Approx. 0
9	BR/R	Blower motor ON signal	ON	A/C switch: ON (Blower motor operates.)	Approx. 0
				OFF switch: ON (A/C system: OFF)	Approx. 5
11	L/B	Compressor feedback signal (Low-pressure cut)	ON	A/C switch: ON (Blower motor operates.)	Approx. 0
				A/C switch: ON (When refrigerant pressure sensor connector is disconnected.)	Approx. 5
12	G/B	A/C LAN signal	ON	-	

HAK0652D

# TROUBLE DIAGNOSIS

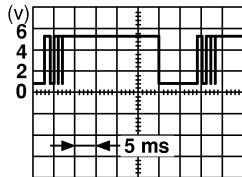
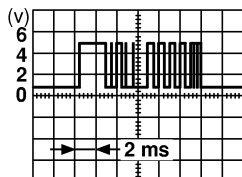
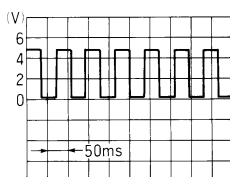
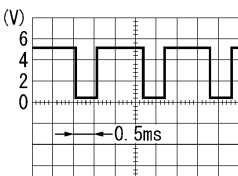
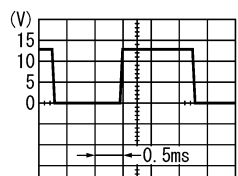
Terminal No.	Wire color	Item	Ignition switch	Condition	Voltage (V)
14	G	Multiplex communication (RX) signal (A/C and audio controller → Display and A/C auto amp.)	ON	-	 <p style="text-align: right; font-size: small;">RJIA0213E</p>
15	L/W	Multiplex communication (TX) signal (Display and A/C auto amp. → A/C and audio controller)	ON	-	 <p style="text-align: right; font-size: small;">RJIA0212E</p>
17	W/G	Vehicle speed sensor	ON	Speedometer operated [When vehicle speed is approx. 40km/h (25MPH)]	 <p style="text-align: right; font-size: small;">ELF1080D</p>
18	BR/R	In-vehicle sensor	-	-	-
19	Y/G	Ambient sensor	-	-	-
20	P/L	Intake sensor	-	-	-
21	R/Y	Illumination ground	ON	-	Approx. 0
23	LG	Power supply for ACC	ACC or ON	-	Battery voltage
25	G	Blower motor control signal	ON	Blower speed: 1st step	 <p style="text-align: right; font-size: small;">SJIA0116J</p>
27	W/B	ECV (Electronic Control Valve) signal	ON	Self-diagnosis: STEP-45	 <p style="text-align: right; font-size: small;">RJIA1606E</p>
29	Y/R	Power supply for each door motor	ON	-	Battery voltage
31	G/Y	Compressor ON signal	ON	A/C switch: ON (Blower motor operates.)	Approx. 0
				OFF switch: ON (A/C system: OFF)	Approx. 5

A  
B  
C  
D  
E  
F  
G  
H  
I  
K  
L  
M

ATC

# TROUBLE DIAGNOSIS

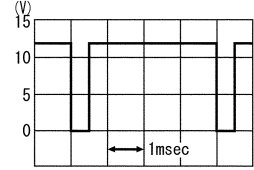
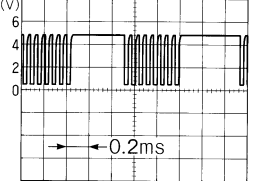
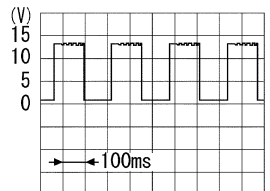
Terminal No.	Wire color	Item	Ignition switch	Condition	Voltage (V)
34	L/Y	Illumination control signal	ON	-	 <p style="text-align: right; font-size: small;">RJIA0646J</p>
35	Y	Multiplex communication (CLK) signal	ON	-	 <p style="text-align: right; font-size: small;">HAK0363D</p>
36	B	Changeover °C/°F (For Canada)	-	-	Approx. 0
37	R/B	Engine coolant temperature sensor signal	ON	At idle [after warming up, approx. 80°C (176°F)] <b>CAUTION:</b> The waveforms vary depending on coolant temperature.	 <p style="text-align: right; font-size: small;">PKIA0098J</p>
39	LG	Sunload sensor	-	-	-
40	W/G	Sensor ground	ON	-	Approx. 0

## Self-Diagnosis Function DESCRIPTION

The self-diagnostic system diagnoses sensors, door motors, blower motor, etc. by system line. Refer to applicable sections (items) for details. Shifting from usual control to the self-diagnostic system is accomplished by starting the engine (turning the ignition switch ON) and pressing OFF switch for at least 5 seconds. The OFF switch must be pressed within 10 seconds after starting the engine (ignition switch is turned ON). This system will be canceled by either pressing AUTO.ECON switch or turning the ignition switch OFF. Shifting from one step to another is accomplished by means of pushing temperature control dial, as required. Additionally shifting from STEP-5 to AUXILIARY MECHANISM is accomplished by means of pushing  (fan) UP switch.

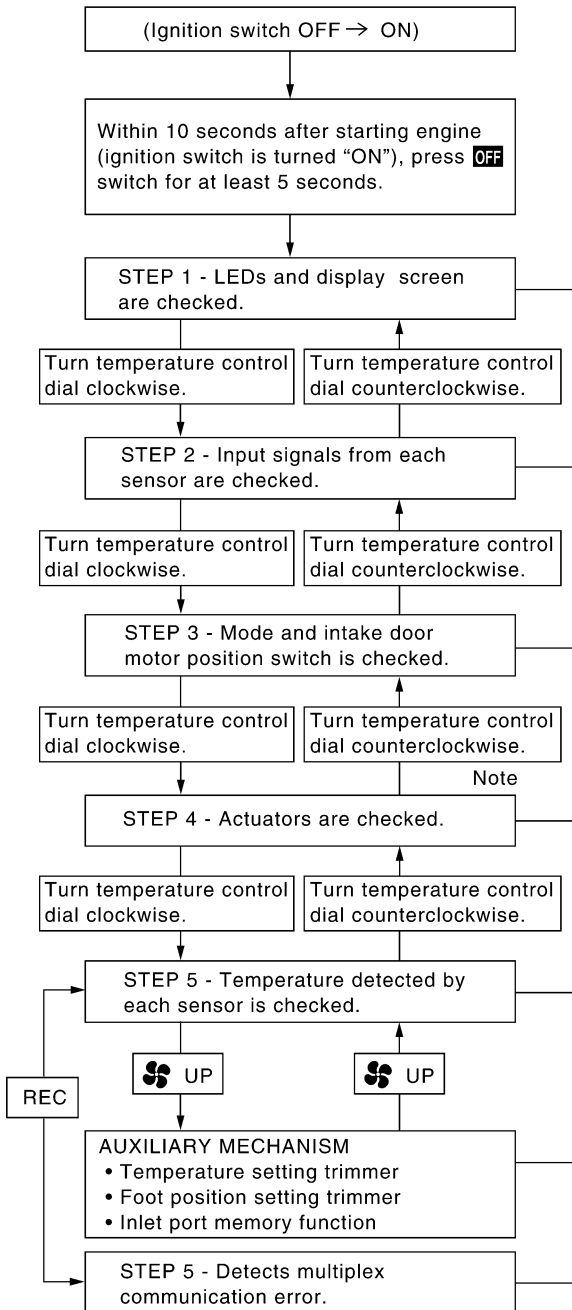

Display screen  
(with left and right ventilation temperature separately control system)

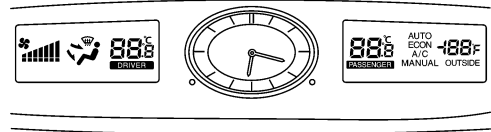

Display screen

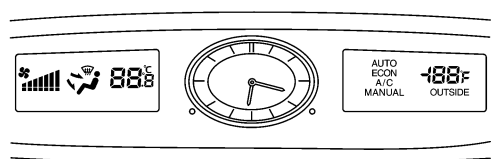

A/C and Audio controller

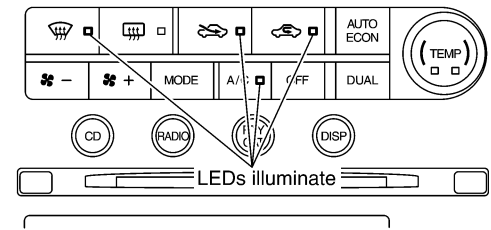

Ignition switch: OFF  
or AUTO. ECON switch: ON → Self-diagnostic function is canceled.

Note:  
For STEP 4 and 5, engine must be running for compressor to operate.

# TROUBLE DIAGNOSIS

## FUNCTION CONFIRMATION PROCEDURE

### 1. SET IN SELF-DIAGNOSTIC MODE

1. Turn ignition switch ON.
2. Set in self-diagnostic mode as follows. Within 10 seconds after starting engine (ignition switch is turned ON.), press OFF switch for at least 5 seconds.

#### CAUTION:

If battery voltage drops below 12V during diagnosis step-3, actuator speed becomes slower and as a result, the system may generate an error even when operation is usual. To avoid this, start engine before performing this diagnosis.

>> GO TO 2.

### 2. STEP-1: LEDS AND DISPLAY ARE CHECKED

Check LED illumination and display screen.

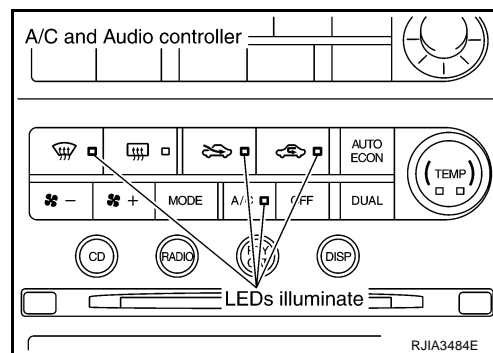
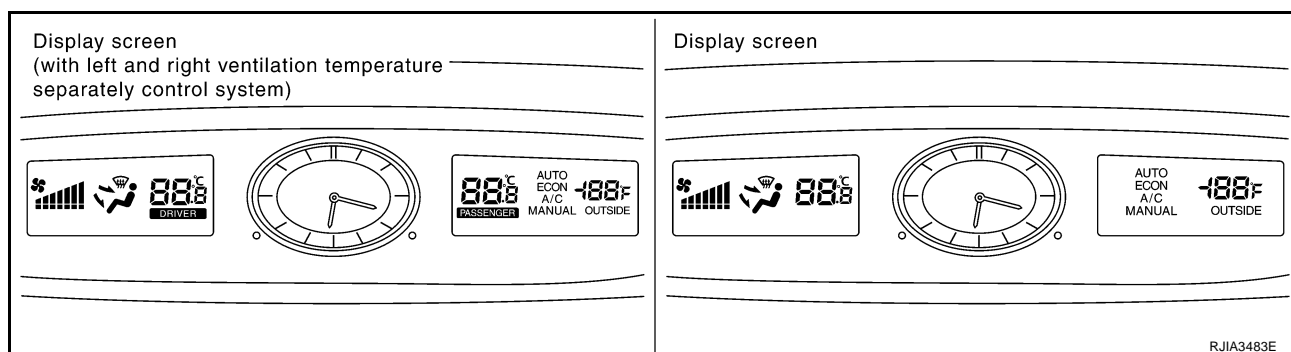

OK or NG

OK >> GO TO 3.

NG >> Malfunctioning OFF switch or display and A/C auto amp. Refer to [ATC-117, "Multiplex Communication Circuit"](#).

### 3. CHECK TO ADVANCE SELF-DIAGNOSIS STEP-2

Turn temperature control dial clockwise.

Advance to self-diagnosis STEP-2?

YES >> GO TO 4.

NO >> Replace A/C and audio controller. (Temperature control dial is malfunctioning.)

### 4. CHECK TO RETURN SELF-DIAGNOSIS STEP-1

Turn temperature control dial counterclockwise.

Return to self-diagnosis STEP-1?

YES >> GO TO 5.

NO >> Replace A/C and audio controller. (Temperature control dial is malfunctioning.)

# TROUBLE DIAGNOSIS

## 5. STEP-2: SENSOR CIRCUITS ARE CHECKED FOR OPEN OR SHORT CIRCUIT

Turn temperature control dial clockwise.

Does code No. 20 appear on the display?

- YES >> GO TO 6.
- NO >> GO TO 14.

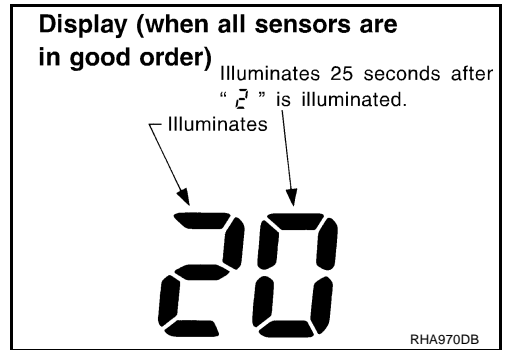

## 6. STEP-3: MODE DOOR AND INTAKE DOOR POSITIONS ARE CHECKED

Turn temperature control dial clockwise.

Does code No. 30 appear on the display?

- YES >> GO TO 7.
- NO >> GO TO 15.

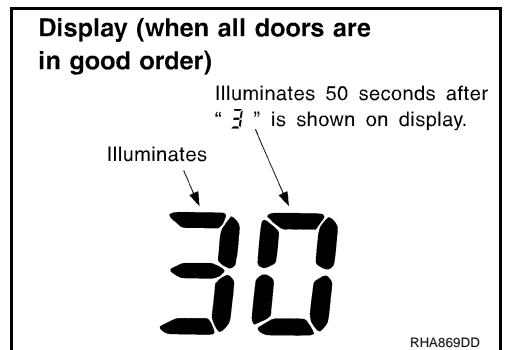

## 7. STEP-4: OPERATION OF EACH DOOR MOTOR IS CHECKED

1. Turn temperature control dial clockwise.
2. Press  (DEF) switch. Code No. of each door motor test is indicated on the display.

>> GO TO 8.

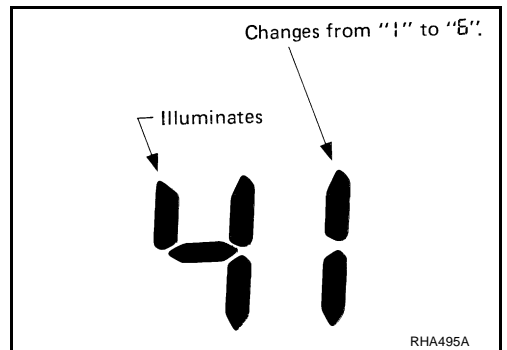





A  
B  
C  
D  
E  
F  
G  
H  
I  
K  
L  
M

ATC

# TROUBLE DIAGNOSIS

## 8. CHECK ACTUATORS

Refer to the following chart and confirm discharge air flow, air temperature, blower motor duty ratio and compressor operation.

Discharge air flow			
Mode door position	Air outlet/distribution		
	Vent	Foot	Defroster
	100%	–	–
	58%	42%	–
	19% (25%)	61% (75%)	20% (–)
	16%	54%	30%
	–	–	100%

( ): Manually control SJIA0565E

Code No.	41	42	43	44	45	46
Mode door position	VENT	B/L 1	B/L 2	FOOT*1	D/F	DEF
Intake door position	REC	REC	20% FRE	FRE	FRE	FRE
Air mix door position	FULL COLD	FULL COLD	FULL HOT	FULL HOT	FULL HOT	FULL HOT
Blower motor duty ratio	37%	91%	65%	65%	65%	91%
Compressor	ON	ON	OFF	OFF	ON	ON
Electronic control valve (ECV) duty ratio	100%	100%	0%	0%	50%	100%

Checks must be made visually, by listening to any noise, or by touching air outlets with your hand, etc. for improper operation.

\*1: FOOT position during automatic control. Refer to [ATC-61, "AUXILIARY MECHANISM: FOOT POSITION SETTING TRIMMER"](#) .

### OK or NG

OK >> GO TO 9.

- NG >>
- Air outlet does not change.  
Go to Mode Door Motor Circuit. Refer to [ATC-71, "Mode Door Motor Circuit"](#) .
  - Intake door does not change.  
Go to Intake Door Motor Circuit. Refer to [ATC-77, "Intake Door Motor Circuit"](#) .
  - Blower motor operation is malfunctioning.  
Go to Blower Motor Circuit. Refer to [ATC-80, "Blower Motor Circuit"](#) .
  - Magnet clutch does not engage.  
Go to Magnet Clutch Circuit. Refer to [ATC-86, "Magnet Clutch Circuit"](#) .
  - Discharge air temperature does not change.  
Go to Air Mix Door Motor Circuit. Refer to [ATC-74, "Air Mix Door Motor Circuit"](#) .

## 9. STEP-5: TEMPERATURE OF EACH SENSOR IS CHECKED

1. Turn temperature control dial clockwise.
2. Code No. 51 appears on the display.

>> GO TO 10.



# TROUBLE DIAGNOSIS

## 10. CHECK AMBIENT SENSOR

Press  (DEF) switch one time. Temperature detected by ambient sensor is indicated on the display.

**NOTE:**

If temperature shown on display greatly differs from actual temperature, check sensor circuit first, then inspect sensor.

OK or NG

OK >> GO TO 11.

NG >> Go to Ambient Sensor Circuit. Refer to [ATC-106, "Ambient Sensor Circuit"](#).

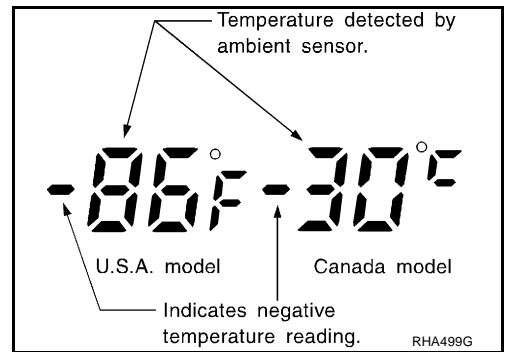

## 11. CHECK IN-VEHICLE SENSOR

Press  (DEF) switch a second time. Temperature detected by in-vehicle sensor is indicated on the display.

**NOTE:**

If temperature shown on display greatly differs from actual temperature, check sensor circuit first, then inspect sensor.

OK or NG

OK >> GO TO 12.

NG >> Go to In-vehicle Sensor Circuit. Refer to [ATC-109, "In-Vehicle Sensor Circuit"](#).

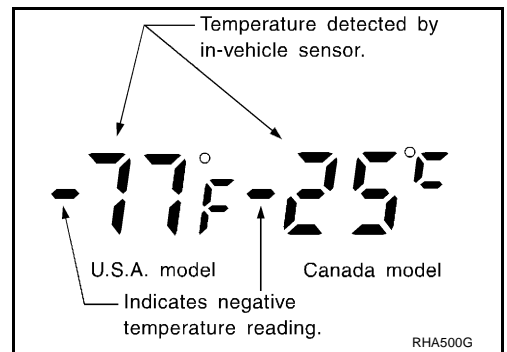

## 12. CHECK INTAKE SENSOR

Press  (DEF) switch a third time. Temperature detected by intake sensor is indicated on the display.

**NOTE:**

If temperature shown on display greatly differs from actual temperature, check sensor circuit first, then inspect sensor.

OK or NG

OK >> GO TO 13.

NG >> Go to Intake Sensor Circuit. Refer to [ATC-115, "Intake Sensor Circuit"](#).

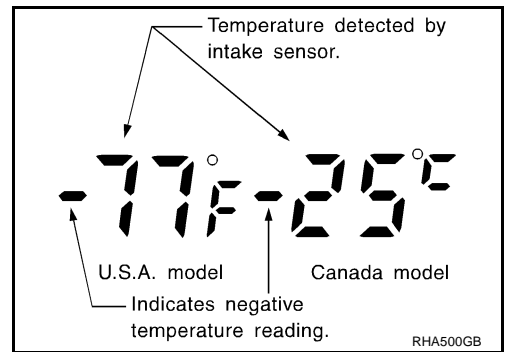



## 13. CHECK MULTIPLEX COMMUNICATION ERROR

1. Press Recirculation  (REC) switch.
2. Multiplex communication error between display and A/C auto amp. and A/C and audio controller can be detected as self-diagnosis results.  
(If plural errors occur, the display of each error will blink twice for 0.5 second intervals.)

Is multiplex communication error detected as self-diagnosis results?

YES >> Go to multiplex communication circuit. Refer to [ATC-117, "Multiplex Communication Circuit"](#).

NO >> 1. Turn ignition switch OFF or AUTO. ECON switch ON.  
2. INSPECTION END

Display	Multiplex communication error
52	In good order
 52	A/C and Audio controller ⇨ Display and A/C Auto amp.
 52	Display and A/C Auto amp. ⇨ A/C and Audio controller

# TROUBLE DIAGNOSIS

## 14. CHECK MALFUNCTIONING SENSOR

Refer to the following chart for malfunctioning code No.

(If two or more sensors malfunction, corresponding code Nos. blink respectively twice.)

\*1: Perform self-diagnosis STEP-2 under sunshine.

When performing indoors, aim a light (more than 60W) at sunload sensor, otherwise code No.25 will indicate despite that sunload sensor is functioning properly.

Code No.	Malfunctioning sensor (Including circuits)		Reference page
21 / -21	Ambient sensor		*2
22 / -22	In-vehicle sensor		*3
24 / -24	Intake sensor		*4
25 / -25	Sunload sensor *1		*5
26 / -26	With DUAL switch	Air mix door motor PBR (Driver side)	*6
	Without DUAL switch	Air mix door motor PBR (Passenger side)	
27 / -27	With DUAL switch only	Air mix door motor PBR (Passenger side)	

\*2: [ATC-107, "DIAGNOSTIC PROCEDURE FOR AMBIENT SENSOR"](#) .

\*3: [ATC-110, "DIAGNOSTIC PROCEDURE FOR IN-VEHICLE SENSOR"](#) .

\*4: [ATC-115, "DIAGNOSTIC PROCEDURE FOR INTAKE SENSOR"](#) .

\*5: [ATC-112, "DIAGNOSTIC PROCEDURE FOR SUNLOAD SENSOR"](#) .

\*6: [ATC-67, "DIAGNOSTIC PROCEDURE FOR LAN CIRCUIT"](#) .

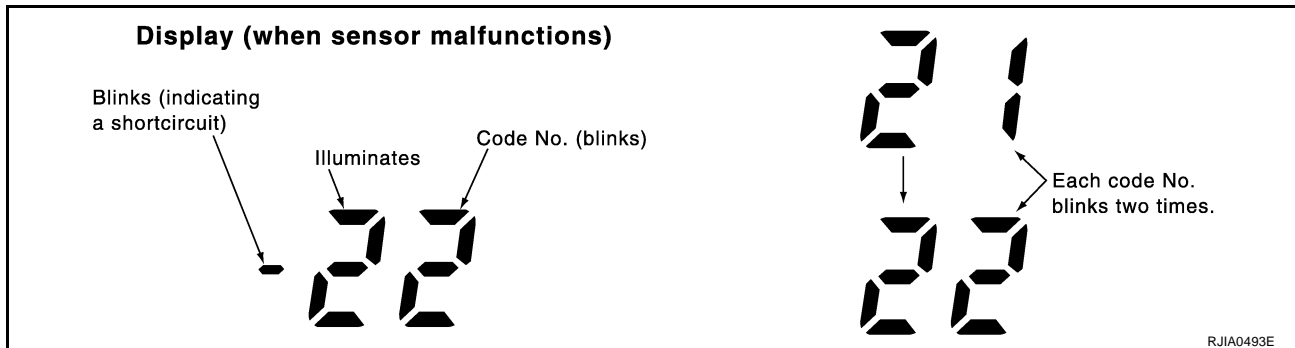

>> INSPECTION END

# TROUBLE DIAGNOSIS

## 15. CHECK MALFUNCTIONING DOOR MOTOR POSITION SWITCH

Mode and/or intake door motor PBR(s) is/are malfunctioning.

Code No. *1 *2	Mode or intake door position	Reference page
31	VENT	*4
32	B/L 1	
33	B/L 2	
34	FOOT*3	
35	D/F	
36	DEF	
37	FRE	*5
38	20% FRE	
39	REC	

(If two or more mode or intake doors are out of order, corresponding code numbers blink respectively twice.)

\*1: If mode door motor harness connector is disconnected, the following display pattern will appear.

31→32→33→34→35→36→Return to 31

\*2: If intake door motor harness connector is disconnected, the following display pattern will appear.

37→38→39→Return to 37

\*3: FOOT position during automatic control. Refer to [ATC-61, "AUXILIARY MECHANISM: FOOT POSITION SETTING TRIMMER"](#).

\*4: [ATC-71, "Mode Door Motor Circuit"](#).

\*5: [ATC-77, "Intake Door Motor Circuit"](#).

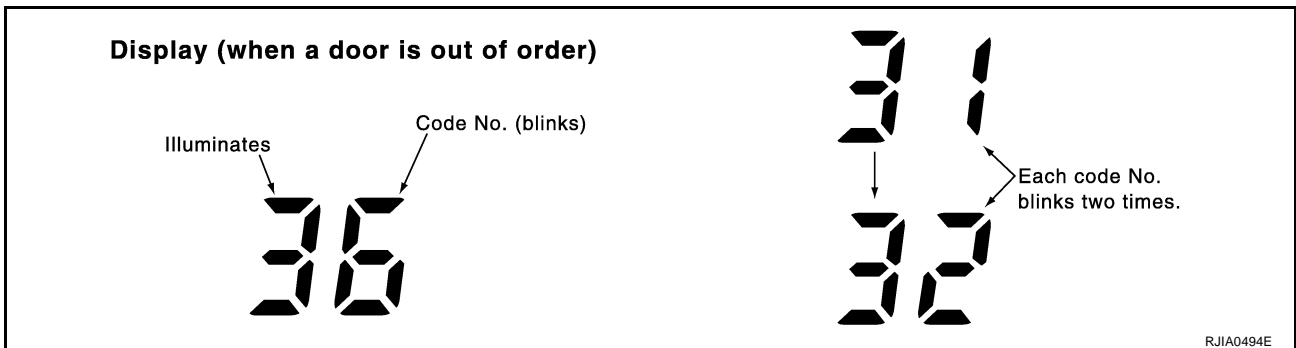

>> INSPECTION END

# TROUBLE DIAGNOSIS

## AUXILIARY MECHANISM: TEMPERATURE SETTING TRIMMER

The trimmer compensates for differences in range of  $\pm 3^{\circ}\text{C}$  ( $\pm 6^{\circ}\text{F}$ ) between temperature setting (displayed digitally) and temperature felt by driver.

Operating procedures for this trimmer are as follows:

1. Begin Self-diagnosis STEP-5 mode. Refer to [ATC-53, "Self-Diagnosis Function"](#).
2. Press  (fan) UP switch to set system in auxiliary mode.
3. Display shows 61 in auxiliary mechanism. It takes approximately 3 seconds.
4. Turn temperature control dial as desired. Temperature will change at a rate of  $0.5^{\circ}\text{C}$  ( $1.0^{\circ}\text{F}$ ) each time a dial is turned.

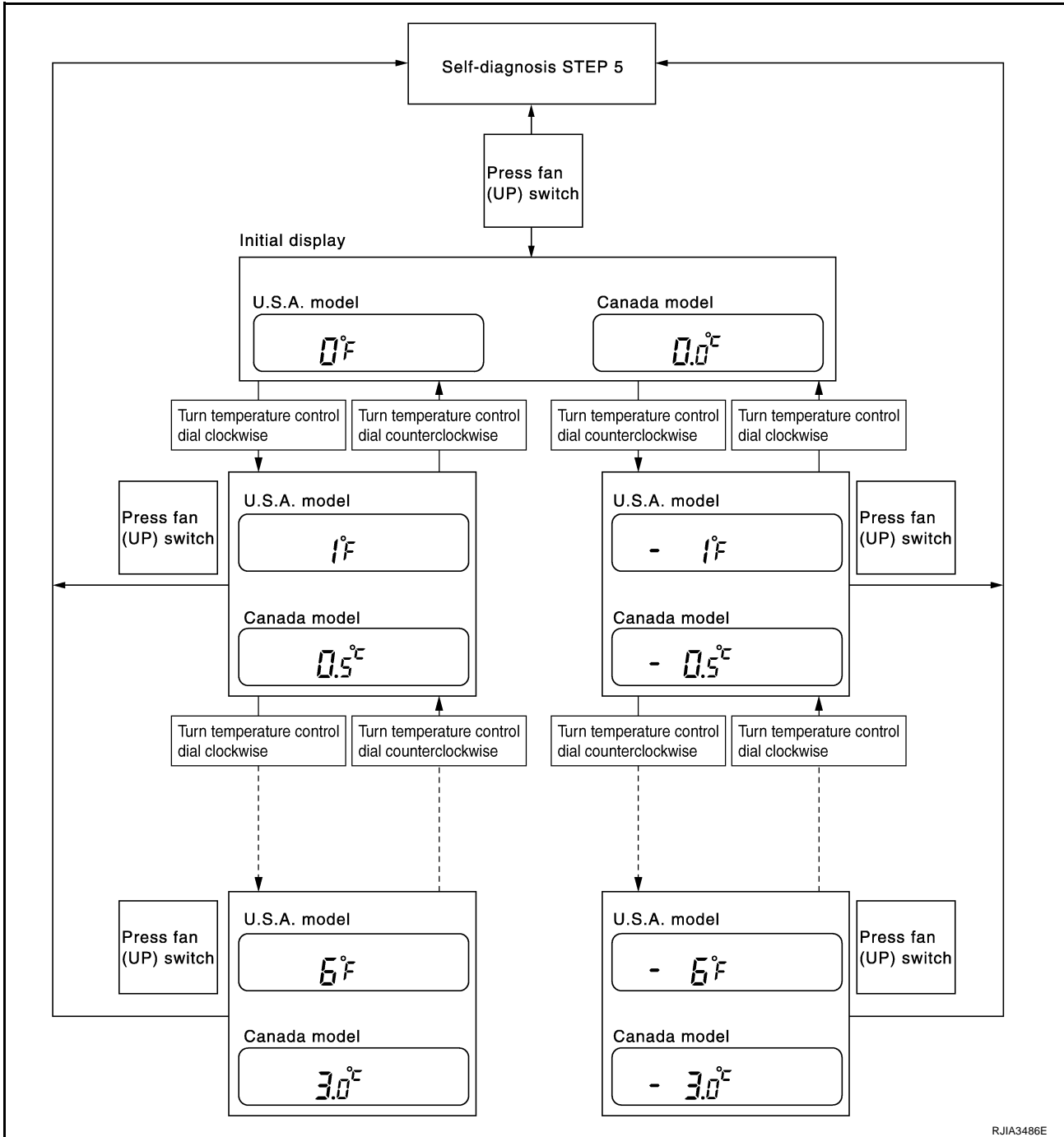

When battery cable is disconnected, trimmer operation is canceled. Temperature set becomes that of initial condition, i.e.  $0^{\circ}\text{C}$  ( $0^{\circ}\text{F}$ ).





# TROUBLE DIAGNOSIS

## AUXILIARY MECHANISM: FOOT POSITION SETTING TRIMMER

Wind distribution ratio in FOOT mode can be set.

Operating procedures for this trimmer are as follows:

1. Begin Self-diagnosis STEP-5 mode. Refer to [ATC-53, "Self-Diagnosis Function"](#).
2. Press  (fan) UP switch to set system in auxiliary mode.
3. Display shows 61 in auxiliary mechanism. It takes approximately 3 seconds.
4. Press the mode switch as desired.

Display	Discharge air flow					
	Automatically controls the mode door			Manually controls the mode door		
	VENT	FOOT	DEF	VENT	FOOT	DEF
	19%	61%	20%	25%	75%	—
	19%	61%	20%	19%	61%	20%
	25%	75%	—	19%	61%	20%
	25%	75%	—	25%	75%	—

RJIA3487E

## AUXILIARY MECHANISM: INLET PORT MEMORY FUNCTION

When ignition switch is turned from OFF to ON, inlet port can be set to AUTO or manual.

Operating procedures for this trimmer are as follows:

1. Begin Self-diagnosis STEP-5 mode. Refer to [ATC-53, "Self-Diagnosis Function"](#).
2. Press  (fan) UP switch to set system in auxiliary mode.
3. Display shows 61 in auxiliary mechanism. It takes approximately 3 seconds.
4. Press the recirculation (REC) and fresh (FRE) switch as desired.

Switch	LED status of REC/FRE switch	Setting status	Setting changeover method
REC	ON	Manual REC status is memorized. (Initial setting)	REC SW: ON
	OFF	AUTO control	
FRE	ON	Manual FRE status is memorized.	FRE SW: ON
	OFF	AUTO control (Initial setting)	

# TROUBLE DIAGNOSIS

AJS00124

## Operational Check

The purpose of the operational check is to confirm that the system operates properly.

**Conditions : Engine running at usual operating temperature**

### CHECKING MEMORY FUNCTION

1. Turn temperature control dial clockwise until 32°C (90°F) is displayed.
2. Press OFF switch.
3. Turn the ignition switch OFF.
4. Turn the ignition switch ON.
5. Press the AUTO.ECON switch.
6. Confirm that the set temperature remains at previous temperature.
7. Press OFF switch.

If NG, go to trouble diagnosis procedure for [ATC-106, "Memory Function"](#).

If OK, continue the check.

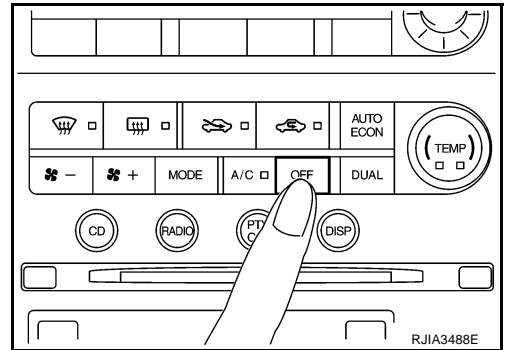

### CHECKING BLOWER

1. Press fan switch (UP: +). Blower should operate on low speed. The fan symbol should have one blade lit.
2. Press fan switch (UP: +), and continue checking blower speed and fan symbol until all speeds are checked.
3. Leave blower on max. speed.

If NG, go to trouble diagnosis procedure for [ATC-80, "Blower Motor Circuit"](#).

If OK, continue the check.

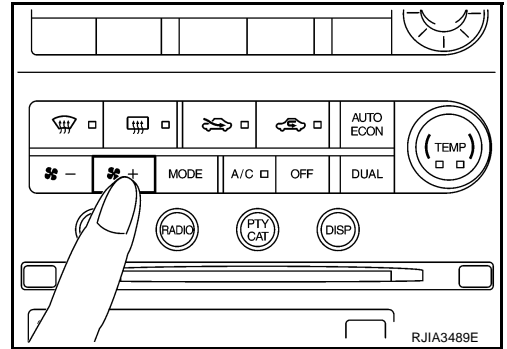

### CHECKING DISCHARGE AIR

1. Press MODE switch and DEF switch.
2. Each position indicator should change shape.

3. Confirm that discharge air comes out according to the air distribution table. Refer to [ATC-36, "Discharge Air Flow"](#).

Intake door position is checked in the next step.

If NG, go to trouble diagnosis procedure for [ATC-71, "Mode Door Motor Circuit"](#).

If OK, continue the check.

#### NOTE:

Confirm that the compressor clutch is engaged (sound or visual inspection) and intake door position is at FRESH when the D/F or DEF is selected.

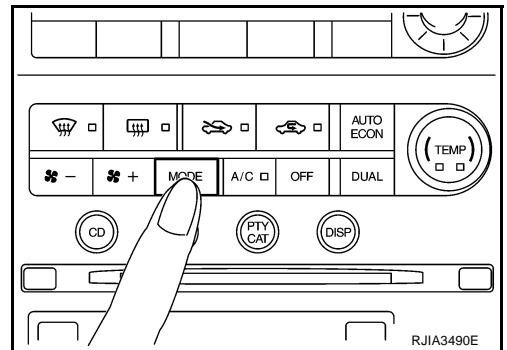

Discharge air flow			
Mode door position	Air outlet/distribution		
	Vent	Foot	Defroster
	100%	-	-
	58%	42%	-
	19% (25%)	61% (75%)	20% (-)
	16%	54%	30%
	-	-	100%

( ): Manually control

SJIA0565E

# TROUBLE DIAGNOSIS

## CHECKING RECIRCULATION

1. Press recirculation (REC) switch one time. Recirculation indicator should illuminate.
2. Press fresh (FRE) switch one time. Fresh indicator should illuminate.
3. Listen for intake door position change (you should hear blower sound change slightly).

If NG, go to trouble diagnosis procedure for [ATC-77, "Intake Door Motor Circuit"](#) .

If OK, continue the check.

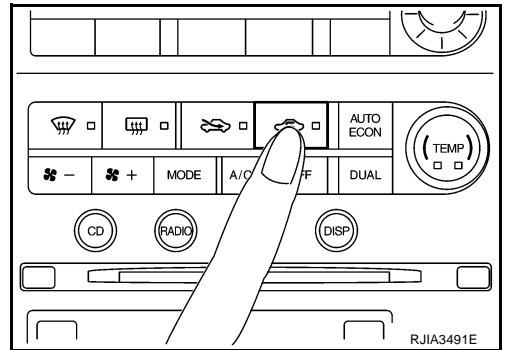

A  
B  
C  
D

## CHECKING TEMPERATURE DECREASE

1. Turn temperature control dial counterclockwise until 18°C (60°F) is displayed.
2. Check for cold air at discharge air outlets.

If NG, go to trouble diagnosis procedure for [ATC-93, "Insufficient Cooling"](#) .

If OK, continue the check.

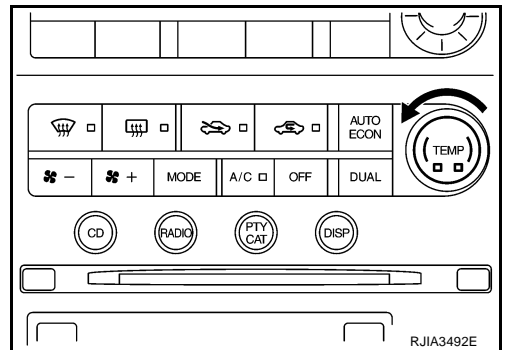

E  
F  
G  
H

## CHECKING TEMPERATURE INCREASE

1. Turn temperature control dial clockwise until 32°C (90°F) is displayed.
2. Check for hot air at discharge air outlets.

If NG, go to trouble diagnosis procedure for [ATC-103, "Insufficient Heating"](#) .

If OK, continue the check.

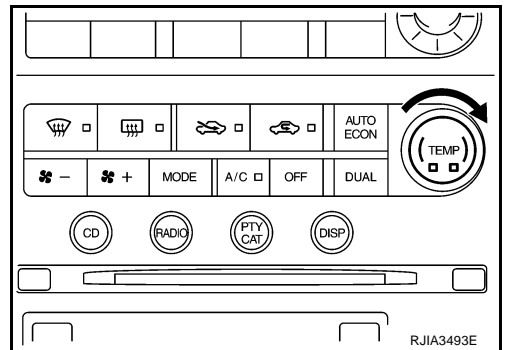

ATC

K  
L

## CHECK A/C SWITCH

1. Press AUTO. ECON switch.
2. Press A/C switch.
3. A/C switch indicator will turn ON.
  - Confirm that the compressor clutch engages (sound or visual inspection).

If NG, go to trouble diagnosis procedure for [ATC-86, "Magnet Clutch Circuit"](#) .

If OK, continue the check.

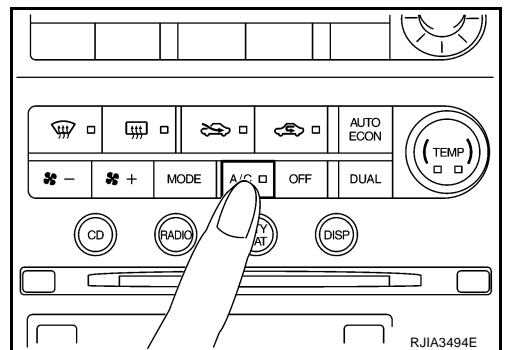

M

# TROUBLE DIAGNOSIS

## CHECKING AUTO. ECON MODE

1. Press AUTO. ECON switch.
2. Display should indicate AUTO (not ECON).
3. Press AUTO. ECON switch again.
4. Display should indicate ECON.
  - Confirm that discharge air and blower speed will depend on ambient, in-vehicle, and set temperatures.

If NG, go to trouble diagnosis procedure for [ATC-64, "Power Supply and Ground Circuit for Auto Amp."](#) , then if necessary, trouble diagnosis procedure for [ATC-86, "Magnet Clutch Circuit"](#) .

If all operational checks are OK (symptom cannot be duplicated), go to Incident Simulation Tests in [GI-26, "How to Perform Efficient Diagnosis for an Electrical Incident"](#) and perform tests as outlined to simulate driving conditions environment. If symptom appears, refer to [ATC-41, "SYMPTOM TABLE"](#) and perform applicable trouble diagnosis procedures.

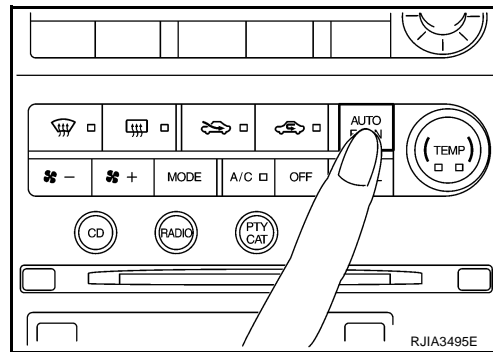

## Power Supply and Ground Circuit for Auto Amp.

AJS00125

SYMPTOM: A/C system does not come on.

## INSPECTION FLOW

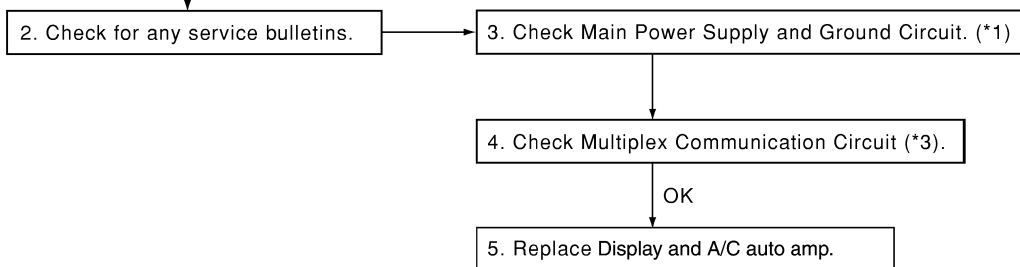
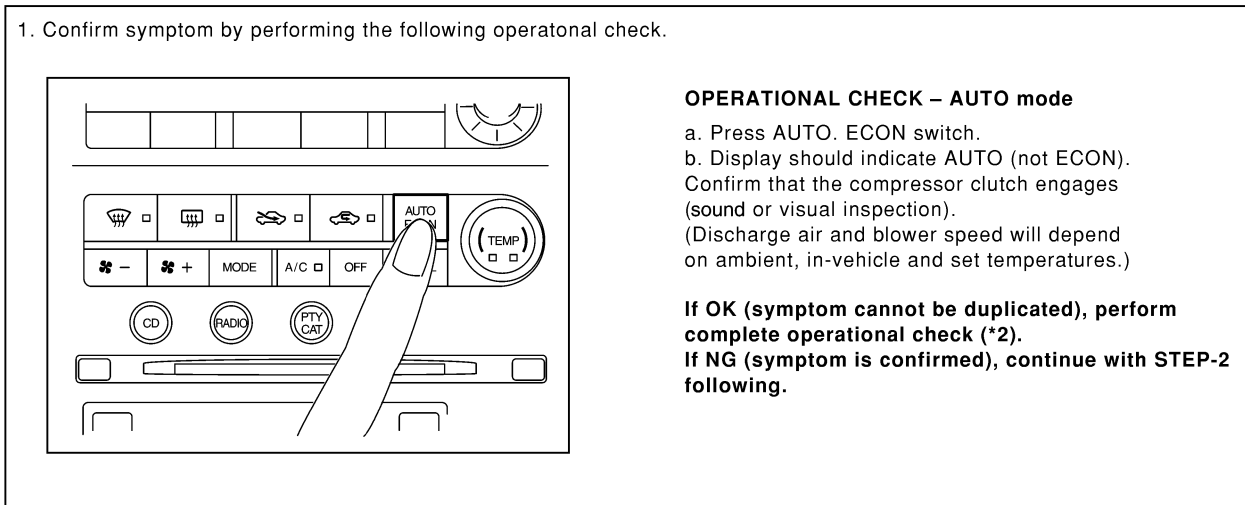

RJIA3496E

\*1 [ATC-65, "DIAGNOSTIC PROCEDURE FOR A/C SYSTEM"](#)

\*2 [ATC-62, "Operational Check"](#)

\*3 [ATC-117, "Multiplex Communication Circuit"](#)



# TROUBLE DIAGNOSIS

## COMPONENT DESCRIPTION

### Display and A/C Auto Amp. (Automatic Amplifier)

The display and A/C auto amp. has a built-in microcomputer which processes information sent from various sensors needed for air conditioner operation. The air mix door motor, mode door motor, intake door motor, blower motor and compressor are then controlled.

The display and A/C auto amp. is unitized with control mechanisms. When the various switches and temperature control dial are operated, data is input to the display and A/C auto amp. from the A/C and Audio controller using multiplex communication.

Self-diagnostic functions are also built into display and A/C auto amp. to provide quick check of malfunctions in the auto air conditioner system.

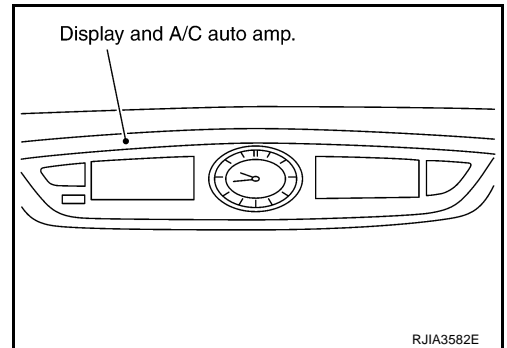

### Potential Temperature Control (PTC)

The PTC is built into the A/C and audio controller. It can be set at an interval of 0.5°C (1.0°F) in the 18°C (60°F) to 32°C (90°F) temperature range by turning temperature control dial. The set temperature is displayed.

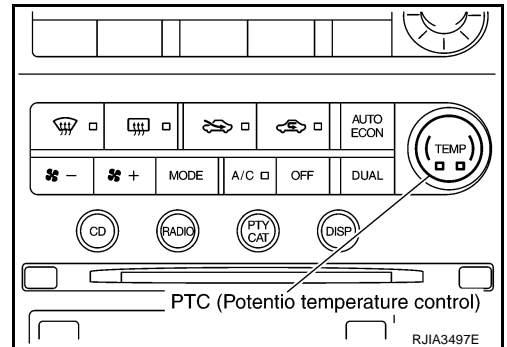

## DIAGNOSTIC PROCEDURE FOR A/C SYSTEM

SYMPTOM: A/C system does not come on.

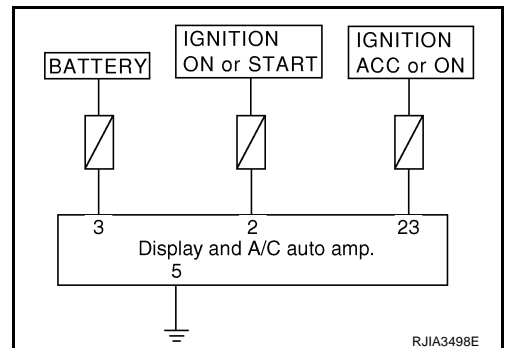

A  
B  
C  
D  
E  
F  
G  
H  
I  
K  
L  
M

ATC

# TROUBLE DIAGNOSIS

## 1. CHECK POWER SUPPLY CIRCUIT FOR DISPLAY AND A/C AUTO AMP.

1. Disconnect display and A/C auto amp. connector.
2. Check voltage between display and A/C auto amp. harness connector M31 terminals 2 (Y/G), 3 (R/W), 23 (LG) and ground.

Terminals		Ignition switch position			
(+)		(-)	OFF	ACC	ON
Display and A/C auto amp. connector	Terminal No. (wire color)				
M31	2 (Y/G)	Ground	Approx. 0V	Approx. 0V	Battery voltage
M31	3 (R/W)		Battery voltage	Battery voltage	Battery voltage
M31	23 (LG)		Approx. 0V	Battery voltage	Battery voltage

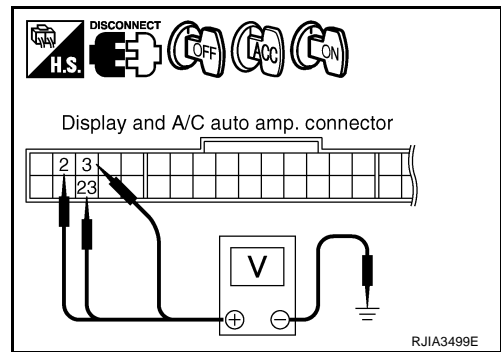

### OK or NG

OK >> GO TO 2.

NG >> Check 10A fuses [Nos. 6, 12 and 19, located in the fuse block (J/B)]. Refer to [PG-76. "FUSE BLOCK - JUNCTION BOX \(J/B\)"](#).

- If fuses are OK, check harness for open circuit. Repair or replace if necessary.
- If fuses are NG, replace fuse and check harness for short circuit. Repair or replace if necessary.

## 2. CHECK GROUND CIRCUIT FOR DISPLAY AND A/C AUTO AMP.

1. Turn ignition switch OFF.
2. Check continuity between display and A/C auto amp. harness connector M31 terminal 5 (B) and ground.

**5 – Ground**

**: Continuity should exist.**

### OK or NG

OK >> Replace display and A/C auto amp.

NG >> Repair or replace harness.

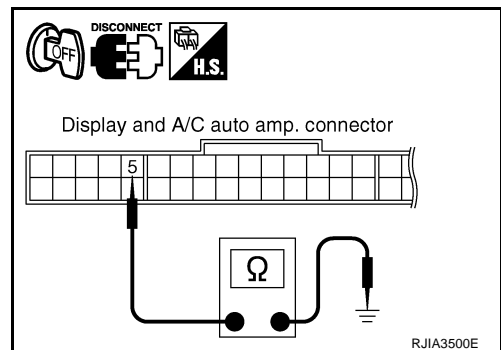

# TROUBLE DIAGNOSIS

AJS00126

## LAN System Circuit

SYMPTOM: Mode door motor, intake door motor and/or air mix door motor(s) does not operate normally.

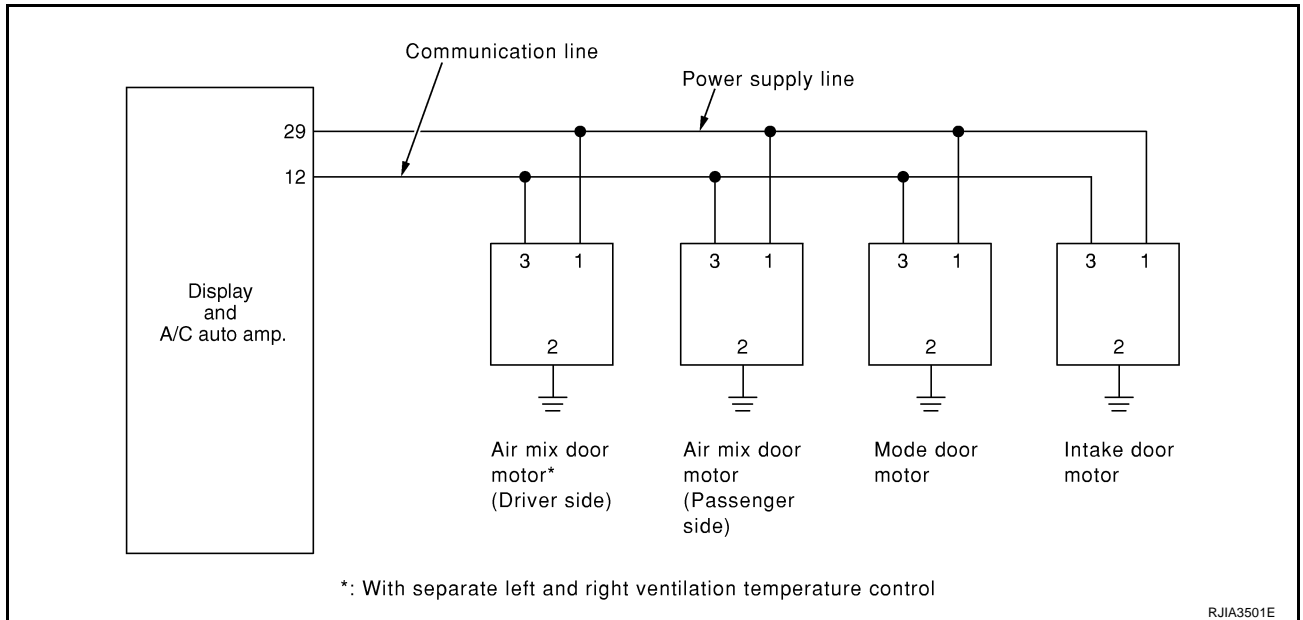

### DIAGNOSTIC PROCEDURE FOR LAN CIRCUIT

#### 1. CHECK POWER SUPPLY FOR DISPLAY AND A/C AUTO AMP.

1. Turn ignition switch ON.
2. Check voltage between display and A/C auto amp. harness connector M31 terminal 29 (Y/R) and ground.

**29 – Ground : Battery voltage**

OK or NG

- OK >> GO TO 2.  
 NG >> Replace display and A/C auto amp.

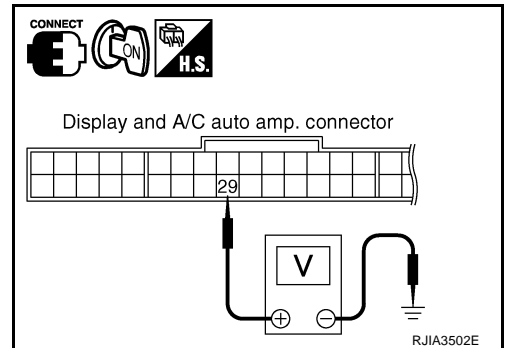

#### 2. CHECK SIGNAL FOR DISPLAY AND A/C AUTO AMP.

Confirm A/C LAN signal between display and A/C auto amp. harness connector M31 terminal 12 (G/B) and ground using an oscilloscope.

Terminals		(-)	Voltage
(+)	Terminal No. (wire color)		
Display and A/C auto amp. connector			
M31	12 (G/B)	Ground	<p>HAK0652D</p>

OK or NG

- OK >> GO TO 3.  
 NG >> Replace display and A/C auto amp.

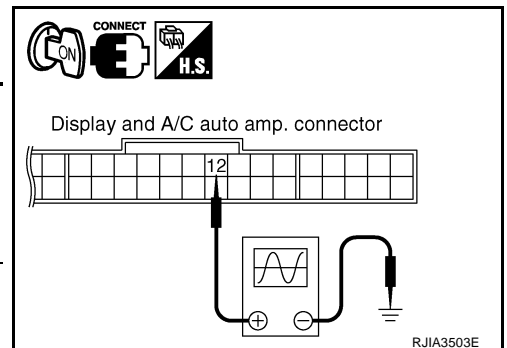

# TROUBLE DIAGNOSIS

## 3. CHECK POWER SUPPLY FOR MOTOR

Check voltage between mode door motor harness connector M252 terminal 1 (G), passenger side air mix door motor harness connector M253 terminal 1 (G), driver side air mix door motor harness connector M254 terminal 1 (G), intake door motor harness connector M255 terminal 1 (G) and ground.

**1 – Ground** : **Battery voltage**

OK or NG

- OK >> GO TO 4.
- NG >> Replace harness or connector.

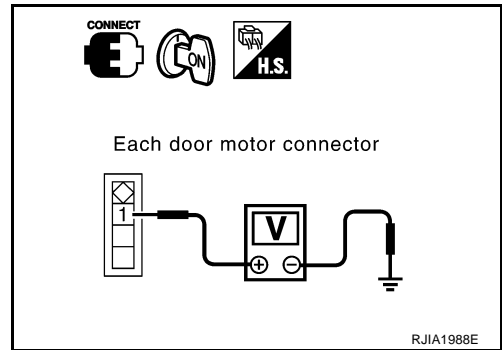

## 4. CHECK SIGNAL FOR MOTOR

Confirm A/C LAN signal between mode door motor harness connector M252 terminal 3 (L), passenger side air mix door motor harness connector M253 terminal 3 (L), driver side air mix door motor harness connector M254 terminal 3 (L), intake door motor harness connector M255 terminal 3 (L) and ground using an oscilloscope.

Door motor	Terminals		(-)	Voltage
	(+)			
	Con- nector	Terminal No. (wire color)		
Mode	M252	3 (L)	Ground	
Air mix (Pas- senger side)	M253	3 (L)		
Air mix (Driver side)	M254	3 (L)		
Intake	M255	3 (L)		

HAK0652D

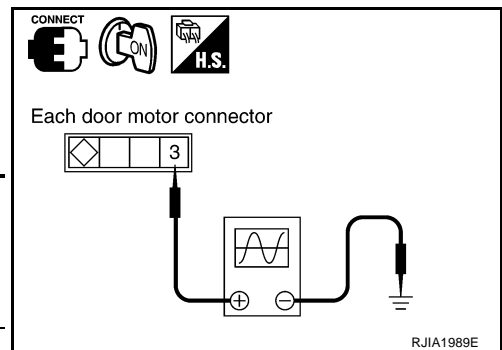

OK or NG

- OK >> GO TO 5.
- NG >> Replace harness or connector.

## 5. CHECK MOTOR GROUND CIRCUIT

1. Turn ignition switch OFF.
2. Disconnect door motor connector.
3. Check continuity between mode door motor harness connector M252 terminal 2 (B), passenger side air mix door motor harness connector M253 terminal 2 (B), driver side air mix door motor harness connector M254 terminal 2 (B), intake door motor harness connector M255 terminal 2 (B) and ground.

**2 – Ground** : **Continuity should exist.**

OK or NG

- OK >> GO TO 6.
- NG >> Replace harness or connector.

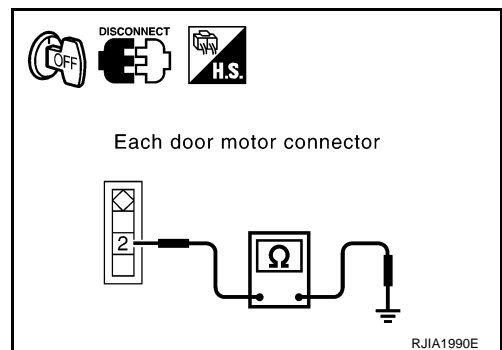

# TROUBLE DIAGNOSIS

## 6. CHECK MOTOR OPERATION

---

1. Turn ignition switch OFF.
2. Disconnect each door motor connector.
3. Reconnect each door motor connector.
4. Turn ignition switch ON.
5. Confirm operation of each door motor.

### OK or NG

- OK >> (Return to operate normally.)
- Poor contact in motor connector.
- NG >> (Does not operate normally.)
- GO TO 7.

## 7. CHECK OPERATION OF AIR MIX DOOR MOTOR AND INTAKE DOOR MOTOR

---

1. Turn ignition switch OFF.
2. Disconnect mode, air mix (driver side, passenger side), and intake door motor connectors.
3. Reconnect air mix (driver side, passenger side) and intake door motor connectors.
4. Turn ignition switch ON.
5. Confirm operation of air mix door motor (driver side, passenger side) and intake door motor.

### OK or NG

- OK >> [Air mix (driver side, passenger side) and intake door motors operate normally.]
- Replace mode door motor.
- NG >> [Air mix (driver side, passenger side) and intake door motors does not operate normally.]
- GO TO 8.

## 8. CHECK OPERATION OF MODE DOOR MOTOR AND INTAKE DOOR MOTOR

---

1. Turn ignition switch OFF.
2. Disconnect air mix door motor (driver side, passenger side) connectors.
3. Reconnect mode door motor connector.
4. Turn ignition switch ON.
5. Confirm operation of mode door motor and intake door motor.

### OK or NG

- OK >> (Mode and intake door motors operate normally.)
- GO TO 10.
- NG >> (Mode and intake door motors does not operate normally.)
- GO TO 9.

## 9. CHECK OPERATION OF MODE DOOR MOTOR AND AIR MIX DOOR MOTOR

---

1. Turn ignition switch OFF.
2. Disconnect intake door motor connector.
3. Reconnect air mix door motor (driver side, passenger side) connectors.
4. Turn ignition switch ON.
5. Confirm operation of mode door motor and air mix door motor (driver side, passenger side).

### OK or NG

- OK >> [Mode and air mix door motor (driver side, passenger side) operate normally.]
- Replace intake door motor.
- NG >> [Mode and air mix door motor (driver side, passenger side) does not operate normally.]
- Replace display and A/C auto amp.

## TROUBLE DIAGNOSIS

---

### 10. CHECK OPERATION OF AIR MIX DOOR MOTOR

---

1. Turn ignition switch OFF.
2. Disconnect air mix door motor (driver side) connector.
3. Turn ignition switch ON.
4. Confirm operation of air mix door motor (passenger side).

#### OK or NG

- OK >> [Air mix door motor (passenger side) operates normally.]
- Replace air mix door motor (driver side).
- NG >> [Air mix door motor (passenger side) does not operate normally.]
- Replace air mix door motor (passenger side).

# TROUBLE DIAGNOSIS

AJS00127

## Mode Door Motor Circuit

SYMPTOM:

- Air outlet does not change.
- Mode door motor does not operate normally.

### INSPECTION FLOW

1. Confirm symptom by performing the following operational check.

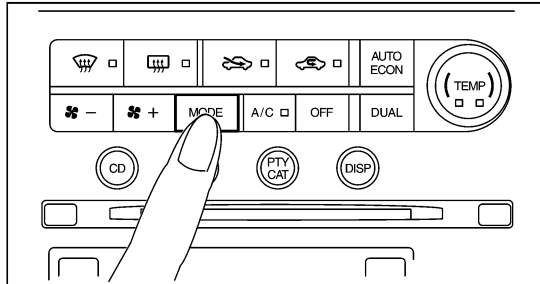

#### OPERATIONAL CHECK – Discharge air

- Press mode switch four times and DEF switch.
- Each position indicator should change shape.

#### Discharge air flow

Mode door position	Air outlet/distribution		
	Vent	Foot	Defroster
	100%	–	–
	58%	42%	–
	25%	75%	–
	16%	54%	30%
	–	–	100%

- Confirm that discharge air comes out according to the air distribution table at left. Refer to "Discharge Air Flow" (\*1).

#### NOTE:

- If OK (symptom cannot be duplicated), perform complete operational check (\*2).
- If NG (symptom is confirmed), continue with STEP-2 following.
- Confirm that the compressor clutch is engaged (sound or visual inspection) and intake door position is at FRESH when D/F or DEF is selected. Intake door position is checked in the next step.

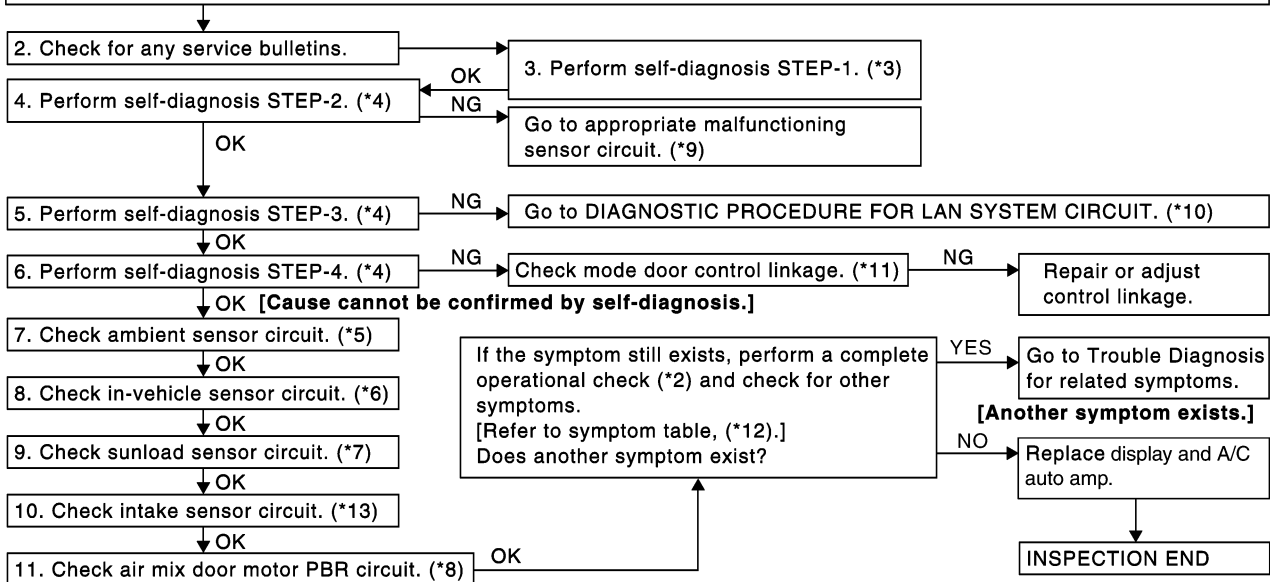

RJIA3504E

\*1 [ATC-36, "Discharge Air Flow"](#)

\*2 [ATC-62, "Operational Check"](#)

\*3 [ATC-54, "FUNCTION CONFIRMATION PROCEDURE"](#), see No. 1.

\*4 [ATC-54, "FUNCTION CONFIRMATION PROCEDURE"](#), see No. 5 to 7.

\*5 [ATC-106, "Ambient Sensor Circuit"](#)

\*6 [ATC-109, "In-Vehicle Sensor Circuit"](#)

\*7 [ATC-112, "Sunload Sensor Circuit"](#)

\*8 [ATC-76, "Air Mix Door Motor PBR Circuit"](#)

\*9 [ATC-54, "FUNCTION CONFIRMATION PROCEDURE"](#), see No. 14.

# TROUBLE DIAGNOSIS

- \*10 [ATC-67, "DIAGNOSTIC PROCEDURE FOR LAN CIRCUIT"](#)
- \*13 [ATC-115, "Intake Sensor Circuit"](#)

\*11 [ATC-134, "MODE DOOR MOTOR"](#)

\*12 [ATC-41, "SYMPTOM TABLE"](#)

## SYSTEM DESCRIPTION

### Component Parts

Mode door control system components are:

- Display and A/C auto amp.
- Mode door motor (LCU)
- A/C LAN system (PBR built-in mode door motor, air mix door motor and intake door motor)
- In-vehicle sensor
- Ambient sensor
- Sunload sensor
- Intake sensor

### System Operation

The display and A/C auto amp. receives data from each of the sensors. The display and A/C auto amp. sends air mix door, mode door and intake door opening angle data to the air mix door motor LCU, mode door motor LCU and intake door motor LCU.

The air mix door motor, mode door motor and intake door motor read their respective signals according to the address signal. Opening angle indication signals received from the display and A/C auto amp. and each of the motor position sensors are compared by the LCUs in each door motor with the existing decision and opening angles. Subsequently, HOT/COLD or DEFROST/VENT or FRESH/RECIRCULATION operation is selected. The new selection data is returned to the display and A/C auto amp.

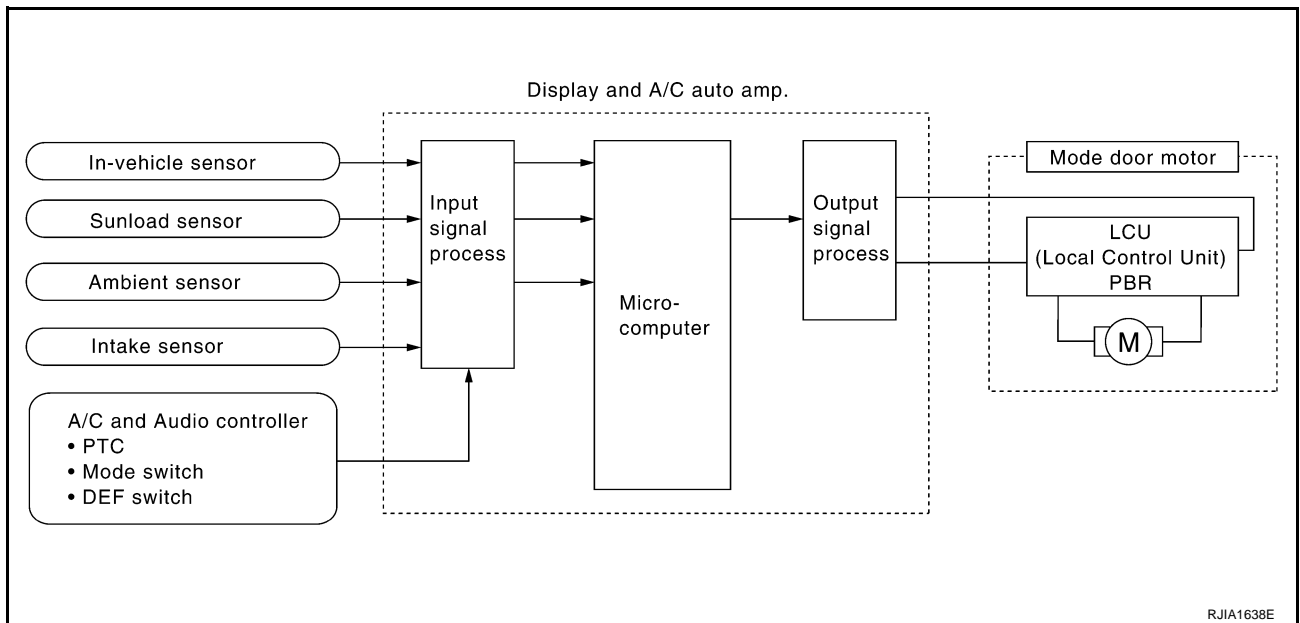

RJIA1638E

### Mode Door Control Specification

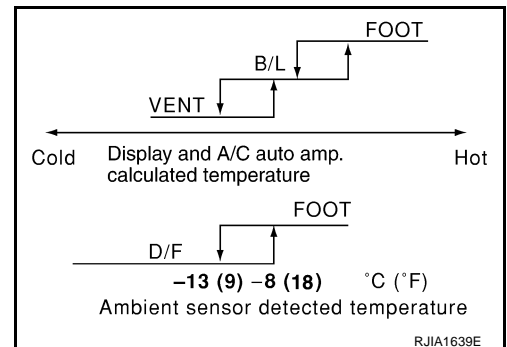

RJIA1638E



# TROUBLE DIAGNOSIS

## COMPONENT DESCRIPTION

### Mode Door Motor

The mode door motor is attached to the heater & cooling unit. It rotates so that air is discharged from the outlet set by the display and A/C auto amp. Motor rotation is conveyed to a link which activates the mode door.

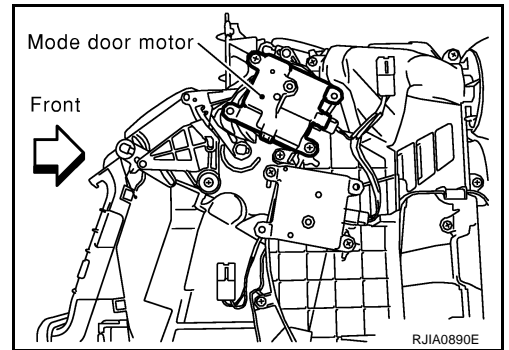

## DIAGNOSTIC PROCEDURE FOR MODE DOOR MOTOR

SYMPTOM: Mode door motor does not operate normally.

Perform diagnostic procedure. Refer to [ATC-67, "DIAGNOSTIC PROCEDURE FOR LAN CIRCUIT"](#).

A  
B  
C  
D  
E  
F  
G  
H  
I  
K  
L  
M

ATC

# TROUBLE DIAGNOSIS

AJS00128

## Air Mix Door Motor Circuit

### SYMPTOM:

- Discharge air temperature does not change.
- Air mix door motor does not operate.

### INSPECTION FLOW

1. Confirm symptom by performing the following operational check.

**OPERATIONAL CHECK**

**Temperature increase**

a. Turn temperature control dial clockwise until 32°C (90°F) is displayed.

b. Check for hot air at discharge air outlets.

**Temperature decrease**

a. Turn temperature control dial counterclockwise until 18°C (60°F) is displayed.

b. Check for cold air at discharge air outlets.

**If OK (symptom cannot be duplicated), perform complete operational check (\* 9 ).**

**If NG (symptom is confirmed), continue with STEP-2 following.**

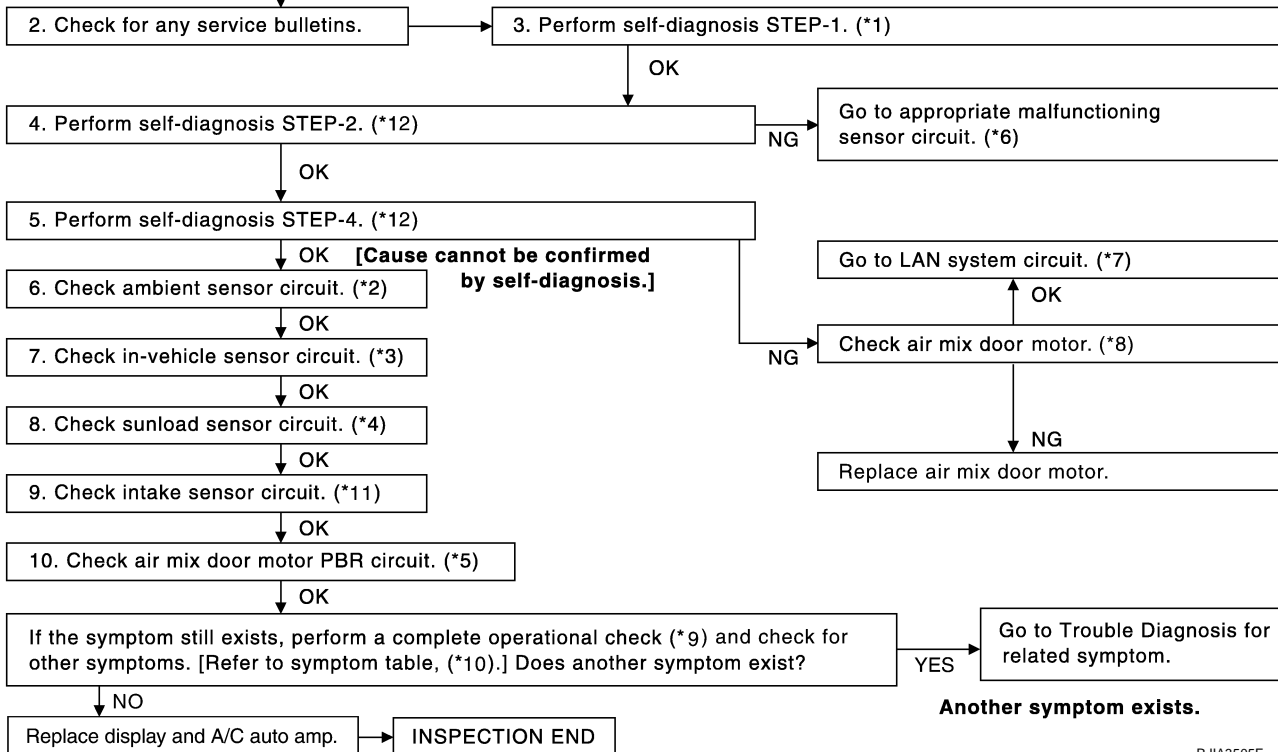

Another symptom exists.

RJIA3505E

- |   |   |   |
|---|---|---|
| *1 <a href="#">ATC-54, "FUNCTION CONFIRMATION PROCEDURE"</a> , see No. 1. | *2 <a href="#">ATC-106, "Ambient Sensor Circuit"</a>        | *3 <a href="#">ATC-109, "In-Vehicle Sensor Circuit"</a>                         |
| *4 <a href="#">ATC-112, "Sunload Sensor Circuit"</a>                      | *5 <a href="#">ATC-76, "Air Mix Door Motor PBR Circuit"</a> | *6 <a href="#">ATC-54, "FUNCTION CONFIRMATION PROCEDURE"</a> , see No. 14.      |
| *7 <a href="#">ATC-67, "LAN System Circuit"</a>                           | *8 <a href="#">ATC-76, "Air Mix Door Motor"</a>             | *9 <a href="#">ATC-62, "Operational Check"</a>                                  |
| *10 <a href="#">ATC-41, "SYMPTOM TABLE"</a>                               | *11 <a href="#">ATC-115, "Intake Sensor Circuit"</a>        | *12 <a href="#">ATC-54, "FUNCTION CONFIRMATION PROCEDURE"</a> , see No. 5 to 7. |

# TROUBLE DIAGNOSIS

## SYSTEM DESCRIPTION

### Component Parts

Air mix door control system components are:

- Display and A/C auto amp.
- Air mix door motor (LCU)
- A/C LAN system (PBR built-in mode door motor, air mix door motor and intake door motor)
- In-vehicle sensor
- Ambient sensor
- Sunload sensor
- Intake sensor

### System Operation

The display and A/C auto amp. receives data from each of the sensors. The display and A/C auto amp. sends air mix door, mode door and intake door opening angle data to the air mix door motor LCU, mode door motor LCU and intake door motor LCU.

The air mix door motor, mode door motor and intake door motor read their respective signals according to the address signal. Opening angle indication signals received from the display and A/C auto amp. and each of the motor position sensors are compared by the LCUs in each door motor with the existing decision and opening angles. Subsequently, HOT/COLD or DEFROST/VENT or FRESH/RECIRCULATION operation is selected. The new selection data is returned to the display and A/C auto amp.

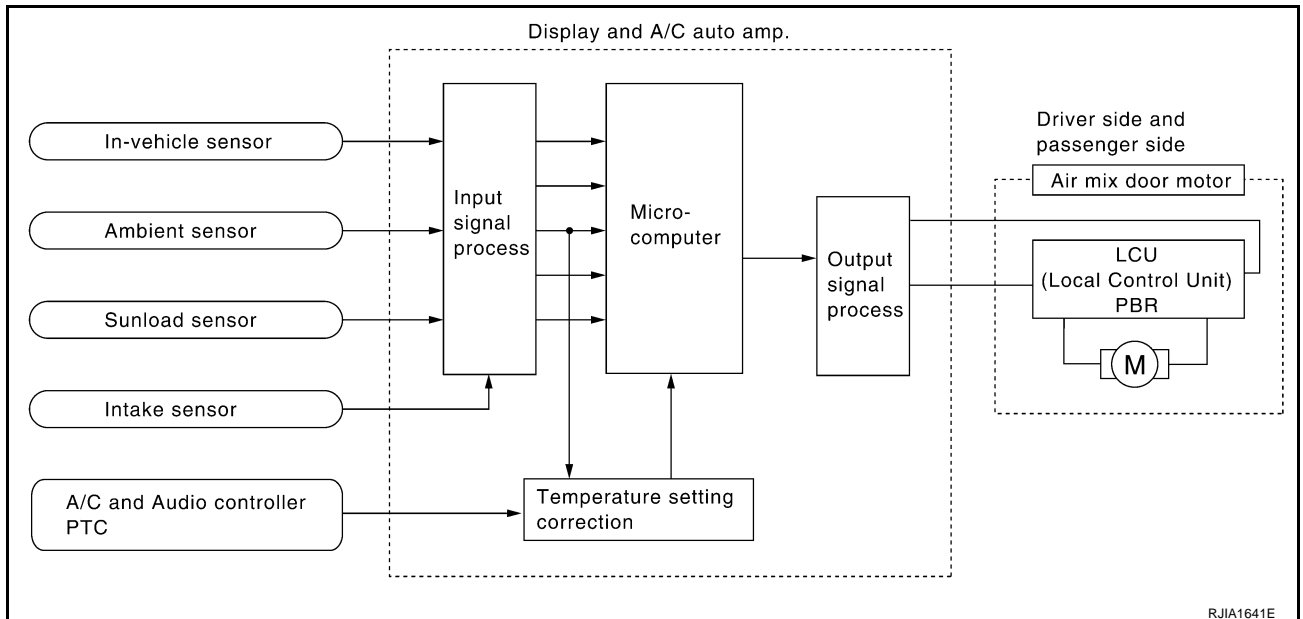

### Air Mix Door Control Specification

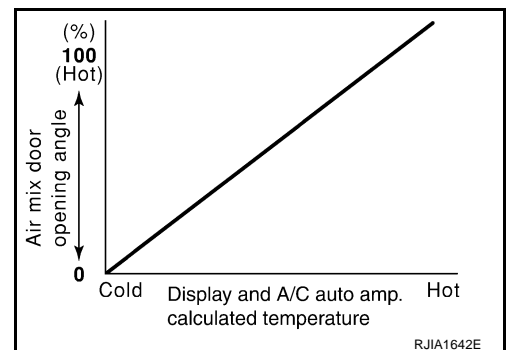

# TROUBLE DIAGNOSIS

## COMPONENT DESCRIPTION

### Air Mix Door Motor

The air mix door motor is attached to the heater & cooling unit. It rotates so that the air mix door is opened or closed to a position set by the display and A/C auto amp. Motor rotation is conveyed through a shaft and the air mix door position is then feedback to the display and A/C auto amp. by PBR built-in air mix door motor.

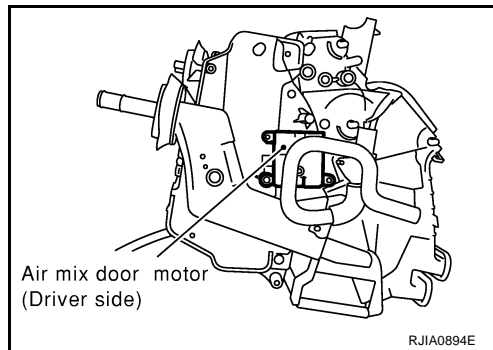
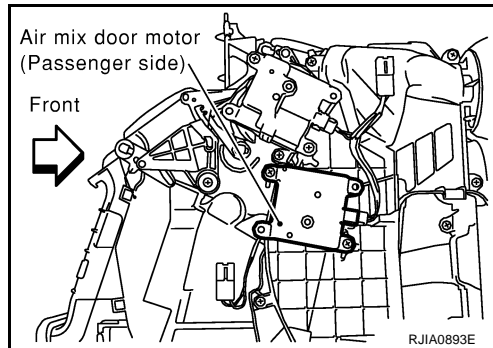

### DIAGNOSTIC PROCEDURE FOR AIR MIX DOOR

SYMPTOM: Discharge air temperature does not change.

Perform diagnostic procedure. Refer to [ATC-67, "DIAGNOSTIC PROCEDURE FOR LAN CIRCUIT"](#).

### Air Mix Door Motor PBR Circuit

AJS00129

SYMPTOM:

- Discharge air temperature does not change.
- PBR circuit is open or shorted.

### DIAGNOSTIC PROCEDURE FOR AIR MIX DOOR PBR

Perform diagnostic procedure. Refer to [ATC-67, "DIAGNOSTIC PROCEDURE FOR LAN CIRCUIT"](#).

# TROUBLE DIAGNOSIS

AJS0012A

## Intake Door Motor Circuit

### SYMPTOM:

- Intake door does not change.
- Intake door motor does not operate normally.

### INSPECTION FLOW

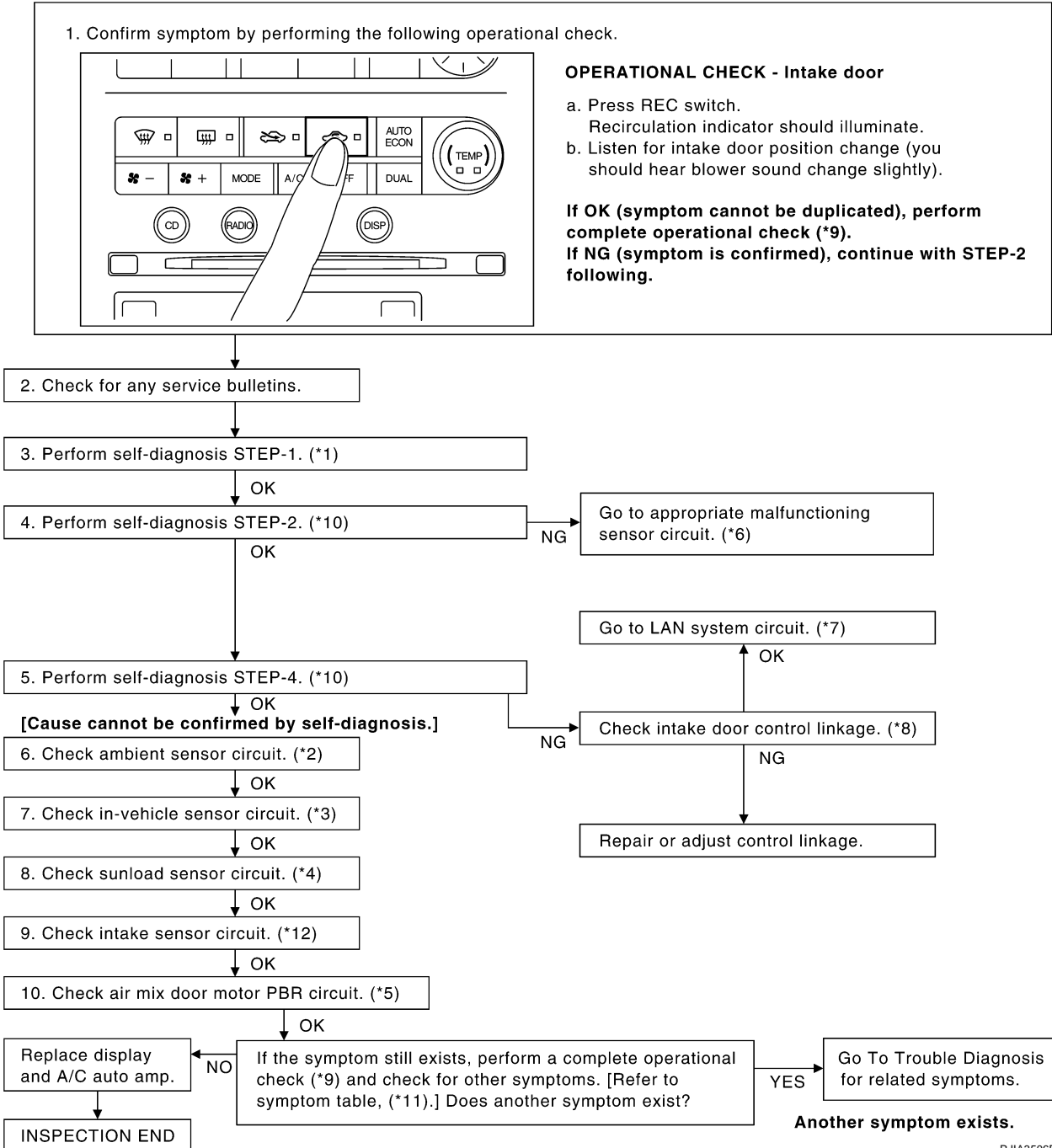

\*1 [ATC-54, "FUNCTION CONFIRMATION PROCEDURE"](#), see No. 1.

\*4 [ATC-112, "Sunload Sensor Circuit"](#)

\*7 [ATC-67, "LAN System Circuit"](#)

\*10 [ATC-54, "FUNCTION CONFIRMATION PROCEDURE"](#), see No. 5 to 7.

\*2 [ATC-106, "Ambient Sensor Circuit"](#)

\*5 [ATC-76, "Air Mix Door Motor PBR Circuit"](#)

\*8 [ATC-128, "INTAKE DOOR MOTOR"](#)

\*11 [ATC-41, "SYMPTOM TABLE"](#)

\*3 [ATC-109, "In-Vehicle Sensor Circuit"](#)

\*6 [ATC-54, "FUNCTION CONFIRMATION PROCEDURE"](#), see No. 14.

\*9 [ATC-62, "Operational Check"](#)

\*12 [ATC-115, "Intake Sensor Circuit"](#)

RJIA3506E

# TROUBLE DIAGNOSIS

## SYSTEM DESCRIPTION

### Component Parts

Intake door control system components are:

- Display and A/C auto amp.
- Intake door motor (LCU)
- A/C LAN system (PBR built-in mode door motor, air mix door motor and intake door motor)
- In-vehicle sensor
- Ambient sensor
- Sunload sensor
- Intake sensor

### System Operation

The intake door control determines intake door position based on the ambient temperature, the intake air temperature and the in-vehicle temperature. When the DEFROST, or OFF switches are pushed, the display and A/C auto amp. sets the intake door at the FRESH position.

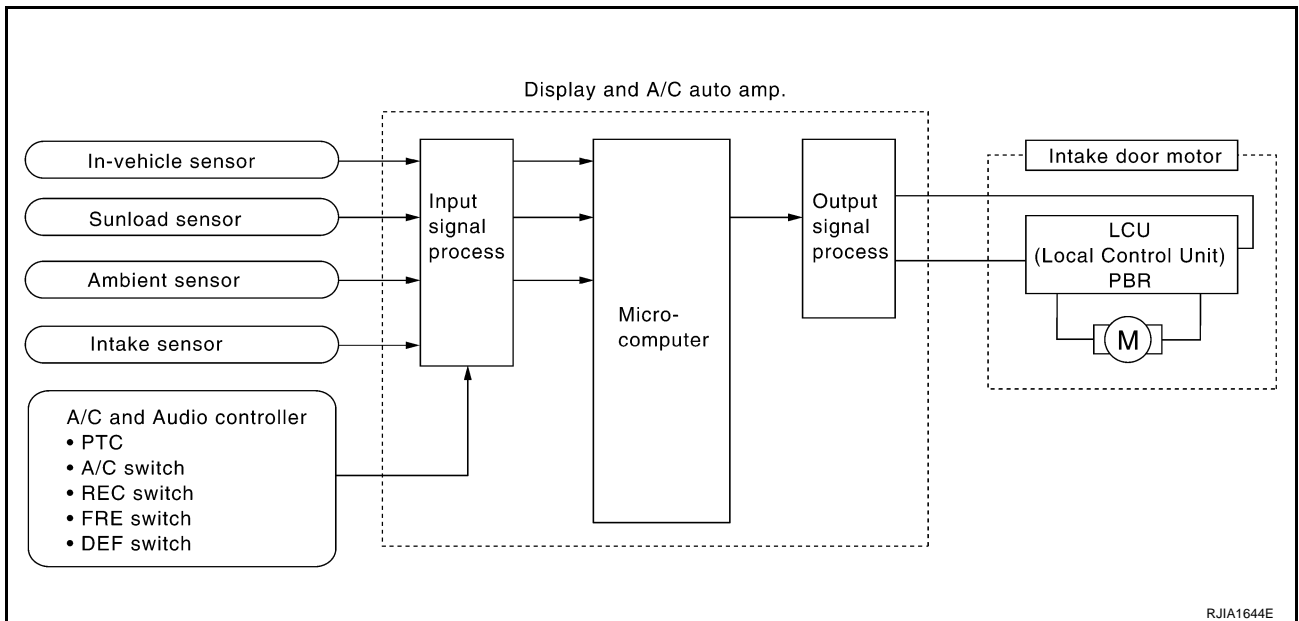

### Intake Door Control Specification

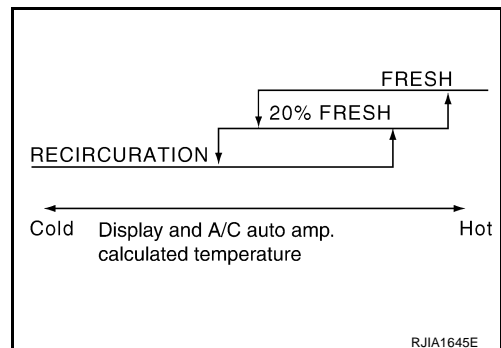

# TROUBLE DIAGNOSIS

## COMPONENT DESCRIPTION

### Intake Door Motor

The intake door motor is attached to the intake unit. It rotates so that air is drawn from inlets set by the display and A/C auto amp. Motor rotation is conveyed to a lever which activates the intake door.

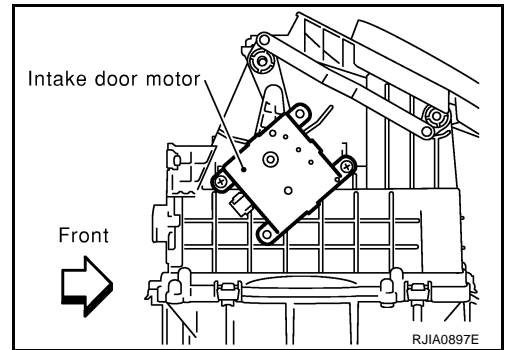

## DIAGNOSTIC PROCEDURE FOR INTAKE DOOR MOTOR

SYMPTOM: Intake door motor does not operate normally.

Perform diagnostic procedure. Refer to [ATC-67, "DIAGNOSTIC PROCEDURE FOR LAN CIRCUIT"](#).

A

B

C

D

E

F

G

H

I

ATC

K

L

M

# TROUBLE DIAGNOSIS

AJS0012B

## Blower Motor Circuit

SYMPTOM: Blower motor operation is malfunctioning.

### INSPECTION FLOW

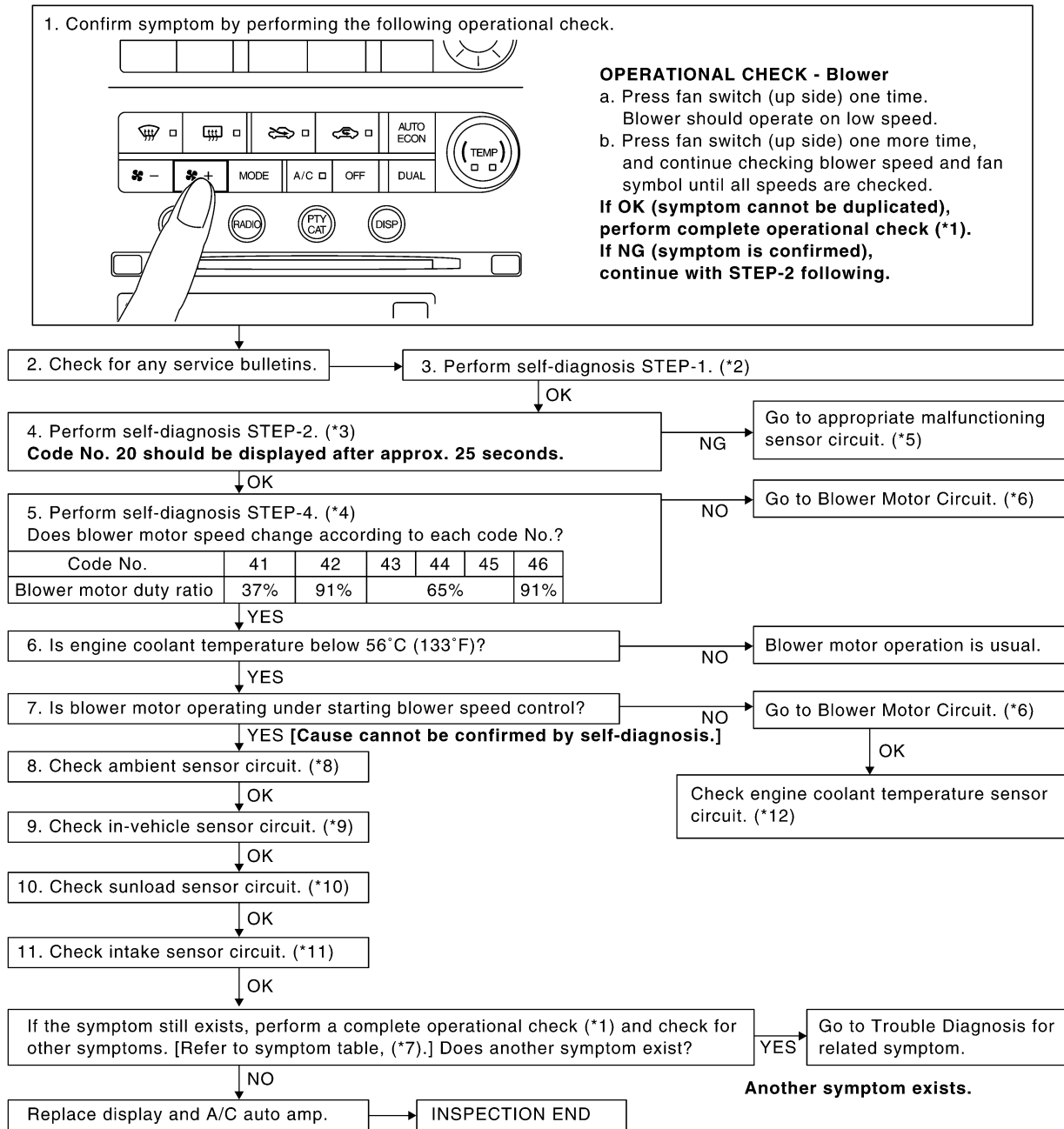

RJIA3507E

\*1 [ATC-62, "Operational Check"](#)

\*2 [ATC-54, "FUNCTION CONFIRMATION PROCEDURE"](#), see No. 1.

\*3 [ATC-54, "FUNCTION CONFIRMATION PROCEDURE"](#), see No. 5.

\*4 [ATC-54, "FUNCTION CONFIRMATION PROCEDURE"](#), see No. 7.

\*5 [ATC-54, "FUNCTION CONFIRMATION PROCEDURE"](#), see No. 14.

\*6 [ATC-82, "DIAGNOSTIC PROCEDURE FOR BLOWER MOTOR"](#)

\*7 [ATC-41, "SYMPTOM TABLE"](#)

\*8 [ATC-106, "Ambient Sensor Circuit"](#)

\*9 [ATC-109, "In-Vehicle Sensor Circuit"](#)

\*10 [ATC-112, "Sunload Sensor Circuit"](#)

\*11 [ATC-115, "Intake Sensor Circuit"](#)

\*12 [EC-202, "DTC P0117, P0118 ECT SENSOR"](#)



# TROUBLE DIAGNOSIS

## SYSTEM DESCRIPTION

### Component Parts

Fan speed control system components are:

- Display and A/C auto amp.
- A/C LAN system (PBR built-in mode door motor, air mix door motor and intake door motor)
- In-vehicle sensor
- Ambient sensor
- Sunload sensor
- Intake sensor

### System Operation

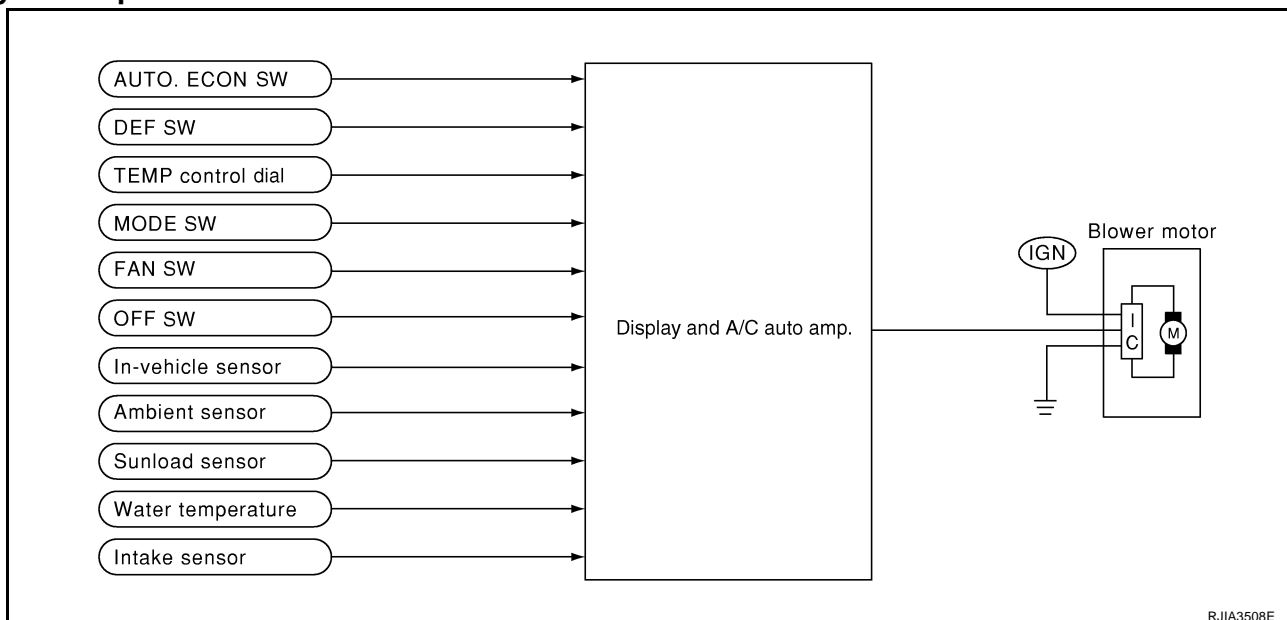

### Automatic Mode

In the automatic mode, the blower motor speed is calculated by the display and A/C auto amp. based on input from the PBR, in-vehicle sensor, sunload sensor, intake sensor and ambient sensor.

When the air flow is increased, the duty ratio of the blower fan motor's drive signal is changed at 8%/sec. to prevent a sudden increase in air flow.

In addition to manual air flow control and the usual automatic air flow control, starting air flow control, low water temperature starting control and high passenger compartment temperature starting control are available.

### Starting Fan Speed Control

Start Up from COLD SOAK Condition (Automatic mode)

In a cold start up condition where the engine coolant temperature is below 56°C (133°F), the blower will not operate for a short period of time (up to 150 seconds). The exact start delay time varies depending on the ambient and engine coolant temperature.

In the most extreme case (very low ambient) the blower starting delay will be 150 seconds as described above. After this delay, the blower will operate at low speed until the engine coolant temperature rises above 56°C (133°F), at which time the blower speed will increase to the objective speed.

Start Up from usual or HOT SOAK Condition (Automatic mode)

The blower will begin operation momentarily after the A/C switch is pushed. The blower speed will gradually rise to the objective speed over a time period of 3 seconds or less (actual time depends on the objective blower speed).

# TROUBLE DIAGNOSIS

## Blower Speed Compensation

### Sunload

When the in-vehicle temperature and the set temperature are very close, the blower will be operating at low speed. The low speed will vary depending on the sunload. During conditions of low or no sunload, the blower low speed is usual low speed (duty ratio 25%). During high sunload conditions, the display and A/C auto amp. causes the blower fan speed to increase (duty ratio 49%).

## Fan Speed Control Specification

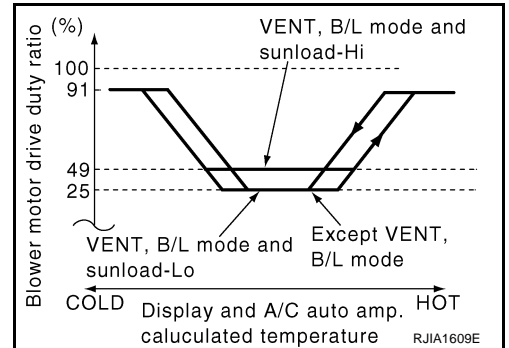

## COMPONENT DESCRIPTION

### Brush-less Motor

The blower motor utilizes a brush-less motor with a rotating magnet. Quietness is improved over previous motors where the brush was the point of contact and the coil rotated.

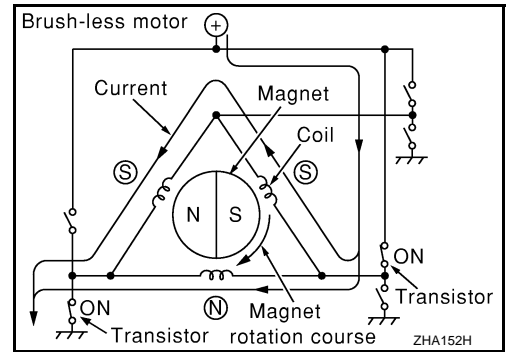

## DIAGNOSTIC PROCEDURE FOR BLOWER MOTOR

SYMPTOM: Blower motor operation is malfunctioning.

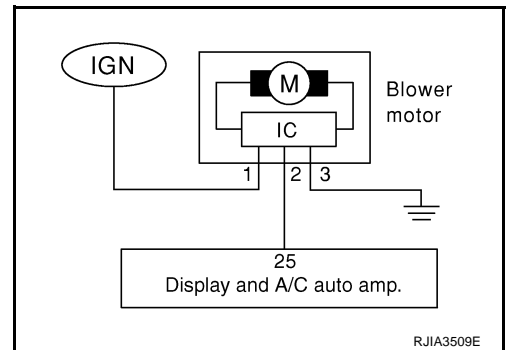

# TROUBLE DIAGNOSIS

## 1. CHECK POWER SUPPLY FOR BLOWER MOTOR

1. Disconnect blower motor connector.
2. Turn ignition switch ON.
3. Check voltage between blower motor harness connector M62 terminal 1 (L/W) and ground.

**1 – Ground** : **Battery voltage**

OK or NG

OK >> GO TO 2.

NG >> Check power supply circuit and 15A fuses [Nos. 10 and 11, located in the fuse block (J/B)]. Refer to [PG-76](#), "[FUSE BLOCK - JUNCTION BOX \(J/B\)](#)".

- If fuses are OK, check harness for open. Repair or replace if necessary.
- If fuses are NG, replace fuse and check harness for short circuit. Repair or replace if necessary.

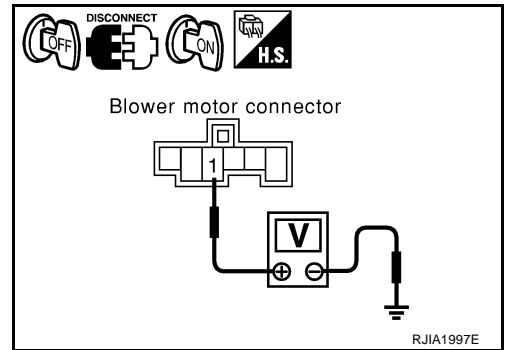

## 2. CHECK GROUND CIRCUIT FOR BLOWER MOTOR

1. Turn ignition switch OFF.
2. Check continuity between blower motor harness connector M62 terminal 3 (B) and ground.

**3 – Ground** : **Continuity should exist.**

OK or NG

OK >> GO TO 3.

NG >> Repair harness or connector.

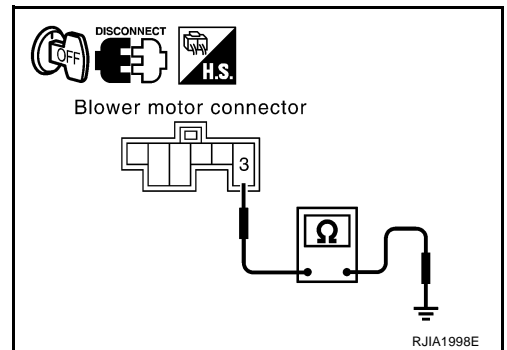

## 3. CHECK CIRCUIT CONTINUITY BLOWER MOTOR AND DISPLAY AND A/C AUTO AMP.

1. Disconnect display and A/C auto amp. connector.
2. Check continuity between blower motor harness connector M62 terminal 2 (G) and display and A/C auto amp. harness connector M31 terminal 25 (G).

**2 – 25** : **Continuity should exist.**

OK or NG

OK >> GO TO 4.

NG >> Repair harness or connector.

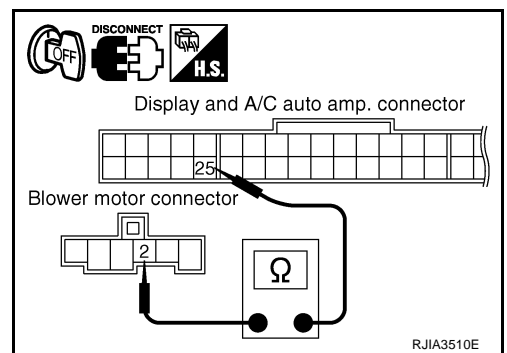

A  
B  
C  
D  
E  
F  
G  
H  
I  
K  
L  
M

ATC

# TROUBLE DIAGNOSIS

## 4. CHECK FOR DISPLAY AND A/C AUTO AMP. OUTPUT

1. Reconnect blower motor connector and display and A/C auto amp. connector.
2. Turn ignition switch ON.

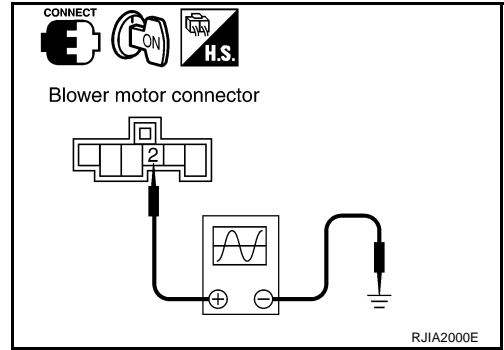

3. Vary the fan speed between Lo and Hi and confirm the duty ratios between blower motor harness connector M62 terminal 2 (G) and ground using an oscilloscope. Usual terminal 2 (G) drive signal duty ratios are shown in the table below.

Blower fan speed	1st	2nd	3rd	4th	5th	6th	7th
Blower motor connector M62 terminal No. 2 (Oscilloscope)							
	Approx. 1.6 ms	Approx. 1.6 ms	Approx. 1.6 ms	Approx. 1.6 ms	Approx. 1.6 ms	Approx. 1.6 ms	Approx. 1.6 ms
Duty ratio	Approx. 21 - 33%	Approx. 35 - 43%	Approx. 45 - 53%	Approx. 55 - 63%	Approx. 65 - 75%	Approx. 77 - 87%	Approx. 89 - 91%

NOTE: Duty ratio =  $\frac{T_x}{\text{Approx. } 1.6 \text{ ms}} \times 100 (\%)$

RJIA3511E

**OK or NG**

- OK >> GO TO 5.
- NG >> Replace display and A/C auto amp.

## 5. CHECK BLOWER MOTOR DRIVE SIGNAL

If the fan air flow does not change, usual terminal 2 (G) drive signal duty ratios are shown in the table above.

**OK or NG**

- OK >> Replace blower motor.
- NG >> INSPECTION END

# TROUBLE DIAGNOSIS

## COMPONENT INSPECTION

### Blower Motor

Confirm smooth rotation of the blower motor.

- Ensure that there are no foreign particles inside the blower unit.

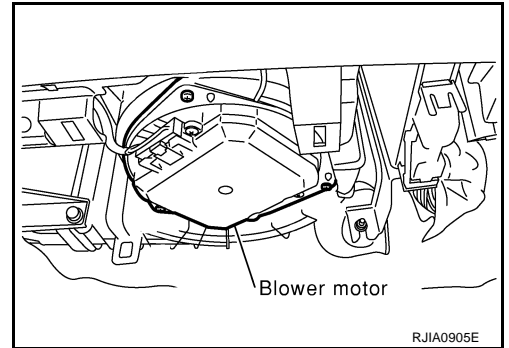

A

B

C

D

E

F

G

H

I

ATC

K

L

M

# TROUBLE DIAGNOSIS

AJS0012C

## Magnet Clutch Circuit

SYMPTOM: Magnet clutch does not engage.

### INSPECTION FLOW

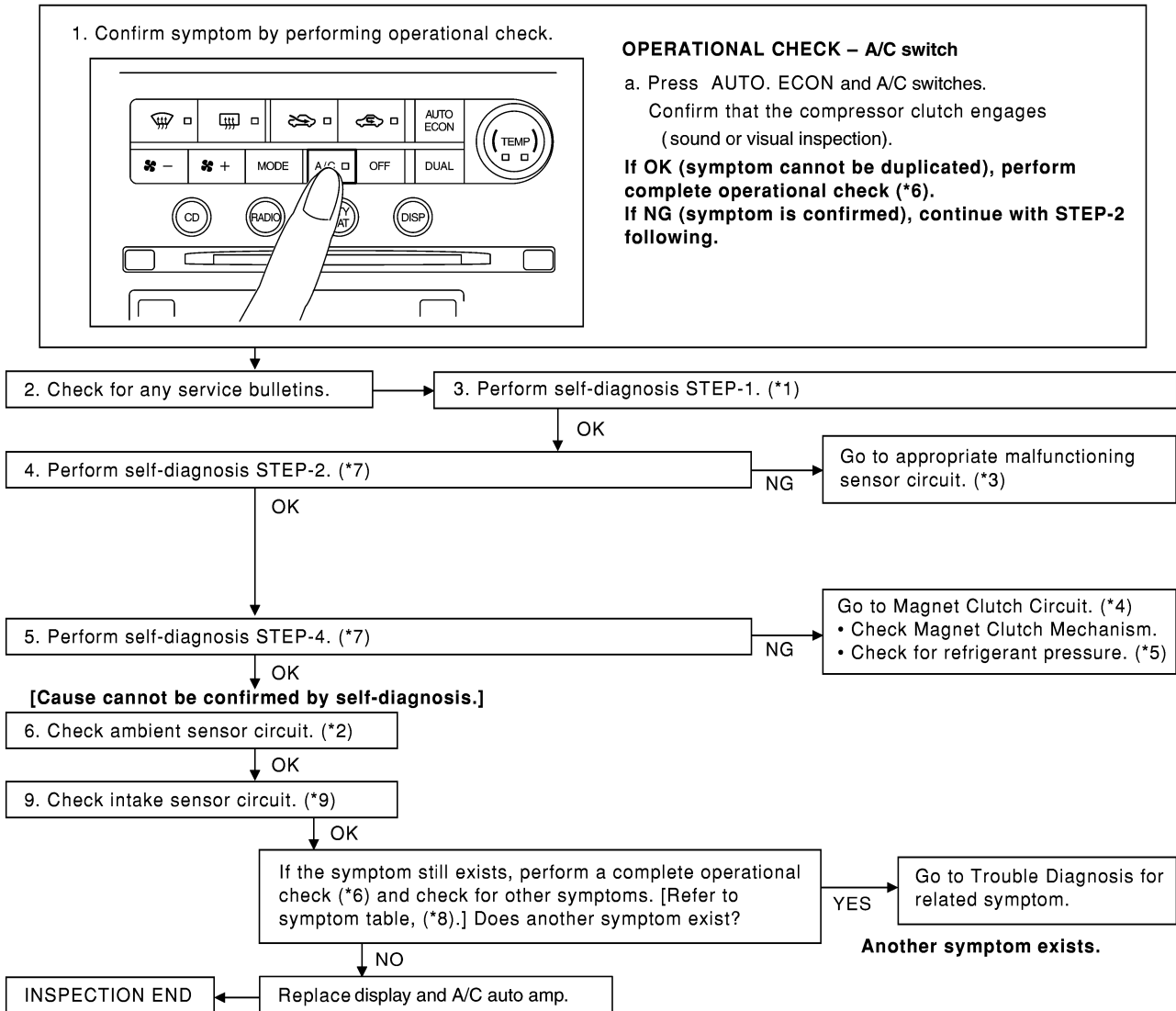

\*1 [ATC-54, "FUNCTION CONFIRMATION PROCEDURE"](#), see No. 1.

\*4 [ATC-87, "DIAGNOSTIC PROCEDURE FOR MAGNET CLUTCH"](#)

\*7 [ATC-54, "FUNCTION CONFIRMATION PROCEDURE"](#), see No. 5 to 7.

\*2 [ATC-106, "Ambient Sensor Circuit"](#)

\*5 [ATC-99, "TROUBLE DIAGNOSIS FOR UNUSUAL PRESSURE"](#)

\*8 [ATC-41, "SYMPTOM TABLE"](#)

\*3 [ATC-54, "FUNCTION CONFIRMATION PROCEDURE"](#), see No. 14.

\*6 [ATC-62, "Operational Check"](#)

\*9 [ATC-115, "Intake Sensor Circuit"](#)

RJIA3512E

# TROUBLE DIAGNOSIS

## SYSTEM DESCRIPTION

Display and A/C auto amp. controls compressor operation by ambient temperature, intake air temperature and signal from ECM.

### Low Temperature Protection Control

Display and A/C auto amp. will turn the compressor ON or OFF as determined by a signal detected by ambient sensor and intake sensor.

When ambient temperatures are higher than  $-2^{\circ}\text{C}$  ( $28^{\circ}\text{F}$ ), the compressor turns ON. The compressor turns OFF when ambient temperatures are lower than  $-5^{\circ}\text{C}$  ( $23^{\circ}\text{F}$ ).

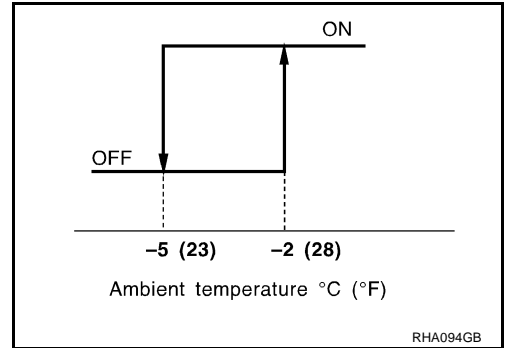

When intake air temperatures are higher than  $1^{\circ}\text{C}$  ( $34^{\circ}\text{F}$ ), the compressor turns ON. The compressor turns OFF when intake air temperatures are lower than  $-5^{\circ}\text{C}$  ( $23^{\circ}\text{F}$ ).

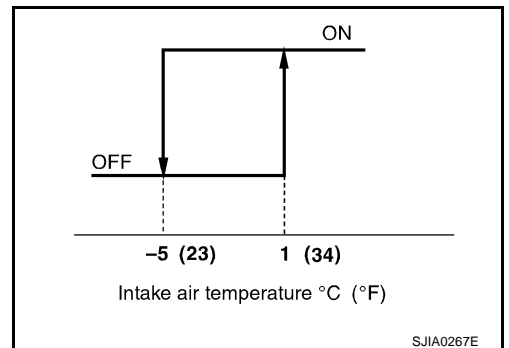

## DIAGNOSTIC PROCEDURE FOR MAGNET CLUTCH

SYMPTOM: Magnet clutch does not engage when A/C switch is ON.

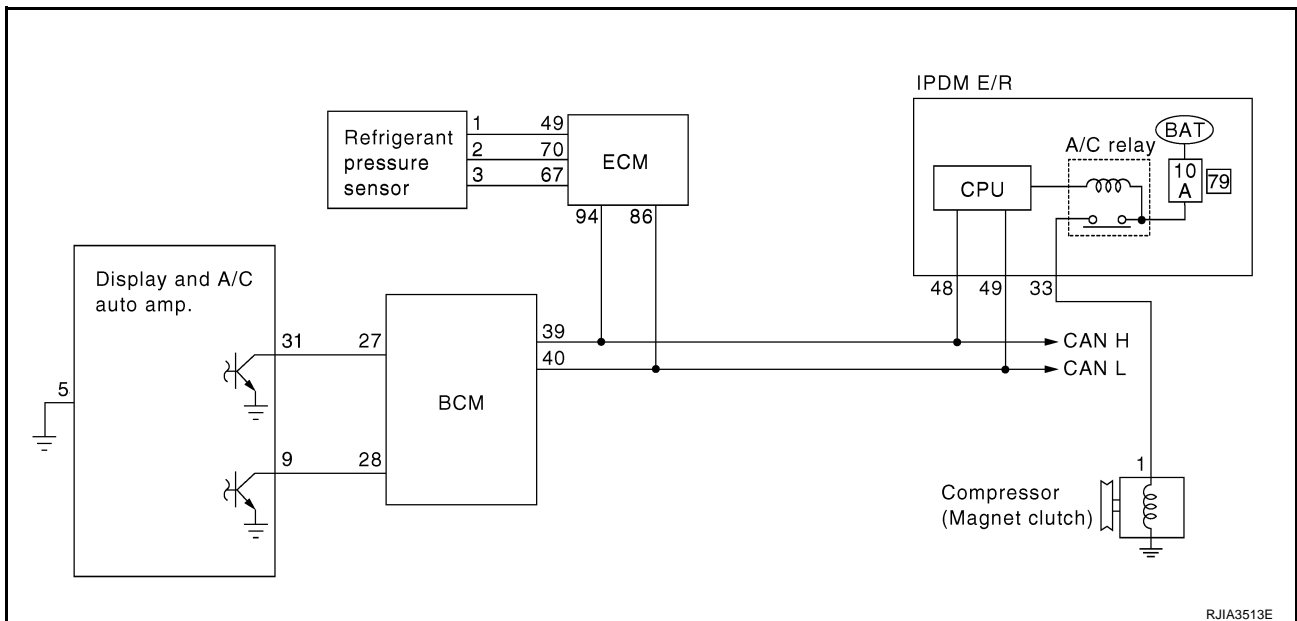

A  
B  
C  
D  
E  
F  
G  
H  
I

ATC

K  
L  
M

# TROUBLE DIAGNOSIS

## 1. CHECK AMBIENT SENSOR CIRCUIT AND INTAKE SENSOR CIRCUIT

Check ambient sensor and intake sensor. Refer to [ATC-54, "FUNCTION CONFIRMATION PROCEDURE"](#) , see Nos. 10 and 12.

OK or NG

OK >> GO TO 2.

NG >> ● Malfunctioning ambient sensor: Refer to [ATC-106, "Ambient Sensor Circuit"](#) .

● Malfunctioning intake sensor: Refer to [ATC-115, "Intake Sensor Circuit"](#) .

## 2. PERFORM AUTO ACTIVE TEST

Refer to [PG-22, "Auto Active Test"](#) .

Does the magnet clutch operate?

YES >> ●  WITH CONSULT-II  
GO TO 5.

●  WITHOUT CONSULT-II  
GO TO 6.

NO >> Check 10A fuse (No. 79, located in IPDM E/R), and GO TO 3.

## 3. CHECK CIRCUIT CONTINUITY BETWEEN IPDM E/R AND COMPRESSOR

1. Turn ignition switch OFF.
2. Disconnect IPDM E/R connector and compressor connector.
3. Check continuity between IPDM E/R harness connector E8 terminal 33 (L/OR) and compressor harness connector F24 terminal 1 (L/OR).

**33 - 1**

**: Continuity should exist.**

OK or NG

OK >> GO TO 4.

NG >> Repair harness or connector.

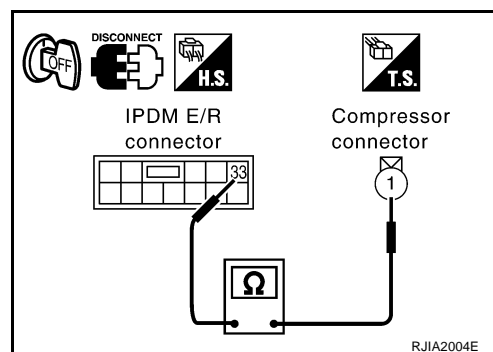

## 4. CHECK MAGNET CLUTCH CIRCUIT

Check for operation sound when applying battery voltage direct current to terminal.

OK or NG

OK >> Replace IPDM E/R.

NG >> Replace magnet clutch. Refer to [ATC-144, "Removal and Installation of Compressor Clutch"](#) .

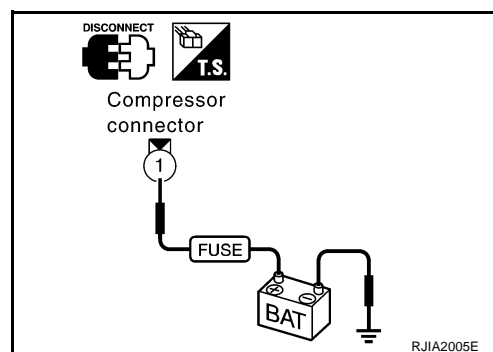



# TROUBLE DIAGNOSIS

## 5. CHECK BCM INPUT (COMPRESSOR ON) SIGNAL

Check compressor ON/OFF signal. Refer to [ATC-39, "CONSULT-II Function \(BCM\)"](#) .

**A/C SW ON : AIR COND SW ON**  
**A/C SW OFF : AIR COND SW OFF**

OK or NG

OK >> GO TO 8.  
 NG >> GO TO 6.

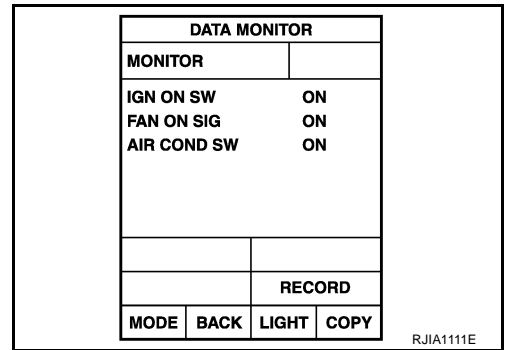

## 6. CHECK CIRCUIT CONTINUITY BETWEEN BCM AND DISPLAY AND A/C AUTO AMP.

- Turn ignition switch OFF.
- Disconnect BCM connector and display and A/C auto amp. connector.
- Check continuity between BCM harness connector M1 terminal 27 (G/Y) and display and A/C auto amp. harness connector M31 terminal 31 (G/Y).

**27 – 31 : Continuity should exist.**

OK or NG

OK >> GO TO 7.  
 NG >> Repair harness or connector.

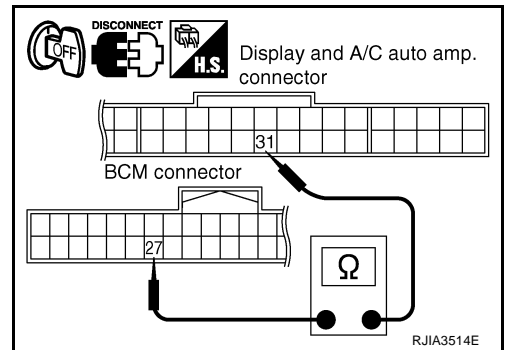

## 7. CHECK VOLTAGE FOR DISPLAY AND A/C AUTO AMP. (COMPRESSOR ON SIGNAL)

- Reconnect BCM connector and display and A/C auto amp. connector.
- Turn ignition switch ON.
- Check voltage between display and A/C auto amp. harness connector M31 terminal 31 (G/Y) and ground.

Terminals		(-)	Condition	Voltage
(+)	Terminal No. (wire color)			
Display and A/C auto amp. connector	Terminal No. (wire color)	(-)	Condition	Voltage
M31	31 (G/Y)	Ground	A/C switch: ON (Blower motor operates.)	Approx. 0V
			OFF switch: ON (A/C system: OFF)	Approx. 5V

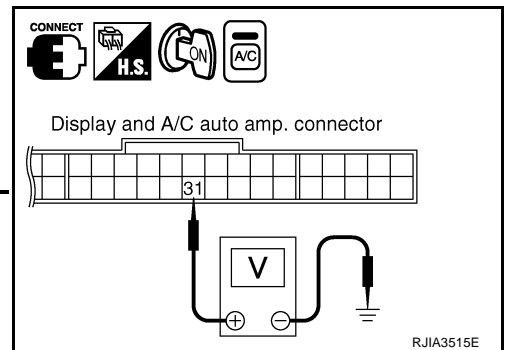

OK or NG

OK >> GO TO 8.  
 NG-1 >> If the voltage is approx. 5V when A/C switch is ON: Replace display and A/C auto amp.  
 NG-2 >> If the voltage is approx. 0V when A/C switch is OFF: Replace BCM.

# TROUBLE DIAGNOSIS

## 8. CHECK REFRIGERANT PRESSURE SENSOR

Ⓜ WITH CONSULT-II

1. Start the engine.
2. Check the voltage of refrigerant pressure sensor. Refer to [EC-140, "CONSULT-II Reference Value in Data Monitor"](#).

ⓧ WITHOUT CONSULT-II

1. Start the engine.
2. Check voltage between ECM harness connector F108 terminal 70 (R/B) and ground.

Terminals		(-)	Condition	Voltage
(+) ECM connector				
Terminal No. (wire color)				
F108	70 (R/B)	Ground	A/C switch: ON (Blower motor operates.)	Approx. 1-4V

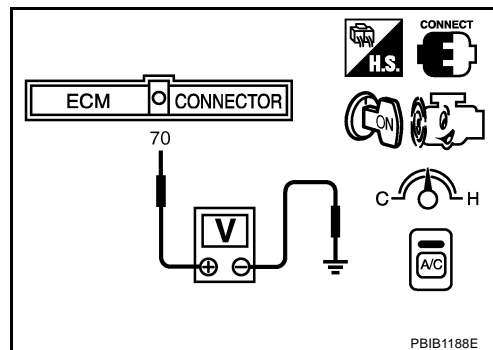

OK or NG

OK >> ● Ⓜ WITH CONSULT-II  
GO TO 9.

- ⓧ WITHOUT CONSULT-II  
GO TO 10.

NG >> Refer to [EC-653, "REFRIGERANT PRESSURE SENSOR"](#).

## 9. CHECK BCM INPUT (FAN ON) SIGNAL

Check FAN ON/OFF signal. Refer to [ATC-39, "CONSULT-II Function \(BCM\)"](#).

**FAN SW ON : FAN ON SIG ON**  
**FAN SW OFF : FAN ON SIG OFF**

OK or NG

OK >> GO TO 12.

NG >> GO TO 10.

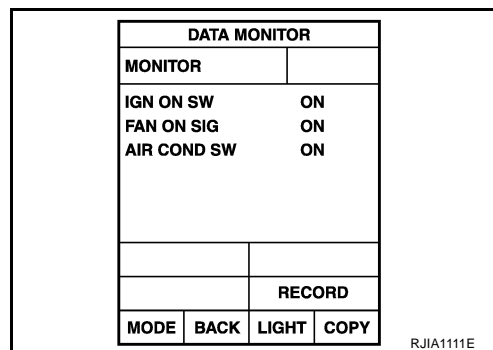

## 10. CHECK CIRCUIT CONTINUITY BETWEEN BCM AND DISPLAY AND A/C AUTO AMP.

1. Turn ignition switch OFF.
2. Disconnect BCM connector and display and A/C auto amp. connector.
3. Check continuity between BCM harness connector M1 terminal 28 (BR/R) and display and A/C auto amp. harness connector M31 terminal 9 (BR/R).

**28 – 9 : Continuity should exist.**

OK or NG

OK >> GO TO 11.

NG >> Repair harness or connector.

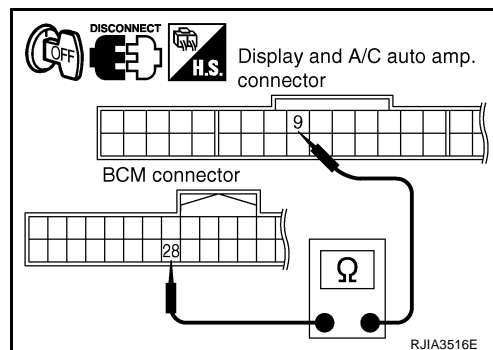

# TROUBLE DIAGNOSIS

## 11. CHECK VOLTAGE FOR DISPLAY AND A/C AUTO AMP. (FAN ON SIGNAL)

1. Reconnect BCM connector and display and A/C auto amp. connector.
2. Turn ignition switch ON.
3. Check voltage between display and A/C auto amp. harness connector M31 terminal 9 (BR/R) and ground.

Terminals			Condition	Voltage
(+)		(-)		
Display and A/C auto amp. connector	Terminal No. (wire color)			
M31	9 (BR/R)	Ground	A/C switch: ON (Blower motor operates.)	Approx. 0V
			OFF switch: ON (A/C system: OFF)	Approx. 5V

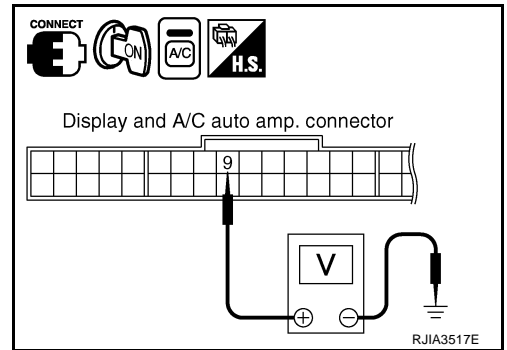

### OK or NG

OK >> GO TO 12.

NG-1 >> If the voltage is approx. 5V when blower motor is ON: Replace display and A/C auto amp.

NG-2 >> If the voltage is approx. 0V when blower motor is OFF: Replace BCM. Refer to [BCS-16, "Removal and Installation of BCM"](#).

## 12. CHECK DISPLAY AND A/C AUTO AMP. INPUT (COMPRESSOR FEEDBACK) SIGNAL

Check voltage between display and A/C auto amp. harness connector M31 terminal 11 (L/B) and ground.

Terminals			Condition	Voltage
(+)		(-)		
Display and A/C auto amp. connector	Terminal No. (wire color)			
M31	11 (L/B)	Ground	A/C switch: ON (Blower motor operates.)	Approx. 0V
			A/C switch: ON (When refrigerant pressure sensor connector is disconnected.)	Approx. 5V

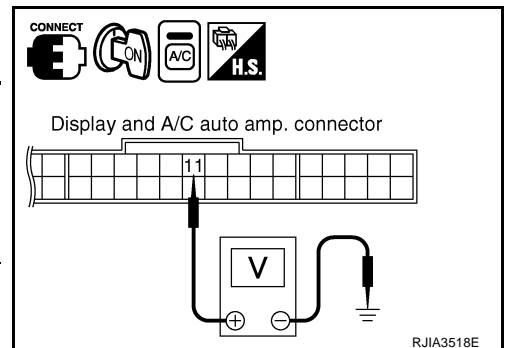

### OK or NG

OK >> GO TO 14.

NG-1 >> If the voltage is approx. 5V when refrigerant pressure sensor connector is connected: GO TO 13.

NG-2 >> If the voltage is approx. 0V when refrigerant pressure sensor connector is disconnected: Replace display and A/C auto amp.

# TROUBLE DIAGNOSIS

## 13. CHECK CIRCUIT CONTINUITY BETWEEN COMBINATION METER AND DISPLAY AND A/C AUTO AMP.

1. Turn ignition switch OFF.
2. Disconnect display and A/C auto amp. connector and combination meter connector.
3. Check continuity between combination meter harness connector M19 terminal 12 (L/B) and display and A/C auto amp. harness connector M31 terminal 11 (L/B).

**12 – 11 : Continuity should exist.**

OK or NG

OK >> GO TO 14.

NG >> Repair harness or connector.

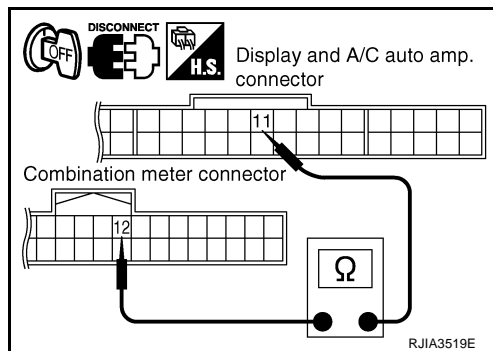

## 14. CHECK CAN COMMUNICATION

Check CAN communication. Refer to [BCS-15, "CAN Communication Inspection Using CONSULT-II \(Self-Diagnosis\)"](#).

- BCM – ECM
- ECM – IPDM E/R
- ECM – Combination meter

OK or NG

OK >> INSPECTION END

NG >> Repair or replace malfunctioning part(s).

### COMPONENT INSPECTION

#### Refrigerant Pressure Sensor

The refrigerant pressure sensor is attached to the condenser. Make sure that the A/C refrigerant pressure and the sensor output voltage are within the specified range as shown in the A/C operating condition figure. Refer to [EC-653, "REFRIGERANT PRESSURE SENSOR"](#).

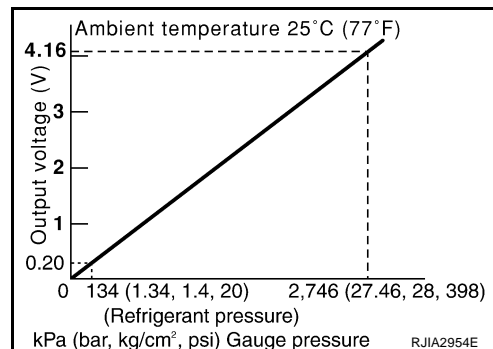
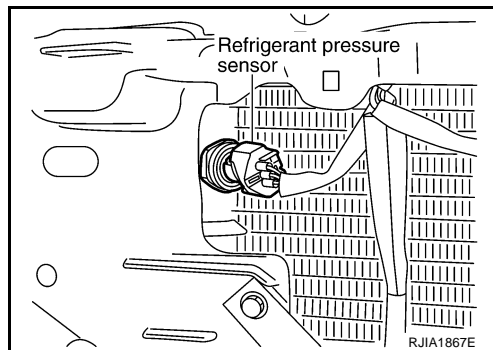

# TROUBLE DIAGNOSIS

AJS0012D

## Insufficient Cooling

SYMPTOM: Insufficient cooling

### INSPECTION FLOW

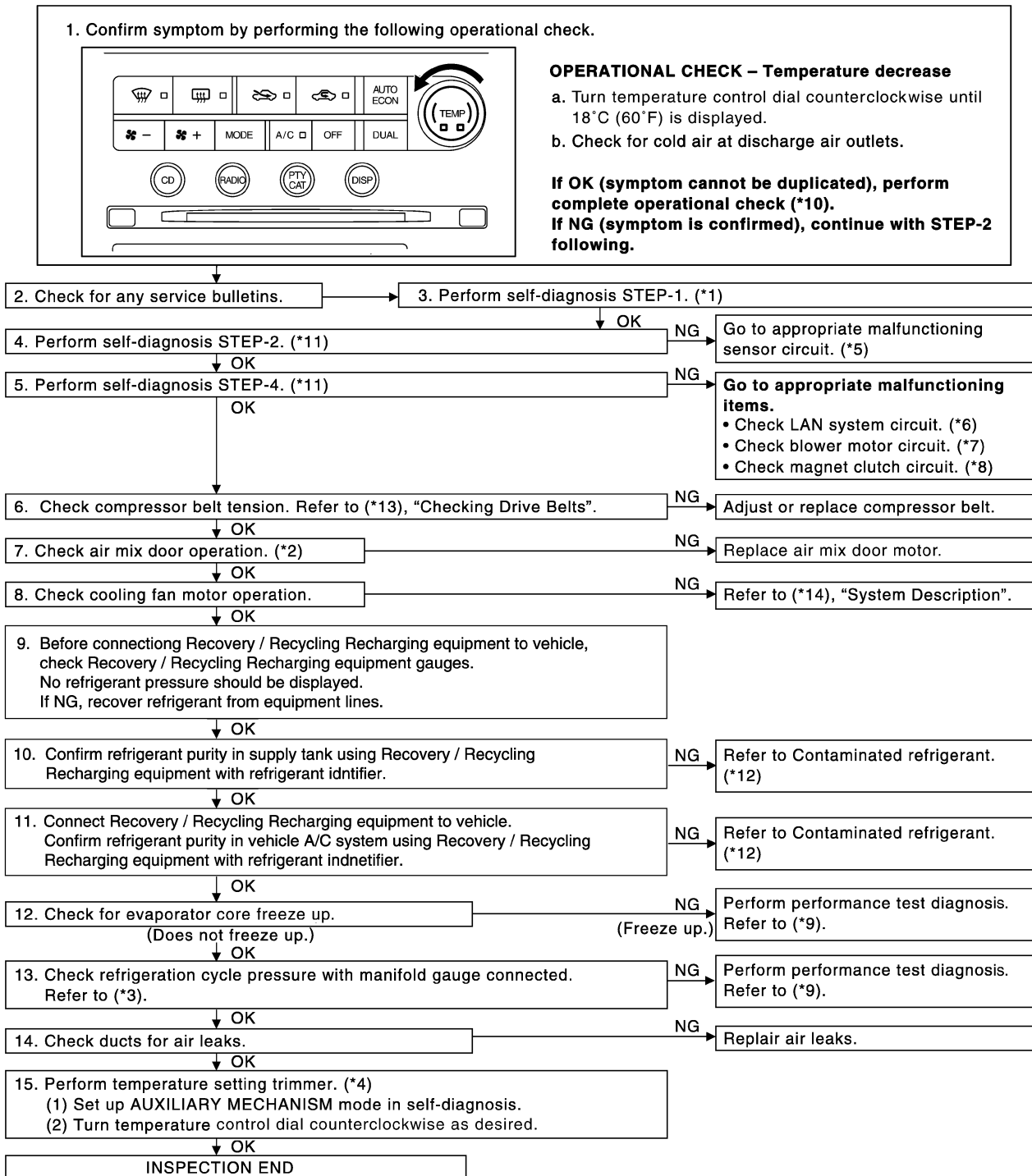

A  
B  
C  
D  
E  
F  
G  
H  
I  
K  
L  
M

ATC

RJIA3520E

# TROUBLE DIAGNOSIS

---

- \*1 [ATC-54, "FUNCTION CONFIRMATION PROCEDURE"](#), see No. 1.
- \*2 [ATC-74, "Air Mix Door Motor Circuit"](#)
- \*3 [ATC-97, "Test Reading \(With M/T\)" or ATC-98, "Test Reading \(With A/T\)"](#).
- \*4 [ATC-60, "AUXILIARY MECHANISM: TEMPERATURE SETTING TRIMMER"](#)
- \*5 [ATC-54, "FUNCTION CONFIRMATION PROCEDURE"](#), see No. 14.
- \*6 [ATC-67, "LAN System Circuit"](#)
- \*7 [ATC-80, "Blower Motor Circuit"](#)
- \*8 [ATC-86, "Magnet Clutch Circuit"](#)
- \*9 [ATC-95, "PERFORMANCE TEST DIAGNOSIS"](#)
- \*10 [ATC-62, "Operational Check"](#)
- \*11 [ATC-54, "FUNCTION CONFIRMATION PROCEDURE"](#), see No. 5 to 7.
- \*12 [ATC-6, "CONTAMINATED REFRIGERANT"](#)
- \*13 [EM-14, "Checking Drive Belts"](#)
- \*14 [EC-456, "SYSTEM DESCRIPTION"](#)

# TROUBLE DIAGNOSIS

## PERFORMANCE TEST DIAGNOSIS

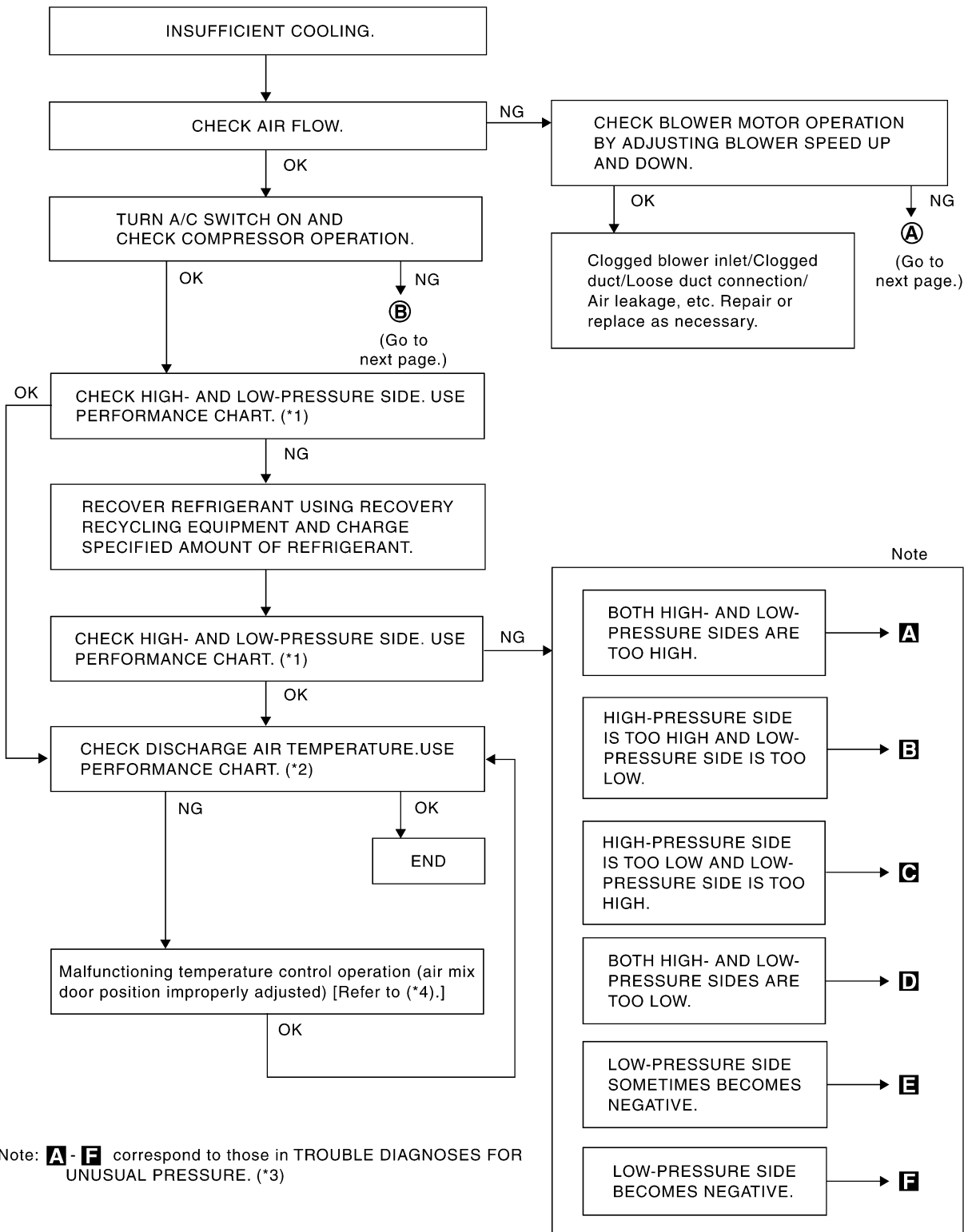

RJIA1601E

\*1 [ATC-97, "PERFORMANCE CHART"](#) \*2 [ATC-97, "PERFORMANCE CHART"](#) \*3 [ATC-99, "TROUBLE DIAGNOSIS FOR UNUSUAL PRESSURE"](#)  
 \*4 [ATC-74, "Air Mix Door Motor Circuit"](#)

# TROUBLE DIAGNOSIS

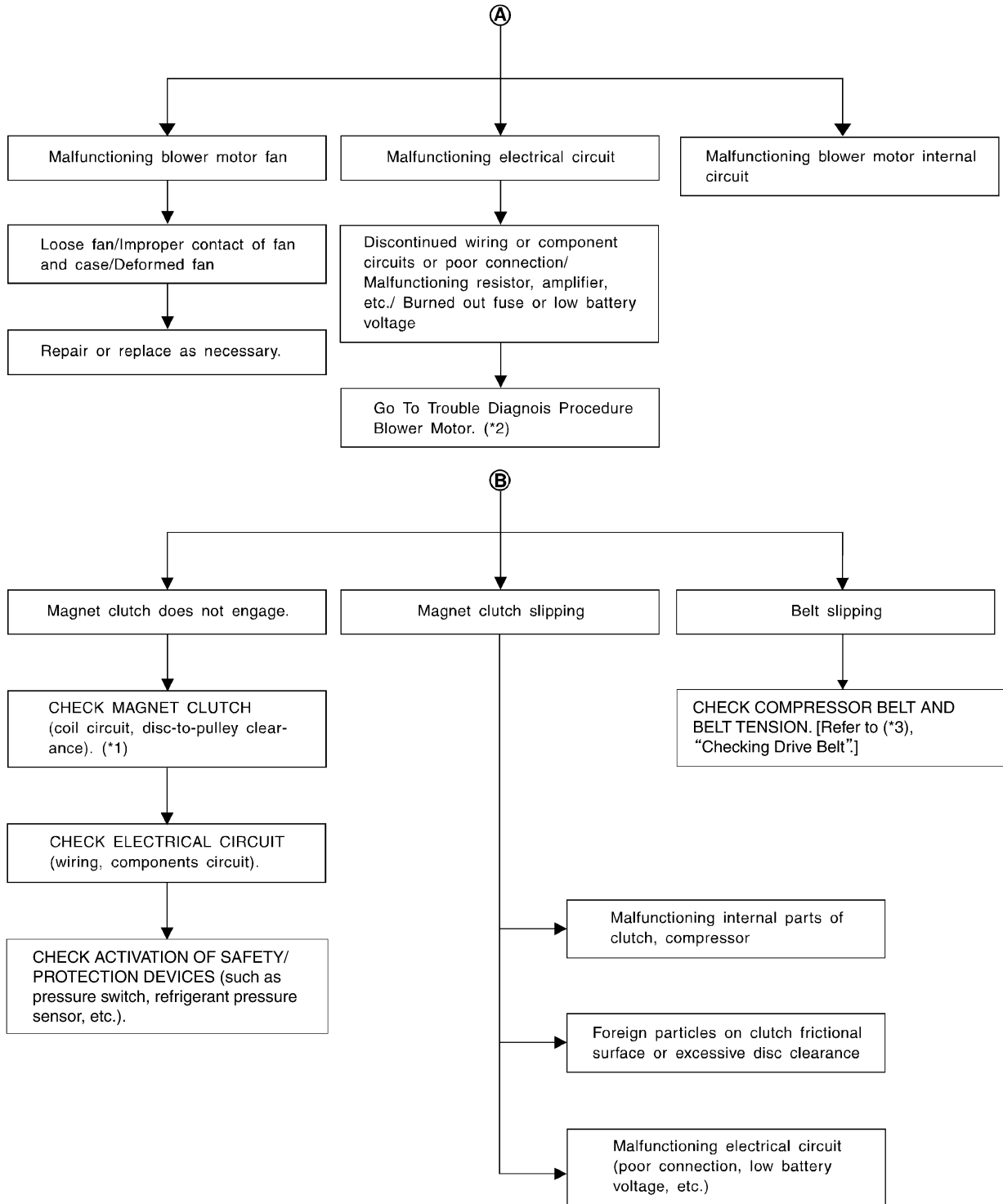

RJIA3107E

\*1 [ATC-144, "Removal and Installation of Compressor Clutch"](#)

\*2 [ATC-80, "Blower Motor Circuit"](#)

\*3 [EM-14, "Checking Drive Belts"](#)





# TROUBLE DIAGNOSIS

## PERFORMANCE CHART

### Test Condition

Testing must be performed as follows:

Vehicle condition	Indoors or in the shade (in a well-ventilated place)
Doors	Closed
Door window	Open
Hood	Open
TEMP.	Max. COLD
Mode switch	 (Ventilation) set
Recirculation (REC) switch	 (Recirculation) set
 Fan (blower) speed	Max. speed set
Engine speed	Idle speed

Operate the air conditioning system for 10 minutes before taking measurements.

### Test Reading (With M/T)

#### Recirculating-to-discharge Air Temperature Table

Inside air (Recirculating air) at blower assembly inlet		Discharge air temperature at center ventilator °C (°F)
Relative humidity %	Air temperature °C (°F)	
50 - 60	20 (68)	6.1 - 7.8 (43 - 46)
	25 (77)	8.8 - 11.0 (48 - 52)
	30 (86)	12.1 - 15.0 (54 - 59)
	35 (95)	16.5 - 19.8 (62 - 68)
	40 (104)	21.8 - 25.4 (71 - 78)
60 - 70	20 (68)	7.8 - 9.6 (46 - 49)
	25 (77)	11.0 - 13.3 (52 - 56)
	30 (86)	15.0 - 17.8 (59 - 64)
	35 (95)	19.8 - 23.1 (68 - 74)
	40 (104)	25.4 - 29.1 (78 - 84)

#### Ambient Air Temperature-to-operating Pressure Table

Ambient air		High-pressure (Discharge side) kPa (kg/cm <sup>2</sup> , psi)	Low-pressure (Suction side) kPa (kg/cm <sup>2</sup> , psi)
Relative humidity %	Air temperature °C (°F)		
50 - 70	20 (68)	805 - 992 (8.2 - 10.1, 117 - 144)	180 - 225 (1.8 - 2.3, 26 - 33)
	25 (77)	1,007 - 1,234 (10.3 - 12.6, 146 - 179)	196 - 239 (2.0 - 2.4, 28 - 35)
	30 (86)	1,202 - 1,467 (12.3 - 15.0, 174 - 213)	220 - 265 (2.2 - 2.7, 32 - 38)
	35 (95)	1,254 - 1,536 (12.8 - 15.7, 182 - 223)	248 - 301 (2.5 - 3.1, 36 - 44)
	40 (104)	1,401 - 1,719 (14.3 - 17.5, 203 - 249)	280 - 345 (2.9 - 3.5, 41 - 50)

## TROUBLE DIAGNOSIS

### Test Reading (With A/T)

Recirculating-to-discharge Air Temperature Table

Inside air (Recirculating air) at blower assembly inlet		Discharge air temperature at center ventilator °C (°F)
Relative humidity %	Air temperature °C (°F)	
50 - 60	20 (68)	7.2 - 9.5 (45 - 49)
	25 (77)	10.8 - 13.3 (51 - 56)
	30 (86)	14.3 - 17.5 (58 - 64)
	35 (95)	18.6 - 22.0 (65 - 72)
	40 (104)	23.2 - 26.7 (74 - 80)
60 - 70	20 (68)	9.5 - 11.8 (49 - 53)
	25 (77)	13.3 - 16.0 (56 - 61)
	30 (86)	17.5 - 20.5 (64 - 69)
	35 (95)	22.0 - 25.3 (72 - 78)
	40 (104)	26.7 - 30.1 (80 - 86)

Ambient Air Temperature-to-operating Pressure Table

Ambient air		High-pressure (Discharge side) kPa (kg/cm <sup>2</sup> , psi)	Low-pressure (Suction side) kPa (kg/cm <sup>2</sup> , psi)
Relative humidity %	Air temperature °C (°F)		
50 - 70	20 (68)	1,108 - 1,363 (11.3 - 13.9, 161 - 198)	161.8 - 201.0 (1.65 - 2.05, 23.5 - 29.2)
	25 (77)	1,344 - 1,648 (13.7 - 16.8, 195 - 239)	186.3 - 235.4 (1.90 - 2.40, 27.0 - 34.1)
	30 (86)	1,569 - 1,912 (16.0 - 19.5, 228 - 277)	225.6 - 269.7 (2.30 - 2.75, 32.7 - 39.1)
	35 (95)	1,785 - 2,177 (18.2 - 22.2, 259 - 316)	265.8 - 319.7 (2.71 - 3.26, 38.5 - 46.4)
	40 (104)	2,010 - 2,452 (20.5 - 25.0, 292 - 356)	313.8 - 372.7 (3.20 - 3.80, 45.5 - 54.0)

# TROUBLE DIAGNOSIS

## TROUBLE DIAGNOSIS FOR UNUSUAL PRESSURE

Whenever system's high and/or low side pressure(s) is/are unusual, diagnose using a manifold gauge. The marker above the gauge scale in the following tables indicates the standard (usual) pressure range. Since the standard (usual) pressure, however, differs from vehicle to vehicle, refer to above table (Ambient air temperature-to-operating pressure table).

### Both High- and Low-pressure Sides are Too High

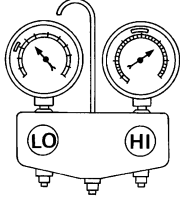
Gauge indication	Refrigerant cycle	Probable cause	Corrective action
<p>Both high- and low-pressure sides are too high.</p>  <p>AC359A</p>	Pressure is reduced soon after water is splashed on condenser.	Excessive refrigerant charge in refrigeration cycle	Reduce refrigerant until specified pressure is obtained.
	Air suction by cooling fan is insufficient.	Insufficient condenser cooling performance ↓ 1. Condenser fins are clogged. 2. Improper fan rotation of cooling fan	<ul style="list-style-type: none"> <li>● Clean condenser.</li> <li>● Check and repair cooling fan if necessary.</li> </ul>
	<ul style="list-style-type: none"> <li>● Low-pressure pipe is not cold.</li> <li>● When compressor is stopped high-pressure value quickly drops by approximately 196 kPa (2 kg/cm<sup>2</sup>, 28 psi). It then decreases gradually thereafter.</li> </ul>	Poor heat exchange in condenser (After compressor operation stops, high-pressure decreases too slowly.) ↓ Air in refrigeration cycle	Evacuate repeatedly and recharge system.
	Engine tends to overheat.	Engine cooling systems malfunction.	Check and repair each engine cooling system.
	<ul style="list-style-type: none"> <li>● An area of the low-pressure pipe is colder than areas near the evaporator outlet.</li> <li>● Plates are sometimes covered with frost.</li> </ul>	<ul style="list-style-type: none"> <li>● Excessive liquid refrigerant on low-pressure side</li> <li>● Excessive refrigerant discharge flow</li> <li>● Expansion valve is open a little compared with the specification.</li> </ul> ↓ Improper expansion valve adjustment	Replace expansion valve.

### High-pressure Side is Too High and Low-pressure Side is Too Low

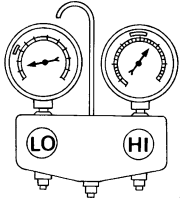
Gauge indication	Refrigerant cycle	Probable cause	Corrective action
<p>High-pressure side is too high and low-pressure side is too low.</p>  <p>AC360A</p>	Upper side of condenser and high-pressure side are hot, however, liquid tank is not so hot.	High-pressure tube or parts located between compressor and condenser are clogged or crushed.	<ul style="list-style-type: none"> <li>● Check and repair or replace malfunctioning parts.</li> <li>● Check lubricant for contamination.</li> </ul>

# TROUBLE DIAGNOSIS

## High-pressure Side is Too Low and Low-pressure Side is Too High

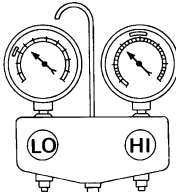
Gauge indication	Refrigerant cycle	Probable cause	Corrective action
High-pressure side is too low and low-pressure side is too high.   AC356A	High- and low-pressure sides become equal soon after compressor operation stops.	Compressor pressure operation is improper. ↓ Damaged inside compressor packings	Replace compressor.
	No temperature difference between high- and low-pressure sides	Compressor pressure operation is improper. ↓ Damaged inside compressor packings.	Replace compressor.

## Both High- and Low-pressure Sides are Too Low

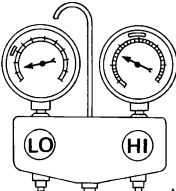
Gauge indication	Refrigerant cycle	Probable cause	Corrective action
Both high- and low-pressure sides are too low.   AC353A	<ul style="list-style-type: none"> <li>There is a big temperature difference between liquid tank outlet and inlet. Outlet temperature is extremely low.</li> <li>Liquid tank inlet and expansion valve are frosted.</li> </ul>	Liquid tank inside is slightly clogged.	<ul style="list-style-type: none"> <li>Replace liquid tank.</li> <li>Check lubricant for contamination.</li> </ul>
	<ul style="list-style-type: none"> <li>Temperature of expansion valve inlet is extremely low as compared with areas near liquid tank.</li> <li>Expansion valve inlet may be frosted.</li> <li>Temperature difference occurs somewhere in high-pressure side.</li> </ul>	High-pressure pipe located between liquid tank and expansion valve is clogged.	<ul style="list-style-type: none"> <li>Check and repair malfunctioning parts.</li> <li>Check lubricant for contamination.</li> </ul>
	Expansion valve and liquid tank are warm or only cool when touched.	Low refrigerant charge ↓ Leaking fittings or components	Check refrigerant for leaks. Refer to <a href="#">ATC-158. "Checking for Refrigerant Leaks"</a> .
	There is a big temperature difference between expansion valve inlet and outlet while the valve itself is frosted.	Expansion valve closes a little compared with the specification. ↓ 1. Improper expansion valve adjustment 2. Malfunctioning expansion valve 3. Outlet and inlet may be clogged.	<ul style="list-style-type: none"> <li>Remove foreign particles by using compressed air.</li> <li>Replace expansion valve.</li> <li>Check lubricant for contamination.</li> </ul>
	An area of the low-pressure pipe is colder than areas near the evaporator outlet.	Low-pressure pipe is clogged or crushed.	<ul style="list-style-type: none"> <li>Check and repair malfunctioning parts.</li> <li>Check lubricant for contamination.</li> </ul>
	Air flow volume is not enough or is too low.	Evaporator is frozen.	<ul style="list-style-type: none"> <li>Check intake sensor circuit. Refer to <a href="#">ATC-115. "Intake Sensor Circuit"</a>.</li> <li>Replace compressor.</li> <li>Repair evaporator fins.</li> <li>Replace evaporator.</li> <li>Refer to <a href="#">ATC-80. "Blower Motor Circuit"</a>.</li> </ul>

# TROUBLE DIAGNOSIS

## Low-pressure Side Sometimes Becomes Negative

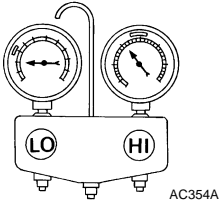
Gauge indication	Refrigerant cycle	Probable cause	Corrective action
<p>Low-pressure side sometimes becomes negative.</p>  <p style="text-align: right; font-size: small;">AC354A</p>	<ul style="list-style-type: none"> <li>● Air conditioning system does not function and does not cyclically cool the compartment air.</li> <li>● The system constantly functions for a certain period of time after compressor is stopped and restarted.</li> </ul>	<p>Refrigerant does not discharge cyclically.</p> <p>↓</p> <p>Moisture is frozen at expansion valve outlet and inlet.</p> <p>↓</p> <p>Water is mixed with refrigerant.</p>	<ul style="list-style-type: none"> <li>● Drain water from refrigerant or replace refrigerant.</li> <li>● Replace liquid tank.</li> </ul>

## Low-pressure Side Becomes Negative

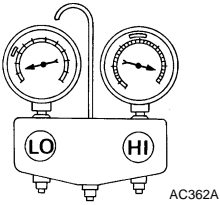
Gauge indication	Refrigerant cycle	Probable cause	Corrective action
<p>Low-pressure side becomes negative.</p>  <p style="text-align: right; font-size: small;">AC362A</p>	<p>Liquid tank or front/rear side of expansion valve's pipe is frosted or dewed.</p>	<p>High-pressure side is closed and refrigerant does not flow.</p> <p>↓</p> <p>Expansion valve or liquid tank is frosted.</p>	<p>Leave the system at rest until no frost is present. Start it again to check whether or not the malfunction is caused by water or foreign particles.</p> <ul style="list-style-type: none"> <li>● If water is the cause, initially cooling is okay. Then the water freezes causing a blockage. Drain water from refrigerant or replace refrigerant.</li> <li>● If due to foreign particles, remove expansion valve and remove the particles with dry and compressed air (not shop air).</li> <li>● If either of the above methods cannot correct the malfunction, replace expansion valve.</li> <li>● Replace liquid tank.</li> <li>● Check lubricant for contamination.</li> </ul>

## DIAGNOSTIC PROCEDURE FOR INSUFFICIENT COOLING

SYMPTOM: Insufficient cooling

### 1. CHECK POWER SUPPLY FOR ECV (ELECTRONIC CONTROL VALVE)

1. Disconnect compressor (ECV) connector.
2. Turn ignition switch ON.
3. Check voltage between compressor (ECV) harness connector F34 terminal 3 (Y/G) and ground.

**3 – Ground : Battery voltage**

OK or NG

OK >> GO TO 2.

NG >> Check power supply circuit and 10A fuse [No. 12, located in the fuse block (J/B)]. Refer to [PG-76, "FUSE BLOCK - JUNCTION BOX \(J/B\)"](#) .

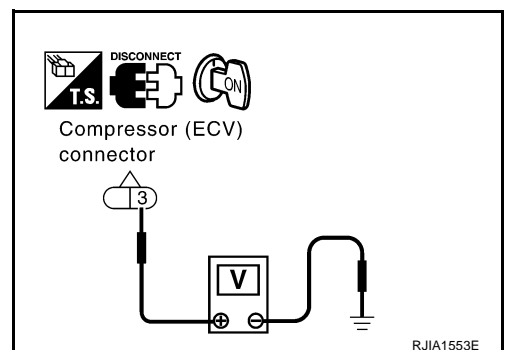

# TROUBLE DIAGNOSIS

## 2. CHECK ECV CONTROL SIGNAL

1. Turn ignition switch OFF.
2. Reconnect compressor (ECV) connector.
3. Perform self-diagnosis. Refer to [ATC-53, "Self-Diagnosis Function"](#).
4. Set in self-diagnosis STEP-45. Refer to [ATC-54, "FUNCTION CONFIRMATION PROCEDURE"](#).
5. Confirm ECV control signal between display and A/C auto amp. harness connector M31 terminal 27 (W/B) and ground using an oscilloscope.

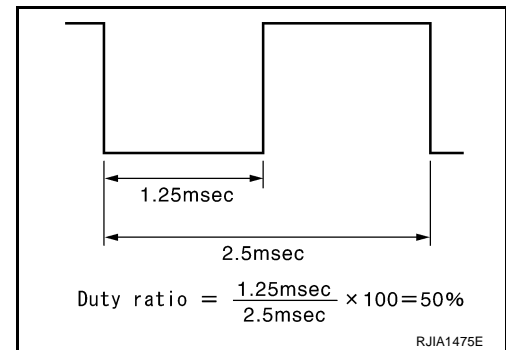
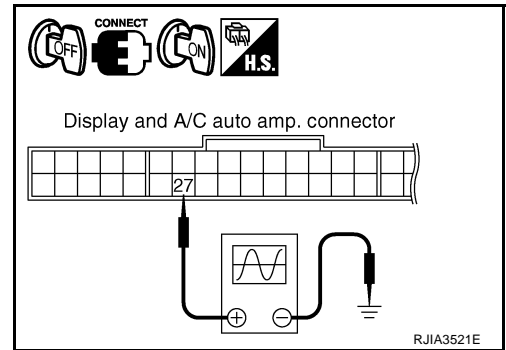

### OK or NG

- OK >> Replace compressor.  
NG >> GO TO 3.

## 3. CHECK CIRCUIT CONTINUITY BETWEEN ECV AND DISPLAY AND A/C AUTO AMP.

1. Turn ignition switch OFF.
2. Disconnect compressor (ECV) and display and A/C auto amp. connector.
3. Check continuity between compressor (ECV) harness connector F34 terminal 2 (W/B) and display and A/C auto amp. harness connector M31 terminal 27 (W/B).

**2 - 27 : Continuity should exist.**

### OK or NG

- OK >> GO TO 4.  
NG >> Repair harness or connector.

## 4. CHECK ECV

Check continuity between compressor (ECV) connector F34 terminals 2 and 3.

**2 - 3 : Continuity should exist.**

### OK or NG

- OK >> Replace display and A/C auto amp.  
NG >> Replace compressor.

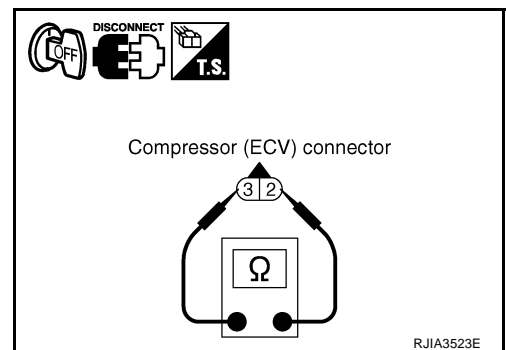
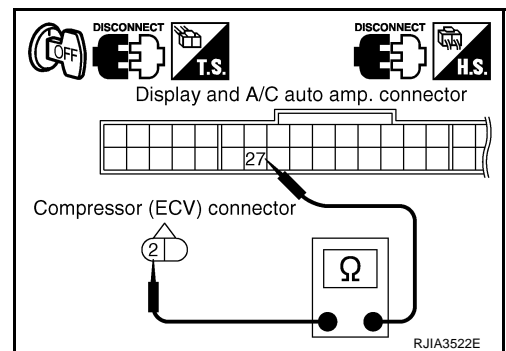

# TROUBLE DIAGNOSIS

AJS0012E

## Insufficient Heating

SYMPTOM: Insufficient heating

### INSPECTION FLOW

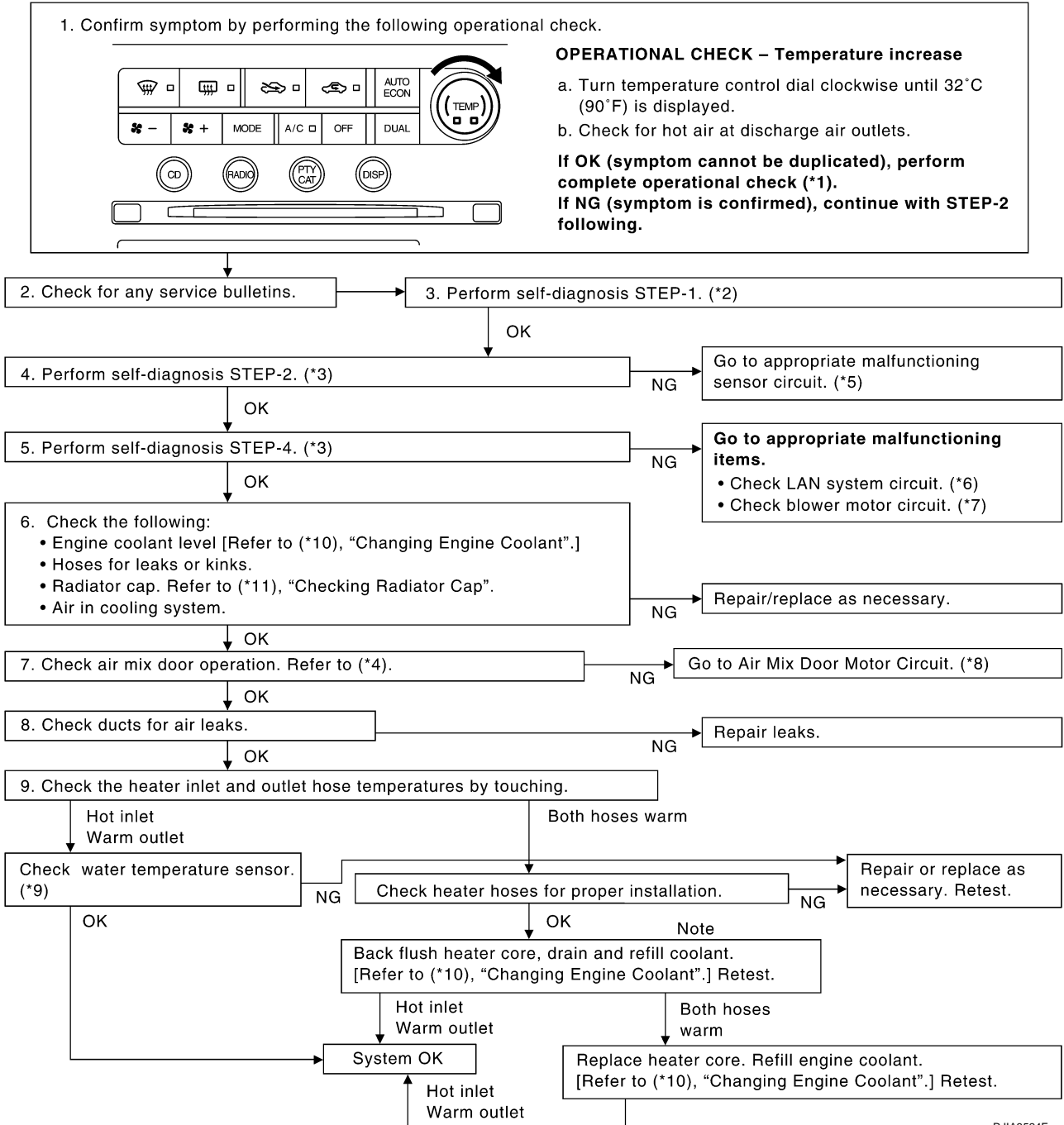

RJIA3524E

- \*1 [ATC-62, "Operational Check"](#)
- \*2 [ATC-54, "FUNCTION CONFIRMATION PROCEDURE"](#), see No. 1.
- \*3 [ATC-54, "FUNCTION CONFIRMATION PROCEDURE"](#), see No. 5 to 7.
- \*4 [ATC-74, "Air Mix Door Motor Circuit"](#)
- \*5 [ATC-54, "FUNCTION CONFIRMATION PROCEDURE"](#), see No. 14.
- \*6 [ATC-67, "LAN System Circuit"](#)
- \*7 [ATC-80, "Blower Motor Circuit"](#)
- \*8 [ATC-74, "Air Mix Door Motor Circuit"](#)
- \*9 [EC-202, "DTC P0117, P0118 ECT SENSOR"](#)
- \*10 [CO-10, "Changing Engine Coolant"](#)
- \*11 [CO-15, "Checking Radiator Cap"](#)

# TROUBLE DIAGNOSIS

AJS0012F

## Noise

SYMPTOM: Noise

### INSPECTION FLOW

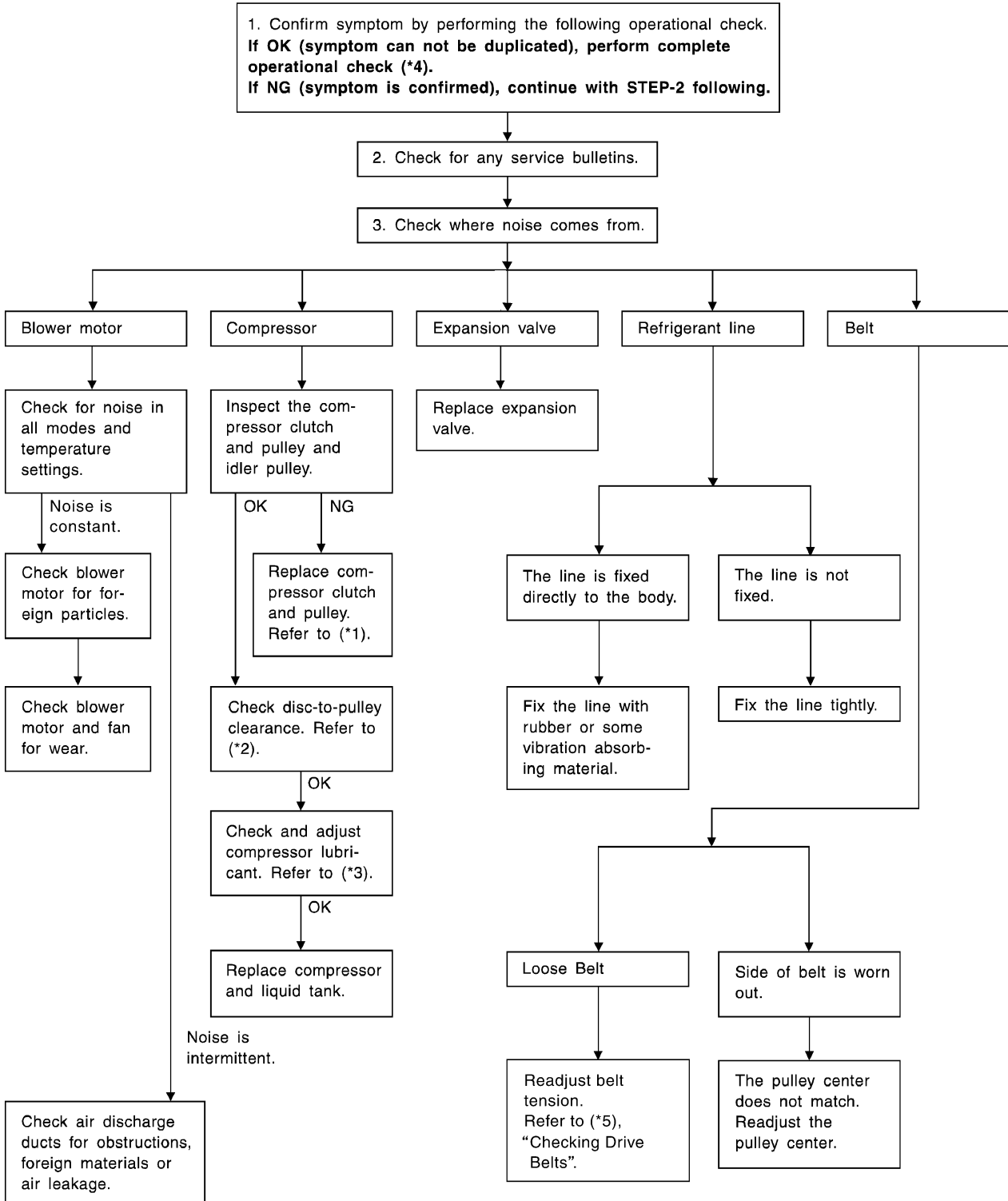

\*1 Compressor clutch, [ATC-144. "REMOVAL"](#)

\*2 Compressor clutch, [ATC-146. "INSTALLATION"](#)

\*3 [ATC-26. "Maintenance of Lubricant Quantity in Compressor"](#)

\*4 [ATC-62. "Operational Check"](#)

\*5 [EM-14. "Checking Drive Belts"](#)

RJIA3108E



# TROUBLE DIAGNOSIS

AJS0012G

## Self-Diagnosis

SYMPTOM: Self-diagnosis cannot be performed.

### INSPECTION FLOW

1. Confirm symptom by performing operational check.

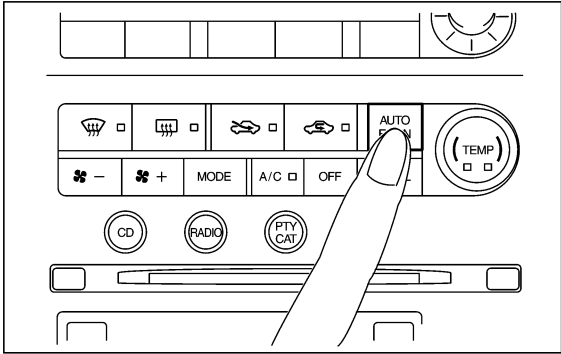

**OPERATIONAL CHECK – AUTO mode**

- Press AUTO. ECON switch.
- Display should indicate AUTO.  
Confirm that the compressor clutch engages (sound or visual inspection).  
(Discharge air and blower speed will depend on ambient, in-vehicle and set temperatures.)

**If OK (symptom cannot be duplicated), perform complete operational check (\*7).  
If NG (symptom is confirmed), continue with STEP-2 following.**

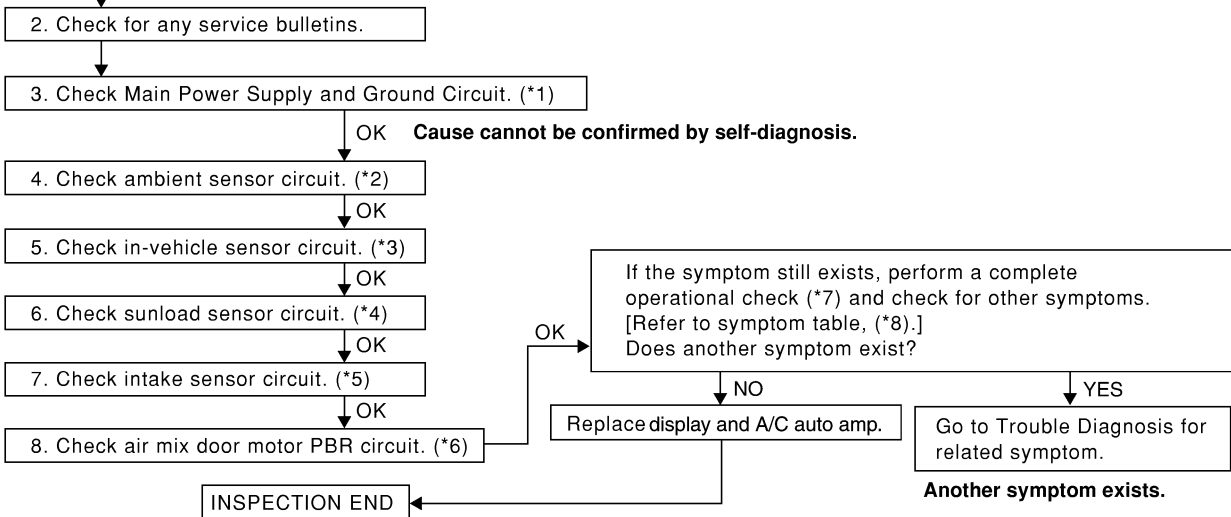

\*1 [ATC-64, "Power Supply and Ground Circuit for Auto Amp."](#)

\*2 [ATC-106, "Ambient Sensor Circuit"](#)

\*3 [ATC-109, "In-Vehicle Sensor Circuit"](#)

\*4 [ATC-112, "Sunload Sensor Circuit"](#)

\*5 [ATC-115, "Intake Sensor Circuit"](#)

\*6 [ATC-76, "Air Mix Door Motor PBR Circuit"](#)

\*7 [ATC-62, "Operational Check"](#)

\*8 [ATC-41, "SYMPTOM TABLE"](#)

RJIA3525E

A  
B  
C  
D  
E  
F  
G  
H  
I  
J  
K  
L  
M

ATC

# TROUBLE DIAGNOSIS

AJS0012H

## Memory Function

SYMPTOM: Memory function does not operate.

### INSPECTION FLOW

1. Confirm symptom by performing the following operational check.

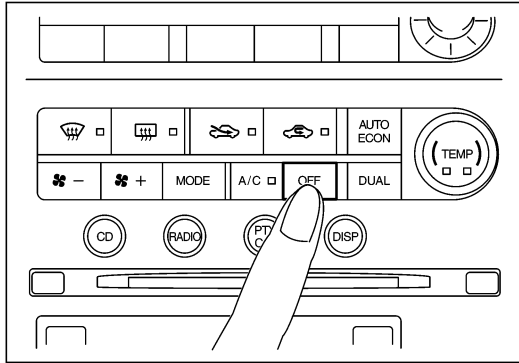

#### OPERATIONAL CHECK – Memory function

- Turn temperature control dial clockwise until 32°C (90°F) is displayed.
- Press OFF switch.
- Turn the ignition off.
- Turn the ignition on.
- Press the AUTO. ECON switch.
- Confirm that the set temperature remains at previous temperature.
- Press OFF switch.

If OK (symptom cannot be duplicated), perform complete operational check (\*2).

If NG (symptom is confirmed), continue with STEP-2 following.

2. Check for any service bulletins.

3. Check Main Power Supply and Ground Circuit. (\*1)

OK

4. Replace display and A/C auto amp.

#### 5. FINAL CHECK

Go to self-diagnosis function confirmation procedure (\*3) and perform self-diagnosis STEP-2.  
Confirm that code No. 20 is displayed.

\*1 [ATC-64. "Power Supply and Ground Circuit for Auto Amp."](#) \*2 [ATC-62. "Operational Check"](#)

\*3 [ATC-54. "FUNCTION CONFIRMATION PROCEDURE"](#)

RJIA3526E

## Ambient Sensor Circuit COMPONENT DESCRIPTION

AJS001RM

### Ambient Sensor

The ambient sensor is attached on the ambient sensor bracket. It detects ambient temperature and converts it into a resistance value which is then input into the display and A/C auto amp.

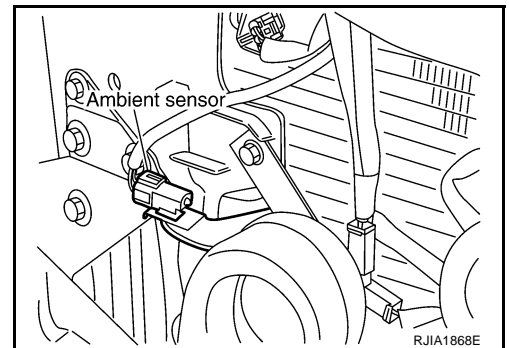

RJIA1868E

# TROUBLE DIAGNOSIS

## AMBIENT TEMPERATURE INPUT PROCESS

The display and A/C auto amp. includes a processing circuit for the ambient sensor input. However, when the temperature detected by the ambient sensor increases quickly, the processing circuit retards the display and A/C auto amp. function. It only allows the display and A/C auto amp. to recognize an ambient temperature increase of 0.33°C (0.6°F) per 100 seconds.

As an example, consider stopping for a few minutes after high speed driving. Although the actual ambient temperature has not changed, the temperature detected by the ambient sensor will increase. This is because the heat from the engine compartment can radiate to the front grille area, location of the ambient sensor.

## DIAGNOSTIC PROCEDURE FOR AMBIENT SENSOR

SYMPTOM: Ambient sensor circuit is open or shorted. (21 or -21 is indicated on display and A/C auto amp. As a result of performing Self-diagnosis STEP-2.)

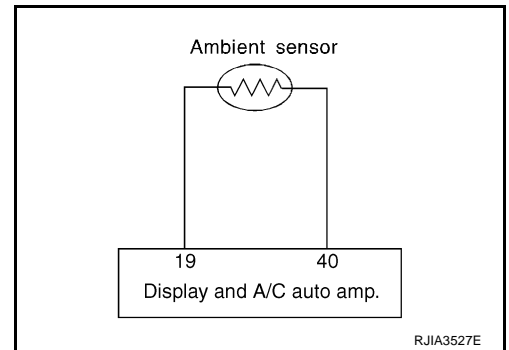

### 1. CHECK VOLTAGE BETWEEN AMBIENT SENSOR AND GROUND

1. Disconnect ambient sensor connector.
2. Turn ignition switch ON.
3. Check voltage between ambient sensor harness connector E34 terminal 1 (Y/G) and ground.

**1 – Ground : Approx. 5V**

OK or NG

- OK >> GO TO 2.  
NG >> GO TO 4.

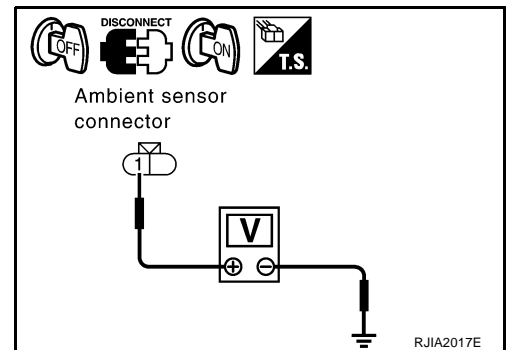

### 2. CHECK CIRCUIT CONTINUITY BETWEEN AMBIENT SENSOR AND DISPLAY AND A/C AUTO AMP.

1. Turn ignition switch OFF.
2. Disconnect display and A/C auto amp. connector.
3. Check continuity between ambient sensor harness connector E34 terminal 2 (W/G) and display and A/C auto amp. harness connector M31 terminal 40 (W/G).

**2 – 40 : Continuity should exist.**

OK or NG

- OK >> GO TO 3.  
NG >> Repair harness or connector.

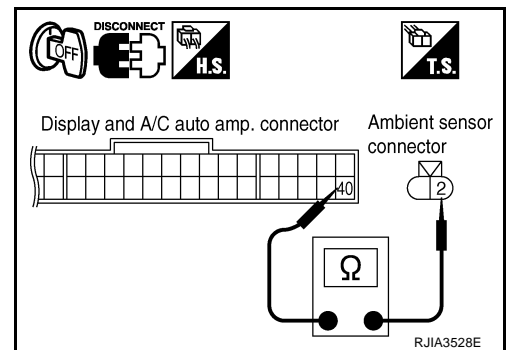

# TROUBLE DIAGNOSIS

## 3. CHECK AMBIENT SENSOR

Refer to [ATC-108, "Ambient Sensor"](#) .

OK or NG

- OK >> 1. Replace display and A/C auto amp.  
 2. Go to self-diagnosis [ATC-54, "FUNCTION CONFIRMATION PROCEDURE"](#) and perform self-diagnosis STEP-2. Confirm that code No. 20 is displayed.
- NG >> 1. Replace ambient sensor.  
 2. Go to self-diagnosis [ATC-54, "FUNCTION CONFIRMATION PROCEDURE"](#) and perform self-diagnosis STEP-2. Confirm that code No. 20 is displayed.

## 4. CHECK CIRCUIT CONTINUITY BETWEEN AMBIENT SENSOR AND DISPLAY AND A/C AUTO AMP.

- Turn ignition switch OFF.
- Disconnect display and A/C auto amp. connector.
- Check continuity between ambient sensor harness connector E34 terminal 1 (Y/G) and display and A/C auto amp. harness connector M31 terminal 19 (Y/G).

**1 – 19 : Continuity should exist.**

- Check continuity between ambient sensor harness connector E34 terminal 1 (Y/G) and ground.

**1 – Ground : Continuity should not exist.**

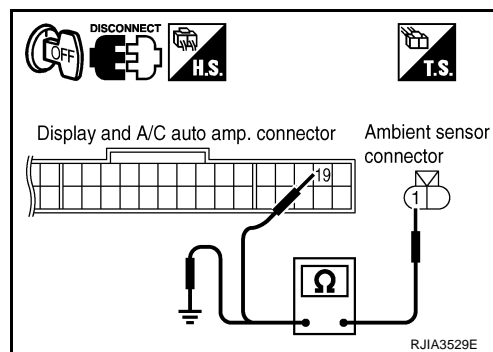

OK or NG

- OK >> 1. Replace display and A/C auto amp.  
 2. Go to self-diagnosis [ATC-54, "FUNCTION CONFIRMATION PROCEDURE"](#) and perform self-diagnosis STEP-2. Confirm that code No. 20 is displayed.
- NG >> Repair harness or connector.

## COMPONENT INSPECTION

### Ambient Sensor

After disconnecting ambient sensor connector E34, measure resistance between terminals 1 (Y/G) and 2 (W/G) at sensor side, using the table below.

Temperature °C (°F)	Resistance kΩ
-15 (5)	12.73
-10 (14)	9.92
-5 (23)	7.80
0 (32)	6.19
5 (41)	4.95
10 (50)	3.99
15 (59)	3.24
20 (68)	2.65
25 (77)	2.19
30 (86)	1.81
35 (95)	1.51
40 (104)	1.27
45 (113)	1.07

If NG, replace ambient sensor.

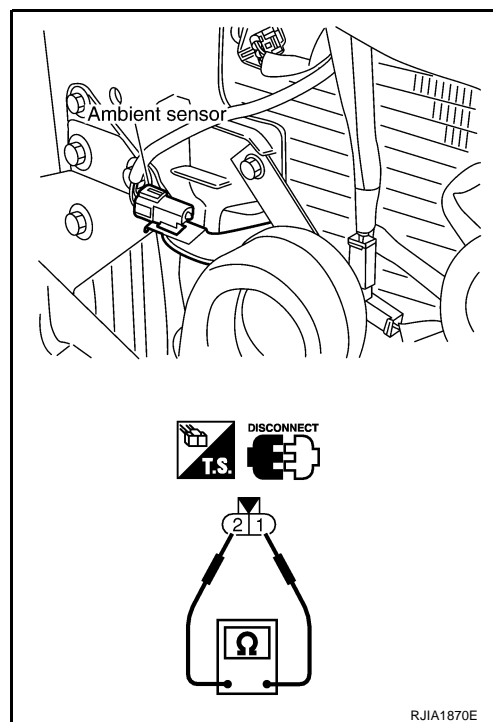

# TROUBLE DIAGNOSIS

## In-Vehicle Sensor Circuit COMPONENT DESCRIPTION

AJS001RL

### In-Vehicle Sensor

The in-vehicle sensor is located on instrument lower driver panel. It converts variations in temperature of compartment air drawn from the aspirator into a resistance value. It is then input into the display and A/C auto amp.

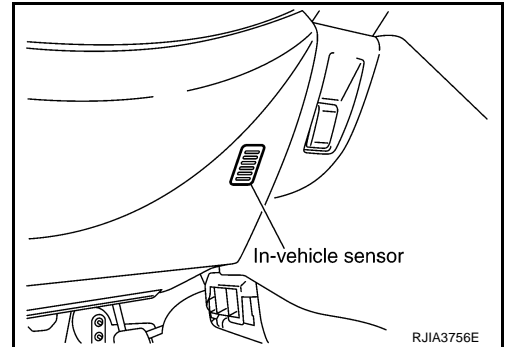

### Aspirator

The aspirator is located on driver's side of heater & cooling unit. It produces vacuum pressure due to air discharged from the heater & cooling unit, continuously taking compartment air in the aspirator.

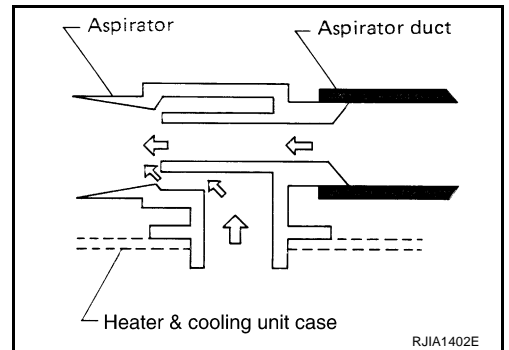
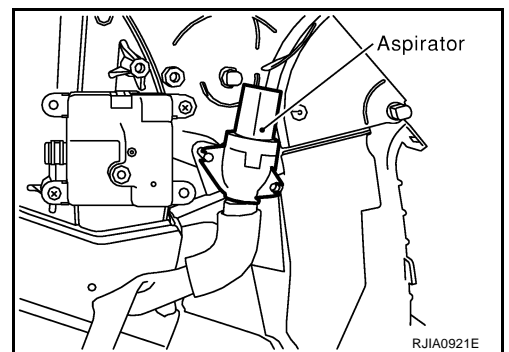

A  
B  
C  
D  
E  
F  
G  
H  
I  
K  
L  
M

ATC

# TROUBLE DIAGNOSIS

## DIAGNOSTIC PROCEDURE FOR IN-VEHICLE SENSOR

SYMPTOM: In-vehicle sensor circuit is open or shorted. (22 or -22 is indicated on display and A/C auto amp. as a result of performing Self-diagnosis STEP-2.)

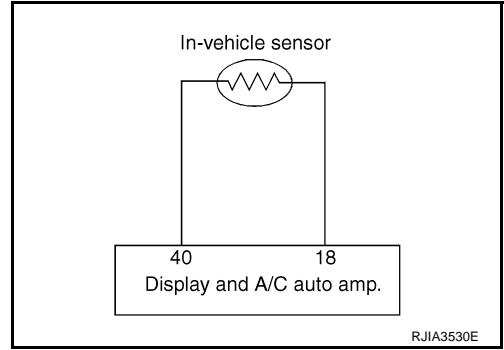

### 1. CHECK VOLTAGE BETWEEN IN-VEHICLE SENSOR AND GROUND

1. Disconnect in-vehicle sensor connector.
2. Turn ignition switch ON.
3. Check voltage between in-vehicle sensor harness connector M42 terminal 1 (BR/R) and ground.

**1 – Ground : Approx. 5V**

OK or NG

- OK >> GO TO 2.  
NG >> GO TO 4.

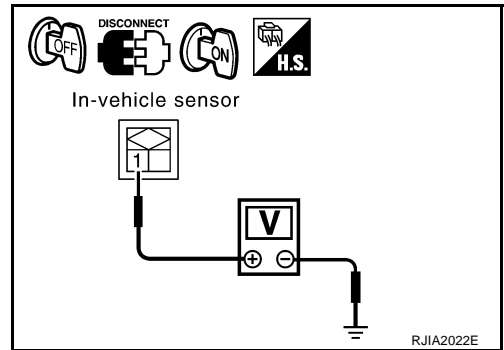

### 2. CHECK CIRCUIT CONTINUITY BETWEEN IN-VEHICLE SENSOR AND DISPLAY AND A/C AUTO AMP.

1. Turn ignition switch OFF.
2. Disconnect display and A/C auto amp. connector.
3. Check continuity between in-vehicle sensor harness connector M42 terminal 2 (W/G) and display and A/C auto amp. harness connector M31 terminal 40 (W/G).

**2 – 40 : Continuity should exist.**

OK or NG

- OK >> GO TO 3.  
NG >> Repair harness or connector.

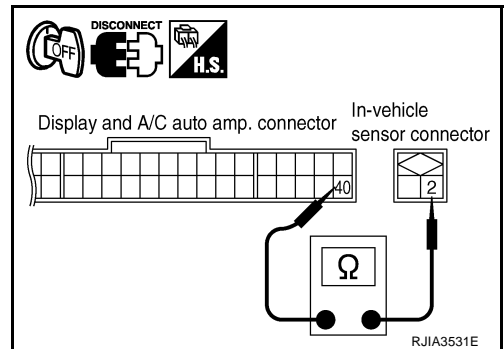

### 3. CHECK IN-VEHICLE SENSOR

Refer to [ATC-111, "In-vehicle Sensor"](#).

OK or NG

- OK >> 1. Replace display and A/C auto amp.  
2. Go to self-diagnosis [ATC-54, "FUNCTION CONFIRMATION PROCEDURE"](#) and perform self-diagnosis STEP-2. Confirm that code No. 20 is displayed.
- NG >> 1. Replace in-vehicle sensor.  
2. Go to self-diagnosis [ATC-54, "FUNCTION CONFIRMATION PROCEDURE"](#) and perform self-diagnosis STEP-2. Confirm that code No. 20 is displayed.

# TROUBLE DIAGNOSIS

## 4. CHECK CIRCUIT CONTINUITY BETWEEN IN-VEHICLE SENSOR AND DISPLAY AND A/C AUTO AMP.

1. Turn ignition switch OFF.
2. Disconnect display and A/C auto amp. connector.
3. Check continuity between in-vehicle sensor harness connector M42 terminal 1 (BR/R) and display and A/C auto amp. harness connector M31 terminal 18 (BR/R).

**1 – 18 : Continuity should exist.**

4. Check continuity between in-vehicle sensor harness connector M42 terminal 1 (BR/R) and ground.

**1 – Ground : Continuity should not exist.**

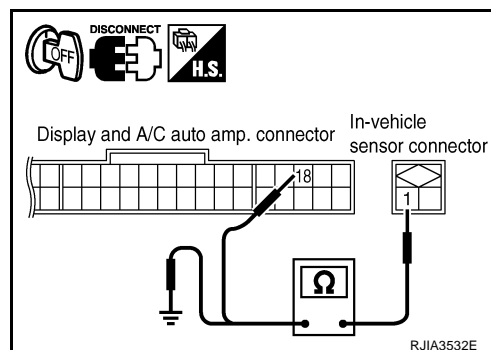

OK or NG

OK >> 1. Replace display and A/C auto amp.

2. Go to self-diagnosis [ATC-54, "FUNCTION CONFIRMATION PROCEDURE"](#) and perform self-diagnosis STEP-2. Confirm that code No. 20 is displayed.

NG >> Repair harness or connector.

### COMPONENT INSPECTION

#### In-vehicle Sensor

After disconnecting in-vehicle sensor connector M42, measure resistance between terminals 1 (BR/R) and 2 (W/G) at sensor side, using the table below.

Temperature °C (°F)	Resistance kΩ
-15 (5)	12.73
-10 (14)	9.92
-5 (23)	7.80
0 (32)	6.19
5 (41)	4.95
10 (50)	3.99
15 (59)	3.24
20 (68)	2.65
25 (77)	2.19
30 (86)	1.81
35 (95)	1.51
40 (104)	1.27
45 (113)	1.07

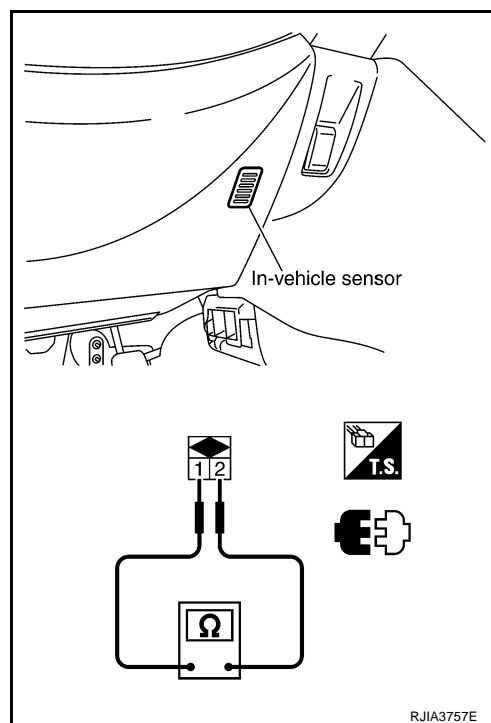

If NG, replace in-vehicle sensor.

# TROUBLE DIAGNOSIS

AJS0010X

## Sunload Sensor Circuit COMPONENT DESCRIPTION

### Sunload Sensor

The sunload sensor is located on the driver's side defroster grille. It detects sunload entering through windshield by means of a photo diode. The sensor converts the sunload into a current value which is then input into the display and A/C auto amp.

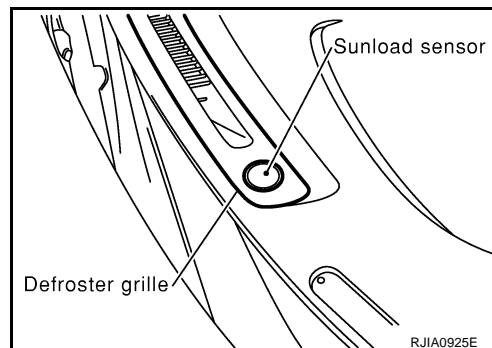

### SUNLOAD INPUT PROCESS

The display and A/C auto amp. also includes a processing circuit which averages the variations in detected sunload over a period of time. This prevents drastic swings in the ATC system operation due to small or quick variations in detected sunload.

For example, consider driving along a road bordered by an occasional group of large trees. The sunload detected by the sunload sensor will vary whenever the trees obstruct the sunlight. The processing circuit averages the detected sunload over a period of time, so that the (insignificant) effect of the trees momentarily obstructing the sunlight does not cause any change in the ATC system operation. On the other hand, shortly after entering a long tunnel, the system will recognize the change in sunload, and the system will react accordingly.

### DIAGNOSTIC PROCEDURE FOR SUNLOAD SENSOR

SYMPTOM: Sunload sensor circuit is open or shorted. (25 or -25 is indicated on display and A/C auto amp. as a result of performing Self-diagnosis STEP-2.)

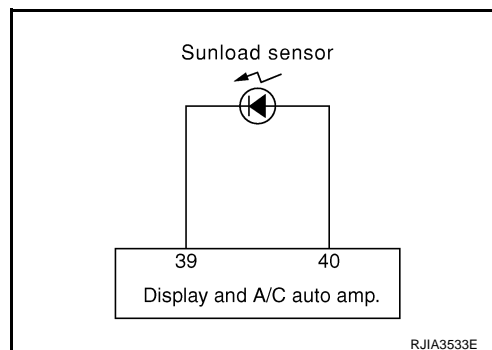

## 1. CHECK VOLTAGE BETWEEN SUNLOAD SENSOR AND GROUND

1. Disconnect sunload sensor connector.
2. Turn ignition switch ON.
3. Check voltage between sunload sensor harness connector M18 terminal 1 (LG) and ground.

**1 – Ground**

**: Approx. 5V**

OK or NG

- OK >> GO TO 2.  
NG >> GO TO 4.

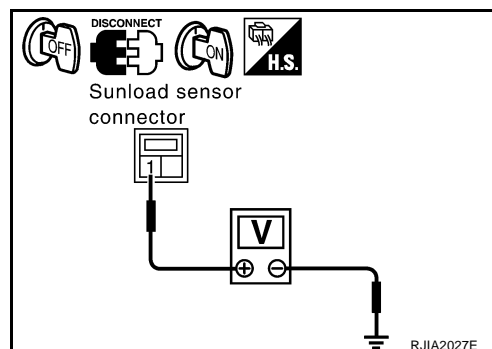



# TROUBLE DIAGNOSIS

## 2. CHECK CIRCUIT CONTINUITY BETWEEN SUNLOAD SENSOR AND DISPLAY AND A/C AUTO AMP.

1. Turn ignition switch OFF.
2. Disconnect display and A/C auto amp. connector.
3. Check continuity between sunload sensor harness connector M18 terminal 2 (W/G) and display and A/C auto amp. harness connector M31 terminal 40 (W/G).

**2 – 40**

**: Continuity should exist.**

OK or NG

OK >> GO TO 3.

NG >> Repair harness or connector.

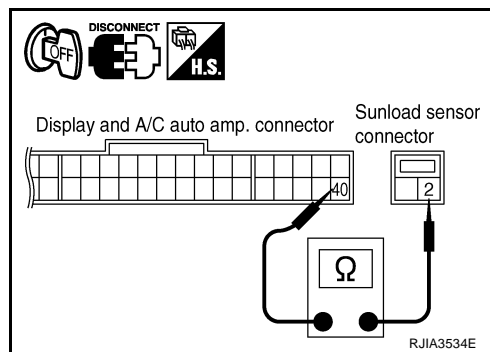

## 3. CHECK SUNLOAD SENSOR

Refer to [ATC-114, "Sunload Sensor"](#) .

OK or NG

OK >> 1. Replace display and A/C auto amp.

2. Go to self-diagnosis [ATC-54, "FUNCTION CONFIRMATION PROCEDURE"](#) and perform self-diagnosis STEP-2. Confirm that code No. 20 is displayed.

NG >> 1. Replace sunload sensor.

2. Go to self-diagnosis [ATC-54, "FUNCTION CONFIRMATION PROCEDURE"](#) and perform self-diagnosis STEP-2. Confirm that code No. 20 is displayed.

## 4. CHECK CIRCUIT CONTINUITY BETWEEN SUNLOAD SENSOR AND DISPLAY AND A/C AUTO AMP.

1. Turn ignition switch OFF.
2. Disconnect display and A/C auto amp. connector.
3. Check continuity between sunload sensor harness connector M18 terminal 1 (LG) and display and A/C auto amp. harness connector M31 terminal 39 (LG).

**1 – 39**

**: Continuity should exist.**

4. Check continuity between sunload sensor harness connector M18 terminal 1 (LG) and ground.

**1 – Ground**

**: Continuity should not exist.**

OK or NG

OK >> 1. Replace display and A/C auto amp.

2. Go to self-diagnosis [ATC-54, "FUNCTION CONFIRMATION PROCEDURE"](#) and perform self-diagnosis STEP-2. Confirm that code No. 20 is displayed.

NG >> Repair harness or connector.

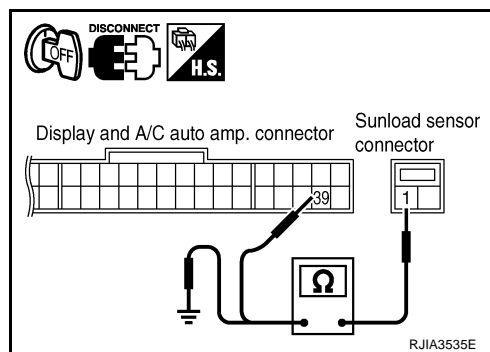

# TROUBLE DIAGNOSIS

## COMPONENT INSPECTION

### Sunload Sensor

Measure voltage between display and A/C auto amp. harness connector M31 terminal 39 (LG) and ground.  
If NG, replace sunload sensor.

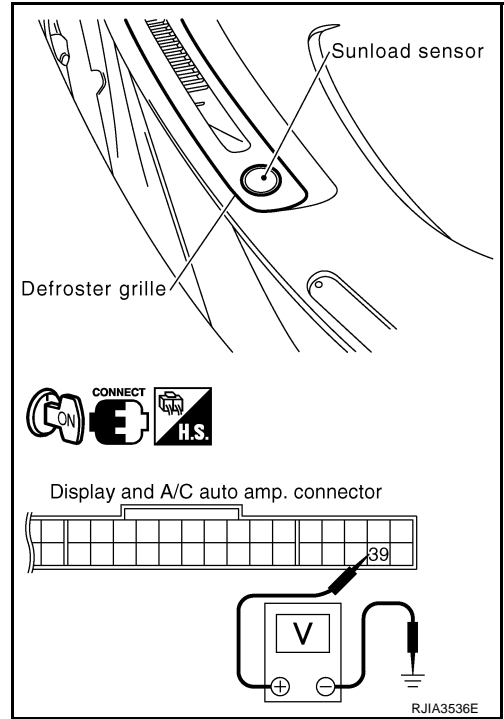

- When checking sunload sensor, select a place where sun shines directly on it.

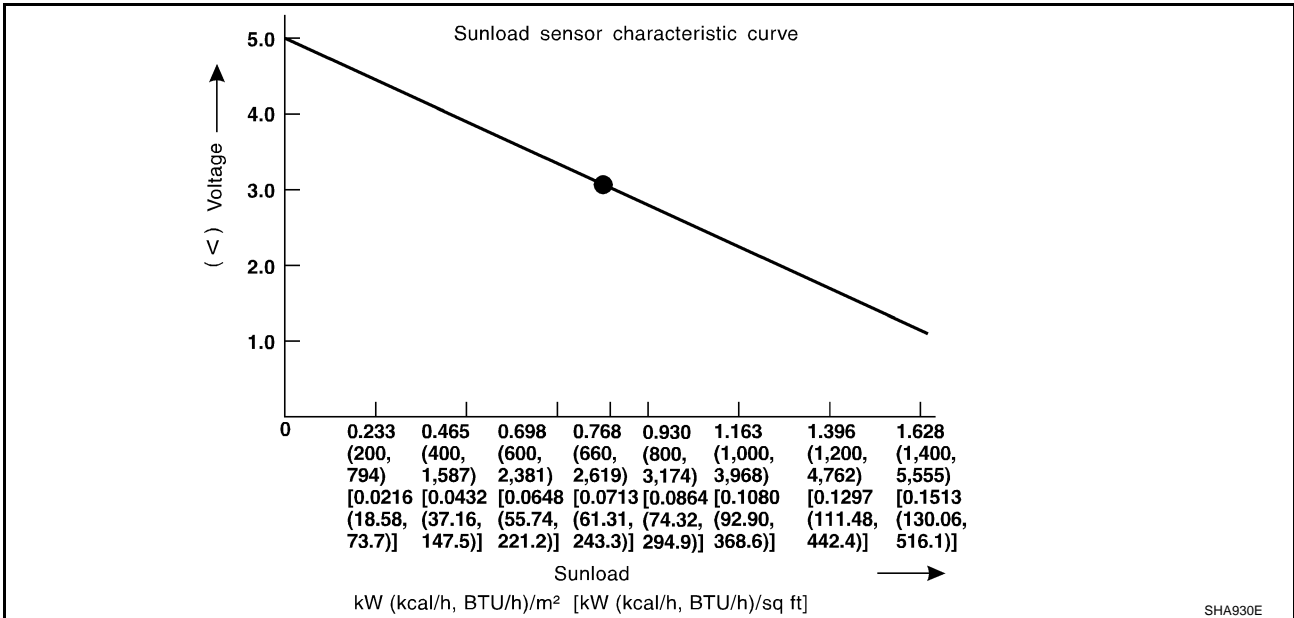

# TROUBLE DIAGNOSIS

AJS001RK

## Intake Sensor Circuit COMPONENT DESCRIPTION

### Intake Sensor

The intake sensor is located on the heater & cooling unit. It converts temperature of air after it passes through the evaporator into a resistance value which is then input to the display and A/C auto amp.

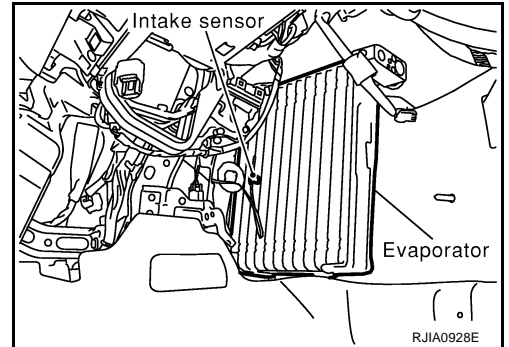

## DIAGNOSTIC PROCEDURE FOR INTAKE SENSOR

SYMPTOM: Intake sensor circuit is open or shorted. (24 or -24 is indicated on display and A/C auto amp. as a result of performing Self-diagnosis STEP-2.)

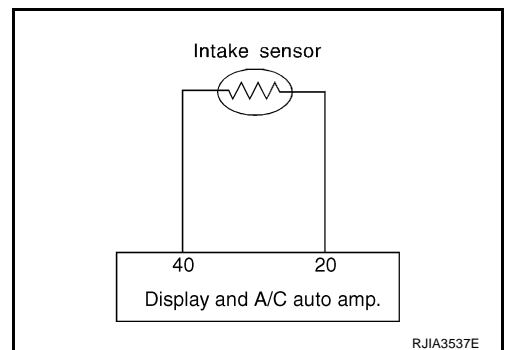

## 1. CHECK VOLTAGE BETWEEN INTAKE SENSOR AND GROUND

1. Disconnect intake sensor connector.
2. Turn ignition switch ON.
3. Check voltage between intake sensor harness connector M256 terminal 2 (R) and ground.

**2 – Ground** : **Approx. 5V**

OK or NG

- OK >> GO TO 2.  
NG >> GO TO 4.

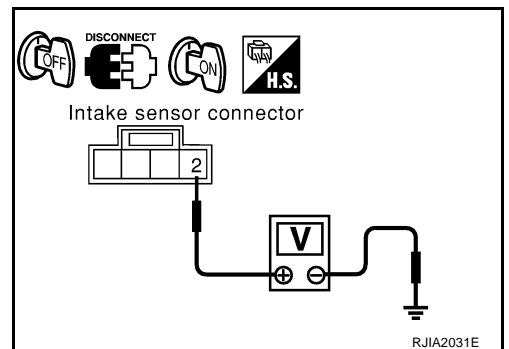

## 2. CHECK CIRCUIT CONTINUITY BETWEEN INTAKE SENSOR AND DISPLAY AND A/C AUTO AMP.

1. Turn ignition switch OFF.
2. Disconnect display and A/C auto amp. connector.
3. Check continuity between intake sensor harness connector M256 terminal 1 (W) and display and A/C auto amp. harness connector M31 terminal 40 (W/G).

**1 – 40** : **Continuity should exist.**

OK or NG

- OK >> GO TO 3.  
NG >> Repair harness or connector.

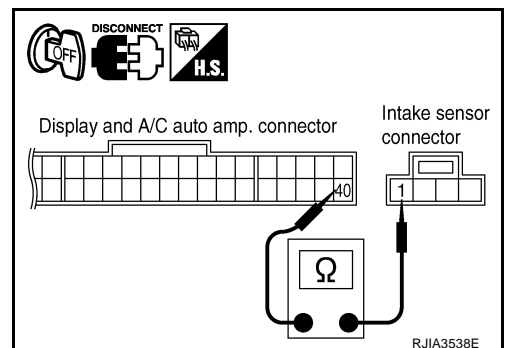

A  
B  
C  
D  
E  
F  
G  
H  
I  
K  
L  
M

ATC

# TROUBLE DIAGNOSIS

## 3. CHECK INTAKE SENSOR

Refer to [ATC-116, "Intake Sensor"](#) .

OK or NG

- OK >> 1. Replace display and A/C auto amp.  
 2. Go to self-diagnosis [ATC-54, "FUNCTION CONFIRMATION PROCEDURE"](#) and perform self-diagnosis STEP-2. Confirm that code No. 20 is displayed.
- NG >> 1. Replace intake sensor.  
 2. Go to self-diagnosis [ATC-54, "FUNCTION CONFIRMATION PROCEDURE"](#) and perform self-diagnosis STEP-2. Confirm that code No. 20 is displayed.

## 4. CHECK CIRCUIT CONTINUITY BETWEEN INTAKE SENSOR AND DISPLAY AND A/C AUTO AMP.

- Turn ignition switch OFF.
- Disconnect display and A/C auto amp. connector.
- Check continuity between intake sensor harness connector M256 terminal 2 (R) and display and A/C auto amp. harness connector M31 terminal 20 (P/L).

**2 – 20 : Continuity should exist.**

- Check continuity between intake sensor harness connector M256 terminal 2 (R) and ground.

**2 – Ground : Continuity should not exist.**

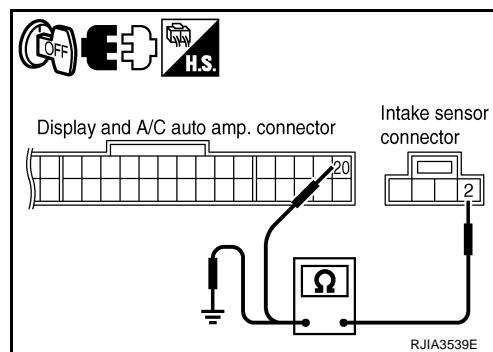

OK or NG

- OK >> 1. Replace display and A/C auto amp.  
 2. Go to self-diagnosis [ATC-54, "FUNCTION CONFIRMATION PROCEDURE"](#) and perform self-diagnosis STEP-2. Confirm that code No. 20 is displayed.
- NG >> Repair harness or connector.

## COMPONENT INSPECTION

### Intake Sensor

After disconnecting intake sensor connector M256, measure resistance between terminals 1 (W) and 2 (R) at sensor side, using the table below.

Temperature °C (°F)	Resistance kΩ
-15 (5)	12.34
-10 (14)	9.62
-5 (23)	7.56
0 (32)	6.00
5 (41)	4.80
10 (50)	3.87
15 (59)	3.15
20 (68)	2.57
25 (77)	2.12
30 (86)	1.76
35 (95)	1.47
40 (104)	1.23
45 (113)	1.04

If NG, replace intake sensor.

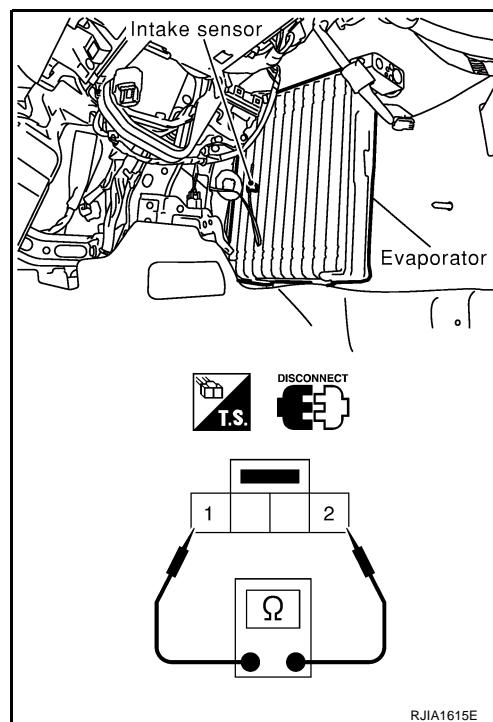

# TROUBLE DIAGNOSIS

## Multiplex Communication Circuit DIAGNOSTIC PROCEDURE FOR MULTIPLEX COMMUNICATION

AJS0012M

SYMPTOM: A/C system cannot be controlled.

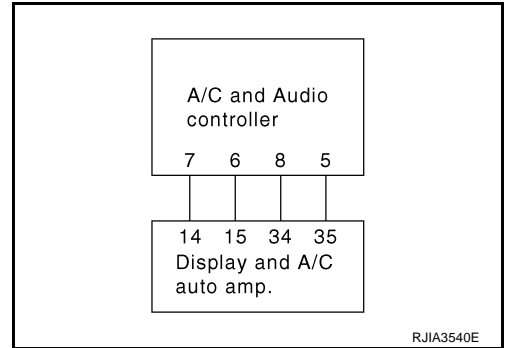

### 1. CHECK FOR DISPLAY AND A/C AUTO AMP. OUTPUT

1. Turn ignition switch ON.
2. Check multiplex communication signal between display and A/C auto amp. harness connector M31 terminals 15 (L/W), 35 (Y) and ground using an oscilloscope.

Terminals		(-)	Voltage
(+)	Terminal No. (wire color)		
Display and A/C auto amp. connector			
M31	15 (L/W)	Ground	<p style="text-align: right;">RJIA0212E</p>
M31	35 (Y)		<p style="text-align: right;">HAK0363D</p>

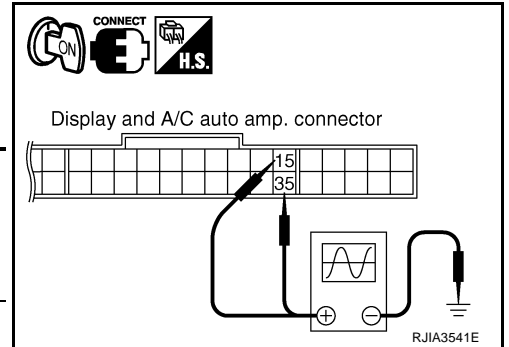

#### OK or NG

- OK >> GO TO 2.  
 NG >> Replace display and A/C auto amp.

A  
B  
C  
D  
E  
F  
G  
H  
I  
K  
L  
M

ATC

# TROUBLE DIAGNOSIS

## 2. CHECK CIRCUIT CONTINUITY BETWEEN A/C AND AUDIO CONTROLLER AND DISPLAY AND A/C AUTO AMP.

1. Turn ignition switch OFF.
2. Disconnect A/C and audio controller connector and display and A/C auto amp. connector.
3. Check continuity between A/C and audio controller harness connector M38 terminals 6 (L/W), 5 (Y) and display and A/C auto amp. harness connector M31 terminals 15 (L/W), 35 (Y).

**6 – 15** : Continuity should exist.  
**5 – 35** : Continuity should exist.

OK or NG

- OK >> GO TO 3.
- NG >> Repair harness or connector.

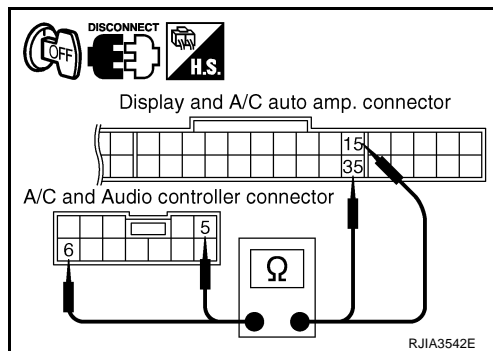

## 3. CHECK FOR DISPLAY AND A/C AUTO AMP. INPUT

1. Reconnect A/C and audio controller connector and display and A/C auto amp. connector.
2. Turn ignition switch ON.
3. Confirm multiplex communication signal between display and A/C auto amp. harness connector M31 terminal 14 (G) and ground using an oscilloscope.

Terminals		(-)	Voltage
(+)	Terminal No. (wire color)		
Display and A/C auto amp. connector	Terminal No. (wire color)	(-)	Voltage
M31	14 (G)	Ground	

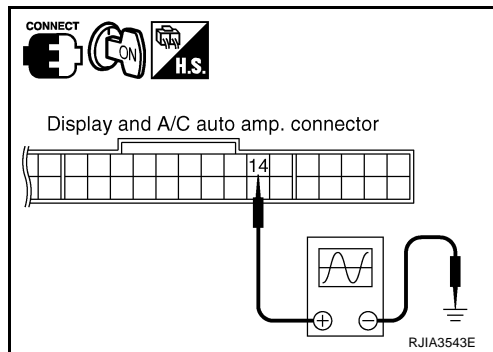

OK or NG

- OK >> Replace display and A/C auto amp.
- NG >> GO TO 4.

## 4. CHECK CIRCUIT CONTINUITY BETWEEN A/C AND AUDIO CONTROLLER AND DISPLAY AND A/C AUTO AMP.

1. Turn ignition switch OFF.
2. Disconnect A/C and audio controller connector and display and A/C auto amp. connector.
3. Check continuity between A/C and audio controller harness connector M38 terminal 7 (G) and display and A/C auto amp. harness connector M31 terminal 14 (G).

**7 – 14** : Continuity should exist.

OK or NG

- OK >> Replace A/C and audio controller.
- NG >> Repair harness or connector.

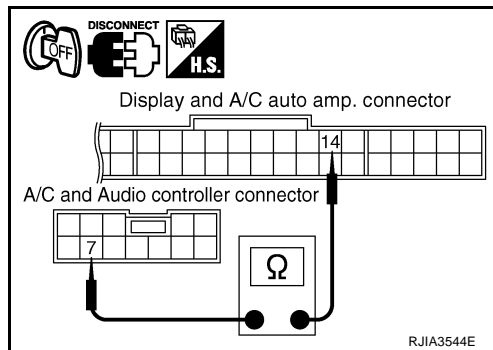

# A/C AND AUDIO CONTROLLER

---

## A/C AND AUDIO CONTROLLER

PFP:28074

### Removal and Installation

AJS0012N

#### REMOVAL

Refer to [AV-28. "Removal and Installation for A/C and Audio Controller"](#) .

#### INSTALLATION

Installation is basically the reverse order of removal.

A

B

C

D

E

F

G

H

I

ATC

K

L

M

# AUTO AMP

## AUTO AMP

PF2:27760

### Removal and Installation of Display and A/C Auto Amp.

AJS0012P

#### REMOVAL

1. Remove cluster lid finisher. Refer to [IP-11, "Removal and Installation"](#) .
2. Remove mounting screws, and then remove display and A/C auto amp.

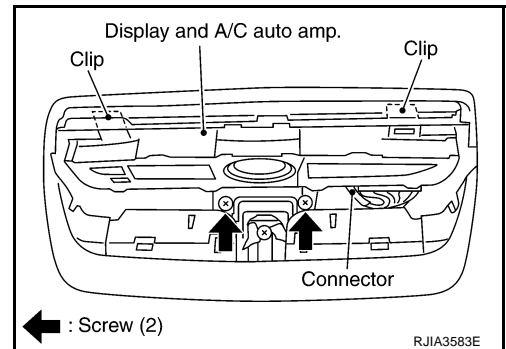

#### INSTALLATION

Installation is basically the reverse order of removal.



# AMBIENT SENSOR

## AMBIENT SENSOR

PFP:27722

### Removal and Installation

AJS0012R

#### REMOVAL

1. Remove front grille. Refer to [EI-20, "FRONT GRILLE"](#) .
2. Disconnect ambient sensor connector, and then remove ambient sensor.

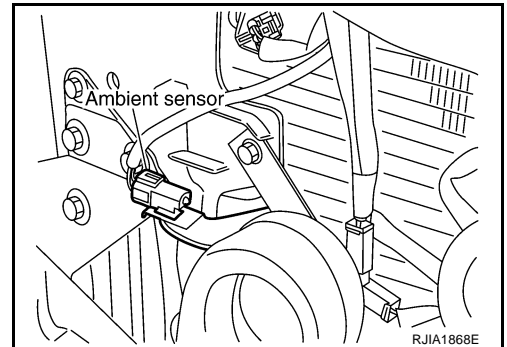

#### INSTALLATION

Installation is basically the reverse order of removal.

A

B

C

D

E

F

G

H

I

ATC

K

L

M

# IN-VEHICLE SENSOR

## IN-VEHICLE SENSOR

PFP:27720

### Removal and Installation

AJS0012S

#### REMOVAL

1. Remove instrument lower driver panel. Refer to [IP-11, "Removal and Installation"](#) .
2. Remove mounting screw, and then remove in-vehicle sensor.

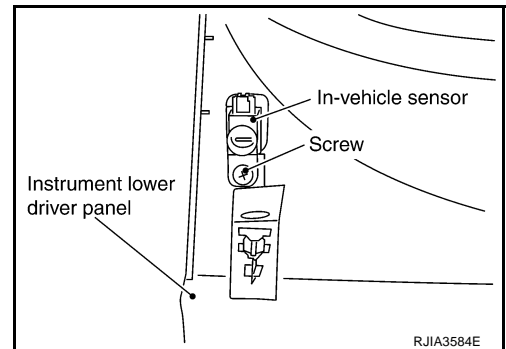

#### INSTALLATION

Installation is basically the reverse order of removal.

# SUNLOAD SENSOR

## SUNLOAD SENSOR

PFP:27721

### Removal and Installation

AJS0012T

#### REMOVAL

1. Remove front defroster grille (LH). Refer to [IP-11, "Removal and Installation"](#).
2. Disconnect sunload sensor connector, and then remove sunload sensor.

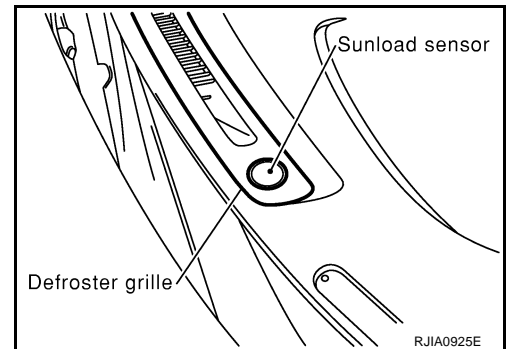

#### INSTALLATION

Installation is basically the reverse order of removal.

A  
B  
C  
D  
E  
F  
G  
H  
I  
K  
L  
M

ATC

# INTAKE SENSOR

## INTAKE SENSOR

PFP:27723

### Removal and Installation

AJS0012U

#### REMOVAL

1. Remove low-pressure pipe 2 and high-pressure pipe 2. Refer to [ATC-151, "Removal and Installation of Low-Pressure Pipe 2 and High-pressure Pipe 2"](#).

#### **CAUTION:**

**Cap or wrap the joint of the pipe with suitable material such as vinyl tape to avoid the entry of air.**

2. Slide evaporator to passenger side, and then remove intake sensor.

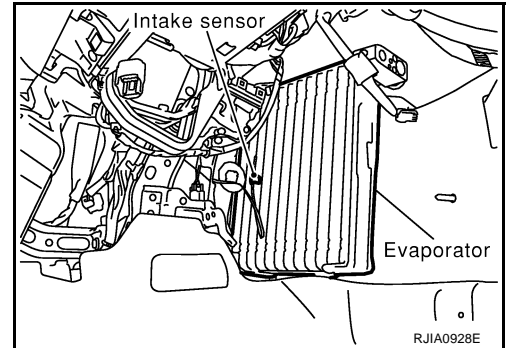

#### INSTALLATION

Installation is basically the reverse order of removal.

#### **CAUTION:**

- Replace O-rings for A/C piping with new one, then apply compressor oil to it when installing it.
- Connection point for female-side piping is thin. So, when inserting male-side piping, take care not to deform female-side piping. Slowly insert in axial direction.
- Insert one-touch joint connection point securely until it clicks.
- After piping has been connected, pull male-side piping by hand to make sure piping does not come off.
- When recharging refrigerant, check for leaks.

# BLOWER UNIT

## BLOWER UNIT

PPF:27200

### Removal and Installation

AJS0012V

#### REMOVAL

1. Remove glove box assembly and instrument lower cover. Refer to [IP-11, "Removal and Installation"](#).
2. Remove mounting nuts, and then remove ECM with bracket attached.
3. Remove mounting bolt and screws, and then remove blower unit.

#### **CAUTION:**

**Move blower unit rightward, and remove locating pin (1) and joint. Then remove blower unit downward.**

4. Disconnect intake door motor connector and blower fan motor connector.
5. Remove blower unit.

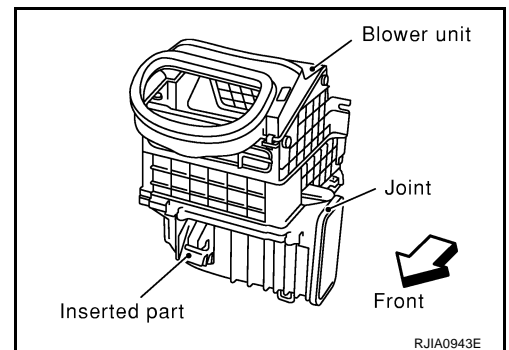
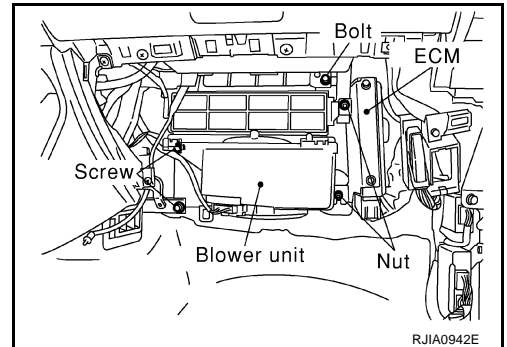

#### INSTALLATION

Installation is basically the reverse order of removal.

#### **CAUTION:**

**Make sure locating pin (1) and joint are securely inserted.**

A  
B  
C  
D  
E  
F  
G  
H  
I  
K  
L  
M

ATC

# BLOWER UNIT

## Disassembly and Assembly

AJS0012W

SEC. 270

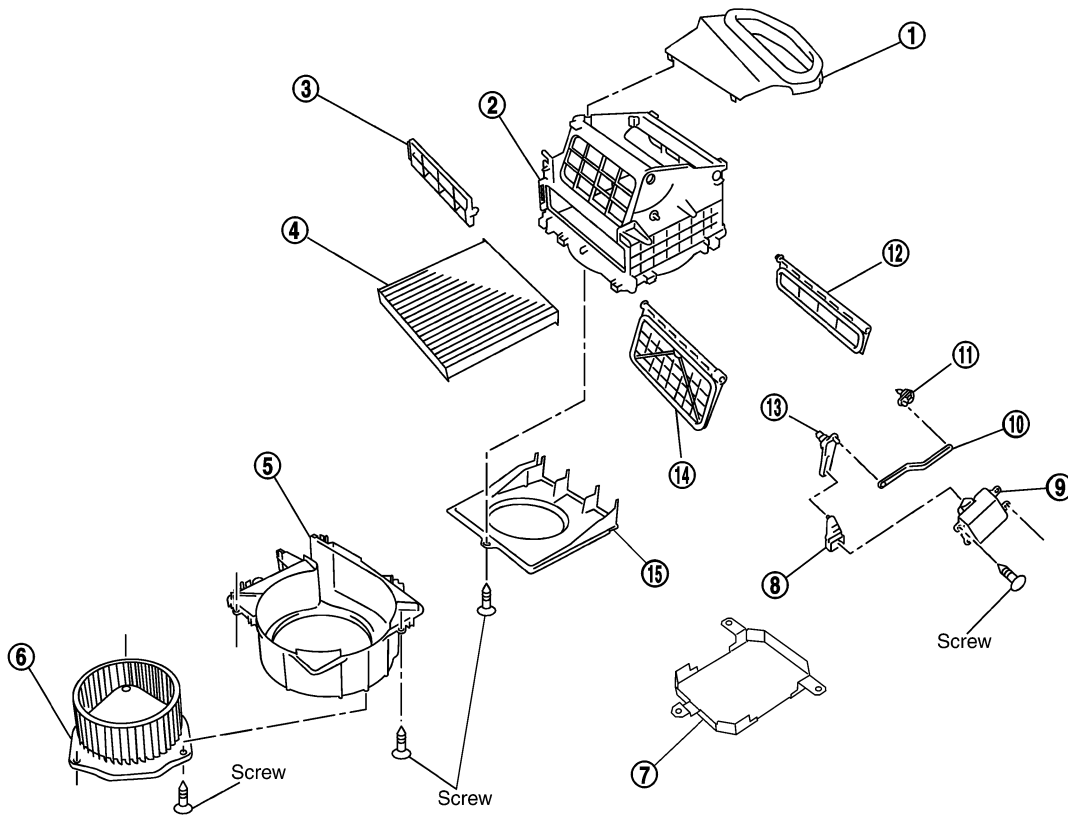

RJIA3585E

- |  |                         |                          |
|--|-------------------------|--------------------------|
| 1. Adapter                                   | 2. Intake upper case    | 3. Filter cover          |
| 4. In-cabin microfilter                      | 5. Intake lower case    | 6. Blower motor assembly |
| 7. Motor cover (with intelligent key system) | 8. Intake door lever 2  | 9. Intake door motor     |
| 10. Intake door link                         | 11. Intake door lever 3 | 12. Intake door 2        |
| 13. Intake door lever 1                      | 14. Intake door 1       | 15. Intake bell mouth    |

# BLOWER MOTOR

## BLOWER MOTOR

PFP:27226

### Removal and Installation

AJS0012X

#### REMOVAL

1. Remove instrument lower cover. Refer to [IP-11, "Removal and Installation"](#) .
2. Disconnect blower motor connector.
3. Remove mounting screws from blower motor, and then remove it.

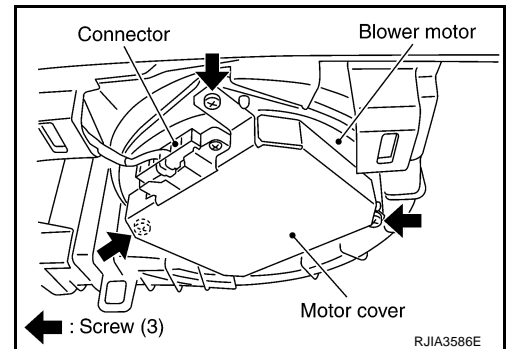

#### INSTALLATION

Installation is basically the reverse order of removal.

A  
B  
C  
D  
E  
F  
G  
H  
I  
K  
L  
M

ATC

# INTAKE DOOR MOTOR

## INTAKE DOOR MOTOR

PFP:27730

### Removal and Installation

AJS0012Y

#### REMOVAL

1. Remove blower unit. Refer to [ATC-125, "BLOWER UNIT"](#) .
2. Remove mounting screws, and then remove intake door motor from blower unit.

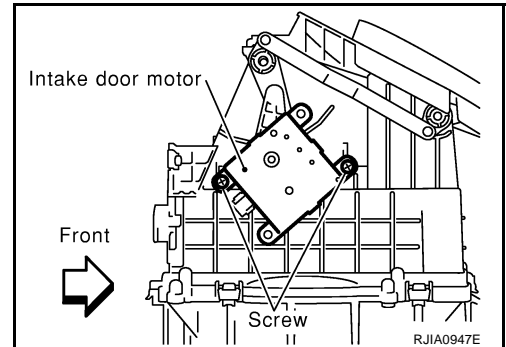

#### INSTALLATION

Installation is basically the reverse order of removal.



# IN-CABIN MICROFILTER

## IN-CABIN MICROFILTER

PFP:27277

### Removal and Installation FUNCTION

AJS0012Z

Air inside passenger compartment is kept clean at either recirculation or fresh mode by installing in-cabin microfilter into blower unit.

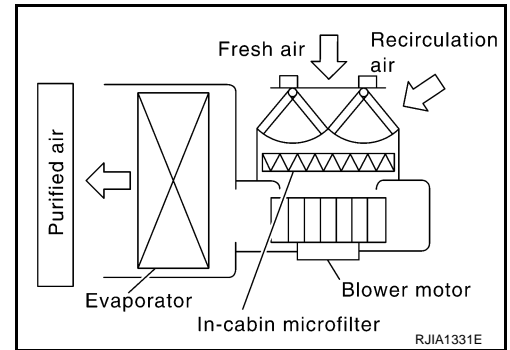

### REPLACEMENT TIMING

Replace in-cabin microfilter.

Refer to [MA-8, "CHASSIS AND BODY MAINTENANCE"](#) in SCHEDULE 1 and [MA-9, "CHASSIS AND BODY MAINTENANCE"](#) in SCHEDULE 2.

Caution label is fixed inside glove box.

### REPLACEMENT PROCEDURES

1. Remove glove box assembly. Refer to [IP-11, "Removal and Installation"](#).
2. Remove filter cover, and then remove in-cabin microfilter.
3. Take out in-cabin microfilter from blower unit.
4. Replace with new one and reinstall on blower unit.
5. Reinstall instrument lower passenger panel.

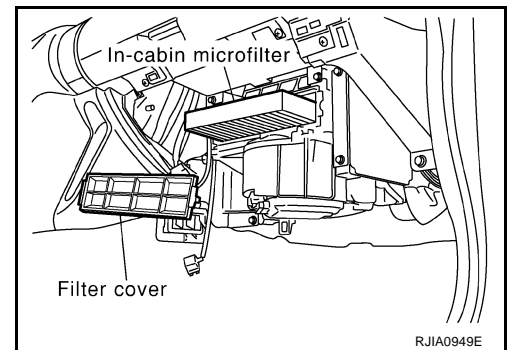

A  
B  
C  
D  
E  
F  
G  
H  
I  
ATC  
K  
L  
M

# HEATER & COOLING UNIT ASSEMBLY

## HEATER & COOLING UNIT ASSEMBLY

PFP:27110

### Removal and Installation REMOVAL

AJS00130

1. Use a refrigerant collecting equipment (for HFC-134a) to discharge refrigerant.
2. Drain coolant from cooling system. Refer to [CO-10, "Changing Engine Coolant"](#) .
3. Remove cowl top cover. Refer to [EI-21, "COWL TOP"](#) .
4. Disconnect low-pressure flexible hose and high-pressure pipe from evaporator.

- a. Set a disconnecter (High-pressure side: 92530-89908, Low-pressure side: 92530-89916) on A/C piping.
- b. Slide a disconnecter toward vehicle front until it clicks.
- c. Slide A/C piping toward vehicle front and disconnect it.

#### **CAUTION:**

**Cap or wrap the joint of the pipe with suitable material such as vinyl tape to avoid the entry of air.**

5. Remove air hose and electronic control throttle assembly.
6. Disconnect two heater hoses from heater core.

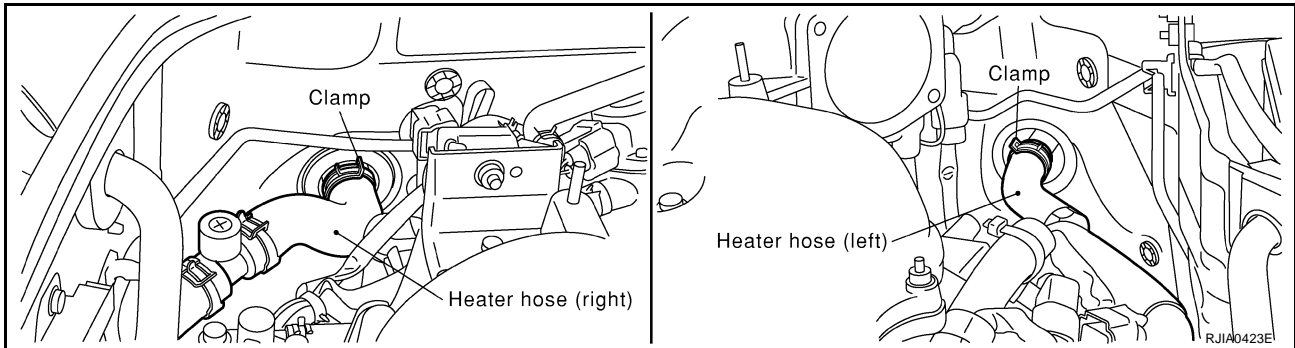
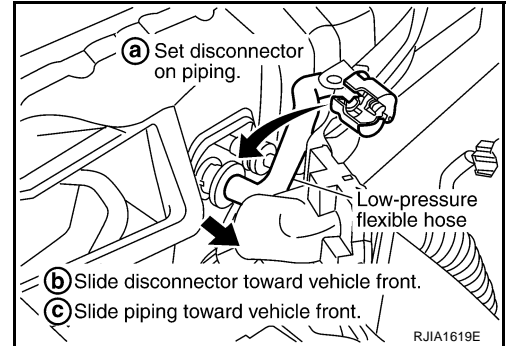

7. Remove instrument panel assembly. Refer to [IP-11, "Removal and Installation"](#) .
8. Remove blower unit. Refer to [ATC-125, "BLOWER UNIT"](#) .
9. Remove clips of vehicle harness from steering member.
10. Remove mounting nuts and bolts, and then remove instrument stays (driver side and passenger side).

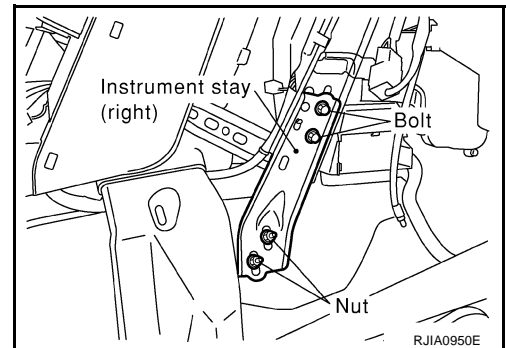

11. Remove mounting bolts from heater & cooling unit.

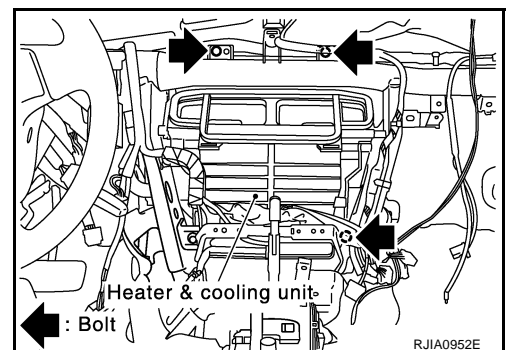

# HEATER & COOLING UNIT ASSEMBLY

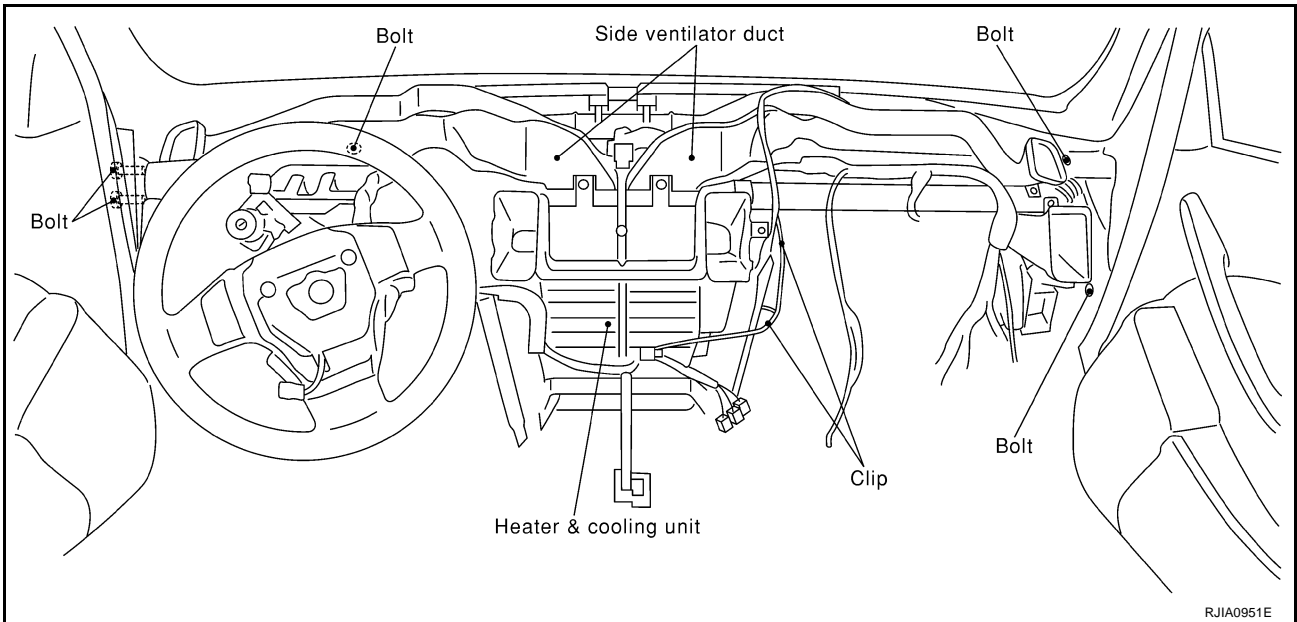

12. Disconnect drain hose.
13. Remove defroster nozzle and ventilator ducts.
14. Remove steering member, and then remove heater & cooling unit.

## INSTALLATION

Installation is basically the reverse order of removal.

### CAUTION:

- Replace O-rings for A/C piping with new one, then apply compressor oil to it when installing it.
- Connection point for female-side piping is thin. So, when inserting male-side piping, take care not to deform female-side piping. Slowly insert in axial direction.
- Insert one-touch joint connection point securely until it clicks.
- After piping has been connected, pull male-side piping by hand to make sure piping does not come off.
- When recharging refrigerant, check for leaks.

### NOTE:

- When filling radiator with coolant, refer to [CO-10, "Changing Engine Coolant"](#).
- Recharge the refrigerant.

#### Heater & cooling unit mounting bolt

Tightening torque : 6.9 N·m (0.7 kg·m, 61 in·lb)

#### Steering member mounting nut and bolt

Tightening torque : 12 N·m (1.25 kg·m, 9 ft·lb)

A  
B  
C  
D  
E  
F

G

H

I

ATC

K

L

M

# HEATER & COOLING UNIT ASSEMBLY

## Disassembly and Assembly

AJS00131

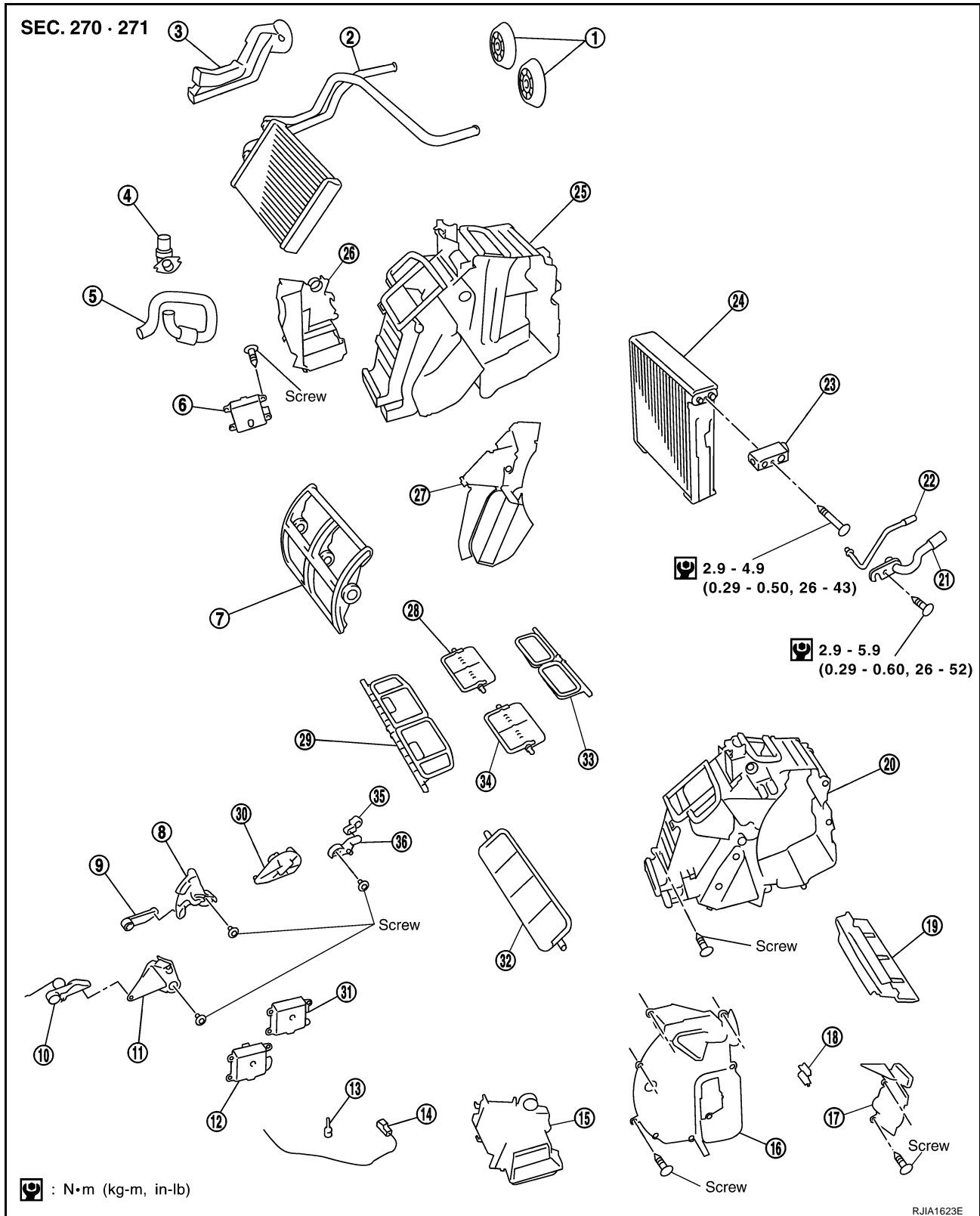

- |                              |                              |   |
|------------------------------|------------------------------|---|
| 1. Heater pipe grommet       | 2. Heater core               | 3. Heater pipe cover                    |
| 4. Aspirator                 | 5. Aspirator hose            | 6. Air mix door motor (driver side)*    |
| 7. Air mix door (Slide door) | 8. Max. cool door link       | 9. Max. cool door lever                 |
| 10. Ventilator door lever    | 11. Ventilator door link     | 12. Air mix door motor (passenger side) |
| 13. Intake sensor bracket    | 14. Intake sensor            | 15. Foot duct (right)                   |
| 16. Evaporator cover         | 17. Evaporator cover adapter | 18. Heater pipe bracket                 |

# HEATER & COOLING UNIT ASSEMBLY

---

19. Insulator	20. Heater case (right)	21. Low-pressure pipe 2	A
22. High-pressure pipe 2	23. Expansion valve	24. Evaporator	
25. Heater case (left)	26. Foot duct (left)	27. Center case*	
28. Max. cool door (left)*	29. Ventilator door	30. Side link	B
31. Mode door motor	32. Max. cool door (Without left and right ventilation temperature separately control system)	33. Defroster door	
34. Max. cool door (right)*	35. Defroster door lever	36. Defroster door link	C

\*: With left and right ventilation temperature separately control system.

D

E

F

G

H

I

**ATC**

K

L

M

# MODE DOOR MOTOR

## MODE DOOR MOTOR

PFP:27731

### Removal and Installation

AJS00132

#### REMOVAL

1. Remove blower unit. Refer to [ATC-125, "BLOWER UNIT"](#) .
2. Remove mounting screws from mode door motor.
3. Disconnect mode door connector.
4. Remove mode door motor.

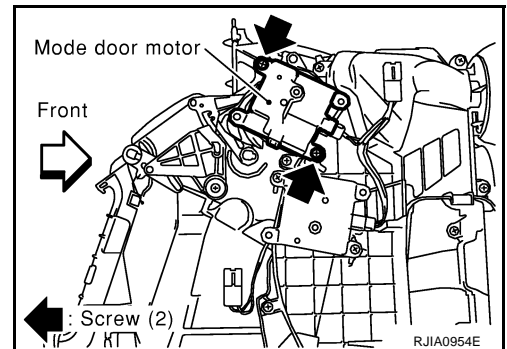

#### INSTALLATION

Installation is basically the reverse order of removal.

# AIR MIX DOOR MOTOR

## AIR MIX DOOR MOTOR

PFP:27732

### Removal and Installation

AJS00133

#### REMOVAL

##### Passenger Side

1. Set the temperature (passenger side) at 18°C (60°F), and then disconnect the battery cable from the negative terminal.
2. Remove blower unit. Refer to [ATC-125, "BLOWER UNIT"](#) .
3. Remove air mix door motor mounting screw.
4. Disconnect air mix door motor connector.
5. Remove air mix door motor.

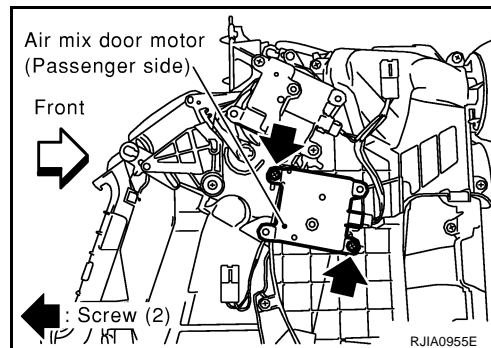

##### Driver Side (If Equipped)

1. Set the temperature (driver side) at 18°C (60°F), and then disconnect the battery cable from the negative terminal.
2. Remove instrument lower driver panel. Refer to [IP-11, "Removal and Installation"](#) .
3. Disconnect throttle sensor connector.
4. Remove air mix door motor mounting screw.
5. Disconnect air mix door motor connector.
6. Remove air mix door motor.

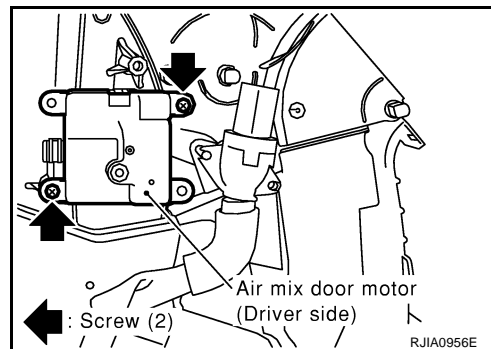

#### INSTALLATION

Installation is basically the reverse order of removal.

A  
B  
C  
D  
E  
F  
G  
H  
I  
K  
L  
M

ATC

# DUCTS AND GRILLES

## DUCTS AND GRILLES

PFP:27860

### Removal and Installation REMOVAL

AJS00134

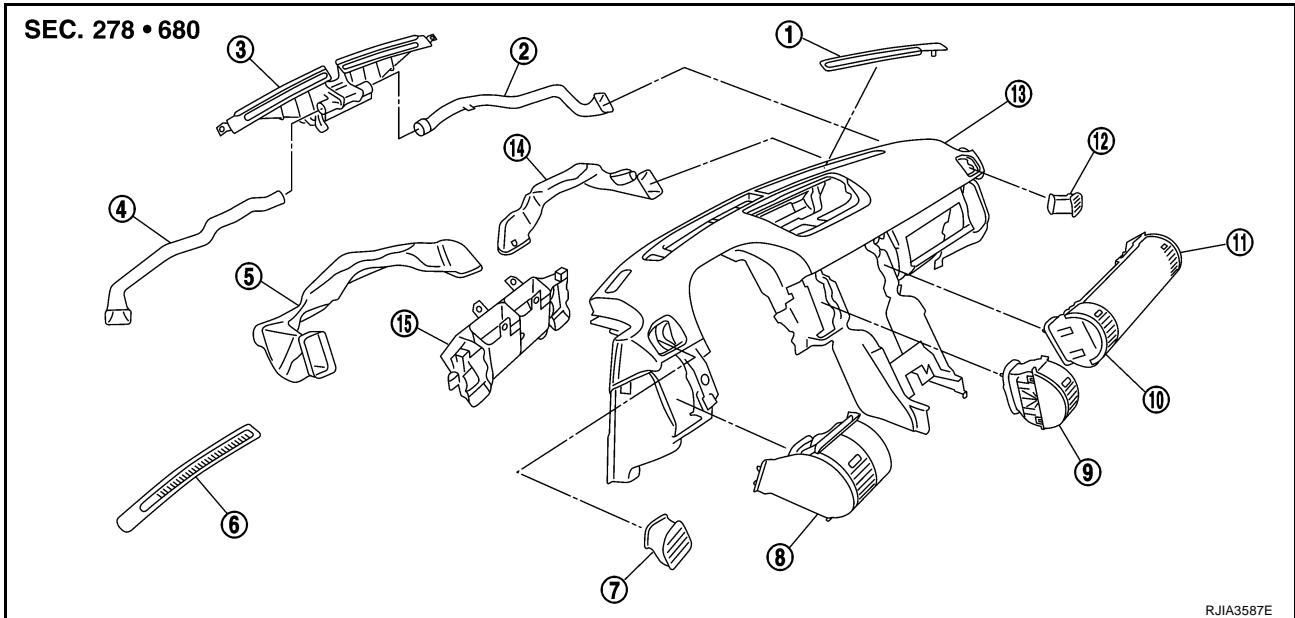

- |                                      |                                    |                                    |
|--------------------------------------|------------------------------------|------------------------------------|
| 1. Defroster grille (right)          | 2. Side defroster duct (right)     | 3. Defroster nozzle                |
| 4. Side defroster duct (left)        | 5. Side ventilator duct (left)     | 6. Defroster grille (left)         |
| 7. Side defroster grille (left)      | 8. Side ventilator grille (left)   | 9. Center ventilator grille (left) |
| 10. Center ventilator grille (right) | 11. Side ventilator grille (right) | 12. Side defroster grille (right)  |
| 13. Instrument panel                 | 14. Side ventilator duct (right)   | 15. Center ventilator duct         |

### Removal of Center Ventilator Grille

1. Remove instrument lower driver panel. Refer to [IP-11, "Removal and Installation"](#) .
2. Remove center ventilator grill (left).
3. Remove center box assembly. Refer to [IP-11, "Removal and Installation"](#) .

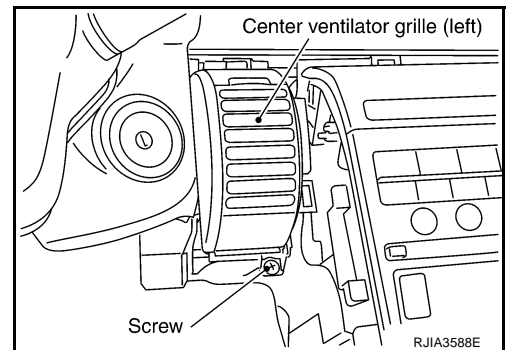

4. Remove center ventilator grille (right).

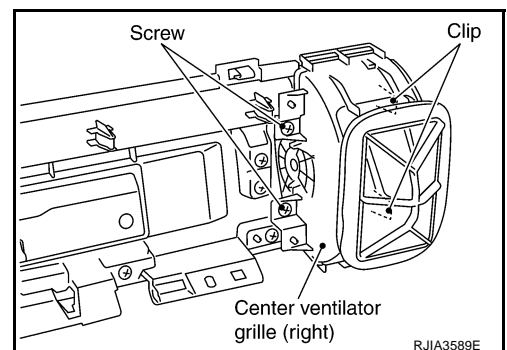



# DUCTS AND GRILLES

## Removal of Side Ventilator Grille

1. Remove center box assembly. Refer to [IP-11, "Removal and Installation"](#) .
2. Remove mounting screw and clips, and then remove side ventilator grille (right).
3. Remove instrument lower driver panel. Refer to [IP-11, "Removal and Installation"](#) .
4. Remove side ventilator grille (left).

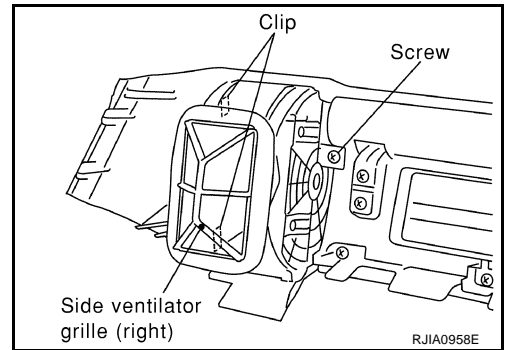

## Removal of Rear Ventilator Grille

1. Remove center console. Refer to [IP-11, "Removal and Installation"](#) .
2. Remove mounting metal clips, and then remove rear ventilator grille.

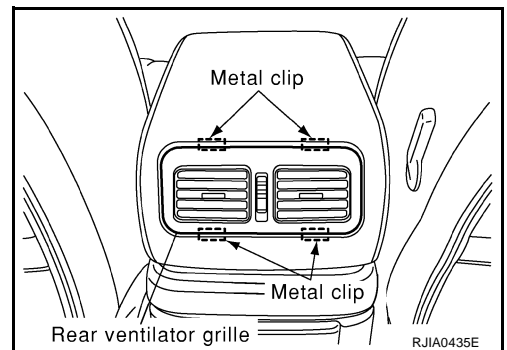

## Removal of Defroster Nozzle, Ducts and Ventilator Ducts

1. Remove instrument panel assembly. Refer to [IP-11, "Removal and Installation"](#) .
2. Remove mounting screws and then remove side defroster ducts.

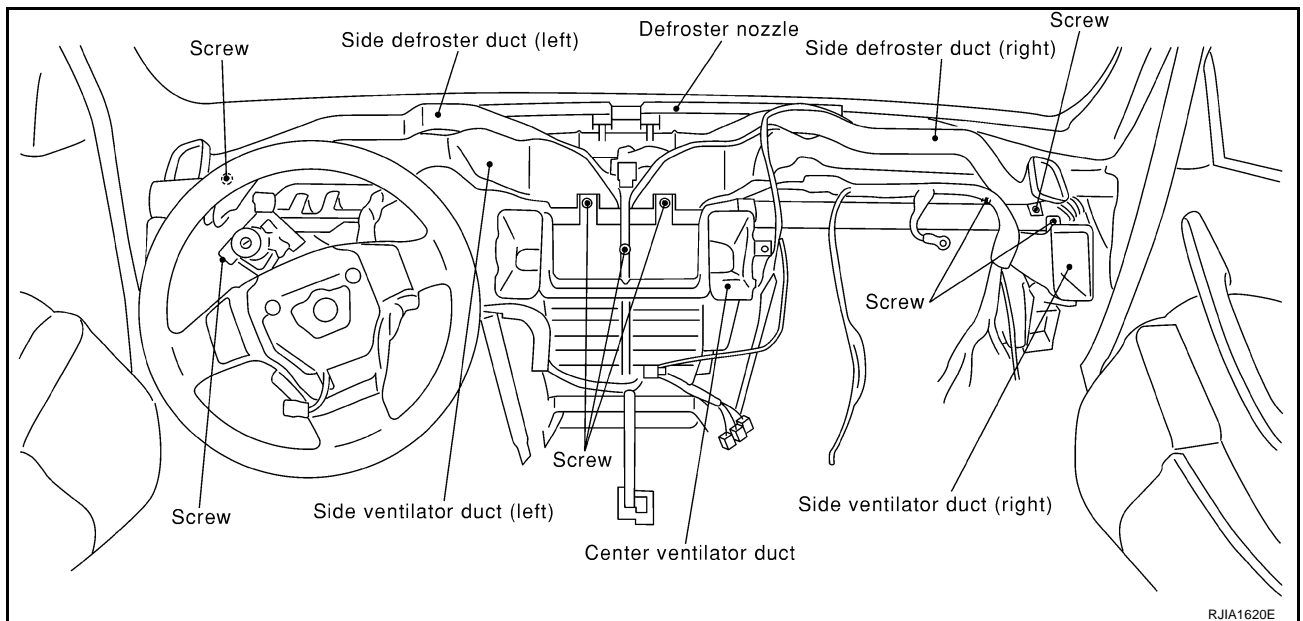

3. Remove defroster nozzle.
4. Remove mounting screws, and then remove center ventilator duct.
5. Remove steering member, and then remove side ventilator ducts.

# DUCTS AND GRILLES

## Removal of Side Defroster Grille

Remove mounting clip, and then remove side defroster grilles.

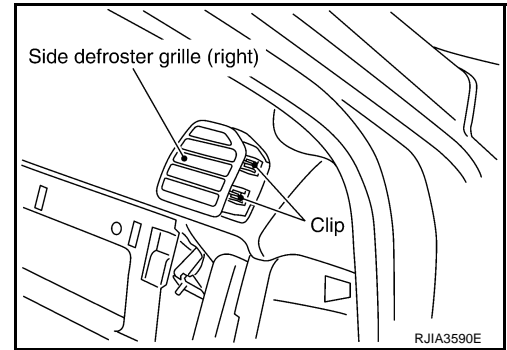

## Removal of Rear Ventilator Ducts

1. Remove center console, and then remove rear ventilator duct 2. Refer to [IP-11, "Removal and Installation"](#).
2. Remove instrument panel and pad. Refer to [IP-11, "Removal and Installation"](#).
3. Remove rear ventilator duct 1.

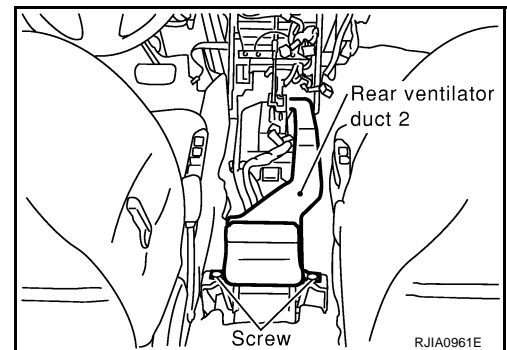

## Removal of Foot Ducts

1. Remove heater & cooling unit. Refer to [ATC-130, "HEATER & COOLING UNIT ASSEMBLY"](#).
2. Remove evaporator cover, and then remove foot duct (passenger side).
3. Remove foot duct (driver side).

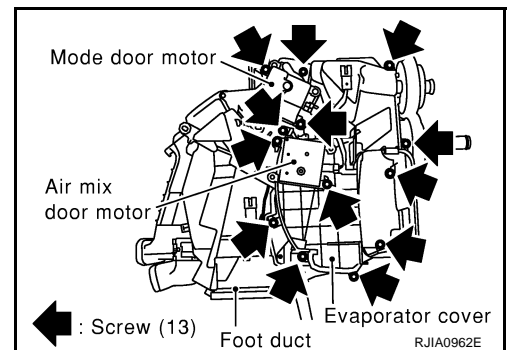

## Removal of Floor Ducts

1. Remove front seats and center console. Refer to [SE-90, "FRONT SEAT"](#) and [IP-11, "Removal and Installation"](#).
2. Peel back floor trim to a point where floor duct is visible.
3. Remove mounting clip, and then remove floor ducts.

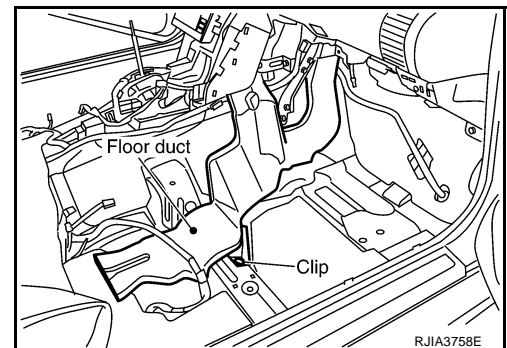

# DUCTS AND GRILLES

4. Remove instrument panel assembly. Refer to [IP-11, "Removal and Installation"](#).
5. Remove front floor duct.

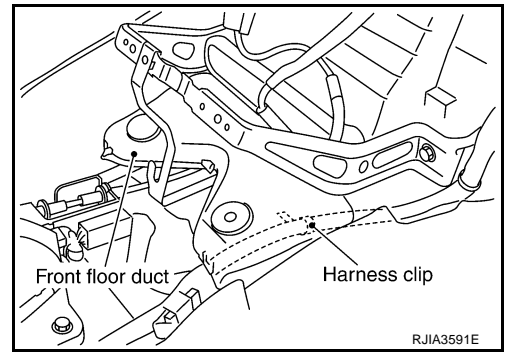

## INSTALLATION

Installation is basically the reverse order of removal.

A  
B  
C  
D  
E  
F  
G  
H  
I  
K  
L  
M

ATC

# REFRIGERANT LINES

## REFRIGERANT LINES

PFP:92600

### HFC-134a (R-134a) Service Procedure SETTING OF SERVICE TOOLS AND EQUIPMENT

AJS00135

#### Discharging Refrigerant

**WARNING:**

Avoid breathing A/C refrigerant and lubricant vapor or mist. Exposure may irritate eyes, nose and throat. Remove HFC-134a (R-134a) from A/C system using certified service equipment meeting requirements of SAE J-2210 [HFC-134a (R-134a) recycling equipment] or J-2209 [HFC-134a (R-134a) recovery equipment]. If accidental system discharge occurs, ventilate work area before resuming service. Additional health and safety information may be obtained from refrigerant and lubricant manufacturers.

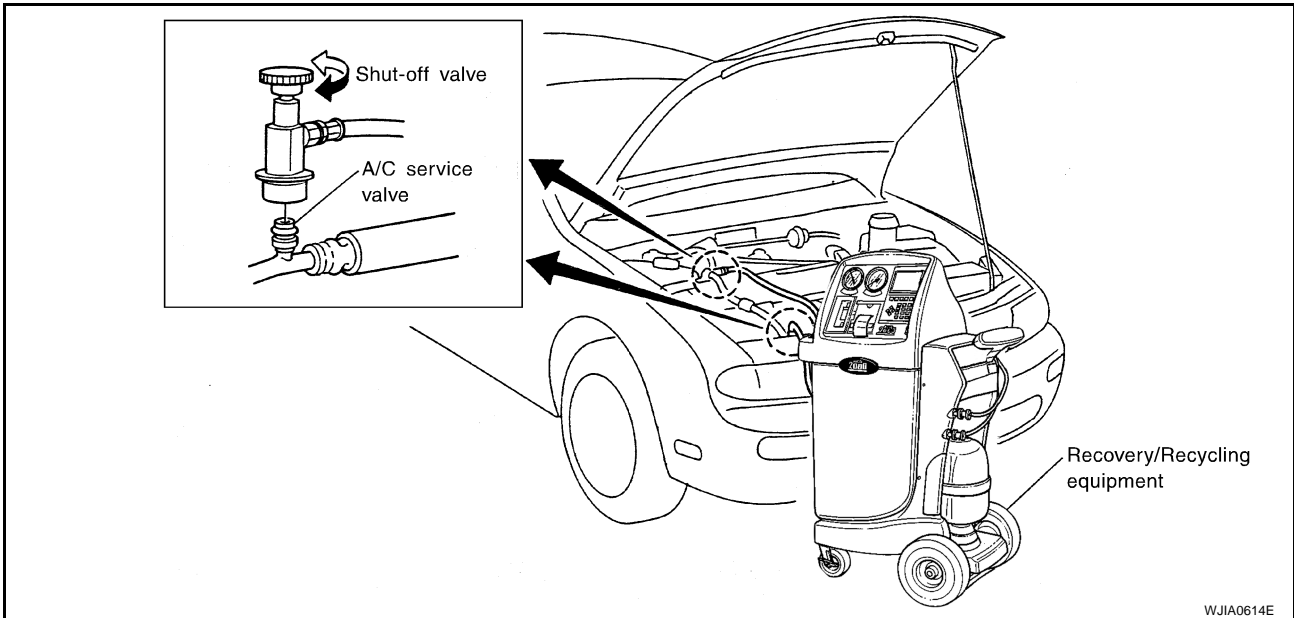

#### Evacuating System and Charging Refrigerant

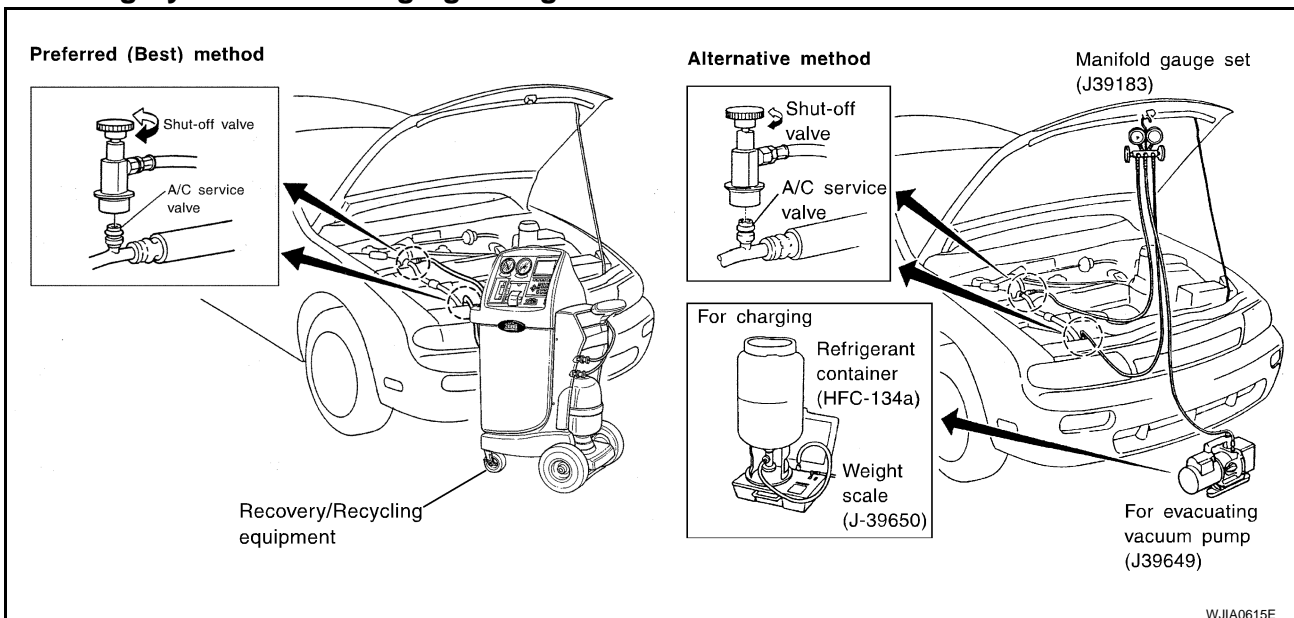

# REFRIGERANT LINES

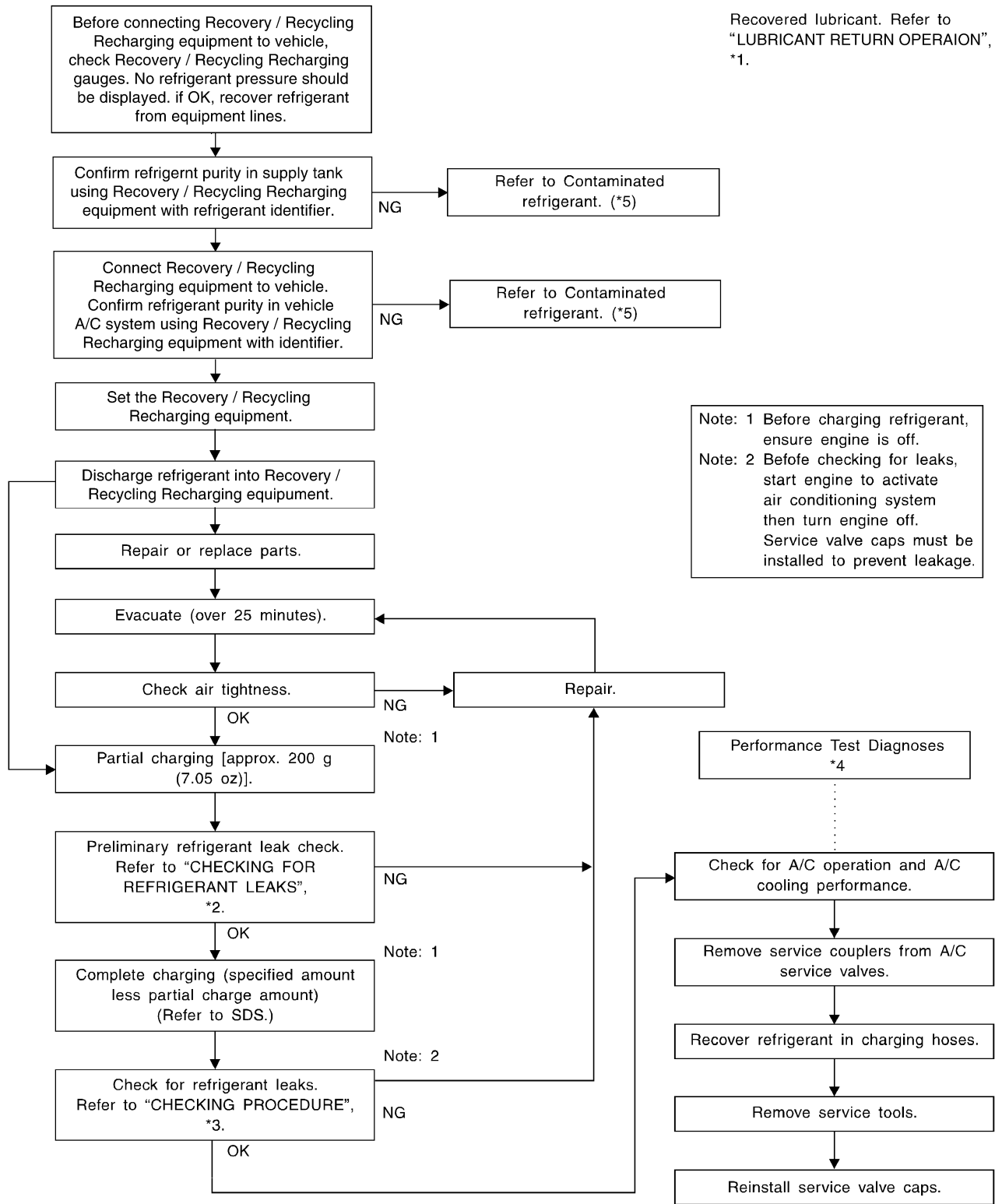

\*1 [ATC-26, "LUBRICANT RETURN OPERATION"](#)

\*2 [ATC-158, "Checking for Refrigerant Leaks"](#)

\*3 [ATC-160, "CHECKING PROCEDURE"](#)

\*4 [ATC-95, "PERFORMANCE TEST DIAGNOSIS"](#)

\*5 [ATC-6, "CONTAMINATED REFRIGERANT"](#)

RJIA3006E

A  
B  
C  
D  
E  
F  
G  
H  
I  
K  
L  
M

ATC

# REFRIGERANT LINES

AJS00136

## Components

Refer to [ATC-7, "Precautions for Refrigerant Connection"](#).

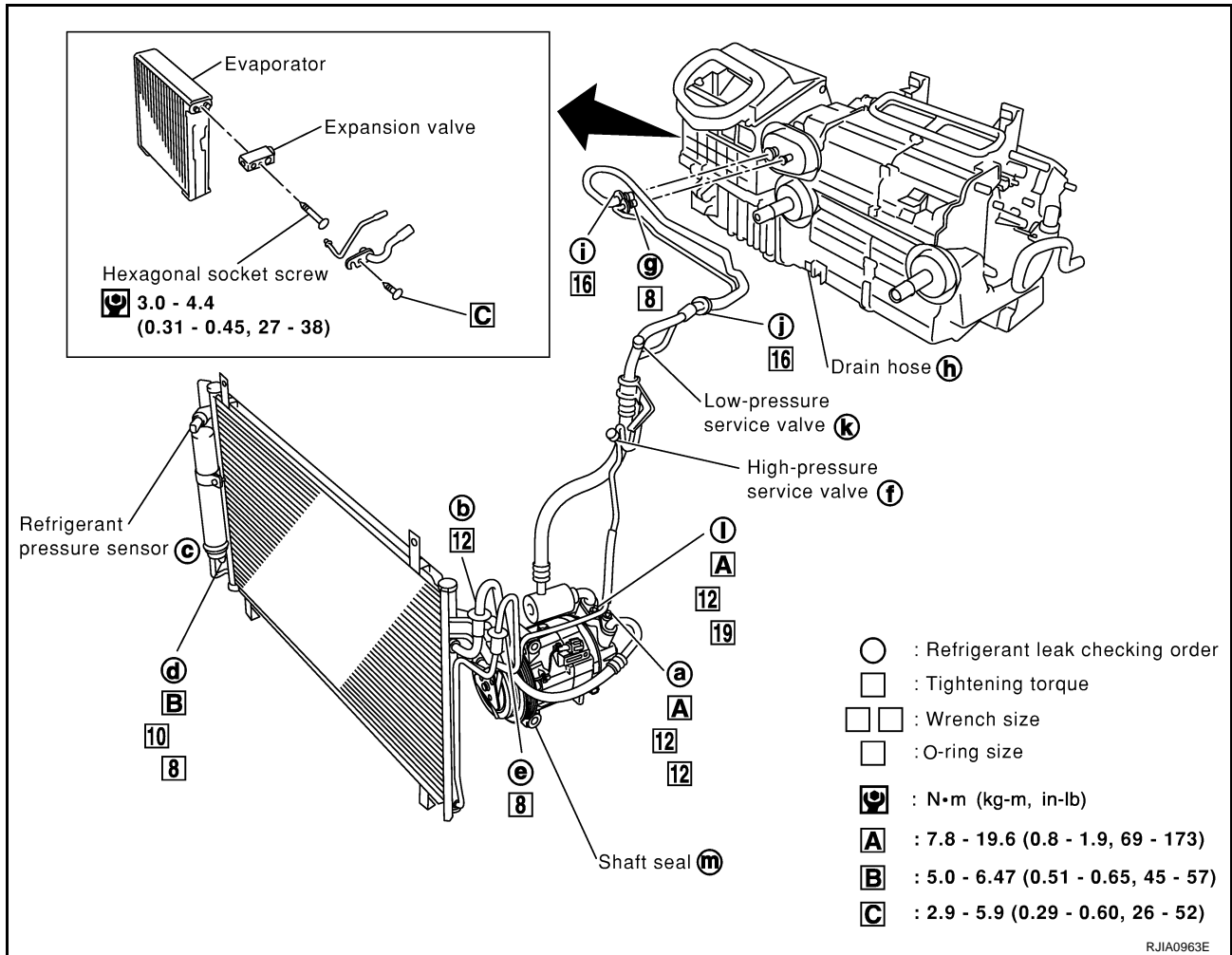

## Removal and Installation of Compressor

### REMOVAL

AJS0010Z

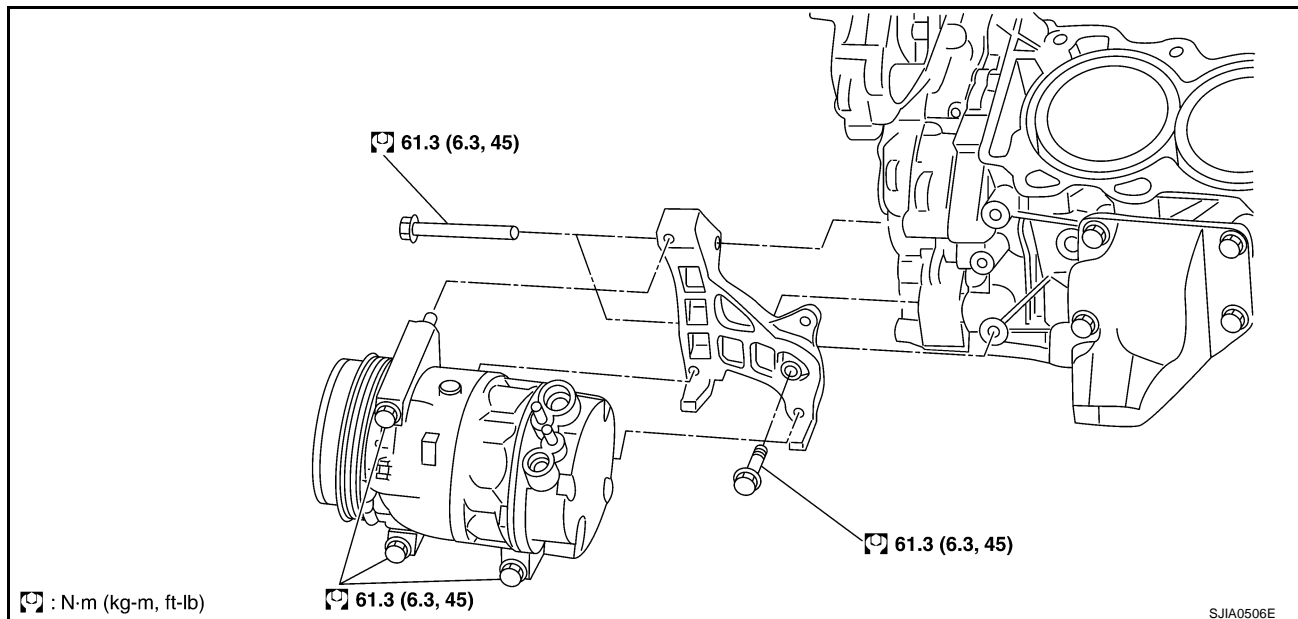

# REFRIGERANT LINES

## 2WD Models

1. Use a refrigerant collecting equipment (for HFC-134a) to discharge the refrigerant.
2. Remove engine cover. Refer to [EM-19, "INTAKE MANIFOLD COLLECTOR"](#) .
3. Remove air duct, air cleaner assembly and air hose. Refer to [EM-17, "AIR CLEANER AND AIR DUCT"](#) .
4. Remove engine under cover, using power tools.

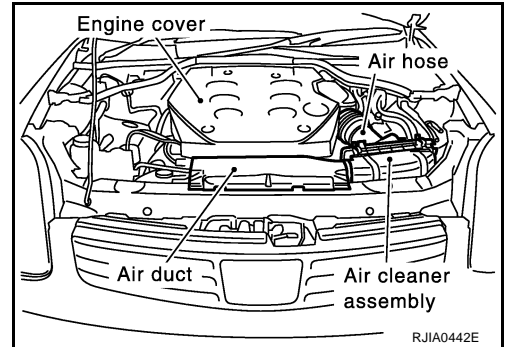

5. Remove mounting nuts from low-pressure and high-pressure flexible hose.

**CAUTION:**

**Cap or wrap the joint of the pipe with suitable material such as vinyl tape to avoid the entry of air.**

6. Disconnect compressor (magnet clutch) connector.
7. Remove A/C compressor belt. Refer to [EM-14, "DRIVE BELTS"](#)

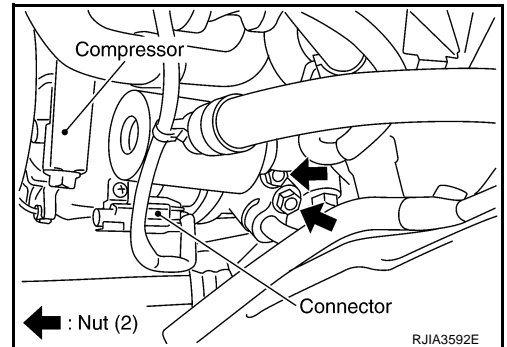

8. Disconnect compressor (ECV) connector.
9. Remove mounting bolts from compressor, using power tools.
10. Remove compressor downward of the vehicle.

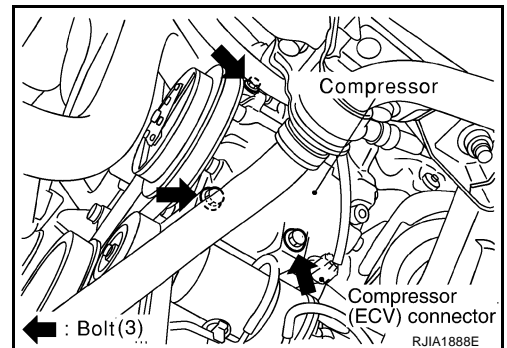

## AWD Models

1. Use a refrigerant collecting equipment (for HFC-134a) to discharge the refrigerant.
2. Remove engine cover. Refer to [EM-19, "INTAKE MANIFOLD COLLECTOR"](#) .
3. Remove duct, air cleaner assembly, air cleaner assembly and air hose. Refer to [EM-17, "AIR CLEANER AND AIR DUCT"](#) .
4. Remove engine under cover, using power tools.
5. Remove dumper.

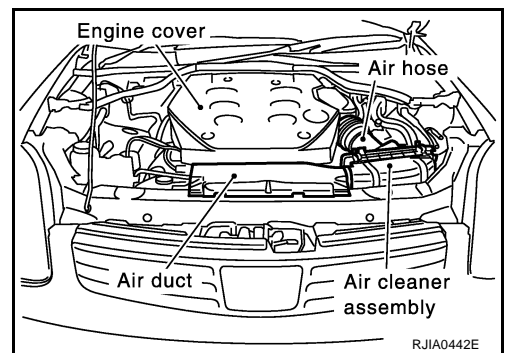



# REFRIGERANT LINES

6. Remove high-pressure flexible hose. Refer to [ATC-148, "Removal and Installation of High-Pressure Flexible Hose"](#).
7. Remove low-pressure flexible hose. Refer to [ATC-147, "Removal and Installation of Low-pressure Flexible Hose"](#).
8. Remove high-pressure pipe 1. Refer to [ATC-150, "Removal and Installation of High-Pressure Pipe 1 \(Engine Compartment\)"](#).
9. Disconnect compressor (magnet clutch) connector.
10. Remove A/C compressor belt. Refer to [EM-14, "DRIVE BELTS"](#).

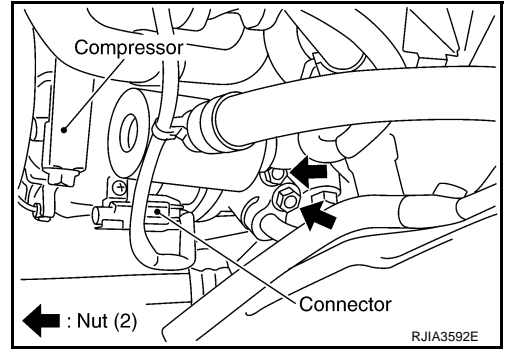

11. Disconnect compressor (ECV) connector.
12. Remove mounting bolts from compressor, using power tools.
13. Remove compressor from upward of the vehicle.

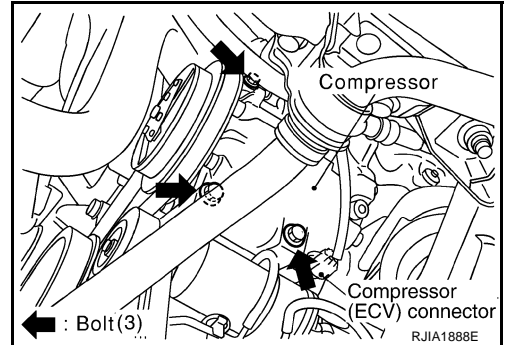

## INSTALLATION

Installation is basically the reverse order of removal.

### CAUTION:

- Replace O-ring of low-pressure flexible hose and high-pressure flexible hose with a new one, then apply compressor oil to it when installing it.
- When recharging refrigerant, check for leaks.

## Removal and Installation of Compressor Clutch

### REMOVAL

#### Overhaul

1. When removing center bolt, hold clutch disc with a wrench.

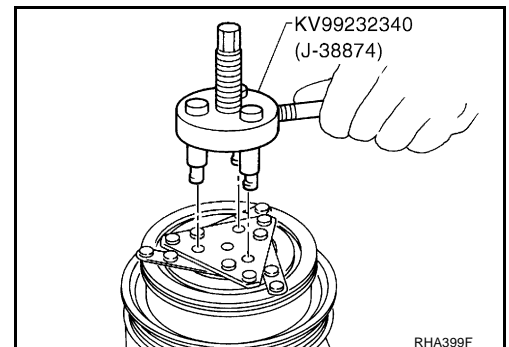
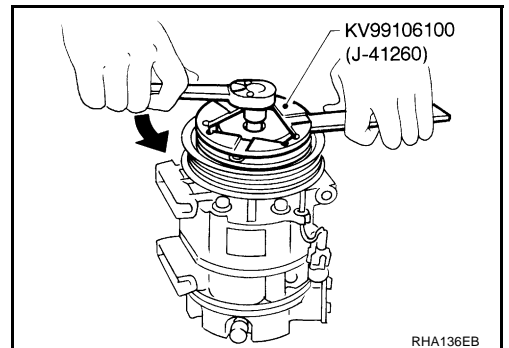



## REFRIGERANT LINES

2. Remove clutch disc using clutch disc puller.

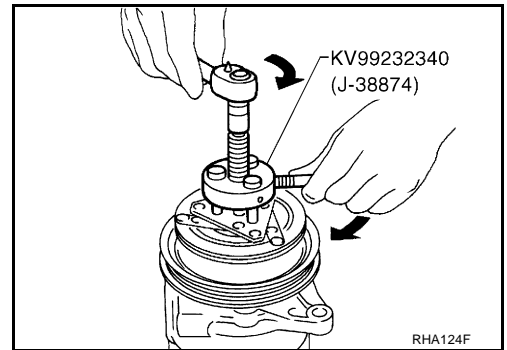

A  
B  
C  
D

3. Remove snap ring using external snap ring pliers.

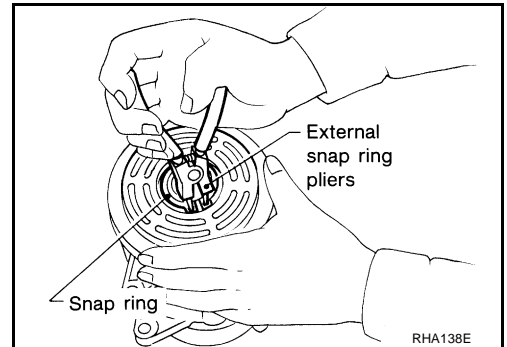

E  
F  
G

4. Position center pulley puller on the end of the driveshaft, and remove pulley assembly using any commercially available pulley puller.  
To prevent pulley groove from being deformed, puller claws should be positioned into edge of pulley assembly.

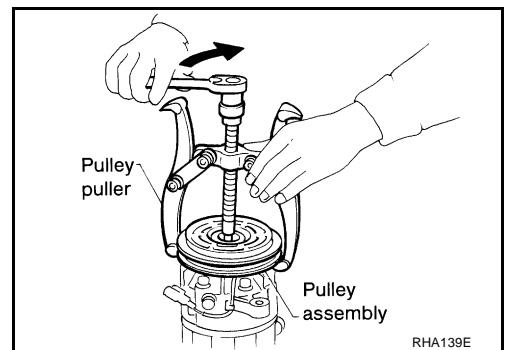

H  
I

ATC

5. Remove field coil harness clip using a pair of pliers.

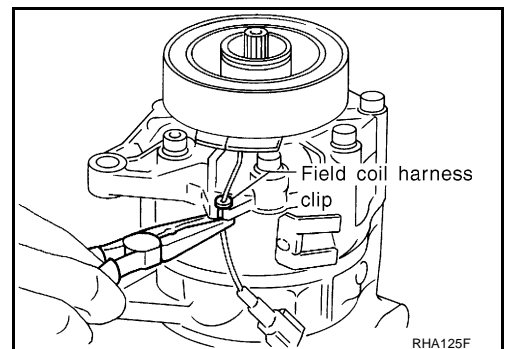

K  
L  
M

6. Remove snap ring using external snap ring pliers.

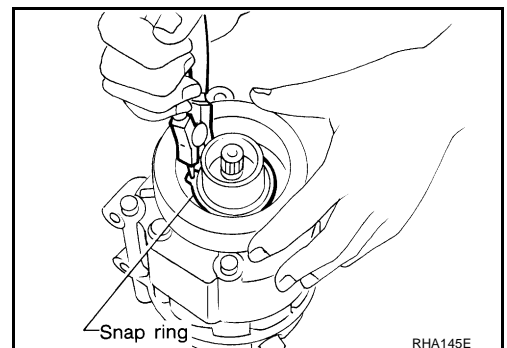

# REFRIGERANT LINES

## Inspection

### Clutch disc

If contact surface shows signs of damage due to excessive heat, replace clutch disc and pulley.

### Pulley

Check appearance of pulley assembly. If contact surface of pulley shows signs of excessive grooving, replace clutch disc and pulley. Contact surfaces of pulley assembly should be cleaned with a suitable solvent before reinstallation.

### Coil

Check coil for loose connection or cracked insulation.

## INSTALLATION

1. Install field coil.  
Be sure to align coil's pin with the hole in the compressor's front head.
2. Install field coil harness clip using a screwdriver.

3. Install pulley assembly using installer and a hand press, and then install snap ring using snap ring pliers.

4. Install clutch disc on driveshaft, together with original shim(s). Press clutch disc down by hand.

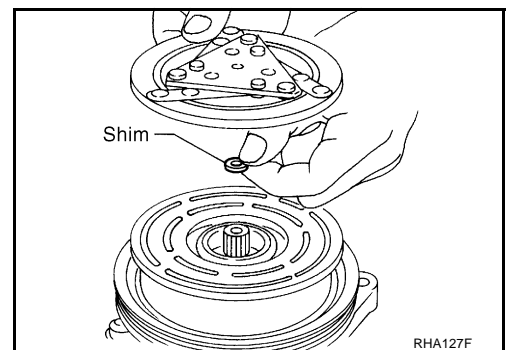
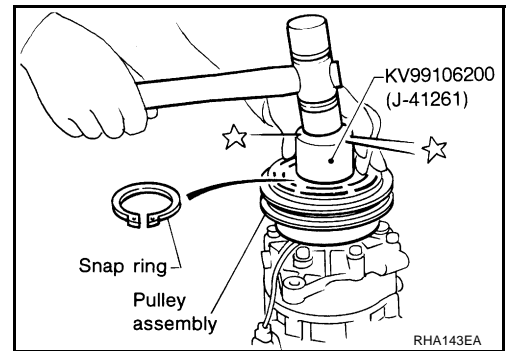
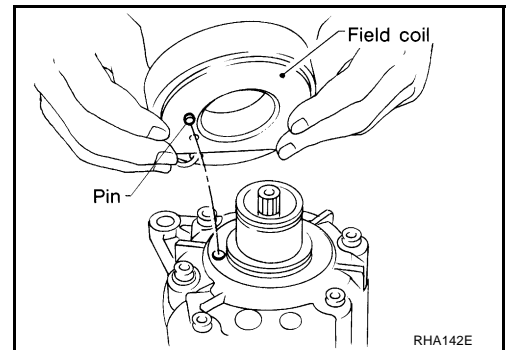
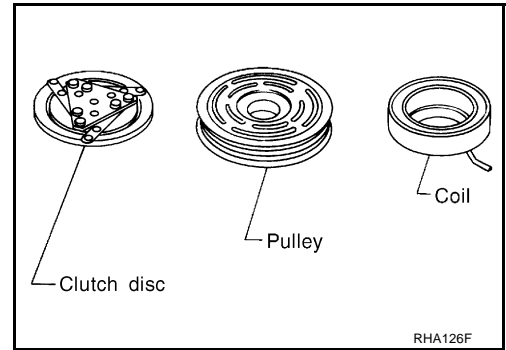

# REFRIGERANT LINES

5. Using holder to prevent clutch disc rotation.

**Tightening torque : 14 N·m (1.4 kg·m, 10 ft·lb)**

After tightening bolt, make sure pulley rotates smoothly.

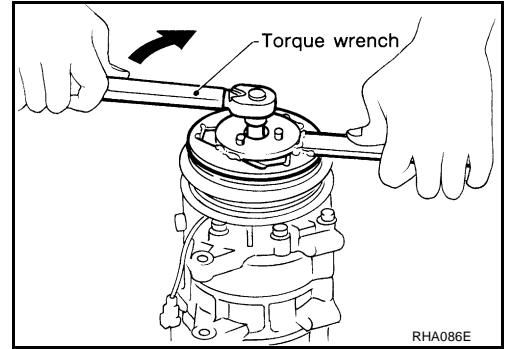

6. Check clearance around entire periphery of clutch disc.

**Disc to pulley clearance : 0.25 - 0.60 mm (0.010 - 0.024 in)**

If specified clearance is not obtained, replace adjusting spacer and readjust.

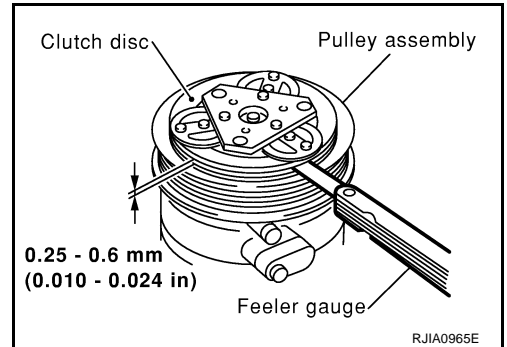

## Break-in Operation

When replacing compressor clutch assembly, always carry out break-in operation. This is done by engaging and disengaging clutch about thirty-times. Break-in operation raises level of transmitted torque.

## Removal and Installation of Low-pressure Flexible Hose

AJS00139

### REMOVAL

1. Use a refrigerant collecting equipment (for HFC-134a) to discharge the refrigerant.
2. Remove engine cover. Refer to [EM-19, "INTAKE MANIFOLD COLLECTOR"](#).
3. Remove air cleaner assembly, air hose and air duct. Refer to [EM-17, "AIR CLEANER AND AIR DUCT"](#).
4. Remove mounting bolt from low-pressure flexible hose bracket.

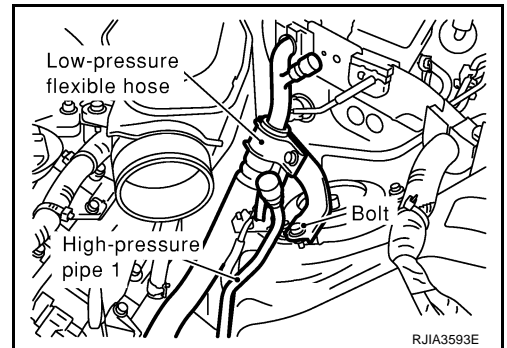

5. Disconnect one-touch joint between low-pressure flexible hose and low-pressure pipe 1.

- a. Set a disconnecter (92530-89916) on A/C piping.
- b. Slide a disconnecter toward vehicle front until it clicks.
- c. Slide A/C piping toward vehicle front and disconnect it.

### CAUTION:

Cap or wrap the joint of the pipe with suitable material such as vinyl tape to avoid the entry of air.

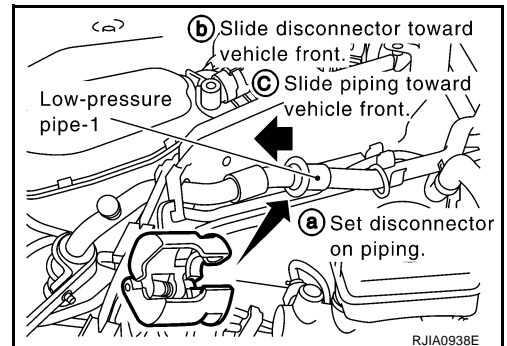

## REFRIGERANT LINES

- Remove mounting nuts from low-pressure flexible hose. (Compressor side)  
**CAUTION:**  
Cap or wrap the joint of the pipe with suitable material such as vinyl tape to avoid the entry of air.
- Remove low-pressure flexible hose.

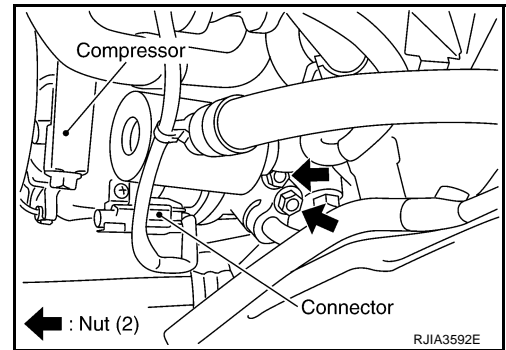

### INSTALLATION

Installation is basically the reverse order of removal.

#### CAUTION:

- Replace O-rings for A/C piping with new one, then apply compressor oil to it when installing it.
- Connection point for female-side piping is thin. So, when inserting male-side piping, take care not to deform female-side piping. Slowly insert in axial direction.
- Insert one-touch joint connection point securely until it clicks.
- After piping has been connected, pull male-side piping by hand to make sure piping does not come off.
- When recharging refrigerant, check for leaks.

**Bolt mounting low-pressure flexible hose bracket**

**Tightening torque : 4.2 N-m (0.43 kg-m, 37 in-lb)**

### Removal and Installation of High-Pressure Flexible Hose

AJS0013A

#### REMOVAL

- Use a refrigerant collecting equipment (for HFC-134a) to discharge the refrigerant.
- Remove engine cover. Refer to [EM-19, "INTAKE MANIFOLD COLLECTOR"](#).
- Remove air cleaner assembly, air hose and air duct. Refer to [EM-17, "AIR CLEANER AND AIR DUCT"](#).
- Remove mounting bolt from high-pressure flexible hose bracket.

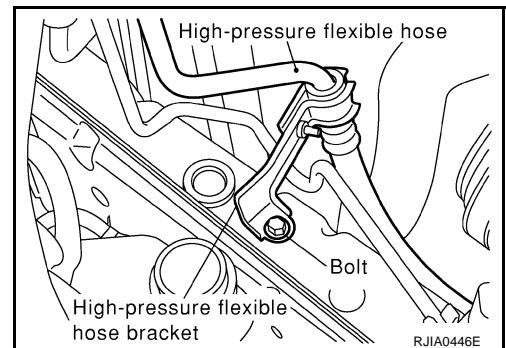

- Disconnect one-touch joint between high-pressure flexible hose and condenser.
  - Set a disconnecter (92530-89912) on A/C piping.
  - Slide a disconnecter upward until it clicks.
  - Slide A/C piping upward and disconnect it.

#### CAUTION:

Cap or wrap the joint of the pipe with suitable material such as vinyl tape to avoid the entry of air.

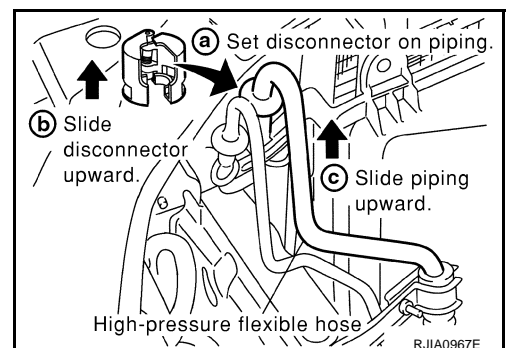

# REFRIGERANT LINES

- Remove mounting nuts from high-pressure flexible hose, and then remove high-pressure flexible hose.

**CAUTION:**

Cap or wrap the joint of the pipe with suitable material such as vinyl tape to avoid the entry of air.

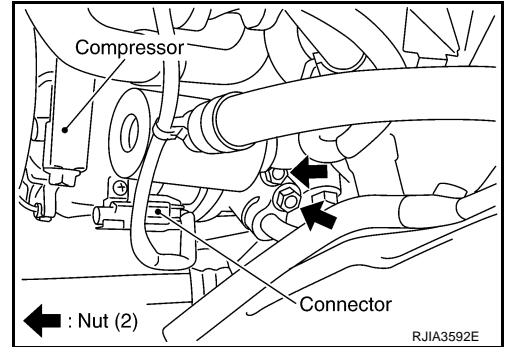

A  
B  
C  
D  
E  
F  
G  
H

## INSTALLATION

Installation is basically the reverse order of removal.

**CAUTION:**

- Replace O-ring of high-pressure flexible hose with a new one, then apply compressor oil to it when installing it.
- Connection point for female-side piping is thin. So, when inserting male-side piping, take care not to deform female-side piping. Slowly insert in axial direction.
- Insert one-touch joint connection point securely until it clicks.
- After piping has been connected, pull male-side piping by hand to make sure piping does not come off.
- When recharging refrigerant, check for leaks.

**Bolt mounting high-pressure flexible hose bracket**

**Tightening torque : 4.2 N·m (0.43 kg·m, 37 in·lb)**

## Removal and Installation of Low-Pressure Pipe 1 (Engine Compartment)

AJS0013B

- Use a refrigerant collecting equipment (for HFC-134a) to discharge the refrigerant.
- Remove cowl top cover and wiper assembly. Refer to [EI-21. "COWL TOP"](#).
- Remove mounting bolt from low-pressure flexible hose bracket.

ATC

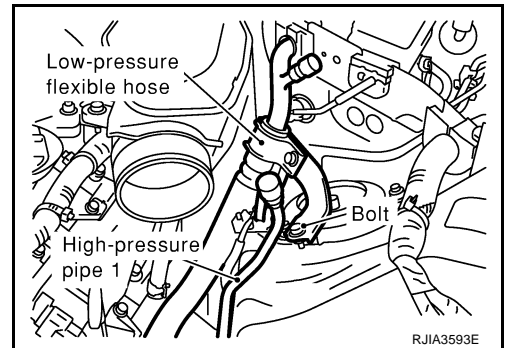

K  
L  
M

- Disconnect one-touch joints.
  - Set a disconnecter (92530-89916) on A/C piping.
  - Slide a disconnecter toward vehicle front until it clicks.
  - Slide A/C piping toward vehicle front and disconnect it.

**CAUTION:**

Cap or wrap the joint of the pipe with suitable material such as vinyl tape to avoid the entry of air.

- Remove low-pressure pipe 1.

**CAUTION:**

Cap or wrap the joint of the pipe with suitable material such as vinyl tape to avoid the entry of air.

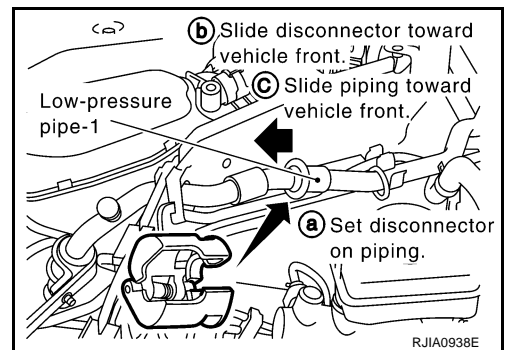

# REFRIGERANT LINES

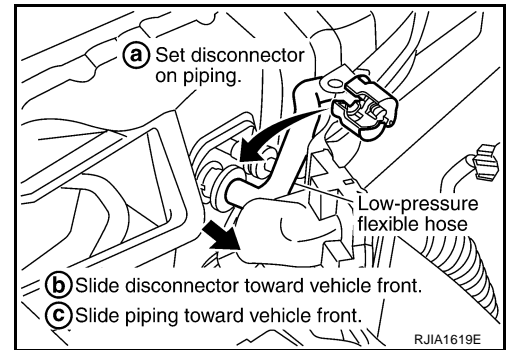

## INSTALLATION

Installation is basically the reverse order of removal.

### CAUTION:

- Replace O-ring of low-pressure pipe 1 with a new one, then apply compressor oil to it when installing it.
- Connection point for female-side piping is thin. So, when inserting male-side piping, take care not to deform female-side piping. Slowly insert in axial direction.
- Insert one-touch joint connection point securely until it clicks.
- After piping has been connected, pull male-side piping by hand to make sure piping does not come off.
- When recharging refrigerant, check for leaks.

## Removal and Installation of High-Pressure Pipe 1 (Engine Compartment)

AJS0013C

### REMOVAL

1. Use a refrigerant collecting equipment (for HFC-134a) to discharge the refrigerant.
2. Remove cowl top cover. Refer to [EI-21, "COWL TOP"](#).
3. Remove air cleaner assembly, air hose and air duct. Refer to [EM-17, "AIR CLEANER AND AIR DUCT"](#).
4. Remove low-pressure flexible hose and pipe 1. Refer to [ATC-147, "Removal and Installation of Low-pressure Flexible Hose"](#) and [ATC-149, "Removal and Installation of Low-Pressure Pipe 1 \(Engine Compartment\)"](#).
5. Remove high-pressure flexible hose bracket.
6. Remove high-pressure pipe 1 from vehicle clips.
7. Disconnect one-touch joints of high-pressure pipe.
  - a. Set a disconnecter (92530-89908) on A/C piping.
  - b. Slide a disconnecter toward (or upward) vehicle front until it clicks.
  - c. Slide A/C piping toward (or upward) vehicle front and disconnect it.

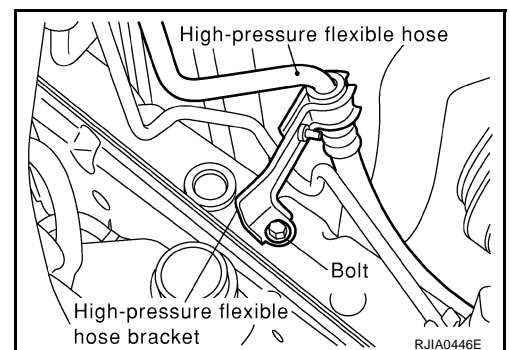

# REFRIGERANT LINES

## CAUTION:

Cap or wrap the joint of the pipe with suitable material such as vinyl tape to avoid the entry of air.

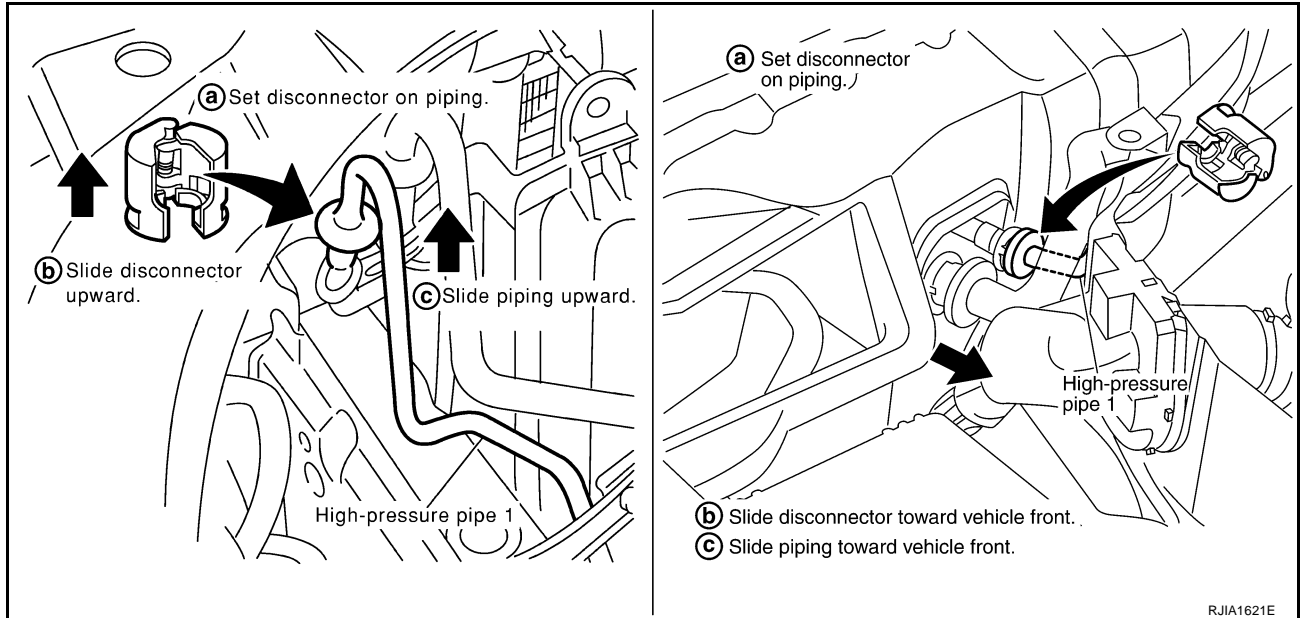

8. Remove high-pressure pipe 1.

## INSTALLATION

Installation is basically the reverse order of removal.

### CAUTION:

- Replace O-ring of high-pressure pipe 1 with a new one, then apply compressor oil to it when installing it.
- Connection point for female-side piping is thin. So, when inserting male-side piping, take care not to deform female-side piping. Slowly insert in axial direction.
- Insert one-touch joint connection point securely until it clicks.
- After piping has been connected, pull male-side piping by hand to make sure piping does not come off.
- When recharging refrigerant, check for leaks.

## Removal and Installation of Low-Pressure Pipe 2 and High-pressure Pipe 2

AJS0013D

### REMOVAL

1. Use a refrigerant collecting equipment (for HFC-134a) to discharge the refrigerant.
2. Set the temperature (passenger side) at 18°C (60°F), and then disconnect the battery negative cable.
3. Remove cowl top cover. Refer to [EI-21, "COWL TOP"](#).
4. Remove mounting bolt from low-pressure flexible hose bracket.
5. Remove high-pressure pipe 1 from vehicle clips.

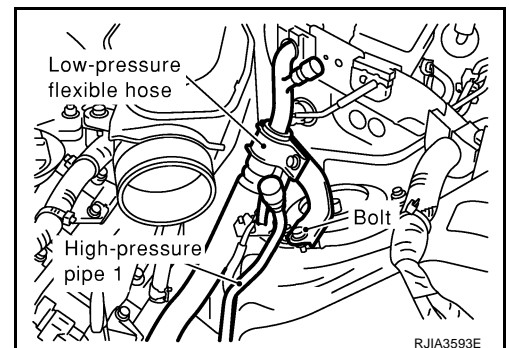



## REFRIGERANT LINES

6. Disconnect one-touch joints.
  - a. Set a disconnecter (High-pressure side: 92530-89908, Low-pressure side: 92530-89916) on A/C piping.
  - b. Slide a disconnecter toward vehicle front until it clicks.
  - c. Slide A/C piping toward vehicle front and disconnect it.

**CAUTION:**

**Cap or wrap the joint of the pipe with suitable material such as vinyl tape to avoid the entry of air.**

7. Remove instrument lower passenger panel and glove box. Refer to [IP-11, "Removal and Installation"](#).
8. Remove blower unit. Refer to [ATC-125, "BLOWER UNIT"](#).
9. Remove air mix door motor (passenger side) and mode door motor.
10. Remove evaporator cover.

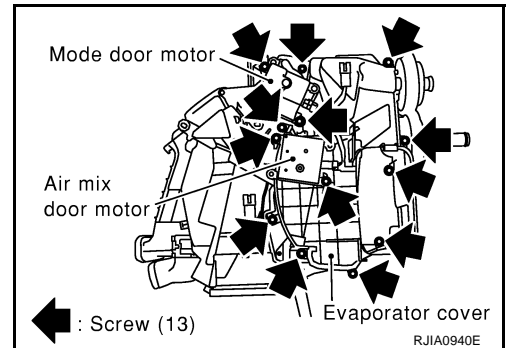
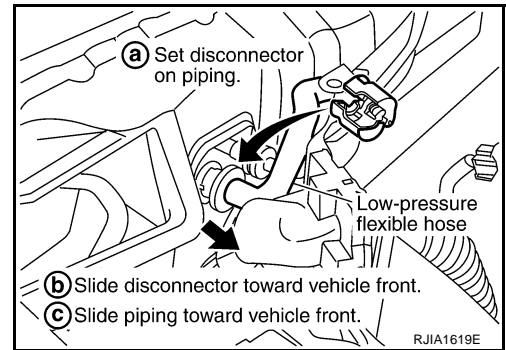

11. Remove mounting bolt, and then remove low-pressure pipe 2 and high-pressure pipe 2.

**CAUTION:**

**Cap or wrap the joint of the pipe with suitable material such as vinyl tape to avoid the entry of air.**

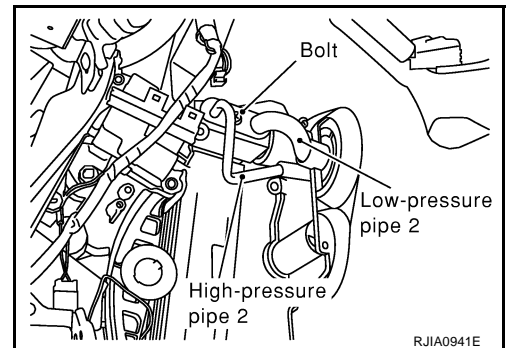

## INSTALLATION

Installation is basically the reverse order of removal.

**CAUTION:**

- Replace O-rings for A/C piping with new ones, then apply compressor oil to it when installing it.
- Connection point for female-side piping is thin. So, when inserting male-side piping, take care not to deform female-side piping. Slowly insert in axial direction.
- Insert one-touch joint connection point securely until it clicks.
- After piping has been connected, pull male-side piping by hand to make sure piping does not come off.
- When recharging refrigerant, check for leaks.

**Bolt mounting low-pressure flexible hose bracket**

**Tightening torque : 4.2 N·m (0.43 kg·m, 37 in·lb)**



# REFRIGERANT LINES

AJS0013E

## Removal and Installation of Liquid Tank

### REMOVAL

1. Use a refrigerant collecting equipment (for HFC-134a) to discharge the refrigerant.
2. Remove front grille and horn (right side). Refer to [EI-20, "FRONT GRILLE"](#).
3. Clean liquid tank and its surrounding area, and remove dirt and rust from tank.

### CAUTION:

**Be sure to clean carefully.**

4. Remove ambient sensor bracket after removing horn.

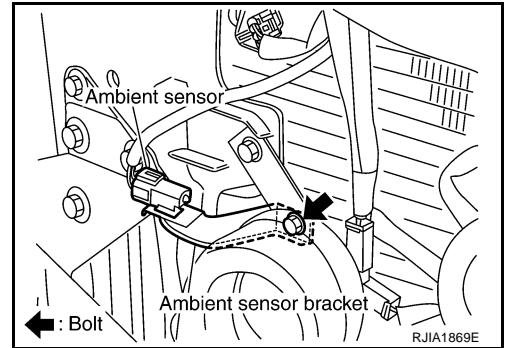

5. Remove mounting bolt from liquid tank.

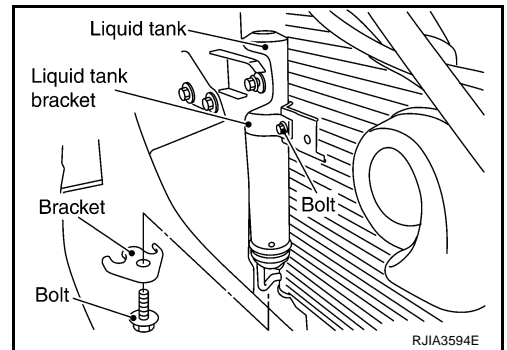

6. Lift liquid tank upward. Remove bracket from protruding part of condenser.
7. Slide liquid tank upward, and then remove liquid tank.

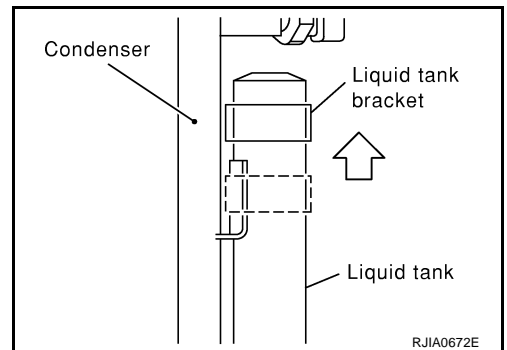

### INSTALLATION

Install liquid tank, and then install liquid tank bracket on condenser.

### CAUTION:

- **Make sure liquid tank bracket is securely installed at protrusion of condenser. (Make sure liquid tank bracket does not move to a position below center of liquid tank.)**
- **Replace O-rings for A/C piping with new ones, then apply compressor oil to it when installing it.**
- **When recharging refrigerant, check for leaks.**

**Bolt mounting liquid tank bracket (upper side)**

**Tightening torque : 3.4 N·m (0.34 kg·m, 30 in·lb)**

**Bolt mounting liquid tank bracket (lower side)**

**Tightening torque : 5.7 N·m (0.58 kg·m, 50 in·lb)**

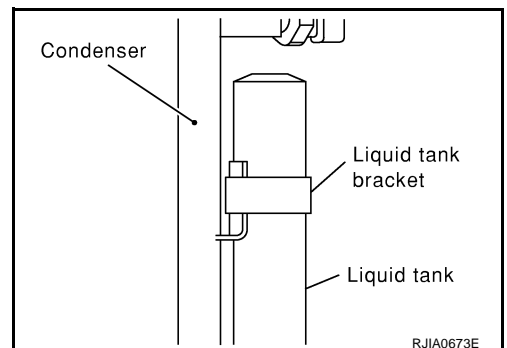

A  
B  
C  
D  
E  
F  
G  
H  
I  
K  
L  
M

ATC

# REFRIGERANT LINES

AJS0013F

## Removal and Installation of Condenser

### REMOVAL

1. Use a refrigerant collecting equipment (for HFC-134a) to discharge the refrigerant.
2. Remove engine cover. Refer to [EM-19, "INTAKE MANIFOLD COLLECTOR"](#).
3. Remove air cleaner assembly, air hose and air duct. Refer to [EM-17, "AIR CLEANER AND AIR DUCT"](#).
4. Remove engine under cover, using power tools.
5. Drain engine coolant. Refer to [CO-10, "Changing Engine Coolant"](#).
6. Remove radiator fan shroud with cooling fan after removing radiator upper hose. Refer to [CO-13, "RADIATOR"](#).
7. Remove reservoir tank and reservoir tank bracket. Refer to [CO-13, "RADIATOR"](#).

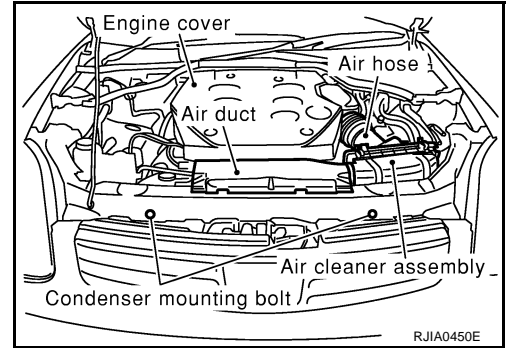

8. Remove ambient sensor bracket after removing horn.

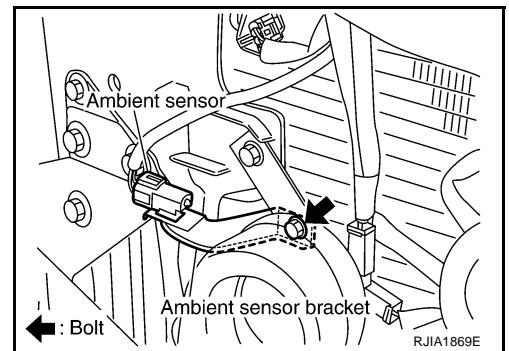

9. Disconnect high-pressure flexible hose and high-pressure pipe 1 from condenser.
  - a. Set a disconnecter (condenser outlet: 92530-89908, condenser inlet: 92530-89912) on A/C piping.
  - b. Slide a disconnecter upward until it clicks.
  - c. Slide A/C piping upward and disconnect it.

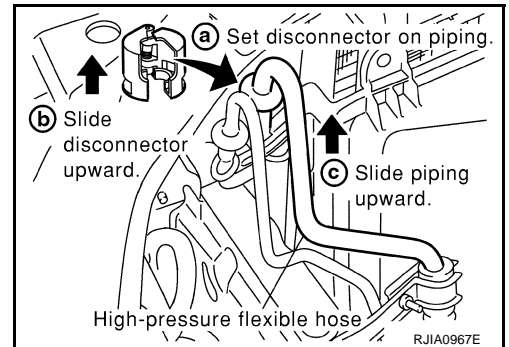

### CAUTION:

Cap or wrap the joint of the pipe with suitable material such as vinyl tape to avoid the entry of air.

10. Remove mounting bolt from condenser.
11. Remove radiator upper mount, move radiator and condenser to the engine side.
12. Lift condenser up slightly and tilt it toward front of vehicle. (This is because condenser lower bracket is on bottom of radiator tank.)

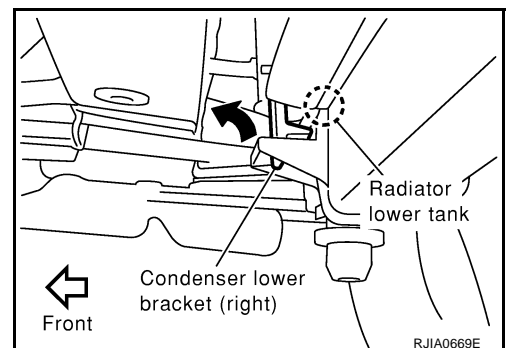

# REFRIGERANT LINES

13. Pull condenser forward at an angle. Remove condenser from radiator.

**CAUTION:**

Be careful not to damage the core surface of condenser and radiator.

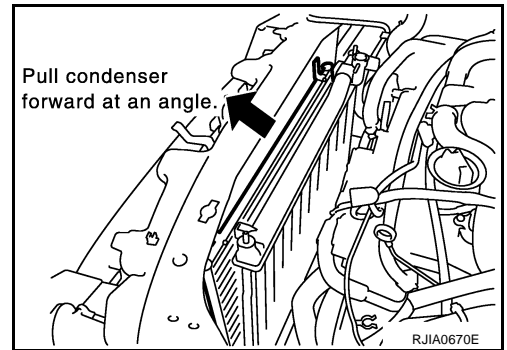

A  
B  
C  
D  
E  
F  
G  
H  
I  
K  
L  
M

## INSTALLATION

Installation is basically the reverse order of removal.

**CAUTION:**

- Replace O-rings for A/C piping with new ones, then apply compressor oil to it when installing it.
- Connection point for female-side piping is thin. So, when inserting male-side piping, take care not to deform female-side piping. Slowly insert in axial direction.
- Insert one-touch joint connection point securely until it clicks.
- After piping has been connected, pull male-side piping by hand to make sure piping does not come off.
- When recharging refrigerant, check for leaks.

**Bolt mounting condenser**

**Tightening torque : 6.1 N·m (0.62 kg·m, 54 in·lb)**

## Removal and Installation of Refrigerant Pressure Sensor

AJS0013G

### REMOVAL

1. Remove condenser. Refer to [ATC-154, "Removal and Installation of Condenser"](#).
2. Remove refrigerant pressure sensor from condenser.

**CAUTION:**

When working, be careful not to damage the condenser fins.

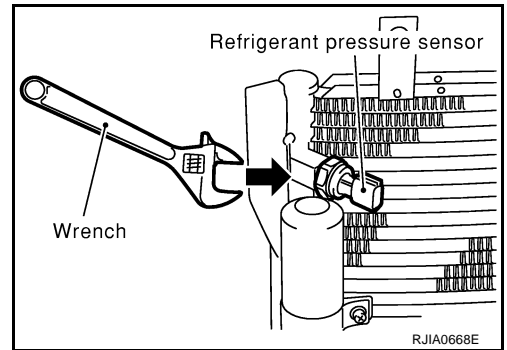

ATC

## INSTALLATION

Installation is basically the reverse order of removal.

**CAUTION:**

Apply compressor oil to O-ring of refrigerant pressure sensor when installing it.

**Refrigerant pressure sensor**

**Tightening torque :10.8 N·m (1.1 kg·m, 8.0 ft·lb)**

# REFRIGERANT LINES

AJS0013H

## Removal and Installation of Evaporator

### REMOVAL

1. Remove low-pressure pipe 2 and high-pressure pipe 2. Refer to [ATC-151, "Removal and Installation of Low-Pressure Pipe 2 and High-pressure Pipe 2"](#) .

#### **CAUTION:**

**Cap or wrap the joint of the pipe with suitable material such as vinyl tape to avoid the entry of air.**

2. Slide evaporator, and then remove it from heater & cooling unit.
3. Remove intake sensor from evaporator, and then remove evaporator.

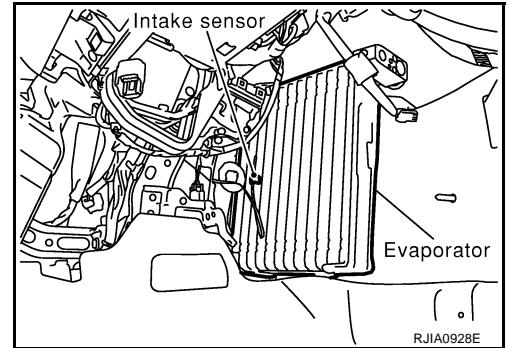

### INSTALLATION

Installation is basically the reverse order of removal.

#### **CAUTION:**

- Replace O-rings for A/C piping with new ones, then apply compressor oil to it when installing it.
- Connection point for female-side piping is thin. So, when inserting male-side piping, take care not to deform female-side piping. Slowly insert in axial direction.
- Insert one-touch joint connection point securely until it clicks.
- After piping has been connected, pull male-side piping by hand to make sure piping does not come off.
- The O-rings are different from low-pressure pipe 1 (high-pressure pipe 1) and low-pressure pipe 2 (high-pressure pipe 2).
- Mark the mounting position of the intake sensor bracket.
- When recharging refrigerant, check for leaks.

**Bolt mounting low-pressure flexible hose bracket**

**Tightening torque : 4.2 N·m (0.43 kg-m, 37 in-lb)**

# REFRIGERANT LINES

## Removal and Installation of Expansion Valve

AJS0013I

### REMOVAL

1. Remove evaporator. Refer to [ATC-156, "Removal and Installation of Evaporator"](#) .
2. Remove mounting bolts, and then remove expansion valve.

#### **CAUTION:**

Cap or wrap the joint of the pipe with suitable material such as vinyl tape to avoid the entry of air.

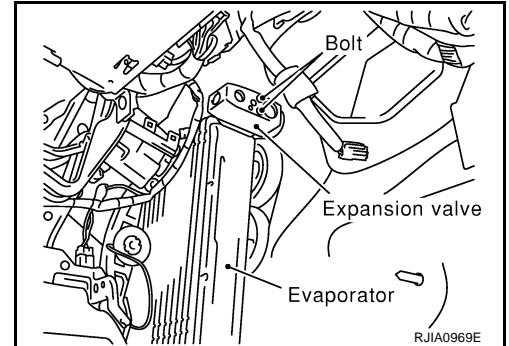

### INSTALLATION

Installation is basically the reverse order of removal.

#### **CAUTION:**

- Replace O-rings with new ones, then apply compressor oil to them when installing them.
- The O-rings are different from low-pressure pipe 1 (high-pressure pipe 1) and low-pressure pipe 2 (high-pressure pipe 2).
- When recharging refrigerant, check for leaks.

**Bolt mounting expansion valve**

**Tightening torque : 3.9 N·m (0.40 kg-m, 35 in-lb)**

A  
B  
C  
D  
E  
F  
G  
H  
I  
K  
L  
M

ATC

# REFRIGERANT LINES

## Checking for Refrigerant Leaks

AJS0013J

Perform a visual inspection of all refrigeration parts, fittings, hoses and components for signs of A/C lubricant leakage, damage and corrosion. A/C lubricant leakage may indicate an area of refrigerant leakage. Allow extra inspection time in these areas when using either an electronic refrigerant leak detector or fluorescent dye leak detector.

If dye is observed, confirm the leak with an electronic refrigerant leak detector. It is possible a prior leak was repaired and not properly cleaned.

When searching for leaks, do not stop when one leak is found but continue to check for additional leaks at all system components and connections.

When searching for refrigerant leaks using an electronic leak detector, move the probe along the suspected leak area at 1 to 2 inches per second and no further than 1/4 inch from the component.

### **CAUTION:**

**Moving the electronic leak detector probe slower and closer to the suspected leak area will improve the chances of finding a leak.**

## Checking System for Leaks Using the Fluorescent Leak Detector

AJS0013K

1. Check A/C system for leaks using the UV lamp and safety goggles (J-42220) in a low sunlight area (area without windows preferable). Illuminate all components, fittings and lines. The dye will appear as a bright green/yellow area at the point of leakage. Fluorescent dye observed at the evaporator drain opening indicates an evaporator core assembly (tubes, core or expansion valve) leak.
2. If the suspected area is difficult to see, use an adjustable mirror or wipe the area with a clean shop rag or cloth, with the UV lamp for dye residue.
3. After the leak is repaired, remove any residual dye using dye cleaner (J-43872) to prevent future misdiagnosis.
4. Perform a system performance check and verify the leak repair with an approved electronic refrigerant leak detector.

### **NOTE:**

Other gases in the work area or substances on the A/C components, for example, anti-freeze, windshield washer fluid, solvents and lubricants, may falsely trigger the leak detector. Make sure the surfaces to be checked are clean.

Clean with a dry cloth or blow off with shop air.

Do not allow the sensor tip of the detector to contact with any substance. This can also cause false readings and may damage the detector.

## Dye Injection

AJS0013L

(This procedure is only necessary when recharging the system or when the compressor has seized and was replaced.)

1. Check A/C system static (at rest) pressure. Pressure must be at least 345 kPa (3.52 kg/cm<sup>2</sup>, 50 psi).
2. Pour one bottle (1/4 ounce / 7.4 cc) of the A/C refrigerant dye into the injector tool (J-41459).
3. Connect the injector tool to the A/C LOW PRESSURE side service fitting.
4. Start engine and switch A/C ON.
5. When the A/C operating (compressor running), inject one bottle (1/4 ounce / 7.4 cc) of fluorescent dye through the low-pressure service valve using dye injector tool J-41459 (refer to the manufacturer's operating instructions).
6. With the engine still running, disconnect the injector tool from the service fitting.

### **CAUTION:**

**Be careful the A/C system or replacing a component, pour the dye directly into the open system connection and proceed with the service procedures.**

7. Operate the A/C system for a minimum of 20 minutes to mix the dye with the system oil. Depending on the leak size, operating conditions and location of the leak, it may take from minutes to days for the dye to penetrate a leak and become visible.

# REFRIGERANT LINES

## Electronic Refrigerant Leak Detector PRECAUTIONS FOR HANDLING LEAK DETECTOR

AJS0013M

When performing a refrigerant leak check, use an A/C leak detector (J-41995) or equivalent. Ensure that the instrument is calibrated and set properly per the operating instructions.

The leak detector is a delicate device. In order to use the leak detector properly, read the operating instructions and perform any specified maintenance.

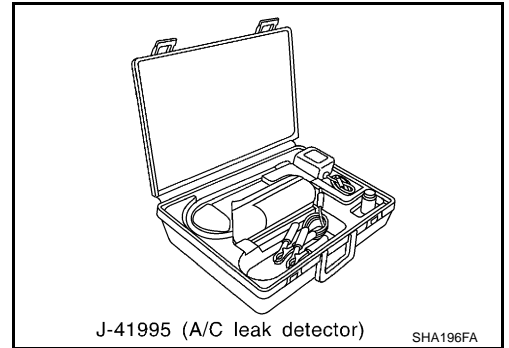

1. Position probe approximately 5 mm (3/16 in) away from point to be checked.

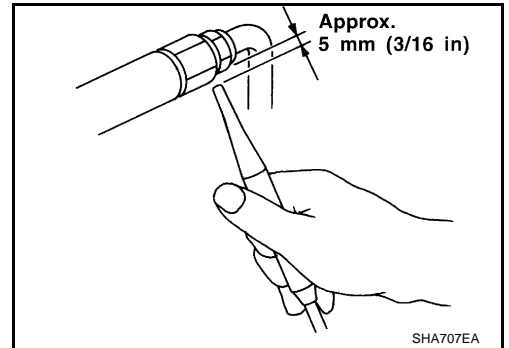

2. When testing, circle each fitting completely with probe.

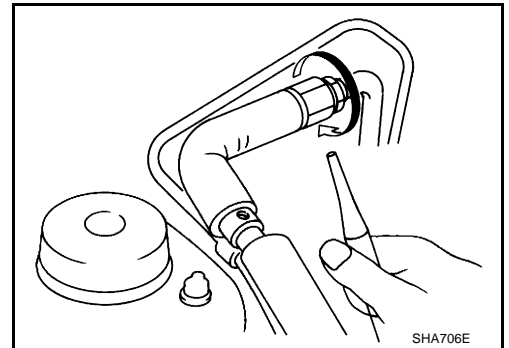

3. Move probe along component approximately 25 to 50 mm (1 to 2 in)/sec.

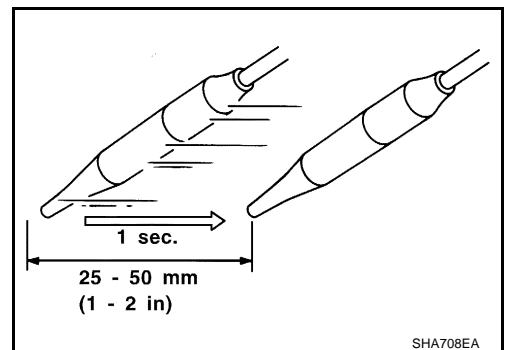

A  
B  
C  
D  
E  
F  
G  
H  
I  
J  
K  
L  
M

ATC

# REFRIGERANT LINES

## CHECKING PROCEDURE

To prevent inaccurate or false readings, make sure there is no refrigerant vapor, shop chemicals, or cigarette smoke in the vicinity of the vehicle. Perform the leak test in calm area (low air/wind movement) so that the leaking refrigerant is not dispersed.

1. Turn engine OFF.
2. Connect a suitable A/C manifold gauge set to the A/C service ports.
3. Check if the A/C refrigerant pressure is at least 345 kPa (3.52 kg/cm<sup>2</sup> , 50 psi) above 16°C (61°F). If less than specification, recover/evacuate and recharge the system with the specified amount of refrigerant.

### NOTE:

At temperatures below 16°C (61°F), leaks may not be detected since the system may not reach 345 kPa (3.52 kg/cm<sup>2</sup> , 50 psi).

4. Perform the leak test from the high-pressure side (compressor discharge a to evaporator inlet g) to the low-pressure side (evaporator drain hose h to shaft seal m). Refer to [ATC-142, "Components"](#) . Perform a leak check for the following areas carefully. Clean the component to be checked and move the leak detected probe completely around the connection/component.

#### Compressor

Check the fitting of high- and low- pressure flexible hoses, relief valve and shaft seal.

#### Condenser

Check the fitting of high-pressure flexible hose and pipe, refrigerant pressure sensor.

#### Liquid tank

Check the refrigerant connection.

#### Service valves

Check all around the service valves. Ensure service valve caps are secured on the service valves (to prevent leaks).

### NOTE:

After removing A/C manifold gauge set from service valves, wipe any residue from valves to prevent any false readings by leak detector.

#### Cooling unit (Evaporator)

With engine OFF, turn blower fan on "High" for at least 15 seconds to dissipate any refrigerant trace in the cooling unit. Wait a minimum of 10 minutes accumulation time (refer to the manufacturer's recommended procedure for actual wait time) before inserting the leak detector probe into the drain hose.

Keep the probe inserted for at least 10 seconds. Use caution not to contaminate the probe tip with water or dirt that may be in the drain hose.

5. If a leak detector detects a leak, verify at least once by blowing compressed air into area of suspected leak, then repeat check as outlined above.
6. Do not stop when one leak is found. Continue to check for additional leaks at all system components. If no leaks are found, perform steps 7-10.
7. Start engine.
8. Set the heater A/C control as follows;
  - a. A/C switch: ON
  - b. MODE switch: VENT (Ventilation)
  - c. Intake position: Recirculation
  - d. Max. cold temperature
  - e. Fan speed: High
9. Run engine at 1,500 rpm for at least 2 minutes.



## REFRIGERANT LINES

- Turn engine off and perform leak check again following steps 4 through 6 above.

Refrigerant leaks should be checked immediately after stopping the engine. Begin with the leak detector at the compressor. The pressure on the high-pressure side will gradually drop after refrigerant circulation stops and pressure on the low-pressure side will gradually rise, as shown in the graph. Some leaks are more easily detected when pressure is high.

- Before connecting recovery/recycling recharging equipment to vehicle, check recovery/recycling recharging equipment gauges. No refrigerant pressure should be displayed. If pressure is displayed, recover refrigerant from equipment lines and then check refrigerant purity.

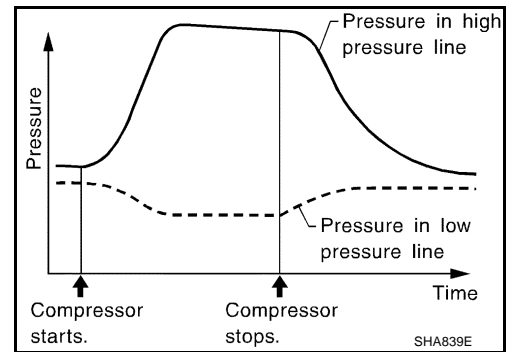

- Confirm refrigerant purity in supply tank using recovery/recycling recharging equipment and refrigerant identifier.
- Confirm refrigerant purity in vehicle A/C system using recovery/recycling recharging equipment and refrigerant identifier.
- Discharge A/C system using approved refrigerant recovery equipment. Repair the leaking fitting or component if necessary.
- Evacuate and recharge A/C system and perform the leak test to confirm no refrigerant leaks.
- Perform A/C performance test to ensure system works properly.

A  
B  
C  
D  
E  
F  
G  
H  
I  
K  
L  
M

ATC

# SERVICE DATA AND SPECIFICATIONS (SDS)

## SERVICE DATA AND SPECIFICATIONS (SDS)

PFP:00030

### Compressor

AJS0013N

Model	Calsonic Kansei make CWE-618	
Type	V-6 variable displacement	
Displacement cm <sup>3</sup> (cu in)/rev	Max.	184 (11.228)
	Min.	14.5 (0.885)
Cylinder bore × stroke mm (in)	37 (1.46) × [2.3 - 28.6 (0.091 - 1.126)]	
Direction of rotation	Clockwise (viewed from drive end)	
Drive belt	Poly V	

### Lubricant

AJS0013O

Model	Calsonic Kansei make CWE-618	
Name	Nissan A/C System Oil Type S (DH-PS)	
Part number	KLH00-PAGS0	
Capacity m ℓ (US fl oz, Imp fl oz)	Total in system	180 (6.0, 6.3)
	Compressor (Service part) charging amount	180 (6.0, 6.3)

### Refrigerant

AJS0013P

Type	HFC-134a (R-134a)
Capacity kg (lb)	0.55 (1.21)

### Engine Idling Speed

AJS0013Q

Refer to [EC-76, "Idle Speed and Ignition Timing Check"](#) .

### Belt Tension

AJS0013R

Refer to [EM-14, "DRIVE BELTS"](#) .