

SECTION **AV**

**AUDIO VISUAL, NAVIGATION & TELEPHONE SYSTEM**

**CONTENTS**

<b>PRECAUTIONS</b> .....	<b>3</b>	Removal and Installation for A/C and Audio Controller .....	28
Precautions for Supplemental Restraint System (SRS) "AIR BAG" and "SEAT BELT PRE-TENSIONER" .....	3	REMOVAL .....	28
Wiring Diagrams and Trouble Diagnosis .....	3	INSTALLATION .....	28
<b>PREPARATION</b> .....	<b>4</b>	Removal and Installation of Door Speaker .....	28
Commercial Service Tools .....	4	REMOVAL .....	28
<b>AUDIO</b> .....	<b>5</b>	INSTALLATION .....	29
System Description .....	5	Removal and Installation of Tweeter Behind Door Mirror .....	29
BASE SYSTEM .....	5	REMOVAL .....	29
BOSE SYSTEM .....	5	INSTALLATION .....	29
SPEED SENSITIVE VOLUME SYSTEM .....	6	Removal and Installation of Woofer .....	29
Component Parts Location .....	7	REMOVAL .....	29
Schematic / Base System .....	8	INSTALLATION .....	29
Wiring Diagram – AUDIO – / Base System .....	9	Removal and Installation of BOSE Speaker Amp... ..	29
Schematic / BOSE System .....	12	REMOVAL .....	29
Wiring Diagram – AUDIO – / BOSE System .....	13	INSTALLATION .....	29
Terminals and Reference Value for Audio Unit for Base System .....	17	<b>AUDIO ANTENNA</b> .....	<b>30</b>
Terminals and Reference Value for Audio Unit for BOSE System .....	18	System Description .....	30
Terminals and Reference Value for BOSE Speaker Amp. ....	20	Wiring Diagram -W/ANT- .....	31
Steering Wheel Audio Control Switch Resistance Check .....	21	WITH SUNROOF .....	31
Trouble Diagnosis .....	22	WITHOUT SUNROOF .....	32
PROBLEM WITH RADIO AND CD .....	22	Location of Antenna .....	33
FOR RADIO ONLY .....	22	Window Antenna Repair .....	33
FOR CD ONLY .....	23	ELEMENT CHECK .....	33
Noise Inspection .....	23	ELEMENT REPAIR .....	34
TYPE OF NOISE AND POSSIBLE CAUSE .....	23	<b>NAVIGATION SYSTEM</b> .....	<b>35</b>
Power Supply Circuit Inspection .....	24	System Description .....	35
Steering Wheel Audio Control Switch Does Not Operate .....	25	TRAVEL DISTANCE .....	35
Speed Sensitive Volume System Does Not Work..	26	TRAVEL DIRECTION .....	35
Locking CD Auto-changer Mechanism .....	27	MAP-MATCHING .....	35
DAMPER LOCK PROCEDURE .....	27	GPS (GLOBAL POSITIONING SYSTEM) .....	36
Removal and Installation of Audio Unit .....	27	COMPONENT DESCRIPTION .....	37
REMOVAL .....	27	BIRD VIEW™ .....	38
INSTALLATION .....	28	MAP DISPLAY .....	39
		FUNCTION OF NAVI SWITCH .....	39
		"VIEW" MODE .....	44
		"HEADING" MODE .....	44
		"NEARBY DISPLAY ICONS" MODE .....	45
		"SAVE CURRENT LOCATION" MODE .....	45

“ADJUST CURRENT LOCATION” MODE .....	45	Guide Sound Is Not Heard .....	84
“AUTO RE-ROUTE” MODE .....	46	No Fuel Information Is Displayed .....	86
“AVOID AREA SETTING” MODE .....	46	Vehicle Condition Setting Is Not Possible .....	86
“BUTTON TONE/BEEP RESPONSE” MODE ....	46	No Warning Message Is Displayed (Combination	
“CLEAR MEMORY” MODE .....	46	Meter Of Warning Lamp Illuminate) .....	86
“EDIT ADDRESS BOOK” MODE .....	47	The Position of The Current-Location Mark Is Not	
“GPS INFORMATION” MODE .....	47	Correct .....	87
“QUICK STOP CUSTOMER SETTING” MODE...	47	Radio Wave From The GPS Satellite Is Not	
“SET AVERAGE SPEED” MODE .....	47	Received .....	87
“TRACKING” MODE .....	48	Driving Test .....	87
GUIDE VOLUME SETTING .....	48	Example of Symptoms Judged Not Malfunction ....	89
TRIP COMPUTER INFORMATION .....	48	BASIC OPERATION .....	89
FUEL ECONOMY INFORMATION .....	48	VEHICLE MARK .....	89
MAINTENANCE INFORMATION .....	49	DESTINATION, PASSING POINTS, AND MENU	
WARNING INDICATIONS .....	49	ITEMS CANNOT BE SELECTED/SET .....	90
Precautions for NAVI Control Unit Replacement ...	50	VOICE GUIDE .....	90
Component Parts Location .....	50	ROUTE SEARCHING .....	90
Schematic .....	51	EXAMPLES OF CURRENT-LOCATION MARK	
Wiring Diagram —NAVI— .....	52	DISPLACEMENT .....	92
Wiring Diagram —COMM— .....	57	THE CURRENT POSITION MARK SHOWS A	
Terminals and Reference Value for NAVI Control		POSITION WHICH IS COMPLETELY WRONG...95	
Unit .....	59	THE CURRENT POSITION MARK JUMPS .....	95
Terminals and Reference Value for Display Unit ...	61	THE CURRENT LOCATION MARK IS IN A	
Terminals and Reference Value for NAVI Switch ...	63	RIVER OR THE SEA .....	96
Self-Diagnosis Function .....	64	WHEN DRIVING ON THE SAME ROAD, SOME-	
DESCRIPTION .....	64	TIMES THE CURRENT-LOCATION MARK IS IN	
DIAGNOSIS ITEM .....	64	THE RIGHT PLACE AND SOMETIMES IT IS THE	
Self-Diagnosis Mode .....	65	WRONG PLACE .....	96
OPERATION PROCEDURE .....	65	LOCATION CORRECTION BY MAP MATCHING	
SELF-DIAGNOSIS RESULT .....	66	IS SLOW .....	96
CONFIRMATION/ADJUSTMENT Mode .....	67	ALTHOUGH THE GPS RECEIVING DISPLAY IS	
OPERATION PROCEDURE .....	67	GREEN, THE VEHICLE MARK DOES NOT	
DISPLAY DIAGNOSIS .....	68	RETURN TO THE CORRECT LOCATION .....	96
VEHICLE SIGNALS .....	69	THE NAME OF THE CURRENT PLACE IS NOT	
NAVIGATION .....	69	DISPLAYED .....	96
HISTORY OF ERRORS .....	70	CONTENTS OF THE DISPLAY DIFFER FOR	
DIAGNOSIS BY HISTORY OF ERRORS .....	70	THE BIRD VIEW™ AND THE (FLAT) MAP	
Power Supply and Ground Circuit Check for NAVI		SCREEN .....	96
Control Unit .....	73	Program Loading .....	97
Power Supply and Ground Circuit Check for Display		Removal and Installation of NAVI Control Unit .....	98
Unit and NAVI Switch .....	74	REMOVAL .....	98
Vehicle Speed Signal Check .....	75	INSTALLATION .....	98
Illumination Signal Check .....	76	Removal and Installation of GPS Antenna .....	98
Ignition Signal Check .....	76	REMOVAL .....	98
Reverse Signal Check (With A/T) .....	77	INSTALLATION .....	98
Reverse Signal Check (With M/T) .....	77	Removal and Installation of NAVI Switch .....	99
Navigation System Is Not Operated by NAVI Switch..	78	REMOVAL .....	99
Screen Is Not Shown .....	79	INSTALLATION .....	99
Color of RGB Image Is Not Proper (Bluish) .....	81	Removal and Installation of Display Unit .....	99
Color of RGB Image Is Not Proper (Reddish) .....	82	REMOVAL .....	99
Color of RGB Image Is Not Proper (Yellowish) .....	83	INSTALLATION .....	99
RGB Screen Is Rolling .....	84		

# PRECAUTIONS

## PRECAUTIONS

PFP:00001

### Precautions for Supplemental Restraint System (SRS) “AIR BAG” and “SEAT BELT PRE-TENSIONER”

AKS008YP

The Supplemental Restraint System such as “AIR BAG” and “SEAT BELT PRE-TENSIONER”, used along with a front seat belt, helps to reduce the risk or severity of injury to the driver and front passenger for certain types of collision. This system includes seat belt switch inputs and dual stage front air bag modules. The SRS system uses the seat belt switches to determine the front air bag deployment, and may only deploy one front air bag, depending on the severity of a collision and whether the front occupants are belted or unbelted. Information necessary to service the system safely is included in the SRS and SB section of this Service Manual.

#### **WARNING:**

- To avoid rendering the SRS inoperative, which could increase the risk of personal injury or death in the event of a collision which would result in air bag inflation, all maintenance must be performed by an authorized NISSAN/INFINITI dealer.
- Improper maintenance, including incorrect removal and installation of the SRS, can lead to personal injury caused by unintentional activation of the system. For removal of Spiral Cable and Air Bag Module, see the SRS section.
- Do not use electrical test equipment on any circuit related to the SRS unless instructed to in this Service Manual. SRS wiring harnesses can be identified by yellow and/or orange harnesses or harness connectors.

### Wiring Diagrams and Trouble Diagnosis

AKS00002

When you read wiring diagrams, refer to the following:

- Refer to [GI-14, "How to Read Wiring Diagrams"](#) .  
Refer to [PG-3, "POWER SUPPLY ROUTING CIRCUIT"](#) .

When you perform trouble diagnosis, refer to the following:

- Refer to [GI-10, "HOW TO FOLLOW TEST GROUPS IN TROUBLE DIAGNOSES"](#) .  
Refer to [GI-26, "How to Perform Efficient Diagnosis for an Electrical Incident"](#) .

A

B

C

D

E

F

G

H

I

J

AV

L

M

# PREPARATION

## PREPARATION

PF0:00002

### Commercial Service Tools

AKS00003

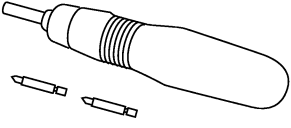
Tool name	Description
<p data-bbox="140 410 252 436">Power tool</p>  <p data-bbox="837 512 911 532">PBIC0191E</p>	<p data-bbox="997 312 1252 340">Loosening bolts and nuts</p>

## AUDIO

PFP:28111

### System Description BASE SYSTEM

AKS00004

Refer to Owner's Manual for audio system operating instructions.

Power is supplied at all times

- through 15A fuse [No. 37, located in the fuse and fusible link box]
- to audio unit terminal 6.

With the ignition switch in the ACC or ON position, power is supplied

- through 10A fuse [No. 6, located in the fuse block (J/B)]
- to audio unit terminal 10.

Ground is supplied through the case of the audio unit.

Audio unit and A/C and audio controller are connected by FPC (Flexible Print Circuit).

A/C and audio controller integrates A/C switches and audio switches.

When A/C and audio controller is pushed to audio switch, it sends audio signal to audio unit. Then audio signals are supplied

- through audio unit terminals 1, 2, 3, and 4
- to terminals 1 and 2 of front door speaker LH and RH
- to terminals 1 and 2 of tweeter LH and RH,
- through audio unit terminals 13, 14, 15, and 16
- to terminals 1 and 2 of rear door speaker LH and RH.

When one of steering wheel audio control switches is pushed to volume up, seek up, or mode ON, resistance in steering wheel audio control switch circuit changes depending on which button is pushed. This will change voltage. Power is supplied

- from audio unit terminal 22
- through combination switch (spiral cable) terminals 24 and 20
- to steering wheel audio control switch.

Ground is supplied

- from steering wheel audio control switch
- through combination switch (spiral cable) terminals 17 and 31
- to audio unit terminal 25.

When one of steering wheel audio control switches is pushed to volume down, seek down, or power ON, resistance in steering wheel audio control switch circuit changes depending on which button is pushed. This will change voltage. Power is supplied

- from audio unit terminal 23
- through combination switch (spiral cable) terminals 32 and 16
- to steering wheel audio control switch.

Ground is supplied

- from steering wheel audio control switch
- through combination switch (spiral cable) terminals 17 and 31
- to audio unit terminal 25.

### BOSE SYSTEM

Refer to Owner's Manual for audio system operating instructions.

Power is supplied at all times

- through 15A fuse [No. 37, located in the fuse and fusible link box]
- to audio unit terminal 6,
- to BOSE speaker amp. terminal 1.

With the ignition switch in the ACC or ON position, power is supplied

- through 10A fuse [No. 6, located in the fuse block (J/B)]
- to audio unit terminal 10.

Ground is supplied through the case of the audio unit.

A  
B  
C  
D  
E  
F  
G  
H  
I  
J  
L  
M

AV

# AUDIO

---

Ground is also supplied

- to BOSE speaker amp. terminal 17
- through body ground B5 and B29.

Audio unit and A/C and audio controller are connected by FPC (Flexible Print Circuit).  
A/C and audio controller integrates A/C switches and audio switches.

When A/C and audio controller is pushed to audio switch, it send audio signal to audio unit.  
Then audio signals are supplied

- through audio unit terminals 1, 2, 3, 4, 13, 14, 15, and 16
- to BOSE speaker amp. terminals 23, 24, 25, 26, 27, 28, 29, and 30.

Audio signals are amplified by the BOSE speaker amp.  
The amplified audio signals are supplied

- through BOSE speaker amp. terminals 13, 14, 15, and 16
- to terminals 1 and 2 of front door speaker LH and RH
- to terminals 1 and 2 of tweeter LH and RH,
- through BOSE speaker amp. terminals 9, 10, 11, and 12
- to terminals 1 and 2 of rear door speaker LH and RH,
- through BOSE speaker amp. terminals 2, and 18
- to terminals 1 and 2 of woofer.

When one of steering wheel audio control switches is pushed to volume up, seek up, or mode ON, resistance in steering wheel audio control switch circuit changes depending on which button is pushed. This will change voltage. Power is supplied

- from audio unit terminal 22
- through combination switch (spiral cable) terminals 24 and 20
- to steering wheel audio control switch.

Ground is supplied

- from steering wheel audio control switch
- through combination switch (spiral cable) terminals 17 and 31
- to audio unit terminal 25.

When one of steering wheel audio control switches is pushed to volume down, seek down, or power ON, resistance in steering wheel audio control switch circuit changes depending on which button is pushed. This will change voltage. Power is supplied

- from audio unit terminal 23
- through combination switch (spiral cable) terminals 32 and 16
- to steering wheel audio control switch.

Ground is supplied

- from steering wheel audio control switch
- through combination switch (spiral cable) terminals 17 and 31
- to audio unit terminal 25.

## **SPEED SENSITIVE VOLUME SYSTEM**

Volume level of this system gone up and down automatically in proportion to the vehicle speed. And the control level can be selected by the customer. This system is equipped for BOSE system.

# AUDIO

## Component Parts Location

AKS009HB

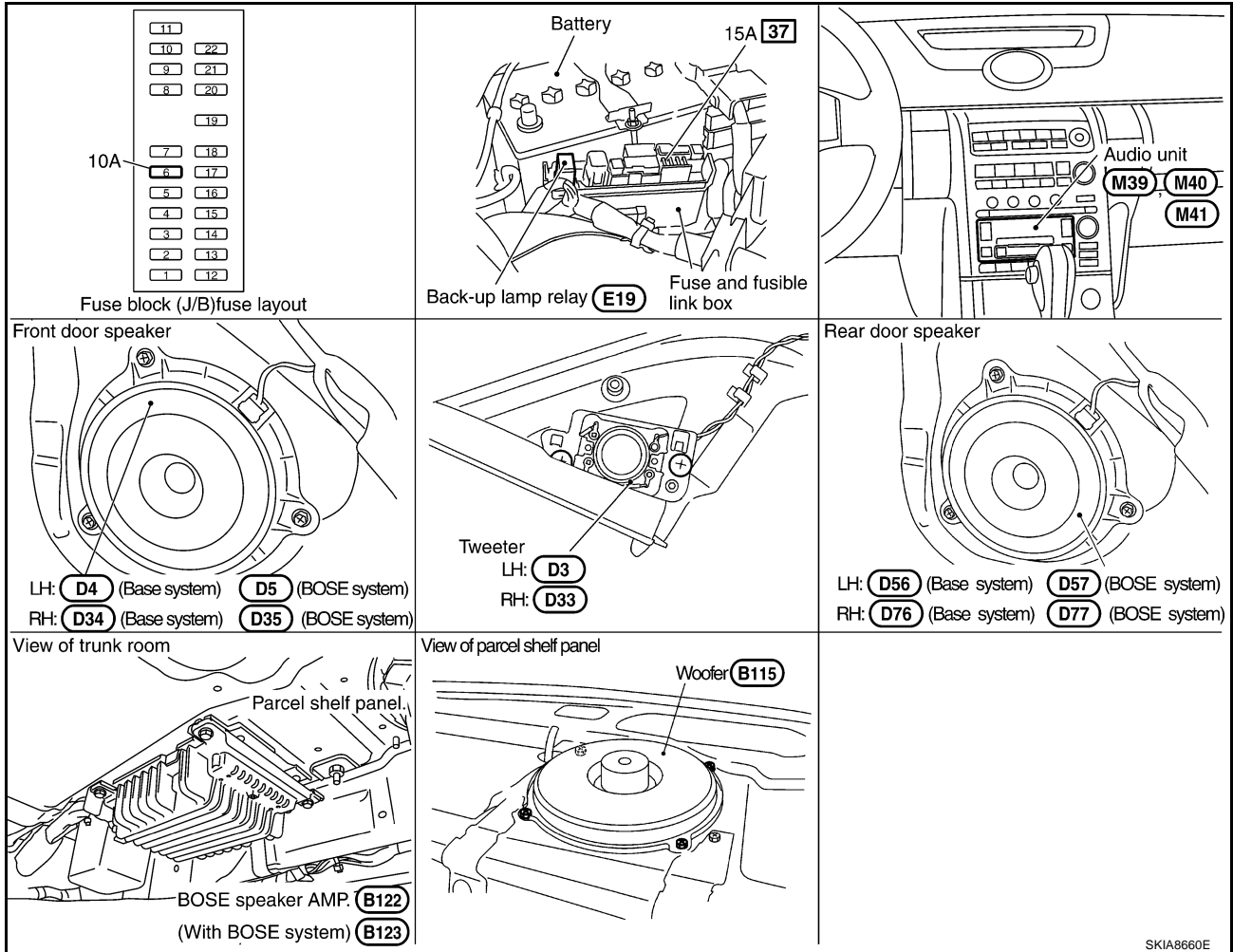

SKIA8660E

A  
B  
C  
D  
E  
F  
G  
H  
I  
J  
L  
M

AV





# AUDIO

## Wiring Diagram – AUDIO – / Base System

AKS00006

AV-AUDIO-01

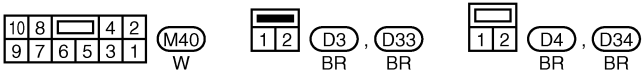
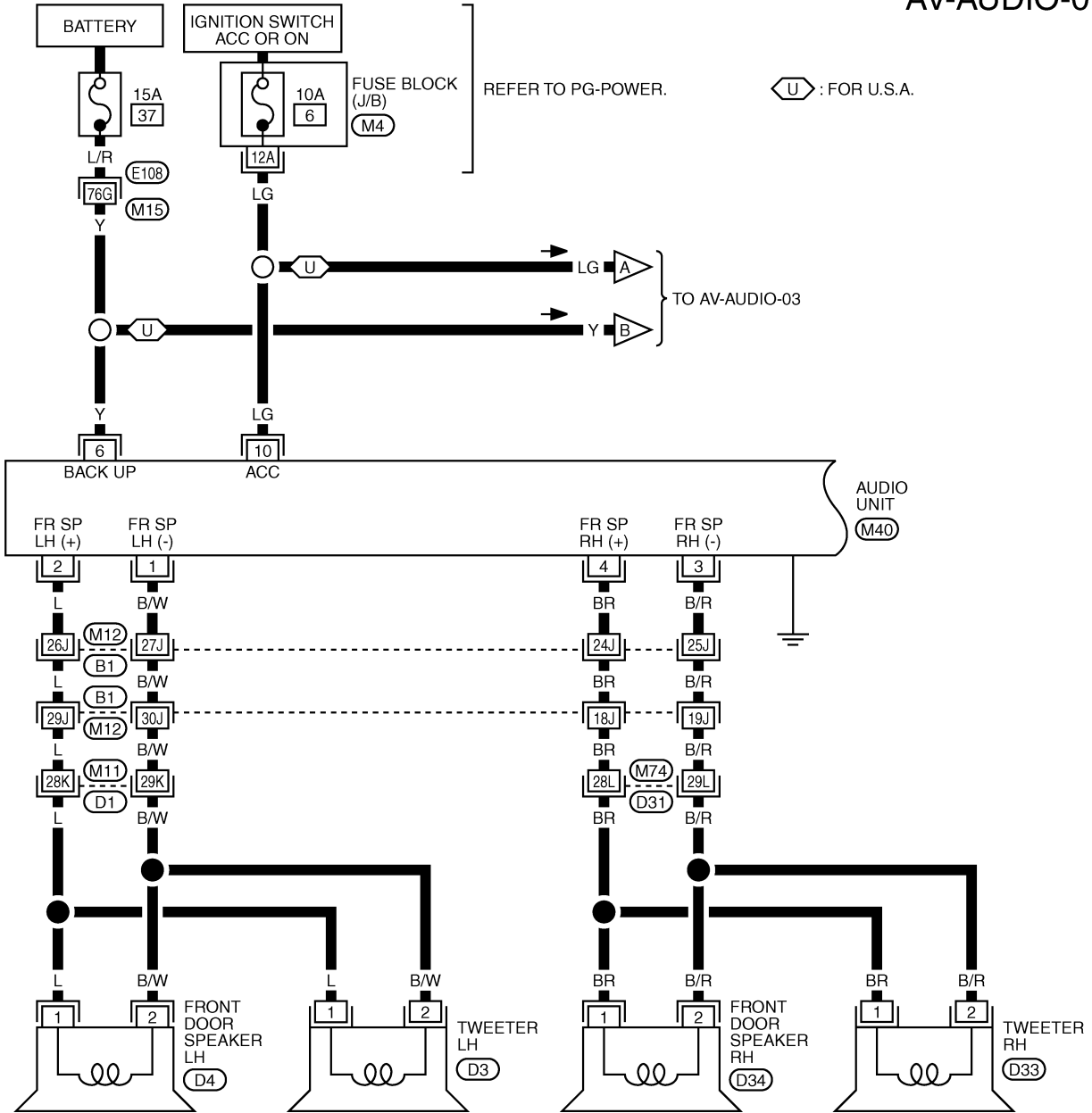

REFER TO THE FOLLOWING.  
 (E108), (B1), (D1), (D31)  
 -SUPER MULTIPLE JUNCTION (SMJ)  
 (M4) -FUSE BLOCK-JUNCTION BOX (J/B)

A  
B  
C  
D  
E  
F  
G  
H  
I  
J  
AV  
L  
M

# AUDIO

## AV-AUDIO-02

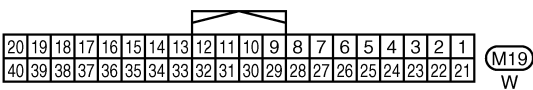
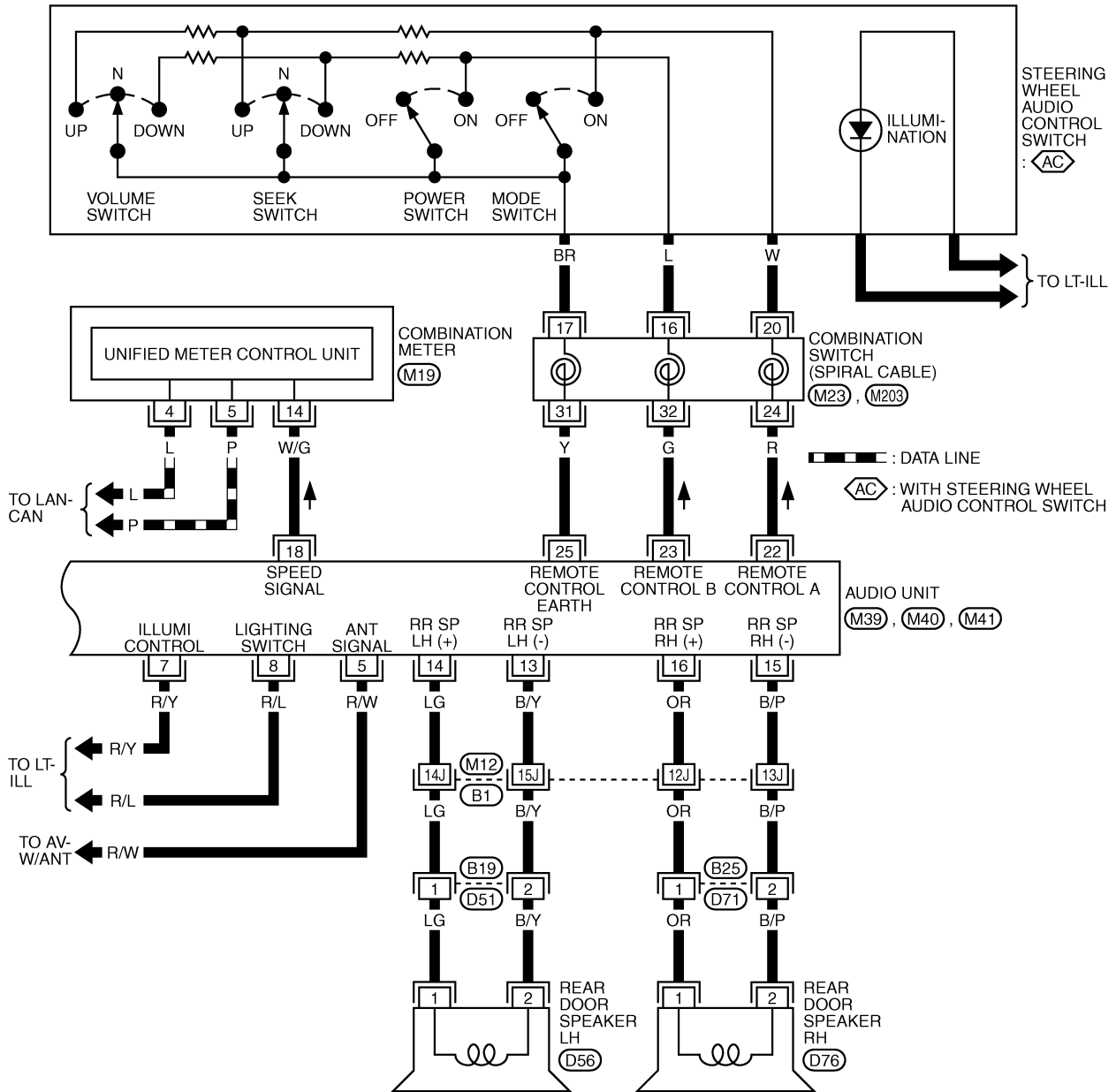

REFER TO THE FOLLOWING.

(B1) -SUPER MULTIPLE JUNCTION (SMJ)

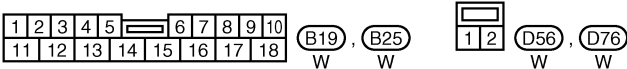
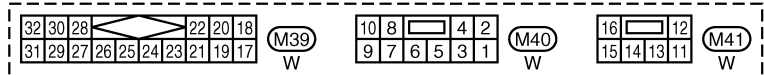
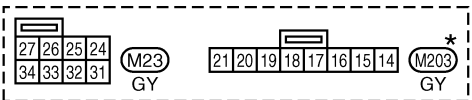

\*: THIS CONNECTOR IS NOT SHOWN IN "HARNESS LAYOUT", PG SECTION.

TKWM2393E

# AUDIO

## AV-AUDIO-03

U : FOR U.S.A.

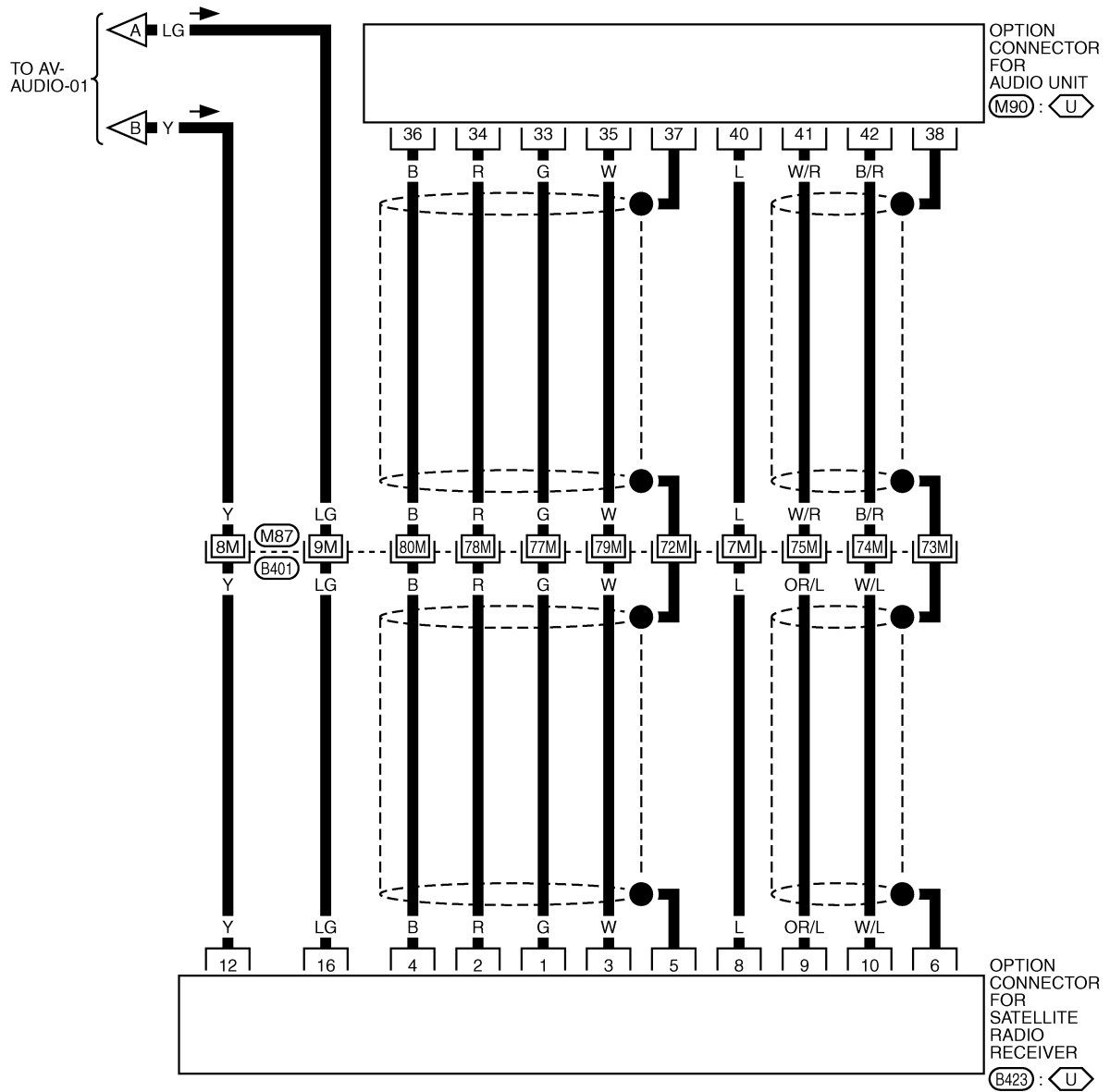

A  
B  
C  
D  
E  
F  
G  
H  
I  
J  
AV  
L  
M

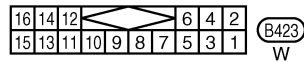
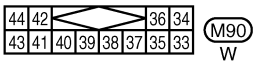

REFER TO THE FOLLOWING.  
B401 -SUPER MULTIPLE JUNCTION (SMJ)

TKWM2394E

# AUDIO

## Schematic / BOSE System

AKS00CS2

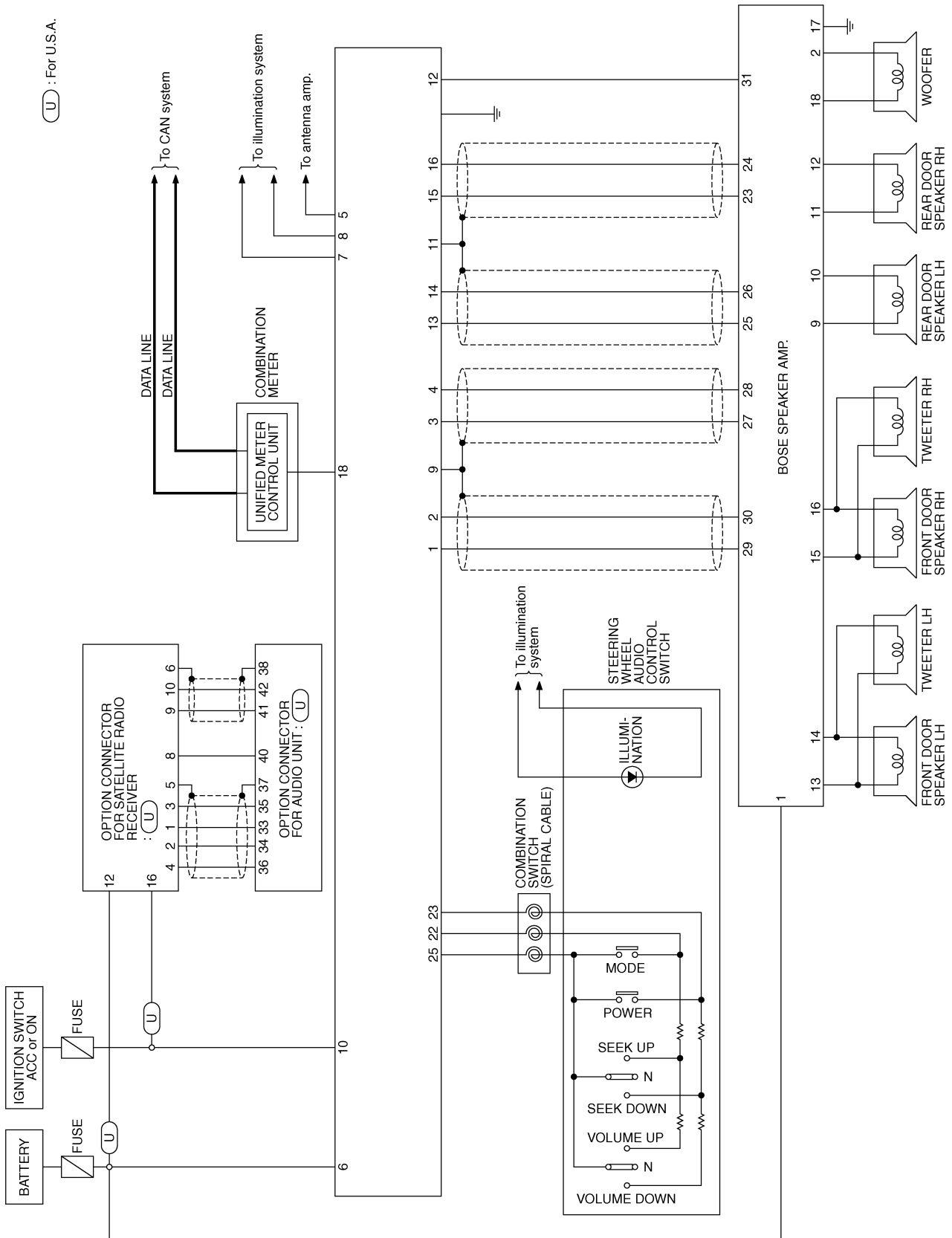

TKWM2391E

# AUDIO

## Wiring Diagram – AUDIO – / BOSE System

AKS00CS3

AV-AUDIO-04

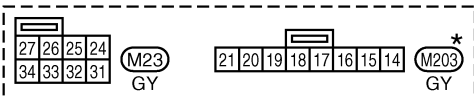
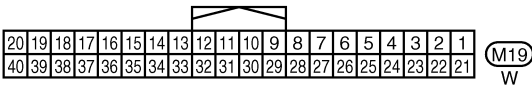
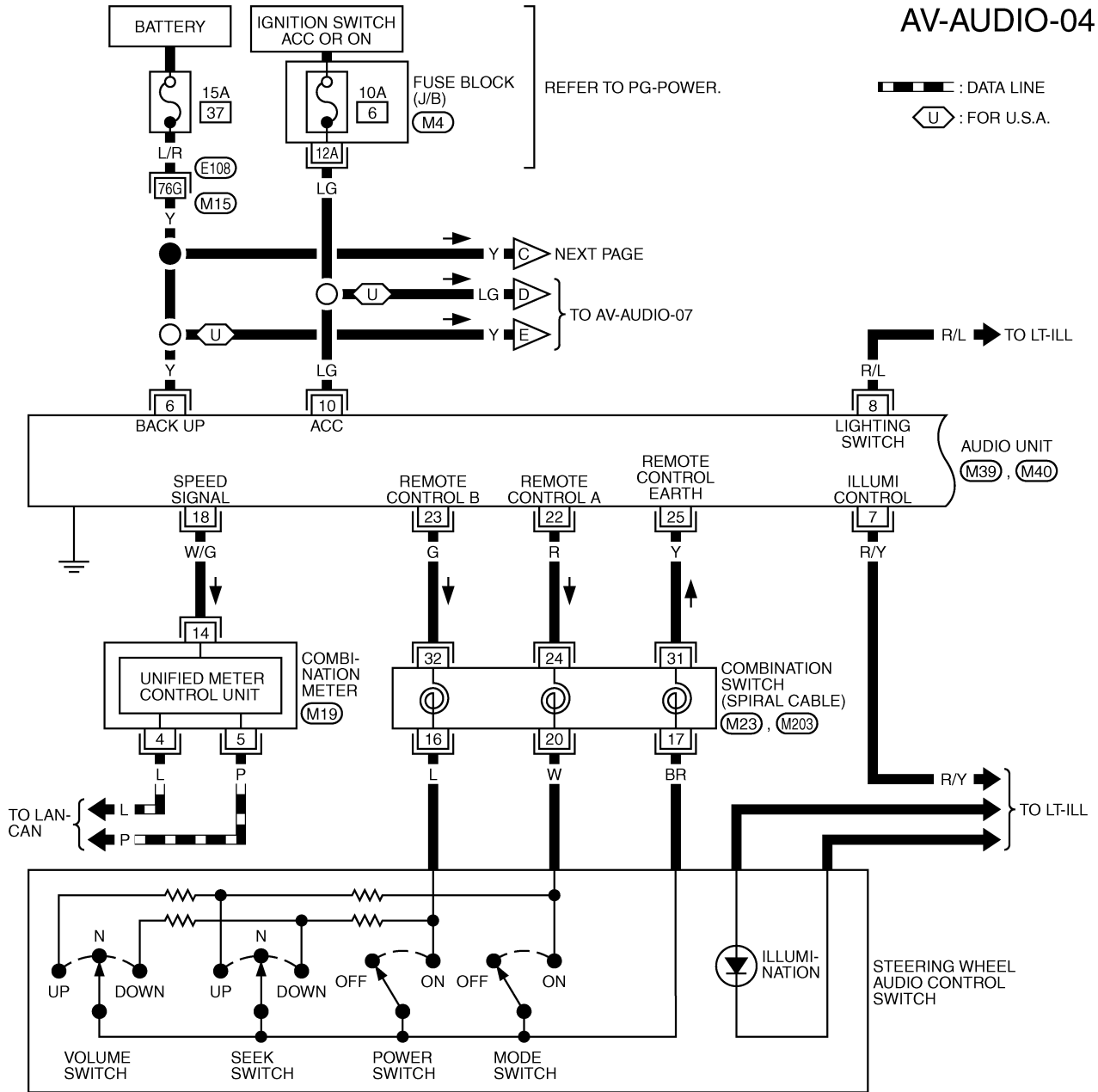

\*: THIS CONNECTOR IS NOT SHOWN IN "HARNESS LAYOUT", PG SECTION.

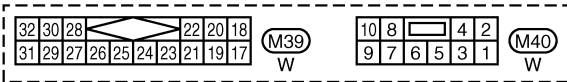

REFER TO THE FOLLOWING.

(E108) -SUPER MULTIPLE JUNCTION (SMJ)

(M4) -FUSE BLOCK-JUNCTION BOX (J/B)

TKWM2395E

# AUDIO

AV-AUDIO-05

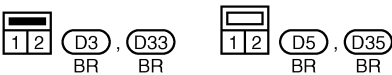
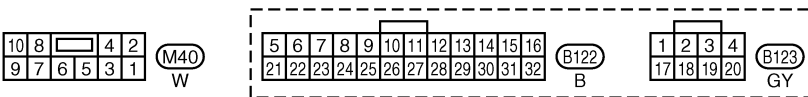
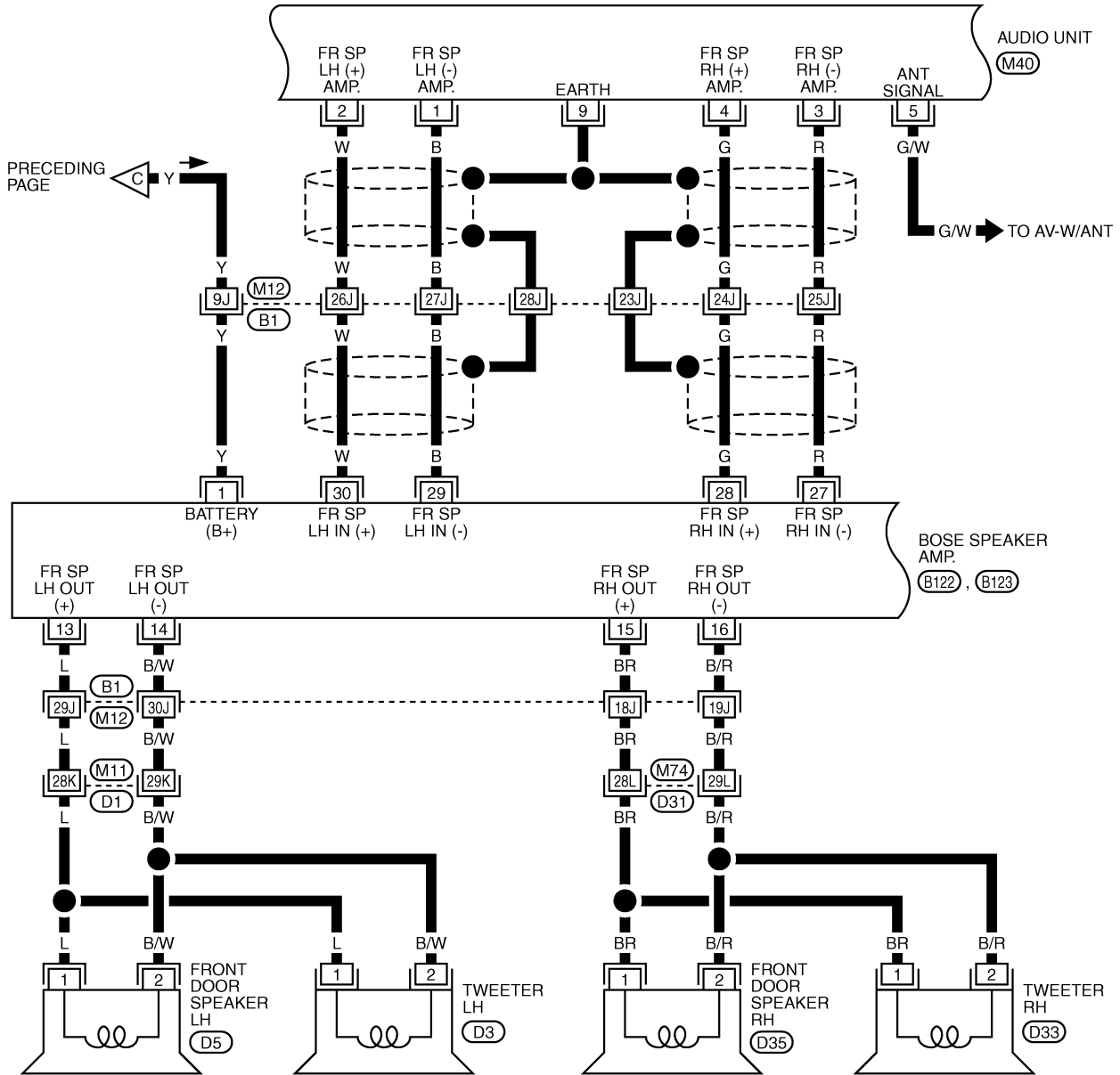

REFER TO THE FOLLOWING.  
 (B1), (D1), (D31) -SUPER  
 MULTIPLE JUNCTION (SMJ)

TKWM2396E

A  
B  
C  
D  
E  
F  
G  
H  
I  
J  
AV  
L  
M

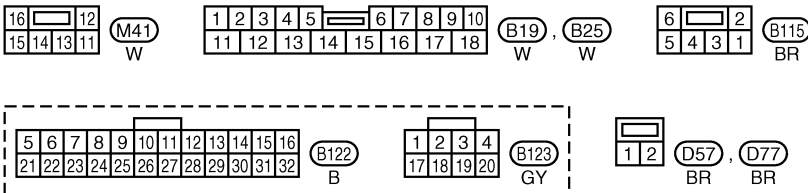
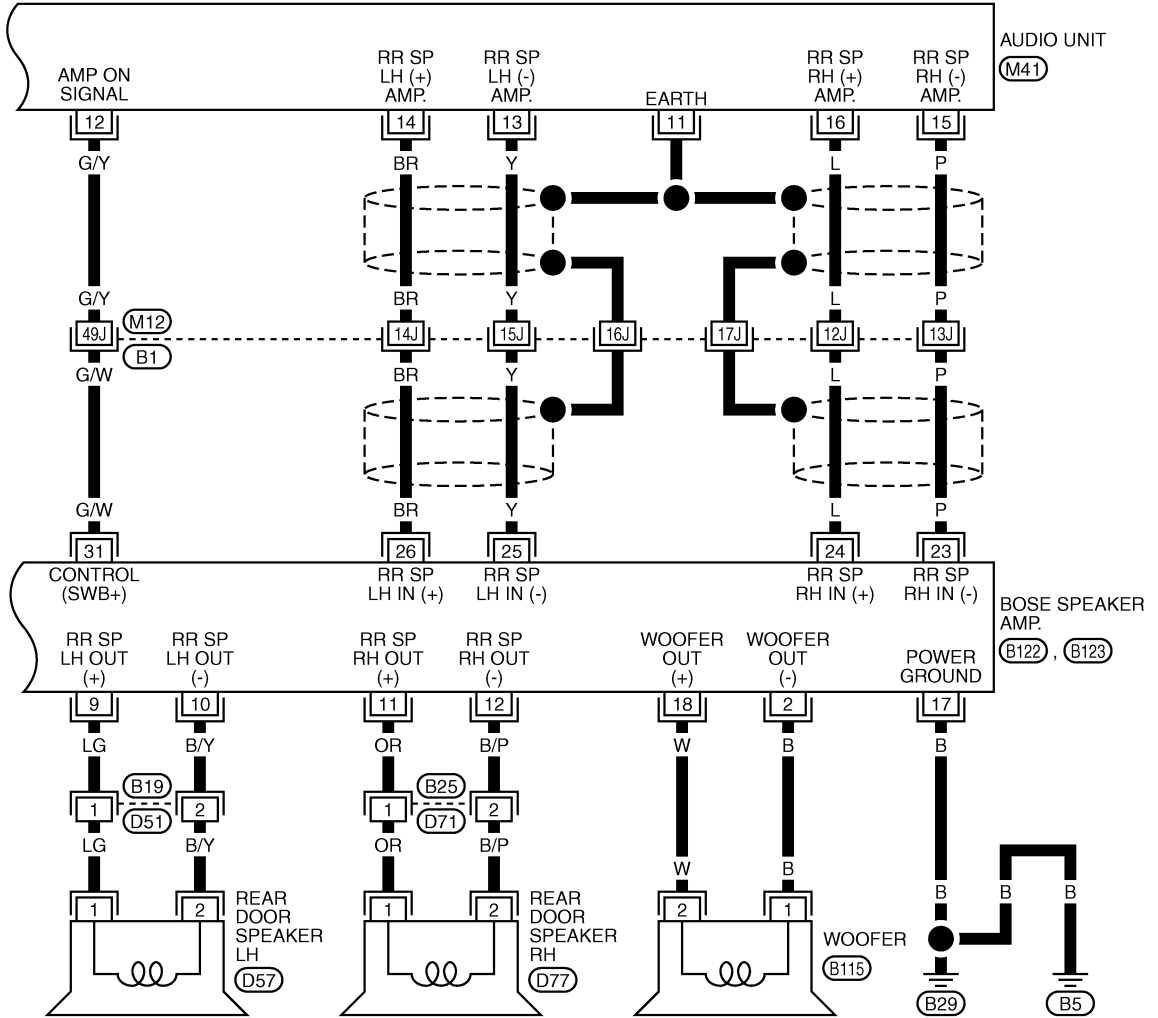

REFER TO THE FOLLOWING.  
 (B1) -SUPER MULTIPLE JUNCTION (SMJ)

TKWM2397E

# AUDIO

## AV-AUDIO-07

U : FOR U.S.A.

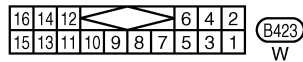
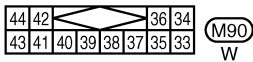
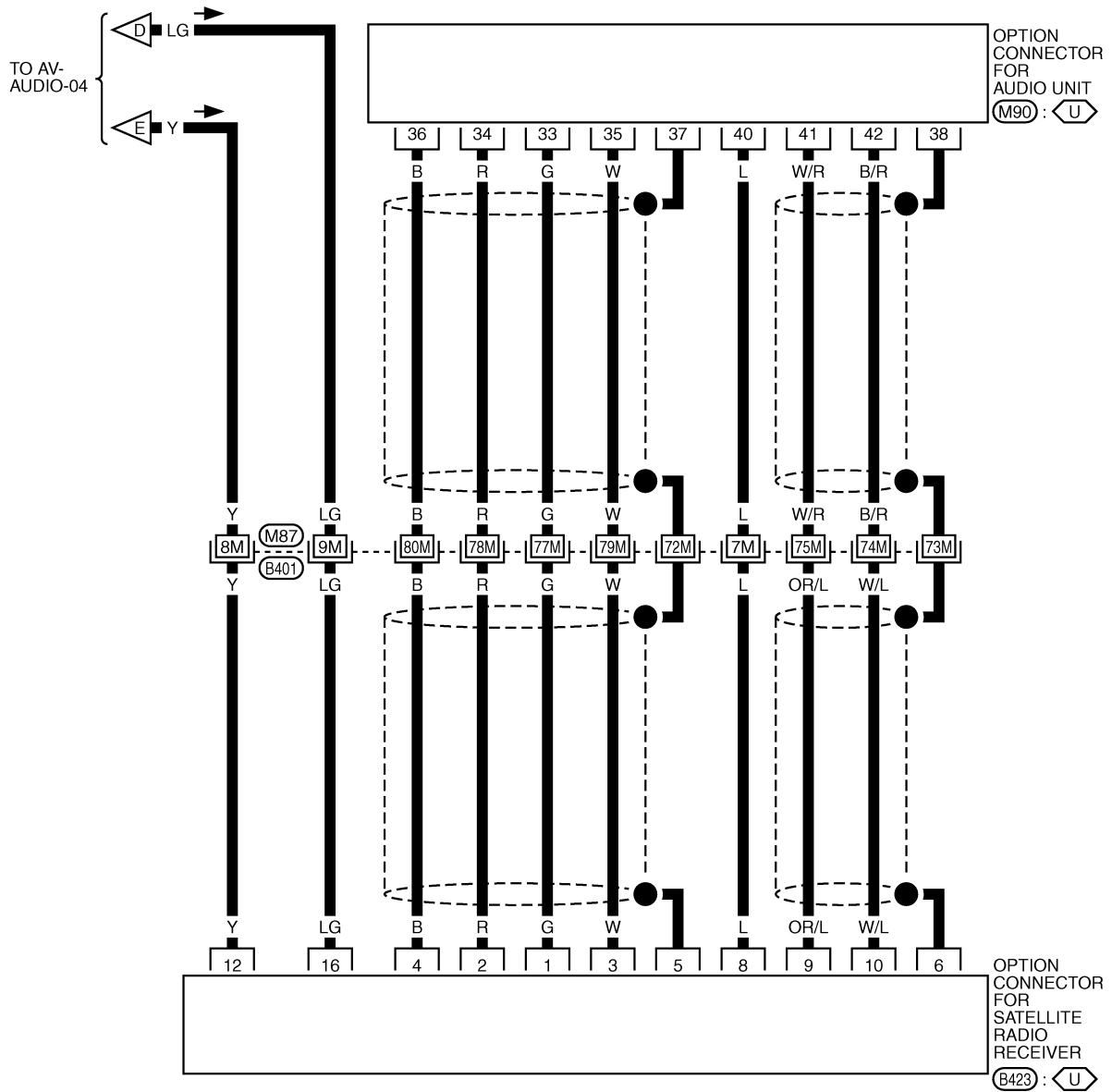

REFER TO THE FOLLOWING.  
 (B401) -SUPER MULTIPLE JUNCTION (SMJ)

TKWM2398E



# AUDIO

## Terminals and Reference Value for Audio Unit for Base System

AKS00008

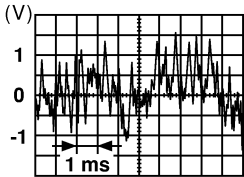
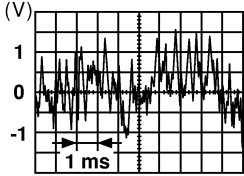
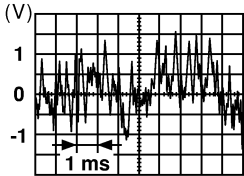
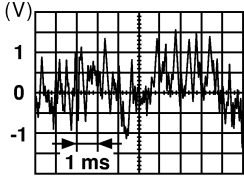
Terminal (Wire color)		Item	Signal input/ output	Condition		Reference value	Example of symptom
+	-			Ignition switch	Operation		
2 (L)	1 (B/W)	Audio sound signal front LH	Output	ON	Receive audio signal	 SKIA0177E	No sound from front door speaker LH and tweeter LH.
4 (BR)	3 (B/R)	Audio sound signal front RH	Output	ON	Receive audio signal	 SKIA0177E	No sound from front door speaker RH and tweeter RH.
5 (R/W)	Ground	Antenna signal	output	ON	-	Approx. 12V	Receiving status of radio broadcast becomes bad.
6 (Y)	Ground	Battery power supply	Input	-	-	Battery voltage	System does not work properly.
7 (R/Y)	Ground	Illumination control signal	Input	ON	Illumination control switch is operated by light- ing switch in ON position	Changes between approx.0V and approx.12V	Audio unit illumina- tion cannot be controlled.
8 (R/L)	Ground	Lighting switch	Input	ON	Lighting switch ON (1st position)	Approx. 12V	Audio unit illumina- tion does not function when lighting switch is ON (position 1).
					Lighting switch OFF	Approx. 0V	
10 (LG)	Ground	ACC power supply	Input	ON	Ignition switch ACC or ON	Battery voltage	System does not work properly.
14 (LG)	13 (B/Y)	Audio sound signal rear LH	Output	ON	Receive audio signal	 SKIA0177E	No sound from rear door speaker LH.
16 (OR)	15 (B/P)	Audio sound signal rear RH	Output	ON	Receive audio signal	 SKIA0177E	No sound from rear door speaker RH.

A  
B  
C  
D  
E  
F  
G  
H  
I  
J  
AV  
L  
M

# AUDIO

Terminal (Wire color)		Item	Signal input/ output	Condition		Reference value	Example of symptom
+	-			Ignition switch	Operation		
18 (W/G)	Ground	Vehicle speed signal (2-pulse)	Input	ON	When vehicle speed is approx 40 km/h (25MPH)		Speed sensitive volume system does not work properly.
22 (R)	Ground	Remote control A	Input	ON	Press MODE switch	Approx.0V	Steering wheel audio controls do not function.
					Press SEEK UP switch	Approx. 1.7V	
					Press VOL UP switch	Approx. 3.3V	
					Except for above	Approx. 5V	
23 (G)	Ground	Remote control B	Input	ON	Press POWER switch	Approx. 0V	Steering wheel audio controls do not function.
					Press SEEK DOWN switch	Approx. 1.7V	
					Press VOL DOWN switch	Approx. 3.3V	
					Except for above	Approx. 5V	
25 (Y)	-	Remote control ground	-	ON	-	-	Steering wheel audio controls do not function.

## Terminals and Reference Value for Audio Unit for BOSE System

AKS00009

Terminal (Wire color)		Item	Signal input/ output	Condition		Reference value	Example of symptom
+	-			Ignition switch	Operation		
2 (W)	1(B)	Audio sound signal front LH	Output	ON	Receive audio signal		No sound from front door speaker LH and tweeter LH.
4 (G)	3 (R)	Audio sound signal front RH	Output	ON	Receive audio signal		No sound from front door speaker RH and tweeter RH.
5 (G/W)	Ground	Antenna signal	Output	ON	-	Approx. 12V	Receiving status of radio broadcast becomes bad.
6 (Y)	Ground	Battery power supply	-	-	-	Battery voltage	System does not work properly.

# AUDIO

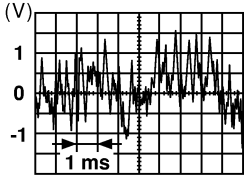
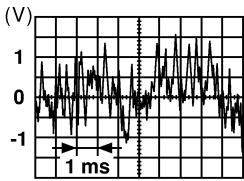
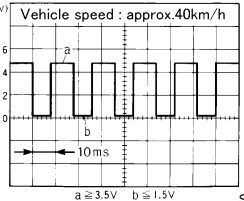
Terminal (Wire color)		Item	Signal input/ output	Condition		Reference value	Example of symptom
+	-			Ignition switch	Operation		
7 (R/Y)	Ground	Illumination control signal	Input	ON	Illumination control switch is operated by lighting switch in ON position	Changes between approx.0V and approx.12V	Audio unit illumination cannot be controlled.
8 (R/L)	Ground	Lighting switch	Input	ON	Light switch ON (1st position)	Approx. 12V	Audio unit illumination does not function when lighting switch is ON (position 1).
					Lighting switch OFF	Approx. 0V	
9	-	Shield	-	-	-	Approx. 0V	Interference and distortion heard from speakers.
10 (LG)	Ground	ACC power supply	Input	ON	-	Battery voltage	System does not work properly.
11	-	Shield	-	-	-	Approx. 0V	Interference and distortion heard from speakers.
12 (G/Y)	Ground	Amp. ON signal	Output	ON	-	Approx. 12V	Amp. does not work properly.
14 (BR)	13 (Y)	Audio sound signal rear LH	Output	ON	Receive audio signal	 SKIA0177E	No sound from rear door speaker LH.
16 (L)	15 (P)	Audio sound signal rear RH	Output	ON	Receive audio signal	 SKIA0177E	No sound from rear door speaker RH.
18(W/G)	Ground	Vehicle speed signal (2-pulse)	Input	ON	When vehicle speed is approx. 40km/h (25 MPH)	 SKIA0168E	Speed sensitive volume system does not work properly.
22 (R)	Ground	Remote control A	Input	ON	Press MODE switch	Approx. 0V	Steering wheel audio controls do not function.
					Press SEEK UP switch	Approx. 1.7V	
					Press VOL UP switch	Approx. 3.3V	
					Except for above	Approx. 5V	

A  
B  
C  
D  
E  
F  
G  
H  
I  
J  
L  
M

AV

# AUDIO

Terminal (Wire color)		Item	Signal input/ output	Condition		Reference value	Example of symptom
+	-			Ignition switch	Operation		
23 (G)	Ground	Remote control B	Input	ON	Press POWER switch	Approx. 0V	Steering wheel audio controls do not function.
					Press SEEK DOWN switch	Approx. 1.7V	
					Press VOL DOWN switch	Approx. 3.3V	
					Except for above	Approx. 5V	
25 (Y)	-	Remote control ground	-	ON	-	-	Steering wheel audio controls do not function.

## Terminals and Reference Value for BOSE Speaker Amp.

AKS0000A

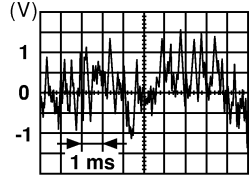
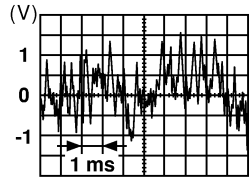
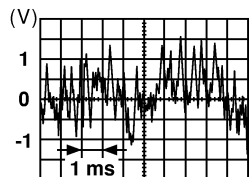
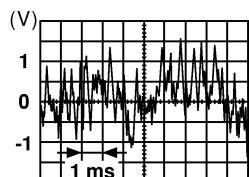
Terminal (Wire color)		Item	Signal input/ output	Condition		Reference value	Example of symptom
+	-			Ignition switch	Operation		
1 (Y)	Ground	Battery power supply	Input	-	-	Battery voltage	Amp. does not work properly.
9 (LG)	10 (B/Y)	Audio sound signal rear LH	Output	ON	Receive audio signal	 SKIA0177E	No sound from rear door speaker LH.
11 (OR)	12 (B/P)	Audio sound signal rear RH	Output	ON	Receive audio signal	 SKIA0177E	No sound from rear door speaker RH.
13 (L)	14 (B/W)	Audio sound signal front door speaker LH and tweeter LH	Output	ON	Receive audio signal	 SKIA0177E	No sound from front door speaker LH and tweeter LH.
15 (BR)	16 (B/R)	Audio sound signal front door speaker RH and tweeter RH	Output	ON	Receive audio signal	 SKIA0177E	No sound from front door speaker RH and tweeter RH.
17 (B)	Ground	Ground	-	-	-	-	-

# AUDIO

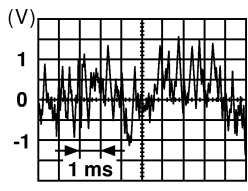
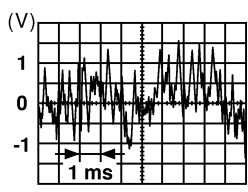
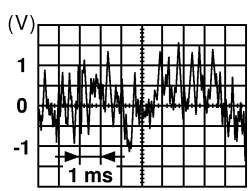
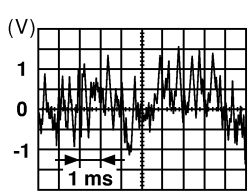
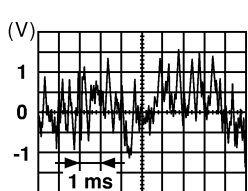
Terminal (Wire color)		Item	Signal input/ output	Condition		Reference value	Example of symptom
+	-			Ignition switch	Operation		
18 (W)	2 (B)	Audio sound signal woofer	Output	ON	Receive audio signal	 SKIA0177E	No sound from woofer.
24 (L)	23 (P)	Audio sound signal rear RH	Input	ON	Receive audio signal	 SKIA0177E	No sound from rear door speaker RH.
26 (BR)	25 (Y)	Audio sound signal rear LH	Input	ON	Receive audio signal	 SKIA0177E	No sound from rear door speaker LH.
28 (G)	27 (R)	Audio sound signal front RH and tweeter RH	Input	ON	Receive audio signal	 SKIA0177E	No sound from front door speaker RH and tweeter RH.
30 (W)	29 (B)	Audio sound signal front LH and tweeter LH	Input	ON	Receive audio signal	 SKIA0177E	No sound from front door speaker LH and tweeter LH.
31 (G/W)	Ground	Control (SWB+)	Input	ON	-	Approx. 12V	Amp. does not work properly

A  
B  
C  
D  
E  
F  
G  
H  
I  
J  
AV  
L  
M

## Steering Wheel Audio Control Switch Resistance Check

AKS0000B

Terminal (Wire color)		Signal name	Condition	Resistance (Ω)
16 (L)	17 (BR)	Power	Depress power switch.	Approx. 0
		Seek down (previous)	Depress (station) down switch.	Approx. 165
		Volume (down)	Depress volume down switch.	Approx. 652
20 (W)	17 (BR)	Mode	Depress mode switch.	Approx. 0
		Seek up (next)	Depress (station) up switch.	Approx. 165
		Volume (up)	Depress volume up switch.	Approx. 652

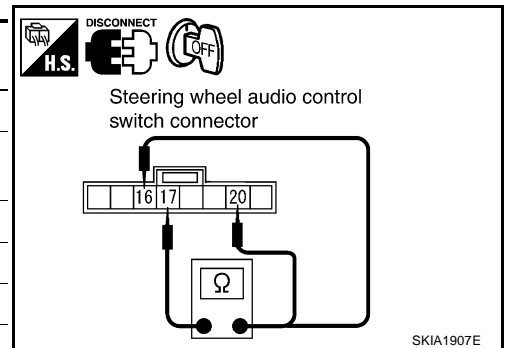

# AUDIO

AKS000DQ

## Trouble Diagnosis

The majority of the audio troubles are the result of outside causes (bad CD/cassette, electromagnetic interference, etc.). Check the inspection items below to diagnose the malfunction.

### PROBLEM WITH RADIO AND CD

Symptom	Check items	Possible cause
Inoperative	<ul style="list-style-type: none"> <li>● Check that the ignition switch is in the ACC position.</li> </ul>	<ul style="list-style-type: none"> <li>● Audio unit</li> <li>● Audio unit power circuit Refer to <a href="#">AV-24, "Power Supply Circuit Inspection"</a> .</li> </ul>
No sound	<ul style="list-style-type: none"> <li>● Check that the volume is not turned down.</li> <li>● Check that the balance and fader control knobs are centered.</li> </ul>	<ul style="list-style-type: none"> <li>● Audio unit</li> <li>● Audio unit power circuit. Refer to <a href="#">AV-24, "Power Supply Circuit Inspection"</a> .</li> <li>● Speaker</li> <li>● BOSE speaker amp. (BOSE system)</li> <li>● Sound signal circuit between speaker and Audio unit (Base system)</li> <li>● Sound signal circuit between speaker and BOSE speaker amp.(BOSE system)</li> </ul>
Poor sound	<ul style="list-style-type: none"> <li>● Check that the bass and treble adjustment knobs are centered.</li> </ul>	<ul style="list-style-type: none"> <li>● Audio unit</li> <li>● BOSE speaker amp. (BOSE system)</li> <li>● Speaker</li> </ul>
Noisy	–	<ul style="list-style-type: none"> <li>● Audio unit</li> <li>● BOSE speaker amp. (BOSE system)</li> <li>● Each electrical equipment</li> </ul>

### FOR RADIO ONLY

Symptom	Check items	Possible cause
No sound	<ul style="list-style-type: none"> <li>● Check that the radio is tuned to a station's frequency.</li> </ul>	<ul style="list-style-type: none"> <li>● Audio unit</li> <li>● Antenna feeder</li> <li>● Antenna amplifier</li> <li>● Window antenna</li> </ul>
Noisy	<ul style="list-style-type: none"> <li>● Check that the radio is tuned to a station's frequency.</li> <li>● Check that the signal of the received station is not weak.</li> <li>● Check that no mirror-type window film nor any metal object (after-market antenna, etc.) is attached on the rear window glass (Note 1).</li> <li>● Check whether or not the malfunction occurs only in a particular area. (Note 2)</li> </ul>	<ul style="list-style-type: none"> <li>● Audio unit</li> <li>● Antenna feeder</li> <li>● Antenna amplifier</li> <li>● window antenna</li> <li>● Noise prevention parts</li> <li>● Each electrical equipment</li> <li>● Wire harness of each piece of electrical equipment</li> </ul>
Selected radio stations stored in memory are deleted	–	<ul style="list-style-type: none"> <li>● Audio unit</li> </ul>

#### NOTE:

1. The cause is a reduction in the receiving sensitivity of the window antenna.
  2. This is noise resulting from variations in field strength, such as fading noise and multi-path noise, or external noise from trains and other sources. It is not a malfunction.
- **Fading noise:** This noise occurs because of variations in the field strength in a narrow range due to mountains or buildings blocking the signal.
  - **Multi-path noise:** This noise results from the waves sent directly from the broadcast station arriving at the antenna at a different time from the waves which reflect off of mountains or buildings.

# AUDIO

## FOR CD ONLY

Symptom	Check items	Possible cause
CD cannot be inserted.	Check that a CD is not already inserted.	● Audio unit
CD cannot be ejected.	–	
The CD cannot be played.	<ul style="list-style-type: none"> <li>● Check that the CD is not upside down.</li> <li>● Check that there is no dirt, damage, or water on the disc.</li> </ul>	● Audio unit
The sound skips, stops suddenly, or is distorted.	<ul style="list-style-type: none"> <li>● Check that there is no dirt, damage, or water on the disc.</li> <li>● Check that the trouble is not due to strong vibration.</li> </ul>	

## Noise Inspection

AKS000DR

The vehicle itself can be a source of noise if noise prevention parts or electrical equipment is malfunction. Check if noise is caused and/or changed by engine rotation, ignition switch turned to each position, and operation of each piece of electrical equipment, and determine the cause.

### NOTE:

The source of the noise can be found easily by listening to the noise while removing the fuses of electrical components, one by one.

### TYPE OF NOISE AND POSSIBLE CAUSE

Occurrence condition		Possible cause
Occurs only when engine is ON.	A continuous growling noise occurs. The speed of the noise varies with changes in the engine speed.	● Problem with the ignition condenser.
	A whistling noise occurs while the engine speed is high. A booming noise occurs while the engine is running and the light switch is ON.	● Problem with the alternator
The occurrence of the noise is linked with the operation of the fuel pump.		● Problem with the fuel pump condenser
Noise only occurs when various electrical components are operating.	A cracking or snapping sound occurs with the operation of various switches.	● Relay malfunction, radio malfunction
	The noise occurs when various motors are operating.	<ul style="list-style-type: none"> <li>● Problem with the motor case ground</li> <li>● Problem with the motor</li> </ul>
The noise occurs constantly, not just under certain conditions.		<ul style="list-style-type: none"> <li>● Rear defogger coil malfunction</li> <li>● Open circuit in printed heater</li> <li>● Poor ground of antenna amplifier or antenna feeder line</li> <li>● Mirror type film is attached on the rear window glass</li> <li>● After-market TV antenna and/or electrical accessories such as radio are attached on the rear window glass.</li> </ul>
A cracking or snapping sound occurs while the vehicle is being driven, especially when it is vibrating excessively.		<ul style="list-style-type: none"> <li>● Problem with the ground wire of body parts.</li> <li>● Problem with ground due to part installation problem</li> <li>● Problem with wiring connections or a short circuit</li> </ul>

A  
B  
C  
D  
E  
F  
G  
H  
I  
J  
L  
M

AV

# AUDIO

AKS000DS

## Power Supply Circuit Inspection

### 1. CHECK FUSE

Check that the following fuses of the BOSE speaker amp. and audio unit are not blown.

Unit	Terminals		Signal name	Fuse No.
	(+)			
	Connector	Terminal (Wire color)		
Audio unit	M40	6 (Y)	Battery power	37
		10(LG)	Ignition switch ACC or ON	6
BOSE speaker amp.	B123	1(Y)	Battery power	37

#### OK or NG

OK >> GO TO 2.

NG >> If fuse is blown, be sure to eliminate cause of problem before installing new fuse. Refer to [PG-3](#), "[POWER SUPPLY ROUTING CIRCUIT](#)".

### 2. POWER SUPPLY CIRCUIT CHECK

1. Check voltage between the audio unit harness connector and ground.

Unit	Terminal No.			OFF	ACC
	(+)				
	Connector	Terminal (Wire color)	(-)		
Audio unit	M40	6 (Y)	Ground	Battery voltage	Battery voltage
		10 (LG)	Ground	0 V	Battery voltage

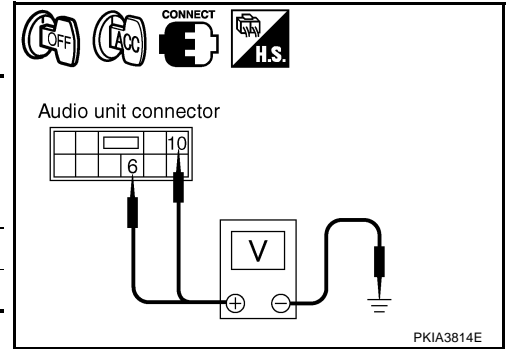

2. Check voltage between BOSE speaker amp. harness connector and ground.

Unit	Terminal No.			OFF	ACC
	(+)				
	Connector	Terminal (Wire color)	(-)		
BOSE speaker amp.	B123	1(Y)	Ground	Battery voltage	Battery voltage

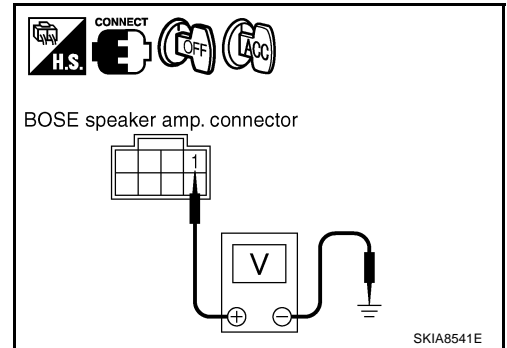

#### OK or NG

OK >> ● Inspection end. (Base system)

● GO TO 3. (BOSE system)

NG >> Repair harness or connector.



## 3. GROUND CIRCUIT CHECK

1. Turn ignition switch OFF.
2. Disconnect BOSE speaker amp.connector.
3. Check continuity between BOSE speaker amp. harness connector B123 terminal 17 (B) and ground.

**Continuity should exist.**

OK or NG

- OK >> Inspection end.  
 NG >> Repair harness or connector.

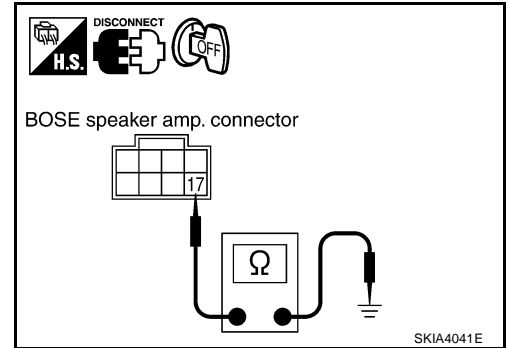

## Steering Wheel Audio Control Switch Does Not Operate

AKS000DU

### 1. STEERING WHEEL AUDIO CONTROL SWITCH RESISTANCE CHECK

1. Turn ignition switch OFF.
2. Disconnect steering wheel audio control switch connector.
3. Check resistance steering wheel audio control switch. Refer to [AV-21, "Steering Wheel Audio Control Switch Resistance Check"](#) .

**Resistance value is OK?**

YES or NO

- YES >> GO TO 2.  
 NO >> Replace steering wheel audio control switch.

### 2. STEERING WHEEL AUDIO CONTROL SWITCH CIRCUIT CHECK

1. Disconnect audio unit connector.
2. Check continuity between audio unit harness connector M39 and combination switch (spiral cable) harness connector M23.

Terminals				Continuity
Connector	Terminal (Wire color)	Connector	Terminal (Wire color)	
M39	22 (R)	M23	24 (R)	Yes
	23 (G)		32 (G)	
	25 (Y)		31 (Y)	

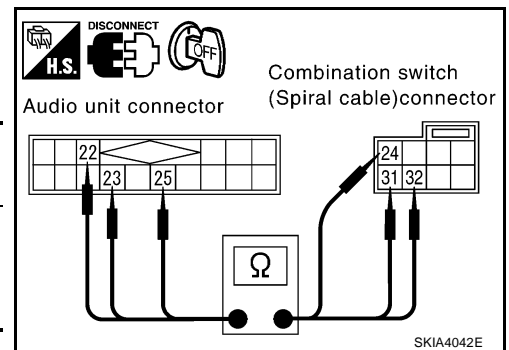

OK or NG

- OK >> GO TO 3.  
 NG >> Repair harness or connector.

### 3. AUDIO UNIT CHECK

1. Connect audio unit connector.
2. Turn ignition switch ON.
3. Check voltage between audio unit harness connector M39 terminal 22 (R), 23 (G) and ground.

**22 (R) - Ground : Approx. 5V**  
**23 (G) - Ground : Approx. 5V**

OK or NG

- OK >> Replace combination switch (spiral cable).  
 NG >> Replace audio unit.

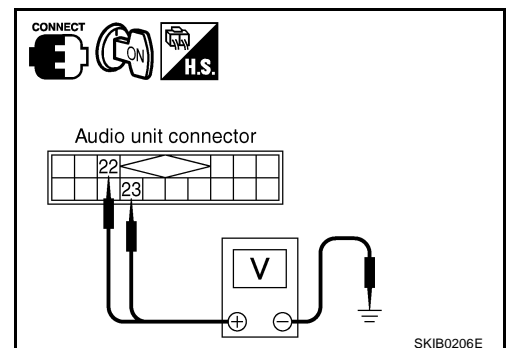

## Speed Sensitive Volume System Does Not Work

### 1. VEHICLE SPEED OPERATION CHECK

Does speedometer is operated normally?

YES or NO

YES >> GO TO 2.

NO >> Check combination meter trouble diagnosis. Refer to [DI-13, "Vehicle Speed Signal Inspection"](#) in "COMBINATION METERS".

### 2. HARNESS CHECK

1. Turn ignition switch OFF.
2. Disconnect audio unit connector and combination meter connector.
3. Check continuity between audio unit harness connector M39 terminal 18 (W/G) and combination meter harness connector M19 terminal 14 (W/G).

**Continuity should exist.**

4. Check continuity between audio unit harness connector M39 terminal 18 (W/G) and ground.

**Continuity should not exist.**

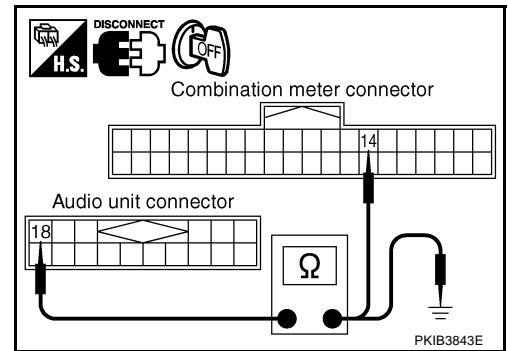

OK or NG

OK >> GO TO 3.

- NG >> ● Check connector housings for disconnected or loose terminals.  
 ● Repair harness or connector.

### 3. VEHICLE SPEED SIGNAL CHECK

1. Connect audio unit connector and combination meter connector.
2. Start engine and drive vehicle at more than 40 km/h (25MPH).
3. Check the signal between audio unit harness connector M39 terminal 18 (W/G) and ground with CONSULT-II or oscilloscope.

**18 (W/G) – Ground : Refer to [AV-18, "Terminals and Reference Value for Audio Unit for BOSE System"](#) .**

OK or NG

OK >> Replace audio unit.

- NG >> Check combination meter system. Refer to [DI-10, "PRE-LIMINARY CHECK"](#) in "COMBINATION METERS".

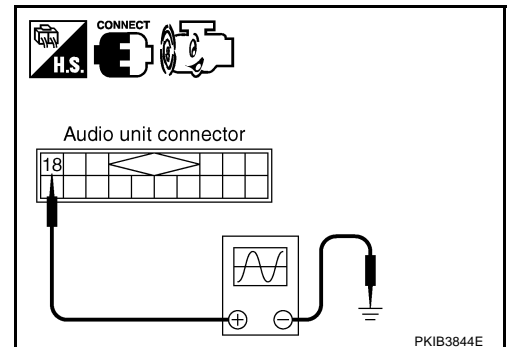

## Locking CD Auto-changer Mechanism

AKS000G3

### CAUTION:

- Prior to removing a malfunctioning CD auto-changer unit that will be shipped for repair, the changer mechanism **MUST BE LOCKED** to prevent the mechanism from being damaged during shipping.
- If a CD is jammed or unable to be removed from the unit, do **NOT** lock the changer mechanism. If the unit is to be shipped for repair, carefully package the unit to prevent vibration and shock.

### DAMPER LOCK PROCEDURE

1. Eject and remove any CDs from the CD auto-changer unit.
2. Turn ignition switch OFF. Wait until CD auto-changer unit display is off and mechanism stops moving (mechanism sound stops).
3. Press any one of the disc selection buttons once. When a display shows on the CD auto-changer unit, press the same disc selection button again within 5 seconds.
  - The changer mechanism will lock itself within 10 seconds.
4. After mechanism stops moving (mechanism sound stops), disconnect negative battery cable.

### NOTE:

After installing a new or remanufactured CD auto-changer unit, switching the CD auto-changer unit ON will automatically unlock the mechanism. A special unlocking procedure is not required.

## Removal and Installation of Audio Unit

AKS0004Y

### REMOVAL

1. Perform damper lock operation. Refer to [AV-27, "Locking CD Auto-changer Mechanism"](#).
2. Remove cluster lid C. Refer to [IP-10, "INSTRUMENT PANEL ASSEMBLY"](#).
3. Unlock FPC (Flexible Print Circuit) connector lock on A/C and audio controller side.
4. Pull off flexible printed circuit from connector.

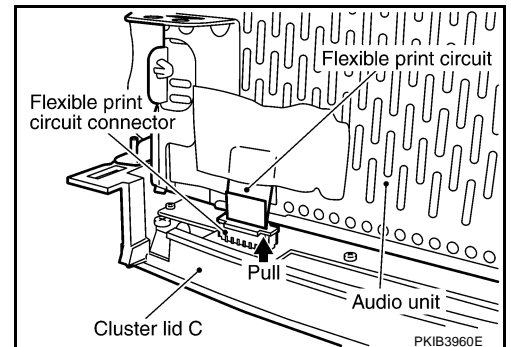

5. Remove screws (8). Remove audio unit and display unit assembly (with navigation system) from cluster lid C.

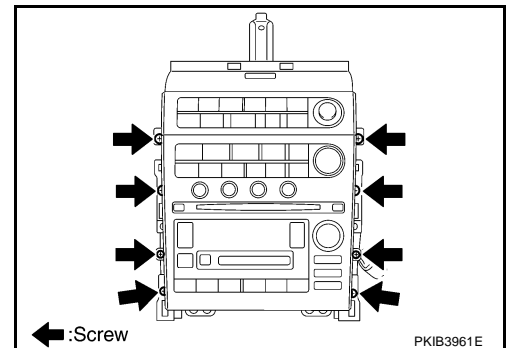

# AUDIO

6. Separate audio unit from display unit assembly (with navigation system).

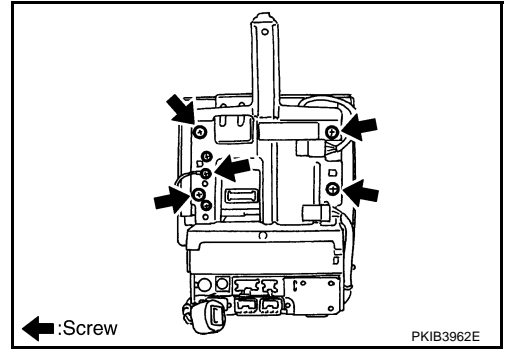

7. Remove 8 screws, and then bracket.

**CAUTION:**

Be careful not to allow foreign material to enter from CD slot.

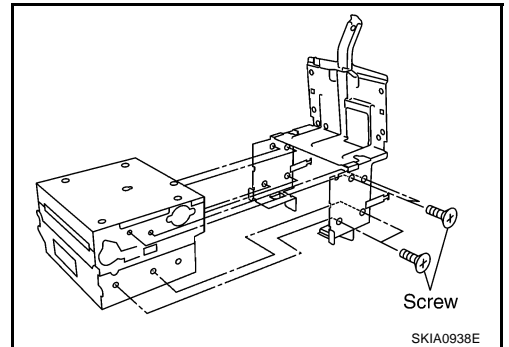

## INSTALLATION

Installation is the reverse order of removal.

### Removal and Installation for A/C and Audio Controller

AKS00051

#### REMOVAL

1. Remove audio unit and display unit assembly (with navigation system) from cluster lid C.
2. Remove NAVI switch. Refer to [AV-99, "Removal and Installation of NAVI Switch"](#).
3. Remove screws (5) and remove A/C and audio controller.

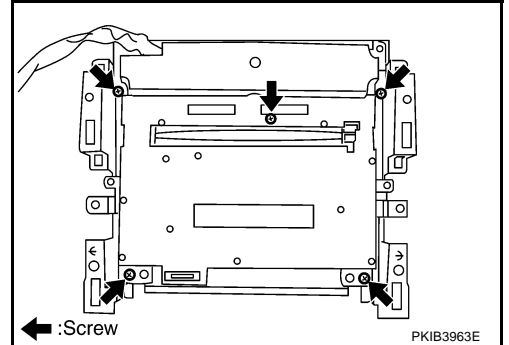

## INSTALLATION

Installation is the reverse order of removal.

### Removal and Installation of Door Speaker

AKS002X0

#### REMOVAL

1. Remove door finisher. Refer to [EI-37, "DOOR FINISHER"](#)
2. Remove bolts (3), and remove speaker.

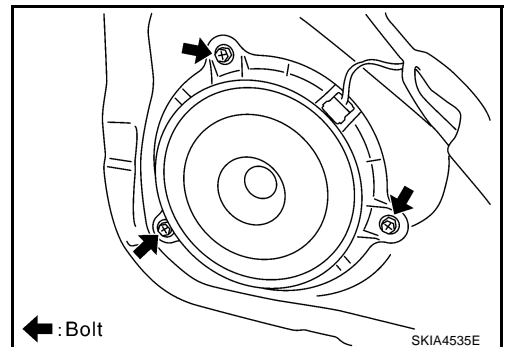

# AUDIO

## INSTALLATION

Installation is the reverse order of removal.

### Removal and Installation of Tweeter Behind Door Mirror

AKS00052

#### REMOVAL

1. Remove corner cover inner. Refer to [GW-108, "DOOR MIRROR"](#).
2. Remove screws (2), and remove tweeter behind door mirror.

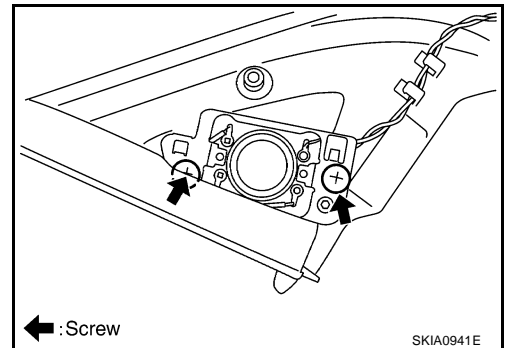

## INSTALLATION

Installation is the reverse order of removal.

### Removal and Installation of Woofer

AKS00054

#### REMOVAL

1. Remove rear parcel shelf finisher. Refer to [EI-41, "REAR PARCEL SHELF FINISHER"](#).
2. Remove bolts (4), and remove woofer.

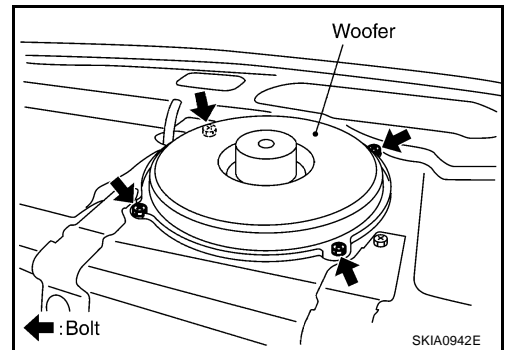

## INSTALLATION

Installation is the reverse order of removal.

### Removal and Installation of BOSE Speaker Amp.

AKS00055

#### REMOVAL

1. Remove trunk trim. Refer to [EI-47, "TRUNK ROOM TRIM & TRUNK LID FINISHER"](#).
2. Remove bolts (4), and remove BOSE speaker amp. from trunk room side.

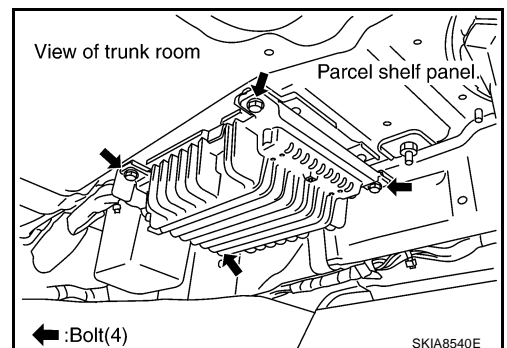

## INSTALLATION

Installation is the reverse order of removal.

A  
B  
C  
D  
E  
F  
G  
H  
I  
J  
AV  
L  
M

---

## AUDIO ANTENNA

PFP:28200

### System Description

AKS0000E

With the ignition switch in ACC or ON, power is supplied

- through 10A fuse [No. 6, located in the fuse block (J/B)]
- to audio unit terminal 10.

Ground is supplied through the case of the antenna amp.

When the radio switch is turned ON, antenna signal is supplied

- through audio unit terminal 5
- to the antenna amp. terminal 2.

Then the antenna amp. is activated.

The amplified radio signals are supplied to the audio unit through the antenna amp.

# AUDIO ANTENNA

## Wiring Diagram -W/ANT- WITH SUNROOF

AKS0000F

### AV-W/ANT-01

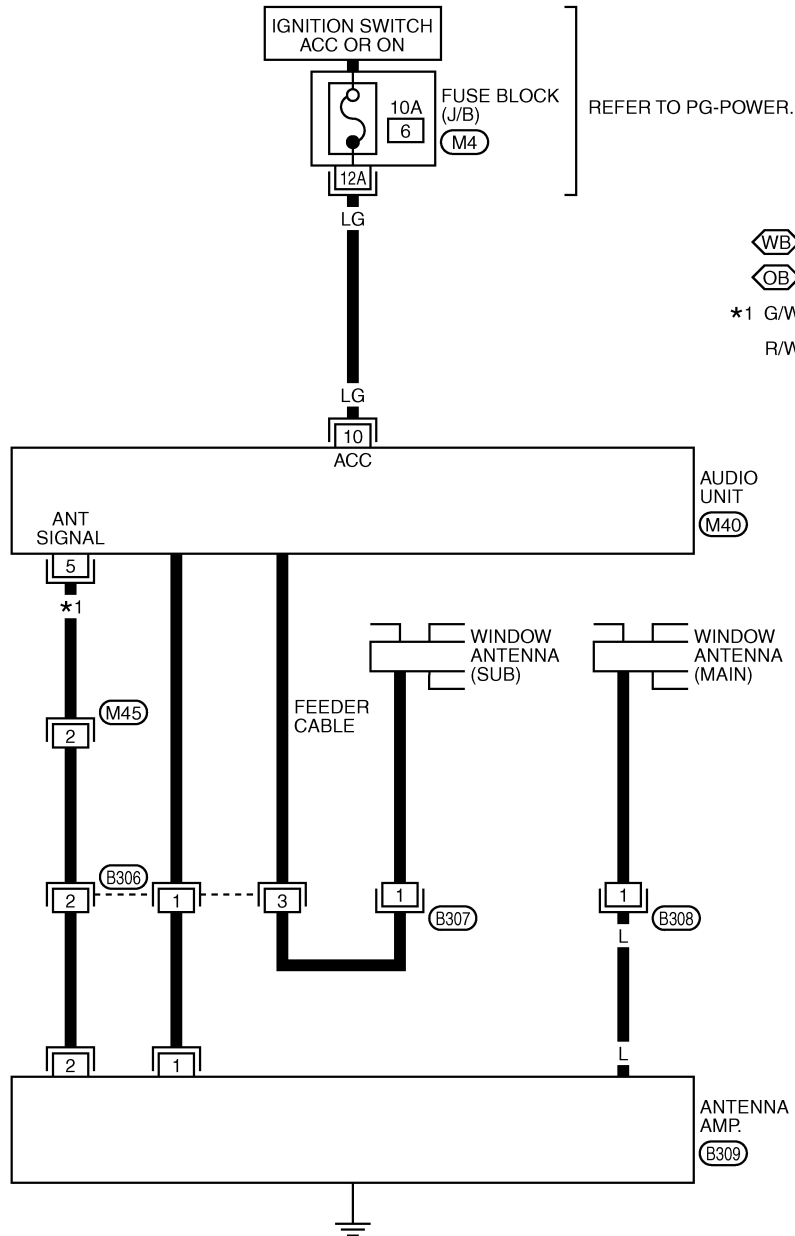

REFER TO PG-POWER.

- WB : WITH BOSE SYSTEM
- OB : WITH BASE SYSTEM
- \*1 G/W : WB
- R/W : OB

A  
B  
C  
D  
E  
F  
G  
H  
I  
J  
AV  
L  
M

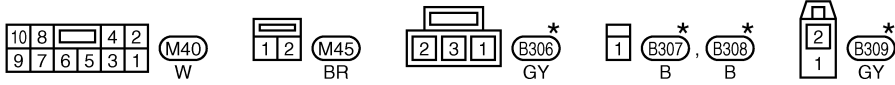

REFER TO THE FOLLOWING.  
M4 - FUSE BLOCK-JUNCTION BOX (J/B)

\*: THIS CONNECTOR IS NOT SHOWN IN "HARNESS LAYOUT", PG SECTION.

TKWM2399E

# AUDIO ANTENNA

WITHOUT SUNROOF

AV-W/ANT-02

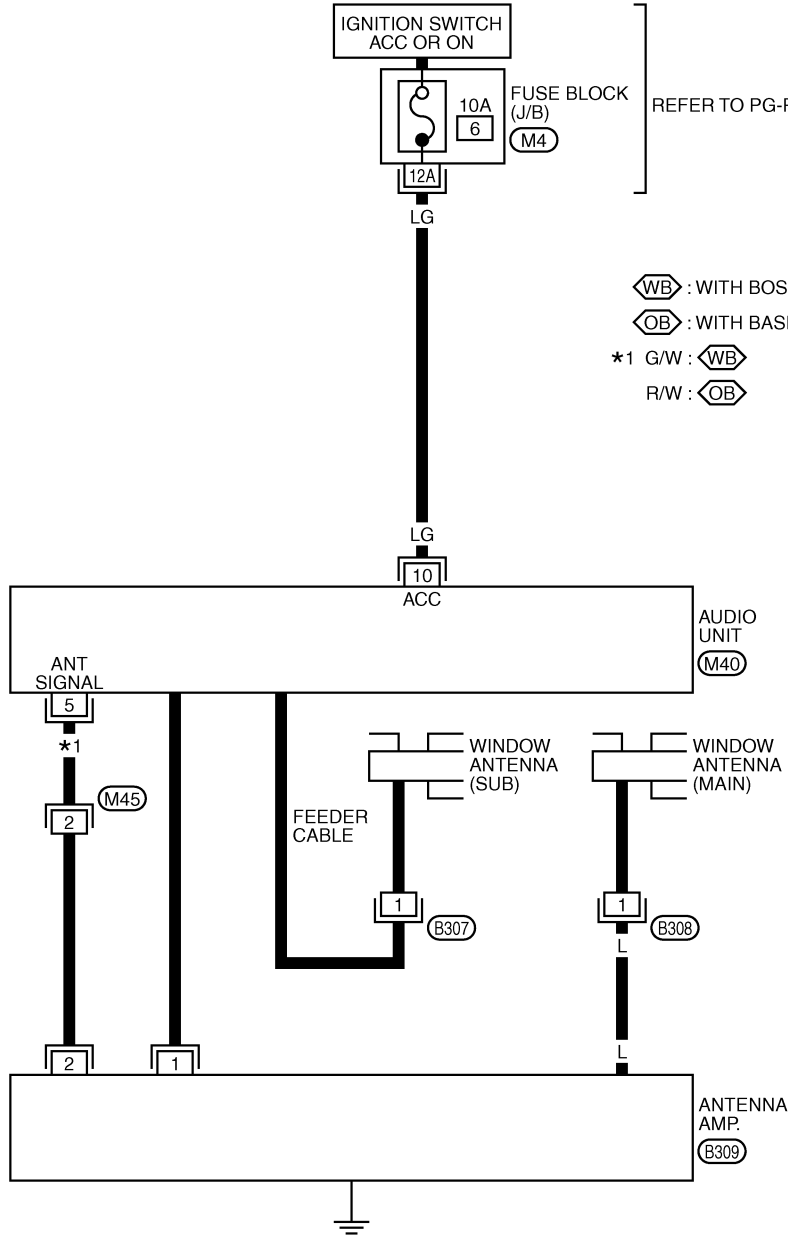

REFER TO PG-POWER.

- ◻WB◻ : WITH BOSE SYSTEM
- ◻OB◻ : WITH BASE SYSTEM
- \*1 G/W : ◻WB◻
- R/W : ◻OB◻

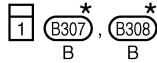
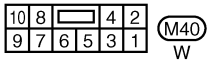

REFER TO THE FOLLOWING.  
 ◻M4◻ - FUSE BLOCK-JUNCTION BOX (J/B)

\*: THIS CONNECTOR IS NOT SHOWN IN "HARNESS LAYOUT", PG SECTION.

TKWT0282E



# AUDIO ANTENNA

## Location of Antenna

AKS0000G

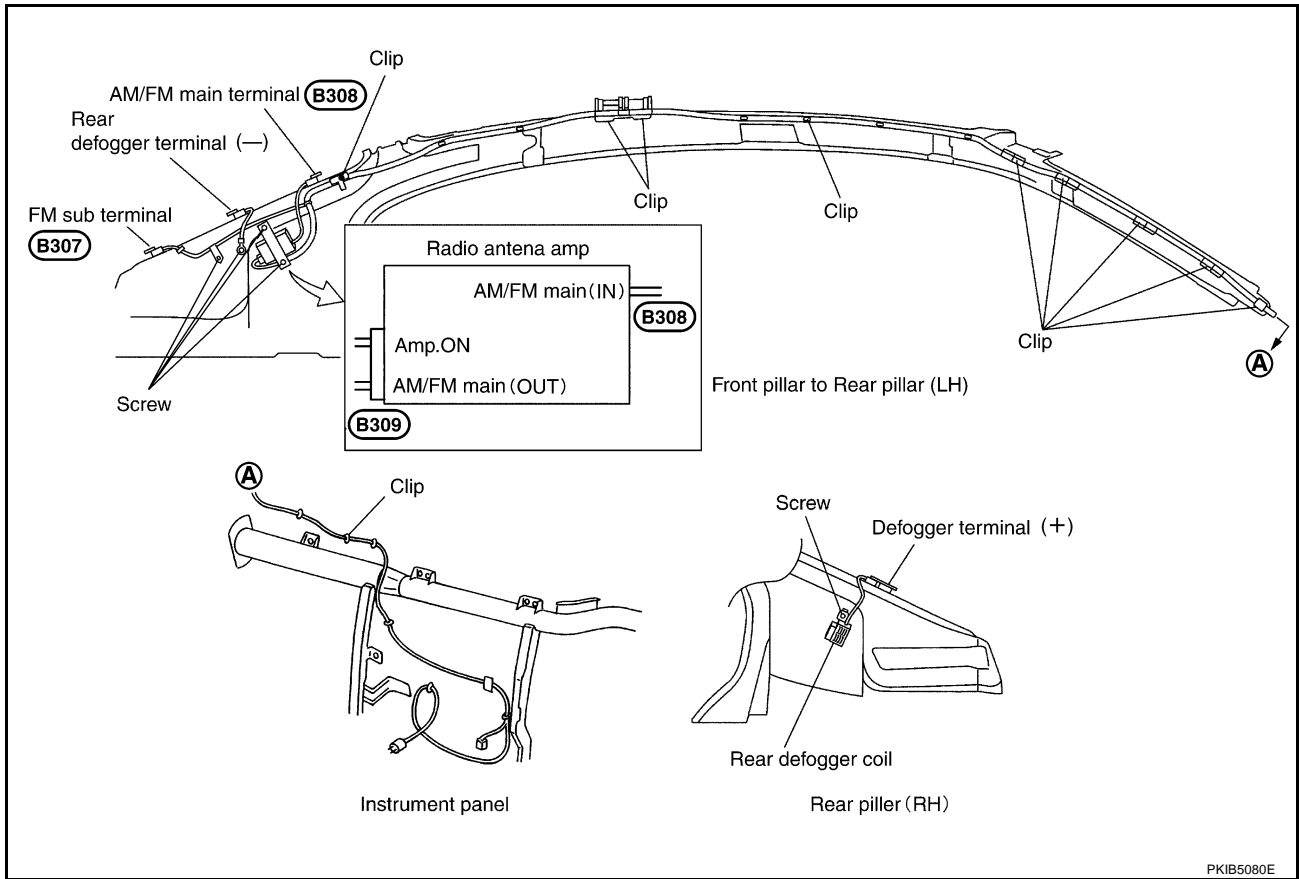

## Window Antenna Repair ELEMENT CHECK

AKS0000H

1. Attach probe circuit tester (ohm setting) to antenna terminal on each side.

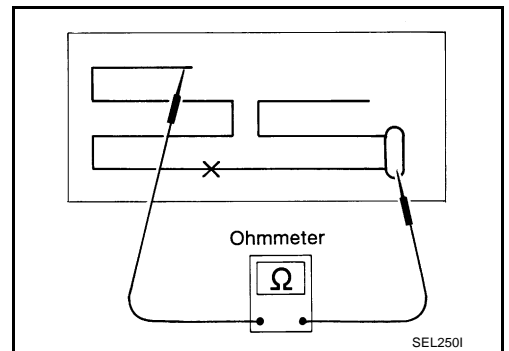

- When measuring continuity, wrap tin foil around the top of probe. Then, press the foil against the wire with your finger.

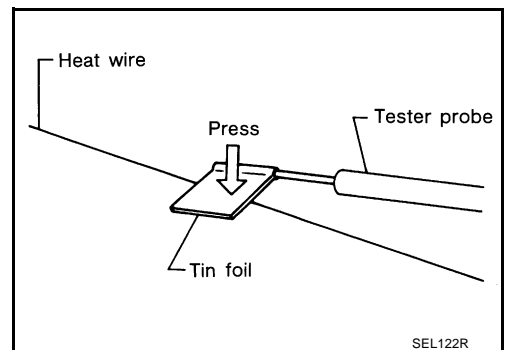

A  
B  
C  
D  
E  
F  
G  
H  
I  
J  
AV  
L  
M

# AUDIO ANTENNA

2. If an element is broken, no continuity will exist.

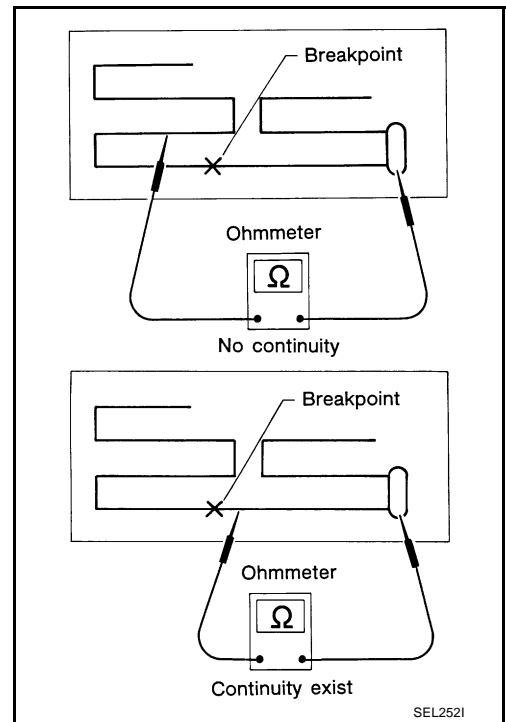

3. To locate a break, move probe along element. Tester needle will swing abruptly when probe passes the broken point.

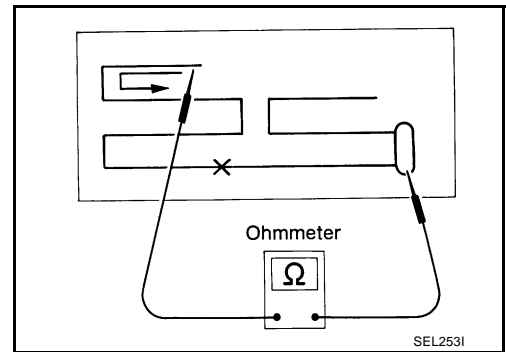

## ELEMENT REPAIR

Refer to [GW-106, "Filament Repair"](#) .

## NAVIGATION SYSTEM

PFP:25915

### System Description

AKS0002R

The navigation system periodically calculates the vehicle's current position according to the following three signals: Travel distance of the vehicle as determined by the vehicle speed sensor, turning angle of the vehicle as determined by the gyroscope (angular velocity sensor), and the direction of vehicle travel as determined by the GPS antenna (GPS information).

The current position of the vehicle is then identified by comparing the calculated vehicle position with map data read from the map DVD-ROM, which is stored in the DVD-ROM drive (map-matching), and indicated on the screen with a current-location mark.

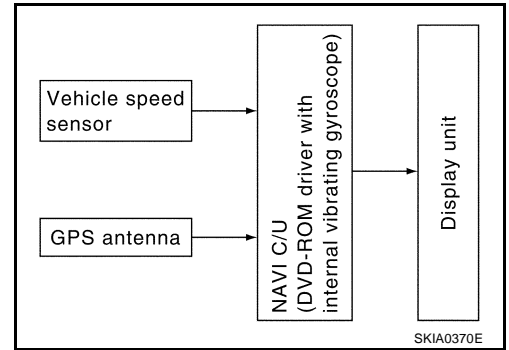

By comparing the vehicle position detection results found by the GPS and by map-matching, more accurate vehicle position data can be used.

The current vehicle position will be calculated by detecting the distance the vehicle moved from the previous calculation point and its direction.

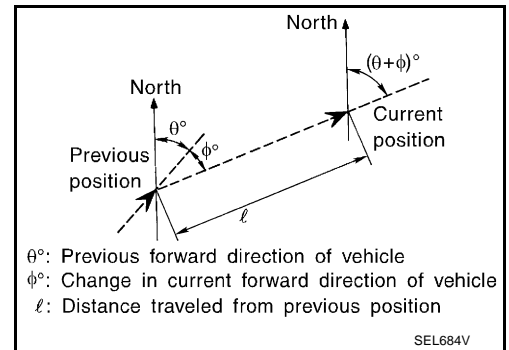

### TRAVEL DISTANCE

Travel distance calculations are based on the vehicle speed sensor input signal. Therefore, the calculation may become incorrect as the tires wear down. To prevent this, an automatic distance fine adjustment function has been adopted.

### TRAVEL DIRECTION

Change in the travel direction of the vehicle is calculated by a gyroscope (angular velocity sensor) and a GPS antenna (GPS information). As the gyroscope and GPS antenna have both merit and demerit, input signals from them are prioritized in each situation. However, this order of priority may change in accordance with more detailed travel conditions so that the travel direction is detected more accurately.

Type	Advantage	Disadvantage
Gyroscope (angular velocity sensor)	<ul style="list-style-type: none"> <li>Can detect the vehicle's turning angle quite accurately.</li> </ul>	<ul style="list-style-type: none"> <li>Direction errors may accumulate when the vehicle is driven for long distances without stopping.</li> </ul>
GPS antenna (GPS information)	<ul style="list-style-type: none"> <li>Can detect the vehicle's travel direction (North/South/East/West).</li> </ul>	<ul style="list-style-type: none"> <li>Correct direction cannot be detected when the vehicle speed is low.</li> </ul>

### MAP-MATCHING

Map-matching is a function that repositions the vehicle on the road map when a new location is judged to be the most accurate. This is done by comparing the current vehicle position, calculated by the method described in the position detection principle, with the road map data around the vehicle, read from the map DVD-ROM stored in the DVD-ROM drive.

Therefore, the vehicle position may not be corrected after the vehicle is driven over a certain distance or time in which GPS information is hard to receive. In this case, the current-location mark on the display must be corrected manually.

#### CAUTION:

The road map data is based on data stored in the map DVD-ROM.

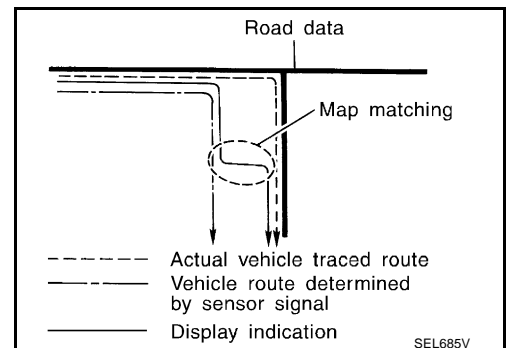

# NAVIGATION SYSTEM

- In map-matching, alternative routes to reach the destination will be shown and prioritized, after the road on which the vehicle is currently driven has been judged and the current-location mark has been repositioned.  
If there is an error in distance and/or direction, the alternative routes will be shown in different order of priority, and the wrong road can be avoided.  
If two roads are running in parallel, they are of the same priority. Therefore, the current-location mark may appear on either of them alternately, depending on maneuvering of the steering wheel and configuration of the road.

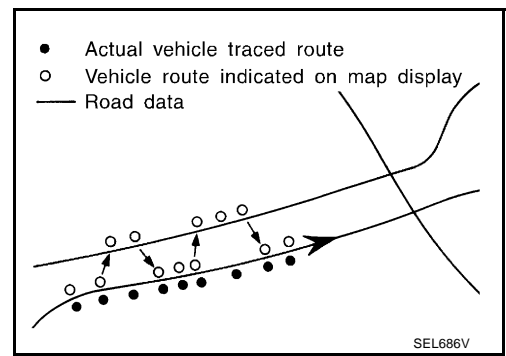

- Map-matching does not function correctly when the road on which the vehicle is driving is new and not recorded in the map DVD-ROM, or when the road pattern stored in the map data and the actual road pattern are different due to repair.  
When driving on a road not present in the map, the map-matching function may find another road and position the current-location mark on it. Then, when the correct road is detected, the current-location mark may leap to it.
- Effective range for comparing the vehicle position and travel direction calculated by the distance and direction with the road data read from the map DVD-ROM is limited. Therefore, when there is an excessive gap between the current vehicle position and the position on the map, correction by map-matching is not possible.

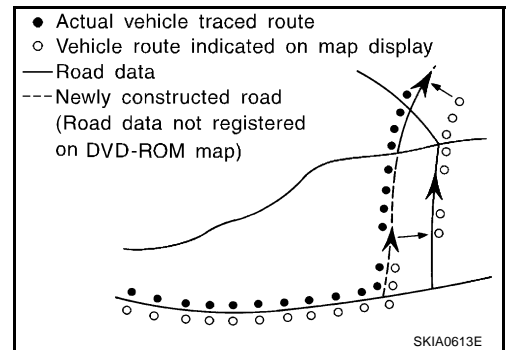

## GPS (GLOBAL POSITIONING SYSTEM)

GPS (Global Positioning System) has been developed and controlled by the US Department of Defense. The system utilizes GPS satellite (NAVSTAR), sending out radio waves while flying on an orbit around the earth at the height of approx. 21,000 km (13,000 miles). The GPS receiver calculates the vehicle's position in three dimensions (latitude/longitude/altitude) according to the time lag of the radio waves received from four or more GPS satellites (three-dimensional positioning). If radio waves were received only from three GPS satellites, the GPS receiver calculates the vehicle's position in two dimensions (latitude/longitude), utilizing the altitude data calculated previously by using radio waves from four or more GPS satellites (two-dimensional positioning).

Accuracy of the GPS will deteriorate under the following conditions.

- In two-dimensional positioning, the GPS accuracy will deteriorate when the altitude of the vehicle position changes.
- There may be an error of approximately 10m (30ft) in position detected by three-dimensional positioning, which is more accurate than two-dimensional positioning. The accuracy can be even lower depending on the arrangement of the GPS satellites utilized for the positioning.
- Position detection is not possible when the vehicle is in an area where radio waves from the GPS satellite do not reach, such as in a tunnel, parking lot in a building, and under an elevated highway. Radio waves from the GPS satellites may not be received when some object is located over the GPS antenna.
- Position correction by GPS is not available while the vehicle is stopped.

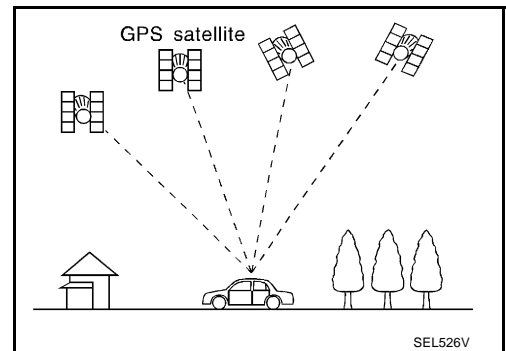

# NAVIGATION SYSTEM

## COMPONENT DESCRIPTION

### NAVI Control Unit

- The gyro (angular speed sensor) and the DVD-ROM drive are built-in units that control the navigation functions.
- Signals are received from the gyro, the vehicle speed sensor, and the GPS antenna. Vehicle location is determined by combining this data with the data contained in the DVD-ROM map. Locational information is shown on LCD (liquid crystal display) screen.

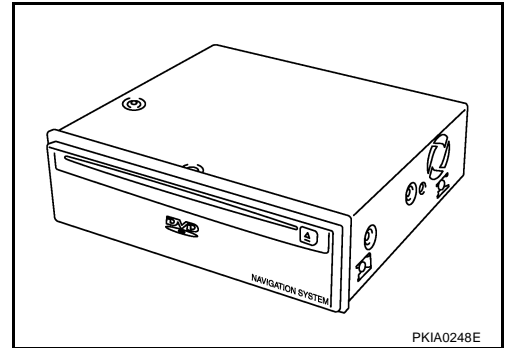

### DVD-ROM Drive

Maps, traffic control regulations, and other pertinent information can be easily read from the DVD-ROM disc.

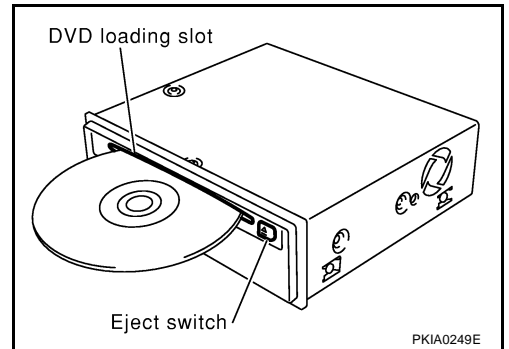

### Map DVD-ROM

- The map DVD-ROM has maps, traffic control regulations, and other pertinent information.
- To improve DVD-ROM map matching and route determination functions, the DVD-ROM uses an exclusive Nissan format. Therefore, the use of a DVD-ROM provided by other manufacturers cannot be used.

### Gyro (Angular Speed Sensor)

- The oscillator gyro sensor is used to detect changes in vehicle steering angle.
- The gyro is built into the NAVI control unit.

A  
B  
C  
D  
E  
F  
G  
H  
I  
J  
L  
M

AV

# NAVIGATION SYSTEM

## BIRD VIEW™

The BIRD VIEW™ provides a detailed and easily seen display of road conditions covering the vehicle's immediate to distant area.

- MAP DISPLAY

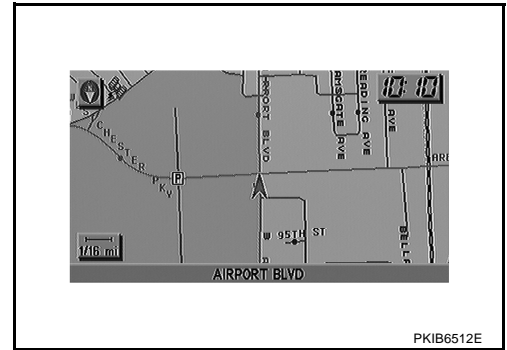

- BIRD VIEW™

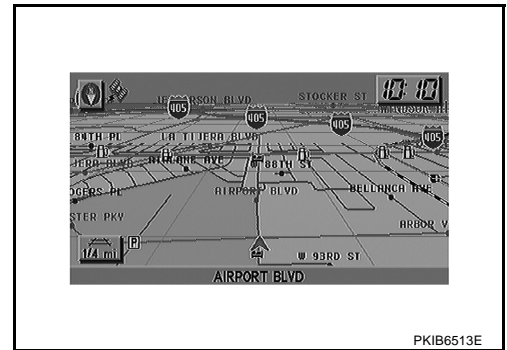

## Description

- Display area: Trapezoidal representation showing approximate distances ( $W_n$ ,  $D$ , and  $W_d$ ).
- Ten horizontal grid lines indicate display width while six vertical grid lines indicate display depth and direction.
- Drawing line area shows open space, depth, and immediate front area. Each area is to a scale of approximately 5:6:25.
- Pushing the "ZOOM IN" button during operation displays the scale change and the view point height on the left side of the screen.  
The height of the view point increases or decreases when "ZOOM" or "WIDE" is selected with the joystick.

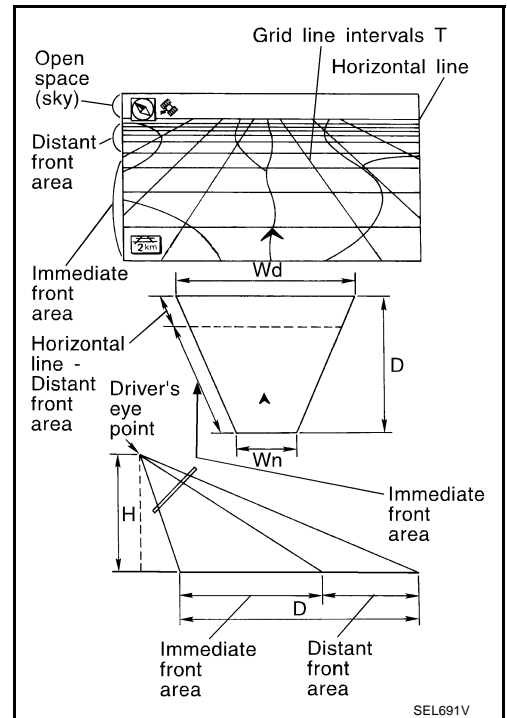

# NAVIGATION SYSTEM

## MAP DISPLAY

Function of each icon is as follows:

1. Azimuth indication
2. Position marker
  - The tip of the arrow shows the current position. The shaft of the arrow indicates the direction in which the vehicle is traveling.
3. GPS reception signal (indicates current reception conditions.)
4. Distance display (shows the distance in a reduced scale.)

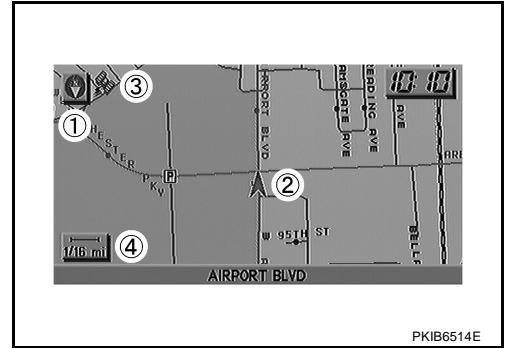

## FUNCTION OF NAVI SWITCH

### Display with Pushed “DEST” Switch

- Easy Mode
- Expert Mode

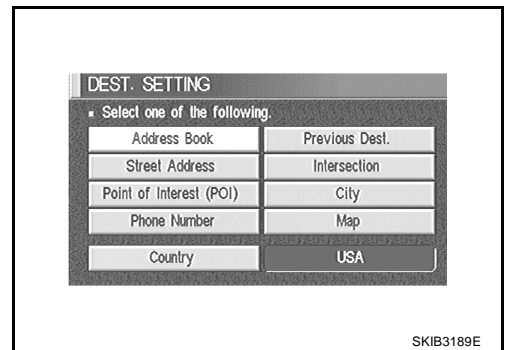
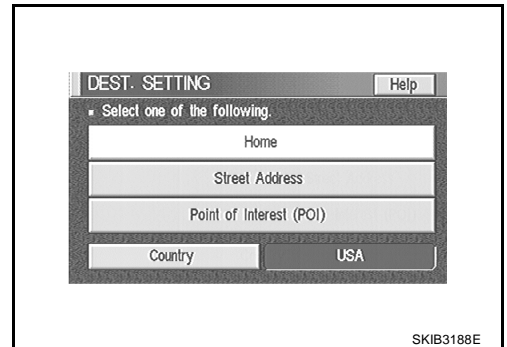

A  
B  
C  
D  
E  
F  
G  
H  
I  
J  
AV  
L  
M





# NAVIGATION SYSTEM

**The function of each icon is as follows:**

Icon	MODE		Description
	Easy	Expert	
Quick Stop	×	×	The selected facility is set as the destination or way point. (Route guidance has been turned OFF or the destination has been reached.)
Where am I?	×	×	Next, current and previous street names can be displayed.
Route Info.*		×	The following items can be set. <ul style="list-style-type: none"> <li>● Complete Route</li> <li>● Turn List</li> <li>● Route Simulation</li> </ul> (Displayed only when the destination area has been set.)
Edit Route*		×	Change the destination or add the transit points of the route set in the route guide. (Displayed only when the automatic reroute function has been turned OFF and the recommended route is not followed.)
Help	×		Explanation of Navigational functions appear on the Display.

\*: When destinations have been entered, route guidance has been turned OFF or destination has been reached, "Route Info." and "Edit Route" are not displayed.

## Display with Pushed "SETTING" Switch

**The function of each icon is as follows:**

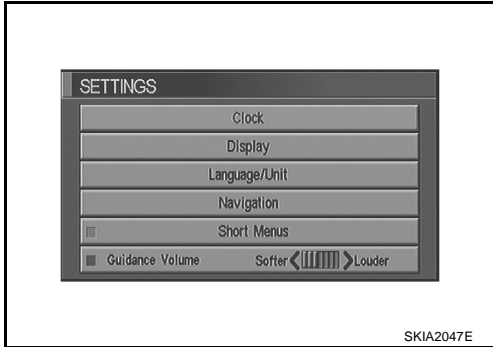

Icon	Description
Clock	Settings of clock can be performed
Display	Settings of display can be performed.
Language/Unit	Settings of Language or unit can be performed.
Navigation	Settings and adjusting of navigation can be performed.
Short Menus	Easy Mode and Expert Easy Mode can be switched.
Guidance Volume	The volume and/or on/off of voice prompt can be controlled by the joystick.
Help (only easy mode)	Explanation of Navigational Functions Appear on the Display.

# NAVIGATION SYSTEM

## Display with Pushed “INFO” Switch

NAVI control unit is communicating combination meter.

1. Push “INFO” switch to display vehicle information display.

**NOTE:**

If a warning signal is received by NAVI at this time, NAVI control unit displays warning message on screen.

2. Select “Trip Computer”, “Fuel Economy” or “Maintenance”.

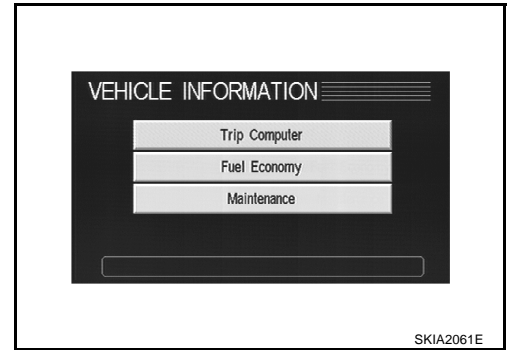

Display items	Display/Setting contents		Reference page
Trip Computer	Elapsed Time	Displays driving time with a range of 0000:00:00 to 9999:59:59.	<a href="#">AV-48. "TRIP COMPUTER INFORMATION"</a>
	Driving Distance	Displays driving distance with a range of 00000.0 to 99999.9.	
	Average speed	Displays average speed with a range of 000.0 to 999.9.	
Fuel Economy	Average Fuel Economy (MPG)	Displays fuel economy with ignition switch ON, average fuel economy each 30 minutes.	<a href="#">AV-48. "FUEL ECONOMY INFORMATION"</a>
	Distance to Empty (Miles)	Displays possible driving distance with remaining fuel.	
	Fuel Economy (MPG)	Displays fuel economy each approx. 100 ms.	
	Fuel Economy Record	Displays Average Fuel Consumption History.	
Maintenance (with Maintenance information*1)	Engine Oil	Maintenance intervals of engine oil and setting of oil change cycle.	<a href="#">AV-49. "MAINTENANCE INFORMATION"</a>
	Oil Filter	Maintenance intervals of oil filter and setting of filter replacement cycle.	

\*1: Maintenance information displays the change cycle of engine oil, oil filter and tire on LCD monitor depending on the driving distance specified by a driver or a technician.

## Clock Setting

How To Perform Navigation Setting

1. Start the engine.
2. Push “SETTING” switch.
3. Select “CLOCK”.
  - GPS time can be changed to offset time.
  - Daylight Savings Time can be set.
  - Time zone can be set.

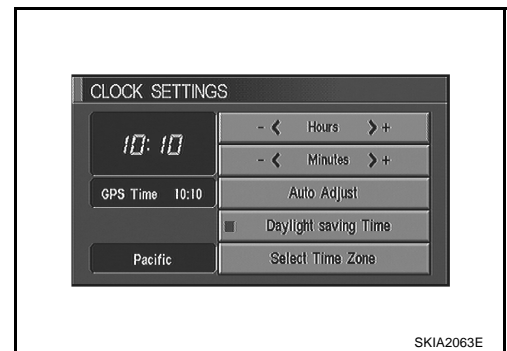

# NAVIGATION SYSTEM

## Display Setting

How To Perform Navigation Setting

1. Start the engine.
2. Push "SETTING" switch.
3. Select "Display".
  - Brightness, contrast, or map background setting can be changed.
  - Display sleep mode ON/OFF can be switched.
  - Display sleep mode timer can be set.

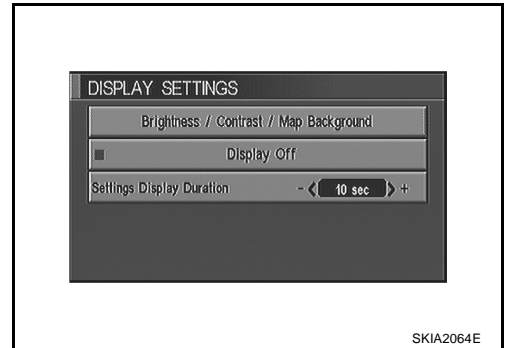

## Language Setting

How To Perform Navigation Setting

1. Start the engine.
2. Push "SETTING" switch.
3. Select "Language".
  - Language setting can be switched.
  - Unit setting can be changed.

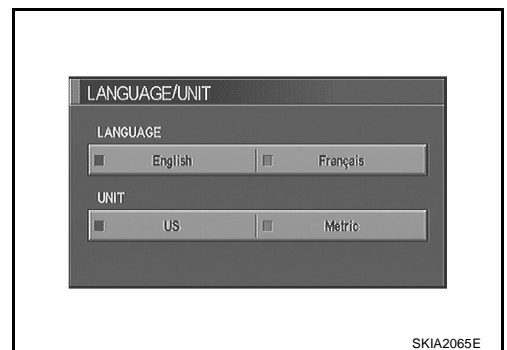

## Navigation Setting

How To Perform Navigation Setting

1. Start the engine.
2. Push "SETTING" switch.
3. Select "Navigation".

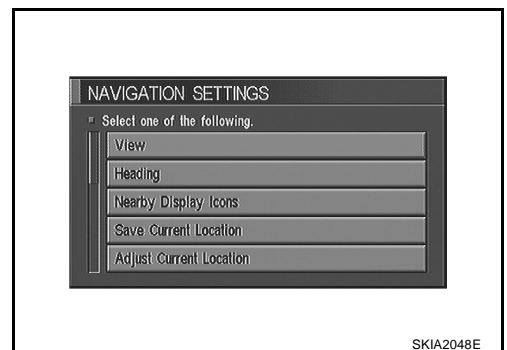

A  
B  
C  
D  
E  
F  
G  
H  
I  
J  
AV  
L  
M

# NAVIGATION SYSTEM

## Application Items

Icon	Description	Reference page
View	Map display mode can be switched.	<a href="#">AV-44</a>
Heading	Heading of the map display can be customized for either north heading or the actual driving direction of the vehicle.	<a href="#">AV-44</a>
Nearby Display Icons	Icons of facilities can be displayed. Facilities to be displayed can be selected from the variety selections.	<a href="#">AV-45</a>
Save Current Location	Current vehicle location can be registered in Address Book.	<a href="#">AV-45</a>
Adjust Current Location	Current location of position marker can be adjusted. Direction of position marker also can be calibrated when heading direction of the vehicle on the display is not matched with the actual direction.	<a href="#">AV-45</a>
Auto Re-route ON/OFF	ON/OFF of Auto Re-route can be switched.	<a href="#">AV-46</a>
Avoid Area Setting	A particular area can be avoided when routing.	<a href="#">AV-46</a>
Button Tone/Beep Response	Button tone can be selected ON/OFF	<a href="#">AV-46</a>
Clear Memory	Address Book, Previous destination or Avoid area can be deleted.	<a href="#">AV-46</a>
Edit Address Book	Address Book can be edited.	<a href="#">AV-47</a>
GPS Information	The GPS data includes longitude, latitude and altitude (distance above sea level) of the present vehicle position, and current date and time for the area in which the vehicle is being driven. Also indicated are the GPS reception conditions and the GPS satellite position.	<a href="#">AV-47</a>
Quick Stop Customer Setting	One facility of your selection can be added to your Quick Stop.	<a href="#">AV-47</a>
Set Average Speed for Estimated Journey Time	Average vehicle speed can be set to calibrate estimated journey time for the destination.	<a href="#">AV-47</a>
Tracking On/Off	Tracking to the present vehicle position can be displayed.	<a href="#">AV-48</a>

### “VIEW” MODE

Select “Bird view” or “Plan view” icon.

- To open the map screen display with Bird View, select “Bird View”.
- To open the map screen display with Plan View, select “Plan View”.

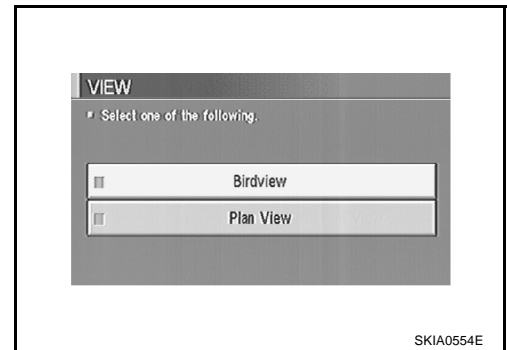

### “HEADING” MODE

- To display North up, select “North up”.
- To display the car heading up, select “Heading up”.

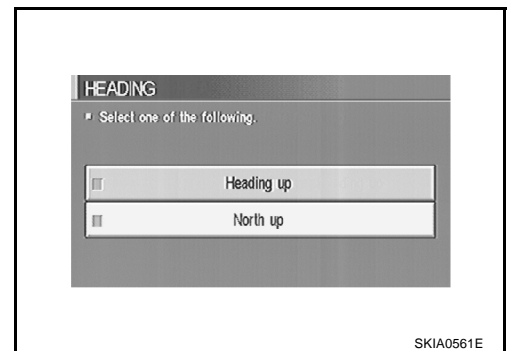

# NAVIGATION SYSTEM

## “NEARBY DISPLAY ICONS” MODE

Select an icon to display on the map screen.

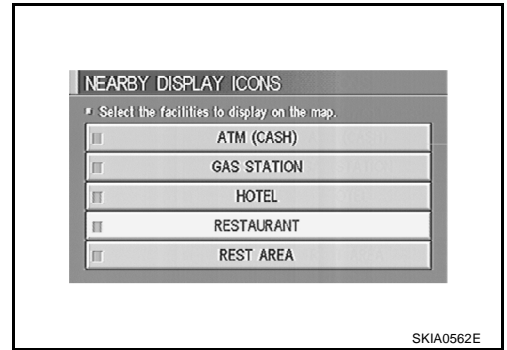

A  
B  
C  
D

## “SAVE CURRENT LOCATION” MODE

The current vehicle location can be registered in “Address Book”.

### NOTE:

“Address Book” can store 50 items max.

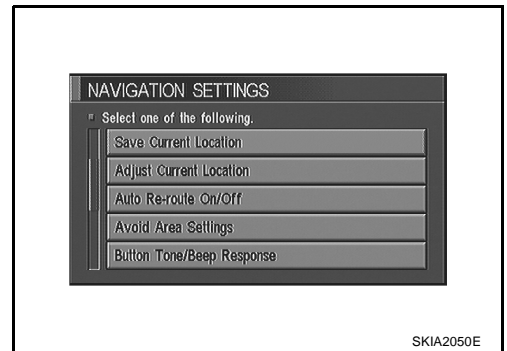

E  
F  
G  
H

## “ADJUST CURRENT LOCATION” MODE

1. Select an icon “right” or “left” to calibrate the heading direction. (Arrow marks will rotate corresponding to the calibration key.)

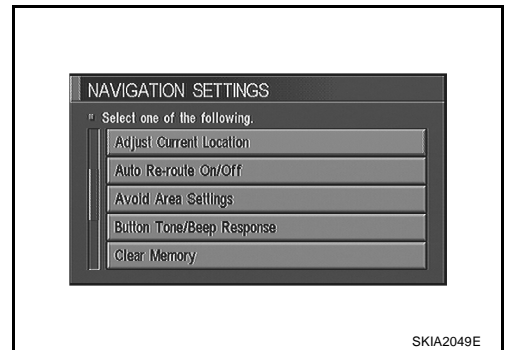

I  
J  
AV  
L

2. Select “Set”. Then the vehicle mark will be matched to the arrow mark.

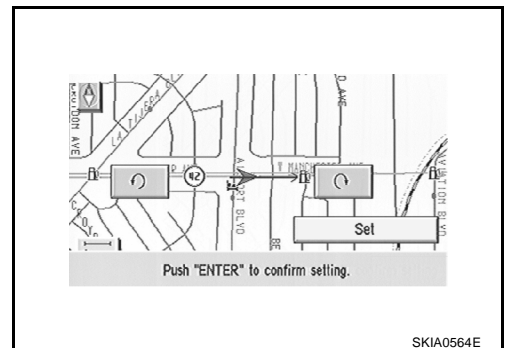

M

# NAVIGATION SYSTEM

## “AUTO RE-ROUTE” MODE

- To perform the auto re-route of route, select “On”.
- Not to perform the auto re-route of route, select “Off”.

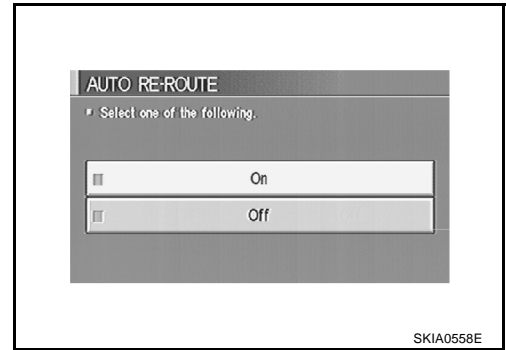

## “AVOID AREA SETTING” MODE

Areas to avoid can be registered.

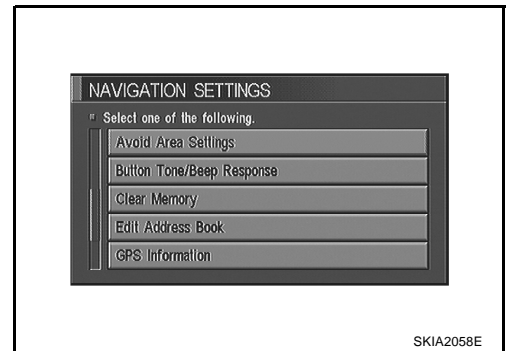

## “BUTTON TONE/BEEP RESPONSE” MODE

- If beep is required, select “On”.
- If no beep is required, select “Off”.

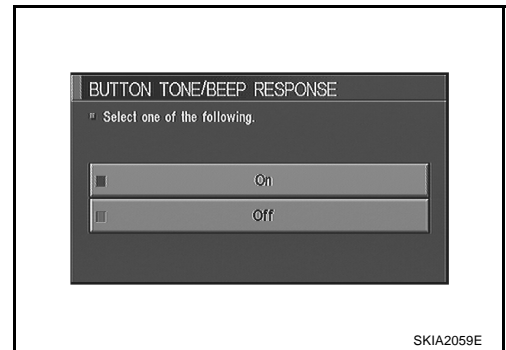

## “CLEAR MEMORY” MODE

To delete all the stored places in “Address Book”, “Avoid Area” and “Previous Dest”, select “Yes”.

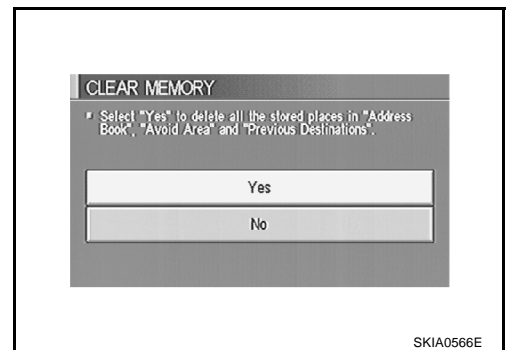

# NAVIGATION SYSTEM

## “EDIT ADDRESS BOOK” MODE

Edit the items registered in Address Book.

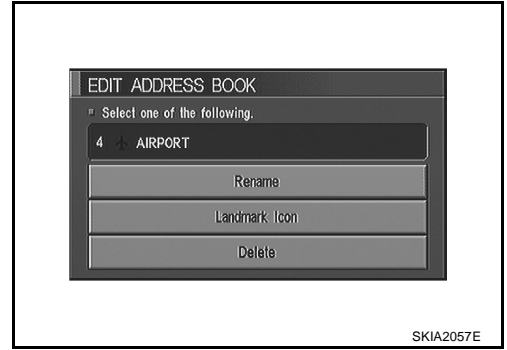

A  
B  
C  
D

## “GPS INFORMATION” MODE

Latitude, longitude, altitude, astronomic state, and satellite location are displayed as GPS information.

### NOTE:

Altitude is displayed only in three-dimensional status.

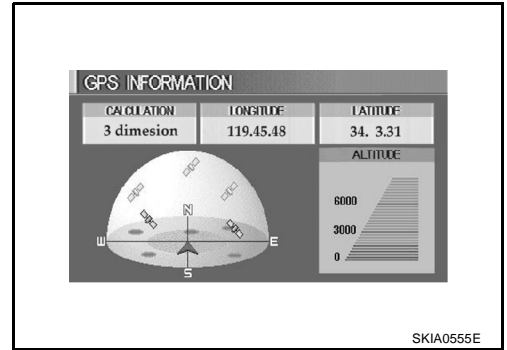

E  
F  
G  
H

## “QUICK STOP CUSTOMER SETTING” MODE

Select a category for the “Quick Stop” menu.

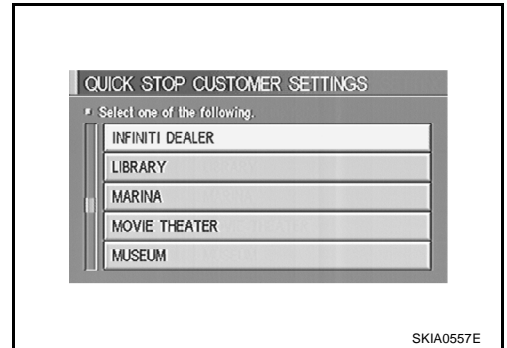

I  
J  
AV  
L

## “SET AVERAGE SPEED” MODE

- Set the average vehicle speed to calibrate the estimated journey time for the destination.
- Set three items; “Freeway”, “Main Roads”, and “Ordinary Roads”.

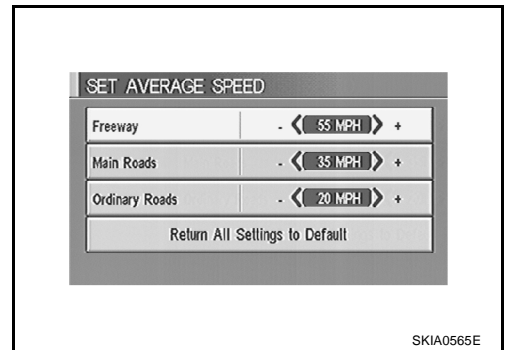

M

# NAVIGATION SYSTEM

## “TRACKING” MODE

- To leave no trail on the map, select “Off”.
- To leave a trail in the map, select “On”.

### NOTE:

When a trail display is turned OFF, trail data is erased from the memory.

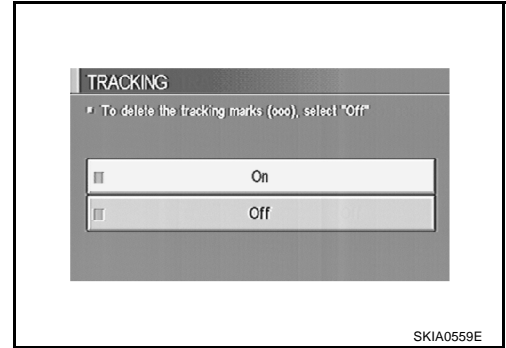

## GUIDE VOLUME SETTING

### Description

Following voice guidance setting can be changed.

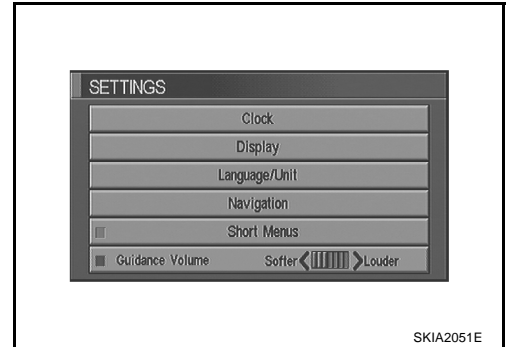

### Activation/Deactivation Setting

The voice prompt can be turned on/off by pushing the “Guidance Volume” button.

### Voice Volume Setting

Volume of the voice can be controlled by bending the joystick to left/right.

## TRIP COMPUTER INFORMATION

Elapsed time, Driving distance and Average speed are displayed as Trip Computer information.

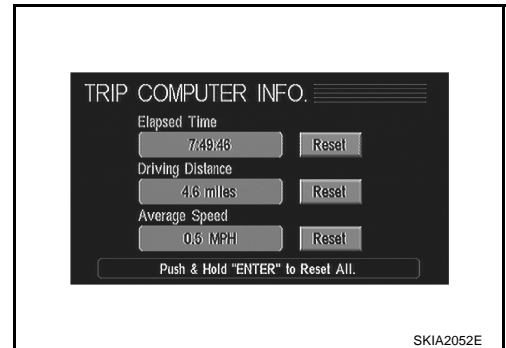

## FUEL ECONOMY INFORMATION

- Average Fuel Economy, Distance to Empty, Fuel Economy are displayed as Fuel Economy information.

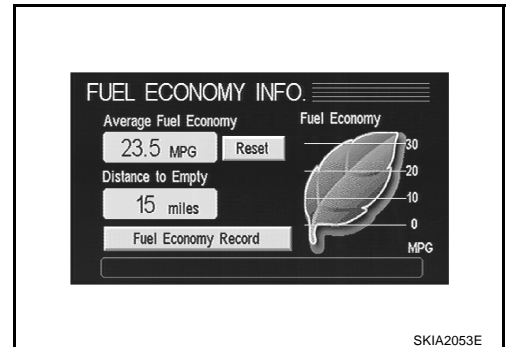



# NAVIGATION SYSTEM

- Select “Fuel Economy Record”. The average fuel consumption history will be displayed in graph along with the average for the previous Reset – to – Reset period.

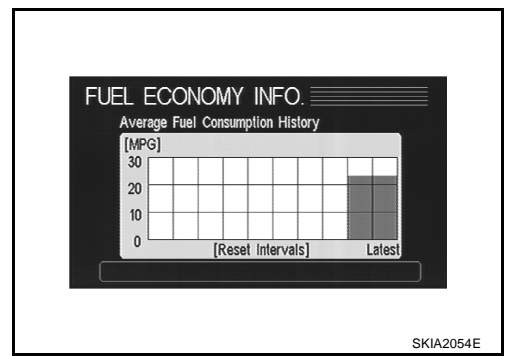

## MAINTENANCE INFORMATION

Engine Oil and Oil Filter are displayed as Maintenance information.

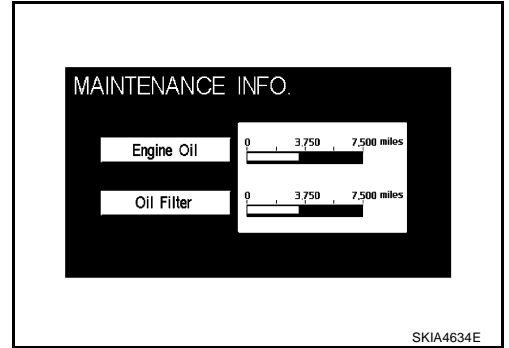

## WARNING INDICATIONS

When combination meter receives warning signal from door switch, combination meter warning lamp is illuminated.

Then combination meter sends warning signal to NAVI control unit to display warning indications on the screen.

Warning indicators	Warning lamps in instrument panel	Warning detection and cancel conditions		Cases of malfunction
DOOR OPEN	Door	Detection condition	Vehicle is running [approx. 5 km/h (3 MPH) or faster] and door ajar of any of the doors is detected.	Door is open.
		Cancel condition	Vehicle is stopped and all the doors lock.	

A  
B  
C  
D  
E  
F  
G  
H  
I  
J  
AV  
L  
M

# NAVIGATION SYSTEM

AKS0002S

## Precautions for NAVI Control Unit Replacement

- When replacing the NAVI control unit, eject the map DVD-ROM before disconnecting the battery.
- The NAVI control unit has the following information stored in its memory. Record the memory contents before replacing the control unit, and input them in the new unit as necessary.

### <Image quality>

- **Brightness of light when ON/OFF**
- **Dimming switching**
- **Display color switching**

### <Navigation mode>

- **Latest status (map screen/bird view™, reduced scale, rotation angle of map screen, route guide ON/OFF, track ON/OFF, etc.)**
- **Current position**
- **Destination, passing point 1 - 5**
- **Registered places, their names, etc.**

### NOTE:

Only removing the battery does not erase the memory.

## Component Parts Location

AKS0002T

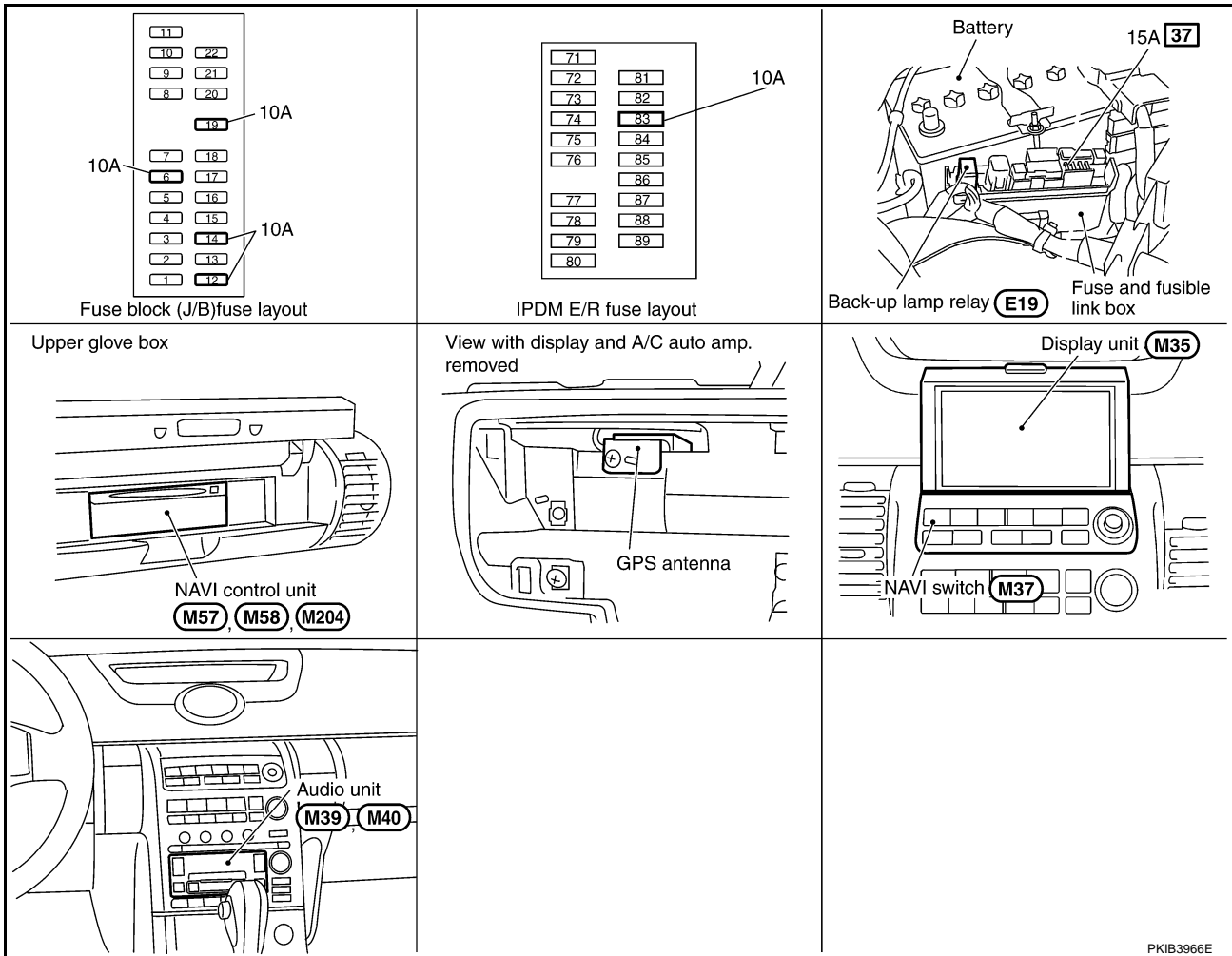

# NAVIGATION SYSTEM

## Schematic

AKS0002V

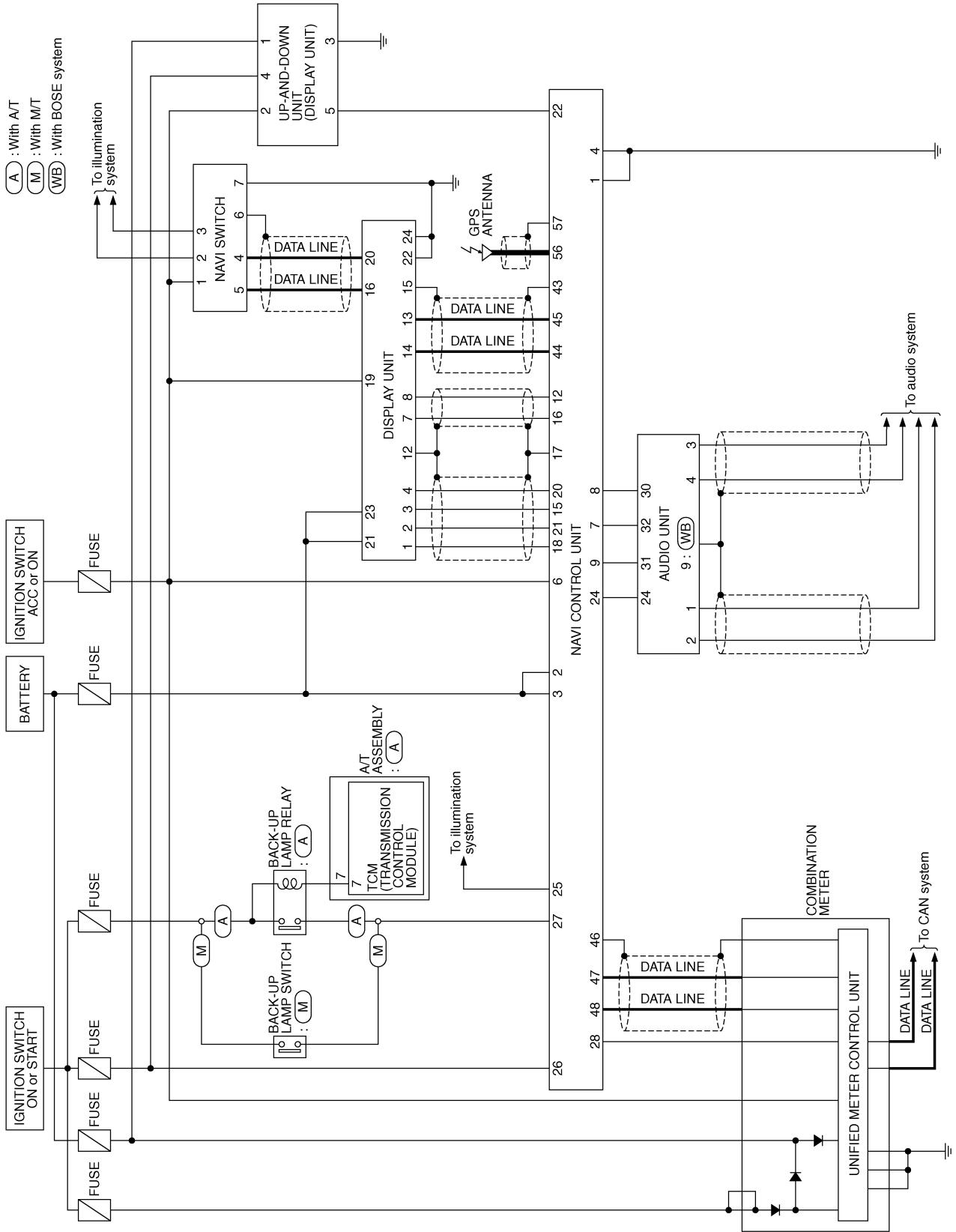

TKWM2400E

A  
B  
C  
D  
E  
F  
G  
H  
I  
J  
AV  
L  
M

# NAVIGATION SYSTEM

AKS0002W

## Wiring Diagram —NAVI—

AV-NAVI-01

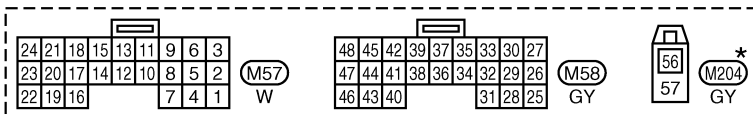
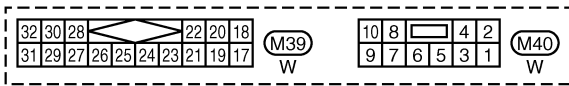
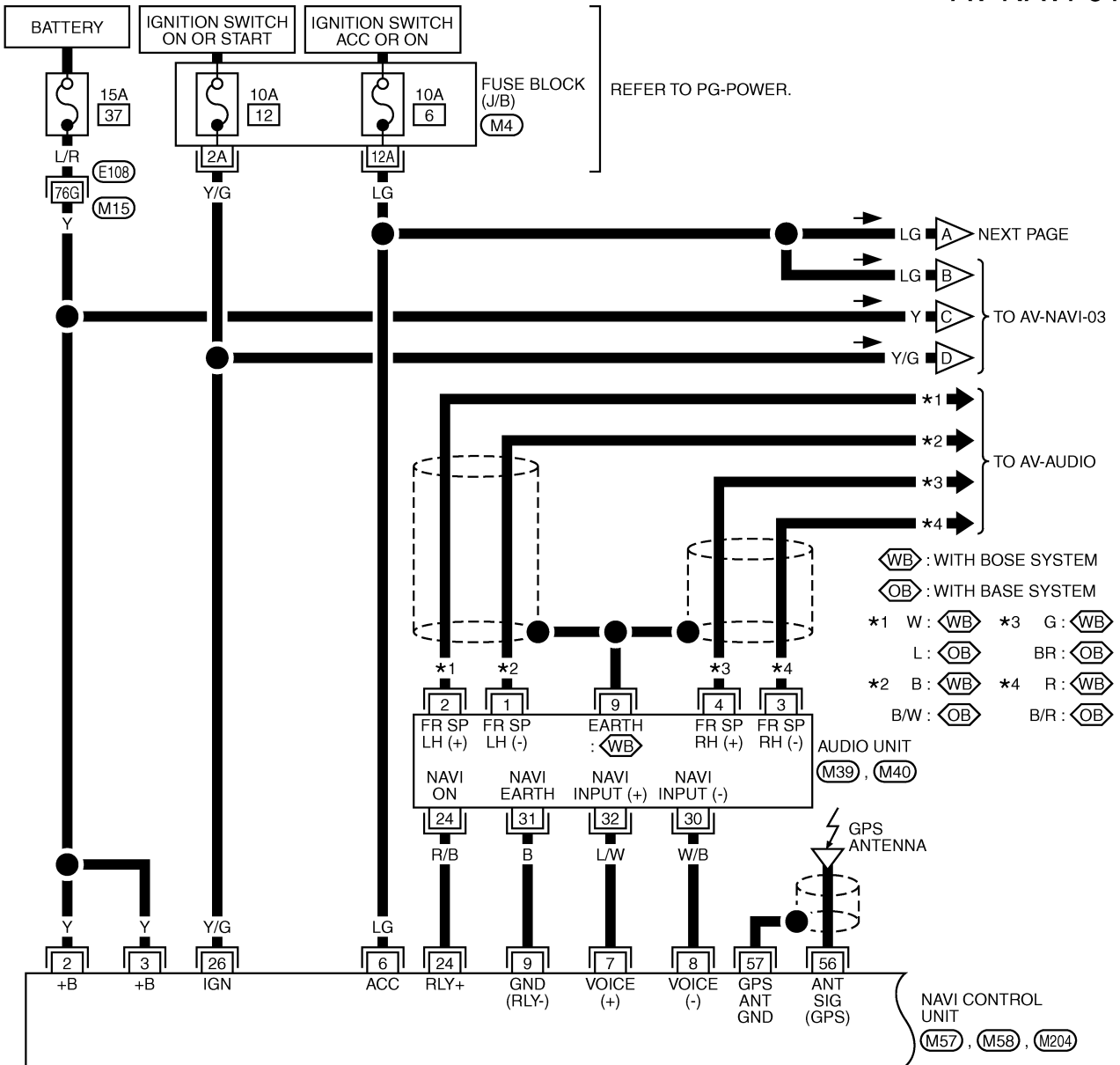

\*: THIS CONNECTOR IS NOT SHOWN IN "HARNESS LAYOUT", PG SECTION.

REFER TO THE FOLLOWING.

(E108) -SUPER MULTIPLE JUNCTION (SMJ)

(M4) -FUSE BLOCK-JUNCTION BOX (J/B)

TKWM2401E

# NAVIGATION SYSTEM

AV-NAVI-02

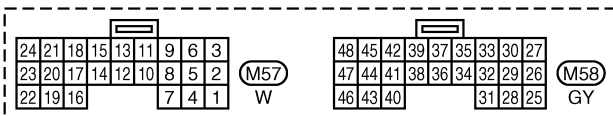
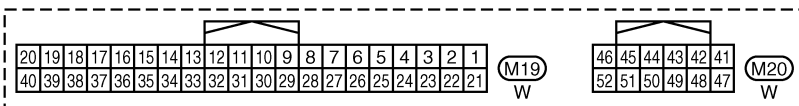
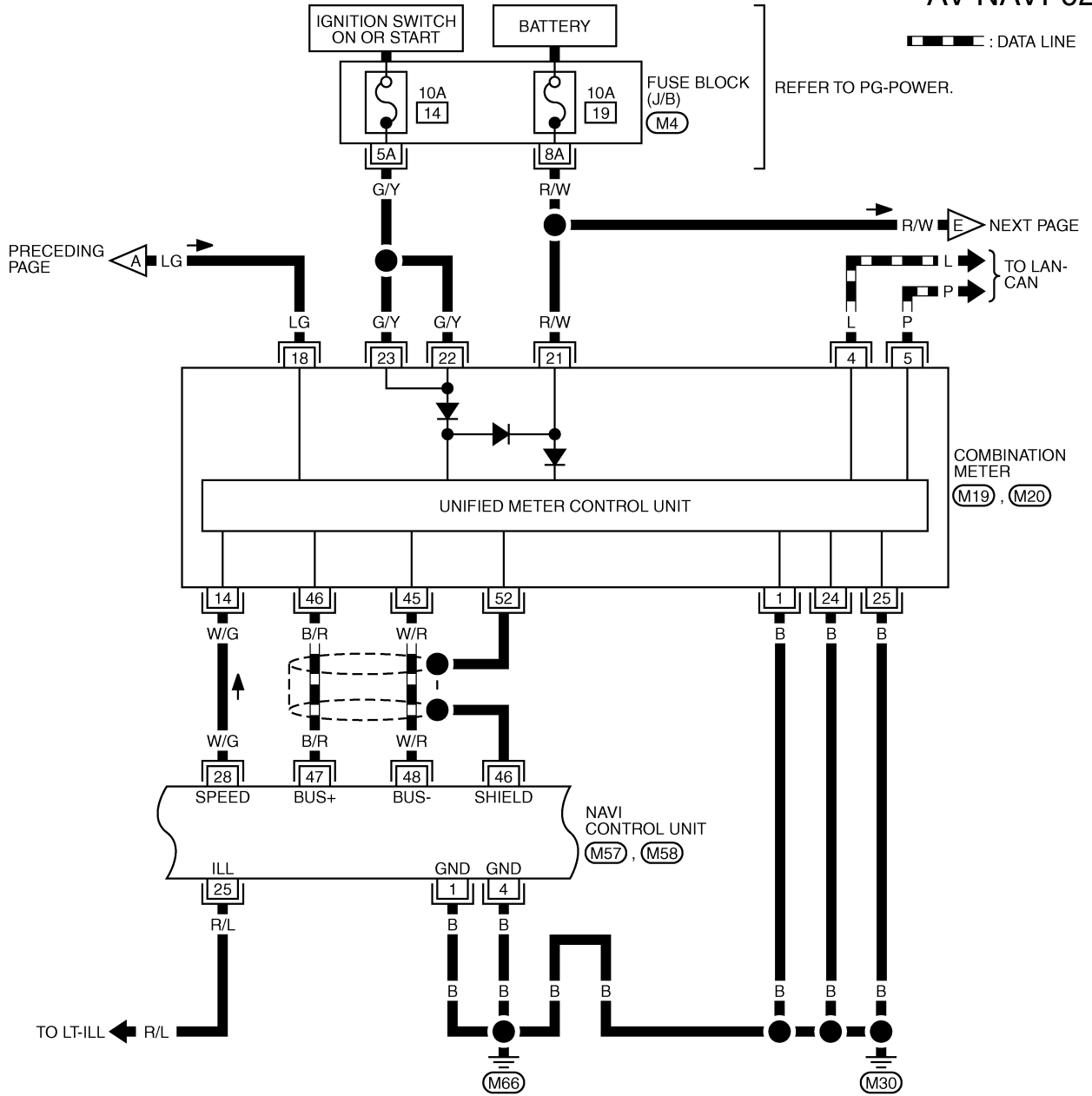

REFER TO THE FOLLOWING.  
 (M4) - FUSE BLOCK-JUNCTION BOX (J/B)

TKWM2402E

A  
B  
C  
D  
E  
F  
G  
H  
I  
J  
AV  
L  
M

# NAVIGATION SYSTEM

AV-NAVI-03

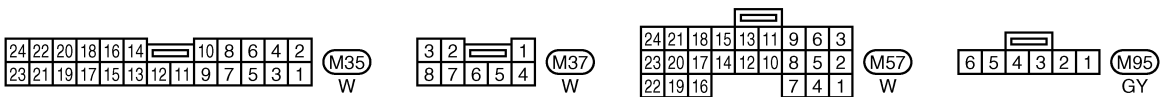
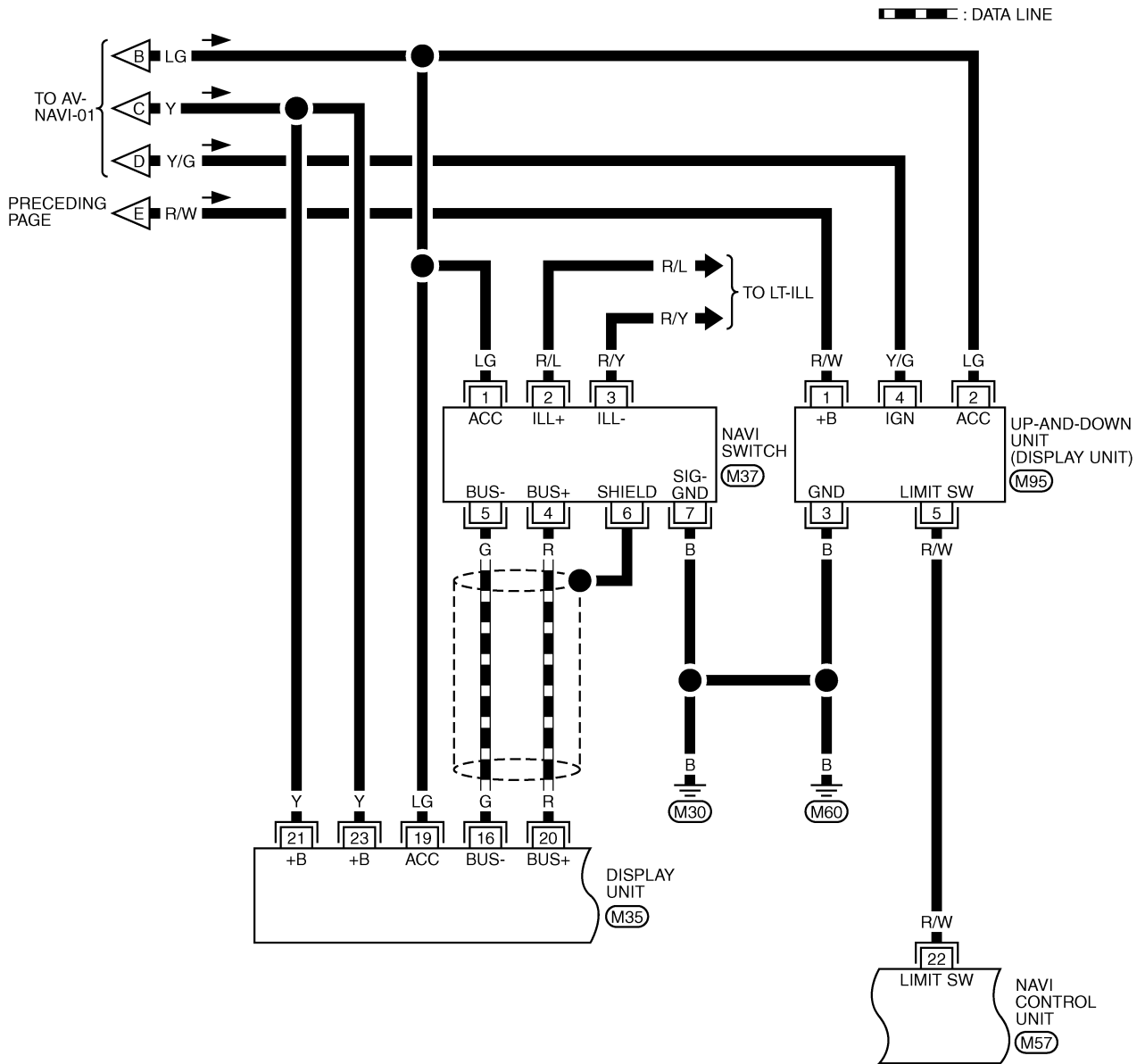

TKWM2403E

# NAVIGATION SYSTEM

AV-NAVI-04

▬ : DATA LINE

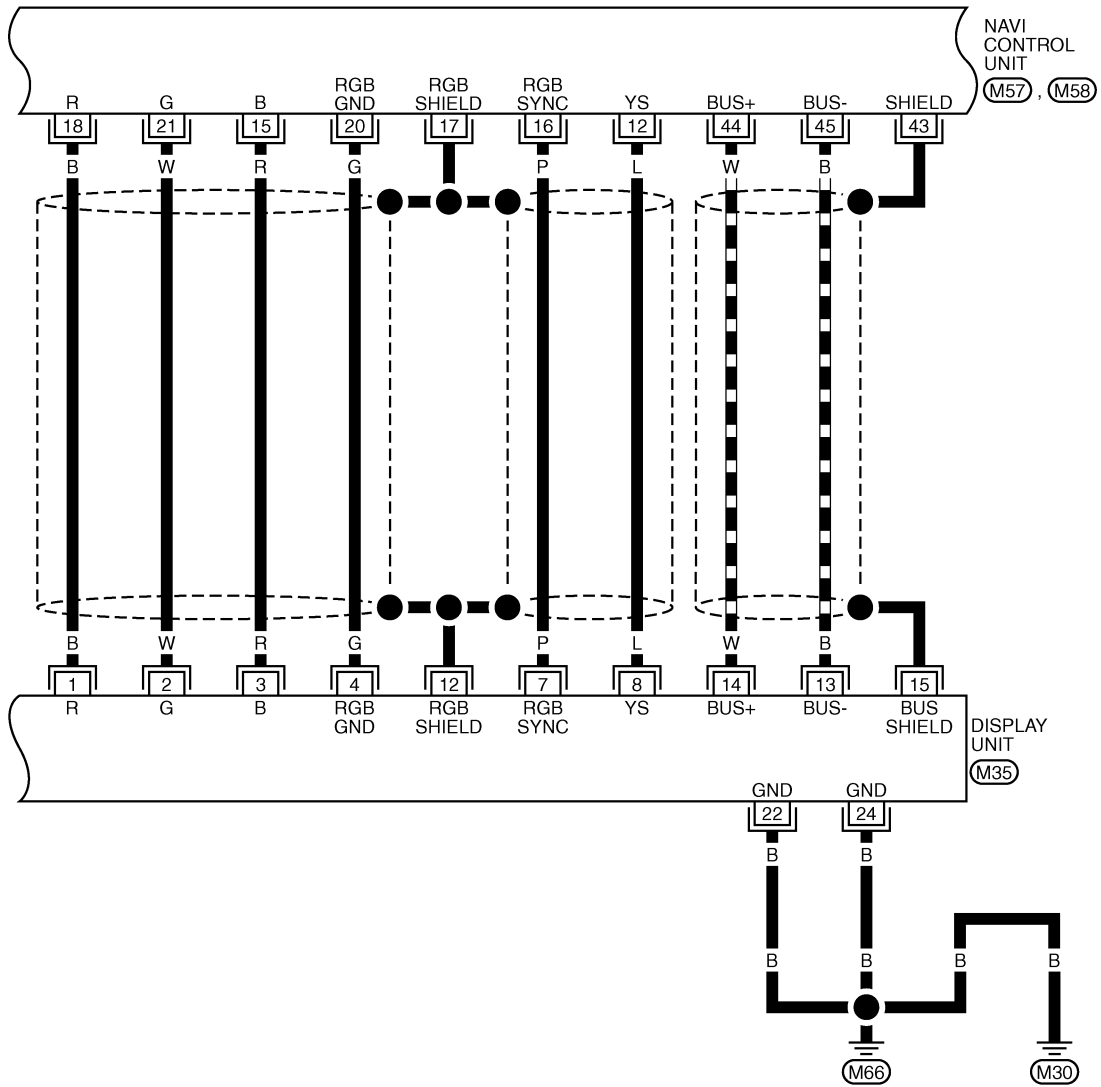

24	22	20	18	16	14	10	8	6	4	2		
23	21	19	17	15	13	12	11	9	7	5	3	1

(M35) W

24	21	18	15	13	11	9	6	3	48	45	42	39	37	35	33	30	27
23	20	17	14	12	10	8	5	2	47	44	41	38	36	34	32	29	26
22	19	16				7	4	1	46	43	40				31	28	25

(M57) W (M58) GY

TKWM2404E

# NAVIGATION SYSTEM

AV-NAVI-05

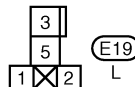
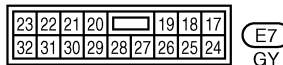
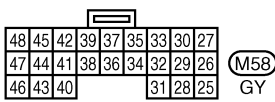
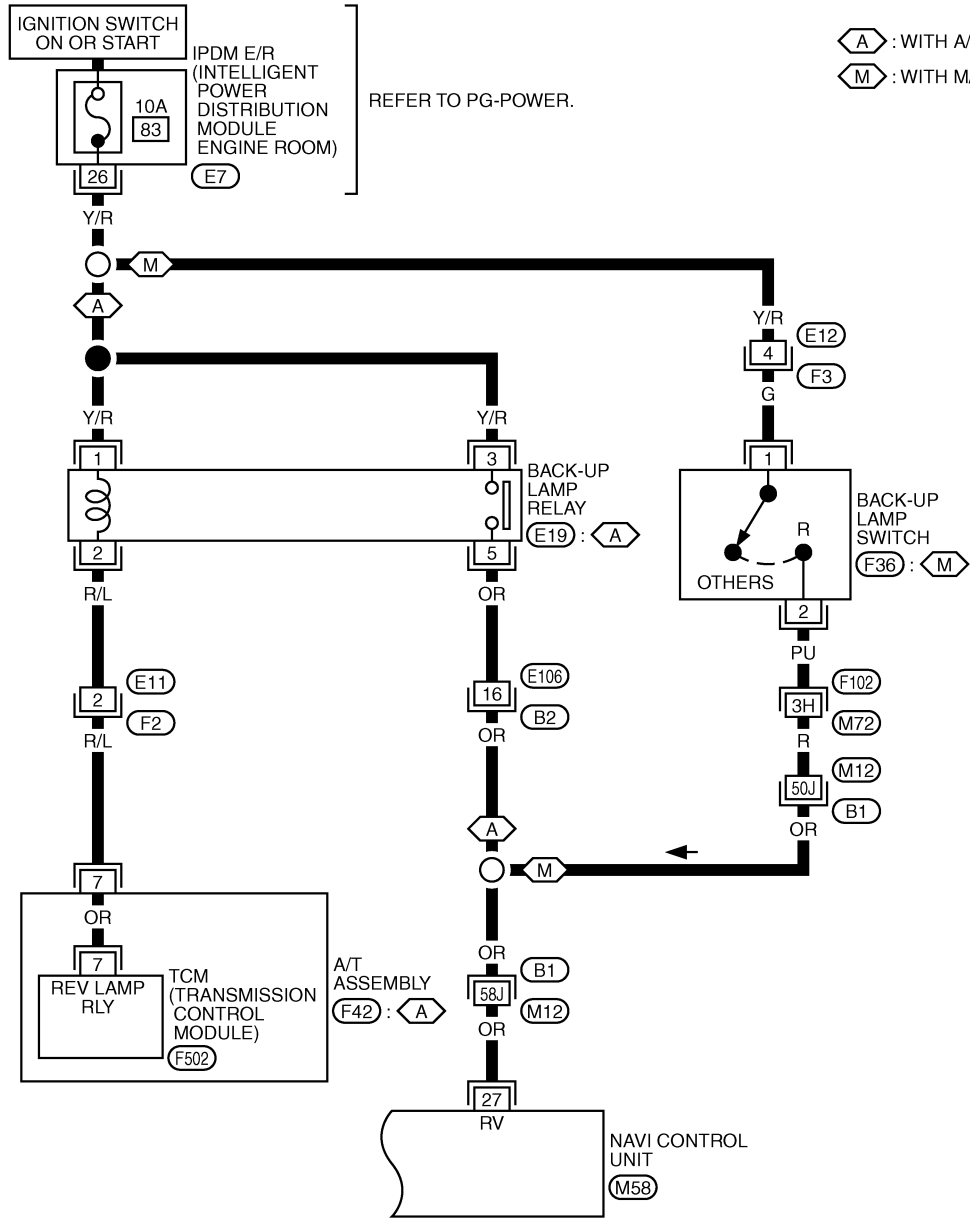

REFER TO THE FOLLOWING.  
F102, B1 -SUPER MULTIPLE JUNCTION (SMJ)

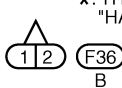
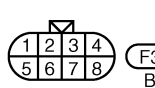
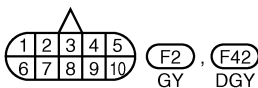

\*: THIS CONNECTOR IS NOT SHOWN IN "HARNESS LAYOUT", PG SECTION.

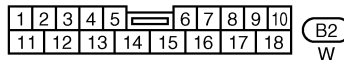
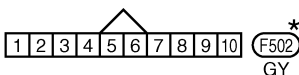

TKWM2405E



# NAVIGATION SYSTEM

## Wiring Diagram —COMM—

AKS00017

### AV-COMM-01

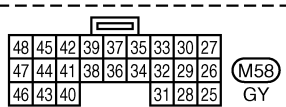
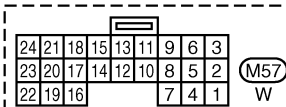
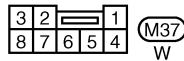
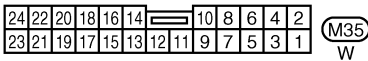
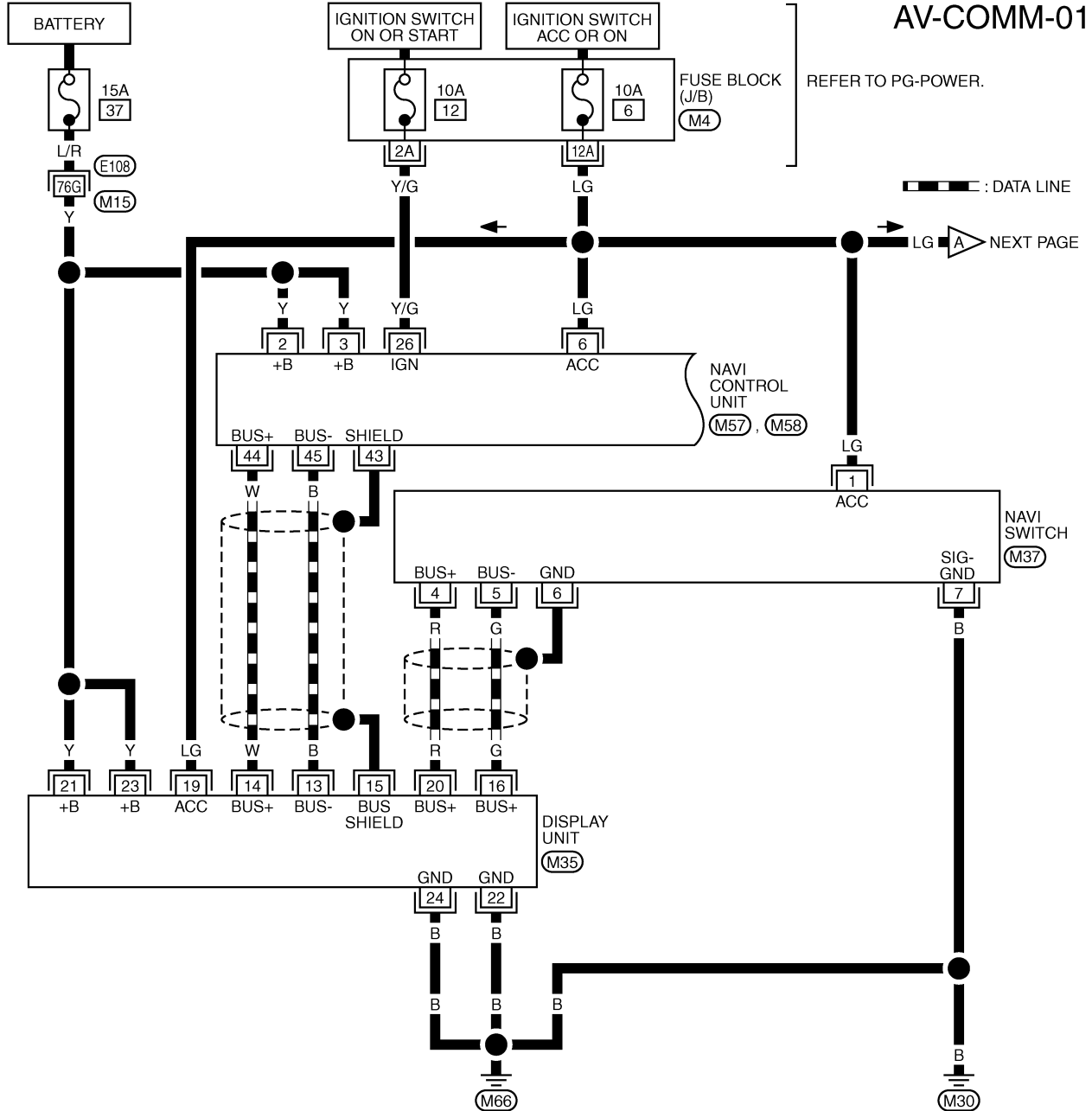

REFER TO THE FOLLOWING.

(E108) -SUPER MULTIPLE JUNCTION (SMJ)

(M4) -FUSE BLOCK-JUNCTION BOX (J/B)

TKWM2406E

# NAVIGATION SYSTEM

AV-COMM-02

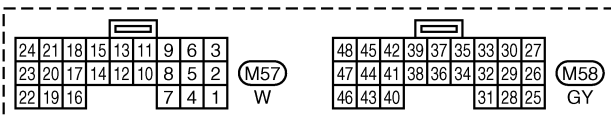
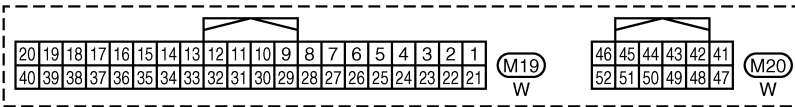
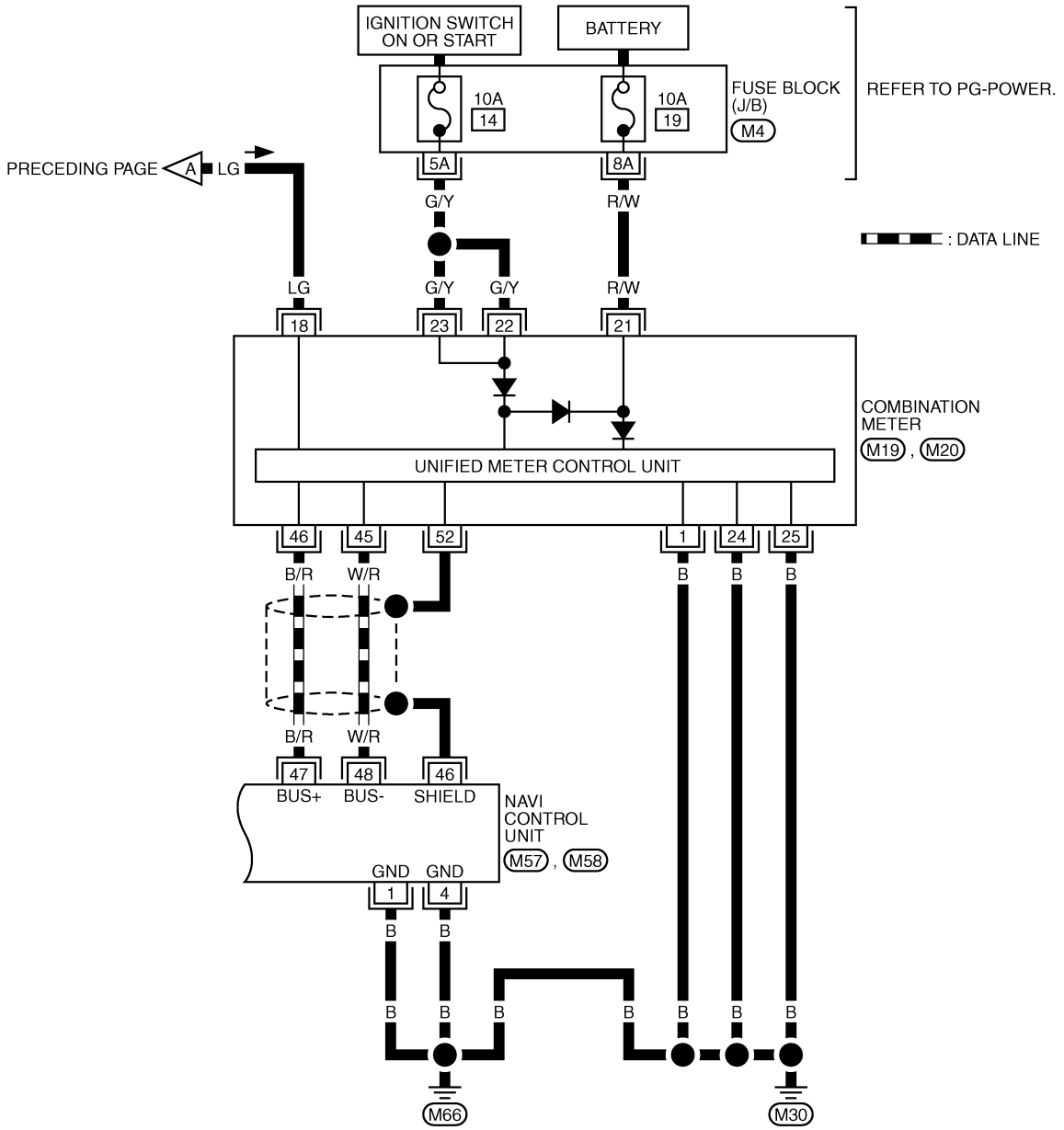

REFER TO THE FOLLOWING.

(M4) - FUSE BLOCK-JUNCTION BOX (J/B)

TKWM2407E

# NAVIGATION SYSTEM

AKS000DV

## Terminals and Reference Value for NAVI Control Unit

- Measure using circuit tester and oscilloscope.
- Measure with connector connected unless otherwise specified.
- CAUTION:**  
**Confirm voltage between negative terminal on each unit and body ground is approximately 0V.**
- If ignition ON is required in measurement condition, measures with engine running to prevent battery discharge.

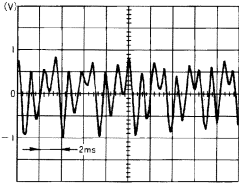
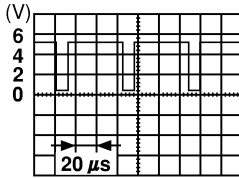
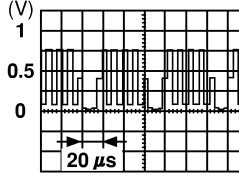
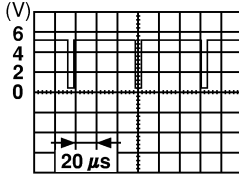
Terminal (Wire color)		Item	Signal input/output	Condition		Reference value	Example of symptom
(+)	(-)			Ignition switch	Operation		
1 (B)	Ground	Ground	-	ON	-	Approx. 0 V	-
2 (Y)	Ground	Battery power supply	Input	OFF	-	Battery voltage	System does not work properly.
3 (Y)							
4 (B)	Ground	Ground	-	ON	-	Approx. 0 V	-
6 (LG)	Ground	ACC power supply	Input	ACC	-	Battery voltage	System does not work properly.
7 (L/W)	8 (W/B)	Voice guide signal	Output	ON	Push the "VOICE" switch.	 <p style="text-align: right; font-size: small;">SKIA0171J</p>	Only route guide and operation guide are not heard.
9 (B)	Ground	Ground	-	ON	-	Approx. 0V	-
12 (L)	17	RGB area (YS) signal	Output	ON	-	 <p style="text-align: right; font-size: small;">SKIA0162E</p>	RGB screen is not shown.
15 (R)	17	RGB signal (B: blue)	Output	ON	Select "Color bar" of CONFIRMATION/ADJUSTMENT function.	 <p style="text-align: right; font-size: small;">SKIA0167E</p>	RGB screen looks yellowish.
16 (P)	17	RGB synchronizing signal	Output	ON	-	 <p style="text-align: right; font-size: small;">SKIA0164E</p>	RGB screen is rolling.
17	Ground	Shield Ground	-	ON	-	Approx. 0V	-

A  
B  
C  
D  
E  
F  
G  
H  
I  
J  
AV  
L  
M

# NAVIGATION SYSTEM

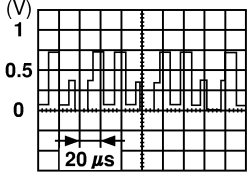
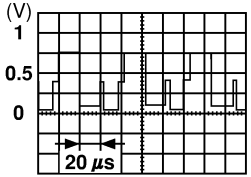
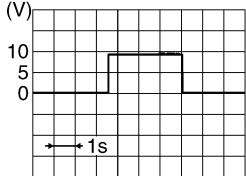
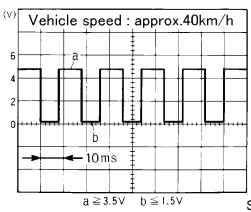
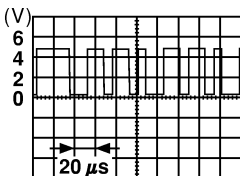
Terminal (Wire color)		Item	Signal input/output	Condition		Reference value	Example of symptom
(+)	(-)			Ignition switch	Operation		
18 (B)	17	RGB signal (R: red)	Output	ON	Select "Color bar" of CONFIRMATION/ADJUSTMENT function.	 <small>SKIA0165E</small>	RGB screen looks bluish.
20 (G)	Ground	RGB Ground	-	ON	-	Approx. 0V	-
21 (W)	17	RGB signal (G: green)	Output	ON	Select "Color bar" of CONFIRMATION/ADJUSTMENT function.	 <small>SKIA0166E</small>	RGB screen looks reddish.
22 (R/W)	Ground	Limit switch signal	Input	ON	Display unit is opened.	Approx. 5V	Display does not work properly.
					Except for above	Approx. 0V	
24 (R/B)	9 (B)	Voice guide ON signal	Output	ON	Push the "VOICE" switch.	 <small>SKIB0232E</small>	Only route guide and operation guide are not heard.
25 (R/L)	Ground	Illumination signal	Input	OFF	Lighting switch position 1st or 2nd	Approx. 12V	Night illumination for switches does not illuminate.
					Lighting switch position OFF	Approx. 0V	
26 (Y/G)	Ground	Ignition signal	Input	ON	-	Battery voltage	Vehicle information setting is not possible.
27 (OR)	Ground	Reverse signal	Input	ON	Select R-position	Approx. 12V	The navigation current-location mark moves strangely when the vehicle is moving backwards.
					Other-position	Approx. 0V	
28 (W/G)	Ground	Vehicle speed signal (2-pulse)	Input	ON	When vehicle speed is approx. 40 km/h (25 MPH)	 <small>SKIA0168E</small>	Navigation current-location mark does not indicate the correct position.
44 (W)	43	Communication signal (+)	Input/Output	ON	Push the "PREVIOUS" switch.	 <small>SKIA0175E</small>	NAVI switch is not controlled.

# NAVIGATION SYSTEM

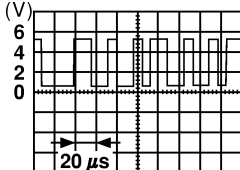
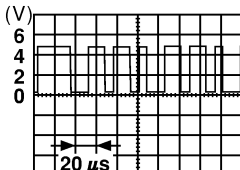
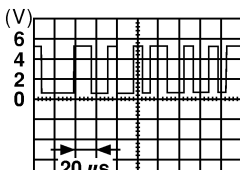
Terminal (Wire color)		Item	Signal input/output	Condition		Reference value	Example of symptom
(+)	(-)			Ignition switch	Operation		
45 (B)	43	Communication signal (-)	Input/Output	ON	Push the "PREVIOUS" switch.	 SKIA0176E	NAVI switch is not controlled.
47 (B/R)	46	Communication signal (+)	Input/Output	ON	-	 SKIA0175E	-
48 (W/R)	46	Communication signal (-)	Input/Output	ON	-	 SKIA0176E	-
56	57	GPS antenna signal	Input	ON	Connector is not connected.	Approx. 5V	Navigation system GPS correction is not possible.

## Terminals and Reference Value for Display Unit

AKS000E5

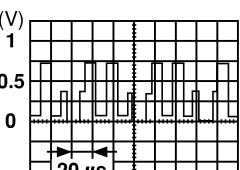
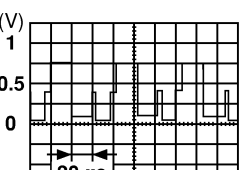
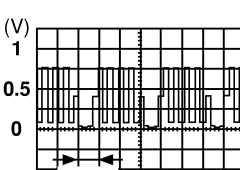
Terminal (Wire color)		Item	Signal input/output	Condition		Reference value	Example of symptom
(+)	(-)			Ignition switch	Operation		
1 (B)	Ground	RGB signal (R: red)	Input	ON	Select "Color bar" of CONFIRMATION/ADJUSTMENT function.	 SKIA0165E	RGB screen looks bluish.
2 (W)	Ground	RGB signal (G: green)	Input	ON	Select "Color bar" of CONFIRMATION/ADJUSTMENT function.	 SKIA0166E	RGB screen looks reddish.
3 (R)	Ground	RGB signal (B: blue)	Input	ON	Select "Color bar" of CONFIRMATION/ADJUSTMENT function.	 SKIA0167E	RGB screen looks yellowish.

# NAVIGATION SYSTEM

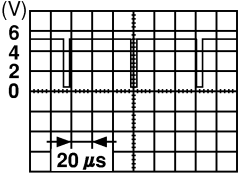
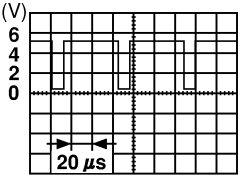
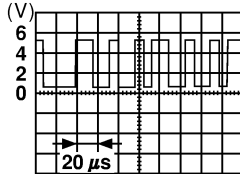
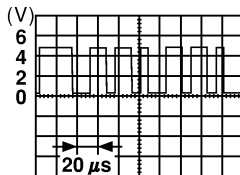
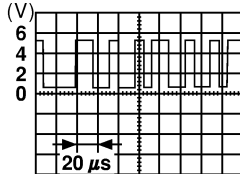
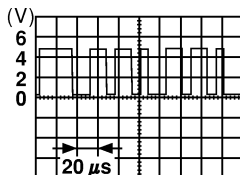
Terminal (Wire color)		Item	Signal input/ output	Condition		Reference value	Example of symptom
(+)	(-)			Ignition switch	Operation		
4 (G)	Ground	RGB Ground	-	ON	-	Approx. 0V	-
7 (P)	Ground	RGB synchronizing signal	Input	ON	-		RGB screen is rolling.
8 (L)	Ground	RGB area(YS) signal	Input	ON	-		RGB screen is not shown.
12	Ground	RGB shield	-	ON	-	Approx. 0V	-
13 (B)	15	Communication signal (-)	Input/Output	ON	Push the "PREVIOUS" switch.		NAVI switch is not controlled.
14 (W)	15	Communication signal (+)	Input/Output	ON	Push the "PREVIOUS" switch.		NAVI switch is not controlled.
15	Ground	Shield ground	-	ON	-	Approx. 0V	-
16 (G)	Ground	Communication signal (-)	Input/Output	ON	Push the "PREVIOUS" switch.		NAVI switch is not controlled.
19 (LG)	Ground	ACC power supply	Input	ACC	-	Battery voltage	System does not work properly.
20 (R)	Ground	Communication signal (+)	Input/Output	ON	Push the "PREVIOUS" switch.		NAVI switch is not controlled.
21 (Y)	Ground	Battery power supply	Input	OFF	-	Battery voltage	System does not work properly.
22 (B)	Ground	Ground	-	ON	-	Approx. 0V	-

# NAVIGATION SYSTEM

Terminal (Wire color)		Item	Signal input/ output	Condition		Reference value	Example of symptom
(+)	(-)			Ignition switch	Operation		
23 (Y)	Ground	Battery power supply	Input	OFF	-	Battery voltage	System does not work properly.
24 (B)	Ground	Ground	-	ON	-	Approx. 0V	-

## Terminals and Reference Value for NAVI Switch

AKS000E6

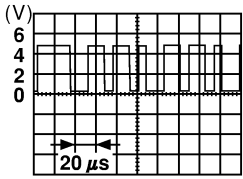
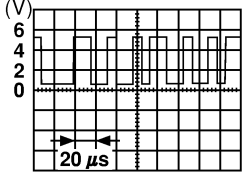
Terminal (Wire color)		Item	Signal input/ output	Condition		Reference value	Example of symptom
(+)	(-)			Ignition switch	Operation		
1 (LG)	Ground	ACC power supply	Input	ACC	-	Battery voltage	All operations do not work.
2 (R/L)	Ground	Illumination signal (+)	Input	OFF	Lighting switch position 1st or 2nd	Approx. 12V	Night illumination for switches does not illuminate.
					Lighting switch position OFF	Approx. 0V	
3(R/Y)	Ground	Illumination signal (-)	-	ON	Illumination control switch is operated by lighting switch in ON position	Approx. 0V	NAVI switch illumination cannot be con- trolled.
4 (R)	6	Communica- tion signal (+)	Input/ Output	ON	Push the "PREVIOUS" switch.	 SKIA0175E	NAVI switch is not controlled.
5 (G)	6	Communica- tion signal (-)	Input/ Output	ON	Push the "PREVIOUS" switch.	 SKIA0176E	
6	Ground	Ground	-	ON	-	Approx. 0V	-
7(B)	Ground	Ground	-	ON	-	Approx. 0V	All operations do not work.

A  
B  
C  
D  
E  
F  
G  
H  
I  
J  
AV  
L  
M

# NAVIGATION SYSTEM

AKS000EB

## Self-Diagnosis Function

### DESCRIPTION

- Diagnosis function consists of the self-diagnosis mode performed automatically and the CONFIRMATION/ADJUSTMENT mode operated manually.
- Self-diagnosis mode checks for connections between the units constituting this system, analyzes each individual unit at the same time, and displays the results on the LCD screen.
- CONFIRMATION/ADJUSTMENT mode is used to perform trouble diagnoses that require operation and judgment by an operator (trouble that cannot be automatically judged by the system), to check/change the set value, and to display the History of Errors of the navigation system.

### DIAGNOSIS ITEM

Mode		Description	
Self-diagnosis		<ul style="list-style-type: none"> <li>● NAVI Control unit diagnosis (DVD-ROM drive will not be diagnosed when no map DVD-ROM is in it.).</li> <li>● Performs diagnosis of each unit and connections between control unit and GPS antenna, as well as between control unit and each unit.</li> </ul>	
CONFIRMATION/ ADJUSTMENT	Display diagnosis	Color tone and shading of the screen can be checked by the display of a color bar and a gray scale.	
	Vehicle signals	Analyzes the following vehicle signals: Vehicle speed signal, light signal, ignition switch signal, and reverse signal.	
	Navigation	Display Longitude & Latitude	Display the map. Use the joystick to adjust position. Longitude and latitude will be displayed.
		Speed Calibration	Under ordinary conditions, the navigation system distance measuring function will automatically compensate for minute decreases in wheel and tire diameter caused by tire wear or low pressure. Speed calibration immediately restores system accuracy in cases such as when distance calibration is needed because of the use of tire chains in inclement weather.
		Angle Adjustment	Corrects difference between actual turning angle of a vehicle and turning angle of the car mark on the display.
		Initialize Location	This mode is for initializing the current location. Use when the vehicle is transported a long distance on a trailer, etc.
History of Errors		Diagnosis results previously stored in the memory (before turning ignition switch ON) are displayed in this mode. Time and location when/where the errors occurred are also displayed.	



# NAVIGATION SYSTEM

## Self-Diagnosis Mode OPERATION PROCEDURE

AKS000DW

1. Start the engine.
2. Push and hold "MAP" and "DAY/NIGHT" switches simultaneously for 5 seconds or more.
  - Push the "PREVIOUS" switch and the initial system screen will be shown.

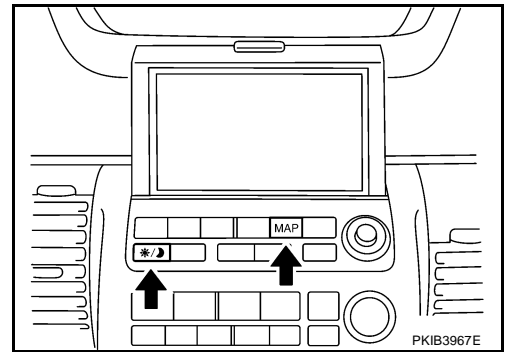

3. The initial trouble diagnosis screen will be shown, and items "SELF-DIAGNOSIS" and "CONFIRMATION/ADJUSTMENT" will become selective.

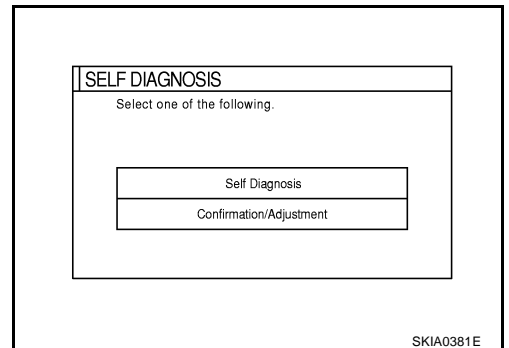

4. Perform self-diagnosis by selecting the "SELF-DIAGNOSIS".
  - Self-diagnosis subdivision screen will be shown and the operation enters the self-diagnosis mode.
  - A bar graph shown below the self-diagnosis subdivision screen indicates progress of the diagnosis.

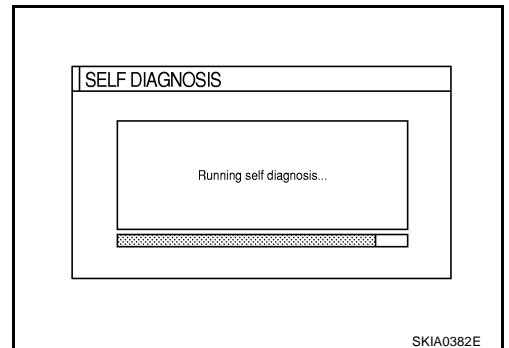

5. On the "Self-diagnosis" screen, each unit name will be colored according to the diagnosis result, as follows.

**Green** : No malfunctioning.

**Yellow** : Cannot be judged by self-diagnosis results.

**Red** : Unit is malfunctioning.

**Gray** : Diagnosis has not been done.

- If multiple malfunctions occur at the same time for a single unit, the screen switch colors are determined according to the following order of priority. Red > yellow > gray
- Display when it is normal
  - Between Navigation Unit and GPS antenna is connected in green
  - Between Navigation Unit and Satellite Switch, Navigation Unit and Display, Navigation Unit and IMU are connected in gray

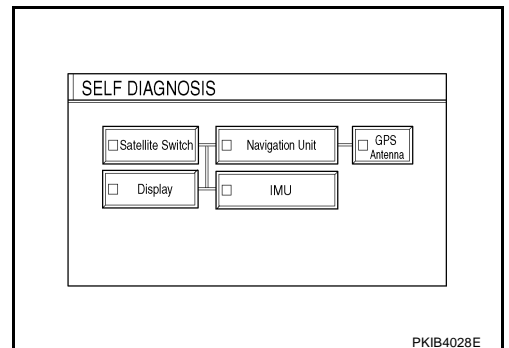

A  
B  
C  
D  
E  
F  
G  
H  
I  
J  
AV  
L  
M

# NAVIGATION SYSTEM

6. Select a switch on the “Self diagnosis” screen and comments for the diagnosis results will be shown.

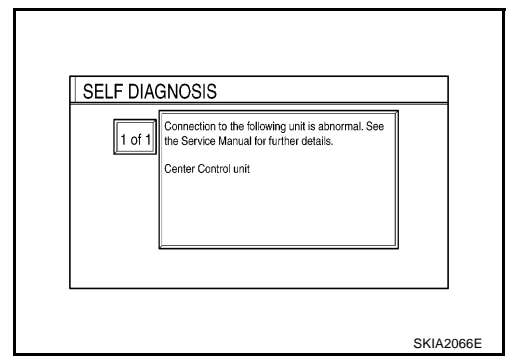

## SELF-DIAGNOSIS RESULT

### Quick Reference Table

1. Select an applicable diagnosis No. in the diagnosis result quick reference table.
2. Find estimated malfunctioning system in the diagnosis No. table and perform check by referring to the AV communication line wiring diagram. Refer to [AV-57, "Wiring Diagram —COMM—"](#) .
3. Turn the ignition switch to OFF and perform self-diagnosis again.

Screen switch				Diagnosis No.
Switch color	Navigation unit <sup>*1</sup>	IMU <sup>*2</sup>	GPS antenna	
Red	×			1
Grey	×			2
Yellow	×			3
	×			4
	×	×		5
	×		×	6

\*1: Navigation unit =NAVI control unit

\*2: IMU =Combination meter

### CAUTION:

- If display has any error, self-diagnosis cannot start.
- If AV communication between display unit and NAVI control unit has any error, self-diagnosis cannot start.

# NAVIGATION SYSTEM

## Self-diagnosis Codes

Diagnosis No.	Possible cause
1	NAVI control unit malfunction
2	NAVI control unit judged no map DVD-ROM is inserted.
3	When "DVD-ROM error. Please check disc." is shown. 1. Eject map DVD-ROM and check if it is compatible with the system. 2. Check ejected DVD-ROM for dirt, damage, and warp age. 3. If no error is found, insert a known good map DVD-ROM of the same type and perform self-diagnosis again. If same result is shown, the NAVI control unit is malfunctioning. If result is normal, the map DVD-ROM is malfunctioning.
4	If "Error found in DVD-ROM or DVD-ROM driver in control unit. Please perform diagnosis in accordance with service manual" is shown, carry out same inspection as diagnosis No. 3.
5	Combination meter system 1. Combination meter power supply and ground circuit 2. Communication line between combination meter and NAVI control unit.
6	GPS antenna system 1. Visually check for a broken wire in the GPS antenna coaxial cable. 2. Disconnect the GPS antenna connector and check that approximately 5V is supplied from NAVI control unit. If not, the NAVI control unit is inoperative. If the voltage is supplied, replace the GPS antenna and perform self-diagnosis again. If the same result is shown, the NAVI control unit is inoperative.

## CONFIRMATION/ADJUSTMENT Mode OPERATION PROCEDURE

AKS000DX

- Start the engine.
- Push and hold "MAP" and "DAY/NIGHT" switches simultaneously for 5 seconds or more.
  - Push the "PREVIOUS" switch and the initial system screen will be shown.
- The initial trouble diagnosis screen will be shown, and items "SELF-DIAGNOSIS" and "CONFIRMATION/ADJUSTMENT" will become selective.

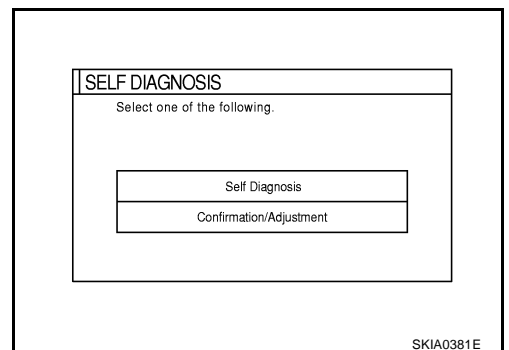
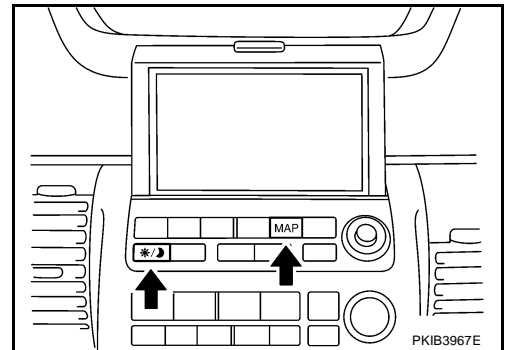

A  
B  
C  
D  
E  
F  
G  
H  
I  
J  
AV  
L  
M

# NAVIGATION SYSTEM

4. When "CONFIRMATION/ADJUSTMENT" is selected on the initial trouble diagnosis screen, the operation will enter the CONFIRMATION/ADJUSTMENT mode. In this mode, check and adjustment of each item will become possible.
5. Select each switch on "CONFIRMATION/ADJUSTMENT" screen to display the relevant diagnosis screen.

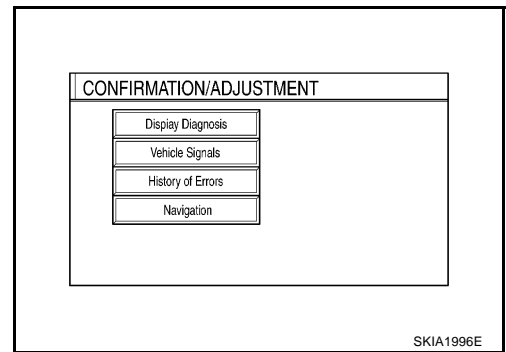

## DISPLAY DIAGNOSIS

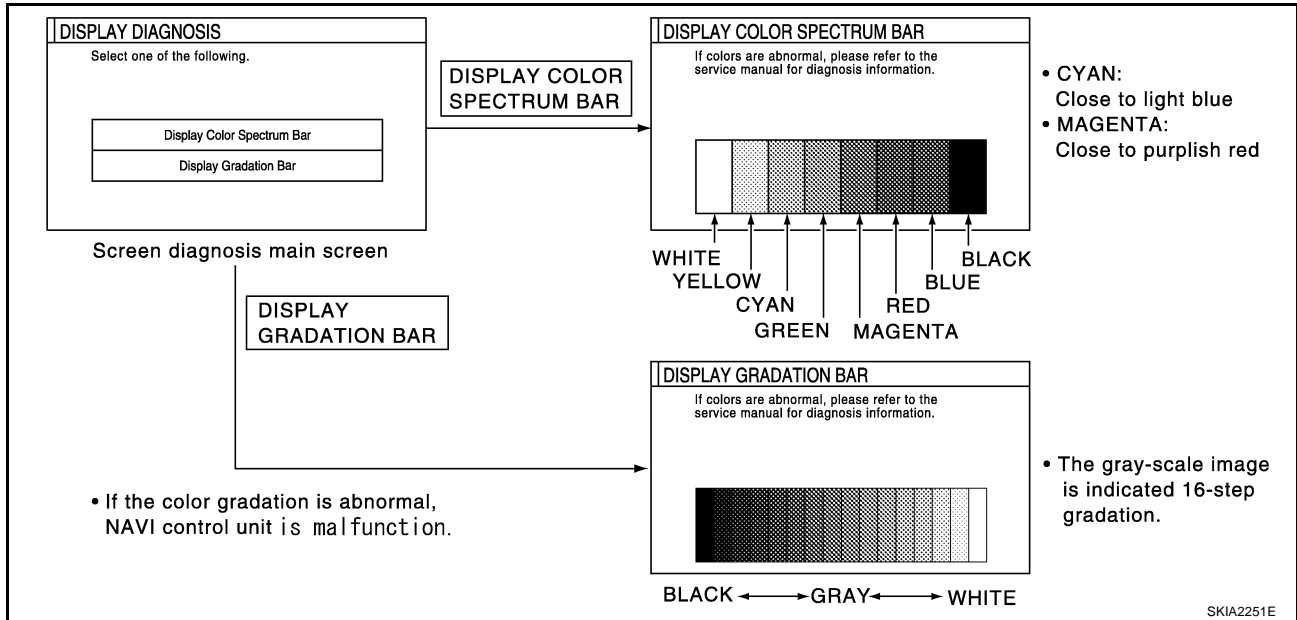

### CAUTION:

When Display Color Spectrum Bar screen is completed after "PREVIOUS" switch is pushed, the screen color changes once. This is normal.

- When RGB signal error occurred in the RGB system, tone of the color bar will change as follows.
  - R (red) signal error** : Screen looks bluish.
  - G (green) signal error** : Screen looks reddish.
  - B (blue) signal error** : Screen looks yellowish.
- When the color of the screen looks unusual, refer to [AV-81, "Color of RGB Image Is Not Proper \(Bluish\)"](#) , [AV-82, "Color of RGB Image Is Not Proper \(Reddish\)"](#) , [AV-83, "Color of RGB Image Is Not Proper \(Yellowish\)"](#) .

# NAVIGATION SYSTEM

## VEHICLE SIGNALS

- A comparison check can be made of each actual vehicle signal and the signals recognized by the system.

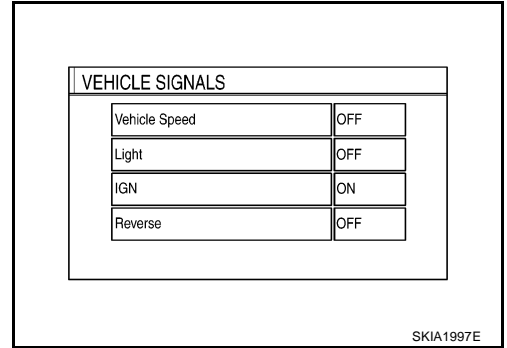

Diagnosis item	Display	Condition	Remarks
Vehicle speed	ON	Vehicle speed > 0 km/h (0 MPH)	Changes in indication may be delayed by approx. 1.5 seconds. This is normal.
	OFF	Vehicle speed = 0 km/h (0 MPH)	
	-	Ignition switch in ACC position	
Lights	ON	Lighting switch ON	-
	OFF	Lighting switch OFF	
IGN	ON	Ignition switch ON	-
	OFF	Ignition switch ACC or OFF	
Reverse	ON	Selector lever in R-position	Changes in indication may be delayed by approx. 1.5 seconds. This is normal.
	OFF	Selector lever in other than R-position	
	-	Ignition switch in ACC position	

- If vehicle speed is NG, refer to [AV-75, "Vehicle Speed Signal Check"](#) .
- If lights are NG, refer to [AV-76, "Illumination Signal Check"](#) .
- If IGN is NG, refer to [AV-76, "Ignition Signal Check"](#) .
- If reverse is NG, refer to [AV-77, "Reverse Signal Check \(With A/T\)"](#) or [AV-77, "Reverse Signal Check \(With M/T\)"](#) .

## NAVIGATION

### Angle Adjustment

- Adjusts turning angle output detected by the gyroscope.

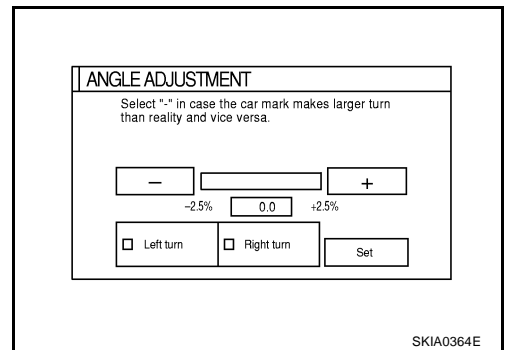

# NAVIGATION SYSTEM

## Speed Calibration

- During normal driving, distance error caused by tire wear and tire pressure change is automatically adjusted for by the automatic distance correction function. This function, on the other hand, is for immediate adjustment, in cases such as driving with tire chain fitted on tires.

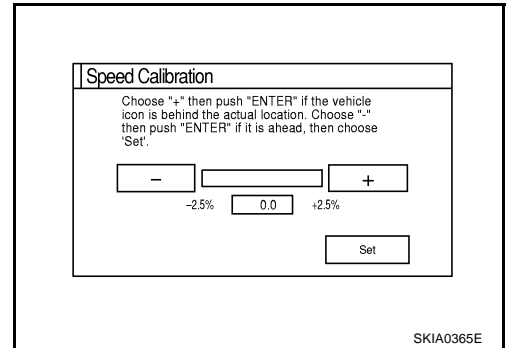

## HISTORY OF ERRORS

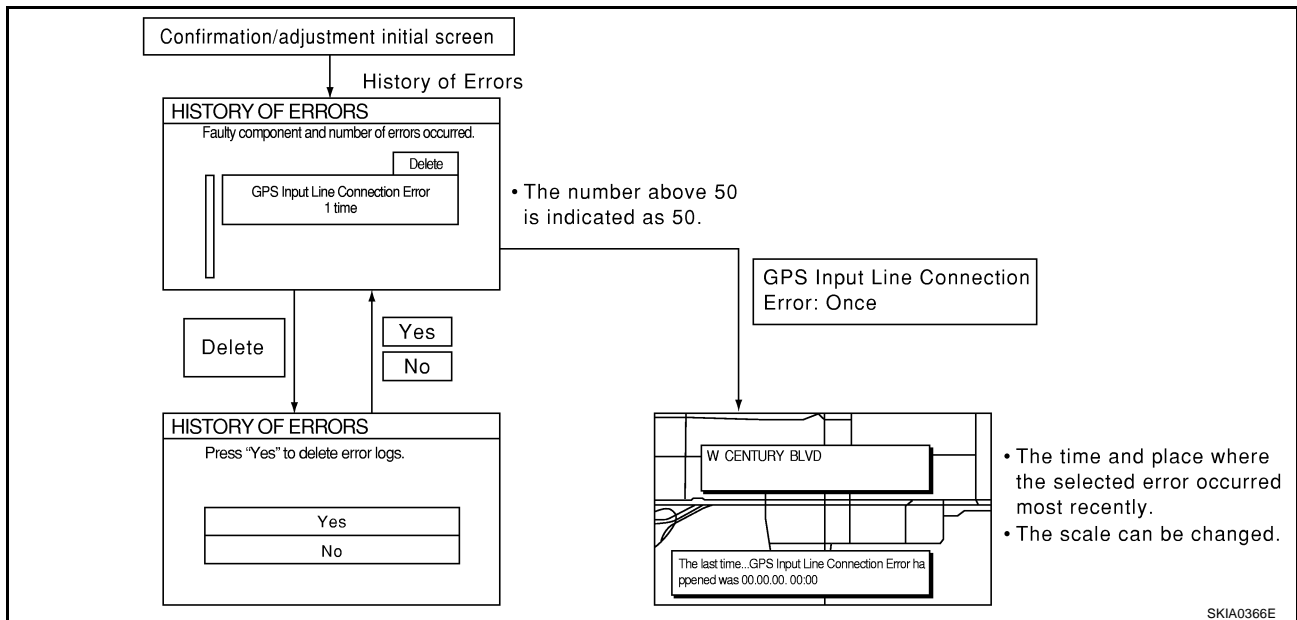

## DIAGNOSIS BY HISTORY OF ERRORS

The "Self-diagnosis" results indicate whether an error occurred during the period from when the ignition switch is turned to ON until "Self-diagnosis" is completed.

If an error occurred before the ignition switch was turned to ON and does not occur again until the "Self-diagnosis" is completed, the diagnosis result will be judged normal. Therefore, those errors in the past, which cannot be found by the "Self-diagnosis", must be found by diagnosing the "History of Errors".

The History of Errors displays the time and place of the most recent occurrence of that error. However, take note of the following points.

- Correct time of the error occurrence may not be displayed when the GPS antenna substrate within the NAVI control unit has malfunctioned.
- Place of the error occurrence is represented by the position of the current-location mark at the time when the error occurred. If the current-location mark has deviated from the correct position, then the place of the error occurrence may be located correctly.
- The maximum number of occurrences which can be stored is 50. For the 51st and later occurrences, the displayed number remains 50.

When a reproducible malfunction occurred but its cause cannot be identified because several errors are present, record the item, number and place (longitude/latitude) of error occurrence (or delete the History of Errors), then turn the ignition switch from OFF to ON to reproduce the malfunction. Check the History of Errors to find the items which show an increased number of occurrences, and diagnose the item.

# NAVIGATION SYSTEM

Error item	Possible causes	Example of symptom	
	Action/symptom		
Gyro sensor disconnected	Communications malfunction between NAVI control unit and internal gyro	<ul style="list-style-type: none"> <li>● Navigation location detection performance has deteriorated. (Angular velocity cannot be detected.)</li> </ul>	A
	<ul style="list-style-type: none"> <li>● Perform self-diagnosis.</li> <li>● When the NAVI control unit is judged normal by self-diagnosis, the symptom may be intermittent, caused by strong radio interference.</li> </ul>		B C
GPS disconnected	Communication error between NAVI control unit and internal GPS substrate	<ul style="list-style-type: none"> <li>● Navigation location detection performance has deteriorated. (Location correction using GPS is not performed.)</li> <li>● GPS receiving status remains gray.</li> </ul>	D
	<ul style="list-style-type: none"> <li>● Perform self-diagnosis.</li> <li>● When the NAVI control unit is judged normal by self-diagnosis, the symptom may be intermittent, caused by strong radio interference.</li> </ul>		E
GPS transmission cable malfunction	Malfunctioning transmission wires to NAVI control unit and internal GPS substrate	<ul style="list-style-type: none"> <li>● During self-diagnosis, GPS diagnosis is not performed.</li> </ul>	F
	<ul style="list-style-type: none"> <li>● Perform self-diagnosis.</li> <li>● When the NAVI control unit is judged normal by self-diagnosis, the symptom may be intermittent, caused by strong radio interference.</li> </ul>		G
GPS input line connection error	Malfunctioning receiving wires to NAVI control unit and internal GPS substrate	<ul style="list-style-type: none"> <li>● Navigation location detection performance has deteriorated. (Location correction using GPS is not performed.)</li> <li>● GPS receiving status remains gray.</li> </ul>	H
	<ul style="list-style-type: none"> <li>● Perform self-diagnosis.</li> <li>● When the NAVI control unit is judged normal by self-diagnosis, the symptom may be intermittent, caused by strong radio interference.</li> </ul>		I
GPS TCX0 over GPS TCX0 under	Oscillating frequency of the GPS substrate frequency synchronizing oscillation circuit exceeded (or below) the specification	<ul style="list-style-type: none"> <li>● Navigation location detection performance has deteriorated. (Location correction using GPS is not performed.)</li> <li>● GPS receiving status remains gray.</li> </ul>	J
	<ul style="list-style-type: none"> <li>● Perform self-diagnosis.</li> <li>● When the NAVI control unit is judged normal by self-diagnosis, the symptom may be intermittent, caused by strong radio interference, or the control unit may have been subjected to excessively high or low temperatures.</li> </ul>		AV
GPS ROM malfunction GPS RAM malfunction	Contents of ROM (or RAM) in GPS substrate are malfunctioning.	<ul style="list-style-type: none"> <li>● Location detection accuracy of the navigation system will deteriorate, depending on the failed area in the memory, because GPS cannot make correct positioning. (Location correction using GPS is not performed.)</li> </ul>	L
	<ul style="list-style-type: none"> <li>● Perform self-diagnosis.</li> <li>● When the NAVI control unit is judged normal by self-diagnosis, the symptom may be intermittent, caused by strong radio interference.</li> </ul>		M
GPS RTC malfunction	Clock IC in GPS substrate is malfunctioning.	<ul style="list-style-type: none"> <li>● Correct time may not be displayed.</li> <li>● After the power is turned on, the system always takes some time until GPS positioning becomes possible. (The GPS receiver starts positioning without re-collecting the whole satellite information when it judged the data stored in the receiver is correct.)</li> <li>● Correct time of error occurrence may not be stored in the "History of Errors".</li> </ul>	
	<ul style="list-style-type: none"> <li>● Perform self-diagnosis.</li> <li>● When the NAVI control unit is judged normal by self-diagnosis, the symptom may be intermittent, caused by strong radio interference.</li> </ul>		
GPS antenna disconnected	Malfunctioning connection between GPS substrate in NAVI control unit and GPS antenna.	<ul style="list-style-type: none"> <li>● Navigation location detection performance has deteriorated. (Location correction using GPS is not performed.)</li> <li>● GPS receiving status remains gray.</li> </ul>	
	<ul style="list-style-type: none"> <li>● Perform self-diagnosis.</li> <li>● When connection between NAVI control unit and GPS antenna is judged normal by self-diagnosis, the symptom may be intermittent, caused by impact or vibration.</li> </ul>		

# NAVIGATION SYSTEM

Error item	Possible causes	Example of symptom
	Action/symptom	
Low voltage of GPS	The power voltage supplied to the GPS circuit board has decreased.	<ul style="list-style-type: none"> <li>● Navigation location detection performance has deteriorated. (Location correction using GPS is not performed.)</li> <li>● GPS receiving status remains gray.</li> </ul>
	<ul style="list-style-type: none"> <li>● Perform self-diagnosis.</li> <li>● When connection between NAVI control unit and GPS antenna is judged normal by self-diagnosis, the symptom may be intermittent, caused by impact or vibration.</li> </ul>	
DVD-ROM Malfunction DVD-ROM Read error DVD-ROM Response Error	Malfunctioning NAVI control unit	-
	Dedicated map DVD-ROM is in the system, but the data cannot be read.	<ul style="list-style-type: none"> <li>● The map of a particular location cannot be displayed.</li> <li>● Specific guidance information cannot be displayed.</li> <li>● Map display is slow.</li> <li>● Guidance information display is slow.</li> <li>● System has been affected by vibration.</li> </ul>
	<ul style="list-style-type: none"> <li>● Is map DVD-ROM damaged, warped, or dirty?                             <ul style="list-style-type: none"> <li>- If damaged or warped, the map DVD-ROM is malfunctioning.</li> <li>- If dirty, wipe the DVD-ROM clean with a soft cloth.</li> </ul> </li> <li>● Perform self-diagnosis.</li> <li>● When NAVI control unit is judged normal by self-diagnosis, the symptom is judged intermittent, caused by vibration.</li> </ul>	



# NAVIGATION SYSTEM

## Power Supply and Ground Circuit Check for NAVI Control Unit

AKS00046

### 1. CHECK FUSE

Check that the following fuses of the NAVI control unit are not blown.

Terminals		Power source	Fuse No.
Connector	Terminal (Wire color)		
M57	2 (Y)	Battery power	37
	3 (Y)		
	6 (LG)	Ignition switch ACC or ON	6

OK or NG

OK >> GO TO 2.

NG >> If fuse is blown, be sure to eliminate case of malfunction before installing new fuse. Refer to [PG-3](#), "[POWER SUPPLY ROUTING CIRCUIT](#)".

### 2. POWER SUPPLY CIRCUIT CHECK

Check voltage between the following harness connector terminals and ground.

Terminals			OFF	ACC	ON
(+)		(-)			
Connector	Terminal (Wire color)				
M57	2 (Y)	Ground	Battery voltage	Battery voltage	Battery voltage
	3 (Y)		Battery voltage	Battery voltage	Battery voltage
	6 (LG)		0V	Battery voltage	Battery voltage

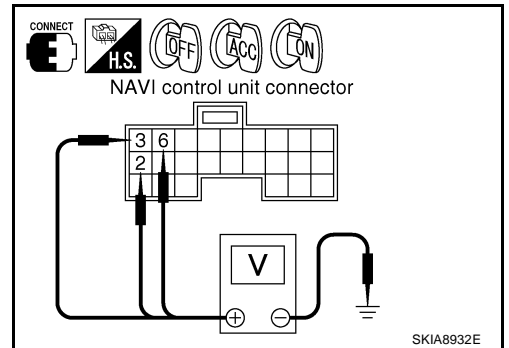

OK or NG

OK >> GO TO 3.

NG >> Check harness for open or short between NAVI control unit and fuse.

### 3. GROUND CIRCUIT CHECK

1. Turn ignition switch OFF.
2. Disconnect NAVI control unit connector.
3. Check continuity between NAVI control unit harness connector and ground.

Terminals			Continuity
Connector	Terminal (Wire color)	Ground	
M57	1 (B)	Ground	Yes
	4 (B)		

OK or NG

OK >> Inspection end.

NG >> Repair harness or connector.

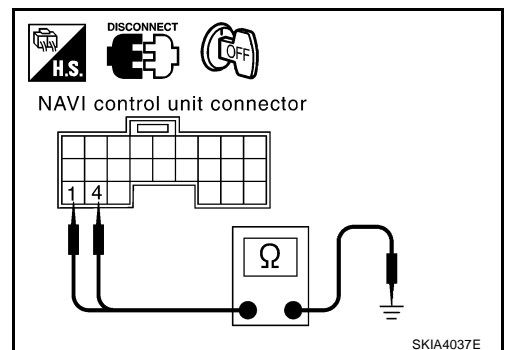

A  
B  
C  
D  
E  
F  
G  
H  
I  
J  
AV  
L  
M

# NAVIGATION SYSTEM

## Power Supply and Ground Circuit Check for Display Unit and NAVI Switch

AKS00039

### 1. CHECK FUSE

Check that the following fuses of the display unit and NAVI switch are not blown.

Unit	Terminals		Power source	Fuse No.
	Connector	Terminal (Wire color)		
Display unit	M35	21 (Y)	Battery power	37
		23 (Y)		
		19 (LG)		
NAVI switch	M37	1 (LG)	Ignition switch ACC or ON	6

OK or NG

OK >> GO TO 2.

NG >> If fuse is blown, be sure to eliminate case of malfunction before installing new fuse. Refer to [PG-3](#), "[POWER SUPPLY ROUTING CIRCUIT](#)".

### 2. POWER SUPPLY CIRCUIT CHECK

1. Check voltage between display unit harness connector and ground.

Unit	Terminals			OFF	ACC	ON
	Connector	(+)	(-)			
Display unit		M35	21 (Y)	Ground	Battery voltage	Battery voltage
	23 (Y)		Battery voltage		Battery voltage	Battery voltage
	19 (LG)		0V		Battery voltage	Battery voltage

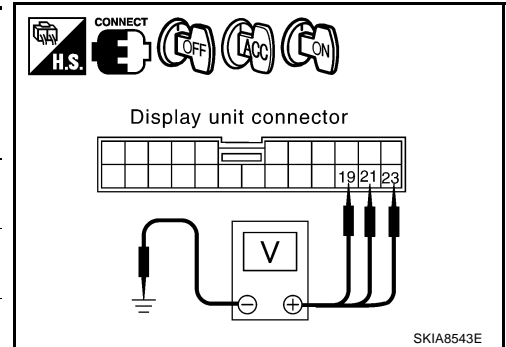

2. Check voltage between NAVI switch harness connector and ground.

Unit	Terminals			OFF	ACC	ON
	Connector	(+)	(-)			
NAVI switch		M37	1 (LG)	Ground	0V	Battery voltage

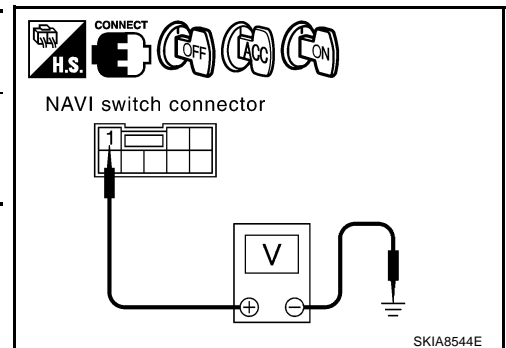

OK or NG

OK >> GO TO 3.

NG >> Check the following.

- Harness for open or short between display unit and fuse.
- Harness for open or short between NAVI switch and fuse.

## 3. GROUND CIRCUIT CHECK

1. Turn ignition switch OFF.
2. Disconnect display unit connector.
3. Check continuity between display unit harness connector and ground.

Unit	Terminals		Continuity
	Terminal (Wire color)		
Display unit	M35	22 (B)	Ground
		24 (B)	
			Yes

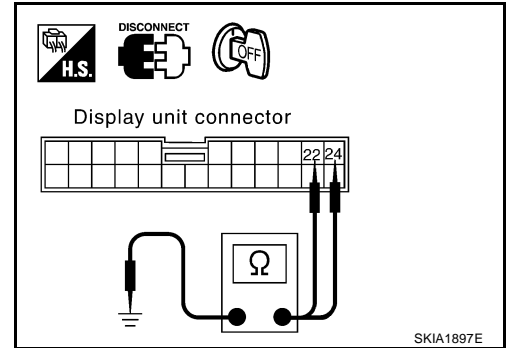

4. Disconnect NAVI switch connector.
5. Check continuity between NAVI switch harness connector M37 terminal 7 (B) and ground.

Continuity should exist.

OK or NG

- OK >> Inspection end.
- NG >> Repair or replace harness.

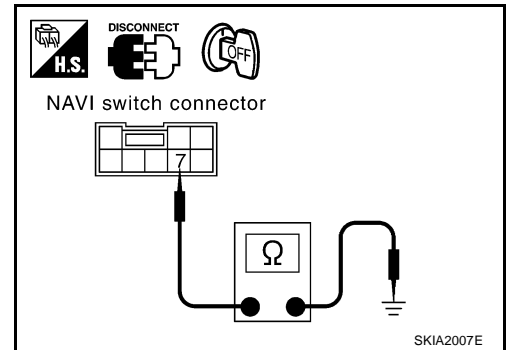

## Vehicle Speed Signal Check

### 1. VEHICLE SPEED OPERATION CHECK

Does speed meter is operated normally?

YES or NO

- YES >> GO TO 2.
- NO >> Check combination meter trouble diagnosis. Refer to [DI-9, "Self-Diagnosis Mode of Combination Meter"](#).

### 2. HARNESS CHECK

1. Turn ignition switch OFF.
2. Disconnect NAVI control unit connector and combination meter connector.
3. Check continuity between NAVI control unit harness connector M58 terminal 28 (W/G) and combination meter harness connector M19 terminal 14 (W/G).

Continuity should exist.

4. Check continuity NAVI control unit harness connector M58 terminal 28 (W/G) and ground.

Continuity should not exist.

OK or NG

- OK >> GO TO 3.
- NG >>
  - Check harness for open or short between NAVI control unit and combination meter.
  - Check connector housings for disconnected or loose terminals.

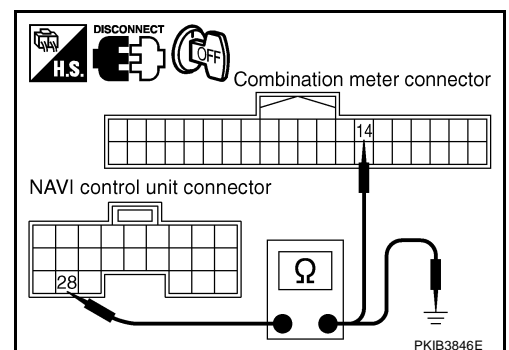

# NAVIGATION SYSTEM

## 3. VEHICLE SPEED SIGNAL CHECK

1. Connect NAVI control unit connector and combination meter connector.
2. Drive vehicle at a constant speed.
3. Check the signal between NAVI control unit harness connector M58 terminal 28 (W/G) and ground with CONSULT-II or oscilloscope.

**28 (W/G) – Ground** : Refer to [AV-59, "Terminals and Reference Value for NAVI Control Unit"](#) .

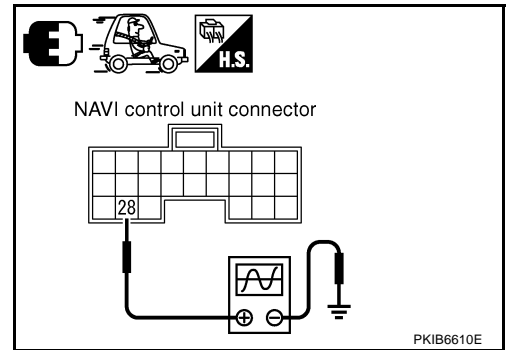

OK or NG

OK >> Replace NAVI control unit.

NG >> Check combination meter system. Refer to [DI-9, "Self-Diagnosis Mode of Combination Meter"](#) .

## Illumination Signal Check

AKS00049

### 1. TAIL LAMP OPERATION CHECK

When lighting switch turned 1st or 2nd position, does tail lamp illuminate?

YES or NO

YES >> GO TO 2.

NO >> Go to tail lamp trouble diagnosis. Refer to [LT-151, "Parking, License Plate and Tail Lamps Do Not Illuminate"](#) .

### 2. ILLUMINATION SIGNAL CHECK

Check voltage between NAVI control unit harness connector and ground.

Terminals		Lighting switch position	Voltage (V)
(+)	(-)		
Connector	Terminal (Wire color)		
M58	25 (R/L)	1st or 2nd position	Approx. 12V
		OFF	Approx. 0V

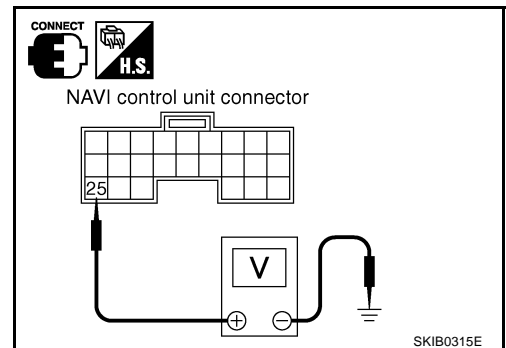

OK or NG

OK >> Replace NAVI control unit.

NG >> Check harness for open or short between NAVI control unit and IPDM E/R. Refer to [LT-146, "Wiring Diagram — TAIL/L —"](#) .

## Ignition Signal Check

AKS0004A

### 1. CHECK FUSE

Check that the following fuses of the NAVI control unit are not blown.

Terminals		Power source	Fuse No.
Connector	Terminal (Wire color)		
M58	26 (Y/G)	Ignition switch ON or START	12

OK or NG

OK >> GO TO 2.

NG >> If fuse is blown, be sure to eliminate case of malfunction before installing new fuse. Refer to [PG-3, "POWER SUPPLY ROUTING CIRCUIT"](#) .

# NAVIGATION SYSTEM

## 2. IGNITION SIGNAL CHECK

1. Turn ignition switch ON.
2. Check voltage between NAVI control unit harness connector and ground.

Terminals			Ignition switch position	
(+)		(-)	ON	OFF
Connector	Terminal (Wire color)		Battery voltage	Approx. 0V
M58	26 (Y/G)	Ground	Battery voltage	Approx. 0V

### OK or NG

- OK >> Replace NAVI control unit.  
 NG >> Repair harness or connector.

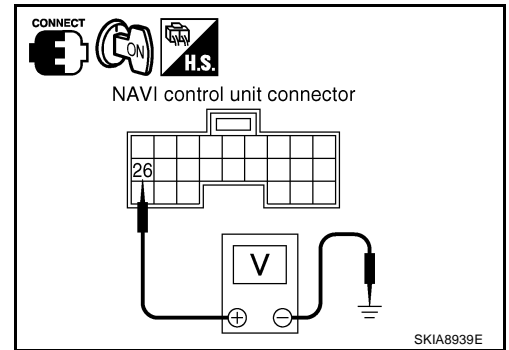

## Reverse Signal Check (With A/T)

AKS0004B

### 1. REVERSE LAMP CHECK

1. Turn ignition switch ON.
2. With the A/T selector lever in R-position. Is the indicator turned?

### YES or NO

- YES >> GO TO 2.  
 NO >> Check back up lamp system. Refer to [LT-140, "BACK-UP LAMP"](#) .

## 2. REVERSE SIGNAL CHECK

1. With the A/T selector lever in R-position.
2. Check voltage between NAVI control unit harness connector and ground.

Terminals			A/T selector lever position	Voltage (V)
(+)		(-)		
Connector	Terminal (Wire color)			R-position
M58	27 (OR)	Ground	Other than R-position	Approx. 0V

### OK or NG

- OK >> Replace NAVI control unit.  
 NG >> Check harness for open or short between NAVI control unit and back up lamp relay.

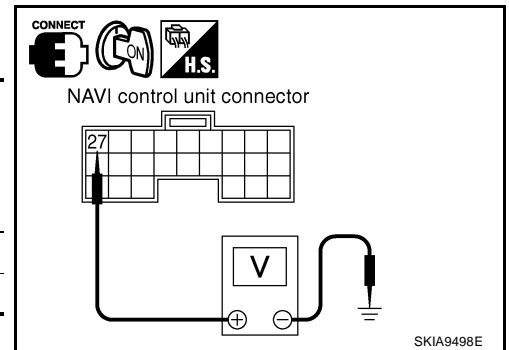

## Reverse Signal Check (With M/T)

AKS007VS

### 1. REVERSE LAMP CHECK

1. Turn ignition switch ON.
2. With the shift lever in R-position. Are reverse ramps turned on?

### YES or NO

- YES >> GO TO 2.  
 NO >> Check back up lamp system. Refer to [LT-140, "BACK-UP LAMP"](#) .

# NAVIGATION SYSTEM

## 2. REVERSE SIGNAL CHECK

1. With the shift lever in R-position.
2. Check voltage between NAVI control unit harness connector and ground.

Terminals		Shift lever position	Voltage (V)
(+)	(-)		
Connector	Terminal (Wire color)		
M58	27 (OR)	R-position	Battery voltage
		Other than R-position	Approx. 0V

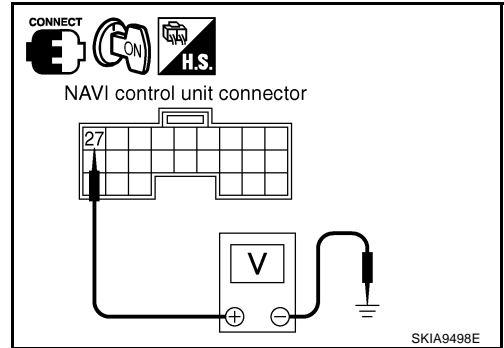

OK or NG

- OK >> Replace NAVI control unit.  
 NG >> Harness for open or short between NAVI control unit and back-up lamp switch.

## Navigation System Is Not Operated by NAVI Switch

AKS00ATT

### 1. CHECK POWER SUPPLY AND GROUND CIRCUIT (DISPLAY UNIT AND NAVI SWITCH)

Check power supply and ground circuit. Refer to [AV-74, "Power Supply and Ground Circuit Check for Display Unit and NAVI Switch"](#).

OK or NG

- OK >> GO TO 2.  
 NG >> Power supply and ground circuit check.

### 2. CHECK HARNESS (BETWEEN NAVI SWITCH AND DISPLAY UNIT)

1. Turn ignition switch OFF.
2. Disconnect display unit connector and NAVI switch connector.
3. Check continuity between display unit harness connector M35 terminal 16 (G), 20 (R) and NAVI switch harness connector M37 terminal 5 (G), 4 (R).

**Continuity should exist.**

4. Check continuity between display unit harness connector M35 terminal 16 (G), 20 (R) and ground.

**Continuity should not exist.**

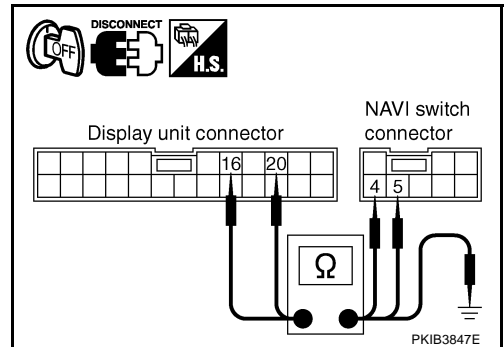

OK or NG

- OK >> GO TO 3.  
 NG >> Repair harness or connector.

# NAVIGATION SYSTEM

## 3. CHECK HARNESS (BETWEEN DISPLAY UNIT AND NAVI CONTROL UNIT)

1. Disconnect NAVI control unit connector and display unit connector.
2. Check continuity between NAVI control unit harness connector M58 terminal 44 (W), 45 (B) and display unit harness connector M35 terminal 14 (W), 13 (B).

**Continuity should exist.**

3. Check continuity between NAVI control unit harness connector M58 terminal 44 (W), 45 (B) and ground.

**Continuity should not exist.**

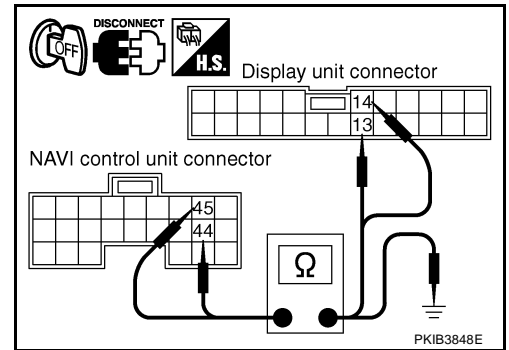

OK or NG

- OK >> GO TO 4.
- NG >> Repair harness or connector.

## 4. CHECK NAVI SWITCH

Replace normal NAVI switch and recheck the symptom.

Is the function normal?

- YES >> Replace NAVI switch.
- NO >> GO TO 5.

## 5. CHECK DISPLAY UNIT

Replace normal display unit and recheck the symptom.

Is the function normal?

- YES >> Replace display unit.
- NO >> Replace NAVI control unit.

## Screen Is Not Shown

AKS00CH7

### 1. CHECK DISPLAY UNIT

Check if brightness of screen changes when DAY/NIGHT switch on NAVI switch is turned on after turning on ignition switch.

Does brightness of screen change?

- YES >> GO TO 3.
- NO >> GO TO 2.

### 2. CHECK DISPLAY UNIT POWER SUPPLY AND GROUND CIRCUIT

Check display unit power supply and ground circuit. Refer to [AV-74, "Power Supply and Ground Circuit Check for Display Unit and NAVI Switch"](#).

OK or NG

- OK >> Replace display unit.
- NG >> Repair malfunctioning parts.

### 3. CHECK NAVI CONTROL UNIT POWER SUPPLY AND GROUND CIRCUIT

Check NAVI control unit power supply and ground circuit. Refer to [AV-73, "Power Supply and Ground Circuit Check for NAVI Control Unit"](#).

OK or NG

- OK >> GO TO 4.
- NG >> Repair malfunctioning parts.

# NAVIGATION SYSTEM

## 4. CHECK HARNESS

1. Turn ignition switch OFF.
2. Disconnect NAVI control unit connector and display unit connector.
3. Check continuity between NAVI control unit harness connector M57 terminal 12 (L) and display unit harness connector M35 terminal 8 (L).

**12 (L) – 8 (L) : Continuity should exist.**

4. Check continuity between NAVI control unit harness connector M57 terminal 12 (L) and ground.

**12 (L) – Ground : Continuity should not exist.**

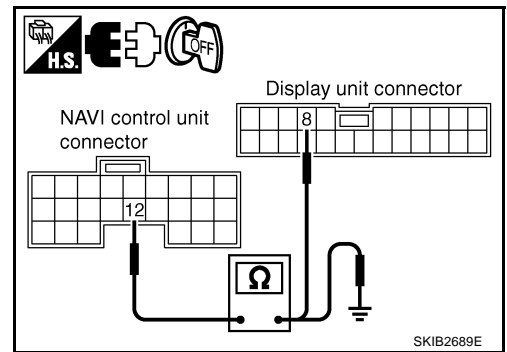

OK or NG

OK >> GO TO 5.

NG >> Repair harness or connector.

## 5. CHECK RGB AREA SIGNAL

1. Connect NAVI control unit connector and display unit connector.
2. Turn ignition switch ON.
3. Check signal between NAVI control unit harness connector M57 terminals 12 (L) and 17 with CONSULT-II or oscilloscope.

**12 (L) – 17 : Refer to [AV-59. "Terminals and Reference Value for NAVI Control Unit"](#) .**

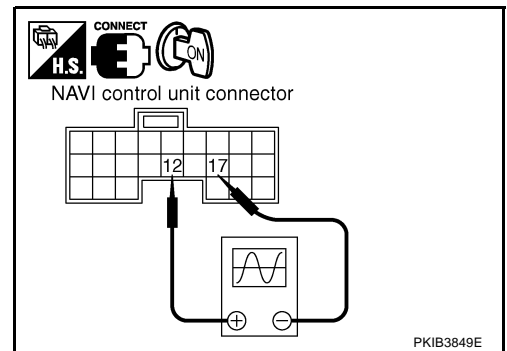

OK or NG

OK >> GO TO 6.

NG >> Replace NAVI control unit.

## 6. CHECK HARNESS

1. Turn ignition switch OFF.
2. Disconnect NAVI control unit connector and cover switch connector.
3. Check continuity between NAVI control unit harness connector M57 terminal 22 (R/W) and ground.

**22 (R/W) – Ground : Continuity should not exist.**

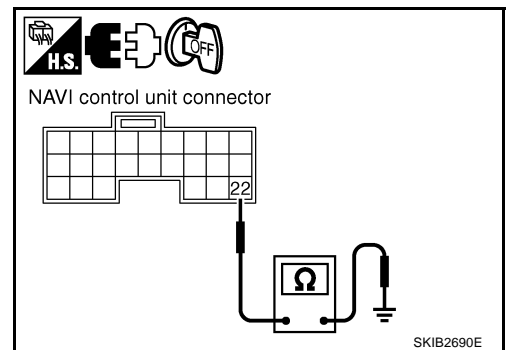

OK or NG

OK >> GO TO 7.

NG >> Repair harness or connector.

## 7. CHECK NAVI CONTROL UNIT INPUT SIGNAL

1. Connect NAVI control unit connector.
2. Turn ignition switch ON.
3. Check voltage between up-and-down unit (display unit) harness connector M95 terminal 5 (R/W) and ground.

**5 (R/W) – Ground : Approx. 5V**

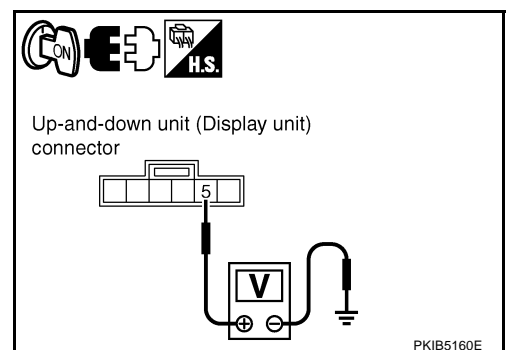

OK or NG

OK >> Replace display unit.

NG >> Replace NAVI control unit.



## Color of RGB Image Is Not Proper (Bluish)

### 1. RGB HARNESS CHECK

1. Turn ignition switch OFF.
2. Disconnect NAVI control unit connector and display unit connector.
3. Check continuity between NAVI control unit harness connector and display unit harness connector.
4. Check continuity between NAVI control unit harness connector and ground.

● **When the screen looks bluish**

Terminals				Continuity
NAVI control unit		Display unit		
Connector	Terminal (Wire color)	Connector	Terminal (Wire color)	
M57	18 (B)	M35	1 (B)	Yes
	17		12	

Terminals				Continuity
NAVI control unit				
Connector	Terminal (Wire color)	Ground		
M57	18 (B)		Ground	
	17			

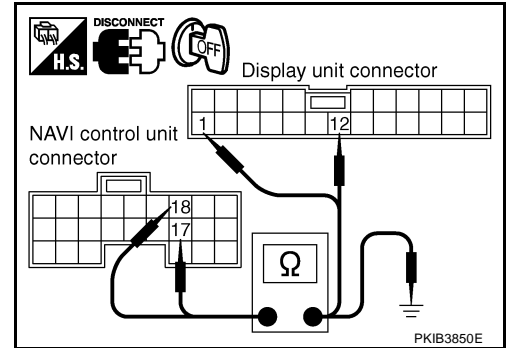

**OK or NG**

- OK >> GO TO 2.  
 NG >> Repair harness or connector.

### 2. RGB SIGNAL CHECK

1. Connect NAVI control unit connector and display unit connector.
2. Turn ignition switch ON.
3. Display "Color bar" by "CONFIRMATION/ADJUSTMENT" mode.
4. Check the signal between NAVI control unit terminal 18 (B) and 17 with CONSULT-II or oscilloscope.

● **When the screen looks bluish**

Terminals				Voltage (v)
NAVI control unit (+)		NAVI control unit (-)		
Connector	Terminal (Wire color)	Connector	Terminal	
M57	18 (B)	M57	17	Refer to <a href="#">AV-59</a> . "Terminals and Reference Value for NAVI Control Unit".

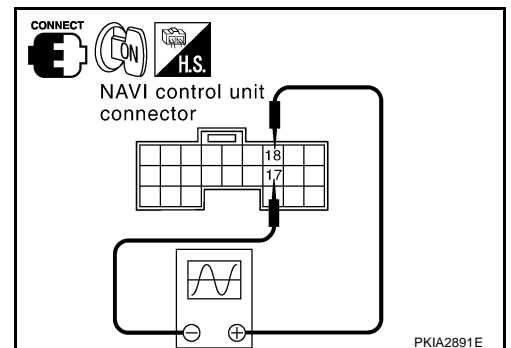

**OK or NG**

- OK >> Replace display unit.  
 NG >> Replace NAVI control unit.

## Color of RGB Image Is Not Proper (Reddish)

### 1. RGB HARNESS CHECK

1. Turn ignition switch OFF.
2. Disconnect NAVI control unit harness connector and display unit harness connector.
3. Check continuity between NAVI control unit harness connector and display unit harness connector.
4. Check continuity between NAVI control unit harness connector and ground.

● **When the screen looks reddish**

Terminals				Continuity
NAVI control unit		Display unit		
Connector	Terminal (Wire color)	Connector	Terminal (Wire color)	
M57	21 (W)	M35	2 (W)	Yes
	17		12	

Terminals			Continuity
NAVI control unit			
Connector	Terminal (Wire color)		
M57	21 (W)	Ground	No
	17		

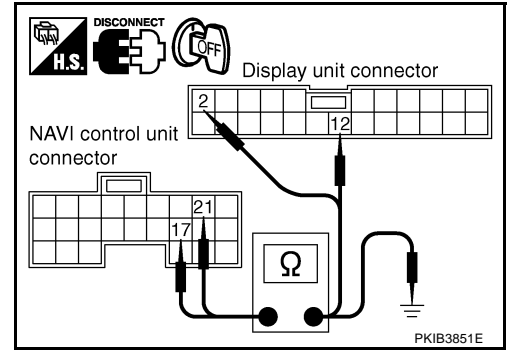

OK or NG

- OK >> GO TO 2.  
 NG >> Repair harness or connector.

### 2. RGB SIGNAL CHECK

1. Connect NAVI control unit connector and display unit connector.
2. Turn ignition switch ON.
3. Display "Color bar" by "CONFIRMATION/ADJUSTMENT" mode.
4. Check the signal between NAVI control unit terminal 21 (W) and 17 with CONSULT-II or oscilloscope.

● **When the screen looks reddish.**

Terminals				Voltage (V)
NAVI control unit (+)		NAVI control unit (-)		
Connector	Terminal (Wire color)	Connector	Terminal	
M57	21 (W)	M57	17	Refer to <a href="#">AV-59</a> , "Terminals and Reference Value for NAVI Control Unit".

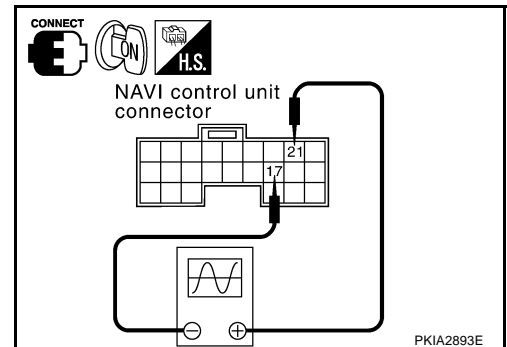

OK or NG

- OK >> Replace display unit.  
 NG >> Replace NAVI control unit.

# NAVIGATION SYSTEM

AKS005SJ

## Color of RGB Image Is Not Proper (Yellowish)

### 1. RGB HARNESS CHECK

1. Turn ignition switch OFF.
2. Disconnect NAVI control unit connector and display unit connector.
3. Check continuity between NAVI control unit harness connector and display unit harness connector.
4. Check continuity between NAVI control unit harness connector and ground.

● **When the screen looks yellowish**

Terminals				Continuity
NAVI control unit		Display unit		
Connector	Terminal (Wire color)	Connector	Terminal (Wire color)	
M57	15 (R)	M35	3 (R)	Yes
	17		12	

Terminals				Continuity
NAVI control unit				
Connector	Terminal (Wire color)		Ground	
M57	15 (R)			Ground
	17			

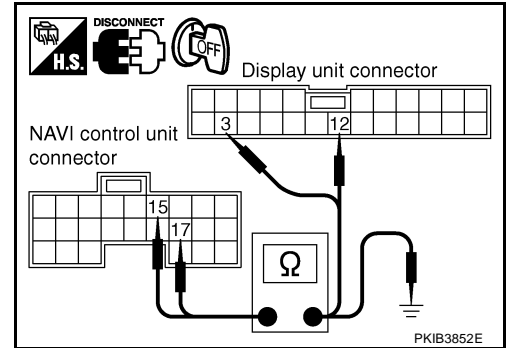

**OK or NG**

- OK >> GO TO 2.  
 NG >> Repair harness or connector.

### 2. RGB SIGNAL CHECK

1. Connect NAVI control unit connector and display unit connector.
2. Turn ignition switch ON.
3. Display "Color bar" by "CONFIRMATION/ADJUSTMENT" mode.
4. Check the signal between NAVI control unit terminal 15 (R) and 17 with CONSULT-II or oscilloscope.

● **When the screen looks yellowish**

Terminals				Voltage (V)
NAVI control unit (+)		NAVI control unit (-)		
Connector	Terminal (Wire color)	Connector	Terminal	
M57	15 (R)	M57	17	Refer to <a href="#">AV-59</a> , "Terminals and Reference Value for NAVI Control Unit" .

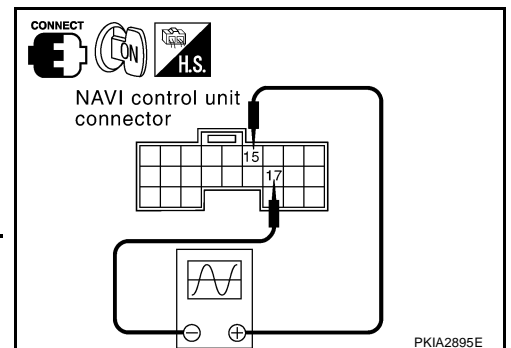

**OK or NG**

- OK >> Replace display unit.  
 NG >> Replace NAVI control unit.

## RGB Screen Is Rolling

### 1. RGB SYNCHRONIZING CIRCUIT CHECK

1. Turn ignition switch OFF.
2. Disconnect NAVI control unit connector and display unit connector.
3. Check continuity between NAVI control unit harness connector and display unit harness connector.

Terminals				Continuity
NAVI control unit		Display unit		
Connector	Terminal (Wire color)	Connector	Terminal (Wire color)	
M57	16 (P)	M35	7 (P)	Yes
	17		12	

4. Check continuity between NAVI control unit harness connector and ground.

Terminals				Continuity
NAVI control unit		Ground		
Connector	Terminal (Wire color)			
M57	16 (P)		No	
	17			

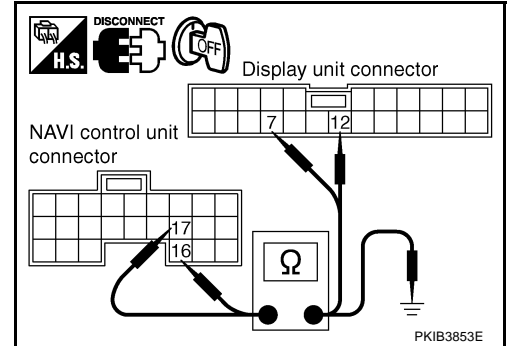

#### OK or NG

- OK >> GO TO 2.  
 NG >> Repair harness or connector.

### 2. RGB SYNCHRONIZING SIGNAL CHECK

1. Connect NAVI control unit connector and display unit connector.
2. Turn ignition switch ON.
3. Push the "MAP" switch.
4. Check the signal between NAVI control unit harness connector M57 terminals 16 (P) and 17 with CONSULT-II or oscilloscope.

**16 (P) - 17** : Refer to [AV-59, "Terminals and Reference Value for NAVI Control Unit"](#) .

#### OK or NG

- OK >> Replace display unit.  
 NG >> Replace NAVI control unit.

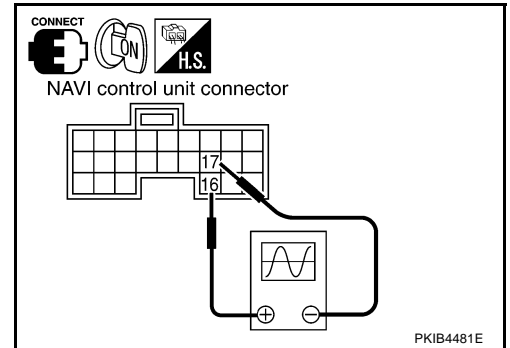

## Guide Sound Is Not Heard

### 1. CHECK VOICE GUIDE SETTING

- While driving in the dark pink route, voice guide does not operate. (note)
- Is volume setting not switched ON?

#### NOTE:

Voice guide is only available at intersections that satisfy certain conditions. Therefore, guidance may not be given even when the route on the map changes direction.

#### YES or NO

- YES >> GO TO 2.  
 NO >> Switch the setting ON and turn the volume up.

# NAVIGATION SYSTEM

## 2. VOICE GUIDE HARNESS CHECK

1. Turn ignition switch OFF.
2. Disconnect NAVI control unit connector and audio unit connector.
3. Check continuity between NAVI control unit harness connector and audio unit harness connector.

Terminals				Continuity
NAVI control unit		Audio unit		
Connector	Terminal (Wire color)	Connector	Terminal (Wire color)	
M57	7 (L/W)	M39	32 (L/W)	Yes
	8 (W/B)		30 (W/B)	
	9 (B)		31 (B)	
	24 (R/B)		24 (R/B)	

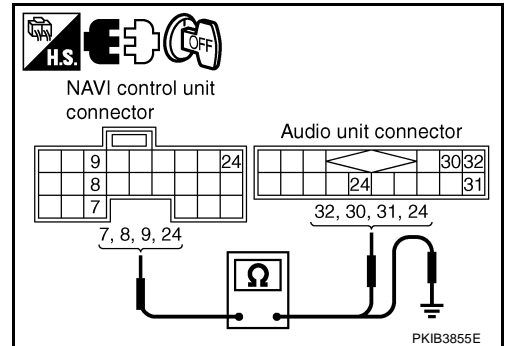

4. Check continuity between NAVI control unit and ground.

Terminals			Continuity
NAVI control unit		Ground	
Connector	Terminal (Wire color)		
M57	7 (L/W)	Ground	No
	8 (W/B)		
	9 (B)		
	24 (R/B)		

OK or NG

OK >> GO TO 3.

NG >> ● Check harness for open or short between NAVI control unit and audio unit.

- Check connector housings for disconnected or loose terminals.

## 3. VOICE GUIDE ON SIGNAL CHECK

1. Connect NAVI control unit connector and audio unit connector.
2. Turn ignition switch ON.
3. Push "VOICE" switch.
4. Check the signal between NAVI control unit harness connector M57 terminal 24 (R/B) and 9 (B) with CONSULT-II or oscilloscope.

**24 (R/B) – 9 (B)** : Refer to [AV-59, "Terminals and Reference Value for NAVI Control Unit"](#) .

OK or NG

OK >> GO TO 4.

NG >> Replace NAVI control unit.

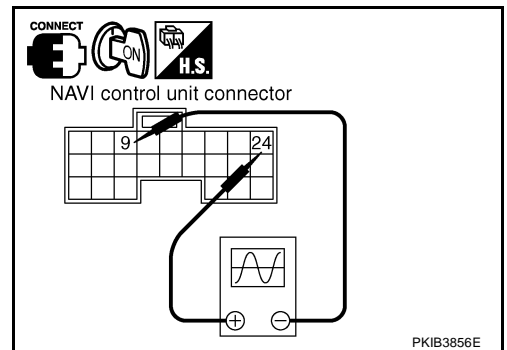

A  
B  
C  
D  
E  
F  
G  
H  
I  
J  
AV  
L  
M

## 4. VOICE GUIDE SIGNAL CHECK

1. Push the "VOICE" switch.
2. Check the signal between NAVI control unit harness connector M57 7 (L/W) and 8 (W/B) with CONSULT-II or oscilloscope.

Terminals		Reference Signal
(+)		
Connector	Terminal (Wire color)	(-)
M57	7 (L/W)	8 (W/B)

Refer to [AV-59, "Terminals and Reference Value for NAVI Control Unit"](#) .

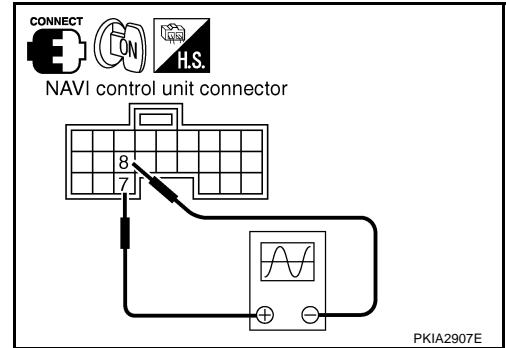

**Ok or NG**

- OK >> Replace audio unit.
- NG >> Replace NAVI control unit

## No Fuel Information Is Displayed

AKS0003U

### 1. SELF-DIAGNOSIS CHECK

Perform self-diagnosis. Refer to [AV-65, "Self-Diagnosis Mode"](#) .

Is self-diagnosis result OK?

- YES >> GO TO 2.
- NO >> Check applicable parts.

### 2. COMBINATION METER CHECK

Using CONSULT-II select "ECM SELF-DIAGNOSIS" to check CAN communication between ECM and combination meter. Refer to [EC-126, "CONSULT-II Function \(ENGINE\)"](#) .

**OK or NG**

- OK >> Replace combination meter.
- NG >> Check applicable parts.

## Vehicle Condition Setting Is Not Possible

AKS0003V

### 1. VEHICLE SPEED SIGNAL CHECK

Check vehicle speed signal check. Refer to [AV-69, "VEHICLE SIGNALS"](#) .

**OK or NG**

- OK >> Replace NAVI control unit.
- NG >> Check combination meter system. Refer to [DI-9, "Self-Diagnosis Mode of Combination Meter"](#) .

## No Warning Message Is Displayed (Combination Meter Of Warning Lamp Illuminate)

AKS0003W

### 1. DISPLAY CONDITION CHECK

Check display condition of warning screen.

Warning screen	Display condition
Door ajar	When door switch is ON and vehicle speed is more than 5 km/h (3 MPH)

>> GO TO 2.

---

## 2. SELF-DIAGNOSIS CHECK

---

Perform self-diagnosis. Refer to [AV-65, "Self-Diagnosis Mode"](#) .

Is self-diagnosis result OK?

- YES >> Replace combination meter.
- NO >> Check applicable parts.

### The Position of The Current-Location Mark Is Not Correct

AKS0004L

#### 1. SELF-DIAGNOSIS

---

"Self-diagnosis mode" of the self-diagnosis function. Refer to [AV-65, "Self-Diagnosis Mode"](#) .

OK or NG

- OK >> GO TO 2.
- NG >> Check the applicable parts.

## 2. HISTORY OF ERRORS DIAGNOSIS

---

Was any error stored in [AV-70, "HISTORY OF ERRORS"](#) of the CONFIRMATION/ADJUSTMENT mode?

YES or NO

- YES >> [AV-70, "HISTORY OF ERRORS"](#).
- NO >> [AV-87, "Driving Test"](#).

### Radio Wave From The GPS Satellite Is Not Received

AKS0004M

#### 1. ENVIRONMENT CHECK

---

Check if any metal object that intercepts radio waves or an object that emits radio waves (such as a portable phone) is located near the GPS antenna. Check if the vehicle is shielded by a building.

OK or NG

- OK >> ● System is normal.  
The GPS antenna may not be able to receive radio waves from the GPS satellite if it is shielded by metal object or an object emitting radio waves is placed near it.
- NG >> GO TO 2.

## 2. SELF-DIAGNOSIS

---

Perform self-diagnosis function. Refer to [AV-65, "Self-Diagnosis Mode"](#) .

OK or NG

- OK >> Replace GPS antenna.
- NG >> Check the applicable parts.

### Driving Test

AKS0004N

#### 1. DRIVING TEST 1

---

1. Scroll the map screen to display the area to make correction. Push "ENTER" and select "CURRENT LOCATION CORRECTION".
2. Correct direction of the vehicle mark.
3. Perform the distance correction of the CONFIRMATION/ADJUSTMENT mode.

**NOTE:**

Normally, adjustment is not necessary because this system has automatic distance correction function. However, when a tire chain is fitted, adjustment in accordance with the tire diameter ratio must be made.

4. Are symptoms applicable to the [AV-89, "Example of Symptoms Judged Not Malfunction"](#) present after driving the vehicle?

YES or NO

- YES >> Limit of the location detection capacity of the navigation system
- NO >> GO TO 2.

# NAVIGATION SYSTEM

---

## 2. DRIVING TEST 2

---

- Did any malfunction occur when the proper test in the following test patterns is performed?
- Test pattern
  - Driving test finds the difference between the symptoms monitored with and without each sensor.
  - Test pattern 1: Test method with no GPS location correction
    - Disconnect the GPS antenna connector connected to the NAVI control unit. Accurately adjust the current position and the direction, and then drive the vehicle.
  - Test pattern 2: Test method with no map-matching
    - Accurately adjust the current position and the direction. Eject the map DVD-ROM from the NAVI control unit with the ignition switch turned to OFF, and then drive the vehicle. After driving, insert the map DVD-ROM back in the unit, display the track of the vehicle on the map screen and compare it with the actual road configuration.
- Sample tests
  - <To determine if the current-location mark skips at the same position, if so, whether it is caused by map-matching or by GPS>
    - Perform test pattern 1.
  - <To determine if the pattern of streets displayed is correct or not>
    - Perform test pattern 1 and 2.
    - Compare the track of the vehicle on the map screen and the actual road configuration. For fairly accurate tracking, plotting shall be made every several hundred meters.
  - <When the distance is adjusted accurately>
    - Perform test pattern 1 and 2.
    - Drive on a road of which distance is accurately known (by utilizing distance posts on a highway). Calculate the rate of change (increased/decreased) of the distance by comparing with the actual distance.
    - Correction = A/B
    - A: Distance shown on the screen
    - B: Actual distance

### YES or NO

- YES >> ● If adjustment is insufficient, perform adjustment again.
- If any error is found in the map, please let us know.
  - Replace NAVI control unit
- NO >> Limit of the location detection capacity of the navigation system



# NAVIGATION SYSTEM

## Example of Symptoms Judged Not Malfunction BASIC OPERATION

AKS00040

Symptom	Cause	Remedy
No image is shown.	Display brightness adjustment is set fully to DARK side.	Adjust the display brightness.
No guide sound is heard. Audio guide volume is too low or too high.	Volume control is set to OFF, MIN or MAX.	Adjust the audio guide volume.
	Audio guidance is not available while the vehicle is driving on a dark pink route.	System is not malfunction.
Screen is too dark. Motion of the image is too slow.	Temperature inside the vehicle is low.	Wait until the temperature inside the vehicle reaches the proper temperature.
Small black or bright spots appear on the screen.	Symptom peculiar to a liquid crystal display.	System is not malfunction.

## VEHICLE MARK

Symptom	Cause	Remedy
Map screen and bird view <sup>TM</sup> Name of the place vary with the screen.	Some thinning of the character data is done to prevent the display becoming to complex. In some cases and in some locations, the display contents may differ. The same place name, street name, etc. may not be displayed every time on account of the data processing.	System is not malfunction.
Vehicle mark is not positioned correctly.	Vehicle is transferred by ferry or by towing after its ignition switch is turned to OFF.	Drive the vehicle for a while in the GPS satellite signal receiving condition.
Screen will not switch to nighttime mode after the lighting switch is turned ON.	The daytime screen is selected by the "SWITCH SCREENS" when the last time the screen dimming setting is done. Switching between daytime/nighttime screens may be inhibited by the automatic illumination adjustment function.	Perform screen dimming and select the nighttime screen by "SWITCH SCREENS".
Map screen will not scroll in accordance with the vehicle travel.	Current location is not displayed.	Push "MAP" switch to display the current location.
Vehicle mark will not be shown.	Current location is not displayed.	Push "MAP" switch to display the current location.
Accuracy indicator (GPS satellite mark) on the map screen stays gray.	GPS satellite signal is intercepted because the vehicle is in or behind a building.	Move the vehicle out to an open space.
	GPS satellite signal cannot be received because an obstacle is placed on top of the display.	Do not place anything in the center on top of the display.
	GPS satellites are located badly.	Wait until the location becomes better.
Vehicle location accuracy is low.	Accuracy indicator (GPS satellite mark) on the map screen stays gray.	Current location is not determined.
	Vehicle speed setting by the vehicle speed pulse has been deviated (advanced or retarded) from the actual vehicle speed because tire chain is fitted or the system has been used on another vehicle.	Drive the vehicle for a while (for approx. 30 minutes at approx. 30 km/h (19MPH)) and the deviation will be automatically adjusted. If advancement or retards still occur, perform the distance adjustment by CONFIRMATION/ADJUSTMENT mode of diagnosis function.
	Map data has error or omission. (Vehicle mark is always deviated to the same position.)	As a rule, an updated map DVD-ROM will be released once a year.

# NAVIGATION SYSTEM

## DESTINATION, PASSING POINTS, AND MENU ITEMS CANNOT BE SELECTED/SET

Symptom	Cause	Remedy
Destination cannot be set.	Destination to be set is on an ex-Pathway.	Set the destination on an ordinary road.
Passing point is not searched when re-searching the route.	The vehicle has already passed the passing point, or the system judged so.	To include the passing points that have been passed into the route again, set the route again.
Route information will not be displayed.	Route searching has not been done.	Set the destination and perform route searching.
	Vehicle mark is not on the recommended route.	Drive on the recommended route.
	Route guide is turned OFF.	Turn the route guide ON.
	Route information is not available on the dark pink route.	System is not malfunction.
After the route searching, no guide sign will appear as the vehicle goes near the entrance/exit to the toll road.	Vehicle mark is not on the recommended route. (On the display, only guide signs related to the recommended route will be shown.)	Drive on the recommended route.
Automatic route searching is not possible.	Vehicle is driving on a highway (gray route), or no recommended route is available.	Drive on a road to be searched. Or re-search the route manually. In this case, however, the whole route will be searched.
Performed automatic detour search (or detour search). However, the result is the same as that of the previous search.	Performed search with every condition considered. However, the result is the same as that of the previous search.	System is not malfunction.
Passing points cannot be set.	More than five passing points were set.	Passing points can be set up to five. To stop at more than five points, perform sharing in several steps.
When setting the route, the starting point cannot be selected.	The current vehicle location is always set as the starting point of a route.	System is not malfunction.
Some menu items cannot be selected.	The vehicle is being driven.	Stop the vehicle at a safe place and then operate the system.

## VOICE GUIDE

Symptom	Cause	Remedy
Voice guide will not operate.	Note: Voice guide is only available at intersections that satisfy certain conditions. Therefore, guidance may not be given even when the route on the map changes direction.	System is not malfunction.
	The vehicle is not on the recommended route.	Return to the recommended route or re-search the route.
	Voice guide is turned OFF.	Turn the voice guide ON.
	Route guide is turned OFF.	Turn the route guide ON.
Voice guide does not match the actual road pattern.	Voice guide may vary with the direction to which the vehicle is turn and the connection of the road to other roads.	Drive in conformity to the actual traffic rules.

## ROUTE SEARCHING

Symptom	Cause	Remedy
No route is shown.	No road to be searched is found around the destination.	Find wider road (orange road or wider) nearby and reset the destination and passing points onto it. Take care of the traveling direction when there are separate up and down roads.
	Starting point and the destination are too close.	Set the destination at more distant point.
	Conditional traffic regulation (day of the week/ time of the day) is set at the area around the current position or the destination.	Turn the time-regulating search conditions OFF. Turn "Avoid regulation time" in the search conditions OFF.

# NAVIGATION SYSTEM

Symptom	Cause	Remedy
Indicated route is intermittent.	In some areas, highways (gray routes) are not used for the search <sup>(Note)</sup> . Therefore, the route to the current position or the passing points may be intermittent.	System is not malfunction.
When the vehicle has passed the recommended route, it is deleted from the screen.	A recommended route is controlled by each section. When the vehicle has passed the passing point 1, then the map data from the starting point up to the passing point 1 will be deleted. (The data may remain undeleted in some area.)	System is not malfunction.
Detouring route is recommended.	In some areas, highways (gray routes) are not used for the search <sup>(Note)</sup> . Therefore, detour route may be recommended.	Set the route closer to the basic route (gray route).
	A detour route may be shown when some traffic regulation (one-way traffic, etc.) is set at the area around the starting point or the destination.	Slightly move the starting point or the destination, or set the passing point on the route of your choice.
	In the area where highways (gray routes) are used for the search, left turn has priority around the current position and the destination (passing points). For this reason, the recommended route may be detouring.	System is not malfunction.
Landmarks on the map do not match the actual ones.	This can happen due to omission or error in the map data.	As a rule, an updated map DVD-ROM will be released once a year. Wait until the latest map has become available.
Recommended route is far from the starting point, passing points, and destination.	Starting point, passing points, and destination of the route guide were set far from the desired points because route searching data around these area were not stored.	Reset the destination onto the road nearby. If this road is one of the highways (gray routes), an ordinary road nearby may be displayed as the recommended route.

**NOTE:**

Except for the ordinance-designated cities and the prefectural capitals (Applicable areas may be changed in the updated map disc.)

A  
B  
C  
D  
E  
F  
G  
H  
I  
J  
L  
M

AV

# NAVIGATION SYSTEM

## EXAMPLES OF CURRENT-LOCATION MARK DISPLACEMENT

Vehicle's travel amount is calculated by reading its travel distance and turning angle. Therefore, if the vehicle is driven in the following manner, an error will occur in the vehicle's current location display. If correct location has not been restored after driving the vehicle for a while, perform location correction.

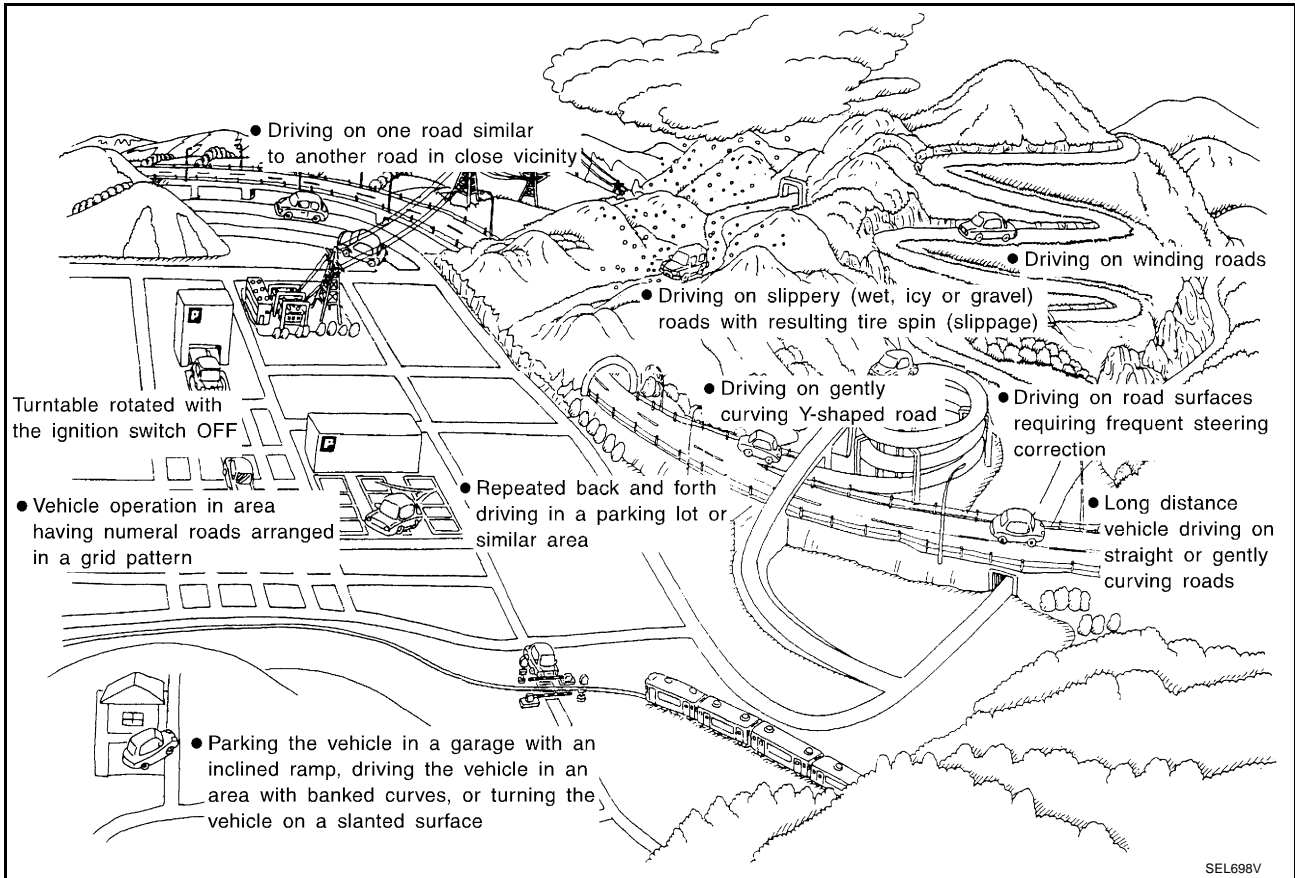

# NAVIGATION SYSTEM

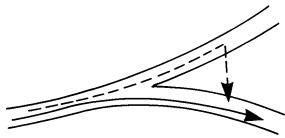
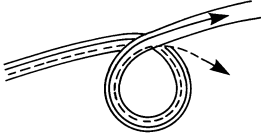
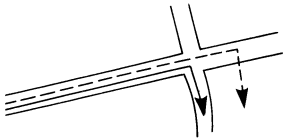
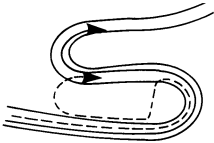
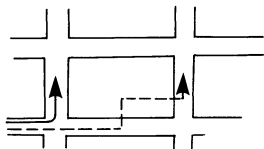
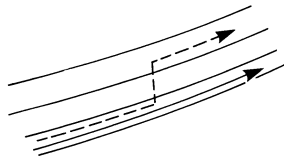
	Cause (condition) -While driving	Driving condition	Remarks (correction, etc.)
Road configura- tion	<p>Y-intersections</p>  <p style="text-align: center; font-size: small;">ELK0192D</p>	<p>At a Y intersection or similar gradual division of roads, error the direction of travel deduced by the sensor may result in the current-location mark appearing on the wrong road.</p>	
	<p>Spiral roads</p>  <p style="text-align: center; font-size: small;">ELK0193D</p>	<p>When driving on a large, continuous spiral road (such as loop bridge), turning angle error is accumulated and the vehicle mark may deviate from the correct location.</p>	
	<p>Straight roads</p>  <p style="text-align: center; font-size: small;">ELK0194D</p>	<p>When driving on a long, straight road and slow curve without stopping, map-matching does not work effectively enough and distance errors may accumulate. As a result, the vehicle mark may deviate from the correct location when the vehicle turned at a corner.</p>	<p>If after traveling about 10 km (6miles) the correct location has not been restored, perform location correction and, if necessary, direction correction.</p>
	<p>Zigzag roads</p>  <p style="text-align: center; font-size: small;">ELK0195D</p>	<p>When driving on a zigzag road, the map may be matched to other roads in the similar direction nearby at every turn, and the vehicle mark may deviate from the correct location.</p>	
	<p>Roads laid out in a grid pattern</p>  <p style="text-align: center; font-size: small;">ELK0196D</p>	<p>When driving at where roads are laid out in a grid pattern, where many roads are running in the similar direction nearby, the map may be matched to them by mistake and the vehicle mark may deviate from the correct location.</p>	
	<p>Parallel roads</p>  <p style="text-align: center; font-size: small;">ELK0197D</p>	<p>When two roads are running in parallel (such as highway and side-way), the map may be matched to the other road by mistake and the vehicle mark may deviate from the correct location.</p>	

A  
B  
C  
D  
E  
F  
G  
H  
I  
J  
AV  
L  
M

# NAVIGATION SYSTEM

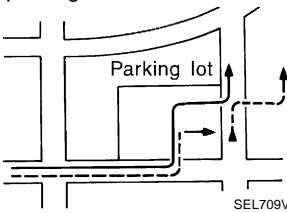
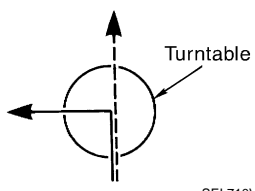
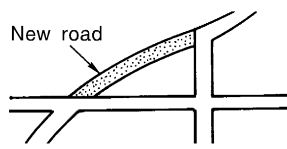
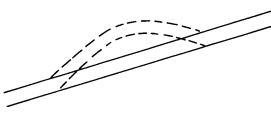
	Cause (condition) -:While driving	Driving condition	Remarks (correction, etc.)
Place	In a parking lot 	When driving in a parking lot, or other location where there are no roads on the map, matching may place the vehicle mark on a nearby road. When the vehicle returns to the road, the vehicle mark may have deviated from the correct location. When driving in circle or turning the steering wheel repeatedly, direction errors accumulate, and the vehicle mark may deviate from the correct location.	If after traveling about 10km (6miles) the correct location has not been restored, perform location correction and, if necessary, direction correction.
	Turn table 	When the ignition switch is OFF, the navigation system cannot get the signal from the gyroscope (angular speed sensor). Therefore, the displayed direction may be wrong and the correct road may not be easily returned to after rotating the vehicle on a turn table with the ignition OFF.	
	Slippery roads	On snow, wet roads, gravel, or other roads where tires may slip easily, accumulated mileage errors may cause the vehicle mark to deviate from the correct road.	
	Slopes	When parking in sloped garages, when traveling on banked roads, or in other cases where the vehicle turns when tilted, an error in the turning angle will occur, and the vehicle mark may deviate from the road.	
Map data	Road not displayed on the map screen 	When driving on new roads or other roads not displayed on the map screen, map matching does not function correctly and matches the location to a nearby road. When the vehicle returns to a road which is on the map, the vehicle mark may deviate from the correct road.	
	Different road pattern (Changed due to repair) 	If the road pattern stored in the map data and the actual road pattern are different, map matching does not function correctly and matches the location to a nearby road. The vehicle mark may deviate from the correct road.	
Vehicle	Use of tire chains	When tire chains are used, the mileage is not correctly detected, and the vehicle mark may deviate from the correct road.	Drive the vehicle for a while. If the distance is still deviated, adjust it by using the distance adjustment function. (If the tire chain is removed, recover the original value.)

# NAVIGATION SYSTEM

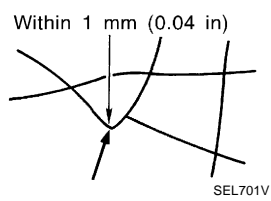
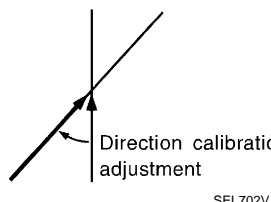
	Cause (condition) -:While driving	Driving condition	Remarks (correction, etc.)
Precautions for driving	Just after the engine is started	If the vehicle is driven off just after the engine is started when the gyroscope (angular speed sensor) correction is not completed, the vehicle can lose its direction and may have deviated from the correct location.	Wait for a short while before driving after starting the engine.
	Continuous driving without stopping	When driving long distances without stopping, direction errors may accumulate, and the current-location mark may deviate from the correct road.	Stop and adjust the orientation.
	Abusive driving	Spinning the wheels or engaging in other kinds of abusive driving may result in the system being unable perform correct detection, and may cause the vehicle mark to deviate from the correct road.	If after traveling about 10 km (6miles) the correct location has not been restored, perform location correction and, if necessary, direction correction.
How to correct location	Position correction accuracy 	If the accuracy of location settings is poor, accuracy may be reduced when the correct road cannot be found, particularly in places where there are many roads.	Enter in the road displayed on the screen with an accuracy of approx. 1mm. Caution: Whenever possible, use detailed map for the correction.
	Direction when location is corrected 	If the accuracy of location settings during correction is poor, accuracy may be reduced afterwards.	Perform direction correction.

## THE CURRENT POSITION MARK SHOWS A POSITION WHICH IS COMPLETELY WRONG

In the following cases, the current-location mark may appear on completely different position in the map depending on the GPS satellite signal receiving conditions. In this case, perform location correction and direction correction.

- When location correction has not been done
  - If the receiving conditions of the GPS satellite signal is poor, if the current-location mark becomes out of place, it may move to a completely different location and not come back if location correction is not done. The position will be corrected if the GPS signal can be received.
- When the vehicle has traveled by ferry, or when the vehicle has been being towed
  - Because calculation of the current location cannot be done when traveling with the ignition OFF, for example when traveling by ferry or when being towed, the location before travel is displayed. If the precise location can be detected with GPS, the location will be corrected.

## THE CURRENT POSITION MARK JUMPS

In the following cases, the current-location mark may appear to jump as a result of automatic correction of the current location.

- When map matching has been done
  - If the current location and the current-location mark are different when map matching is done, the current-location mark may seem to jump. At this time, the location may be "corrected" to the wrong road or to a location which is not on a road.
- When GPS location correction has been done
  - If the current location and the current-location mark are different when the location is corrected using GPS measurements, the current-location mark may seem to jump. At this time, the location may be "corrected" to a location which is not on a road.

A  
B  
C  
D  
E  
F  
G  
H  
I  
J

AV

L  
M

# NAVIGATION SYSTEM

---

## **THE CURRENT LOCATION MARK IS IN A RIVER OR THE SEA**

The navigation system moves the current location mark with no distinction between land and rivers or sea. If the location mark is somehow out of place, it may appear that the vehicle is driving in a river or the sea.

## **WHEN DRIVING ON THE SAME ROAD, SOMETIMES THE CURRENT-LOCATION MARK IS IN THE RIGHT PLACE AND SOMETIMES IT IS THE WRONG PLACE**

The conditions of the GPS antenna (GPS data) and gyroscope (angular speed sensor) change gradually. Depending on the road traveled and the operation of the steering wheel, the location detection results will be different. Therefore, even on a road on which the location has never been wrong, conditions may cause the vehicle mark to deviate.

## **LOCATION CORRECTION BY MAP MATCHING IS SLOW**

- The map matching function needs to refer to the data of the surrounding area. It is necessary to drive some distance for the function to work.
- Because map matching operates on this principle, when there are many roads running in similar directions in the surrounding area, no matching determination may be made. The location may not be corrected until some special feature is found.

## **ALTHOUGH THE GPS RECEIVING DISPLAY IS GREEN, THE VEHICLE MARK DOES NOT RETURN TO THE CORRECT LOCATION**

- The GPS accuracy has an error of about 10 m (30ft). In some cases the current-location mark may not be on the correct street, even when GPS location-correction is done.
- The navigation system compares the results of GPS location detection with the results from map-matching location detection. The one which is determined to have higher accuracy is used.
- GPS location correction may not be performed when the vehicle is stopped.

## **THE NAME OF THE CURRENT PLACE IS NOT DISPLAYED**

The current place name may not be displayed if there are no place names displayed on the map screen.

## **CONTENTS OF THE DISPLAY DIFFER FOR THE BIRD VIEW™ AND THE (FLAT) MAP SCREEN**

**Difference of the Bird View™ Screen From the Flat Map Screen Are as Follows.**

- The current place name displays names which are primarily in the direction of vehicle travel.
- The amount of time before the vehicle travel or turn angle is updated on the screen is longer than for the (flat) map display.
- The conditions for display of place names, roads, and other data are different for nearby areas and for more distant areas.
- Some thinning of the character data is done to prevent the display becoming too complex. In some cases and in some locations, the display contents may differ.
- The same place name, street name, etc. may be displayed multiple times.



## Program Loading

AKS0004P

A  
B  
C  
D  
E  
F  
G  
H  
I  
J  
AV  
L  
M

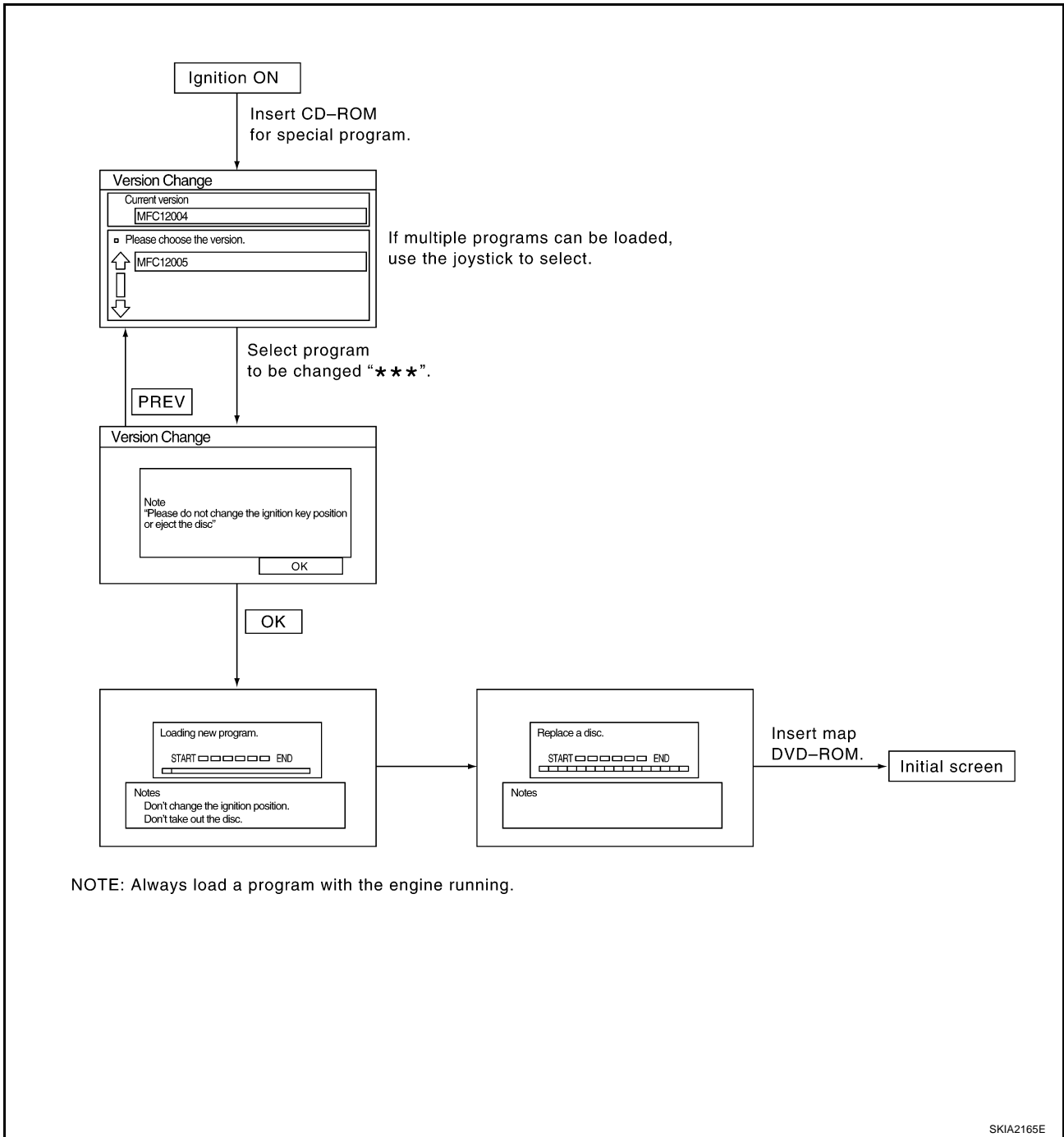

# NAVIGATION SYSTEM

## Removal and Installation of NAVI Control Unit

AKS0004Q

### REMOVAL

1. Remove center box assy. Refer to [IP-10, "INSTRUMENT PANEL ASSEMBLY"](#)
2. Remove screws (4), and remove NAVI control unit.

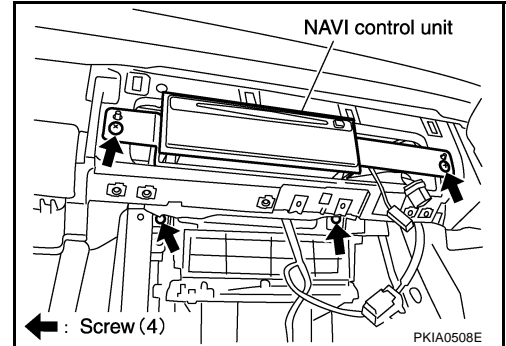

3. Remove screws (4), and remove bracket.

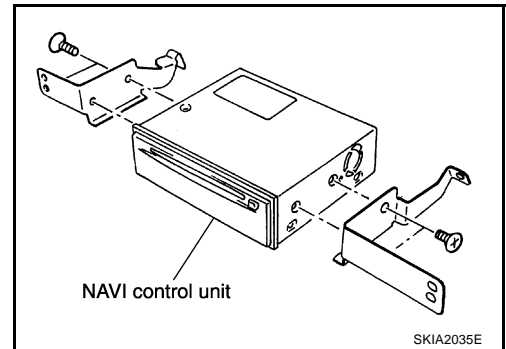

### INSTALLATION

Installation is the reverse order of removal.

## Removal and Installation of GPS Antenna

AKS002XR

### REMOVAL

1. Remove instrument panel and antenna feeder installation screws on backside. Refer to [IP-10, "INSTRUMENT PANEL ASSEMBLY"](#).

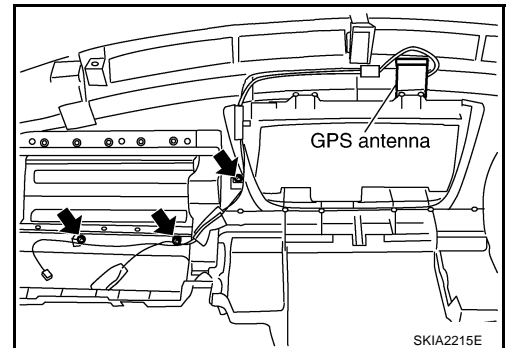

2. Remove screw and remove GPS antenna.

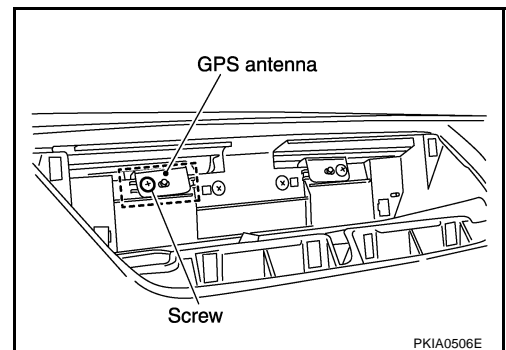

### INSTALLATION

Installation is the reverse order of removal.

# NAVIGATION SYSTEM

## Removal and Installation of NAVI Switch

AKS002XS

### REMOVAL

1. Remove cluster lid C. Refer to [IP-10, "INSTRUMENT PANEL ASSEMBLY"](#) .
2. Remove audio unit and display unit assembly. Refer to [IP-10, "INSTRUMENT PANEL ASSEMBLY"](#) .
3. Remove screws (2) and remove NAVI switch from cluster lid C.

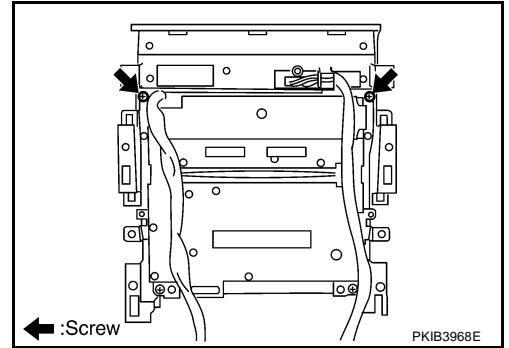

### INSTALLATION

Installation is the reverse order of removal.

## Removal and Installation of Display Unit

AKS0004T

### REMOVAL

1. Remove cluster lid C. Refer to [IP-10, "INSTRUMENT PANEL ASSEMBLY"](#) .
2. Remove audio unit and display unit assembly from cluster lid C. Refer to [IP-10, "INSTRUMENT PANEL ASSEMBLY"](#) .
3. Remove screws (5) and remove display unit assembly from audio unit bracket.

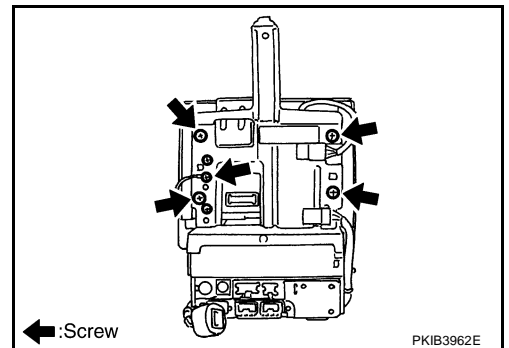

### INSTALLATION

Installation is the reverse order of removal.

A  
B  
C  
D  
E  
F  
G  
H  
I  
J  
AV  
L  
M

# NAVIGATION SYSTEM

---