

SECTION **BL**

BODY, LOCK & SECURITY SYSTEM

CONTENTS

PRECAUTIONS	5	RADIATOR CORE SUPPORT	18
Precautions for Supplemental Restraint System (SRS) "AIR BAG" and "SEAT BELT PRE-TENSIONER"	5	Removal and Installation	18
Precautions for Work	5	REMOVAL	18
Wiring Diagrams and Trouble Diagnosis	5	INSTALLATION	19
PREPARATION	6	POWER DOOR LOCK SYSTEM	20
Special Service Tools	6	Component Parts and Harness Connector Location..	20
Commercial Service Tools	6	System Description	21
SQUEAK AND RATTLE TROUBLE DIAGNOSIS	7	DOOR SWITCH OPERATION	22
Work Flow	7	FUEL LID OPERATION	22
CUSTOMER INTERVIEW	7	OUTLINE	22
DUPLICATE THE NOISE AND TEST DRIVE	8	CAN Communication System Description	23
CHECK RELATED SERVICE BULLETINS	8	CAN Communication Unit	23
LOCATE THE NOISE AND IDENTIFY THE ROOT CAUSE	8	Schematic / With Intelligent Key	24
REPAIR THE CAUSE	8	Wiring Diagram -D/LOCK- / With Intelligent Key ...	25
CONFIRM THE REPAIR	9	FIG. 1	25
Generic Squeak and Rattle Troubleshooting	9	FIG. 2	26
INSTRUMENT PANEL	9	FIG. 3	27
CENTER CONSOLE	9	FIG. 4	28
DOORS	9	FIG. 5	29
TRUNK	10	Schematic / Without Intelligent Key	30
SUNROOF/HEADLINING	10	Wiring Diagram -D/LOCK- / Without Intelligent Key..	31
SEATS	10	FIG. 1	31
UNDERHOOD	10	FIG. 2	32
Diagnostic Worksheet	11	FIG. 3	33
HOOD	13	FIG. 4	34
Fitting Adjustment	13	Terminals and Reference Value of BCM	35
LONGITUDINAL AND LATERAL CLEARANCE ADJUSTMENT	13	Work Flow	35
FRONT END HEIGHT ADJUSTMENT	13	CONSULT-II Function (BCM)	36
SURFACE HEIGHT ADJUSTMENT	14	CONSULT-II INSPECTION PROCEDURE	36
Removal and Installation of Hood Assembly	15	CONSULT-II APPLICATION ITEMS	37
REMOVAL	15	Trouble Diagnosis Chart by Symptom	39
INSTALLATION	15	Power Supply and Ground Circuit Check of BCM..	40
Removal and Installation of Hood Lock Control	16	Check Door Switch	41
REMOVAL	16	Check Key Switch	43
INSTALLATION	17	Check Door Lock and Unlock Switch	45
Hood Lock Control Inspection	17	Check Door Lock Actuator (Driver Side)	48
		Check Door Lock Actuator (Passenger Side and Rear LH/RH)	48
		Check Fuel Lid Opener Actuator	49
		Door Key Cylinder Switch Check	50

Check Select Unlock Relay Circuit	51	PRELIMINALY CHECK	118
Check Ignition Knob Switch	52	WORK FLOW	119
REMOTE KEYLESS ENTRY SYSTEM	54	CONSULT-II Functions (INTELLIGENT KEY)	120
Component Parts and Harness Connector Location..	54	CONSULT-II Inspection Procedure	120
System Description	55	BASIC OPERATION	120
INPUTS	55	CONSULT-II Application Items	121
OPERATED PROCEDURE	56	SELF-DIAGNOSTIC RESULTS	121
CAN Communication System Description	57	DATA MONITOR	121
CAN Communication Unit	57	WORK SUPPORT	122
Schematic	58	ACTIVE TEST	123
Wiring Diagram —KEYLES—	59	Trouble Diagnosis Symptom Chart	124
FIG. 1	59	KEY WARNING LAMP (GREEN) ILLUMINATES	124
FIG. 2	60	KEY WARNING LAMP (RED) ILLUMINATES	124
FIG. 3	61	KEY WARNING LAMP DOES NOT ILLUMINATE	125
FIG. 4	62	NON DTC ITEM	125
Terminals and Reference Value for BCM	63	ENGINE START CONDITION CHECK	125
Terminals and Reference Value for IPDM E/R	64	DOOR LOCK/UNLOCK FUNCTION MALFUNCTION	126
CONSULT-II Function	65	REMOTE KEYLESS ENTRY FUNCTION MALFUNCTION	127
INSPECTION PROCEDURE	65	TRUNK OPEN FUNCTION MALFUNCTION	128
CONSULT-II APPLICATION ITEMS	66	HAZARD AND HORN REMINDER FUNCTION MALFUNCTION	128
Work Flow	68	POWER WINDOW DOWN FUNCTION MALFUNCTION	129
Trouble Diagnosis Chart by Symptom	69	WARNING CHIME FUNCTION MALFUNCTION	129
Check Key Fob Battery and Function	71	WARNING LAMP FUNCTION MALFUNCTION	131
Check ACC Switch	72	Check CAN Communication System	131
Check Door Switch	73	Check Power Supply and Ground Circuit	132
Check Key Switch	76	Check Key Switch (Intelligent Key Unit Input)	133
Check Remote Keyless Entry Receiver	77	Check Key Switch (BCM Input)	135
Check IPDM E/R Operation	79	Check Ignition Knob Switch	136
Check Hazard Function	80	Check Door Switch	138
Check Horn Function	80	Check Trunk Room Lamp Switch	140
Check Headlamp Function	80	Check Door Request Switch	142
Check Map Lamp and Ignition Keyhole Illumination Function	80	Check Trunk Opener Request Switch	144
ID Code Entry Procedure	81	Check Unlock Sensor	146
KEY FOB ID SET UP WITH CONSULT-II	81	Check Intelligent Key Warning Buzzer (Instrument Panel)	147
KEY FOB ID SET UP WITHOUT CONSULT-II	83	Check Intelligent Key Warning Buzzer (ENGINE ROOM)	148
Key Fob Battery Replacement	84	Check Outside Key Antenna	149
INTELLIGENT KEY SYSTEM	85	Check Inside Key Antenna	151
Component Parts and Harness Connector Location..	85	Check Steering Lock Unit	152
System Description	87	Check Stop Lamp Switch	154
DOOR LOCK/UNLOCK/TRUNK OPEN FUNCTION	88	Check Park Position Switch	156
REMOTE KEYLESS ENTRY FUNCTIONS	92	Check Select Unlock Relay	158
ENGINE START FUNCTION	95	Check "P-SHIFT" Warning Lamp	159
WARNING CHIME FUNCTION	96	Check "KEY" Warning Lamp (RED)	161
CHANGE SETTINGS FUNCTION	98	Check "KEY" Warning Lamp (GREEN)	162
INTELLIGENT KEY REGISTRATION	98	Check Hazard Function	163
STEERING LOCK UNIT REGISTRATION	99	Check Horn Function	163
CAN Communication System Description	99	Check IPDM E/R Operation	164
CAN Communication Unit	99	Removal and Installation of Intelligent Key Unit	164
Schematic	100	REMOVAL	164
Wiring Diagram — I/KEY—	102	INSTALLATION	164
Terminals and Reference Value for Intelligent Key Unit	114	Intelligent Key Battery Replacement	165
Terminals and Reference Value for Steering Lock Unit	116	INTELLIGENT KEY BATTERY INSPECTION	165
Terminals and Reference Value for BCM	116	DOOR	166
Terminals and Reference Value for IPDM E/R	117		
Trouble Diagnosis Procedure	118		

Fitting Adjustment	166	System Description	181	
FRONT DOOR	166	TRUNK LID OPENER OPERATION	182	A
REAR DOOR	166	Wiring Diagram —TLID— / With Intelligent Key ..	183	
STRIKER ADJUSTMENT	166	Wiring Diagram —TLID— / Without Intelligent Key	184	
Removal and Installation of Front door	167	Terminals and Reference Value for BCM	186	B
REMOVAL	167	CONSULT-II Function (BCM)	187	
INSTALLATION	167	CONSULT-II INSPECTION PROCEDURE	187	C
Removal and Installation of Rear Door	168	DATA MONITOR	188	
REMOVAL	168	ACTIVE TEST	188	
INSTALLATION	168	Trouble Diagnosis	189	
Door Weatherstrip	169	TRUNK DOSE NOT OPEN WITH TRUNK LID		
REMOVAL	169	OPENER SWITCH / WITHOUT INTELLIGENT		D
INSTALLATION	169	KEY	189	
FRONT DOOR LOCK	170	TRUNK DOSE NOT OPEN WITH OUTSIDE		
Component Structure	170	TRUNK LID OPENER SWITCH / WITHOUT		E
Inspection and Adjustment	170	INTELLIGENT KEY	192	
OUTSIDE HANDLE ROD ADJUSTMENT	170	TRUNK DOSE NOT OPEN WITH TRUNK LID		
Removal and Installation	170	OPENER SWITCH / WITH INTELLIGENT KEY	195	F
REMOVAL	170	VEHICLE SECURITY (THEFT WARNING) SYSTEM 199		
INSTALLATION	171	Component Parts and Harness Connector Location	199	
Disassembly and Assembly	171	System Description	200	
DISASSEMBLY	171	DESCRIPTION	200	G
ASSEMBLY	172	POWER SUPPLY AND GROUND CIRCUIT	201	
REAR DOOR LOCK	173	INITIAL CONDITION TO ACTIVATE THE SYS-		
Component Structure	173	TEM	201	H
INSPECTION AND ADJUSTMENT	173	VEHICLE SECURITY SYSTEM ALARM OPER-		
OUTSIDE HANDLE ROD ADJUSTMENT	173	ATION	202	
Removal and Installation	174	VEHICLE SECURITY SYSTEM DEACTIVATION	202	
REMOVAL	174	PANIC ALARM OPERATION	202	BL
INSTALLATION	174	CAN Communication System Description	203	
Disassembly and Assembly	174	CAN Communication Unit	203	
DISASSEMBLY	174	Schematic	204	J
ASSEMBLY	175	Wiring Diagram —VEHSEC—	205	
TRUNK LID	176	Terminals and Reference Value of BCM	210	
Fitting Adjustment	176	Terminals and Reference Value of IPDM E/R	211	K
LONGITUDINAL AND LATERAL CLEARANCE		CONSULT-II Inspection Procedure	212	
ADJUSTMENT	176	CONSULT-II APPLICATION ITEM	213	
SURFACE HEIGHT ADJUSTMENT	176	Trouble Diagnosis	214	L
Removal and Installation of Trunk Lid Assembly .	177	WORK FLOW	214	
REMOVAL	177	Preliminary Check	215	
INSTALLATION	177	Trouble Diagnosis Symptom Chart	216	
Removal and Installation of Trunk Lid Stay	178	Diagnostic Procedure 1	217	M
REMOVAL	178	1 – 1 DOOR SWITCH CHECK	217	
INSTALLATION	178	1 – 2 HOOD SWITCH CHECK	219	
Removal and Installation of Trunk Lid Lock	178	1 – 3 TRUNK ROOM LAMP SWITCH CHECK .	221	
REMOVAL	178	Diagnostic Procedure 2	222	
INSTALLATION	178	SECURITY INDICATOR LAMP CHECK	222	
Removal and Installation of Trunk Lid Striker	178	Diagnostic Procedure 3	223	
REMOVAL	178	FRONT DOOR KEY CYLINDER SWITCH		
INSTALLATION	178	CHECK	223	
Removal and Installation of Trunk lid Emergency		Diagnostic Procedure 4	223	
Opener Cable	179	VEHICLE SECURITY HORN ALARM CHECK .	223	
REMOVAL	179	Diagnostic Procedure 5	224	
INSTALLATION	179	VEHICLE SECURITY HEADLAMP ALARM		
Removal and Installation of Trunk Lid Weatherstrip	180	CHECK	224	
REMOVAL	180	Diagnostic Procedure 6	224	
INSTALLATION	180	DOOR LOCK AND UNLOCK SWITCH CHECK	224	
TRUNK LID OPENER	181	IVIS (INFINITI VEHICLE IMMOBILIZER SYSTEM-		
Component Parts and Harness Connector Location	181	NATS)	225	

Component Parts and Harness Connector Location	225	BODY COMPONENT PARTS	253
System Description	227	Corrosion Protection	255
DESCRIPTION	227	DESCRIPTION	255
SECURITY INDICATOR	227	ANTI-CORROSIVE WAX	256
System Composition	228	UNDERCOATING	257
ECM Re-communicating Function	228	STONE GUARD COAT	258
Wiring Diagram — NATS —/WITH INTELLIGENT KEY SYSTEM	229	Body Sealing	259
Wiring Diagram/WITHOUT INTELLIGENT KEY SYSTEM	231	DESCRIPTION	259
Terminals and Reference Value for Steering Lock Unit/with Intelligent Key System	232	Body Construction	262
Terminals and Reference Value for Intelligent Key Unit/with Intelligent Key System	232	BODY CONSTRUCTION	262
Terminals and Reference Value for BCM	233	Body Alignment	263
CONSULT-II	233	BODY CENTER MARKS	263
CONSULT-II INSPECTION PROCEDURE	233	PANEL PARTS MATCHING MARKS	264
CONSULT-II DIAGNOSTIC TEST MODE FUNCTION	234	DESCRIPTION	265
HOW TO READ SELF-DIAGNOSTIC RESULTS	235	ENGINE COMPARTMENT	266
IVIS (NATS) SELF-DIAGNOSTIC RESULTS ITEM CHART	235	UNDERBODY (2WD MODELS)	268
Preliminary Check	236	UNDERBODY (AWD MODELS)	270
Work Flow	237	PASSENGER COMPARTMENT	272
Trouble Diagnoses	238	REAR BODY	274
SYMPTOM MATRIX CHART 1	238	Handling Precautions For Plastics	276
SYMPTOM MATRIX CHART 2	238	HANDLING PRECAUTIONS FOR PLASTICS	276
Diagnostic Procedure 1	239	LOCATION OF PLASTIC PARTS	277
Diagnostic Procedure 2	241	Precautions In Repairing High Strength Steel	279
Diagnostic Procedure 3	241	HIGH STRENGTH STEEL (HSS) USED IN NISSAN VEHICLES	279
Diagnostic Procedure 4	244	Replacement Operations	282
Diagnostic Procedure 5	245	DESCRIPTION	282
Diagnostic Procedure 6	246	HOODLEDGE	285
How to Replace NATS Antenna Amp.	247	FRONT SIDE MEMBER (2WD MODELS)	286
INTEGRATED HOMELINK TRANSMITTER	248	FRONT SIDE MEMBER (AWD MODELS)	287
Wiring Diagram —TRNSCV—	248	FRONT SIDE MEMBER (PARTIAL REPLACEMENT) (2WD MODELS)	288
Trouble Diagnoses	249	FRONT SIDE MEMBER (PARTIAL REPLACEMENT) (AWD MODELS)	289
DIAGNOSTIC PROCEDURE	249	FRONT PILLAR	290
BODY REPAIR	250	CENTER PILLAR	291
Body Exterior Paint Color	250	OUTER SILL	292
Body Component Parts	251	OUTER SILL (CONT'D)	293
UNDERBODY COMPONENT PARTS	251	REAR FENDER	294
		REAR PANEL	295
		REAR FLOOR REAR	296
		REAR SIDE MEMBER EXTENSION	297

PRECAUTIONS

PRECAUTIONS

PPF:00001

Precautions for Supplemental Restraint System (SRS) “AIR BAG” and “SEAT BELT PRE-TENSIONER”

AIS000AS

The Supplemental Restraint System such as “AIR BAG” and “SEAT BELT PRE-TENSIONER”, used along with a front seat belt, helps to reduce the risk or severity of injury to the driver and front passenger for certain types of collision. This system includes seat belt switch inputs and dual stage front air bag modules. The SRS system uses the seat belt switches to determine the front air bag deployment, and may only deploy one front air bag, depending on the severity of a collision and whether the front occupants are belted or unbelted. Information necessary to service the system safely is included in the SRS and SB section of this Service Manual.

WARNING:

- To avoid rendering the SRS inoperative, which could increase the risk of personal injury or death in the event of a collision which would result in air bag inflation, all maintenance must be performed by an authorized NISSAN/INFINITI dealer.
- Improper maintenance, including incorrect removal and installation of the SRS, can lead to personal injury caused by unintentional activation of the system. For removal of Spiral Cable and Air Bag Module, see the SRS section.
- Do not use electrical test equipment on any circuit related to the SRS unless instructed to in this Service Manual. SRS wiring harnesses can be identified by yellow and/or orange harnesses or harness connectors.

Precautions for Work

AIS0000M

- After removing and installing the opening/closing parts, be sure to carry out fitting adjustments to check their operation.
- Check the lubrication level, damage, and wear of each part. If necessary, grease or replace it.

Wiring Diagrams and Trouble Diagnosis

AIS0000N

When you read wiring diagrams, refer to the following:

- [GI-14, "How to Read Wiring Diagrams"](#)
- [PG-3, "POWER SUPPLY ROUTING CIRCUIT"](#)

When you perform trouble diagnosis, refer to the following:

- [GI-10, "HOW TO FOLLOW TEST GROUPS IN TROUBLE DIAGNOSES"](#)
- [GI-26, "How to Perform Efficient Diagnosis for an Electrical Incident"](#)
Check for any Service bulletins before servicing the vehicle.

PREPARATION

PREPARATION

PFP:00002

Special Service Tools

AIS005AQ

The actual shapes of Kent-Moore tools may differ from those of special service tools illustrated here.

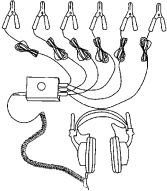
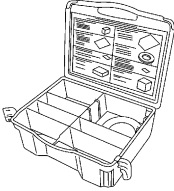
Tool number (Kent-Moore No.) Tool name	Description
(J-39570) Chassis ear	 <p style="text-align: right;">SIIA0993E</p> Locating the noise
(J-43980) NISSAN Squeak and Rattle Kit	 <p style="text-align: right;">SIIA0994E</p> Repairing the cause of noise

Commercial Service Tools

AIS005AR

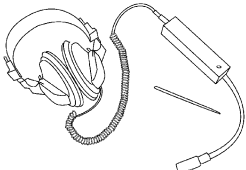
Tool name	Description
Engine ear	 <p style="text-align: right;">SIIA0995E</p> Locating the noise

SQUEAK AND RATTLE TROUBLE DIAGNOSIS

SQUEAK AND RATTLE TROUBLE DIAGNOSIS

PFP:00000

Work Flow

AIS005AS

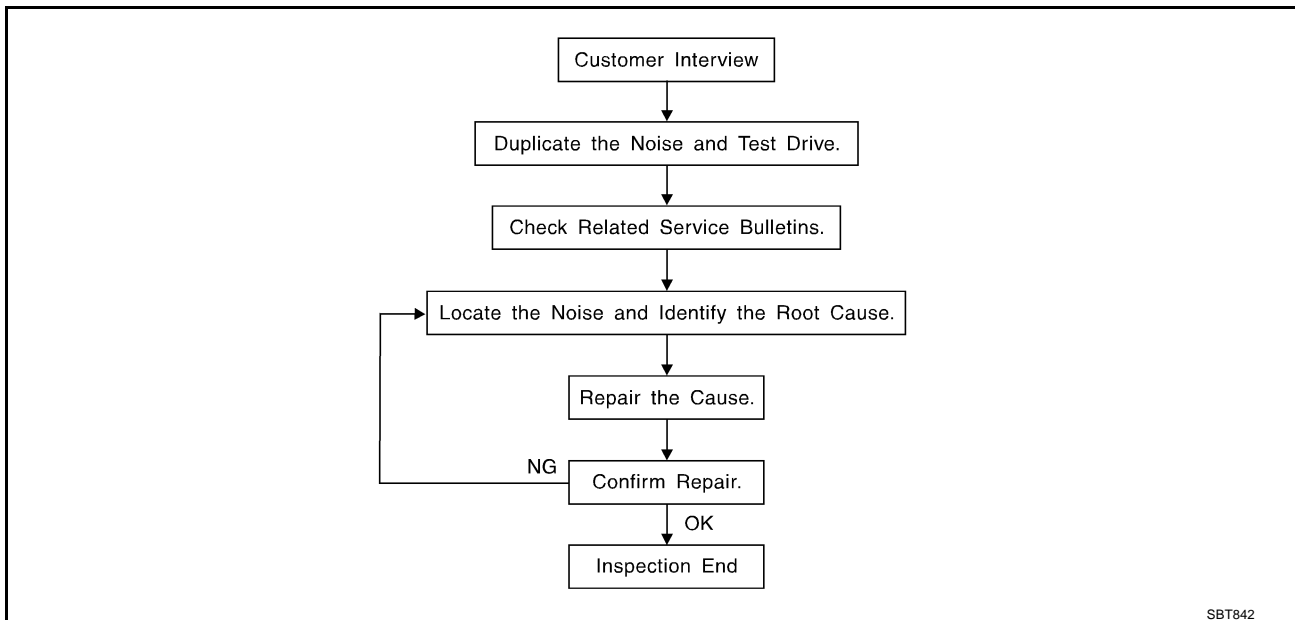

CUSTOMER INTERVIEW

Interview the customer if possible, to determine the conditions that exist when the noise occurs. Use the Diagnostic Worksheet during the interview to document the facts and conditions when the noise occurs and any customer's comments; refer to [BL-11, "Diagnostic Worksheet"](#). This information is necessary to duplicate the conditions that exist when the noise occurs.

- The customer may not be able to provide a detailed description or the location of the noise. Attempt to obtain all the facts and conditions that exist when the noise occurs (or does not occur).
- If there is more than one noise in the vehicle, be sure to diagnose and repair the noise that the customer is concerned about. This can be accomplished by test driving the vehicle with the customer.
- After identifying the type of noise, isolate the noise in terms of its characteristics. The noise characteristics are provided so the customer, service adviser and technician are all speaking the same language when defining the noise.
- Squeak—(Like tennis shoes on a clean floor)
Squeak characteristics include the light contact/fast movement/brought on by road conditions/hard surfaces=higher pitch noise/softer surfaces=lower pitch noises/edge to surface=chirping
- Creak—(Like walking on an old wooden floor)
Creak characteristics include firm contact/slow movement/twisting with a rotational movement/pitch dependent on materials/often brought on by activity.
- Rattle—(Like shaking a baby rattle)
Rattle characteristics include the fast repeated contact/vibration or similar movement/loose parts/missing clip or fastener/incorrect clearance.
- Knock—(Like a knock on a door)
Knock characteristics include hollow sounding/sometimes repeating/often brought on by driver action.
- Tick—(Like a clock second hand)
Tick characteristics include gentle contacting of light materials/loose components/can be caused by driver action or road conditions.
- Thump—(Heavy, muffled knock noise)
Thump characteristics include softer knock/dead sound often brought on by activity.
- Buzz—(Like a bumble bee)
Buzz characteristics include high frequency rattle/firm contact.
- Often the degree of acceptable noise level will vary depending upon the person. A noise that you may judge as acceptable may be very irritating to the customer.
- Weather conditions, especially humidity and temperature, may have a great effect on noise level.

SQUEAK AND RATTLE TROUBLE DIAGNOSIS

DUPLICATE THE NOISE AND TEST DRIVE

If possible, drive the vehicle with the customer until the noise is duplicated. Note any additional information on the Diagnostic Worksheet regarding the conditions or location of the noise. This information can be used to duplicate the same conditions when you confirm the repair.

If the noise can be duplicated easily during the test drive, to help identify the source of the noise, try to duplicate the noise with the vehicle stopped by doing one or all of the following:

- 1) Close a door.
 - 2) Tap or push/pull around the area where the noise appears to be coming from.
 - 3) Rev the engine.
 - 4) Use a floor jack to recreate vehicle "twist".
 - 5) At idle, apply engine load (electrical load, half-clutch on M/T model, drive position on A/T model).
 - 6) Raise the vehicle on a hoist and hit a tire with a rubber hammer.
- Drive the vehicle and attempt to duplicate the conditions the customer states exist when the noise occurs.
 - If it is difficult to duplicate the noise, drive the vehicle slowly on an undulating or rough road to stress the vehicle body.

CHECK RELATED SERVICE BULLETINS

After verifying the customer concern or symptom, check ASIST for Technical Service Bulletins (TSBs) related to that concern or symptom.

If a TSB relates to the symptom, follow the procedure to repair the noise.

LOCATE THE NOISE AND IDENTIFY THE ROOT CAUSE

1. Narrow down the noise to a general area. To help pinpoint the source of the noise, use a listening tool (Chassis Ear: J-39570, Engine Ear and mechanics stethoscope).
2. Narrow down the noise to a more specific area and identify the cause of the noise by:
 - removing the components in the area that you suspect the noise is coming from.
Do not use too much force when removing clips and fasteners, otherwise clips and fastener can be broken or lost during the repair, resulting in the creation of new noise.
 - tapping or pushing/pulling the component that you suspect is causing the noise.
Do not tap or push/pull the component with excessive force, otherwise the noise will be eliminated only temporarily.
 - feeling for a vibration with your hand by touching the component(s) that you suspect is (are) causing the noise.
 - placing a piece of paper between components that you suspect are causing the noise.
 - looking for loose components and contact marks.
Refer to [BL-9, "Generic Squeak and Rattle Troubleshooting"](#) .

REPAIR THE CAUSE

- If the cause is a loose component, tighten the component securely.
- If the cause is insufficient clearance between components:
 - separate components by repositioning or loosening and retightening the component, if possible.
 - insulate components with a suitable insulator such as urethane pads, foam blocks, felt cloth tape or urethane tape. A Nissan Squeak and Rattle Kit (J-43980) is available through your authorized Nissan Parts Department.

CAUTION:

Do not use excessive force as many components are constructed of plastic and may be damaged.

Always check with the Parts Department for the latest parts information.

The following materials are contained in the Nissan Squeak and Rattle Kit (J-43980). Each item can be ordered separately as needed.

URETHANE PADS [1.5 mm (0.059 in) thick]

Insulates connectors, harness, etc.

76268-9E005: 100 × 135 mm (3.94 × 5.31 in)/76884-71L01: 60 × 85 mm (2.36 × 3.35 in)/76884-71L02: 15 × 25 mm (0.59 × 0.98 in)

INSULATOR (Foam blocks)

Insulates components from contact.Can be used to fill space behind a panel.

73982-9E000: 45 mm (1.77 in) thick, 50 × 50 mm (1.97 × 1.97 in)/73982-50Y00: 10 mm (0.39 in) thick, 50 × 50 mm (1.97 × 1.97 in)

SQUEAK AND RATTLE TROUBLE DIAGNOSIS

INSULATOR (Light foam block)

80845-71L00: 30 mm (1.18 in) thick, 30 × 50 mm (1.18×1.97 in)

FELT CLOTHTAPE

Used to insulate where movement does not occur. Ideal for instrument panel applications.

68370-4B000: 15 × 25 mm (0.59 × 0.98 in) pad/68239-13E00: 5 mm (0.20 in) wide tape roll

The following materials, not found in the kit, can also be used to repair squeaks and rattles.

UHMW(TEFLON) TAPE

Insulates where slight movement is present. Ideal for instrument panel applications.

SILICONE GREASE

Used in place of UHMW tape that will be visible or not fit.

Note: Will only last a few months.

SILICONE SPRAY

Use when grease cannot be applied.

DUCT TAPE

Use to eliminate movement.

CONFIRM THE REPAIR

Confirm that the cause of a noise is repaired by test driving the vehicle. Operate the vehicle under the same conditions as when the noise originally occurred. Refer to the notes on the Diagnostic Worksheet.

Generic Squeak and Rattle Troubleshooting

AIS005AT

Refer to Table of Contents for specific component removal and installation information.

INSTRUMENT PANEL

Most incidents are caused by contact and movement between:

1. The cluster lid A and instrument panel
2. Acrylic lens and combination meter housing
3. Instrument panel to front pillar garnish
4. Instrument panel to windshield
5. Instrument panel mounting pins
6. Wiring harnesses behind the combination meter
7. A/C defroster duct and duct joint

These incidents can usually be located by tapping or moving the components to duplicate the noise or by pressing on the components while driving to stop the noise. Most of these incidents can be repaired by applying felt cloth tape or silicon spray (in hard to reach areas). Urethane pads can be used to insulate wiring harness.

CAUTION:

Do not use silicone spray to isolate a squeak or rattle. If you saturate the area with silicone, you will not be able to recheck the repair.

CENTER CONSOLE

Components to pay attention to include:

1. Shifter assembly cover to finisher
2. A/C control unit and cluster lid C
3. Wiring harnesses behind audio and A/C control unit

The instrument panel repair and isolation procedures also apply to the center console.

DOORS

Pay attention to the:

1. Finisher and inner panel making a slapping noise
2. Inside handle escutcheon to door finisher
3. Wiring harnesses tapping
4. Door striker out of alignment causing a popping noise on starts and stops

Tapping or moving the components or pressing on them while driving to duplicate the conditions can isolate many of these incidents. You can usually insulate the areas with felt cloth tape or insulator foam blocks from the Nissan Squeak and Rattle Kit (J-43980) to repair the noise.

A
B
C
D
E
F
G
H
BL
J
K
L
M

SQUEAK AND RATTLE TROUBLE DIAGNOSIS

TRUNK

Trunk noises are often caused by a loose jack or loose items put into the trunk by the owner. In addition look for:

1. Trunk lid dumpers out of adjustment
2. Trunk lid striker out of adjustment
3. The trunk lid torsion bars knocking together
4. A loose license plate or bracket

Most of these incidents can be repaired by adjusting, securing or insulating the item(s) or component(s) causing the noise.

SUNROOF/HEADLINING

Noises in the sunroof/headlining area can often be traced to one of the following:

1. Sunroof lid, rail, linkage or seals making a rattle or light knocking noise
2. Sunvisor shaft shaking in the holder
3. Front or rear windshield touching headlining and squeaking

Again, pressing on the components to stop the noise while duplicating the conditions can isolate most of these incidents. Repairs usually consist of insulating with felt cloth tape.

SEATS

When isolating seat noise it's important to note the position the seat is in and the load placed on the seat when the noise is present. These conditions should be duplicated when verifying and isolating the cause of the noise.

Cause of seat noise include:

1. Headrest rods and holder
2. A squeak between the seat pad cushion and frame
3. The rear seatback lock and bracket

These noises can be isolated by moving or pressing on the suspected components while duplicating the conditions under which the noise occurs. Most of these incidents can be repaired by repositioning the component or applying urethane tape to the contact area.

UNDERHOOD

Some interior noise may be caused by components under the hood or on the engine wall. The noise is then transmitted into the passenger compartment.

Causes of transmitted underhood noise include:

1. Any component mounted to the engine wall
2. Components that pass through the engine wall
3. Engine wall mounts and connectors
4. Loose radiator mounting pins
5. Hood bumpers out of adjustment
6. Hood striker out of adjustment

These noises can be difficult to isolate since they cannot be reached from the interior of the vehicle. The best method is to secure, move or insulate one component at a time and test drive the vehicle. Also, engine RPM or load can be changed to isolate the noise. Repairs can usually be made by moving, adjusting, securing, or insulating the component causing the noise.

SQUEAK AND RATTLE TROUBLE DIAGNOSIS

Diagnostic Worksheet

AI5005AU



SQUEAK & RATTLE DIAGNOSTIC WORKSHEET

Dear Infiniti Customer:

We are concerned about your satisfaction with your Infiniti vehicle. Repairing a squeak or rattle sometimes can be very difficult. To help us fix your Infiniti right the first time, please take a moment to note the area of the vehicle where the squeak or rattle occurs and under what conditions. You may be asked to take a test drive with a service advisor or technician to ensure we confirm the noise you are hearing.

I. WHERE DOES THE NOISE COME FROM? (circle the area of the vehicle)

The illustrations are for reference only, and may not reflect the actual configuration of your vehicle.

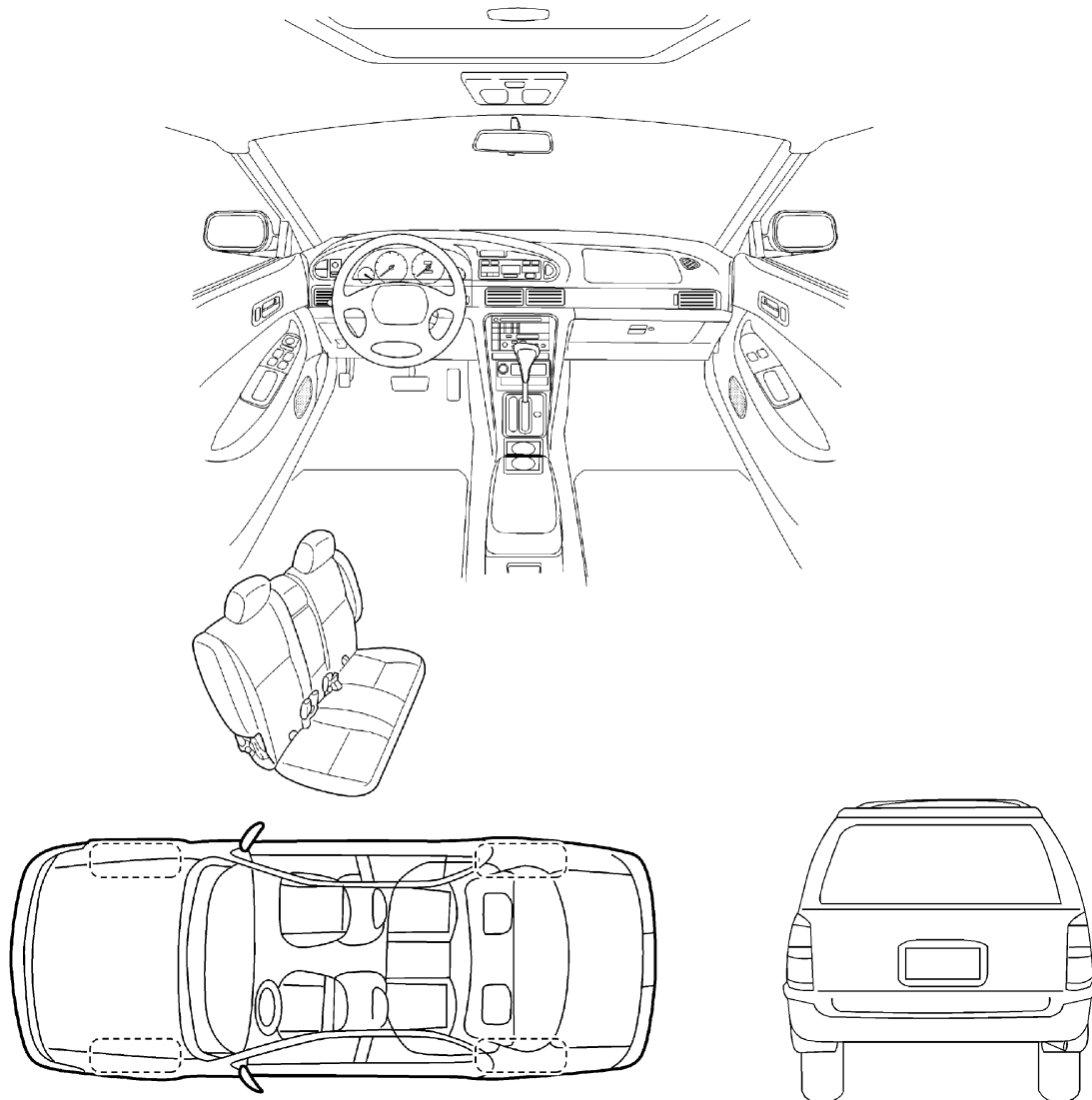

Continue to the back of the worksheet and briefly describe the location of the noise or rattle. In addition, please indicate the conditions which are present when the noise occurs.

SBT860

A
B
C
D
E
F
G
H
BL
J
K
L
M

SQUEAK AND RATTLE TROUBLE DIAGNOSIS

SQUEAK & RATTLE DIAGNOSTIC WORKSHEET- page 2

Briefly describe the location where the noise occurs:

II. WHEN DOES IT OCCUR? (check the boxes that apply)

- | | |
|--|---|
| <input type="checkbox"/> anytime | <input type="checkbox"/> after sitting out in the sun |
| <input type="checkbox"/> 1 st time in the morning | <input type="checkbox"/> when it is raining or wet |
| <input type="checkbox"/> only when it is cold outside | <input type="checkbox"/> dry or dusty conditions |
| <input type="checkbox"/> only when it is hot outside | <input type="checkbox"/> other: _____ |

III. WHEN DRIVING:

- through driveways
- over rough roads
- over speed bumps
- only at about ____ mph
- on acceleration
- coming to a stop
- on turns : left, right or either (circle)
- with passengers or cargo
- other: _____
- after driving ____ miles or ____ minutes

IV. WHAT TYPE OF NOISE?

- squeak (like tennis shoes on a clean floor)
- creak (like walking on an old wooden floor)
- rattle (like shaking a baby rattle)
- knock (like a knock on a door)
- tick (like a clock second hand)
- thump (heavy, muffled knock noise)
- buzz (like a bumble bee)

TO BE COMPLETED BY DEALERSHIP PERSONNEL

Test Drive Notes:

	YES	NO	Initials of person performing
Vehicle test driven with customer	<input type="checkbox"/>	<input type="checkbox"/>	_____
- Noise verified on test drive	<input type="checkbox"/>	<input type="checkbox"/>	_____
- Noise source located and repaired	<input type="checkbox"/>	<input type="checkbox"/>	_____
- Follow up test drive performed to confirm repair	<input type="checkbox"/>	<input type="checkbox"/>	_____

VIN: _____ Customer Name: _____

W.O. #: _____ Date: _____

This form must be attached to Work Order

SBT844

HOOD

HOOD

PFP:F5100

Fitting Adjustment

AIS0000T

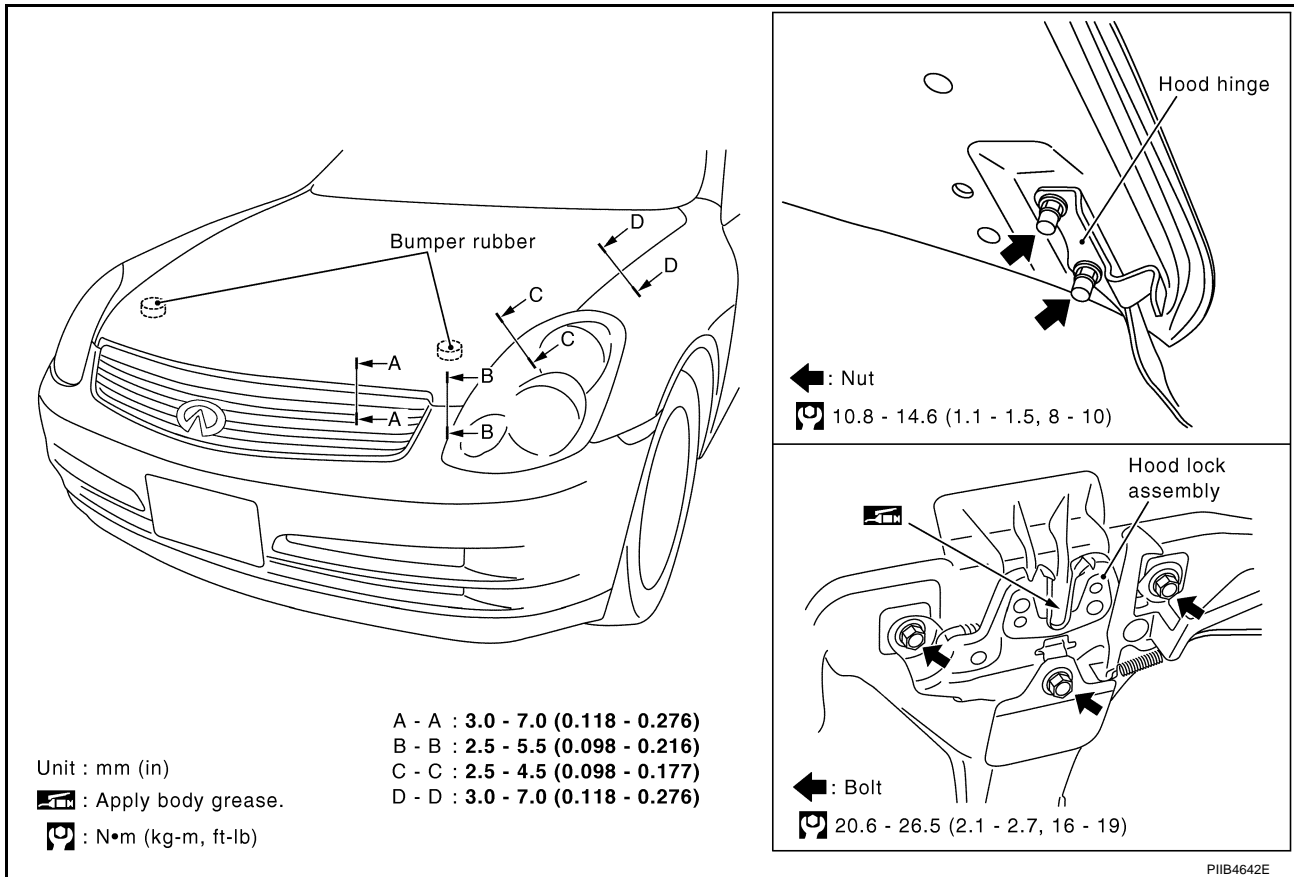

LONGITUDINAL AND LATERAL CLEARANCE ADJUSTMENT

1. Remove hood lock assembly, loosen the hood hinge nuts and close the hood.
2. Adjust the lateral and longitudinal clearance, and open the hood to tighten the hood hinge mounting bolts to the specified torque.
3. Install the hood lock temporarily, and align the hood striker and lock so that the centers of striker and lock become vertical viewed from the front, by moving the hood lock laterally.
4. Tighten hood lock mounting bolts to the specified torque.

FRONT END HEIGHT ADJUSTMENT

1. Remove the hood lock and adjust the height by rotating the bumper rubber until the hood becomes 1 to 1.5 mm (0.04 to 0.059 in) lower than the fender.
2. Temporarily tighten the hood lock, and position it by engaging it with the hood striker. Check the lock and striker for looseness, and tighten the hood lock mounting bolts to the specified torque.

CAUTION:

Adjust right/left clearance between hood and each part to the following specification.

Hood and front bumper (B-B)	: Less than 2.0 mm (0.08 in)
Hood and head lamp (C-C)	: Less than 2.0 mm (0.08 in)
Hood and fender (D-D)	: Less than 1.0 mm (0.04 in)

HOOD

SURFACE HEIGHT ADJUSTMENT

1. Remove hood lock, and adjust the surface height difference of hood, fender and headlamp according to the fitting standard dimension, by rotating RH and LH bumper rubbers.
2. Install hood lock temporarily, and move hood lock laterally until the centers of striker and lock become vertical when viewed from the front.
3. Make sure that the hood lock secondary latch is properly engaged with the secondary striker with hood's own weight.
4. Make sure that the hood lock primary latch is securely engaged with the hood striker with hood's own weight by dropping hood from approx. 200 mm (7.87in) height.

CAUTION:

Do not drop hood from a height of 300 mm (11.81 in) or more.

5. Move hood lockup and down until striker smoothly engages the lock when the hood is closed.
6. When pulling the hood opener lever gently, make sure that front end of the hood rises by approximately 20 mm (0.79 in) and that hood striker and hood lock primary latch is disengaged. Also make sure that hood opener returns to the original position.
7. After adjustment, tighten lock bolts to the specified torque.

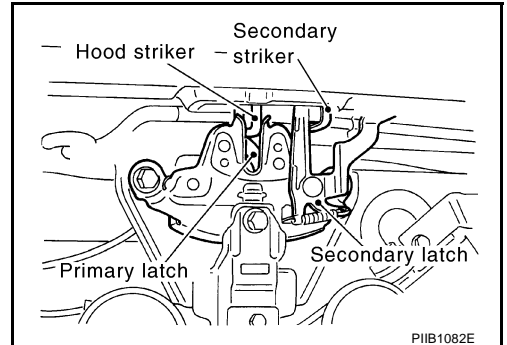

CAUTION:

Adjust evenness between hood and each part to the following specification.

- | | |
|---------------------------------|--------------------------------------|
| Hood and head lamp (C-C) | : Less than 1.5 mm (0.059 in) |
| Hood and fender (D-D) | : Less than 1.0 mm (0.04 in) |

HOOD

Removal and Installation of Hood Assembly

AIS0000U

A
B
C
D
E
F
G
H
BL
J
K
L
M

SEC. 650

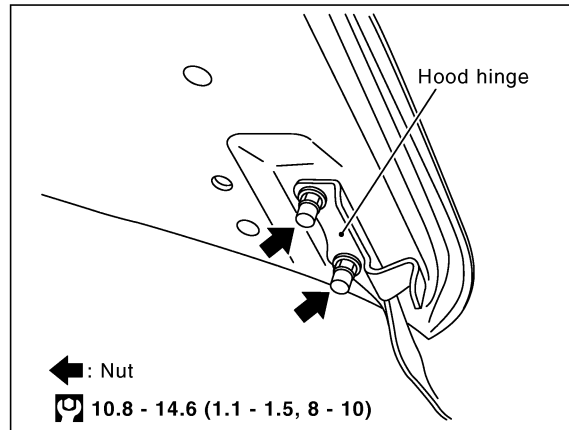
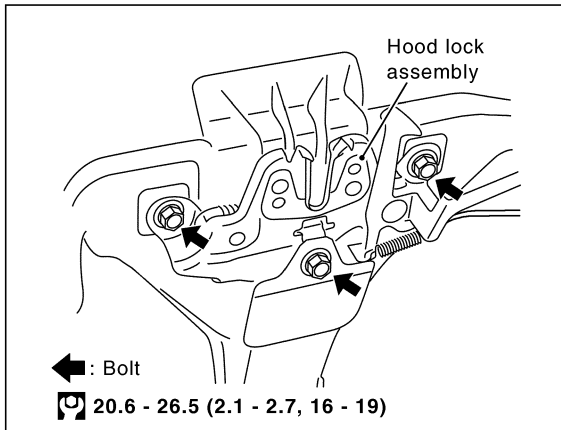
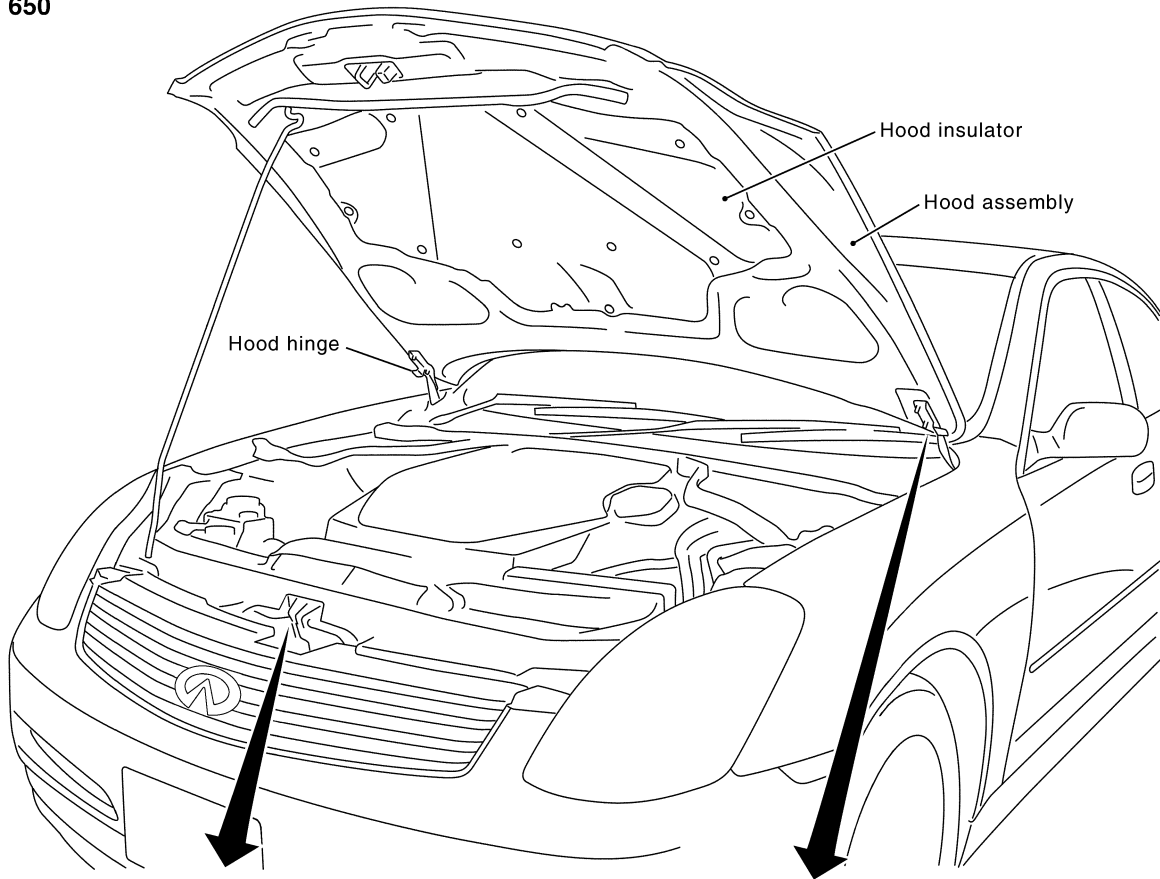

: N·m (kg-m, ft-lb)

PIIA1087E

REMOVAL

Remove the hinge mounting nuts on the hood to remove the hood assembly.

CAUTION:

Operate with two workers, because of its heavy weight.

INSTALLATION

Install in the reverse order of removal.

CAUTION:

- Before installing hood hinge, apply anticorrosive agent onto the mounting surface of the vehicle body.
- After installing, perform hood fitting adjustment. Refer to [BL-13, "Fitting Adjustment"](#).

HOOD

Removal and Installation of Hood Lock Control

AIS0000V

SEC. 656

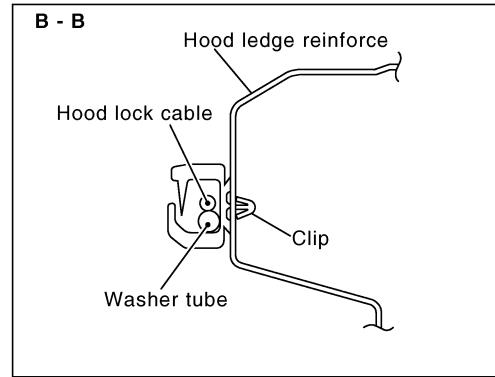
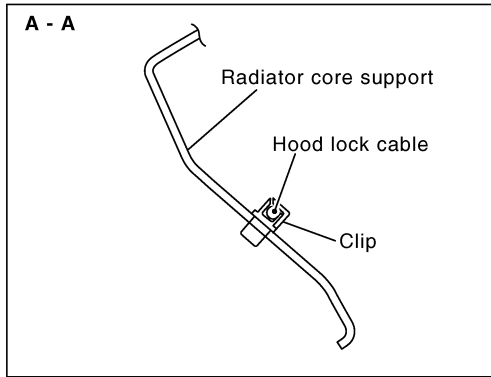
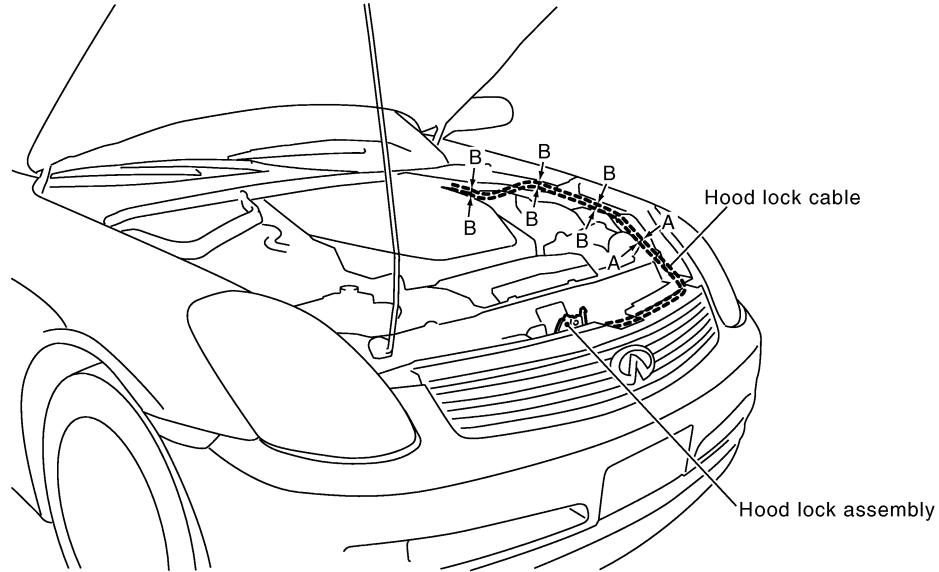

PIIA1088E

REMOVAL

1. Remove the front grill. Refer to [EI-20, "Removal and Installation"](#).
2. Remove the fender protector. Refer to [EI-22, "Removal and Installation"](#).
3. Remove the hood lock assembly. Refer to [BL-15, "Removal and Installation of Hood Assembly"](#).
4. Remove the instrument lower driver panel. Refer to [IP-10, "Component Parts Drawing"](#).
5. Disconnect the hood lock cable from the hood lock, and clip it from the radiator core upper support and hood ledge.
6. Remove the mounting screws, and remove the hood opener.
7. Remove the grommet on the instrument panel, and pull the hood lock cable toward the passenger compartment.

CAUTION:

While pulling, be careful not to damage (peeling) the outside of the hood lock cable.

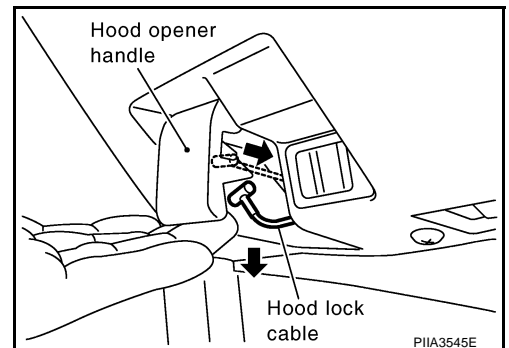

PIIA3545E

HOOD

INSTALLATION

1. Pull the hood lock cable through the panel hole to the engine compartment.
Be careful not to bend the cable too much, keeping the radius 100 mm (3.94 in) or more.
2. Check that the cable is not offset from the positioning grommet, and push the grommet into the panel hole securely.
3. Apply the sealant to the grommet (at * mark) properly.

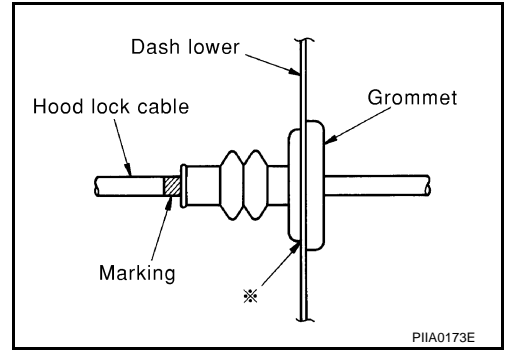

4. Install the cable securely to the lock.
5. After installing, check the hood lock adjustment and hood opener operation.

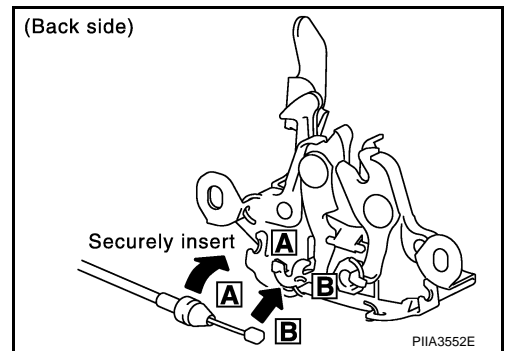

Hood Lock Control Inspection

CAUTION:

If the hood lock cable is bent or deformed, replace it.

1. Check that the hood lock secondary latch is properly engaged with the secondary striker with hood's own weight.
2. Check that the hood lock primary latch is securely engaged with the hood striker with hood's own weight by dropping it from approx. 200 mm (7.87 in) height.

CAUTION:

Do not drop hood from a height of 300 mm (11.81 in) or more.

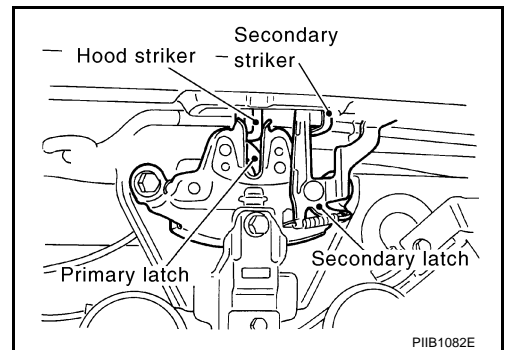

3. When pulling hood opener lever gently, make sure that front end of the hood rises by approximately 20 mm (0.79 in) and that hood striker and hood lock primary latch are disengaged. Also make sure that hood opener returns to the original position.
4. Confirm hood lock is properly lubricated. If necessary, apply grease at the point shown in the figure.

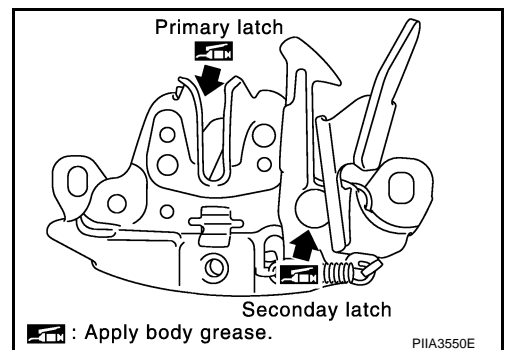

RADIATOR CORE SUPPORT

PFP:62500

RADIATOR CORE SUPPORT

Removal and Installation

AIS0007V

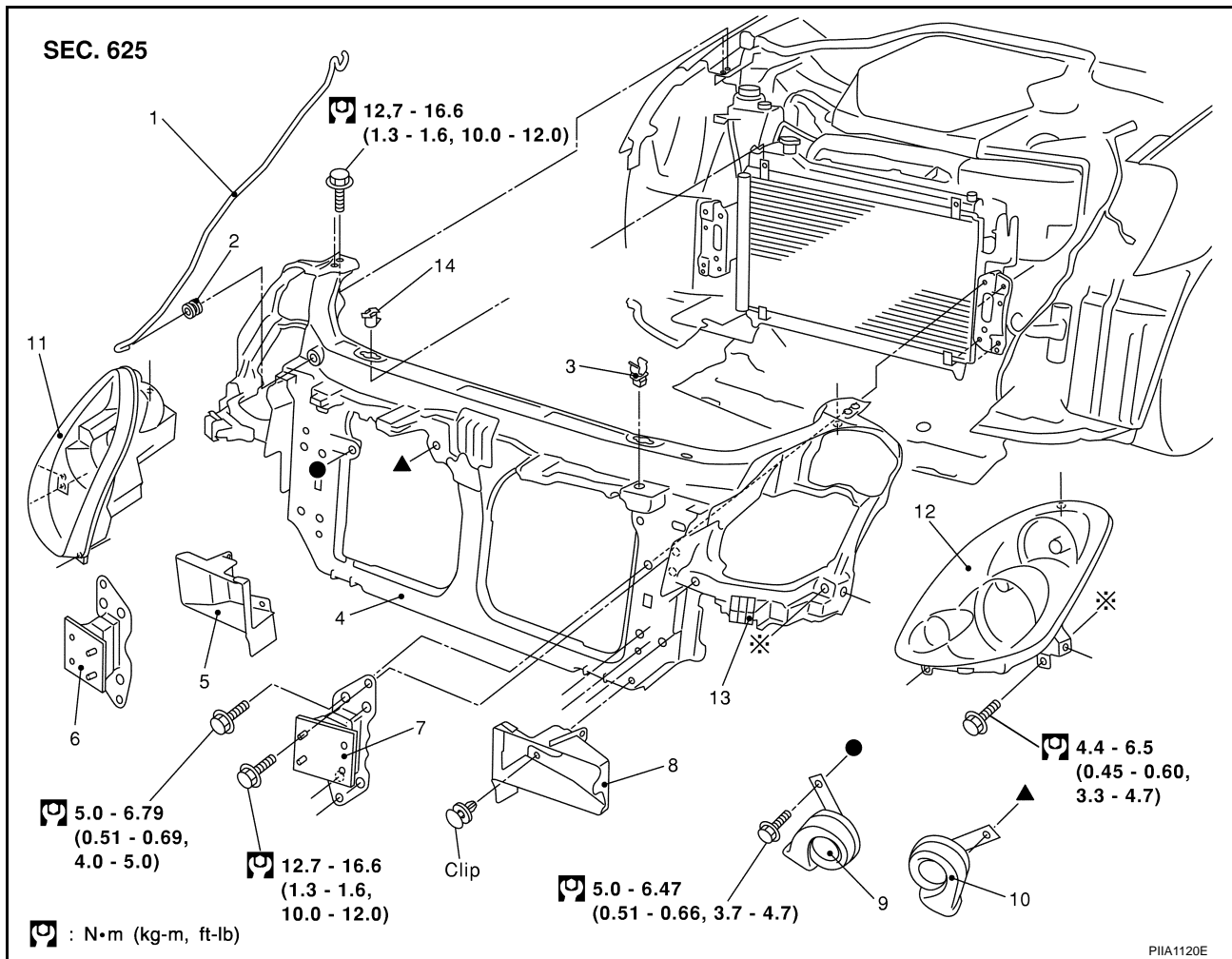

- | | | |
|-----------------------------------|----------------------------|------------------------|
| 1. Hood stay | 2. Grommet | 3. Hood rod clamp |
| 4. Radiator core support assembly | 5. Air intake duct (RH) | 6. Bumper bracket (RH) |
| 7. Bumper bracket (LH) | 8. Air intake duct (LH) | 9. Horn (Low) |
| 10. Horn (High) | 11. Headlamp (RH) | 12. Headlamp (LH) |
| 13. Front bumper clip | 14. Upper radiator bracket | |

REMOVAL

1. Remove hood assembly. Refer to [BL-15, "Removal and Installation of Hood Assembly"](#).
2. Remove front bumper, bumper reinforcement and bumper bracket. Refer to [EI-14, "Removal and Installation"](#).
3. Remove hood lock assembly, then remove hood lock cable.
4. Remove washer tank. Refer to [WW-36, "Removal and Installation of Washer Tank"](#).
5. Remove horn connectors.
6. Remove mounting harness clip on radiator core support assembly, the harness is separate.
7. Remove resonator mounting screws. Refer to [EM-17, "AIR CLEANER AND AIR DUCT"](#).
8. Remove air intake duct (LH/RH), and remove washer tank inlet clip.
9. Remove headlamp (LH/RH). Refer to [LT-35, "Removal and Installation"](#).
10. Remove upper radiator bracket.

RADIATOR CORE SUPPORT

11. Remove radiator core support assembly mounting bolts. Remove bolts with power tool.

CAUTION:

Put a wooden block under the radiator assembly to prevent the radiator assembly from falling.

12. Remove radiator core support assembly.
13. After removing radiator core support assembly, the following parts are separate.
 - Remove the hood stay, grommet and hood rod clamp
 - Horn (High/Low)
 - Air intake duct (LH/RH)
 - Front bumper clip (LH/RH)

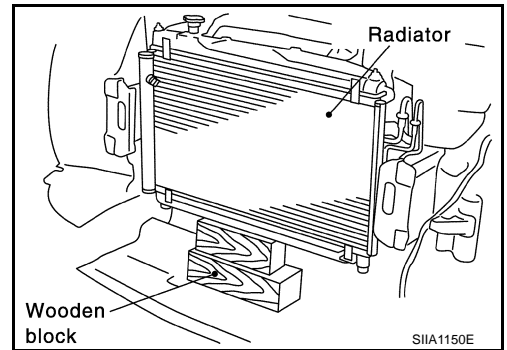

A
B
C
D
E
F
G
H
BL
J
K
L
M

INSTALLATION

Install in the reverse order of removal.

POWER DOOR LOCK SYSTEM

POWER DOOR LOCK SYSTEM

PFP:24814

Component Parts and Harness Connector Location

AIS0049F

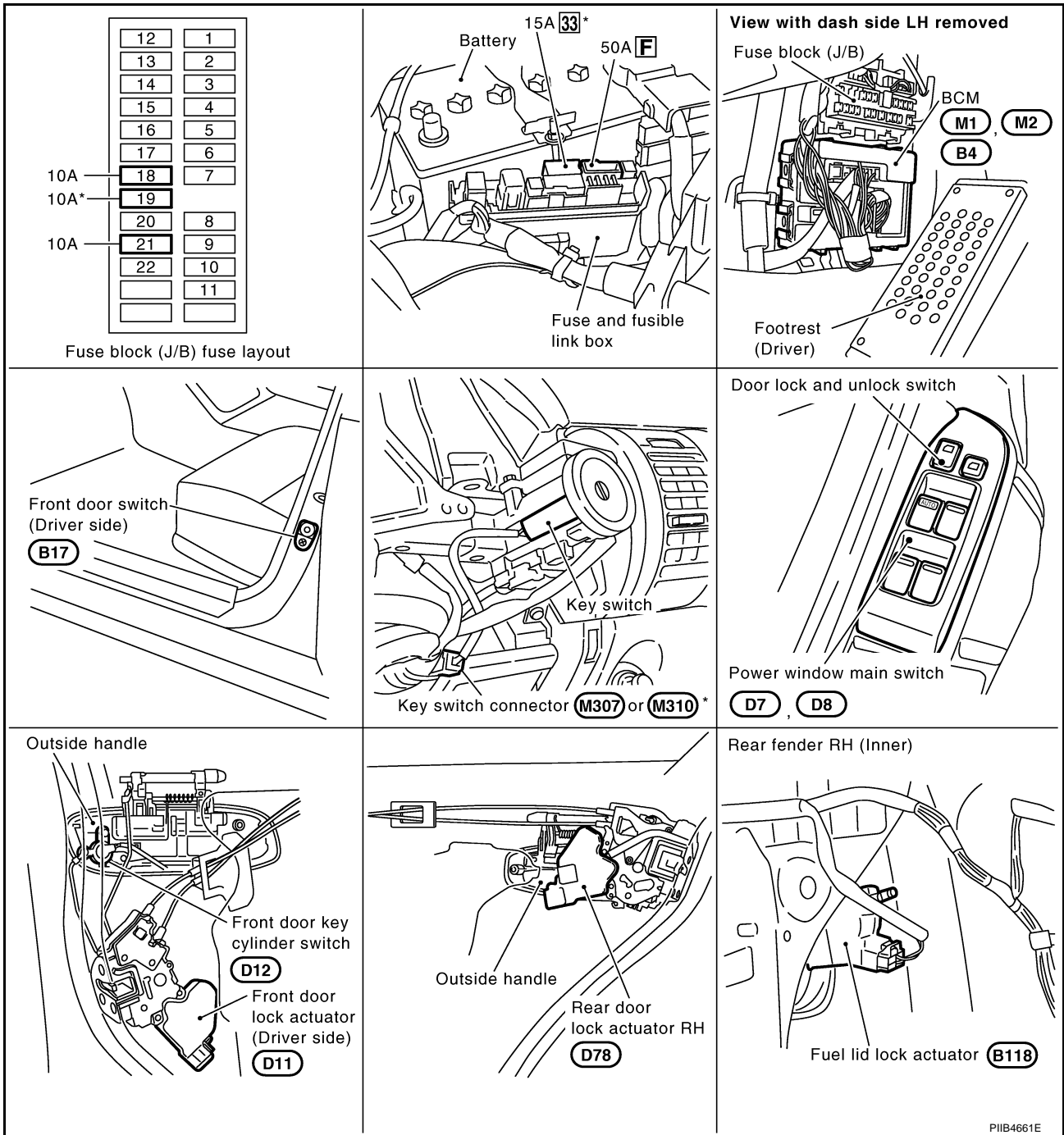

*:With Intelligent Key

POWER DOOR LOCK SYSTEM

System Description

AI50049H

A

Power is supplied at all times

- through 50A fusible link (letter **F** , located in the fuse and fusible link box).
- to BCM terminal 55,
- through 10A fuse [No. 18, located in the fuse block (J/B)]
- to BCM terminal 42,
- through 10A fuse [No. 21, located in the fuse block (J/B)]
- to key switch terminal 2. (without Intelligent Key)
- through 15A fuse [No. 33, located in the fuse block (J/B)]
- to key switch and ignition knob switch terminal 3. (with Intelligent Key)
- through 10A fuse [No. 19, located in the fuse block (J/B)]
- to passenger side select unlock relay terminal 2 . (with Intelligent Key)

B

C

D

When key switch is ON (key is inserted in ignition key cylinder), power is supplied

- through key switch terminal 1 (Without Intelligent Key)
- through key switch and ignition switch terminal 4 (With Intelligent Key)
- to BCM terminal 37.

E

F

Ground is supplied

- to BCM terminal 52
- through body grounds M30 and M66.

G

When the door is locked or unlocked with power window main switch (door lock and unlock switch), ground is supplied

- to CPU of power window main switch
- through power window main switch (door lock and unlock switch) terminal 17
- through grounds M30 and M66.

H

BL

Then power window main switch (door lock and unlock switch) operation signal is sent.

- to BCM terminal 22
- from power window main switch (door lock and unlock switch) terminal 14

J

When the door is locked or unlocked with power window sub-switch (front passenger side) (door lock and unlock switch), ground is supplied

- to CPU of power window sub-switch
- through power window sub-switch (front passenger side) (door lock and unlock switch) terminal 11
- through grounds M30 and M66.

K

L

Then power window sub-switch (front passenger side) (door lock and unlock switch) operation signal is sent

- to BCM terminal 22
- from power window sub-switch (front passenger side) (door lock and unlock switch) terminal 16.

M

When the door is locked with front door key cylinder switch (driver side), ground is supplied

- to CPU of power window main switch
- through power window main switch (door lock and unlock switch) terminal 4
- through front door key cylinder switch (driver side) terminals 1 and 2
- through grounds M30 and M66.

Then front door key cylinder switch (driver side) operation signal (lock) is sent

- to BCM terminal 22
- from power window main switch (door lock and unlock switch) terminal 14

When the door is unlocked with front door key cylinder switch (driver side), ground is supplied

- to CPU of power window main switch
- through power window main switch (door lock and unlock switch) terminal 6
- through front door key cylinder switch (driver side) terminals 3 and 2
- through grounds M30 and M66.

Then front door key cylinder switch (driver side) operation signal (unlock) is sent

POWER DOOR LOCK SYSTEM

- to BCM terminal 22
- from power window main switch (door lock and unlock switch) terminal 14

BCM is connected to power window main switch and power window sub-switch as serial link.

DOOR SWITCH OPERATION

When the front door switch driver side is ON (door is OPEN), ground is supplied

- to BCM terminal 62
- through front door switch driver side terminal 1 and
- through front door switch driver side case ground.

When the front door switch passenger side is ON (door is OPEN), ground is supplied

- to BCM terminal 12
- through front door switch passenger side terminal 1 and
- through front door switch passenger side case ground.

When the rear door switch LH is ON (door is OPEN), ground is supplied

- to BCM terminal 63
- through rear door switch LH terminal 1 and
- through rear door switch LH case ground.

When the rear door switch RH is ON (door is OPEN), ground is supplied

- to BCM terminal 13
- through front door switch RH terminal 1 and
- through rear door switch RH case ground.

FUEL LID OPERATION

When door is unlocked with power window main switch (door lock and unlock switch), fuel lid lock actuator is unlocked. Ground is supplied

- to BCM terminal 44
- through fuel lid lock actuator terminals 1 and 2
- through passenger side select unlock relay 4 and 3 (With Intelligent Key)
- through BCM terminal 50.

In this condition, fuel lid can be opened if it is pushed.

OUTLINE

Functions Available by Operating the Door Lock and Unlock Switches on Driver's Door and Passenger's Door

- Interlocked with the locking operation of door lock and unlock switch, door lock actuators of all doors and fuel lid lock actuator are locked.
- Interlocked with the unlocking operation of door lock and unlock switch, door lock actuators of all doors and fuel lid lock actuator are unlocked.

Functions Available by Operating the Key Cylinder Switch on Driver's

- Interlocked with the locking operation of door key cylinder, door lock actuators of all doors and fuel lid lock actuator are locked.

Select Unlock Operation

- When door key cylinder is unlocked, door lock actuator driver side and fuel lid lock actuator are unlocked.
- When door key cylinder is unlocked for the second time within 5 seconds after the first operation, door lock actuators on all doors are unlocked.
Select unlock operation mode can be changed using "DOOR LOCK-UNLOCK SET" mode in "WORK SUPPORT". Refer to [BL-37, "Work Support"](#).

Key Reminder Door System

When door lock and unlock switch is operated to lock doors with ignition key put in key cylinder and any door open, all door lock actuators are locked and then unlocked.

Key reminder door mode can be changed using "WORK SUPPORT" mode in "ANTI-LOCK OUT SET". Refer to [BL-37, "Work Support"](#).

POWER DOOR LOCK SYSTEM

CAN Communication System Description

AIS0049I

CAN (Controller Area Network) is a serial communication line for real time application. It is an on-vehicle multiplex communication line with high data communication speed and excellent error detection ability. Many electronic control units are equipped onto a vehicle, and each control unit shares information and links with other control units during operation (not independent). In CAN communication, control units are connected with 2 communication lines (CAN H line, CAN L line) allowing a high rate of information transmission with less wiring. Each control unit transmits/receives data but selectively reads required data only.

CAN Communication Unit

AIS004CP

Refer to [LAN-21, "CAN COMMUNICATION"](#) .

A

B

C

D

E

F

G

H

BL

J

K

L

M

POWER DOOR LOCK SYSTEM

Schematic / With Intelligent Key

AIS0049J

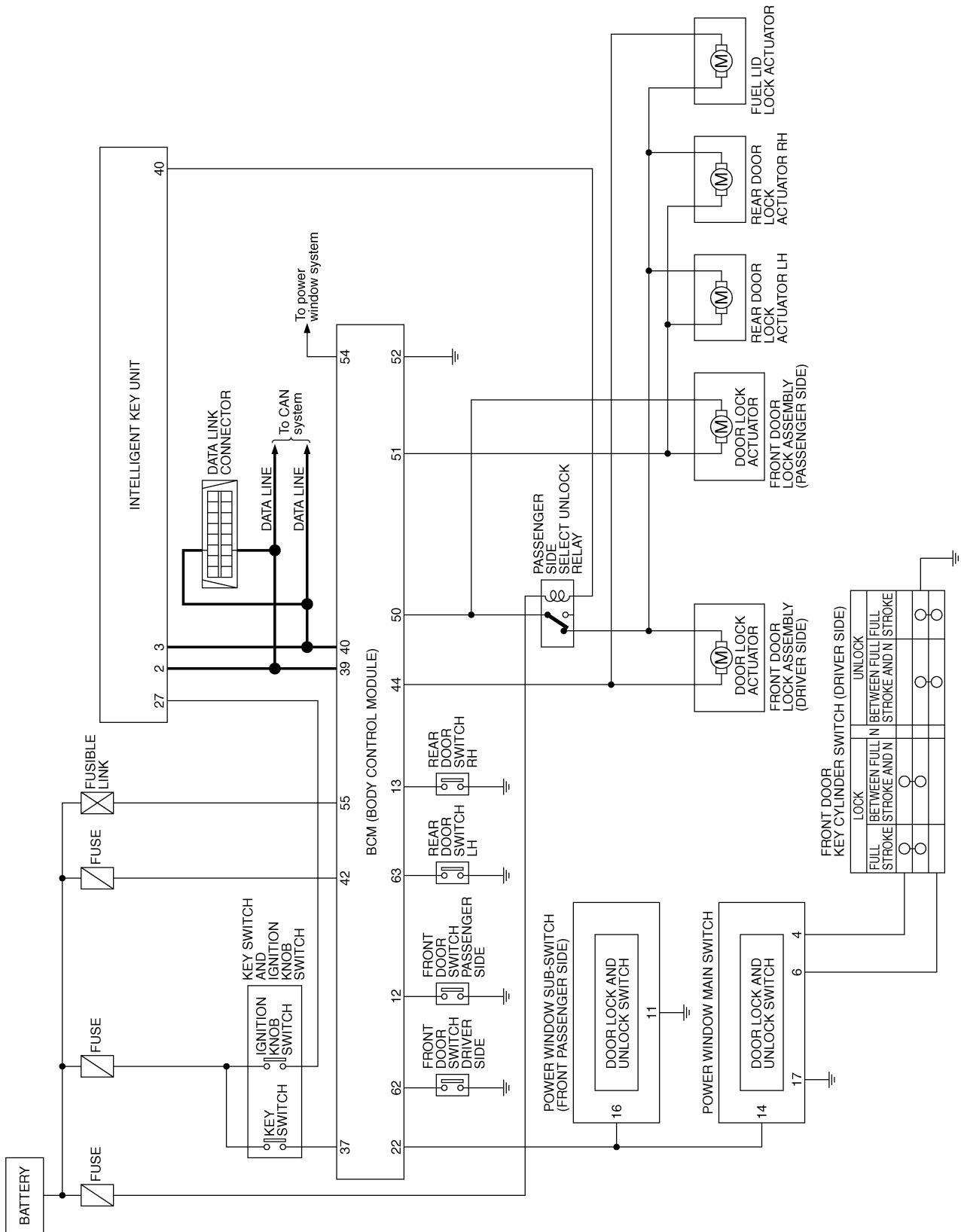

TIWM1030E

POWER DOOR LOCK SYSTEM

Wiring Diagram -D/LOCK- / With Intelligent Key
FIG. 1

AIS0049K

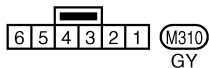
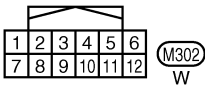
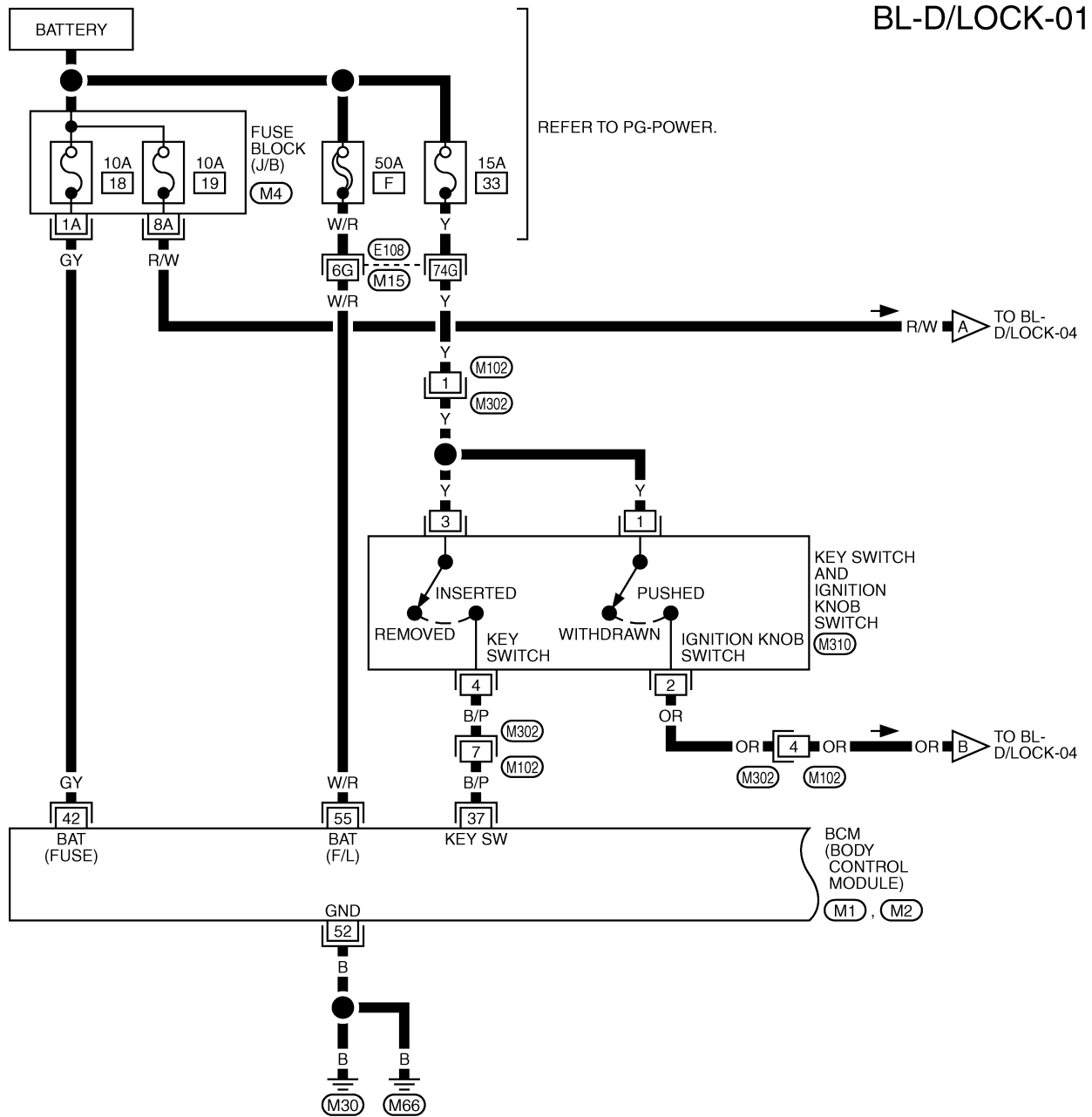

REFER TO THE FOLLOWING.

- (E108) -SUPER MULTIPLE JUNCTION (SMJ)
- (M4) -FUSE BLOCK-JUNCTION BOX (J/B)
- (M1), (M2) -ELECTRICAL UNITS

TIWM1031E

POWER DOOR LOCK SYSTEM

FIG. 2

BL-D/LOCK-02

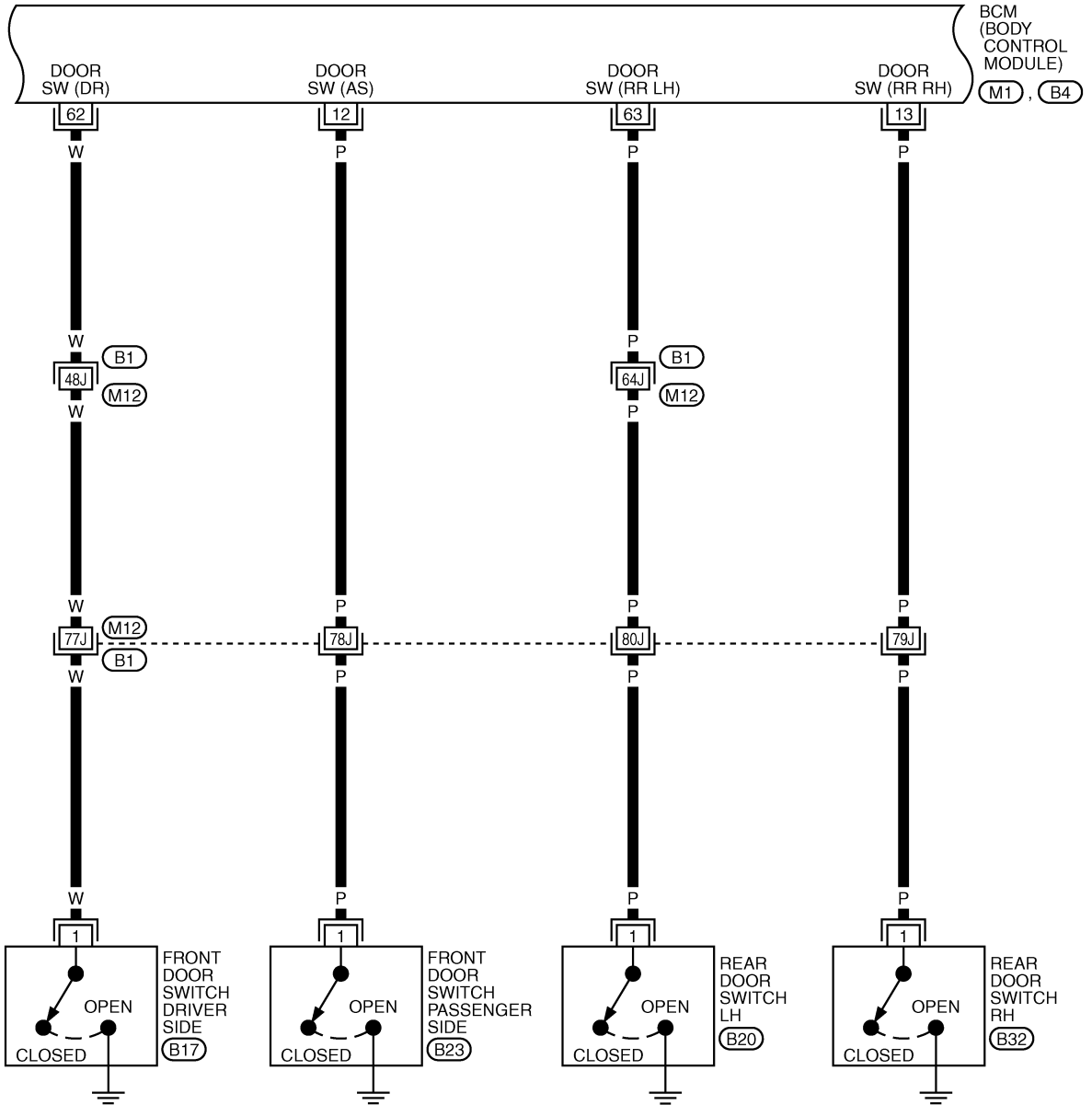

1	
2	(B17), (B20), (B23), (B32)
3	W, W, W, W

REFER TO THE FOLLOWING.
 (B1) -SUPER MULTIPLE JUNCTION (SMJ)
 (M1), (B4) -ELECTRICAL UNITS

T1WM1032E

POWER DOOR LOCK SYSTEM

FIG. 4

BL-D/LOCK-04

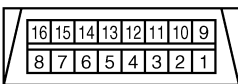
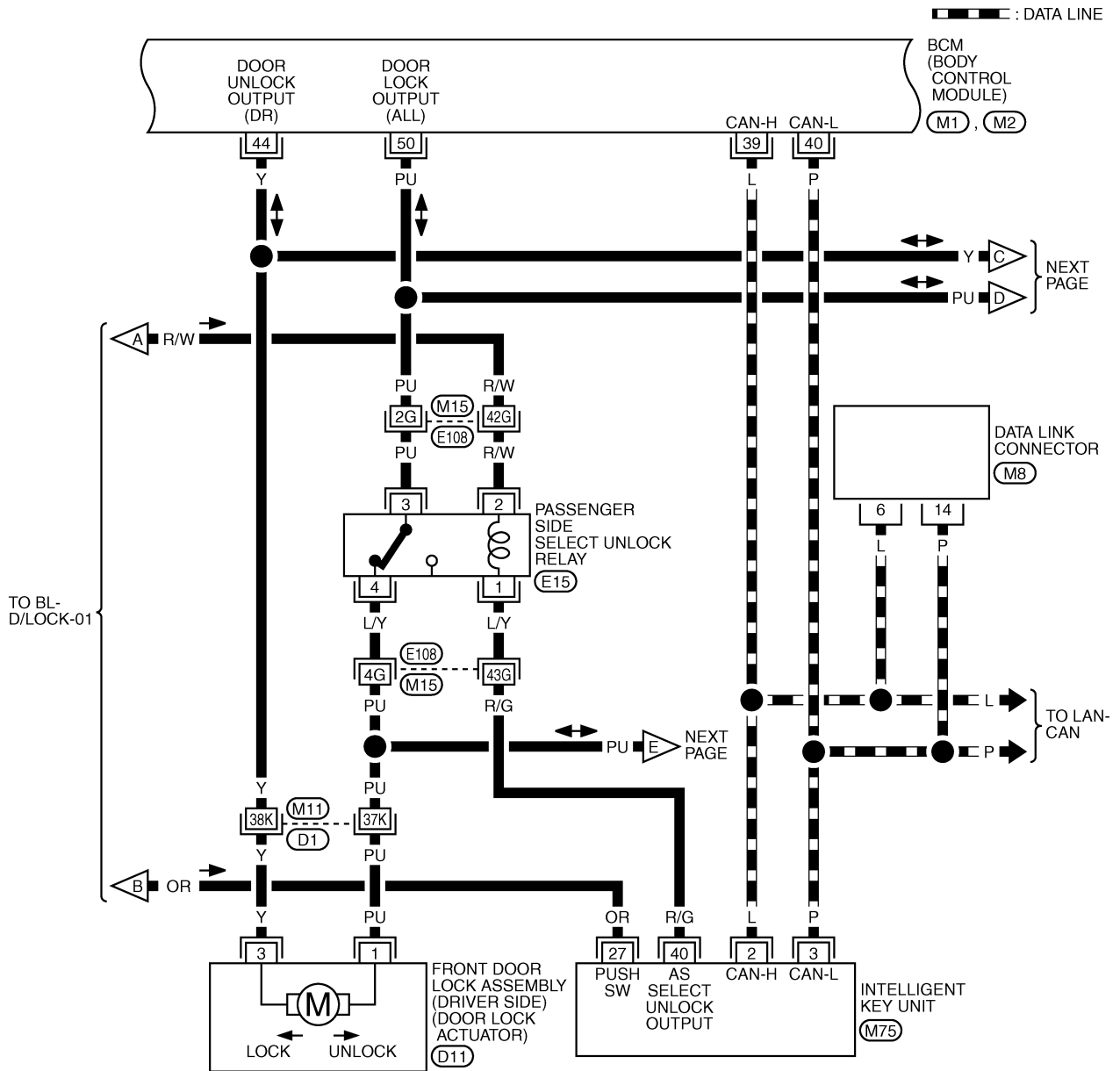

REFER TO THE FOLLOWING.

(E108), (D1) -SUPER MULTIPLE JUNCTION (SMJ)

(M1), (M2), (M75) -ELECTRICAL UNITS

T1WM1034E

POWER DOOR LOCK SYSTEM

FIG. 5

BL-D/LOCK-05

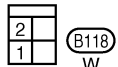
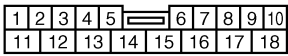
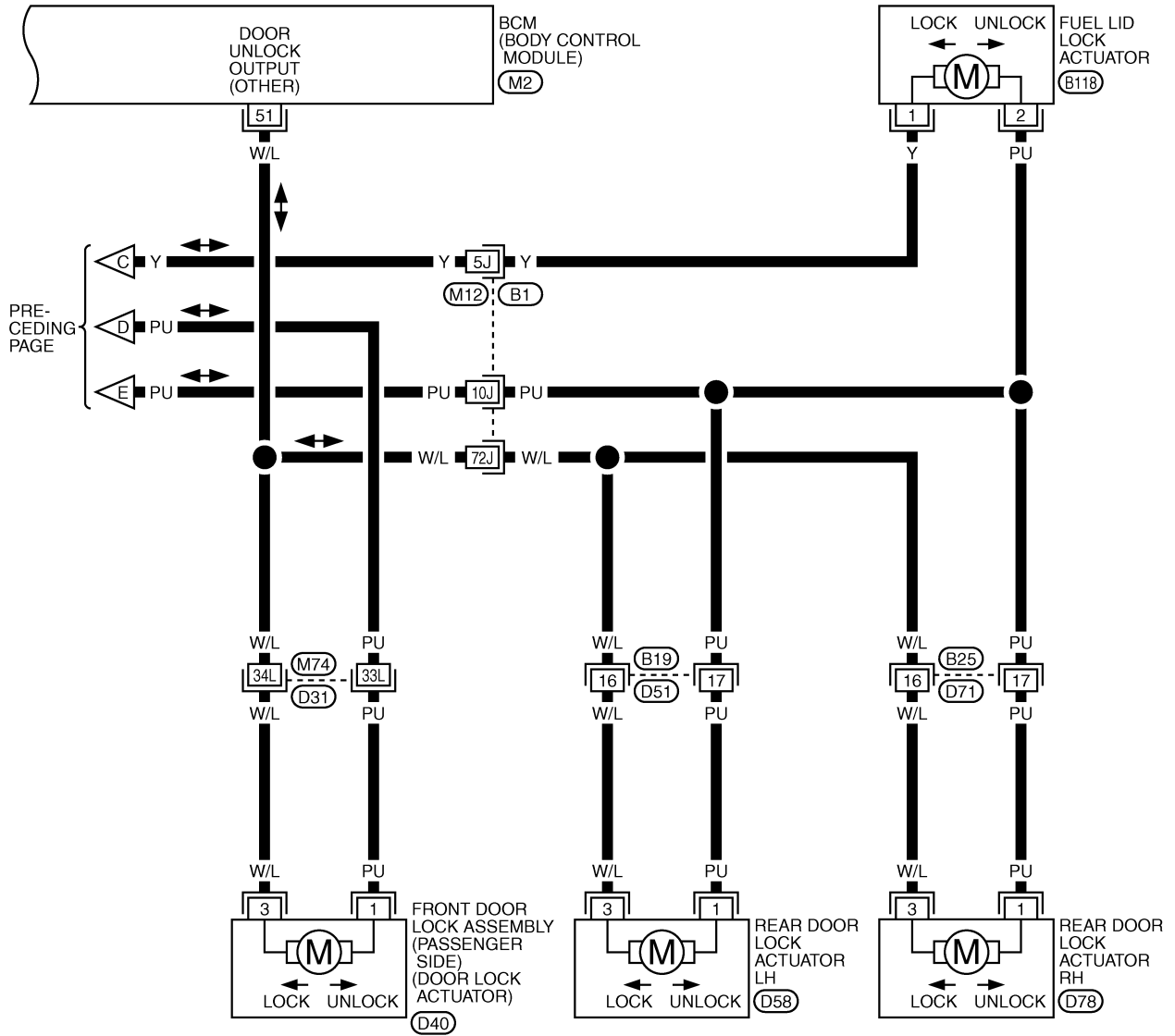

REFER TO THE FOLLOWING.
 (B1), (D31) -SUPER MULTIPLE JUNCTION (SMJ)
 (M2) -ELECTRICAL UNITS

T1WM1035E

POWER DOOR LOCK SYSTEM

Wiring Diagram -D/LOCK- / Without Intelligent Key
FIG. 1

AIS006A7

BL-D/LOCK-06

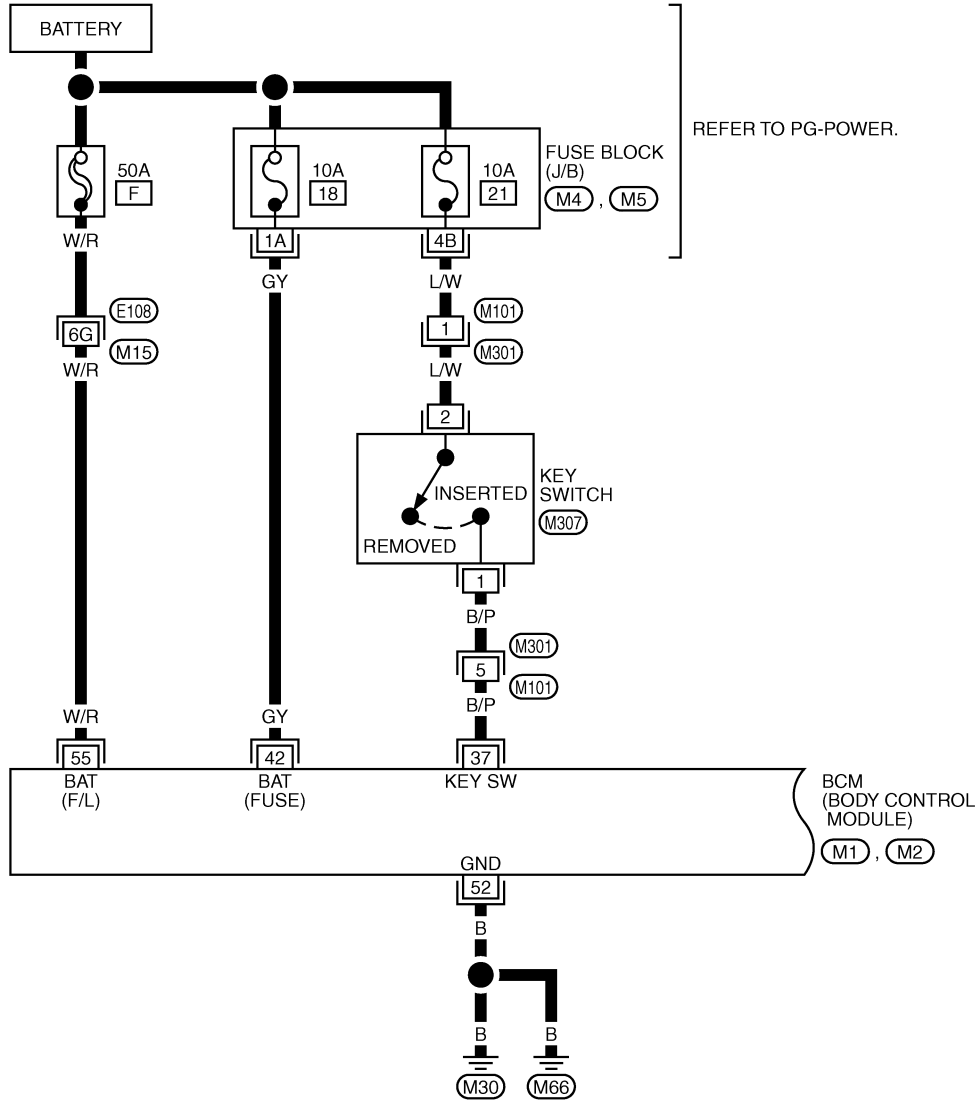

A
B
C
D
E
F
G
H
BL
J
K
L
M

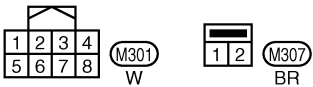

REFER TO THE FOLLOWING.
 (E108) -SUPER MULTIPLE JUNCTION (SMJ)
 (M4), (M5) -FUSE BLOCK-JUNCTION BOX (J/B)
 (M1), (M2) -ELECTRICAL UNITS

TIWM1037E

POWER DOOR LOCK SYSTEM

FIG. 2

BL-D/LOCK-07

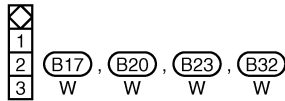
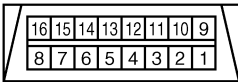
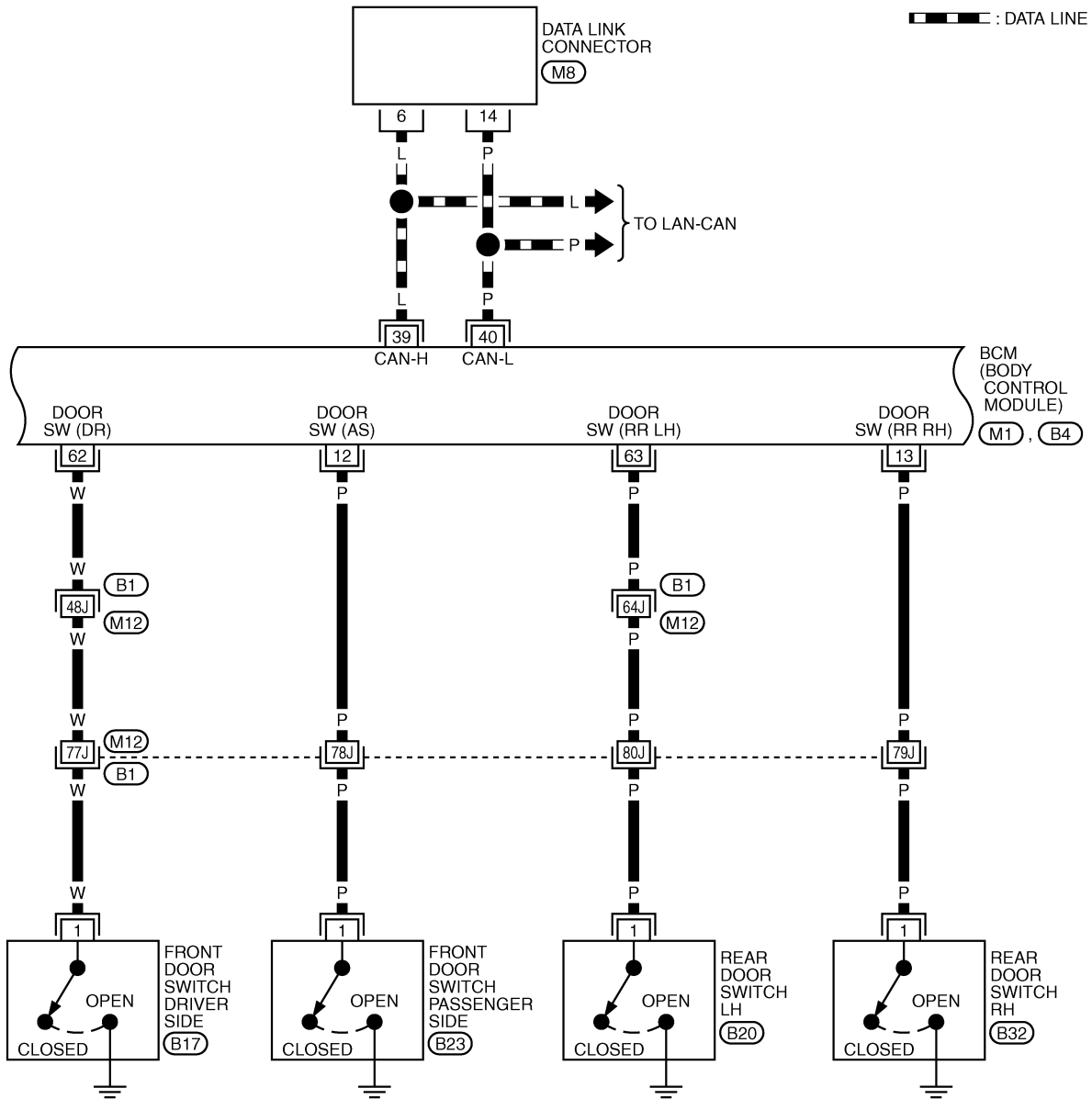

REFER TO THE FOLLOWING.

(B1) -SUPER MULTIPLE JUNCTION (SMJ)

(M1), (B4) -ELECTRICAL UNITS

TIWM1038E

POWER DOOR LOCK SYSTEM

FIG. 3

BL-D/LOCK-08

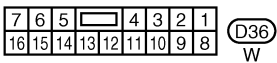
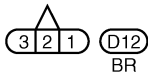
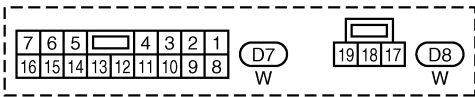
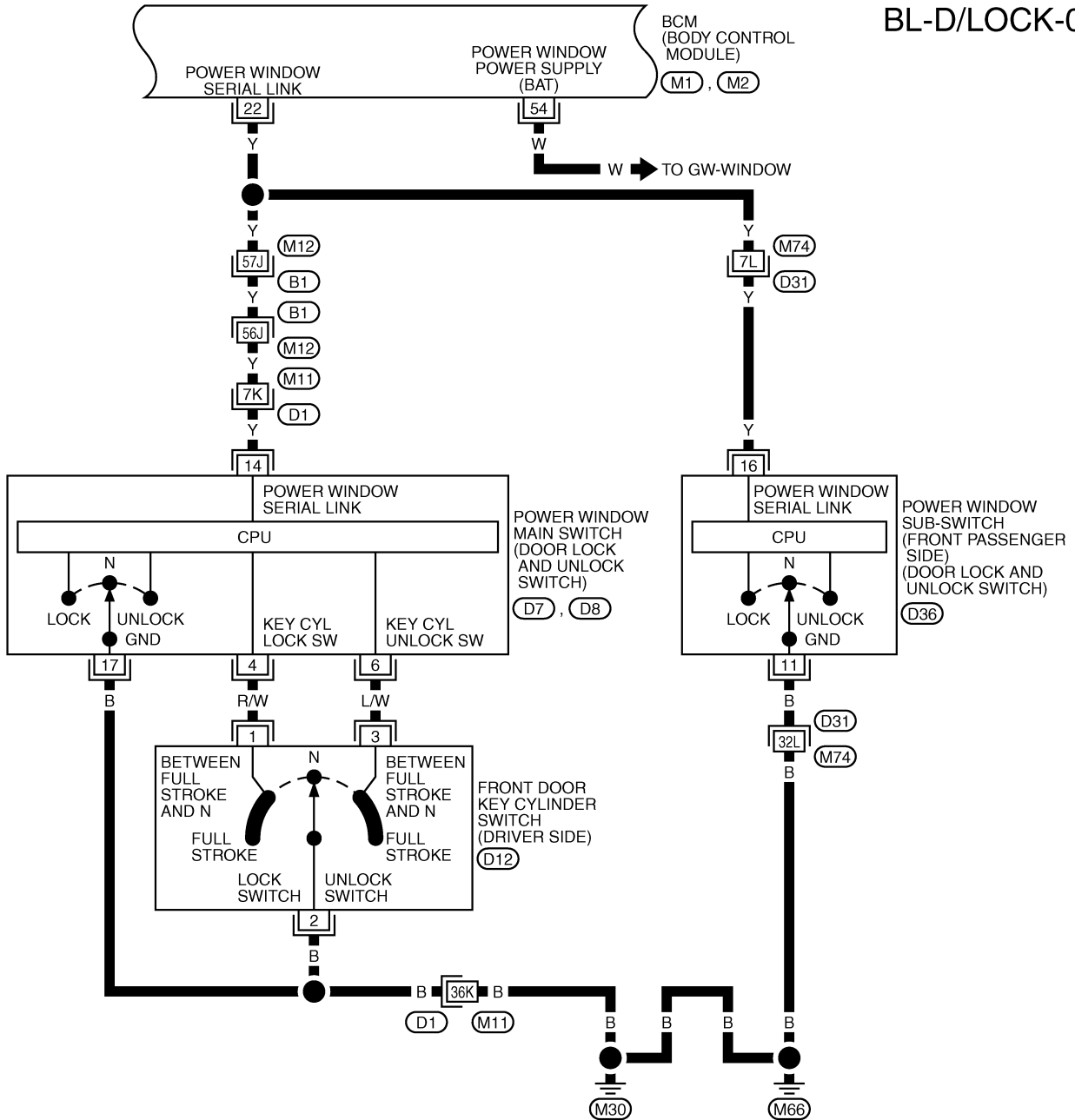

REFER TO THE FOLLOWING.
 (B1), (D1), (D31) -SUPER
 MULTIPLE JUNCTION (SMJ)
 (M1), (M2) -ELECTRICAL
 UNITS

A
B
C
D
E
F
G
H
J
K
L
M

BL

POWER DOOR LOCK SYSTEM

FIG. 4

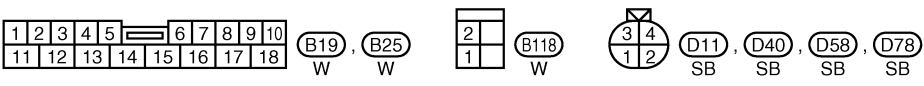
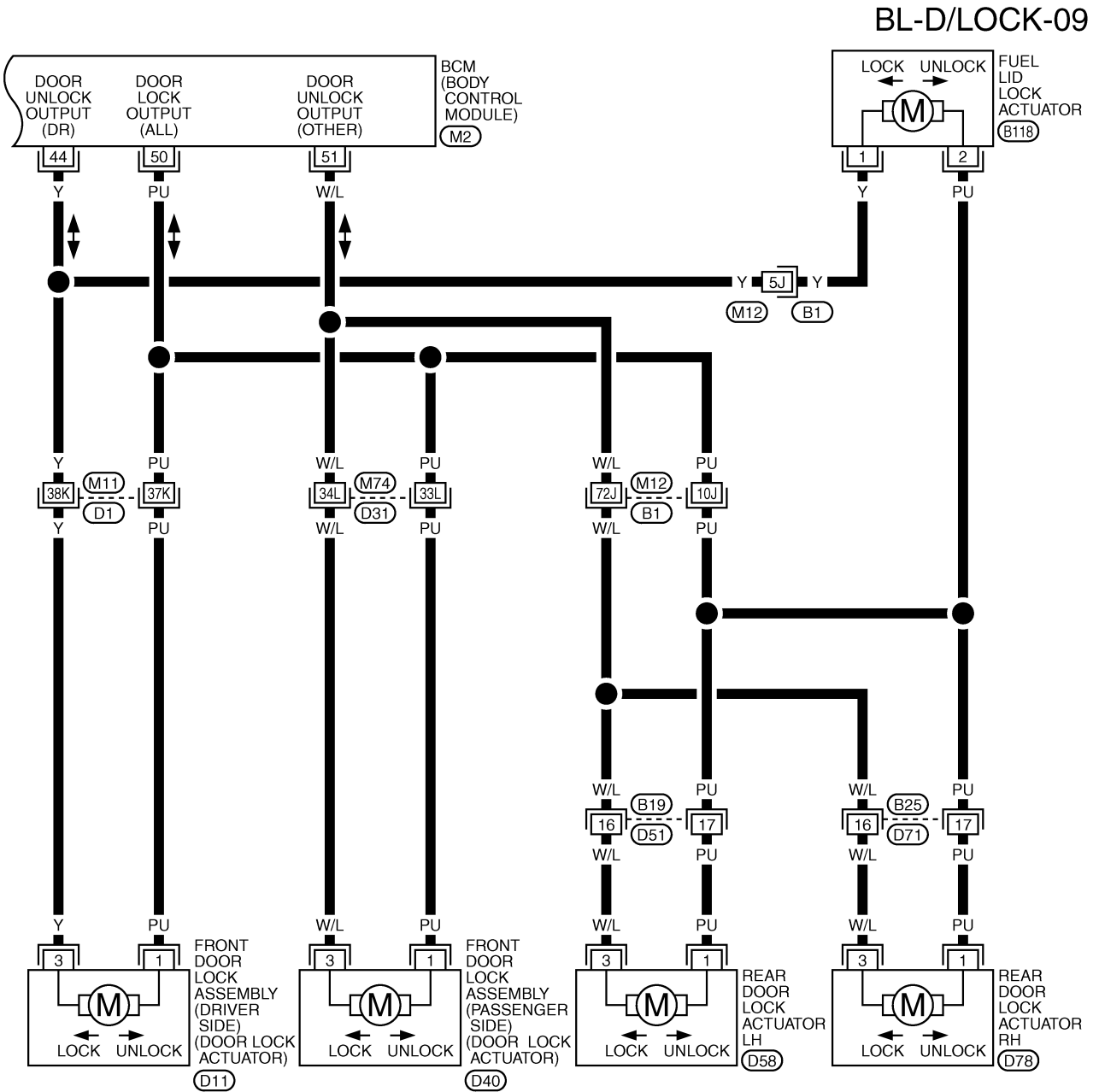

REFER TO THE FOLLOWING.
 (B1), (D1), (D31) -SUPER
 MULTIPLE JUNCTION (SMJ)
 (M2) -ELECTRICAL UNITS

POWER DOOR LOCK SYSTEM

Terminals and Reference Value of BCM

AIS0049N

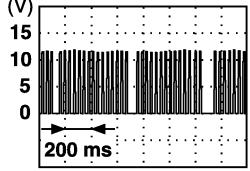
Terminal	Wire color	Item	Condition	Voltage [V] (Approx.)
12	P	Front door switch passenger side	ON (door open) → OFF (door closed)	0 → Battery voltage
13	P	Rear door switch RH	ON (door open) → OFF (door closed)	0 → Battery voltage
22	Y	Power window serial link	Ignition switch ON	 PIIA2344J
37	B/P	Key switch	ON (Key inserted) → OFF (Key removed from IGN key cylinder)	Battery voltage → 0
39	L	CAN H	—	—
40	P	CAN L	—	—
42	GY	Battery power supply	—	Battery voltage
44	Y	Driver door lock actuator and fuel lid lock actuator (unlock) signal	Door lock / unlock switch (Free → Unlock)	0 → Battery voltage → 0
50	PU	Door lock actuator (lock) signal	Door lock / unlock switch (Free → Lock)	0 → Battery voltage → 0
51	W/L	Passenger and rear doors lock actuator (unlock) signal	Door lock / unlock switch (Free → Unlock)	0 → Battery voltage → 0
52	B	Ground	—	0
55	W/R	Power source (Fusible link)	—	Battery voltage
62	W	Front door switch driver side	ON (door open) → OFF (door closed)	0 → Battery voltage
63	P	Rear door switch LH	ON (Door open) → OFF (Door closed)	0 → Battery voltage

Work Flow

AIS0049P

1. Check the symptom and customer's requests.
2. Understand the outline of system. Refer to [BL-21, "System Description"](#) .
3. According to the trouble diagnosis chart by symptom, repair or replace the cause of the malfunction. Refer to [BL-39, "Trouble Diagnosis Chart by Symptom"](#) .
4. Does power door lock system operate normally?
YES: GO TO 5.
NO: GO TO 3.
5. INSPECTION END

POWER DOOR LOCK SYSTEM

AIS0049R

CONSULT-II Function (BCM)

CONSULT-II can display each diagnostic item using the diagnostic test modes shown following.

BCM diagnosis part	Inspection item, self-diagnosis mode	Content
Door lock	DATA MONITOR	Displays the input data of BCM in real time basis.
	ACTIVE TEST	Give a drive signals to load to check the operation check.
	WORK SUPPORT	Change the setting for each function.

CONSULT-II INSPECTION PROCEDURE

CAUTION:

If CONSULT-II is used with no connection of CONSULT-II CONVERTER, malfunction might be detected in self-diagnosis depending on control unit which carry out CAN communication.

1. Turn ignition switch "OFF".
2. Connect "CONSULT-II" and "CONSULT-II CONVERTER" to the data link connector.

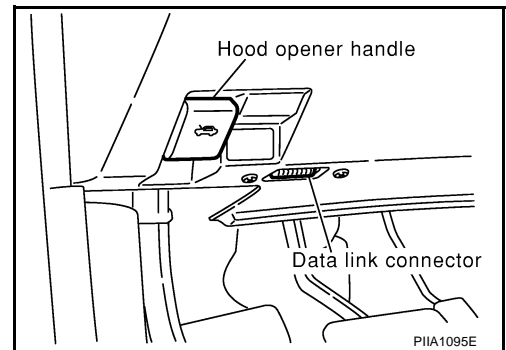

3. Turn ignition switch "ON".
4. Touch "START". (NISSAN BASED VHCL)

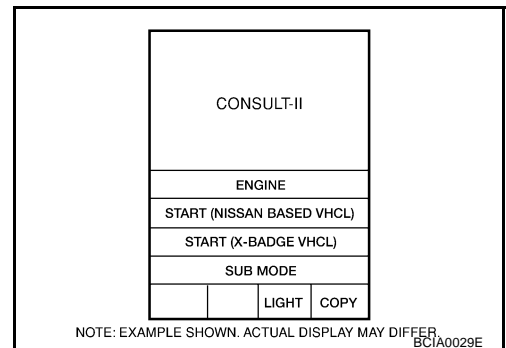

5. Touch "BCM" on "SELECT SYSTEM" screen.
If "BCM" is not indicated, go to [GI-38. "CONSULT-II Data Link Connector \(DLC\) Circuit"](#).

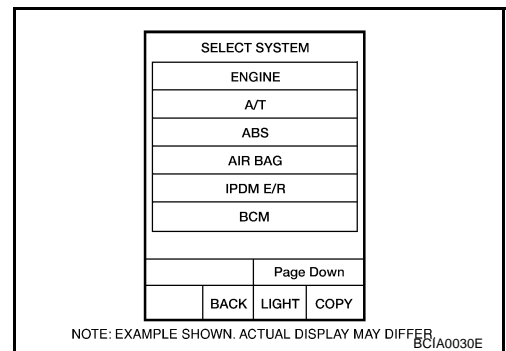

POWER DOOR LOCK SYSTEM

6. Touch "DOOR LOCK" on "SELECT TEST ITEM" screen.

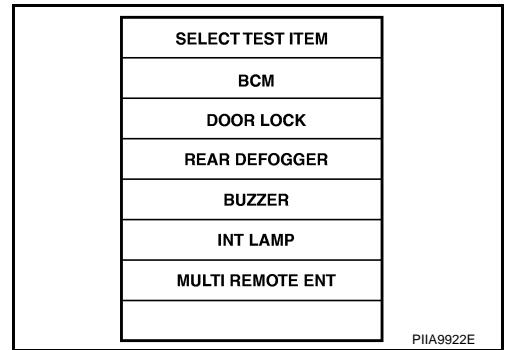

7. Select diagnosis mode. "DATA MONITOR", "ACTIVE TEST" and "WORK SUPPORT" are available.

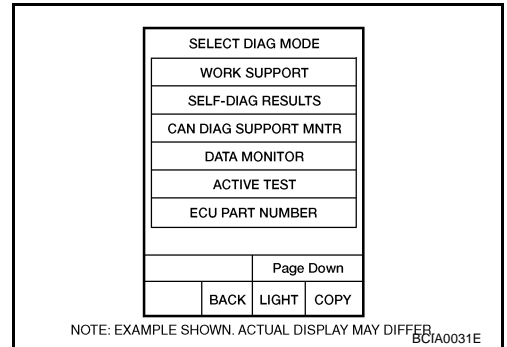

CONSULT-II APPLICATION ITEMS

Work Support

Work item	Description
DOOR LOCK-UNLOCK SET	Select unlock mode can be changed in this mode. Selects ON-OFF of select unlock mode.
ANTI-LOCK OUT SET	Key reminder door mode can be changed in this mode. Selects ON-OFF of key reminder door mode.

Data Monitor

Monitor item	Content
IGN ON SW	Indicates [ON/OFF] condition of ignition switch in ON position.
KEY ON SW	Indicates [ON/OFF] condition of key switch.
CDL LOCK SW	Indicates [ON/OFF] condition of lock signal from door lock and unlock switch.
CDL UNLOCK SW	Indicates [ON/OFF] condition of unlock signal from door lock and unlock switch.
DOOR SW-DR	Indicates [ON/OFF] condition of front door switch driver side.
DOOR SW-AS	Indicates [ON/OFF] condition of front door switch passenger side.
DOOR SW-RR	Indicates [ON/OFF] condition of rear door switch RH.
DOOR SW-RL	Indicates [ON/OFF] condition of rear door switch LH.
BACK DOOR SW	This is displayed even if it is not equipped.
KEY CYL LK-SW	Indicates [ON/OFF] condition of lock signal from key cylinder.
KEY CYL UN-SW	Indicates [ON/OFF] condition of unlock signal from key cylinder.
KEYLESS LOCK	Indicates [ON/OFF] condition of lock signal from key fob.
KEYLESS UNLOCK	Indicates [ON/OFF] condition of unlock signal from key fob.
I - KEY LOCK*	Indicates [ON/OFF] condition of lock signal from door request switch.
I - KEY UNLOCK*	Indicates [ON/OFF] condition of unlock signal from door request switch.

* : With Intelligent Key

POWER DOOR LOCK SYSTEM

Active Test

Test item in "DOOR LOCK"	Content
ALL LOCK	This test is able to check all door lock actuators lock operation. These actuators lock when "ALL LOCK" on CONSULT-II screen is touched.
ALL UNLOCK	This test is able to check all door lock actuators unlock operation. These actuators unlock when "ALL UNLOCK" on CONSULT-II screen is touched.
DR UNLOCK	This test is able to check door lock actuator (driver side) lock/unlock operation. This actuator unlock when "DR UNLOCK" on CONSULT-II screen is touched.
OTHER UNLOCK	This test is able to check all door lock actuators (except driver side) unlock operation. These actuators unlock when "OTHER UNLOCK" on CONSULT-II screen is touched.

POWER DOOR LOCK SYSTEM

Trouble Diagnosis Chart by Symptom

AIS0049S

Always check the "Work Flow" before troubleshooting. Refer to [BL-35, "Work Flow"](#) .

Symptom	Diagnoses service procedure	Reference page
Key reminder door system does not operate properly.	1. Check key reminder door mode.* *: Key reminder door mode can be changed. First check key reminder door mode.	BL-37
	2. Power supply and ground circuit check of BCM.	BL-40
	3. Check key switch.	BL-43
	3. Check ignition knob switch*1	BL-52
	4. Check door switch.	BL-41
	5. Replace BCM.	BCS-16
Power door lock does not operate with door lock and unlock switch.	1. Power supply and ground circuit check of BCM.	BL-40
	2. Check door lock and unlock switch.	BL-45
	3. Replace BCM.	BCS-16
Power door lock does not operate with door key cylinder operation. (Power door lock operate properly with door lock and unlock switch.)	1. Check front door key cylinder switch.	BL-50
	2. Replace power window main switch.	-
Specific door lock actuator does not operate.	1. Check door lock actuator.	BL-48 BL-48
	2. Replace BCM.	BCS-16
All door lock actuator (except passenger side) does not operate.*1	1. Check select unlock relay circuit	BL-51
Select unlock does not operate. (All other power door lock system is "OK".)	1. Check select unlock mode.* *: Select unlock mode can be changed. First check select unlock mode.	BL-37
	2. Replace BCM.	BCS-16
Fuel lid opener actuator does not operate. (All door lock actuators operates properly.)	1. Check fuel lid opener actuator.	BL-49

*1: With Intelligent Key

A
B
C
D
E
F
G
H
BL
J
K
L
M

POWER DOOR LOCK SYSTEM

AIS0049Q

Power Supply and Ground Circuit Check of BCM

1. CHECK FUSE

Check the following fuse and fusible link.

- 50A fusible link (letter **F** , located in the fuse and fusible link box)
- 10A fuse [No.18, located in the fuse block (J/B)]

NOTE:

Refer to [BL-20, "Component Parts and Harness Connector Location"](#) .

OK or NG

OK >> GO TO 2.

NG >> If fuse is blown, be sure to eliminate cause of malfunction before installing new fuse, refer to [PG-3, "POWER SUPPLY ROUTING CIRCUIT"](#) .

2. CHECK POWER SUPPLY CIRCUIT

1. Turn ignition switch OFF.
2. Disconnect BCM connectors.
3. Check voltage between BCM and ground.

Connector	Terminals (Wire color)		Ignition switch position		
	(+)	(-)	OFF	ACC	ON
M2	42 (GY)	Ground	Battery voltage	Battery voltage	Battery voltage
	55 (W/R)				

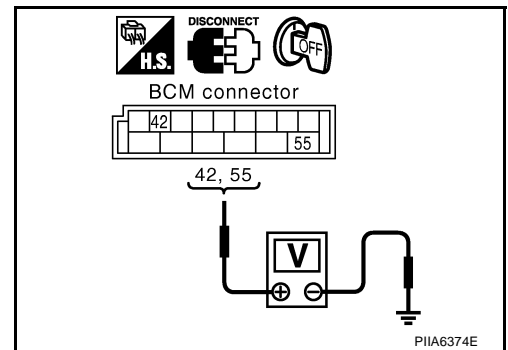

OK or NG

OK >> GO TO 3.

NG >> Repair or replace BCM power supply circuit.

3. CHECK GROUND CIRCUIT

Check continuity between BCM harness connector M2 terminal 52 and ground.

52 (B) - Ground : Continuity should exist.

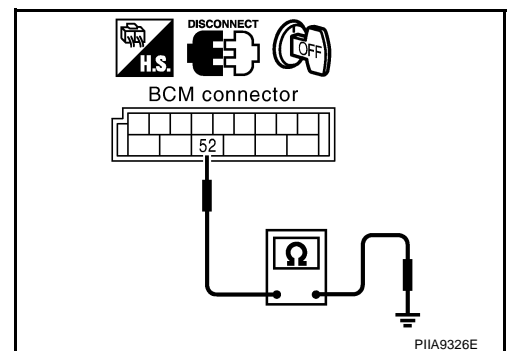

OK or NG

OK >> Power supply and ground circuit are OK.

NG >> Repair or replace BCM ground circuit.

POWER DOOR LOCK SYSTEM

AIS0049T

Check Door Switch

1. CHECK DOOR SWITCH INPUT SIGNAL

With CONSULT-II

Check door switches ("DOOR SW-DR", "DOOR SW-AS", "DOOR SW-RL" and "DOOR SW-RR") in "DATA MONITOR" mode with CONSULT-II.

Monitor item	Condition
DOOR SW-DR	CLOSE → OPEN: OFF → ON
DOOR SW-AS	
DOOR SW-RL	
DOOR SW-RR	

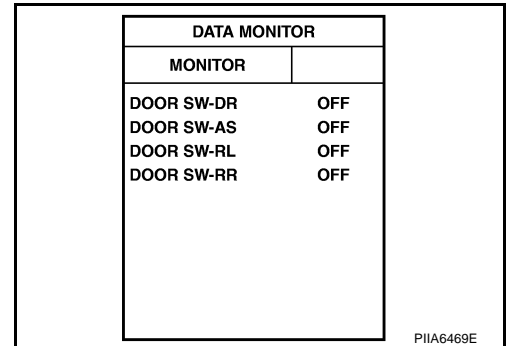

Without CONSULT-II

Check voltage between BCM connector and ground.

Item	Connector	Terminals (Wire color)		Door condition	Voltage (V) (Approx.)
		(+)	(-)		
Driver side	B4	62 (W)	Ground	CLOSE ↓ OPEN	Battery voltage ↓ 0
Rear LH		63 (P)			
Passenger side	M1	12 (P)			
Rear RH		13 (P)			

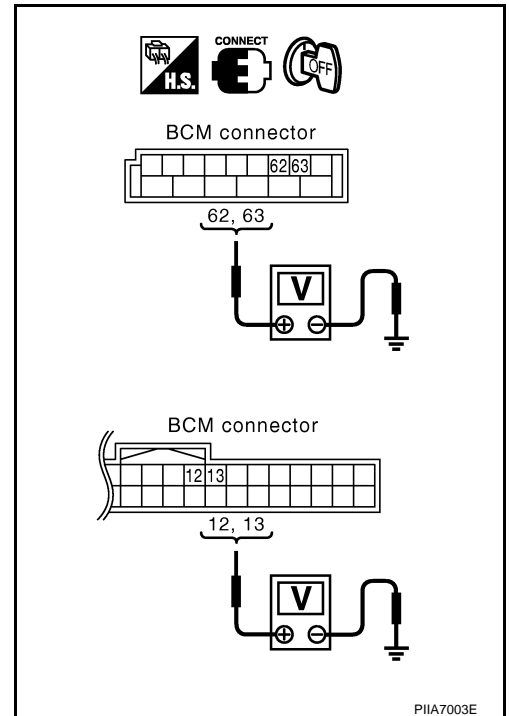

OK or NG

- OK >> Door switch circuit is OK.
- NG >> GO TO 2.

A
B
C
D
E
F
G
H
BL
J
K
L
M

POWER DOOR LOCK SYSTEM

2. CHECK DOOR SWITCH

1. Turn ignition switch OFF.
2. Disconnect door switch connector.
3. Check continuity between door switch terminal 1 and ground part of door switch.

Terminal	Condition of door switch	Continuity
1	Pushed	No
	Released	Yes

OK or NG

- OK >> GO TO 3.
 NG >> Replace door switch.

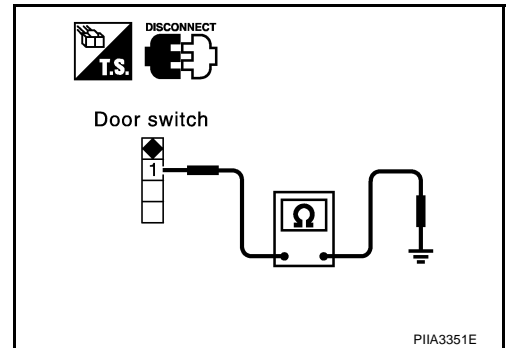

3. CHECK DOOR SWITCH CIRCUIT

1. Disconnect BCM connector.
2. Check continuity between door switch connector B17, B20, B23, B32 terminals 1 and BCM connector M1, B4 terminals 62, 12, 63, 13.

Driver side door

1 (W) – 62 (W) : Continuity should exist.

Passenger side door

1 (P) – 12 (P) : Continuity should exist.

Rear door LH

1 (P) – 63 (P) : Continuity should exist.

Rear door RH

1 (P) – 13 (P) : Continuity should exist.

3. Check continuity between door switch connector B17, B20, B23, B32 terminal 1 and ground.

1 (W or P) – Ground : Continuity should not exist.

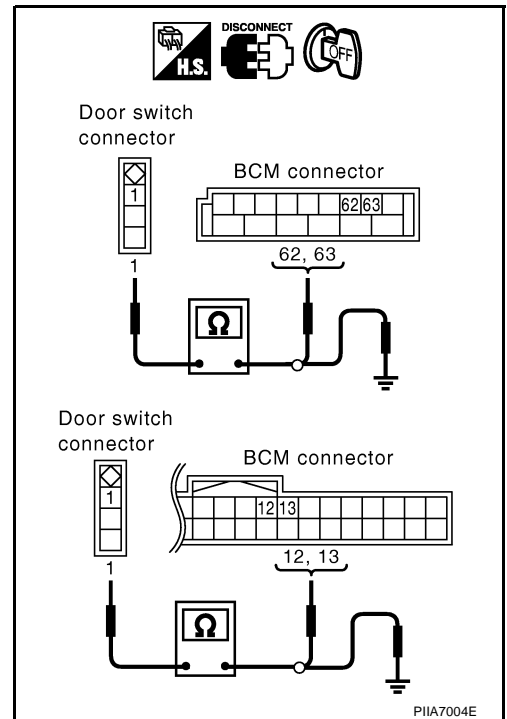

OK or NG

- OK >> Check door switch case ground condition.
 NG >> Repair or replace harness.

POWER DOOR LOCK SYSTEM

AIS0049U

Check Key Switch

1. CHECK KEY SWITCH INPUT SIGNAL

① With CONSULT-II

Check ignition key switch "KEY ON SW" in "DATA MONITOR" mode with CONSULT-II.

- When key is inserted in ignition key cylinder

KEY ON SW : ON

- When key is removed from ignition key cylinder

KEY ON SW : OFF

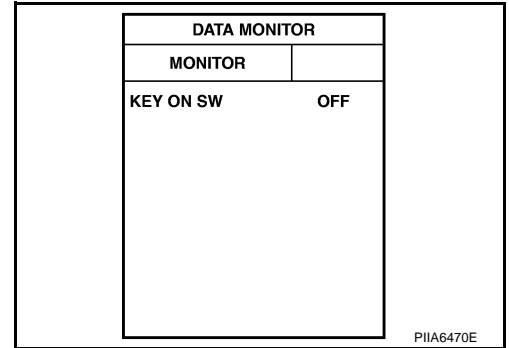

⊗ Without CONSULT-II

Check voltage between BCM connector and ground.

Connector	Terminals (wire color)		Condition of key switch	Voltage [V] Approx.
	(+)	(-)		
M1	37 (B/P)	Ground	Key is inserted	Battery voltage
			Key is removed	0

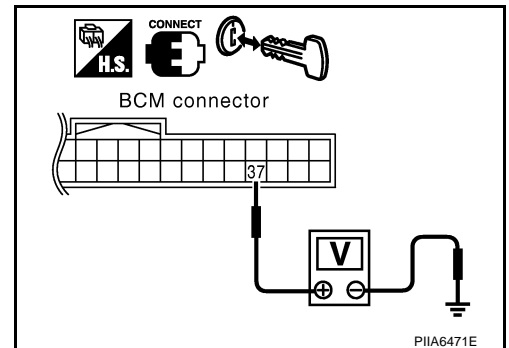

OK or NG

- OK >> Key switch circuit is OK.
- NG >> GO TO 2. (with Intelligent Key)
- NG >> GO TO 3. (without Intelligent Key)

A
B
C
D
E
F
G
H
I
J
K
L
M

BL

POWER DOOR LOCK SYSTEM

2. CHECK KEY SWITCH (WITH INTELLIGENT KEY)

1. Turn ignition switch OFF.
2. Disconnect key switch connector.
3. Check continuity between key switch and ignition knob switch terminal 3 and 4.

Terminals		Condition of key switch	Continuity
3	4	Key is inserted	Yes
		Key is removed	No

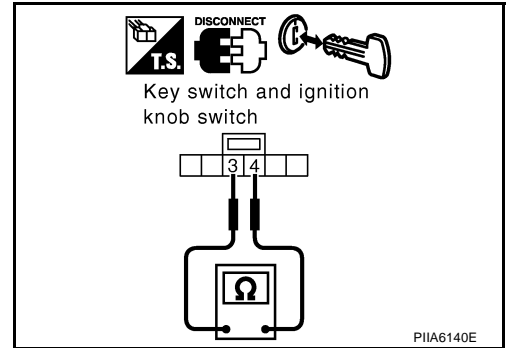

OK or NG

OK >> Check the following.

- 15A fuse (No.33, located in fuse and fusible link block)
- Harness for open or short between key switch and ignition knob switch and fuse.
- Harness for open or short between BCM and key switch and ignition knob switch.

NG >> Replace key switch.

3. CHECK KEY SWITCH (WITHOUT INTELLIGENT KEY)

1. Turn ignition switch OFF.
2. Disconnect key switch connector.
3. Check continuity between key switch terminal 1 and 2.

Terminals		Condition of key switch	Continuity
1	2	Key is inserted	Yes
		Key is removed	No

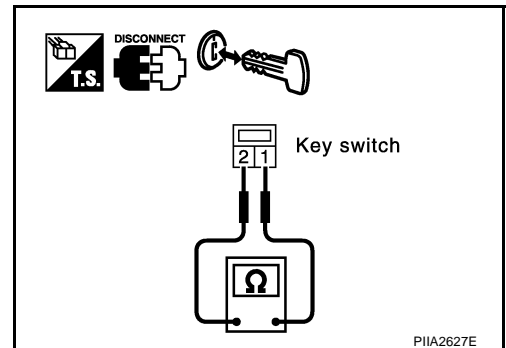

OK or NG

OK >> Check the following.

- 10A fuse (No.21, located in fuse and fusible link block)
- Harness for open or short between key switch and fuse.
- Harness for open or short between BCM and key switch.

NG >> Replace key switch.

POWER DOOR LOCK SYSTEM

AIS004CY

Check Door Lock and Unlock Switch

1. CHECK POWER WINDOW OPERATION

Does power window system operate normally?

OK or NG?

OK >> GO TO 2.

NG >> Refer to [GW-16, "POWER WINDOW SYSTEM"](#) .

2. CHECK DOOR LOCK AND UNLOCK SWITCH INPUT SIGNAL

① With CONSULT-II

Check door lock and unlock switch ("CDL LOCK SW", "CDL UNLOCK SW") in DATA MONITOR mode with CONSULT-II.

- When door lock and unlock switch is turned to LOCK

CDL LOCK SW :ON

- When door lock and unlock switch is turned to UNLOCK

CDL UNLOCK SW :ON

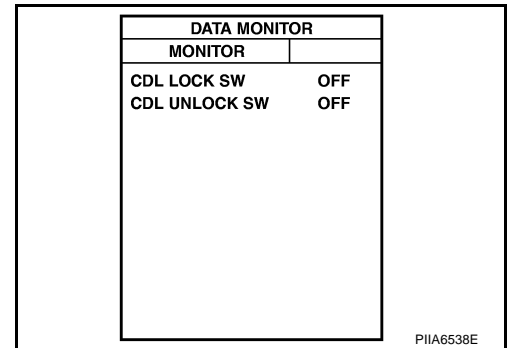

② Without CONSULT-II

- Remove key from ignition key cylinder,
- Check the signal between BCM connector M1 terminal 22 and ground with oscilloscope when door lock and unlock switch is turned "LOCK" or "UNLOCK".
- Make sure signals which are shown in the figure below can be detected during 10 second just after door lock and unlock switch is turned "LOCK" or "UNLOCK".

Connector	Terminal (wire color)		Signal (Reference value)
	(+)	(-)	
M1	22 (Y)	Ground	

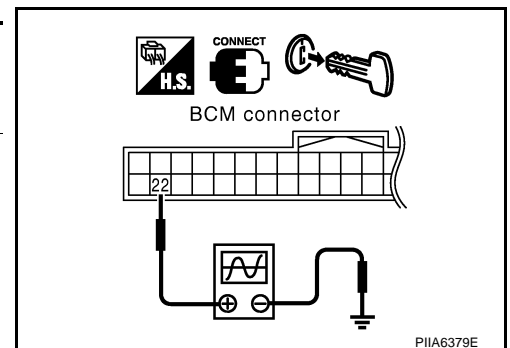

OK or NG

OK >> Door lock and unlock switch is OK.

NG >> GO TO 3.

POWER DOOR LOCK SYSTEM

3. CHECK POWER WINDOW SERIAL LINK CIRCUIT

1. Turn ignition switch OFF.
2. Disconnect BCM, power window main switch and power window sub-switch connectors.
3. Check continuity between BCM connector M1 terminal 22 and power window main switch (door lock and unlock switch) connector D7 terminal 14.

22 (Y) - 14 (Y) : Continuity should exist.

4. Check continuity between BCM connector M1 terminal 22 and ground.

22 (Y) - Ground : Continuity should not exist.

5. Check continuity between BCM connector M1 terminal 22 and power window sub-switch (door lock and unlock switch) connector D36 terminal 16.

22 (Y) - 16 (Y) : Continuity should exist.

6. Check continuity between BCM connector M1 terminal 22 and ground.

22 (Y) - Ground : Continuity should not exist.

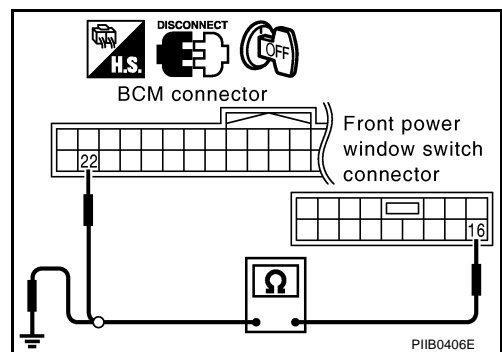
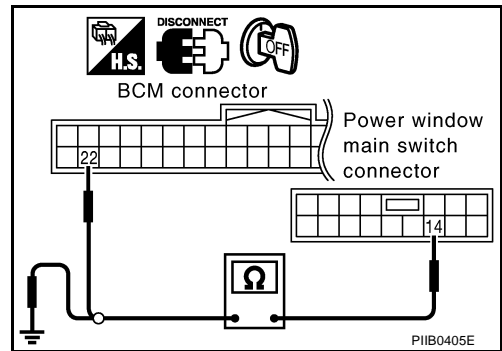

OK or NG

- OK >> GO TO 4.
- NG >> Repair or replace harness.

POWER DOOR LOCK SYSTEM

4. CHECK DOOR LOCK AND UNLOCK SWITCH GROUND CIRCUIT

1. Check continuity between power window main switch (door lock and unlock switch) connector D8 terminal 17 and ground.

17 (B) - Ground : Continuity should exist.

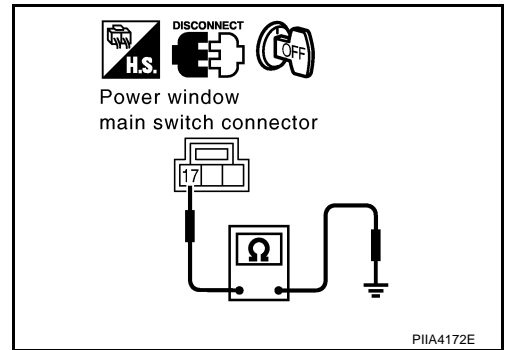

2. Check continuity between power window sub-switch (front passenger side) (door lock and unlock switch) connector D36 terminal 11 and ground.

11 (B) - Ground : Continuity should exist.

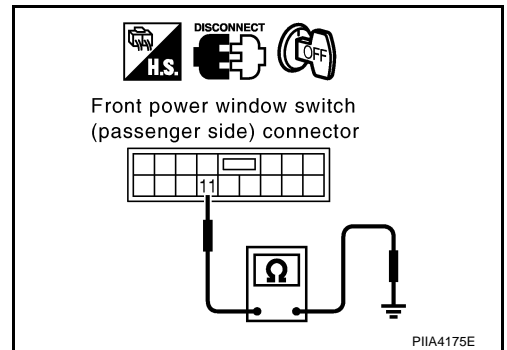

OK or NG

- OK >> Replace power window main switch or power window sub-switch.
- NG >> Repair or replace ground harness.

A
B
C
D
E
F
G
H

BL

J
K
L
M

POWER DOOR LOCK SYSTEM

Check Door Lock Actuator (Driver Side)

AIS0049W

1. CHECK OUTPUT SIGNAL

Check voltage between BCM connector and ground.

Con- nector	Terminal (Wire color)		Condition of driver door lock and unlock switch	Voltage [V] (Approx.)
	(+)	(-)		
M2	44 (Y)	Ground	Unlocked.	0 → Battery voltage → 0
	50 (PU)		Locked.	0 → Battery voltage → 0

OK or NG

- OK >> GO TO 2.
NG >> Replace BCM.

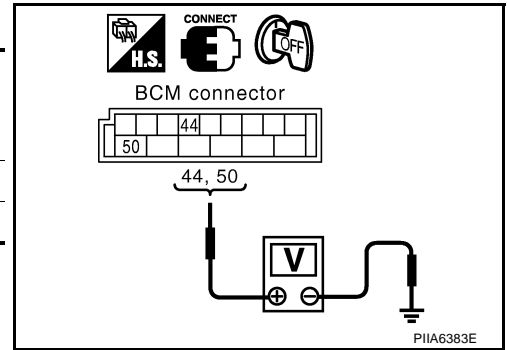

2. CHECK DOOR LOCK ACTUATOR CIRCUIT

- Turn ignition switch OFF.
- Disconnect BCM and front door lock actuator driver side connector.
- Check continuity between BCM connector M2 terminals 44, 50 and front door lock actuator driver side connector D11 terminals 1, 3.

44 (Y) – 3 (Y) : Continuity should exist.

50 (PU) – 1 (PU) : Continuity should exist.

- Check continuity between BCM connector M2 terminals 44, 50 and ground.

44 (Y) – Ground : Continuity should not exist.

50 (PU) – Ground : Continuity should not exist.

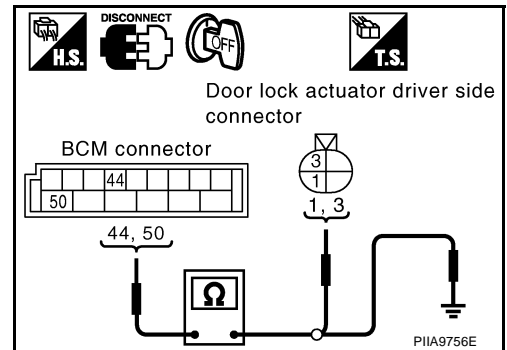

OK or NG

- OK >> Replace front door lock actuator.
NG >> Repair or replace harness.

Check Door Lock Actuator (Passenger Side and Rear LH/RH)

AIS0049X

1. CHECK DOOR LOCK ACTUATOR SIGNAL

Check voltage between BCM connector and ground.

Conne- ctor	Terminal (Wire color)		Condition of door lock and unlock switch	Voltage [V] (Approx.)
	(+)	(-)		
M2	50 (PU)	Ground	Locked.	0 → Battery voltage → 0
	51 (W/L)		Unlocked.	0 → Battery voltage → 0

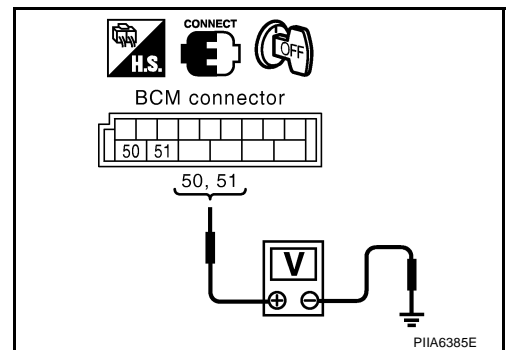

OK or NG

- OK >> GO TO 2.
NG >> Replace BCM.

POWER DOOR LOCK SYSTEM

2. CHECK DOOR LOCK ACTUATOR CIRCUIT

1. Disconnect BCM and each door lock actuator connectors.
2. Check continuity between BCM connector M2 terminals 50, 51 and front door lock actuator passenger side, rear door lock actuator LH/RH connectors D40, D58, D78 terminals 1, 3.

50 (PU) – 1 (PU) : Continuity should exist.

51 (W/L) – 3 (W/L) : Continuity should exist.

3. Check continuity between BCM connector M2 terminals 50, 51 and ground.

50 (PU) – Ground : Continuity should not exist.

51 (W/L) – Ground : Continuity should not exist.

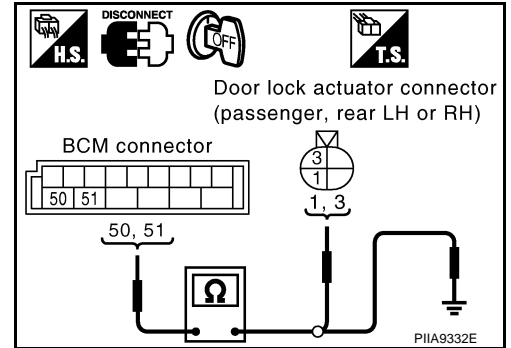

OK or NG

OK >> Replace door lock actuator.

NG >> Repair or replace harness.

Check Fuel Lid Opener Actuator

1. CHECK FUEL LID OPENER ACTUATOR CIRCUIT

1. Turn ignition switch OFF.
2. Disconnect BCM and fuel lid lock actuator connector.
3. Check continuity between BCM connector M2 terminals 44, 50 and fuel lid lock actuator connector B118 terminals 1, 2.

44 (Y) – 1 (Y) : Continuity should exist.

50 (PU) – 2 (PU) : Continuity should exist.

4. Check continuity between BCM connector M2 terminals 44, 50 and ground.

44 (Y) – Ground : Continuity should not exist.

50 (PU) – Ground : Continuity should not exist.

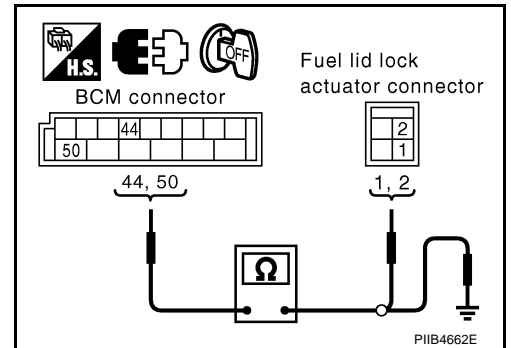

OK or NG

OK >> Replace fuel lid actuator.

NG >> Repair or replace harness.

POWER DOOR LOCK SYSTEM

AIS004A0

Door Key Cylinder Switch Check

1. CHECK DOOR KEY CYLINDER SWITCH INPUT SIGNAL

With CONSULT-II

- Check door key cylinder switch ("KEY CYL LK SW") in "DATA MONITOR" mode with CONSULT-II.

"KEY CYL LK-SW" should be "ON" when key inserted in door key cylinder is turned to lock.

- Check door key cylinder switch ("KEY CYL UN-SW") in "DATA MONITOR" mode with CONSULT-II.

"KEY CYL UN-SW" should be "ON" when key inserted in door key cylinder is turned to unlock.

DATA MONITOR	
MONITOR	
KEY CYL LK-SW	OFF
KEY CYL UN-SW	OFF

PIIB1425E

Without CONSULT-II

Check voltage between power window main switch (door lock and unlock switch) connector and ground.

Connector	Terminal (Wire color)		Key position	Voltage [V] (Approx.)
	(+)	(-)		
D7	4 (R/W)	Ground	Neutral/Unlock	5
			Lock	0
	6 (L/W)		Neutral/Lock	5
			Unlock	0

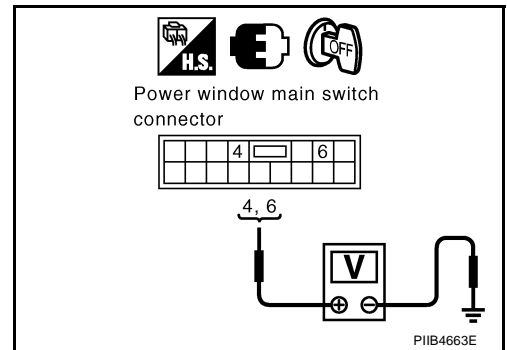

OK or NG

- OK >> Further inspection is necessary. Refer to symptom chart.
 NG >> GO TO 2.

2. CHECK DOOR KEY CYLINDER SWITCH CIRCUIT

- Turn ignition switch OFF.
- Disconnect power window main switch (door lock and unlock switch) and door key cylinder switch connector.
- Check continuity between power window main switch (door lock and unlock switch) connector D7 terminals 4, 6 and door key cylinder switch connector D12 terminals 1, 3.

4 (R/W) – 1 (R/W) :Continuity should exist.

6 (L/W) – 3 (L/W) :Continuity should exist.

- Check continuity between power window main switch (door lock and unlock switch) connector D7 terminals 4, 6 and ground.

4 (R/W) – Ground :Continuity should not exist.

6 (L/W) – Ground :Continuity should not exist.

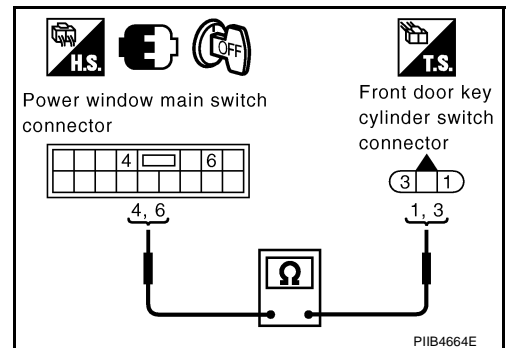

OK or NG

- OK >> GO TO 3.
 NG >> Repair or replace harness between power window main switch and door key cylinder switch.

POWER DOOR LOCK SYSTEM

3. CHECK DOOR KEY CYLINDER SWITCH GROUND CHECK

Check continuity between door key cylinder switch connector D12 terminal 2 and ground.

2 (B) – Ground :Continuity should exist.

OK or NG

- OK >> GO TO 4.
- NG >> Repair or replace harness.

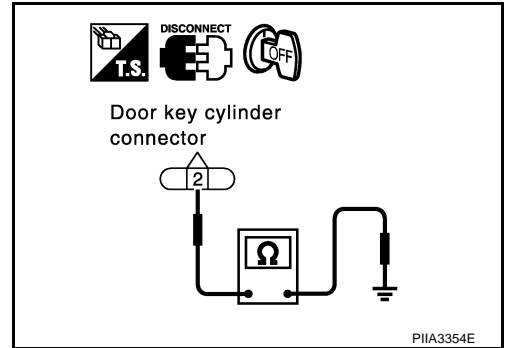

4. CHECK DOOR KEY CYLINDER SWITCH

Check continuity between door key cylinder switch terminals 1, 3 and 2.

Terminals	Key position	Continuity
1	Neutral / Unlock	No
	Lock	Yes
3	Neutral / Lock	No
	Unlock	Yes

OK or NG

- OK >> Further inspection is necessary. Refer to symptom chart.
- NG >> Replace door key cylinder switch.

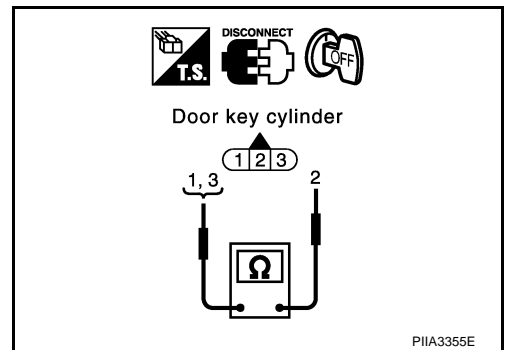

Check Select Unlock Relay Circuit

1. CHECK PASSENGER SIDE SELECT UNLOCK RELAY CIRCUIT 1

1. Turn ignition switch OFF.
2. Disconnect BCM and passenger side select unlock relay connector.
3. Check continuity between BCM connector M2 terminal 50 and passenger side select unlock relay connector E15 terminal 3.

50 (PU) – 3 (PU) :Continuity should exist.

4. Check continuity between BCM connector M2 terminal 50 and ground.

50 (PU) – Ground :Continuity should not exist.

OK or NG

- OK >> GO TO 2.
- NG >> Repair or replace harness between BCM and passenger side select unlock relay.

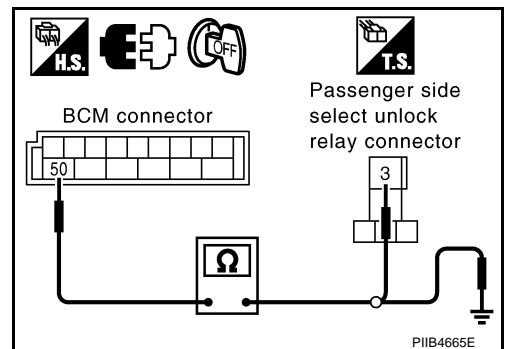

POWER DOOR LOCK SYSTEM

2. CHECK PASSENGER SIDE SELECT UNLOCK RELAY CIRCUIT 2

1. Disconnect front door lock assembly (driver side) connector.
2. Check continuity between passenger side select unlock relay connector E15 terminal 4 and front door lock assembly (driver side) connector D11 terminal 1.

4 (L/Y) – 1 (PU) : Continuity should exist.

3. Check continuity between passenger side select unlock relay connector E15 terminal 4 and ground.

4 (L/Y) – Ground : Continuity should not exist.

OK or NG

OK >> Refer to [BL-142](#)

NG >> Repair or replace harness.

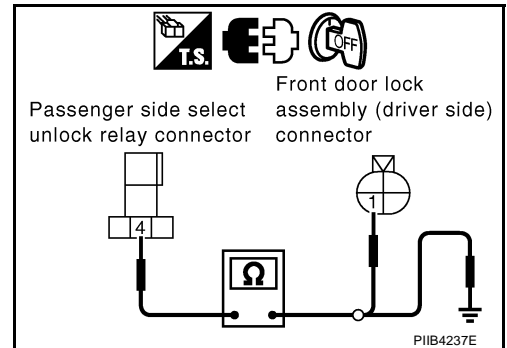

Check Ignition Knob Switch

1. CHECK IGNITION KNOB SWITCH

With CONSULT-II

Display "PUSH SW" on "DATA MONITOR" screen, and check if ON/OFF display is linked to ignition knob operation.

Press ignition knob. : ON

Return ignition knob (release hands from ignition knob) : OFF

OK or NG

OK >> Ignition knob switch is OK.

NG >> GO TO 2.

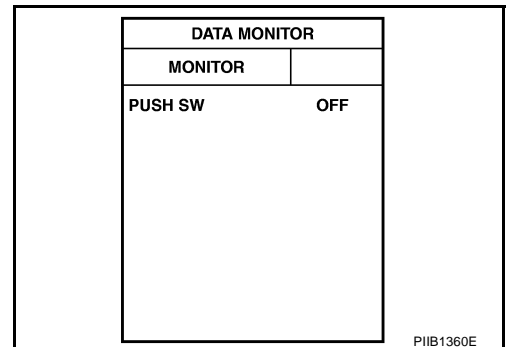

2. CHECK IGNITION KNOB SWITCH POWER SUPPLY CIRCUIT

1. Turn ignition knob LOCK position.
2. Disconnect key switch and ignition knob switch connector.
3. Check voltage between key switch and ignition knob switch connector M310 terminal 1 and ground.

1 (Y) - Ground : Battery voltage

OK or NG

OK >> GO TO 3.

NG >> Repair or replace key switch and ignition knob switch power supply circuit.

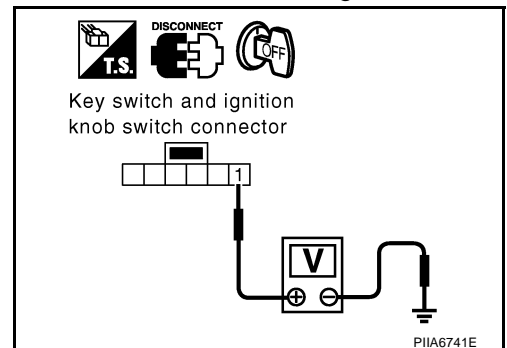

POWER DOOR LOCK SYSTEM

3. CHECK IGNITION KNOB SWITCH OPERATION

Check continuity between key switch and ignition knob switch terminals 1 and 2.

Connector	Terminal		Condition	Continuity
M310	1	2	Press ignition knob	Yes
			Return ignition knob (Release hands from ignition knob)	No

OK or NG

OK >> GO TO 4.

NG >> Replace key switch and ignition knob switch.

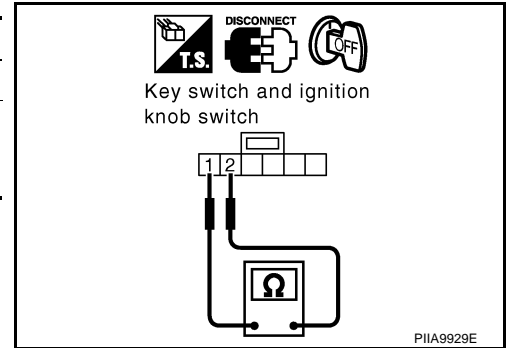

4. CHECK IGNITION KNOB SWITCH CIRCUIT

1. Disconnect Intelligent Key unit connector.
2. Check continuity between Intelligent Key unit connector M34 terminal 27 and key switch and ignition knob switch connector M310 terminal 2.

27 (OR) - 2 (OR) : Continuity should exist.

3. Check continuity between key switch and ignition knob switch connector M310 terminal 2 and ground.

2 (OR) - Ground : Continuity should not exist.

OK or NG

OK >> Replace Intelligent Key unit.

NG >> Repair or replace harness between Intelligent Key unit and key switch and ignition knob switch.

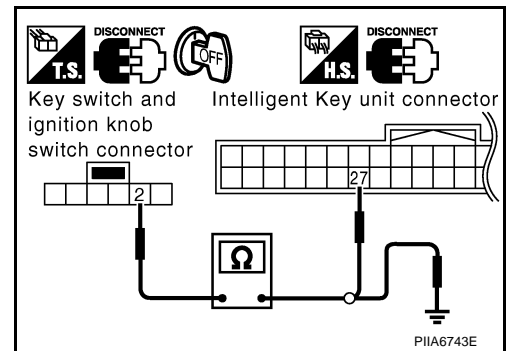

REMOTE KEYLESS ENTRY SYSTEM

PF28596

AIS004A2

REMOTE KEYLESS ENTRY SYSTEM

Component Parts and Harness Connector Location

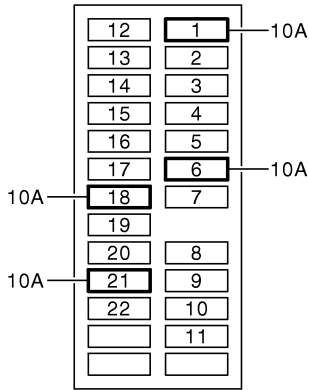

Fuse block (J/B) fuse layout

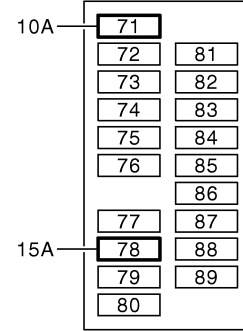
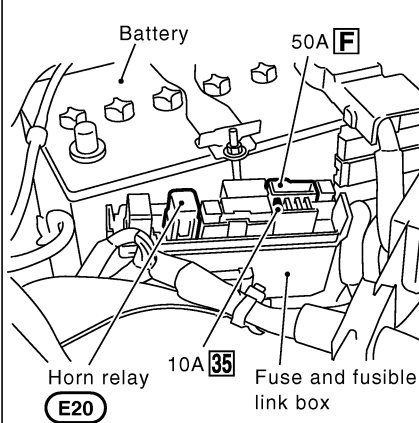

IPDM E/R fuse layout

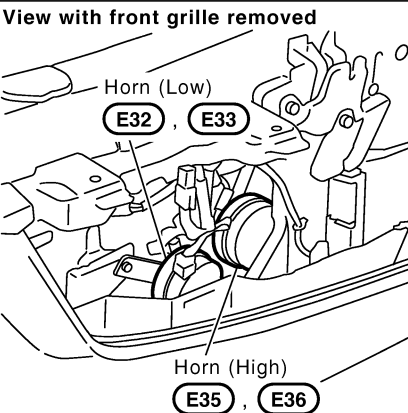
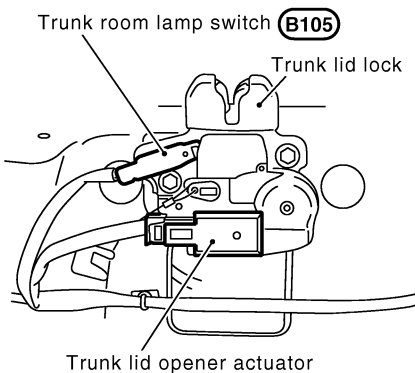
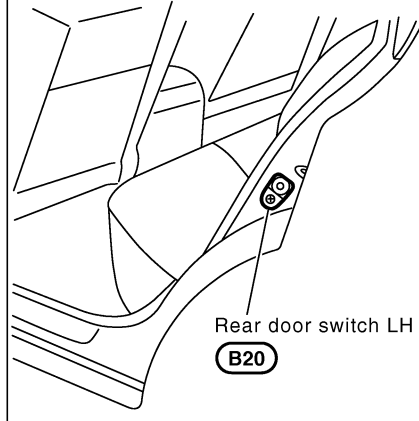
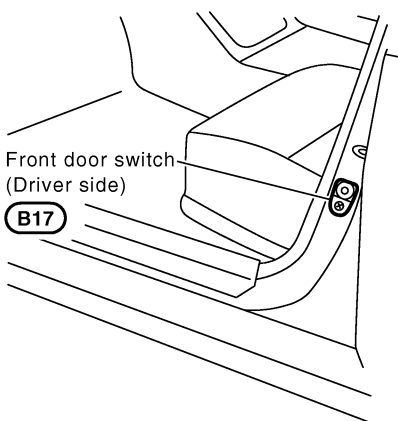
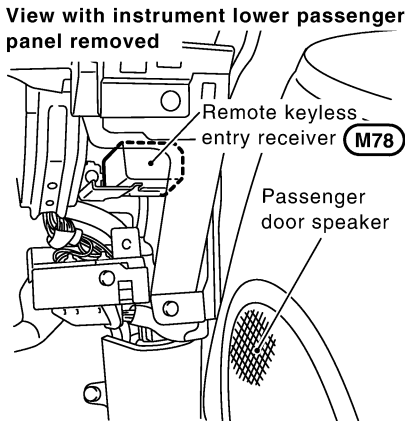
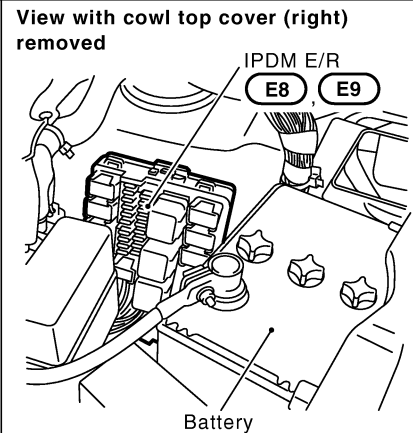
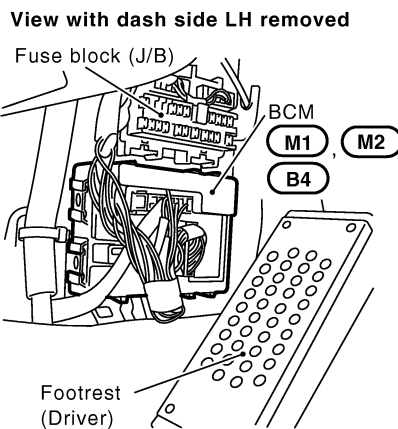
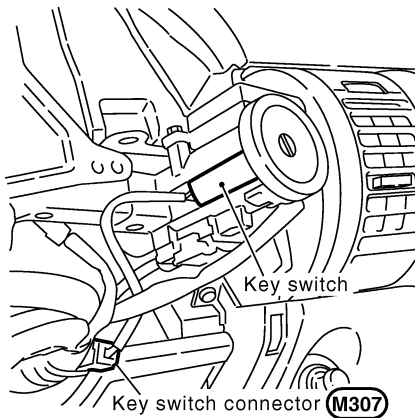

PIIB4666E

REMOTE KEYLESS ENTRY SYSTEM

AIS004A3

System Description

INPUTS

Power is supplied at all times

- through 50A fusible link (letter **F** , located in the fuse and fusible link box)
- to BCM terminal 55,
- through 15A fuse (No. 18, located in the fuse and fusible link box)
- to BCM terminal 42,
- through 10A fuse (No. 21, located in the fuse and fusible link box)
- to key switch terminal 2
- through BCM terminal 19
- to remote keyless entry receiver terminal 4.

When the key switch is ON (key is inserted in ignition key cylinder), power is supplied

- through key switch terminal 1 and 2
- to BCM terminal 37.

When the ignition switch is ACC or ON, power is supplied

- through 10A fuse [No. 6, located in the fuse block (J/B)]
- to BCM terminal 11.

When the ignition switch is ON or START, power is supplied

- through 10A fuse [No. 1, located in the fuse block (J/B)]
- to BCM terminal 38.

Ground is supplied

- to remote keyless entry receiver terminal 1
- through BCM terminal 18,
- to BCM terminal 52
- through body grounds M30 and M66.

When the front door switch (driver side) is ON (door is OPEN), ground is supplied

- to BCM terminal 62
- through front door switch (driver side) terminal 1 and
- through front door switch (driver side) case ground.

When the front door switch (passenger side) is ON (door is OPEN), ground is supplied

- to BCM terminal 12
- through front door switch (passenger side) terminal 1 and
- through front door switch (passenger side) case ground.

When the rear door switch LH is ON (door is OPEN), ground is supplied

- to BCM terminal 63
- through rear door switch LH terminal 1 and
- through rear door switch LH case ground.

When the rear door switch RH is ON (door is OPEN), ground is supplied

- to BCM terminal 13
- through rear door switch RH terminal 1 and
- through rear door switch RH case ground.

Key fob signal is inputted to remote keyless entry receiver (the antenna of the system is built in remote keyless entry receiver).

Remote keyless entry receiver sends key fob signal

- to BCM terminal 20
- from remote keyless entry receiver terminal 2.

The remote keyless entry system controls operation of the

- power door lock
- hazard and horn reminder

A

B

C

D

E

F

G

H

BL

J

K

L

M

REMOTE KEYLESS ENTRY SYSTEM

- auto door lock
- panic alarm
- keyless power window down (open)
- room lamp and key ring illumination

OPERATED PROCEDURE

Power Door Lock Operation

BCM locks all doors with input of LOCK signal from remote keyless entry receiver.

When an UNLOCK signal is sent from remote keyless entry receiver once, driver's door is unlocked.

Then, if an UNLOCK signal is sent from remote keyless entry receiver again within 5 seconds, all other doors are unlocked.

NOTE:

Remote keyless entry receiver receives key fob signal from key fob.

Power door lock operation mode can be changed using "DOOR LOCK-UNLOCK SET" mode in "WORK SUPPORT" of "POWER DOOR LOCK SYSTEM".

Refer to [BL-66, "Work Support"](#).

Hazard and Horn Reminder

When the doors are locked or unlocked by key fob, power is supply to hazard warning lamp and lamps flashes as follows

- LOCK operation: C mode (flash twice) or S mode (flash twice)
- UNLOCK operation: C mode (flash once) or S mode (does not flash)

BCM outputs to IPDM E/R for horn reminder signal as DATA LINE (CAN H line and CAN L line).

The hazard and horn reminder has C mode (horn chirp mode) and S mode (non-horn chirp mode).

Operating function of hazard and horn reminder

Remote controller operation	C mode		S mode	
	Lock	Unlock	Lock	Unlock
Hazard warning lamp flash	Twice	Once	Twice	—
Horn sound	Once	—	—	—

Hazard and horn reminder not operate if any door switch is ON (any door is OPEN).

How to change hazard and horn reminder mode

④ With CONSULT-II

Hazard and horn reminder can be changed using "MULTI ANSWER BACK SET" mode in "WORK SUPPORT".

Refer to [BL-66, "Work Support"](#).

⊗ Without CONSULT-II

When LOCK and UNLOCK signals are sent from the key fob for more than 2 seconds at the same time, the hazard and horn reminder mode is changed and hazard warning lamp flashes and horn sounds as follows:

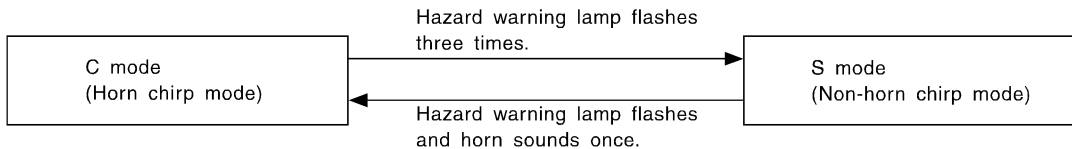

SEL153WA

REMOTE KEYLESS ENTRY SYSTEM

Auto Door Lock Operation

Auto lock function signal is sent for operation when any of the following signals are not sent within 1 minute after the unlock signal is sent from the key fob:

- when door switch is turned ON for open.
- when the key switch is turned ON.
- when the lock signal is sent from the key fob.

Auto door lock mode can be changed using "AUTO LOCK SET" mode in "WORK SUPPORT".

Refer to [BL-66, "Work Support"](#).

Panic Alarm Operation

When key switch is OFF (when ignition key is not inserted in key cylinder), BCM turns on and off horn and headlamp intermittently with input of PANIC ALARM signal from key fob.

The alarm automatically turns off after 25 seconds or when BCM receives any signal from key fob.

Panic alarm operation mode can be changed using "PANIC ALARM SET" mode in "WORK SUPPORT".

Refer to [BL-66, "Work Support"](#).

For detailed description, refer to [BL-199, "VEHICLE SECURITY \(THEFT WARNING\) SYSTEM"](#).

Keyless Power Window Down (Open) Operation

When key fob unlock switch is turned ON with ignition switch OFF, and key fob unlock switch is detected to be on continuously for 3 seconds, the driver's door and passenger's door power windows are simultaneously opened.

Power window is operated to open and the operation continues as long as the key fob unlock switch is pressed.

Keyless power window down operation mode can be changed using "PW DOWN SET" mode in "WORK SUPPORT". Refer to [BL-66, "Work Support"](#).

Room Lamp and Ignition Key Ring Illumination Operation

When the following conditions come:

- condition of interior lamp switch is DOOR position;
- door switch OFF (when all the doors are closed);

Remote keyless entry system turns on interior lamp (for 30 seconds) with input of UNLOCK signal from key fob. For detailed description, refer to [LT-169, "INTERIOR ROOM LAMP"](#).

CAN Communication System Description

AIS004A4

CAN (Controller Area Network) is a serial communication line for real time application. It is an on-vehicle multiplex communication line with high data communication speed and excellent error detection ability. Many electronic control units are equipped onto a vehicle, and each control unit shares information and links with other control units during operation (not independent). In CAN communication, control units are connected with 2 communication lines (CAN H line, CAN L line) allowing a high rate of information transmission with less wiring. Each control unit transmits/receives data but selectively reads required data only.

CAN Communication Unit

AIS004CS

Refer to [LAN-21, "CAN COMMUNICATION"](#).

REMOTE KEYLESS ENTRY SYSTEM

Schematic

AIS004A5

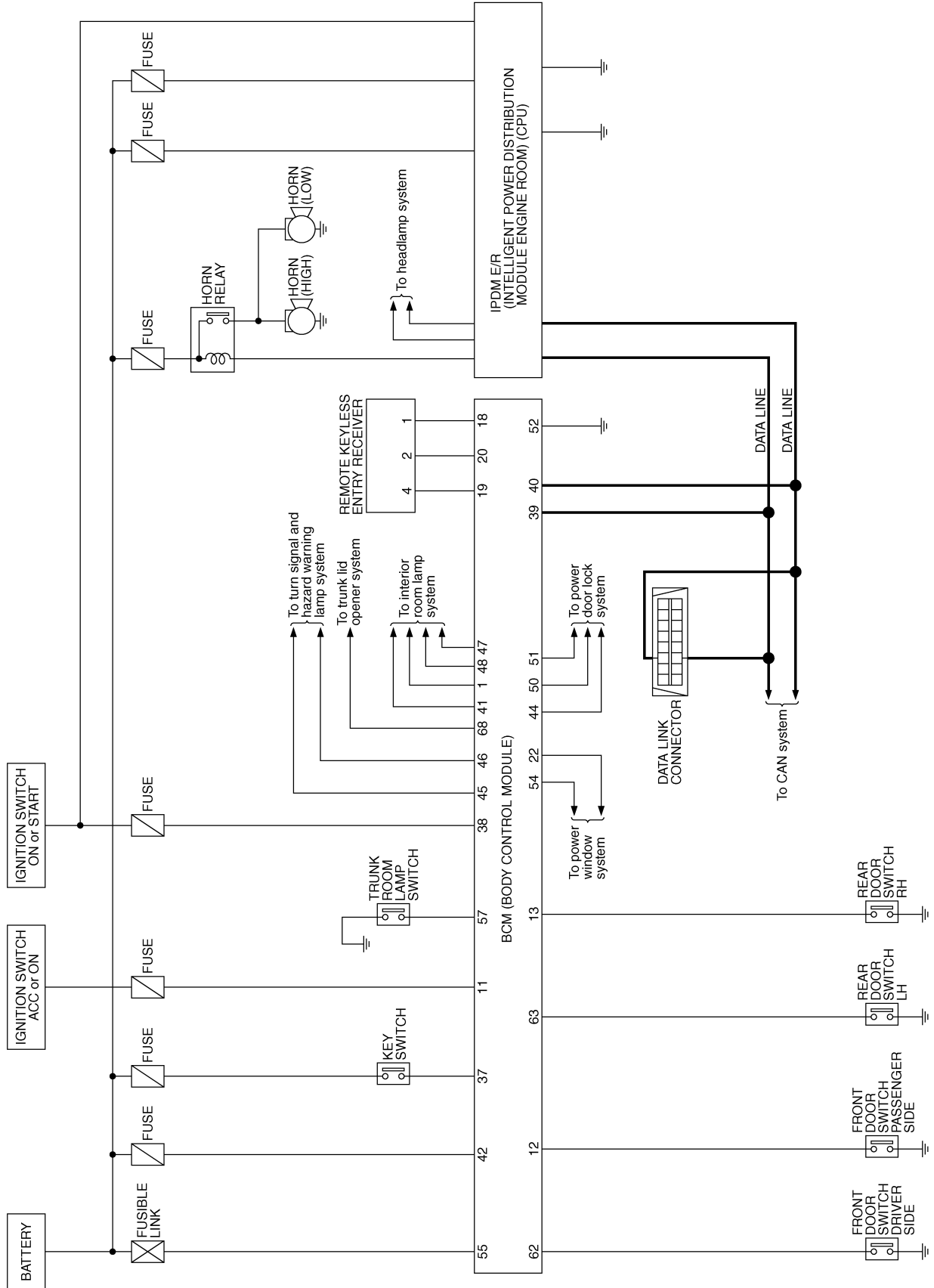

TIWM1041E

REMOTE KEYLESS ENTRY SYSTEM

AIS004A6

Wiring Diagram —KEYLES—
FIG. 1

A
B
C
D
E
F
G
H
BL
J
K
L
M

BL-KEYLES-01

REFER TO PG-POWER.

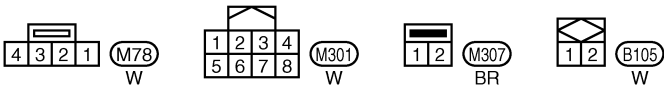
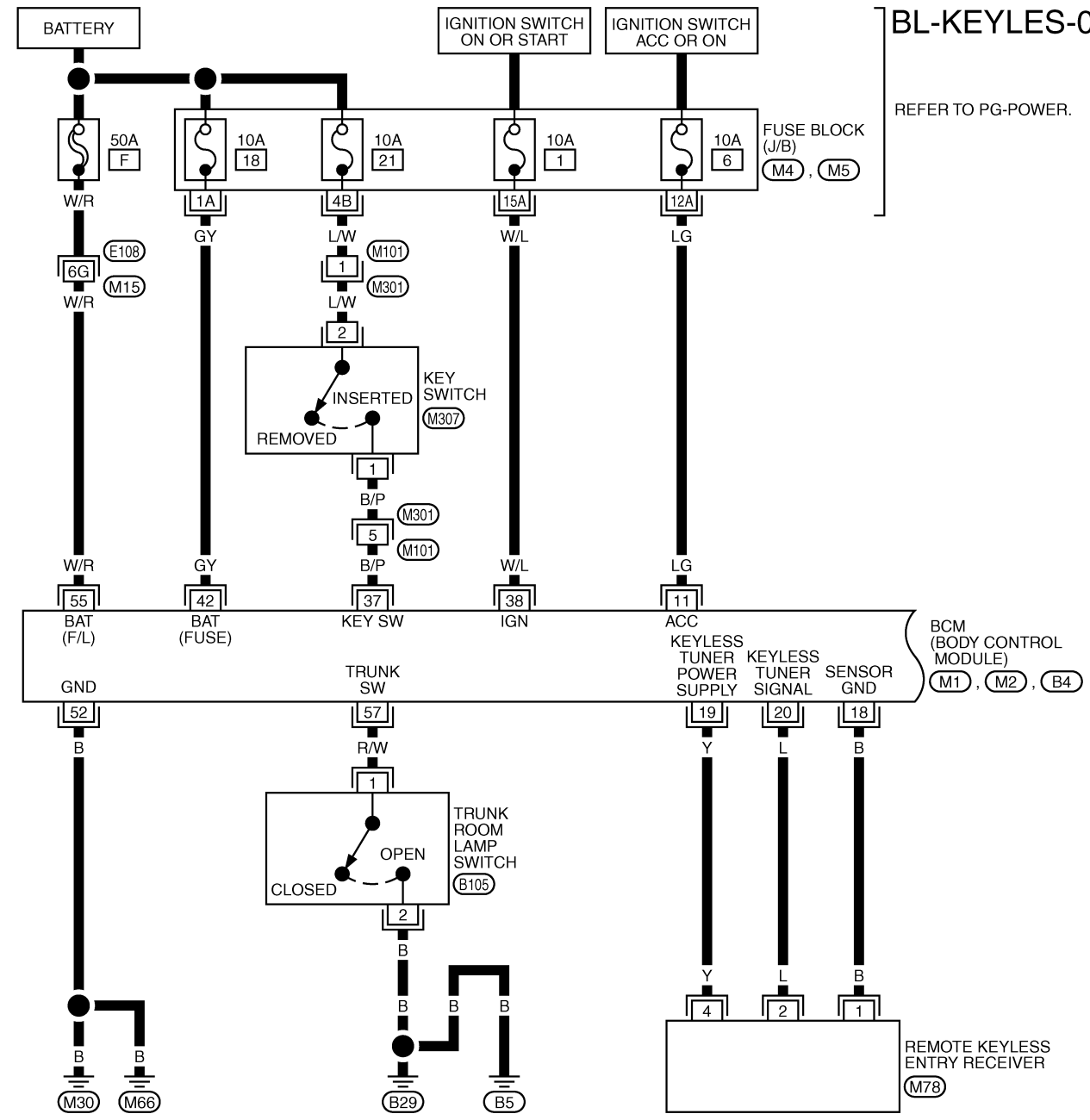

REFER TO THE FOLLOWING.

- (E108) -SUPER MULTIPLE JUNCTION (SMJ)
- (M4), (M5) -FUSE BLOCK-JUNCTION BOX (J/B)
- (M1), (M2), (B4) -ELECTRICAL UNITS

TIWM1125E

REMOTE KEYLESS ENTRY SYSTEM

FIG. 2

BL-KEYLES-02

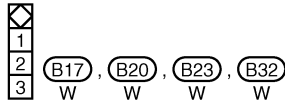
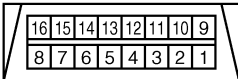
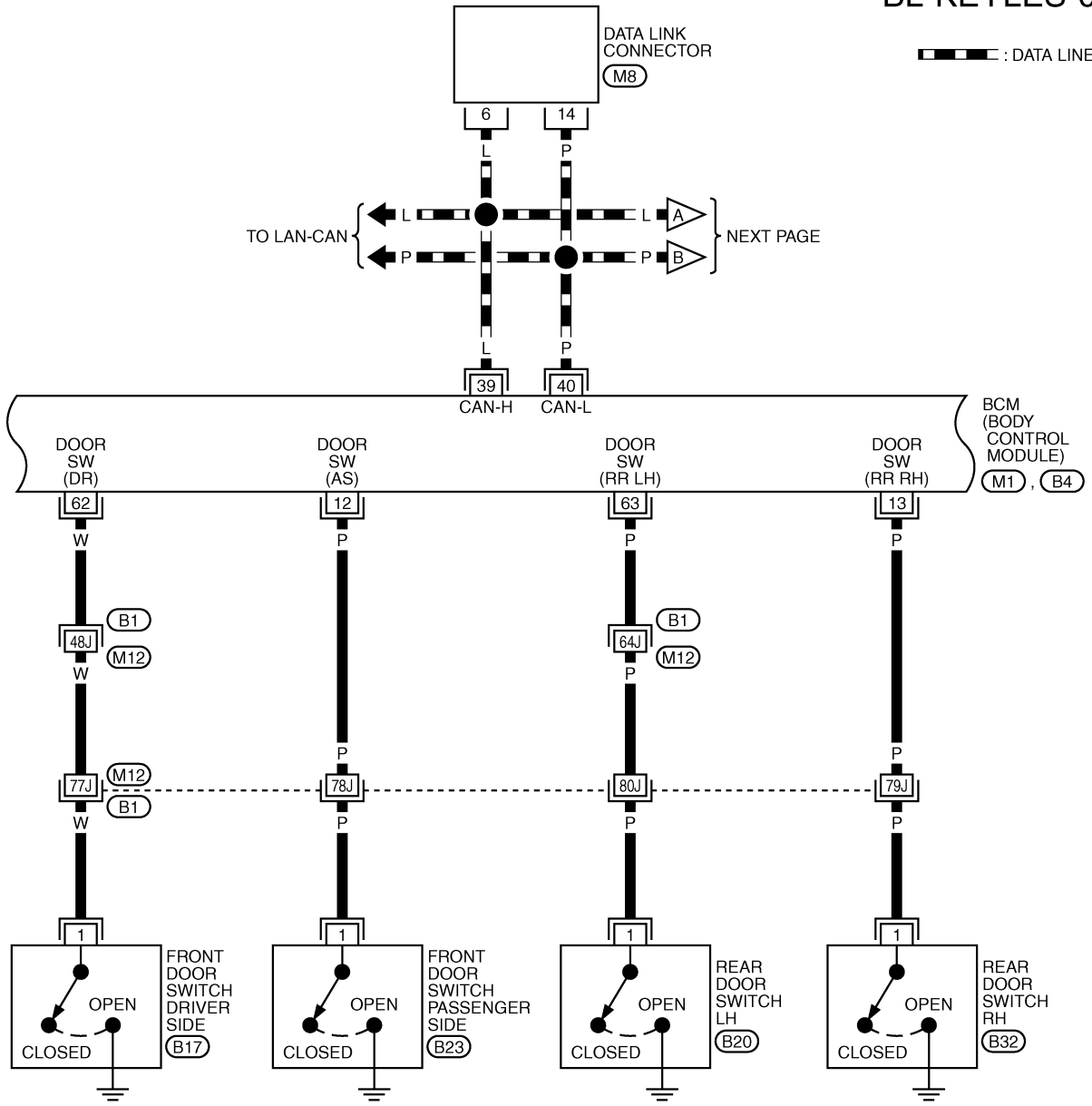

REFER TO THE FOLLOWING.

- (B1) -SUPER MULTIPLE JUNCTION (SMJ)
- (M1), (B4) -ELECTRICAL UNITS

REMOTE KEYLESS ENTRY SYSTEM

FIG. 3

BL-KEYLES-03

▬ : DATA LINE

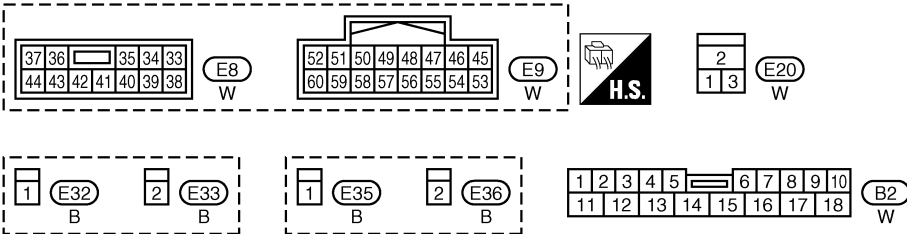
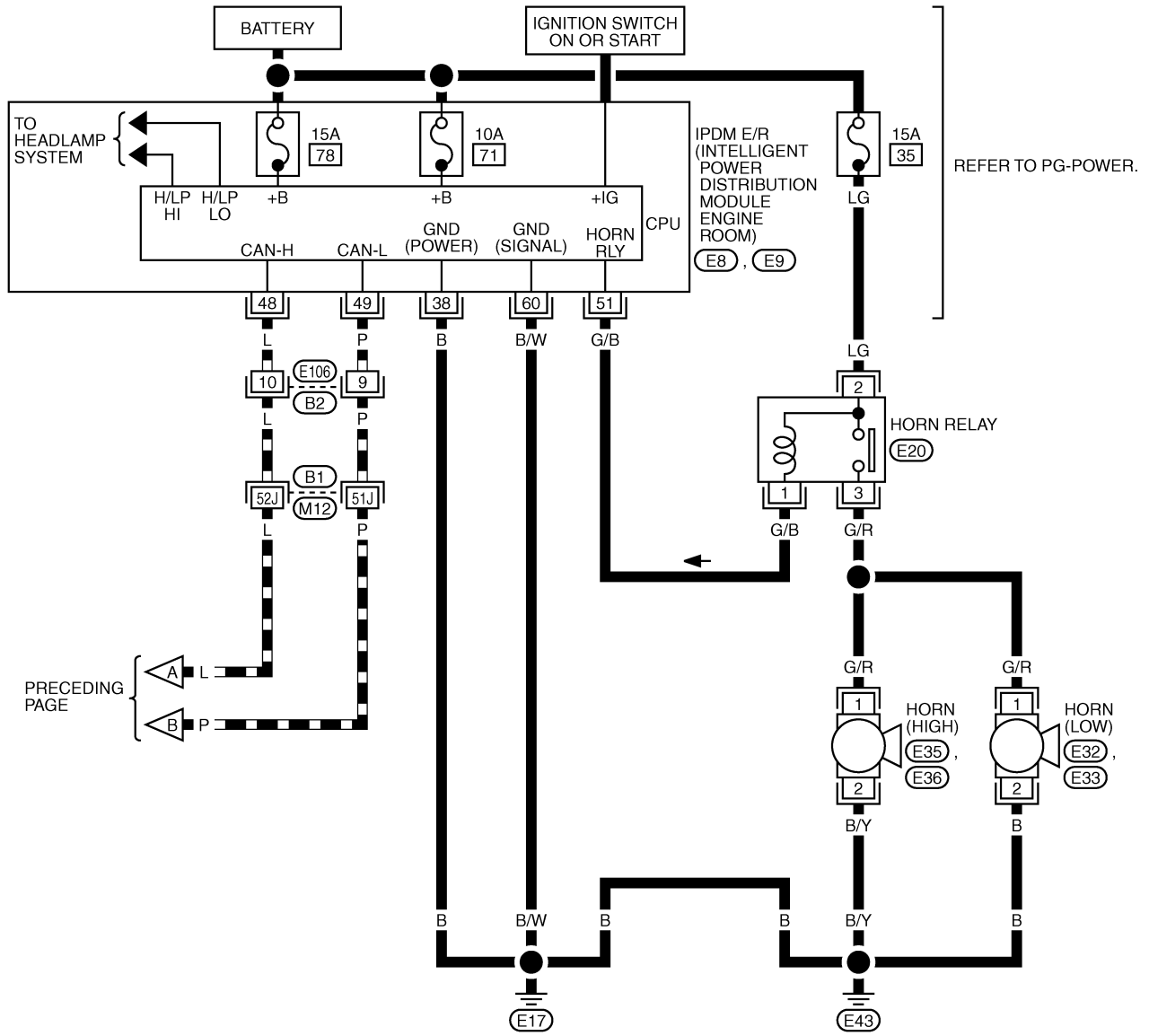

REFER TO THE FOLLOWING.

(B1) -SUPER MULTIPLE JUNCTION (SMJ)

T1WM1043E

REMOTE KEYLESS ENTRY SYSTEM

FIG. 4

BL-KEYLES-04

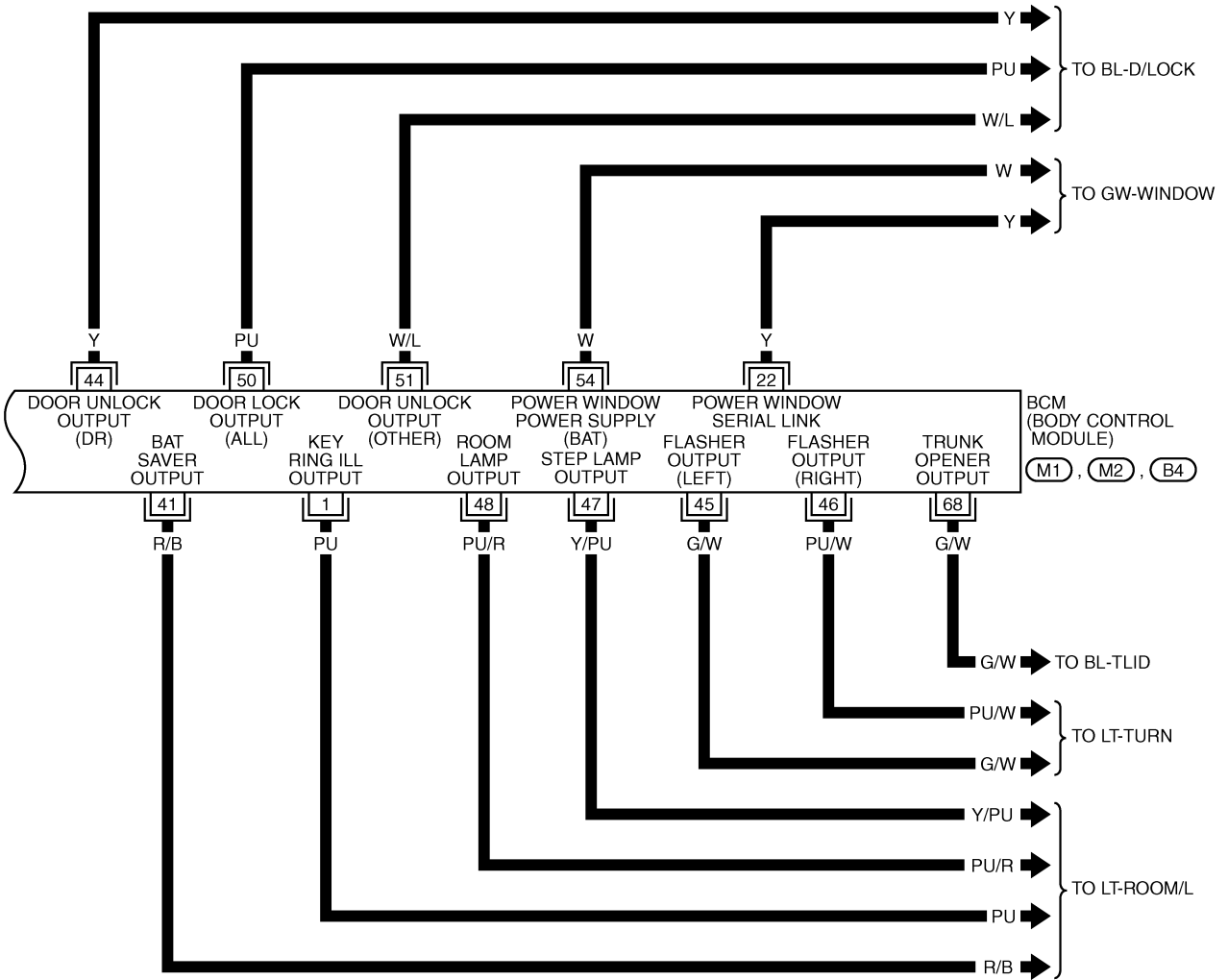

REFER TO THE FOLLOWING.

(M1), (M2), (B4)
-ELECTRICAL UNITS

T1WM1070E

REMOTE KEYLESS ENTRY SYSTEM

Terminals and Reference Value for BCM

AIS004A7

Terminal	Wire color	Item	Condition	Voltage [V] (Approx.)	
1	PU	Key ring illumination output signal	Key ring illumination is lighting.	Battery voltage	
			Key ring illumination is being turned off.	0	
11	LG	Ignition switch (ACC)	Ignition switch is in ACC or ON position	Battery voltage	
12	P	Front door switch (Passenger side)	ON (door open) → OFF (door closed)	0 → Battery voltage	
13	P	Rear door switch RH	ON (door open) → OFF (door closed)	0 → Battery voltage	
18	B	Sensor ground	—	0	
19	Y	Remote keyless entry receiver power supply	Ignition key is removed from key cylinder	Waiting state	<p style="text-align: right; font-size: small;">OCC3881D</p>
				Any operation using key fob	<p style="text-align: right; font-size: small;">OCC3882D</p>
20	L	Remote keyless entry receiver signal	Ignition key is removed from key cylinder	Waiting state	<p style="text-align: right; font-size: small;">OCC3879D</p>
				Any operation using key fob	<p style="text-align: right; font-size: small;">OCC3880D</p>
22	Y	Power window link signal	—	<p style="text-align: right; font-size: small;">PIIA2344J</p>	
37	B/P	Key switch	ON (Key is inserted in IGN key cylinder) → OFF (Key is removed from IGN key cylinder)	Battery voltage → 0	
38	W/L	Ignition switch (ON)	Ignition switch is in ON or START position	Battery voltage	
39	L	CAN H	—	—	
40	P	CAN L	—	—	
41	R/B	Battery saver output signal	30 minutes after ignition switch is turned to OFF	0	
			Ignition switch is in ON position	Battery voltage	

A
B
C
D
E
F
G
H
J
K
L
M

BL

REMOTE KEYLESS ENTRY SYSTEM

Terminal	Wire color	Item	Condition	Voltage [V] (Approx.)
42	GY	Power source (Fuse)	—	Battery voltage
44	Y	Driver door lock actuator (Unlock)	Door lock / unlock switch (Free → Unlock)	0 → Battery voltage → 0
45	G/W	Left turn signal lamp	When door lock or unlock is operated using key fob.* ¹ (ON → OFF)	Battery voltage → 0
46	PU/W	Right turn signal lamp	When door lock or unlock is operated using key fob.* ¹ (ON → OFF)	Battery voltage → 0
47	Y/PU	Step lamp output signal	Step lamp is lighting	0
			Step lamp is being turned off	Battery voltage
48	PU/R	Room lamp output signal	Room lamp is lighting.* ²	0
			Room lamp is being turned off.* ²	Battery voltage
50	PU	Door lock actuator (Lock)	Door lock / unlock switch (Free → Lock)	0 → Battery voltage → 0
51	W/L	Passenger and rear doors lock actuator (Unlock)	Door lock / unlock switch (Free → Unlock)	0 → Battery voltage → 0
52	B	Ground	—	0
54	W	Battery power supply (power window)	—	Battery voltage
55	W/R	Power source (Fusible link)	—	Battery voltage
57	R/W	Trunk room lamp switch	close → open	Battery voltage → 0
62	W	Front door switch (Driver side)	ON (door open) → OFF (door close)	0 → Battery voltage
63	P	Rear door switch LH	ON (door open) → OFF (door close)	0 → Battery voltage

*¹ : In the state that hazard reminder operates.

*² : In the state that room lamp switch is in "DOOR" position.

Terminals and Reference Value for IPDM E/R

AIS004A8

Terminal	Wire color	Item	Condition	Voltage [V] (Approx.)
38	B	Ground	—	0
48	L	CAN H	—	—
49	P	CAN L	—	—
51	G/B	Horn relay	When door lock is operated using key fob* (OFF → ON)	Battery voltage → 0
60	B/W	Ground	—	0

* : In the state that horn reminder operates.

REMOTE KEYLESS ENTRY SYSTEM

AIS004A9

CONSULT-II Function

CONSULT-II can display each diagnostic item using the diagnostic test modes shown following.

BCM diagnosis position	Inspection items and diagnosis mode		Description
BCM C/U*	Self-diagnosis results		Carries out the self-diagnosis.
	DATA MONITOR	CAN diagnosis support monitor	Displays CAN communication system diagnosis, disabled transmission status, and communication status of each unit communicated with BCM.
		Selection from menu	Displays the input data to BCM on real-time basis.
MULTI REMOTE ENT	DATA MONITOR		Displays the input data to BCM in real time basis.
	ACTIVE TEST		Gives a drive signal to a load to check the operation.
	WORK SUPPORT		Changes setting of each function.

*:Refer to [BCS-15, "CAN Communication Inspection Using CONSULT-II \(Self-Diagnosis\)"](#) .

INSPECTION PROCEDURE

CAUTION:

If CONSULT-II is used with no connection of CONSULT-II CONVERTER, malfunctions might be detected in self-diagnosis depending on control unit which carry out CAN communication.

1. Turn ignition switch "OFF".
2. Connect "CONSULT-II" and "CONSULT-II CONVERTER" to the data link connector.

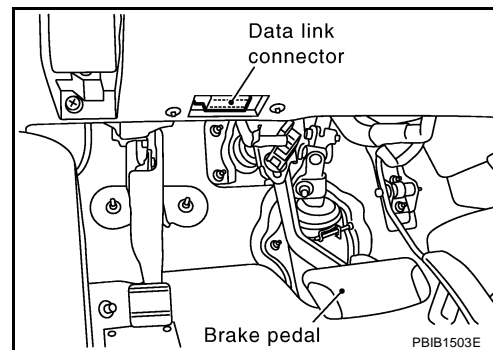

3. Turn ignition switch "ON".
4. Touch "START (NISSAN BASED VHCL)".

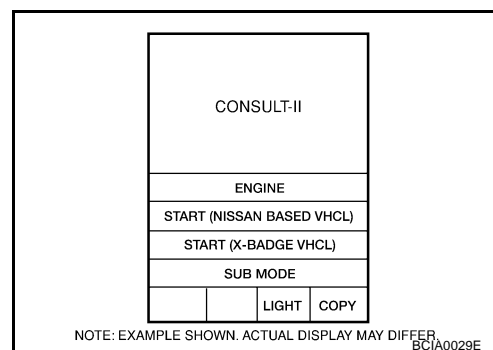

5. Touch "BCM".
If "BCM" is not indicated, go to [GI-38, "CONSULT-II Data Link Connector \(DLC\) Circuit"](#) .

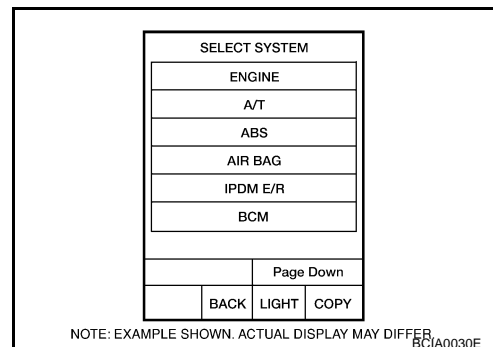

REMOTE KEYLESS ENTRY SYSTEM

6. Touch "MULTI REMOTE ENT".

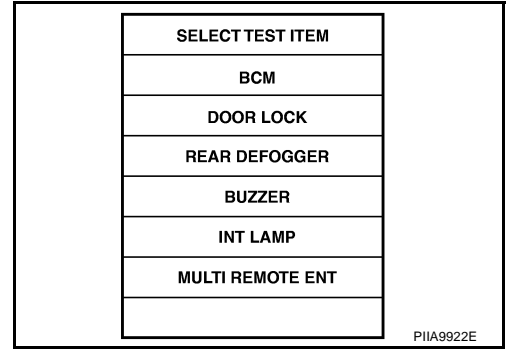

7. Select diagnosis mode. "DATA MONITOR", "ACTIVE TEST" and "WORK SUPPORT" are available.

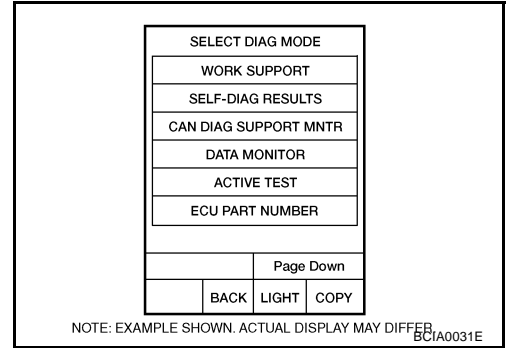

CONSULT-II APPLICATION ITEMS

Work Support

Test Item	Description
HORN CHIRP SET*	Horn reminder mode can be changed in this mode. The horn reminder mode will be changed when "CHANGE SETT" on CONSULT-II screen is touched.
HAZARD LAMP SET*	Hazard reminder mode can be changed in this mode. The hazard reminder mode will be changed when "CHANGE SETT" on CONSULT-II screen is touched.
MULTI ANSWER BACK SET	Hazard and horn reminder mode can be changed in this mode. The hazard and horn reminder mode will be changed when "CHANGE SETT" on CONSULT-II screen is touched.
AUTO LOCK SET	Auto locking function mode can be changed in this mode. The function mode will be changed when "CHANGE SETT" on CONSULT-II screen is touched.
PANIC ALRM SET	Panic alarm operation mode can be changed in this mode. The operation mode will be changed when "CHANGE SETT" on CONSULT-II screen is touched.
TRUNK OPEN SET	Trunk lid opener operation mode can be changed in this mode. The operation mode will be changed when "MODE SET" on CONSULT-II screen is touched.
PW DOWN SET	Keyless power window down (open) operation mode can be changed in this mode. The operation mode will be changed when "CHANGE SETT" on CONSULT-II screen is touched.

*: Perform this mode always in the state of C mode. Refer to [BL-56. "Hazard and Horn Reminder"](#) .

HORN CHIRP SET*

Horn chirp function	ON	OFF

*: Perform this mode always in the state of C mode. Refer to [BL-56. "Hazard and Horn Reminder"](#) .

HAZARD LAMP BACK SET*

	MODE1	MODE2	MODE3	MODE4
Hazard lamp operation mode	Nothing	Unlock only	Lock only	Lock and Unlock

*: Perform this mode always in the state of C mode. Refer to [BL-56. "Hazard and Horn Reminder"](#) .

REMOTE KEYLESS ENTRY SYSTEM

MULTI ANSWER BACK SET

	MODE 1 (C mode)		MODE 2 (S mode)	
	Lock	Unlock	Lock	Unlock
Key fob operation	Lock	Unlock	Lock	Unlock
Hazard warning lamp flash	Twice	Once	Twice	—
Horn sound	Once	—	—	—

AUTO LOCK SET

	MODE 1	MODE 2	MODE 3
Auto locking function	1 minutes	Nothing	5 minutes

PANIC ALARM SET

	MODE 1	MODE 2	MODE 3
Key fob operation	0.5 seconds	Nothing	1.5 seconds

Trunk open operation mode

	MODE 1	MODE 2	MODE 3
Key fob operation	0.5 seconds	Nothing	1.5 seconds

PW DOWN SET

	MODE 1	MODE 2	MODE 3
Key fob operation	3 seconds	Nothing	5 seconds

A
B
C
D
E
F
G
H

BL

J
K
L
M

REMOTE KEYLESS ENTRY SYSTEM

Data Monitor

Monitored Item	Description
IGN ON SW	Indicates [ON/OFF] condition of ignition switch in ON position.
KEY ON SW	Indicates [ON/OFF] condition of key switch.
ACC ON SW	Indicates [ON/OFF] condition of ignition switch in ACC position.
KEYLESS LOCK	Indicates [ON/OFF] condition of lock signal from key fob.
KEYLWSS UNLOCK	Indicates [ON/OFF] condition of unlock signal from key fob.
KEYLESS PANIC	Indicates [ON/OFF] condition of panic signal from key fob.
KEYLESS TRUNK	Indicates [ON/OFF] condition of panic signal from key fob.
DOOR SW-DR	Indicates [ON/OFF] condition of front door switch driver side.
DOOR SW-AS	Indicates [ON/OFF] condition of front door switch passenger side.
DOOR SW-RR	Indicates [ON/OFF] condition of rear door switch RH.
DOOR SW-RL	Indicates [ON/OFF] condition of rear door switch LH.
BACK DOOR SW	This is displayed even when it is not equipped.
TRUNK OPN MNTR	Indicates [ON/OFF] condition of trunk room lamp switch.
CDL LOCK SW	Indicates [ON/OFF] condition of lock signal from door lock and unlock switch.
CDL UNLOCK SW	Indicates [ON/OFF] condition of unlock signal from door lock and unlock switch.
RKE LCK-UNLOCK	Indicates [ON/OFF] condition of simultaneous signal of lock and unlock from key fob.
RKE KEEP UNLK	Indicates [ON/OFF] condition of unlock continuousness signal from key fob.
KEY CYL LK-SW	Indicates [ON/OFF] condition of lock signal from door key cylinder switch.
KEY CYL UN-SW	Indicates [ON/OFF] condition of unlock signal from door key cylinder switch.

Active Test

Test Item	Description
FLASHER	This test is able to check right hazard reminder operation. The right hazard lamp turns on when "ON" on CONSULT-II screen is touched.
POWER WINDOW DOWN	This test is able to check power window open operation. The front power windows activate for 10 seconds after "ON" on CONSULT-II screen is touched.
HORN	This test is able to check panic alarm and horn reminder operations. The horn activate for 0.5 seconds after "ON" on CONSULT-II screen is touched.
DOOR LOCK	This test is able to check door lock actuator operation. <ul style="list-style-type: none"> ● The all door lock actuator are locked when "ALL LOCK" on CONSULT-II screen is touched. ● The all door lock actuator are unlocked when "ALL UNLOCK" on CONSULT-II screen is touched. ● The door lock actuator (driver side) is unlocked when "DR UNLOCK" on CONSULT-II screen is touched. ● The all door lock actuator (except driver side) are unlocked when "OTHER UNLOCK" on CONSULT-II screen is touched.
TRUNK/BACK DOOR	This is displayed even when it is not equipped.

Work Flow

AIS004AA

1. Check the symptom and customer's requests.
2. Understand outline of system. Refer to [BL-55, "System Description"](#) .
3. Confirm that power door lock system operates normally.
Refer to [BL-20, "POWER DOOR LOCK SYSTEM"](#) .
4. Repair or replace any malfunctioning parts.
Refer to [BL-69, "Trouble Diagnosis Chart by Symptom"](#) .
5. INSPECTION END

REMOTE KEYLESS ENTRY SYSTEM

AIS004AB

Trouble Diagnosis Chart by Symptom

NOTE:

- Always check the "Work Flow" before troubleshooting. Refer to [BL-68, "Work Flow"](#) .
- Always check key fob battery before replacing key fob.

Symptom	Diagnoses/service procedure	Reference page
All function of remote keyless entry system do not operate.	1. Check key fob battery and function.	BL-71
	2. Replace key fob. Refer to ID Code Entry Procedure. NOTE: If the result of key fob function check with CONSULT-II is OK, key fob is not malfunctioning.	BL-81
	3. Check remote keyless entry receiver	BL-77
	4. Replace BCM.	BCS-16
The new ID of key fob cannot be registered.	1. Check key fob battery and function.	BL-71
	2. Check key switch.	BL-76
	3. Check door switch.	BL-73
	4. Check ACC switch.	BL-72
	5. Replace key fob. Refer to ID Code Entry Procedure. NOTE: If the result of key fob function check with CONSULT-II is OK, key fob is not malfunctioning.	BL-81
	6. Replace BCM.	BCS-16
Door lock or unlock does not function with key fob. (Power door lock system is "OK".)	1. Check key fob battery and function.	BL-71
	2. Replace key fob. Refer to ID Code Entry Procedure. NOTE: If the result of key fob function check with CONSULT-II is OK, key fob is not malfunctioning.	BL-81
	3. Replace BCM.	BCS-16
Hazard and horn reminder does not activate properly when pressing lock or unlock button of key fob.	1. Check hazard and horn reminder mode.* *: Hazard and horn reminder mode can be changed. First check the hazard and horn reminder setting.	BL-66
	2. Check door switch.	BL-73
	3. Replace BCM.	BCS-16
Hazard reminder does not activate properly when pressing lock or unlock button of key fob. (Horn reminder is "OK".)	1. Check hazard reminder mode.* *: Hazard reminder mode can be changed. First check the hazard reminder setting.	BL-66
	2. Check hazard function.	BL-80
	3. Replace BCM.	BCS-16
Horn reminder does not activate properly when pressing lock button of key fob. (Hazard reminder is "OK".)	1. Check horn reminder mode.* *: Horn reminder can be changed. First check the horn chirp setting.	BL-66
	2. Check horn function.	BL-80
	3. Check IPDM E/R operation.	BL-79
	4. Replace BCM.	BCS-16

A
B
C
D
E
F
G
H
BL
J
K
L
M

REMOTE KEYLESS ENTRY SYSTEM

Symptom	Diagnoses/service procedure	Reference page
Panic alarm (horn and headlamp) does not activate when panic alarm button is continuously pressed.	1. Check panic alarm mode.* *: Panic alarm mode can be changed. First check the panic alarm setting.	BL-66
	2. Check key fob battery and function.	BL-71
	3. Check headlamp function.	BL-80
	4. Check horn function.	BL-80
	5. Check IPDM E/R operation.	BL-79
	6. Check key switch.	BL-76
	7. Replace key fob. Refer to ID Code Entry Procedure. NOTE: If the result of key fob function check with CONSULT-II is OK, key fob is not malfunctioning.	BL-81
	8. Replace BCM.	BCS-16
Auto door lock operation does not activate properly. (All other remote keyless entry system function is OK.)	1. Check auto door lock operation mode.* *: Auto door lock operation mode can be changed. First check the auto door lock operation setting.	BL-66
	2. Replace BCM.	BCS-16
Keyless power window down (open) operation does not activate properly. (All other remote keyless entry system function is OK.)	1. Check power window down operation mode.* *: Power window down operation mode can be changed. First check the power window down setting.	BL-66
	2. Check power window function.	GW-16
	3. Replace BCM.	BCS-16
Map lamp and ignition keyhole illumination operation does not activate properly.	1. Check map lamp and ignition keyhole illumination operation.	BL-80
	2. Check door switch.	BL-73
	3. Replace BCM.	BCS-16

REMOTE KEYLESS ENTRY SYSTEM

AIS004AC

Check Key Fob Battery and Function

1. CHECK KEY FOB BATTERY

1. Remove key fob battery. Refer to [BL-84, "Key Fob Battery Replacement"](#) .
2. Measure voltage between battery positive and negative terminals, (+) and (-).

Voltage : 2.5 – 3.0V

NOTE:

Key fob does not function if battery is not set correctly.

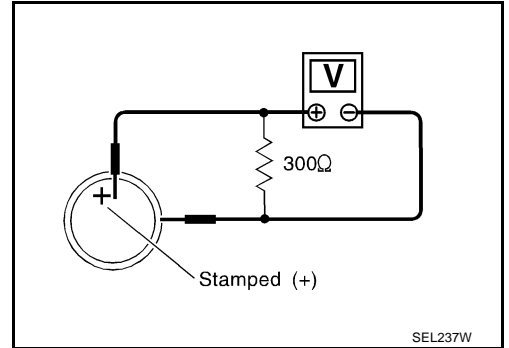

OK or NG

- OK >> GO TO 2.
- NG >> Replace battery.

2. CHECK KEY FOB FUNCTION

With CONSULT-II

Check key fob function in “DATA MONITOR” mode with CONSULT-II. When pushing each button of key fob, the corresponding monitor item should be turned as follows.

Condition	Monitor item
Pushing LOCK	KEYLESS LOCK : ON
Pushing UNLOCK	KEYLESS UNLOCK : ON
Keep pushing UNLOCK	RKE KEEP UNLK : ON
	*: UN BUTTON ON turns to ON three seconds after UNLOCK button keeps pushing.
Pushing PANIC	KEYLESS PANIC : ON
Pushing LOCK and UNLOCK at the same time	RKE LCK-UNLOCK : ON

DATA MONITOR	
MONITOR	
KEYLESS LOCK	OFF
KEYLESS UNLOCK	OFF
RKE KEEP UNLK	OFF
RKE LCK-UNLOCK	OFF
KEYLESS PANIC	OFF

PIIA6468E

OK or NG

- OK >> Keyfob is OK.
- NG >> Replace key fob.

REMOTE KEYLESS ENTRY SYSTEM

AIS004AD

Check ACC Switch

1. CHECK ACC SWITCH

With CONSULT-II

Check ACC switch ("ACC ON SW") in "DATA MONITOR" mode with CONSULT-II.

Monitor item	Condition
ACC SW	Ignition switch position is ACC or ON : ON
	Ignition switch position is OFF : OFF

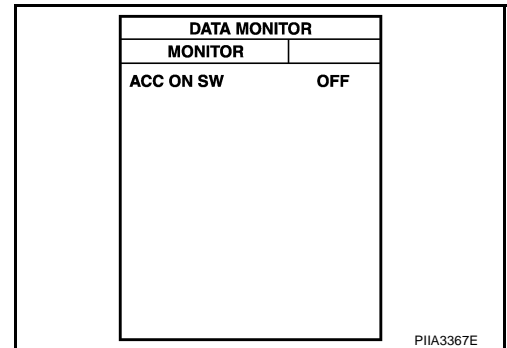

Without CONSULT-II

Check voltage between BCM connector and ground.

Connector	Terminal (Wire color)		Ignition switch position	Voltage [V] (Approx.)
	(+)	(-)		
M1	11 (LG)	Ground	ACC	Battery voltage
			OFF	0

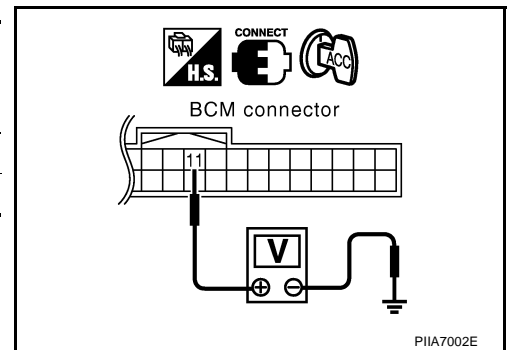

OK or NG

OK >> ACC switch is OK.

NG >> Check the following.

- 10A fuse [No. 6, located in the fuse block (J/B)]
- Harness for open or short between BCM and fuse

REMOTE KEYLESS ENTRY SYSTEM

AIS005A3

Check Door Switch

1. CHECK DOOR SWITCH INPUT SIGNAL

With CONSULT-II

Check door switches ("DOOR SW-DR", "DOOR SW-AS", "DOOR SW-RL" and "DOOR SW-RR") in "DATA MONITOR" mode with CONSULT-II.

Monitor item	Condition
DOOR SW-DR	CLOSE → OPEN: OFF → ON
DOOR SW-AS	
DOOR SW-RL	
DOOR SW-RR	

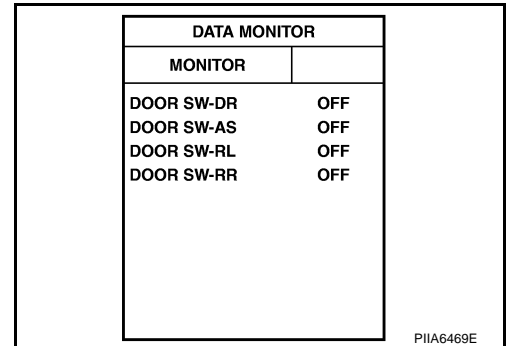

Without CONSULT-II

Check voltage between BCM connector and ground.

Item	Connector	Terminals (Wire color)		Door condition	Voltage [V] (Approx.)
		(+)	(-)		
Driver side	B4	62 (W)	Ground	CLOSE ↓ OPEN	Battery voltage ↓ 0
Rear LH		63 (P)			
Passenger side	M1	12 (P)			
Rear RH		13 (P)			

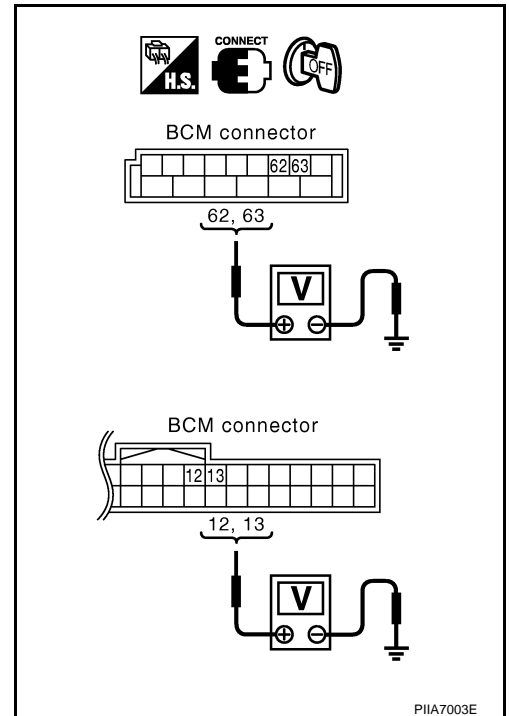

OK or NG

- OK >> Door switch circuit is OK.
- NG >> GO TO 2.

REMOTE KEYLESS ENTRY SYSTEM

2. CHECK DOOR SWITCH

1. Turn ignition switch OFF.
2. Disconnect door switch connector.
3. Check continuity between door switch terminal 1 and ground part of door switch.

Terminal	Door switch condition	Continuity
1	Pushed	No
	Released	Yes

OK or NG

- OK >> GO TO 3.
 NG >> Replace door switch.

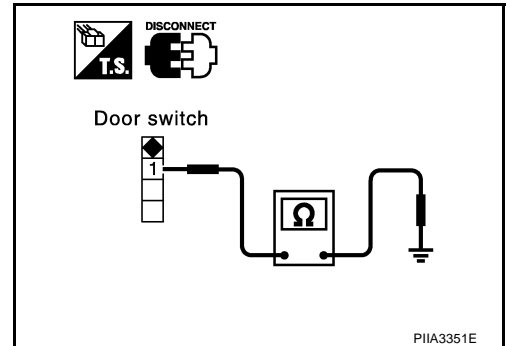

3. CHECK DOOR SWITCH CIRCUIT

1. Disconnect BCM connector.
2. Check continuity between door switch connector B17, B23, B20, B32 terminals 1 and BCM connector M1, B4 terminals 62, 12, 63, 13.

Driver side door

1 (W) – 62 (W) : Continuity should exist.

Passenger side door

1 (P) – 12 (P) : Continuity should exist.

Rear door LH

1 (P) – 63 (P) : Continuity should exist.

Rear door RH

1 (P) – 13 (P) : Continuity should exist.

3. Check continuity between door switch connector B26, B36, B46, B206 terminal 1 and ground.

1 (W or P) – Ground : Continuity should not exist.

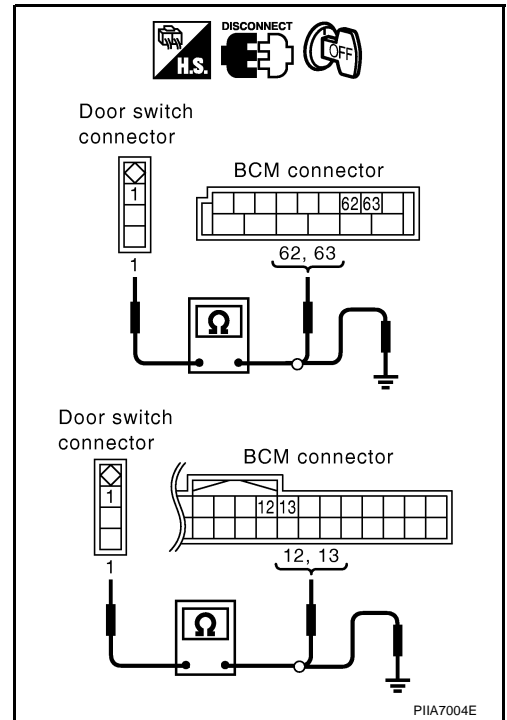

OK or NG

- OK >> GO TO 4.
 NG >> Repair or replace harness.

REMOTE KEYLESS ENTRY SYSTEM

4. CHECK BCM OUTPUT SIGNAL

1. Connect BCM connector.
2. Check voltage between BCM connector M1, B4 terminal 62, 12, 63, 13 and ground.

62 (W) – Ground	: Battery voltage
12 (P) – Ground	: Battery voltage
63 (P) – Ground	: Battery voltage
13 (P) – Ground	: Battery voltage

OK or NG

- | | |
|----|-----------------------------|
| OK | >> Check harness condition. |
| NG | >> Replace BCM. |

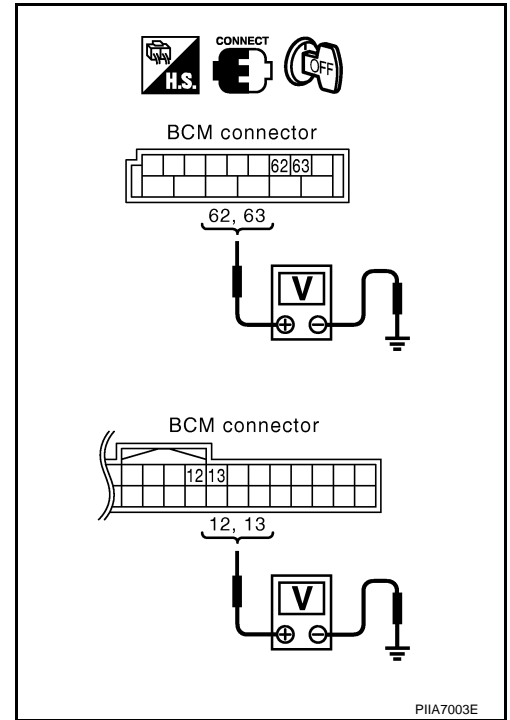

A
B
C
D
E
F
G
H
J
K
L
M

BL

REMOTE KEYLESS ENTRY SYSTEM

AIS005A4

Check Key Switch

1. CHECK KEY SWITCH INPUT SIGNAL

With CONSULT-II

Check ignition key switch "KEY ON SW" in "DATA MONITOR" mode with CONSULT-II.

- When key is inserted in ignition key cylinder
KEY ON SW : ON
- When key is removed from ignition key cylinder
KEY ON SW : OFF

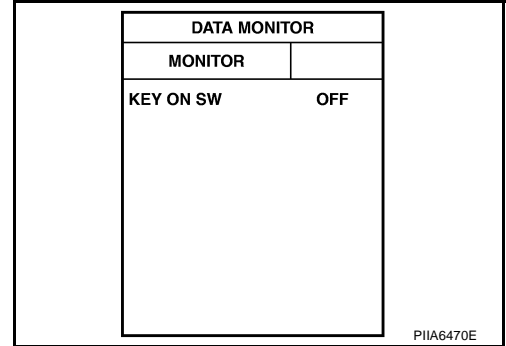

PIIA6470E

Without CONSULT-II

Check voltage between BCM connector and ground.

Terminal (Wire color)		Condition of key switch	Voltage [V] (Approx.)
(+)	(-)		
37 (B/P)	Ground	Key is inserted in ignition key cylinder.	Battery voltage
		Key is removed from ignition key cylinder.	0

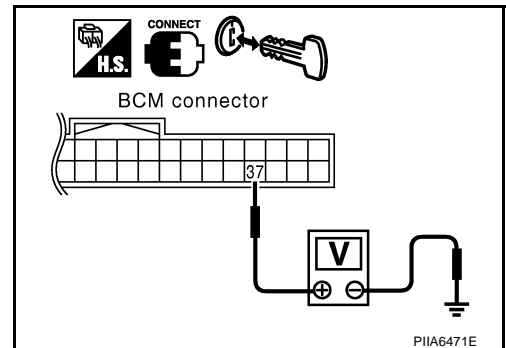

PIIA6471E

OK or NG

- OK >> Key switch circuit is OK.
- NG >> GO TO 2.

2. CHECK KEY SWITCH (WITHOUT INTELLIGENT KEY)

- Turn ignition switch OFF.
- Disconnect key switch connector.
- Check continuity between key switch terminals 1 and 2.

Key switch condition	Continuity
Key switch is "ON". (Key is inserted in IGN key cylinder.)	Yes
Key switch is "OFF". (Key is removed from IGN key cylinder.)	No

OK or NG

- OK >> Check the following.
 - 10A fuse [No. 21, located in fuse block (J/B)]
 - Harness for open or short between key switch and fuse
 - Harness for open or short between BCM and key switch
- NG >> Replace key switch.

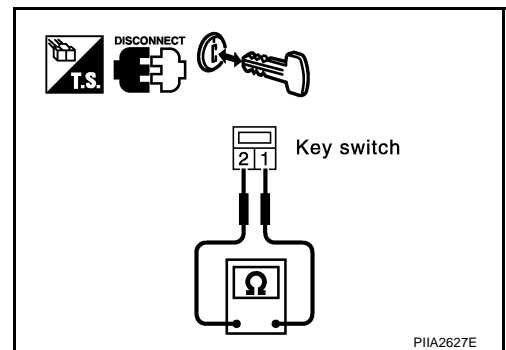

PIIA2627E

REMOTE KEYLESS ENTRY SYSTEM

AIS006EE

Check Remote Keyless Entry Receiver

1. CHECK REMOTE KEYLESS ENTRY RECEIVER OUTPUT SIGNAL

1. Turn ignition switch OFF.
2. Check remote keyless entry receiver connector M78 terminal 2 and ground signal with oscilloscope.

Connector	Terminal (Wire color)		Condition of keyfob	Voltage (Reference value)
	(+)	(-)		
M78	2	Ground	No function	
			Any button is pressed	

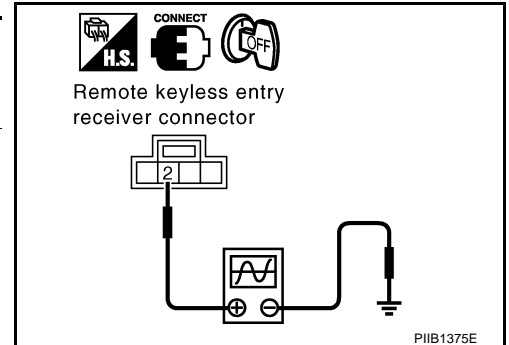

OK or NG

- OK >> Remote keyless entry receiver circuit is OK.
 NG >> GO TO 2.

2. CHECK REMOTE KEYLESS ENTRY RECEIVER INPUT VOLTAGE

1. Disconnect remote keyless entry receiver connector.
2. Check voltage between remote keyless entry receiver connector M78 terminal 4 and ground.

4 (Y) – Ground : Approx. 4.5V

OK or NG

- OK >> GO TO 4.
 NG >> GO TO 3.

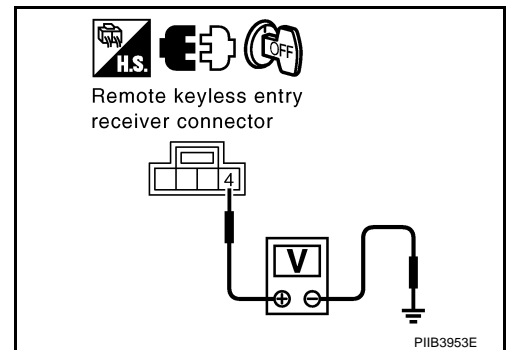

REMOTE KEYLESS ENTRY SYSTEM

3. CHECK REMOTE KEYLESS ENTRY RECEIVER POWER SUPPLY CIRCUIT

1. Disconnect BCM connector.
2. Check continuity between remote keyless entry receiver connector M78 terminal 4 and BCM connector M1 terminal 19.

4 (R) – 19 (R) : Continuity should exist.

3. Check continuity between remote keyless entry receiver connector M78 terminal 4 and ground.

4 (R) – Ground : Continuity should not exist.

OK or NG

- OK >> Check harness connection.
- If it is OK, replace BCM.
 - If it is NG, repair or replace malfunction part.
- NG >> Repair or replace the harness.

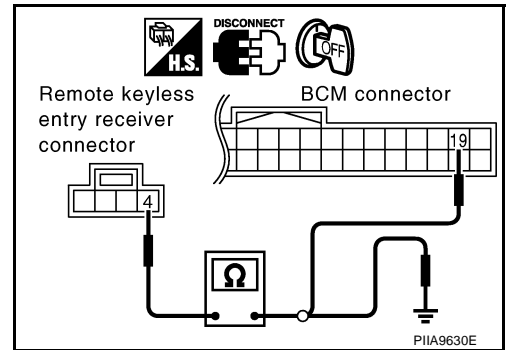

4. CHECK REMOTE KEYLESS ENTRY RECEIVER GROUND CIRCUIT

Check continuity between remote keyless entry receiver connector M78 terminal 1 and ground.

1 (B) – Ground : Continuity should exist.

OK or NG

- OK >> GO TO 6.
- NG >> GO TO 5.

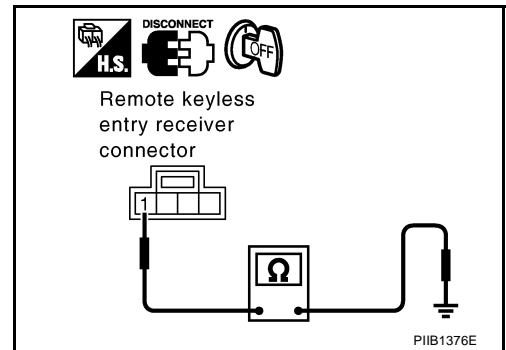

5. CHECK REMOTE KEYLESS ENTRY RECEIVER GROUND CIRCUIT

Check continuity between remote keyless entry receiver connector M78 terminal 1 and BCM connector M1 terminal 18.

1 (B) – 18 (B) : Continuity should exist.

OK or NG

- OK >> Check harness connection.
- If it is OK, replace BCM.
 - If it is NG, repair or replace malfunction part.
- NG >> Repair or replace the harness.

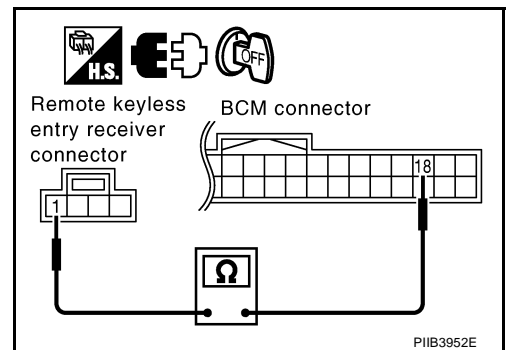

REMOTE KEYLESS ENTRY SYSTEM

6. CHECK REMOTE KEYLESS ENTRY RECEIVER SIGNAL CIRCUIT

1. Check continuity between remote keyless entry receiver connector M78 terminal 2 and BCM connector M1 terminal 20.

2 (Y) – 20 (Y) : Continuity should exist.

2. Check continuity between remote keyless entry receiver connector M78 terminal 2 and ground.

2 (Y) – Ground : Continuity should not exist.

OK or NG

OK >> Check harness connection.

- If it is OK, replace remote keyless entry receiver.
- If it is NG, repair or replace malfunction part.

NG >> Repair or replace harness.

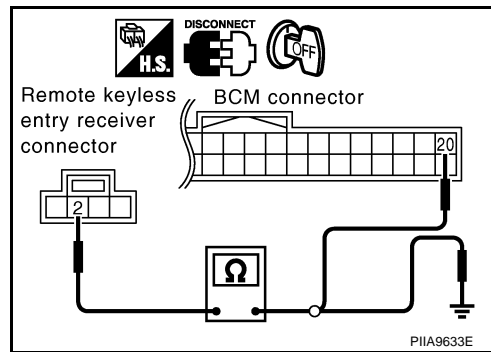

Check IPDM E/R Operation

1. CHECK IPDM E/R INPUT VOLTAGE

Check voltage between IPDM E/R connector E9 terminal 51 and ground.

51 (G/B) – Ground : Battery voltage

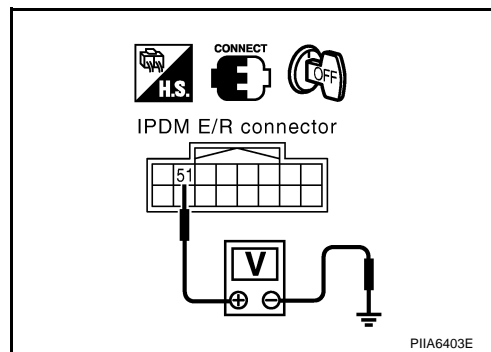

OK or NG

OK >> Replace IPDM E/R.

NG >> GO TO 2.

2. CHECK IPDM E/R HARNESS

1. Turn ignition switch OFF.
2. Disconnect IPDM E/R and horn relay connector.
3. Check continuity between IPDM E/R connector E9 terminal 51 and horn relay connector E20 terminal 1.

51 (G/B) – 1 (G/B) : Continuity should exist.

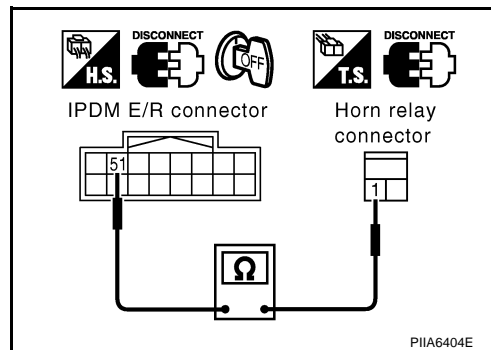

OK or NG

OK >> Check the condition of the harness and the connector.

NG >> Repair or replace harness.

REMOTE KEYLESS ENTRY SYSTEM

Check Hazard Function

AIS005A6

1. CHECK HAZARD WARNING LAMP

Does hazard warning lamp flash with hazard switch?

YES or NO

YES >> Hazard warning lamp circuit is OK.

NO >> Check hazard circuit. Refer to [LT-113, "TURN SIGNAL AND HAZARD WARNING LAMPS"](#) .

Check Horn Function

AIS005A7

First perform the "SELF-DIAG RESULTS" in "BCM" with CONSULT-II, then perform the trouble diagnosis of malfunction system indicated "SELF-DIAG RESULTS" of "BCM". Refer to [BCS-15, "CAN Communication Inspection Using CONSULT-II \(Self-Diagnosis\)"](#) .

1. CHECK HORN FUNCTION

Does horn sound with horn switch?

YES or NO

YES >> Horn circuit is OK.

NO >> Check horn circuit. Refer to [WW-42, "HORN"](#) .

Check Headlamp Function

AIS005A8

First perform the "SELF-DIAG RESULTS" in "BCM" with CONSULT-II, then perform the trouble diagnosis of malfunction system indicated "SELF-DIAG RESULTS" of "BCM". Refer to [BCS-15, "CAN Communication Inspection Using CONSULT-II \(Self-Diagnosis\)"](#) .

1. CHECK HEADLAMP OPERATION

Does headlamp come on when turning lighting switch "ON"?

YES or NO

YES >> Headlamp operation circuit is OK.

NO >> Check headlamp system. Refer to [LT-7, "HEADLAMP \(FOR USA\)"](#) or [LT-38, "HEADLAMP \(FOR CANADA\) - DAYTIME LIGHT SYSTEM -"](#) .

Check Map Lamp and Ignition Keyhole Illumination Function

AIS005A9

1. CHECK MAP LAMP AND IGNITION KEYHOLE ILLUMINATION FUNCTION

When map lamp switch is in "DOOR" position, open the front door (LH or RH).

Map lamp and ignition keyhole illumination should illuminate.

OK or NG

OK >> Map lamp and ignition switch key hole illumination circuit is OK.

NG >> Check ignition illumination circuit. Refer to [LT-169, "INTERIOR ROOM LAMP"](#) .

REMOTE KEYLESS ENTRY SYSTEM

AIS005AA

ID Code Entry Procedure KEY FOB ID SET UP WITH CONSULT-II

NOTE:

- If a key fob is lost, the ID code of the lost key fob must be erased to prevent unauthorized use. A specific ID code can be erased with CONSULT-II. However, when the ID code of a lost key fob is not known, all controller ID codes should be erased. After all ID codes are erased, the ID codes of all remaining and/or new key fobs must be re-registered.
- When registering an additional key fob, the existing ID codes in memory may or may not be erased. If five ID codes are stored in memory, when an additional code is registered, only the oldest code is erased. If less than five ID codes are stored in memory, when an additional ID code is registered, the new ID code is added and no ID codes are erased.
- Entry of maximum five ID codes is allowed. When more than five ID codes are entered, the oldest ID code will be erased.
- Even if same ID code that is already in the memory is input, the same ID code can be entered. The code is counted as an additional code.

CAUTION:

If CONSULT-II is used with no connection of CONSULT-II CONVERTER, malfunctions might be detected in self-diagnosis depending on control unit which carry out CAN communication.

1. Turn ignition switch "OFF".
2. Connect "CONSULT-II" and "CONSULT-II CONVERTER" to the data link connector.

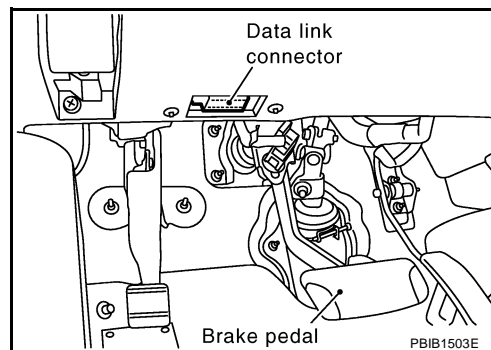

3. Turn ignition switch ON.
4. Touch "START (NISSAN BASED VHCL)".

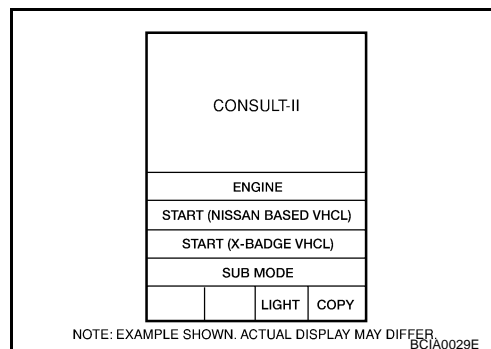

5. Touch "BCM".
If "BCM" is not indicated, go to [GI-38, "CONSULT-II Data Link Connector \(DLC\) Circuit"](#).

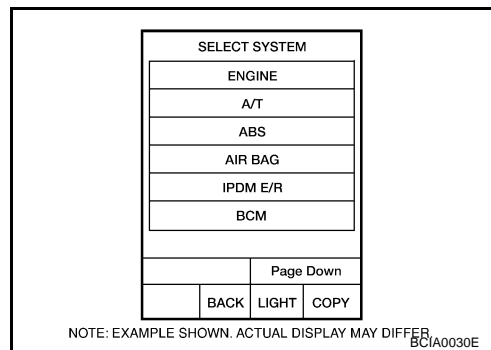

REMOTE KEYLESS ENTRY SYSTEM

6. Touch "MULTI REMOTE ENT".

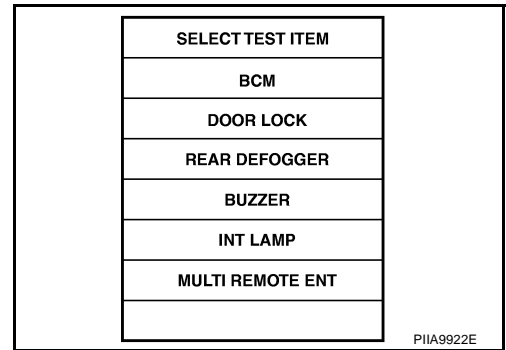

7. Touch "WORK SUPPORT".

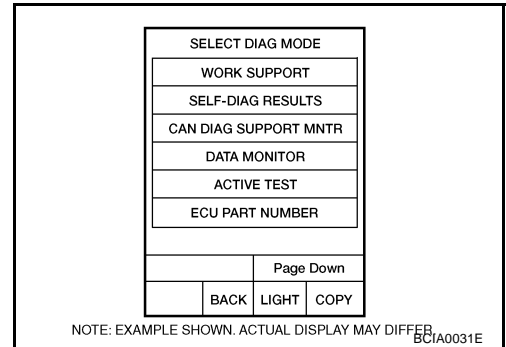

8. The items are shown on the figure can be set up.

- "REMO CONT ID REGIST"
Use this mode to register a key fob ID code.

NOTE:

Register the ID code when key fob or BCM is replaced, or when additional key fob is required.

- "REMO CONT ID ERASUR"
Use this mode to erase a key fob ID code.
- "REMO CONT ID CONFIR"
Use this mode to confirm if a key fob ID code is registered or not.

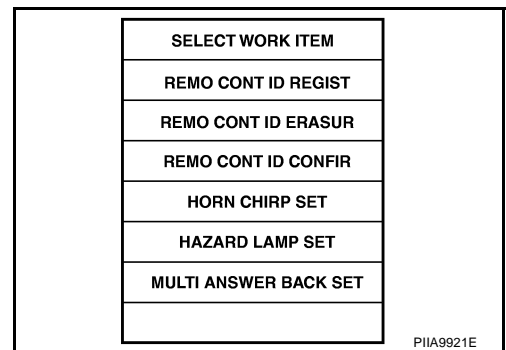

REMOTE KEYLESS ENTRY SYSTEM

KEY FOB ID SET UP WITHOUT CONSULT-II

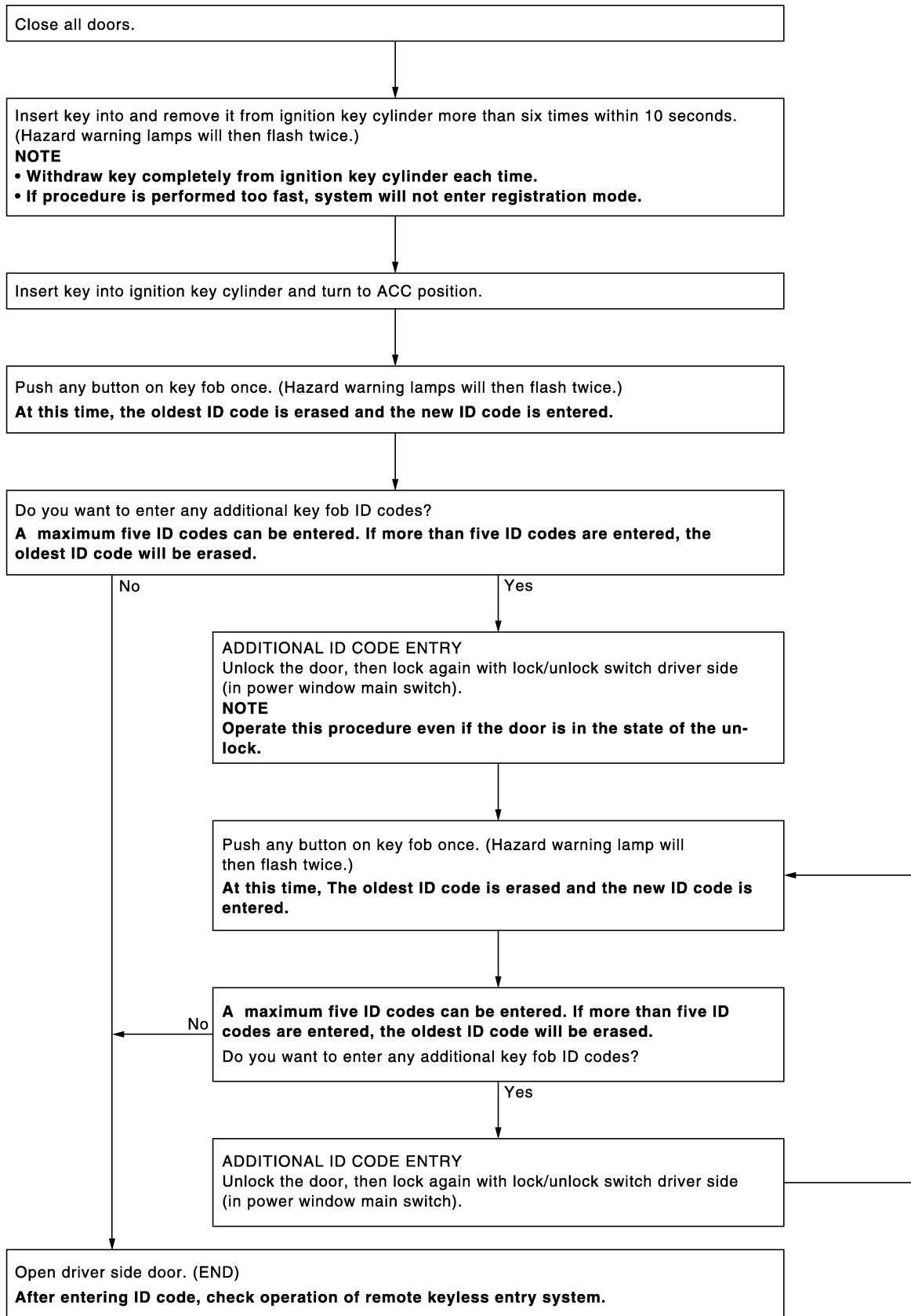

A
B
C
D
E
F
G
H
J
K
L
M

BL

PIIA2839E

REMOTE KEYLESS ENTRY SYSTEM

NOTE:

- If a key fob is lost, the ID code of the lost key fob must be erased to prevent unauthorized use. A specific ID code can be erased with CONSULT-II. However, when the ID code of a lost key fob is not known, all controller ID codes should be erased. After all ID codes are erased, the ID codes of all remaining and/or new key fobs must be re-registered.
To erase all ID codes in memory, register one ID code (key fob) five times. After all ID codes are erased, the ID codes of all remaining and/or new key fobs must be re-registered.
- When registering an additional key fob, the existing ID codes in memory may or may not be erased. If five ID codes are stored in memory, when an additional code is registered, only the oldest code is erased. If less than five ID codes are stored in memory, when an additional ID code is registered, the new ID code is added and no ID codes are erased.
- If you need to activate more than two additional new key fobs, repeat the procedure “Additional ID code entry” for each new key fob.
- Entry of maximum five ID codes is allowed. When more than five ID codes are entered, the oldest ID code will be erased.
- Even if same ID code that is already in the memory is input, the same ID code can be entered. The code is counted as an additional code.

Key Fob Battery Replacement

AIS005AB

SEC. 998

NOTE:

- Be careful not to touch the circuit board or battery terminal.
- The keyfob is water-resistant. However, if it does get wet, immediately wipe it dry.

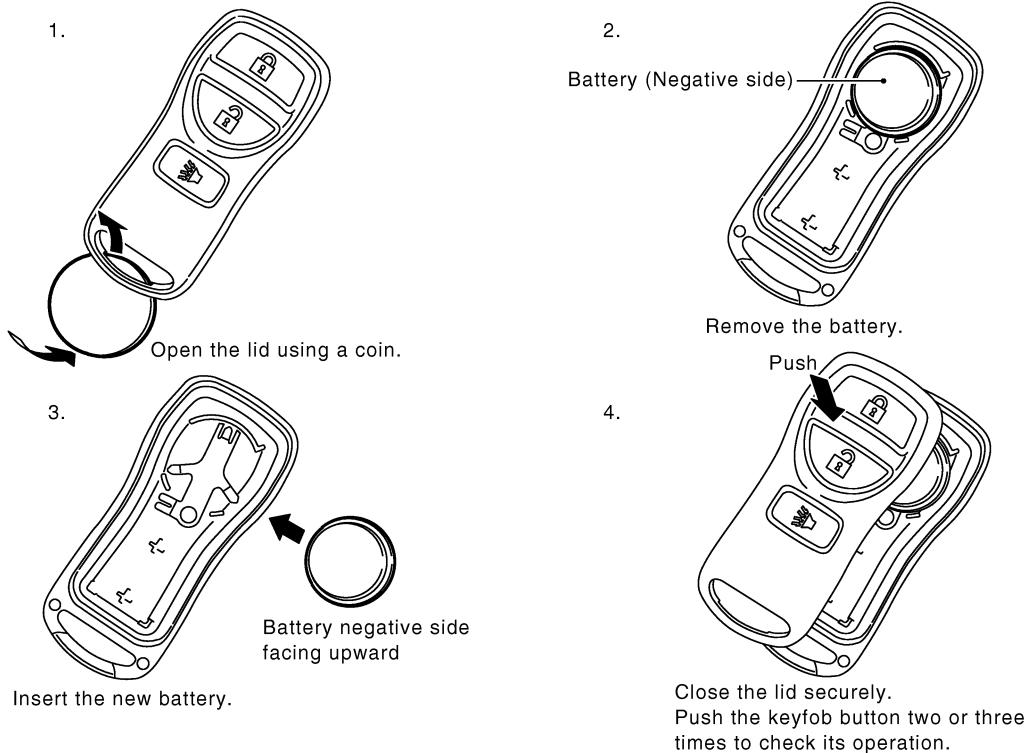

PIIA4706E

INTELLIGENT KEY SYSTEM

Component Parts and Harness Connector Location

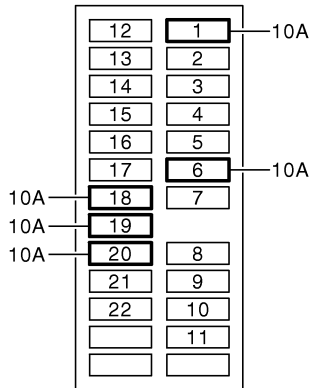

Fuse block (J/B) fuse layout

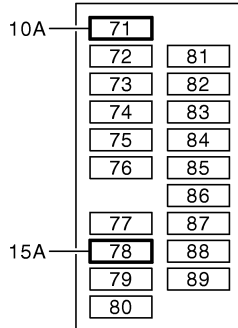

IPDM E/R fuse layout

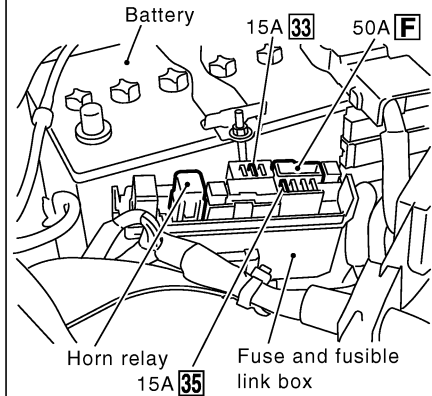

View with dash side LH removed

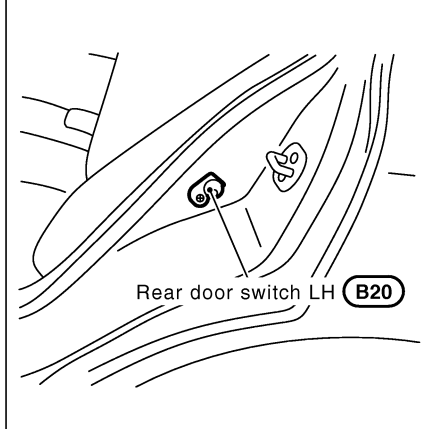
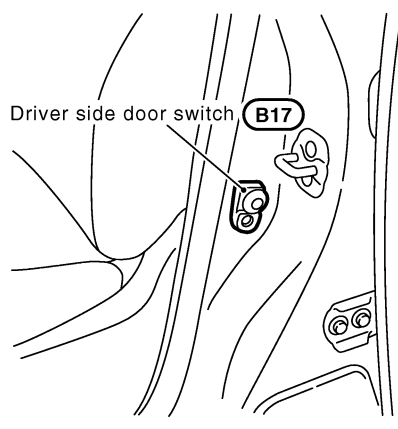
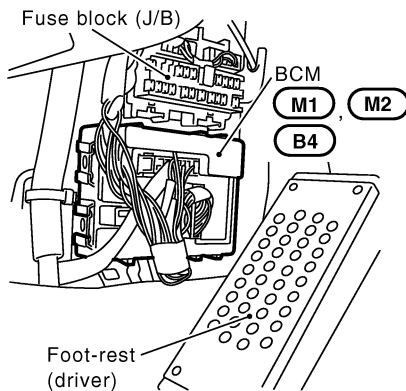

Outside handle

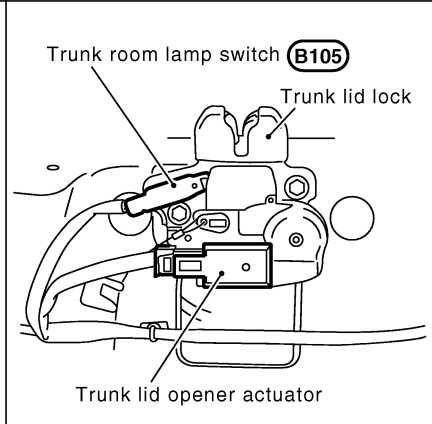
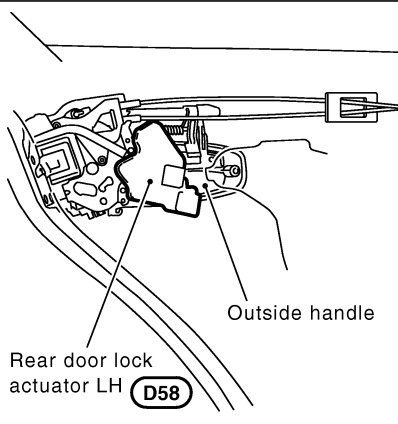
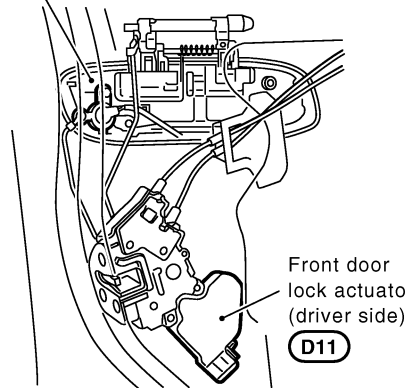

View with steering column cover removed

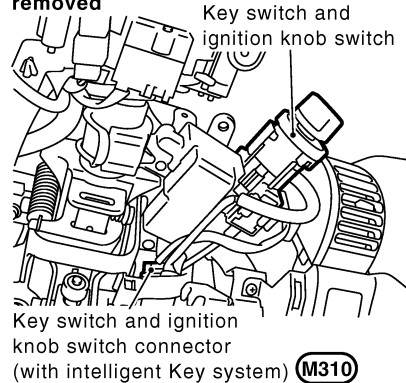

View with cowl top cover (right) removed

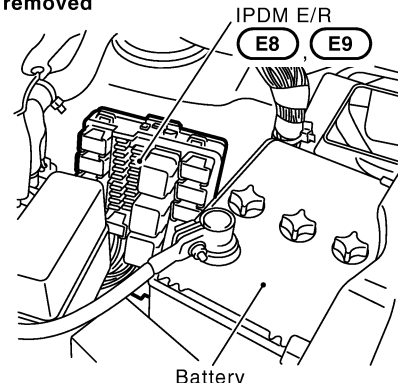

View with front grille removed

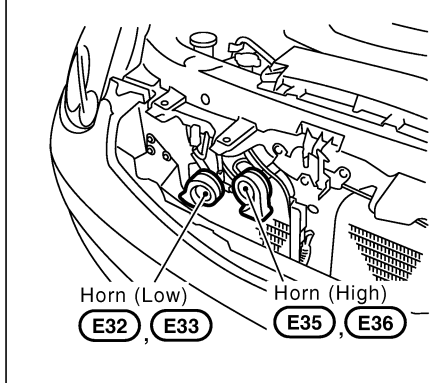

A
B
C
D
E
F
G
H
J
K
L
M

BL

INTELLIGENT KEY SYSTEM

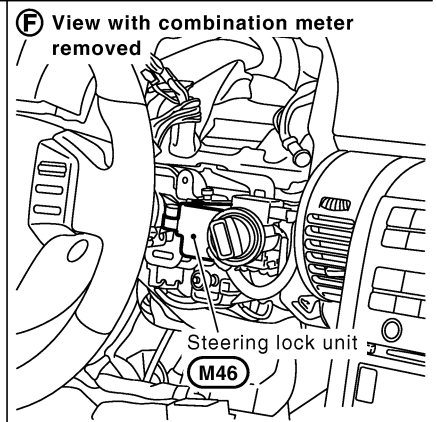
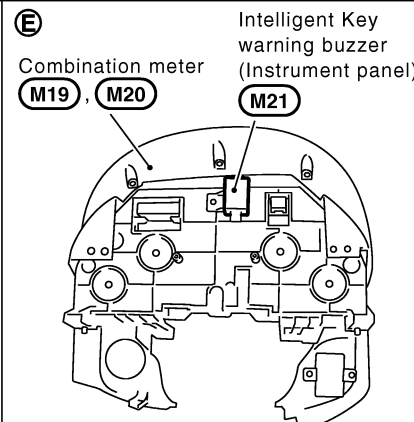
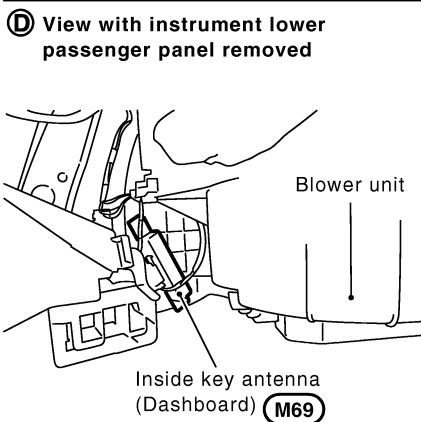
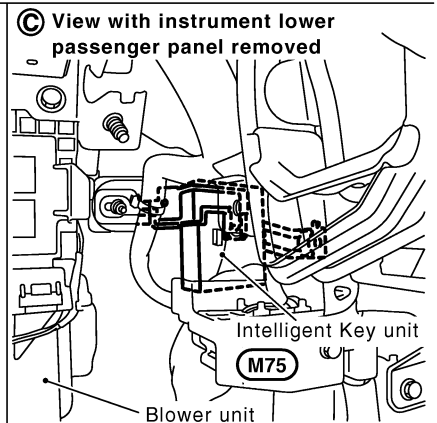
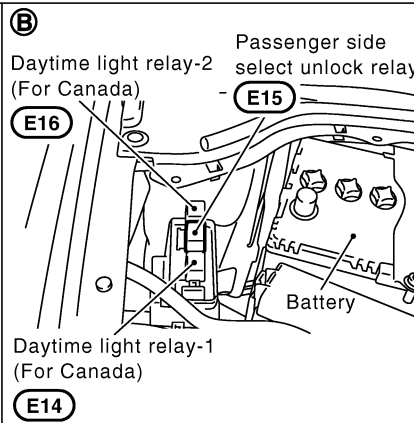
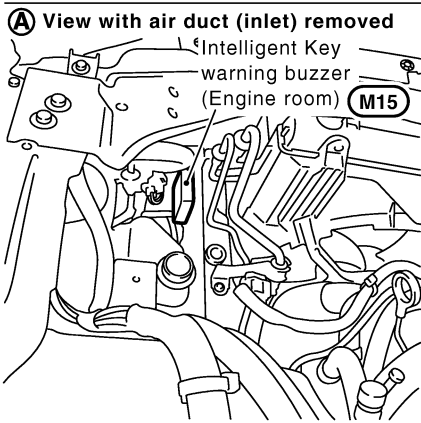
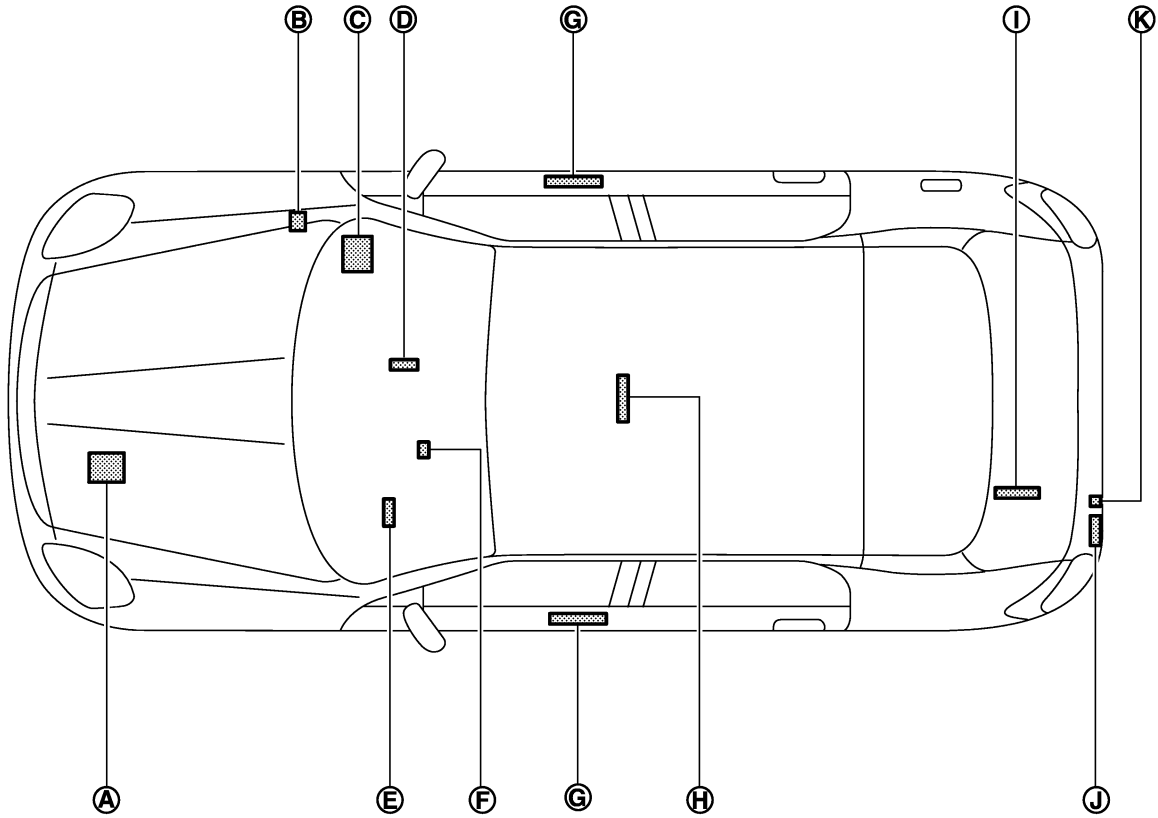

PIIB4032E

INTELLIGENT KEY SYSTEM

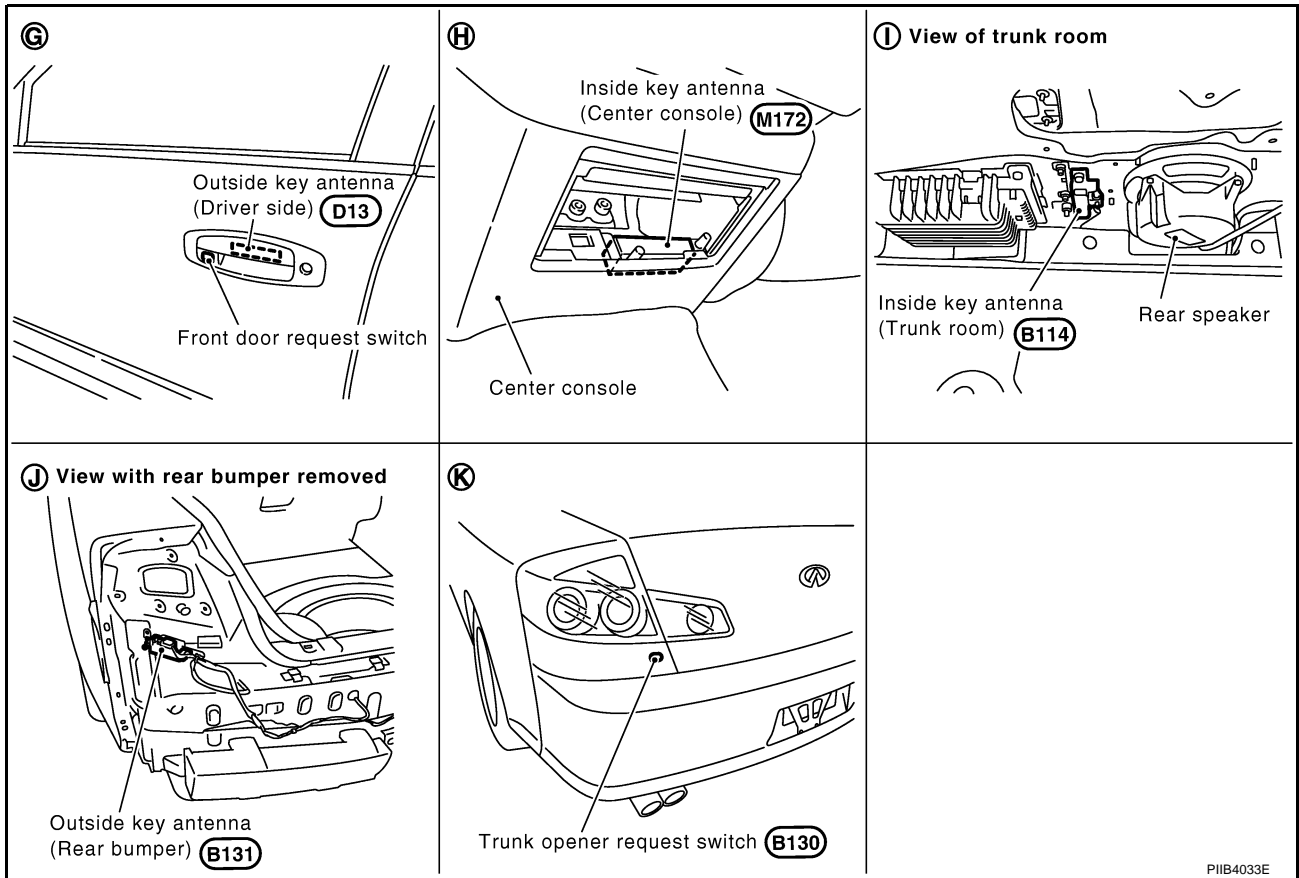

A
B
C
D
E
F
G
H

BL

System Description

AIS00695

- The Intelligent Key system is a system that makes it possible to lock and unlock the door locks (door lock/unlock function), open the trunk (trunk open function), and start the engine (engine start function) by carrying around the Intelligent Key (without some key operation), which operates based on the results of electronic ID verification using two-way communications between the Intelligent Key and the vehicle (Intelligent Key unit).

CAUTION:

The driver should always carry the Intelligent Key

- Operation of the remote controller buttons on the Intelligent Key also provides the same functions as the remote controller entry system. (Remote keyless entry functions)
- If an action that does not meet the operating conditions of the Intelligent Key system is taken, the buzzer goes off to inform the driver. (Warning chime functions)
- When a door lock is locked or unlocked with request switch or remote controller button operation, the hazard lamps flash and the buzzer (outside vehicle) sounds (Hazard and horn reminder function).
- Even if the Intelligent Key battery is completely discharged, the door locks can be locked and unlocked and the engine started with the mechanical key built into the Intelligent Key.
- The settings for each function can be changed with the CONSULT-II.
- If an Intelligent Key is lost, a new Intelligent Key can be registered. A maximum of 4 Intelligent Keys can be registered.
- It has been made possible to diagnose the system and register an Intelligent Key with the CONSULT-II.

J
K
L
M

INTELLIGENT KEY SYSTEM

DOOR LOCK/UNLOCK/TRUNK OPEN FUNCTION

Only when pressing the request switch, it is possible to lock and unlock the door and open the trunk by carrying around the Intelligent Key (without some key operation).

System Diagram

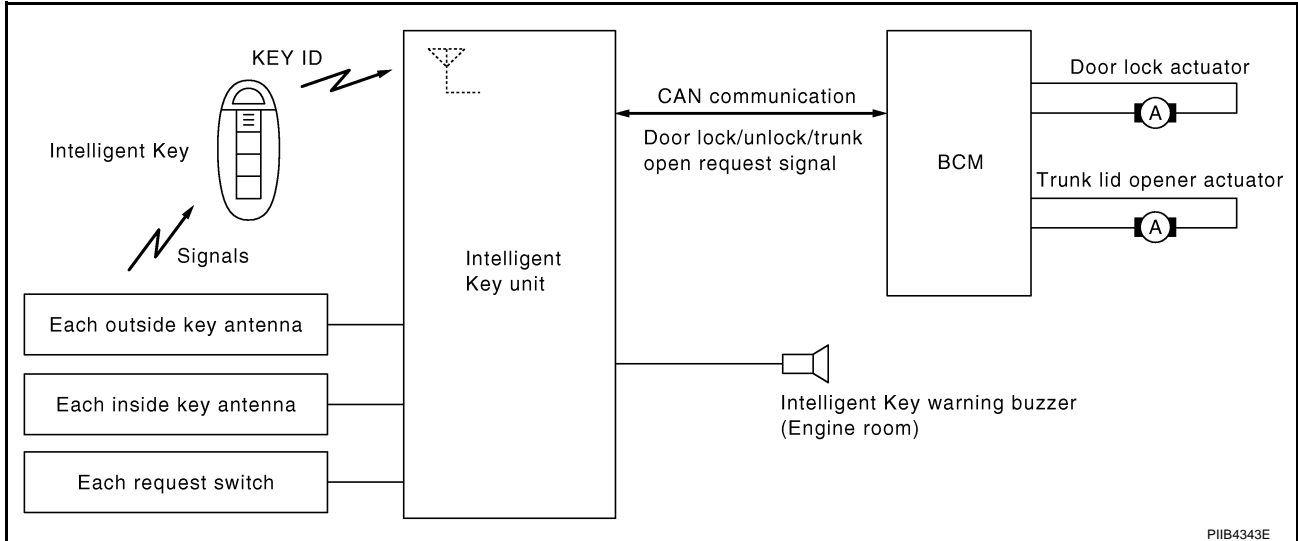

Operation Description

- When the Intelligent Key unit detects that each request switch is pressed, it starts the outside antenna corresponding to the pressed request switch and sends the request signal to the Intelligent Key. And then, make sure that the Intelligent Key is near the door or the trunk.
- If the Intelligent Key is within the outside antenna detection area, it receives the request signal and sends the key ID signal to the Intelligent Key unit.
- Intelligent Key receives the key ID signal and compares it with the registered key ID.
- If the key ID check result is OK, the Intelligent Key unit sends the door lock/unlock or trunk open request signal to BCM (Body control module) via CAN communication line.
- Intelligent Key unit sends the door lock/unlock signal and sounds Intelligent Key buzzer (Engine room) warning (lock: 1 time, unlock: 2 times trunk open: 4 times) at the same time.
- When BCM receives the door lock/unlock signal, it operates door lock actuator and flashes the hazard lamp (lock: 1 time, unlock: 2 times) at the same time as an operation check.
- When BCM receives the trunk open request signal, it operates the trunk lid opener actuator and opens the trunk.

INTELLIGENT KEY SYSTEM

Operation Condition

If the following conditions are not satisfied, door lock/unlock or trunk open operations are not performed even if the request switch is operated.

Each request switch operation	Operation condition
Lock operation	<ul style="list-style-type: none"> ● All doors are closed ● Intelligent Key is outside the vehicle ● Intelligent Key is with in outside key antenna detection area ● OFF position warning chime is not operated
Unlock Operation	<ul style="list-style-type: none"> ● Intelligent Key is outside the vehicle ● Intelligent Key is with in outside key antenna detection area
Trunk open operation	<ul style="list-style-type: none"> ● Intelligent Key is in the outside key antenna (rear bumper) detection area and Intelligent Key is not inside vehicle. ● Intelligent Keys are in the outside key antenna (rear bumper) detection area and Intelligent Key is inside vehicle. But both Intelligent Key IDs are different. ● Trunk cancel switch is ON ● Key reminder functions operate (trunk).

Outside Key Antenna Detection Area

The outside key antenna detection area of door lock/unlock function is in the range of approximately 80 cm (31.50 in) surrounding the driver and passenger door handles. The outside key antenna detection area of trunk open function is in the range of approximately 80 cm (31.50 in) surrounding Trunk opener request switch. However, this operating range depends on the ambient conditions.

Key Reminder Function

Key reminder functions have the following 3 functions.

Key remainder function	Operation condition	Operation
When the driver door is open	Key reminder function is operated when <ul style="list-style-type: none"> ● Intelligent Key is inside the vehicle, ● Driver door is open, and ● Door is locked by door lock and unlock switch or door lock knob 	All doors unlock operation
When the door is open/closed	Key reminder function is operated when <ul style="list-style-type: none"> ● Intelligent Key is inside the vehicle, ● Any door is open, ● All doors are locked by door lock and unlock switch or door lock knob, and ● All door are closed. 	<ul style="list-style-type: none"> ● All doors unlock operation ● Sound Intelligent Key warning buzzer (Engine room) for 3 seconds
When the trunk is closed	Key remainder function is operated when <ul style="list-style-type: none"> ● Intelligent Key is inside trunk room, ● all door are closed, ● all door are locked, and ● trunk is closed 	<ul style="list-style-type: none"> ● Trunk open operation. ● Sound Intelligent Key warning buzzer (Engine room) for 10 seconds

CAUTION:

- **The above function operates when the Intelligent Key is inside the vehicle. However, there may be times when the Intelligent Key cannot be detected, and this function will not operate when the Intelligent Key is on the instrument panel, rear parcel shelf, or in the glove box. Also, this system sometimes does not operate if the Intelligent Key is in the door pocket for the open door.**
- **When the key reminder function is operated when the trunk is open/closed and the buzzers sound, if the following operations are performed, the key reminder function is cleared and buzzer sounds are stopped.**
 - Remote controller door lock button operation of Intelligent Key
 - Remote controller door unlock button operation of Intelligent Key
 - When the trunk is closed, the Intelligent Key is not inside the vehicle

INTELLIGENT KEY SYSTEM

- When any door is open

Selective Unlock Function for Driver Side

When an LOCK signal is sent from door request switch (driver side), all doors will be locked.
 When an UNLOCK signal is sent from door request switch (driver side) once, driver's door will be unlocked.
 Then, if an UNLOCK signal is sent from door request switch (driver side) again within 5 seconds, all other door will be unlocked.

Selective Unlock Function for Passenger Side

When an LOCK signal is sent from request switch (passenger side), all doors will be locked.
 When an UNLOCK signal is sent from request switch (passenger side) once, Intelligent Key unit turns on passenger side select unlock relay. And then passenger's door will be unlocked.
 If an UNLOCK signal is sent from request switch (passenger side) again within 5 seconds, all other door will be unlocked.

Hazard and Horn Reminder

When doors are locked or unlocked by door request switch, Intelligent Key unit sends hazard and horn request signal to BCM via CAN communication line.
 BCM flashes hazard warning lamps as a reminder and sends horn chirp signal to IPDM E/R. IPDM E/R sounds horn as a reminder.
 The hazard and horn reminder has a horn chirp mode (C mode) and a non-horn chirp mode (S mode).

Operating function of hazard and horn reminder

	C mode		S mode	
Remote controller of Intelligent Key operation	Lock	Unlock	Lock	Unlock
Hazard warning lamp flash	Twice	Once	Twice	—
Horn sound	Once	—	—	—

Hazard and horn reminder does not operate if any door switch is ON (any door is OPEN).

How to change hazard and horn reminder mode

📖 With CONSULT-II

Hazard and horn reminder can be changed using "HAZARD ANSWER BACK", "ANSWER BACK WITH I-KEY LOCK" and "ANSWER BACK WITH I-KEY UNLOCK" mode in "WORK SUPPORT". Refer to [BL-122, "WORK SUPPORT"](#).

🚫 Without CONSULT-II

When LOCK and UNLOCK signals are sent from the remote controller of Intelligent Key for more than 2 seconds at the same time, the hazard and horn reminder mode is changed and hazard warning lamp flashes and horn sounds as follows:

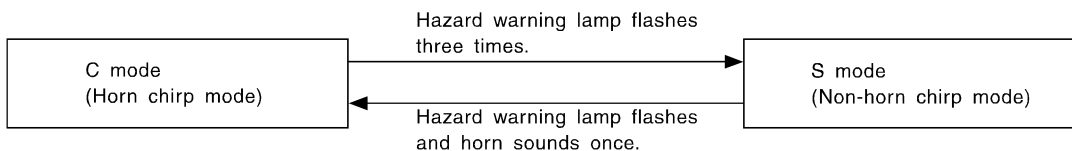

SEL153WA

INTELLIGENT KEY SYSTEM

Auto Door Lock Function

When all doors are locked, ignition knob switch is OFF (when ignition switch is not pressed) and key switch is OFF (when mechanical key is not inserted in key cylinder), doors are unlocked with door request switch. When Intelligent Key unit does not receive the following signals within 30 seconds, all doors are locked.

- Door switch is ON (door is opened)
- Door is locked
- Ignition knob switch is ON (ignition switch is pressed)
- Key switch is ON (mechanical key is inserted in key cylinder)

Auto door lock mode can be changed by "AUTO RELOCK TIMER" mode in "WORK SUPPORT". Refer to [BL-122. "WORK SUPPORT"](#).

Room Lamp Operation

When the following conditions are met:

- Condition of interior lamp switch is in DOOR position
- Door switch OFF (when all the doors are closed)

Intelligent Key system turns on interior lamp (for 30 seconds) by receiving UNLOCK signal from door request switch. For detailed description, refer to [LT-172. "ROOM LAMP TIMER OPERATION"](#).

List of Operation Related Parts

Parts marked with × are the parts related to operation.

Door lock/trunk open function	Intelligent Key	Key switch	Ignition knob switch	Door unlock sensor	Door switch	Trunk room lamp switch	Door request switch (Driver, Passenger)	Trunk opener request switch	Door lock actuator	Trunk lid opener actuator	Inside key antenna	Outside key antenna (Driver, Passenger)	Outside key antenna (rear bumper)	Intelligent Key warning buzzer	Intelligent Key unit	CAN communication system	BCM	Select unlock relay	Hazard warning lamp
Door lock/unlock function by request switch	×	×	×	×	×		×		×		×	×			×	×	×		
Door lock/unlock function by mechanical key									×								×		
Trunk open function by the trunk opener switch	×				×	×		×		×			×		×	×	×		
Hazard and horn reminder function														×	×	×	×		×
Key reminder function	×			×	×		×	×	×		×	×	×	×	×	×	×		×
Selective unlock function by request switch (Driver side)	×						×		×		×	×			×	×	×		
Selective unlock function by request switch (Passenger side)	×						×		×		×	×			×	×	×	×	
Auto door lock function	×	×	×		×		×								×	×	×		

INTELLIGENT KEY SYSTEM

REMOTE KEYLESS ENTRY FUNCTIONS

Door Lock/Unlock Function

The Intelligent Key has the same functions as the remote control entry system. Therefore, it can be used in the same manner as the remote controller by operating the door lock/unlock button and trunk open button.

System Diagram

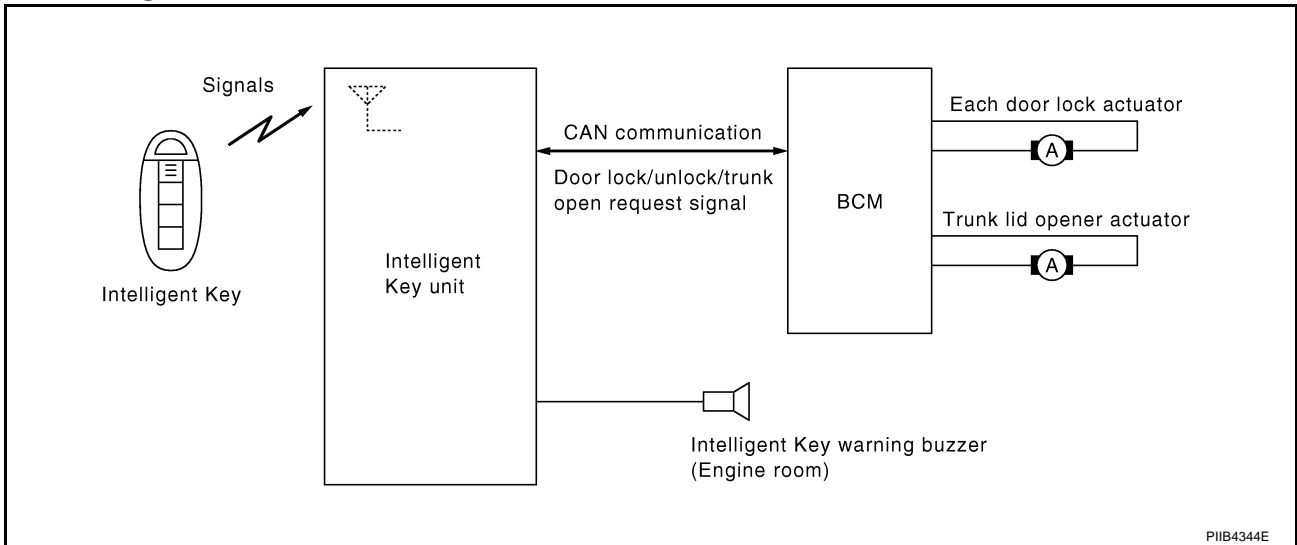

Door Lock/Unlock Function

- When door lock/unlock button of the Intelligent Key is passed, lock signal or unlock signal is sent from Intelligent Key to Intelligent Key unit.
- Intelligent Key unit sends the door lock/unlock request signal to BCM via CAN communication line.
- Intelligent Key unit sends the door lock/unlock signal and sounds Intelligent Key buzzer (Engine room) warning (lock: 1 time, unlock: 2 times trunk open: 4 times) at the same time.
- When BCM receives the door lock/unlock signal, it operates door lock actuator and flashes the hazard lamp (lock: 1 time, unlock: 2 times) at the same time as an operation check.

Trunk Open Function

- When pressing the trunk button of the Intelligent Key, the trunk open signal is sent from the Intelligent Key to the Intelligent Key unit.
- Intelligent Key unit sends trunk open request signal to BCM via CAN communication line and sounds Intelligent Key warning buzzer (Engine room) 4 times at the same time.
- When BCM receives the trunk open request signal, it operates the trunk lid opener actuator and opens the trunk.

Operation Condition

Remote controller operation	Operation condition
Lock	<ul style="list-style-type: none"> • All doors closed • OFF position warning chime is not operated.
Unlock	—
Trunk open	<ul style="list-style-type: none"> • Ignition switch is in OFF position. • Press and hold the trunk open button for 0.5 second or more

Selective Unlock Function

When an LOCK signal is sent from remote controller of Intelligent Key, all doors will be locked. When an UNLOCK signal is sent from remote controller of Intelligent Key once, driver's door will be unlocked. Then, if an UNLOCK signal is sent from remote controller of Intelligent Key again within 5 seconds, all other door will be unlocked.

Hazard and Horn Reminder

When doors are locked or unlocked by remote controller of Intelligent Key, Intelligent Key unit sends hazard and horn request signal to BCM via CAN communication line.

INTELLIGENT KEY SYSTEM

BCM flashes hazard warning lamps as a reminder and sends horn chirp signal to IPDM E/R. IPDM E/R sounds horn as a reminder.

The hazard and horn reminder has a horn chirp mode (C mode) and a non-horn chirp mode (S mode).

Operating function of hazard and horn reminder

	C mode		S mode	
Remote controller of Intelligent Key operation	Lock	Unlock	Lock	Unlock
Hazard warning lamp flash	Twice	Once	Twice	—
Horn sound	Once	—	—	—

Hazard and horn reminder does not operate if any door switch is ON (any door is OPEN).

How to change hazard and horn reminder mode

📱 With CONSULT-II

Hazard and horn reminder can be changed using “HORN WITH KEYLESS LOCK” and “HAZARD ANSWER BACK” mode in “WORK SUPPORT”. Refer to [BL-122, "WORK SUPPORT"](#).

⊗ Without CONSULT-II

When LOCK and UNLOCK signals are sent from the remote controller of Intelligent Key for more than 2 seconds at the same time, the hazard and horn reminder mode is changed and hazard warning lamp flashes and horn sounds as follows:

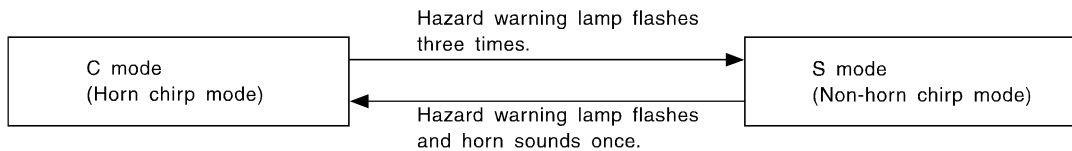

SEL153WA

Auto Door Lock Function

When all doors are locked, ignition knob switch is OFF (when ignition switch is not pressed) and key switch is OFF (when mechanical key is not inserted in key cylinder), doors are unlocked with remote controller of Intelligent Key. When Intelligent Key unit does not receive the following signals within 30 seconds, all doors are locked.

- Door switch is ON (door is opened)
- Door is locked
- Ignition knob switch is ON (ignition switch is pressed)
- Key switch is ON (mechanical key is inserted in key cylinder)

Auto door lock mode can be changed by “AUTO RELOCK TIMER” mode in “WORK SUPPORT”. Refer to [BL-122, "WORK SUPPORT"](#).

Panic Alarm Function

When ignition knob switch is OFF (when ignition switch is not pressed) and key switch is OFF (when mechanical key is not inserted in key cylinder), Intelligent Key unit receives PANIC ALARM signal from remote controller of Intelligent Key.

Intelligent Key unit sends alarm request signal to BCM via CAN communication line.

BCM turns on and off headlamp intermittently and sends theft warning horn signal to IPDM E/R. Then, IPDM E/R turns on and off horn intermittently.

The headlamp flashes and the horn sounds intermittently.

The alarm automatically turns off:

- After 25 seconds
- When Intelligent Key unit receives any signal from remote controller of Intelligent Key
- When door request switch is pressed (Intelligent Key is outside vehicle)

INTELLIGENT KEY SYSTEM

Panic alarm function mode can be changed by "PANIC ALARM DELAY" mode in "WORK SUPPORT". Refer to [BL-122, "WORK SUPPORT"](#).

Keyless Power Window Down (Open) Function

All power windows open when the unlock button on remote controller of Intelligent Key is activated and kept pressed for more than 3 seconds with the ignition switch OFF. The windows keep opening if the unlock button is continuously pressed.

The power window opening stops when the following operations are performed:

- When the unlock button is kept pressed more than 15 seconds.
- When the ignition switch is turned ON while the power window opening is operated.
- When the unlock button is released.

While retained power operation activate, Keyless power window down (open) Function cannot be operated. Keyless power window down operation mode can be changed by "P/W DOWN DELAY" mode in "WORK SUPPORT". Refer to [BL-122, "WORK SUPPORT"](#).

Room Lamp Illumination Operation

When the following conditions are met:

- Condition of interior lamp switch is in DOOR position
- Door switch OFF (when all the doors are closed)

Intelligent Key system turns on interior lamp (for 30 seconds) by receiving UNLOCK signal from remote controller of Intelligent Key. For detailed description, refer to [LT-172, "ROOM LAMP TIMER OPERATION"](#).

List of Operation Related Parts

Parts marked with × are the parts related to operation.

Remote keyless entry functions	Intelligent Key	Key switch	Ignition knob switch	Door request switch (Driver, Passenger)	Door switch	Trunk room lamp switch	Door lock actuator	Trunk lid opener actuator	Intelligent Key warning buzzer	Intelligent Key unit	CAN communication system	BCM	Combination meter	Hazard warning lamp	Horn	IPDM E/R	Head lamp
Door lock/unlock function by remote control button	×	×	×		×		×			×	×	×					
Trunk open function by remote control button	×	×	×			×		×		×	×	×					
Hazard and horn reminder function	×								×	×	×	×	×	×	×	×	
Selective unlock function	×				×		×			×	×	×					
Keyless power window down (open) function	×	×								×		×					
Auto door lock function	×	×	×		×					×	×	×					
Panic alarm function	×			×						×	×	×			×	×	×

INTELLIGENT KEY SYSTEM

ENGINE START FUNCTION

When the registered Intelligent Key is carried, the engine can be started without inserting the key.

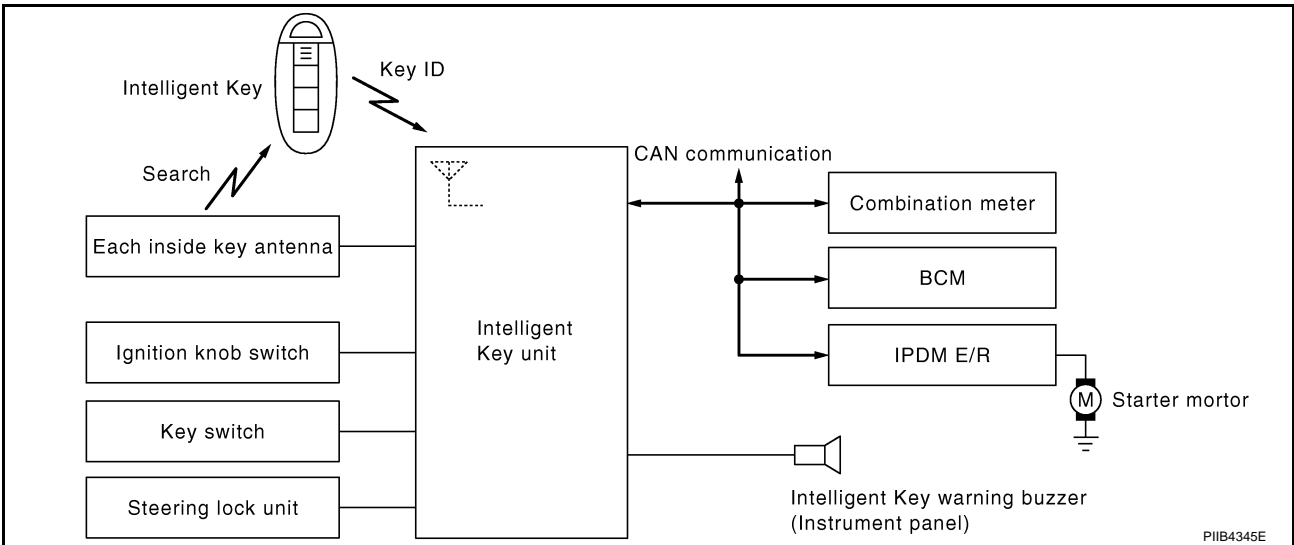

When ignition knob switch is ON (press ignition switch), Intelligent Key unit searches Intelligent Key in the vehicle using inside key antenna.

When Intelligent Key is inside the vehicle, it performs the following operation.

- Illuminate green "KEY" warning lamp in combination meter.
- Released steering lock and ignition switch can be turned from OFF to ACC, ON or START position.

NOTE:

If Intelligent Key is not registered, "KEY" warning lamp in combination meter illuminates red.

- Intelligent Key sends engine start signal via CAN communication line.

When ignition switch turns to START position, BCM sends starter request signal to IPDM E/R. Then, engine starts.

Even if Intelligent Key battery runs down, Intelligent key unit can start engine with mechanical key built Intelligent Key. For details, refer to [BL-225, "IVIS \(INFINITI VEHICLE IMMOBILIZER SYSTEM-NATS\)"](#).

All of the originally supplied Intelligent Key IDs (except for key) have been registered in Intelligent Key system. If requested by the vehicle owner, a maximum of four Intelligent Key IDs can be registered into the Intelligent Key system components.

List of Operation Related Parts

Parts marked with × are the parts related to operation.

Engine start functions	Intelligent Key	Key switch	Ignition knob switch	Inside key antenna	Intelligent Key unit	CAN communication system	BCM	Combination meter	IPDM E/R	NATS antenna amp.	Steering lock unit
Engine start function by the Intelligent Key	×	×	×	×	×	×	×	×	×		×
Engine start function by the mechanical key		×			×	×	×		×	×	×

INTELLIGENT KEY SYSTEM

WARNING CHIME FUNCTION

Operation Description

The warning chimes are as follows and are given to the user as warning information and warnings using combinations of Intelligent Key warning buzzer (in instrument panel and engine room), and warning lamps "KEY" and "P-SHIFT".

- Ignition switch warning chime
- Ignition key warning chime
- OFF position warning chime
- OFF position warning chime (after door closed)
- Take away warning chime
- Take away warning chime (from window)
- Door lock operation warning chime
- Intelligent key low battery warning
- P position warning

INTELLIGENT KEY SYSTEM

Operation Condition

Operation	Condition	Intelligent Key warning buzzer sounds	Warning lamp illuminates
Ignition switch warning chime	<ul style="list-style-type: none"> ● Key switch is OFF. ● Ignition switch is in the ACC, OFF or LOCK position. [Ignition switch is pressed (ignition knob switch is ON).] ● Driver door is open. 	Instrument panel side	—
Ignition key warning chime (When mechanical key is used)	<ul style="list-style-type: none"> ● Mechanical key is inserted in ignition switch (key switch is ON). ● Ignition switch is in the ACC, OFF or LOCK position. ● Driver door is open. 	Instrument panel side	—
OFF position warning chime	<ul style="list-style-type: none"> ● Ignition switch is turned from ACC to OFF. [Ignition switch is pressed (ignition knob switch is ON).] ● Ignition switch is in the LOCK position and pressed for 1 second. 	Instrument panel side	—
OFF position warning chime (after door closed)	When driver door is opened and then closed while the OFF position warning chime above is operating	Engine room side	—
Take away warning chime	<ul style="list-style-type: none"> ● Engine is running. ● Door open to close. ● Intelligent Key is not found inside vehicle. 	Engine room side	"KEY" (red)
Take away warning chime (from window)	<ul style="list-style-type: none"> ● Engine is running. ● Door is closed. ● Intelligent Key is not found inside vehicle. 	Instrument panel side	"KEY" (red)
Door lock operation warning chime	When request switch is pushed under the following conditions <ul style="list-style-type: none"> ● All door are closed ● Door is unlocked. ● Intelligent Key is inside vehicle. ● Ignition switch is not pressed. 	Engine room side	—
	When request switch is pushed under the following conditions <ul style="list-style-type: none"> ● All door are closed ● Door is unlocked. ● Ignition switch is pressed. ● Intelligent Key is within the detection area of operated request switch. 	Engine room side	—
	When request switch is pushed under the following conditions <ul style="list-style-type: none"> ● Any door is opened. ● Intelligent Key is within the detection area of operated request switch. 	Engine room side	—
Intelligent Key low battery warning	When Intelligent Key is low battery, Intelligent Key unit is detected after ignition switch is turned ON.	—	"KEY" (green)
P position warning	When selector lever is except for P position, ignition switch is turned from ON to OFF.	—	"P-SHIFT"

A
B
C
D
E
F
G
H
BL
J
K
L
M

INTELLIGENT KEY SYSTEM

List of Operation Related Parts

Parts marked with × are the parts related to operation.

Warning and alarm functions	Intelligent Key	Key switch	Ignition knob switch	Ignition switch ACC position input signal	Ignition switch ON position input signal	Door switch	Door request switch	Inside key antenna	Outside key antenna (Driver, Passenger)	Outside key antenna (rear bumper)	Intelligent Key warning buzzer	Intelligent Key unit	CAN communication system	BCM	Combination meter	Park position switch
Ignition switch warning chime			×		×	×						×				
Ignition key warning chime (When mechanical key used)		×			×	×							×	×	×	
OFF position warning chime			×	×	×						×	×				
OFF position warning chime (after door close)			×	×	×	×					×	×				
Take away warning chime	×		×			×		×			×	×				×
Take away warning chime (from window)	×		×			×		×			×	×				×
Door lock operation warning chime	×		×			×	×	×	×		×	×				
Intelligent Key low battery warning	×				×			×				×				×
P position warning					×							×			×	×

CHANGE SETTINGS FUNCTION

The settings for each function can be changed with the CONSULT-II.

Changing Settings Using CONSULT-II

The settings for the Intelligent Key system functions can be changed using CONSULT-II (WORK SUPPORT). Refer to [BL-122, "WORK SUPPORT"](#) .

NOTE:

Once a function setting is changed, it will remain effective even if the battery is disconnected.

INTELLIGENT KEY REGISTRATION

Intelligent Key-ID registration is performed using the CONSULT-II.

CAUTION:

- After a new Intelligent Key-ID is registered, be sure to check the function.
- When registering an additional Intelligent Key-ID, take any Intelligent Keys already registered and Intelligent Keys for any other vehicles out of the vehicle before starting.

CONSULT-II can be used to check and delete Intelligent Key-IDs.

For future information, see the CONSULT-II Operation Manual NATS.

INTELLIGENT KEY SYSTEM

STEERING LOCK UNIT REGISTRATION

Steering Lock Unit ID Registration

CAUTION:

- The method for registering a steering lock unit ID depends on the status of the steering lock unit and Intelligent Key unit (new or old unit).
- After registration is completed, press ignition switch with a portable unit in the vehicle so that it can be turned, and confirm that it cannot be turned even when ignition switch is pressed without a portable unit in the vehicle.

For future information, see the CONSULT-II Operation Manual NATS.

CAN Communication System Description

AIS00696

CAN (Controller Area Network) is a serial communication line for real time application. It is an on-vehicle multiplex communication line with high data communication speed and excellent error detection ability. Many electronic control units are equipped onto a vehicle, and each control unit shares information and links with other control units during operation (not independent). In CAN communication, control units are connected with 2 communication lines (CAN H line, CAN L line) allowing a high rate of information transmission with less wiring. Each control unit transmits/receives data but selectively reads required data only.

CAN Communication Unit

AIS00697

Refer to [LAN-21, "CAN COMMUNICATION"](#).

A

B

C

D

E

F

G

H

BL

J

K

L

M

INTELLIGENT KEY SYSTEM

Schematic

AIS00698

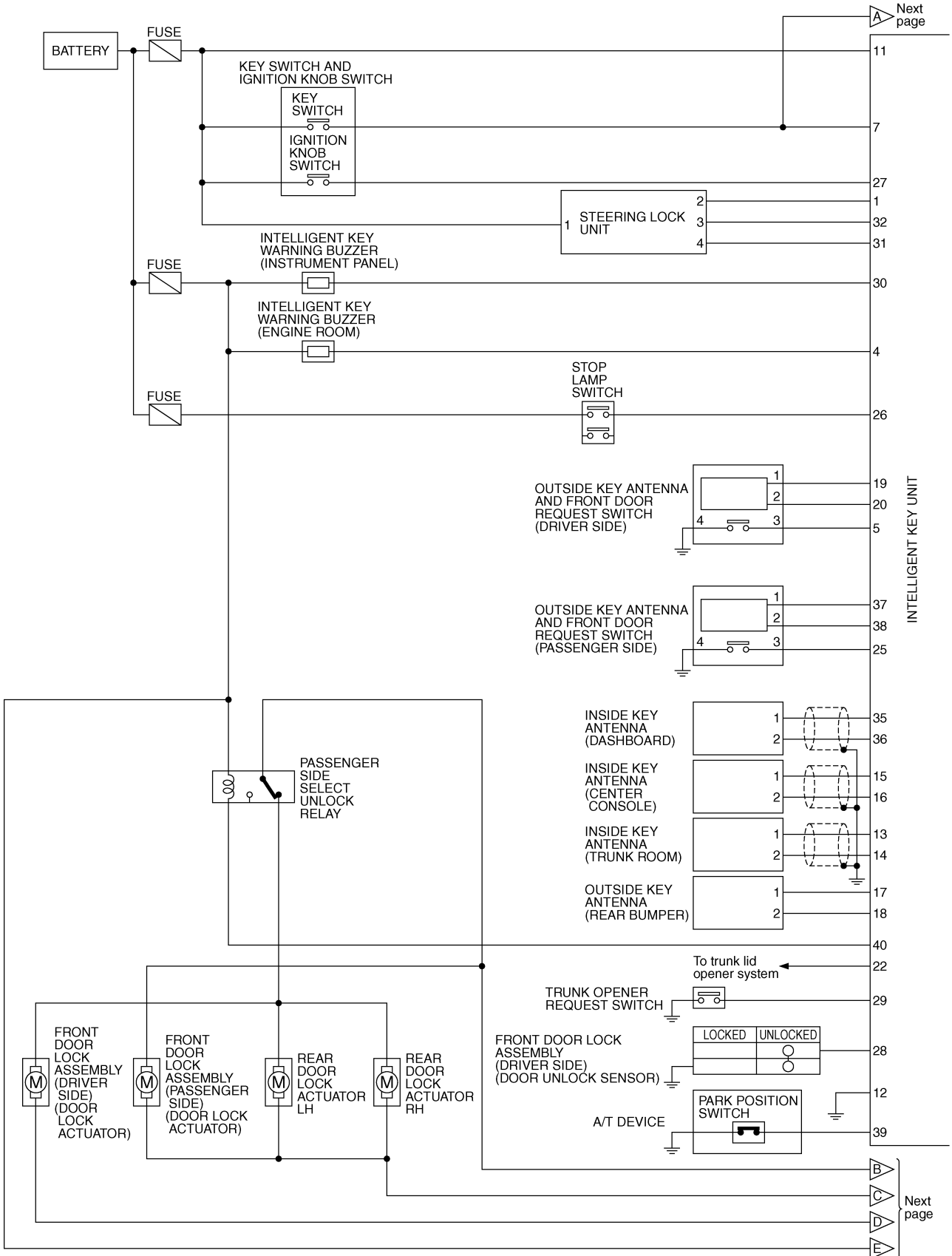

TIWM1044E

INTELLIGENT KEY SYSTEM

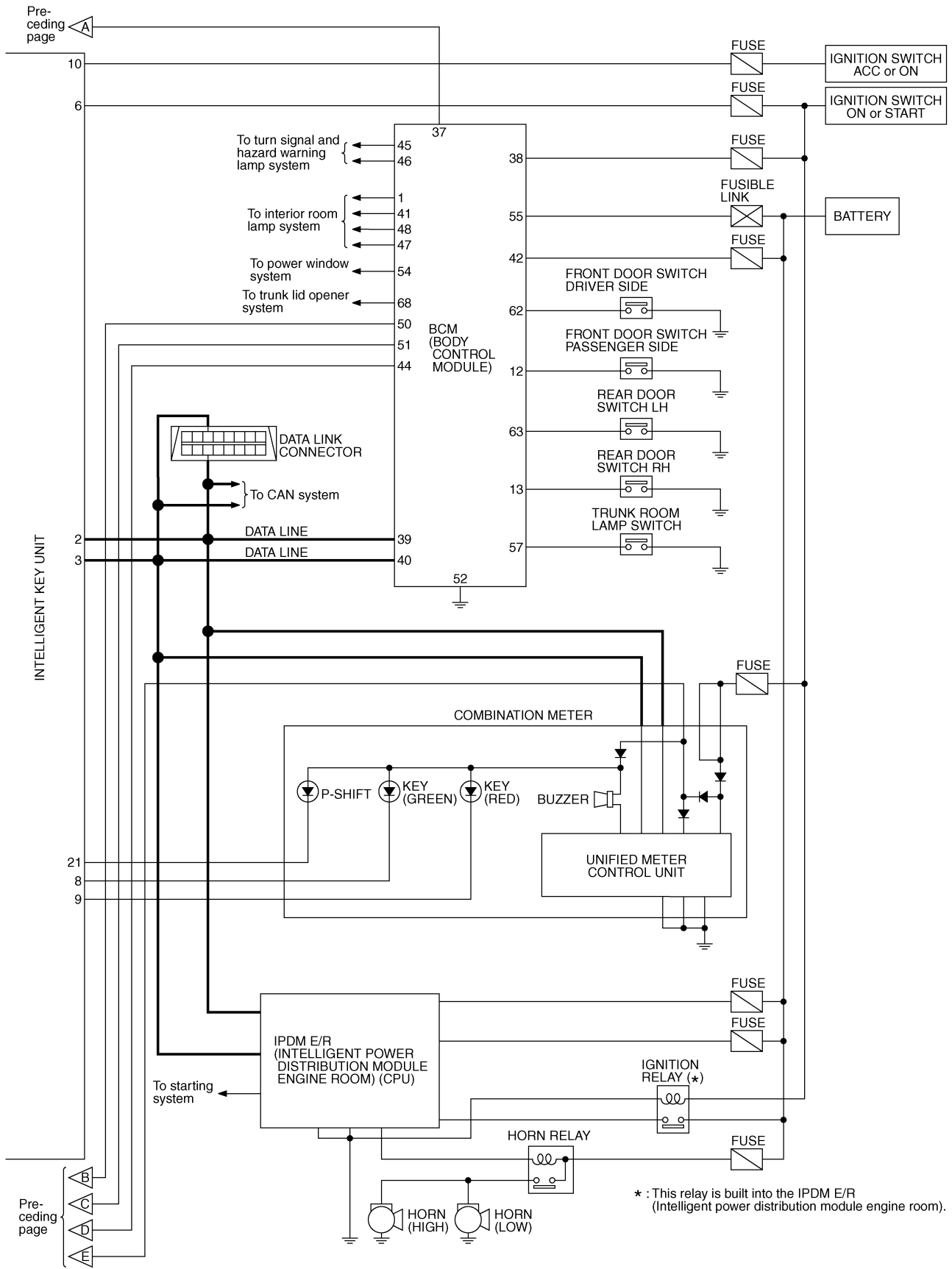

A
B
C
D
E
F
G
H
BL
J
K
L
M

TIWM1045E

INTELLIGENT KEY SYSTEM

AIS00699

Wiring Diagram — I/KEY—

BL-I/KEY-01

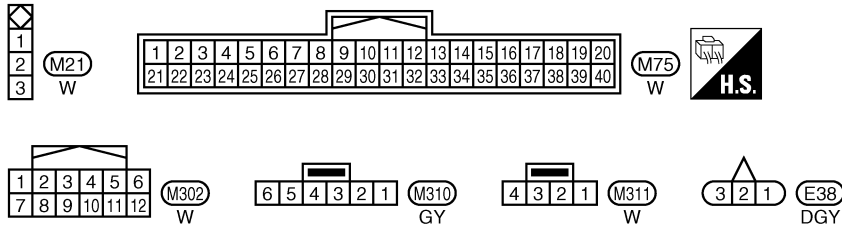
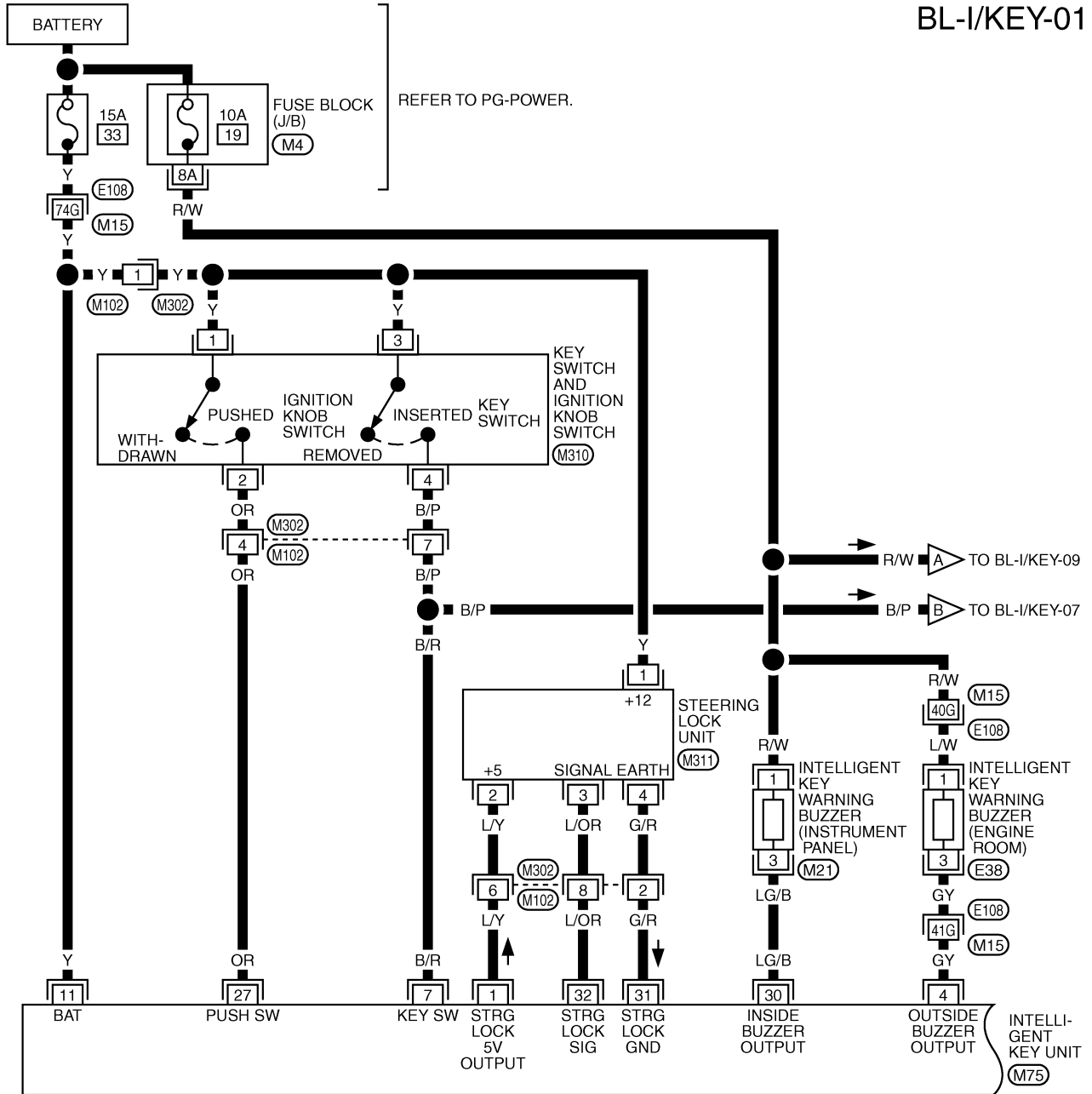

REFER TO THE FOLLOWING.

- (E108) -SUPER MULTIPLE JUNCTION (SM)
- (M4) -FUSE BLOCK-JUNCTION BOX (J/B)

TIWM1046E

INTELLIGENT KEY SYSTEM

BL-I/KEY-02

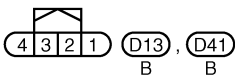
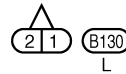
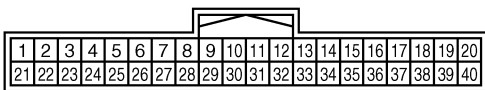
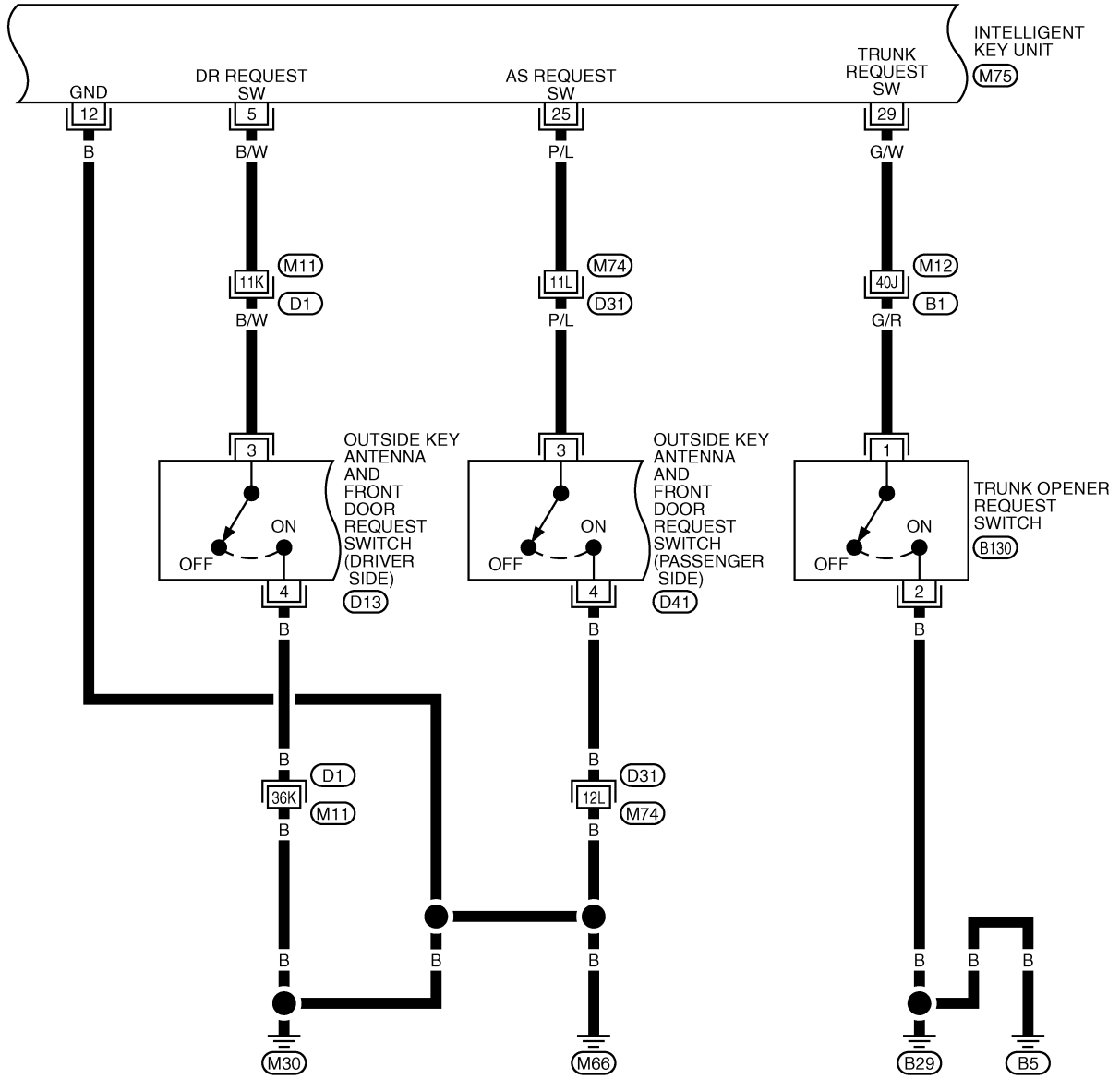

REFER TO THE FOLLOWING.
 (B1), (D1), (D31) -SUPER
 MULTIPLE JUNCTION (SMJ)

TIWM1047E

INTELLIGENT KEY SYSTEM

BL-I/KEY-03

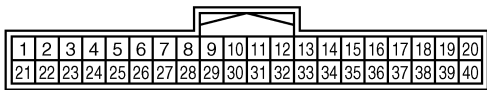
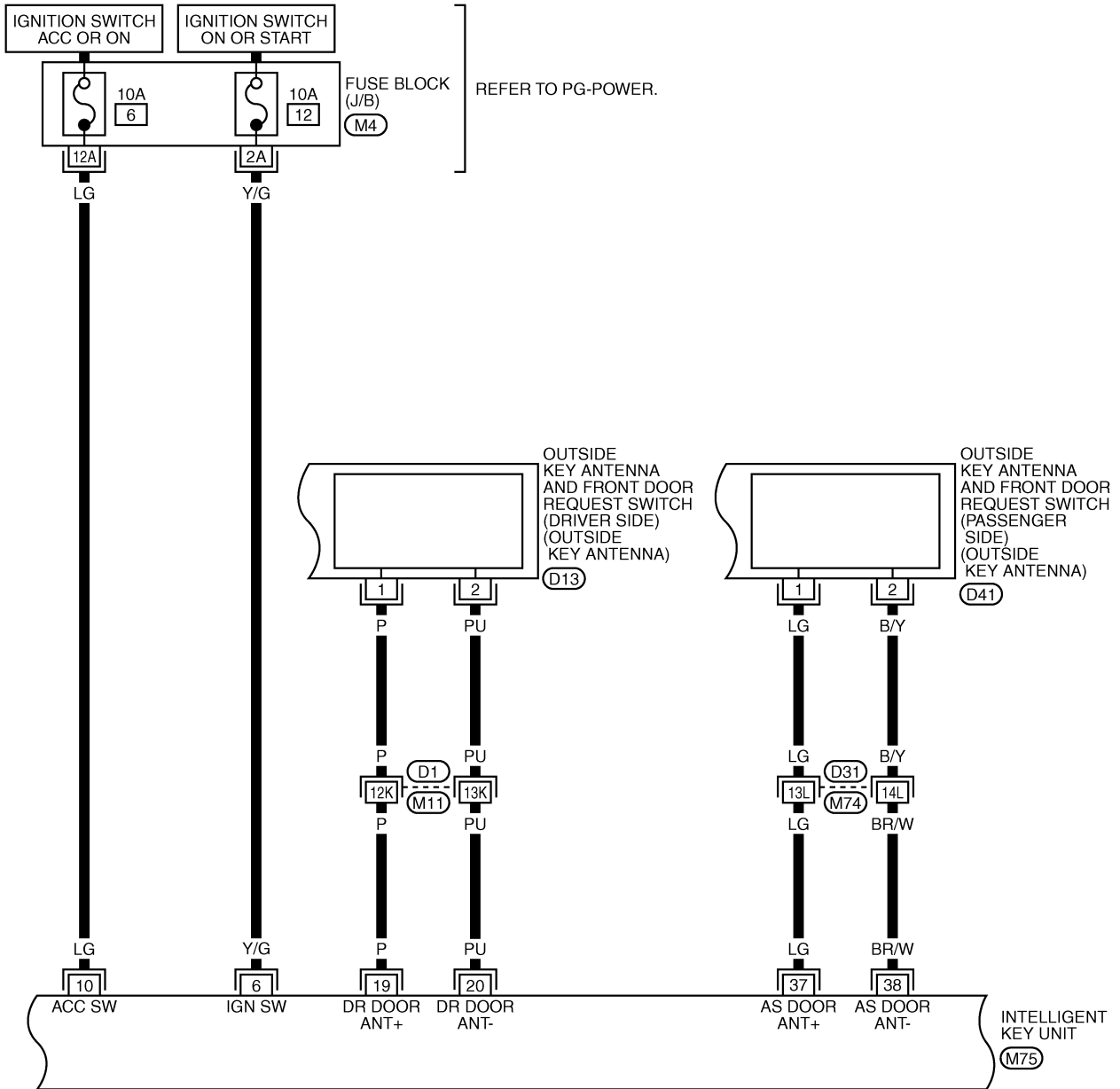

(M75)
W

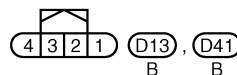

(D13), (D41)
B B

REFER TO THE FOLLOWING.

(D1), (D31) -SUPER MULTIPLE JUNCTION (SMJ)

(M4) -FUSE BLOCK-JUNCTION BOX (J/B)

TIWM1048E

INTELLIGENT KEY SYSTEM

BL-I/KEY-04

A
B
C
D
E
F
G
H
I
J
K
L
M

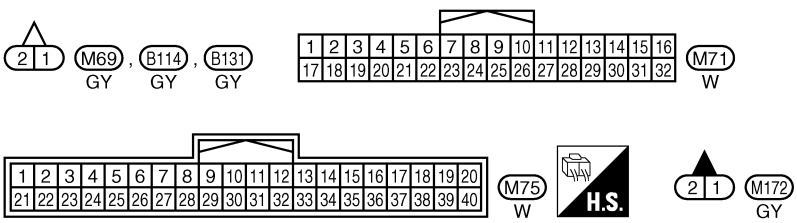
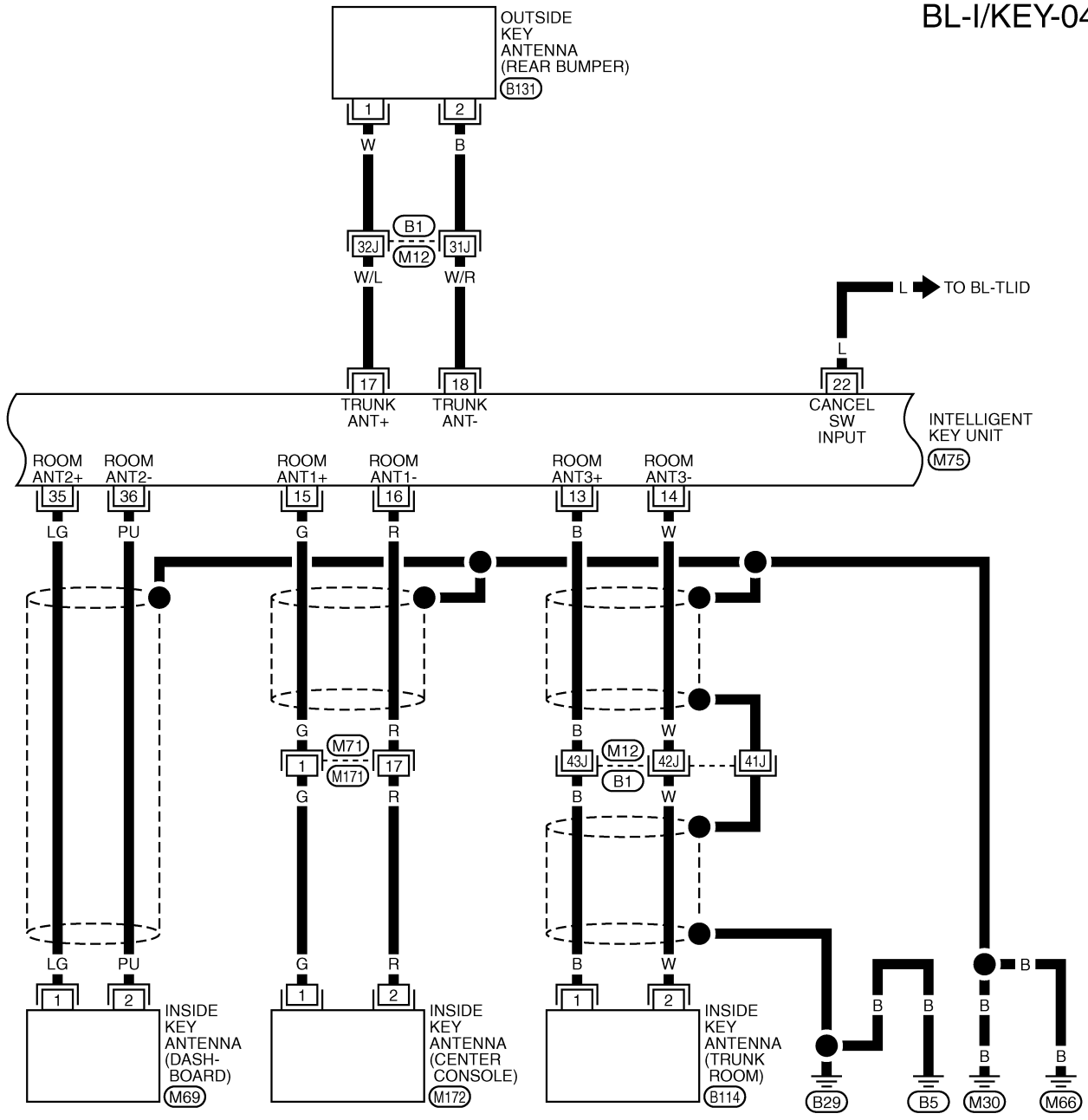

REFER TO THE FOLLOWING.
 (B1) -SUPER MULTIPLE JUNCTION (SMJ)

TIWM1049E

INTELLIGENT KEY SYSTEM

BL-I/KEY-05

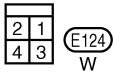
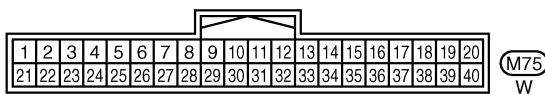
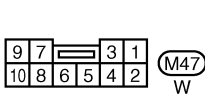
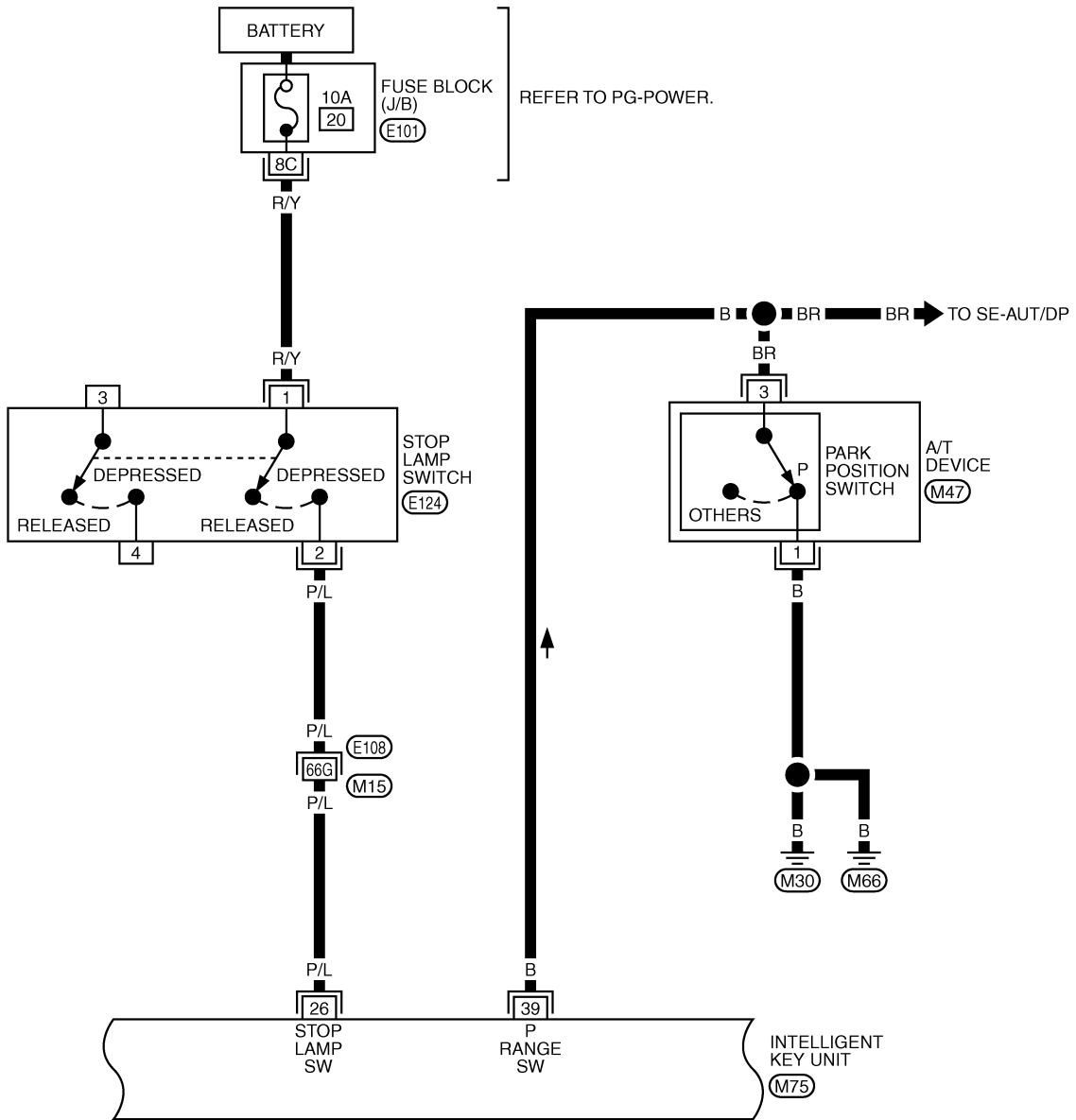

REFER TO THE FOLLOWING.

(E108) -SUPER MULTIPLE JUNCTION (SMJ)

(E101) -FUSE BLOCK-JUNCTION BOX (J/B)

TIWM1050E

INTELLIGENT KEY SYSTEM

BL-I/KEY-06

▬ : DATA LINE

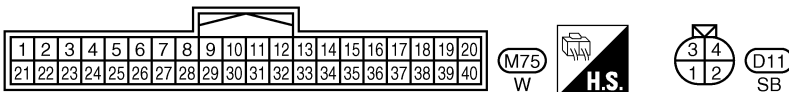
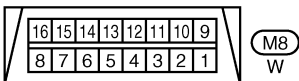
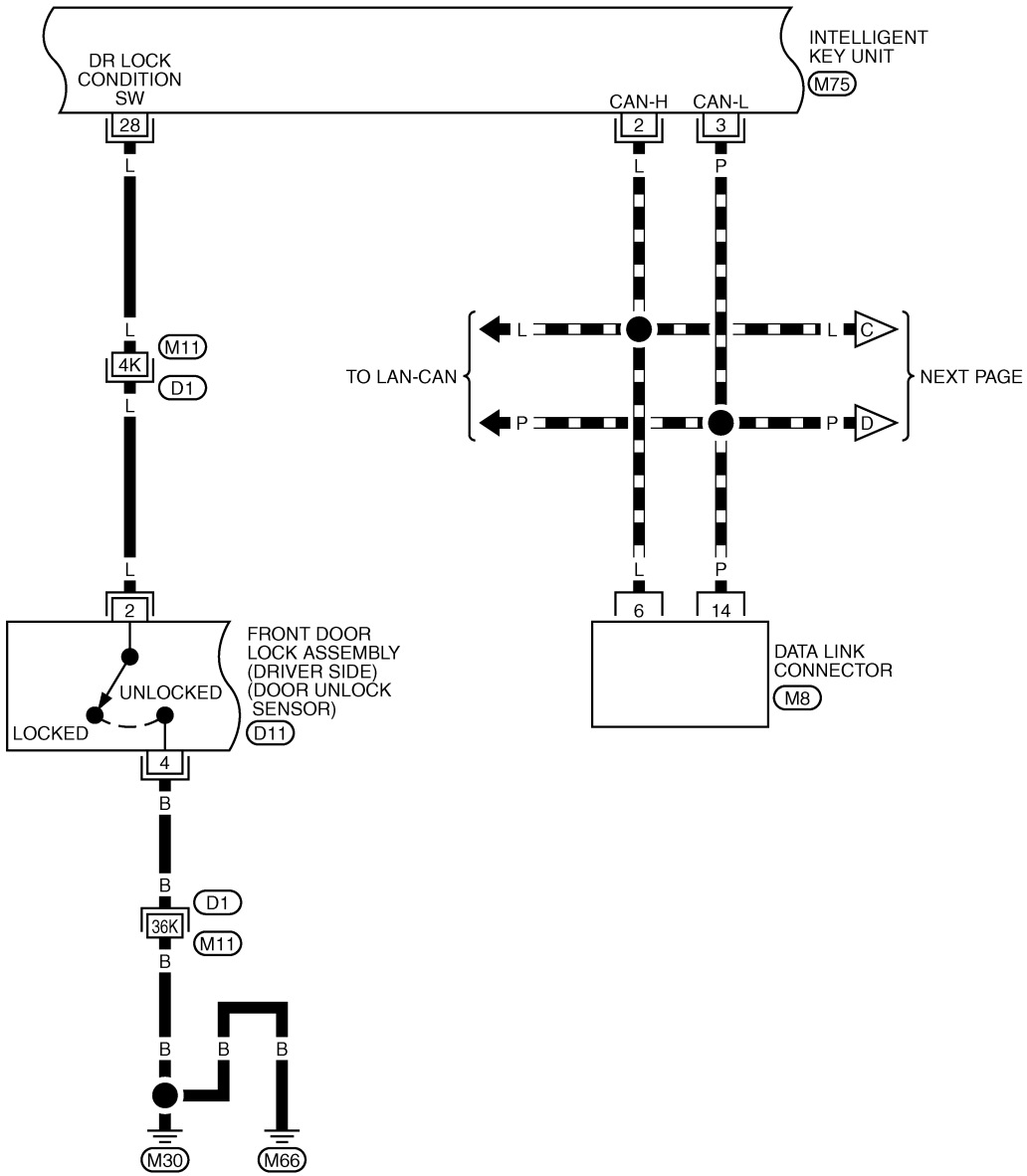

REFER TO THE FOLLOWING.
 (D1) -SUPER MULTIPLE JUNCTION (SMJ)

TIWM1051E

INTELLIGENT KEY SYSTEM

BL-I/KEY-07

▬ : DATA LINE

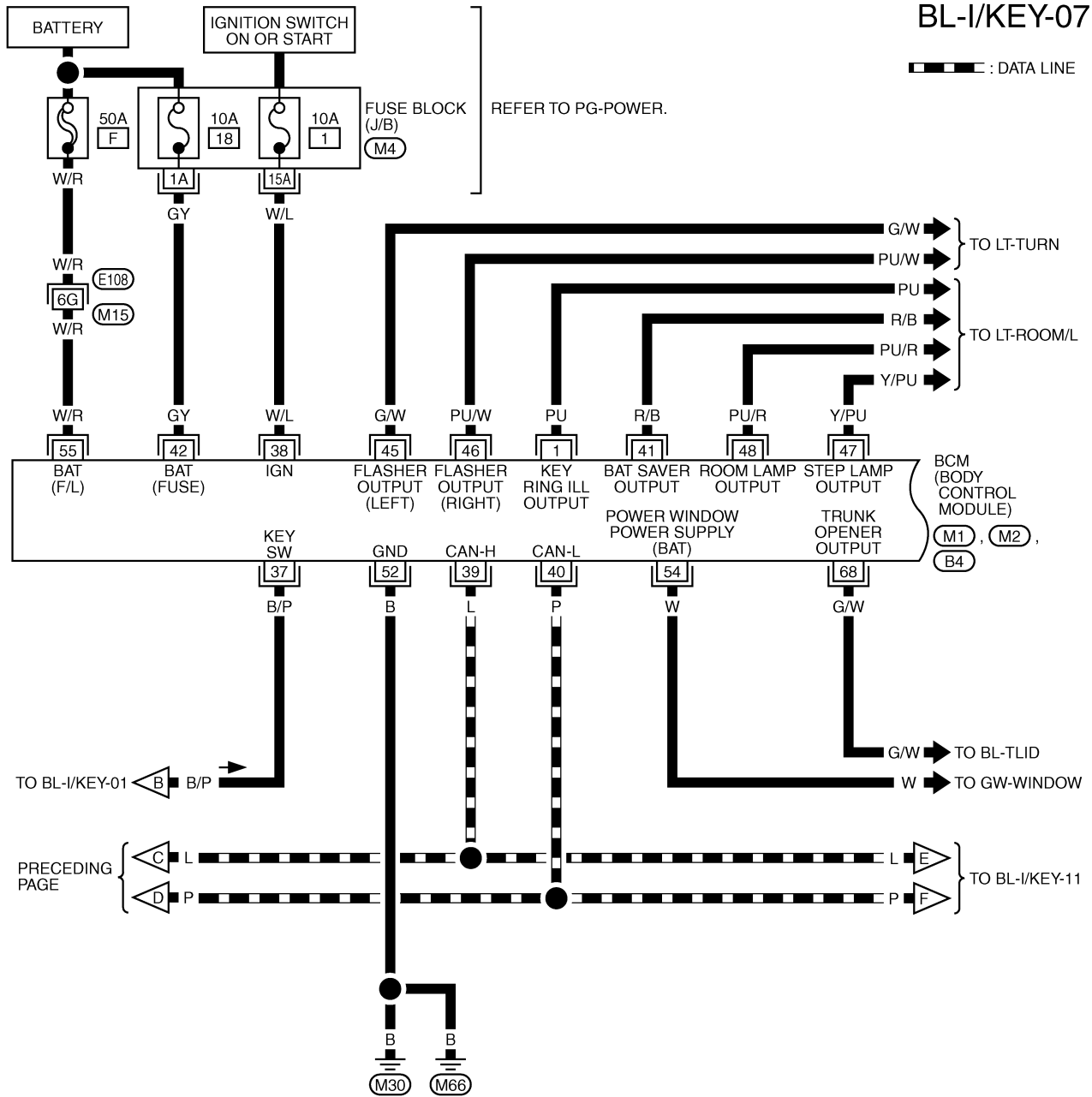

REFER TO THE FOLLOWING.

- (E108) -SUPER MULTIPLE JUNCTION (SMJ)
- (M4) -FUSE BLOCK-JUNCTION BOX (J/B)
- (M1), (M2), (B4) -ELECTRICAL UNITS

TIWM1052E

INTELLIGENT KEY SYSTEM

BL-I/KEY-08

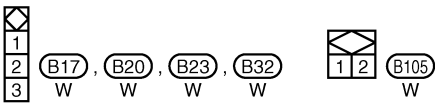
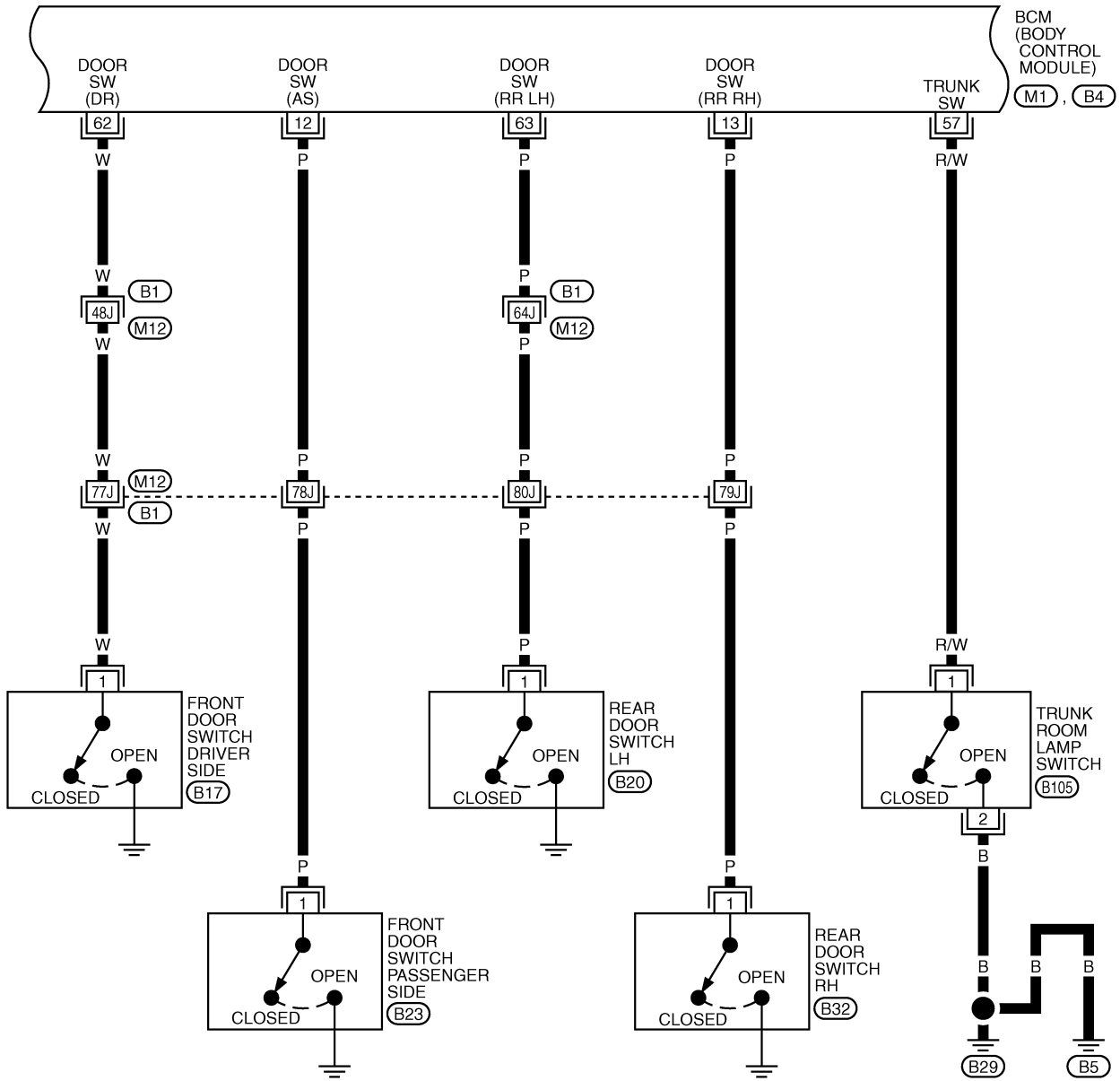

REFER TO THE FOLLOWING.
 (B1) -SUPER MULTIPLE JUNCTION (SMJ)
 (M1), (B4) -ELECTRICAL UNITS

TIWM1053E

A
B
C
D
E
F
G
H
I
J
K
L
M

BL

INTELLIGENT KEY SYSTEM

BL-I/KEY-09

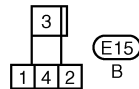
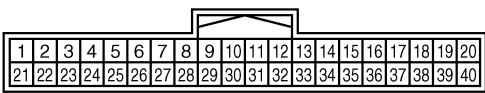
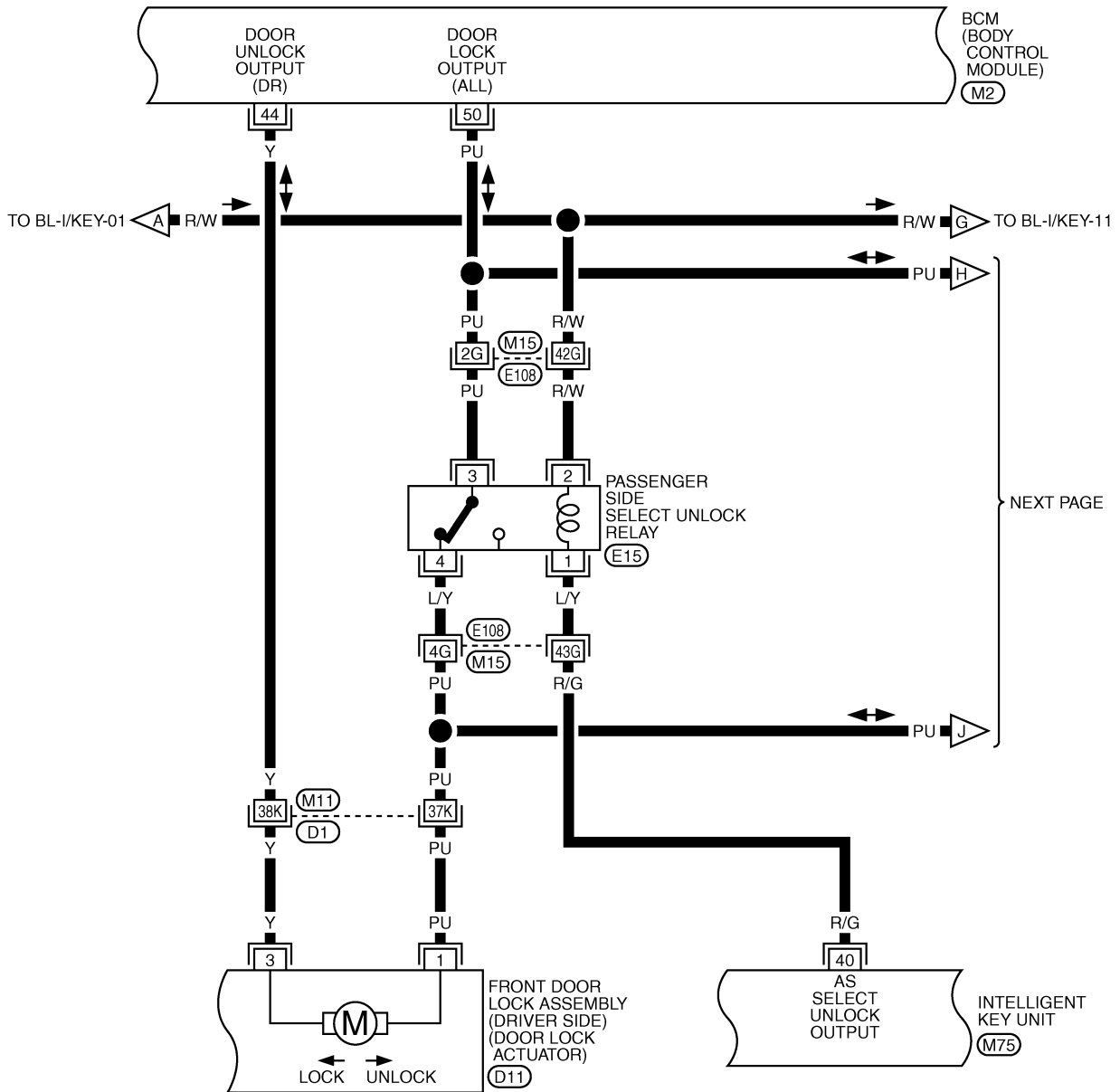

REFER TO THE FOLLOWING.

(E108), (D1) -SUPER MULTIPLE JUNCTION (SMJ)

(M2) -ELECTRICAL UNITS

TIWM1054E

INTELLIGENT KEY SYSTEM

BL-I/KEY-10

A
B
C
D
E
F
G
H
BL
J
K
L
M

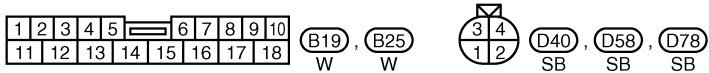
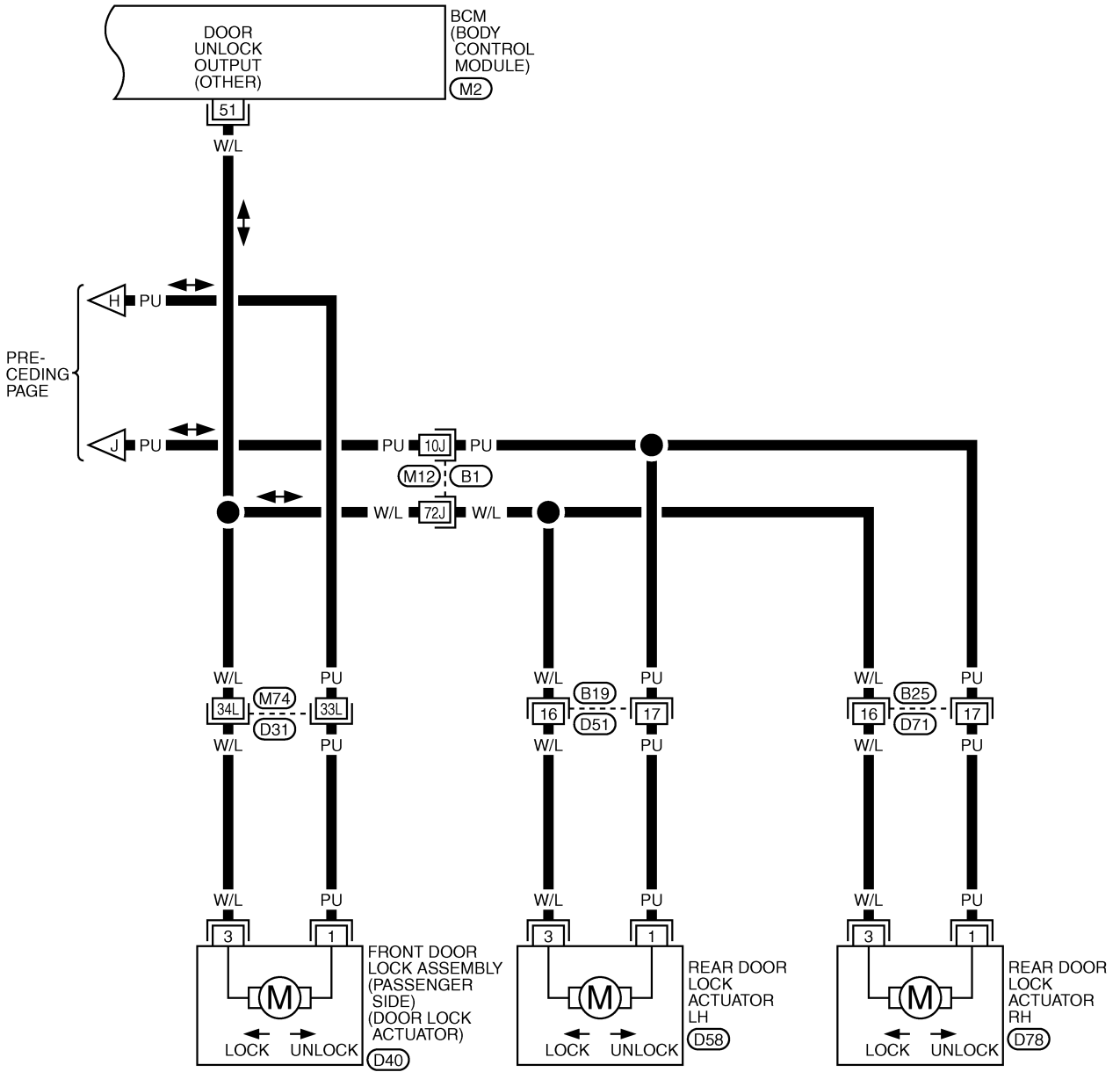

REFER TO THE FOLLOWING.
 (B1), (D31) -SUPER MULTIPLE JUNCTION (SMJ)
 (M2) -ELECTRICAL UNITS

TIWM1055E

INTELLIGENT KEY SYSTEM

BL-I/KEY-11

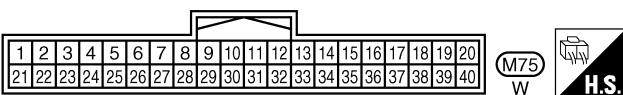
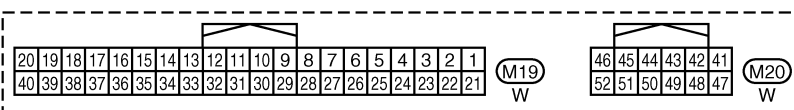
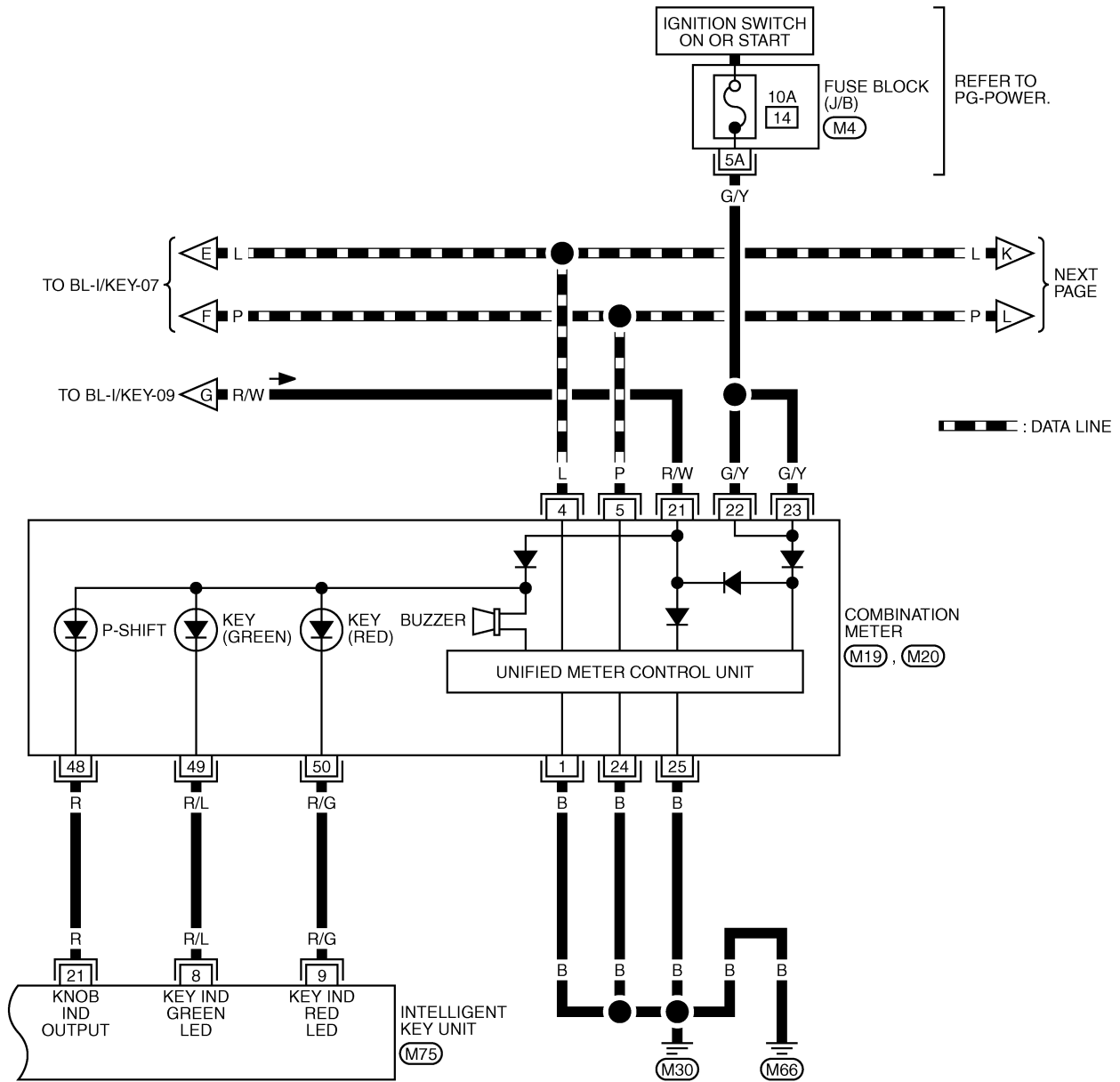

REFER TO THE FOLLOWING.

M4 -SUPER MULTIPLE JUNCTION (SMJ)

TIWM1056E

INTELLIGENT KEY SYSTEM

BL-I/KEY-12

A
B
C
D
E
F
G
H
J
K
L
M

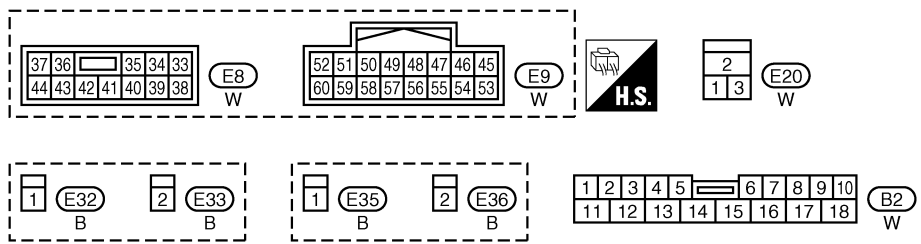
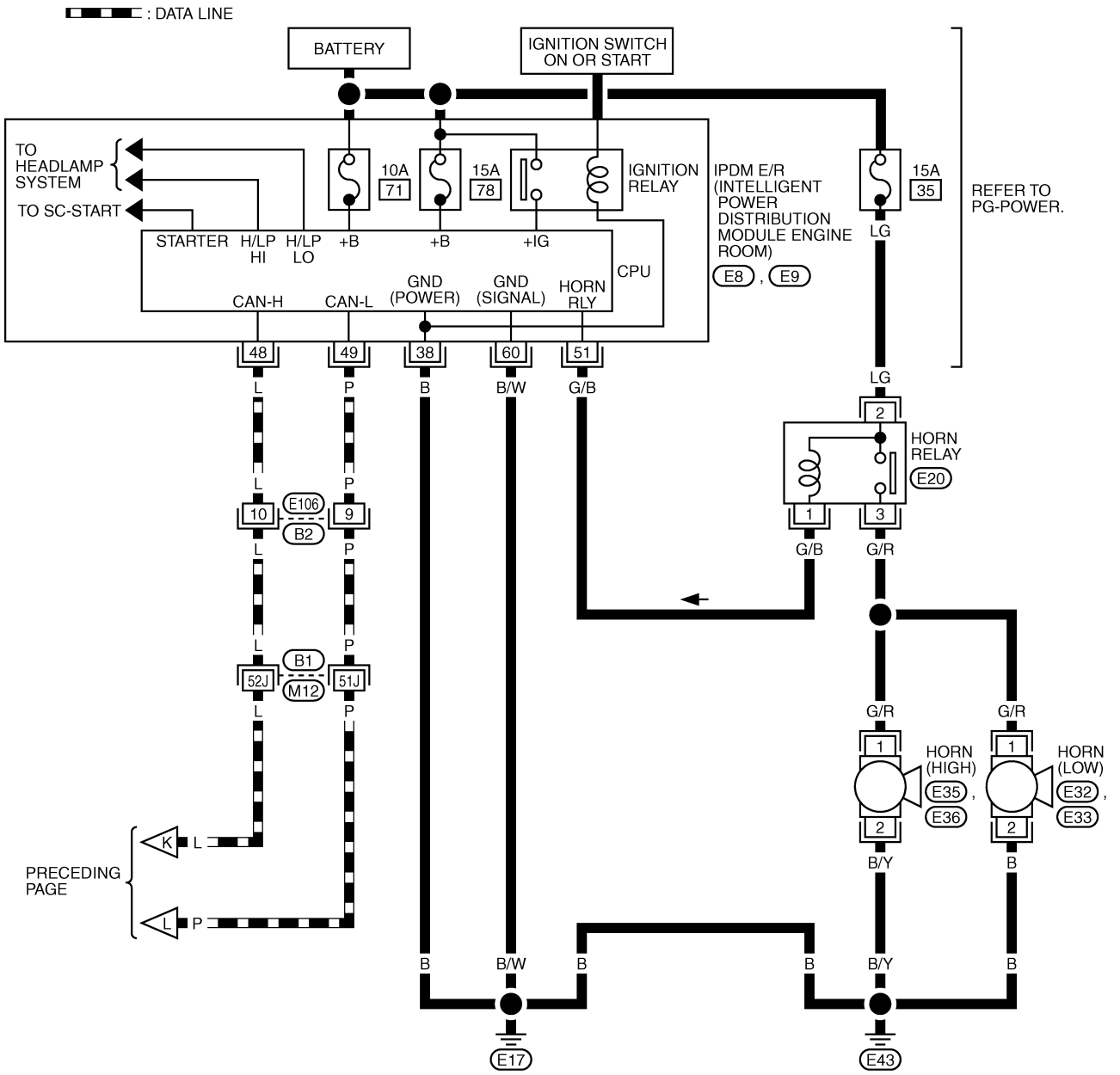

REFER TO THE FOLLOWING.
 (B1) -SUPER MULTIPLE JUNCTION (SMJ)

TIWM1057E

INTELLIGENT KEY SYSTEM

Terminals and Reference Value for Intelligent Key Unit

AIS0069A

Terminal	Wire Color	Item	Condition		Voltage (V) Approx.	
			Ignition Switch Position	Operation or Conditions		
1	L/Y	Steering lock unit power supply	LOCK	—	5	
2	L	CAN-H	—	—	—	
3	P	CAN-L	—	—	—	
4	GY	Intelligent Key warning buzzer (engine room)	LOCK	Operate door request switch.	Buzzer OFF	Battery voltage
					Sound buzzer	0
5	B/W	Door request switch (driver side)	—	Press door request switch (driver side).	0	
				Other than above	5	
6	Y/G	Ignition switch (ON)	ON	—	Battery voltage	
7	B/R	Key switch	LOCK	Insert mechanical key into ignition key cylinder.	Battery voltage	
				Remove mechanical key from ignition key cylinder.	0	
8	R/L	KEY indicator (green)	LOCK	When Intelligent Key is inside vehicle, press ignition knob switch.	0	
				Ignition knob switch OFF	Battery voltage	
9	R/G	KEY warning lamp (red)	LOCK	When Intelligent Key is outside vehicle, press ignition knob switch.	0	
				Ignition knob switch OFF	Battery voltage	
10	LG	Ignition switch (ACC)	ACC	—	Battery voltage	
11	Y	Power source (Fuse)	—	—	Battery voltage	
12	B	Ground	—	—	0	
13	B	Inside key antenna (+) signal (Trunk room)	LOCK	Any door open → all door close		
14	W	Inside key antenna (-) signal (Trunk room)				
15	G	Inside key antenna (+) signal (Center console)	LOCK	Press ignition knob switch: ON (Ignition knob switch)		
16	R	Inside key antenna (-) signal (Center console)				
17	W/L	Outside key antenna (+) signal (Rear bumper)	LOCK	Press trunk opener request switch.		
18	W/R	Outside key antenna (-) signal (Rear bumper)				

SIIA1910J

SIIA1910J

SIIA1910J

INTELLIGENT KEY SYSTEM

Terminal	Wire Color	Item	Condition		Voltage (V) Approx.
			Ignition Switch Position	Operation or Conditions	
19	P	Outside key antenna (+) signal (driver side)	LOCK	Press door request switch (driver side).	<p style="text-align: right; font-size: small;">SIIA1910J</p>
20	PU	Outside key antenna (-) signal (driver side)			
21	R	"P-SHIFT" warning lamp	ON	Within 2 seconds after ignition knob switch is turned ON	0
				Other than above	Battery voltage
25	P/L	Door request switch (passenger side)	—	Press door request switch (passenger side).	0
				Other than above	5
26	P/L	Stop lamp switch	—	Depress brake pedal.	Battery voltage
				Other than above	0
27	OR	Ignition knob switch	—	Press ignition switch.	Battery voltage
				Return ignition switch to LOCK position.	0
28	L	Unlock sensor (driver side)	—	Door (driver side) is locked.	5
				Door (driver side) is unlocked.	0
29	G/W	Trunk opener request switch	—	Press trunk opener request switch.	0
				Other than above	5
30	LG/B	Intelligent Key warning buzzer (instrument panel)	ACC	Driver's door open (sounds buzzer)	0
				Driver's door close (buzzer OFF)	Battery voltage
31	G/R	Steering lock unit ground	—	—	0
32	L/OR	Steering lock unit communication signal	LOCK	When Intelligent Key is inside vehicle, press ignition knob switch.	<p style="text-align: right; font-size: small;">SIIA1911J</p>
				Other than above	5
35	LG	Inside key antenna (+) signal (Dashboard)	LOCK	Press ignition knob switch: ON (Ignition knob switch)	<p style="text-align: right; font-size: small;">SIIA1910J</p>
36	PU	Inside key antenna (-) signal (Dashboard)			
37	LG	Outside key antenna (+) signal (passenger side)	LOCK	Press door request switch (passenger side).	<p style="text-align: right; font-size: small;">SIIA1910J</p>
38	BR/W	Outside key antenna (-) signal (passenger side)			

A
B
C
D
E
F
G
H
BL
J
K
L
M

INTELLIGENT KEY SYSTEM

Terminal	Wire Color	Item	Condition		Voltage (V) Approx.
			Ignition Switch Position	Operation or Conditions	
39	B	P range switch	—	Selector lever is in "P" position.	0
				Other than above	5
40	R/G	Assist select unlock output	—	Press door request switch (passenger side).	Battery voltage → 0 → Battery voltage

Terminals and Reference Value for Steering Lock Unit

AIS0069B

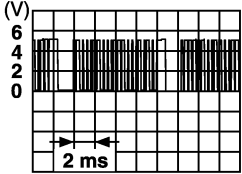
Terminal	Wire Color	Signal Designation	Condition		Voltage (V) Approx.
			Ignition Switch Position	Operation or Conditions	
1	Y	Battery power supply	LOCK	—	Battery voltage
2	L/Y	Steering lock unit power supply	LOCK	—	5
3	L/OR	Steering lock unit communication signal	LOCK	When Intelligent Key is inside vehicle, press ignition knob switch.	
				Other than the above	5
4	G/R	Steering lock unit ground	—	—	0

SIIA1911J

Terminals and Reference Value for BCM

AIS0069C

Terminal	Wire Color	Item	Condition	Voltage (V) Approx.
12	P	Front door switch passenger side	Door open (ON) → Close (OFF)	0 → Battery voltage
13	P	Rear door switch RH	Door open (ON) → Close (OFF)	0 → Battery voltage
37	B/P	Key switch	Insert mechanical key from ignition key cylinder.	Battery voltage
			Remove mechanical key into ignition key cylinder.	0
38	W/L	Ignition switch (ON)	Ignition switch is in ON or START position.	Battery voltage
39	L	CAN-H	—	—
40	P	CAN-L	—	—
42	GY	Battery power supply (fuse)	—	Battery voltage
44	Y	Driver side door lock actuator (unlock)	Door lock/ unlock switch (Free → Unlock)	0 → Battery voltage → 0
50	PU	All door lock actuator (lock)	Door lock/ unlock switch (Free → Lock)	0 → Battery voltage → 0
51	W/L	Passenger and rear doors lock actuator (unlock)	Door lock/ unlock switch (Free → Unlock)	0 → Battery voltage → 0
52	B	Ground	—	0
55	W/R	Battery power supply (Fusible link)	—	Battery voltage
57	R/W	Trunk room lamp switch	Trunk lid open (ON) → Close (OFF)	0 → Battery voltage

INTELLIGENT KEY SYSTEM

Terminal	Wire Color	Item	Condition	Voltage (V) Approx.
62	W	Front door switch driver side	Door open (ON) → Close (OFF)	0 → Battery voltage
63	P	Rear door switch LH	Door open (ON) → Close (OFF)	0 → Battery voltage

*1: In the state that hazard reminder operates.

*2: In the state that room lamp switch is in "DOOR" position.

Terminals and Reference Value for IPDM E/R

AIS0069D

Terminal	Wire Color	Item	Condition	Voltage (V) Approx.	
38	B	Ground	—	0	
48	L	CAN-H	—	—	
49	P	CAN-L	—	—	
51	G/B	Horn relay	Press panic alarm bottom.	Horn sounds.	0
				Horn does not sound.	Battery voltage
60	B/W	Ground	—	0	

A
B
C
D
E
F
G
H
J
K
L
M

BL

INTELLIGENT KEY SYSTEM

AIS0069E

Trouble Diagnosis Procedure PRELIMINALY CHECK

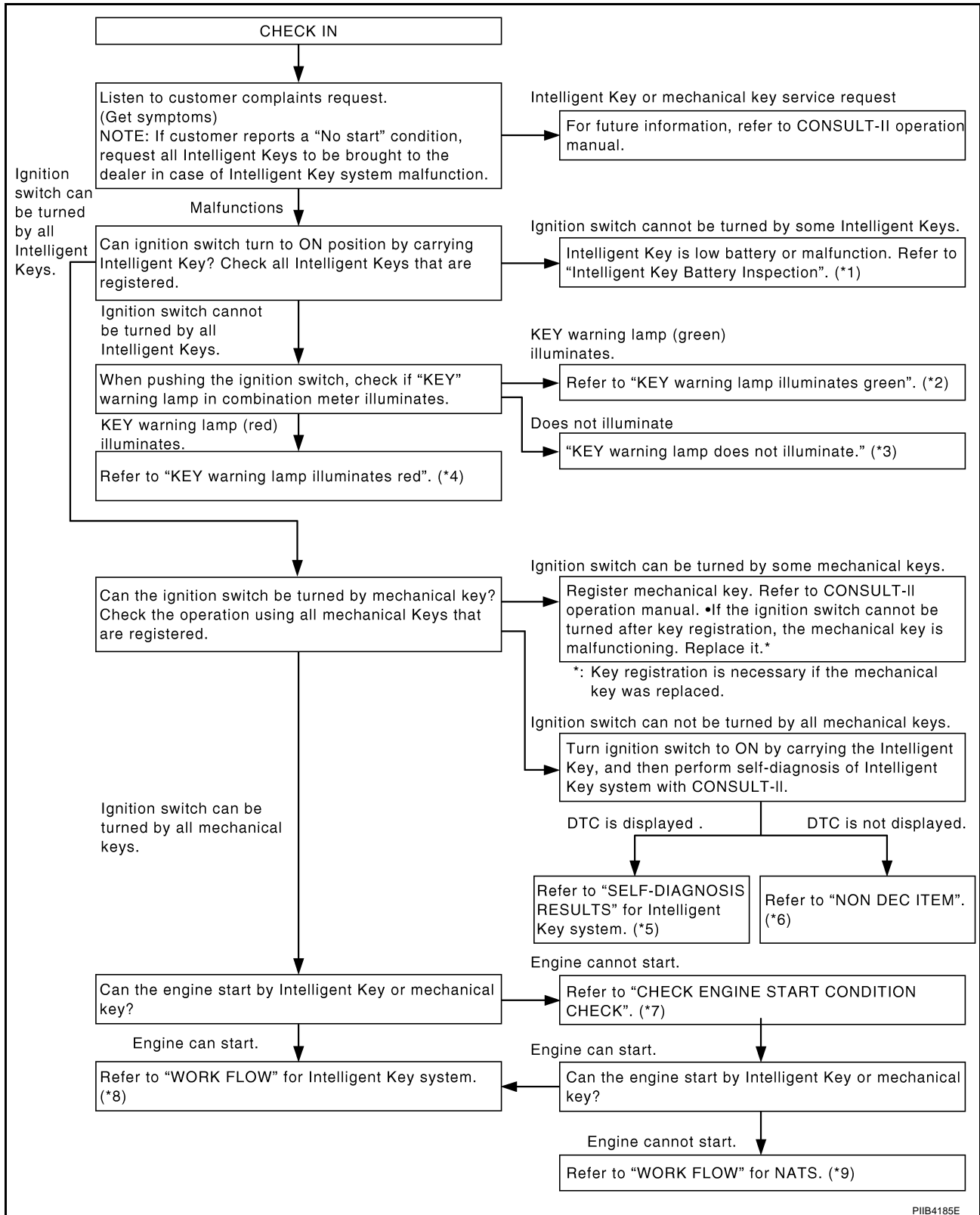

PIIB4185E

*1: [BL-165](#)

*4: [BL-124](#)

*7: [BL-125](#)

*2: [BL-124](#)

*5: [BL-121](#)

*8: [BL-119](#)

*3: [BL-125](#)

*6: [BL-125](#)

*9: [BL-237](#)

INTELLIGENT KEY SYSTEM

WORK FLOW

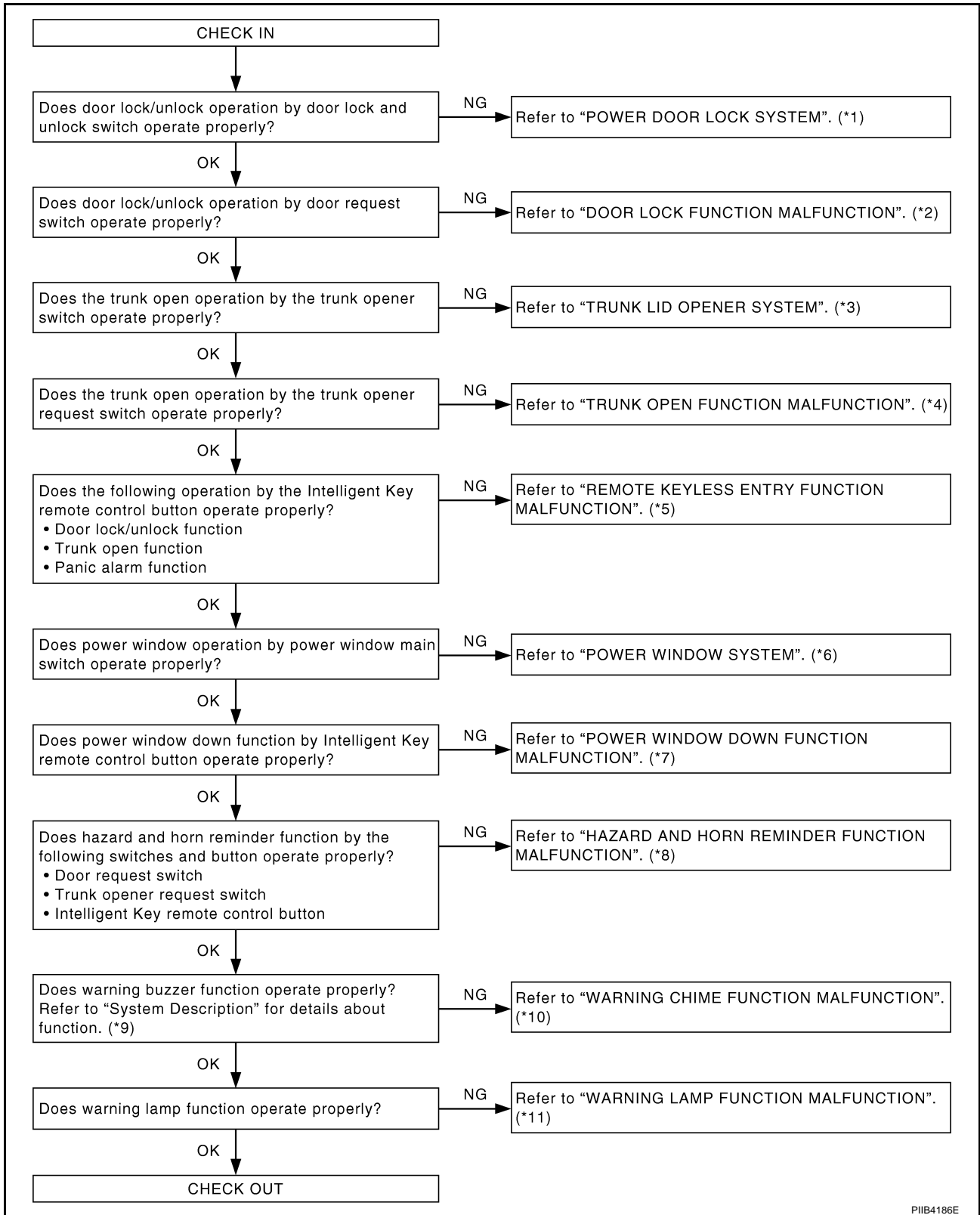

A
B
C
D
E
F
G
H
BL
J
K
L
M

*1: [BL-20](#)

*2: [BL-126](#)

*3: [BL-181](#)

*4: [BL-128](#)

*5: [BL-127](#)

*6: [GW-16](#)

*7: [BL-129](#)

*8: [BL-128](#)

*9: [BL-96](#)

*10: [BL-129](#)

*11: [BL-131](#)

PIIB4186E

INTELLIGENT KEY SYSTEM

CONSULT-II Functions (INTELLIGENT KEY)

AI50069F

CONSULT-II can display each diagnostic item using the diagnostic test modes as shown below.

Part to be diagnosed	Test item, Diagnosis mode	Description
Intelligent Key	WORK SUPPORT	Changes settings for each function.
	SELF-DIAG RESULTS	Intelligent Key unit performs CAN communication diagnosis.
	DATA MONITOR	Displays Intelligent Key unit input data in real time.
	CAN DIAGNOSTIC SUPPORT MONITOR	The results of transmit/receive diagnosis of CAN Communication can be read.
	ACTIVE TEST	Operation of electrical loads can be checked by sending driving signal to them.
	ECU PART NUMBER	Displays Intelligent Key unit part No.

CONSULT-II Inspection Procedure

AI50069G

CAUTION:

If CONSULT-II is used with no connection CONSULT-II CONVERTER, malfunctions might be detected in self-diagnosis depending on control unit which performs CAN Communication.

BASIC OPERATION

1. Turn ignition switch OFF.
2. Connect CONSULT-II CONVERTER and CONSULT-II to data link connector.

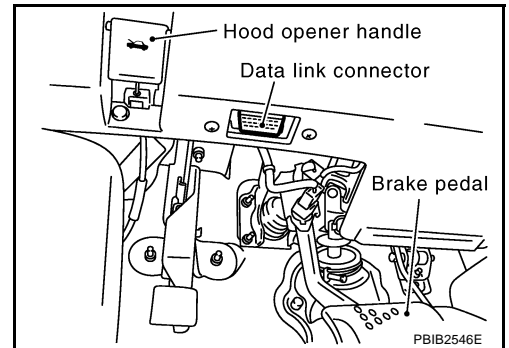

3. Use mechanical key to turn ignition switch to ON.
4. Touch "START (NISSAN BASED VHCL)".

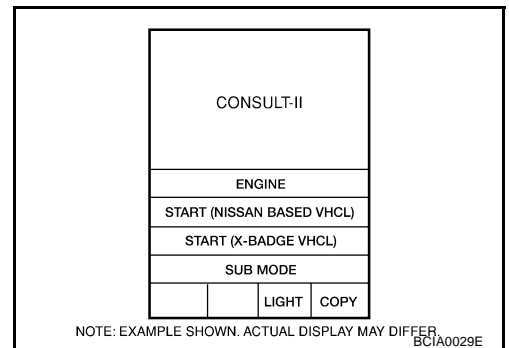

5. Touch "INTELLIGENT KEY" on "SELECT SYSTEM" screen. If "INTELLIGENT KEY" is not indicated, go to [GI-38, "CONSULT-II Data Link Connector \(DLC\) Circuit"](#).

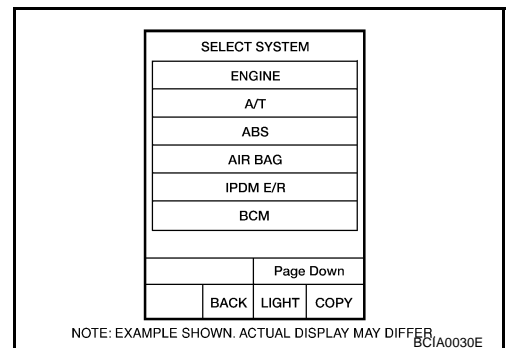

INTELLIGENT KEY SYSTEM

6. Select diagnosis mode. "WORK SUPPORT", "SELF-DIAG RESULTS", "CAN DIAG SUPPORT MNTR", "DATA MONITOR", "ACTIVE TEST" and "ECU PART NUMBER" are available.

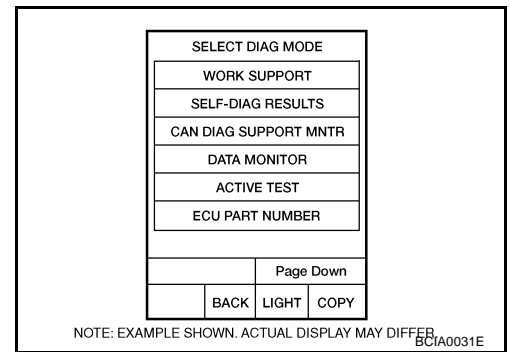

A
B
C
D
E
F
G
H
J
K
L
M

CONSULT-II Application Items SELF-DIAGNOSTIC RESULTS

AIS0069H

Self-diag results	Description	Diagnosis procedure	Reference page
CAN COMM	Malfunction is detected in CAN communication.	Check CAN communication system.	BL-131
CAN COMM2	Intelligent Key unit internal malfunction	Check CAN communication system.	BL-131
STRG COMM	Malfunction is detected in communication of Intelligent Key unit and steering lock unit.	Check steering lock unit.	BL-152
I-KEY C/U	Intelligent Key unit internal malfunction	Replace Intelligent Key unit.	BL-164
IMMU	NATS malfunction	Check NATS.	BL-225

DATA MONITOR

Monitor item	Content
PUSH SW	Indicates [ON/OFF] condition of ignition knob switch.
KEY SW	Indicates [ON/OFF] condition of key switch.
DR REQ SW	Indicates [ON/OFF] condition of door request switch (driver side).
AS REQ SW	Indicates [ON/OFF] condition of door request switch (passenger side).
BD/TR REQ SW	Indicates [ON/OFF] condition of trunk opener request switch.
IGN SW	Indicates [ON/OFF] condition of ignition switch in ON position.
ACC SW	Indicates [ON/OFF] condition of ignition switch in ACC position.
DOOR STAT SW	Indicates [ON/OFF] condition of stop lamp switch.
STOP LAMP SW	Indicates [ON/OFF] condition of door unlock sensor.
P RANGE SW*	Indicates [ON/OFF] condition of park position switch.
TR CANCEL SW*	Indicates [ON/OFF] condition of trunk cancel switch.
DOOR LOCK SIG*	Indicates [ON/OFF] condition of door lock signal from Intelligent Key remote controller button.
DOOR UNLOCK SIG*	Indicates [ON/OFF] condition of door unlock signal from Intelligent Key remote controller button.
KEYLESS TRUNK*	Indicates [ON/OFF] condition of trunk open signal from Intelligent Key remote controller button.
KEYLESS PANIC*	Indicates [ON/OFF] condition of panic alarm signal from Intelligent Key remote controller button.
DOOR SW DR*	Indicates [OPEN/CLOSE] condition of front door switch driver side from BCM via CAN communication line.
DOOR SW AS*	Indicates [OPEN/CLOSE] condition of front door switch passenger side from BCM via CAN communication line.
DOOR SW RR*	Indicates [OPEN/CLOSE] condition of rear door switch LH from BCM via CAN communication line.
DOOR SW RL*	Indicates [OPEN/CLOSE] condition of rear door switch RH from BCM via CAN communication line.
DOOR BK SW*	Indicates [OPEN/CLOSE] condition of back door switch from BCM via CAN communication line.
TRUNK SW*	Indicates [OPEN/CLOSE] condition of trunk room lamp switch from BCM via CAN communication line.
VEHICLE SPEED*	Indicates [km/h] condition of vehicle speed.

*: Select "SELECTION FROM MENU".

INTELLIGENT KEY SYSTEM

WORK SUPPORT

Monitor item	Description
CONFIRM KEY FOB ID	It can be checked whether Intelligent Key ID code is registered or not in this mode.
TAKE OUT FROM WINDOW WARN	Take away warning chime (from window) mode can be changed to operate (ON) or not operate (OFF) with this mode. The operation mode will be changed when "CHANGE SETT" on CONSULT-II screen is touched.
LOW BAT OF KEY FOB WARN	Intelligent Key low battery warning mode can be changed to operate (ON) or not operate (OFF) with this mode. The operation mode will be changed when "CHANGE SETT" on CONSULT-II screen is touched.
SELECTIVE UNLOCK FUNCTION	Selective unlock function mode can be changed to operate (ON) or not operate (OFF) with this mode. The operation mode will be changed when "CHANGE SETT" on CONSULT-II screen is touched.
ANTI KEY LOCK IN FUNCTION	Key reminder function mode can be changed to operate (ON) or not operate (OFF) with this mode. The operation mode will be changed when "CHANGE SETT" on CONSULT-II screen is touched.
HORN WITH KEYLESS LOCK	Horn reminder function mode by Intelligent Key remote control button can be changed to operate (ON) or not operate (OFF) with this mode. The operation mode will be changed when "CHANGE SETT" on CONSULT-II screen is touched.
HAZARD ANSWER BACK	<p>Hazard reminder function mode can be selected from the following with this mode. The operation mode will be changed when "CHANGE SETT" on CONSULT-II screen is touched.</p> <ul style="list-style-type: none"> ● LOCK ONLY: Door lock operation only ● UNLOCK ONLY: Door unlock operation only ● LOCK/UNLOCK: Lock/Unlock operation ● OFF: Non-operation
ANSWER BACK WITH I-KEY LOCK	<p>Horn reminder function (lock operation) mode by door request switch (driver side, passenger side and trunk) can be selected from the following with this mode. The operation mode will be changed when "CHANGE SETT" on CONSULT-II screen is touched.</p> <ul style="list-style-type: none"> ● HORN CHIRP: Sound horn ● BUZZER: Sound buzzer ● OFF: Non-operation
ANSWER BACK WITH I-KEY UNLOCK	Horn reminder function (unlock operation) mode by door request switch can be changed to operate (ON) or not operate (OFF) with this mode.
AUTO RELOCK TIMER	<p>Auto door lock timer mode can select the following with this mode.</p> <ul style="list-style-type: none"> ● 1 minute ● 5 minute ● OFF: Non-operation
PANIC ALARM DELAY	<p>Panic alarm button's pressing time on Intelligent Key remote control button can be selected from the following with this mode. The operation mode will be changed when "CHANGE SETT" on CONSULT-II screen is touched.</p> <ul style="list-style-type: none"> ● 0.5 second ● 1.5 second ● OFF: Non-operation
TRUNK/GLASS HATCH OPEN	Hazard and horn reminder function mode by trunk request switch can be changed to operate (ON) or not operate (OFF) with this mode. The operation mode will be changed when "CHANGE SETT" on CONSULT-II screen is touched.
TRUNK OPEN DELAY	<p>Trunk button's pressing time on Intelligent Key remote control button can be selected from the following with this mode. The operation mode will be changed when "CHANGE SETT" on CONSULT-II screen is touched.</p> <ul style="list-style-type: none"> ● 0.5 second ● 1.5 second ● OFF: Non-operation

INTELLIGENT KEY SYSTEM

Monitor item	Description
P/W DOWN DELAY	<p>Unlock button's pressing time on Intelligent Key remote control button can be selected from the following with this mode. The operation mode will be changed when "CHANGE SETT" on CONSULT-II screen is touched.</p> <ul style="list-style-type: none"> ● 3 seconds ● 5 seconds ● OFF: Non-operation
ENGINE START BY I-KEY	<p>Engine start function mode can be changed to operate (ON) or not operate (OFF) with this mode. The operation mode will be changed when "CHANGE SETT" on CONSULT-II screen is touched.</p>
LOCK/UNLOCK BY I-KEY	<p>Door lock/unlock function by door request switch (driver side, passenger side and trunk) mode can be changed to operate (ON) or not operate (OFF) with this mode. The operation mode will be changed when "CHANGE SETT" on CONSULT-II screen is touched.</p>

ACTIVE TEST

Test item	Description
DOOR LOCK/UNLOCK	<p>This test is able to check door lock/unlock operation.</p> <ul style="list-style-type: none"> ● The all door lock actuators are unlocked when "ALL UNLK" on CONSULT-II screen is touched. ● The door lock actuator (driver side) is unlocked when "DR UNLK" on CONSULT-II screen is touched. ● The door lock actuator (passenger side) is unlocked when "AS UNLK" on CONSULT- II screen is touched. ● The door lock actuator (back door) is unlocked when "BK UNLK" on CONSULT- II screen is touched. ● The all door lock actuators are locked when "LOCK" on CONSULT-II screen is touched.
ANTENNA	<p>This test is able to check Intelligent Key antenna operation. When the following conditions are met, hazard warning lamps flash.</p> <ul style="list-style-type: none"> ● Inside key antenna (Dashboard) detects Intelligent Key, when "RM ANT1" on CONSULT-II screen is touched. ● Inside key antenna (Center console) detects Intelligent Key, when "RM ANT2" on CONSULT-II screen is touched. ● Inside key antenna (Trunk room) detects Intelligent Key, when "LAG ANT" on CONSULT-II screen is touched. ● Outside key antenna (Driver side) detects Intelligent Key, when "DR ANT" on CONSULT-II screen is touched. ● Outside key antenna (Passenger side) detects Intelligent Key, when "AS ANT" on CONSULT-II screen is touched. ● Outside key antenna (Rear bumper) detects Intelligent Key, when "BD ANT" on CONSULT-II screen is touched.
OUTSIDE BUZZER	<p>This test is able to check Intelligent Key warning buzzer (engine room) operation. Intelligent Key warning buzzer (engine room) sounds when "ON" on CONSULT-II screen is touched.</p>
INSIDE BUZZER	<p>This test is able to check Intelligent Key warning buzzer (Instrument panel) operation.</p> <ul style="list-style-type: none"> ● Take away warning chime sounds when "TAKE OUT" on CONSULT-II screen is touched. ● Ignition switch warning chime sounds when "KNOB" on CONSULT-II screen is touched. ● Ignition key warning chime sounds when "KEY" on CONSULT-II screen is touched.
INDICATOR	<p>This test is able to check warning lamp operation.</p> <ul style="list-style-type: none"> ● "KEY" Warning lamp (Green) illuminates when "BLUE ON" on CONSULT-II screen is touched. ● "KEY" Warning lamp (Red) illuminates when "RED ON" on CONSULT-II screen is touched. ● "P-SHIFT" Warning lamp illuminates when "KNOB ON" on CONSULT-II screen is touched. ● "KEY" Warning lamp (Green) flashes when "BLUE IND" on CONSULT-II screen is touched. ● "KEY" Warning lamp (RED) flashes when "BLUE IND" on CONSULT-II screen is touched. ● "P-SHIFT" Warning lamp flashes when "KNOB ON" on CONSULT-II screen is touched.

INTELLIGENT KEY SYSTEM

AI50069I

Trouble Diagnosis Symptom Chart KEY WARNING LAMP (GREEN) ILLUMINATES

NOTE:

- Before performing the diagnosis in the following table, check “Trouble Diagnosis Procedure”. Refer to [BL-118, "Trouble Diagnosis Procedure"](#)
- Make sure that vehicle is under the condition shown in “Conditions of vehicle” before starting diagnosis, and check each symptom.
- If the following “symptoms” are detected, check systems shown in the “Diagnoses/service procedure” column in this order.

Conditions of Vehicle (Operating Conditions)

- Intelligent Key is registered.
- Key is not inserted in ignition switch.
- One or more registered Intelligent Keys are in the vehicle.

Symptom	Diagnosis/service procedure	Reference page
Ignition switch does not turn on with Intelligent Key. [KEY warning lamp (green) illuminates.]	1. Check steering lock unit.	BL-152
	2. Replace Intelligent Key unit.	BL-164

KEY WARNING LAMP (RED) ILLUMINATES

NOTE:

- Before performing the diagnosis in the following table, check “Trouble Diagnosis Procedure”. Refer to [BL-118, "Trouble Diagnosis Procedure"](#).
- Make sure that vehicle is under the condition shown in “Conditions of vehicle” before starting diagnosis, and check each symptom.
- If the following “symptoms” are detected, check systems shown in the “Diagnoses/service procedure” column in this order.

Conditions of Vehicle (Operating Conditions)

- Intelligent Key is registered.
- Key is not inserted in ignition switch.
- One or more registered Intelligent Keys are in the vehicle.

Symptom	Diagnosis/service procedure	Reference page
Ignition switch does not turn on with Intelligent Key. [KEY warning lamp (red) illuminates.]	1. Check inside key antenna.	BL-151
	2. Replace Intelligent Key unit.	BL-164

INTELLIGENT KEY SYSTEM

KEY WARNING LAMP DOES NOT ILLUMINATE

NOTE:

- Before performing the diagnosis in the following table, check “Trouble Diagnosis Procedure”. Refer to [BL-118, "Trouble Diagnosis Procedure"](#).
- Make sure that vehicle is under the condition shown in “Conditions of vehicle” before starting diagnosis, and check each symptom.
- If the following “symptoms” are detected, check systems shown in the “Diagnoses/service procedure” column in this order.
- Check if ignition switch turns using mechanical key. If it turns, check if “ENGINE START BY I-KEY” in “WORK SUPPORT” mode is ON.

Conditions of Vehicle (Operating Conditions)

- Intelligent Key is registered.
- Key is not inserted in ignition switch.
- One or more registered Intelligent Keys are in the vehicle.

Symptom	Diagnosis/service procedure	Reference page
Ignition switch does not turn on with Intelligent Key. [KEY warning lamp does not illuminate.]	1. Check Intelligent Key unit power supply and ground circuit.	BL-132
	2. Check ignition knob switch.	BL-136
	3. Check key switch.	BL-133
	4. Replace Intelligent Key unit.	BL-164

NON DTC ITEM

NOTE:

- Before performing the diagnosis in the following table, check “Trouble Diagnosis Procedure”. Refer to [BL-118, "Trouble Diagnosis Procedure"](#).
- Make sure that vehicle is under the condition shown in “Conditions of vehicle” before starting diagnosis, and check each symptom.
- If the following “symptoms” are detected, check systems shown in the “Diagnoses/service procedure” column in this order.

Conditions of Vehicle (Operating Conditions)

- Intelligent Key is registered.
- Multiple mechanical keys are not set in a keyfob.
(If mechanical keys are near the ignition switch, the operation may not work properly.)

Symptom	Diagnosis/service procedure	Reference page
Non DTC Item	1. Check key switch.	BL-133
	2. Check NATS antenna amp.	BL-241

ENGINE START CONDITION CHECK

NOTE:

- Before performing the diagnosis in the following table, check “Trouble Diagnosis Procedure”. Refer to [BL-118, "Trouble Diagnosis Procedure"](#).
- If the following “symptoms” are detected, check systems shown in the “Diagnoses/service procedure” column in this order.

Symptom	Diagnosis/service procedure	Reference page
Engine start condition check	1. Check park position switch.	BL-156
	2. Check stop lamp switch.	BL-154

INTELLIGENT KEY SYSTEM

DOOR LOCK/UNLOCK FUNCTION MALFUNCTION

NOTE:

- Before performing the diagnosis in the following table, check “Trouble Diagnosis Procedure”. Refer to [BL-118, "Trouble Diagnosis Procedure"](#) .
- Make sure that vehicle is under the condition shown in “Conditions of vehicle” before starting diagnosis, and check each symptom.
- If the following “symptoms” are detected, check systems shown in the “Diagnosis/procedure” column in this order.

Conditions of Vehicle (Operating Conditions)

- “LOCK/UNLOCK BY I-KEY” is ON when setting on CONSULT-II.
- Ignition switch is not depressed.
- All doors are closed.

Symptom	Diagnosis/service procedure	Reference page
Door lock/unlock do not operate by request switch.	1. Check door switch.	BL-138
	2. Check ignition knob switch.	BL-136
	3. Replace Intelligent Key unit.	BL-164
Door lock/unlock does not operate by request switch (driver side).	1. Check door request switch (driver side).	BL-142
	2. Check outside key antenna (driver side).	BL-149
	3. Replace Intelligent Key unit.	BL-164
Door lock/unlock does not operate by request switch (passenger side).	1. Check door request switch (passenger side).	BL-142
	2. Check outside key antenna (passenger side).	BL-149
	3. Replace Intelligent Key unit.	BL-164
Selective unlock function does not operate by door request switch (driver side) (other door lock function operate properly).	1. Check “SELECT UNLOCK FUNCTION” setting in “WORK SUPPORT”.	BL-122
	2. Check selective unlock function with a remote controller or door key cylinder.	BL-56
	3. Replace BCM.	BCS-16
Selective unlock function does not operate by door request switch (passenger side) (other door lock function operate properly).	1. Check “SELECT UNLOCK FUNCTION” setting in “WORK SUPPORT”.	BL-122
	2. Check select unlock relay.	BL-158
	3. Replace Intelligent Key unit.	BL-164
Auto lock function does not operate properly.	1. Check “AUTO RELOCK TIMER” setting in “WORK SUPPORT”.	BL-122
	2. Check key switch.	BL-133
	3. Check ignition knob switch.	BL-136
	4. Check door switch.	BL-138
	5. Replace Intelligent Key unit.	BL-164
Key reminder function does not operate properly.	1. Check “ANTI KEY LOCK IN FUNCTION” setting in “WORK SUPPORT”.	BL-122
	2. Check door switch.	BL-138
	3. Check inside key antenna.	BL-151
	4. Check unlock sensor.	BL-146
	5. Check Intelligent Key battery inspection.	BL-165
	6. Replace Intelligent Key unit.	BL-164

INTELLIGENT KEY SYSTEM

REMOTE KEYLESS ENTRY FUNCTION MALFUNCTION

NOTE:

- Before performing the diagnosis in the following table, check “Trouble Diagnosis Procedure”. Refer to [BL-118, "Trouble Diagnosis Procedure"](#) .
- Make sure that vehicle is under the condition shown in “Conditions of vehicle” before starting diagnosis, and check each symptom.
- If the following “symptoms” are detected, check systems shown in the “Diagnosis/service procedure” column in this order.

Conditions of Vehicle (Operating Conditions)

- Ignition switch is not depressed.
- All doors are closed.

Symptom	Diagnosis/service procedure	Reference page
All of the remote keyless entry functions do not operate.	1. Check Intelligent Key battery inspection.	BL-165
	2. Replace Intelligent Key unit.	BL-164
Selective unlock function does not operate by Intelligent Key remote control button.	1. Check “SELECT UNLOCK FUNCTION” setting in “WORK SUPPORT”.	BL-122
	2. Check Intelligent Key battery inspection.	BL-165
	3. Replace Intelligent Key unit.	BL-164
Auto lock function does not operate properly.	1. Check “AUTO RELOCK TIMER” setting in “WORK SUPPORT”.	BL-122
	2. Check key switch.	BL-133
	3. Check ignition knob switch.	BL-136
	4. Check door switch.	BL-138
	5. Replace Intelligent Key unit.	BL-164
Key reminder function does not operate properly.	1. Check “ANTI KEY LOCK IN FUNCTION” setting in “WORK SUPPORT”.	BL-122
	2. Check door switch.	BL-138
	3. Check inside key antenna.	BL-151
	4. Check unlock sensor.	BL-146
	5. Check Intelligent Key battery inspection.	BL-165
	6. Replace Intelligent Key unit.	BL-164
Panic alarm function does not operate properly.	1. Check “PANIC ALARM DELAY” setting in “WORK SUPPORT”.	BL-122
	2. Theft warning operation check.	BL-199
	3. Check Intelligent Key battery inspection.	BL-165
	4. Check key switch.	BL-133
	5. Check ignition knob switch.	BL-136
	6. Replace Intelligent Key unit	BL-164
Trunk open function does not operate properly.	1. Check “TRUNK OPEN DELAY” setting in “WORK SUPPORT”.	BL-122
	2. Check trunk lid opener system.	BL-181
	3. Check trunk room lamp switch	BL-140
	4. Check Intelligent Key battery inspection.	BL-165
	5. Replace Intelligent Key unit	BL-164

INTELLIGENT KEY SYSTEM

TRUNK OPEN FUNCTION MALFUNCTION

NOTE:

- Before performing the diagnosis in the following table, check “Trouble Diagnosis Procedure”. Refer to [BL-118, "Trouble Diagnosis Procedure"](#) .
- Make sure that vehicle is under the condition shown in “Conditions of vehicle” before starting diagnosis, and check each symptom.
- If the following “symptoms” are detected, check systems shown in the “Diagnosis/service procedure” column in this order.

Conditions of Vehicle (Operating Conditions)

- “LOCK/UNLOCK BY I-KEY” is ON when setting on CONSULT-II.
- Trunk cancel switch is in ON position.

Symptom	Diagnosis procedure	Reference page
Trunk open function does not operate by trunk opener request switch.	1. Check trunk opener request switch.	BL-144
	2. Check outside key antenna (rear bumper).	BL-149
	3. Replace Intelligent Key unit.	BL-164

HAZARD AND HORN REMINDER FUNCTION MALFUNCTION

NOTE:

- Before performing the diagnosis in the following table, check “Trouble Diagnosis Procedure”. Refer to [BL-118, "Trouble Diagnosis Procedure"](#) .
- Make sure that vehicle is under the condition shown in “Conditions of vehicle” before starting diagnosis, and check each symptom.
- If the following “symptoms” are detected, check systems shown in the “Diagnosis/service procedure” column in this order.

Conditions of Vehicle (Operating Conditions)

- Ignition switch is not depressed.
- All doors are closed.

Symptom	Diagnosis/service procedure	Reference page
Hazard reminder does not operate properly by request switch. (Horn reminder operate properly.)	1. Check “HAZARD ANSWER BACK” setting in “WORK SUPPORT”.	BL-122
	2. Check hazard function with hazard switch.	LT-113
	3. Replace Intelligent Key unit	BL-164
Horn reminder does not operate properly by request switch. (Hazard reminder operate properly.)	1. Check “ANSWER BACK WITH I-KEY LOCK” or “ANSWER BACK WITH I-KEY UNLOCK” setting in “WORK SUPPORT”.	BL-122
	2. Check Intelligent Key warning buzzer (engine room).	BL-148
	3. Check horn function.	BL-163
	4. Check IPDM E/R operation.	BL-164
	5. Replace Intelligent Key unit	BL-164
Hazard reminder does not operate properly by Intelligent Key remote control button. (Horn reminder operate properly.)	1. Check “HAZARD ANSWER BACK” setting in “WORK SUPPORT”.	BL-122
	2. Check hazard function.	BL-163
	3. Replace Intelligent Key	BL-164
Horn reminder does not operate properly by Intelligent Key remote control button (door lock/unlock button). (Hazard reminder operate properly.)	1. Check “HORN WITH KEYLESS LOCK” setting in “WORK SUPPORT”.	BL-122
	2. Check Intelligent Key warning buzzer (engine room).	BL-148
	3. Check horn function.	BL-163
	4. Check IPDM E/R operation.	BL-164
	5. Replace Intelligent Key unit	BL-164

INTELLIGENT KEY SYSTEM

Symptom	Diagnosis/service procedure	Reference page
Horn reminder does not operate properly by trunk opener request switch.	1. Check "TRUNK/GLASS HATCH OPEN" setting in "WORK SUPPORT".	BL-122
	2. Check Intelligent Key warning buzzer (engine room).	BL-148
	3. Check trunk opener lid system.	BL-181
	4. Replace Intelligent Key unit	BL-164

POWER WINDOW DOWN FUNCTION MALFUNCTION

NOTE:

- Before performing the diagnosis in the following table, check "Trouble Diagnosis Procedure". Refer to [BL-118, "Trouble Diagnosis Procedure"](#).
- If the following "symptoms" are detected, check systems shown in the "Diagnoses/service procedure" column in this order.

Conditions of Vehicle (Operating Conditions)

- Key is not inserted in ignition key cylinder.
- One or more registered Intelligent Keys are in the vehicle.

Symptom	Diagnosis/service procedure	Reference page
Power window down function does not operate properly.	1. Check "P/W DOWN DELAY" setting in "WORK SUPPORT".	BL-122
	2. Check Intelligent Key battery inspection.	BL-165

WARNING CHIME FUNCTION MALFUNCTION

NOTE:

- Before performing the diagnosis in the following table, check "Trouble Diagnosis Procedure". Refer to [BL-118, "Trouble Diagnosis Procedure"](#).
- Make sure that vehicle is under the condition shown in "Conditions of vehicle" before starting diagnosis, and check each symptom.
- If the following "symptoms" are detected, check systems shown in the "Diagnosis/service procedure" column in this order.

Conditions of Vehicle (Operating Conditions)

Each warning chime function is ON when setting on CONSULT-II.

Symptom	Diagnosis/service procedure	Reference page
Ignition switch warning chime does not operate.	1. Check ignition knob switch.	BL-136
	2. Check door switch	BL-138
	3. Check key switch	BL-133
	2. Check Intelligent Key warning buzzer (instrument panel).	BL-147
	3. Replace Intelligent Key unit.	BL-164
Ignition key warning chime does not operate properly. (When mechanical key used)	1. Check key switch (Intelligent Key unit input).	BL-133
	2. Check key switch (BCM input).	BL-135
	3. Check door switch.	BL-138
	4. Check warning chime.	DI-39
	5. Replace Intelligent Key unit.	BL-164
OFF position warning chime does not operate.	1. Check ignition knob switch.	BL-136
	2. Check key switch	BL-133
	3. Check power supply and ground circuit	BL-132
	4. Check Intelligent Key warning buzzer (instrument panel).	BL-147
	5. Replace Intelligent Key unit.	BL-164
OFF position warning chime (after door closed) does not operate properly.	1. Check ignition knob switch.	BL-136
	2. Check Intelligent Key warning buzzer (engine room).	BL-148
	3. Replace Intelligent Key unit.	BL-164

INTELLIGENT KEY SYSTEM

Symptom	Diagnosis/service procedure	Reference page
Take away warning chime does not operate properly.	1. Check door switch.	BL-138
	2. Check power supply and ground circuit	BL-132
	3. Check Intelligent Key battery inspection	BL-165
	4. Check inside key antenna.	BL-151
	5. Check Intelligent Key warning buzzer (engine room).	BL-148
	6. Replace Intelligent Key unit.	BL-164
Take away warning chime (from window) does not operate properly.	1. Check "TAKE OUT FROM WINDOW WARN" setting in "WORK SUPPORT"	BL-122
	2. Check inside key antenna.	BL-151
	3. Check power supply and ground circuit	BL-132
	4. Check Intelligent Key battery inspection	BL-165
	5. Check Intelligent Key warning buzzer (instrument panel).	BL-147
	6. Replace Intelligent Key unit.	BL-164
Door lock operation warning chime does not operate properly.	1. Check door switch	BL-138
	2. Check ignition knob switch	BL-136
	3. Check door request switch (driver side)	BL-142
	4. Check outside key antenna (driver side)	BL-149
	5. Check inside key antenna	BL-151
	6. Check Intelligent Key warning buzzer (engine room).	BL-148
	7. Replace Intelligent Key unit.	BL-164

INTELLIGENT KEY SYSTEM

WARNING LAMP FUNCTION MALFUNCTION

NOTE:

- Before performing the diagnosis in the following table, check "Trouble Diagnosis Procedure". Refer to [BL-118, "Trouble Diagnosis Procedure"](#).
- If the following "symptoms" are detected, check systems shown in the "Diagnosis/service procedure" column in this order.

Symptom	Diagnosis/service procedure	Reference page
Intelligent Key low battery warning does not operate properly.	1. Check "LOW BAT OF KEY FOB WARN" setting in "WORK SUPPORT".	BL-122
	2. Check Intelligent Key battery inspection.	BL-165
	3. Check KEY warning lamp (green).	BL-162
	4. Replace Intelligent Key unit.	BL-164
P position warning lamp does not illuminate properly.	1. Check park position switch.	BL-156
	2. Check "P-SHIFT" warning lamp (red).	BL-159
	3. Replace Intelligent Key unit.	BL-164
Take away warning lamp does not illuminate properly. (Take away warning chime is operated.)	1. Check KEY warning lamp (red).	BL-161
	2. Replace Intelligent Key unit.	BL-164
Ignition switch warning lamp does not illuminate properly. (Ignition switch warning chime is operated)	1. Check KEY warning lamp (red).	BL-161
	2. Replace Intelligent Key unit.	BL-164

Check CAN Communication System

AIS0069J

1. CHECK SELF-DIAGNOSTIC RESULTS

CAUTION:

If CONSULT-II is used with no connection of CONSULT-II CONVERTER, malfunctions might be detected in self-diagnosis depending on control unit which performs CAN communication.

Ⓟ With CONSULT-II

- Connect CONSULT-II, and turn ignition switch ON.
- Touch "INTELLIGENT KEY" on "SELECT SYSTEM" screen.
- Touch "SELF-DIAG RESULTS" on "SELECT DIAG MODE" screen.
- Check display content in self-diagnostic results.

CONSULT-II display item	DTC code
NO DTC IS DETECTED	—
CAN COMM	U1000
CAN COMM2	U1010

OK or NG

NO DTC IS DETECTED>> INSPECTION END

CAN COMM [U1000]>> After printing "SELF-DIAGNOSIS RESULTS", go to "CAN SYSTEM", Refer to [LAN-3, "Precautions When Using CONSULT-II"](#).

CAN COMM2 [U1010]>> Replace Intelligent Key unit.

INTELLIGENT KEY SYSTEM

AIS0069K

Check Power Supply and Ground Circuit

1. CHECK POWER SUPPLY CIRCUIT

1. Turn ignition switch OFF.
2. Disconnect Intelligent Key unit connector.
3. Check voltage between Intelligent Key unit harness connector and ground.

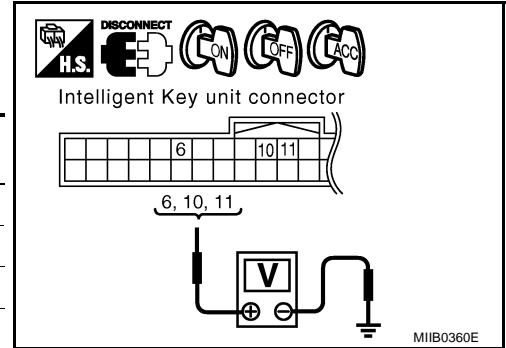

Connector	Terminal (Wire color)		Ignition switch position		
	(+)	(-)	OFF	ACC	ON
M75	6 (Y/G)	Ground	0V	0V	Battery voltage
	10 (LG)		0V	Battery voltage	Battery voltage
	11 (Y)		Battery voltage	Battery voltage	Battery voltage

OK or NG

OK >> GO TO 2.

NG >> Repair or replace Intelligent Key power supply circuit.

2. CHECK GROUND CIRCUIT

Check continuity between Intelligent Key unit harness connector M75 terminal 12 (B) and ground.

12 (B) - Ground : Continuity should exist.

OK or NG

OK >> Power supply and ground circuits are OK.

NG >> Repair or replace the Intelligent Key unit ground circuit.

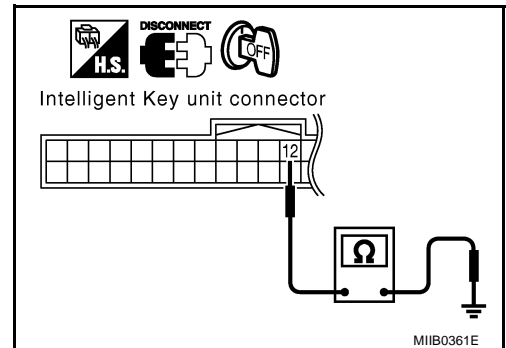

INTELLIGENT KEY SYSTEM

Check Key Switch (Intelligent Key Unit Input)

AI50069L

1. CHECK KEY SWITCH

With CONSULT-II

Check key switch ("KEY SW") in "DATA MONITOR" mode with CONSULT-II.

Monitor item	Condition
KEY SW	Insert mechanical key into ignition switch: ON
	Remove mechanical key from ignition switch: OFF

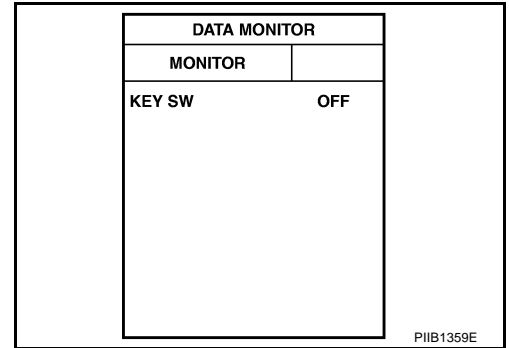

Without CONSULT-II

1. Turn ignition switch OFF.
2. Disconnect Intelligent Key unit harness connector.
3. Check voltage between Intelligent Key unit harness connector M75 terminal 7 and ground.

Connector	Terminal (Wire color)		Condition	Voltage (V) (Approx.)
	(+)	(-)		
M75	7 (B/R)	Ground	Insert mechanical key into ignition switch	Battery voltage
			Remove mechanical key from ignition switch	0

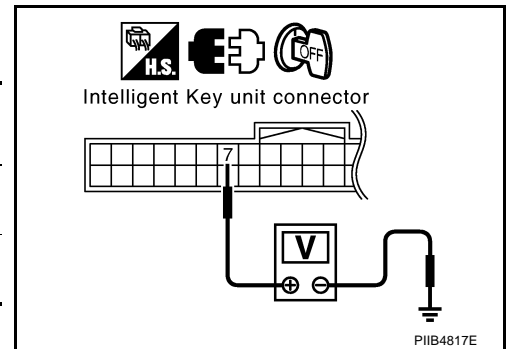

OK or NG

- OK >> Key switch is OK.
 NG >> GO TO 2.

2. CHECK KEY SWITCH POWER SUPPLY CIRCUIT

1. Remove mechanical key from ignition switch.
2. Disconnect key switch and ignition knob switch connector.
3. Check voltage between key switch and ignition knob switch harness connector M310 terminal 3 and ground.

3 (Y) - Ground : Battery voltage

OK or NG

- OK >> GO TO 3.
 NG >> Repair or replace key switch and ignition knob switch power supply circuit.

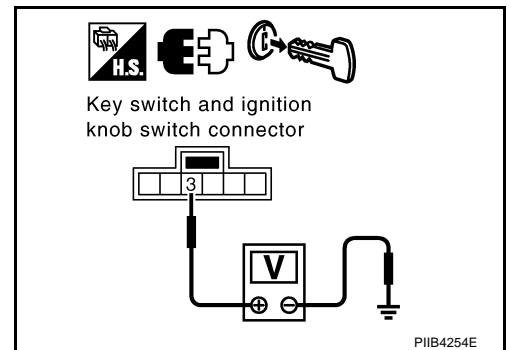

INTELLIGENT KEY SYSTEM

3. CHECK KEY SWITCH OPERATION

Check continuity between key switch and ignition knob switch harness connector M310 terminal 3 and 4.

Connector	Terminal		Condition	Continuity
M310	3	4	Insert mechanical key into ignition switch.	Yes
			Remove mechanical key from ignition switch.	No

OK or NG

OK >> GO TO 4.

NG >> Replace key cylinder assembly (built-in key switch).

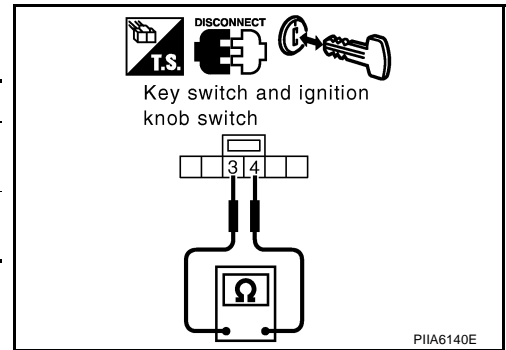

4. CHECK KEY SWITCH CIRCUIT

1. Disconnect Intelligent Key unit connector.
2. Check continuity between Intelligent Key unit harness connector M75 terminal 7 and key switch and ignition knob switch harness connector M310 terminal 4.

7 (B/R) - 4 (B/P) : Continuity should exist.

3. Check continuity between Intelligent Key unit harness connector M75 terminal 7 and ground.

7 (B/R) - Ground : Continuity should not exist.

OK or NG

OK >> Check the condition of harness and harness connector.

NG >> Repair or replace harness between Intelligent Key unit and key switch and ignition knob switch.

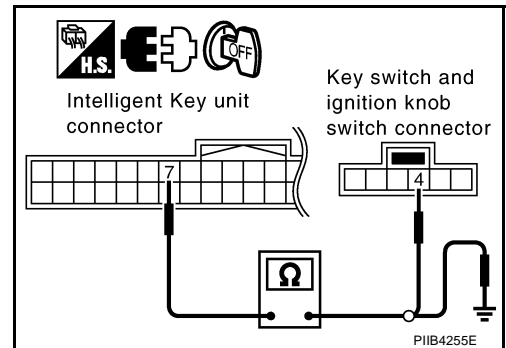

INTELLIGENT KEY SYSTEM

AIS0069M

Check Key Switch (BCM Input)

1. CHECK KEY SWITCH POWER SUPPLY CIRCUIT

1. Turn ignition switch OFF.
2. Disconnect key switch and ignition knob switch connector.
3. Check voltage between key switch and ignition knob switch harness connector M310 terminal 3 and ground.

3 (Y) – Ground : Battery voltage.

OK or NG

- OK >> GO TO 2.
 NG >> Check harness between key switch and ignition knob switch and fuse.

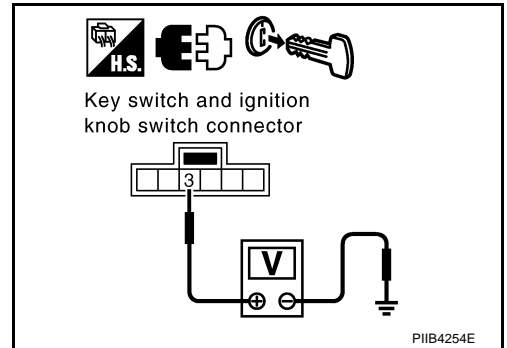

2. CHECK KEY SWITCH

Check continuity between key switch and ignition knob switch harness connector M310 terminals 3 and 4.

Connector	Terminal		Condition	Continuity
M310	3	4	Insert mechanical key into ignition switch.	Yes
			Remove mechanical key from ignition switch.	No

OK or NG

- OK >> GO TO 3.
 NG >> Replace key cylinder assembly (built-in key switch).

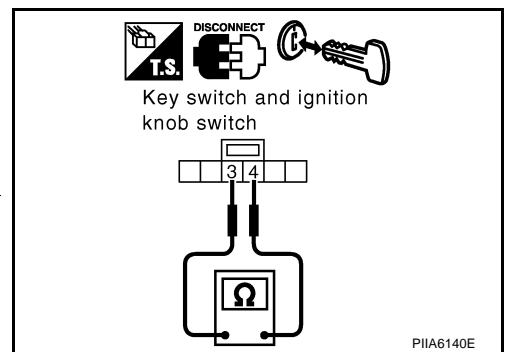

3. CHECK KEY SWITCH SIGNAL CIRCUIT

1. Disconnect BCM connector.
2. Check continuity between BCM harness connector M1 terminal 37 and key switch and ignition knob switch harness connector M310 terminal 4.

37 (B/P) – 4 (B/P) : Continuity should exist.

3. Check continuity between BCM harness connector M1 terminal 37 (B/P) and ground.

37 (B/P) – Ground : Continuity should not exist.

OK or NG

- OK >> Key switch (BCM input) circuit is OK.
 NG >> Repair or replace harness between key switch and ignition knob switch and BCM.

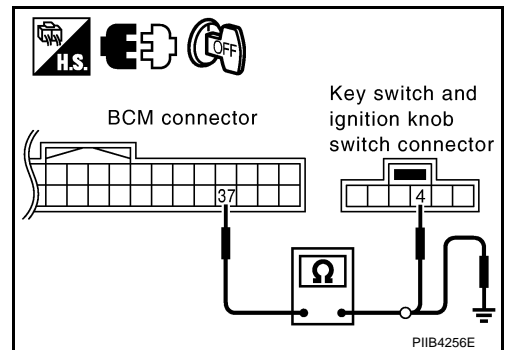

INTELLIGENT KEY SYSTEM

AIS0069N

Check Ignition Knob Switch

1. CHECK IGNITION KNOB SWITCH

With CONSULT-II

Display "PUSH SW" on DATA MONITOR screen, and check if ON/OFF display is linked to ignition switch operation.

Monitor item	Condition
PUSH SW	Ignition switch is pushed: ON
	Ignition switch is withdrawn: OFF

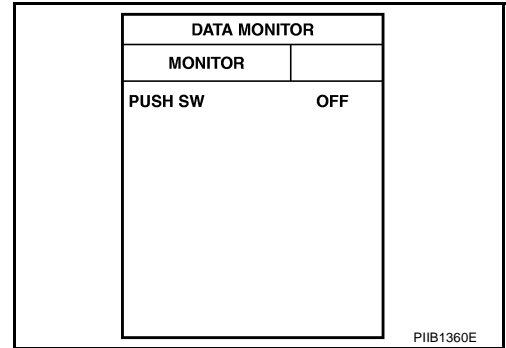

PIIB1360E

Without CONSULT-II

1. Turn ignition switch OFF.
2. Disconnect Intelligent Key unit connector.
3. Check voltage between Intelligent Key unit harness connector M75 terminal 27 and ground.

Connector	Terminal (Wire color)		Condition	Voltage (V) (Approx.)
	(+)	(-)		
M75	27 (OR)	Ground	Ignition switch is pushed	Battery voltage
			Ignition switch is released	0

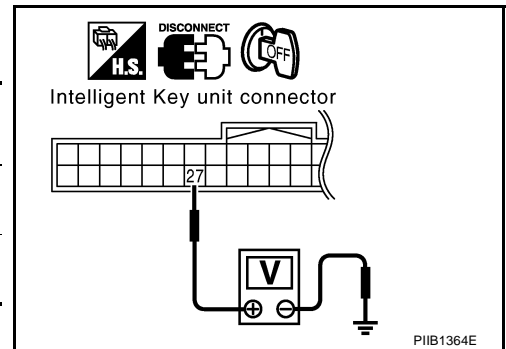

PIIB1364E

OK or NG

- OK >> Ignition knob switch is OK.
 NG >> GO TO 2.

2. CHECK IGNITION KNOB SWITCH POWER SUPPLY CIRCUIT

1. Turn ignition switch OFF.
2. Disconnect key switch and ignition knob switch connector.
3. Check voltage between key switch and ignition knob switch harness connector M310 terminal 1 and ground.

1 (Y) - Ground : Battery voltage

OK or NG

- OK >> GO TO 3.
 NG >> Repair or replace key switch and ignition knob switch power supply circuit.

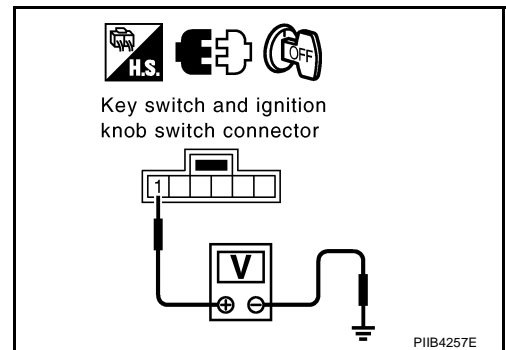

PIIB4257E

INTELLIGENT KEY SYSTEM

3. CHECK IGNITION KNOB SWITCH OPERATION

Check continuity between ignition knob switch harness connector M310 terminal 1 and 2.

Connector	Terminal		Condition	Continuity
M310	1	2	Ignition switch is pushed	Yes
			Ignition switch is with-drawn	No

OK or NG

OK >> GO TO 4.

NG >> Replace key switch and ignition knob switch.

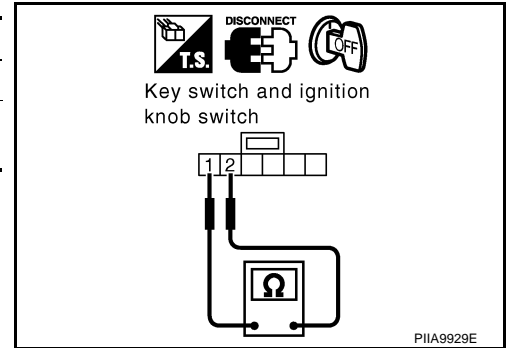

4. CHECK IGNITION KNOB SWITCH CIRCUIT

- Check continuity between Intelligent Key unit harness connector M75 terminal 27 and key switch and ignition knob switch harness connector M310 terminal 2.

27 (OR) - 2 (OR) : Continuity should exist.

- Check continuity between Intelligent Key unit harness connector M75 terminal 2 and ground.

2 (OR) - Ground : Continuity should not exist.

OK or NG

OK >> Check the condition of harness and harness connector.

NG >> Repair or replace harness between Intelligent Key unit and key switch and ignition knob switch.

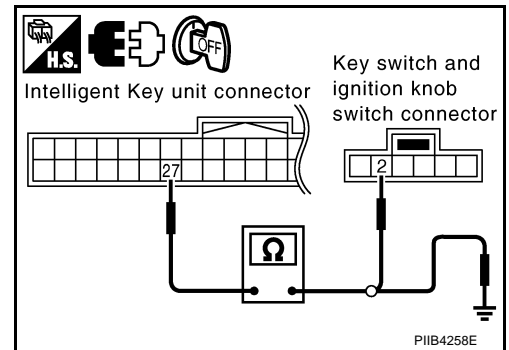

INTELLIGENT KEY SYSTEM

AIS00690

Check Door Switch

1. CHECK DOOR SWITCH INPUT SIGNAL

With CONSULT-II

Check door switches ("DOOR SW-DR", "DOOR SW-AS", "DOOR SW-RL" and "DOOR SW-RR") in "DATA MONITOR" mode with CONSULT-II.

Monitor item	Condition
DOOR SW-DR	CLOSE → OPEN: OFF → ON
DOOR SW-AS	
DOOR SW-RL	
DOOR SW-RR	

DATA MONITOR	
MONITOR	
DOOR SW-DR	OFF
DOOR SW-AS	OFF
DOOR SW-RL	OFF
DOOR SW-RR	OFF

PIA6469E

Without CONSULT-II

- Turn ignition switch OFF.
- Check voltage between BCM harness connector and ground.

Item	Connector	Terminals (Wire color)		Door condition	Voltage (V) (Approx.)
		(+)	(-)		
Driver side	B4	62 (W)	Ground	CLOSE ↓ OPEN	Battery voltage ↓ 0
Rear LH		63 (P)			
Passenger side	M1	12 (P)			
Rear RH		13 (P)			

OK or NG

- OK >> Door switch circuit is OK.
 NG >> GO TO 2.

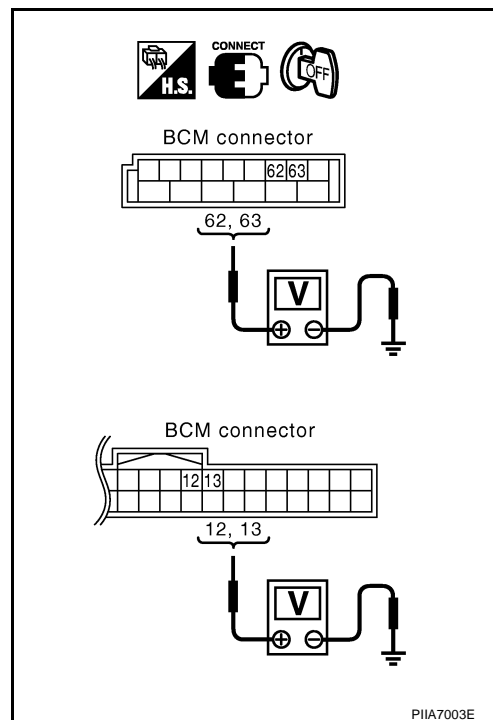

INTELLIGENT KEY SYSTEM

2. CHECK DOOR SWITCH

1. Turn ignition switch OFF.
2. Disconnect door switch connector.
3. Check continuity between door switch terminal 1 and ground part of door switch.

Terminal	Door switch condition	Continuity
1	Pushed	No
	Released	Yes

OK or NG

- OK >> GO TO 3.
 NG >> Replace door switch.

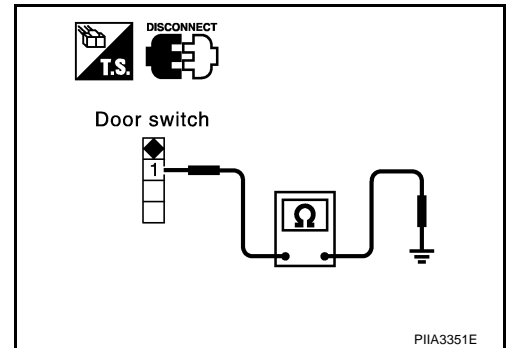

3. CHECK DOOR SWITCH CIRCUIT

1. Disconnect BCM connector.
2. Check continuity between door switch harness connector B17, B20, B23, B32 terminal 1 and BCM harness connector M1, B4 terminals 12, 13, 62, 63.

Driver door

1 (W) – 62 (W) : Continuity should exist.

Passenger door

1 (P) – 12 (P) : Continuity should exist.

Rear door LH

1 (P) – 63 (P) : Continuity should exist.

Rear door RH

1 (P) – 13 (P) : Continuity should exist.

3. Check continuity between door switch harness connector B17, B20, B23, B32 terminal 1 and ground.

1 (W or P) – Ground : Continuity should not exist.

OK or NG

- OK >> Check door switch case ground condition.
 NG >> Repair or replace harness between BCM and door switch.

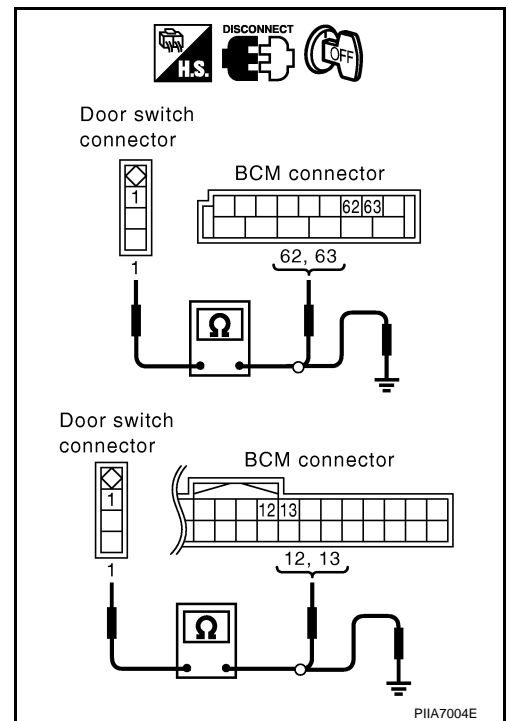

INTELLIGENT KEY SYSTEM

AIS006AB

Check Trunk Room Lamp Switch

1. CHECK TRUNK ROOM LAMP SWITCH INPUT SIGNAL

With CONSULT-II

Check ("TRUNK SW") in "DATA MONITOR" mode with CONSULT-II.

Monitor item	Condition
TRUNK SW	OPEN : ON
	CLOSE : OFF

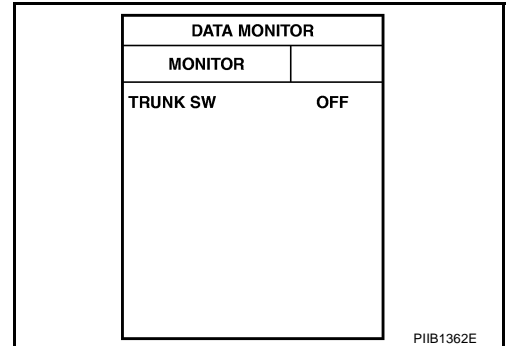

Without CONSULT-II

- Turn ignition switch OFF.
- Check voltage between BCM harness connector and ground.

Connector	Terminal (Wire color)		Trunk condition	Voltage (V) (Approx.)
	(+)	(-)		
B4	57 (R/W)	Ground	CLOSE	Battery voltage
			OPEN	0

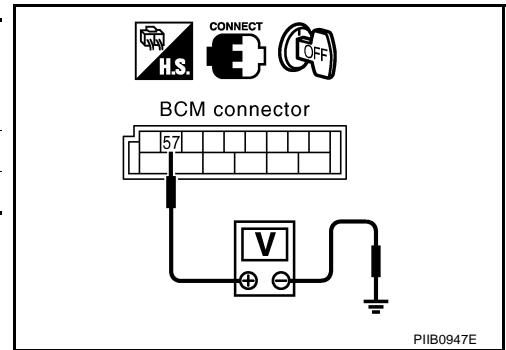

OK or NG

- OK >> Trunk room lamp switch circuit is OK.
 NG >> GO TO 2.

2. CHECK TRUNK ROOM LAMP SWITCH

- Turn ignition switch OFF.
- Disconnect trunk room lamp switch connector.
- Check continuity between trunk room lamp switch terminals 1 and 2.

Terminal		Back door condition	Continuity
1	2	Closed	No
		Open	Yes

OK or NG

- OK >> GO TO 3.
 NG >> Replace trunk room lamp switch.

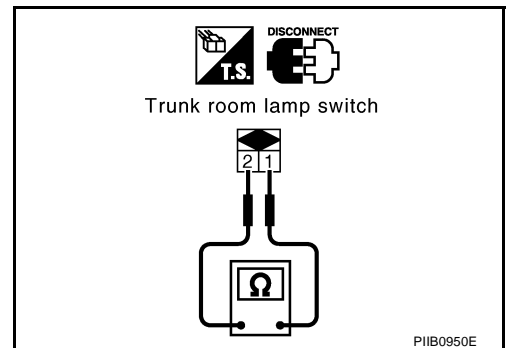

INTELLIGENT KEY SYSTEM

3. CHECK TRUNK ROOM LAMP SWITCH CIRCUIT

1. Disconnect BCM connector.
2. Check continuity between BCM harness connector B4 terminal 57 and trunk room lamp switch harness connector B105 terminal 1.

57 (R/W) – 1 (R/W) : Continuity should exist.

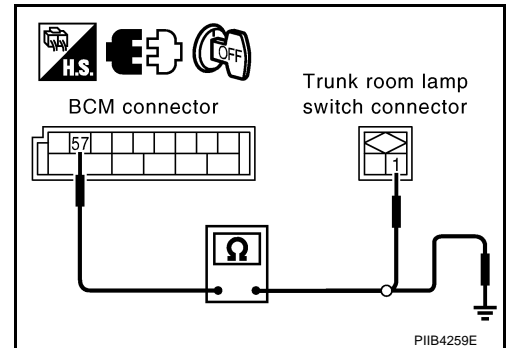

3. Check continuity between harness connector B4 terminals 57 and ground.

57 (R/W) – Ground : Continuity should not exist.

OK or NG

OK >> GO TO 4.

NG >> Repair or replace harness between BCM and trunk room lamp switch.

4. CHECK TRUNK ROOM LAMP SWITCH GROUND CIRCUIT

Check continuity between trunk room lamp switch harness connector B105 terminal 2 and ground.

2 (B) – Ground : Continuity should exist.

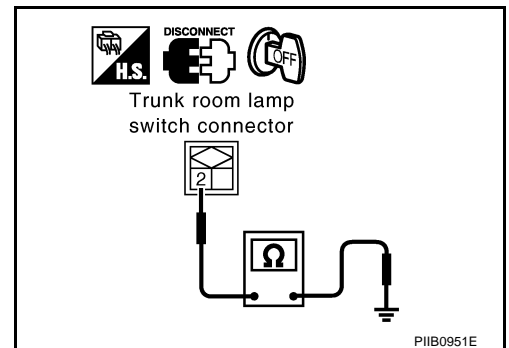

OK or NG

OK >> Check connection of harness and connector.

NG >> Repair or replace trunk room lamp switch ground circuit.

INTELLIGENT KEY SYSTEM

AIS0069P

Check Door Request Switch

1. CHECK DOOR REQUEST SWITCH

With CONSULT-II

Check door request switch ("DR REQ SW" or "AS REQ SW") in "DATA MONITOR" mode.

Monitor item	Condition
DR REQ SW	Door request switch is pressed: ON
AS REQ SW	Door request switch is released: OFF

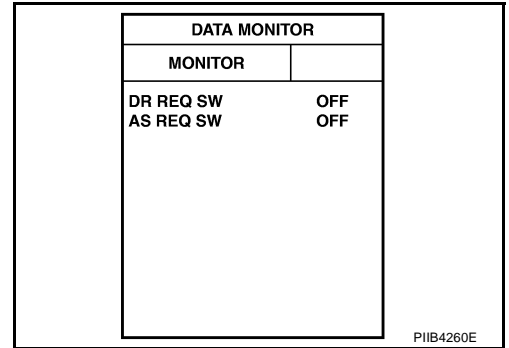

Without CONSULT-II

- Turn ignition switch OFF.
- Check voltage between Intelligent Key unit harness connector and ground.

Connector	Item	Terminal (Wire color)		Condition	Voltage (V) (Approx.)
		(+)	(-)		
M75	Door request switch (driver side)	5 (B/W)	Ground	Door request switch is pressed	0
	Door request switch (passenger side)	25 (P/L)		Door request switch is released	5

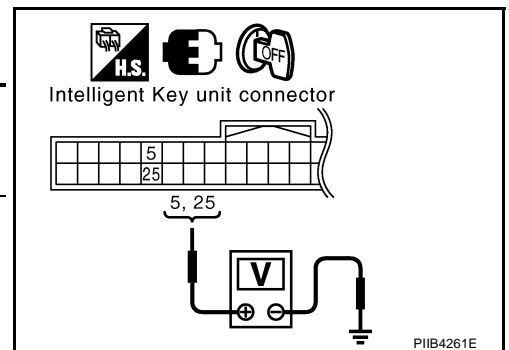

OK or NG

- OK >> Door request switch is OK.
 NG >> GO TO 2.

2. CHECK DOOR REQUEST SWITCH OPERATION

- Turn ignition switch OFF.
- Disconnect outside key antenna and front door request switch connector.
- Check continuity between outside key antenna and front door request switch harness connector D13 (driver door), D41 (passenger door) terminals 3 and 4.

Item	Connector	Terminal (wire color)		Condition	Continuity
		(+)	(-)		
Driver side	D13	3	4	Door request switch is pressed	Yes
Passenger side	D41			Door request switch is released	No

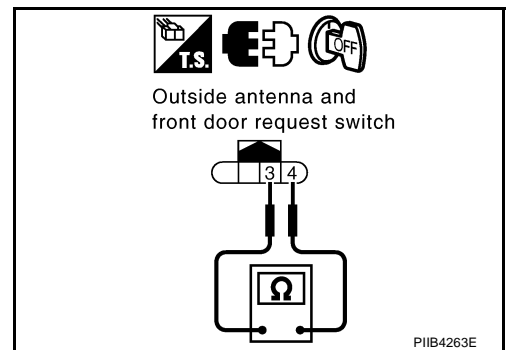

OK or NG

- OK >> GO TO 3.
 NG >> Replace outside key antenna and front door request switch.

INTELLIGENT KEY SYSTEM

3. CHECK DOOR REQUEST SWITCH GROUND CIRCUIT

Check continuity between outside key antenna and front door request switch harness connector D13 (driver door), D41 (passenger door) terminal 4 and ground.

4 (B) - Ground : Continuity should exist.

OK or NG

OK >> GO TO 4.

NG >> Repair or replace door request switch ground circuit.

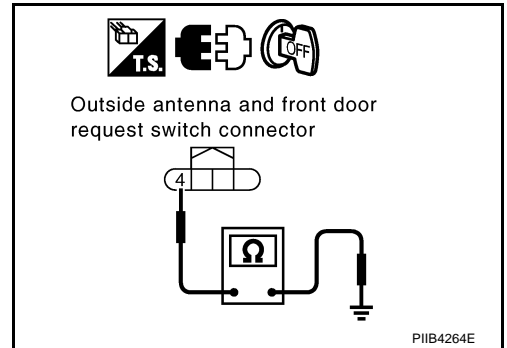

4. CHECK DOOR REQUEST SWITCH CIRCUIT

1. Disconnect Intelligent Key unit connector.
2. Check continuity between Intelligent Key unit harness connector M75 terminals 5 (driver door), 25 (passenger door) and door request switch harness connector D13 (driver door), D41 (passenger door) terminal 3.

Driver side 5 (B/W) - 3 (B/W) : Continuity should exist.

Passenger side 25 (P/L) - 3 (P/L) : Continuity should exist.

3. Check continuity between door request switch harness connector D25 (driver door), D43 (passenger door), terminals 3 and ground.

3 (B/W, P/L) - Ground : Continuity should not exist.

OK or NG

OK >> GO TO 5.

NG >> Repair or replace harness between Intelligent Key unit and door request switch.

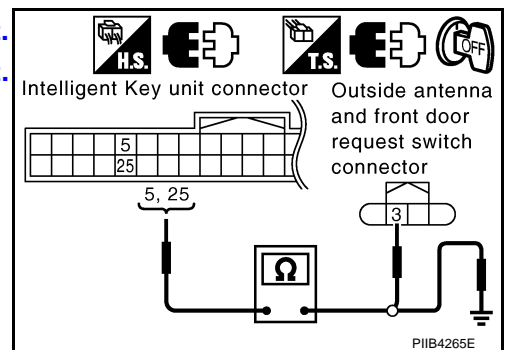

5. CHECK DOOR REQUEST SWITCH SIGNAL

1. Connect Intelligent Key unit connector.
2. Check voltage between outside key antenna and front door request switch harness connector D13 (driver door), D41 (passenger door) terminal 3 and ground.

Driver 3 (B/W) - Ground : Approx. 5V

Passenger 3 (P/L) - Ground : Approx. 5V

OK or NG

OK >> Check condition of harness and connector.

NG >> Replace Intelligent Key unit.

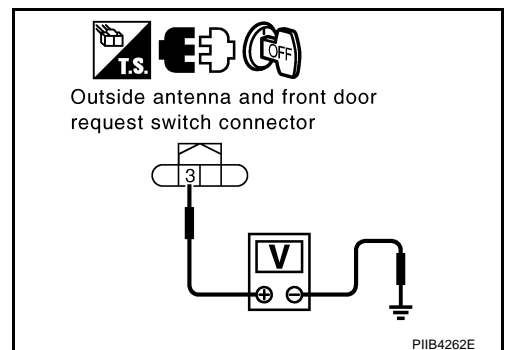

INTELLIGENT KEY SYSTEM

AIS006AR

Check Trunk Opener Request Switch

1. CHECK TRUNK OPENER REQUEST SWITCH

With CONSULT-II

Check trunk opener request switch ("BD/TR REQ SW") in "DATA MONITOR" mode.

Monitor item	Condition
BD/TR REQ SW	Trunk opener request switch is pressed: ON
	Trunk opener request switch is released: OFF

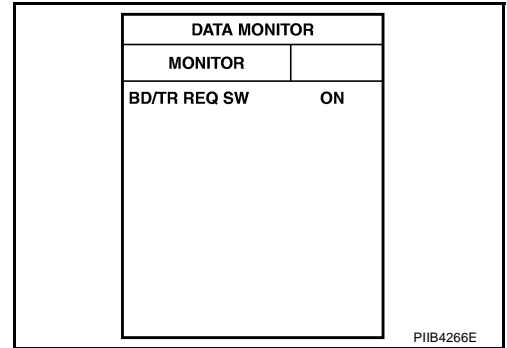

Without CONSULT-II

- Turn ignition switch OFF.
- Check voltage between Intelligent Key unit connector and ground.

Connector	Terminal (Wire color)		Condition	Voltage (V) (Approx.)
	(+)	(-)		
M75	29 (G/W)	Ground	Trunk opener request switch is pressed	0
			Trunk opener request switch is released	5

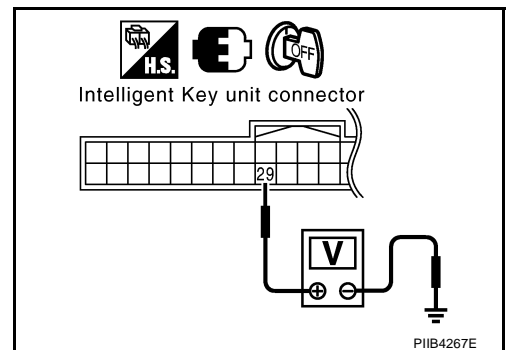

OK or NG

- OK >> Trunk opener request switch is OK.
 NG >> GO TO 2.

2. CHECK TRUNK OPENER REQUEST SWITCH OPERATION

- Turn ignition switch OFF.
- Disconnect trunk opener request switch connector.
- Check continuity between trunk opener request switch harness connector B130 terminals 1 and 2.

Connector	Terminal (wire color)		Condition	Continuity
	(+)	(-)		
B130	1	2	Door request switch is pressed	Yes
			Door request switch is released	No

OK or NG

- OK >> GO TO 3.
 NG >> Replace trunk opener request switch.

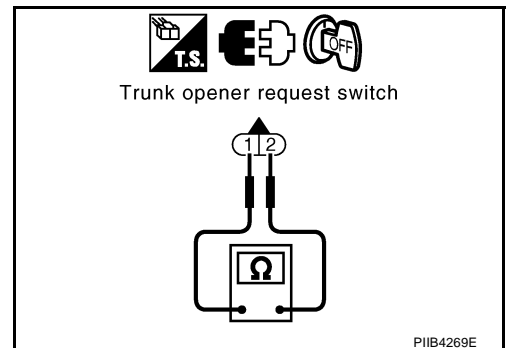

INTELLIGENT KEY SYSTEM

3. CHECK TRUNK OPENER REQUEST SWITCH GROUND CIRCUIT

Check continuity between trunk opener request switch harness connector B130 terminal 2 and ground.

2 (B) - Ground : Continuity should exist.

OK or NG

OK >> GO TO 4.

NG >> Repair or replace trunk opener request switch ground circuit.

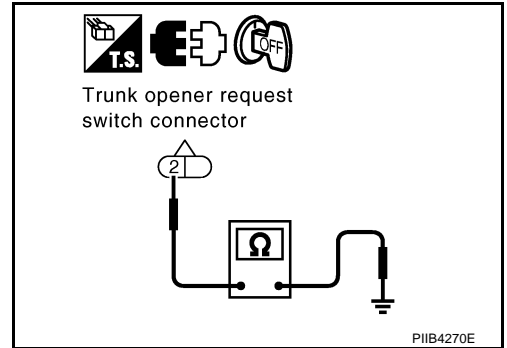

4. CHECK TRUNK OPENER REQUEST SWITCH CIRCUIT

1. Disconnect Intelligent Key unit connector.

2. Check continuity between Intelligent Key unit harness connector M75 terminals 29 and trunk opener request switch harness connector B130 terminal 1.

29 (G/W) - 1 (G/R) : Continuity should exist.

3. Check continuity between Intelligent Key unit harness connector M75 terminals 29 and ground.

29 (G/W) - Ground : Continuity should not exist.

OK or NG

OK >> GO TO 5.

NG >> Repair or replace harness between Intelligent Key unit and trunk opener request switch.

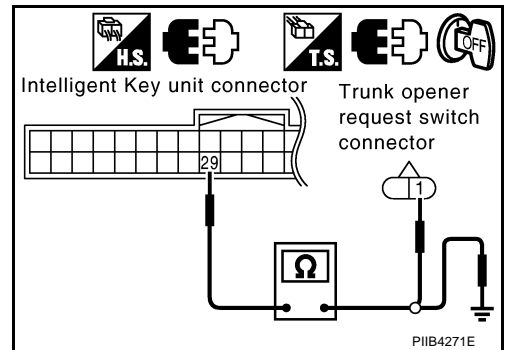

5. CHECK TRUNK OPENER REQUEST SWITCH SIGNAL

1. Connect Intelligent Key unit connector.

2. Check voltage between trunk opener request switch harness connector B130 terminal 1 and ground.

1 (G/R) - Ground : Approx. 5V

OK or NG

OK >> Check condition of harness and connector.

NG >> Replace Intelligent Key unit.

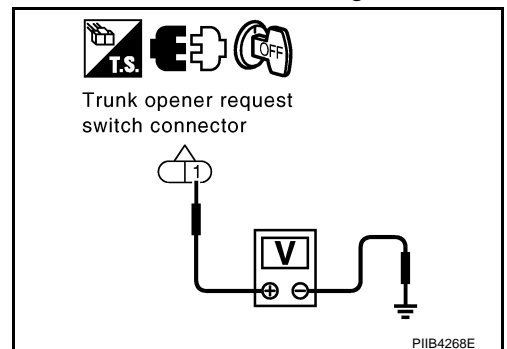

INTELLIGENT KEY SYSTEM

AIS006AC

Check Unlock Sensor

1. CHECK UNLOCK SENSOR POWER SUPPLY

Check voltage between Intelligent Key unit connector and ground.

Connector	Terminals (Wire color)		Condition	Voltage (V) (Approx.)
	(+)	(-)		
M75	28 (L)	Ground	Driver side door lock is locked	5
			Driver side door lock is unlocked	0

OK or NG

- OK >> Unlock sensor is OK.
 NG >> GO TO 2.

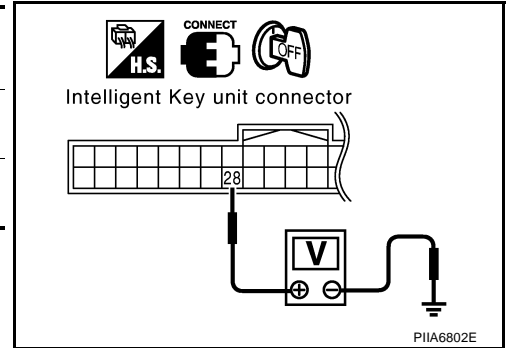

2. CHECK UNLOCK SENSOR CIRCUIT

1. Turn ignition switch OFF.
2. Disconnect Intelligent Key unit and front door lock assembly (driver side) connector.
3. Check continuity between Intelligent Key unit harness connector M75 terminal 28 and front door lock assembly (driver side) harness connector D11 terminal 2.

28 (L) – 2 (L) : Continuity should exist.

4. Check continuity between Intelligent Key unit harness connector M75 terminal 28 and ground.

28 (L) – Ground : Continuity should not exist.

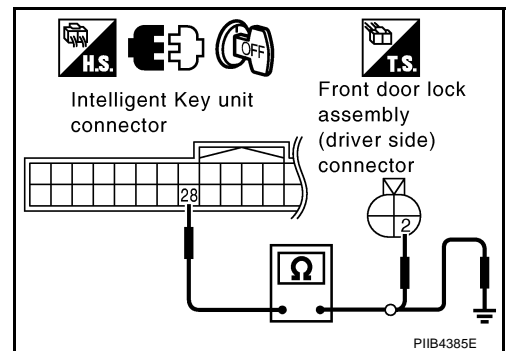

OK or NG

- OK >> GO TO 3.
 NG >> Repair or replace harness between Intelligent Key unit and front door lock assembly (driver side).

3. CHECK UNLOCK SENSOR GROUND CIRCUIT

Check continuity between front door lock assembly (driver side) harness connector D11 terminal 4 and ground.

4 (B) – Ground : Continuity should exist.

OK or NG

- OK >> GO TO 4.
 NG >> Repair or replace harness.

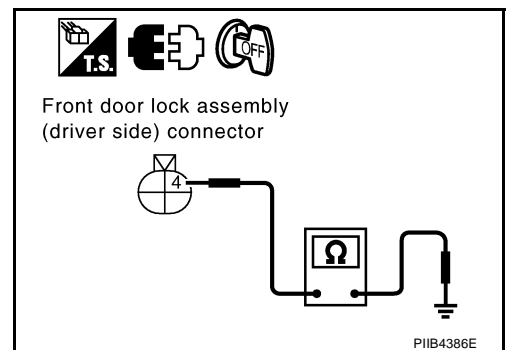

INTELLIGENT KEY SYSTEM

4. CHECK INTELLIGENT KEY UNIT OUTPUT SIGNAL

1. Connect Intelligent Key unit harness connector.
2. Check voltage between Intelligent Key unit harness connector M75 terminal 28 and ground.

28 (L) – Ground : Approx. 5V

OK or NG

- OK >> Replace front door lock assembly (driver side).
NG >> Replace Intelligent Key unit.

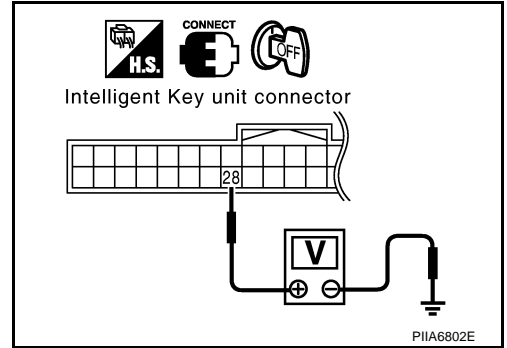

Check Intelligent Key Warning Buzzer (Instrument Panel)

AIS0069Q

1. CHECK INTELLIGENT KEY WARNING BUZZER (INSTRUMENT PANEL) POWER SUPPLY CIRCUIT

1. Turn ignition switch OFF.
2. Disconnect Intelligent Key warning buzzer (instrument panel) connector.
3. Check voltage between Intelligent Key warning buzzer (instrument panel) harness connector M21 terminal 1 and ground.

1 (R/W) - Ground : Battery voltage

OK or NG

- OK >> GO TO 2.
NG >> Repair or replace Intelligent Key warning buzzer (instrument panel) power supply circuit.

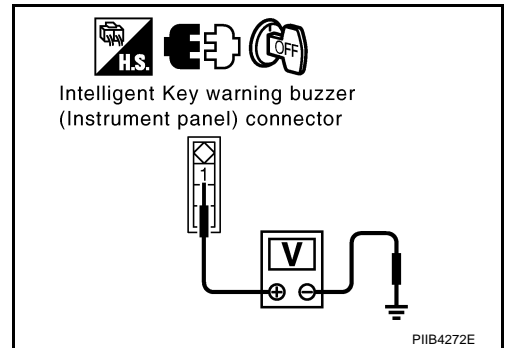

2. CHECK INTELLIGENT KEY WARNING BUZZER (INSTRUMENT PANEL) CIRCUIT

1. Disconnect Intelligent Key unit connector.
2. Check continuity between Intelligent Key unit harness connector M75 terminal 30 and Intelligent Key warning buzzer (instrument panel) harness connector M21 terminal 3.

30 (LG/B) - 3 (LG/B) : Continuity should exist.

3. Check continuity between Intelligent Key unit harness connector M75 terminal 30 and ground.

30 (LG/B) - Ground : Continuity should not exist.

OK or NG

- OK >> GO TO 3.
NG >> Repair or replace harness between Intelligent Key warning buzzer (instrument panel) and Intelligent Key unit.

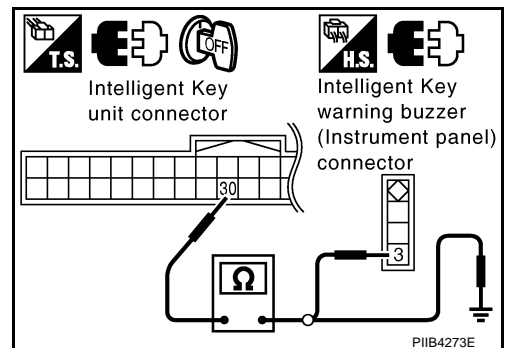

INTELLIGENT KEY SYSTEM

3. CHECK INTELLIGENT KEY WARNING BUZZER (INSTRUMENT PANEL) OPERATION

Connect battery power supply to Intelligent Key warning buzzer (instrument panel) harness connector M21 terminals 1 and 3, and check the operation.

1 (BAT+) - 3 (BAT-) : the buzzer sounds

OK or NG

- OK >> Intelligent Key warning buzzer (instrument panel) is OK.
- NG >> Replace Intelligent Key warning buzzer (instrument panel).

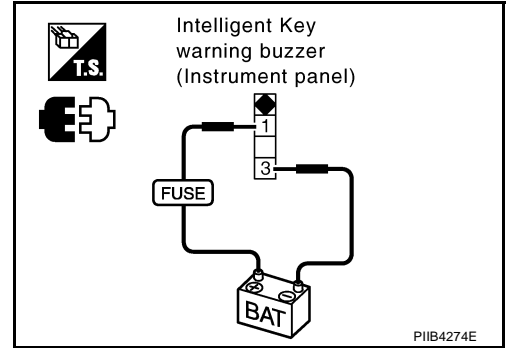

Check Intelligent Key Warning Buzzer (ENGINE ROOM)

AIS006AD

1. CHECK INTELLIGENT KEY WARNING BUZZER (ENGINE ROOM) POWER SUPPLY CIRCUIT

1. Turn ignition switch OFF.
2. Disconnect Intelligent Key warning buzzer (engine room) connector.
3. Check voltage between Intelligent Key warning buzzer (engine room) harness connector E38 terminal 1 and ground.

1 (L/W) - Ground : Battery voltage

OK or NG

- OK >> GO TO 2.
- NG >> Repair or replace Intelligent Key warning buzzer (engine room) power supply circuit.

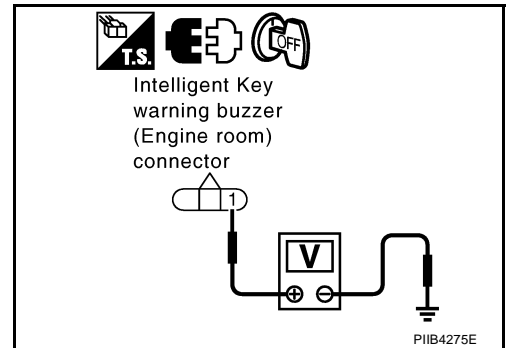

2. CHECK INTELLIGENT KEY WARNING BUZZER (ENGINE ROOM) CIRCUIT

1. Disconnect Intelligent Key unit connector.
2. Check continuity between Intelligent Key unit harness connector M75 terminal 4 and Intelligent Key warning buzzer (engine room) harness connector E38 terminal 3.

4 (GY) - 3 (GY) : Continuity should exist.

3. Check continuity between Intelligent Key warning buzzer (engine room) harness connector E38 terminal 3 and ground.

3 (GY) - Ground : Continuity should not exist.

OK or NG

- OK >> GO TO 3.
- NG >> Repair or replace harness between Intelligent Key warning buzzer (engine room) and Intelligent Key unit.

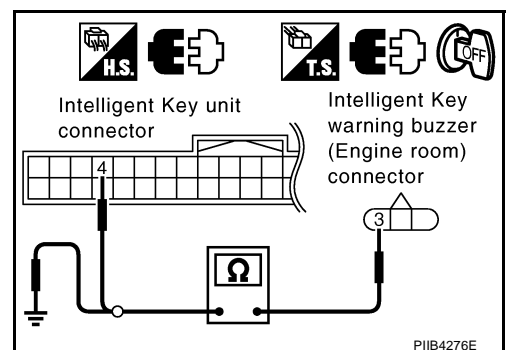

INTELLIGENT KEY SYSTEM

3. CHECK INTELLIGENT KEY WARNING BUZZER (ENGINE ROOM) OPERATION

Connect battery power supply to Intelligent Key warning buzzer (engine room) harness connector E38 terminals 1 and 3, and check the operation.

1 (BAT+) - 3 (BAT-) : the buzzer sounds

OK or NG

- OK >> Intelligent Key warning buzzer (engine room) is OK.
- NG >> Replace Intelligent Key warning buzzer (engine room).

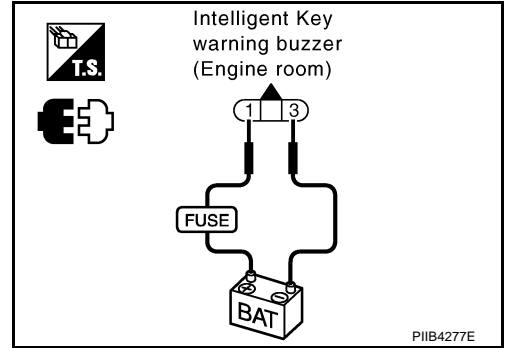

Check Outside Key Antenna

1. CHECK OUTSIDE KEY ANTENNA INPUT SIGNAL

1. Turn ignition switch OFF.
2. Check signal between Intelligent Key unit connector and ground with oscilloscope.

Con- nec- tor	Item	Terminal (wire color)		Condi- tion	Signal (Reference value)
		(+)	(-)		
M75	Rear bumper	17 (W/L)	Ground	Request switch is pushed	<p>SIIA1910J</p>
	Driver side	19 (P)			
	Passenger side	37 (LG)			

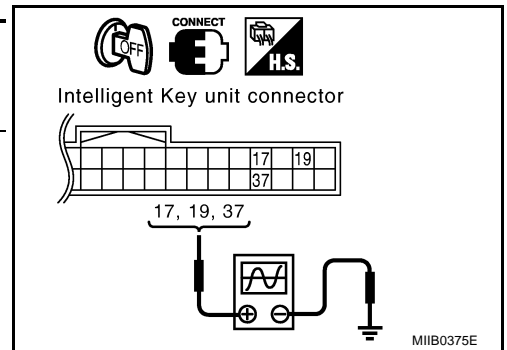

OK or NG

- OK >> Outside key antenna is OK.
- NG >> GO TO 2.

INTELLIGENT KEY SYSTEM

2. CHECK OUTSIDE KEY ANTENNA CIRCUIT

1. Disconnect Intelligent Key unit connector and outside key antenna connector.
2. Check continuity between each outside key antenna harness connector D13 (driver side), D41 (passenger side), B131 (rear bumper) terminals 1, 2 and Intelligent Key unit harness connector M75 terminals 17, 18, 19, 20, 37, and 38.

Item	Connector	Terminal (Wire color)	Connector	Terminal (Wire color)	Continuity
Rear bumper	B131	1 (W)	M75	17 (W/L)	Yes
		2 (B)		18 (W/R)	
Driver side	D13	1 (P)		19 (P)	
		2 (PU)		20 (PU)	
Passenger side	D41	1 (LG)		37 (LG)	
		2 (B/Y)		38 (BR/W)	

3. Check continuity between each outside key antenna harness connector terminals 1, 2 and ground.

Item	Connector	Terminal	Continuity
Rear bumper	B131	1 (W)	No
		2 (B)	
Driver side	D13	1 (P)	
		2 (PU)	
Passenger side	D41	1 (LG)	
		2 (B/Y)	

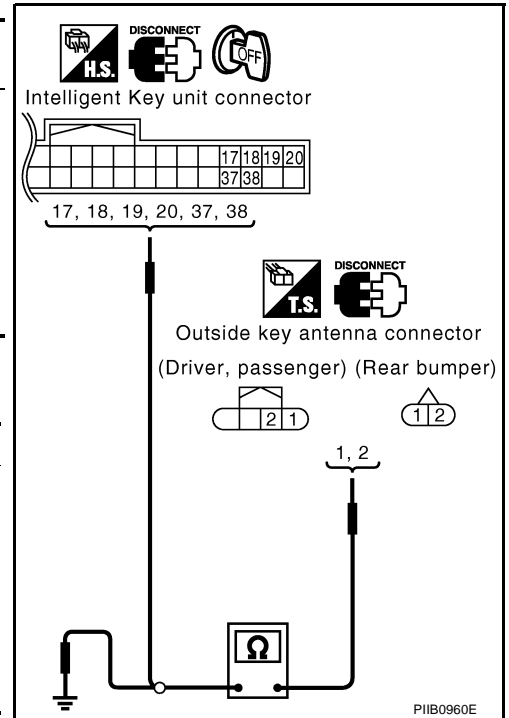

OK or NG

OK >> GO TO 3.

NG >> Replace harness between outside key antenna and Intelligent Key unit.

3. CHECK OUTSIDE KEY ANTENNA POWER SUPPLY

1. Replace outside key antenna. (New antenna or other antenna)
2. Connect Intelligent Key unit connector and outside key antenna connector.
3. Check signal between Intelligent Key unit connector and ground with oscilloscope.

Con- nec- tor	Item	Terminal (wire color)		Condi- tion	Signal (Reference value)
		(+)	(-)		
M75	Rear bumper	17 (W/L)	Ground	Request switch is pushed	
	Driver side	19 (P)			
	Passenger side	37 (LG)			

SIIA1910J

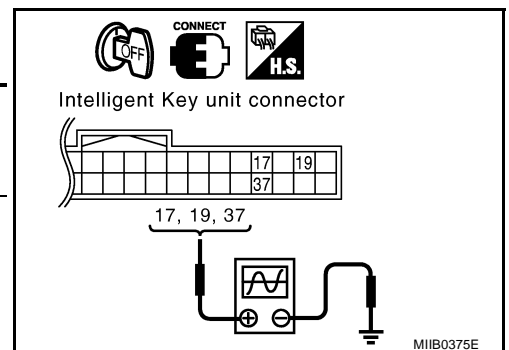

OK or NG

OK >> Replace outside key antenna.

NG >> Replace Intelligent Key unit.

INTELLIGENT KEY SYSTEM

AIS0069S

Check Inside Key Antenna

1. CHECK INSIDE KEY ANTENNA POWER SUPPLY SIGNAL

1. Turn ignition switch OFF.
2. Check signal between Intelligent Key unit connector and ground with oscilloscope.

Con- nec- tor	Item	Terminal (Wire color)		Condition	Signal (V) (Reference value)
		(+)	(-)		
M75	Trunk room	13 (B)	Ground	Any door is open → All doors are closed	<p>(V) 15 10 5 0</p> <p>10 µs</p> <p>SIIA1910J</p>
	Center console	15 (G)	Ground	Ignition switch is pushed.	
	Dash-board	35 (LG)			

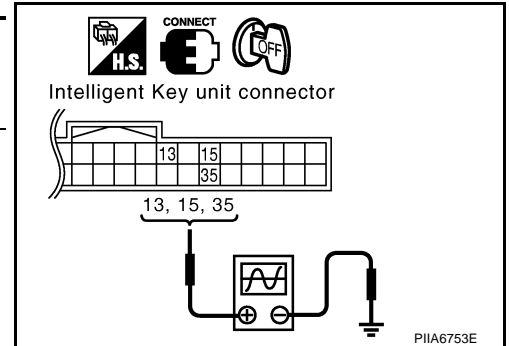

OK or NG

- OK >> Inside key antenna is OK.
 NG >> GO TO 2.

2. CHECK INSIDE KEY ANTENNA

1. Disconnect Intelligent Key unit connector and inside key antenna connectors.
2. Check continuity between inside key antenna harness connector M172 (center console), M69 (dashboard), B114 (trunk room) terminals 1, 2 and Intelligent Key unit harness connector M75 terminals 13, 14, 15, 16, 35 and 36.

Item	Connector	Terminal (Wire color)	Connec- tor	Terminal (Wire color)	Continuity
Trunk room	B114	1 (B)	M75	13 (B)	Yes
		2 (W)		14 (W)	
Center console	M172	1 (G)		15 (G)	
		2 (R)		16 (R)	
Dashboard	M69	1 (LG)		35 (LG)	
		2 (PU)		36 (PU)	

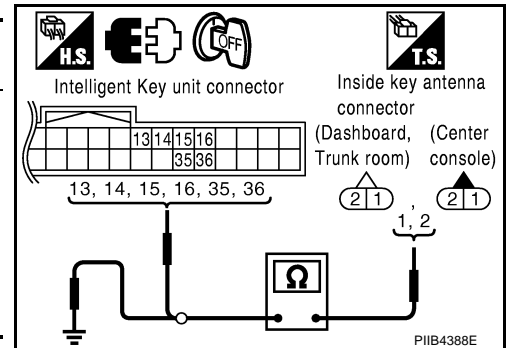

3. Check continuity between inside key antenna harness connector M172 (center console), M69 (dashboard), B114 (trunk room) terminals 1, 2 and ground.

Item	Connector	Terminal (Wire color)	Continuity
Trunk room	B114	1 (B)	No
		2 (W)	
Center console	M172	1 (G)	
		2 (R)	
Dashboard	M69	1 (LG)	
		2 (PU)	

OK or NG

- OK >> GO TO 3.
 NG >> Repair or replace harness between inside key antenna and Intelligent Key unit.

INTELLIGENT KEY SYSTEM

3. CHECK INSIDE KEY ANTENNA POWER SUPPLY SIGNAL

1. Replace inside key antenna. (New antenna or other antenna)
2. Connect Intelligent Key unit connector.
3. Check signal between Intelligent Key unit connector and ground with oscilloscope.

Con- nec- tor	Item	Terminal (Wire color)		Condition	Signal (V) (Reference value)
		(+)	(-)		
M75	Trunk room	13 (B)	Ground	Any door is open → All doors are closed	
	Center console	15 (G)	Ground	Ignition switch is pushed.	
	Dash-board	35 (LG)			

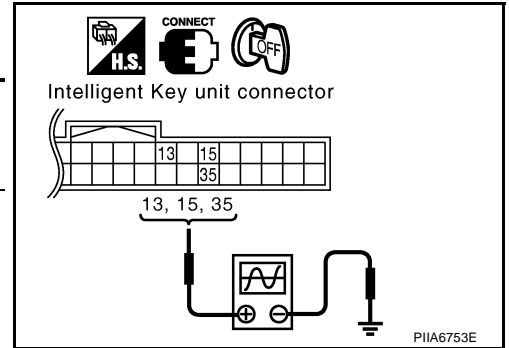

OK or NG

- OK >> Replace inside key antenna.
 NG >> Replace Intelligent key unit.

Check Steering Lock Unit

AIS0069T

1. CHECK STEERING LOCK UNIT POWER SUPPLY

1. Turn ignition switch OFF.
2. Disconnect steering lock unit connector.
3. Check voltage between steering lock unit harness connector M311 terminal 1 and ground.

1 (Y) - Ground : Battery voltage

OK or NG

- OK >> GO TO 2.
 NG >> Repair or replace steering lock unit power supply circuit.

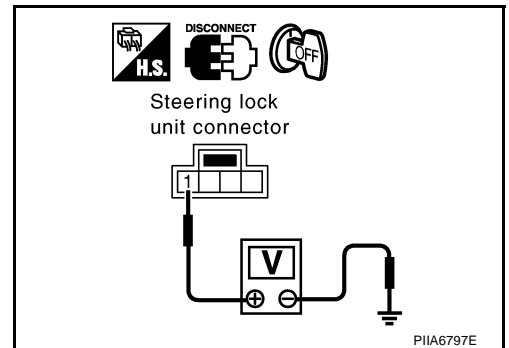

2. CHECK STEERING LOCK UNIT GROUND CIRCUIT

Check continuity between steering lock unit harness connector M311 terminal 4 and ground.

4 (G/R) - Ground : Continuity should exist.

OK or NG

- OK >> GO TO 3.
 NG >> GO TO 6.

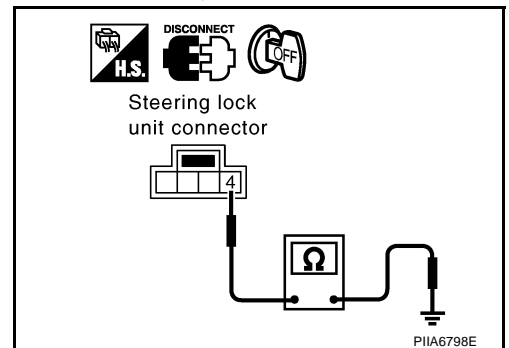

INTELLIGENT KEY SYSTEM

3. CHECK INTELLIGENT KEY UNIT OUTPUT SIGNAL

1. Connect steering lock unit connector.
2. Check voltage between Intelligent Key unit harness connector M75 terminal 1 and ground.

1 (L/Y) - Ground : Approx. 5V

OK or NG

- OK >> GO TO 4.
 NG >> Replace Intelligent Key unit.

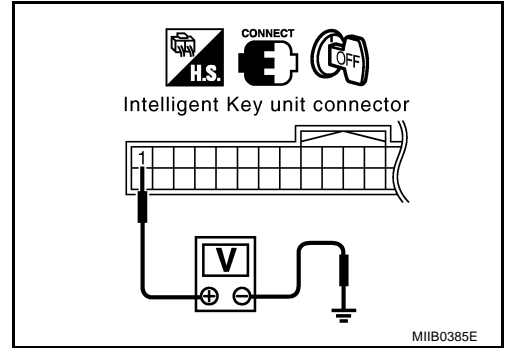

4. CHECK STEERING LOCK COMMUNICATION SIGNAL

Check signal between Intelligent Key unit connector M75 terminal 32 and ground with oscilloscope.

Connector	Terminal (Wire color)		Condition	Signal (V) (Reference value)
	(+)	(-)		
M75	32 (L/OR)	Ground	Ignition switch is pushed	

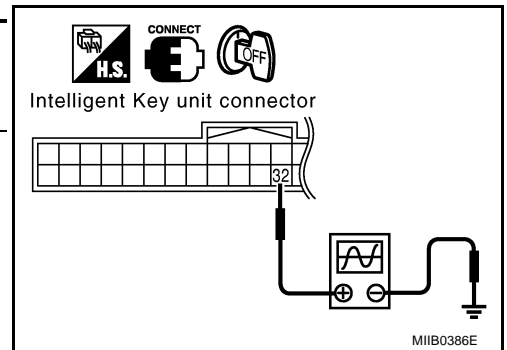

OK or NG

- OK >> GO TO 5.
 NG >> Replace Intelligent Key unit.

5. CHECK STEERING LOCK UNIT COMMUNICATION CIRCUIT

1. Disconnect Intelligent Key unit and steering lock unit connectors.
2. Check continuity between Intelligent Key unit harness connector M75 terminals 1, 31, 32 and steering lock unit connector M311 terminals 2, 3, 4.

1 (L/Y) - 2 (L/Y) : Continuity should exist.
31 (G/R) - 4 (G/R) : Continuity should exist.
32 (L/OR) - 3 (L/OR) : Continuity should exist.

3. Check continuity between steering lock unit harness connector M311 terminals 2, 3, 4 and ground.

2 (L/Y) - Ground : Continuity should not exist.
3 (L/OR) - Ground : Continuity should not exist.
4 (G/R) - Ground : Continuity should not exist.

OK or NG

- OK >> Replace steering lock unit.
- After replacing steering lock unit, perform registration procedure. Refer to "CONSULT-II Operation Manual NATS".
- NG >> Repair or replace harness between steering lock unit and Intelligent Key unit.

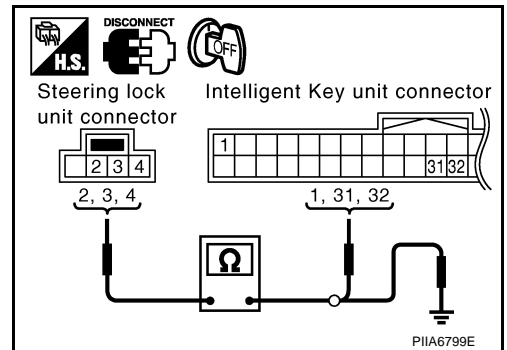

INTELLIGENT KEY SYSTEM

6. CHECK STEERING LOCK UNIT COMMUNICATION CIRCUIT

1. Disconnect Intelligent Key unit connector.
2. Check continuity between Intelligent Key unit harness connector M75 terminal 31 and steering lock unit connector M311 terminal 4.

31 (G/R) - 4 (G/R) : Continuity should exist.

3. Check continuity between steering lock unit harness connector M311 terminal 4 and ground.

4 (G/R) - Ground : Continuity should not exist.

OK or NG

- OK >> Replace Intelligent Key unit.
 NG >> Repair or replace harness between steering lock unit and Intelligent Key unit.

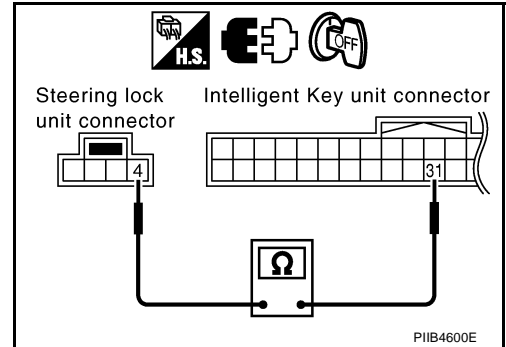

Check Stop Lamp Switch

1. CHECK STOP LAMP SWITCH INPUT SIGNAL

1. Turn ignition switch OFF.
2. Disconnect Intelligent Key unit connector.
3. Check voltage between Intelligent Key unit harness connector M75 terminal 1 and ground.

Connector	Terminal (wire color)		Condition	Voltage (V) (Approx.)
	(+)	(-)		
M75	26 (P/L)	Ground	Brake pedal depressed	Battery voltage
			Brake pedal released	0

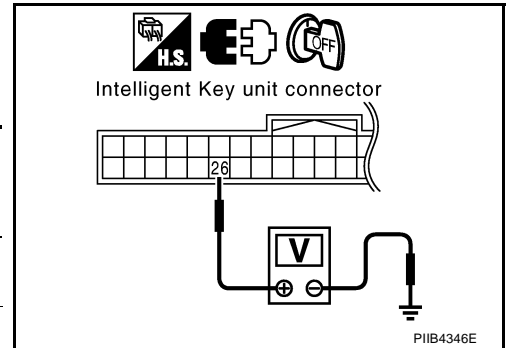

OK or NG

- OK >> Stop lamp switch is OK.
 NG >> GO TO 2.

2. CHECK STOP LAMP SWITCH POWER SUPPLY CIRCUIT

Check voltage between stop lamp switch harness connector E116 terminal 1 and ground.

1 (R/Y) - Ground : Battery voltage

OK or NG

- OK >> GO TO 3.
 NG >> Repair or replace harness between stop lamp switch power supply circuit and fuse.

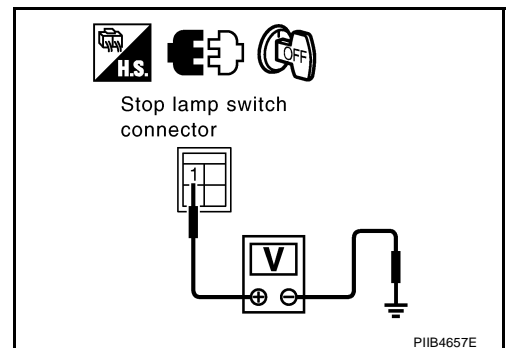

INTELLIGENT KEY SYSTEM

3. CHECK STOP LAMP SWITCH OPERATION

Check continuity between stop lamp switch connector E210 terminal 1 and 2.

Connector	Terminal		Condition	Continuity
E210	1	2	Brake pedal depressed	Yes
			Brake pedal not depressed	No

OK or NG

OK >> GO TO 4.

NG >> Replace stop lamp switch.

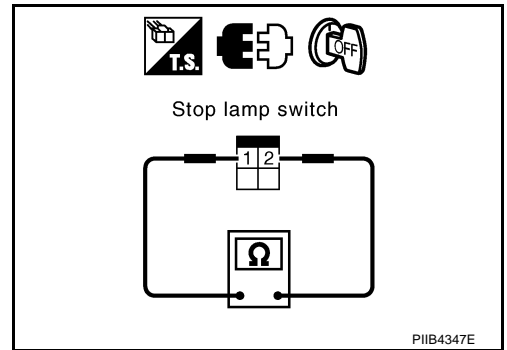

4. CHECK STOP LAMP SWITCH CIRCUIT

1. Check continuity between Intelligent Key unit harness connector M75 terminal 26 and stop lamp switch harness connector E124 terminal 2.

26 (P/L) - 2 (P/L) : Continuity should exist.

2. Check continuity between Intelligent Key unit harness connector M75 terminal 26 and ground.

26 (P/L) - Ground : Continuity should not exist.

OK or NG

OK >> Check condition of harness and connector.

NG >> Repair or replace harness.

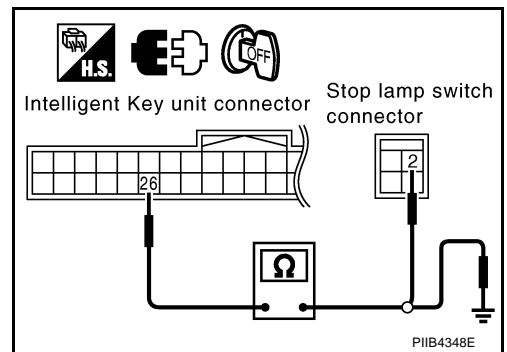

A
B
C
D
E
F
G
H
J
K
L
M

BL

INTELLIGENT KEY SYSTEM

AIS006AF

Check Park Position Switch

1. CHECK PARK POSITION SWITCH INPUT SIGNAL

1. Turn ignition switch OFF.
2. Check voltage between Intelligent Key unit harness connector and ground.

Connector	Terminal (Wire color)		Condition	Voltage (V) (Approx.)
	(+)	(-)		
M75	39 (B)	Ground	Selector lever is in "P" position	0
			Other than above	5

OK or NG

- OK >> Park position switch circuit is OK.
 NG >> GO TO 2.

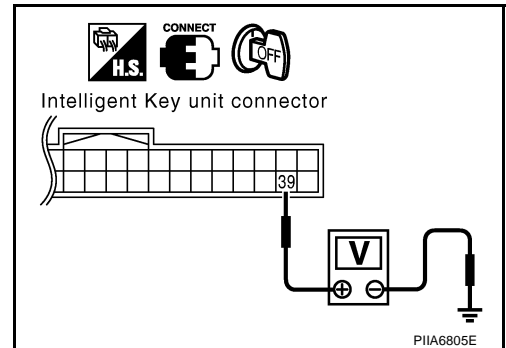

2. CHECK PARK POSITION SWITCH

1. Disconnect A/T device (park position switch) connector.
2. Check continuity between A/T device (park position switch) terminals 1 and 3.

Connector	Terminal		Condition	Continuity
M47	3	1	Selector lever is in "P" position	Yes
			Other than above	No

OK or NG

- OK >> GO TO 3.
 NG >> Check A/T shift lock system. Refer to [AT-241, "A/T SHIFT LOCK SYSTEM"](#).

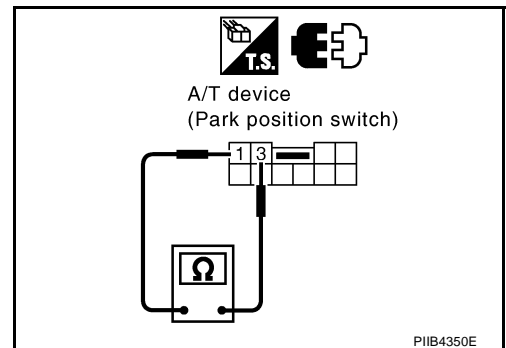

3. CHECK PARK POSITION SWITCH GROUND CIRCUIT

Check continuity between A/T device (park position switch) harness connector M47 terminal 1 and ground.

1 (B) – Ground : Continuity should exist.

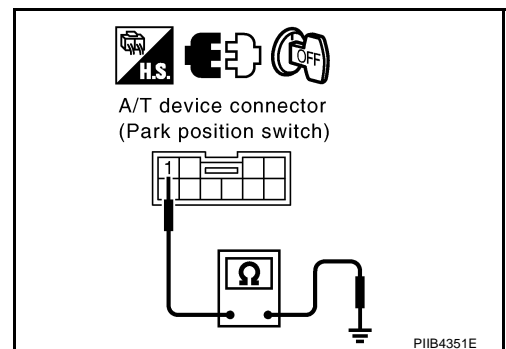

OK or NG

- OK >> GO TO 4.
 NG >> Repair or replace harness.

INTELLIGENT KEY SYSTEM

4. CHECK PARK POSITION SWITCH CIRCUIT

1. Disconnect Intelligent Key unit connector.
2. Check continuity between Intelligent Key unit harness connector M75 terminal 39 and A/T device (park position switch) harness connector M47 terminal 3.

39 (B) – 3 (BR) : Continuity should exist.

3. Check continuity between Intelligent Key unit harness connector M75 terminals 39 and ground.

39 (B) – Ground : Continuity should not exist.

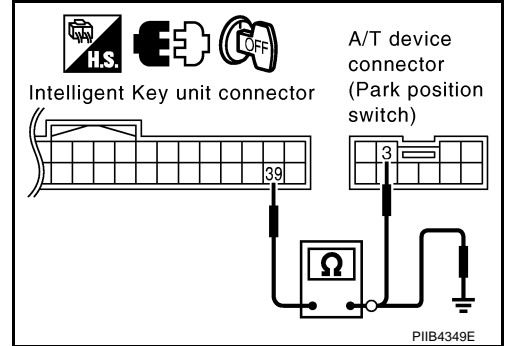

OK or NG

- OK >> GO TO 5.
 NG >> Repair or replace harness.

5. CHECK INTELLIGENT KEY OUTPUT SIGNAL

1. Connect Intelligent Key unit connector and A/T device (park position switch) connector.
2. Check voltage between Intelligent Key unit connector and ground.

Connector	Terminal (Wire color)		Condition	Voltage (V) (Approx.)
	(+)	(-)		
M75	39 (B)	Ground	Selector lever is in "P" position	0
			Other than above	5

OK or NG

- OK >> Check condition of harness and connector.
 NG >> Replace Intelligent Key unit.

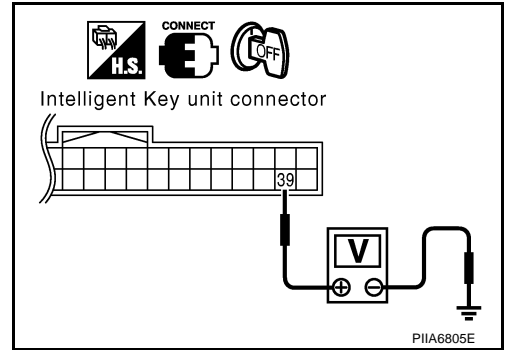

INTELLIGENT KEY SYSTEM

AIS006AJ

Check Select Unlock Relay

1. CHECK PASSENGER SIDE SELECT UNLOCK RELAY INPUT SIGNAL

1. Turn ignition switch OFF.
2. Check voltage between Intelligent Key unit harness connector and ground.

Connector	Terminals		Condition	Voltage (V) (Approx.)
	(+)	(-)		
M75	40 (R/G)	Ground	Press door request switch (passenger side) once	0
			Other than above	Battery voltage

OK or NG

- OK >> Passenger side select unlock relay circuit is OK.
 NG >> GO TO 2.

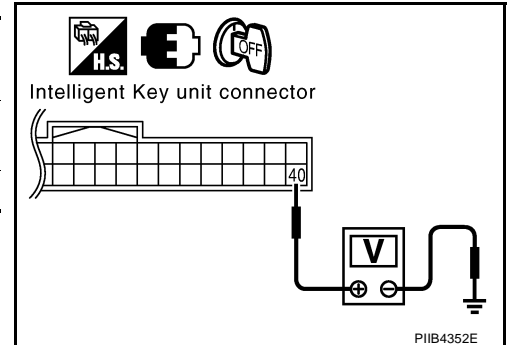

2. CHECK PASSENGER SIDE SELECT UNLOCK RELAY POWER SUPPLY CIRCUIT

1. Disconnect passenger side select unlock relay connector.
2. Check voltage between passenger side select unlock harness connector E15 terminal 2 and ground.

2 (R/W) – Ground : Battery voltage.

OK or NG

- OK >> GO TO 3.
 NG >> Repair or replace passenger side select unlock relay power circuit.

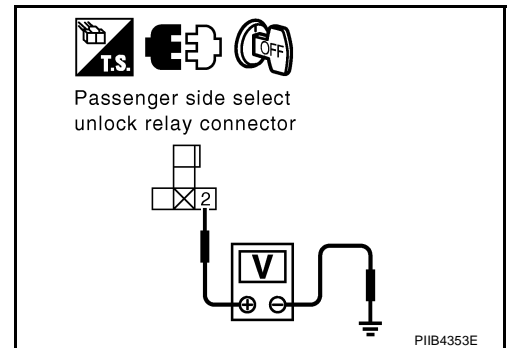

3. CHECK PASSENGER SIDE SELECT UNLOCK RELAY

1. Turn ignition switch OFF.
2. Disconnect passenger side select unlock relay connector.
3. Check continuity between passenger side select unlock relay terminals 3 and 4.

Connector	Terminals	Condition	Continuity
E15	3 4	12V direct current supply between terminals 1 and 2	No
		Other than above	Yes

OK or NG

- OK >> GO TO 4
 NG >> Replace passenger side select unlock relay.

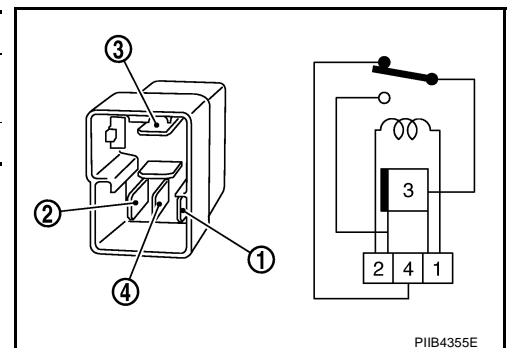

INTELLIGENT KEY SYSTEM

4. CHECK PASSENGER SIDE SELECT UNLOCK RELAY CIRCUIT

1. Disconnect Intelligent Key unit connector.
2. Check continuity between Intelligent Key unit harness connector M75 terminal 40 and passenger side select unlock relay harness connector E15 terminal 1.

40 (R/G) – 1 (L/Y) : Continuity should exist.

3. Check continuity between Intelligent Key unit harness connector M75 terminal 40 and ground.

40 (R/G) – Ground : Continuity should not exist.

OK or NG

- OK >> Check condition of harness and connector.
 NG >> Repair or replace harness between Intelligent Key unit and passenger side select unlock relay.

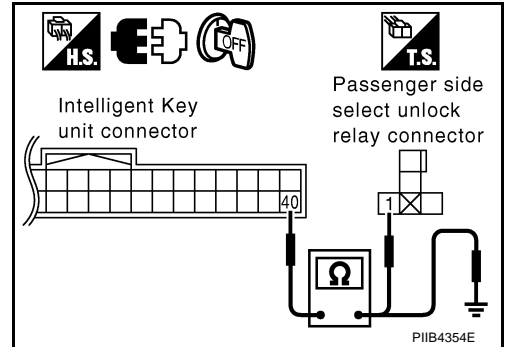

AIS006BU

Check “P-SHIFT” Warning Lamp

1. CHECK WARNING LAMP OPERATION

Ⓜ With CONSULT-II

- Check “INDICATOR” in “ACTIVE TEST” mode with CONSULT-II.
- Select “KNOB ON”.

“P-SHIFT” warning lamp should illuminate.

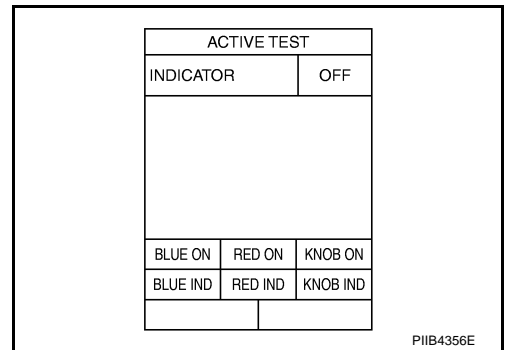

⊗ Without CONSULT-II

Check voltage between Intelligent Key unit harness connector M75 terminal 21 and ground.

Connector	Terminal (Wire color)		Condition	Voltage (V) (Approx.)
	(+)	(-)		
M75	21 (R)	Ground	Within 2 seconds after ignition knob switch is turned ON	0
			Other than above	Battery voltage

OK or NG

- OK >> INSPECTION END
 NG >> GO TO 2.

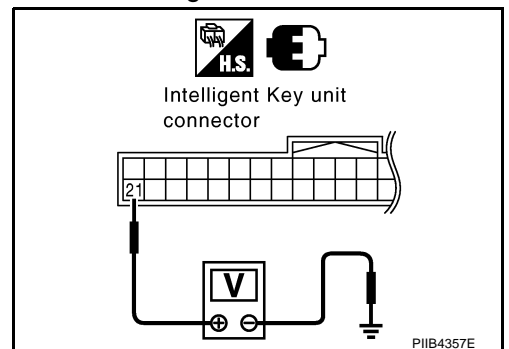

INTELLIGENT KEY SYSTEM

2. CHECK COMBINATION METER CIRCUIT

1. Turn ignition switch OFF.
2. Disconnect Intelligent Key unit connector and combination meter connector.
3. Check continuity Intelligent Key unit harness connector M75 terminal 21 and combination meter harness connector M20 terminal 48.

21(R) - 48 (R) : Continuity should exist.

4. Check continuity Intelligent Key unit harness connector M75 terminal 21 and ground.

21(R) - Ground : Continuity should not exist.

OK or NG

OK >> GO TO 3.

NG >> Repair or replace harness between Intelligent Key unit and combination meter.

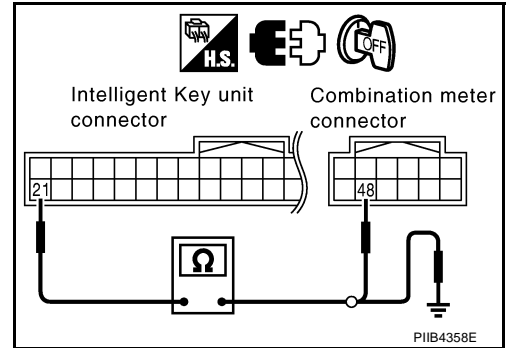

3. CHECK INTELLIGENT KEY UNIT INPUT SIGNAL

1. Connect combination meter connector.
2. Check voltage between Intelligent Key unit harness connector M75 terminal 21 and ground.

21 (R) - Ground : Batter voltage

OK or NG

OK >> Check condition of harness and connector.

NG >> Check combination meter. Refer to [DI-4, "COMBINATION METERS"](#).

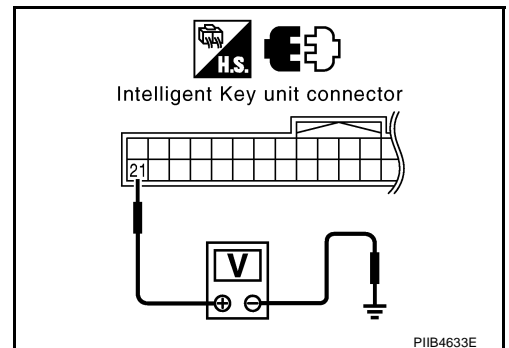

INTELLIGENT KEY SYSTEM

AIS006BV

Check "KEY" Warning Lamp (RED)

1. CHECK WARNING LAMP OPERATION

With CONSULT-II

- Check "INDICATOR" in "ACTIVE TEST" mode with CONSULT-II.
- Select "RED ON".

"KEY" warning lamp (red) should illuminate.

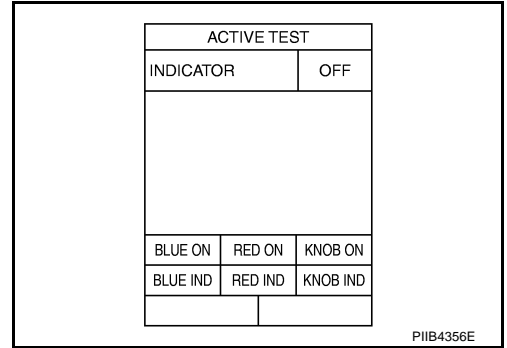

Without CONSULT-II

Check voltage between Intelligent Key unit harness connector M75 terminal 9 and ground.

Connector	Terminal (Wire color)		Condition	Voltage (V) (Approx.)
	(+)	(-)		
M75	9 (R/G)	Ground	When Intelligent Key is outside vehicle, press ignition switch.	0
			Ignition switch OFF	Battery voltage

OK or NG

- OK >> INSPECTION END
- NG >> GO TO 2.

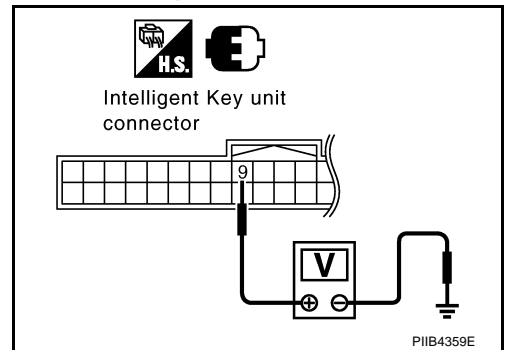

2. CHECK COMBINATION METER CIRCUIT

1. Turn ignition switch OFF.
2. Disconnect Intelligent Key unit connector and combination meter connector.
3. Check continuity Intelligent Key unit harness connector M75 terminal 9 and combination meter harness connector M20 terminal 50.

9 (R/G) - 50 (R/G) : Continuity should exist.

4. Check continuity Intelligent Key unit harness connector M75 terminal 9 and ground.

9 (R/G) - Ground : Continuity should not exist.

OK or NG

- OK >> GO TO 3.
- NG >> Repair or replace harness between Intelligent Key unit and combination meter.

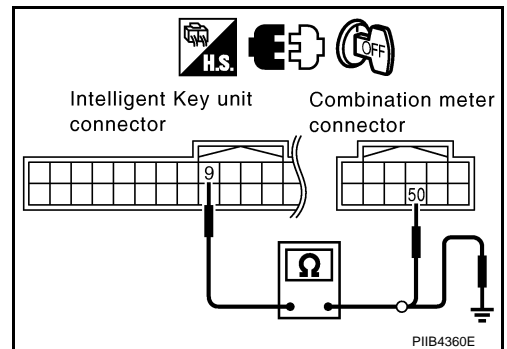

INTELLIGENT KEY SYSTEM

3. CHECK INTELLIGENT KEY UNIT INPUT SIGNAL

1. Connect combination meter connector.
2. Check voltage between Intelligent Key unit harness connector M75 terminal 9 and ground.

9 (R/G) - Ground : Batter voltage

OK or NG

- OK >> Check condition of harness and connector.
 NG >> Check combination meter. Refer to [DI-4, "COMBINATION METERS"](#).

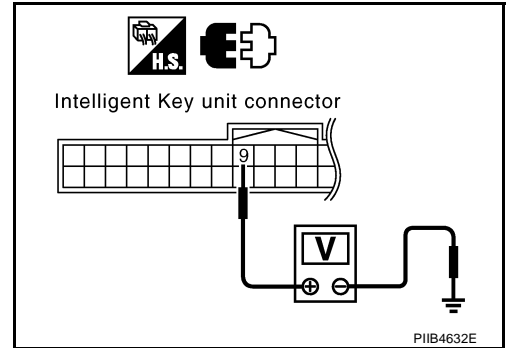

AIS006BW

Check "KEY" Warning Lamp (GREEN)

1. CHECK WARNING LAMP OPERATION

With CONSULT-II

- Check "INDICATOR" in "ACTIVE TEST" mode with CONSULT-II.
- Select "BLUE ON".

"KEY" warning lamp (green) should illuminate.

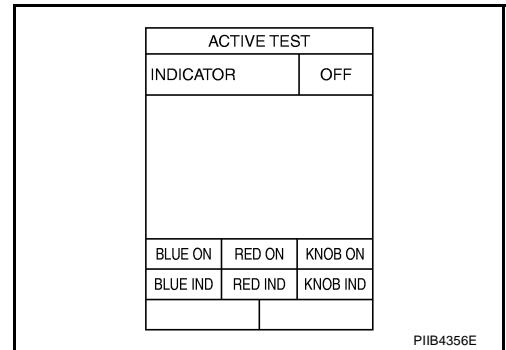

Without CONSULT-II

Check voltage between Intelligent Key unit harness connector M75 terminal 8 and ground.

Connector	Terminal (Wire cooler)		Condition	Voltage (V) (Approx.)
	(+)	(-)		
M75	8 (R/L)	Ground	When Intelligent Key is inside vehicle, press ignition switch.	0
			Ignition switch OFF	Battery voltage

OK or NG

- OK >> INSPECTION END
 NG >> GO TO 2.

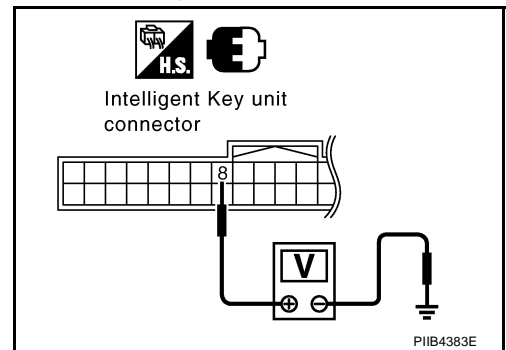

INTELLIGENT KEY SYSTEM

2. CHECK COMBINATION METER CIRCUIT

1. Turn ignition switch OFF.
2. Disconnect Intelligent Key unit connector and combination meter connector.
3. Check continuity Intelligent Key unit harness connector M75 terminal 8 and combination meter harness connector M20 terminal 49.

8 (R/L) - 49 (R/L) : Continuity should exist.

4. Check continuity Intelligent Key unit harness connector M75 terminal 8 and ground.

8 (R/L) - Ground : Continuity should not exist.

OK or NG

OK >> GO TO 3.

NG >> Repair or replace harness between Intelligent Key unit and combination meter.

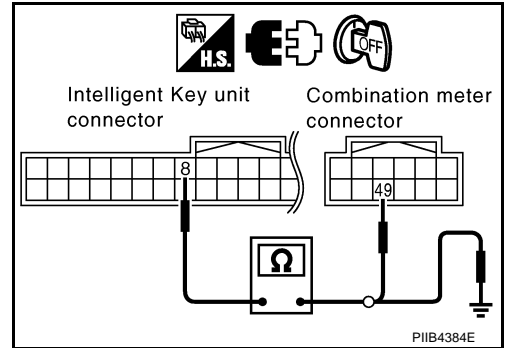

3. CHECK INTELLIGENT KEY UNIT INPUT SIGNAL

1. Connect combination meter connector.
2. Check voltage between Intelligent Key unit harness connector M75 terminal 8 and ground.

8 (R/L) - Ground : Batter voltage

OK or NG

OK >> Check condition of harness and connector.

NG >> Check combination meter. Refer to [DI-4, "COMBINATION METERS"](#).

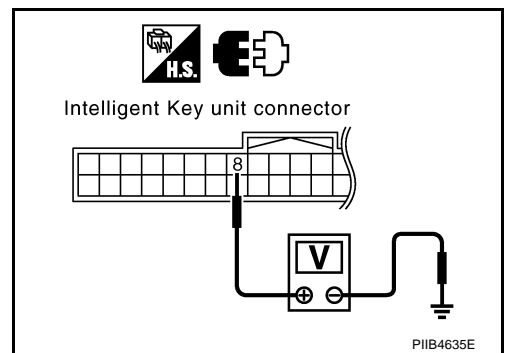

Check Hazard Function

1. CHECK HAZARD WARNING LAMP

Does hazard warning lamp flash with hazard switch?

YES or NO

YES >> Hazard warning lamp circuit is OK.

NO >> Check hazard circuit. Refer to [LT-113, "TURN SIGNAL AND HAZARD WARNING LAMPS"](#).

Check Horn Function

First perform the "SELF-DIAG RESULTS" in "BCM" with CONSULT-II, then perform the trouble diagnosis of malfunction system indicated "SELF-DIAG RESULTS" of "BCM". Refer to [BCS-15, "CAN Communication Inspection Using CONSULT-II \(Self-Diagnosis\)"](#).

1. CHECK HORN FUNCTION

Does horn sound with horn switch?

YES or NO

YES >> Horn circuit is OK.

NO >> Check horn circuit. Refer to [WW-42, "HORN"](#).

INTELLIGENT KEY SYSTEM

AIS006AI

Check IPDM E/R Operation

1. CHECK IPDM E/R INPUT SIGNAL

Check voltage between IPDM E/R harness connector E9 terminal 51 and ground.

51 (G/B) – Ground : Battery voltage

OK or NG

- OK >> Replace IPDM E/R.
- NG >> GO TO 2.

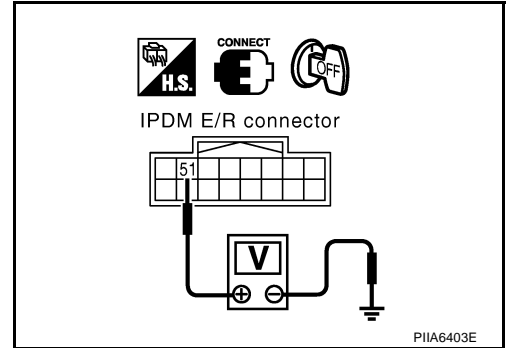

2. CHECK IPDM E/R CIRCUIT

1. Turn ignition switch OFF.
2. Disconnect IPDM E/R and horn relay connector.
3. Check continuity between IPDM E/R harness connector E9 terminal 51 and horn relay harness connector E20 terminal 1.

51 (G/B) – 1 (G/B) : Continuity should exist.

OK or NG

- OK >> Check harness connection.
- NG >> Repair or replace harness.

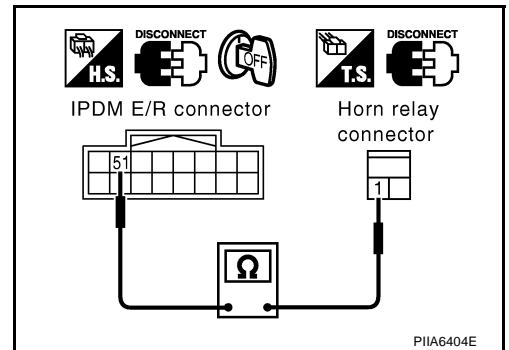

Removal and Installation of Intelligent Key Unit

REMOVAL

1. Remove the ECM.
2. Disconnect Intelligent Key unit connector, remove screw and Intelligent Key unit.

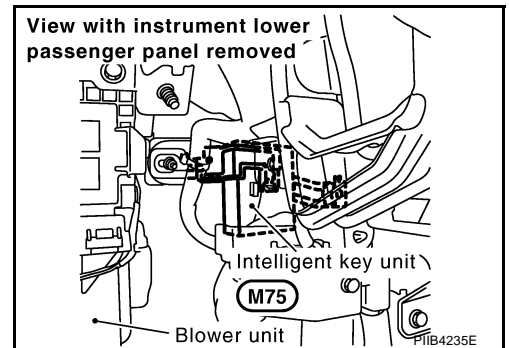

INSTALLATION

Installation is in the reverse order of removal.

INTELLIGENT KEY SYSTEM

Intelligent Key Battery Replacement

AIS0069W

SEC.998

NOTE:

- Be careful not to touch the circuit board or battery terminal.
- The keyfob is water-resistant. However, if it does get wet, immediately wipe it dry.

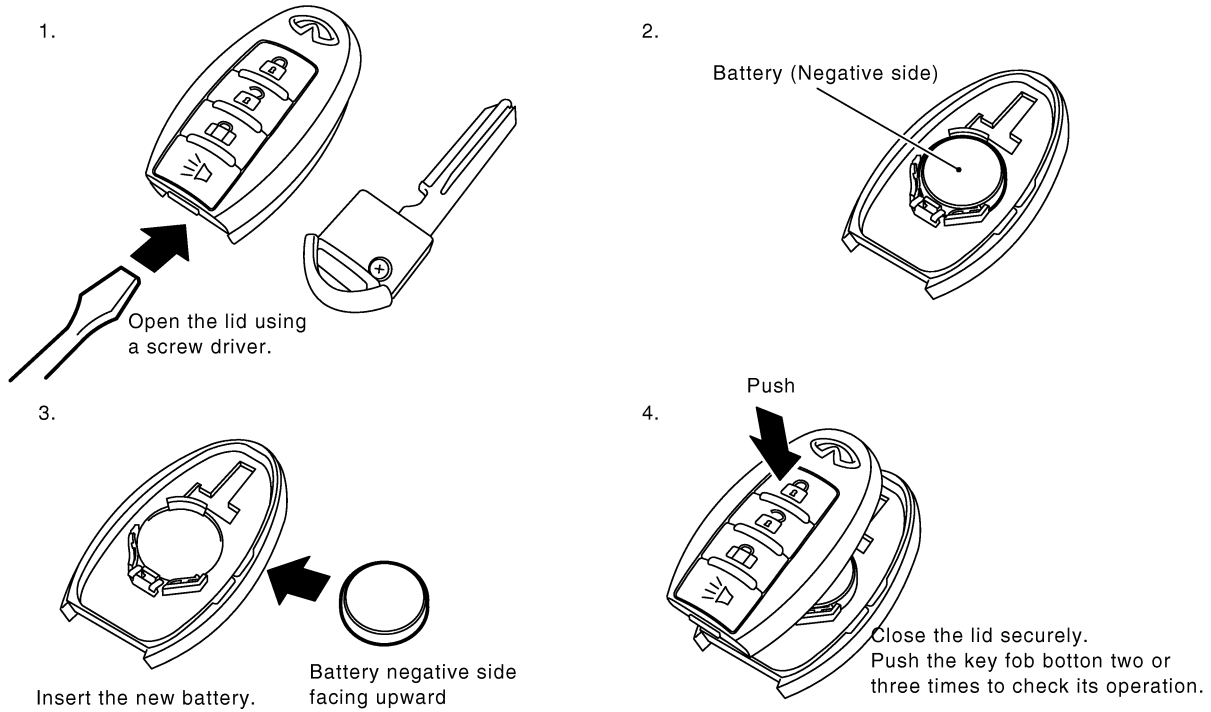

INTELLIGENT KEY BATTERY INSPECTION

Check by connecting a resistance (approximately 300Ω) so that the current value becomes about 10 mA.

Standard : **Approx. 2.5 - 3.0V**

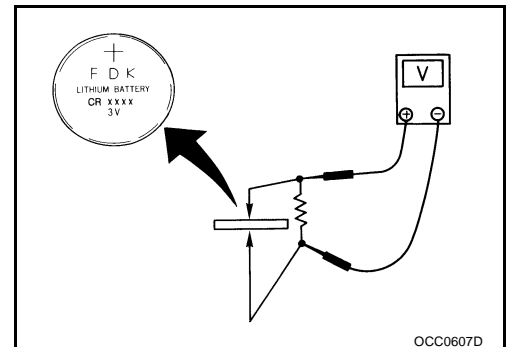

DOOR

PFP:80100

AIS00022

DOOR

Fitting Adjustment

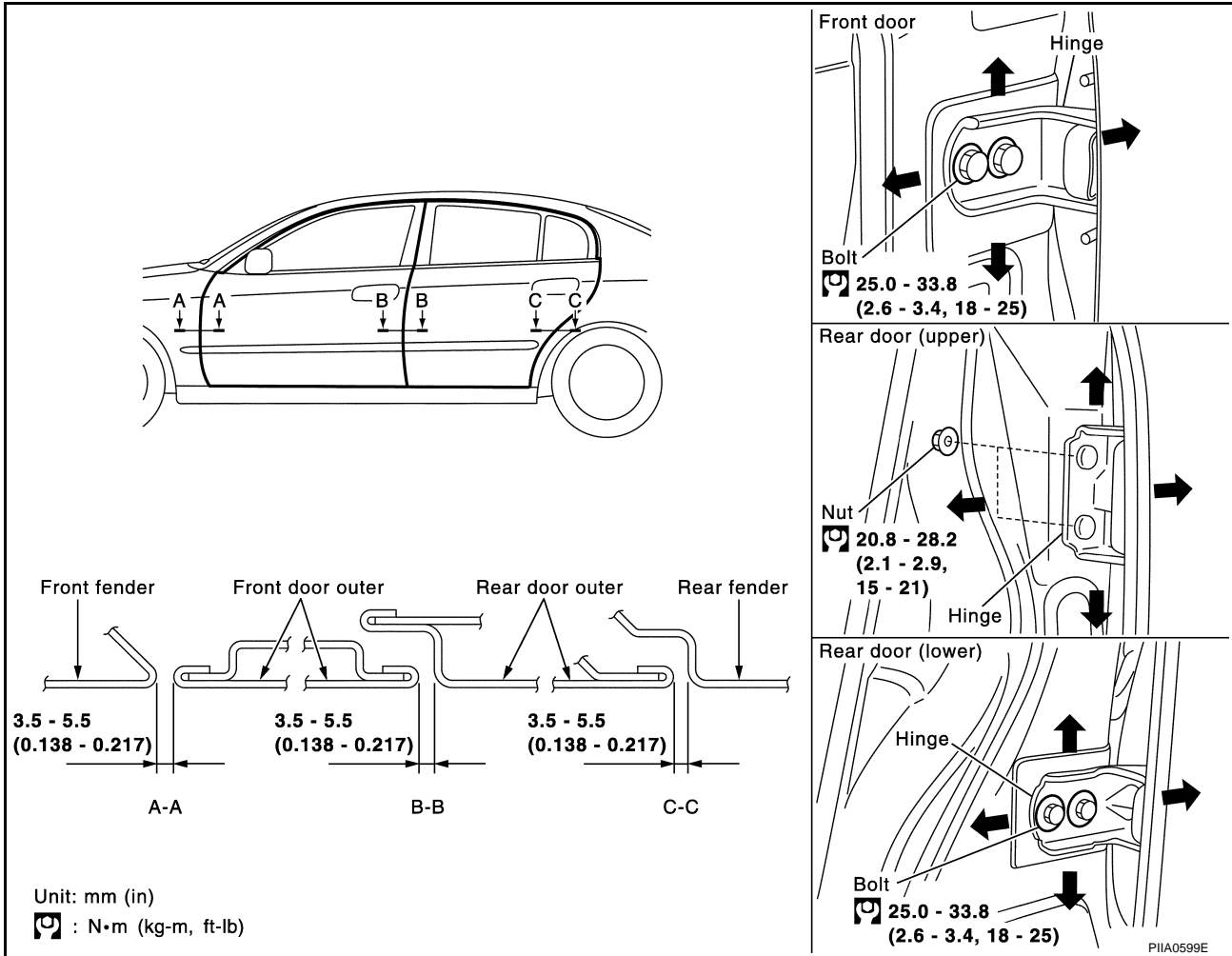

FRONT DOOR

Longitudinal Clearance and Surface Height Adjustment At Front End

Loosen the hinge mounting bolts. Raise the front door at rear end to adjust.

REAR DOOR

Longitudinal Clearance and Surface Height Adjustment At Front End

1. Remove the center pillar upper garnish and center pillar lower garnish. Refer to [EI-39. "Removal and Installation"](#).
2. Accessing from inside the vehicle, loosen the mounting nuts. Open the rear door, and raise the rear door at rear end to adjust.

STRIKER ADJUSTMENT

1. Adjust the striker so that it becomes parallel with the lock insertion direction.

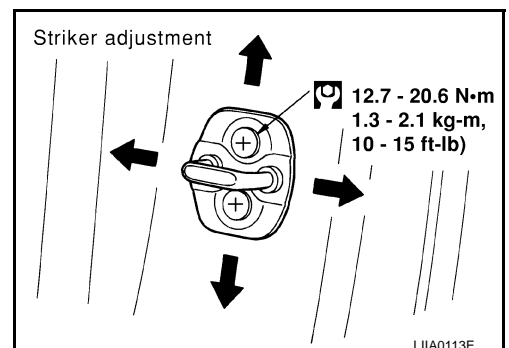

DOOR

Removal and Installation of Front door

AIS0062E

CAUTION:

- When removing and installing the front door assembly, support the door with a jack and cloth to protect the door and body.
- When removing and installing front door assembly, be sure to carry out the fitting adjustment. Refer to [BL-166. "Fitting Adjustment"](#) .
- After installing, apply touch-up paint (the body color) onto the head of the hinge mounting nuts.
- Check the hinge rotating part for poor lubrication. If necessary, apply "body grease".
- Operate with two workers, because of its heavy weight.
- Check rear door open/close operation after installation.

REMOVAL

1. Pull the lever and disconnect the door harness connector while removing tabs of door harness connector.

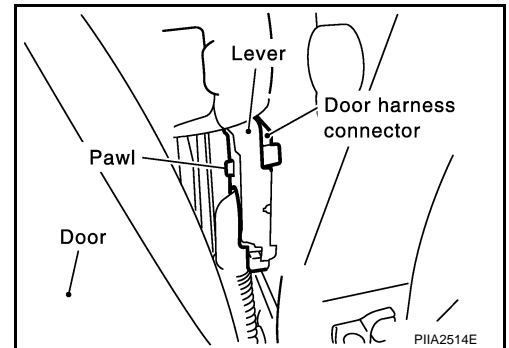

2. Remove the mounting bolts of the check link on the vehicle.

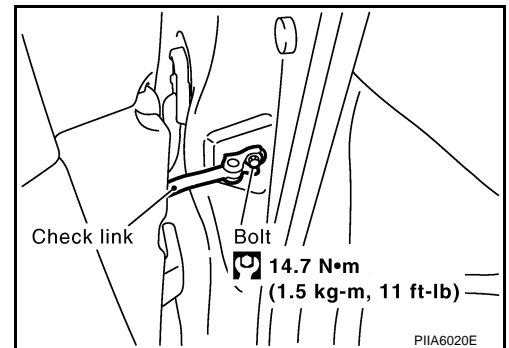

3. Remove the door-side hinge mounting nuts, then remove the door assembly.

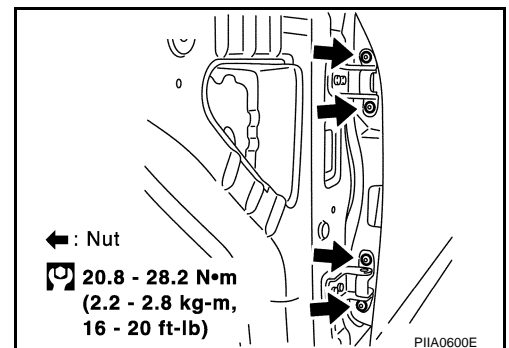

INSTALLATION

Install in the reverse order of removal.

A
B
C
D
E
F
G
H
BL
J
K
L
M

DOOR

AIS0062F

Removal and Installation of Rear Door

CAUTION:

- When removing and installing the rear door assembly, support the door with a jack and cloth to protect the door and body.
- When removing and installing rear door assembly, be sure to carry out the fitting adjustment. Refer to [BL-166, "Fitting Adjustment"](#) .
- Check the hinge rotating part for poor lubrication. If necessary, apply "body grease".
- After installing, apply touch-up paint (the body color) onto the head of the hinge mounting nuts.
- Operate with two workers, because of its heavy weight.
- Check rear door open/close operation after installation.

REMOVAL

1. Pull out grommet and disconnect rear door harness connector.

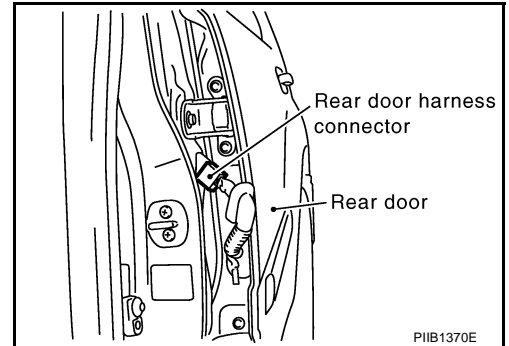

2. Remove the mounting bolts of the check link on the vehicle.

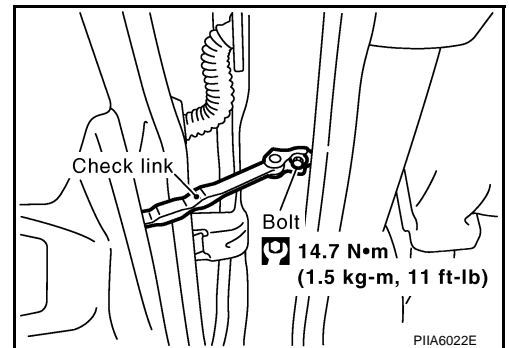

3. Remove the door-side hinge mounting nuts, and remove the door assembly.

 : $24.5 \text{ N}\cdot\text{m}$ (2.5 kg-m, 18 ft-lb)

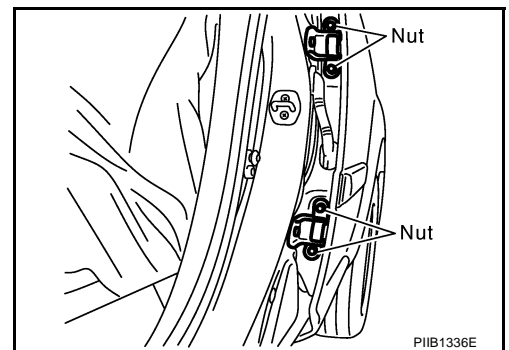

INSTALLATION

Install in the reverse order of removal.

DOOR

Door Weatherstrip

AIS0062G

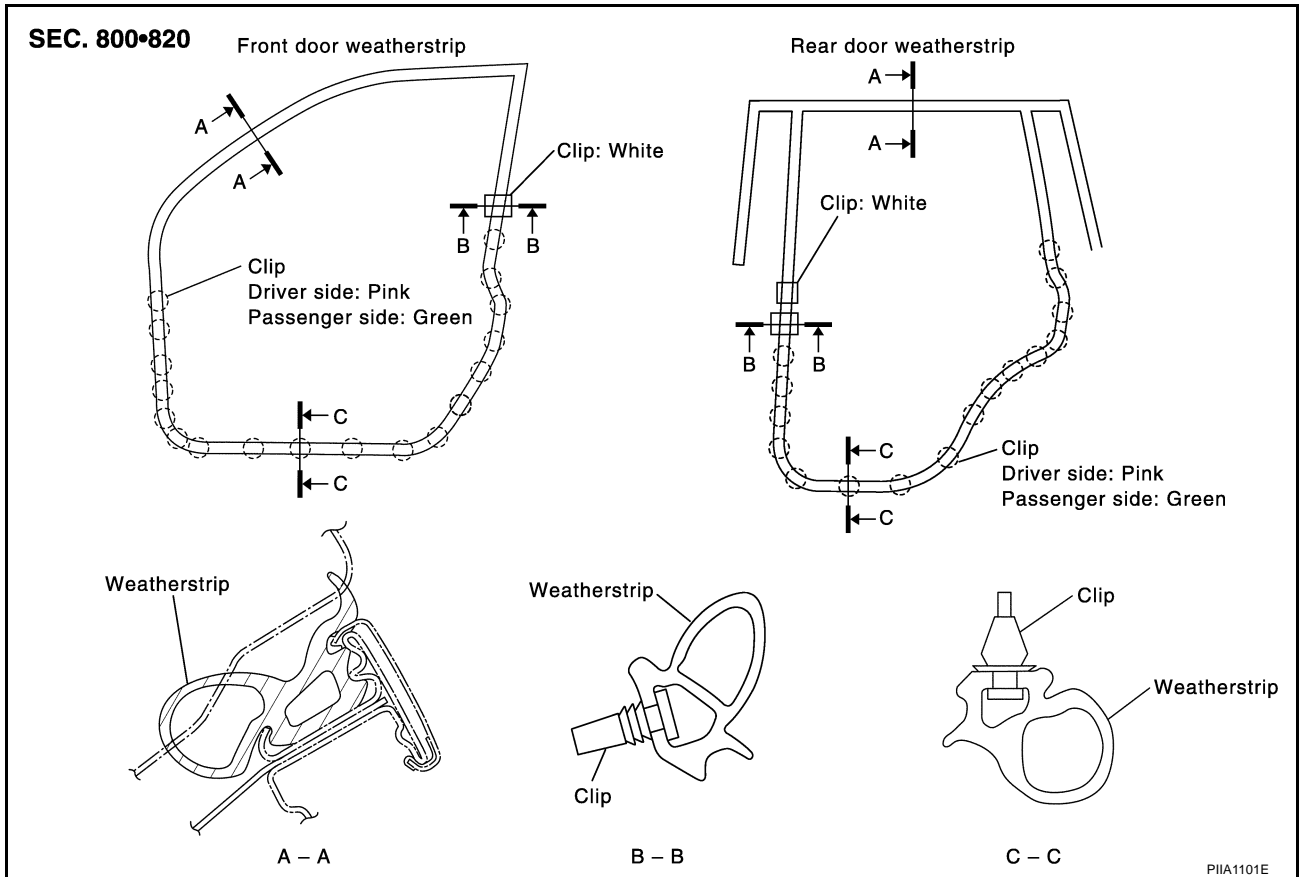

A
B
C
D
E
F
G
H

BL

REMOVAL

1. Remove the mounting bolts of the check link on the vehicle. Refer to [BL-167, "Removal and Installation of Front door"](#) or [BL-168, "Removal and Installation of Rear Door"](#).
2. Remove the weatherstrip clips and remove weatherstrip.

CAUTION:

After removal, do not pull strongly on the weatherstrip.

INSTALLATION

Install in the reverse order of removal.

J
K
L
M

FRONT DOOR LOCK

FRONT DOOR LOCK

PFP:80502

Component Structure

AIS00025

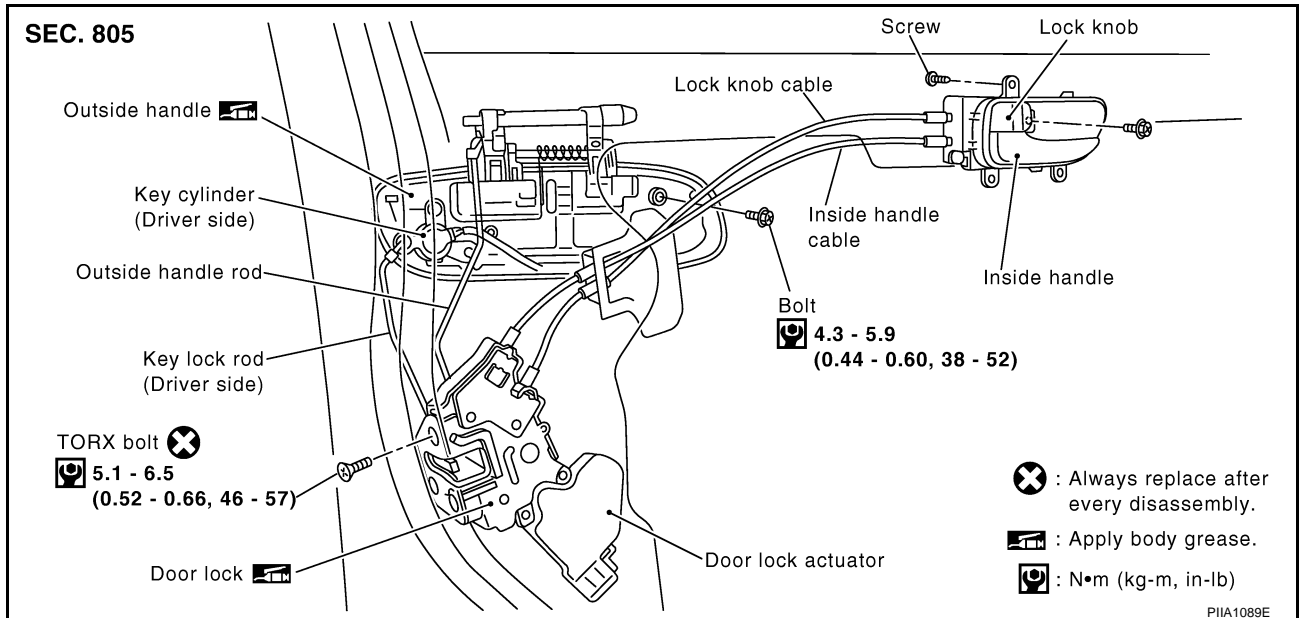

Inspection and Adjustment

AIS00026

1. Remove the front door finisher. Refer to [EI-37, "Removal and Installation"](#).
2. Remove the front door speaker. Refer to [AV-28, "Removal and Installation of Door Speaker"](#).
3. Remove the front door window and front door module assembly. Refer to [GW-76, "Removal and Installation"](#).

OUTSIDE HANDLE ROD ADJUSTMENT

Rotate the bushing to adjust so that the clearance between the bushing and rod becomes as shown in the figure.

CAUTION:

Be careful not to make the clearance 0 mm (0 in) or the rod will be pressed continuously.

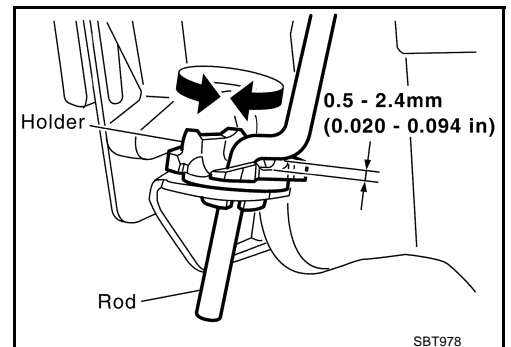

Removal and Installation

REMOVAL

AIS00027

1. Remove the front door finisher. Refer to [EI-37, "Removal and Installation"](#).
2. Remove the front door speaker. Refer to [AV-28, "Removal and Installation of Door Speaker"](#).
3. Remove the front door window and front door module assembly. Refer to [GW-76, "Removal and Installation"](#).

FRONT DOOR LOCK

4. Disconnect the inside handle cable and lock knob cable from the back side of the front door finisher.

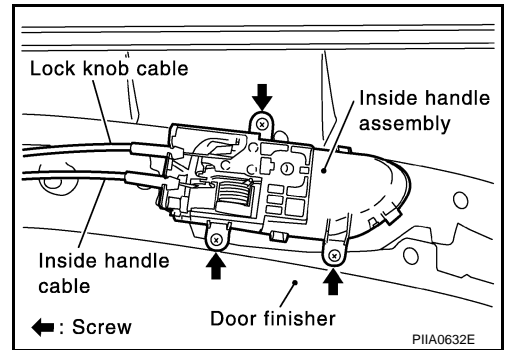

5. Reach to separate the key lock rod and outside handle rod connection (on the handle).
6. Remove the mounting bolts (TORX T30), remove the door lock assembly.
7. Disconnect the door lock actuator connector.

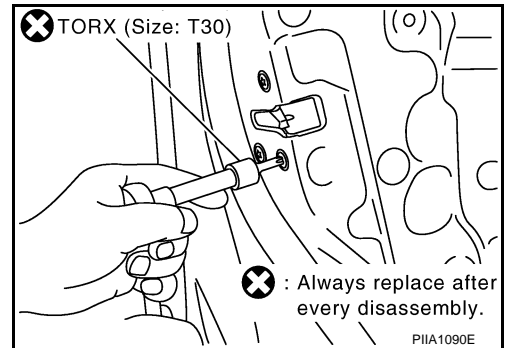

8. Disconnect outside key antenna and front door request switch harness connector. (with Intelligent Key system)

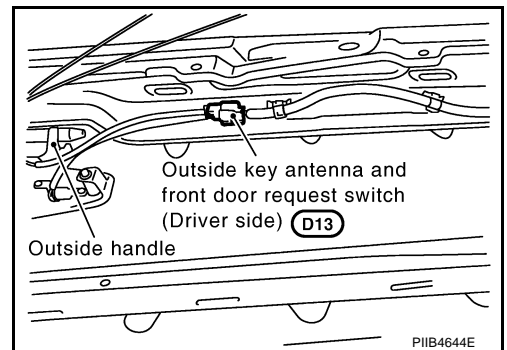

9. Remove the outside handle mounting bolts, move the outside handle assembly backward, and then remove it from the panel in front of the outside handle escutcheon.

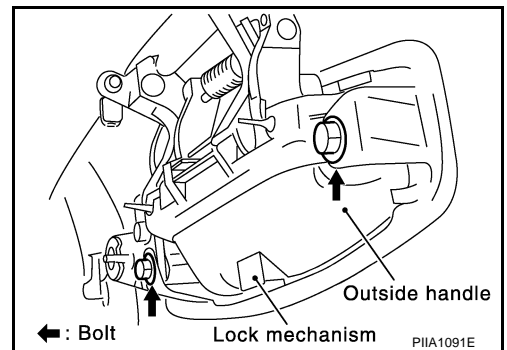

INSTALLATION

Install in the reverse order of removal.

CAUTION:

To install each rod, be sure to rotate the rod holder until a click is felt.

Disassembly and Assembly DISASSEMBLY

AIS00028

CAUTION:

Be sure to remove or install the actuator with the door lock assembly removed.

A
B
C
D
E
F
G
H
J
K
L
M

BL

FRONT DOOR LOCK

1. Remove the mounting screws, and remove the actuator from the door lock assembly.
2. Pull the actuator straight downward to separate it from the door lock assembly.

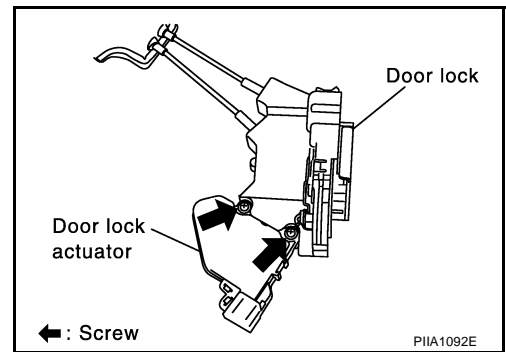

ASSEMBLY

1. Align the actuator pivot with the cutout on the knob lever of the door lock assembly, then assemble the actuator.
2. Move the knob lever and the actuator pivot toward the lock-on direction, and check that it engages securely.

REAR DOOR LOCK

REAR DOOR LOCK Component Structure

PFP:82502

AIS0002A

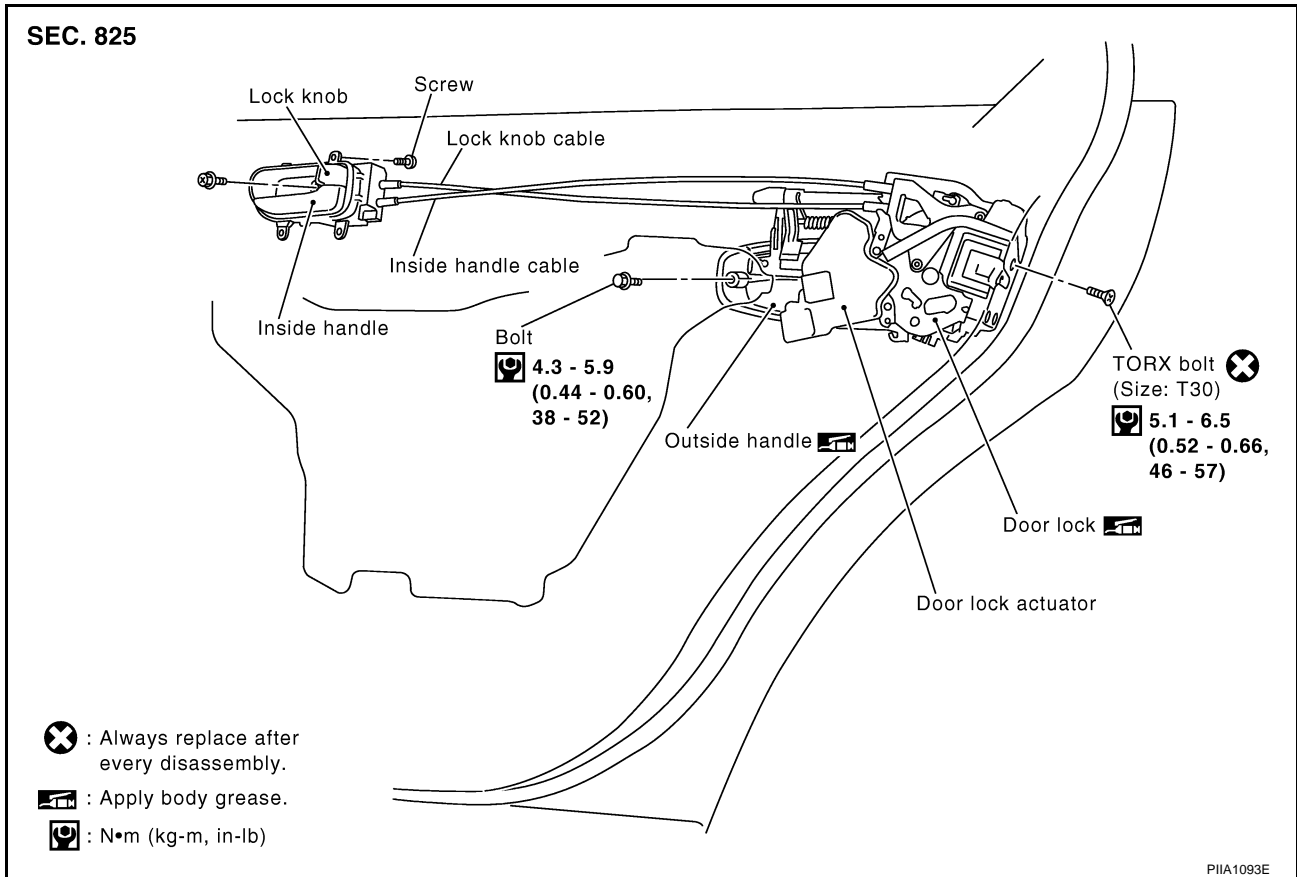

INSPECTION AND ADJUSTMENT

Remove the rear door finisher. Refer to [EI-37, "Removal and Installation"](#).

OUTSIDE HANDLE ROD ADJUSTMENT

Rotate the bushing to adjust so that the clearance between the bushing and rod becomes as shown in the figure.

CAUTION:

Be careful not to make the clearance 0 mm (0 in) or the rod will be pressed continuously.

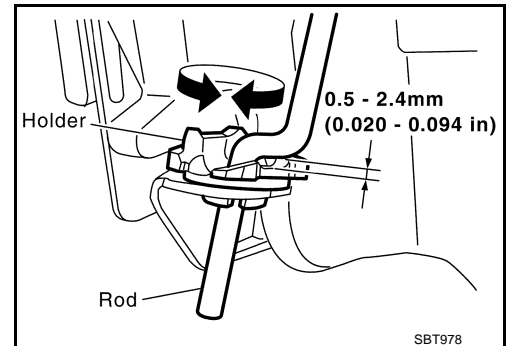

A
B
C
D
E
F
G
H
J
K
L
M

BL

REAR DOOR LOCK

Removal and Installation

AI/S0002B

REMOVAL

1. Remove the rear door finisher. Refer to [EI-37, "Removal and Installation"](#).
2. After gaining access to the inside handle on the back side of the rear door finisher, disconnect the inside handle cable and lock knob cable.

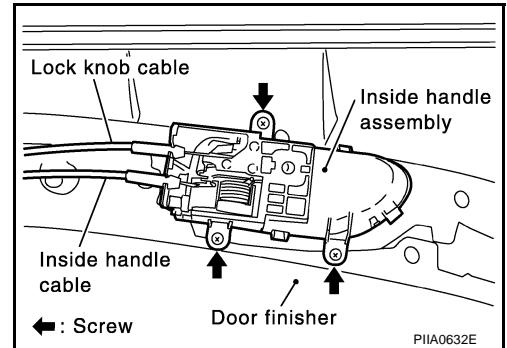

3. Remove the mounting bolts (TORX T30), remove the door lock assembly.
4. Disconnect the door lock actuator connector.

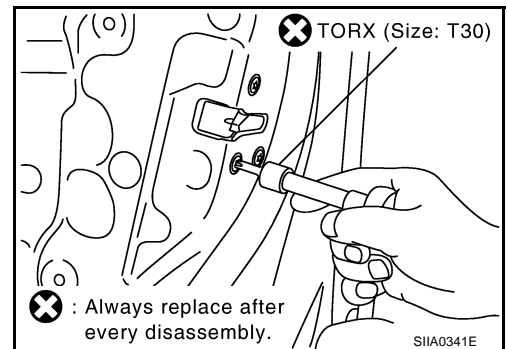

5. Remove the outside handle mounting bolts, and move the handle backward to disengage it from the panel in front of the outside handle escutcheon, then remove the handle.

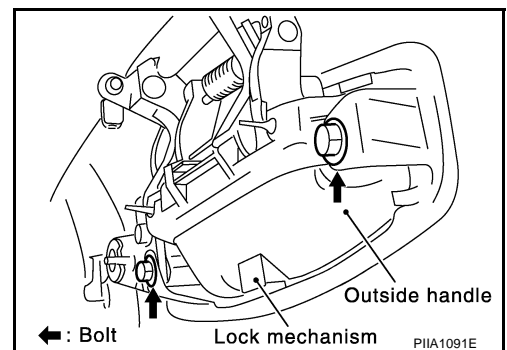

INSTALLATION

Install in the reverse order of removal.

CAUTION:

To install each rod, be sure to rotate the rod holder until a click is felt.

Disassembly and Assembly

DISASSEMBLY

AI/S0002C

CAUTION:

Be sure to remove or install the actuator with the door lock assembly removed.

REAR DOOR LOCK

1. Remove the mounting screws, and remove the actuator from the door lock assembly.
2. Pull the actuator straight downward to separate it from the door lock assembly.

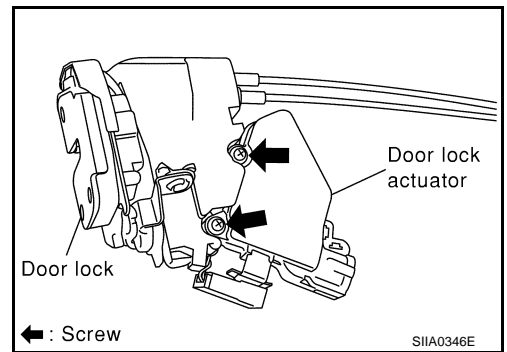

ASSEMBLY

1. Align the actuator pivot with the cutout on the knob lever of the door lock assembly, then assemble the actuator.
2. Move the knob lever and the actuator pivot toward the lock-on direction, and check that it engages securely.

A

B

C

D

E

F

G

H

BL

J

K

L

M

TRUNK LID

PFP:H4300

AIS005WL

TRUNK LID

Fitting Adjustment

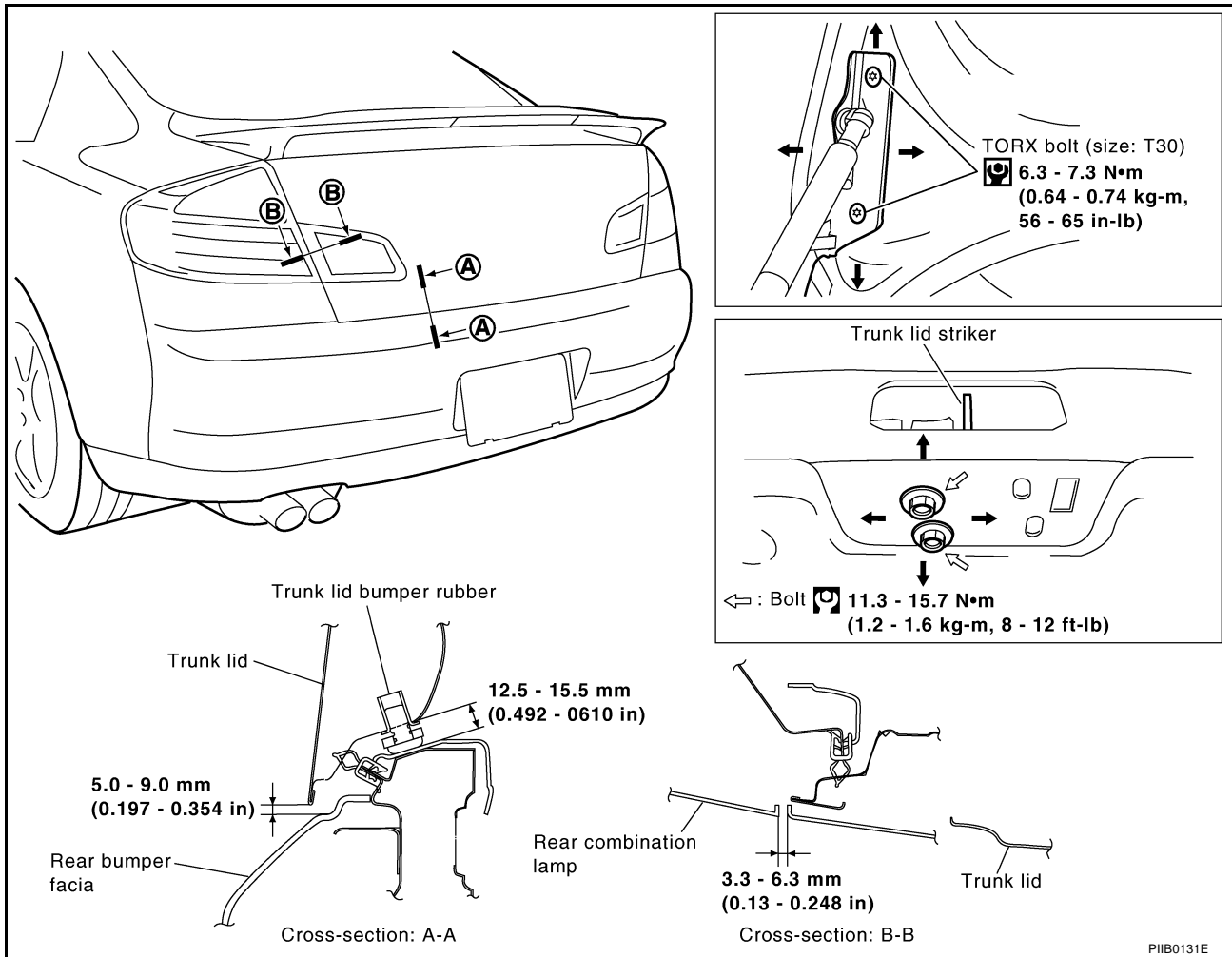

LONGITUDINAL AND LATERAL CLEARANCE ADJUSTMENT

1. With the striker released, loosen the trunk lid hinge mounting bolts to close the trunk lid.
2. Make the lateral clearance and the clearance to the rear window glass equal, and open the trunk lid to tighten the mounting bolts to the specified torque.

SURFACE HEIGHT ADJUSTMENT

1. Loosen the striker mounting bolts. Raise the striker to the top position, and temporarily tighten the upper mounting bolt at the position.
2. Loosen the bumper rubber collar, and the damper is drawn out.
3. Close the trunk lid lightly and adjust the surface height, then open the trunk lid to finally tighten the striker mounting bolts to the specified torque or bumper rubber collar is tighten by the hand.

TRUNK LID

Removal and Installation of Trunk Lid Assembly

AIS005WM

A
B
C
D
E
F
G
H
J
K
L
M

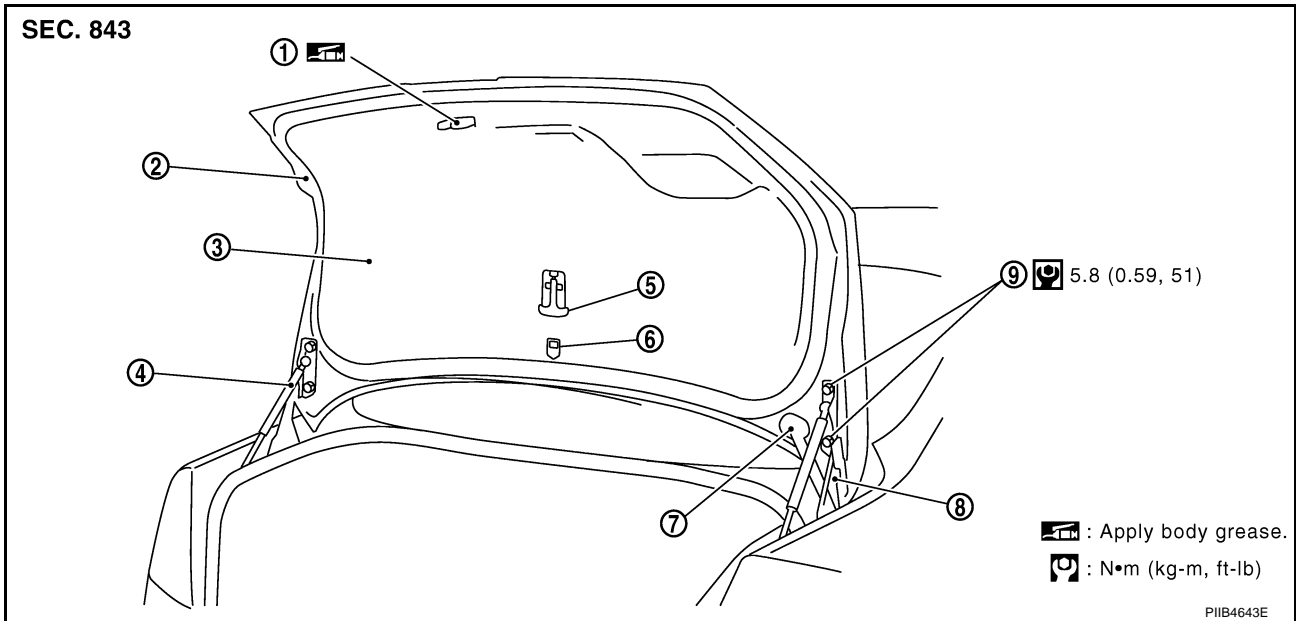

- | | | |
|----------------------------|---|------------------------------------|
| 1. Trunk lid lock assembly | 2. Trunk lid assembly | 3. Trunk lid finisher |
| 4. Trunk lid stay | 5. Trunk lid opener emergency lever (secondary) | 6. Trunk lid opener emergency hook |
| 7. Trunk lid harness | 8. Trunk lid hinge | 9. TORX bolt |

CAUTION:

- After installing, apply touch-up paint (the body color) onto the head of the hinge mounting bolts.
- After installing, check operation.
- After installing, perform fitting adjustment. Refer to [BL-176. "Fitting Adjustment"](#).

REMOVAL

1. Disconnect the connectors in the trunk lid, and remove the harness clamps to pull the harness out of the trunk lid.
2. Insert flat-bladed screwdriver into the gap and remove holder.
3. Remove trunk lid stay (gas stay).
4. Remove the mounting bolts, and remove the trunk lid assembly.

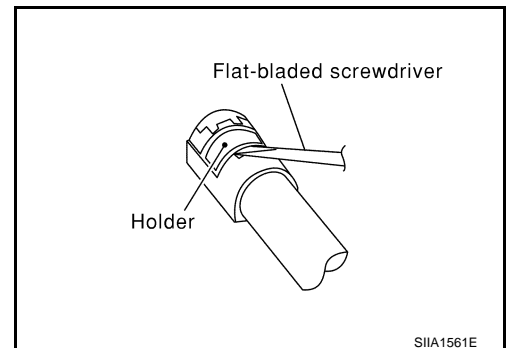

INSTALLATION

Install in the reverse order of removal.

TRUNK LID

Removal and Installation of Trunk Lid Stay

AIS005WN

REMOVAL

1. Insert flat-bladed screwdriver into the gap and remove holder.
2. Remove trunk lid stay on the trunk lid.
3. Remove the stud balls, and trunk lid stay.

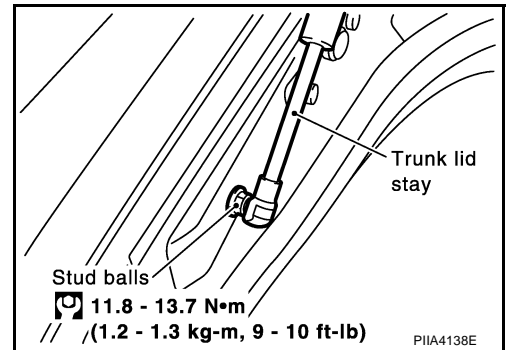

INSTALLATION

1. Install in the reverse order of removal.
2. After installing, check the operation.

Removal and Installation of Trunk Lid Lock

AIS005WO

REMOVAL

1. Remove the trunk lid finisher. Refer to [EI-47, "TRUNK ROOM TRIM & TRUNK LID FINISHER"](#).
2. Disconnect the trunk lid emergency opener cable from the trunk lid lock.
3. After removing the harness connector, remove the mounting bolts, and remove the trunk lid lock.

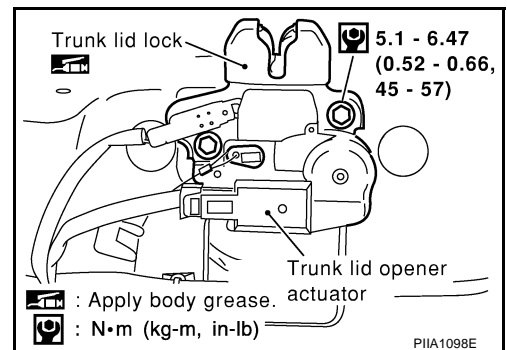

INSTALLATION

1. Install in the reverse order of removal.
2. After installing, close the trunk lid height. Perform the lock and surface height adjustment. Refer to [BL-176, "Fitting Adjustment"](#).
3. After installing, check the operation.

Removal and Installation of Trunk Lid Striker

AIS005WP

REMOVAL

1. Remove the trunk rear plate and trunk rear finisher. Refer to [EI-47, "TRUNK ROOM TRIM & TRUNK LID FINISHER"](#).
2. Remove the mounting bolts, and remove the striker from the trunk lock support.

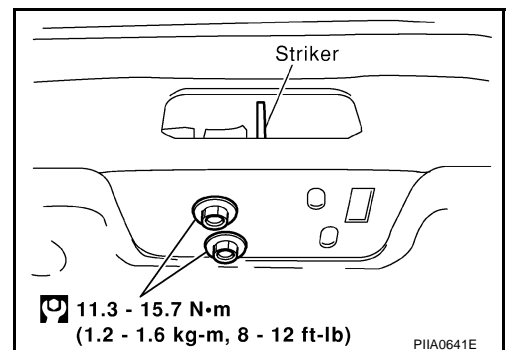

INSTALLATION

1. Install in the reverse order of removal.
2. After installing, close the trunk lid height. Perform the lock and surface height adjustment. Refer to [BL-176, "Fitting Adjustment"](#).
3. After installing, check the operation.

TRUNK LID

Removal and Installation of Trunk lid Emergency Opener Cable

AIS005WQ

A
B
C
D
E
F
G
H
BL
J
K
L
M

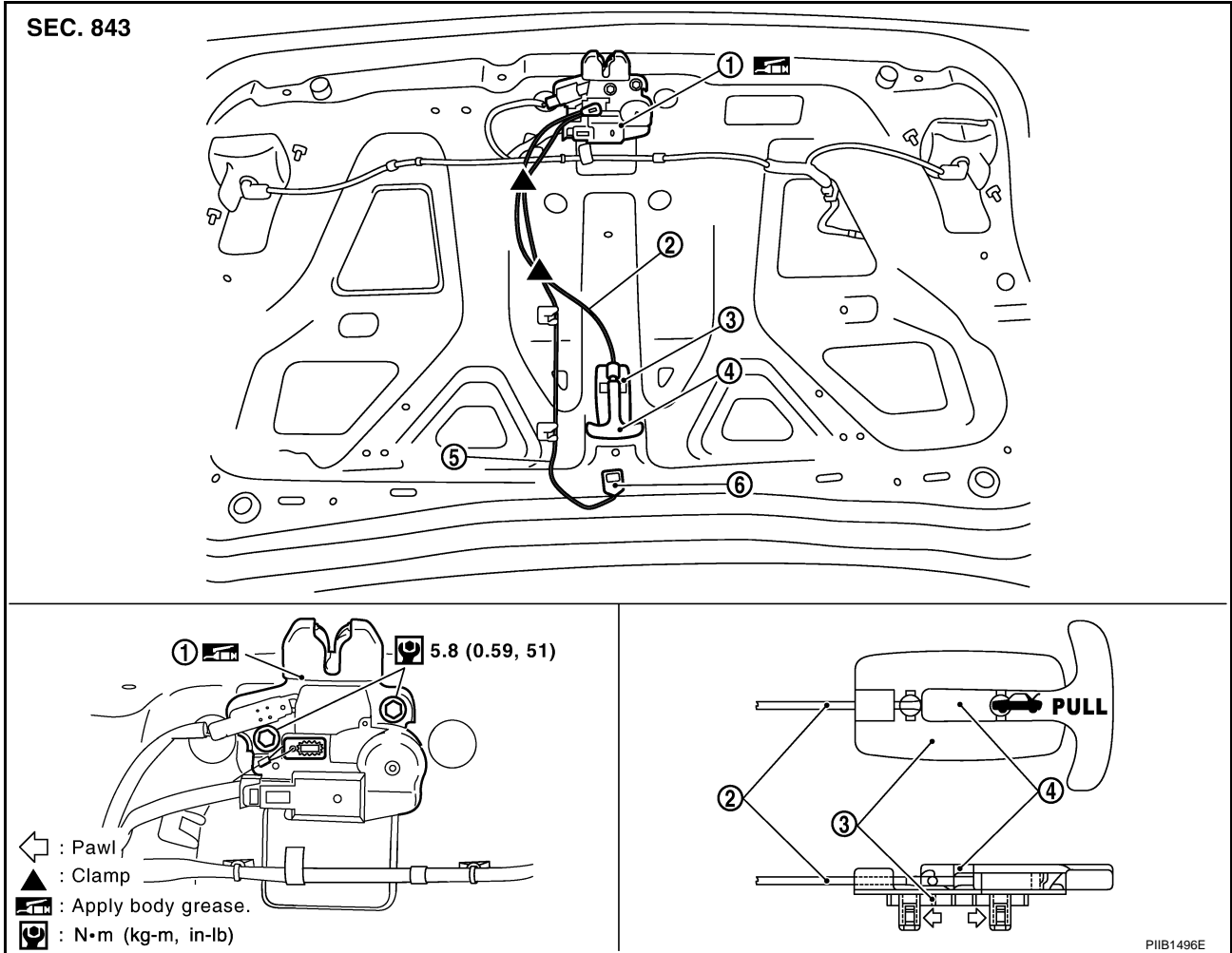

- | | | |
|---|---|--|
| 1. Trunk lid lock assembly | 2. Trunk lid emergency opener cable (secondary) | 3. Trunk lid emergency opener lever holder |
| 4. Trunk lid emergency opener lever (secondary) | 5. Trunk lid emergency opener cable | 6. Trunk lid emergency opener hook |

REMOVAL

1. Remove trunk lid finisher. Refer to [EI-47, "TRUNK ROOM TRIM & TRUNK LID FINISHER"](#).
2. Disconnect each clamp of trunk lid emergency opener cable.
3. Disconnect the trunk lid emergency opener cable and from the trunk lid lock assembly.
4. Disconnect the trunk lid emergency opener cable (secondary) from the trunk lid emergency opener lever holder.
5. Remove trunk lid emergency opener cable.

INSTALLATION

Install in the reverse order of removal.

CAUTION:

After installing, check the operation.

TRUNK LID

Removal and Installation of Trunk Lid Weatherstrip

AIS005WR

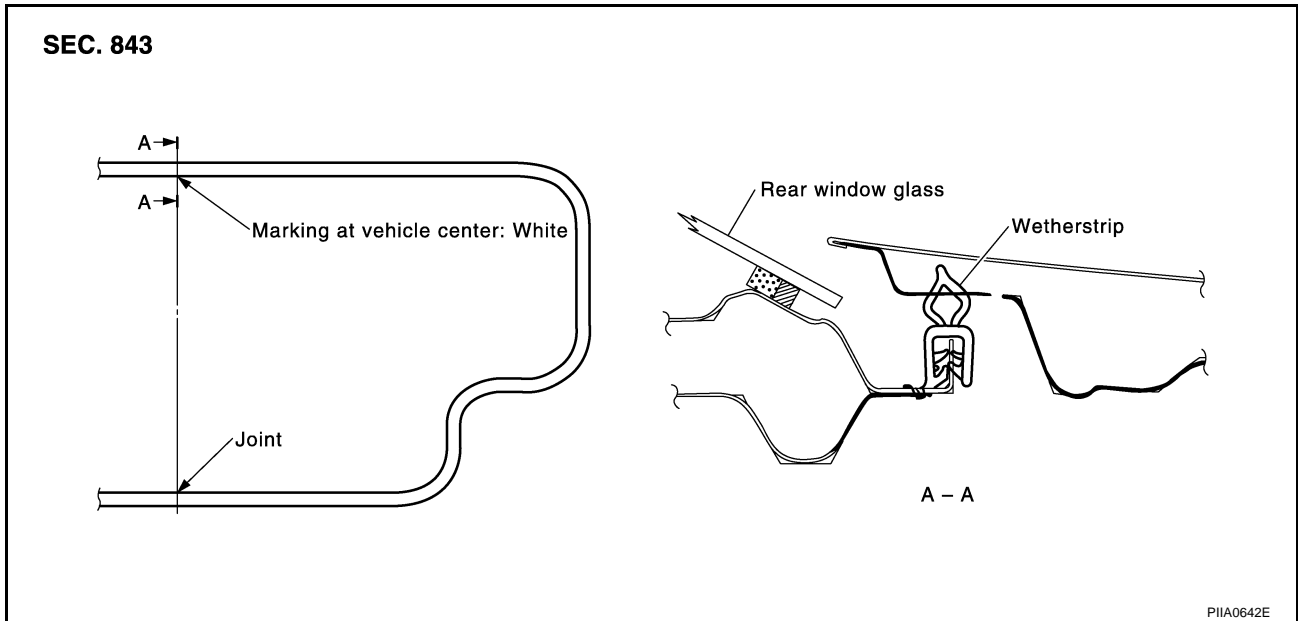

REMOVAL

Pull up and remove engagement with body from weatherstrip joint.

CAUTION:

After removal, do not pull strongly on the weatherstrip.

INSTALLATION

1. Working from the upper section, align weatherstrip mark with vehicle center position mark and install weatherstrip onto the vehicle.
2. For the lower section, align the weatherstrip seam with center of the striker.
3. After installation, pull the weatherstrip gently to ensure that there is no loose section.

NOTE:

Make sure the weatherstrip is fit tightly at each corner and back door rear plate.

TRUNK LID OPENER

PFP:84640

TRUNK LID OPENER

Component Parts and Harness Connector Location

AIS004CT

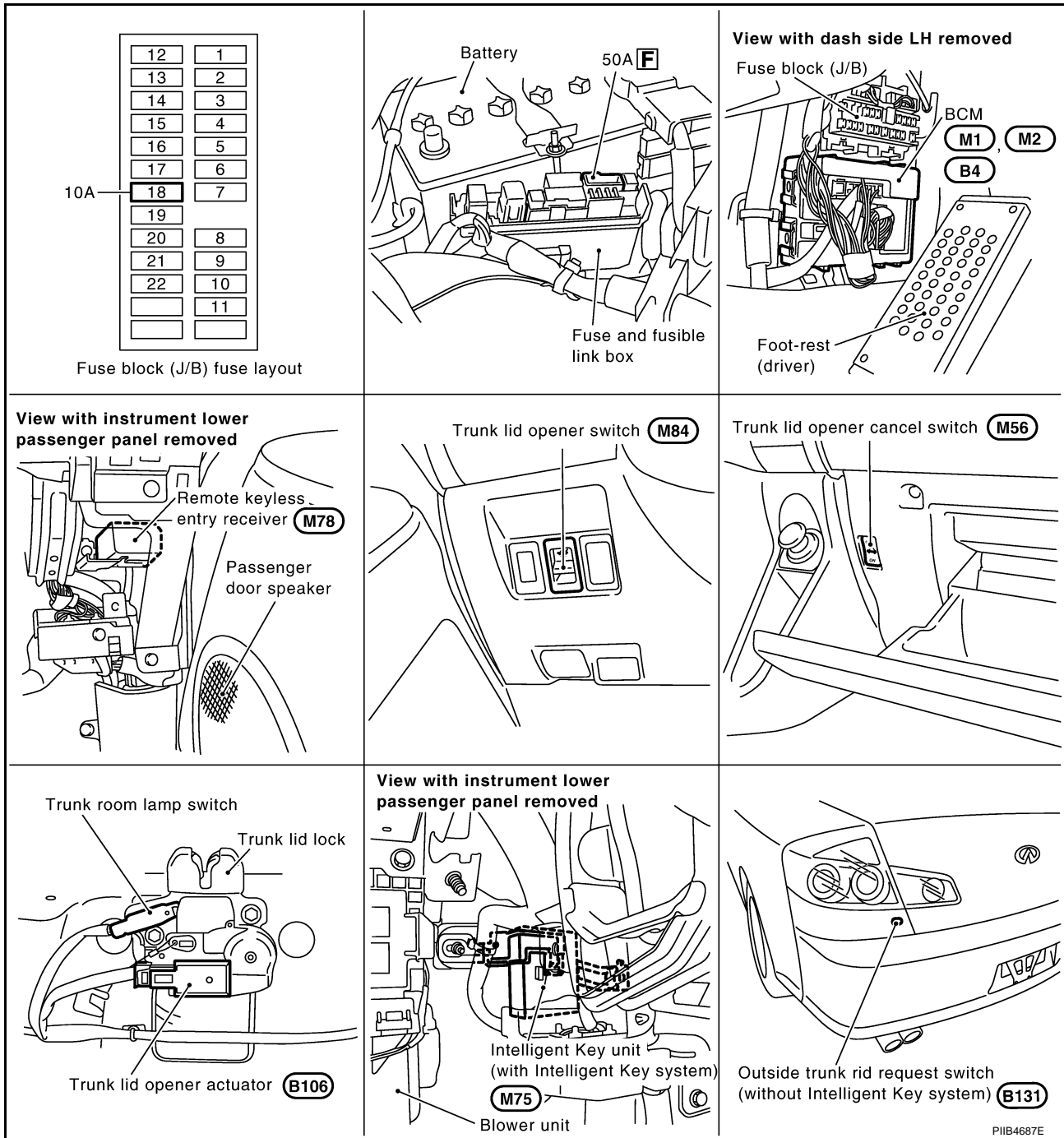

System Description

AIS004CU

Power is supplied at all times

- through 50A fusible link (letter **F**, located in the fuse and fusible link box)
- to BCM terminal 55,
- through 10A fuse [No.18, located in the fuse block (J/B)]
- to BCM terminal 42.

Ground is supplied

- to BCM terminal 52
- through body grounds M30 and M66.

A
B
C
D
E
F
G
H
I
J
K
L
M

BL

TRUNK LID OPENER

When trunk lid opener cancel switch is ON and trunk lid opener switch is ON (pushed)

Ground is supplied
(With Intelligent Key)

- to BCM terminal 30
- through trunk lid opener switch terminals 1 and 2
- through trunk lid opener cancel switch terminals 1 and 2 and
- through body grounds M30 and M66.

(Without Intelligent Key)

- to BCM terminal 30
- through trunk lid opener cancel switch terminals 1 and 2
- through trunk lid opener switch terminals 1 and 2 and
- through body grounds M30 and M66.

And power is supplied

- through BCM terminal 68
- to trunk lid opener actuator terminal 1.

Ground is supplied

- to trunk lid opener actuator terminal 2
- through body grounds B5 and B29.

Then BCM unlocks trunk lid opener actuator.

When trunk lid opener cancel switch is ON, passenger side door lock is unlock and outside trunk lid opener switch is ON (pushed)

Ground is supplied
(Without Intelligent Key)

- to BCM terminal 30
- through trunk lid opener cancel switch terminals 1 and 2
- through outside trunk lid opener switch terminals 1 and 2
- through front door lock assembly (passenger side) terminal 2 and 4 and,
- through body grounds M30 and M66.

And power is supplied

- through BCM terminal 68
- to trunk lid opener actuator terminal 1.

Ground is supplied

- to trunk lid opener actuator terminal 2
- through body grounds B5 and B29.

TRUNK LID OPENER OPERATION

When trunk lid opener switch or trunk button of key fob is ON, BCM is unlocked trunk opener actuator.

BCM can unlock trunk lid opener actuator when

- vehicle speed is less than 5 km/h (3MPH)
- vehicle security system is disarmed or pre-armed phase

BCM does not unlock trunk lid opener actuator when

- trunk lid opener cancel switch is OFF (CANSSEL)
- vehicle speed is more than 5 km/h (3MPH)
- vehicle security system is armed or alarm phase
- key is inserted in ignition key cylinder

TRUNK LID OPENER

Wiring Diagram —TLID— / With Intelligent Key

AIS0002H

BL-TLID-01

— : DATA LINE

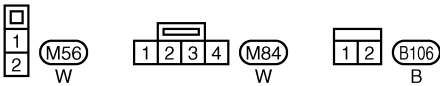
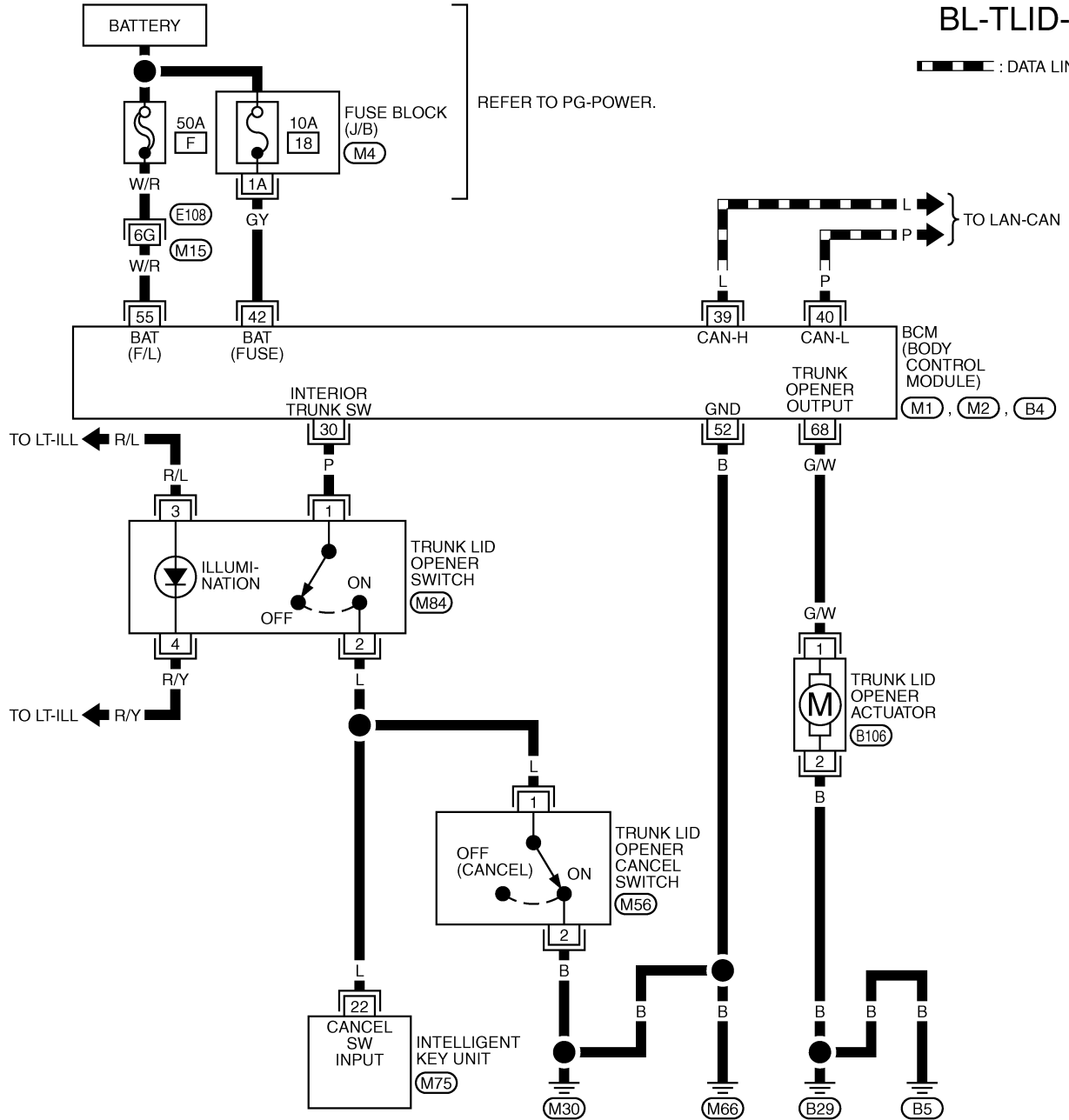

REFER TO THE FOLLOWING.

- (E108) -SUPER MULTIPLE JUNCTION (SMJ)
- (M4) -FUSE BLOCK-JUNCTION BOX (J/B)
- (M1), (M2), (M75), (B4) -ELECTRICAL UNITS

TIWM1058E

TRUNK LID OPENER

AIS006AA

Wiring Diagram —TLID— / Without Intelligent Key

BL-TLID-02

▬▬▬▬ : DATA LINE

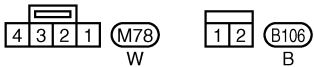
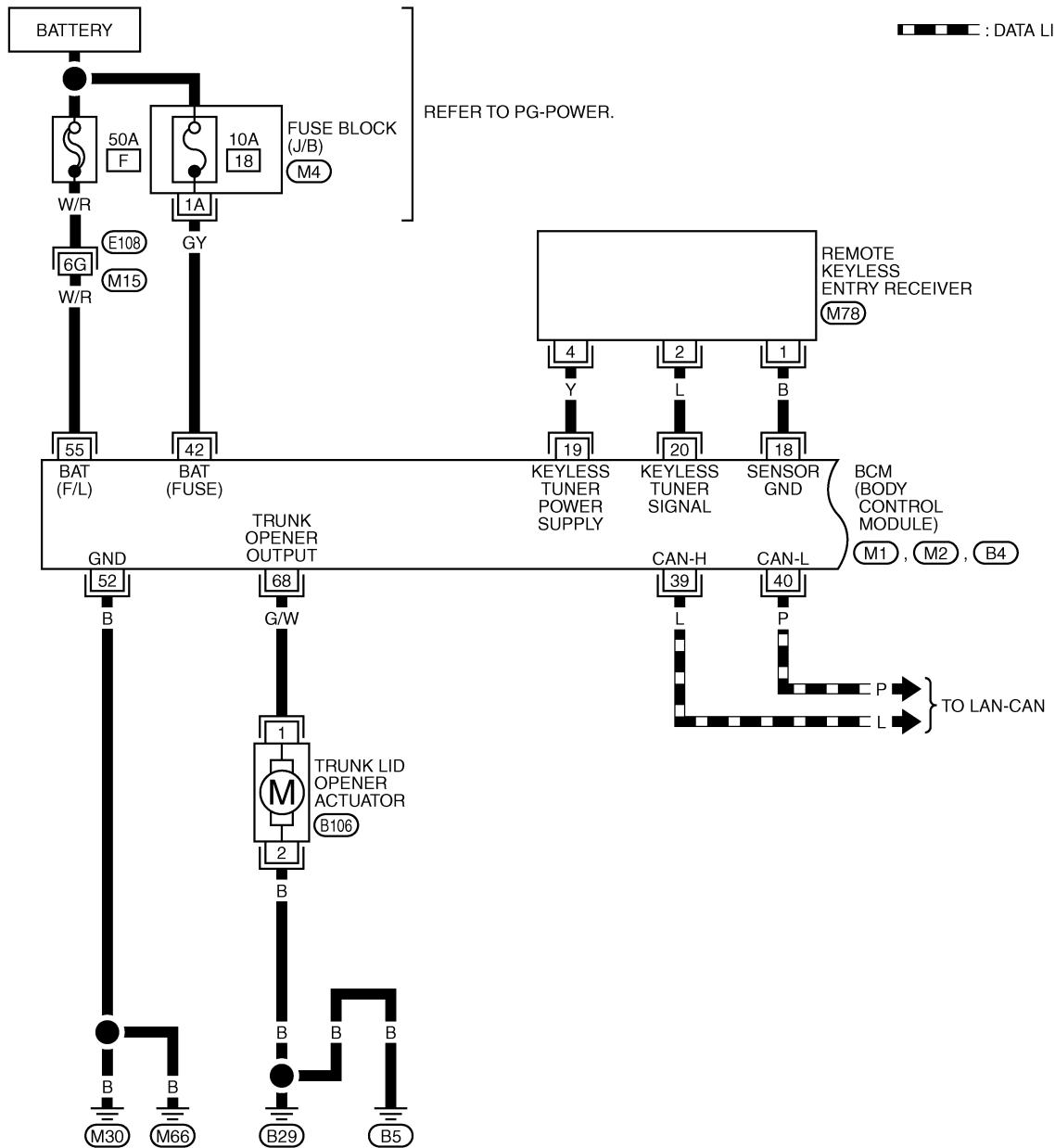

REFER TO THE FOLLOWING.

- (E108) -SUPER MULTIPLE JUNCTION (SMJ)
- (M4) -FUSE BLOCK-JUNCTION BOX (J/B)
- (M1), (M2), (B4) -ELECTRICAL UNITS

TIWM1059E

TRUNK LID OPENER

BL-TLID-03

A
B
C
D
E
F
G
H
BL
J
K
L
M

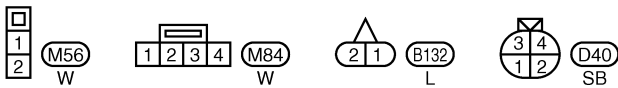
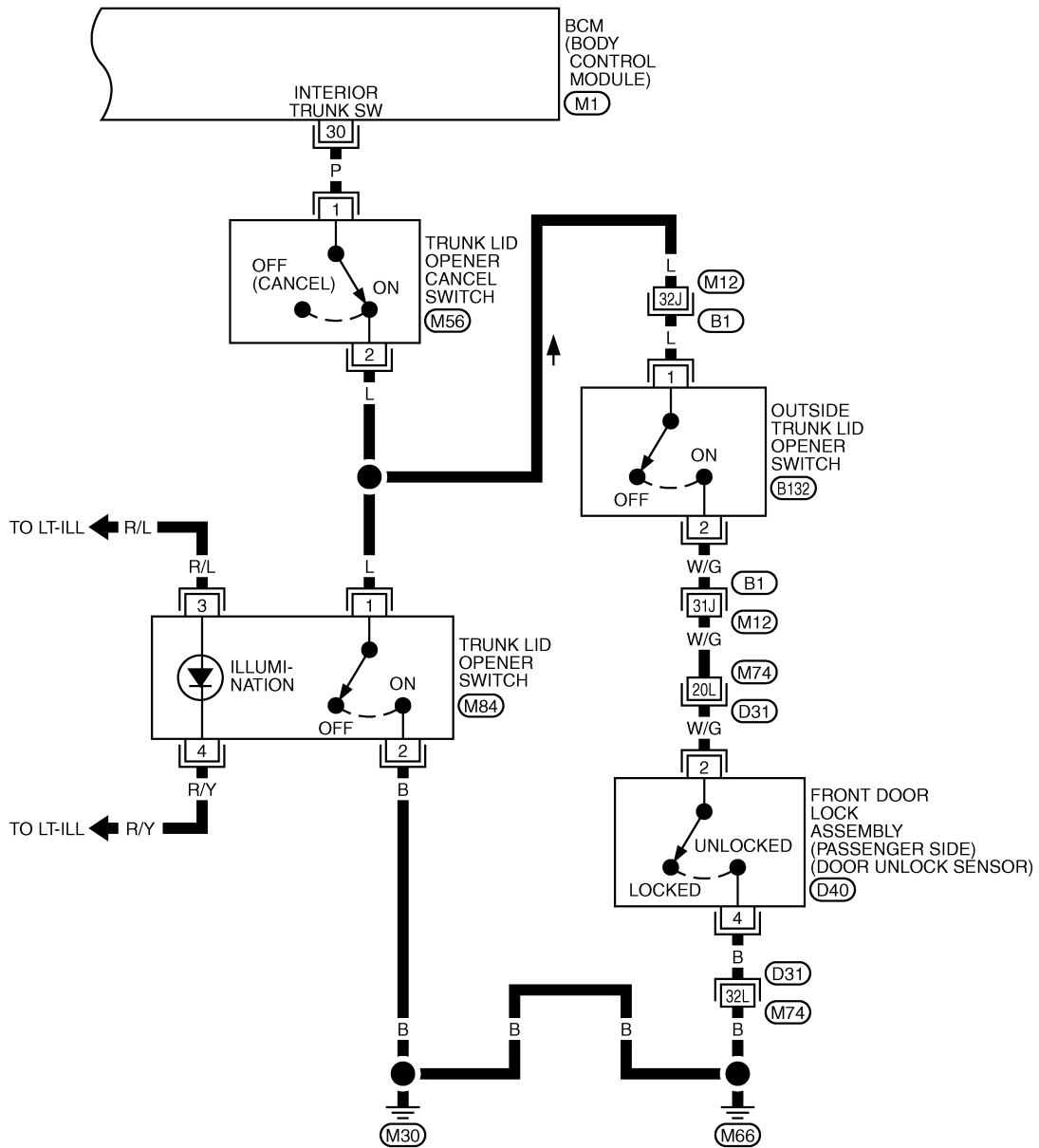



REFER TO THE FOLLOWING.
 (B1), (D31) -SUPER MULTIPLE JUNCTION (SMJ)
 (M1) -ELECTRICAL UNITS

TIWM1060E

TRUNK LID OPENER

Terminals and Reference Value for BCM

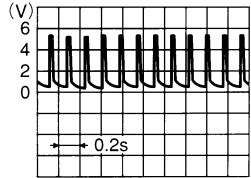
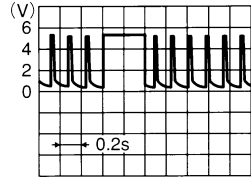
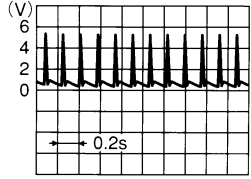
AI500021

TERMI- NAL	WIRE COLOR	ITEM	CONDITION		VOLTAGE (V) (Approx.)
18*	B	Sensor ground	—		0
19*	Y	Remote keyless entry receiver power supply	Ignition switch is removed from key cylinder	Waiting state	 OCC3881D
				Any operation using key fob	 OCC3882D
20*	L	Remote keyless entry receiver signal	Ignition switch is removed from key cylinder	Waiting state	 OCC3879D
				Any operation using key fob	 OCC3880D
30	P	Trunk lid opener switch	Trunk lid opener cancel switch is ON position	Trunk lid opener switch is ON	0
			Trunk lid opener cancel switch is OFF position	Trunk lid opener switch is OFF	5
					5
39	L	CAN-H	—		—
40	P	CAN-L	—		—
42	GY	Power source (Fuse)	—		Battery voltage
52	B	Ground	—		0
55	W/R	Power source (Fusible link)	—		Battery voltage
68	G/W	Trunk lid opener output signal	Locked (OFF) → Unlocked (ON)		0 → Battery voltage → 0

* : With Intelligent Key

TRUNK LID OPENER

CONSULT-II Function (BCM)

AIS004CV

CONSULT-II can display each diagnostic item using the diagnostic test modes shown following.

BCM diagnosis part	Inspection item, self-diagnosis mode	Content
Door lock	DATA MONITOR	Displays the input data of BCM in real time basis.
	ACTIVE TEST	Give a drive signals to load to check the operation check.
	WORK SUPPORT	Change the setting for each function.

CONSULT-II INSPECTION PROCEDURE

CAUTION:

If CONSULT-II is used with no connection of CONSULT-II CONVERTER, malfunctions might be detected in self-diagnosis depending on control unit which carry out CAN communication.

1. Turn ignition switch "OFF".
2. Connect "CONSULT-II" and CONSULT-II CONVERTER to data link connector.

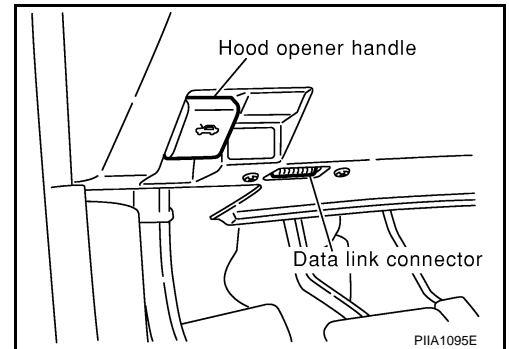

3. Turn ignition switch "ON".
4. Touch "START(NISSAN BASED VHCL)".

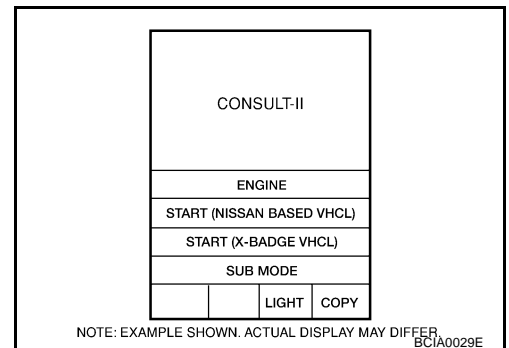

5. Touch "BCM".
If "BCM" is not indicated, go to [GI-38, "CONSULT-II Data Link Connector \(DLC\) Circuit"](#).

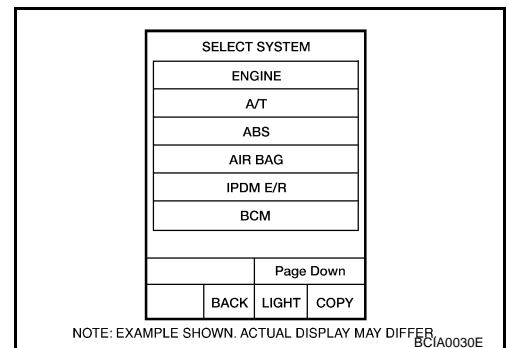

TRUNK LID OPENER

6. Touch "TRUNK".

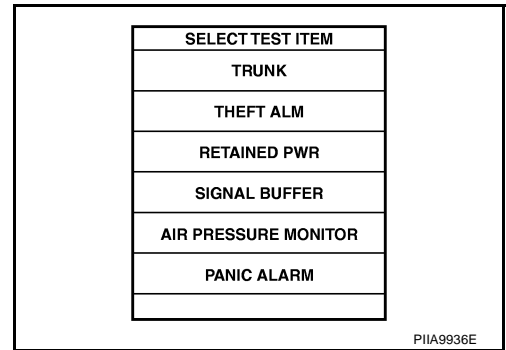

7. Select diagnosis mode.
"DATA MONITOR" and "ACTIVE TEST" are available

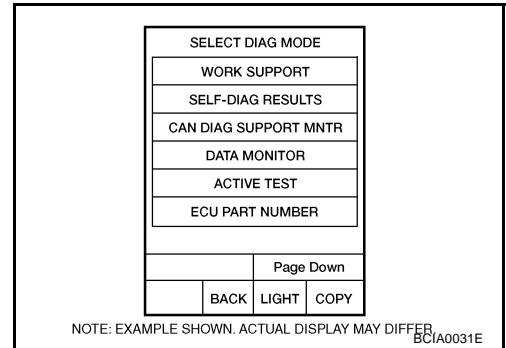

DATA MONITOR

Monitored Item	Description
IGN ON SW	Indicates [ON/OFF] condition of ignition switch in ON position.
KEYLESS TRUNK	Indicates [ON/OFF] condition of trunk open signal from key fob.
TRUNK OPNR SW	Indicates [ON/OFF] condition of trunk lid opener switch.
VEHICLE SPEED	This item displays vehicle speed.

ACTIVE TEST

Test item	Content
TRUNK/BACK DOOR	This test is able to check trunk lid opener actuator unlock operation. This actuator unlocks when "ON" on CONSULT-II screen is touched.

TRUNK LID OPENER

AIS004CW

Trouble Diagnosis

TRUNK DOSE NOT OPEN WITH TRUNK LID OPENER SWITCH / WITHOUT INTELLIGENT KEY

1. CHECK TRUNK LID OPENER CANCEL SWITCH

Check trunk lid opener cancel switch position.

Does trunk lid opener cancel switch turn OFF (CANCEL)?

- Yes >> Turn on trunk lid opener cancel switch.
- No >> GO TO 2.

2. CHECK TRUNK LID OPEN INPUT SIGNAL

Ⓜ With CONSULT-II

Check trunk lid opener switch ("TRNK OPNR SW") in "DATA MONITOR" mode with CONSULT-II.

- When trunk lid opener switch is turned to "LOCK".

TRNK OPNR SW : ON

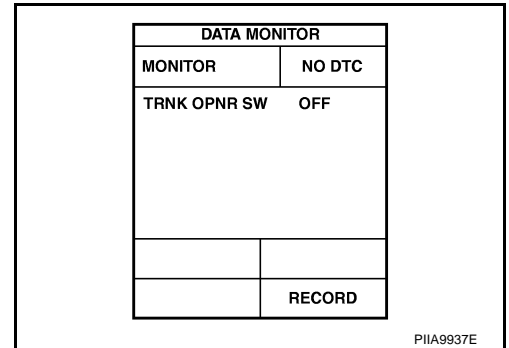

⊗ Without CONSULT-II

1. Remove key from ignition key cylinder.
2. Turn on trunk lid opener cancel switch.
3. Check voltage between BCM connector and ground.

Connector	Terminal (Wire color)		Condition	Voltage [V] (Approx.)
	(+)	(-)		
M1	30 (P)	Ground	Trunk lid opener switch ON	0
			Trunk lid opener switch OFF	5

OK or NG

- OK >> GO TO 3.
- NG >> GO TO 6.

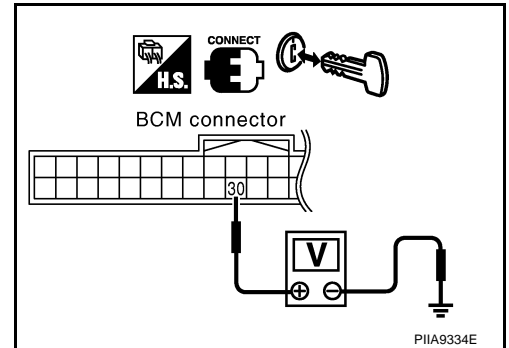

3. CHECK TRUNK LID OPEN OUTPUT SIGNAL

Check voltage between BCM connector and ground.

Connector	Terminal (Wire color)		Condition	Voltage [V] (Approx.)
	(+)	(-)		
B4	68 (G/W)	Ground	Trunk lid opener switch ON	Battery voltage
			Trunk lid opener switch OFF	0

OK or NG

- OK >> GO TO 4.
- NG >> Replace BCM. Refer to [BCS-16, "Removal and Installation of BCM"](#).

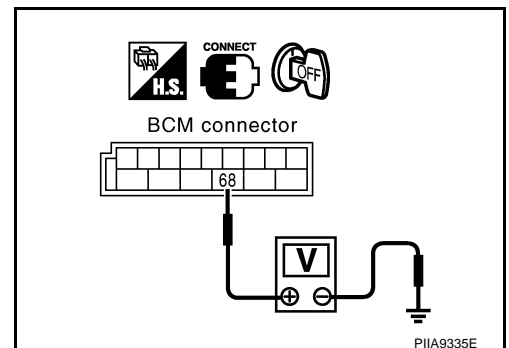

TRUNK LID OPENER

4. CHECK TRUNK LID OPENER ACTUATOR CIRCUIT

1. Disconnect BCM connector and trunk lid opener actuator connector.
2. Check continuity between BCM harness connector B4 terminal 68 and trunk lid opener actuator harness connector B106 terminal 1.

68 (G/W) - 1 (G/W) : Continuity should exist.

3. Check continuity between BCM harness connector B4 terminal 68 and ground.

68 (G/W) - ground : Continuity should not exist.

OK or NG

OK >> GO TO 5.

NG >> Repair harness or connector.

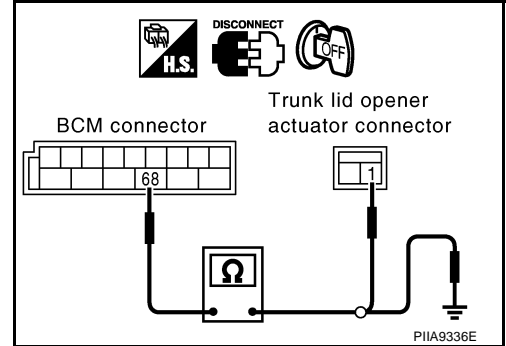

5. CHECK TRUNK LID OPENER ACTUATOR GROUND CIRCUIT

Check continuity between trunk lid opener actuator connector B106 terminal 2 and ground.

2 (B) - ground : Continuity should exist.

OK or NG

OK >> Replace trunk lid opener actuator.

NG >> Repair harness or connector.

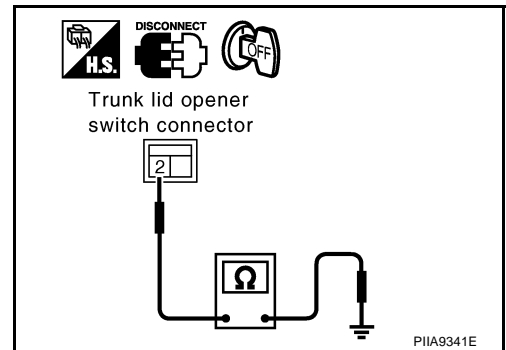

6. CHECK TRUNK LID OPENER CANCEL SWITCH

1. Turn ignition switch OFF.
2. Disconnect trunk lid opener cancel switch connector.
3. Check continuity between trunk lid opener cancel switch connector M56 terminals 1 and 2.

Terminals		Trunk lid opener cancel switch condition	Continuity
1	2		
		ON	Yes
		OFF	No

OK or NG

OK >> GO TO 7.

NG >> Replace trunk lid opener cancel switch.

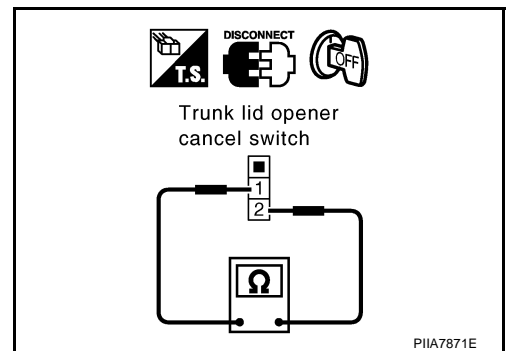

TRUNK LID OPENER

7. CHECK TRUNK LID OPENER SWITCH

1. Disconnect trunk lid opener switch connector.
2. Check continuity between trunk lid opener switch connector M84 terminals 1 and 2.

Terminals		Trunk lid opener switch condition	Continuity
1	2	ON (Pushed)	Yes
		OFF (Released)	No

OK or NG

- OK >> GO TO 8.
 NG >> Replace trunk lid opener switch.

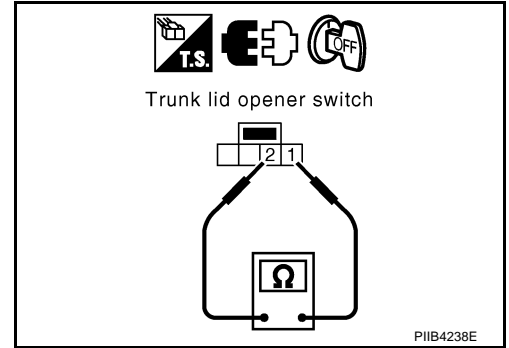

8. CHECK TRUNK LID OPENER CANCEL SWITCH CIRCUIT

1. Disconnect BCM connector.
2. Check continuity between BCM connector M1 terminal 30 and trunk lid opener cancel switch connector M56 terminal 1.

30 (P) - 1 (P) : Continuity should exist.

3. Check continuity between BCM connector M1 terminal 30 and ground.

30 (P) - Ground : Continuity should not exist.

OK or NG

- OK >> GO TO 9.
 NG >> Repair harness or connector.

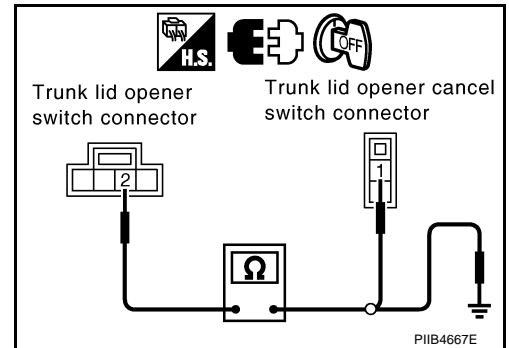

9. CHECK TRUNK LID OPENER SWITCH CIRCUIT

1. Check continuity between trunk lid opener cancel switch connector M56 terminal 2 and trunk lid opener switch connector M84 terminal 1.

2 (L) - 1 (L) : Continuity should exist.

2. Check continuity between trunk lid opener cancel switch connector M56 terminal 2 and ground.

2 (L) - Ground : Continuity should not exist.

OK or NG

- OK >> GO TO 10.
 NG >> Repair harness or connector.

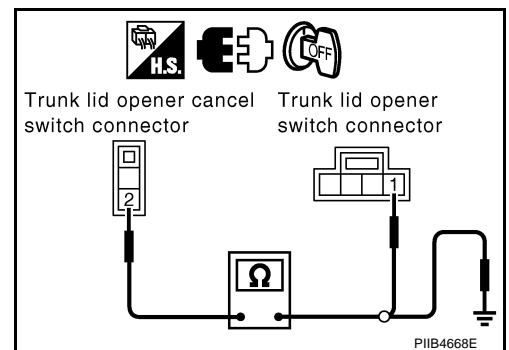

10. CHECK TRUNK LID OPENER SWITCH GROUND CIRCUIT

- Check continuity between trunk lid opener switch connector M84 terminal 2 and ground.

2 (B) - Ground : Continuity should exist.

OK or NG

- OK >> Check condition of harness and connector.
 NG >> Repair or replace harness.

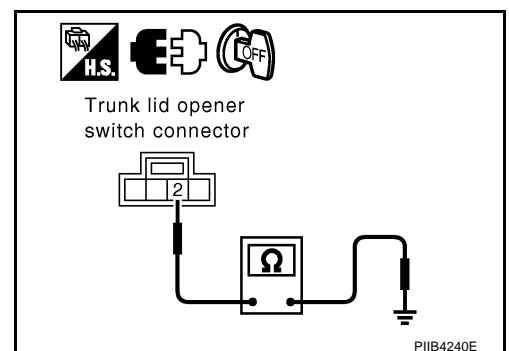

TRUNK LID OPENER

TRUNK DOSE NOT OPEN WITH OUTSIDE TRUNK LID OPENER SWITCH / WITHOUT INTELLIGENT KEY

1. CHECK TRUNK LID OPENER CANCEL SWITCH

Check trunk lid opener cancel switch position.

Does trunk lid opener cancel switch turn OFF (CANCEL)?

- Yes >> Turn on trunk lid opener cancel switch.
- No >> GO TO 2.

2. CHECK TRUNK LID OPEN INPUT SIGNAL

With CONSULT-II

Check trunk lid opener switch ("TRNK OPNR SW") in "DATA MONITOR" mode with CONSULT-II.

- When trunk lid opener switch is turned to "LOCK".

TRNK OPNR SW : ON

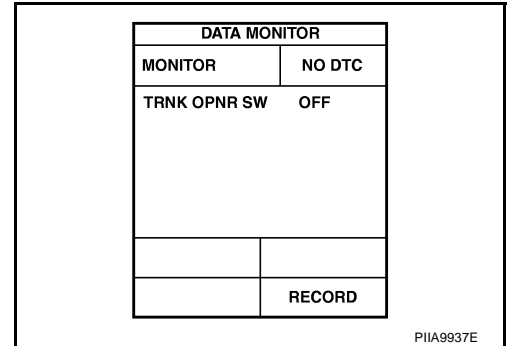

Without CONSULT-II

1. Remove key from ignition key cylinder.
2. Turn on trunk lid opener cancel switch.
3. Check voltage between BCM connector and ground.

Connector	Terminal (Wire color)		Condition	Voltage [V] (Approx.)
	(+)	(-)		
M1	30 (P)	Ground	Trunk lid opener switch ON	0
			Trunk lid opener switch OFF	5

OK or NG

- OK >> GO TO 3.
- NG >> GO TO 6.

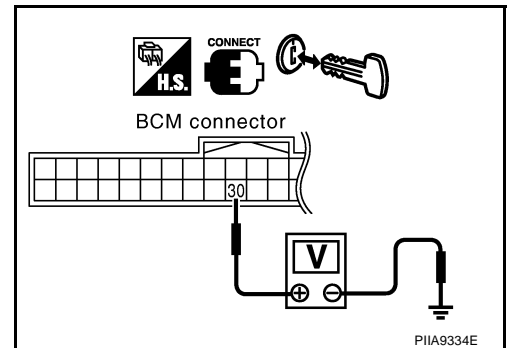

3. CHECK TRUNK LID OPEN OUTPUT SIGNAL

Check voltage between BCM connector and ground.

Connector	Terminal (Wire color)		Condition	Voltage [V] (Approx.)
	(+)	(-)		
B4	68 (G/W)	Ground	Trunk lid opener switch ON	Battery voltage
			Trunk lid opener switch OFF	0

OK or NG

- OK >> GO TO 4.
- NG >> Replace BCM. Refer to [BCS-16, "Removal and Installation of BCM"](#).

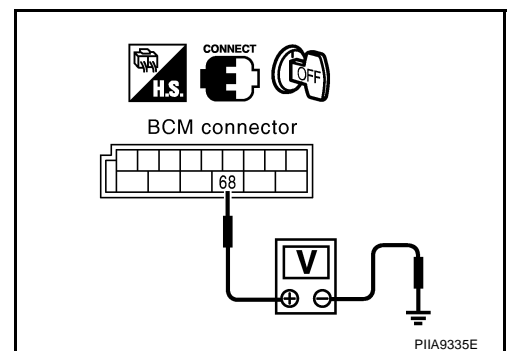

TRUNK LID OPENER

4. CHECK TRUNK LID OPENER ACTUATOR CIRCUIT

1. Disconnect BCM connector and trunk lid opener actuator connector.
2. Check continuity between BCM harness connector B4 terminal 68 and trunk lid opener actuator harness connector B106 terminal 1.

68 (G/W) - 1 (G/W) : Continuity should exist.

3. Check continuity between BCM harness connector B4 terminal 68 and ground.

68 (G/W) - ground : Continuity should not exist.

OK or NG

OK >> GO TO 5.

NG >> Repair harness or connector.

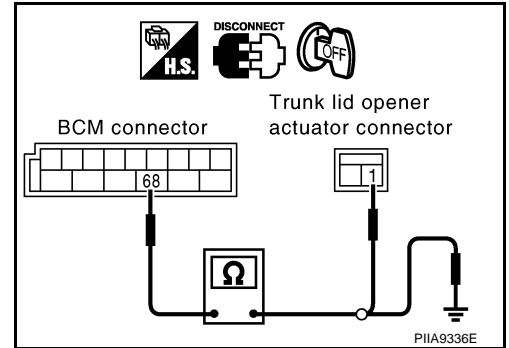

5. CHECK TRUNK LID OPENER ACTUATOR GROUND CIRCUIT

Check continuity between trunk lid opener actuator connector B106 terminal 2 and ground.

2 (B) - ground : Continuity should exist.

OK or NG

OK >> Replace trunk lid opener actuator.

NG >> Repair harness or connector.

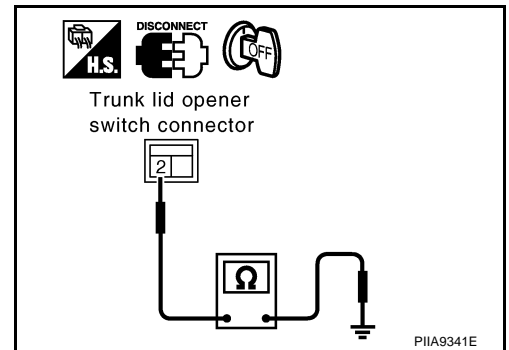

6. CHECK TRUNK LID OPENER CANCEL SWITCH

1. Turn ignition switch OFF.
2. Disconnect trunk lid opener cancel switch connector.
3. Check continuity between trunk lid opener cancel switch connector M56 terminals 1 and 2.

Terminals		Trunk lid opener cancel switch condition	Continuity
1	2	ON	Yes
		OFF	No

OK or NG

OK >> GO TO 7.

NG >> Replace trunk lid opener cancel switch.

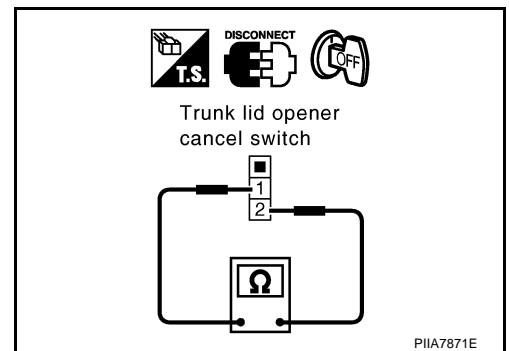

TRUNK LID OPENER

7. CHECK OUTSIDE TRUNK LID OPENER SWITCH

1. Disconnect outside trunk lid opener switch connector.
2. Check continuity between outside trunk lid opener switch connector B132 terminals 1 and 2.

Terminals		Outside trunk lid opener switch condition	Continuity
1	2	ON (Pushed)	Yes
		OFF (Released)	No

OK or NG

- OK >> GO TO 8.
 NG >> Replace outside trunk lid opener switch.

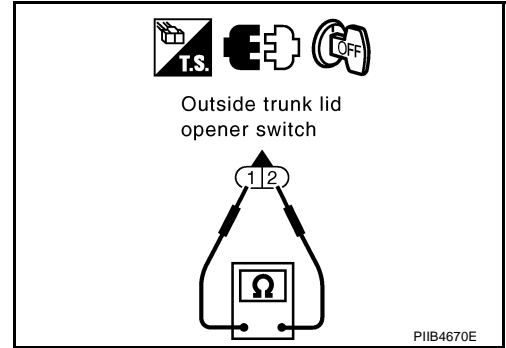

8. CHECK TRUNK LID OPENER CANCEL SWITCH CIRCUIT

1. Disconnect BCM connector.
2. Check continuity between BCM connector M1 terminal 30 and trunk lid opener cancel switch connector M56 terminal 1.

30 (P) - 1 (P) : Continuity should exist.

3. Check continuity between BCM connector M1 terminal 30 and ground.

30 (P) - Ground : Continuity should not exist.

OK or NG

- OK >> GO TO 9.
 NG >> Repair harness or connector.

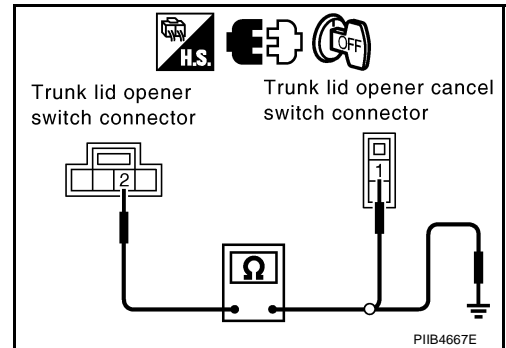

9. CHECK OUTSIDE TRUNK LID OPENER SWITCH CIRCUIT

1. Check continuity between trunk lid opener cancel switch connector M56 terminal 2 and outside trunk lid opener switch connector B132 terminal 1.

2 (P) - 1 (P) : Continuity should exist.

2. Check continuity between trunk lid opener cancel switch connector M56 terminal 2 and ground.

2 (P) - Ground : Continuity should not exist.

OK or NG

- OK >> GO TO 10.
 NG >> Repair harness or connector.

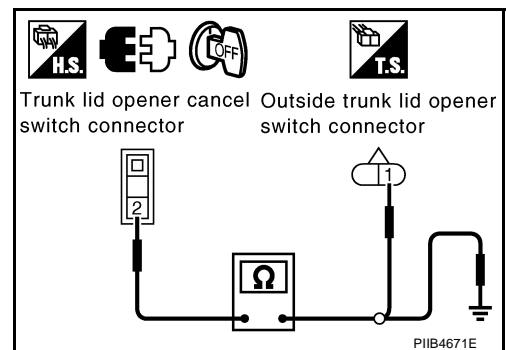

TRUNK LID OPENER

10. CHECK FRONT DOOR LOCK ASSEMBLY CIRCUIT

1. Disconnect front door lock assembly (passenger side) connector.
2. Check continuity between outside trunk lid opener switch connector B132 terminal 2 and front door lock assembly (passenger side) connector D40 terminal 2.

2 (W/G) - 2 (W/G) : Continuity should exist.

3. Check continuity between trunk lid opener cancel switch connector M56 terminal 2 and ground.

2 (W/G) - Ground : Continuity should not exist.

OK or NG

OK >> GO TO 11.

NG >> Repair harness or connector.

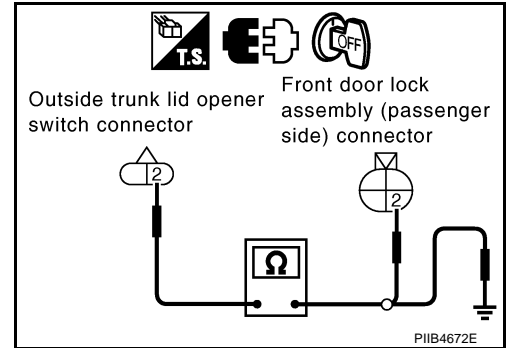

11. CHECK FRONT DOOR LOCK ASSEMBLY

Check continuity between front door lock assembly (passenger side) connector D40 terminals 2 and 4.

Terminals		Trunk lid opener cancel switch condition	Continuity
2	4	Lock (OFF)	No
		Unlock (ON)	Yes

OK or NG

OK >> GO TO 12.

NG >> Replace front door lock assembly (passenger side).

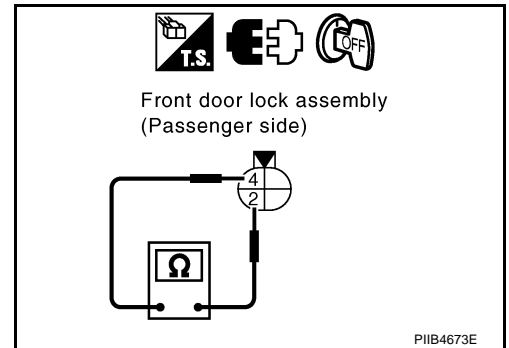

12. CHECK FRONT DOOR LOCK ASSEMBLY GROUND CIRCUIT

Check continuity between front door lock assembly (passenger side) connector D40 terminal 4 and ground.

4 (B) - Ground : Continuity should exist.

OK or NG

OK >> Check condition of harness and connector.

NG >> Repair or replace harness.

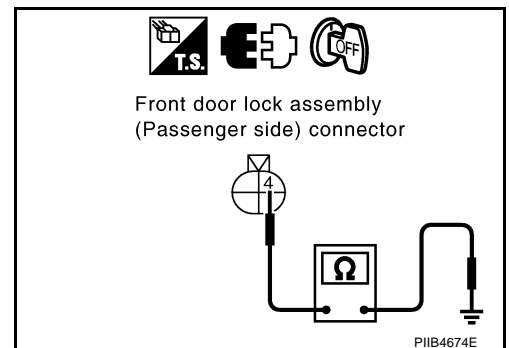

TRUNK DOSE NOT OPEN WITH TRUNK LID OPENER SWITCH / WITH INTELLIGENT KEY

1. CHECK TRUNK LID OPENER CANCEL SWITCH

Check trunk lid opener cancel switch position.

Does trunk lid opener cancel switch turn OFF (CANCEL)?

Yes >> Turn on trunk lid opener cancel switch.

No >> GO TO 2.

TRUNK LID OPENER

2. CHECK TRUNK LID OPEN INPUT SIGNAL

With CONSULT-II

Check trunk lid opener switch ("TRNK OPNR SW") in "DATA MONITOR" mode with CONSULT-II.

- When trunk lid opener switch is turned to "LOCK".

TRNK OPNR SW : ON

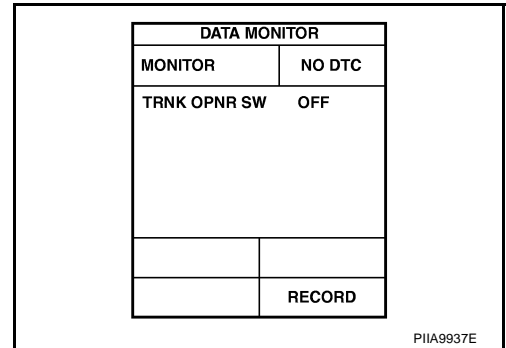

Without CONSULT-II

- Remove key from ignition key cylinder.
- Turn on trunk lid opener cancel switch.
- Check voltage between BCM connector and ground.

Connector	Terminal (Wire color)		Condition	Voltage [V] (Approx.)
	(+)	(-)		
M1	30 (P)	Ground	Trunk lid opener switch ON	0
			Trunk lid opener switch OFF	5

OK or NG

- OK >> GO TO 3.
 NG >> GO TO 6.

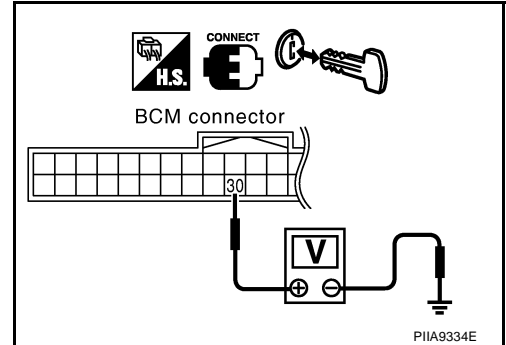

3. CHECK TRUNK LID OPEN OUTPUT SIGNAL

Check voltage between BCM connector and ground.

Connector	Terminal (Wire color)		Condition	Voltage [V] (Approx.)
	(+)	(-)		
B4	68 (G/W)	Ground	Trunk lid opener switch ON	Battery voltage
			Trunk lid opener switch OFF	0

OK or NG

- OK >> GO TO 4.
 NG >> Replace BCM. Refer to [BCS-16, "Removal and Installation of BCM"](#).

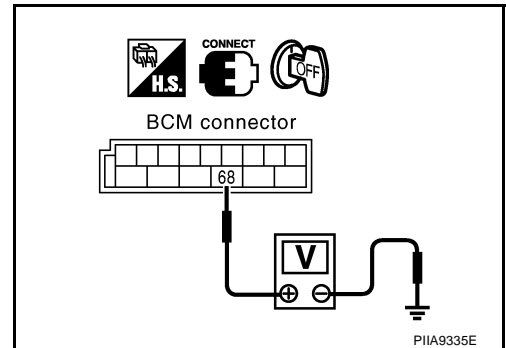

TRUNK LID OPENER

4. CHECK TRUNK LID OPENER ACTUATOR CIRCUIT

1. Disconnect BCM connector and trunk lid opener actuator connector.
2. Check continuity between BCM harness connector B4 terminal 68 and trunk lid opener actuator harness connector B106 terminal 1.

68 (G/W) - 1 (G/W) : Continuity should exist.

3. Check continuity between BCM harness connector B4 terminal 68 and ground.

68 (G/W) - ground : Continuity should not exist.

OK or NG

OK >> GO TO 5.

NG >> Repair harness or connector.

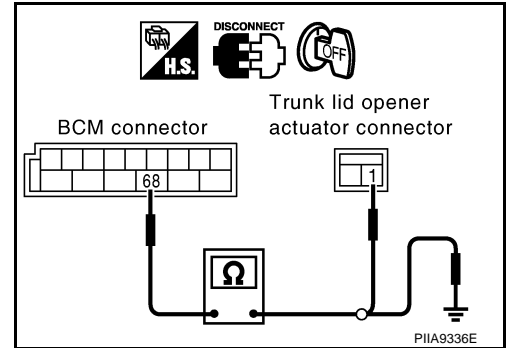

5. CHECK TRUNK LID OPENER ACTUATOR GROUND CIRCUIT

Check continuity between trunk lid opener actuator connector B106 terminal 2 and ground.

2 (B) - ground : Continuity should exist.

OK or NG

OK >> Replace trunk lid opener actuator.

NG >> Repair harness or connector.

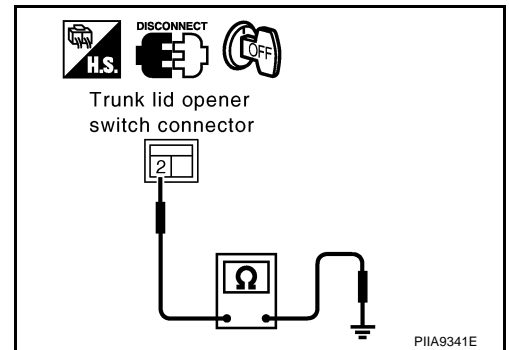

6. CHECK TRUNK LID OPENER SWITCH

1. Turn ignition switch OFF.
2. Disconnect trunk lid opener switch connector.
3. Check continuity between trunk lid opener switch connector M84 terminals 1 and 2.

Terminals		Trunk lid opener switch condition	Continuity
1	2	ON (Pushed)	Yes
		OFF (Released)	No

OK or NG

OK >> GO TO 7.

NG >> Replace trunk lid opener switch.

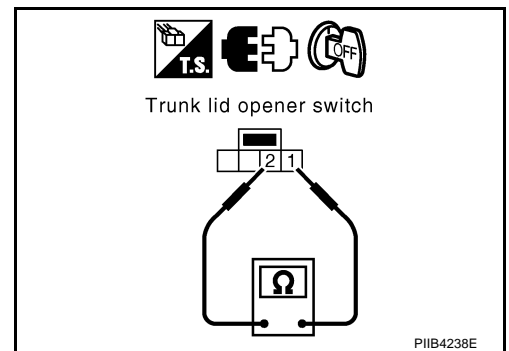

TRUNK LID OPENER

7. CHECK TRUNK LID OPENER CANCEL SWITCH

1. Disconnect trunk lid opener cancel switch connector.
2. Check continuity between trunk lid opener cancel switch connector M56 terminals 1 and 2.

Terminals		Trunk lid opener cancel switch condition	Continuity
1	2	ON	Yes
		OFF	No

OK or NG

- OK >> GO TO 8.
 NG >> Replace trunk lid opener cancel switch.

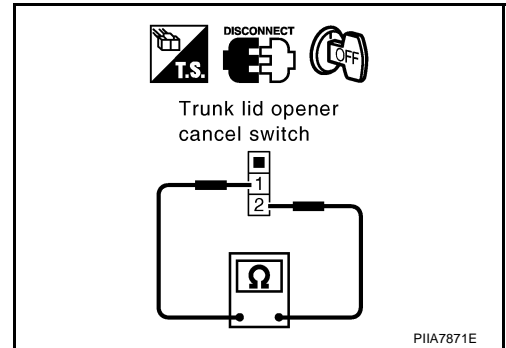

8. CHECK TRUNK LID OPENER SWITCH CIRCUIT

1. Disconnect BCM connector.
2. Check continuity between BCM connector M1 terminal 30 and trunk lid opener switch connector M84 terminal 1.

30 (P) - 1 (P) : Continuity should exist.

3. Check continuity between BCM connector M1 terminal 30 and ground.

30 (P) - Ground : Continuity should not exist.

OK or NG

- OK >> GO TO 9.
 NG >> Repair harness or connector.

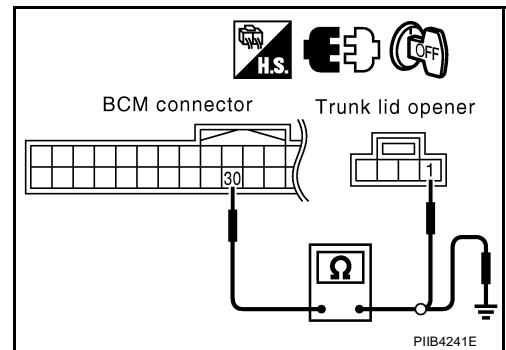

9. CHECK TRUNK LID OPENER CANCEL SWITCH CIRCUIT

1. Check continuity between trunk lid opener switch connector M84 terminal 2 and trunk lid opener cancel switch connector M56 terminal 1.

2 (L) - 1 (L) : Continuity should exist.

2. Check continuity between trunk lid opener switch connector M84 terminal 2 and ground.

2 (L) - Ground : Continuity should not exist.

OK or NG

- OK >> GO TO 10.
 NG >> Repair harness or connector.

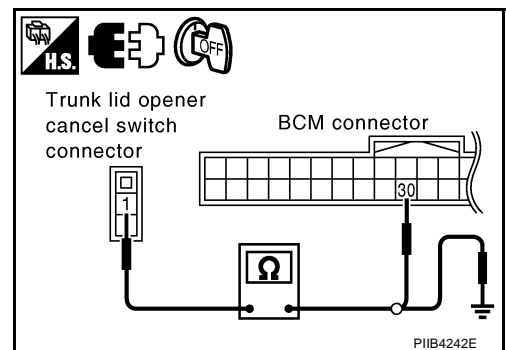

10. CHECK TRUNK LID OPENER SWITCH GROUND CIRCUIT

Check continuity between trunk lid opener switch connector M84 terminal 2 and ground.

2 (B) - Ground : Continuity should exist.

OK or NG

- OK >> Check condition of harness and connector.
 NG >> Repair or replace harness.

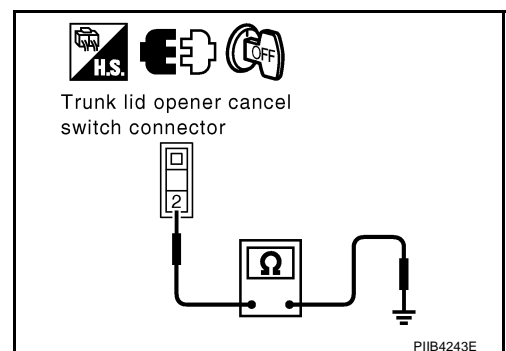

VEHICLE SECURITY (THEFT WARNING) SYSTEM

PPF:28491

AIS004AN

VEHICLE SECURITY (THEFT WARNING) SYSTEM

Component Parts and Harness Connector Location

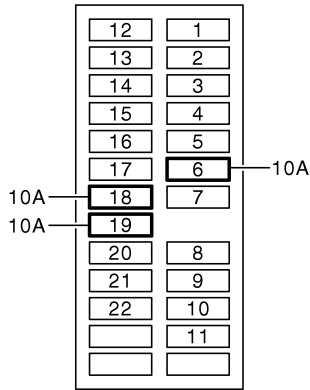

Fuse block (J/B) fuse layout

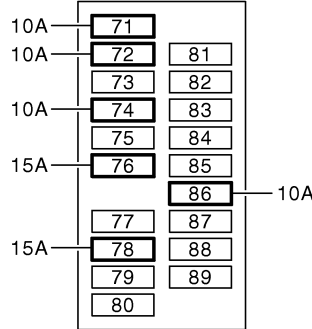

IPDM E/R fuse layout

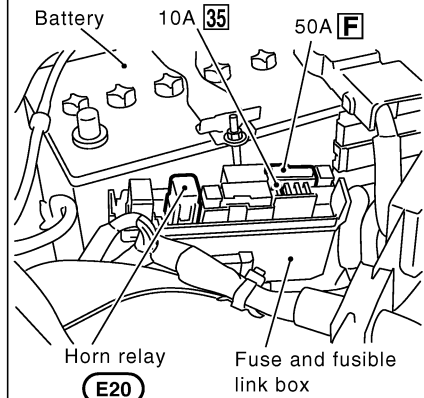

View with dash side LH removed

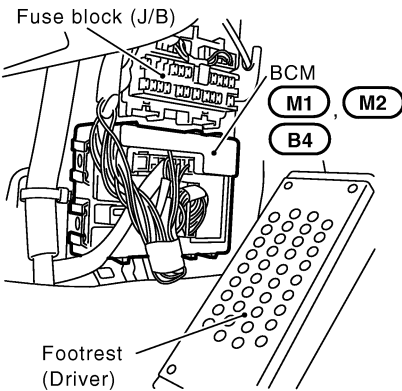

View with cowl top cover (right) removed

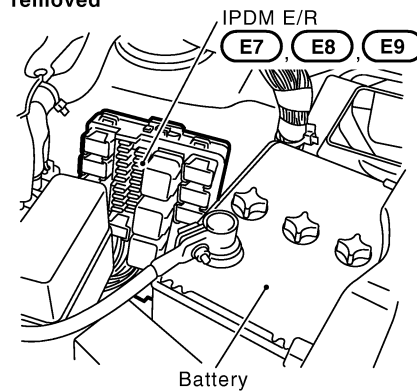

Door lock and unlock switch

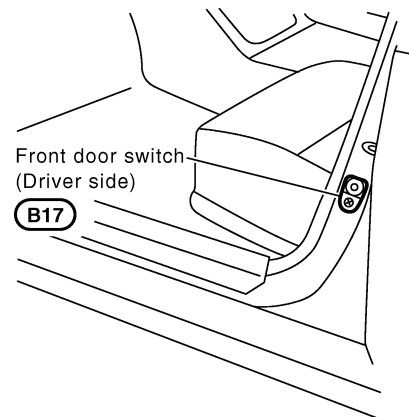
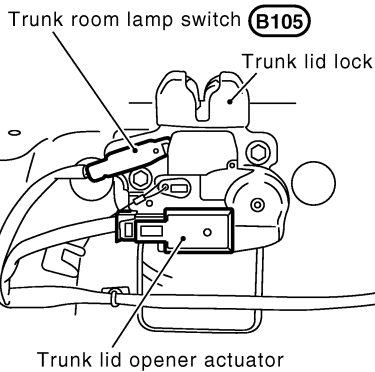
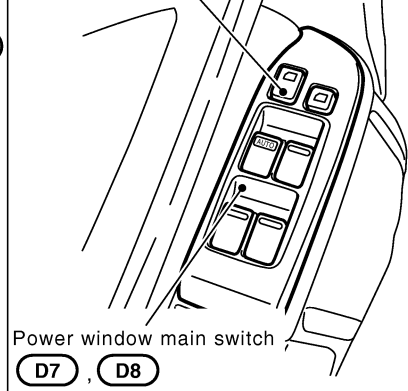

View with front grille removed

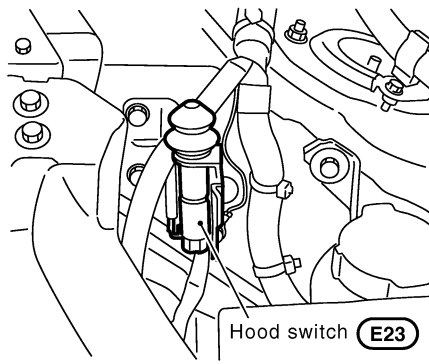
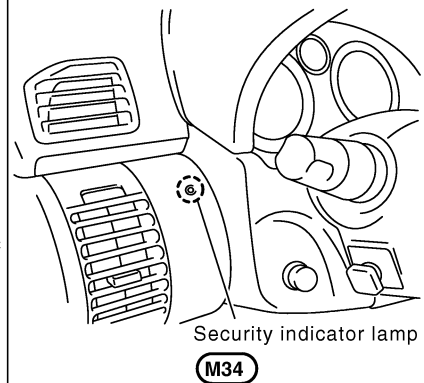
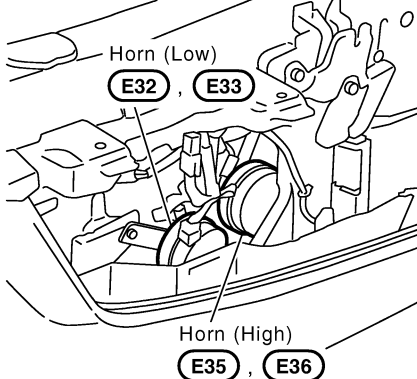

PIIB4669E

A
B
C
D
E
F
G
H
I
J
K
L
M

BL

VEHICLE SECURITY (THEFT WARNING) SYSTEM

System Description

AIS004AO

DESCRIPTION

Operation Flow

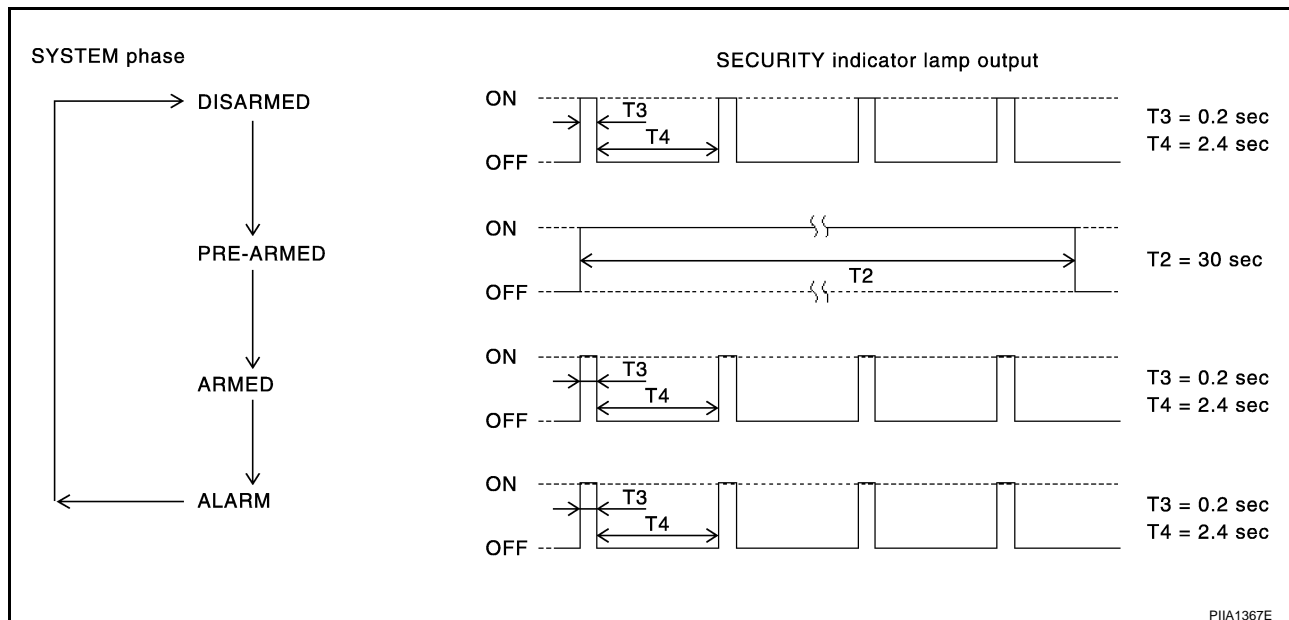

Setting the Vehicle Security System

Initial condition

- Ignition switch is in OFF position.

Disarmed phase

- When hood, doors or trunk is open, the vehicle security system is set in the disarmed phase on the assumption that the owner is inside or near the vehicle.
- When the vehicle security system is in the disarmed phase, the security indicator lamp blinks every 2.4 seconds.

Pre-armed phase and armed phase

When the following operation 1 or 2 is performed, the vehicle security system turns into the “pre-armed” phase. (The security indicator lamp illuminates.)

1. BCM receives LOCK signal from front door key cylinder switch or key fob, after hood, trunk and all doors are closed.
2. Hood, trunk and all doors are closed after front doors are locked by key or door lock and unlock switch. The security indicator lamp illuminates for 30 seconds. Then, the system automatically shifts into the “armed” phase.

VEHICLE SECURITY (THEFT WARNING) SYSTEM

Canceling the Set Vehicle Security System

When one of the following operations is performed, the armed phase is canceled.

1. Unlock the doors with the key or key fob.
2. Turn ignition switch "ON" or "ACC" position.

Canceling the Alarm Operation of the Vehicle Security System

When unlock the door with the key or key fob the alarm operation is canceled.

Activating the Alarm Operation of the Vehicle Security System

Make sure the system is in the armed phase. (The security indicator lamp brinks every 2.4 seconds.)

When the following operation 1 or 2 is performed, the system sounds the horns and flashes the headlamps for about 50 seconds.

1. Hood, trunk or any door is opened during armed phase.
2. Disconnecting and connecting the battery connector before canceling armed phase.

POWER SUPPLY AND GROUND CIRCUIT

Power is supplied at all times

- through 50A fusible link (letter **F** , located in the fuse and fusible link box)
- to BCM terminal 55,
- through 10A fuse [No. 18, located in the fuse block (J/B)]
- to BCM terminal 42,
- through 15A fuse [No. 35, located in the fuse block (J/B)]
- to horn relay terminal 2,
- through 10A fuse [No. 71, located in the IPDM E/R]
- to IPDM E/R internal CPU,
- through 15A fuse [No. 78, located in the IPDM E/R]
- to IPDM E/R internal CPU,
- through 10A fuse [No. 19, located in the fuse block (J/B)]
- to security indicator lamp terminal 1.

With the ignition switch in the ACC or ON position, power is supplied

- through 10A fuse [No. 6, located in the fuse block (J/B)]
- to BCM terminal 11.

Ground is supplied

- to BCM terminal 52
- through body grounds M30 and M66.

INITIAL CONDITION TO ACTIVATE THE SYSTEM

The operation of the vehicle security system is controlled by the doors, hood and trunk.

To activate the vehicle security system, BCM must receive signals indicating the doors, hood and trunk are closed and the doors are locked by key fob.

When a door is open, terminal 12 (passenger side door), 13 (rear RH door), 62 (driver side door), 63 (rear LH door) receives a ground signal from each door switch.

When front door LH is unlocked by power window main switch (door lock and unlock switch), BCM terminal 22 receives an unlock signal from terminal 14 of power window main switch with power window serial link.

When front door RH is unlocked by power window sub-switch (passenger side) (door lock and unlock switch), BCM terminal 22 receives an unlock signal from terminal 16 of power window sub-switch (passenger side) with power window serial link.

When front door key cylinder switch is in LOCK position, ground is supplied

- to power window main switch terminal 4
- through front door key cylinder switch terminals 1 and 2
- through body grounds M30 and M66.

When the hood is open, IPDM E/R receives a ground signal

- to IPDM E/R terminal 56
- through hood switch terminal 2

A
B
C
D
E
F
G
H
BL
J
K
L
M

VEHICLE SECURITY (THEFT WARNING) SYSTEM

- through hood switch terminal 1
- through body grounds E17, and E43.

The IPDM E/R then sends a signal to BCM via CAN communication line.

When the trunk is open, ground is supplied

- to BCM terminal 57
- through trunk room lamp switch terminal 1
- through trunk room lamp switch terminal 2
- through body grounds B5 and B29.

VEHICLE SECURITY SYSTEM ALARM OPERATION

The vehicle security system is triggered by

- opening a door
- opening the trunk
- opening the hood
- detection of battery disconnect and connect.

The vehicle security system will be triggered once the system is in armed phase, when BCM receives a ground signal at terminals 12 (passenger side door), 13 (rear RH door), 57 (trunk), 62 (driver side door), 63 (rear LH door), or receives a signal from the IPDM E/R (hood switch).

When the vehicle security system is triggered,

ground is supplied intermittently to both headlamp relay and horn relay.

When headlamp relay (with built-in IPDM E/R) and horn relay are energized, then power is supplied to headlamps (LH and RH) and horns (HIGH and LOW).

The headlamps flash and the horn sounds intermittently.

The alarm automatically turns off after 50 seconds, but will reactivate if the vehicle is tampered with again.

VEHICLE SECURITY SYSTEM DEACTIVATION

To deactivate the vehicle security system, a door or the trunk must be unlocked with the key, key fob.

When the key is used to unlock a door, BCM terminal 22 receives signal

- from the power window main switch (door lock and unlock switch) terminal 14.

When the BCM receives either one of these signals or unlock signal from key cylinder switch or key fob, the vehicle security system is deactivated. (Disarmed phase)

PANIC ALARM OPERATION

Remote keyless entry system may or may not operate vehicle security system (horn and headlamps) as required.

When the remote keyless entry system is triggered, ground is supplied intermittently to both headlamp relay and horn relay.

When headlamp relay (with built-in IPDM E/R) and horn relay are energized, then power is supplied to headlamps (LH and RH) and horns (HIGH and LOW).

The headlamp flashes and the horn sounds intermittently.

The alarm automatically turns off after 25 seconds or when BCM receives any signal from key fob.

VEHICLE SECURITY (THEFT WARNING) SYSTEM

CAN Communication System Description

AIS004AP

CAN (Controller Area Network) is a serial communication line for real time application. It is an on-vehicle multiplex communication line with high data communication speed and excellent error detection ability. Many electronic control units are equipped onto a vehicle, and each control unit shares information and links with other control units during operation (not independent). In CAN communication, control units are connected with 2 communication lines (CAN H line, CAN L line) allowing a high rate of information transmission with less wiring. Each control unit transmits/receives data but selectively reads required data only.

CAN Communication Unit

AIS004AQ

Refer to [LAN-21, "CAN COMMUNICATION"](#) .

A

B

C

D

E

F

G

H

BL

J

K

L

M

VEHICLE SECURITY (THEFT WARNING) SYSTEM

Schematic

AIS004AR

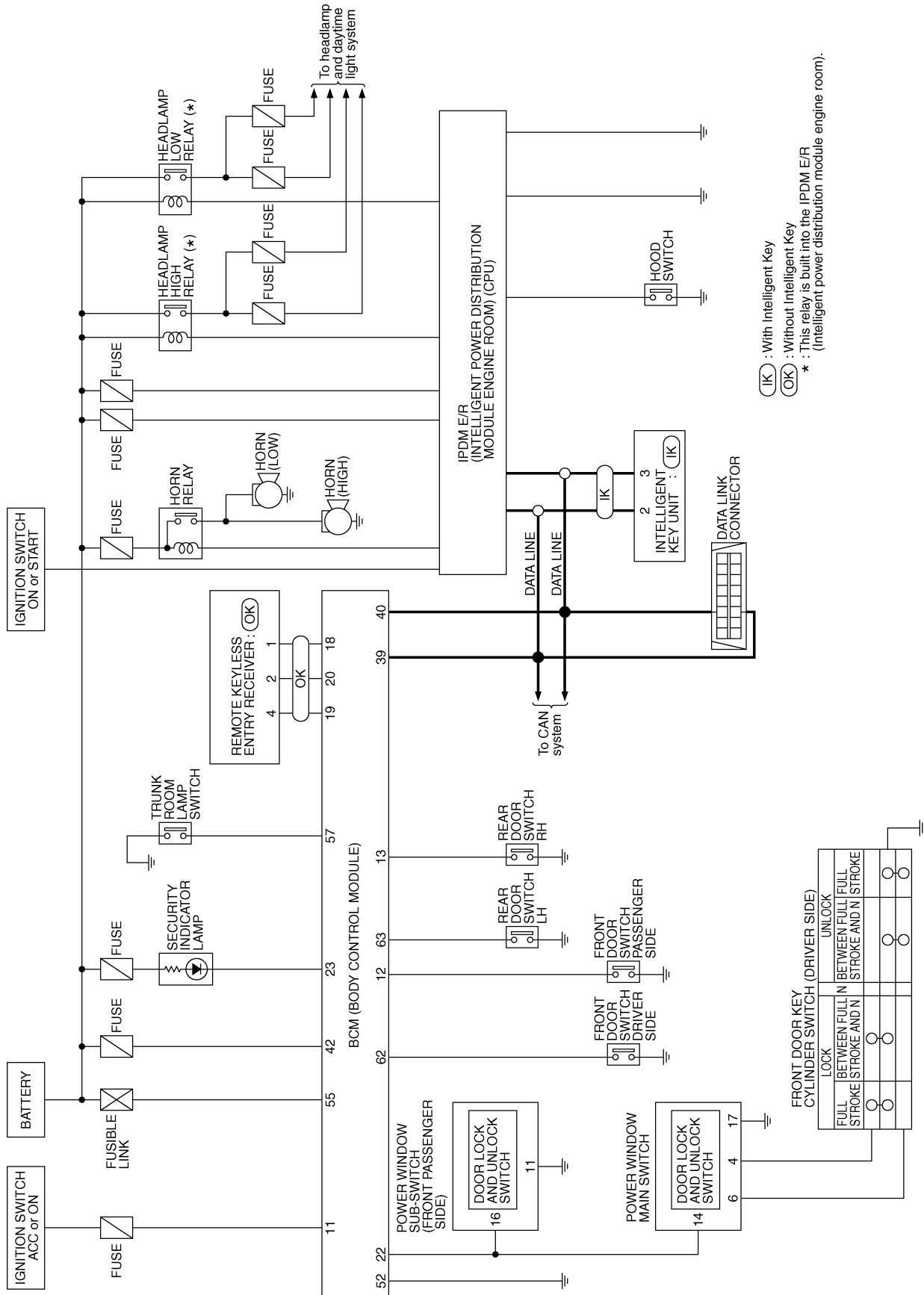

TIWM1061E

VEHICLE SECURITY (THEFT WARNING) SYSTEM

Wiring Diagram —VEHSEC—

AIS004AS

BL-VEHSEC-01

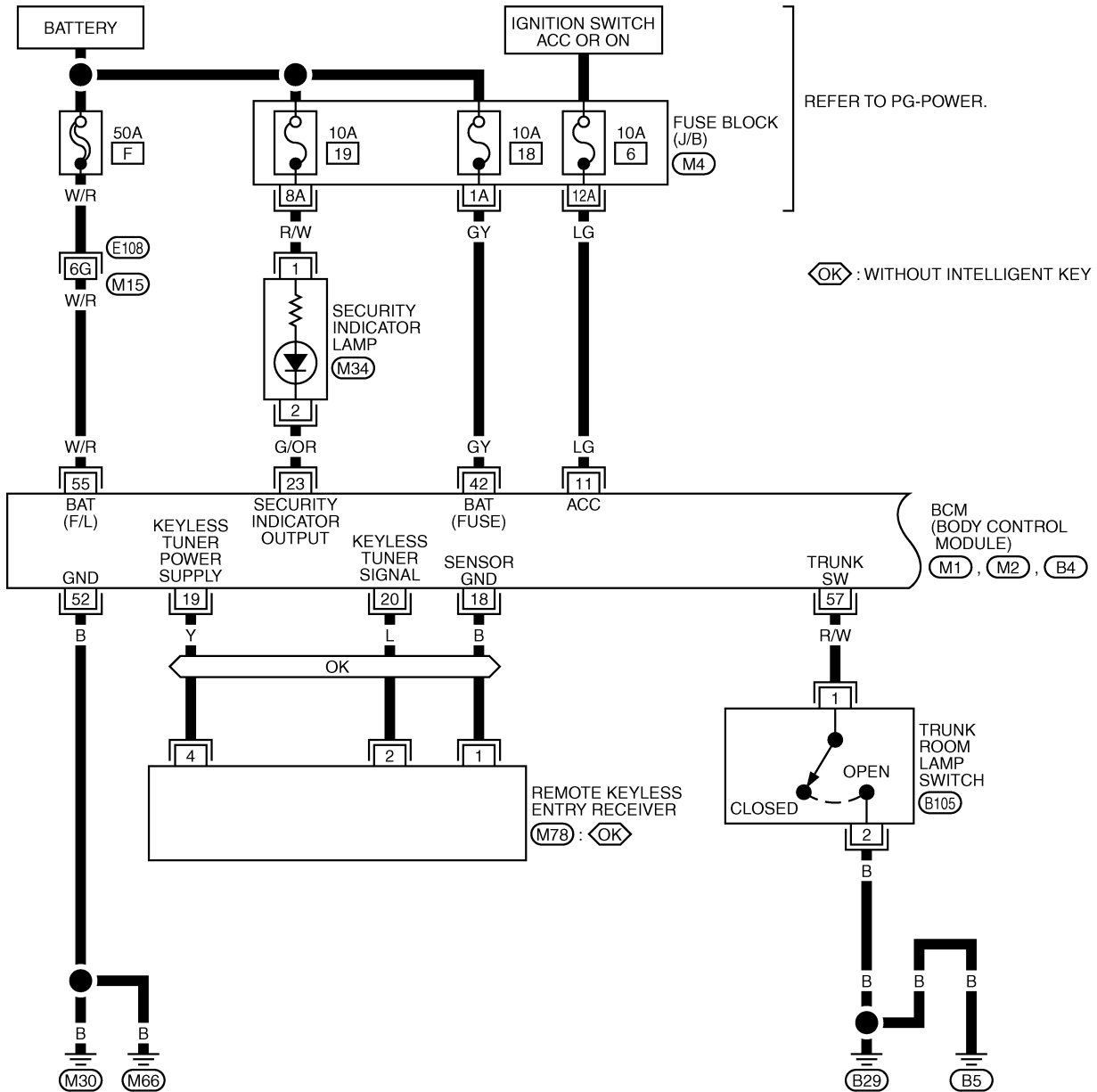

REFER TO PG-POWER.

Ⓞ : WITHOUT INTELLIGENT KEY

BCM (BODY CONTROL MODULE) (M1), (M2), (B4)

REMOTE KEYLESS ENTRY RECEIVER (M78) : Ⓞ

TRUNK ROOM LAMP SWITCH (B105)

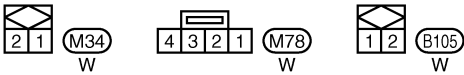

REFER TO THE FOLLOWING.

- Ⓞ -SUPER MULTIPLE JUNCTION (SMJ)
- Ⓞ -FUSE BLOCK-JUNCTION BOX (J/B)
- Ⓞ, Ⓞ, Ⓞ -ELECTRICAL UNITS

TIWM1062E

VEHICLE SECURITY (THEFT WARNING) SYSTEM

BL-VEHSEC-02

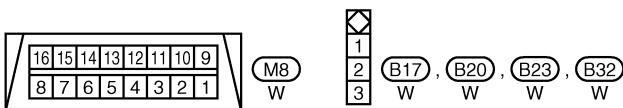
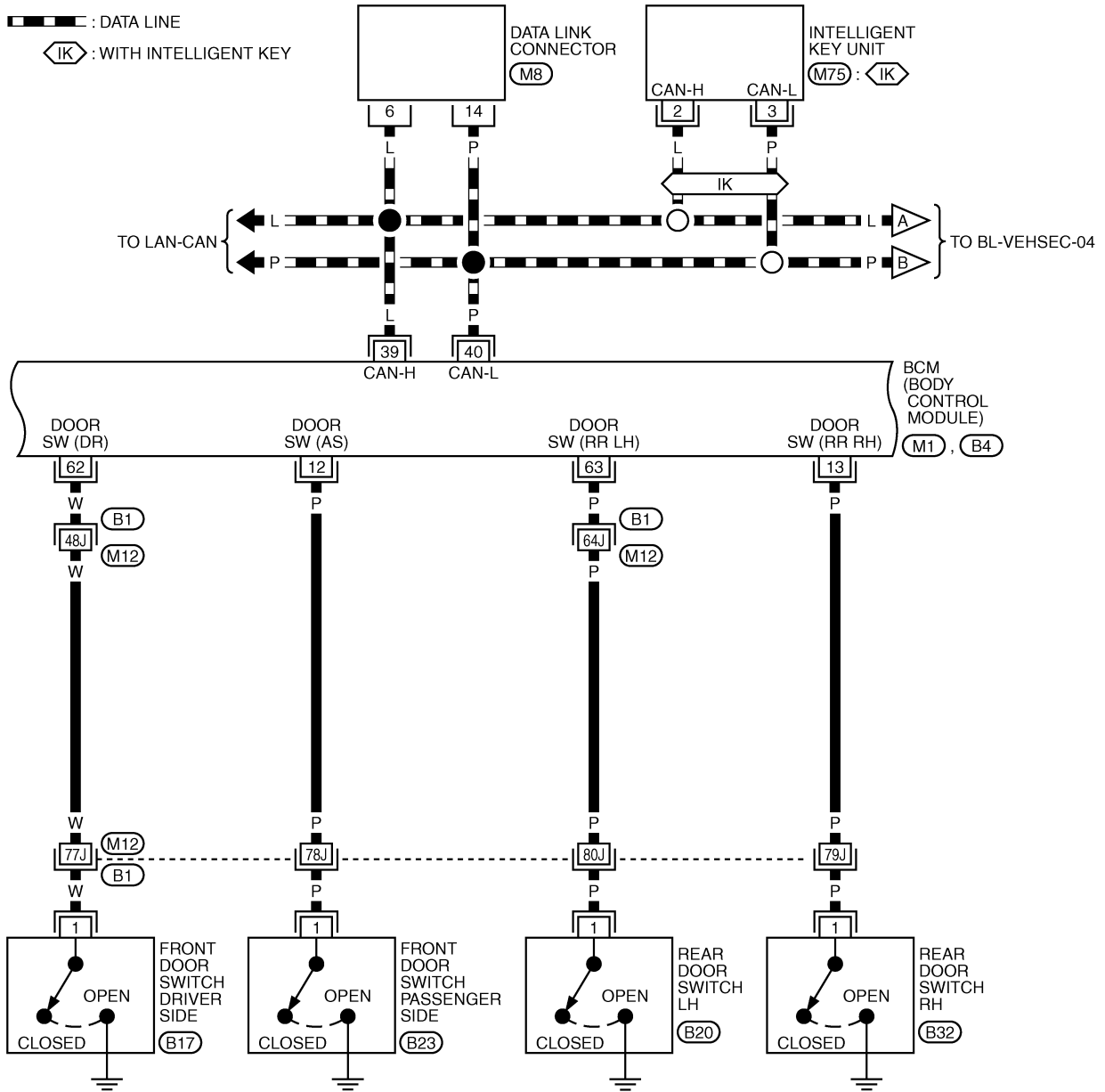

REFER TO THE FOLLOWING.

(B1) -SUPER MULTIPLE JUNCTION (SMJ)

(M1), (M75), (B4)
 -ELECTRICAL UNITS

TIWM1063E

VEHICLE SECURITY (THEFT WARNING) SYSTEM

BL-VEHSEC-03

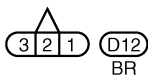
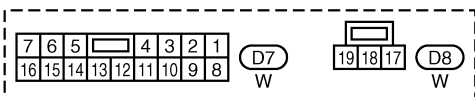
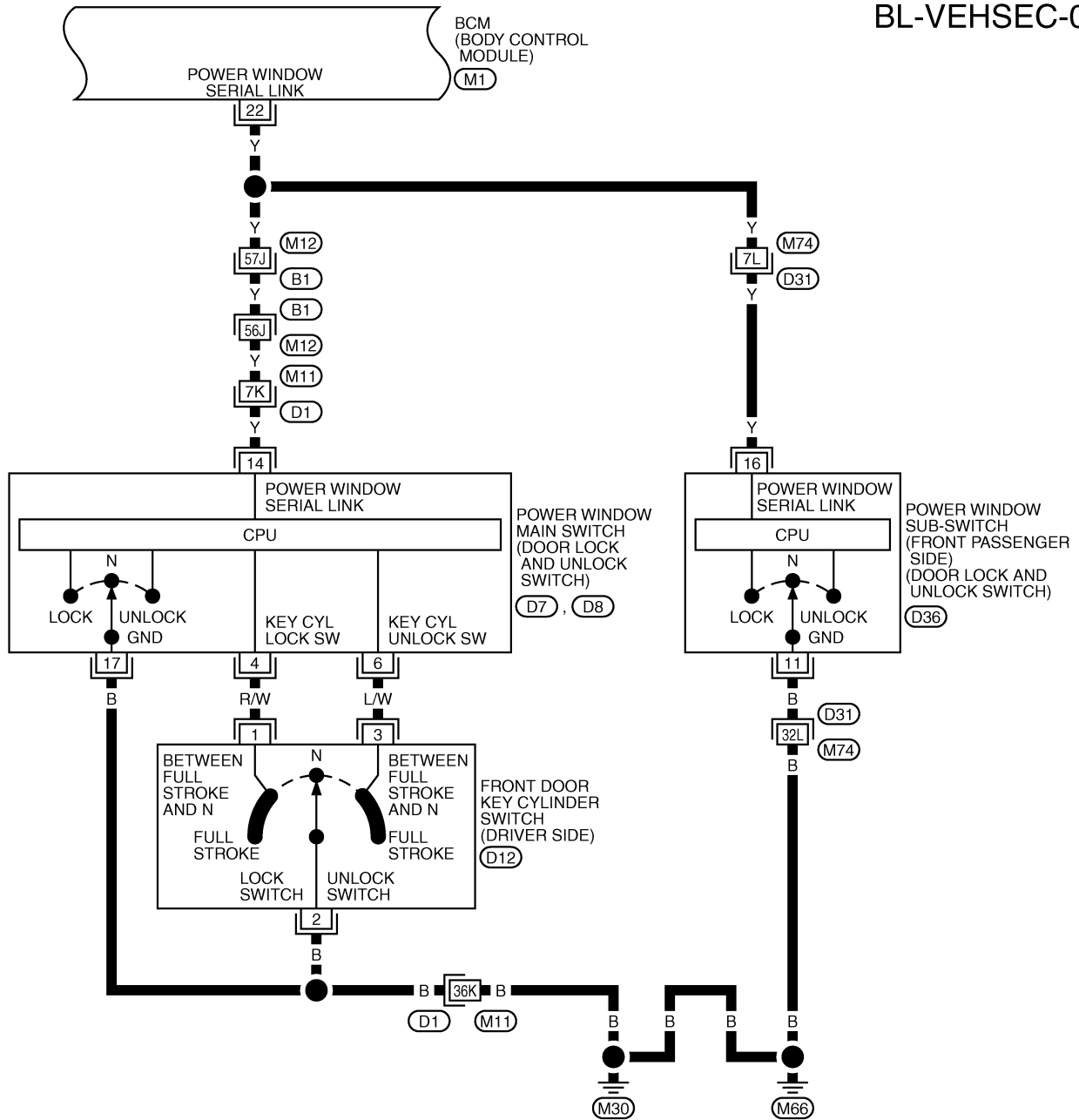

REFER TO THE FOLLOWING.
 (B1), (D1), (D31) -SUPER MULTIPLE JUNCTION (SMJ)
 (M1) -ELECTRICAL UNITS

TIWM1064E

VEHICLE SECURITY (THEFT WARNING) SYSTEM

BL-VEHSEC-04

▬ : DATA LINE

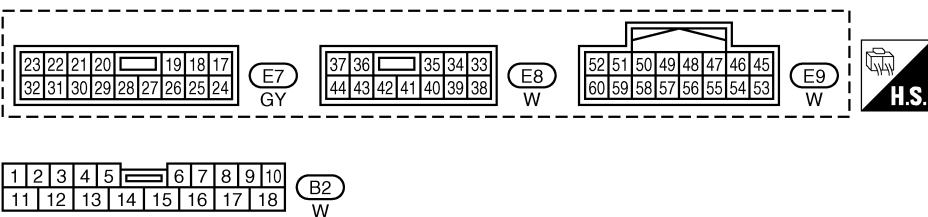
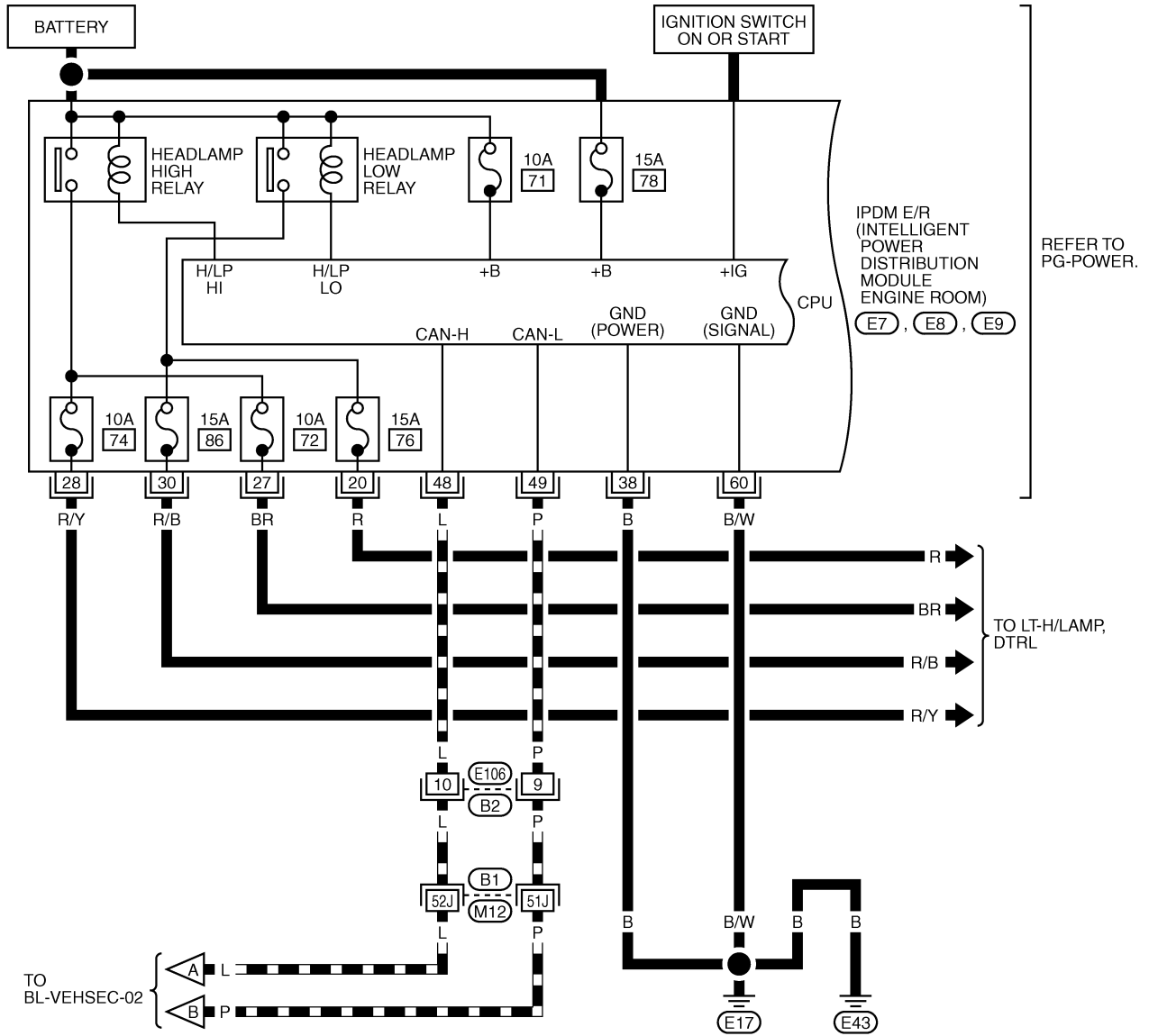

REFER TO THE FOLLOWING.

(B1) -SUPER MULTIPLE JUNCTION (SMJ)



TIWM1065E

VEHICLE SECURITY (THEFT WARNING) SYSTEM

BL-VEHSEC-05

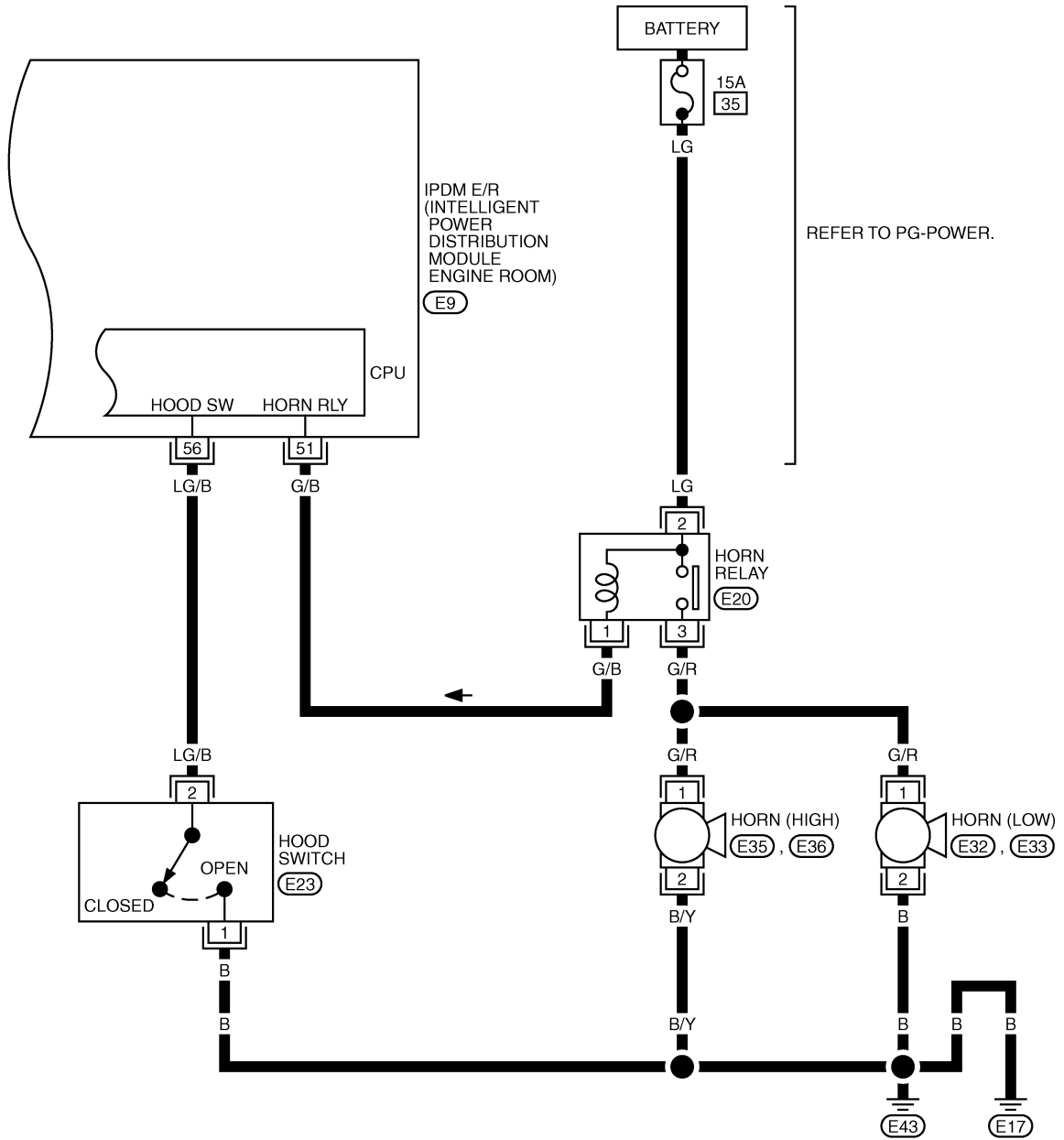

REFER TO PG-POWER.

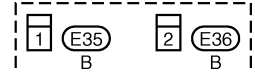
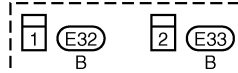
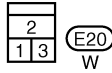
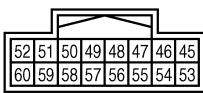

TIWM1126E

VEHICLE SECURITY (THEFT WARNING) SYSTEM

Terminals and Reference Value of BCM

A1S004AT

Terminal	Wire color	Item	Condition	Voltage [V] (Approx.)	
11	LG	Power supply (ACC)	Ignition switch (ACC or ON position)	Battery voltage	
12	P	Front door switch passenger side signal	ON (Open) → OFF (Closed)	0 → Battery voltage	
13	P	Rear door (RH) switch signal	ON (Open) → OFF (Closed)	0 → Battery voltage	
18*	B	sensor ground	—	0	
19*	Y	Remote keyless entry receiver power supply	Ignition switch is removed from key cylinder	Waiting state	<p style="text-align: right; font-size: small;">OCC3881D</p>
				Any operation using keyfob	<p style="text-align: right; font-size: small;">OCC3882D</p>
20*	L	Remote keyless entry receiver signal	Ignition switch is removed from key cylinder	Waiting state	<p style="text-align: right; font-size: small;">OCC3879D</p>
				Any operation using keyfob	<p style="text-align: right; font-size: small;">OCC3880D</p>
22	Y	Power window serial link	Ignition switch ON or power window timer operating	<p style="text-align: right; font-size: small;">PIIA2344J</p>	
23	G/OR	Security indicator lamp	Goes off → Illuminates	Battery voltage → 0	
39	L	CAN-H	—	—	
40	P	CAN-L	—	—	
42	GY	Battery power supply (fuse)	—	Battery voltage	
52	B	Ground	—	0	
55	W/R	Battery power supply (fusible link)	—	Battery voltage	
57	R/W	Trunk room lamp switch signal	ON (Open) → OFF (Closed)	0 → Battery voltage	

VEHICLE SECURITY (THEFT WARNING) SYSTEM

Terminal	Wire color	Item	Condition	Voltage [V] (Approx.)
62	W	Front door switch driver side signal	ON (Open) → OFF (Closed)	0 → Battery voltage
63	P	Rear door (LH) switch signal	ON (Open) → OFF (Closed)	0 → Battery voltage

* : Without Intelligent Key

Terminals and Reference Value of IPDM E/R

AIS004AU

Terminal	Wire color	Item	Condition	Voltage [V] (Approx.)
38	B	Ground (power)	—	0
48	L	CAN-H	—	—
49	P	CAN-L	—	—
51	G/B	Horn relay control signal	Panic alarm is operating	0
			Other than above	Battery voltage
56	LG/B	Hood switch signal	ON (Open) → OFF (closed)	0 → Battery voltage
60	B/W	Ground (signal)	—	0

VEHICLE SECURITY (THEFT WARNING) SYSTEM

AIS004AV

CONSULT-II Inspection Procedure

CONSULT-II can display each diagnostic item using the diagnostic test modes shown following.

BCM diagnosis position	Inspection items and diagnosis mode	Description
THEFT ALM	DATA MONITOR	Displays the input data to BCM in real time basis.
	ACTIVE TEST	Gives a drive signal to a load to check the operation.
	WORK SUPPORT	Changes setting of each function.

CAUTION:

CONSULT-II is used with no connection of CONSULT-II CONVERTER, malfunction might be detected in self-diagnosis depending on control units with carry out CAN communication.

1. Turn ignition switch OFF.
2. Connect CONSULT-II and CONSULT-II CONVERTER to data link connector.

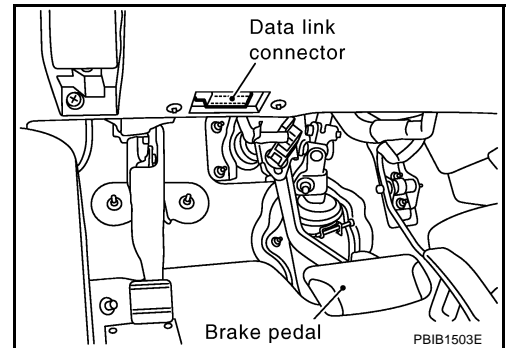

3. Turn ignition switch ON.
4. Touch "START" (NISSAN BASED VHCL).

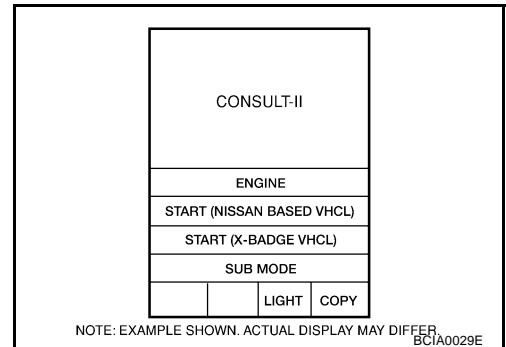

5. Touch "BCM".
If "BCM" is not indicated, go to [GI-38, "CONSULT-II Data Link Connector \(DLC\) Circuit"](#).

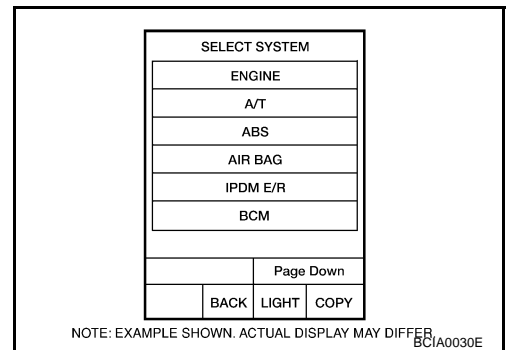

VEHICLE SECURITY (THEFT WARNING) SYSTEM

6. Touch "THEFT ALM".

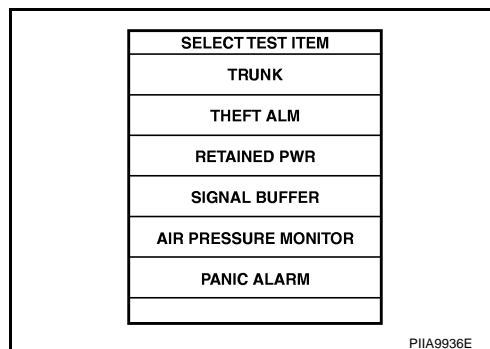

7. Select diagnosis mode.
"WORK SUPPORT", "DATA MONITOR" and "ACTIVE TEST"

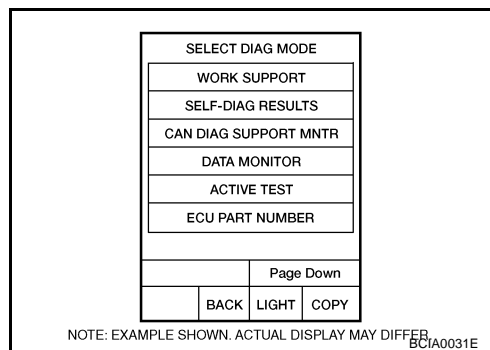

CONSULT-II APPLICATION ITEM

Work Support

Test Item	Description
SECURITY ALARM SET	This mode is able to confirm and change security alarm ON-OFF setting.
THEFT ALM TRG	The switch which triggered vehicle security alarm is recorded. This mode is able to confirm and erase the record of vehicle security alarm. The trigger data can be erased by touching "CLEAR" on CONSULT-II screen.

Data Monitor

Monitored Item	Description
IGN ON SW	Indicates [ON/OFF] condition of ignition switch.
ACC ON SW	Indicates [ON/OFF] condition of ignition switch in ACC position.
KEY ON SW	Indicates [ON/OFF] condition of key switch.
KEYLESS LOCK	Indicates [ON/OFF] condition of lock signal from key fob.
KEYLESS UNLOCK	Indicates [ON/OFF] condition of unlock signal from key fob.
KEYLESS TRUNK	Indicates [ON/OFF] condition of trunk opener signal from key fob.
TRUNK OPNR SW	This is displayed even when it is not equipped.
TRUNK CYL SW	This is displayed even when it is not equipped.
TRUNK OPN MNTR	Indicates [ON/OFF] condition of trunk room lamp switch.
HOOD SW	Indicates [ON/OFF] condition of hood switch.
DOOR SW-DR	Indicates [ON/OFF] condition of front door switch LH.
DOOR SW-AS	Indicates [ON/OFF] condition of front door switch RH.
DOOR SW-RR	Indicates [ON/OFF] condition of rear door switch RH.
DOOR SW-RL	Indicates [ON/OFF] condition of rear door switch LH.
BACK DOOR SW	This is displayed even when it is not equipped.
KEY CYL LK-SW	Indicates [ON/OFF] condition of lock signal from front door key cylinder switch.
KEY CYL UN-SW	Indicates [ON/OFF] condition of unlock signal from front door key cylinder switch.
CDL LOCK SW	Indicates [ON/OFF] condition of lock signal from door lock/unlock switch LH and RH.
CDL UNLOCK SW	Indicates [ON/OFF] condition of unlock signal from door lock/unlock switch LH and RH.

VEHICLE SECURITY (THEFT WARNING) SYSTEM

Active Test

Test Item	Description
THEFT IND	This test is able to check security indicator lamp operation. The lamp will be turned on when "ON" on CONSULT-II screen is touched.
VEHICLE SECURITY HORN	This test is able to check vehicle security horn operation. The horns will be activated for 0.5 seconds after "ON" on CONSULT-II screen is touched.
HEADLAMP(HI)	This test is able to check vehicle security lamp operation. The headlamps will be activated for 0.5 seconds after "ON" on CONSULT-II screen is touched.

Trouble Diagnosis WORK FLOW

AIS004AW

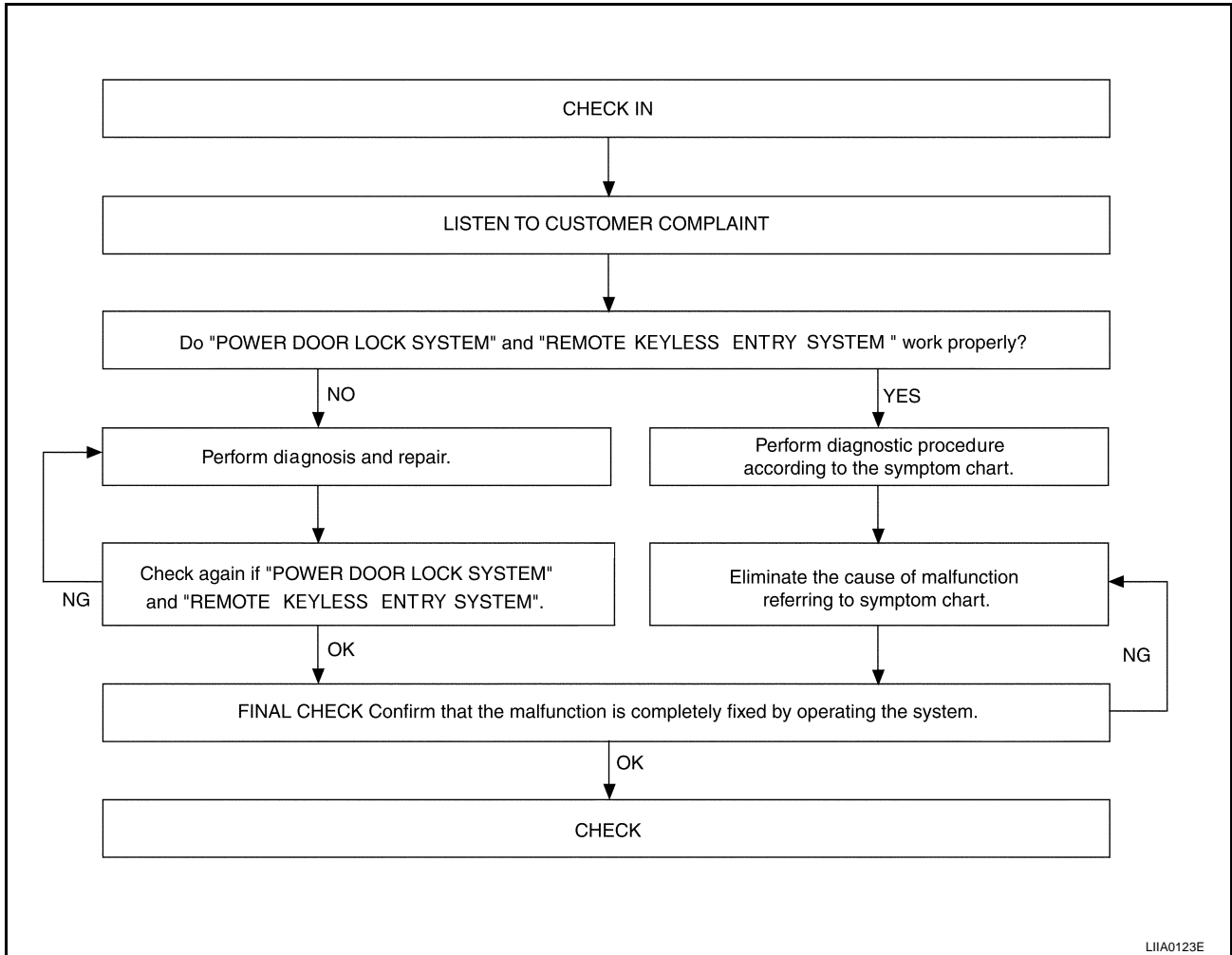

- "POWER DOOR LOCK SYSTEM" Diagnosis; refer to [BL-35, "Work Flow"](#) .
- "REMOTE CONTROL SYSTEM" Diagnosis; refer to [BL-68, "Work Flow"](#) .

VEHICLE SECURITY (THEFT WARNING) SYSTEM

AIS004AX

Preliminary Check

The system operation is canceled by turning ignition switch to "ACC" at any step between START and ARMED in the following flow chart.

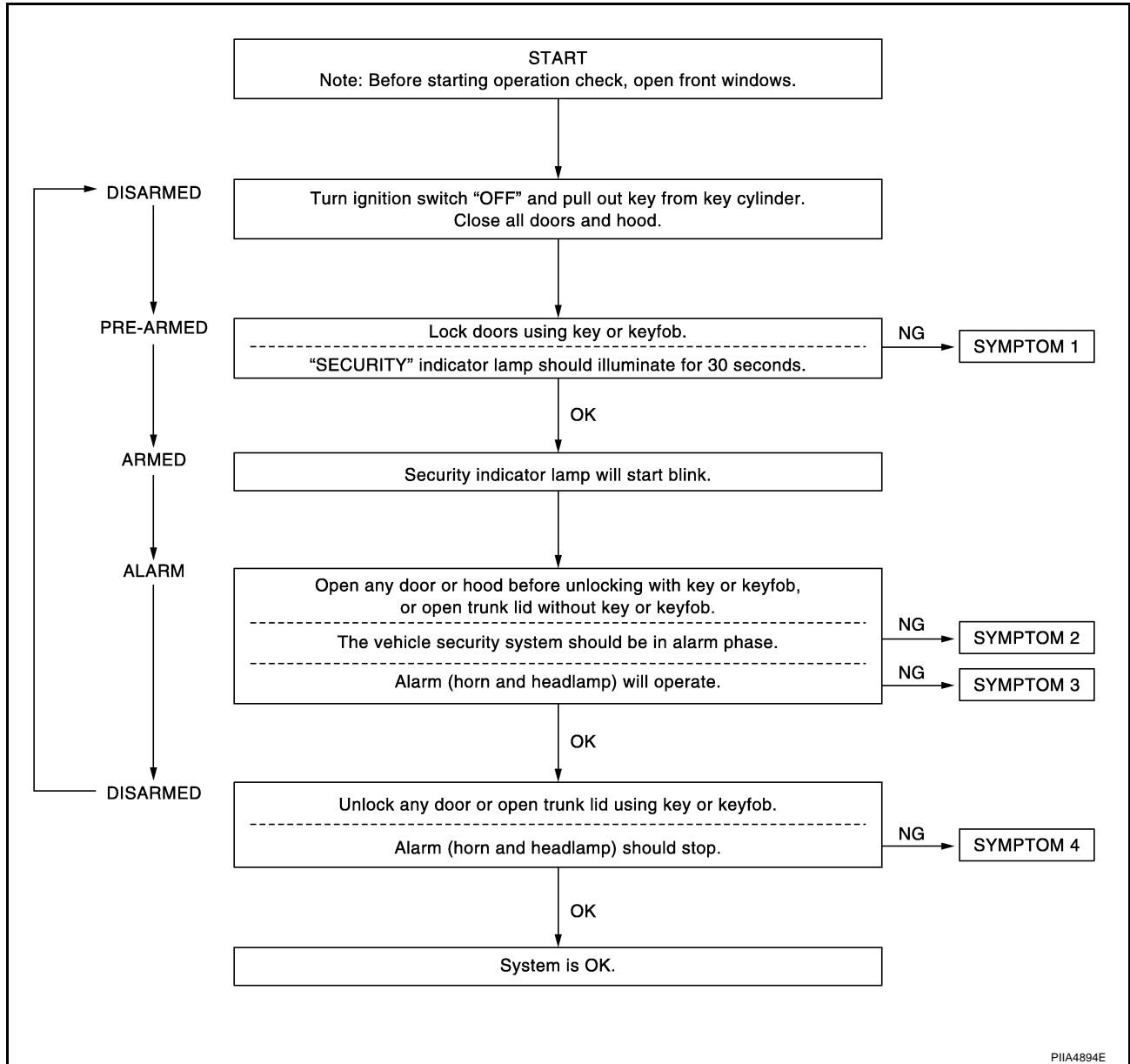

After performing preliminary check, go to symptom chart. Refer to [BL-216, "Trouble Diagnosis Symptom Chart"](#).

VEHICLE SECURITY (THEFT WARNING) SYSTEM

Trouble Diagnosis Symptom Chart

AIS004AY

Procedure		Diagnostic procedure	Refer to page
Symptom			
1	Vehicle security system cannot be set by	Door switch	Diagnostic Procedure 1 (Check door, hood and trunk switch) BL-217
		Lock / unlock switch	Diagnostic Procedure 6 (Check door lock / unlock switch) BL-224
		Door outside key	Diagnostic Procedure 3 (Check door key cylinder switch) BL-223
		Key fob	Check remote keyless entry. BL-69
		—	If the above systems are "OK", replace BCM. BCS-16
Security indicator does not turn "ON".		Diagnostic Procedure 2 (Check security indicator lamp) BL-222	
		If the above systems are "OK", replace BCM. BCS-16	
2	*1 Vehicle security system does not alarm when	Any door is opened.	Diagnostic Procedure 1 (Check door, hood and trunk switch) BL-217
			If the above systems are "OK", replace BCM. BCS-16
3	Vehicle security alarm does not activate.	Horn alarm	Diagnostic Procedure 4 (Check vehicle security horn alarm) BL-223
			If the above systems are "OK", replace BCM. BCS-16
		Head lamp alarm	Diagnostic Procedure 5 (Check head lamp alarm) BL-224
			If the above systems are "OK", replace BCM. BCS-16
4	Vehicle security system cannot be canceled by	Door outside key	Diagnostic Procedure 3 (Check door key cylinder switch) BL-223
			If the above systems are "OK", check power window main switch. EI-37
		Key fob	Check remote keyless entry function. BL-55
			If the above systems are "OK", replace BCM. BCS-16

*1: Make sure the system is in the armed phase.

VEHICLE SECURITY (THEFT WARNING) SYSTEM

AIS004AZ

Diagnostic Procedure 1 1 – 1 DOOR SWITCH CHECK

1. CHECK DOOR SWITCH INPUT SIGNAL

Ⓜ With CONSULT-II

Check ("DOOR SW-DR", "DOOR SW-AS", "DOOR SW-RR" and "DOOR SW-RL") in "DATA MONITOR" mode with CONSULT-II.

Monitor item	Condition
DOOR SW-DR	CLOSE → OPEN: OFF → ON
DOOR SW-AS	
DOOR SW-RR	
DOOR SW-RL	

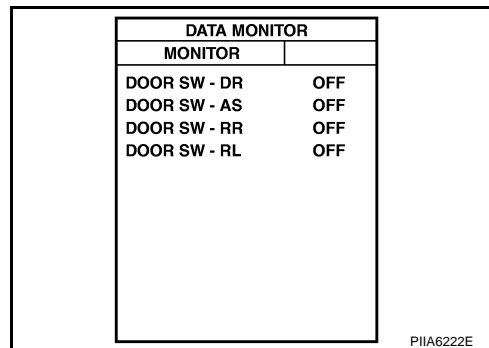

⊗ Without CONSULT-II

Check voltage between BCM connector and ground.

Item	Connector	Terminals (Wire color)		Condition	Voltage [V] (Approx.)
		(+)	(-)		
Driver side	B4	62 (W)	Ground	CLOSE	Battery voltage
Rear LH		63 (P)			
Passenger side	M1	12 (P)		OPEN	0
Rear RH		13 (P)			

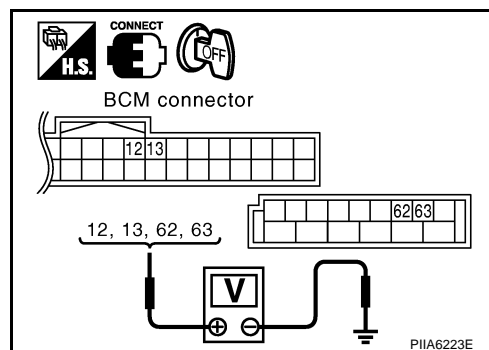

OK or NG

OK >> Door switch circuit is OK, and go to [BL-219, "1 – 2 HOOD SWITCH CHECK"](#).

NG >> GO TO 2.

2. CHECK DOOR SWITCH

1. Turn ignition switch OFF.
2. Disconnect door switch connector.
3. Check continuity between each door switches terminals 1 and ground part of door switch.

Terminal	Condition of door switch	Continuity
1	Pushed	No
	Released	Yes

OK or NG

OK >> GO TO 3.

NG >> Replace malfunctioning door switch.

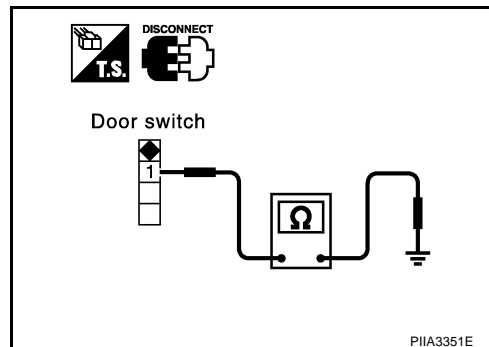

VEHICLE SECURITY (THEFT WARNING) SYSTEM

3. CHECK DOOR SWITCH CIRCUIT

1. Disconnect BCM connector.
2. Check continuity between BCM connector B4 terminal 62, 63 and door switch connector B17, B20 terminal 1 and ground.

Front door switch driver side

62 (W) – 1 (W) : Continuity should exist.
62 (W) – Ground : Continuity should not exist.

Rear door switch LH

63 (P) – 1 (P) : Continuity should exist.
63 (P) – Ground : Continuity should not exist.

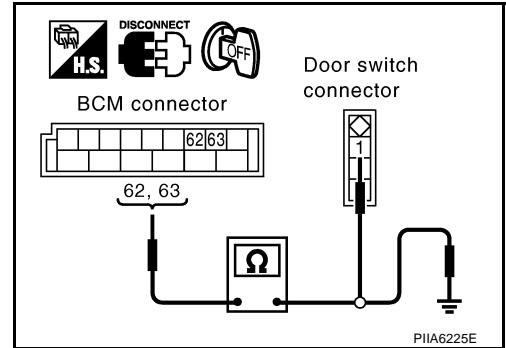

3. Check continuity between BCM connector M1 terminals 12, 13 and door switch connector B23, B32 terminal 1 and ground.

Front door switch passenger side

12 (P) – 1 (P) : Continuity should exist.
12 (P) – Ground : Continuity should not exist.

Rear door switch RH

13 (P) – 1 (P) : Continuity should exist.
13 (P) – Ground : Continuity should not exist.

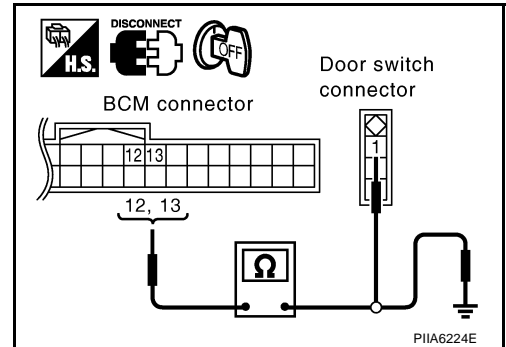

OK or NG

OK >> GO TO 4.
NG >> Repair or replace harness.

4. CHECK BCM OUTPUT SIGNAL

1. Connect BCM connector.
2. Check voltage between BCM connector M1, B4 terminals 12, 13, 62, 63 and ground.

12 (P) – Ground : Battery voltage
13 (P) – Ground : Battery voltage
62 (W) – Ground : Battery voltage
63 (P) – Ground : Battery voltage

OK or NG

OK >> Check condition of harness and connector.
NG >> Replace BCM.

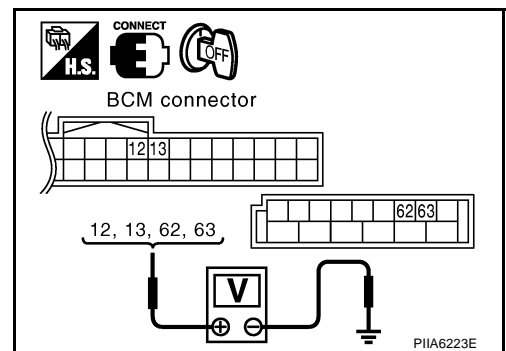

VEHICLE SECURITY (THEFT WARNING) SYSTEM

1 – 2 HOOD SWITCH CHECK

1. CHECK HOOD SWITCH

Check hood switch and hood fitting condition.

OK or NG

OK >> GO TO 2.

NG >> Adjust installation of hood switch.

2. CHECK HOOD SWITCH INPUT SIGNAL

Ⓟ With CONSULT-II

Check ("HOOD SW") in "DATA MONITOR" mode with CONSULT-II.

- When hood is opened:

HOOD SW : ON

- When hood is closed:

HOOD SW : OFF

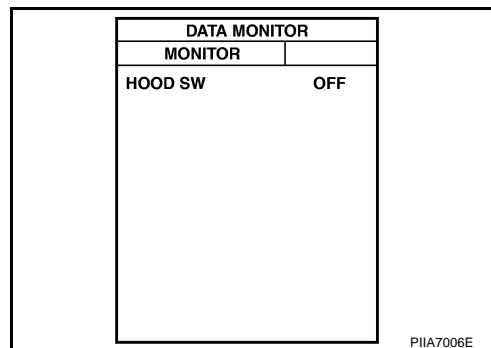

ⓧ Without CONSULT-II

Check voltage between IPDM E/R connector and ground.

Connector	Terminals (Wire color)		Condition of hood	Voltage [V] (Approx.)
	(+)	(-)		
E9	56 (LG/B)	Ground	OPEN	0
			CLOSE	Battery voltage

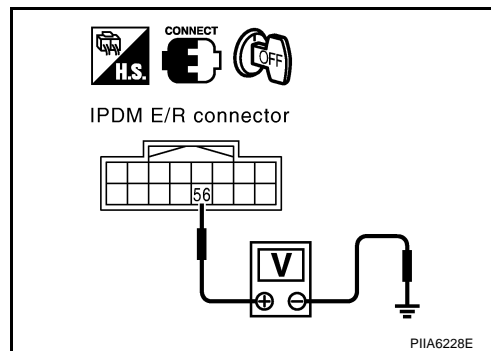

OK or NG

OK >> Hood switch is OK, and go to [BL-221, "1 – 3 TRUNK ROOM LAMP SWITCH CHECK"](#).

NG >> GO TO 3.

3. CHECK HOOD SWITCH

- Turn ignition switch OFF.
- Disconnect hood switch connector.
- Check continuity between hood switch terminals 1 and 2.

Terminals		Condition of hood switch	Continuity
1	2	Pressed	No
		Released	Yes

OK or NG

OK >> GO TO 4.

NG >> Replace hood switch.

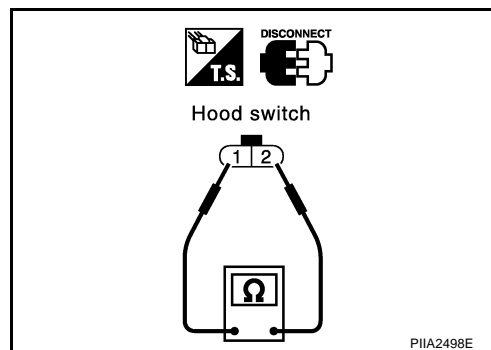

VEHICLE SECURITY (THEFT WARNING) SYSTEM

4. CHECK HOOD SWITCH CIRCUIT

1. Disconnect IPDM E/R connector.
2. Check continuity between hood switch connector E23 terminal 2 and IPDM E/R connector E9 terminal 56.

2 (LG/B) - 56 (LG/B) : Continuity should exist.

3. Check continuity between hood switch connector E23 terminal 2 and ground.

2 (LG/B) - Ground : Continuity should not exist.

OK or NG

OK >> GO TO 5.

NG >> Repair or replace hood switch harness.

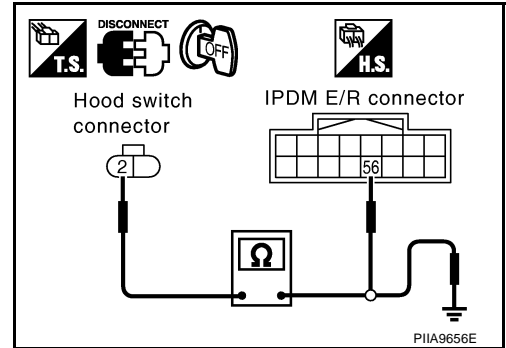

5. CHECK HOOD SWITCH GROUND CIRCUIT

Check continuity between hood switch connector E23 terminal 1 and ground.

1 (B) - Ground : Continuity should exist.

OK or NG

OK >> Check condition of harness and connector.

NG >> Repair or replace hood switch harness.

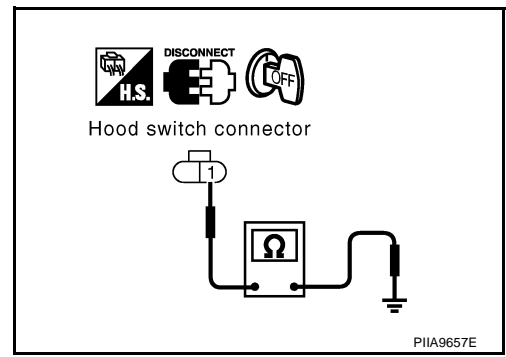

VEHICLE SECURITY (THEFT WARNING) SYSTEM

1 – 3 TRUNK ROOM LAMP SWITCH CHECK

1. CHECK TRUNK ROOM LAMP SWITCH INPUT SIGNAL

ⓑ With CONSULT-II

Check trunk lid opener switch (“TRUNK OPN MNTR”) in “DATA MONITOR” mode in “BCM”.

- When trunk is opened:

TRNK OPN MNTR : ON

- When trunk is closed:

TRNK OPN MNTR : OFF

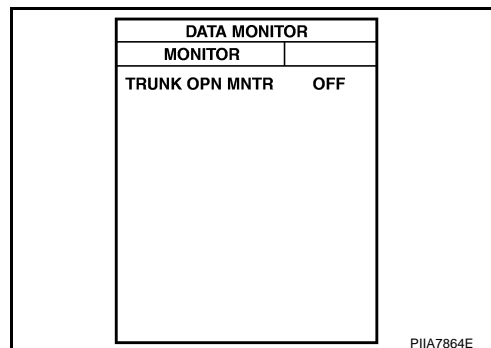

ⓧ Without CONSULT-II

Check voltage between BCM connector and ground.

Connector	Terminals (Wire color)		Condition of trunk	Voltage [V] (Approx.)
	(+)	(-)		
B4	57 (R/W)	Ground	OPEN	0
			CLOSE	Battery voltage*

*: When interior lamp battery saver is in OFF position: Approx. 5V.

OK or NG

- OK >> Trunk room lamp switch is OK.
- NG >> GO TO 2.

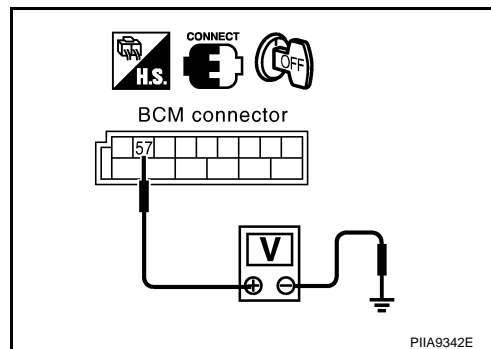

2. CHECK TRUNK ROOM LAMP SWITCH CIRCUIT

- Turn ignition switch OFF.
- Disconnect trunk room lamp switch and BCM connector.
- Check continuity between trunk room lamp switch connector B105 terminal 1 and BCM connector B4 terminal 57.

1 (R/W) - 57 (R/W) : Continuity should exist.

- Check continuity between trunk room lamp switch connector B105 terminal 1 and ground.

1 (R/W) - Ground : Continuity should not exist.

OK or NG

- OK >> GO TO 3.
- NG >> Replace trunk room lamp switch harness.

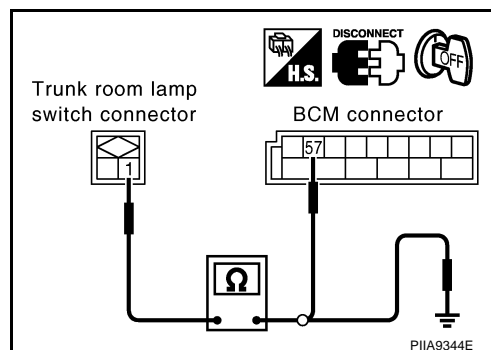

VEHICLE SECURITY (THEFT WARNING) SYSTEM

3. CHECK TRUNK ROOM LAMP SWITCH GROUND CIRCUIT

1. Turn ignition switch OFF.
2. Check continuity between trunk room lamp switch connector B105 terminal 2 and ground.

2 (B) - Ground : Continuity should exist.

OK or NG

- OK >> Check trunk room lamp switch.
NG >> Repair or replace trunk room lamp switch harness.

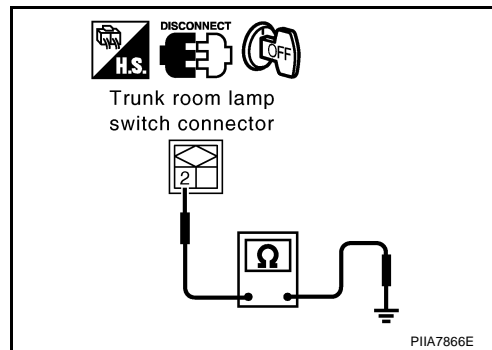

Diagnostic Procedure 2 SECURITY INDICATOR LAMP CHECK

1. SECURITY INDICATOR LAMP ACTIVE TEST

With CONSULT-II

Check ("THEFT IND") in "ACTIVE TEST" mode with CONSULT-II.

Perform operation shown on display indicator lamp should illuminate.

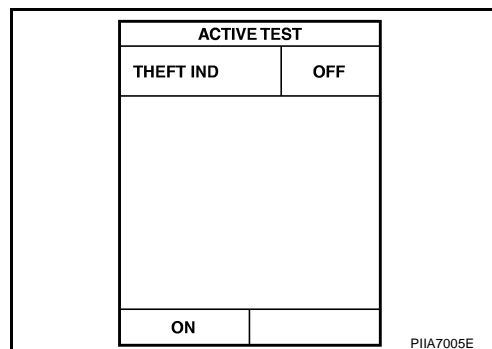

OK or NG

- OK >> Security indicator lamp is OK.
NG >> GO TO 2.

2. CHECK HARNESS CONTINUITY

1. Turn ignition switch OFF.
2. Disconnect security indicator lamp connector.
3. Check voltage between security indicator lamp connector M34 terminal 1 and ground.

1 (R/W) – Ground : Battery voltage

OK or NG

- OK >> Check the following.
- Harness for open or short between BCM and security indicator lamp
 - Security indicator lamp condition
- NG >> Check the following.
- 10A fuse [No.19, located in fuse block (J/B)]
 - Harness for open or short between security indicator lamp and fuse

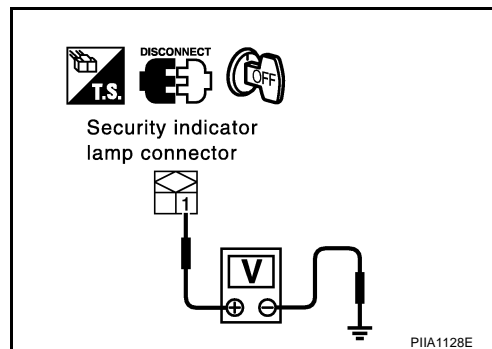

VEHICLE SECURITY (THEFT WARNING) SYSTEM

Diagnostic Procedure 3 FRONT DOOR KEY CYLINDER SWITCH CHECK

AIS004B1

1. CHECK KEY CYLINDER SWITCH OPERATION

Check if door key cylinder switch using key.

Do doors lock / unlock when using the key?

YES >> Front door key cylinder switch operation is OK.

NO >> Check door key cylinder switch circuit. Refer to [BL-50, "Door Key Cylinder Switch Check"](#).

Diagnostic Procedure 4 VEHICLE SECURITY HORN ALARM CHECK

AIS004B2

First perform the "SELF-DIAG RESULTS" of "BCM" with CONSULT-II, then perform the trouble diagnosis of malfunction system indicated in "SELF-DIAG RESULTS" of "BCM". Refer to [BCS-15, "CAN Communication Inspection Using CONSULT-II \(Self-Diagnosis\)"](#).

1. CHECK HORN OPERATION

Check if horn sounds with horn switch.

Does horn operate?

Yes >> GO TO 2.

No >> Check horn circuit. Refer to [WW-42, "HORN"](#).

2. CHECK IPDM E/R INPUT SIGNAL

Check voltage between IPDM E/R connector E9 terminal 51 and ground.

51 (G/B) – Ground : Battery voltage

OK or NG

OK >> Replace IPDM E/R.

NG >> GO TO 3.

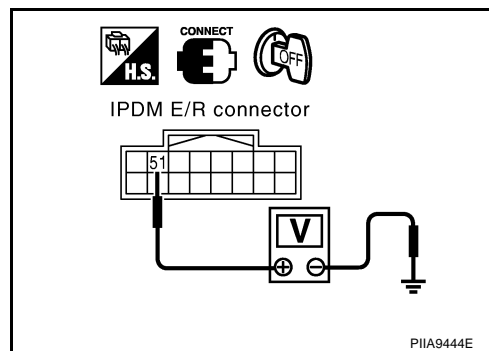

3. CHECK HORN RELAY CIRCUIT

1. Turn ignition switch OFF.
2. Disconnect IPDM E/R and horn relay connector.
3. Check continuity between IPDM E/R connector E9 terminal 51 and horn relay connector E20 terminal 1.

51 (G/B) – 1 (G/B) : Continuity should exist.

OK or NG

OK >> Check harness connection.

NG >> Repair or replace harness.

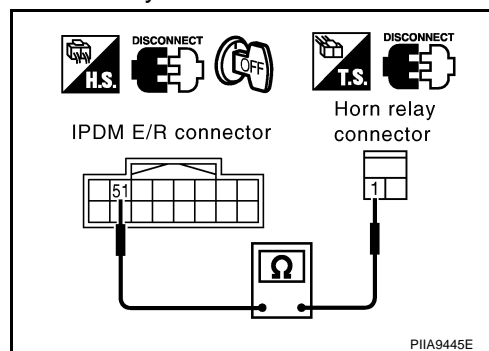

VEHICLE SECURITY (THEFT WARNING) SYSTEM

Diagnostic Procedure 5

AIS004B3

VEHICLE SECURITY HEADLAMP ALARM CHECK

1. CHECK HEADLAMP OPERATION

Check if headlamp operate by lighting switch.

Does headlamp come on when turning switch "ON"?

YES >> Headlamp circuit is OK.

NO >> Check headlamp system. Refer to [LT-7, "HEADLAMP \(FOR USA\)"](#) or [LT-38, "HEADLAMP \(FOR CANADA\) - DAYTIME LIGHT SYSTEM -"](#) .

Diagnostic Procedure 6

AIS004B4

DOOR LOCK AND UNLOCK SWITCH CHECK

1. CHECK DOOR LOCK AND UNLOCK SWITCH INPUT SIGNAL

Check if power door lock operated by door lock and unlock switch.

Do doors lock / unlock when using each door lock and unlock switches?

YES >> Door lock and unlock switch is OK.

NO >> Check door lock and unlock switch. Refer to [BL-45, "Check Door Lock and Unlock Switch"](#)

IVIS (INFINITI VEHICLE IMMOBILIZER SYSTEM-NATS)

IVIS (INFINITI VEHICLE IMMOBILIZER SYSTEM-NATS)

PFP:28591

Component Parts and Harness Connector Location

AIS004BP

A
B
C
D
E
F
G
H
BL
J
K
L
M

<p>Fuse block (J/B) fuse layout</p>	<p>IPDM E/R fuse layout</p>	<p>Battery 15A 33 50A F Fuse and fusible link box</p>
<p>View with dash side LH removed Fuse block (J/B)</p> <p>BCM M1 M2 B4 Foot-rest (driver)</p>	<p>View with instrument lower passenger panel removed</p> <p>ECM ECM harness connector</p>	<p>View with instrument lower passenger panel removed</p> <p>Intelligent Key unit M75 Blower unit</p>
<p>View with combination meter removed</p> <p>Steering lock unit M46</p>	<p>Security indicator lamp M34</p>	<p>NATS antenna amp.</p> <p>M308</p>
<p>View with steering column cover removed</p> <p>Key switch and ignition knob switch (with intelligent Key system) Key switch and ignition knob switch connector (with intelligent Key system) M310</p>		

PIIB4394E

IVIS (INFINITI VEHICLE IMMOBILIZER SYSTEM-NATS)

NOTE:

If customer reports a “No start” condition, request ALL KEYS to be brought to an INFINITI dealer in case of a IVIS (NATS) malfunction.

IVIS (INFINITI VEHICLE IMMOBILIZER SYSTEM-NATS)

AIS004BQ

System Description

DESCRIPTION

IVIS (Infiniti Vehicle Immobilizer System – NATS) has the following immobilizer functions:

- Engine immobilizer shows high anti-theft performance to prevent engine start by other than the owner (registered key: ignition key, mechanical key and Intelligent Key).
- Only a key with key ID registered in BCM and ECM can start engine, and shows high anti-theft performance to prevent key from being copied or stolen.
- In the vehicle without Intelligent Key system, security indicator always flashes with other than ignition switch ON or START position.
- In the vehicle with Intelligent Key system, security indicator always flashes with mechanical key removed condition (key switch OFF) and ignition knob released condition on LOCK position (ignition knob switch OFF).
- Therefore, IVIS (NATS) warns outsiders that the vehicle is equipped with the anti-theft system.
- If system detects malfunction, it turns on security indicator in ignition switch ON position.
- If the owner requires, ignition key ID or mechanical key ID can be registered for up to 5 keys.
- During trouble diagnosis or when the following parts have been replaced, and if ignition key or mechanical key is added, registration* is required.

*: All keys kept by the owner of the vehicle should be registered with ignition key or mechanical key.

- ECM
- BCM
- Ignition key (models without Intelligent Key system)
- Mechanical key (models with Intelligent Key system)
- IVIS (NATS) trouble diagnoses, system initialization and additional registration of other IVIS (NATS) ignition key or mechanical key IDs must be carried out using CONSULT-II hardware and CONSULT-II IVIS (NATS) software. When IVIS (NATS) initialization has been completed, the ID of the inserted ignition key or mechanical key or mechanical key IDs can be carried out.
Regarding the procedures of IVIS (NATS) initialization and ignition key or mechanical key ID registration, refer to CONSULT-II operation manual, NATS-IVIS/NVIS.

SECURITY INDICATOR

- Warns that the vehicle has IVIS (NATS).
- In the vehicle without Intelligent Key system, security indicator always flashes with other than ignition switch ON or START position. In the vehicle with Intelligent Key system, security indicator always flashes with mechanical key removed condition (key switch OFF) and ignition knob released condition on LOCK position (ignition knob switch OFF).

NOTE:

Because security indicator is highly efficient, the battery is barely affected.

Condition of Security Indicator

WITHOUT INTELLIGENT KEY SYSTEM

Security indicator condition	Ignition key	Operation or condition of ignition key			
		Ignition switch: ON position	Ignition switch: ACC position	Ignition switch: OFF position (Key is inserted.)	Ignition switch: OFF position (Remove key.)
	Register key	OFF	Flashing	Flashing	Flashing
	Ignition key not registered	ON	Flashing	Flashing	Flashing

WITH INTELLIGENT KEY SYSTEM

- In ignition knob operation with Intelligent Key, it always turns on with pushing ignition knob, and always flashes with ignition knob released (ignition knob switch OFF) condition on ignition knob “LOCK” position.
- In ignition knob operation with mechanical key, it turns off on the condition that mechanical key is inserted in key cylinder, and always flashes with ignition knob released (ignition knob switch OFF) condition on mechanical key removed condition.

IVIS (INFINITI VEHICLE IMMOBILIZER SYSTEM-NATS)

AI5004BR

System Composition

The immobilizer function of the IVIS (NATS) consists of the following:

- NATS ignition key (without Intelligent Key system)
- Mechanical key (with Intelligent Key system)
- NATS antenna amp. located in the ignition key cylinder
- BCM
- Engine control module (ECM)
- Security indicator
- Steering lock unit (with Intelligent Key system)
- Intelligent Key unit (with Intelligent Key system)

NOTE:

The communication between ECM, BCM and/or Intelligent Key unit uses the CAN communication system.

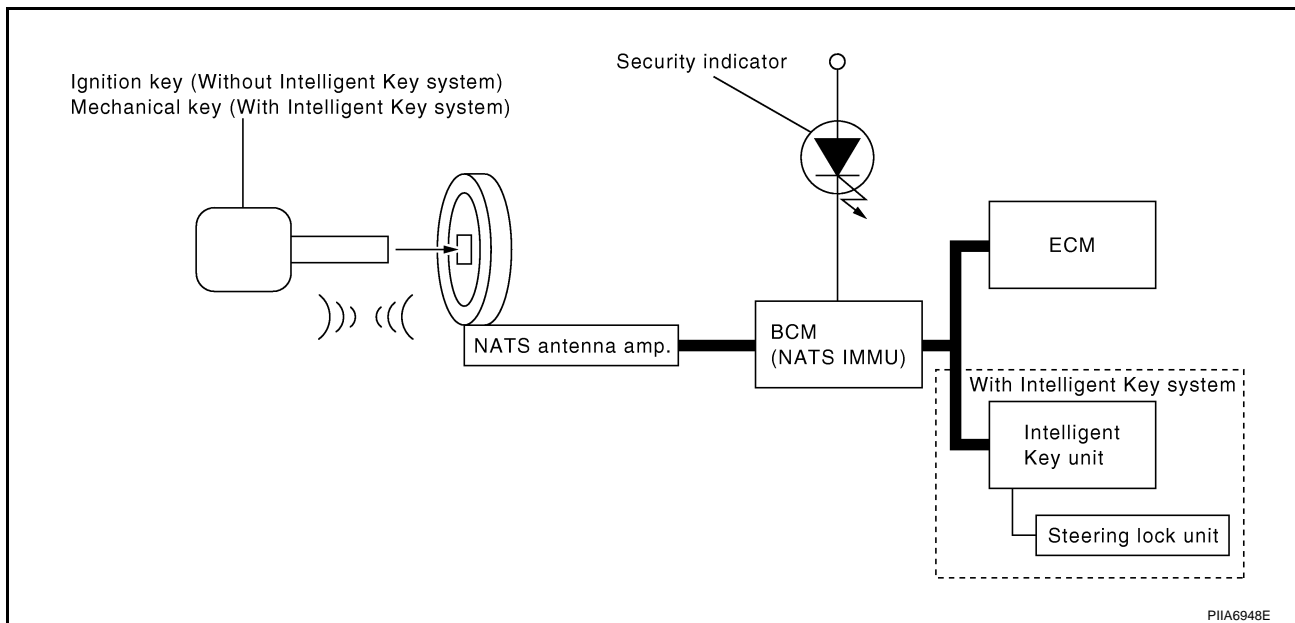

ECM Re-communicating Function

AI5004BS

Performing following procedure can automatically perform re-communication of ECM and BCM or Intelligent Key unit, but only when the ECM has been replaced with a new one (*1).

*1: New one means a virgin ECM which has never been energized on-board.

(In this step, initialization procedure by CONSULT-II is not necessary)

NOTE:

- When registering new Key IDs or replacing the ECM other than brand new, refer to CONSULT-II Operation Manual NATS-IVIS/NVIS.

- If multiple keys are attached to the key holder, separate them before work.

- Distinguish keys with unregistered key ID from those with registered ID.

1. Install ECM.

2. Using a registered key (*2), turn ignition switch to "ON".

*2: To perform this step, use the key (except for card plate key) that has been used before performing ECM replacement.

3. Maintain ignition switch in "ON" position for at least 5 seconds.

4. Turn ignition switch to "OFF".

5. Start engine.

If engine can be started, procedure is completed.

If engine cannot be started, refer to CONSULT-II Operation Manual NATS-IVIS/NVIS and initialize control unit.

IVIS (INFINITI VEHICLE IMMOBILIZER SYSTEM-NATS)

Wiring Diagram — NATS —/WITH INTELLIGENT KEY SYSTEM

AIS004BT

BL-NATS-01

— — — — — : DATA LINE

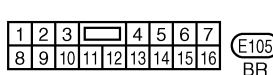
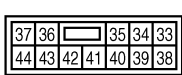
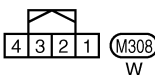
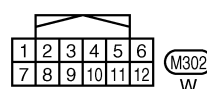
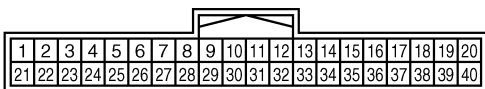
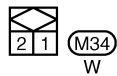
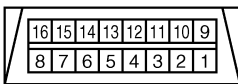
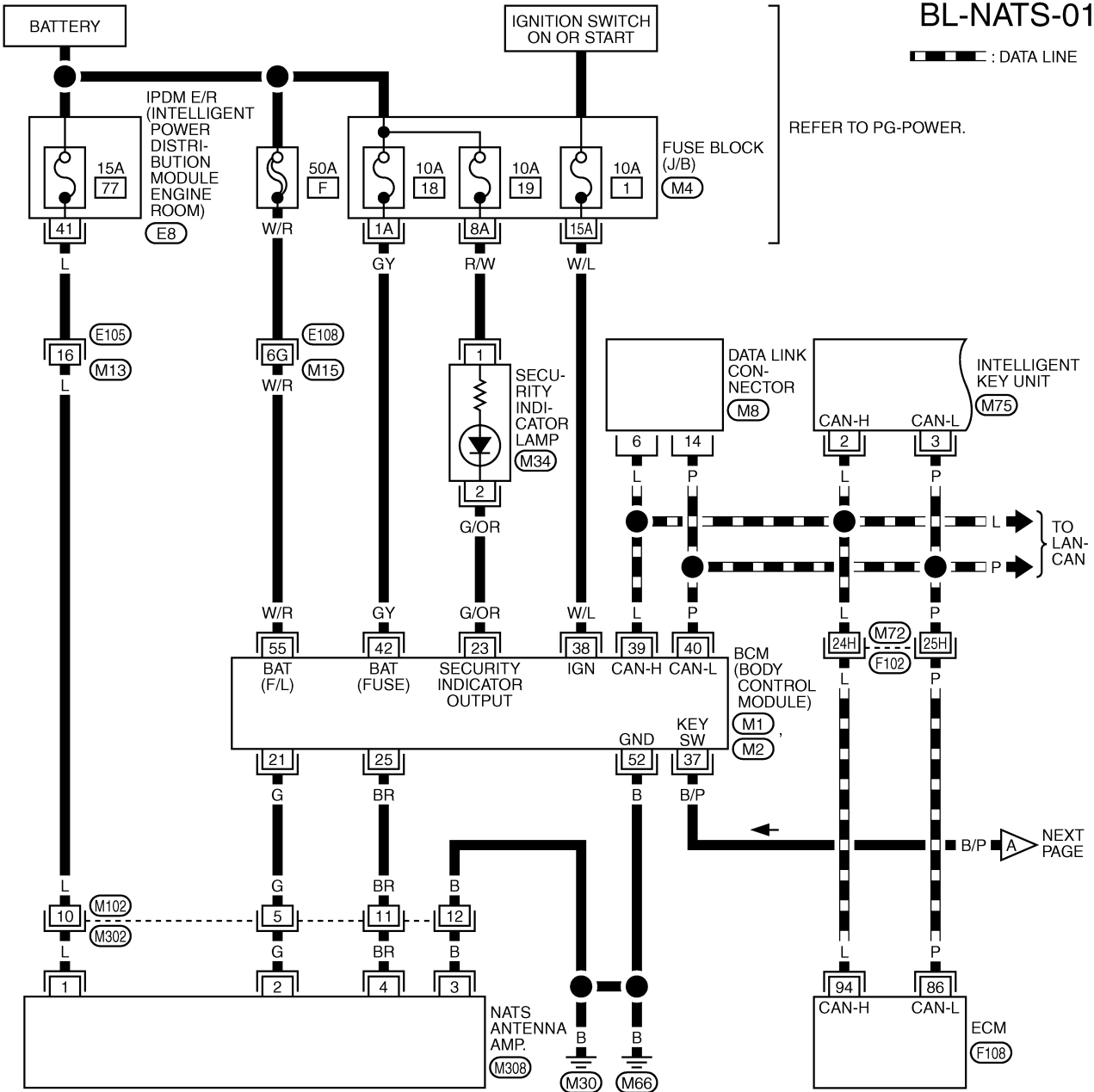

REFER TO THE FOLLOWING.

(E108), (F102) -SUPER MULTIPLE JUNCTION (SMJ)

(M4) -FUSE BLOCK-JUNCTION BOX (J/B)

(M1), (M2), (F108) -ELECTRICAL UNITS

TIWM1066E

IVIS (INFINITI VEHICLE IMMOBILIZER SYSTEM-NATS)

BL-NATS-02

REFER TO PG-POWER.

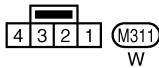
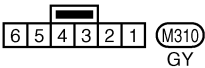
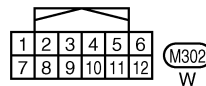
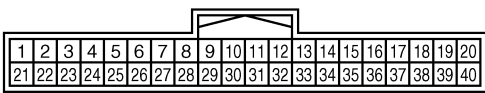
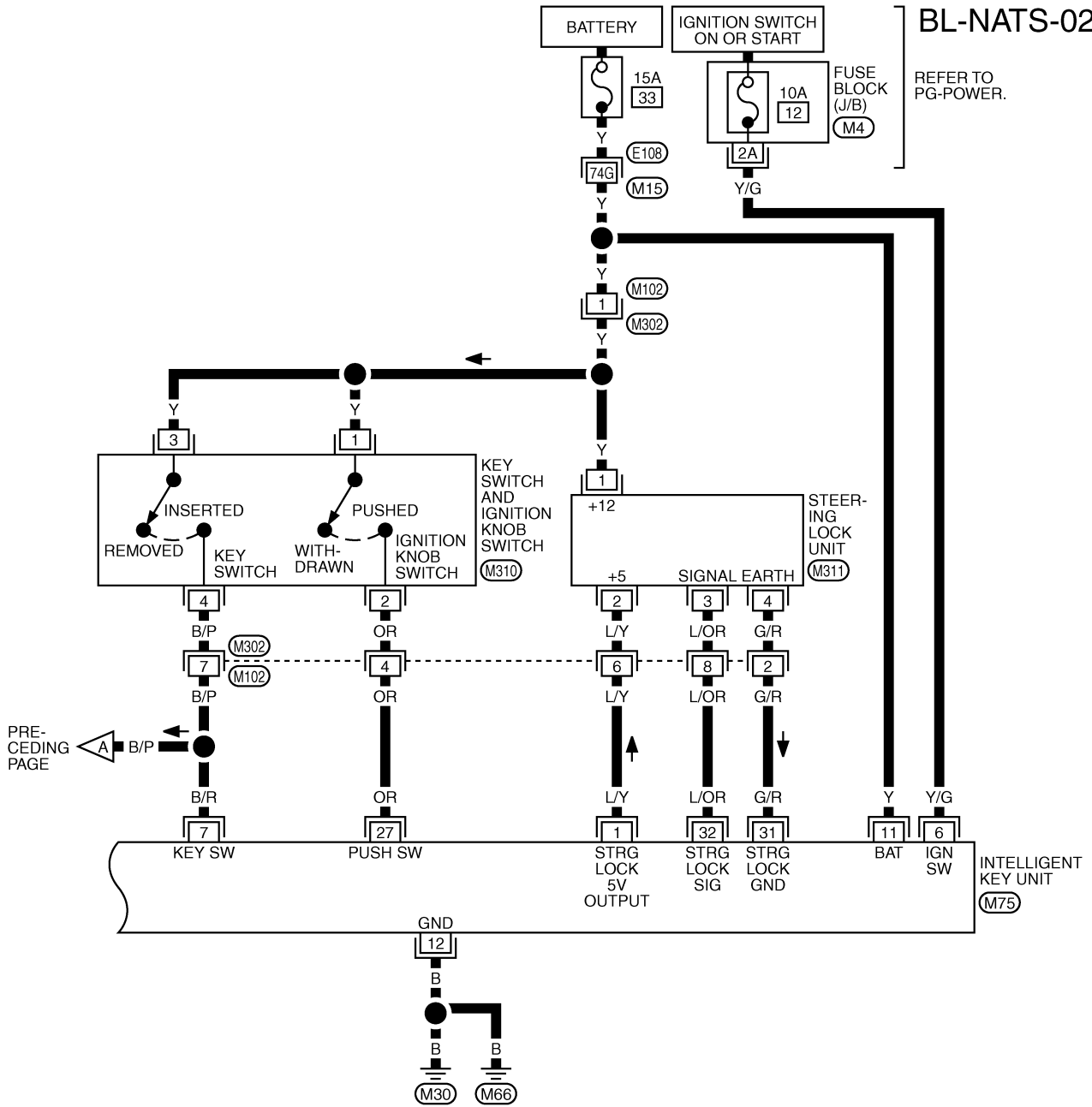

REFER TO THE FOLLOWING.

- (E108) -SUPER MULTIPLE JUNCTION (SMJ)
- (M4) -FUSE BLOCK-JUNCTION BOX (J/B)

TIWM1067E

IVIS (INFINITI VEHICLE IMMOBILIZER SYSTEM-NATS)

AIS006AN

Wiring Diagram/WITHOUT INTELLIGENT KEY SYSTEM

BL-NATS-03

— : DATA LINE

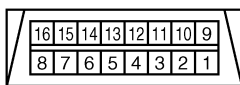
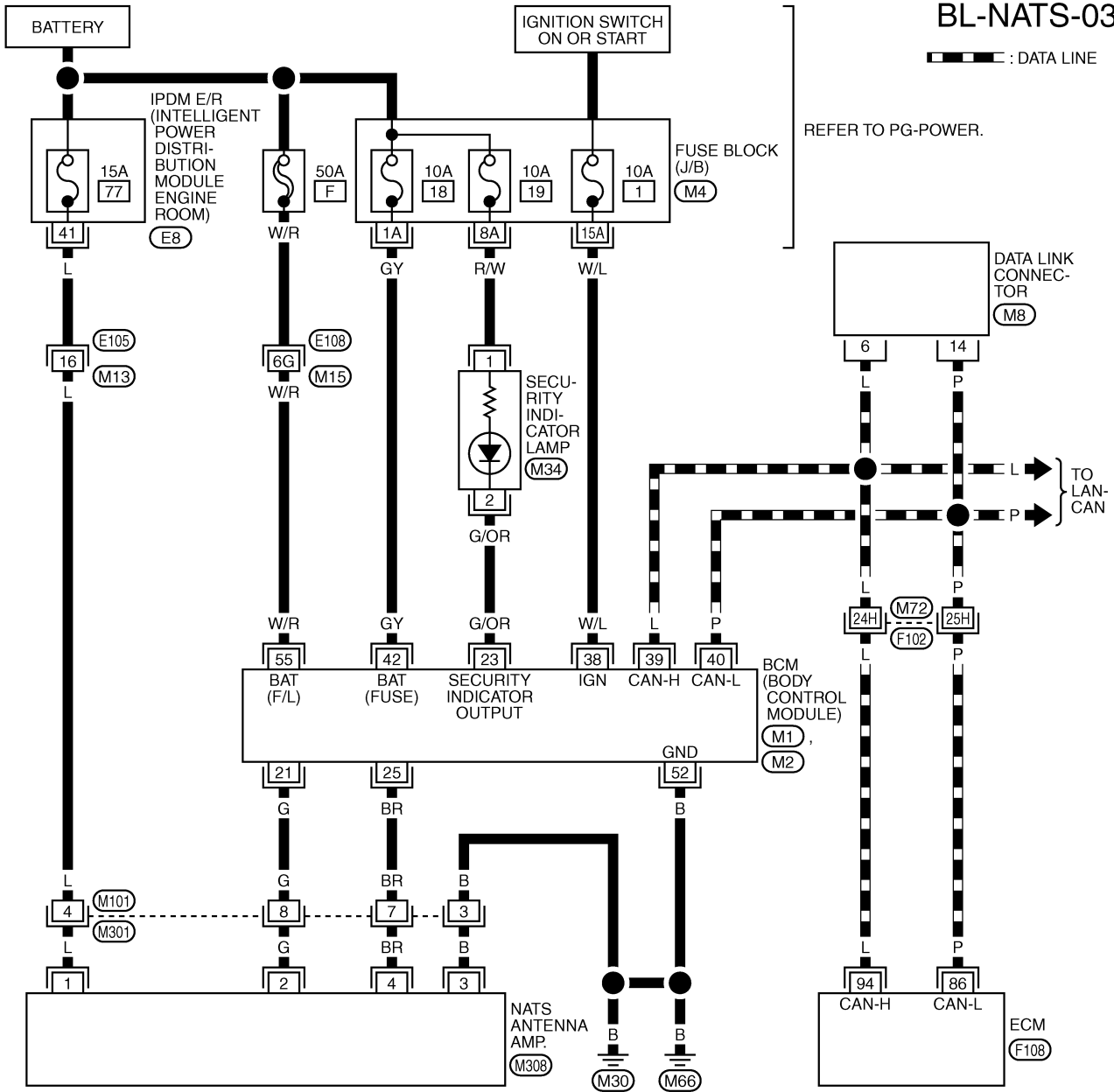

M8
W



M34
W

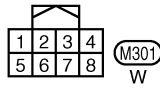

M301
W

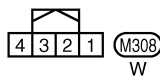

M308
W

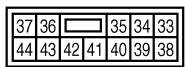

E8
W

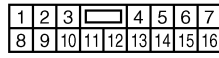

E105
BR

REFER TO THE FOLLOWING.

(E108), (F102) -SUPER MULTIPLE JUNCTION (SMJ)

(M4) -FUSE BLOCK-JUNCTION BOX (J/B)

(M1), (M2), (F108) -ELECTRICAL UNITS

TIWM1068E

IVIS (INFINITI VEHICLE IMMOBILIZER SYSTEM-NATS)

Terminals and Reference Value for Steering Lock Unit/with Intelligent Key System

AIS006AO

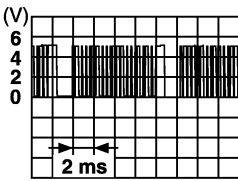
Terminal No.	Wire color	Signal Designation	Measuring condition		Voltage (V) (Approx.)
			Ignition knob position	Operation or conditions	
1	Y	Power source (Fuse)	—	—	Battery voltage
2	L/Y	Steering lock unit power supply	LOCK	—	5
3	L/OR	Steering lock unit communication signal	LOCK	Press ignition knob with Intelligent Key inside vehicle.	
				Other than the above	5
4	G/R	Steering lock unit ground	—	—	0

SIIA1911J

Terminals and Reference Value for Intelligent Key Unit/with Intelligent Key System

AIS006AP

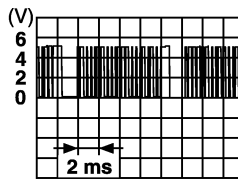
Terminal No.	Wire color	Signal designation	Measuring condition		Voltage (V) (Approx.)
			Ignition knob position	Operation or conditions	
1	L/Y	Steering lock unit power supply	LOCK	—	5
2	L	CAN-H	—	—	—
3	P	CAN-L	—	—	—
6	Y/G	Ignition power supply (ON)	ON	Ignition knob ON or START position	Battery voltage
7	B/R	Key switch	LOCK	Insert mechanical key into ignition key cylinder.	Battery voltage
				Remove mechanical key from ignition key cylinder.	0
11	Y	Power source (Fuse)	—	—	Battery voltage
12	B	Ground	—	—	0
27	OR	Ignition knob switch	—	Press ignition knob.	Battery voltage
				Return ignition knob to LOCK position.	0
31	G/R	Steering lock unit ground	—	—	0
32	L/OR	Steering lock unit communication signal	LOCK	Press ignition knob with Intelligent Key inside vehicle.	
				Other than the above	5

SIIA1911J

IVIS (INFINITI VEHICLE IMMOBILIZER SYSTEM-NATS)

Terminals and Reference Value for BCM

AIS004BU

Terminal	Wire color	Item	Condition	Voltage [V] (Approx.)
21	G	NATS antenna amp.	Ignition switch (OFF → ON)	Just after turning ignition switch "ON": Pointer of tester should move.
23	G/OR	Security indicator lamp	Goes OFF → illuminates (Every 2.4 seconds)	Battery voltage → 0
25	BR	NATS antenna amp.	Ignition switch (OFF → ON)	Just after turning ignition switch "ON": Pointer of tester should move.
37*	B/P	Key switch	Insert mechanical key into ignition key cylinder.	Battery voltage
			Remove mechanical key from ignition key cylinder.	0
38	W/L	Ignition switch (ON or START)	Ignition switch (ON or START position)	Battery voltage
39	L	CAN-H	—	—
40	P	CAN-L	—	—
42	GY	Power source (Fuse)	—	Battery voltage
52	B	Ground	—	0
55	W/R	Power source (Fusible link)	—	Battery voltage

*: With Intelligent Key system

CONSULT-II CONSULT-II INSPECTION PROCEDURE

AIS004BV

1. Turn ignition switch OFF.
2. Insert IVIS (NATS) program card into CONSULT-II.
Program card : NATS (AEN02C)
3. Connect CONSULT-II and CONSULT-II CONVERTER to data link connector.
4. Turn ignition switch ON.
5. Touch "START".

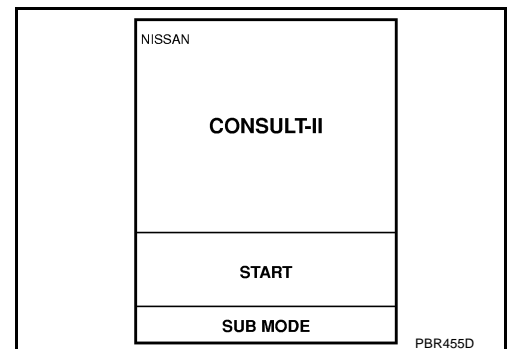
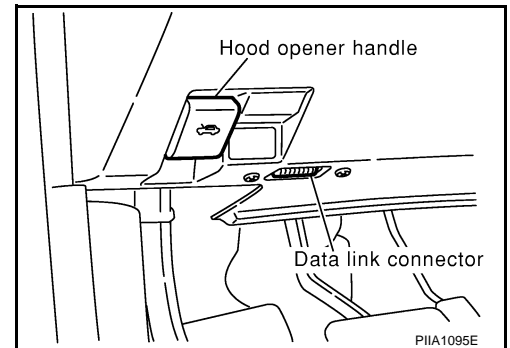

IVIS (INFINITI VEHICLE IMMOBILIZER SYSTEM-NATS)

6. Touch "OTHER".

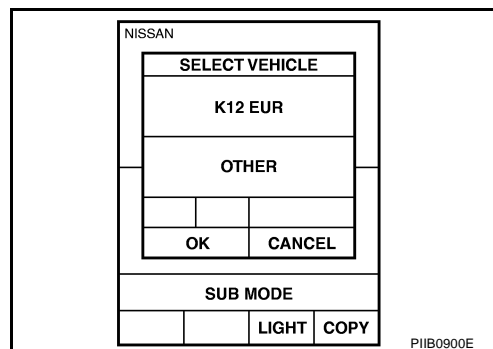

7. Select "NATS V.5.0".
If "NATS V5.0" is not indicated, go to [GI-38, "CONSULT-II Data Link Connector \(DLC\) Circuit"](#) .

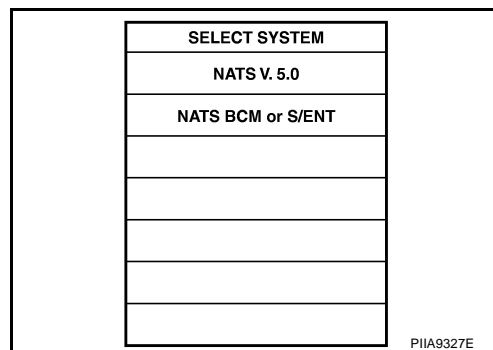

8. Perform each diagnostic test mode according to each service procedure.
For further information, see the CONSULT-II Operation Manual NATS-IVIS/NVIS.

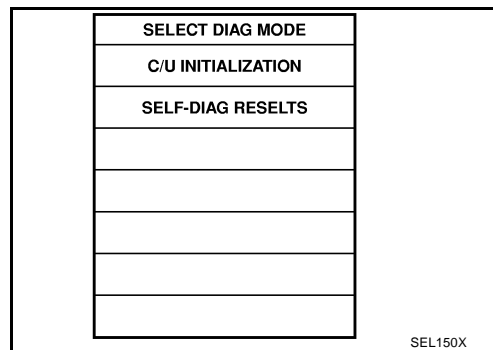

CONSULT-II DIAGNOSTIC TEST MODE FUNCTION

CONSULT-II DIAGNOSTIC TEST MODE	Description
C/U INITIALIZATION	When replacing any of the following components, C/U initialization and re-registration of all NATS ignition keys are necessary. [NATS ignition key/ BCM/ ECM*]
SELF-DIAG RESULTS	Detected items (screen terms) are as shown in the chart. Refer to BL-235, "IVIS (NATS) SELF-DIAGNOSTIC RESULTS ITEM CHART" .

*: When replace ECM, refer to [BL-228, "ECM Re-communicating Function"](#) .

NOTE:

- When any initialization is performed, all ID previously registered will be erased and all NATS ignition keys must be registered again.
- The engine cannot be started with an unregistered key. In this case, the system will show "DIFFERENCE OF KEY" or "LOCK MODE" as a self-diagnostic result on the CONSULT-II screen.
- In rare case, "CHAIN OF ECM-IMMU" might be stored as a self-diagnostic result during key registration procedure, even if the system is not malfunctioning.

IVIS (INFINITI VEHICLE IMMOBILIZER SYSTEM-NATS)

AIS006AQ

Preliminary Check

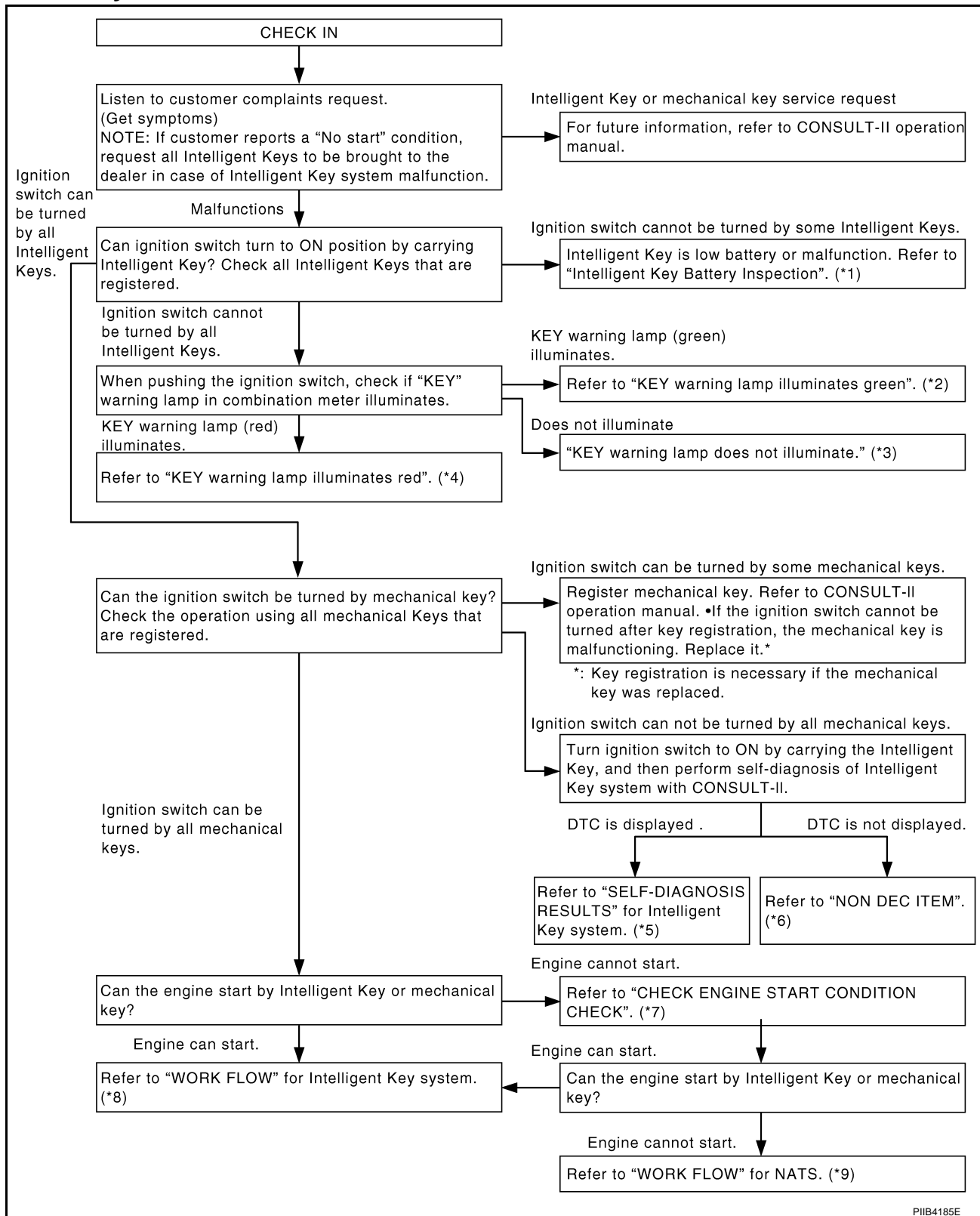

PIIB4185E

*1: [BL-165](#)

*2: [BL-124](#)

*3: [BL-125](#)

*4: [BL-124](#)

*5: [BL-121](#)

*6: [BL-125](#)

*7: [BL-125](#)

*8: [BL-119](#)

*9: [BL-237](#)

IVIS (INFINITI VEHICLE IMMOBILIZER SYSTEM-NATS)

Work Flow

AIS004BW

A
B
C
D
E
F
G
H
BL
J
K
L
M

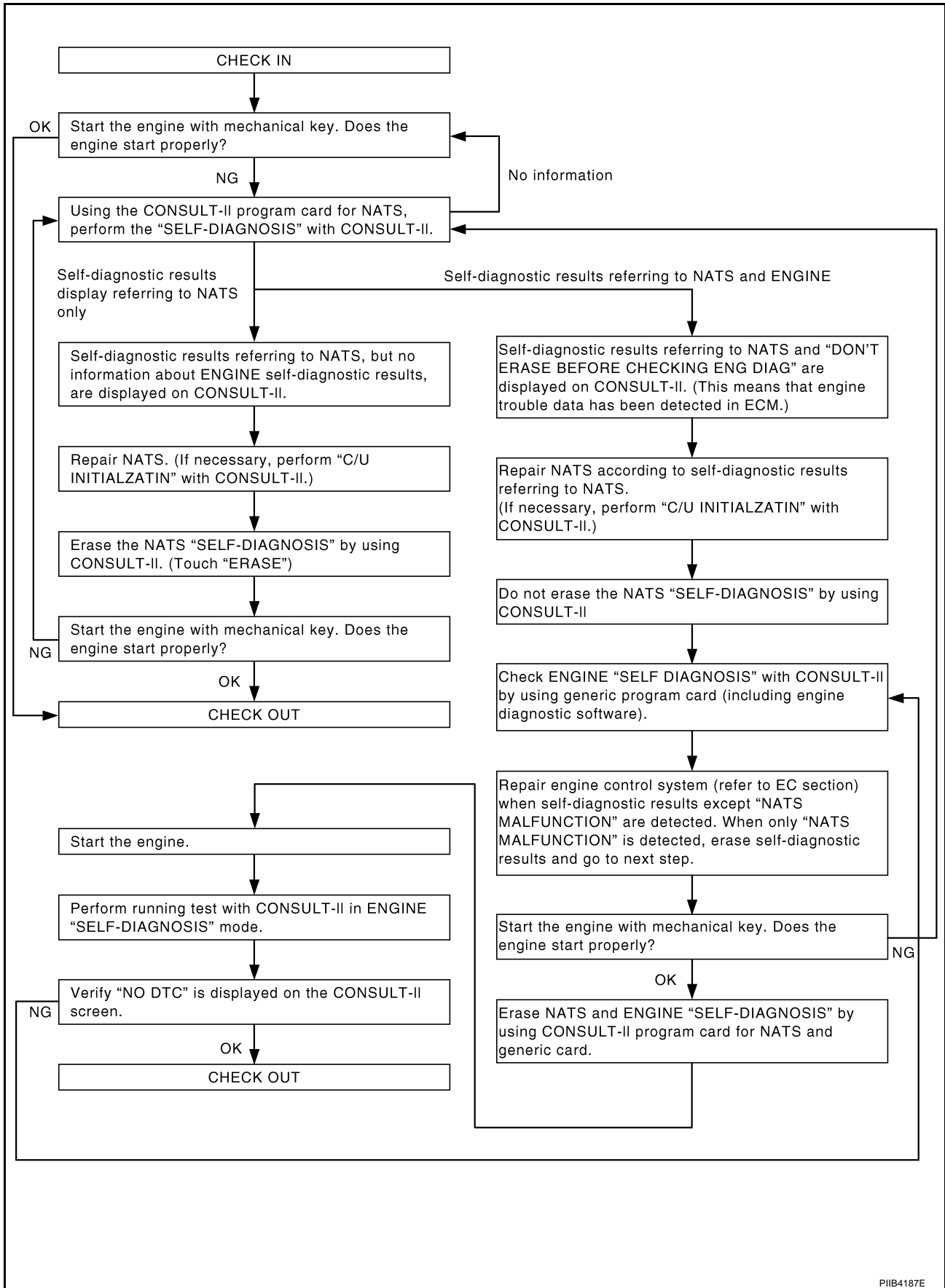

PIIB4187E

IVIS (INFINITI VEHICLE IMMOBILIZER SYSTEM-NATS)

AIS004BX

Trouble Diagnoses SYMPTOM MATRIX CHART 1

Self-diagnosis related item

SYMPTOM	Displayed "SELF-DIAG RESULTS" on CONSULT-II screen.	DIAGNOSTIC PROCEDURE (Reference page)	SYSTEM (Malfunctioning part or mode)
<ul style="list-style-type: none"> Security indicator lighting up* Engine cannot be started 	CHAIN OF ECM-IMMU [P1612]	PROCEDURE 1 (BL-239)	In rare case, "CHAIN OF ECM-IMMU" might be stored during key registration procedure, even if the system is not malfunctioning.
			Open circuit in battery voltage line of BCM circuit
			Open circuit in ignition line of BCM circuit
			Open circuit in ground line of BCM circuit
			Open or short circuit between BCM and ECM communication line
			ECM
			BCM
	DIFFERENCE OF KEY [P1615]	PROCEDURE 2 (BL-241)	Unregistered key
			BCM
	CHAIN OF IMMU-KEY [P1614]	PROCEDURE 3 (BL-241)	Malfunction of key ID chip
Communication line between ANT/ AMP and BCM: Open circuit or short circuit of battery voltage line or ground line			
Open circuit in power source line of ANT/ AMP circuit			
Open circuit in ground line of ANT/ AMP circuit			
NATS antenna amp.			
ID DISCORD, IMM-ECM [P1611]	PROCEDURE 4 (BL-244)	System initialization has not yet been completed.	
		ECM	
<ul style="list-style-type: none"> Security indicator lighting up* Engine cannot be started 	LOCK MODE [P1610]	PROCEDURE 6 (BL-246)	When the starting operation is carried out five or more times consecutively under the following conditions, IVIS (NATS) will shift the mode to one which prevents the engine from being started.
			<ul style="list-style-type: none"> Unregistered ignition key is used. BCM or ECM's malfunctioning.
Security indicator lighting up*	DON'T ERASE BEFORE CHECKING ENG DIAG	WORK FLOW (BL-237)	Engine trouble data and IVIS (NATS) trouble data have been detected in ECM

*: When IVIS (NATS) detects trouble, the security indicator lights up while ignition key is in the "ON" position.

SYMPTOM MATRIX CHART 2

Non self-diagnosis related item

SYMPTOM	DIAGNOSTIC PROCEDURE (Reference page)	SYSTEM (Malfunctioning part or mode)
Security indicator does not light up*.	PROCEDURE 5 (BL-245)	Security indicator.
		Open circuit between Fuse and BCM
		BCM

*: CONSULT-II self-diagnostic results display screen "no malfunction is detected".

IVIS (INFINITI VEHICLE IMMOBILIZER SYSTEM-NATS)

AI5004BY

Diagnostic Procedure 1

Self-diagnostic results:

“CHAIN OF ECM-IMMU” displayed on CONSULT-II screen

First perform the “SELF-DIAG RESULTS” in “BCM” with CONSULT-II, then perform the trouble diagnosis of malfunction system indicated “SELF-DIAG RESULTS” of “BCM”. Refer to [BCS-15, "CAN Communication Inspection Using CONSULT-II \(Self-Diagnosis\)"](#) .

1. CONFIRM SELF-DIAGNOSTIC RESULTS

Confirm SELF-DIAGNOSTIC RESULTS “CHAIN OF ECM-IMMU” displayed on CONSULT-II screen.

NOTE:

In rare case, “CHAIN OF ECM-IMMU” might be stored during key registration procedure, even if the system is not malfunctioning.

Is CONSULT-II screen displayed as shown in figure?

Yes >> GO TO 2.

No >> GO TO [BL-238, "SYMPTOM MATRIX CHART 1"](#) .

SELF DIAGNOSIS	
DTC RESULTS	TIME
CHAIN OF ECM-IMMU [P1612]	0

PIIA1260E

2. CHECK POWER SUPPLY CIRCUIT FOR BCM

1. Turn ignition switch OFF.
2. Disconnect BCM connector.
3. Check voltage between BCM and ground with CONSULT-II or tester.

Connector	Terminals (Wire color)		Voltage [V] (Approx.)
	(+)	(-)	
M2	42 (GY)	Ground	Battery voltage
	55 (W/R)		

OK or NG

OK >> GO TO 3.

NG >> Check the following.

- 50A fusible link (letter **F** , located in the fuse and fusible link box)
- 10A fuse [No.18, located in the fuse block (J/B)]
- Harness for open or short between fusible link and BCM
- Harness for open or short between fuse and BCM

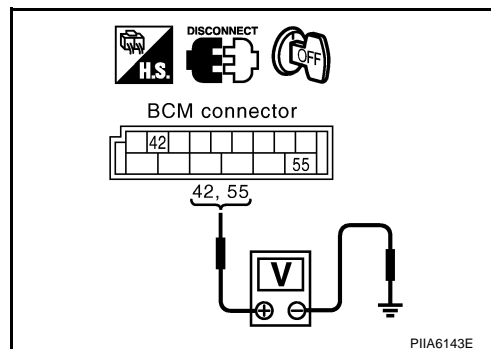

3. CHECK IGNITION SWITCH ON SIGNAL

1. Turn ignition switch ON.
2. Check voltage between BCM connector M1 terminal 38 and ground with CONSULT-II or tester.

38 (W/L) - Ground : Battery voltage

OK or NG

OK >> GO TO 4.

NG >> Check the following.

- 10A fuse [No. 1, located in the fuse block (J/B)]
- Harness for open or short between fuse and BCM

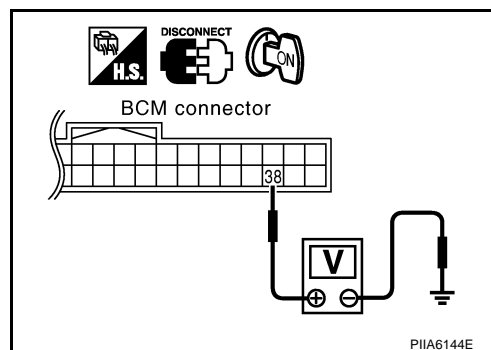

IVIS (INFINITI VEHICLE IMMOBILIZER SYSTEM-NATS)

4. CHECK GROUND CIRCUIT FOR BCM

1. Turn ignition switch OFF.
2. Check continuity between BCM connector M2 terminal 52 and ground.

52 (B) – Ground : Continuity should exist.

OK or NG

- OK >> GO TO 5.
NG >> Repair or replace harness.

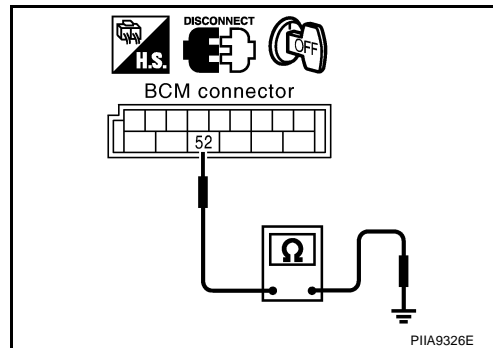

5. REPLACE BCM

1. Replace BCM
2. Perform initialization with CONSULT-II.
For initialization, refer to “CONSULT-II Operation Manual NATS-IVIS/NVIS”.

Does the engine start?

- Yes >> BCM is malfunctioning.
- Replace BCM.
 - Perform initialization with CONSULT-II
 - For initialization, refer to “CONSULT-II Operation Manual NATS-IVIS/NVIS”
- No >> ECM is malfunctioning.
- Replace ECM.
 - Perform initialization or re-communicating function
 - For initialization, refer to “CONSULT-II Operation Manual NATS-IVIS/NVIS”
 - For re-communicating function, refer to [BL-228, "ECM Re-communicating Function"](#)

IVIS (INFINITI VEHICLE IMMOBILIZER SYSTEM-NATS)

AIS004BZ

Diagnostic Procedure 2

Self-diagnostic results:

“DIFFERENCE OF KEY” displayed on CONSULT-II screen

1. CONFIRM SELF-DIAGNOSTIC RESULTS

Confirm SELF-DIAGNOSTIC RESULTS “DIFFERENCE OF KEY” displayed on CONSULT-II screen.

Is CONSULT-II screen displayed as shown in figure?

Yes >> GO TO 2.

No >> GO TO [BL-238, "SYMPTOM MATRIX CHART 1"](#).

SELF DIAG RESULTS	
DTC RESULTS	TIME
DIFFERENCE OF KEY [P1615]	0

PIIA1261E

2. PERFORM INITIALIZATION WITH CONSULT-II

Perform initialization with CONSULT-II. Re-register all NATS ignition key IDs.

For initialization and registration of NATS ignition key IDs, refer to “CONSULT-II Operation Manual NATS-IVIS/NVIS”.

NOTE:

If the initialization is not completed or malfunctions, CONSULT-II shows message on the screen.

Can the system be initialized and can the engine be started with re-registered NATS ignition key?

Yes >> Ignition key ID was unregistered.

No >> BCM is malfunctioning.

- Replace BCM.
- Perform initialization with CONSULT-II
- For initialization, refer to “CONSULT-II Operation Manual NATS-IVIS/NVIS”

IMMU INITIALIZATION
INITIALIZATION FAIL
THEN IGN KEY SW 'OFF' AND 'ON', AFTER CONFIRMING SELF-DIAG AND PASSWORD, PERFORM C/U INITIALIZATION AGAIN.

SEL297W

Diagnostic Procedure 3

AIS004C0

Self-diagnostic results:

“CHAIN OF IMMU-KEY” displayed on CONSULT-II screen

1. CONFIRM SELF-DIAGNOSTIC RESULTS

Confirm SELF-DIAGNOSTIC RESULTS “CHAIN OF IMMU-KEY” displayed on CONSULT-II screen.

Is CONSULT-II screen displayed as shown in figure?

Yes >> GO TO 2.

No >> GO TO [BL-238, "SYMPTOM MATRIX CHART 1"](#).

SELF DIAGNOSIS	
DTC RESULTS	TIME
CHAIN OF IMMU-KEY [P1614]	0

PIIA1263E

2. CHECK NATS ANTENNA AMP. INSTALLATION

Check NATS antenna amp. installation. Refer to [BL-247, "How to Replace NATS Antenna Amp."](#)

OK or NG

OK >> GO TO 3.

NG >> Reinstall NATS antenna amp. correctly.

IVIS (INFINITI VEHICLE IMMOBILIZER SYSTEM-NATS)

3. CHECK IVIS (NATS) IGNITION KEY ID CHIP

Start engine with another registered NATS ignition key.

Does the engine start?

Yes >> Ignition key ID chip is malfunctioning.

- Replace the ignition key
- Perform initialization with CONSULT-II
For initialization, refer to "CONSULT-II Operation Manual NATS-IVIS/NVIS"

No >> GO TO 4.

4. CHECK POWER SUPPLY FOR NATS ANTENNA AMP.

1. Turn ignition switch "OFF".
2. Check voltage between NATS antenna amp. connector M308 terminal 1 and ground.

2 (G) – Ground : Battery voltage.

OK or NG

OK >> GO TO 5.

NG >> Check the following.

- 15A fuse [No. 77, located in IPDM E/R]
- Harness for open or short between fuse and NATS antenna amp.

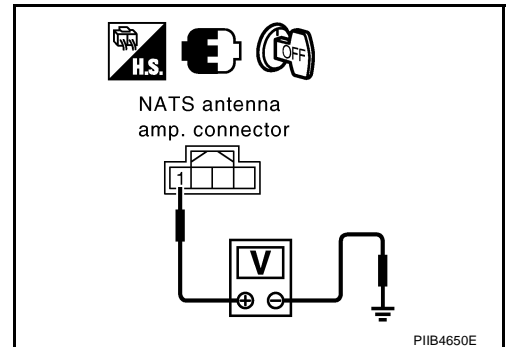

5. CHECK NATS ANTENNA AMP. SIGNAL LINE- 1

Check voltage between NATS antenna amp. connector M308 terminal 2 and ground with analogue tester.

Before turning ignition switch "ON"

Voltage: Approx. 0V

Just after turning ignition switch "ON"

: Pointer of tester should move.

OK or NG

OK >> GO TO 6.

NG >> ● Check harness for open or short between NATS antenna amp. and BCM.

NOTE:

If harness is OK, replace BCM, perform initialization with CONSULT-II. For initialization, refer to "CONSULT-II Operation Manual NATS-IVIS/NVIS".

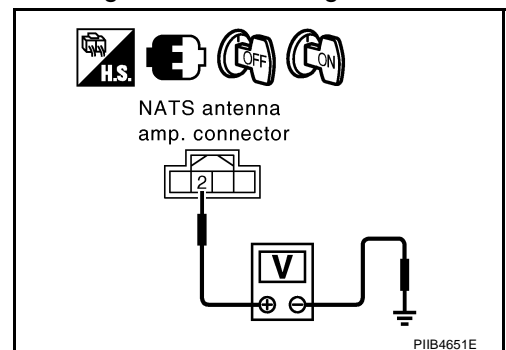

IVIS (INFINITI VEHICLE IMMOBILIZER SYSTEM-NATS)

6. CHECK NATS ANTENNA AMP. SIGNAL LINE- 2

Check voltage between NATS antenna amp. connector M308 terminal 4 and ground with analogue tester.

Before turning ignition switch "ON"

Voltage: Approx. 0V

Just after turning ignition switch "ON"

: Pointer of tester should move.

OK or NG

OK >> GO TO 7.

NG >> ● Check harness for open or short between NATS antenna amp. and BCM.

NOTE:

If harness is OK, replace BCM, perform initialization with CONSULT-II. For initialization, refer to "CONSULT-II Operation Manual NATS-IVIS/NVIS".

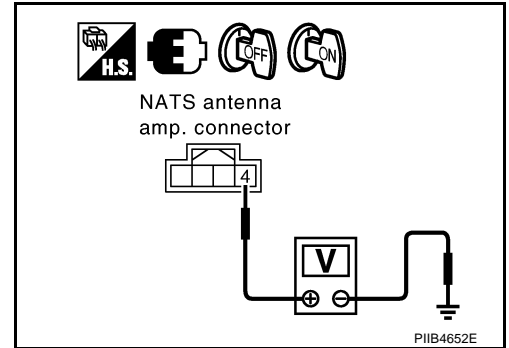

7. CHECK NATS ANTENNA AMP. GROUND LINE CIRCUIT

1. Turn ignition switch "OFF".
2. Disconnect NATS antenna amp. connector.
3. Check continuity between NATS antenna amp. connector M308 terminal 3 and ground.

3 (B) – Ground : Continuity should exist.

OK or NG

OK >> NATS antenna amp. is malfunctioning.

NG >> Repair or replace NATS antenna amp. ground circuit.

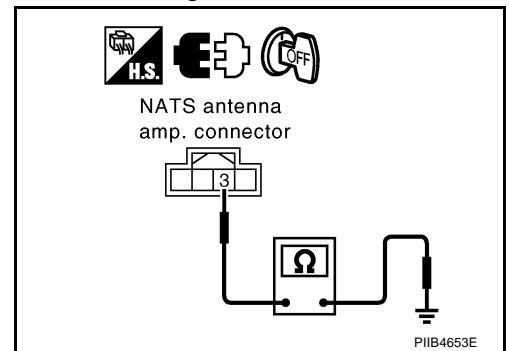

IVIS (INFINITI VEHICLE IMMOBILIZER SYSTEM-NATS)

AIS004C1

Diagnostic Procedure 4

Self-diagnostic results:

“ID DISCORD, IMM-ECM” displayed on CONSULT-II screen

1. CONFIRM SELF-DIAGNOSTIC RESULTS

Confirm SELF-DIAGNOSTIC RESULTS “ID DISCORD, IMM-ECM” displayed on CONSULT-II screen.

NOTE:

“ID DISCORD IMM-ECM”:

Registered ID of BCM is in discord with that of ECM.

Is CONSULT-II screen displayed as shown in figure?

Yes >> GO TO 2.

No >> GO TO [BL-238, "SYMPTOM MATRIX CHART 1"](#) .

SELF DIAG RESULTS	
DTC RESULTS	TIME
ID DISCORD, IMM-ECM [P1611]	0

PIIA1262E

2. PERFORM INITIALIZATION WITH CONSULT-II

Perform initialization with CONSULT-II. Re-register all NATS ignition key IDs.

For initialization, refer to “CONSULT-II Operation Manual NATS-IVIS/NVIS”.

NOTE:

If the initialization is not completed or malfunctions, CONSULT-II shows message on the screen.

Can the system be initialized?

Yes >> ● Start engine. (END)

- (System initialization had not been completed.)

No >> ECM is malfunctioning.

- Replace ECM.

- Perform initialization with CONSULT-II

For initialization, refer to “CONSULT-II Operation Manual NATS-IVIS/NVIS”

IMMU INITIALIZATION
INITIALIZATION FAIL
THEN IGN KEY SW 'OFF' AND 'ON', AFTER CONFIRMING SELF-DIAG AND PASSWORD, PERFORM C/U INITIALIZATION AGAIN.

SEL297W

IVIS (INFINITI VEHICLE IMMOBILIZER SYSTEM-NATS)

AI/S004C2

Diagnostic Procedure 5

“SECURITY INDICATOR LAMP DOES NOT LIGHT UP”

1. CHECK FUSE

Check 10A fuse [No.19, located in the fuse block (J/B)]

OK or NG

- OK >> GO TO 2.
- NG >> Replace fuse.

2. CHECK SECURITY INDICATOR LAMP

1. Install 10A fuse.
2. Start engine and turn ignition switch OFF.
3. Check the security indicator lamp lights up.

Security indicator lamp should light up.

OK or NG

- OK >> INSPECTION END.
- NG >> GO TO 3.

3. CHECK SECURITY INDICATOR LAMP POWER SUPPLY CIRCUIT

1. Disconnect security indicator lamp connector.
2. Check voltage between security indicator lamp connector M34 terminal 1 and ground.

1 (R/W) - Ground : Battery voltage

OK or NG

- OK >> GO TO 4.
- NG >> Check harness for open or short between fuse and security indicator lamp.

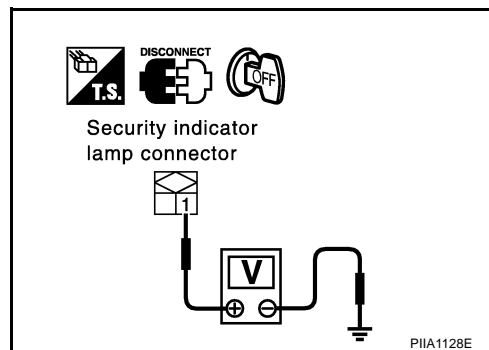

4. CHECK BCM FUNCTION

1. Connect security indicator lamp connector.
2. Disconnect BCM connector.
3. Check voltage between BCM connector M1 terminal 23 and ground.

23 (G/OR) - Ground : Battery voltage

OK or NG

- OK >> BCM is malfunctioning.
 - Replace BCM.
 - Perform initialization with CONSULT-II
 - For initialization, refer to “CONSULT-II Operation Manual NATS-IVIS/NVIS”
- NG >> Check the following.
 - Harness for open or short between security indicator lamp and BCM
 - Indicator lamp condition

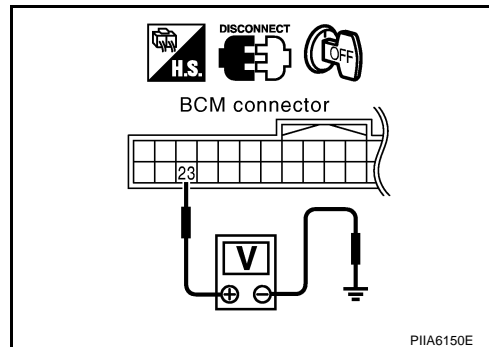

IVIS (INFINITI VEHICLE IMMOBILIZER SYSTEM-NATS)

AI5004C3

Diagnostic Procedure 6

Self-diagnostic results:

“LOCK MODE” displayed on CONSULT-II screen

1. CONFIRM SELF-DIAGNOSTIC RESULTS

Confirm SELF-DIAGNOSTIC RESULTS “LOCK MODE” is displayed on CONSULT-II screen.

Is CONSULT-II screen displayed as shown in figure?

Yes >> GO TO 2.

No >> GO TO [BL-238, "SYMPTOM MATRIX CHART 1"](#).

SELF DIAG RESULTS	
DTC RESULTS	TIME
LOCK MODE [P1610]	0

PIIA1264E

2. ESCAPE FROM LOCK MODE

1. Turn ignition switch OFF.
2. Turn ignition switch ON with registered key. (Do not start engine.) Wait 5 seconds.
3. Return the key to OFF position. Wait 5 seconds.
4. Repeat steps 2 and 3 twice (total of three cycles).
5. Start the engine.

Does engine start?

Yes >> System is OK (Now system is escaped from “LOCK MODE”).

No >> GO TO 3.

3. PERFORM INITIALIZATION WITH CONSULT-II

Perform initialization with CONSULT-II.

For initialization, refer to “CONSULT-II Operation Manual NATS-IVIS/NVIS”.

NOTE:

If the initialization is not completed or malfunctions, CONSULT-II shows the message on the screen.

Can the system be initialized?

Yes >> System is OK.

No >> GO TO 4.

IMMU INITIALIZATION
INITIALIZATION FAIL
THEN IGN KEY SW 'OFF' AND 'ON', AFTER CONFIRMING SELF-DIAG AND PASSWORD, PERFORM C/U INITIALIZATION AGAIN.

SEL297W

IVIS (INFINITI VEHICLE IMMOBILIZER SYSTEM-NATS)

4. PERFORM INITIALIZATION WITH CONSULT-II AGAIN

1. Replace BCM.
2. Perform initialization with CONSULT-II.
For initialization, refer to "CONSULT-II Operation Manual NATS-IVIS/NVIS".

NOTE:

If the initialization is not completed or malfunctions, CONSULT-II shows the message on the screen.

Can the system be initialized?

- Yes >> System is OK. (BCM is malfunctioning.)
No >> ECM is malfunctioning.

- Replace ECM.
- Perform initialization with CONSULT-II
- For initialization, refer to "CONSULT-II Operation Manual NATS-IVIS/NVIS"

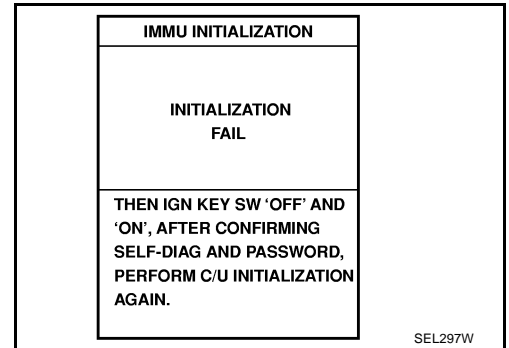

How to Replace NATS Antenna Amp.

AIS004C4

NOTE:

- If NATS antenna amp. is not installed correctly, IVIS (NATS) system will not operate properly and SELF-DIAG RESULTS on CONSULT-II screen will show "LOCK MODE" or "CHAIN OF IMMU-KEY".
- Initialization is not necessary only when NATS antenna amp. is replaced with a new one.

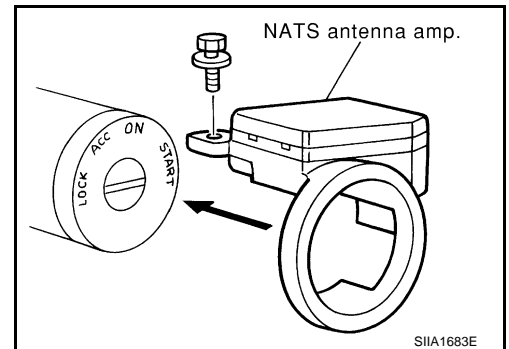

INTEGRATED HOMELINK TRANSMITTER

PFP:96401

INTEGRATED HOMELINK TRANSMITTER

Wiring Diagram —TRNSCV—

AIS00036

BL-TRNSCV-01

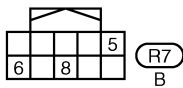
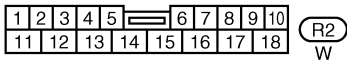
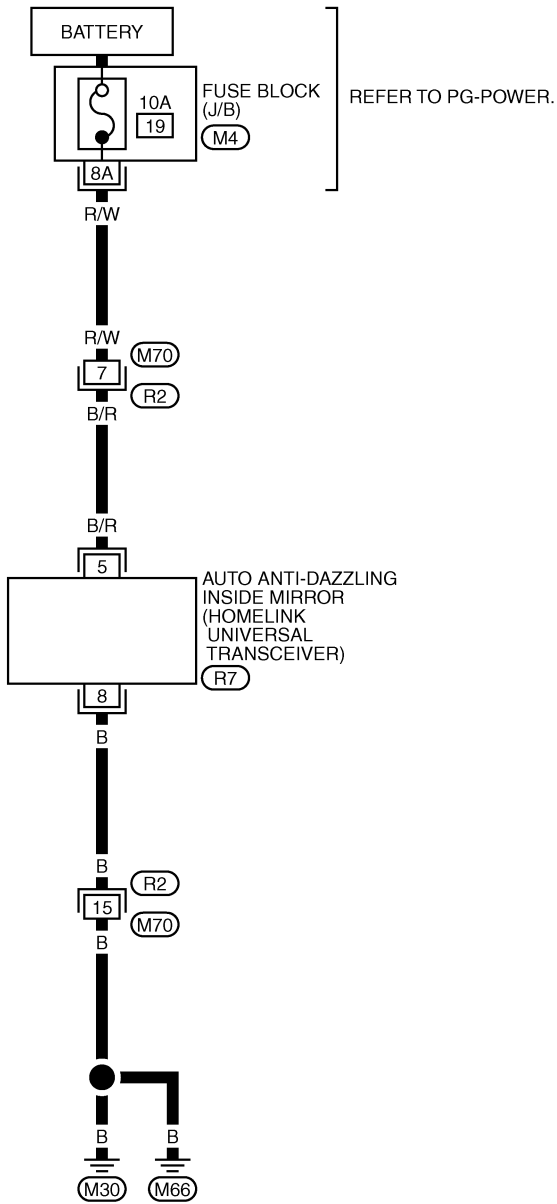

REFER TO THE FOLLOWING.

(M4) -FUSE BLOCK-JUNCTION BOX (J/B)

TIWM1069E

INTEGRATED HOMELINK TRANSMITTER

AIS00037

Trouble Diagnoses DIAGNOSTIC PROCEDURE

SYMPTOM: Transmitter does not activate receiver.

Before conducting the procedure given below, make sure that system receiver (garage door opener, etc.) operates with original, hand-held transmitter. If NG, receiver or hand-held transmitter is malfunctioning, not vehicle related.

1. ILLUMINATE CHECK

1. Turn ignition switch "OFF".
2. Does red light (LED) of transmitter illuminate when any transmitter button is pressed?

YES or NO

- YES >> GO TO 2.
NO >> GO TO 3.

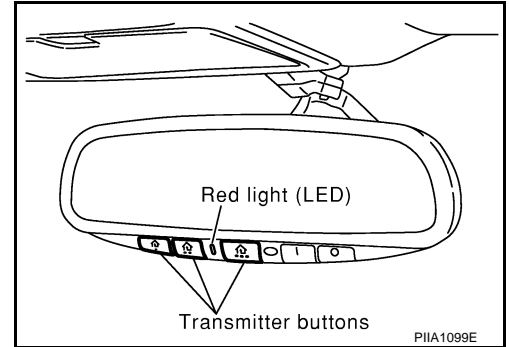

2. TRANSMITTER CHECK

Check transmitter with Tool*.

*:For details, refer to Technical Service Bulletin.

OK or NG

- OK >> Receiver or hand-held transmitter malfunction, not vehicle related.
NG >> Replace auto anti-dazzling inside mirror.

3. CHECK POWER SUPPLY

1. Disconnect auto anti-dazzling inside mirror connector.
2. Check voltage between auto anti-dazzling inside mirror harness connector R7 terminal 5 and ground.

5 (B/R) – Ground : Battery voltage

OK or NG

- OK >> GO TO 4.
NG >> Check the following.
- 10A fuse [No. 19 located in the fuse block (J/B)]
 - Harness for open or short between fuse and auto anti-dazzling inside mirror

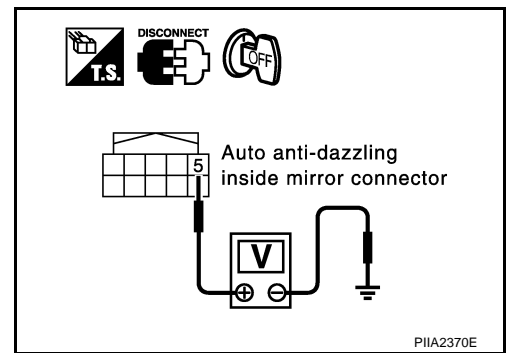

4. GROUND CIRCUIT CHECK

Check continuity between auto anti-dazzling inside mirror harness connector R7 terminal 8 and ground.

8 (B) – Ground : Continuity should exist.

OK or NG

- OK >> Replace auto anti-dazzling inside mirror.
NG >> Repair harness.

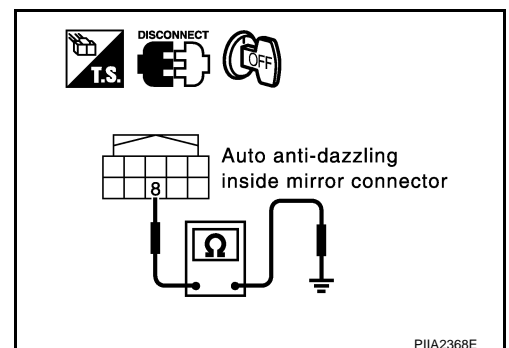

BODY REPAIR

BODY REPAIR

PFP:60100

Body Exterior Paint Color

AIS00001

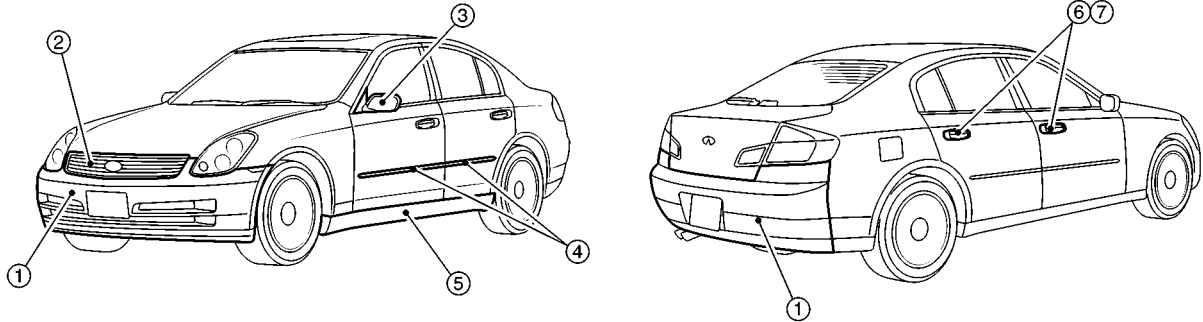

SIIA2352E

Component			Color code	BAY2	BB30	BBW5	BK32	BKH3	BKY0	BQX1	BWV2
			Description	Red	Blue	Dark Blue	Yellowish Silver	Black	Silver	White	Silver
			Paint type	PM	M	P	TM	2S	M	3P	M
			Hard clear coat	×	×	×	-	×	-	-	-
1	Bumper fascia	Upper	Body color	BAY2	BB30	BBW5	BK32	BKH3	BKY0	BQX1	BWV2
		Lower	Material color	G64-1	G64-1	G64-1	G64-1	G64-1	G64-1	G64-1	G64-1
2	Front grille		Chromium-plate + Smoke clear	Cr + HFM-09	Cr + HFM-09	Cr + HFM-09	Cr + HFM-09	Cr + HFM-09	Cr + HFM-09	Cr + HFM-09	Cr + HFM-09
3	Door outside mirror	Case	Body color	BAY2	BB30	BBW5	BK32	BKH3	BKY0	BQX1	BWV2
		Base	Material color	AG01	AG01	AG01	AG01	AG01	AG01	AG01	AG01
4	Side guard molding		Body color	BAY2	BB30	BBW5	BK32	BKH3	BKY0	BQX1	BWV2
5	Center mudguard		Material color	G64-1	G64-1	G64-1	G64-1	G64-1	G64-1	G64-1	G64-1
6	Door outside handle escutcheon		Body color	BAY2	BB30	BBW5	BK32	BKH3	BKY0	BQX1	BWV2
7	Door outside handle		Chromium-plate	Cr	Cr	Cr	Cr	Cr	Cr	Cr	Cr

2S:Solid + Clear, M:Metallc, P: Pearl, 2P:2-Coat pearl, 3P:3-Coat pearl, TM: Micro titanium metallic, PM: Pearl metallic

BODY REPAIR

Body Component Parts UNDERBODY COMPONENT PARTS

AIS00002

A
B
C
D
E
F
G
H
BL
J
K
L
M

* Indicates aluminum portion

▨ : Indicates both sided anti-corrosive pre-coated steel portions

▧ : Indicates high strength steel (HSS) portions

▩ : Indicates both sided anti-corrosive steel and HSS portions

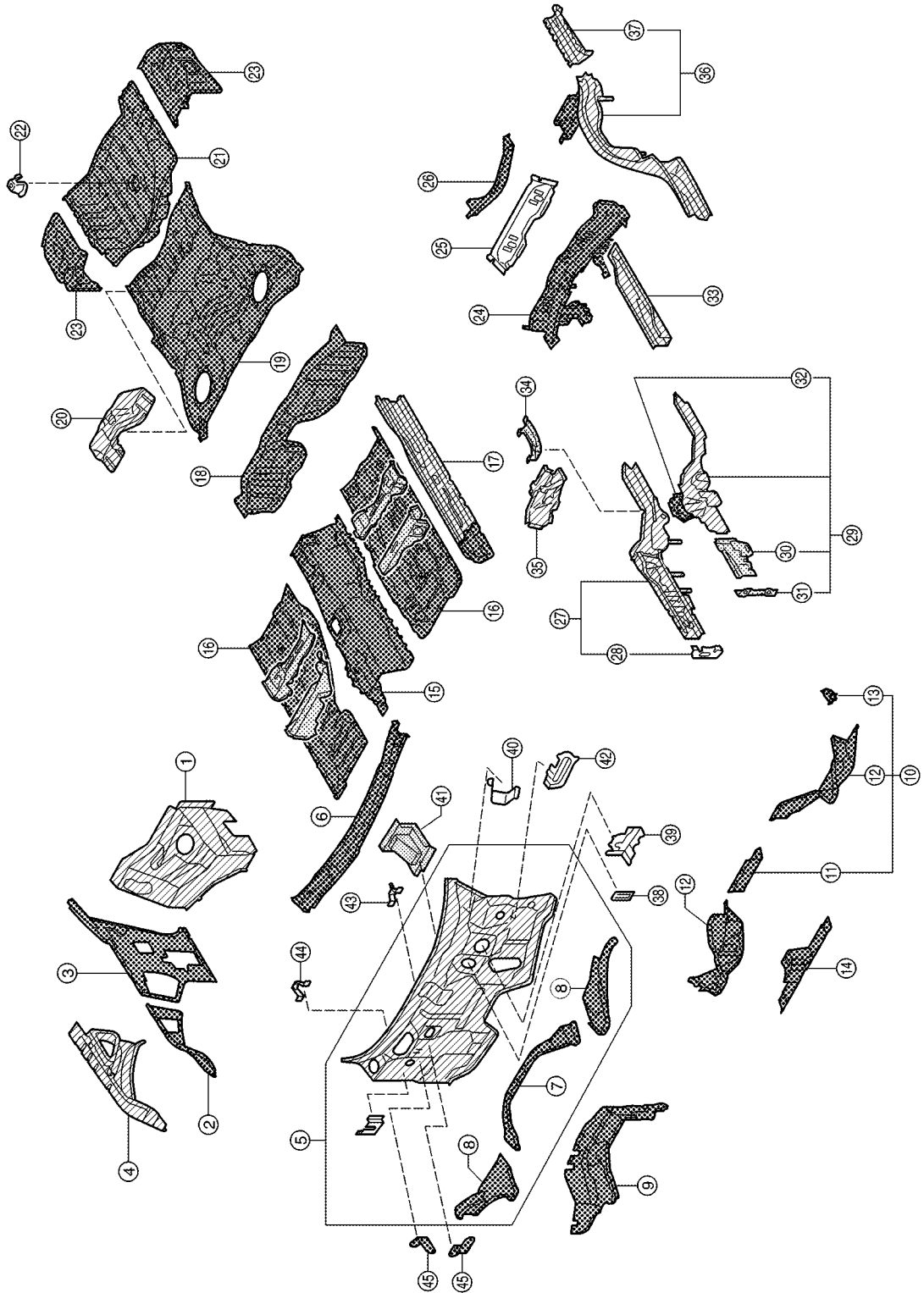



SIIA2354E

BODY REPAIR

1. Front strut housing (RH&LH)
2. Upper front hoodledge (RH&LH)
3. Upper rear hoodledge (RH&LH)
4. Hoodledge reinforcement (RH&LH)
5. Upper dash assembly
6. Upper dash crossmember assembly
7. Lower center dash crossmember reinforcement
8. Lower dash crossmember reinforcement
9. Cowl top
10. Lower dash crossmember assembly
11. Front crossmember center
12. Lower dash crossmember
13. Steering column mounting reinforcement
14. Lower dash
15. Front floor center
16. Front floor
17. Inner sill (RH&LH)
18. Rear seat crossmember assembly
19. Rear floor front
20. Rear floor seat belt anchor reinforcement
21. Rear floor rear
22. Spare tire clamp bracket
23. Rear floor side (RH&LH)
24. Rear seat crossmember
25. 2ND rear crossmember assembly
26. Rear crossmember center assembly
27. Front side member (RH&LH)
28. Front towing hook inner bracket (RH&LH)
29. Front side member closing plate assembly (RH&LH)
30. Front side member front closing plate (RH&LH)
31. Front towing hook outer bracket (RH&LH)
32. Front side member rear extension (RH&LH)
33. Front side member center closing plate (RH&LH)
34. Front side member rear reinforcement (RH&LH)
35. Front side member outrigger assembly (RH&LH)
36. Rear side member (RH&LH)
37. Rear side member extension (RH&LH)
38. Accel pedal bracket
39. Pedal bracket
40. Wiper mounting bracket
41. Parking brake mounting bracket
42. Parking brake bracket assembly
43. Instrument bracket
44. Upper instrument mounting bracket (RH&LH)
45. Harness clamp bracket

BODY REPAIR

BODY COMPONENT PARTS

-  : Indicates both sided anti-corrosive pre-coated steel portions
-  : Indicates high strength steel (HSS) portions
-  : Indicates both sided anti-corrosive steel and HSS portions
- * : Indicates aluminum portion

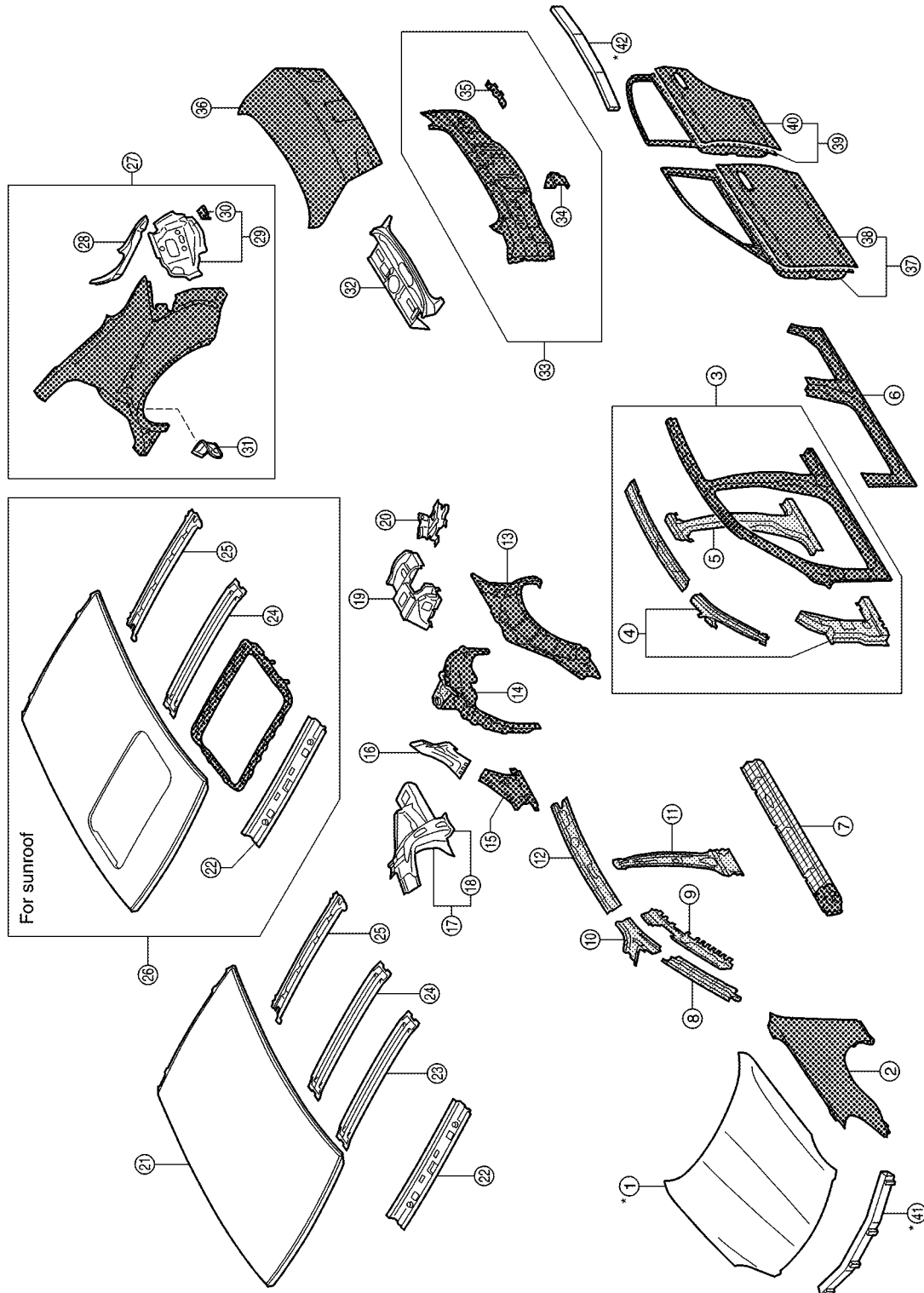

A
B
C
D
E
F
G
H
BL
J
K
L
M

SIIA2355E

BODY REPAIR

1. Hood
2. Front fender (RH&LH)
3. Side body assembly (RH&LH)
4. Outer front pillar reinforcement (RH&LH)
5. Center pillar reinforcement (RH&LH)
6. Outer sill (RH&LH)
7. Outer sill reinforcement (RH&LH)
8. Upper inner front pillar (RH&LH)
9. Inner front pillar reinforcement (RH&LH)
10. Front roof rail brace (RH&LH)
11. Inner center pillar (RH&LH)
12. Inner side roof rail (RH&LH)
13. Outer rear wheelhouse (RH&LH)
14. Inner rear wheelhouse (RH&LH)
15. Outer rear wheelhouse extension (RH&LH)
16. Seat back support (RH&LH)
17. Inner rear pillar assembly (RH&LH)
18. Inner rear pillar reinforcement (RH&LH)
19. Side parcel shelf (RH&LH)
20. Jack mounting bracket
21. Roof
22. Front roof rail
23. Front roof bow
24. Rear roof bow
25. Rear roof rail
26. Roof assembly
27. Rear fender assembly (RH&LH)
28. Rear fender extension (RH&LH)
29. Rear combination lamp base assembly (RH&LH)
30. Center rear bumper bracket (RH&LH)
31. Striker tapping retainer (RH&LH)
32. Parcel shelf
33. Upper rear panel assembly
34. Rear bumper side bracket
35. Rear bumper fascia bracket (RH&LH)
36. Trunk lid
37. Front door (RH&LH)
38. Outer front door panel (RH&LH)
39. Rear door (RH&LH)
40. Outer rear door panel (RH&LH)
41. Front bumper reinforcement
42. Rear bumper reinforcement

BODY REPAIR

Corrosion Protection

AIS00003

DESCRIPTION

To provide improved corrosion prevention, the following anti-corrosive measures have been implemented in NISSAN production plants. When repairing or replacing body panels, it is necessary to use the same anti-corrosive measures.

Anti-corrosive precoated steel (Galvannealed steel)

To improve repairability and corrosion resistance, a new type of anti-corrosive precoated steel sheet has been adopted replacing conventional zinc-coated steel sheet.

Galvannealed steel is electroplated and heated to form Zinc-iron alloy, which provides excellent and long term corrosion resistance with cationic electrodeposition primer.

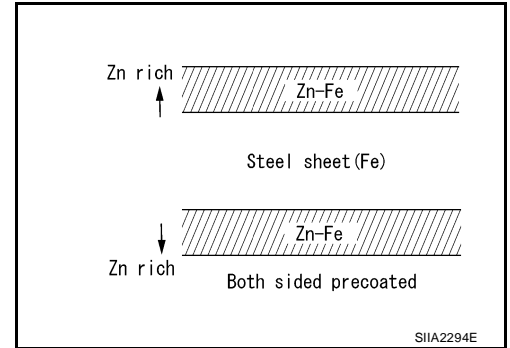

Nissan Genuine Service Parts are fabricated from galvannealed steel. Therefore, it is recommended that GENUINE NISSAN PARTS or equivalent be used for panel replacement to maintain the anti-corrosive performance built into the vehicle at the factory.

Phosphate coating treatment and cationic electrodeposition primer

A phosphate coating treatment and a cationic electrodeposition primer, which provide excellent corrosion protection, are employed on all body components.

CAUTION:

Confine paint removal during welding operations to an absolute minimum.

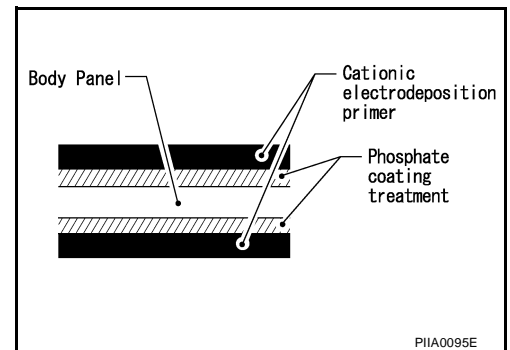



Nissan Genuine Service Parts are also treated in the same manner. Therefore, it is recommended that GENUINE NISSAN PARTS or equivalent be used for panel replacement to maintain anti-corrosive performance built into the vehicle at the factory.

BODY REPAIR

ANTI-CORROSIVE WAX

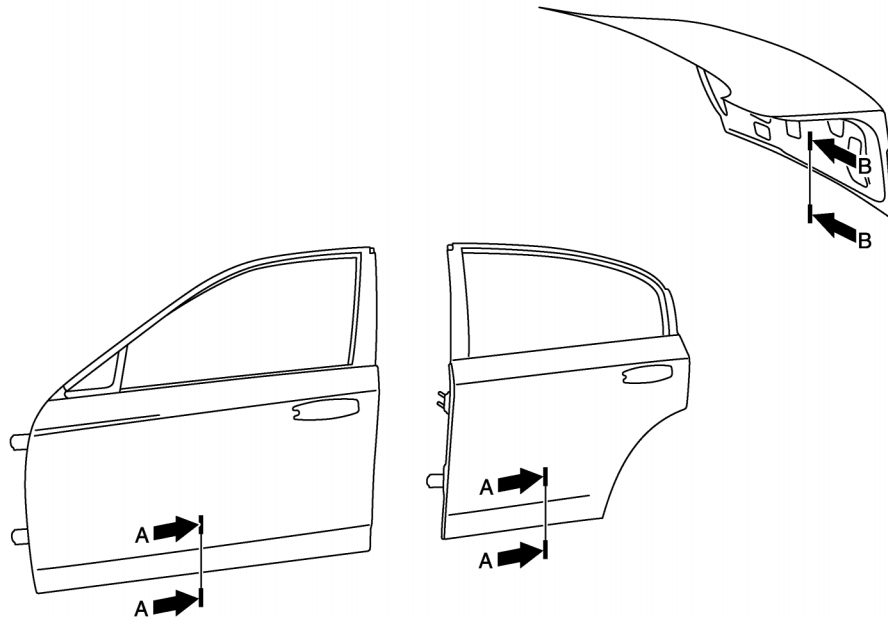
To improve corrosion resistance, anti-corrosive wax is applied inside the body sill and inside other closed sections. Accordingly, when replacing these parts, be sure to apply anti-corrosive wax to the appropriate areas of the new parts. Select an excellent anti-corrosive wax which will penetrate after application and has a long shelf life.



 : Indicates anti-corrosive wax coated portions.

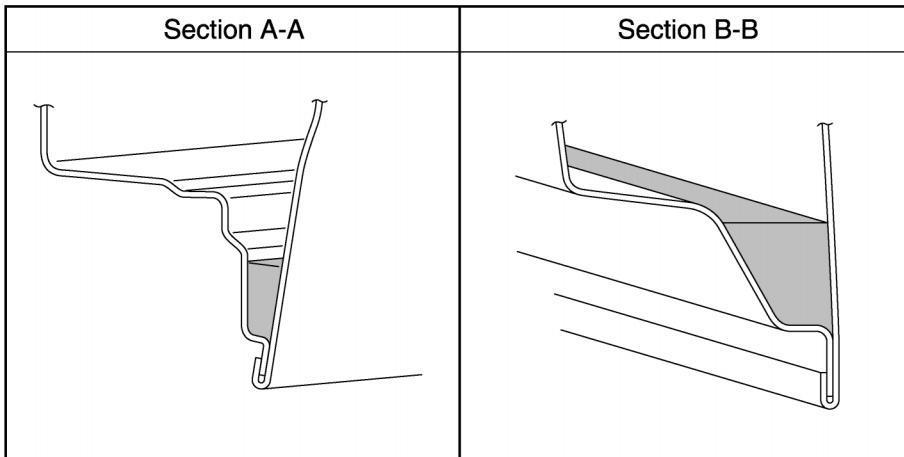

PIIA1202E

BODY REPAIR

UNDERCOATING

The underside of the floor and wheelhouse are undercoated to prevent rust, vibration, noise and stone chipping. Therefore, when such a panel is replaced or repaired, apply undercoating to that part. Use an undercoating which is rust preventive, soundproof, vibration-proof, shock-resistant, adhesive, and durable.

Precautions in Undercoating

1. Do not apply undercoating to any place unless specified (such as the areas above the muffler and three way catalyst which are subjected to heat).
2. Do not undercoat the exhaust pipe or other parts which become hot.
3. Do not undercoat rotating parts.
4. Apply bitumen wax after applying undercoating.

 : Indicates undercoated portions.

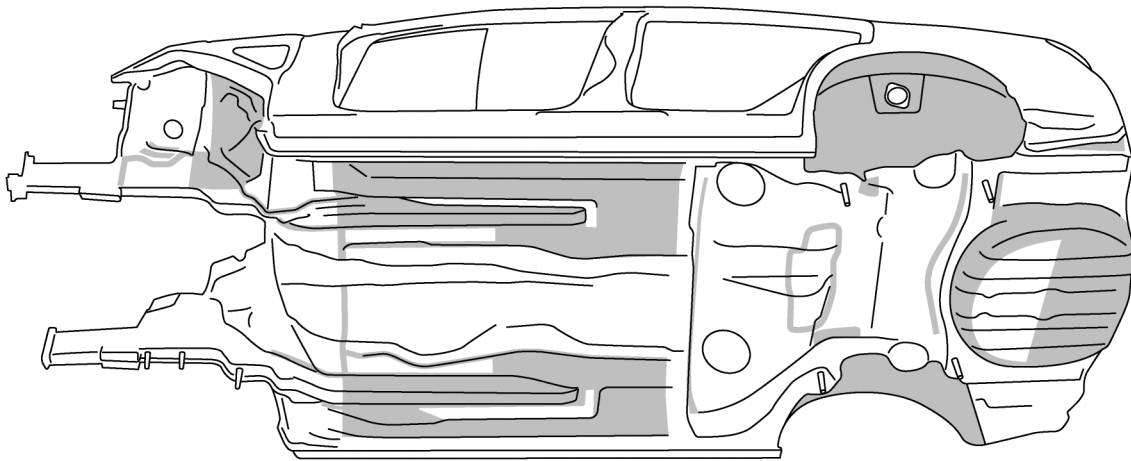

PIIA0735E

BODY REPAIR

STONE GUARD COAT

To prevent damage caused by stones, the lower outer body panel (fender, door, etc.) have an additional layer of Stone Guard Coating over the ED primer coating. When replacing or repairing these panels, apply Stone Guard coating to the same portions as before. Use a coating which is rust preventive, durable, shock-resistant and has a long shelf life.

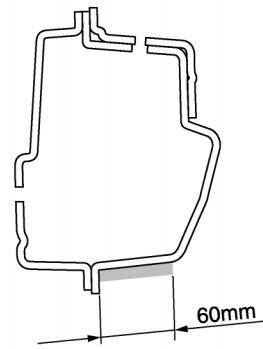
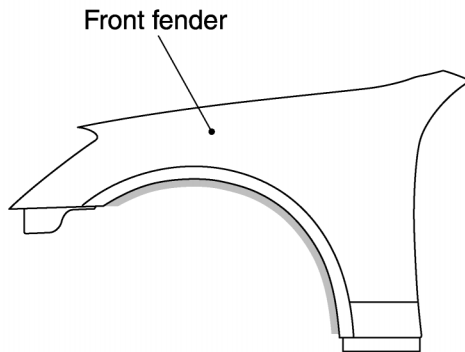
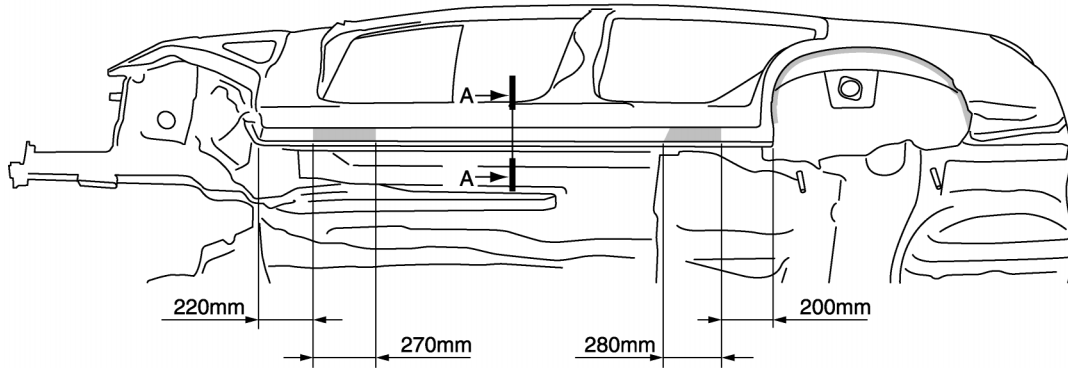

PIIA0736E

BODY REPAIR

Body Sealing DESCRIPTION

AIS00004

The following figure shows the areas which are sealed at the factory. Sealant which has been applied to these areas should be smooth and free from cuts or gaps. Care should be taken not to apply an excess amount of sealant and not to allow other unaffected parts to come into contact with the sealant.

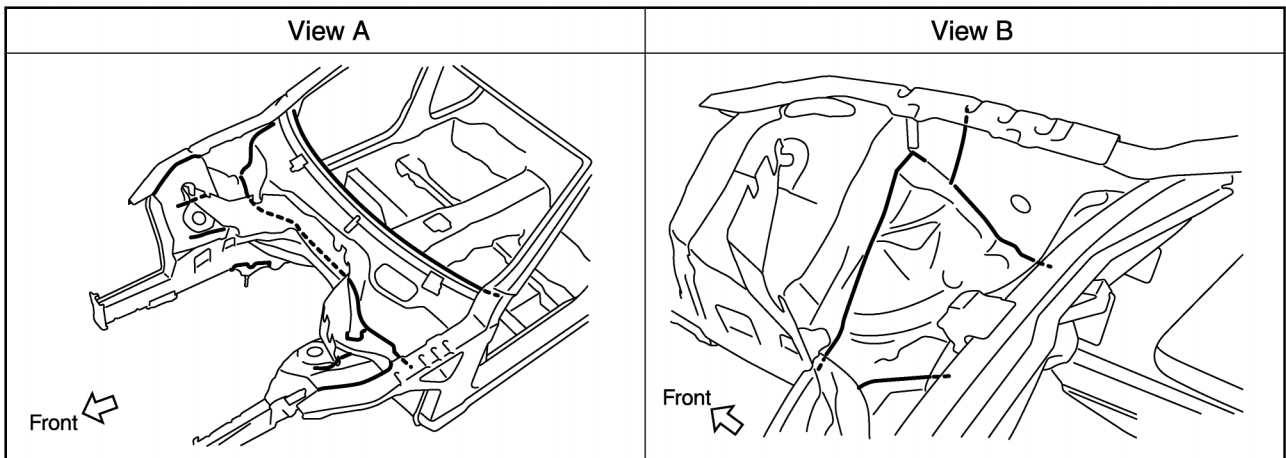
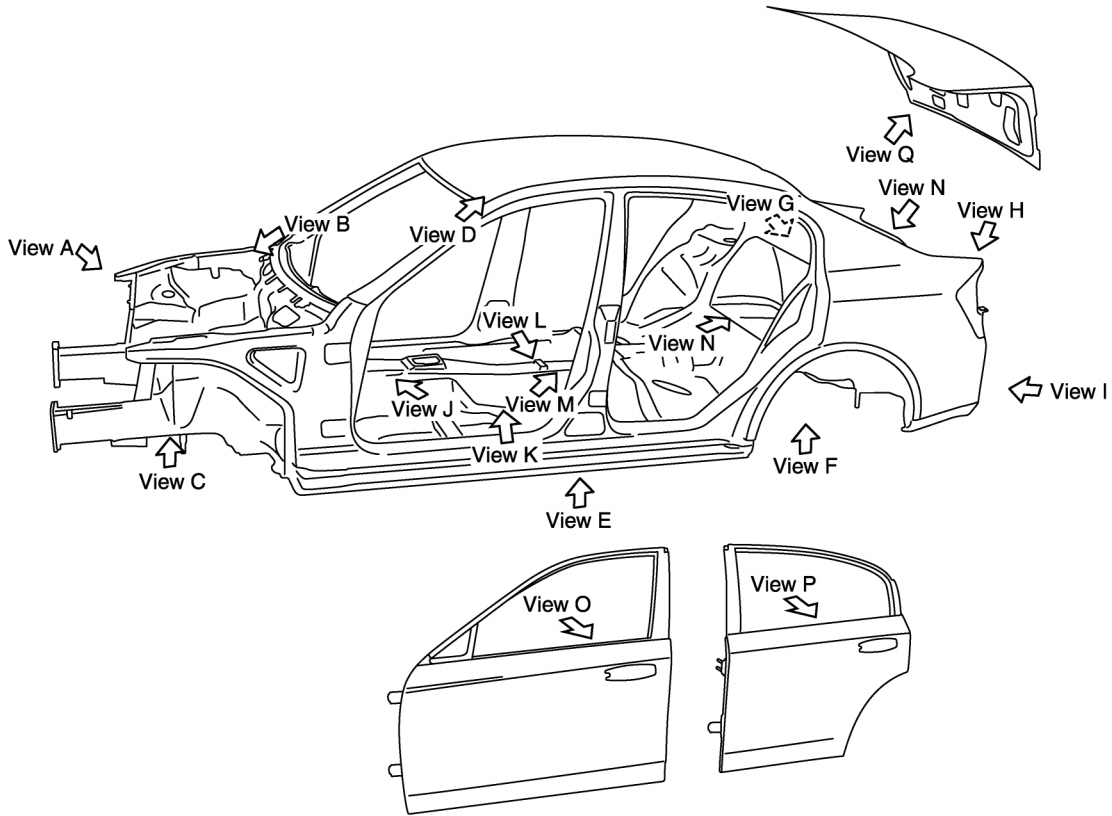

PIIA0732E

A
B
C
D
E
F
G
H
BL
J
K
L
M

BODY REPAIR

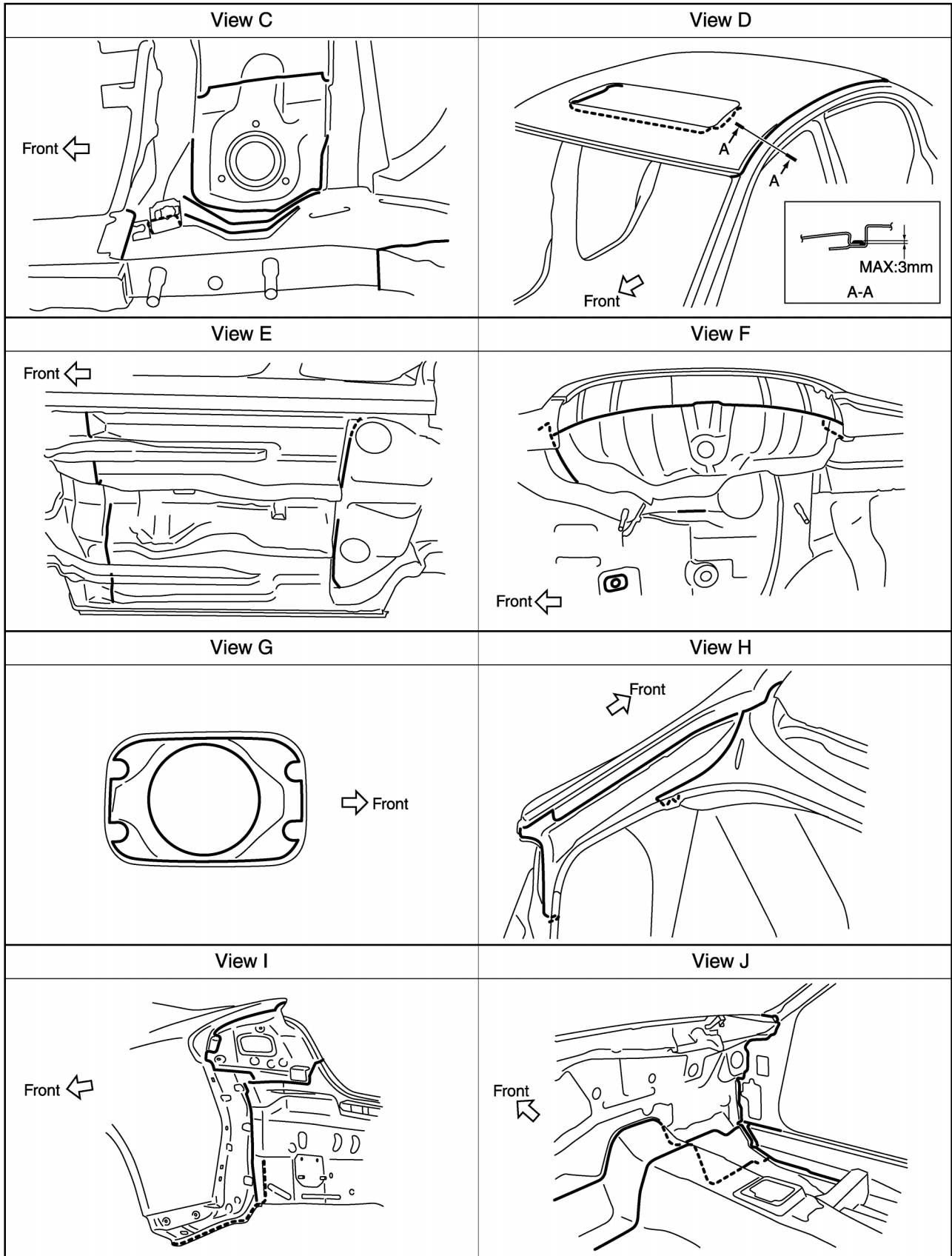

PIA0733E

BODY REPAIR

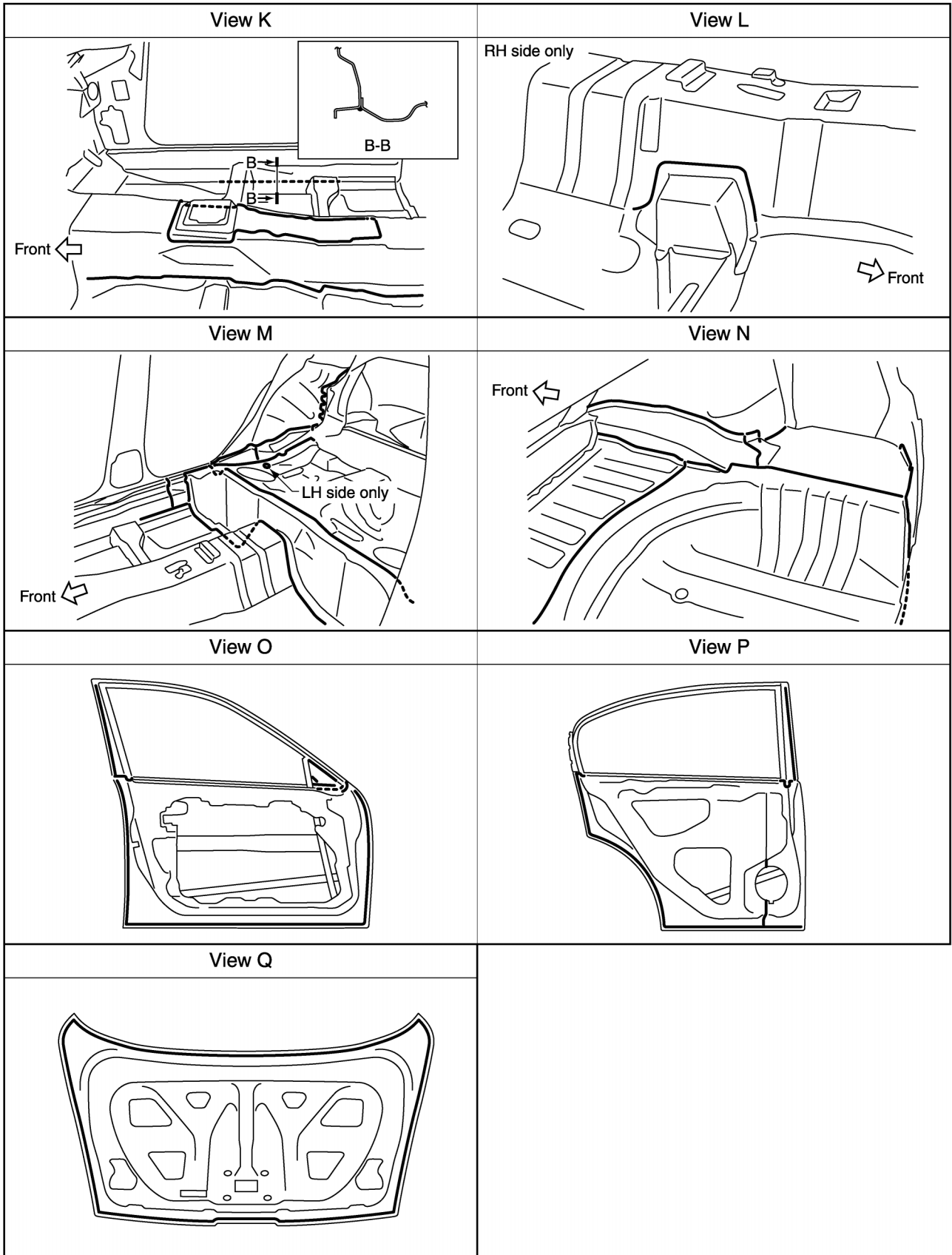

A
B
C
D
E
F
G
H
BL
J
K
L
M

PIIA0734E

BODY REPAIR

Body Construction BODY CONSTRUCTION

AI500005

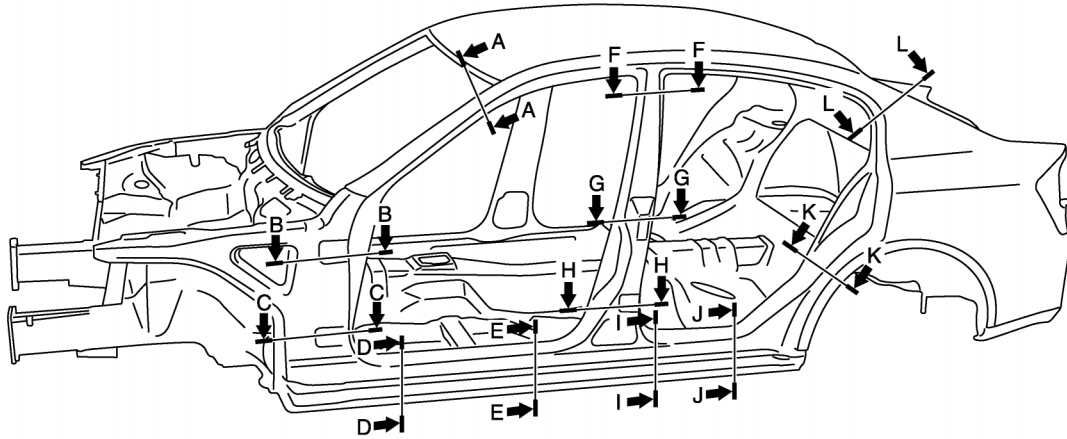

Section A-A	Section B-B	Section C-C	Section D-D
Section E-E	Section F-F	Section G-G	Section H-H
Section I-I	Section J-J	Section K-K	Section L-L

PIIA0744E

BODY REPAIR

Body Alignment BODY CENTER MARKS

AI500006

A mark has been placed on each part of the body to indicate the vehicle center. When repairing parts damaged by an accident which might affect the vehicle frame (members, pillars, etc.), more accurate and effective repair will be possible by using these marks together with body alignment specifications.

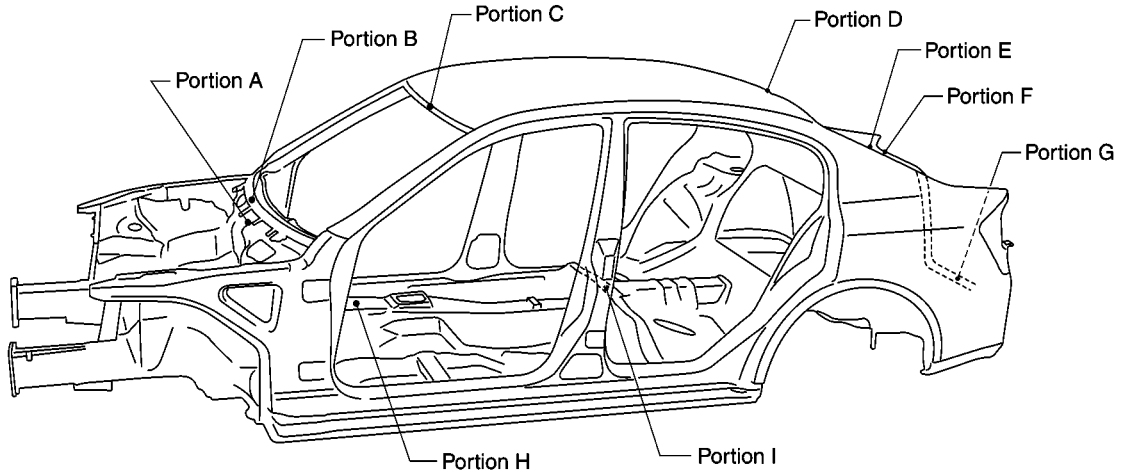

Portion A,B	Portion C,D	Portion E,F
<p>Embossment</p> <p>Embossment</p> <p>Front</p> <p>● Cowl top</p>	<p>Embossment</p> <p>Front</p> <p>● Front roof</p> <p>● Rear roof</p>	<p>Front</p> <p>Groove</p> <p>Embossment</p> <p>● Rear waist panel</p>
<p>Front</p> <p>Flange end</p> <p>● Rear panel</p>	<p>Front</p> <p>Hole 5dia.</p> <p>Embossment</p> <p>● Front floor</p> <p>● Rear floor</p>	

PIIA0730E

BODY REPAIR

PANEL PARTS MATCHING MARKS

A mark has been placed on each body panel to indicate the parts matching positions. When repairing parts damaged by an accident which might affect the vehicle structure (members, pillars, etc.), more accurate and effective repair will be possible by using these marks together with body alignment specifications.

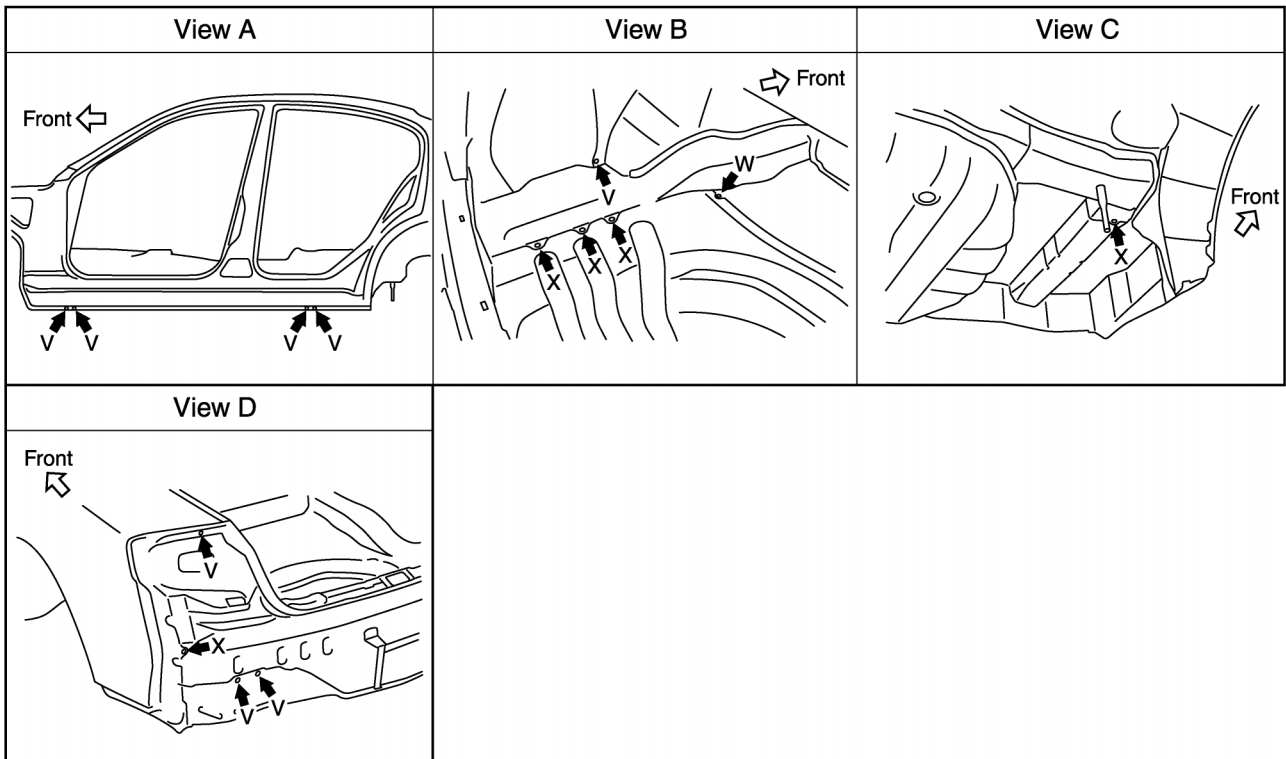
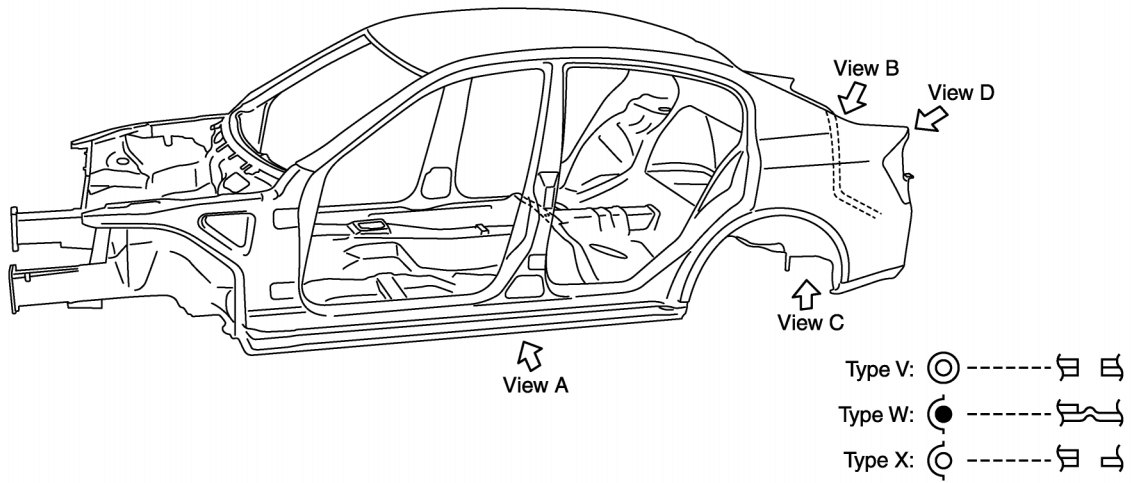

PIA0731E

BODY REPAIR

DESCRIPTION

- All dimensions indicated in the figures are actual.
- When using a tracking gauge, adjust both pointers to equal length. Then check the pointers and gauge itself to make sure there is no free play.
- When a measuring tape is used, check to be sure there is no elongation, twisting or bending.
- Measurements should be taken at the center of the mounting holes.
- An asterisk (*) following the value at the measuring point indicates that the measuring point on the other side is symmetrically the same value.
- The coordinates of the measurement points are the distances measured from the standard line of "X", "Y" and "Z".

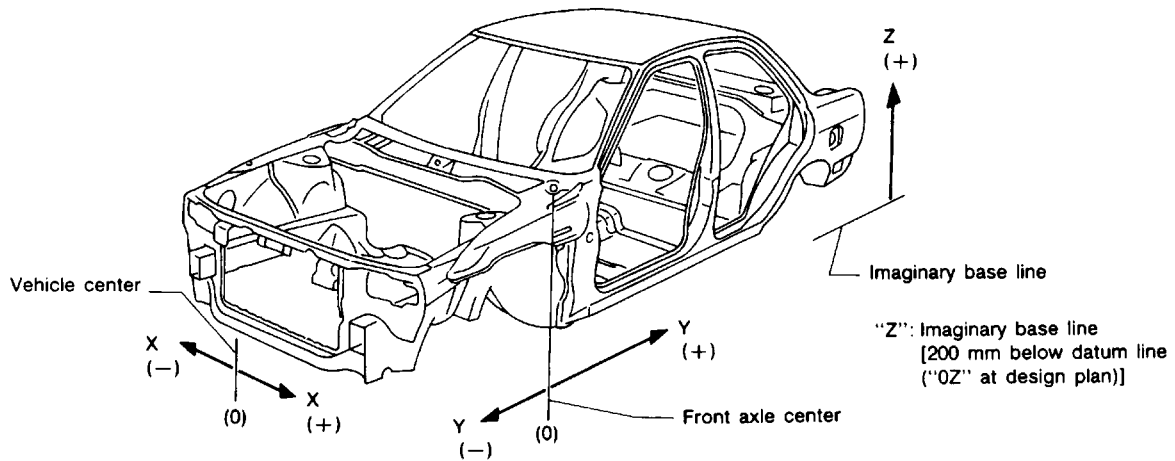

PIIA0104E

A
B
C
D
E
F
G
H
BL
J
K
L
M

BODY REPAIR

ENGINE COMPARTMENT

Measurement

Figures marked with a (*) indicate symmetrically identical dimensions on both right and left hand sides of the vehicle.

Unit : mm

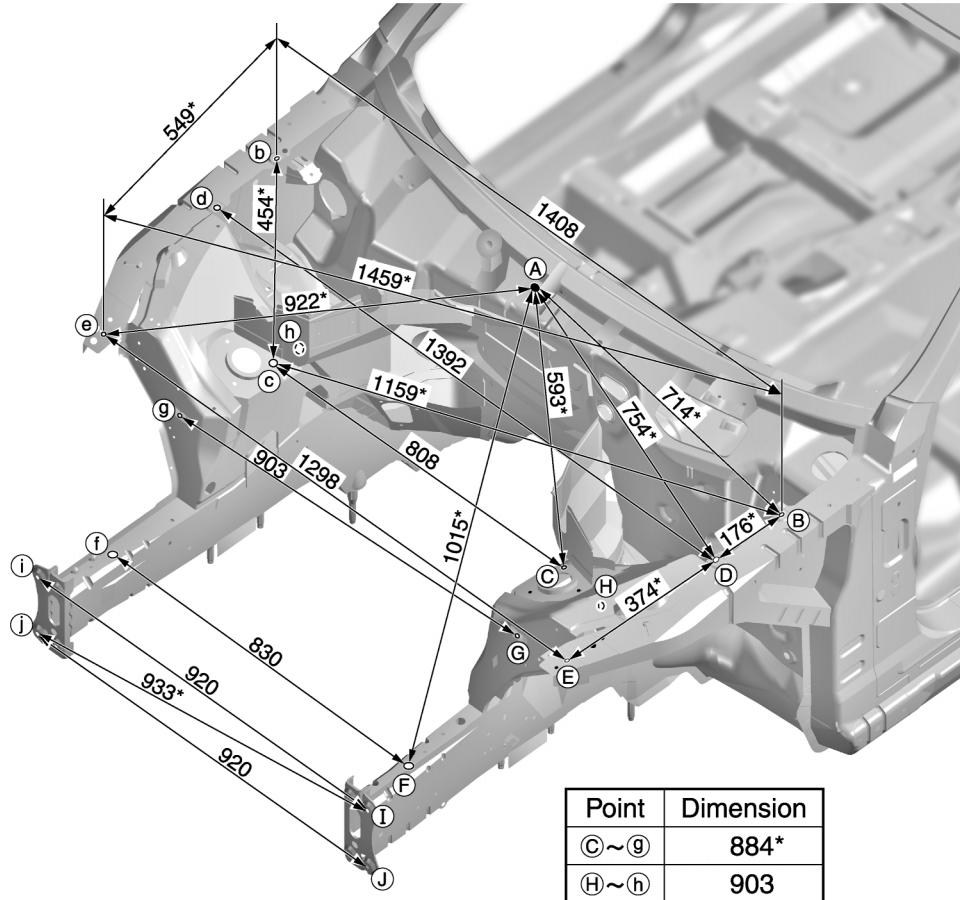

PIIA0739E

BODY REPAIR

Measurement Points

(A) : Upper dash positioning mark center of center positioning mark

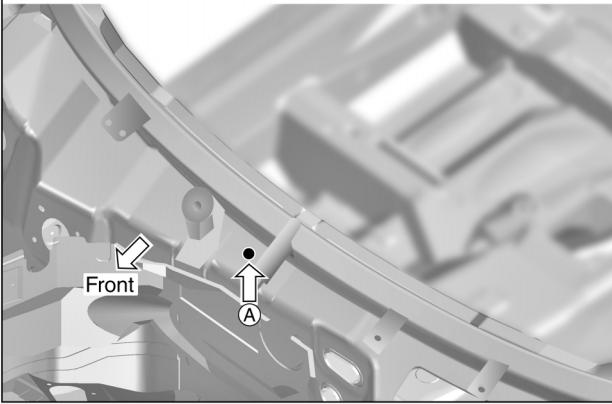

(B), (b), (D), (d) : Front fender installing hole center (7dia.)
 (C), (c) : Front strut installing hole center (9dia.)
 (E), (e) : Radiator core support installing hole center (9dia.)

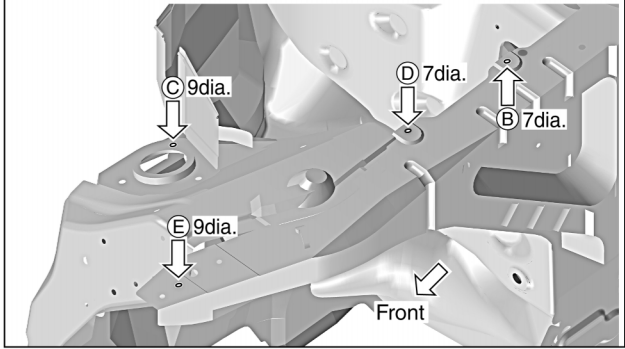

(F), (f) : Front side member hole center (20dia.)
 (G), (g) : Nut holder hole center (16dia.)
 (I), (i), (J), (j) : Front bumper stay installing hole center (9dia.)

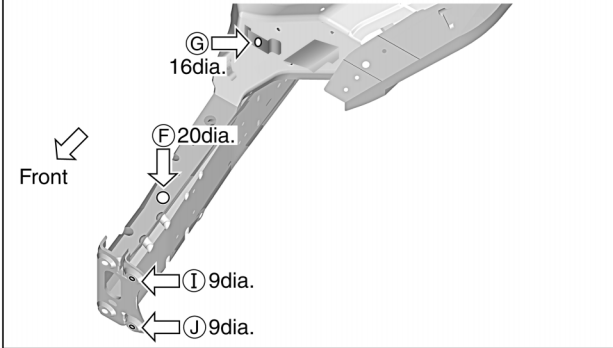

(H), (h) : Nut holder hole center (16dia.)

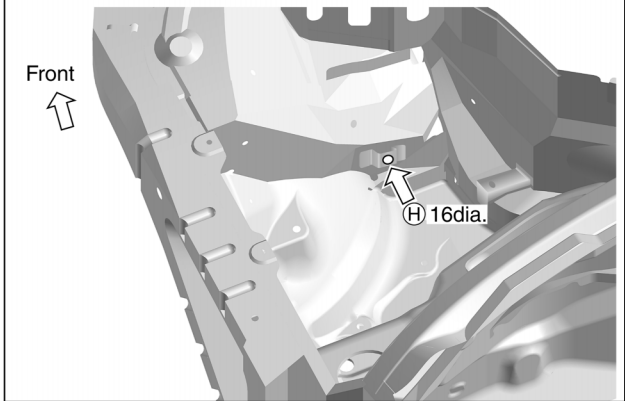

A
B
C
D
E
F
G
H
BL
J
K
L
M

PIIA0743E

BODY REPAIR

Measurement Points

Unit : mm

As viewed from underside.

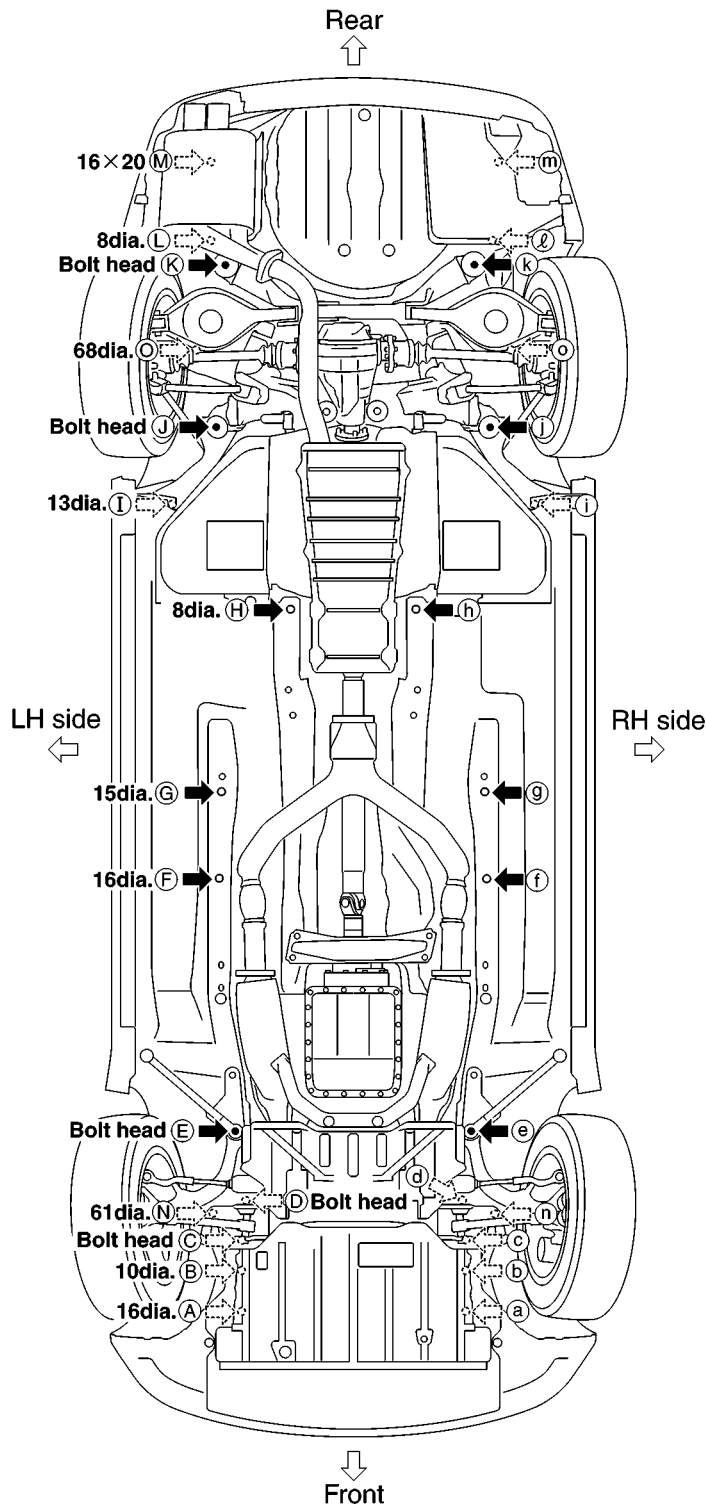

Coordinates:

(A), (a)	(I), (i)
X:413	X:605
Y:-368	Y:2391
Z:305	Z:128
(B), (b)	(J), (j)
X:415	X:473
Y:-238	Y:2604
Z:274	Z:114
(C), (c)	(K), (k)
X:405	X:452
Y:-100	Y:3164
Z:225	Z:179
(D), (d)	(L)
X:405	X:550
Y:39	Y:3265
Z:224	Z:316
(E), (e)	(l)
X:388	X:-500
Y:279	Y:3273
Z:82	Z:316
(F), (f)	(M), (m)
X:438	X:535
Y:1100	Y:3540
Z:79	Z:329
(G), (g)	
X:440	
Y:1400	
Z:79	
(H), (h)	
X:205	
Y:1992	
Z:59	

Front and rear strut tower centers

Coordinates:

(N), (n)
X:434
Y:29
Z:682

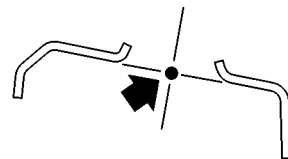

(O), (o)
X:524
Y:2882
Z:785

Front: (N), (n) 61dia.
Rear: (O), (o) 68dia.

SIIA2368E

BODY REPAIR

Measurement Points

Unit : mm

As viewed from underside.

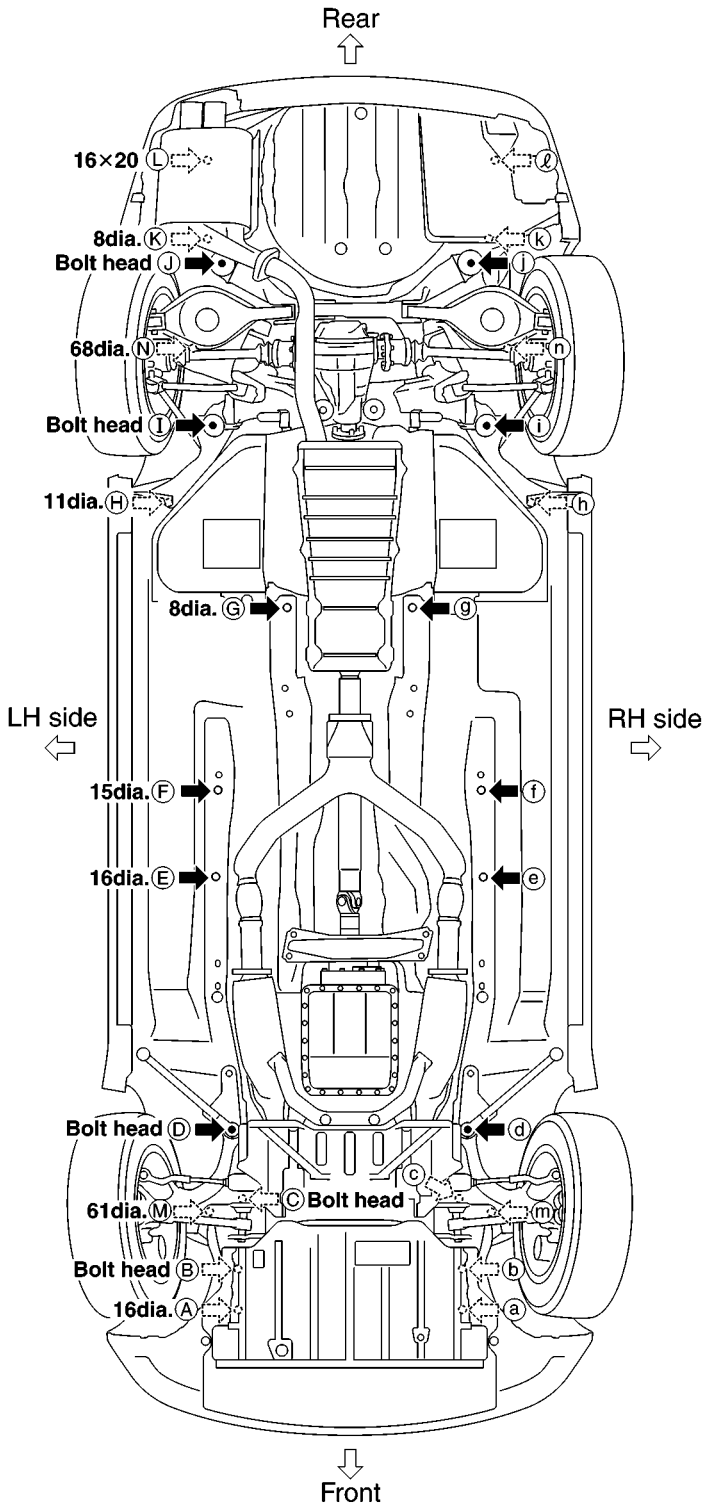

Coordinates:

(A), (a)	(I), (i)
X:413	X:473
Y:-368	Y:2604
Z:305	Z:114
(B), (b)	(J), (j)
X:411	X:452
Y:-261	Y:3164
Z:95	Z:179
(C), (c)	(K)
X:395	X:550
Y:76	Y:3265
Z:120	Z:316
(D), (d)	(k)
X:388	X:-500
Y:279	Y:3273
Z:47	Z:316
(E), (e)	(L), (l)
X:438	X:535
Y:1100	Y:3540
Z:79	Z:329
(F), (f)	
X:440	
Y:1400	
Z:79	
(G), (g)	
X:205	
Y:1992	
Z:59	
(H), (h)	
X:605	
Y:2391	
Z:128	

Front and rear strut tower centers

Coordinates:

(M), (m)
X:434
Y:29
Z:682
(N), (n)
X:524
Y:2882
Z:785

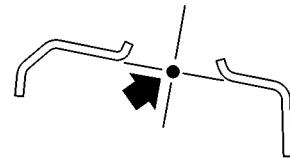

Front: (M), (m) 61dia.

Rear: (N), (n) 68dia.

SIIA2396E

BODY REPAIR

PASSENGER COMPARTMENT

Measurement

Unit : mm

Figures marked with a (*) indicate symmetrically identical dimensions on both right and left hand sides of the vehicle.

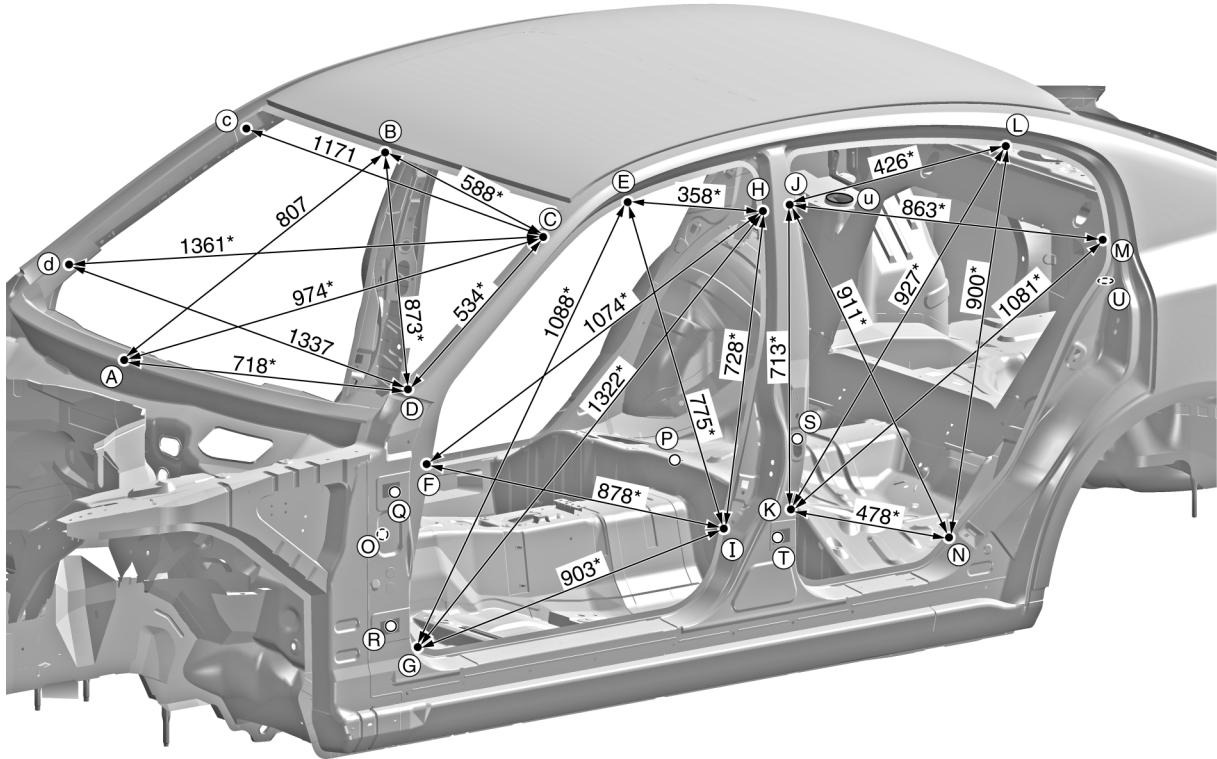

Point	Dimension	Point	Dimension	Point	Dimension
E~e	1,169	J~k	1,516*	Q~Q	755*
E~g	1,697*	J~l	1,269*	Q~H	1,319*
E~h	1,253*	J~m	1,549*	Q~I	1,007*
E~i	1,516*	J~n	1,619*	P~J	998*
F~f	1,452	K~k	1,452	P~K	771*
F~h	1,716*	K~l	1,593*	P~L	1,044*
F~i	1,696*	K~m	1,765*	P~M	1,136*
G~g	1,452	K~n	1,528*	P~N	758*
G~h	1,881*	L~l	1,157	P~U	1,063*
G~i	1,709*	L~n	1,578*	Q~S	1,150*
H~h	1,233	M~m	1,342	Q~T	1,125*
H~i	1,523*	N~n	1,452	R~S	1,219*
I~i	1,452	O~E	1,131*	R~T	1,108*
J~j	1,233	O~F	834*		

SIIA2369E

BODY REPAIR

Measurement Points

(A) : Upper dash crossmember positioning mark center of center positioning mark

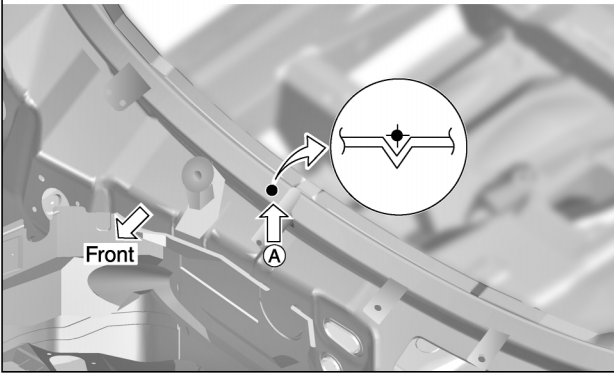

(B) : Front roof flange end of center positioning mark
(C), (c) : Front pillar flange end

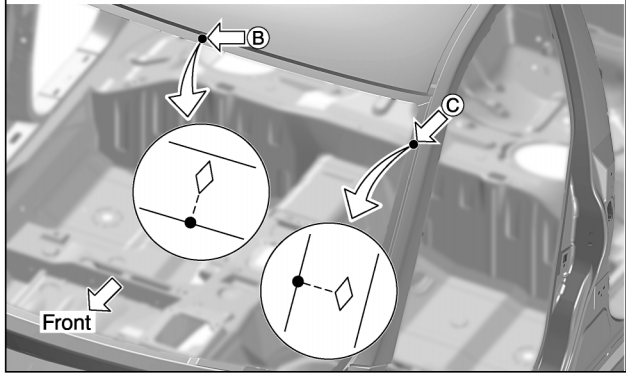

(D), (d) : Front pillar flange end

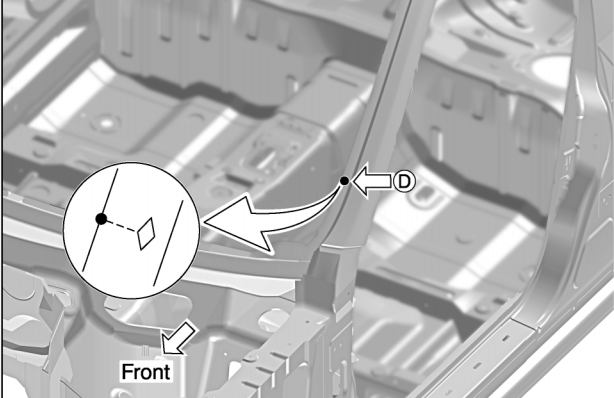

(E), (e), (G), (g) : Front pillar indent
(F), (f) : Front pillar flange end
(Q), (q), (R), (r) : Door hinge installing nut center(12dia.)

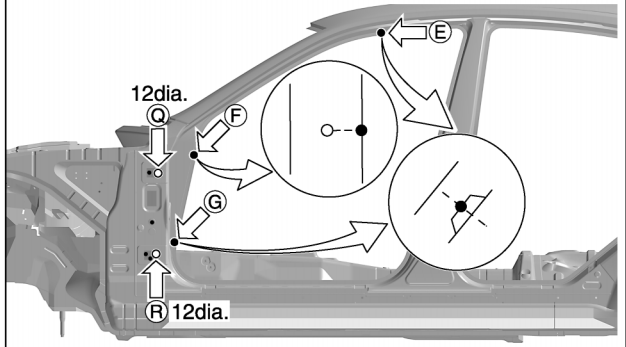

(H), (h), (I), (i), (J), (j), (K), (k) : Center pillar indent
(S), (s), (T), (t) : Door hinge installing nut center (S, s: 9dia., T, t: 12dia.)

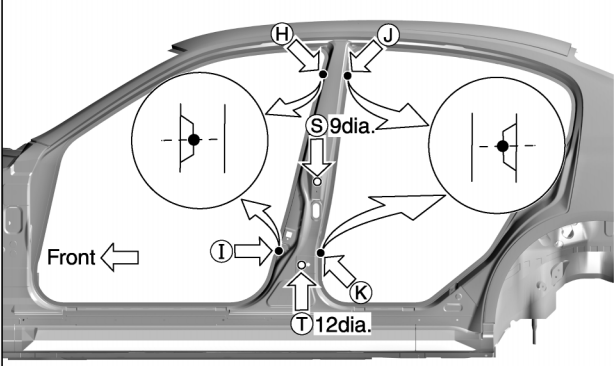

(L), (l), (N), (n) : Rear fender indent
(M), (m) : Rear fender flange end

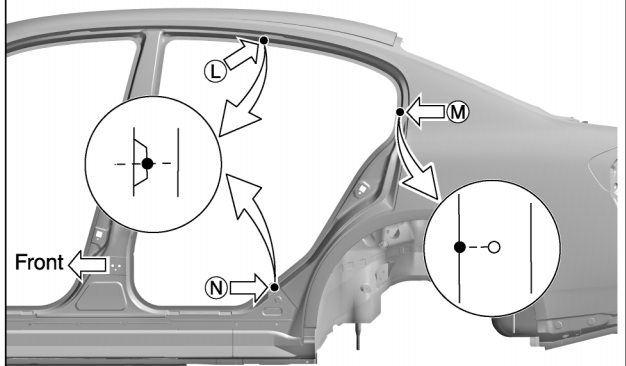

(O) : Center front floor positioning mark center of center positioning mark
(P) : Harness installing hole center of center positioning mark (5dia.)

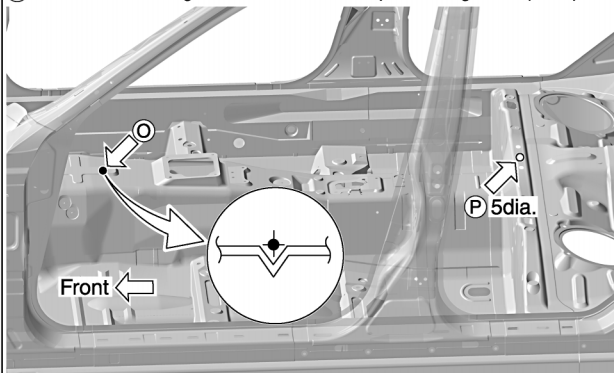

(U), (u) : Rear strut installing hole center (68dia.)

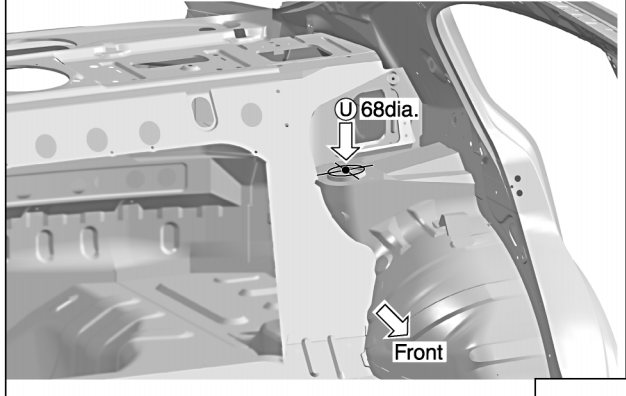

PIIA0742E

A
B
C
D
E
F
G
H
J
K
L
M

BL

BODY REPAIR

REAR BODY Measurement

Figures marked with a (*) indicate symmetrically identical dimensions on both right and left hand sides of the vehicle.

Unit : mm

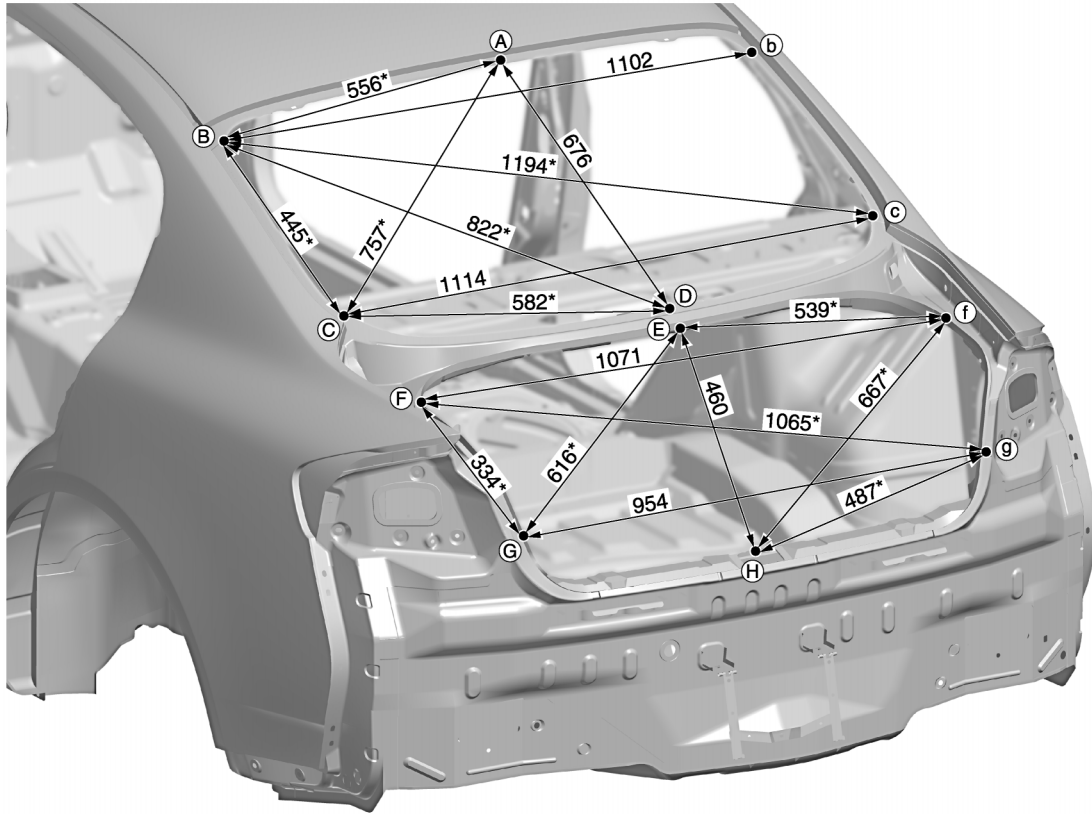

PIA0737E

BODY REPAIR

Measurement Points

- (A) : Rear roof flange end of center positioning mark
(B) , (b) : Rear fender flange end

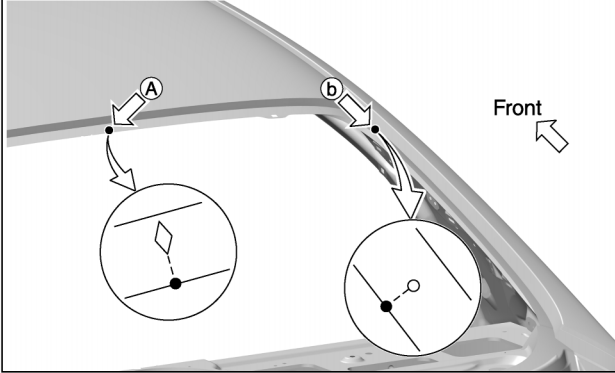

- (C) , (c) : Rear fender flange end
(F) , (f) , (G) , (g) : Rear fender joggle

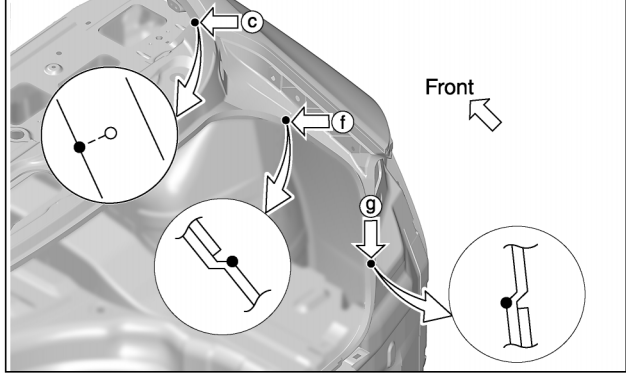

- (D) : Parcel shelf positioning mark center of center positioning mark
(E) : Parcel shelf flange end of center positioning mark

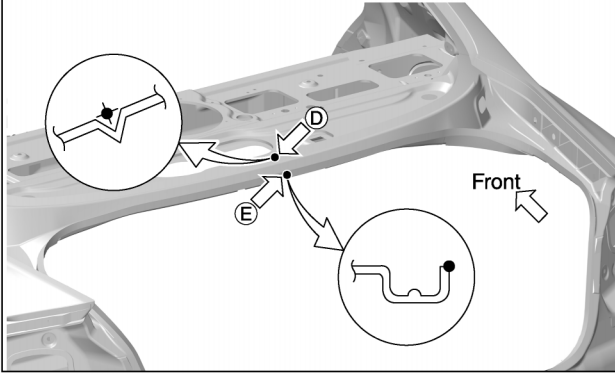

- (H) : Upper rear panel reinforcement of center positioning mark

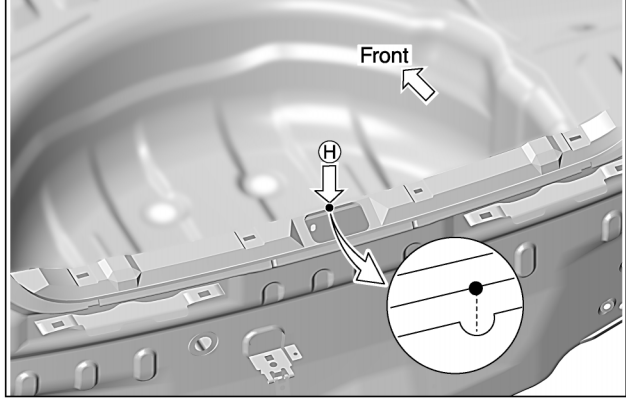

A

B

C

D

E

F

G

H

BL

J

K

L

M

PIIA0741E

BODY REPAIR

Handling Precautions For Plastics HANDLING PRECAUTIONS FOR PLASTICS

AIS00007

Abbreviation	Material name	Heat resisting temperature °C(°F)	Resistance to gasoline and solvents	Other cautions
PE	Polyethylene	60(140)	Gasoline and most solvents are harmless if applied for a very short time (wipe up quickly).	Flammable
PVC	Poly Vinyl Chloride	80(176)	Same as above.	Poison gas is emitted when burned.
EPM/EPDM	Ethylene Propylene (Diene) copolymer	80(176)	Same as above.	Flammable
PP	Polypropylene	90(194)	Same as above.	Flammable, avoid battery acid.
UP	Unsaturated Polyester	90(194)	Same as above.	Flammable
PS	Polystyrene	80(176)	Avoid solvents.	Flammable
ABS	Acrylonitrile Butadiene Styrene	80(176)	Avoid gasoline and solvents.	
PMMA	Poly Methyl Methacrylate	85(185)	Same as above.	
EVAC	Ethylene Vinyl Acetate	90(194)	Same as above.	
ASA	Acrylonitrile Styrene Acrylate	100(222)	Same as above.	Flammable
PPE	Poly Phenylene Ether	110(230)	Same as above.	
PC	Polycarbonate	120(248)	Same as above.	
PAR	Polyarylate	180(356)	Same as above.	
PUR	Polyurethane	90(194)	Same as above.	
POM	Poly Oxymethylene	120(248)	Same as above.	Avoid battery acid.
PBT+PC	Poly Butylene Terephthalate + Polycarbonate	120(248)	Same as above.	Flammable
PA	Polyamide	140(284)	Same as above.	Avoid immersing in water.
PBT	Poly Butylene Terephthalate	140(284)	Same as above.	
PET	Polyester	180(356)	Same as above.	
PEI	Polyetherimide	200(392)	Same as above.	

1. When repairing and painting a portion of the body adjacent to plastic parts, consider their characteristics (influence of heat and solvent) and remove them if necessary or take suitable measures to protect them.
2. Plastic parts should be repaired and painted using methods suiting the materials' characteristics.

BODY REPAIR

LOCATION OF PLASTIC PARTS

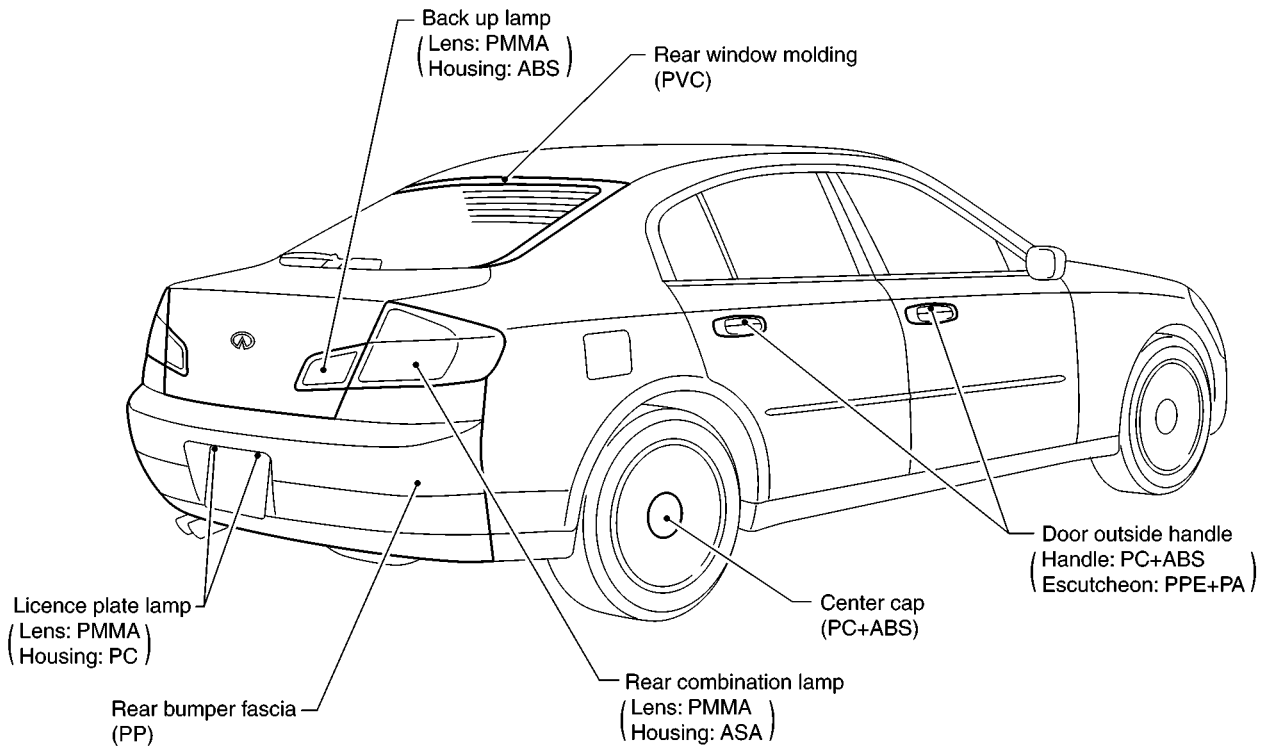
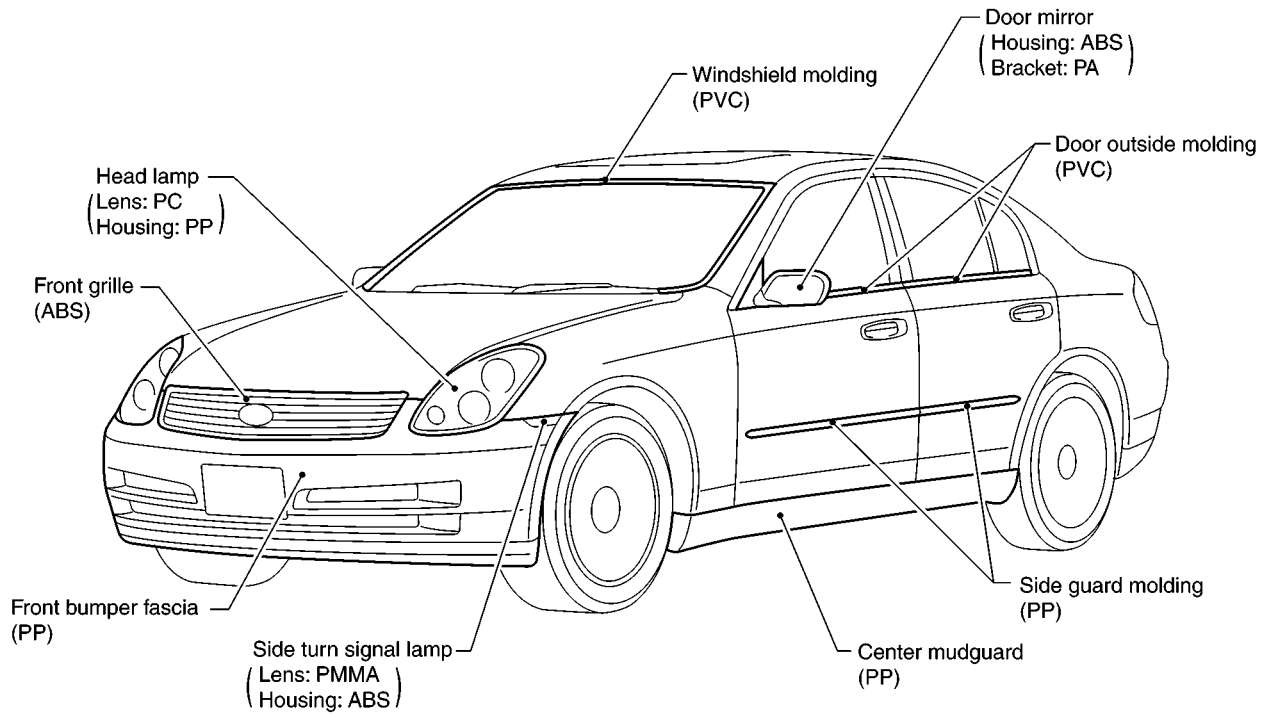

SIIA2353E

BODY REPAIR

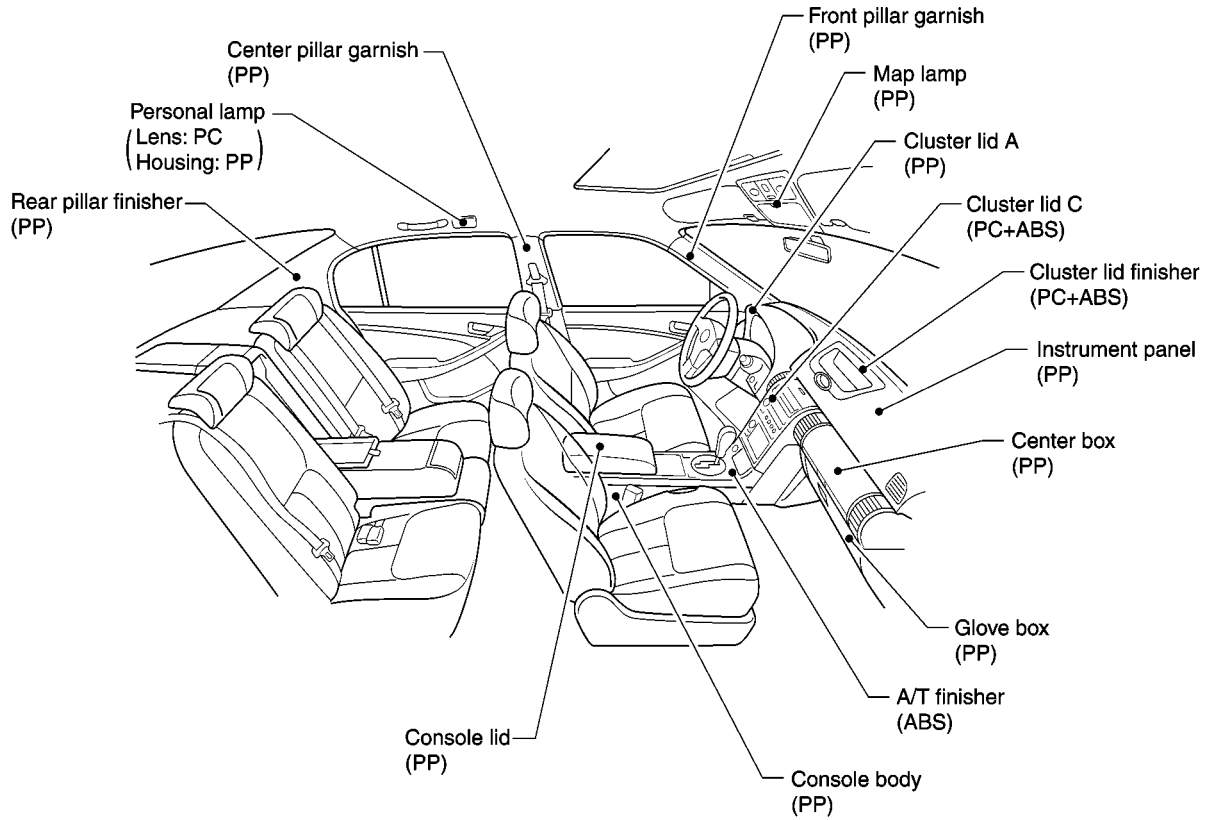

PIIA0841E

BODY REPAIR

Precautions In Repairing High Strength Steel

AIS00008

High strength steel is used for body panels in order to reduce vehicle weight. Accordingly, precautions in repairing automotive bodies made of high strength steel are described below:

HIGH STRENGTH STEEL (HSS) USED IN NISSAN VEHICLES

Tensile strength	Nissan/Infiniti designation	Major applicable parts
373 N/mm ² (38kg/mm ² ,54klb/sq in)	SP130	<ul style="list-style-type: none">● Front side member assembly● Hoodledge assembly● Upper dash● Rear side member assembly● Other reinforcements

SP130 is the most commonly used HSS.

A
B
C
D
E
F
G
H
BL
J
K
L
M

BL

BODY REPAIR

Read the following precautions when repairing HSS:

1. Additional points to consider

- The repair of reinforcements (such as side members) by heating is not recommended since it may weaken the component. When heating is unavoidable, do not heat HSS parts above 550°C (1,022°F). Verify heating temperature with a thermometer. (Crayon-type and other similar type thermometer are appropriate.)

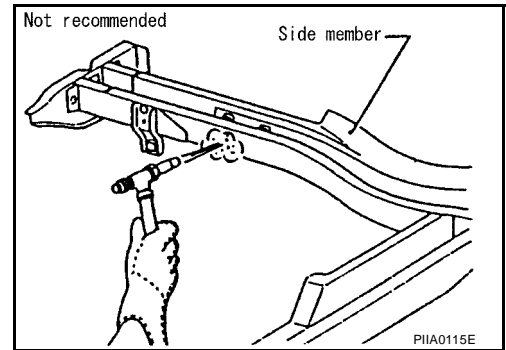

- When straightening body panels, use caution in pulling any HSS panel. Because HSS is very strong, pulling may cause deformation in adjacent portions of the body. In this case, increase the number of measuring points, and carefully pull the HSS panel.

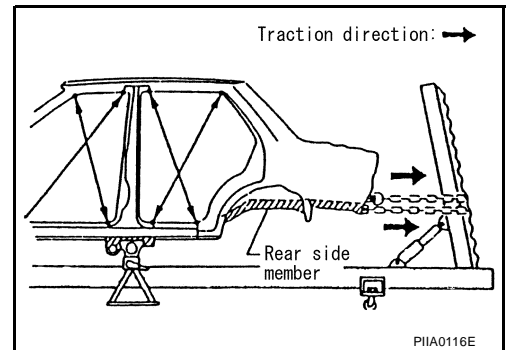

- When cutting HSS panels, avoid gas (torch) cutting if possible. Instead, use a saw to avoid weakening surrounding areas due to heat. If gas (torch) cutting is unavoidable, allow a minimum margin of 50 mm (1.97in).

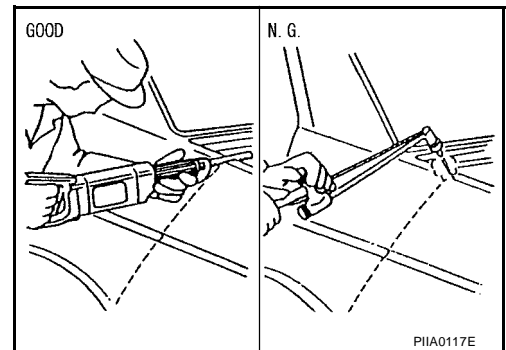

- When welding HSS panels, use spot welding whenever possible in order to minimize weakening surrounding areas due to heat. If spot welding is impossible, use M.I.G. welding. Do not use gas (torch) welding because it is inferior in welding strength.

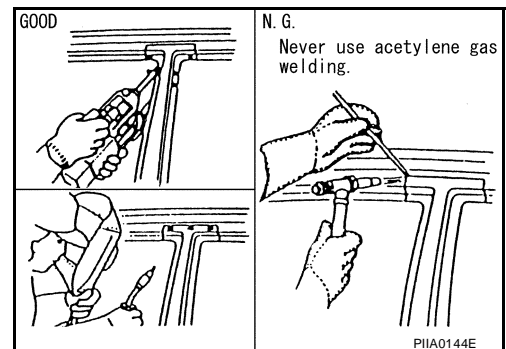

BODY REPAIR

- The spot weld on HSS panels is harder than that of an ordinary steel panel. Therefore, when cutting spot welds on a HSS panel, use a low speed high torque drill (1,000 to 1,200 rpm) to increase drill bit durability and facilitate the operation.

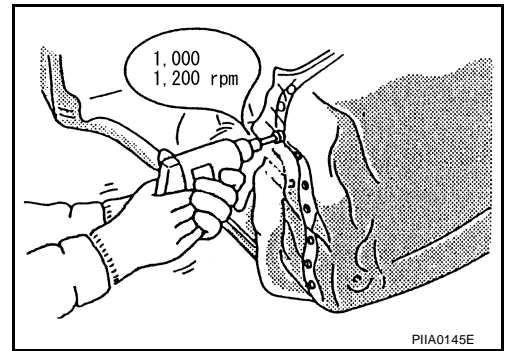

2. Precautions in spot welding HSS

This work should be performed under standard working conditions. Always note the following when spot welding HSS:

- The electrode tip diameter must be sized properly according to the metal thickness.

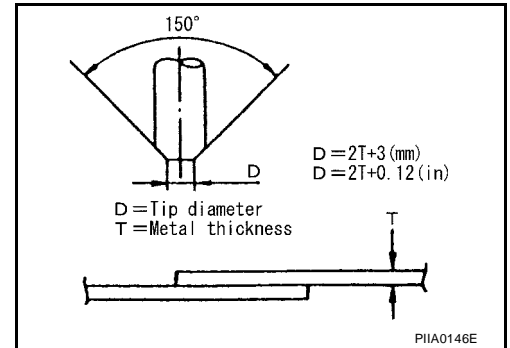

- The panel surfaces must fit flush to each other, leaving no gaps.

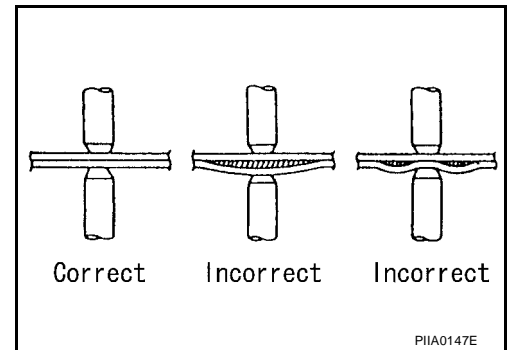

- Follow the specifications for the proper welding pitch.

Thickness (t)	Minimum pitch (l)
0.6 (0.024)	10 (0.39) or over
0.8 (0.031)	12 (0.47) or over
1.0 (0.039)	18 (0.71) or over
1.2 (0.047)	20 (0.79) or over
1.6 (0.063)	27 (1.06) or over
1.8 (0.071)	31 (1.22) or over

Unit:mm

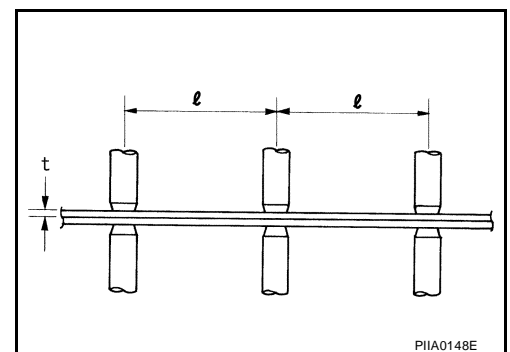

BODY REPAIR

Replacement Operations

AI500009

DESCRIPTION









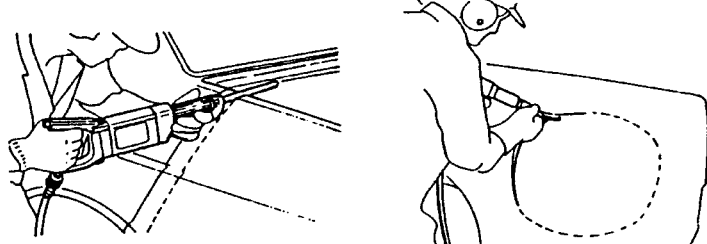
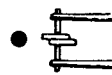
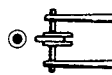

This section is prepared for technicians who have attained a high level of skill and experience in repairing collision-damaged vehicles and also use modern service tools and equipment. Persons unfamiliar with body repair techniques should not attempt to repair collision-damaged vehicles by using this section.

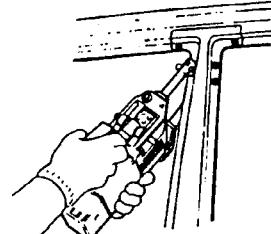
Technicians are also encouraged to read Body Repair Manual (Fundamentals) in order to ensure that the original functions and quality of the vehicle can be maintained. The Body Repair Manual (Fundamentals) contains additional information, including cautions and warning, that are not including in this manual. Technicians should refer to both manuals to ensure proper repairs.

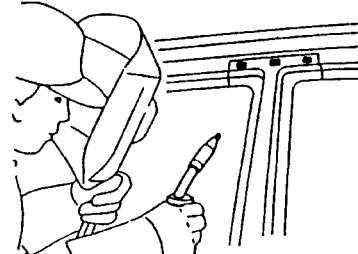
Please note that these information are prepared for worldwide usage, and as such, certain procedures might not apply in some regions or countries.

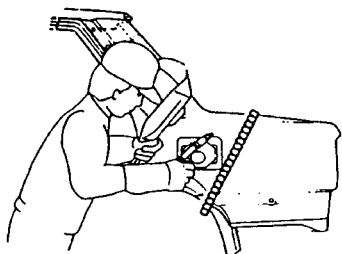
BODY REPAIR

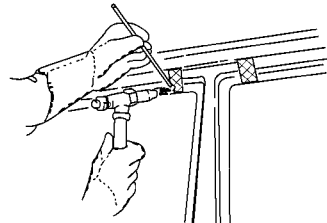
The symbols used in this section for cutting and welding / brazing operations are shown below.

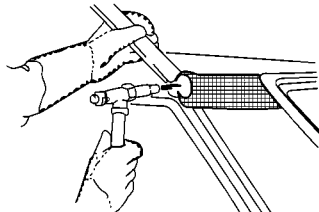
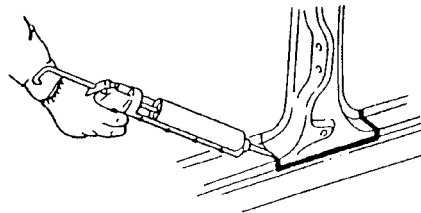
 <p>Saw cut or air chisel cut</p>	
<p>Spot weld</p> <p>●●●● 2-spot welds</p>  <p>●●●● 3-spot welds</p> 	<p>2-spot welds (2-panel overlapping portions)</p>  <p>3-spot welds (3-panel overlapping portions)</p> 
<p>■ ■ ■ ■</p> <p>MIG plug weld</p> 	
 <p>MIG seam weld/ Point weld</p> 	
 <p>Brazing</p> 	
 <p>Soldering</p> 	
<p>Sealing</p>	

A
B
C
D
E
F
G
H
BL
J
K
L
M

BODY REPAIR

- Front pillar butt joint can be determined anywhere within shaded area as shown in the figure. The best location for the butt joint is at position A due to the construction of the vehicle. Refer to the front pillar section.

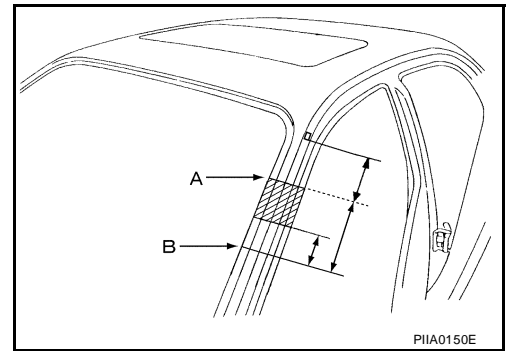

- Determine cutting position and record distance from the locating indent. Use this distance when cutting the service part. Cut outer front pillar over 60 mm above inner front pillar cut position.

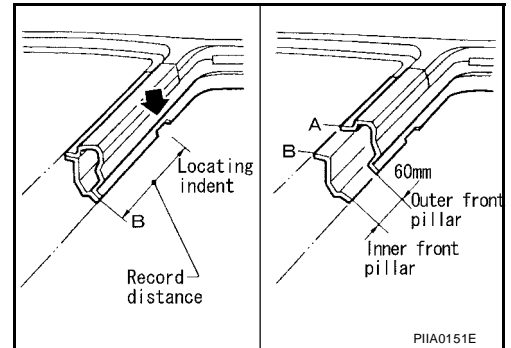

- Prepare a cutting jig to make outer pillar easier to cut. Also, this will permit service part to be accurately cut at joint position.

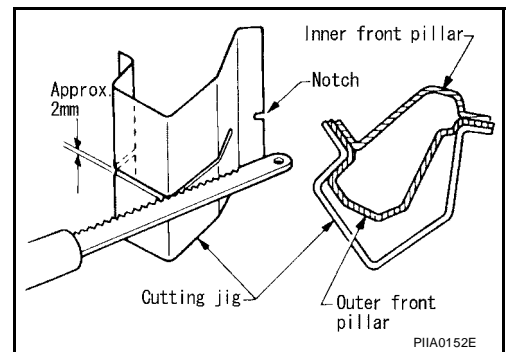

- An example of cutting operation using a cutting jig is as follows.

1. Mark cutting lines.
A: Cut position of outer pillar
B: Cut position of inner pillar
2. Align cutting line with notch on jig. Clamp jig to pillar.
3. Cut outer pillar along groove of jig. (At position A)
4. Remove jig and cut remaining portions.
5. Cut inner pillar at position B in same manner.

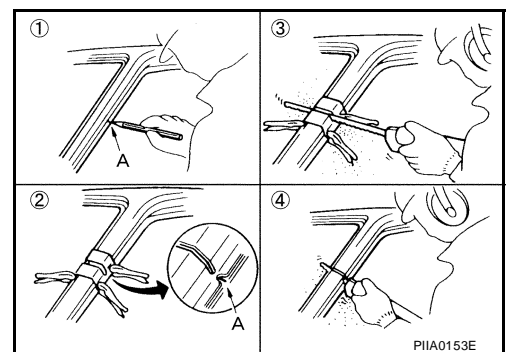

BODY REPAIR

HOODLEDGE

Service Joint

Remove front side member center closing plate for easier installation.

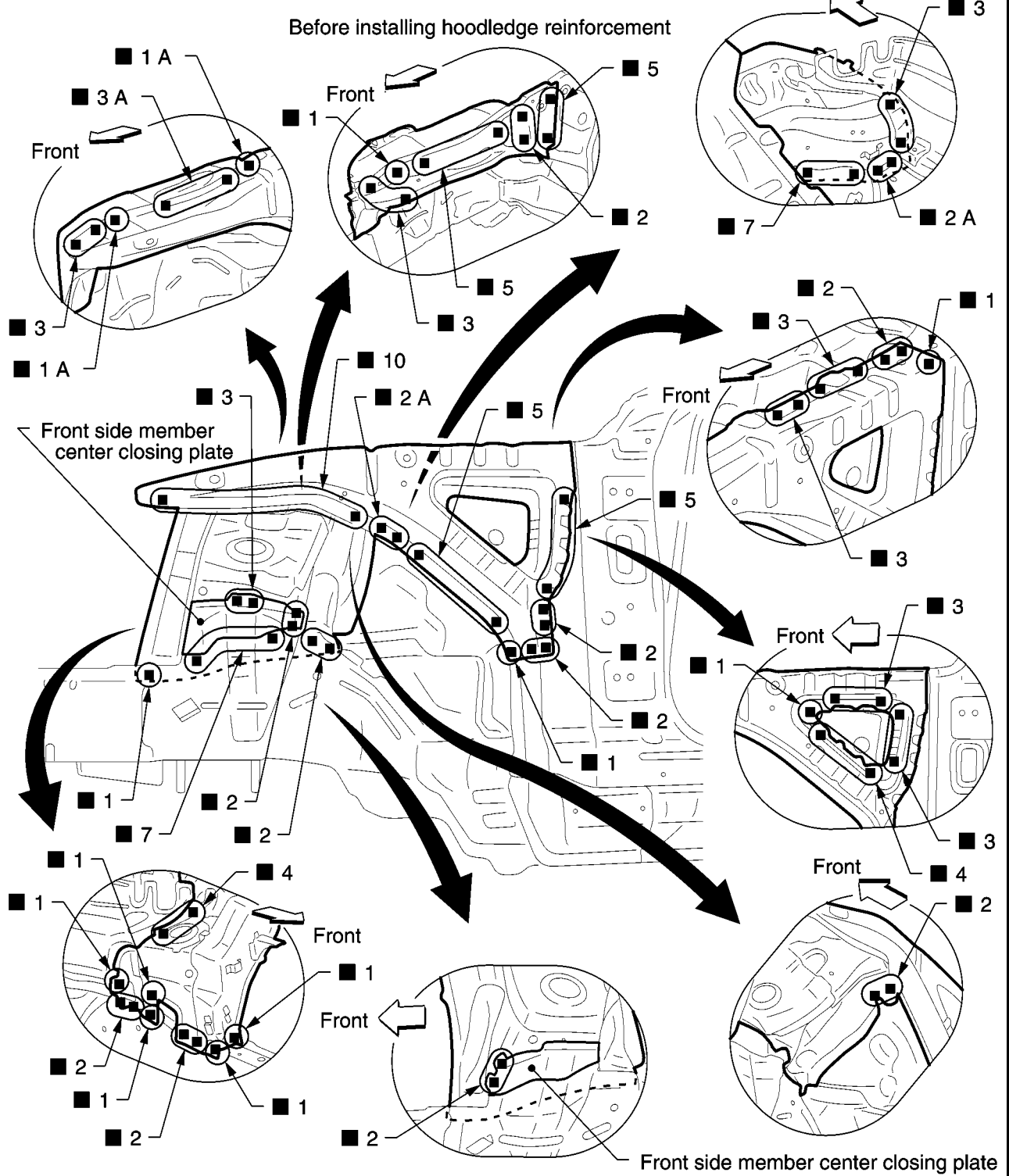

2-spot welds

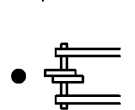

3-spot welds

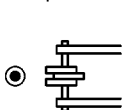

M I G plug weld



For 3 panels plug weld method



M I G seam weld/
Point weld



PIIA0953E

A
B
C
D
E
F
G
H
BL
J
K
L
M

BODY REPAIR

FRONT SIDE MEMBER (PARTIAL REPLACEMENT) (AWD MODELS)

A
B
C
D
E
F
G
H
BL
J
K
L
M

Service Joint

(This figure shows right front side member)

Remove front suspension mounting member bracket for easier installation.

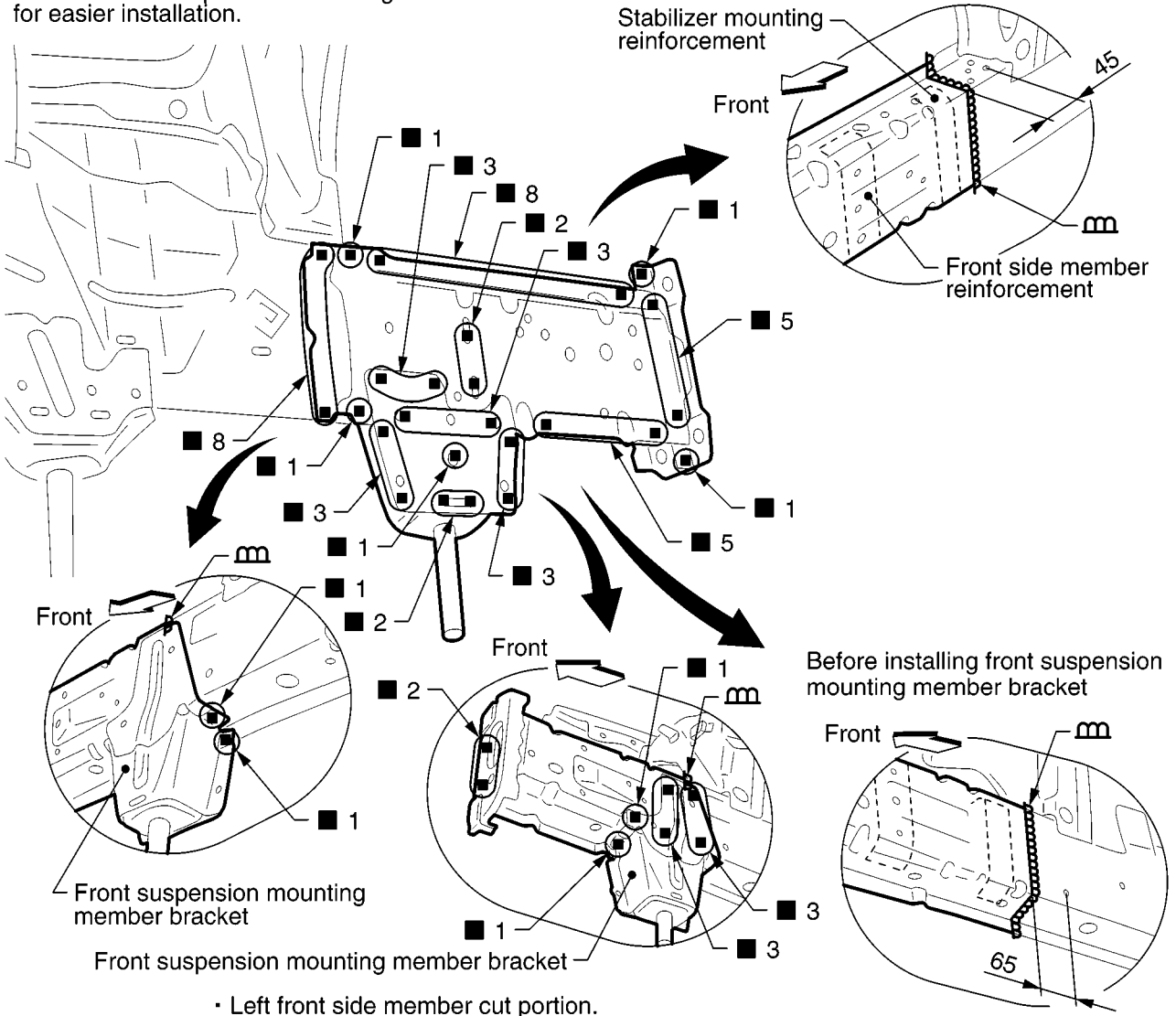

• Left front side member cut portion.

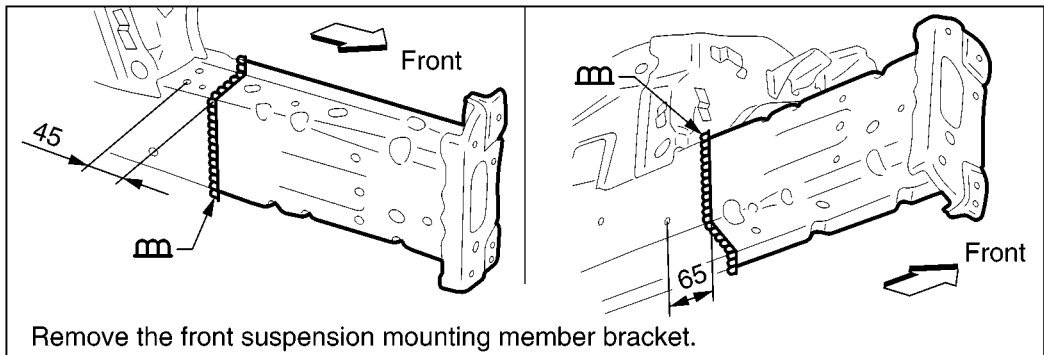

Unit:mm

2-spot welds



3-spot welds



MIG plug weld



For 3 panels plug weld method

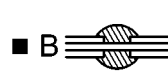

MIG seam weld/
Point weld



SIIA2398E

BODY REPAIR

FRONT PILLAR

- Work after hoodledge reinforcement has been removed.

Service Joint

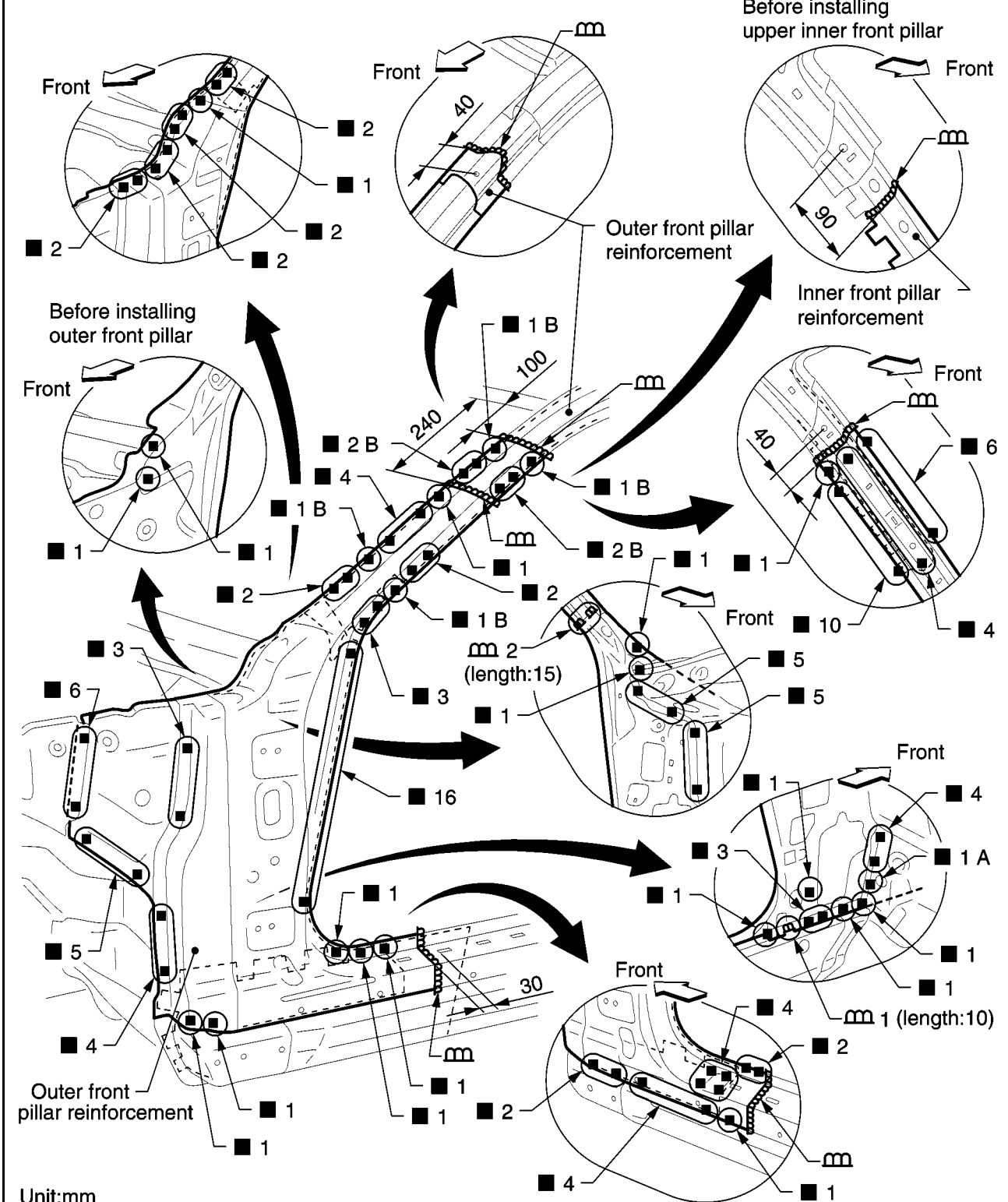

Unit:mm

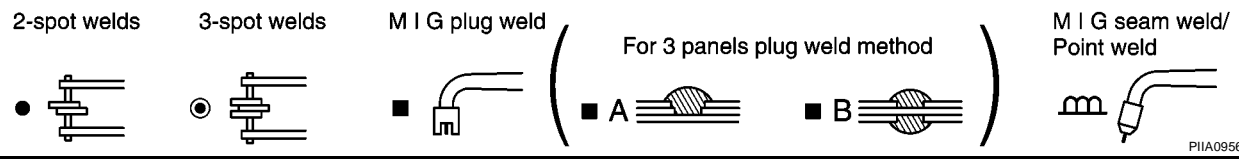

PIA0956E

BODY REPAIR

OUTER SILL (CONT'D)

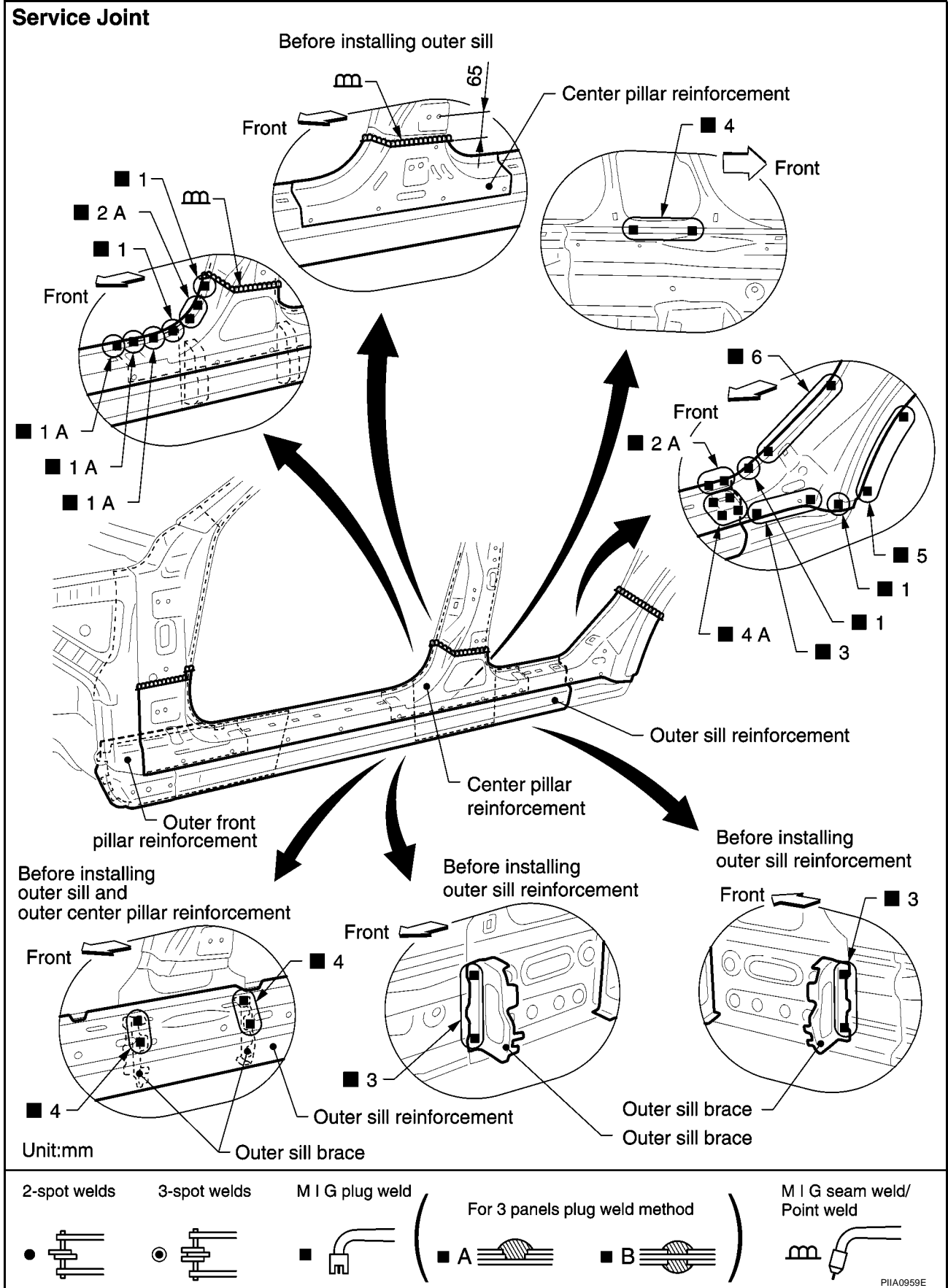

A
B
C
D
E
F
G
H
BL
J
K
L
M

BODY REPAIR

REAR PANEL

Service Joint

★ indicates that there is an equivalent welding portion with the same dimensions on the opposite side.

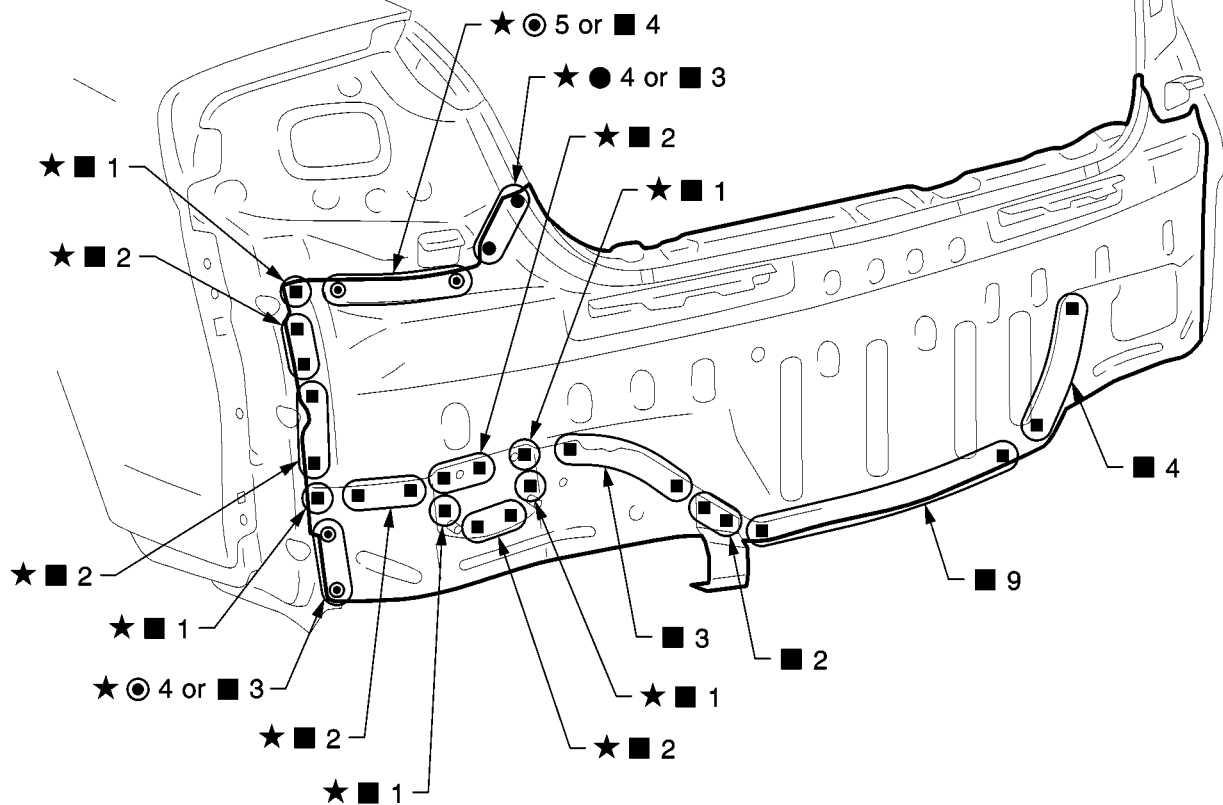

2-spot welds

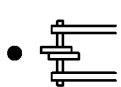

3-spot welds



M I G plug weld



For 3 panels plug weld method



M I G seam weld/
Point weld



PIIA0961E

A
B
C
D
E
F
G
H
BL
J
K
L
M

BODY REPAIR

REAR FLOOR REAR

- Work after upper rear panel assembly has been removed.

Service Joint

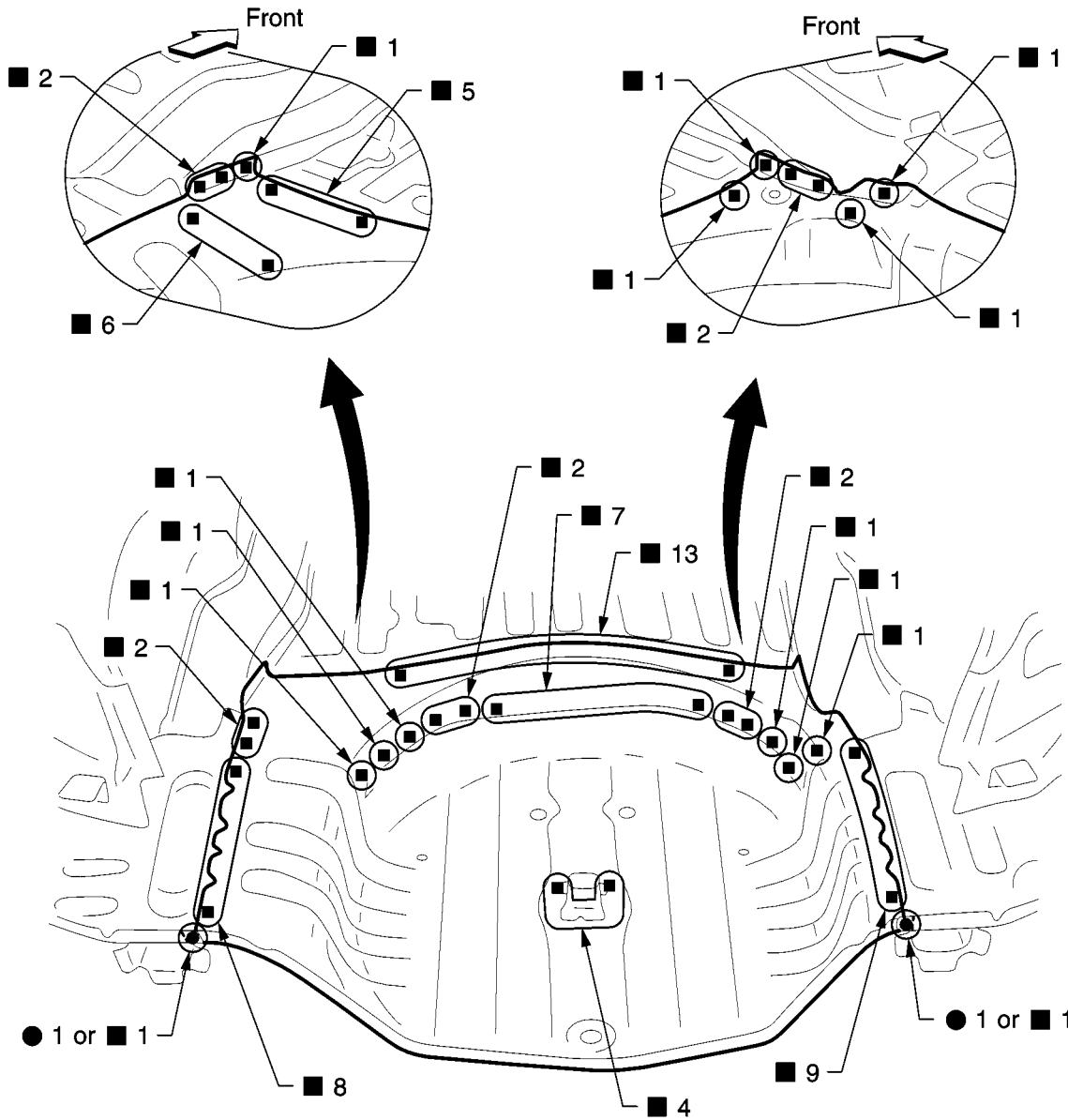

2-spot welds

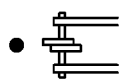

3-spot welds

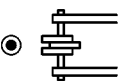

M I G plug weld

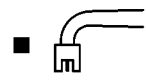

For 3 panels plug weld method



M I G seam weld/
Point weld

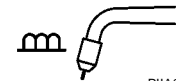

PIIA0962E

BODY REPAIR

REAR SIDE MEMBER EXTENSION

- Work after upper rear panel assembly has been removed.

Service Joint

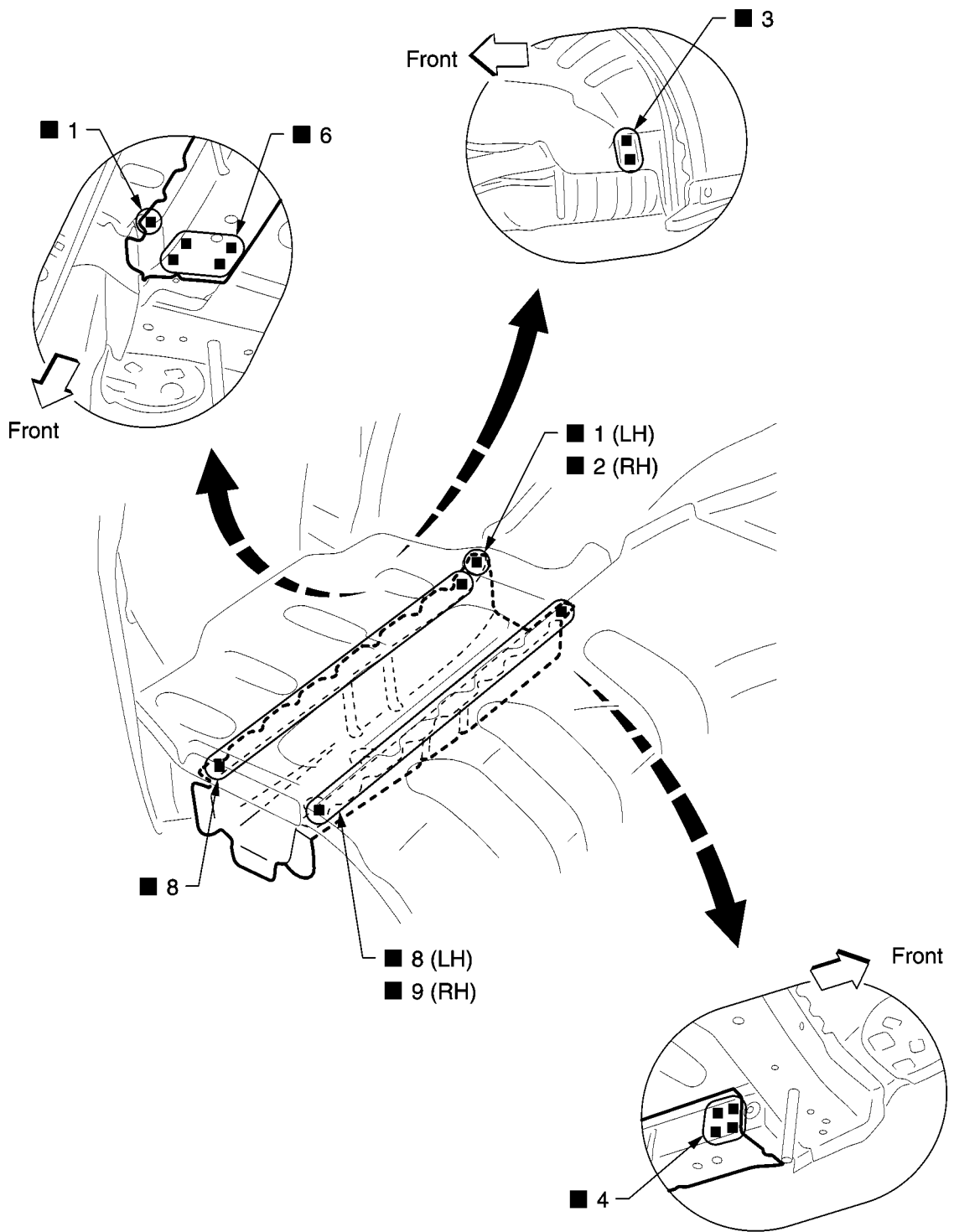

2-spot welds

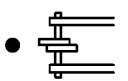

3-spot welds

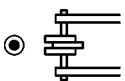

M I G plug weld

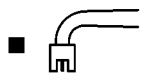

For 3 panels plug weld method



M I G seam weld/
Point weld

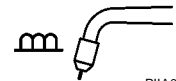

PIIA0963E

A
B
C
D
E
F
G
H
BL
J
K
L
M

BODY REPAIR
