

SECTION **FAX**
FRONT AXLE

A
B
C

FAX

CONTENTS

E

2WD

PREPARATION 2
 Special Service Tools (SST) 2
 Commercial Service Tools 2

NOISE, VIBRATION AND HARSHNESS (NVH)

TROUBLESHOOTING 3
 NVH Troubleshooting Chart 3

FRONT WHEEL HUB AND KNUCKLE 4
 On-Vehicle Inspection and Service 4
 WHEEL BEARING INSPECTION 4
 Removal and Installation 4
 REMOVAL 4
 INSPECTION AFTER REMOVAL 5
 INSTALLATION 6

SERVICE DATA 7
 Wheel Bearing 7
 Ball Joint 7

AWD

PRECAUTIONS 8
 Caution 8

PREPARATION 9
 Special Service Tools (SST) 9
 Commercial Service Tools 10

NOISE, VIBRATION AND HARSHNESS (NVH)

TROUBLESHOOTING 11
 NVH Troubleshooting Chart 11

FRONT WHEEL HUB AND KNUCKLE 12
 On-Vehicle Inspection and Service 12
 WHEEL BEARING INSPECTION 12
 Removal and Installation 12
 REMOVAL 12
 INSPECTION AFTER REMOVAL 13
 INSTALLATION 14
 Disassembly and Assembly 14
 DISASSEMBLY 14
 INSPECTION AFTER DISASSEMBLY 14
 ASSEMBLY 15

FRONT DRIVE SHAFT 16
 On Vehicle Inspection and Service 16
 DRIVE SHAFT BOOT REPLACEMENT 16
 Removal and installation 19
 REMOVAL 19
 INSPECTION AFTER REMOVAL 20
 INSTALLATION 20
 Disassembly and Assembly 21
 DISASSEMBLY 21
 INSPECTION AFTER DISASSEMBLY 22
 ASSEMBLY 23

SERVICE DATA 27
 Wheel Bearing 27
 Ball Joint 27
 Drive Shaft 27
 Z80T70C 27
 Z80T82F 27
 Tightening Torque 27

F
G
H
I
J
K
L
M

PREPARATION

[2WD]

PFP:00002

ADS000YS

PREPARATION

Special Service Tools (SST)

The actual shapes of Kent-Moore tools may differ from those of special service tools illustrated here.

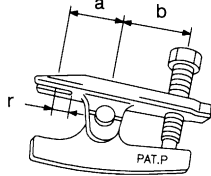
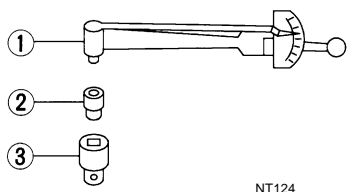
Tool number (Kent-Moore No.) Tool name	Description
HT7252 0000 (J25730-A) Ball joint remover a: 33 mm (1.30 in) b: 50 mm (1.97 in) r: 11.5 mm (0.453 in)	 <p>NT546</p> <p>Removing steering outer socket</p>
ST3127 S000 (See J25742-1) Preload Gauge 1. GG91030000 Torque wrench (J25765) 2. HT62940000 (—) Socket adapter (1/2") 3. HT62900000 (—) Socket adapter (3/8")	 <p>NT124</p> <p>Measuring rotating torque of ball joint</p>

Commercial Service Tools

ADS000YT

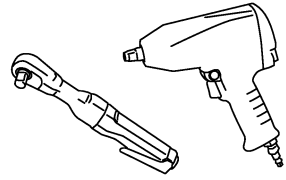
Tool name	Description
Power tool	 <p>PBIC0190E</p> <ul style="list-style-type: none"> ● Removing wheel nuts ● Removing undercover ● Removing brake caliper assembly

NOISE, VIBRATION AND HARSHNESS (NVH) TROUBLESHOOTING

[2WD]

NOISE, VIBRATION AND HARSHNESS (NVH) TROUBLESHOOTING

PFP:00003

NVH Troubleshooting Chart

ADS000YU

Use chart below to help you find the cause of the symptom. If necessary, repair or replace these parts.

Reference page			FAX-4	—	FAX-4	NVH in WT section.	NVH in WT section.	NVH in PS section.
Possible cause and SUSPECTED PARTS			Improper installation, looseness	Parts interference	Wheel bearing damage	TIRES	ROAD WHEEL	STEERING
Symptom	FRONT AXLE	Noise	x	x		x	x	x
		Shake	x	x		x	x	x
		Vibration	x	x		x		x
		Shimmy	x	x		x	x	x
		Judder	x			x	x	x
		Poor quality ride or handling	x	x	x	x	x	

x: Applicable

A
B
C
FAX
E
F
G
H
I
J
K
L
M

FRONT WHEEL HUB AND KNUCKLE

PFP:40202

On-Vehicle Inspection and Service

ADS000YV

Make sure the mounting conditions (looseness, back lash) of each component and component status (wear, damage) are normal.

WHEEL BEARING INSPECTION

- Move wheel hub in the axial direction by hand. Make sure there is no looseness of wheel bearing.

Axial end play limit : 0.05 mm (0.002 in) or less

- Rotate wheel hub and make sure there is no unusual noise or other irregular conditions. If there are any irregular conditions, replace wheel hub and bearing assembly.

Removal and Installation

ADS000YW

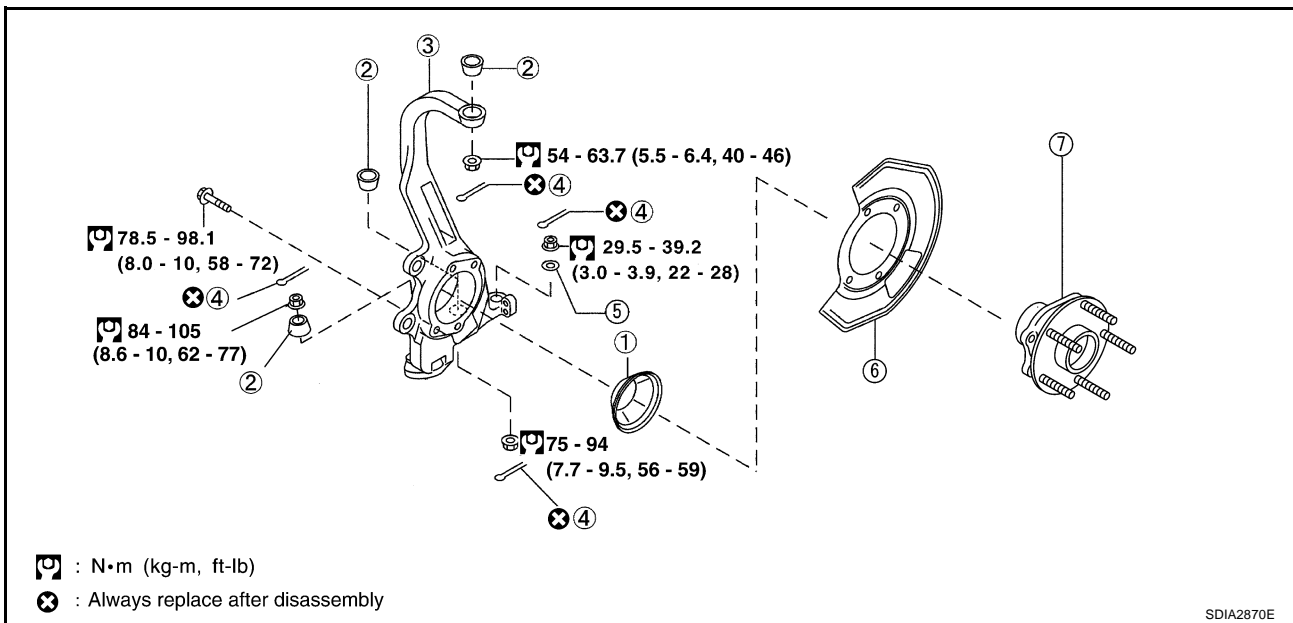

- | | | |
|-----------------------------------|--------------|---------------------|
| 1. Hub cap | 2. Ball seat | 3. Steering knuckle |
| 4. Cotter pin | 5. Washer | 6. Splash guard |
| 7. Wheel hub and bearing assembly | | |

REMOVAL

1. Remove tire from vehicle with power tool.
2. Remove undercover with power tool.
3. Remove brake caliper with power tool. Hang it in a place where it will not interfere with work. Refer to [BR-25, "FRONT DISC BRAKE"](#).

NOTE:

Avoid depressing brake pedal while brake caliper is removed.

4. Remove disc rotor.
5. Remove wheel sensor from steering knuckle. Refer to [BRC-66, "WHEEL SENSOR"](#).

CAUTION:

Do not pull on wheel sensor harness.

6. Remove brake hose bracket from steering knuckle. Refer to [BR-11, "BRAKE PIPING AND HOSE"](#).
7. Remove cotter pin at steering outer socket, then loosen mounting nut.

FRONT WHEEL HUB AND KNUCKLE

[2WD]

8. Use a ball joint remover (SST) to remove steering outer socket from steering knuckle. Be careful not to damage ball joint boot.

CAUTION:

Tighten temporarily mounting nut to prevent damage to threads and to prevent ball joint remover (SST) from coming off.

9. After removing upper link, transverse link, compression rod and cotter pin at steering knuckle, loosen mounting nut.
10. Use a ball joint remover (suitable tool) to remove upper link, transverse link and compression rod from steering knuckle. Be careful not to damage ball joint boot.

CAUTION:

Tighten temporarily mounting nut to prevent damage to threads and to prevent ball joint remover (suitable tool) from coming off.

11. Remove steering knuckle and wheel hub bearing assembly fixing bolt.
12. Remove wheel hub bearing assembly from steering knuckle.

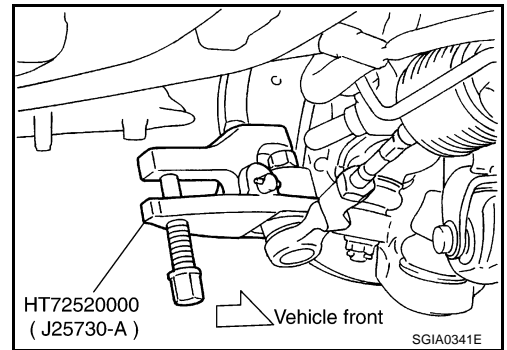

INSPECTION AFTER REMOVAL

- About the inspection for upper link, compression rod, steering outer socket, refer to [FSU-13, "UPPER LINK"](#), [FSU-15, "COMPRESSION ROD"](#), [PS-17, "POWER STEERING GEAR AND LINKAGE"](#).

Visual Inspection

- Check steering knuckle and ball seat for deformation, cracks, and other damage. Replace steering knuckle and ball seat if cracks, deformation or other damage is found.
- Check ball joint boot for deformation, damage, and also for grease leakage. Replace steering knuckle assembly if cracks, deformation or also for grease leakage is found.

Steering Knuckle Ball Joint Inspection

- Manually move ball stud to confirm it moves smoothly with no binding.

Swing Torque Inspection

CAUTION:

Before measurement, move ball joint at least ten times by hand to check for smooth movement.

- Hook spring scale at cotter pin mounting hole. Confirm spring scale measurement value is within specifications when ball stud begins moving.

Standard value

Swing force:

0.147 - 1.4 N·m (0.02 - 0.14 kg·m, 2 - 12 in·lb)

Measurement force:

2.23 - 21.2 N (0.22 - 2.16 kg, 0.50 - 4.77 lb)

- If the value is outside the standard, replace steering knuckle.

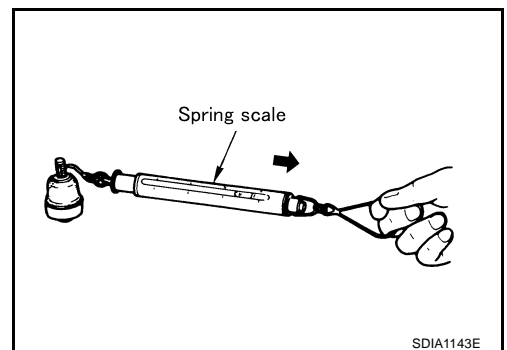

Rotating Torque Inspection

- Attach mounting nut to ball stud. Check that rotating torque is within specifications with a preload gauge (SST).

Standard value

Rotating torque:

0.147 - 1.4 N·m (0.02 - 0.14 kg·m, 2 - 12 in·lb)

- If the value is outside the standard, replace steering knuckle.

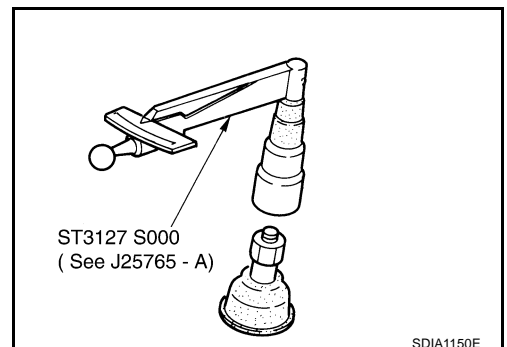

Axial End Play

- Move tip of ball joint in axial direction to check for looseness.

Standard value

Axial end play : 0 mm (0 in)

- If the value is outside the standard, replace steering knuckle.

INSTALLATION

- Refer to [FAX-4, "Removal and Installation"](#) for tightening torque. Install in the reverse order of removal.

NOTE:

Refer to component parts location and do not reuse non-reusable parts.

- Wheel hub and bearing assembly and disc must be installed to fit the marked position each other.

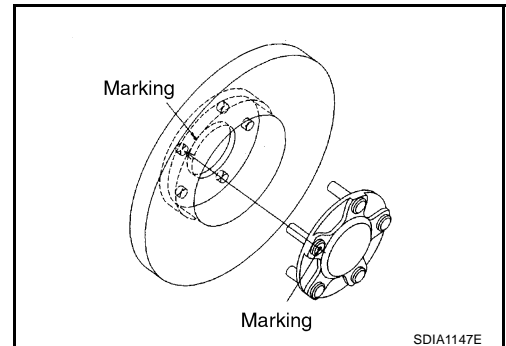

SERVICE DATA

[2WD]

SERVICE DATA

PF0:00030

Wheel Bearing

ADS000YX

Axial end play	0.05 mm (0.002 in) or less
----------------	----------------------------

Ball Joint

ADS000YY

Swing force	0.147 - 1.4 N·m (0.02 - 0.14 kg-m, 2 - 12 in-lb)
Measurement on spring balance (Spring scale hooking position: cotter pin mounting hole)	2.23 - 21.2 N (0.22 - 2.16 kg, 0.50 - 4.77 lb)
Rotating torque	0.147 - 1.4 N·m (0.02 - 0.14 kg-m, 2 - 12 in-lb)
Axial end play limit	0 mm (0 in)

A
B
C
FAX
E
F
G
H
I
J
K
L
M

PRECAUTIONS

PF0:00001

Caution

ADS000YE

Observe the following precautions when disassembling and servicing drive shaft.

- Bearing in wheel joint does not disassemble because it is non-overhaul parts.
- Perform work in a location which is as dust-free as possible.
- Before disassembling and servicing, clean the outside of parts.
- Prevention of the entry of foreign objects must be taken into account during disassembly of the service location.
- Disassembled parts must be carefully reassembled in the correct order. If work is interrupted, a clean cover must be placed over parts.
- Paper shop cloths must be used. Fabric shop cloths must not be used because of the danger of lint adhering to parts.
- Disassembled parts (except for rubber parts) should be cleaned with kerosene which shall be removed by blowing with air or wiping with paper shop cloths.

PREPARATION

[AWD]

PF0:00002



ADS000YF

PREPARATION

Special Service Tools (SST)

The actual shapes of Kent-Moore tools may differ from those of special service tools illustrated here.

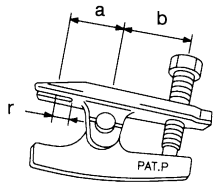
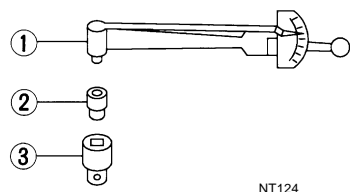
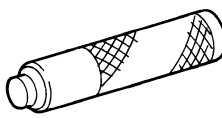
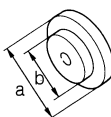
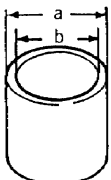
A
B
C
FAX
E
F
G
H
I
J
K
L
M

Tool number (Kent-Moore No.) Tool name	Description
HT7252 0000 (J25730-A) Ball joint remover a: 33 mm (1.30 in) b: 50 mm (1.97 in) r: 11.5 mm (0.453 in)	 Removing steering outer socket
ST3127 S000 (See J25742-1) Preload Gauge 1. GG91030000 Torque wrench (J25765) 2. HT62940000 (—) Socket adapter (1/2") 3. HT62900000 (—) Socket adapter (3/8")	 Measurement ball joint of rotating torque
ST3325 1000 (—) Drift	 Removing wheel bearing outer side inner race
ST3302 2000 (—) Drift a: ϕ 67 mm (2.64 in) b: ϕ 51 mm (2.01 in)	 Installing wheel bearing
KV401 05310 (—) Drift a: ϕ 89.1 mm (3.508 in) b: ϕ 80.7 mm (3.177 in)	 Installing wheel bearing
KV401007500 (—) Drive shaft attachment	 Removing drive shaft

PREPARATION

[AWD]

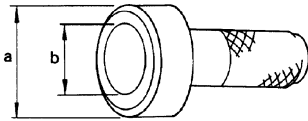
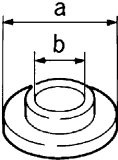
Tool number (Kent-Moore No.) Tool name	Description
KV381 00500 (—) Drift a: ϕ 80 mm (3.15 in) b: ϕ 60 mm (2.36 in)	 <p style="text-align: center;">ZZA0701D</p> Installing drive shaft plug
KV381 02200 (—) Drift a: ϕ 90 mm (3.54 in) b: ϕ 31 mm (1.22 in)	 <p style="text-align: center;">ZZA0920D</p> Installing drive shaft plug

Commercial Service Tools

ADS000YG

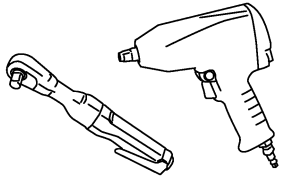
Tool name	Description
Power tool	 <p style="text-align: center;">PBIC0190E</p> <ul style="list-style-type: none"> ● Removing wheel nuts ● Removing undercover ● Removing brake caliper assembly ● Removing wheel bearing lock nut ● Remove fixing bolt of wheel hub and bearing assembly

NOISE, VIBRATION AND HARSHNESS (NVH) TROUBLESHOOTING

[AWD]

NOISE, VIBRATION AND HARSHNESS (NVH) TROUBLESHOOTING

PFP:00003

NVH Troubleshooting Chart

ADS00106

Use chart below to help you find the cause of the symptom. If necessary, repair or replace these parts.

Reference page			—	FAX-22	—	FAX-12	—	FAX-12	NVH in FFD section	NVH in FAX and FSU section	Refer to FRONT AXLE in this chart.	NVH in WT section	NVH in WT section	Refer to DRIVE SHAFT in this chart.	NVH in BR section	NVH in PS section	
Possible cause and SUSPECTED PARTS			Excessive joint angle	Joint sliding resistance	Imbalance	Improper installation, looseness	Parts interference	Wheel bearing damage	FRONT DIFFERENTIAL	FRONT AXLE AND FRONT SUSPENSION	FRONT AXLE	TIRES	ROAD WHEEL	DRIVE SHAFT	BRAKES	STEERING	
Symptom	DRIVE SHAFT	Noise	x	x				x	x	x	x	x	x		x	x	
		Shake	x		x			x		x	x	x	x		x	x	
	FRONT AXLE	Noise				x	x	x	x		x	x	x	x	x	x	x
		Shake				x	x	x			x	x	x	x	x	x	x
		Vibration				x	x	x			x	x		x		x	x
		Shimmy				x	x				x	x	x		x	x	x
		Judder				x					x	x	x		x	x	x
		Poor quality ride or handling				x	x				x	x	x				

x: Applicable

A
B
C
D
E
F
G
H
I
J
K
L
M

FAX

FRONT WHEEL HUB AND KNUCKLE

PFP:40202

On-Vehicle Inspection and Service

ADS000YI

Make sure the mounting conditions (looseness, back lash) of each component and component status (wear, damage) are normal.

WHEEL BEARING INSPECTION

- Move wheel hub in the axial direction by hand. Make sure there is no looseness of wheel bearings.

Axial end play : 0.05 mm (0.002 in) or less

- Rotate wheel hub and make sure there is no unusual noise or other irregular conditions. If there are any irregular conditions, replace wheel bearings.

Removal and Installation

ADS000YJ

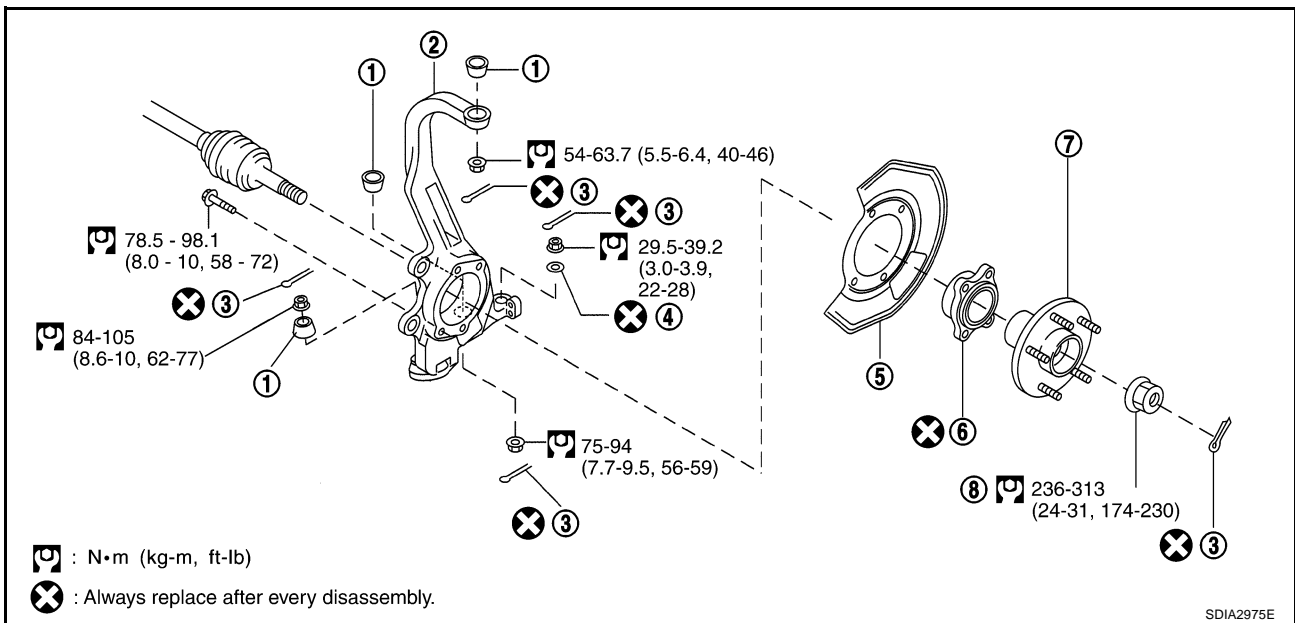

- | | | |
|--------------|---------------------------|------------------|
| 1. Ball seat | 2. Steering knuckle | 3. Cotter pin |
| 4. Washer | 5. Splash guard | 6. Wheel bearing |
| 7. Wheel hub | 8. Wheel bearing lock nut | |

REMOVAL

1. Remove tire from vehicle with power tool.
2. Remove undercover with power tool.
3. Remove brake caliper with power tool. Hang it in a place where it will not interfere with work. Refer to [BR-25, "FRONT DISC BRAKE"](#).

NOTE:

Avoid depressing brake pedal while brake caliper is removed.

4. Remove disc rotor.
5. Remove wheel sensor from steering knuckle. Refer to [BRC-66, "WHEEL SENSOR"](#).

CAUTION:

Do not pull on wheel sensor harness.

6. Remove brake hose bracket from steering knuckle. Refer to [BR-11, "BRAKE PIPING AND HOSE"](#).
7. Remove cotter pin, then remove wheel bearing lock nut from drive shaft with power tool.
8. Remove cotter pin at steering outer socket, then loosen mounting nut.

FRONT WHEEL HUB AND KNUCKLE

[AWD]

9. Use a ball joint remover (SST) to remove steering outer socket from steering knuckle. Be careful not to damage ball joint boot.

CAUTION:

Tighten temporarily mounting nut to prevent damage to threads and to prevent ball joint remover (SST) from coming off.

10. After removing upper link, transverse link, compression rod and cotter pin at steering knuckle, loosen mounting nut.
11. Use a ball joint remover (suitable tool) to remove upper link, transverse link and compression rod from steering knuckle. Be careful not to damage ball joint boot.

CAUTION:

Tighten temporarily mounting nut to prevent damage to threads and to prevent ball joint remover (suitable tool) from coming off.

12. Remove fixing bolts between steering knuckle and wheel hub and bearing assembly with power tool.
13. Remove splash guard and wheel hub and bearing assembly from steering knuckle.

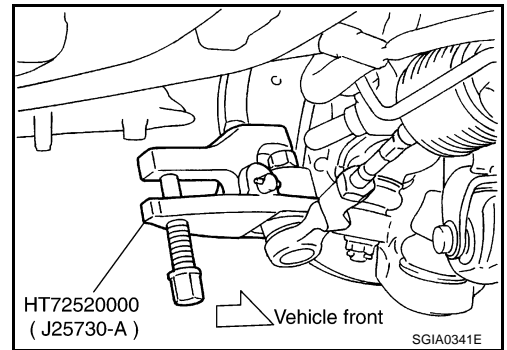

INSPECTION AFTER REMOVAL

- About the inspection for upper link, compression rod, steering outer socket, refer to [FSU-30, "UPPER LINK"](#) , [FSU-32, "COMPRESSION ROD"](#) , [PS-19, "POWER STEERING GEAR"](#) .

Visual Inspection

- Check steering knuckle and ball seat for deformation, cracks, and other damage. Replace steering knuckle and ball seat if cracks, deformation or other damage is found.
- Check ball joint boot for deformation, damage, and also for grease leakage. Replace steering knuckle assembly if cracks, deformation or also for grease leakage is found.

Steering Knuckle Ball Joint Inspection

- Manually move ball stud to confirm it moves smoothly with no binding.

Swing Torque Inspection

CAUTION:

Before measurement, move ball joint at least ten times by hand to check for smooth movement.

- Hook spring scale at cotter pin mounting hole. Confirm spring scale measurement value is within specifications when ball stud begins moving.

Standard value

Swing force:

0.147 - 1.4 N·m (0.02 - 0.14 kg·m, 2 - 12 in·lb)

Measurement force:

2.23 - 21.2 N (0.22 - 2.16 kg, 0.50 - 4.77 lb)

- If the value is outside the standard, replace steering knuckle.

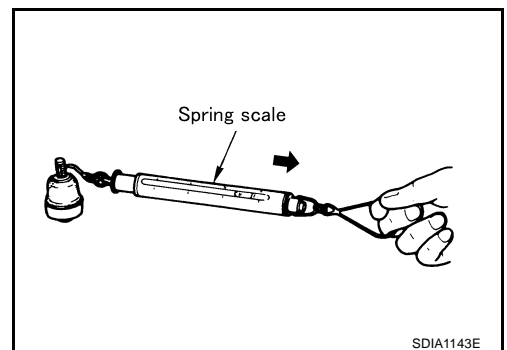

Rotating Torque Inspection

- Attach mounting nut to ball stud. Check that rotating torque is within specifications with a preload gauge (SST).

Standard value

Rotating torque:

0.147 - 1.4 N·m (0.02 - 0.14 kg·m, 2 - 12 in·lb)

- If the value is outside the standard, replace steering knuckle.

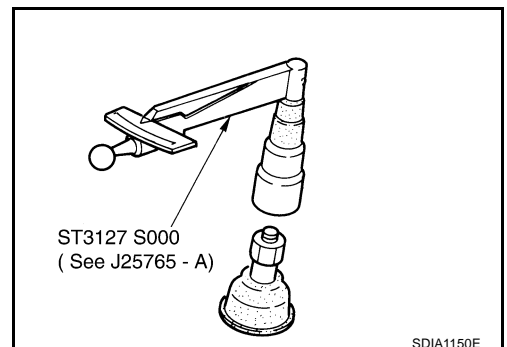

Axial End Play Inspection

- Move tip of ball joint in axial direction to check for looseness.

Standard value

Axial end play : 0 mm (0 in)

- If the value is outside the standard, replace steering knuckle.

INSTALLATION

- Refer to [FAX-12, "Removal and Installation"](#) for tightening torque. Install in the reverse order of removal.

NOTE:

Refer to component parts location and do not reuse non-reusable parts.

Disassembly and Assembly

ADS000YK

CAUTION:

Do not disassemble if wheel bearing has no trouble.

1. Using a drift (SST) and a puller (suitable tool), press wheel hub out to remove from wheel bearing.

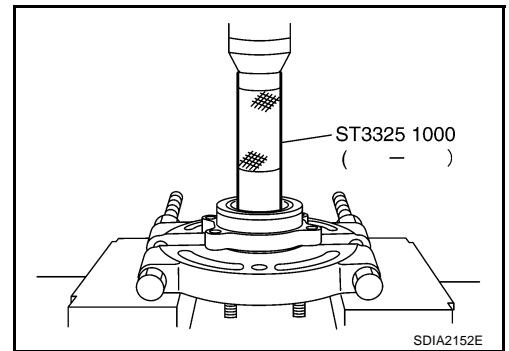

2. Using a drift (SST) and a puller (suitable tool), press wheel bearing outer side inner race out to remove from wheel hub.

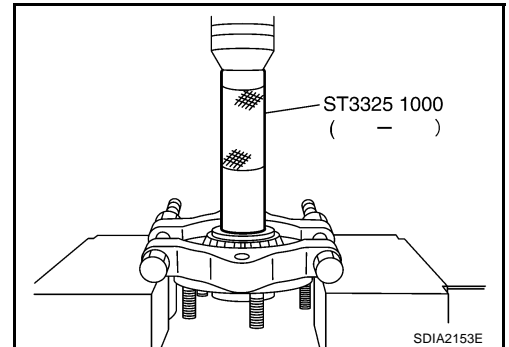

INSPECTION AFTER DISASSEMBLY

Check for deformity, cracks and damage of each parts, replace if necessary.

Wheel Hub

Inspect wheel hub for deformation, cracks, and other damage. If any irregular conditions are found, replace wheel hub.

Steering Knuckle

Inspect steering knuckle for deformation, cracks, and other damage. If any irregular conditions are found, replace steering knuckle.

Splash Guard

Inspect splash guard for deformation, cracks, and other damage. If any irregular conditions are found, replace splash guard.

FRONT WHEEL HUB AND KNUCKLE

[AWD]

ASSEMBLY

1. Press fit a wheel bearing into wheel hub with a drift (SST).

CAUTION:

- Do not reuse wheel bearing.
- Press fit a drift (SST) while holding it against wheel bearing inner side inner race.
- When installing wheel bearing, do not deformation dust shield.

NOTE:

Final press load guideline 49,033 N (5,000 kg, 11,000lb)

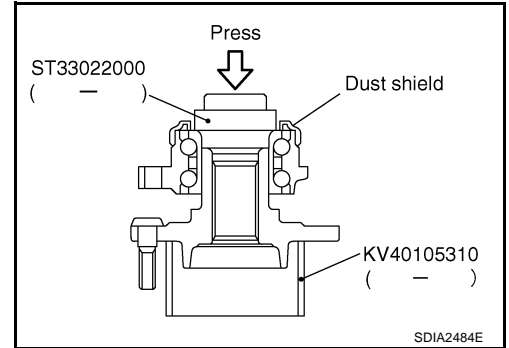

2. Attach spring scale in the position shown in illustration and pull at a rate of 10 ± 2 rpm to measure rotating torque.

Standard value

Rotating torque:

Less than 2.296 N-m (0.23 kg-m, 20 in-lb)

Spring scale reading:

Less than 42.9 N (4.4 kg, 9.7 lb)

3. Install splash guard and wheel hub and bearing assembly to steering knuckle.

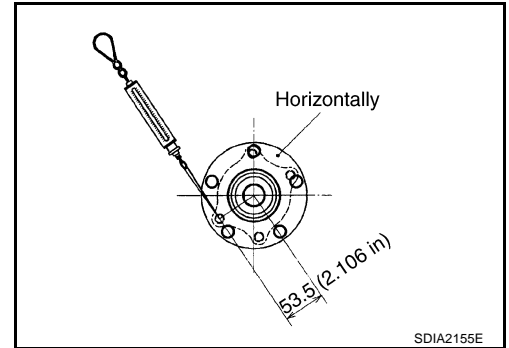

A

B

C

FAX

E

F

G

H

I

J

K

L

M

FRONT DRIVE SHAFT

On Vehicle Inspection and Service

- Check drive shaft mounting point and joint for looseness and other damage.
- Check boot for cracks and other damage.

CAUTION:

Replace entire drive shaft assembly when noise or vibration occur from drive shaft.

DRIVE SHAFT BOOT REPLACEMENT

1. Remove tire from vehicle with power tool.
2. Remove undercover from vehicle.
3. Remove brake caliper with power tool. Hang it in a place where it will not interfere with work. Refer to [BR-25, "FRONT DISC BRAKE"](#).

NOTE:

Avoid depressing brake pedal while brake caliper is removed.

4. Remove disc rotor.
5. Remove wheel sensor from steering knuckle. Refer to [BRC-66, "WHEEL SENSOR"](#).

CAUTION:

Do not pull on wheel sensor harness.

6. Remove brake hose bracket from steering knuckle. Refer to [BR-11, "BRAKE PIPING AND HOSE"](#).
7. Remove cotter pin. Then remove lock nut from drive shaft with power tool.
8. Remove cotter pin at steering outer socket, then loosen mounting nut.
9. Use a ball joint remover (SST) to remove steering outer socket from steering knuckle. Be careful not to damage ball joint boot.

CAUTION:

Tighten temporarily mounting nut to prevent damage to threads and to prevent ball joint remover (SST) from coming off.

10. After removing upper link and cotter pin at steering knuckle, then loosen mounting nut.
11. Use a ball joint remover (suitable tool) to remove upper link from steering knuckle. Be careful not to damage ball joint boot.

CAUTION:

Tighten temporarily mounting nut to prevent damage to threads and to prevent ball joint remover (suitable tool) from coming off.

12. Remove drive shaft from wheel hub and bearing assembly.
13. Remove boot bands, and then remove boot from the joint sub-assembly.
14. Screw drive shaft puller (suitable tool) into joint sub-assembly screw part to a depth of 30 mm (1.18 in) or more. Fix drive shaft with one hand and pull out joint sub-assembly with sliding hammer (suitable tool) from shaft.

CAUTION:

- **Align sliding hammer and drive shaft and remove them by pulling firmly and uniformly.**
- **When joint sub-assembly cannot be pulled out, try after removing drive shaft from the vehicle.**

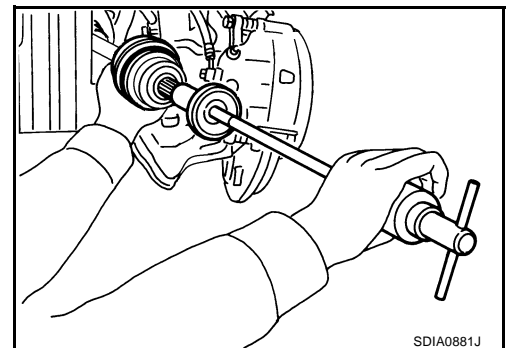
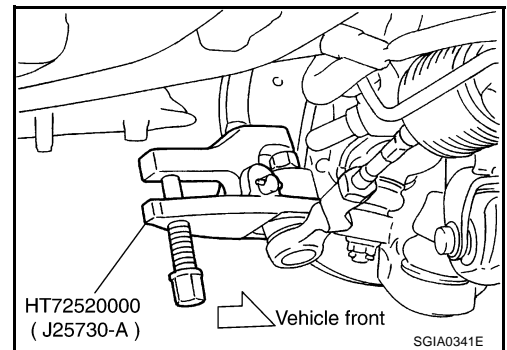

FRONT DRIVE SHAFT

[AWD]

15. Remove circlip from shaft.
16. Remove boot from shaft.
17. Remove old grease on joint sub-assembly with paper towels while rotating ball cage.

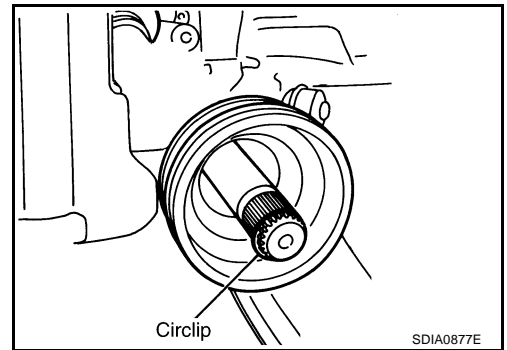

18. Insert the amount grease (Nissan genuine grease or equivalent) into joint sub-assembly serration hole until grease begins to ooze from ball groove and serration hole. After inserting grease, use a shop cloth to wipe off old grease that has oozed out.

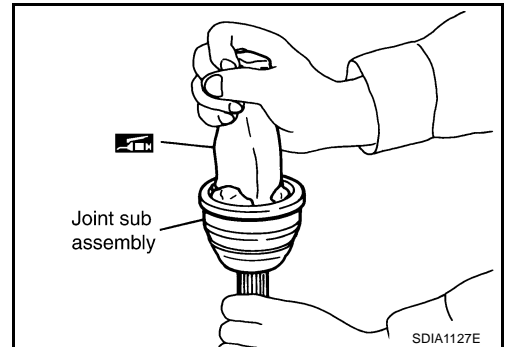

19. Wind serrated part of shaft with tape. Install boot band and boot to shaft. Be careful not to damage boot.

NOTE:

Discard old boot band and boot; replace with new ones.

20. Remove protective tape wound around serrated part of shaft.

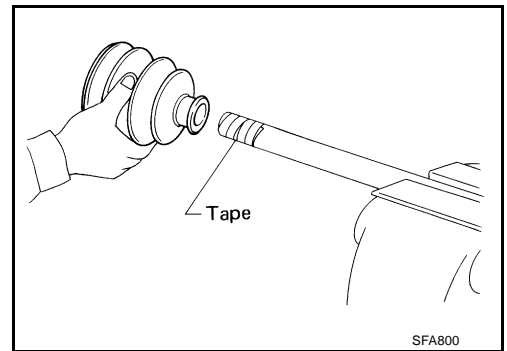

21. Install circlip on circlip groove at the shaft edge. Align the shaft edge and joint sub-assembly center axle. Then, assemble on the circlip groove, holding circlip with screwdriver tip.

CAUTION:

Do not reuse circlip.

NOTE:

Drive joint inserter (suitable tool) is recommended when installing circlip.

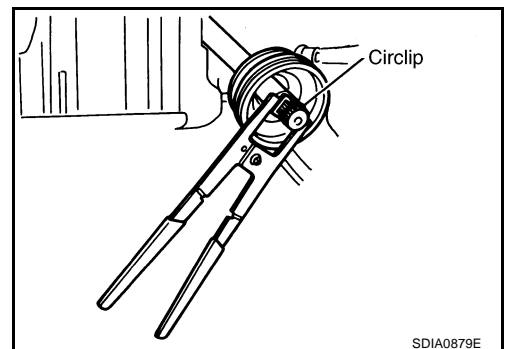

22. Install joint sub-assembly to shaft using plastic hammer.

CAUTION:

Confirm that joint sub-assembly is correctly engaged while rotating drive shaft.

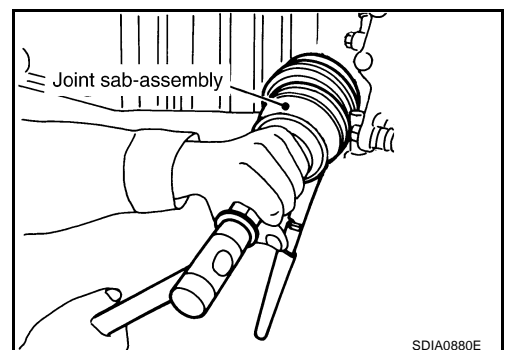

A
B
C
FAX
E
F
G
H
I
J
K
L
M

FRONT DRIVE SHAFT

[AWD]

23. Insert the specified amount of grease (Nissan genuine grease or equivalent) listed below into boot from large end of boot.

Grease amount : 71 – 81 (2.50 – 2.86 oz)

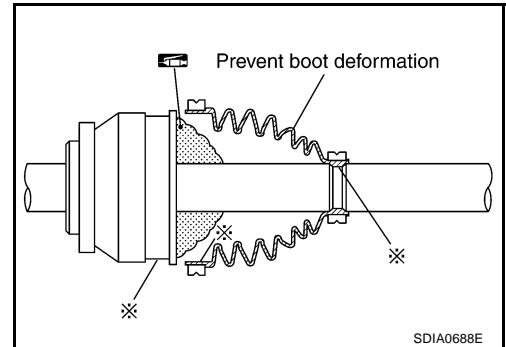

24. Install boot securely into grooves (indicated by* marks) shown in figure.

CAUTION:

If there is grease on boot mounting surfaces (indicated by* marks) of shaft and housing of joint sub-assembly, boot may come off. Remove all grease from surfaces.

25. Make sure boot installation length "L" is the length indicated below. Insert flat-bladed screwdriver or similar tool into smaller side of boot. Bleed air from boot to prevent boot deformation.

Boot installation length "L" : 90.4 mm (3.559 in)

CAUTION:

- **Boot may brake if boot installation length is less than standard value.**
- **Be careful that screwdriver tip does not contact inside surface of boot.**

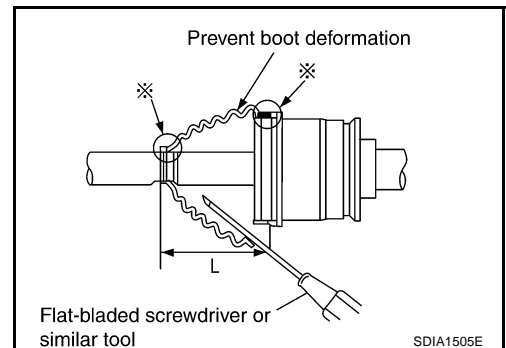

26. Install new larger and smaller boot bands securely with a suitable tool.

NOTE:

- Discard old boot bands; replace with new ones.

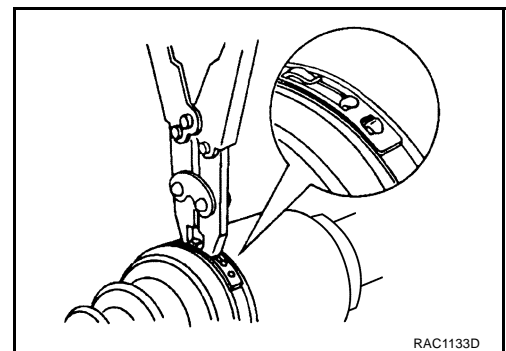

- Secure boot band so that dimension "M" shown bellow right satisfies the following:

Large diameter side : 3.0 mm (0.118 in)

Small diameter side : 2.0 mm (0.079 in)

27. After installing joint sub-assembly and shaft, rotate boot to check whether or not the actual position is correct. If boot position is not correct, secure boot with boot bands again.

28. Insert drive shaft to wheel hub and bearing assembly, and then temporarily tighten hub lock nut.

29. Install steering outer socket to steering knuckle. Refer to [PS-17, "POWER STEERING GEAR AND LINKAGE"](#) .

30. Install upper link to steering knuckle. Refer to [FSU-26, "Components"](#) .

31. Tighten wheel bearing lock nut to the specified torque.

32. Install cotter pin.

CAUTION:

Do not reuse cotter pin.

33. Install brake hose bracket to steering knuckle. Refer to [BR-11, "BRAKE PIPING AND HOSE"](#) .

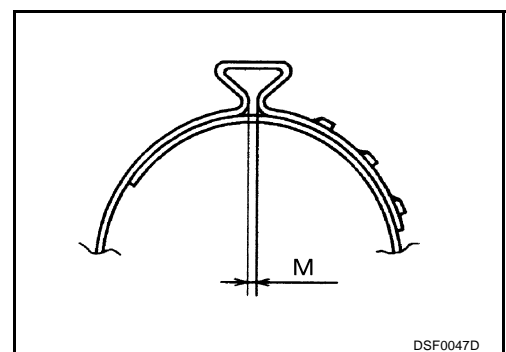

FRONT DRIVE SHAFT

[AWD]

34. Install wheel sensor to steering knuckle. Refer to [BRC-66, "WHEEL SENSOR"](#) .
35. Install disc rotor.
36. Install brake caliper to steering knuckle. Refer to [BR-25, "FRONT DISC BRAKE"](#) .
37. Install under cover.
38. Install tires to the vehicle.

Removal and installation

ADS000YM

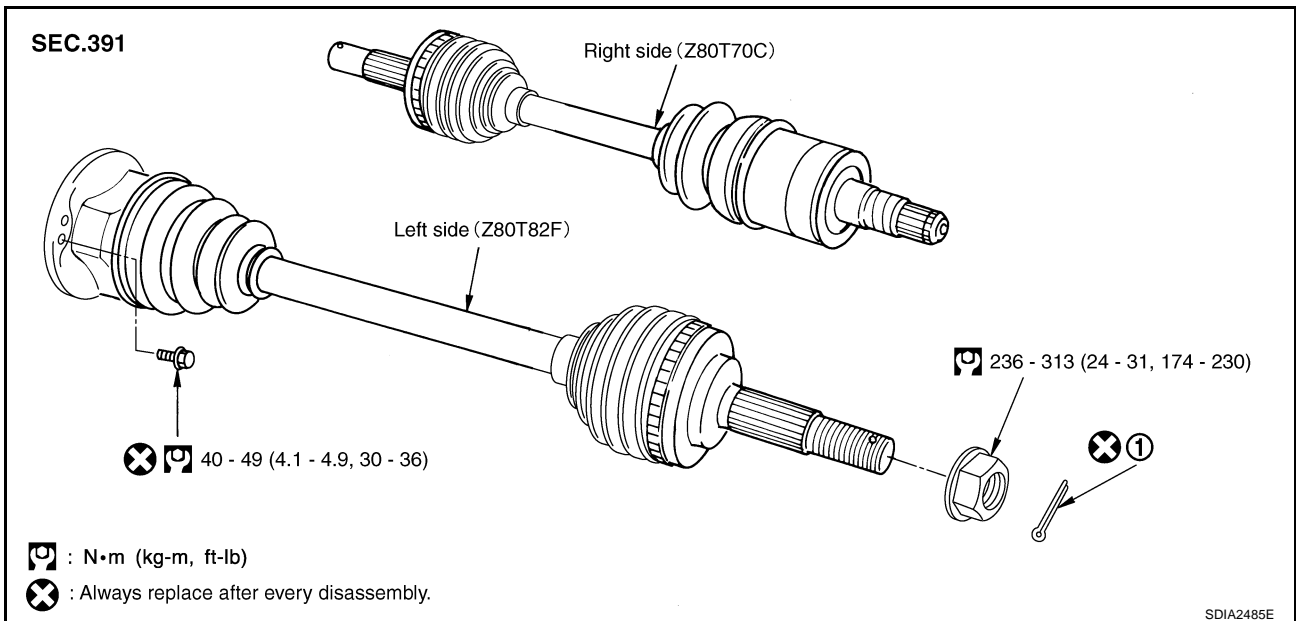

1. Cotter pin

REMOVAL

Left Side

1. Remove tire from vehicle with power tool.
2. Remove undercover with power tool.
3. Remove brake caliper with power tool. Hang it in a place where it will not interfere with work. Refer to [BR-25, "FRONT DISC BRAKE"](#) .

NOTE:

Avoid depressing brake pedal while brake caliper is removed.

4. Remove disc rotor.
5. Remove wheel sensor from steering knuckle. Refer to [BRC-66, "WHEEL SENSOR"](#) .

CAUTION:

Do not pull on wheel sensor harness.

6. Remove brake hose bracket from steering knuckle. Refer to [BR-11, "BRAKE PIPING AND HOSE"](#) .
7. Remove cotter pin. Then remove lock nut from drive shaft with power tool.
8. Remove cotter pin at steering outer socket, then loosen mounting nut.
9. Use a ball joint remover (SST) to remove steering outer socket from steering knuckle. Be careful not to damage ball joint boot.

CAUTION:

Tighten temporarily mounting nut to prevent damage to threads and to prevent ball joint remover (SST) from coming off.

10. After removing upper link and cotter pin at steering knuckle, loosen mounting nut.
11. Use a ball joint remove (suitable tool) to remove upper link from steering knuckle. Be careful not to damage ball joint boot.

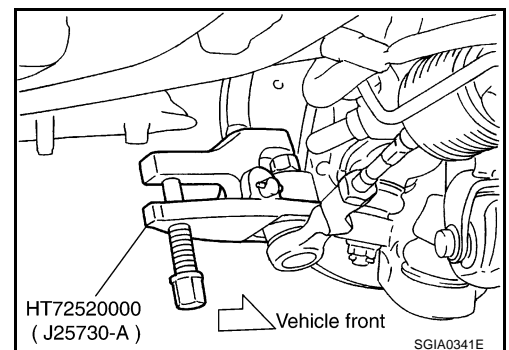

CAUTION:

Tighten temporarily mounting nut to prevent damage to threads and to prevent ball joint remover (suitable tool) from coming off.

12. Remove drive shaft from wheel hub and bearing assembly.
13. Remove fixing bolts of front final drive assembly drive shaft, then remove drive shaft from vehicle.

Right Side

1. Remove tire from vehicle with power tool.
2. Remove undercover with power tool.
3. Remove brake caliper with power tool. Hang it in a place where it will not interfere with work. Refer to [BR-25, "FRONT DISC BRAKE"](#) .
4. Remove disc rotor.
5. Remove wheel sensor from steering knuckle. Refer to [BRC-66, "WHEEL SENSOR"](#) .
6. Remove brake hose bracket from steering knuckle. Refer to [BR-11, "BRAKE PIPING AND HOSE"](#) .
7. Remove cotter pin. Then remove lock nut from drive shaft with power tool.
8. Remove cotter pin at steering outer socket, then loosen mounting nut.
9. Use a ball joint remover (SST) to remove steering outer socket from steering knuckle. Be careful not to damage ball joint boot.

CAUTION:

Tighten temporarily mounting nut to prevent damage to threads and to prevent ball joint remover (SST) from coming off.

10. After removing upper link and cotter pin at steering knuckle, loosen mounting nut.
11. Use a ball joint remove (suitable tool) to remove upper link from steering knuckle. Be careful not to damage ball joint boot.

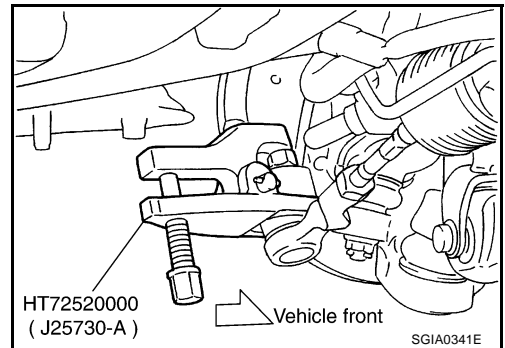

CAUTION:

Tighten temporarily mounting nut to prevent damage to threads and to prevent ball joint remover (suitable tool) from coming off.

12. Remove drive shaft from wheel hub and bearing assembly.
13. Remove drive shaft from final drive.
 - Set an drive shaft attachment (SST) and a drive shaft puller (suitable tool) between drive shaft (slide joint side) and transaxle as shown in the figure and remove drive shaft.

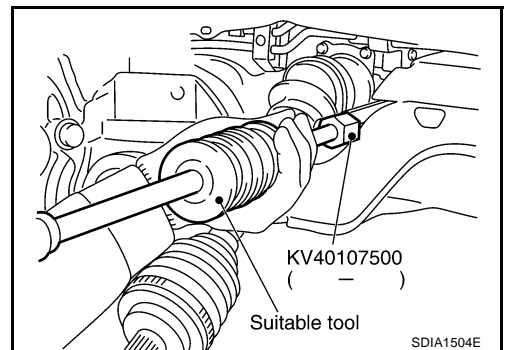

INSPECTION AFTER REMOVAL

- Move joint up/down, left/right, and in the axial direction. Check for any rough movement or significant looseness.
- Check boot for cracks or other damage, and also for grease leakage.
- If a trouble is found, disassemble drive shaft, and then replace with new one.

INSTALLATION

- Refer to [FAX-19, "Removal and installation"](#) for tightening torque. Install in the reverse order of removal.

NOTE:

Refer to component parts location and do not reuse non-reusable parts.

- Check the following item after service.
 - Installation condition of wheel sensor harness.

FRONT DRIVE SHAFT

[AWD]

- In order to prevent damage to front final drive assembly side oil seal, first fit a protector onto oil seal before inserting drive shaft. Slide drive shaft into slide joint and tap with a hammer to install securely.

CAUTION:

Be sure to check that circular clip is securely fastened.

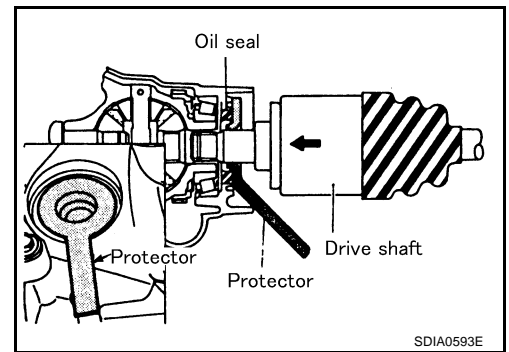

Disassembly and Assembly

ADS000YN

FAX

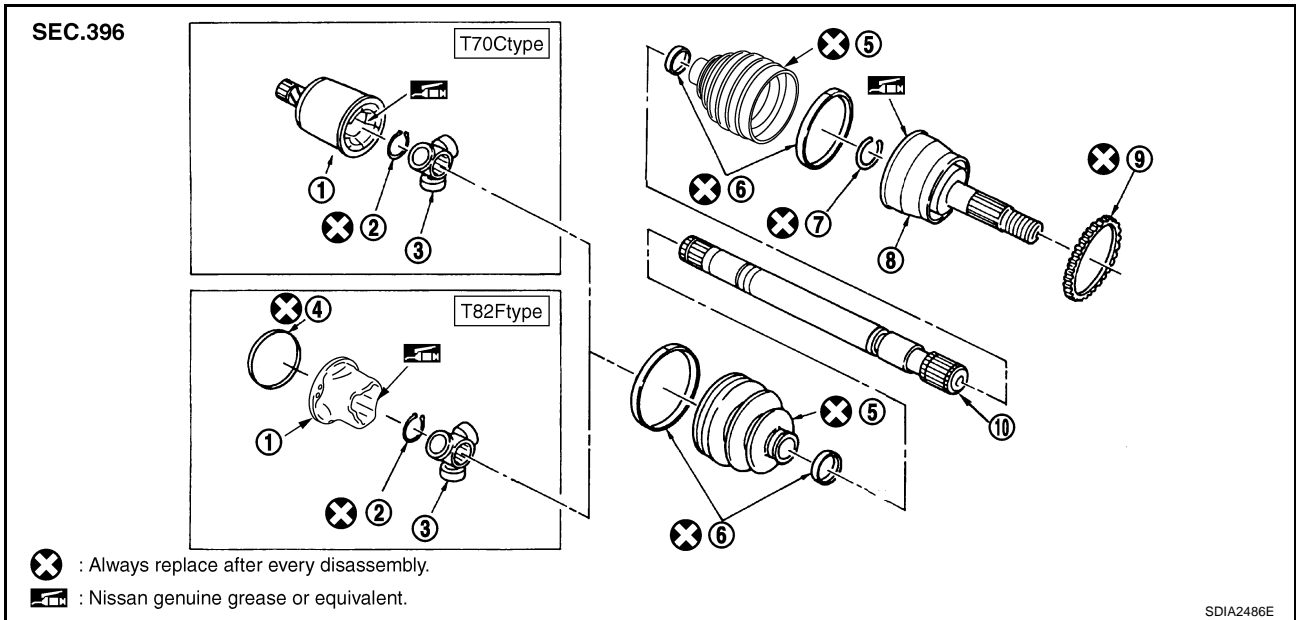

E

F

G

H

I

J

K

L

M

- | | | |
|------------------|-----------------------|--------------------|
| 1. Housing | 2. Snap ring | 3. Spider assembly |
| 4. Plug | 5. Boot | 6. Boot band |
| 7. Circular clip | 8. joint sub-assembly | 9. sensor rotor |
| 10. Shaft | | |

DISASSEMBLY

Wheel Side

- As shown in the figure, use a bearing replacer (suitable tool) and a puller (suitable tool) to remove sensor rotor from drive shaft.

- Place drive shaft in a vice.

CAUTION:

When retaining shaft in a vice, always use copper or aluminum plates between vice and shaft.

- Remove boot bands. Then remove boot from joint sub-assembly.

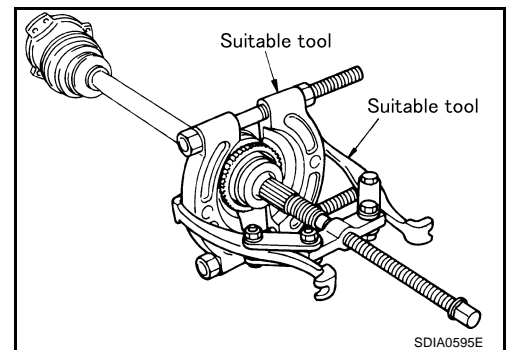

FRONT DRIVE SHAFT

[AWD]

4. Screw a drive shaft puller (suitable tool) 30 mm (1.18 in) or more into threaded part of joint sub-assembly. Pull joint sub-assembly out of shaft.

CAUTION:

- If joint sub-assembly cannot be removed after five or more unsuccessful attempts, replace shaft and joint sub-assembly as a set.
- Align sliding hammer and drive shaft and remove them by pulling directory.

5. Remove boot from shaft.
6. Remove circular clip from shaft.
7. While rotating ball cage, remove old grease on joint sub-assembly with paper towels.

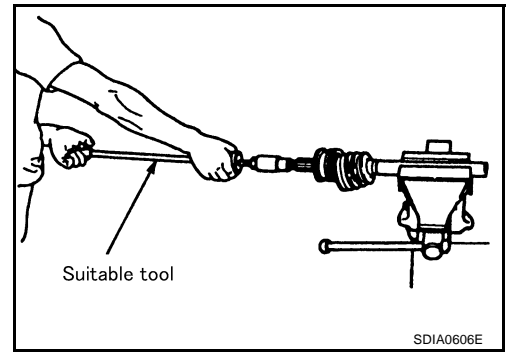

Front Final Drive Side

1. Place drive shaft in a vice.

CAUTION:

When retaining drive shaft in a vice, always use copper or aluminum plates between a vise and shaft.

2. Remove boot bands.
3. If plug needs to be removed, move boot to wheel side, and drive it out with a plastic hammer. (T82F type only)
4. Put matching marks on spider assembly and shaft.

CAUTION:

Use paint for matching mark, but don't damage to spider assembly and drive shaft.

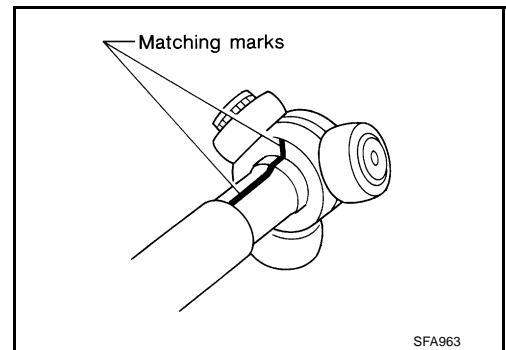

5. Remove snap ring, then remove spider assembly from shaft.
6. Remove boot from shaft.
7. Remove old grease on slide joint assembly with paper towels.

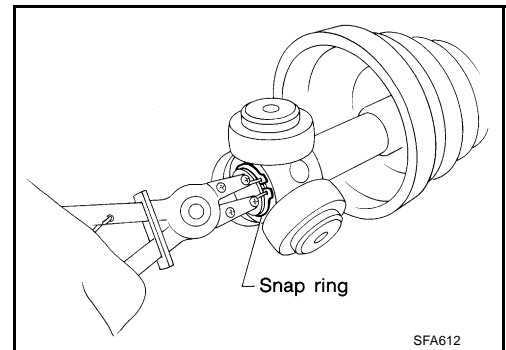

INSPECTION AFTER DISASSEMBLY

Shaft

- Replace shaft if there is any runout, cracking, or other damage.

Joint Sub-Assembly

- Make sure there is no rough rotation or unusual axial looseness.
- Make sure there is no foreign material inside joint sub-assembly.
- Check joint sub-assembly for compression scar, cracks or fractures.

CAUTION:

If there are any irregular conditions of joint sub-assembly components, replace the entire joint sub-assembly.

Slide Joint Side

Housing and spider assembly

- If roller or roller surface of spider assembly has scratch or wear, replace housing and spider assembly.

NOTE:

Housing and spider assembly are components which are used as a set.

ASSEMBLY

Wheel Side

1. Use a drift (SST) to press-fit sensor rotor into joint sub-assembly.

NOTE:

Do not reuse sensor rotor.

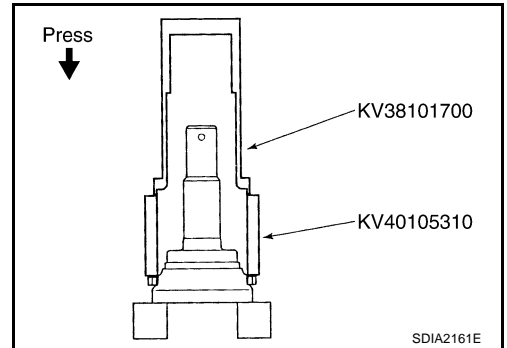

2. Insert the amount grease (Nissan genuine grease or equivalent) into joint sub-assembly serration hole until grease begins to ooze from ball groove and serration hole. After inserting grease, use a shop cloth to wipe off old grease that has oozed out.

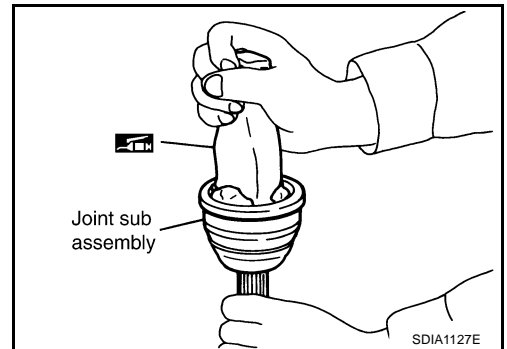

3. Wind serrated part of shaft with tape. Install boot band and boot to shaft. Be careful not to damage boot.

NOTE:

Discard old boot band and boot; replace with new ones.

4. Remove protective tape wound around serrated part of shaft.

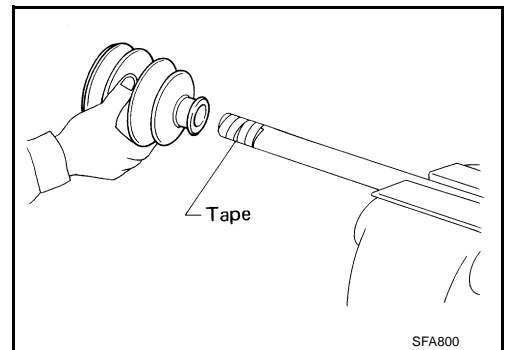

5. Attach circular clip to shaft. At this time, circular clip must fit securely into shaft groove. Attach nut to joint sub-assembly. Use a wooden hammer to press-fit.

NOTE:

Discard old circular clip; replace with new one.

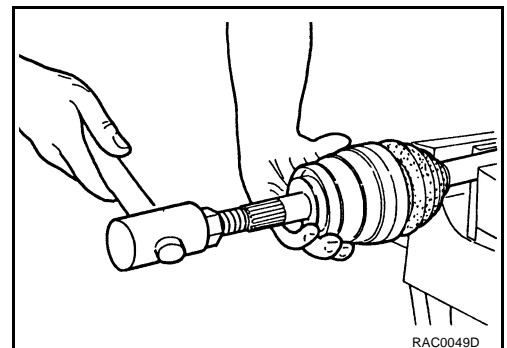

A
B
C
FAX
E
F
G
H
I
J
K
L
M

FRONT DRIVE SHAFT

[AWD]

6. Insert the specified amount of grease (Nissan genuine grease or equivalent) listed below into boot from large end of boot.

Grease amount : 71 – 81 g (2.50 – 2.86 oz)

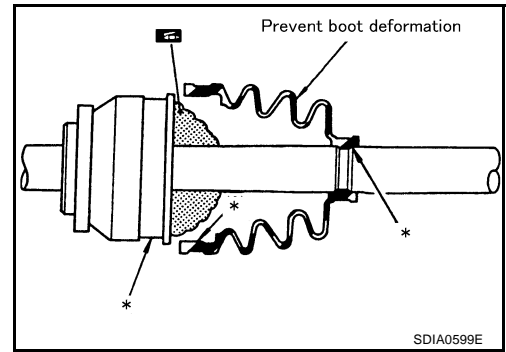

7. Install boot securely into grooves (indicated by * marks) shown in the figure.

CAUTION:

If there is grease on boot mounting surfaces (indicated by* marks) of shaft and housing of joint sub assembly, boot may come off. Remove all grease from surfaces.

8. Make sure boot installation length “L” is the length indicated below. Insert a flat-bladed screwdriver or similar tool into smaller side of boot. Bleed air from boot to prevent boot deformation.

Boot installation length “L” : 90.4 mm (3.559 in)

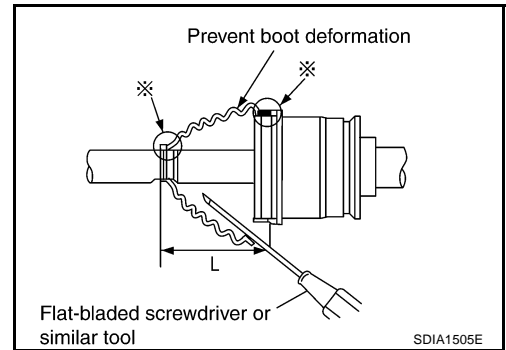

CAUTION:

- Boot may brake if boot installation length is less than standard value.
- Be careful that screwdriver tip does not contact inside surface of boot.

9. Install new larger and smaller boot bands securely with a suitable tool.

NOTE:

- Discard old boot bands; replace with new ones.

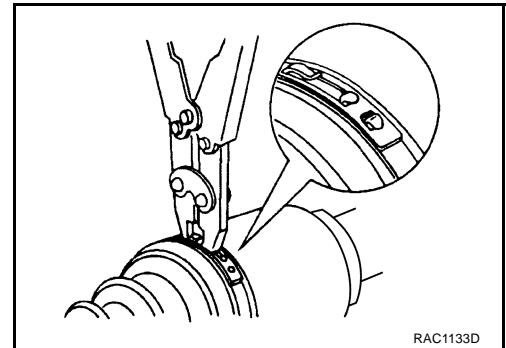

- Secure boot band so that dimension “M” shown bellow right satisfies the following:

Large diameter side : 3.0 mm (0.118 in)

Small diameter side : 2.0 mm (0.079 in)

10. After installing joint sub-assembly and shaft, rotate boot to check whether or not the actual position is correct. If boot position is not correct, secure boot with new boot bands again.

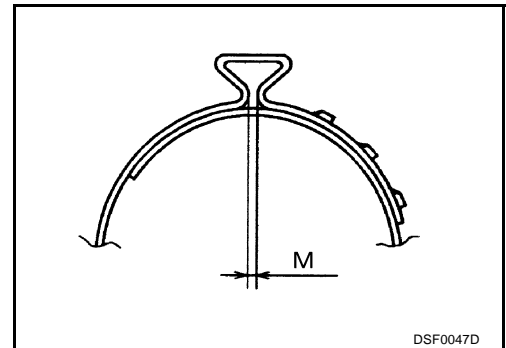

FRONT DRIVE SHAFT

[AWD]

Front Final Drive Side

1. If plug has been removed, use a drift (SST) to press in a new one. (T82F type only)

NOTE:

Discard old plug; replace with new ones.

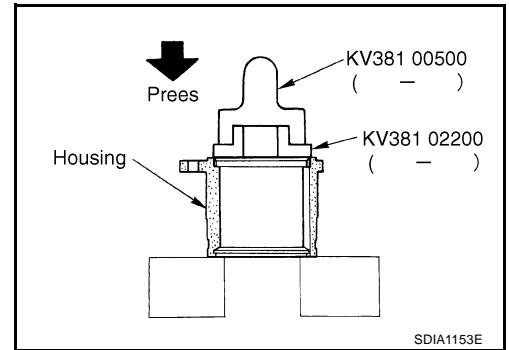

2. Wind serrated part of shaft with tape. Install boot band and boot to shaft. Be careful not to damage boot.

NOTE:

Discard old boot band and boot; replace with each new one.

3. Remove protective tape wound around serrated part of shaft.

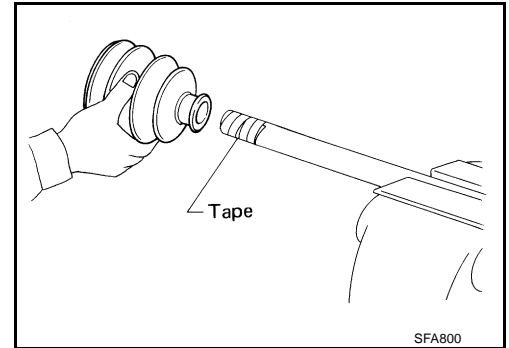

4. Line up alignment marks which were made when spider assembly was removed. Install spider assembly, with serration chamfer facing shaft.

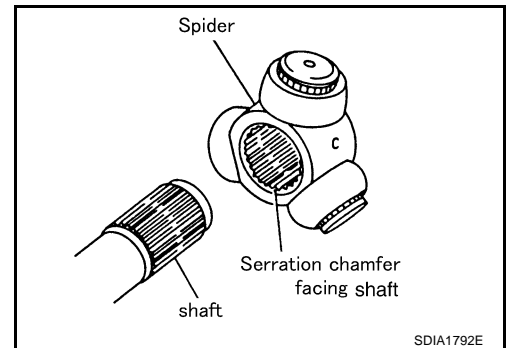

5. Secure spider assembly with snap ring.

NOTE:

Discard old snap ring; replace with new one.

6. Apply Nissan genuine grease or equivalent to spider assembly and sliding surface.

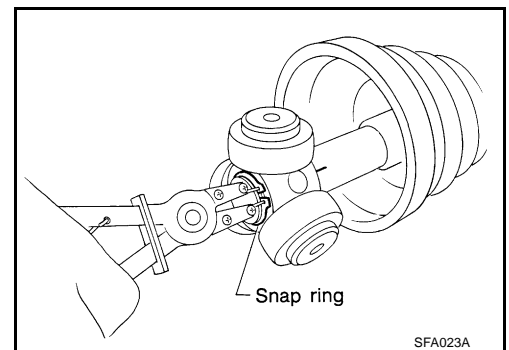

A

B

C

FAX

E

F

G

H

I

J

K

L

M

FRONT DRIVE SHAFT

[AWD]

7. Install housing to spider assembly. Apply Nissan genuine grease or equivalent to housing.

Grease amount **T70C type** : 109 – 119 g (3.84 – 4.20 oz)
 T82F type : 101 – 111 g (3.56 – 3.91 oz)

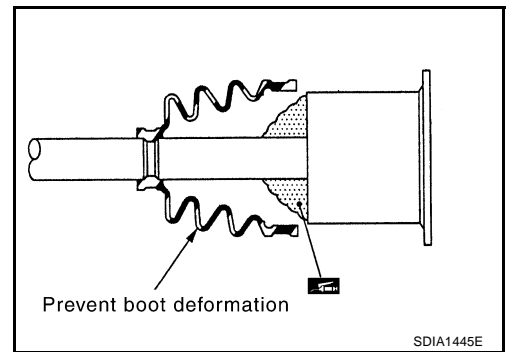

8. Install boot securely into grooves (indicated by * marks) shown in the figure.

CAUTION:

If there is grease on boot mounting surfaces (indicated by * marks) of shaft and housing, boot may come off. Remove all grease from surfaces.

9. Make sure boot installation length "L" is the length indicated below. Insert a flat-bladed screwdriver or similar tool into smaller side of boot. Bleed air from boot to prevent boot deformation.

Boot installation Length "L"

T70C type : 95.5 – 97.5 mm (3.760 – 3.839 in)

T82F type : 95 – 97 mm (3.74 – 3.82 in)

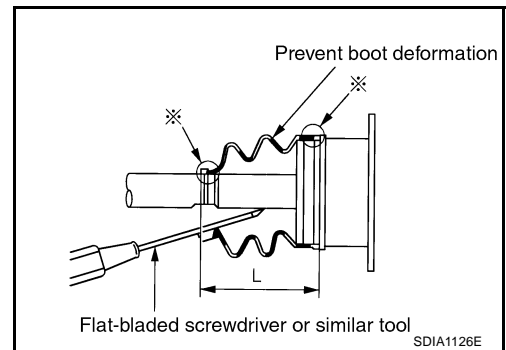

CAUTION:

- **Boot may break if boot installation length is less than standard value.**
- **Take care not to touch the tip of screwdriver to inside surface of boot.**

10. FSecure big and small ends of boot with new boot bands as shown in figure.

NOTE:

- Discard old boot bands; replace with new ones.

11. After installing housing and shaft, rotate boot to check whether or not the actual position is correct. If boot position is not correct, secure boot with new boot bands again.

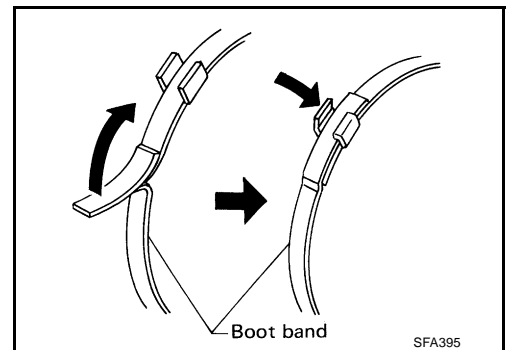

SERVICE DATA

[AWD]

SERVICE DATA

PFP:00030

Wheel Bearing

ADS000YO

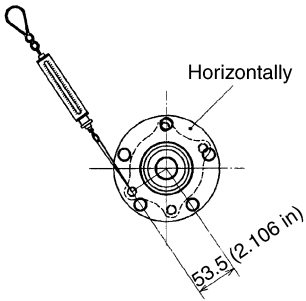
Axial end play	0.05 mm (0.002 in) or less
Rotating torque	At a load of 49,033 N (5,000 kg, 11,000 lb) Less than 2.296 N·m (0.23 kg-m, 20 in-lb)
Measurement of spring scale	Less than 42.9 N (4.4 kg, 9.7 lb)
Installation location of spring scale	 <p style="text-align: right;">SDIA2155E</p>

Ball Joint

ADS000YP

Axial end play	0 mm (0 in)
Swing torque	0.147 - 1.4 N·m (0.02 - 0.14 kg-m, 2 - 12 in-lb)
Measurement on spring balance (Spring scale hooking position: cotter pin mounting hole)	2.23 - 21.2 N (0.22 - 2.16 kg, 0.50 - 4.77 lb)
Sliding torque	0.147 - 1.4 N·m (0.02 - 0.14 kg-m, 2 - 12 in-lb)

Drive Shaft Z80T70C

ADS000YQ

Joint type	Final drive side	Wheel side
Grease quantity	109 - 119 (3.84 - 4.20 oz)	71 - 81 (2.50 - 2.86 oz)
Boot installed length	95.5 - 97.5 mm (3.760 - 3.839 in)	90.4 mm (3.559 in)

Z80T82F

Joint type	Final drive side	Wheel side
Grease quantity	101 - 111 (3.56 - 3.91 oz)	71 - 81 (2.50 - 2.86 oz)
Boot installed length	95 - 97 mm (3.74 - 3.82 in)	90.4 mm (3.559 in)

Tightening Torque

ADS000YR

Drive shaft - Side flange (AWD left side)	40 - 49 N·m (4.1 - 4.9 kg-m, 30 - 36 lb)
Hub lock nut	236 - 313 N·m (24 - 31kg-m, 174 - 230 lb)

