

SECTION MA
MAINTENANCE

A
B
C
D
E
F
G
H
I
J
K
MA
M

CONTENTS

PREPARATION	3	INSPECTION AFTER REMOVAL	19
Special Service Tools	3	INSTALLATION	20
Commercial Service Tools	3	Checking EVAP Vapor Lines	20
GENERAL MAINTENANCE	4	CHASSIS AND BODY MAINTENANCE	21
Explanation of General Maintenance	4	Checking Exhaust System	21
PERIODIC MAINTENANCE	6	Checking Clutch Fluid Level and Leaks	21
Introduction of Periodic Maintenance	6	Checking M/T Oil	21
Schedule 1	7	Changing M/T Oil	21
EMISSION CONTROL SYSTEM MAINTENANCE	7	Checking A/T Fluid	22
CHASSIS AND BODY MAINTENANCE	8	Changing A/T Fluid	24
Schedule 2	9	Checking Transfer Fluid	24
EMISSION CONTROL SYSTEM MAINTENANCE	9	Changing Transfer Fluid	25
CHASSIS AND BODY MAINTENANCE	9	Checking Propeller Shaft	25
RECOMMENDED FLUIDS AND LUBRICANTS	11	Checking Differential Gear Oil	25
Fluids and Lubricants	11	Changing Differential Gear Oil	26
SAE Viscosity Number	12	Balancing Wheels (Bonding Weight Type)	26
GASOLINE ENGINE OIL	12	REMOVAL	26
Anti-Freeze Coolant Mixture Ratio	12	WHEEL BALANCE ADJUSTMENT	26
ENGINE MAINTENANCE	13	Tire Rotation	28
Checking Drive Belts	13	Checking Brake Fluid Level and Leaks	28
Tension Adjustment	14	Checking Brake Lines and Cables	28
ALTERNATOR AND POWER STEERING OIL PUMP BELT	14	Changing Brake Fluid	28
A/C COMPRESSOR BELT	14	Checking Disc Brake	29
Changing Engine Coolant	15	ROTOR	29
DRAINING ENGINE COOLANT	15	CALIPER	29
REFILLING ENGINE COOLANT	15	PAD	29
FLUSHING COOLING SYSTEM	17	Checking Steering Gear and Linkage	29
Checking Fuel Lines	17	STEERING GEAR	29
Changing Air Cleaner Filter	17	STEERING LINKAGE	29
VISCOUS PAPER TYPE	17	Checking Power Steering Fluid and Lines	30
Changing Engine Oil	17	Axle and Suspension Parts	30
Changing Oil Filter	18	Drive Shaft	31
REMOVAL	18	Lubricating Locks, Hinges and Hood Latch	31
INSTALLATION	18	Checking Seat Belt, Buckles, Retractors, Anchors and Adjusters	32
INSPECTION AFTER INSTALLATION	19	SERVICE DATA AND SPECIFICATIONS (SDS)	33
Changing Spark Plugs (Platinum-Tipped Type)	19	Standard and Limit	33
REMOVAL	19	BELT DEFLECTION AND TENSION	33
		ENGINE COOLANT CAPACITY (APPROXIMATE)	33

ENGINE OIL CAPACITY (APPROXIMATE)	33	WHEEL BALANCE	33
SPARK PLUG (PLATINUM-TIPPED TYPE)	33	Tightening Torque	34

PREPARATION

PREPARATION

PF0:00002

Special Service Tools

ALS00013

The actual shapes of Kent-Moore tools may differ from those of special service tools illustrated here.

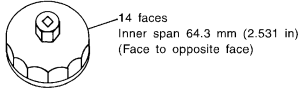
Tool number (Kent-Moore No.) Tool name	Description
KV10115801 (J38956) Oil filter wrench <div style="text-align: center;">  <p>14 faces Inner span 64.3 mm (2.531 in) (Face to opposite face)</p> <p>S-NT772</p> </div>	Removing and installing oil filter

Commercial Service Tools

ALS00014

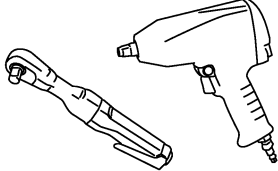
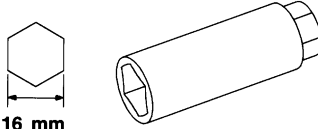
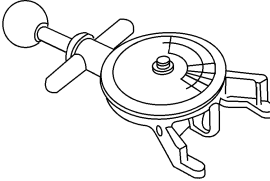
Tool name (Kent-Moore No.)	Description
Power tool <div style="text-align: center;">  <p>PBIC0190E</p> </div>	Loosening bolts and nuts
Spark plug wrench <div style="text-align: center;">  <p>16 mm (0.63 in)</p> <p>S-NT047</p> </div>	Removing and installing spark plug
Belt tension gauge (BT3373-F) <div style="text-align: center;">  <p>AMA126</p> </div>	Checking drive belt tension

A
B
C
D
E
F
G
H
I
J
K
M

MA

GENERAL MAINTENANCE

GENERAL MAINTENANCE

PFP:00000

Explanation of General Maintenance

ALS0001C

General maintenance includes those items which should be checked during the normal day-to-day operation of the vehicle. They are essential if the vehicle is to continue operating properly. The owners can perform checks and inspections themselves or have their INFINITI dealers do them.

OUTSIDE THE VEHICLE

The maintenance items listed here should be performed from time to time, unless otherwise specified.

Item		Reference page
Tires	Check the pressure with a gauge, including the spare, at least once a month and always prior to a long distance trips. Adjust to the specified pressure if necessary. Check carefully for damage, cuts or excessive wear.	—
Wheel nuts	When checking the tires, make sure no nuts are missing, and check for any loose nuts. Tighten if necessary.	—
Windshield	Clean the windshield on a regular basis. Check the windshield at least every six months for cracks or other damage. Repair as necessary.	—
Tire rotation	Tires should be rotated every 12,000 km (7,500 miles).	MA-28
Wheel alignment and balance	If the vehicle pulls to either side while driving on a straight and level road, or if you detect uneven or abnormal tire wear, there may be a need for wheel alignment. If the steering wheel or seat vibrates at normal highway speeds, wheel balancing may be needed.	MA-26 , FSU-7
Windshield wiper blades	Check for cracks or wear if they do not wipe properly.	—
Doors and engine hood	Check that all doors and the engine hood operate smoothly as well as the trunk lid and back hatch. Also make sure that all latches lock securely. Lubricate if necessary. Make sure that the secondary latch keeps the hood from opening when the primary latch is released. When driving in areas using road salt or other corrosive materials, check lubrication frequently.	MA-31
Lamps	Make sure that the headlamps, stop lamps, tail lamps, turn signal lamps, and other lamps are all operating properly and installed securely. Also check headlamp aim. Clean the headlamps on a regular basis.	—

INSIDE THE VEHICLE

The maintenance items listed here should be checked on a regular basis, such as when performing periodic maintenance, cleaning the vehicle, etc.

Item		Reference page
Warning lamps and chimes	Make sure that all warning lamps and chimes are operating properly.	—
Windshield wiper and washer	Check that the wipers and washer operate properly and that the wipers do not streak.	—
Windshield defroster	Check that the air comes out of the defroster outlets properly and in sufficient quantity when operating the heater or air conditioner.	—
Steering wheel	Check that it has the specified play. Be sure to check for changes in the steering condition, such as excessive play, hard steering or strange noises. Free play: Less than 35 mm (1.38 in)	—
Seats	Check seat position controls such as seat adjusters, seatback recliner, etc. to make sure they operate smoothly and that all latches lock securely in every position. Check that the head restraints move up and down smoothly and that the locks (if equipped) hold securely in all latched positions. Check that the latches lock securely for folding-down rear seatbacks.	—
Seat belts	Check that all parts of the seat belt system (e.g. buckles, anchors, adjusters and retractors) operate properly and smoothly, and are installed securely. Check the belt webbing for cuts, fraying, wear or damage.	MA-32
Accelerator pedal	Check the pedal for smooth operation and make sure the pedal does not catch or require uneven effort. Keep the floor mats away from the pedal.	—
Brakes	Check that the brake does not pull the vehicle to one side when applied.	—

GENERAL MAINTENANCE

Item		Reference page
Brake pedal and booster	Check the pedal for smooth operation and make sure it has the proper distance under it when depressed fully. Check the brake booster function. Be sure to keep the floor mats away from the pedal.	BR-6 , BR-21
Clutch pedal	Make sure the pedal operates smoothly and check that it has the proper free play.	CL-5 , " CLUTCH PEDAL "
Parking brake	Check that the pedal or lever has the proper travel and make sure that the vehicle is held securely on a fairly steep hill when only the parking brake is applied.	PB-3 , PB-3
Automatic transmission "Park" mechanism	Check that the lock release button on the selector lever operates properly and smoothly. On a fairly steep hill check that the vehicle is held securely with the selector lever in the "P" position without applying any brakes.	—

UNDER THE HOOD AND VEHICLE

The maintenance items listed here should be checked periodically (e.g. each time you check the engine oil or refuel).

Item		Reference page
Windshield washer fluid	Check that there is adequate fluid in the tank.	—
Engine coolant level	Check the coolant level when the engine is cold.	MA-15
Radiator and hoses	Check the front of the radiator and clean off any dirt, insects, leaves, etc., that may have accumulated. Make sure the hoses have no cracks, deformation, deterioration or loose connections.	—
Brake and clutch fluid level	Make sure that the brake and clutch fluid levels are between the "MAX" and "MIN" lines on the reservoir.	MA-28 , MA-21
Battery	Check the fluid level in each cell. It should be between the "MAX" and "MIN" lines. Vehicles operated in high temperatures or under severe conditions require frequent checks of the battery fluid level.	—
Engine drive belts	Make sure that no belt is frayed, worn, cracked or oily.	MA-13
Engine oil level	Check the level on the dipstick after parking the vehicle on a level spot and turning off the engine.	MA-17
Power steering fluid level and lines	Check the level on the dipstick with the engine off. Check the lines for improper attachment, leaks, cracks, etc.	MA-30
Exhaust system	Make sure there are no loose supports, cracks or holes. If the sound of the exhaust seems unusual or there is a smell of exhaust fumes, immediately locate the trouble and correct it.	MA-21
Underbody	The underbody is frequently exposed to corrosive substances such as those used on icy roads or to control dust. It is very important to remove these substances, otherwise rust will form on the floor pan, frame, fuel lines and around the exhaust system. At the end of winter, the underbody should be thoroughly flushed with plain water, being careful to clean those areas where mud and dirt can easily accumulate.	—
Fluid leaks	Check under the vehicle for fuel, oil, water or other fluid leaks after the vehicle has been parked for a while. Water dripping from the air conditioner after use is normal. If you should notice any leaks or gasoline fumes are evident, check for the cause and correct it immediately.	—

PERIODIC MAINTENANCE

PERIODIC MAINTENANCE

PFP:00026

Introduction of Periodic Maintenance

ALS0001D

Two different maintenance schedules are provided, and should be used, depending upon the conditions in which the vehicle is mainly operated. **After 60,000 miles (96,000 km) or 48 months, continue the periodic maintenance at the same mileage/time intervals.**

Schedule 1	Follow Periodic Maintenance Schedule 1 if the driving habits frequently include one or more of the following driving conditions: <ul style="list-style-type: none"> ● Repeated short trips of less than 5 miles (8 km). ● Repeated short trips of less than 10 miles (16 km) with outside temperatures remaining below freezing. ● Operating in hot weather in stop-and-go “rush hour” traffic. ● Extensive idling and/or low speed driving for long distances, such as police, taxi or door-to-door delivery use. ● Driving in dusty conditions. ● Driving on rough, muddy, or salt spread roads. ● Towing a trailer, using a camper or a car-top carrier. 	Emission Control System Maintenance	MA-7
		Chassis and Body Maintenance	MA-8
Schedule 2	Follow Periodic Maintenance Schedule 2 if none of driving conditions shown in Schedule 1 apply to the driving habits.	Emission Control System Maintenance	MA-9
		Chassis and Body Maintenance	MA-9

PERIODIC MAINTENANCE

Schedule 1 EMISSION CONTROL SYSTEM MAINTENANCE

ALS0001E

Abbreviations: R = Replace. I = Inspect. Correct or replace if necessary. []: At the mileage intervals only

MAINTENANCE OPERATION		MAINTENANCE INTERVAL								Reference Section - Page or - Content Title
Perform at number of miles, kilometers or months, whichever comes first.	Miles x 1,000 (km x 1,000) Months	3.75 (6) 3	7.50 (12) 6	11.25 (18) 9	15 (24) 12	18.75 (30) 15	22.5 (36) 18	26.25 (42) 21	30 (48) 24	
Drive belts	NOTE (1)									MA-13
Air cleaner filter	NOTE (2)								[R]	MA-17
EVAP vapor lines									I*	MA-20
Fuel lines									I*	MA-17
Fuel filter	NOTE (3)									-
Engine coolant	NOTE (4)									MA-15
Engine oil		R	R	R	R	R	R	R	R	MA-17
Engine oil filter (Use part No. 15208 31U00 or 15208 65F00 or equivalent.)		R	R	R	R	R	R	R	R	MA-18
Spark plugs (PLATINUM-TIPPED type)		Replace every 105,000 miles (169,000 km).								MA-19
Intake & exhaust valve clearance*	NOTE (5)									EM-93. "Valve Clearance"

MAINTENANCE OPERATION		MAINTENANCE INTERVAL								Reference Section - Page or - Content Title
Perform at number of miles, kilometers or months, whichever comes first.	Miles x 1,000 (km x 1,000) Months	33.75 (54) 27	37.5 (60) 30	41.25 (66) 33	45 (72) 36	48.75 (78) 39	52.5 (84) 42	56.25 (90) 45	60 (96) 48	
Drive belts	NOTE (1)								I*	MA-13
Air cleaner filter	NOTE (2)								[R]	MA-17
EVAP vapor lines									I*	MA-20
Fuel lines									I*	MA-17
Fuel filter	NOTE (3)									-
Engine coolant	NOTE (4)								R*	MA-15
Engine oil		R	R	R	R	R	R	R	R	MA-17
Engine oil filter (Use part No. 15208 31U00 or 15208 65F00 or equivalent.)		R	R	R	R	R	R	R	R	MA-18
Spark plugs (PLATINUM-TIPPED type)		Replace every 105,000 miles (169,000 km).								MA-19
Intake & exhaust valve clearance*	NOTE (5)									EM-93. "Valve Clearance"

NOTE:

- (1) After 60,000 miles (96,000 km) or 48 months, inspect every 15,000 miles (24,000 km) or 12 months. Replace the drive belts if found damaged.
- (2) If operating mainly in dusty conditions, more frequent maintenance may be required.
- (3) Maintenance-free item. For service procedures, refer to FL section.
- (4) After 60,000 miles (96,000 km) or 48 months, replace every 30,000 miles (48,000 km) or 24 months.
- (5) If valve noise increases, inspect valve clearance.

* Maintenance items and intervals with "*" are recommended by INFINITI for reliable vehicle operation. The owner need not perform such maintenance in order to maintain the emission warranty or manufacturer recall liability. Other maintenance items and intervals are required.

PERIODIC MAINTENANCE

CHASSIS AND BODY MAINTENANCE

Abbreviations: R = Replace. I = Inspect. Correct or replace if necessary.

MAINTENANCE OPERATION		MAINTENANCE INTERVAL								Reference Section - Page or - Content Title
Perform at number of miles, kilometers or months, whichever comes first.	Miles x 1,000 (km x 1,000) Months	3.75 (6) 3	7.50 (12) 6	11.25 (18) 9	15 (24) 12	18.75 (30) 15	22.5 (36) 18	26.25 (42) 21	30 (48) 24	
Brake lines & cables					I				I	MA-28
Brake pads & rotors			I		I		I		I	MA-29
Automatic transmission fluid, manual transmission gear oil, transfer fluid & differential gear oil	NOTE (1)				I				I	MA-22 , MA-25 , MA-21 , MA-24
Drive shaft boots and propeller shaft (AWD models)			I		I		I		I	MA-31 , MA-25
Steering gear & linkage, axle & suspension parts			I		I		I		I	MA-29 , RSU-5 , MA-30
Tire rotation	NOTE (2)									MA-4 , MA-28
Exhaust system			I		I		I		I	MA-21
In-cabin microfilter					R				R	ATC-129

MAINTENANCE OPERATION		MAINTENANCE INTERVAL								Reference Section - Page or - Content Title
Perform at number of miles, kilometers or months, whichever comes first.	Miles x 1,000 (km x 1,000) Months	33.75 (54) 27	37.5 (60) 30	41.25 (66) 33	45 (72) 36	48.75 (78) 39	52.5 (84) 42	56.25 (90) 45	60 (96) 48	
Brake lines & cables					I				I	MA-28
Brake pads & rotors			I		I		I		I	MA-29
Automatic transmission fluid, manual transmission gear oil, transfer fluid & differential gear oil	NOTE (1)				I				I	MA-22 , MA-25 , MA-21 , MA-24
Drive shaft boots and propeller shaft (AWD models)			I		I		I		I	MA-31 , MA-25
Steering gear & linkage, axle & suspension parts			I		I		I		I	MA-29 , RSU-5 , MA-30
Tire rotation	NOTE (2)									MA-4 , MA-28
Exhaust system			I		I		I		I	MA-21
In-cabin microfilter					R				R	ATC-129

NOTE:

(1) If towing a trailer, using a camper or a car-top carrier, or driving on rough or muddy roads, change (not just inspect) oil at every 30,000 miles (48,000 km) or 24 months. **Using automatic transmission fluid other than Genuine Nissan Matic J ATF will cause deterioration in driveability and automatic transmission durability, and may damage the automatic transmission, which is not covered by the INFINITI new vehicle limited warranty.**

(2) Refer to "Tire rotation" under the "General maintenance" heading earlier in this section.

PERIODIC MAINTENANCE

Schedule 2 EMISSION CONTROL SYSTEM MAINTENANCE

ALS0001F

Abbreviations: R = Replace. I = Inspect. Correct or replace if necessary. []: At the mileage intervals only

MAINTENANCE OPERATION	Miles x 1,000 (km x 1,000) Months	MAINTENANCE INTERVAL								Reference Section - Page or - Content Title
		7.5 (12) 6	15 (24) 12	22.5 (36) 18	30 (48) 24	37.5 (60) 30	45 (72) 36	52.5 (84) 42	60 (96) 48	
Perform at number of miles, kilometers or months, whichever comes first.										
Drive belts	NOTE (1)								I*	MA-13
Air cleaner filter					[R]				[R]	MA-17
EVAP vapor lines					I*				I*	MA-20
Fuel lines					I*				I*	MA-17
Fuel filter	NOTE (2)									-
Engine coolant	NOTE (3)								R*	MA-15
Engine oil		R	R	R	R	R	R	R	R	MA-17
Engine oil filter (Use part No. 15208 31U00 or 15208 65F00 or equivalent.)		R	R	R	R	R	R	R	R	MA-18
Spark plugs (PLATINUM-TIPPED type)		Replace every 105,000 miles (169,000 km).								MA-19
Intake & exhaust valve clearance*	NOTE (4)									EM-93, "Valve Clearance"

NOTE:

(1) After 60,000 miles (96,000 km) or 48 months, inspect every 15,000 miles (24,000 km) or 12 months. Replace the drive belts if found damaged.

(2) Maintenance-free item. For service procedures, refer to FL section.

(3) After 60,000 miles (96,000 km) or 48 months, replace every 30,000 miles (48,000 km) or 24 months.

(4) If valve noise increases, inspect valve clearance.

* Maintenance items and intervals with "*" are recommended by INFINITI for reliable vehicle operation. The owner need not perform such maintenance in order to maintain the emission warranty or manufacturer recall liability. Other maintenance items and intervals are required

CHASSIS AND BODY MAINTENANCE

Abbreviations: R = Replace. I = Inspect. Correct or replace if necessary.

MAINTENANCE OPERATION	Miles x 1,000 (km x 1,000) Months	MAINTENANCE INTERVAL								Reference Section - Page or - Content Title
		7.5 (12) 6	15 (24) 12	22.5 (36) 18	30 (48) 24	37.5 (60) 30	45 (72) 36	52.5 (84) 42	60 (96) 48	
Perform at number of miles, kilometers or months, whichever comes first.										
Brake lines & cables			I		I		I		I	MA-28
Brake pads & rotors			I		I		I		I	MA-29
Automatic transmission fluid, manual transmission gear oil, transfer fluid & differential gear oil	NOTE (1)		I		I		I		I	MA-22, MA-25, MA-24, MA-21
Drive shaft boots and propeller shaft (AWD models)			I		I		I		I	MA-31, MA-25
Steering gear & linkage, axle & suspension parts					I				I	MA-29, RSU-5, MA-30
Tire rotation	NOTE (2)									MA-4, MA-28
Exhaust system					I				I	MA-21
In-cabin microfilter			R		R		R		R	ATC-129

PERIODIC MAINTENANCE

NOTE:

(1) Using automatic transmission fluid other than Genuine Nissan Matic J ATF will cause deterioration in driveability and automatic transmission durability, and may damage the automatic transmission, which is not covered by the INFINITI new vehicle limited warranty.

(2) Refer to "Tire rotation" under the "General maintenance" heading earlier in this section.

RECOMMENDED FLUIDS AND LUBRICANTS

RECOMMENDED FLUIDS AND LUBRICANTS

PF0:00000

Fluids and Lubricants

ALS0001G

		Capacity (Approximate)			Recommended Fluids/Lubricants
		US measure	Imp measure	Liter	
Engine oil Drain and refill	With oil filter change	5 qt	4-1/8 qt	4.7	<ul style="list-style-type: none"> ● API Certification Mark*1 ● API grade SG/SH, Energy Conserving I & II or API grade SJ or SL, Energy Conserving*1 ● ILSAC grade GF-I, GF-II & GF-III *1
	Without oil filter change	4-5/8 qt	3-7/8 qt	4.4	
Dry engine (Overhaul)		5-3/4 qt	4-3/4 qt	5.4	
Cooling system	With reservoir tank	9-1/4 qt	7-5/8 qt	8.7	Genuine Nissan Long Life Antifreeze/ Coolant or equivalent
	Reservoir tank	7/8 qt	3/4 qt	0.8	
Manual transmission gear oil		3-1/8 qt	2-1/2 qt	2.9	Genuine Nissan Manual Transmission Fluid (MTF) HQ Multi 75W-85 or API GL-4, Viscosity SAE 75W-85 or 75W-90
Automatic transmission fluid		10-7/8 qt	9-1/8 qt	10.3	Genuine Nissan Matic J ATF *2
Transfer fluid		2-5/8 pt	2-1/4 pt	1.25	Genuine Nissan Matic D ATF (Continental U.S. and Alaska) or Canada NISSAN Automatic Transmission Fluid *3
Power steering fluid (PSF)		1-1/8 qt	7/8 qt	1.0	Genuine NISSAN PSF or equivalent *4
Brake (and clutch) fluid		—	—	—	Genuine Nissan Super Heavy Duty Brake Fluid*5 or equivalent DOT 3 (US FMVSS No. 116)
Differential gear oil	Front	1-3/8 pt	1-1/8 pt	0.65	API GL-5, Viscosity SAE 80W-90 *6
	Rear	3 pt	2-1/2 pt	1.4	
Multi-purpose grease		—	—	—	NLGI No. 2 (Lithium soap base)
Windshield washer fluid		—	—	—	Genuine Nissan Windshield Washer Concentrate Cleaner & Antifreeze Fluid or equivalent
Fuel recommendation		—	—	—	Refer to GL-5, "Precautions for Fuel (Unleaded Premium Gasoline Recommended)"

*1: For further details, see "SAE Viscosity Number".

***2: Using automatic transmission fluid other than Genuine Nissan Matic J ATF will cause deterioration in driveability and automatic transmission durability, and may damage the automatic transmission, which is not covered by the INFINITI new vehicle limited warranty.**

*3: DEXRON™ III/ MERCON™ or equivalent may also be used. Outside the continental United States and Alaska contact an INFINITI dealer for more information regarding suitable fluids, including recommended brand(s) of DEXRON™ III/ MERCON™ automatic transmission fluid.

*4: For Canada, NISSAN Automatic Transmission Fluid (ATF), DEXRON™ III/ MERCON™, or equivalent ATF may also be used.

*5: Available in mainland U.S.A. through your INFINITI dealer.

*6: For hot climates, viscosity SAE 90 is suitable for ambient temperatures above 0°C (32°F).

RECOMMENDED FLUIDS AND LUBRICANTS

ALS0001H

SAE Viscosity Number GASOLINE ENGINE OIL

SAE 5W-30 viscosity oil is preferred for all temperatures. SAE 10W-30 and 10W-40 viscosity oil may be used if the ambient temperature is above -18°C(0°F)

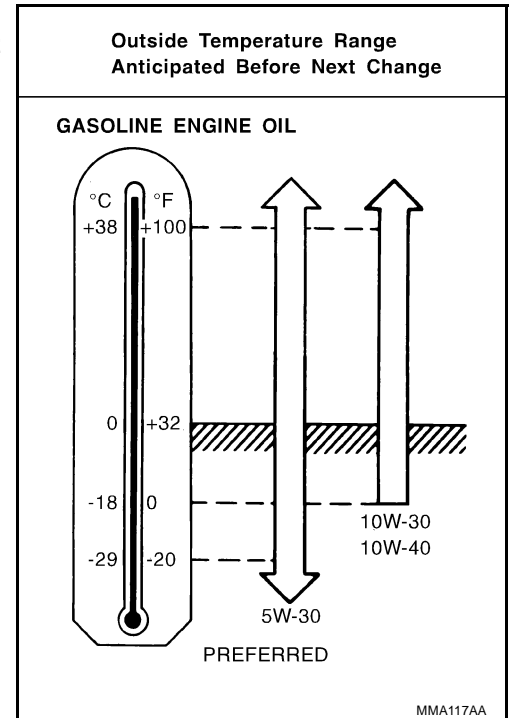

Anti-Freeze Coolant Mixture Ratio

ALS000A2

The engine cooling system is filled at the factory with a high-quality, year-round, anti-freeze coolant solution. The anti-freeze solution contains rust and corrosion inhibitors. Therefore, additional cooling system additives are not necessary.

CAUTION:

When adding or replacing coolant, be sure to use only Genuine Nissan Long Life Antifreeze/ Coolant or equivalent with the proper mixture ratio of 50% anti-freeze and 50% demineralized water/distilled water.

Other types of coolant solutions may damage your cooling system.

Outside temperature down to		Anti-freeze	Demineralized water or distilled water
°C	°F		
-35	-30	50%	50%

SMA947CA

ENGINE MAINTENANCE

ENGINE MAINTENANCE

PF0:00000

Checking Drive Belts

ALS00010

WARNING:

Be sure to perform when the engine is stopped.

1. Inspect belts for cracks, fraying, wear and oil. If necessary, replace.
2. Inspect drive belt deflection or tension at a point on the belt mid-way between pulleys.
 - Inspection should be done only when engine is cold, or over 30 minutes after engine is stopped.
 - Measure the belt tension with belt tension gauge (commercial service tool: BT3373-F or equivalent) at points marked ▼ shown in the figure.
 - When measuring deflection, apply 98 N (10 kg, 22 lb) at the ▼ marked point.
 - Adjust if belt deflection exceeds the limit or if belt tension is not within specifications.

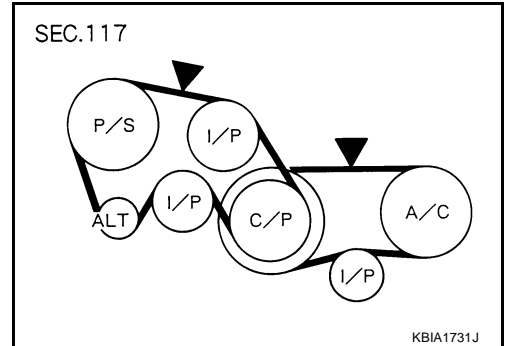

CAUTION:

- When checking belt deflection or tension immediately after installation, first adjust it to the specified value. Then, after turning the crankshaft two turns or more, re-adjust to the specified value to avoid variation in deflection between pulleys.
- Tighten idler pulley lock nut by hand and measure the deflection or tension without looseness.

Belt deflection and tension

	Deflection adjustment		Unit: mm (in)	Tension adjustment*		Unit: N (kg, lb)
	Used belt		New belt	Used belt		New belt
	Limit	After adjustment		Limit	After adjustment	
Alternator and power steering oil pump belt	7 (0.28)	4 - 5 (0.16 - 0.20)	3.5 - 4.5 (0.138 - 0.177)	294 (30, 66)	730 - 818 (74.5 - 83.5, 164 - 184)	838 - 926 (85.5 - 94.5, 188 - 208)
A/C compressor belt	12 (0.47)	9 - 10 (0.35 - 0.39)	8 - 9 (0.31 - 0.35)	196 (20, 44)	348 - 436 (35.5 - 44.5, 78 - 98)	470 - 559 (48 - 57, 106 - 126)
Applied pushing force	98 N (10 kg, 22 lb)			—		

* : If belt tension gauge cannot be installed at check points shown, check drive belt tension at different location on the belt.

ENGINE MAINTENANCE

Tension Adjustment

ALS0001P

Portion	Belt tightening method for adjustment
Alternator and power steering oil pump belt	Adjusting bolt on idler pulley
A/C compressor belt	Adjusting bolt on idler pulley

CAUTION:

- When belt is replaced with a new one, adjust it to value for “New belt” to accommodate for insufficient adaptability with pulley grooves.
- When deflection or tension of belt being used exceeds “Limit”, adjust it to value for “After adjustment”.
- When checking belt deflection or tension immediately after installation, first adjust it to the specified value. Then, after turning crankshaft two turns or more, re-adjust to the specified value to avoid variation in deflection between pulleys.
- When installing belt, make sure that it is correctly engaged with pulley groove.
- Keep oil and water away from belt.
- Do not twist or bend belt excessively.

ALTERNATOR AND POWER STEERING OIL PUMP BELT

1. Remove undercover with power tool.
2. Loosen idler pulley lock nut (A) and adjust tension by turning adjusting bolt (B).
 - For specified belt tension, refer to [EM-14, "Checking Drive Belts"](#) .
3. Tighten nut (A).

 : 34.8 N·m (3.5 kg·m, 26 ft·lb)

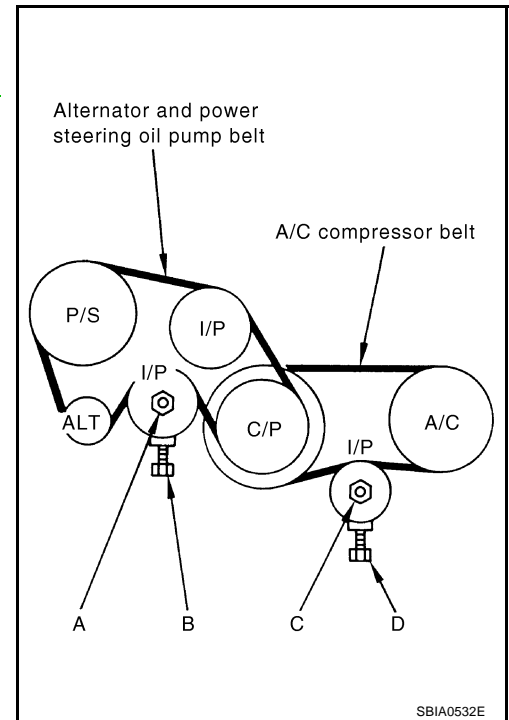

A/C COMPRESSOR BELT

1. Remove undercover with power tool.

ENGINE MAINTENANCE

- Loosen idler pulley lock nut (C) and adjust tension by turning adjusting bolt (D).
 - For specified belt tension, refer to [EM-14, "Checking Drive Belts"](#).
- Tighten nut (C).

 : 34.8 N·m (3.5 kg-m, 26 ft-lb)

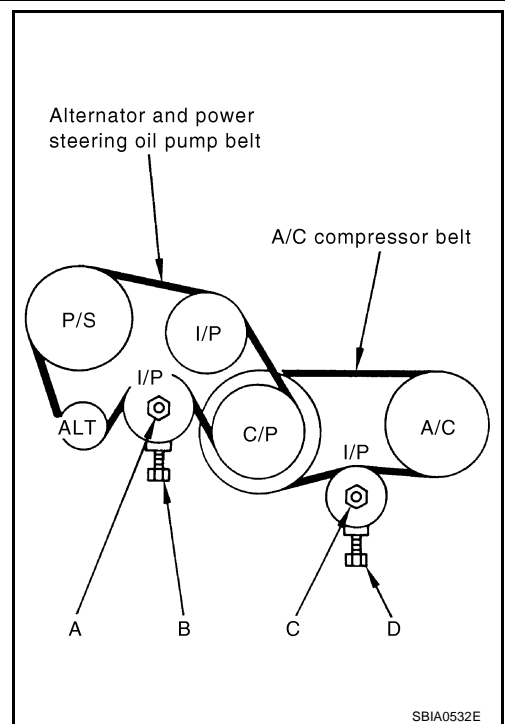

Changing Engine Coolant

WARNING:

- To avoid being scalded, do not change engine coolant when engine is hot.
- Wrap a thick cloth around radiator cap and carefully remove radiator cap. First, turn cap a quarter of a turn to release built-up pressure. Then turn radiator cap all the way.
- Be careful not to allow engine coolant to contact drive belts.

DRAINING ENGINE COOLANT

- Remove undercover with power tool.
- Open radiator drain plug at the bottom of radiator, and then remove radiator cap.

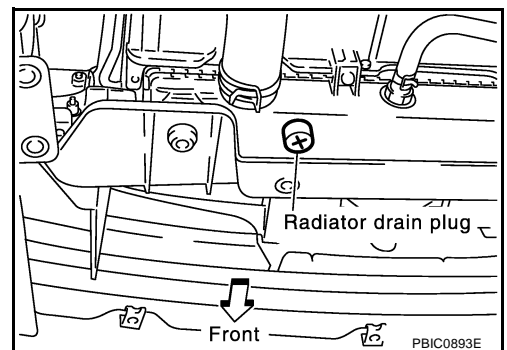

When drain all of engine coolant in the system, open water drain plugs on engine cylinder block. Refer to [EM-124, "DISASSEMBLY"](#).

- Remove reservoir tank, drain engine coolant and clean tank before installing.
- Check drained engine coolant for contaminants such as rust, corrosion or discoloration. If contaminated, flush the engine cooling system. Refer to [MA-17, "FLUSHING COOLING SYSTEM"](#).

REFILLING ENGINE COOLANT

- Install reservoir tank, and radiator drain plug.

CAUTION:

Be sure to clean drain plug and install with new O-ring.

Radiator drain plug:

 : 1.2 N·m (0.12 kg-m, 11 in-lb)

ENGINE MAINTENANCE

If cylinder block drain plugs are removed, close and tighten them. Refer to [EM-129, "ASSEMBLY"](#) .

- Remove air relief plug on heater hose.

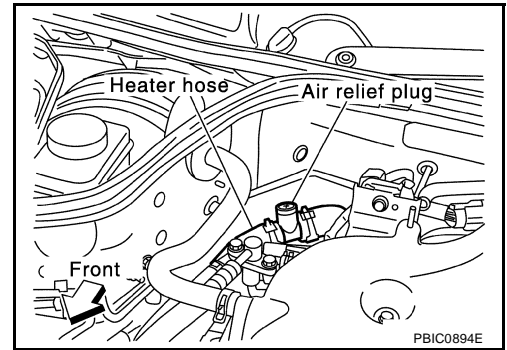

- Fill radiator and reservoir tank to specified level.

- Pour engine coolant through engine coolant filler neck slowly of less than 2 ℓ (2-1/8 US qt, 1-3/4 Imp qt) a minute to allow air in system to escape.
- Use Genuine Nissan Long Life Antifreeze/ Coolant or equivalent mixed with water (distilled or demineralized). Refer to [MA-11, "RECOMMENDED FLUIDS AND LUBRICANTS"](#) .

**Engine coolant capacity (Approximate)
(with reservoir tank at "MAX" level)**

: 8.7 ℓ (9-1/4 US qt, 7-5/8 Imp qt)

Reservoir tank capacity (at "MAX" level)

: 0.8 ℓ (7/8 US qt, 3/4 Imp qt)

- When engine coolant overflows air relief hole on heater hose, install air relief plug with new O-ring.

Air relief plug:

 **: 1.2 N·m (0.12 kg·m, 11 in·lb)**

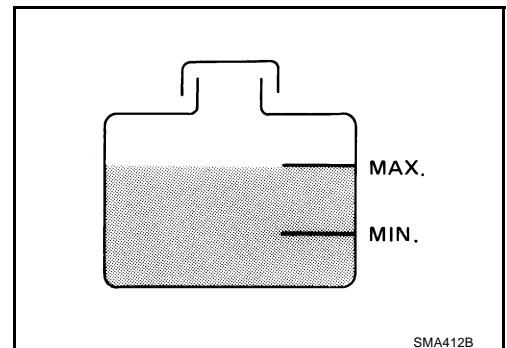
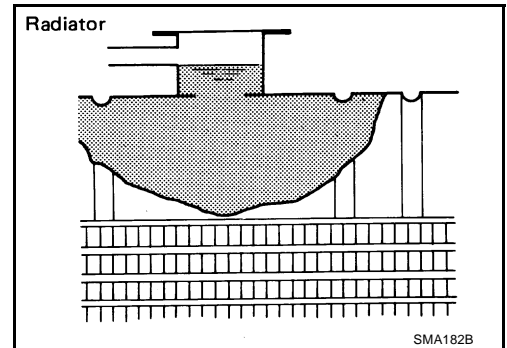

- Warm up engine to normal operating temperature with radiator cap installed.
 - Run engine at 3,000 rpm for 10 seconds and return to idle speed.
 - Repeat two or three times.
- CAUTION:**
Watch water temperature gauge so as not to overheat engine.
- Stop engine and cool down to less than approximately 50°C (122°F).
 - Cool down using a fan to reduce the time.
 - If necessary, refill radiator up to filler neck with engine coolant.
 - Refill reservoir tank to "MAX" level line with engine coolant.
 - Repeat steps 3 through 6 two or more times with radiator cap installed until engine coolant level no longer drops.
 - Check cooling system for leaks with engine running.
 - Warm up engine, and check for sound of engine coolant flow while running engine from idle up to 3,000 rpm with heater temperature controller set at several position between "COOL" and "WARM".
 - Sound may be noticeable at heater unit.
 - Repeat step 10 three times.
 - If sound is heard, bleed air from cooling system by repeating step 3 through 6 until engine coolant level no longer drops.

ENGINE MAINTENANCE

- Clean excess engine coolant from engine.

FLUSHING COOLING SYSTEM

1. Fill radiator with water until water spills from the air relief hole, then close air relief plug. Fill radiator and reservoir tank with water and reinstall radiator cap.
2. Run engine and warm it up to normal operating temperature.
3. Rev engine two or three times under no-load.
4. Stop engine and wait until it cools down.
5. Drain water from the system. Refer to [MA-15, "DRAINING ENGINE COOLANT"](#) .
6. Repeat steps 1 through 5 until clear water begins to drain from radiator.

Checking Fuel Lines

Inspect fuel lines, fuel filler cap and fuel tank for improper attachment, leaks, cracks, damage, loose connections, chafing or deterioration.

If necessary, repair or replace damaged parts.

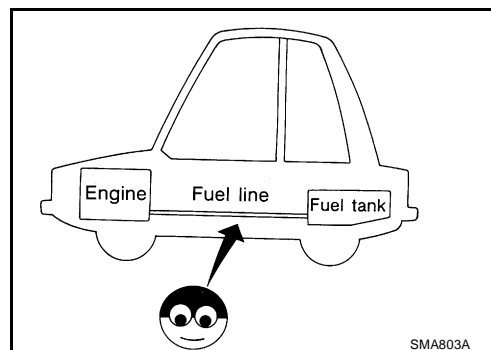

Changing Air Cleaner Filter

VISCOUS PAPER TYPE

The viscous paper type filter does not need cleaning between replacement intervals. Refer to [MA-6, "PERIODIC MAINTENANCE"](#) .

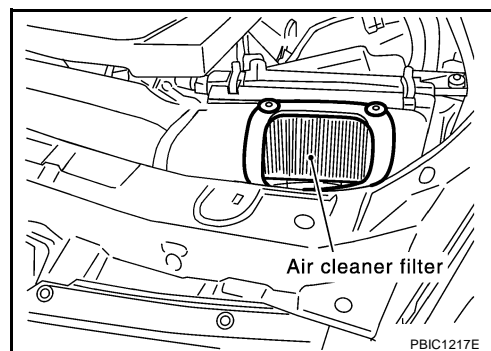

Changing Engine Oil

WARNING:

- Be careful not to burn yourself, as the engine oil may be hot.
 - Prolonged and repeated contact with used engine oil may cause skin cancer; try to avoid direct skin contact with used engine oil. If skin contact is made, wash thoroughly with soap or hand cleaner as soon as possible.
1. Warm up engine, put vehicle horizontally and check for oil leakage from engine components. Refer to [LU-6, "OIL LEAKAGE"](#) .
 2. Stop engine and wait for 10 minutes.
 3. Loosen oil filler cap and then remove drain plug.
 4. Drain engine oil.
 5. Install drain plug with new washer. Refer to [EM-30, "OIL PAN AND OIL STRAINER"](#) .

CAUTION:

Be sure to clean drain plug and install with new washer.

Oil pan drain plug:

 : 34.3 N-m (3.5 kg-m, 25 ft-lb)

6. Refill with new engine oil.

ENGINE MAINTENANCE

Engine oil specification and viscosity:

Refer to [MA-11, "RECOMMENDED FLUIDS AND LUBRICANTS"](#) .

Engine oil capacity (Approximate):

Unit: ℓ (US qt, Imp qt)

Drain and refill	With oil filter change	4.7 (5, 4-1/8)
	Without oil filter change	4.4 (4-5/8, 3-7/8)
Dry engine (Overhaul)		5.4 (5-3/4, 4-3/4)

CAUTION:

- When filling engine oil, do not pull out oil level gauge.
- The refill capacity depends on the engine oil temperature and drain time. Use these specifications for reference only.

7. Warm up engine and check area around drain plug and oil filter for oil leakage.
8. Stop engine and wait for 10 minutes.
9. Check the engine oil level. Refer to [LU-6, "OIL LEVEL"](#) .

Changing Oil Filter REMOVAL

ALS0008

1. Remove undercover.
2. Using oil filter wrench [SST], remove oil filter.

CAUTION:

- Oil filter is provided with relief valve. Use Genuine Nissan Oil Filter or equivalent.
- Be careful not to get burned when engine and engine oil may be hot.
- When removing, prepare a shop cloth to absorb any engine oil leakage or spillage.
- Do not allow engine oil to adhere to drive belts.
- Completely wipe off any engine oil that adheres to engine and vehicle.

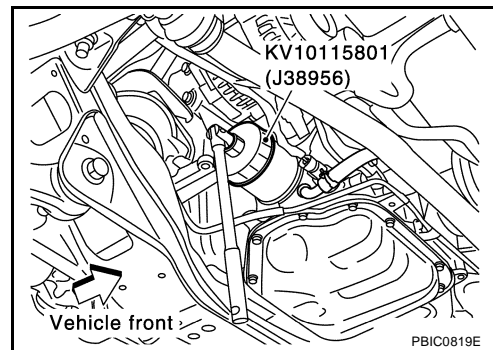

INSTALLATION

1. Remove foreign materials adhering to oil filter installation surface.
2. Apply engine oil to the oil seal contact surface of new oil filter.

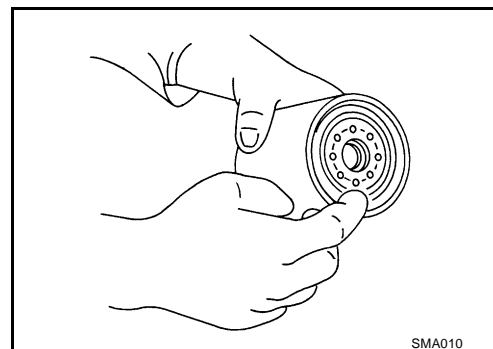

3. Screw oil filter manually until it touches the installation surface, then tighten it by 2/3 turn. Or tighten to specification.

Oil filter:

 : 17.6 N·m (1.8 kg·m, 13 ft·lb)

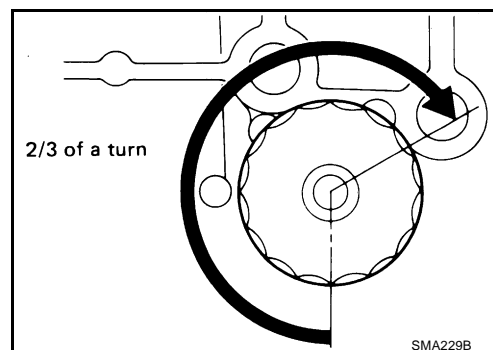

ENGINE MAINTENANCE

INSPECTION AFTER INSTALLATION

1. Start engine, and check there is no leak of engine oil.
2. Stop engine and wait for 10 minutes.
3. Check the engine oil level and add engine oil. Refer to [MA-17, "Changing Engine Oil"](#) .

Changing Spark Plugs (Platinum-Tipped Type) REMOVAL

ALS00009

1. Remove engine cover with power tool. Refer to [EM-19, "INTAKE MANIFOLD COLLECTOR"](#) .
2. Remove ignition coil. Refer to [EM-43, "IGNITION COIL"](#) .
3. Remove spark plug using spark plug wrench (commercial service tool).

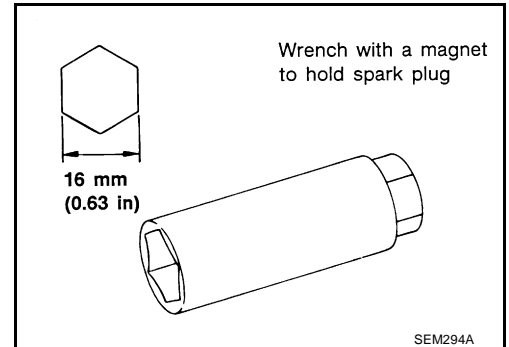

INSPECTION AFTER REMOVAL

Use standard type spark plug for normal condition.

Hot type spark plug is suitable when fouling occurs with standard type spark plug under conditions such as:

- Frequent engine starts
- Low ambient temperatures

Cold type spark plug is suitable when spark plug knock occurs with standard type spark plug under conditions such as:

- Extended highway driving
- Frequent high engine revolution

Make	NGK
Standard type	PLFR5A-11
Hot type	PLFR4A-11
Cold type	PLFR6A-11

Gap (Nominal) : 1.1 mm (0.043 in)

CAUTION:

- Do not drop or shock spark plug.
- Do not use wire brush for cleaning.
- If plug tip is covered with carbon, spark plug cleaner may be used.

Cleaner air pressure:

Less than 588 kPa (6 kg/cm² , 85 psi)

Cleaning time:

Less than 20 seconds

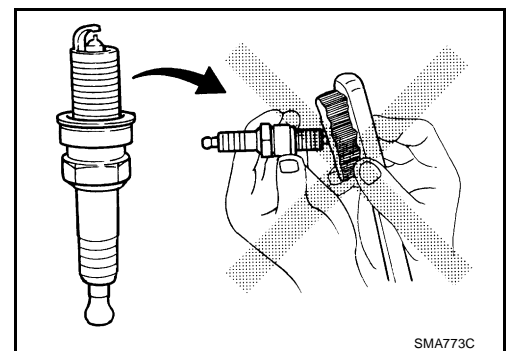

ENGINE MAINTENANCE

- Checking and adjusting plug gap is not required between change intervals.

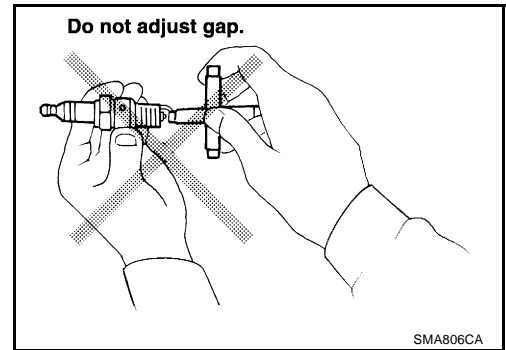

INSTALLATION

Install in the reverse order of removal.

Spark plug:

 : 19.6 - 29.4 N·m (2.0 - 2.9 kg·m, 15 - 21 ft·lb)

Checking EVAP Vapor Lines

ALS0000A

1. Visually inspect EVAP vapor lines for improper attachment and for cracks, damage, loose connections, chafing and deterioration.
2. Inspect fuel tank filler cap vacuum relief valve for clogging, sticking, etc.
Refer to [EC-31, "EVAPORATIVE EMISSION SYSTEM"](#) .

CHASSIS AND BODY MAINTENANCE

PFP:00100

Checking Exhaust System

ALS0000M

Check exhaust pipes, muffler and mounting for improper attachment, leaks, cracks, damage, chafing or deterioration.

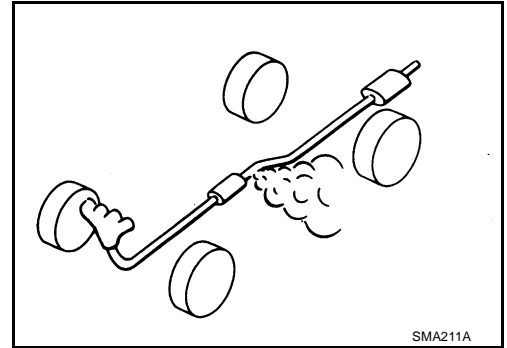

Checking Clutch Fluid Level and Leaks

ALS000HC

If fluid level is extremely low, check clutch system for leaks.

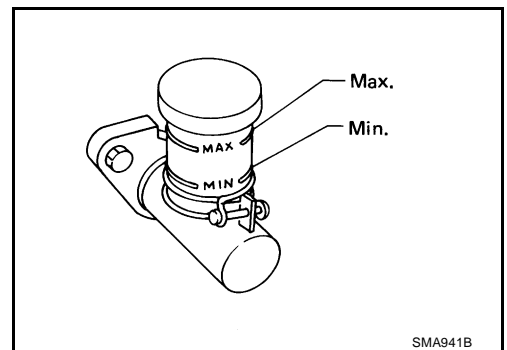

Checking M/T Oil

1. Check for oil leakage.

ALS000HD

Changing M/T Oil

1. Drain oil from drain plug and refill with new gear oil.
2. Check oil level.

ALS000Q5

Oil grade and viscosity:

Refer to [MA-11, "RECOMMENDED FLUIDS AND LUBRICANTS"](#).

Oil capacity:

Approx. 2.9 ℓ (3-1/8 US qt, 2-1/2 Imp qt)

Filler plug and drain plug:

 : 34.5 N·m (3.5 kg·m, 25 ft·lb)

CAUTION:

Do not reuse gaskets.

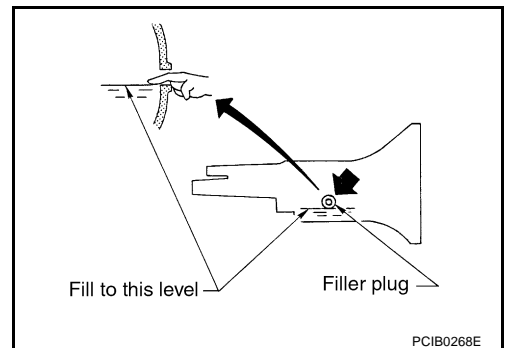

A
B
C
D
E
F
G
H
I
J
K
M

MA

Checking A/T Fluid

1. Warm up engine.
2. Check for fluid leakage.
3. Loosen the level gauge bolt.
4. Before driving, A/T fluid level can be checked at fluid temperatures of 30 to 50°C (86 to 122°F) using “COLD” range on A/T fluid level gauge as follows.
 - a. Park vehicle on level surface and set parking brake.
 - b. Start engine and move selector lever through each gear position. Leave selector lever in “P” position.
 - c. Check A/T fluid level with engine idling.
 - d. Remove A/T fluid level gauge and wipe clean with lint-free paper.

CAUTION:

When wiping away the A/T fluid level gauge, always use lint-free paper, not a cloth one.

- e. Re-insert A/T fluid level gauge into A/T fluid charging pipe as far as it will go.

CAUTION:

To check A/T fluid level, insert the A/T fluid level gauge until the cap contacts the end of the A/T fluid charging pipe, with the A/T fluid level gauge reversed from the normal attachment conditions.

- f. Remove A/T fluid level gauge and note reading. If reading is at low side of range, add fluid to the A/T fluid charging pipe.

CAUTION:

Do not overfill.

5. Drive vehicle for approximately 5 minutes in urban areas.
6. Make the fluid temperature approximately 65°C (149°F).

NOTE:

Fluid level will be greatly affected by temperature as shown in figure. Therefore, be certain to perform operation while checking data with CONSULT-II.

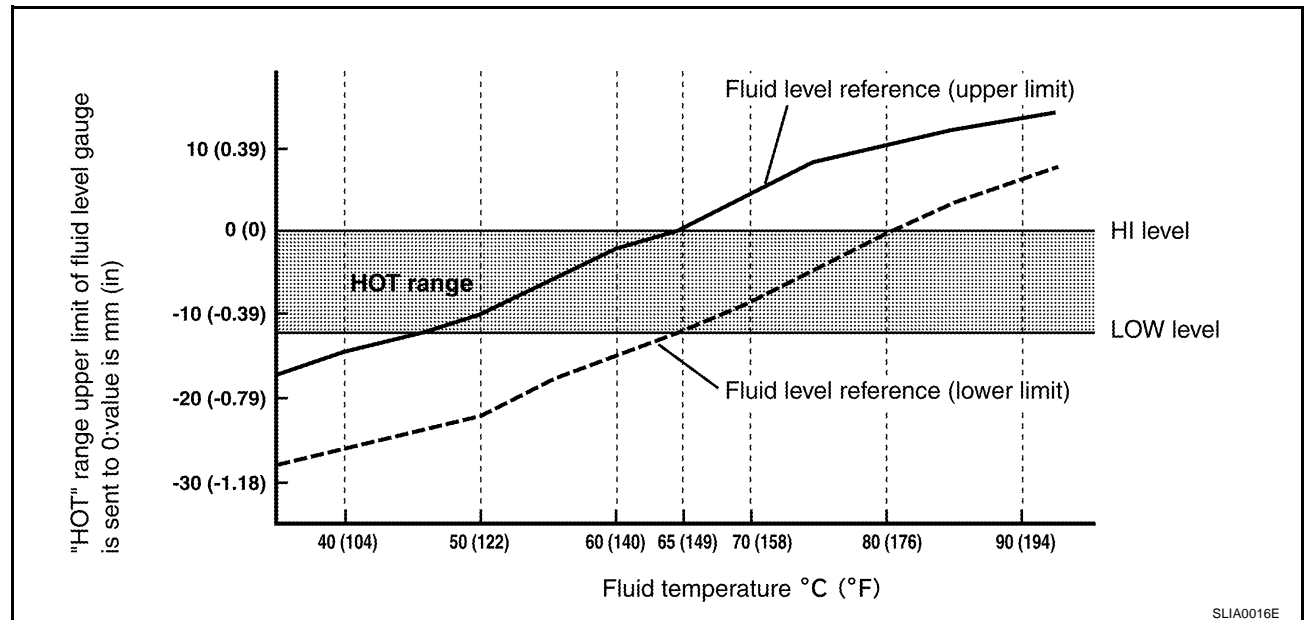
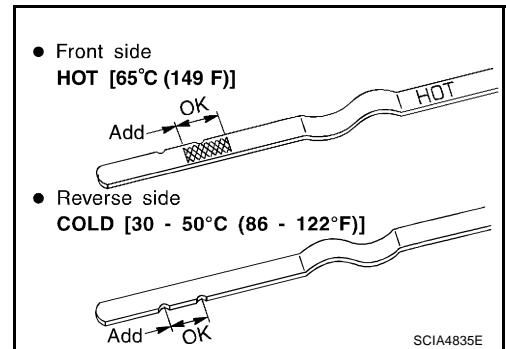

- a. Connect CONSULT-II to data link connector. Refer to [AT-94, "CONSULT-II SETTING PROCEDURE"](#).
- b. Select “MAIN SIGNALS” in “DATA MONITOR” mode for “A/T” with CONSULT-II.
- c. Read out the value of “ATF TEMP 1”.

CHASSIS AND BODY MAINTENANCE

7. Recheck fluid level at fluid temperatures of approximately 65°C (149°F) using "HOT" range on A/T fluid level gauge.

CAUTION:

- When wiping away the A/T fluid level gauge, always use lint-free paper, not a cloth one.
- To check fluid level, insert the A/T fluid level gauge until the cap contacts the end of the A/T fluid charging pipe, with the A/T fluid level gauge reversed from the normal attachment conditions as shown.

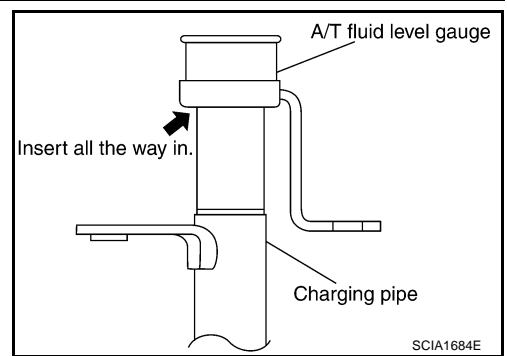

8. Check A/T fluid condition.

- If ATF is very dark or smells burned, check operation of A/T. Flush cooling system after repair of A/T.
- If ATF contains frictional material (clutches, bands, etc.), replace radiator and flush cooler line using cleaning solvent and compressed air after repair of A/T. Refer to [CO-13, "RADIATOR"](#) and [AT-14, "A/T Fluid Cooler Cleaning"](#).

9. Install the removed A/T fluid level gauge in the A/T fluid charging pipe.

10. Tighten the level gauge bolt.

Level gauge bolt:

 : 5.1 N·m (0.52 kg·m, 45 in-lb)

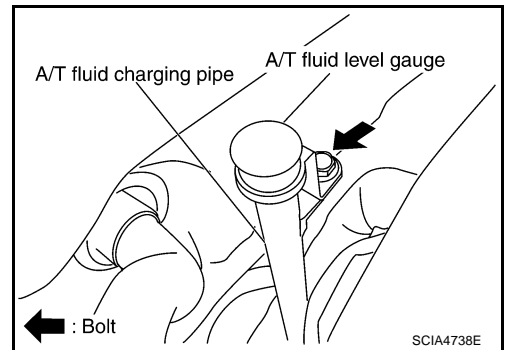

A
B
C
D
E
F
G
H
I
J
K
MA
M

CHASSIS AND BODY MAINTENANCE

Changing A/T Fluid

ALS00000

1. Warm up ATF.
2. Stop engine.
3. Loosen the level gauge bolt.
4. Drain ATF from drain plug and refill with new ATF. Always refill same volume with drained fluid.
 - To replace the ATF, pour in new fluid at the A/T fluid charging pipe with the engine idling and at the same time drain the old fluid from the radiator cooler hose return side.
 - When the color of the fluid coming out is about the same as the color of the new fluid, the replacement is complete. The amount of new A/T fluid to use should be 30 to 50% increase of the stipulated amount.

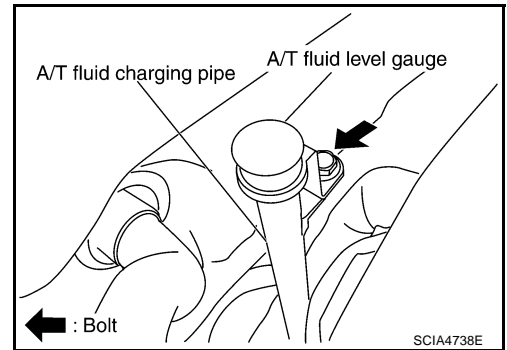

ATF: Genuine Nissan Matic J ATF

Fluid capacity: 10.3 ℓ (10-7/8 US qt, 9-1/8 Imp qt)

CAUTION:

- Use only Genuine Nissan Matic J ATF. Do not mix with other fluid.
- Using A/T fluid other than Genuine Nissan Matic J ATF will cause deterioration in driveability and automatic transmission durability, and may damage the automatic transmission, which is not covered by the warranty.
- When filling ATF, take care not to scatter heat generating parts such as exhaust.
- Do not reuse drain plug gasket.

Drain plug:

 : 34 N·m (3.5 kg·m, 25 ft·lb)

5. Run engine at idle speed for 5 minutes.
6. Check A/T fluid level and condition. Refer to [AT-12, "Checking A/T Fluid"](#) . If ATF is still dirty, repeat step 2. through 5.
7. Install the removed A/T fluid level gauge in the A/T fluid charging pipe.
8. Tighten the level gauge bolt.

Level gauge bolt:

 : 5.1 N·m (0.52 kg·m, 45 in·lb)

Checking Transfer Fluid

ALS000QK

Check for fluid leakage and fluid level.

CAUTION:

- Never start engine while checking fluid level.
- Do not reuse gasket.

Filler plug:

 : 35 N·m (3.6 kg·m, 26 ft·lb)

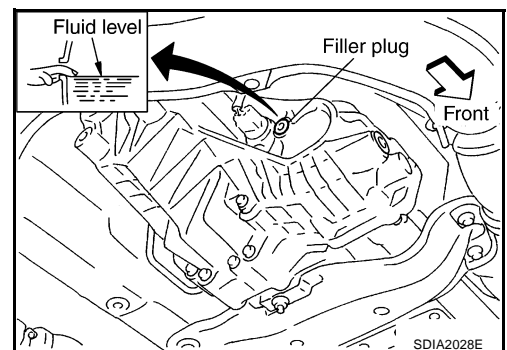

CHASSIS AND BODY MAINTENANCE

Changing Transfer Fluid

ALS000QL

CAUTION:

When draining fluid, protect exhaust tube flange with cover.

1. Drain fluid from drain plug and refill with new fluid.
2. Check fluid level.

CAUTION:

- Do not reuse gasket.
- Carefully fill the fluid. (Fill up for Approx. 3 minutes.)

Fluid grade:

Genuine Nissan Matic D ATF (Continental U.S. and Alaska) or Canada NISSAN Automatic Transmission Fluid

Refer to [MA-11, "RECOMMENDED FLUIDS AND LUBRICANTS"](#).

Fluid capacity:

: Approx. 1.25 ℓ (2-5/8 US pt, 2-1/4 Imp pt)

Drain plug:

: 29.4 N-m (3.0 kg-m, 22 ft-lb)

Filler plug:

: 35 N-m (3.6 kg-m, 26 ft-lb)

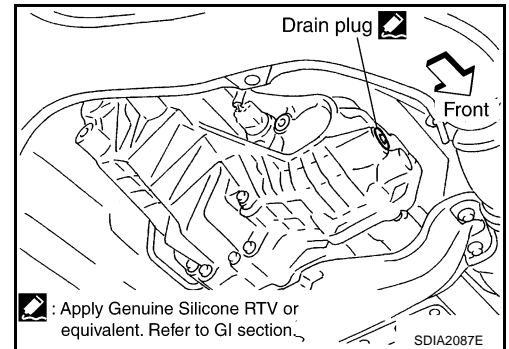

Checking Propeller Shaft

ALS0001I

Check propeller shaft for damage, looseness or grease leakage.

Tightening torque:

Refer to [PR-4, "REAR PROPELLER SHAFT"](#).

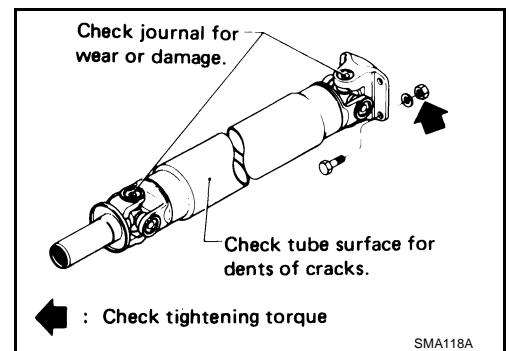

Checking Differential Gear Oil

ALS0001J

Check for oil leakage.

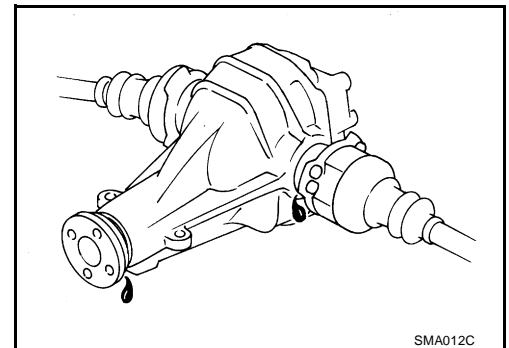

A
B
C
D
E
F
G
H
I
J
K
MA
M

Changing Differential Gear Oil

1. Drain oil from drain plug and refill with new gear oil.
2. Check oil level.

Oil grad and Viscosity:

Refer to [MA-11, "RECOMMENDED FLUIDS AND LUBRICANTS"](#) .

Front final drive(F160A)

Capacity:0.65 ℓ (1-3/8 USpt, 1-1/8 Imp pt)

Filler plug:

: 34.5 N·m (3.5 kg-m, 25 ft-lb)

Drain plug:

: 34.5 N·m (3.5 kg-m, 25 ft-lb)

Rear final drive(R200,R200V)

Capacity:1.4 ℓ (3 USpt, 2-1/2 Imp pt)

Filler plug:

: 34.5 N·m (3.5 kg-m, 25 ft-lb)

Drain plug:

: 34.5 N·m (3.5 kg-m, 25 ft-lb)

CAUTION:

Gaskets are not reusable. Never reuse them.

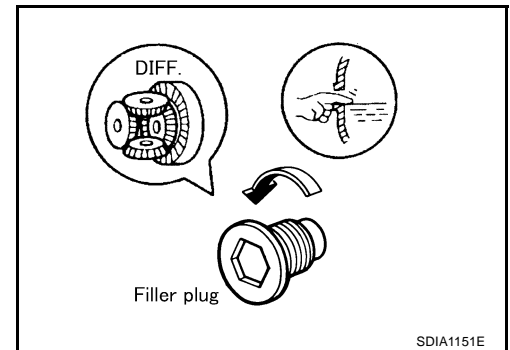

Balancing Wheels (Bonding Weight Type) REMOVAL

1. Remove inner and outer balance weights from the road wheel.

CAUTION:

Be careful not to scratch the road wheel during removal.

2. Using releasing agent, remove double-faced adhesive tape from the road wheel.

CAUTION:

- Be careful not to scratch the road wheel during removal.
- After removing double-faced adhesive tape, wipe clean traces of releasing agent from the road wheel.

WHEEL BALANCE ADJUSTMENT

- If a tire balance machine has adhesion balance weight mode settings and drive-in weight mode setting, select and adjust a drive-in weight mode suitable for road wheels.
1. Set road wheel on wheel balancer using the center hole as a guide. Start the tire balance machine.
 2. When inner and outer unbalance values are shown on the wheel balancer indicator, multiply outer unbalance value by 5/3 to determine balance weight that should be used. Select the outer balance weight with a value closest to the calculated value above and install it to the designated outer position of, or at the designated angle in relation to the road wheel.

CAUTION:

- Do not install the inner balance weight before installing the outer balance weight.

CHASSIS AND BODY MAINTENANCE

- Before installing the balance weight, be sure to clean the mating surface of the road wheel.

Indicated unbalance value $\times 5/3$ = balance weight to be installed

Calculation example:

23 g (0.81 oz) $\times 5/3$ = 38.33 g (1.35 oz) = 40 g (1.41 oz) balance weight (closer to calculated balance weight value)

Note that balance weight value must be closer to the calculated balance weight value.

Example:

37.4 = 35 g (1.23 oz)

37.5 = 40 g (1.41 oz)

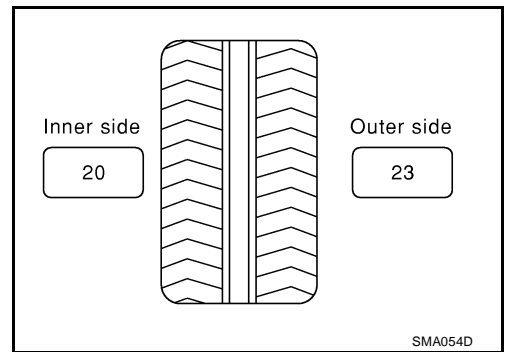

- Install balance weight in the position shown in the figure at right.
- When installing balance weight to road wheels, set it into the grooved area on the inner wall of the road wheel as shown in the figure so that the balance weight center is aligned with the wheel balancer indication position (angle).

CAUTION:

- Always use genuine Nissan adhesion balance weights.
- Balance weights are un reusable; always replace with new ones.
- Do not install more than three sheets of balance weight.

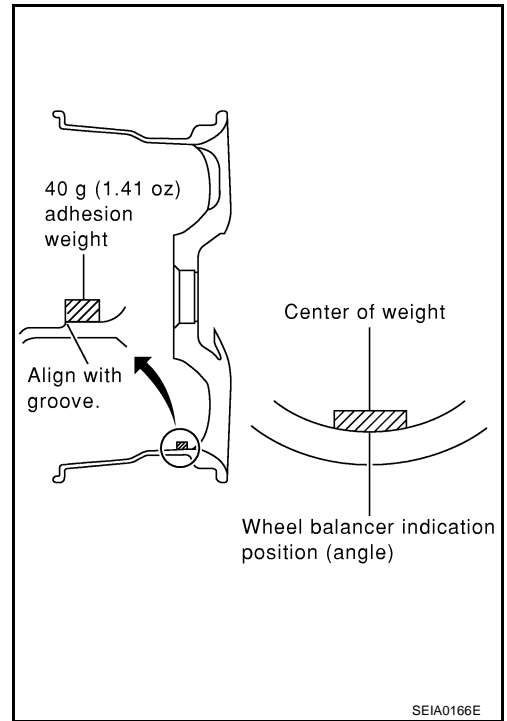

- If calculated balance weight value exceeds 50 g (1.76 oz), install two balance weight sheets in line with each other (as shown in the figure).

CAUTION:

Do not install one balance weight sheet on top of another.

- Start wheel balancer again.
- Install drive-in balance weight on inner side of road wheel in the wheel balancer indication position (angle).

CAUTION:

Do not install more than two balance weights.

- Start wheel balancer. Make sure that inner and outer residual unbalance values are 10 g (0.35 oz) each or below.

- If either residual unbalance value exceeds 10 g (0.35 oz), repeat installation procedures.

Wheel balance (Maximum allowable unbalance):

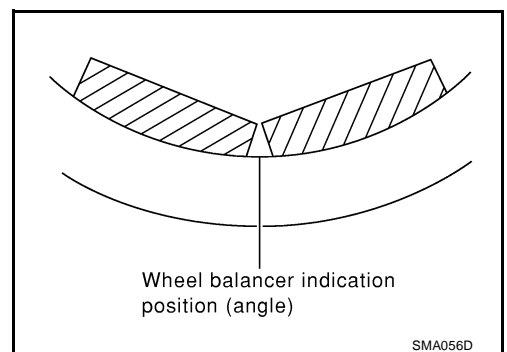

Maximum allowable unbalance	Dynamic (At rim flange)	Less than 10 g (0.35 oz) (one side)
	Static (At rim flange)	Less than 20 g (0.70 oz)

A
B
C
D
E
F
G
H
I
J
K
MA
M

CHASSIS AND BODY MAINTENANCE

Tire Rotation

ALS0000D

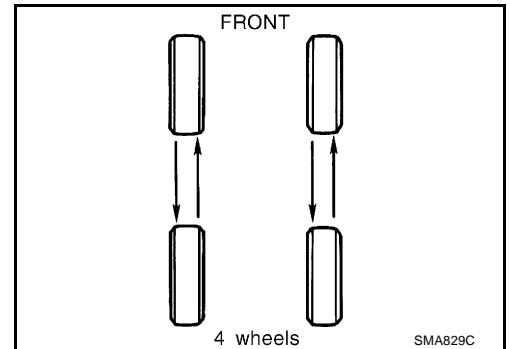

Do not include the T-type spare tire when rotating the tires.

Wheel nuts

 : 98 - 118 N·m (10.0 - 12.0 kg·m, 72 - 87 ft·lb)

Checking Brake Fluid Level and Leaks

ALS0000E

- If fluid level is extremely low, check brake system for leaks.

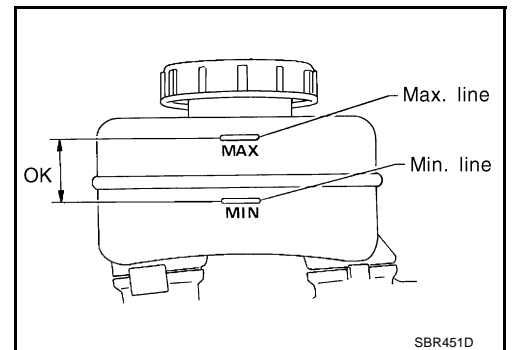

Checking Brake Lines and Cables

ALS0000F

- Check brake fluid lines and parking brake cables for improper attachment, leaks, chafing, abrasions, deterioration, etc.

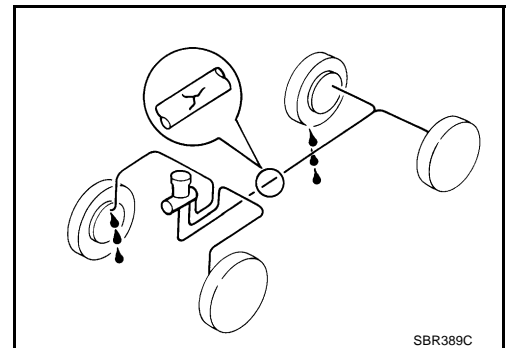

Changing Brake Fluid

ALS0000G

1. Drain brake fluid from each air bleeder valve.
2. Refill until new brake fluid comes out from each air bleeder valve.
Use same procedure as in bleeding hydraulic system to refill brake fluid.
Refer to [BR-10, "Bleeding Brake System"](#).
 - Refill with recommended Genuine Brake Fluid or equivalent DOT 3 (US FMVSS No. 116).
Refer to [MA-11, "RECOMMENDED FLUIDS AND LUBRICANTS"](#).
 - Never reuse drained brake fluid.
 - Be careful not to splash brake fluid on painted areas.

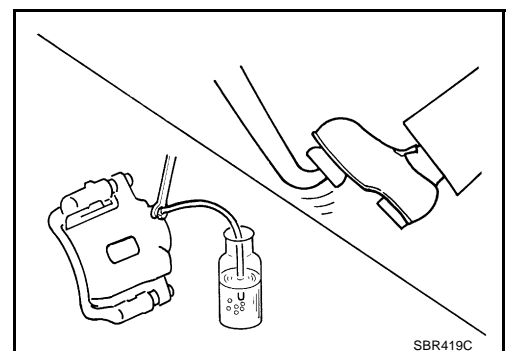

CHASSIS AND BODY MAINTENANCE

Checking Disc Brake ROTOR

ALS0000H

Check condition, wear, and damage.

Brake model	Front		Rear	
	CLZ25VD	CLZ31VD	AD14VE	AD14VF
Standard thickness	24.0 mm (0.945 in)	28.0 mm (1.102 in)	16.0 mm (0.630 in)	
Maximum runout	0.035 mm (0.0014 in)		0.10 mm (0.0039 in)	0.055 mm (0.0022 in)
Minimum thickness (Wear limit)	22.0 mm (0.866 in)	26.0 mm (1.024 in)	14.0 mm (0.551 in)	

CALIPER

- Check for leakage.

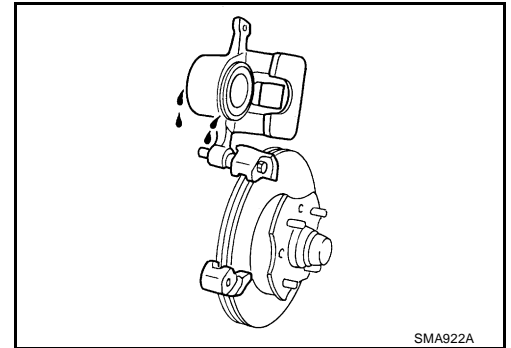

PAD

- Check for wear or damage.

Brake model	CLZ25VD	CLZ31VD	AD14VE	AD14VF
Standard thickness	11.0 mm (0.433 in)		8.5 mm (0.335 in)	
Minimum thickness (Wear limit)	2.0 mm (0.079 in)		2.0 mm (0.079 in)	

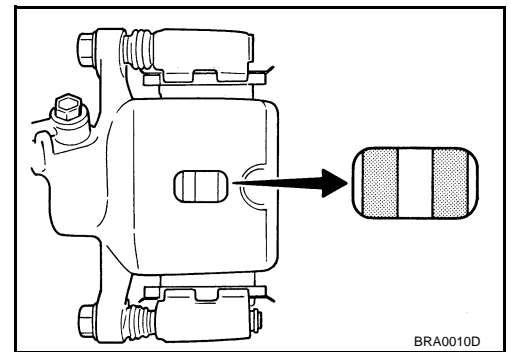

Checking Steering Gear and Linkage STEERING GEAR

ALS0000I

- Check gear housing and boots for looseness, damage and grease leakage.
- Check connection with steering column for looseness.

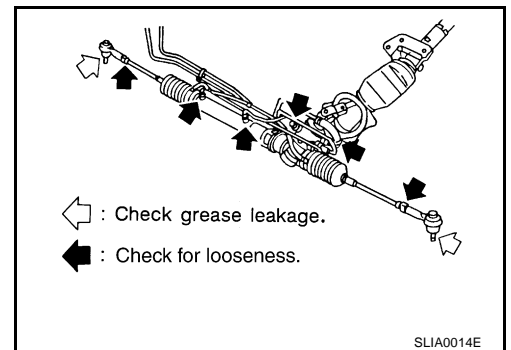

STEERING LINKAGE

Check ball joint, dust cover and other component parts for looseness, wear, damage and grease leakage.

CHASSIS AND BODY MAINTENANCE

Checking Power Steering Fluid and Lines

ALS0000J

Check fluid level in reservoir tank with engine off.

Use "HOT" range at fluid temperatures of 50 to 80°C (122 to 176°F) or "COLD" range at fluid temperatures of 0 to 30°C (32 to 86°F).

CAUTION:

- Do not overfill.
- Recommended fluid is Genuine NISSAN PSF or equivalent. Refer to [MA-11, "RECOMMENDED FLUIDS AND LUBRICANTS"](#)
- Check lines for improper attachment, leaks, cracks, damage, loose connections, chafing and deterioration.
- Check rack boots for accumulation of power steering fluid.

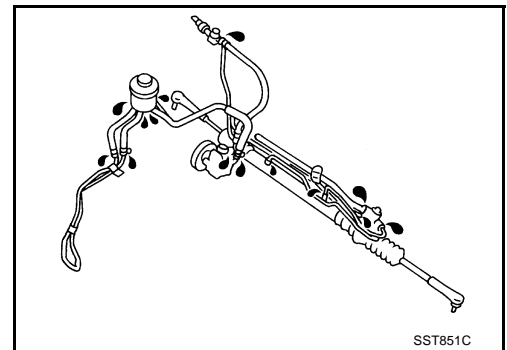
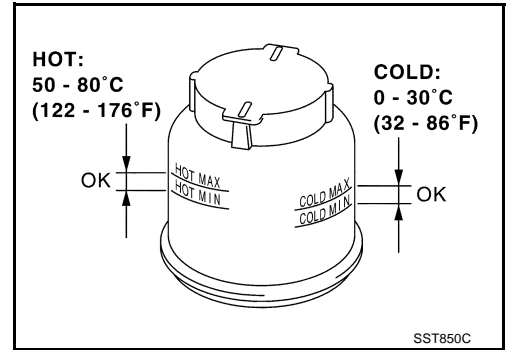

Axle and Suspension Parts

ALS0000K

Check front and rear axle and suspension parts for excessive play, cracks, wear or other damage.

- Shake each wheel to check for excessive play.
- Check wheel bearings for smooth operation.
- Check axle and suspension nuts and bolts for looseness.
- Check strut (shock absorber) for oil leakage or other damage.
- Check suspension ball joint for grease leakage and ball joint dust cover for cracks or other damage.

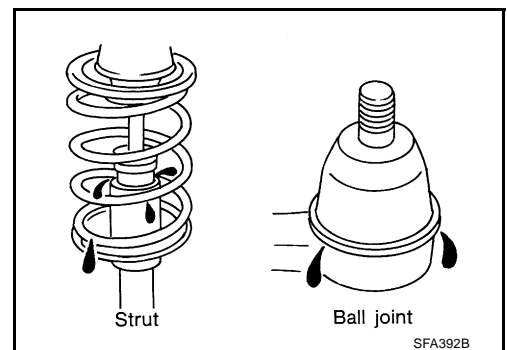
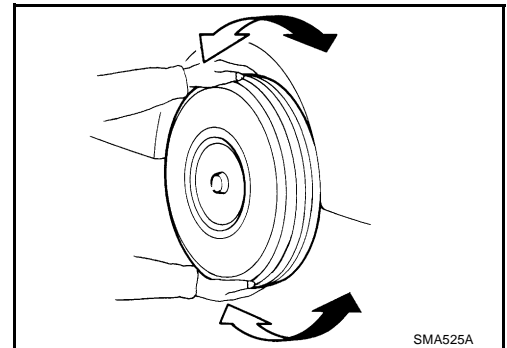

CHASSIS AND BODY MAINTENANCE

Drive Shaft

Check boot and drive shaft for cracks, wear, damage and grease leakage.

ALS0000L

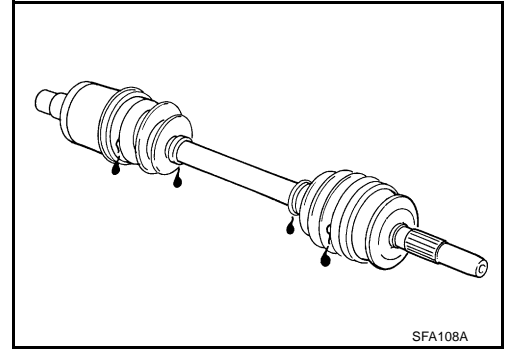

Lubricating Locks, Hinges and Hood Latch

ALS0001L

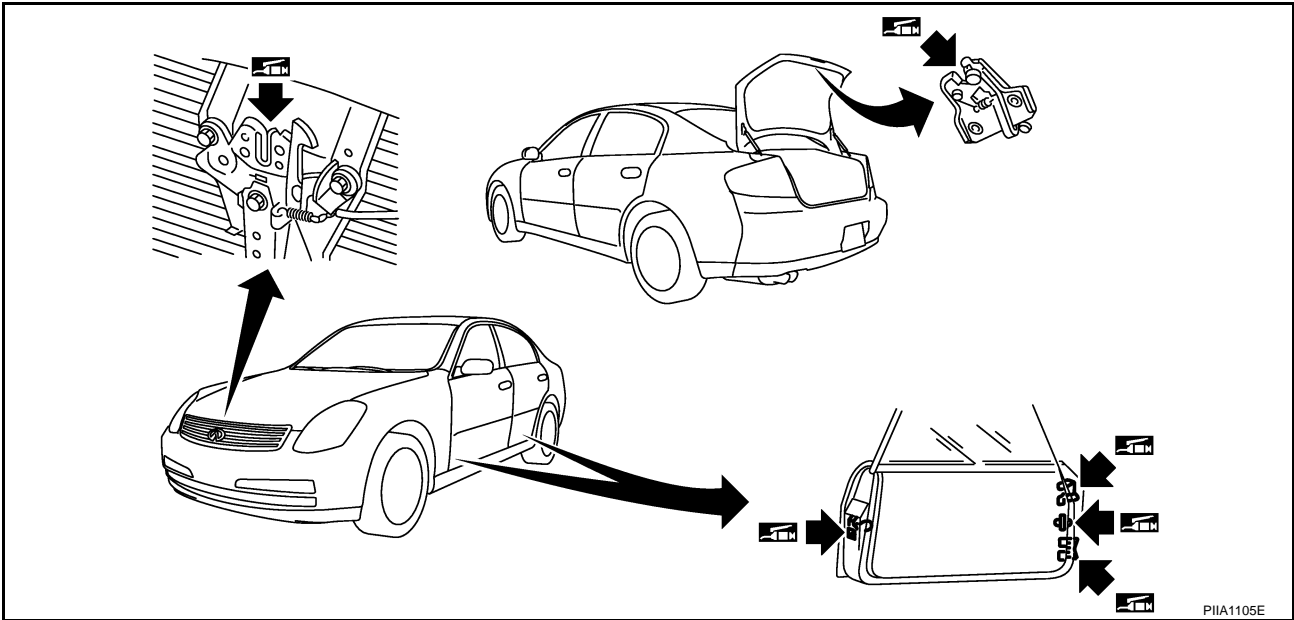

A
B
C
D
E
F
G
H
I
J
K
MA
M

CHASSIS AND BODY MAINTENANCE

Checking Seat Belt, Buckles, Retractors, Anchors and Adjusters

ALS0001M

CAUTION:

- After any collision, inspect all seat belt assemblies, including retractors and other attached hardware (i.e. anchor bolt, guide rail set). Nissan recommends to replace all seat belt assemblies in use during a collision, unless not damaged and properly operating after minor collision. Also inspect seat belt assemblies not in use during a collision, and replace if damaged or improperly operating. Seat belt pre-tensioner should be replaced even if the seat belts are not in use during a frontal collision where the driver and passenger air bags are deployed.
- If any component of seat belt assembly is questionable, do not repair. Replace as seat belt assembly.
- If webbing is cut, frayed, or damaged, replace belt assembly.
- Never oil tongue and buckle.
- Use a genuine NISSAN seat belt assembly.

For details, refer to "Seat Belt Inspection" in SB section.

Anchor bolt

 43.1 - 54.9 (4.4 - 5.5, 32 - 40)

 N•m (kg-m, ft-lb)

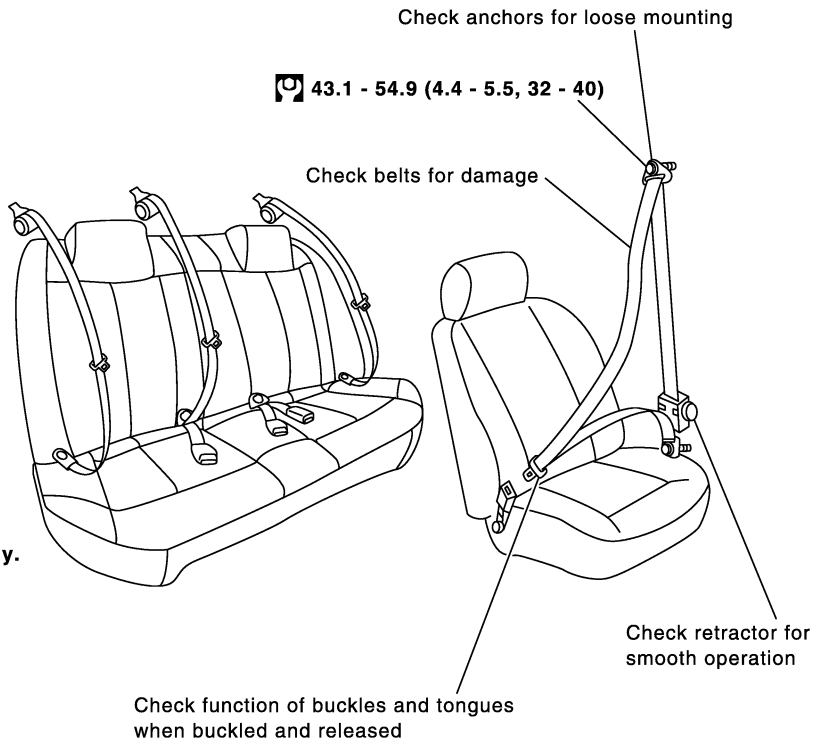

PIA1111E

SERVICE DATA AND SPECIFICATIONS (SDS)

SERVICE DATA AND SPECIFICATIONS (SDS)

PFP:00030

Standard and Limit BELT DEFLECTION AND TENSION

ALS0000B

	Deflection adjustment		Unit: mm (in)	Tension adjustment*		Unit: N (kg, lb)
	Used belt		New belt	Used belt		New belt
	Limit	After adjustment		Limit	After adjustment	
Alternator and power steering oil pump belt	7 (0.28)	4 - 5 (0.16 - 0.20)	3.5 - 4.5 (0.138 - 0.177)	294 (30, 66)	730 - 818 (74.5 - 83.5, 164 - 184)	838 - 926 (85.5 - 94.5, 188 - 208)
Air conditioner compressor	12 (0.47)	9 - 10 (0.35 - 0.39)	8 - 9 (0.31 - 0.35)	196 (20, 44)	348 - 436 (35.5 - 44.5, 78 - 98)	470 - 559 (48 - 57, 106 - 126)
Applied pushing force	98 N(10 kg, 22 lb)			—		

SEC.117

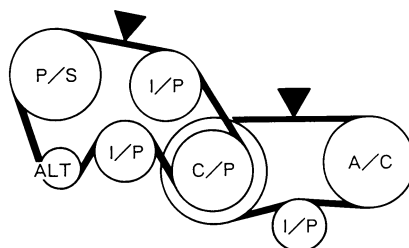

KBIA1731J

*: If belt tension gauge cannot be installed at check points shown, check drive belt tension at different location on the belt.

ENGINE COOLANT CAPACITY (APPROXIMATE)

Unit: ℓ (US qt, Imp qt)

Engine coolant capacity (With reservoir tank at MAX level)	8.7 (9-1/4, 7-5/8)
Reservoir tank engine coolant capacity (At MAX level)	0.8 (7/8, 3/4)

ENGINE OIL CAPACITY (APPROXIMATE)

Unit: ℓ (US qt, Imp qt)

Drain and refill	With oil filter change	4.7 (5, 4-1/8)
	Without oil filter change	4.4 (4-5/8, 3-7/8)
Dry engine (Overhaul)		5.4 (5-3/4, 4-3/4)

SPARK PLUG (PLATINUM-TIPPED TYPE)

Make	NGK	
Type	Standard	PLFR5A-11
	Hot	PLFR4A-11
	Cold	PLFR6A-11
Spark plug gap	Nominal: 1.1 mm (0.043 in)	

WHEEL BALANCE

Maximum allowable unbalance	Dynamic (At rim flange)	Less than 10 g (0.35 oz) (one side)
	Static (At rim flange)	Less than 20 g (0.71 oz)

SERVICE DATA AND SPECIFICATIONS (SDS)

Tightening Torque

ALS000A5

Unit: N·m (kg-m, ft-lb)

Unit: N·m (kg-m, in-lb)*

Radiator drain plug	1.2 (0.12, 11)*
Cylinder block drain plug (LH)	19.6 (2.0, 14)
Cylinder block drain plug (RH)	19.6 (2.0, 14)
Cylinder block drain plug (Front side)	9.8 (1.0, 87)*
Air relief plug	1.2 (0.12, 11)*
Oil pan drain plug	34.3 (3.5, 25)
Oil filter	17.6 (1.8, 13)
Spark plug	19.6 - 29.4 (2.0 - 2.9, 15 - 21)