

A
B
MT
D
E
F
G
H
I
J
K
L
M

SECTION **MT**

MANUAL TRANSMISSION

CONTENTS

<p>PRECAUTIONS 2</p> <p style="padding-left: 20px;">Caution 2</p> <p>PREPARATION 3</p> <p style="padding-left: 20px;">Special Service Tools 3</p> <p style="padding-left: 20px;">Commercial Service Tools 6</p> <p>NOISE, VIBRATION AND HARSHNESS (NVH)</p> <p>TROUBLESHOOTING 7</p> <p style="padding-left: 20px;">NVH Troubleshooting Chart 7</p> <p style="padding-left: 40px;">MANUAL TRANSMISSION 7</p> <p>DESCRIPTION 8</p> <p style="padding-left: 20px;">Cross-Sectional View 8</p> <p style="padding-left: 40px;">DOUBLE-CONE SYNCHRONIZER 8</p> <p style="padding-left: 40px;">TRIPLE-CONE SYNCHRONIZER 9</p> <p>M/T OIL 10</p> <p style="padding-left: 20px;">Replacement 10</p> <p style="padding-left: 40px;">DRAINING 10</p> <p style="padding-left: 40px;">FILLING 10</p> <p style="padding-left: 20px;">Checking 10</p> <p style="padding-left: 40px;">OIL LEAKAGE AND OIL LEVEL 10</p> <p>REAR OIL SEAL 11</p> <p style="padding-left: 20px;">Removal and Installation 11</p> <p style="padding-left: 40px;">REMOVAL 11</p> <p style="padding-left: 40px;">INSTALLATION 11</p> <p>POSITION SWITCH 12</p> <p style="padding-left: 20px;">Checking 12</p> <p style="padding-left: 40px;">COMPONENT LOCATION 12</p> <p style="padding-left: 40px;">BACK-UP LAMP SWITCH 12</p> <p style="padding-left: 40px;">NEUTRAL POSITION SWITCH 12</p>	<p>SHIFT CONTROL 13</p> <p style="padding-left: 20px;">Removal and Installation 13</p> <p style="padding-left: 40px;">REMOVAL 13</p> <p style="padding-left: 40px;">INSTALLATION 15</p> <p style="padding-left: 40px;">INSPECTION AFTER INSTALLATION 17</p> <p>AIR BREATHER HOSE 18</p> <p style="padding-left: 20px;">Removal and Installation 18</p> <p>TRANSMISSION ASSEMBLY 19</p> <p style="padding-left: 20px;">Removal and Installation from Vehicle 19</p> <p style="padding-left: 40px;">REMOVAL 19</p> <p style="padding-left: 40px;">INSTALLATION 21</p> <p style="padding-left: 20px;">Component Parts Drawing 22</p> <p style="padding-left: 40px;">CASE COMPONENTS 22</p> <p style="padding-left: 40px;">GEAR COMPONENTS 23</p> <p style="padding-left: 40px;">SHIFT CONTROL COMPONENTS 25</p> <p style="padding-left: 20px;">Disassembly and Assembly 27</p> <p style="padding-left: 40px;">DISASSEMBLY 27</p> <p style="padding-left: 40px;">INSPECTION AFTER DISASSEMBLY 38</p> <p style="padding-left: 40px;">ASSEMBLY 43</p> <p>SERVICE DATA AND SPECIFICATIONS (SDS) 61</p> <p style="padding-left: 20px;">General Specifications 61</p> <p style="padding-left: 20px;">End Play 61</p> <p style="padding-left: 20px;">Snap Rings 62</p> <p style="padding-left: 20px;">Baulk Ring Clearance 63</p>
---	---

PRECAUTIONS

PRECAUTIONS

PFP:00001

Caution

ACS003SV

- Do not reuse transmission oil, once it has been drained.
- Check oil level or replace oil with vehicle on level ground.
- During removal or installation, keep inside of transmission clear of dust or dirt.
- Check for the correct installation status prior to removal or disassembly. If mating marks are required, be certain they do not interfere with the function of the parts they are applied to.
- In principle, tighten bolts or nuts gradually in several steps working diagonally from inside to outside. If tightening sequence is specified, observe it.
- Be careful not to damage sliding surfaces and mating surfaces.

PREPARATION

PREPARATION

PFP:00002

Special Service Tools

ACS003L6

The actual shapes of Kent-Moore tools may differ from those of special service tools illustrated here.

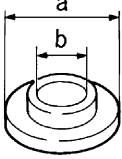
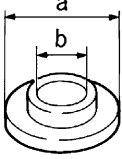
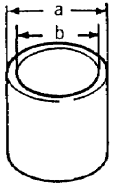
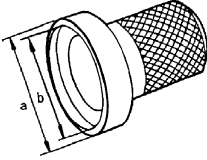
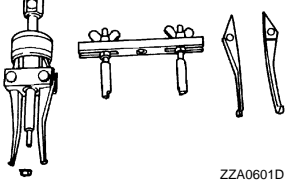
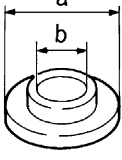
Tool number (Kent-Moore No.) Tool name	Description
ST30911000 (—) a: 98 mm (3.86 in) dia. b: 40 mm (1.57 in) dia. Inserter	 <p style="text-align: center;">ZZA0920D</p> <ul style="list-style-type: none"> ● Main shaft bearing installation ● 5th-6th synchronizer assembly installation ● Reverse main gear bushing installation ● 3rd gear bushing installation ● 3rd-4th synchronizer assembly installation
ST30022000 (—) a: 110 mm (4.33 in) dia. b: 46 mm (1.81 in) dia. Inserter	 <p style="text-align: center;">ZZA0920D</p> <ul style="list-style-type: none"> ● 3rd main gear installation ● 4th main gear installation
ST27861000 (—) a: 62 mm (2.44 in) dia. b: 52 mm (2.05 in) dia. Support ring	 <p style="text-align: center;">ZZA0832D</p> <ul style="list-style-type: none"> ● 1st-2nd synchronizer assembly installation ● 1st gear bushing installation
ST33400001 (J-26082) a: 60 mm (2.36 in) dia. b: 47 mm (1.85 in) dia. Drift	 <p style="text-align: center;">ZZA0814D</p> <p>Rear oil seal installation</p>
KV381054S0 (—) Oil seal puller	 <p style="text-align: center;">ZZA0601D</p> <p>Remove rear oil seal</p>
ST30032000 (J-26010-01) a: 80 mm (3.15 in) dia. b: 31 mm (1.22 in) dia. Inserter	 <p style="text-align: center;">ZZA0920D</p> <p>Counter rear bearing inner race installation</p>

A
B
MT
D
E
F
G
H
I
J
K
L
M

PREPARATION

Tool number (Kent-Moore No.) Tool name	Description
KV32102700 (—) a: 48 mm (1.89 in) dia. b: 41 mm (1.61 in) dia. Drift	Main drive gear bearing installation
ST23860000 (—) a: 38 mm (1.50 in) dia. b: 33 mm (1.30 in) dia. Drift	Reverse counter gear installation
ST01530000 (—) a: 50 mm (1.97 in) dia. b: 41 mm (1.61 in) dia. Drift	Reverse synchronizer assembly installation
ST35291000 (—) a: 40 mm (1.57 in) dia. b: 29.5 mm (1.161 in) dia. c: 22.5 mm (0.886 in) dia. Drift	Striking rod oil seal installation
KV40100630 (J-26092) a: 67 mm (2.64 in) dia. b: 38 mm (1.50 in) dia. Inserter	4th counter gear thrust washer installation
KV38102100 (J-25803-01) a: 44 mm (2.36 in) dia. b: 28 mm (1.10 in) dia. Drift	Front cover oil seal installation
KV32103300 (J-46529) Press plate	Reverse synchronizer assembly installation

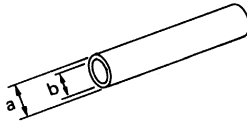

ZZA0534D

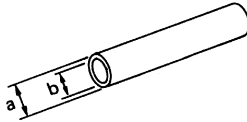

ZZA0534D

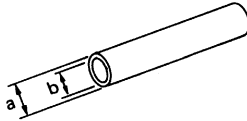

ZZA0534D

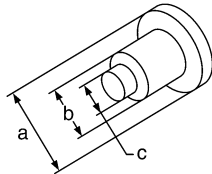

SCIA1575E

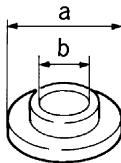

ZZA0920D

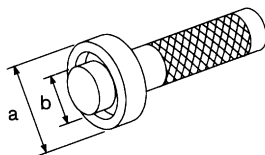

NT084

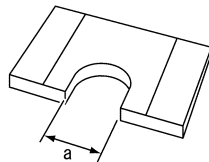

PCIB0165J

PREPARATION

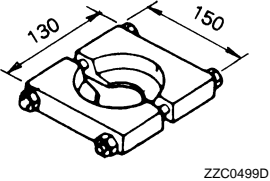
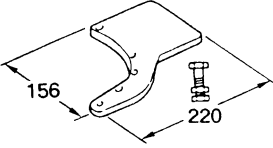

Tool number (Kent-Moore No.) Tool name	Description	
ST30031000 (J-22912-01) Puller	 <p style="text-align: right; margin-right: 50px;">ZZC0499D</p>	A B MT
ST224490000 (—) Adapter setting plate	 <p style="text-align: right; margin-right: 50px;">ZZC0465D</p>	D E F

MT

PREPARATION

Commercial Service Tools

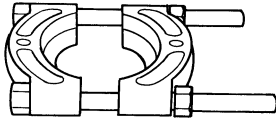
ACS003L7

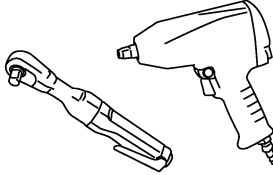
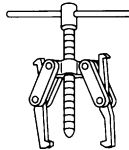
Tool name	Description
<p>Puller</p>  <p style="text-align: right;">ZZB0823D</p>	<p>Each bearing, gear and bushing removal</p>
<p>Pin punch Tip diameter: 6.0 mm (0.24 in) dia.</p>  <p style="text-align: right;">ZZA0815D</p>	<p>Each retaining pin removal and installation</p>
<p>Power tool</p>  <p style="text-align: right;">PBIC0190E</p>	<p>Loosening bolts and nuts</p>
<p>Puller</p>  <p style="text-align: right;">NT077</p>	<ul style="list-style-type: none"> ● Reverse synchronizer assembly removal ● Reverse counter gear removal ● Reverse main gear removal

NOISE, VIBRATION AND HARSHNESS (NVH) TROUBLESHOOTING

NOISE, VIBRATION AND HARSHNESS (NVH) TROUBLESHOOTING

PF0:00003

NVH Troubleshooting Chart

ACS003L8

Use the chart below to help you find the cause of the symptom. The numbers indicate the order of the inspection. If necessary, repair or replace these parts.

MANUAL TRANSMISSION

Reference page	MT-10	MT-10	MT-10	MT-22	MT-22	MT-13	MT-25	MT-25	MT-23	MT-23	MT-23	MT-23
SUSPECTED PARTS (Possible cause)	OIL (Oil level is low.)	OIL (Wrong oil.)	OIL (Oil level is high.)	GASKET (Damaged)	OIL SEAL (Worn or damaged)	SHIFT CONTROL LINKAGE (Worn)	CHECK PLUG RETURN SPRING AND CHECK BALL (Worn or damaged)	SHIFT FORK (Worn)	GEAR (Worn or damaged)	BEARING (Worn or damaged)	BAULK RING (Worn or damaged)	INSERT SPRING (Damaged)
Symptoms	Noise	1	2						3	3		
	Oil leakage		3	1	2	2						
	Hard to shift or will not shift		1	1		2					2	2
	Jumps out of gear					1	1	2	2			

A
B
MT
D
E
F
G
H
I
J
K
L
M

DESCRIPTION

DESCRIPTION

PFP:00000

Cross-Sectional View

ACS003L9

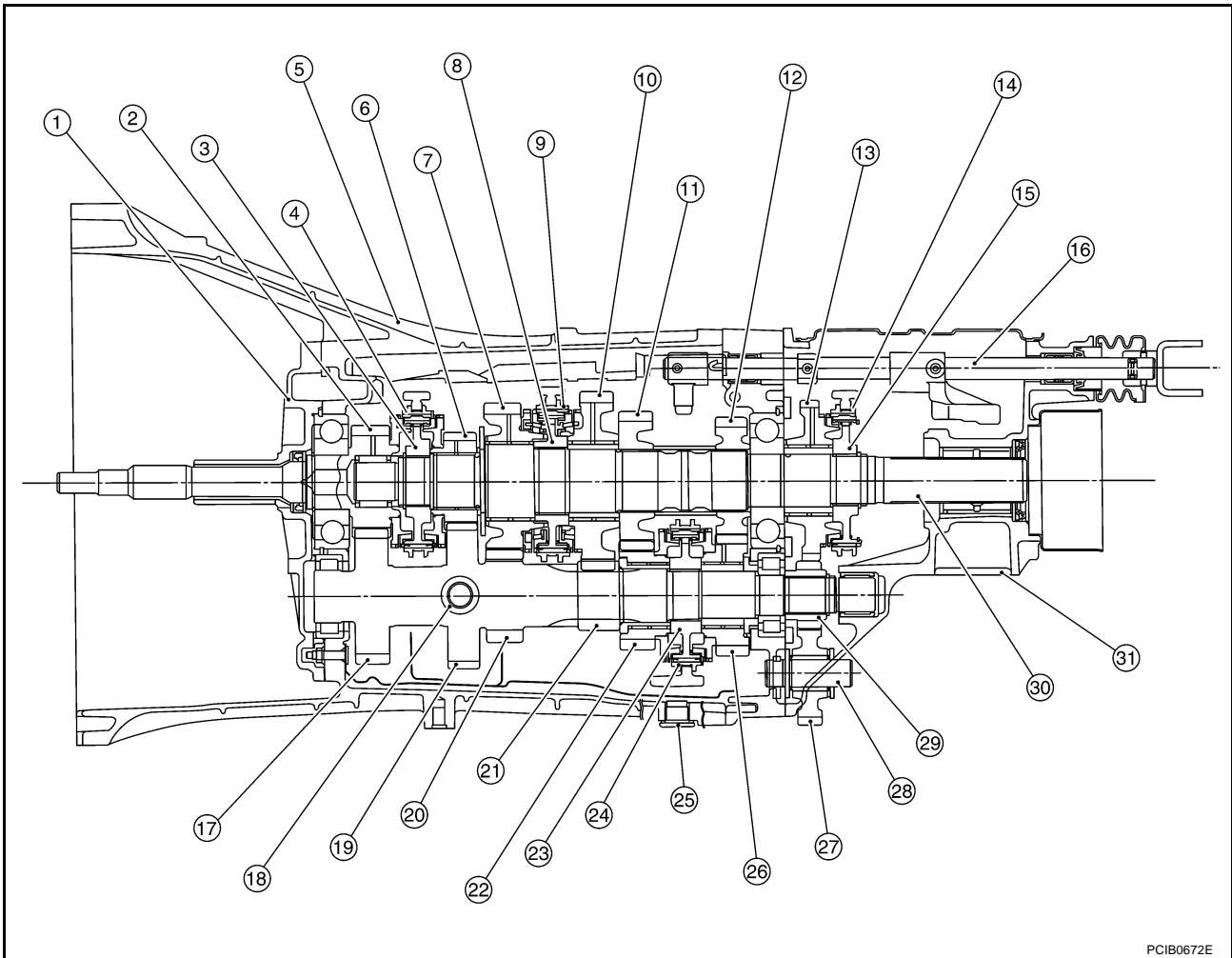

PCIB0672E

- | | | |
|----------------------------|------------------------------|------------------------------|
| 1. Front cover | 2. Main drive gear | 3. 5th-6th synchronizer hub |
| 4. 5th-6th coupling sleeve | 5. Transmission case | 6. 6th main gear |
| 7. 2nd main gear | 8. 1st-2nd synchronizer hub | 9. 1st-2nd coupling sleeve |
| 10. 1st main gear | 11. 3rd main gear | 12. 4th main gear |
| 13. Reverse main gear | 14. Reverse coupling sleeve | 15. Reverse synchronizer hub |
| 16. Striking rod | 17. Counter shaft | 18. Filler plug |
| 19. 6th counter gear | 20. 2nd counter gear | 21. 1st counter gear |
| 22. 3rd counter gear | 23. 3rd-4th synchronizer hub | 24. 3rd-4th coupling sleeve |
| 25. Drain plug | 26. 4th counter gear | 27. Reverse idler gear |
| 28. Reverse idler shaft | 29. Reverse counter gear | 30. Main shaft |
| 31. Rear extension | | |

DOUBLE-CONE SYNCHRONIZER

The 1st, 3rd and 4th gears are equipped with a double-cone synchronizer to reduce the operating force of the shift lever as shown.

DESCRIPTION

TRIPLE-CONE SYNCHRONIZER

The 2nd gear is equipped with a triple-cone synchronizer to reduce the operating force of the shift lever as shown.

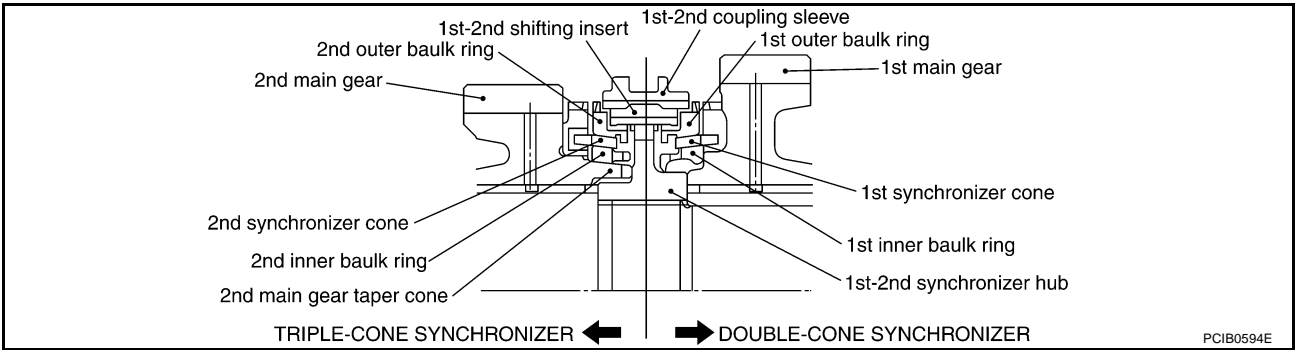

A
B
MT
D
E
F
G
H
I
J
K
L
M

M/T OIL**Replacement
DRAINING**

ACS003LA

1. Start the engine and warm up the transmission unit sufficiently.
2. After stopping engine, remove filler plug and drain plug to drain oil.
3. Replace gasket on drain plug with new one. Screw drain plug into transmission case, and tighten to the specified torque. Refer to [MT-22, "CASE COMPONENTS"](#).

CAUTION:**Do not reuse gasket.****FILLING**

1. Fill new oil into the transmission to the level of the filler plug mounting hole.

Oil grade and Viscosity: Refer to [MA-11, "RECOMMENDED FLUIDS AND LUBRICANTS"](#)**Oil capacity**: **Approx. 2.9 ℓ (3-1/8 US qt, 2-1/2 Imp qt)**

2. Replace gasket on filler plug with new one. Screw filler plug into transmission case, and tighten to the specified torque. Refer to [MT-22, "CASE COMPONENTS"](#).

CAUTION:**Do not reuse gasket.****Checking****OIL LEAKAGE AND OIL LEVEL**

ACS003LB

- Check if oil is leaking from transmission or around it.
- Check oil level from filler hole as shown in the figure.

CAUTION:**Never start engine while checking oil level.**

- When screwing in filler plug with a new gasket, first screw into the transmission by hand, then tighten to the specified torque. Refer to [MT-22, "CASE COMPONENTS"](#).

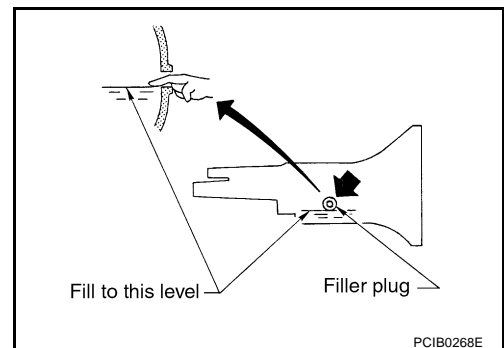
CAUTION:**Do not reuse gasket.**

REAR OIL SEAL

REAR OIL SEAL

PFP:33140

Removal and Installation

ACS003LC

1. Remove propeller shaft. Refer to [PR-5, "Removal and Installation"](#) .
2. Remove rear oil seal using oil seal puller.

Tool number : KV381054S0 (—)

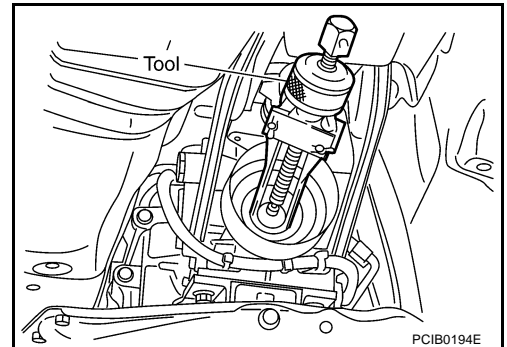

INSTALLATION

1. Apply multi-purpose grease to rear oil seal lip. Drive in rear oil seal until the edge is approximately 1.2 - 2.2 mm (0.047 - 0.087 in) above the boss edge using drift.

Tool number : ST33400001 (J-26082)

CAUTION:

- Do not reuse rear oil seal.
- When installing, do not tilt oil seal.

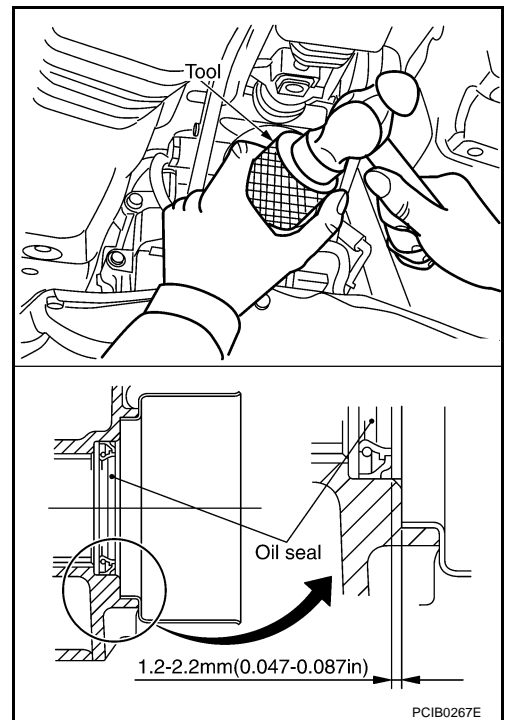

2. Install propeller shaft. Refer to [PR-5, "Removal and Installation"](#) .

CAUTION:

- If lubricant leak has occurred during the repair work, check oil level after finishing work. Refer to [MT-10, "Checking"](#) .

POSITION SWITCH

PFP:32005

ACS003LD

POSITION SWITCH

Checking COMPONENT LOCATION

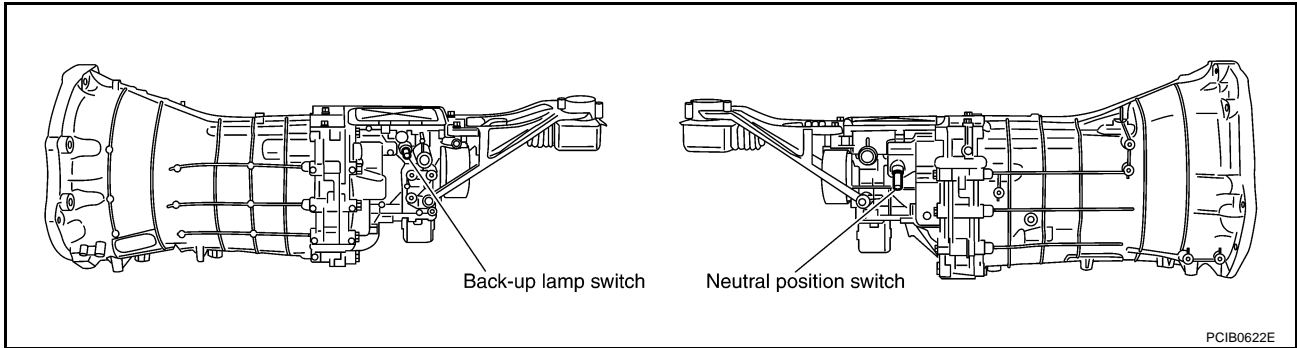

BACK-UP LAMP SWITCH

- Check continuity.

Gear position	Continuity
Reverse	Yes
Except reverse	No

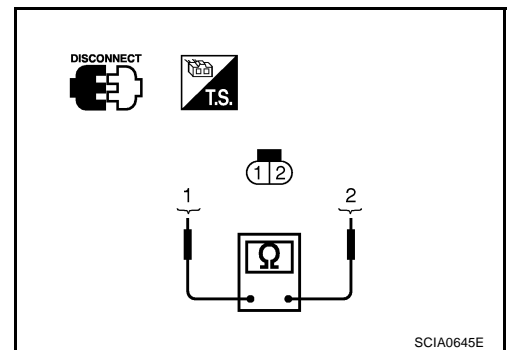

NEUTRAL POSITION SWITCH

- Check continuity.

Gear position	Continuity
Neutral	Yes
Except neutral	No

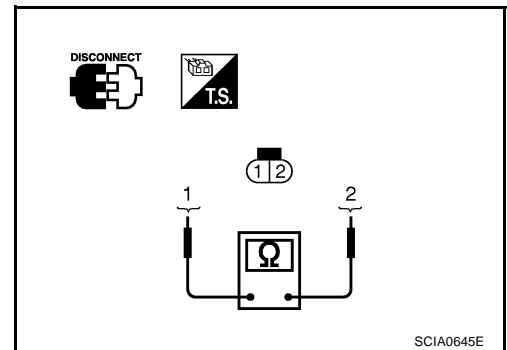

SHIFT CONTROL

SHIFT CONTROL

PPF:34103

Removal and Installation

ACS003LE

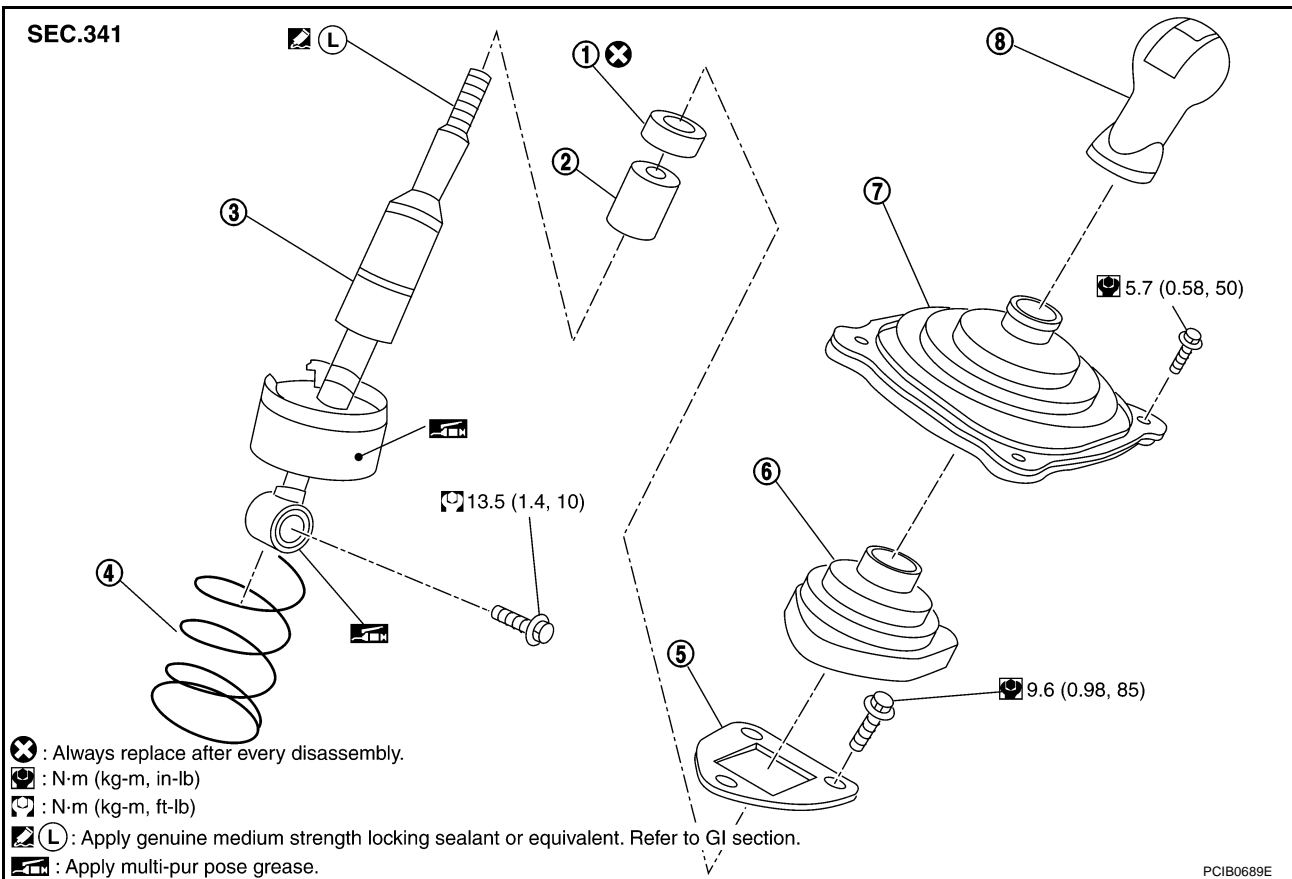

- | | | |
|-------------------------|----------------|-----------------------|
| 1. Insulator | 2. Seat | 3. Control lever |
| 4. Control lever spring | 5. Guide plate | 6. Control lever boot |
| 7. Hole cover | 8. Shift knob | |

REMOVAL

1. Remove shift knob with the following procedure.
 - a. Release metal clips on console boots from center console. Refer to [IP-10, "Component Parts Drawing"](#).

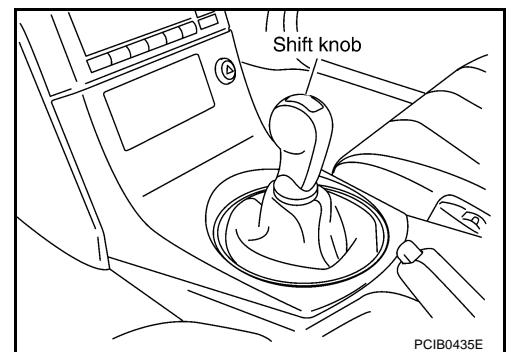

A
B
MT
D
E
F
G
H
I
J
K
L
M

SHIFT CONTROL

- b. Lift console boot, and push down hole cover. Set water pump plier or a suitable tool to control lever.

CAUTION:

Put waste cloth between water pump plier and control lever assembly to avoid damaging control lever.

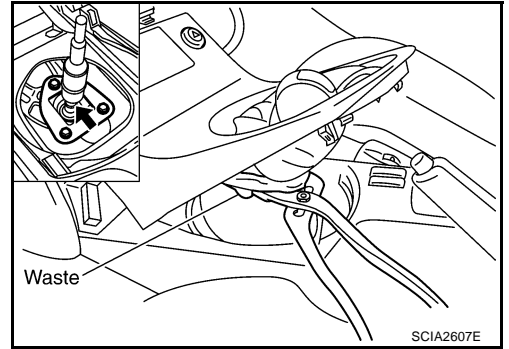

- c. Set monkey wrench to shift knob.

CAUTION:

Put waste cloth between shift knob and monkey wrench to avoid damaging shift knob.

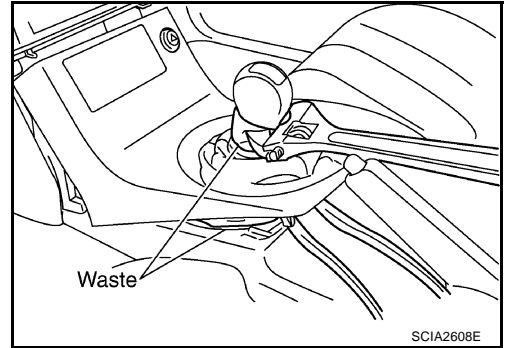

- d. Keeping control lever in place with water pump plier, turn monkey wrench counterclockwise to loosen shift knob.

NOTE:

Remove shift knob from control lever keeping water pump plier in place because a certain power to turn shift knob is still necessary even after adhesive is peeled.

2. Remove insulator and seat from control lever.
3. Remove console boot. Refer to [IP-10, "Component Parts Drawing"](#).

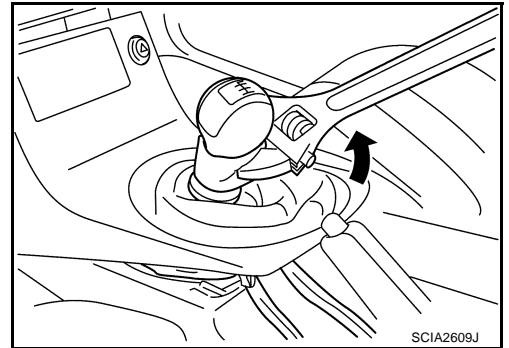

4. Release the boot, remove control rod mounting bolt, and separate control lever and control rod.

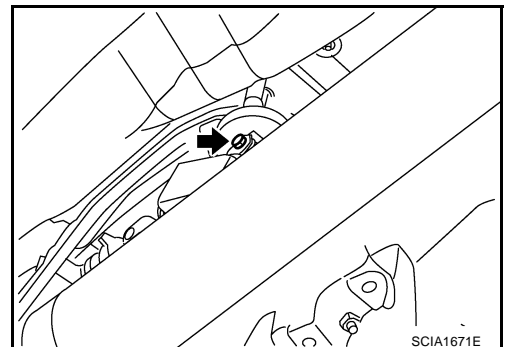

5. Remove the mounting bolts to remove hole cover.
6. Remove the control lever boot.

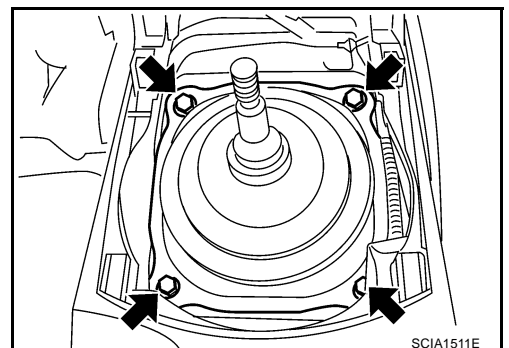

SHIFT CONTROL

7. Remove guide plate mounting bolts, and then remove control lever and control lever spring from shift lever housing.

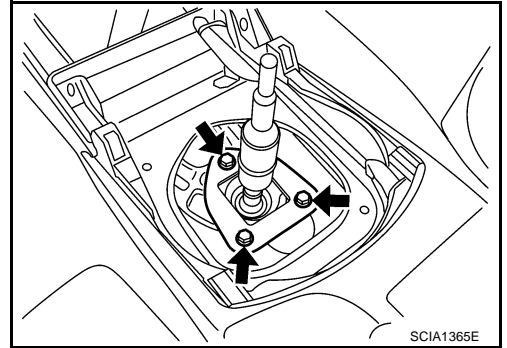

A
B
MT

INSTALLATION

1. Set control lever and control lever spring in the vehicle and loosely mount guide plate.
2. After installing control lever in control rod, tighten bolts to the specified torque. Refer to [MT-13, "Removal and Installation"](#).

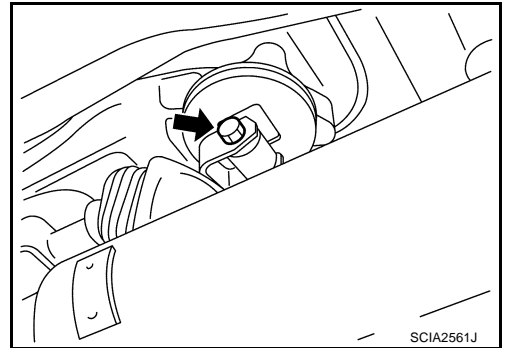

E
F
G
H

3. After shifting control lever into 6th gear, push it toward reverse gear (to the right) until it comes to a stop.
4. At the point where the control lever assembly stops, bring the guide plate closer until guide plate stopper contacts control lever assembly claw, and then loosely tighten mounting bolt A.

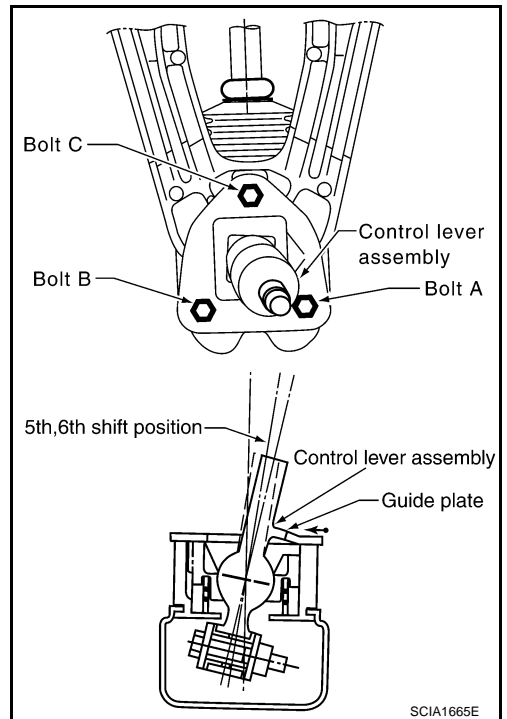

I
J
K
L
M

SHIFT CONTROL

5. After shifting control lever into 5th gear, push it toward reverse gear (to the right) until it comes to a stop.
6. At the point where control lever assembly stops, bring guide plate closer until the guide plate stopper contacts control lever assembly claw, and then tighten mounting bolt C to the specified torque. Refer to [MT-13, "Removal and Installation"](#) .
7. Tighten guide plate bolts A and B to the specified torque. Refer to [MT-13, "Removal and Installation"](#) .
8. Install control lever boot.
9. Install hole cover and tighten bolts to the specified torque. Refer to [MT-13, "Removal and Installation"](#) .
10. Install console boot to the center console. Refer to [IP-10, "Component Parts Drawing"](#) .

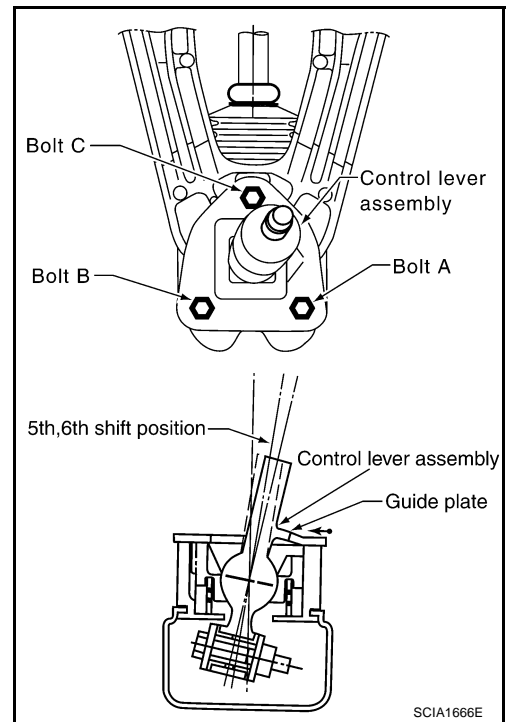

11. As shown in the figure, assemble seat and insulator to control lever assembly.

CAUTION:

Do not reuse the insulator.

12. Apply locking sealant to control lever threads, install shift knob.

CAUTION:

Remove the remaining adhesive on control lever and shift knob threads.

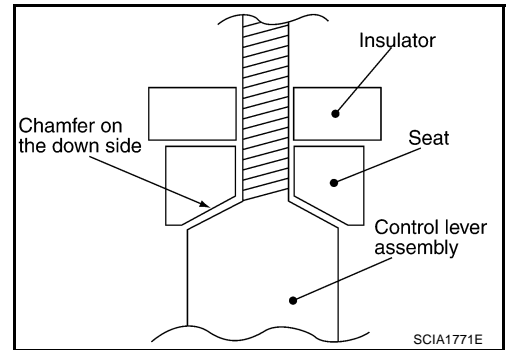

13. Put the shift knob in the correct position as the following indicates.

SHIFT CONTROL

- When tightening shift knob, if shift knob comes to the proper position within 1/2 turn from the position at which resistance begins to be felt, tighten it 1 more turn to set it in the proper position.
- If it takes more than 1/2 turn from the position at which resistance begins to be felt tighten it to set it in the proper position.

CAUTION:

- Do not adjust the knob with loosing.
- After adjusting to the regular position, until 30 minutes pass, do not operate the shift intensely such as screwing or turning the shift knob to opposite direction since a locking sealant because stiff.

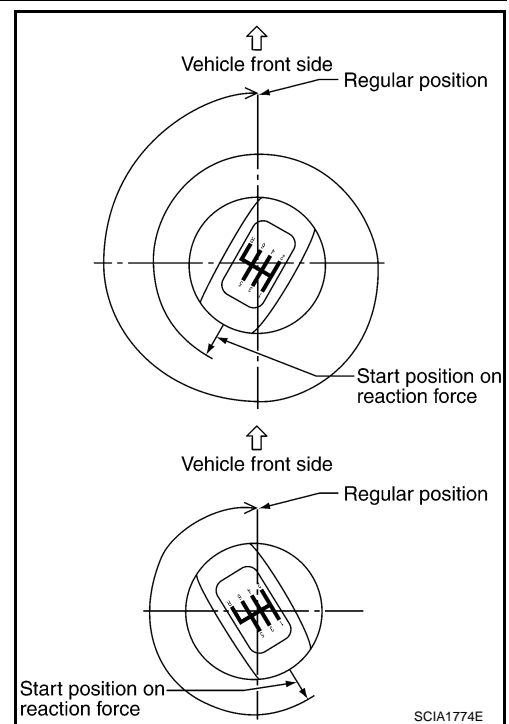

INSPECTION AFTER INSTALLATION

After installing, confirm the following items:

- When control lever assembly is shifted to each position, make sure there is no binding or disconnection in each boot.
- When shifted to each position, make sure there is no noise, binding, and backlash. Especially when control lever assembly is shifted to 5th, 6th without pressing downward, check for binding.
- When control lever assembly is shifted to 1st, 2nd side and 5th, 6th side, confirm control lever assembly returns to neutral position smoothly.
- In any position other than reverse, confirm that control lever assembly can be pressed downward.
- With control lever assembly pressed downward, confirm that it can be shifted to reverse.
- When shifted from reverse to neutral position, confirm control lever assembly returns to neutral position smoothly with spring power.
- Without control lever assembly pressed downward, confirm that it cannot be shifted to reverse.

AIR BREATHER HOSE

PFP:31098

AIR BREATHER HOSE Removal and Installation

ACS003LF

Refer to the figure for air breather hose removal and installation information.

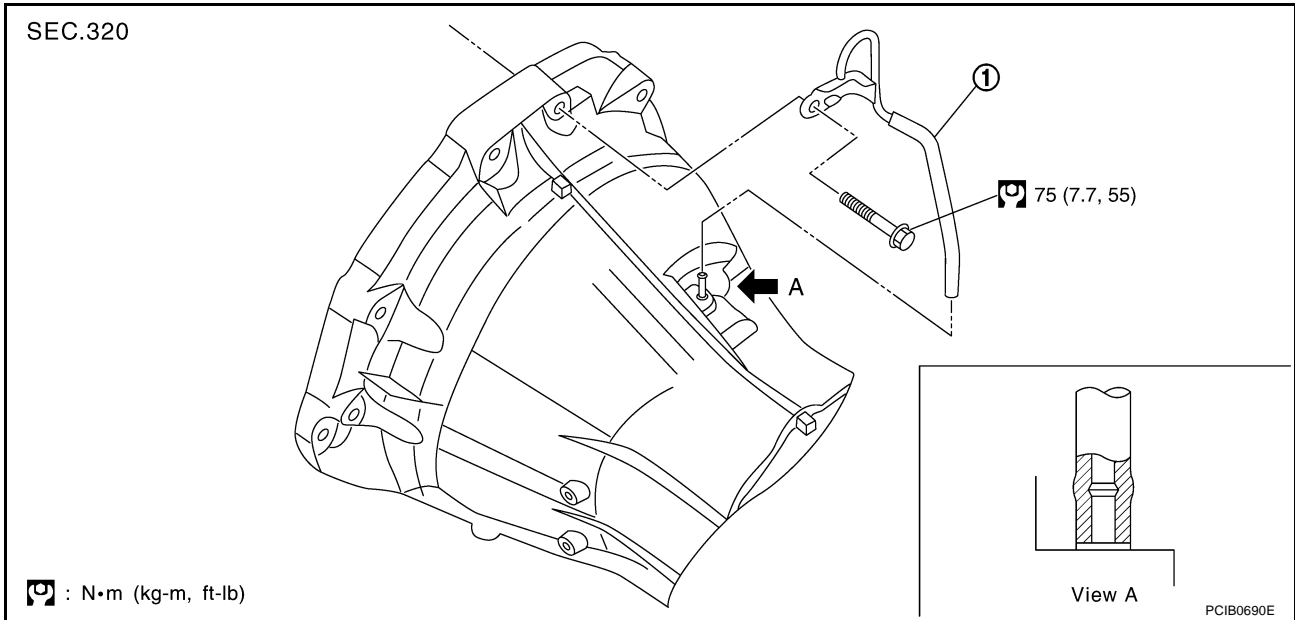

1. Air breather hose

CAUTION:

- Make sure there are no pinched or blocked areas on the air breather hose caused by bending when installing it.
- Insert overlap width of air breather hose as far as it will go.

TRANSMISSION ASSEMBLY

TRANSMISSION ASSEMBLY

PF3:32010

Removal and Installation from Vehicle

ACS003LG

A
B
MT
D
E
F
G
H
I
J
K
L
M

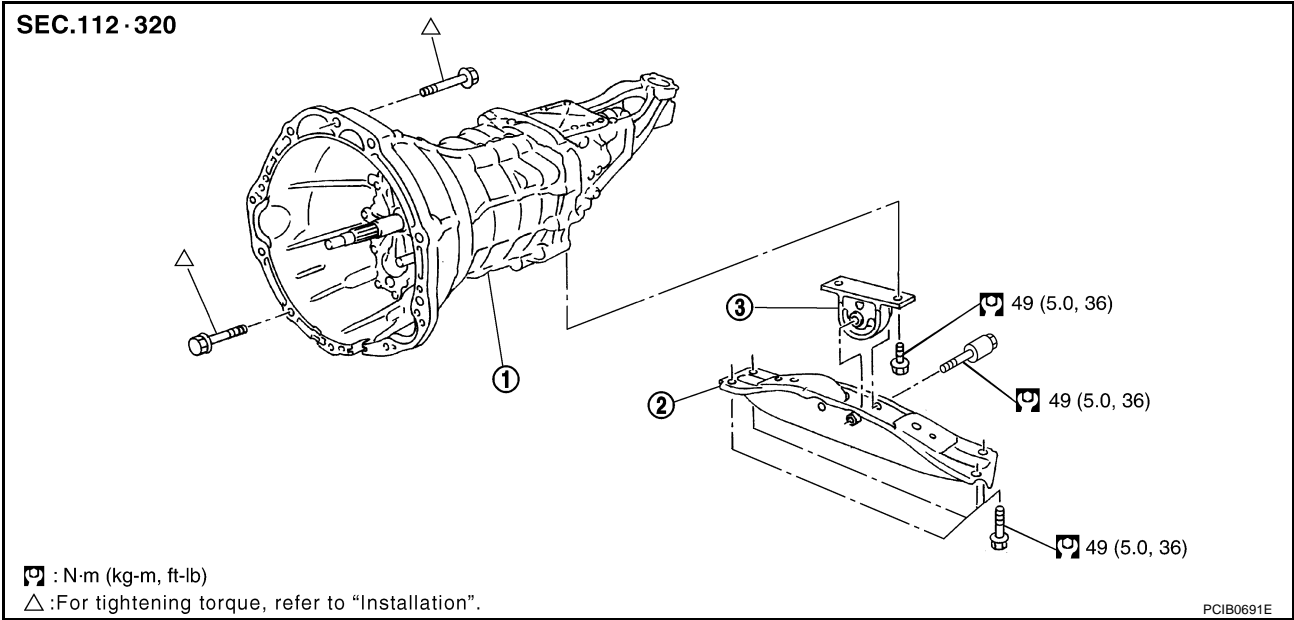

1. Transmission case
2. Rear engine mounting member
3. Insulator

REMOVAL

1. Disconnect battery negative cable.
2. Remove catalytic converter stay mounting nuts and bolts, and then remove exhaust mounting bracket. Refer to [EX-3, "Removal and Installation"](#).

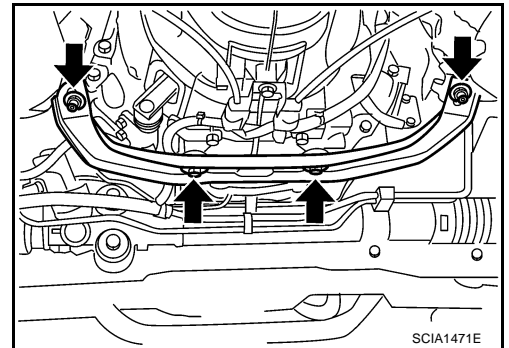

3. Remove nut connecting catalytic converter to exhaust manifold, and then remove catalytic converter and exhaust front tube as one unit.
4. Remove propeller shaft. Refer to [PR-5, "Removal and Installation"](#).
5. Remove control rod mounting bolts and then separate shift lever assembly from the control rod assembly.

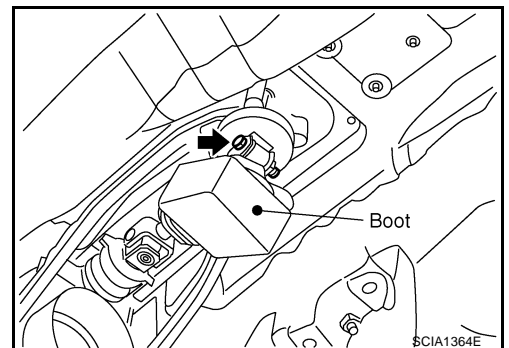

TRANSMISSION ASSEMBLY

6. Using a suitable tool, release claws and separate console boot from center console. Refer to [IP-10, "Component Parts Drawing"](#).

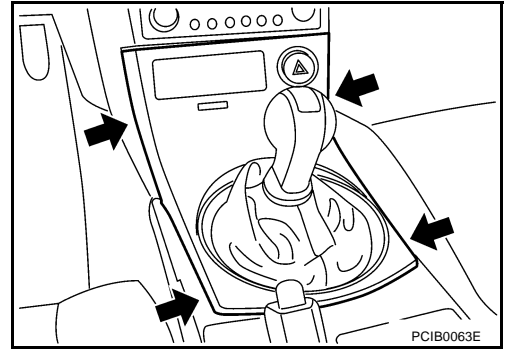

7. Remove hole cover mounting bolts and then separate hole cover from the floor panel.
8. Separate control lever boot from guide plate.

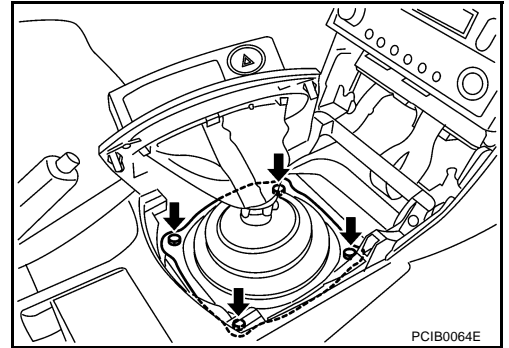

9. Remove guide plate mounting bolts and then separate shift lever assembly from the shift lever housing.

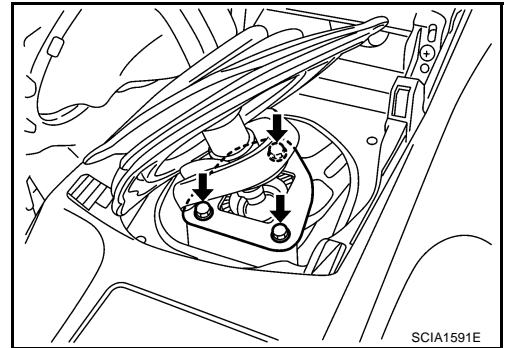

10. Remove clutch operating cylinder mounting bolts and then separate heat insulator and clutch operating cylinder from the transmission case. Refer to [CL-11, "Removal and Installation"](#).

11. Remove crankshaft position sensor (POS).

CAUTION:

- Do not subject it to impact by dropping or hitting.
- Do not disassemble.
- Do not allow iron dust, etc., to get on the sensor's front edge magnetic area.
- Do not place in an area affected by magnetism.

12. Disconnect neutral position switch and back-up lamp switch.
13. Separate heated oxygen sensor 2 wire harness, crankshaft position sensor (POS) wire harness, back-up lamp switch wire harness and PNP switch wire harness from the transmission.

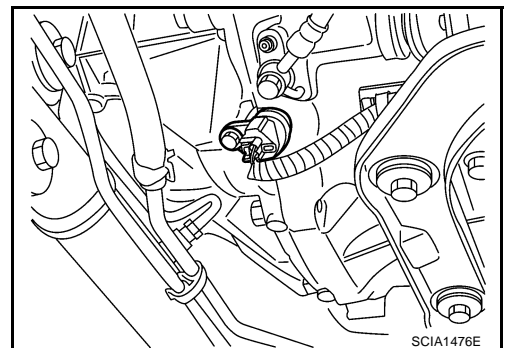

14. Remove starter motor. Refer to [SC-18, "Removal and Installation"](#).
15. Set transmission jack to the transmission.

CAUTION:

When setting transmission jack, be careful so that it does not contact with the switch.

TRANSMISSION ASSEMBLY

16. Remove rear engine mounting member. Refer to [EM-113, "Removal and Installation \(2WD Model\)"](#).
17. Remove engine and transmission mounting bolts with power tool.
18. Remove transmission from the vehicle.

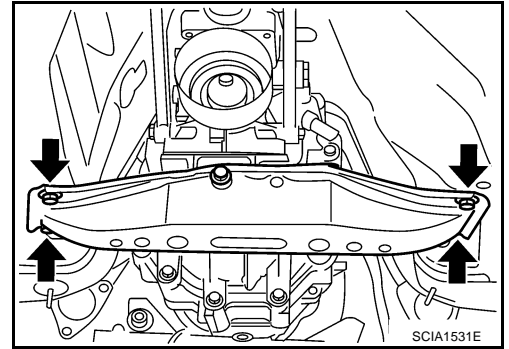

INSTALLATION

Install in the reverse order of removal procedure, following the cautions below:

- When installing transmission to the engine, install mounting bolts in accordance with the standards below.

LHD Model

Bolt No.	1	2	3	4	5
Quantity	1	5	2	2	2
" ℓ " mm (in)	55 (2.17)	65 (2.56)	50 (1.97)	35 (1.38)	65 (2.56)
Tightening torque N·m (kg·m, ft·lb)	75 (7.7, 55)		55.4 (5.7, 41)	46.6 (4.8, 34)	55.4 (5.7, 41)

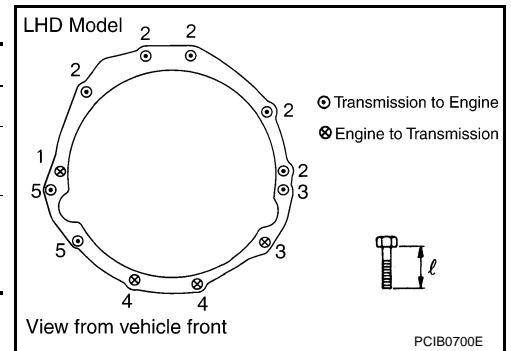

CAUTION:

- When installing, be careful to avoid interference between transmission main drive shaft and clutch cover.
- If flywheel is removed, align dowel pin with the smallest hole of flywheel. Refer to [EM-129, "ASSEMBLY"](#).
- Refer to [MT-15, "INSTALLATION"](#) and [MT-17, "INSPECTION AFTER INSTALLATION"](#) for control lever installation information.
- After installation, check for oil leakage, oil level and proper operation of shifting mechanism.

TRANSMISSION ASSEMBLY

ACS003LH

Component Parts Drawing CASE COMPONENTS

SEC.321

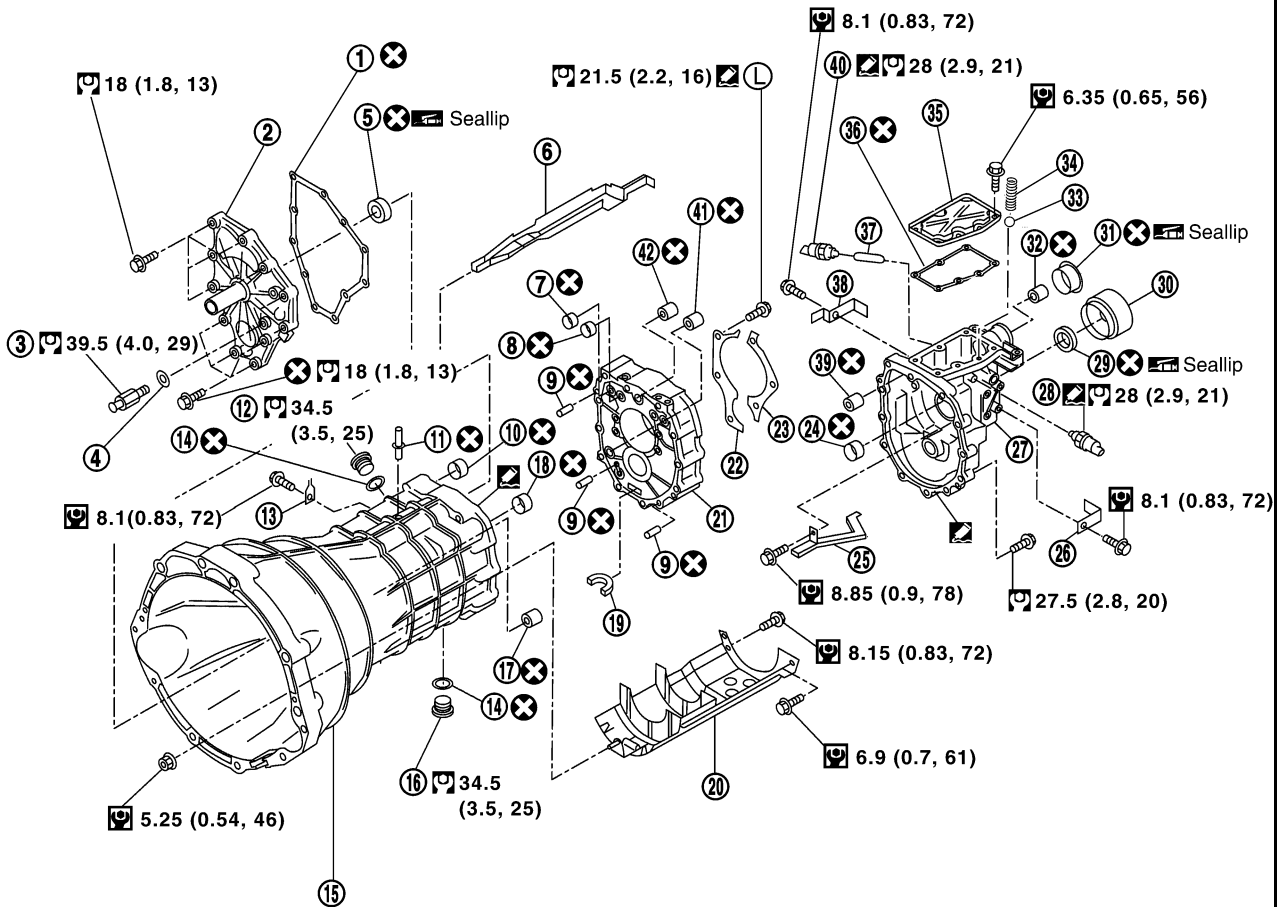

☐ : N·m (kg-m, in-lb)

☐ : N·m (kg-m, ft-lb)

☐ : Apply Genuine Silicone RTV or equivalent. Refer to GI section.

☐ L : Apply Genuine Medium Strength Thread Locking Sealant or equivalent. Refer to GI section.

☆ : Pay attention to its direction.

☐ : Apply multi-purpose grease.

⊗ : Always replace after every disassembly.

PCIB0900E

- | | | |
|---------------------------------|---------------------------------|-------------------------------|
| 1. Front cover gasket | 2. Front cover | 3. Withdrawal lever ball pin |
| 4. Washer | 5. Front cover oil seal | 6. Oil gutter |
| 7. Bushing | 8. Bushing | 9. Dowel pin |
| 10. Bushing | 11. Breather | 12. Filler plug |
| 13. Bracket | 14. Gasket | 15. Transmission case |
| 16. Drain plug | 17. Sliding ball bearing | 18. Bushing |
| 19. Magnet | 20. Baffle plate | 21. Adapter plate |
| 22. Main shaft bearing retainer | 23. Main shaft bearing retainer | 24. Bushing |
| 25. Rear extension oil gutter | 26. Bracket | 27. Rear extension |
| 28. Back-up lamp switch | 29. Rear oil seal | 30. Rear extension dust cover |
| 31. Striking rod oil seal | 32. Sliding ball bearing | 33. Check ball |

TRANSMISSION ASSEMBLY

- | | | |
|-----------------------------|--------------------------------|---------------------------------------|
| 34. Check select spring | 35. Rear extension upper cover | 36. Rear extension upper cover gasket |
| 37. Plunger | 38. Bracket | 39. Sliding ball bearing |
| 40. Neutral position switch | 41. Sliding ball bearing | 42. Sliding ball bearing |

GEAR COMPONENTS

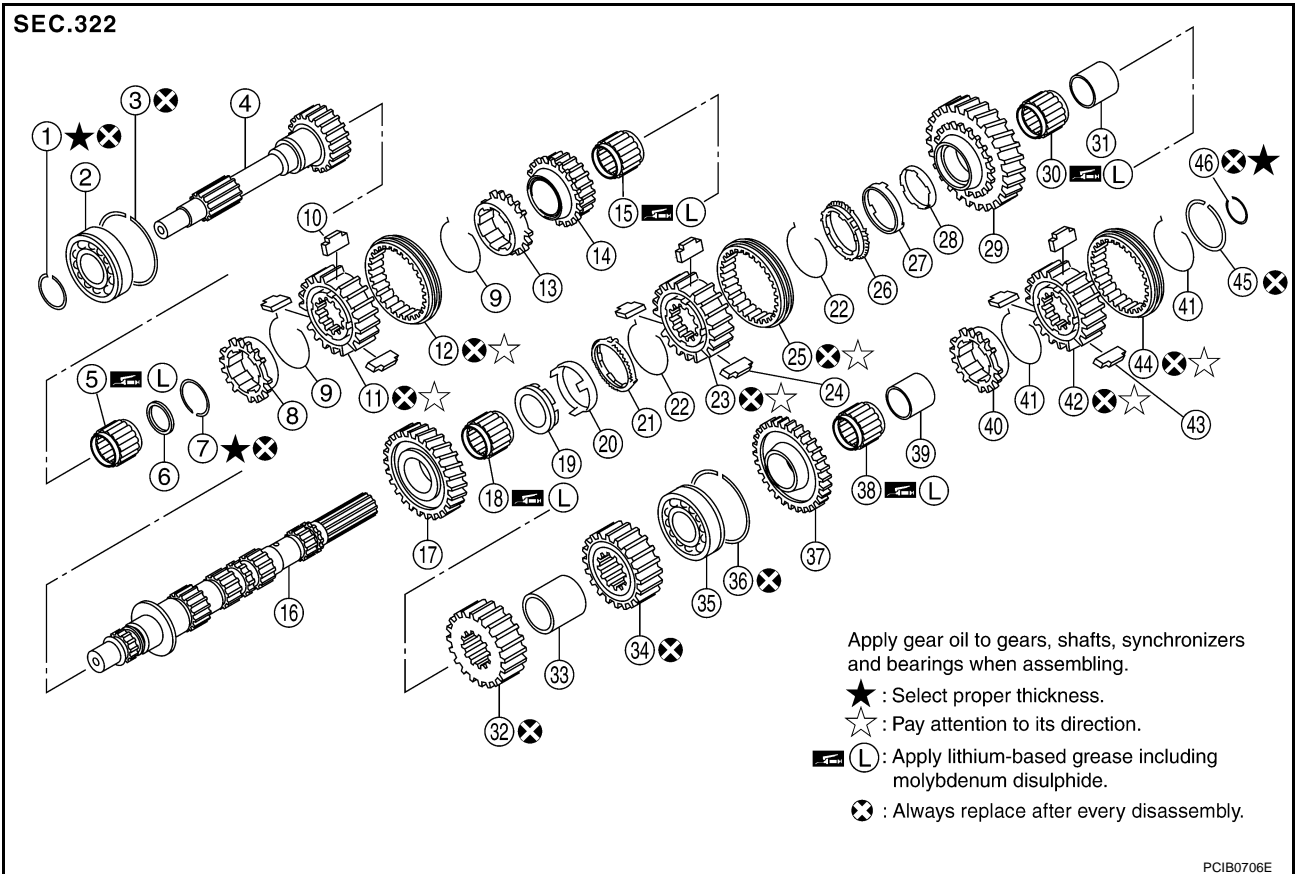

- | | | |
|-----------------------------|---------------------------------|-------------------------------|
| 1. Snap ring | 2. Main drive gear bearing | 3. Snap ring |
| 4. Main drive gear | 5. Main pilot bearing | 6. Pilot bearing spacer |
| 7. Snap ring | 8. 5th baulk ring | 9. 5th-6th spread spring |
| 10. 5th-6th shifting insert | 11. 5th-6th synchronizer hub | 12. 5th-6th coupling sleeve |
| 13. 6th baulk ring | 14. 6th main gear | 15. 6th needle bearing |
| 16. Main shaft | 17. 2nd main gear | 18. 2nd needle bearing |
| 19. 2nd inner baulk ring | 20. 2nd synchronizer cone | 21. 2nd outer baulk ring |
| 22. 1st-2nd spread spring | 23. 1st-2nd synchronizer hub | 24. 1st-2nd shifting insert |
| 25. 1st-2nd coupling sleeve | 26. 1st outer baulk ring | 27. 1st synchronizer cone |
| 28. 1st inner baulk ring | 29. 1st main gear | 30. 1st needle bearing |
| 31. 1st gear bushing | 32. 3rd main gear | 33. 3rd-4th main spacer |
| 34. 4th main gear | 35. Main shaft bearing | 36. Snap ring |
| 37. Reverse main gear | 38. Reverse main needle bearing | 39. Reverse main gear bushing |
| 40. Reverse baulk ring | 41. Reverse spread spring | 42. Reverse synchronizer hub |
| 43. Reverse shifting insert | 44. Reverse coupling sleeve | 45. Snap ring |
| 46. Snap ring | | |

A
B
MT
D
E
F
G
H
I
J
K
L
M

TRANSMISSION ASSEMBLY

SEC.322

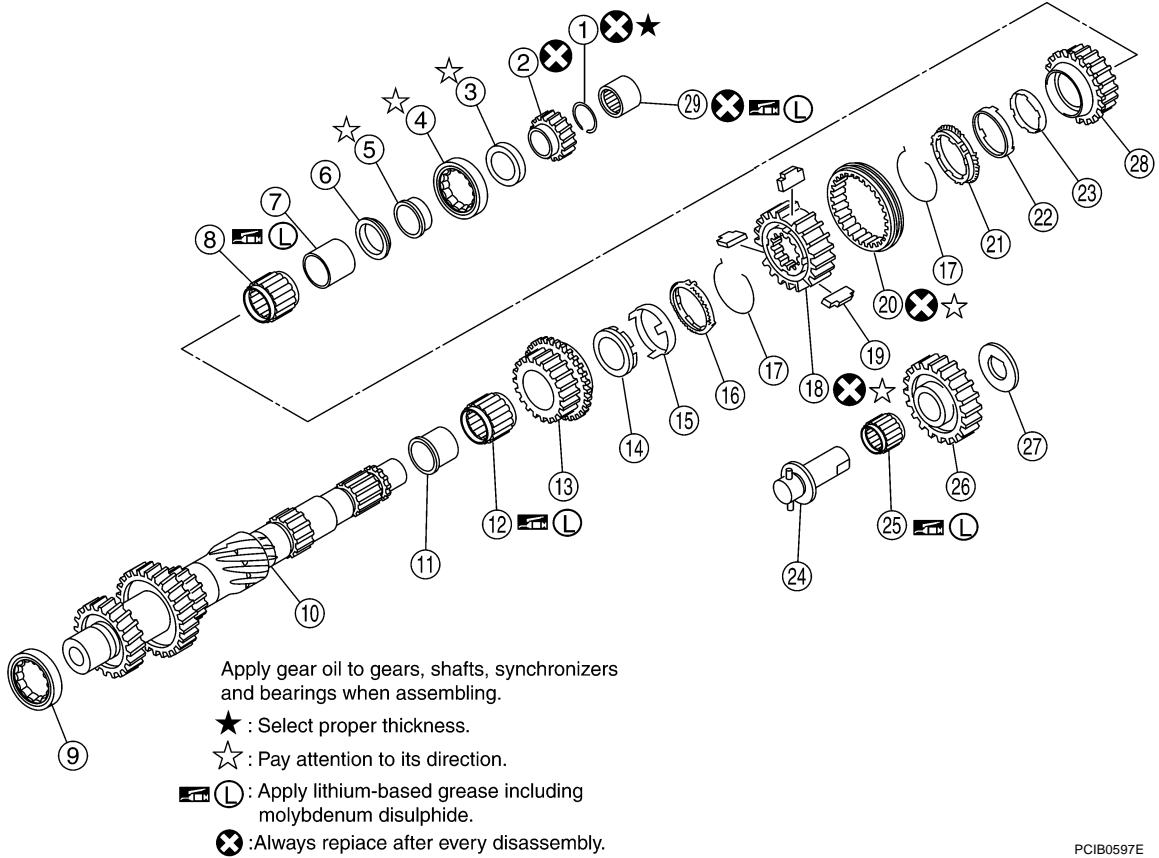

PCIB0597E

- | | | |
|----------------------------------|------------------------------------|-----------------------------------|
| 1. Snap ring | 2. Reverse counter gear | 3. Counter rear bearing spacer |
| 4. Counter rear bearing | 5. Counter rear bearing inner race | 6. 4th counter gear thrust washer |
| 7. 4th gear bushing | 8. 4th needle bearing | 9. Counter front bearing |
| 10. Counter shaft | 11. 3rd gear bushing | 12. 3rd needle bearing |
| 13. 3rd counter gear | 14. 3rd inner baulk ring | 15. 3rd synchronizer cone |
| 16. 3rd outer baulk ring | 17. 3rd-4th spread spring | 18. 3rd-4th synchronizer hub |
| 19. 3rd-4th shifting insert | 20. 3rd-4th coupling sleeve | 21. 4th outer baulk ring |
| 22. 4th synchronizer cone | 23. 4th inner baulk ring | 24. Reverse idler shaft |
| 25. Reverse idler needle bearing | 26. Reverse idler gear | 27. Reverse idler thrust washer |
| 28. 4th counter gear | 29. Counter end bearing | |

TRANSMISSION ASSEMBLY

SHIFT CONTROL COMPONENTS

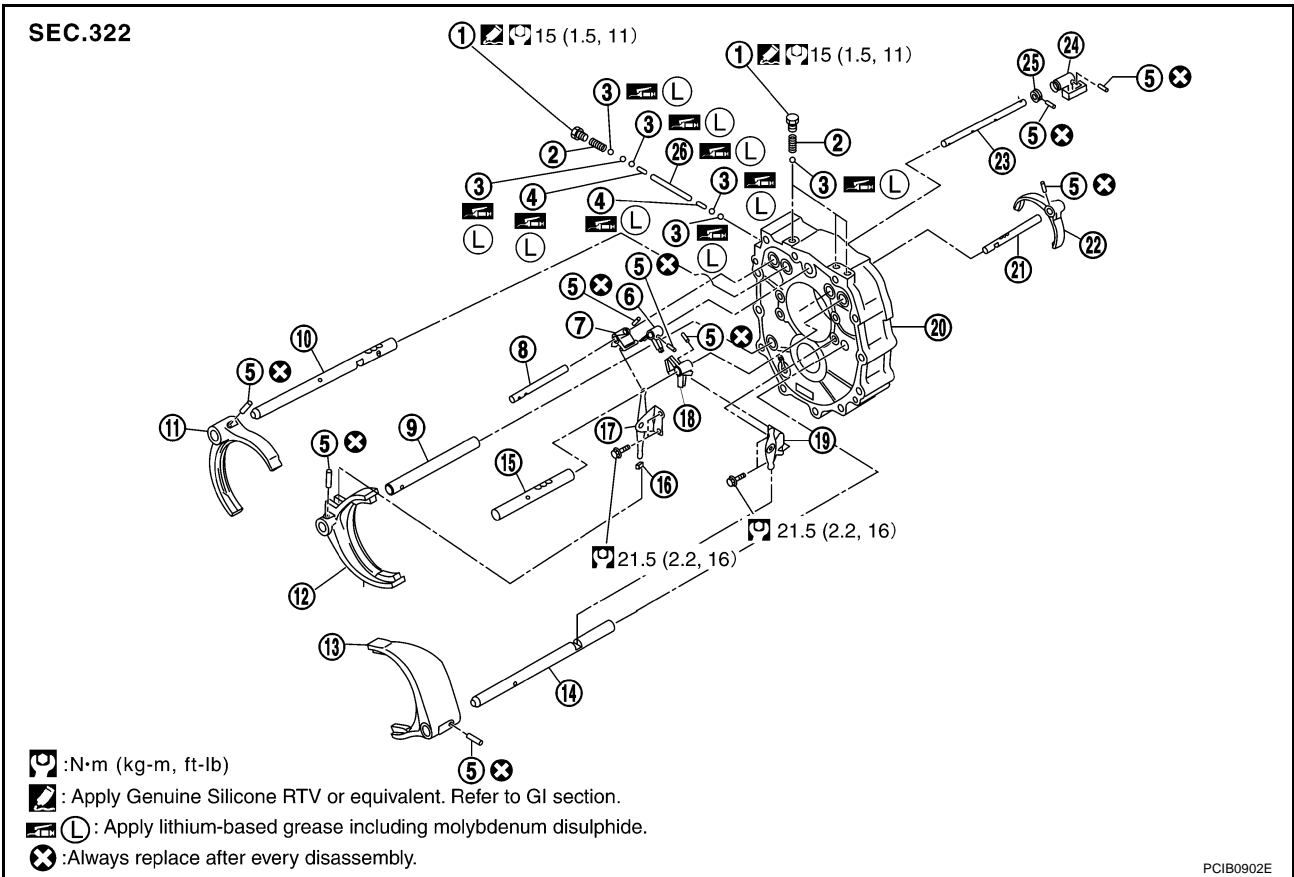

- | | | |
|-----------------------------|--------------------------------------|-------------------------------------|
| 1. Check ball plug | 2. Check ball spring | 3. Check ball |
| 4. Interlock pin | 5. Retaining pin | 6. Striking lever |
| 7. 3rd-4th fork rod bracket | 8. 3rd-4th fork rod | 9. 3rd-4th fork rod (reversal side) |
| 10. 1st-2nd fork rod | 11. 1st-2nd shift fork | 12. 3rd-4th shift fork |
| 13. 5th-6th shift fork | 14. 5th-6th fork rod (reversal side) | 15. 5th-6th fork rod |
| 16. Shifter cap | 17. 3rd-4th control lever | 18. 5th-6th fork rod bracket |
| 19. 5th-6th control lever | 20. Adapter plate | 21. Reverse fork rod |
| 22. Reverse shift fork | 23. Striking rod | 24. Low/high control lever |
| 25. Stopper ring | 26. Interlock plunger | |

A
B
MT
D
E
F
G
H
I
J
K
L
M

TRANSMISSION ASSEMBLY

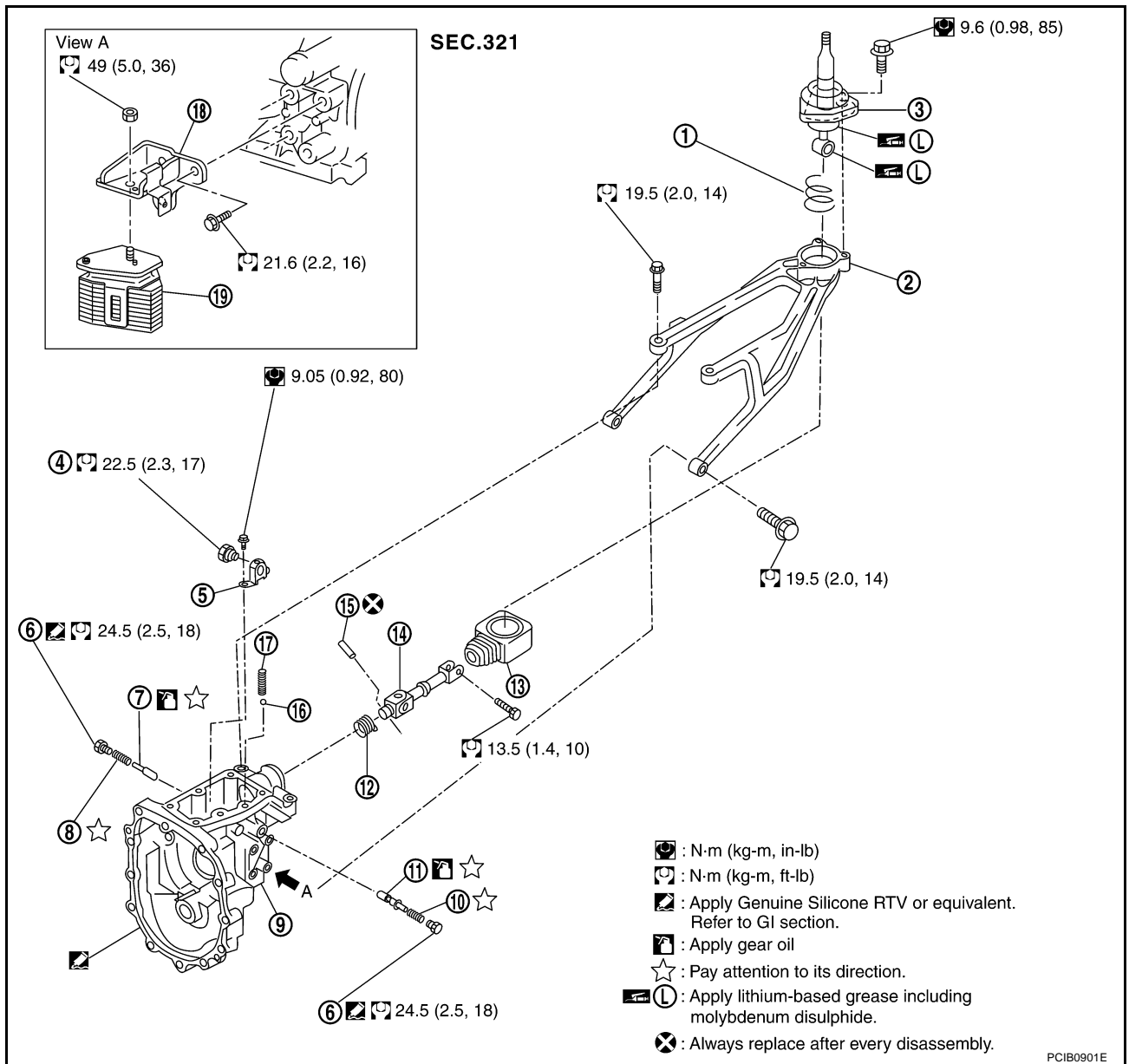

- | | | |
|--------------------------|---------------------------|----------------------------|
| 1. Control lever spring | 2. Control lever housing | 3. Control lever |
| 4. Check shift pin | 5. Control bracket | 6. Return spring plug |
| 7. Return spring plunger | 8. Return spring | 9. Rear extension |
| 10. Return spring | 11. Return spring plunger | 12. Boot |
| 13. Boot | 14. Control rod | 15. Retaining pin |
| 16. Check ball | 17. Check select spring | 18. Dynamic damper bracket |
| 19. Dynamic damper | | |

TRANSMISSION ASSEMBLY

Disassembly and Assembly DISASSEMBLY

ACS003LI

Case Components

1. Remove rear extension upper cover mounting bolts, rear extension upper cover and rear extension upper cover gasket from rear extension.

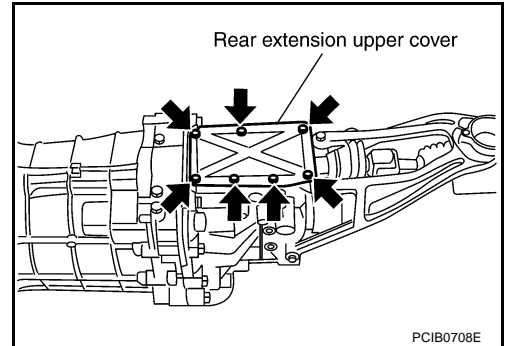

2. Remove check select spring and check ball from rear extension.

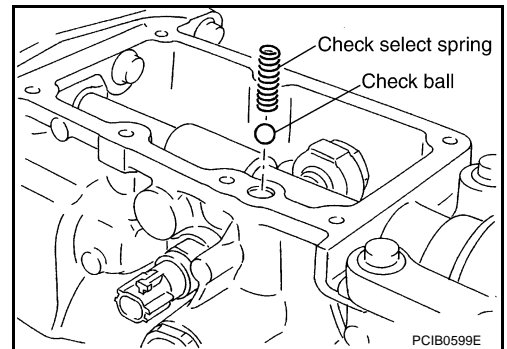

3. Drive out retaining pin using a pin punch [6 mm (0.24 in) dia.], and remove control rod.
4. Remove neutral position switch, plunger and back-up lamp switch from rear extension.

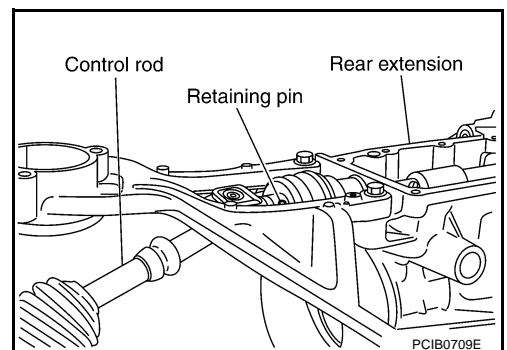

5. Remove control bracket mounting bolts. Then remove check shift pin and control bracket as one unit from rear extension.

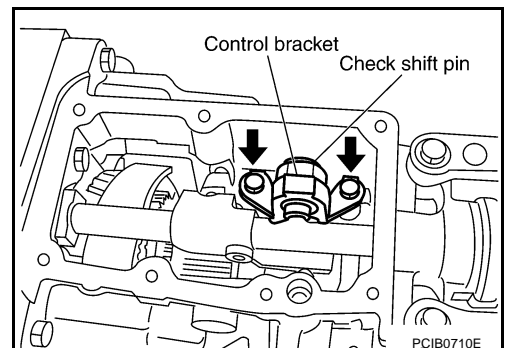

A
B
MT
D
E
F
G
H
I
J
K
L
M

TRANSMISSION ASSEMBLY

- Remove right and left return spring plugs. Then remove return spring and return spring plunger from rear extension.

CAUTION:

Return springs and return spring plungers have different lengths for right and left sides. Identify right and left side and then store.

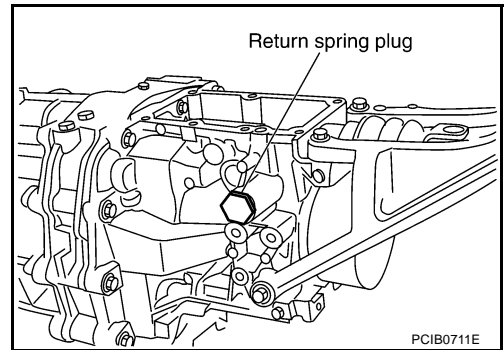

- Remove rear oil seal from rear extension using the oil seal puller.

Tool number : KV381054S0 (—)

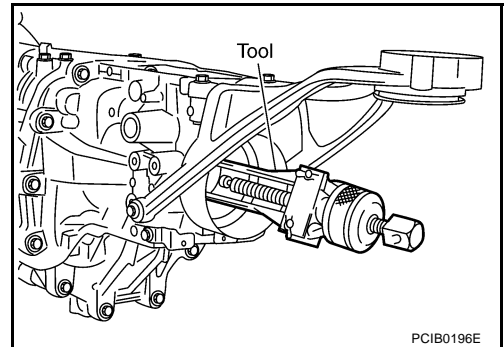

- Remove rear extension mounting bolts. Using a soft hammer, tap rear extension assembly to remove.
- Remove control lever housing mounting bolts and control lever housing from rear extension.
- Remove striking rod oil seal from rear extension. Refer to [MT-22, "CASE COMPONENTS"](#).
- Remove rear extension oil gutter mounting bolt and rear extension oil gutter from rear extension. Refer to [MT-22, "CASE COMPONENTS"](#).

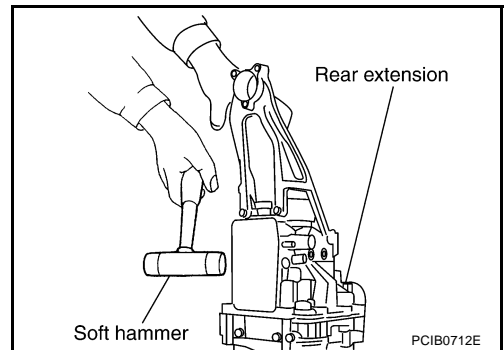

- Remove reverse idler thrust washer, reverse idler gear and reverse idler needle bearing from reverse idler shaft.
- Remove reverse idler shaft from adapter plate.

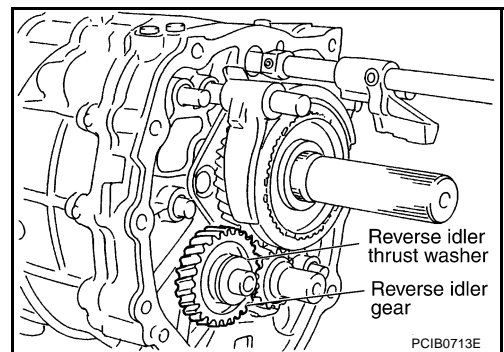

- Remove withdrawal lever ball pin and washer from front cover.
- Remove front cover mounting bolts. Then remove front cover and front cover gasket from transmission case.

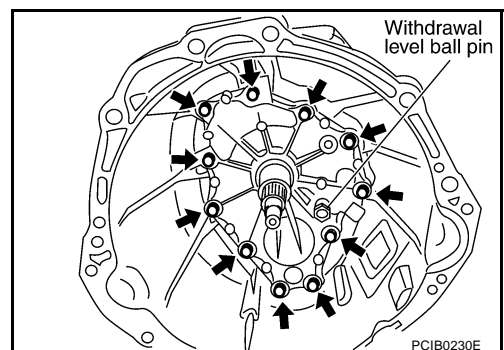

TRANSMISSION ASSEMBLY

16. Remove front cover oil seal from front cover using a flat-bladed screwdriver.

CAUTION:

Be careful not to damage front cover mating surface.

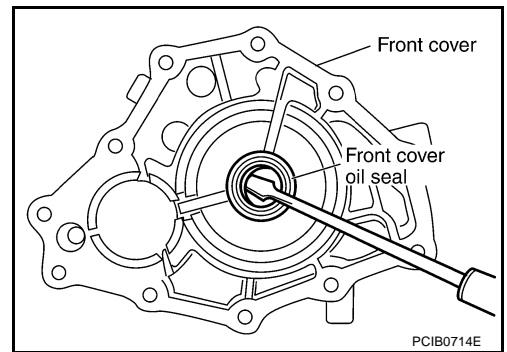

17. Remove baffle plate mounting nut from transmission case.

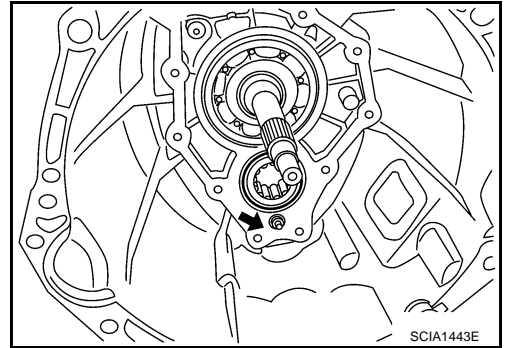

18. Remove snap ring from main drive gear bearing using snap ring pliers.

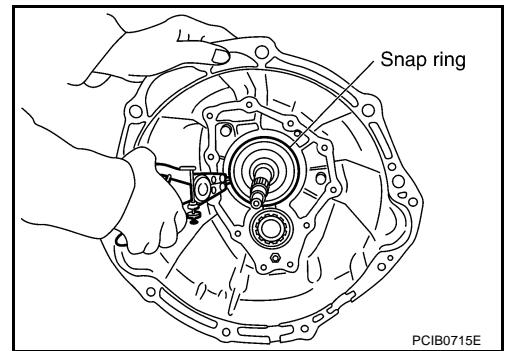

19. Carefully tap on transmission case to separate it from adapter plate using a soft hammer.

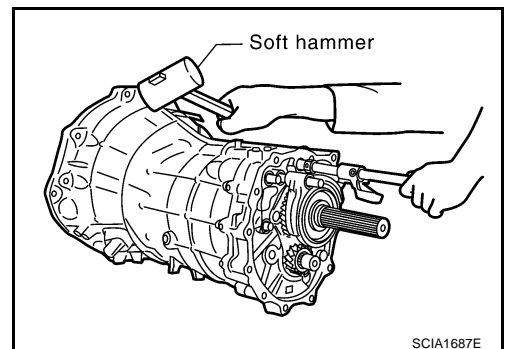

20. Remove counter front bearing from transmission case.

21. Remove oil gutter from transmission case.

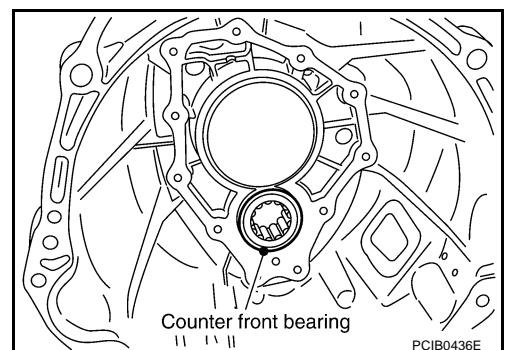

A

B

MT

D

E

F

G

H

I

J

K

L

M

TRANSMISSION ASSEMBLY

Shift Control Components

1. Install adapter setting plate to adapter plate, and then secure adapter setting plate in a vise.

Tool number : ST224490000 (—)

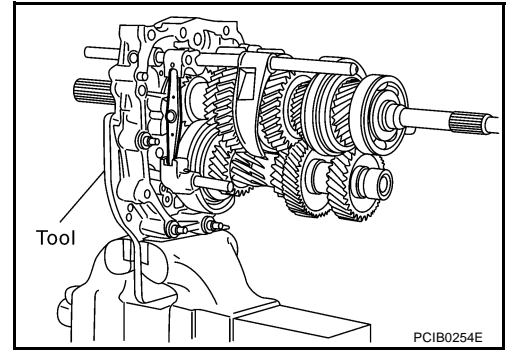

2. Remove baffle plate mounting bolts and baffle plate from adapter plate.

NOTE:

Mounting bolts are installed both from the front side and the reverse side of adapter plate.

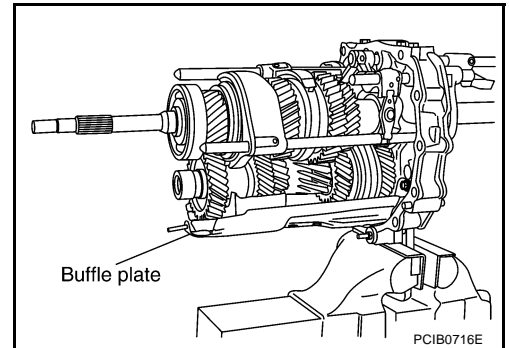

3. Remove magnet from adapter plate.
4. Drive out retaining pin using a pin punch [6 mm (0.24 in) dia.], and remove striking lever and striking rod.

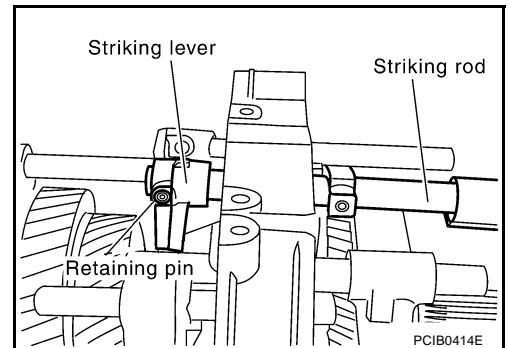

5. Remove check ball plugs, check ball springs and check balls from adapter plate.

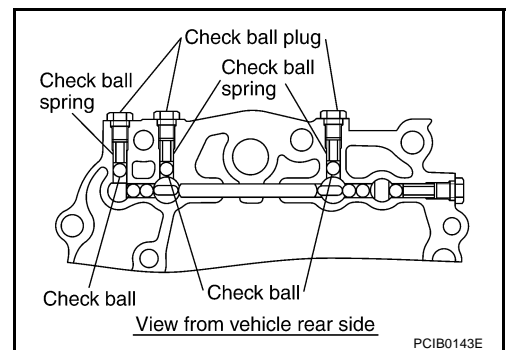

TRANSMISSION ASSEMBLY

6. Remove 3rd-4th control lever mounting bolts and 3rd-4th control lever from adapter plate.

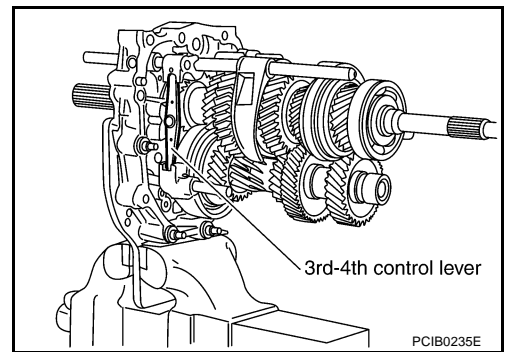

A
B
MT

7. Remove shifter cap from 3rd-4th control lever.
8. Remove check ball plug, check ball spring and check ball from adapter plate.

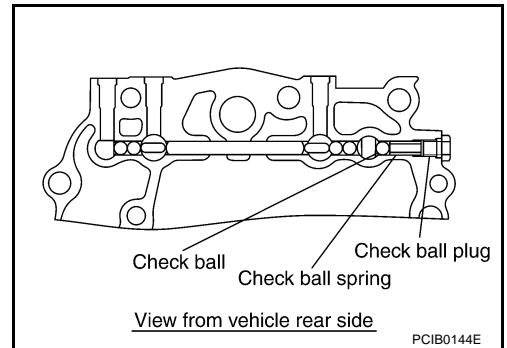

D
E
F
G
H

9. Drive out retaining pin using a pin punch [6mm (0.24in) dia.], and remove 3rd-4th fork rod bracket and 3rd-4th fork rod.

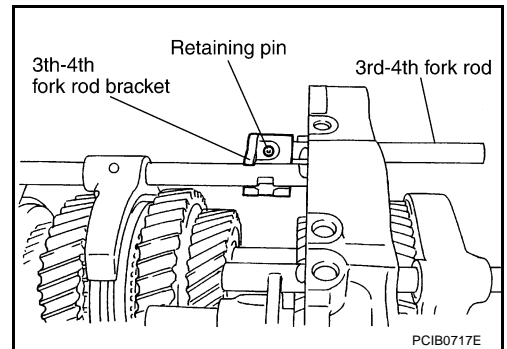

I
J
K

10. Drive out retaining pin using a pin punch [6 mm (0.24 in) dia.], and remove 3rd-4th fork rod (reversal side) and 3rd-4th shift fork.

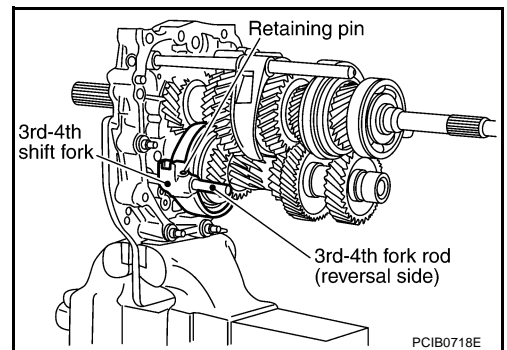

L
M

TRANSMISSION ASSEMBLY

11. Remove check balls and interlock pin from adapter plate.

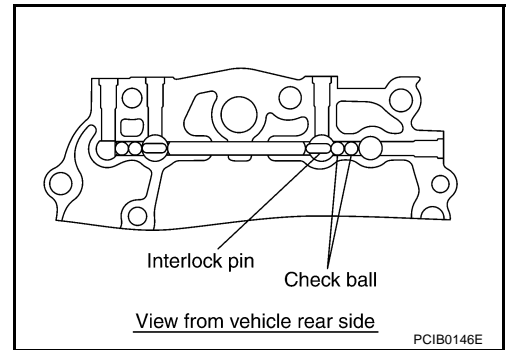

12. Drive out retaining pin using a pin punch [6 mm (0.24 in) dia.], and remove 1st-2nd fork rod and 1st-2nd shift fork.

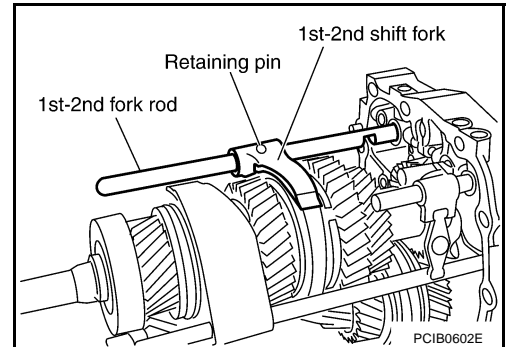

13. Remove interlock plunger and interlock pin from adapter plate.

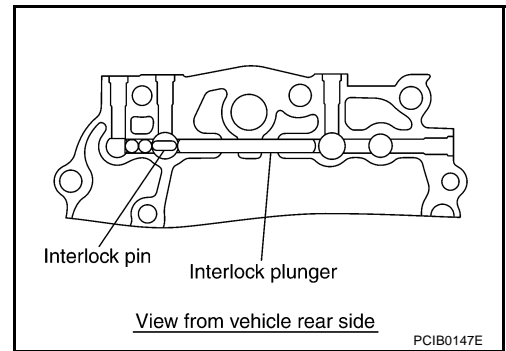

14. Drive out retaining pin using a pin punch [6 mm (0.24 in) dia.], and remove reverse fork rod and reverse shift fork.

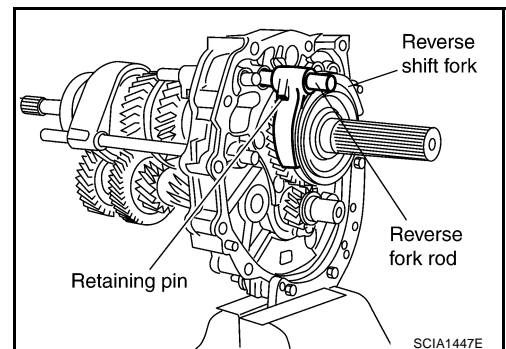

15. Remove check balls from adapter plate.

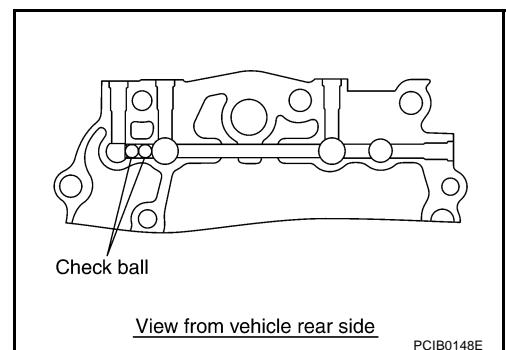

TRANSMISSION ASSEMBLY

16. Remove 5th-6th control lever mounting bolts, and 5th-6th control lever from adapter plate.

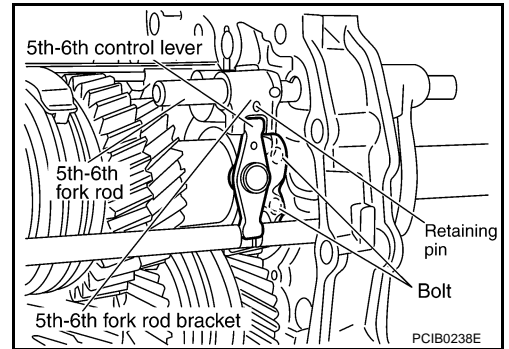

17. Drive out retaining pin using a pin punch [6 mm (0.24 in) dia.], and remove 5th-6th fork rod and 5th-6th fork rod bracket.

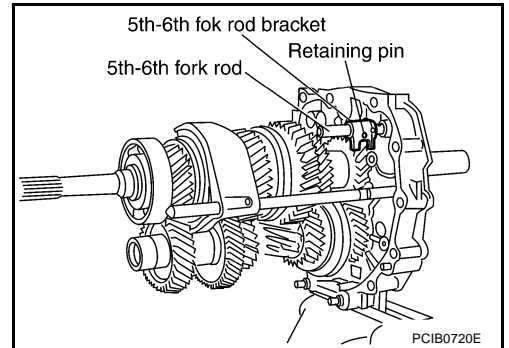

18. Drive out retaining pin using a pin punch [6 mm (0.24 in) dia.], and remove 5th-6th fork rod (reversal side) and 5th-6th shift fork.

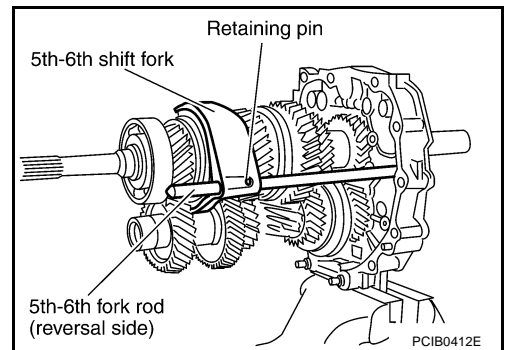

Gear Components

- Before disassembly, measure end play for each position. If the end play is outside the specifications, disassemble and inspect.
- Main drive gear

End play : 0 - 0.1mm (0 - 0.004in)

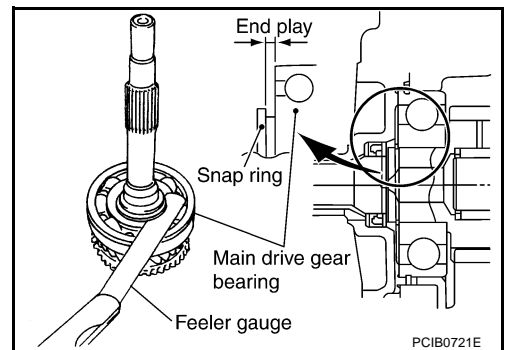

TRANSMISSION ASSEMBLY

- Main shaft rear side

End play : 0 - 0.1mm (0 - 0.004in)

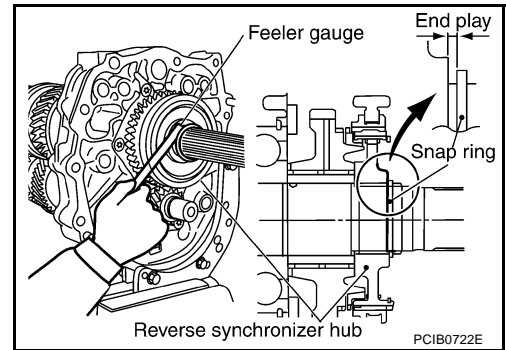

- Counter gear

End play : 0 - 0.1mm (0 - 0.004in)

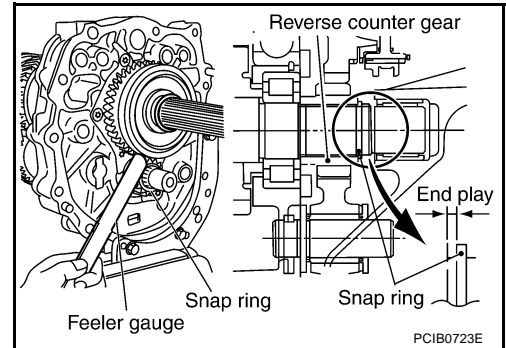

1. After removing snap ring, remove reverse synchronizer assembly and reverse main gear from main shaft using a puller.

Tool number : Commercial service tool

2. Remove reverse main needle bearing from main shaft.

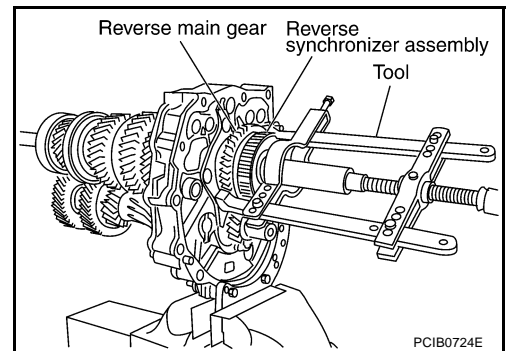

3. Remove main shaft bearing retainer mounting bolts and main shaft bearing retainers from adapter plate.

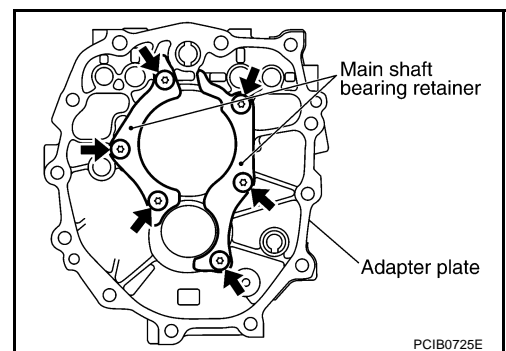

4. After removing snap ring, remove reverse counter gear and counter rear bearing spacer using a puller.

Tool number : Commercial service tool

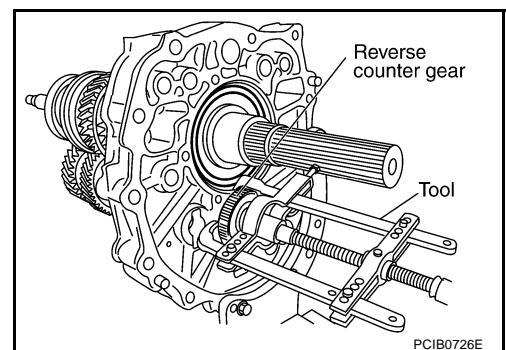

TRANSMISSION ASSEMBLY

5. Remove snap ring from main shaft bearing.

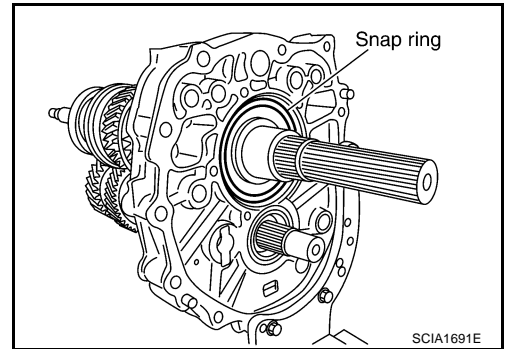

6. Remove main shaft assembly and counter shaft assembly together from adapter plate.

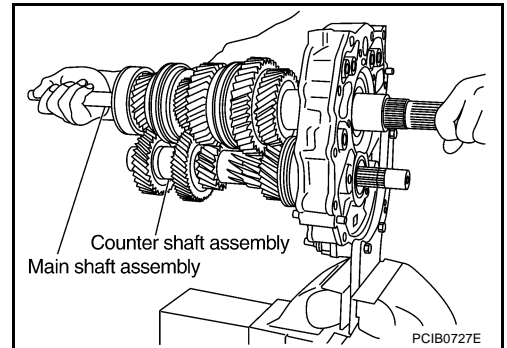

7. Remove counter rear bearing from adapter plate.

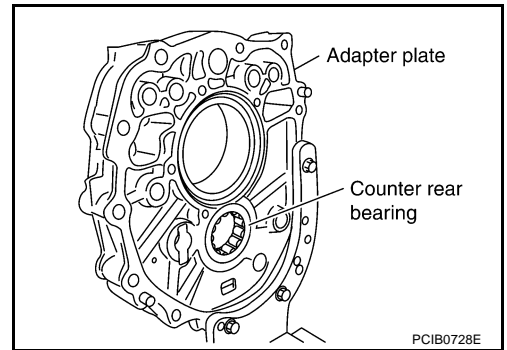

8. Remove main drive gear, main pilot bearing, pilot bearing spacer and 5th baulk ring from main shaft.

9. Remove snap ring from main drive gear using snap ring pliers.

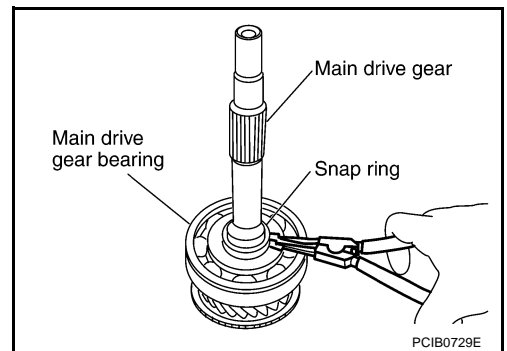

A
B
MT
D
E
F
G
H
I
J
K
L
M

TRANSMISSION ASSEMBLY

10. Set a puller on main drive gear bearing, and remove main drive gear bearing from main drive gear using a press.

Tool number : **Commercial service tool**

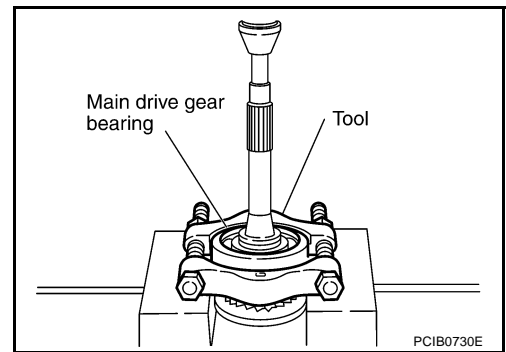

11. Set a puller on 4th main gear, and remove reverse main gear bushing, main shaft bearing and 4th main gear from main shaft using a press.

Tool number : **Commercial service tool**

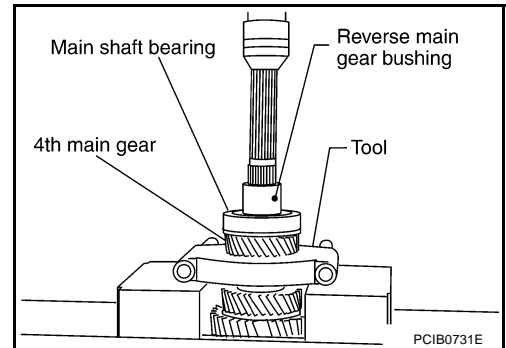

12. Remove 3rd-4th main spacer from main shaft.

13. Set a puller on 1st main gear, and remove 3rd main gear and 1st main gear from main shaft using a press.

Tool number : **Commercial service tool**

CAUTION:

Be careful not to damage baulk ring.

14. Remove 1st needle bearing from main shaft.

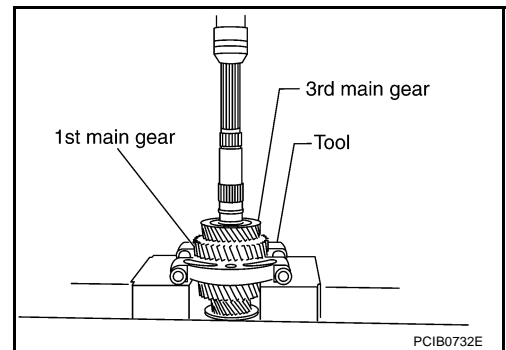

15. Set a puller on 2nd main gear, and remove 1st-2nd synchronizer assembly and 2nd main gear from main shaft using a press.

Tool number : **Commercial service tool**

CAUTION:

Be aware that when using the press, if the main shaft gear positioner catches on the V-block, etc., the main shaft could be damaged.

16. Remove 2nd needle bearing from the main shaft.

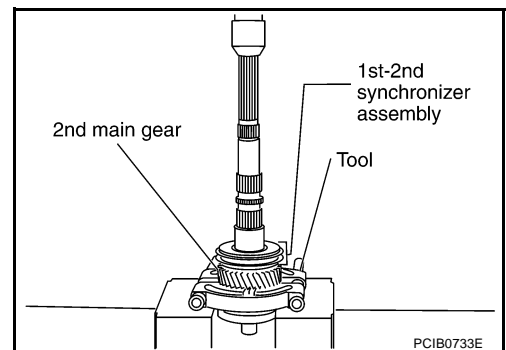

TRANSMISSION ASSEMBLY

17. Remove snap ring, then set a puller on 6th main gear, and remove 5th-6th synchronizer assembly, 6th baulk ring and 6th main gear from main shaft using a press.

Tool number : **Commercial service tool**

18. Remove 6th needle bearing from main shaft.

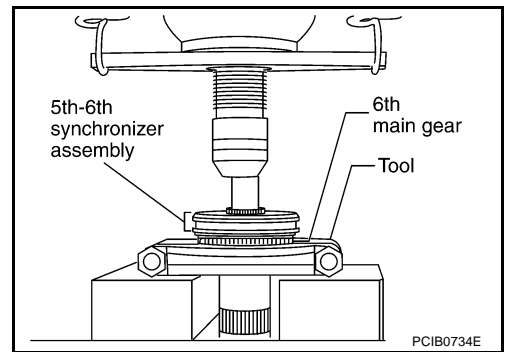

19. Set a puller on 3rd counter gear, and remove counter rear bearing inner race, 4th counter gear thrust washer, 4th counter gear, 4th inner baulk ring, 4th synchronizer cone, 4th outer baulk ring, 4th needle bearing, 4th gear bushing, 3rd-4th synchronizer assembly, 3rd outer baulk ring, 3rd synchronizer cone, 3rd inner baulk ring and 3rd counter gear from counter shaft using a press.

Tool number : **Commercial service tool**

20. Remove 3rd needle bearing from counter shaft.

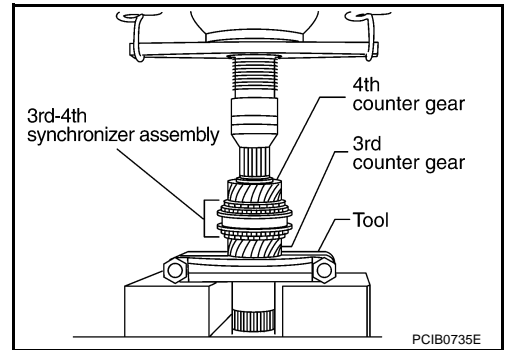

21. Set a puller on 3rd gear bushing, and remove 3rd gear bushing from counter shaft using a press.

Tool number : **Commercial service tool**

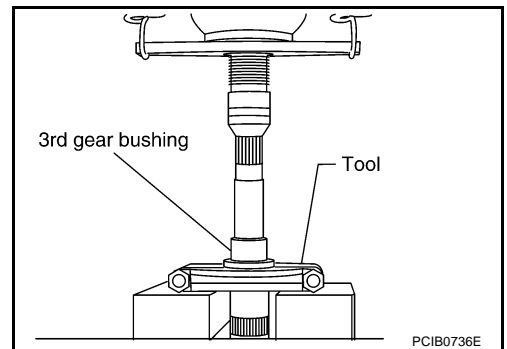

A
B
MT
D
E
F
G
H
I
J
K
L
M

TRANSMISSION ASSEMBLY

INSPECTION AFTER DISASSEMBLY

Shift Control Components

If the contact surfaces of striking lever, fork rod, shift fork, etc. have excessive wear, abrasion, bend, or any other damage, replace the component.

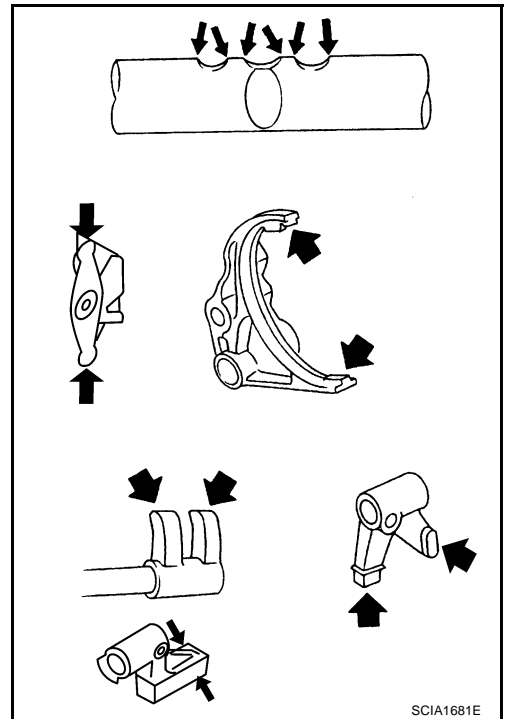

Gear and Shaft Components

If the contact surfaces of each gear, main shaft, main drive gear and counter shaft, etc. have damage, peeling, abrasion, dent, bend, or any other damage, replace the component.

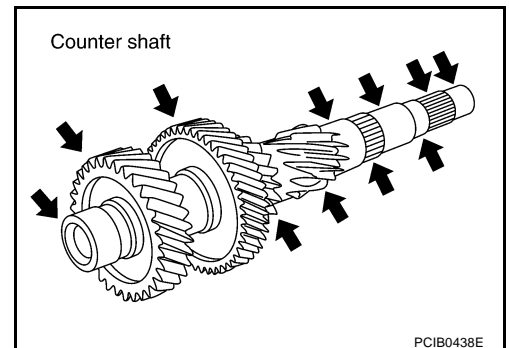
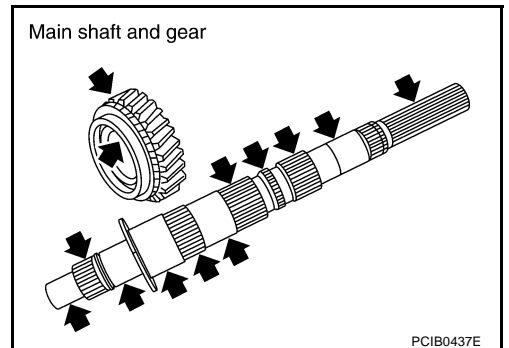

TRANSMISSION ASSEMBLY

Synchronizer Components

- If the contact surfaces of coupling sleeves, synchronizer hubs and shifting inserts have damage or abrasion, replace the component.
- Each set of coupling sleeve and synchronizer hub should move smoothly.

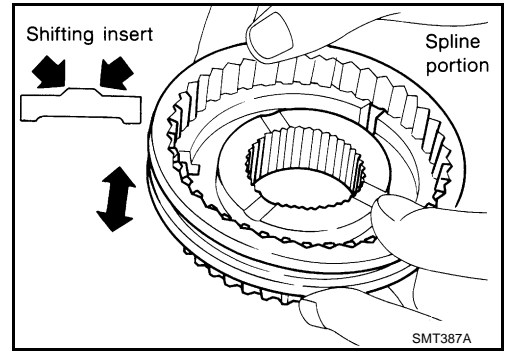

- If the cam surfaces of baulk rings or contact surfaces of shifting inserts have damage or excessive wear, replace with a new one.
- If spread springs are damaged, replace with a new one.

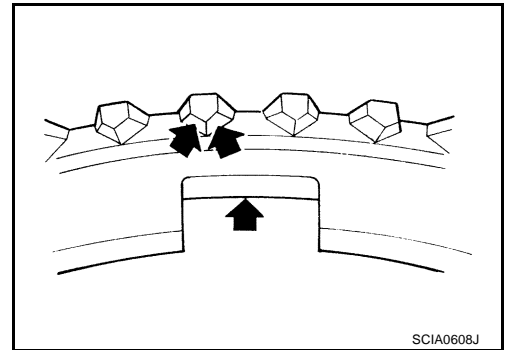

Single-Cone Synchronizer (5th and 6th)

- Push baulk ring on cone and measure baulk ring back surface clearance at two locations or more on opposite sides. Find the average value, and replace baulk ring if it is below the limit value.

Clearance

Standard : 0.7 - 1.25 mm (0.028 - 0.049 in)

Limit value : 0.5 mm (0.02 in) or less

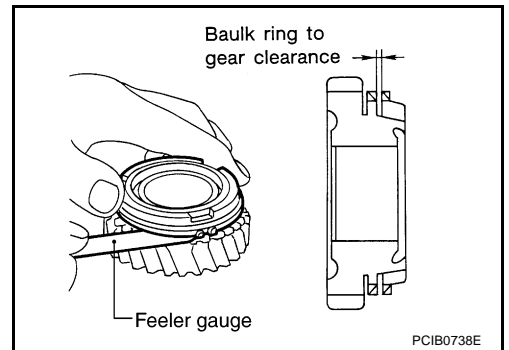

NOTE:

- 5th and 6th baulk rings have three spaces that two gear teeth are missing as shown in the figure.

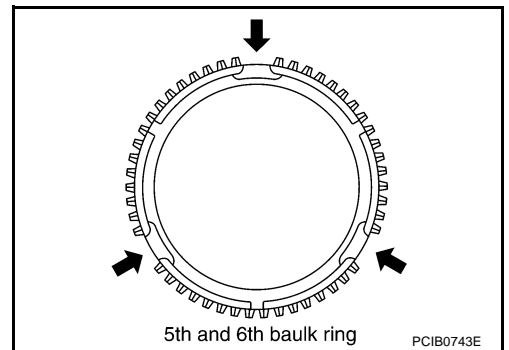

A
B
MT
D
E
F
G
H
I
J
K
L
M

TRANSMISSION ASSEMBLY

Double -Cone Synchronizer (1st, 3rd and 4th)

Follow the instructions below and inspect the clearances of outer baulk ring, synchronizer cone, inner baulk ring for 1st, 3rd and 4th gears.

NOTE:

Clearances "A" and "B" of the outer baulk ring, synchronizer cone and inner baulk ring are controlled as a set. If the clearance is below the limit value, replace them as a set.

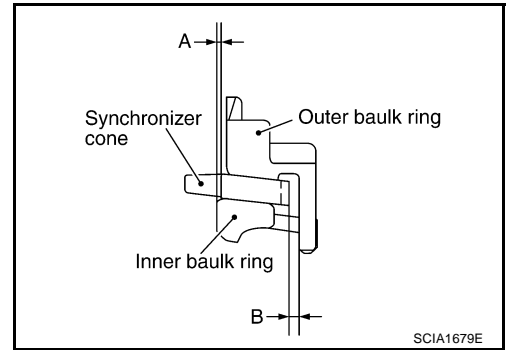

1. Measure clearance "A" at 2 or more points diagonally opposite, and calculate mean value using a dial indicator.

Clearance "A"

Standard :0.5 - 0.7 mm (0.02 - 0.028 in)

Limit value :0.3 mm (0.012 in) or less

Tool number : ST30031000 (J-22912 - 01)

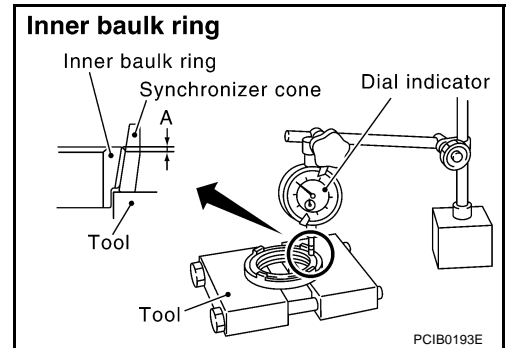

2. Measure clearance "B" at 2 or more points diagonally opposite, and calculate mean value using a feeler gauge.

Clearance "B"

Standard 1st : 1.0 - 1.5 mm (0.039 - 0.059 in)

3rd and 4th : 0.85 - 1.35 mm (0.033 - 0.053 in)

Limit value : 0.7 mm (0.028 in) or less

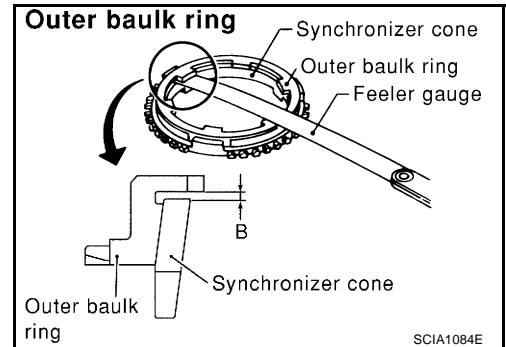

TRANSMISSION ASSEMBLY

NOTE:

1st and 4th baulk rings have three spaces that one gear tooth is missing as shown in the figure.

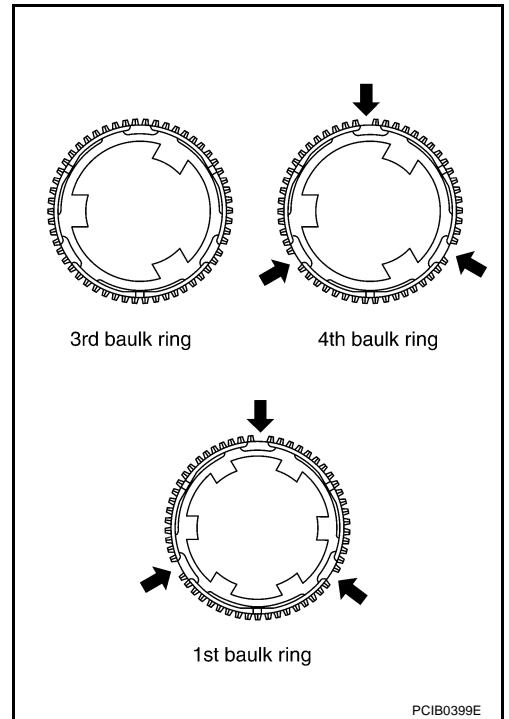

A
B
MT
D
E
F
G
H
I
J
K
L
M

Triple-Cone synchronizer (2nd)

Follow the instructions below and inspect the clearances of 2nd outer baulk ring, 2nd synchronizer cone and 2nd inner baulk ring.

NOTE:

Clearances “A”, “B” and “C” of 2nd outer baulk ring, 2nd synchronizer cone and 2nd inner baulk ring are controlled as a set. If the clearance is below the limit value, replace them as a set.

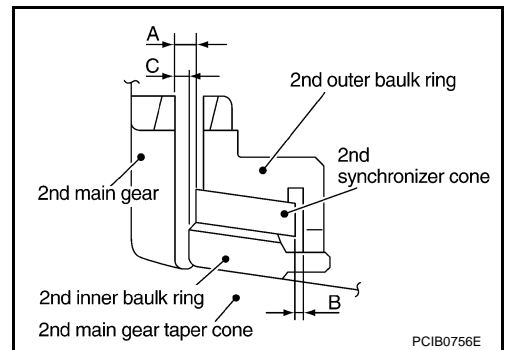

1. Push 2nd outer baulk ring on 2nd main gear taper cone. Measure clearance “A” at 2 or more points diagonally opposite, and calculate mean value using a feeler gauge.

Clearance “A”

Standard value : 0.6 - 1.3 mm (0.024 - 0.051 in)

Limit value : 0.3 mm (0.012 in) or less

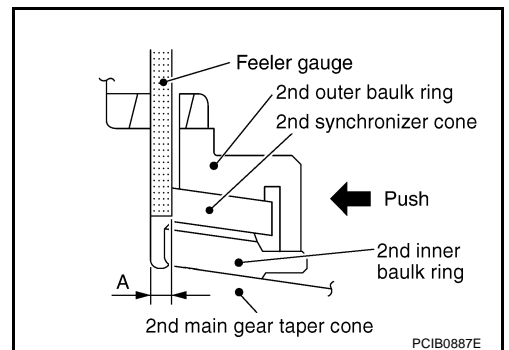

TRANSMISSION ASSEMBLY

2. Measure clearance "B" at 2 or more points diagonally opposite, and calculate mean value using a feeler gauge.

Clearance "B"

Standard value : 0.85 - 1.35 mm (0.033 - 0.053 in)
Limit value : 0.7 mm (0.028 in) or less

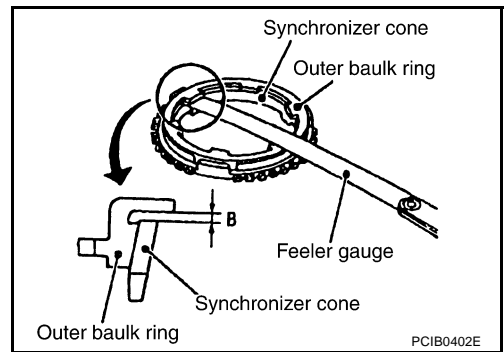

3. Push 2nd outer baulk ring on 2nd main gear taper cone. Measure clearance "C" at 2 or more points diagonally opposite, and calculate mean value using a feeler gauge.

Clearance "C"

Standard value : 0.7 - 1.25 mm (0.028 - 0.049 in)
Limit value : 0.3 mm (0.012 in) or less

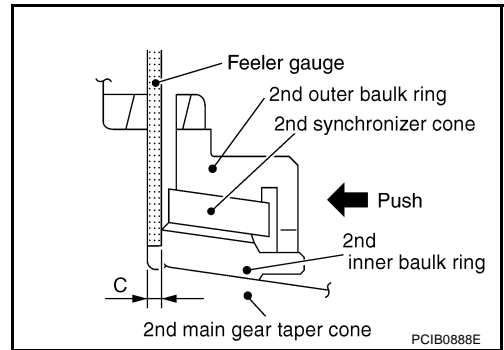

NOTE:

2nd baulk ring has three spaces that the gear teeth are missing as shown in the figure.

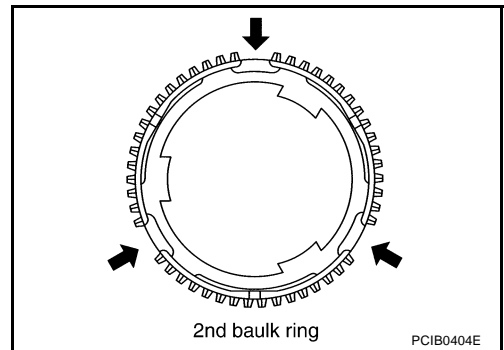

Reverse Synchronizer

Push baulk ring on cone and measure baulk ring back surface clearance at two locations or more on opposite sides. Find the average value, and replace baulk ring if it is below the limit value.

Clearance

Standard : 0.75 - 1.2 mm (0.03 - 0.047 in)
Limit value : 0.5 mm (0.02 in) or less

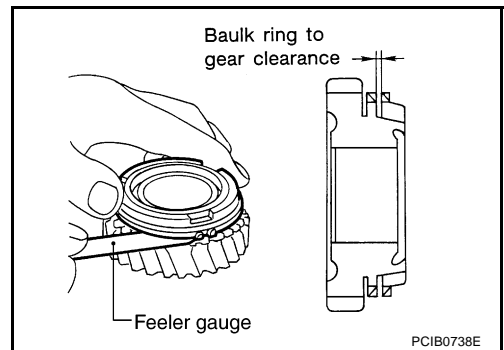

TRANSMISSION ASSEMBLY

NOTE:

Reverse baulk ring has three spaces that two gear teeth are missing, and each space has groove for identification as shown in the figure.

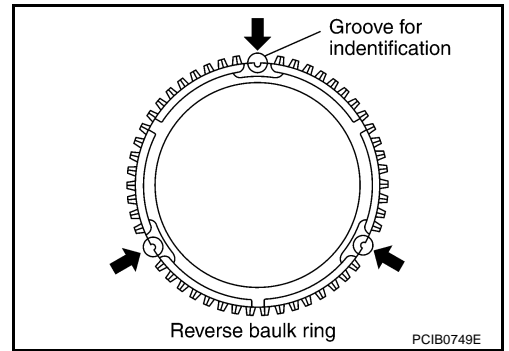

A
B
MT

Bearing

If the bearings do not rotate smoothly or the contact surface on ball or race is damaged or peeled, replace with a new one.

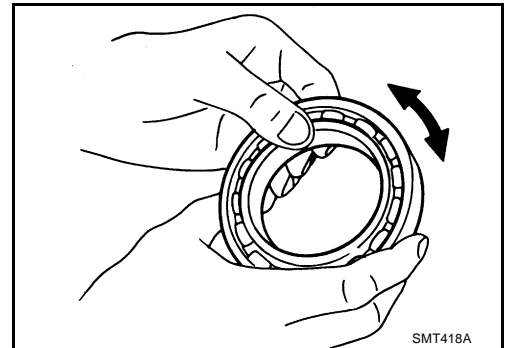

E
F
G
H

ASSEMBLY

Gear Components

1. Install 5th-6th coupling sleeve and 5th-6th shifting inserts onto 5th-6th synchronizer hub.

CAUTION:

- Do not reuse 5th-6th synchronizer hub and 5th-6th coupling sleeve.
- Install 5th-6th coupling sleeve with the larger chamfer on the rear side.

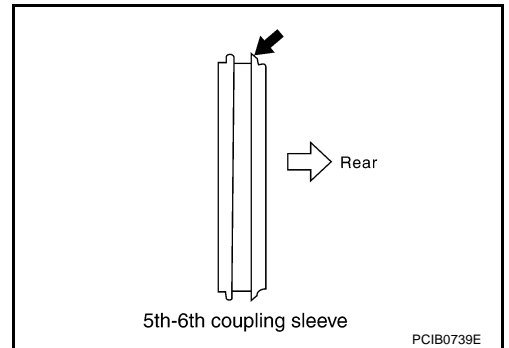

I
J
K
L

CAUTION:

Be careful with the shape of shifting insert to avoid misassembly.

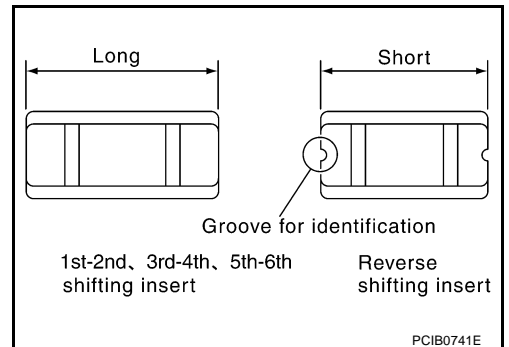

M

TRANSMISSION ASSEMBLY

2. Install 5th-6th spread springs in 5th-6th shifting inserts.

CAUTION:

Install the hook of each spread spring onto separate shifting inserts.

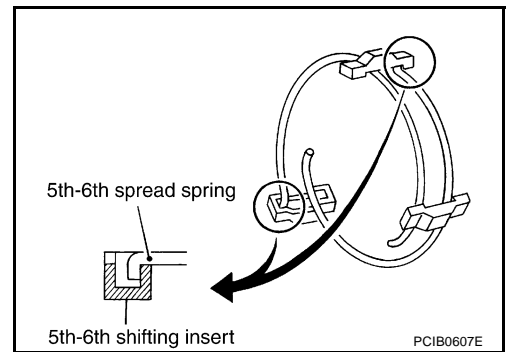

3. Install 6th needle bearing, 6th main gear, 6th baulk ring and 5th-6th synchronizer assembly onto main shaft using a press and the inserter.

Tool number : ST30911000 (—)

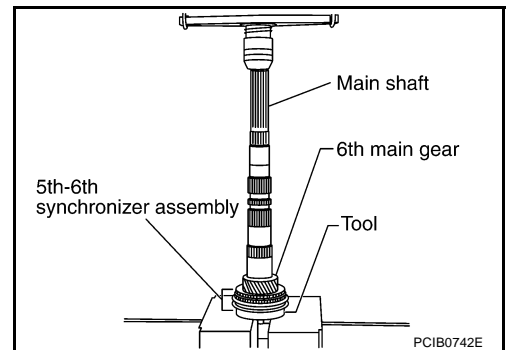

CAUTION:

The rear side of synchronizer hub has three oil grooves. When press fitting, install the rear side to the rearward.

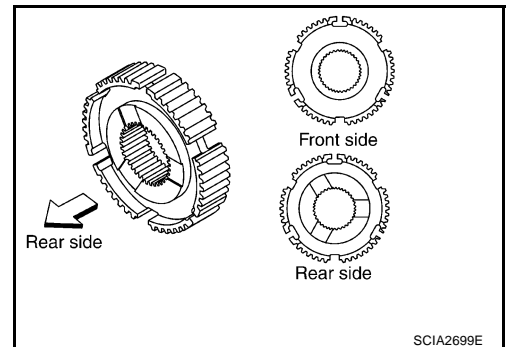

4. Select and install snap ring onto the front side of main shaft so that the end play comes within the specifications. Refer to [MT-62, "Snap Rings"](#).

End play : 0 - 0.1 mm (0 - 0.004 in)

CAUTION:

Do not reuse snap ring.

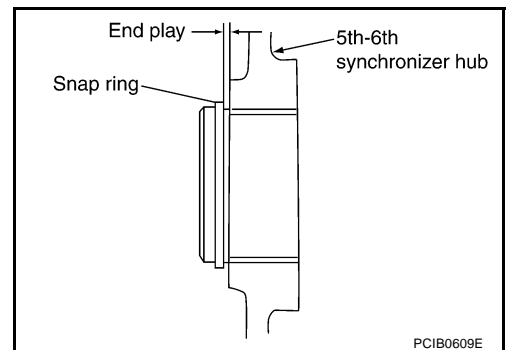

TRANSMISSION ASSEMBLY

5. Install 1st-2nd coupling sleeve and 1st-2nd shifting inserts onto 1st-2nd synchronizer hub.

CAUTION:

- Do not reuse 1st-2nd synchronizer hub and 1st-2nd coupling sleeve.
- Install 1st-2nd coupling sleeve with the thicker flange faced the front side.

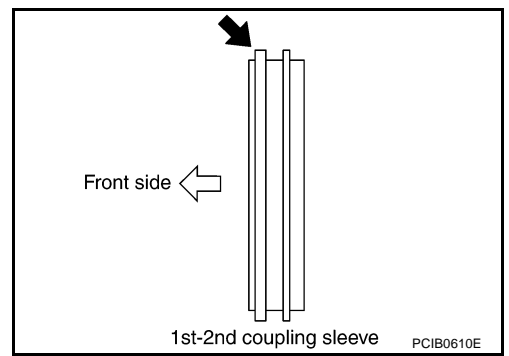

CAUTION:

Be careful with the shape of shifting insert to avoid misassembly.

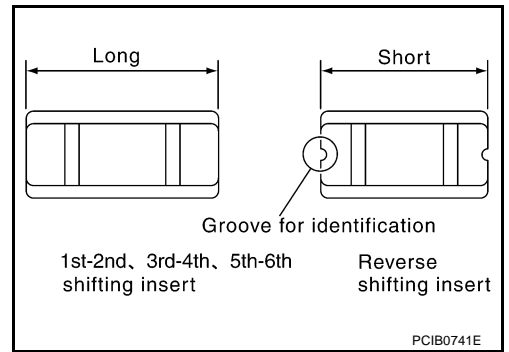

6. Install 1st-2nd spread spring in 1st-2nd shifting inserts onto 1st-2nd synchronizer hub.

CAUTION:

Install hook of each spread spring onto separate shifting inserts.

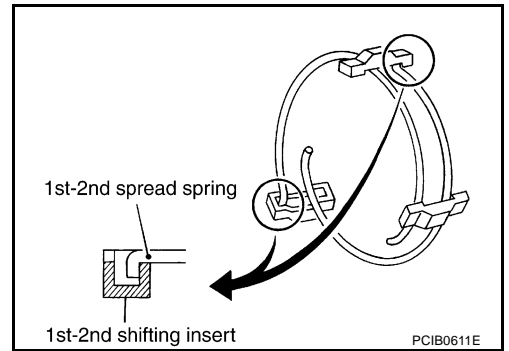

7. Install 2nd needle bearing, 2nd main gear, 2nd inner baulk ring, 2nd synchronizer cone, 2nd outer baulk ring and 1st-2nd synchronizer assembly onto main shaft using a press and the support ring.

Tool number : ST27861000 (—)

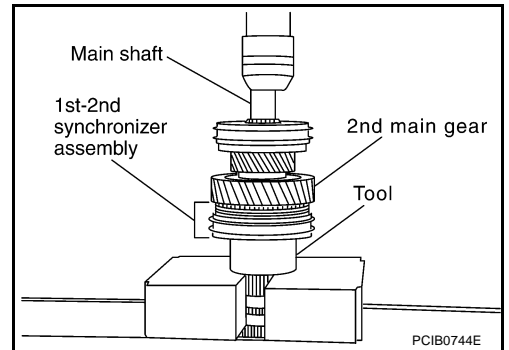

A
B
MT
D
E
F
G
H
I
J
K
L
M

TRANSMISSION ASSEMBLY

CAUTION:

Install with the side, which has identification mark on one of four oil grooves on the boss edge surface, facing rearward.

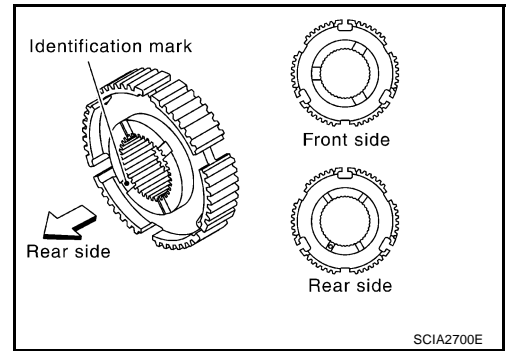

8. Install 1st gear bushing onto main shaft using a press and the support ring.

Tool number : ST27861000 (—)

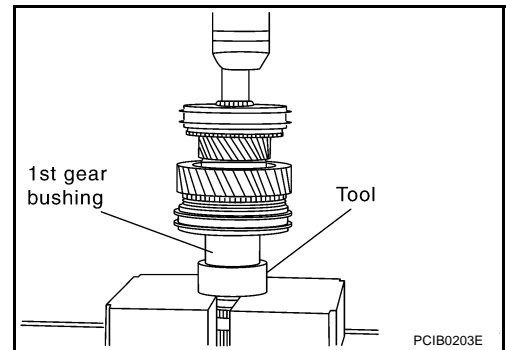

9. Install 1st needle bearing, 1st outer baulk ring, 1st synchronizer cone, 1st inner baulk ring, 3rd main gear and 1st main gear onto main shaft using a press and the inserter.

Tool number : ST30022000 (—)

CAUTION:

Do not reuse 3rd main gear.

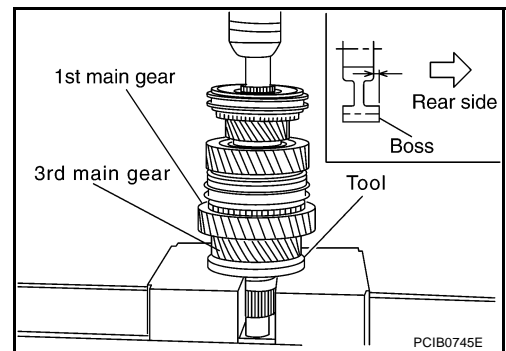

10. Install 3rd-4th main spacer and 4th main gear onto main shaft using a press and the inserter.

Tool number : ST30022000 (—)

CAUTION:

- Do not reuse 4th main gear.
- Install with the side on which the boss protrudes out of gear edge surface facing rearward.

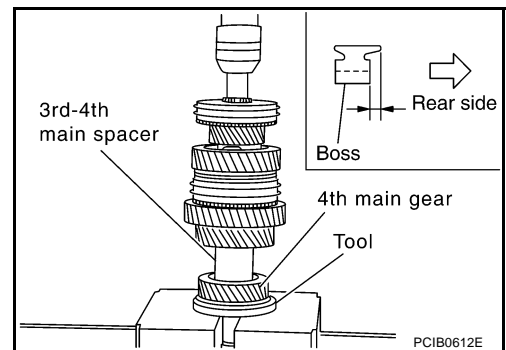

TRANSMISSION ASSEMBLY

11. Install main shaft bearing onto main shaft using a press and the inserter.

Tool number : ST30911000 (—)

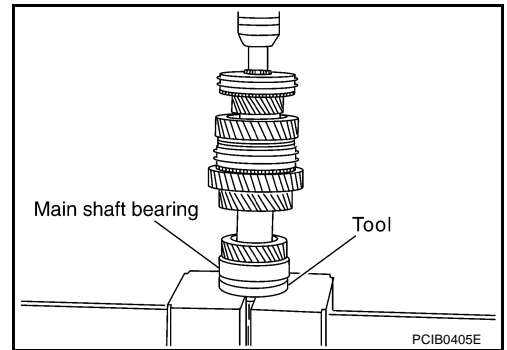

12. Install reverse main gear bushing onto main shaft using a press and the inserter.

Tool number : ST30911000 (—)

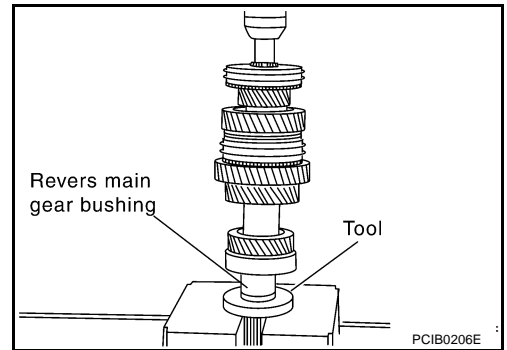

13. Install 3rd gear bushing onto counter shaft using a press and the inserter.

Tool number : ST30911000 (—)

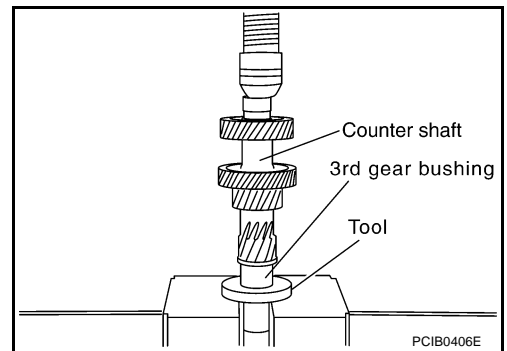

14. Install 3rd-4th coupling sleeve and 3rd-4th shifting inserts onto 3rd-4th synchronizer hub.

CAUTION:

- Do not reuse 3rd-4th synchronizer hub and 3rd-4th coupling sleeve.
- Install 3rd-4th coupling sleeve with the thicker flange faced the front side.

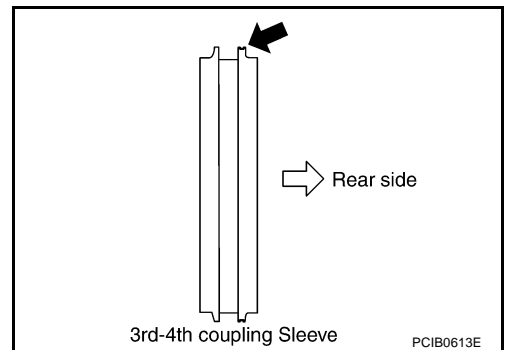

CAUTION:

Be careful with the shape of shifting insert to avoid misassembly.

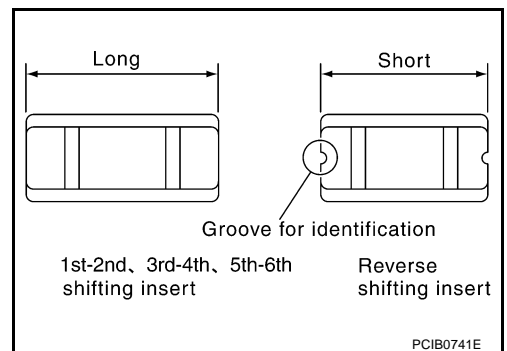

A
B
MT
D
E
F
G
H
I
J
K
L
M

TRANSMISSION ASSEMBLY

15. Install 3rd-4th spread springs into 3rd-4th shifting insert.

CAUTION:

Install the hook of each spread spring onto separate shifting inserts.

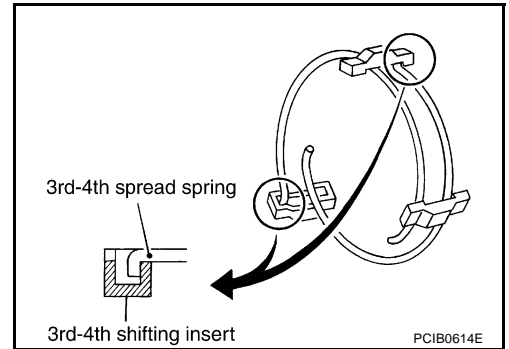

16. Install 3rd needle bearing, 3rd counter gear, 3rd inner baulk ring, 3rd synchronizer cone, 3rd outer baulk ring and 3rd-4th synchronizer assembly onto counter shaft using a press and the drift.

Tool number : ST30911000 (—)

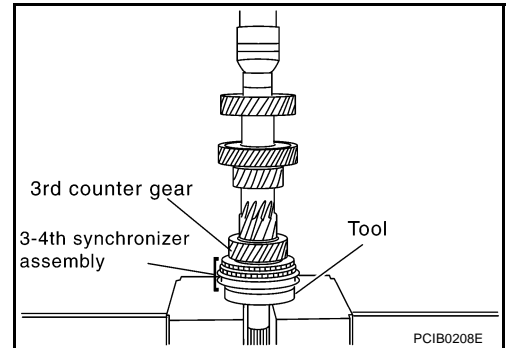

17. Install 4th outer baulk ring, 4th synchronizer cone, 4th inner baulk ring, 4th gear bushing, 4th needle bearing, 4th counter gear and 4th counter shaft thrust washer onto counter shaft using a press and the drift.

Tool number : KV40100630 (J-26029)

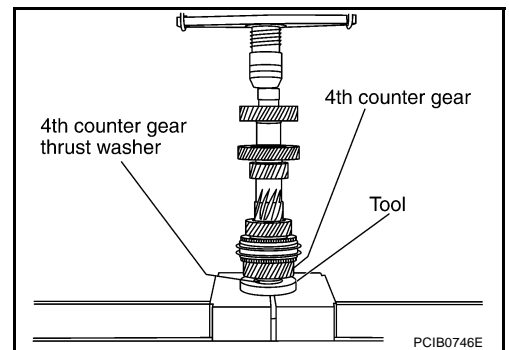

18. Install counter rear bearing inner race onto counter shaft using a press and the drift.

Tool number : ST30032000 (J-26010-01)

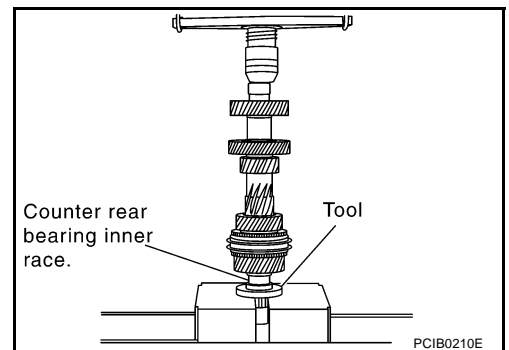

19. Install main drive bearing onto main drive gear using a press and the drift.

Tool number : KV32102700 (—)

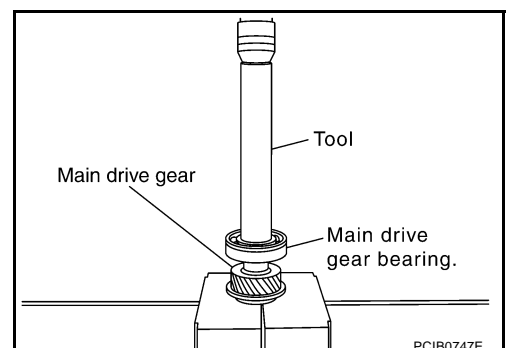

TRANSMISSION ASSEMBLY

20. Select and install snap ring on main drive gear so that comes within the specifications. Refer to [MT-62, "Snap Rings"](#) .

End play : 0 - 0.1 mm (0 - 0.004 in)

CAUTION:

Do not reuse snap ring.

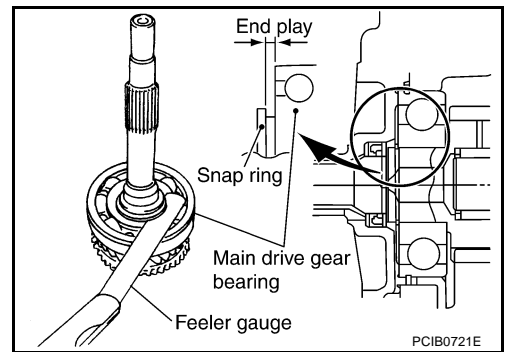

21. Install 5th baulk ring, pilot bearing spacer, main pilot bearing and main drive gear onto main shaft.

22. Install main shaft and counter shaft combined in one unit to adapter plate, and secure main shaft bearing with a snap ring.

- a. Tap main shaft bearing slightly via brass bar or the equivalent to install snap ring.
- b. After installing snap ring, hammer snap ring and adapter plate slightly in the reverse direction to make them in contact with each other.

CAUTION:

Do not reuse snap ring.

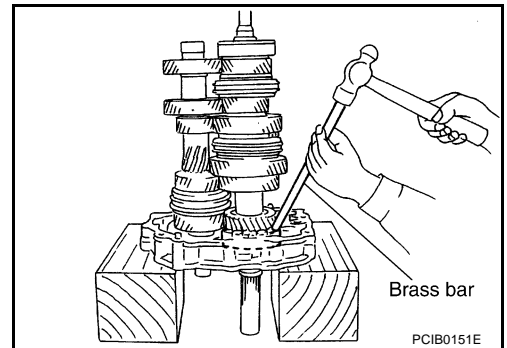

23. Install counter rear bearing outer race onto adapter plate using plastic hammer or equivalent.

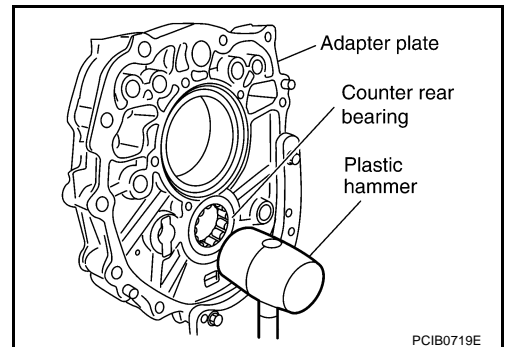

24. Apply genuine medium strength locking sealant or equivalent (refer to GI section) to the end of the bolt (first 3 to 4 threads). Install main shaft bearing retainer onto adapter plate, and tighten bolts to the specified torque. Refer to [MT-22, "CASE COMPONENTS"](#) .

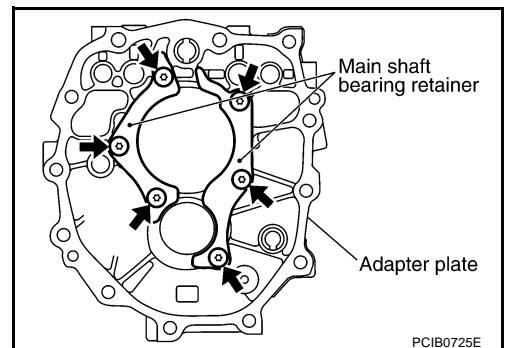

A
B
MT
D
E
F
G
H
I
J
K
L
M

TRANSMISSION ASSEMBLY

25. Install reverse coupling sleeve and reverse shifting inserts onto reverse synchronizer hub.

CAUTION:

- Do not reuse reverse synchronizer hub and reverse coupling sleeve.
- Install reverse coupling sleeve with the flat flange on the rear side.

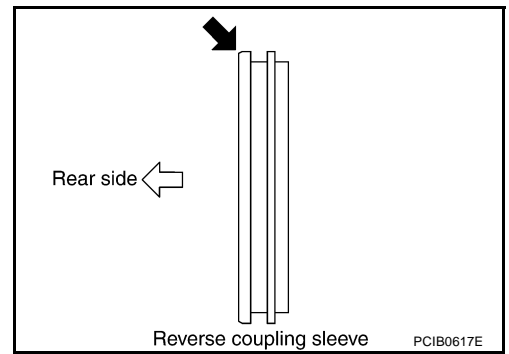

CAUTION:

Be careful with the shape of shifting insert to avoid misassembly.

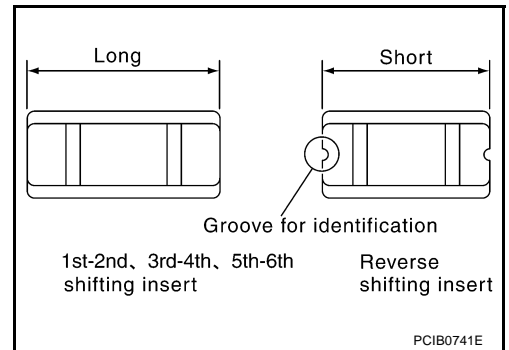

26. Install spread springs into shifting insert.

CAUTION:

Install the hook of each spread spring onto separate shifting inserts.

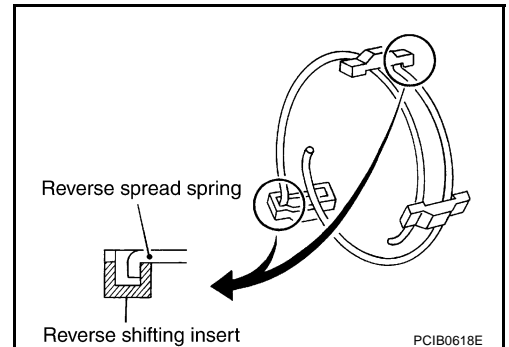

TRANSMISSION ASSEMBLY

27. Install reverse main needle bearing, reverse main gear, reverse baulk ring and reverse synchronizer assembly onto main shaft using a press, the press plate and the drift.

Tool number (A) : KV32103300 (J-46529)

Tool number (B) : ST01530000 (—)

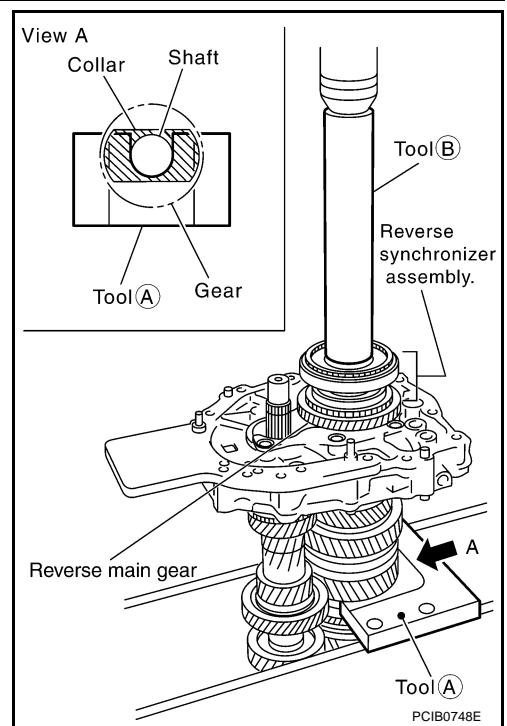

CAUTION:

When installing, face the side with three grooves to the front side.

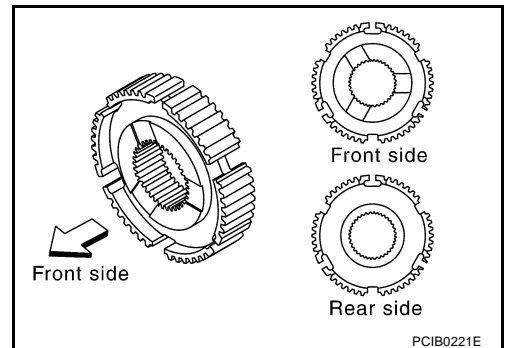

28. Select and install a snap ring to the main shaft rear side so that the end play comes within the standard value. Refer to [MT-62, "Snap Rings"](#) .

End play : 0 - 0.1 mm (0 - 0.004 in)

CAUTION:

Do not reuse snap ring.

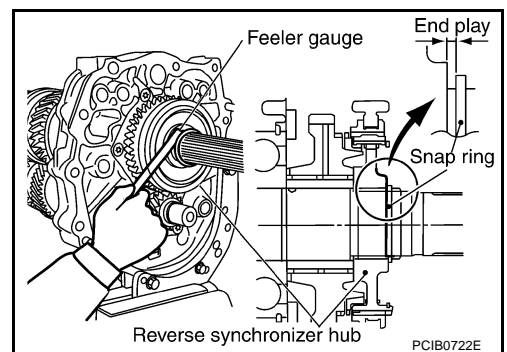

TRANSMISSION ASSEMBLY

29. Install counter rear bearing spacer and reverse counter gear using a press and the drift.

Tool number : ST23860000 (—)

CAUTION:

- Do not reuse reverse counter gear.
- When installing counter rear bearing spacer, maker's stamp should face to the rear.

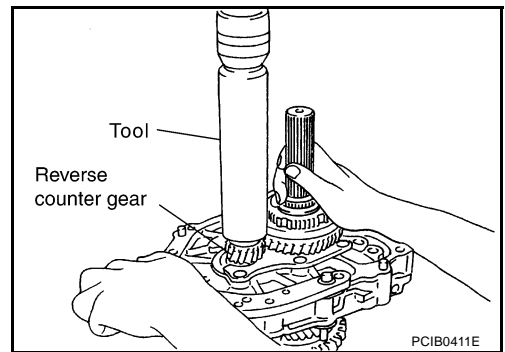

30. Select and install a snap ring to the counter shaft so that the end play comes within the standard value. Refer to [MT-62, "Snap Rings"](#).

End play : 0 - 0.1 mm (0 - 0.004 in)

CAUTION:

Do not reuse snap ring.

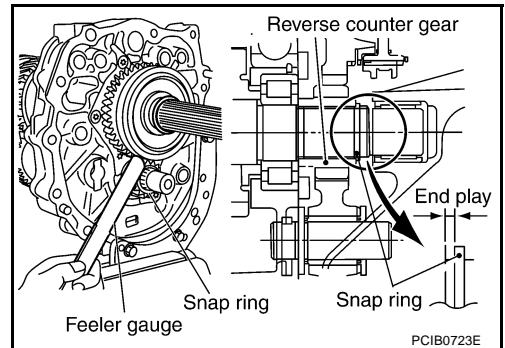

Shift Control Components

1. Install 5th-6th shift fork to 5th-6th coupling sleeve.
2. Install 5th-6th fork rod (reversal side) to 5th-6th shift fork.
3. Drive retaining pin into 5th-6th shift fork using a pin punch [6 mm (0.24in) dia.].

CAUTION:

Do not reuse retaining pin.

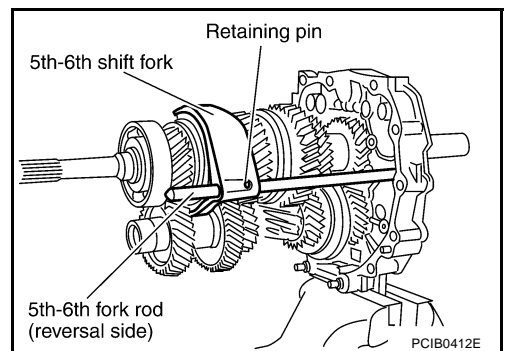

4. Install 5th-6th fork rod to adapter plate.
5. Install 5th-6th fork rod bracket to 5th-6th fork rod.
6. Drive retaining pin into 5th-6th fork rod bracket using a pin punch [6 mm (0.24in) dia.].

CAUTION:

Do not reuse retaining pin.

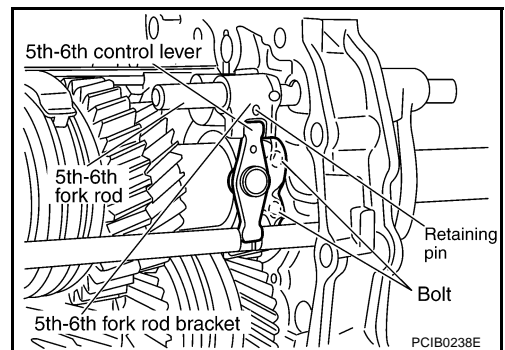

TRANSMISSION ASSEMBLY

7. Install 5th-6th control lever to adapter plate, and then tighten mounting bolts to the specified torque. Refer to [MT-25, "SHIFT CONTROL COMPONENTS"](#).

CAUTION:

Set the projection upward.

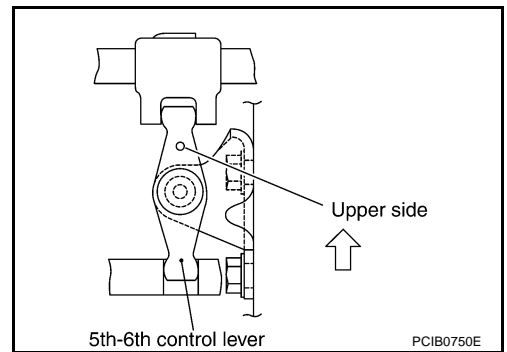

8. Insert check balls into adapter plate.

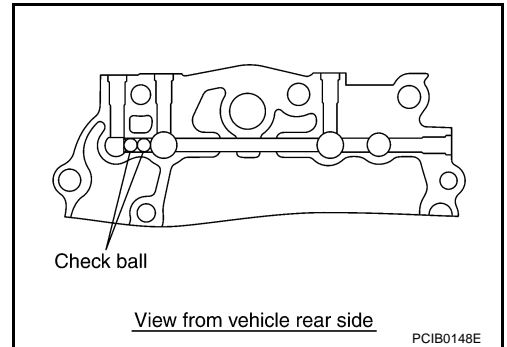

9. Install reverse shift fork onto reverse coupling sleeve.
10. Insert reverse fork rod to reverse shift fork.
11. Drive retaining pin into reverse shift fork using a pin punch [6 mm (0.24 in) dia.].

CAUTION:

Do not reuse retaining pin.

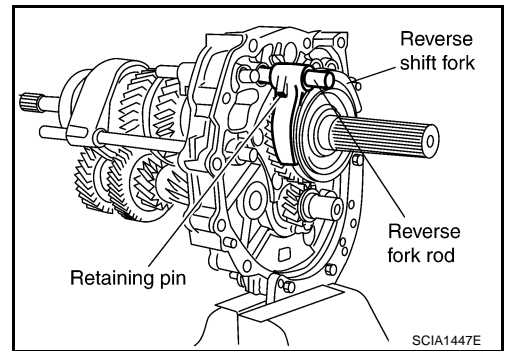

12. Insert interlock pin and interlock plunger into adapter plate.

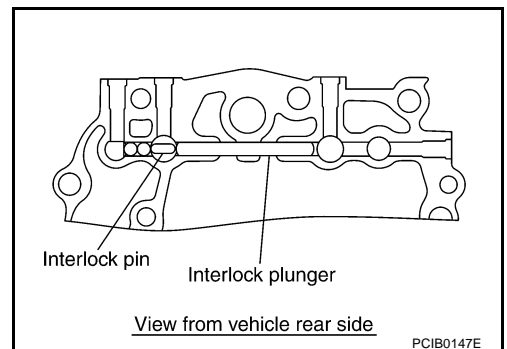

13. Install 1st-2nd shift fork onto 1st-2nd coupling sleeve.
14. Insert 1st-2nd fork rod to 1st-2nd shift fork.
15. Drive retaining pin into 1st-2nd shift fork using a pin punch [6 mm (0.24 in) dia.].

CAUTION:

Do not reuse retaining pin.

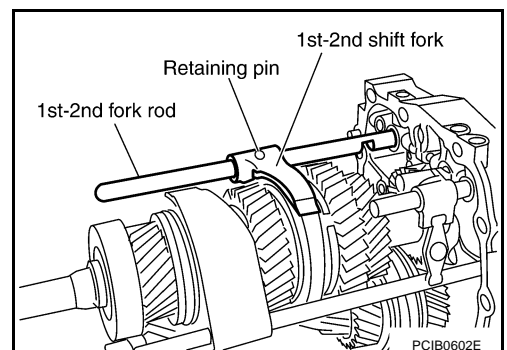

A
B
MT
D
E
F
G
H
I
J
K
L
M

TRANSMISSION ASSEMBLY

16. Install 3rd-4th shift fork onto 3rd-4th coupling sleeve.
17. Install 3rd-4th fork rod (reversal side) to 3rd-4th shift fork.
18. Drive retaining pin into 3rd-4th shift fork (reversal side) using a pin punch [6 mm (0.24 in) dia.].

CAUTION:

Do not reuse retaining pin.

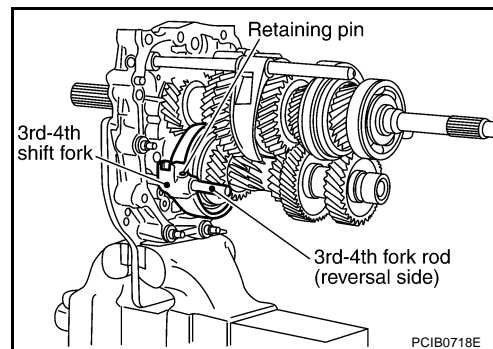

19. Insert interlock pin and check balls into adapter plate.

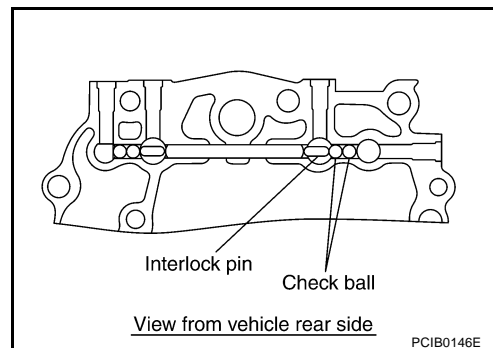

20. Install 3rd-4th fork rod to adapter plate.
21. Install 3rd-4th fork rod bracket to 3rd-4th fork rod.
22. Drive retaining pin into 3rd-4th fork rod bracket using a pin punch [6 mm (0.24 in) dia.].

CAUTION:

Do not reuse retaining pin.

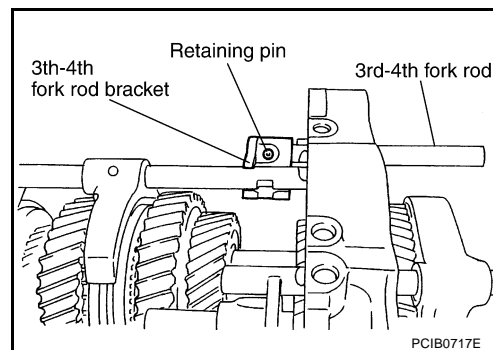

23. Insert check ball, check ball spring into adapter plate, apply Genuine Silicone RTV or equivalent (refer to GI section) to check ball plug threads, and tighten to the specified torque. Refer to [MT-25, "SHIFT CONTROL COMPONENTS"](#).

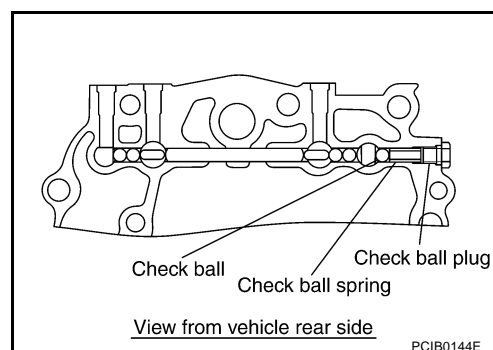

24. Install shifter cap to 3rd-4th control lever.

TRANSMISSION ASSEMBLY

25. Insert 3rd-4th control lever to adapter plate, and then tighten mounting bolts to the specified torque. Refer to [MT-25, "SHIFT CONTROL COMPONENTS"](#) .

CAUTION:

Make sure the top and bottom are oriented correctly.

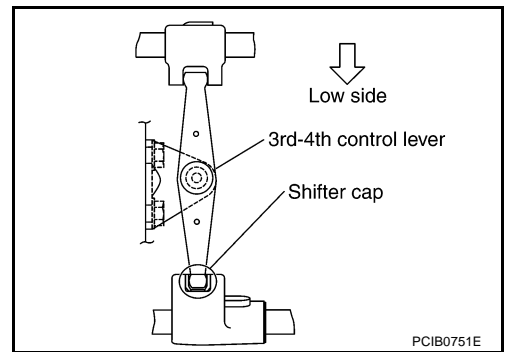

26. Insert check ball spring and check ball into the adapter plate, apply Genuine Silicone RTV or equivalent (refer to GI section) to the check ball plug threads, and tighten to the specified torque. Refer to [MT-25, "SHIFT CONTROL COMPONENTS"](#) .

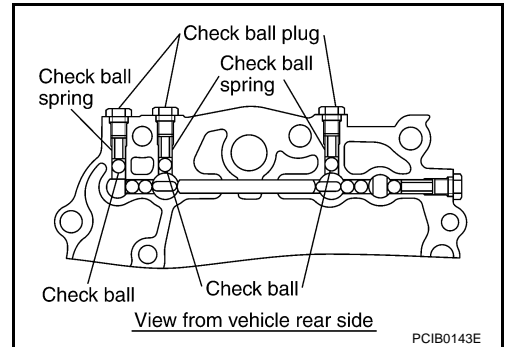

27. Install striking rod to adapter plate.
28. Install striking lever to striking rod.
29. Drive retaining pin into striking lever using a pin punch [6 mm (0.24 in) dia.].

CAUTION:

Do not reuse retaining pin.

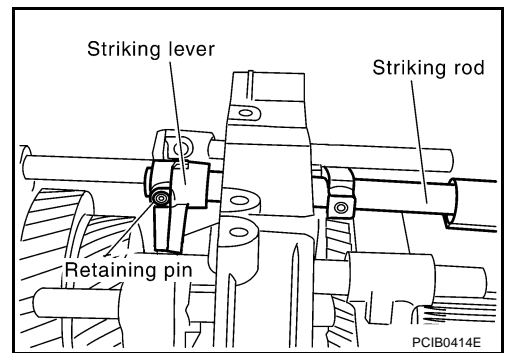

30. Install baffle plate onto adapter plate, and tighten mounting bolts to the specified torque.

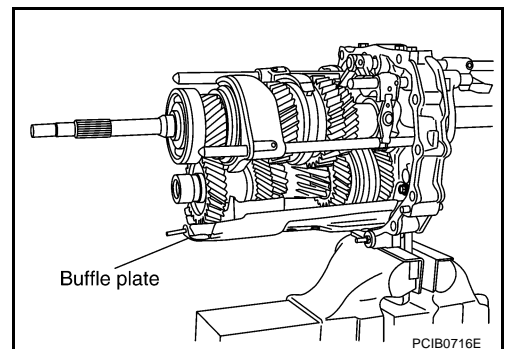

A
B
MT
D
E
F
G
H
I
J
K
L
M

TRANSMISSION ASSEMBLY

Case Components

1. Install counter front bearing in transmission case.
2. Install oil gutter to transmission case.

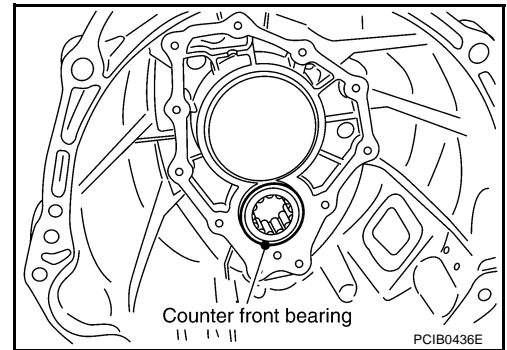

3. Apply Genuine Silicone RTV or equivalent (refer to GI section) to adapter plate mounting surface of transmission case as shown in the figure.

CAUTION:

Completely remove all moisture and oil, etc., from the transmission case and adapter plate mounting surfaces.

4. Install magnet to adapter plate.

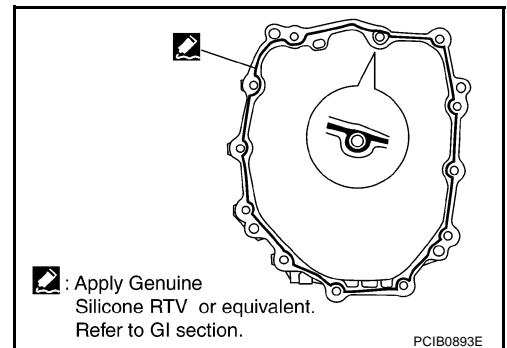

5. Install adapter plate onto transmission case and then tap adapter plate with a soft hammer to seat it completely on transmission case.

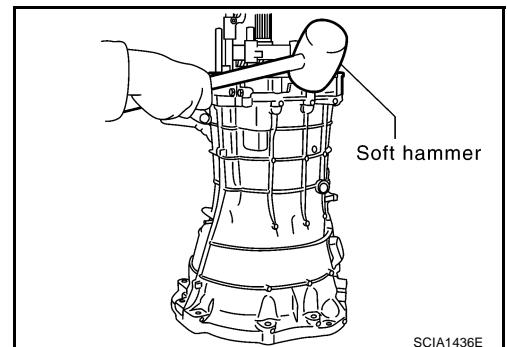

6. Install snap ring to main drive gear bearing using snap ring pliers.

CAUTION:

Do not reuse snap ring.

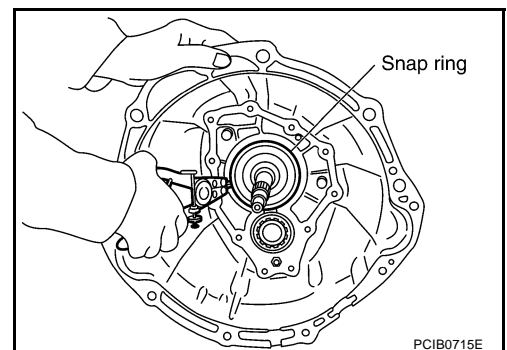

TRANSMISSION ASSEMBLY

7. Tighten baffle plate mounting nut to the specified torque. Refer to [MT-22, "CASE COMPONENTS"](#).

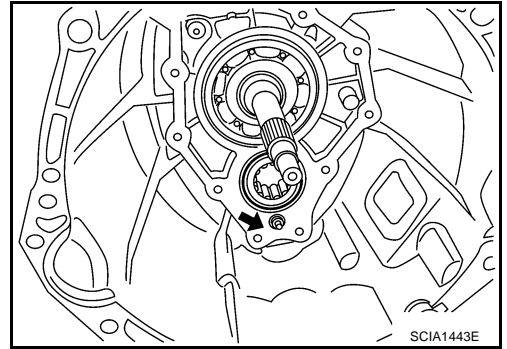

8. Apply multi-purpose grease to the lip of front cover oil seal. Install front cover oil seal approx. 8.55-9.55 mm (0.336-0.376 in) above from the front cover edge surface using a drift.

Tool number : KV38102100 (J-25803-01)

CAUTION:

- Do not reuse front cover oil seal.
- When installing, do not tilt front cover oil seal.

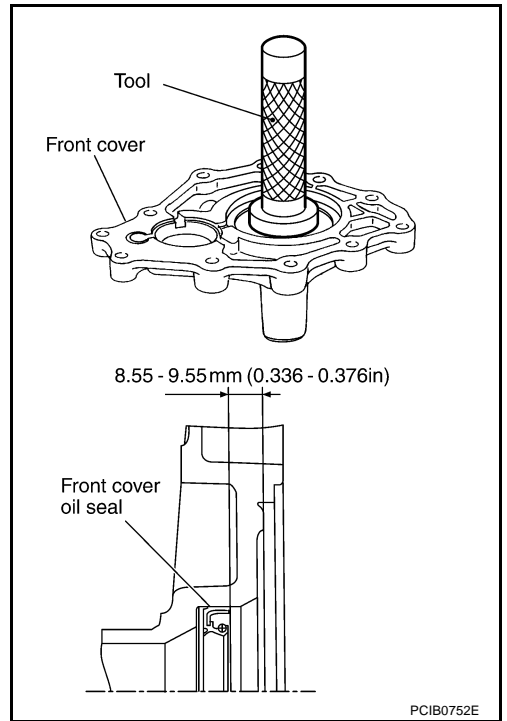

9. Install front cover gasket and front cover to transmission case.

CAUTION:
Do not reuse gasket.

10. Temporarily tighten bolts in the positions shown in the figure.

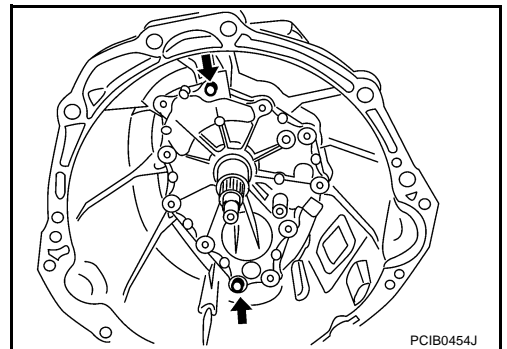

11. Install remaining bolts, and tighten them by hand.

CAUTION:
Four bolts pointed by arrows in the figure are not reusable.

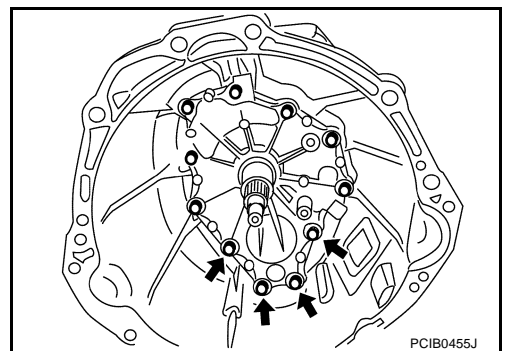

A
B
MT
D
E
F
G
H
I
J
K
L
M

TRANSMISSION ASSEMBLY

12. Tighten bolts to the specified torque in order as shown in the figure. Refer to [MT-22, "CASE COMPONENTS"](#) .

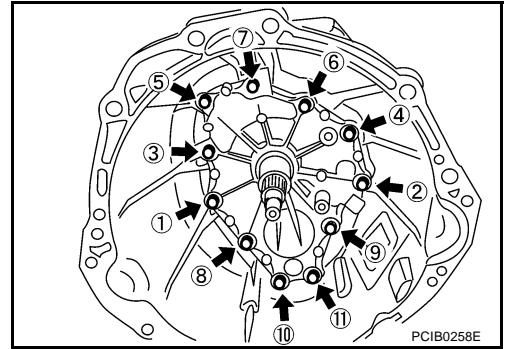

13. Install washer to withdrawal lever ball pin, and install it to front cover. Tighten withdrawal lever ball pin to the specified torque. Refer to [MT-22, "CASE COMPONENTS"](#) .

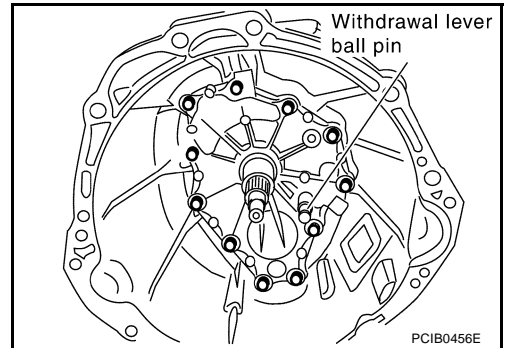

14. Install rear extension oil gutter to rear extension, and then tighten bolt to specified torque. Refer to [MT-22, "CASE COMPONENTS"](#) .

15. Install reverse idler shaft, reverse idler needle bearing, reverse idler gear and reverse thrust washer to adapter plate.

16. Apply multi -purpose grease to the lip of striking rod seal. Install control shaft oil seal to rear extension using the drift.

Tool number : ST35291000 (—)

CAUTION:

- Do not reuse striking rod oil seal.
- When installing, do not tilt striking rod seal.

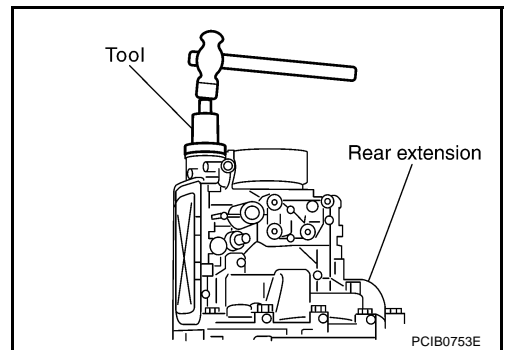

17. Apply multi - purpose grease to the lip of the rear oil seal. Using a drift, to install rear oil seal. 1.2-2.2 mm (0.047-0.087 in) above from the rear extension edge surface.

Tool number : ST33400001 (J-26082)

CAUTION:

- Do not reuse rear oil seal.
- When installing, do not tilt rear oil seal.

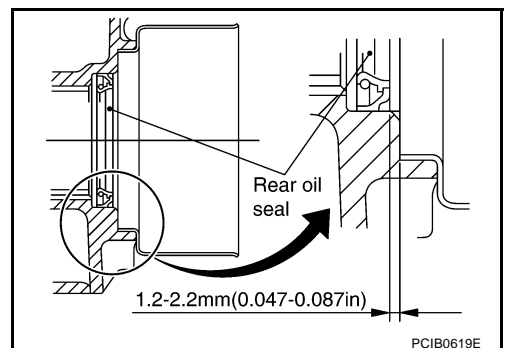

18. Place shift forks in neutral position.

TRANSMISSION ASSEMBLY

19. Apply Genuine Silicone RTV or equivalent (refer to GI section) to rear extension mounting surface of adapter plate as shown in the figure.

CAUTION:

Completely remove all moisture, oil, etc., from the adapter plate and rear extension mating surfaces.

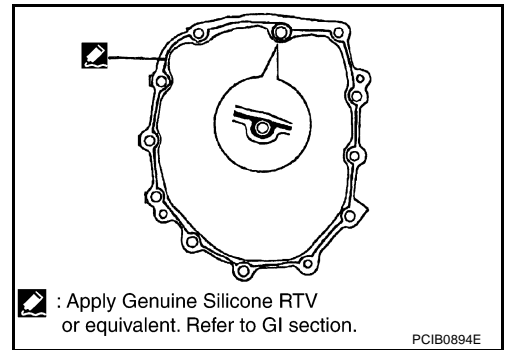

20. Install rear extension to transmission case, and tighten mounting bolts to the specified torque in order as shown in the figure. Refer to [MT-22, "CASE COMPONENTS"](#) .
21. Install control lever housing to rear extension, and then tighten mounting bolts to the specified torque. Refer to [MT-25, "SHIFT CONTROL COMPONENTS"](#) .

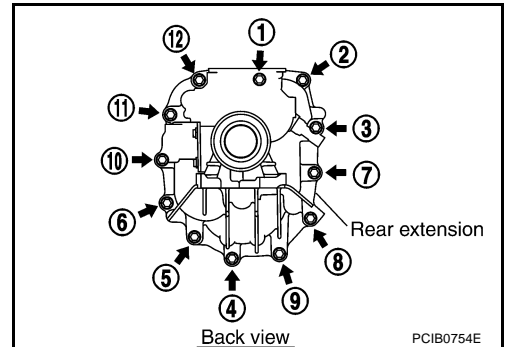

22. Insert return spring and plunger into the rear extension, apply Genuine Silicone RTV or equivalent (refer to GI section) to the return spring plug threads, and then tighten to the specified torque. Refer to [MT-25, "SHIFT CONTROL COMPONENTS"](#) .

	Return spring identification mark	Plunger notch
RH	Brown	No
LH	Blue	Yes

CAUTION:

The right and left return springs and plungers are different, so make sure they are installed correctly.

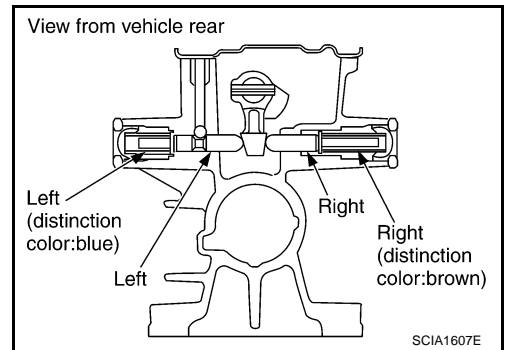

23. Install shift check pin and control bracket as a one unit to rear extension, and then tighten mounting bolts to specified torque. Refer to [MT-25, "SHIFT CONTROL COMPONENTS"](#) .
24. After screwing plunger, neutral position switch and back-up lamp switch to rear extension with 1-2 pitches, apply Genuine Silicone RTV or equivalent (refer to GI section) to the switch threads, and tighten them to the specified torque. Refer to [MT-22, "CASE COMPONENTS"](#) .

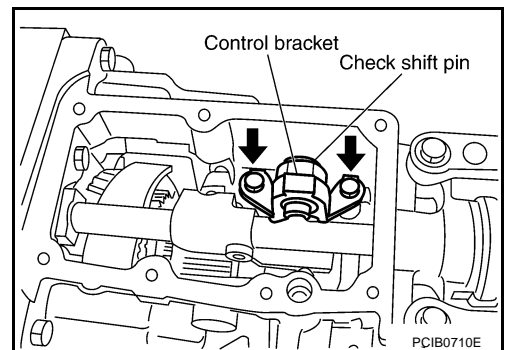

TRANSMISSION ASSEMBLY

25. Drive retaining pin into control rod using a pin punch [6 mm (0.24 in) dia.].

CAUTION:

Do not reuse retaining pin.

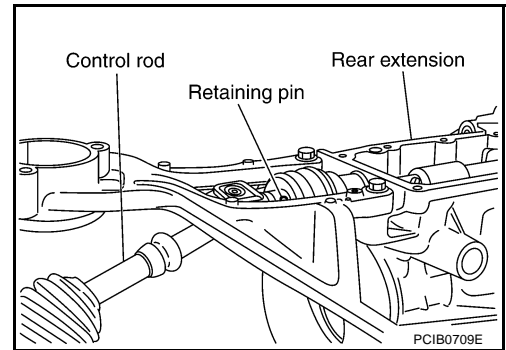

26. Insert check select spring and check ball into rear extension.

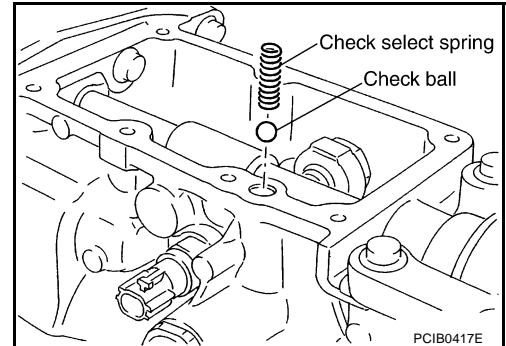

27. Install rear extension upper cover gasket and rear extension upper cover to rear extension.

CAUTION:

- Do not reuse rear extension upper cover gasket.
- Avoid tangling check select spring.

28. Tighten rear extension upper cover bolts to specified torque in order as shown in the figure. Refer to [MT-22, "CASE COMPONENTS"](#) .

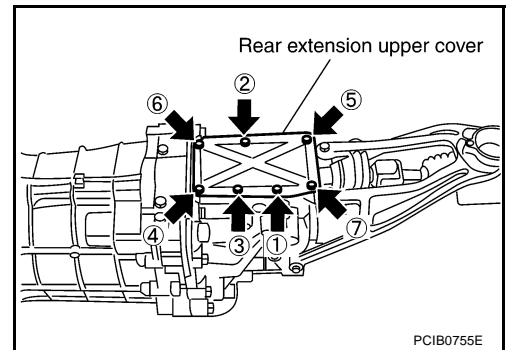

SERVICE DATA AND SPECIFICATIONS (SDS)

SERVICE DATA AND SPECIFICATIONS (SDS)

PPF:00030

General Specifications

ACS003LJ

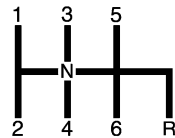
Applied model		VQ35DE
Transmission		FS6R31A
Number of speed		6
Shift pattern		 <p style="text-align: right; margin-right: 50px;">SCIA0955E</p>
Synchronmesh type		Warner
Gear ratio	1st	3.794
	2nd	2.324
	3rd	1.624
	4th	1.271
	5th	1.000
	6th	0.794
	Reverse	3.446
Main gear (Number of teeth)	Drive	26
	1st	37
	2nd	34
	3rd	33
	4th	31
	6th	31
	Reverse	42
Counter gear (Number of teeth)	Drive	32
	1st	12
	2nd	18
	3rd	25
	4th	30
	6th	48
	Reverse	15
Reverse idler gear (Number of teeth)		26
Oil capacity	ℓ (US qt, Imp qt)	Approx. 2.9 (3-1/8, 2-1/2)
Remarks	Reverse synchronizer	Installed
	Double cone synchronizer	1st, 3rd and 4th
	Triple cone synchronizer	2nd

End Play

ACS003LL

Unit: mm (in)

Item	Standard
Counter gear	0 - 0.1 (0 - 0.004)
Main drive gear	0 - 0.1 (0 - 0.004)
Main shaft front side	0 - 0.1 (0 - 0.004)
Main shaft rear side	0 - 0.1 (0 - 0.004)

SERVICE DATA AND SPECIFICATIONS (SDS)

Snap Rings

ACS003LM

Unit: mm (in)

Selective parts	Thickness	Part No.	
Main drive gear	1.89 (0.0744)	32204 01G60	
	1.95 (0.0768)	32204 01G61	
	1.99 (0.0783)	32204 01G62	
	2.03 (0.0799)	32204 01G63	
	2.07 (0.0815)	32204 01G64	
	2.11 (0.0831)	32204 01G65	
Counter shaft	1.96 (0.0772)	32236 CD000	
	2.02 (0.0795)	32236 CD001	
	2.08 (0.0819)	32236 CD002	
	2.14 (0.0843)	32236 CD003	
	2.20 (0.0866)	32236 CD004	
	2.26 (0.0890)	32236 CD005	
	2.32 (0.0913)	32236 CD006	
	2.38 (0.0937)	32236 CD007	
	2.44 (0.0961)	32236 CD008	
	2.50 (0.0984)	32236 CD009	
	2.56 (0.1008)	32236 CD010	
2.62 (0.1031)	32236 CD011		
Main shaft	Front side	2.08 (0.0819)	32204 CD000
		2.14 (0.0843)	32204 CD001
		2.20 (0.0866)	32204 CD002
		2.26 (0.0890)	32204 CD003
	Rear side	2.08 (0.0819)	32204 CD000
		2.14 (0.0843)	32204 CD001
		2.20 (0.0866)	32204 CD002
		2.26 (0.0890)	32204 CD003
		2.32 (0.0913)	32204 CD004
		2.38 (0.0937)	32204 CD005
		2.44 (0.0961)	32204 CD006
		2.50 (0.0984)	32204 CD007
		2.56 (0.1008)	32204 CD008
		2.62 (0.1031)	32204 CD009
		2.68 (0.1055)	32204 CD010
2.74 (0.1079)	32204 CD011		
2.80 (0.1102)	32204 CD012		
2.86 (0.1126)	32204 CD013		
2.92 (0.1150)	32204 CD014		
2.98 (0.1173)	32204 CD015		

SERVICE DATA AND SPECIFICATIONS (SDS)

Baulk Ring Clearance

ACS003LN

Unit: mm (in)

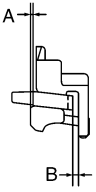
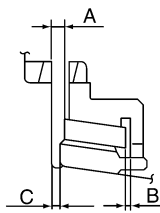
Measurement point	Standard	Limit value
1st, 3rd and 4th (Double - cone synchronizer) <ul style="list-style-type: none"> ● Clearance between synchronizer cone and inner baulk ring end face "A" ● Clearance between outer baulk ring pawl and synchronizer cone "B" <div style="text-align: center;">  <p>PCIB0249E</p> </div>	A: 0.5 - 0.7 (0.02 - 0.028) B (1st): 1.0 - 1.5 (0.039 - 0.059) B (3rd, 4th): 0.85 - 1.35 (0.033 - 0.053)	0.3 (0.012) 0.7 (0.028) 0.7 (0.028)
2nd (Triple - cone synchronizer) <ul style="list-style-type: none"> ● Clearance between synchronizer and clutch gear end face "A" ● Clearance between outer baulk ring pawl and synchronizer cone "B" ● Clearance between inner baulk ring and clutch gear end face "C" <div style="text-align: center;">  <p>PCIB0835J</p> </div>	A: 0.6 - 1.3 (0.024 - 0.051) B: 0.85 - 1.35 (0.033 - 0.053) C: 0.7 - 1.25 (0.028 - 0.049)	0.3 (0.012) 0.7 (0.028) 0.3 (0.012)
5th and 6th	0.7 - 1.25 (0.028 - 0.049)	0.5 (0.02)
Reverse	0.75 - 1.2 (0.03 - 0.047)	0.5 (0.02)

A
B
MT
D
E
F
G
H
I
J
K
L
M

SERVICE DATA AND SPECIFICATIONS (SDS)
