

SECTION **RSU**  
REAR SUSPENSION

A  
B  
C  
D

RSU

CONTENTS

<b>PRECAUTIONS</b> .....	<b>2</b>	<b>SUSPENSION ARM</b> .....	<b>11</b>	F
Precautions .....	2	Removal and Installation .....	11	
<b>PREPARATION</b> .....	<b>3</b>	REMOVAL .....	11	G
Special Service Tools (SST) .....	3	INSPECTION AFTER REMOVAL .....	11	
Commercial Service Tools .....	3	INSTALLATION .....	12	H
<b>NOISE, VIBRATION AND HARSHNESS (NVH)</b>		<b>RADIUS ROD</b> .....	<b>13</b>	
<b>TROUBLESHOOTING</b> .....	<b>4</b>	Removal and Installation .....	13	I
NVH Troubleshooting Chart .....	4	REMOVAL .....	13	J
<b>REAR SUSPENSION ASSEMBLY</b> .....	<b>5</b>	INSPECTION AFTER REMOVAL .....	13	
On-Vehicle Inspection and Service .....	5	INSTALLATION .....	13	K
INSPECTION OF SUSPENSION ARM BALL		<b>FRONT LOWER LINK</b> .....	<b>14</b>	L
JOINT END PLAY .....	5	Removal and Installation .....	14	M
SHOCK ABSORBER INSPECTION .....	5	REMOVAL .....	14	
Wheel Alignment Inspection .....	5	INSPECTION AFTER REMOVAL .....	14	
DESCRIPTION .....	5	INSTALLATION .....	14	
PRELIMINARY INSPECTION .....	5	<b>REAR LOWER LINK &amp; COIL SPRING</b> .....	<b>15</b>	
CAMBER INSPECTION .....	5	Removal and Installation .....	15	
TOE-IN .....	6	REMOVAL .....	15	
Components .....	7	INSPECTION AFTER REMOVAL .....	15	
Removal and Installation .....	8	INSTALLATION .....	15	
REMOVAL .....	8	<b>STABILIZER BAR</b> .....	<b>16</b>	
INSTALLATION .....	8	Removal and Installation .....	16	
<b>SHOCK ABSORBER</b> .....	<b>9</b>	REMOVAL .....	16	
Removal and Installation .....	9	INSPECTION AFTER REMOVAL .....	16	
REMOVAL .....	9	INSTALLATION .....	16	
INSPECTION AFTER REMOVAL .....	9	<b>REAR SUSPENSION MEMBER</b> .....	<b>17</b>	
INSTALLATION .....	9	Removal and Installation .....	17	
Disassembly and Assembly .....	9	REMOVAL .....	17	
DISASSEMBLY .....	9	INSPECTION AFTER REMOVAL .....	17	
INSPECTION AFTER DISASSEMBLY .....	10	INSTALLATION .....	17	
ASSEMBLY .....	10	<b>SERVICE DATA</b> .....	<b>18</b>	
		Wheel Alignment (Unladen)* .....	18	
		Ball Joint .....	18	
		Wheelarch Height (Unladen)* .....	18	

# PRECAUTIONS

---

## PRECAUTIONS

PFP:00001

### Precautions

AES0000C

- When installing rubber bushings, final tightening must be carried out under unladen conditions with tires on ground. Oil will shorten the life of rubber bushings. Be sure to wipe off any spilled oil.
- Unladen conditions mean that fuel, engine coolant and lubricant are full. Spare tire, jack, hand tools and mats are in designated positions.
- After servicing suspension parts, be sure to check wheel alignment.
- Caulking nuts are not reusable. Always use new ones when installing. Since new caulking nuts are pre-oiled, tighten as they are.

# PREPARATION

## PREPARATION

PPF:00002

### Special Service Tools (SST)

AES0000D

The actual shapes of Kent-Moore tools may differ from those of special service tools illustrated here.

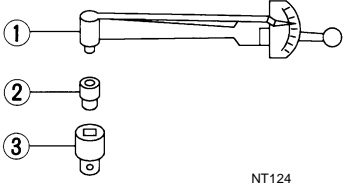
Tool number (Kent-Moore No.) Tool name	Description
ST3127S000 (See J25742-1) Preload Gauge 1. GG91030000 Torque wrench (J25765) 2. HT62940000 ( — ) Socket adapter (1/2") 3. HT62900000 ( — ) Socket adapter (3/8")	 <p style="text-align: right;">NT124</p> Measuring rotating torque of ball joint

A  
B  
C  
D  
**RSU**

### Commercial Service Tools

AES0002I

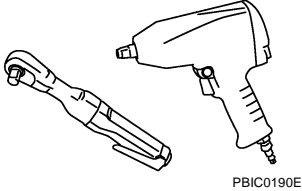
Tool name	Description
Power tool	 <p style="text-align: right;">PBIC0190E</p> <ul style="list-style-type: none"> <li>● Removing wheel nuts</li> <li>● Removing brake caliper assembly</li> <li>● Removing rear suspension component parts</li> </ul>

F  
G  
H  
I  
J  
K  
L  
M

# NOISE, VIBRATION AND HARSHNESS (NVH) TROUBLESHOOTING

## NOISE, VIBRATION AND HARSHNESS (NVH) TROUBLESHOOTING

PFP:00003

### NVH Troubleshooting Chart

AES0000E

Use chart below to help you find the cause of the symptom. If necessary, repair or replace these parts.

Reference page		RSU-7	RSU-10	—	—	—	RSU-7	RSU-5	RSU-16	NVH in PR section.	NVH in RFD section.	NVH in RAX and RSU sections.	NVH in WT section.	NVH in WT section.	NVH in RAX section.	NVH in BR section.	NVH in PS section.		
Possible cause and SUSPECTED PARTS		Improper installation, looseness	Shock absorber deformation, damage or deflection	Bushing or mounting deterioration	Parts interference	Spring fatigue	Suspension looseness	Incorrect wheel alignment	Stabilizer bar fatigue	PROPELLER SHAFT	DIFFERENTIAL	REAR AXLE AND REAR SUSPENSION	TIRES	ROAD WHEEL	DRIVE SHAFT	BRAKES	STEERING		
Symptom	REAR SUSPENSION	Noise	x	x	x	x	x			x	x	x	x	x	x	x	x		
		Shake	x	x	x	x		x		x		x	x	x	x	x	x	x	
		Vibration	x	x	x	x	x				x		x		x			x	x
		Shimmy	x	x	x	x			x				x	x	x		x	x	x
		Judder	x	x	x								x	x	x		x	x	x
		Poor quality ride or handling	x	x	x	x	x		x	x			x	x	x				

x: Applicable

# REAR SUSPENSION ASSEMBLY

## REAR SUSPENSION ASSEMBLY

PFP:55020

### On-Vehicle Inspection and Service

AES0000G

Make sure the mounting conditions (looseness, back lash) of each component and component status (wear, damage) are normal.

#### INSPECTION OF SUSPENSION ARM BALL JOINT END PLAY

- Measure axial end play by installing and moving up/down with an iron pry bar or something similar between suspension arm and axle.

**Standard value**

**Axial end play : 0 mm (0 in)**

**CAUTION:**

**Be careful not to damage ball joint boot.**

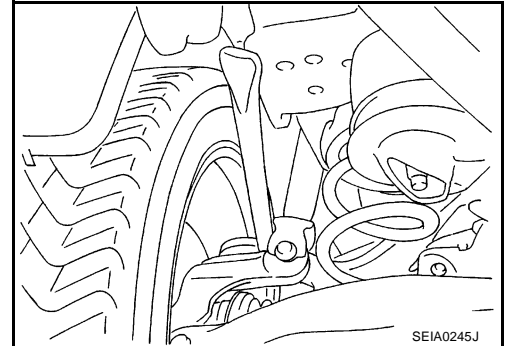

#### SHOCK ABSORBER INSPECTION

Check shock absorber for oil leakage, damage and replace if necessary.

#### Wheel Alignment Inspection DESCRIPTION

AES0000H

- Measure wheel alignment under unladen conditions. "Unladen conditions" means that fuel, engine coolant, and lubricant are full. Spare tire, jack, hand tools and mats in designated positions.

#### PRELIMINARY INSPECTION

1. Check tires for improper air pressure and wear.
2. Check road wheels for runout.
3. Check wheel bearing axial end play.
4. Check ball joint axial end play of suspension arm.
5. Check shock absorber operation.
6. Check each mounting point of axle and suspension for looseness and deformation.
7. Check each link, arm and member for cracks, deformation, and other damage.
8. Check vehicle posture.

#### CAMBER INSPECTION

- Measure camber of both right and left wheels with a suitable alignment gauge and adjust in accordance with the following procedures.

**Standard value**

**Camber : Refer to [RSU-18, "SERVICE DATA"](#)**

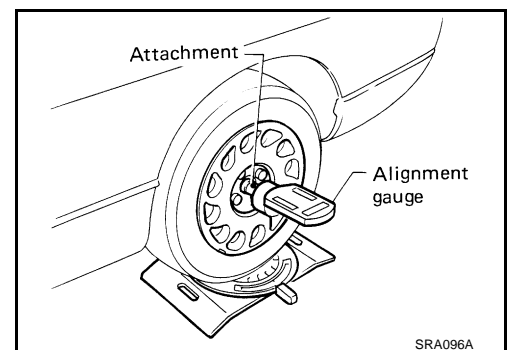

# REAR SUSPENSION ASSEMBLY

If outside the standard value, adjust with adjusting bolt in front lower link.

**NOTE:**

After adjusting camber, be sure to check toe-in.

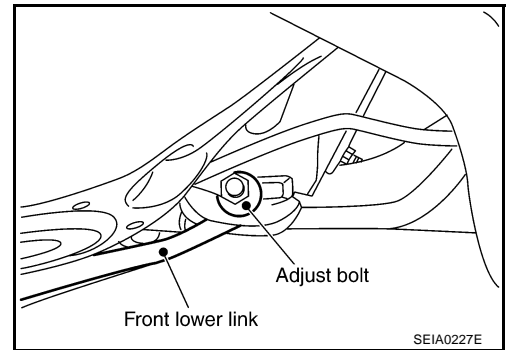

## TOE-IN

Measure toe-in using following procedure. If out of specification, inspect and replace any damaged or worn rear suspension parts.

**WARNING:**

- Always perform following procedure on a flat surface.
- Make sure that no person is in front of vehicle before pushing it.

1. Bounce rear of vehicle up and down to stabilize the posture.
2. Push vehicle straight ahead about 5 m (16 ft).
3. Put a mark on base line of the tread (rear side) of both tires at the same height of hub center. These are measuring point.
4. Measure distance "A" (rear side).

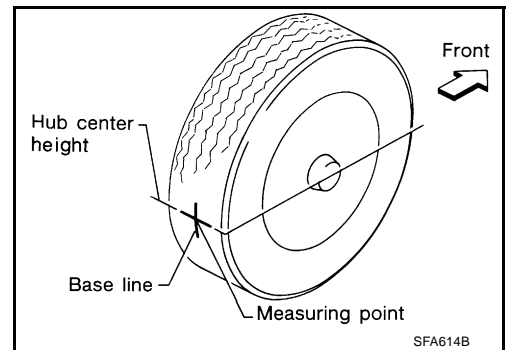

5. Push vehicle slowly ahead to rotate wheels 180 degrees (1/2 turn).  
If wheels have rotated more than 180 degrees (1/2 turn), try the above procedure again from the beginning. Never push vehicle backward.

6. Measure distance "B" (front side).

**Standard value**

**Total toe-in : Refer to [RSU-18, "SERVICE DATA"](#) .**

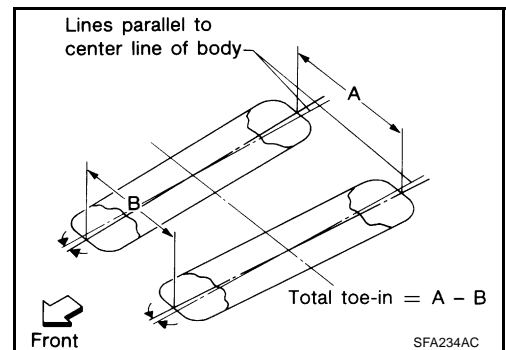

7. If outside the standard value, adjust with adjusting bolt in rear lower link.

**CAUTION:**

Be sure to adjust equally on RH and LH side with adjusting bolt.

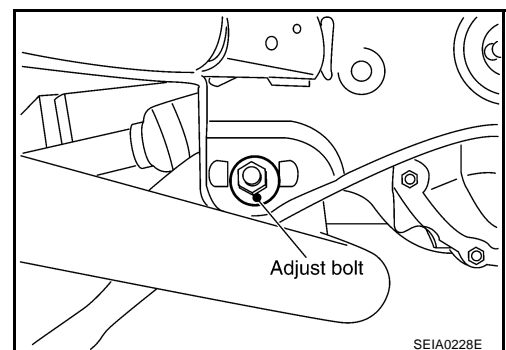

# REAR SUSPENSION ASSEMBLY

## Components

AES0000F

A  
B  
C  
D  
E  
F  
G  
H  
I  
J  
K  
L  
M

RSU

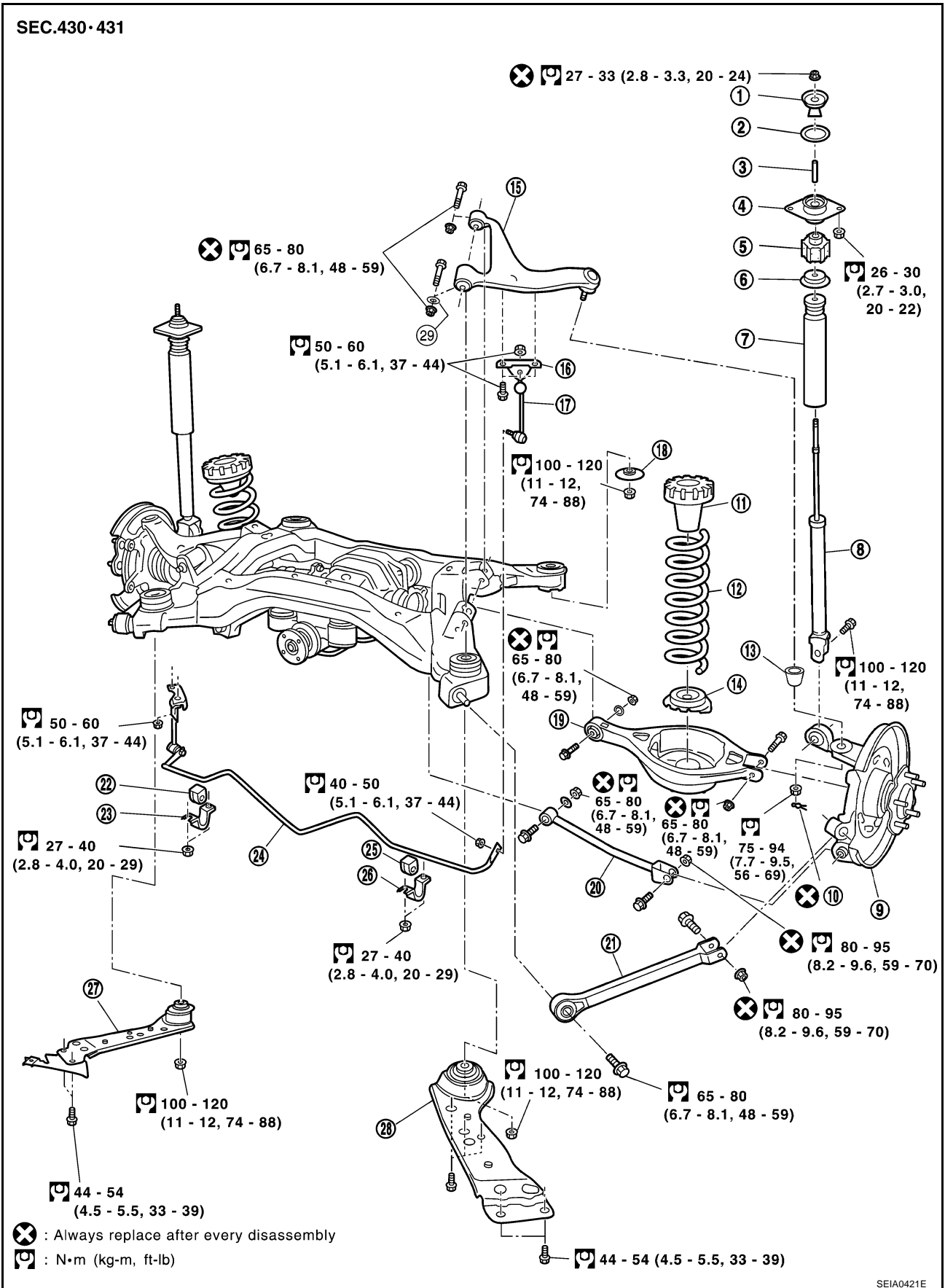

SEIA0421E

# REAR SUSPENSION ASSEMBLY

- |                                      |                                 |                       |
|--------------------------------------|---------------------------------|-----------------------|
| 1. Washer                            | 2. Shock absorber mounting seal | 3. Distance tube      |
| 4. Shock absorber mounting insulator | 5. Bushing                      | 6. Bound bumper cover |
| 7. Bound bumper                      | 8. Shock absorber               | 9. Axle assembly      |
| 10. Cotter pin                       | 11. Upper seat                  | 12. Coil spring       |
| 13. Ball seat                        | 14. Rubber seat                 | 15. Suspension arm    |
| 16. Connecting rod mounting bracket  | 17. Connecting rod              | 18. Mount stopper     |
| 19. Rear lower link                  | 20. Front lower link            | 21. Radius rod        |
| 22. Bushing                          | 23. Clamp                       | 24. Stabilizer bar    |
| 25. Bushing                          | 26. Clamp                       | 27. Member stay       |
| 28. Member stay                      | 29. Stopper rubber              |                       |

## Removal and Installation REMOVAL

AES00001

1. Remove tire with power tool.
2. Remove brake caliper with power tool. Hang it in a place where it will not interfere with work. Refer to [BR-38, "REAR DISC BRAKE"](#).

### NOTE:

Avoid depressing brake pedal while brake caliper is removed.

3. Remove stabilizer bar. Refer to [RSU-16, "STABILIZER BAR"](#).
4. Remove rear exhaust tube. Refer to [EX-3, "EXHAUST SYSTEM"](#).
5. Remove rear propeller shaft. Refer to [PR-4, "REAR PROPELLER SHAFT"](#) (2WD models), [PR-16, "REAR PROPELLER SHAFT"](#) (AWD models).
6. Separate attachment bolts between parking brake cable and vehicle and rear suspension member. Refer to [PB-5, "PARKING BRAKE CONTROL"](#).
7. Remove wheel sensor from rear final drive.
8. Remove rear lower link and coil spring. Refer to [RSU-15, "REAR LOWER LINK & COIL SPRING"](#).
9. Remove fixing bolt in upper side of mounting seal bracket. Refer to [RSU-9, "SHOCK ABSORBER"](#).
10. Set jack under rear final drive.
11. Remove member stay from vehicle.
12. Remove mount stopper mounting nut.
13. Gradually lowering jack, remove rear suspension assembly.

## INSTALLATION

- Refer to [RSU-7, "Components"](#) for tightening torque. Install in the reverse order of removal.

### NOTE:

Refer to component parts location and do not reuse non-reusable parts.

- Perform final tightening of installation position of links (rubber bushing) under unladen condition with tires on level ground. Check wheel alignment. Refer to [RSU-18, "SERVICE DATA"](#).



# SHOCK ABSORBER

## SHOCK ABSORBER

PPF:56210

### Removal and Installation

AES0001Y

#### REMOVAL

1. Remove tire with power tool.
2. Set jack under rear lower link.
3. Remove rear seat cushion, rear seat back and rear parcel shelf finisher.
4. Remove shock absorber mounting insulator fixing nuts of shock absorber upper side with tool and remove shock absorber from vehicle.

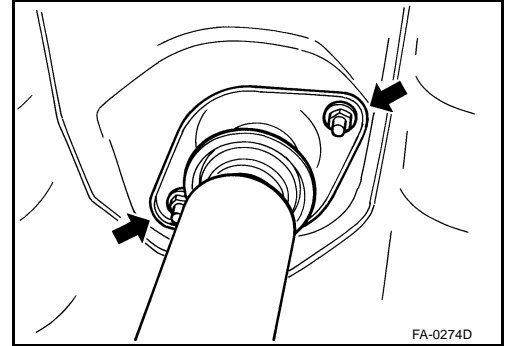

#### INSPECTION AFTER REMOVAL

- Check shock absorber assembly for deformation, cracks, damage, and replace if necessary.
- Check piston rod for damage, uneven wear or distortion, and replace if necessary.
- Check welded and sealed areas for oil leakage, and replace if necessary.

#### INSTALLATION

- Refer to [RSU-7, "Components"](#) for tightening torque. Install in the reverse order of removal.

##### NOTE:

Refer to component parts location and do not reuse non-reusable parts.

- Perform final tightening of shock absorber assembly lower side (rubber bushing) under unladen condition with tires on level ground. Check wheel alignment. Refer to [RSU-5, "Wheel Alignment Inspection"](#).

### Disassembly and Assembly

#### DISASSEMBLY

AES0002N

##### CAUTION:

**Make sure piston rod on shock absorber is not damaged when removing components from shock absorber.**

1. Remove shock absorber mounting seal from shock absorber mounting insulator.
2. Wrap a shop cloth around lower side of shock absorber and fix it in a vise.

##### CAUTION:

**Do not set the cylindrical part of shock absorber in vise.**

3. Secure piston rod tip so that piston rod does not turn, and remove piston rod lock nut.
4. Remove washer, distance tube, bushing, bound bumper cover and bound bumper from shock absorber.

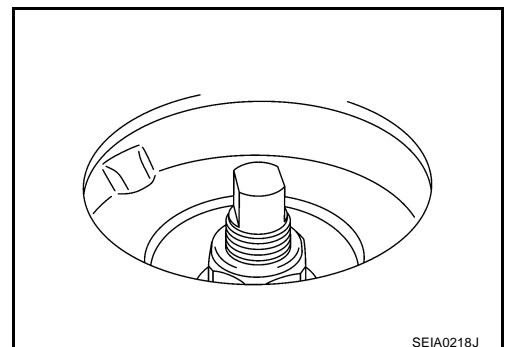

# SHOCK ABSORBER

---

## INSPECTION AFTER DISASSEMBLY

### Bound Bumper and Bushing

- Check bound bumper and bushing for cracks, deformation or other damage. Replace if necessary.

## ASSEMBLY

- Refer to [RSU-7, "Components"](#) for tightening torque. Install in the reverse order of removal.

### NOTE:

Refer to component parts location and do not reuse non-reusable parts.

### CAUTION:

**Make sure piston rod on shock absorber is not damaged when attaching components to shock absorber.**

## SUSPENSION ARM

PFP:55501

### Removal and Installation

#### REMOVAL

1. Remove tire with power tool.
2. Remove drive shaft. Refer to [RAX-10, "REAR DRIVE SHAFT"](#).
3. Remove connecting rod mounting bracket from suspension arm with power tool.
4. Remove fixing nuts and bolts between suspension arm and rear suspension member.
5. Remove cotter pin of suspension arm ball joint, and loosen nut.
6. Use a ball joint remover (suitable tool) to remove suspension arm from axle. Be careful not to damage ball joint boot.

#### CAUTION:

**Tighten temporarily mounting nut to prevent damage to threads and to prevent ball joint remover (suitable tool) from coming off.**

7. Remove suspension arm and stopper rubber from vehicle.

#### INSPECTION AFTER REMOVAL

##### Visual Inspection

- Check suspension arm and bushing for deformation, cracks or damage. If any non-standard condition is found, replace it.
- Check boot of ball joint for cracks or damage, and also for grease leakage.

##### Ball Joint Inspection

- Manually move ball joint at least ten times by hand to check for smooth movement.

##### Swing Torque Inspection

- Hook spring scale at cotter pin mounting hole. Confirm spring scale measurement value is within specifications when ball stud begins moving.

**Standard value**

**Swing torque:**

**0.5 - 3.4 N·m (0.06 - 0.34 kg·m, 5 - 30 in·lb)**

**Measured value of spring scale:**

**8.06 - 54.8 N (0.82 - 5.5 kg, 1.81 - 12.32 lb)**

- If it is outside the specified range, replace suspension arm assembly.

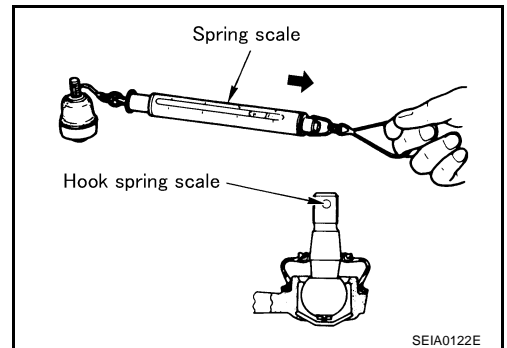

##### Rotating Torque Inspection

- Attach mounting nut to ball stud. Make sure that rotating torque is within the specifications with a preload gauge (SST)

**Standard value**

**Rotating torque:**

**0.5 - 3.4 N·m (0.06 - 0.34 kg·m, 5 - 30 in·lb)**

- If it is outside the specified range, replace suspension arm assembly.

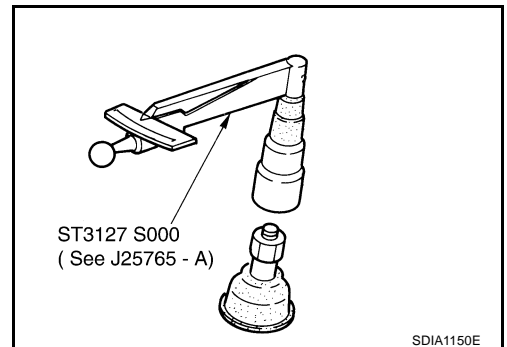

##### Axial End Play Inspection

- Move tip of ball joint in axial direction to check for looseness.

**Standard value**

**Axial end play : 0 mm (0 in)**

- If it is outside the specified range, replace suspension arm assembly.

# SUSPENSION ARM

---

## INSTALLATION

- Refer to [RSU-7, "Components"](#) for tightening torque. Install in the reverse order of removal.

**NOTE:**

Refer to component parts location and do not reuse non-reusable parts.

- Perform final tightening of rear suspension member installation position (rubber bushing) under unladen condition with tires on level ground. Refer to [RSU-5, "Wheel Alignment Inspection"](#) .

# RADIUS ROD

## RADIUS ROD

PPF:55110

### Removal and Installation

AES0001U

#### REMOVAL

1. Remove tire with power tool.
2. Remove brake caliper with power tool. Hang it in a place where it will not interfere with work. Refer to [BR-38, "REAR DISC BRAKE"](#).

#### NOTE:

Avoid depressing brake pedal while brake caliper is removed.

3. Remove fixing bolt and nut in axle side of radius rod with power tool.
4. Remove rear lower link and coil spring. Refer to [RSU-15, "REAR LOWER LINK & COIL SPRING"](#).
5. Remove fixing bolt in lower side of shock absorber with power tool.
6. Remove fixing bolt and nut in axle side of front lower link with power tool.
7. Remove fixing bolt in rear suspension member side of radius rod with power tool, then remove radius rod from vehicle.

#### INSPECTION AFTER REMOVAL

- Check radius rod and bushing for any deformation, cracks, or damage. Replace if necessary.

#### INSTALLATION

- Refer to [RSU-7, "Components"](#) for each tightening torque. Install in the reverse order of removal.

#### NOTE:

Refer to component parts location and do not reuse non-reusable parts.

- Perform final tightening of rear suspension member and axle installation position (rubber bushing) under unladen condition with tires on level ground. Check wheel alignment. Refer to [RSU-5, "Wheel Alignment Inspection"](#).

---

## FRONT LOWER LINK

PFP:55110

### Removal and Installation

AES0001V

#### REMOVAL

1. Remove tire with power tool.
2. Set jack under rear lower link.
3. Remove fixing nut and bolt between front lower link and rear suspension member with power tool.
4. Remove fixing nut and bolt between front lower link and axle with power tool.
5. Remove front lower link from vehicle.

#### INSPECTION AFTER REMOVAL

- Check front lower link and bushing for any deformation, cracks, or damage. Replace if necessary.

#### INSTALLATION

- Refer to [RSU-7, "Components"](#) for tightening torque. Install in the reverse order of removal.

##### NOTE:

Refer to component parts location and do not reuse non-reusable parts.

- Perform final tightening of rear suspension member and axle installation position (rubber bushing) under unladen condition with tires on level ground. Check wheel alignment. Refer to [RSU-5, "Wheel Alignment Inspection"](#) .

# REAR LOWER LINK & COIL SPRING

## REAR LOWER LINK & COIL SPRING

PFP:551B0

### Removal and Installation

AES0001W

#### REMOVAL

1. Remove tire with power tool.
2. Set jack under rear lower link.
3. Loosen fixing bolt and nut of rear lower link in side of suspension member, and then remove fixing bolt and nut in side of axle with power tool.
4. Slowly lower jack, then remove upper seat, coil spring and rubber sheet from rear lower link.
5. Remove fixing bolt and nut in side of suspension member to remove rear lower link with power tool.

#### INSPECTION AFTER REMOVAL

- Check rear lower link, bushing and coil spring for deformation, cracks, and damage. Replace rear lower link and coil spring if necessary.

#### INSTALLATION

- Refer to [RSU-7, "Components"](#) for tightening torque. Install in the reverse order of removal.

##### NOTE:

Refer to component parts location and do not reuse non-reusable parts.

- Check that upper seat is attached as shown in the figure.

##### NOTE:

Insert bracket tabs (3) and the inside protrusion on upper seat into each other beforehand as shown in the figure.

- Match up rubber seat indentions and rear lower link grooves and attach.

##### NOTE:

Make sure spring is not up side down. The top and bottom are indicated by paint color.

- Perform final tightening of rear suspension member and axle installation position (rubber bushing) under unladen condition with tires on level ground. Check wheel alignment. Refer to [RSU-5, "Wheel Alignment Inspection"](#).

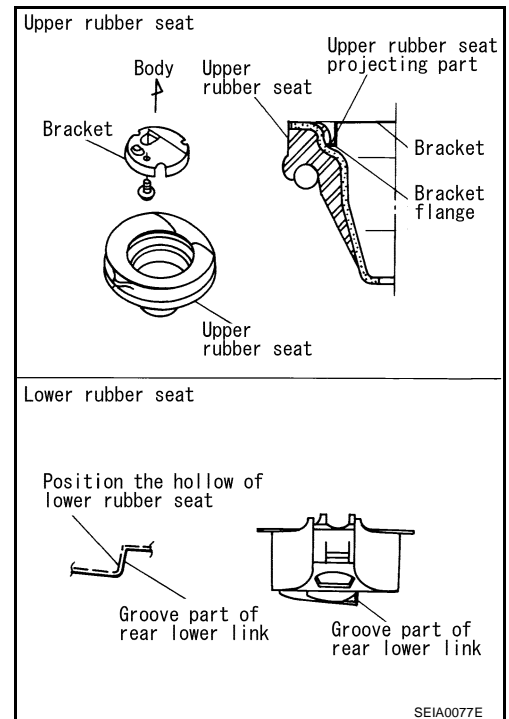

A  
B  
C  
D  
RSU  
F  
G  
H  
I  
J  
K  
L  
M

# STABILIZER BAR

## STABILIZER BAR

PFP:56230

### Removal and Installation

AES0001X

#### REMOVAL

1. Remove dynamic damper of exhaust tube.
2. Remove lower side fixing nut on stabilizer connecting rod and remove stabilizer connecting rod from stabilizer bar with power tool.
3. Remove fixing nut on stabilizer clamp and remove stabilizer from vehicle with power tool.

#### INSPECTION AFTER REMOVAL

- Check stabilizer bar, stabilizer bushings, stabilizer clamp, stabilizer connecting rod, stabilizer connecting rod mounting bracket for any deformation, crack or damage. Replace if necessary.

#### INSTALLATION

- Refer to [RSU-7, "Components"](#) for tightening torque. Install in the reverse order of removal.

##### NOTE:

Refer to component parts location and do not reuse non-reusable parts.

- Stabilizer bar uses pillow ball type connecting rod, position ball joint with case on pillow ball head parallel to stabilizer bar.

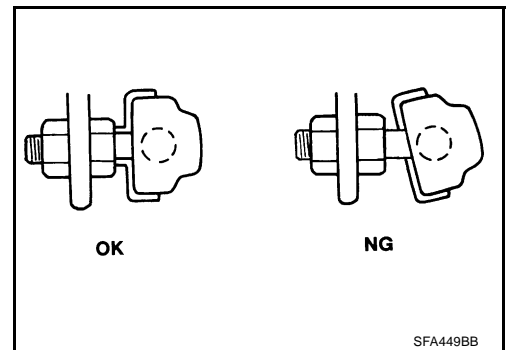



# REAR SUSPENSION MEMBER

## REAR SUSPENSION MEMBER

PFP:55501

### Removal and Installation

AES000TT

#### REMOVAL

1. Remove tire with power tool.
2. Remove brake caliper with power tool. Hang it in a place where it will not interfere with work. Refer to [BR-38, "REAR DISC BRAKE"](#).

#### NOTE:

Avoid depressing brake pedal while brake caliper is removed.

3. Remove rear exhaust tube. Refer to [EX-3, "EXHAUST SYSTEM"](#).
4. Remove stabilizer bar. Refer to [RSU-16, "STABILIZER BAR"](#).
5. Remove drive shaft. Refer to [RAX-10, "REAR DRIVE SHAFT"](#).
6. Remove final drive. Refer to [RFD-15, "REAR FINAL DRIVE ASSEMBLY"](#).
7. Separate the attachment between parking brake cable and vehicle and rear suspension member. Refer to [PB-5, "PARKING BRAKE CONTROL"](#).
8. Remove rear lower link and coil spring. Refer to [RSU-15, "REAR LOWER LINK & COIL SPRING"](#).
9. Remove fixing bolt in lower side of shock absorber.
10. Set jack under rear suspension member.
11. Remove mounting bolts and nuts of member stay from vehicle.
12. Remove mounting nuts of mount stopper.
13. Slowly lowering jack, then remove rear suspension member, suspension arm, radius rod, front lower link and axle from vehicle as a unit.
14. Remove fixing bolts and nuts, then remove suspension arm, front lower link, radius rod from rear suspension member.

#### INSPECTION AFTER REMOVAL

- Check rear suspension member for deformation, cracks, and other damage and replace if necessary.

#### INSTALLATION

- Refer to [RSU-7, "Components"](#) for tightening torque. Install in the reverse order of removal.

#### NOTE:

Refer to component parts location and do not reuse non-reusable parts.

- Perform final tightening of installation position of links (rubber bushing) under unladen condition with tires on level ground. Check wheel alignment. Refer to [RSU-18, "SERVICE DATA"](#).

# SERVICE DATA

## SERVICE DATA

PFP:00030

### Wheel Alignment (Unladen)\*

AES0000P

		A/T	M/T
Camber Degree minute (Decimal degree)	Minimum	- 1°05' (- 1.08°)	- 1°10' (- 1.17°)
	Nominal	- 0°35' (- 0.58°)	- 0°40' (- 0.67°)
	Maximum	- 0°05' (- 0.08°)	- 0°10' (- 0.17°)
	Left and right difference	45' (0.75°)	
Total toe-in	Distance (A - B)	Minimum	0.1 mm (0.004 in)
		Nominal	2.8 mm (0.110 in)
		Maximum	5.5 mm (0.217 in)

### Ball Joint

AES0000Q

Axial end play	0 mm (0 in)
Swing torque	0.5 - 3.4 N·m (0.06 - 0.34 kg·m, 5 - 30 in·lb)
Measurement on spring balance (cotter pinhole position)	8.06 - 54.8 N (0.83 - 5.5 kg, 1.81 - 12.32 lb)
Rotating torque	0.5 - 3.4 N·m (0.06 - 0.34 kg·m, 5 - 30 in·lb)

### Wheelarch Height (Unladen\*)

AES0000R

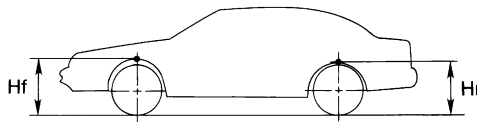

SFA818A

Applied model	A/T		M/T
	205/65R16	215/55R17	
Front (Hf)	711 mm (27.99 in)		710 mm (27.95 in)
Rear (Hr)	703 mm (27.68 in)	704 mm (27.72 in)	703 mm (27.68 in)

\*: Fuel, engine coolant and engine oil full. Spare tire, jack, hand tools and mats in designated positions.