

BRAKE SYSTEM

SECTION **BR**

CONTENTS

PRECAUTIONS AND PREPARATION	3	Disassembly.....	18
Precautions.....	3	Inspection — Caliper.....	18
Commercial Service Tools.....	3	Inspection — Rotor.....	19
CHECK AND ADJUSTMENT	4	Assembly.....	19
Checking Brake Fluid Level.....	4	Installation.....	19
Checking Brake Line.....	4	REAR DISC BRAKE	20
Changing Brake Fluid.....	4	Pad Replacement.....	20
Bleeding Brake System.....	4	Removal.....	21
BRAKE HYDRAULIC LINE	6	Disassembly.....	22
Removal.....	6	Inspection — Caliper.....	22
Inspection.....	6	Inspection — Rotor.....	22
Installation.....	6	Assembly.....	23
CONTROL VALVE	7	Installation.....	23
Proportioning Valve.....	7	REAR DISC BRAKE — Parking Drum Brake	24
BRAKE PEDAL AND BRACKET	8	Removal.....	24
Removal and Installation.....	8	Inspection — Drum.....	25
Inspection.....	8	Inspection — Lining.....	25
Adjustment.....	8	Installation.....	26
MASTER CYLINDER	10	Shoe Clearance Adjustment.....	26
Removal.....	10	Breaking in Drum and Lining.....	27
Disassembly.....	10	PARKING BRAKE CONTROL	28
Inspection.....	11	Removal and Installation.....	28
Assembly.....	11	Inspection.....	29
Installation.....	12	Adjustment.....	29
BRAKE BOOSTER	13	ANTI-LOCK BRAKE SYSTEM	30
On-vehicle Service.....	13	Wiring Diagram.....	31
Removal.....	13	Removal and Installation.....	32
Inspection.....	14	TROUBLE DIAGNOSES	34
Installation.....	14	Contents.....	34
VACUUM HOSE	15	Component Parts and Harness Connector	
Removal and Installation.....	15	Location.....	39
Inspection.....	15	SERVICE DATA AND SPECIFICATIONS (SDS)	57
FRONT DISC BRAKE	16	General Specifications.....	57
Pad Replacement.....	16	Inspection and Adjustment.....	57
Removal.....	18		

GE
MA
EM
LC
EF &
EC
FE
AT
PD
FA
RA
BR
ST
RS
BT
HA
EL
IDX

CONTENTS (Cont'd.)

When you read wiring diagrams:

- **Read GI section, "HOW TO READ WIRING DIAGRAMS".**
- **See EL section, "POWER SUPPLY ROUTING" for power distribution circuit.**

When you perform trouble diagnoses, read GI section, "HOW TO FOLLOW FLOW CHART IN TROUBLE DIAGNOSES".

PRECAUTIONS AND PREPARATION

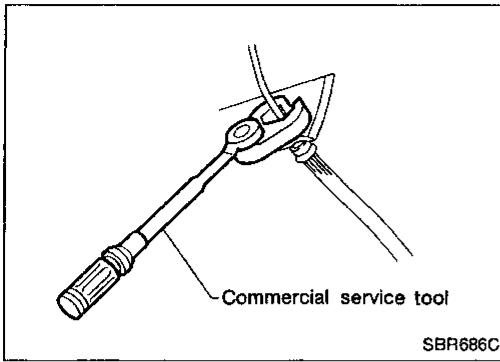

Precautions

- Recommended fluid is brake fluid "DOT 3".
- Never reuse drained brake fluid.
- Be careful not to splash brake fluid on painted areas.
- To clean or wash all parts of master cylinder, disc brake caliper and wheel cylinder, use clean brake fluid.
- Never use mineral oils such as gasoline or kerosene. They will ruin rubber parts of the hydraulic system.
- Use flare nut wrench when removing and installing brake tube.
- Always torque brake lines when installing.

WARNING:

- Clean brake pads and shoes with a waste cloth, then wipe with a dust collector.

Commercial Service Tools

Tool name	Description
① Flare nut crows foot ② Torque wrench	<p>NT360</p> <p>a: 10 mm (0.39 in)</p> <p>Removing and installing each brake piping</p>
Brake fluid pressure gauge	<p>NT151</p> <p>Measuring brake fluid pressure</p>

GI

MA

EM

LC

EF &

EC

FE

AT

PD

FA

RA

BR

ST

RS

BT

HA

EL

IDX

CHECK AND ADJUSTMENT

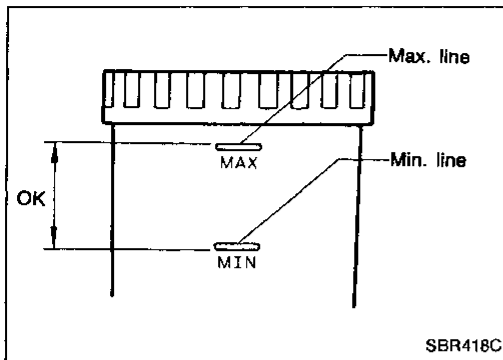

Checking Brake Fluid Level

- Check fluid level in reservoir tank. It should be between Max. and Min. lines on reservoir tank.
- If fluid level is extremely low, check brake system for leaks.
- When brake warning lamp comes on even when parking brake lever is released, check brake system for leaks.

Checking Brake Line

CAUTION:

If leakage occurs around joints, retighten or, if necessary, replace damaged parts.

1. Check brake lines (tubes and hoses) for cracks, deterioration or other damage. Replace any damaged parts.
2. Check for oil leakage by fully depressing brake pedal while engine is running.

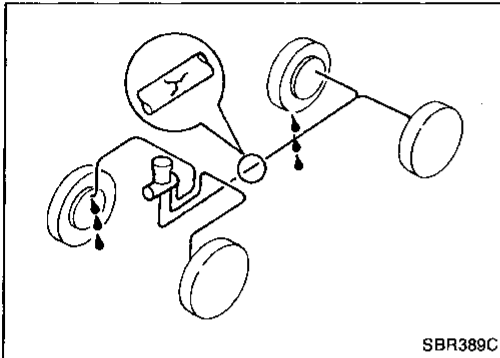

Changing Brake Fluid

CAUTION:

- Refill with new brake fluid "DOT 3".
- Always keep fluid level higher than minimum line on reservoir tank.
- Never reuse drained brake fluid.
- Be careful not to splash brake fluid on painted areas; it may cause paint damage. If brake fluid is splashed on painted areas, wash it away with water immediately.

1. Clean inside of reservoir tank, and refill with new brake fluid.
2. Connect a vinyl tube to each air bleeder valve.
3. Drain brake fluid from each air bleeder valve by depressing brake pedal.
4. Refill until brake fluid comes out of each air bleeder valve. Use same procedure as in bleeding hydraulic system to refill brake fluid. Refer to "Bleeding Brake System" (See below).

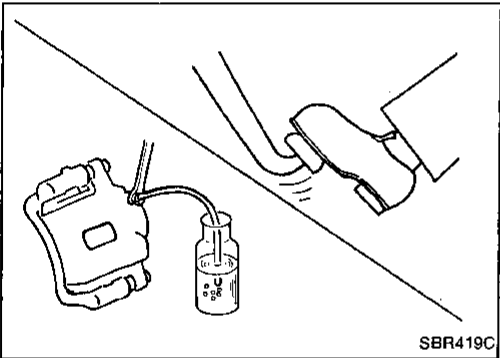

Bleeding Brake System

CAUTION:

- Carefully monitor brake fluid level at master cylinder during bleeding operation.
- Fill reservoir with new brake fluid "DOT 3". Make sure it is full at all times while bleeding air out of system.
- Place a container under master cylinder to avoid spillage of brake fluid.
- Bleed air in the following order.
 1. Right rear caliper
 2. Left rear caliper
 3. Right front caliper
 4. Left front caliper

MODELS WITHOUT ABS

1. Connect a transparent vinyl tube to air bleeder valve.
2. Fully depress brake pedal several times.
3. With brake pedal depressed, open air bleeder valve to release air.
4. Close air bleeder valve.
5. Release brake pedal slowly.
6. Repeat steps 2. through 5. until clear brake fluid comes out of air bleeder valve.

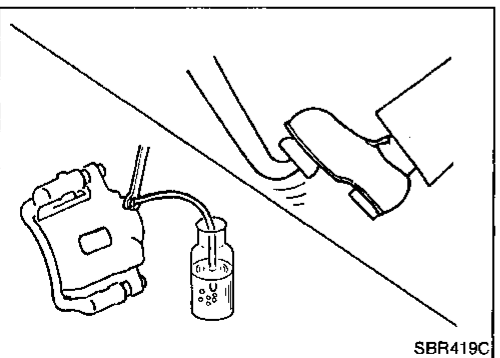
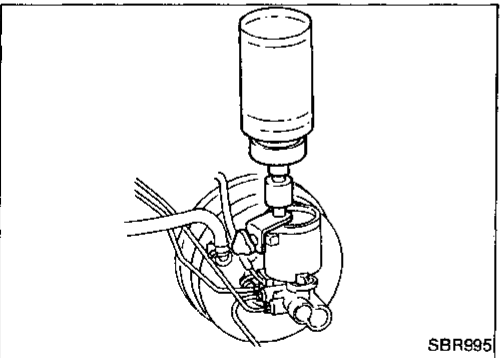

CHECK AND ADJUSTMENT

Bleeding Brake System (Cont'd)

MODELS WITH ABS

1. Turn ignition switch OFF and disconnect battery cable and ABS actuator connector.
2. Fill master cylinder reservoir tank with brake fluid. Refill brake fluid so that fluid level is always higher than middle of reservoir tank. Bleed air using the same method for models without ABS.

CAUTION:

- No air bleeder is provided on actuator.
- Do not loosen actuator connection during air bleeding.

GI

MA

EM

LC

EF &
EC

FE

AT

PD

FA

RA

BR

ST

RS

BT

HA

EL

IDX

BRAKE HYDRAULIC LINE

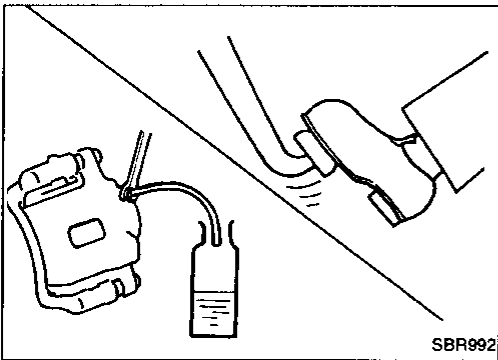
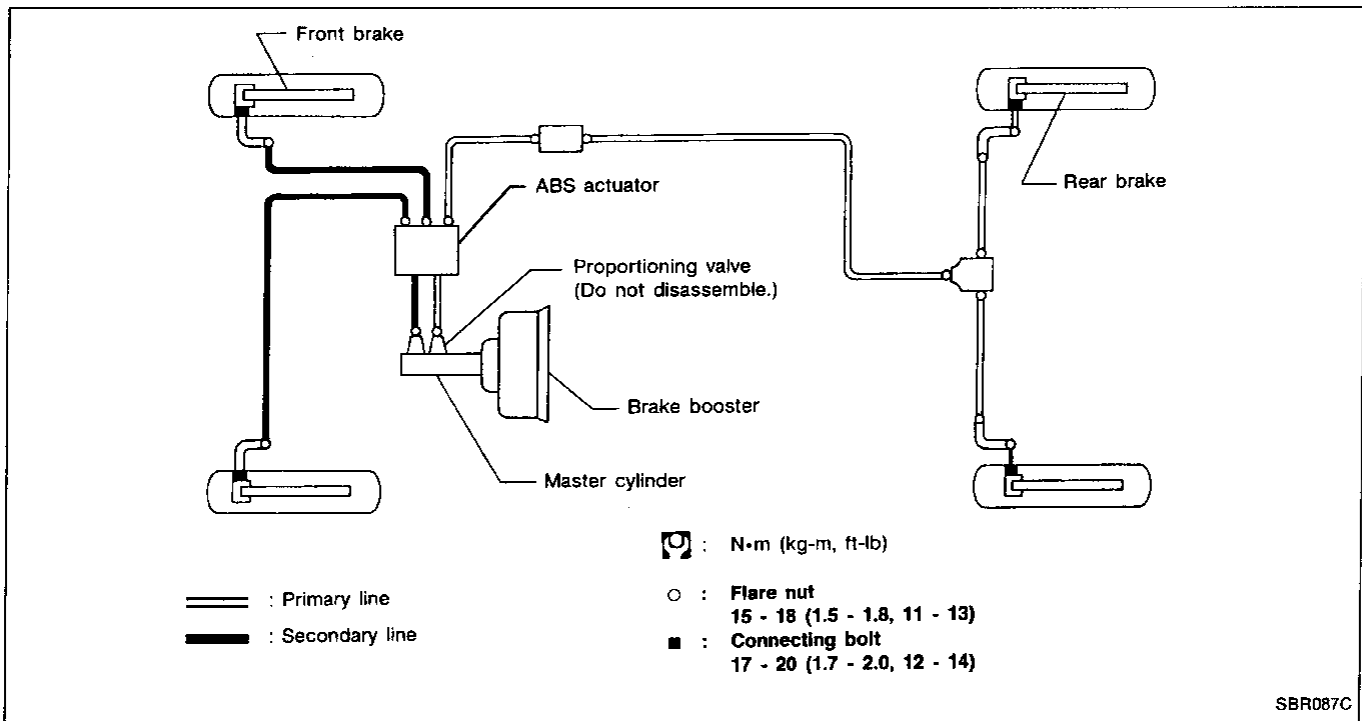

Removal

CAUTION:

- Be careful not to splash brake fluid on painted areas; it may cause paint damage. If brake fluid is splashed on painted areas, wash it away with water immediately.

- All hoses must be free from excessive bending, twisting and pulling.

1. Connect a vinyl tube to air bleeder valve.
2. Drain brake fluid from each air bleeder valve by depressing brake pedal.
3. Remove flare nut securing brake tube to hose, then withdraw lock spring.
4. Cover openings to prevent entrance of dirt whenever disconnecting hydraulic line.

Inspection

Check brake lines (tubes and hoses) for cracks, deterioration or other damage. Replace any damaged parts.

Installation

CAUTION:

- Refill with new brake fluid "DOT 3".
- Never reuse drained brake fluid.

1. Tighten all flare nuts and connecting bolts.

Flare nut:

□: 15 - 18 N·m (1.5 - 1.8 kg·m, 11 - 13 ft·lb)

Connecting bolt:

□: 17 - 20 N·m (1.7 - 2.0 kg·m, 12 - 14 ft·lb)

2. Refill until new brake fluid comes out of each air bleeder valve.
3. Bleed air. Refer to "Bleeding Brake System" (BR-4).

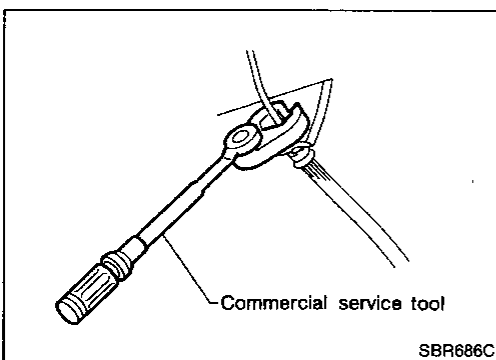

CONTROL VALVE

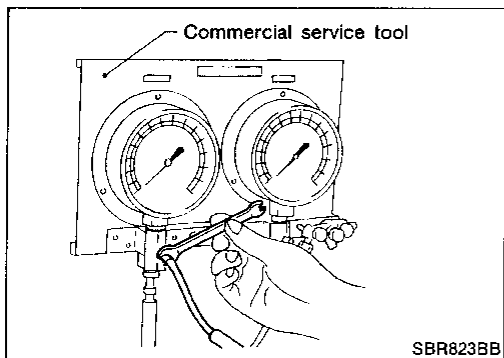
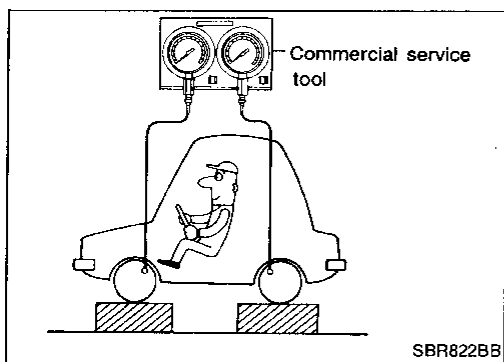

Proportioning Valve

INSPECTION

CAUTION:

- Carefully monitor brake fluid level at master cylinder.
- Use new brake fluid "DOT 3".
- Be careful not to splash brake fluid on painted areas; it may cause paint damage. If brake fluid is splashed on paint areas, wash it away with water immediately.
- Depress pedal slowly when raising front brake pressure.
- Check rear brake pressure 2 seconds after front brake pressure reaches specified value.

- Disconnect harness connectors from ABS actuator relay before checking.

1. Connect Tool to air bleeders of front and rear brakes on either LH and RH side.
2. Bleed air from the Tool.
3. Check rear brake pressure by depressing brake pedal (increasing front brake pressure).

Unit: kPa (kg/cm², psi)

Applied pressure (Front brake)	D ₁	5,394 (55, 782)
Output pressure (Rear brake)	D ₂	3,138 - 3,531 (32 - 36, 455 - 512)

If output pressure is out of specifications, replace master cylinder assembly (built-in type).

4. Bleed air after disconnecting the Tool. Refer to "Bleeding Brake System" (BR-4).

REMOVAL AND INSTALLATION (Built-in type)

Always replace together with master cylinder as an assembly.

- Refer to "MASTER CYLINDER" (BR-10).

BRAKE PEDAL AND BRACKET

Removal and Installation

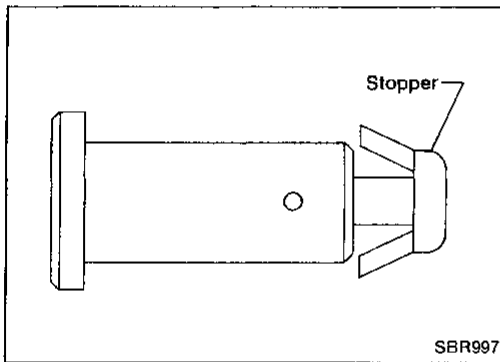
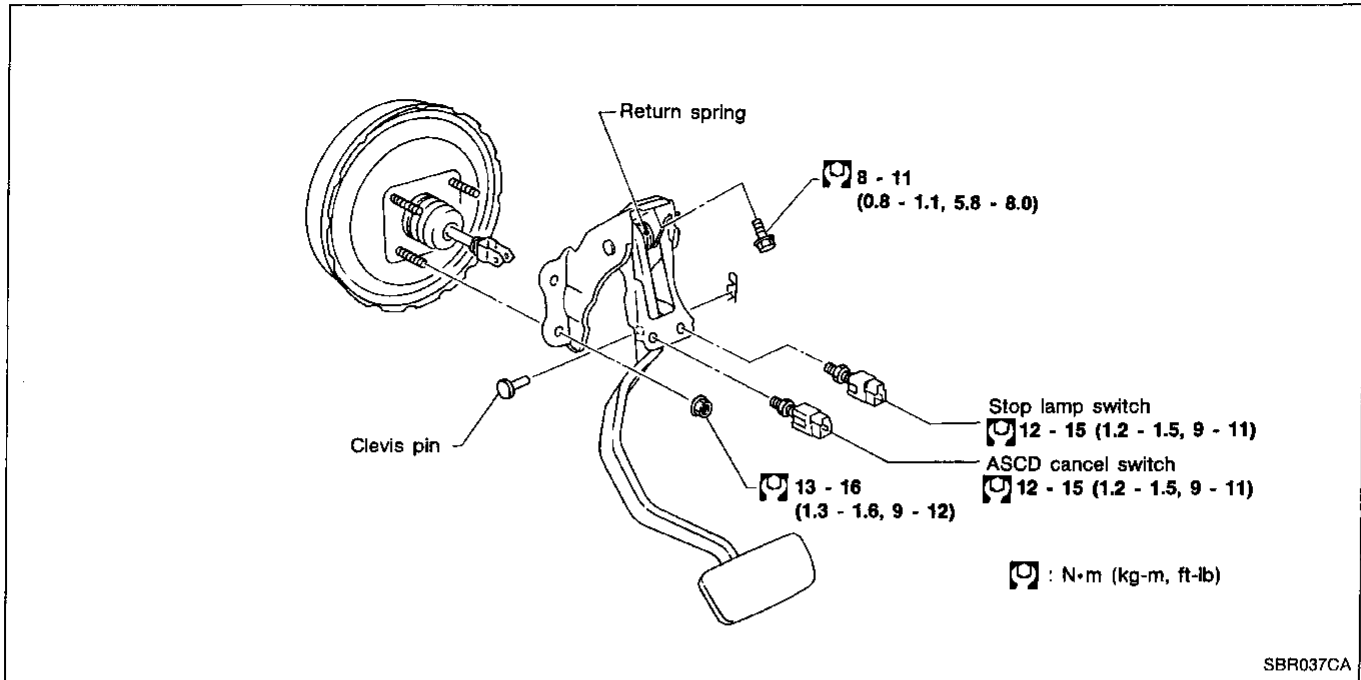

Inspection

Check brake pedal for following items:

- Brake pedal bend
- Clevis pin deformation
- Crack of any welded portion
- Crack or deformation of clevis pin stopper

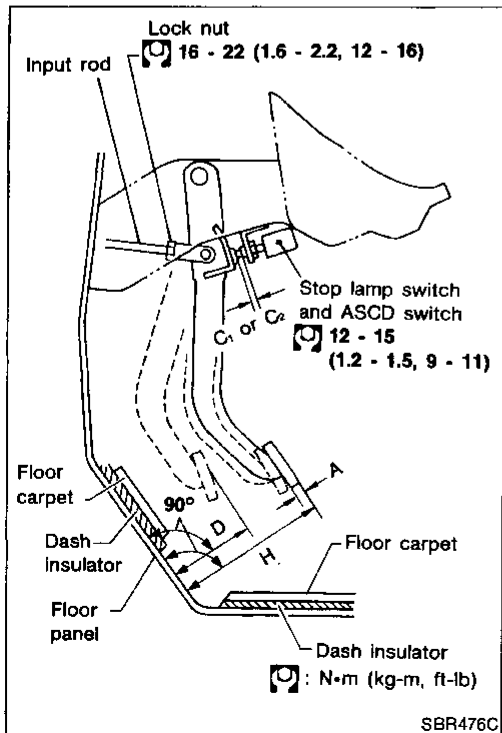

Adjustment

Check brake pedal free height from dash reinforcement panel.

- H:** Free height
Refer to SDS.
- D:** Depressed height
Refer to SDS.
Under force of 490 N (50 kg, 110 lb)
with engine running
- C_1, C_2 :** Clearance between pedal stopper and threaded end of stop lamp switch and ASCD switch
0.3 - 1.0 mm (0.012 - 0.039 in)
- A:** Pedal free play
1.0 - 3.0 mm (0.039 - 0.118 in)

BRAKE PEDAL AND BRACKET

Adjustment (Cont'd)

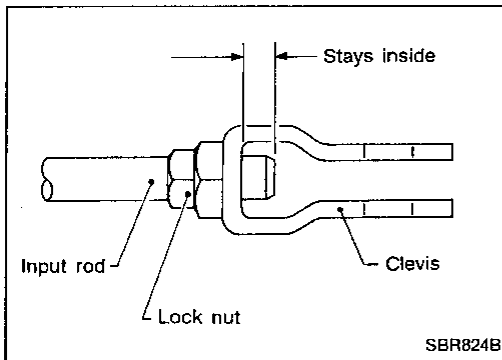

If necessary, adjust brake pedal free height.

1. Loosen lock nut and adjust pedal free height by turning brake booster input rod. Then tighten lock nut.

Make sure that tip of input rod stays inside of clevis.

2. Loosen lock nut and adjust clearance "C₁" and "C₂" with stop lamp switch and ASCD switch respectively. Then tighten lock nuts.

3. Check pedal free play.

Make sure that stop lamps go off when pedal is released.

4. Check brake pedal's depressed height while engine is running.

If depressed height is below specifications, check brake system. If leaks, accumulation of air or any damage to components (master cylinder, etc.) are found, make necessary repairs.

GI

MA

EM

LC

EF &
EC

FE

AT

PD

FA

RA

BR

ST

RS

BT

HA

EL

IDX

MASTER CYLINDER

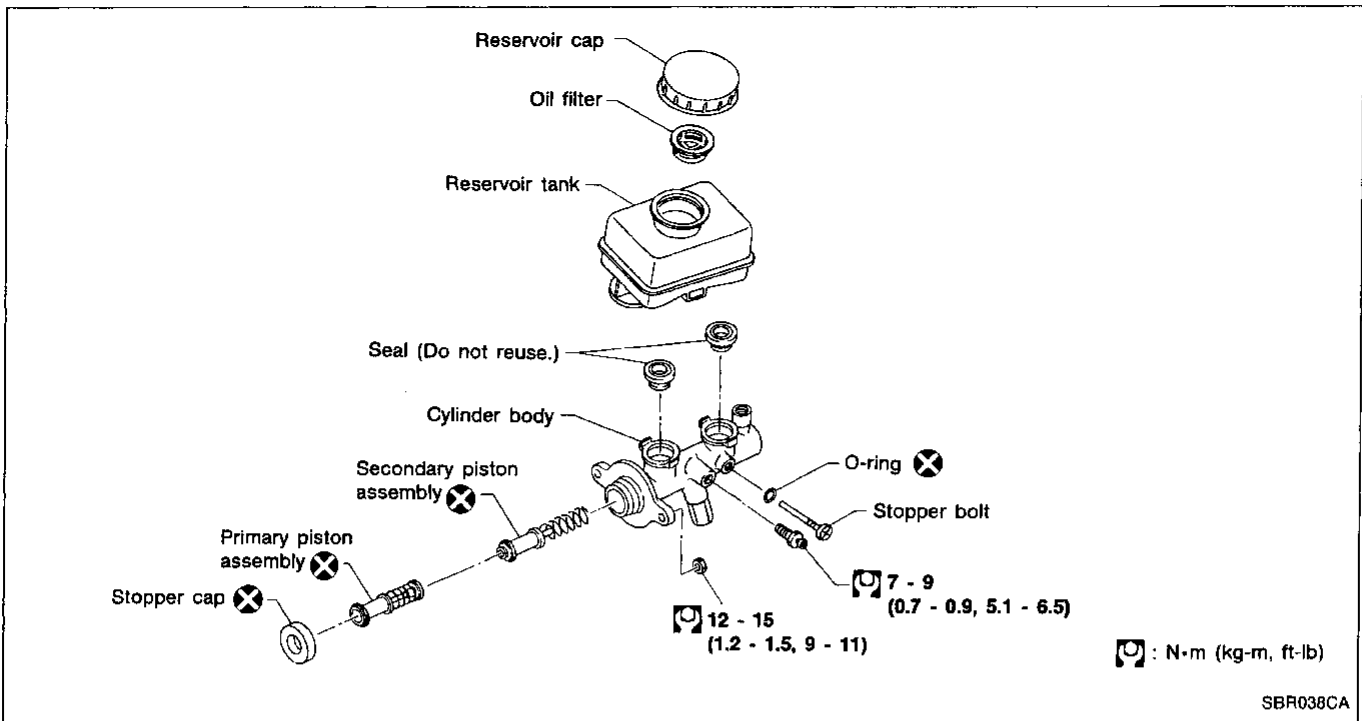

Removal

CAUTION:

Be careful not to splash brake fluid on painted areas; it may cause paint damage. If brake fluid is splashed on painted areas, wash it away with water immediately.

1. Connect a vinyl tube to air bleeder valve.
2. Drain brake fluid from each air bleeder valve, depressing brake pedal to empty fluid from master cylinder.
3. Remove brake pipe flare nuts.
4. Remove master cylinder mounting nuts.

Disassembly

1. Bend claws of stopper cap outward.

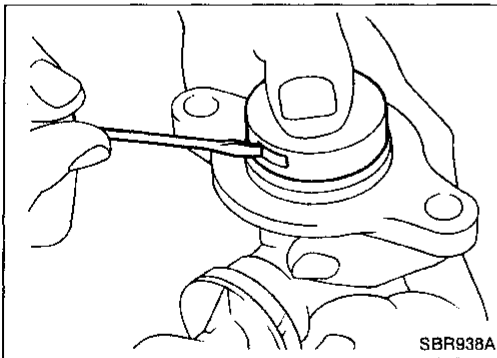

2. Remove valve stopper while piston is pushed into cylinder.

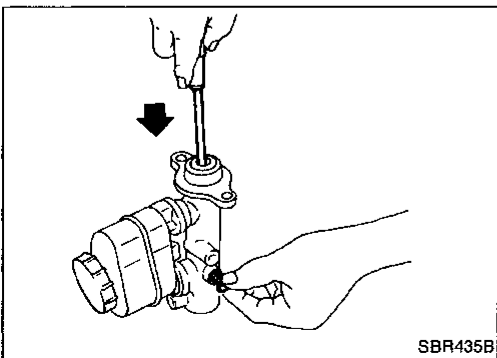

MASTER CYLINDER

Disassembly (Cont'd)

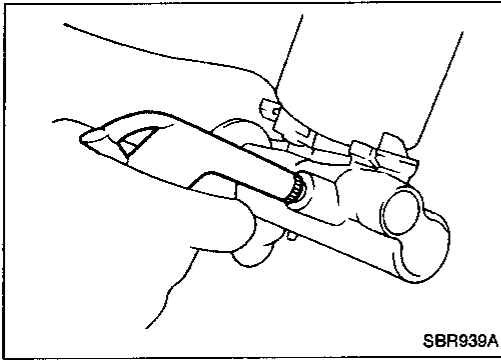

3. Remove piston assemblies.

If it is difficult to remove secondary piston assembly, gradually apply compressed air through fluid outlet.

4. Draw out reservoir tank.

Inspection

Check for the following items.

Replace any part if damaged.

Master cylinder:

- Pin holes or scratches on inner wall.

Piston:

- Deformation of or scratches on piston cups.

Assembly

1. Insert secondary piston assembly. Then insert primary piston assembly.

- Pay attention to direction of piston cups in figure at left. Also, insert pistons squarely to avoid scratches on cylinder bore.

- Pay attention to alignment of secondary piston slit with valve stopper mounting hole of cylinder body.

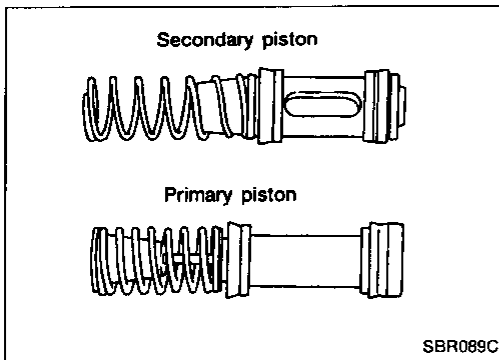

2. Install stopper cap.

Before installing stopper cap, ensure that claws are bent inward.

3. Push reservoir tank seals.

4. Push reservoir tank into master cylinder.

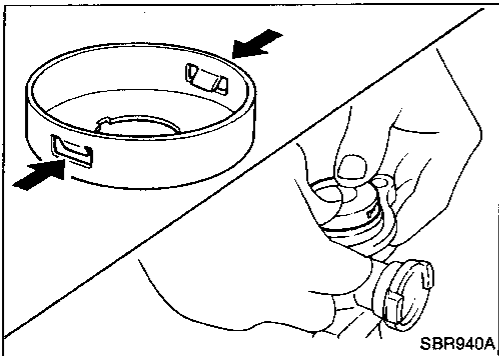

5. Install valve stopper while piston is pushed into cylinder.

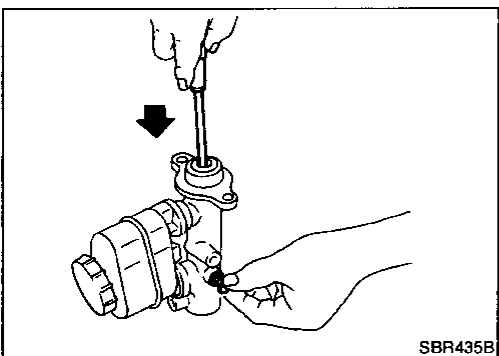

MASTER CYLINDER

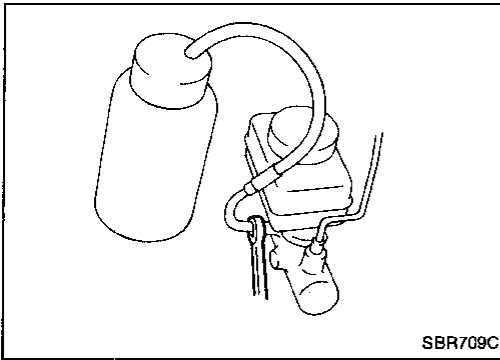

Installation

CAUTION:

- Refill with new brake fluid "DOT 3".
 - Never reuse drained brake fluid.
1. Place master cylinder onto brake booster and secure mounting nuts lightly.
 2. Torque mounting nuts.
12 - 15 N·m (1.2 - 1.5 kg-m, 9 - 11 ft-lb)
 3. Fit brake lines to master cylinder.
 4. Torque flare nuts.
15 - 18 N·m (1.5 - 1.8 kg-m, 11 - 13 ft-lb)
 5. Fill up reservoir tank with new brake fluid.
 6. Connect a vinyl tube to air bleeder of master cylinder.
 7. Open air bleeder of master cylinder
 8. Have driver slowly depress brake pedal and hold.
 9. Close air bleeder.
 10. Have driver release brake pedal slowly.
 11. Repeat steps 7. through 10. until no air bubbles come out of air bleeder.
 12. Torque air bleeder.
7 - 9 N·m (0.7 - 0.9 kg-m, 5.1 - 6.5 ft-lb)
 13. Bleed air from each caliper. Refer to "Bleeding Brake System" (BR-4).

BRAKE BOOSTER

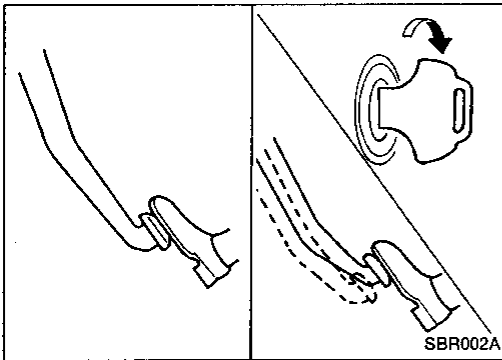

On-vehicle Service

OPERATING CHECK

- Depress brake pedal several times with engine off, and check that there is no change in pedal stroke.
- Depress brake pedal, then start engine. If pedal goes down slightly, operation is normal.

GI

MA

EM

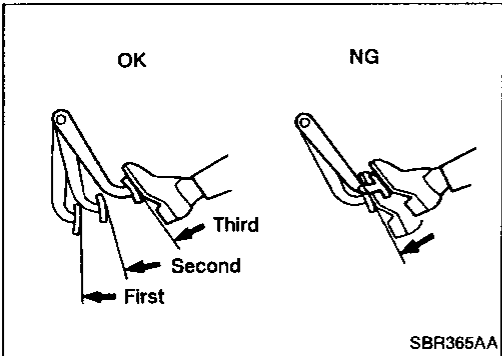

AIRTIGHT CHECK

- Start engine, and stop it after one or two minutes. Depress brake pedal several times slowly. If pedal goes further down the first time and gradually rises after second or third time, booster is airtight.
- Depress brake pedal while engine is running, and stop engine with pedal depressed. If there is no change in pedal stroke after holding pedal down **30 seconds**, brake booster is airtight.

LC

EF &
EC

FE

AT

Removal

PD

FA

RA

BR

ST

RS

BT

HA

EL

IDX

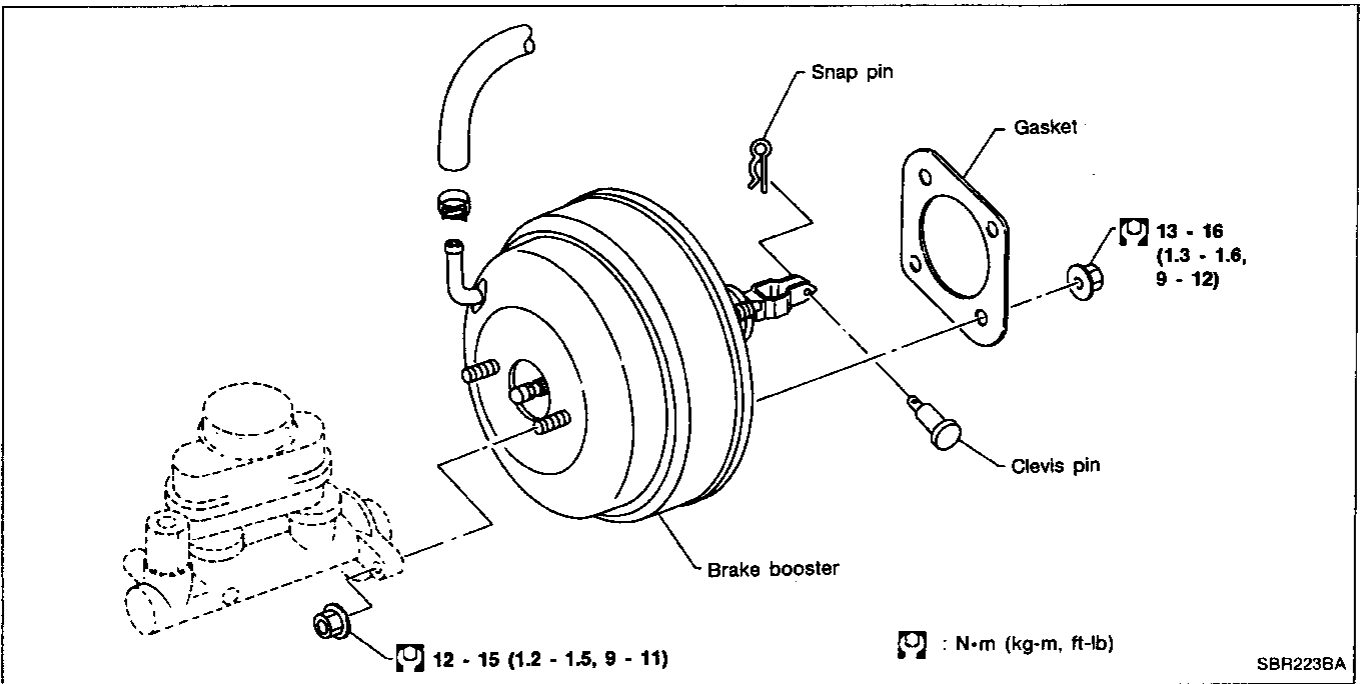

CAUTION:

- Be careful not to splash brake fluid on painted areas; it may cause paint damage. If brake fluid is splashed on painted areas, wash it away with water immediately.
- Be careful not to deform or bend brake pipes, during removal of booster.

BRAKE BOOSTER

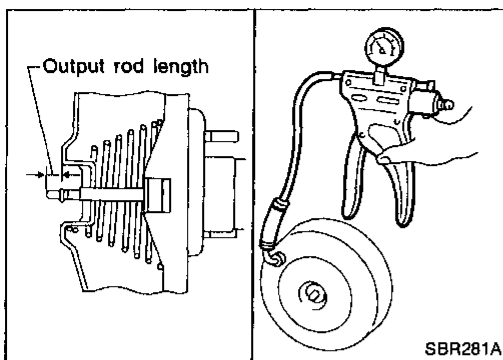

Inspection

OUTPUT ROD LENGTH CHECK

1. Apply vacuum of -66.7 kPa (-500 mmHg, -19.69 inHg) to brake booster with a handy vacuum pump.
2. Check output rod length.

Specified length:

10.275 - 10.525 mm (0.4045 - 0.4144 in)

Installation

CAUTION:

- Be careful not to deform or bend brake pipes, during installation of booster.
 - Replace clevis pin if damaged.
 - Refill with new brake fluid "DOT 3".
 - Never reuse drained brake fluid.
 - Take care not to damage brake booster mounting bolt thread when installing. Due to the acute angle of installation, the threads can be damaged on the metal surrounding the dash panel holes.
1. Fit booster, then secure mounting nuts (brake pedal bracket to brake booster) lightly.
 2. Connect brake pedal and booster input rod with clevis pin.
 3. Secure mounting nuts.
⚙️: 13 - 16 N·m (1.3 - 1.6 kg-m, 9 - 12 ft-lb)
 4. Install master cylinder. Refer to "Installation" in "MASTER CYLINDER" (BR-12).
 5. Bleed air. Refer to "Bleeding Brake System" (BR-4).
 6. Adjust brake pedal if necessary. Refer to "Adjustment" in "BRAKE PEDAL AND BRACKET" (BR-8).

VACUUM HOSE

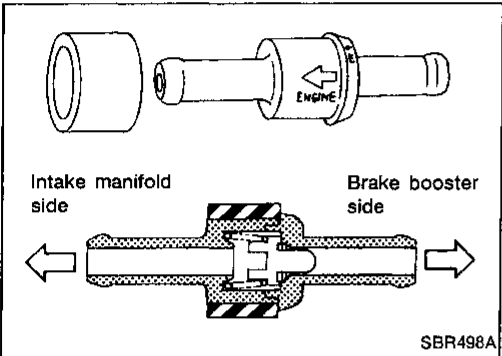
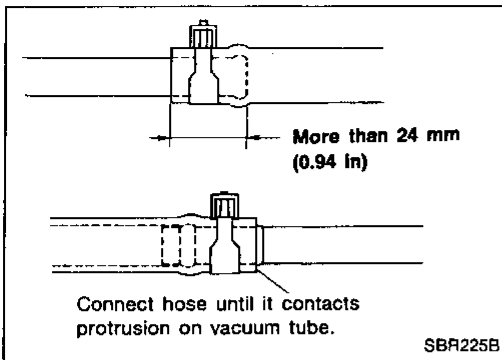

Removal and Installation

CAUTION:

When installing vacuum hoses, pay attention to the following points.

- Do not apply any oil or lubricants to vacuum hose and check valve.
- Insert vacuum tube into vacuum hose as shown.

- Install check valve, paying attention to its direction.

Inspection

HOSES AND CONNECTORS

Check vacuum lines, connections and check valve for airtightness, improper attachment, chafing and deterioration.

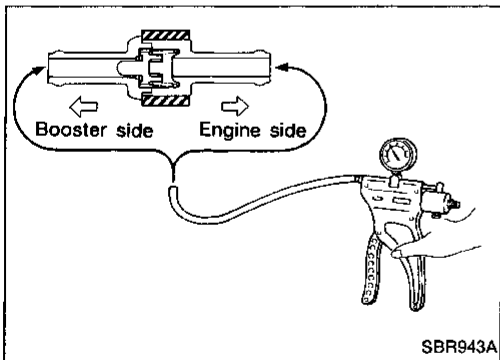

CHECK VALVE

Check vacuum with a vacuum pump.

Connect to booster side	Vacuum should exist.
Connect to engine side	Vacuum should not exist.

GI
MA
EM
LC
EF & EC
FE
AT
PD
FA
RA
BR
ST
RS
BT
HA
EL
IDX

Pad Replacement

WARNING:

Clean brakes with a vacuum dust collector to minimize the hazard of airborne particles.

CAUTION:

- When cylinder body is open, do not depress brake pedal, or piston will pop out.
- Be careful not to damage piston boot or get oil on rotor. Always replace shims when replacing pads.
- If shims are rusted or show peeling of the rubber coat, replace them with new shims.
- It is not necessary to remove connecting bolt except for disassembly or replacement of caliper assembly. In this case, suspend cylinder body with wire so as not to stretch brake hose.
- Carefully monitor brake fluid level because brake fluid will return to reservoir when pushing back piston.

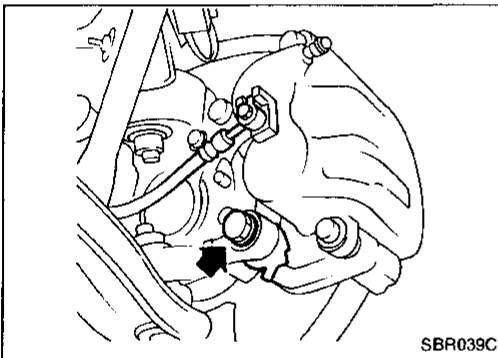

1. Remove master cylinder reservoir cap.
2. Remove lower pin bolt.

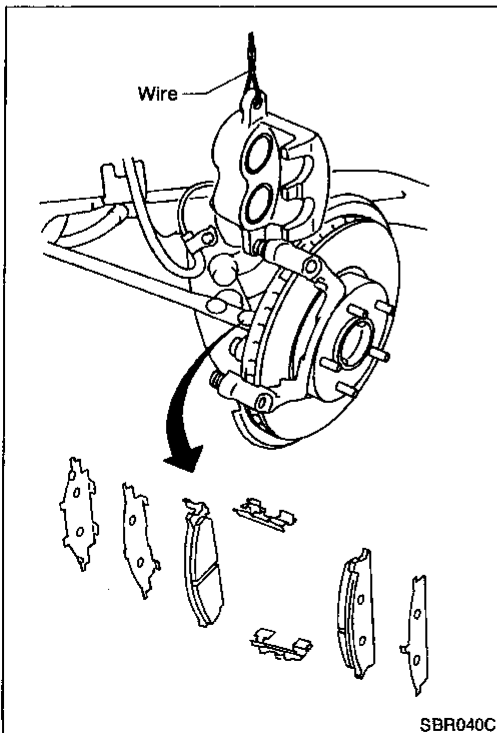

3. Open cylinder body upward. Then remove pad retainers, and inner and outer shims.
Standard pad thickness:
9.5 mm (0.374 in)
Pad wear limit:
2.0 mm (0.079 in)
- Carefully monitor brake fluid level because brake fluid will return to reservoir when pushing back piston.

FRONT DISC BRAKE

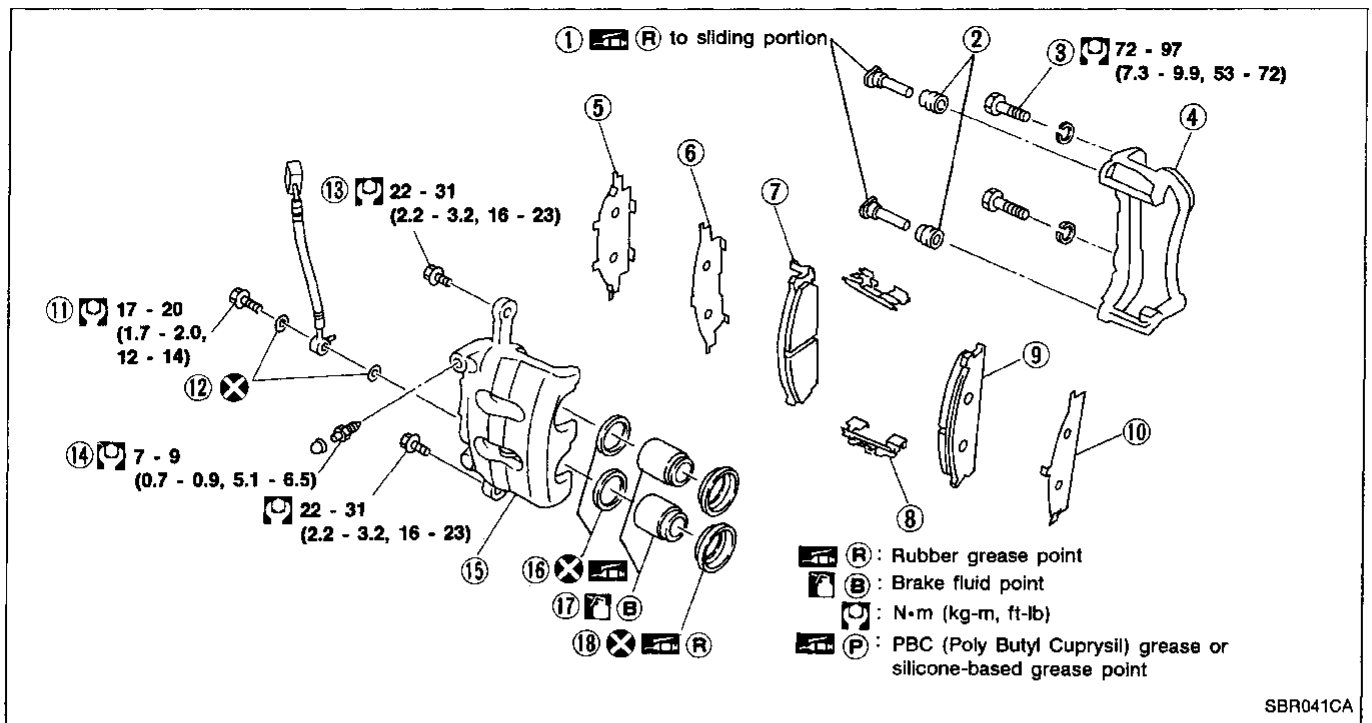

- | | | |
|-----------------------------|-------------------|-----------------|
| ① Main pin | ⑦ Inner pad | ⑬ Main pin bolt |
| ② Pin boot | ⑧ Pad retainer | ⑭ Bleed valve |
| ③ Torque member fixing bolt | ⑨ Outer pad | ⑮ Cylinder body |
| ④ Torque member | ⑩ Outer shim | ⑯ Piston seal |
| ⑤ Shim cover | ⑪ Connecting bolt | ⑰ Piston |
| ⑥ Inner shim | ⑫ Copper washer | ⑱ Piston boot |

GI
MA
EM
LC
EF &
EC
FE
AT
PD
FA
RA
BR
ST
RS
BT
HA
EL
IDX

FRONT DISC BRAKE

Removal

WARNING:

Clean brakes with a vacuum dust collector to minimize the hazard of airborne particles.

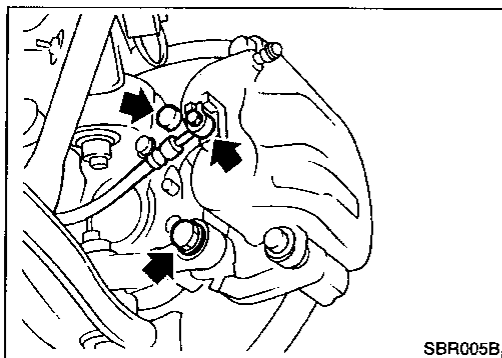

Remove torque member fixing bolts and connecting bolt.

It is not necessary to remove connecting bolt except for disassembly or replacement of caliper assembly. In this case, suspend caliper assembly with wire so as not to stretch brake hose.

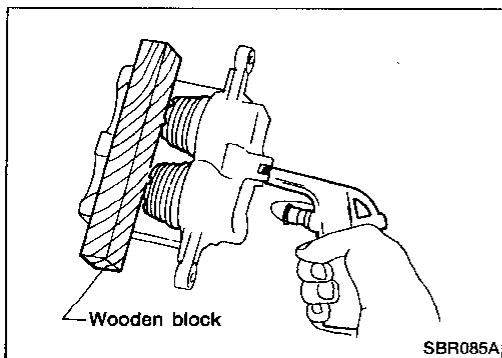

Disassembly

WARNING:

Do not place your fingers in front of piston.

CAUTION:

Do not scratch or score cylinder wall.

1. Push out piston with dust seal with compressed air.
2. Remove piston seal with a suitable tool.

Inspection — Caliper

CYLINDER BODY

- Check inside surface of cylinder for score, rust, wear, damage or presence of foreign objects. If any of the above conditions are observed, replace cylinder body.
- Minor damage from rust or foreign objects may be eliminated by polishing surface with a fine emery paper. Replace cylinder body if necessary.

CAUTION:

Use brake fluid to clean. Never use mineral oil.

PISTON

CAUTION:

Piston sliding surface is plated. Do not polish with emery paper even if rust or foreign objects are stuck to sliding surface.

Check piston for score, rust, wear, damage or presence of foreign objects. Replace if any of the above conditions are observed.

SLIDE PIN, PIN BOLT AND PIN BOOT

Check for wear, cracks, rust or other damage. Replace if any of the above conditions are observed.

FRONT DISC BRAKE

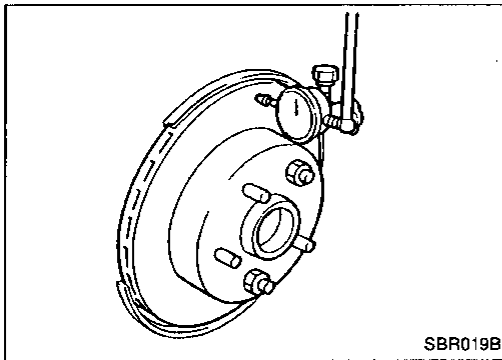

Inspection — Rotor

RUNOUT

1. Secure rotor to wheel hub with at least two nuts (M12 × 1.25).
2. Check runout using a dial indicator.

Make sure that wheel bearing axial end play is within the specifications before measuring. Refer to "Front Wheel Bearing" in FA section.

Maximum runout:

0.07 mm (0.0028 in)

3. If the runout is out of specification, find minimum runout position as follows:
 - a. Remove nuts and rotor from wheel hub.
 - b. Shift the rotor one hole and secure rotor to wheel hub with nuts.
 - c. Measure runout.
 - d. Repeat steps a. to c. so that minimum runout position can be found.
4. If the runout is still out of specification, turn rotor with on-car brake lathe ("MAD, DL-8700", "AMMCO 700 and 705" or equivalent).

GI

MA

EM

LC

EF &
EC

FE

AT

PD

FA

RA

BR

ST

RS

BT

HA

EL

IDX

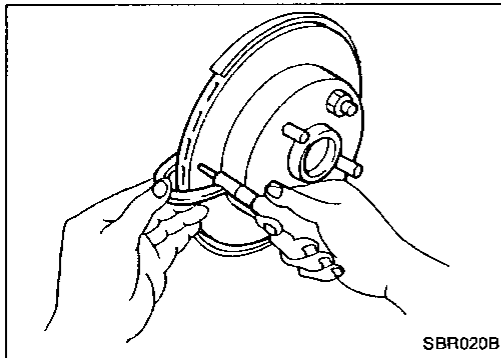

THICKNESS

Thickness variation (At least 8 positions):

Maximum 0.01 mm (0.0004 in)

If thickness variation exceeds the specification, turn rotor with on-car brake lathe.

Rotor repair limit:

26.0 mm (1.024 in)

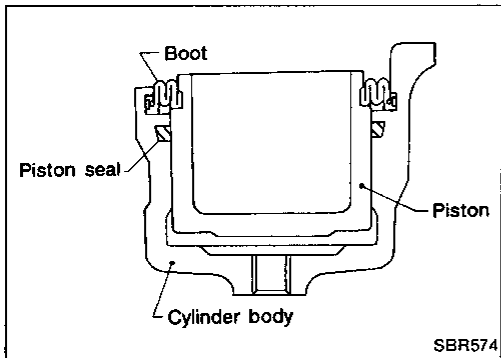

Assembly

1. Insert piston seal into groove on cylinder body.
2. With piston boot fitted to piston, insert piston boot into groove on cylinder body and install piston.
3. Properly secure piston boot

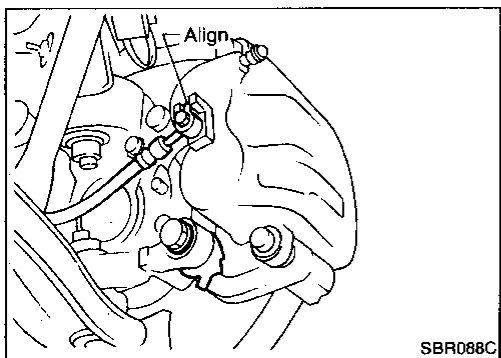

Installation

CAUTION:

- Refill with new brake fluid "DOT 3".
- Never reuse drained brake fluid.

1. Install caliper assembly.
2. Install brake hose to caliper securely.
3. Install all parts and secure all bolts.
4. Bleed air. Refer to "Bleeding Brake System" (BR-4).

REAR DISC BRAKE

Pad Replacement

WARNING:

Clean brakes with a vacuum dust collector to minimize the hazard of airborne particles.

CAUTION:

- When cylinder body is open, do not depress brake pedal, or piston will pop out.
- Be careful not to damage piston boot or get oil on rotor. Always replace shims when replacing pads.
- If shims are rusted or show peeling of rubber coat, replace them with new shims.
- It is not necessary to remove connecting bolt except for disassembly or replacement of caliper assembly. In this case, suspend cylinder body with wire so as not to stretch brake hose.

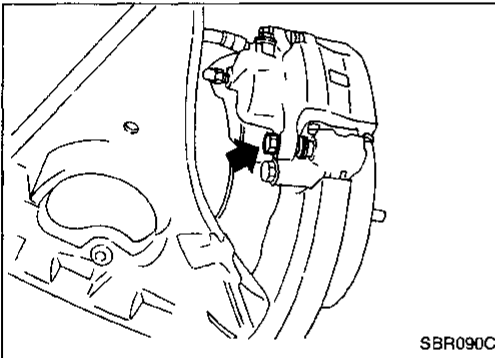

1. Remove master cylinder reservoir cap.
2. Remove lower pin bolt.

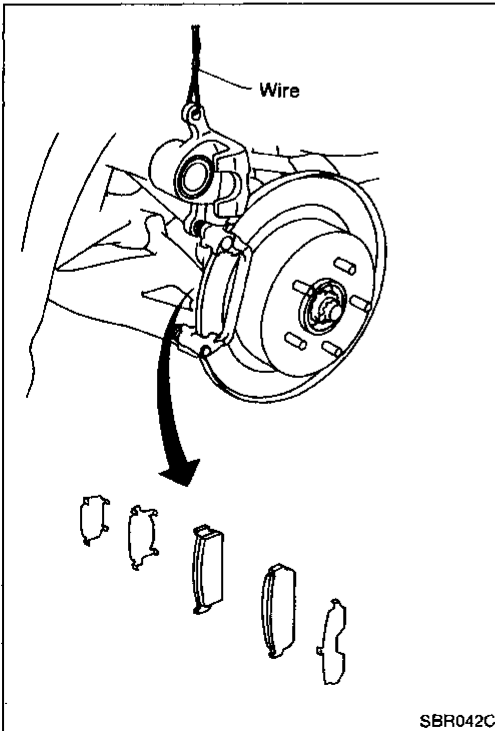

3. Open cylinder body upward. Then remove pad retainers, and inner and outer shims.
Standard pad thickness:
10 mm (0.39 in)
Pad wear limit:
2.0 mm (0.079 in)
- Carefully monitor brake fluid level because brake fluid will return to reservoir when pushing back piston.

REAR DISC BRAKE

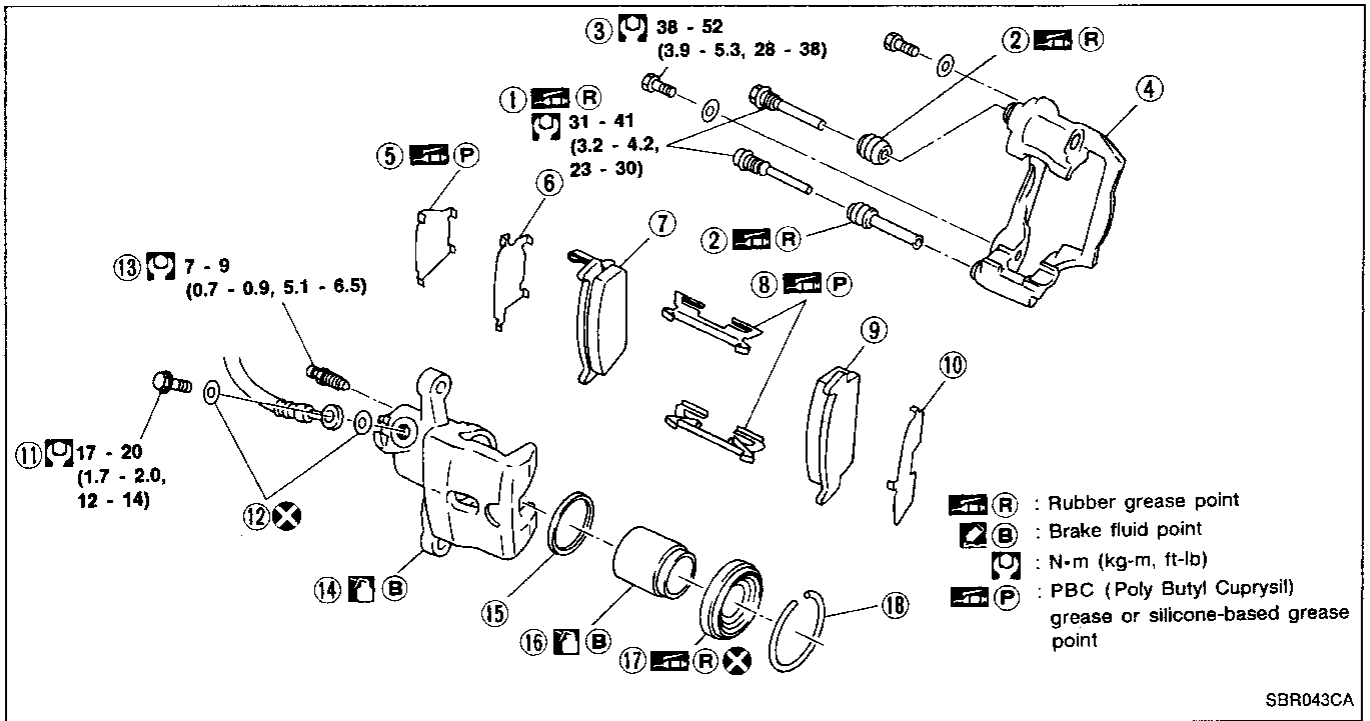

- | | | |
|-----------------------------|-------------------|-----------------|
| ① Main pin bolt | ⑦ Inner pad | ⑬ Bleed valve |
| ② Pin boot | ⑧ Pad retainer | ⑭ Cylinder body |
| ③ Torque member fixing bolt | ⑨ Outer pad | ⑮ Piston seal |
| ④ Torque member | ⑩ Outer shim | ⑯ Piston |
| ⑤ Shim cover | ⑪ Connecting bolt | ⑰ Piston boot |
| ⑥ Inner shim | ⑫ Copper washer | ⑱ Retainer |

Removal

WARNING:

Clean brakes with a vacuum dust collector to minimize the hazard of airborne particles.

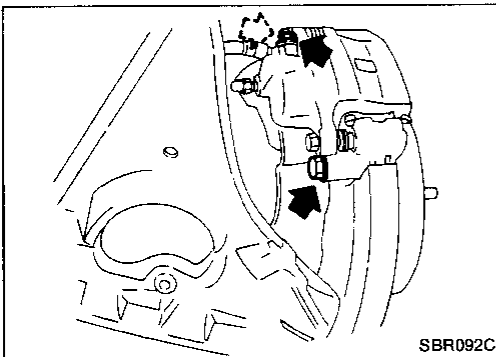

Remove torque member fixing bolts and connecting bolt.

It is not necessary to remove connecting bolt except for disassembly or replacement of caliper assembly. In this case, suspend caliper assembly with wire so as not to stretch brake hose.

REAR DISC BRAKE

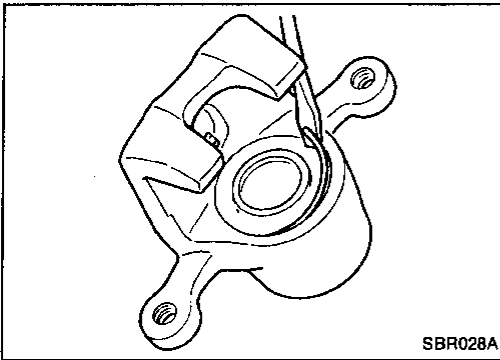

SBR028A

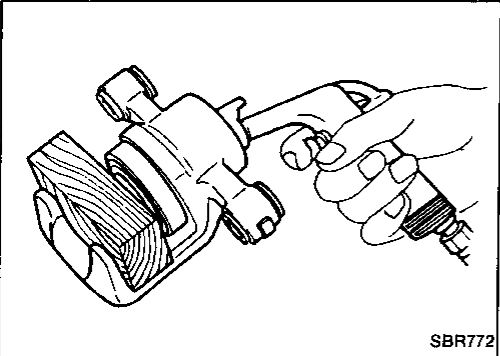

SBR772

Disassembly

1. Remove piston boot retainer with a screwdriver.

WARNING:

Do not place your fingers in front of piston.

CAUTION:

Do not scratch or score cylinder wall.

2. Push out piston and piston boot with compressed air.
3. Remove piston seal with a suitable tool.

Inspection — Caliper

CYLINDER BODY

- Check inside surface of cylinder for score, rust, wear, damage or presence of foreign objects. If any of the above conditions are observed, replace cylinder body.
- Minor damage from rust or foreign objects may be eliminated by polishing surface with a fine emery paper. Replace cylinder body if necessary.

CAUTION:

Use brake fluid to clean cylinder. Never use mineral oil.

PISTON

CAUTION:

Piston sliding surface is plated. Do not polish with emery paper even if rust or foreign objects are stuck to sliding surface.

Check piston for score, rust, wear, damage or presence of foreign objects. Replace if any of the above conditions are observed.

SLIDE PIN, PIN BOLT AND PIN BOOT

Check for wear, cracks, rust or other damage. Replace if any of the above conditions are observed.

Inspection — Rotor

RUBBING SURFACE

Check rotor for roughness, cracks or chips.

REAR DISC BRAKE

Inspection — Rotor (Cont'd)

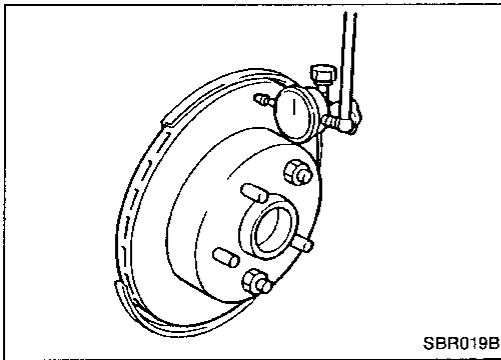

RUNOUT

1. Secure rotor to wheel hub with two nuts (M12 x 1.25).
2. Check runout using a dial indicator.

Make sure that wheel bearing axial end play is within the specifications before measuring. Refer to "Rear Wheel Bearing" in RA section.

3. Change relative positions of rotor and wheel hub so that runout is minimized.

Maximum runout
0.15 mm (0.0059 in)

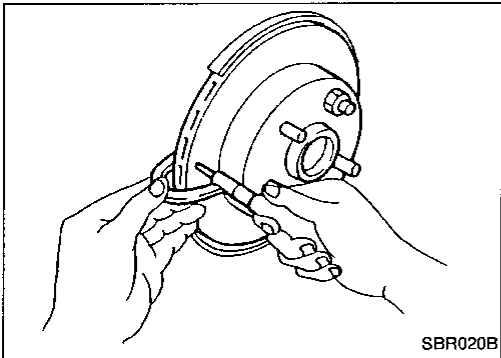

THICKNESS

Rotor repair limit:

Minimum thickness
14.0 mm (0.551 in)

Thickness variation (At least 8 portions)
Maximum 0.02 mm (0.0008 in)

Replace rotor if any of the above do not meet the specifications.

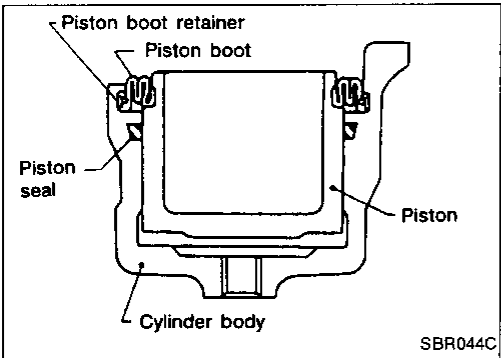

Assembly

1. Insert piston seal into groove on cylinder body.
2. With piston boot fitted to piston, insert piston boot into groove on cylinder body and install piston.
3. Properly secure piston boot.
4. Secure piston boot with retainer.

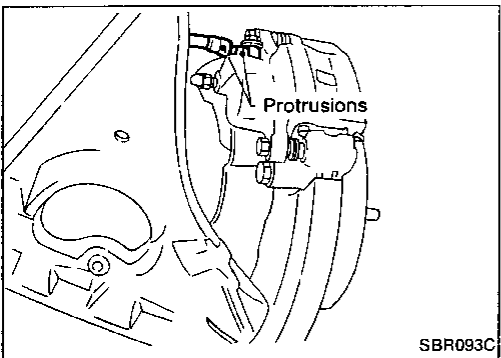

Installation

CAUTION:

- Refill with new brake fluid "DOT 3".
- Never reuse drained brake fluid.

1. Install caliper assembly.

Do not forget to install shims and washers.

2. Install brake hose to caliper securely.
3. Install all parts and secure all bolts.
4. Bleed air. Refer to "Bleeding Brake System" (BR-4).

GI

MA

EM

LC

EF &
EC

FE

AT

PD

FA

RA

BR

ST

RS

BT

HA

EL

IDX

REAR DISC BRAKE — Parking Drum Brake

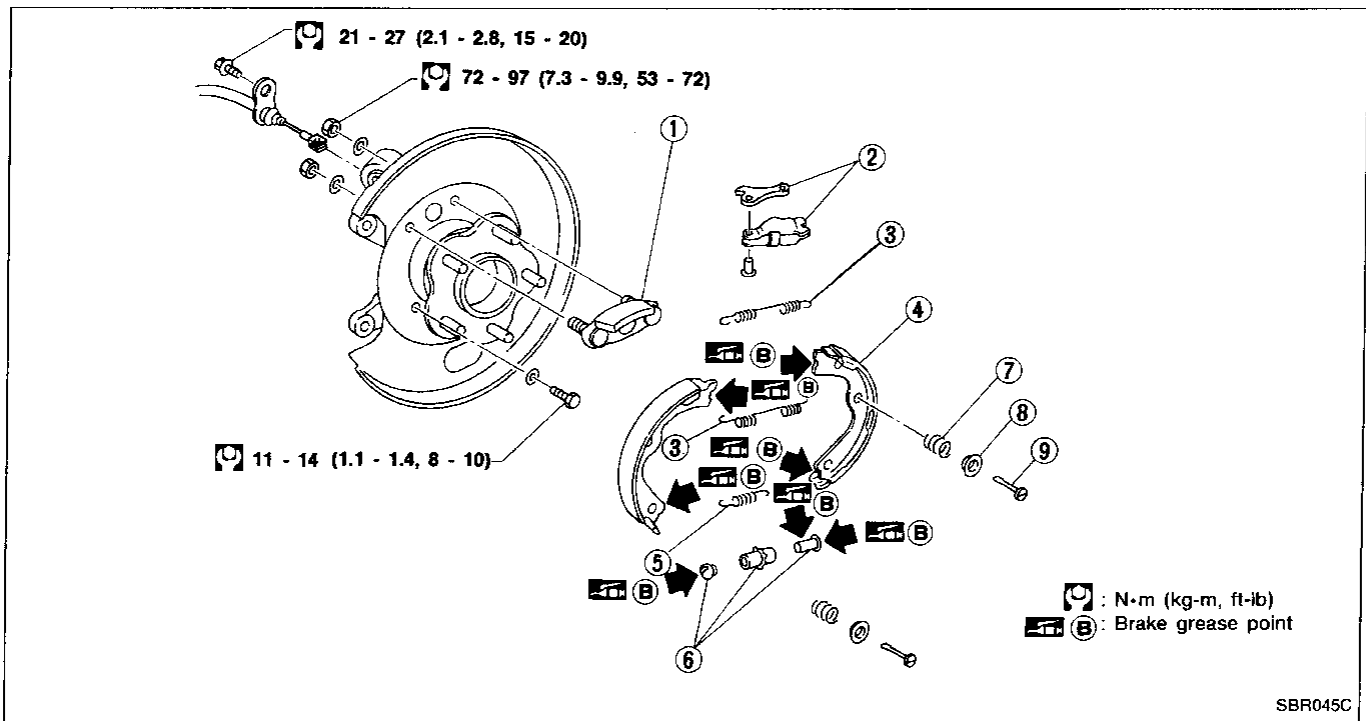

SBR045C

- ① Anchor block
- ② Toggle lever
- ③ Return spring

- ④ Shoe
- ⑤ Adjuster spring
- ⑥ Adjuster

- ⑦ Anti-rattle spring
- ⑧ Retainer
- ⑨ Anti-rattle pin

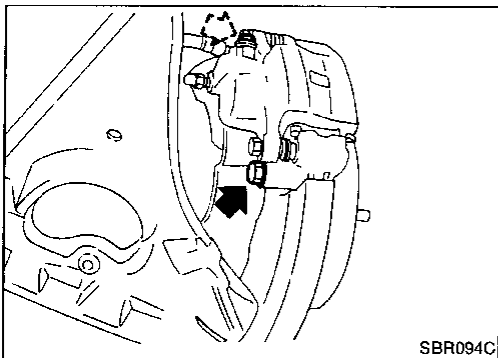

SBR094C

Removal

WARNING:

Clean brakes with a vacuum dust collector to minimize the hazard of airborne particles.

CAUTION:

Make sure parking brake lever is released completely.

1. Remove torque member fixing bolts (Rear disc brake assembly mounting bolts).

Suspend caliper assembly with wire so as not to stretch brake hose.

2. Release parking brake lever fully, then remove drum.

If drum is hard to remove, the following procedures should be carried out:

- a. Remove plug.
- b. Insert screwdriver through plug hole.
- c. Turn adjuster to make clearance between brake shoe and drum.

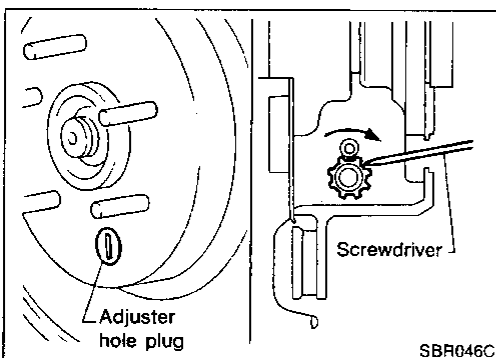

SBR046C

REAR DISC BRAKE — Parking Drum Brake

Removal (Cont'd)

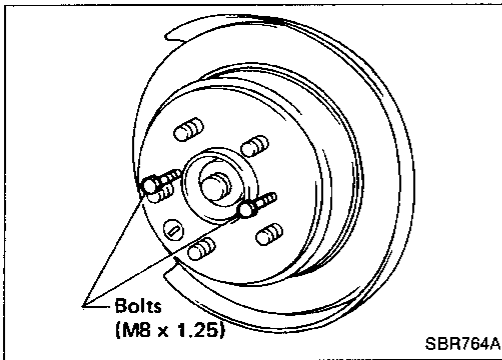

d. Fit two bolts to the drum as shown and tighten gradually.

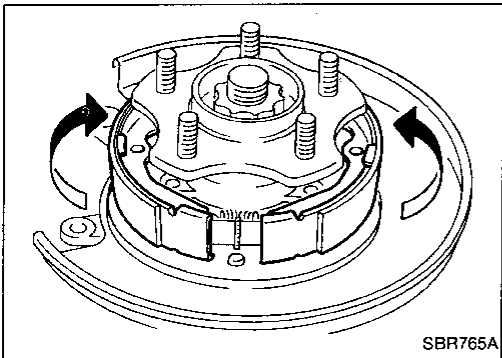

3. After removing retainer, remove spring by rotating shoes.
4. Remove adjuster.

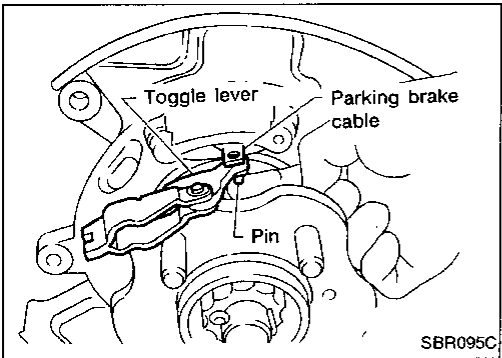

5. Disconnect parking brake cable from toggle lever after drawing out toggle lever pin.

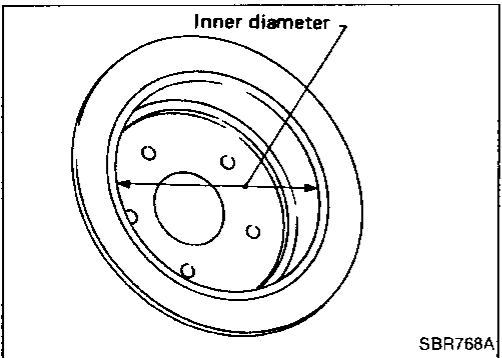

Inspection — Drum

Maximum inner diameter:
173.0 mm (6.81 in)

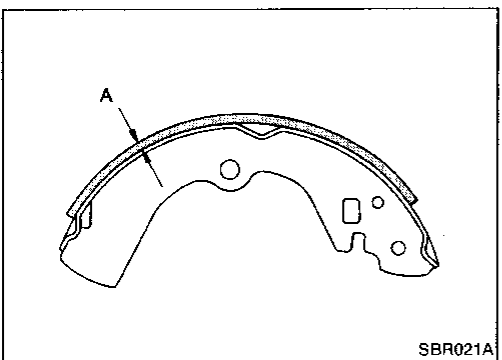

Inspection — Lining

Check lining thickness.

Standard lining thickness:
3.0 mm (0.118 in)
Lining wear limit (A):
1.5 mm (0.059 in)

GI

MA

EM

LC

EF &
EC

FE

AT

PD

FA

RA

BR

ST

RS

BT

HA

EL

IDX

REAR DISC BRAKE — Parking Drum Brake

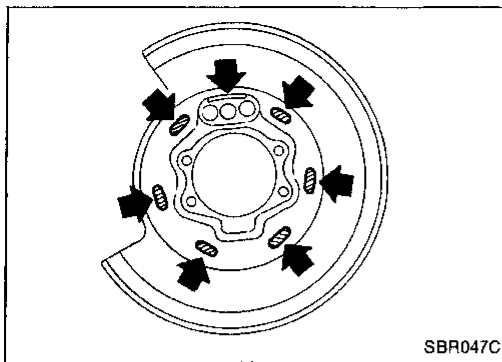

Installation

1. Apply brake grease to the contact areas shown at left.

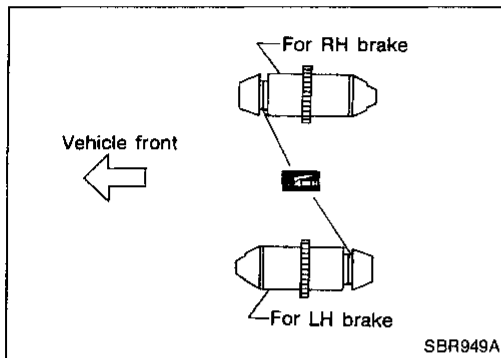

2. Shorten adjuster by rotating it.
Pay attention to direction of adjuster.

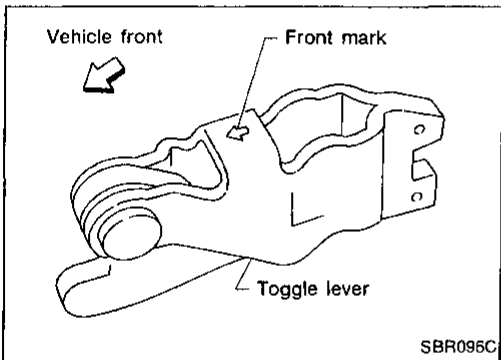

3. Connect parking brake cable to toggle lever.

Pay attention to direction of adjuster.

4. Install all parts.

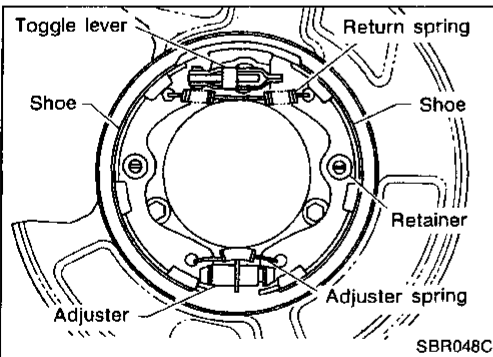

5. Check all parts are installed properly.

Pay attention to direction of adjuster and toggle lever.

6. Install drum.

7. Install rear disc brake assembly.

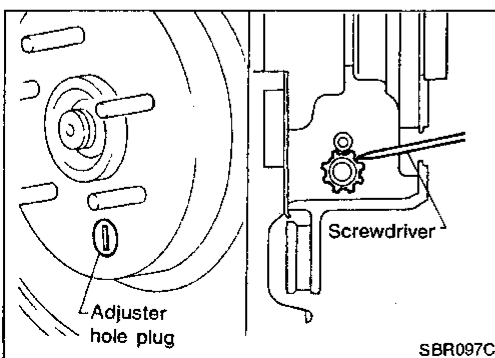

Shoe Clearance Adjustment

1. Remove adjuster hole plug, and turn down adjuster wheel with a screwdriver until brake is locked.

Make sure that parking control lever is released completely.

2. Return adjuster wheel 5 to 6 latches.

3. Install adjuster hole plug, and make sure that there is no drag between shoes and brake drum when rotating disc rotor.

4. Adjust parking brake cable. Refer to "Adjustment" in "PARKING BRAKE CONTROL" (BR-29).

Breaking in Drum and Lining

Perform the followings when stopping effect of parking brake is weakened, or brake shoes and/or drums are replaced. Doing so, parking brake will bed down.

1. Drive the unloaded vehicle on a safe, level and dry road. GI
2. Depress parking brake pedal with a force of 255N (26 kg, 57 lb).
3. While depressing the pedal, continue to drive the vehicle forward 100 m (328 ft) at approximately 35 km/h (22 MPH). MA
4. After releasing the pedal, drive the vehicle under the normal conditions for two minutes to cool down the parking drum brake. EM
5. Repeat steps 1 through 4 two times. LC

EF &
EC

FE

AT

PD

FA

RA

BR

ST

RS

BT

HA

EL

IDX

PARKING BRAKE CONTROL

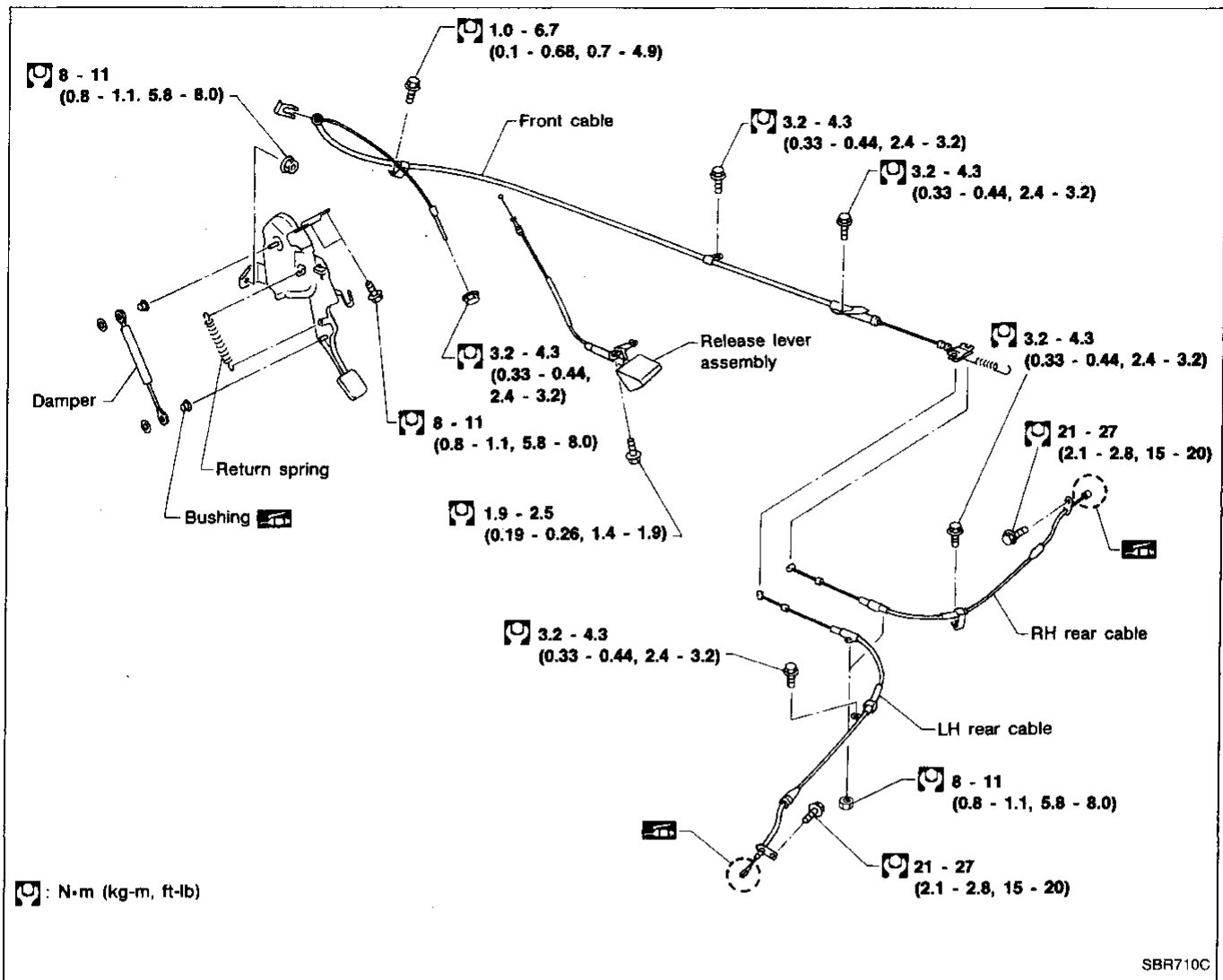

Removal and Installation

- Parking brake cables can be removed without removing pedal assembly.
- In order to remove front cable, it is necessary to remove center console. (Refer to "INSTRUMENT PANEL" in BF section.)
- In order to remove pedal assembly, it is necessary to remove instrument panel assembly and air duct. (Refer to "INSTRUMENT PANEL" in BF section.)
- The figure at left shows how front and release cables are connected to pedal assembly.

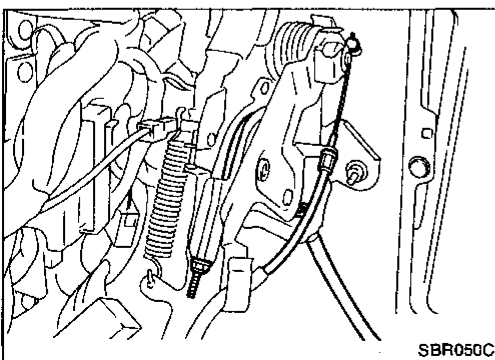

PARKING BRAKE CONTROL

Inspection

1. Check control lever for wear or other damage. Replace if necessary.
2. Check wires for discontinuity or deterioration. Replace if necessary.
3. Check warning lamp and switch. Replace if necessary.
4. Check parts at each connecting portion and, if deformed or damaged, replace.

GI

MA

Adjustment

On models equipped with parking drum brake, perform shoe clearance adjustment before adjusting parking brake control. Refer to "Shoe Clearance Adjustment" in "REAR DISC BRAKE — Parking Drum Brake" (BR-26).

EM

LC

EF &
EC

FE

AT

PD

FA

RA

BR

ST

RS

BT

HA

EL

IDX

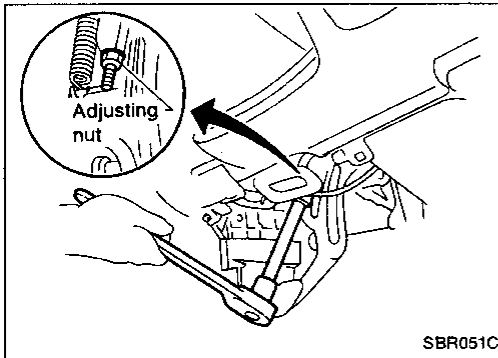

1. Release parking brake pedal and loosen adjusting nut. Adjust parking brake by turning adjusting nut.

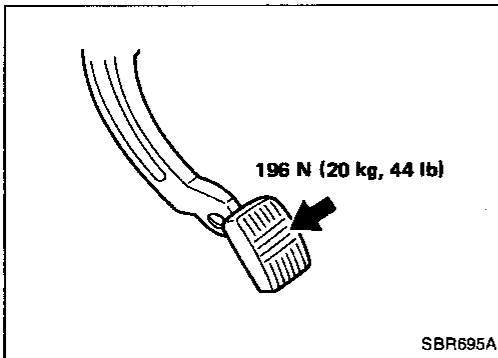

2. Depress parking brake pedal several times with specified amount of force. Check pedal stroke and ensure smooth operation.

Pedal stroke:

75 - 90 mm (2.95 - 3.54 in)

ANTI-LOCK BRAKE SYSTEM

System components

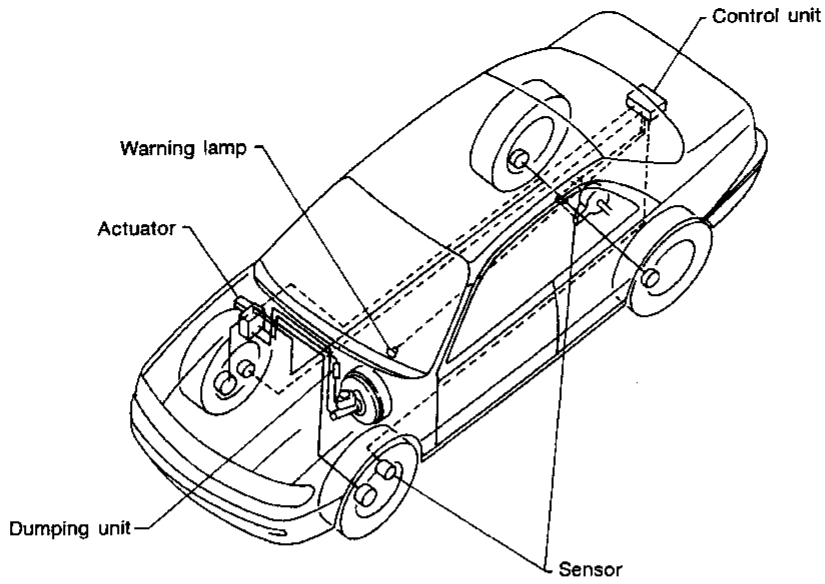

SBR103C

Operation of actuator hydraulic circuit

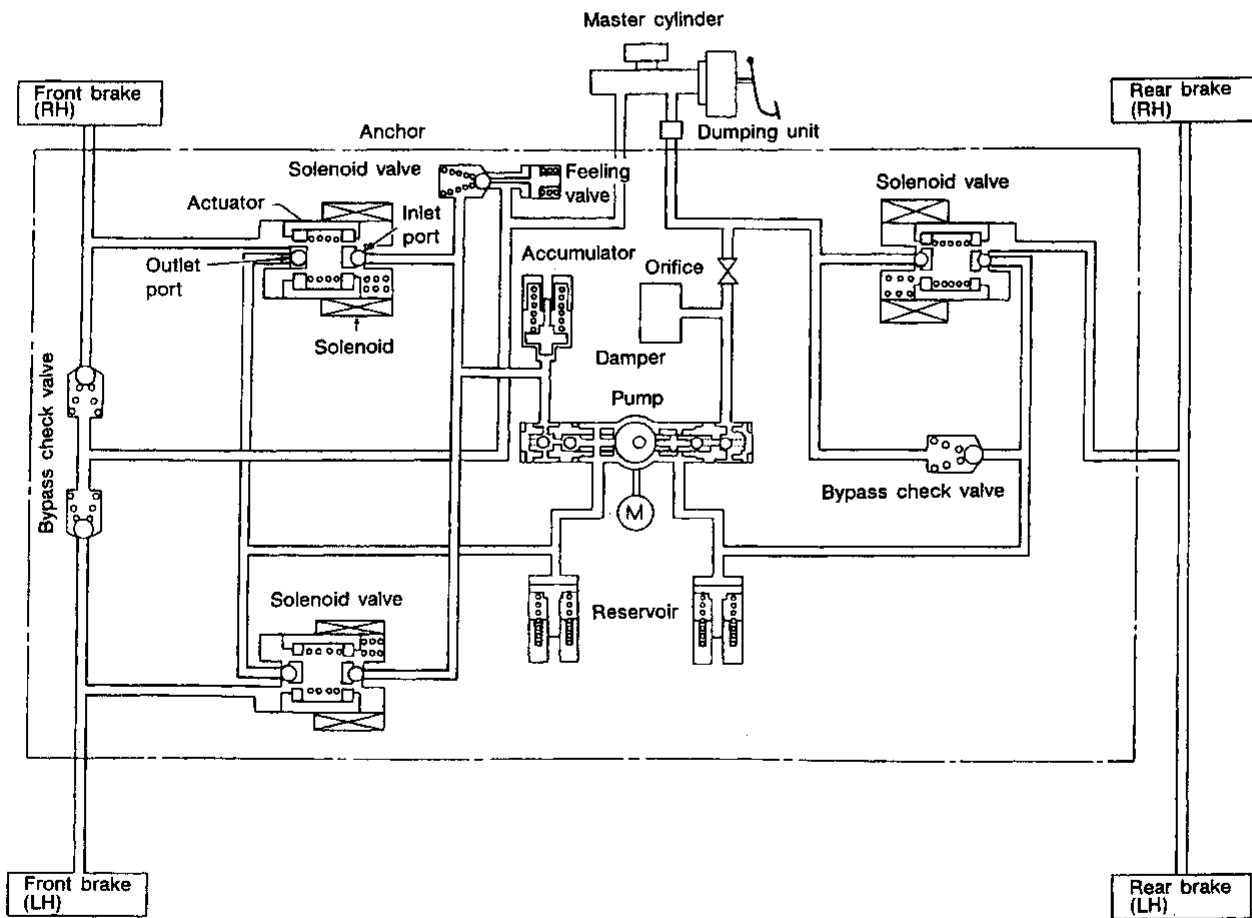

SBR104CA

ANTI-LOCK BRAKE SYSTEM

Wiring Diagram

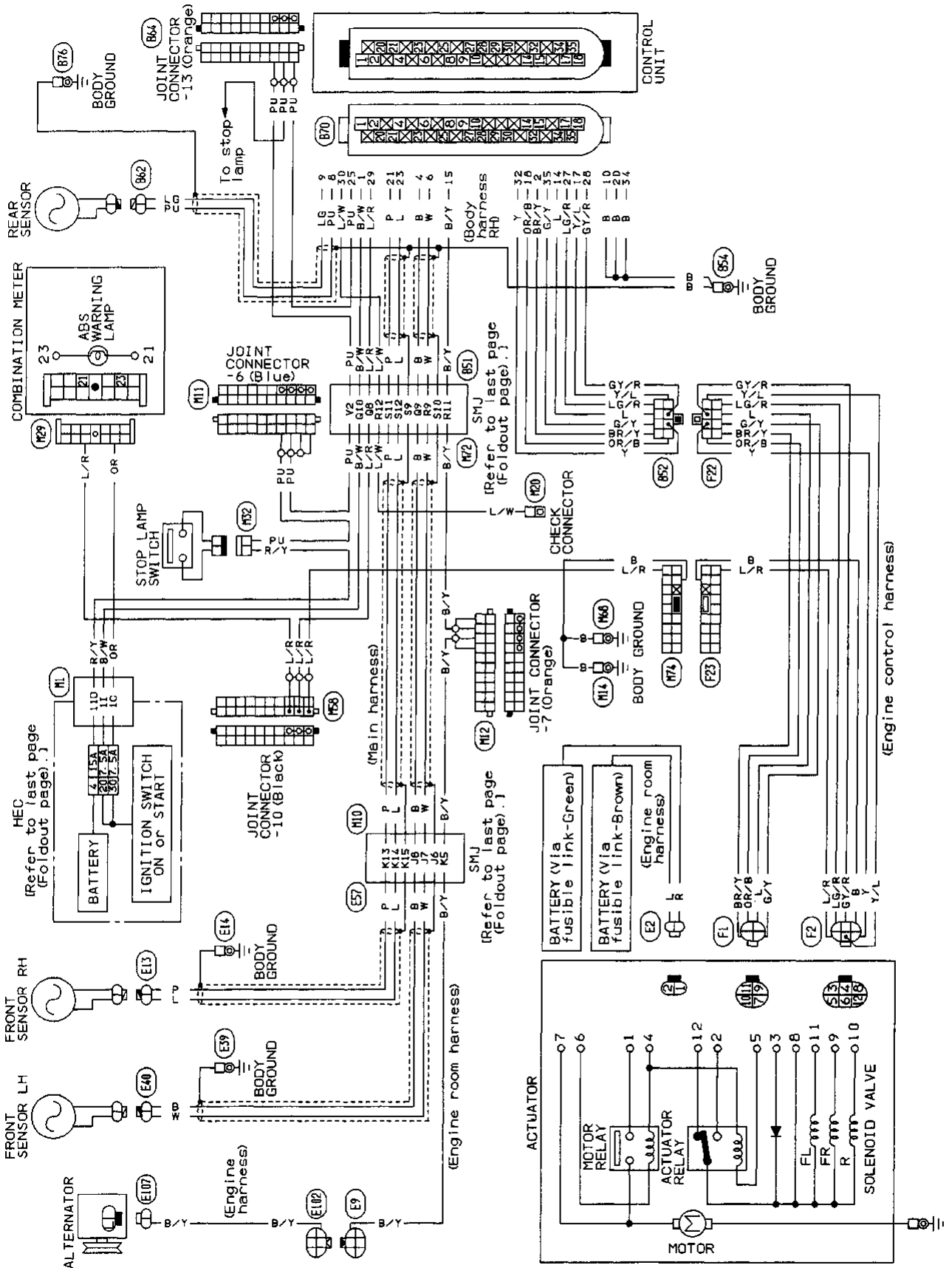

GI
MA
EM
LC
EF & EC
FE
AT
PD
FA
RA
BR
ST
RS
BT
HA
EL
IDX

ANTI-LOCK BRAKE SYSTEM

Removal and Installation

CAUTION:

Be careful not to damage sensor edge and sensor rotor teeth. If the front wheel hub or final drive assembly needs to be removed, disconnect the ABS wheel sensor from the assembly. Then, move it away. Failure to do so may result in damage to the sensor wires making the sensor inoperative.

FRONT WHEEL SENSOR

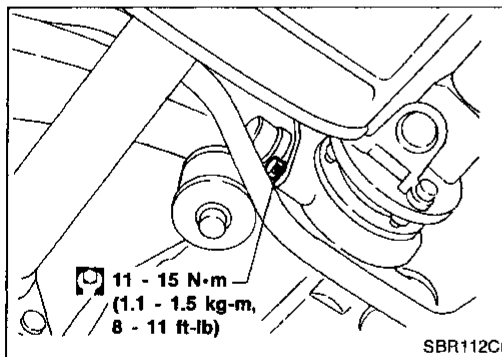
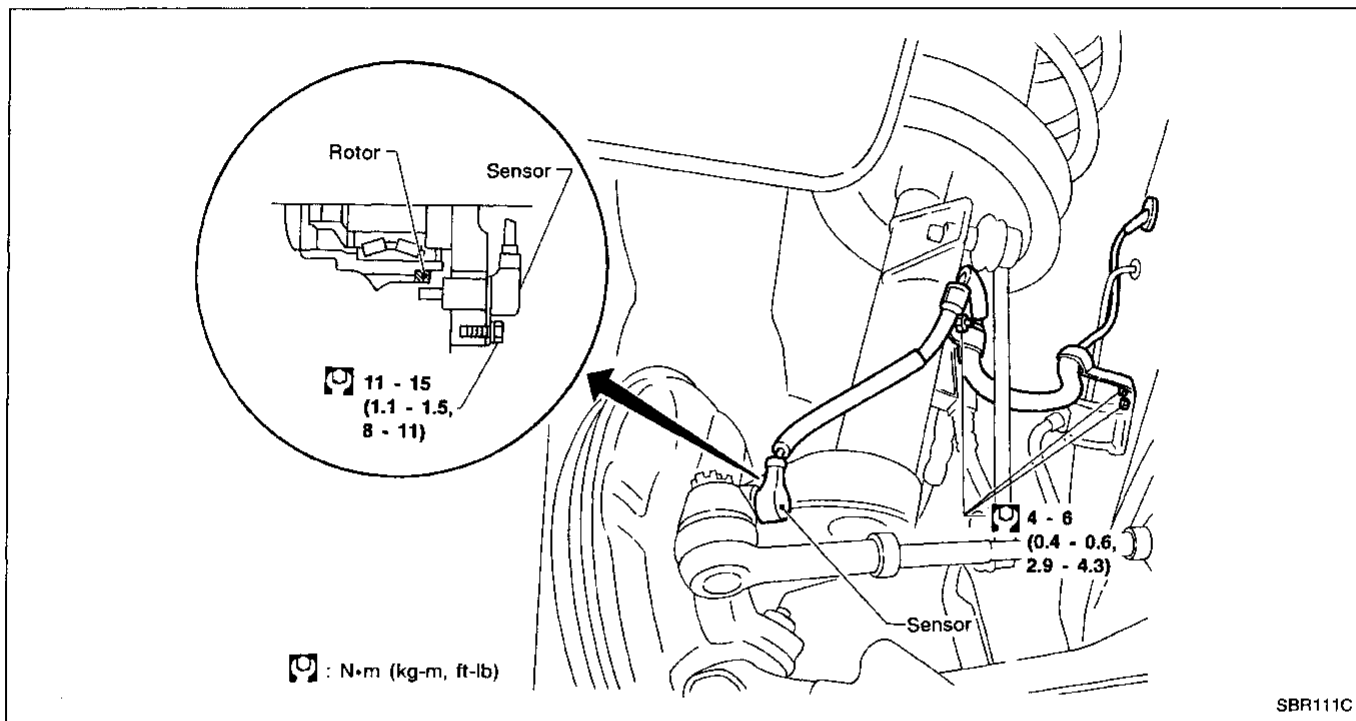

REAR WHEEL SENSOR

Rear wheel sensor is installed in final drive.

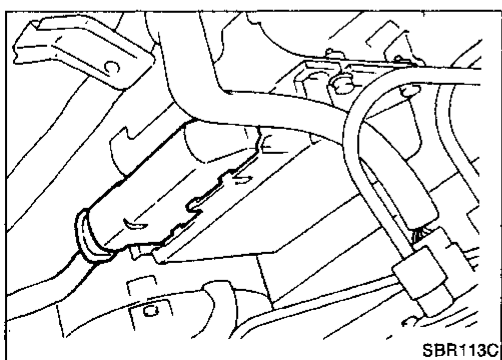

CONTROL UNIT

Control unit is located in-luggage compartment.

ANTI-LOCK BRAKE SYSTEM

Removal and Installation (Cont'd) ACTUATOR

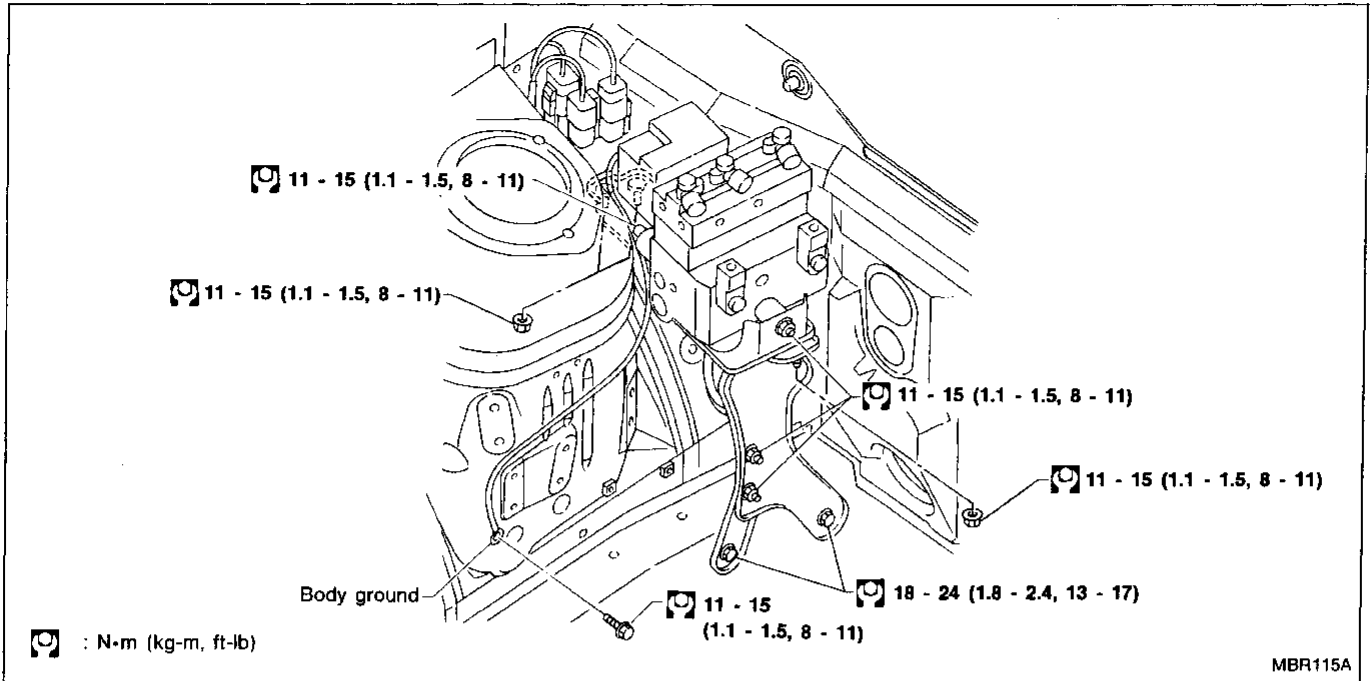

CAUTION:

After installation, pay attention to the following points.

- Refill brake fluid and bleed air. Refer to "Bleeding Brake System" (BR-4).

1. Drain brake fluid. Disconnect brake tubes.
2. Remove actuator.

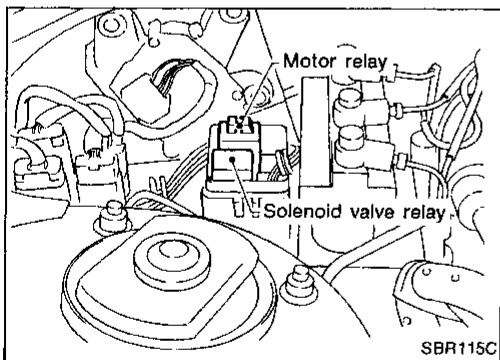

ACTUATOR RELAYS

4-terminals: MOTOR RELAY

5-terminals: SOLENOID VALVE RELAY

1. Disconnect battery cable.
2. Remove actuator relay cover.

TROUBLE DIAGNOSES

Contents

How to Perform Trouble Diagnoses for Quick and Accurate Repair	BR-35
Self-diagnosis	BR-36
Component Parts and Harness Connector Location	BR-39
Preliminary Check	BR-40
Ground Circuit Check	BR-41
Circuit Diagram for Quick Pinpoint Check	BR-41
Diagnostic Procedure 1	BR-42
Diagnostic Procedure 2	BR-43
Diagnostic Procedure 3	BR-46
Diagnostic Procedure 4	BR-47
Diagnostic Procedure 5	BR-49
Diagnostic Procedure 6	BR-53
Diagnostic Procedure 7	BR-55
Diagnostic Procedure 8	BR-55
Diagnostic Procedure 9	BR-55
Electrical Component Inspection	BR-56

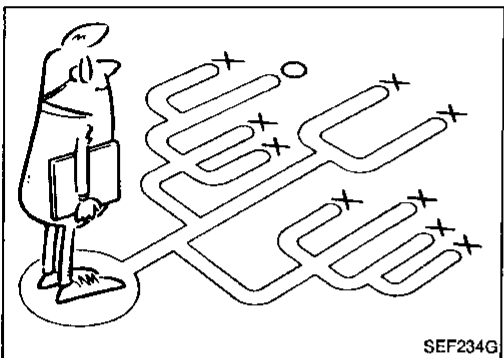
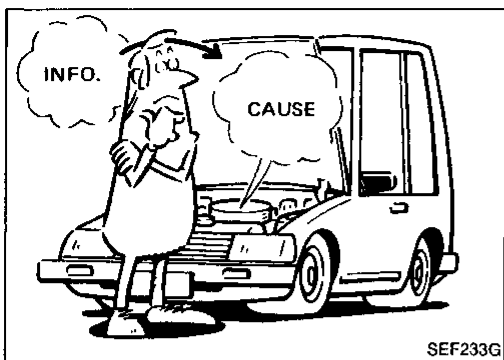

How to Perform Trouble Diagnoses for Quick and Accurate Repair

INTRODUCTION

The ABS system has an electronic control unit to control major functions. The control unit accepts input signals from sensors and instantly drives actuators. It is essential that both kinds of signals are proper and stable. Also, it is important that there are no conventional problems as follows. Air leaks in the booster or lines, lack of brake fluid, or other problems with brake system.

It is much more difficult to diagnose a problem that occurs intermittently rather than continuously. Most intermittent problems are caused by poor electric connections or faulty wiring. In this case, careful checking of suspicious circuits may help prevent the replacement of good parts.

A visual check only may not find the cause of the problems, so a road test should be performed.

Before undertaking actual checks, take just a few minutes to talk with a customer who approaches with a ABS complaint. The customer is a very good source of information on such problems; especially intermittent ones. Through the talks with the customer, find out what symptoms are present and under what conditions they occur.

Start your diagnosis by looking for "conventional" problems first. This is one of the best ways to troubleshoot brake problems on an ABS controlled vehicle.

GI

MA

EM

LC

EF &
EC

FE

AT

PD

FA

RA

BR

ST

RS

BT

HA

EL

IDX

TROUBLE DIAGNOSES

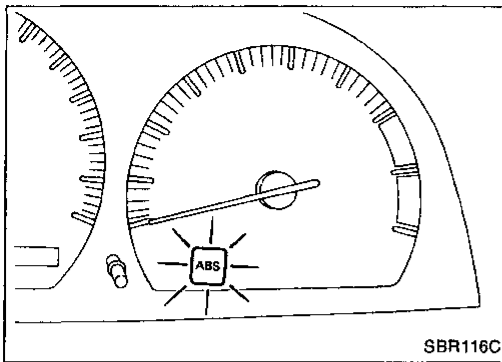

Self-diagnosis

FUNCTION

- When a problem occurs in the ABS, the warning lamp on the instrument panel comes on. The warning lamp is also lit by grounding the self-diagnostic (check) terminal located on the check connector to actuate the self-diagnostic results mode. The location of the malfunction is indicated by the warning lamp flashing on the instrument panel.

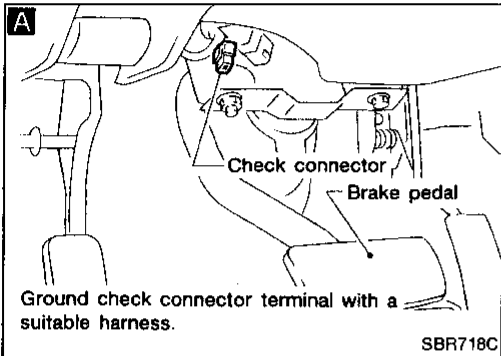

SELF-DIAGNOSIS PROCEDURE

Drive vehicle over 30 km/h (20 MPH) for at least one minute.

Turn ignition switch "OFF".

A

Ground terminal "L" of check connector with a suitable harness.

Turn ignition switch "ON" while grounding terminal "L".
Do not depress brake pedal.

B

After 3.6 seconds, the warning lamp starts flashing to indicate the malfunction code No. (See NOTE 1 below.)

After verifying the location of the malfunction with the malfunction code chart, make the necessary repairs. Be sure to follow the instructions in the diagnostic procedures.

After the malfunctions are repaired, erase the malfunction codes stored in the control unit. See "HOW TO ERASE SELF-DIAGNOSTIC RESULTS" (BR-38).

Rerun the self-diagnostic results mode to verify that the malfunction codes have been erased.

C

Disconnect the check terminal from the ground. The self-diagnostic results mode is now complete.

NOTE 1: The indication terminates after five minutes. However, when the ignition switch is turned from "OFF" to "ON", the indication starts flashing again.

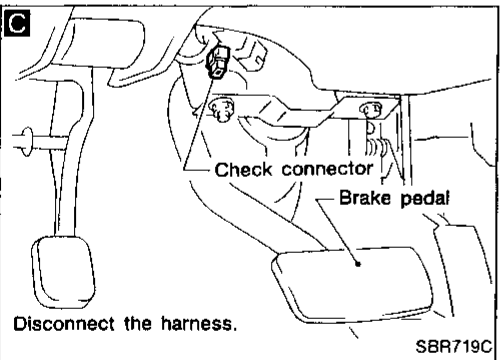
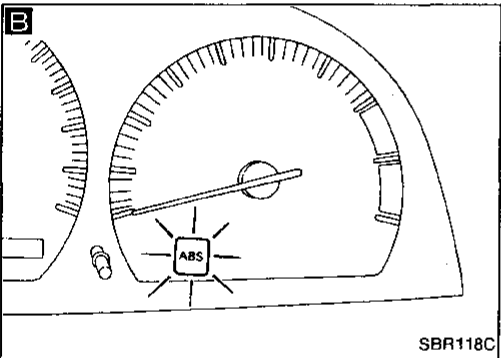

A

TROUBLE DIAGNOSES

Self-diagnosis (Cont'd)

Ⓐ

Check warning lamp for deactivation after driving vehicle over 30 km/h (20 MPH) for at least one minute.

Make certain that warning lamp does not come on. Then, test the ABS in a safe area to verify that it functions properly.

HOW TO READ SELF-DIAGNOSTIC RESULTS (Malfunction codes)

- Determine the code No. by counting the number of times the warning lamp flashes on and off.
- When several malfunctions occur at one time, up to three code Nos. can be stored; the latest malfunction will be indicated first.
- The indication begins with the start code 12, after which a maximum of three code Nos. appear in the order of the latest one first. The indication then returns to the start code to repeat (the indication will stay on for five minutes at the most).
- The malfunction code chart is given on the next page.

Example: Code No. 32 REAR SENSOR SHORT-CIRCUIT

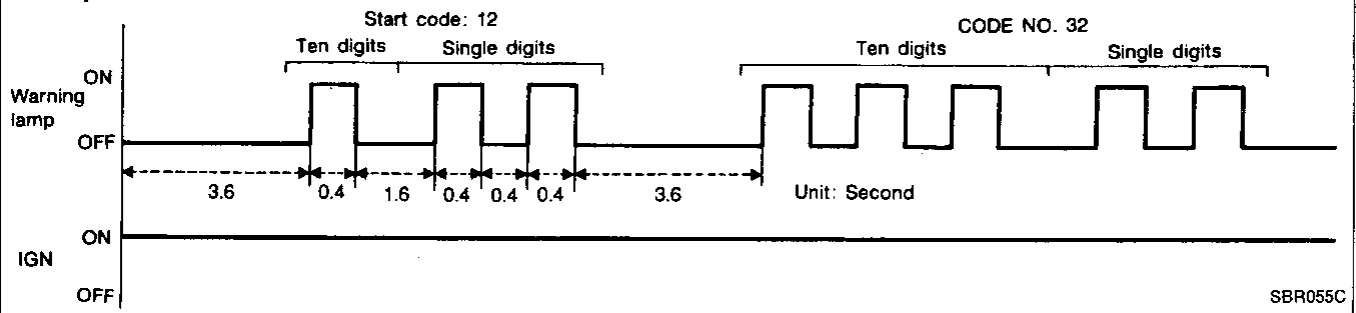

TROUBLE DIAGNOSES

Self-diagnosis (Cont'd)

HOW TO ERASE SELF-DIAGNOSTIC RESULTS (Malfunction codes)

- a. Under the self-diagnostic results mode, the malfunction memory erase mode starts when the check terminal is disconnected from the ground.
- b. Ground the check terminal more than three times successively within 12.5 seconds after the erase mode starts. Then, the self-diagnostic results (malfunction codes) will be erased. (Each grounding must be longer than one second.) The ABS warning lamp stays on while the self-diagnosis is in the erase mode. The lamp goes out after the erase operation has been completed.

The self-diagnosis is also completed at the same time.

After the erase operation is completed, it is necessary to rerun the self-diagnostic mode to verify that malfunction codes no longer appear. Only the start code should be indicated when erase operation is completed and system is functioning normally.

MALFUNCTION CODE CHART

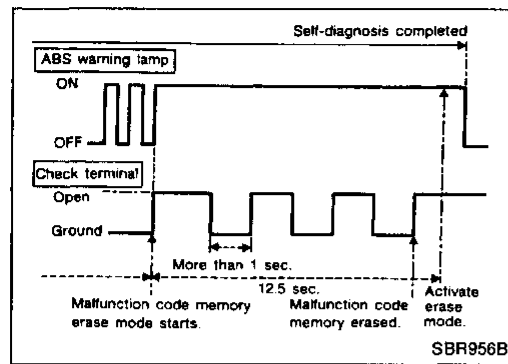

Code No.	Malfunctioning part	Diagnostic procedure
12	Self-diagnosis could not detect any malfunctions	—
45	Front left actuator solenoid	3
41	Front right actuator solenoid	3
55	Rear actuator solenoid	3
25	Front left sensor (open-circuit)	4
26	Front left sensor (short-circuit)	4
21	Front right sensor (open-circuit)	4
22	Front right sensor (short-circuit)	4
31 or 35	Rear sensor (open-circuit)	4
32 or 36	Rear sensor (short-circuit)	4
18	Sensor rotor	4
61	Actuator motor or motor relay	5
63	Solenoid valve relay	6
57	Power supply (Low voltage)	7
16	Stop lamp switch circuit	8
71	Control unit	9
Warning lamp comes on for 1 second after ignition switch is turned on.	Normal operation	—
Warning lamp stays on continuously after the ignition switch is turned on.	Control unit power supply circuit Warning lamp bulb circuit Control unit or control unit connector Solenoid valve relay stuck Power supply for solenoid valve relay coil	2
Warning lamp stays on, continuously during self-diagnosis.	Control unit	—
Warning lamp does not come on when ignition switch is turned on.	Fuse, warning lamp bulb or warning lamp circuit Control unit	1
Warning lamp does not come on during self-diagnosis, but does come on for 1 sec after ignition switch is turned on.	Control unit	—

TROUBLE DIAGNOSES

Component Parts and Harness Connector Location

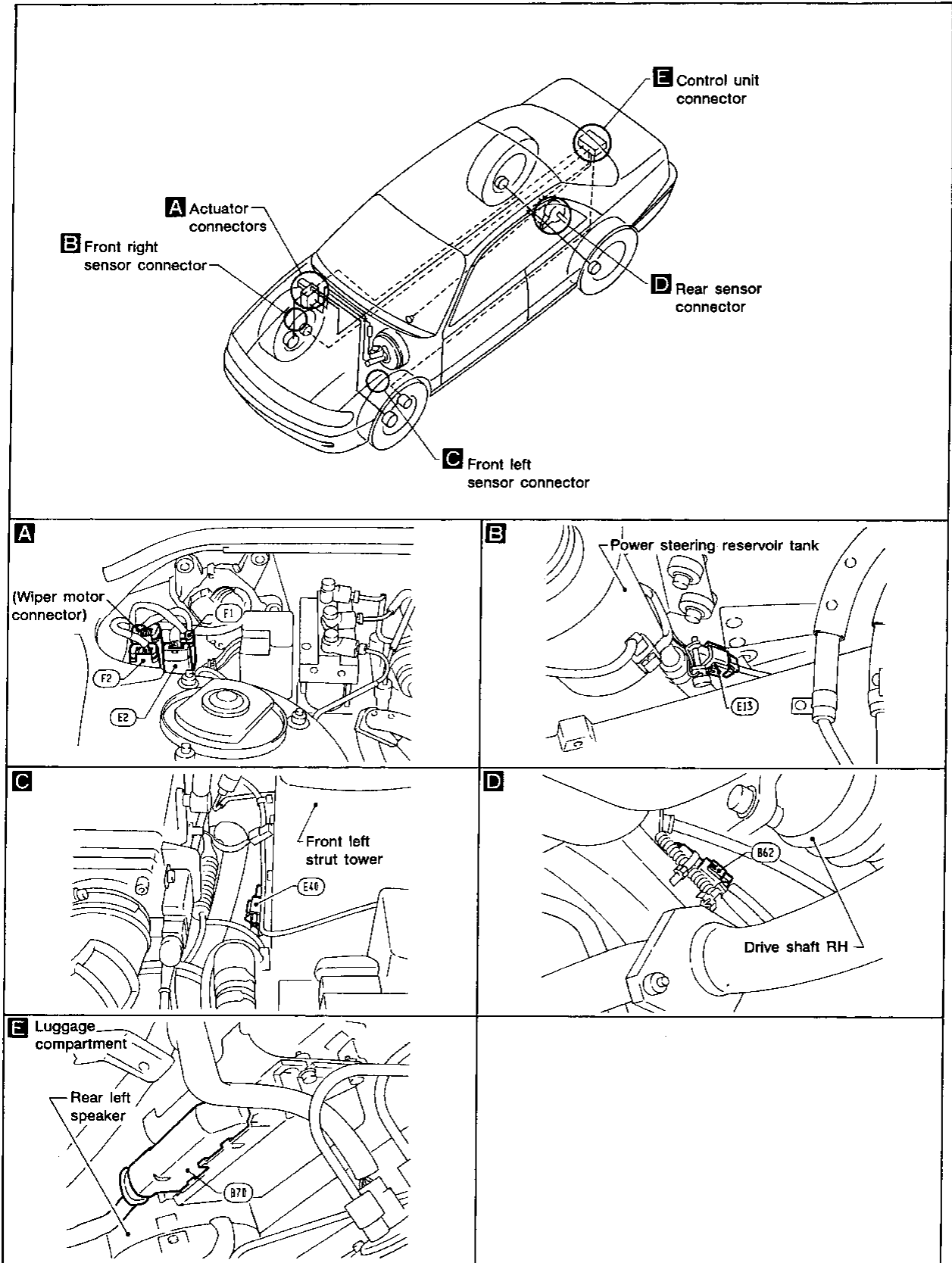

GI

MA

EM

LC

EF &
EC

FE

AT

PD

FA

RA

BR

ST

RS

BT

HA

EL

IDX

TROUBLE DIAGNOSES

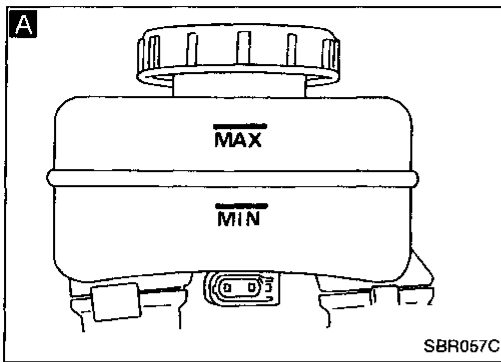

Preliminary Check

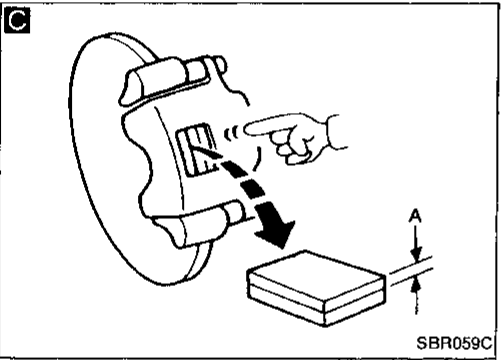
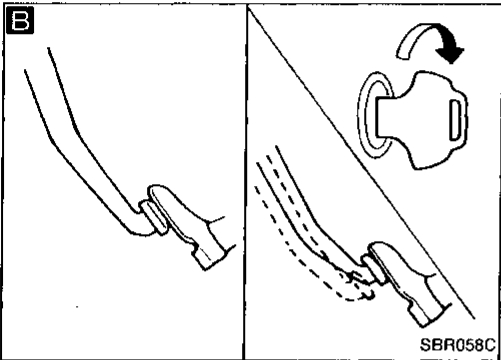
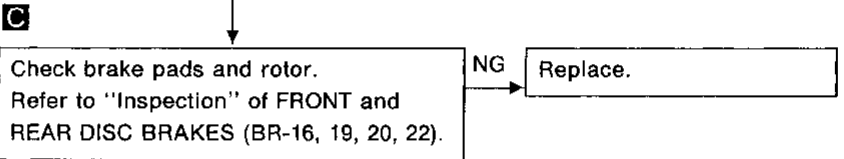
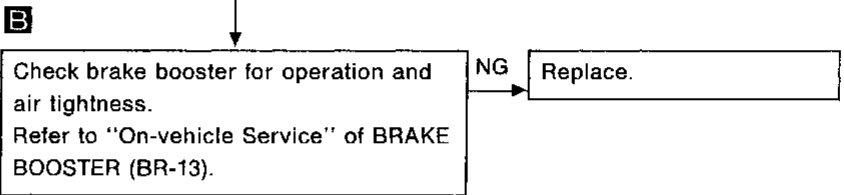
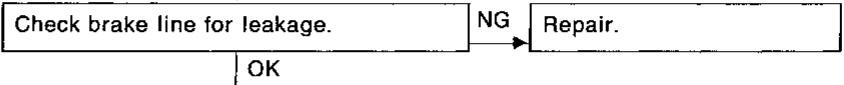
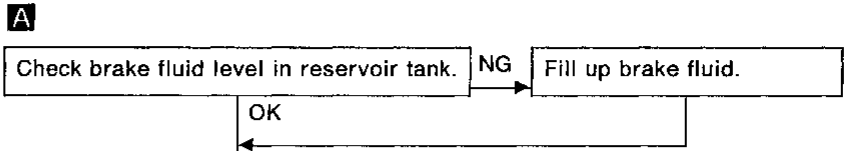

TROUBLE DIAGNOSES

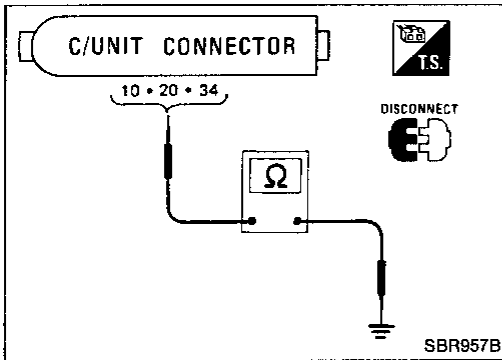

Ground Circuit Check

CONTROL UNIT GROUND

- Check resistance between both terminals.
Resistance: 0Ω

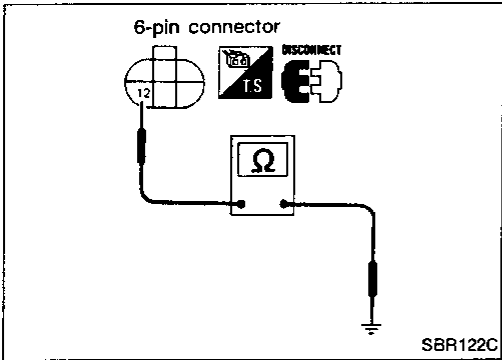

ACTUATOR GROUND

- Check resistance between actuator harness connector terminal ⑫ and ground.
Resistance: 0Ω

Circuit Diagram for Quick Pinpoint Check

- The unit side connectors with a double circle "⊖" are connected to the harness side connectors shown in the "Component Parts and Connector Location". (See page BR-39.)
- The terminal numbers in the connector coincide with the circuit numbers surrounded by a single circle "○".

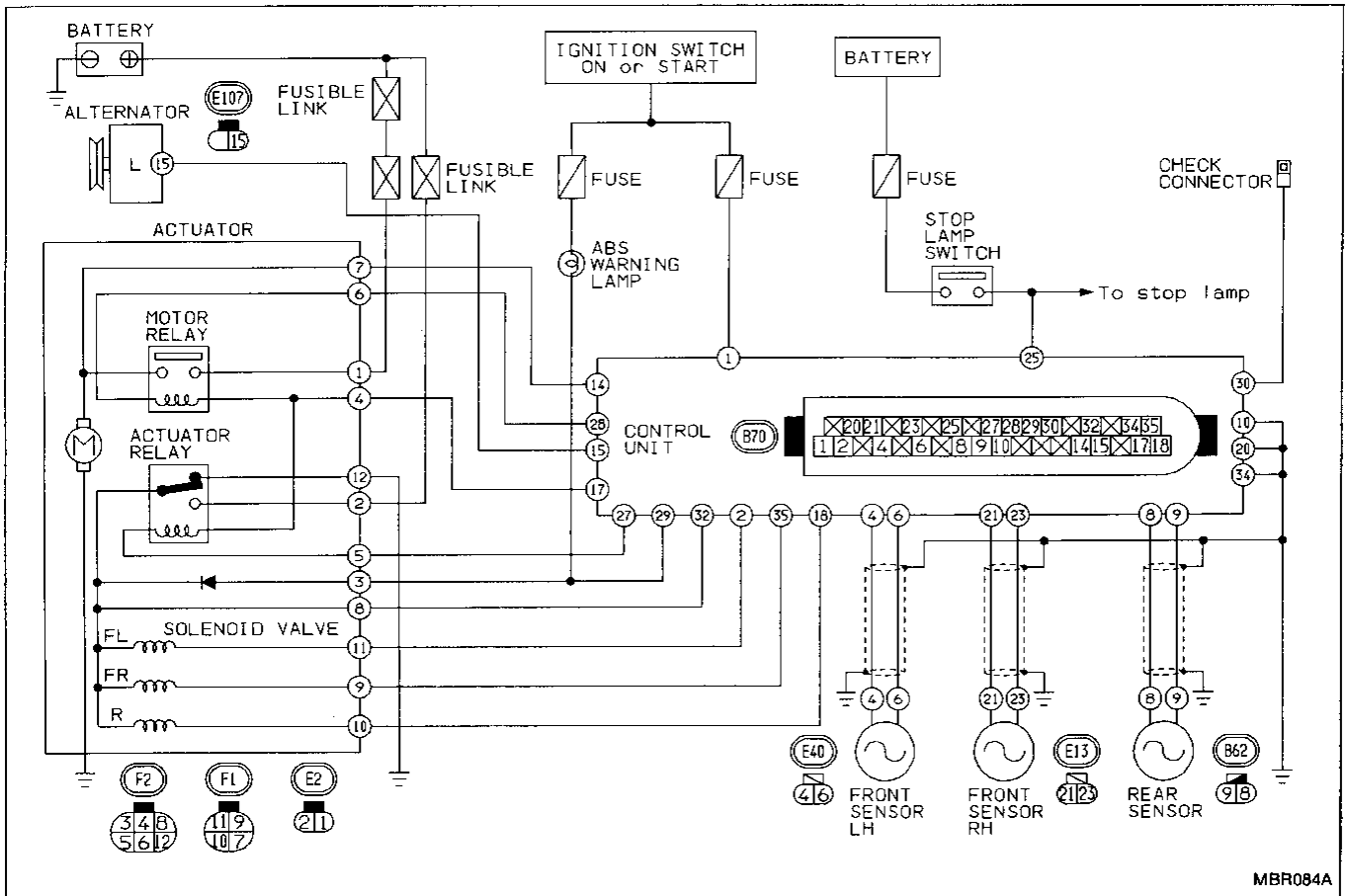

MBR084A

TROUBLE DIAGNOSES

Diagnostic Procedure 1 (Not self-diagnostic item)

Warning lamp does not work before engine starts.

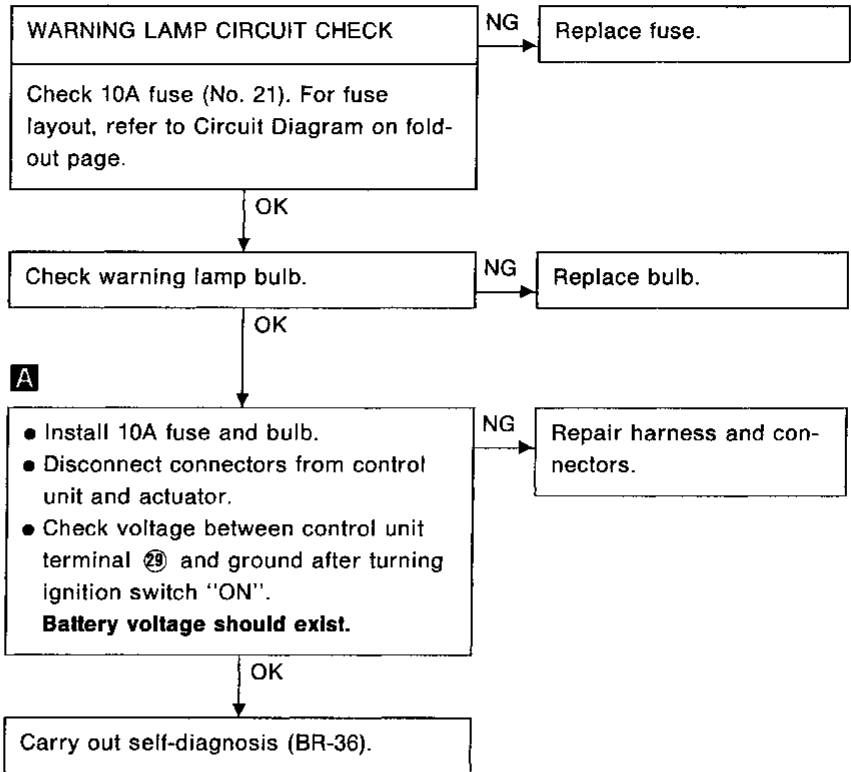
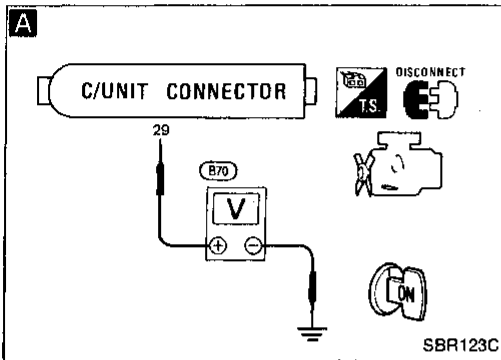

TROUBLE DIAGNOSES

Diagnostic Procedure 2 (Not Self-diagnostic item)

Warning lamp stays on continuously.

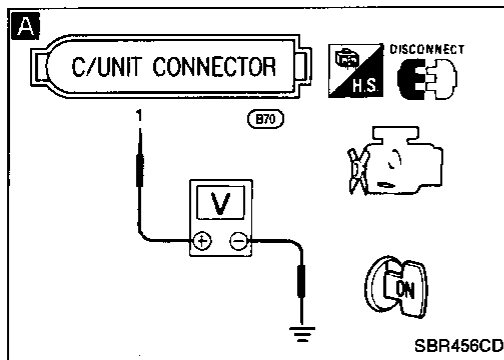

CONTROL UNIT POWER SUPPLY CIRCUIT

NG → **B**

Check 10A fuse for control unit.
For fuse layout, refer to Wiring Diagram and SMJ terminal arrangement.

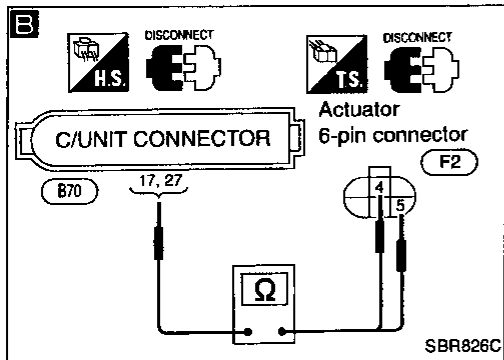

A

OK

- Disconnect connector from control unit.
- Check voltage between control unit connector terminal ① and ground after turning ignition switch "ON". **Battery voltage should exist.**

NG → Repair harness and connector.

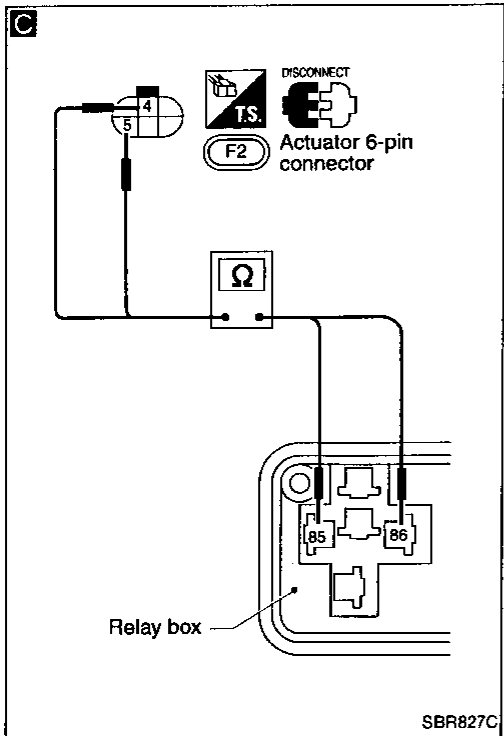

B

OK

SOLENOID VALVE RELAY COIL POWER SUPPLY CIRCUIT

NG → Repair harness and connector.

- Turn ignition switch "OFF". Disconnect actuator 6-pin connector.
- Check continuity between control unit connector terminals and actuator 6-pin connector (body side) terminals.

Control unit	Actuator
⑰	④
⑳	⑤

Continuity should exist.

C

OK

CIRCUIT CHECK

NG → Replace actuator.

- Disconnect solenoid valve relay.
- Check continuity between actuator 6-pin connector (actuator side) terminals and solenoid valve relay box terminals.

Actuator	Relay box
④	⑧⑧
⑤	⑧⑨

Continuity should exist.

OK

SOLENOID VALVE RELAY CHECK

NG → Replace solenoid valve relay.

Refer to SOLENOID VALVE RELAY in Electrical Components Inspection (BR-56).

OK
→ **A**

GI

MA

EM

LC

EF &
EC

FE

AT

PD

FA

RA

BR

ST

RS

BT

HA

EL

IDX

TROUBLE DIAGNOSES

Diagnostic Procedure 2 (Not Self-diagnostic item) (Cont'd)

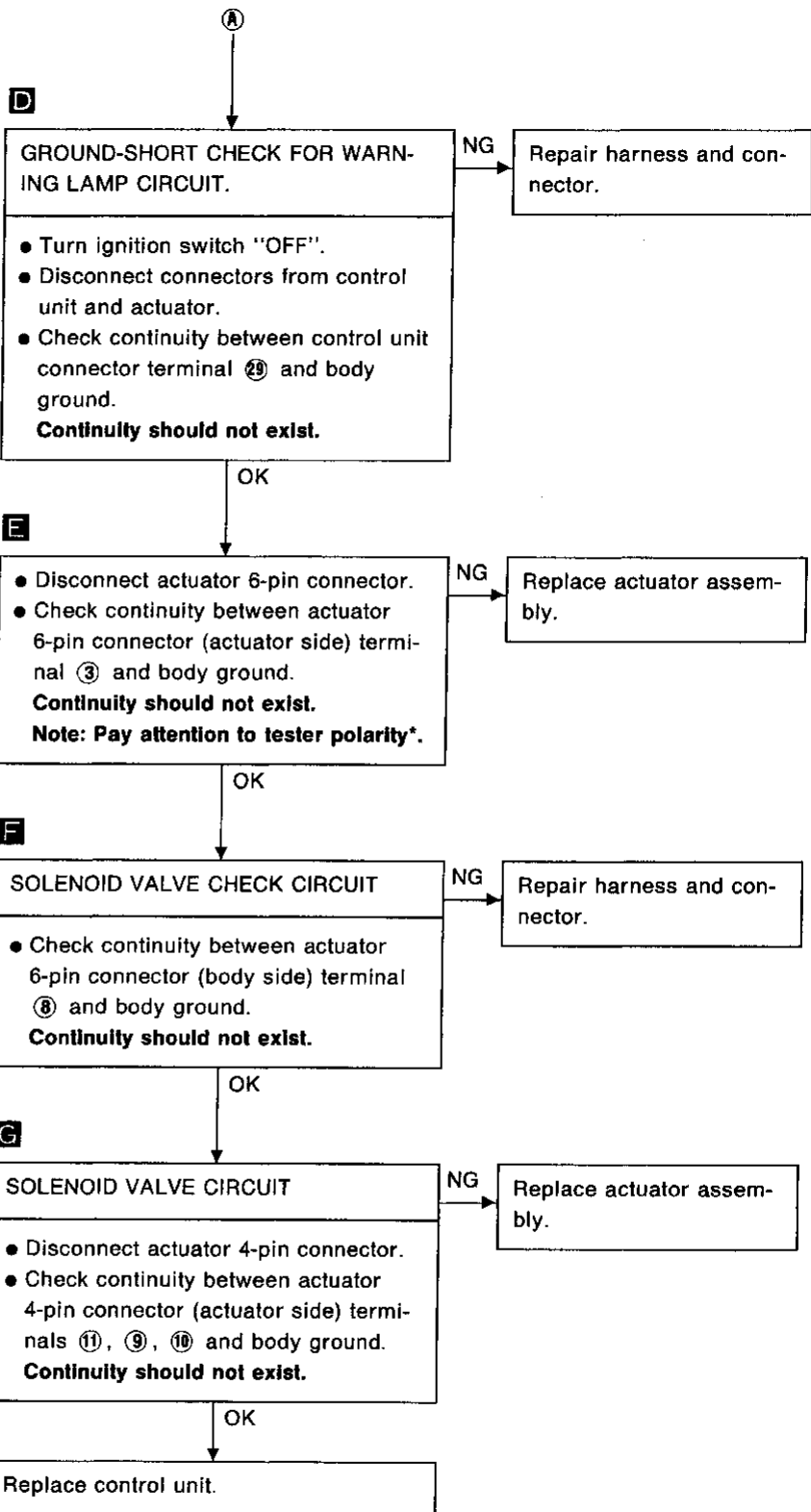
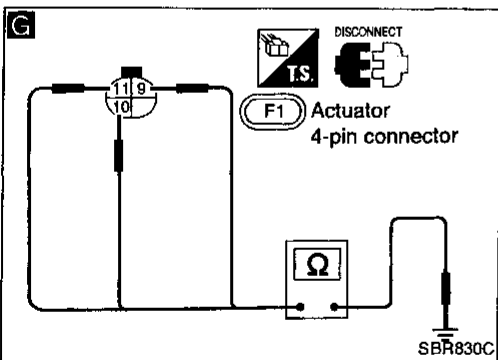
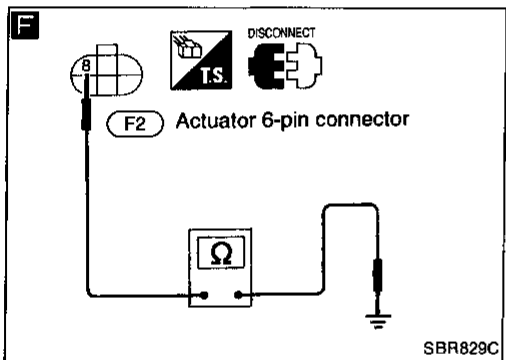
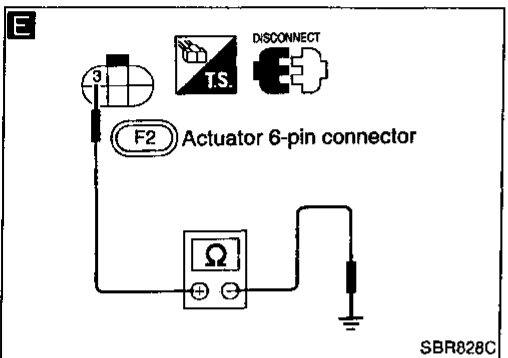
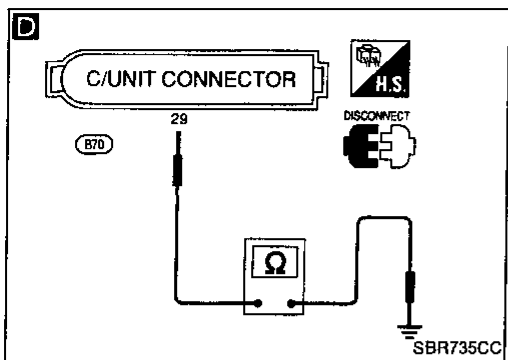

*: Specifications may vary depending on the type of tester.
Before performing this inspection, refer to the instruction manual of the tester.

TROUBLE DIAGNOSES

Diagnostic Procedure 2 (Not Self-diagnostic item) (Cont'd)

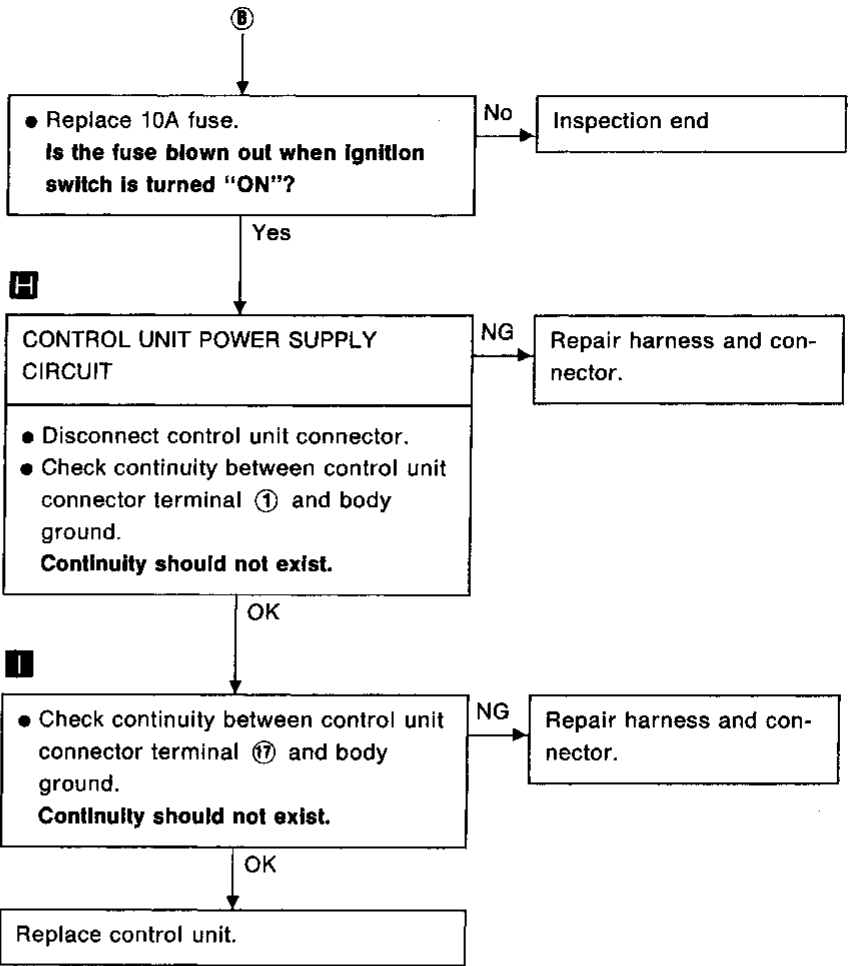
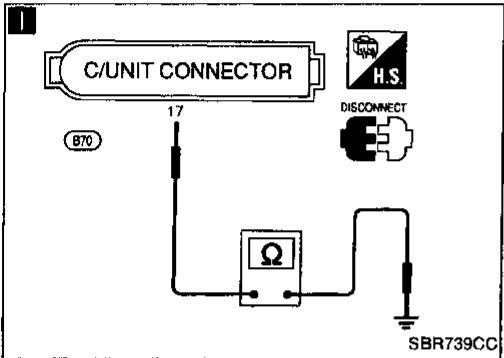
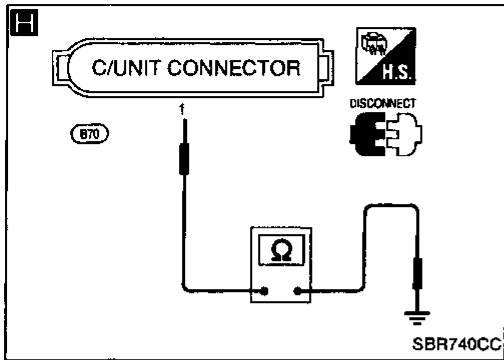

GI
MA
EM
LC
EF & EC
FE
AT
PD
FA
RA
BR
ST
RS
BT
HA
EL
IDX

Diagnostic Procedure 3

ACTUATOR SOLENOID VALVE (Malfunction code No. 45, 41 or 55)

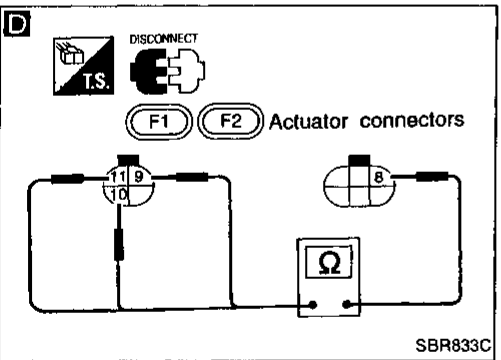
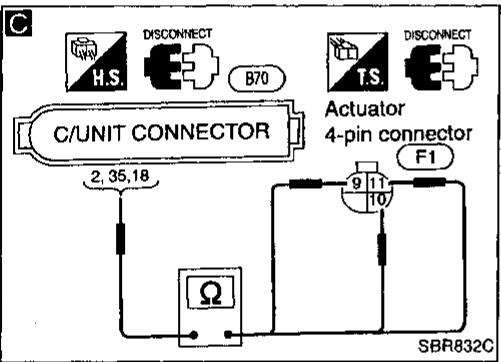
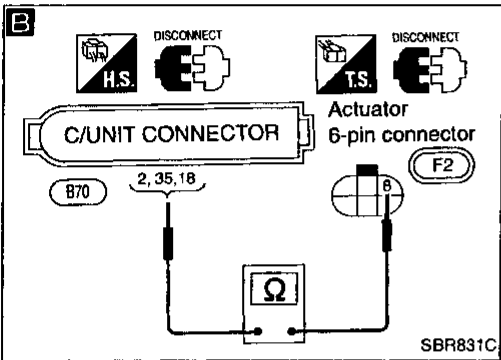
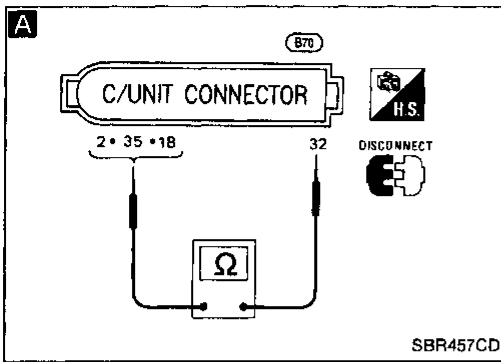

A

ACTUATOR SOLENOID VALVE CHECK

OK → Replace control unit.

- Disconnect control unit connector.
- Check resistance between control unit connector terminals.

Code No.	Terminals
45	Ⓓ - ②
41	Ⓓ - ⑳
55	Ⓓ - ⑱

Resistance: 0.8 - 1.5Ω

NG →

B

- Disconnect actuator 6-pin connector.
- Check resistance between control unit connector terminals and actuator 6-pin connector (actuator side) terminal.

OK → Repair harness and connector between control unit connector terminal Ⓓ and actuator 6-pin connector terminal ⑧.

Code No.	Control unit	Actuator
45	②	⑧
41	⑳	⑧
55	⑱	⑧

Resistance: 0.8 - 1.5Ω

NG →

C

- Disconnect actuator 4-pin connector.
- Check continuity between control unit connector terminals and actuator 4-pin connector (body side) terminals.

NG → Repair harness and connector.

Code No.	Control unit	Actuator
45	②	⑪
41	⑳	⑨
55	⑱	⑩

Continuity should exist.

OK →

D

- Disconnect actuator connectors.
- Check resistance between actuator connector (actuator side) terminals.

OK → Repair harness and connectors between actuator connector and control unit connector.

Code No.	Terminals
45	⑧ - ⑪
41	⑧ - ⑨
55	⑧ - ⑩

Resistance: 0.8 - 1.5Ω

NG →

Replace actuator.

TROUBLE DIAGNOSES

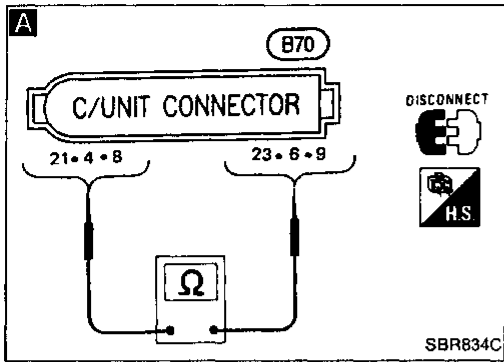

Diagnostic Procedure 4

WHEEL SENSOR OR ROTOR

(Malfunction code No. 21, 22, 25, 26, 31, 32, 35, 36 or 18)

A

WHEEL SENSOR ELECTRICAL CHECK

OK → **A** (See next page.)

- Disconnect control unit connector.
 - Check resistance between control unit connector terminals.
- Code No. 21 or 22 (Front RH wheel)
Terminals ① and ③
Code No. 25 or 26 (Front LH wheel)
Terminals ④ and ⑥
Code No. 31, 32, 35 or 36 (Rear wheel)
Terminals ⑧ and ⑨
Resistance: 0.9 - 1.1 kΩ

NG

Note

CHECK WHEEL SENSOR.

Refer to WHEEL SENSOR in Electrical Components Inspection (BR-56).

NG

Note

Replace wheel sensor.

OK

Note

Repair harness and connectors between control unit connector and wheel sensor connector.

Note: Wheel position should be distinguished by code No. except code No. 18 (sensor rotor).

GI

MA

EM

LC

EF &
EC

FE

AT

PD

FA

RA

BR

ST

RS

BT

HA

EL

IDX

TROUBLE DIAGNOSES

Diagnostic Procedure 4 (Cont'd)

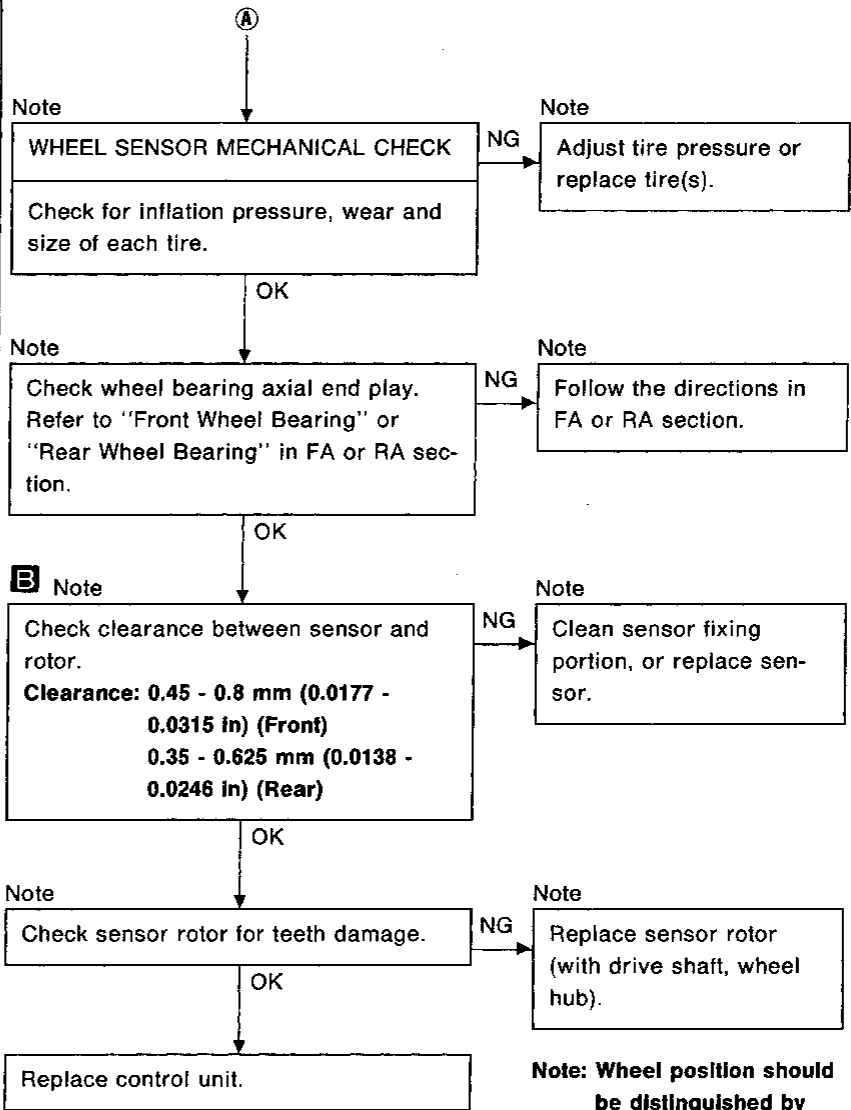
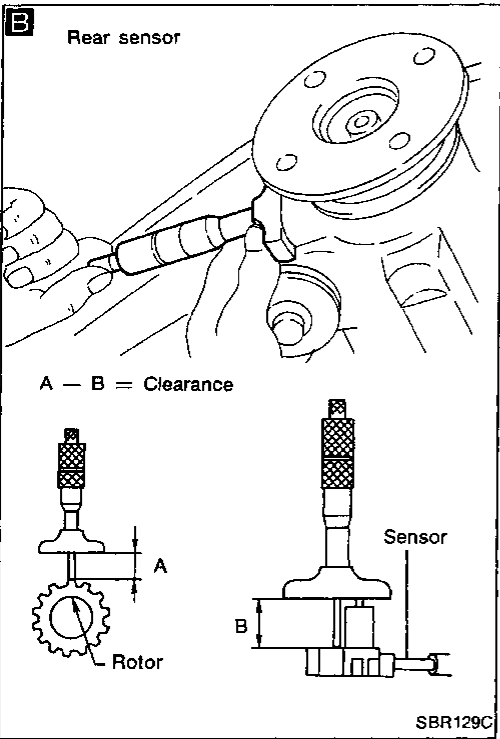
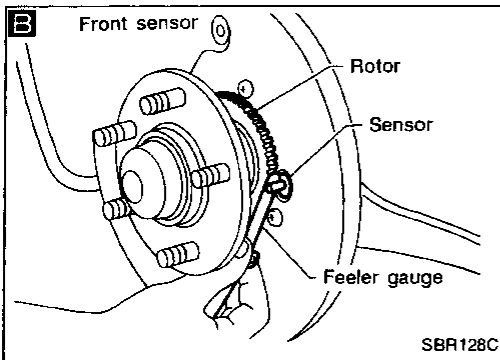

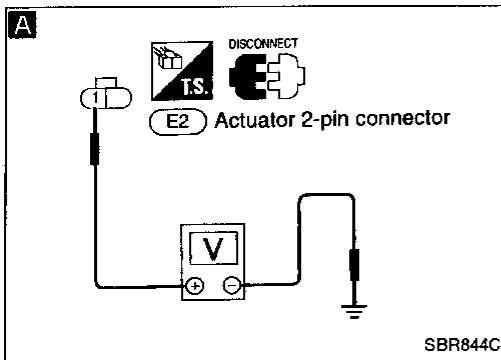

Diagnostic Procedure 5 MOTOR RELAY OR MOTOR (Malfunction code No. 61)

MOTOR POWER SUPPLY CIRCUIT

NG → (Skip page.)

- Check fusible link for actuator. For fusible link layout, refer to Wiring Diagram and SMJ terminal arrangement.

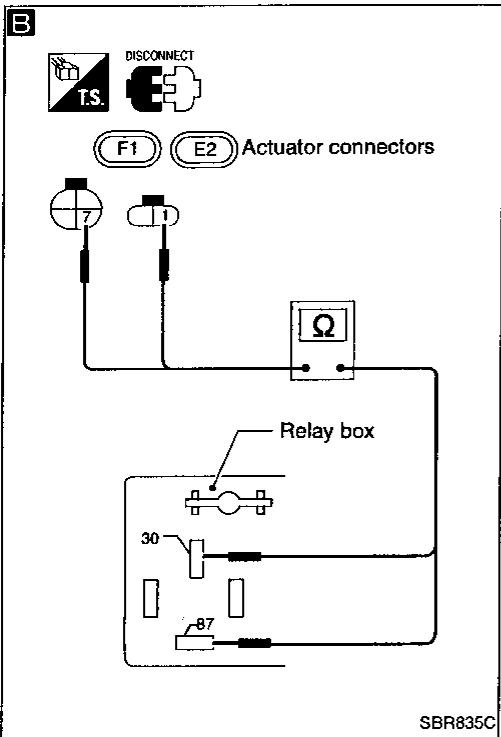

A

- Disconnect actuator 2-pin connector.
- Check voltage between connector (actuator side) terminal ① and ground.

Battery voltage should exist.

NG → Repair harness and connectors.

B

MOTOR RELAY CIRCUIT

- Remove motor relay.
- Disconnect actuator connectors.
- Check continuity between actuator connector (actuator side) terminals and relay connector terminals.

Actuator connector	Relay connector
①	⑧7
⑦	⑩0

Continuity should exist.

NG → Replace actuator assembly.

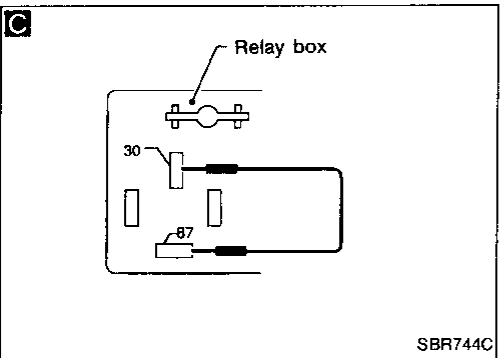

C

MOTOR CHECK

- Connect actuator connectors.
- Connect suitable wire between relay connector terminals ⑧7 and ⑩0.

Motor should operate.

Do not connect wire for more than 5 seconds.

NG → Replace actuator assembly.

MOTOR RELAY CHECK

NG → Replace motor relay.

Refer to ACTUATOR MOTOR RELAY in Electrical Components Inspection (BR-56).

OK
↓
Ⓐ

GI
MA
EM
LC
EF & EC
FE
AT
PD
FA
RA
BR
ST
RS
BT
HA
EL
IDX

TROUBLE DIAGNOSES

Diagnostic Procedure 5 (Cont'd)

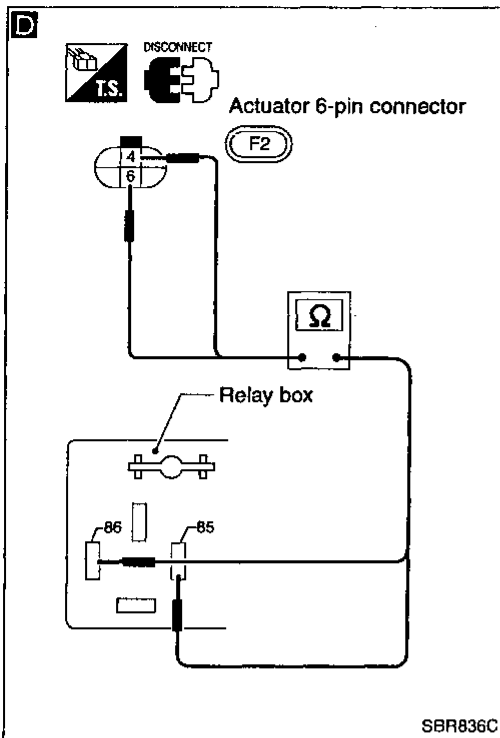

D

MOTOR RELAY CIRCUIT

NG → Replace actuator assembly.

- Disconnect actuator 6-pin connector.
- Check continuity between actuator connector (actuator side) terminals and relay connector terminals.

Actuator connector	Relay connector
④	⑧⑥
⑥	⑧⑤

Continuity should exist.

OK

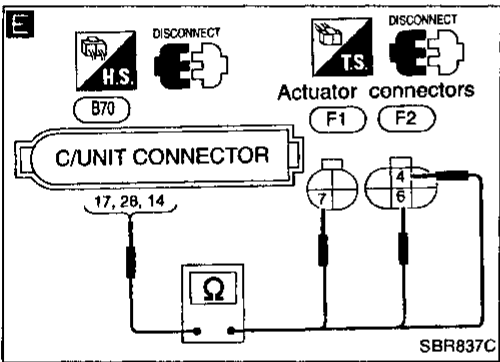

E

CIRCUIT CHECK

NG → Repair harness and connectors.

- Disconnect control unit connector.
- Check continuity between control unit connector terminals and actuator connector (body side) terminals.

Control unit	Actuator connector
⑰	④
⑳	⑥
⑭	⑦

Continuity should exist.

OK

Replace control unit.

NG → Repair harness and connectors.

TROUBLE DIAGNOSES

Diagnostic Procedure 5 (Cont'd)

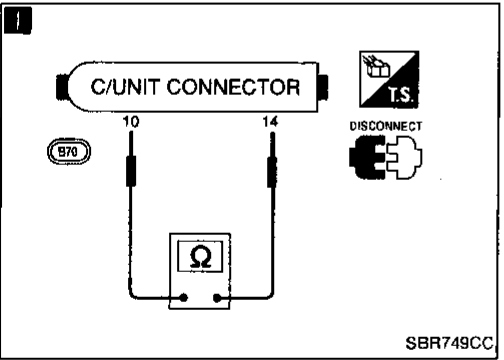
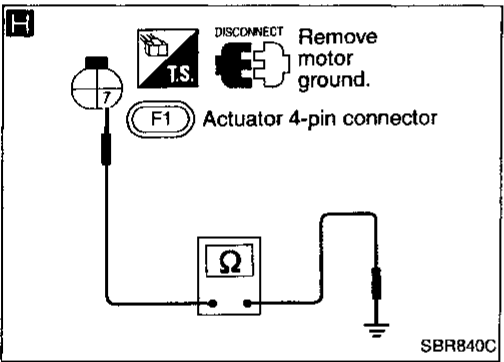
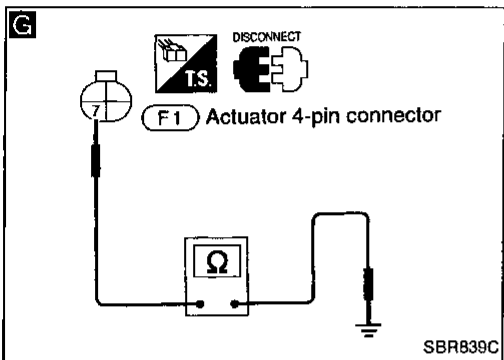
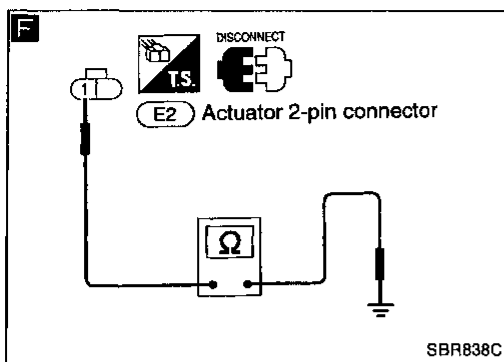

B

● Replace fusible link.

Is the fusible link blown out when ignition switch is turned "ON"?

No → Inspection end

Yes →

F

MOTOR POWER SUPPLY CIRCUIT

● Disconnect actuator 2-pin connector.

● Check continuity between actuator 2-pin connector (body side) terminal ① and ground.

Continuity should not exist.

NG → Repair harness and connector.

OK →

G

● Disconnect actuator 4-pin connector and control unit connector.

● Check continuity between actuator 4-pin connector (body side) terminal ⑦ and ground.

Continuity should not exist.

NG → Repair harness and connector.

OK →

H

● Remove motor ground.

● Check continuity between actuator 4-pin connector (actuator side) terminal ⑦ and ground.

Continuity should not exist.

NG → Replace actuator assembly.

OK →

I

● Check continuity between control unit terminals ⑭ and ⑩.

Continuity should not exist.

NG → Replace control unit.

OK →

Replace actuator assembly.

GI
MA
EM
LC
EF & EC
FE
AT
PD
FA
RA
BR
ST
RS
BT
HA
EL
IDX

TROUBLE DIAGNOSES

Diagnostic Procedure 5 (Cont'd)

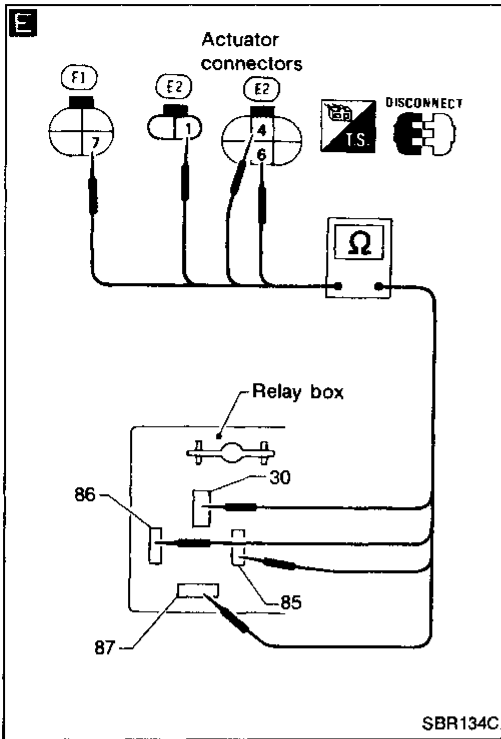

(A)

E ACTUATOR RELAY BOX CHECK

Check continuity between relay terminals and actuator connector terminals.

Relay terminals	Connector terminals
87	1
86	4
85	6
80	7

Continuity should exist.

NG → Replace actuator.

OK ↓

Replace control unit.

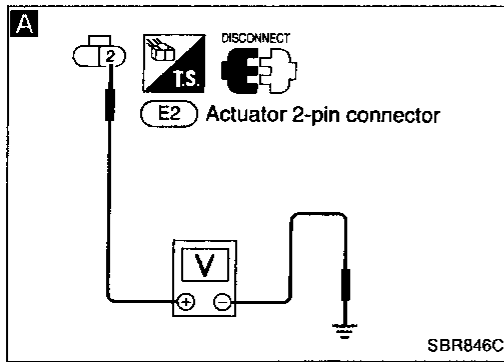

Diagnostic Procedure 6

SOLENOID VALVE RELAY (Malfunction code No. 63)

SOLENOID VALVE POWER SUPPLY CHECK

- Check 20A fuse. For fuse layout, refer to Wiring Diagram and SMJ terminal arrangement.

NG → **A** (See next page.)

OK

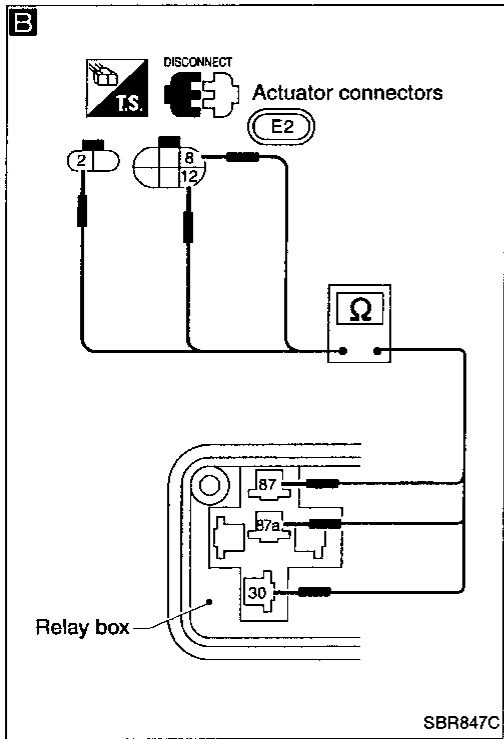

A SOLENOID VALVE POWER SUPPLY CHECK

- Disconnect connectors from actuator.
 - Check voltage between actuator 2-pin connector (body side) terminal ② and ground.
- Battery voltage should exist.**

NG → Repair harness and connector.

OK

SOLENOID VALVE RELAY CHECK

Refer to SOLENOID VALVE RELAY in Electrical Components Inspection (BR-56).

NG → Replace solenoid valve relay.

OK

B SOLENOID VALVE RELAY CIRCUIT CHECK

Check continuity between relay terminals and actuator connector (actuator side) terminals.

NG → ● Replace actuator.

Relay terminals	Connector terminals
③⑥	⑧
⑦	②
⑧7a	⑫

Continuity should exist.

OK

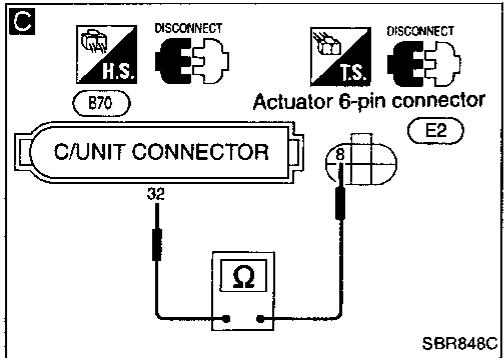

C CIRCUIT CHECK

- Disconnect control unit connector.
 - Check continuity between control unit connector terminal ⑫ and actuator connector (body side) terminal ⑧.
- Continuity should exist.**

NG → Repair harness and connectors.

OK

Replace control unit.

GI

MA

EM

LC

EF &
EC

FE

AT

PD

FA

RA

BR

ST

RS

BT

HA

EL

IDX

TROUBLE DIAGNOSES

Diagnostic Procedure 6 (Cont'd)

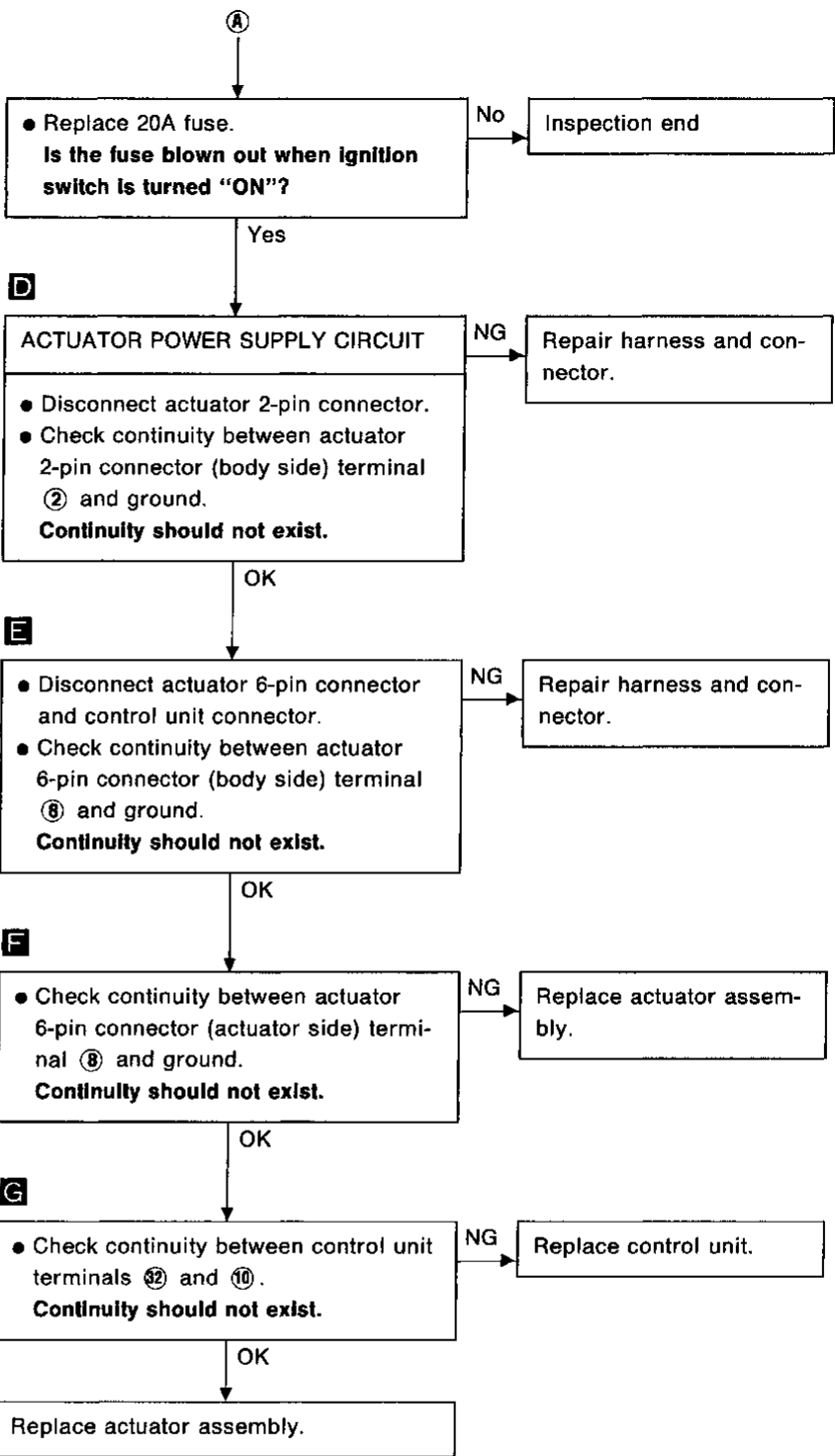
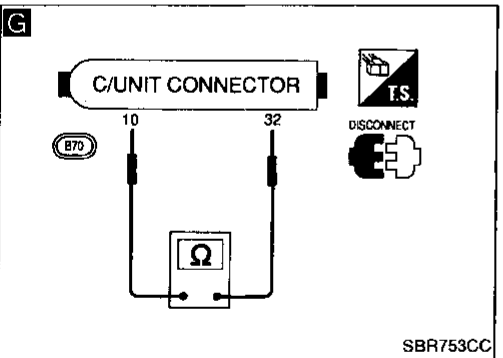
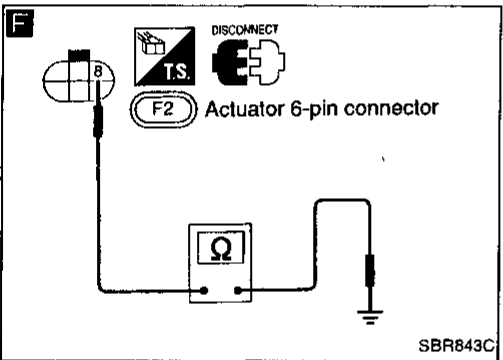
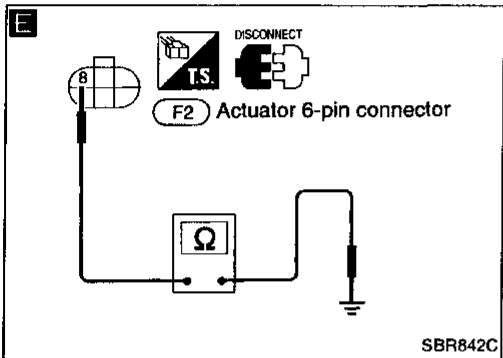
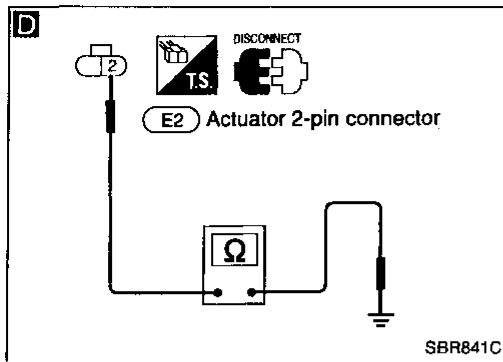

TROUBLE DIAGNOSES

Diagnostic Procedure 7

POWER SUPPLY (Low voltage) (Malfunction code No. 57)

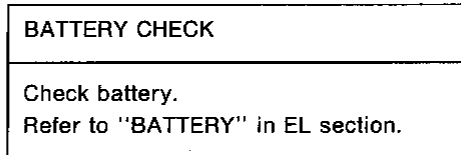

GI

MA

EM

Diagnostic Procedure 8

STOP LAMP SWITCH CIRCUIT (Malfunction code No. 16)

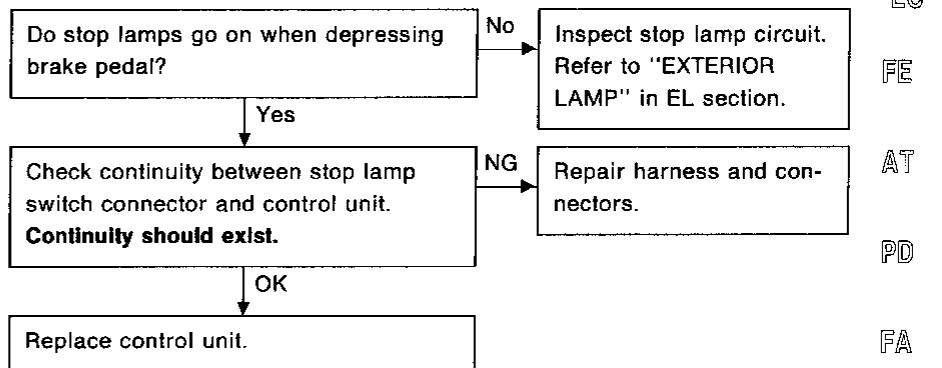

LC

EF &
EC

FE

AT

PD

FA

RA

Diagnostic Procedure 9

CONTROL UNIT (Malfunction code No. 71)

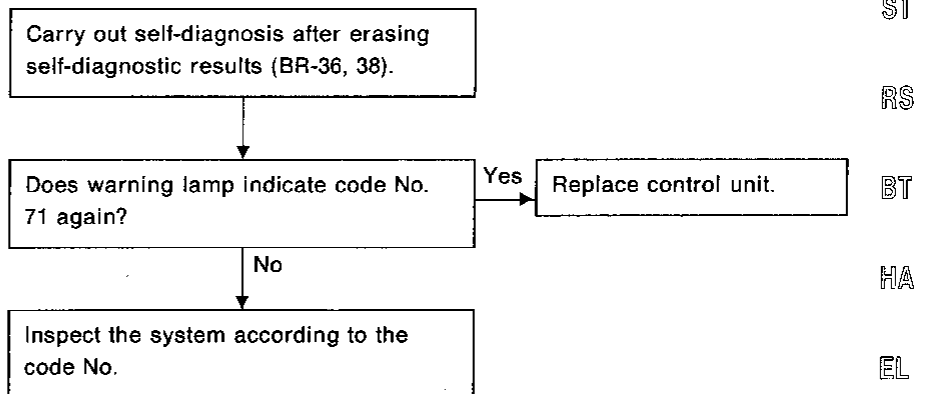

BR

ST

RS

BT

HA

EL

IDX

TROUBLE DIAGNOSES

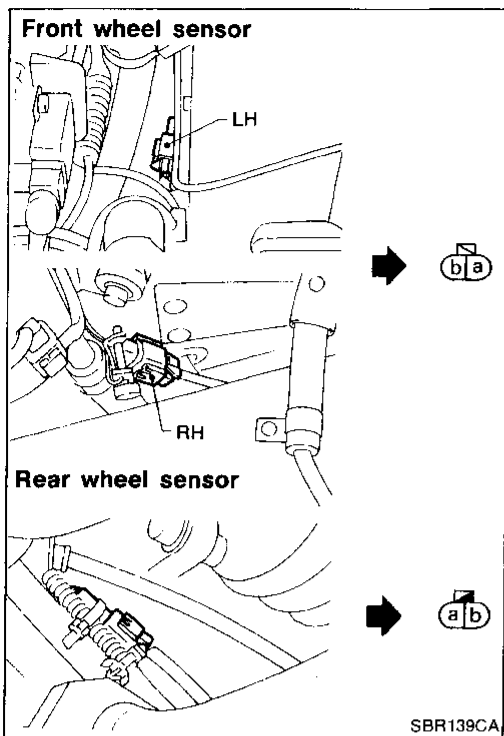

Electrical Components Inspection

WHEEL SENSOR

Check resistance between terminals **a** and **b**.

Resistance: 0.9 - 1.1 kΩ

For the locations of sensors, refer to Component Parts and Harness Connector Location.

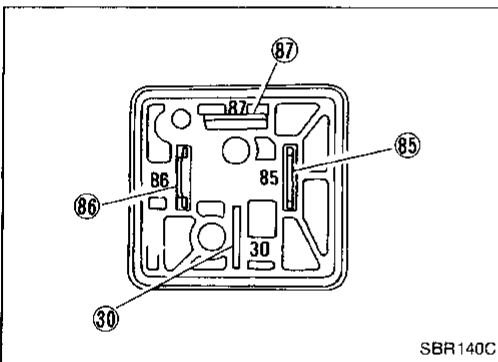

ACTUATOR MOTOR RELAY

Condition	Continuity existence between terminals 30 and 87
Battery voltage not applied between terminals 85 and 86 .	No
Battery voltage applied between terminals 85 and 86 .	Yes

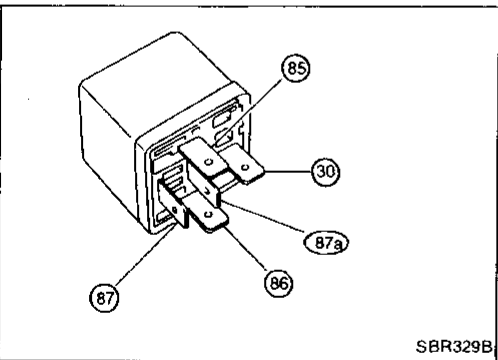

SOLENOID VALVE RELAY

Condition	Continuity existence between terminals 30 and 87a	Continuity existence between terminals 30 and 87
Battery voltage not applied between terminals 85 and 86 .	Yes	No
Battery voltage applied between terminals 85 and 86 .	No	Yes

SERVICE DATA AND SPECIFICATIONS (SDS)

General Specifications

Front brake	
Brake model	CL28VF disc brake
Cylinder bore diameter x number of pistons mm (in)	42.8 (1.685) x 2
Lining length x width x thickness mm (in)	127 x 56 x 9.5 (5.00 x 2.20 x 0.374)
Rotor outer diameter x thickness mm (in)	280 x 28 (11.02 x 1.10)
Rear brake	
Brake model	AD11VB disc brake
Cylinder bore diameter x number of piston mm (in)	38.2 (1.504) x 1
Lining length x width x thickness mm (in)	97.4 x 33.9 x 10 (3.835 x 1.335 x 0.39)
Rotor outer diameter x thickness mm (in)	292 x 16 (11.50 x 0.63)

Parking brake	
Brake model	DS17HE drum brake
Lining length x width x thickness mm (in)	154.1 x 25.0 x 3.0 (6.07 x 0.984 x 0.118)
Drum inner diameter mm (in)	172.0 (6.77)
Master cylinder	
Cylinder bore diameter mm (in)	25.40 (1)
Control valve	
Valve model	Proportioning valve (within master cylinder)
Split point [kPa (kg/cm ² , psi)] x reducing ratio	1,961 (20, 284) x 0.4
Brake booster	
Booster model	M215T
Diaphragm diameter mm (in)	Primary: 230 (9.06) Secondary: 205 (8.07)
Brake fluid	
Recommended brake fluid	DOT 3

Inspection and Adjustment

DISC BRAKE

	Unit: mm (in)	
Location	Front	Rear
Brake model	CL28VF	AD11VB
Pad wear limit		
Minimum thickness	2.0 (0.079)	
Rotor repair limit		
Minimum thickness	26.0 (1.024)	14.0 (0.551)

DRUM BRAKE

	Unit: mm (in)
Location	Rear
Brake model	DS17HE
Lining wear limit	
Minimum thickness	1.5 (0.059)
Drum repair limit	
Maximum inner diameter	173.0 (6.81)
Brake shoe "backoff" adjustment	5 - 6 latches

BRAKE PEDAL

	Unit: mm (in)
Free height "H"	178 - 188 (7.01 - 7.40)
Depressed height "D" [under force of 490 N (50 kg, 110 lb) with engine running]	95 (3.74) or more
Clearance "C" between pedal stopper and threaded end of stop lamp switch or ASCD switch	0.3 - 1.0 (0.012 - 0.039)
Pedal free play	1.0 - 3.0 (0.039 - 0.118)

PARKING BRAKE

	Unit: mm (in)
Control type	Foot lever
Pedal stroke [under force of 196 N (20 kg, 44 lb)]	75 - 90 (2.95 - 3.54)