

# RESTRAINT SYSTEM

## SECTION **RS**

GI

MA

EM

LC

EF &  
EC

## CONTENTS

FE

AT

PD

FA

RA

BR

ST

**RS**

BT

HA

EL

IDX

<b>PRECAUTION</b> .....	2	Removal — Front Passenger Air Bag Module.....	10
Supplemental Restraint System (SRS) "AIR BAG" and "SEAT BELT PRE-TENSIONER".....	2	Installation — Air Bag Module and Spiral Cable .....	11
<b>SEAT BELTS</b> .....	3	Installation — Front Passenger Air Bag Module.....	12
Front Seat Belt.....	3	Disposal of Air Bag Module and Seat Belt Pre-tensioner.....	12
Rear Seat Belt.....	4	<b>TROUBLE DIAGNOSES — Supplemental Restraint System (SRS)</b> .....	17
<b>SUPPLEMENTAL RESTRAINT SYSTEM (SRS)</b> .....	5	Schematic.....	17
Precautions for SRS "Air Bag" and "Seat Belt Pre-tensioner" Service.....	5	Wiring Diagram.....	18
Special Service Tools.....	5	Self-diagnosis.....	19
Description.....	6	Trouble Diagnoses for Air Bag.....	26
SRS Component Parts Location.....	6	Trouble Diagnosis for Seat Belt Pre-tensioner.....	28
Maintenance Items.....	7	Collision Diagnosis.....	30
Removal and Installation — Diagnosis Sensor Unit and Seat Belt Pre-tensioner.....	8		
Removal — Air Bag Module and Spiral Cable.....	9		

**When you read wiring diagrams:**

- Read GI section, "HOW TO READ WIRING DIAGRAMS".
- See EL section, "POWER SUPPLY ROUTING" for power distribution circuit.

**When you perform trouble diagnoses, read GI section, "HOW TO FOLLOW FLOW CHART IN TROUBLE DIAGNOSES".**

## PRECAUTION

---

### **Supplemental Restraint System (SRS) “AIR BAG” and “SEAT BELT PRE-TENSIONER”**

The Supplemental Restraint System “Air Bag” and “Seat Belt Pre-tensioner”, used along with a seat belt, help to reduce the risk or severity of injury to the driver and front passenger in a frontal collision. The Supplemental Restraint System consists of air bag modules (located in the center of the steering wheel and on the instrument panel on the passenger side), seat belt pre-tensioners, a diagnosis sensor unit, warning lamp, wiring harness and spiral cable.

**WARNING:**

- **To avoid rendering the SRS inoperative, which could increase the risk of personal injury or death in the event of a collision which would result in air bag inflation, all maintenance must be performed by an authorized INFINITI dealer.**
- **Improper maintenance, including incorrect removal and installation of the SRS, can lead to personal injury caused by unintentional activation of the system.**
- **All SRS electrical wiring harnesses and connectors are covered with yellow outer insulation. Do not use electrical test equipment on any circuit related to the SRS.**

# SEAT BELTS

## CAUTION:

- Before removing the seat belt assembly, turn the ignition switch off, disconnect battery ground cable and wait for at least 10 minutes.
- Do not disassemble buckle or seat belt assembly.
- Replace anchor bolts if they are deformed or worn out.
- Never oil tongue and buckle.
- If any component of seat belt assembly is questionable, do not repair. Replace as seat belt assembly.
- If webbing is cut, frayed, or damaged, replace seat belt assembly.
- When replacing seat belt assembly, use a genuine seat belt assembly.
- After any collision, inspect all seat belt assemblies, including retractors and other attached hardware (i.e., guide rail set).

## Front Seat Belt

- ① Remove front seat. Refer to "SEAT" in BT section for details.
- ② Remove floor anchor cover. Refer to "INTERIOR TRIM" in BT section for details.
- ③ Remove floor anchor bolt.
- ④ Remove center pillar garnish. Refer to "INTERIOR TRIM" in BT section for details.
- ⑤ Disconnect seat belt pre-tensioner connector.
- ⑥ Pull out seat belt from center pillar garnish.
- ⑦ Remove through anchor nut from adjuster.
- ⑧ Remove second sash guide.
- ⑨ Remove screw securing seat belt pre-tensioner retractor, then remove seat belt pre-tensioner retractor.

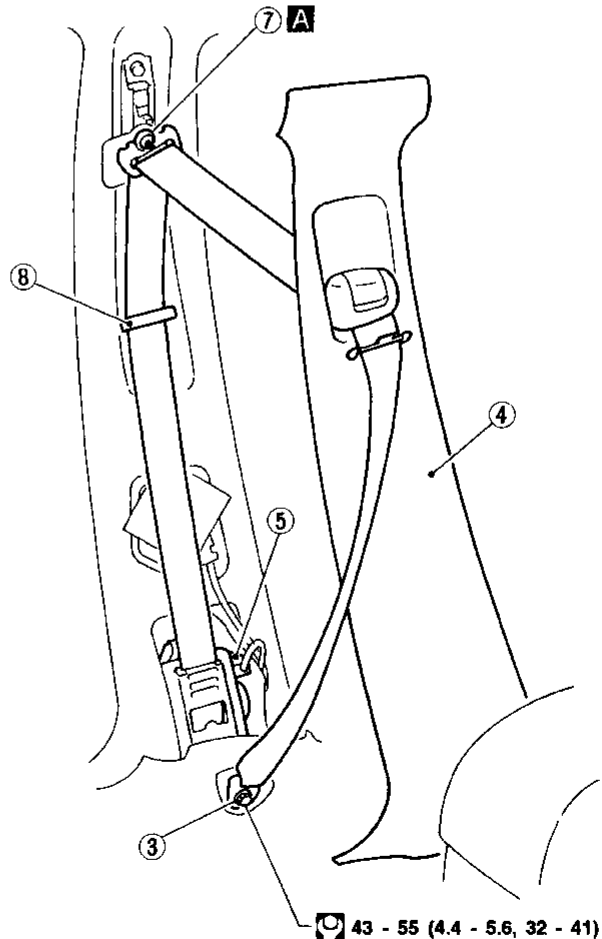
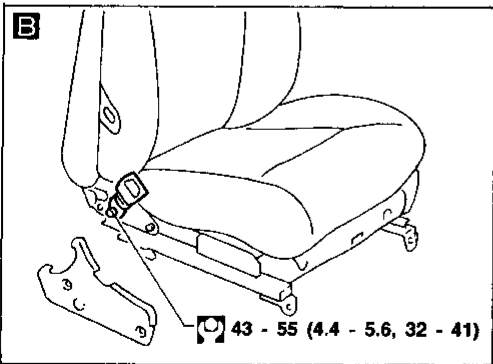
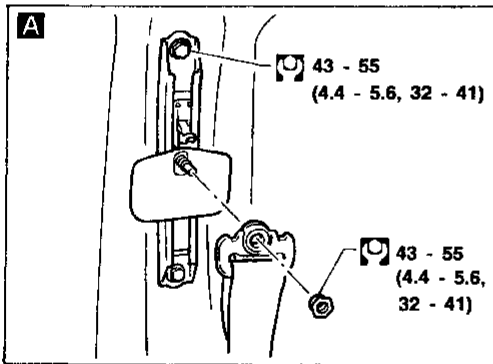

: N·m (kg-m, ft-lb)

MRS011A

# SEAT BELTS

## Rear Seat Belt

- ① Remove rear seat. Refer to "SEAT" in BT section for details.
- ② Remove rear parcel shelf finisher. Refer to "INTERIOR TRIM" in BT section for details.
- ③ Remove each anchor bolt.
- ④ Remove the anchor bolt securing rear seat belt retractor.

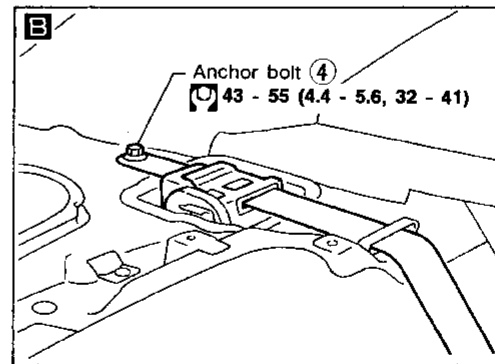
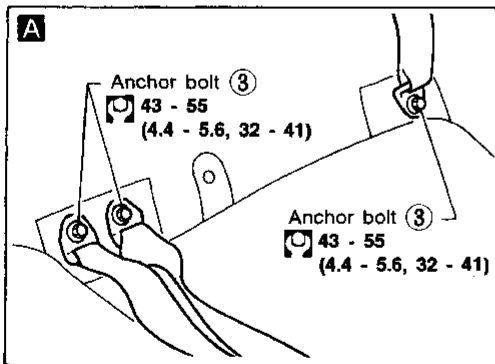
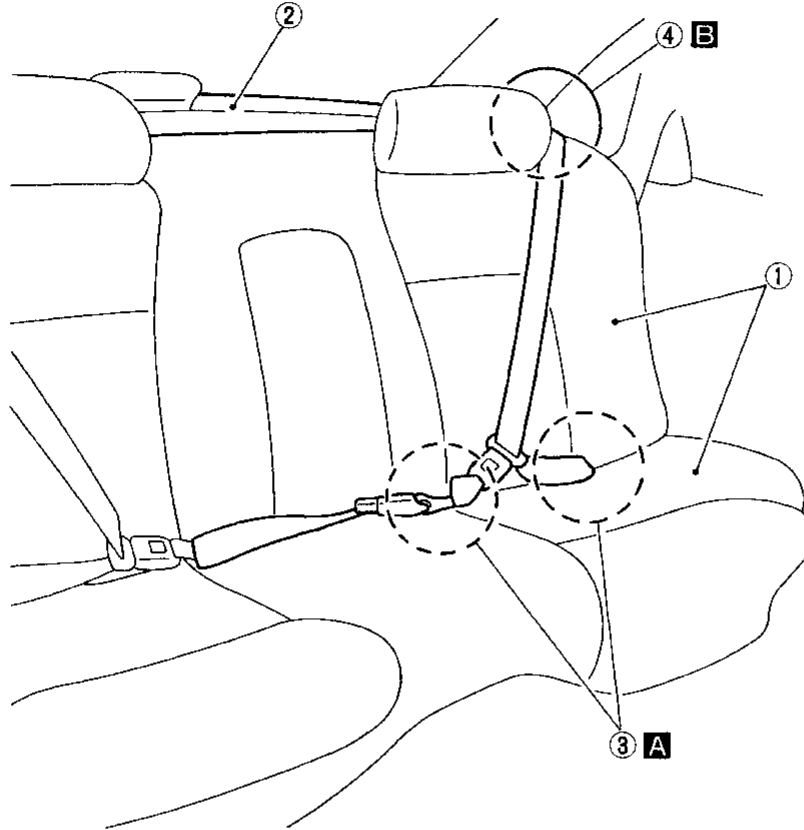

 : N·m (kg-m, ft-lb)

MRS012A

# SUPPLEMENTAL RESTRAINT SYSTEM (SRS)

## Precautions for SRS “Air Bag” and “Seat Belt Pre-tensioner” Service

- Do not use a circuit tester to check SRS circuits.
- Before servicing the SRS, turn ignition switch “OFF”, disconnect battery ground cable and wait for at least 10 minutes.  
For approximately ten minutes after the cables are removed, it is still possible for the air bag and seat belt pre-tensioner to deploy. Therefore, do not work on any SRS connectors or wires until at least ten minutes have passed.
- Diagnosis sensor unit must always be installed with their arrow marks “←” pointing towards the front of the vehicle for proper operation. Also check diagnosis sensor unit for cracks, deformities or rust before installation and replace as required.
- The spiral cable must be aligned with the neutral position since its rotations are limited. Do not attempt to turn steering wheel or column after removal of steering gear.
- Handle air bag module carefully. Always place it with the pad side facing upward.
- After removing any SRS parts, discard old bolts and replace with new ones. Conduct self-diagnosis to check entire SRS for proper function.
- After air bag inflates, the front instrument panel assembly should be replaced.

## Special Service Tools

\*: Special tool or commercial equivalent

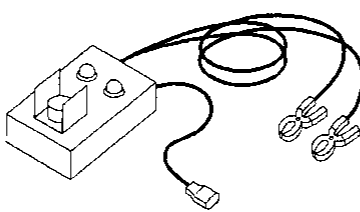
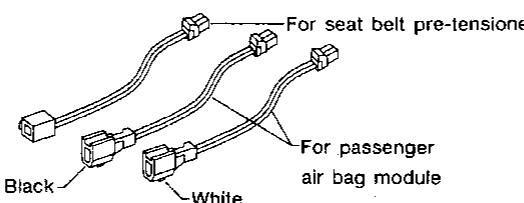
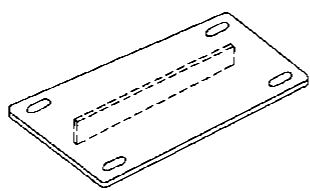
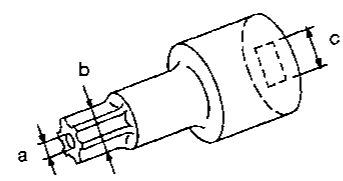
Tool number (Kent-Moore No.) Tool name	Description	
KV991072S0 (J38381-KIT) Air bag deployment kit  KV99106400 (J38381) Deployment tool	 NT357	Disposing of air bag module    PD FA RA
KV991065S0 (J38381-30) Deployment tool adapters	 NT353 Black White For seat belt pre-tensioner For passenger air bag module	BR ST
KV99105300 (J41246) Passenger air bag bracket	 NT354	Anchor the passenger air bag module   RS BT HA
HT61961000 and HT62152000 combined (J38219) *Special torx bit	 NT361	Use for special bolts [TAMPER RESISTANT TORX (Size T50)]  a: 3.5 (0.138) dia. b: 8.5 - 8.6 (0.335 - 0.339) dia. c: approx. 10 (0.39) sq.  EL IDX  Unit: mm (in)

# SUPPLEMENTAL RESTRAINT SYSTEM (SRS)

## Description

The air bag deploys if the diagnosis sensor unit activates while the ignition switch is in "ON" or "START" position.

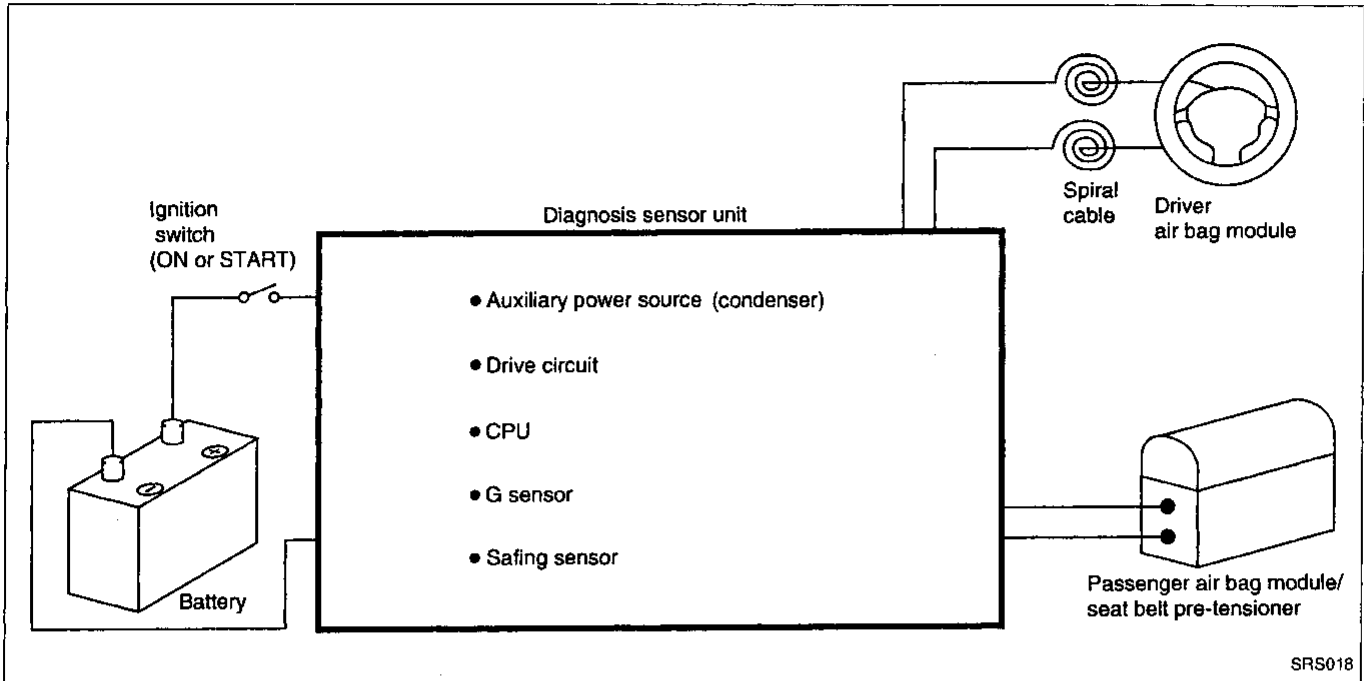

## SRS Component Parts Location

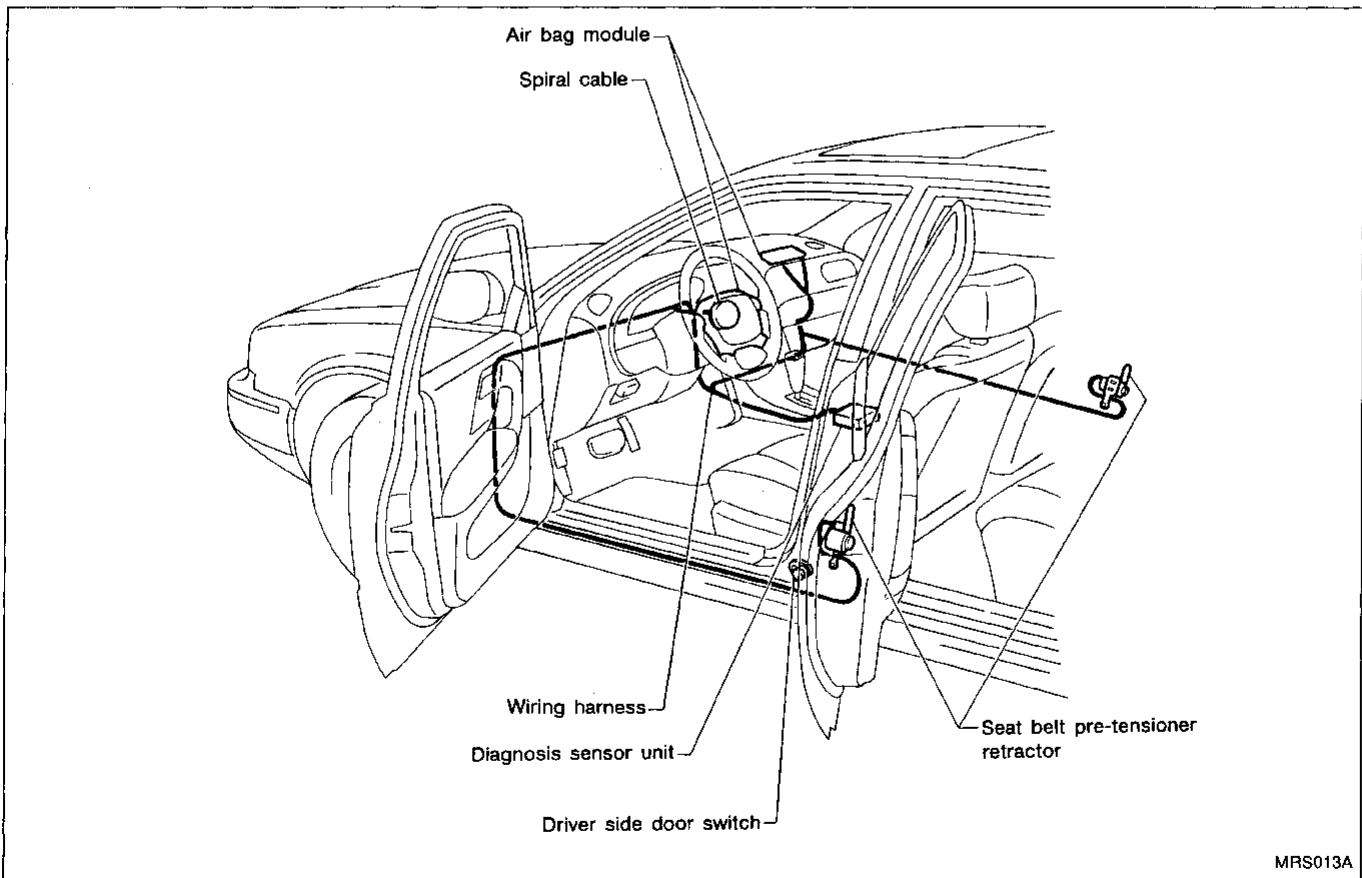

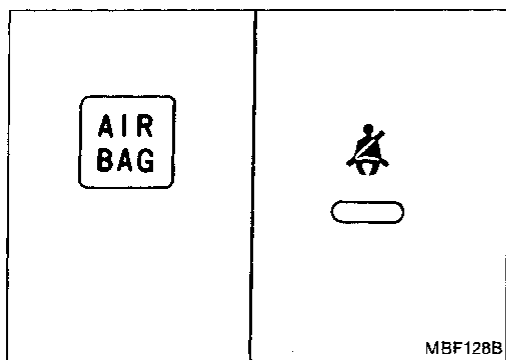

## Maintenance Items

1. Check "AIR BAG" and "Seat belt" warning lamps.
  - (1) Fasten the seat belt.
  - (2) Ignition key is in the "ON" or "START" position.
  - (3) The "AIR BAG" and "SEAT BELT" warning lamps will illuminate for about 7 seconds and then turn off.

This means that the systems are operational.

When a warning lamp flashes, check and correct cause of the problem.

2. Visually check SRS components

- (1) Diagnosis sensor unit — Airbag
  - Check case and bracket for dents, cracks or deformities.
  - Check connectors for damage, and terminals for deformities.

- (2) Main harness and air bag harness

- Check connectors for poor connections.
- Check harnesses for binding, connectors for damage, and terminals for deformities.

- (3) Spiral cable

- Visually check lock (engagement) pins and combination switch for damage.
- Check connectors, flat cable and protective tape for damage.
- Check steering wheel for noise, binding or difficult operation.

- (4) Air bag module and steering wheel

- Remove air bag module from steering wheel or instrument panel. Check harness cover and connectors for damage, terminals for deformities, and harness for binding.
- Install driver side air bag module to steering wheel to check fit or alignment with the wheel.
- Check steering wheel for excessive free play.
- Install passenger side air bag module to instrument panel to check fit or alignment with the instrument panel.

### CAUTION:

Replace previously used screws with new ones.

- (5) Seat belt pre-tensioner

- Check harness cover and connectors for damage, terminals for deformities, and harness for binding.
- Check belts for damage and anchors for loose mounting.
- Check retractor for smooth operation.
- Perform self-diagnosis for seat belt pre-tensioner using "Seat belt" warning lamp or CONSULT. Refer to "Self-diagnosis" for details. (RS-19)

## Removal and Installation — Diagnosis Sensor Unit and Seat Belt Pre-tensioner

### CAUTION:

- Before servicing SRS, turn the ignition switch off, disconnect battery ground cable and wait for at least 10 minutes.
- The special bolts are coated with bonding agent. Discard old ones after removal; replace with new ones.
- Check diagnosis sensor unit for proper installation.
- Check diagnosis sensor unit to ensure they are free of deformities, dents, cracks or rust. If they show any visible signs of damage, replace them with new ones.
- Check diagnosis sensor unit brackets to ensure they are free of deformities or rust.
- Do not attempt to disassemble seat belt pre-tensioner.
- Do not drop or impact seat belt pre-tensioner. If any portion is damaged, replace the seat belt pre-tensioner.
- Do not expose seat belt pre-tensioner to temperatures exceeding 80°C (176°F).
- Whenever seat belts (equipped with pre-tensioner) are moved, ensure that cylinder faces down. Do not hold cylinder.

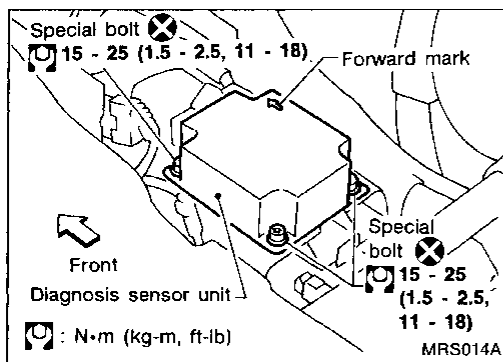

### REMOVAL OF DIAGNOSIS SENSOR UNIT

1. Disconnect driver and passenger air bag module connectors. Also, disconnect seat belt pre-tensioner connector.
2. Remove rear floor console assembly. Refer to "INSTRUMENT PANEL" in BT section.
3. Disconnect diagnosis sensor unit connector.
4. Remove bolt and also remove special bolts using the TAMPER RESISTANT TORX (Size T50), from diagnosis sensor unit.  
Then remove the diagnosis sensor unit.

### NOTE:

- To install, reverse the removal procedure sequence.

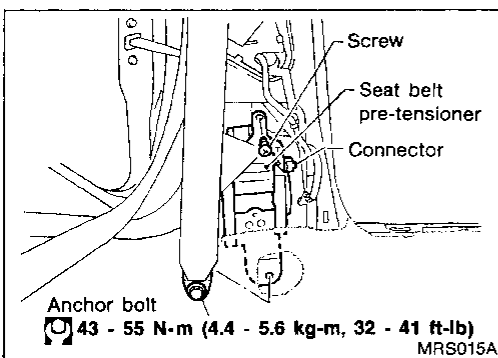

### REMOVAL OF SEAT BELT PRE-TENSIONER

For removal of seat belt pre-tensioner, refer to "Front Seat Belt" for details. (RS-3)

### NOTE:

- To install, reverse the removal procedure sequence.
- After replacement, perform self-diagnosis for seat belt pre-tensioner using "Seat belt" warning lamp or CONSULT. Refer to "Self-diagnosis" for details. (RS-19)



**Removal — Air Bag Module and Spiral Cable**

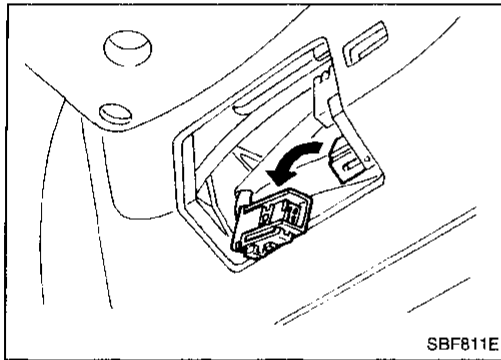
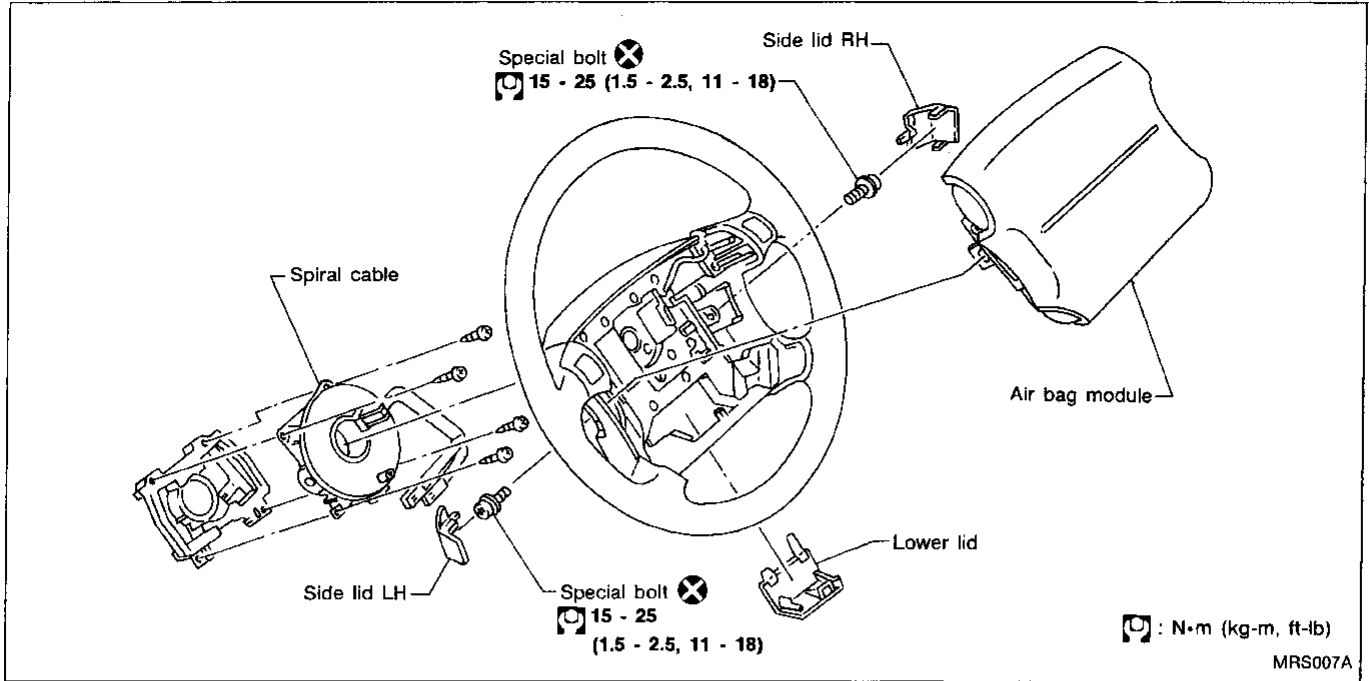

**CAUTION:**

**Before servicing SRS, turn the ignition switch off, disconnect battery ground cable and wait for at least 10 minutes.**

1. Remove lower lid from steering wheel, and disconnect air bag module connector.

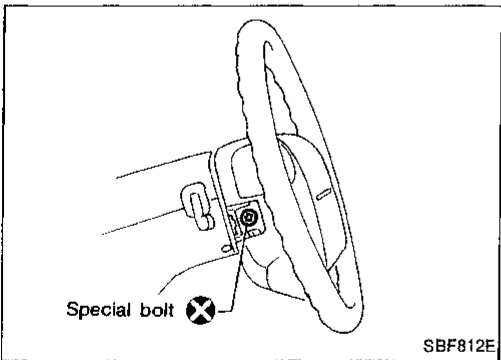

2. Remove side lid. Using the TAMPER RESISTANT TORX (Size T50), remove left and right special bolts. Air bag module can then be removed.

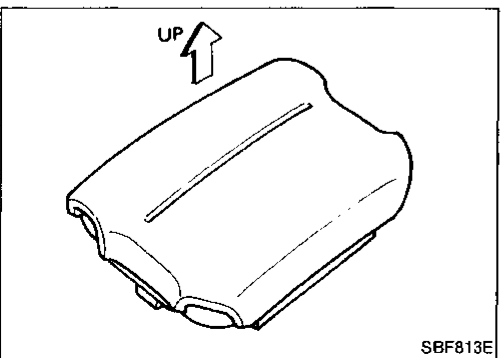

**CAUTION:**

- Always place air bag module with pad side facing upward.
- Do not attempt to disassemble air bag module.
- The special bolts are coated with bonding agent. Discard old ones after removal; replace with new ones.

GI  
MA  
EM  
LC  
EF &  
EC  
FE  
AT  
PD  
FA  
RA  
BR  
ST  
RS  
BT  
HA  
EL  
IDX

## SUPPLEMENTAL RESTRAINT SYSTEM (SRS)

### Removal — Air Bag Module and Spiral Cable (Cont'd)

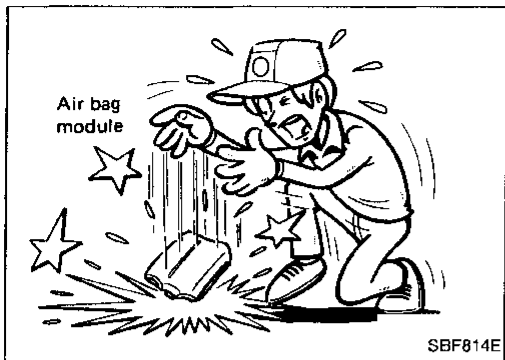

- Do not drop or impact air bag module. If any portion is deformed or cracked, replace the module.
- Do not expose the air bag module to temperatures exceeding 93°C (199°F).
- Do not allow oil, grease or water to come in contact with the air bag module.

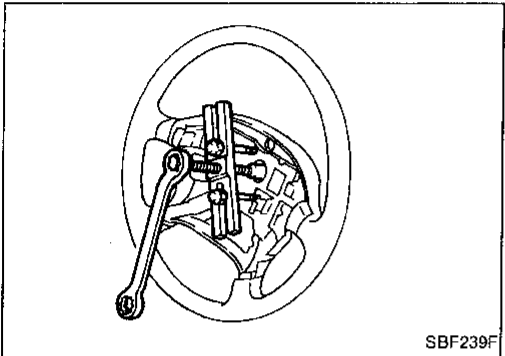

3. Set steering wheel in the neutral position.
4. Disconnect horn connector and remove nuts.
5. Using steering wheel puller, remove steering wheel. Be careful not to over-tighten puller bolt on steering wheel.
6. Remove steering column cover.
7. Disconnect connector and remove the four screws. The spiral cable can then be removed.

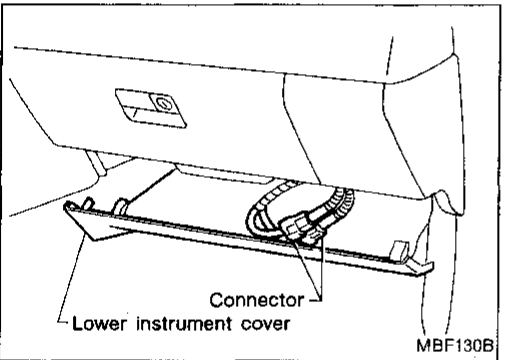

### Removal — Front Passenger Air Bag Module

#### CAUTION:

Before servicing SRS, turn the ignition switch off, disconnect battery ground cable and wait for at least 10 minutes.

1. Remove glove box and glove box inner cover.
  2. Remove connector bracket from air bag module and disconnect inflator connector from body harness air bag connector.
  3. Remove instrument panel.
  4. Remove the special bolt from left and right sides of front passenger air bag module and remove the air bag module from the steering member.
- Air bag module is heavy and should be supported using both hands during removal.

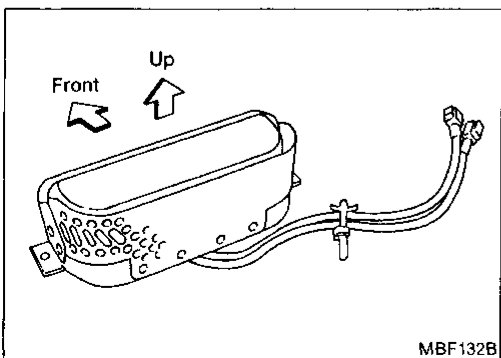
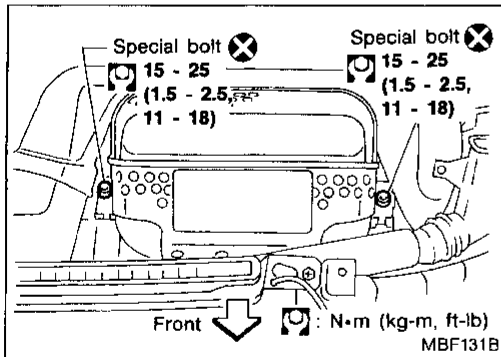

#### CAUTION:

- Always place air bag module with pad side facing upward.
- Do not attempt to disassemble air bag module.
- The special bolts are coated with bonding agent. Discard old ones after removal; replace with new ones.

# SUPPLEMENTAL RESTRAINT SYSTEM (SRS)

## Removal — Front Passenger Air Bag Module (Cont'd)

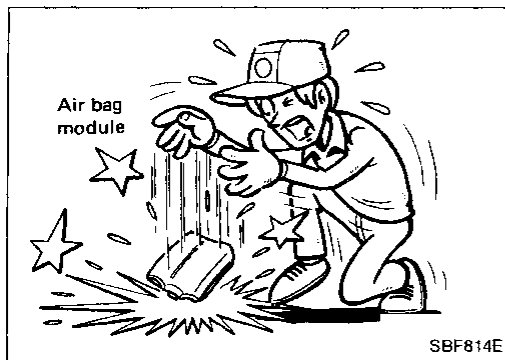

- Do not drop or impact air bag module. If any portion is deformed or cracked, replace the module.
- Do not expose the air bag module to temperatures exceeding 93°C (199°F).
- Do not allow oil, grease or water to come in contact with the air bag module.

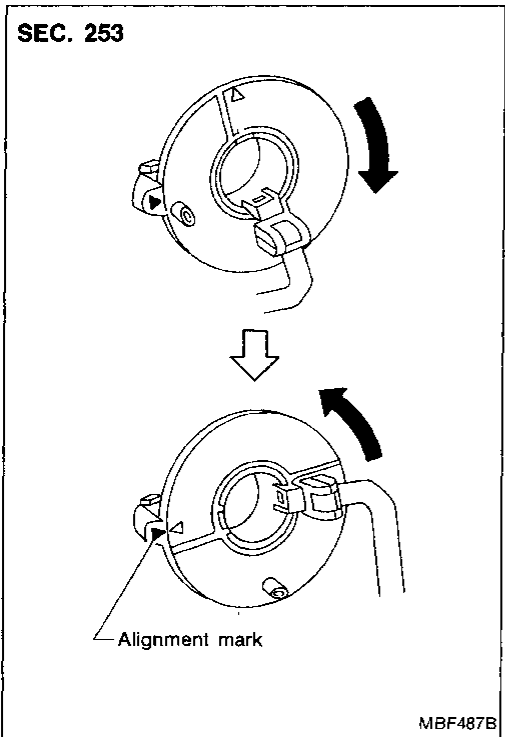

## Installation — Air Bag Module and Spiral Cable

1. Set the front wheels in the straight-ahead position.
2. Make sure that the spiral cable is in the neutral position. The neutral position is detected by turning left about 2.5 revolutions from the right end position. Align the two marks (X).

### CAUTION:

The spiral cable may snap due to steering operation if the cable is installed in an improper position.

Also, with the steering linkage disconnected, the cable may snap by turning the steering wheel beyond the limited number of turns. (The spiral cable can be turned up to 2.5 turns from the neutral position to both the right and left.)

3. Connect spiral cable connector and tighten with screws. Install steering column cover.

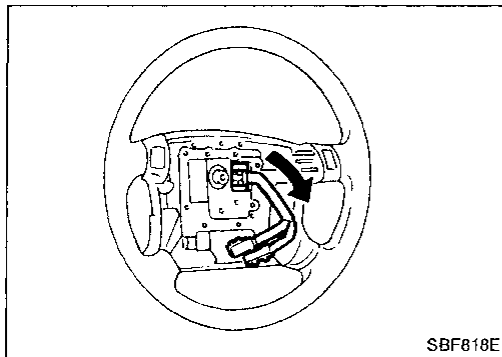

4. Install steering wheel setting spiral cable pin guides, and pull spiral cable through.
5. Connect horn connector and engage spiral cable with pawls in steering wheel.
6. Tighten nut.

- Turn steering wheel to the left end and to the right end. Make sure "AIRBAG" warning lamp does not blink or stay ON (in the user mode).

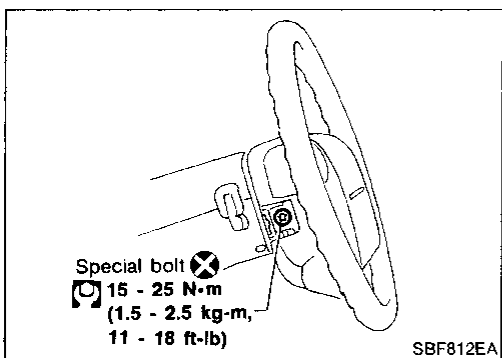

7. Position air bag module and tighten with new special bolts.
8. Connect air bag module connector.
9. Install all lids.
10. Conduct self-diagnosis to ensure entire SRS operates properly. (Use CONSULT or warning lamp check.) Refer to RS-19.

## SUPPLEMENTAL RESTRAINT SYSTEM (SRS)

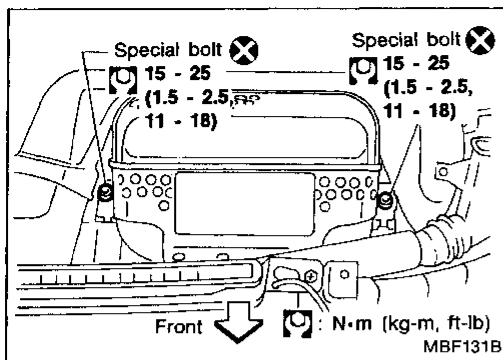

### Installation — Front Passenger Air Bag Module

1. Install front passenger air bag module on steering member.
  - Ensure harness is not caught between rear of air bag module and steering member.
2. Install instrument panel.
3. Connect air bag module connector to body harness connector.
4. Install air bag module connector on connector bracket.
5. Install connector bracket on air bag module, then install glove box inner cover and glove box.

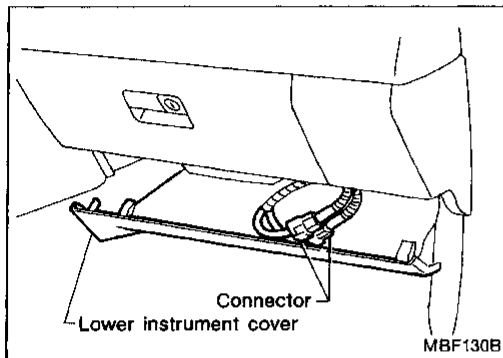

### Disposal of Air Bag Module and Seat Belt Pre-tensioner

- Make sure to deactivate air bag modules and seat belt pre-tensioners before disposing of them. Also, before disposing of a vehicle equipped with an SRS system, deactivate air bag modules and seat belt pre-tensioners. If such systems have already been deployed due to an accident, dispose of as indicated in "DISPOSING OF AIR BAG MODULE AND SEAT BELT PRE-TENSIONER" (RS-16).
- When deploying the air bag module and seat belt pre-tensioner, always use the Special Service Tool; Deployment tool KV99106400 (Kent-Moore No. J38381).
- When deploying the air bag module and seat belt pre-tensioner, stand at least 5 m (16 ft) away from the deployment component.
- Due to heat, do not touch air bag module for at least 30 minutes after deployment. Also do not touch seat belt pre-tensioner for at least 10 minutes after deployment.
- Be sure to wear gloves when handling a deployed air bag module and seat belt pre-tensioner.
- Never apply water to a deployed air bag module and seat belt pre-tensioner.
- Wash your hands clean after finishing work.

# SUPPLEMENTAL RESTRAINT SYSTEM (SRS)

## Disposal of Air Bag Module and Seat Belt Pre-tensioner (Cont'd)

### CHECKING DEPLOYMENT TOOL

#### Connecting to battery

- Place vehicle outdoors with at least 6 m (20 ft) of open space on all sides.
- Use a voltmeter to make sure the vehicle battery is fully charged.

#### CAUTION:

**The battery must show voltage of 9.6V or more.**

Remove the battery from the vehicle and place it on dry wood blocks approximately 5 m (16 ft) away from the vehicle.

- Wait 10 to 12 minutes after the vehicle battery is disconnected before proceeding.
- Connect red clip of deployment tool to battery positive terminal and black clip to negative terminal.

#### CAUTION:

**Make sure the polarity is correct. The right side lamp in the tool, marked "deployment tool power", should glow with a green light. If the right side lamp glows red, reverse the connections to the battery.**

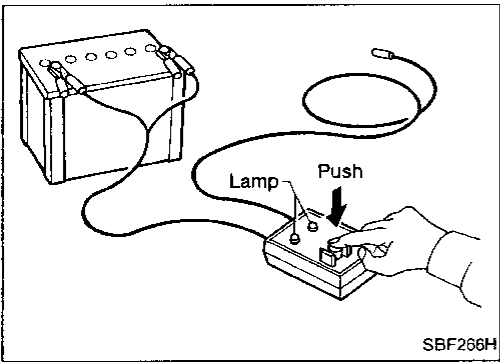
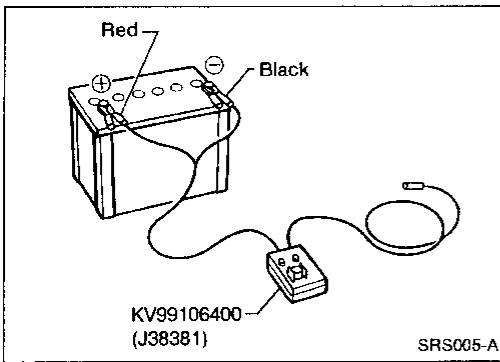

#### Deployment tool check

Press the deployment tool switch to the "ON" position. The left side lamp in the tool, marked "air bag connector voltage" should illuminate. If it does not illuminate, replace the tool.

#### Air bag deployment tool lamp illumination chart (Battery connected)

Switch operation	Left side lamp, green* "AIR BAG CONNECTOR VOLTAGE"	Right side lamp, green* "DEPLOYMENT TOOL POWER"
OFF	OFF	ON
ON	ON	ON

\*: If this lamp glows red, the tool is connected to the battery incorrectly. Reverse the connections and make sure the lamp glows green.

GI  
MA  
EM  
LC  
EF & EC  
FE  
AT  
PD  
FA  
RA  
BR  
ST  
RS  
BT  
HA  
EL  
IDX

## SUPPLEMENTAL RESTRAINT SYSTEM (SRS)

### Disposal of Air Bag Module and Seat Belt Pre-tensioner (Cont'd)

#### DEPLOYMENT PROCEDURES FOR AIR BAG MODULE AS A UNIT

Deploying air bag module while it is mounted in vehicle may damage vehicle. Deploy air bag module as a unit except when disposing of vehicle.

Anchor air bag module in a vise secured to a firm foundation during deployment.

#### Deployment of driver's air bag module as a unit

1. Prepare two sets of nuts and bolts (see figure at left). These bolts are required to secure driver's air bag module to the vise.
2. Install one set of nuts and bolts to each side of the air bag module.

#### CAUTION:

**Make sure to install two bolts and nuts on each side.**

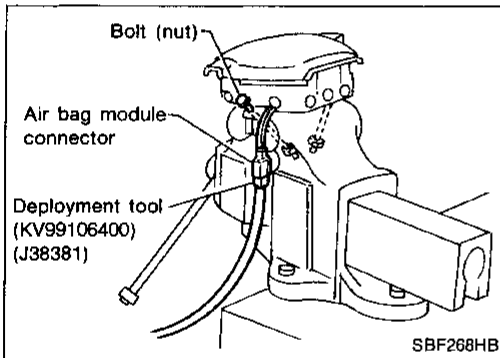
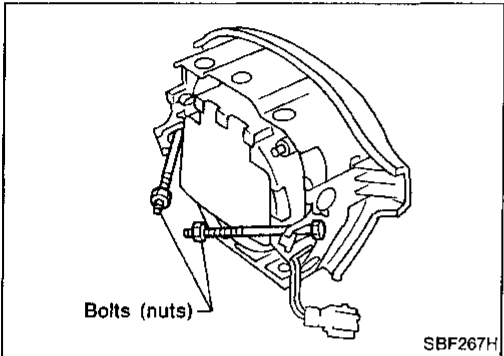
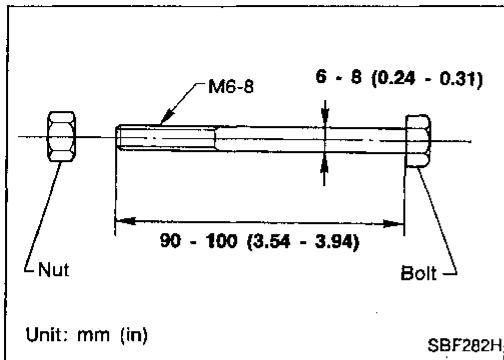

3. Firmly place two nuts (secured to air bag module) in the vise.

#### CAUTION:

**Ensure these two nuts are equally placed in the vise. Never finish the installation with just one nut.**

4. Connect deployment tool (SST: KV99106400; Kent-Moore No. J38381) to air bag module connector.

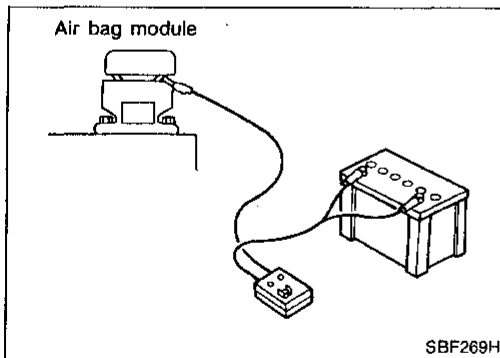

5. Connect red clip of deployment tool to battery positive terminal and black clip to negative terminal.

6. The lamp on the right side of the tool, marked "deployment tool power", should glow green, not red.

7. Press the button on the deployment tool. The left side lamp on the tool, marked "air bag connector voltage", will illuminate and the air bag module will deploy.

#### CAUTION:

**When deploying the air bag module, stand at least 5 m (16 ft) away from the air bag module.**

#### Deployment of passenger air bag module as a unit

1. Using wire, secure air bag module to passenger air bag bracket (SST: KV99105300; Kent-Moore No. J41246) at two places.

#### CAUTION:

**Use wire of at least 1 mm (0.04 in) in diameter.**

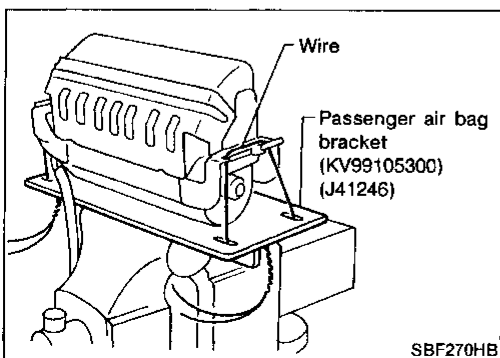

## SUPPLEMENTAL RESTRAINT SYSTEM (SRS)

### Disposal of Air Bag Module and Seat Belt Pre-tensioner (Cont'd)

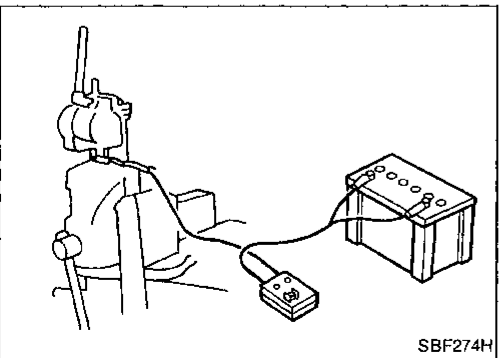
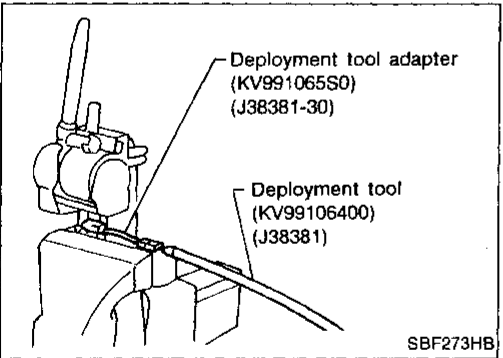
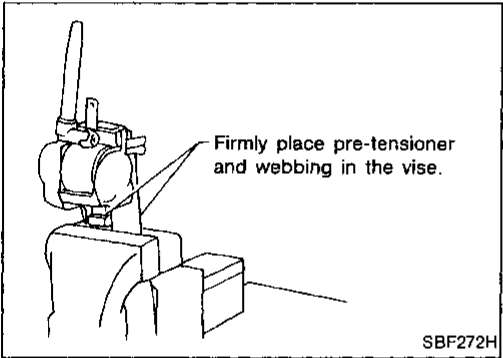
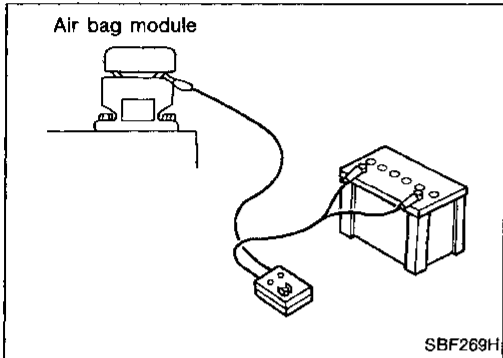
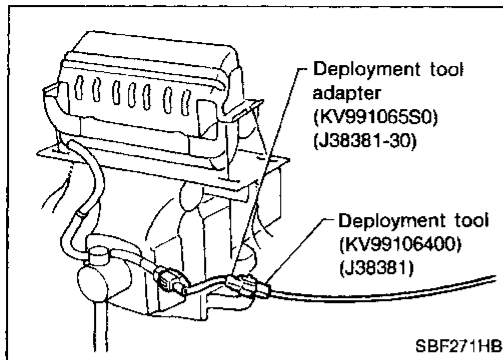

2. Firmly anchor passenger air bag bracket in a vise.
3. Connect deployment tool adapter (SST: KV991065S0; Kent-Moore No. J38381-30) to deployment tool (SST: KV99106400; Kent-Moore No. J38381) connector and connector on either side of air bag module.

4. Connect red clip of deployment tool to battery positive terminal and black clip to negative terminal.
5. The lamp on the right side of the tool, marked "deployment tool power", should glow green, not red.
6. Press the button on the deployment tool. The left side lamp on the tool, marked "air bag connector voltage", will illuminate and the air bag module will deploy.

#### CAUTION:

When deploying the air bag module, stand at least 5 m (16 ft) away from the air bag module.

#### CAUTION:

Always activate one inflator at a time.

### Deployment of seat belt pre-tensioner as a unit

1. Firmly anchor seat belt pre-tensioner in a vise.

#### CAUTION:

Ensure bracket and webbing are placed in the vise.

2. Connect deployment tool adapter (SST: KV991065S0; Kent-Moore No. J38381-30) to deployment tool (SST: KV99106400; Kent-Moore No. J38381) connector and seat belt pre-tensioner connector.

3. Connect red clip of deployment tool to battery positive terminal and black clip to negative terminal.
4. The lamp on the right side of the tool, marked "deployment tool power", should glow green, not red.
5. Press the button on the deployment tool. The left side lamp on the tool, marked "air bag connector voltage", will illuminate and the seat belt pre-tensioner will deploy.

#### CAUTION:

When deploying the seat belt pre-tensioner, stand at least 5 m (16 ft) away from the seat belt pre-tensioner.

## SUPPLEMENTAL RESTRAINT SYSTEM (SRS)

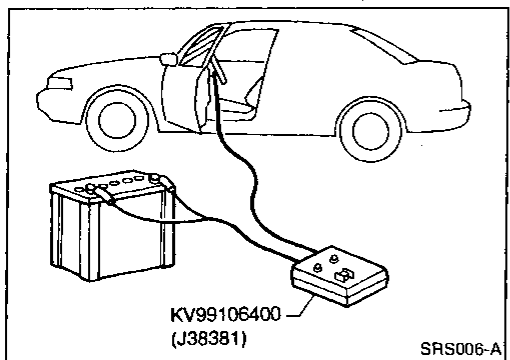
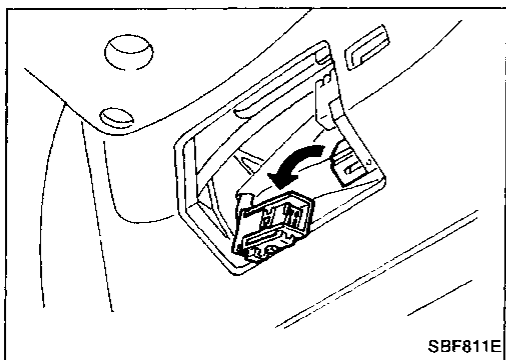

### Disposal of Air Bag Module and Seat Belt Pre-tensioner (Cont'd)

#### DEPLOYMENT OF AIR BAG MODULE AND SEAT BELT PRE-TENSIONER WHILE MOUNTED IN VEHICLE

When disposing of a vehicle, deploy air bag modules and seat belt pre-tensioners while they are mounted in vehicle.

#### CAUTION:

When deploying air bag module or seat belt pre-tensioner, ensure vehicle is empty.

1. Disconnect battery ground cable and wait 10 minutes.
2. Disconnect air bag modules and seat belt pre-tensioners connector.
3. Connect deployment tool connector (SST: KV99106400; Kent-Moore No. J38381) to air bag module or seat belt pre-tensioner.  
For front passenger air bag module and seat belt pre-tensioner, attach deployment tool adapters (SST: KV991065S0; Kent-Moore No. J38381-30) to the tool connector.
4. Connect red clip of deployment tool to battery positive terminal and black clip to negative terminal.
5. The lamp on the right side of the tool, marked "deployment tool power", should glow green, not red.
6. Press the button on the deployment tool. The left side lamp on the tool, marked "air bag connector voltage", will illuminate and the air bag module or seat belt pre-tensioner will deploy.
7. After deployment, remove them from vehicle and seal them up in plastic bags, then dispose of them.

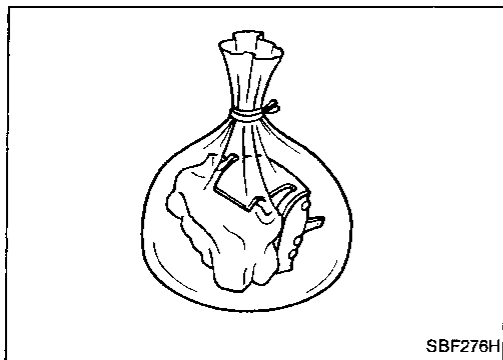

#### DISPOSING OF AIR BAG MODULE AND SEAT BELT PRE-TENSIONER

Deployed air bag modules and seat belt pre-tensioners are very hot. Before disposing of air bag module, and seat belt pre-tensioner, wait at least 30 minutes, and 10 minutes, respectively. Seal them in a plastic bag before disposal.

#### CAUTION:

- Never apply water to a deployed air bag module and seat belt pre-tensioner.
- Be sure to wear gloves when handling a deployed air bag module and seat belt pre-tensioner.
- No poisonous gas is produced upon air bag module deployment. However, be careful not to inhale gas since it irritates throat and can cause choking.
- Do not attempt to disassemble air bag module and seat belt pre-tensioner.
- Air bag module and seat belt pre-tensioner can not be re-used.
- Wash your hands clean after finishing work.



Schematic

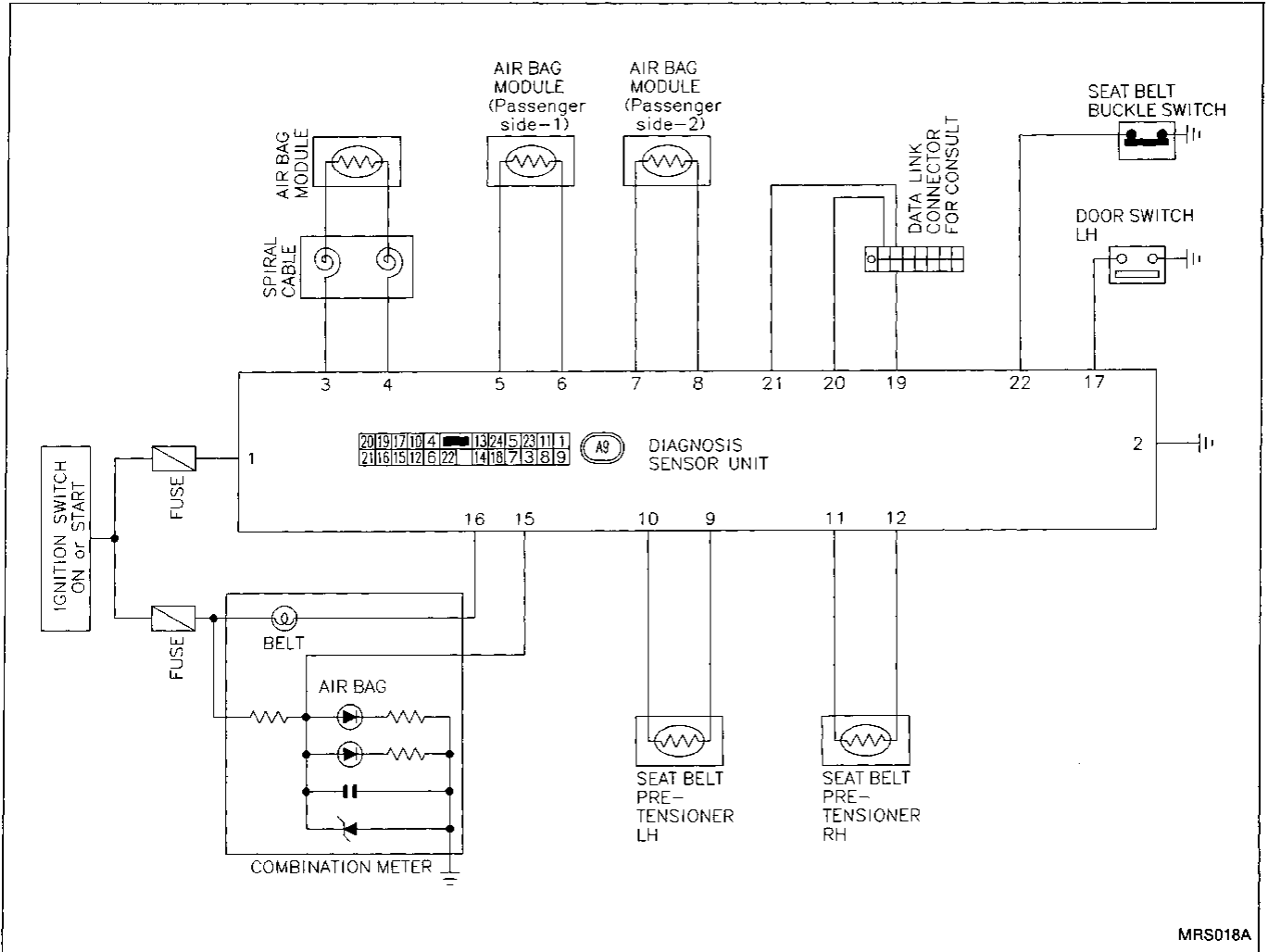

GI  
MA  
EM  
LC  
EF &  
EC  
FE  
AT  
PD  
FA  
RA  
BR  
ST  
RS  
BT  
HA  
EL  
IDX



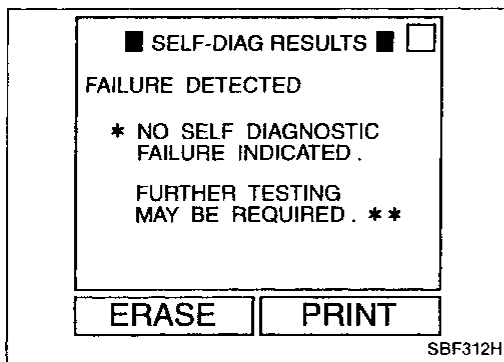
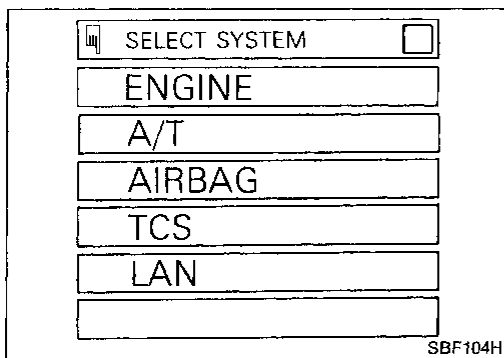
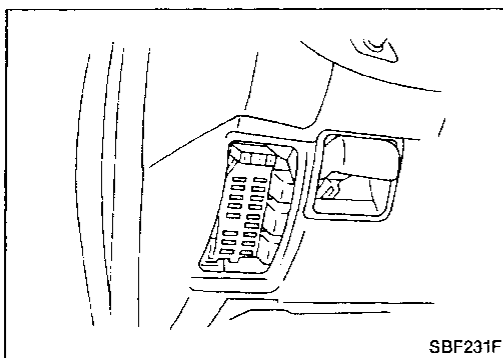

## Self-diagnosis

### USING CONSULT

The self-diagnosis results can be read by CONSULT, as follows:

1. Connect "CONSULT" to data link connector for CONSULT. (Data link connector for CONSULT is located in left instrument lower panel.)
2. Turn ignition switch to "ON". (When CONSULT is connected, the "AIR BAG" warning lamp will be turned to present diagnosis mode.)
3. Touch "START" to operate "CONSULT".
4. Touch "AIR BAG" to choose air bag system.
5. Touch "SELF DIAG RESULTS" to read self-diagnosis results.
6. Problem codes are displayed on "SELF DIAG RESULTS".
7. When "PRINT" is pressed, information displayed on "SELF DIAG RESULTS" is printed out.

### WARNING:

- While CONSULT is displaying this "SELF-DIAG RESULTS" information, do not disconnect CONSULT from data link connector.
- When finishing diagnosis, make sure to change CONSULT display to SELECT SYSTEM mode by using BACK KEY.

8. After repairing malfunctioning parts, press "ERASE" to clear self-diagnosis results.
- "ERASE" function requires selecting "ERASE", and completing step 9.

9. Push BACK KEY of CONSULT until SELECT SYSTEM mode appears to make "SELF-DIAGNOSIS" user mode.

- If malfunctioning parts are not completely repaired, "AIR BAG" warning lamp will blink every 0.5 seconds.

10. Push the power off switch.

11. Turn off ignition switch, disconnect CONSULT.

12. Turn ignition switch to "ON". "AIR BAG" warning lamp should come on for about 7 seconds and then go off.

GI

MA

EM

LC

EF &  
EC

FE

AT

PD

FA

RA

BR

ST

RS

BT

HA

EL

IDX

# TROUBLE DIAGNOSES — Supplemental Restraint System (SRS)

## Self-diagnosis (Cont'd)

### Self-diagnosis results

Diagnostic item	Explanation	Repair order Recheck SRS system at each replacement.
NO SELF DIAGNOSTIC FAILURE INDICATED.	Normal. The SRS system is in good order.	—
AIRBAG MODULE [OPEN]	The circuit for driver's air bag module is open. (including the spiral cable)	<ol style="list-style-type: none"> <li>1. Visually check the wiring harness connections.</li> <li>2. Replace the spiral cable.</li> <li>3. Replace driver's air bag module. (Before disposing of it, it must be deployed.)</li> <li>4. Replace the diagnosis sensor unit.</li> <li>5. Replace the air bag harness.</li> <li>6. Replace the main harness.</li> </ol>
AIRBAG MODULE [VB-SHORT]	The circuit for driver's air bag module is shorted to some power supply circuit. (including the spiral cable)	
AIRBAG MODULE [GND-SHORT]	The circuit for driver's air bag module is shorted to ground. (including the spiral cable)	
AIRBAG MODULE [SHORT]	The circuits for driver's air bag module are shorted to each other.	
ASSIST A/B MODULE 1 [OPEN]	The circuit for front passenger air bag module 1 is open.	<ol style="list-style-type: none"> <li>1. Visually check the wiring harness connections.</li> <li>2. Replace front passenger air bag module. (Before disposing of it, it must be deployed.)</li> <li>3. Replace the diagnosis sensor unit.</li> <li>4. Replace the air bag harness.</li> <li>5. Replace the main harness.</li> </ol>
ASSIST A/B MODULE 1 [VB-SHORT]	The circuit for front passenger air bag module 1 is shorted to some power supply circuit.	
ASSIST A/B MODULE 1 [GND-SHORT]	The circuit for front passenger air bag module 1 is shorted to ground.	
ASSIST A/B MODULE 1 [SHORT]	The circuits for front passenger air bag module 1 are shorted to each other.	
ASSIST A/B MODULE 2 [OPEN]	The circuit for front passenger air bag module 2 is open.	<ol style="list-style-type: none"> <li>1. Visually check the wiring harness connections.</li> <li>2. Replace front passenger air bag module. (Before disposing of it, it must be deployed.)</li> <li>3. Replace the diagnosis sensor unit.</li> <li>4. Replace the air bag harness.</li> <li>5. Replace the main harness.</li> </ol>
ASSIST A/B MODULE 2 [VB-SHORT]	The circuit for front passenger air bag module 2 is shorted to some power supply circuit.	
ASSIST A/B MODULE 2 [GND-SHORT]	The circuit for front passenger air bag module 2 is shorted to ground.	
ASSIST A/B MODULE 2 [SHORT]	The circuits for front passenger air bag module 2 are shorted to each other.	
DRIVE PRE-TENSION [OPEN/VB-SHORT]	The circuit for the driver's pre-tensioner is open or shorted to some power supply circuit.	<ol style="list-style-type: none"> <li>1. Visually check the wiring harness connections.</li> <li>2. Replace the driver's seat belt. (Before disposing, it must be deactivated.)</li> <li>3. Replace the diagnosis sensor unit.</li> <li>4. Replace the main harness.</li> </ol>
DRIVE PRE-TENSION [GND-SHORT]	The circuit for the driver's pre-tensioner is shorted to ground.	
ASSIST PRE-TENSION [OPEN/VB-SHORT]	The circuit for the front passenger pre-tensioner is open or shorted to some power supply circuit.	<ol style="list-style-type: none"> <li>1. Visually check the wiring harness connections.</li> <li>2. Replace the front passenger seat belt. (Before disposing, it must be deactivated.)</li> <li>3. Replace the diagnosis sensor unit.</li> <li>4. Replace the main harness.</li> </ol>
ASSIST PRE-TENSION [GND-SHORT]	The circuit for the front passenger pre-tensioner is shorted to ground.	

# TROUBLE DIAGNOSES — Supplemental Restraint System (SRS)

## Self-diagnosis (Cont'd)

Diagnostic item	Explanation	Repair order Recheck SRS system at each replacement.	
CONTROL UNIT	The diagnosis sensor unit is out of order.	1. Visually check the wiring harness connections. 2. Replace the diagnosis sensor unit. 3. Replace the air bag harness. 4. Replace the main harness.	GI  MA  EM  LC
INDEFINITE FAILURES [AIR BAG]	A problem which cannot be specified occurs because more than two parts are out of order.	1. Visually check the wiring harness connections. 2. Replace the diagnosis sensor unit. 3. Replace spiral cable and air bag modules. 4. Replace the air bag harness. 5. Replace the main harness.	EF & EC  FE  AT
INDEFINITE FAILURES [PRE-TENSIONER]	Driver's and front passenger seat belt pretensioners are out of order.	1. Visually check the wiring harness connections. 2. Replace the driver's and front passenger seat belts. (Before disposing, they must be deactivated.) 3. Replace the diagnosis sensor unit. 4. Replace the main harness.	PD  FA  RA  BR  ST  RS  BT  HA  EL  IDX

# TROUBLE DIAGNOSES — Supplemental Restraint System (SRS)

## Self-diagnosis (Cont'd)

### USING "AIR BAG" WARNING LAMP

Air bag self-diagnosis results can be read by using the "AIR BAG" warning lamp for SRS.

The "Air bag" warning lamp operates as shown below:

#### WARNING:

When the "AIR BAG" warning lamp is flashing, compare the flash time to the chart below.

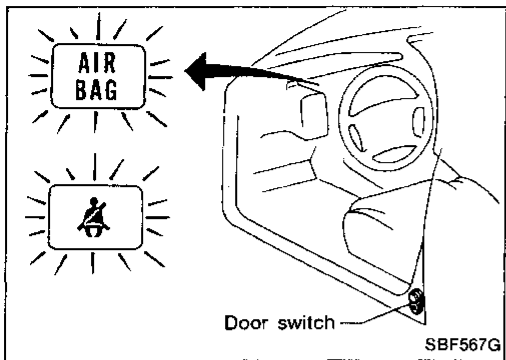

### How to alternate self-diagnosis

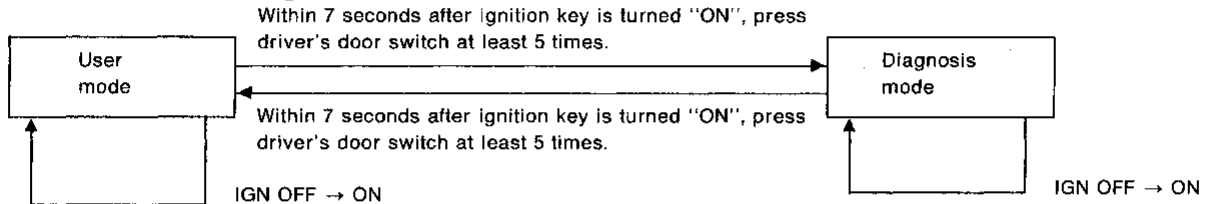

Problem codes are displayed in diagnosis mode (self-diagnosis results).

### Warning lamp indication

- After repairing malfunctioning part, use driver's door switch to return the system to user mode. This will clear self-diagnosis results from memory.
- If a malfunctioning part is not completely repaired, self-diagnosis results will not be cleared.

#### User mode

<p>① Normal (OFF)</p> <p style="text-align: right;">SBF298HA</p>	<p>No problem.</p>
<p>② Malfunction (blinking)</p> <p style="text-align: right;">SBF299HA</p>	<p>The system has problem. Perform self-diagnosis with "Diagnosis mode".</p>
<p>③ Air bag is deployed or diagnosis sensor unit is malfunctioning and continuously sends an "ON" signal.</p> <p style="text-align: right;">SBF284HA</p>	<p>The system needs to be repaired. (Refer to page RS-27.)</p>
<p>④ Diagnosis sensor unit or warning lamp circuit is malfunctioning.</p> <p style="text-align: right;">SRS016</p>	<p>The system needs to be repaired. (Refer to page RS-26.)</p>

# TROUBLE DIAGNOSES — Supplemental Restraint System (SRS)

## Self-diagnosis (Cont'd)

### Diagnosis mode (Self-diagnosis result)

- Indicate malfunctioning part — The system needs to be repaired.

ⓑ Start signal: Start signal identifies display modes.

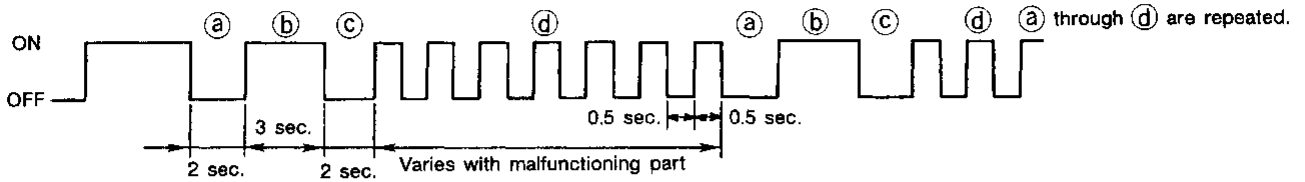

SBF300HA

- No malfunctioning (or intermittent trouble/repair completion)

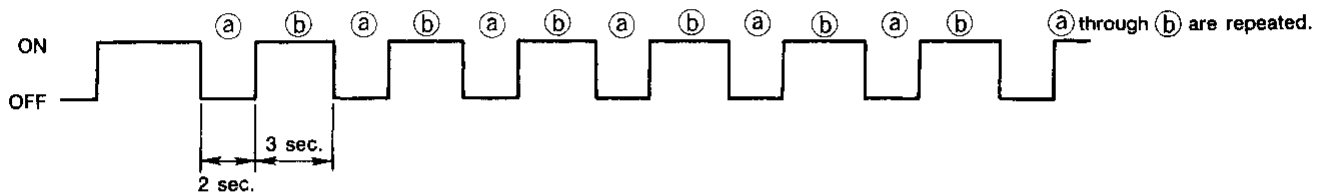

SBF285H

### WARNING:

- After the malfunctioning parts have been repaired, return the system to "User mode".

Self-diagnosis results in diagnosis mode can be identified by number of flashes ⓓ. Refer to Table on next page for identifying the malfunctioning part.

GI

MA

EM

LC

EF &  
EC

FE

AT

PD

FA

RA

BR

ST

RS

BT

HA

EL

IDX

# TROUBLE DIAGNOSES — Supplemental Restraint System (SRS)

## Self-diagnosis (Cont'd)

### Warning lamp flashing times and repair

Warning lamp	Flash code ① (# of flashes)	Explanation/Possible causes	Repair order Recheck SRS at each replacement.
"AIR BAG" warning lamp	0	<ul style="list-style-type: none"> <li>● Normal. SRS "Air Bag" is in good order.</li> </ul>	—
	2	<ul style="list-style-type: none"> <li>● Driver's air bag module circuit is out of order.</li> </ul>	<ol style="list-style-type: none"> <li>1. Visually check wiring harness connections.</li> <li>2. Replace spiral cable.</li> <li>3. Replace driver's air bag module. (Before disposal of it, it must be deployed.)</li> <li>4. Replace diagnosis sensor unit.</li> <li>5. Replace air bag harness.</li> <li>6. Replace main harness.</li> </ol>
	7	<ul style="list-style-type: none"> <li>● Diagnosis sensor unit is out of order.</li> </ul>	<ol style="list-style-type: none"> <li>1. Visually check wiring harness connections.</li> <li>2. Replace diagnosis sensor unit.</li> <li>3. Replace air bag harness.</li> <li>4. Replace main harness.</li> </ol>
	8	<ul style="list-style-type: none"> <li>● Front passenger air bag module circuit is out of order.</li> </ul>	<ol style="list-style-type: none"> <li>1. Visually check wiring harness connections.</li> <li>2. Replace front passenger air bag module. (Before disposal, it must be deployed.)</li> <li>3. Replace diagnosis sensor unit.</li> <li>4. Replace air bag harness.</li> <li>5. Replace main harness.</li> </ol>
	9	<ul style="list-style-type: none"> <li>● More than two parts groups are out of order.</li> </ul>	<ol style="list-style-type: none"> <li>1. Visually check wiring harness connections.</li> <li>2. Replace diagnosis sensor unit.</li> <li>3. Replace spiral cable and air bag module.</li> <li>4. Replace air bag harness.</li> <li>5. Replace main harness.</li> </ol>



# TROUBLE DIAGNOSES — Supplemental Restraint System (SRS)

## Self-diagnosis (Cont'd)

### USING THE "SEAT BELT" WARNING LAMP

Seat belt pretensioner self-diagnosis results can also be read by using the "SEAT BELT" warning lamp.

The "SEAT BELT" warning lamp operates as shown below:

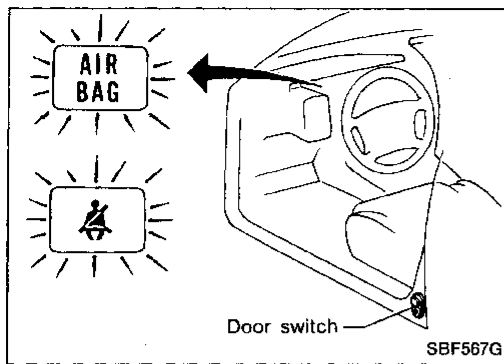

#### ① Normal

- When seat belt has initially been fastened

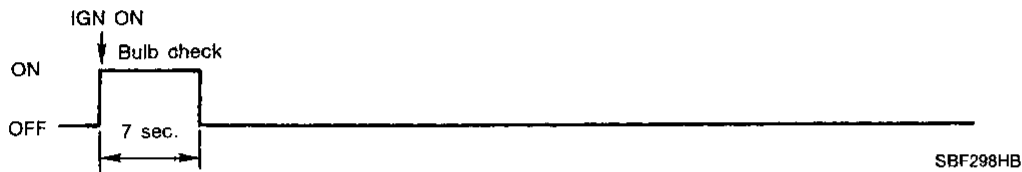

No problem.  
The seat belt pretensioner is in good order.

- When seat belt has not initially been fastened

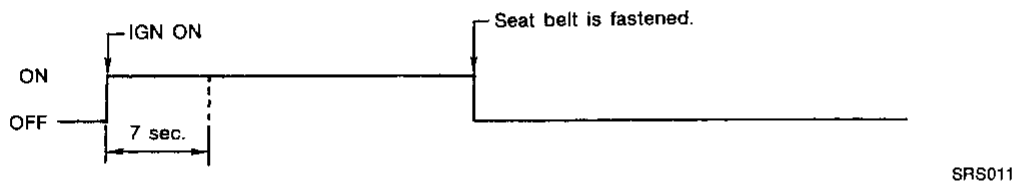

SRS011

#### ② Malfunction

- When seat belt has initially been fastened



SRS012

- When seat belt has not initially been fastened

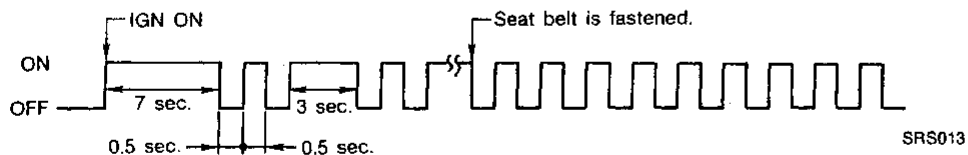

SRS013

- Open in the seat belt pretensioner circuit or
  - Short in the seat belt pretensioner power supply or ground circuit
1. Visually check the wiring harness connections.
  2. Replace the seat belt assembly. (Before disposing, it must be deactivated.)
  3. Replace the diagnosis sensor unit.
  4. Replace air bag harness and main harness. **Recheck "SEAT BELT" warning lamp at each replacement.**

- Seat belt pre-tensioner is deployed or diagnosis sensor unit is malfunctioning and continuously sends an "ON" signal regardless of seat belt condition.

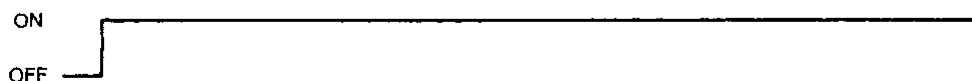

SBF284HB

The system needs to be repaired.  
(Refer to page RS-29.)

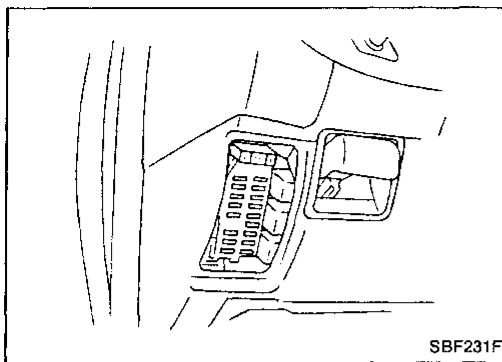

**Trouble Diagnoses for Air Bag**

**DIAGNOSTIC PROCEDURE 1**

**SYMPTOM:** "AIR BAG" warning lamp flashes.

**WARNING:**

Determine if the flash rate is every 0.5 seconds, or 3 seconds "ON" and 2 seconds "OFF".

If every 0.5 seconds, perform self-diagnosis.

If 3 seconds "ON" and 2 seconds "OFF", the system is in diagnosis mode, refer to page RS-22 for instructions.

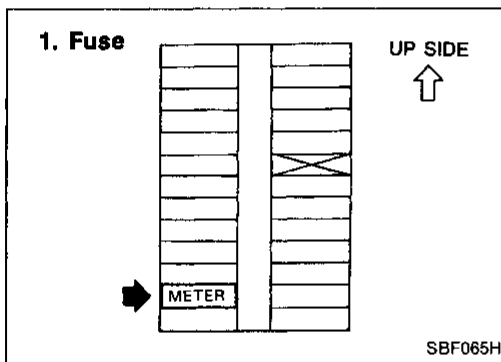
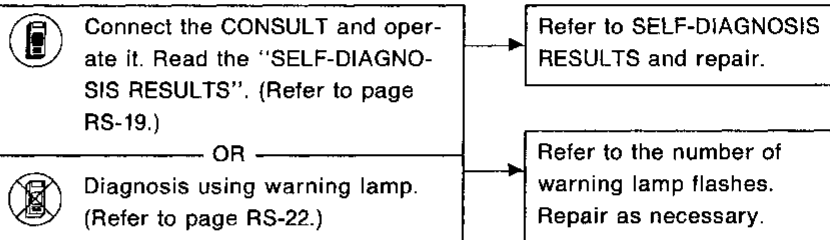

**DIAGNOSTIC PROCEDURE 2**

**SYMPTOM:** "AIR BAG" warning lamp does not turn on.

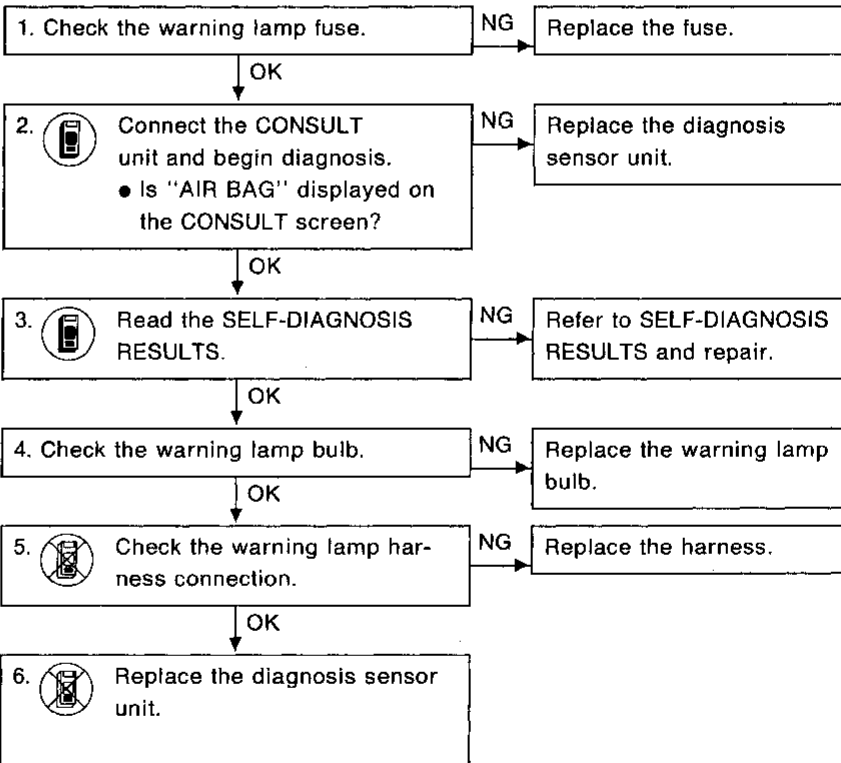
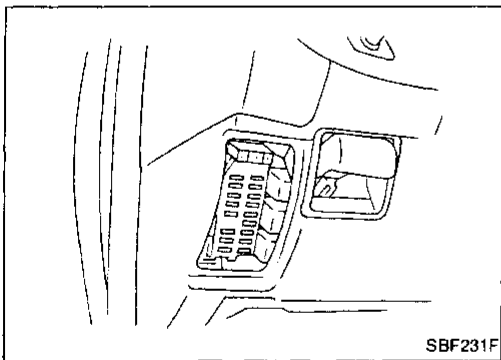

# TROUBLE DIAGNOSES — Supplemental Restraint System (SRS)

## Trouble Diagnoses for Air Bag (Cont'd)

### DIAGNOSTIC PROCEDURE 3

**SYMPTOM: Warning lamp does not turn off.**

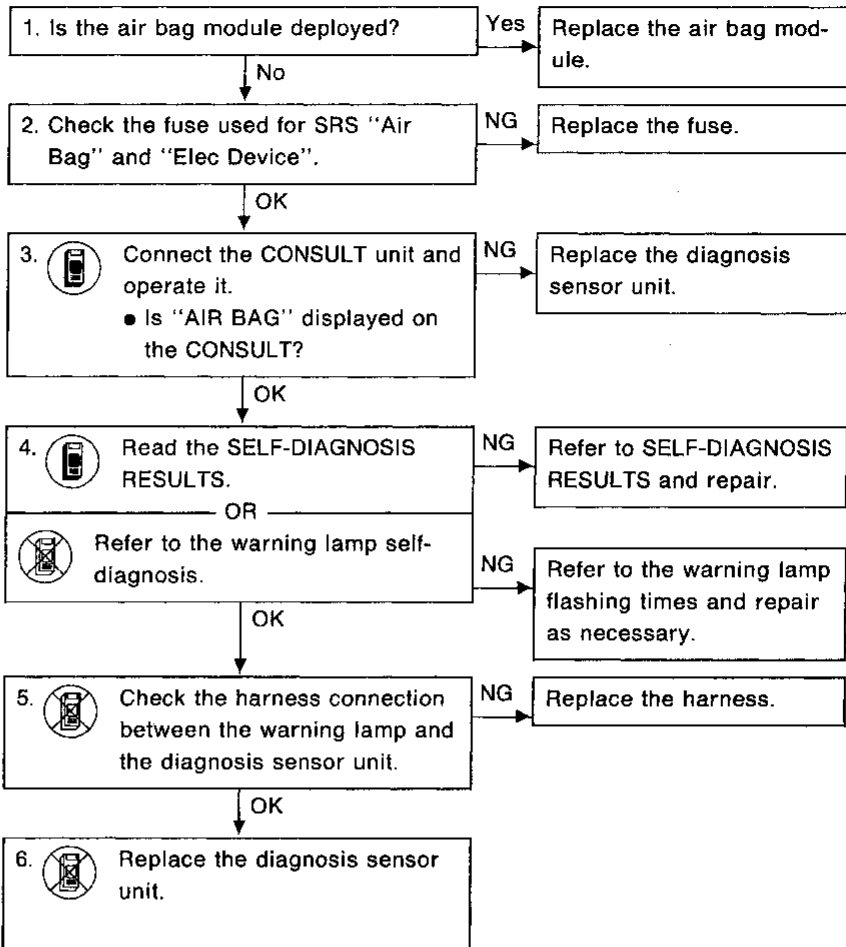
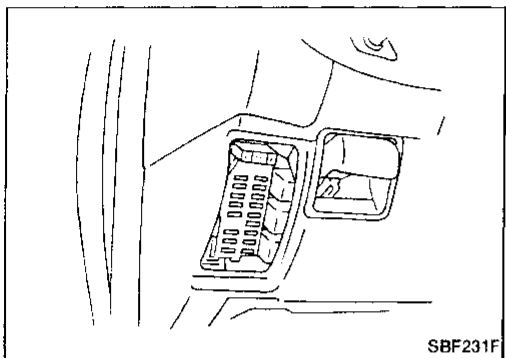
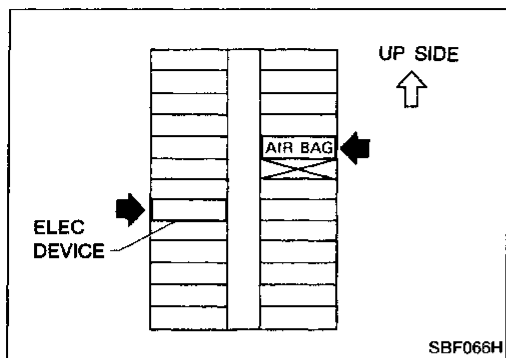

GI

MA

EM

LC

EF &  
EC

FE

AT

PD

FA

RA

BR

ST

**RS**

BT

HA

EL

IDX

**Trouble Diagnosis for Seat Belt Pre-tensioner  
DIAGNOSTIC PROCEDURE 1**

**SYMPTOM: "Seat belt" warning lamp flashes.**

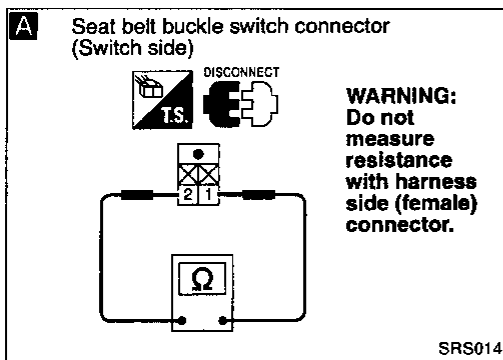
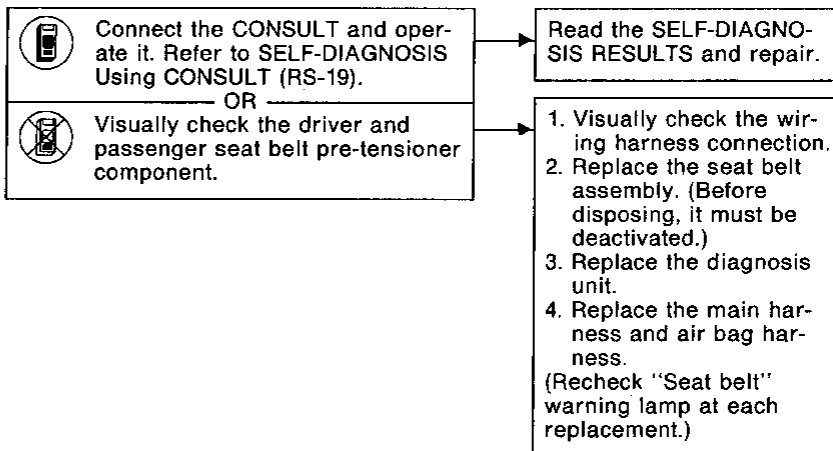

**DIAGNOSTIC PROCEDURE 2**

**SYMPTOM: "Seat belt" warning lamp does not turn on.**

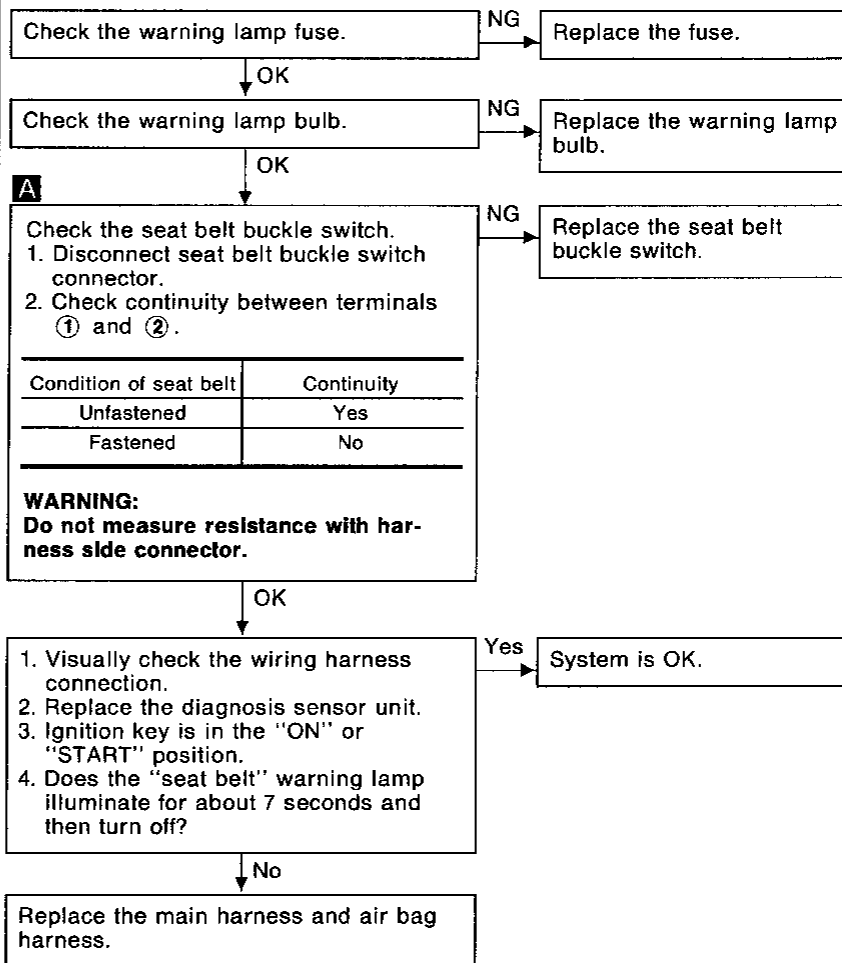

**Trouble Diagnosis for Seat Belt Pre-tensioner (Cont'd)**

**DIAGNOSTIC PROCEDURE 3**

**SYMPTOM: "Seat belt" warning lamp does not turn off.**

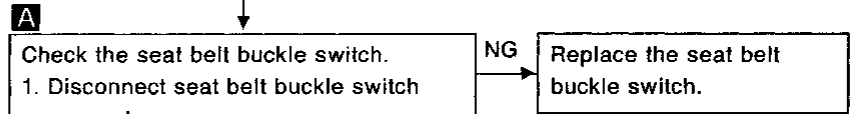
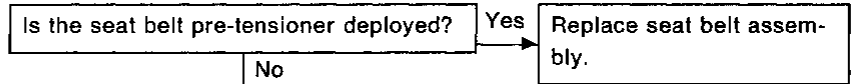
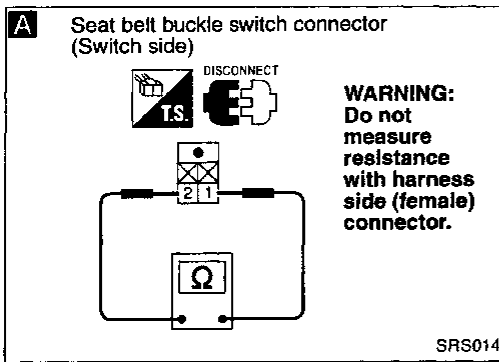

Condition of seat belt	Continuity
Unfastened	Yes
Fastened	No

**WARNING:**  
Do not measure resistance with harness side connector.

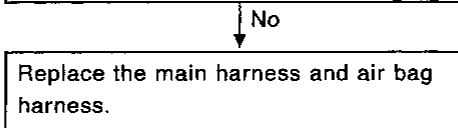
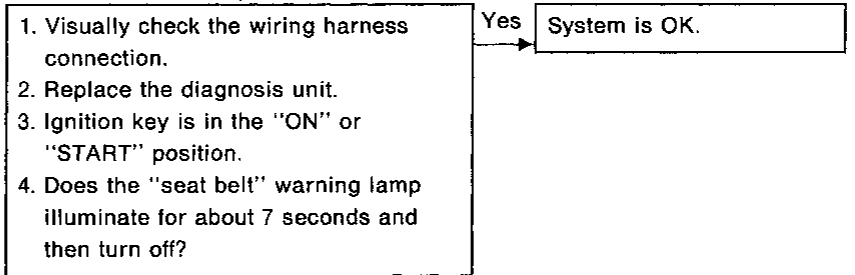

GI  
MA  
EM  
LC  
EF & EC  
FE  
AT  
PD  
FA  
RA  
BR  
ST  
RS  
BT  
HA  
EL  
IDX

## Collision Diagnosis

To repair the SRS, perform the following steps.

### When air bag deploys in a collision:

- ① Replace the diagnosis sensor unit.
- ② Remove the air bag modules and seat belt pre-tensioners.
- ③ Check the SRS components using the table shown below:
  - Replace any SRS components showing visible signs of damage (dents, cracks, deformation).
- ④ Conduct self-diagnosis. Refer to "Self-diagnosis" for details (RS-19). Ensure the remainder of the SRS is operating properly.
- ⑤ Install new air bag modules.
- ⑥ Conduct self-diagnosis again.

### When air bag does not deploy in a collision:

- ① Check the SRS components using the table shown below:
  - Replace any SRS components showing visible signs of damage (dents, cracks, deformation).
- ② Conduct self-diagnosis. Refer to "Self-diagnosis" for details (RS-19). Ensure entire SRS operates properly.

### SRS inspection

Part	Air bag deployed	Air bag did NOT deploy
Air bag module (driver and passenger side)	REPLACE Install with new bolts.	<ol style="list-style-type: none"> <li>1. Remove air bag module. Check harness cover and connectors for damage, terminals for deformities, and harness for binding.</li> <li>2-1. Install driver air bag module into the steering wheel to check fit and alignment with the wheel.</li> <li>2-2. Install passenger air bag module into the instrument panel to check fit with the instrument panel.</li> <li>3. No damage found, reinstall with new bolts.</li> <li>4. If damaged—REPLACE. Air bag must be deployed before discarding.</li> </ol>
Instrument panel	REPLACE Install with new bolts.	<ol style="list-style-type: none"> <li>1. Check instrument panel for bending, deformities, or cracks.</li> <li>2. If no damage is found, reinstall with new bolts.</li> <li>3. If damaged—REPLACE.</li> </ol>
Seat belt pre-tensioner assembly	REPLACE Install with new bolts.	<ol style="list-style-type: none"> <li>1. Remove seat belt pre-tensioners. Check harness cover and connectors for damage, terminals for deformities, and harness for binding.</li> <li>2. Check belts for damage and anchors for loose mounting.</li> <li>3. Check retractor for smooth operation.</li> <li>4. If no damage is found, reinstall with new bolts.</li> <li>5. If damaged—REPLACE.</li> </ol>
Diagnosis sensor unit	REPLACE Install with new bolts.	<ol style="list-style-type: none"> <li>1. Check case and bracket for dents, cracks or deformities.</li> <li>2. Check connectors for damage, and terminals for deformities.</li> <li>3. If no damage is found, reinstall with new bolts.</li> <li>4. If damaged—REPLACE.</li> </ol>
Steering wheel		<ol style="list-style-type: none"> <li>1. Check harness (built into steering wheel) and connectors for damage, and terminals for deformities.</li> <li>2. Install air bag module to check fit or alignment with steering wheel.</li> <li>3. Check steering wheel for excessive free play.</li> <li>4. If no damage is found, reinstall with new bolts.</li> <li>5. If damaged—REPLACE.</li> </ol>
Spiral cable		<ol style="list-style-type: none"> <li>1. Visually check lock (engagement) pins and combination switch for damage.</li> <li>2. Check connectors, flat cable and protective tape for damage.</li> <li>3. Check steering wheel for noise, binding or heavy operation.</li> <li>4. If no damage is found, reinstall with new bolts.</li> <li>5. If damaged—REPLACE.</li> </ol>
Harness and Connectors		<ol style="list-style-type: none"> <li>1. Check connectors for poor connection, damage, and terminals for deformities.</li> <li>2. Check harness for binding, chafing, cuts, or deformities.</li> <li>3. If no damage is found, reinstall</li> <li>4. Damaged—REPLACE damaged section of harness. Do not attempt to repair, splice or modify any SRS harness.</li> </ol>