

SECTION **FL**  
FUEL SYSTEM

CONTENTS

<b>FUEL SYSTEM</b> .....	<b>2</b>	INSPECTION AFTER INSTALLATION .....	5	F
Checking Fuel Lines .....	2	Disassembly and Assembly .....	5	
General Precautions .....	2	DISASSEMBLY .....	5	
<b>FUEL LEVEL SENSOR UNIT, FUEL FILTER AND</b>		ASSEMBLY .....	5	G
<b>FUEL PUMP ASSEMBLY</b> .....	<b>3</b>	<b>FUEL TANK</b> .....	<b>6</b>	
Removal and Installation .....	3	Removal and Installation .....	6	
REMOVAL .....	3	REMOVAL .....	6	H
INSPECTION AFTER REMOVAL .....	4	INSTALLATION .....	7	
INSTALLATION .....	4	INSPECTION AFTER INSTALLATION .....	7	
		<b>SERVICE DATA AND SPECIFICATIONS (SDS) .....</b>	<b>8</b>	I
		Standard and Limit .....	8	
		Tightening Torque .....	8	

## FUEL SYSTEM

PF17503

### Checking Fuel Lines

EBS00259

Inspect fuel lines, filler cap and tank for improper attachment, leaks, cracks, damage, loose connections, chafing or deterioration. If necessary, repair or replace faulty parts.

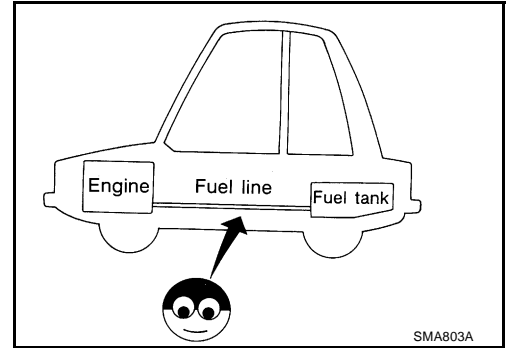

### General Precautions

EBS003GI

#### WARNING:

When replacing fuel line parts, be sure to observe the following.

- Put a “CAUTION: FLAMABLE” sign in workshop.
- Be sure to work in a well-ventilated area and furnish workshop with a CO<sub>2</sub> fire extinguisher.
- Do not smoke while servicing fuel system. Keep open flames and spark away from work area.

#### CAUTION:

- Before removing fuel line parts, carry out the following procedures:
  - a) Put drained fuel in an explosion-proof container and put the lid on securely. Keep the container in safe area.
  - b) Release fuel pressure from fuel line. Refer to [EC-48, "FUEL PRESSURE RELEASE"](#)
  - c) Disconnect battery ground cable.
- Always replace O-ring and clamps with new ones.
- Do not kink or twist tubes when they are being installed.
- Do not tighten hose clamps excessively to avoid damaging hoses. Tighten high-pressure rubber hose clamp so that clamp end is 3 mm (0.12 in) from hose end. Tightening torque specifications are the same for all rubber hose clamps. Ensure that screw does not contact adjacent parts.
- After installing tubes, make sure there is no fuel leakage at connections.
  - a) Apply fuel pressure to fuel lines with turning ignition switch ON (with engine stopped). Then check for fuel leaks at connections.
  - b) Start the engine and rev it up and check for fuel leaks at connections.
- Use only a genuine NISSAN fuel filler cap as a replacement. If an incorrect fuel filler cap is used, the MIL may come on.
- For servicing “Evaporative Emission System” parts, refer to [EC-606, "EVAPORATIVE EMISSION SYSTEM"](#) .
- For servicing “On Board Refueling Vapor Recovery (ORVR)” parts, refer to [EC-612, "ON BOARD REFUELING VAPOR RECOVERY \(ORVR\)"](#) .

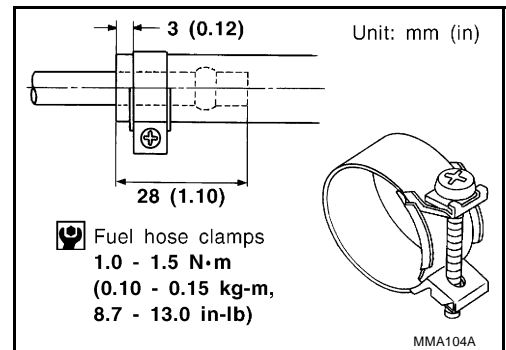

# FUEL LEVEL SENSOR UNIT, FUEL FILTER AND FUEL PUMP ASSEMBLY

## FUEL LEVEL SENSOR UNIT, FUEL FILTER AND FUEL PUMP ASSEMBLY PFP:17042

### Removal and Installation

EBS00240

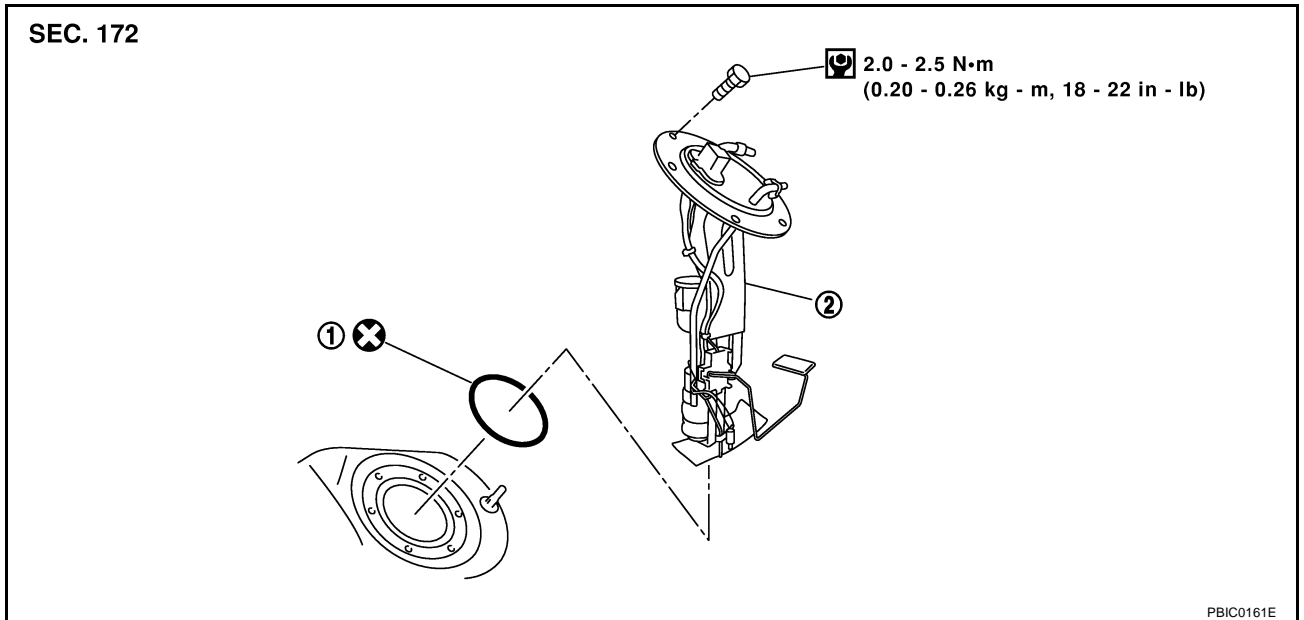

### REMOVAL

#### WARNING:

Be sure to read "General Precautions" when working on fuel system. Refer to [FL-2, "General Precautions"](#).

1. Release fuel pressure.  
Refer to [EC-48, "FUEL PRESSURE RELEASE"](#).
2. Open fuel filler lid.
3. Open the filler cap and release the pressure inside the fuel tank.
4. Open the trunk lid and remove the trunk front finisher.
5. Disconnect battery ground cable.
6. Disconnect the harness connector, fuel feed tube and fuel return tube.

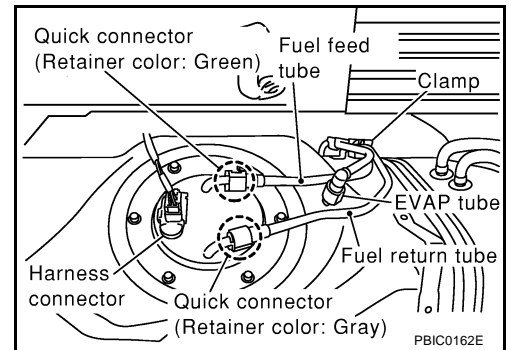

- Remove the quick connectors of the fuel tube as follows.

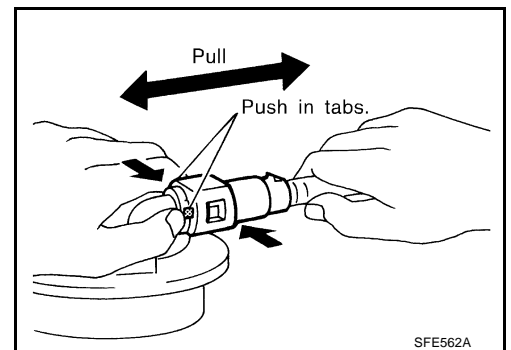

# FUEL LEVEL SENSOR UNIT, FUEL FILTER AND FUEL PUMP ASSEMBLY

## NOTE:

The followings are also applied to the quick connector of EVAP tube.

- Hold the sides of the connector, push in tubs and pull out the tube.
- If the connector and the tube are stuck together, push and pull several times until they start to move. Then disconnect them by pulling.

## CAUTION:

- The tube can be removed when the tabs are completely depressed. Do not twist it more than necessary.
- Do not use any tools to remove the quick connector.
- Keep the resin tube away from heat. Be especially careful when welding near the tube.
- Prevent acid liquid such as battery electrolyte etc. from getting on the resin tube.
- Do not bend or test the tube during installation and removal.
- Only when the tube is replaced, remove the remaining retainer.
- When the tube is replaced, also replace the retainer with a new one.

Retainer color:

Feed tube : Green

Return tube : Gray

- To keep clean the connecting portion and to avoid damage and foreign materials, cover them completely with plastic bags or something similar.
7. Remove fuel level sensor unit, fuel filter and fuel pump assembly.

## CAUTION:

- Do not bend the float arm during removal.
- Avoid impacts such as falling when handling components.

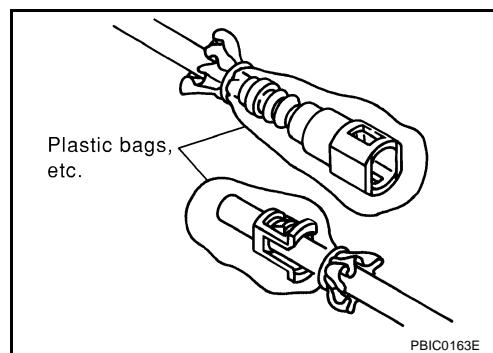
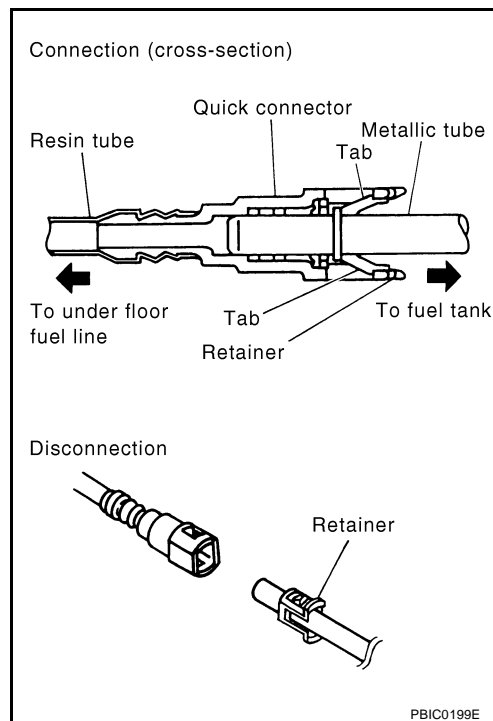

## INSPECTION AFTER REMOVAL

Make sure the fuel pump strainer is free from foreign materials. If any are found, remove them.

## INSTALLATION

- Install in the reverse order of removal.
- Set the fuel tube connector of the fuel level sensor unit facing the right side of the vehicle. Install it by matching the notches on its outer circumference and the fuel tank.
- Tighten the mounting bolts evenly.

## CAUTION:

Use the genuine bolts or equivalent.

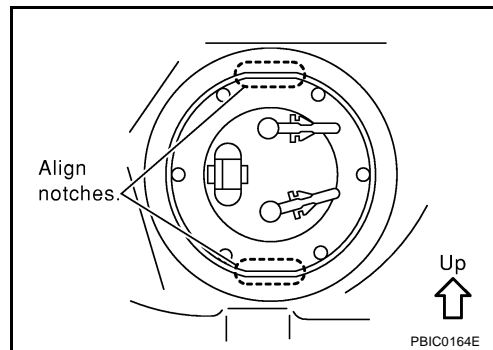

# FUEL LEVEL SENSOR UNIT, FUEL FILTER AND FUEL PUMP ASSEMBLY

- Connect the quick connector as follows.
  1. Check the connection for damage and foreign materials.
  2. Align the connector with the tube, then insert the connector straight into the tube until a click is heard.
  3. After connecting, make sure that the connection is secure by following the steps below.
    - a. Visually confirm that the two retainer tabs are connected to the connector.
    - b. Pull the tube and the connector to make sure they are securely connected.

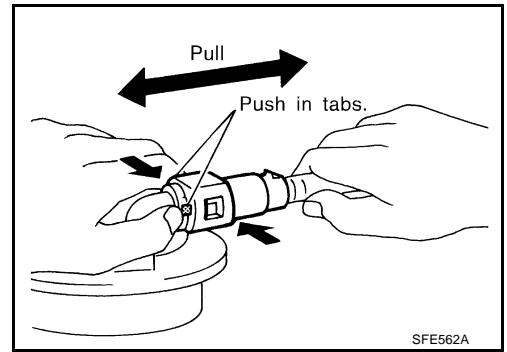

## INSPECTION AFTER INSTALLATION

- After installing tubes, make sure there is no fuel leakage at connections in the following steps.
  - 1) Apply fuel pressure to fuel lines with turning ignition switch ON (with engine stopped). Then check for fuel leaks at connections.
  - 2) Start the engine and rev it up and check for fuel leaks at connections.

## Disassembly and Assembly

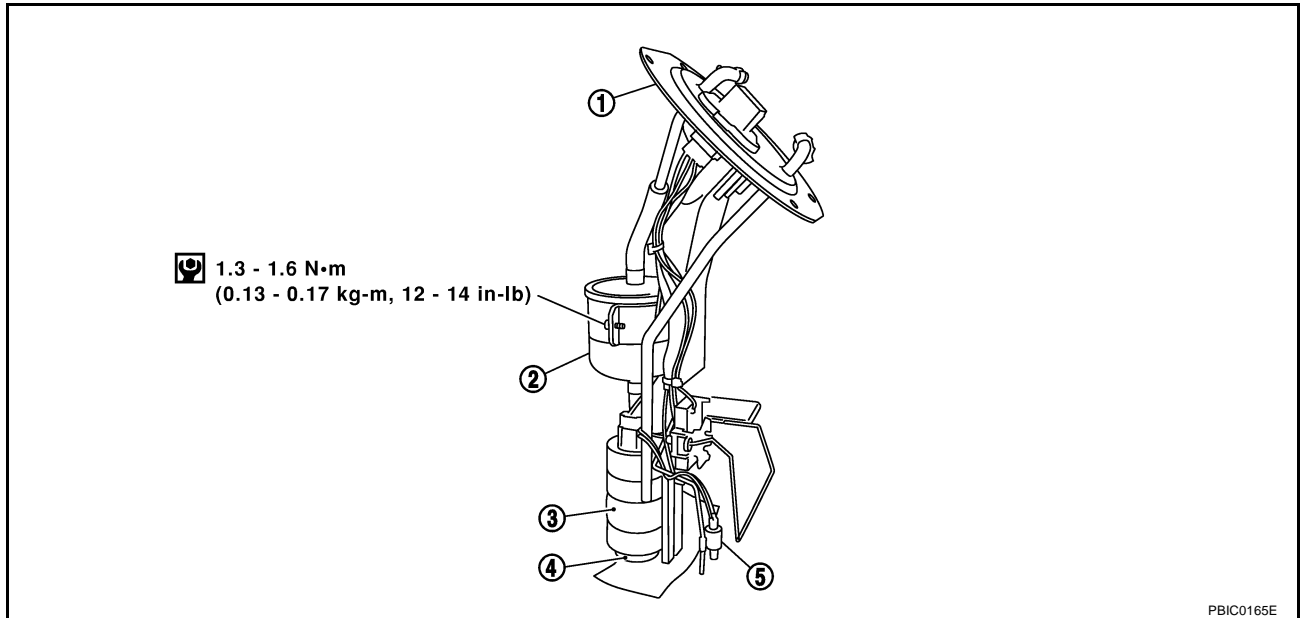

- |                           |                       |              |
|---------------------------|-----------------------|--------------|
| 1. Fuel level sensor unit | 2. Fuel filter        | 3. Fuel pump |
| 4. Rubber                 | 5. Temperature sensor |              |

## DISASSEMBLY

While referring to the exploded view diagram, remove components starting from the fuel pump.

## ASSEMBLY

- Install in the reverse order of removal.
- Install the clamps of each hose, avoiding interference with bulges.
- Securely connect the harness connector of the fuel pump.

### CAUTION:

- Install fuel pump mount rubber between fuel pump and bracket without looseness.

# FUEL TANK

PFP:17202

## FUEL TANK

### Removal and Installation

EBS001KT

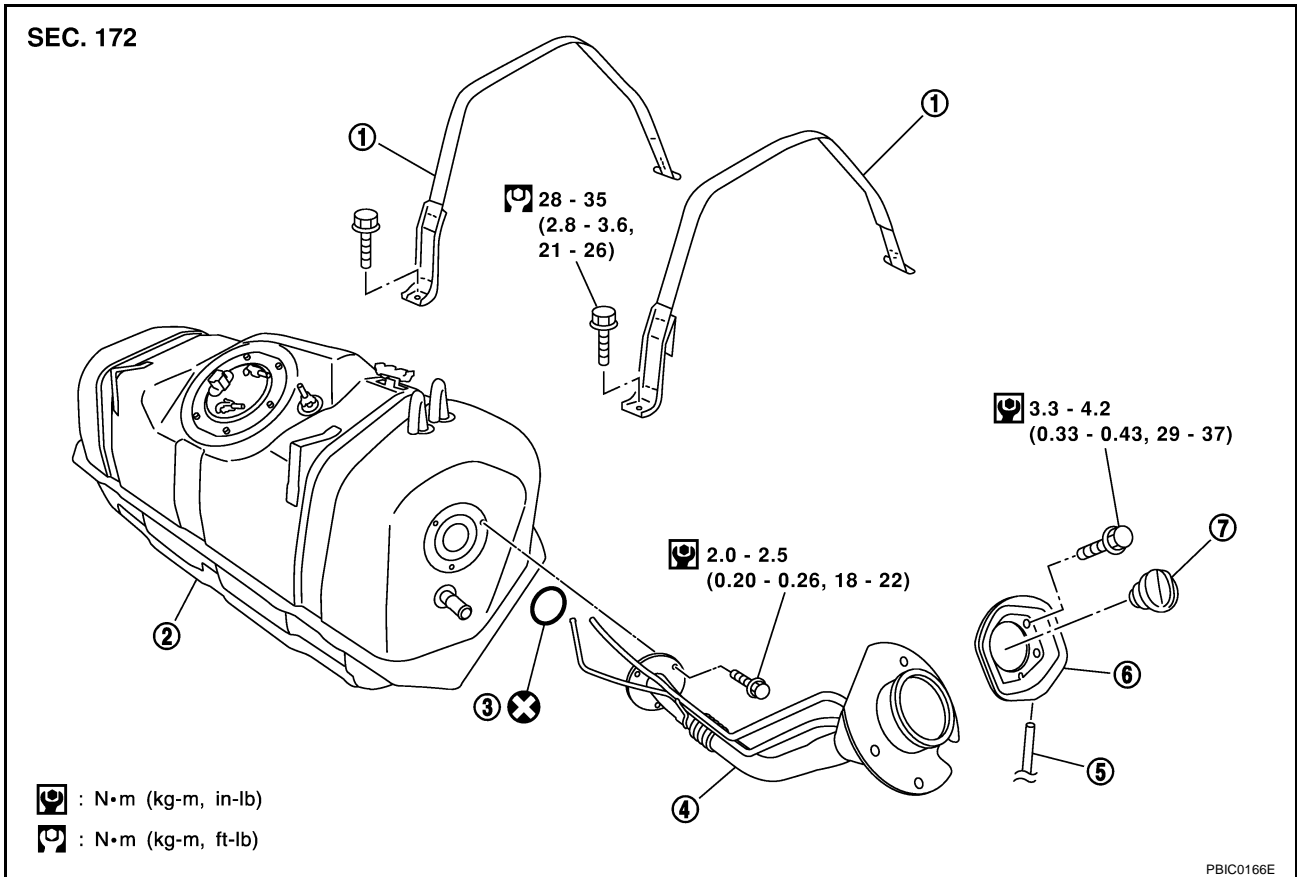

1. Mounting band

2. Fuel tank

3. O-ring

4. Filler tube

5. Drain hose

6. Fuel filler neck cover

7. Cap

## REMOVAL

### WARNING:

Be sure to read "General Precautions" when working on fuel system. Refer to [FL-2, "General Precautions"](#).

1. Follow step 1 to 6 in [FL-3, "REMOVAL"](#) and remove EVAP tubes from fuel tank.

- Put mating marks on tubes and connectors for correct installation.

2. Check the amount of fuel, and drain some if necessary.

3. Remove fuel tubes and EVAP tubes from two clamps securing pipings on fuel tank.

- Put mating marks on tubes and clamps for correct installation.

4. Remove the trunk right finisher.

5. Remove drain hose from fuel filler neck cover reaching from inside trunk.

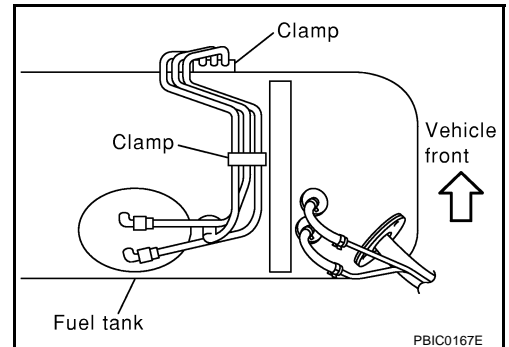

# FUEL TANK

6. Remove bolts for fixing fuel filler neck cover.
7. Remove cover.

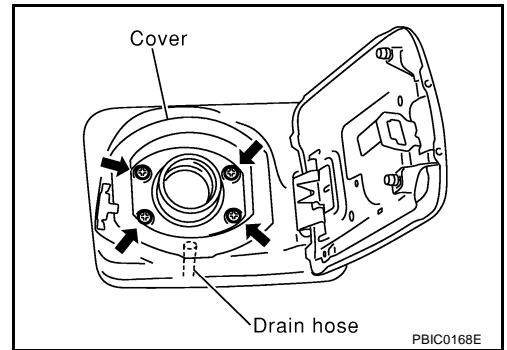

8. Remove filler tube.
9. Remove fuel tank band mounting bolts.

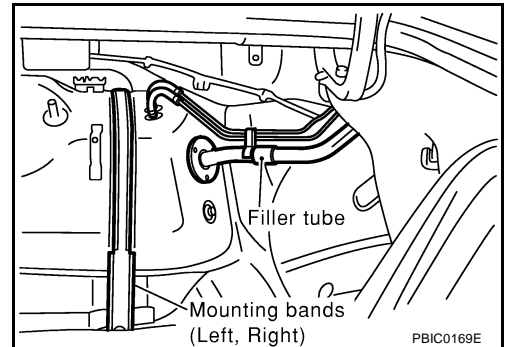

10. If the bottom of the fuel tank hard contacts to remove from the trunk floor panel, insert a wood block or something similar to separate them.

**CAUTION:**

Use a shop cloth or others like that to avoid deformation or damage to the fuel tank and the trunk floor panel.

11. Pull the fuel tank backwards to remove.

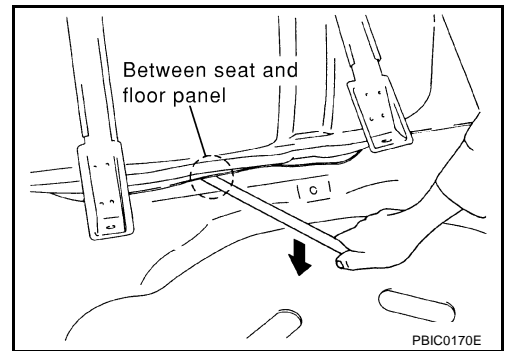

## INSTALLATION

- Install in the reverse order of removal.
- Push the mounting band pin to the vehicle side securely.
- Referring to the mating marks marked during removal, install the fuel tubes and the EVAP tubes and fix to the clamps securely.
- Before fixing the fuel tank, temporarily install the filler tube.

**CAUTION:**

Use genuine filler tube mounting bolts or equivalent. Make sure to tighten them to the specified torque.

- To connect the quick connector, refer to Fuel Level Sensor Unit, Fuel Filter and Fuel Pump Assembly, [FL-3, "Removal and Installation"](#).

## INSPECTION AFTER INSTALLATION

- After installing tubes, make sure there is no fuel leakage at connections in the following steps.
  - 1) Apply fuel pressure to fuel lines with turning ignition switch ON (with engine stopped). Then check for fuel leaks at connections.
  - 2) Start the engine and rev it up and check for fuel leaks at connections.

A  
FL  
C  
D  
E  
F  
G  
H  
I  
J  
K  
L  
M

# SERVICE DATA AND SPECIFICATIONS (SDS)

## SERVICE DATA AND SPECIFICATIONS (SDS)

PF0:00030

### Standard and Limit

EBS001Z7

Fuel tank capacity	Approx. 80 ℓ (21-1/8 US gal, 17-5/8 Imp gal)
--------------------	--

### Tightening Torque

EBS00208

Unit: N·m (kg·m, ft·lb)  
Unit: N·m (kg·m, in·lb)\*

Fuel tank mounting band	28 - 35 (2.8 - 3.6, 21 - 26)
Filler tube	2.0 - 2.5 (0.20 - 0.26, 18 - 22)*
Fuel level sensor unit	2.0 - 2.5 (0.20 - 0.26, 18 - 22)*