

SECTION **SCS**

SUSPENSION CONTROL SYSTEM

A
B
C
D

SCS

CONTENTS

<p>TROUBLE DIAGNOSIS FOR ACTIVE DAMPER SUSPENSION 2</p> <p> Precautions 2</p> <p> PRELIMINARY CHECK 2</p> <p> Fail-Safe 2</p> <p> FAIL-SAFE FUNCTIONS 2</p> <p> FAIL-SAFE ITEMS 2</p> <p> Active Damper Suspension Configuration 3</p> <p> SYSTEM COMPONENTS 3</p> <p> SCHEMATIC 4</p> <p> CONTROL UNIT TERMINALS AND REFERENCE 14</p> <p> CONSULT-II Inspection Procedure 15</p> <p> SELF-DIAGNOSIS PROCEDURE 15</p> <p> DATA MONITOR PROCEDURE 16</p> <p> DATA MONITOR MODE 16</p>	<p> ACTIVE TEST PROCEDURE 17</p> <p> Self-Diagnosis 19</p> <p> FUNCTION 19</p> <p> SELF-DIAGNOSTICS PROCEDURE 19</p> <p> HOW TO READ SELF-DIAGNOSTIC RESULTS.. 19</p> <p> MALFUNCTION CODE/SYMPTOM CHART 19</p> <p> HOW TO ERASE SELF-DIAGNOSTIC RESULTS 20</p> <p> TROUBLE DIAGNOSIS FOR SELF-DIAGNOSTIC ITEMS 21</p> <p> Inspection 1: Vehicle Speed Sensor 21</p> <p> Inspection 2: Steering Angle Sensor 21</p> <p> Inspection 3: Stop Lamp Switch 22</p> <p> Inspection 4: Vertical G sensor 23</p> <p> TROUBLE DIAGNOSIS FOR SYMPTOMS 25</p> <p> Inspection 5: Hard or Soft Feel 25</p>	<p>F G H I J K L M</p>
--	---	--

TROUBLE DIAGNOSIS FOR ACTIVE DAMPER SUSPENSION

TROUBLE DIAGNOSIS FOR ACTIVE DAMPER SUSPENSION

PF2:25962

Precautions

EES000EX

PRELIMINARY CHECK

- Check power steering fluid level.
- Check power steering fluid line for improper attachment, leaks, cracks, damage, loose connections, chafing and deterioration.
- Check tire pressure.
- Check wheel alignment.
- Check shock absorber for oil leakage or other damage.

Fail-Safe

EES000EY

FAIL-SAFE FUNCTIONS

The active damper suspension electronically controls the shock absorber dampening force. If, for some reason, the dampening force falls under any of the conditions listed in the "Fail-safe items" table below, the fail-safe system will activate to maintain a constant level of shock absorber dampening force. If symptoms (such as unstable steering, unpleasant riding comfort, etc.) are pointed out, check and correct the malfunctioning part or area using the diagnostic procedure outlined under "Diagnostic Procedure 6 (Hard or soft feel)". Refer to [SCS-25, "TROUBLE DIAGNOSIS FOR SYMPTOMS"](#)

FAIL-SAFE ITEMS

Item	Fail-safe input conditions	Fail-safe end conditions	Fail-safe processing
Vehicle speed sensor	<ul style="list-style-type: none"> ● Vehicle speed signal cannot be entered for more than 10 seconds when the vehicle is running with the engine revolution greater than 1,500 rpm. ● Vehicle speed signal changes from a value of greater than 30 km/h (19 MPH) to a value of less than 2 km/h (1 MPH) within 1.4 seconds. 	A signal corresponding to a vehicle speed of greater than 2 km/h (1 MPH) is entered.	<ul style="list-style-type: none"> ● Shock absorber dampening force is maintained at a preset value. ● Power steering control current is maintained at approximately 0.18A.
Steering angle sensor	A steering signal of greater than 1° does not change for more than 180 seconds when vehicle speed is greater than 60 km/h (37 MPH).	A steering signal of greater than 1° is entered.	Shock absorber dampening force is maintained at a preset value.
Steering angle (neutral) signal	<ul style="list-style-type: none"> ● Steering neutral signal is not entered ("ON") at all while vehicle is being driven a distance of 10 km (6 miles) or more. ● Steering neutral signal is not entered ("ON") at all when steering wheel is turned at least 360° in either direction. ● Steering neutral signal is staying "ON" only while steering wheel is being turned at least 50° in either direction. 	More than one ON-OFF signal is entered.	Shock absorber dampening force is maintained at a preset value.
Vertical G sensor	<ul style="list-style-type: none"> ● Vertical G sensor signal corresponding to a voltage of greater than 4.5 volts does not change for 2 seconds. ● Vertical G sensor signal corresponding to a voltage of less than 0.5 volts does not change for 2 seconds. 	Vertical G sensor signal corresponding to a voltage of greater than 1 volt or less than 4 volts.	When any of the vertical G sensors are determined to be faulty, shock absorber dampening force is maintained at a preset value.
Stop lamp switch	Fail-safe system does not process data. DTC is displayed when self-diagnosis is performed.		

NOTE:

Even after the fail-safe function is canceled, the fail-safe processed history is retained in the control unit memory.

TROUBLE DIAGNOSIS FOR ACTIVE DAMPER SUSPENSION

Active Damper Suspension Configuration SYSTEM COMPONENTS

EES000EZ

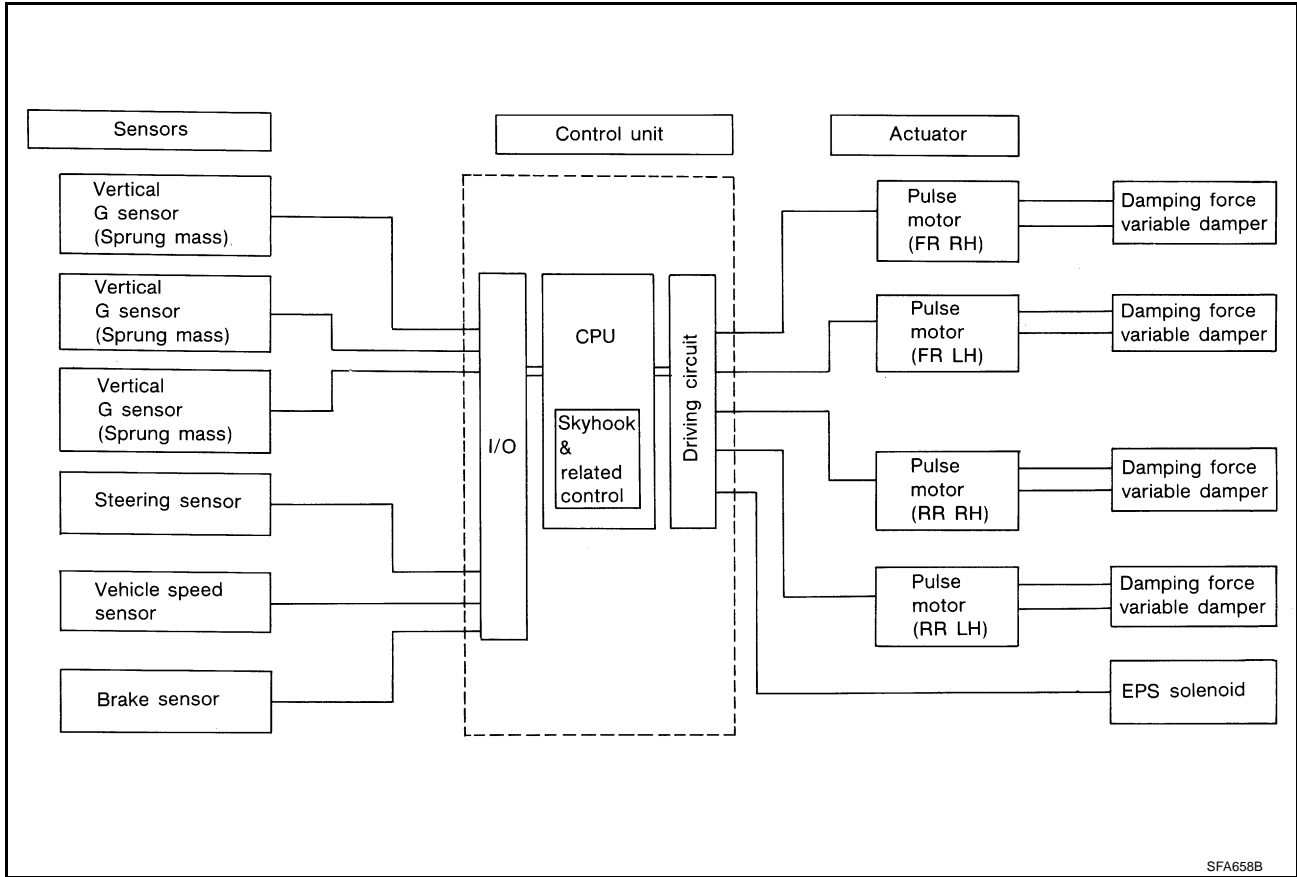

A
B
C
D
SCS
F
G
H
I
J
K
L
M

TROUBLE DIAGNOSIS FOR ACTIVE DAMPER SUSPENSION

SCHEMATIC

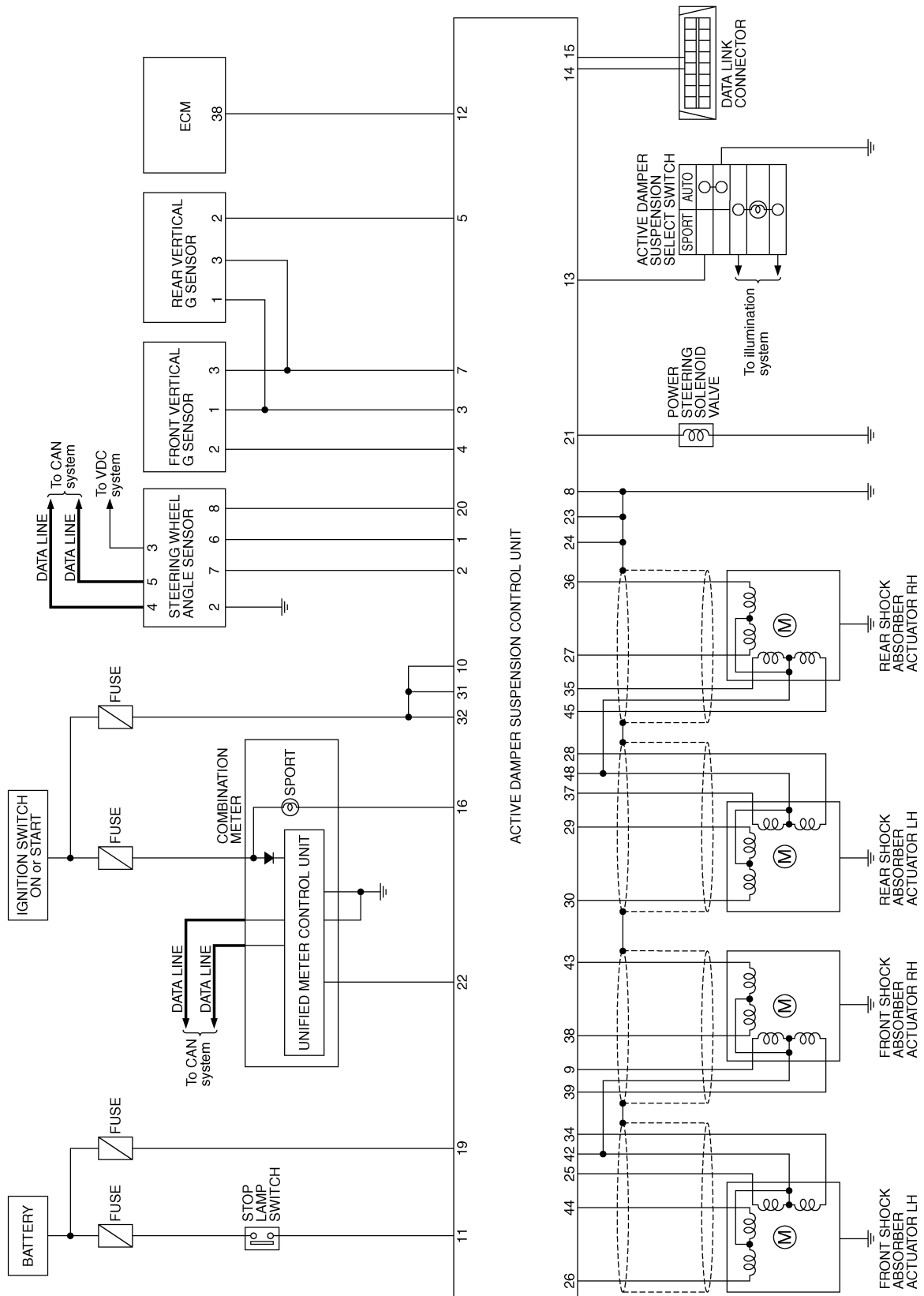

TEWM0005E

TROUBLE DIAGNOSIS FOR ACTIVE DAMPER SUSPENSION

SCS-ACTIVE-01

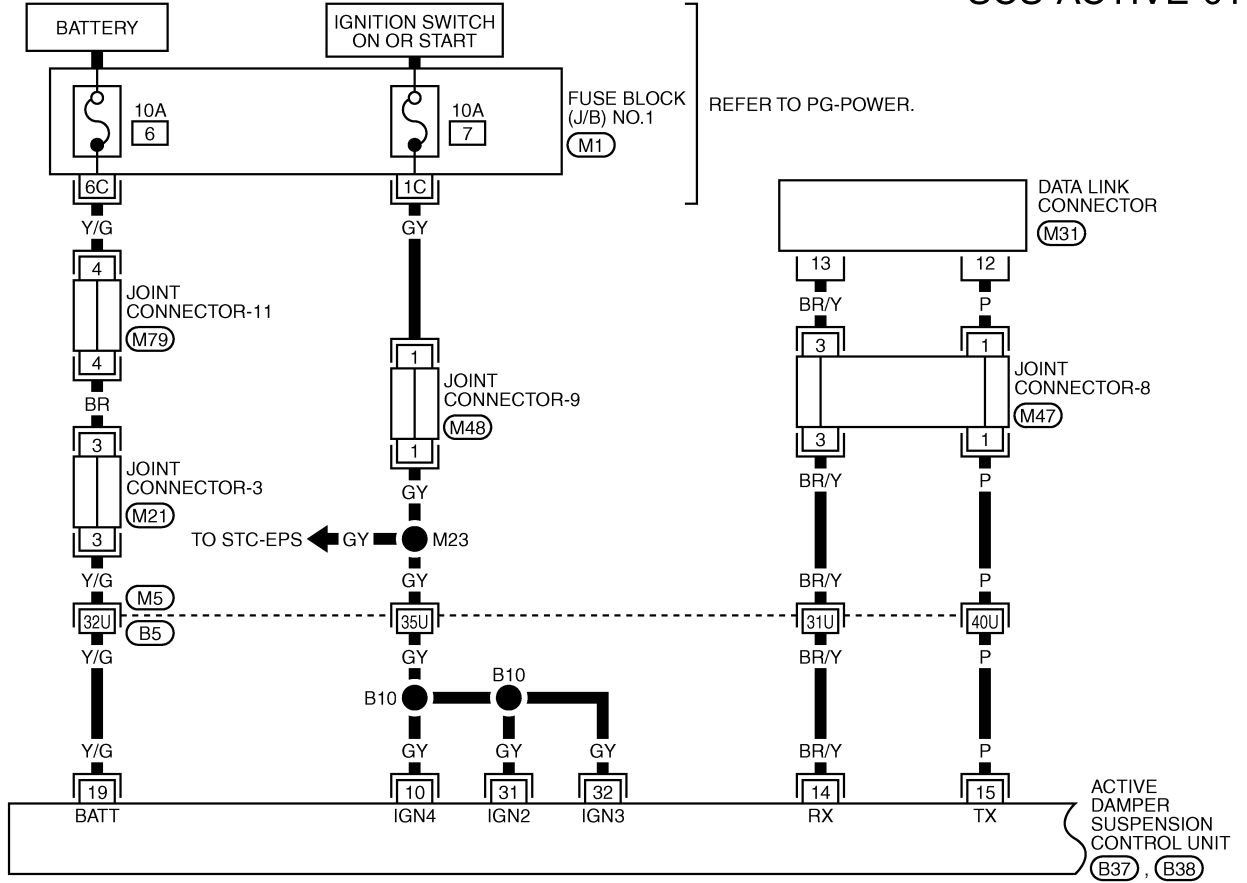

A
B
C
D
SCS
F
G
H
I
J
K
L
M

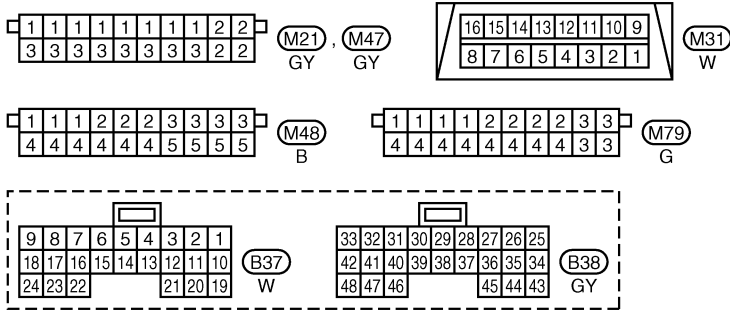

REFER TO THE FOLLOWING.
 (M5) -SUPER MULTIPLE JUNCTION (SMJ)
 (M1) -FUSE BLOCK-JUNCTION BOX (J/B) NO.1

TROUBLE DIAGNOSIS FOR ACTIVE DAMPER SUSPENSION

SCS-ACTIVE-02

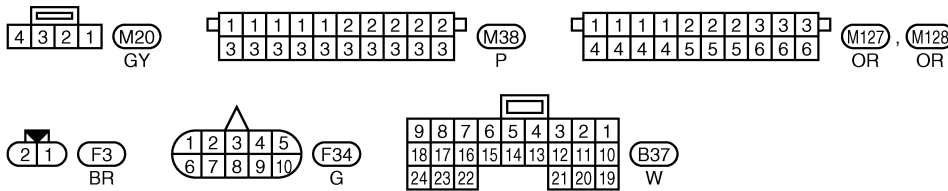
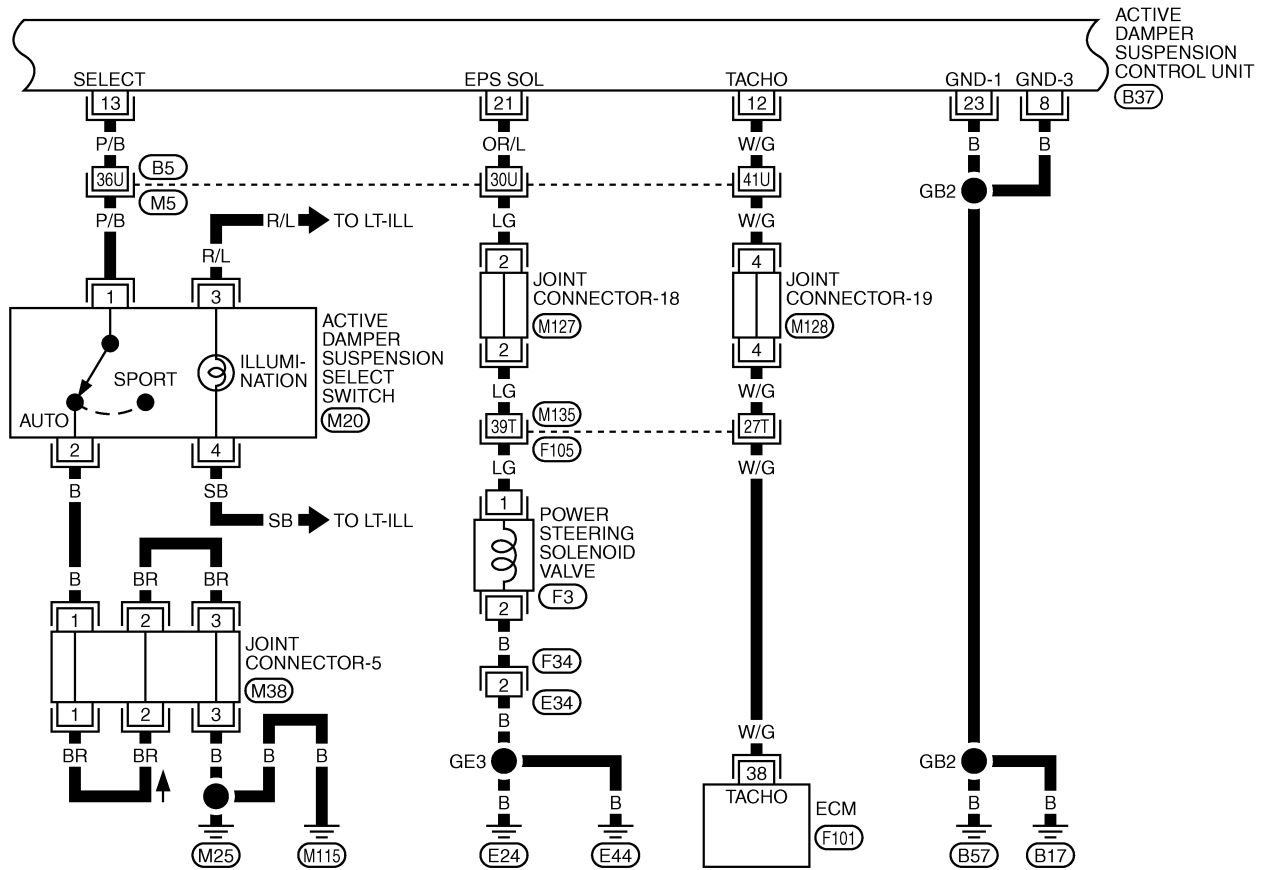

REFER TO THE FOLLOWING.
 (M5), (F105) - SUPER MULTIPLE JUNCTION (SMJ)
 (F101) - ELECTRICAL UNITS

TROUBLE DIAGNOSIS FOR ACTIVE DAMPER SUSPENSION

SCS-ACTIVE-03

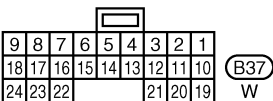
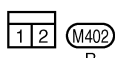
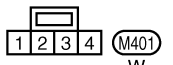
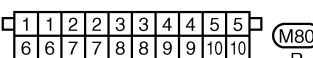
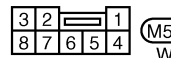
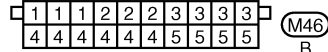
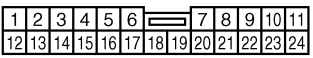
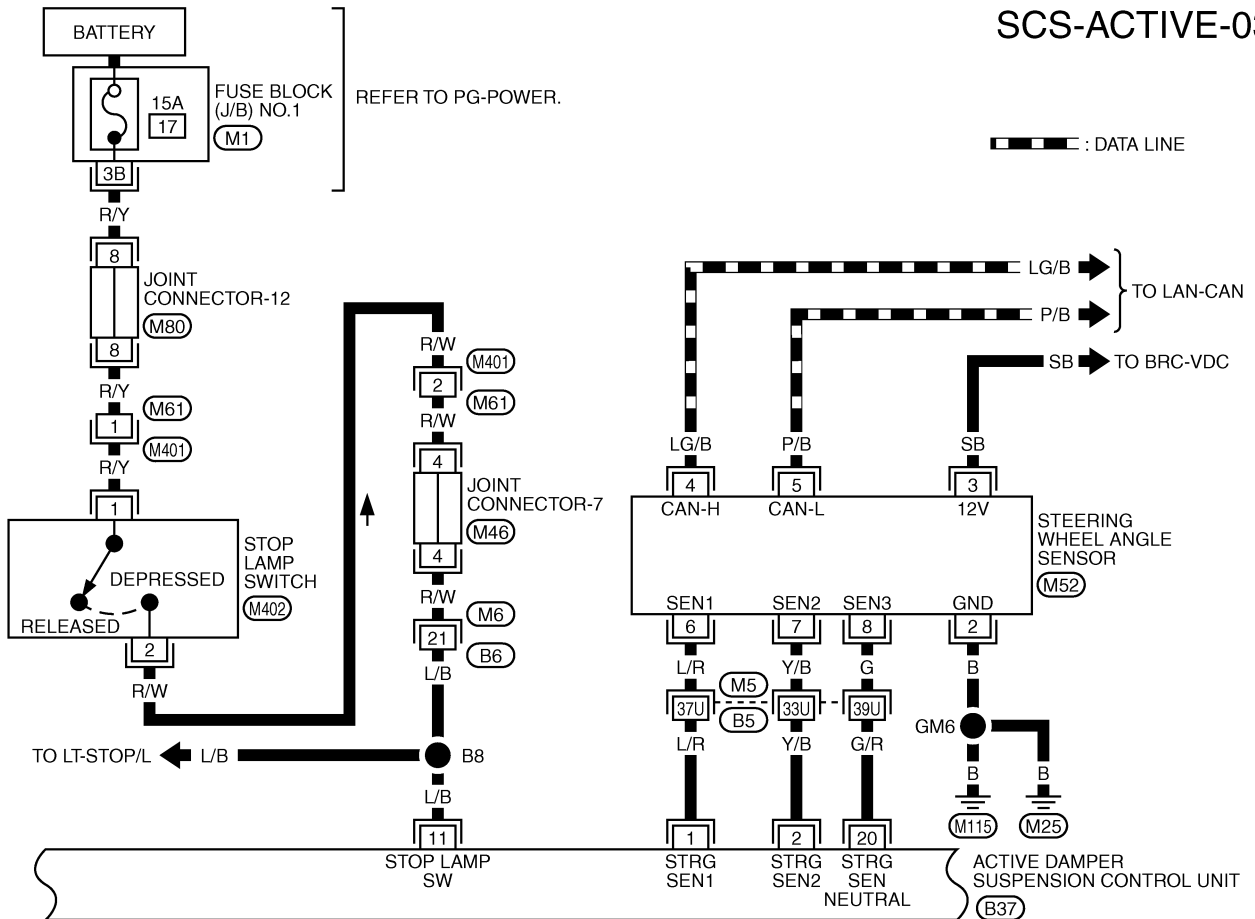

REFER TO THE FOLLOWING.

(M5) -SUPER MULTIPLE JUNCTION (SMJ)

(M1) -FUSE BLOCK-JUNCTION BOX (J/B) NO.1

A
B
C
D
E
F
G
H
I
J
K
L
M

SCS

TROUBLE DIAGNOSIS FOR ACTIVE DAMPER SUSPENSION

SCS-ACTIVE-04

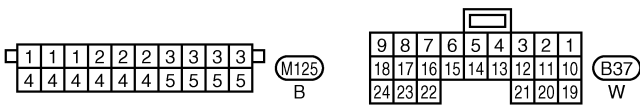
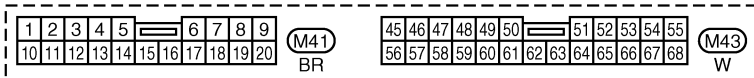
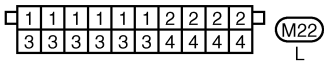
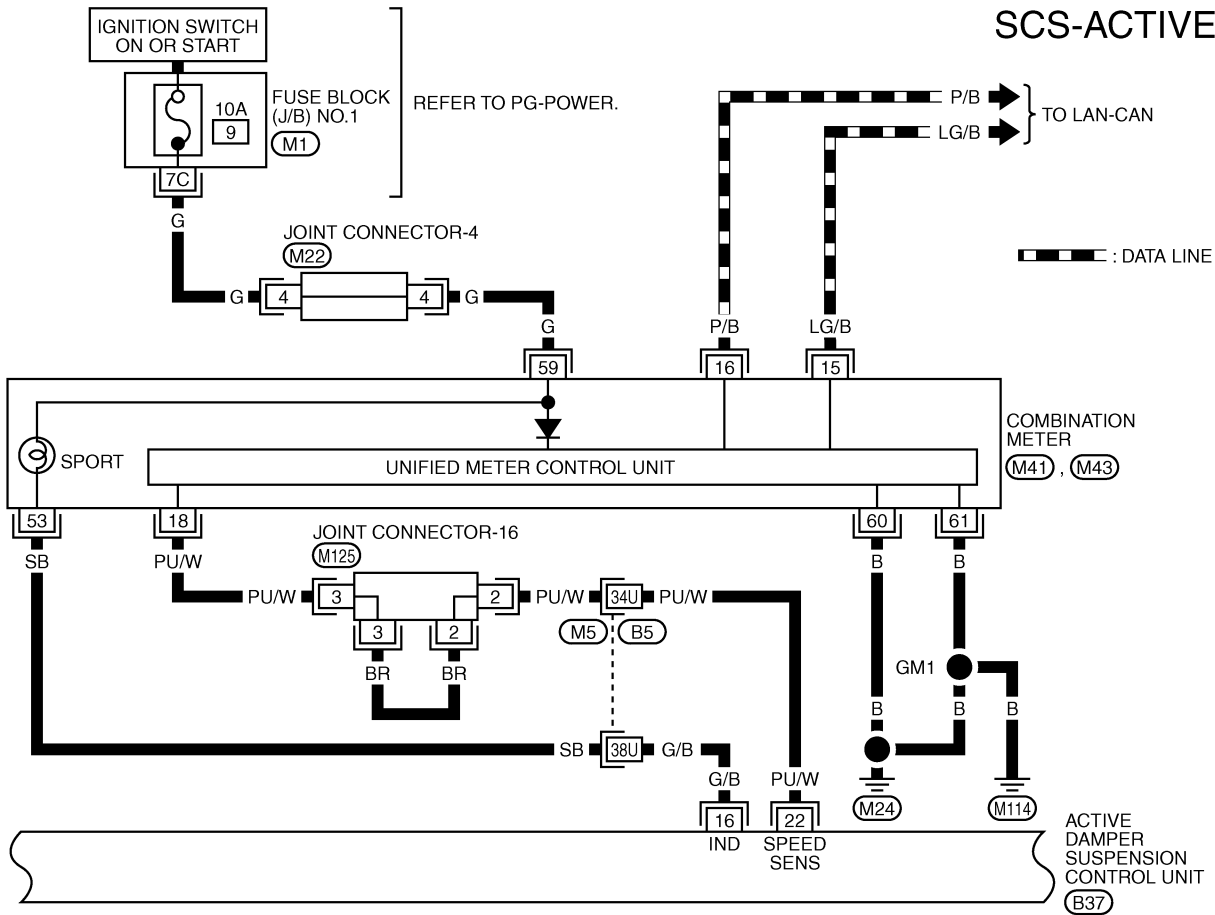

REFER TO THE FOLLOWING.

(M5) -SUPER MULTIPLE JUNCTION (SMJ)

(M1) -FUSE BLOCK-JUNCTION BOX (J/B) NO.1

TROUBLE DIAGNOSIS FOR ACTIVE DAMPER SUSPENSION

SCS-ACTIVE-05

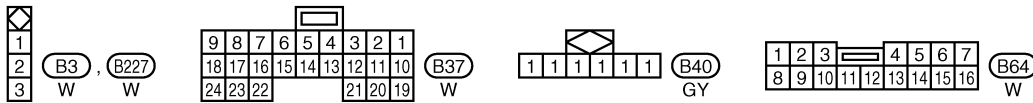
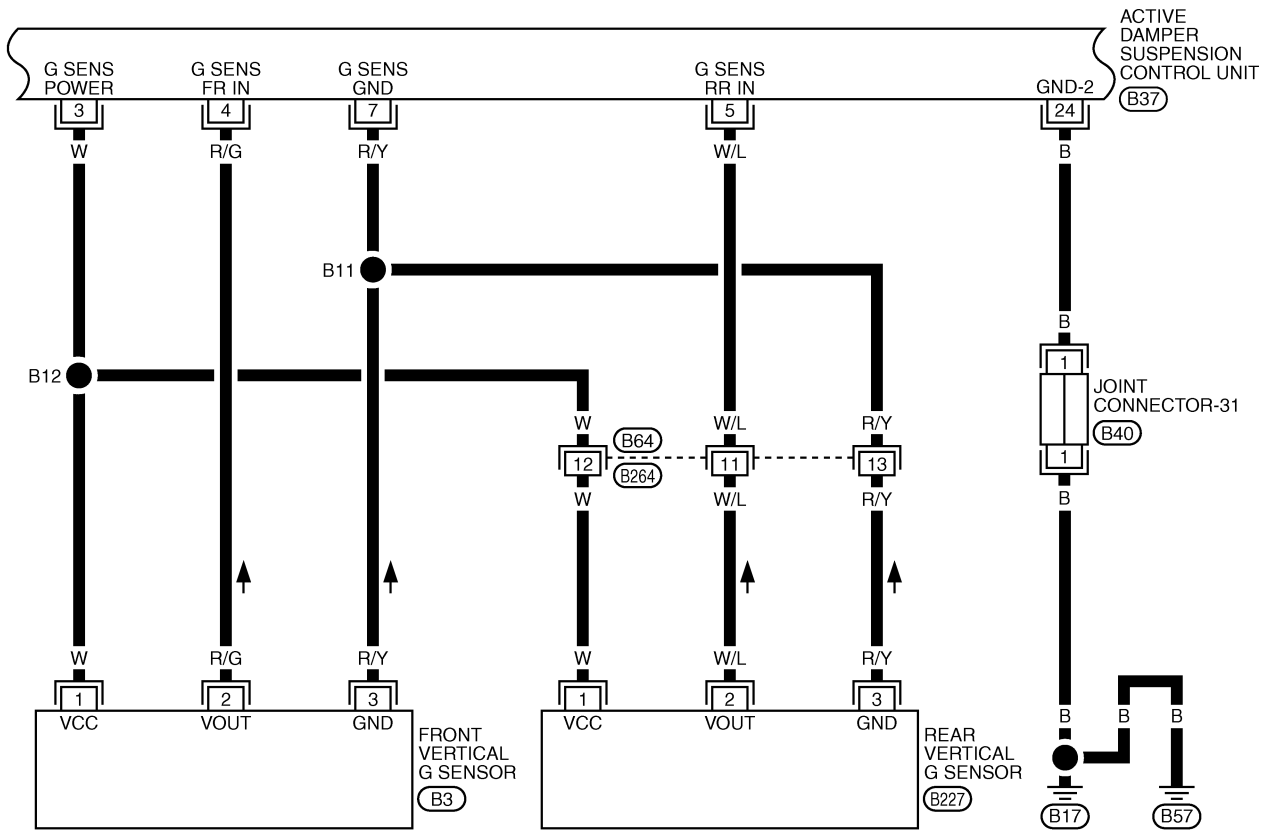

A
B
C
D
SCS
F
G
H
I
J
K
L
M

TEWM0010E

TROUBLE DIAGNOSIS FOR ACTIVE DAMPER SUSPENSION

SCS-ACTIVE-06

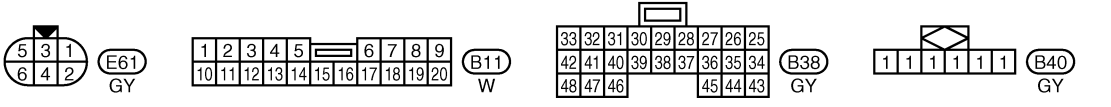
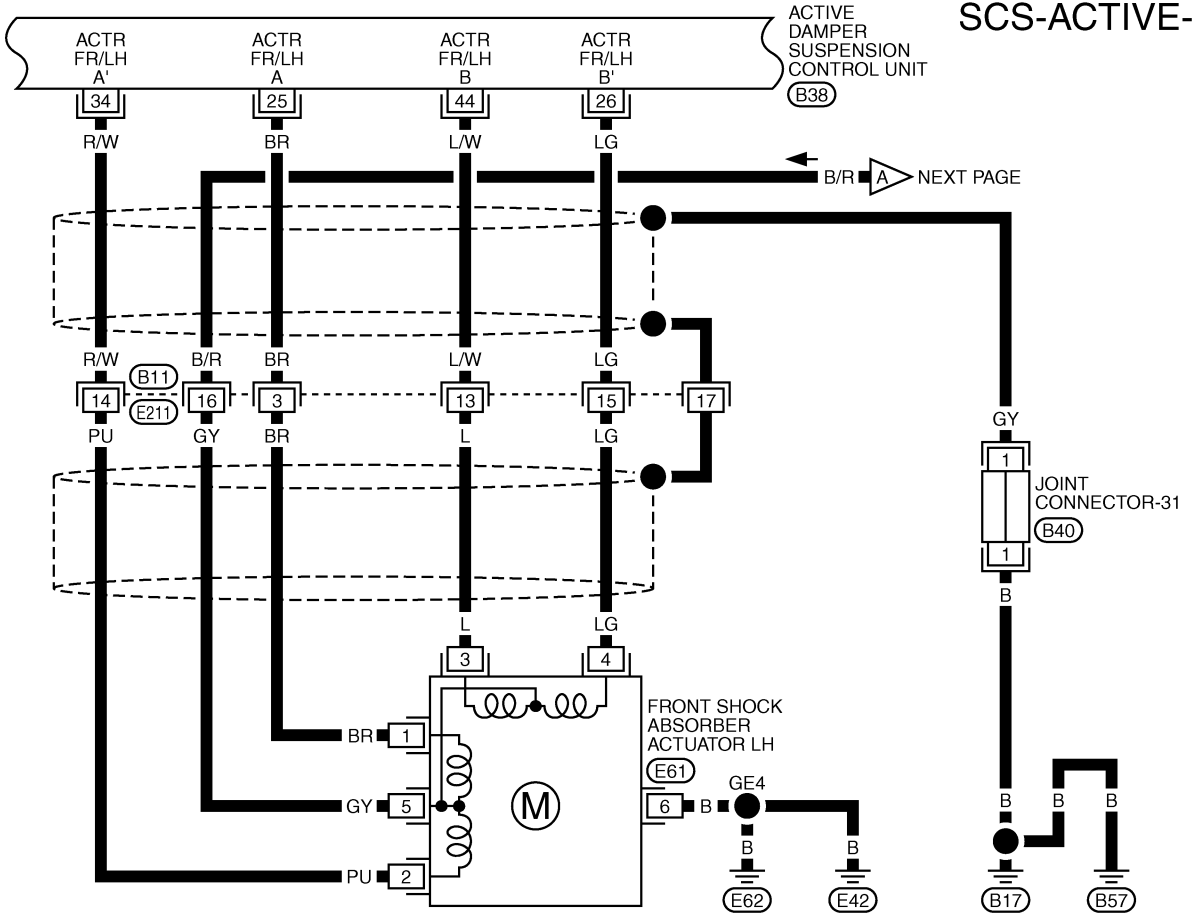

TEWM0011E

TROUBLE DIAGNOSIS FOR ACTIVE DAMPER SUSPENSION

A
B
C
D
E
F
G
H
I
J
K
L
M

SCS-ACTIVE-07

ACTIVE DAMPER SUSPENSION CONTROL UNIT (B37, B38)

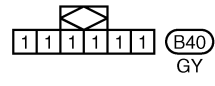
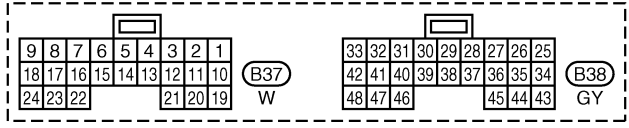
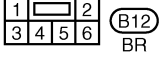
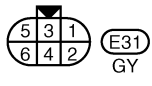
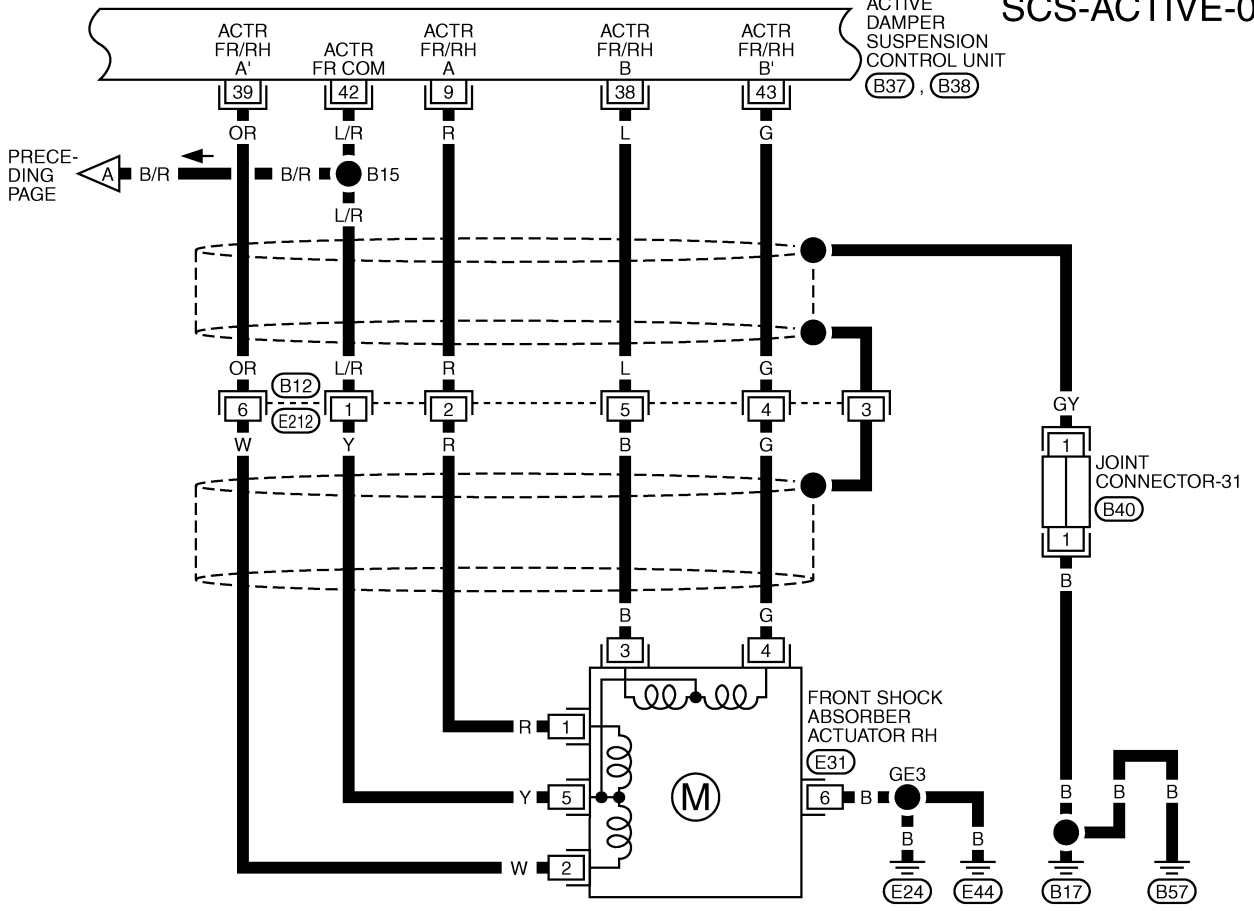

TEWM0012E

TROUBLE DIAGNOSIS FOR ACTIVE DAMPER SUSPENSION

SCS-ACTIVE-08

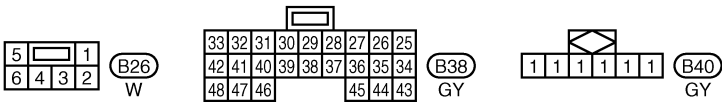
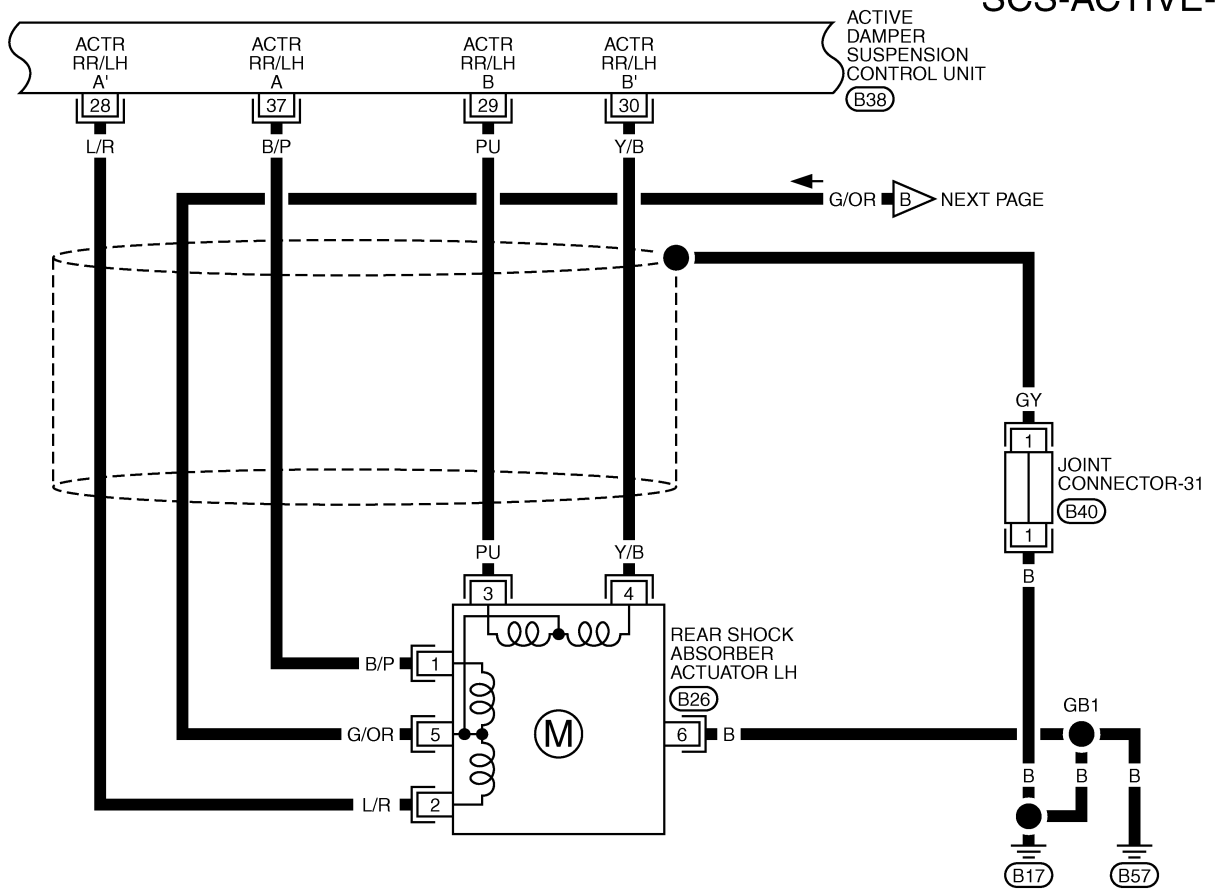

TEWM0013E

TROUBLE DIAGNOSIS FOR ACTIVE DAMPER SUSPENSION

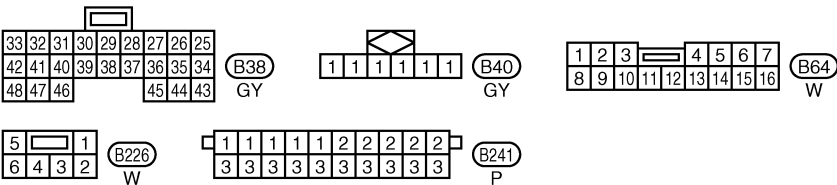
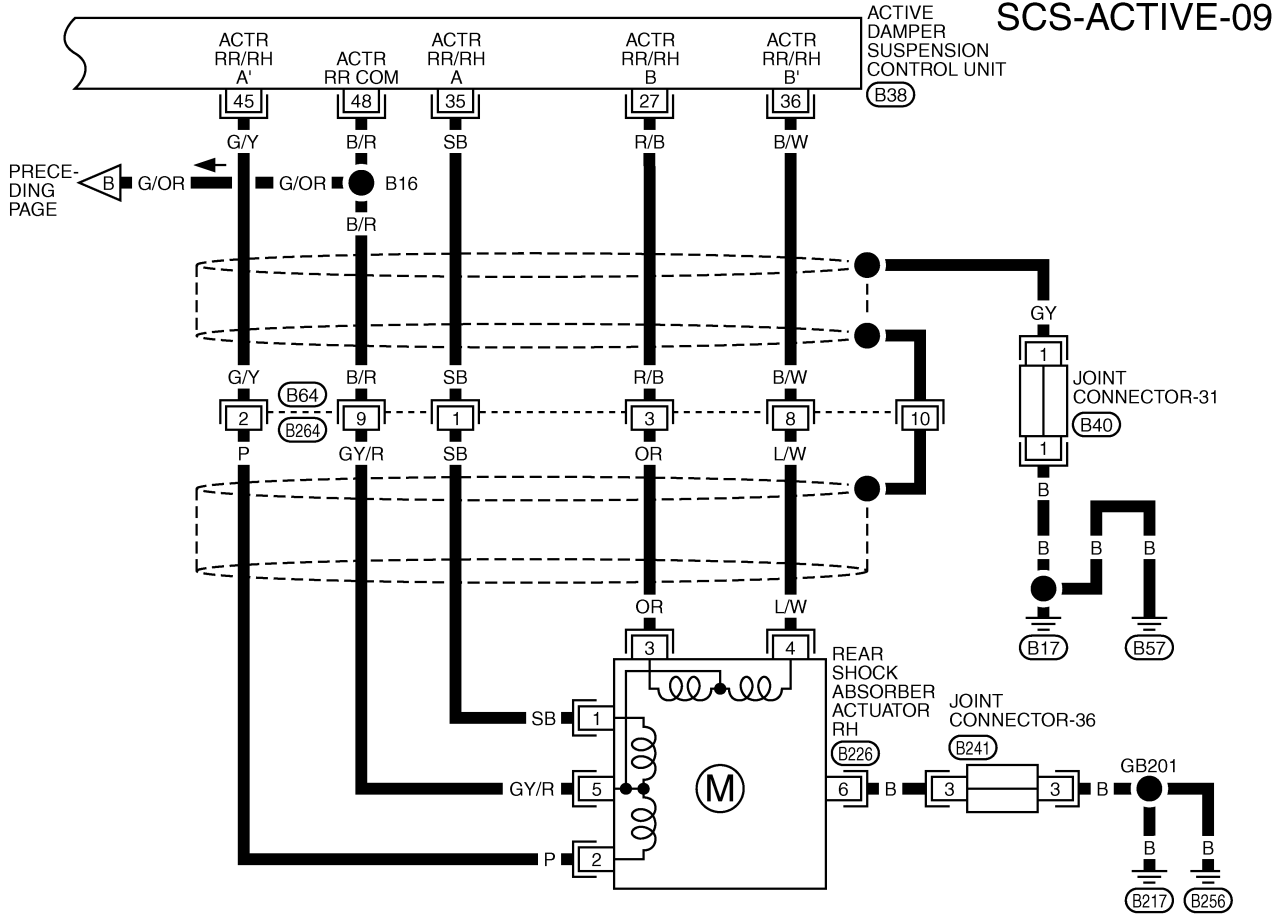

A
B
C
D
E
F
G
H
I
J
K
L
M

SCS

TEWM0014E

TROUBLE DIAGNOSIS FOR ACTIVE DAMPER SUSPENSION

CONTROL UNIT TERMINALS AND REFERENCE

Reference Values

1	2	3	4	5	6	7	8	9
10	11	12	13	14	15	16	17	18
19	20	21				22	23	24

25	26	27	28	29	30	31	32	33
34	35	36	37	38	39	40	41	42
43	44	45				46	47	48

FAD0186D

Terminal number		Inspection location	Reference value		
+	-				
1,2	Ground	Steering angle sensor	When steering wheel turned slowly	Repeats Approx. 0 - 5V	
3		G sensor power supply	Approx. 5V		
4,6		G sensor	When stopped	Approx. 5V	
7		G sensor ground	—		
8,23,24		Ground	—		
9,25,26 27,28,29 30,34,35 36,37,38 39,43,44 45		Shock absorber actuator	—		
10,19,31 32		Power supply	Ignition switch is ON	Battery voltage	
11		Stop lamp switch	When brake pedal not depressed	Approx. 0V	
			When brake pedal depressed	Battery voltage	
12		ECM	—		
13		Select switch	Sport	Approx. 5V	
			Auto	Approx. 0V	
14,15		-	CONSULT-II	—	
16		Indicator lamp (SPORT)	Sport	Approx. 0V	
	Auto		Battery voltage		
20	Steering angle sensor	Neutral position	Approx. 5V		
21	EPS solenoid valve	0 km/h (0 MPH) (engine idling)	Approx. 1.05 A		
		100 km/h (62 MPH)	Approx. 0.7 A		
22	Vehicle speed sensor	—			
42,48	Actuator	Battery voltage			

TROUBLE DIAGNOSIS FOR ACTIVE DAMPER SUSPENSION

CONSULT-II Inspection Procedure

EES000BL

The troubleshooting system provides four functional modes - self diagnosis, data monitor, active test and control unit part number display modes.

Mode type	Description	Mode selection	Display representation
SELF-DIAG RESULTS	Self-diagnosis	The desired functional mode can easily be selected by touching key on CONSULT-II.	The desired functional mode can easily be shown on the CONSULT-II display.
DATA MONITOR	<ul style="list-style-type: none"> Helps locate main trouble cause according to a self-diagnostic result. Provides active damper suspension control unit input and output monitoring and print-out function (observation and recording). 		
ACTIVE TEST	<ul style="list-style-type: none"> Used to precisely locate the main cause for trouble according to the self-diagnostic result obtained in the monitor mode. Provides operational checks of indicator light and actuator circuits. 		
ECU PART NUMBER	Active damper control unit part numbers are shown on the CONSULT-II display.		

SELF-DIAGNOSIS PROCEDURE

1. Connect CONSULT-II to data link connector and start the engine.
2. Touch "START (NISSAN BASED VHCL)", "ACT D/SUS" and "SELF-DIAG RESULTS".
 - a. When a malfunction item is displayed, record the item.
 - b. Touch "ERASE".
3. A self-diagnostic result is displayed again. If "NO SELF DIAGNOSTIC FAILURE INDICATED" is displayed, check the item first shown on the display.

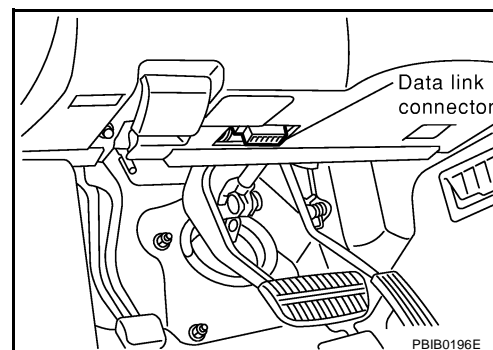

Items Shown on Display

Malfunctioning system or circuit	Detecting conditions
VEHICLE SPEED SEN	<ul style="list-style-type: none"> Input signal does not change for some length of time while driving. Input signal changes abruptly while driving.
VERTI G SENSOR F	<ul style="list-style-type: none"> Voltage is greater than or less than the standard value.
VERTI G SENSOR R/R	
VERTI G SENSOR R/L	
STEERING ANGLE SEN [ANG SIGNAL] (.a)	Input signal does not change for some length of time while driving at speeds greater than 60 km/h (37 MPH).
STEERING ANGLE SEN [NEUT SIGNAL] (.b)	<ul style="list-style-type: none"> Neutral ("ON") signal is not entered at all while driving a distance of more than 10 km (6 miles). Neutral ("ON") signal is not entered at all when steering wheel is turned at least 360°. Neutral ("ON") signal is entered when steering wheel is turned at least 50°.

TROUBLE DIAGNOSIS FOR ACTIVE DAMPER SUSPENSION

DATA MONITOR PROCEDURE

1. Connect CONSULT-II to data link connector, then start the engine.
2. Touch "START (NISSAN BASED VHCL)", "ACT D/SUS" and "DATA MONITOR".
3. Select the signal to be monitored.
 - a. When "ALL SIGNALS" is selected, touch "START".
 - b. When "SELECTION FROM MENU" is to be selected, touch "SETTING". "MONITOR ITEM MENU" will then be indicated on the display. Touch the item to be monitored, then "ENTER" and "START".
 - c. Print out the data if necessary.

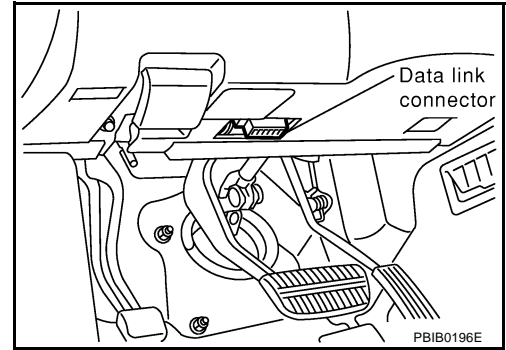

DATA MONITOR MODE

Monitored item	Display	Data item selection		Remarks
		Main item	Item menu selection	
Vehicle speed sensor	VHCL SPEED SE [km/h] or [mph]	×	×	—
Vertical G sensor front	VERTI G SE F [G]	×	×	—
Vertical G sensor rear right side	VERTI G SE RR [G]	×	×	—
Vertical G sensor rear left side	VERTI G SE RL [G]	×	×	—
Steering angle sensor (steering angle signal)	STEERING ANG [°]	×	×	When the battery is disconnected and then reconnected, an abnormal value is displayed until the straight ahead position (0°) is set during driving.
Active damper select switch	SELECT SWITCH [AUTO-SPORT]	×	×	—
Stop lamp switch	STOP LAMP SW [ON-OFF]	×	×	—
Steering angle sensor (steering neutral signal)	NEUTRAL SIG [ON-OFF]	×	×	—
Damper motor front right	DAMP MTR F/R [Step]	×	×	—
Damper motor front left	DAMP MTR F/L [Step]	×	×	—
Damper motor rear right	DAMP MTR R/R [Step]	×	×	—
Damper motor rear left	DAMP MTR R/L [Step]	×	×	—
Power steering solenoid valve	POWER STR SOL [A]	×	×	EPS solenoid control current flow from control unit
Active damper indicator lamp (SPORT)	INDICATOR [ON-OFF]	×	×	—
Voltage	■ VOLTAGE [V]	—	×	Voltage measured by the voltage probe
Pulse	■ PULSE [msec] or [Hz] or [%]	—	×	Pulse width, frequency or duty cycle measured by the pulse probe. Only "#" is displayed if item is unable to be measured. Figures with "#" s are temporary ones. They are the same figures as an actual piece and data which was just previously measured.

×: Applicable

—: Not applicable

TROUBLE DIAGNOSIS FOR ACTIVE DAMPER SUSPENSION

ACTIVE TEST PROCEDURE

1. Connect the CONSULT-II to data link connector, then start the engine.
2. Touch "START (NISSAN BASED VHCL)", "ACT D/SUS" and "ACTIVE TEST".
3. Touch "INDICATOR" or "DAMPER".

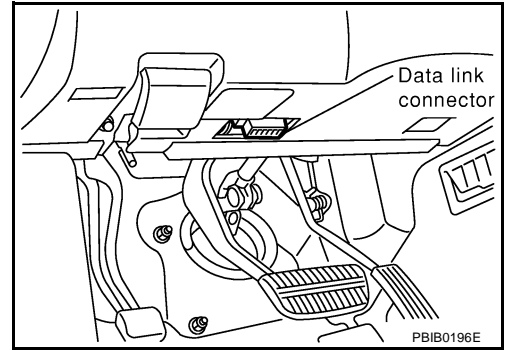

(A) When "INDICATOR" Is Selected

1. Touch "MAIN SIGNAL", then "START".
2. When "OFF" is touched, indicator lamp goes out regardless of select switch positions. Monitor indicator will then be turned "OFF".
3. When "ON" is touched, indicator lamp comes on regardless of select switch positions. Monitor indicator will then be turned "ON".

ACTIVE TEST	
DAMPER TEST CONDITION	
FL-N	FR-N
RL-N	RR-N
MONITOR	
DAMP MTR FR	XXX
DAMP MTR FL	XXX

SFA989B

(B) When "DAMPER" Is Selected

1. Touch "SELECTION FROM MENU".
2. Select and touch "DAMP MTR F/R" or "DAMP MTR F/L", and "DAMP MTR R/R" or "DAMP MTR R/L", as required.
3. Touch "ENTER", then "START".
4. "4 Step" for front damper motors and "4 step" for rear damper motor will be then shown on the display.
5. Touch "CONDITION CHANGE", "FL-HS, FR-HS, RL-HS, RR-HS" and "START".
6. "80 step" for front damper motors and "80 step" for rear damper motor will be then shown on the display.
7. Print out data as required.

ACTIVE TEST	
DAMPER TEST CONDITION	
FL-HS	FR-HS
RL-HS	RR-HS
MONITOR	
DAMP MTR FR	XXX
DAMP MTR FL	XXX

SFA990B

8. The actuator center shaft becomes as shown in the figure.

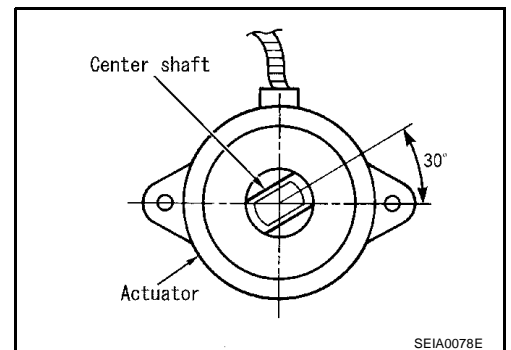

TROUBLE DIAGNOSIS FOR ACTIVE DAMPER SUSPENSION

9. Touch "CONDITION CHANGE" FL-SS, FR-SS, RL-SS, RR-SS" and "START".
10. "0 step" for front damper motors and "0 step" for rear damper motor will be then shown on the display.
11. Print out data as required.

ACTIVE TEST	
DAMPER TEST CONDITION	
FL-SS	FR-SS
RL-SS	RR-SS
MONITOR	
DAMP MTR FR	XXX
DAMP MTR FL	XXX

SFA991B

12. The actuator center shaft becomes as shown in the figure.

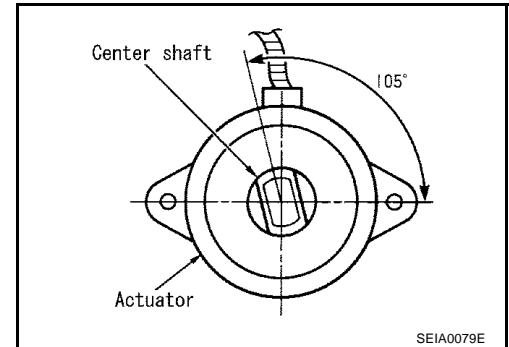

13. Touch "CONDITION CHANGE" "FL-SH, FR-SH, RL-SH, RR-SH" and "START".
14. "- 60 step" for front damper motors and "- 60 step" for rear damper motor will be then shown on the display.
15. Print out data as required.

ACTIVE TEST	
DAMPER TEST CONDITION	
FL-SH	FR-SH
RL-SH	RR-SH
MONITOR	
DAMP MTR FR	XXX
DAMP MTR FL	XXX

SFA992B

16. The actuator center shaft becomes as shown in the figure.

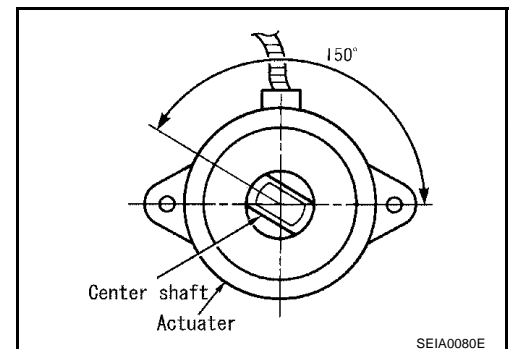

ECU (Active Damper Suspension Control Unit) Part Number Mode

Ignore the ECU part number displayed in the ECU PART NUMBER MODE. Refer to parts catalog to order the ECU.

TROUBLE DIAGNOSIS FOR ACTIVE DAMPER SUSPENSION

EES000BD

Self-Diagnosis FUNCTION

The self-diagnosis system can be used without using CONSULT-II. With this system, both self-diagnostic history and fail-safe history are indicated by the SPORT indicator lamp.

SELF-DIAGNOSTICS PROCEDURE

1. Turn ignition switch to "OFF".
2. Start the engine.
3. Quickly switch the active damper suspension select switch from "SPORT" to "AUTO", and vice versa, at least 5 times within 10 seconds immediately after the engine has started.
 - 2 or 3 seconds following the above switch operation, the indicator lamp will come on. This is not the indication of self-diagnosis.
4. Perform the following procedures to enter the corresponding signals.
 - Turn steering wheel 180° in either direction from neutral.
 - Depress brake pedal.
 - Release brake pedal.
 - Move the vehicle at least 5 m (16 ft) forward.

HOW TO READ SELF-DIAGNOSTIC RESULTS

(Malfunction codes)

Following the steps listed under the "Self-diagnostic procedure" above, a malfunctioning area or malfunctioning areas, if any, are indicated by a flashing SPORT indicator lamp located in the meter cluster.

The indicator lamp flashes to show malfunctioning areas corresponding with No. 11 through 14, then No. 21, 23 and 24, in that order. 2 seconds after all items are indicated, the indicator lamp repeats the flash sequence for all items again.

- When all items are in good order, the indicator lamp flashes at a cycle of 1/4 Hz [ON (2 seconds) and OFF (2 seconds)].

Display mode:

First digit "ON" (0.6 seconds)

Second digit "ON" (0.3 seconds)

- The upper part of the figure at left shows an example of a malfunctioning area corresponding with No. 23.
- The lower part of the figure at left shows an example of a malfunctioning area (No. 23) which previously fell under the fail-safe history data and is still stored in the current fail-safe data history.

After repairing the malfunctioning area(s), erase the self-diagnostic data stored in memory.

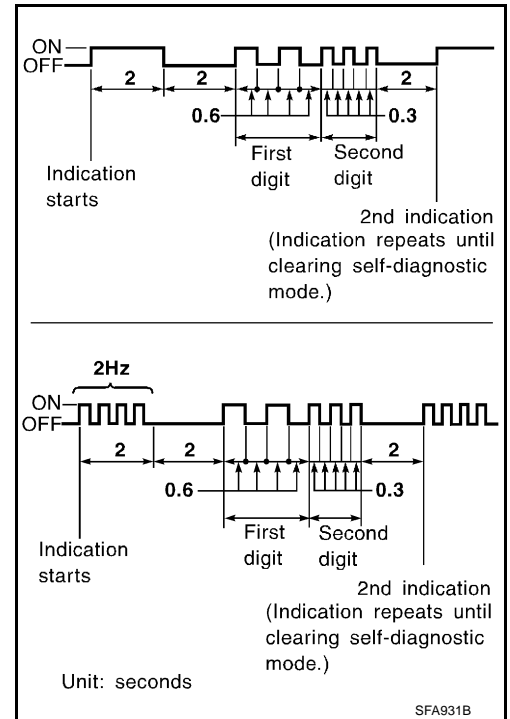

MALFUNCTION CODE/SYMPTOM CHART

Code No.	Diagnostic item
11	Vehicle speed sensor
12	Steering angle sensor
13	Steering angle (neutral) sensor
14	Stop lamp switch
22	Vertical G sensor (front)
23	Vertical G sensor (rear)
31	Engine speed signal

TROUBLE DIAGNOSIS FOR ACTIVE DAMPER SUSPENSION

HOW TO ERASE SELF-DIAGNOSTIC RESULTS

(Malfunction codes)

Disconnecting the Self-Diagnostic Function

Disconnect the self-diagnostic function using one of the following three methods:

- Turn the ignition switch to "OFF".
- Drive the vehicle at speeds greater than 30 km/h (19 MPH).
- Connect CONSULT-II.

Clearing the Self-Diagnostic Memory

Clear self-diagnostic data and fail-safe data stored in memory as follows:

- While self-diagnosis is being performed, depress the brake pedal at least 5 times and shift the select switch position at least 5 times. Pedal depression and switch shifting must be done within 10 seconds during self-diagnosis.

TROUBLE DIAGNOSIS FOR SELF-DIAGNOSTIC ITEMS

TROUBLE DIAGNOSIS FOR SELF-DIAGNOSTIC ITEMS

PFP:00000

Inspection 1: Vehicle Speed Sensor

EES000ES

1. CHECK INPUT SIGNAL

- Check control unit input signal.

Refer to [EC-109, "ECM INSPECTION TABLE"](#).

OK or NG

- OK >> Replace control unit.
- NG >> GO TO 2.

2. CHECK SPEEDOMETER

- Does the speedometer operate properly?

OK or NG

- OK >> Repair or replace speed sensor or vehicle speed sensor-to-control unit harness.
- NG >> Repair or replace speedometer circuit.

Inspection 2: Steering Angle Sensor

EES000ET

1. CHECK CONTROL UNIT INPUT SIGNAL

- Slowly turn the steering wheel at least 90° to the right (or the left) from neutral.
- Measure voltage between control unit connector terminals 1(L/R), 2 (Y/B) and body ground, 20 (G/R) and body ground.

1 (L/R), 2 (Y/B) - Body ground : Varies 0 - approx. 5V
20 (G/R) - Body ground : Approx. 5V (Neutral position)

OK or NG

- OK >> Repair or replace control unit-to-steering angle sensor harness.
- NG >> GO TO 2.

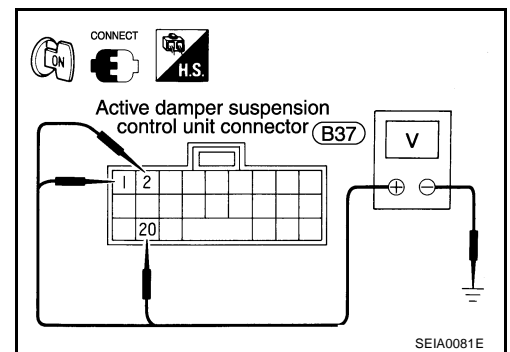

2. CHECK STEERING ANGLE SENSOR OUTPUT SIGNAL

- Slowly turn the steering wheel at least 90° to left or right from neutral.
- Measure voltage between steering angle sensor connector terminals 6 (L/R), 7 (Y/B) and body ground, 8 (G) and body ground.

6 (L/R), 7 (Y/B) - Body ground: Repeats approx. 0 - 5V
8 (G) - Body ground: Neutral position approx. 5V

OK or NG

- OK >> Repair or replace control unit-to-steering angle sensor harness.
- NG >> GO TO 3.

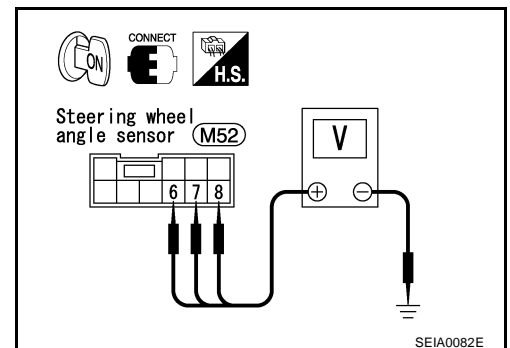

TROUBLE DIAGNOSIS FOR SELF-DIAGNOSTIC ITEMS

3. CHECK STEERING ANGLE SENSOR POWER SUPPLY CIRCUIT

- Measure voltage between steering angle sensor connector terminals 3 (SB) and body ground.

3 (SB) - Body ground : Battery voltage

OK or NG

- OK >> GO TO 4.
NG >> Repair or replace power circuit or steering angle sensor.

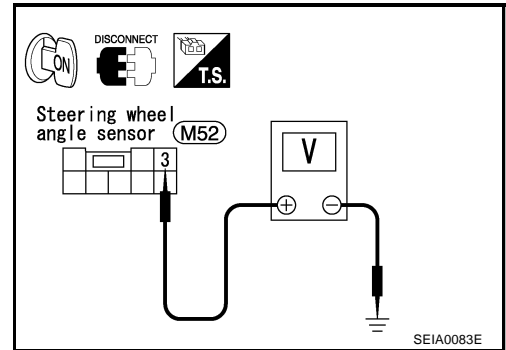

4. CHECK STEERING ANGLE SENSOR GROUND CIRCUIT

- Check continuity between steering angle sensor connector terminal 2 (B) and body ground.

2 (B) - Body ground : Continuity should exist

OK or NG

- OK >> Replace steering angle sensor.
NG >> Repair or replace ground harness.

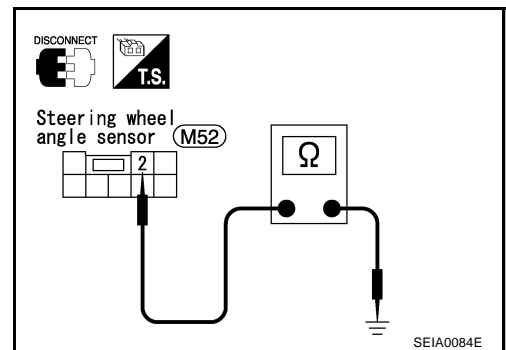

Inspection 3: Stop Lamp Switch

1. CHECK CONTROL UNIT INPUT SIGNAL

- Measure voltage between control unit connector terminal 11 (L/B) and body ground.

11 (L/B) - Body ground

Brake pedal depressed : Battery voltage

Brake pedal released : Approx. 0V

OK or NG

- OK >> GO TO 2.
NG >> Repair or replace control unit-to-stop lamp switch harness.

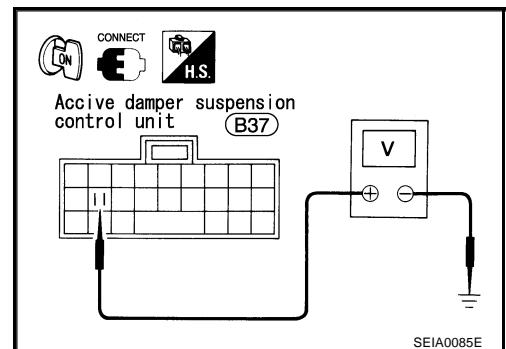

2. CHECK STOP LAMP

- Does the stop lamp light up when brake pedal is depressed?

OK or NG

- OK >> Repair or replace control unit-to-body ground harness or control unit.
NG >> Repair or replace battery-to-stop lamp switch harness or stop lamp switch.

TROUBLE DIAGNOSIS FOR SELF-DIAGNOSTIC ITEMS

EES000EV

Inspection 4: Vertical G sensor

1. CHECK CONTROL UNIT VERTICAL G SENSOR POWER SUPPLY CIRCUIT

- Measure voltage between control unit connector terminal 3 (W) and body ground.

3 (W) - Body ground : Approx. 5V

OK or NG

OK >> GO TO 2.

NG >> Replace control unit.

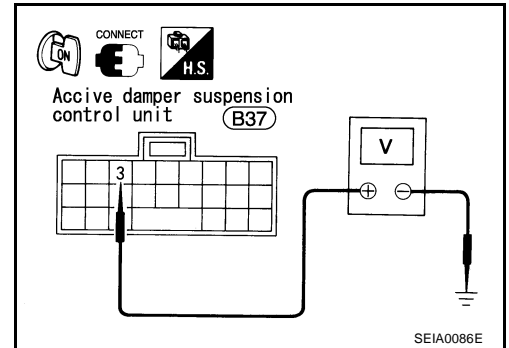

2. CHECK CONTROL UNIT VERTICAL G SENSOR INPUT SIGNAL

- Measure voltage between control unit connector terminals 4,6 and body ground.

4 (R/G), 5 (W/L) - Body ground : Approx. 2.5V

OK or NG

OK >> Replace control unit.

NG >> GO TO 3.

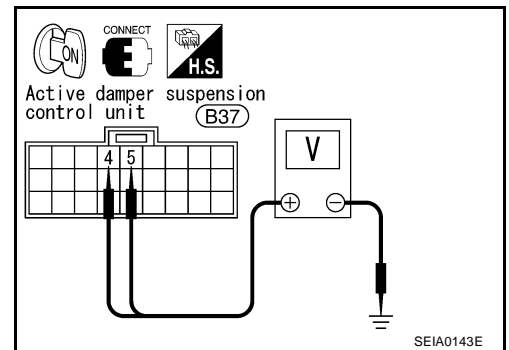

3. CHECK CONTROL UNIT VERTICAL G SENSOR INPUT SIGNAL CIRCUIT

- Check continuity between control unit connector terminals 4 (R/G),6 (W/L) and body ground.

**4 (R/G), 5 (W/L) - Body ground:
Continuity should not exist**

OK or NG

OK >> GO TO 4.

NG >> Repair or replace control unit-to-vertical G sensor harness.

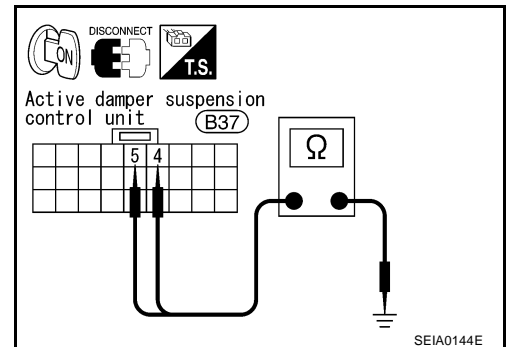

4. CHECK VERTICAL G SENSOR POWER SUPPLY CIRCUIT

- Measure voltage between vertical G sensor connector terminal 1 (W) and body ground.

1 (W) - Body ground : Approx. 5V

OK or NG

OK >> GO TO 5.

NG >> Repair or replace control unit-to-vertical G sensor harness.

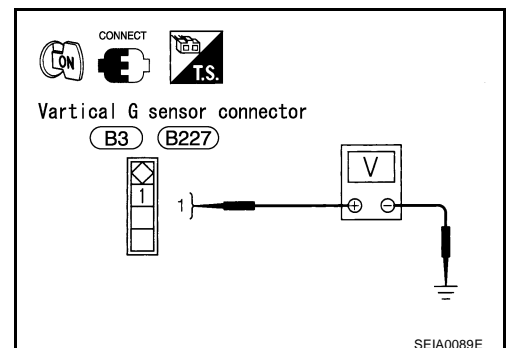

A
B
C
D
SCS
F
G
H
I
J
K
L
M

TROUBLE DIAGNOSIS FOR SELF-DIAGNOSTIC ITEMS

5. CHECK VERTICAL G SENSOR OUTPUT SIGNAL

- Measure voltage between vertical G sensor connector terminal 2 (B3:R/G or B227:W/L) and body ground

2 (B3:R/G or B227:W/L) - Body ground : Approx. 2.5V

OK or NG

- OK >> Repair or replace control unit-to-vertical G sensor harness.
- NG >> Replace vertical G sensor.

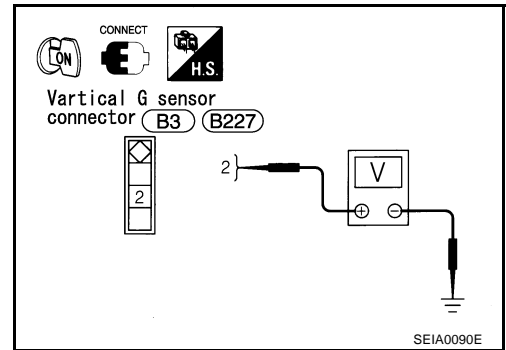

NOTE:

The front vertical G sensor is installed on the rear of the inner pillar and the rear vertical G sensor is located on the rear of the outer wheelhouse. To check each vertical G sensor output signal, remove the vertical G sensor, set it vertical, then measure voltage between terminals.

Be careful not to drop or bump the vertical G sensor as it is easy to break. If dropped or bumped, replace with a new one.

TROUBLE DIAGNOSIS FOR SYMPTOMS

TROUBLE DIAGNOSIS FOR SYMPTOMS

PPF:00007

Inspection 5: Hard or Soft Feel

EES000EW

1. SELF-DIAGNOSTICS INSPECTION

- Disconnect control unit connector and shock absorber actuator connector, then re-connect them.
- Perform self-diagnosis to check that proper test results are obtained.

OK or NG

- OK >> GO TO 2.
- NG >> Check and repair detected area.

2. CHECK SHOCK ABSORBER ACTUATOR OPERATION

- Set the diagnostic system in the self-diagnosis mode.
- Depress parking brake pedal.
- Set select switch to "AUTO", then move vehicle body up and down to check that dampening force of each shock absorber is high. Brake pedal should be released during tests.
- Set select lever to "SPORT", then move vehicle body up and down to check that dampening force of each shock absorber is high.

OK or NG

- OK >> GO TO 11.
- NG >> GO TO 3.

3. CHECK SHOCK ABSORBER ACTUATOR

- Measure resistance between shock absorber actuator terminals.

Front

1, 2, 4, 5 - 3 : Approx. 12Ω

Rear

1, 3, 4, 5 - 2 : Approx. 12Ω

OK or NG

- OK >> GO TO 4.
- NG >> Replace actuator.

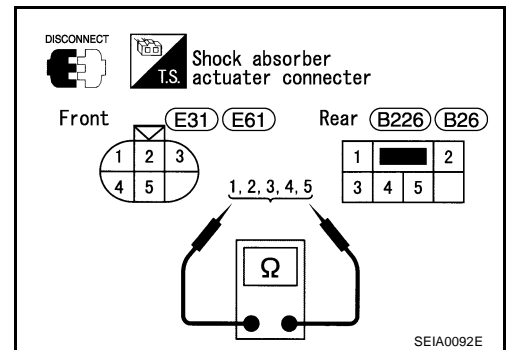

4. CHECK CONTROL UNIT OUTPUT SIGNAL

- Measure voltage between control unit connector terminals 42 (L/R), 48 (B/R) and body ground.

42 (L/R), 48 (B/R) - Body ground : Battery voltage

OK or NG

- OK >> GO TO 6.
- NG >> GO TO 5.

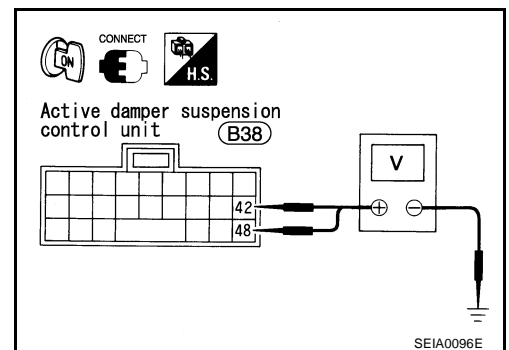

5. CHECK HARNESS CONNECTOR

- Check continuity between control unit and shock absorber actuator terminals.

OK or NG

- OK >> Replace control unit
- NG >> Replace harness connector.

TROUBLE DIAGNOSIS FOR SYMPTOMS

6. CHECK SHOCK ABSORBER ACTUATOR OPERATION

- Remove actuator from strut.
- Set diagnostic system in the self-diagnostic mode.
- Check that actuator operates as shown in the figure when select switch is set to "AUTO" or "SPORT", and brake pedal is depressed or released.

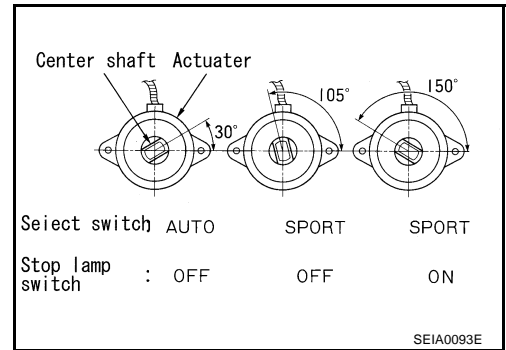

OK or NG

- OK >> GO TO 8.
- NG >> GO TO 7.

7. CHECK HARNESS CONNECTOR

- Check continuity between control unit and shock absorber actuator terminals.

OK or NG

- OK >> Replace control unit
- NG >> Repair or replace harness or connector.

8. CHECK SHOCK ABSORBER CONTROL ROD

- Pinch control rod with your fingers, then turn it 2 or 3 rotations to check that it rotates smoothly without free play.

OK or NG

- OK >> GO TO 9.
- NG >> Replace shock absorber.

9. SELF-DIAGNOSTICS 1

- Install actuator and perform self-diagnosis.
- Turn ignition switch to "ON" to initialize actuator positioning, then re-perform self-diagnosis to check actuator operation.

OK or NG

- OK >> END.
- NG >> GO TO 10.

10. SELF-DIAGNOSTICS 2

- Replace with a new actuator, then perform self-diagnosis.
- Turn ignition switch to "ON" to initialize actuator positioning, then re-perform self-diagnosis to check actuator operation.

OK or NG

- OK >> Replace actuator
- NG >> Replace shock absorber.

11. CHECK RIDE COMFORT

- Check for improved riding comfort.

OK or NG

- OK >> INSPECTION END.
- NG >> Replace shock absorber.