

SECTION **SRS**

SUPPLEMENTAL RESTRAINT SYSTEM (SRS)

A
B
C
D
E
F
G
H
I
J
K
L
M

CONTENTS

<p>PRECAUTIONS 3</p> <p> Supplemental Restraint System (SRS) "AIR BAG" and "SEAT BELT PRE-TENSIONER" 3</p> <p> Precautions for SRS "AIR BAG" and "SEAT BELT PRE-TENSIONER" Service 3</p> <p> Trouble Diagnosis Precaution 3</p> <p>PREPARATION 4</p> <p> Special Service Tools 4</p> <p> Commercial Service Tools 5</p> <p>SUPPLEMENTAL RESTRAINT SYSTEM (SRS) 6</p> <p> SRS Configuration 6</p> <p> Front Seat Belt Pre-Tensioner With Load Limiter 7</p> <p> Front Side Air Bag 7</p> <p> Side Curtain Air Bag 7</p> <p>TROUBLE DIAGNOSIS 8</p> <p> Trouble Diagnoses-Introduction 8</p> <p> DIAGNOSIS FUNCTION 8</p> <p> HOW TO PERFORM TROUBLE DIAGNOSIS FOR QUICK AND ACCURATE REPAIR 8</p> <p> WORK FLOW 9</p> <p> SRS Components Parts Location 10</p> <p> Schematic 11</p> <p> Wiring Diagram-SRS- 12</p> <p> CONSULT-II Function 18</p> <p> DIAGNOSIS MODE FOR CONSULT-II 18</p> <p> HOW TO CHANGE SELF-DIAGNOSIS MODE WITH CONSULT-II 18</p> <p> HOW TO ERASE SELF-DIAGNOSIS RESULTS. 18</p> <p> Self-Diagnosis Function (Without CONSULT-II) 19</p> <p> HOW TO CHANGE SELF-DIAGNOSIS MODE. 19</p> <p> HOW TO ERASE SELF-DIAGNOSIS RESULTS. 19</p> <p> SRS Operation Check 20</p> <p> DIAGNOSTIC PROCEDURE 1 20</p> <p> Trouble Diagnoses with CONSULT-II 22</p> <p> DIAGNOSTIC PROCEDURE 2 22</p> <p> DIAGNOSTIC PROCEDURE 3 24</p> <p> DIAGNOSTIC PROCEDURE 4 24</p> <p> Trouble Diagnoses without CONSULT-II. 27</p>	<p> DIAGNOSTIC PROCEDURE 5 27</p> <p> WARNING LAMP FLASH CODE CHART 28</p> <p> Trouble Diagnoses: "AIR BAG" Warning Lamp Does Not Turn Off 32</p> <p> DIAGNOSTIC PROCEDURE 6 32</p> <p> Trouble Diagnoses: "AIR BAG" Warning Lamp Does Not Turn On 33</p> <p> DIAGNOSTIC PROCEDURE 7 33</p> <p>DRIVER AIR BAG MODULE 34</p> <p> Removal and Installation 34</p> <p> REMOVAL 34</p> <p> INSTALLATION 35</p> <p>SPIRAL CABLE 37</p> <p> Removal and Installation 37</p> <p> REMOVAL 37</p> <p> INSTALLATION 38</p> <p>FRONT PASSENGER AIR BAG MODULE 39</p> <p> Removal and Installation 39</p> <p> REMOVAL 39</p> <p> INSTALLATION 39</p> <p>FRONT SIDE AIR BAG MODULE 40</p> <p> Removal and Installation 40</p> <p> REMOVAL 40</p> <p> INSTALLATION 41</p> <p>SIDE CURTAIN AIR BAG MODULE 42</p> <p> Removal and Installation 42</p> <p> REMOVAL 42</p> <p> INSTALLATION 42</p> <p>CRASH ZONE SENSOR 43</p> <p> Removal and Installation 43</p> <p> REMOVAL 43</p> <p> INSTALLATION 43</p> <p>SIDE AIR BAG (SATELLITE) SENSOR 44</p> <p> Removal and Installation 44</p> <p> REMOVAL 44</p> <p> INSTALLATION 44</p> <p>FRONT SEAT BELT PRE-TENSIONER 45</p> <p> Removal and Installation 45</p>
---	--

SRS

DIAGNOSIS SENSOR UNIT	46	SEAT BELT PRE-TENSIONER WHILE	
Removal and Installation	46	MOUNTED IN VEHICLE	52
REMOVAL	46	DISPOSING OF AIR BAG MODULE AND SEAT	
INSTALLATION	46	BELT PRE-TENSIONER	53
ECU DISCRIMINATED NO.	46	COLLISION DIAGNOSIS	54
DISPOSAL OF AIR BAG MODULE AND SEAT BELT		For Frontal Collision	54
PRE-TENSIONER	47	SRS INSPECTION (FOR FRONTAL COLLI-	
Caution for Air Bag Module and Seat Belt Pre-ten-		SION)	54
sioner	47	For Side Collision	55
CHECKING DEPLOYMENT TOOL	47	WHEN THE SIDE AIR BAG IS ACTIVATED IN	
DEPLOYMENT PROCEDURES FOR AIR BAG		THE SIDE COLLISION:	55
MODULE (OUTSIDE OF VEHICLE)	48	WHEN SRS IS NOT ACTIVATED IN THE SIDE	
DEPLOYMENT PROCEDURES FOR SEAT		COLLISION:	55
BELT PRE-TENSIONER (OUTSIDE OF VEHI-		SRS INSPECTION (FOR SIDE COLLISION)	56
CLE)	52		
DEPLOYMENT OF AIR BAG MODULE AND			

PRECAUTIONS

PRECAUTIONS

PPF:00001

Supplemental Restraint System (SRS) “AIR BAG” and “SEAT BELT PRE-TENSIONER”

EHS0008A

The Supplemental Restraint System such as “AIR BAG” and “SEAT BELT PRE-TENSIONER” used along with a front seat belt, helps to reduce the risk or severity of injury to the driver and front passenger for certain types of collision.

WARNING:

- To avoid rendering the SRS inoperative, which could increase the risk of personal injury or death in the event of a collision which would result in air bag inflation, all maintenance should be performed by an authorized NISSAN/INFINITI dealer.
- Improper maintenance, including incorrect removal and installation of the SRS, can lead to personal injury caused by unintentional activation of the system.
- Do not use electrical test equipment on any circuit related to the SRS unless instructed to in this Service Manual. SRS wiring harnesses can be identified by yellow and/or orange harness connector.

Precautions for SRS “AIR BAG” and “SEAT BELT PRE-TENSIONER” Service

EHS0008B

- Do not use electrical test equipment to check SRS circuits unless instructed to in this Service Manual.
- Before servicing the SRS, turn ignition switch “OFF”, disconnect battery ground cable and wait at least 3 minutes.

For approximately 3 minutes after the cables is removed, it is still possible for the air bag and seat belt pre-tensioner to deploy. Therefore, do not work on any SRS connectors or wires until at least 3 minutes have passed.

- Diagnosis sensor unit must always be installed with their arrow marks “←” pointing towards the front of the vehicle for proper operation. Also check diagnosis sensor unit for cracks, deformities or rust before installation and replace as required.
- The spiral cable must be aligned with the neutral position since its rotations are limited. Do not attempt to turn steering wheel or column after removal of steering gear.
- Handle air bag module carefully. Always place driver and front passenger air bag modules with the pad side facing upward and place front side air bag module standing with stud bolt side setting bottom.
- Conduct self-diagnosis to check entire SRS for proper function after replacing any components.
- After air bag inflates, the front instrument panel assembly should be replaced if damaged.

Trouble Diagnosis Precaution

EHS0009L

When you read wiring diagrams, refer to the followings:

- “HOW TO READ WIRING DIAGRAMS” in GI section
- [PG-2, "POWER SUPPLY ROUTING"](#) in PG section

When you perform trouble diagnosis, refer to the followings:

- “HOW TO FOLLOW TEST GROUP IN TROUBLE DIAGNOSIS” in GI section
- “HOW TO PERFORM EFFICIENT DIAGNOSIS FOR AN ELECTRICAL INCIDENT” in GI section

Check for any service bulletins before servicing the vehicle.

PREPARATION

PFP:00002

PREPARATION

Special Service Tools

EHS0008C

The actual shapes of Kent-Moore tools may differ from those of special service tools illustrated here.

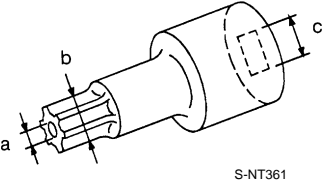
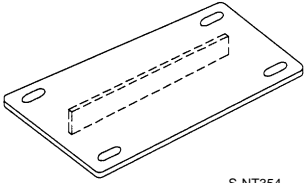
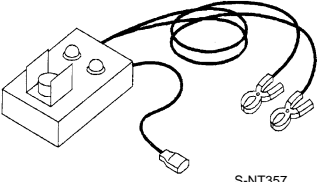
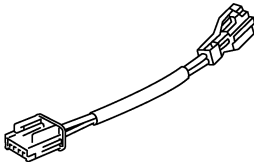
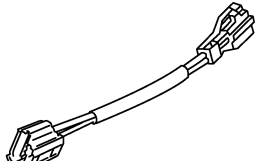
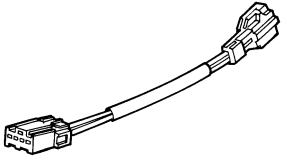
Tool number (Kent-Moore No.) Tool name	Description
HT61961000 and HT62152000 combined (J38219) *Special torx bit	 <p>Use for special bolts [TAMPER RESISTANT TORX (Size T50)] a: 3.5 (0.138) dia. b: 8.5 - 8.6 (0.335 - 0.339) dia. c: approx. 10 (0.39) sq. Unit: mm (in)</p>
KV99105300 (J41246) Air bag module bracket	 <p>Anchoring air bag module</p>
KV99106400 (J38381) Deployment tool	 <p>Disposing of air bag module and front seat belt pre-tensioner</p>
(J38381-70) Deployment tool adapter for driver air bag module	 <p>Connection between the deployment tool and driver air bag module</p>
(J38381-65) Deployment tool adapter for front passenger air bag	 <p>Connection between the deployment tool and front passenger air bag module</p>
KV99108200 (J38381-50) Deployment tool adapter for front seat belt pre-tensioner	 <p>Connection between the deployment tool and front seat belt pre-tensioner</p>

PREPARATION

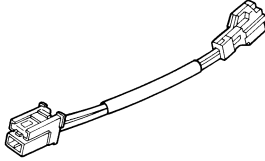
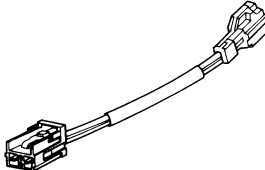
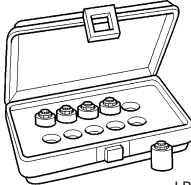
Tool number (Kent-Moore No.) Tool name	Description	A
KV99109000 (J44230) Deployment tool adapters for side curtain air bag	 <p style="text-align: center;">ZZA1190D</p> Connection between the deployment tool and side curtain air bag module	B C
KV99108300 (J38381-35) Deployment tool adapters for front side air bag	 <p style="text-align: center;">ZZA1166D</p> Connection between the deployment tool and front side air bag module	D E
(J-44615) Air bag lock master key set	 <p style="text-align: center;">LRS191</p> Removing and installation air bag lock	F G

SRS

Commercial Service Tools

EHS0008Z

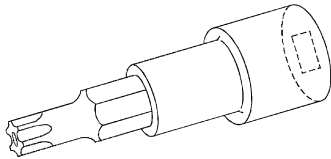
Tool name	Description	I
Tamper resistant torx socket	 <p style="text-align: center;">S-NT757</p> Size:T30	J K

L
M

SUPPLEMENTAL RESTRAINT SYSTEM (SRS)

SUPPLEMENTAL RESTRAINT SYSTEM (SRS)

PF2:28556

SRS Configuration

EHS0009E

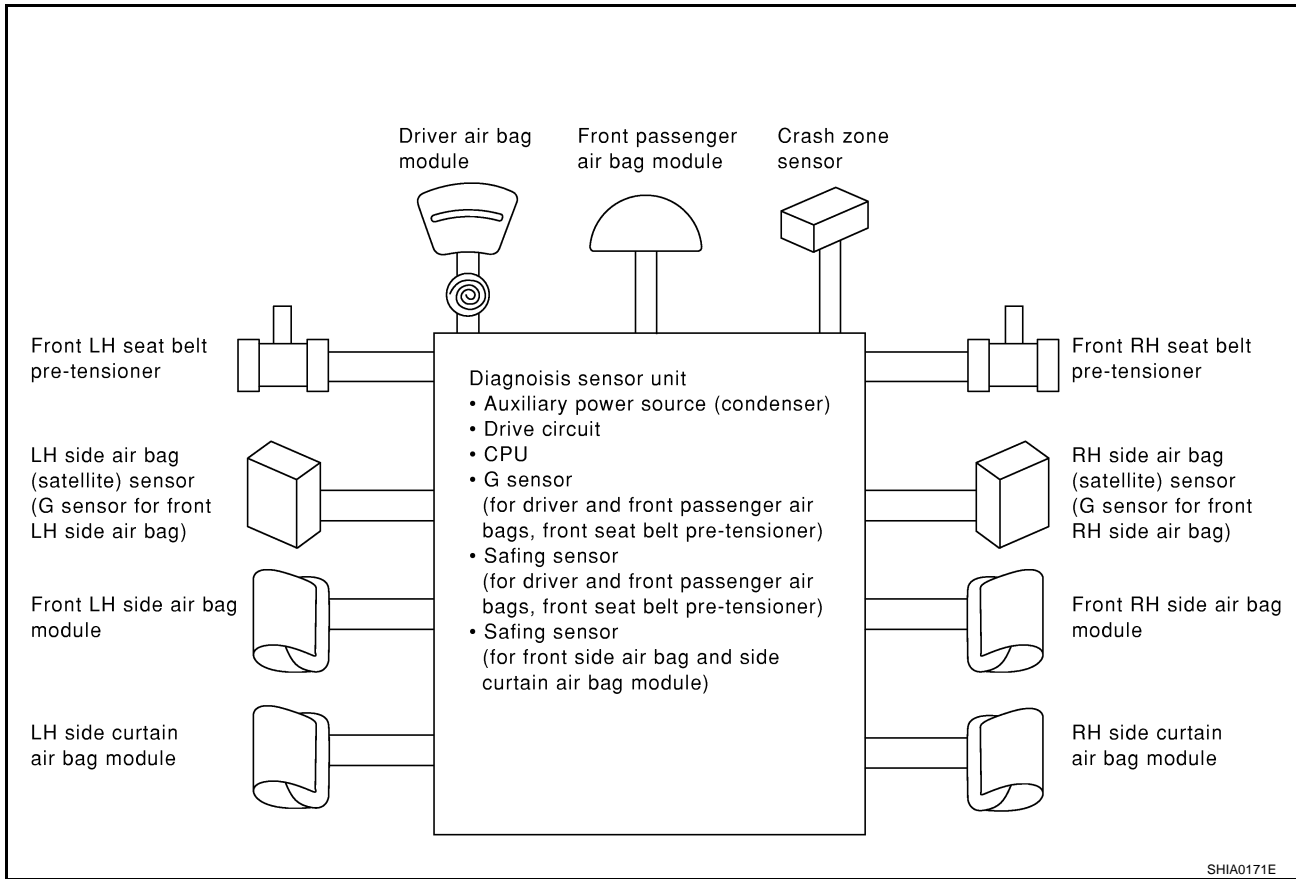

The air bag deploys if the diagnosis sensor unit activates while the ignition switch is in the “ON” or “START” position.

The collision modes for which supplemental restraint systems are activated are different among the SRS systems. For example, the driver air bag module and front passenger air bag module are activated in a frontal collision but not in a side collision.

SRS configurations which are activated for some collision modes are as follows;

SRS configuration	Frontal collision	Left side collision	Right side collision
Driver air bag module	×	—	—
Front passenger air bag module	×	—	—
Front LH seat belt pre-tensioner	×	—	—
Front RH seat belt pre-tensioner	×	—	—
Crash zone sensor	×	—	—
Front LH side air bag module	—	×	×
Front RH side air bag module	—	—	×
LH side curtain air bag module	—	×	—
RH side curtain air bag module	—	—	×

SUPPLEMENTAL RESTRAINT SYSTEM (SRS)

Front Seat Belt Pre-Tensioner With Load Limiter

EHS0009F

The seat belt pre-tensioner system with load limiter is installed to both the driver's seat and the front passenger's seat. It operates simultaneously with the SRS air bag system in the event of a frontal collision with an impact exceeding a specified level.

When the frontal collision with an impact exceeding a specified level occurs, seat belt slack resulting from clothing or other factors is immediately taken up by the pre-tensioner. Vehicle passengers are securely restrained.

When passengers in a vehicle are thrown forward in a collision and the restraining force of the seat belt exceeds a specified level, the load limiter permits the specified extension of the seat belt by the twisting of the ELR shaft, and a relaxation of the chest-area seat belt web tension while maintaining force.

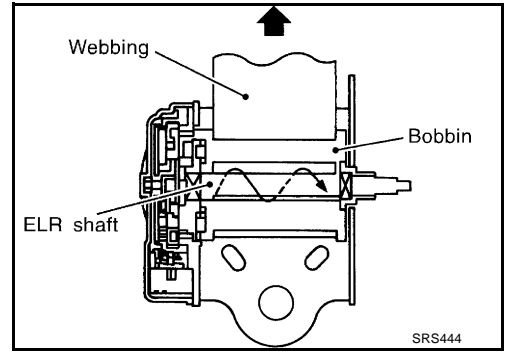

Front Side Air Bag

EHS0009G

Front side air bag is built-in type.

The front seat backs with built-in type side air bag have the labels shown in figure at right.

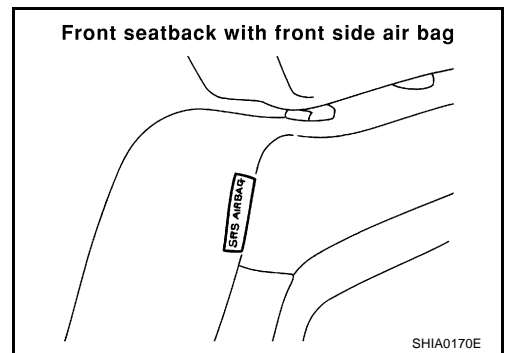

Side Curtain Air Bag

EHS0009H

The side curtain air bag have the labels shown in figure at right.

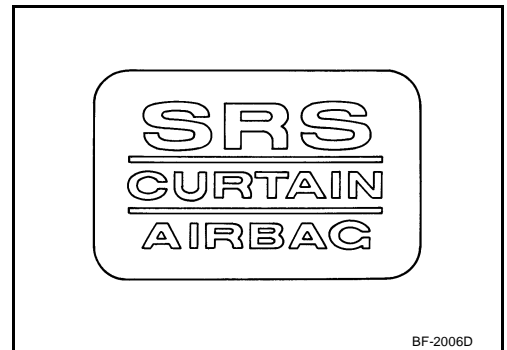

A
B
C
D
E
F
G
SRS
I
J
K
L
M

TROUBLE DIAGNOSIS

TROUBLE DIAGNOSIS

PFP:00004

Trouble Diagnoses-Introduction

EHS0008D

CAUTION:

- Do not use electrical test equipment on any circuit related to the SRS unless instructed to in this Service Manual. SRS wiring harness can be identified by yellow harness connector.
- Do not attempt to repair, splice or modify the SRS wiring harness. If the harness is damaged, replace it with a new one.
- Keep ground portion clean.

DIAGNOSIS FUNCTION

The SRS self-diagnosis results can be read by using "AIR BAG" warning lamp and/or CONSULT-II.

The User mode is exclusively prepared for the customer (driver). This mode warns the driver of a system malfunction through the operation of the "AIR BAG" warning lamp.

The Diagnosis mode allows the technician to locate and inspect the malfunctioning part.

The mode applications for the "AIR BAG" warning lamp and CONSULT-II are as follows:

	User mode	Diagnosis mode	Display type
"AIR BAG" warning lamp	X	X	ON-OFF operation
CONSULT-II	—	X	Monitoring

NOTE:

Seat belt pre-tensioner malfunction is indicated by "AIR BAG" warning lamp.

HOW TO PERFORM TROUBLE DIAGNOSIS FOR QUICK AND ACCURATE REPAIR

A good understanding of the malfunction conditions can make troubleshooting faster and more accurate.

In general, each customer feels differently about a malfunction. It is important to fully understand the symptoms or conditions for a customer complaint.

Information From Customer

WHAT..... Vehicle model

WHEN..... Date, Frequencies

WHERE..... Road conditions

HOW..... Operating conditions, Symptoms

Preliminary Check

Check that the following parts are in good order.

- Battery [Refer to [SC-4, "How to Handle Battery"](#) .]
- Fuse [Refer to [PG-2, "Schematic"](#) .]
- System component-to-harness connections

TROUBLE DIAGNOSIS

WORK FLOW

NOTE:

Seat belt pre-tensioner malfunction is indicated by "AIR BAG" warning lamp.

A
B
C
D
E
F
G
SRS
I
J
K
L
M

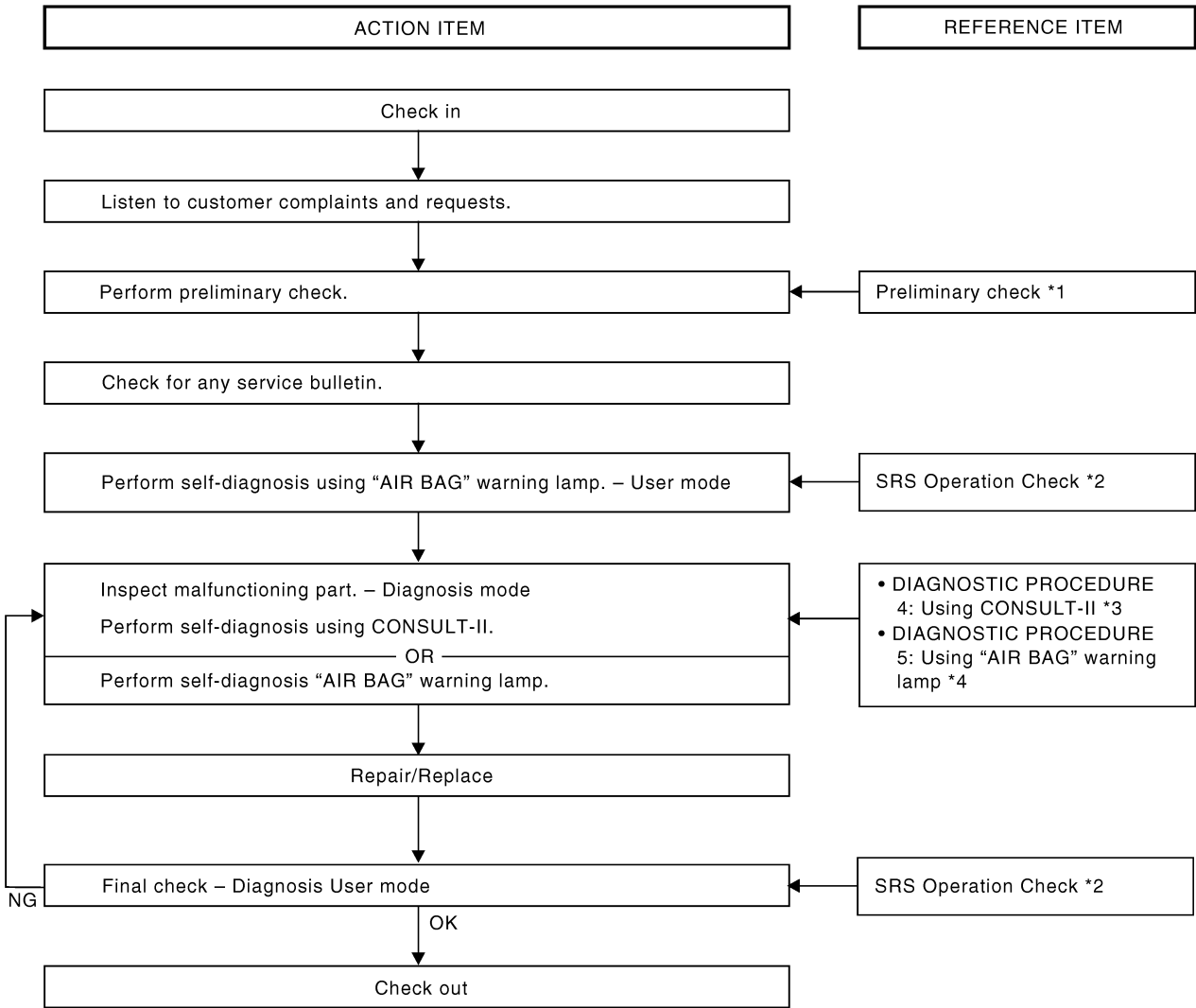

*1: [SRS-8](#)

*2: [SRS-20](#)

*3: [SRS-24](#)

*4: [SRS-27](#)

SHIA0175E

TROUBLE DIAGNOSIS

SRS Components Parts Location

EHS00091

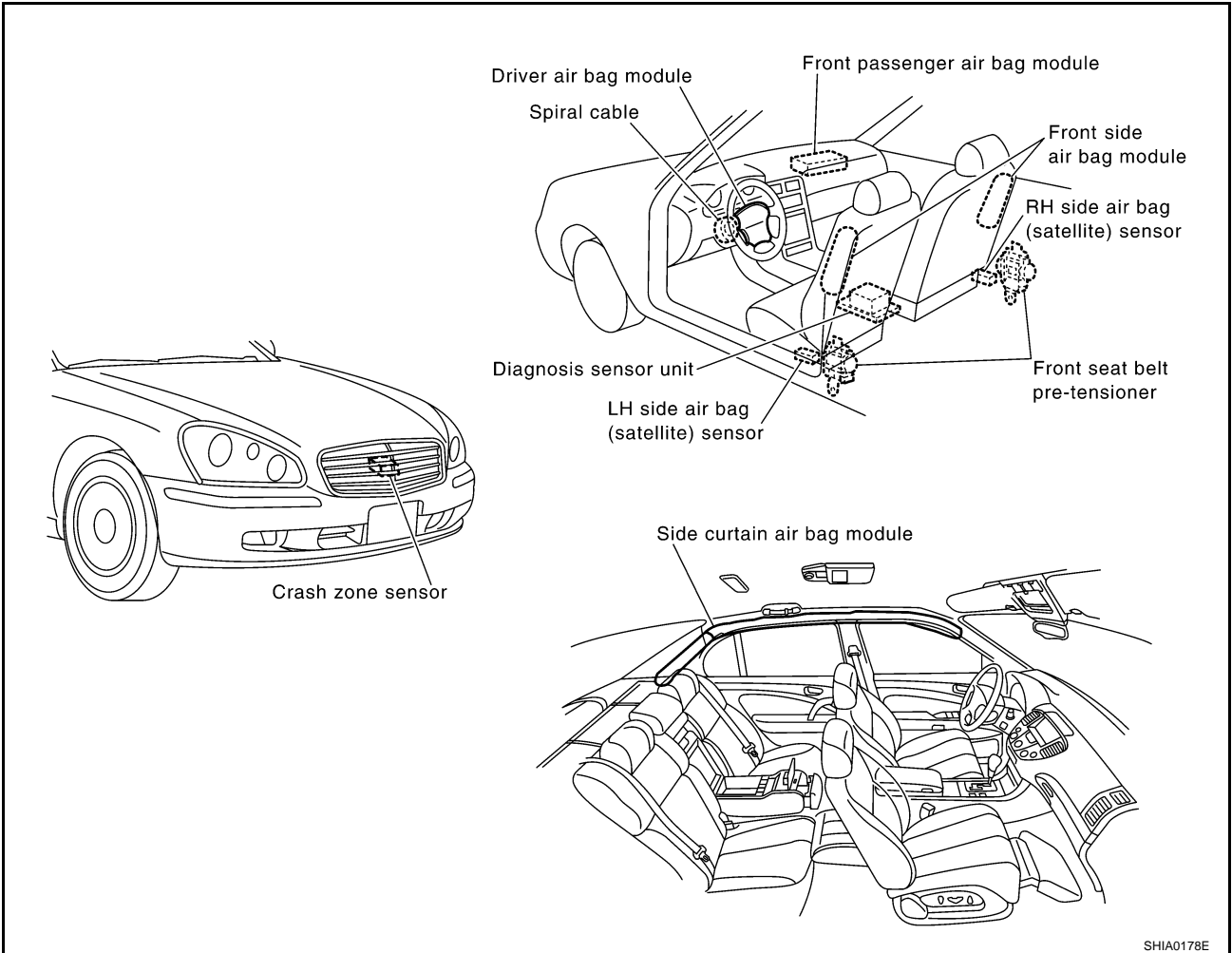

TROUBLE DIAGNOSIS

Schematic

EHS00094

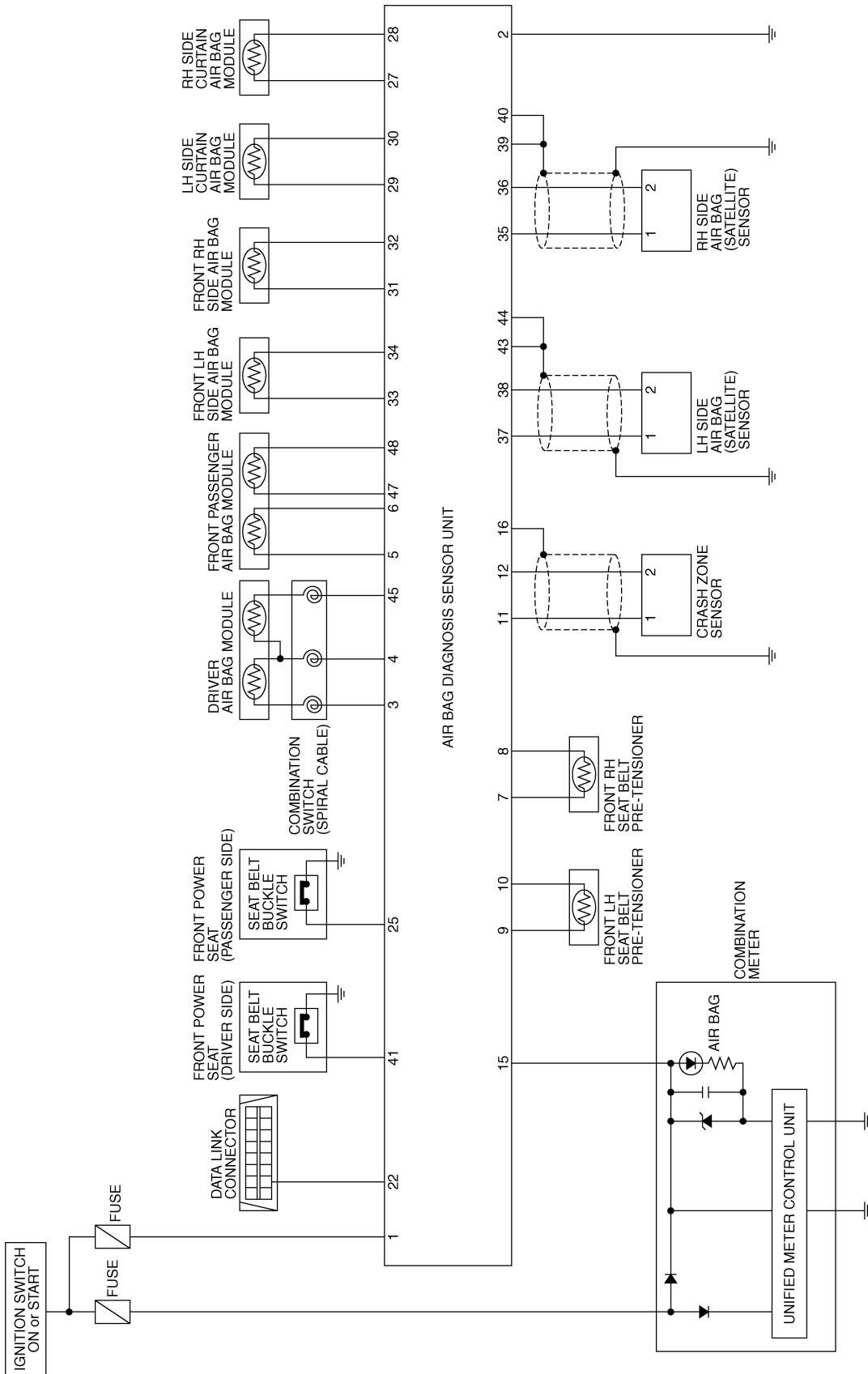

A
B
C
D
E
F
G
H
I
J
K
L
M

SRS

THWM0001E

TROUBLE DIAGNOSIS

Wiring Diagram-SRS-

EHS0008E

SRS-SRS-01

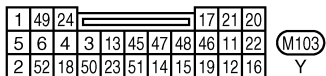
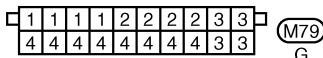
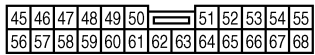
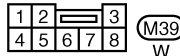
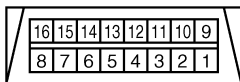
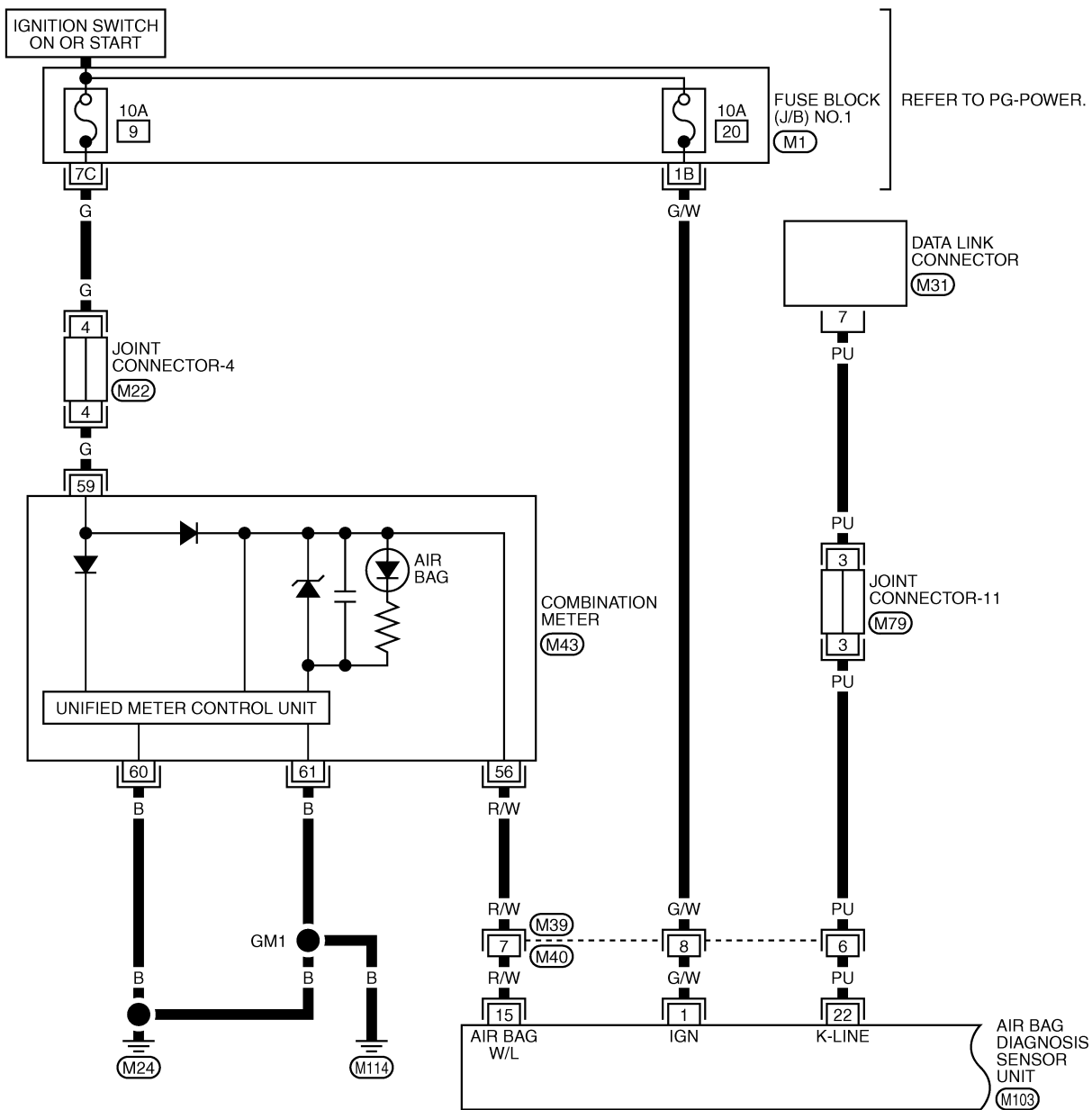

REFER TO THE FOLLOWING.
 (M1) -FUSE BLOCK-JUNCTION BOX (J/B) NO.1

THWM0002E

TROUBLE DIAGNOSIS

SRS-SRS-03

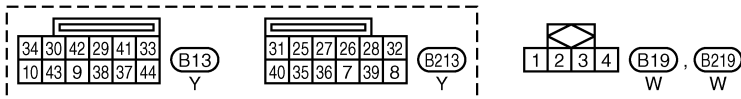
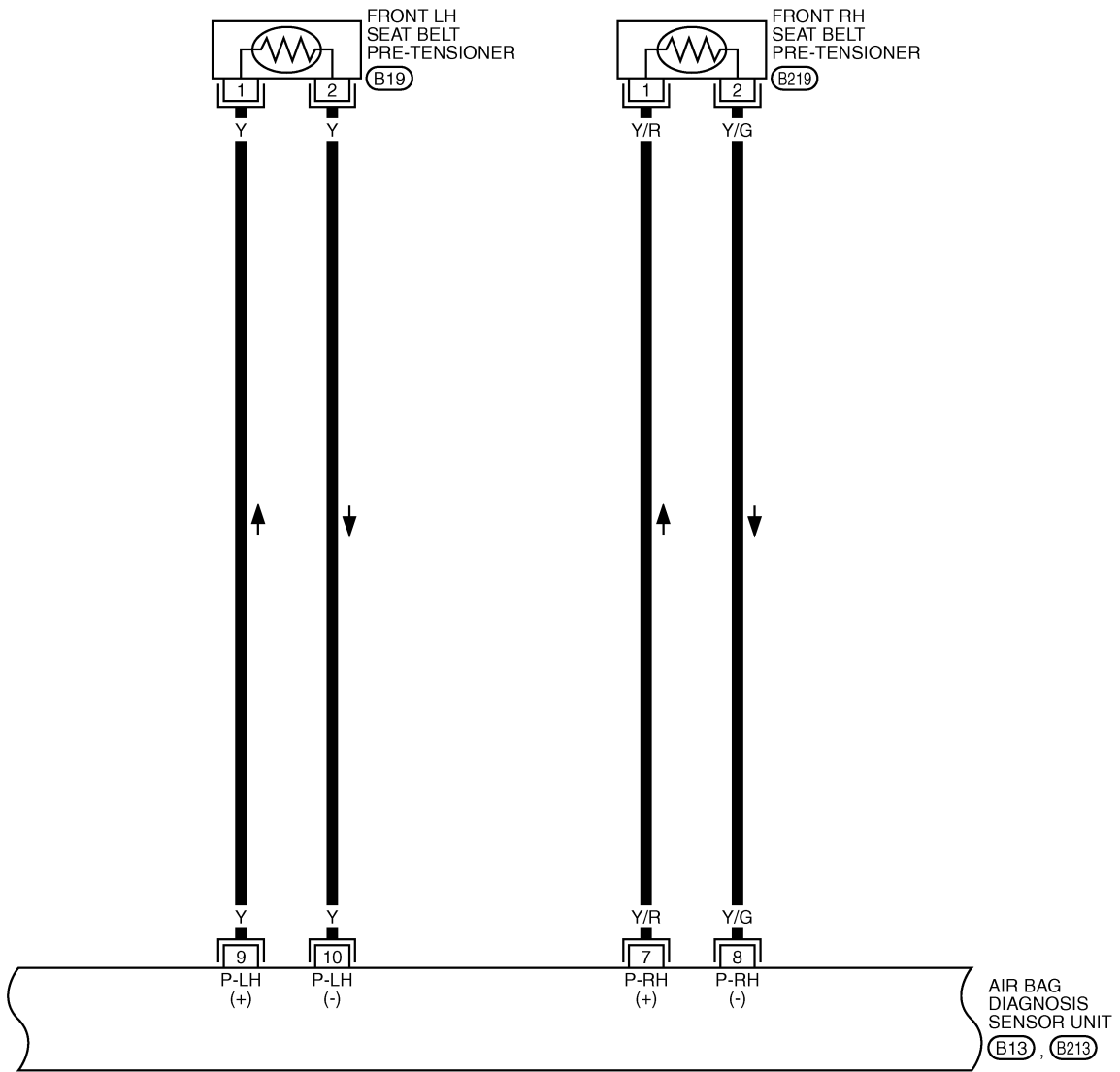

THWM0004E

TROUBLE DIAGNOSIS

SRS-SRS-04

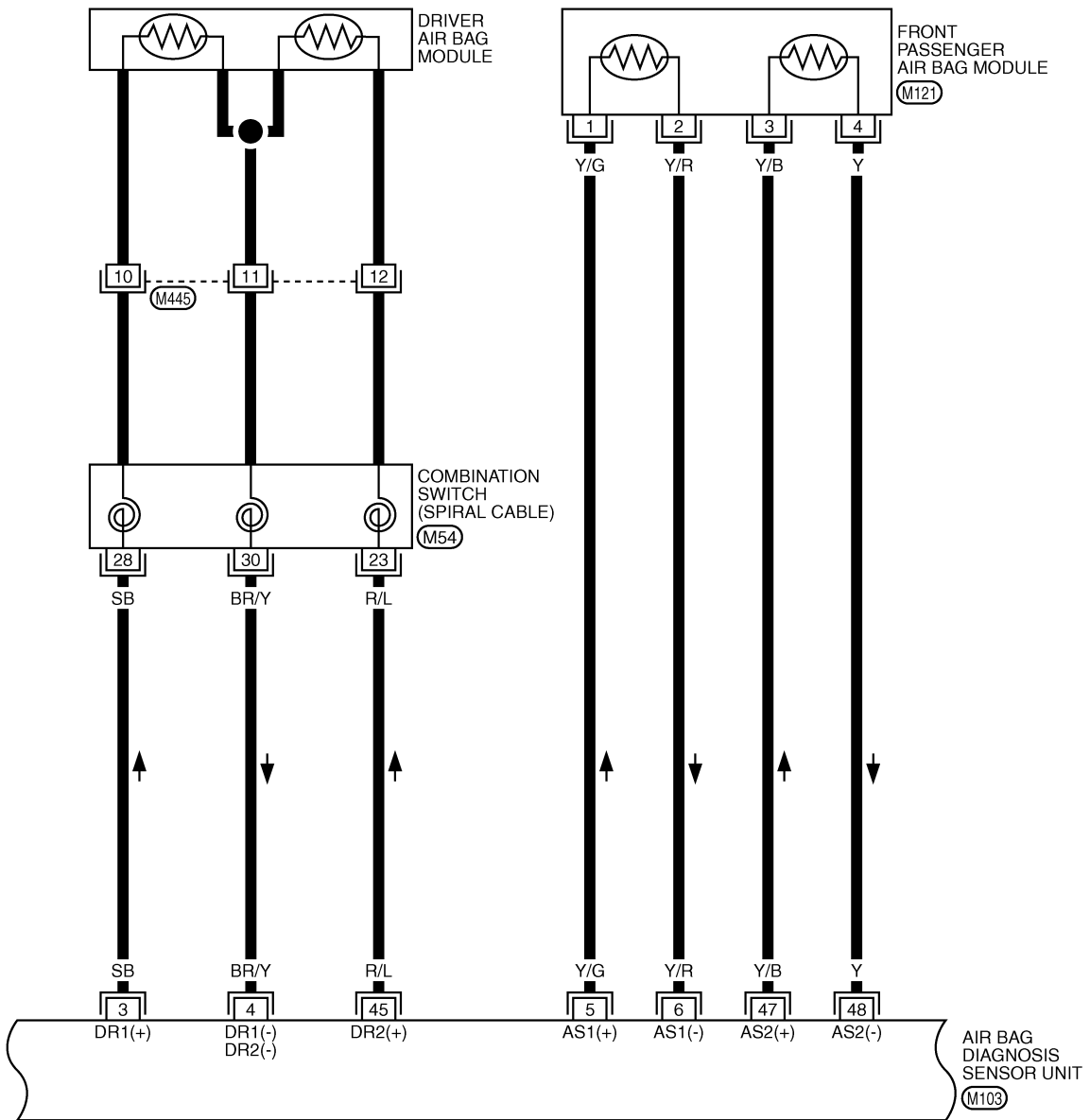

A
B
C
D
E
F
G
SRS
I
J
K
L
M

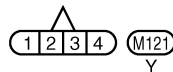
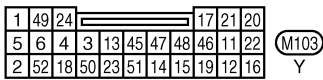
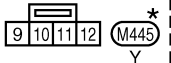
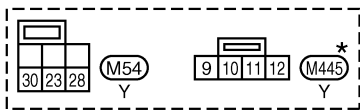

*: THIS CONNECTOR IS NOT SHOWN IN "HARNESS LAYOUT", PG SECTION.

THWM0005E

TROUBLE DIAGNOSIS

SRS-SRS-05

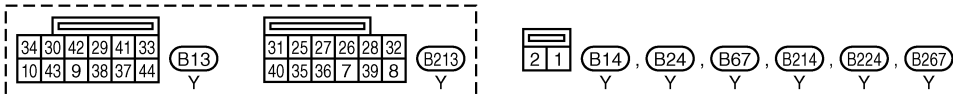
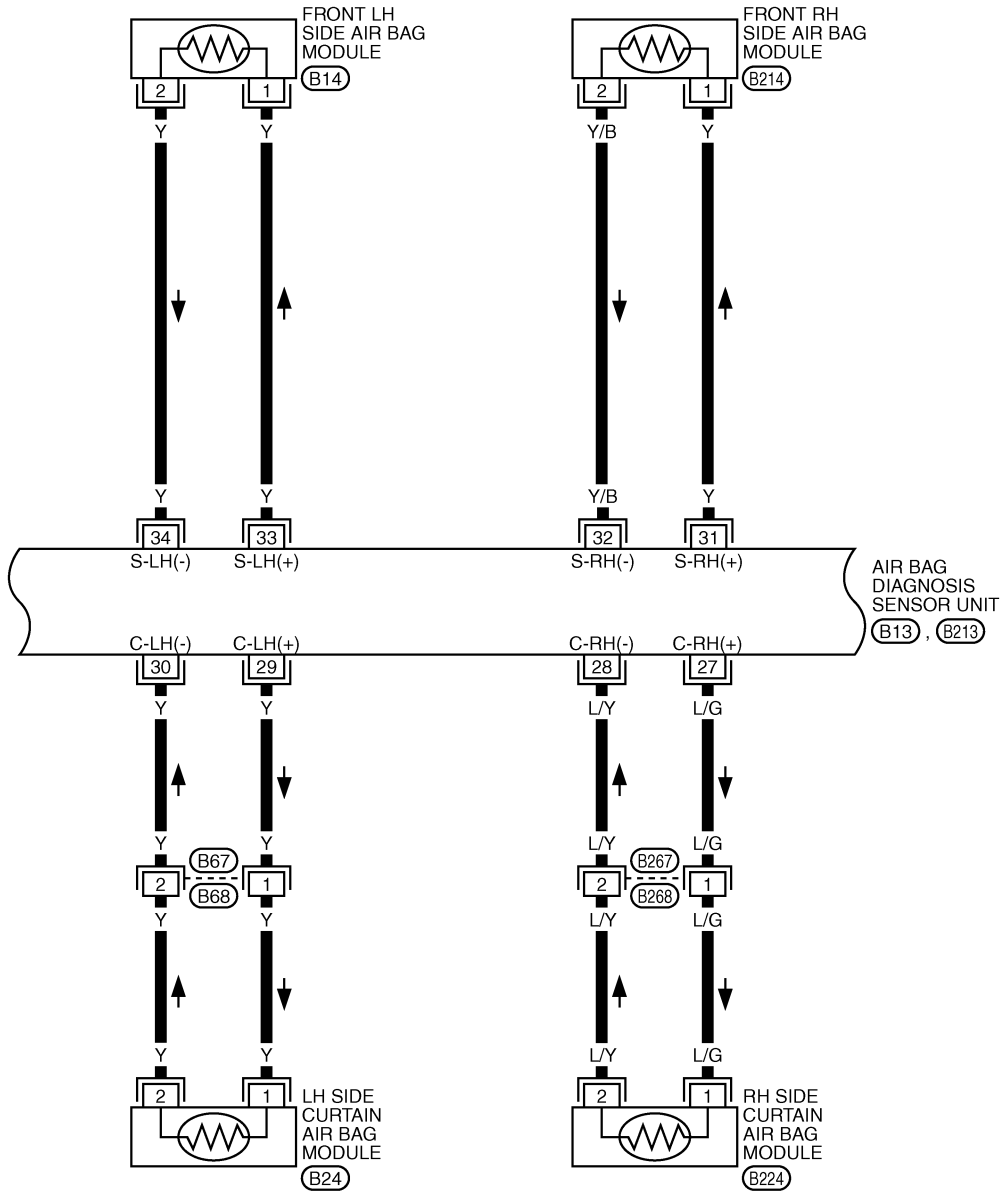

THWM0006E

TROUBLE DIAGNOSIS

SRS-SRS-06

A
B
C
D
E
F
G
H
I
J
K
L
M

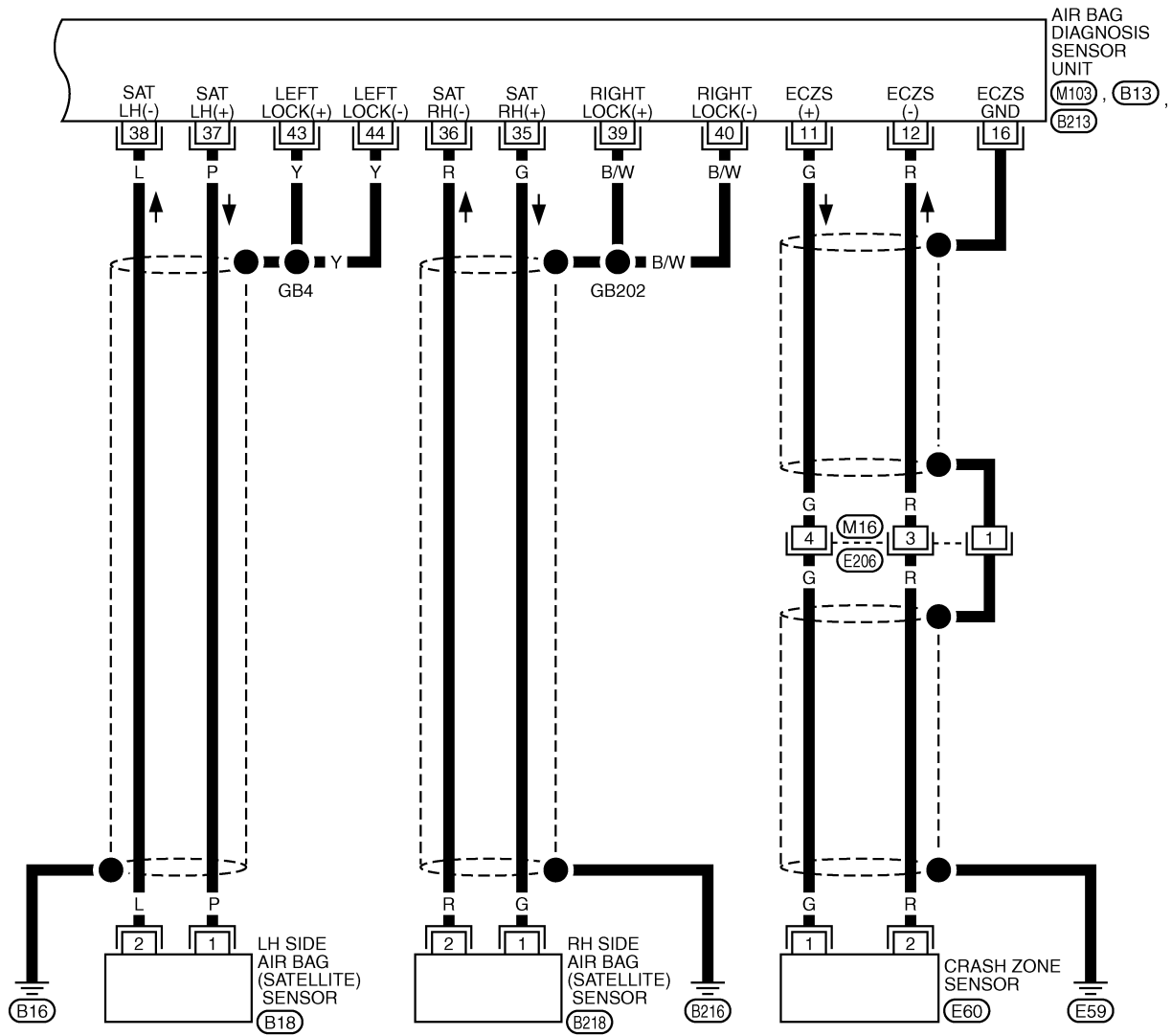

SRS

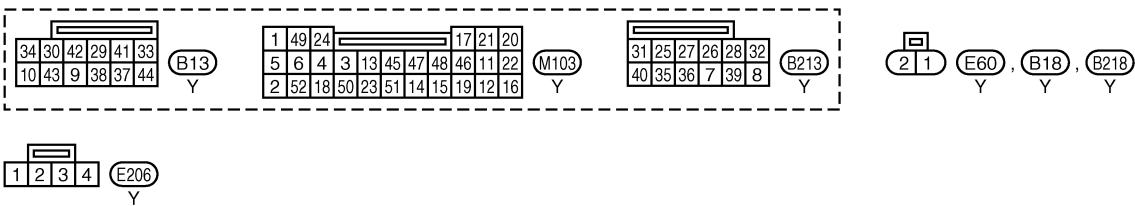

THWM0007E

TROUBLE DIAGNOSIS

EHS0009J

CONSULT-II Function DIAGNOSIS MODE FOR CONSULT-II

- “SELF-DIAG [CURRENT]”
A current Self-diagnosis result (also indicated by the number of warning lamp flashes in the Diagnosis mode) is displayed on the CONSULT-II screen in real time. This refers to a malfunctioning part requiring repairs.
- “SELF-DIAG [PAST]”
Diagnosis results previously stored in the memory are displayed on the CONSULT-II screen. The stored results are not erased until memory erasing is executed.
- “TROUBLE DIAG RECORD”
With TROUBLE DIAG RECORD, diagnosis results previously erased by a reset operation can be displayed on the CONSULT-II screen.
- “ECU DISCRIMINATED NO.”
The diagnosis sensor unit for each vehicle model is assigned with its own, individual classification number. This number will be displayed on the CONSULT-II screen, as shown below. When replacing the diagnosis sensor unit, refer to the part number for the compatibility. After installation, replacement with a correct unit can be checked by confirming this classification number on the CONSULT-II screen.

HOW TO CHANGE SELF-DIAGNOSIS MODE WITH CONSULT-II

From User Mode to Diagnosis Mode

After selecting “AIR BAG” on the “SELECT SYSTEM” screen, User mode automatically changes to Diagnosis mode.

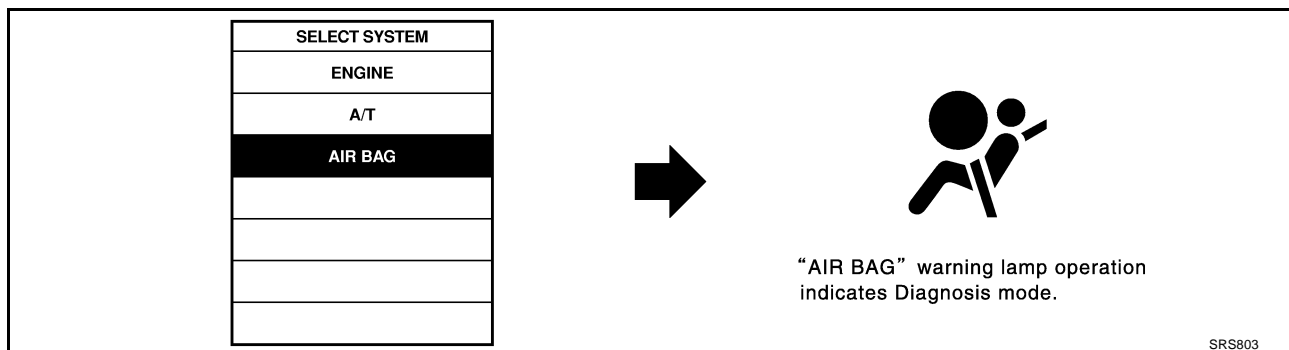

From Diagnosis Mode to User Mode

To return to User mode from Diagnosis mode, touch “BACK” key of CONSULT-II until “SELECT SYSTEM” appears, Diagnosis mode automatically changes to User mode.

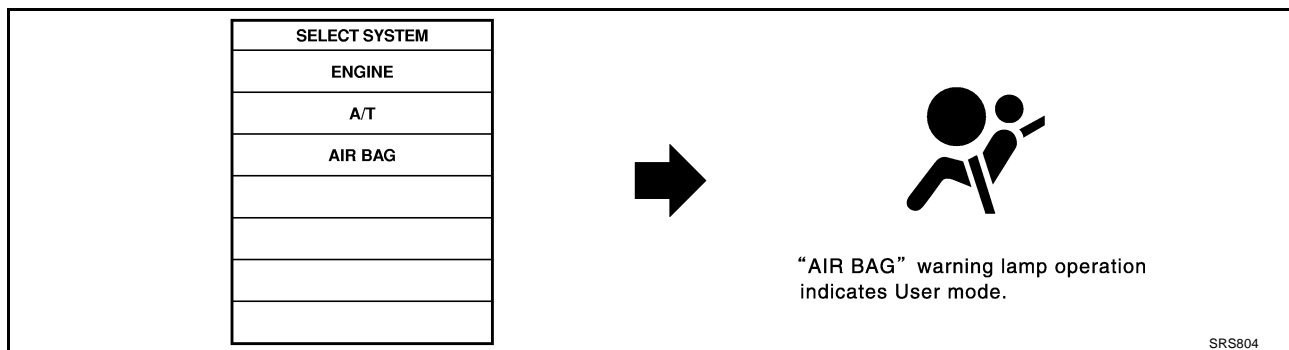

HOW TO ERASE SELF-DIAGNOSIS RESULTS

- “SELF-DIAG [CURRENT]”
A current Self-diagnosis result is displayed on the CONSULT-II screen in real time. After the malfunction is repaired completely, no malfunction is detected on “SELF-DIAG [CURRENT]”.
- “SELF-DIAG [PAST]”

TROUBLE DIAGNOSIS

Return to the "SELF-DIAG [CURRENT]" CONSULT-II screen by touching "BACK" key of CONSULT-II and select "SELF-DIAG [CURRENT]" in SELECT DIAG MODE. Touch "ERASE" in "SELF-DIAG [CURRENT]" mode.

NOTE:

If the memory of the malfunction in "SELF-DIAG [PAST]" is not erased, the User mode shows the system malfunction by the operation of the warning lamp even if the malfunction is repaired completely.

- "TROUBLE DIAG RECORD"
The memory of "TROUBLE DIAG RECORD" cannot be erased

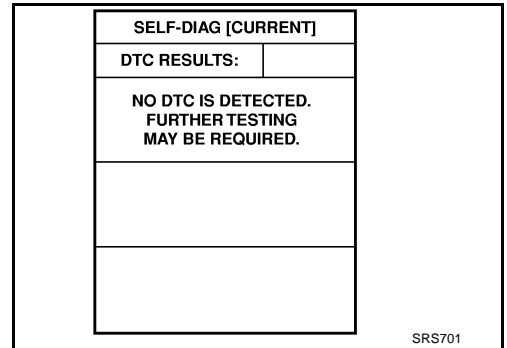

Self-Diagnosis Function (Without CONSULT-II)

EHS0009K

- The reading of these results is accomplished using one of two modes — "User mode" and "Diagnosis mode".
- After a malfunction is repaired, turn the ignition switch "OFF" for at least one second, then back "ON". Diagnosis mode returns to the User mode. At that time, the self-diagnostic result is cleared.

HOW TO CHANGE SELF-DIAGNOSIS MODE

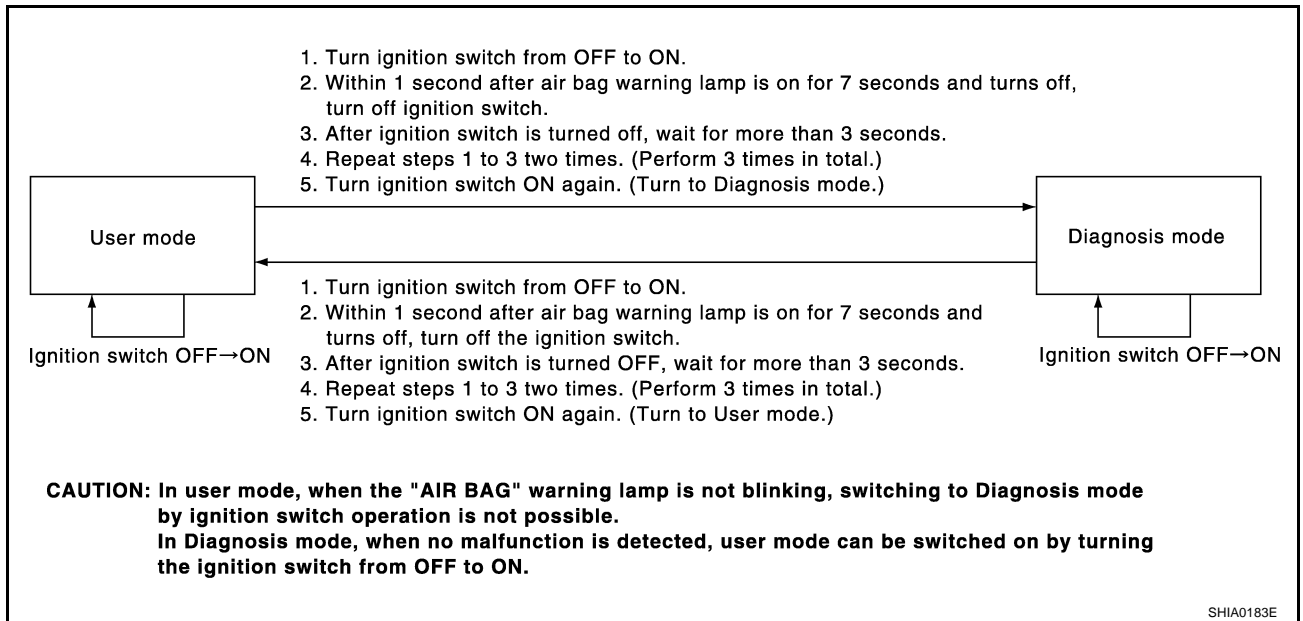

TROUBLE DIAGNOSIS

SRS Operation Check DIAGNOSTIC PROCEDURE 1

EHS00081

Checking Air Bag Operation by Using “AIR BAG” Warning Lamp-User Mode

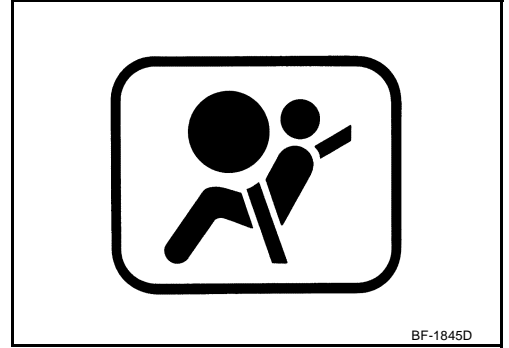

1. Turn the ignition switch from OFF to ON, and check that the air bag warning lamp blinks.
2. Compare the SRS air bag warning lamp blinking pattern with the examples.



BF-1845D

TROUBLE DIAGNOSIS

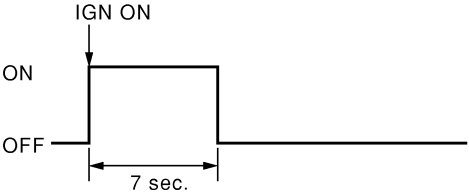
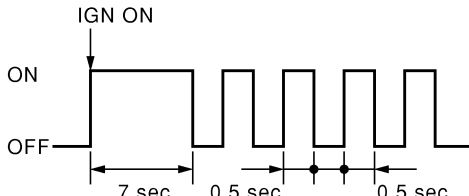
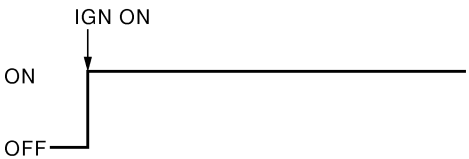
Warning lamp examples

"AIR BAG" warning lamp operation-User mode-	SRS condition	Reference item
 <p style="text-align: right;">SHIA0011E</p>	<ul style="list-style-type: none"> ● No malfunction is detected. ● No further action is necessary. 	—
 <p style="text-align: right;">SHIA0012E</p>	<ul style="list-style-type: none"> ● The system is malfunctioning and need to be repaired as indicated. 	<p>Go to SRS-24, "DIAGNOSTIC PROCEDURE 4" .</p>
 <p style="text-align: right;">SHIA0013E</p>	<ul style="list-style-type: none"> ● Air bag is deployed. ● Seat belt pre-tensioner is deployed. 	<p>Go to SRS-54, "COLLISION DIAGNOSIS" .</p>
 <p style="text-align: right;">SHIA0014E</p>	<ul style="list-style-type: none"> ● Diagnosis sensor unit is malfunctioning. ● Air bag power supply circuit is malfunctioning. ● SRS air bag warning lamp circuit is malfunctioning. 	<p>Go to SRS-32, "Trouble Diagnoses: "AIR BAG" Warning Lamp Does Not Turn Off" .</p>

A
B
C
D
E
F
G
I
J
K
L
M

SRS

TROUBLE DIAGNOSIS

EHS0008J

Trouble Diagnoses with CONSULT-II DIAGNOSTIC PROCEDURE 2

1. Turn ignition switch OFF.
2. Connect CONSULT-II to the data link connector.

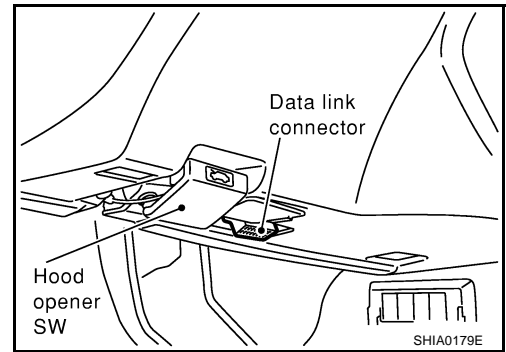

3. Turn ignition switch ON.
4. Touch "START".

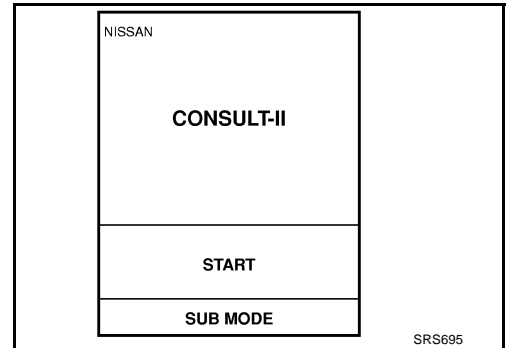

5. Touch "AIR BAG".

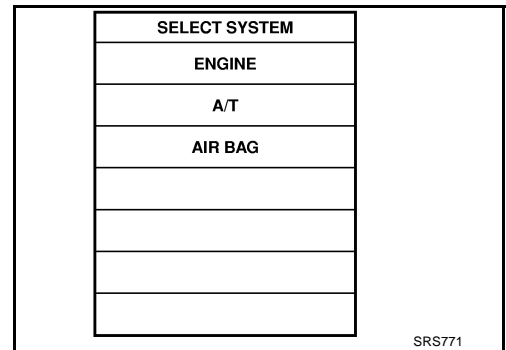

6. On the "self-diagnosis mode selection" screen of CONSULT-II, select the desired "self-diagnosis mode key".

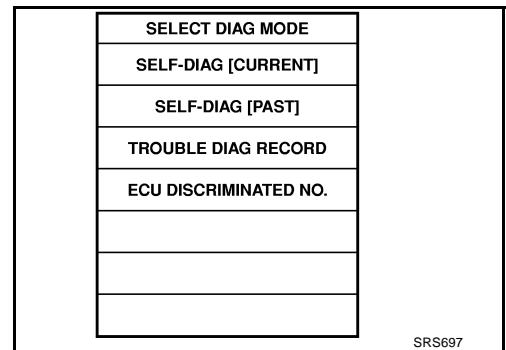

TROUBLE DIAGNOSIS

- a. Touch “SELF-DIAG [CURRENT]”.
- Diagnostic code is displayed on “SELF-DIAG [CURRENT]”.

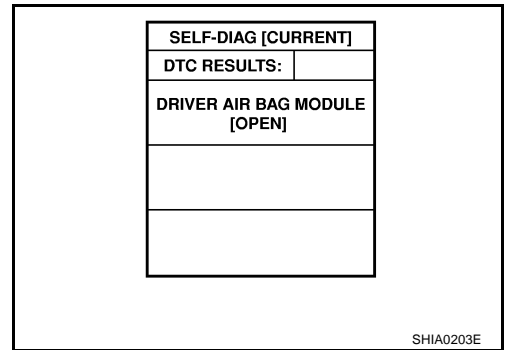

A
B
C
D
E
F
G

- i. If the malfunction is displayed in the “SRS Operation Check (Air bag warning lamp blinking) but no malfunction is displayed in the “SELF-DIAG [CURRENT]”, the following possibilities shall be checked.
- After the malfunction part is repaired, the diagnosis results in “SELF-DIAG [PAST]” has not been erased.
 - An intermittent malfunction has been stored in the past.

NOTE:

Intermittent malfunction is a malfunction that has occurred once in the past, but soon recovered. Refer to [SRS-24, "DIAGNOSTIC PROCEDURE 3"](#) and [SRS-24, "DIAGNOSTIC PROCEDURE 4"](#).

- b. Touch “SELF-DIAG [PAST]”.
- The diagnostic code is displayed until erasing the memory in the “SELF-DIAG [CURRENT]”.

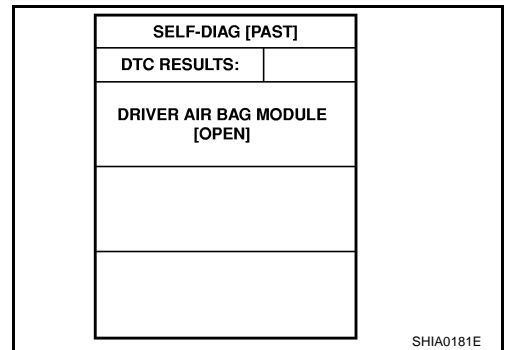

SRS

I
J
K
L
M

- c. Touch “TROUBLE DIAG RECORD”.
- The diagnosis results (malfunction parts stored in the diagnosis sensor unit) stored in the self-diagnosis results are displayed.
 - The memory of “TROUBLE DIAG RECORD” cannot be erased.

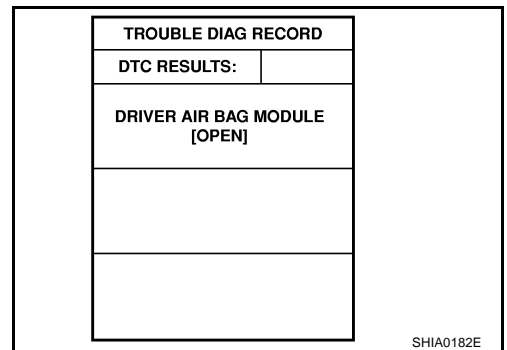

7. Each diagnostic code is displayed.
8. Touch “PRINT,” if required.
9. Based on each diagnosis result, repair or replace the malfunction parts.

CAUTION:

Be sure to start the work after the following steps. Turn the ignition switch OFF, and disconnect the battery ground cable. Then wait for at least 3 minutes.

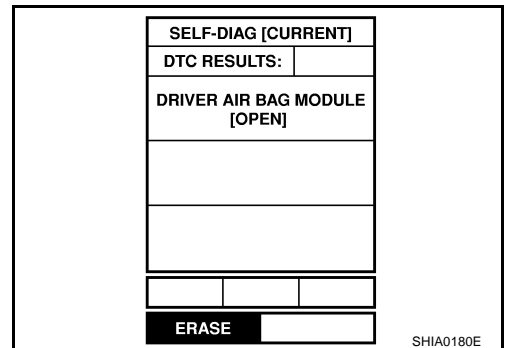

TROUBLE DIAGNOSIS

10. After repairing the malfunction, touch "SELF-DIAG [CURRENT]" to check that "No DTC IS DETECTED" is displayed.
 - After checking the display, touch "ERASE".
 - If any malfunction is displayed on "SELF-DIAG [CURRENT]", repair or replace the malfunctioning again.
11. Touch "BACK" key of CONSULT-II to "SELECT SYSTEM" screen. Touch "SELF-DIAG [PAST]."

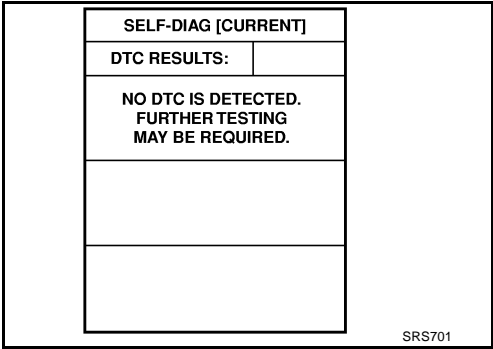

12. Check that no malfunction is detected on "SELF-DIAG [PAST]".
 - If any malfunction is deployed, Touch "ERASE" in the "SELF-DIAG [CURRENT]" screen, and check the display.

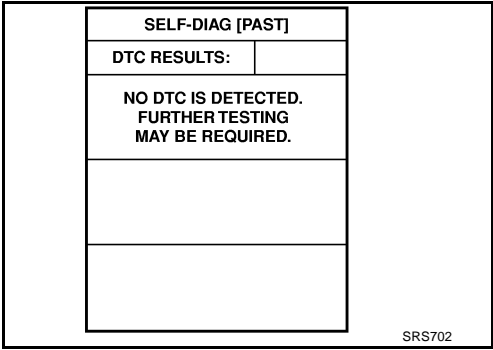

13. Turn ignition switch OFF, then turn off and disconnect CONSULT-II.
14. Turn ignition switch ON, and check the system with the SRS air bag warning lamp (User mode).
15. Check that no malfunction is detected. Now the diagnosis is complete.

DIAGNOSTIC PROCEDURE 3 Inspecting SRS Malfunctioning Record

If the warning lamp (preys mode) indicates any malfunction, but no malfunction is detected in "SELF-DIAG [CURRENT]" on CONSULT-II, carry out the following steps.

- Erase the memory that stored in diagnosis sensor unit.
- Check that no malfunction is detected on "SELF-DIAG [PAST]" and "TROUBLE DIAG RECORD" then go to [SRS-24, "DIAGNOSTIC PROCEDURE 3"](#).
- Check that the battery voltage is 9V or more. If it is below 9V, charge the battery.

DIAGNOSTIC PROCEDURE 4 Inspecting SRS malfunctioning parts by using CONSULT-II-Diagnosis mode-

- Touch "SELF-DIAG[PAST]" on CONSULT-II, repair or replace the malfunction part displayed on the screen.
- If no malfunction is displayed on "SELF-DIAG [PAST]", touch "BACK" key of CONSULT-II, then touch "TROUBLE DIAG RECORD". Malfunction part is displayed on CONSULT-II screen, and repair or replace the malfunction part displayed on the screen.

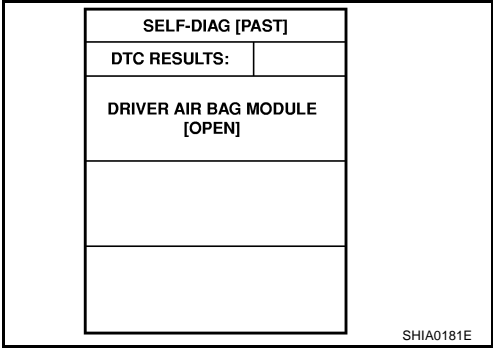

TROUBLE DIAGNOSIS

Diagnostic Code Chart

Diagnostic item	Explanation	Repair order "Recheck SRS at each replacement"	
NO DTC IS DETECTED.	When malfunction is indicated by the "AIR BAG" warning lamp in User mode.	<ul style="list-style-type: none"> ● Low battery voltage (Less than 9V) 	<ul style="list-style-type: none"> ● Go to SRS-24, "DIAGNOSTIC PROCEDURE 3".
		<ul style="list-style-type: none"> ● Self-diagnostic result "SELF-DIAG [PAST]" (previously stored in the memory) might not be erased after repair. ● Intermittent malfunction has been detected in the past. 	<ul style="list-style-type: none"> ● Go to SRS-22, "DIAGNOSTIC PROCEDURE 2".
	<ul style="list-style-type: none"> ● No malfunction is detected. 	—	
DRIVER AIRBAG MODULE [OPEN]	<ul style="list-style-type: none"> ● Driver air bag module circuit is open (including the spiral cable). 	<ol style="list-style-type: none"> 1. Visually check the wiring harness connection. 2. Replace the harness if it has visible damage. 3. Replace driver air bag module. (Before disposal, it must be deployed.) 4. Replace the spiral cable. 5. Replace the diagnosis sensor unit. 6. Replace the related harness. 	
DRIVER AIRBAG MODULE [VB-SHORT]	<ul style="list-style-type: none"> ● Driver air bag module circuit is shorted to some power supply circuit (including the spiral cable). 		
DRIVER AIRBAG MODULE [GND-SHORT]	<ul style="list-style-type: none"> ● Driver air bag module circuit is shorted to ground (including the spiral cable). 		
DRIVER AIRBAG MODULE [SHORT]	<ul style="list-style-type: none"> ● Driver air bag module circuits are shorted to each other. 		
ASSIST A/B MODULE [VB-SHORT]	<ul style="list-style-type: none"> ● Front passenger air bag module circuit is shorted to some power supply circuit. 	<ol style="list-style-type: none"> 1. Visually check the wiring harness connection. 2. Replace the harness if it has visible damage. 3. Replace front passenger air bag module. (Before disposal of it, it must be deployed.) 4. Replace the diagnosis sensor unit. 5. Replace the related harness. 	
ASSIST A/B MODULE [OPEN]	<ul style="list-style-type: none"> ● Front passenger air bag module circuit is open. 		
ASSIST A/B MODULE [GND-SHORT]	<ul style="list-style-type: none"> ● Front passenger air bag module circuit is shorted to ground. 		
ASSIST A/B MODULE [SHORT]	<ul style="list-style-type: none"> ● Front passenger air bag module circuits are shorted to each other. 		
CRASH ZONE SEN [UNIT FAIL] CRASH ZONE SEN [COMM FAIL] CRASH ZONE SEN [UNMATCH]	<ul style="list-style-type: none"> ● Crash zone sensor 	<ol style="list-style-type: none"> 1. Visually check the wiring harness connection. 2. Replace the harness if it has visible damage. 3. Replace the crash zone sensor. 4. Replace the diagnosis sensor unit. 5. Replace the related harness. 	
SIDE MODULE LH [OPEN]	<ul style="list-style-type: none"> ● Front LH side air bag module circuit is open. 	<ol style="list-style-type: none"> 1. Visually check the wiring harness connection. 2. Replace the harness if it has visible damage. 3. Replace front LH side air bag module. (Before disposal, it must be deployed.) 4. Replace the diagnosis sensor unit. 5. Replace the related harness. 	
SIDE MODULE LH [VB-SHORT]	<ul style="list-style-type: none"> ● Front LH side air bag module circuit is shorted to some power supply circuit. 		
SIDE MODULE LH [GND-SHORT]	<ul style="list-style-type: none"> ● Front LH side air bag module circuit is shorted to ground. 		
SIDE MODULE LH [SHORT]	<ul style="list-style-type: none"> ● Front LH side air bag module circuits are shorted to each other. 		

A
B
C
D
E
F
G
SRS
I
J
K
L
M

TROUBLE DIAGNOSIS

Diagnostic item	Explanation	Repair order "Recheck SRS at each replacement"
SIDE MODULE RH [OPEN]	● Front RH side air bag module circuit is open.	1. Visually check the wiring harness connection.
SIDE MODULE RH [VB-SHORT]	● Front RH side air bag module circuit is shorted to some power supply circuit.	2. Replace the harness if it has visible damage.
SIDE MODULE RH [GND-SHORT]	● Front RH side air bag module circuit is shorted to ground.	3. Replace front RH side air bag module. (Before disposal, it must be deployed.)
SIDE MODULE RH [SHORT]	● Front RH side air bag module circuits are shorted to each other.	4. Replace the diagnosis sensor unit. 5. Replace the related harness.
SATELLITE SENS LH [UNIT FAIL] SATELLITE SENS LH [COMM FAIL] SATELLITE SENS LH [UNMATCH]	● LH side air bag (Satellite) sensor	1. Visually check the wiring harness connection. 2. Replace the harness if it has visible damage. 3. Replace the LH side air bag (satellite) sensor. 4. Replace the diagnosis sensor unit. 5. Replace the related harness.
SATELLITE SENS RH [UNIT FAIL] SATELLITE SENS RH [COMM FAIL] SATELLITE SENS RH [UNMATCH]	● RH side air bag (Satellite) sensor	1. Visually check the wiring harness connection. 2. Replace the harness if it has visible damage. 3. Replace the RH side air bag (satellite) sensor. 4. Replace the diagnosis sensor unit. 5. Replace the related harness.
PRE-TEN FRONT LH [OPEN]	● The circuit for front LH pre-tensioner is open.	1. Visually check the wiring harness connections.
PRE-TEN FRONT LH [VB-SHORT]	● The circuit for front LH pre-tensioner is shorted to some power supply circuit.	2. Replace the harness if it has visible damage.
PRE-TEN FRONT LH [GND-SHORT]	● The circuit for front LH pre-tensioner is shorted to ground.	3. Replace front LH seat belt. (Before disposing, it must be deactivated.)
PRE-TEN FRONT RH [OPEN]	● The circuit for front RH pre-tensioner is shorted to some power supply circuit.	4. Replace the diagnosis sensor unit. 5. Replace the related harness.
PRE-TEN FRONT RH [VB-SHORT]	● The circuit for front RH pre-tensioner is shorted to some power supply circuit.	1. Visually check the wiring harness connections. 2. Replace the harness if it has visible damage.
PRE-TEN FRONT RH [GND-SHORT]	● The circuit for front RH pre-tensioner is shorted to ground.	3. Replace front RH seat belt. (Before disposing, it must be deactivated.) 4. Replace the diagnosis sensor unit. 5. Replace the related harness.

TROUBLE DIAGNOSIS

Diagnostic item	Explanation	Repair order "Recheck SRS at each replacement"
CURTAIN MODULE LH [OPEN]	● The LH side curtain air bag module circuit is open.	1. Visually check the wiring harness connection.
CURTAIN MODULE LH [VB-SHORT]	● The LH side curtain air bag module circuit is shorted to some power supply circuits.	2. Replace the harness if it has visible damage.
CURTAIN MODULE LH [GND-SHORT]	● The LH side curtain air bag module circuit is shorted to ground.	3. Replace LH side curtain air bag module. (Before disposal, it must be deployed.) 4. Replace the diagnosis sensor unit. 5. Replace the related harness.
CURTAIN MODULE RH [OPEN]	● The RH side curtain air bag module circuit is open.	1. Visually check the wiring harness connection.
CURTAIN MODULE RH [VB-SHORT]	● The RH side curtain air bag module circuit is shorted to some power supply circuit.	2. Replace the harness if it has visible damage.
CURTAIN MODULE RH [GND-SHORT]	● The RH side curtain air bag module circuit is shorted to ground.	3. Replace RH side curtain air bag module. (Before disposal, it must be deployed.) 4. Replace the diagnosis sensor unit. 5. Replace the related harness.
CONTROL UNIT	● Diagnosis sensor unit is malfunctioning.	1. Visually check the wiring harness connection. 2. Replace the diagnosis sensor unit.

A
B
C
D
E
F
G
SRS

NOTE:

- Follow the procedures in numerical order when repairing malfunctioning parts. Confirm whether malfunction is eliminated using air bag warning lamp or CONSULT-II each time repair is finished. If malfunction is still observed, proceed to the next step. When malfunction is eliminated, further repair work is not required.
- Follow the procedures in numerical order when repairing malfunctioning parts, then make the system check.
- The screen contents are the same as the self-diagnosis results, self-diagnosis results "SELF-DIAG [CURRENT]" and "SELF-DIAG [PAST]".

I
J
K
L
M

**Trouble Diagnoses without CONSULT-II.
DIAGNOSTIC PROCEDURE 5**

EHS0009B

CAUTION:

SRS will not enter diagnosis mode if no malfunction is detected in user mode.

1. Turn ignition switch "ON".
2. After "AIR BAG" warning lamp lights for 7seconds, turn ignition switch "OFF" within 1seconds.
3. Wait more than 3 seconds.
4. Repeat the steps 1 to 2 two times.
5. Turn ignition switch ON".
6. Compare the number of flashes to Air Bag Warning Lamp Flash Code.
7. Turn the ignition switch OFF, and disconnect the battery ground terminal.
8. Repair the system as outlined by the "REAPIR ORDER" in "Warning Lamp Flash Code Chart" that corresponds to flash code.
9. After the repairing of malfunction, connect the battery ground cable, and turn the ignition switch ON.
10. Check that no malfunction is detected.

TROUBLE DIAGNOSIS

WARNING LAMP FLASH CODE CHART

<Diagnosis results (previously stored in the memory) might not be erased after repair or intermittent malfunctions have been detected in the past.>

Flash pattern	Repair order
<p>a through b are repeated.</p> <p>IGN ON ON OFF</p> <p>7 sec. 2 sec. 3 sec. 2 sec.</p> <p>a b a b a b</p>	<ol style="list-style-type: none"> 1. Go to DIAGNOSTIC PROCEDURES 2 and 3.

SHIA0026E

<Driver air bag module>

Flash pattern	Repair order
<p>a through d are repeated. d: One flash indicates malfunctioning driver air bag module circuit.</p> <p>ON OFF</p> <p>7 sec. 2 sec. 3 sec. 2 sec. 2 flashes 0.5 sec. 3 sec. 2 sec.</p> <p>a b c d a b</p>	<ol style="list-style-type: none"> 1. Visually check the wiring harness connection. 2. Replace the harness if it has visible damage. 3. Replace the spiral cable. 4. Replace driver air bag module. (Before disposal, it must be deployed.) 5. Replace the diagnosis sensor unit. 6. Replace the related harness.

SHIA0027E

<Diagnosis sensor unit>

Flash pattern	Repair order
<p>a through d are repeated. d: Seven flashes indicate malfunctioning diagnosis sensor unit circuit.</p> <p>ON OFF</p> <p>7 sec. 2 sec. 3 sec. 2 sec. 7 flashes 0.5 sec. 3 sec. 2 sec.</p> <p>a b c d a b</p>	<ol style="list-style-type: none"> 1. Visually check the wiring harness connections. 2. Replace the harness if it has visible damage. 3. Replace the diagnosis sensor unit. 4. Replace the related harness.

SHIA0028E

<Front passenger air bag module>

Flash pattern	Repair order
<p>a through d are repeated. d: Eight flashes indicate malfunctioning front passenger air bag module circuit.</p> <p>ON OFF</p> <p>7 sec. 2 sec. 3 sec. 2 sec. 8 flashes 0.5 sec. 3 sec. 2 sec.</p> <p>a b c d a b</p>	<ol style="list-style-type: none"> 1. Visually check the wiring harness connection. 2. Replace the harness if it has visible damage. 3. Replace front passenger air bag module. (Before disposal, it must be deployed.) 4. Replace the diagnosis sensor unit. 5. Replace the related harness.

SHIA0029E

TROUBLE DIAGNOSIS

<Crash zone sensor>	
Flash pattern	Repair order
<p>a through d are repeated. d: Six flashes indicate malfunctioning crash zone sensor circuit.</p>	<ol style="list-style-type: none"> 1. Visually check the wiring harness connection. 2. Replace the harness if it has visible damage. 3. Replace the crash zone sensor. 4. Replace the diagnosis sensor unit. 5. Replace the related harness.

SHIA0083E

<Front RH seat belt pre-tensioner>	
Flash pattern	Repair order
<p>a through d are repeated. d: One flash indicates malfunctioning front RH seat belt pre-tensioner circuit.</p>	<ol style="list-style-type: none"> 1. Visually check the wiring harness connections. 2. Replace the harness if it has visible damage. 3. Replace front RH seat belt pre-tensioner. (Before disposal, it must be activated.) 4. Replace the diagnosis sensor unit. 5. Replace the related harness.

SHIA0030E

<Front LH seat belt pre-tensioner>	
Flash pattern	Repair order
<p>a through d are repeated. d: Three flashes indicate malfunctioning front LH seat belt pre-tensioner circuit.</p>	<ol style="list-style-type: none"> 1. Visually check the wiring harness connections. 2. Replace the harness if it has visible damage. 3. Replace front LH seat belt pre-tensioner. (Before disposal, it must be activated.) 4. Replace the diagnosis sensor unit. 5. Replace the related harness.

SHIA0031E

<RH side air bag (Satellite) sensor>	
Flash pattern	Repair order
<p>a through f are repeated. f: Three flashes indicate malfunctioning RH side air bag (Satellite) sensor circuit.</p>	<ol style="list-style-type: none"> 1. Visually check the wiring harness connection. 2. Replace the harness if it has visible damage. 3. Replace the RH side air bag (Satellite) sensor. 4. Replace the diagnosis sensor unit. 5. Replace the related harness.

SHIA0032E

A
B
C
D
E
F
G
SRS
I
J
K
L
M

TROUBLE DIAGNOSIS

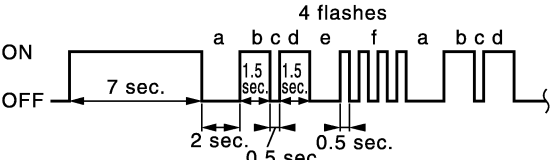
<LH side air bag (Satellite) sensor>	
Flash pattern	Repair order
<p>a through f are repeated. f: Four flashes indicate malfunctioning LH side air bag (Satellite) sensor.</p> 	<ol style="list-style-type: none"> 1. Visually check the wiring harness connection. 2. Replace the harness if it has visible damage. 3. Replace the LH side air bag (Satellite) sensor. 4. Replace the diagnosis sensor unit. 5. Replace the related harness.

SHIA0033E

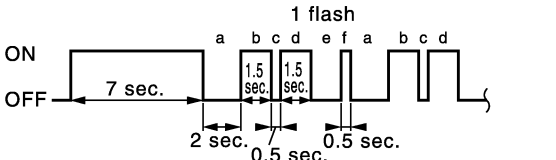
<Front RH side air bag module>	
Flash pattern	Repair order
<p>a through f are repeated. f: One flash indicate malfunctioning front RH side air bag module circuit.</p> 	<ol style="list-style-type: none"> 1. Visually check the wiring harness connection. 2. Replace the harness if it has visible damage. 3. Replace front RH side air bag module. (Before disposal, it must be deployed.) 4. Replace the diagnosis sensor unit. 5. Replace the related harness.

SHIA0034E

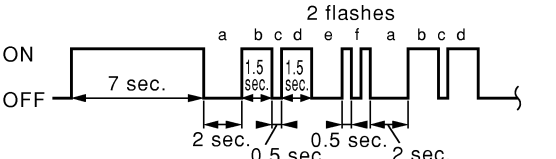
<Front LH side air bag module>	
Flash pattern	Repair order
<p>a through f are repeated. f: Two flashes indicate malfunctioning front LH side air bag module circuit.</p> 	<ol style="list-style-type: none"> 1. Visually check the wiring harness connection. 2. Replace the harness if it has visible damage. 3. Replace front LH side air bag module. (Before disposal, it must be deployed.) 4. Replace the diagnosis sensor unit. 5. Replace the related harness.

SHIA0035E

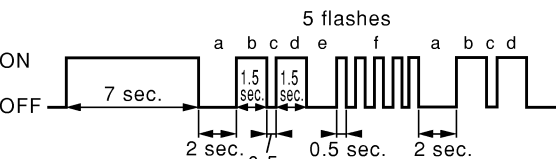
<RH side curtain air bag module>	
Flash pattern	Repair order
<p>a through f are repeated. f: Five flashes indicate malfunctioning RH side curtain air bag module circuit.</p> 	<ol style="list-style-type: none"> 1. Visually check the wiring harness connection. 2. Replace the harness if it has visible damage. 3. Replace RH side curtain air bag module. (Before disposal, it must be deployed.) 4. Replace the diagnosis sensor unit. 5. Replace the related harness.

SHIA0084E

TROUBLE DIAGNOSIS

<LH side curtain air bag module>

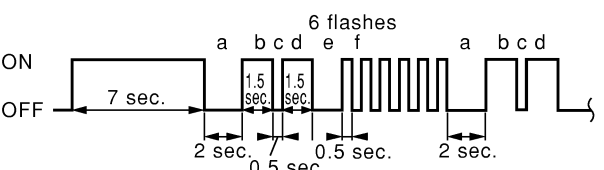
Flash pattern	Repair order
<p>a through f are repeated. f: Six flashes indicate malfunctioning LH side curtain air bag module circuit.</p> 	<ol style="list-style-type: none"> 1. Visually check the wiring harness connection. 2. Replace the harness if it has visible damage. 3. Replace LH side curtain air bag module. (Before disposal, it must be deployed.) 4. Replace the diagnosis sensor unit. 5. Replace the related harness.

SHIA0086E

A
B
C
D
E
F
G
I
J
K
L
M

SRS

TROUBLE DIAGNOSIS

Trouble Diagnoses: "AIR BAG" Warning Lamp Does Not Turn Off DIAGNOSTIC PROCEDURE 6

EHS00095

1. SEE THE DEPLOYMENT OF AIR BAG MODULE

Is air bag module deployed?

Yes or No

- Yes >> Refer to [SRS-54, "COLLISION DIAGNOSIS"](#).
- No >> GO TO 2.

2. CHECK THE AIR BAG FUSE

Check the fuse (No.20).

Refer to [PG-2, "POWER SUPPLY ROUTING"](#).

OK or NG

- OK >> GO TO 4.
- NG >> GO TO 3.

3. CHECK AIR BAG FUSE AGAIN

Replace "AIR BAG" fuse and turn ignition switch ON.

Is "AIR BAG" fuse blown again?

- Yes >> Repair main harness.
- No >> **INSPECTION END**

4. CHECK DIAGNOSIS SENSOR UNIT



Connect CONSULT-II and touch "START".

- Is "AIR BAG" displayed on CONSULT-II?

Yes or No

- Yes >> GO TO 5.
- No >> Visually check the wiring harness connection of diagnosis sensor unit. If the harness connection check result is OK, replace diagnosis sensor unit.

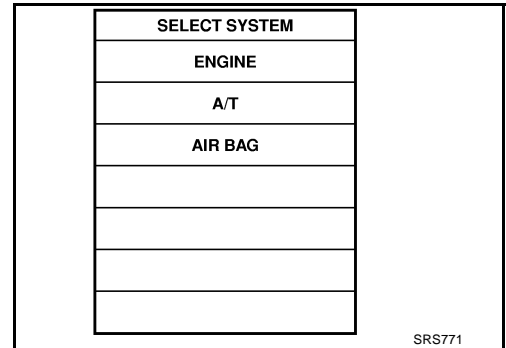

5. CHECK HARNESS CONNECTION

Is harness connection between warning lamp and diagnosis sensor unit OK?

OK or NG

- OK >> Replace diagnosis sensor unit.
- NG >> Connect "AIR BAG" warning lamp and diagnosis sensor unit connector properly. If "AIR BAG" warning lamp still does not go off, replace harness.

TROUBLE DIAGNOSIS

Trouble Diagnoses: "AIR BAG" Warning Lamp Does Not Turn On DIAGNOSTIC PROCEDURE 7

EHS00096

1. CHECK "METER" FUSE

Check the "METER" fuse (No.9).
Refer to [PG-2, "POWER SUPPLY ROUTING"](#) .

OK or NG

- OK >> GO TO 3.
- NG >> GO TO 2.

2. CHECK "METER" FUSE AGAIN

Replace meter fuse and turn ignition switch ON.

Is meter fuse blown again?

- Yes >> Repair the related harness.
- No >> **INSPECTION END**

3. CHECK HARNESS CONNECTION BETWEEN DIAGNOSIS SENSOR UNIT AND COMBINATION METER

Disconnect diagnosis sensor unit connector and turn ignition switch "ON".

- Does "AIR BAG" warning lamp turn on?

Yes or No

- Yes >> Replace diagnosis sensor unit.
- No >> Check the ground circuit of "AIR BAG" warning lamp.

A

B

C

D

E

F

G

SRS

I

J

K

L

M

DRIVER AIR BAG MODULE

DRIVER AIR BAG MODULE

PFP:K8510

Removal and Installation

EHS0008N

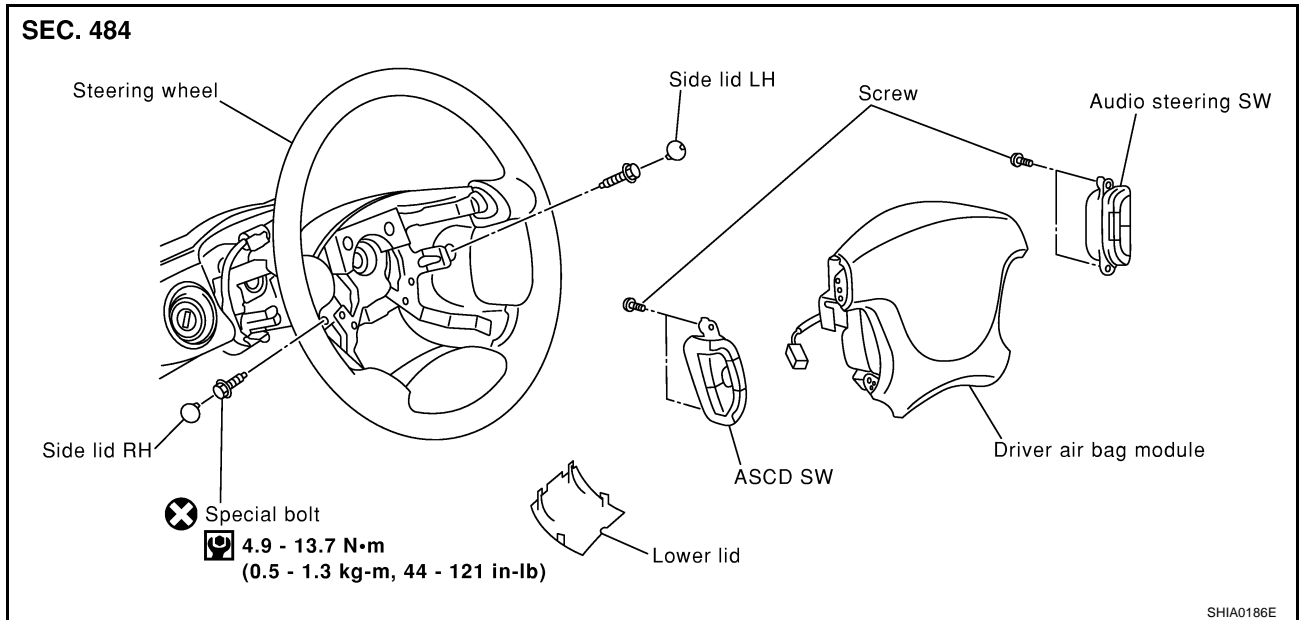

REMOVAL

CAUTION:

- Before servicing SRS, turn the ignition switch off, disconnect battery ground cable and wait at least 3 minutes.
 - Always work from the side of driver air bag module.
1. Remove the side lids. Using Tamper resistant torx socket (T30), remove the special bolts at right and left.

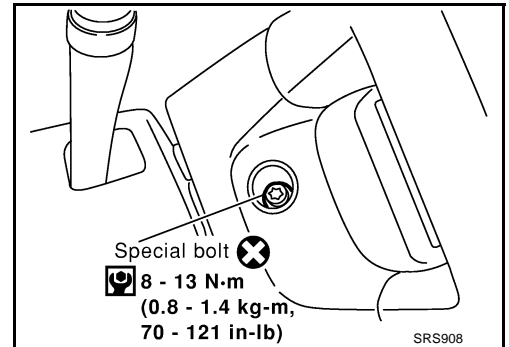

2. Disconnect the air bag harness connector, and remove the air bag module.

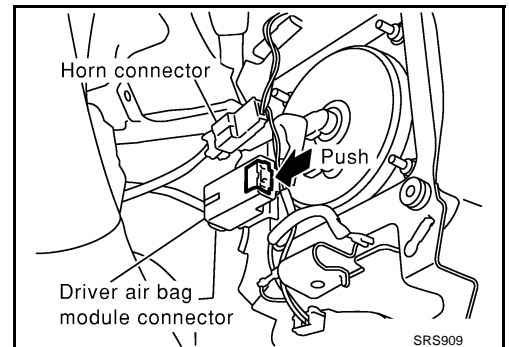

DRIVER AIR BAG MODULE

3. Remove the steering switch from the air bag module.

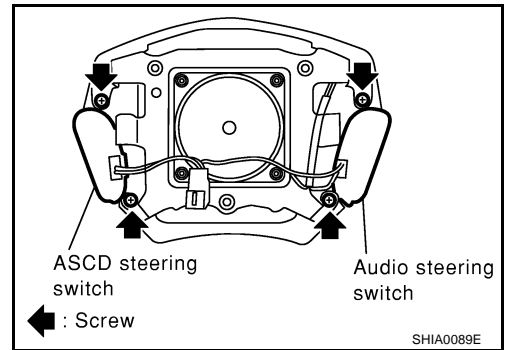

CAUTION:

- Always work from the side of driver air bag module.
- Always place driver air bag module with pad side facing upward.
- Do not insert any foreign objects (screwdriver, etc.) into driver air bag module.
- Do not attempt to disassemble driver air bag module.
- Do not use old bolts after removal; replace with new bolts.

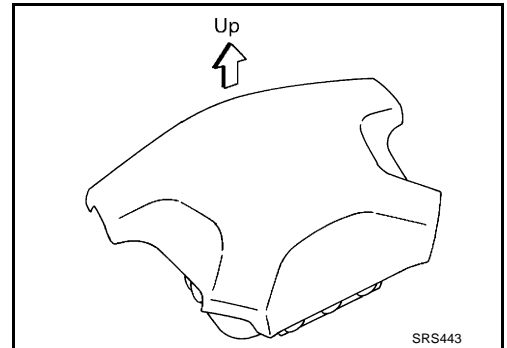

- Do not expose the driver air bag module to temperatures exceeding 90°C(194°F).
- Replace driver air bag module if it has been dropped or sustained an impact.
- Do not allow oil, grease or water to come in contact with the front passenger air bag module.

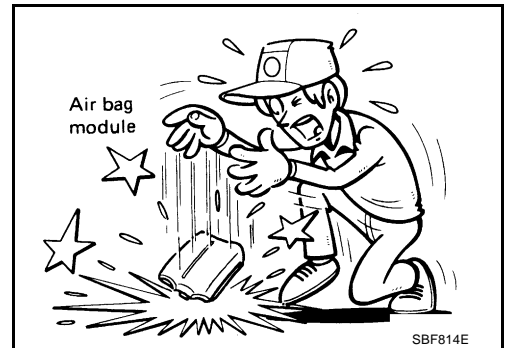

INSTALLATION

To install, reverse the removal procedure sequence.

- After installing the air bag module, check that the contact clearance of the horn switch is in the specified range in the right.

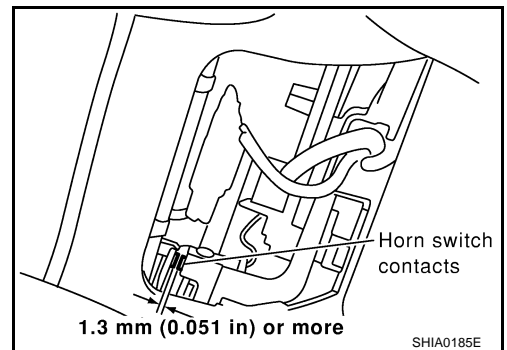

A
B
C
D
E
F
G
SRS
I
J
K
L
M

DRIVER AIR BAG MODULE

- For installing the air bag module, tighten the special bolts with the center of the horn pad pressed to make the contacts (RH/LH) ON.
- After the work is completed, perform self-diagnosis to check that no malfunction is detected. Refer to [SRS-20, "SRS Operation Check"](#).

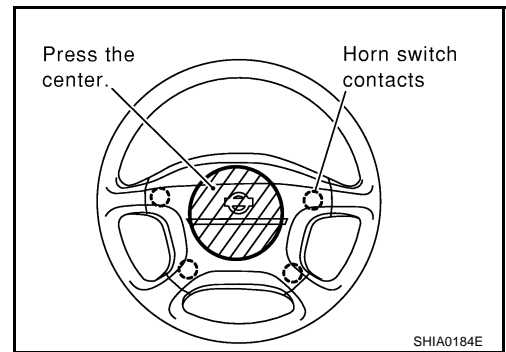

SPIRAL CABLE

SPIRAL CABLE

PF2:25554

Removal and Installation

EHS00080

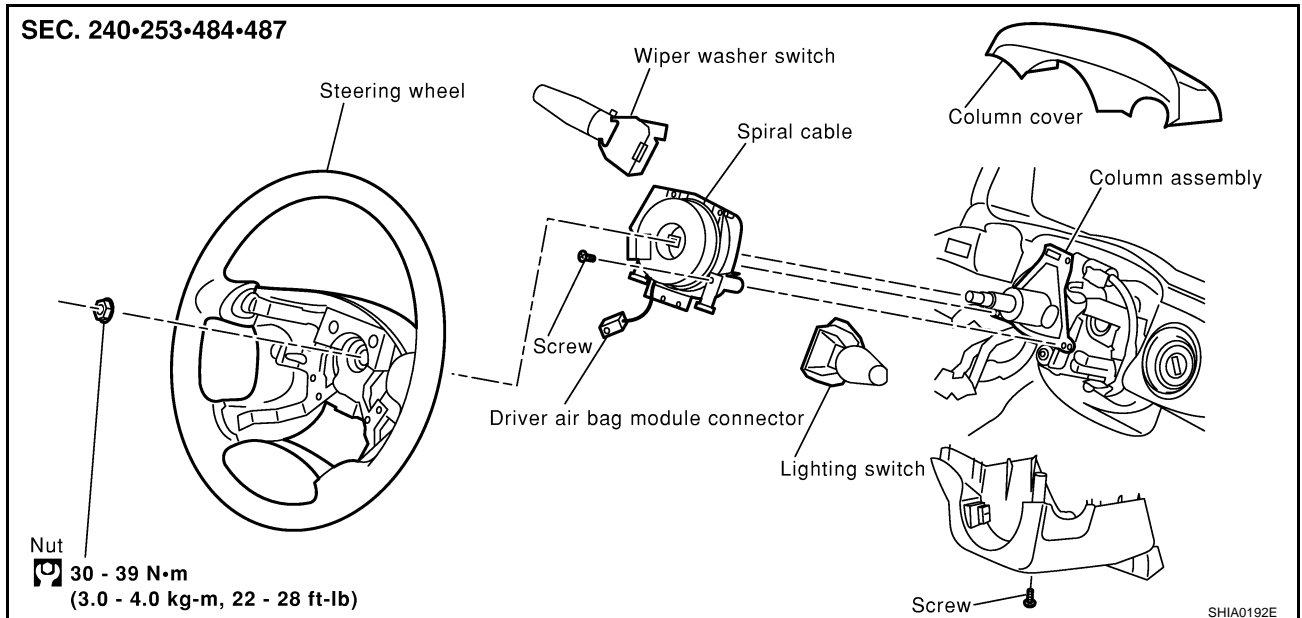

REMOVAL

CAUTION:

- Before servicing SRS, turn the ignition switch off, disconnect the battery ground cable and wait at least 3 minutes.

1. Remove driver air bag module. Refer to [SRS-34, "Removal and Installation"](#).
2. Set the steering wheel in the neutral position.
3. Disconnect the horn connector.
4. Remove the column cover. Refer to [IP-10, "INSTRUMENT PANEL ASSEMBLY"](#).
5. Disconnect the horn switch connector, then the spiral cable connector.

CAUTION:

Do not tap or bump the steering wheel.

6. Remove steering wheel with steering wheel puller. Be careful not to over-tighten puller on steering wheel.

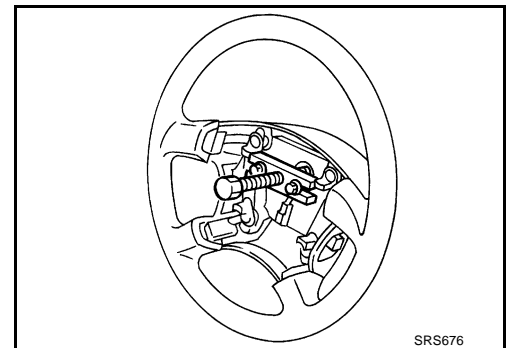

7. Remove the spiral cable fixing screws, and while pushing the upper plastic tab, remove the spiral cable.

CAUTION:

- Do not attempt to disassemble spiral cable.
- Do not apply lubricant to the spiral cable.

8. Remove the wiper washer switch and lighting switch from the spiral cable.

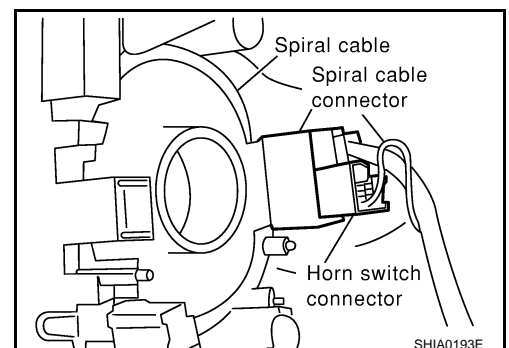

SPIRAL CABLE

CAUTION:

- The spiral cable may snap due to steering operation if the cable is installed in an improper position.
- Also, with the steering linkage disconnectedly cable may snap by turning the steering wheel beyond the limited number of turns. The spiral cable can be turned to the left about 2.5turns from the right end position.

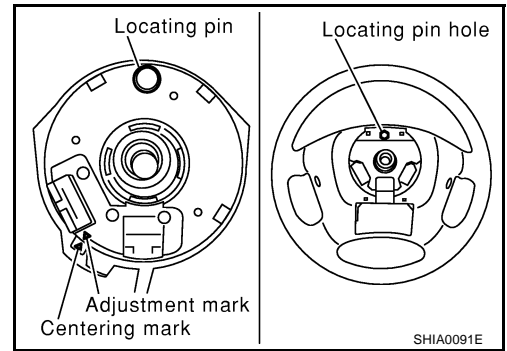

INSTALLATION

To install, reverse the removal procedure sequence.

- After the work is completed, perform self-diagnosis to check that no malfunction is detected. Refer to [SRS-20, "SRS Operation Check"](#) .

FRONT PASSENGER AIR BAG MODULE

FRONT PASSENGER AIR BAG MODULE

PFP:K8515

Removal and Installation REMOVAL

EHS0008Q

CAUTION:

- Before servicing SRS, turn the ignition switch off, disconnect the battery ground cable and wait at least 3 minutes.
- Always work from the side of or under front passenger air bag module.

1. Remove the instrument lower cover, and disconnect the passenger air bag harness connector.
2. Remove the glove box. Refer to [IP-10, "INSTRUMENT PANEL ASSEMBLY"](#).
3. Remove the special bolts.

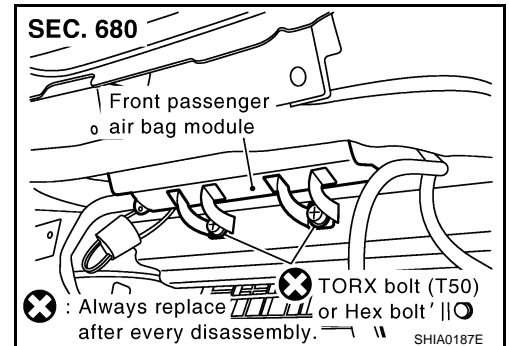

4. Pull the passenger air bag module toward the rear of the vehicle, while being careful not to impact it. Pull it from between the instrument panel and the steering wheel member downward to remove.

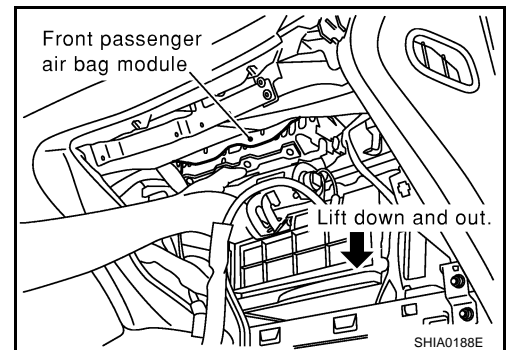

CAUTION:

- Always place front passenger air bag module with caution label side facing upward.
- Do not insert any foreign objects (screwdriver, etc.) into front passenger air bag module.
- Do not attempt to disassemble front passenger air bag module.
- Do not use old bolts after removal; replace with new bolts.
- Replace front passenger air bag module if it has been dropped or sustained an impact.
- Do not expose the front passenger air bag module to temperatures exceeding 90°C(194°F).
- Do not allow oil, grease or water to come in contact with the front passenger air bag module.
- After front passenger air bag module inflates, the instrument panel assembly should be replaced.



INSTALLATION

To install, reverse the removal procedure.

CAUTION:

- Always work from the side of or under front passenger air bag module.
- After the work is completed, perform self-diagnosis to check that no malfunction is detected. Refer to [SRS-20, "SRS Operation Check"](#)

FRONT SIDE AIR BAG MODULE

FRONT SIDE AIR BAG MODULE

PFP:K8EH0

Removal and Installation

EHS0008R

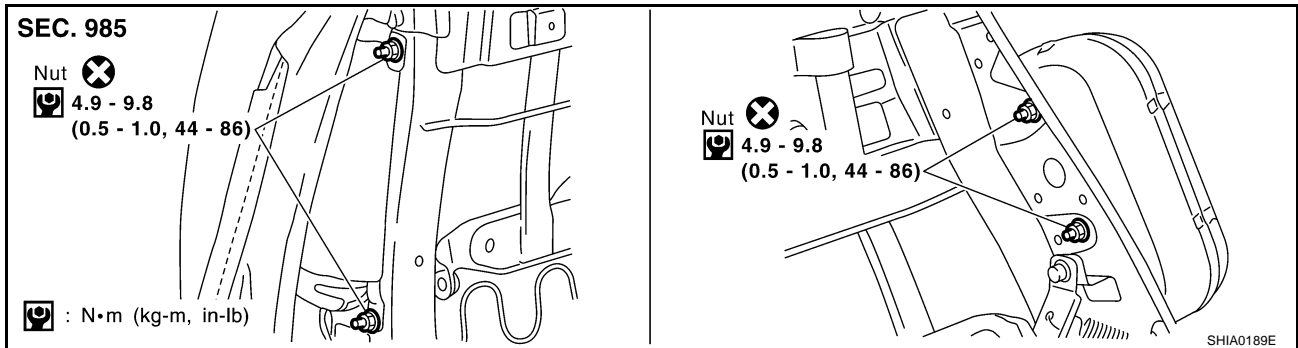

REMOVAL

WARNING:

- Removal of front side air bag module should only be done to allow deployment of front side air bag module prior to disposal of seatback assembly. Only complete seatback assemblies can be replaced. Refer to SEC. 985 [SE-117, "REMOVAL OF SEATBACK ASSEMBLY"](#)

CAUTION:

- Before servicing SRS, turn the ignition switch off, disconnect the battery ground cable and wait at least 3 minutes.
 - Always work from the rear of the front side air bag module.
1. Remove the front seat. Refer to [SE-111, "Removal and Installation"](#).
 2. Remove the seat back board. Refer to [SE-116, "SEATBACK TRIM AND PAD"](#).
 3. Remove the seat back trim and pad. Refer to [SE-116, "SEATBACK TRIM AND PAD"](#).
 4. Remove the seat back rear finisher, and remove the retainers securing the seat cushion trim. Refer to [SE-117, "SEAT CUSHION TRIM AND PAD"](#).
 5. Uncap the air bag module harness fixing, and remove the harness connector on the side air bag from the seat cushion.
 6. Remove the side air bag module fixing nuts, and remove the front side air bag module.

CAUTION:

- When using a clip removal tool to remove the seat back board, take care not to damage the harness for front side air bag module.
- Always place the front side air bag module standing with the stud bolt side setting bottom.
- Do not insert any foreign objects (screwdrivers) into front side air bag module
- Do not attempt to disassemble front side air bag module.

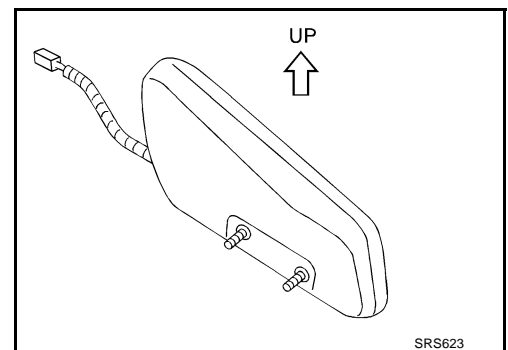

- Do not use old bolts after removal; replace with new bolts.

FRONT SIDE AIR BAG MODULE

- Replace front side air bag module if it has been dropped or sustained an impact.
- Do not expose the front side air bag module to temperatures exceeding 90°C(194°F).
- Do not allow oil, grease or water to come in contact with the front side air bag module.
- After front side air bag module inflates, front seatback assembly must be replaced.

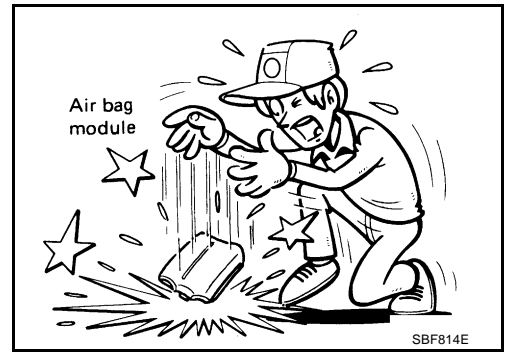

INSTALLATION

To install, reverse the removal procedure.

CAUTION:

- Always work from the rear of the front side air bag module.
- After the work is completed, perform self-diagnosis to check that no malfunction is detected. Refer to [SRS-20, "SRS Operation Check"](#).

A
B
C
D
E
F
G
I
J
K
L
M

SRS

SIDE CURTAIN AIR BAG MODULE

SIDE CURTAIN AIR BAG MODULE

PFP:985P0

Removal and Installation

EHS0008S

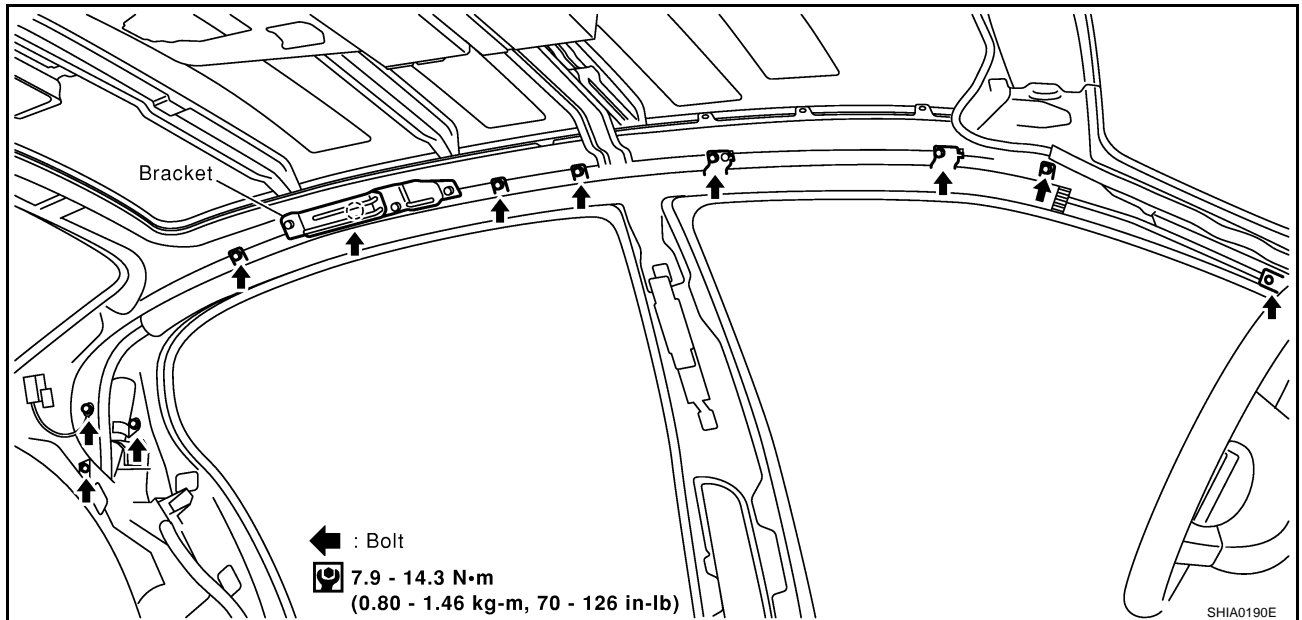

REMOVAL

CAUTION:

- Before servicing SRS, turn the ignition switch off, disconnect the battery ground cable and wait at least 3 minutes.
 - Always work from the side of the side curtain air bag module.
1. Remove rear pillar finisher. Refer to [EI-38, "Removal and Installation"](#).
 2. Disconnect the side curtain air bag module connector.
 3. Remove headlining. Refer to [EI-48, "Removal and Installation"](#).
 4. Remove side curtain air bag module fixing bolts, and remove the side curtain air bag module.

CAUTION:

- Always place the side curtain air bag module with the caution label facing upward.
- Do not attempt to disassemble side curtain air bag module.
- Do not insert any foreign objects (screwdriver, etc.) into air bag module connector.
- Replace side curtain air bag module if it has been dropped or sustained an impact.
- Do not expose the air bag module to temperatures exceeding 90°C (194°F).
- Do not allow oil, grease or water to come in contact with the side curtain air bag module.

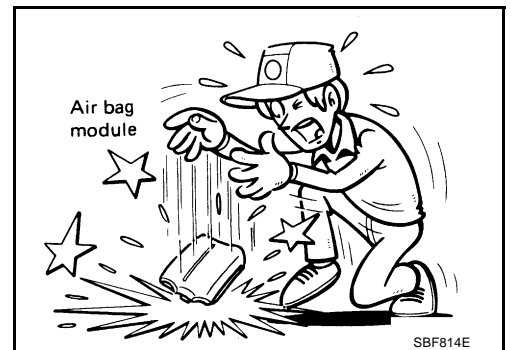

INSTALLATION

To install, reverse the removal procedure sequence.

CAUTION:

- Always work from the side of the side curtain air bag module.
- After replacement of side curtain air bag module, perform self-diagnosis to check that no malfunction is detected. Refer to [SRS-20, "SRS Operation Check"](#).

CRASH ZONE SENSOR

CRASH ZONE SENSOR

PFP:98531

Removal and Installation

EHS0009M

REMOVAL

CAUTION:

- Before servicing SRS, turn the ignition switch off, disconnect the battery ground cable and wait at least 3 minutes.
1. Remove front grille. Refer to [EI-20, "Removal and Installation"](#).
 2. Remove crash zone sensor connector.
 3. Remove crash zone sensor fixing nuts.

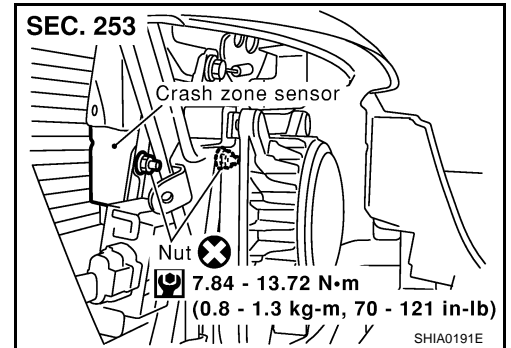

CAUTION:

- Replace crash zone sensor if it has been dropped or sustained an impact.
- Do not attempt to disassemble crash zone sensor.

INSTALLATION

To install, reverse the removal procedure sequence.

CAUTION:

- Check crash zone sensor for proper installation.
- After the work is complete, perform self-diagnosis to check that no malfunction is detected. Refer to [SRS-20, "SRS Operation Check"](#).

A
B
C
D
E
F
G
I
J
K
L
M

SRS

SIDE AIR BAG (SATELLITE) SENSOR

PFP:98830

EHS0008U

SIDE AIR BAG (SATELLITE) SENSOR

Removal and Installation REMOVAL

CAUTION:

- Before servicing SRS, turn the ignition switch off, disconnect the battery ground cable and wait at least 3 minutes.
1. Remove seat belt pre-tensioner. Refer to [EI-38, "BODY SIDE TRIM"](#) and [SB-3, "Removal and Installation of Front Seat Belt"](#).
 2. Remove side air bag (satellite) sensor fixing nuts.
 3. Remove the side air bag (satellite) sensor connector.

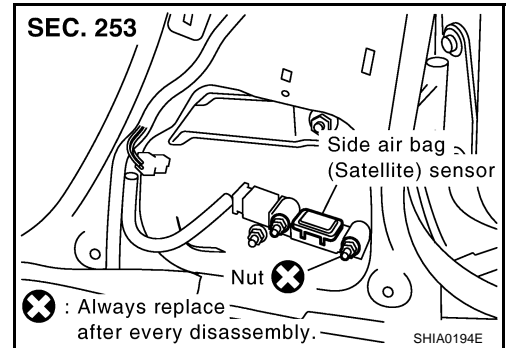

CAUTION:

- Do not use old bolts, replace with new ones.
- Check side air bag (satellite) sensor to ensure they are free of deformities, dents, cracks or rust. If it shows any visible signs of damage, replace it with new one.
- Do not attempt to disassemble side air bag (satellite) sensor.
- Replace side air bag (satellite) sensor if it has been dropped or sustained an impact.
- When the front side air bag or side curtain air bag deploys, always replace it with a new one.

INSTALLATION

To install, reverse the removal procedure sequence.

CAUTION:

- Check side air bag (satellite) sensor for proper installation.
- After replacement of side air bag (satellite) sensor, perform self-diagnosis to check that no malfunction is detected. Refer to [SRS-20, "SRS Operation Check"](#).

FRONT SEAT BELT PRE-TENSIONER

FRONT SEAT BELT PRE-TENSIONER

PFP:86884

Removal and Installation

EHS008V

To removal and installation procedures, refer to [SB-3, "Removal and Installation of Front Seat Belt"](#) .

A

B

C

D

E

F

G

SRS

I

J

K

L

M

DIAGNOSIS SENSOR UNIT

DIAGNOSIS SENSOR UNIT

PFP:28556

Removal and Installation

EHS0008W

REMOVAL

CAUTION:

- Before servicing SRS, turn the ignition switch off, disconnect the battery ground cable and wait at least 3 minutes.
1. Disconnect each harness connector for the air bag module and seat belt pre-tensioner.
 2. Remove center console. Refer to [IP-10, "INSTRUMENT PANEL ASSEMBLY"](#).
 3. Disconnect diagnosis sensor unit connector.
 4. To remove special bolts, using TAMPER RESISTANT TORX (T50) from diagnosis sensor unit.

CAUTION:

- Do not use old bolts. Replace with new ones.
- Check diagnosis sensor unit brackets to ensure it is free of deformities, dents, cracks or rust. If it shows any visible signs of damage, replace it with new one.
- Replace diagnosis sensor unit if it has been dropped or sustained an impact.

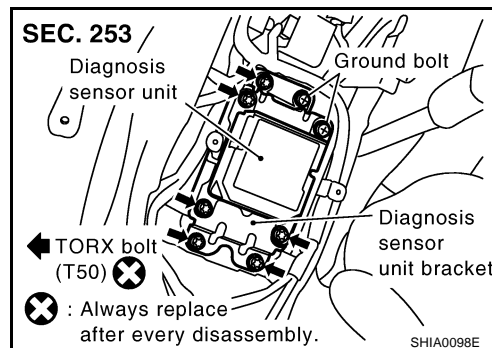

INSTALLATION

To install, reverse the removal procedure sequence.

CAUTION:

- Check the diagnosis sensor unit for proper installation.
- After replacement of diagnosis sensor unit, perform self-diagnosis to check that no malfunction is detected. Refer to [SRS-20, "SRS Operation Check"](#).

ECU DISCRIMINATED NO.

After replacing the diagnosis sensor unit, confirm that the diagnosis sensor unit identification No. is F317.

DISPOSAL OF AIR BAG MODULE AND SEAT BELT PRE-TENSIONER

DISPOSAL OF AIR BAG MODULE AND SEAT BELT PRE-TENSIONER

PFP:00014

Caution for Air Bag Module and Seat Belt Pre-tensioner

EHS0009A

- Before disposing of air bag module and seat belt pre-tensioner, or vehicles equipped with such systems, deploy the systems. If such systems have already been deployed due to an accident, dispose of them as indicated in [SRS-53, "DISPOSING OF AIR BAG MODULE AND SEAT BELT PRE-TENSIONER"](#)
- When deploying the air bag module and seat belt pre-tensioner, always use the Special Service Tool; Deployment tool [KV99106400 (J38381)].
- When deploying the air bag module and seat belt pre-tensioner, stand at least 5 m (16 ft) away from the deployment component.
- When deploying air bag module and seat belt pre-tensioner, a fairly loud noise is made, followed by smoke being released. The smoke is not poisonous, however, be careful not to inhale smoke since it irritates the throat and can cause choking.
- Always activate one air bag module at a time.
- Due to heat, leave air bag module unattended for more than 30 minutes after deployment. Also leave seat belt pre-tensioner unattended for more than 10 minutes after deployment.
- Be sure to wear gloves when handling a deployed air bag module and seat belt pre-tensioner.
- Never apply water to the deployed air bag module and seat belt pre-tensioner.
- Wash your hands clean after finishing work.
- Place the vehicle outdoors with an open space of at least 6 m (20 ft) on all sides when deploying air bag module and seat belt pre-tensioner while mounted in vehicle.
- Use a voltmeter to make sure the vehicle battery is fully charged.
- Do not dispose of the air bag module and seat belt pre-tensioner un-deployed.

A
B
C
D
E
F
G

SRS

CHECKING DEPLOYMENT TOOL

Connecting to Battery

CAUTION:

The battery must show voltage of 9.6V or more.

Remove the battery from the vehicle and place it on dry wood blocks approximately 5 m (16 ft) away from the vehicle.

- Wait 3 minutes after the vehicle battery is disconnected before proceeding.
- Connect red clip of deployment tool to battery positive terminal and black clip to negative terminal.

Make sure the polarity is correct. The right side lamp in the tool, marked "deployment tool power", should glow with a green light. If the right side lamp glows red, reverse the connections to the battery.

Deployment Tool Check

Press the deployment tool switch to the "ON" position. The left side lamp in the tool, marked "air bag connector voltage" should illuminate. If it does not illuminate, replace the tool.

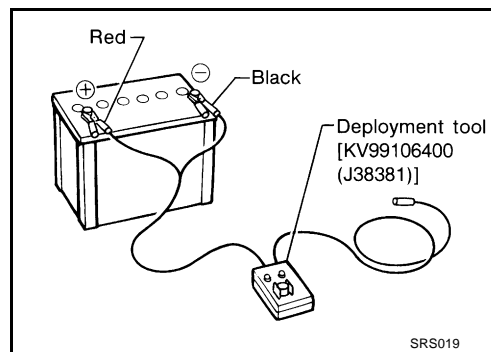

I
J
K
L
M

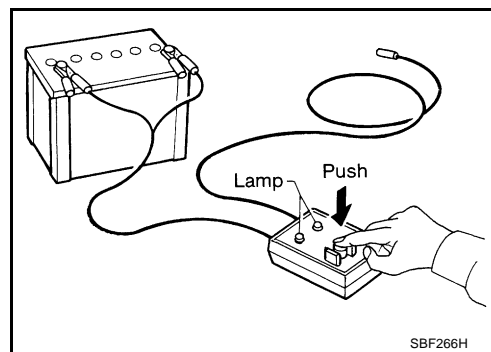

DISPOSAL OF AIR BAG MODULE AND SEAT BELT PRE-TENSIONER

Air Bag Deployment Tool Lamp Illumination Chart (Battery connected)

Switch operation	Left side lamp, green* "AIR BAG CONNECTOR VOLTAGE"	Right side lamp, green* "DEPLOYMENT TOOL POWER"
OFF	OFF	ON
ON	ON	ON

*: If this lamp glows red, the tool is connected to the battery incorrectly. Reverse the connections and make sure the lamp glows green.

DEPLOYMENT PROCEDURES FOR AIR BAG MODULE (OUTSIDE OF VEHICLE)

Unless the vehicle is being scrapped, deploying the air bag in the vehicle is not recommended. This may cause damage to the vehicle interior.

Anchor air bag module bracket [KV99105300 (J41246)] in a vise secured to a firm foundation during deployment.

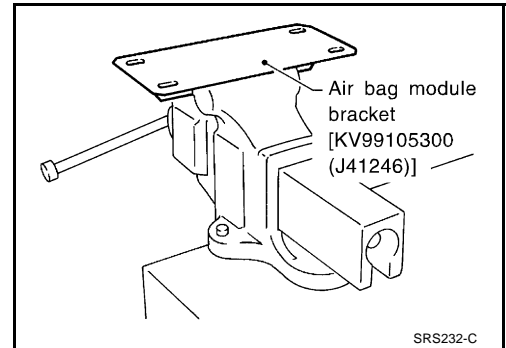

Deployment of Driver Air Bag Module (Outside of vehicle)

- Using wire, secure air bag module to air bag module bracket [SST: KV99105300 (J41246)] at two places.

CAUTION:

Use wire of at least 1 mm (0.04 in) diameter.

- Firmly secure air bag module bracket [SST: KV99105300 (J41246)] with air bag module attached, in a vise.

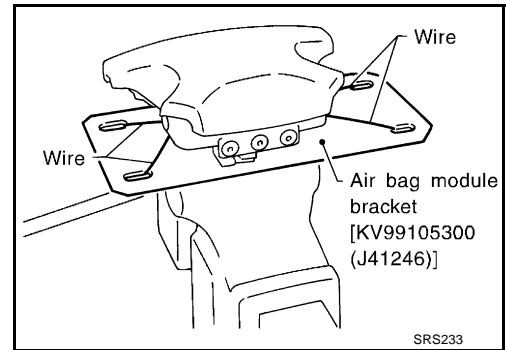

- Connect deployment tool adapter (SST: J38381-70) to deployment tool [SST: KV99106400 (J38381)] to air bag module connector.

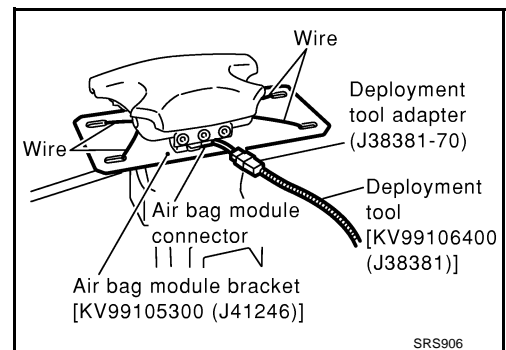

- Connect red clip of deployment tool to battery positive terminal and black clip to negative terminal.
- The lamp on the right side of the tool, marked "deployment tool power", should glow green, not red.
- Press the button on the deployment tool. The left side lamp on the tool, marked "air bag connector voltage", will illuminate and the air bag module will deploy.

CAUTION:

When deploying the driver air bag module, stand at least 5 m (16 ft) away from the air bag module.

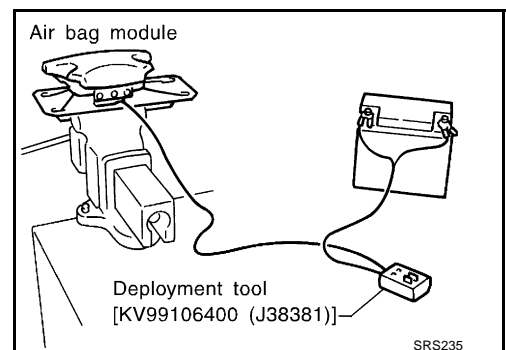

DISPOSAL OF AIR BAG MODULE AND SEAT BELT PRE-TENSIONER

Deployment of Front Passenger Air Bag Module (Outside of vehicle)

1. Make an 8.5 mm (0.335 in) diameter hole in air bag module bracket [SST: KV99105300 (J41246)] at the position shown in figure at right.
2. Firmly secure air bag module bracket [SST: KV99105300 (J41246)] in a vise.

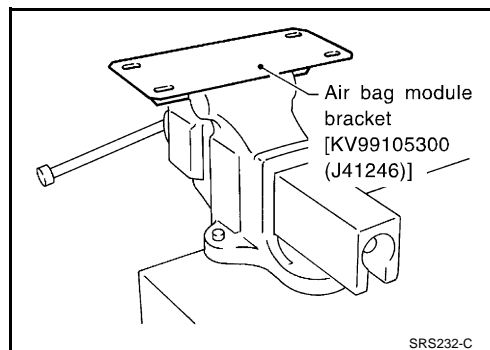

3. Match the two holes in air bag module bracket (held in vise) and front passenger air bag module and fix them with two bolts [M8 x 25 - 30 mm (0.98 - 1.18 in)].

CAUTION:

If a gap exists between front passenger air bag module and air bag module bracket, use a piece of wood inserted in the gap to stabilize the air bag module.

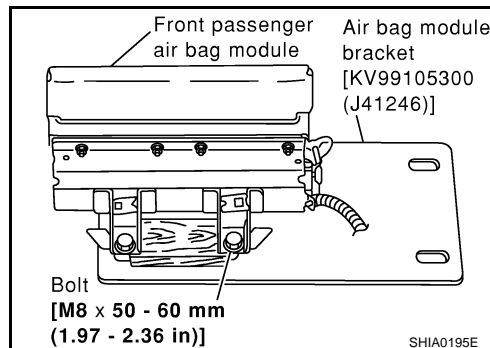

4. Connect deployment tool adapter (SST: J38381-65) to deployment tool [SST: KV99106400 (J38381)] connector and front passenger air bag module connector.
5. Connect red clip of deployment tool to battery positive terminal and black clip to negative terminal.
6. The lamp on the right side of the tool, marked "deployment tool power", should glow green, not red.

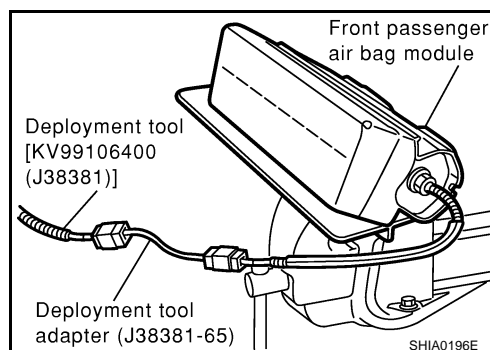

7. Press the button on the deployment tool. The left side lamp on the tool, marked "air bag connector voltage", will illuminate and the air bag module will deploy.

CAUTION:

- When deploying the front passenger air bag module, do not stand on the deploying side.
- Stand at least 5 m (16 ft) away from the air bag module.

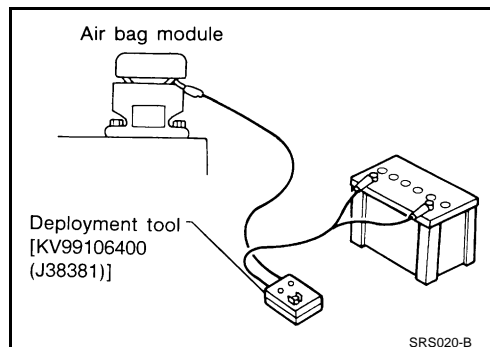

A
B
C
D
E
F
G
SRS
I
J
K
L
M

DISPOSAL OF AIR BAG MODULE AND SEAT BELT PRE-TENSIONER

Deployment of Front Side Air Bag Module (Outside of vehicle)

1. Make 6.5 mm (0.256 in) diameter holes in air bag module bracket [SST: KV99105300 (J41246)] at the position shown in figure at left.

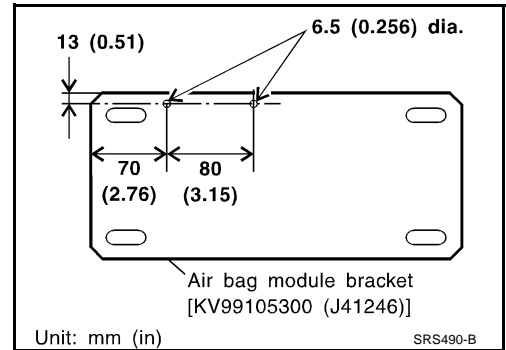

2. Firmly secure air bag module bracket [SST: KV99105300 (J41246)] in a vise.
3. Insert the stud bolts of side air bag module into the two holes in air bag module bracket (held in vise) and fix them with two M6 nuts.

CAUTION:

Side air bag module should be secured to air bag module bracket [SST: KV99105300 (J41246)] in a vise with stud bolt side setting bottom.

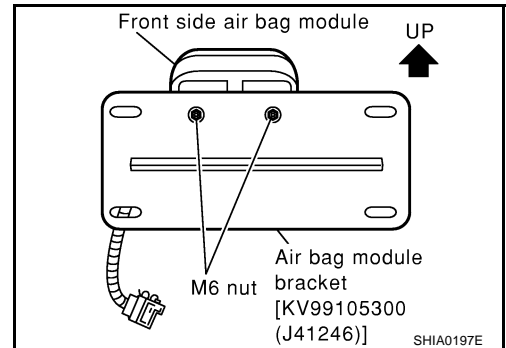

4. Connect deployment tool adapter [SST: KV99108300 (J38381-35)] to deployment tool [SST: KV99106400 (J38381)] connector and connector on air bag module.

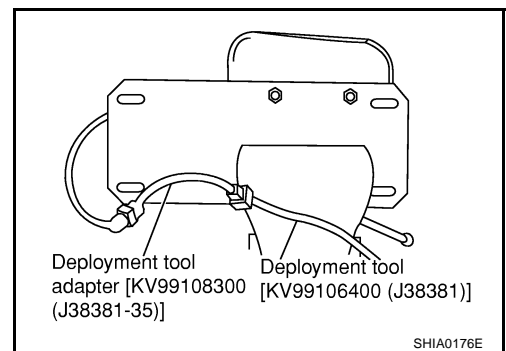

5. Connect red clip of deployment tool to battery positive terminal and black clip to negative terminal.
6. The lamp on the right side of the tool, marked "deployment tool power", should glow green, not red.
7. Press the button on the deployment tool. The left side lamp on the tool, marked "air bag connector voltage", will illuminate and the air bag module will deploy.

CAUTION:

When deploying the front side air bag module, stand at least 5 m (16 ft) away from the air bag module.

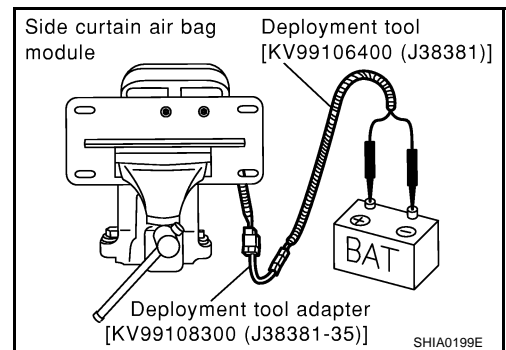

DISPOSAL OF AIR BAG MODULE AND SEAT BELT PRE-TENSIONER

Deployment of Side Curtain Air Bag Module (Outside of vehicle)

1. Cut the inflator from side curtain air bag module.

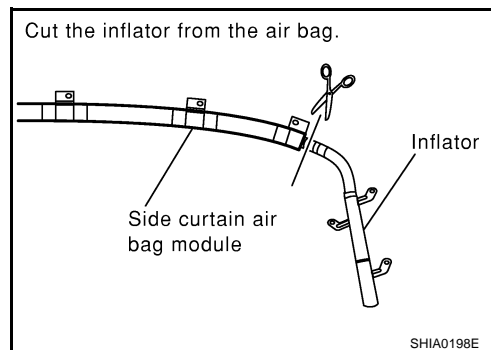

2. Connect deployment tool adapter [SST:KV99109000 (J44230)] to the inflator.

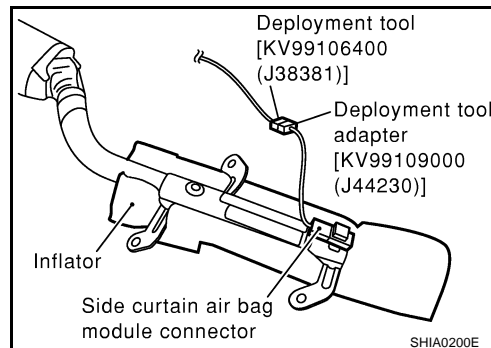

3. Put the inflator connected with the deployment tool adaptor [SST:KV99109000(J44230)] into a tire without wheel.

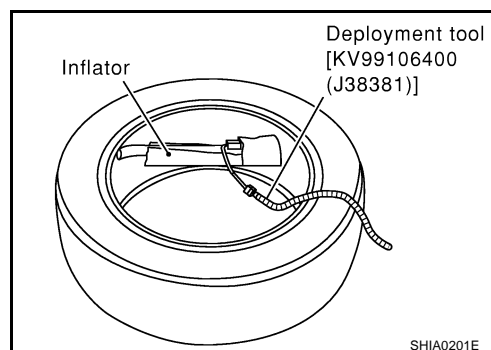

4. Put the tire with the inflator onto another tire without wheel. Add an additional tire without wheel and then a tire mounted on a wheel on top.

CAUTION:

Tie all tires together with a strap in order keep them standing.

5. Connect red clip of deployment tool to battery positive terminal and black clip to negative terminal.
6. The lamp on the right side of the tool, marked "deployment tool power", should glow green, not red.
7. Press the button on the deployment tool. The left side lamp on the tool, marked "air bag connector voltage", will illuminate and the air bag module will deploy.

CAUTION:

When deploying the side curtain air bag module, stand at least 5 m (16 ft) away from the side curtain air bag module.

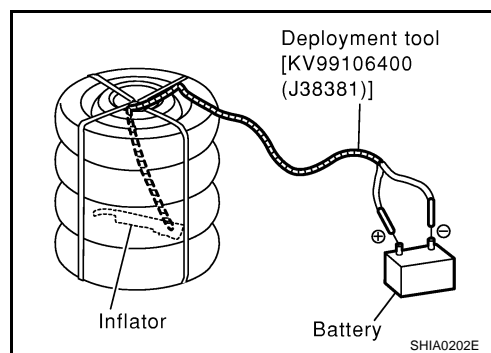

A
B
C
D
E
F
G
SRS
I
J
K
L
M

DISPOSAL OF AIR BAG MODULE AND SEAT BELT PRE-TENSIONER

DEPLOYMENT PROCEDURES FOR SEAT BELT PRE-TENSIONER (OUTSIDE OF VEHICLE)

1. Firmly grip pre-tensioner in a vise and cut the webbing off.

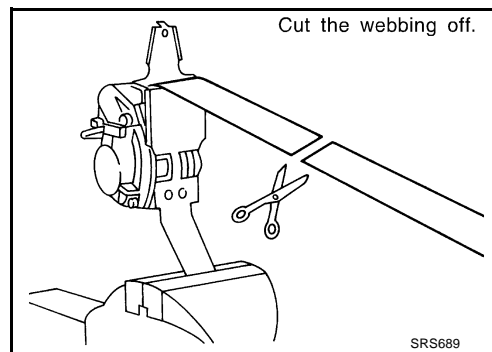

2. Connect deployment tool adapter [SST: KV99108200 (J38381-50)] to deployment tool [SST: KV99106400 (J38381)] connector and front seat belt pre-tensioner connector.

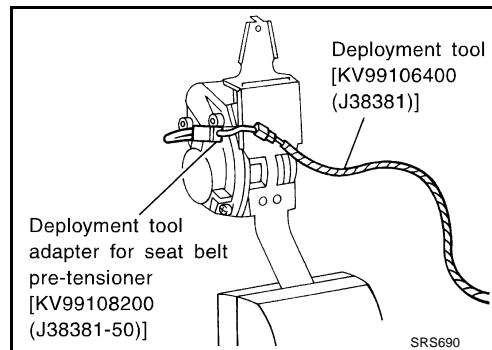

3. Connect red clip of deployment tool to battery positive terminal and black clip to negative terminal.
4. The lamp on the right side of the tool, marked "deployment tool power", should glow green, not red.
5. Press the button on the deployment tool. The left side lamp on the tool, marked "seat belt pre-tensioner connector voltage", will illuminate and the seat belt pre-tensioner will deploy.

CAUTION:

When deploying the front seat belt pre-tensioner, stand at least 5 m (16 ft) away from the seat belt pre-tensioner.

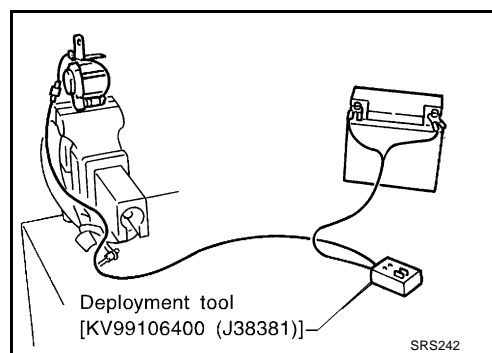

DEPLOYMENT OF AIR BAG MODULE AND SEAT BELT PRE-TENSIONER WHILE MOUNTED IN VEHICLE

When disposing of a vehicle, deploy air bag module and seat belt pre-tensioners while they are mounted in vehicle.

CAUTION:

When deploying air bag module or seat belt pre-tensioner, ensure vehicle is empty.

1. Disconnect both the vehicle battery cables and wait 3 minutes.
2. Disconnect air bag module and seat belt pre-tensioner connector.
3. Connect deployment tool [SST: KV99106400 (J38381)] to air bag module or seat belt pre-tensioner. For driver air bag module, attach deployment tool adapter (SST: J38381-70) to the tool connector. For front passenger air bag module, attach deployment tool adapter (SST: J38381-65) to the tool connector. For side air bag module, attach deployment tool adapter [SST: KV99108300 (J38381-35)]. For curtain air bag module, attach deployment tool adapter [SST: KV99109000(J44230)], For seat belt pre-tensioner, attach deployment tool adapter [SST: KV99108200 (J38381-50)] to the tool connector.

DISPOSAL OF AIR BAG MODULE AND SEAT BELT PRE-TENSIONER

4. Connect red clip of deployment tool to battery positive terminal and black clip to negative terminal.
5. The lamp on the right side of the tool, marked "deployment tool power", should glow green, not red.
6. Press the button on the deployment tool. The left side lamp on the tool, marked "air bag connector voltage", will illuminate and the air bag module or seat belt pre-tensioner will deploy.

CAUTION:

Activate only one air bag module or seat belt pre-tensioner at a time.

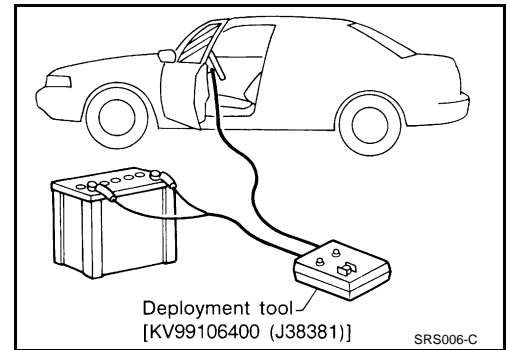

A
B
C
D

DISPOSING OF AIR BAG MODULE AND SEAT BELT PRE-TENSIONER

Deployed air bag module and seat belt pre-tensioner are very hot. Before disposing of air bag module, and seat belt pre-tensioner wait at least 30 minutes, and 10 minutes, respectively. Seal them in a plastic bag before disposal.

CAUTION:

- Never apply water to a deployed air bag module and seat belt pre-tensioner.
- Be sure to wear gloves when handling a deployed air bag module and seat belt pre-tensioner.
- No poisonous gas is produced upon air bag module deployment. However, be careful not to inhale gas since it irritates throat and can cause choking.
- Do not attempt to disassemble air bag module and seat belt pre-tensioner.
- Air bag module and seat belt pre-tensioner cannot be reused.
- Wash your hands clean after finishing work.

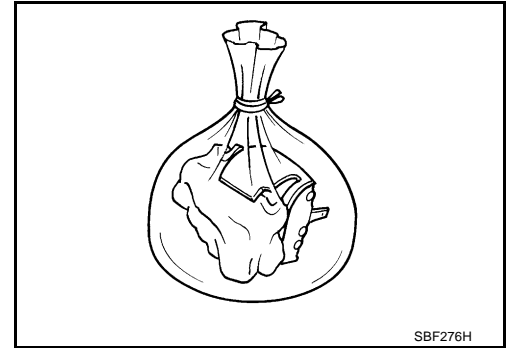

F
G

SRS

I
J
K
L
M

COLLISION DIAGNOSIS

PFP:00015

COLLISION DIAGNOSIS

For Frontal Collision

EHS00098

To repair the SRS, perform the following steps.

When SRS (except the front side air bag and side curtain air bag modules) is activated in a collision:

1. Replace the diagnosis sensor unit.
2. Remove the air bag modules (except the front side air bag module and side curtain air bag module), crash zone sensor assembly, bracket and seat belt pre-tensioner assemblies.
3. Check the SRS components using the table shown below:
 - Replace any SRS components showing visible signs of damage (dents, cracks and deformation).
4. Install new air bag modules (except the front side air bag module and side curtain air bag module) and seat belt pre-tensioner assemblies.
5. Conduct self-diagnosis using CONSULT-II or "AIR BAG" warning lamp. Refer to [SRS-20, "SRS Operation Check"](#) for details. Ensure entire SRS operation properly.

When SRS is not activated in a collision:

1. Check the SRS components using the table shown below:
 - Replace any SRS components showing visible signs of damage (dents, cracks and deformation).
2. Conduct self-diagnosis using CONSULT-II or "AIR BAG" warning lamp. Refer to [SRS-20, "SRS Operation Check"](#) for details. Ensure entire SRS operation properly.

SRS INSPECTION (FOR FRONTAL COLLISION)

Part	SRS is activated	SRS is NOT activated
Air bag module (driver and front passenger air bag module)	REPLACE Install with new bolts.	1. Remove air bag module. Check harness cover and connectors for damage, terminals for deformities, and harness for binding. 2. - Install driver air bag module into the steering wheel to check fit and alignment with the wheel. - Install passenger air bag module into the instrument panel to check fit with the instrument panel. 3. No damage found, reinstall with new bolts. 4. If damaged—REPLACE. Install air bag modules with new special bolts Air bag must be deployed before discarding.
Crash zone sensor	REPLACE the crash zone sensor and bracket with new nuts.	1. Remove the crash zone sensor. Check harness connectors for damage, terminals for deformities, and harness for binding. 2. Check for visible signs of damage (dents, cracks, deformation) of the crash zone sensor and bracket. 3. Install the crash zone sensor to check fit. 4. If no damage is found, reinstall the crash zone sensor with new nuts agent. 5. If damaged—REPLACE the crash zone sensor and bracket with new nuts
Seat belt pre-tensioner assembly	REPLACE Install seat belt pre-tensioner with new bolts.	1. Remove seat belt pre-tensioners. Check harness cover and connectors for damage, terminals for deformities, and harness for binding. 2. Check belts for damage and anchors for loose mounting. 3. Check retractor for smooth operation. 4. If no damage is found, reinstall seat belt pre-tensioner assembly. 5. If damaged—REPLACE. Install the seat belt pre-tensioners with new bolts. Seat belt pre-tensioners must be deployed before discarding.
Diagnosis sensor unit	REPLACE Install with new bolts.	1. Check case for dents, cracks or deformities. 2. Check connectors for damage, and terminals for deformities. 3. If no damage is found, reinstall with new bolts and ground bolt. 4. If damaged—REPLACE. Install diagnosis sensor unit with new bolts and ground bolt.

COLLISION DIAGNOSIS

Part	SRS is activated	SRS is NOT activated
Steering wheel	<ol style="list-style-type: none"> 1. Visually check steering wheel for deformities. 2. Check harness (built into steering wheel) and connectors for damage, and terminals for deformities. 3. Install air bag module to check fit or alignment with steering wheel. 4. Check steering wheel for excessive free play. 5. If no damage is found, reinstall with bolts. 6. If damaged—REPLACE. 	
Spiral cable	<ol style="list-style-type: none"> 1. Visually check spiral cable and combination switch for damage. 2. Check connectors and protective tape for damage. 3. Check steering wheel for noise, binding or heavy operation. 4. If no damage is found, reinstall with bolts. 5. If damaged—REPLACE. 	
Harness and Connectors	<ol style="list-style-type: none"> 1. Check connectors for poor connection, damage, and terminals for deformities. 2. Check harness for binding, chafing, cuts, or deformities. 3. If no damage is found, reinstall the harness and connectors. 4. Damaged—REPLACE damaged section of harness. Do not attempt to repair, splice or modify any SRS harness. 	
Instrument panel	<ol style="list-style-type: none"> 1. Visually check instrumental panel for damage. 2. If no damage is found, reinstall the instrument panel. 3. If damaged—REPLACE the instrument panel with bolts. 	

A
B
C
D
E
F
G

For Side Collision

EHS00099

SRS

WHEN THE SIDE AIR BAG IS ACTIVATED IN THE SIDE COLLISION:

1. Replace the following component:
 - All parts of front seat back (including front seat back frame) with front side air bag module (on the side on which front side air bag is activated)
 - Curtain air bag module (on the side on which side curtain air bag is activated)
 - Diagnosis sensor unit
 - Satellite sensor (on the side on which side air bag and side curtain air bag is activated)
2. Check the SRS components and the related parts using the table shown below.
 - Replace any SRS components and the related parts showing visible signs of damage (dents, cracks, deformation).
3. Conduct self-diagnosis using CONSULT-II or “AIR BAG” warning lamp. Refer to [SRS-20, "SRS Operation Check"](#) . Ensure entire SRS operation properly.

I
J
K
L
M

WHEN SRS IS NOT ACTIVATED IN THE SIDE COLLISION:

1. Check the SRS components and the related parts using the table shown below.
 - Replace any SRS components and the related parts showing visible signs of damage (dents, cracks, deformation).
2. Conduct self-diagnosis using CONSULT-II or “AIR BAG” warning lamp. Refer to [SRS-20, "SRS Operation Check"](#) . Ensure entire SRS operation properly.

COLLISION DIAGNOSIS

SRS INSPECTION (FOR SIDE COLLISION)

Part	Front side air bag and side curtain air bag is activated	Front side air bag and side curtain air bag is NOT activated
(LH or RH) side curtain air bag module	Replace the side curtain air bag module. (Repair the center pillar inner, etc. before installing new one if damaged.)	<ol style="list-style-type: none"> 1. Check for visible signs of damage (dents, tears, deformation) of the center pillar on the collision side. 2. If damaged— Remove the side curtain air bag module. 3. Check for visible signs of damaged (tears etc.) of the side curtain air bag module. 4. Check harness and connectors for damage, and terminals for deformities. 5. If no damage is found, reinstall the side curtain air bag module with new bolts. 6. If damaged—REPLACE the side curtain air bag module with new bolts. Air bag must be deployed before disposing of it.
Front (LH or RH) side air bag module	REPLACE all parts of seat back with deployed front side air bag module.	<ol style="list-style-type: none"> 1. Check for visible signs of damage (dents, tears, deformation) of the seat back on the collision side. 2. If damaged—REPLACE the damaged seat parts with new bolts and remove the front side air bag module. 3. Check for visible signs of damaged (tears etc.) of the front side air bag module. 4. Check harness and connectors for damage, and terminals for deformities. 5. If no damaged is found, reinstall the front side air bag module with new nuts. 6. If damaged—REPLACE the front side air bag module with new nut. Air bag must be deployed before disposing of it.
(LH or RH) side air bag (satellite) sensor	REPLACE the side air bag (satellite) sensor on the collision side with new nuts. (Repair the center pillar inner, etc. before installing new one if damaged.)	<ol style="list-style-type: none"> 1. Remove the side air bag (satellite) sensor on the collision side. Check harness connectors for damage, terminals for deformities, and harness for binding. 2. Check for visible signs of damage (dents, cracks, deformation) of the side air bag (satellite) sensor. 3. Install the side air bag (satellite) sensor to check fit. 4. If no damage is found, reinstall the side sir bag (satellite) sensor with new nuts. 5. If damaged—REPLACE the side air bag (satellite) sensor with new nuts.
Diagnosis sensor unit	REPLACE the diagnosis sensor unit with the new bolts.	<ol style="list-style-type: none"> 1. Check case and bracket for dents, cracks or deformities. 2. Check connectors for damage, and terminals for deformities. 3. If no damage is found, reinstall the diagnosis sensor unit with new bolts and ground bolt. 4. If damaged—REPLACE the diagnosis sensor unit with new bolts and ground bolt.
Seat belt pre-tensioner assembly	<ol style="list-style-type: none"> 1. Check if the seat belt can be extended smoothly. If the seat belt cannot be extended smoothly, <ul style="list-style-type: none"> – Check for deformities of the center pillar inner. – If the center pillar inner has no damage, REPLACE the seat belt pre-tensioner assembly. 2. Remove the seat belt pre-tensioner assembly on the collision side. Check harness cover and connectors for damage, terminals for deformities, and harness for binding. 3. Check for visible signs of damage (dents, cracks, deformation) of the seat belt pre-tensioner assembly. 4. If no damage is found, reinstall the seat belt pre-tensioner assembly. 5. If damaged—REPLACE the seat belt pre-tensioner assembly with new bolts. The seat belt pre-tensioner assembly must be deployed before disposing of it. 	
Seat with front side air bag	REPLACE all parts of front seat back (including front seat back frame)	<ol style="list-style-type: none"> 1. Visually check the seat on the collision side. 2. Remove the seat on the collision side and check the following for damage and deformities. <ul style="list-style-type: none"> – Harness, connectors and terminals – Frame and recliner (for front and rear seat), and also adjuster and slides (for front seat) 3. If no damage is found, reinstall the seat. 4. If damaged—REPLACE the damaged seat parts with new bolts.

COLLISION DIAGNOSIS

Part	Front side air bag and side curtain air bag is activated	Front side air bag and side curtain air bag is NOT activated
Center pillar inner	1. Check the center pillar inner on the collision side for damage (dents, cracks, deformation). 2. If damaged—REPAIR the center pillar inner.	
Trim	1. Check for visible signs of damage (dents, cracks, deformation) of the interior trim on the collision side. 2. If damaged—REPLACE the damaged trim parts.	

A
B
C
D
E
F
G
I
J
K
L
M

SRS

COLLISION DIAGNOSIS
