

SECTION **RSU**
 REAR SUSPENSION

A
B
C
D

RSU

CONTENTS

PRECAUTIONS	2	RADIUS ROD	13	F
Cautions	2	Removal and Installation	13	
PREPARATION	3	REMOVAL	13	G
Special Service Tools	3	INSPECTION AFTER REMOVAL	13	
Commercial Service Tools	3	INSTALLATION	13	H
NOISE, VIBRATION AND HARSHNESS (NVH)		FRONT LOWER LINK	14	
TROUBLESHOOTING	4	Removal and Installation	14	I
NVH Troubleshooting Chart	4	REMOVAL	14	
REAR SUSPENSION ASSEMBLY	5	INSPECTION AFTER REMOVAL	14	J
Components	5	INSTALLATION	14	
On-Vehicle Inspection and Service	6	REAR LOWER LINK & COIL SPRING	15	K
INSPECTION OF BALL JOINT END PLAY	6	Removal and Installation	15	
SHOCK ABSORBER INSPECTION	6	REMOVAL	15	L
Wheel Alignment Inspection	6	INSPECTION AFTER REMOVAL	15	
DESCRIPTION	6	INSTALLATION	15	M
PRELIMINARY INSPECTION	6	STABILIZER BAR	16	
CAMBER INSPECTION	7	Removal and Installation	16	
TOE-IN	7	REMOVAL	16	
SHOCK ABSORBER	9	INSPECTION AFTER REMOVAL	16	
Removal and Installation	9	INSTALLATION	16	
REMOVAL	9	REAR SUSPENSION MEMBER	17	
INSPECTION AFTER REMOVAL	9	Removal and Installation	17	
INSTALLATION	9	REMOVAL	17	
Disassembly and Assembly	9	INSPECTION AFTER REMOVAL	17	
DISASSEMBLY	9	INSTALLATION	17	
INSPECTION AFTER DISASSEMBLY	10	SERVICE DATA	18	
ASSEMBLY	10	Wheel Alignment	18	
SUSPENSION ARM	11	Ball Joint	18	
Removal and Installation	11	Wheelarch Height (Unladen*)	18	
REMOVAL	11			
INSPECTION AFTER REMOVAL	11			
INSTALLATION	12			

PRECAUTIONS

PRECAUTIONS

PFP:00001

Cautions

EES000U6

- When installing rubber bushings, final tightening must be carried out under unladen condition with tires on level ground. Oil will shorten the life of rubber bushings. Be sure to wipe off any spilled oil.
- Unladen condition means that fuel, coolant and lubricant are full. Spare tire, jack, hand tools and mats in designated positions.
- After servicing suspension parts, be sure to check wheel alignment.
- Caulking nuts are not reusable. Always use new ones when installing. Since new caulking nuts are pre-oiled, tighten as they are.

PREPARATION

PREPARATION

PFP:00002

Special Service Tools

EES000U7

The actual shapes of Kent-Moore tools may differ from those of special service tools illustrated here.

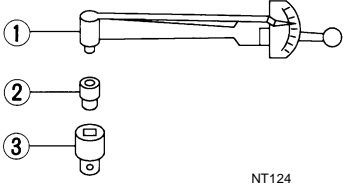
Tool number (Kent-Moore No.) Tool name	Description
ST3127 S000 (See J25742-A) Preload gauge 1. GC91030000 Torque wrench (J25765) 2. HT62940000 (—) Socket adapter (1/2") 3. HT62900000 (—) Socket adapter (3/8")	 <p style="text-align: right;">NT124</p> Measuring rotating torque of ball joint

A
B
C
D
RSU

Commercial Service Tools

EES000U8

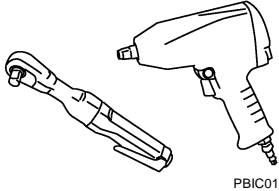
Tool name	Description
Power tool	 <p style="text-align: right;">PBIC0190E</p> <ul style="list-style-type: none"> ● Removing wheel nuts ● Removing brake caliper ● Removing stabilizer assembly

F
G
H
I
J
K
L
M

NOISE, VIBRATION AND HARSHNESS (NVH) TROUBLESHOOTING

NOISE, VIBRATION AND HARSHNESS (NVH) TROUBLESHOOTING

PF0:00003

NVH Troubleshooting Chart

EES000U9

Use chart below to help you find the cause of the symptom. If necessary, repair or replace these parts.

Symptom		Possible cause and SUSPECTED PARTS	Reference page															
			RSU-5	RSU-9	—	—	—	RSU-5	RSU-6	RSU-16	NVH in PR section.	NVH in RFD section.	NVH in FAX and FSU sections.	NVH in WT section.	NVH in WT section.	NVH in RAX section.	NVH in BR section.	NVH in PS section.
REAR SUSPENSION	Noise	Improper installation, looseness	x	x	x	x	x	x			x	x	x	x	x	x	x	x
	Shake	Shock absorber defamation, damage or deflection	x	x	x	x		x			x		x	x	x	x	x	x
	Vibration	Bushing or mounting deterioration	x	x	x	x	x						x	x		x		x
	Shimmy	Parts interference	x	x	x	x								x	x		x	x
	Judder	Spring fatigue	x	x	x										x	x		x
	Poor quality ride or handling	Suspension looseness	x	x	x													
		Incorrect wheel alignment																
		Stabilizer bar fatigue																
		PROPELLER SHAFT																
		DIFFERENTIAL																
		FRONT AXLE AND FRONT SUSPENSION																
		TIRES																
		ROAD WHEEL																
		DRIVE SHAFT																
		BRAKES																
		STEERING																

x: Applicable

REAR SUSPENSION ASSEMBLY

REAR SUSPENSION ASSEMBLY

PFP:55020

Components

EES000UA

A
B
C
D
RSU
F
G
H
I
J
K
L
M

SEC.430 · 431

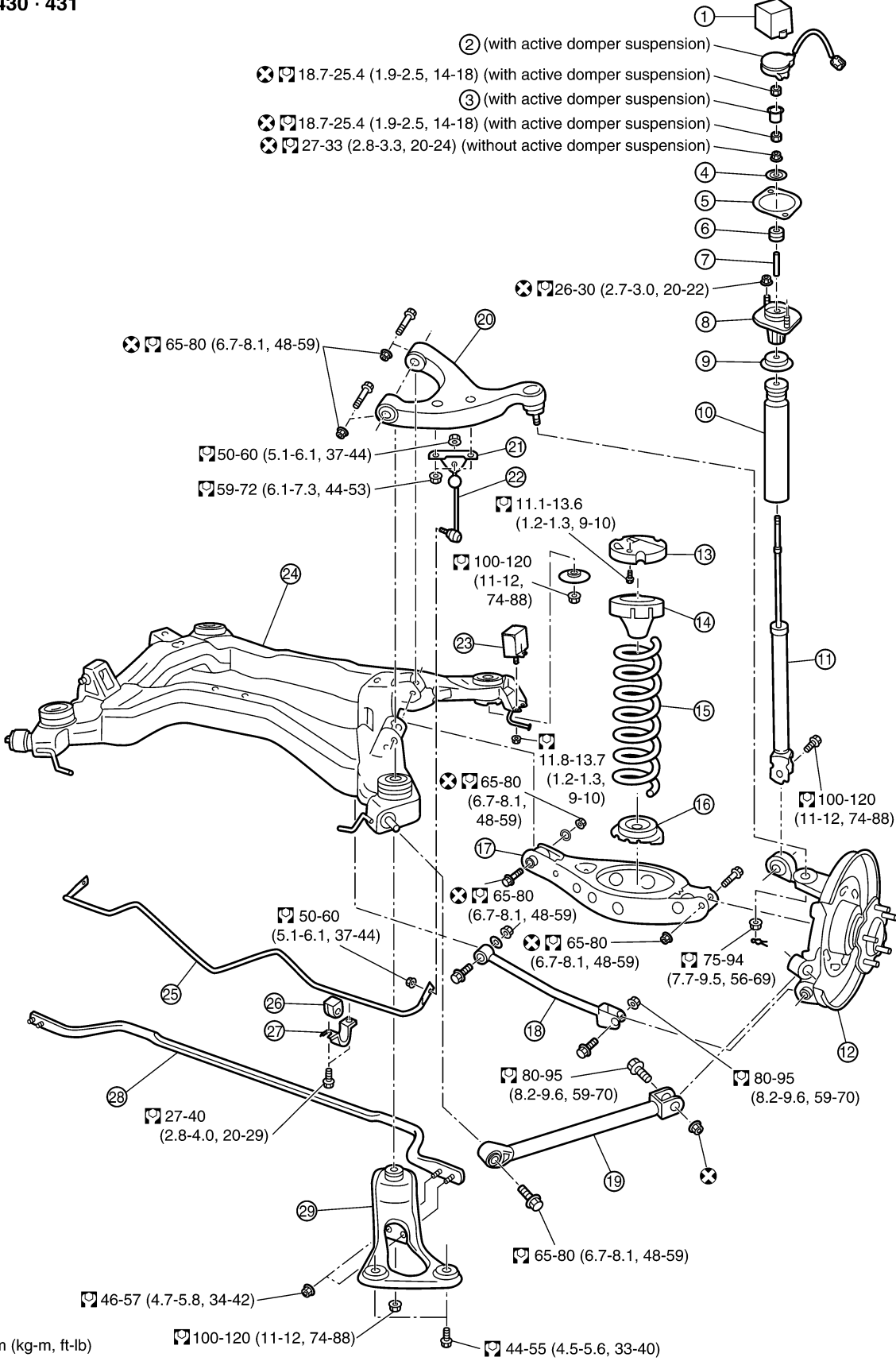

SEIA0398E

REAR SUSPENSION ASSEMBLY

- | | | |
|-------------------------------|------------------------------------|--|
| 1. Cap | 2. Actuator assembly | 3. Actuator plate |
| 4. Washer | 5. Shock absorber mounting seal | 6. Bushing |
| 7. Distance tube | 8. Shock absorber mounting bracket | 9. Bound bumper cover |
| 10. Bound bumper | 11. Shock absorber | 12. Axle |
| 13. Bracket | 14. Upper seat | 15. Coil spring |
| 16. Rubber seat | 17. Rear lower link | 18. Front lower link |
| 19. Radius rod | 20. Suspension arm | 21. Stabilizer connecting rod mounting bracket |
| 22. Stabilizer connecting rod | 23. Dynamic damper | 24. Rear suspension member |
| 25. Stabilizer bar | 26. Stabilizer bushing | 27. Stabilizer clamp |
| 28. Cross bar | 29. Member stay | |

On-Vehicle Inspection and Service

EES000UB

Check that the mounting conditions (looseness, back lash) of each component and component status (wear, damage) are normal.

INSPECTION OF BALL JOINT END PLAY

- Measure axial end play by installing and moving up/down with an iron pry bar or something similar between suspension arm and axle.

Standard value

Axial end play : 0 mm (0 in)

CAUTION:

Be careful not to damage ball joint boot.

SHOCK ABSORBER INSPECTION

- Check shock absorber for oil leakage damage and replace if necessary.

Wheel Alignment Inspection DESCRIPTION

EES000UC

- Measure wheel alignment under unladen conditions. "Unladen conditions" means that fuel, coolant, and lubricant are full. Spare tire, jack, hand tools and mats in designated positions.

PRELIMINARY INSPECTION

1. Check tires for improper air pressure and wear.
2. Check road wheels for runout.
3. Check wheel bearing axial end play.
4. Check ball joint axial end play of suspension arm.
5. Check shock absorber operation.
6. Check each mounting point of axle and suspension for looseness and deformation.
7. Check each link, arm and member for cracks, deformation, and other damage.
8. Check vehicle posture.

REAR SUSPENSION ASSEMBLY

CAMBER INSPECTION

- Measure camber of both right and left wheels with a suitable alignment gauge and adjust in accordance with the following procedures.

Standard value

Camber : Refer to [RSU-18, "SERVICE DATA"](#) .

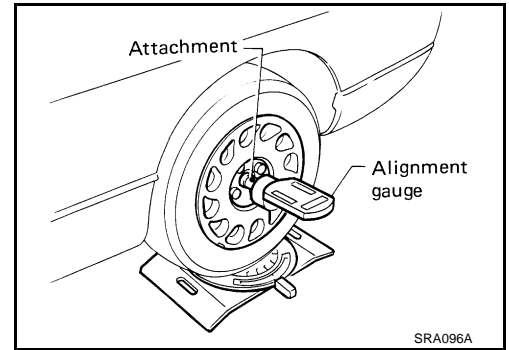

If outside the standard value, adjust with adjusting bolt in front lower link.

CAUTION:

After adjusting camber, be sure to check toe-in.

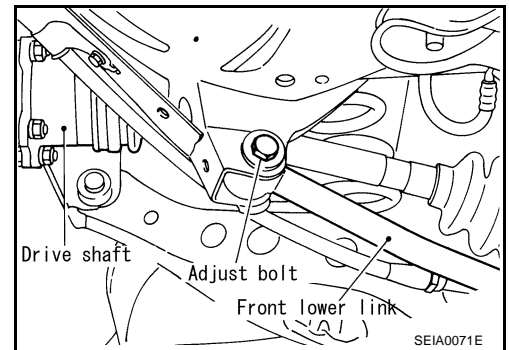

TOE-IN

Measure toe-in using following procedure. If out of specification, inspect and replace any damaged or worn rear suspension parts.

WARNING:

- Always perform following procedure on a flat surface.
 - Make sure that no person is in front of vehicle before pushing it.
1. Bounce rear of vehicle up and down to stabilize the posture.
 2. Push vehicle straight ahead about 5 m (16 ft).
 3. Put a mark on base line of the tread (rear side) of both tires at the same height of hub center. These are measuring point.
 4. Measure distance "A" (rear side).

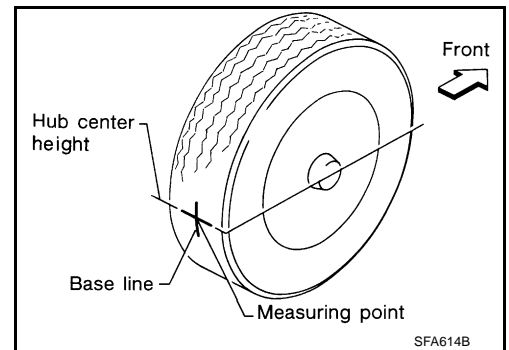

5. Push vehicle slowly ahead to rotate wheels 180 degrees (1/2 turn).

If wheels have rotated more than 180 degrees (1/2 turn), try the above procedure again from the beginning. Never push vehicle backward.

6. Measure distance "B" (front side).

Standard value

Total toe-in : Refer to [RSU-18, "SERVICE DATA"](#) .

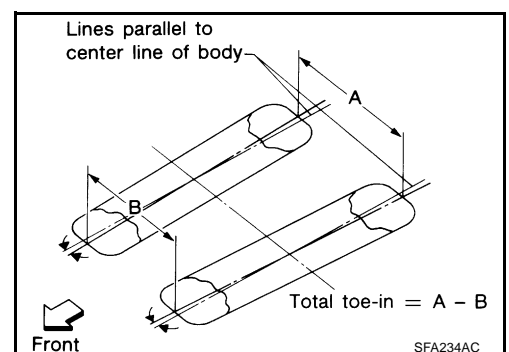

REAR SUSPENSION ASSEMBLY

7. If outside the standard value, adjust with adjusting bolt in rear lower link.

CAUTION:

Be sure to adjust equally on RH and LH side with adjusting bolt.

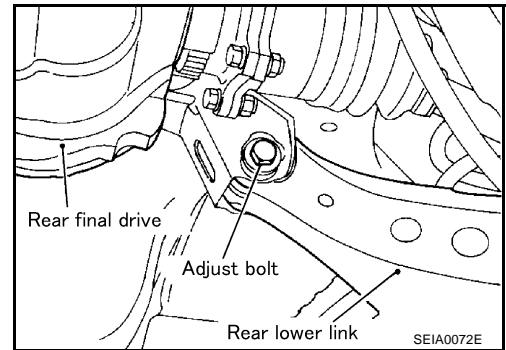

SHOCK ABSORBER

SHOCK ABSORBER

PFP:56210

Removal and Installation

REMOVAL

1. Remove tire with power tool.
2. Set jack under rear lower link to remove fixing bolt in lower side of shock absorber.
3. Remove jack from rear lower link.
4. Remove rear seat cushion, rear seat back and rear parcel shelf finisher.
5. Remove cap and actuator assembly (with active damper suspension).
6. Remove fixing nut in upper side of shock absorber.

INSPECTION AFTER REMOVAL

- Check shock absorber for deformation, cracks, damage, and replace if necessary.
- Check piston rod for damage, uneven wear, distortion, and replace if necessary.
- Check welded and sealed areas for oil leakage, and replace if necessary.

INSTALLATION

- Refer to [RSU-5, "Components"](#) for tightening torque. Tighten in the reverse order of removal.

CAUTION:

Refer to component parts location and do not reuse non-reusable parts.

- Perform final tightening of shock absorber lower side (rubber bushing) under unladen condition with tires on level ground. Check wheel alignment. Refer to [RSU-18, "SERVICE DATA"](#).
- Be sure to install actuator assembly correctly as shown in illustration. (With active damper suspension).

CAUTION:

If a strong shock has been given to actuator assembly or if it has been dropped, replace it with a new one.

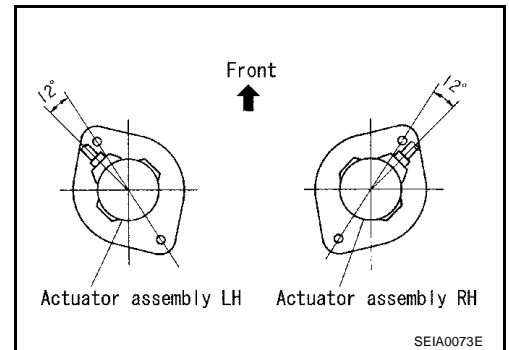

Disassembly and Assembly

DISASSEMBLY

CAUTION:

Make sure piston rod on shock absorber is not damaged when removing components from shock absorber.

1. Remove shock absorber mounting seal from shock absorber mounting bracket.
2. Wrap a shop cloth around lower side of shock absorber and fix it in a vice

CAUTION:

Do not set the cylindrical part of shock absorber in vice.

3. Fix piston rod using suitable socket wrench, and remove actuator plate fixing nut with suitable tool. Then remove actuator plate. (With active damper suspension)

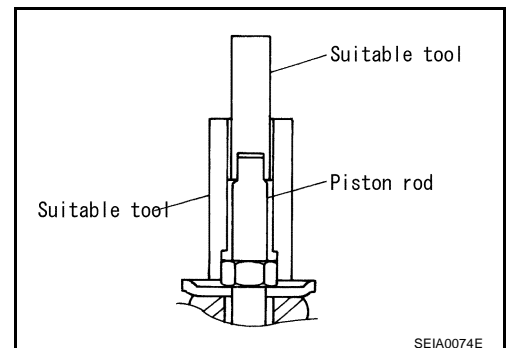

4. Secure piston rod tip so that piston rod does not turn, and remove piston rod lock nut.

SHOCK ABSORBER

- Remove washer, bushing, distance tube, shock absorber mounting bracket, bound bumper cover and bound bumper from shock absorber.

INSPECTION AFTER DISASSEMBLY

Bound bumper and Bushing

- Check bound bumper and bushing for cracks, deformation or other damage. Replace if necessary.

ASSEMBLY

- Refer to [RSU-5, "Components"](#) for tightening torque. Tighten in the reverse order of removal.

CAUTION:

- Refer to component parts location and do not reuse non-reusable parts.
- Make sure piston rod on shock absorber is not damaged when attaching components to shock absorber.
- Be sure to install actuator plate correctly as shown in illustration. (With active damper suspension)

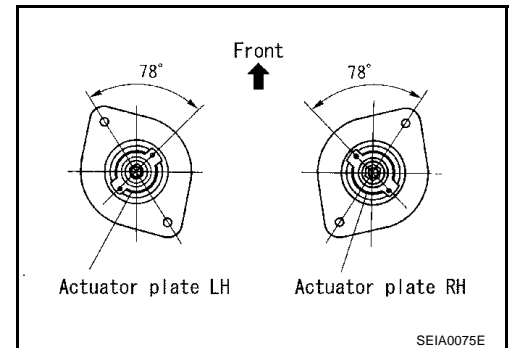

- Confirm that piston rod end is higher than actuator plate as specified in illustration. (With active damper suspension)

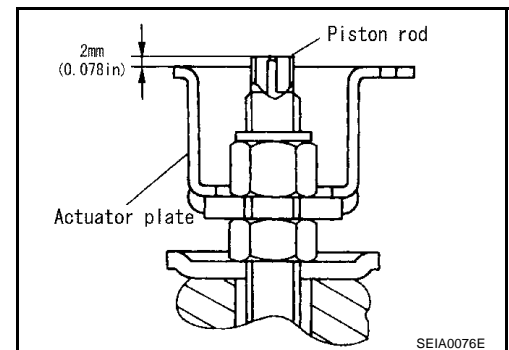

SUSPENSION ARM

PFP:55501

Removal and Installation

EES000UF

REMOVAL

1. Remove tire with power tool.
2. Remove brake caliper with power tool. Hang it in a place where it will not interfere with work. Refer to [BR-30, "REAR DISC BRAKE"](#).

CAUTION:

Avoid depressing brake pedal while brake caliper is removed.

3. Remove stabilizer connecting rod mounting bracket from suspension arm with power tool.
4. Remove fixing bolts and nuts in suspension member side of suspension arm with power tool.
5. Remove cotter pin of suspension arm ball joint, then loosen mounting nut.
6. Use a ball joint remover (suitable tool) to remove suspension arm from axle. Be careful not to damage ball joint boot.

CAUTION:

To prevent damage to threads and to prevent ball joint remover (suitable tool) from coming off, and temporarily tighten lock nuts.

INSPECTION AFTER REMOVAL

Visual Inspection

- Check suspension arm and bushing for deformation, cracks, or damage. If any non-standard condition is found, replace it.
- Check boot of ball joint for cracks, or damage, and also for grease leakage.

Ball Joint Inspection

- Manually move ball stud to confirm it moves smoothly with no binding.

Swing Torque Inspection

CAUTION:

Before measuring, move ball joint at least ten times by hand to check for smooth movement.

- Hook spring scale at cotter pin mounting hole. Confirm spring scale measurement value is within specifications when ball stud begins moving.

Standard value

Swing torque:

0.50 - 3.43 N·m (0.05 - 0.35 kg·m, 5 - 30 in·lb)

Measured value of spring scale:

7.85 - 54.4 N (0.80 - 5.55 kg, 1.77 - 12.27 lb)

- If it is outside the specified range, replace suspension arm assembly.

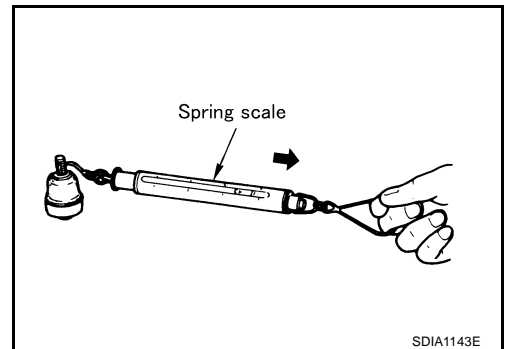

Rotating Torque Inspection

- Attach mounting nut to ball stud. Check that rotating torque is within specifications with a preload gauge (special service tool).

Standard value

Rotating torque:

0.50 - 3.43 N·m (0.05 - 0.35 kg·m, 5 - 30 in·lb)

- If it is outside the specified range, replace suspension arm assembly.

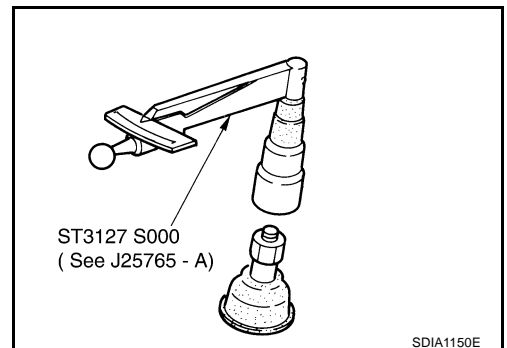

SUSPENSION ARM

Axial End Play Inspection

- Move tip of ball joint in axial direction to check for looseness.

Standard value

Axial end play : 0 mm (0 in)

- If it is outside the specified range, replace suspension arm assembly.

INSTALLATION

- Refer to [RSU-5, "Components"](#) for tightening torque. Tighten in the reverse order of removal.

CAUTION:

Refer to component parts location and do not reuse non-reusable parts.

- Perform final tightening of rear suspension member installation position (rubber bushing) under unladen condition with tires on level ground. Check wheel alignment. Refer to [RSU-18, "SERVICE DATA"](#) .

RADIUS ROD

RADIUS ROD

PPF:55110

Removal and Installation

EES000UG

REMOVAL

1. Remove tire with power tool.
2. Remove fixing bolt and nut in axle side of radius rod.
3. Remove fixing bolt and nut in rear suspension member side of radius rod, then remove radius rod from vehicle.

INSPECTION AFTER REMOVAL

- Check radius rod and bushing for any deformation, crack, or damage. Replace if necessary.

INSTALLATION

- Refer to [RSU-5, "Components"](#) for tightening torque. Tighten in the reverse order of removal.

CAUTION:

Refer to component parts location and do not reuse non-reusable parts.

- Perform final tightening of rear suspension member and axle installation position (rubber bushing) under unladen condition with tires on level ground. Check wheel alignment. Refer to [RSU-18, "SERVICE DATA"](#)

A

B

C

D

RSU

F

G

H

I

J

K

L

M

FRONT LOWER LINK

FRONT LOWER LINK

PFP:55110

Removal and Installation

EES000UH

REMOVAL

1. Remove tire with power tool.
2. Set jack under rear lower link.
3. Remove fixing bolt and nut between front lower link and rear suspension member.
4. Remove fixing bolt and nut between front lower link and axle.
5. Remove front lower link from vehicle.

INSPECTION AFTER REMOVAL

- Check front lower link and bushing for any deformation, crack, or damage. Replace if necessary.

INSTALLATION

- Refer to [RSU-5, "Components"](#) for tightening torque. Tighten in the reverse order of removal.

CAUTION:

Refer to component parts location and do not reuse non-reusable parts.

- Perform final tightening of rear suspension member and axle installation position (rubber bushing) under unladen condition with tires on level ground. Check wheel alignment. Refer to [RSU-18, "SERVICE DATA"](#)

REAR LOWER LINK & COIL SPRING

REAR LOWER LINK & COIL SPRING

PFP:551B0

Removal and Installation

REMOVAL

1. Remove tire with power tool.
2. Set jack under rear lower link.
3. Loosen fixing bolt and nut of rear lower link in side of rear suspension member, and then remove fixing bolt and nut in side of axle.
4. Slowly lower jack, then remove upper seat, coil spring and rubber seat from rear lower link.
5. Remove fixing bolt and nut in side of rear suspension member to remove rear lower link.

INSPECTION AFTER REMOVAL

- Check rear lower link, bushing and coil spring for deformation, cracks, and damage. Replace rear lower link and coil spring if necessary.

INSTALLATION

- Refer to [RSU-5, "Components"](#) for tightening torque. Tighten in the reverse order of removal.

CAUTION:

Refer to component parts location and do not reuse non-reusable parts.

- Check that the projecting part inside upper seat and the flange part of bracket are attached as shown in the figure.
- Check that the projection part outside upper seat directs to vehicle front.
- Position the hollow of rubber seat with the groove part of rear lower link to install.
- Install coil spring with the side of 2 paint markers directing to lower side.

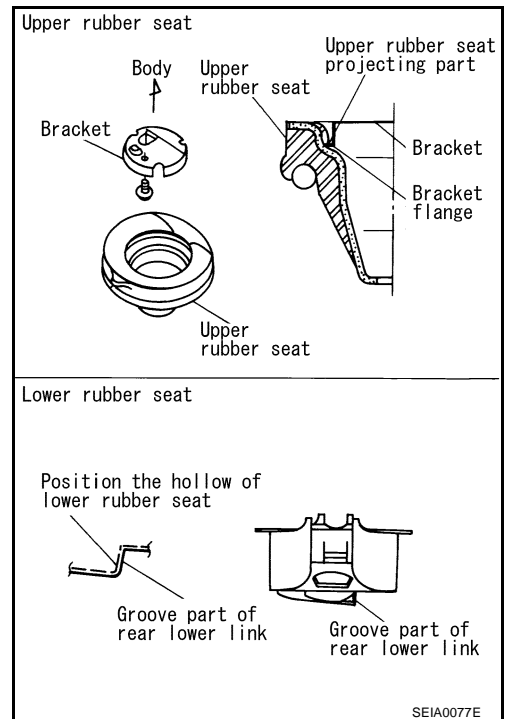

- Perform final tightening of rear suspension member and axle installation position (rubber bushing) under unladen condition with tires on level ground. Check wheel alignment. Refer to [RSU-18, "SERVICE DATA"](#)

STABILIZER BAR

STABILIZER BAR

PFP:54611

Removal and Installation

EES000JJ

REMOVAL

1. Remove dynamic dampener of exhaust tube.
2. Remove stabilizer connecting rod from stabilizer bar with power tool.
3. Remove mounting bolts of stabilizer clamp and then remove stabilizer clamp and stabilizer bushing from stabilizer bar.
4. Remove stabilizer bar from vehicle behind.

INSPECTION AFTER REMOVAL

- Check stabilizer bar, stabilizer bushing, stabilizer clamp, stabilizer connecting rod, stabilizer connecting rod mounting bracket for any deformation, crack or damage. Replace if necessary.

INSTALLATION

- Refer to [RSU-5, "Components"](#) for tightening torque. Tighten in the reverse order of removal.

CAUTION:

Refer to component parts location and do not reuse non-reusable parts.

- Stabilizer bar uses pillow ball type connecting rod, position ball joint with case on pillow ball head parallel to stabilizer bar.
- When stabilizer bushing and stabilizer clamp are installed to stabilizer bar, position stabilizer bushing and stabilizer clamp inside of the side slip prevention clamp.

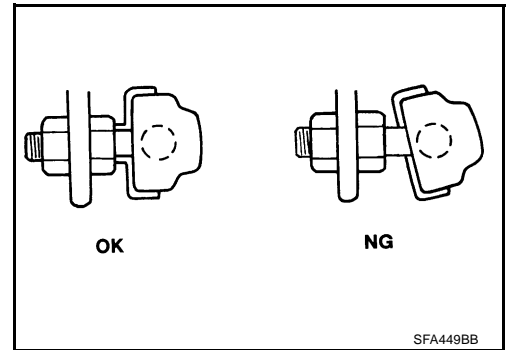

REAR SUSPENSION MEMBER

REAR SUSPENSION MEMBER

PFP:55501

Removal and Installation

EES000UK

REMOVAL

1. Remove tire with power tool.
2. Remove brake caliper with power tool. Hang it in a place where it will not interfere with work. Refer to [BR-30, "REAR DISC BRAKE"](#).

CAUTION:

Avoid depressing brake pedal while brake caliper is removed.

3. Remove stabilizer bar with power tool. Refer to [RSU-16, "STABILIZER BAR"](#).
4. Remove rear final drive from vehicle. Refer to [RFD-10, "REAR FINAL DRIVE ASSEMBLY"](#).
5. Remove parking brake cable from body and rear suspension member. Refer to [PB-4, "PARKING BRAKE CONTROL"](#).
6. Set jack under rear lower link.
7. Remove fixing bolt in lower side of shock absorber.
8. Remove fixing nut in axle housing side of suspension arm.
9. Remove rear lower link. Refer to [RSU-15, "REAR LOWER LINK & COIL SPRING"](#).
10. Move jack which has been set in rear lower link, to rear suspension member.
11. Remove fixing bolt in body side of member stay.
12. Remove fixing nuts of rear suspension member.
13. Slowly jack to remove rear suspension member from vehicle.
14. Remove front lower link from rear suspension member.
15. Remove radius rod from rear suspension member.
16. Remove suspension arm from rear suspension member.

INSPECTION AFTER REMOVAL

- Check rear suspension member for deformation, cracks, and other damage and replace if necessary.

INSTALLATION

- Refer to [RSU-5, "Components"](#) for tightening torque. Tighten in the reverse order of removal.

CAUTION:

Refer to component parts location and do not reuse non-reusable parts.

- After installation, perform final tightening of each part under unladen conditions with tires on ground. Check wheel alignment. Refer to [RSU-18, "SERVICE DATA"](#).

A
B
C
D
RSU
F
G
H
I
J
K
L
M

SERVICE DATA

SERVICE DATA

PFP:00030

Wheel Alignment

EES000UL

Tire			17 inch	18 inch
Camber Degree minute (Decimal degree)	Minimum		- 0°55' (- 0.92°)	- 1°05' (- 1.08°)
	Nominal		- 0°25' (- 0.42°)	- 0°35' (- 0.58°)
	Maximum		0°05' (0.08°)	- 0°05' (- 0.08°)
	Left and right difference		45' (0.75°)	
Total toe-in	Distance (A - B)	Minimum	- 2.0 mm (- 0.079 in)	- 1.6 mm (- 0.063 in)
		Nominal	0.8 mm (0.031 in)	1.2 mm (0.047 in)
		Maximum	3.6 mm (0.142 in)	4.0 mm (0.157 in)
	Angle (left plus right) Degree (Decimal degree)	Minimum	- 5' (0.08°)	- 4' (0.07°)
		Nominal	2' (0.03°)	3' (0.05°)
		Maximum	9' (0.15°)	10' (0.17°)

Ball Joint

EES000UM

Axial end play	0 mm (0 in)
Swing torque	0.50 - 3.43 N·m (0.05 - 0.35 kg·m, 5 - 30 in·lb)
Measurement on spring balance (cotter pinhole position)	7.85 - 54.4 N (0.80 - 5.55 kg, 1.77 - 12.27 lb)
Rotating torque	0.50 - 3.43 N·m (0.05 - 0.35 kg·m, 5 - 30 in·lb)

Wheelarch Height (Unladen*)

EES000UN

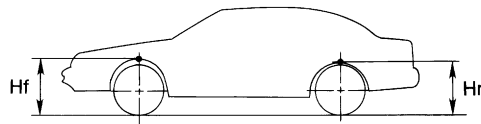

SFA818A

Tire	225/55R17	225/55R17 (Runflat tire)	245/45R18
Front (Hf)	730 mm (28.74 in)	734 mm (28.90 in)	726 mm (28.58 in)
Rear (Hr)	704 mm (27.72 in) [USA model]	707 mm (27.83 in) [USA model]	700 mm (27.56 in) [USA model]
	705 mm (27.76 in) [Canada model]	708 mm (27.87 in) [Canada model]	701 mm (27.60 in) [Canada model]

*: Fuel, radiator coolant and engine oil full. Spare tire, jack, hand tools and mats in designated positions.