

RX-7

Factory Service Material

This manual can be downloaded for free from
<http://members.xoom.com/twinturboteddy/fsm/rx7.htm>

Or you can donate \$10 to diepat@earthlink.net through **paypal.com** and a gift CD with all manuals and resources I carry will be sent to you.

This includes

- 1993 Factory Service Manual
- 1988 Factory Service Manual
- 1995 Printed Microfiche of all parts
- 1989 Printed Microfiche of all parts*
- 1990 Printed Microfiche of all parts*
- 1986 Printed Microfiche of all parts*
- 1987 Printed Microfiche of all parts*
- 1988 Printed Microfiche of all parts*

The \$10 donation is used to offset the tremendous amount of time it takes to make everything available.



* These works are currently in process and may or not be readily available upon request. They will be hosted on the same link above and for download

CLUTCH

OUTLINE	6— 2
STRUCTURAL VIEW	6— 2
SPECIFICATIONS	6— 3
TROUBLESHOOTING GUIDE	6— 3
INSPECTION AND ADJUSTMENT	6— 4
CLUTCH PEDAL HEIGHT	6— 4
CLUTCH PEDAL PLAY	6— 4
CLUTCH PEDAL	6— 5
REMOVAL AND INSTALLATION	6— 5
INSPECTION	6— 5
MASTER CYLINDER	6— 6
REMOVAL AND INSTALLATION	6— 6
DISASSEMBLY AND ASSEMBLY	6— 7
INSPECTION	6— 8
RELEASE CYLINDER	6— 9
REMOVAL AND INSTALLATION	6— 9
DISASSEMBLY, INSPECTION AND ASSEMBLY	6—10
AIR BLEEDING	6—10
CLUTCH AND FLYWHEEL	6—11
REMOVAL	6—11
INSPECTION	6—12
INSTALLATION	6—15

6 OUTLINE

OUTLINE

STRUCTURAL VIEW

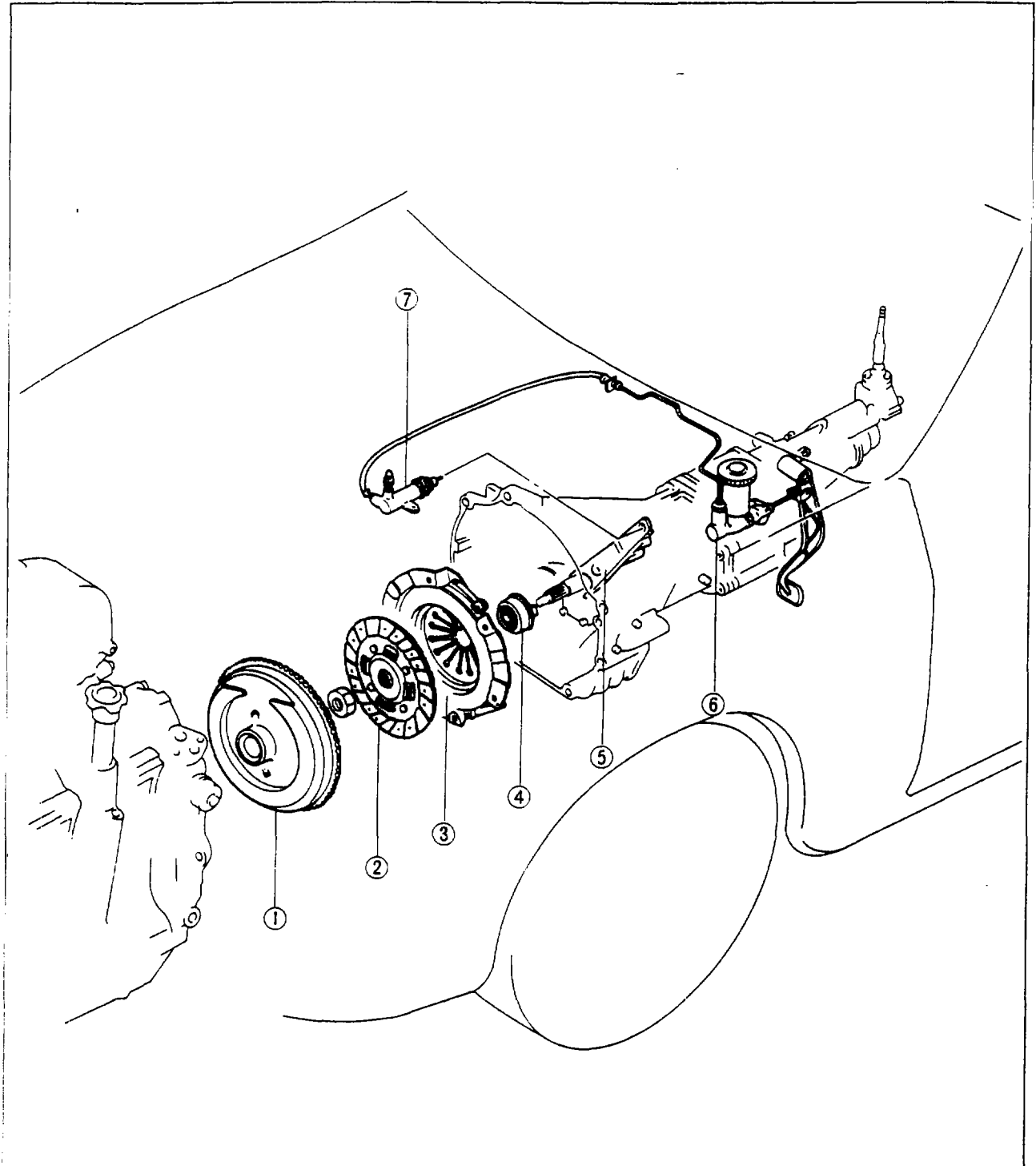

67U06X-002

- 1. Flywheel
- 2. Clutch disc
- 3. Clutch cover
- 4. Clutch release bearing

- 5. Clutch release fork
- 6. Master cylinder
- 7. Release cylinder

SPECIFICATIONS

		Turbo model	Non-turbo model
Clutch control		Hydraulic type	
Clutch cover	Spring type	Diaphragm spring	
	Set load	N (kg, lb)	5.494 (560, 1,232) ; 4.807 (490, 1,078)
Clutch disc	Outer diameter	mm (in)	240 (9.45) ; 225 (8.86)
	Inner diameter	mm (in)	160 (6.30) ; 150 (5.91)
	Thickness of pressure plate side	mm (in)	3.5 (0.14) ; 4.1 (0.16)
	Thickness of flywheel side	mm (in)	3.5 (0.14) ; 3.5 (0.14)
Clutch pedal	Type	Suspended	
	Pedal ratio	6.25 : 1	
	Full stroke	mm (in)	135 (5.31)
	Height	mm (in)	220 \pm $\frac{5}{0}$ (8.66 \pm $\frac{0.20}{0}$)
Master cylinder inner diameter		mm (in)	15.9 (0.625)
Release cylinder inner diameter		mm (in)	19.1 (0.750)
Clutch fluid		SAE J1703a or FMVSS116, DOT-3 or DOT-4	

77U06X-101

TROUBLESHOOTING GUIDE

Problem	Possible Cause	Remedy	Page
Slipping	Clutch disc facing worn excessively	Replace	6-11
	Clutch disc facing surface hardened, or oil on surface	Repair or replace	6-12
	Pressure plate deformed	Repair or replace	6-12
	Diaphragm spring damaged or weakened	Replace	6-12
	Insufficient clutch pedal play	Adjust	6-4
	Clutch pedal does not function smoothly	Repair or replace	6-5
	Flywheel deformed	Repair or replace	6-13
Faulty disengagement	Excessive runout or deformity of clutch disc	Replace	6-11
	Clutch disc splines rusted or worn	Remove rust, or replace	-
	Oil on facing surface	Repair or replace	6-13
	Diaphragm spring weakened	Replace	6-12
	Excessive clutch pedal play	Adjust	6-4
	Insufficient clutch fluid	Add fluid	-
Clutch vibrates when starting	Leakage of clutch fluid	Repair or replace	-
	Oil on facing	Repair or replace	6-13
	Torsion spring weakened	Replace	-
	Clutch disc facing surface hardened or deformed	Repair or replace	6-13
	Clutch disc facing rivets loose	Replace	6-13
	Pressure plate deformed or excessive run-out	Replace	6-12
	Flywheel surface hardened or deformed	Repair or replace	6-13
Loose or worn engine mount	Tighten or replace	-	
Clutch pedal does not function smoothly	Pedal shaft not properly lubricated	Lubricate or replace	6-5
Abnormal noise	Clutch release bearing damaged	Replace	6-14
	Poor lubrication of release clutch bearing sleeve	Lubricate or replace	6-14
	Torsion spring weakened	Replace	6-12
	Excessive crankshaft end play	Repair	Refer to Section 1
	Pilot bearing worn or damaged by heat	Replace	6-15
	Worn pivot points of release fork	Repair or replace	6-14

67U06X-004

6 INSPECTION AND ADJUSTMENT

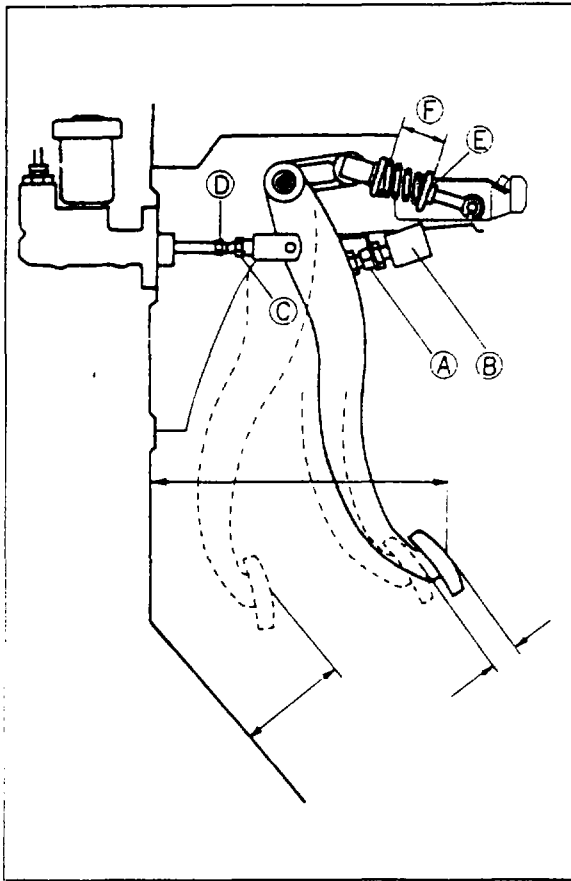

67U06X-005

INSPECTION AND ADJUSTMENT

CLUTCH PEDAL HEIGHT

Inspection

Measure the distance from the upper surface of the pedal pad to the firewall, after removing the carpet.

Standard height:

220 ± 5 mm (8.66 ± 0.20 in)

Adjustment

1. Adjust the clutch pedal height by loosening lock nut (A) and turning clutch switch (B).
2. After the adjustment, tighten lock nut (A).

CLUTCH PEDAL PLAY

Inspection

Depress the clutch pedal lightly by hand and measure the free play.

Standard play: 0.6—3.0 mm (0.02—0.12 in)

Adjustment

1. Adjust the free play by loosening lock nut (C) and turning push rod (D).
2. After adjustment, tighten lock nut (C).
3. Check that the distance from the floor to the center of the upper surface of the pedal pad is correct when the clutch pedal is fully depressed. If it is not within specification, readjust.
Disengagement height: 60 mm (2.4 in) min.

Disengagement height:

82 mm (3.23 in) min.

ASSIST SPRING

Inspection

Measure to check whether the dimension (F) is normal.

Standard dimension: 39 mm (1.54 in)

Adjustment

Adjust the dimension (F) by turning nut (E).

CLUTCH PEDAL

REMOVAL AND INSTALLATION

1. Remove in the sequence shown in the figure.
2. Install in the reverse order of removal.
3. Adjust the clutch pedal free play.

67U06X-006

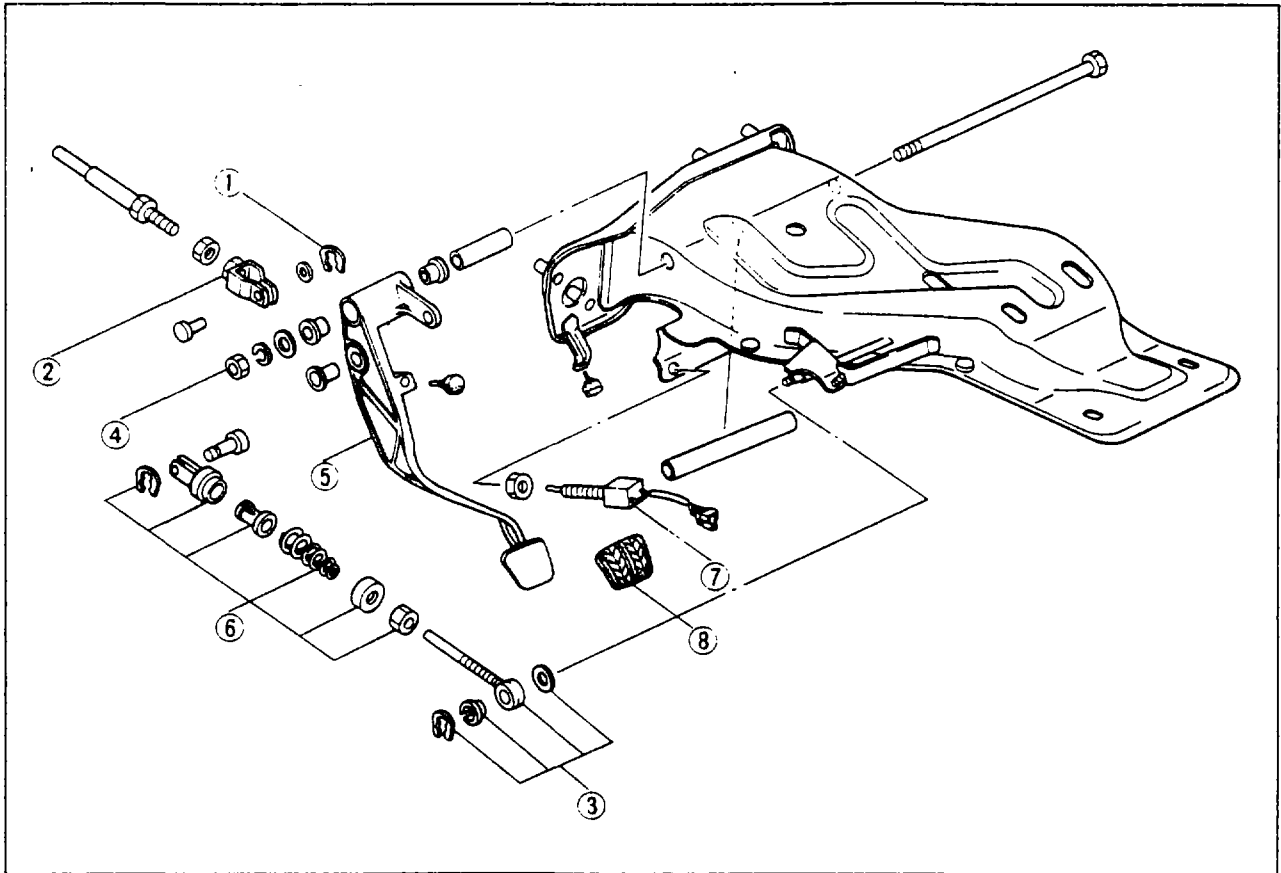

67U06X-007

- | | |
|-----------------------------|---------------------------------|
| 1. Clip | 5. Clutch pedal |
| 2. Push rod | 6. Clutch assist lever assembly |
| 3. Clip, bushing and washer | 7. Clutch switch |
| 4. Nut, bushing and washer | 8. Pedal pad |

Caution

Apply grease (lithium base, NLGI No. 2) to the bushings and pivot points.

INSPECTION

Check the following, and replace if necessary.

1. Worn or damaged bushings.
2. Twisted or bent clutch pedal.
3. Worn or damaged pedal pad.

48G06X-121

6 MASTER CYLINDER

MASTER CYLINDER

REMOVAL AND INSTALLATION

1. Remove in the sequence shown in the figure.
2. Install in the reverse order of removal.
3. After installation, perform air bleeding.

67U06X-008

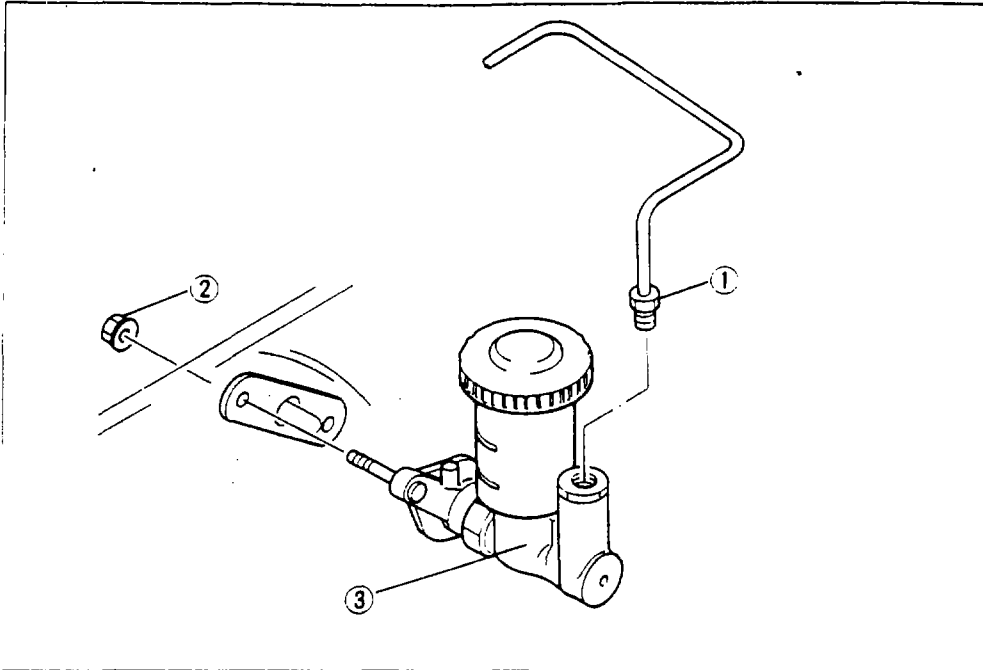

1. Clutch pipe
2. Nut
3. Master cylinder

67U06X-009

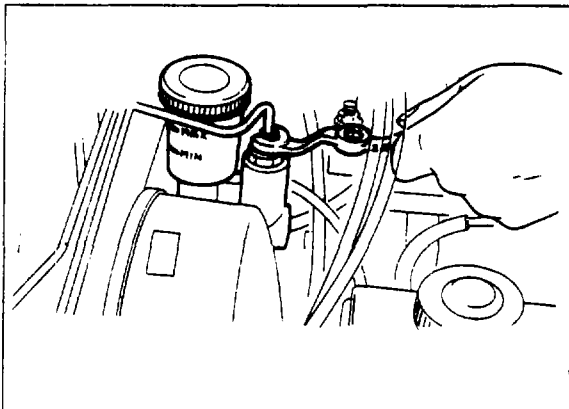

67U06X-010

Clutch Pipe

Use **flare nut wrench** (49 0259 770B) to disconnect and connect the clutch pipe.

Caution

Clutch fluid will damage painted surfaces. Use a container or rags to collect the fluid. If fluid does get on a painted surface, wipe it off immediately.

DISASSEMBLY AND ASSEMBLY

1. Disassemble in the sequence shown in the figure.
2. Assemble in the reverse order of removal.
3. Disassemble and assemble in a clean location free from dirt and dust.
4. Use clutch fluid to wash the inner parts.

67U06X-012

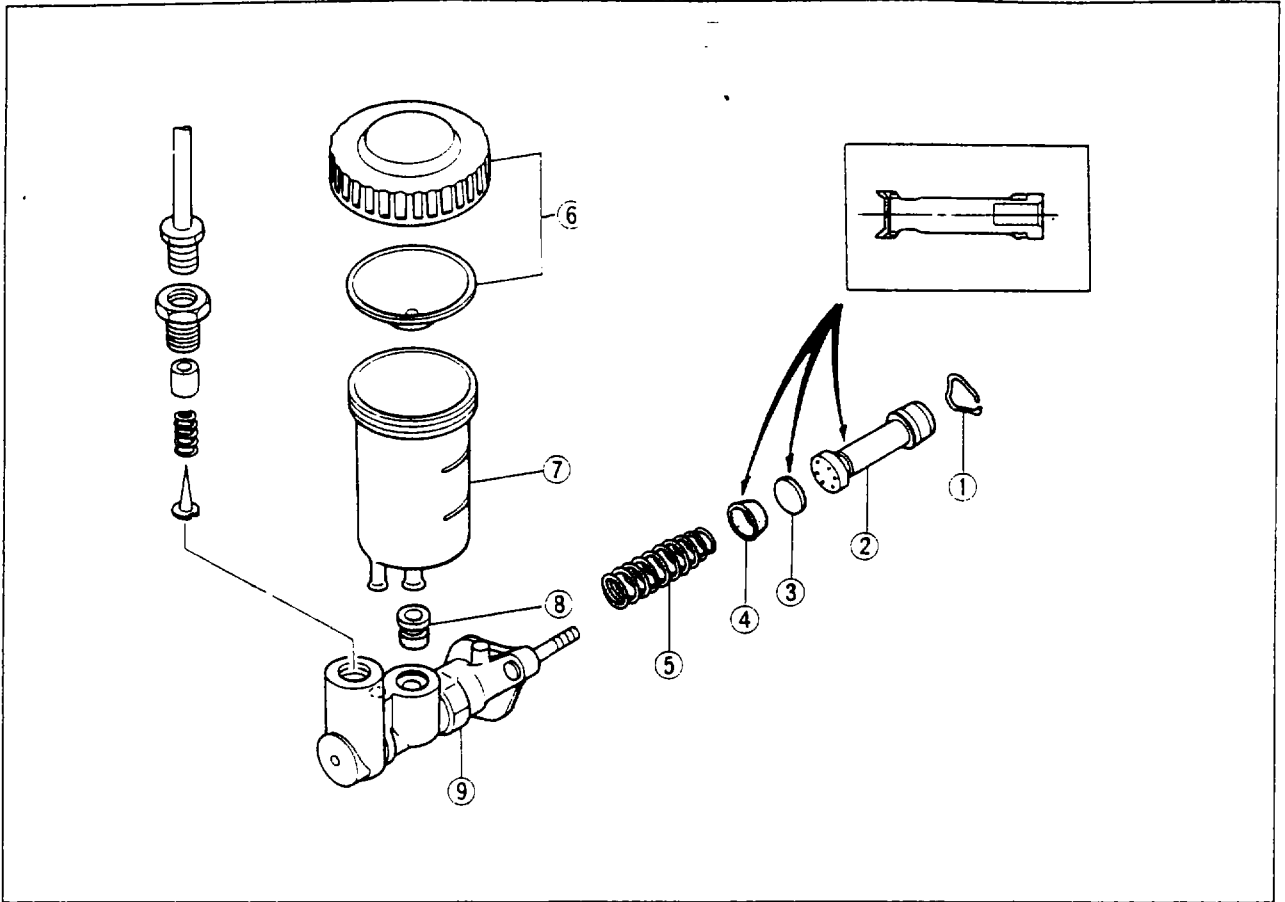

67U06X-013

1. Snap ring
2. Piston and secondary cup assembly
3. Protector
4. Primary cup
5. Return spring

6. Tank cap and baffle
7. Reservoir tank
8. Bushing
9. Master cylinder

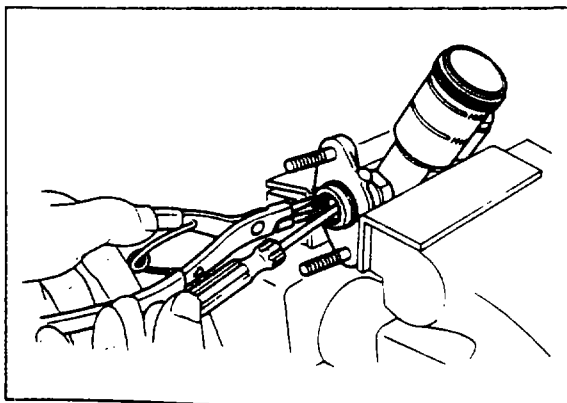

48G06X-010

Snap Ring

Press down on the piston and remove the snap ring with snap ring pliers.

Caution

Do not damage the push rod contact surface of piston.

6 MASTER CYLINDER

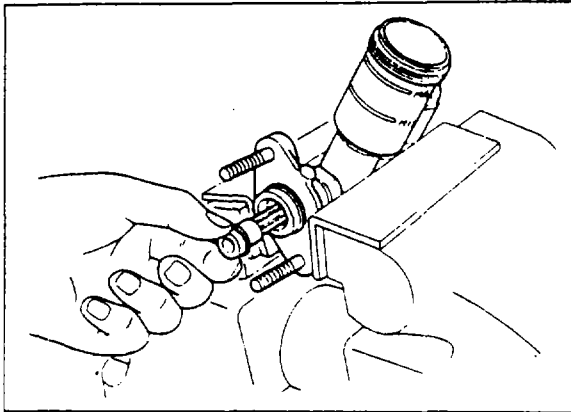

67U06X-014

Piston and Secondary Cup Assembly

Remove the piston and secondary cup assembly.

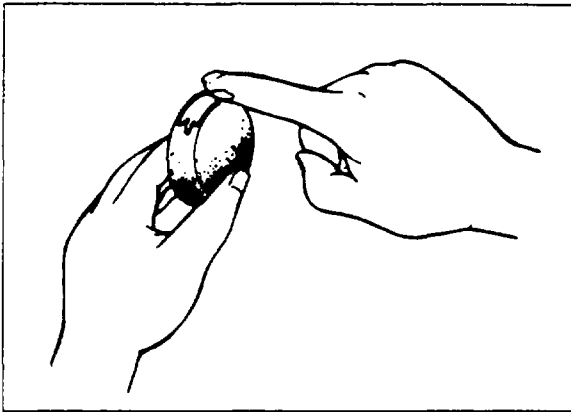

67U06X-015

ASSEMBLY

Assemble the clutch master cylinder in the reverse order of disassembly.

Note

- a) Before assembling, coat edges of the piston and cups with clean brake fluid.
- b) After assembling, fill the cylinder with new brake fluid and operate the piston with a screwdriver until fluid is ejected from the outlet.

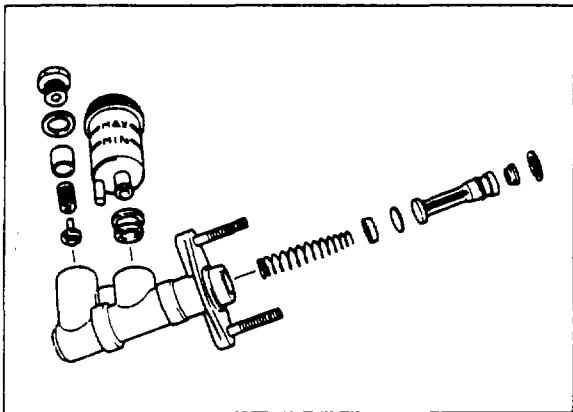

48G06X-025

INSPECTION

After cleaning each part, check the following points. Replace with new parts if necessary. Rubber parts should be cleaned with brake fluid.

1. Worn or damaged master cylinder bore and piston.
2. Weakened return spring.
3. Worn or damaged primary or secondary cups.

RELEASE CYLINDER

REMOVAL AND INSTALLATION

1. Remove in the sequence shown in the figure.
2. Install in the reverse order of removal.
3. After installation, perform air bleeding.

67U06X-016

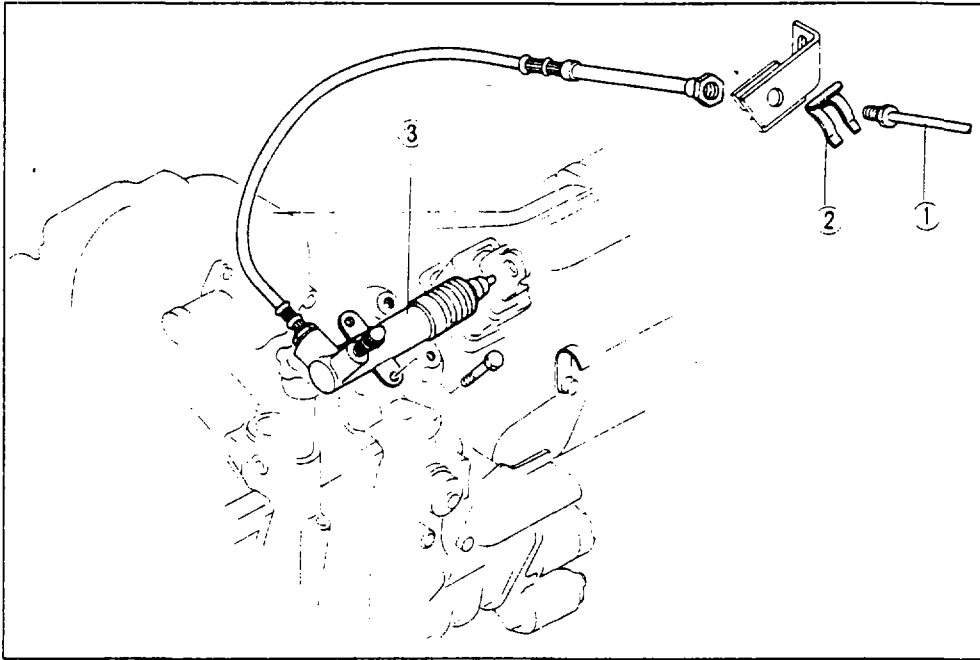

1. Clutch pipe
2. Clip
3. Release cylinder

67U06X-017

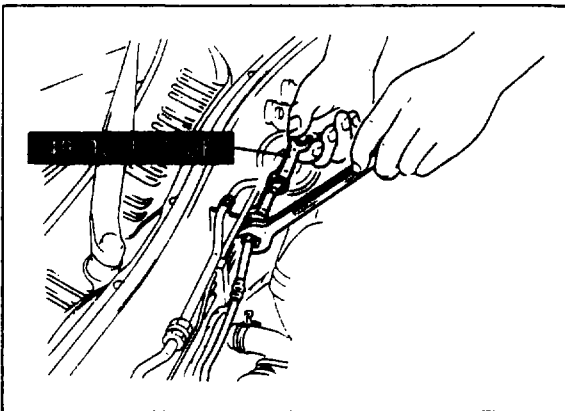

67U06X-018

Flare Nut

Use **flare nut wrench** (49 0259 770b) to loosen and tighten the flare nut of the clutch pipe.

Note

After disconnecting the clutch pipe, plug it to avoid fluid leakage.

Caution

Clutch fluid will damage painted surfaces. Use a container or rags to collect the fluid. If fluid does get on a painted surface, wipe it off immediately.

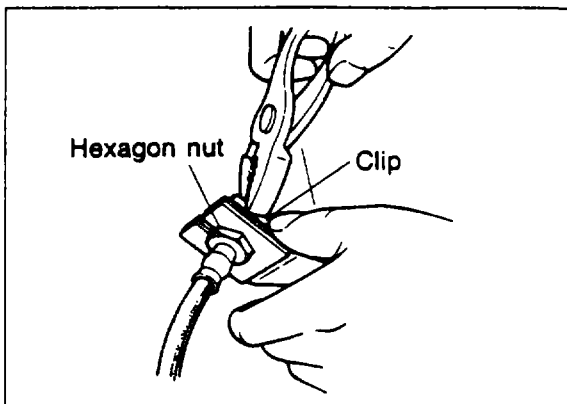

67U06X-019

Clip

Insert the clip between the bracket and flare nut of the clutch pipe.

Caution

- a) The hexagon nut must seat correctly into the hexagonal groove of the bracket.
- b) The flex hose must not be twisted.

6 RELEASE CYLINDER

DISASSEMBLY, INSPECTION AND ASSEMBLY

1. Disassemble in the sequence shown in the figure.
2. Assemble in the reverse order of removal.
3. Disassemble and assemble in a clean location free from dirt and dust.
4. Use clutch fluid to wash the inner parts.
5. To inspect, refer to Master Cylinder Section.

67U06X-020

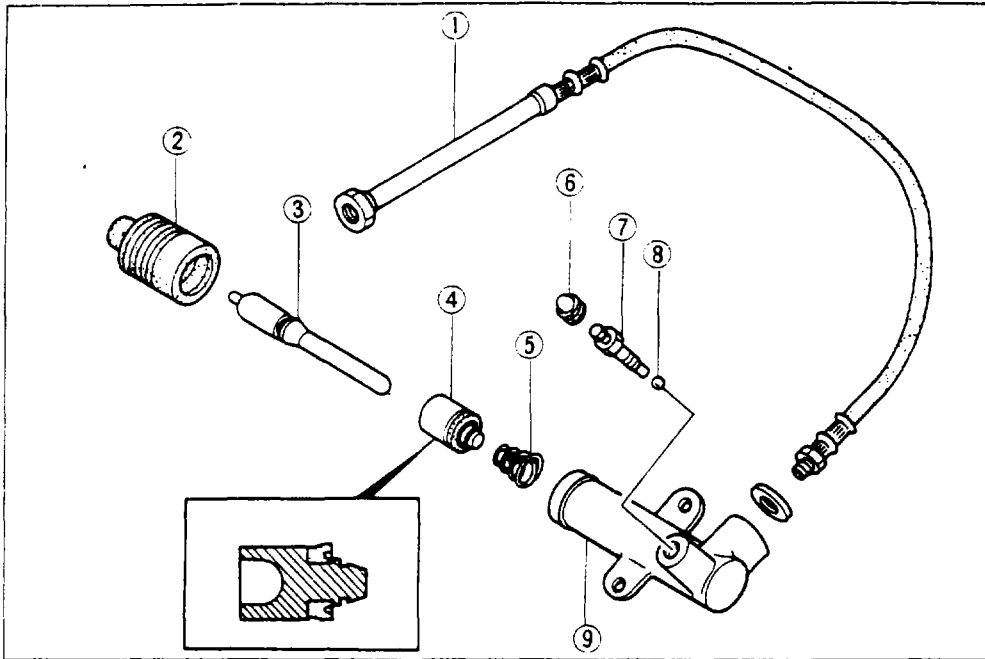

1. Flex hose
2. Boot
3. Push rod
4. Piston and cap assembly
5. Return spring
6. Bleeder cap
7. Bleeder screw
8. Steel ball
9. Release cylinder

67U06X-021

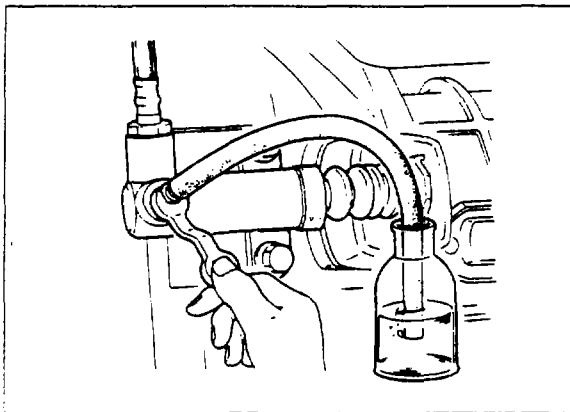

4BG06X-015

AIR BLEEDING

The clutch hydraulic system must be bled to remove air which has entered when the pipes are disconnected for repairs, etc. This bleeding is done as described below.

Caution

- a) The fluid in the reservoir tank must be maintained at the 3/4 level or higher during air bleeding.
- b) Be careful not to spill clutch fluid onto painted surfaces.

1. Remove the bleeder cap and attach a vinyl hose to the bleeder plug.
2. Place the other end of the vinyl tube in a container.
3. Slowly pump the clutch pedal several times.
4. While the clutch pedal is pressed, loosen the bleeder screw to let fluid and air escape. Then tighten the bleeder screw.
5. Repeat steps 3 and 4 until there are no more air bubbles in the fluid.
6. Check for correct clutch operation.

4BG06X-016

CLUTCH AND FLYWHEEL

REMOVAL

1. Disconnect the negative battery cable.
2. Jack up the vehicle and support it with safety stands.
3. Remove in the sequence shown in the figure.

67U06X-022

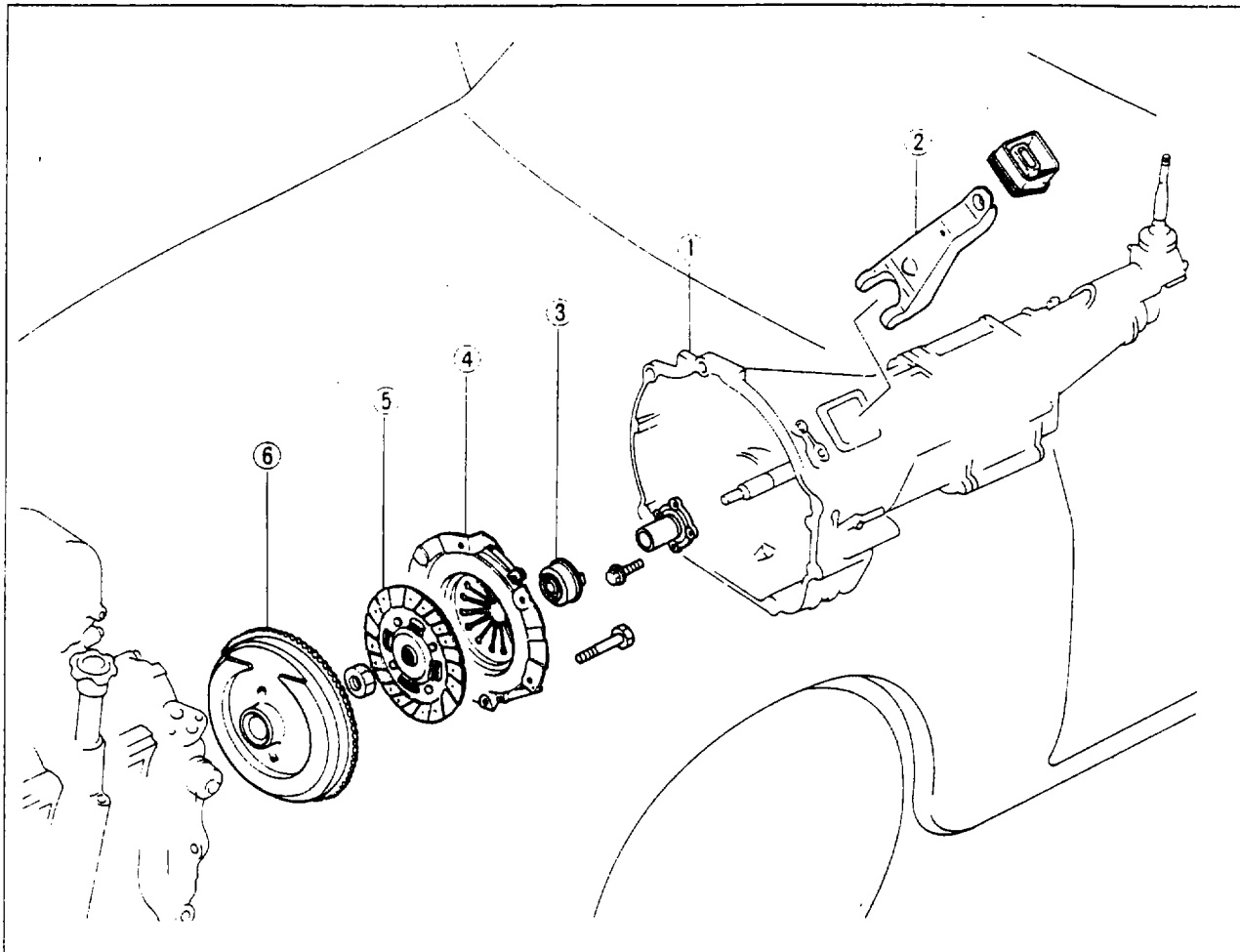

67U06X-023

- | | | |
|--------------------------------------|---------------------------|----------------|
| 1. Transmission (refer to section 7) | 3. Clutch release bearing | 5. Clutch disc |
| 2. Clutch release bearing | 4. Clutch cover | 6. Flywheel |

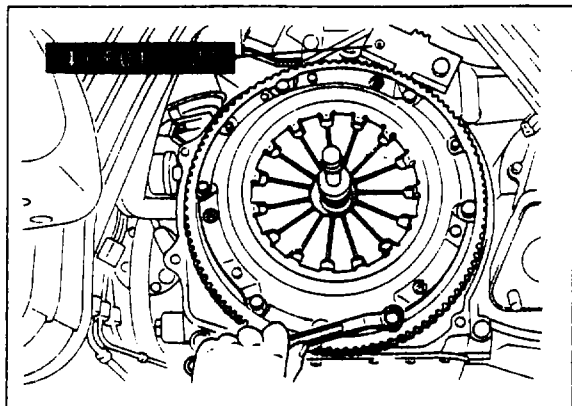

67U06X-024

Clutch Cover

Attach **ring gear brake** (49 F011 101) and **clutch disc centering tool** (49 SE01 310), and remove the clutch cover mounting bolts.

Caution

Do not get oil or grease on the clutch disc lining, or the pressure plate or flywheel surface where it contacts the clutch disc.

6 CLUTCH AND FLYWHEEL

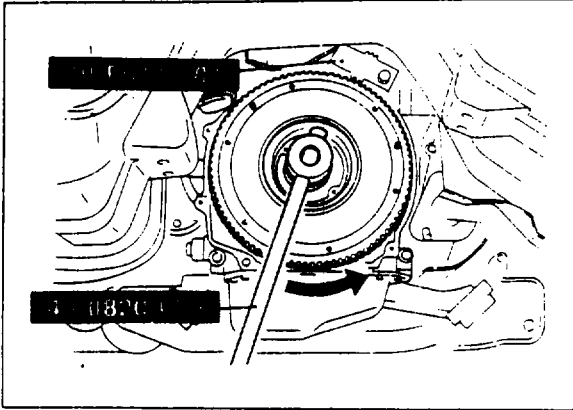

67U06X-025

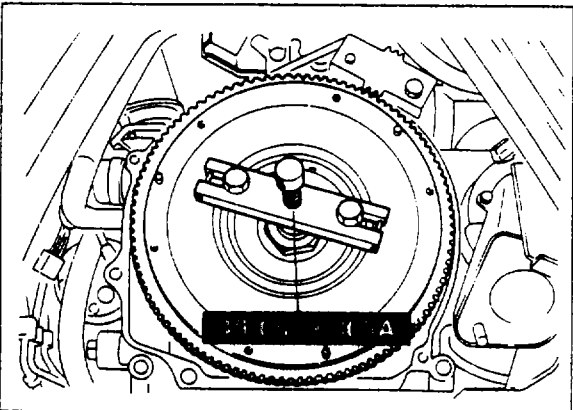

67U06X-026

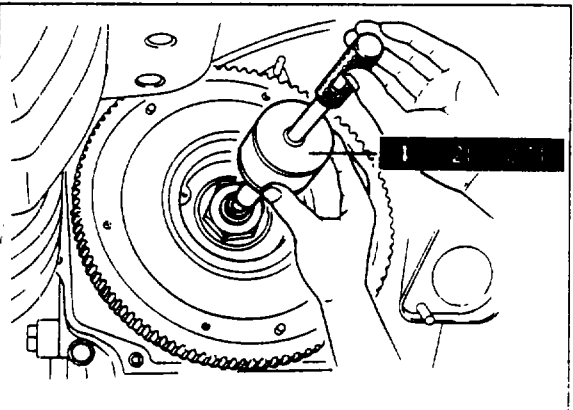

67U06X-027

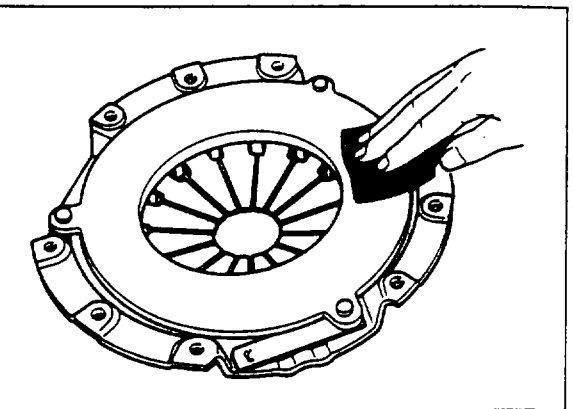

48G06X-018

Flywheel

Note

Before removing the flywheel, check the flywheel runout (Refer to Inspection Section).

1. Attach the **ring gear brake** (49 F011 101).
2. Loosen the locknut using the **flywheel box wrench** (49 0820 035).

3. Remove the flywheel using the **counter weight puller** (49 0839 305A). Turn the puller handle and lightly hit the puller head. Be careful not to allow the flywheel to fall.

Note

After removing the flywheel, inspect for oil leaking through the eccentric shaft rear oil seal.

Needle Bearing (Pilot Bearing)

Remove the bearing and seal using the **eccentric shaft bearing puller** (49 1285 071).

INSPECTION

Check the following parts, and repair or replace if necessary.

Clutch Cover

1. Contact surface of the clutch disc for scoring, cracks, or discoloration.

Caution

Minor scratches or discoloration should be removed with emery paper.

2. Diaphragm spring for damage, or damage to the cover.

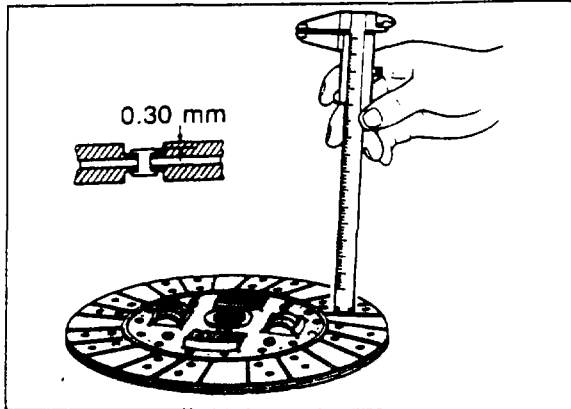

67U06X-029

Clutch Disc

1. Facing surface for hardening or oil contamination.

Note

Use sandpaper if the trouble is minor.

2. Loose facing rivets.
3. Worn clutch disc.
Measure the depth of the rivet heads with a slide caliper.

Depth: 0.3 mm (0.012 in) min.

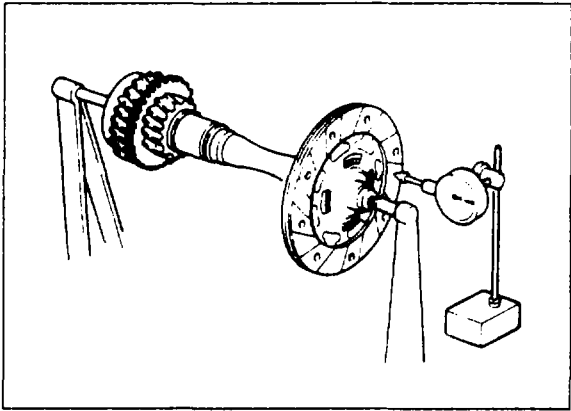

67U06X-029

4. Runout of clutch disc.

Runout: 1.0 mm (0.039 in) max.

5. Wear or rust on splines.
Remove any minor rust.

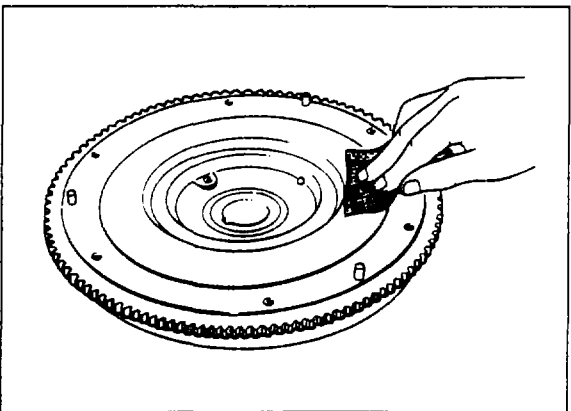

67U06X-030

Flywheel

2. Surface marks, scoring or discoloration of clutch disc contact surface.

Note

If problem is minor, repair can be made by cleaning with emery paper.

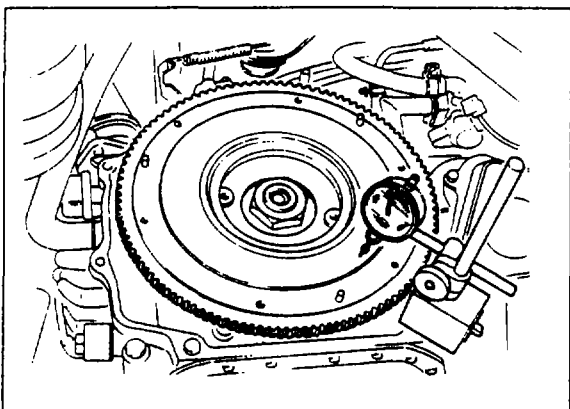

67U06X-031

2. Runout of flywheel at disc contact surface
(1) To measure, set a dial gauge on the flywheel to clutch disc contact surface, and turn the flywheel.

Runout: 0.2 mm (0.008 in) max.

- (2) If the runout exceeds the limit, repair by grinding.

Grinding amount: 0.5 mm (0.020 in) max.

6 CLUTCH AND FLYWHEEL

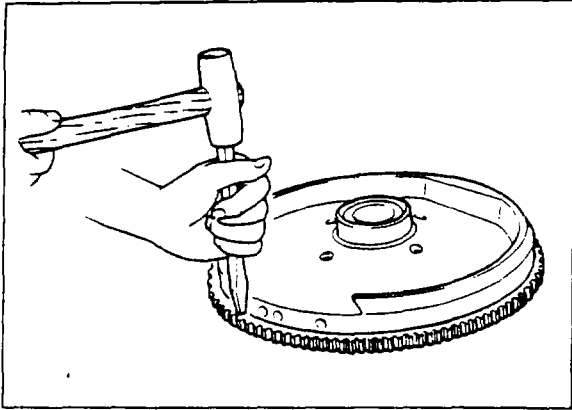

67U06X-032

3. Damaged or worn ring gear teeth.
If necessary, replace the ring gear as follows:

- (1) Heat the ring gear using a blowtorch, and tap around the gear to remove it from the flywheel.
- (2) Heat the new ring gear to 250—300°C (480—570°F), and fit it onto the flywheel.

Caution

The bevelled side of the ring gear must face toward the starter.

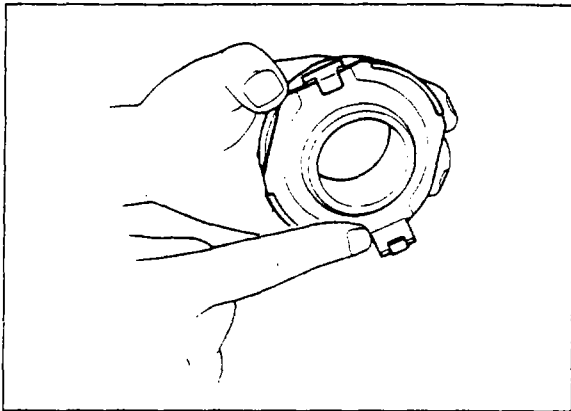

67U06X-033

Clutch Release bearing

1. Turn the bearing both directions and check for binding or abnormal noise.
2. Wear of diaphragm spring or release fork contact surface.

Caution

The clutch release bearing is grease-sealed and must not be washed.

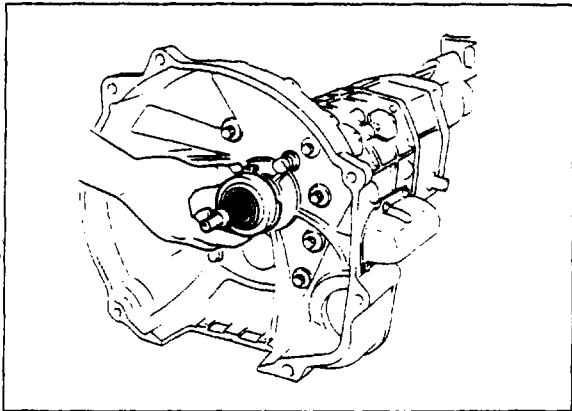

67U-06X-034

3. Freedom of bearing.
Install the bearing on the front cover and check for smooth movement.

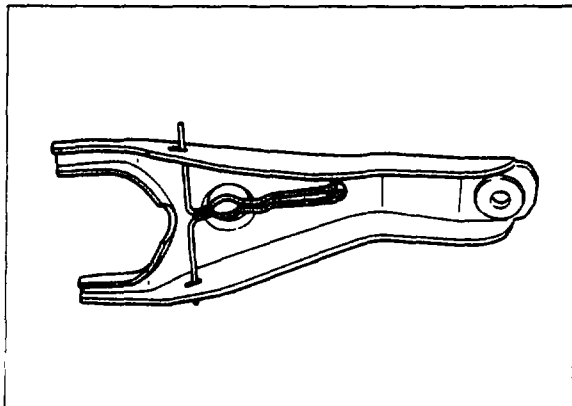

67U06X-035

Clutch Release Fork

Cracked or bent clutch release fork.

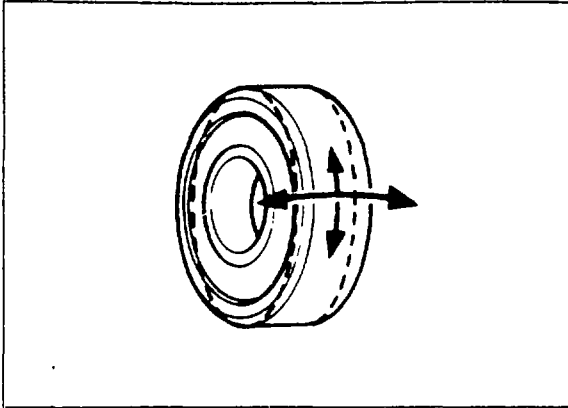

67U06X-036

Needle Bearing (Pilot Bearing)

Turn the bearing while applying force in both directions to the inner race and check for binding or abnormal noise.

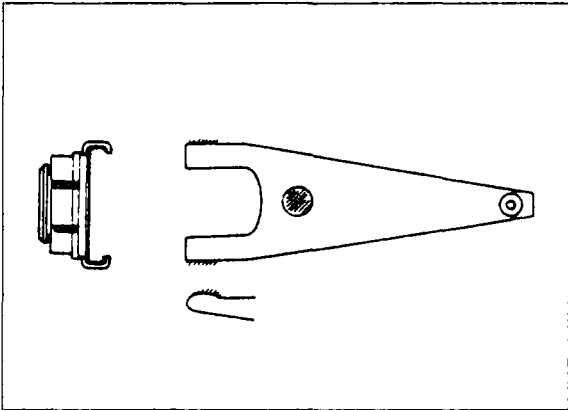

67U06X-037

INSTALLATION

Install the clutch in the reverse order of removal, noting the following:

1. Apply molybdenum disulphide grease to the clutch release bearing and fork as indicated by the shaded lines in the figure.

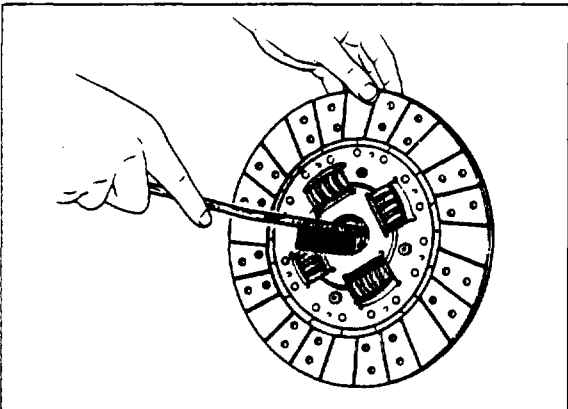

67U06X-038

2. Clean the clutch disc splines and the splines of the main drive gear, and apply a thin coat of molybdenum disulphide grease.

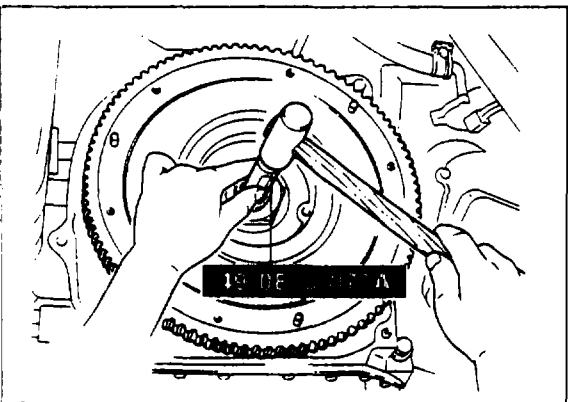

67U06X-039

3. Install a new needle bearing using the **eccentric shaft bearing installer** (49 0823 072A) and apply multipurpose grease to it.
4. Install the oil seal.

6 CLUTCH AND FLYWHEEL

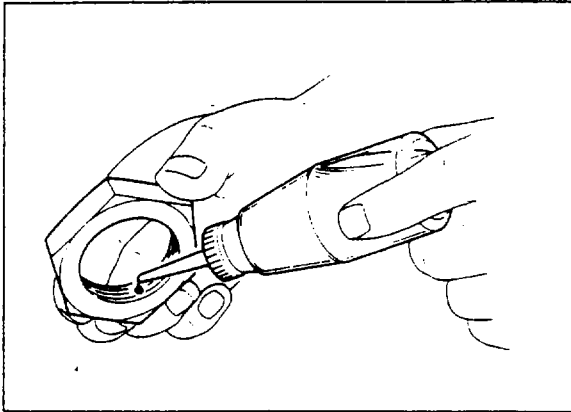

67U06X-040

5. Apply sealing agent to the locknut surface that contacts the flywheel and install the locknut.

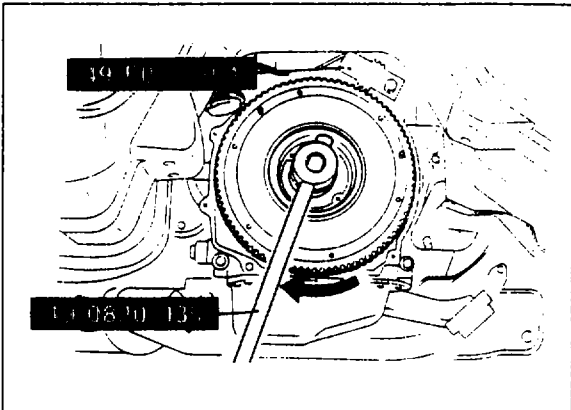

67U06X-041

6. Attach **ring gear brake** (49 1881 060) and tighten the locknut to specification using the **flywheel box wrench** (49 0820 035).

Tightening torque:

400—500 N·m (40—50 m·kg, 289—362 ft·lb)

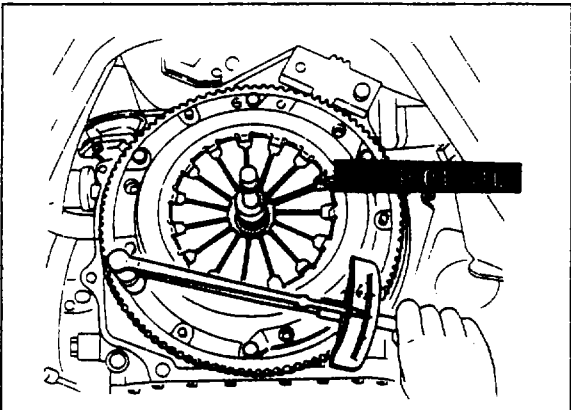

67U06X-042

7. Hold the clutch disc in its mounting position using the **clutch disc centering tool** (49 SE01 310). If the tool is not available, use a spare main drive shaft.
8. Install the pressure plate and cover assembly, aligning the three knock pins of the clutch cover. To avoid pressure plate cover distortion, tighten the bolts a few turns at a time until they are all tight. Torque the bolts to specifications.

Tightening torque:

18—27 N·m (1.8—2.8 m·kg, 13—20 ft·lb)