

1989 Mazda RX-7 Factory Service Manual

This Online/PC version of the Manual has been brought to you by “Scott 89t2” and www.1300cc.com

Thanks to those who are hosting it for me.



Some parts of the manual may be hard to read or see on the screen, but if you print the pages out it's perfect. Well except for the crookedness ☺.

***Terms of Use:** This online/PC copy of the manual is only to be used and in your possession if you already own the printed version. It is for backup purposes only in case yours (or part of) is lost or damaged. If you downloaded this manual by mistake, Please Remove it from your possession. I also take no responsibility for what you do to yourself or your car while you use this manual.

BODY ELECTRICAL SYSTEM

INDEX	T- 2	INSPECTION	T- 51
FUSE AND CPU	T- 2	CIRCUIT DIAGRAM	T- 53
RELAY	T- 3	INSPECTION	T- 53
METER AND SWITCHES	T- 4	RETRACTABLE HEADLIGHTS	T- 55
EXTERIOR LIGHTS	T- 5	REAR COMBINATION LIGHTS, SIDE MARKER LIGHT, AND HIGH-MOUNT STOPLIGHT	T- 58
INTERIOR LAMPS	T- 6	FRONT FOG LIGHT AND DAYTIME RUNNING LIGHT	T- 61
REAR WINDOW DEFROSTER	T- 7	INTERIOR LAMPS	T- 62
CRUISE CONTROL SYSTEM	T- 8	STRUCTURAL VIEW	T- 62
THEFT-DETERRENT SYSTEM	T- 9	TROUBLESHOOTING GUIDE	T- 62
AUDIO SYSTEM	T- 10	SPOT AND ROOM LAMP	T- 64
OUTLINE	T- 11	ROOM LAMP	T- 65
HOW TO USE THIS SECTION	T- 11	CARGO ROOM LAMP	T- 65
ELECTRICAL TROUBLESHOOTING TOOLS	T- 11	TRUNK ROOM LAMP	T- 65
ELECTRICAL SYMBOLS	T- 12	COURTESY LAMP	T- 65
FUSE AND JOINT BOX	T- 13	REAR WINDOW DEFROSTER	T- 66
STRUCTURAL VIEW	T- 13	STRUCTURAL VIEW	T- 66
MAIN FUSE BLOCK	T- 15	CIRCUIT DIAGRAM	T- 67
FUSE BOX	T- 15	INSPECTION	T- 67
SWITCHES	T- 16	FILAMENT CORRECTION	T- 68
STRUCTURAL VIEW	T- 16	CRUISE CONTROL SYSTEM	T- 69
IGNITION SWITCH	T- 17	STRUCTURAL VIEW	T- 69
CLUSTER SWITCH PANEL	T- 17	CIRCUIT DIAGRAM	T- 70
FRONT FOG LIGHT SWITCH	T- 27	TROUBLESHOOTING GUIDE	T- 71
TURN CANCEL AND ANGLE SENSOR	T- 28	SELF-DIAGNOSTIC SYSTEM INSPECTION	T- 72
STRUCTURAL VIEW	T- 28	TROUBLESHOOTING	T- 75
DISASSEMBLY AND ASSEMBLY	T- 29	INSPECTION	T- 76
INSPECTION	T- 30	THEFT-DETERRENT SYSTEM	T- 78
CENTRAL PROCESSING UNIT (CPU)	T- 32	STRUCTURAL VIEW	T- 78
REMOVAL AND INSTALLATION	T- 32	CIRCUIT DIAGRAM	T- 79
INTERCONNECTING DIAGRAM OF CPU	T- 33	SYSTEMS INSPECTION	T- 80
INSTRUMENT CLUSTER	T- 34	INSPECTION	T- 83
STRUCTURAL VIEW	T- 34	AUDIO SYSTEM	T- 85
REMOVAL AND INSTALLATION	T- 35	STRUCTURAL VIEW	T- 85
DISASSEMBLY AND ASSEMBLY	T- 36	OUTLINE OF AUDIO	T- 87
METER PRINTED CIRCUIT BOARD INSPECTION	T- 37	SYSTEM	T- 90
TROUBLESHOOTING GUIDE	T- 38	TROUBLESHOOTING	T- 92
INSPECTION	T- 38	CAUSES OF NOISE	T-102
WARNING AND CLOCK UNIT	T- 42	POWER ANTENNA	T-104
STRUCTURAL VIEW	T- 42	WINDSHIELD ANTENNA	T-107
REMOVAL AND INSTALLATION	T- 43	AUDIO COMPONENT ASSEMBLY ..	T-108
CIRCUIT DIAGRAM	T- 44	HEADREST SPEAKER	T-109
INSPECTION OF CIRCUIT AND PARTS	T- 45	FRONT SPEAKER	T-110
EXTERIOR LIGHTS	T- 49	DOOR SPEAKER	T-110
STRUCTURAL VIEW	T- 49	REAR SPEAKER	T-111
TROUBLESHOOTING	T- 49	DOOR WOOFER AMPLIFIER	T-111
CIRCUIT DIAGRAM	T- 50	HEADREST SPEAKER AMPLIFIER ..	T-112
		HEADREST SPEAKER SWITCH	T-112

INDEX

FUSE AND CPU

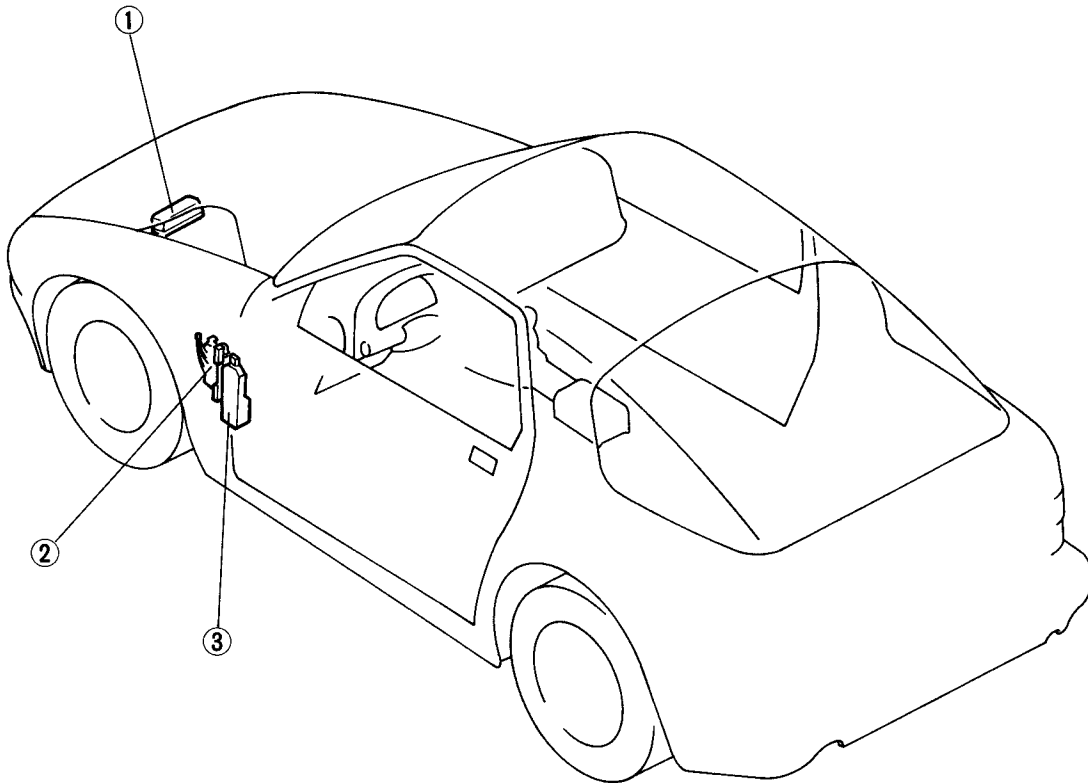

97U0TX-002

- 1. Main fuse block
Removal and Installation..... page T-15
- 2. Fuse box
Removal and Installation..... page T-15

- 3. CPU
Removal and Installation..... page T-32

RELAY

COOLING FAN RELAY
SERVICE SECTION E

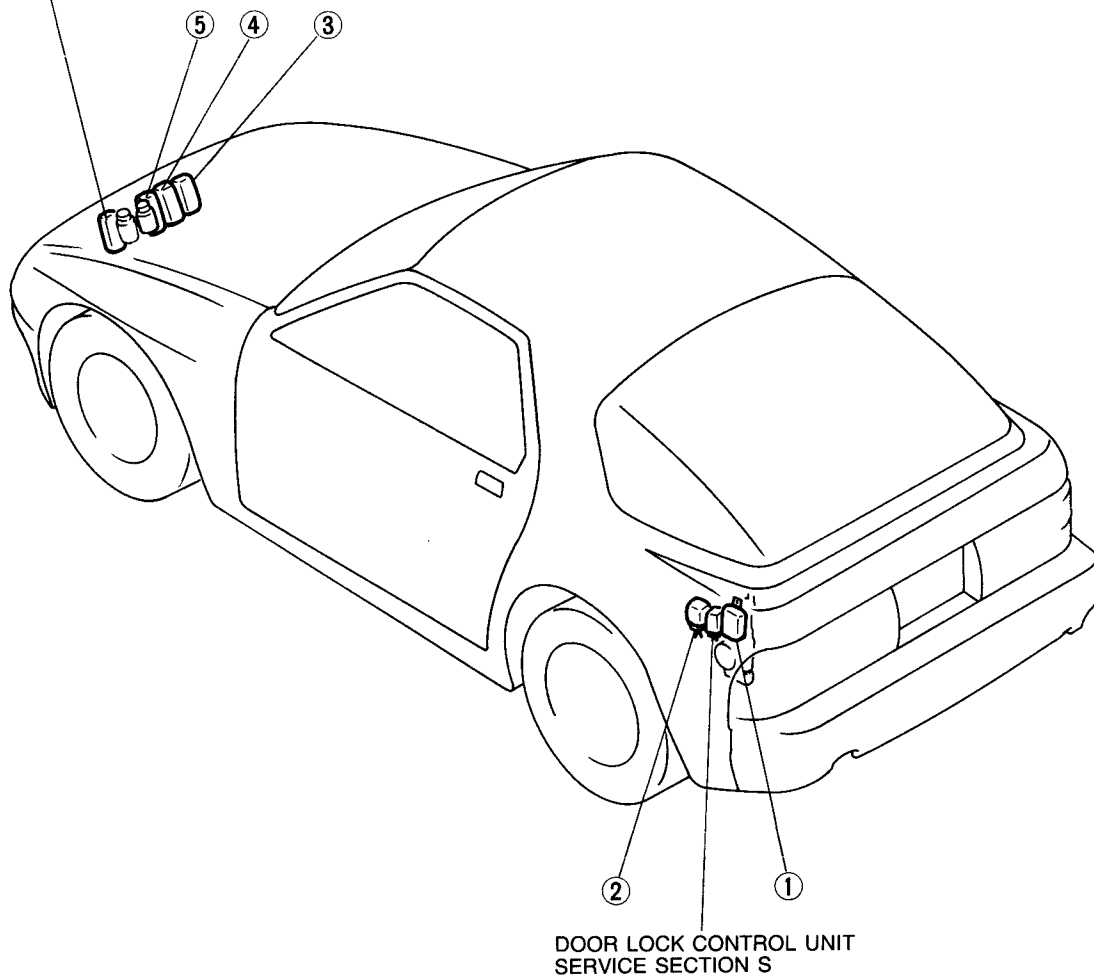

DOOR LOCK CONTROL UNIT
SERVICE SECTION S

97U0TX-003

- 1. Power antenna relay
Removal and Installation..... page T-104
Inspection page T-106
- 2. Rear defroster relay
Inspection page T- 24
- 3. Dimmer relay
Inspection page T- 51

- 4. Headlight relay
Inspection page T- 51
- 5. Front fog light relay
Inspection page T- 52

METER AND SWITCHES

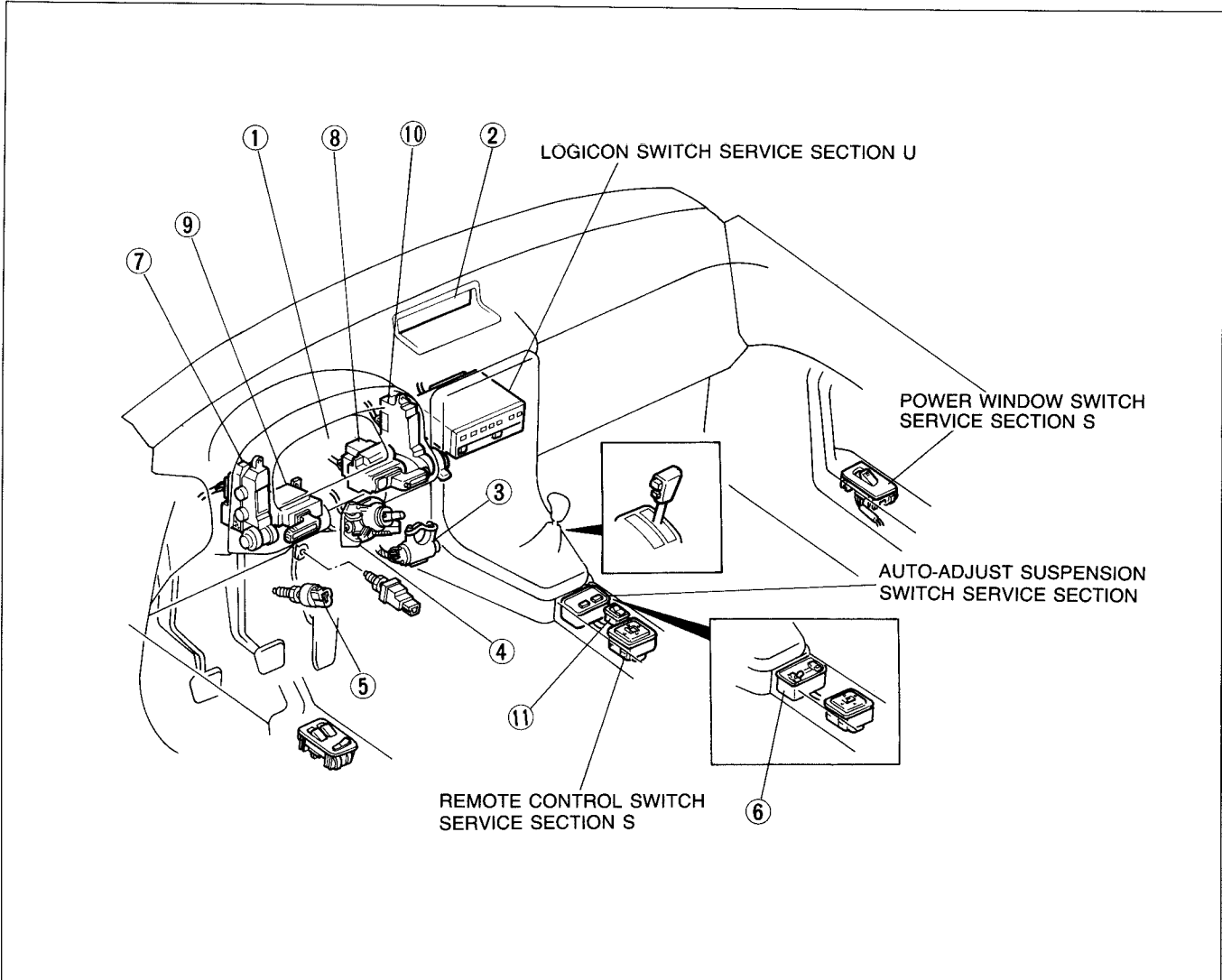

97U0TX-004

- | | |
|--|---|
| 1. Instrument cluster
Removal and Installation..... page T- 35
Disassembly and Assembly..... page T- 36
Inspection page T- 38 | 8. Cluster switch (Cruise control)
Removal and Installation..... page T- 17
Disassembly and Assembly..... page T- 19
Inspection page T- 26 |
| 2. Warning and clock
Removal and Installation..... page T- 43
Inspection page T- 45 | 9. Cluster switch
(Turn signal, dimmer and passing)
Removal and Installation..... page T- 17
Disassembly and Assembly..... page T- 18
Inspection page T- 23 |
| 3. Ignition switch
Removal and Installation..... page T- 17
Inspection page T- 17 | 10. Cluster switch
(Hazard, rear wiper and washer,
front wiper and washer) [For Coupe]
(Hazard, convertible top control, front
wiper and washer) [For Convertible]
Removal and Installation..... page T- 17
Disassembly and Assembly..... page T- 19
Inspection page T- 25 |
| 4. Turn cancel and angle sensor
Disassembly and Assembly..... page T- 29
Inspection page T- 30 | 11. Front fog light switch
Removal and Installation..... page T- 27
Inspection page T- 27 |
| 5. Stoplight switch
Inspection page T- 52 | |
| 6. Headrest speaker switch [For Convertible]
Removal and Installation..... page T-112
Inspection page T-113 | |
| 7. Cluster switch (Rear defroster, headlight,
headlight cleaner, panel lamp control)
Removal and Installation..... page T- 17
Disassembly and Assembly..... page T- 18
Inspection page T- 24 | |

EXTERIOR LIGHTS

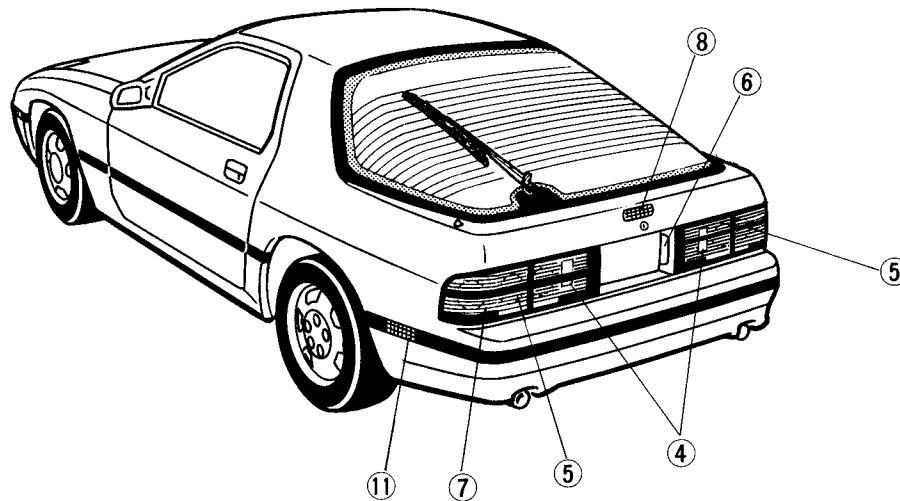
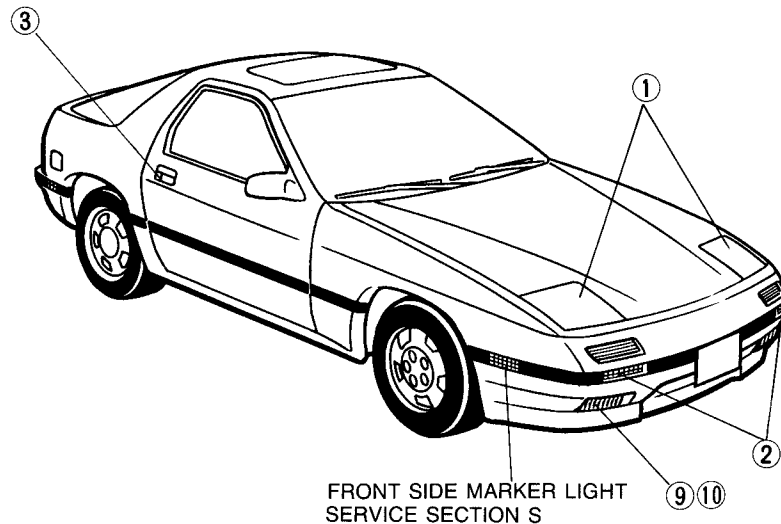

97U0TX-005

- | | |
|--|---|
| <p>1. Headlight
 Disassembly and Assembly..... page T-55
 Replacement of headlight bulb .. page T-56
 Adjustment of headlight aim
 and hinge page T-56
 Adjustment of retractor
 motor position..... page T-57
 Inspection page T-51</p> <p>2. Turn and hazard light
 Inspection page T-53</p> <p>3. Door lock cylinder light
 Inspection page T-54</p> <p>4. Back-up light
 Removal and Installation..... page T-58
 Inspection page T-54</p> | <p>5. Stop and tail light
 Removal and Installation..... page T-58
 Inspection page T-52</p> <p>6. Licence light
 Removal and Installation..... page T-58</p> <p>7. Rear combination light lens
 Disassembly and Assembly..... page T-60</p> <p>8. High mount stop light
 Removal and Installation..... page T-58</p> <p>9. Front fog light (For USA)
 Removal and Installation..... page T-61</p> <p>10. Daytime running light (For Canada)
 Removal and Installation..... page T-61
 Inspection page T-52</p> <p>11. Rear side maker light
 Removal and Installation..... page T-58</p> |
|--|---|

INTERIOR LAMPS

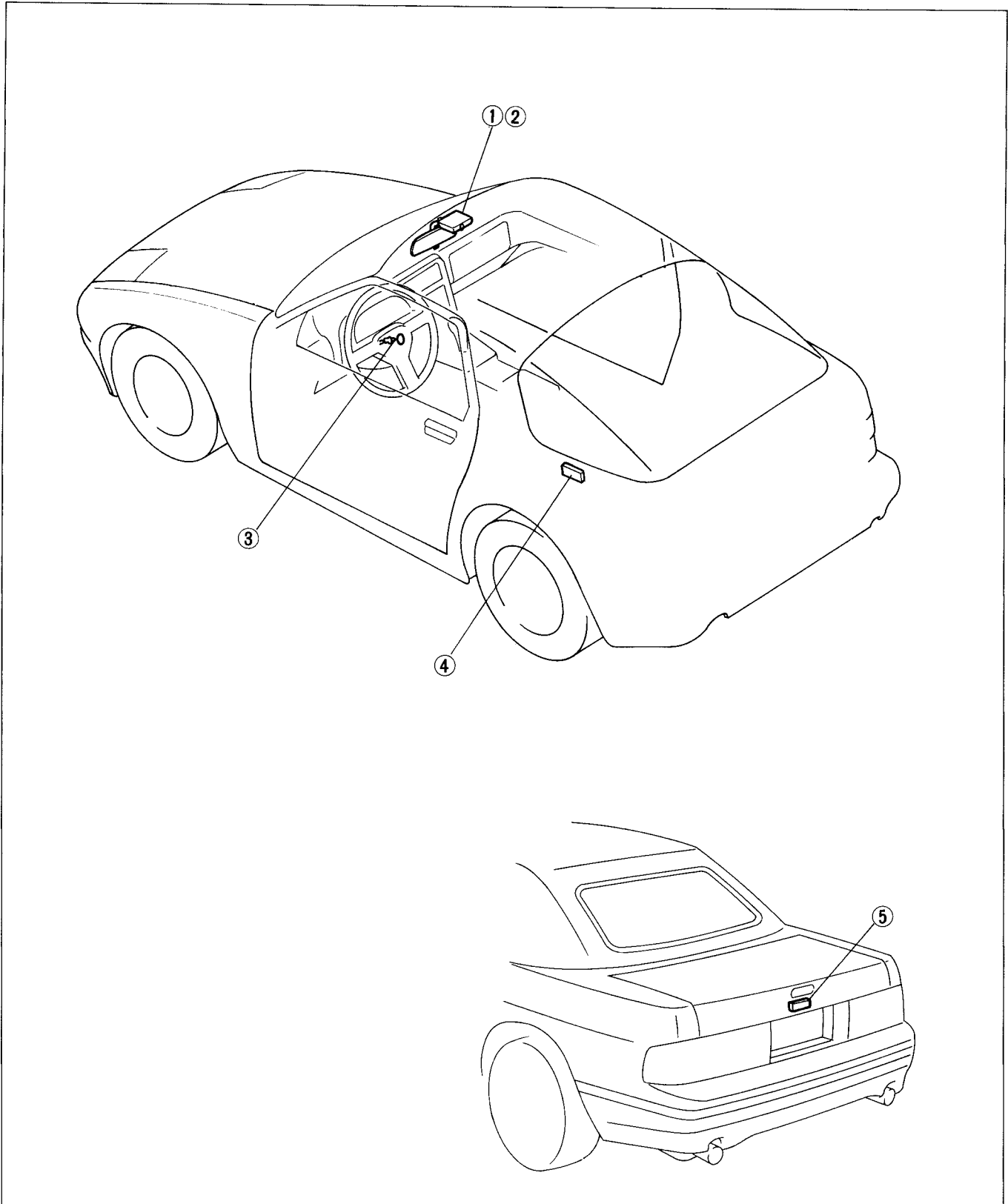

97U0TX-006

- 1. Spot and room lamp (For Coupe)
Removal and Installation..... page T-64
- 2. Room lamp (For Convertible)
Removal and Installation..... page T-65
- 3. Ignition key cylinder lamp
Inspection page T-63

- 4. Cargo room lamp (For Coupe)
Removal and Installation..... page T-65
- 5. Trunk room lamp (For Convertible)
Removal and Installation..... page T-65

REAR WINDOW DEFROSTER

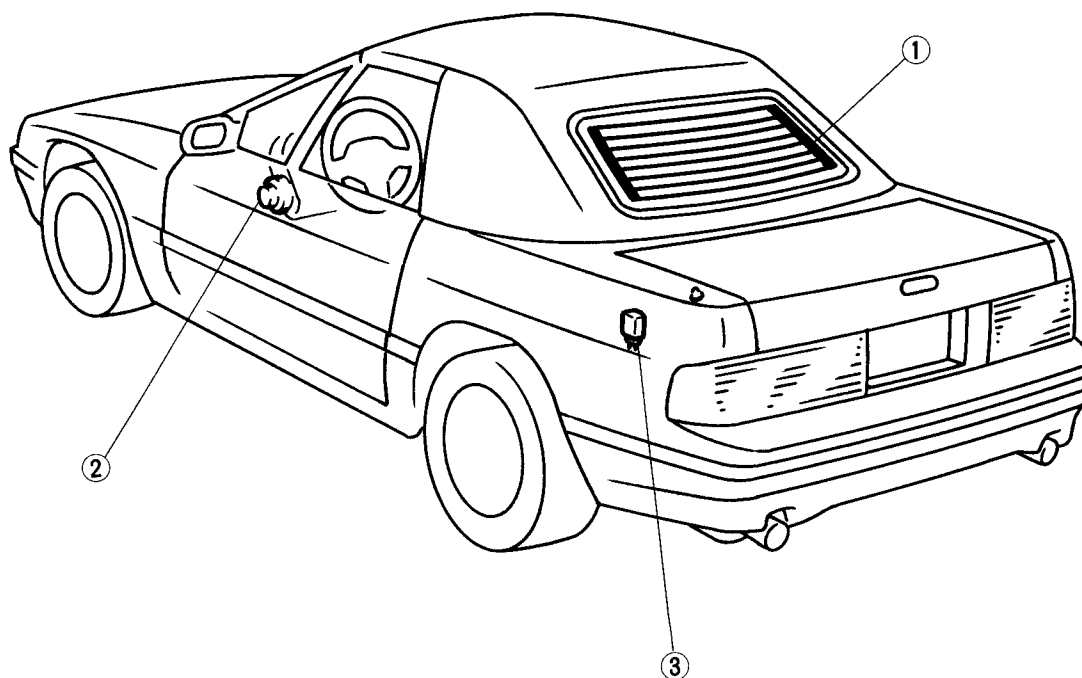

97U0TX-007

- 1. Rear window defroster (Filament)
 - Inspection page T-67
 - Filament correction page T-68
- 2. Rear window defroster switch (in the cluster)
 - Removal and Installation..... page T-17
 - Inspection page T-67

- 3. Rear window defroster relay
 - Inspection page T-24

CRUISE CONTROL SYSTEM

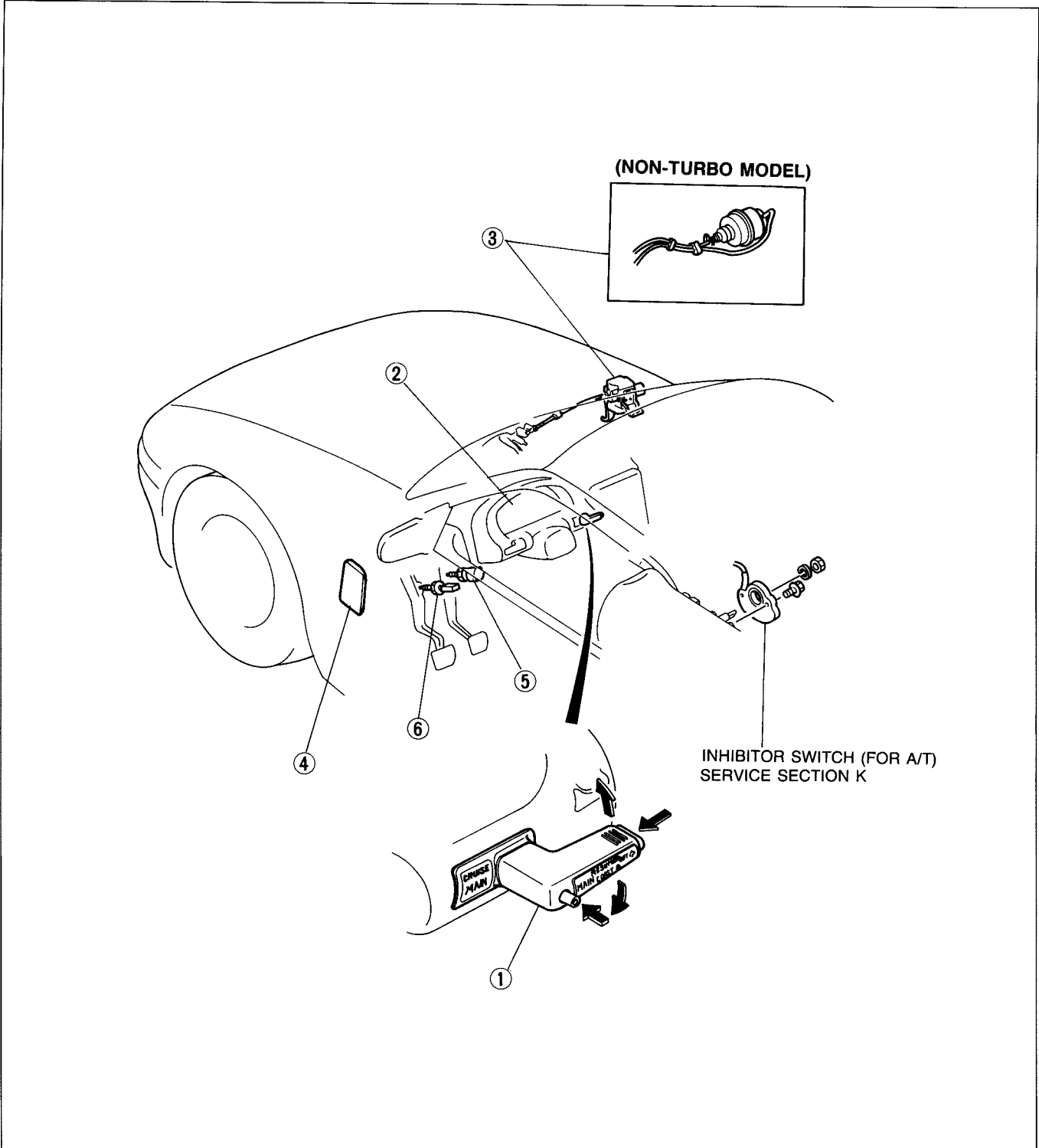

97U0TX-008

- | | |
|--|---|
| <p>1. Cruise control switch
 Removal and Installation..... page T-17
 Disassembly and Assembly..... page T-18</p> <p>2. Speed sensor (in the meter)
 Disassembly and Assembly..... page T-36</p> <p>3. Actuator
 Inspection page T-77</p> <p>4. Cruise control unit
 Troubleshooting page T-75
 Inspection page T-76</p> | <p>5. Stoplight switch
 Inspection page T-52 and T-77
 Adjustment..... page T-77</p> <p>6. Clutch switch (For M/T)
 Adjustment..... page T-77</p> |
|--|---|

THEFT-DETERRENT SYSTEM

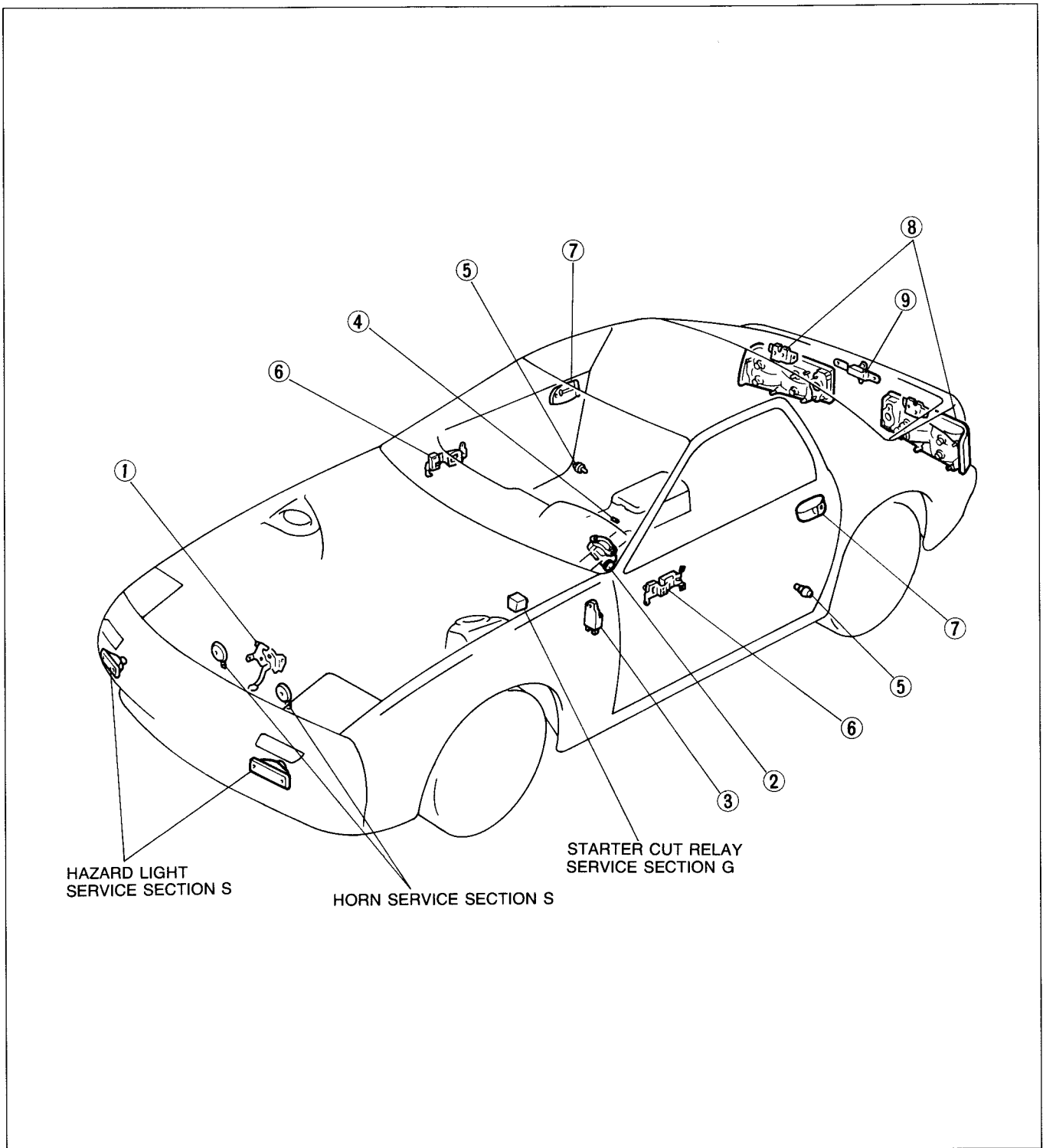

97U0TX-009

- | | |
|--|--|
| <p>1. Hood switch
Inspection page T-83</p> <p>2. Ignition switch and key reminder switch
Removal and Installation..... page T-17
Inspection page T-17</p> <p>3. Theft-deterrent control unit (in CPU)
Troubleshooting page T-80</p> <p>4. Security lamp
Inspection page T-84</p> | <p>5. Door switch
Inspection page T-83</p> <p>6. Door lock switch
Inspection page T-83</p> <p>7. Door key cylinder switch
Inspection page T-83</p> <p>8. Rear hatch(or trunk) switch
Inspection page T-83</p> <p>9. Rear hatch (or trunk) key cylinder switch
Inspection page T-83</p> |
|--|--|

AUDIO SYSTEM

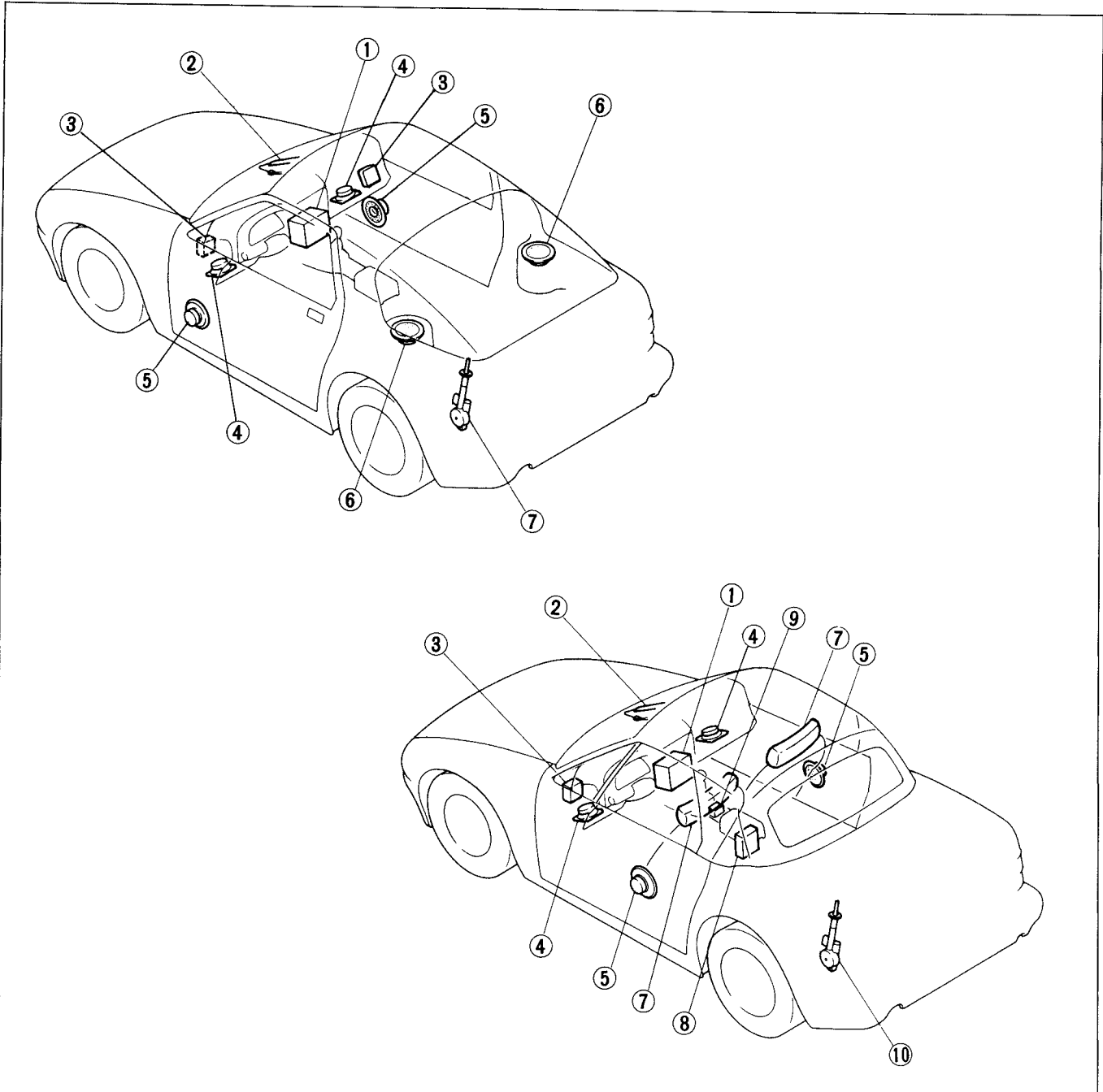

97U0TX-010

1. Audio component assembly
 Troubleshooting page T- 92
 Removal and Installation..... page T-108
2. Windshield antenna
 Removal and Installation..... page T-107
3. Door woofer amplifier
 Removal and Installation..... page T-111
 Inspection page T-112
4. Front speaker
 Removal and Installation..... page T-110
 Inspection page T-110
5. Door woofer speaker
 Removal and Installation..... page T-110
 Inspection page T-110

6. Rear speaker (For Coupe)
 Removal and Installation..... page T-111
 Inspection page T-110
7. Headrest speaker (For Convertible)
 Removal and Installation..... page T-109
 Inspection page T-110
8. Headrest speaker amplifier (For Convertible)
 Removal and Installation..... page T-112
9. Headrest speaker switch (For Convertible)
 Removal and Installation..... page T-112
 Inspection page T-112
10. Power antenna
 Removal and Installation..... page T-106
 Disassembly and Assembly..... page T-104
 Inspection page T-106

OUTLINE

HOW TO USE THIS SECTION

Information regarding removal and installation of electrical equipment is given in **SECTION S**. Understanding will be easier if this section is used in conjunction with the **WIRING DIAGRAMS**.

9MU0TX-008

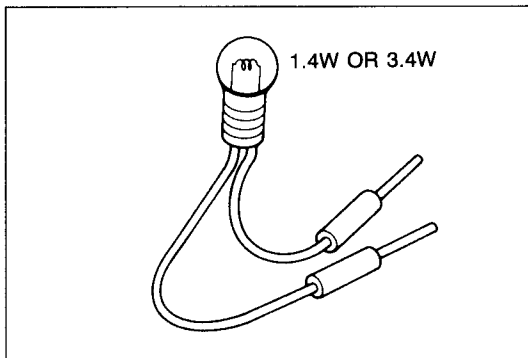

69G15X-002

ELECTRICAL TROUBLESHOOTING TOOLS

Test Light

The test light, as shown in the figure, uses a 12V bulb. The two leads should be connected to probes. The test light is used for simple voltage checks and to check for open circuits.

Caution

When checking the control unit, never use a bulb over 3.4W.

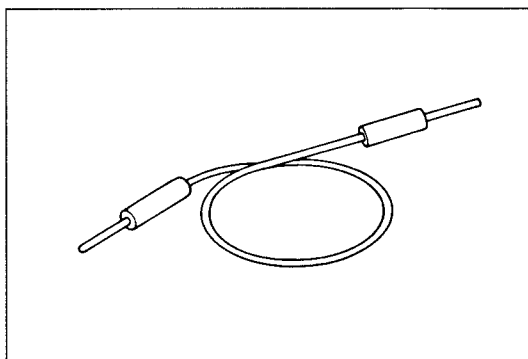

61G15X-002

Jumper Wire

The jumper wire is used for testing by short-circuiting switch terminals and for verifying the condition of ground connections.

Caution

Do not connect the jumper wire between a power source line and body ground because this may cause burning or other damage to harnesses or electronic components.

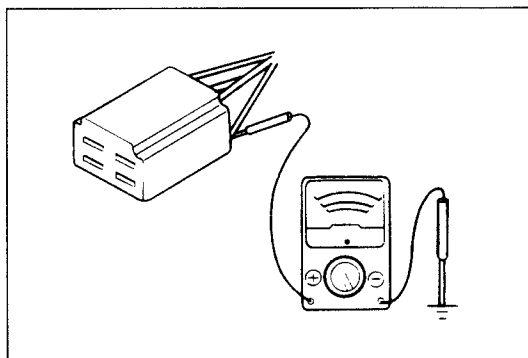

69G15X-003

Voltmeter

The DC voltmeter is used for measuring circuit voltage. A voltmeter with a range of 15V or more is used by connecting the positive (+) probe (red lead) to the point where voltage is to be measured, and the negative (-) probe (black lead) to the body ground.

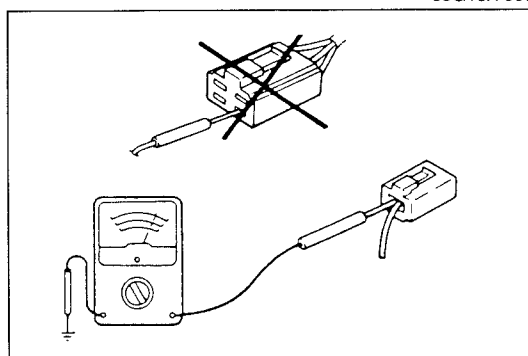

63U15X-005

Ohmmeter

The ohmmeter is used to measure the resistance between two points in a circuit, and is also used to check for continuity and diagnosis of short circuits.

Caution







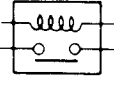

Do not attempt to connect the ohmmeter to any circuit to which voltage is applied because this may burn or otherwise damage the ohmmeter.

T OUTLINE

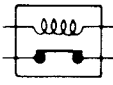
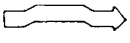

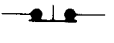
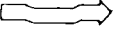
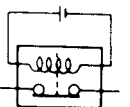
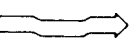
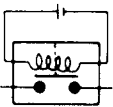

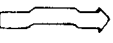
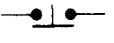





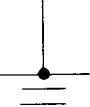

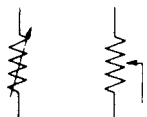

ELECTRICAL SYMBOLS

Switches and Relays

There is an NC (normally closed) and NO (normally open) indication for switches and relays which shows when no change of operation conditions has occurred.

	Relay		Switch	
	NO type relay	NC type relay	NO switch	NC switch
Not in operation (No power supply)	  STOP	  FLOW	  STOP	  FLOW
In operation (Power supply)	  FLOW	  STOP	  FLOW	  STOP

Other Electrical Symbols

		 HOLDER	 BOX	
BATTERY	BODY GROUND	FUSE		FUSIBLE LINK
				
MOTOR	COIL, SOLENOID	RESISTOR	VARIABLE RESISTOR	
				
THERMISTER	DIODE	CONDENSER	LIGHT	
				
TRANSISTOR	SPEAKER	CIGARETTE LIGHTER	HEATER	

69G15X-009

FUSE AND JOINT BOX

STRUCTURAL VIEW

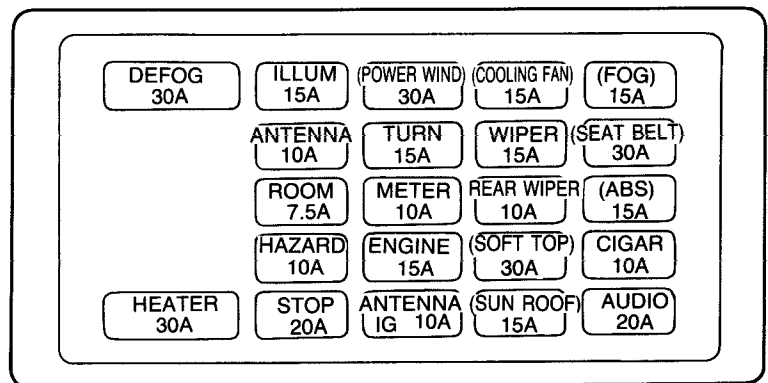
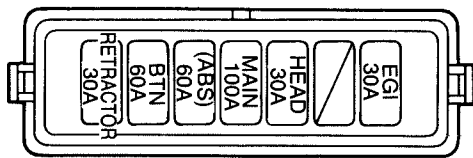
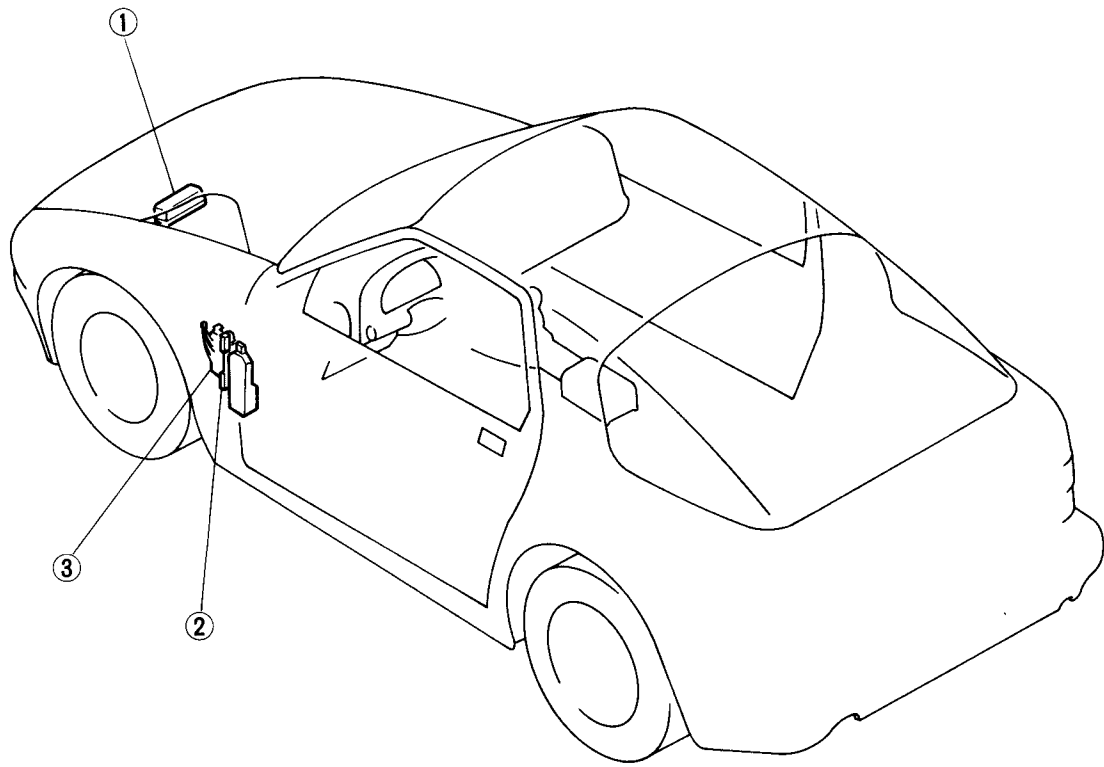

97U0TX-011

1. Main fuse block

2. Fuse box
(in joint box)

3. Joint box

T FUSE AND JOINT BOX

Specification

Main fuse block

Fuse	Protected circuit
BTN 60A	Light switch, Heater and air conditioner Circuit also protected in fuse box (STOP 20A, HAZARD 10A, ROOM 7.5A, ANTENNA 10A, ILLUMI 15A, ABS 15A, SEAT BELT 30A, FOG 15A)
HEAD 30A	Headlight
RETRACTOR 30A	Retractable headlight
EGI 30A	EGI and emission control system
MAIN 100A	Starter and charge system
ABS 60A	Anti-lock brake system

97U0TX-012

Fuse box

Fuse	Protected circuit
HEATER 30A	Heater and air conditioner
DEFOG 30A	Rear window defroster
STOP 20A	Stoplight, Cruise control system
HAZARD 10A	Turn and hazard lights
ROOM 7.5A	Cargo light, Courtesy lights, Room and stop light, Warning and buzzer or chime, Door lock cylinder and ignition key cylinder light, EGI and emission control system, Warning and auto clock system, Theft-deterrent system, EC-AT control system
ANTENNA 10A	Power door lock system, Power antenna
ILLUMI 15A	Headlight
ABS 15A	Anti-lock brake system
SEAT BELT 30A	Passive shoulder belt
FOG 15A	Front fog light
CIGAR 10A	Warning and auto clock, Remote control mirror, Heater and air conditioner
AUDIO 20A	Audio system
REAR WIPER 10A	Rear wiper and washer
SUNROOF 15A	Sunroof, Anti-lock brake system, AAS system
SOFT TOP 30A	Convertible top system
COOLING FAN 15A	Cooling fan system
WIPER 15A	Front wiper and washer, DRL system, Heater and air conditioner
ENGINE 15A	EC-AT control system, Fuel system, EGI and emission control system
METER 10A	Back-up light, Cruise control system, Shift lock system, EC-AT control system, Meter, Warning and auto clock, Cooling fan system
ANTENNA IG 10A	Rear window defroster, Starter and charge system, EC-AT control system, Power antenna, Horn, Stoplight, Power steering
POWER WIND 30A	Power window, AAS system
TURN 15A	Turn and hazard, Rear window defroster, Passive shoulder belt

97U0TX-013

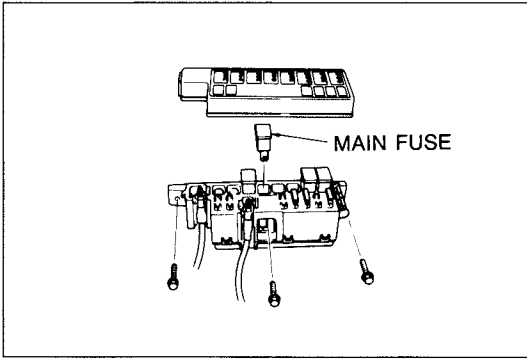

97U0TX-014

MAIN FUSE BLOCK Removal and Installation

When replacing a fuse, be sure to replace it with one of the specified capacity.

If after a fuse has been replaced it fails again, there is probably a short in the circuit, and the wiring should be checked.

Caution

- a) Check that the negative battery terminal is disconnected before replacing a fuse.
- b) When replacing a fuse, use the supplied fuse puller supplied in the fuse box.

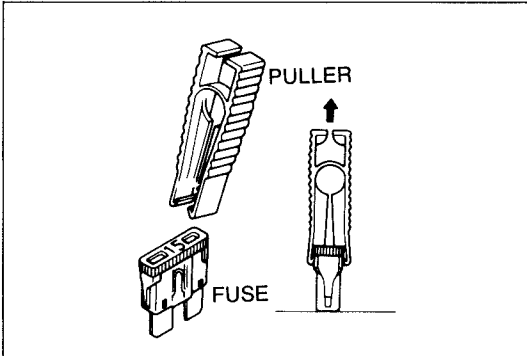

97U0TX-015

FUSE BOX Removal and Installation

1. Remove the fuses with a puller.
2. Install in the reverse order of removal.

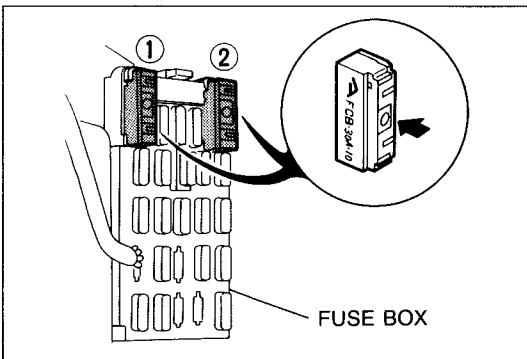

97U0TX-016

Note

Push button to reset circuit breaker

- (1) Heater and air conditioner
- (2) Rear window defroster

SWITCHES

STRUCTURAL VIEW

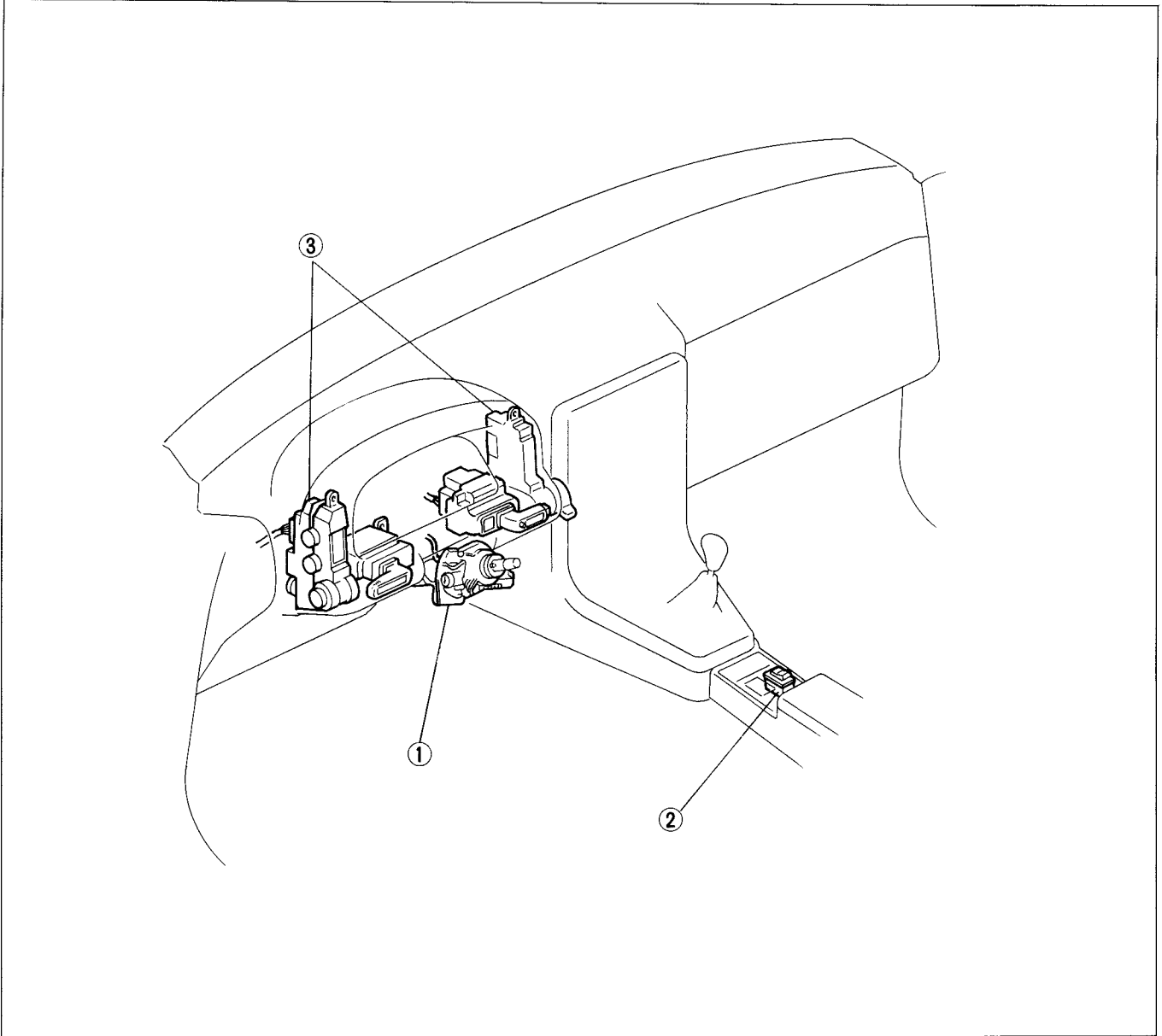

97U0TX-017

- 1. Ignition switch
- 2. Front fog switch

- 3. Cluster switch

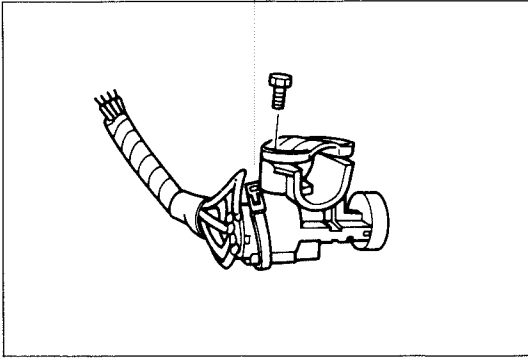

97U0TX-018

IGNITION SWITCH Removal and Installation

Refer to page N-11.

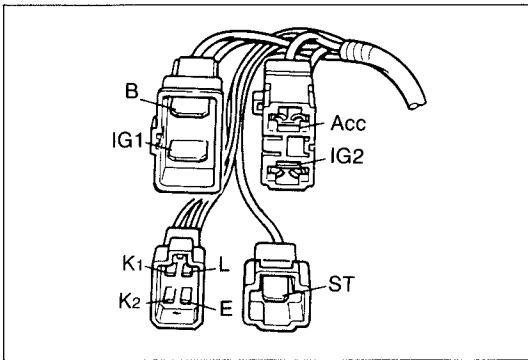

97U0TX-019

Inspection

Use an ohmmeter to check the continuity of each terminal of the switch.
If the continuity is not as specified, replace the switch.

Terminal Position	B	ACC	IG1	IG2	ST	L	E	K1	K2
LOCK								○—○	○—○
ACC	○—○							○—○	○—○
ON	○—○	○—○	○—○	○—○				○—○	○—○
START	○—○		○—○		○—○	○—○	○—○	○—○	○—○

○—○ : Indicates continuity

CLUSTER SWITCH PANEL Removal and Installation

1. Disconnect the negative battery cable. Remove in the sequence shown in the figure.
2. Install in the reverse order of removal.

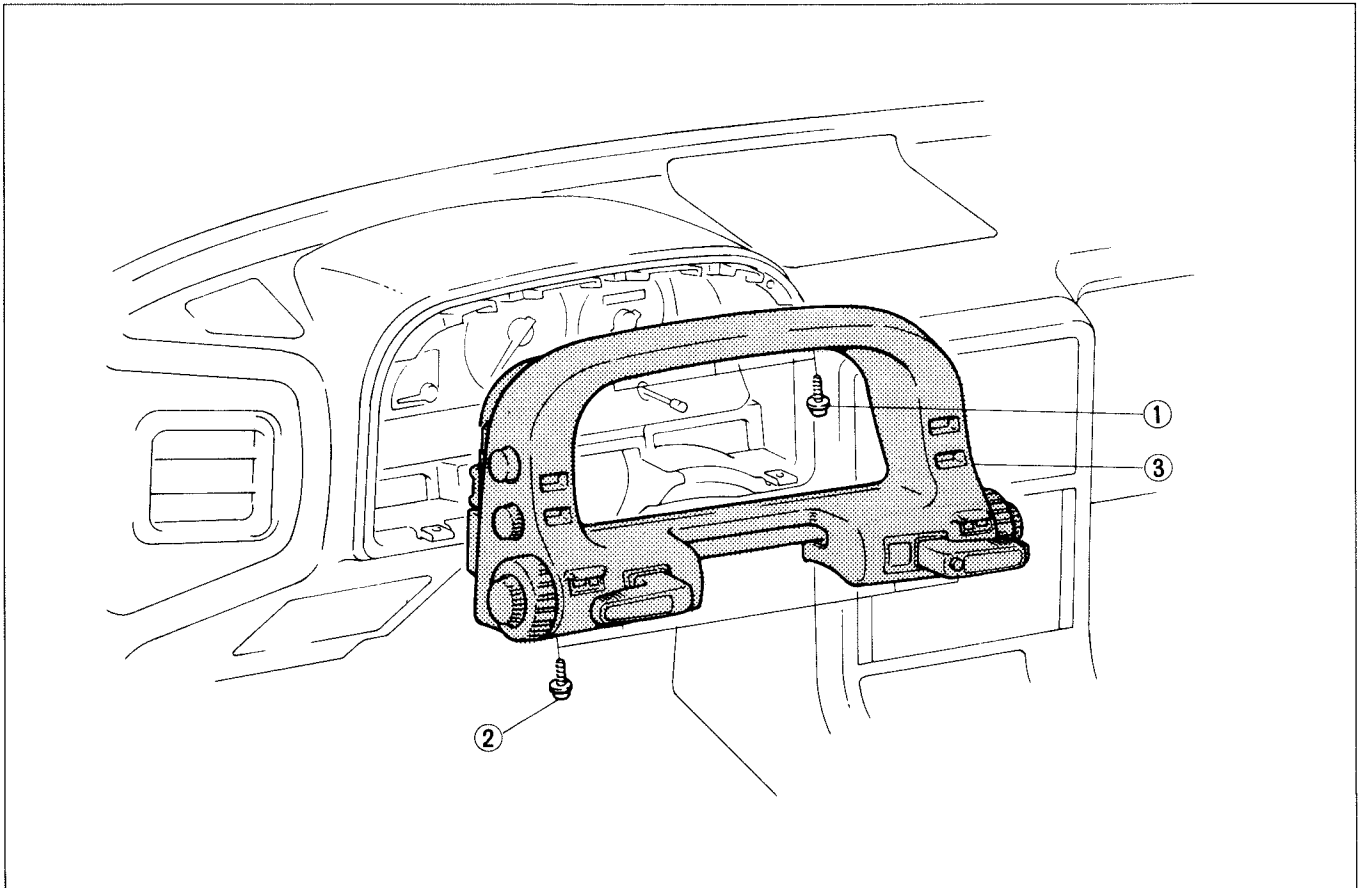

97U0TX-020

1. Tapping screws

2. Tapping screws

3. Cluster switch panel

T SWITCHES

Disassembly and Assembly (Left Side)

1. Disassemble in the sequence shown in the figure.
2. Assemble in the reverse order of disassembly.

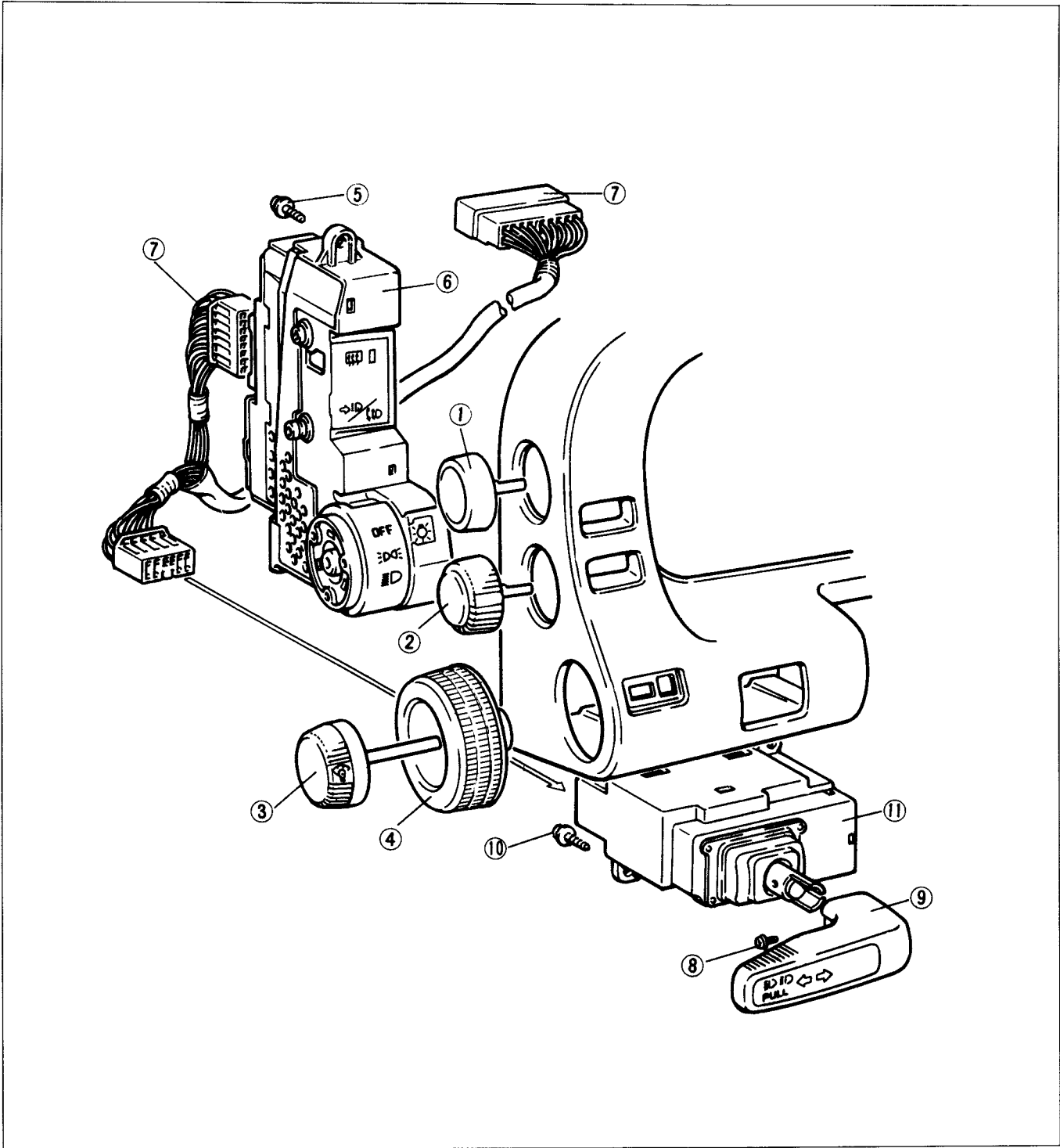

97U0TX-021

1. Knob (Rear defroster switch)
2. Knob (Retractable headlight and headlight cleaner switch)
3. Knob (Panel light control)
4. Knob (Headlight switch)
5. Screw and washer
6. Cluster switch (Rear defroster, retractable headlight, headlight cleaner, panel light control and headlight switch)
7. Harness (Cluster switch L.H.)
8. Screw and washer
9. Knob (Turn signal, dimmer and passing switch)
10. Screw and washer
11. Cluster switch (Turn signal, dimmer and passing switch)

Disassembly and Assembly (Right Side)

1. Disassemble in the sequence shown in the figure.
2. Assemble in the reverse order of disassembly.

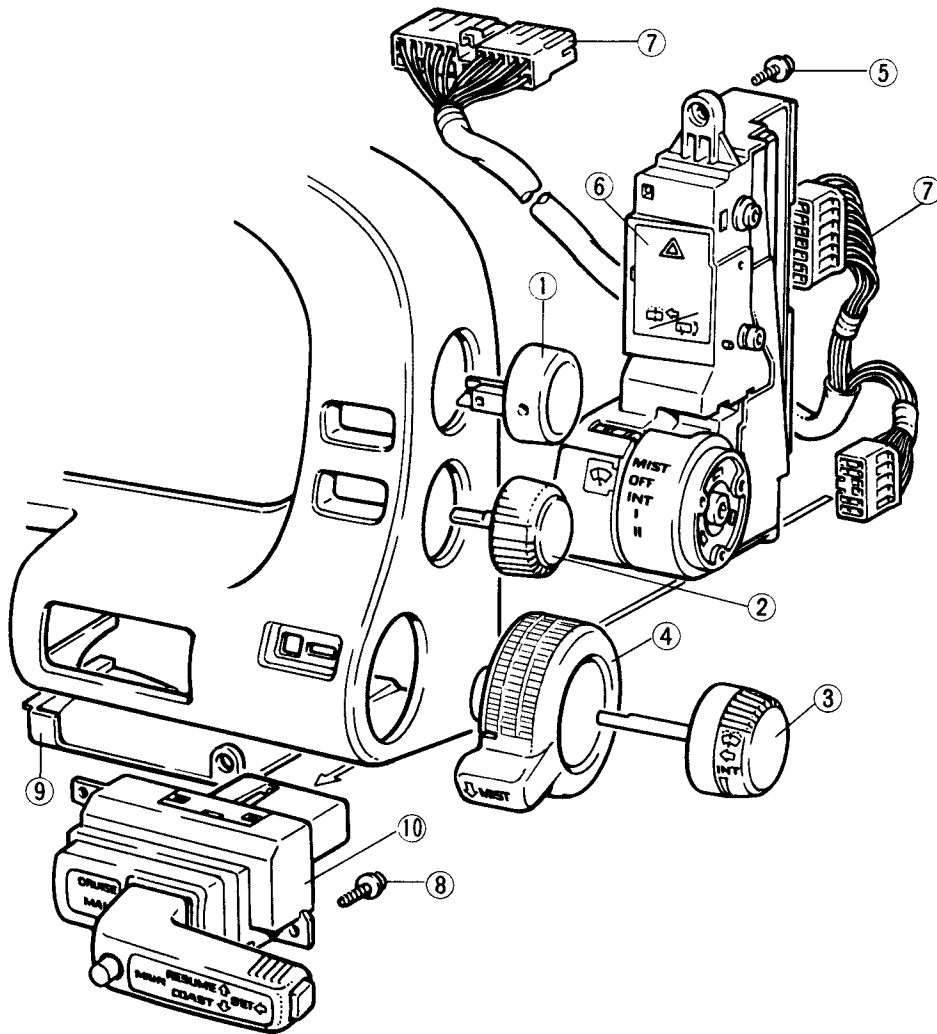

97U0TX-022

- | | |
|--|---|
| 1. Knob (Hazard warning switch) | 6. Cluster switch (Hazard warning, rear wiper & washer and front wiper & washer switch) |
| 2. Knob (Rear wiper and washer switch)
(Convertible top control switch) For Convertible | 7. Harness (Cluster switch RH) |
| 3. Knob (Front washer switch) | 8. Screw and washer |
| 4. Knob (Front wiper switch) | 9. Cover |
| 5. Screw and washer | 10. Cluster switch (Cruise control switch) |

T SWITCHES

Circuit Diagram (Cluster Switch Panel, Right Side) Coupe type

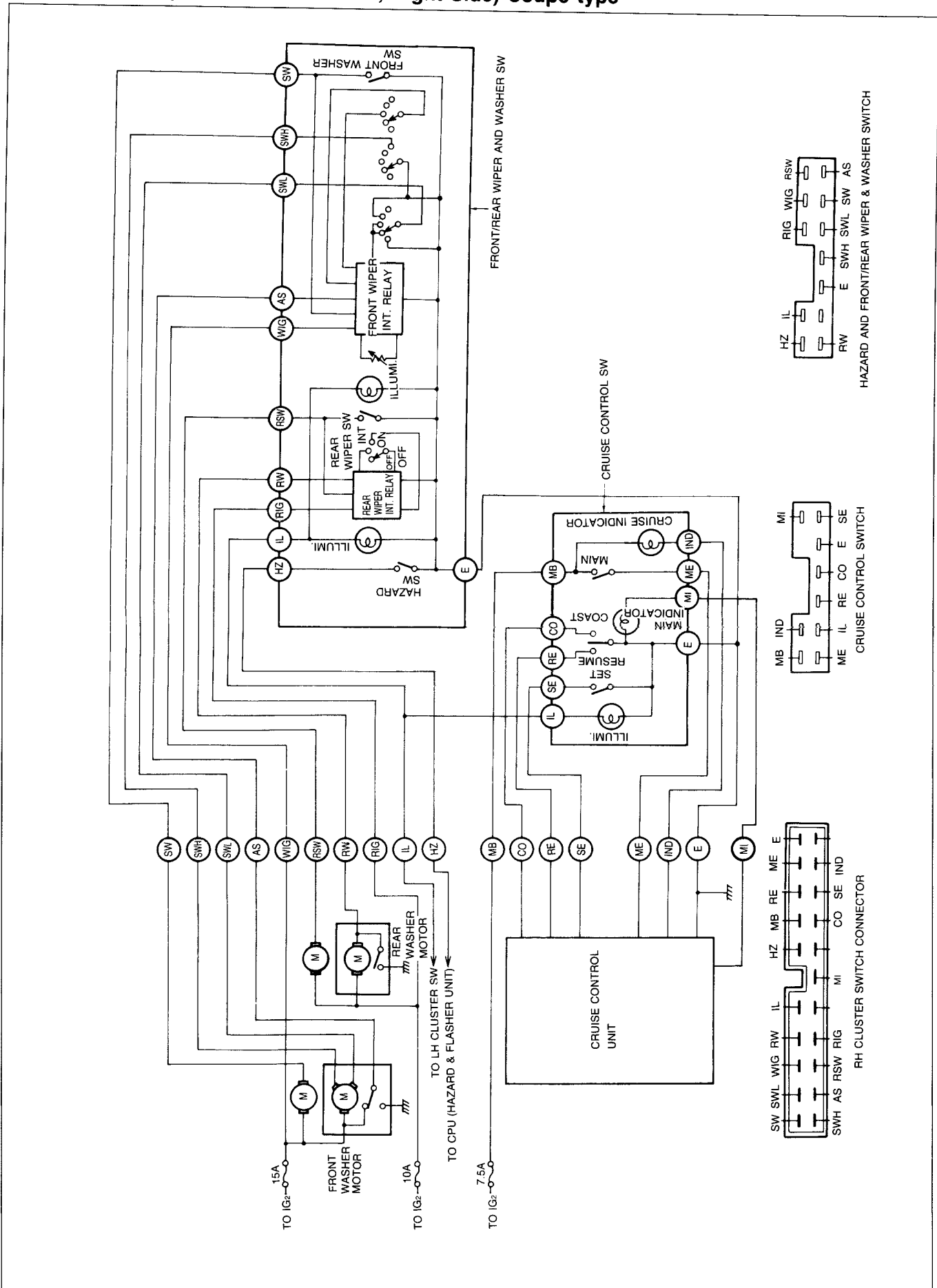

(Cluster Switch Panel, Right Side) For Convertible

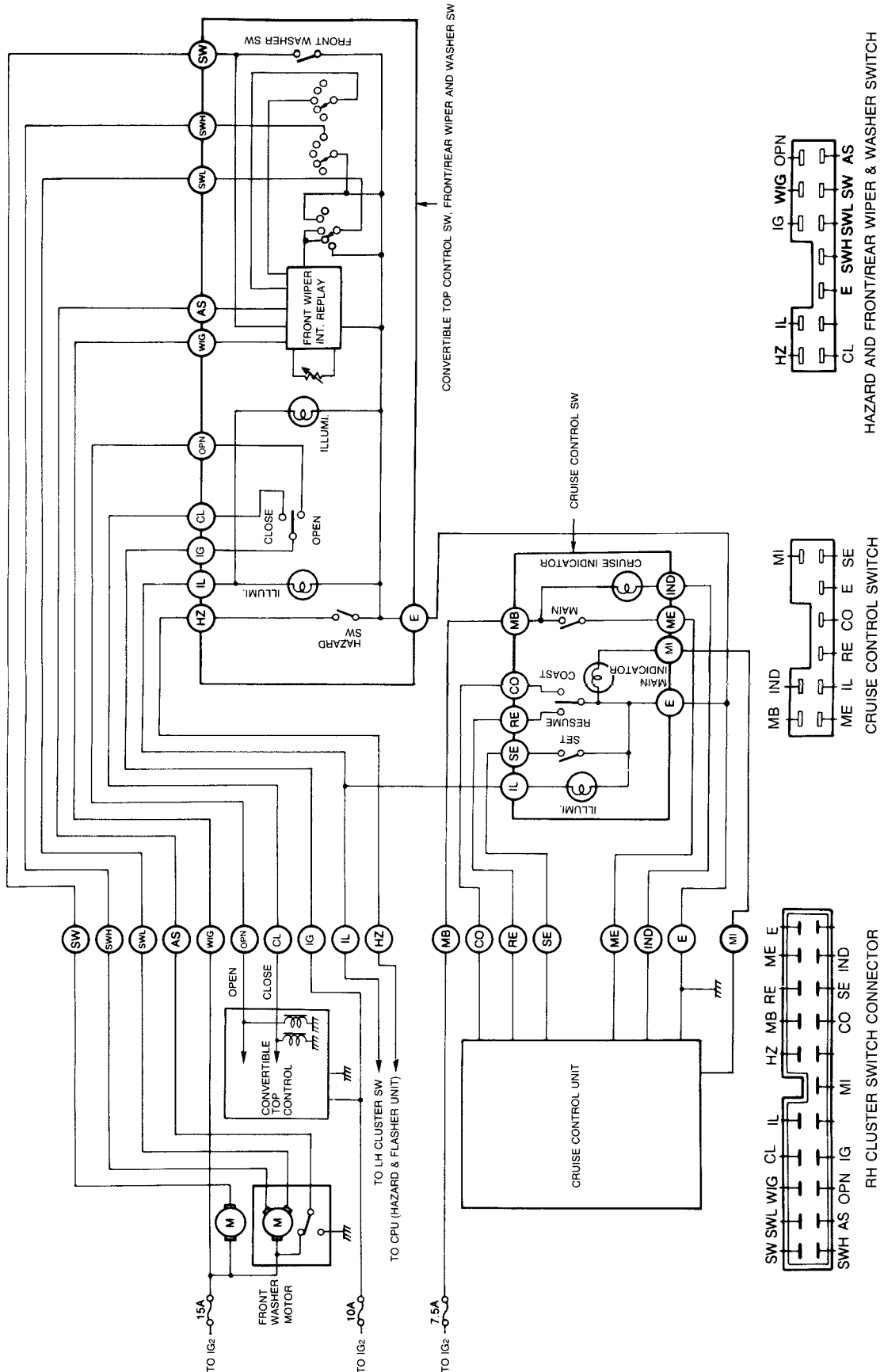

T SWITCHES

(Cluster Switch Panel, Left Side)

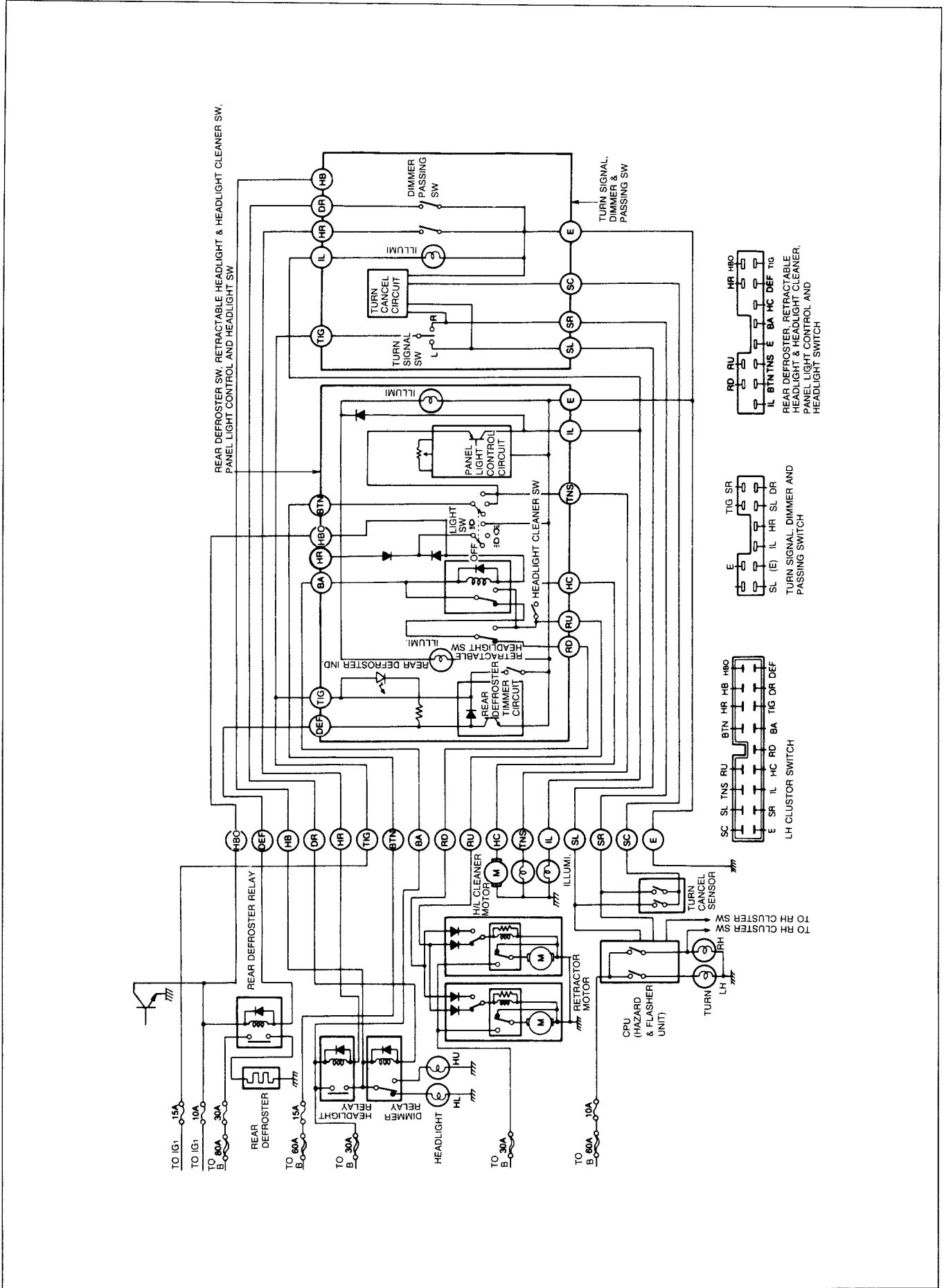

Inspection

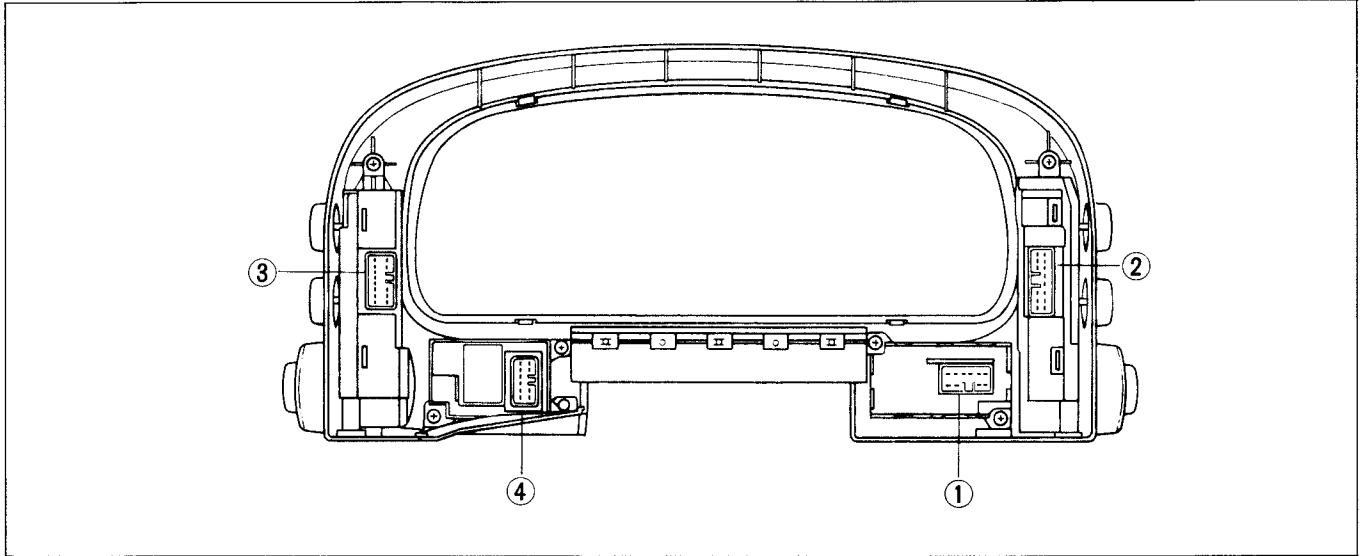

Check the continuity or voltage between terminals using a circuit tester and battery.



97U0TX-026

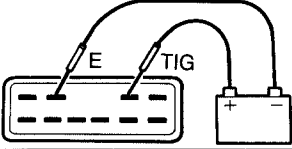
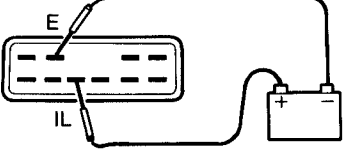

Turn signal, dimmer and passing switch

Turn signal, dimmer and passing switch				○—○ : Indicates continuity	
Turn signal switch		TIG	SR	SL	 CONTINUITY
	Right	○—○			
	Left	○—○		○—○	
Turn cancel circuit					
	Procedure			Result	
	Turn switch right — apply 12V to SC			Turn switch cancelled	
Turn switch left — apply 12V to SC			Turn switch cancelled		
Illumination lamps (Turn signal, dimmer and passing switch)					
	—————			 ON	
Dimmer and passing switch					
Dimmer and passing switch		HR	E	 CONTINUITY	
	OFF				
	ON	○—○	+	HR	E

97U0TX-027

T SWITCHES

Rear window defroster switch
 Retractable headlight and
 headlight cleaner switch
 Headlight switch
 Panel lamp control

②

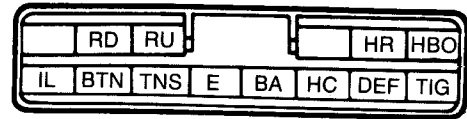

○—○ Indicates continuity

Rear window defroster switch							
Rear window defroster switch		TIG	E	OHMMETER 	CONTINUITY		
	OFF						
	ON	○—○	○—○				
Rear window defroster timer circuit							
		DEF—E		VOLTMETER 	E — DEF		
	OFF	12V					
	ON	0V					
	TIMER	10—20 min after switch turned on: 12V					
Retractable headlight and headlight cleaner switch							
Retractable headlight switch		BA	RD	RU	OHMMETER 	CONTINUITY	
	OFF	○—○					
	ON	○—○		○—○			
Headlight cleaner switch (This inspection is operated with the retractable headlights in the open position)		BA	HC		OHMMETER 	CONTINUITY	
	OFF						
	ON	○—○	○—○				
Headlight switch							
Headlight switch		BTN	TNS	HR	E	OHMMETER 	CONTINUITY
	OFF						
		○—○					
		BA	RU		OHMMETER 	CONTINUITY	
		○—○	○—○				
Illumination lamp (Retractable headlight, headlight cleaner, and headlight switch)							
		—————				ON	
Panel lamp control							
		Illumination lamps					ON
		All illumination lamps on and controlled by panel lamp control switch					
		Same as above					

- Hazard warning switch
- Rear wiper and washer switch
- Front wiper and washer switch
- Convertible top control switch

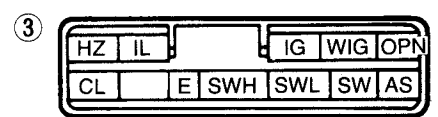









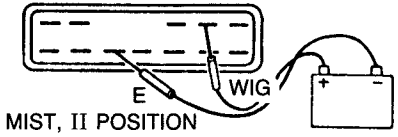

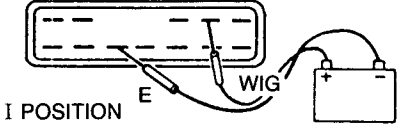
○—○ Indicates continuity

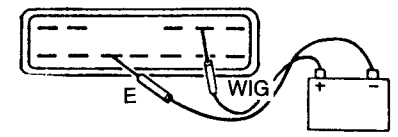
Hazard warning switch				
Hazard warning switch		HZ	E	OHMMETER CONTINUITY
	OFF			
	ON	○—○	○—○	
Rear washer switch				
Rear washer switch		RSW	E	OHMMETER CONTINUITY
	OFF			
	ON	○—○	○—○	
One-touch wiper circuit				
		RW—E		VOLTMETER RW
	OFF	Approx. 12V		
	ON	OV		
	INT	Check for clicking sound of the relay by connecting the battery as shown in the figure		
Rear wiper switch				
		RW—E		VOLTMETER RW
	OFF	Approx. 12V		
	INT			
	ON	Check for clicking sound of the relay by connecting the battery as shown in the figure.		
Illumination lamp (Rear wiper switch)				
		—		ON
Front washer switch				
Front washer switch		SW	E	OHMMETER CONTINUITY
	OFF			
	ON	○—○	○—○	
One-touch wiper circuit				
		SWH—E		VOLTMETER SWH
	OFF	Approx. 12V		
	ON	When switch pressed-after 0.5 sec-OV		
	OFF	When switch released-after 3 sec-12V		

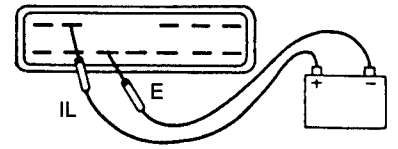
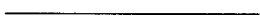
97U0TX-029

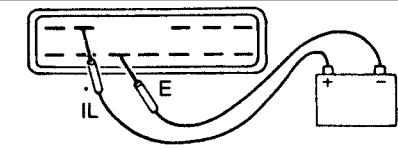
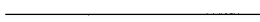
T SWITCHES



Front wiper switch					
 <p>MIST, II POSITION</p>		SWH-E	VOLTMETER  E - ⊕ SWH		
	MIST	0V			
	II	0V			
 <p>I POSITION</p>		SWL-E	VOLTMETER  E - ⊕ SWL		
	I	0V			
 <p>INT POSITION</p>		SWL-E	VOLTMETER  E - ⊕ SWL		
	AS- ⊕	0V			
	AS- ⊖	0V			
	AS- ⊕	Approx. -12V After few sec-0V			
Illumination lamp (Front wiper switch)					
			 ON		
Convertible top control switch					
Check terminals for continuity		IG	OPN	CL	Result
	OPEN	○	○		Continuity
	CLOSE	○	○	○	
Illumination lamp (Convertible top control switch)					
			 ON		



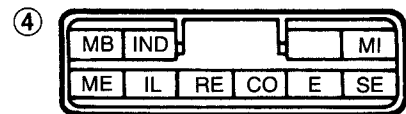

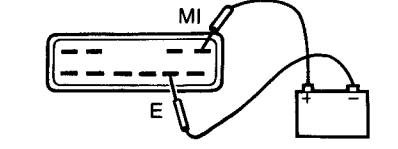

97U0TX-030

Cruise control switch

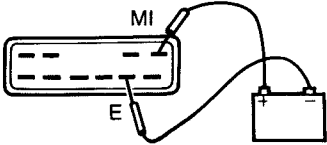

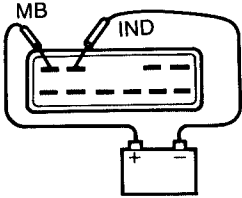
○—○ Indicates continuity

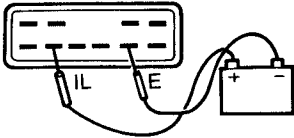
Cruise control switch								
		ME	MB	SE	RE	CO	E	OHMMETER  CONTINUITY
	OFF							
	MAIN		○	○				
	SET				○	○	○	
	RESUME					○	○	
	COAST						○	

Main switch		
	_____	 MAIN INDICATOR ON
Indicator lamp		
	_____	 CRUISE INDICATOR ON
Illumination lamp(Cruise control switch)		
	_____	 ON

97U0TX-031

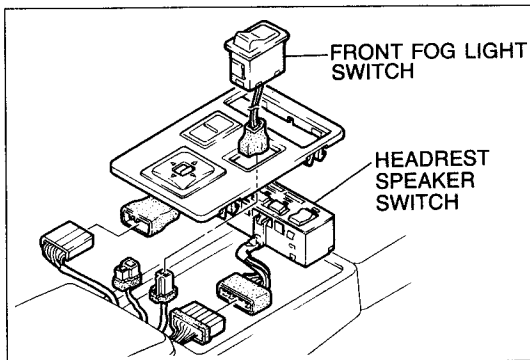

97U0TX-032

FRONT FOG LIGHT SWITCH Removal and Installation

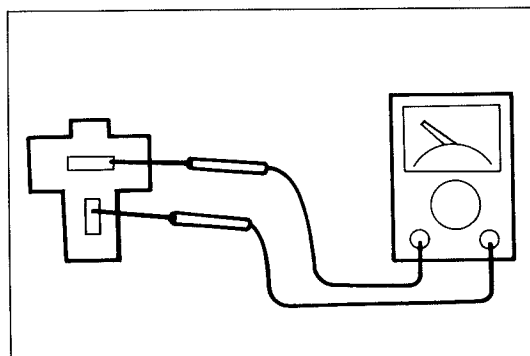

1. Remove the switch panel.
2. Disconnect the connector.
3. Remove the front fog light switch.



97U0TX-033

Inspection

Check for continuity between the terminals of the switch.

Switch	Terminal	a	b
OFF			
ON			

 : Indicates continuity

T TURN CANCEL AND ANGLE SENSOR

TURN CANCEL AND ANGLE SENSOR

STRUCTURAL VIEW

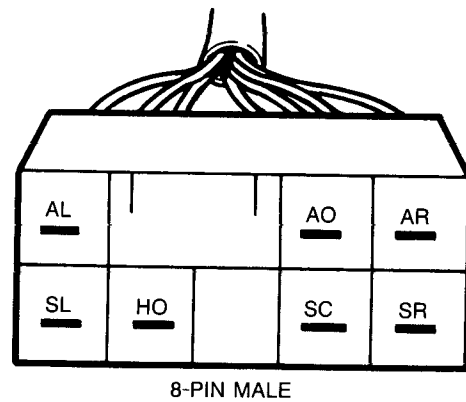
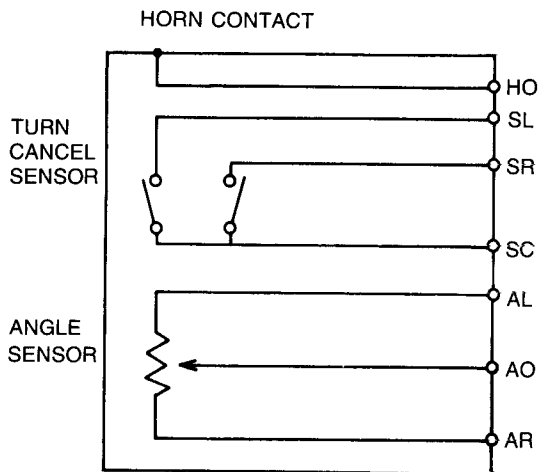
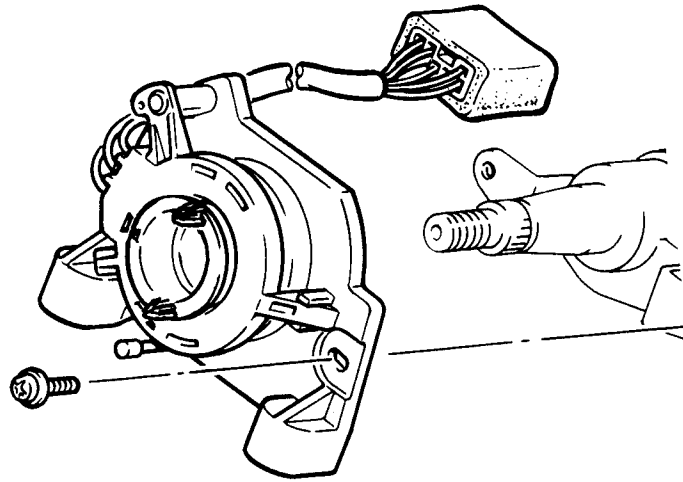

DISASSEMBLY AND ASSEMBLY

1. Disassemble in the sequence shown in the figure.
2. Assemble in the reverse order of disassembly.

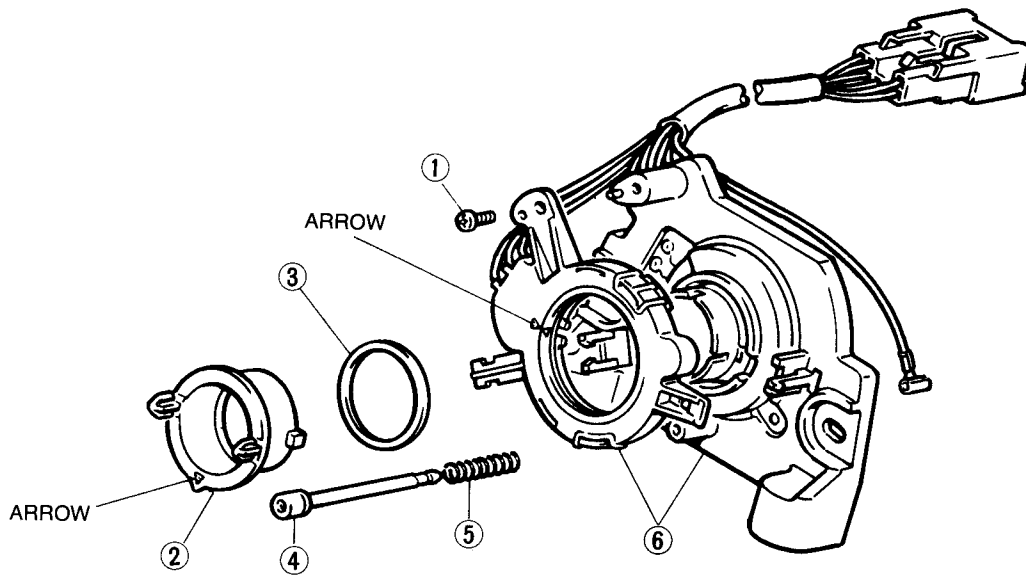

97U0TX-034

1. Tapping screw
2. Cancel cam
3. Washer

4. Horn contact
5. Contact spring
6. Turn cancel & angle sensor

Caution

Align the arrow heads when installing the sensor.

T TURN CANCEL AND ANGLE SENSOR

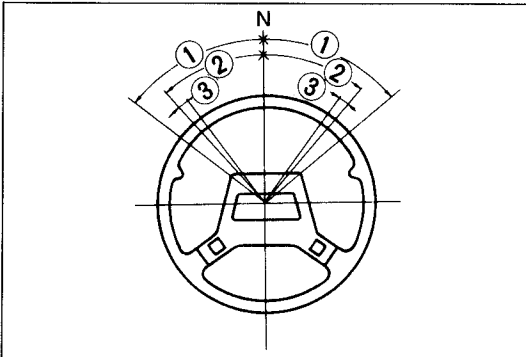

67U15X-011

INSPECTION

Function of turn cancel sensor

Steering wheel position	Angle
Cancel — set angle ①	53°—63°
Cancel angle ②	38°—48°
Contact ON angle ③	2°—8°

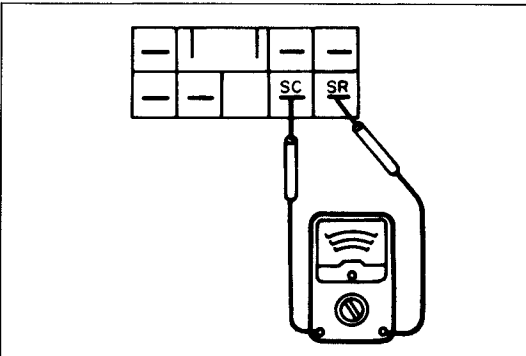

67U15X-012

Checking Turn Cancel Sensor

1. Check the TURN fuse.
2. If the fuse is not burned, remove the column cover and disconnect the connector to the sensor.
3. Connect an ohmmeter to the connector terminals of the turn cancel sensor, and check the continuity when the steering wheel is turned as shown in the table below.

Terminal	Steering wheel position	Continuity
SC—SR	When turned 63° or more to the right from the straight-ahead position and returned to the straight-ahead position.	Yes
SC—SL	When turned 63° or more to the left from the straight-ahead position and returned to the straight-ahead position.	Yes

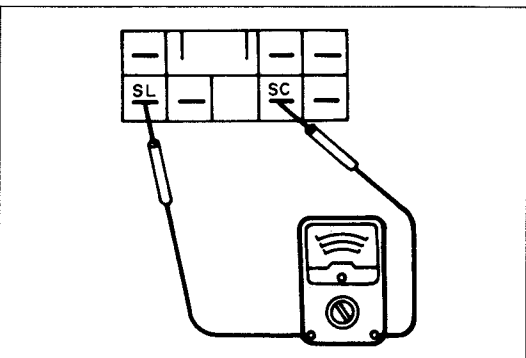

67U15X-013

Checking Angle Sensor

1. Remove the column cover, and disconnect the connector of the sensor.
2. Connect an ohmmeter to the connector terminals at the angle sensor, and perform the inspections described in the table below.

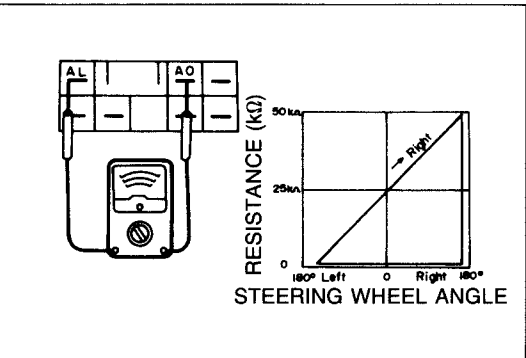

67U15X-014

Terminal	Steering wheel position	Resistance value
AO—AL	Turn the wheel a little at a time from the straight-ahead position 180° to the right	Increases from approx. 25 kΩ to approx. 50 kΩ
AO—AL	Straight-ahead position	Approx. 25 kΩ

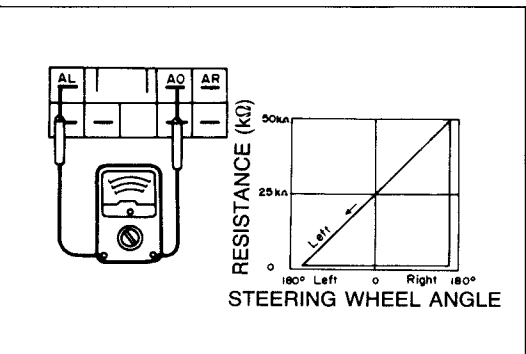

67U15X-015

3. Connect an ohmmeter to the connector terminals of the sensor, and perform the inspections described in the table below.

Terminal	Steering wheel position	Resistance value
AO—AL	Turn the wheel a little at a time from the straight-ahead position 180° to the left.	Decreases from approx. 25 kΩ to approx. 200Ω.
AR—AL	Straight-ahead position	Approx. 50 kΩ

TURN CANCEL AND ANGLE SENSOR T

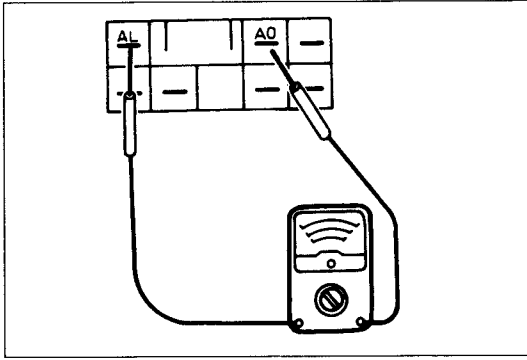

67U15X-016

Terminal	Steering wheel position	Resistance value
AO—AL	When turned 180° or more to the right from the straight-ahead position.	Resistance slowly and gradually increases after there is once an indication of approx. 200Ω.
AO—AL	When turned 180° or more to the left from the straight-ahead position.	Resistance slowly and gradually decreases after there is once an indication of approx. 50 kΩ.

T CENTRAL PROCESSING UNIT (CPU)

CENTRAL PROCESSING UNIT (CPU)

REMOVAL AND INSTALLATION

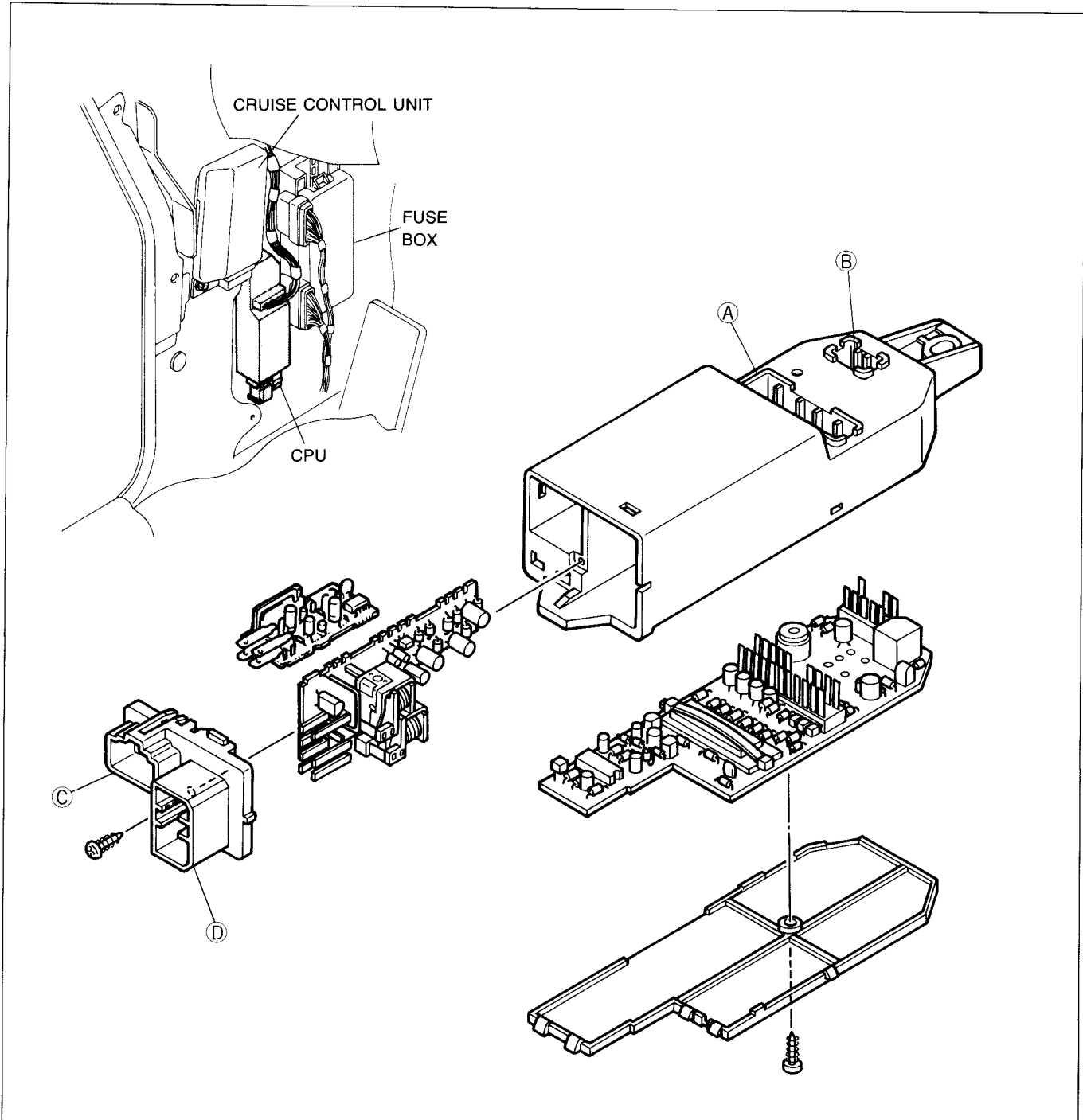

97U0TX-035

Function	Connector	U.S.A.	Canada
Turn and hazard unit	C	○	○
Burglar buzzer	B	○	○
Passive belt warning	A	○	X
Seat belt timer & buzzer	A	○	○
Key reminder buzzer	A	○	○
Key illumination timer	A	○	○
DRL unit	D	X	○

INTERCONNECTING DIAGRAM OF CPU

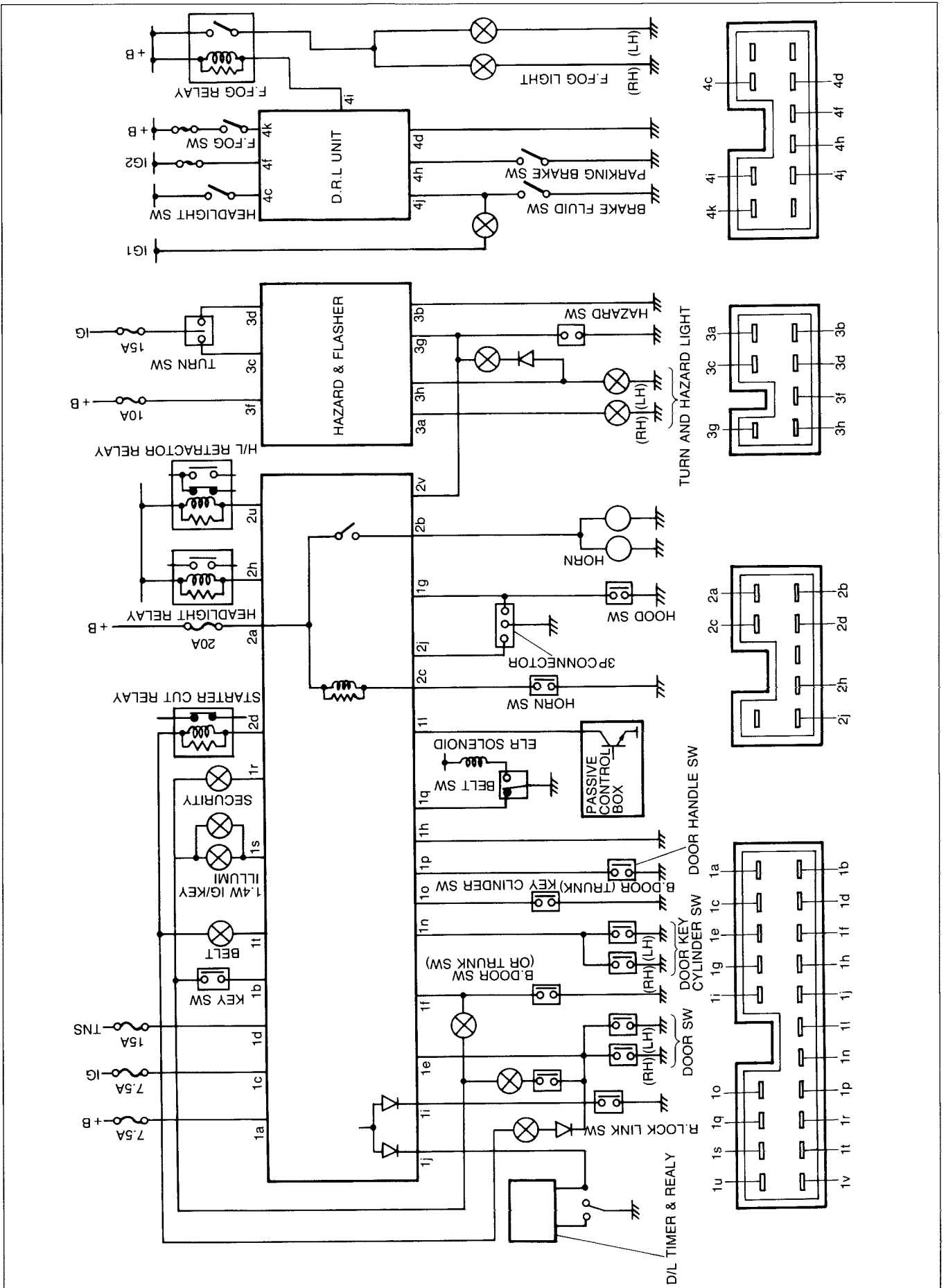

T INSTRUMENT CLUSTER

INSTRUMENT CLUSTER

STRUCTURAL VIEW

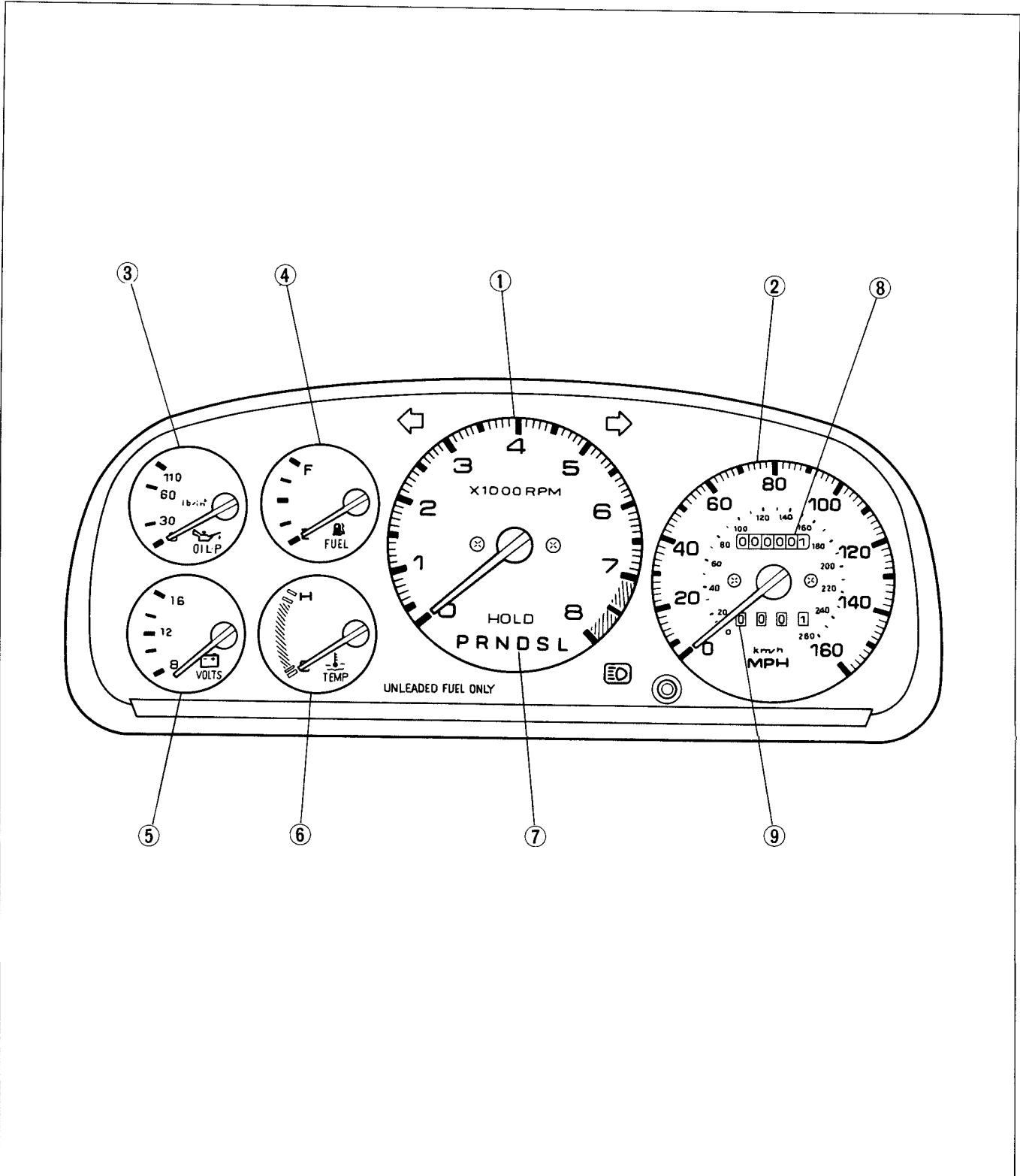

97U0TX-037

- | | |
|---|----------------------------|
| 1. Tachometer | 6. Water temperature gauge |
| 2. Speedmeter | 7. A/T position indicator |
| 3. Oil pressure gauge | 8. Odometer |
| 4. Fuel gauge | 9. Tripmeter |
| 5. Voltmeter (Non-Turbo model)
Boost meter (Turbo model) | |

REMOVAL AND INSTALLATION

1. Disconnect the negative battery cable. Remove in the sequence shown in the figure.
2. Assemble in the reverse order of disassembly.

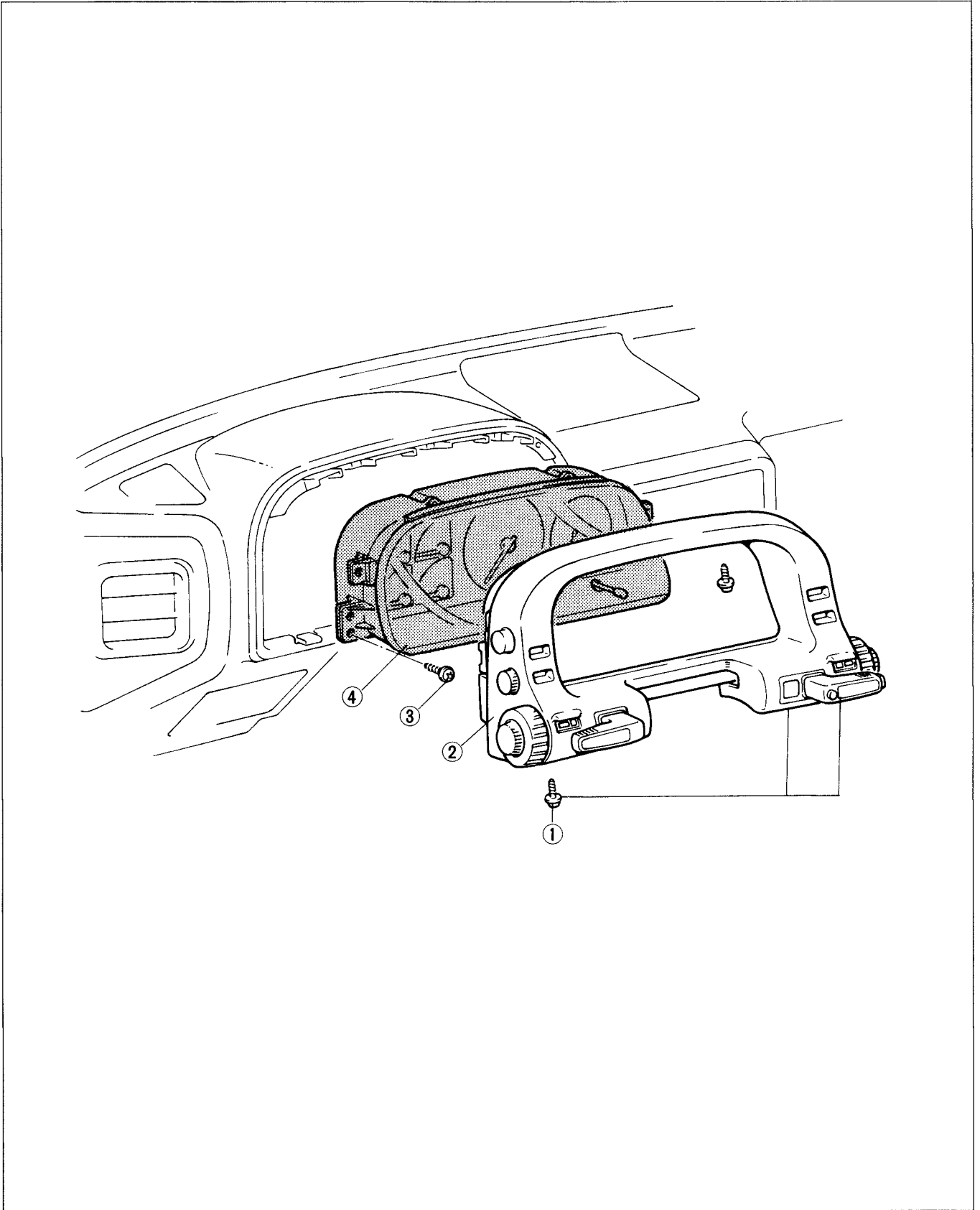

1. Tapping screws
2. Cluster switch panel

3. Tapping screws
4. Meter

97U0TX-038

T INSTRUMENT CLUSTER

DISASSEMBLY AND ASSEMBLY

1. Disassemble in the sequence shown in the figure.
2. Assemble in the reverse order of disassembly.

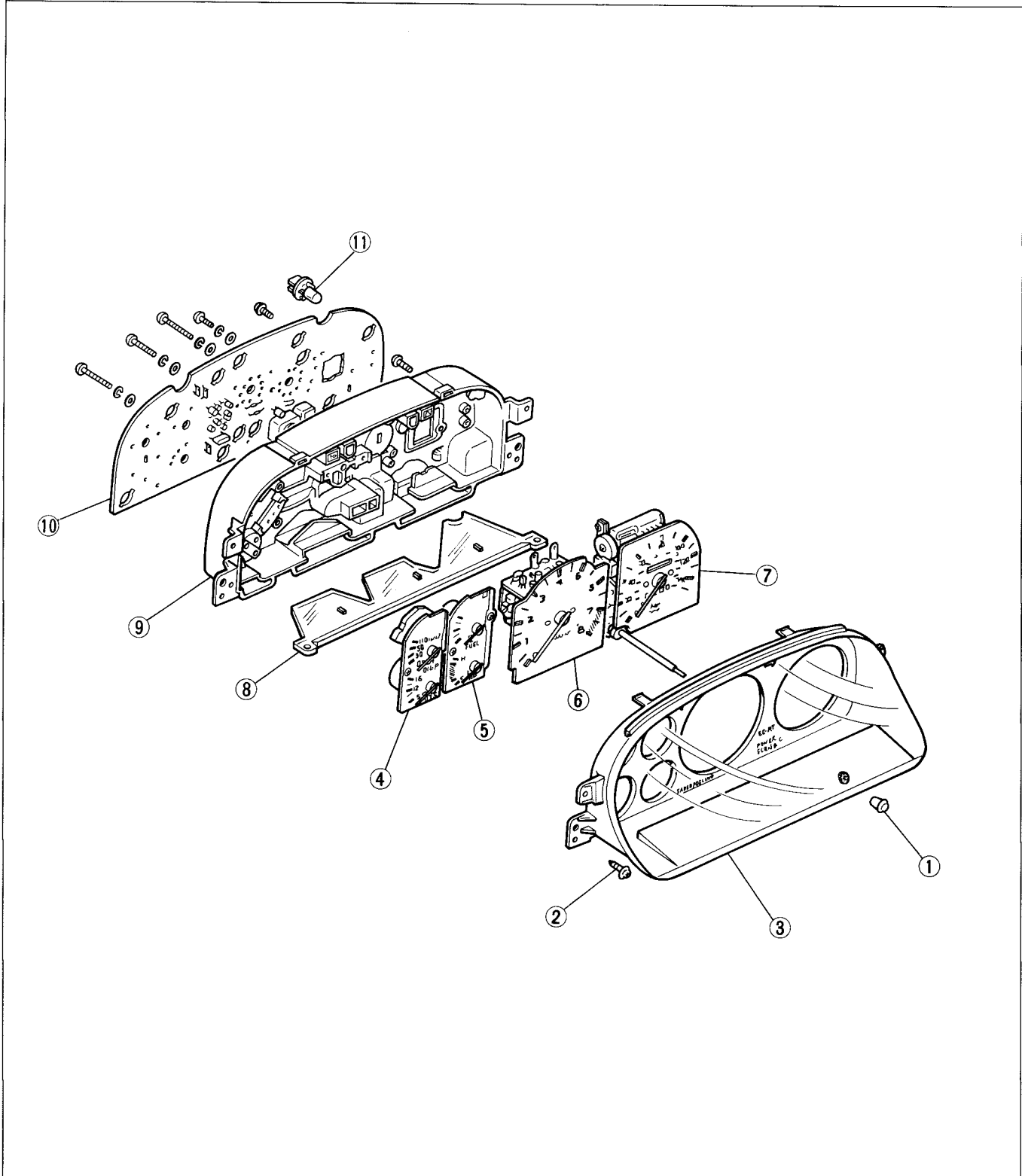

97U0TX-039

- | | |
|---|---------------------------|
| 1. Trip meter knob | 6. Tachometer |
| 2. Screws | 7. Speedometer |
| 3. Front lens & window plate | 8. Plate |
| 4. Boost meter & oil pressure gauge (Turbo) | 9. Meter case |
| Voltmeter & oil pressure gauge (Non-Turbo) | 10. Printed circuit board |
| 5. Fuel & water temperature gauge | 11. Bulb & socket |

METER PRINTED CIRCUIT BOARD INSPECTION

1. Check the printed circuit board for damage or rust.
2. Use an ohmmeter to check for continuity at the connector terminals.

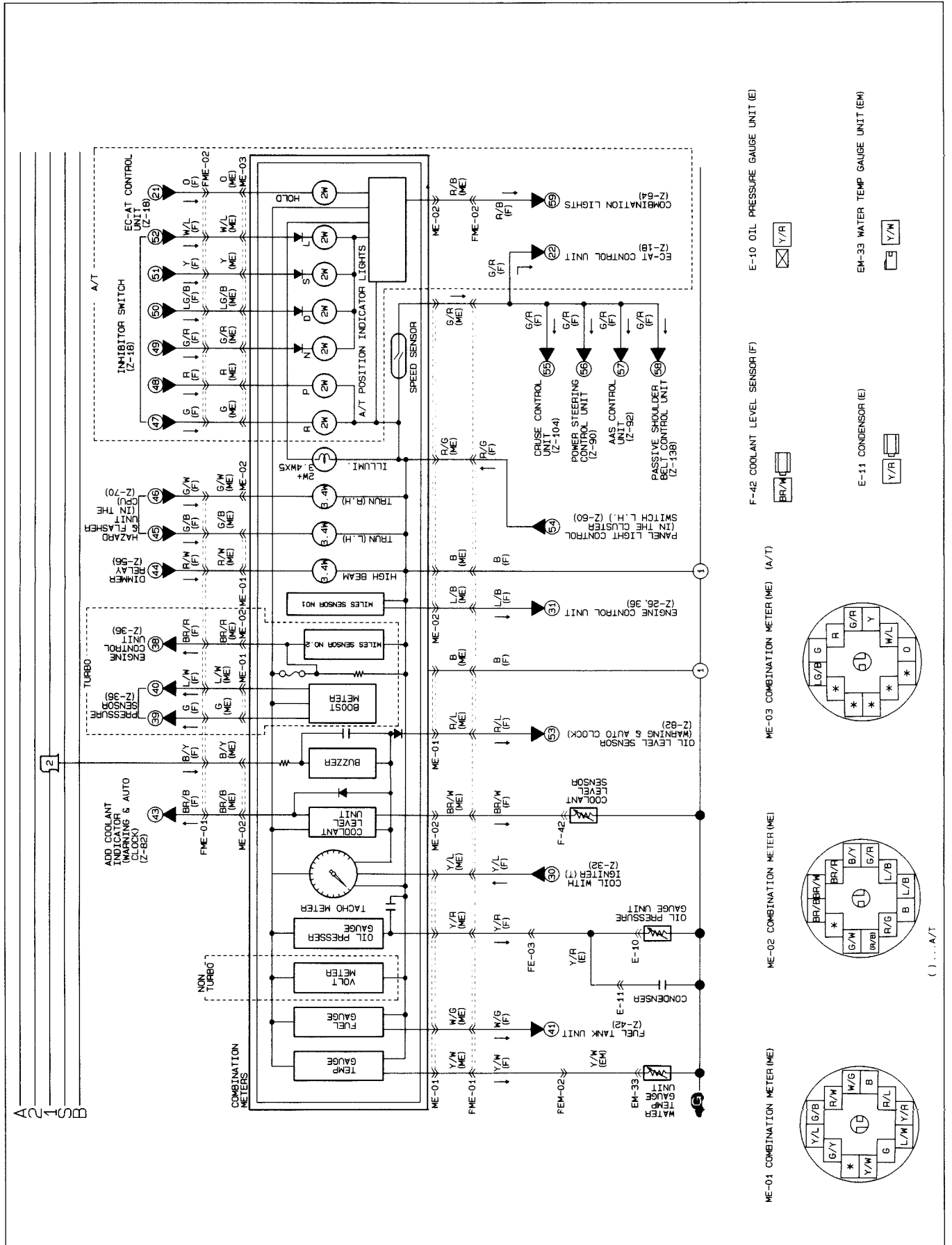

T INSTRUMENT CLUSTER

TROUBLESHOOTING GUIDE

Problem	Possible Cause	Remedy	Page
Speedometer does not work	Defective speedometer cable Defective speedometer	Replace Replace	T-38
Speedometer fluctuation	Defective speedometer cable Defective speedometer	Replace Replace	T-38
Tachometer does not work	METER fuse blown Defective tachometer Faulty wiring	Replace Check Repair	T-38
Fuel gauge does not work	METER fuse blown Defective fuel gauge Defective fuel tank sender unit Ground or wiring	Replace Check Check Repair	T-39 T-40
Water temperature gauge does not work	METER fuse blown Defective water temperature gauge Defective water temperature gauge sender unit Faulty wiring	Replace Check Check Repair	T-41

97U0TX-041

Standard indication (km/h)	Allowable range (km/h)
20	20— 22.7
40	40— 42.9
60	60— 63.5
80	80— 84.1
100	100—105.0
120	120—126.0
140	140—147.0
160	160—168.0
180	180—189.0

Standard indication (mph)	Allowable range (mph)
10	10—11.4
30	30—31.8
60	60—63.0
90	90—94.5

97U0TX-042

INSPECTION Speedometer

- Using chassis rollers, test the speedometer for allowable indication error, and check the operation of the odometer.
- Check the speedometer for fluctuation and/or abnormal noise.

Caution

- If significant fluctuation occurs or the speedometer does not move at all, remove and check the speedometer cable; if normal, replace the speedometer assembly.**
- Tire wear and improper inflation increases speedometer error.**

Tachometer

Compare a test tachometer rpm reading with the tachometer's indications. If there is significant error, replace the tachometer.

Caution

When removing or installing the tachometer, be careful not to drop it or subject it to sharp impact.

Standard indication (rpm)	Allowable range (rpm)
1000	940—1,120
2000	1,880—2,120
3000	2,850—3,150
4000	3,820—4,180
5000	4,790—5,210
6000	5,760—6,240
7000	6,727—7,273

at 20°C (68°F)

97U0TX-043

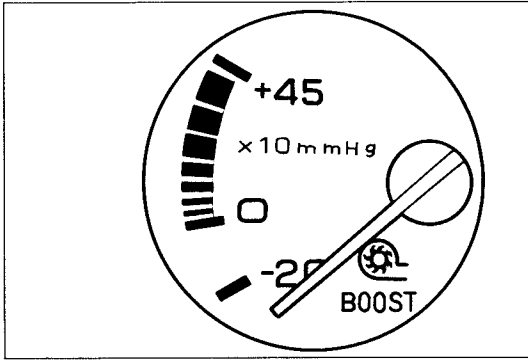

97U0TX-044

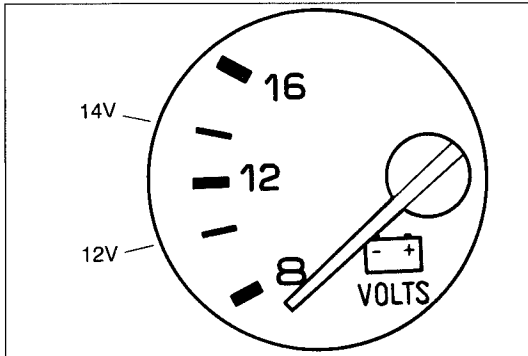

97U0TX-045

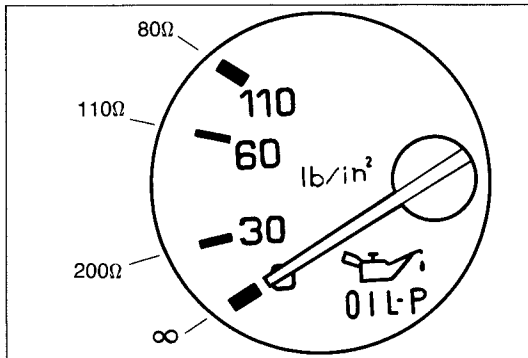

97U0TX-046

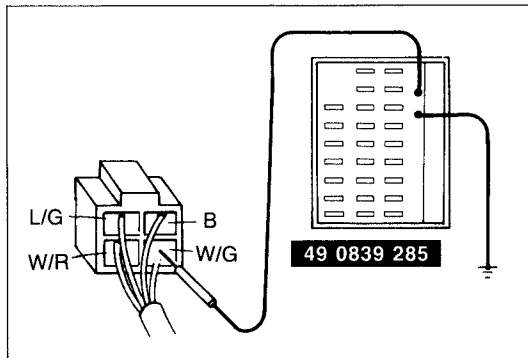

97U0TX-047

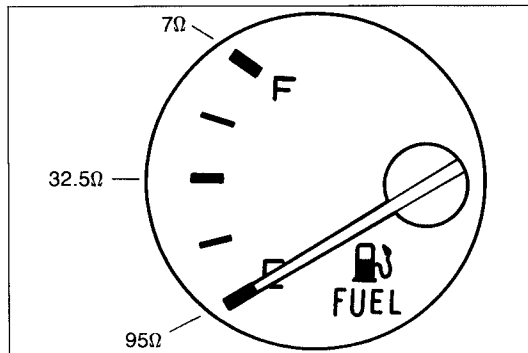

97U0TX-048

Boost Meter (Turbo model)

1. Check that the boost meter registers at less than 0 position when the engine is idling or the vehicle is moving at extremely low speeds.
2. Check that the pointer moves to a higher than "0" position when the pressure in the intake manifold increases, when the turbocharger is operating or when the engine speed increases.

Voltmeter (Non-Turbo model)

1. Connect a voltmeter to the battery terminals and then start the engine.
2. Compare the voltmeter and vehicle voltmeter indications. If there is significant error, replace the vehicle voltmeter.

Note

The allowable indication error is twice the width of the needle.

Oil Pressure Gauge

1. Remove the connector from the gauge sender unit.
2. Connect the red lead wire of the **checker** (49 0839 285) to the connector and the black lead wire to a body ground.
3. Turn ON the ignition switch and check that the needle indicator displays the correct values.

Note

- a) Continue the above inspections for at least two minutes each to correctly judge the condition.
- b) The allowable indication error is twice the width of the needle.
- c) Oil pressure becomes low when engine is cold because the eccentric shaft bypass valve operates.

Fuel Gauge

1. Disconnect the connector from the fuel tank sender unit.
2. Connect the red lead wire of the **checker** (49 0839 285) to the connector and the black lead wire to a body ground.

3. Set the checker to the resistance values shown in the figure.
4. Turn ON the ignition switch and check that the needle indicator displays the correct values.
If the needle displays the correct values, the fault is in the gauge sender unit; if not, the fault is in the meter.

Caution

- a) Continue the above inspections for at least two minutes each to correctly determine the condition.
- b) The allowable indication error is twice the width of the needle.

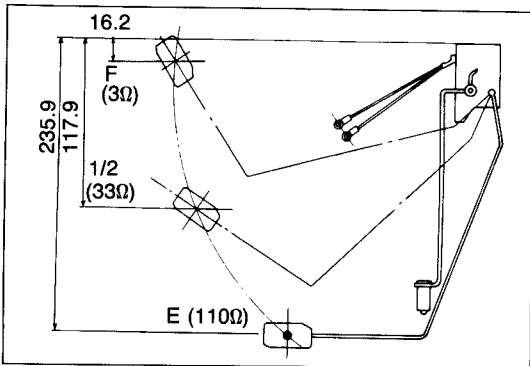

97U0TX-049

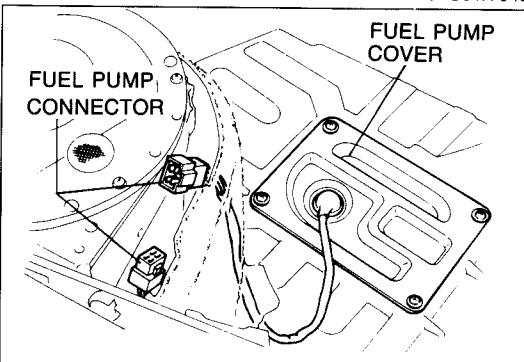

97U0TX-050

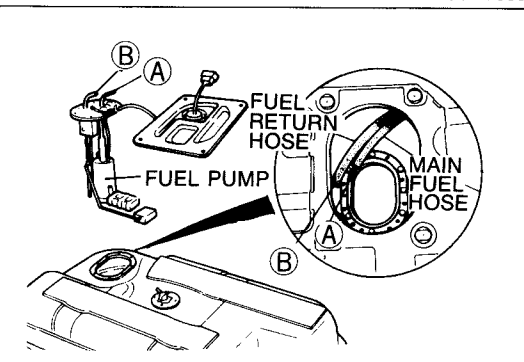

87U15X-081

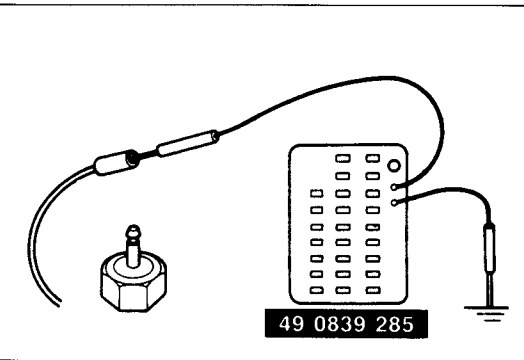

97U0TX-051

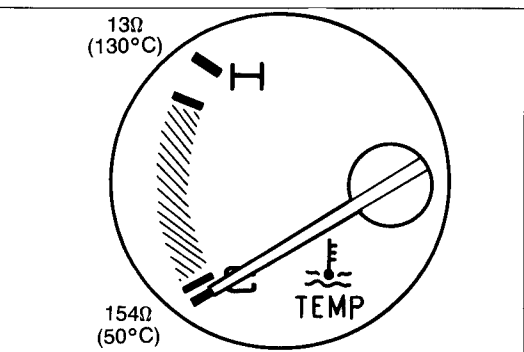

97U0TX-052

Fuel Tank Sender Unit

1. Connect an ohmmeter to the tank sender unit.
2. Move the unit arm slowly from point (E) to point (F) and read the resistance value. If this value is not as specified, replace the sender unit.

Removal

Warning

Before performing the following procedures, release the fuel pressure from the fuel system to reduce the possibility of injury or fire.

1. Lift up the rear mat.
2. Remove the fuel pump cover.
3. Disconnect the fuel pump connector.
4. Disconnect the fuel main hose and the return fuel hose.
5. Remove the fuel pump screws.
6. Remove the fuel pump from the fuel tank.

Installation

Install in the reverse order of removal.

Water Temperature Gauge

1. Remove the connector from the gauge sender unit.
2. Connect the red lead wire of the **checker** (49 0839 285) to the connector, and the black lead wire to a body ground.
3. Set the **checker** as shown in the figure.
4. Turn ON the ignition switch and check that the needle indicator displays the correct values. If the needle displays the correct values, the fault is in the gauge sender unit; if not, the fault is in the meter.

Note

- a) Continue the above inspection for at least two minutes to correctly judge the condition.
- b) The allowable indication error is twice the width of the needle.

Cooling Fan Warning Light (with ABS)

1. Disconnect the connector from the electric cooling fan unit.
2. Connect (BR) terminal wire to a body ground.
3. Start the engine, check that the cooling fan warning illuminates.
4. If there is no illumination, check the fuse, bulb, and wiring harness.

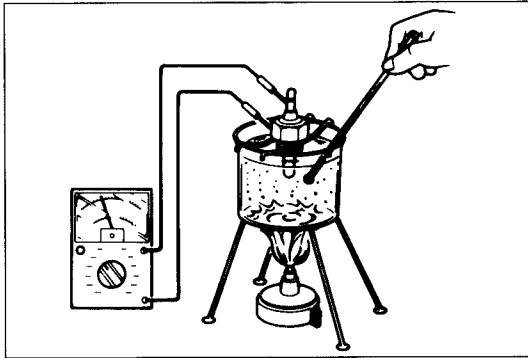

97U0TX-053

Water Temperature Gauge Sender Unit

1. Remove the gauge sender unit.
2. Place the gauge unit in a container of water, and heat the water to **80°C (176°F)**.
3. Use an ohmmeter to measure the resistance.

Resistance: 57.7—49.3Ω

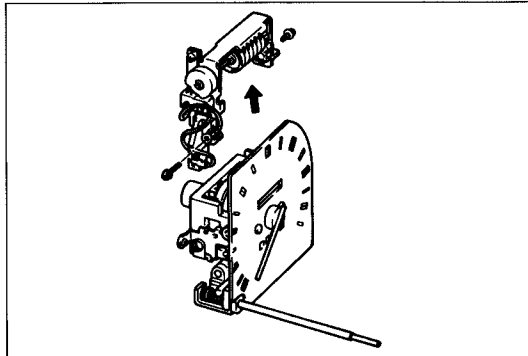

97U0TX-054

Mileage Sensor

Caution

When replacing the speedometer within 20,000 mile (For U.S.A.), 34,000 km (For Canada), continue to use the same 20,000 mile switch by transferring it to the new speedometer.

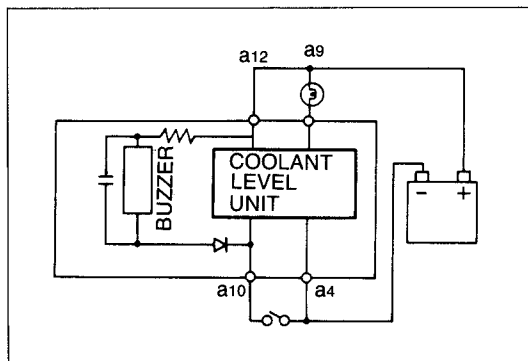

67U15X-031

Coolant Level Sensor Unit

1. Remove the meters from the instrument panel.
2. Make connections between the unit and the battery as shown in the figure.
3. The unit is normal if the test bulb does not illuminate when the switch is closed, and if it does illuminate 9 to 16 seconds after the switch is opened.
4. Replace the meters if there is a malfunction.

T WARNING AND CLOCK UNIT

WARNING AND CLOCK UNIT

STRUCTURAL VIEW

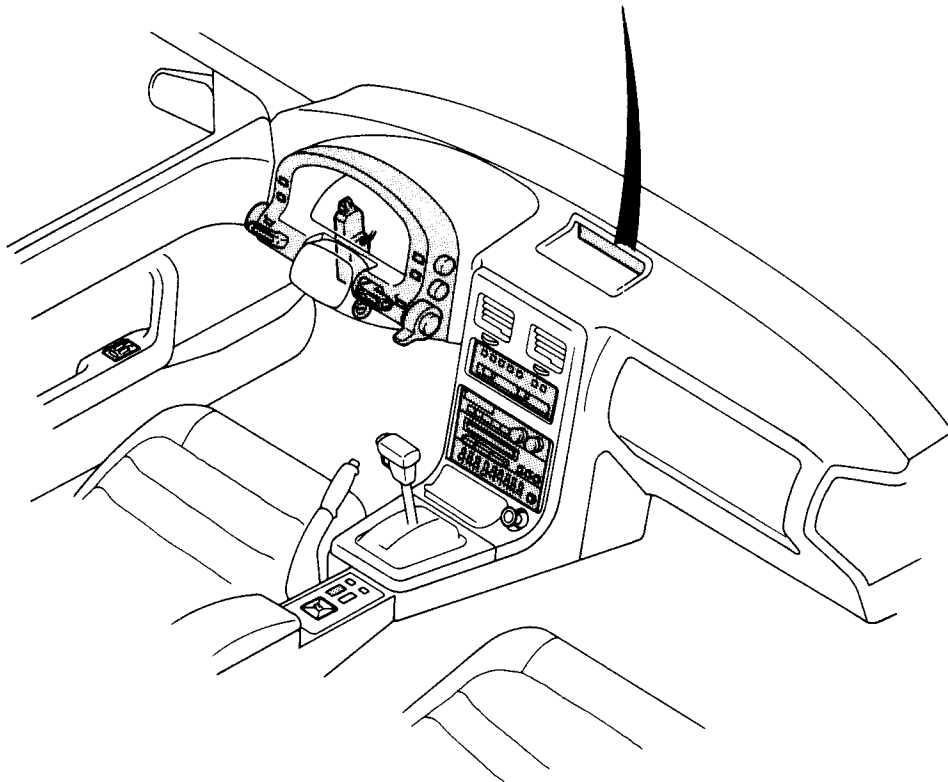
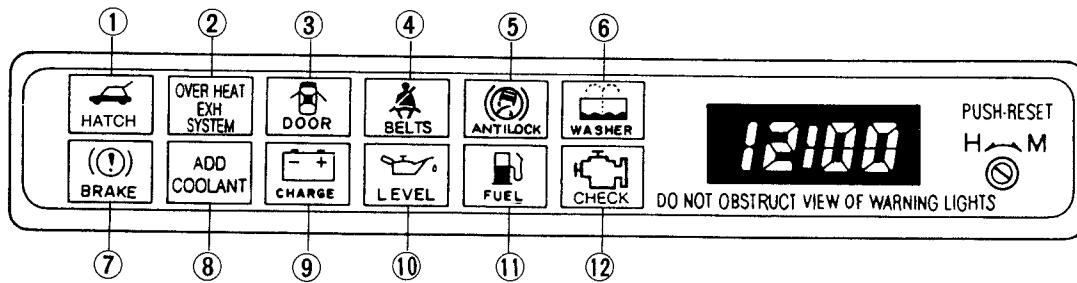

97U0TX-055

- | | |
|------------------------------------|------------------------------|
| 1. Rear hatch ajar warning | 7. Brake fluid level warning |
| 2. Overheat exhaust system warning | 8. Coolant level warning |
| 3. Door ajar warning | 9. Alternator warning |
| 4. Seat belt warning | 10. Engine oil level warning |
| 5. ABS warning | 11. Fuel level warning |
| 6. Washer fluid level warning | 12. Malfunction indicator |

REMOVAL AND INSTALLATION

1. Disconnect the negative battery cable, remove in the sequence shown in the figure.
2. Install in the reverse order of removal.

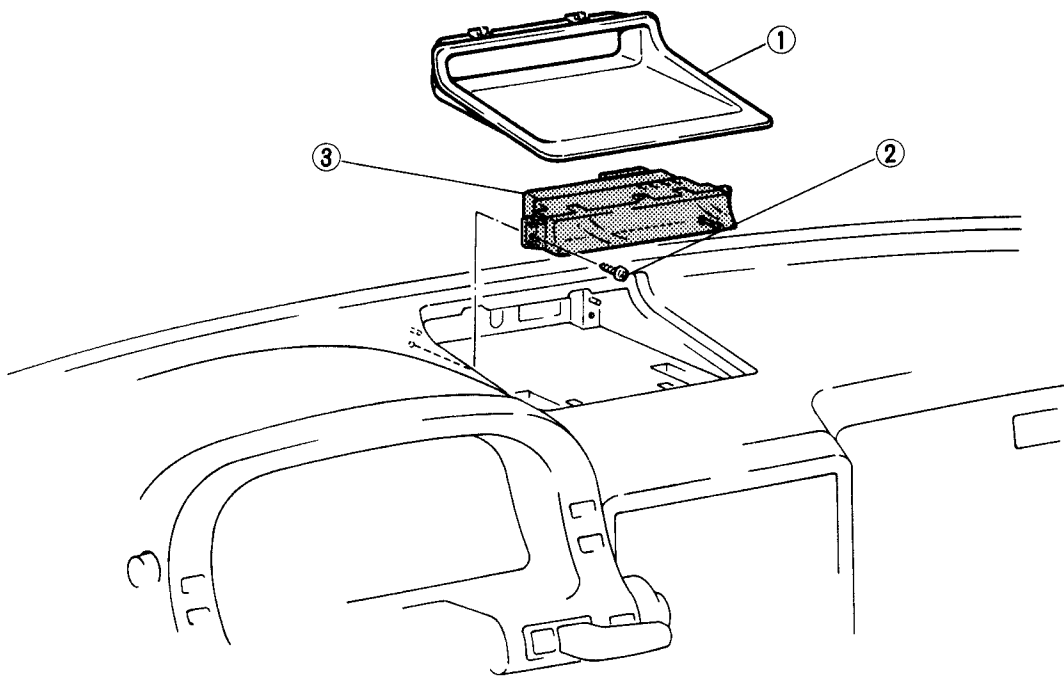

97U0TX-056

1. Clock bezel assembly

2. Tapping screws

3. Warning and clock unit

T WARNING AND CLOCK UNIT

CIRCUIT DIAGRAM

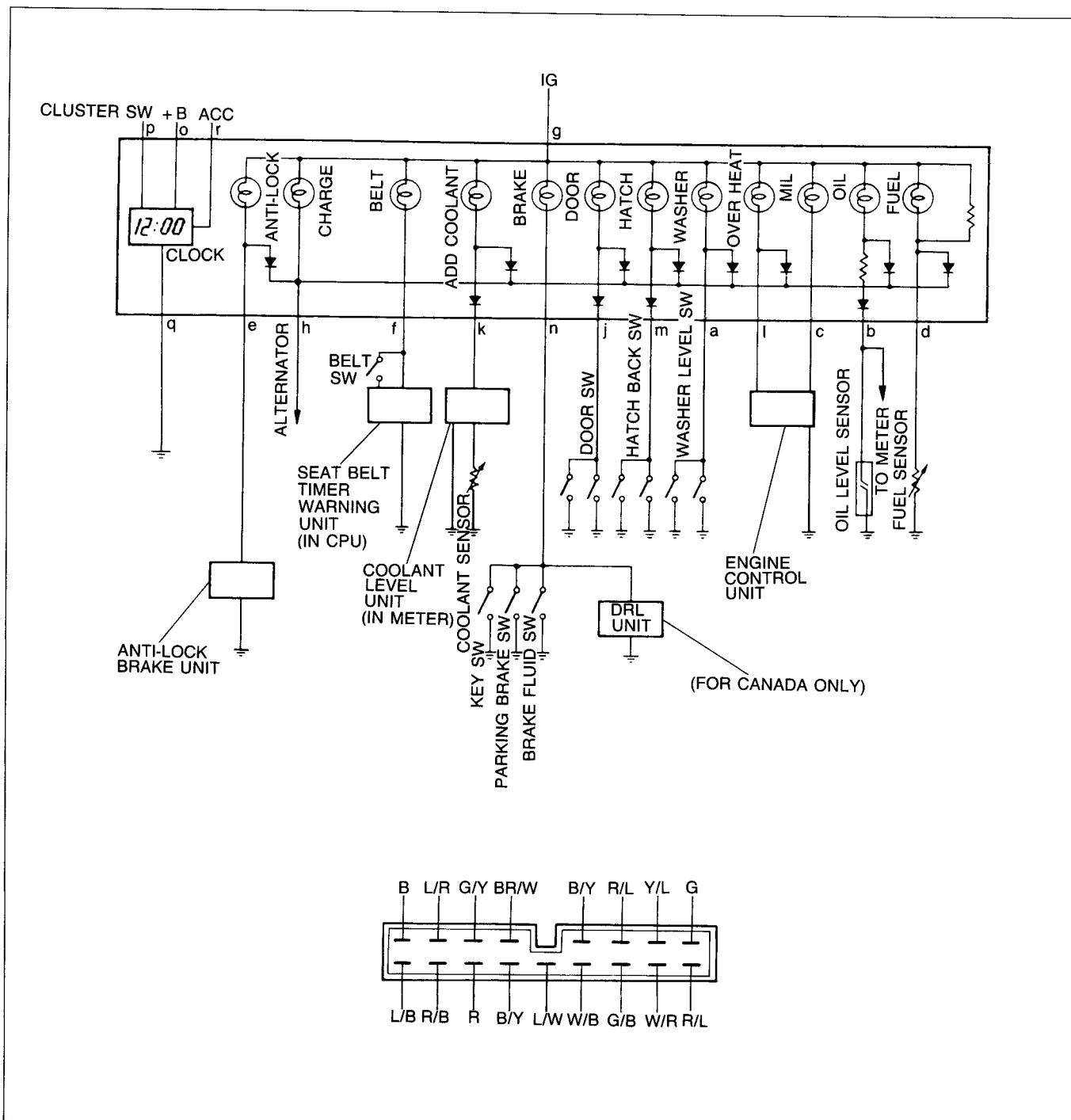

97U0TX-057

No.	Connections	No.	Connections
a	Washer fluid level sensor	k	Meter
b	Oil level sensor	l	Engine control unit
c	Engine control unit	m	Rear hatch switch (Without Convertible)
d	Fuel tank unit	n	Brake fluid level switch
e	ABS unit (With ABS only)	o	Fuse box (battery)
f	Seat belt timer & buzzer (in CPU)	p	Cluster switch
g	+ Ig	q	Ground
h	Alternator	r	Fuse box (accessory)
j	Door switch		

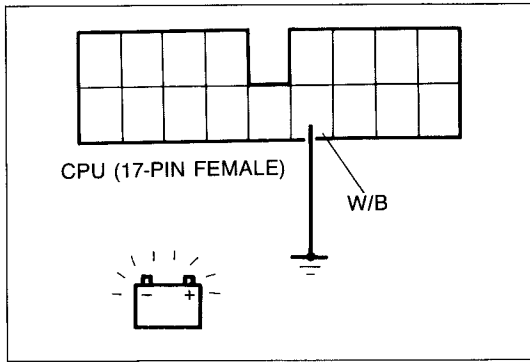

INSPECTION OF CIRCUIT AND PARTS

Alternator Warning Light

1. Disconnect the connector (17-pin) from the central processing unit.
2. Connect the (W/B) terminal wire to a body ground.
3. Start the engine and check that the CHARGE warning light illuminates.

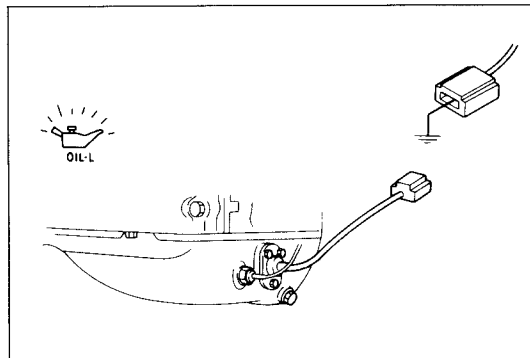

Oil Level Warning Light

1. Disconnect the connector from the oil level sensor.
2. Connect the (R/L) terminal wire to a body ground.
3. Start the engine and check that the OIL-L warning light illuminates.
4. If there is no illumination, check the fuse, bulb, and wiring harness.

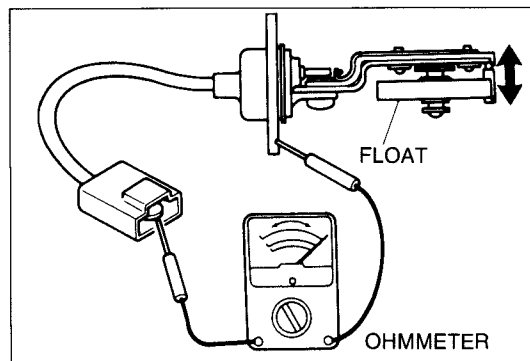

Oil Level Sensor

Connect an ohmmeter to the level sensor and check the continuity by moving the float up and down. When the float is in the upper position the ohmmeter should not show continuity, and when moved to the lower position it should show continuity. Replace the oil level sensor if it is not operating correctly.

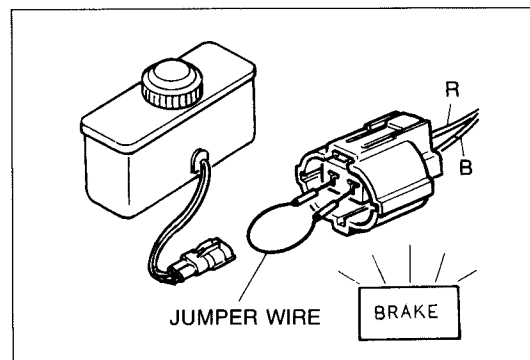

Brake System Warning Light

1. Disconnect the connector from the brake fluid level sensor.
2. Connect a jumper wire between the (R) and (B) terminal wire.
3. Start the engine and check that the BRAKE warning light illuminates.

Note

Check that the parking brake is fully released before checking.

4. If there is no illumination, check the fuse, bulb, and wiring harness.

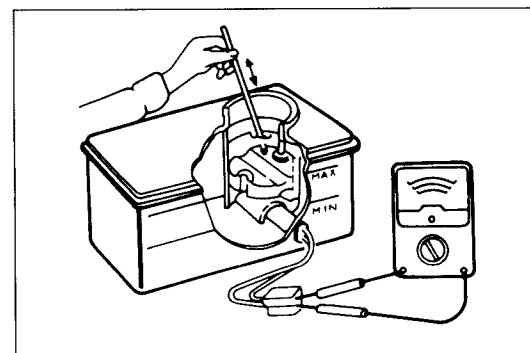

Brake Fluid Level Sensor

Connect an ohmmeter to the terminals of the brake fluid level sensor connector. Check for continuity when the float is moved up and down. The sensor is operating properly if there is continuity when the float is below the "MIN" mark, and if there is no continuity when the float is above the "MAX" mark. If the sensor does not pass this test, replace it.

T WARNING AND CLOCK UNIT

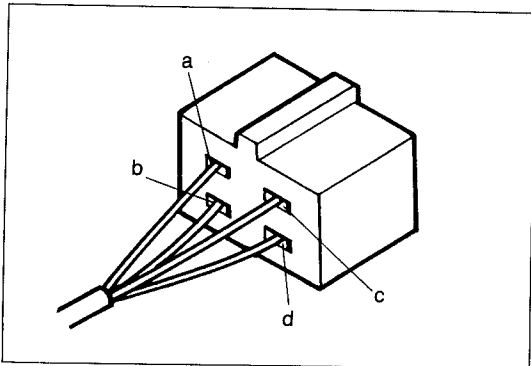

97U0TX-060

Seat Belt Warning Switch (With Passive Shoulder Belt)

1. Remove the center pillar trim, and disconnect the passive seat belt retractor connector.
2. Check continuity between the terminals when the passive seat belt is at the rear lock position.

Seat belt position		Terminal			
		Left side		Right side	
Locked	Belt fastened	○	○	○	○
	Belt unfastened				

○—○: Indicates continuity

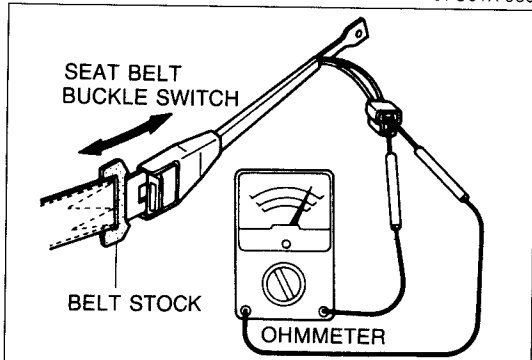

97U0TX-196

Buckle Switch (Lap Belt)

Insert the seat belt stock into the buckle, and use an ohmmeter to check for continuity of the switch.

Belt inserted.....no continuity
Belt not inserted.....continuity

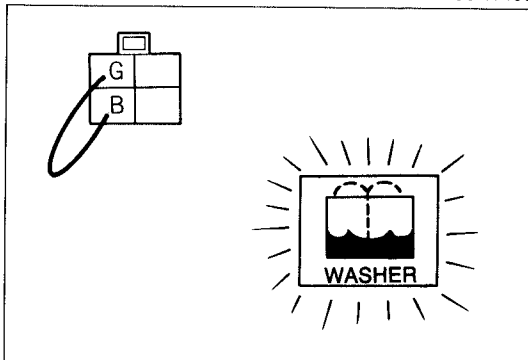

97U0TX-061

Washer Fluid Level Warning Light

1. Disconnect the connector from the washer fluid level sensor.
2. Connect a jumper wire between the (G) and (B) terminal wires.
3. Start the engine and check that the WASHER warning light illuminates.
4. If there is no illumination, check the fuse, bulb, and wiring harness.

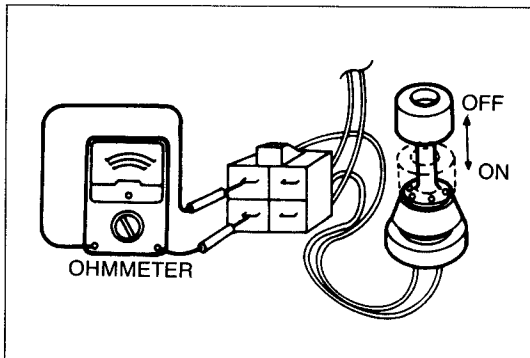

67U15X-041

Washer Fluid Level Sensor

1. Connect the sensor connector to a tester.
2. Move the sensor float up and down.
3. Check that there is continuity when the float is at the lowest point.

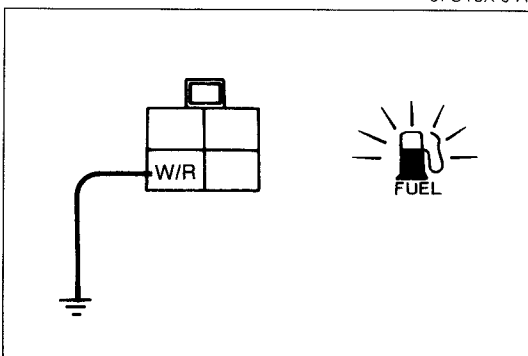

97U0TX-062

Low Fuel Level Warning Light

1. Disconnect the connector from the fuel tank sender unit.
2. Connect the (W/R) terminal wire to a body ground.
3. Start the engine and check that the FUEL warning light illuminates.
4. If there is no illumination, check the fuse, warning light, and wiring harness.

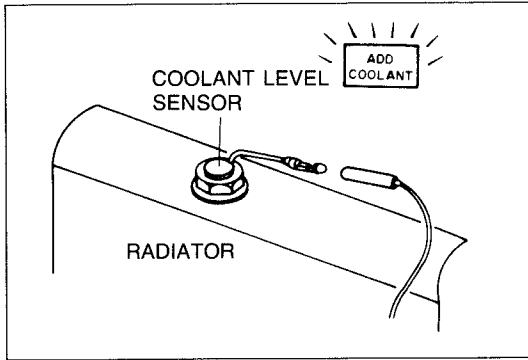

67U15X-046

Coolant Level Warning Light

1. Disconnect the connector from the coolant level sensor.
2. Start the engine and check that the coolant warning light illuminates 9—16 seconds after starting the engine.
3. If there is no illumination, check the fuse, bulb, coolant level sensor unit, and wiring harness.

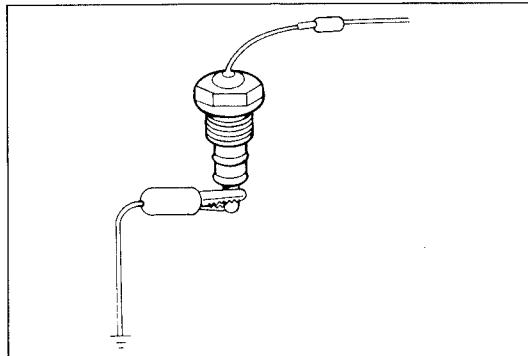

67U15X-047

Coolant Level Sensor

1. Remove the level sensor and connect the connector.
2. With the sensor not grounded to the body, start the engine.
3. After checking that the warning light illuminates, ground the threaded part of the sensor.
4. If the warning light remains illuminated, the sensor is normal. If it does not, the sensor is faulty and should be replaced.

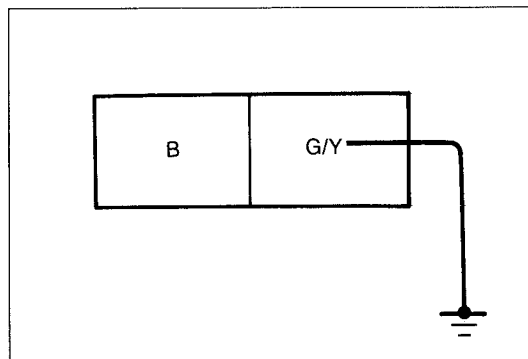

97U0TX-063

Rear Hatch Ajar Warning Light

1. Disconnect the connector from the rear hatch connector.
2. Connect (G) terminal wire to a body ground.
3. Start the engine and check that the rear hatch ajar warning light illuminates.
4. If there is no illumination, check the fuse, bulb, and wiring harness.

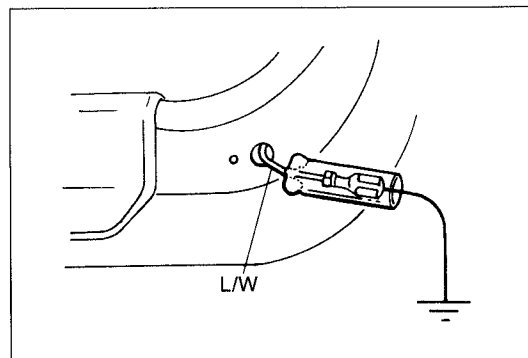

97U0TX-064

Door Ajar Warning Light

1. Disconnect the connector from the door switch.
2. Connect (L/W) terminal wire to a body ground.
3. Start the engine, check that the door ajar warning light illuminates.

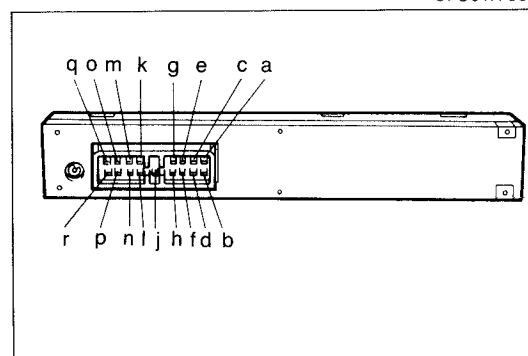

97U0TX-065

ABS Warning Light (with ABS)

1. Remove the clock bezel assembly.
2. Slide the warning and clock unit out of the instrument panel.
3. Connect R/L wire (e terminal) to a body ground.
4. Start the engine, check that the ABS warning light illuminates.
5. If there is no illumination, check the fuse, bulb, and wiring harness.

T WARNING AND CLOCK UNIT

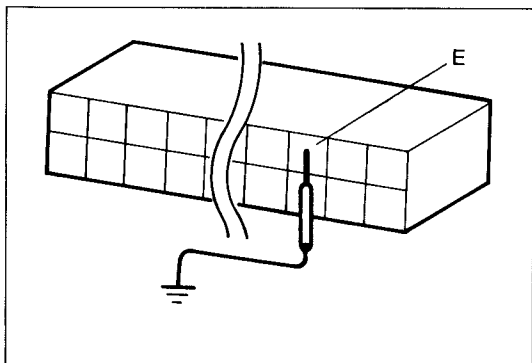

97U0TX-066

Malfunction Indicator Light

1. Disconnect the engine control unit.
2. Connect the E terminal of harness side connector to a body ground.
3. Start the engine and check that the warning light illuminates.
4. If there is no illumination, check the fuse bulb, and wiring harness between warning lamp and engine control unit.

Overheat Exhaust System Warning Light

Refer to Section F1 or F2

97U0TX-067

EXTERIOR LIGHTS

STRUCTURAL VIEW

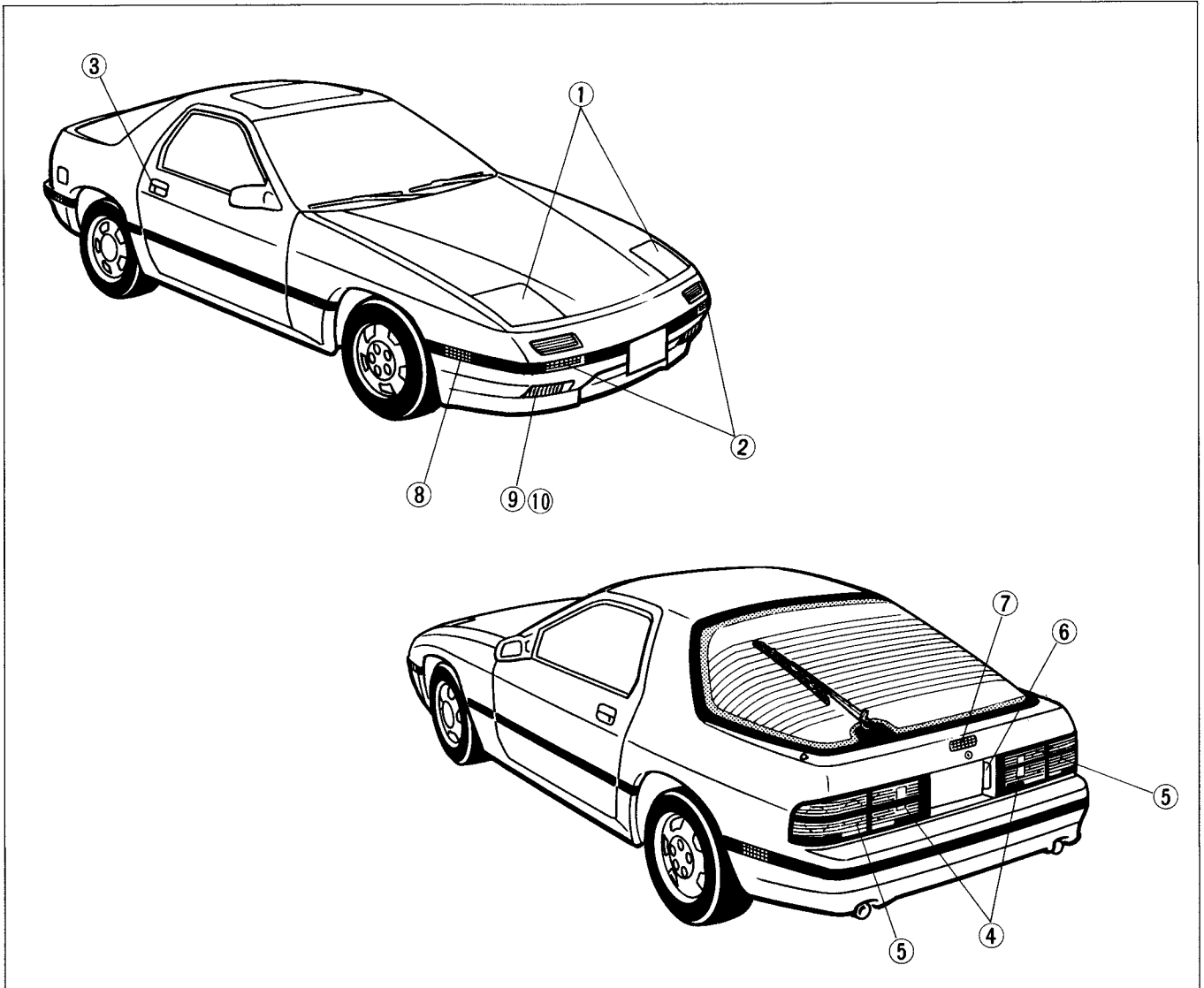

97U0TX-068

- | | |
|-----------------------------|--|
| 1. Headlight | 6. Licence light |
| 2. Turn and hazard light | 7. High mount stop light |
| 3. Door lock cylinder light | 8. Front side marker light |
| 4. Back-up light | 9. Front fog light (For USA) |
| 5. Stop and tail light | 10. Daytime running light (For Canada) |

TROUBLESHOOTING GUIDE

Problem	Possible Cause	Action	Page
Retractable headlight system does not work	Retractor fuse blown	Replace fuse and check for short	T-51
	Defective cluster switch	Check	T-51
	Defective retractor motor	Check	T-51
	Defective wiring or ground	Repair	T-51
Headlights do not come on	Main fuse blown	Replace main fuse and check for short	T-51
	Defective cluster switch	Check	T-51
	Defective wiring or ground	Repair	T-51
High beam lights do not operate	Defective cluster switch	Check	T-51
	Defective wiring	Repair	T-51

T EXTERIOR LIGHTS

Problem	Possible Cause	Action	Page
All exterior lights, tail lights and parking lights do not come on	TAIL, ILLUMI fuse blown	Replace fuse and check for short	T-51
	Defective cluster switch	Check	T-51
	Defective wiring or ground	Repair	
Stoplights do not come on	HORN, STOP fuse blown	Replace fuse and check for short	T-52
	Defective stoplight switch	Check or replace	T-52
	Defective wiring or ground	Repair	
Turn signals do not operate	METER, BACK fuse blown	Replace fuse and check for short	T-53
	Defective cluster switch	Check	T-53
	Defective central processing unit (Flasher unit)	Check	T-53
Daytime running lights do not come on	F.FOG fuse blown	Replace fuse and check for short	T-52
	Defective front fog light switch	Check	T-52
	Defective central processing unit	Check	T-52
	Defective wiring or ground	Repair	

97U0TX-069

CIRCUIT DIAGRAM

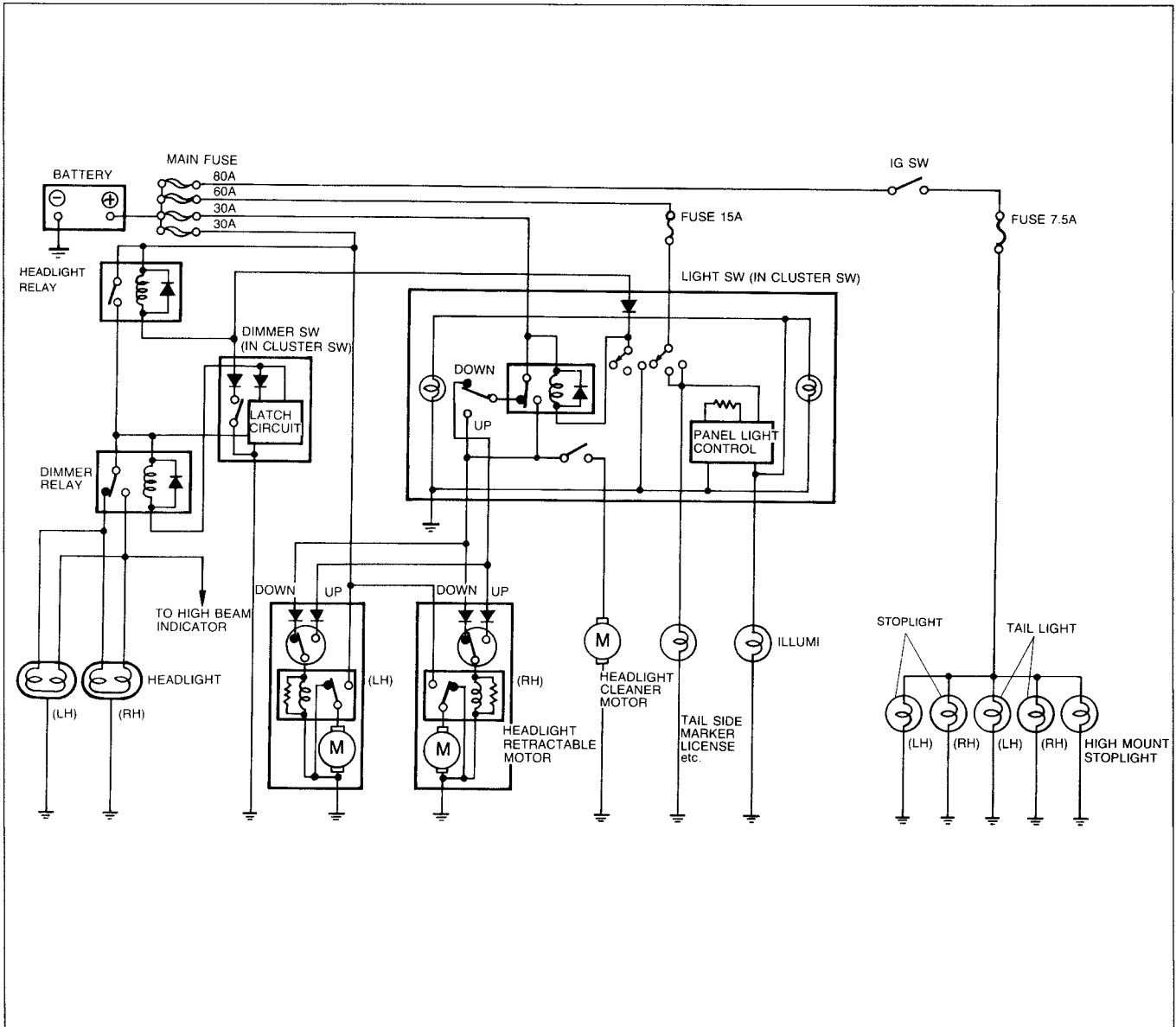

97U0TX-070

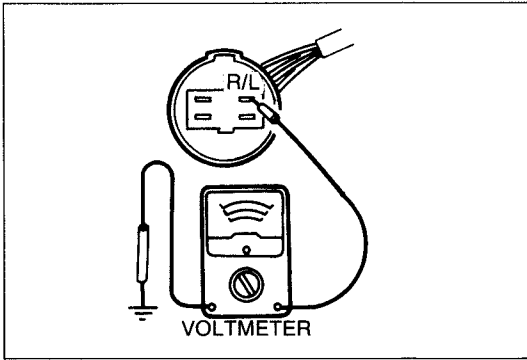

97U0TX-071

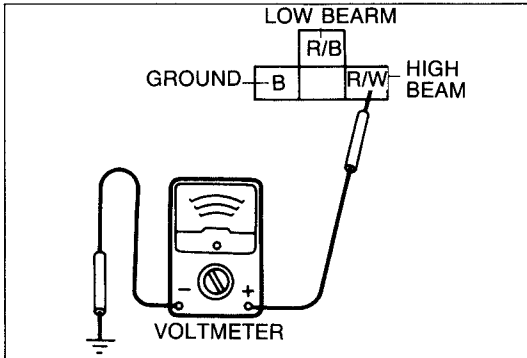

97U0TX-072

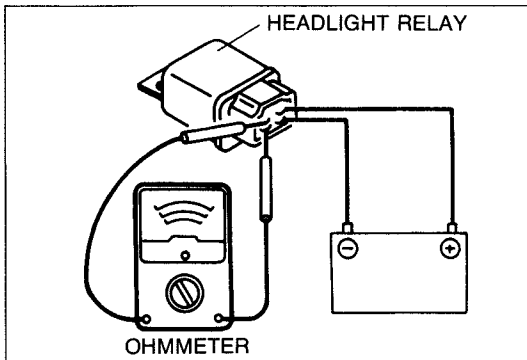

67U15X-053

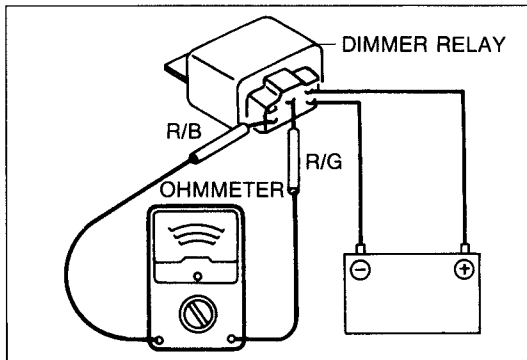

97U0TX-073

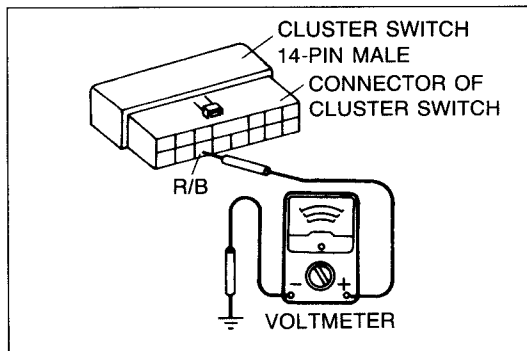

97U0TX-074

INSPECTION

Retractable Headlight System

(Retractable headlight system does not operate)

1. Check that the main fuse is not burned.
2. If the main fuse is not burned, connect a voltmeter to the (R/L) wire of the connector for the retractor motor, and measure the voltage when the light switch or retractor switch is in the ON (UP) position.
3. If battery voltage is shown, there may be improper grounding of the motor or a malfunction of the motor.
4. If there is no voltage shown, a malfunction of the wiring or light switch and/or retractable switch may be the problem.

(Headlights do not come on)

1. Check that the main fuse is not burned.
2. Check that battery voltage is applied to the (R/B) or (R/W) wires of the headlight connect when the light switch is in the ON position.
3. If battery voltage is shown, there may be a malfunction of the headlights or a bad ground connection.
4. If there is no voltage shown, check the headlight relay, dimmer relay, and light switch.

Headlight relay

1. Connect the headlight relay, battery, and an ohmmeter as shown in the figure.
2. First check that there is continuity, then disconnect the battery and check that there is no continuity.
3. If the continuity is not as specified, replace the relay.

Dimmer relay

1. Check that there is continuity between (R/G) and (R/B) wires.
2. Connect the dimmer relay, battery, and an ohmmeter as shown in the figure.
3. Check that there is no continuity, then disconnect the battery and check that there is continuity.
4. If the continuity is not as specified, replace the relay.

Taillight System

(Taillights do not light)

1. Check that a fuse is not burned.
2. If the fuse is not burned, connect a voltmeter to the (R/B) wire of connector for the left cluster switch.
3. Check that battery voltage is applied when the headlight switch is in the ON position.
4. If there is no voltage shown, check the light switch. If battery voltage is shown, there may be poor contact of the connector connecting the front and rear harness.

T EXTERIOR LIGHTS

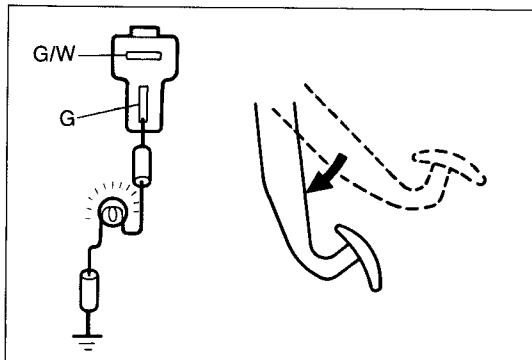

97U0TX-075

Stoplight System (Stoplights do not light)

1. Check that a fuse is not burned.
2. If not, connect a test light between the (G) wire of the stoplight switch connector and a body ground, and check that the test light illuminates when the brake pedal is depressed.
3. If it does not illuminate, connect the test light to the (G/W) wire and check that it illuminates. If it does, there may be a malfunction or improper adjustment of the stoplight switch.
4. Check that the stoplight is properly grounded.

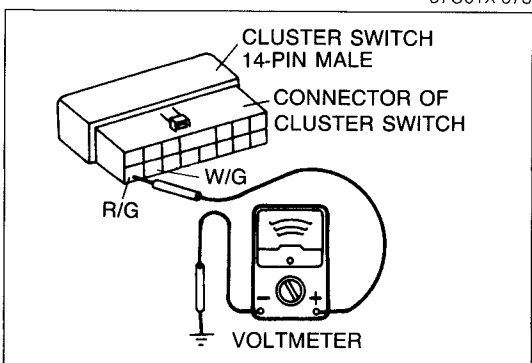

97U0TX-076

Illumination Light Control System (The illumination light does not illuminate)

1. Connect a voltmeter to the (R/G) wire of the connector for the left cluster switch.
2. Check that voltage is applied when the headlight switch is moved to the tail light position and panel light control is in MAX position.
3. If there is approx. 12V, there may be a poor grounding of the illumination lights.
4. If there is no continuity, check that there is battery voltage to the (W/G) wire.

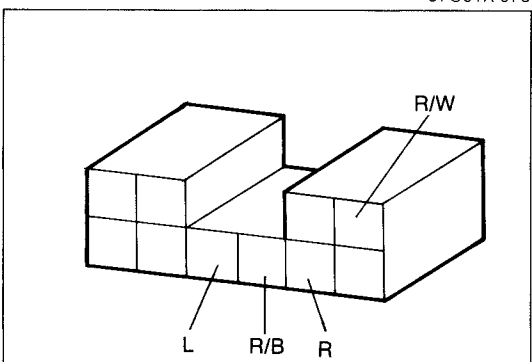

97U0TX-077

Checking the panel lamp control (Refer to page T-24.)

Daytime Running Light System (For Canada) (The daytime running lights do not come on)

1. Check that a fuse is not burned.
2. If the fuse is not burned, check for 12V on the (L) wire of the CPU.
3. Check for 12V on the (R/W) wire of the CPU when the headlight switch is not in the ON position.
4. Check for continuity of the (R/B) wire of the CPU to ground when the side brake is in the ON position.
5. Check for continuity of the (R) wire of the CPU to ground when the brake fluid level sensor is in the ON position.
6. If these are OK, check the front fog light relay.

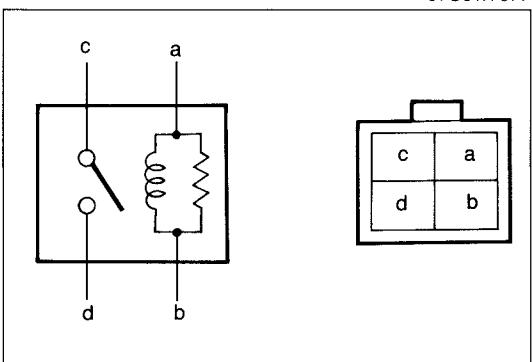

97U0TX-078

Front fog light relay

1. Disconnect the front fog light relay.
2. Check for continuity between the "C" terminal and the "d" terminal when connecting the 12V to the "a" terminal and the ground to the "b" terminal.
3. If these are OK, replace the CPU.

CIRCUIT DIAGRAM

■ TURN SIGNAL & HAZARD FLASHER LIGHTS ■ BACK-UP LIGHTS

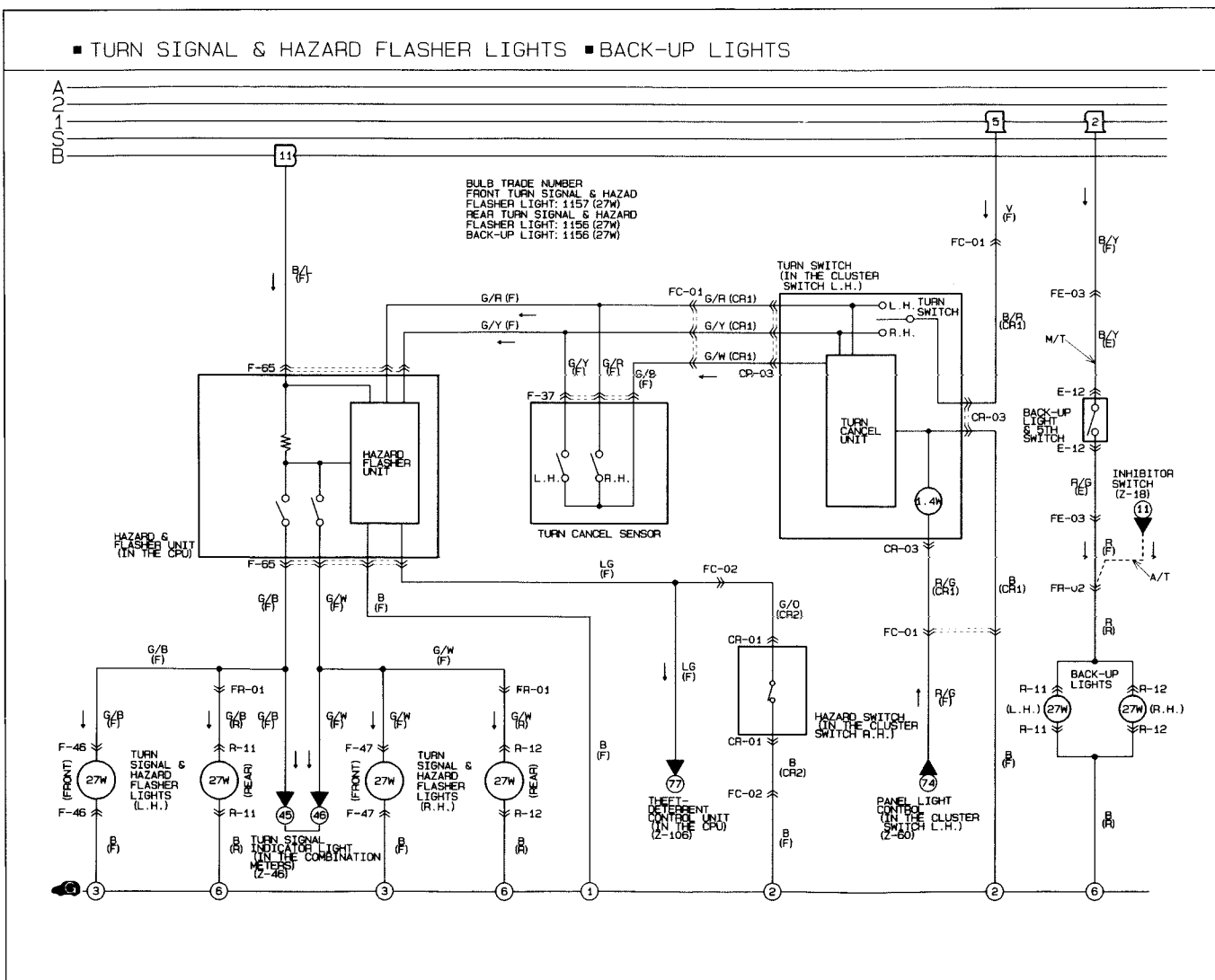

97U0TX-079

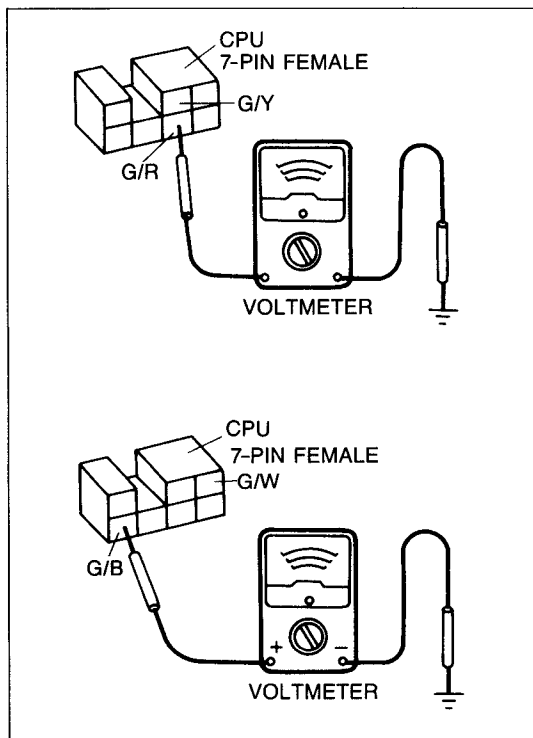

97U0TX-080

INSPECTION

Turn Signal Light System (Turn signals do not function)

1. Check the turn fuse.
2. If OK, connect a voltmeter to the (G/Y) or (G/R) wire of the central processing unit, and check that battery voltage is applied when the turn signal switch is ON while the ignition switch is ON. If not correct, there may be a malfunction of the turn signal switch.
3. If there is voltage, connect a voltmeter to the (G/B) or (G/W) wire of the turn and hazard unit and check that battery voltage is applied when the turn signal switch is ON while the ignition switch is ON. If not correct, check the printed board of the turn and hazard unit in the central processing unit.
4. If there is voltage, there may be a poor ground of the central processing unit.

(Turn signals work only for one direction)

Check the turn signal switch, or turn signal light ground.

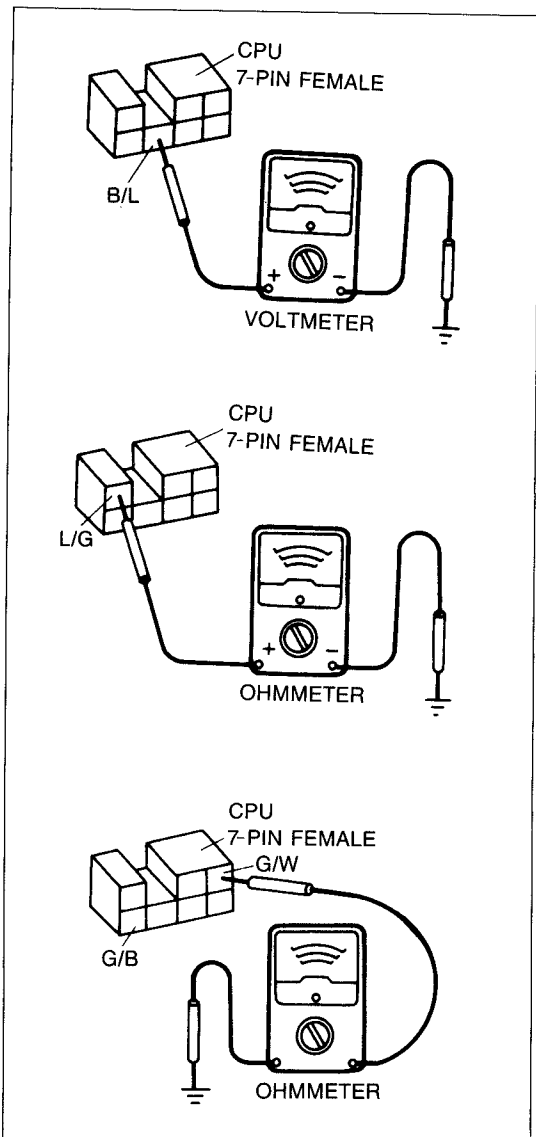

97U0TX-081

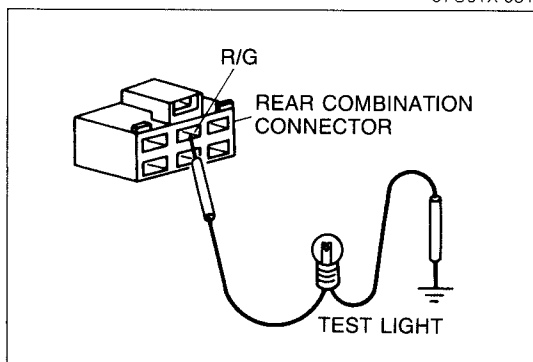

97U0TX-082

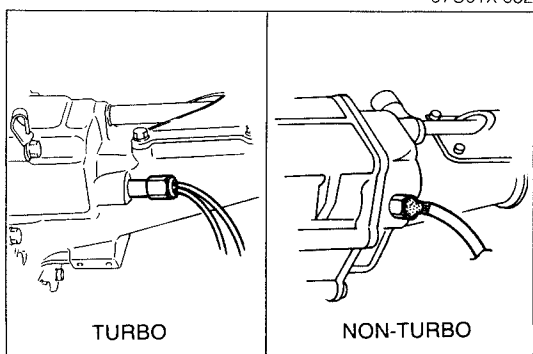

97U0TX-176

Hazard Warning Light System (Turn signals function but the hazard warning lights do not)

1. Check the hazard fuse.
2. If OK, connect a voltmeter to the (B/L) wire of the turn and hazard unit in the central processing unit and check that battery voltage is applied.
3. If there is no voltage, check the wiring between the hazard fuse and the central processing unit.
4. If there is voltage, connect a voltmeter to the (L/G) wire of the turn and hazard unit and check for no voltage when the hazard warning light switch is ON.
5. If there is voltage, there may be a malfunction of the hazard warning light switch or a poor ground of the switch.
6. If there is no voltage, connect a voltmeter to (G/B) or (G/W) wire of the turn and hazard unit and check that battery voltage is applied when the hazard warning light switch is ON.
7. If there is no voltage, there may be a malfunction of the turn and hazard unit.
8. If there is voltage, check the wiring or ground.

Back-up Light System (with M/T) (Back-up lights do not come on)

1. Check the meter fuse.
2. If OK, connect a test light to the (R/G) wire of the rear combination light connector. With the ignition switch ON, check that the test light illuminates when the shift lever is shifted to the reverse position.
3. If it illuminates, there may be a poor ground of the rear combination lights.
If it does not illuminate, check the back-up light and 5th switch and the wiring.

Back-up light and 5th switch (For M/T)

1. Disconnect the back-up light and 5th switch connectors.
2. Check continuity between terminals of the switch as shown.

Transmission	Continuity
Reverse	Yes
5th	No

3. If not as specified, replace the switch.

RETRACTABLE HEADLIGHTS Disassembly and Assembly

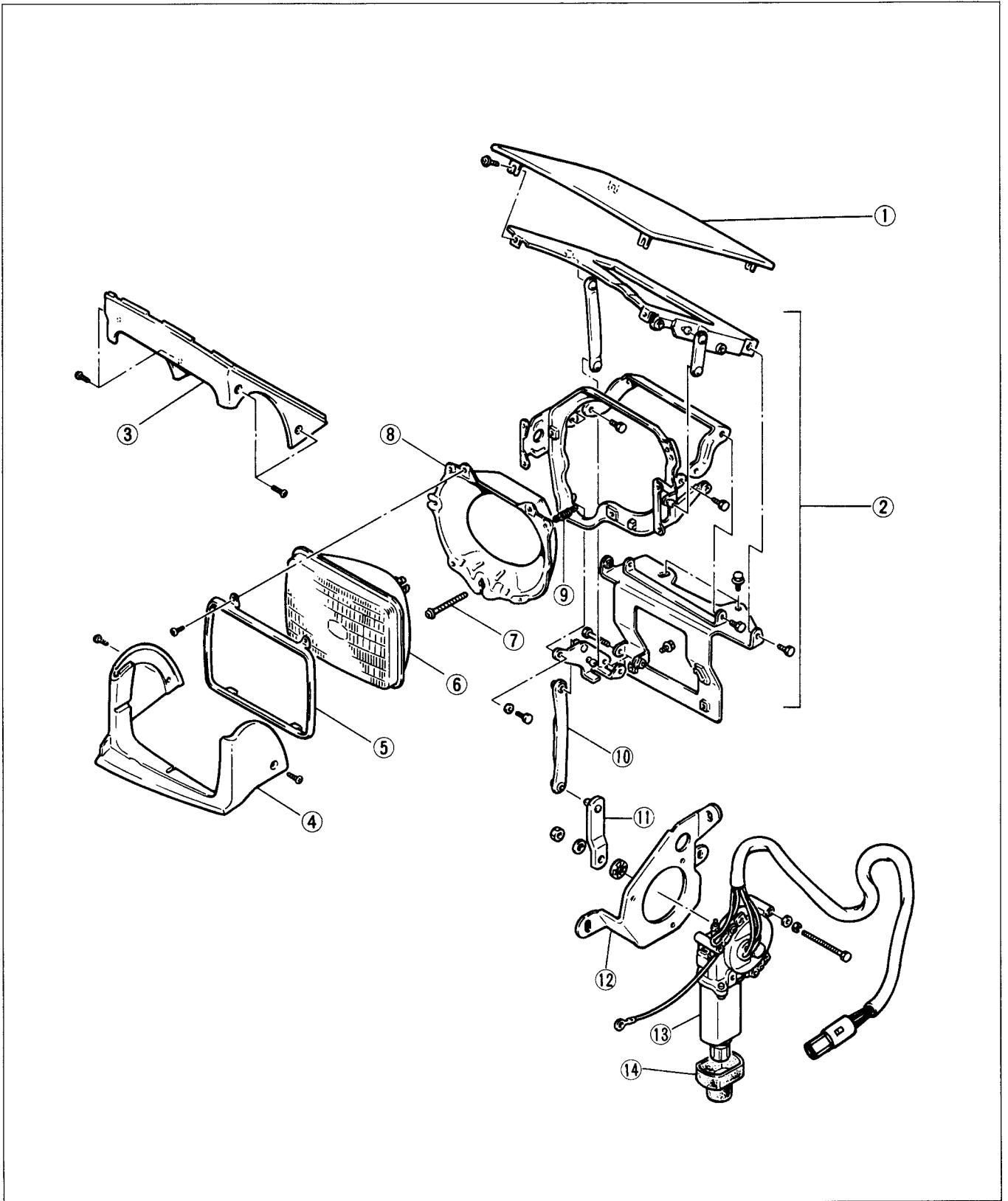

97U0TX-083

- 1. Headlight lid
- 2. Retractor hinge unit
- 3. Upper bezel
- 4. Lower bezel
- 5. Retaining ring

- 6. Headlight lens
- 7. Adjusting screw
- 8. Lamp bezel
- 9. Spring
- 10. Motor link

- 11. Motor arm
- 12. Motor bracket
- 13. Retractor motor
- 14. Rubber cap

T EXTERIOR LIGHTS

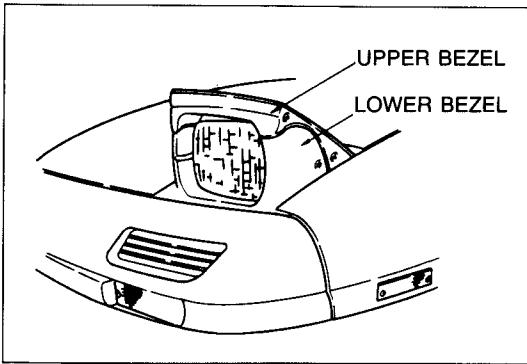

97U0TX-084

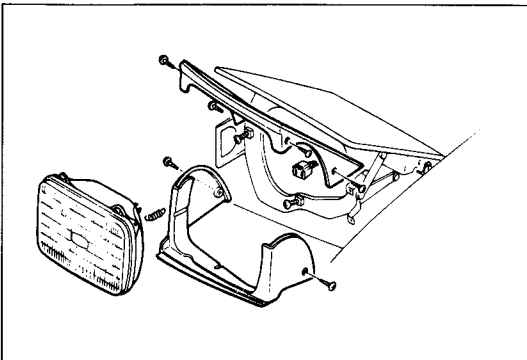

97U0TX-197

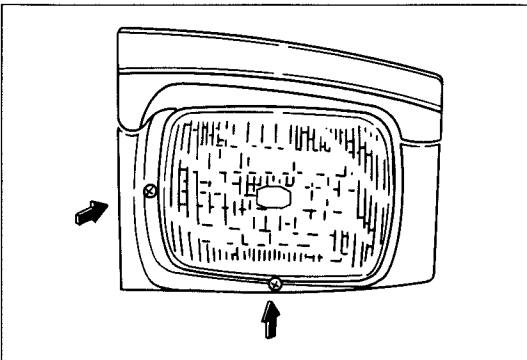

97U0TX-085

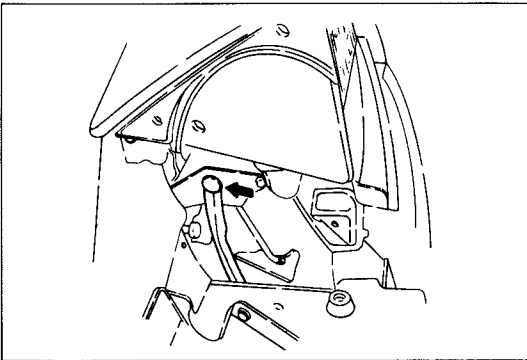

97U0TX-086

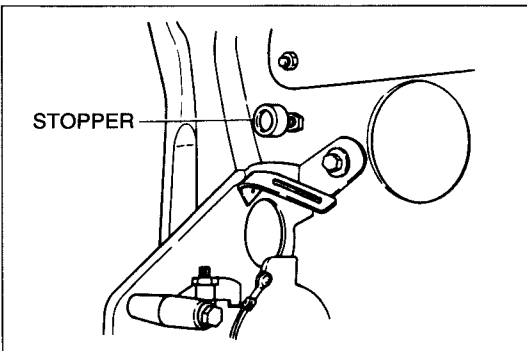

67U14X-075

Replacement of Headlight Lens

1. Raise the headlight.
2. Disconnect the negative battery cable.
3. Remove the upper bezel and lower bezel of the headlight.

Warning

Disconnect the negative battery cable to prevent accidental lowering of the headlight and possible personal injury while work is being performed.

4. Disconnect the light connector.
5. Remove the headlight lens attaching screws and replace the lens.

Caution

Do not disassemble the headlight lens and bulb. Replace the headlight lens and the bulb as a unit.

Adjustment of Headlight aim

1. Raise the headlight.
2. Adjust the headlight aim to local regulations by turning the adjusting screws.

Adjustment of Headlight Hinge

1. Disconnect the motor link.
2. Lower the retractor hinge until the hinge is stopped by the stopper.

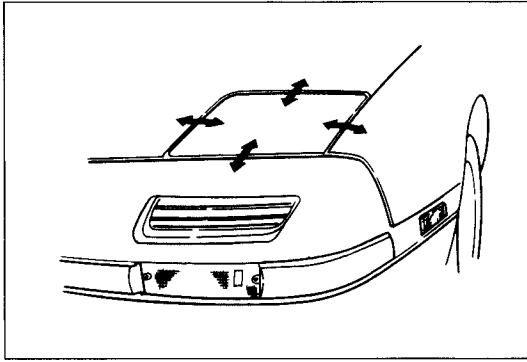

67U14X-076

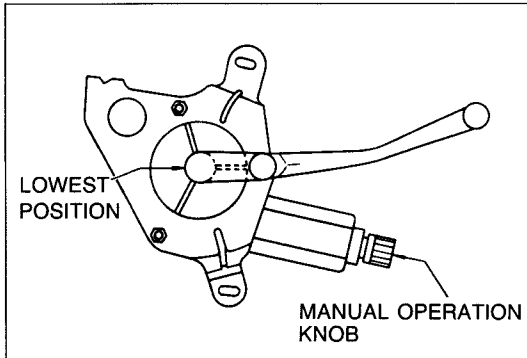

97U0TX-087

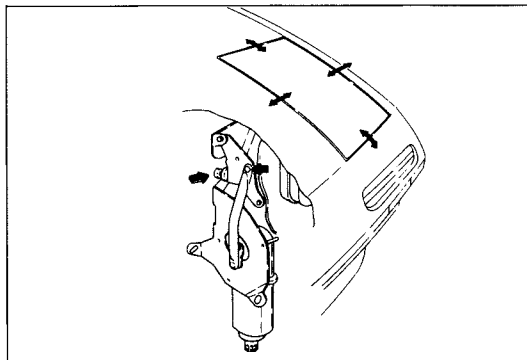

67U14X-078

3. Adjust the stopper so that the headlight lid is flush with the fender and the hood.

Adjustment of Retractor Motor Position

1. Remove the front soft fascia.
2. Lower the retractor hinge until the hinge is stopped by the stopper.
3. Remove the motor assembly.
4. Adjust the motor arm position by turning the manual operation knob so that the motor arm is in its lowest position, as shown in the figure.

Caution

Do not remove the motor arm from the shaft, because doing so may cause incorrect automatic stop operation.

5. Check that the retractor hinge is against the stopper and the headlight lid is flush with the fender and the hood.
6. Connect the motor link to the hinge.
7. Mount the motor assembly to the body.

T EXTERIOR LIGHTS

REAR COMBINATION LIGHT, SIDE MARKER LIGHT, AND HIGH-MOUNT STOPLIGHT Structural View

COUPE

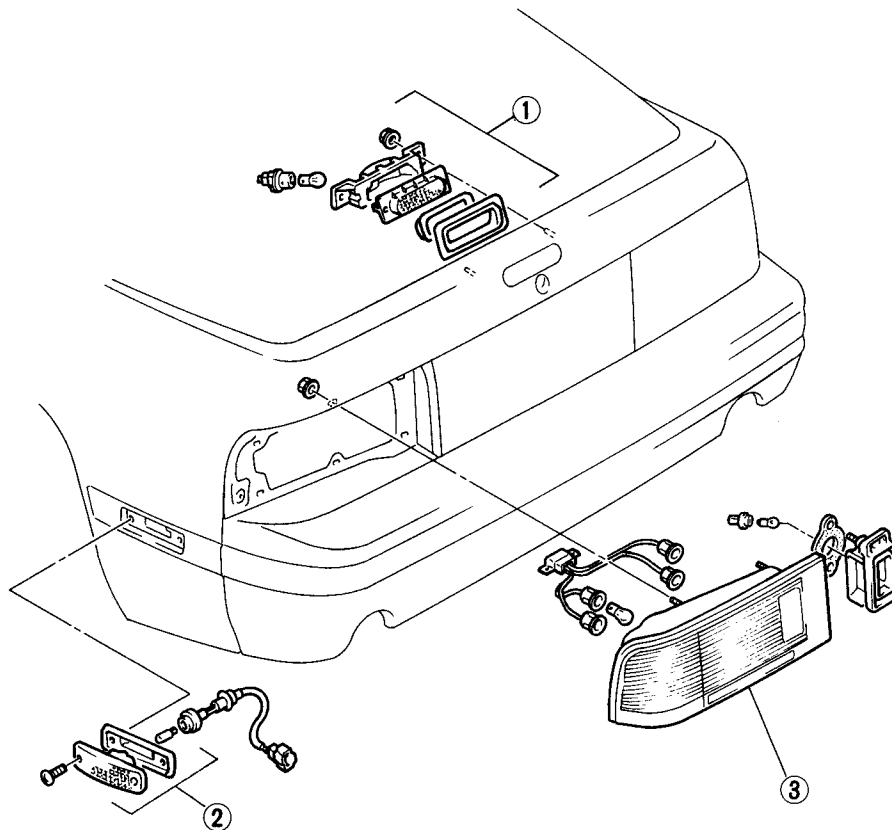

97U0TX-088

- 1. High-mount stoplight
Bulb: 27W (1156)
- 2. Rear side marker light
Bulb: 3.8W (194)

- 3. Rear combination light
Bulbs: Back-up light 27W (1156)
Stop/Taillight 27/8W x 2 (1157)
Turn signal light 27W (1156)
License plate light 7.5W (89)

CONVERTIBLE

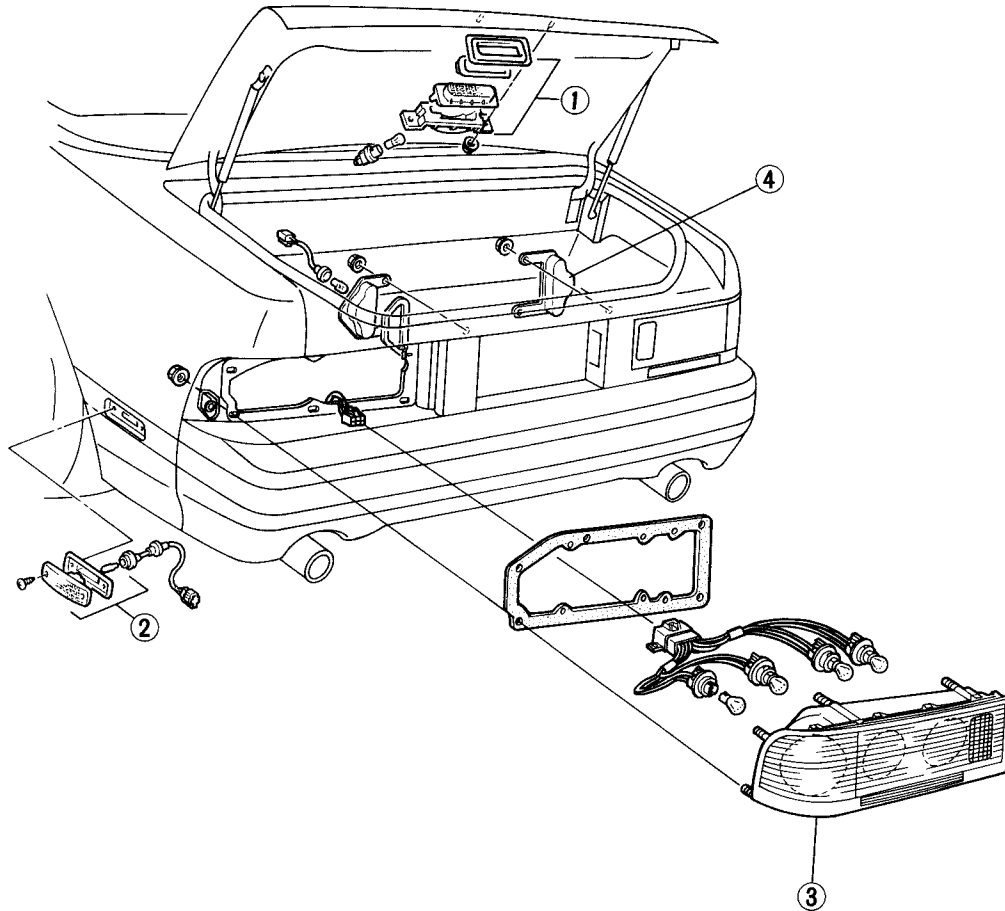

97U0TX-089

- | | | | |
|---------------------------|------------|----------------------------|------------------|
| 1. High-mount stoplight | | 3. Rear combination light | |
| Bulb: | 27W (1156) | Bulbs: Back-up light | 27W (1156) |
| 2. Rear side marker light | | Stop/Taillight | 27/8W x 2 (1157) |
| Bulb: | 3.8W (194) | Turn signal light | 27W (1156) |
| | | 4. License plate light | |
| | | Bulb: | 7.5W (89) |

T EXTERIOR LIGHTS

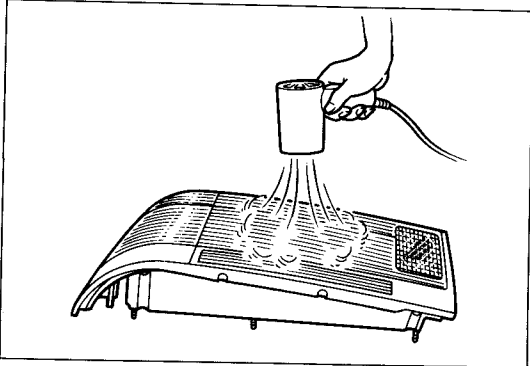

97U0TX-090

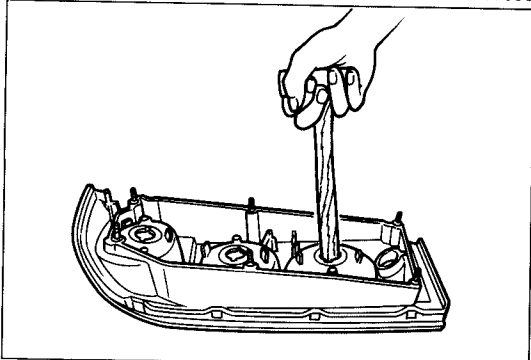

97U0TX-091

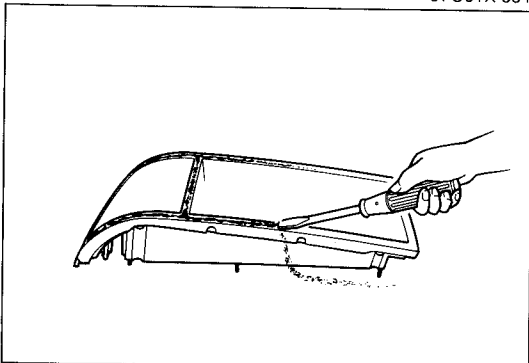

97U0TX-092

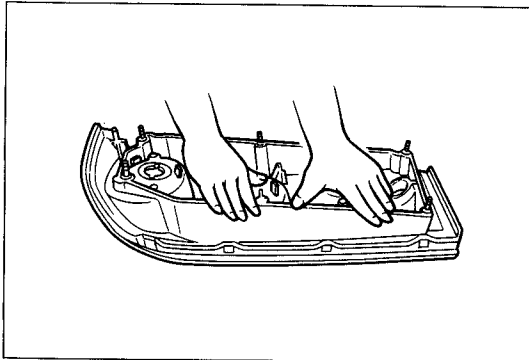

97U0TX-093

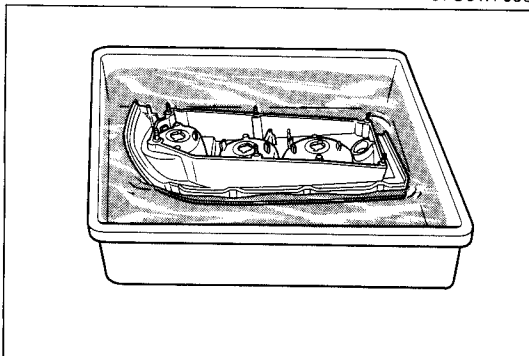

97U0TX-094

Replacement of Combination Light Lens

1. Use a blow dryer to soften the "hot melt" (bonding agent) around the lens to be replaced.

2. Remove the lens from the light housing by pushing the rear of the lens with a hammer handle or round bar.

3. While heating the light housing, remove the "hot melt" and any remaining fragments of the lens.

Note

The "hot melt" should be reused if possible.

4. If the hot melt is not being reused, put **Uni-sealer** (8531 77 739) in the light housing groove for adhesive, and press the light housing in gently.

5. Fit the new lens to the light housing, and press the lens firmly so that it will adhere.

6. Immerse the combination light in water to check for leaks.

FRONT FOG LIGHT AND DAYTIME RUNNING LIGHT
Removal and Installation

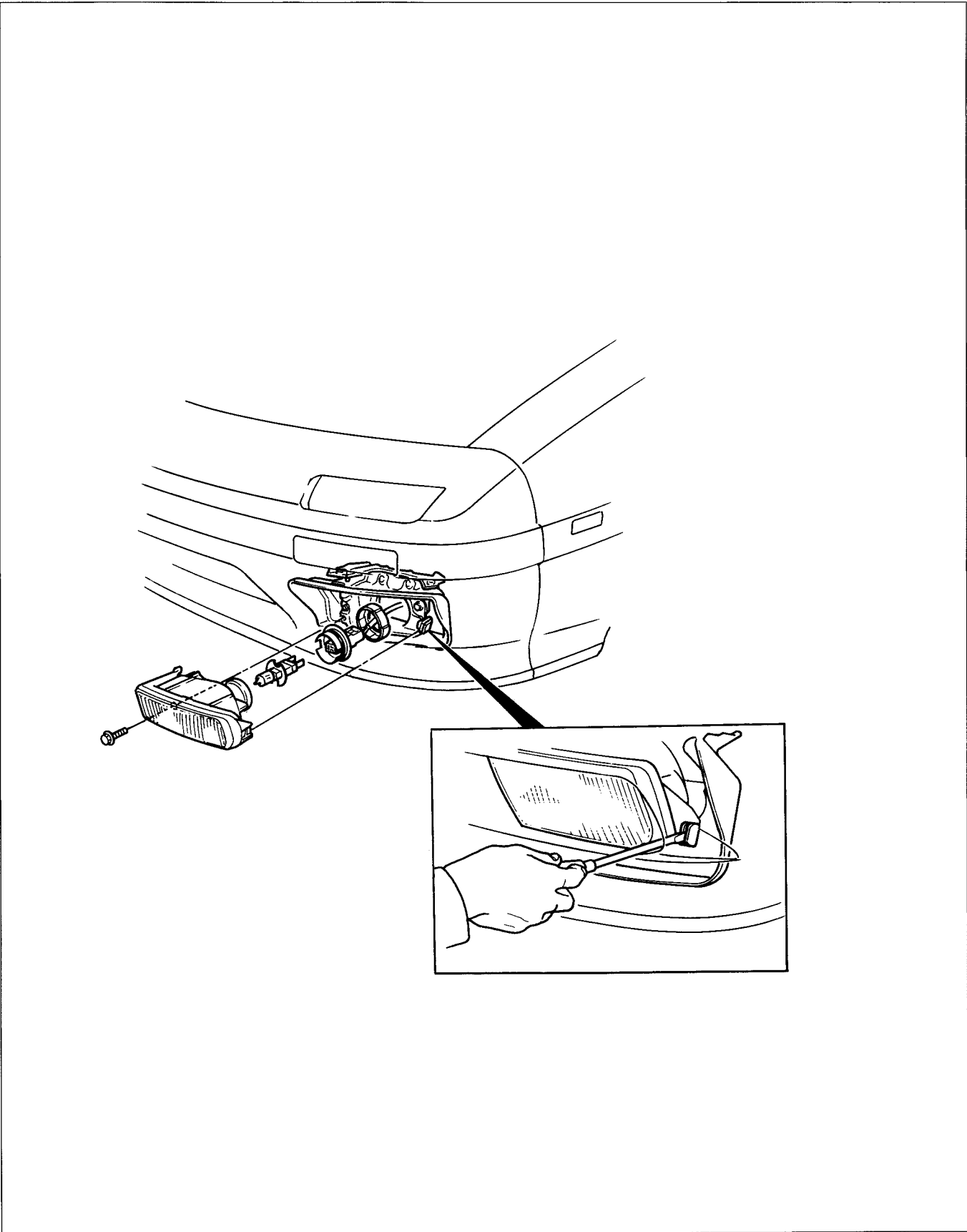

97U0TX-095

1. Front fog light (For USA)
Bulb:..... 55W

2. Daytime running light (For Canada)
Bulb:..... 55W

T INTERIOR LAMPS

INTERIOR LAMPS

STRUCTURAL VIEW

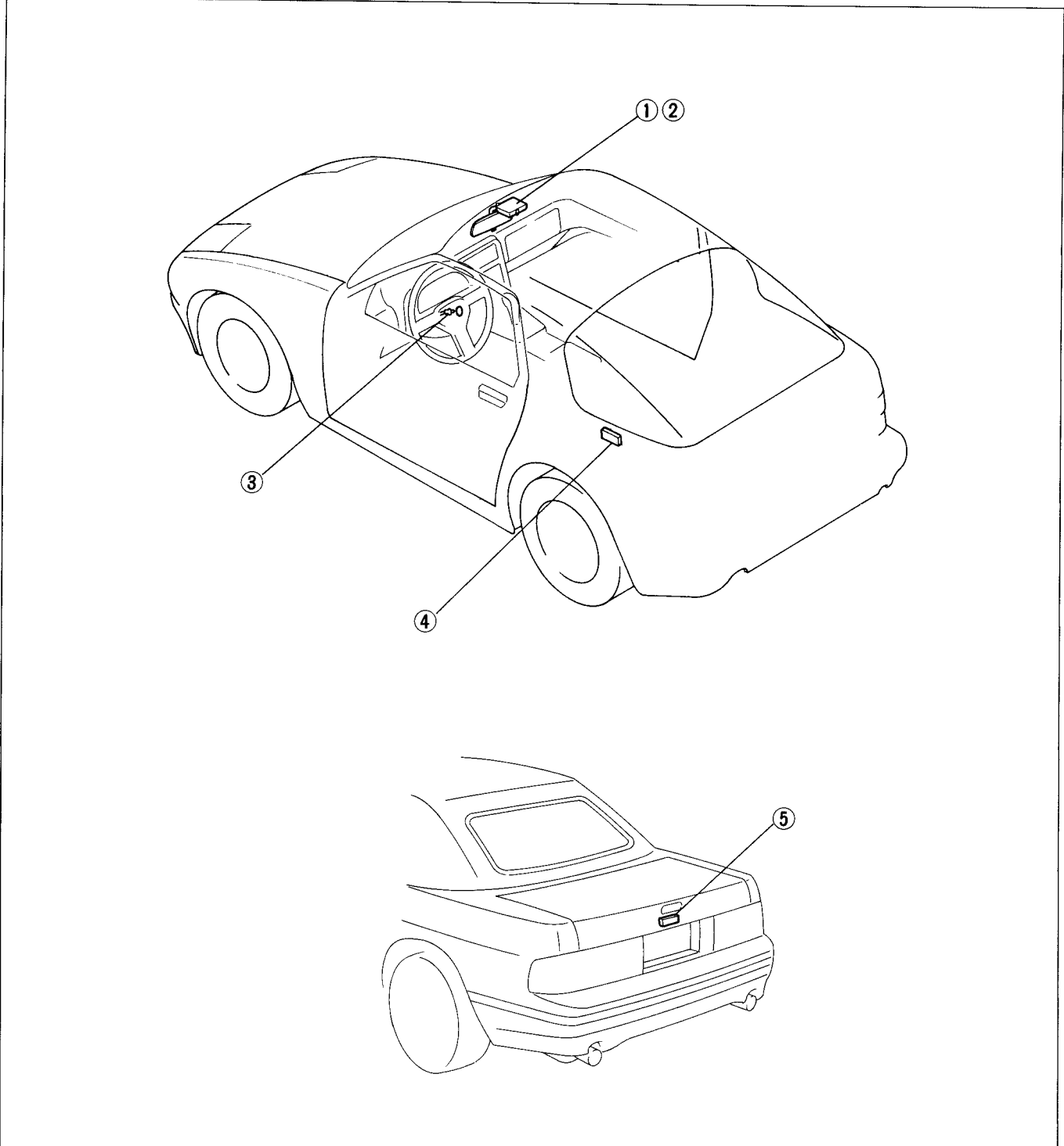

97U0TX-096

- 1. Spot and room lamp (For Coupe)
- 2. Room lamp (For Convertible)
- 3. Ignition key cylinder lamp

- 4. Cargo room lamp (For Coupe)
- 5. Trunk room lamp (For Convertible)

TROUBLESHOOTING GUIDE

		Action	Page
No illumination of instrument panel	Defective instrument panel lamp control	Check	T-63

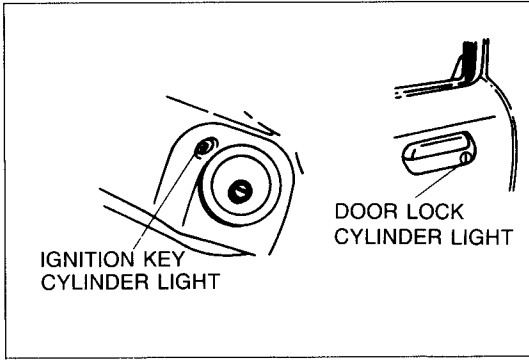

67U15X-063

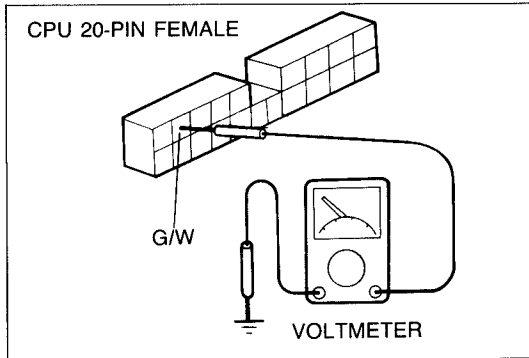

97U0TX-097

Door Lock Cylinder Light and Ignition Key Cylinder Light (If only the door lock cylinder light illuminates)

The bulb may be burned out, or there may be a poor contact of the bulb connector.

(If only the key cylinder light illuminates)

Check for a burned out bulb or for a poor contact of the bulb connector.

(Neither comes on)

1. Check the ROOM fuse.
2. If OK, connect a voltmeter to the (G/W) wire for the key illumination timer of the central processing unit, and check that battery voltage is applied.
3. If there is no voltage, check the wiring. If there is voltage, the central processing unit may be poorly grounded or there may be a malfunction in the unit.

T INTERIOR LAMPS

SPOT AND ROOM LAMP (For Coupe) Removal and Installation

1. Remove the negative battery cable.
2. Remove in the sequence shown in the figure.
3. Install in the reverse order of removal.

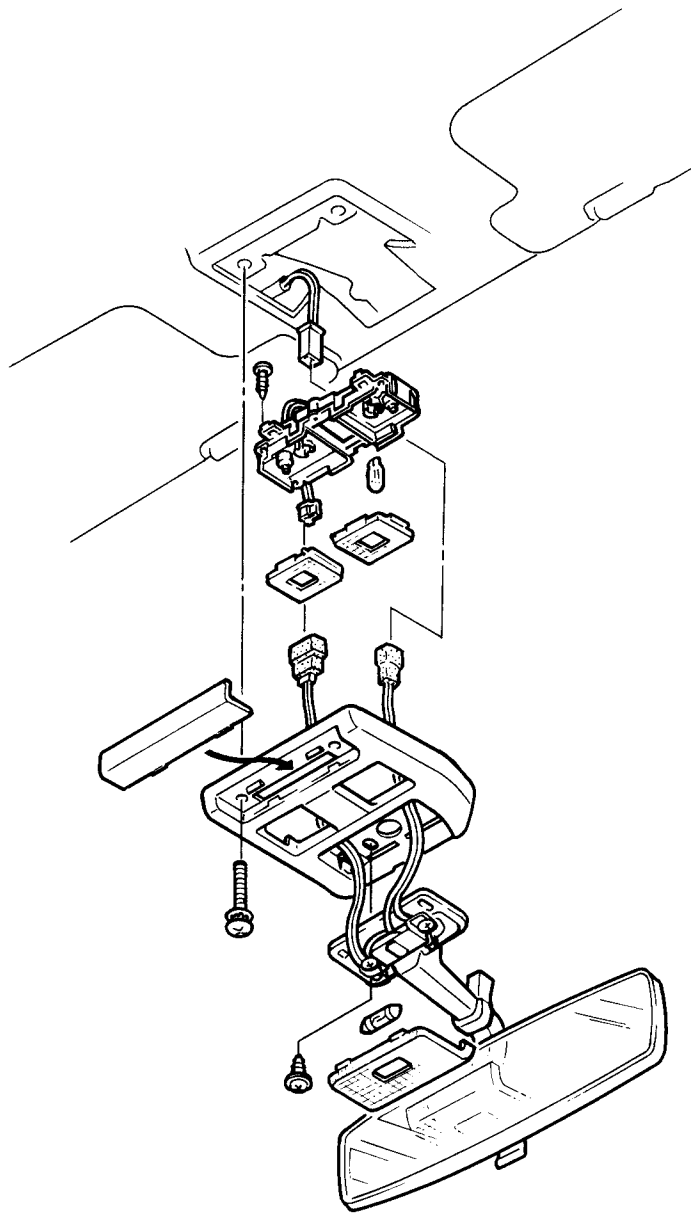

1. Lens
2. Cover
3. Bulb
10W x 1

4. Rearview mirror
5. Lens
6. Bulb
5W x 2

97U0TX-098

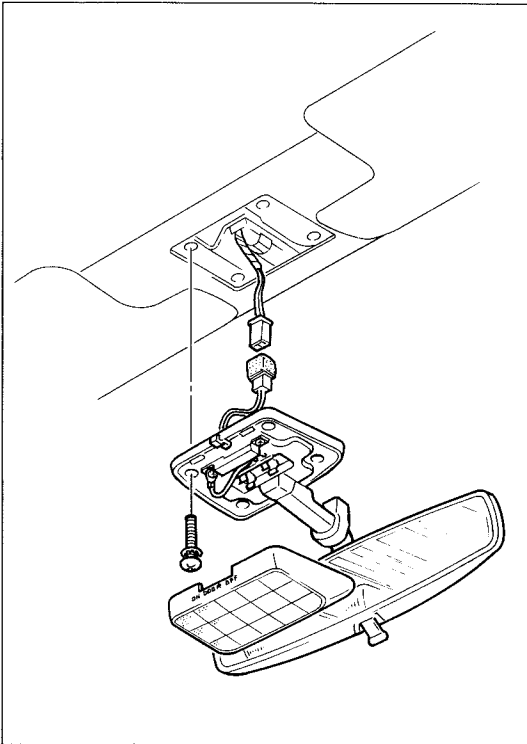

97U0TX-099

ROOM LAMP (For Convertible) Removal and Installation

1. Remove the lens and the screws.
2. Disconnect the terminal.
3. Remove the rearview mirror.
4. Remove the bulb.

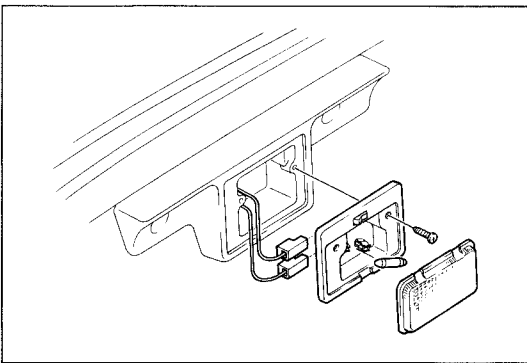

97U0TX-100

CARGO ROOM LAMP (For Coupe) Removal and Installation

1. Remove the lens and the screws.
2. Remove the bulb.

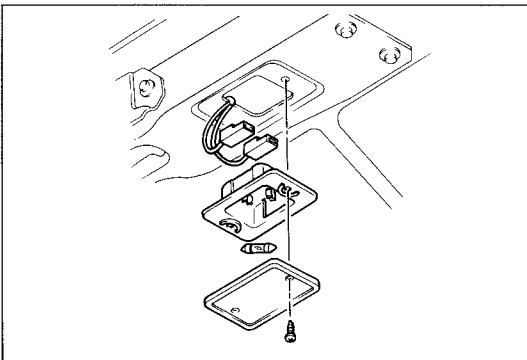

97U0TX-101

TRUNK ROOM LAMP (For Convertible) Removal and Installation

1. Remove the screws and the lens.
2. Remove the cover.
3. Remove the bulb.

COURTESY LAMP Removal and Installation

Refer to page S-42.

97U0TX-102

T REAR WINDOW DEFROSTER

REAR WINDOW DEFROSTER

STRUCTURAL VIEW

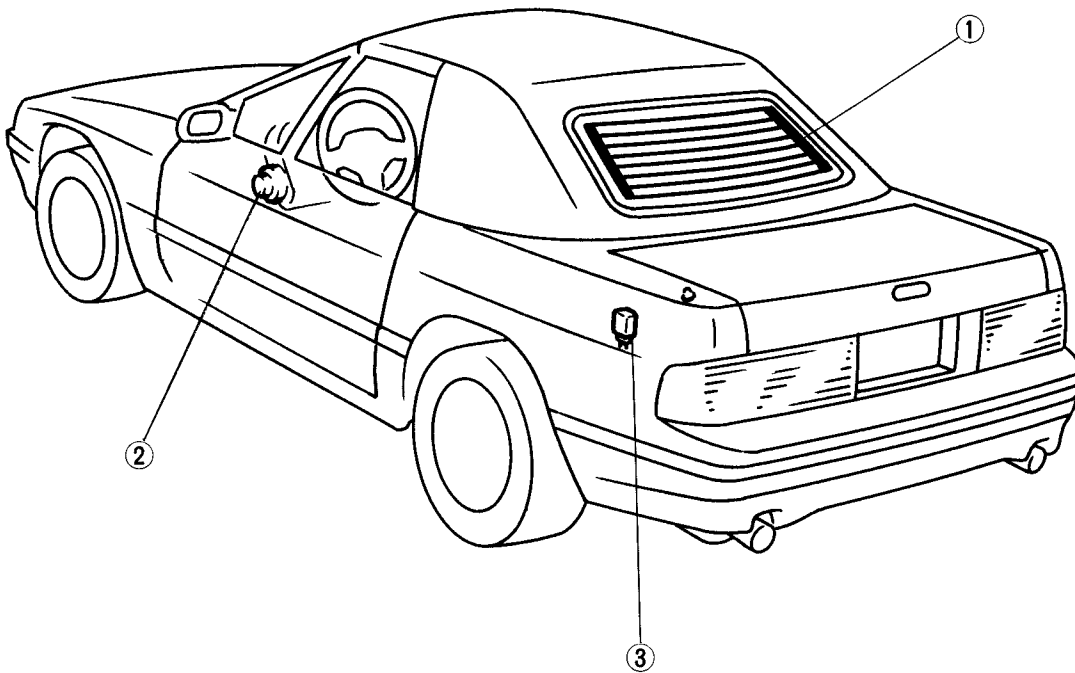

97U0TX-103

1. Rear window defroster
(Filament)

2. Rear window defroster switch

3. Rear window defroster relay

CIRCUIT DIAGRAM

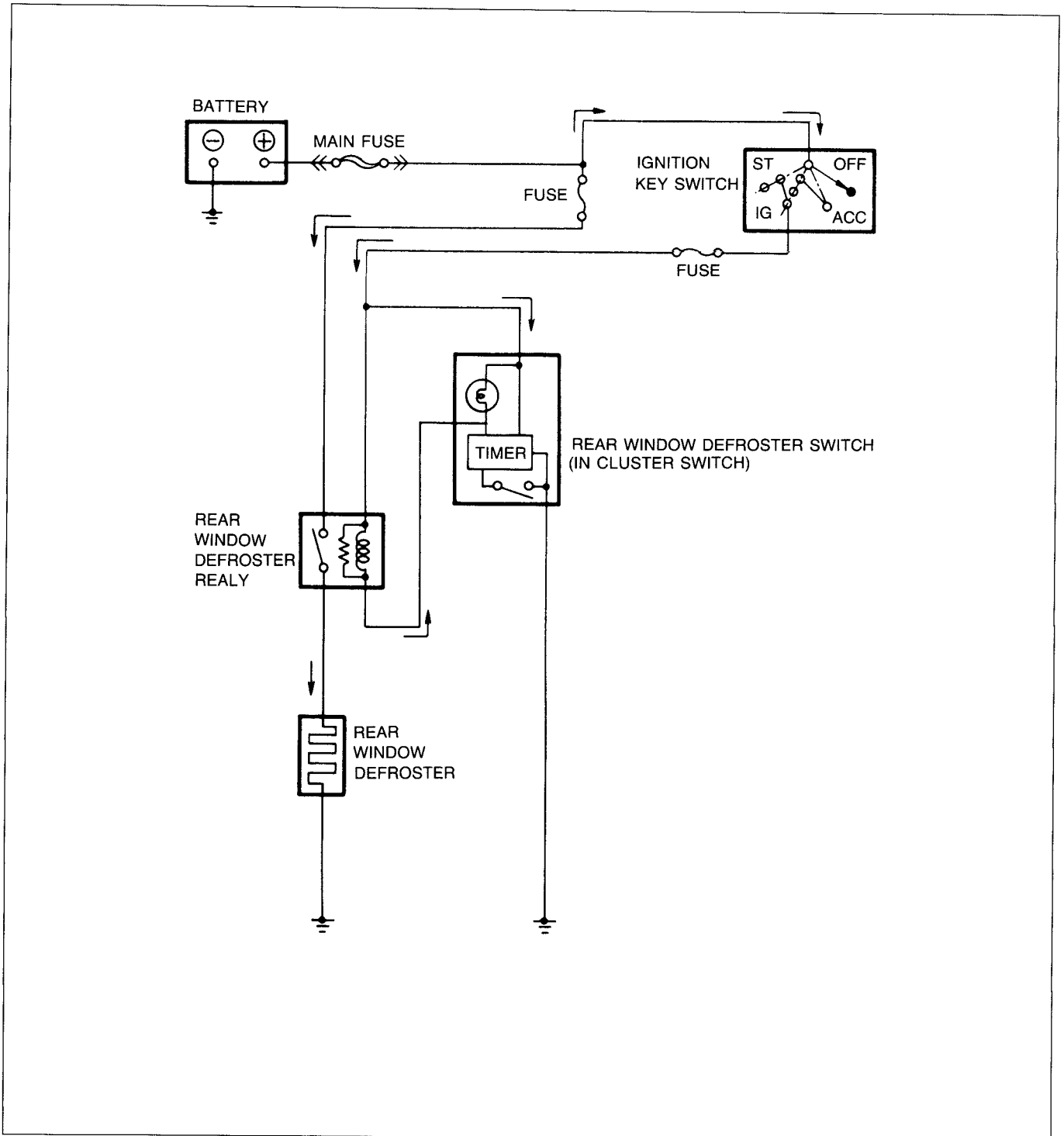

97U0TX-104

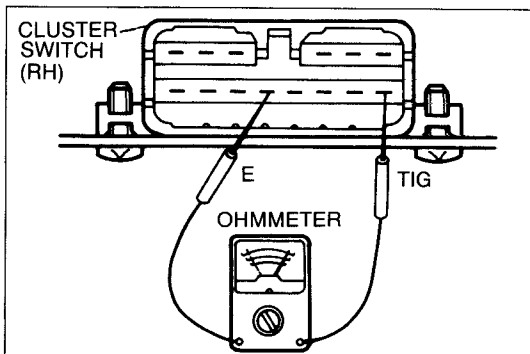

97U0TX-105

INSPECTION

Rear Window Defroster Switch

Connect an ohmmeter to the terminals of the switch and check for continuity.

Terminal	Switch position	Continuity
TIG — E	ON	Yes
TIG — E	OFF	No

If continuity is not as specified, replace the switch.

T REAR WINDOW DEFROSTER

Rear Window Defroster Timer Circuit (Refer to page T-24.)

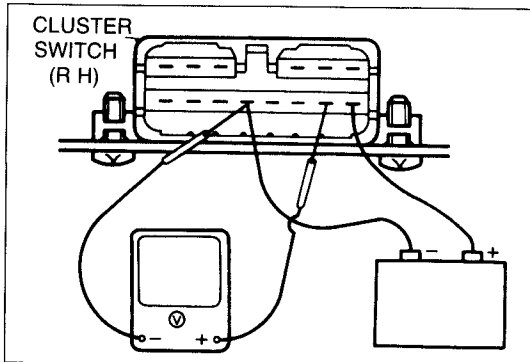

97U0TX-106

Rear Window Defroster Filament

1. Turn on the rear window defroster switch.
2. Connect the positive lead of a voltmeter to the center of each filament, and connect the negative lead to the body of the vehicle.

The standard voltage at the center of the filament is 6V. If the meter indication is higher than this value, a problem exists in the ground side of the filament.

If the indication is low, or zero, a problem is between the center and the power side.

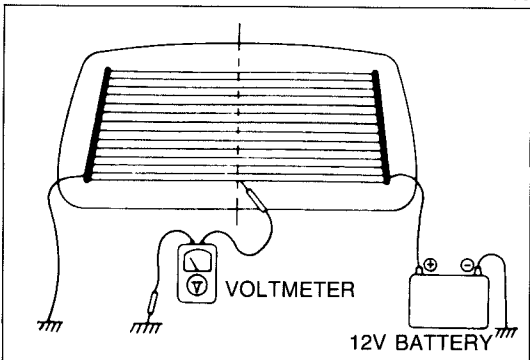

97U0TX-107

FILAMENT CORRECTION

1. Clean the faulty portion using thinner or ethyl alcohol.
2. Apply tape to both sides of the faulty portion, leaving the filament exposed.
3. Use a small paint brush or drafting pen to apply **silver paint** (No.2835 77 600).
4. Completely dry the corrected portion by letting it stand [at a temperature of 20°C (68°F)] for 24 hours. [The corrected portion may also be dried in 30 minutes by using a blow dryer at 60°C (140°F).]

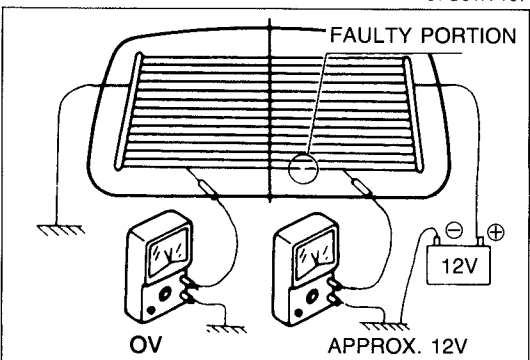

97U0TX-108

Caution

- a) Do not turn on the rear window defroster until the paint is completely dry.
- b) Do not use gasoline or other solvents to clean the faulty portion.

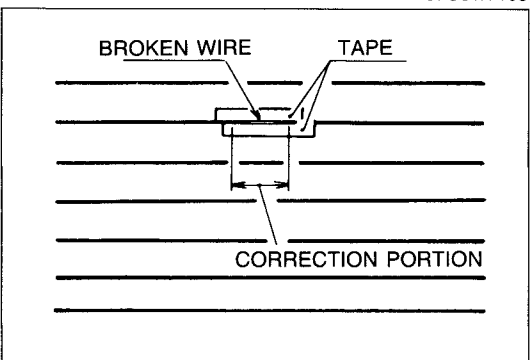

67U15X-074

CRUISE CONTROL SYSTEM

STRUCTURAL VIEW

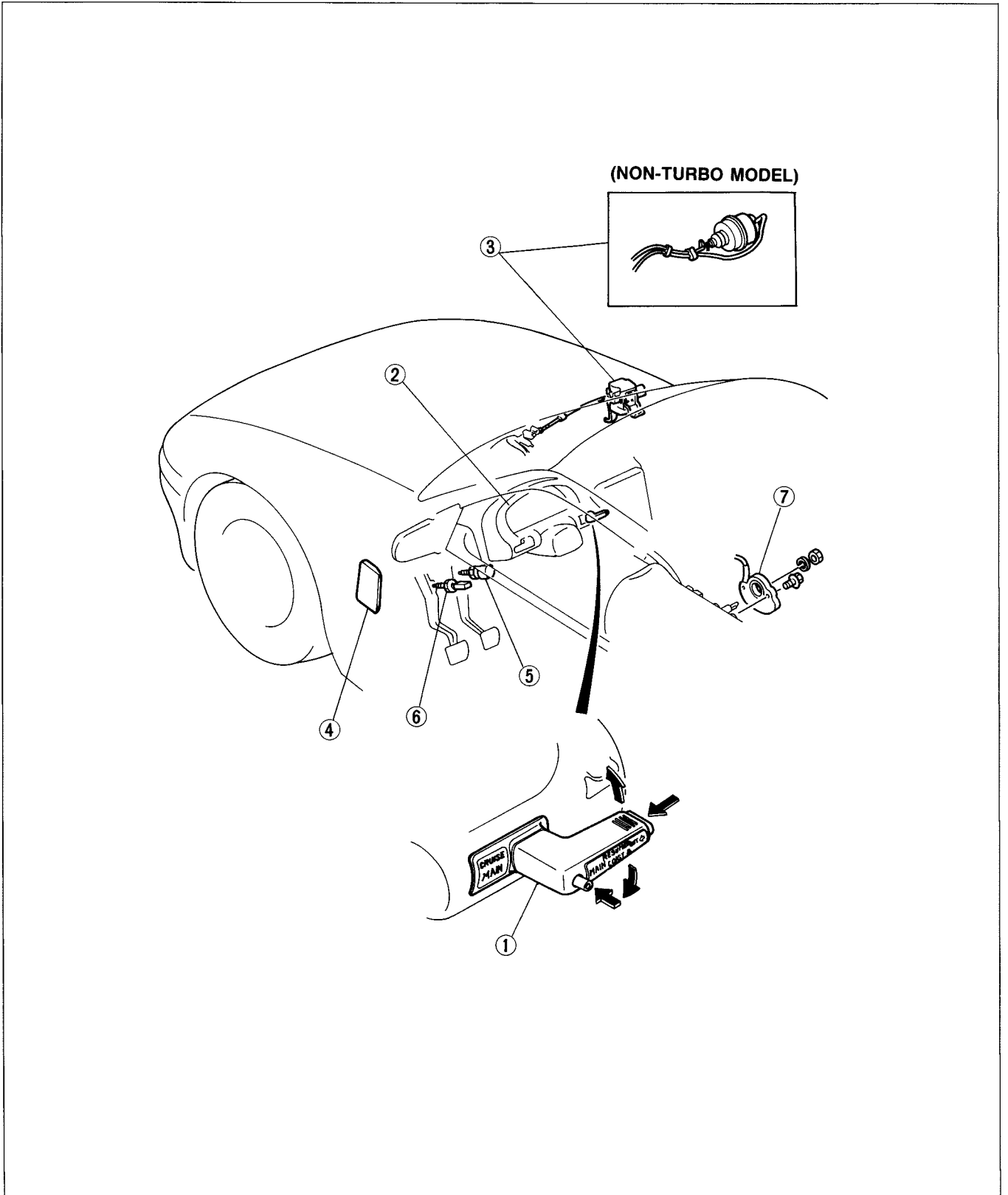

77U15X-094

- | | |
|--------------------------------|-------------------------------------|
| 1. Cruise control switch | 5. Stoplight switch |
| 2. Speed sensor (in the meter) | 6. Clutch switch (for M/T model) |
| 3. Actuator | 7. Inhibitor switch (for A/T model) |
| 4. Cruise control unit | |

T CRUISE CONTROL SYSTEM

CIRCUIT DIAGRAM

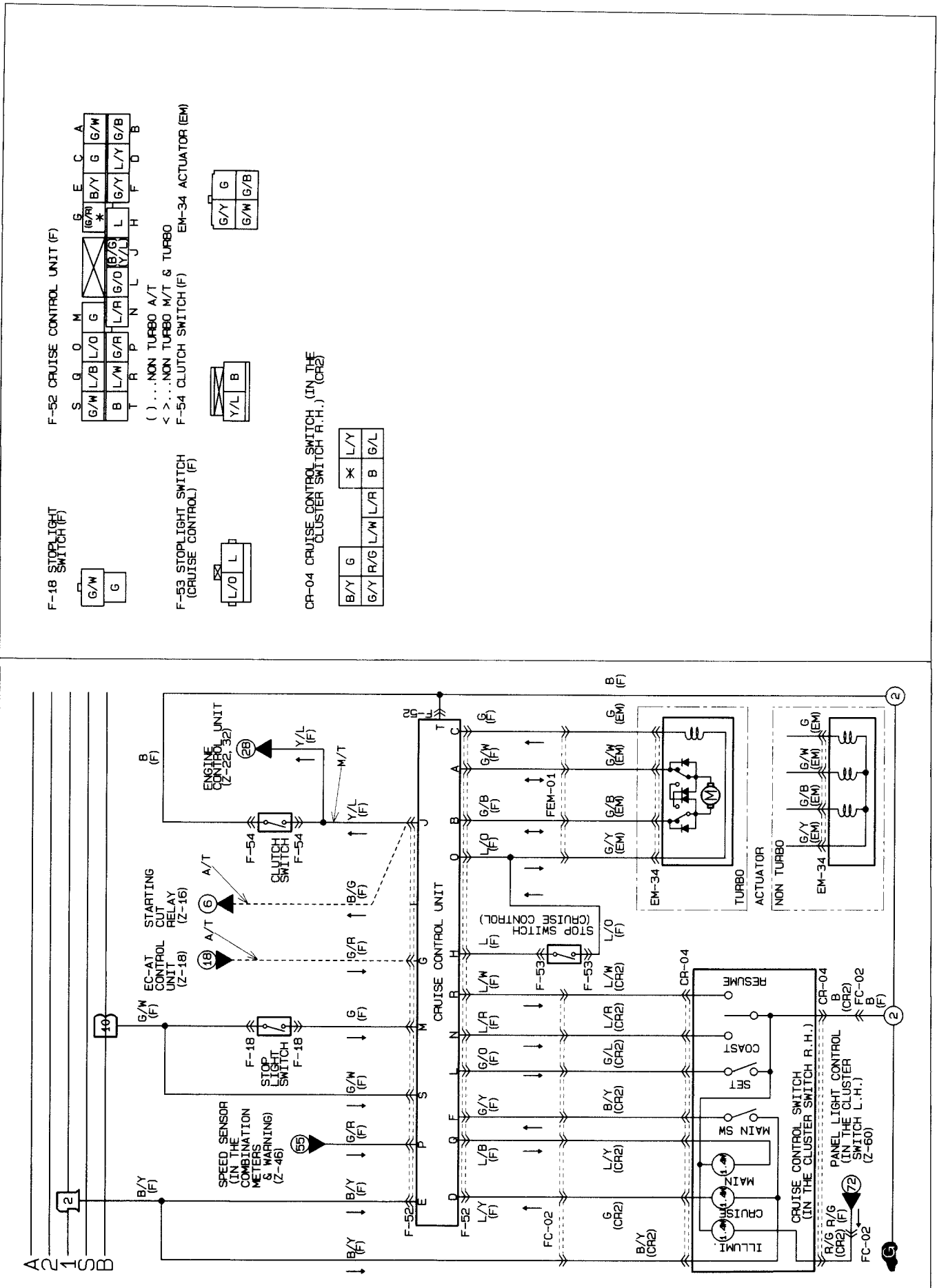

F-52 CRUISE CONTROL UNIT (F)

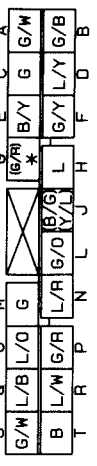

() ...NON TURBO A/T
 < > ...NON TURBO M/T & TURBO
 F-54 CLUTCH SWITCH (F) EM-34 ACTUATOR (EM)

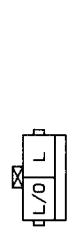

F-53 STOPLIGHT SWITCH (CRUISE CONTROL) (F)

CR-04 CRUISE CONTROL SWITCH (IN THE CLUSTER SWITCH R.H.) (CR2)

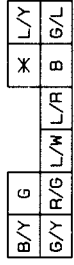

TROUBLESHOOTING GUIDE

General Note

Troubleshooting and inspection of the cruise control is done in two steps. First is the quick, self-diagnostic inspection using the built-in self-diagnostic function and cruise control switch. The other is a detailed inspection of parts using a voltmeter and an ohmmeter.

97U0TX-177

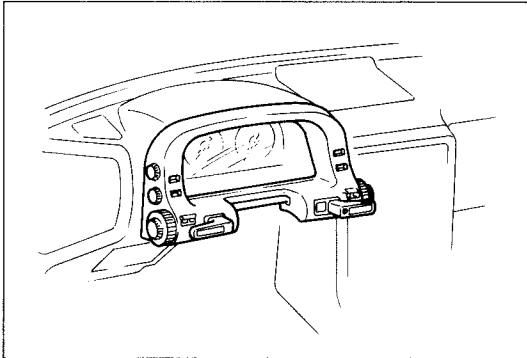

97U0TX-178

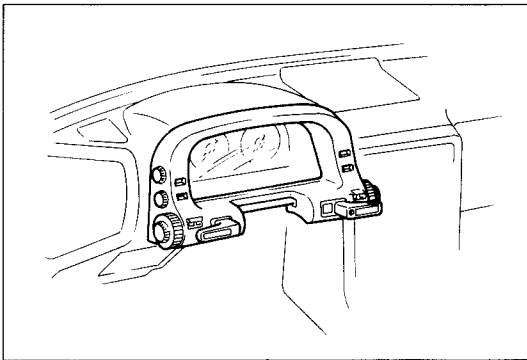

97U0TX-179

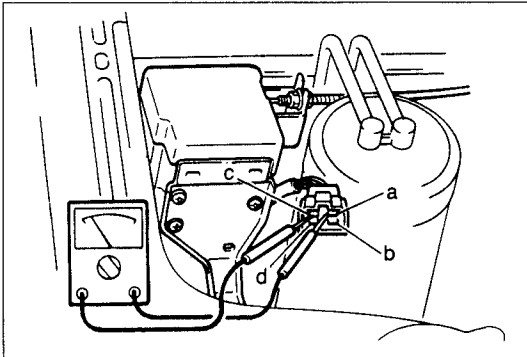

97U0TX-180

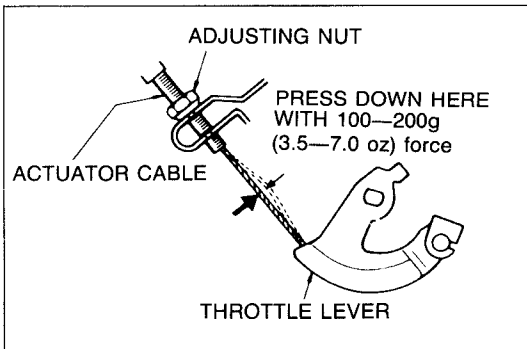

97U0TX-181

Step 1: Self-diagnostic Inspection (Self-diagnosis of malfunction)

Check for condition code(s) memorized in the cruise control unit by using the cruise control switch. (Refer to page T-72.) If no condition code exists, go to Step 2. If a condition code(s) is indicated, go to Step 3.

Step 2: Self-diagnostic Inspection (Quick inspection of cruise control system)

Verify operation codes by using of the cruise control switch. (Refer to page T-72.) If the operation code is correctly indicated, the part under inspection is OK. If an operation code is not indicated, go to Step 3.

Step 3: Inspection of Circuit and Parts

Check the cruise control wiring and parts with a voltmeter and an ohmmeter. (Refer to page T-79.)

Adjustment

Checking freeplay of actuator inner cable.

Remove the clip and adjust the nut so that the actuator control cable play is as follows when the cable is pressed lightly.

Freeplay of actuator inner cable:
1-3mm (0.039-0.118 in)

SELF-DIAGNOSTIC INSPECTION

Self-diagnostic Function

The self-diagnostic function intergrated within the cruise control unit diagnoses the condition of the cruise control system.

Condition codes are indicated by flashing of the CRUISE indicator. (Refer to condition code numbers on page T-73.) This operation continues until canceled.

97U0TX-182

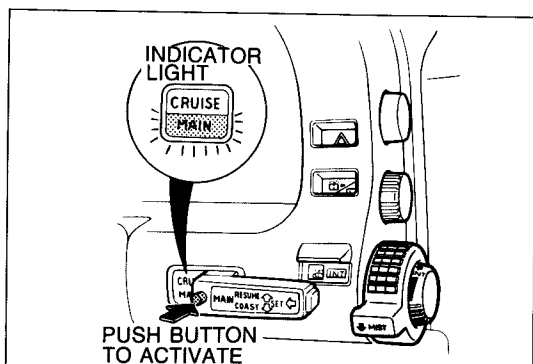

97U0TX-183

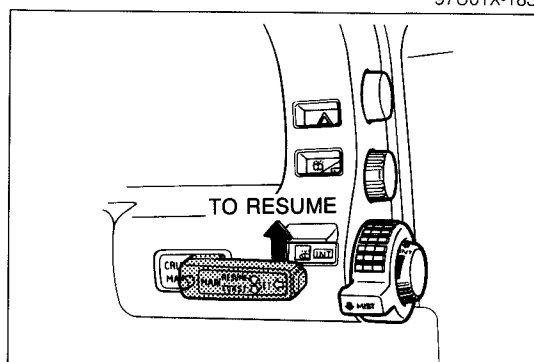

97U0TX-184

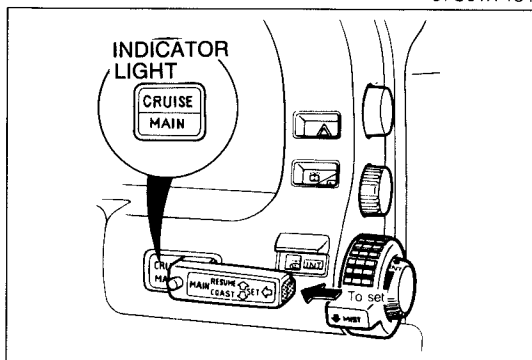

97U0TX-185

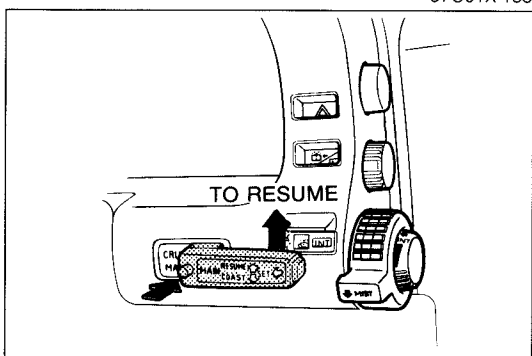

97U0TX-186

Inspection Procedure

Self-diagnosis of malfunction

1. Turn ignition switch to ON.
2. Push the cruise control MAIN switch. (The MAIN indicator lamp comes on.)
3. Move the control lever upward to the RESUME position and hold it more than 3 seconds.
4. Release the lever.
5. The self-diagnosis is now activated.
6. Note the condition code number(s). (Refer to page T-74.)
7. Drive the vehicle at more than 16 km/h (10 mph), or push the MAIN switch (The MAIN indicator lamp goes out.) to deactivate self-diagnosis.

Quick inspection of cruise control system

1. Turn ignition switch to ON.
2. Verify that the MAIN switch is OFF. (The MAIN indicator lamp off.)
3. Move the control lever upward to the RESUME position and hold it.
4. Push the MAIN switch to activate inspection of system. (The MAIN indicator lamp comes on.)
5. Operate each switch as described and verify operation codes. (Refer to page T-74.)
6. Push the MAIN switch to deactivate inspection of system. (The MAIN indicator lamp goes out.)

Note

The cruise control system does not operate as fas as the self-diagnostic function is not canceled.

Principle of Code Cycle

Condition and operation codes are determined by flashing of the CRUISE indicator as shown below.

97U0TX-187

1. Code cycle break

The time between condition/operation code cycles is 4.0 seconds (the time the lamp is off).

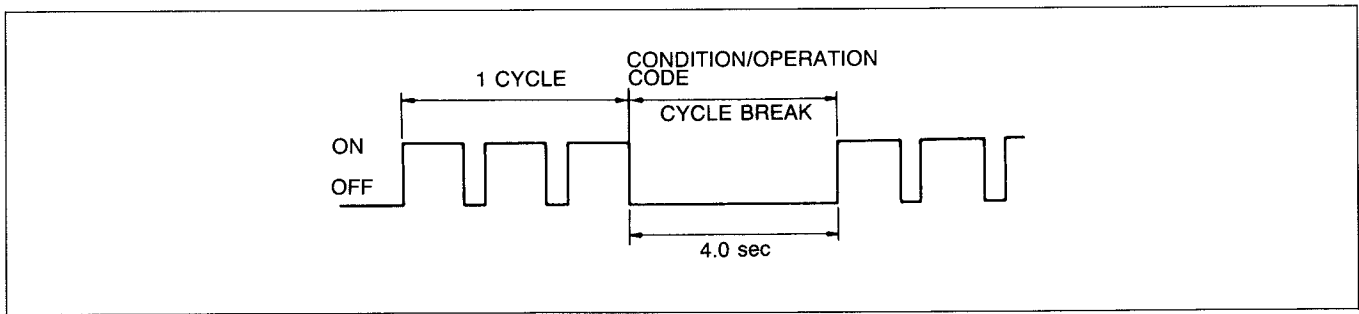

97U0TX-188

2. Second digit of condition/operation code (ones position)

The digit in the ones position of the condition/operation code represents the number of times the lamp is on 0.4 second during one cycle.

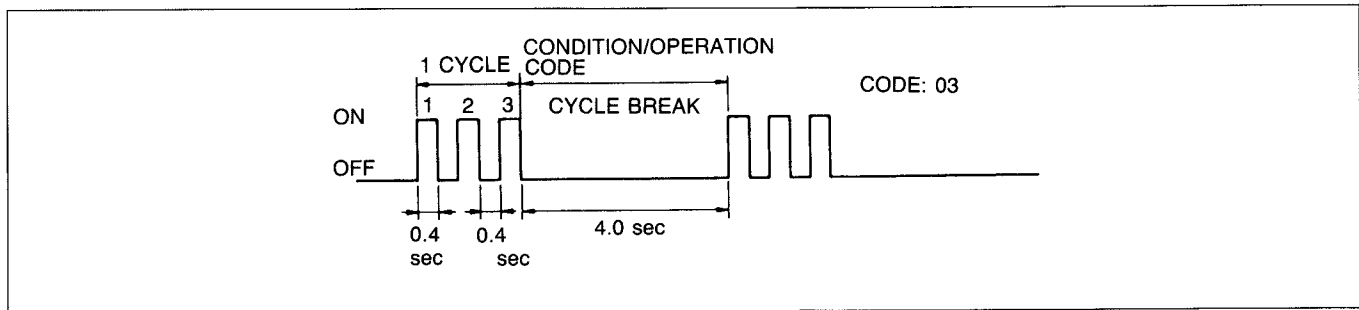

97U0TX-189

3. First digit of condition/operation code (tens position)

The digit in the tens position of the condition/operation code represents the number of times the lamp is on 1.2 seconds during one cycle.

The lamp remains off for 1.6 seconds between the long and short flashes.

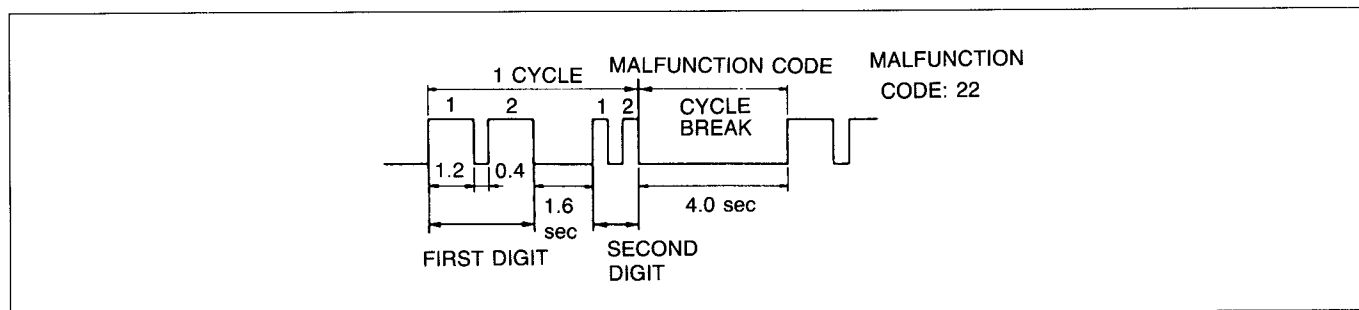





97U0TX-190

T CRUISE CONTROL SYSTEM

Condition/Operation Code Numbers Self-diagnosis of malfunction

The CRUISE indicator will flash if a malfunction is present.

Pattern of output signal (CRUISE indicator lamp)	Code No.	Possible Cause	Action
ON  OFF	01	Defective wiring or ground Defective actuator Defective stoplight switch (For cruise)	Repair harness Inspect actuator (Refer to page T-77.)
ON  OFF	05	STOP fuse blown	Replace fuse
ON  OFF	07	Both stoplight switches (for vehicle and cruise) are ON simultaneously	Inspect stoplight switches (Refer to pages T-52 and T-77)
ON  OFF	11	Defective SET, COAST, or RESUME switch	Inspect cluster switch (Refer to page T-26)
ON  OFF	15	Defective cruise control unit	Go to troubleshooting (Refer to page T-75)







Note

97U0TX-191

If there is more than one malfunction, the code numbers will be indicated in numerical order.

Inspection of cruise control system

The CRUISE indicator will flash if the system is operating correctly. If the lamp fails to flash, inspect the system.

Procedure	Pattern of output signal (CRUISE indicator lamp)	Code No.	Action to inspect
Press SET button	ON  OFF	21	Inspect cluster switch (Refer to page T-26)
Move control lever downward to COAST position	ON  OFF	22	Inspect cluster switch (Refer to page T-26)
Move control lever upward to RESUME position	ON  OFF	23	Inspect cluster switch (Refer to page T-26)
Depress brake pedal	ON  OFF	31	Inspect stoplight switches (Refer to page T-52 and T-77)
Turn ignition switch to ON and shift the selector lever to P or N rang (For A/T). Depress clutch pedal (For M/T)	ON  OFF	35	Inspect inhibitor switch (Refer to Section K) or clutch switch (Refer to Section F)
Drive vehicle above 40 km/h (25 mph)	ON  OFF	37	Inspect speed sensor or wire harness

97U0TX-192

TROUBLESHOOTING

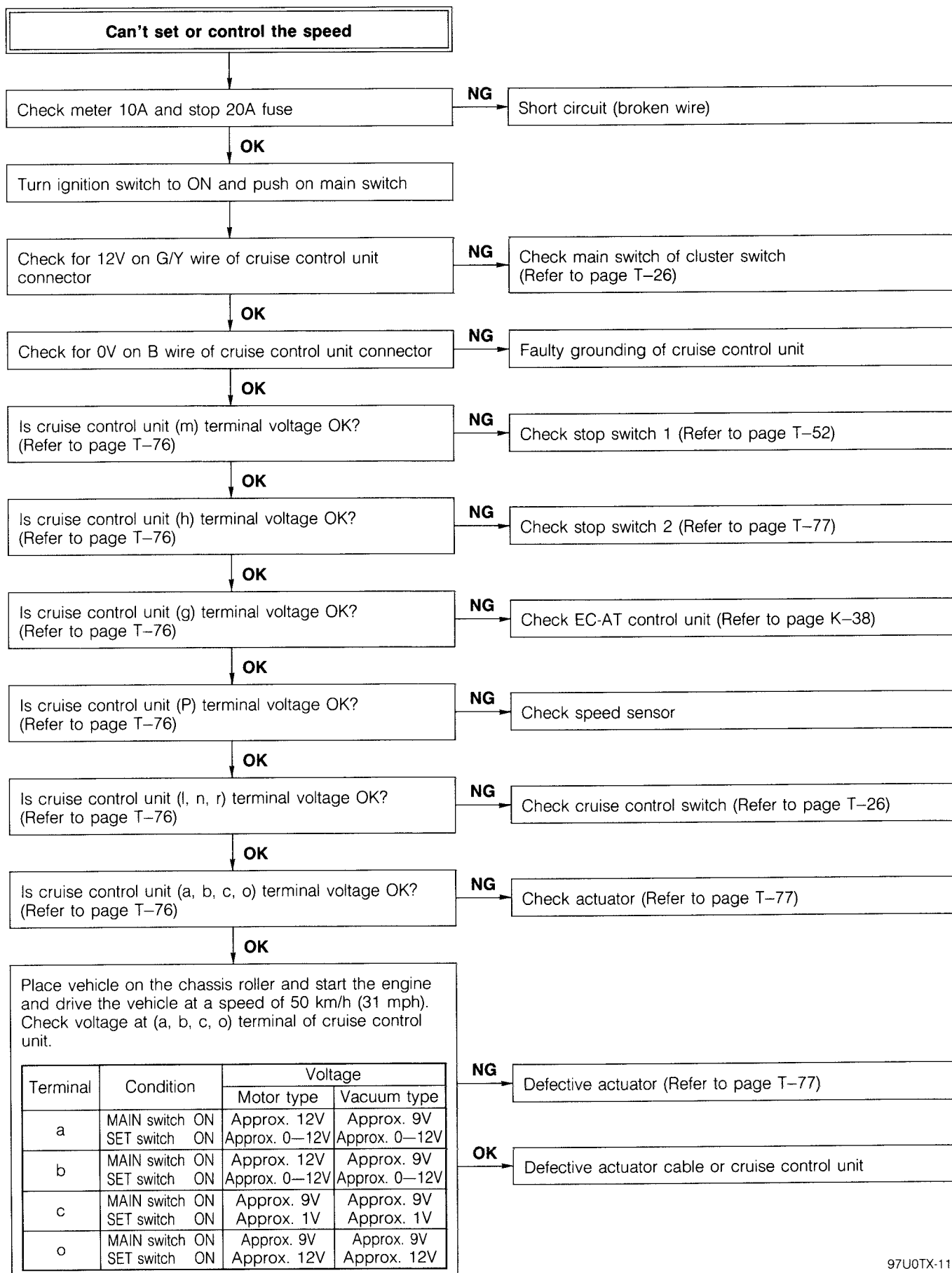

T CRUISE CONTROL SYSTEM

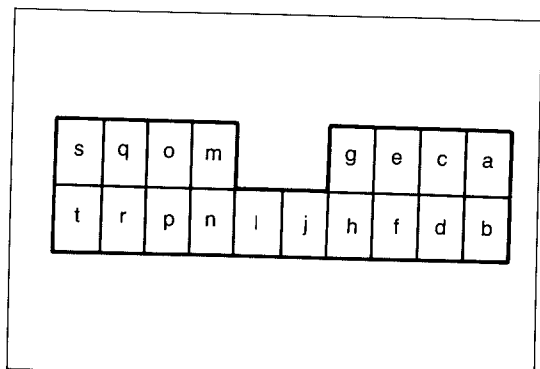

97U0TX-111

INSPECTION

Cruise Control Unit

1. Connect a voltmeter between cruise control unit and ground.
2. Turn the ignition switch ON and check the terminal voltages as described below.

Terminal	Connected to	Voltage	Procedure
a (Output)	Actuator (Motor type)	Approx. 0V Approx. 12V	Ignition switch ON Main switch ON
	Actuator (Vacuum type)	Approx. 0V Approx. 9V	Ignition switch ON Main switch ON
b (Output)	Actuator (Motor type)	Approx. 0V Approx. 12V	Ignition switch ON Main switch ON
	Actuator (Vacuum type)	Approx. 0V Approx. 9V	Ignition switch ON Main switch ON
c (Output)	Actuator (Motor type)	Approx. 0V Approx. 12V	Ignition switch ON Main switch ON
	Actuator (Vacuum type)	Approx. 0V Approx. 9V	Ignition switch ON Main switch ON
d (Output)	Cruise indicator	Approx. 12V Approx. 1V	Ignition switch ON Cruise indicator light comes on
e	Ignition switch	Approx. 12V	Ignition switch ON
f (Input)	Cruise control switch (Main switch)	Approx. 12V	While pushing the main switch
g (Output)	EC-AT control unit (Only A/T)	Approx. 12V	Ignition switch ON
h (Input)	Stop switch 2	Approx. 9V Approx. 12V	Ignition switch ON and main switch ON Brake pedal depressed
j (Input) Note Disconnect EGL control unit connector	Inhibitor switch (A/T)	Approx. 0V Approx. 5V	"N" or "P" range, ignition switch ON and main switch ON Other range, ignition switch ON and main switch ON
	Clutch switch (M/T)	Approx. 0V Approx. 5V	Clutch pedal depressed, ignition switch ON and main switch ON Ignition switch ON and main switch ON
l (Input)	Cruise control switch (Set switch)	Approx. 12V Approx. 0V	Main switch ON While pushing the set switch after main switch ON
m (Input)	Stop switch 1	Approx. 0V Approx. 12V	Ignition switch ON Brake pedal depressed
n (Input)	Cruise control switch (Coast switch)	Approx. 12V Approx. 0V	Main switch ON While turning the COAST position after main switch ON
o (Output)	Actuator	Approx. 0V Approx. 9V	Ignition switch ON Main switch ON
p (Input)	Speed sensor	Run out between 0—10V	While rotating the real tire
q (Output)	Main indicator	Approx. 0V Approx. 12V	Ignition switch ON Main switch ON
r (Input)	Cruise control switch (Resume switch)	Approx. 12V Approx. 0V	Main switch ON While turning the RESUME position after main switch ON
s	Battery	Approx. 12V	—
t	Ground	Approx. 0V	—

97U0TX-112

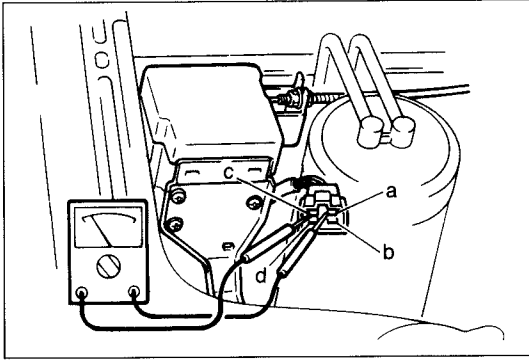

97U0TX-113

Actuator (Turbo model)

1. Measure the actuator clutch solenoid resistance using an ohmmeter.

Check terminal	Resistance
c—a	Approx. 20 ohms

2. Check continuity at the terminals of the actuator connector.

Check terminal	Continuity
c—a	Yes
b—d	Yes

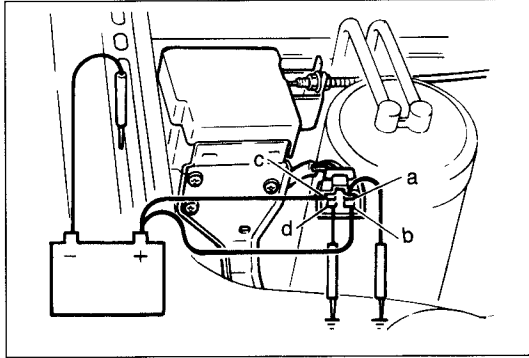

77U15X-022

3. Connect battery power and ground as follows, and check the operation of the control cable.

Terminal condition				Operation condition of control cable
a	b	c	d	
Ground	Power	Power	Ground	Pull
Ground	—	Power	—	Stop
Ground	Ground	Power	Power	Extend
—	—	—	—	Release

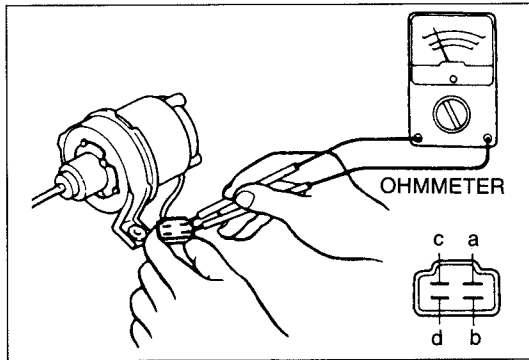

97U0TX-198

Actuator (Non-Turbo model)

Measure the actuator solenoid resistance using an ohmmeter.

Check terminals	Resistance
c—a	Approx. 23 to 55Ω
c—b	
c—d	

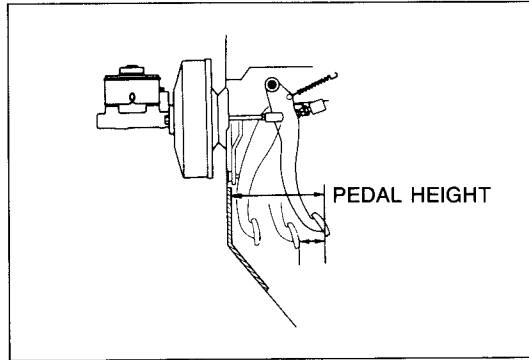

97U0TX-114

Clutch switch, Brake switch

When servicing these switches, adjust them so that the corresponding pedal height is as specified.

Pedal height: (With carpet)

Clutch..... 183—193mm (7.20—7.60 in)

Brake..... 184—189mm (7.24—7.44 in)

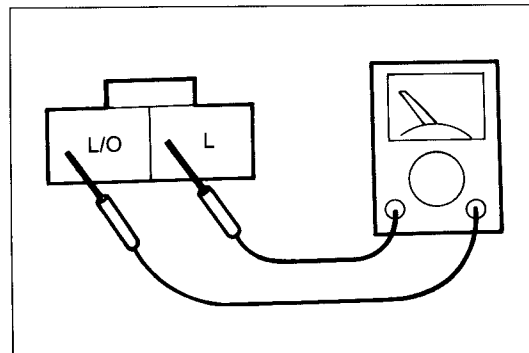

97U0TX-193

Stoplight switch (For cruise)

Check that there is continuity between (L/O) and (L) wires when the brake pedal is released.

T THEFT-DETERRENT SYSTEM

THEFT-DETERRENT SYSTEM

STRUCTURAL VIEW

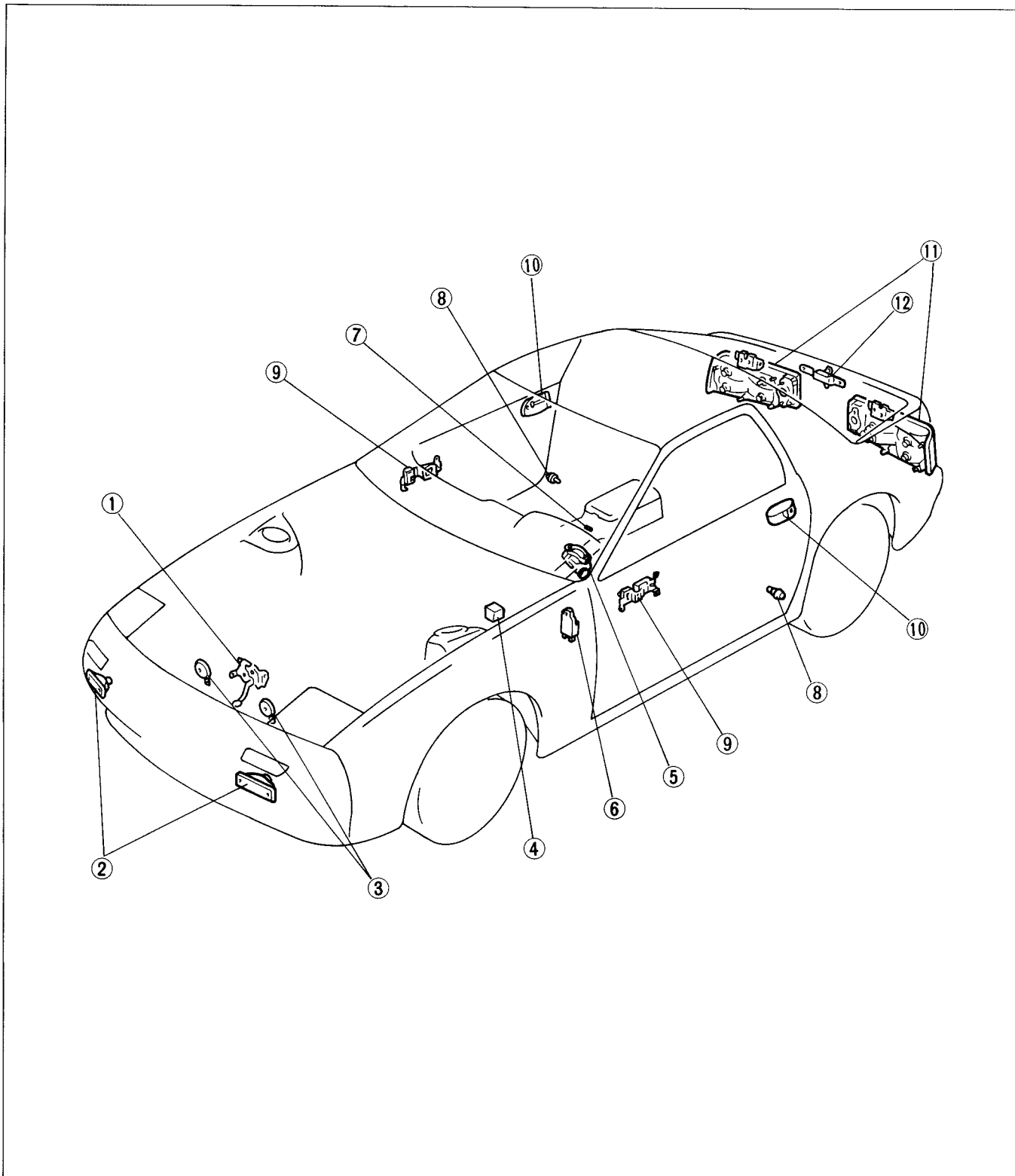

97U0TX-115

- | | |
|--|---|
| 1. Hood switch | 7. Security lamp |
| 2. Hazard warning lights | 8. Door switches |
| 3. Horns | 9. Door lock switches |
| 4. Starter cut relay | 10. Door key cylinder switches |
| 5. Ignition switch & key reminder switch | 11. Rear hatch (or trunk) switches |
| 6. Theft-deterrent control unit (in CPU) | 12. Rear hatch (or trunk) key cylinder switch |

CIRCUIT DIAGRAM

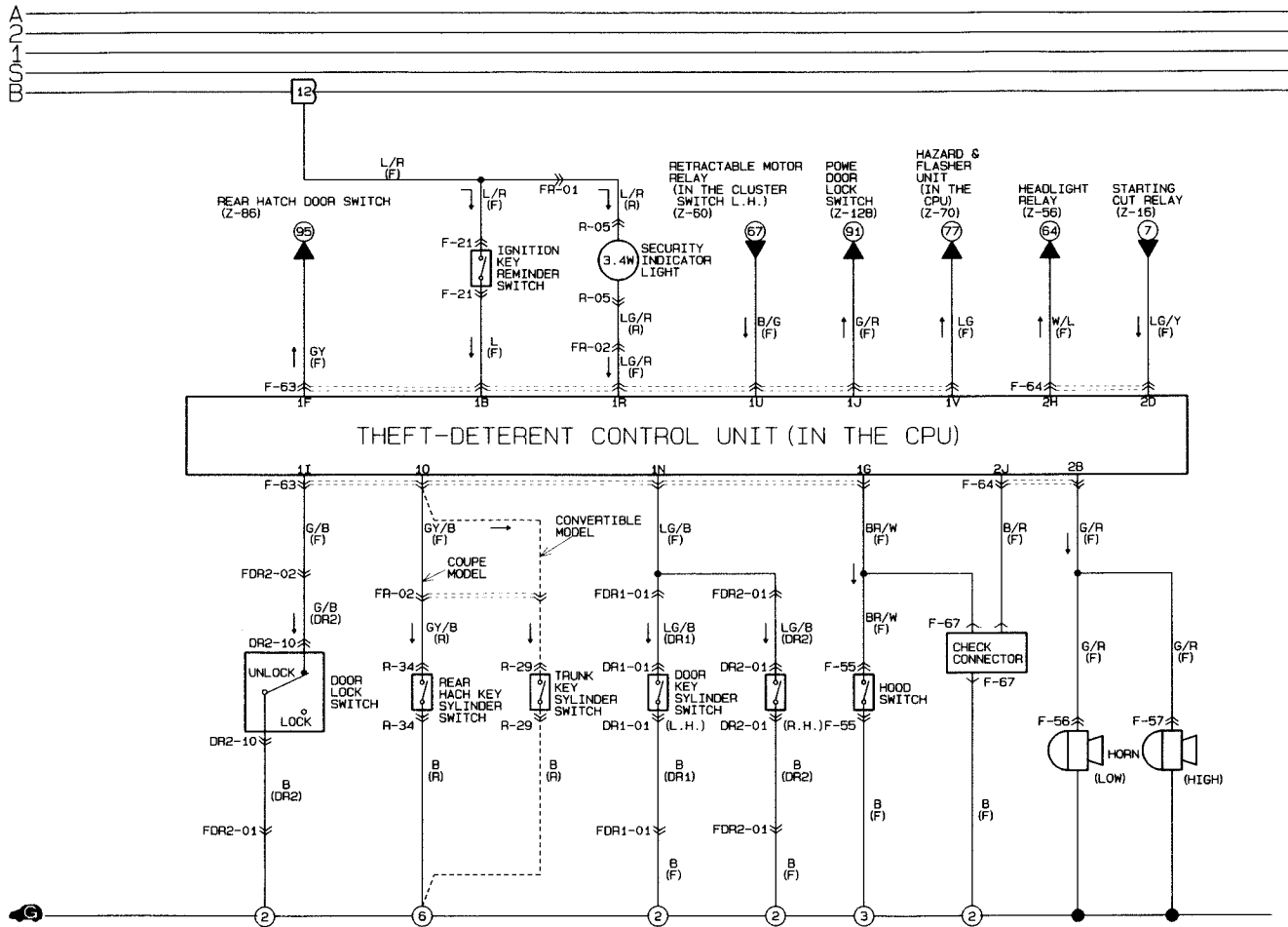

F-21 IGNITION KEY REMINDER SWITCH (F) F-55 HOOD SWITCH (F)



F-56 HORN (LOW) (F)



F-57 HORN (HIGH) (F)



F-63 CPU (F)

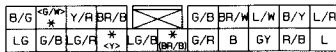

F-64 CPU (F)



F-67 CHECK CONNECTOR (F)



R-05 SECURITY LIGHT (R)



() ... WITH PASSIVE SHOULDER BELT
 < > ... WITH POWER WINDOW & DOOR LOCK KEY CYLINDER ILLUMI

R-29 TRUNK KEY SYLINDER SWITCH (R)



R-34 REAR HATCH KEY SYLINDER SWITCH (R)



DR1-01 DOOR KEY SYLINDER SWITCH (DR1)



DR2-01 DOOR KEY SYLINDER SWITCH (DR2)



DR2-10 DOOR LOCK SWITCH (DR2)



T THEFT-DETERRENT SYSTEM

SYSTEMS INSPECTION

Perform the Systems Inspection to check overall operation of the theft-deterrent system. Refer to the Inspection flowchart or Diagnosis Chart as directed if a problem is found.

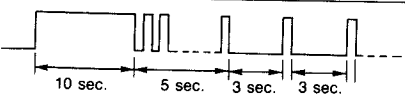
Step	Procedure	Proper operation	Problem	Action
1	Open door A* window, and remove ignition key	Go to step 2		
2	Open door A, and lock A and B lock knobs	Security lamp ON OFF — DOOR LOCKED	Lamp does not come on	Go to Insp. A
		Buzzer DOOR LOCKED	Buzzer does not sound	Replace control unit
3	Close and lock door A without key	Security lamp 	Lamp does not come on	Replace control unit
4	Open trunk/rear hatch with key	Go to step 5		
5	Unlock door A lock knob	Horn sounds	Horn does not sound	Go to Insp. B
		Headlights and hazard warning lights flash	Light does not come on	Go to Insp. C
6	Turn ignition switch to START	Starter does not operate	Starter works	Go to Insp. D
7	Turn door A key cylinder to "unlock"	Go to step 8		
8	Remove STOP fuse, and retest steps 1,2,3, and 5	Headlights and hazard warning lights flash for 5 min.	Lights do not continue flashing for 5 min.	Replace control unit

97U0TX-117

*Door guide

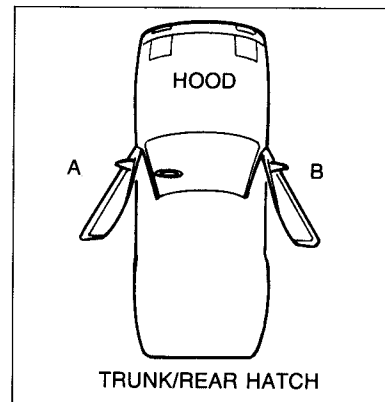

Inspection Flowchart

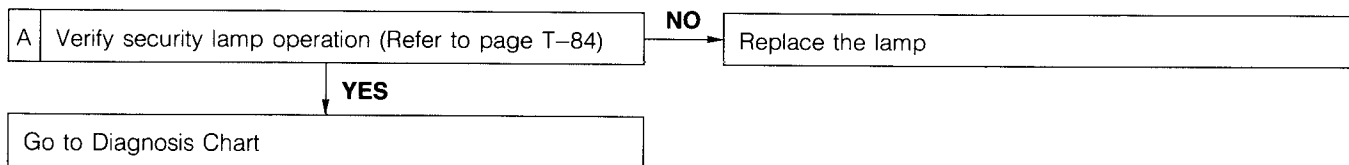

97U0TX-118

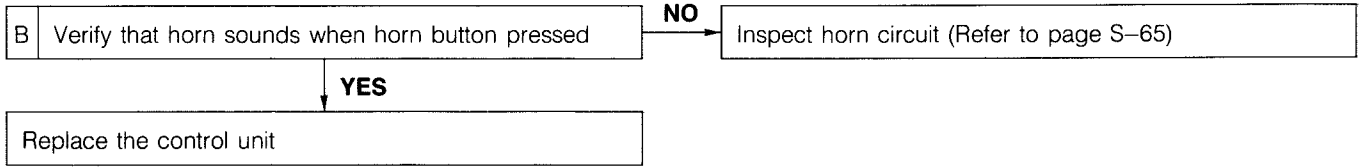

97U0TX-119

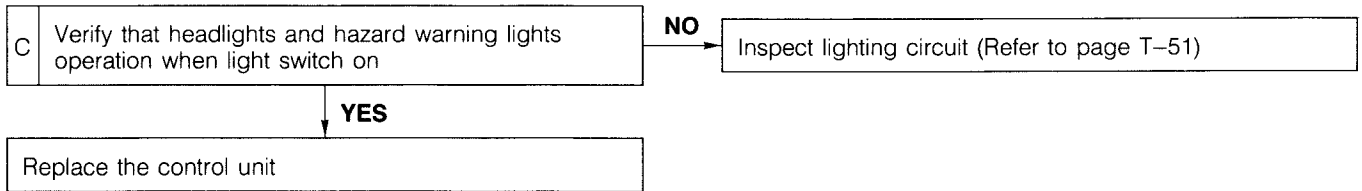



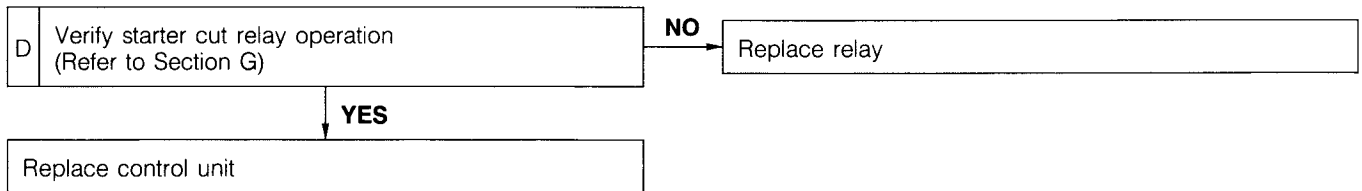









97U0TX-120







97U0TX-121

Diagnosis Chart

No.	Procedure	Proper operation			Action
		Security lamp	Buzzer	Interior lamp	
1	Turn ignition switch OFF Open door A*	OFF			Inspect ignition switch (Open circuit) (Refer to page T-17)
2	Remove ignition key	OFF	OFF		Inspect ignition switch (Short circuit) (Refer to page T-17)
3	Sit in driver's seat with door A open Lock A and B lock knobs				Inspect door A or B lock switch (Refer to page T-83)
4	Unlock door A and B lock knobs	OFF	OFF		
5	Pull hood release lever		OFF		Inspect hood switch (Refer to page T-83)
6	Pull trunk/rear hatch release lever		OFF		Inspect trunk (or back door) switch (Refer to page T-83)
7	Remove key and exit vehicle	OFF	OFF		
8	Close door A	OFF	OFF	OFF	Inspect door A switch (Refer to page T-83)

↓
Cont'd

T THEFT-DETERRENT SYSTEM

No.	Procedure	Proper operation			Action
		Security lamp	Chime	Interior lamp	
9	Turn door A key cylinder to "unlock" and hold in position		OFF	OFF	Inspect door A key cylinder switch (Refer to page T-83)
10	Remove key	OFF	OFF	OFF	
11	Turn trunk/rear hatch key cylinder to "unlock" and hold in position		OFF	OFF	Inspect trunk key cylinder switch (Refer to page T-83)
12	Remove key	OFF	OFF	OFF	
13	Close trunk/rear hatch	OFF	OFF	OFF	
14	Turn door B key cylinder to "unlock" and hold in position		OFF	OFF	Inspect door B key cylinder switch (Refer to page T-83)
15	Remove key	OFF	OFF	OFF	
16	Open door B	OFF	OFF		Inspect door B switch (Refer to page T-83)
17	Close door B	OFF	OFF	OFF	
18	Close hood	OFF	OFF	OFF	

All OK

97U0TX-122

Replace the control unit

*Door guide

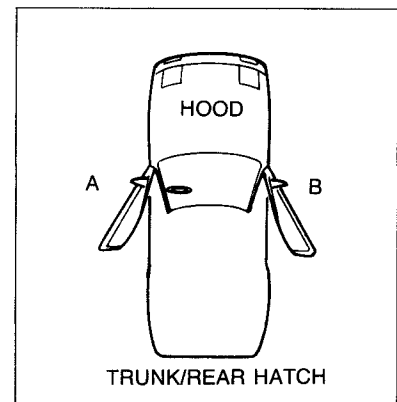

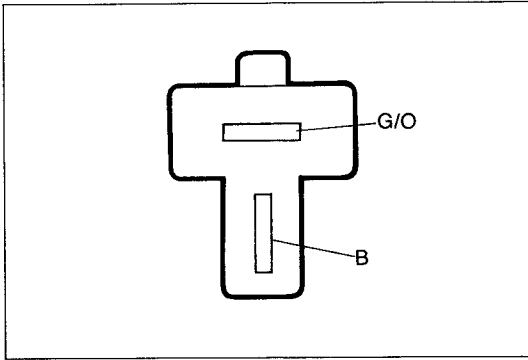

97U0TX-123

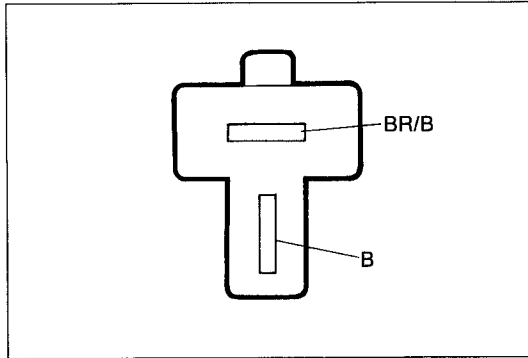

97U0TX-124

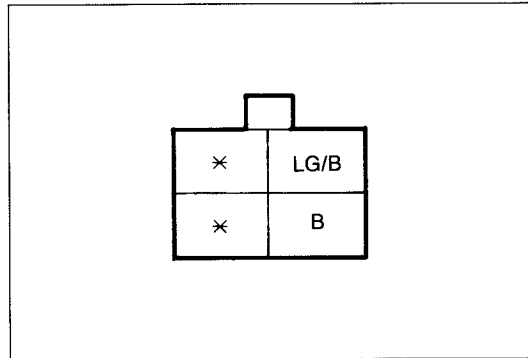

97U0TX-125

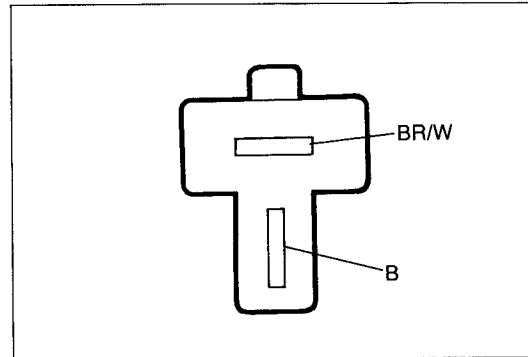

97U0TX-126

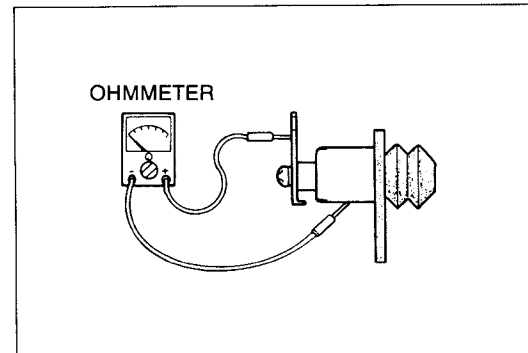

86U15X-068

INSPECTION

Door Lock Switch

1. Check for continuity of the switches with an ohmmeter.

Door	Terminals	Condition	Continuity
Driver's side	G10—B	Unlocked	Yes
		Locked	No
Passenger's side	G10—B	Unlocked	Yes
		Locked	No

2. If not, replace the switch.

Trunk (or Rear Hatch) Key Cylinder Switch

1. Check for continuity of the switches with an ohmmeter.

Door	Terminals	Condition	Continuity
Trunk (or Rear hatch)	BR/B—B	Unlocked	Yes
		Locked	No

2. If not, replace the switch.

Door Key Cylinder Switch

1. Check for continuity of the switch with an ohmmeter.

Door	Terminals	Condition	Continuity
Driver side	LG/B—B	Unlocked	Yes
		Locked	No
Front left side	LG/B—B	Unlocked	Yes
		Locked	No

2. If not, replace the switch.

Hood Switch

1. Check for continuity of the switch with an ohmmeter.

Terminals	Condition	Continuity
BR/W—B	Open	Yes
	Close	No

2. If not, replace the switch.

Door Switch

1. Check for continuity of the switch with an ohmmeter.

Switch	Continuity
Pushed	No
Released	Yes

2. If continuity is not as specified, replace the switch.

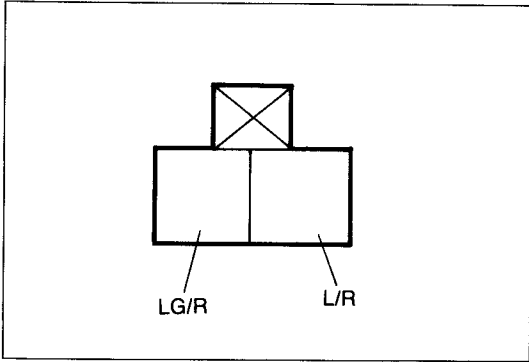

97U0TX-127

Security Lamp

1. Check for continuity between terminals.
2. If not, replace the lamp.

Ignition Switch

Refer to page T-17.

97U0TX-128

AUDIO SYSTEM

STRUCTURAL VIEW (For Coupe)

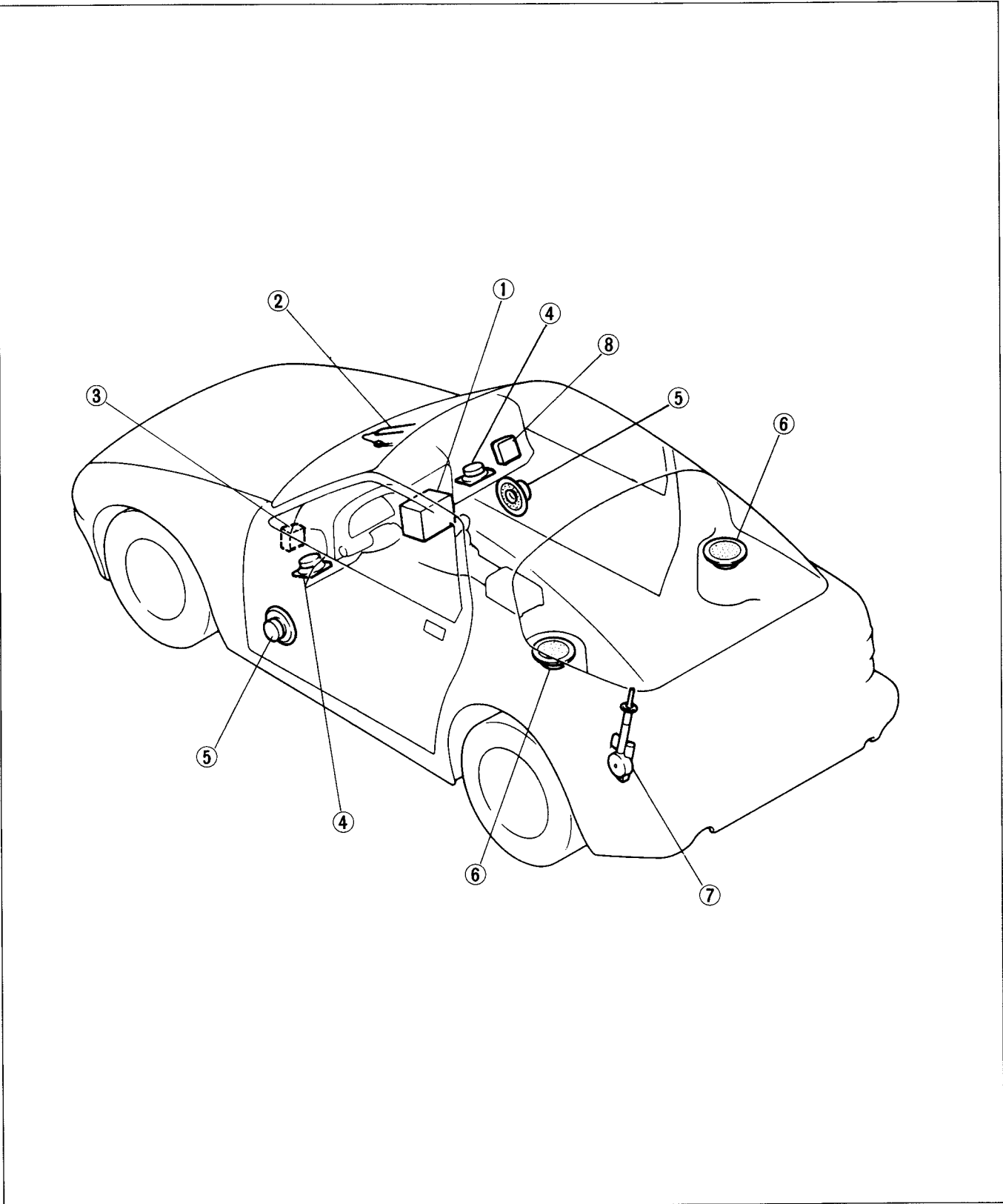

97U0TX-129

- 1. Audio component assembly
- 2. Windshield antenna
- 3. Door woofer amplifier (Without Passive belt)
- 4. Front speakers

- 5. Door woofer speakers
- 6. Rear speakers
- 7. Power antenna
- 8. Door woofer amplifier (With Passive belt)

T AUDIO SYSTEM

(For Convertible)

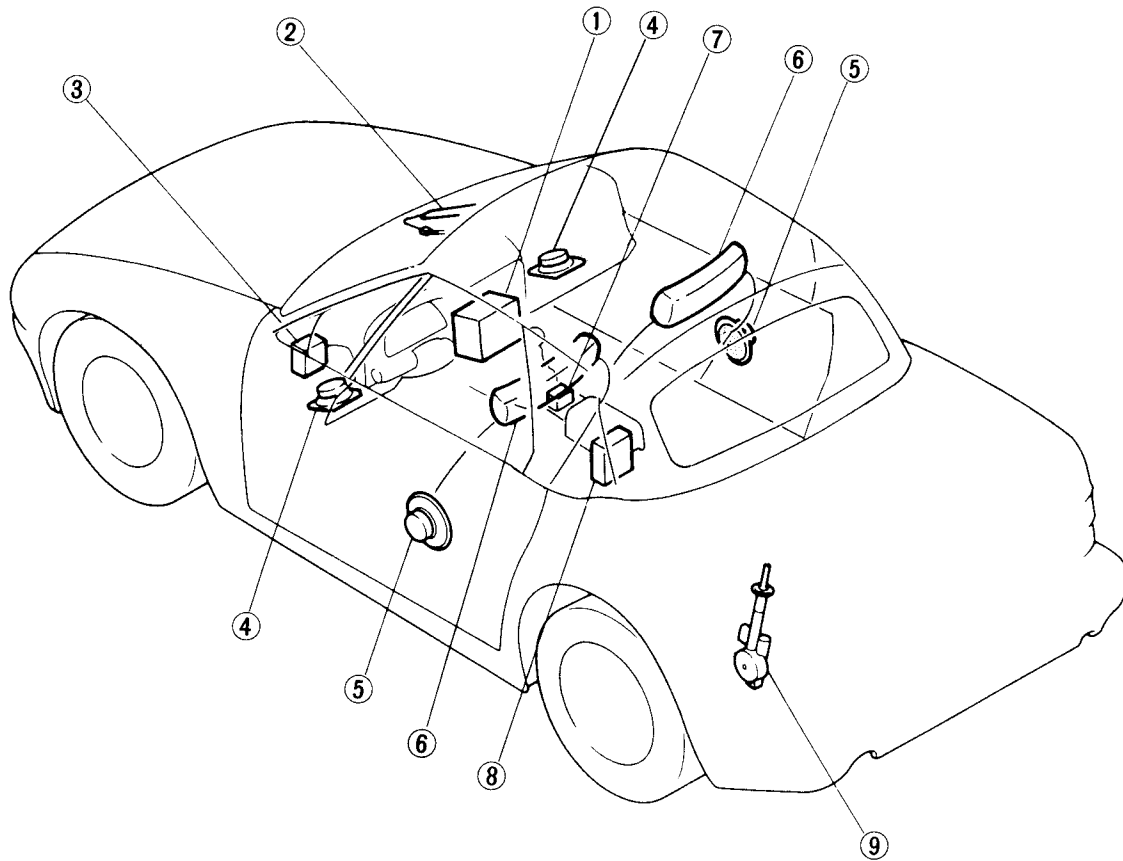

- 1. Compact disc player
Full logic auto-reverse cassette deck
AM/FM MPX ETR
Acoustic Equilibration (AE) system
- 2. Windshield antenna
- 3. Door woofer amplifier

- 4. Front speakers
- 5. Door woofer speaker
- 6. Headrest speaker
- 7. Headrest speaker switch
- 8. Headrest speaker AMP
- 9. Power antenna

97U0TX-130

OUTLINE OF AUDIO

For Coupe
TYPE 1 (RADIO)

ID No.2E60

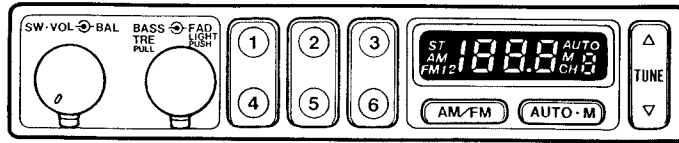

TYPE 2 (RADIO, CASSETE DECK)

ID No.2260

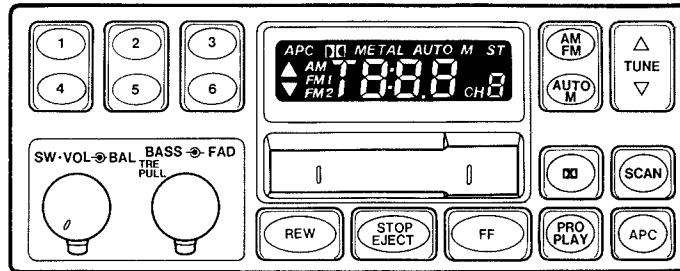

TYPE 3 (RADIO, CASSETE DECK + GRAPHIC EQUALIZER)

ID No.2260

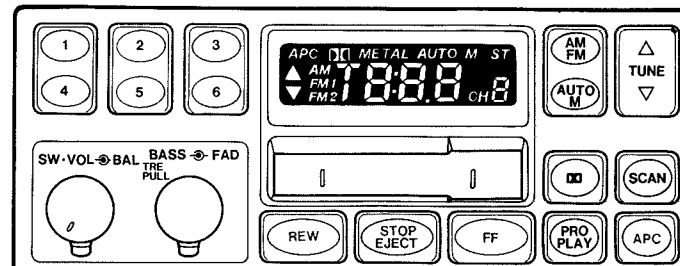

ID No.2G02

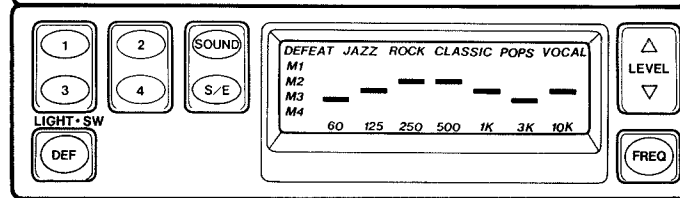

TYPE 4 (RADIO, CASSETE DECK, CD PLAYER + AE SYSTEM)

ID No.6263

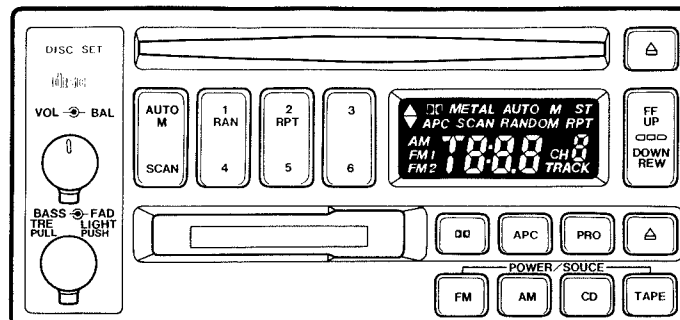

ID No.6V04

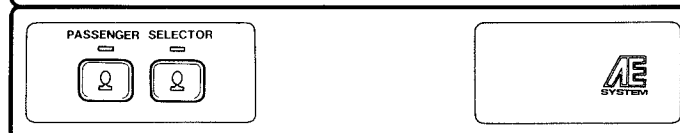

For Convertible
TYPE 1 (RADIO, CASSETTE DECK, CD PLAYER + AE SYSTEM)

ID No.6263

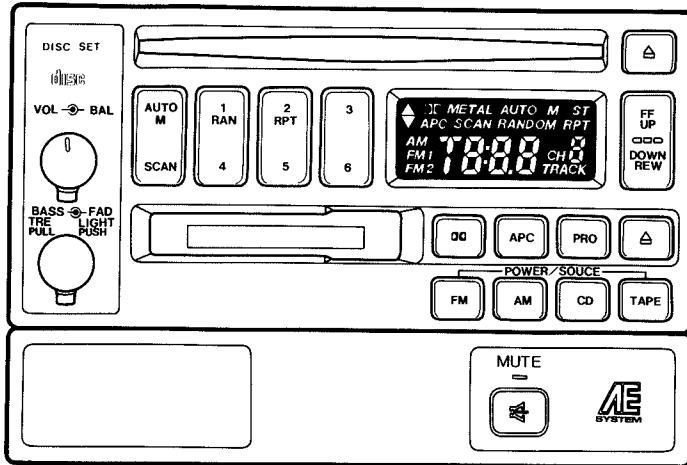

ID No.6V05

97U0TX-132

Rear View

(RADIO)

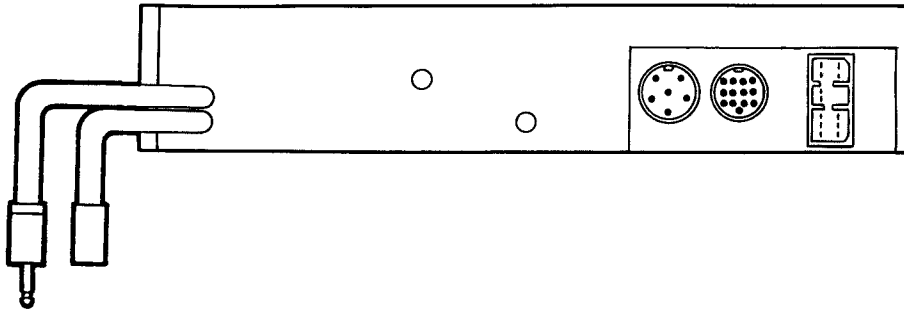

(RADIO, CASSETTE DECK)

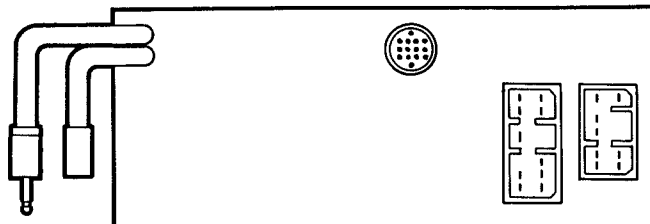

97U0TX-133

(GRAPHIC EQUALIZER)

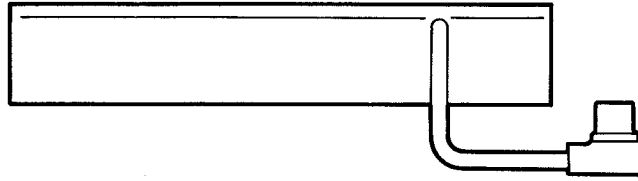

(RADIO, CASSETE DECK, CD PLAYER)

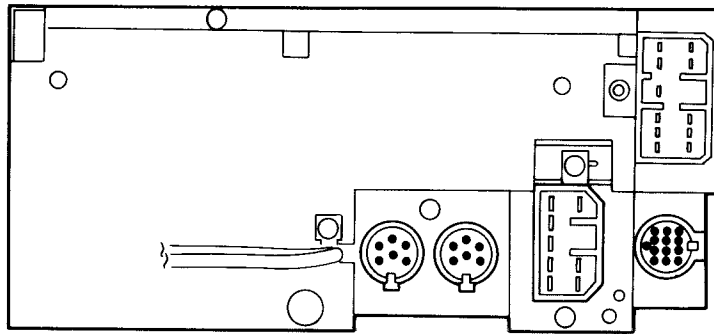

(AE SYSTEM)

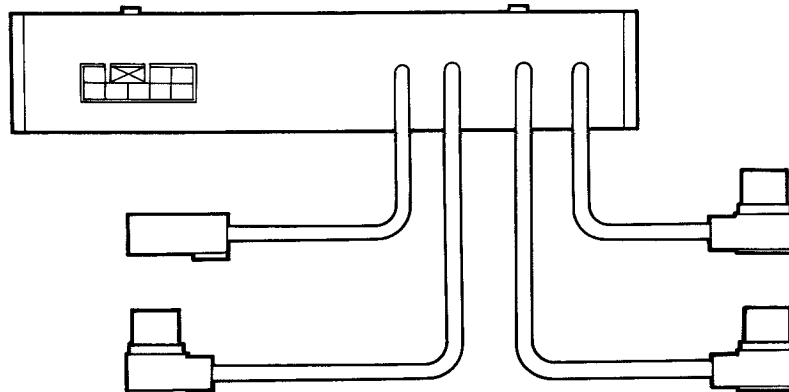

T AUDIO SYSTEM

SYSTEM

FOR COUPE
TYPE 1

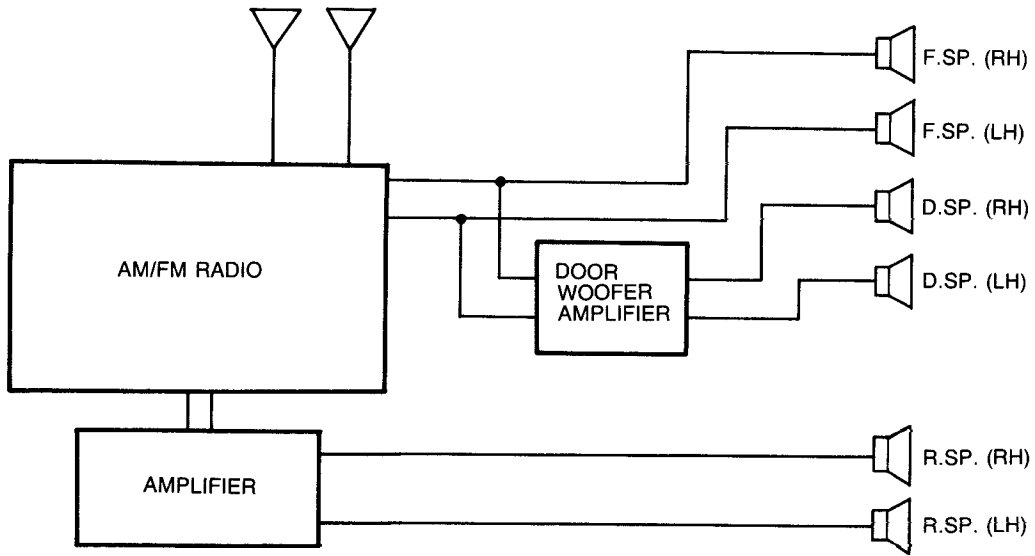

TYPE 2, 3

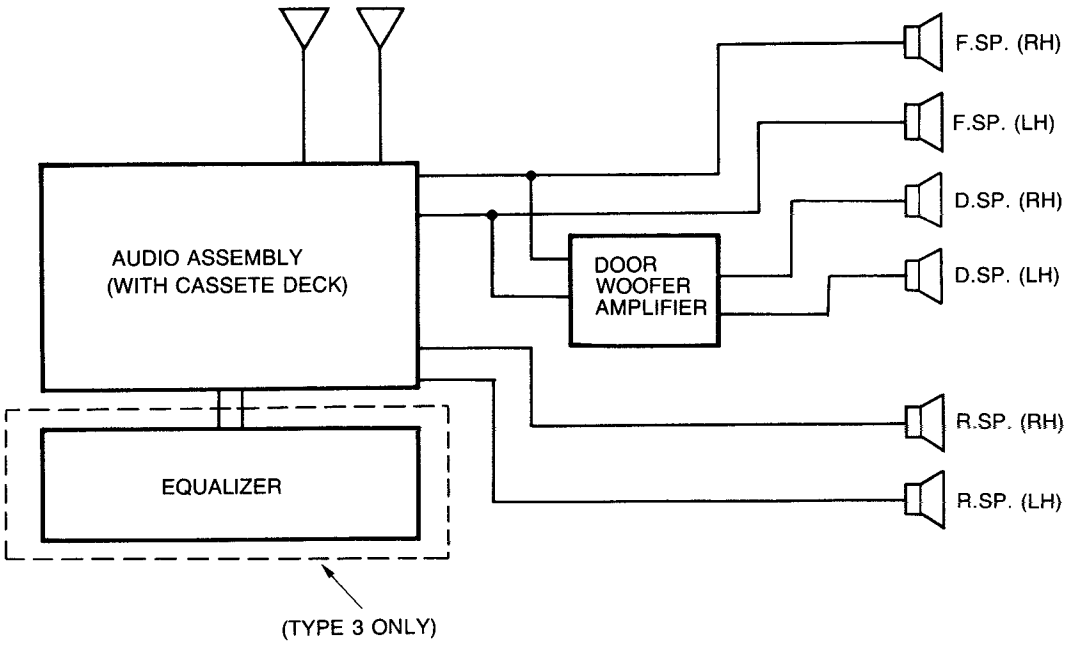

TYPE 4

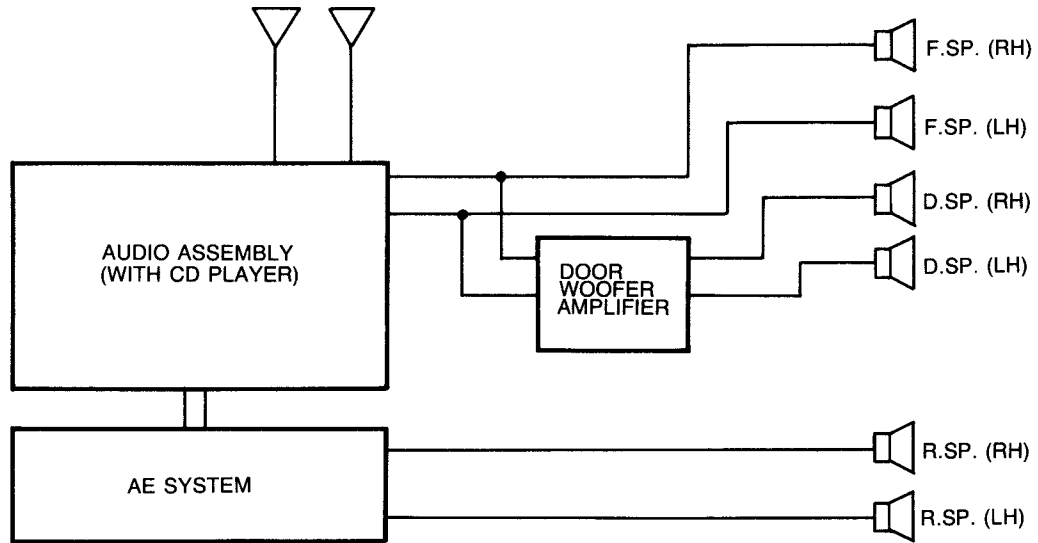

FOR CONVERTIBLE TYPE 1

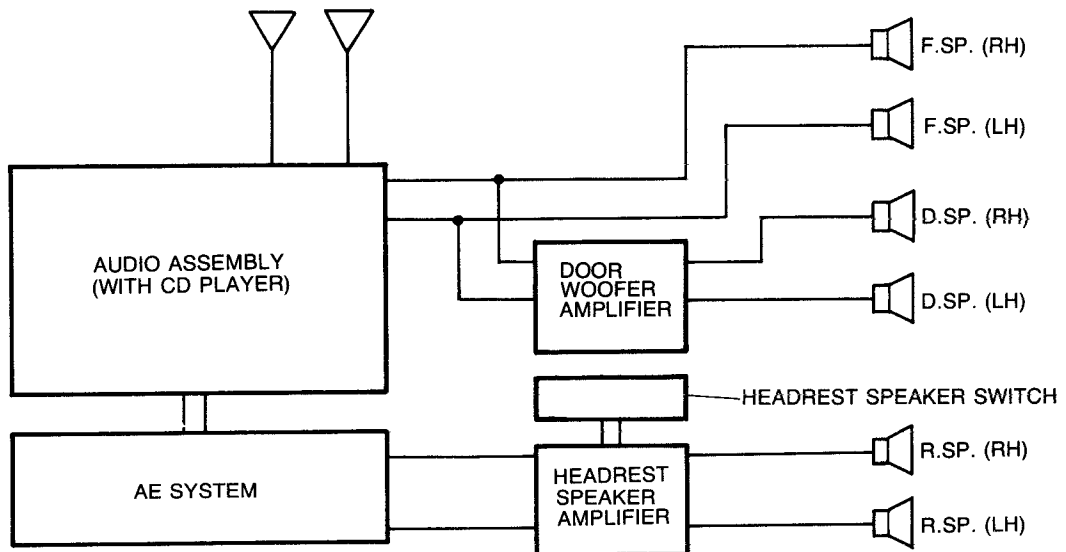

AUDIO SYSTEM

TROUBLESHOOTING

Circuit Diagram

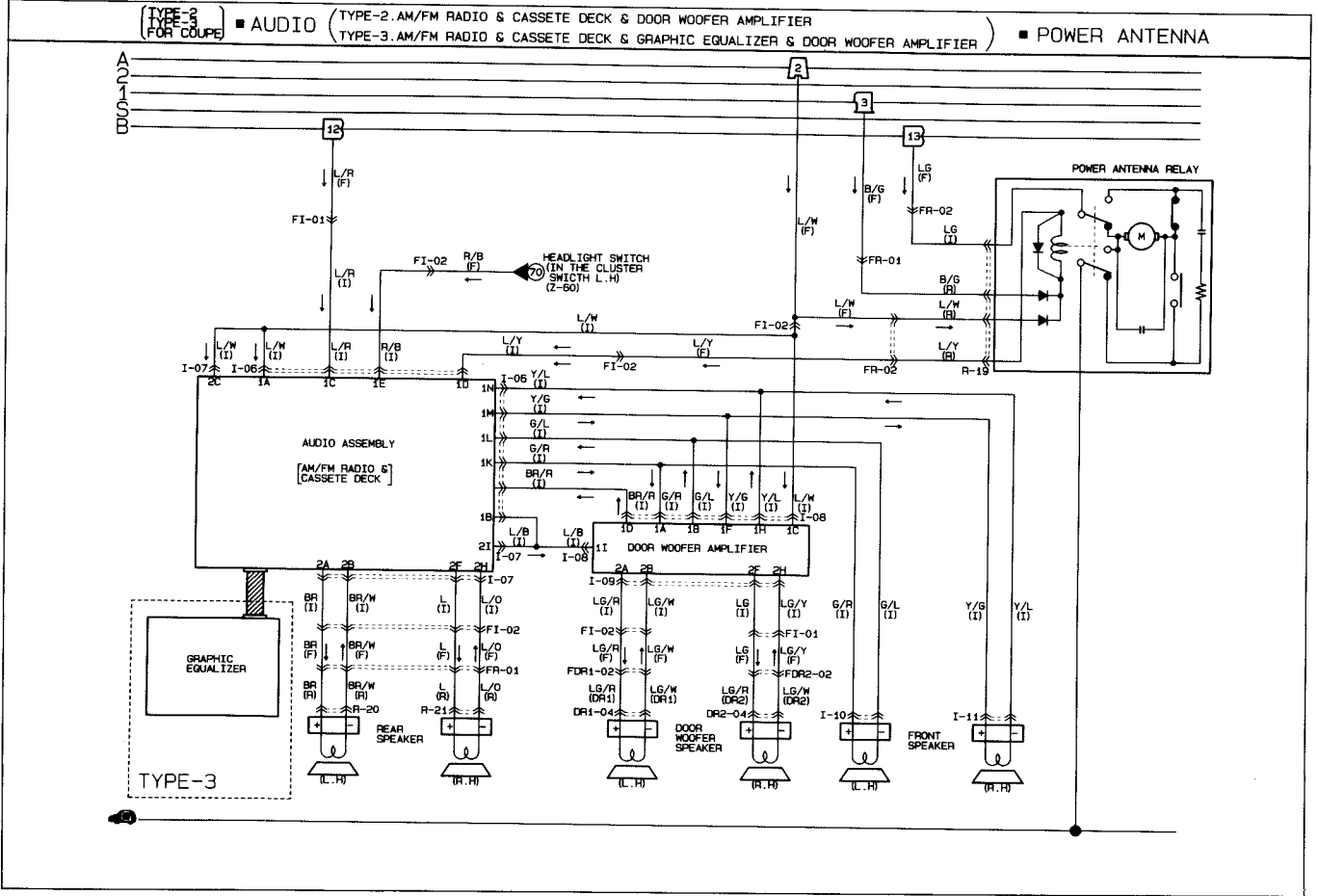
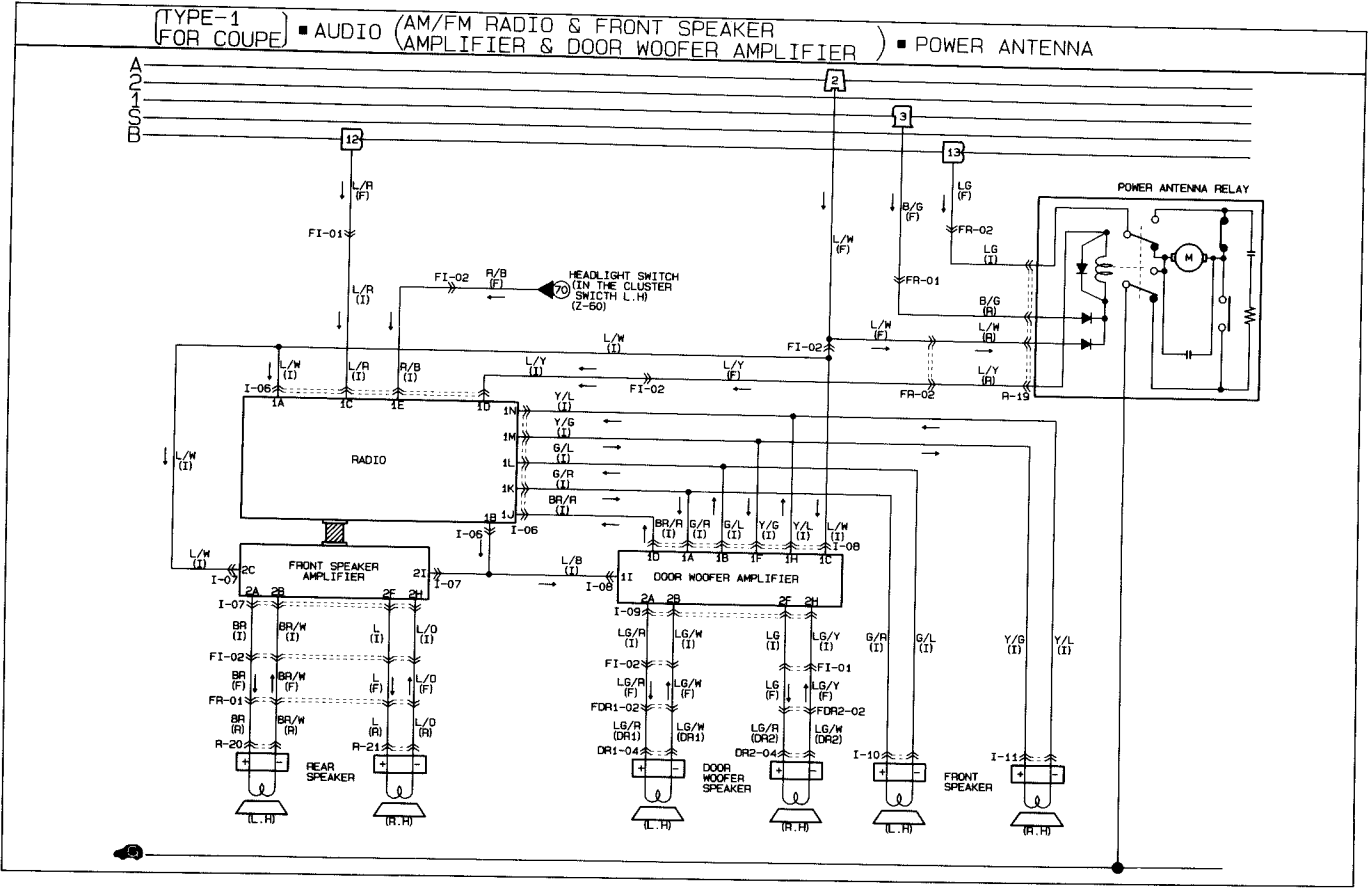

(TYPE-4 FOR COUPE) ■ AUDIO (AM/FM RADIO & CASSETTE DECK & COMPACT DISK) ■ POWER ANTENNA
 (PLAYER & AE SYSTEM & DOOR WOOFER AMPLIFIER)

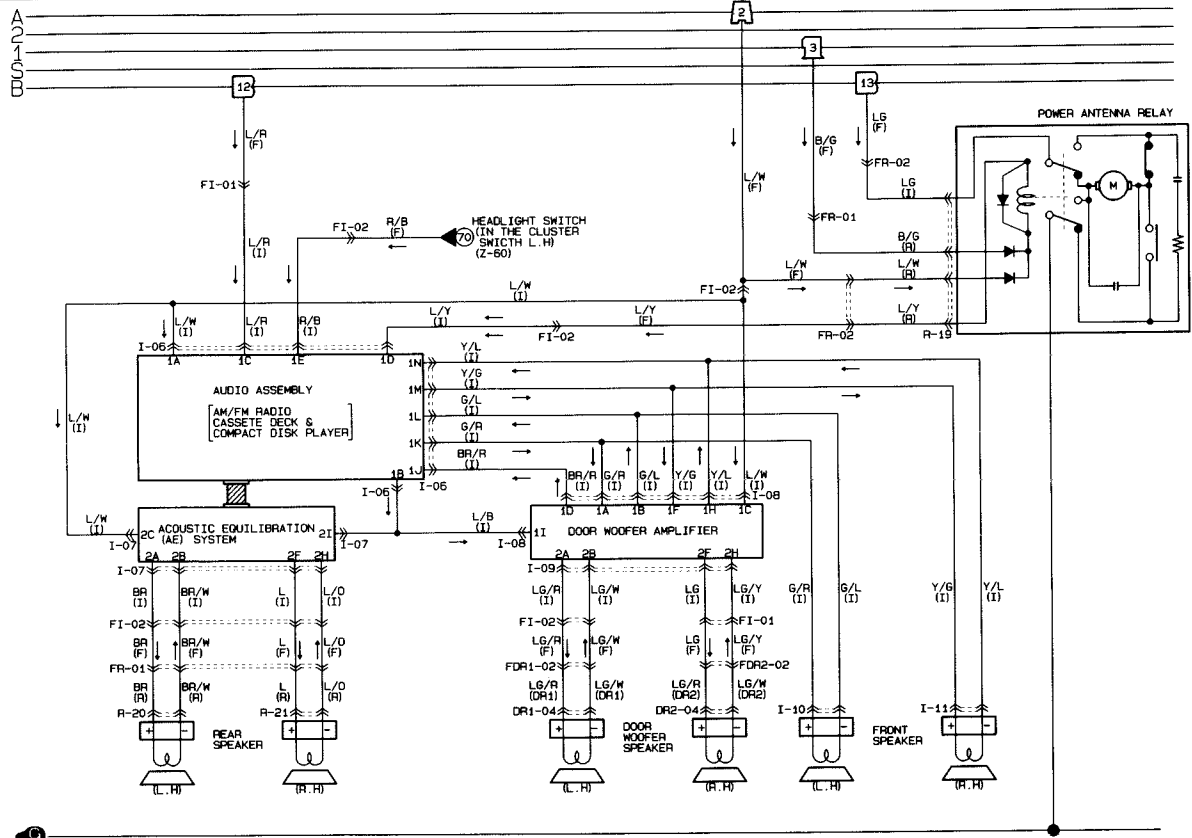

(TYPE-1 FOR CONVERTIBLE) ■ AUDIO (AM/FM RADIO & CASSETTE DECK & COPACT DISC) 10F2 ■ POWER ANTENNA
 (PLAYER & AE SYSTEM & HEADREST SPEAKER AMPLIFIER)

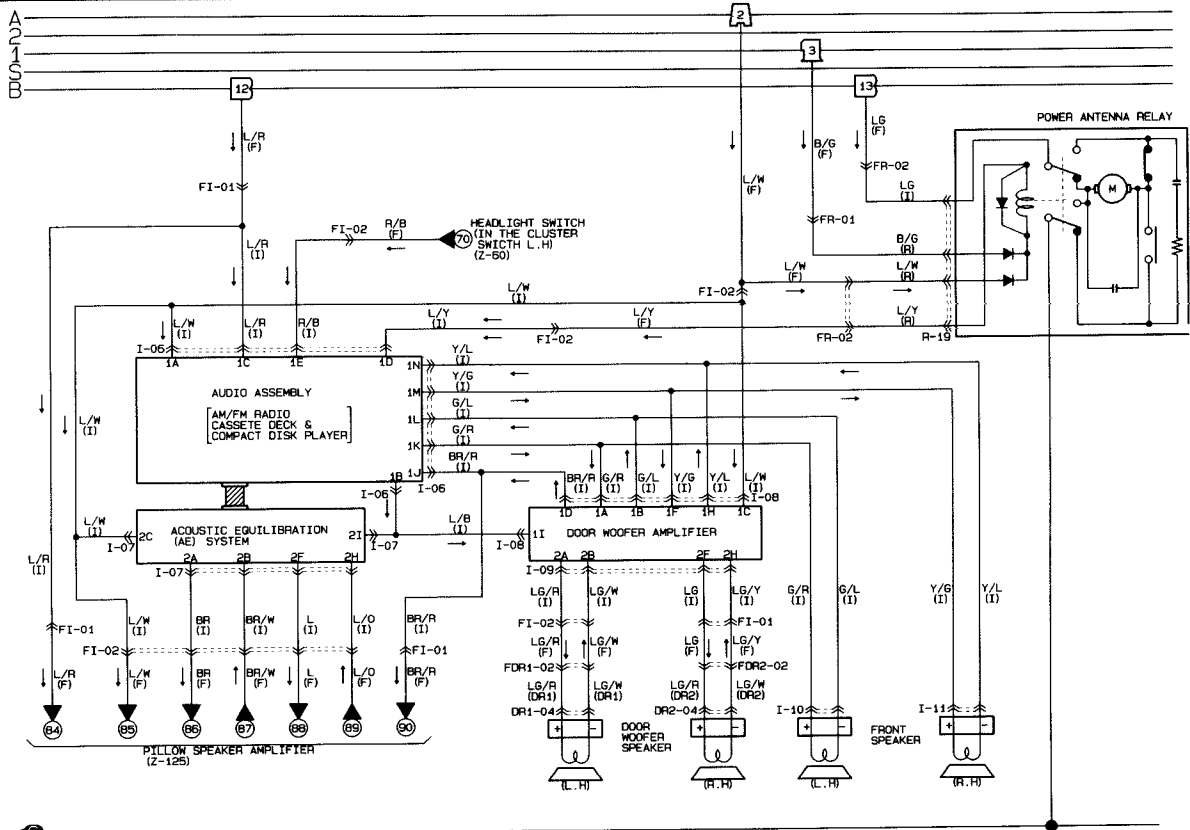

T AUDIO SYSTEM

(TYPE-1 FOR CONVERTIBLE) ■ AUDIO (AM/FM RADIO & CASSETTE DECK & COMPACT DISC PLAYER & AE SYSTEM & HEADREST SPEAKER AMPLIFIER) 20F2

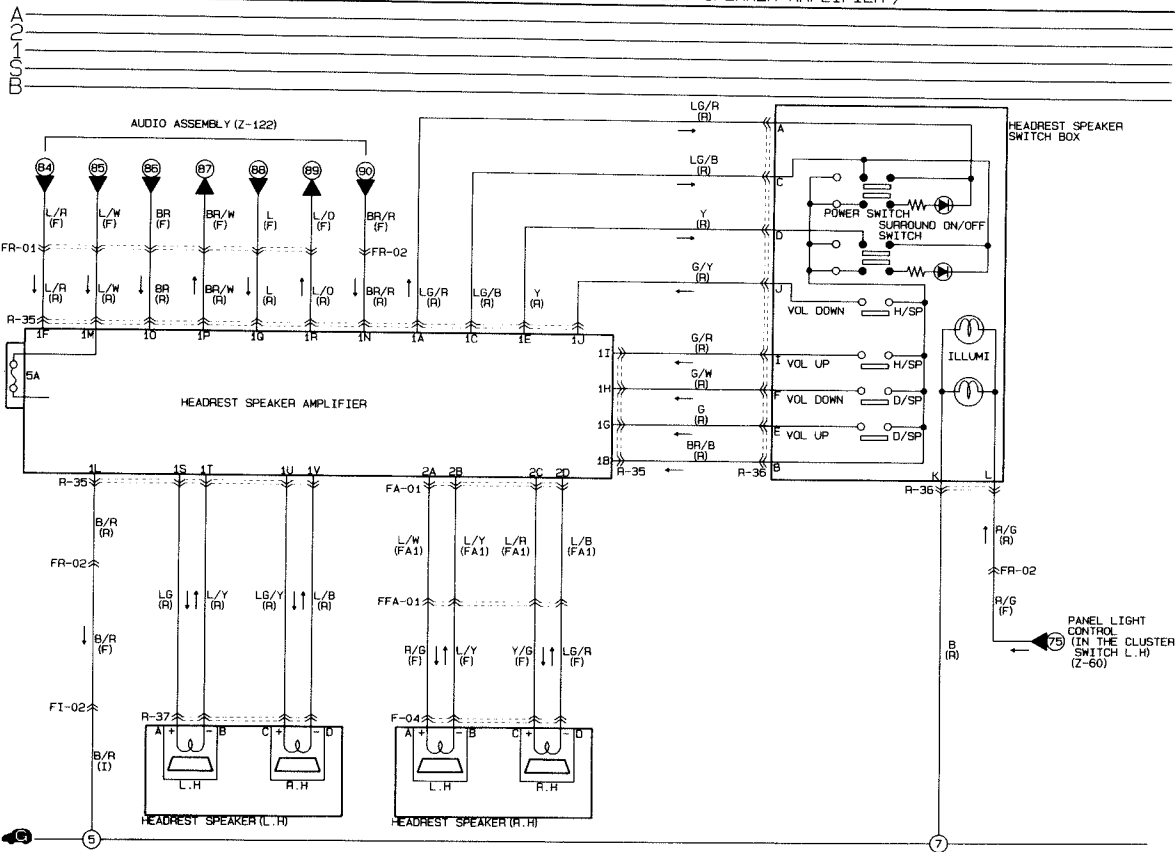

I-06 AUDIO (I)

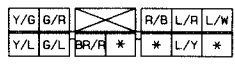

I-07 AUDIO (I)

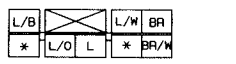

I-08 DOOR WOOFER AMPLIFIER (I)

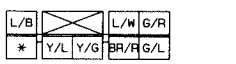

I-09 DOOR WOOFER AMPLIFIER (I)



I-10 FRONT SPEAKER (L, H) (I)



I-11 FRONT SPEAKER (R, H) (I)



R-19 POWER ANTENNA MOTOR (R)



R-20 REAR SPEAKER (L, H) (R)



R-21 REAR SPEAKER (R, H) (R)



DR1-04 DOOR WOOFER SPEAKER (L, H) (DR1)



DR2-04 DOOR WOOFER SPEAKER (R, H) (DR2)



F-04 HEADREST SPEAKER (R, H.) (F)



R-35 HEADREST SPEAKER AMPLIFIER (R)

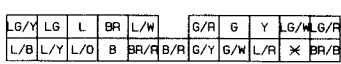

R-36 HEADREST SPEAKER SWITCH BOX (R)

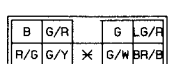

R-37 HEADREST SPEAKER (L, H.) (F)



FA-01 HEADREST SPEAKER AMPLIFIER (FA)



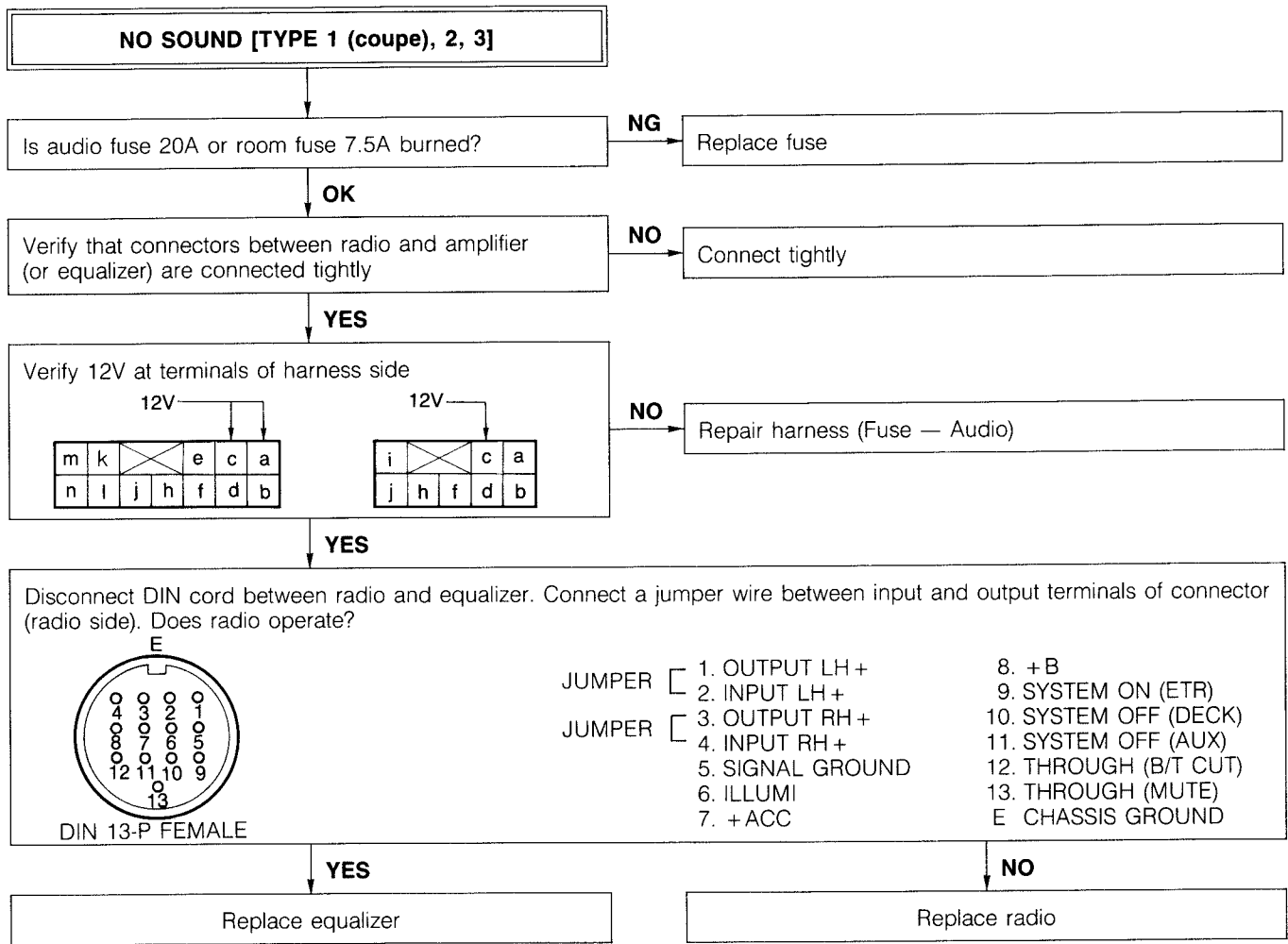

97U0TX-139

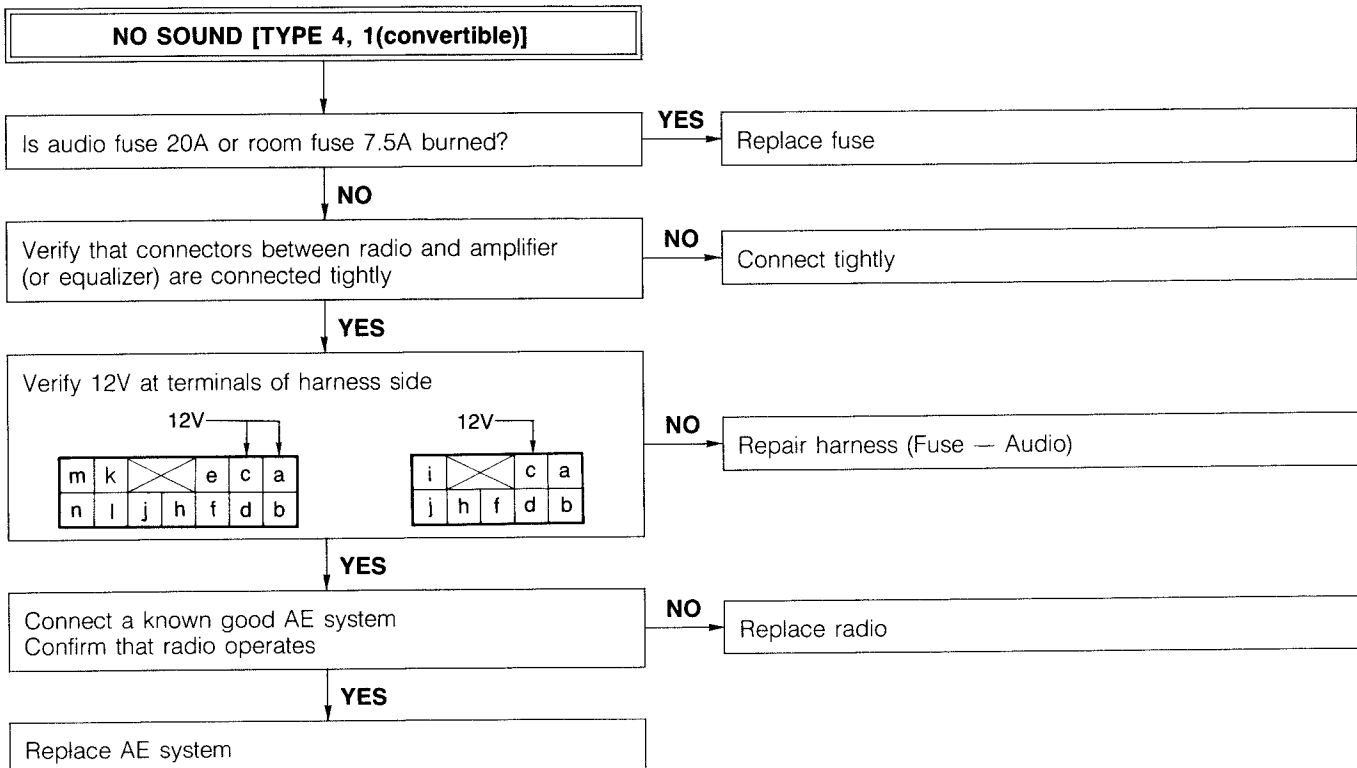

97U0TX-140

Sound is partial

Table 1

Speaker	Fader	Balance	Tone		Speaker operates	Judgement
			Bass	Treble		
Left front	Front	Left	MIN	MAX	Yes	Left front speaker OK
					No	Left front speaker circuit faulty (Go to Table 2)
Right front	Front	Right	MIN	MAX	Yes	Right front speaker OK
					No	Right front speaker circuit faulty (Go to Table 2)
Left rear	Rear	Left	MIN	MAX	Yes	Left rear speaker OK
					No	Left rear speaker circuit faulty (Go to Table 2)
Right rear	Rear	Right	MIN	MAX	Yes	Right rear speaker OK
					No	Right rear speaker circuit faulty (Go to Table 2)
Left door	Rear	Left	MAX	MIN	Yes	Left door speaker OK
					No	Left door speaker circuit faulty (Go to Table 2)
Right door	Rear	Right	MAX	MIN	Yes	Right door speaker OK
					No	Right door speaker circuit faulty (Go to Table 2)

97U0TX-141

Note

- a) When inspecting the door speakers, the rear speakers also operate. Listen carefully for rear speaker operation and door speaker operation.
- b) When checking the door speakers, it may be difficult to hear some sounds because the door speakers are woofer speakers only. If necessary, use a tape with abundant low-frequency sound.

Table 2

No operation	Action
Left front speaker	Inspect the speaker. (Refer to page T-110)
Right front speaker	Inspect the speaker. (Refer to page T-110)
Left rear speaker	Inspect the speaker. (Refer to page T-111)
Right rear speaker	Inspect the speaker. (Refer to page T-111)
Left door speaker	Inspect the speaker. (Refer to page T-110)
Right door speaker	Inspect the speaker. (Refer to page T-110)
Both front speakers	Inspect the speaker. (Refer to page T-110)
Both rear speakers	Inspect the speaker. (Refer to page T-111)
Both door speakers	Inspect the door woofer amplifier. (Refer to page T-112)
Front and door speakers	Replace the audio component assembly
All speakers	Replace the audio component assembly

97U0TX-142

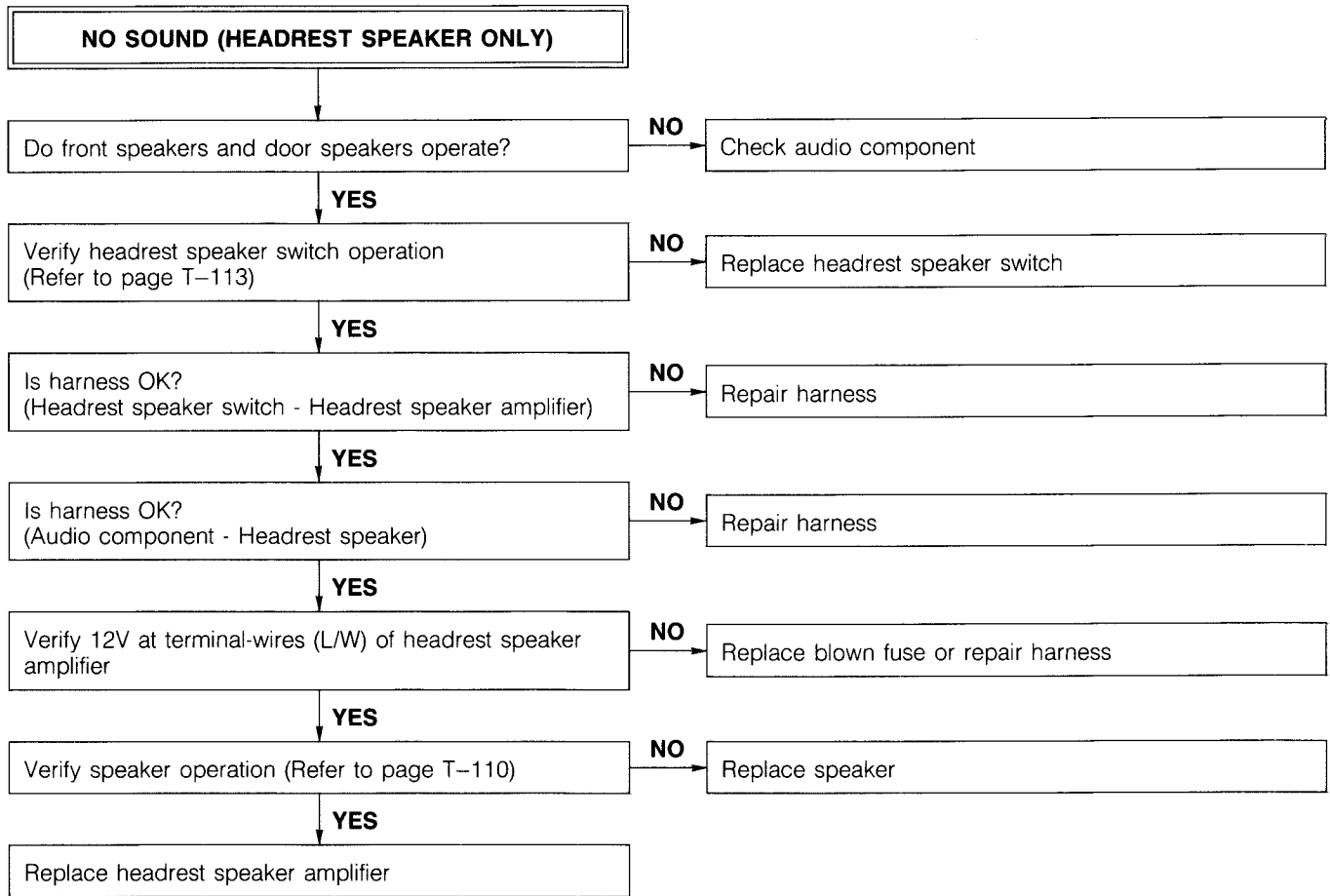

97U0TX-143

T AUDIO SYSTEM

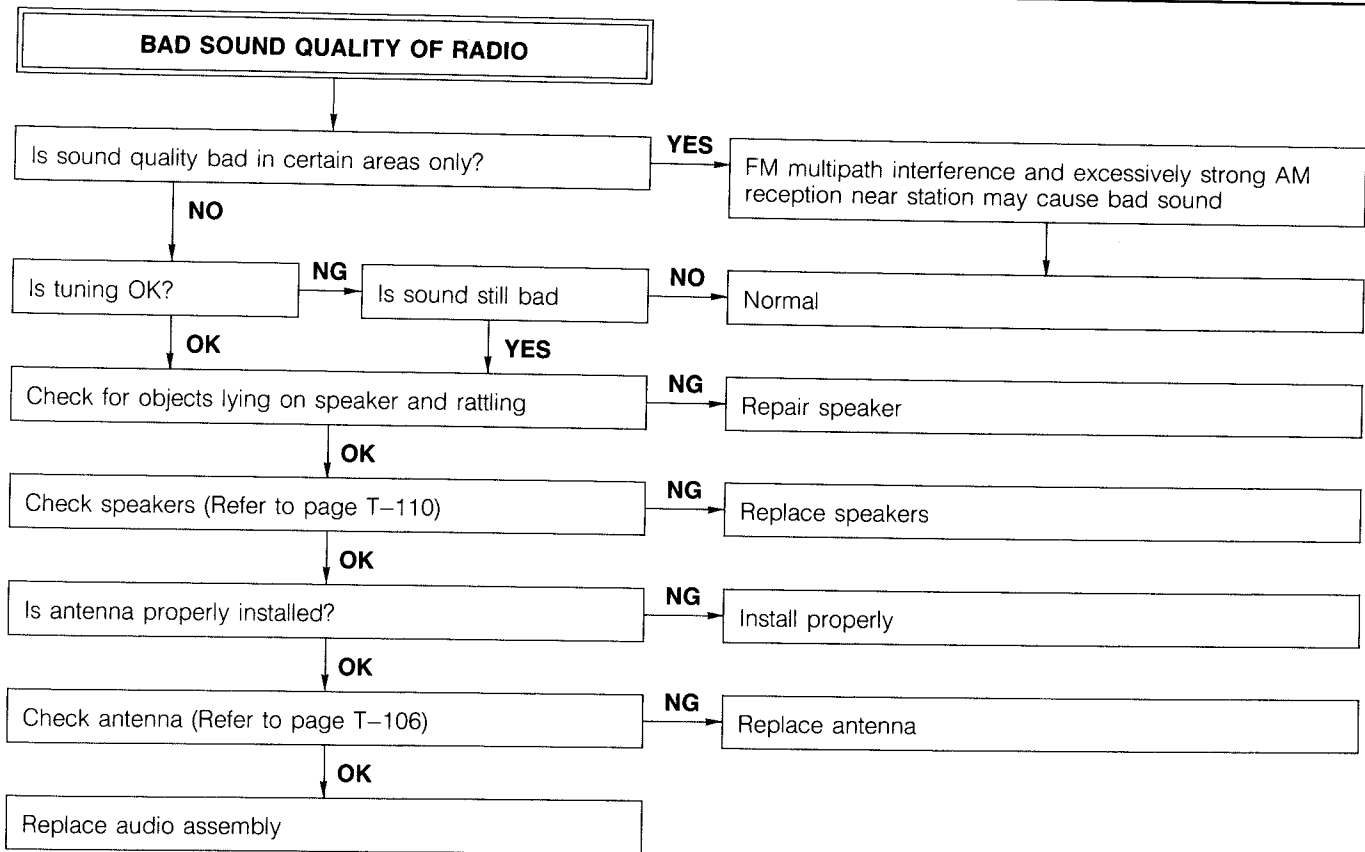

97U0TX-144

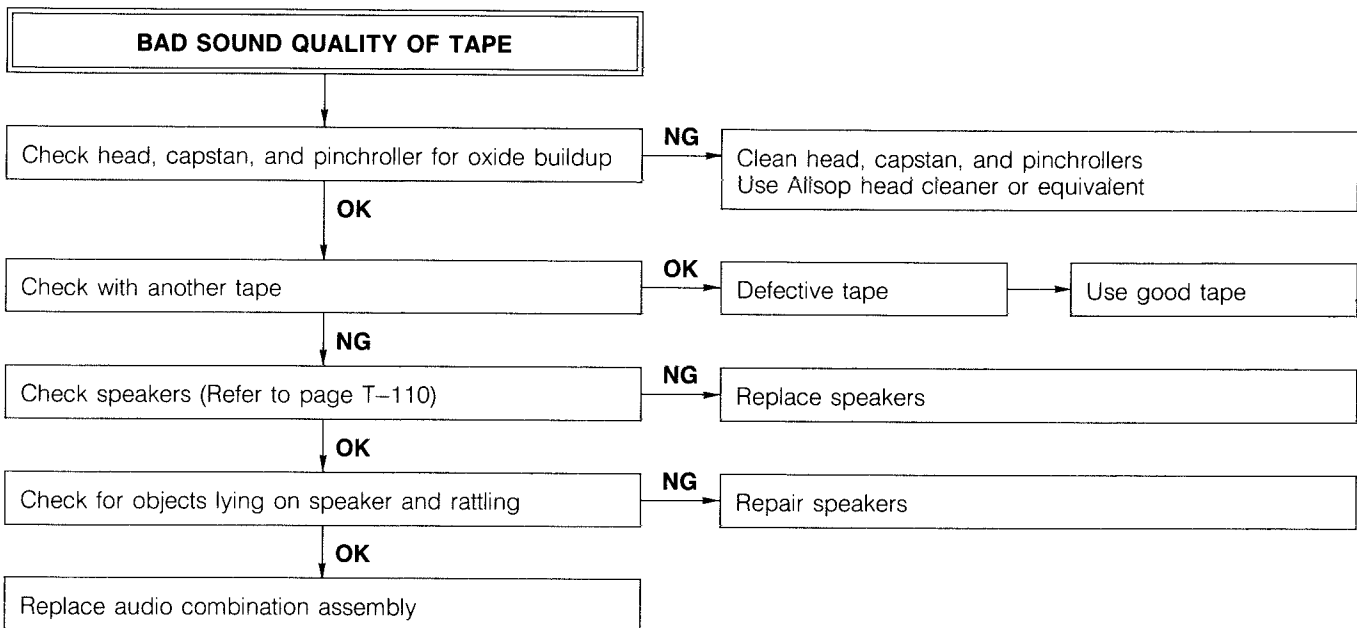

97U0TX-145

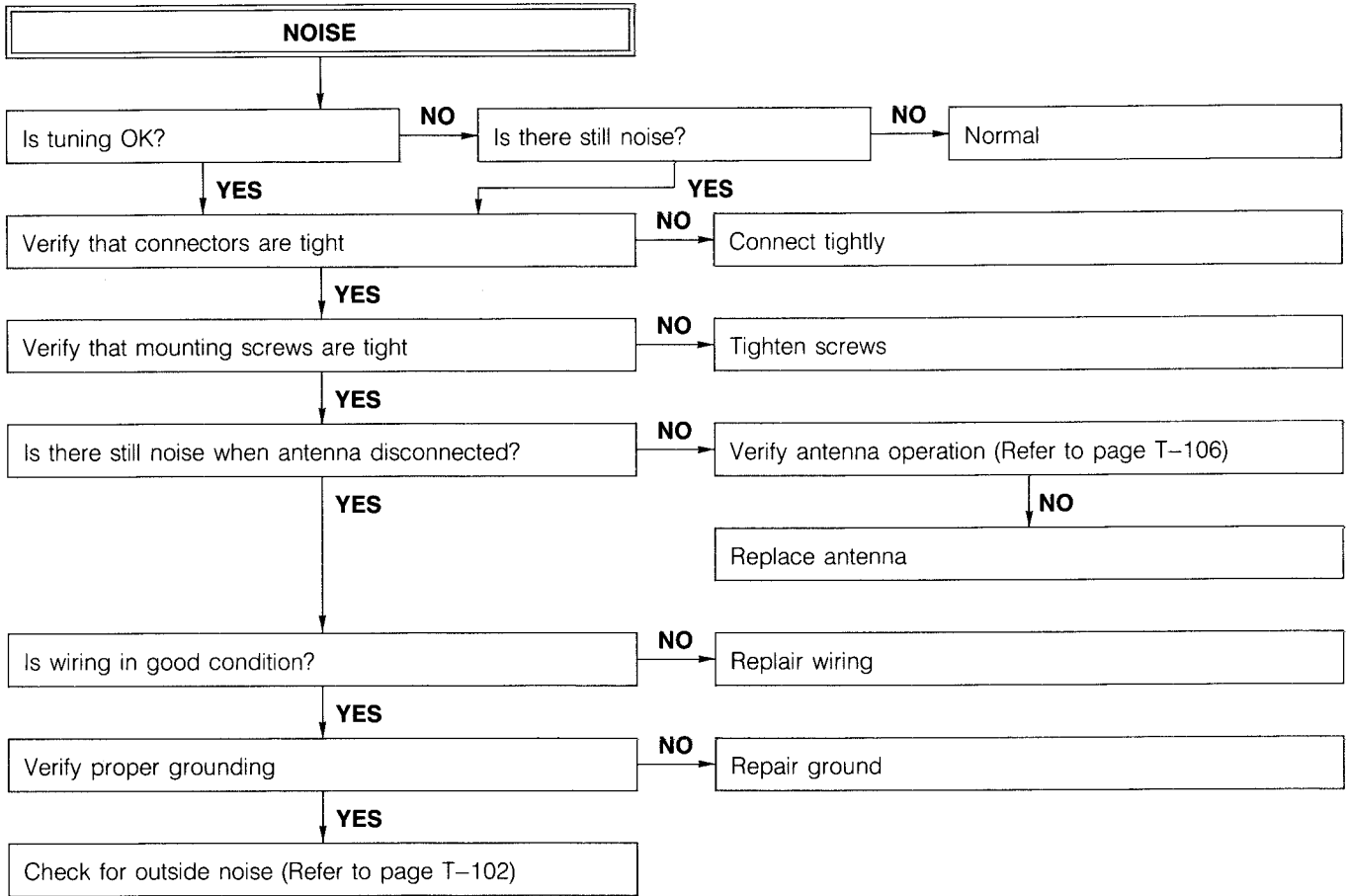

97U0TX-146

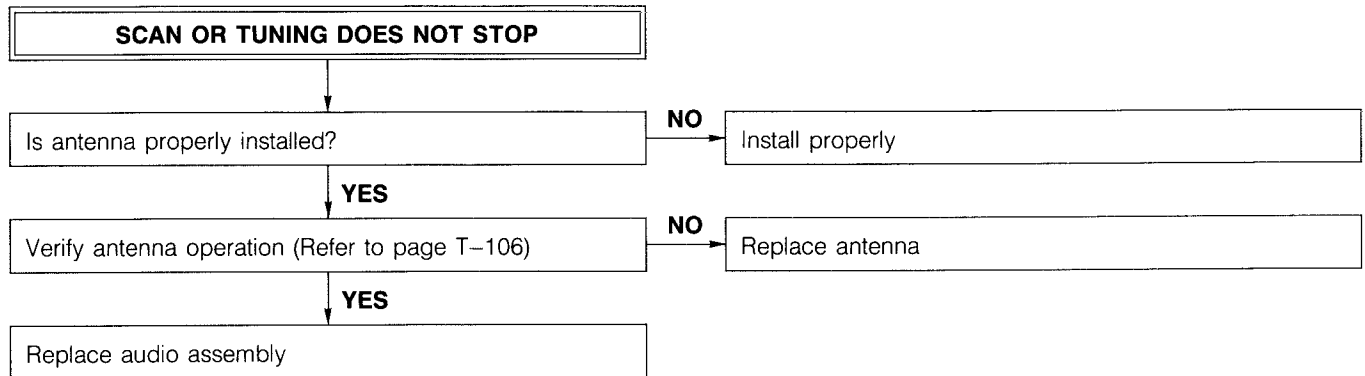

97U0TX-147

T AUDIO SYSTEM

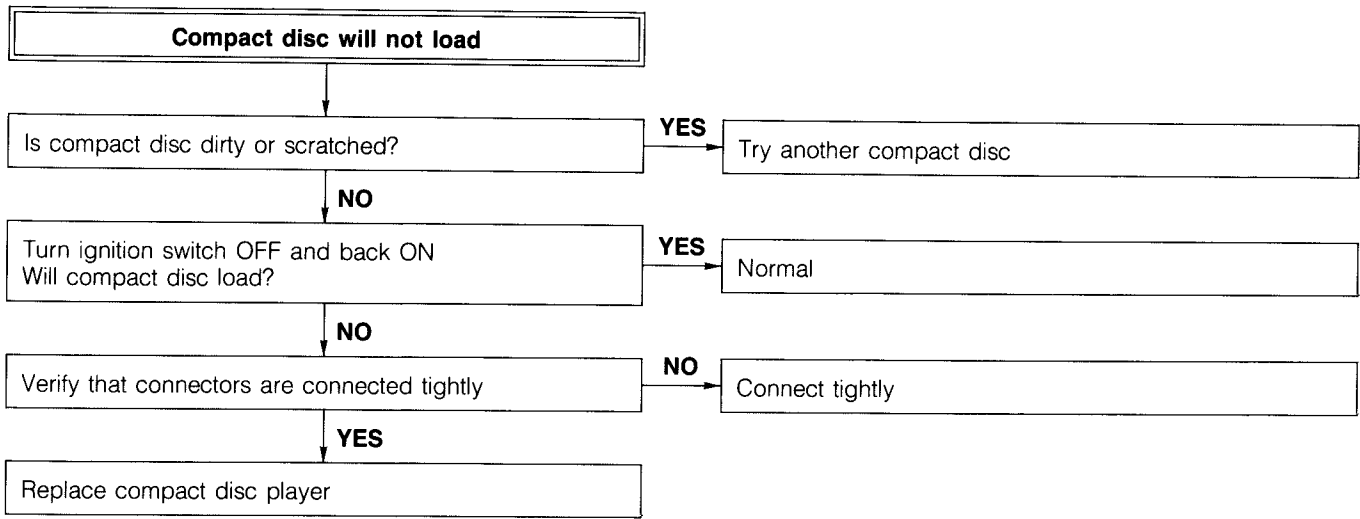

97U0TX-148

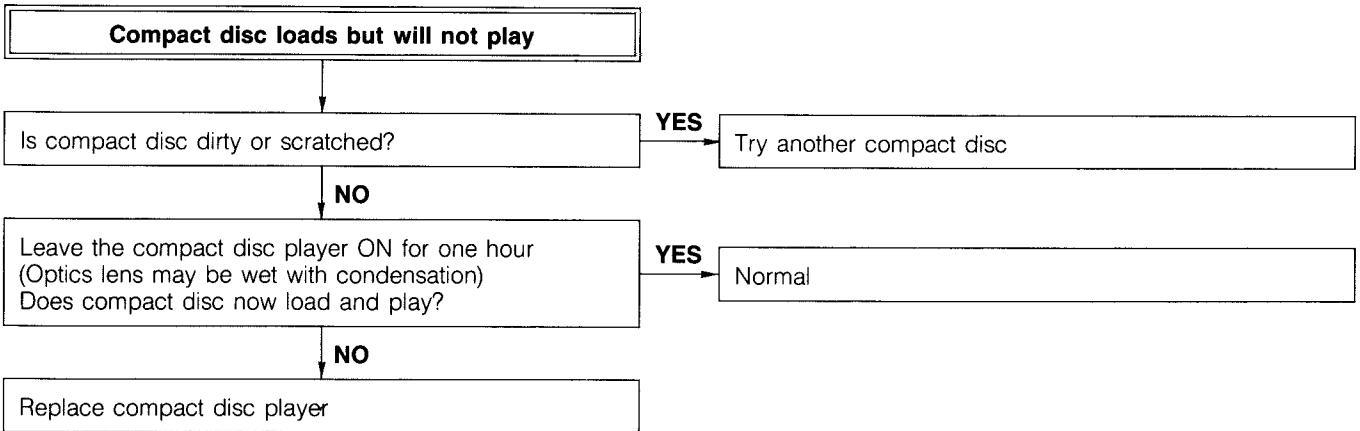

Caution
Never insert anything into the compact disc slot to attempt to set the compact disc.

97U0TX-149

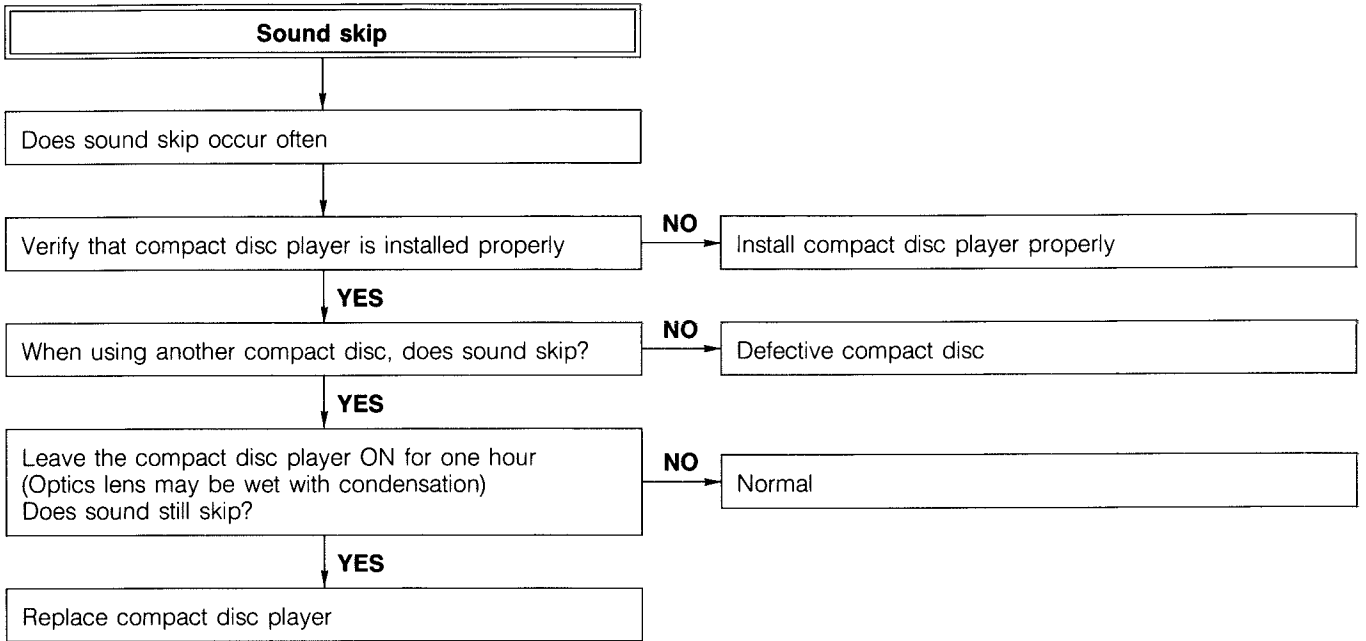

Note

Compact disc skip may be hard to recreate because it may be a result of the vehicle encountering sharp road shocks. This is a normal condition if it happens only infrequently.

97U0TX-150

T AUDIO SYSTEM

CAUSES OF NOISE

When the radio receives a signal from a station, there may be some noise interference. The cause could be

1. Defective audio system
2. The vehicle itself inducts noise. (called outside noise.)
3. Noise from other cars or neon signs, for example. (ambience noise.)

Since ambience noise is a temporary occurrence, this section does not deal with it. For noise problems, first, the cause of the noise must be determined through troubleshooting guide. Once it has been determined, refer to the suppression chart to find the proper procedure for eliminating the noise.

93U15X-070

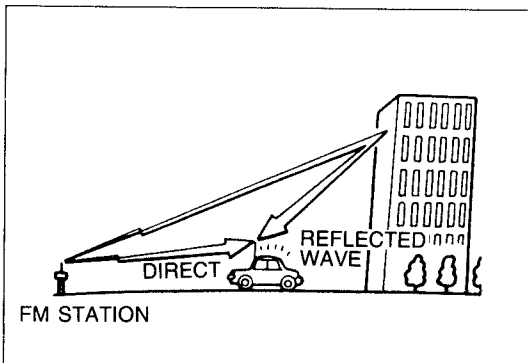

93U15X-071

FM multipath

FM waves can cause a problem called multipath receiving. This happens when the radio picks up a direct wave and reflected wave at the same time. This results in a "Dead Spot" or distorted sound.

Troubleshooting

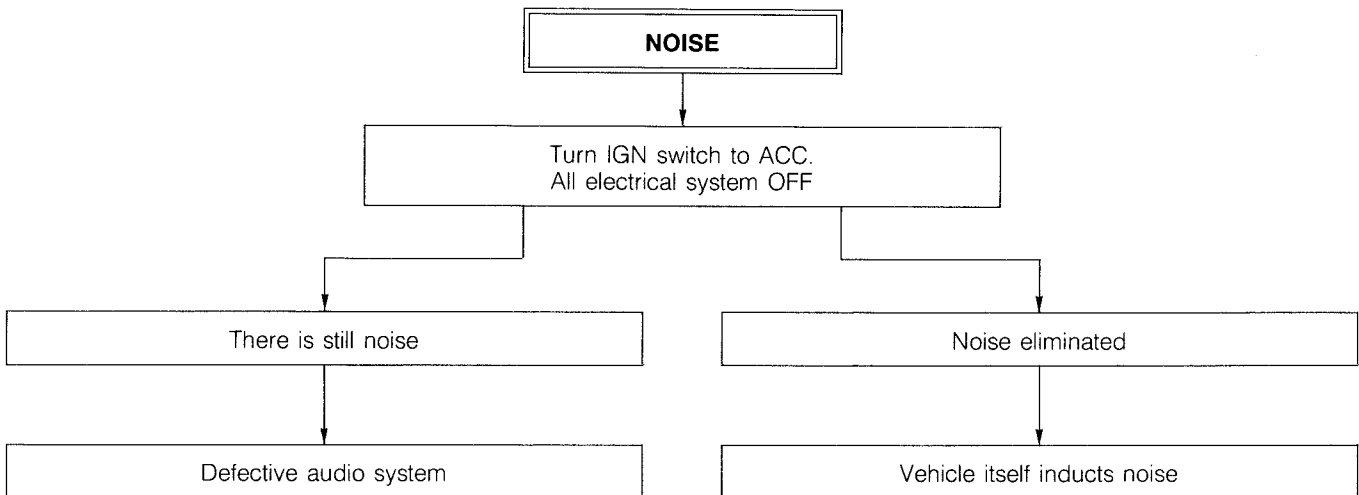

93U15X-072

Noise Suppression Chart

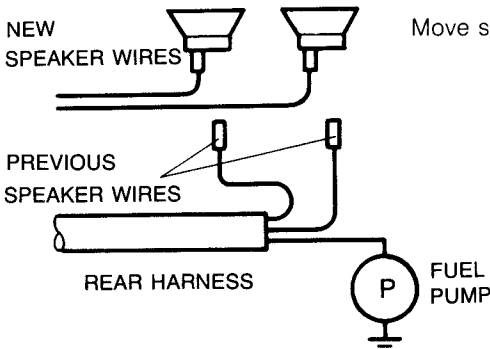
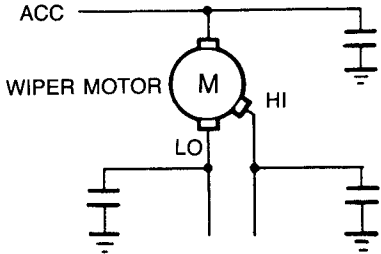
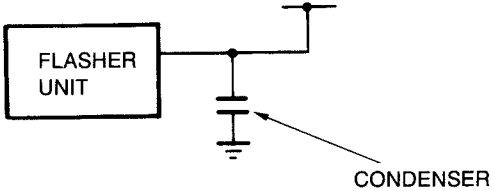
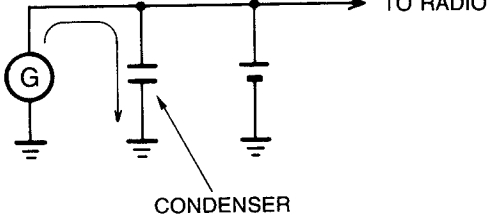
Cause	Remedy
Fuel pump noise	<div style="display: flex; align-items: center;">  <div style="margin-left: 20px;"> <p>Move speaker wiring away from fuel pump wire.</p> </div> </div>
Motor noise (Wiper, washer, power window, for example.)	<ol style="list-style-type: none"> 1. Check grounding. 2. Install condensers to motor circuit. <div style="text-align: center;">  </div>
Turn signal noise	<p>Connect condenser (0.5 μF) to power line of filter unit.</p> <div style="text-align: center;">  </div> <p style="text-align: center;">Note Condenser should be placed near flasher unit.</p>
Alternator noise	<p>Connect condenser (0.5 μF) near alternator.</p> <div style="text-align: center;">  </div>

97U0TX-151

POWER ANTENNA Disassembly and Assembly

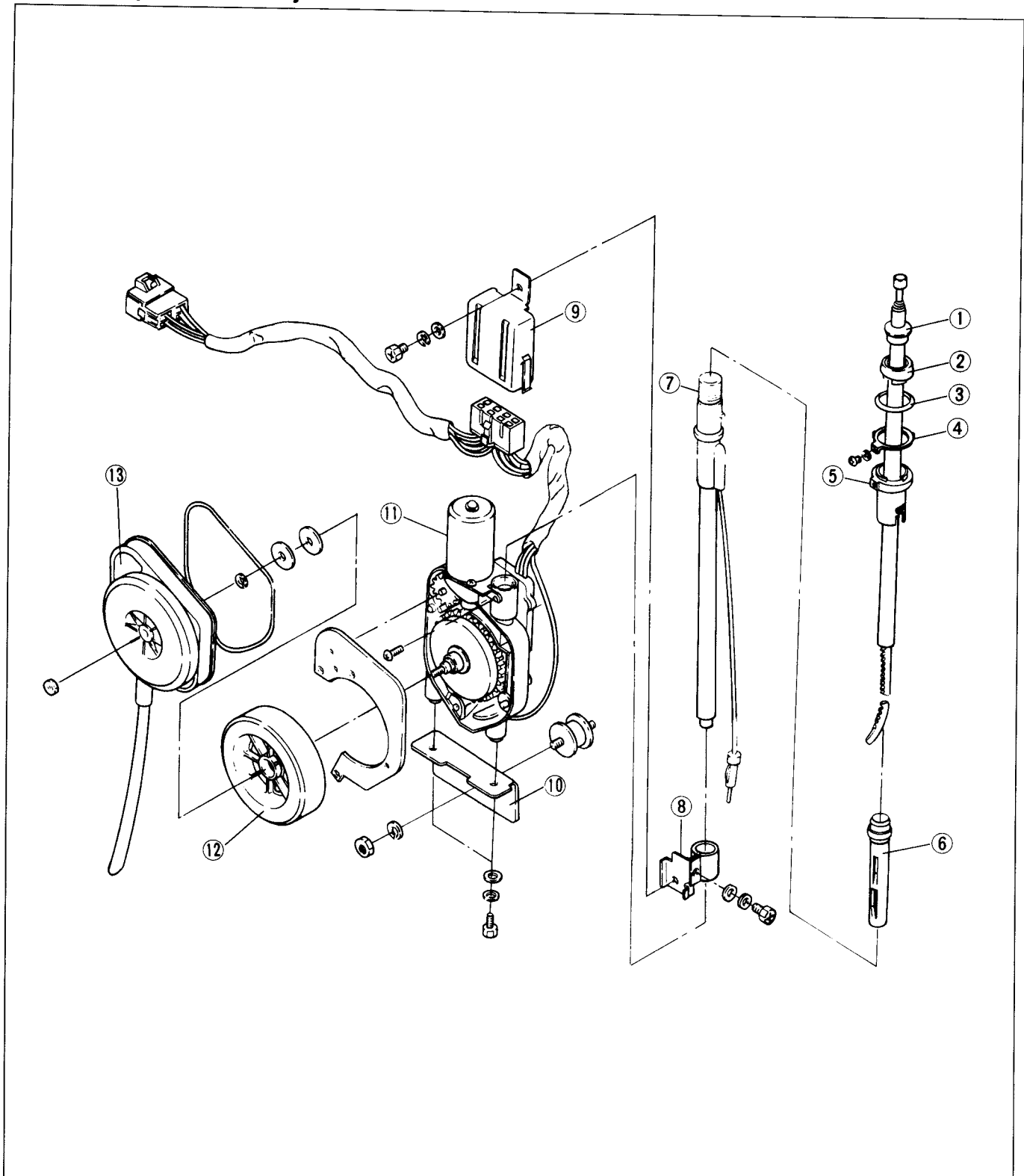

97U0TX-152

- | | |
|------------------|---------------------------|
| 1. Mounting nut | 8. Relay bracket |
| 2. Base | 9. Antenna relay |
| 3. Base pad | 10. Bracket |
| 4. Ground plate | 11. Motor drive unit |
| 5. Ground base | 12. Drive mechanism |
| 6. Rod insulator | 13. Drive mechanism cover |
| 7. Mast assembly | |

Circuit Diagram

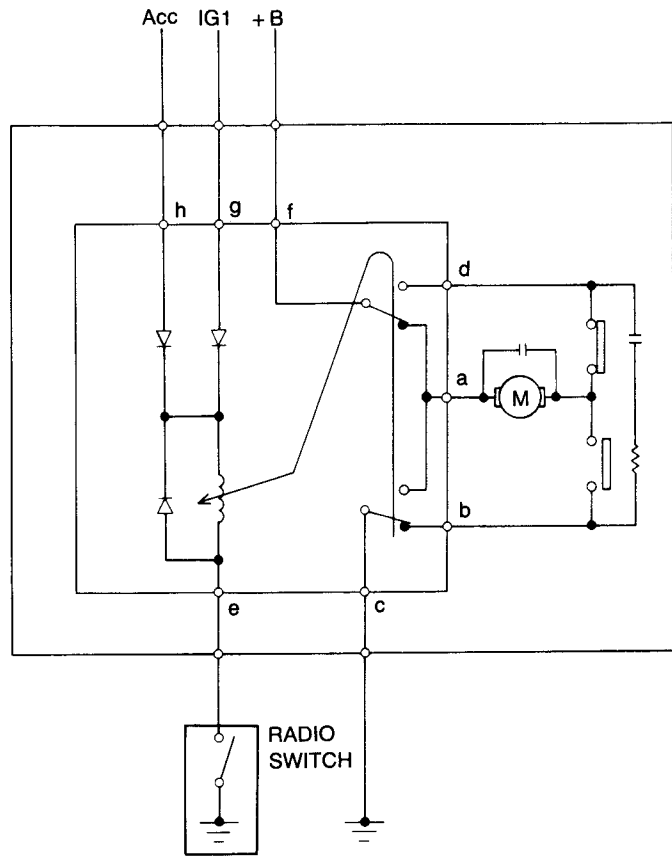

	RADIO SW	ACC or IG	a	b	c	d	f
UP	○	○	○	○	○	○	○
DOWN	X	○	○	○	○		
	○	X		○	○		

○—○ Indicates continuity

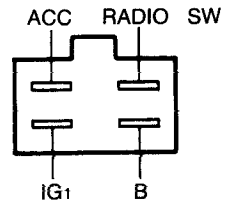
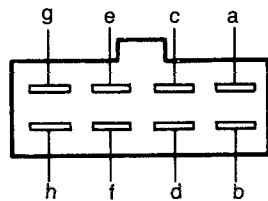

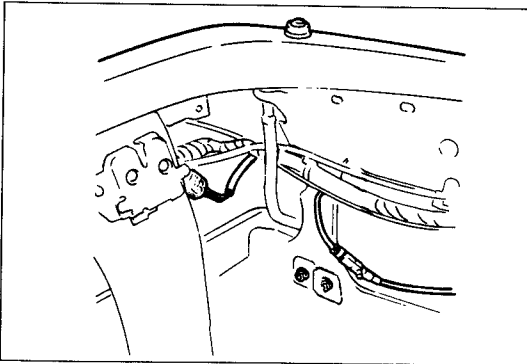

97U0TX-154

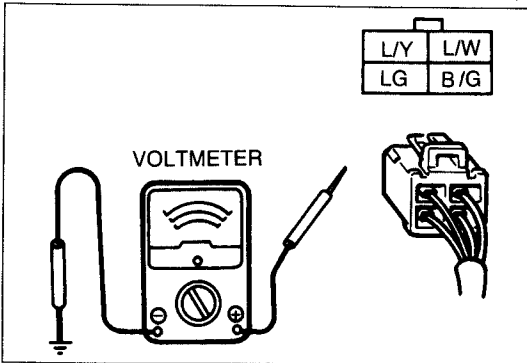

97U0TX-155

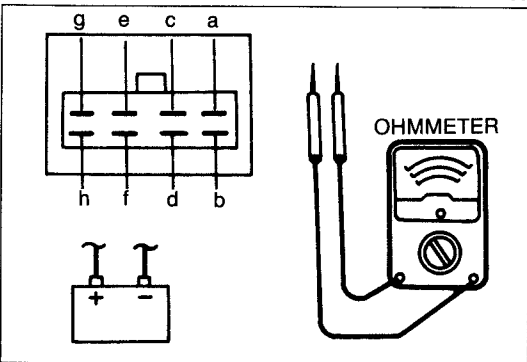

97U0TX-156

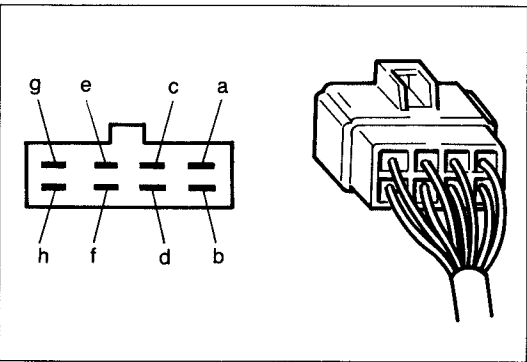

97U0TX-157

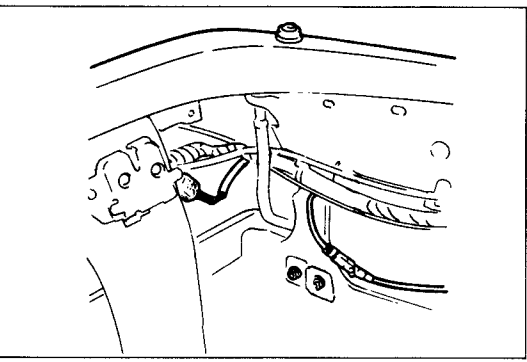

97U0TX-158

Inspection

If the antenna fails to raise or lower, make the following checks:

1. Check the audio component assembly and antenna fuse (10A).
2. Disconnect the power antenna connector, and measure the harness side connector terminal voltage.

3. Measure the voltage between the terminals and a body ground.

Terminal	Voltage
LG	12V
B/G	12V (Ignition switch ON)
L/W	12V (Ignition switch ACC)
L/Y	0V (Radio power switch ON, Ignition switch ACC)

If the voltage is not correct, check the antenna relay.

4. Check for continuity between the terminals of the power antenna relay. If there is no continuity, replace the relay.

Battery		Terminal							
Pos.	Neg.	a	b	c	d	e	f	g	h
		○		○					
			○					○	
g	e	○		○	○			○	
h	e	○		○	○			○	

○—○: Indicates continuity

If the antenna does not function even though there is continuity, the problem may be either in the wiring harness or in the audio component assembly.

5. Apply battery voltage to the terminals and check the operation.

Battery		Function of antenna
Pos.	Neg.	
d	a	UP
a	b	DOWN

Removal and Installation

Power antenna

1. Remove the left rear trunk side trim.
2. Disconnect the antenna feeder and connector.
3. Remove the attaching nuts and remove the power antenna assembly.

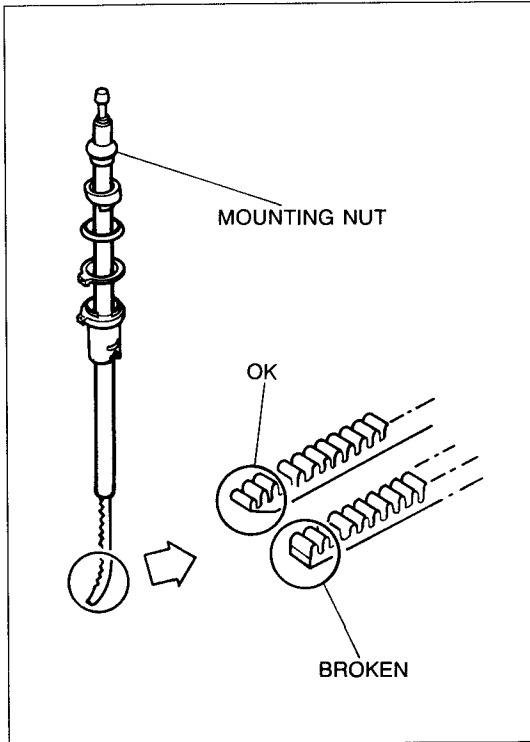

97U0TX-159

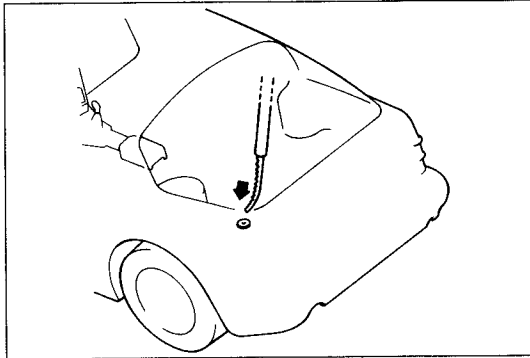

97U0TX-160

Antenna mast

1. Using snap-ring pliers, remove the mounting nut.
2. With the ignition switch in the "ACC" or "ON" position, turn the radio switch "ON". At the same time, pull the antenna mast out and remove.

Caution

Check the plastic rack end for damage.

If the rack end is kinked at a sharp angle or broken off as shown, the broken piece may be left inside the motor. Replace the motor in this case.

3. With the ignition switch in the "ACC" or "ON" position and the radio "ON", feed the rack of the new mast into the motor with toothed side facing toward the front of the vehicle. Turn the radio switch "OFF". While the motor is retracting the rack, feed the mast into the motor.
4. Reinstall the mounting nut.
5. With the ignition switch in the "ACC" or "ON" position, turn the radio "ON" and "OFF" a few times and check to see that the antenna operates smoothly.

WINDSHIELD ANTENNA Removal and Installation

When the windshield antenna has malfunction, replace the windshield. (Refer to page S-55.)

97U0TX-195

T AUDIO SYSTEM

AUDIO COMPONENT ASSEMBLY

Removal and Installation

1. Disconnect the negative battery cable.
2. Remove in the sequence shown in the figure.
3. Install in the reverse order of removal.

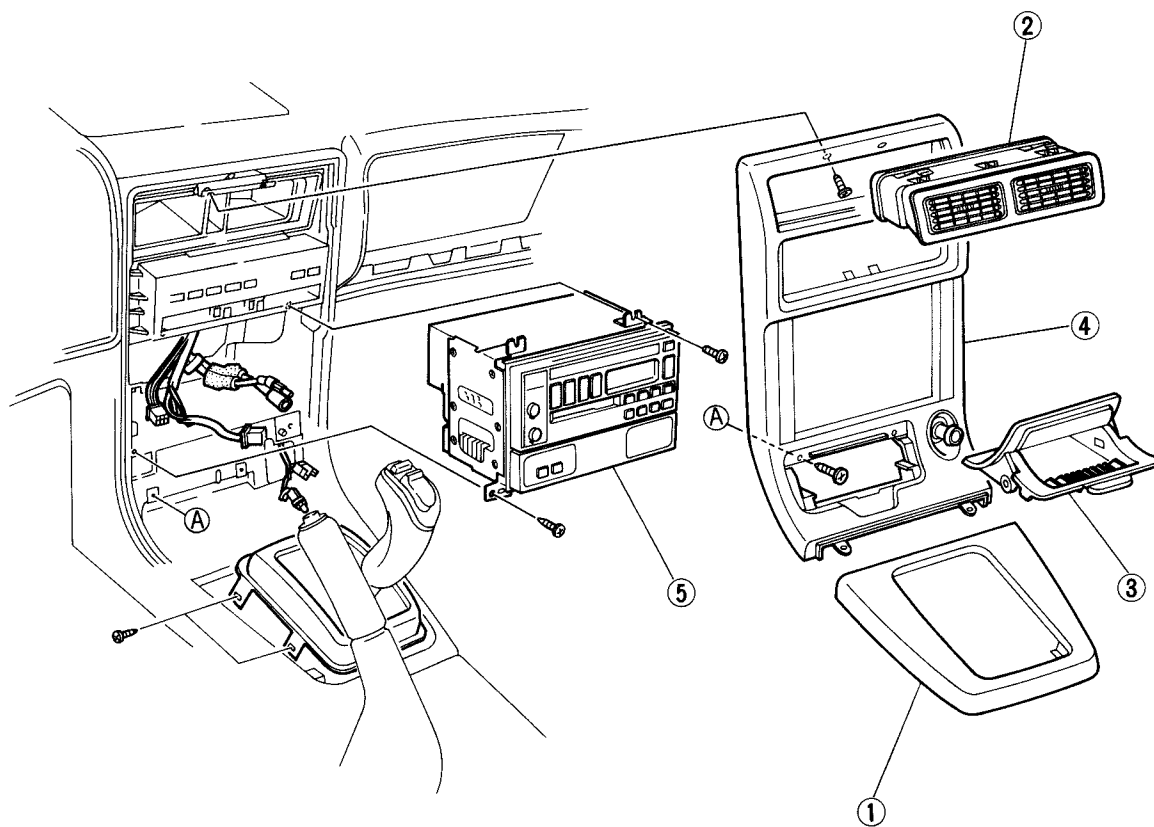

1. Cover
2. Center louver
3. Ashtray

4. Center panel
5. Audio component assembly

97U0TX-161

HEADREST SPEAKER
Removal and Installation

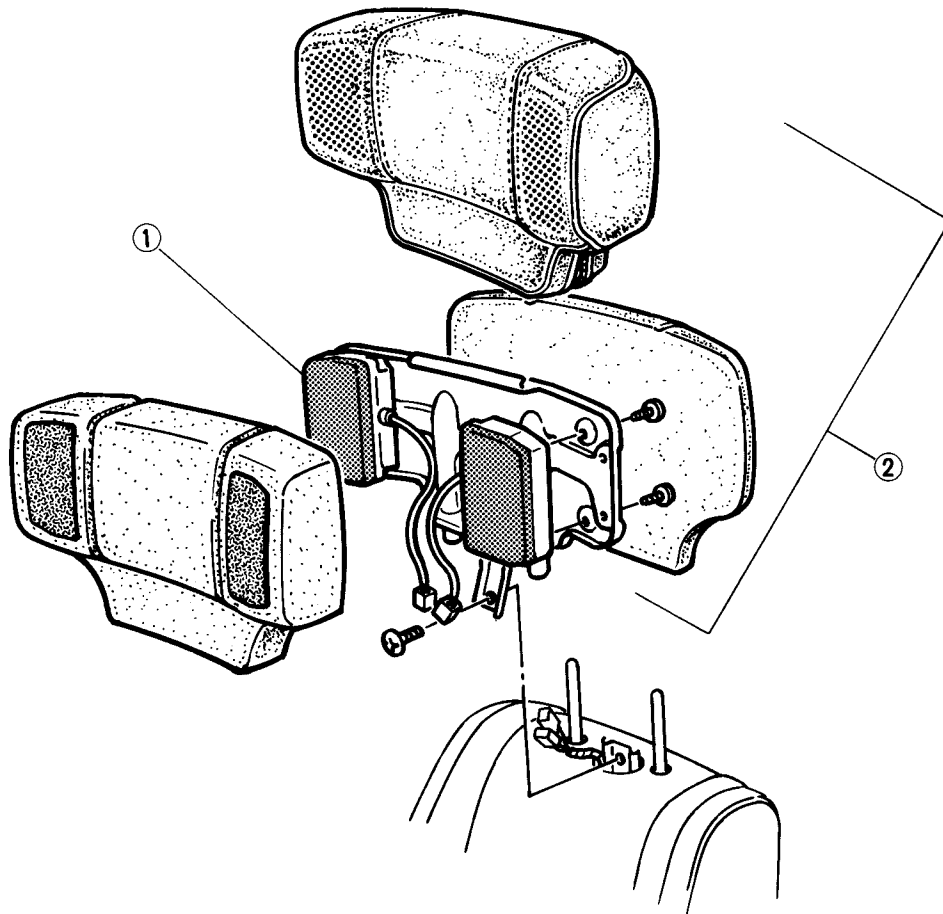

1. Headrest speaker

2. Headrest assembly

97U0TX-162

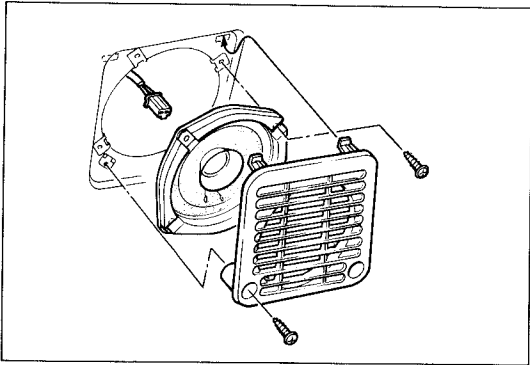

97U0TX-163

FRONT SPEAKER Removal and Installation Driver's side

1. Remove the speaker grille.
2. Remove the speaker.

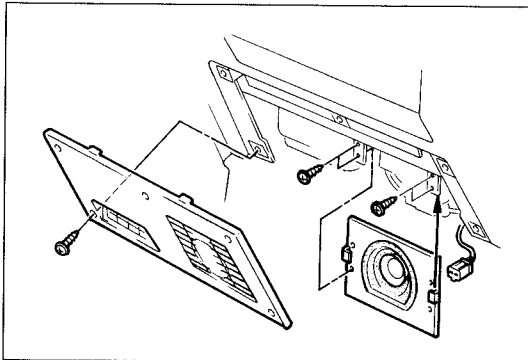

97U0TX-164

Passenger's side (With passive belt)

1. Remove the lower panel.
2. Remove the speaker.

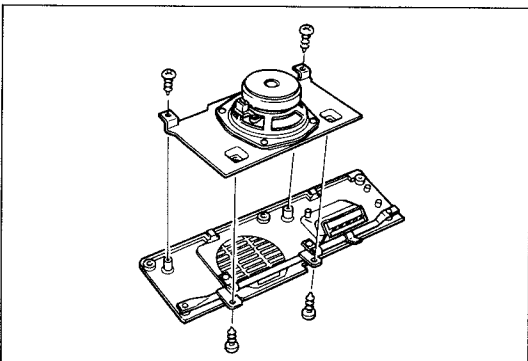

97U0TX-165

(Without passive belt or Convertible)

1. Remove the lower panel.
2. Remove the speaker.

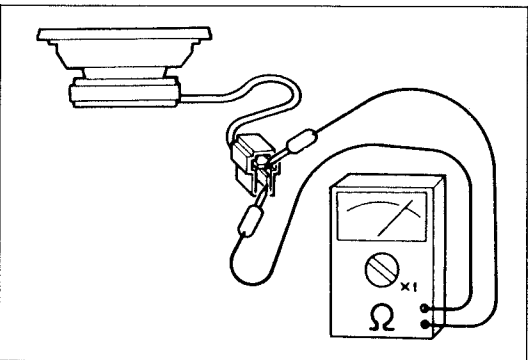

97U0TX-166

Inspection

1. Check for resistance with ohmmeter.

Note

- a) Set the ohmmeter to $\times 1\Omega$ range.
- b) Resistance: approximately 4Ω

2. Confirm that clicking comes from the speaker when touching the connectors. If not, replace speaker.

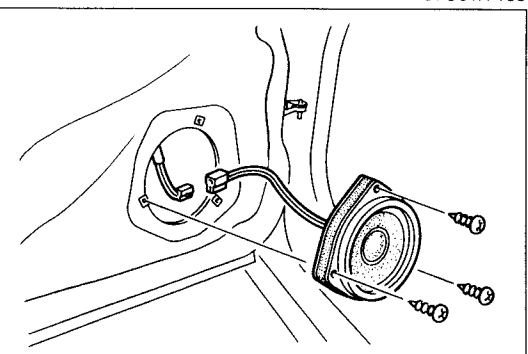

97U0TX-167

DOOR SPEAKER Removal and Installation

1. Remove the door trim. (Refer to page S-43.)
2. Remove the speaker.

Inspection

Refer to inspection of the front speaker.
(Refer to page T-110.)

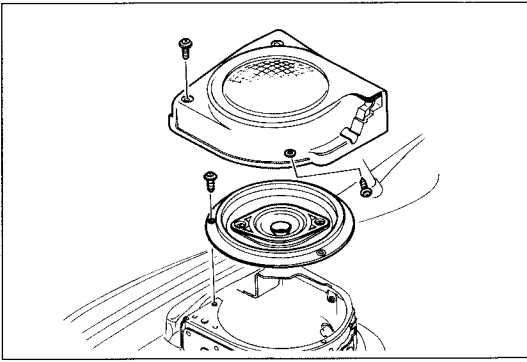

97U0TX-168

REAR SPEAKER (For Coupe) Removal and Installation

1. Remove the speaker grille.
2. Remove the screws and the speaker.

Inspection

Refer to inspection of the front speaker.
(Refer to page T-110.)

DOOR WOOFER AMPLIFIER

Removal and Installation

Remove the negative battery cable.

WITHOUT PASSIVE BELT OR CONVERTIBLE

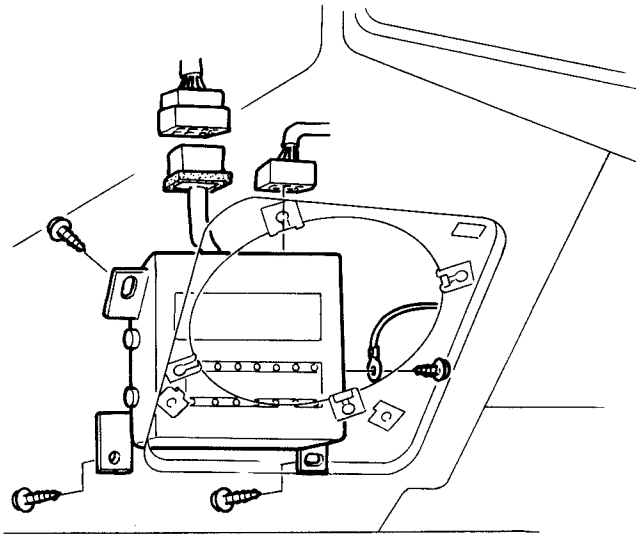

WITH PASSIVE BELT

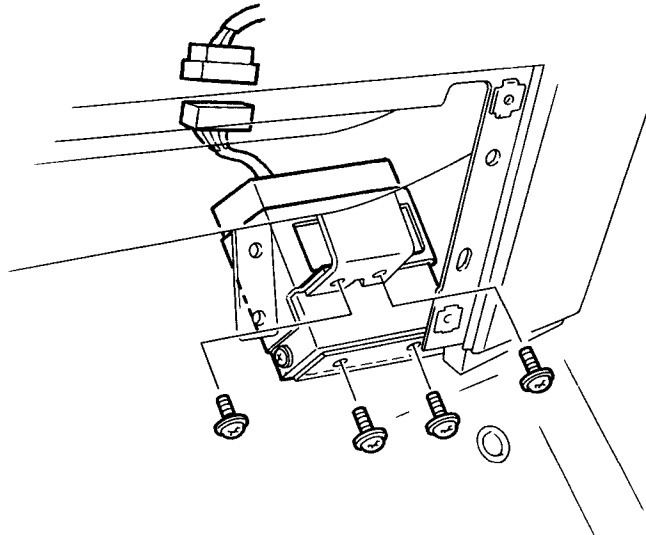

97U0TX-169

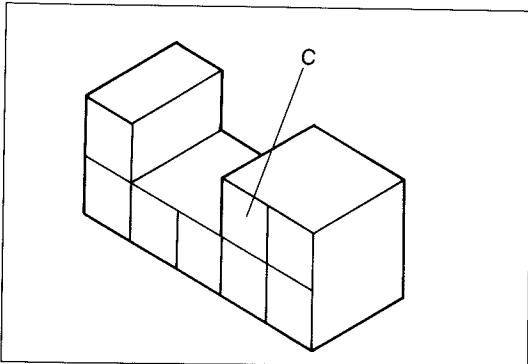

97U0TX-170

Inspection

1. When the door woofer speaker(s) do not operate only, check for 12V on the terminal C of the connector.
2. If not, repair the harness. If it is OK, go to 3.
3. Check the door woofer speaker(s) and the harness (door woofer amplifier-door woofer speaker)
4. If these are OK, replace the door woofer amplifier.

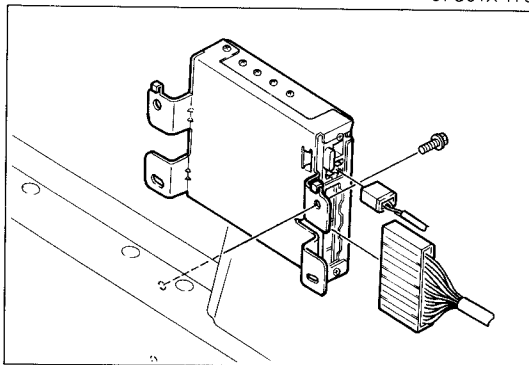

97U0TX-171

HEADREST SPEAKER AMPLIFIER

Removal and Installation

1. Remove the spare tire cover. (Refer to page S-75.)
2. Remove the headrest speaker amplifier.

HEADREST SPEAKER SWITCH

Structural View

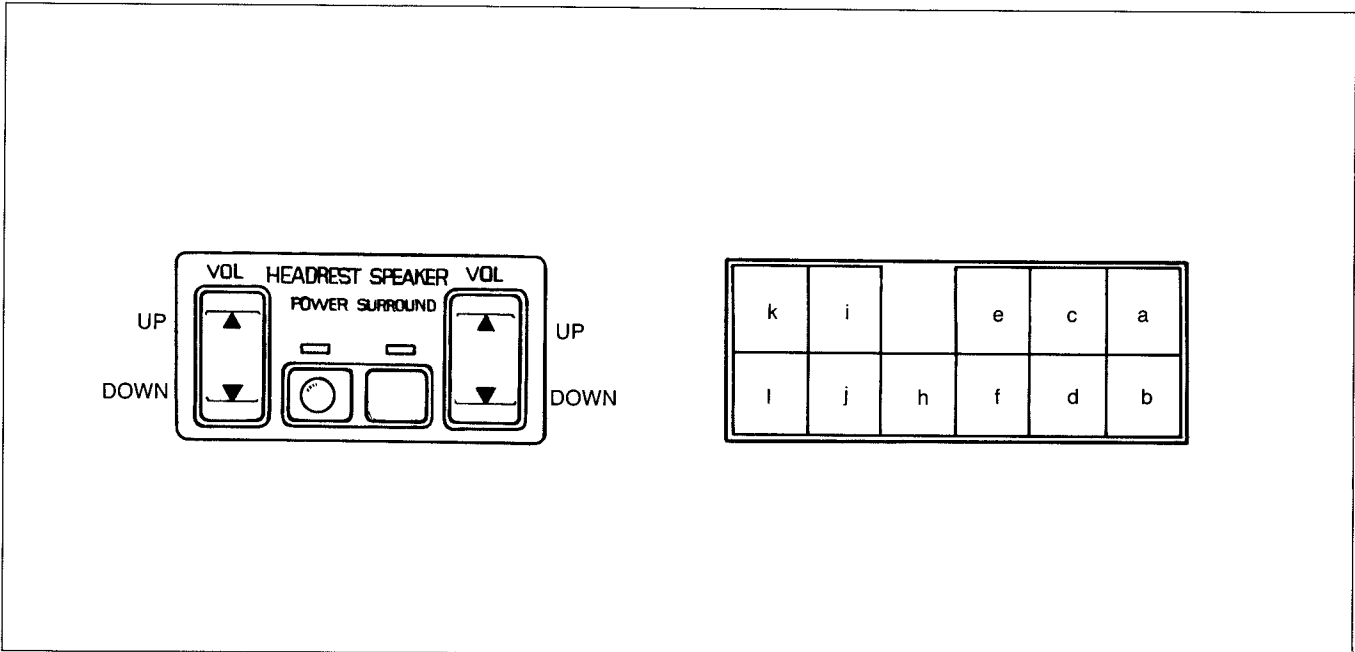

97U0TX-172

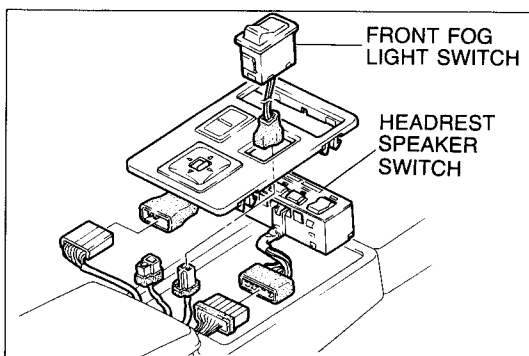

97U0TX-173

Removal and Installation

1. Remove the switch panel.
2. Disconnect the connector of the switch.
3. Remove the headrest speaker switch.
4. Install in the reverse order of removal.

Inspection

Check for continuity between the switch terminals.

Volume button			a	b	c	d	e	f	h	i	j
Main switch ON	Right	Up	○	○						○	
		Down	○	○							○
	Left	Up	○	○			○				
		Down	○	○				○			
Surround switch ON			○	○	○						

○—○ : Indicates continuity

97U0TX-174