

CLUTCH

SECTION **CL**

CONTENTS

| | |
|--|-------|
| HYDRAULIC CLUTCH CONTROL | CL- 2 |
| CLUTCH CONTROL – Release Bearing | CL- 6 |
| CLUTCH UNIT | CL- 7 |
| SERVICE DATA AND SPECIFICATIONS (S.D.S.) | CL-10 |
| SPECIAL SERVICE TOOLS | CL-12 |

CL

HYDRAULIC CLUTCH CONTROL

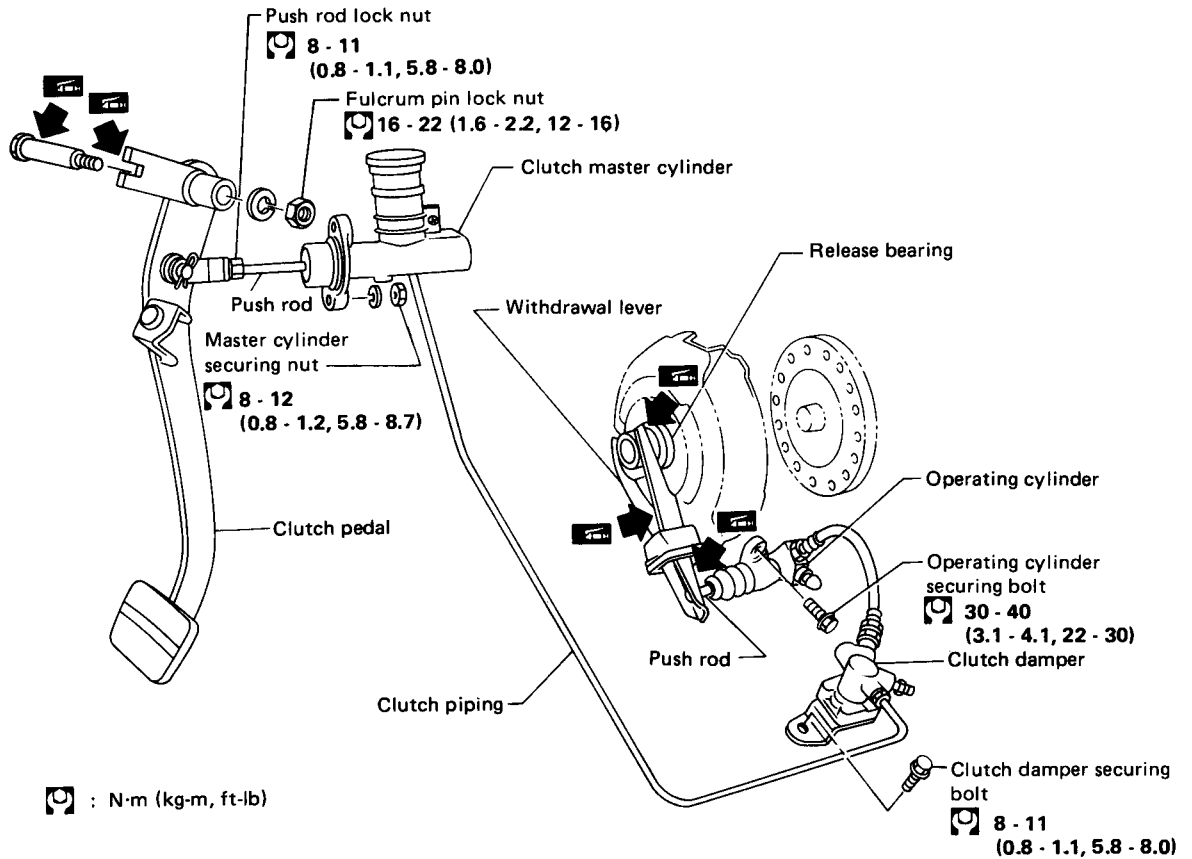

SCL161

Precautions

- Recommended fluid is brake fluid "DOT 3".
- Do not reuse drained brake fluid.
- Be careful not to splash brake fluid on painted areas.
- When removing and installing clutch tube, use Tool GG94310000.
- To clean or wash all parts of master cylinder, operating cylinder and clutch damper, clean brake fluid must be used.
- Never use mineral oils such as gasoline or kerosene. It will ruin the rubber parts of the hydraulic system.

HYDRAULIC CLUTCH CONTROL

Bleeding Procedure

- Carefully monitor fluid level at master cylinder during bleeding operation.
- Bleed air according to the following procedure.
Clutch damper → Operating cylinder

1. Top up reservoir with recommended brake fluid.
2. Connect a transparent vinyl tube to air bleeder valve.

Clutch damper

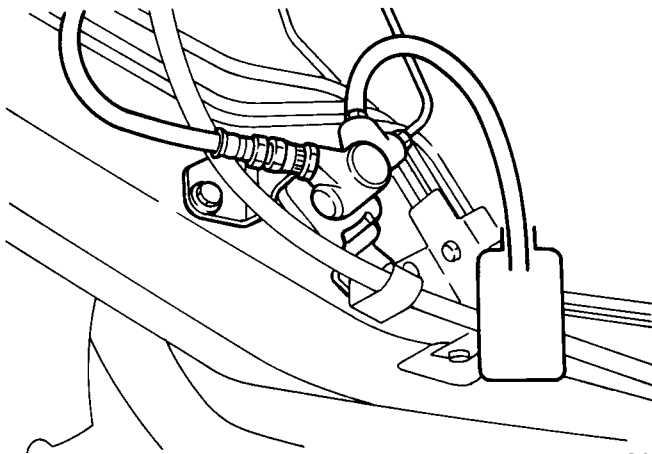

SCL204

Operating cylinder

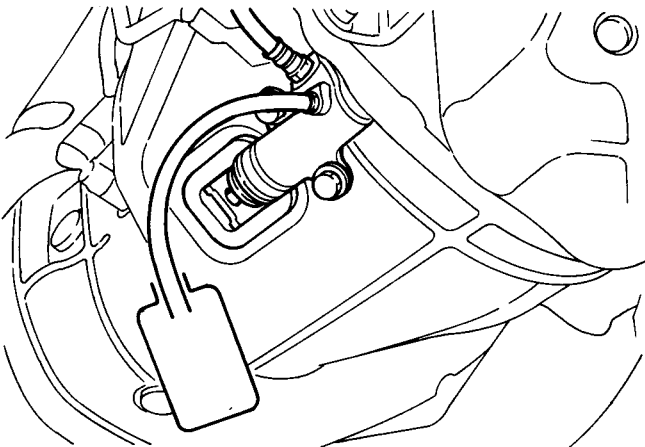

SCL203

3. Fully depress clutch pedal several times.
4. With clutch pedal depressed, open bleeder valve to release air.
5. Close bleeder valve.
6. Repeat steps 3 through 5 above until brake fluid comes out of air bleeder valve without air bubbles.

Adjusting Clutch Pedal

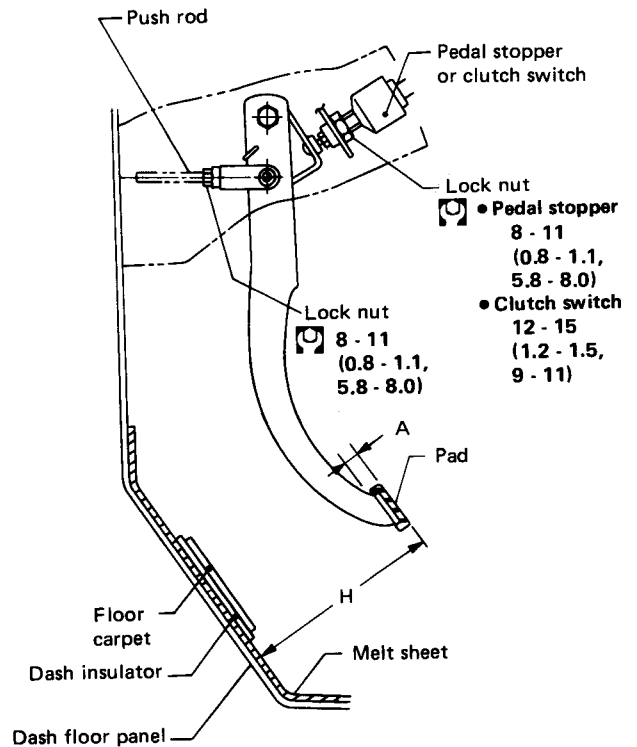

: N·m (kg·m, ft·lb)

SCL162

Pedal height "H"

195 - 205 mm (7.68 - 8.07 in)

Pedal free play "A"

1 - 3 mm (0.04 - 0.12 in)

1. Adjust pedal height with pedal stopper or clutch switch.
2. Adjust pedal free play with push rod.

HYDRAULIC CLUTCH CONTROL

Clutch Master Cylinder

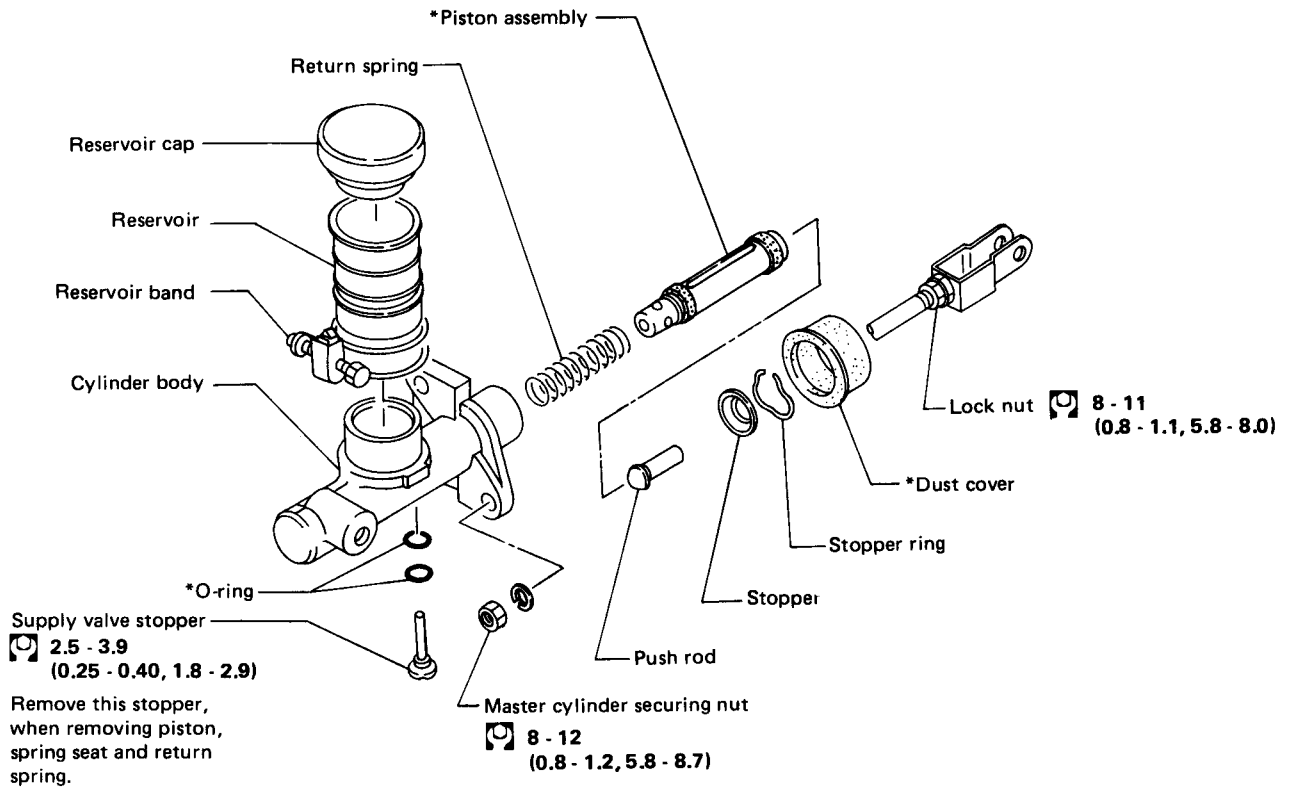

* Always replace when disassembled.

N·m (kg-m, ft-lb)

SCL163

INSPECTION

- Check parts for wear or damage. Replace component if any wear or damage is found.

HYDRAULIC CLUTCH CONTROL

Operating Cylinder

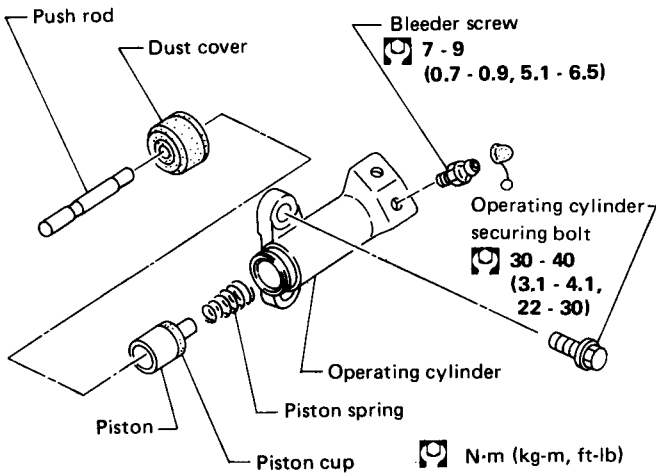

SCL164

- Do not reuse piston cup and dust cover.

Clutch Damper

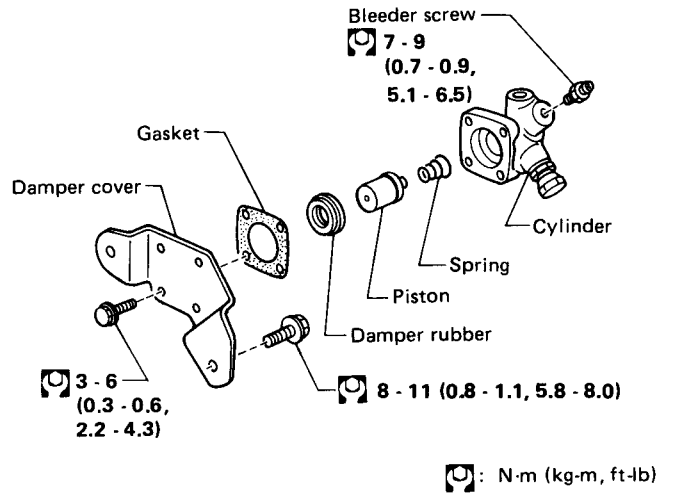

SCL205

- Do not reuse piston cup.
- Do not let oil touch the damper rubber as it will ruin the rubber.

CLUTCH CONTROL — Release Bearing

Release Bearing

REMOVAL AND INSTALLATION

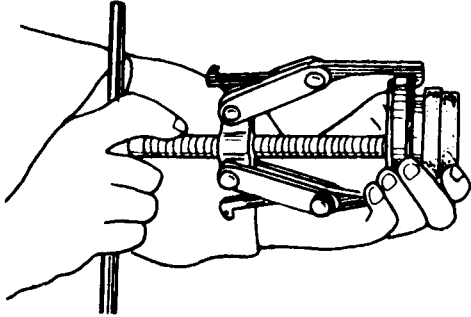

CL145

Press

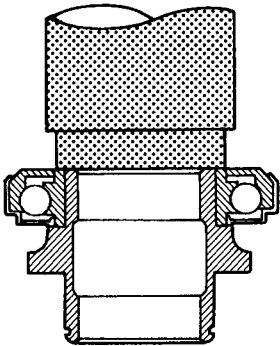

SCL166

LUBRICATION

- Apply recommended grease to contact surface and sliding surface.

Too much lubricant might cause clutch disc facing damage.

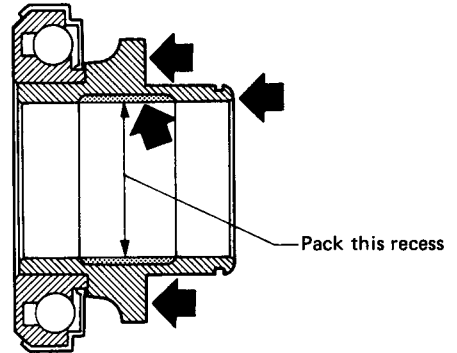

SCL167

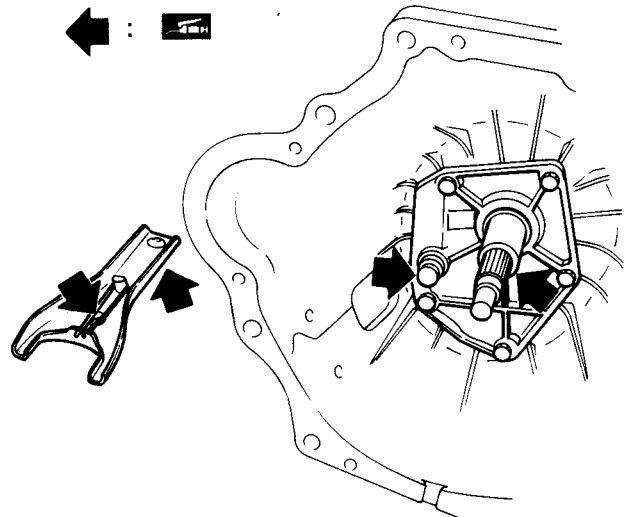

SCL168

CLUTCH UNIT

Clutch Unit

*1: Slight burn or discoloration of contact surface with clutch disc can be corrected by polishing with emery paper.

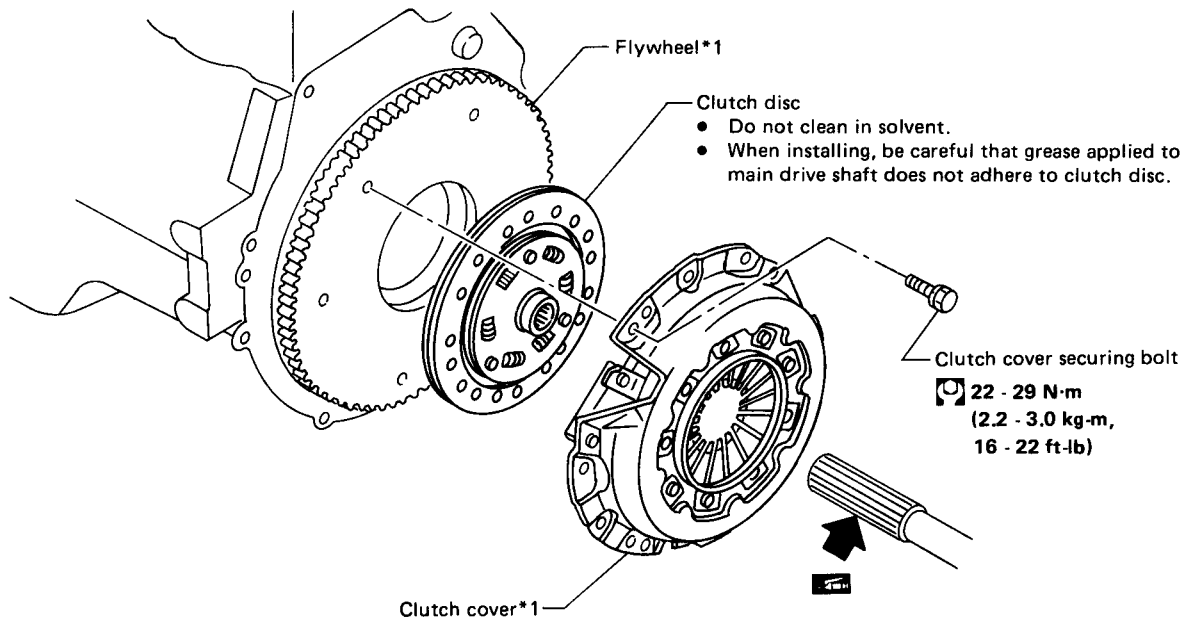

SCL206

WARNING:

Clean away clutch disc dust using a dust collector after cleaning with a cloth. Do not use compressed air.

CLUTCH UNIT

Inspecting Clutch Disc

Inspecting Clutch Cover

Check clutch disc for runout, etc.

Runout limit of facing
[at 115 mm (4.53 in) from the hub center]:
1.0 mm (0.039 in)

Maximum backlash of spline
(at outer edge of disc):
1.0 mm (0.039 in)

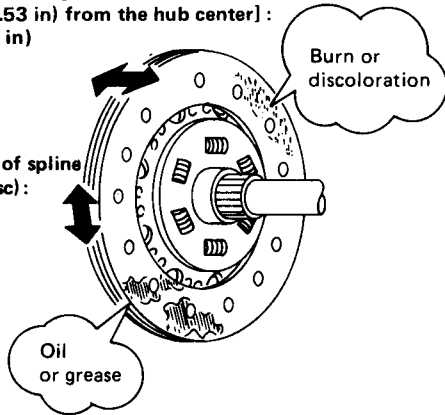

SCL153

Check clutch disc for wear.

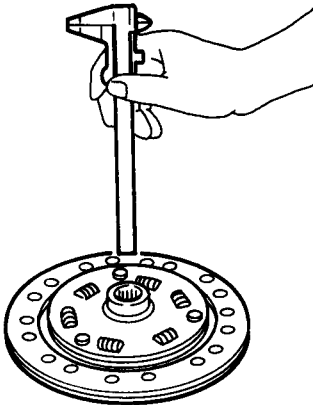

- Measure the depth of rivet head
More than 0.3 mm (0.012 in)

SCL207

- Check height and unevenness of diaphragm spring after setting Tool.

Diaphragm spring height "A":
37.5 - 39.5 mm (1.476 - 1.555 in)
Uneven limit: 0.5 mm (0.020 in)

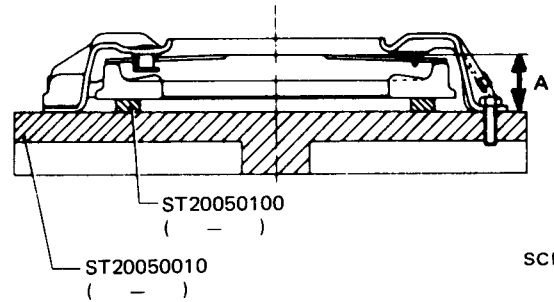

SCL155

- Adjust unevenness of diaphragm spring with Tool.

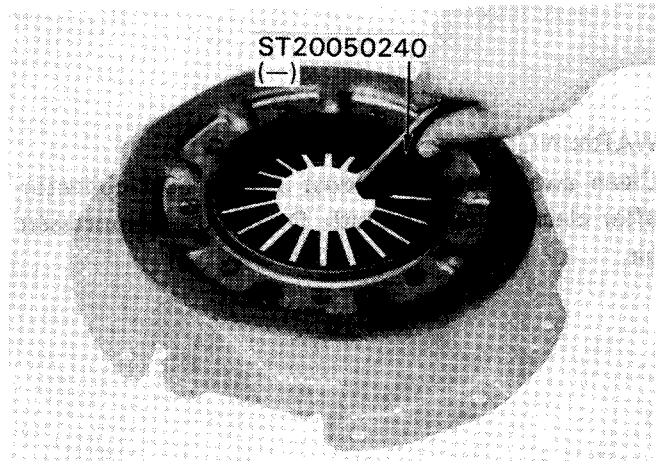

- Check thrust rings for wear or damage by shaking cover assembly up and down to listen for chattering noise, or lightly hammering on rivets for a slightly cracked noise.

CLUTCH UNIT

Installing Clutch Cover

- Insert Tool into clutch disc hub when installing clutch cover and disc.

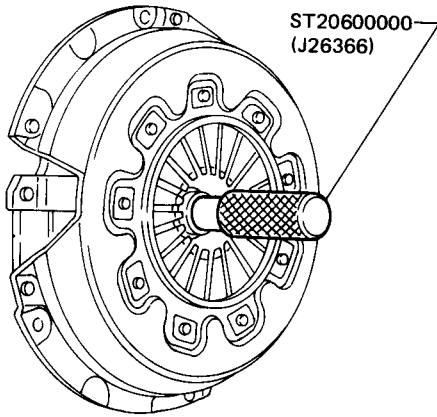

SCL208

SERVICE DATA AND SPECIFICATIONS (S.D.S.)

General Specifications

CLUTCH CONTROL SYSTEM

| | |
|------------------------|-----------|
| Type of clutch control | Hydraulic |
|------------------------|-----------|

CLUTCH MASTER CYLINDER

| | | |
|----------------|---------|-------------|
| Inner diameter | mm (in) | 15.87 (5/8) |
|----------------|---------|-------------|

CLUTCH OPERATING CYLINDER

| | | |
|----------------|---------|-------------|
| Inner diameter | mm (in) | 19.05 (3/4) |
|----------------|---------|-------------|

CLUTCH DISC

| | |
|-------|--------|
| Model | 240TBL |
|-------|--------|

| | |
|-------------------------------------|--|
| Facing size | 240 x 160 x 3.5 (9.45 x 6.30 x 0.138) |
| Outer dia. x inner dia. x thickness | mm (in) |

| | | |
|---|---------|---------------------------|
| Thickness of disc assembly | | |
| With load 5,884 N (600 kg, 1,323 lb) | mm (in) | 7.8 - 8.2 (0.307 - 0.323) |

CLUTCH COVER

| | |
|-------|-------|
| Model | C240S |
|-------|-------|

| | | |
|---------------|------------|--------------------|
| Full load | N (kg, lb) | |
| VG30E engine | | 5,688 (580, 1,279) |
| VG30ET engine | | 5,884 (600, 1,323) |

Inspection and Adjustment

CLUTCH PEDAL

Unit: mm (in)

| | |
|------------------|-------------------------|
| Pedal height "H" | 195 - 205 (7.68 - 8.07) |
|------------------|-------------------------|

| | |
|---------------------|---------------------|
| Pedal free play "A" | 1 - 3 (0.04 - 0.12) |
|---------------------|---------------------|

CLUTCH DISC

Unit: mm (in)

| | |
|-------|--------|
| Model | 240TBL |
|-------|--------|

| | |
|--|-------------|
| Wear limit of facing surface to rivet head | 0.3 (0.012) |
|--|-------------|

| | |
|--------------|-------------|
| Runout limit | 1.0 (0.039) |
|--------------|-------------|

| | |
|---|------------|
| Distance of runout checkpoint (from the hub center) | 115 (4.53) |
|---|------------|

| | |
|--|-------------|
| Maximum backlash of spline (at outer edge of disc) | 1.0 (0.039) |
|--|-------------|

CLUTCH COVER

Unit: mm (in)

| | |
|-------|-------|
| Model | C240S |
|-------|-------|

| | |
|-------------------------|-----------------------------|
| Diaphragm spring height | 37.5 - 39.5 (1.476 - 1.555) |
|-------------------------|-----------------------------|



| | |
|---|-------------|
| Uneven limit of diaphragm spring toe height | 0.5 (0.020) |
|---|-------------|

SERVICE DATA AND SPECIFICATIONS (S.D.S.)

Tightening Torque

| Unit | N·m | kg-m | ft-lb |
|--|-----------|-------------|-----------|
| Pedal stopper lock nut | 8 - 11 | 0.8 - 1.1 | 5.8 - 8.0 |
| Clutch switch lock nut | 12 - 15 | 1.2 - 1.5 | 9 - 11 |
| Fulcrum pin securing nut | 16 - 22 | 1.6 - 2.2 | 12 - 16 |
| Master cylinder push rod lock nut | 8 - 11 | 0.8 - 1.1 | 5.8 - 8.0 |
| Master cylinder securing nut | 8 - 12 | 0.8 - 1.2 | 5.8 - 8.7 |
| Supply valve stopper | 2.5 - 3.9 | 0.25 - 0.40 | 1.8 - 2.9 |
| Operating cylinder securing bolt | 30 - 40 | 3.1 - 4.1 | 22 - 30 |
| Bleeder screw | 7 - 9 | 0.7 - 0.9 | 5.1 - 6.5 |
| Clutch damper securing bolt | 8 - 11 | 0.8 - 1.1 | 5.8 - 8.0 |
| Damper cover to cylinder | 3 - 6 | 0.3 - 0.6 | 2.2 - 4.3 |
| Clutch tube flare nut | 15 - 18 | 1.5 - 1.8 | 11 - 13 |
| Clutch hose to operating cylinder and clutch damper securing nut | 17 - 20 | 1.7 - 2.0 | 12 - 14 |
| Clutch cover securing bolt | 22 - 29 | 2.2 - 3.0 | 16 - 22 |

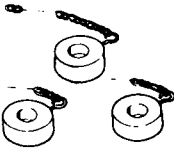
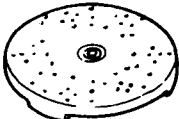
SPECIAL SERVICE TOOLS

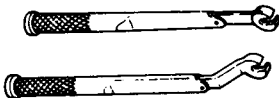
| Tool number (Kent-Moore No.) | Tool name |
|---------------------------------|---|
| ST20600000 (J26366) | Clutch aligning bar  |
| ST20050100 (-) | Distance piece  |
| ST20050010 (-) | Base plate  |
| ST20050240 (-) | Diaphragm spring adjusting wrench  |
| GG94310000 (-) | Flare nut torque wrench  |