

BRAKE SYSTEM

SECTION **BR**

CONTENTS

PRECAUTIONS AND PREPARATION	BR- 2
CHECK AND ADJUSTMENT	BR- 3
BRAKE HYDRAULIC LINE	BR- 4
BRAKE PEDAL AND BRACKET	BR- 6
BRAKE BOOSTER	BR- 8
VACUUM PIPING	BR- 9
MASTER CYLINDER	BR-11
FRONT DISC BRAKE (OPZ25V and OPF25V) — Caliper	BR-12
FRONT DISC BRAKE (OPZ25V and OPF25V) — Rotor	BR-15
REAR DISC BRAKE — Caliper	BR-16
REAR DISC BRAKE — Rotor	BR-20
PARKING BRAKE CONTROL	BR-21
PARKING DRUM BRAKE	BR-23
ANTI-LOCK BRAKING SYSTEM	BR-25
TROUBLE DIAGNOSES	BR-30
SERVICE DATA AND SPECIFICATIONS (S.D.S.)	BR-55

PRECAUTIONS AND PREPARATION

Precautions

- Recommended fluid is brake fluid "DOT 3".
- Never reuse drained brake fluid.
- Be careful not to splash brake fluid on painted areas.
- To clean or wash all parts of master cylinder, disc brake caliper and wheel cylinder, use clean brake fluid.
- Never use mineral oils such as gasoline or kerosene. They will ruin rubber parts of hydraulic system.

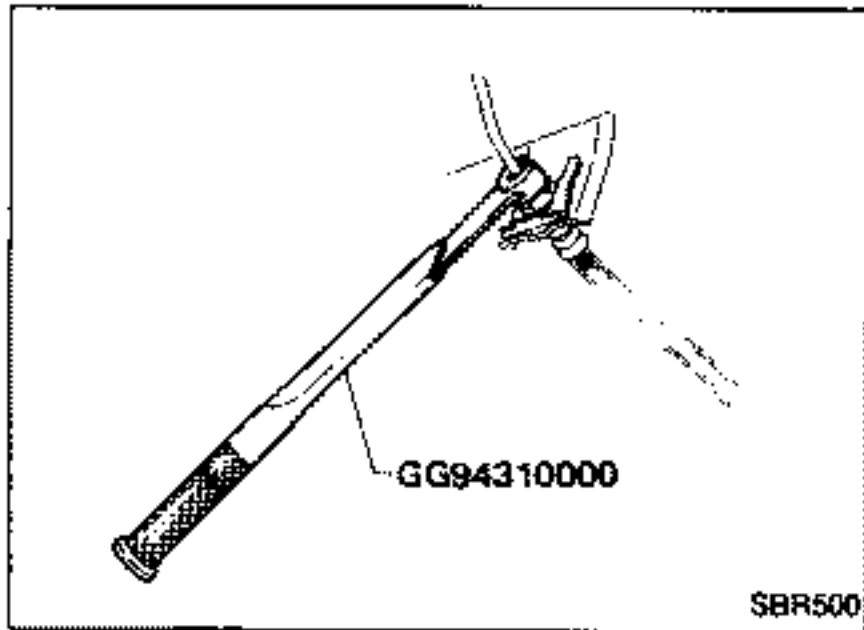

- Use Tool when removing and installing brake tube.

WARNING:

- Clean brake pads and shoes with a waste cloth, then collect dust with a dust collector.

Preparation

SPECIAL SERVICE TOOLS

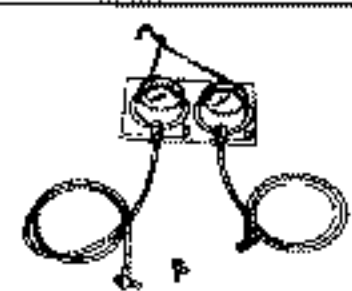
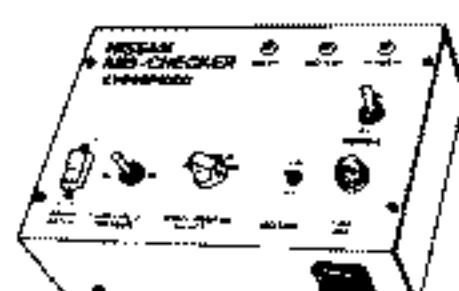
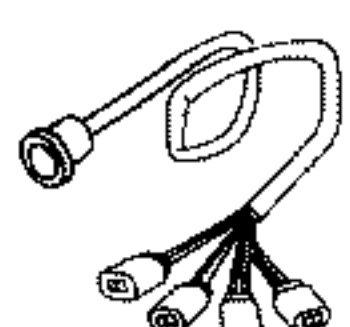
Tool number Tool name	Description
GG94310000 Flare nut torque wrench	 <p>Removing and installing each brake piping</p>
KV991V0010 Brake fluid pressure gauge	 <p>Measuring brake fluid pressure</p>
KV999P1000 A.B.S. checker	 <p>Checking brake fluid pressure of A.B.S. actuator</p>
KV999P1020 A.B.S. checker adapter harness	 <p>Checking brake fluid pressure of A.B.S. actuator</p>

CHECK AND ADJUSTMENT

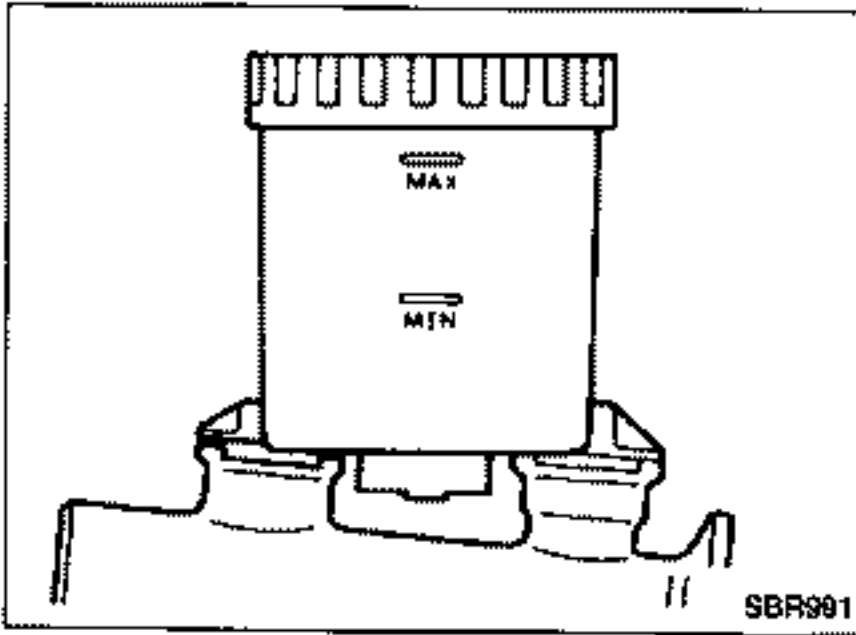

Checking Brake Fluid Level

- Check fluid level in reservoir tank. It should be between Max. and Min. lines on reservoir tank.
- If fluid level is extremely low, check brake system for leaks.

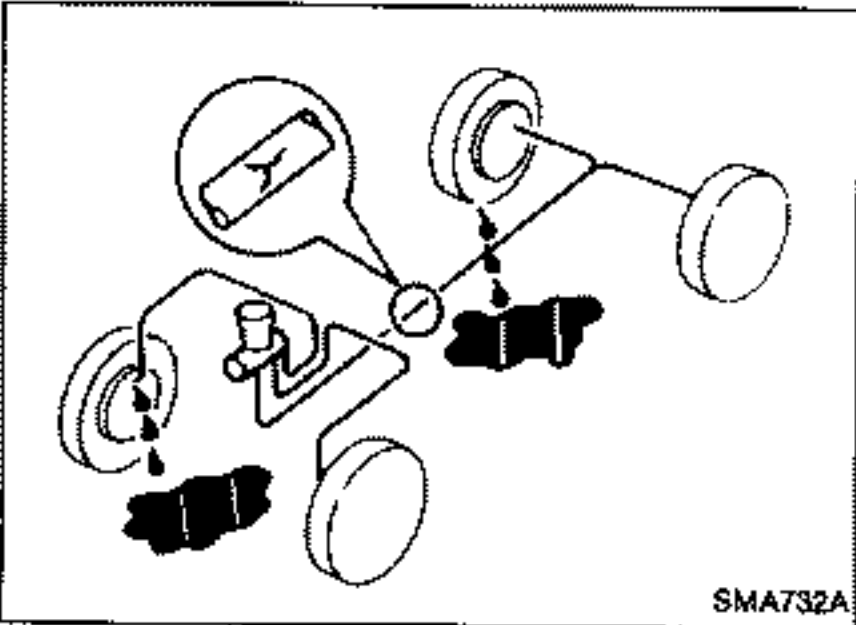

Checking Brake System

- Check brake lines (lines and flexible hoses) for cracks, deterioration or other damage. Replace any damaged parts.
If leakage occurs around joints, retighten or, if necessary, replace damaged parts.
- Check for oil leakage by fully depressing brake pedal.

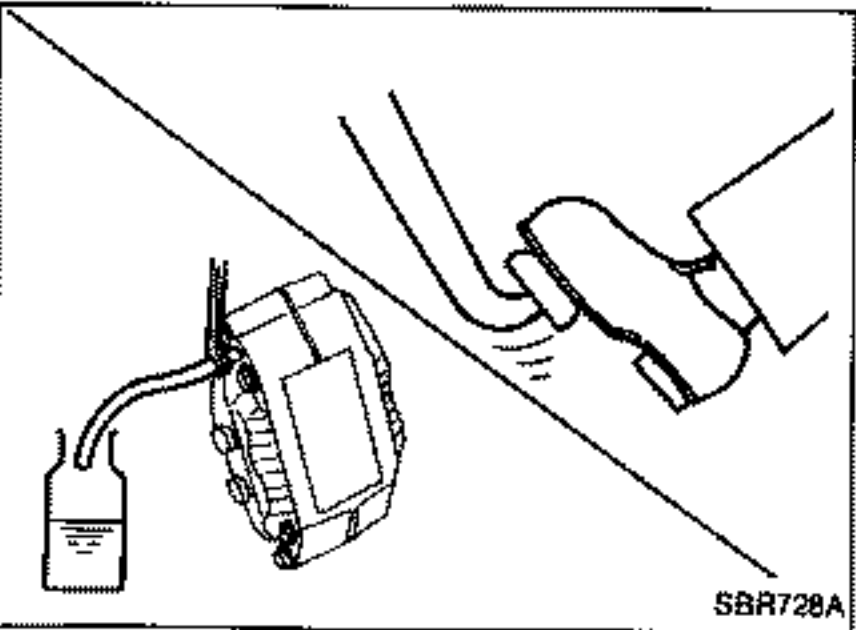

Changing Brake Fluid

1. Drain brake fluid in each air bleeder valve.
 2. Refill until new brake fluid comes out of each air bleeder valve.
- Use same procedure as in bleeding hydraulic system to refill brake fluid.
Refer to Bleeding Procedure.
- Refill with recommended brake fluid "DOT 3".
 - Never reuse drained brake fluid.
 - Be careful not to splash brake fluid on painted areas.

BRAKE HYDRAULIC LINE

Models with A.B.S.

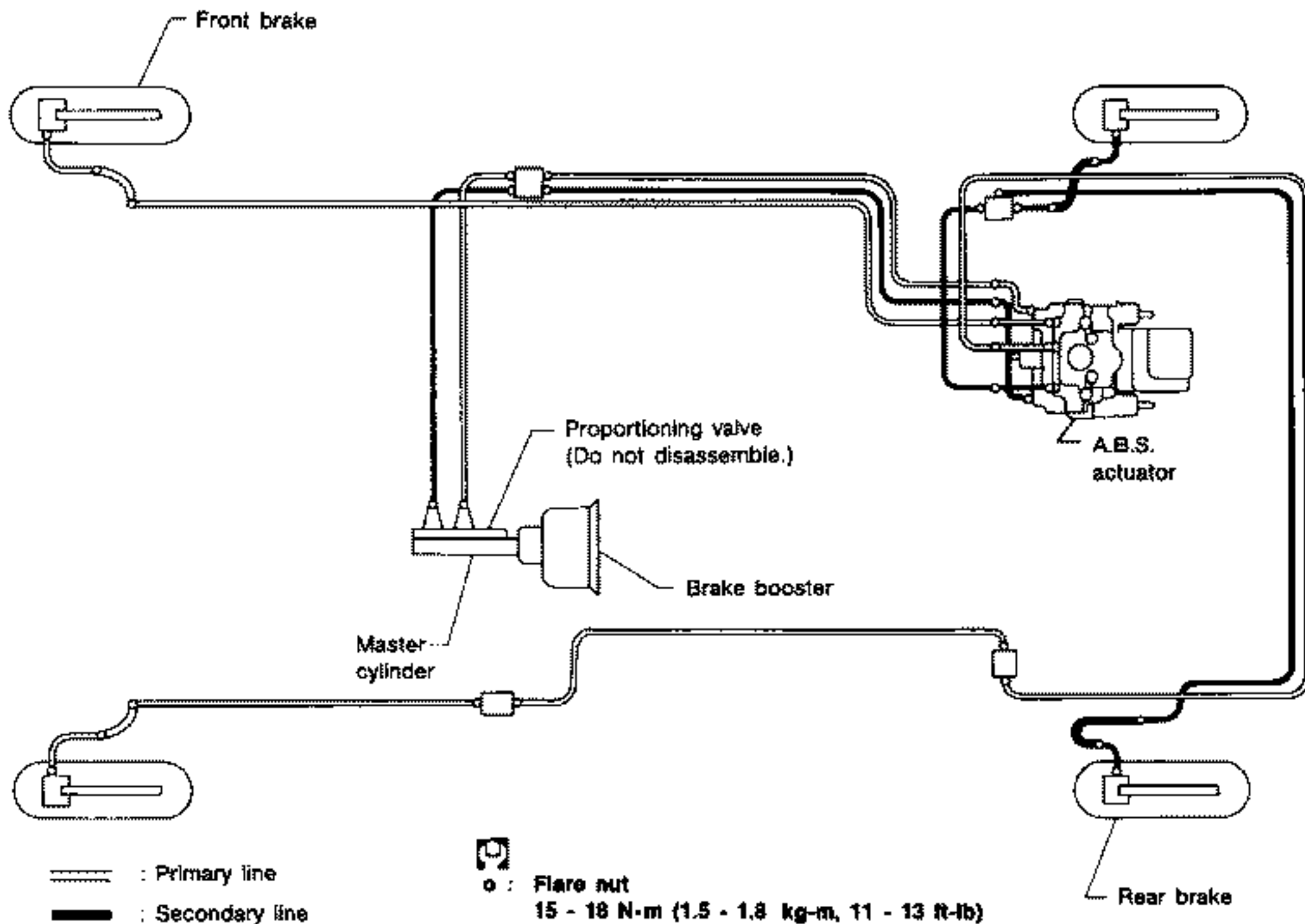

SBR071B

Models without A.B.S.

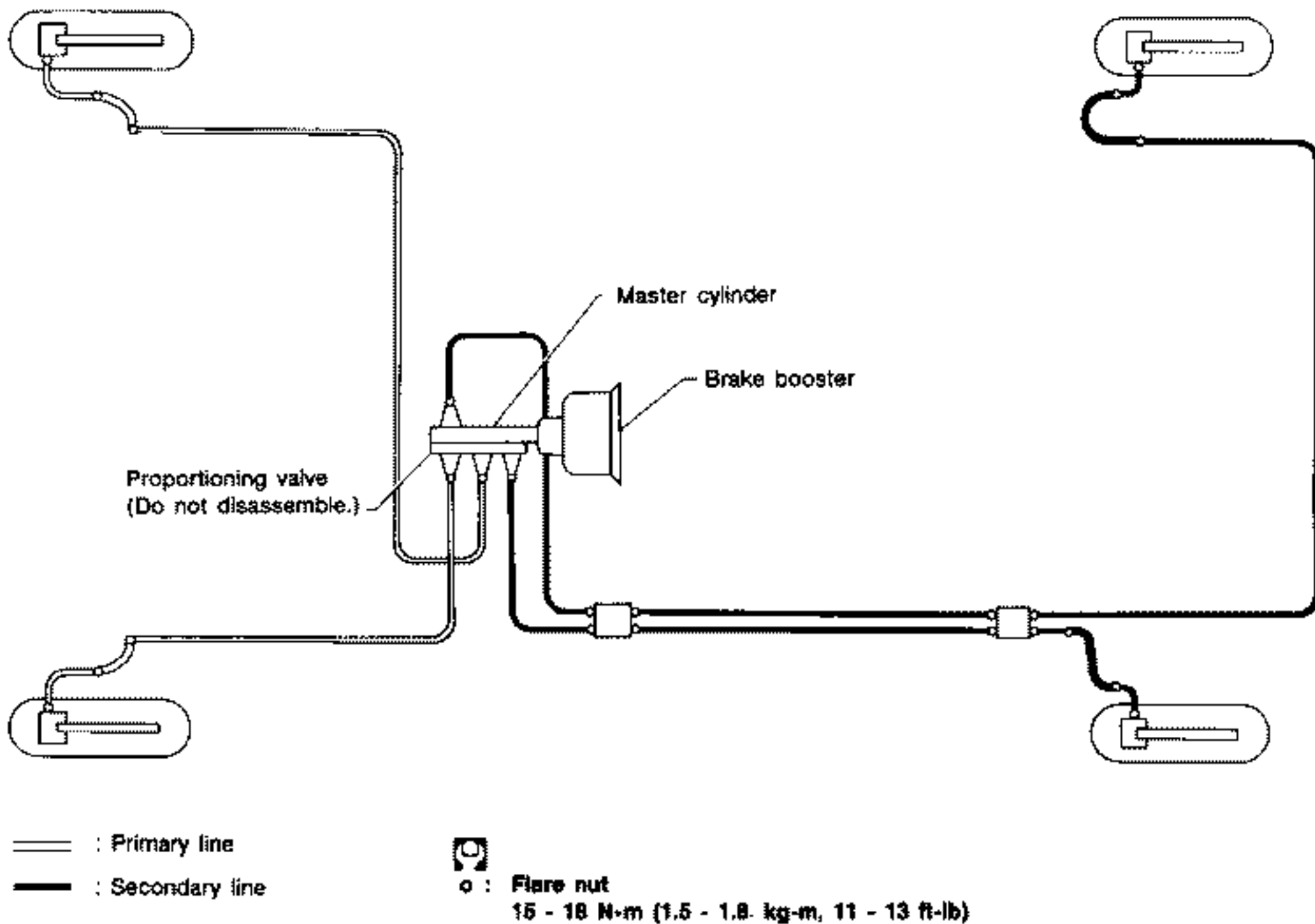

SBR072B

BRAKE HYDRAULIC LINE

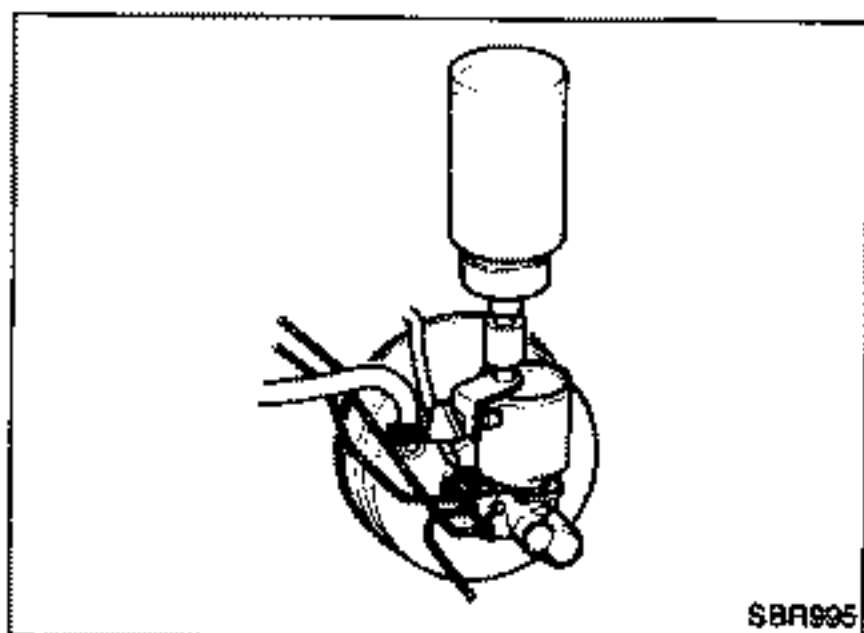

Bleeding Procedure

CAUTION:

- Carefully monitor brake fluid level at master cylinder during bleeding operation.
- Fill reservoir with recommended brake fluid. Make sure it is full at all times while bleeding air out of system.
- Place a container beneath master cylinder to avoid spillage of brake fluid.

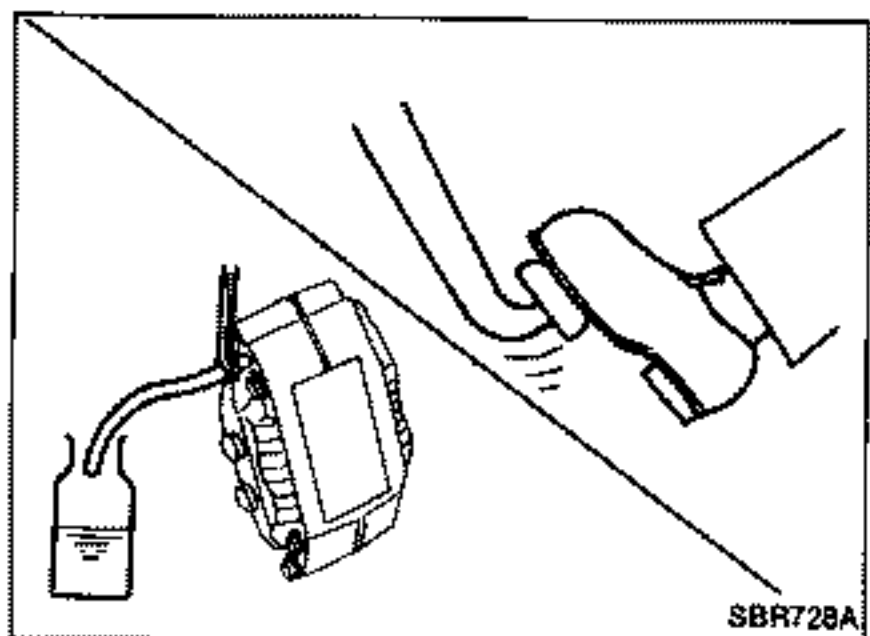

- Bleed air according to the following procedure.
Left rear caliper
↓
Right rear caliper
↓
Left front caliper
↓
Right front caliper
↓
Front side air bleeder on A.B.S. actuator (Models with A.B.S.)
↓
Rear side air bleeder on A.B.S. actuator (Models with A.B.S.)
- To bleed air out of lines, wheel cylinders and calipers, use the following procedure.
 - 1) Connect a transparent vinyl tube to air bleeder valve.
 - 2) Fully depress brake pedal several times.
 - 3) With brake pedal depressed, open air bleeder valve to release air.
 - 4) Close air bleeder valve.
 - 5) Release brake pedal slowly.
 - 6) Repeat steps 2) through 5) until clear brake fluid comes out of air bleeder valve.

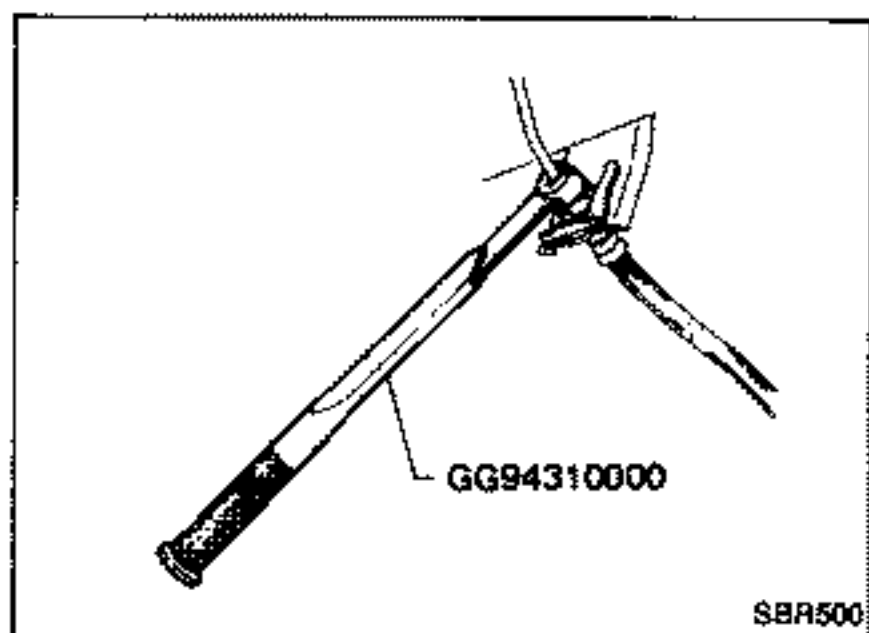

Removal and Installation

1. To remove brake flexible hose, first remove flare nut securing brake line to hose, then withdraw lock spring.
2. Cover openings to prevent entrance of dirt whenever disconnecting hydraulic line.
3. All hoses must be free from excessive bending, twisting and pulling.
4. After installing brake lines, check for oil leakage by fully depressing brake pedal.

Inspection

Check brake lines (lines and flexible hoses) for cracks, deterioration or other damage. Replace any damaged parts. If leakage occurs around joints, retighten or, if necessary, replace damaged parts.

BRAKE PEDAL AND BRACKET

Removal and Installation

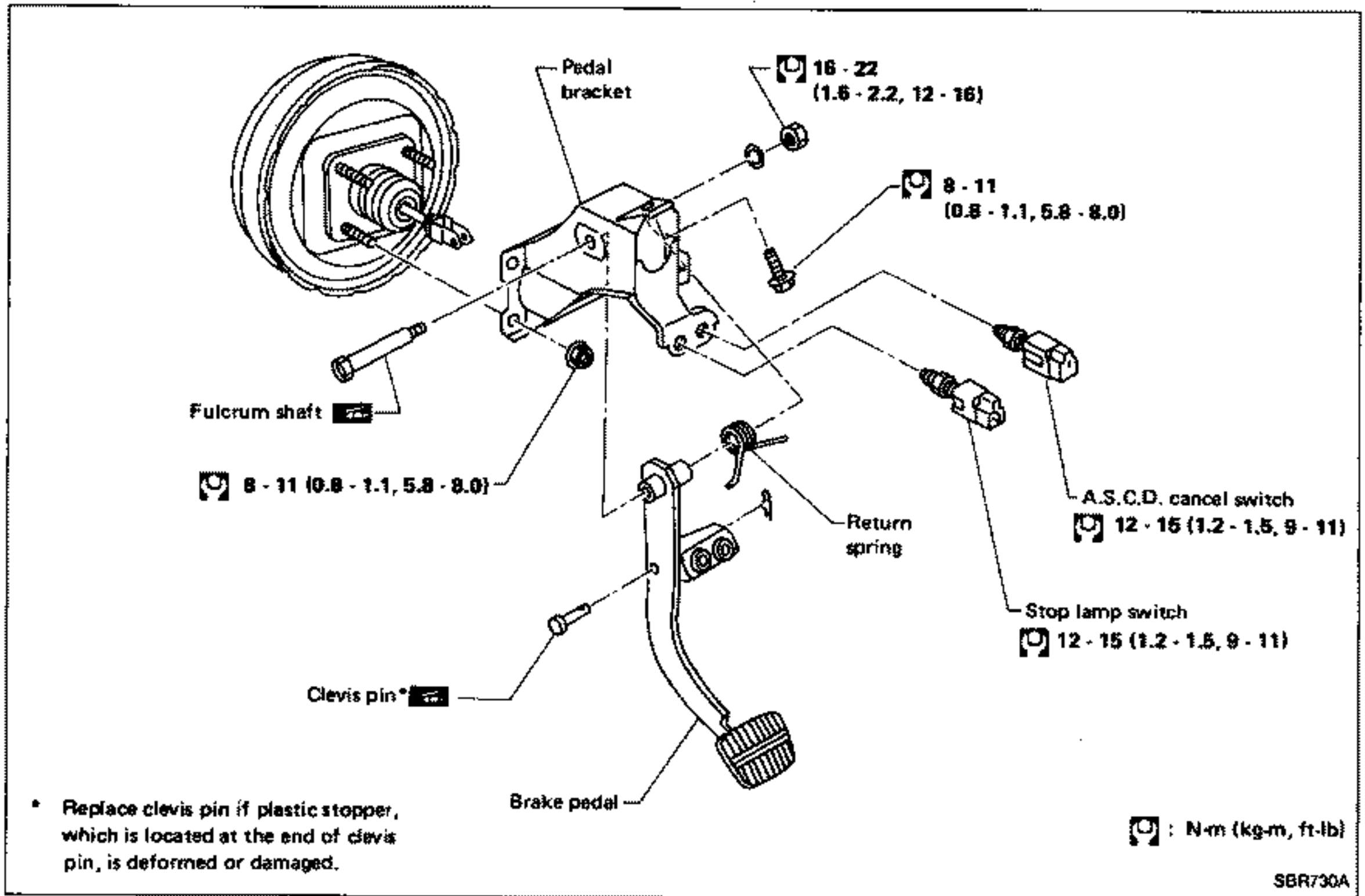

Inspection

Check brake pedal for following items.

- Brake pedal bend
- Clevis pin deformation
- Crack of any welded portion

BRAKE PEDAL AND BRACKET

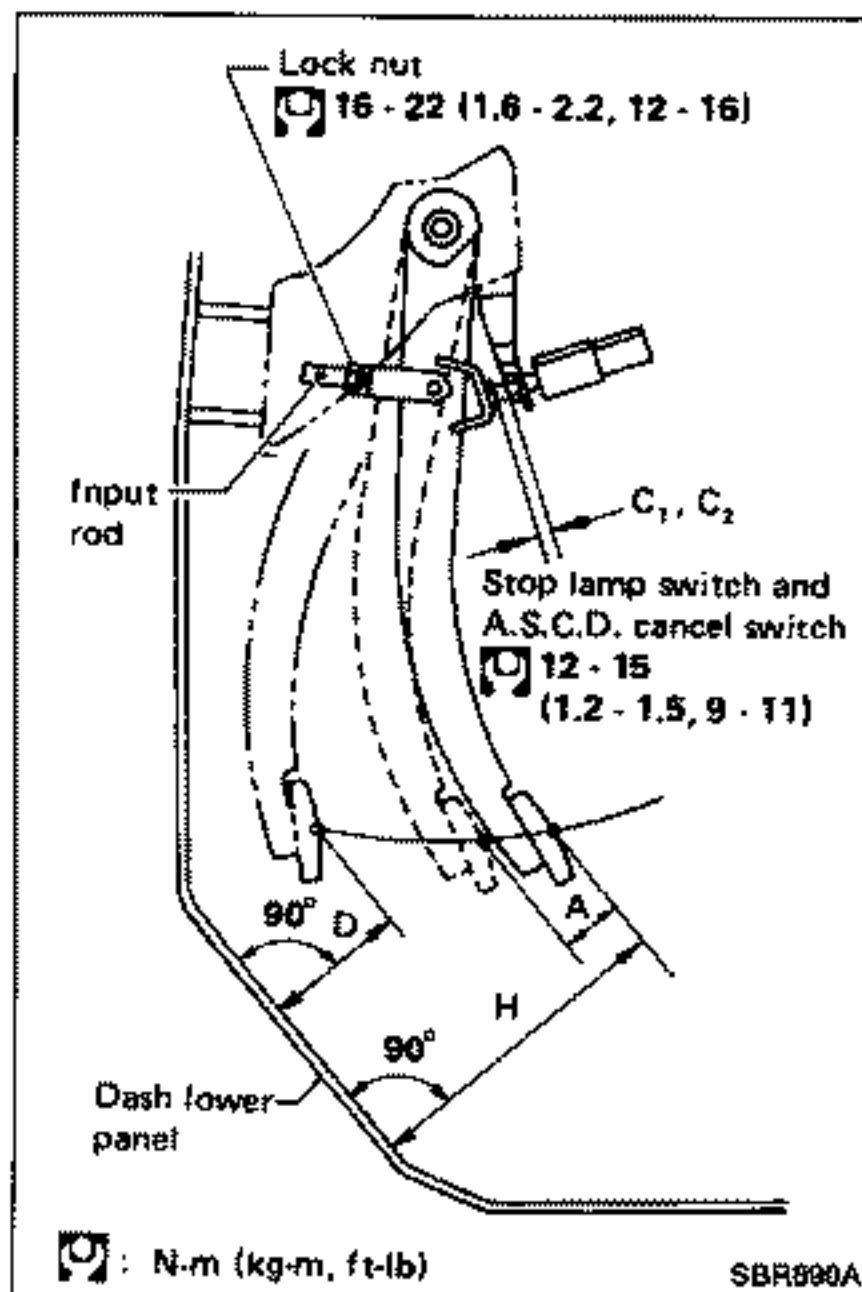

Adjustment

Check brake pedal free height from dash reinforcement panel. Adjust if necessary.

- H:** Free height
Refer to S.D.S.
- D:** Depressed height
Refer to S.D.S.
Under force of 490 N (50 kg, 110 lb)
with engine running
- C₁:** Clearance between pedal stopper and threaded end of stop lamp switch
0.3 - 1.0 mm (0.012 - 0.039 in)
- C₂:** Clearance between pedal stopper and threaded end of A.S.C.D. switch
0.3 - 1.0 mm (0.012 - 0.039 in)
- A:** Pedal free play
1 - 3 mm (0.04 - 0.12 in)

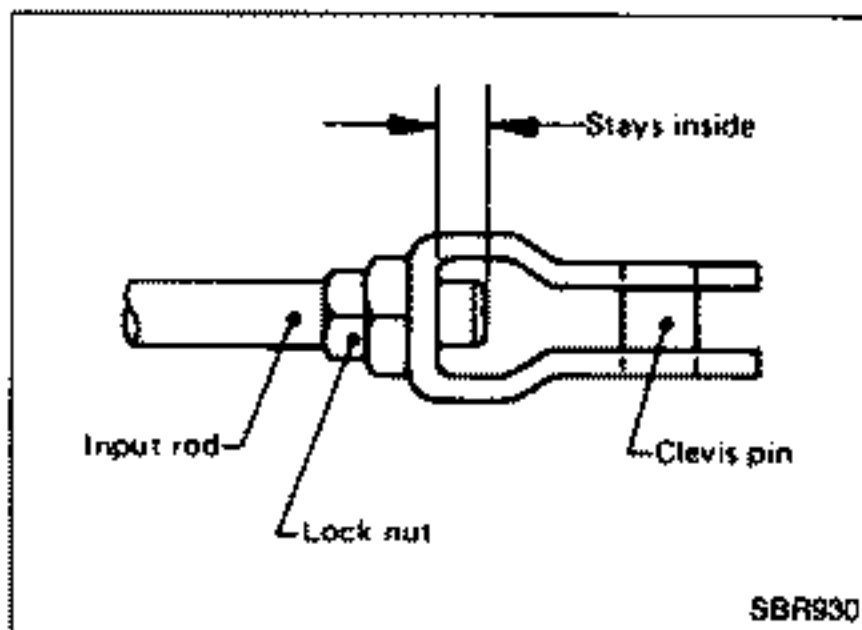

1. Adjust pedal free height with brake booster input rod. Then tighten lock nut.

Make sure that tip of input rod stays inside.

2. Adjust clearance "C₁" and "C₂" with stop lamp switch and A.S.C.D. switch respectively. Then tighten lock nuts.
3. Check pedal free play.

Make sure that stop lamp is off when pedal is released.

4. Check brake pedal's depressed height while engine is running.

If depressed height is below specified value, check brake system for leaks, accumulation of air or any damage to components (master cylinder, wheel cylinder, etc.); then make necessary repairs.

BRAKE BOOSTER

Removal and Installation

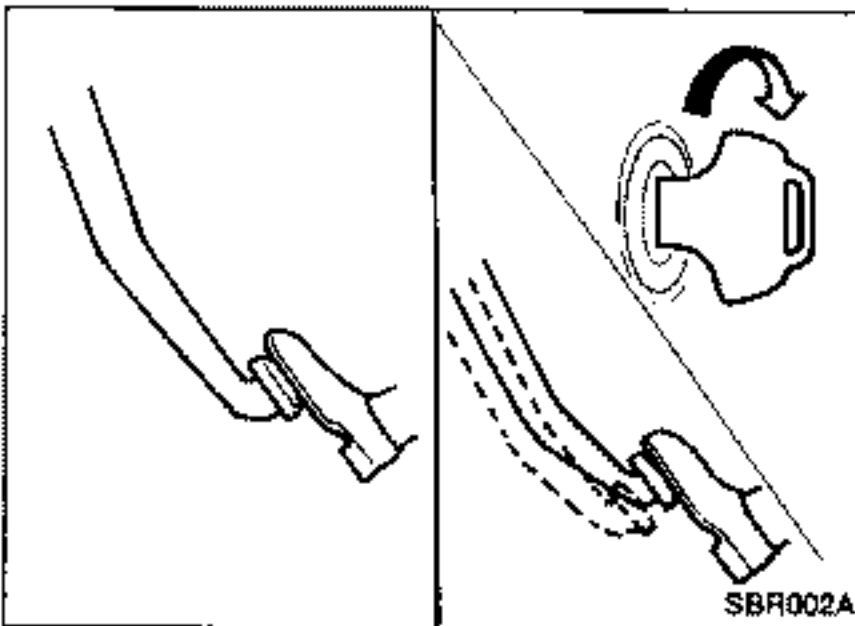
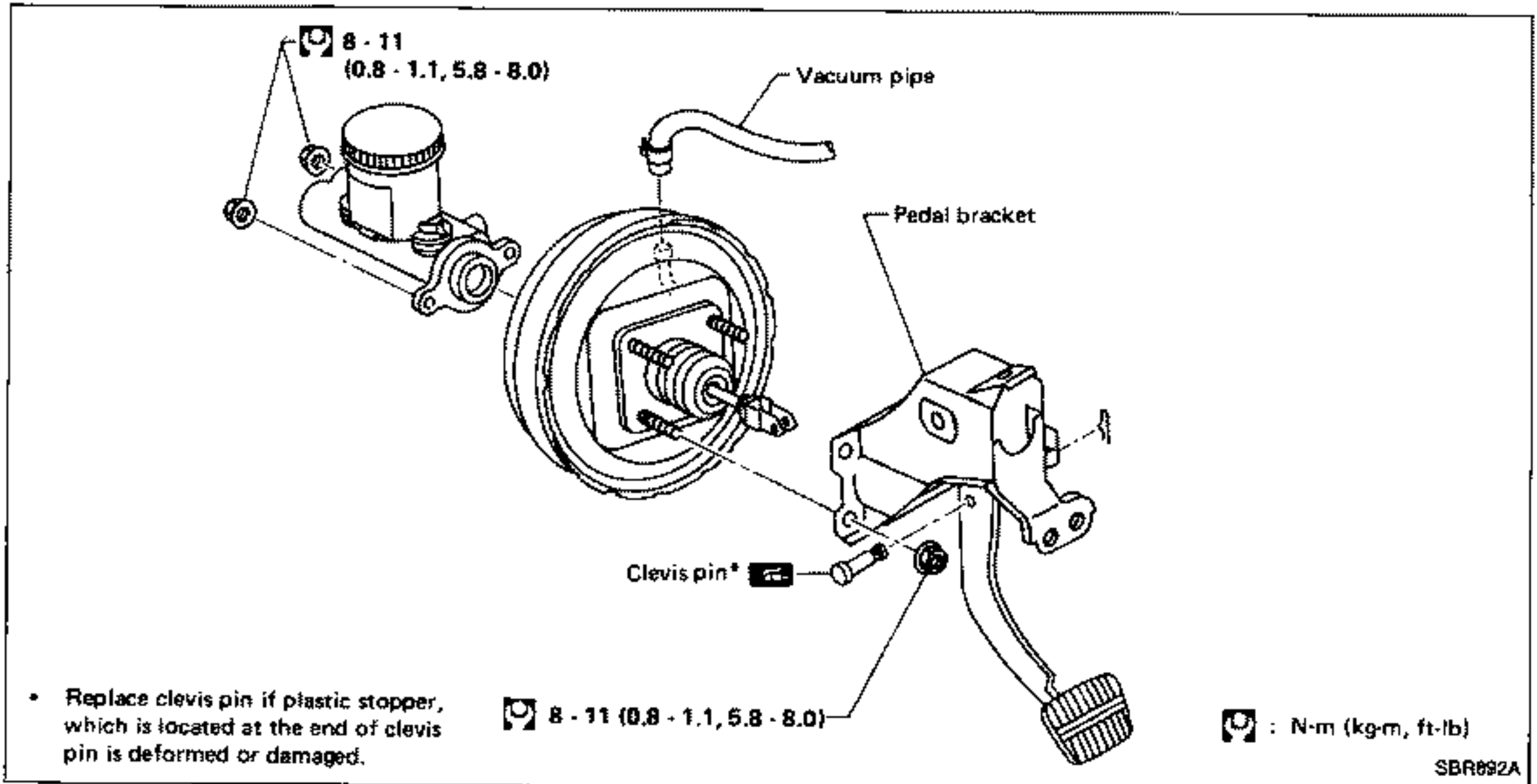

Inspection

OPERATING CHECK

- Depress brake pedal several times with engine off, and check that there is no change in pedal stroke.
- Depress brake pedal, then start engine. If pedal goes down slightly, operation is normal.

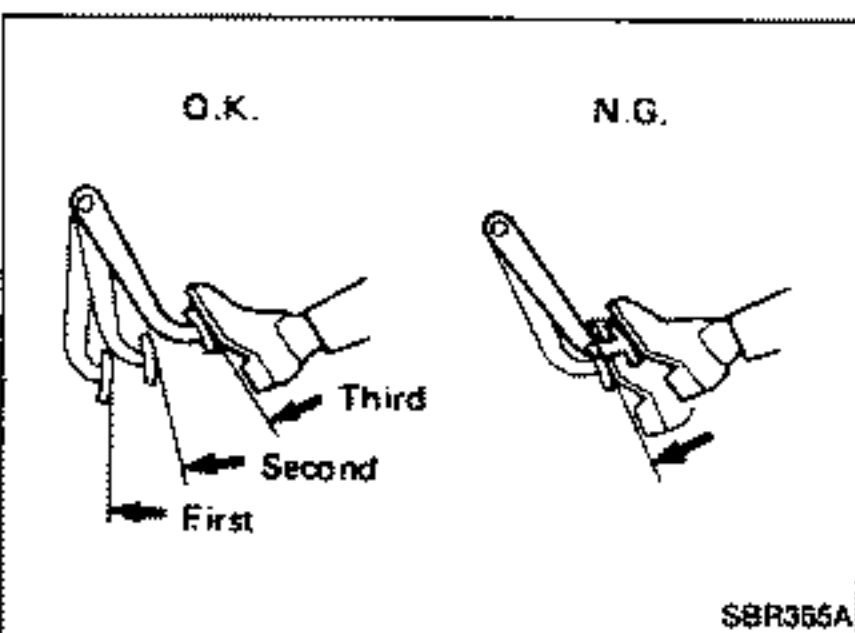

AIRTIGHT CHECK

- Start engine, and stop it after one or two minutes. Depress brake pedal several times slowly. If pedal goes further down the first time and gradually rises after second or third time, booster is airtight.
- Depress brake pedal while engine is running, and stop engine with pedal depressed. If there is no change in pedal stroke after holding pedal down **30 seconds**, brake booster is airtight.

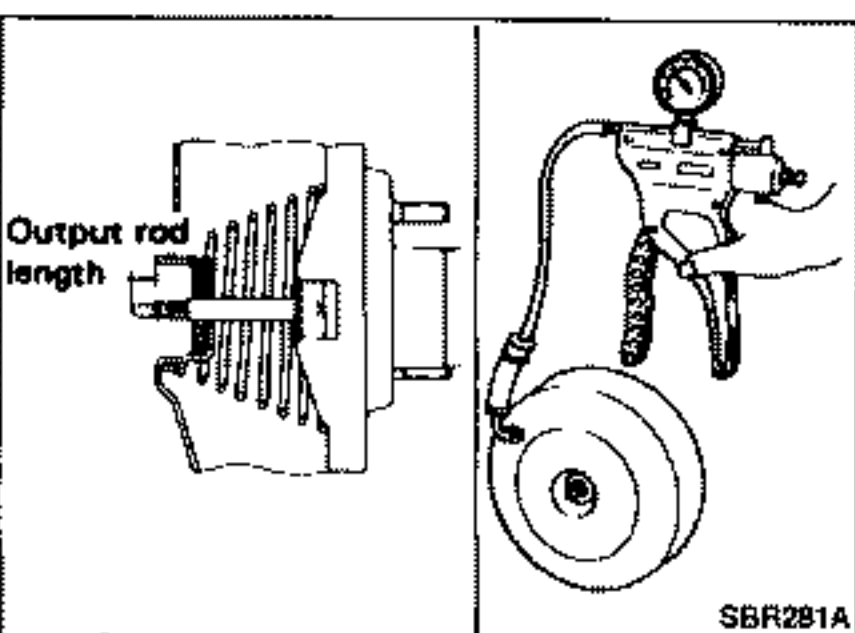

OUTPUT ROD LENGTH CHECK

1. Supply brake booster with vacuum of -66.7 kPa (-667 mbar, -500 mmHg, -19.69 inHg) using a handy vacuum pump.
2. Check output rod length.

Specified length:

10.275 - 10.525 mm (0.4045 - 0.4144 in)

VACUUM PIPING

Removal and Installation

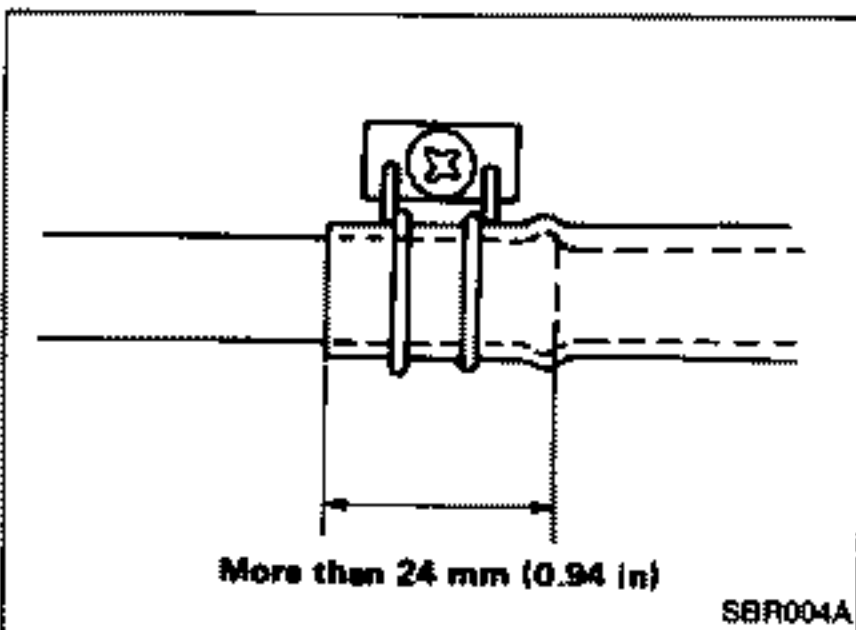
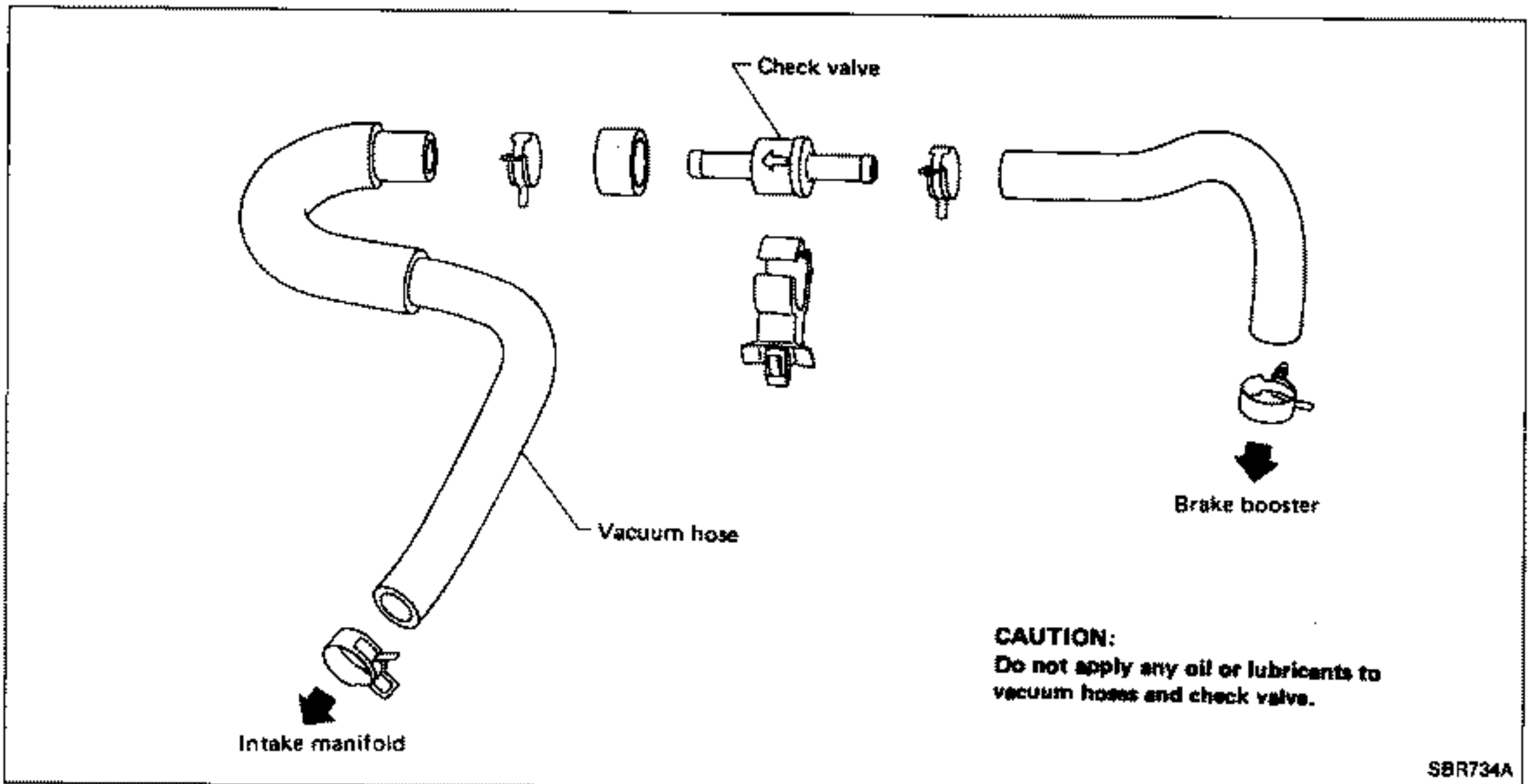

- Insert vacuum tube into vacuum hose more than 24 mm (0.94 in).

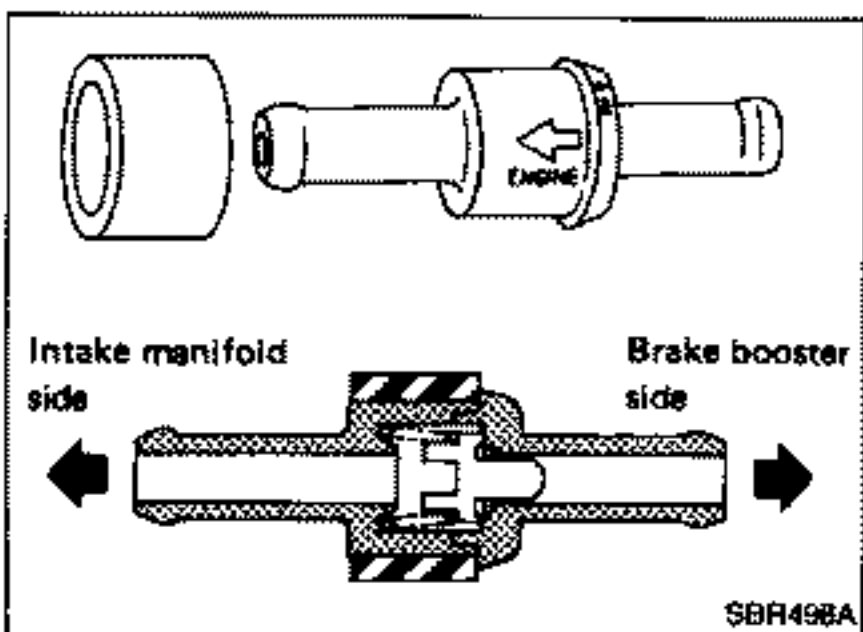

- Install check valve, paying attention to its direction.

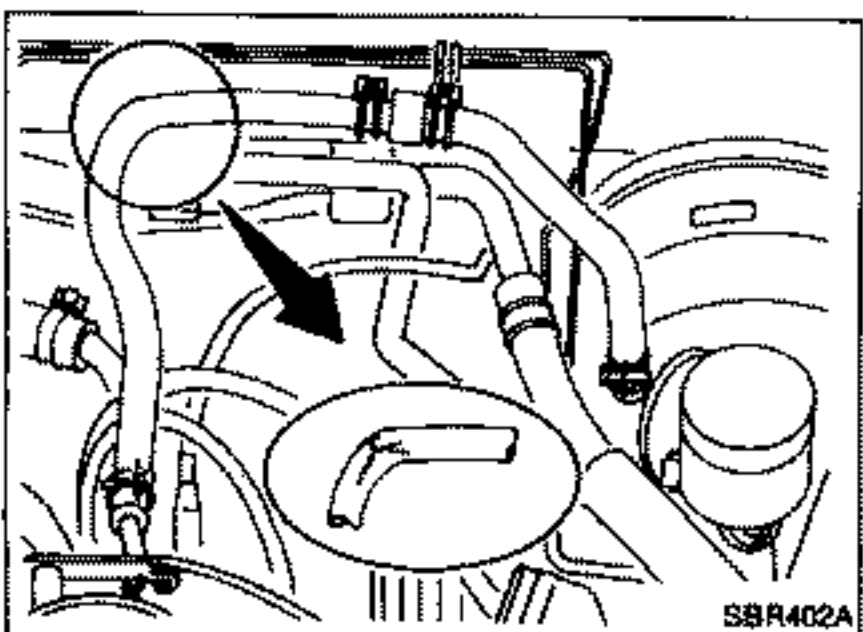

Inspection

HOSES AND CONNECTORS

- Check vacuum lines, connections and check valve for airtightness, improper attachment chafing and deterioration.

VACUUM PIPING

Inspection (Cont'd)

CHECK VALVE

Check vacuum with a vacuum pump.

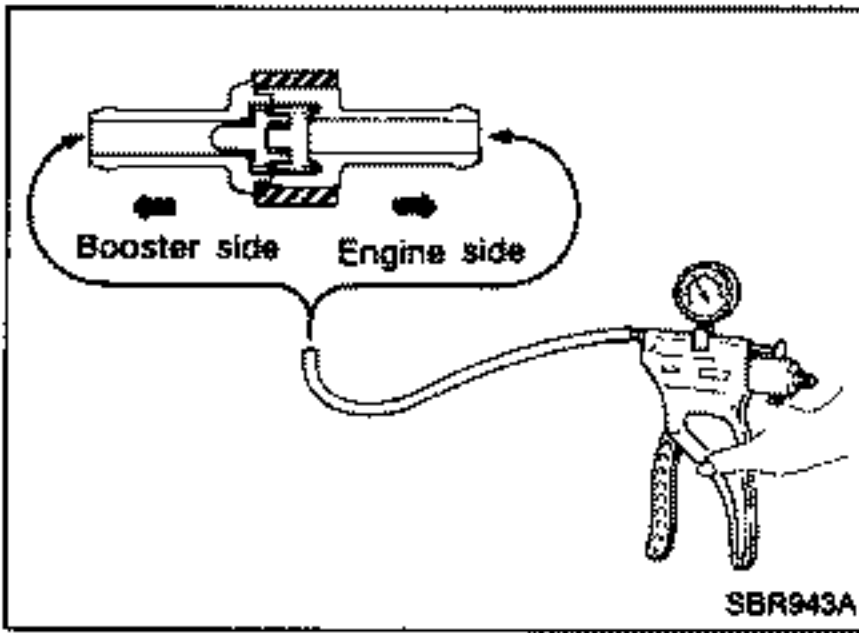

Connect to booster side	Vacuum should exist.
Connect to engine side	Vacuum should not exist.

MASTER CYLINDER

Removal and Installation

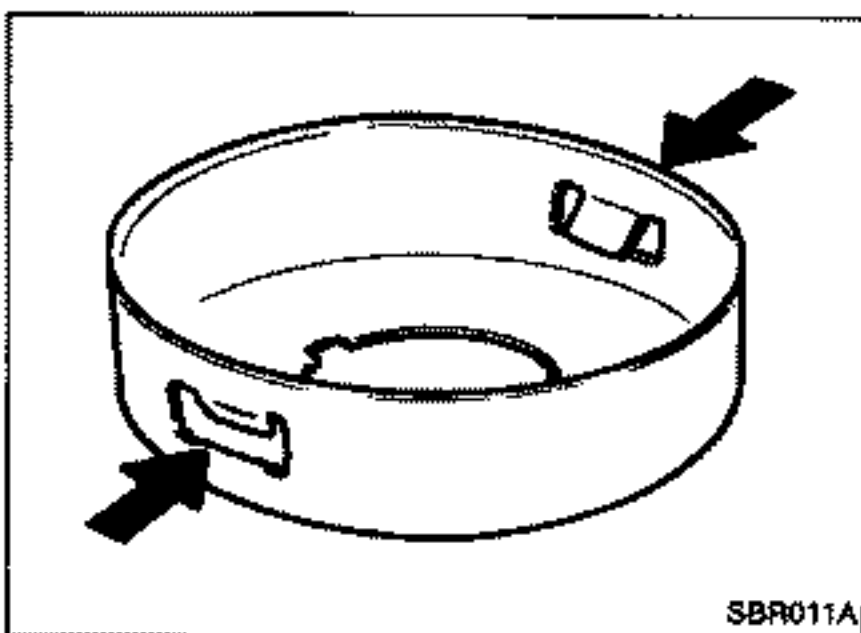
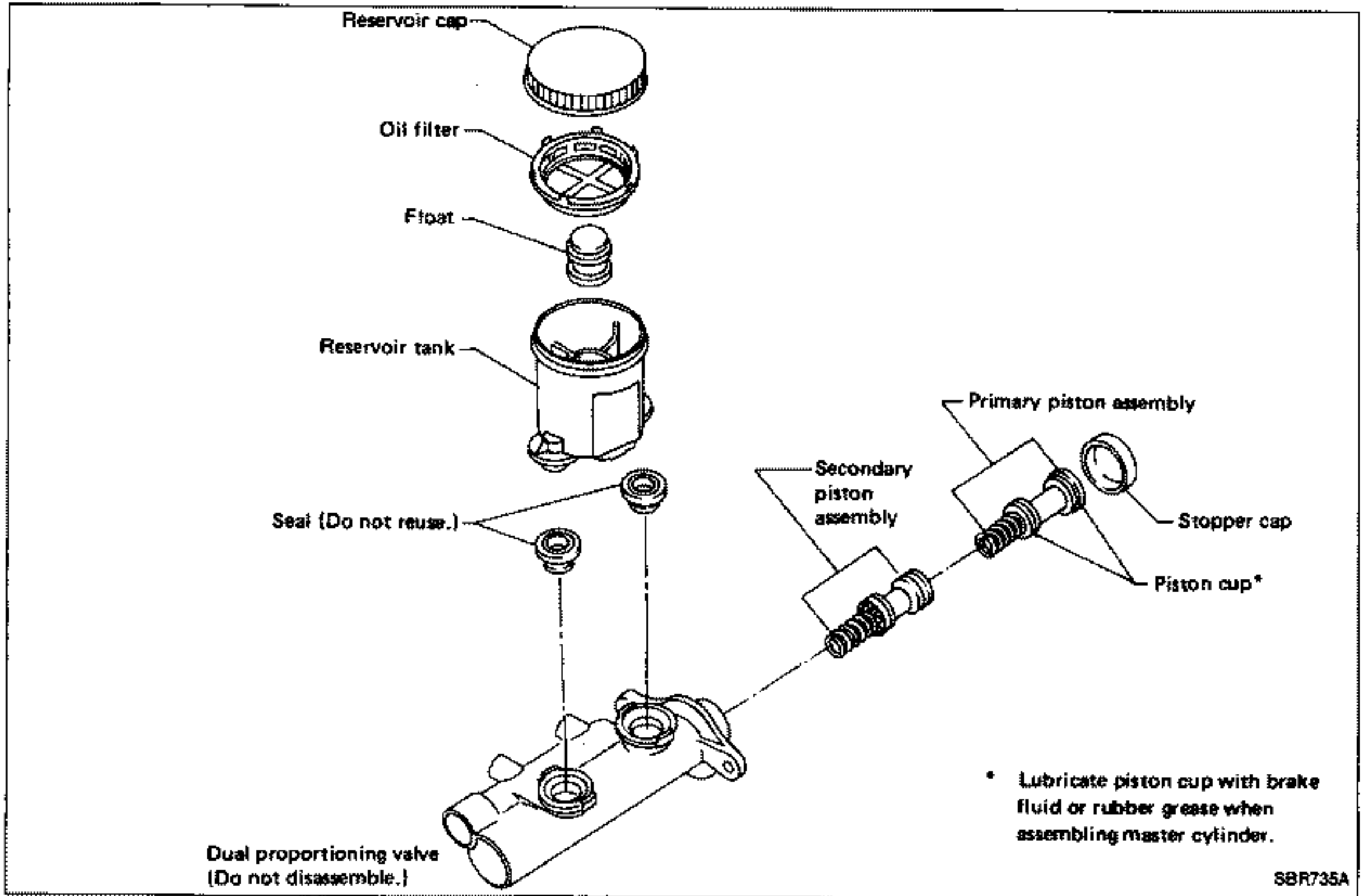

- Replace stopper cap if claw is damaged or deformed.
- Bend claws inward when installing stopper cap.

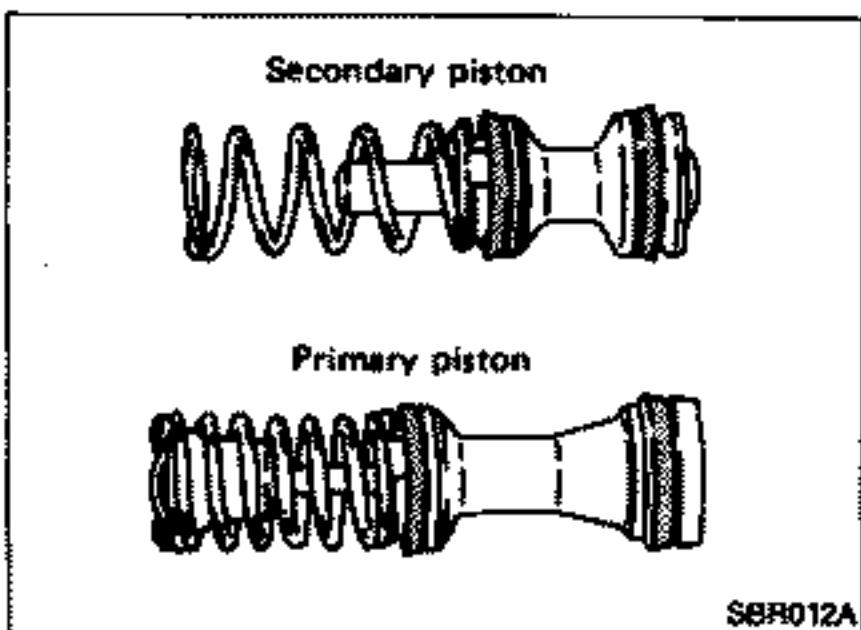

- Pay attention to direction of piston cups in figure at left.
- Check parts for wear or damage. Replace if necessary.

FRONT DISC BRAKE (OPZ25V and OPF25V) — Caliper

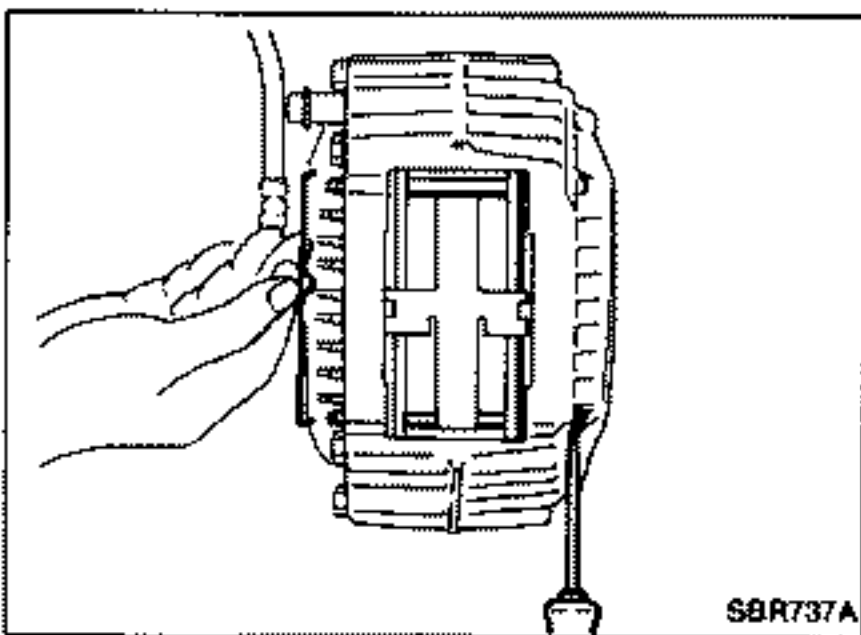
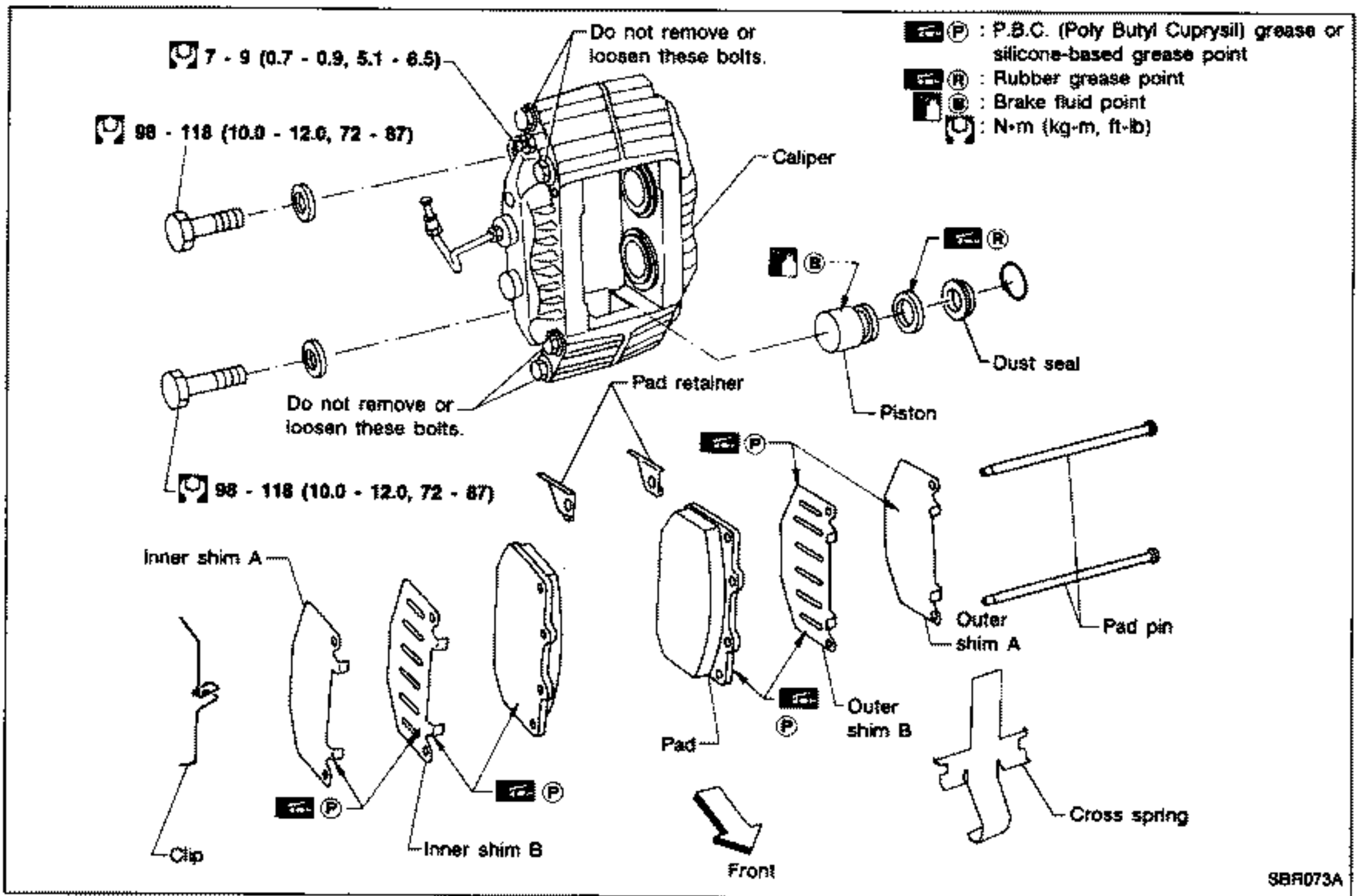

Pad Replacement

CAUTION:

- When pads are removed, do not depress brake pedal because piston will pop out.
- Be careful not to damage dust seal or get oil on rotor. Always replace shims when replacing pads.

1. Remove clip from pad pin and then remove pad pin.
2. Remove cross spring.

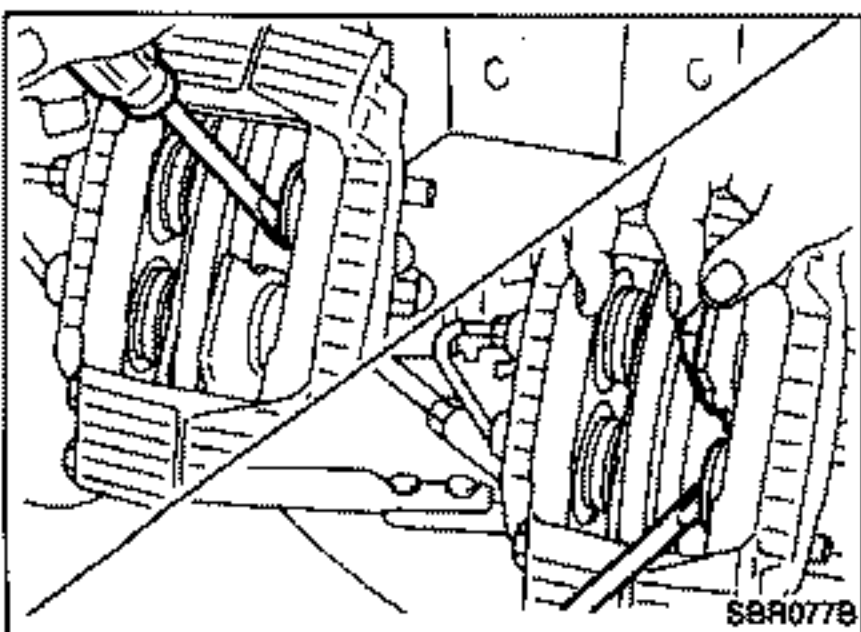

3. Pull out outer pad and insert it temporarily between lower piston and rotor as shown.
4. Push back upper piston with a suitable tool and insert new pad so it contacts upper piston as shown.
5. Pull out old pad.
6. Push back lower piston with a suitable tool.
7. Pull out new pad and reinstall it in the proper position.
8. Repeat step 3 to 7 for inner pad.
9. Install cross spring, pad pin and clip.

FRONT DISC BRAKE (OPZ25V and OPF25V) — Caliper

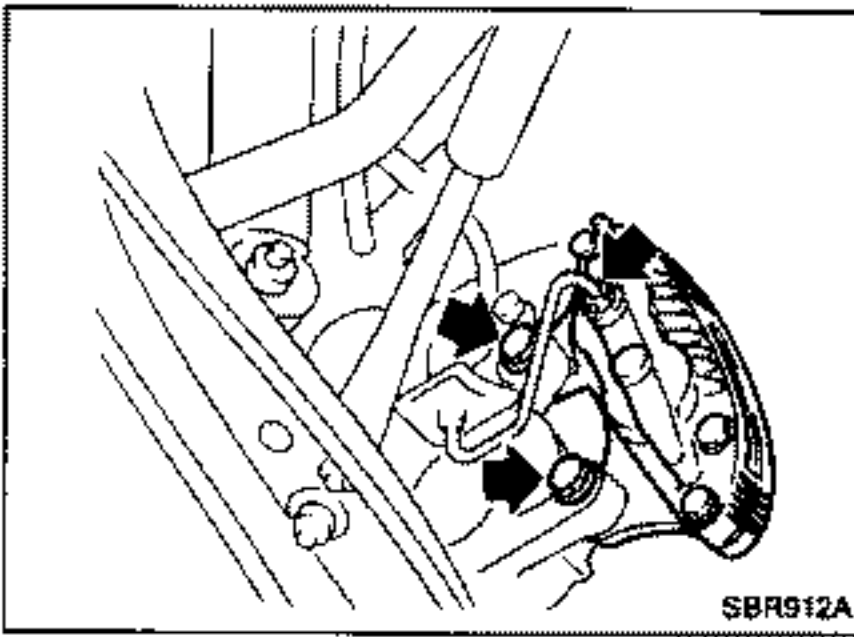

Removal and Installation

1. Disconnect brake tube.
2. Remove brake pad.
3. Remove brake caliper mounting bolts.

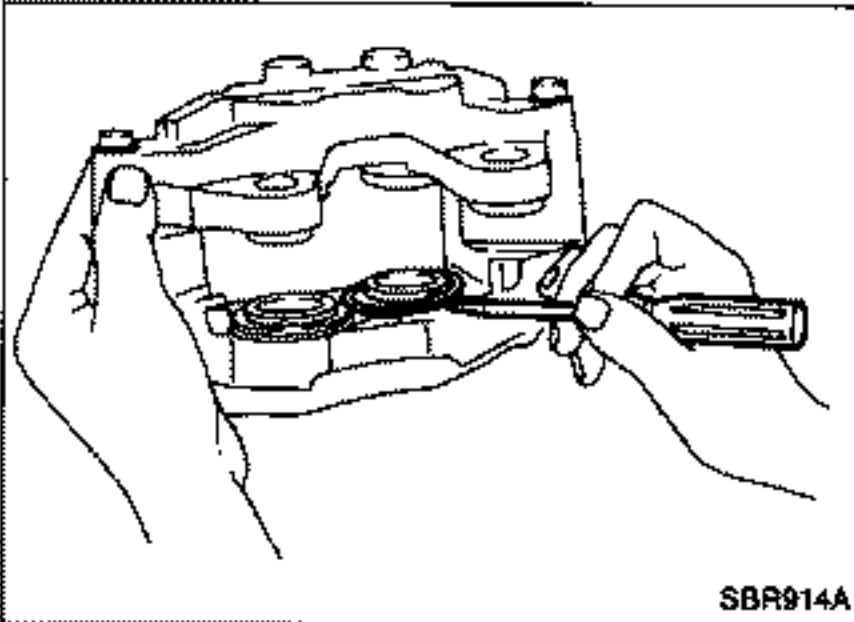

Disassembly

1. Remove retaining ring.

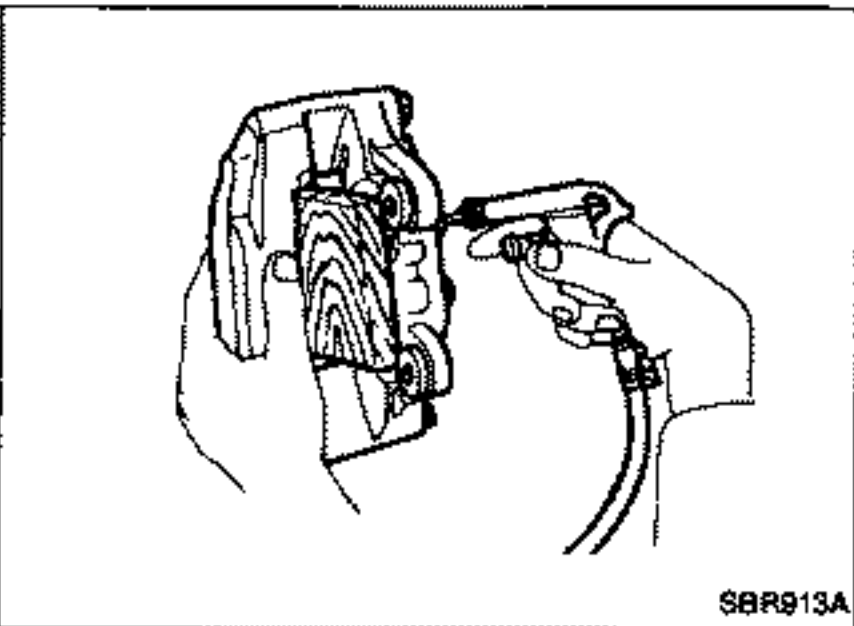

2. Push out piston with dust seal using compressed air.

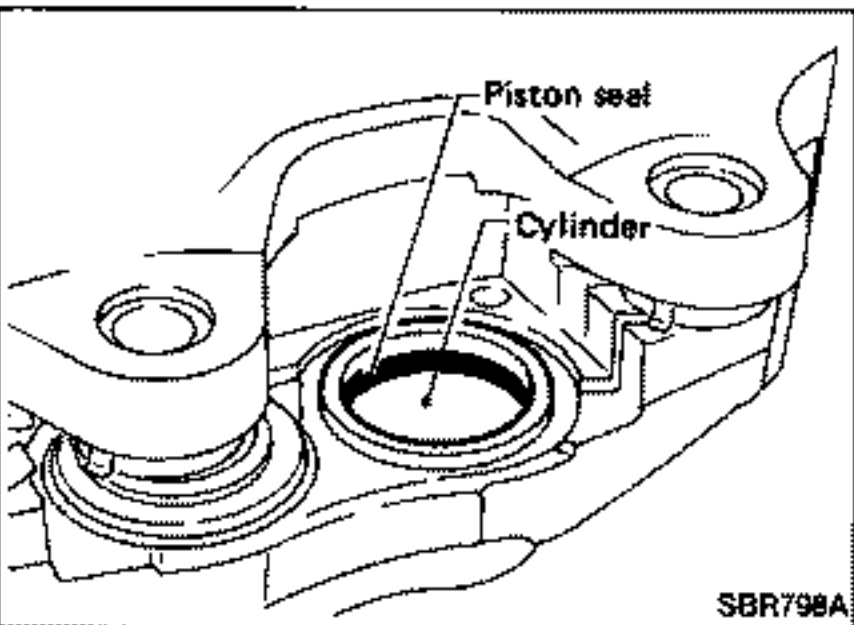

3. Remove piston seal.

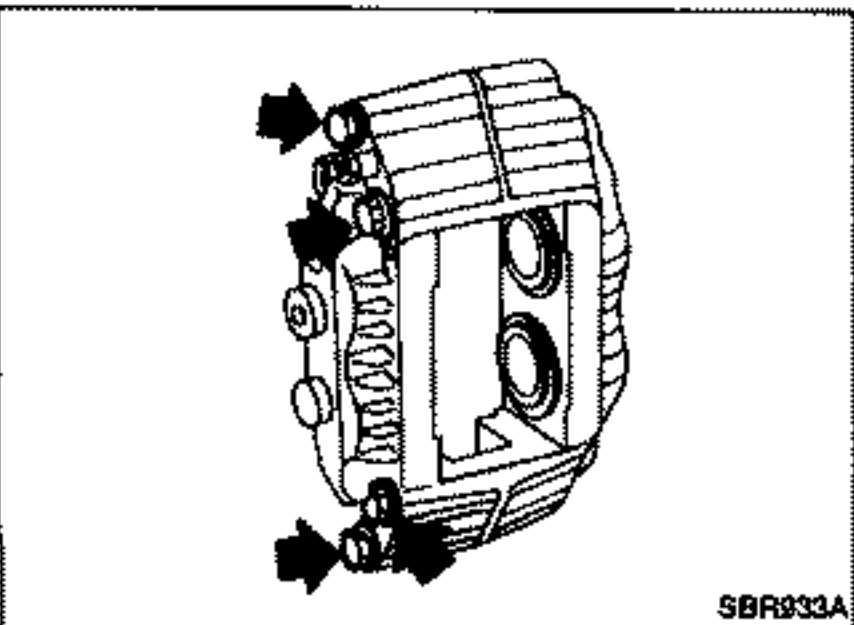

CAUTION:

Be careful not to loosen or remove bolts joining both sides of caliper.

If there is any fluid leakage, replace caliper assembly.

Inspection

CALIPER

- Check dust seals for damage.
- Check calipers for damage, rust or foreign materials.
- Check inside surface of cylinder for scoring, rust, wear, damage or foreign materials. Replace if any such condition exists.
- Eliminate minor damage from rust or foreign materials by polishing surface with fine emery paper.

CAUTION:

Use brake fluid to clean.

PISTON

Check piston for scoring, rust, wear, damage or foreign materials. Replace if any condition exists.

CAUTION:

Piston sliding surface is plated. Do not polish with emery paper even if rust or foreign materials are stuck to sliding surface.

PAD PIN AND CLIPS

Check for wear, cracks deformation, deterioration, rust or other damage. Replace if any such condition exists.

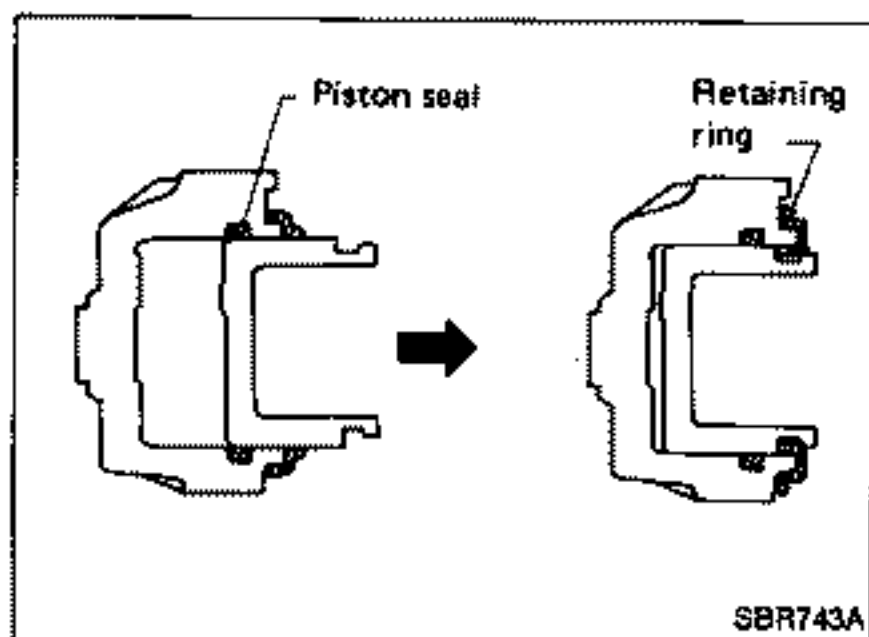

Assembly

1. Insert piston seal into groove on cylinder body.
2. With dust seal fitted to piston, install piston into cylinder body.
3. Secure dust seal properly.
4. Install retaining ring.

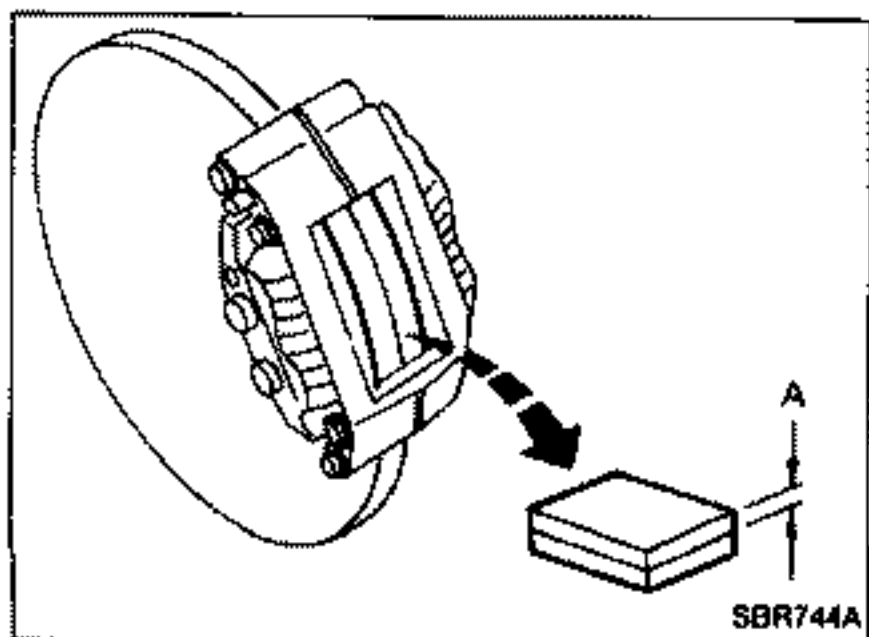

Inspection (On-vehicle)

DISC PAD

- Check pad shims for deformation or damage.
- Check disc pad for wear or damage.

Pad standard thickness (A):

10.0 mm (0.394 in)

Pad wear limit (A):

2.0 mm (0.079 in)

Inspection

RUBBING SURFACE

Check rotor for roughness, cracks or chips.

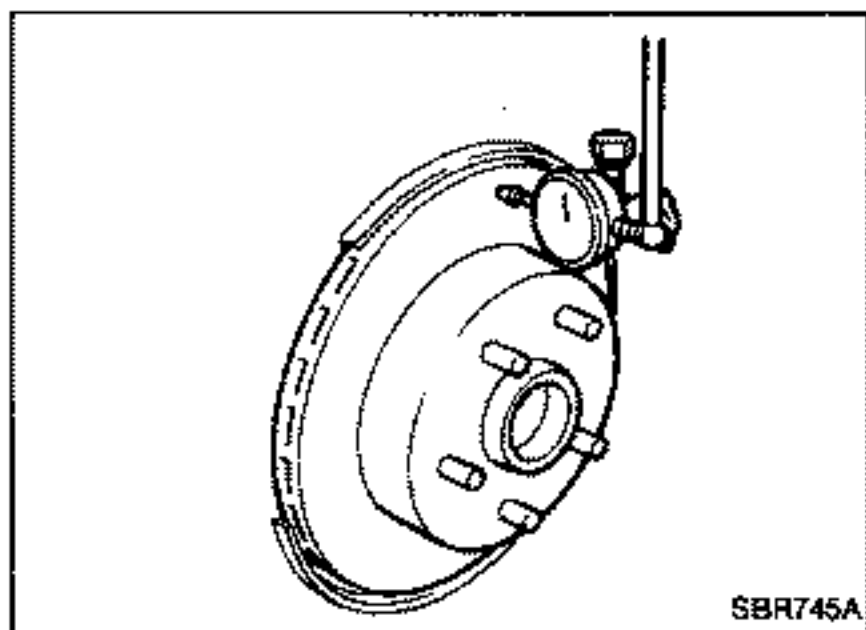

RUNOUT

Check runout using a dial indicator. Make sure that axial end play is within the specifications before measuring. Refer to section FA.

Rotor repair limit:

Maximum runout

(Total indicator reading at center of rotor pad contact surface)

0.07 mm (0.0028 in)

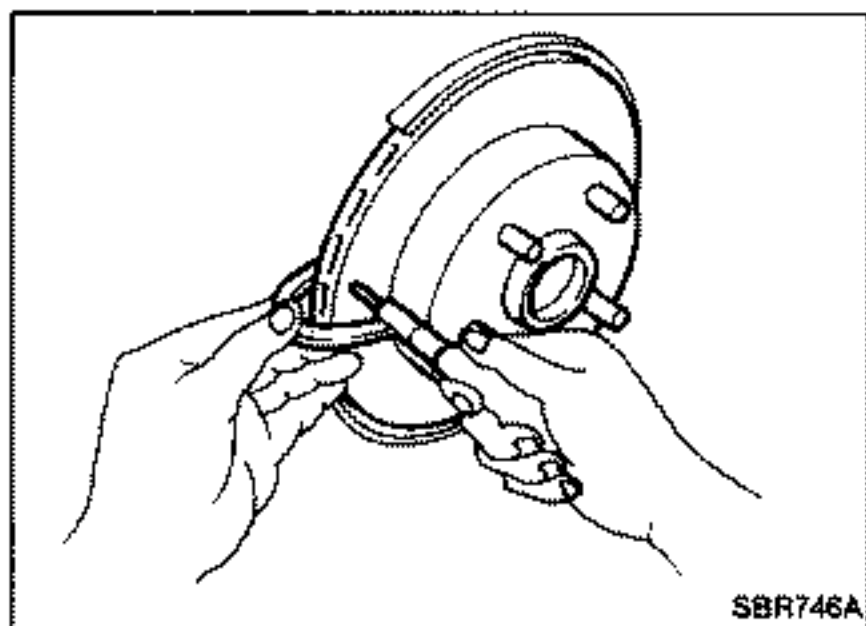

THICKNESS

Standard thickness:

OPZ25V

26.0 mm (1.024 in)

OPF25V

30.0 mm (1.181 in)

Minimum thickness:

OPZ25V

24.0 mm (0.945 in)

OPF25V

28.0 mm (1.102 in)

REAR DISC BRAKE — Caliper

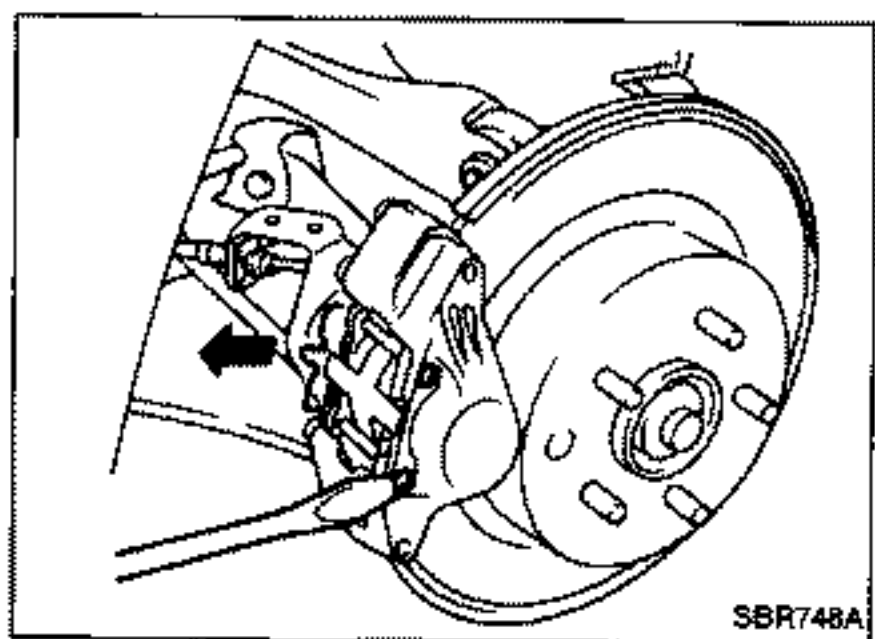
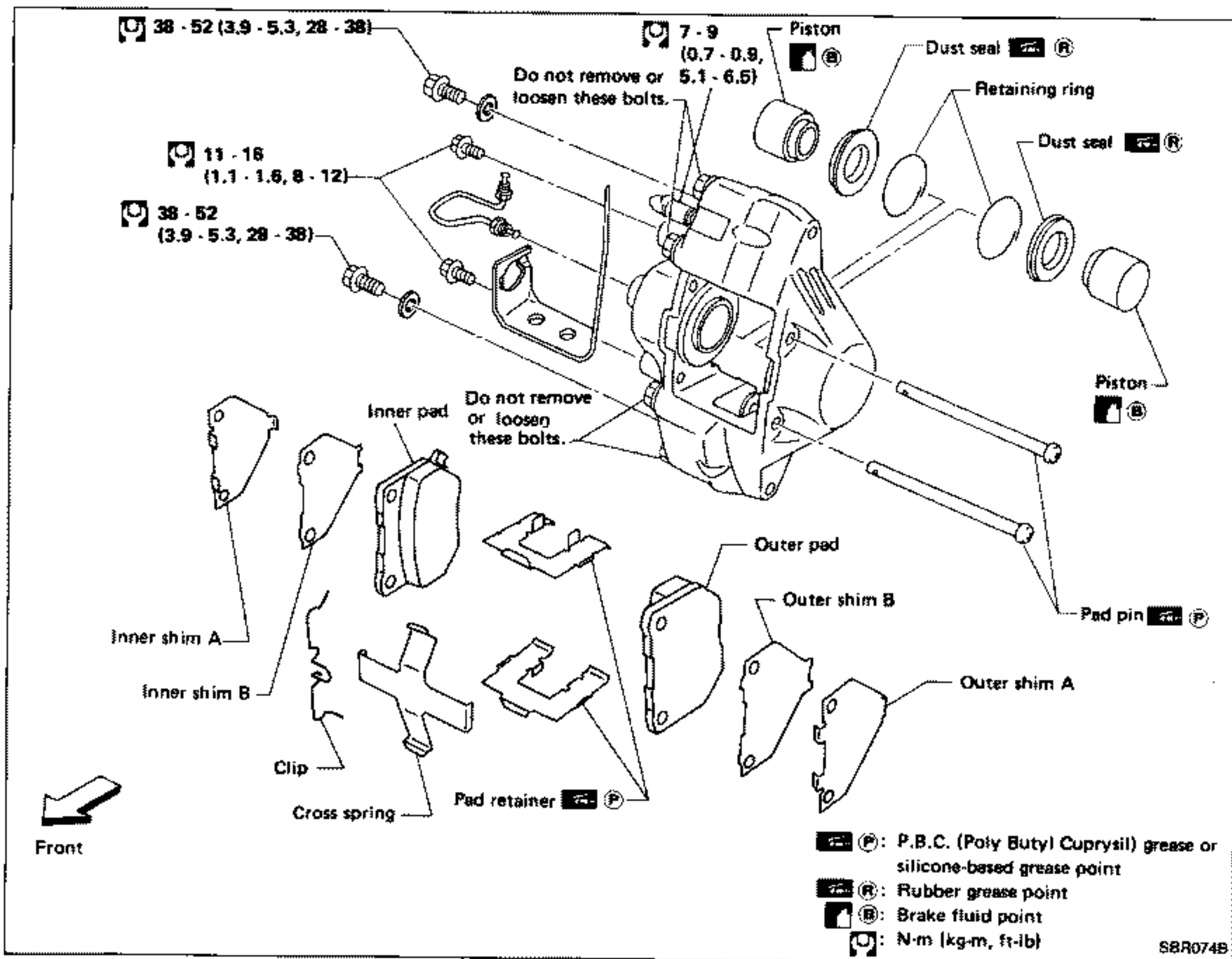

Pad Replacement

CAUTION:

When pads are removed, do not depress brake pedal because piston will pop out.

1. Remove clip from pad pin and then remove pad pin.
2. Remove cross spring.

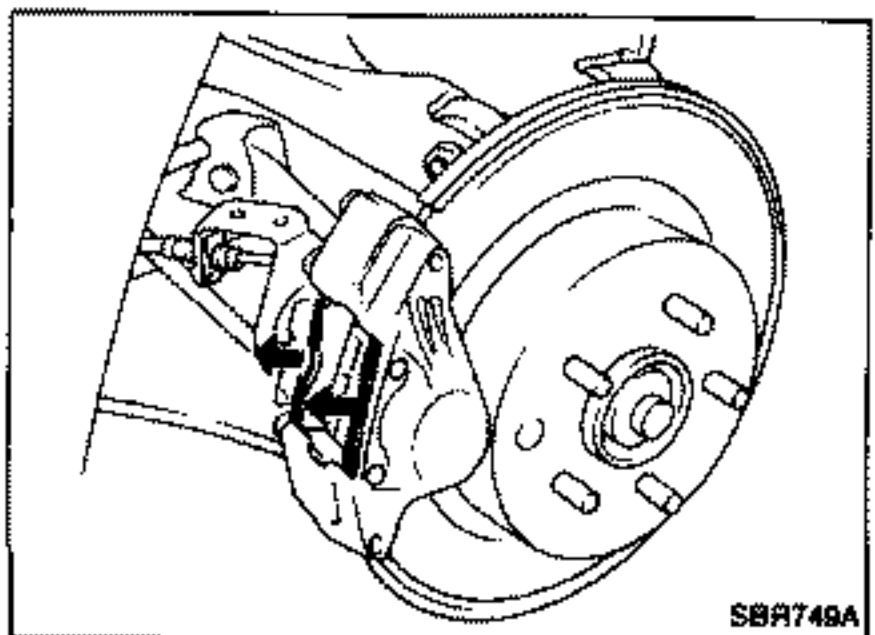

3. Pull out inner and outer pads.

CAUTION:

Be careful not to damage dust seal or get oil on rotor. Always replace shims when replacing pads.

REAR DISC BRAKE — Caliper

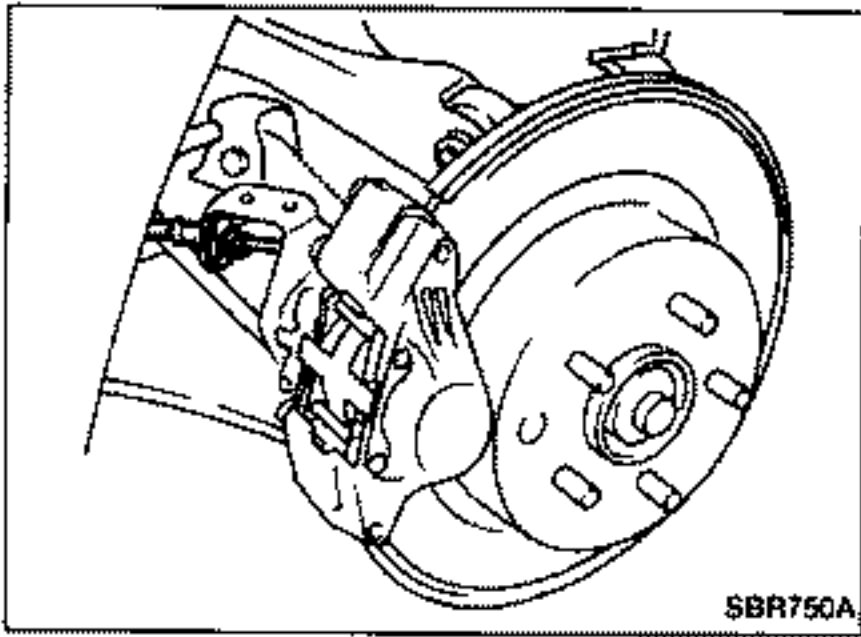

Removal and Installation

1. Disconnect brake tube.
2. Remove brake pad.

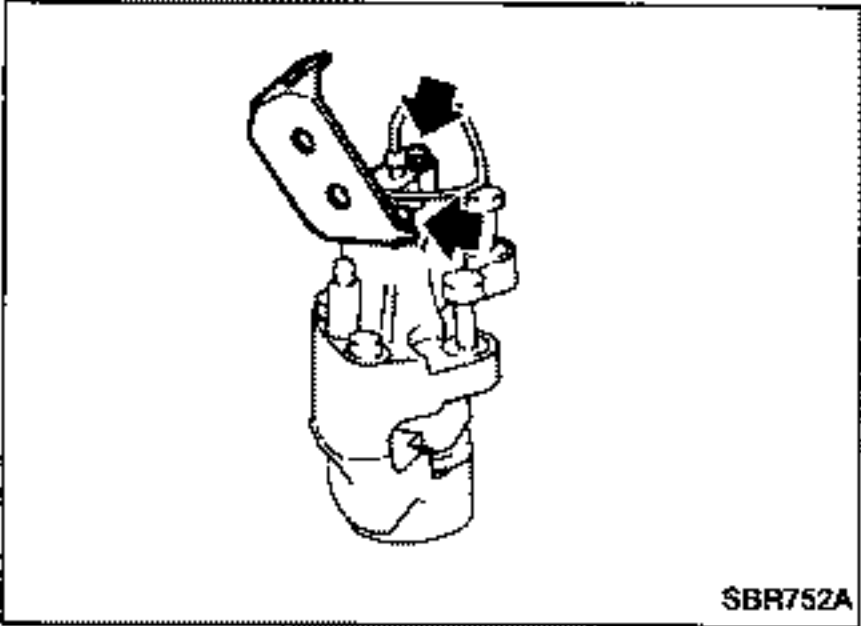

3. Remove brake cable and bracket.

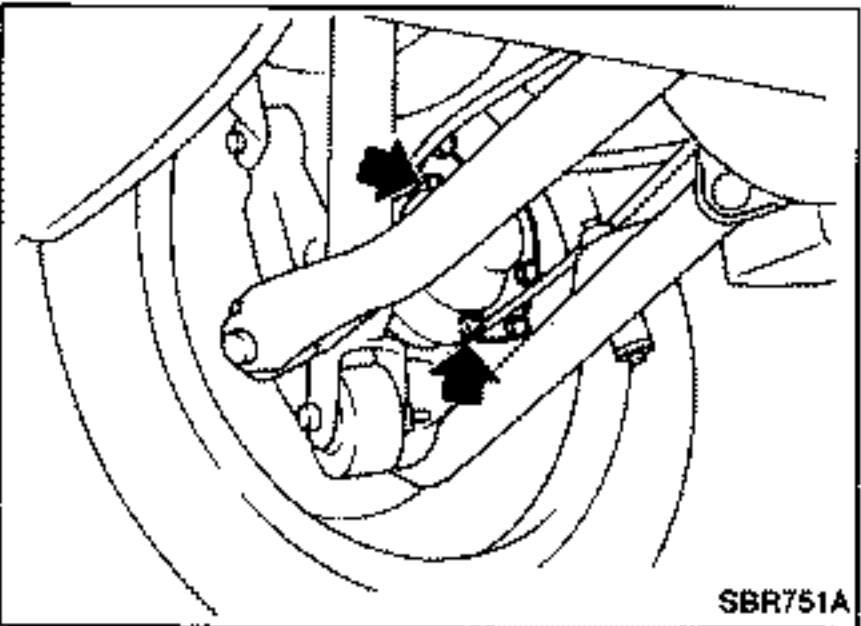

4. Remove axle housing fixing bolts.

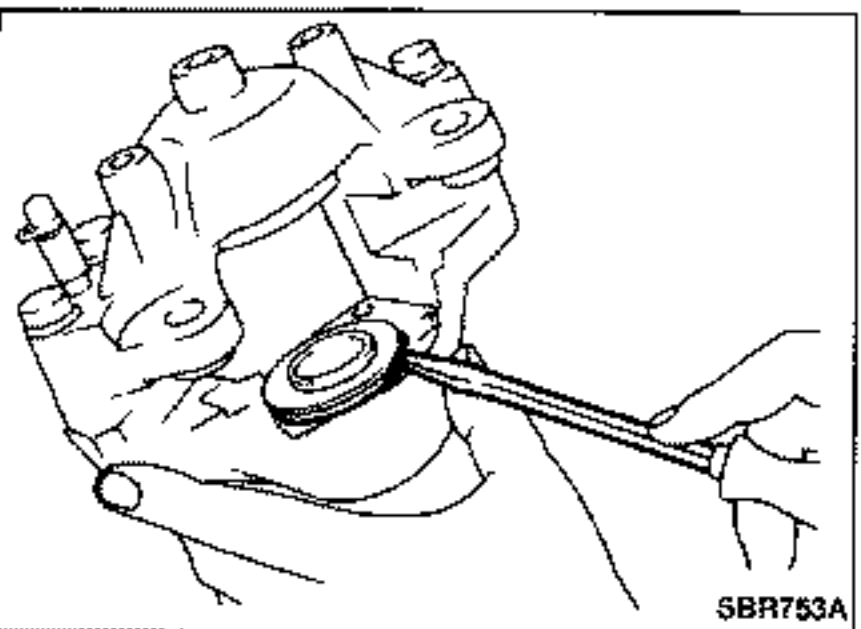

Disassembly

1. Remove retaining ring.

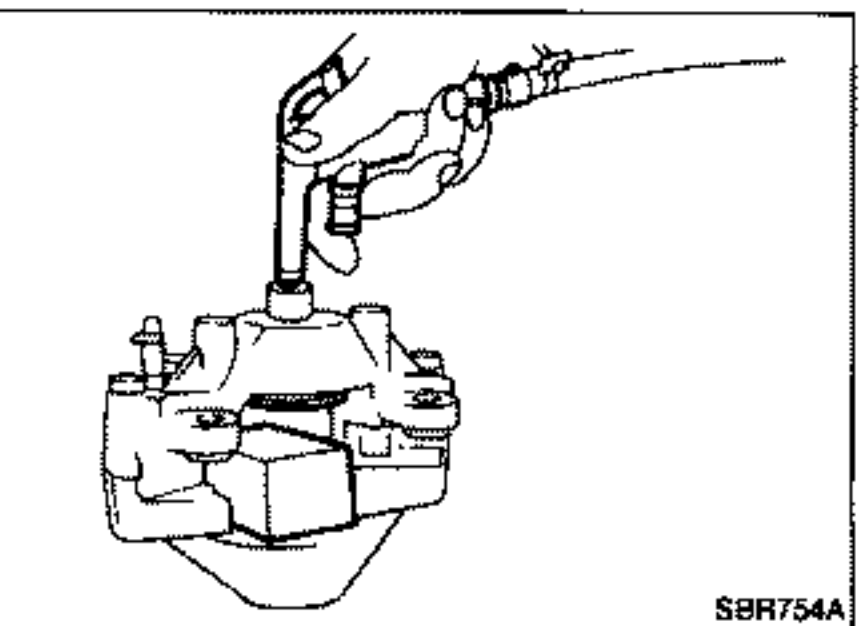

2. Push out piston with dust seal using compressed air.

REAR DISC BRAKE — Caliper

Disassembly (Cont'd)

3. Remove piston seal.

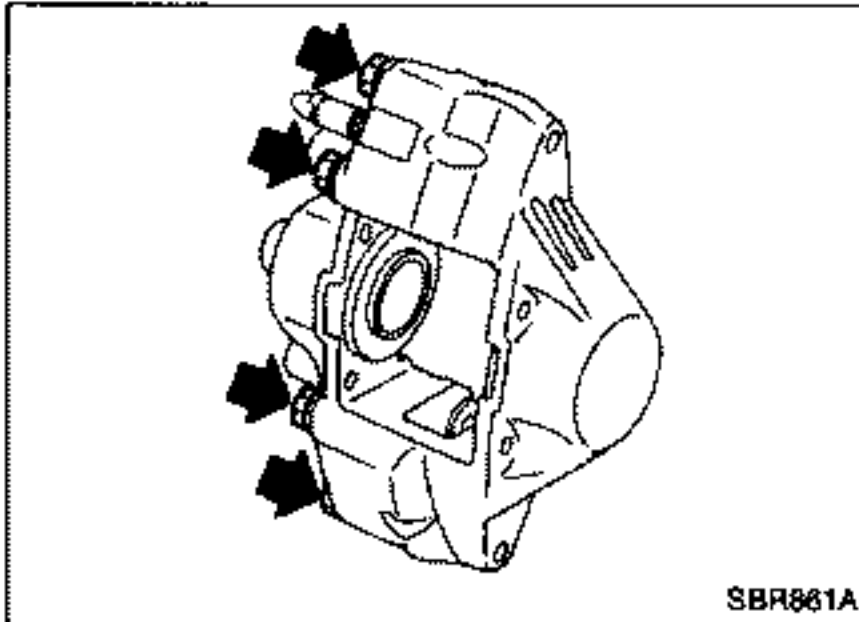
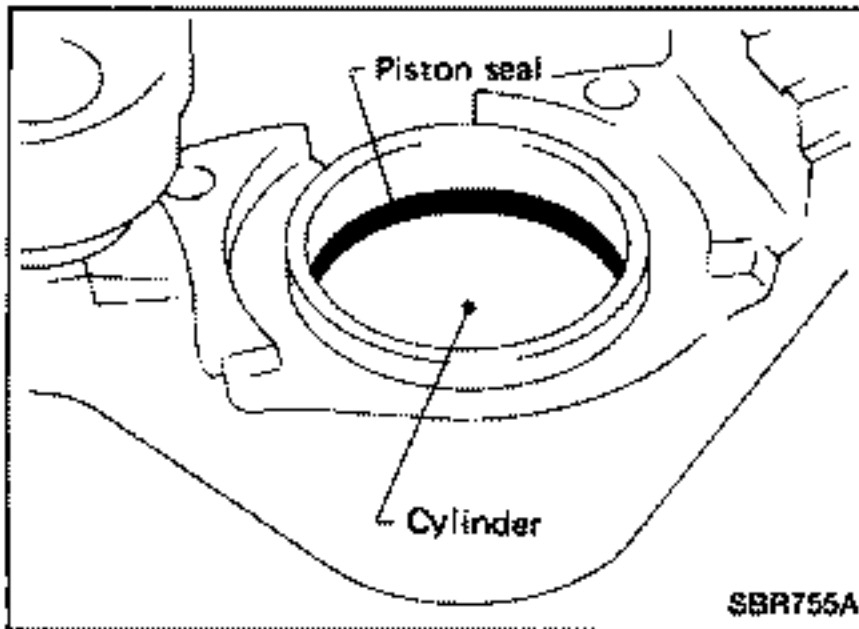

CAUTION:

Be careful not to loosen or remove bolts joining both sides of caliper.

If there is any fluid leakage, replace caliper assembly.

Inspection

CALIPER

- Check dust seals for damage.
- Check calipers for damage, rust or foreign materials.
- Check inside surface of cylinder for score, rust, wear or other damage.
- Minor damage from rust or foreign materials may be eliminated by polishing surface with a fine emery paper. Replace if necessary.

CAUTION:

Use brake fluid to clean.

PISTON

Check piston for score, rust, wear or other damage. Replace if necessary.

CAUTION:

Piston sliding surface is plated. Do not polish with emery paper even if rust or foreign matter is stuck to sliding surface.

PAD PIN AND CLIP

Check for wear, cracks deformation, deterioration, rust or other damage. Replace if necessary.

REAR DISC BRAKE — Calliper

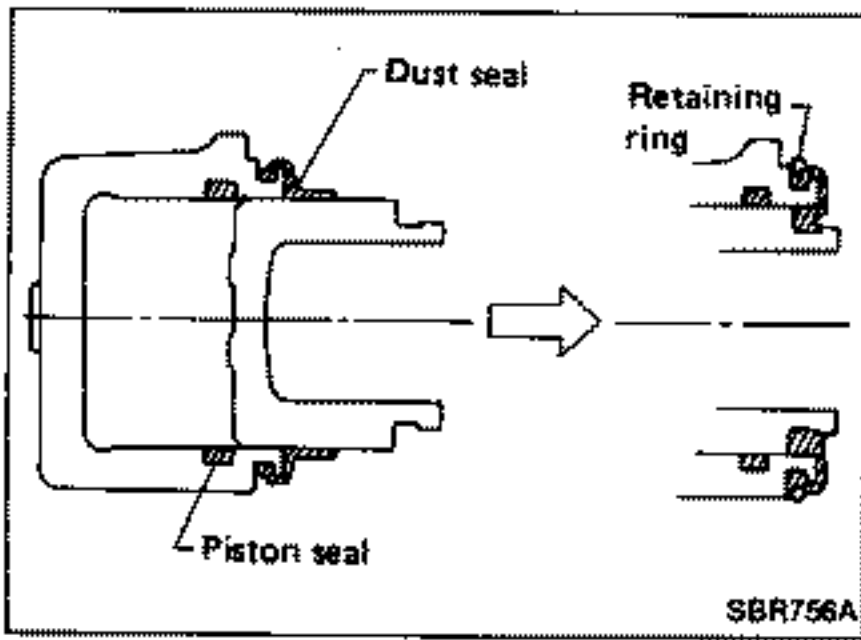

Assembly

1. Insert piston seal into groove on cylinder body.
2. With dust seal fitted to piston, install piston into cylinder body.
3. Secure dust seal properly.
4. Install retaining ring.

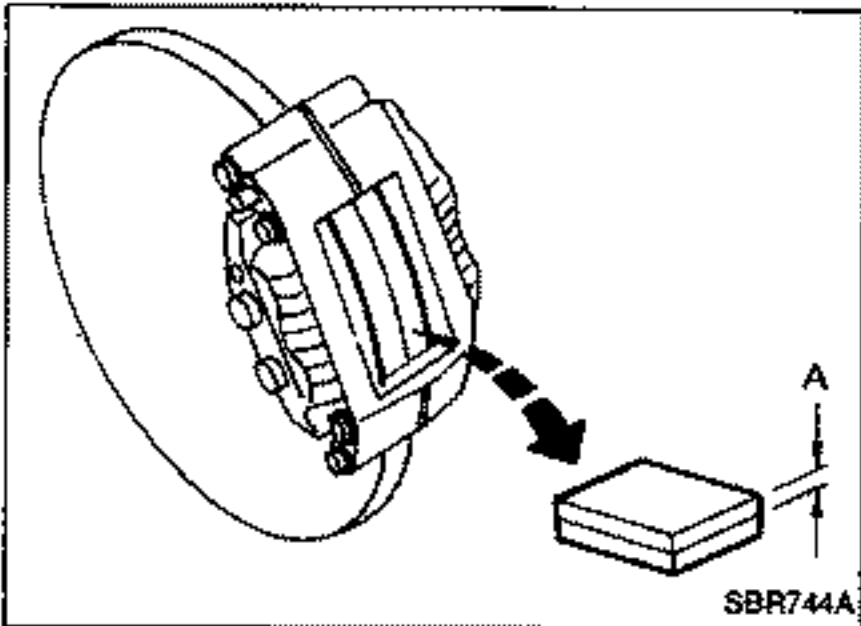

Inspection (On-vehicle)

DISC PAD

- Check pad shims for deformation or damage.
- Check disc pad for wear or damage.

Standard thickness (A):

11.5 mm (0.453 in)

Pad wear limit (A):

2.0 mm (0.079 in)

REAR DISC BRAKE — Rotor

Inspection

RUBBING SURFACE

Check rotor for roughness, cracks or chips.

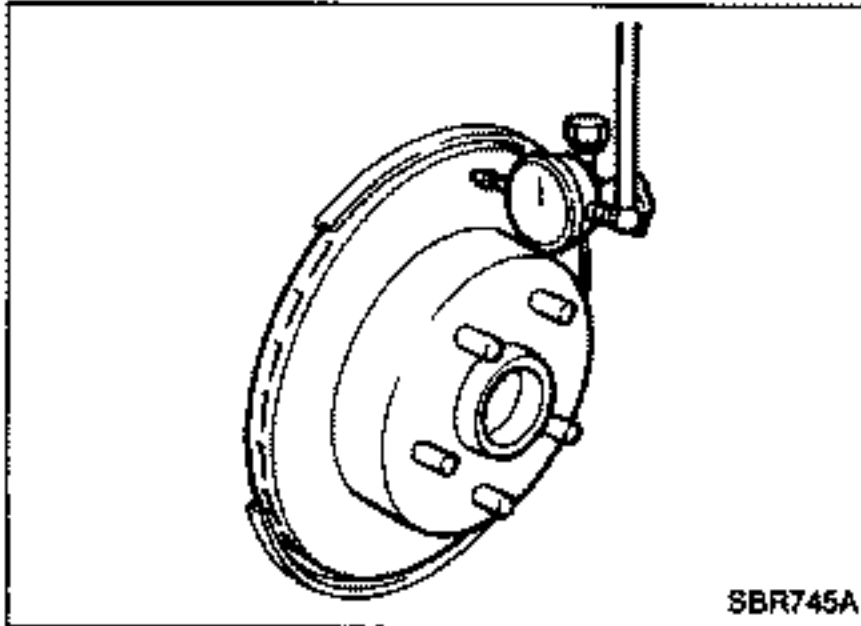

RUNOUT

- Check runout using a dial indicator.
- Make sure that axial end play is within the specifications before measuring. Refer to section RA.

Rotor repair limit:

Maximum runout

(Total indicator reading at center of rotor pad contact surface)

0.07 mm (0.0028 in)

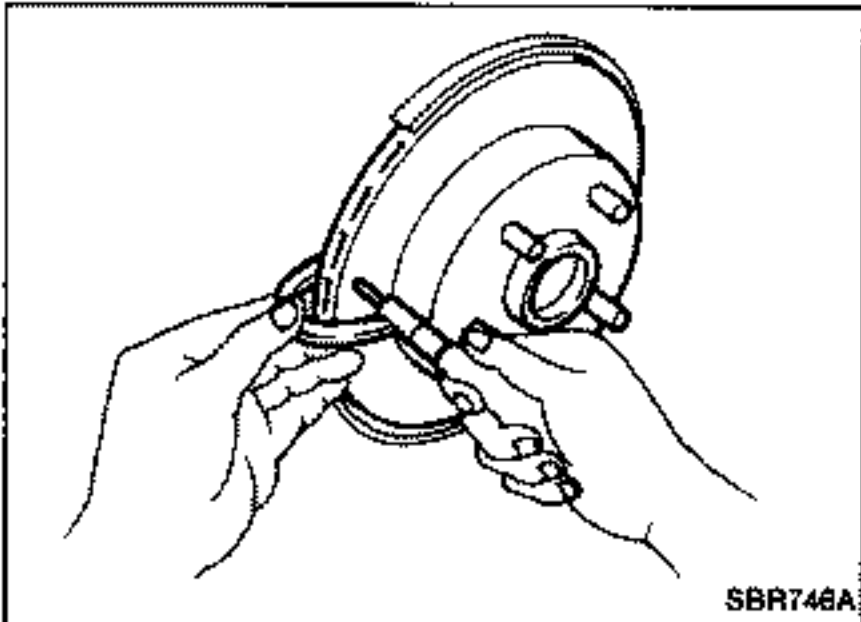

THICKNESS

Standard thickness:

18.0 mm (0.709 in)

Minimum thickness:

16.0 mm (0.630 in)

PARKING BRAKE CONTROL

Removal and Installation

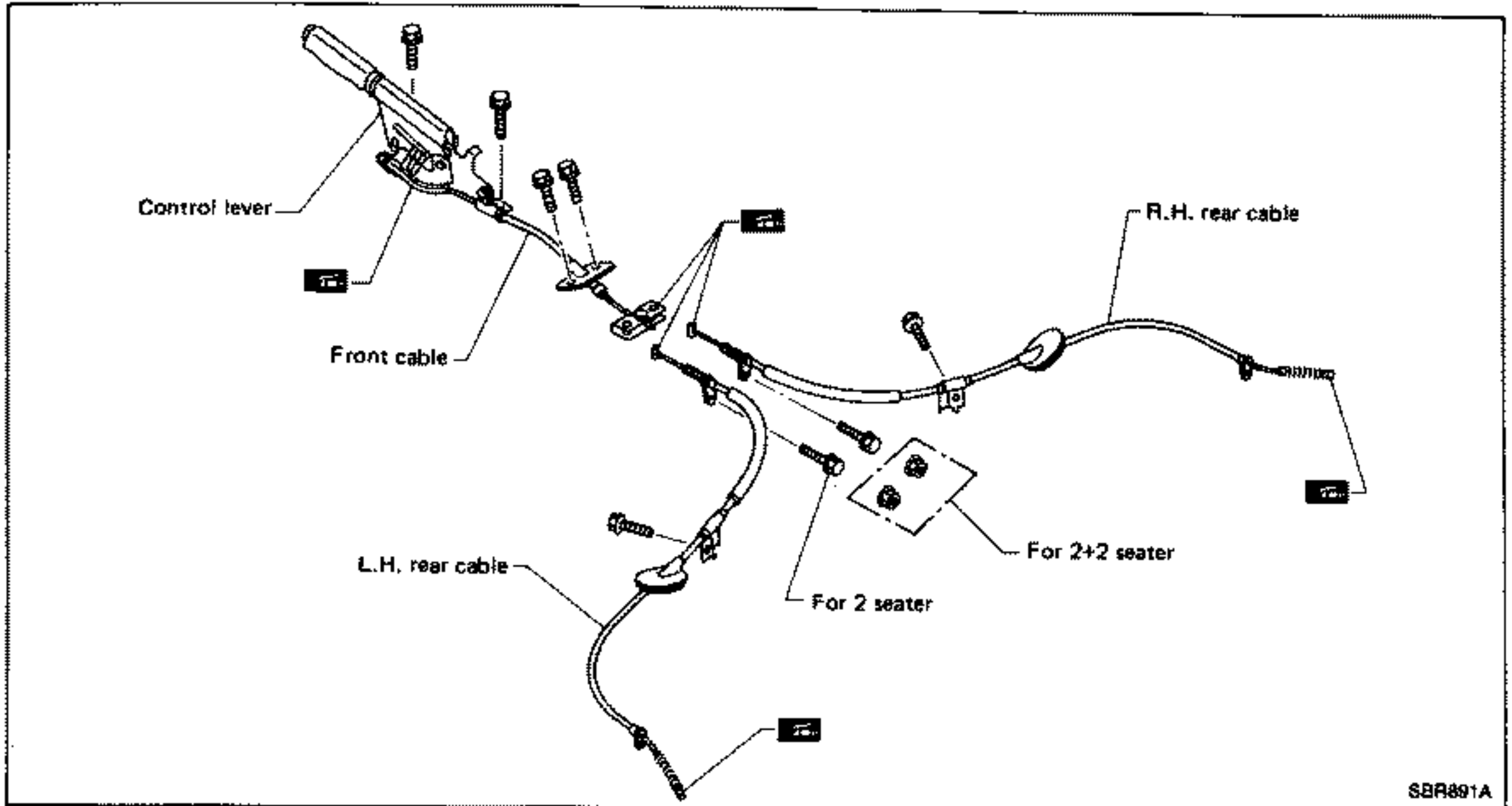

- Before removing parking brake control, remove console box.
- Loosen cable using control lever adjuster, and separate front and rear cables.

Apply multi-purpose grease to areas between control lever drum and cables.

Be careful not to damage boot and inner cable.

Inspection

1. Check control lever for wear or other damage. Replace if necessary.
2. Check parking brake cables, lamp and switch. Replace if necessary.
3. Check parts at each connecting portion for deformation or damage. If found, replace.

Adjustment

Perform shoe clearance adjustment before adjusting control lever stroke.

1. Turn adjusting nut.

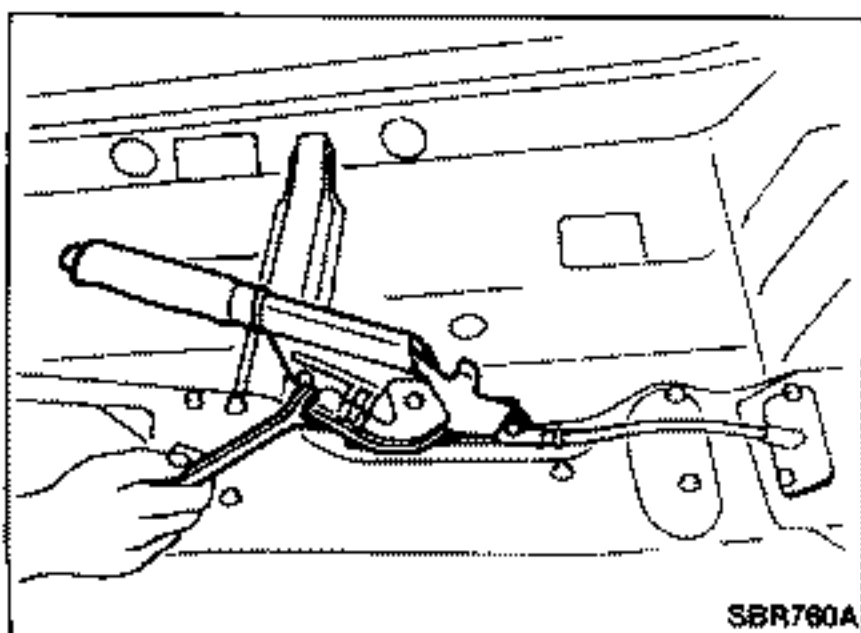

PARKING BRAKE CONTROL

Adjustment (Cont'd)

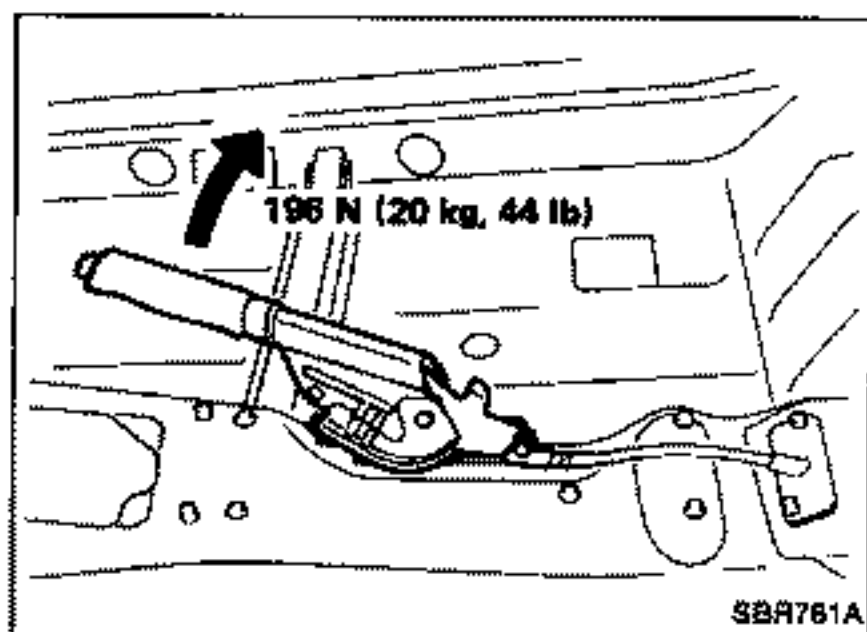

2. Pull control lever with specified amount of force. Check lever stroke and ensure smooth operation.
Number of notches: 6 - 7

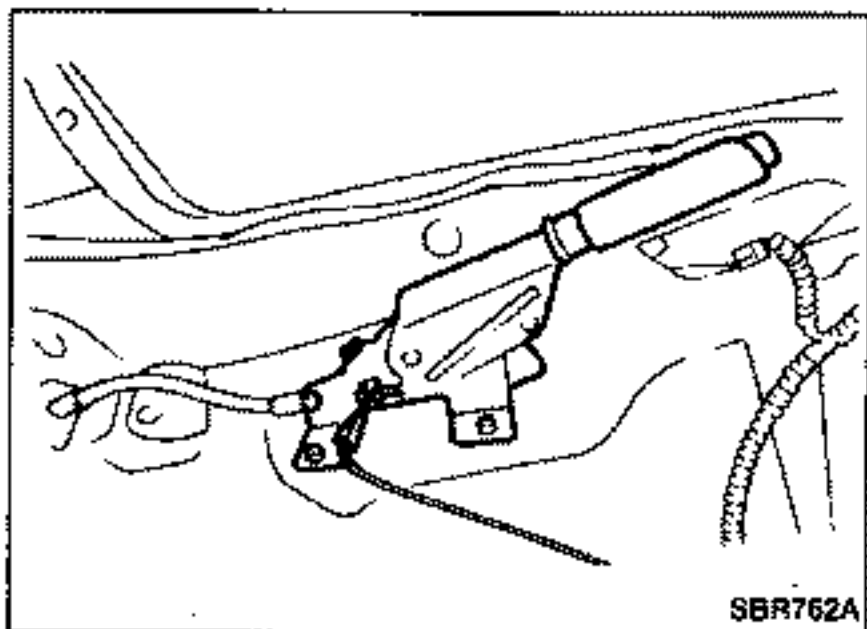

3. Bend parking brake warning lamp switch plate so that brake warning light comes on when ratchet at parking brake lever is pulled "A" notches and goes out when fully released.
Number of notches "A": 1

PARKING DRUM BRAKE

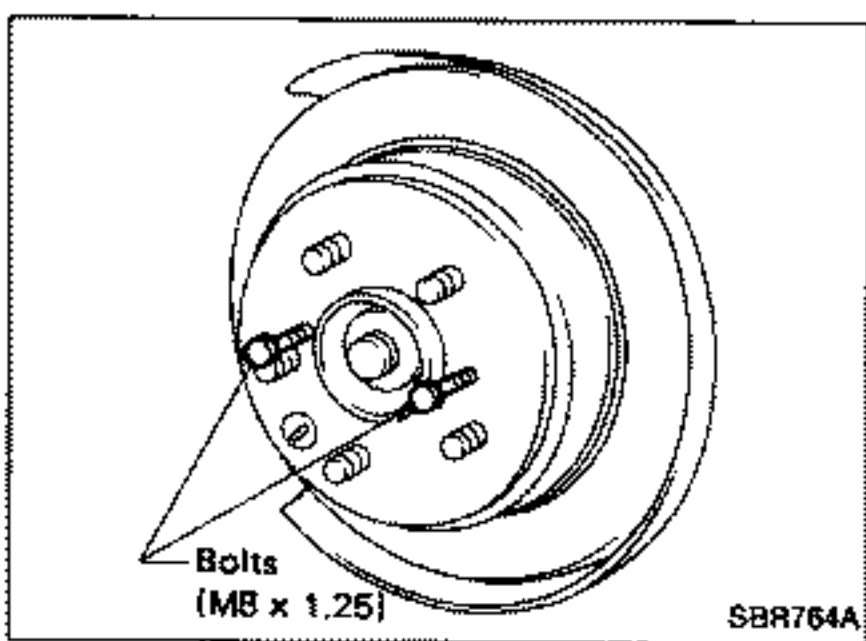
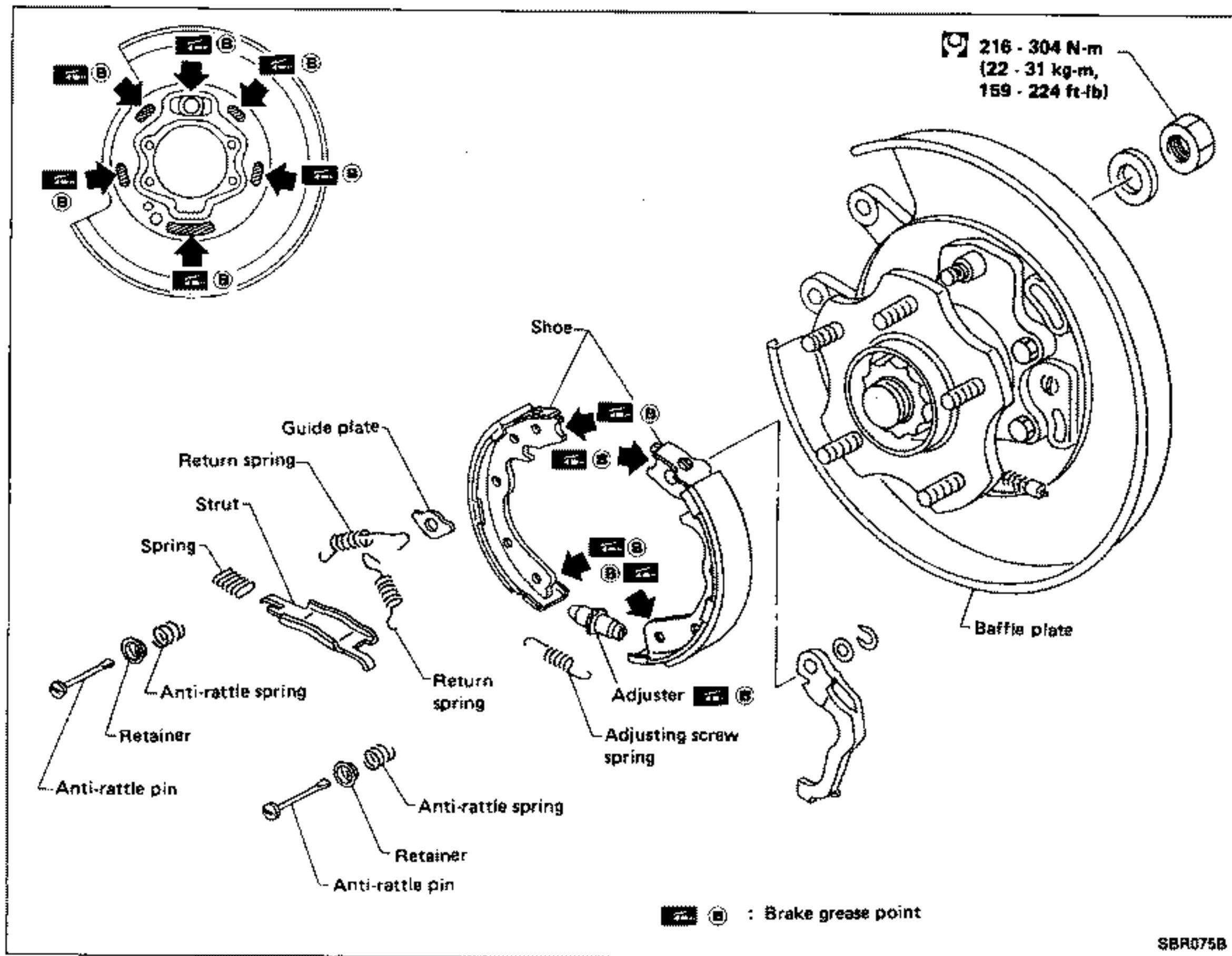

Shoe Replacement

1. Remove disc rotor (With parking drum brake).
Tighten two bolts gradually if disc rotor is hard to remove.

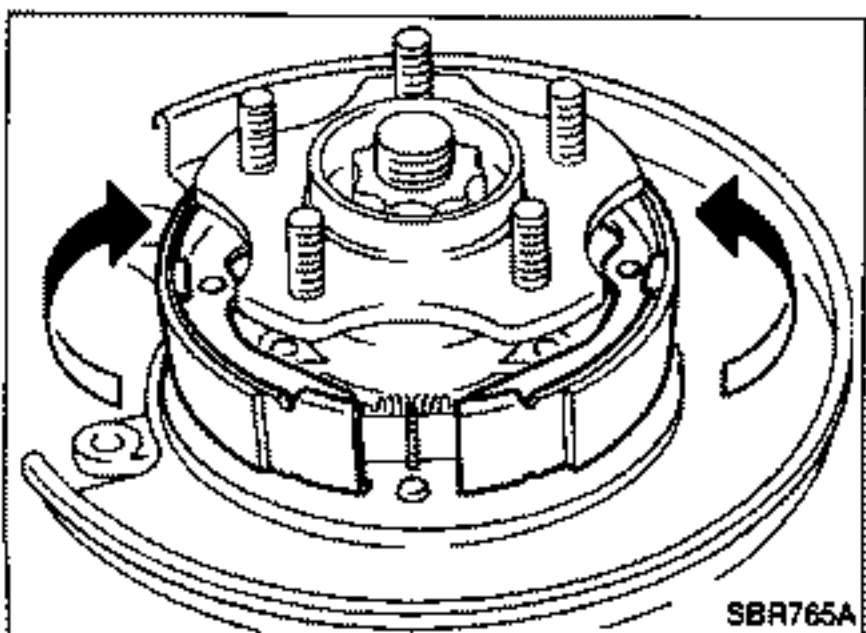

2. After removing anti-rattle pin, remove spring by rotating shoes.

Be careful not to damage parking brake cable when separating it.

PARKING DRUM BRAKE

Shoe Replacement (Cont'd)

3. Apply brake grease to the contact areas shown at left.

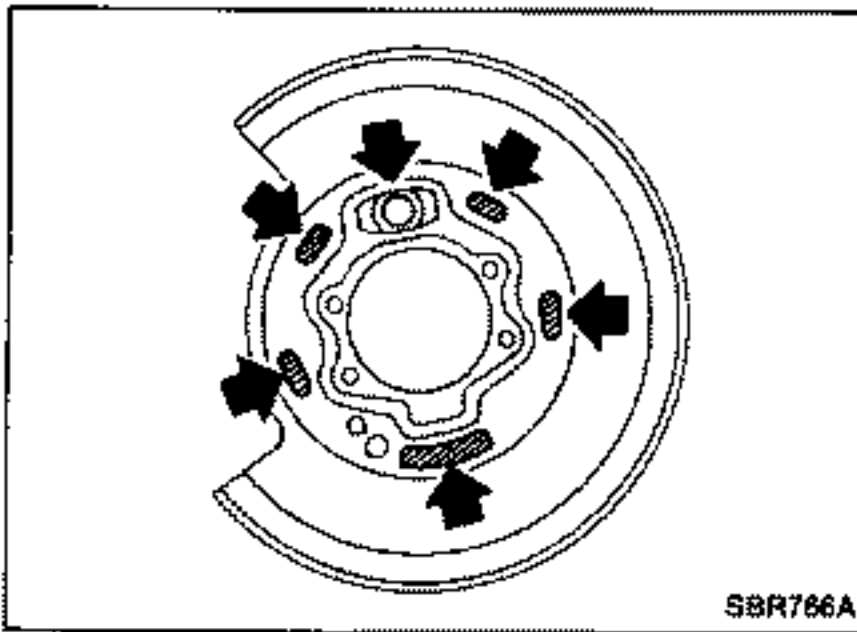

Shoe Clearance Adjustment

1. Remove adjuster hole plug, and turn adjuster wheel with a screwdriver until shoe touches brake drum.

Make sure that parking control lever is released completely.

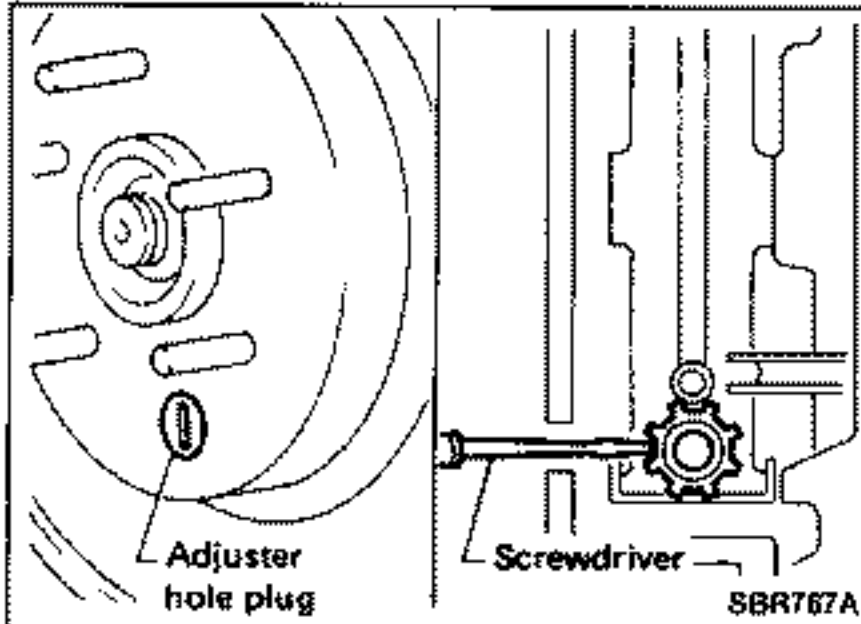

2. Return adjuster wheel 5 to 6 latches.
3. Install adjuster hole plug; and make sure that there is no drag between shoes and brake drum when rotating disc rotor.

Breaking In Drum and Lining

1. Using either low or 2nd transmission speed, drive the unloaded vehicle on a safe, level and dry road.
2. Depress the release button of parking brake lever, then pull the lever with a force of 98 N (10 kg, 22 lb).
3. While holding the lever, continue to drive the vehicle forward 100 m (328 ft) at approximately 35 km/h (22 MPH).
4. While holding the lever, drive the vehicle in reverse 10 m (33 ft) at approximately 10 km/h (6 MPH).
5. Repeat steps 1 through three times and then repeat only step 4 one more time.

Drum Inspection

Standard inner diameter:

172.0 mm (6.77 in)

Maximum inner diameter:

173.0 mm (6.81 in)

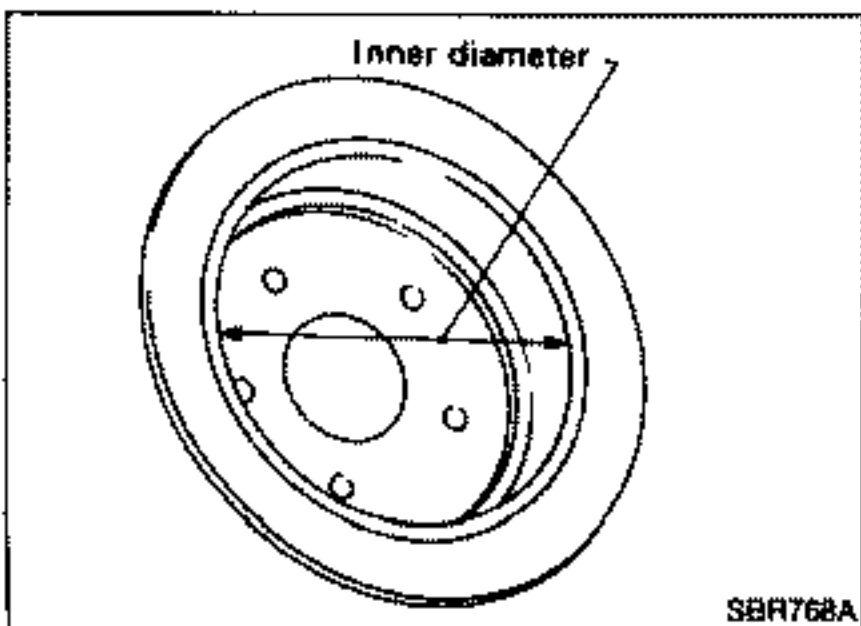

ANTI-LOCK BRAKING SYSTEM

System Components

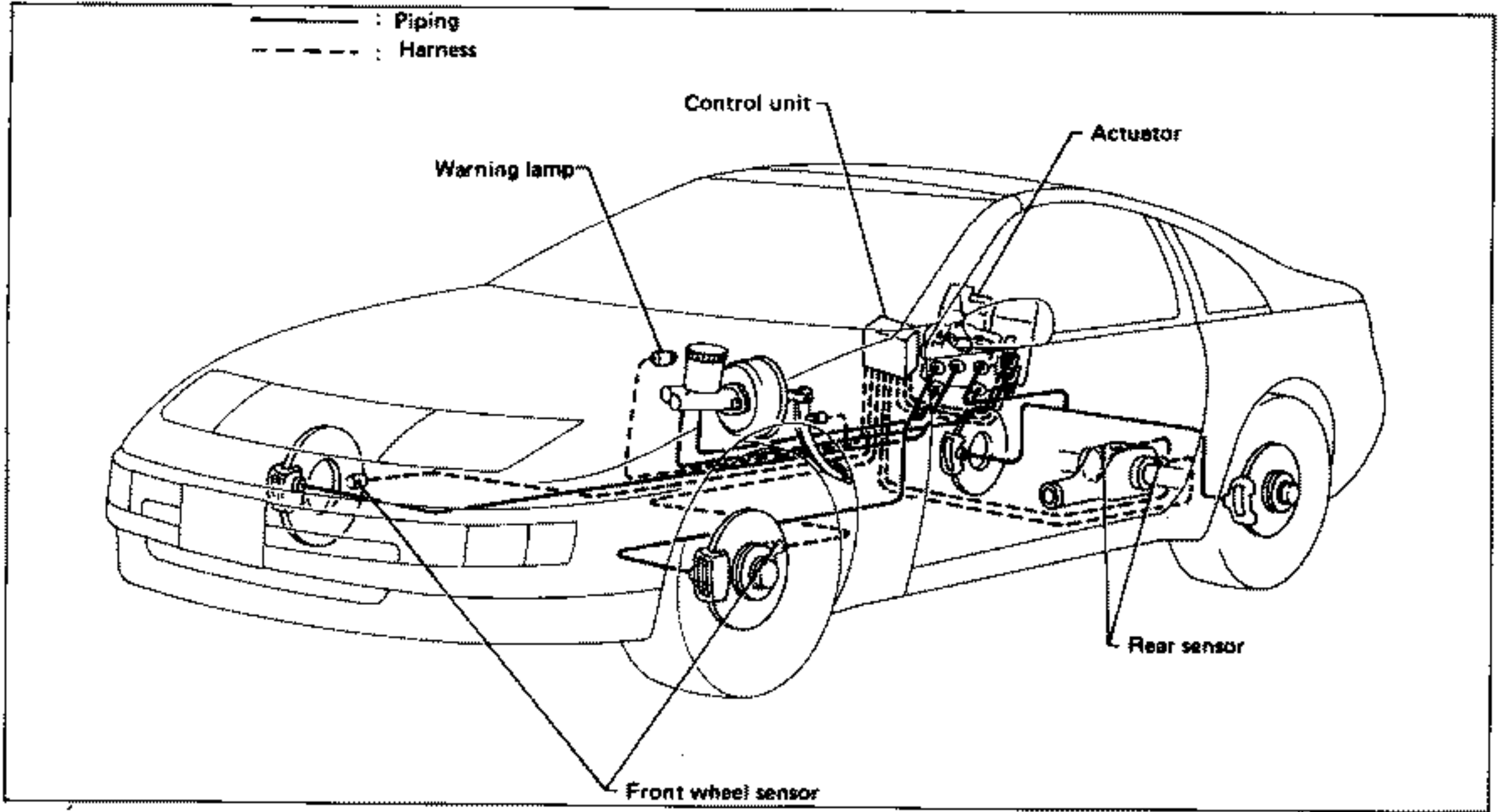

Hydraulic Circuit

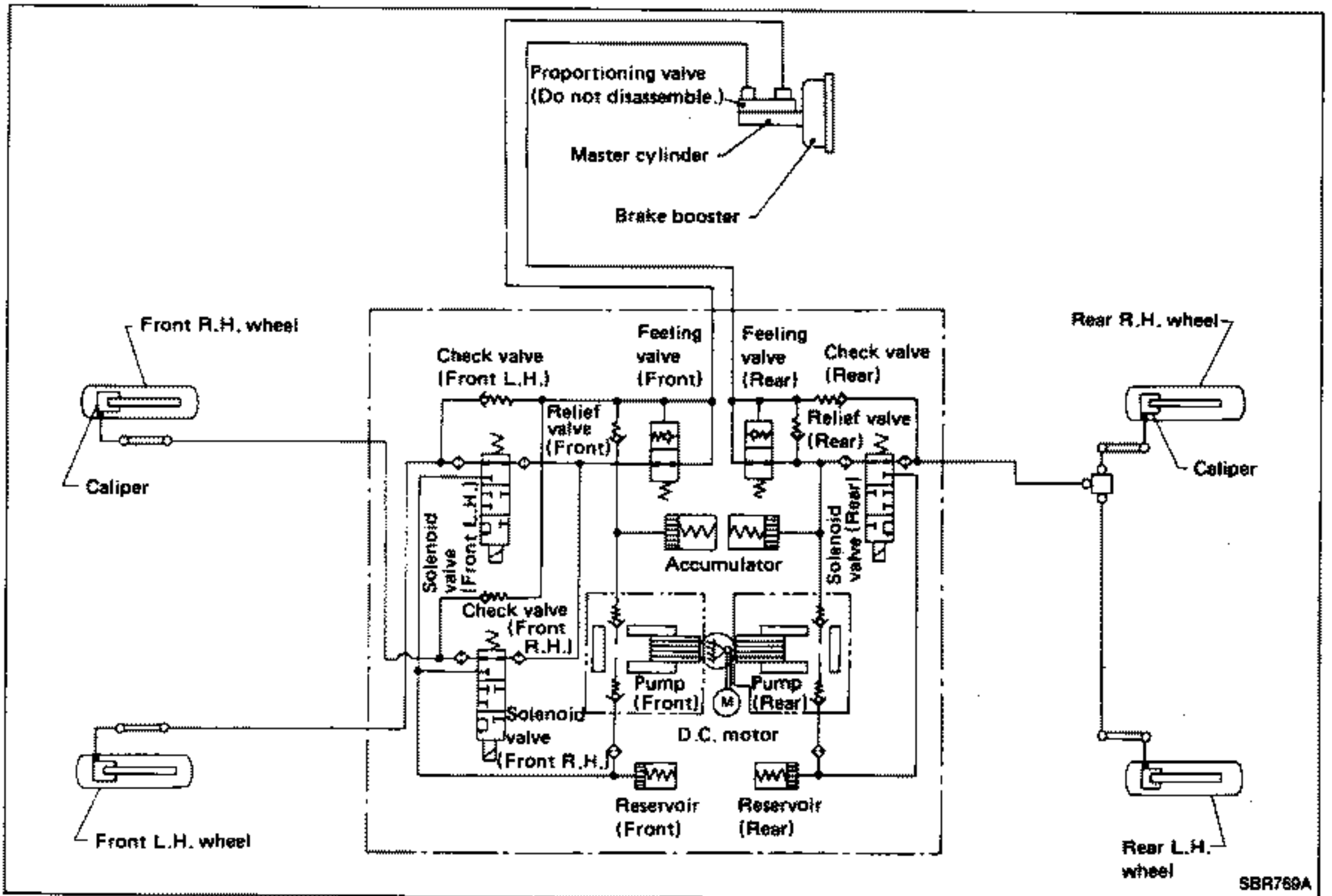

SBR769A

ANTI-LOCK BRAKING SYSTEM

Wiring Diagram

L.H.D.

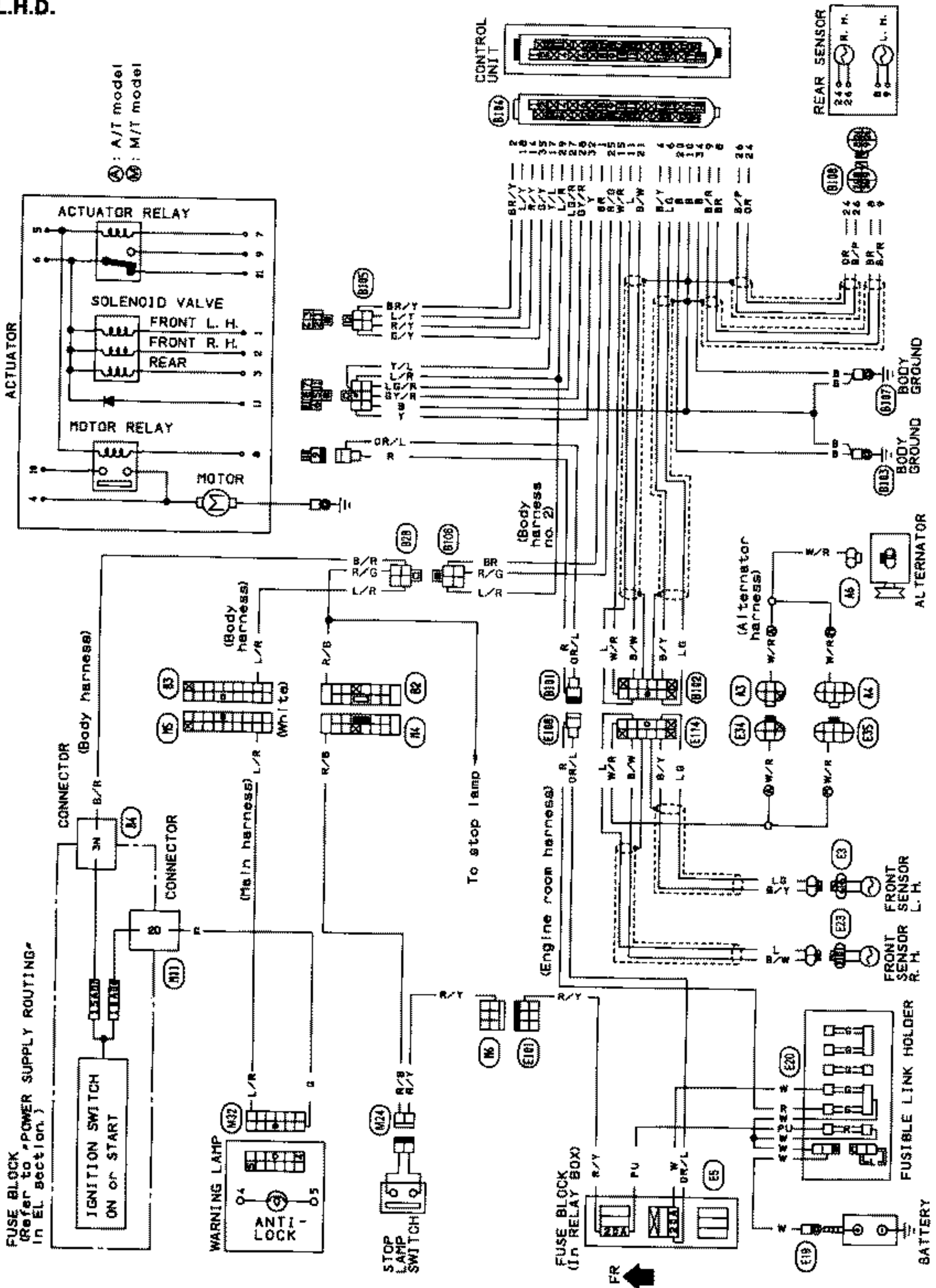

ANTI-LOCK BRAKING SYSTEM Wiring Diagram (Cont'd)

R.H.D.

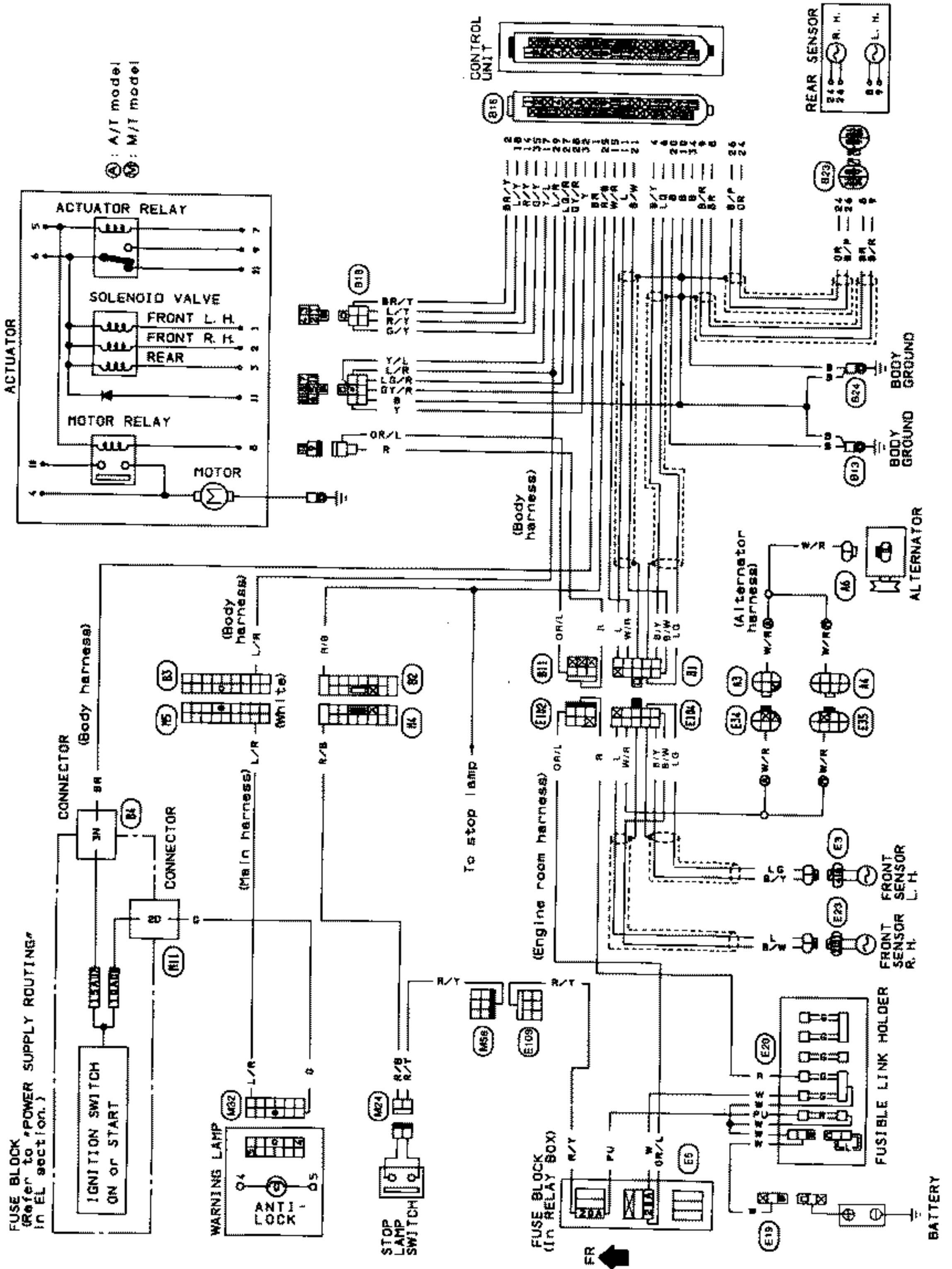

ANTI-LOCK BRAKING SYSTEM

Removal and Installation

CAUTION:

Be careful not to damage sensor edge and sensor rotor teeth.

FRONT WHEEL SENSOR

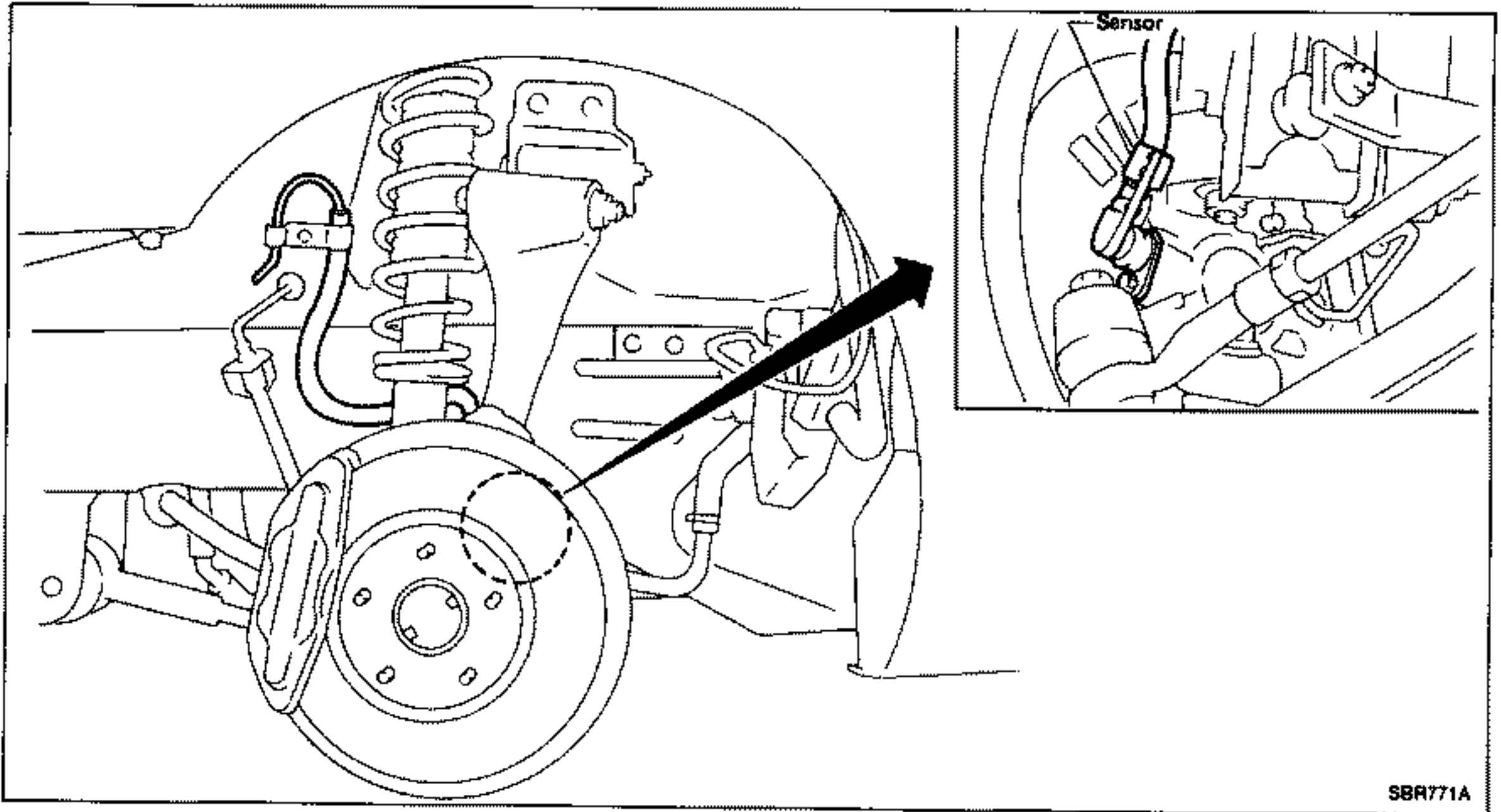

SBR771A

REAR SENSOR

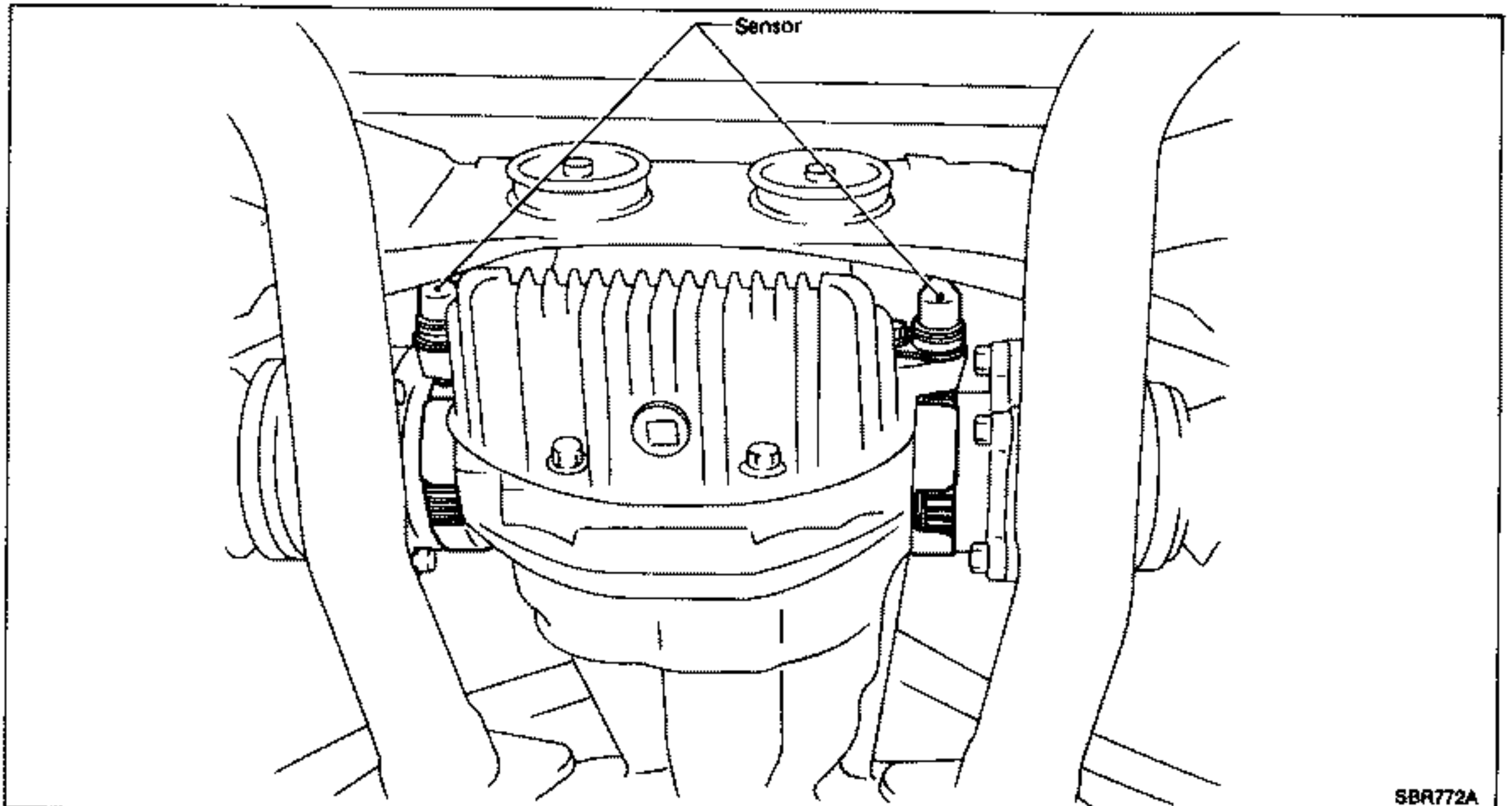

SBR772A

- Remove rear sensor rotor with differential side flange after drive shaft removal. Refer to RA section.

ANTI-LOCK BRAKING SYSTEM

Removal and Installation (Cont'd) ACTUATOR

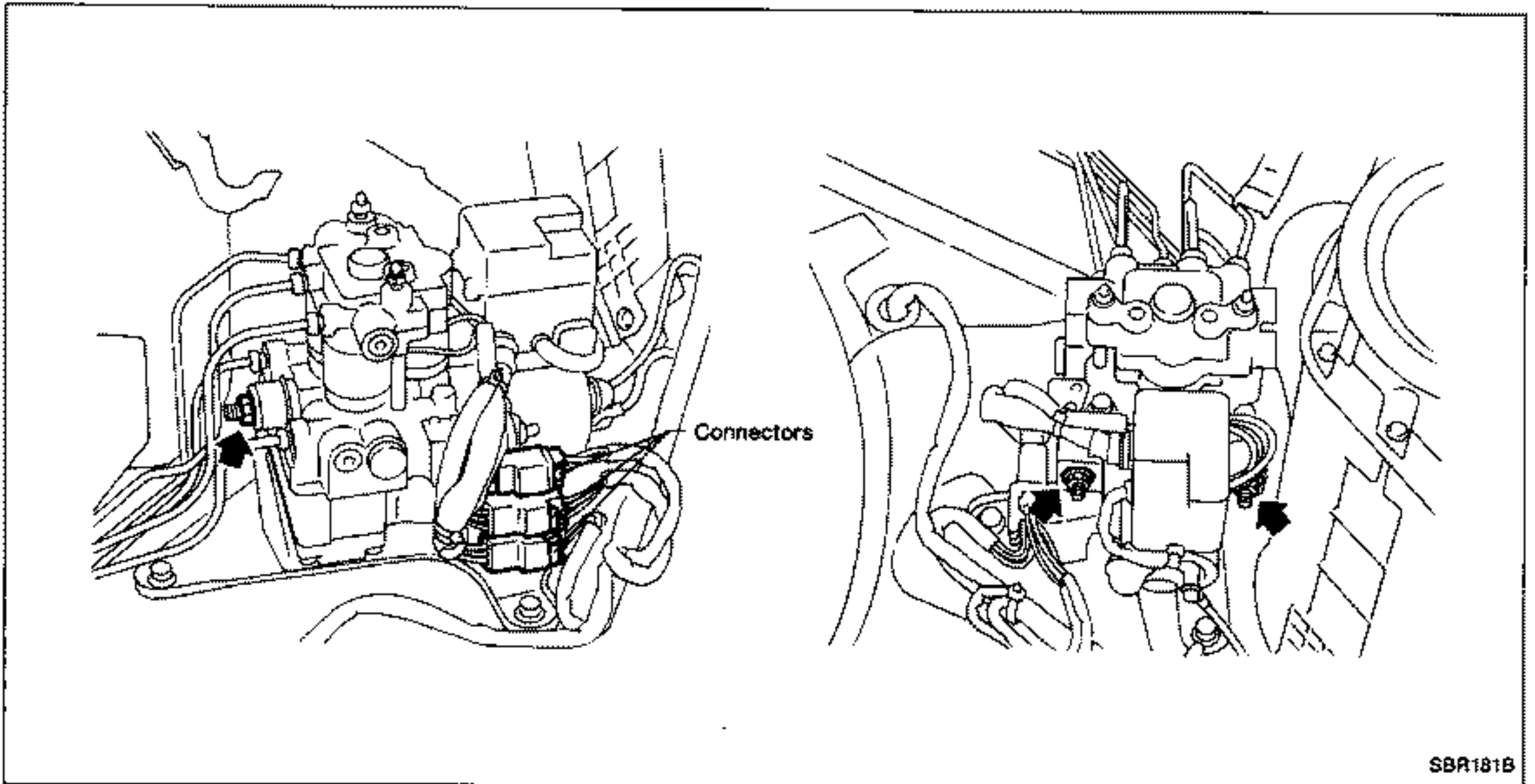

- Disconnect 3 connectors and brake tubes.
- Remove 3 nuts fixing actuator to bracket.

TROUBLE DIAGNOSES

Contents

How to Perform Trouble Diagnoses for Quick and Accurate Repair	BR-31
Symptom Chart	BR-34
Preliminary Check 1	BR-35
Preliminary Check 2	BR-36
Preliminary Check 3, 4	BR-37
Self-diagnosis	BR-38
Component Parts Location	BR-39
Harness Connector Location	BR-40
Ground Circuit Check	BR-41
Circuit Diagram for Quick Pinpoint Check	BR-42
Diagnostic Procedure 1	BR-43
Diagnostic Procedure 2	BR-45
Diagnostic Procedure 3	BR-45
Diagnostic Procedure 4	BR-46
Diagnostic Procedure 5	BR-46
Diagnostic Procedure 6	BR-47
Diagnostic Procedure 7	BR-48
Diagnostic Procedure 8	BR-49
Diagnostic Procedure 9	BR-50
Diagnostic Procedure 10	BR-51
Diagnostic Procedure 11	BR-52
Electrical Components Inspection	BR-53

TROUBLE DIAGNOSES

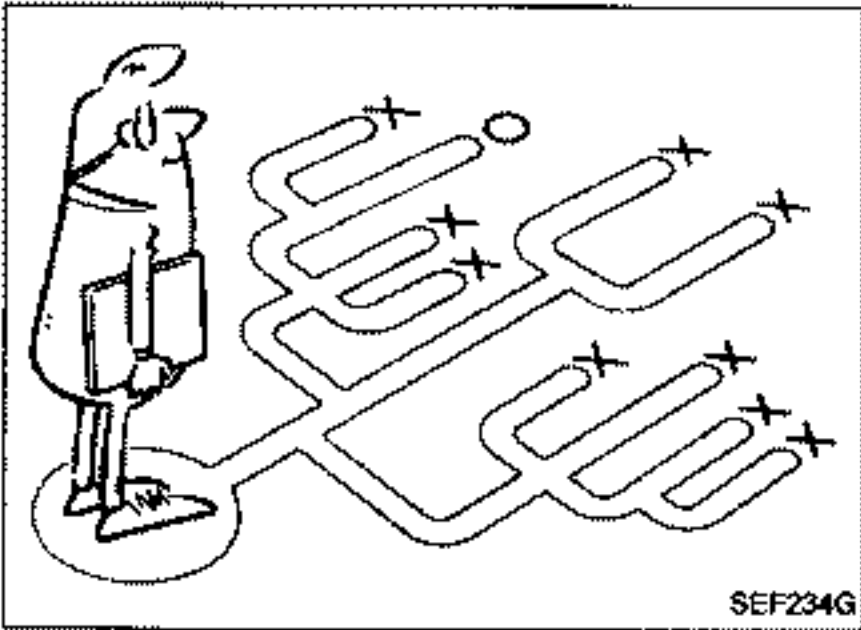
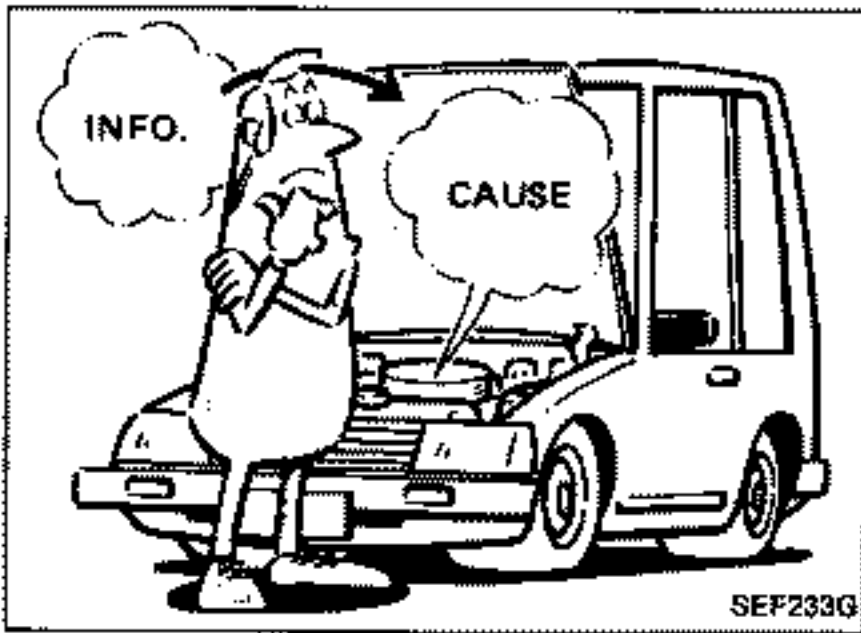

How to Perform Trouble Diagnoses for Quick and Accurate Repair

INTRODUCTION

The A.B.S. system has an electronic control unit to control major functions. The control unit accepts input signals from sensors and instantly drives actuators. It is essential that both kinds of signals are proper and stable. At the same time, it is important that there are no conventional problems such as air leaks in the booster or lines, lack of brake fluid, or other problems with brake system.

It is much more difficult to diagnose a problem that occurs intermittently rather than continuously. Most intermittent problems are caused by poor electric connections or faulty wiring. In this case, careful checking of suspicious circuits may help prevent the replacement of good parts.

A visual check only may not find the cause of the problems, so a road test should be performed.

Before undertaking actual checks, take just a few minutes to talk with a customer who approaches with a A.B.S. complaint. The customer is a very good source of information on such problems; especially intermittent ones. Through the talks with the customer, find out what symptoms are present and under what conditions they occur.

Start your diagnosis by looking for "conventional" problems first. This is one of the best ways to troubleshoot brake problems on an A.B.S. controlled vehicle.

TROUBLE DIAGNOSES

How to Perform Trouble Diagnoses for Quick and Accurate Repair (Cont'd)

WORK FLOW

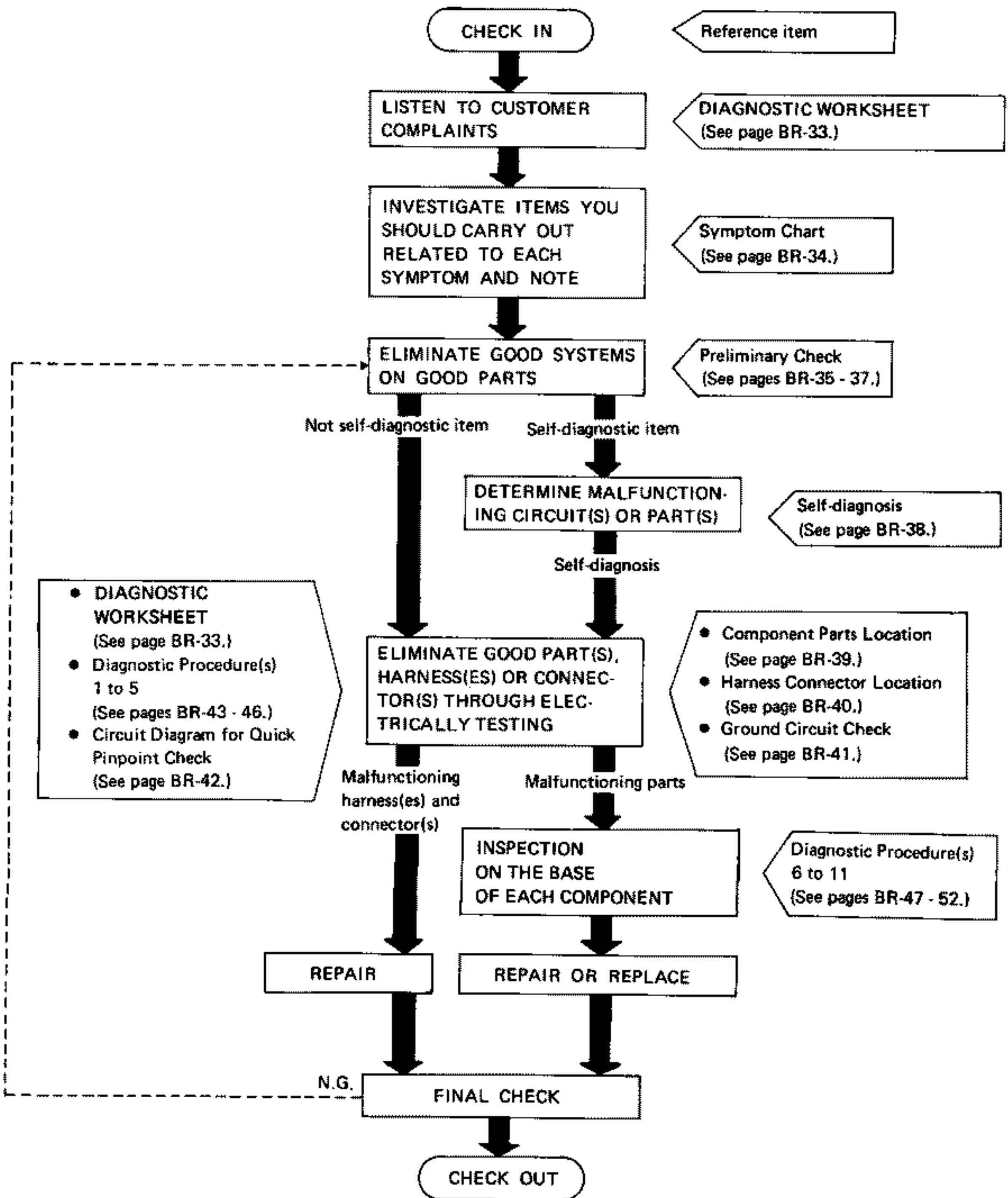

TROUBLE DIAGNOSES

How to Perform Trouble Diagnoses for Quick and Accurate Repair (Cont'd)

KEY POINTS

WHAT Vehicle model
WHEN Date, Frequencies
WHERE Road conditions
HOW Operating conditions,
 Weather conditions,
 Symptoms

DIAGNOSTIC WORKSHEET

There are many kinds of operating conditions that lead to customer complaints, even if the system is normal.

A good grasp of such conditions can make trouble-shooting faster and more accurate.

In general, feelings for a problem depend on each customer's information. It is therefore important to fully understand the symptoms or under what conditions a customer complains.

Make good use of a diagnostic worksheet such as the one shown below in order to utilize all the complaints for trouble-shooting.

Worksheet sample

Customer name MR/MS		Model & Year			VIN		
Engine #		Trans.			Mileage		
Incident Date		Manuf. Date			In Service Date		
Symptoms	<input type="checkbox"/> Pedal vibration and noise	<input type="checkbox"/> Warning activates	<input type="checkbox"/> Long stopping distance	<input type="checkbox"/> Abnormal pedal action	<input type="checkbox"/> A.B.S. doesn't work	<input type="checkbox"/> A.B.S. works but warning activates	<input type="checkbox"/> A.B.S. works frequently
Engine conditions		<input type="checkbox"/> When starting <input type="checkbox"/> After starting <input type="checkbox"/> Engine speed: 5,000 rpm or more					
Road conditions		<input type="checkbox"/> Low friction road (<input type="checkbox"/> Snow <input type="checkbox"/> Gravel <input type="checkbox"/> Other) <input type="checkbox"/> Protrusion					
Driving conditions		<input type="checkbox"/> High speed cornering <input type="checkbox"/> Vehicle speed: Greater than 10 km/h (6 MPH) <input type="checkbox"/> Vehicle speed: 10 km/h (6 MPH) or less <input type="checkbox"/> Vehicle is stopped					
Applying brake conditions		<input type="checkbox"/> Suddenly <input type="checkbox"/> Gradually					
Other conditions		<input type="checkbox"/> Operation of electrical equipment <input type="checkbox"/> Large pedal stroke <input type="checkbox"/> Operation of clutch					

TROUBLE DIAGNOSES

Symptom Chart

PROCEDURE	REFERENCE PAGE							
		SYMPTOM	Pedal vibration & noise	Warning activates	Long stopping distance	Abnormal pedal action	A.B.S. doesn't work	A.B.S. works but warning activates
Preliminary Check	BR-35	Preliminary Check 1			○	○		
	BR-36	Preliminary Check 2		○			○	
	BR-37	Preliminary Check 3	○	○				
	BR-37	Preliminary Check 4	○	○	○	○	○	○
Diagnostic Procedure	BR-43	Diagnostic Procedure 1	○					
	BR-45	Diagnostic Procedure 2			○			
	BR-45	Diagnostic Procedure 3				○		
	BR-46	Diagnostic Procedure 4					○	
	BR-46	Diagnostic Procedure 5						○
Diagnostic Procedure (Select inspection with L.E.D. flashing No.)	BR-47	Diagnostic Procedure 6	○	○	○	○	○	○
	BR-48	Diagnostic Procedure 7	○	○	○	○	○	○
	BR-49	Diagnostic Procedure 8	○	○	○	○	○	○
	BR-50	Diagnostic Procedure 9	○	○	○	○	○	○
	BR-51	Diagnostic Procedure 10	○	○	○	○	○	○
	BR-52	Diagnostic Procedure 11	○	○	○	○	○	○
Ground Circuit Check	BR-41	Motor ground					○	
	BR-41	Control unit ground					○	
Electrical Components Inspection	BR-53	Actuator inspection					○	

TROUBLE DIAGNOSES

Preliminary Check 1

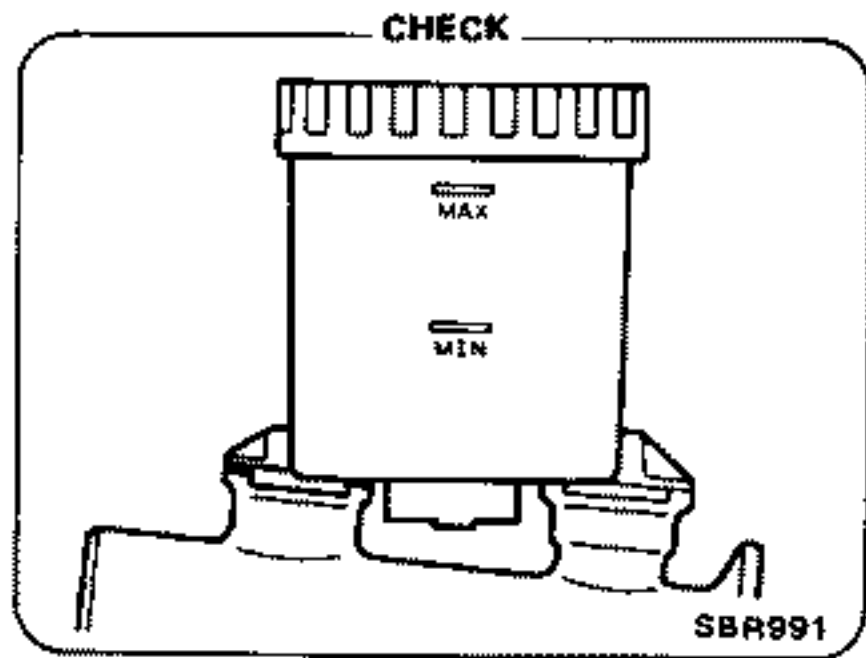

Check brake fluid level in reservoir tank.

N.G. → Fill up brake fluid.

O.K. →

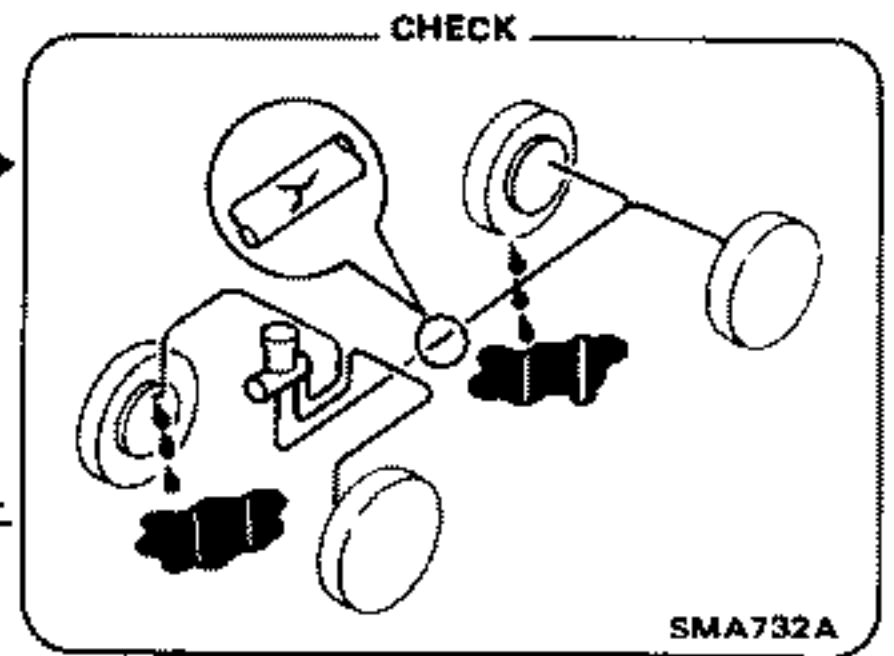

Check brake system.
Refer to CHECK AND ADJUSTMENT.

Repair brake system. ← N.G.

O.K. ↓

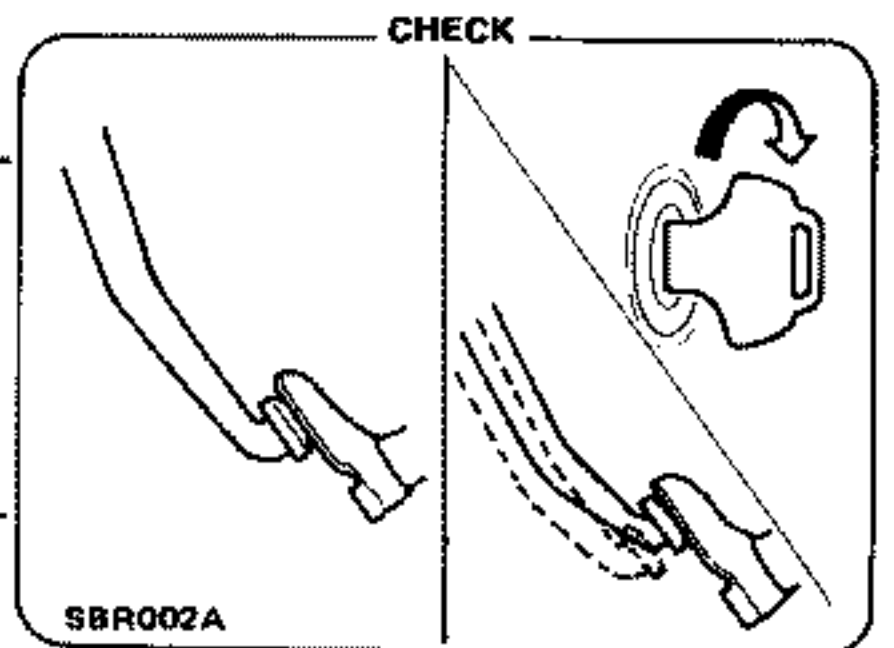

Check brake booster operation and airtightness.
Refer to "Inspection" of BRAKE BOOSTER.

Repair or replace booster system. ← N.G.

O.K. →

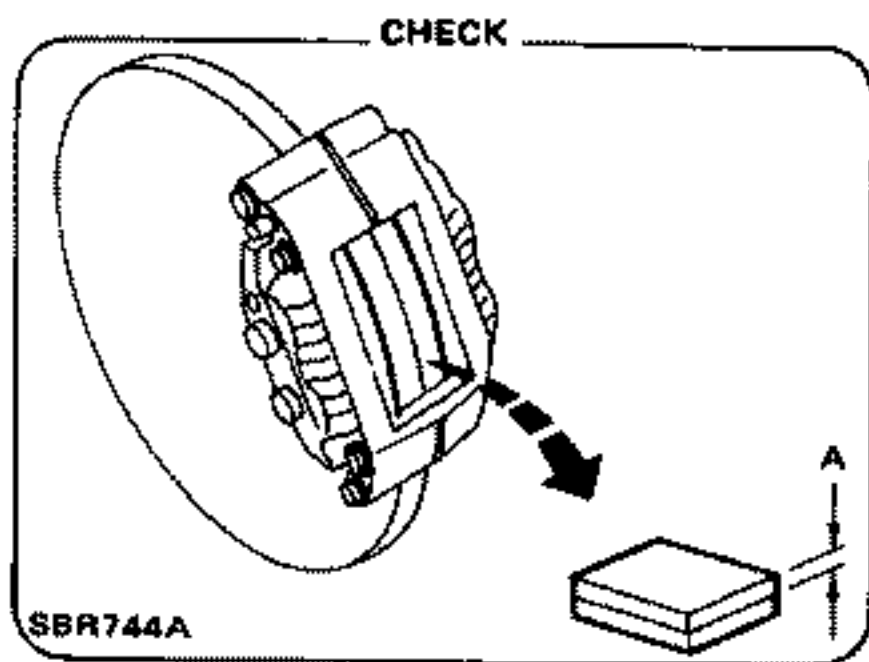

Check brake pads and rotor.
Refer to "Inspection" of FRONT and REAR DISC BRAKE.

Replace malfunctioning parts. ← N.G.

TROUBLE DIAGNOSES

Preliminary Check 2

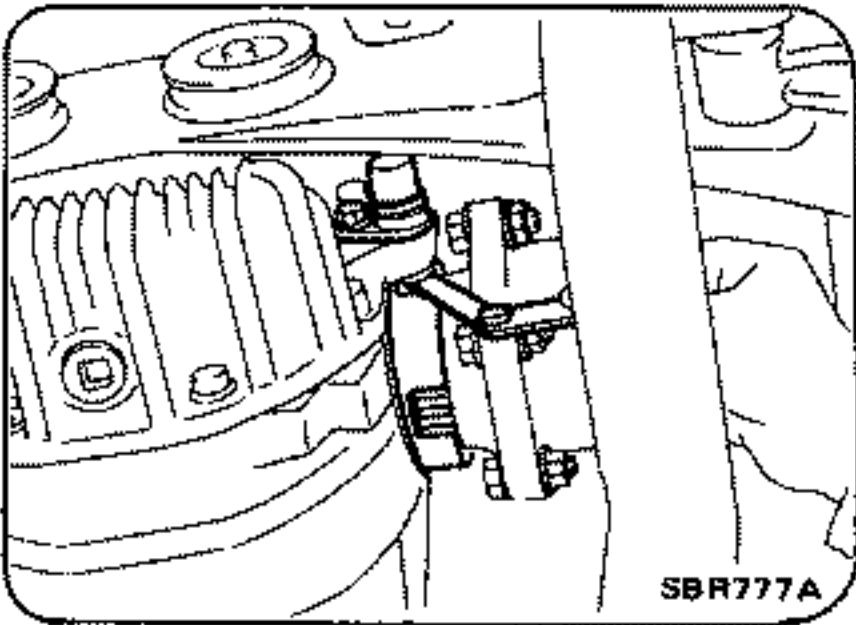
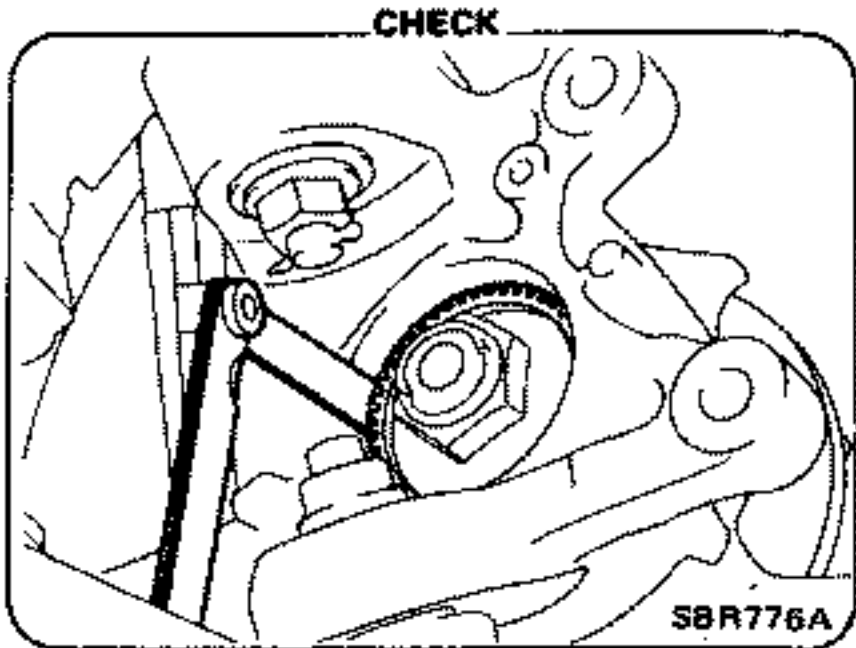

Check sensor clearance.

	Clearance mm (in)
Front wheel sensor	0.06 - 0.93 (0.0024 - 0.0366)
Rear sensor	0.18 - 1.15 (0.0071 - 0.0453)

N.G.

Check sensor for the following items:

- Dust, foreign materials, etc., at fastening portion
- Improper installation
- Breakage

O.K.

O.K.

N.G.

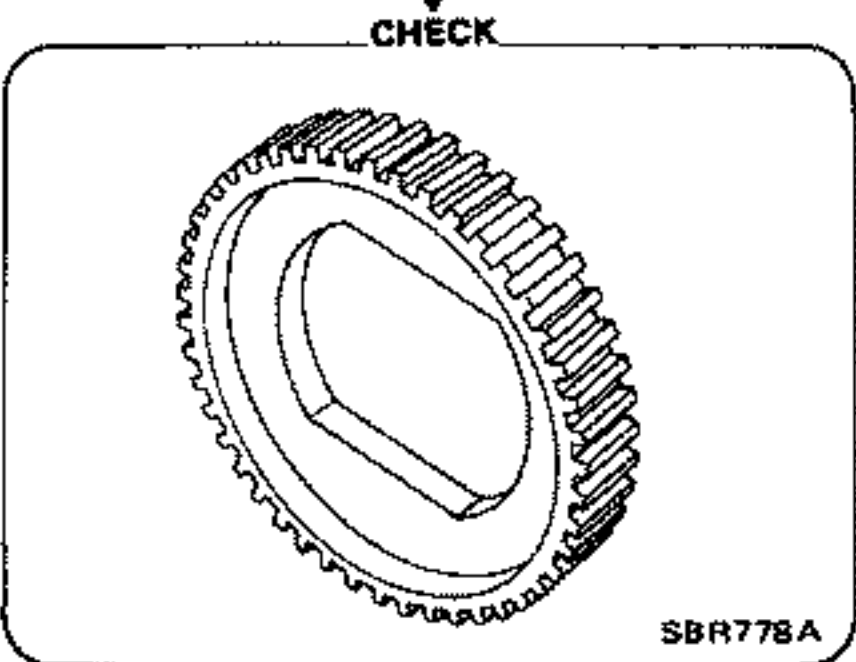

N.G.

Replace sensor rotor.

Repair or replace malfunctioning sensor.

Check sensor rotor for teeth damage.

TROUBLE DIAGNOSES

Preliminary Check 3 CHECK

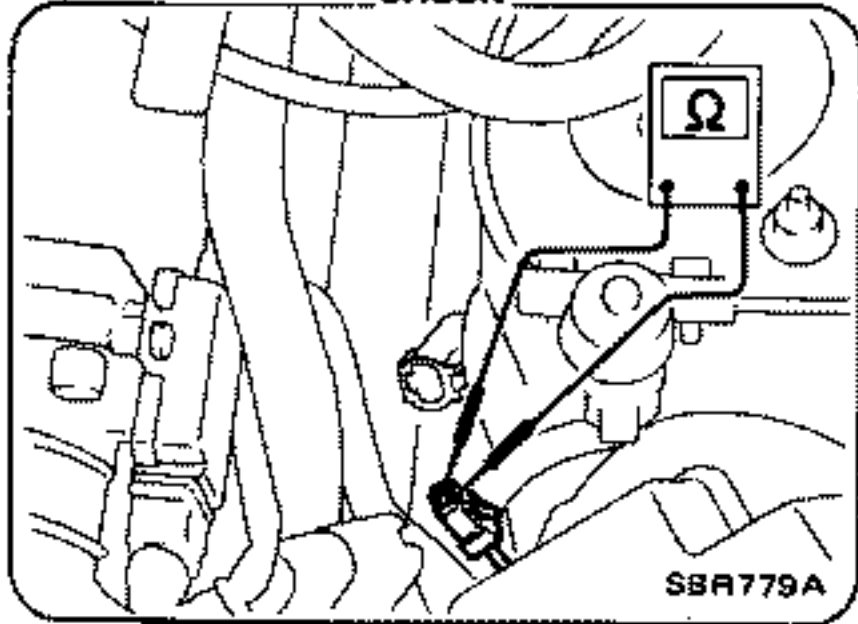

Measure each sensor resistance.
0.8 - 1.2 kΩ

N.G. → Replace.

O.K. →

Preliminary Check 3, 4

Preliminary Check 4 CHECK

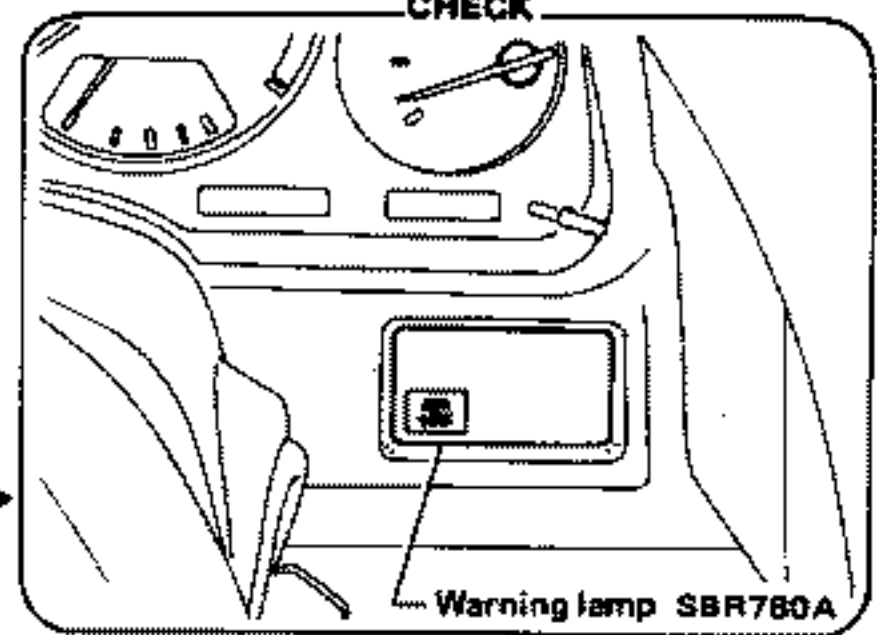

Check warning lamp activation.
When ignition switch is turned on, warning lamp turns on.

O.K. →

N.G. ↓

Check fuse.
Check bulb condition and remedy.

CHECK

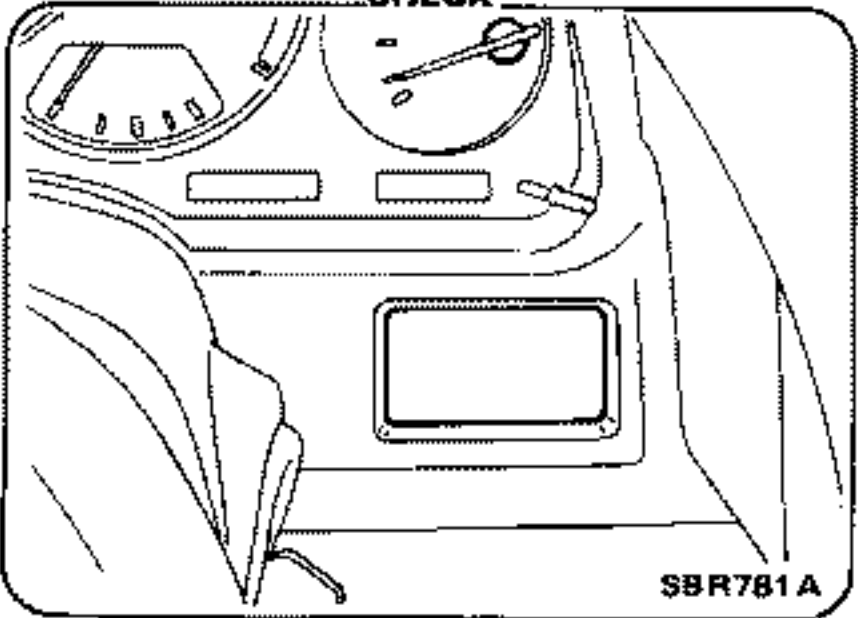

Check warning lamp for deactivation.
When engine starts, warning lamp deactivates.

O.K. ↓

DRIVE

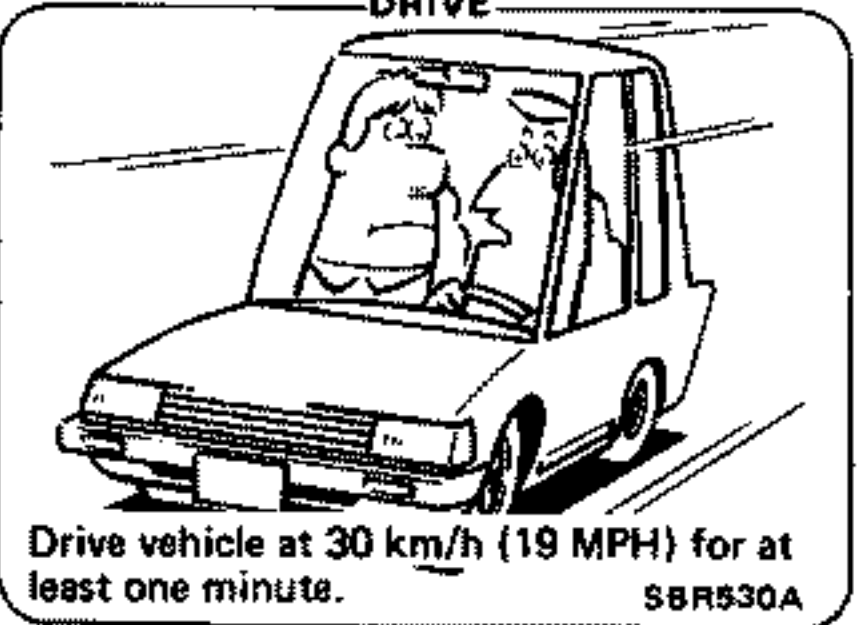

Drive vehicle at 30 km/h (19 MPH) for at least one minute.

CHECK

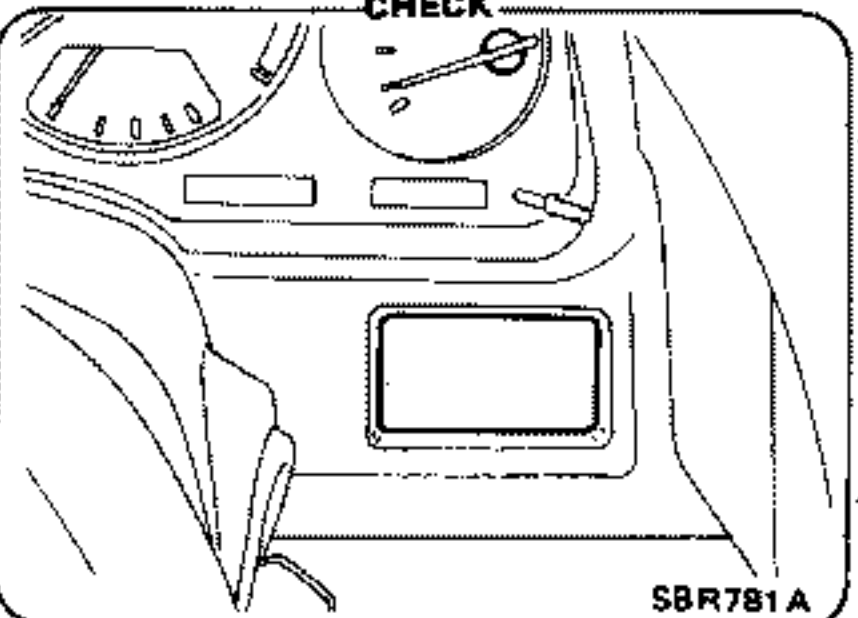

Ensure warning lamp remains off while driving.

N.G. →

O.K. →

If Preliminary Check 2 is not performed and there is abnormal A.B.S. operation, perform Preliminary Check 2.

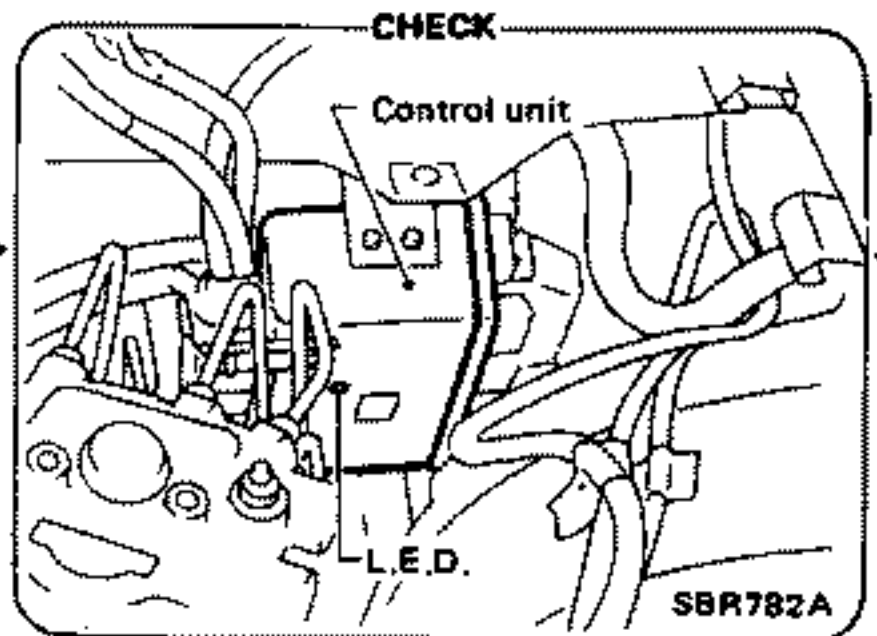

- Keep engine on and running.
- Count the number of L.E.D. flashes during 5 to 10 second "OFF" period.

Go to Self-diagnosis.
(See page BR-38.)

TROUBLE DIAGNOSES

Self-diagnosis

CHECKING THE NUMBER OF L.E.D. FLASHES

When a problem occurs in the A.B.S., the warning light on the instrument panel comes on. As shown in the Table, the control unit performs self-diagnosis.

To obtain satisfactory self-diagnosing results, the vehicle must be driven above 30 km/h (19 MPH) for at least one minute before the self-diagnosis is performed. After the vehicle is stopped, the number of L.E.D. flashes is counted while the engine is running.

The L.E.D. is located on the control unit, identifying a malfunctioning part or unit by the number of flashes. Both the warning light and the L.E.D. persistently activate, even after a malfunctioning part or unit has been repaired, unless the ignition switch is turned "OFF". After repairs, turn the ignition switch "OFF". Then start the engine and drive the vehicle over 30 km/h (19 MPH) for at least one minute to ensure that the malfunctioning part or unit has been repaired properly.

If more than two circuits malfunction at the same time, the L.E.D. will flash to indicate one of the malfunctioning circuits. After the circuit has been repaired, the L.E.D. will then flash to indicate that the other circuit is malfunctioning.

No. of L.E.D. flashes	Malfunctioning part or unit	Diagnostic Procedure
1	Left front actuator solenoid circuit	Diagnostic Procedure 6
2	Right front actuator solenoid circuit	
3 or 4	Rear actuator solenoid circuit	
5	Left front wheel sensor circuit	Diagnostic Procedure 7
6	Right front wheel sensor circuit	
7 or 8	Rear wheel sensor circuit	
9	Motor and motor relay	Diagnostic Procedure 8
10	Solenoid valve relay	Diagnostic Procedure 9
16 or continuous	Control unit	Diagnostic Procedure 10
Warning activates and L.E.D. "OFF"	Power supply or ground circuit for control unit	Diagnostic Procedure 11

Example

Improper operation of left front rotor sensor circuit

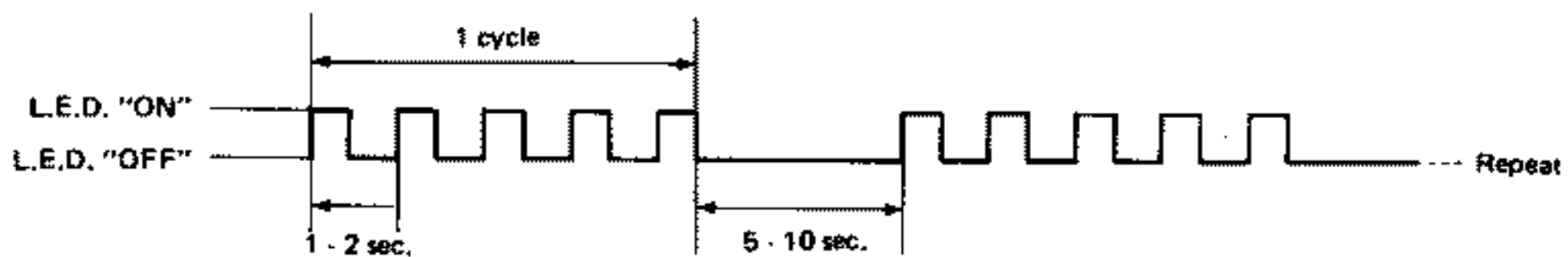

SBR531A

TROUBLE DIAGNOSES

Component Parts Location

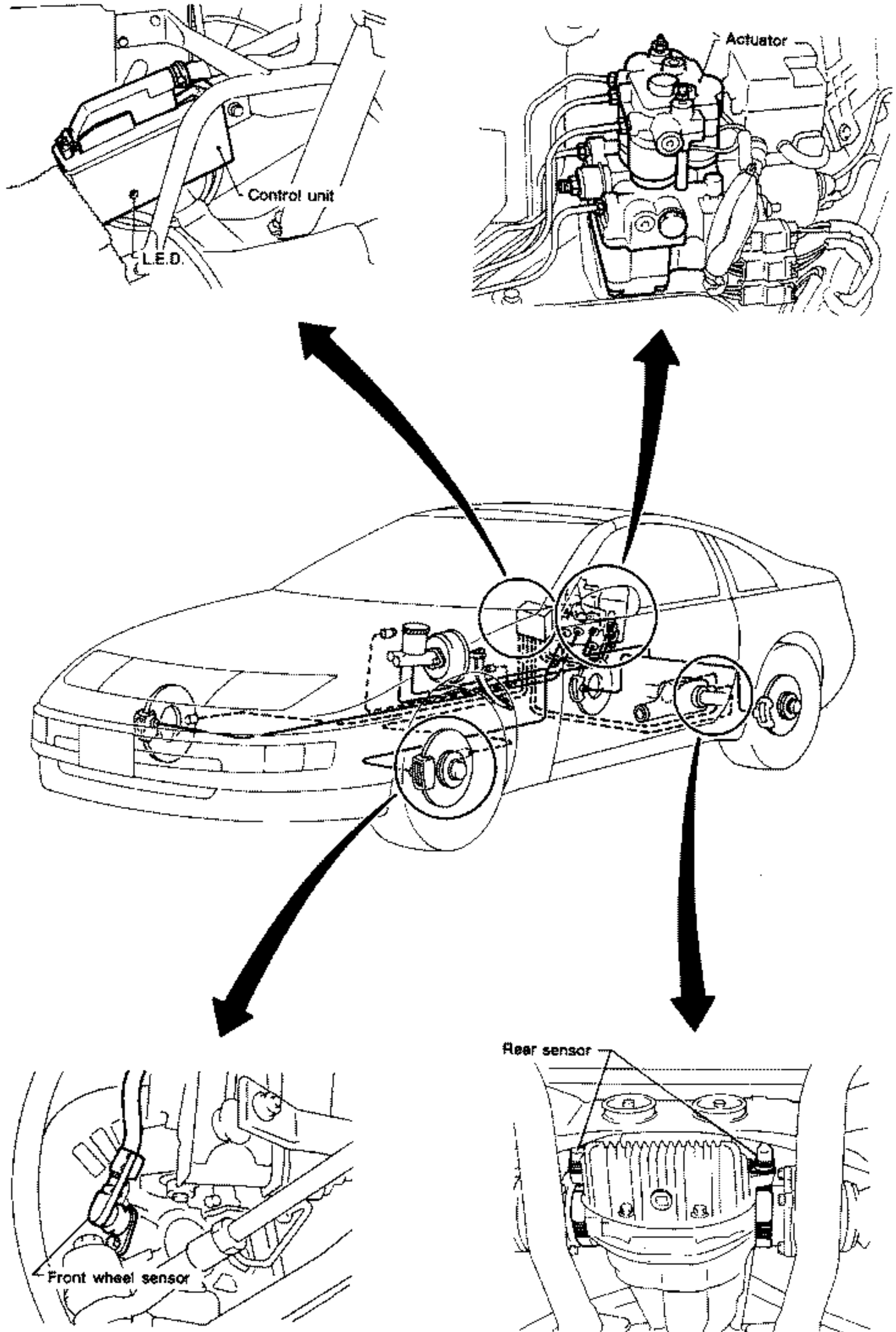

TROUBLE DIAGNOSES

Harness Connector Location

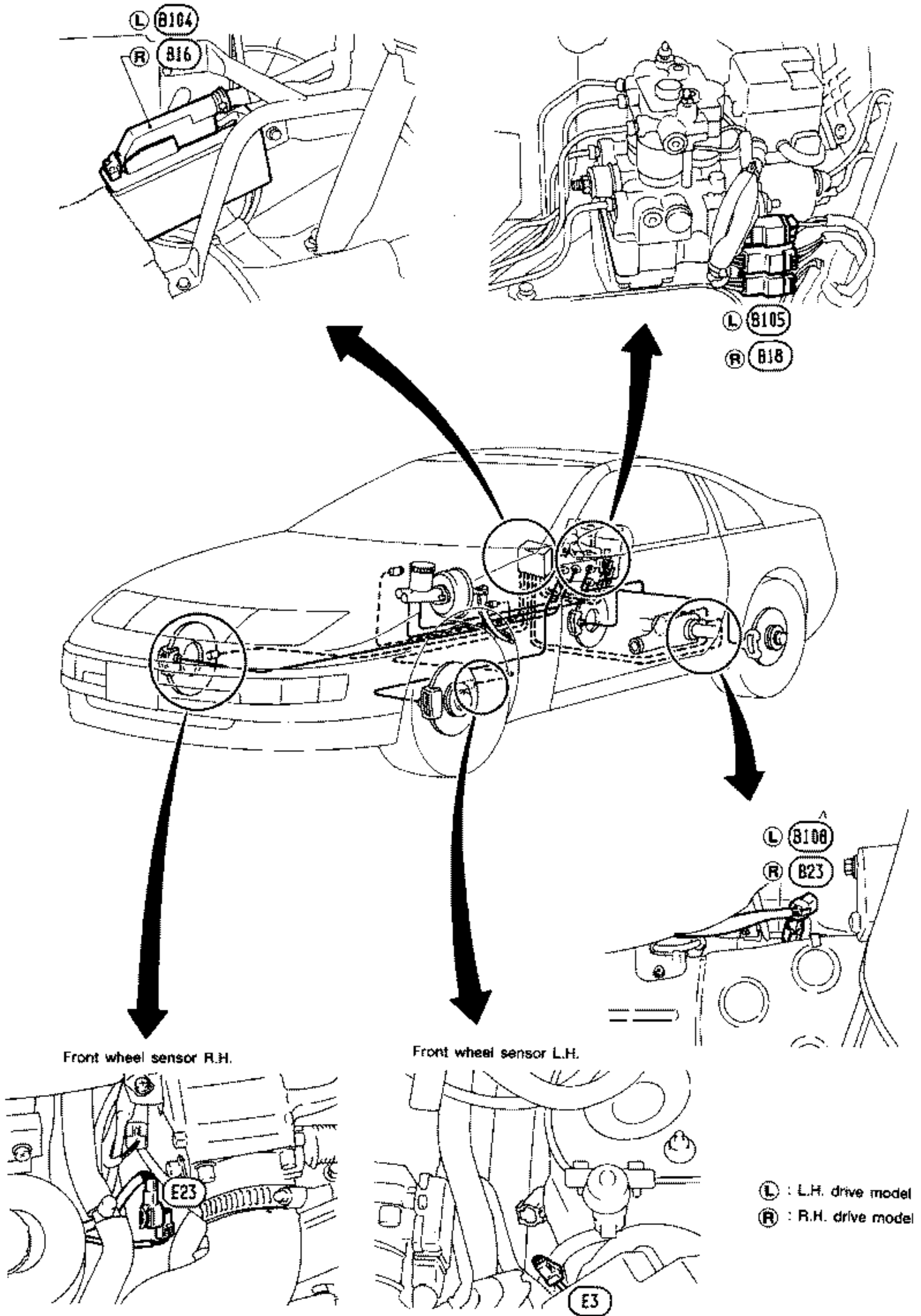

TROUBLE DIAGNOSES

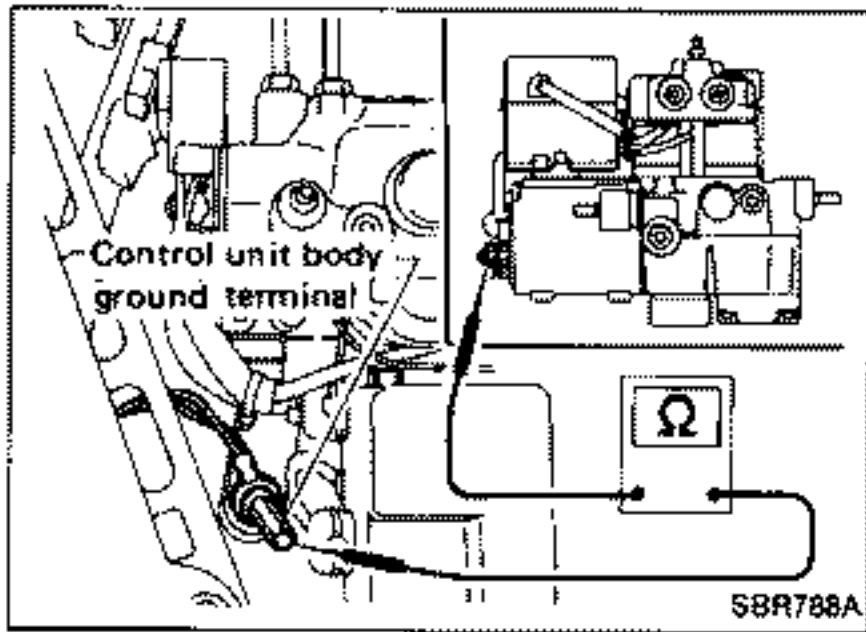

Ground Circuit Check

ACTUATOR MOTOR GROUND

- Check resistance between both terminals.
Resistance: approx. 0Ω

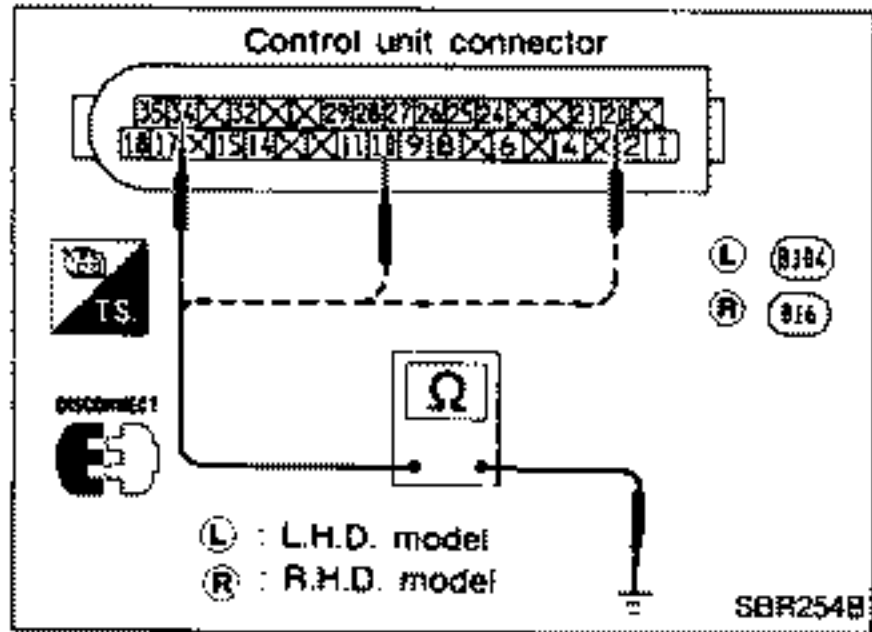

CONTROL UNIT GROUND

- Check resistance between both terminals.
Resistance: 0Ω

TROUBLE DIAGNOSES

Circuit Diagram for Quick Pinpoint Check

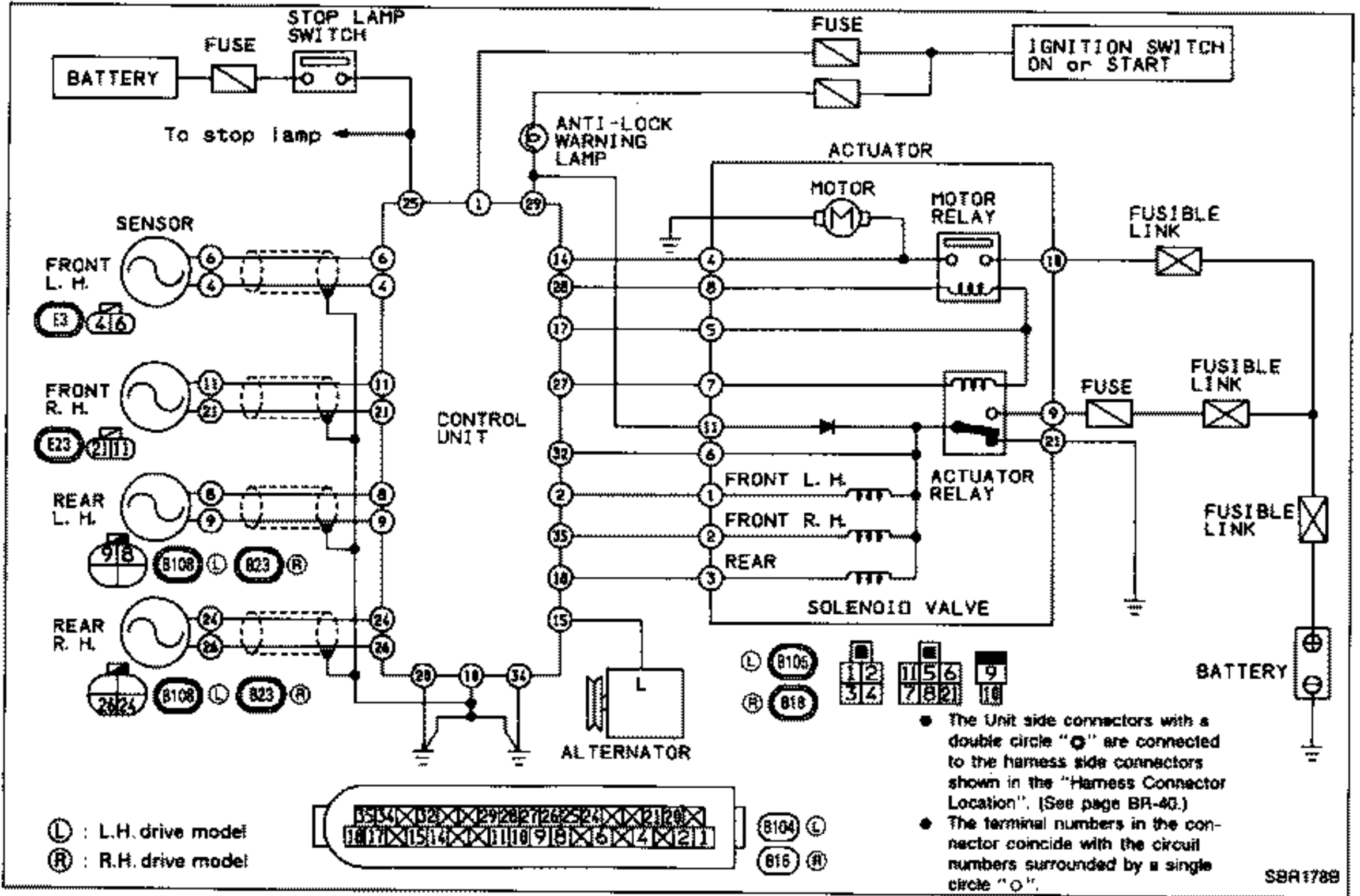

TROUBLE DIAGNOSES

Diagnostic Procedure 1

SYMPTOM: Pedal vibration and noise

Refer to worksheet result.

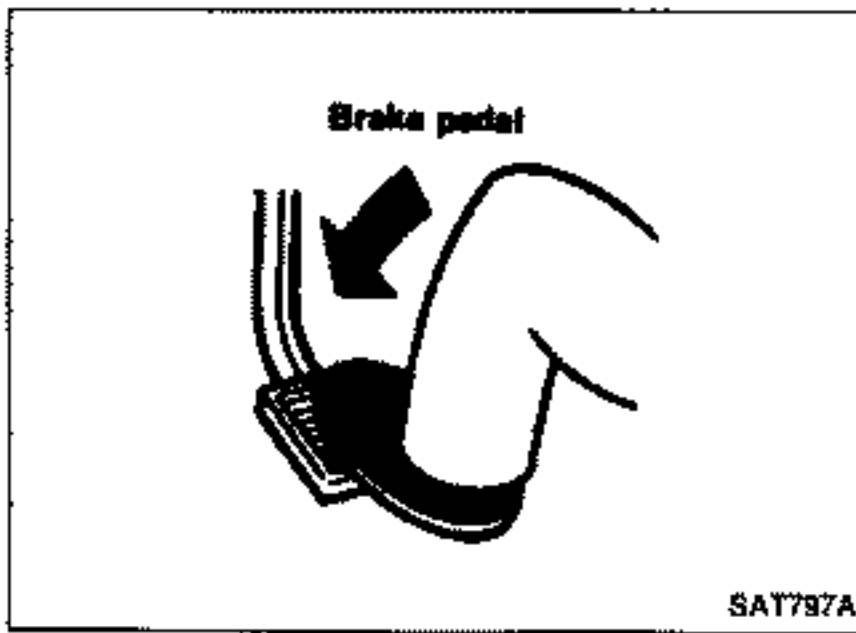

Check whether the symptom appears only when brake is applied suddenly.

Yes → When brake is normally applied, A.B.S. works and produces pedal vibration or noise.

No → Check whether the symptom appears only when engine is started.

Yes → Refer to Preliminary Check 4 result.

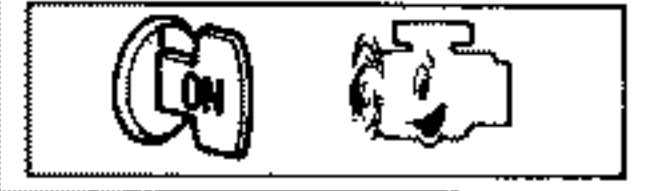

No → Check whether the symptom appears only when the vehicle speed is within 10 km/h (6 MPH) after starting engine.

Yes → Check whether the symptom disappears within 5 seconds.

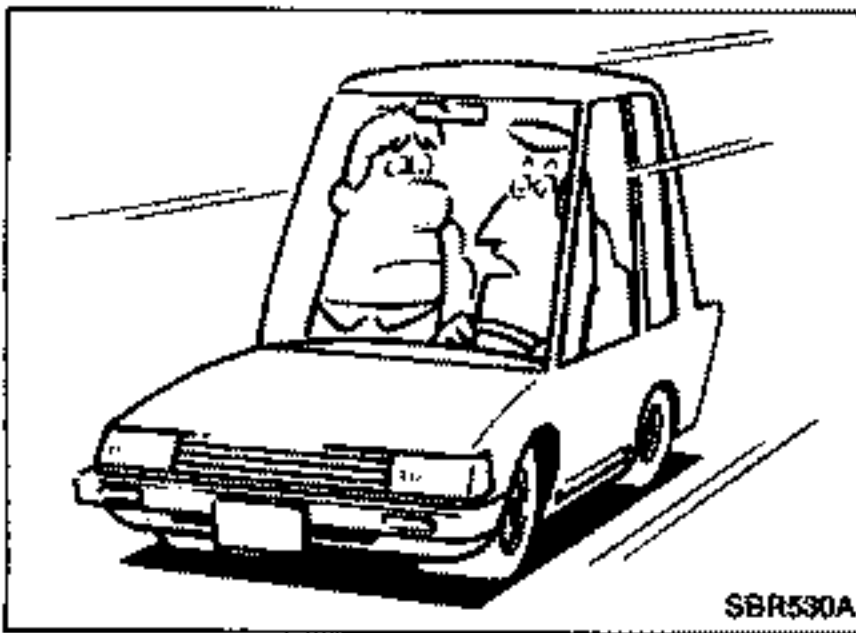

No → (A)
Yes → A.B.S. may sometimes operate when load is high and voltage is low due to insufficient alternator output.

No → (A)
Yes → Check whether the symptom appears while the vehicle is being driven.

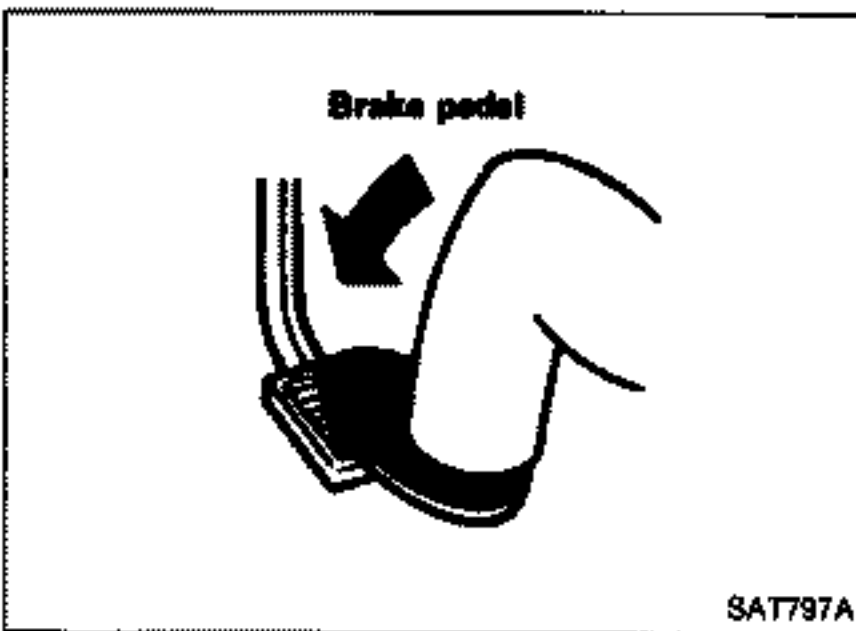

Check whether the symptom appears when brake is applied gradually.

No (Appears when brake is not applied.) → Check if there are any conditions, among those listed below, when symptom appears.
• Shifting
• Operating clutch
• Passing over bumps/potholes

Yes → (B)

No → (A)
Yes → Under these conditions individual wheel speed can change suddenly. This may sometimes cause the A.B.S. to operate.

TROUBLE DIAGNOSES

Diagnostic Procedure 1 (Cont'd)

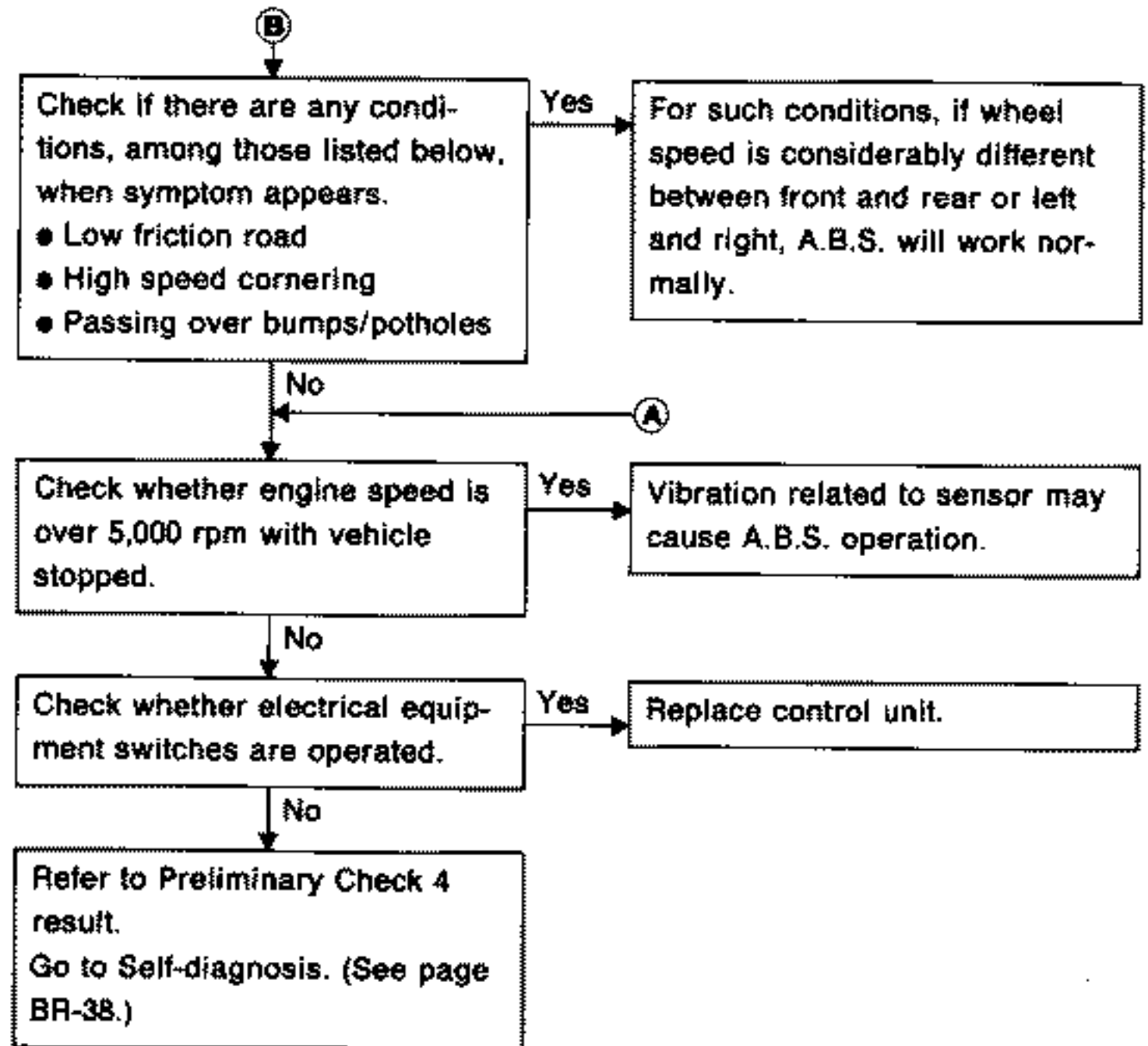

TROUBLE DIAGNOSES

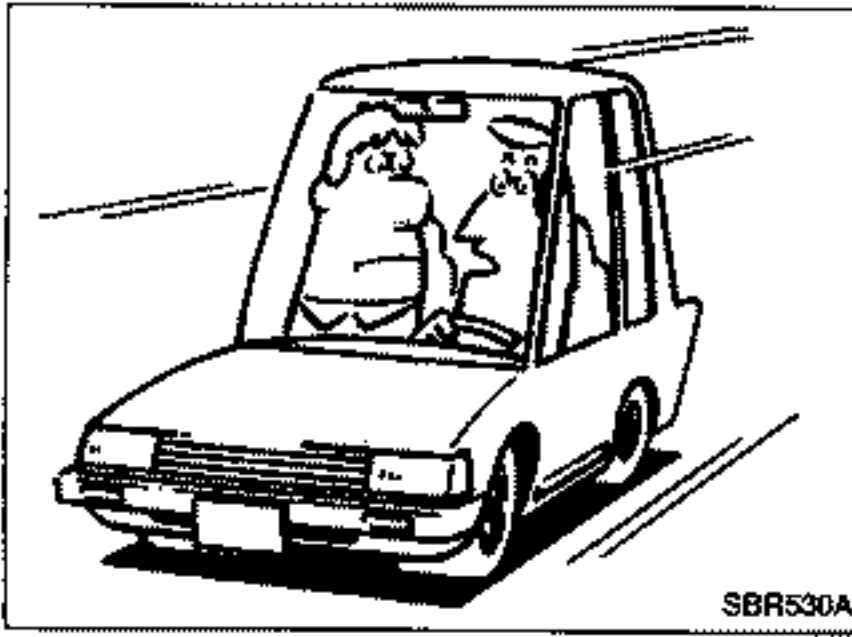

Diagnostic Procedure 2

SYMPTOM: Long stopping distance
Refer to worksheet results.

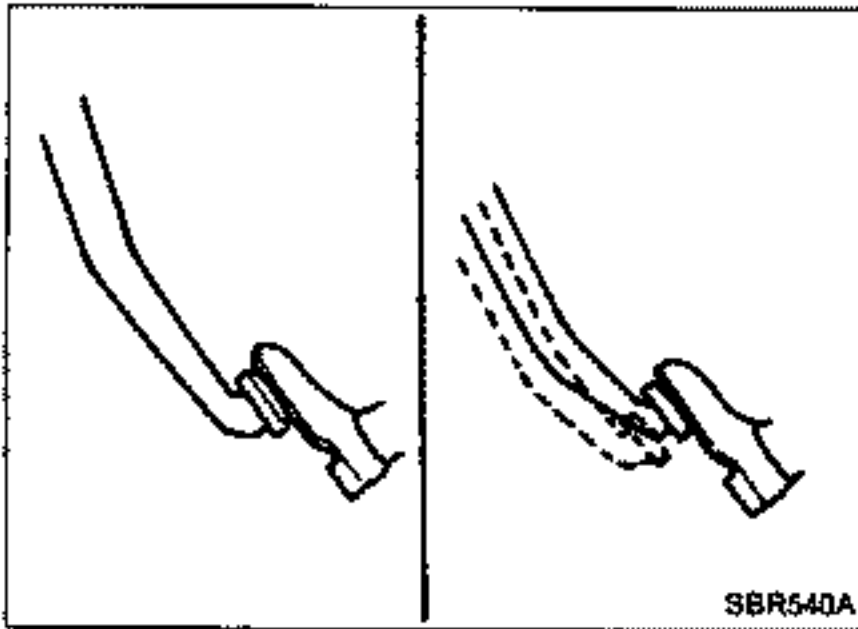
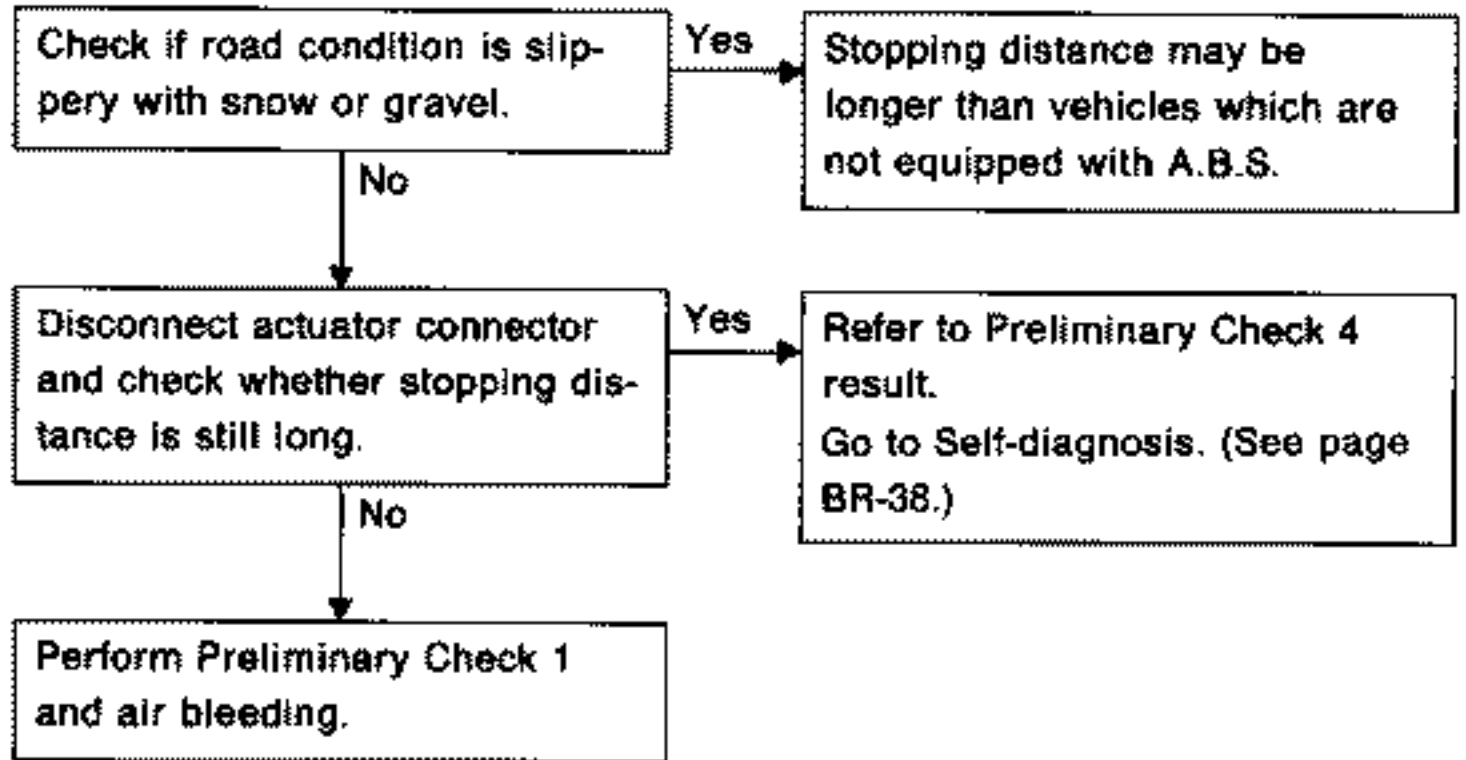

Diagnostic Procedure 3

SYMPTOM: Abnormal pedal action
Refer to worksheet results.

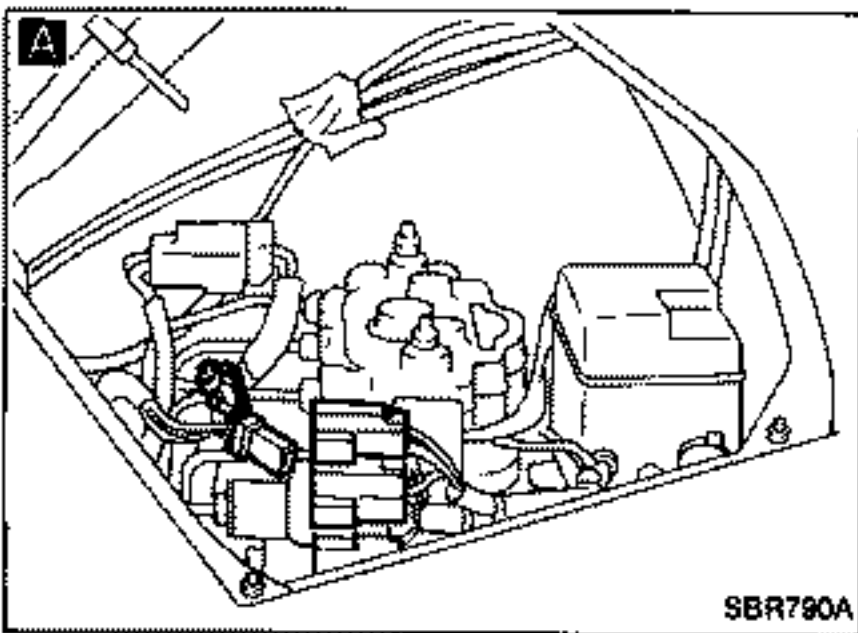
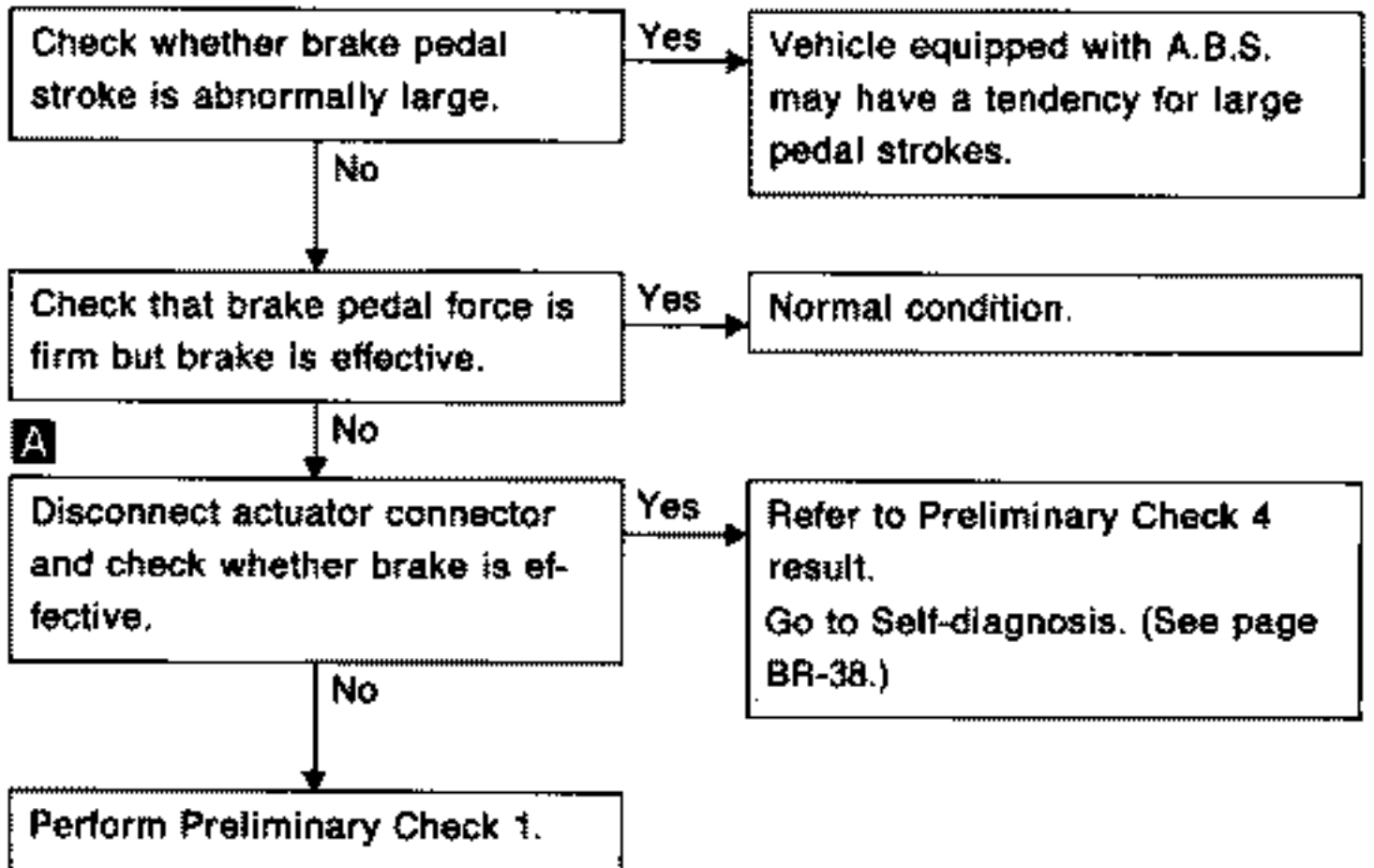

TROUBLE DIAGNOSES

Diagnostic Procedure 4

SYMPTOM: A.B.S. doesn't work.

Refer to worksheet results.

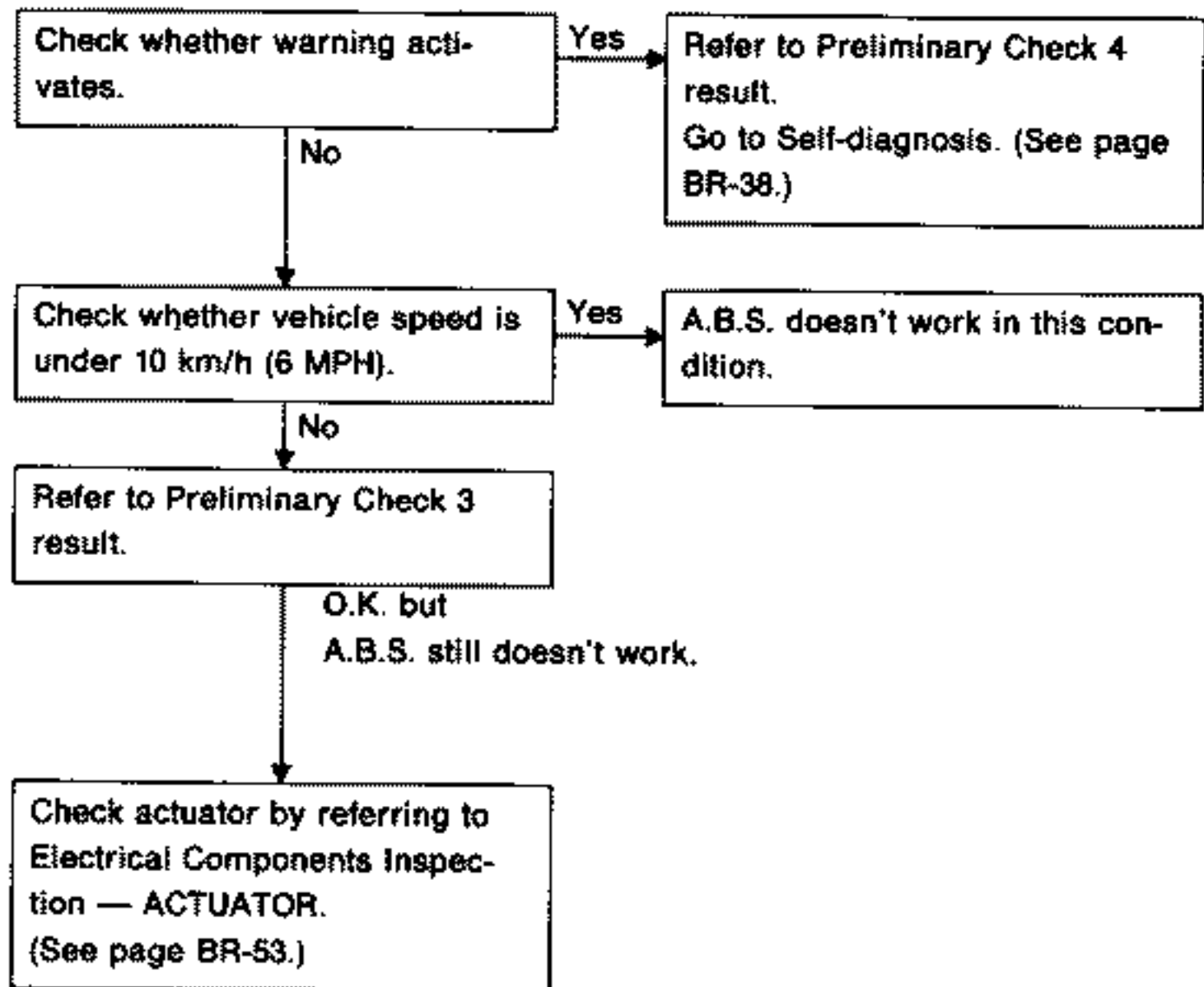

Diagnostic Procedure 5

SYMPTOM: A.B.S. works but warning activates.

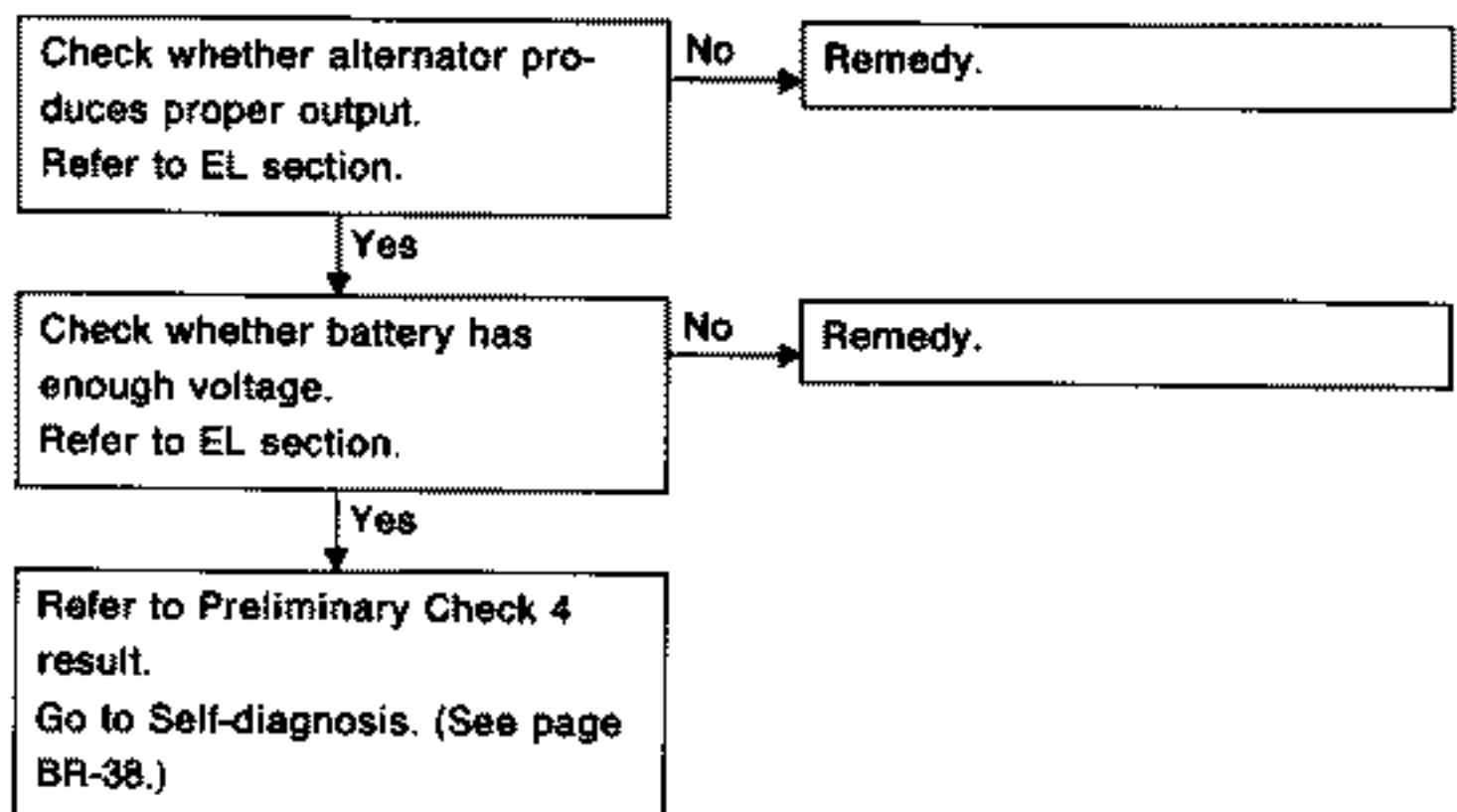

TROUBLE DIAGNOSES

Diagnostic Procedure 6

ACTUATOR SOLENOID (L.E.D. flashing number 1 - 4)

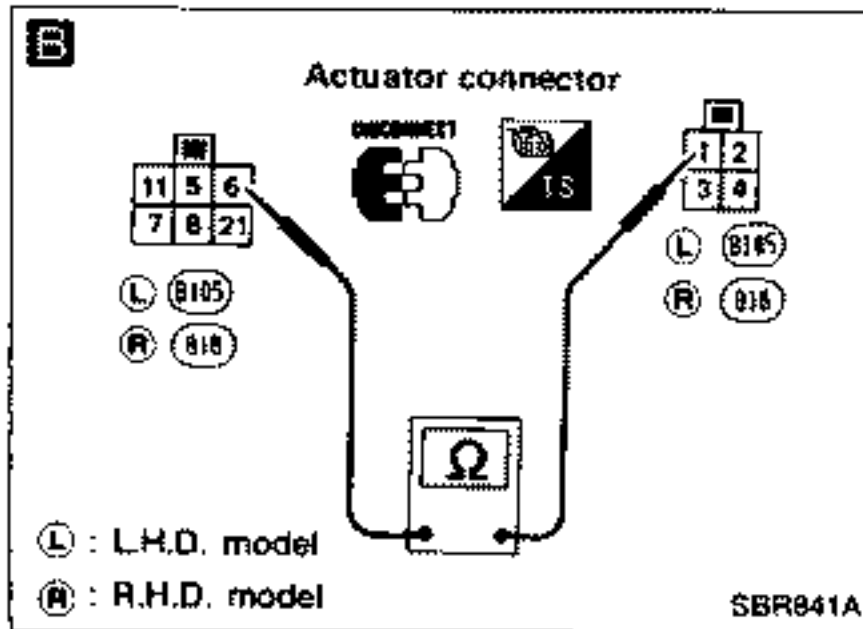
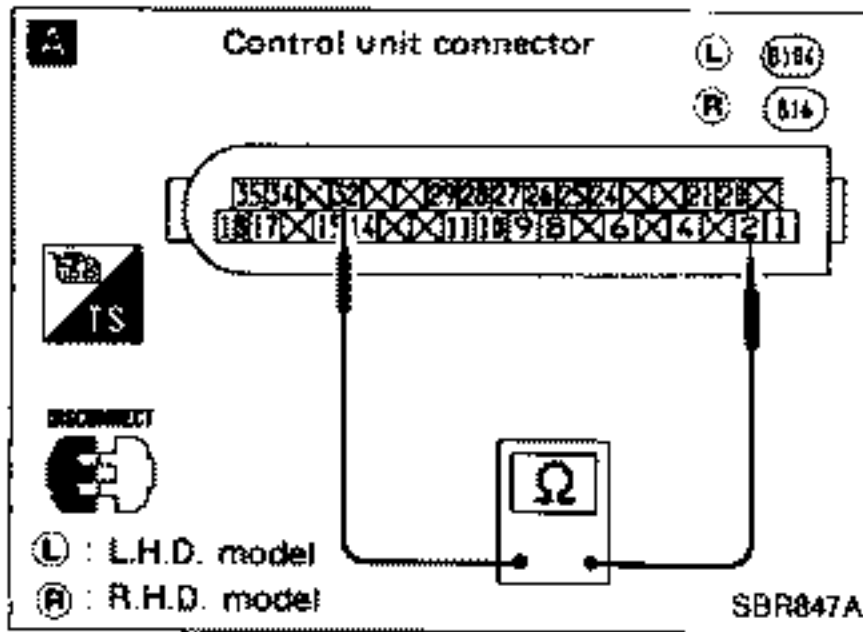

INSPECTION START
Remove battery negative terminal connector.

A
CHECK SOLENOID VALVE RESISTANCE.
Disconnect control unit connector.
Check resistance between control unit connector (vehicle side) terminals.
Flashing number 1:
Terminals ② and ⑩
Flashing number 2:
Terminals ② and ⑤
Flashing number 3 or 4:
Terminals ② and ⑧
Resistance: 0.7 - 1.6Ω

O.K. → Replace control unit.

B
N.G.
Disconnect actuator connector.
Check resistance between actuator connector (actuator side) terminals.
Flashing number 1:
Terminals ⑥ and ①
Flashing number 2:
Terminals ⑥ and ②
Flashing number 3 or 4:
Terminals ⑥ and ③
Resistance: 0.7 - 1.6Ω

O.K. → Repair harness between actuator connector and control unit connector.

N.G.
Replace actuator.

TROUBLE DIAGNOSES

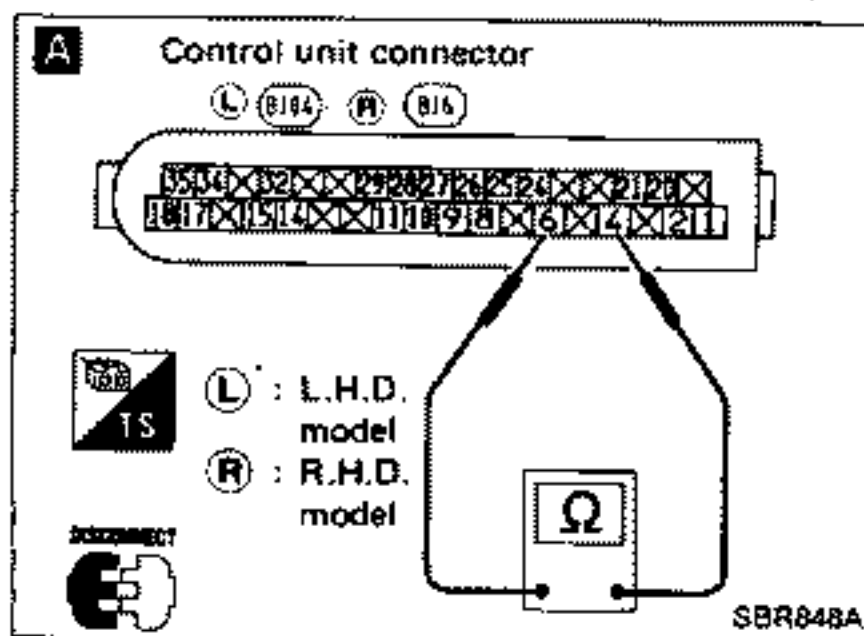

Diagnostic Procedure 7

WHEEL SPEED SENSOR (L.E.D. flashing number 5 - 8)

INSPECTION START

Remove battery negative terminal connector.

A

CHECK SPEED SENSOR RESISTANCE.

Disconnect control unit connector.

Check resistance between control unit connector (vehicle side) terminals.

Flashing number 5:

Terminals ④ and ⑥

Flashing number 6:

Terminals ⑪ and ⑬

Flashing number 7 or 8:

Terminals ⑮ and ⑰

Resistance: 0.8 - 1.2 kΩ

O.K.

Replace control unit.

N.G.

Refer to Preliminary Check 3 result.

Check whether sensor has 0.8 - 1.2 kΩ resistance.

N.G.

Replace sensor.

O.K.

Repair harness between sensor connector and control unit connector.

Diagnostic Procedure 8

ACTUATOR MOTOR RELAY (L.E.D. flashing number 9)

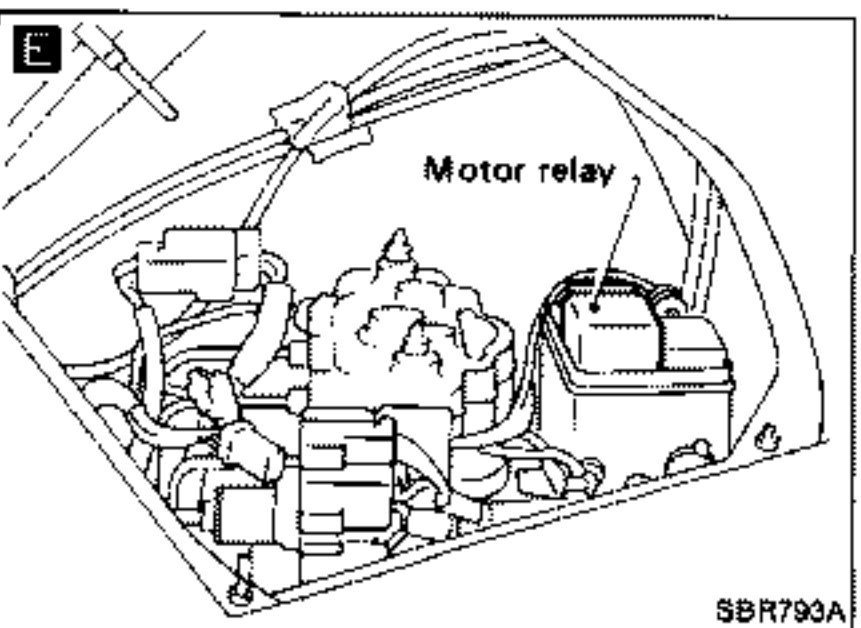
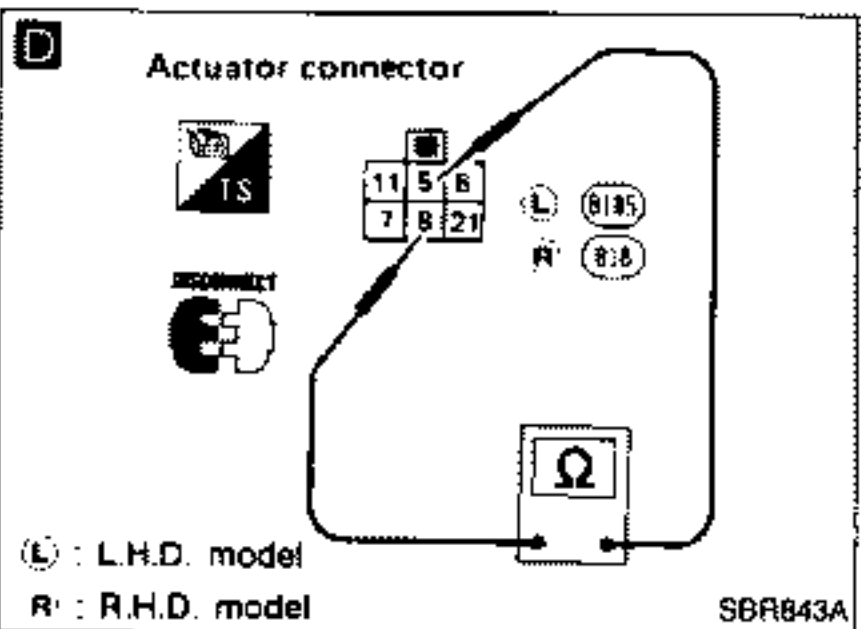
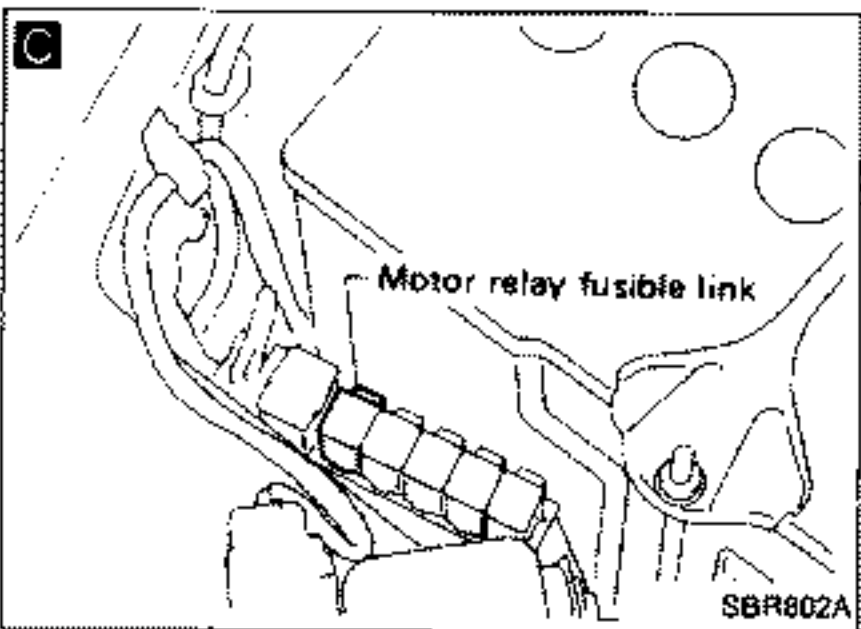
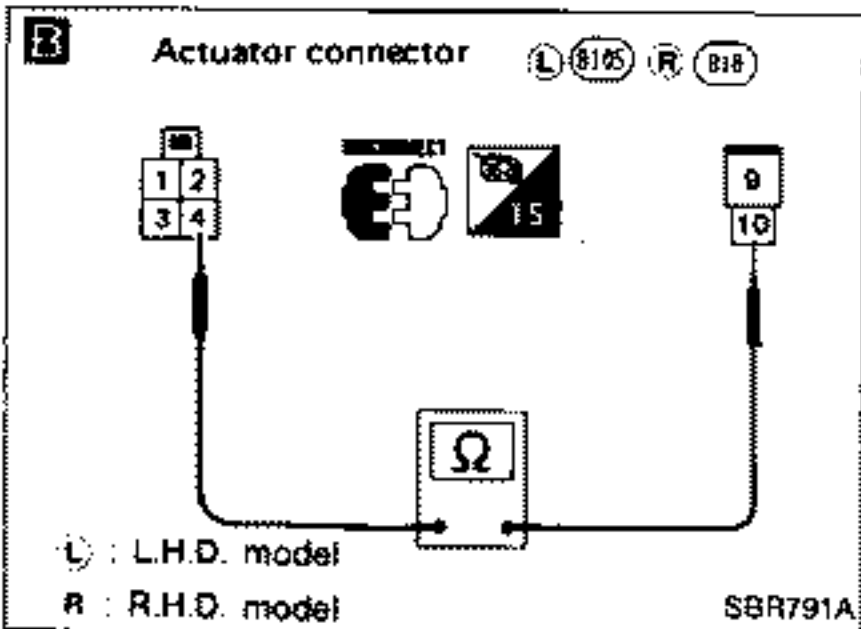
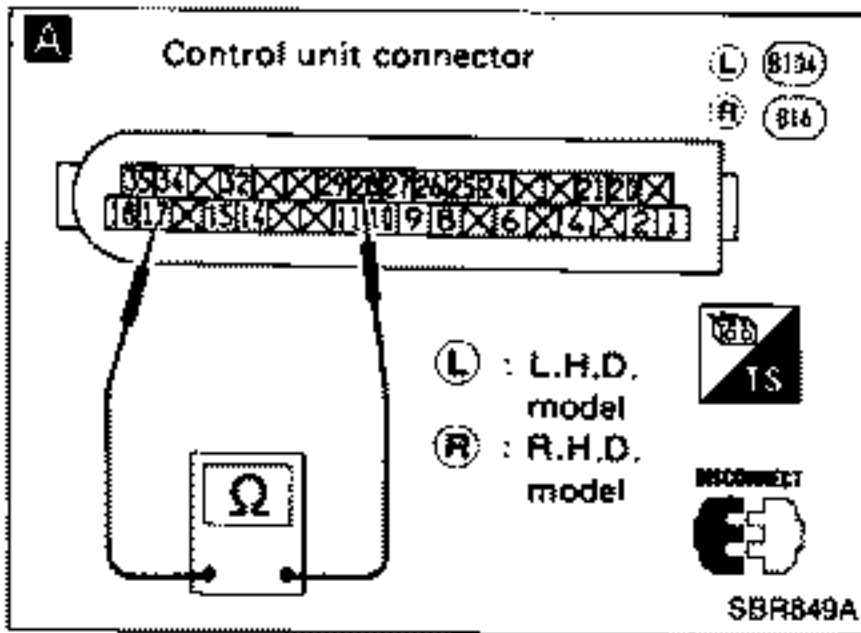

INSPECTION START
Remove battery negative terminal connector.

A **CHECK MOTOR RELAY SOLENOID RESISTANCE.**
Disconnect control unit connector.
Check resistance between control unit connector (vehicle side) terminals ⑰ and ⑳.
Resistance: 45 - 55Ω

O.K. → **B**

B **CHECK MOTOR RELAY DEACTIVATION.**
Disconnect actuator connector.
Check continuity between actuator connector (actuator side) terminals ④ and ⑩.

No → **C**
C Check if motor's fusible link is blown.
Yes → Replace fusible link.
No → **D**

D Perform Electrical Components Inspection — ACTUATOR. (See page BR-53.)

O.K. → **E**
E Replace control unit.

N.G. → **D** Disconnect actuator connector. Check resistance between actuator connector (actuator side) terminals ⑧ and ⑤.
Resistance: 45 - 55Ω

O.K. → **E** Replace motor relay.
N.G. → Repair harness between actuator and control unit.

E Replace motor relay.

N.G. → Replace actuator.

TROUBLE DIAGNOSES

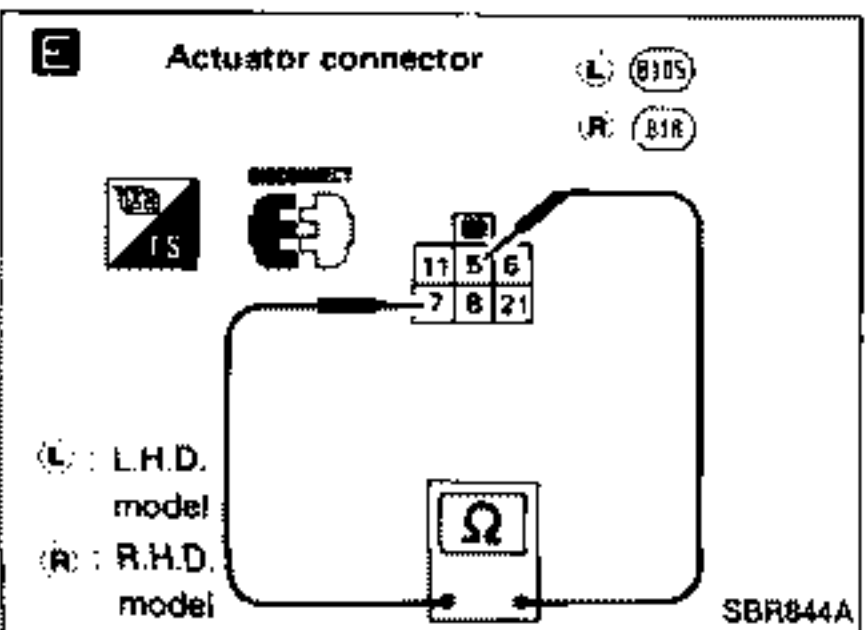
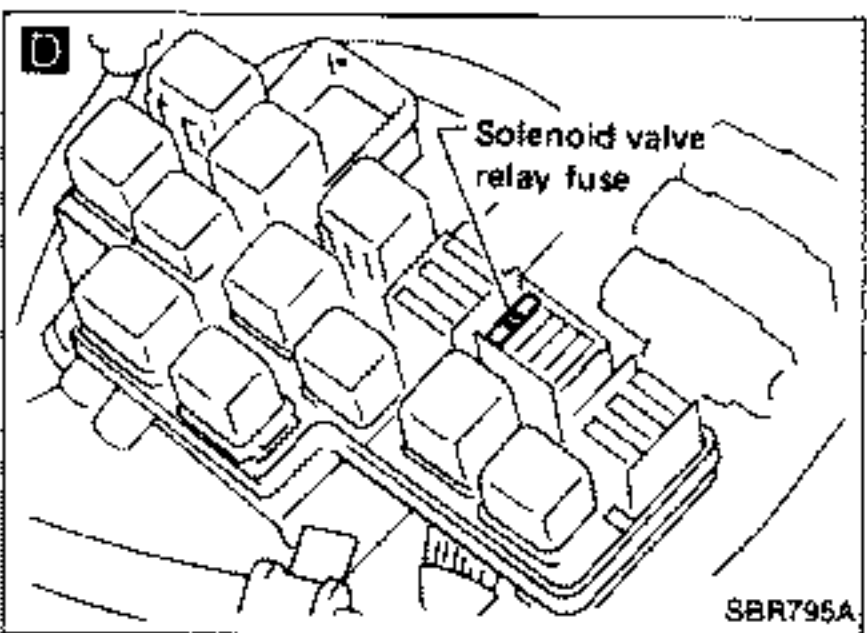
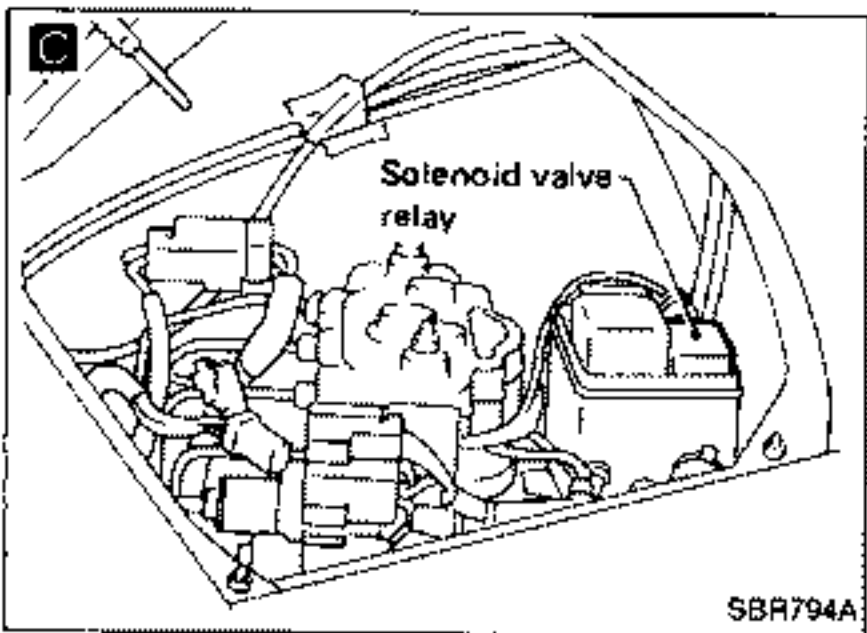
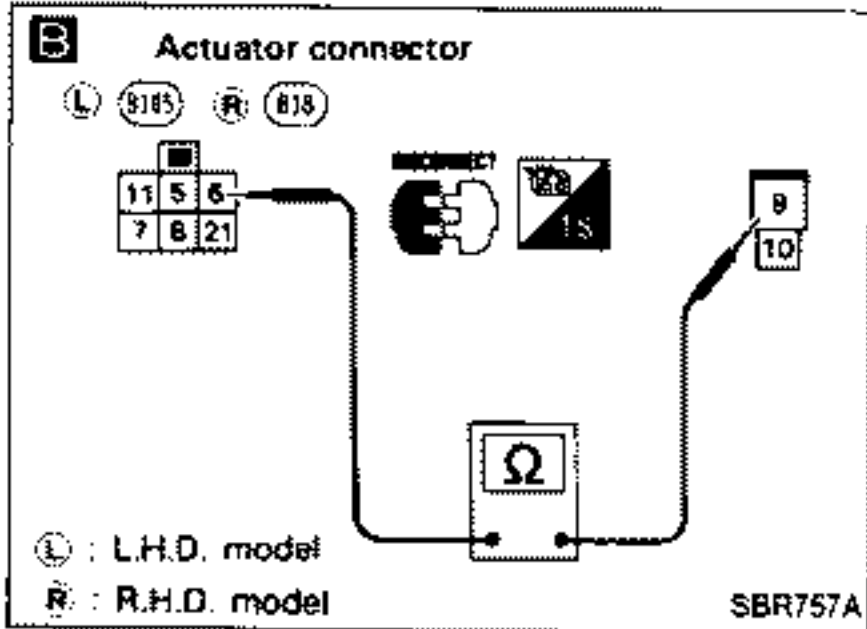
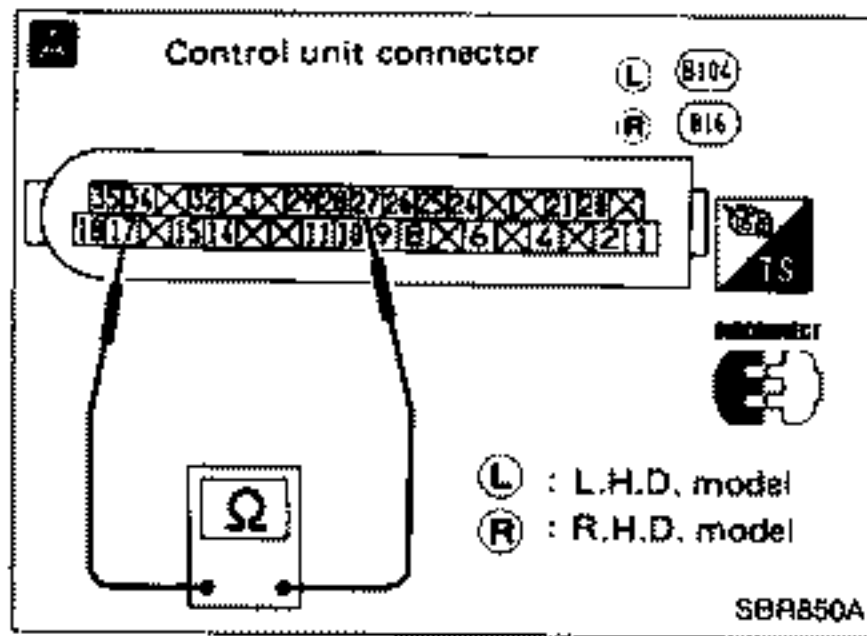

Diagnostic Procedure 9

ACTUATOR SOLENOID VALVE RELAY (L.E.D. flashing number 10)

INSPECTION START

Remove battery negative terminal connector.

CHECK SOLENOID VALVE RELAY RESISTANCE.

Disconnect control unit connector.

Check resistance between control unit connector (vehicle side) terminals ⑦ and ⑤.

Resistance: 80 - 90Ω

N.G.

Check resistance between actuator connector (actuator side) terminals ⑦ and ⑤.

Resistance: 80 - 90Ω

O.K.

N.G.

Replace solenoid valve relay.

Repair harness between actuator and control unit.

CHECK SOLENOID VALVE RELAY MOVEMENT.

Disconnect actuator connector. Check continuity between actuator connector (actuator side) terminals ⑥ and ⑨.

Yes

Replace solenoid valve relay.

No

Check if solenoid valve relay fuse is blown.

No

Perform Electrical Components Inspection — ACTUATOR. (See page BR-53.)

Yes

Replace fuse.

N.G.

O.K.

Replace control unit.

Replace actuator.

TROUBLE DIAGNOSES

Diagnostic Procedure 10

CONTROL UNIT (L.E.D. flashing number 16)

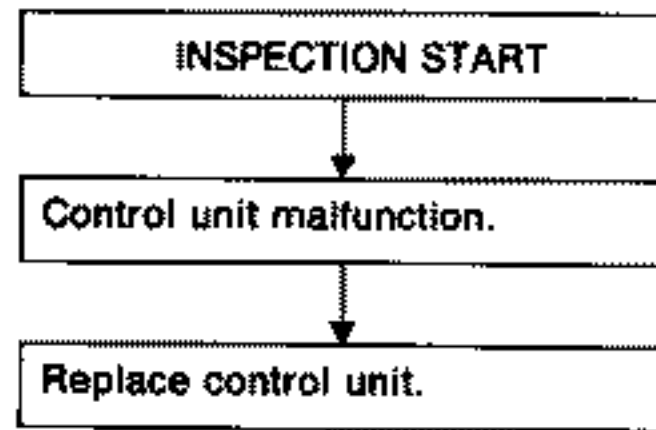

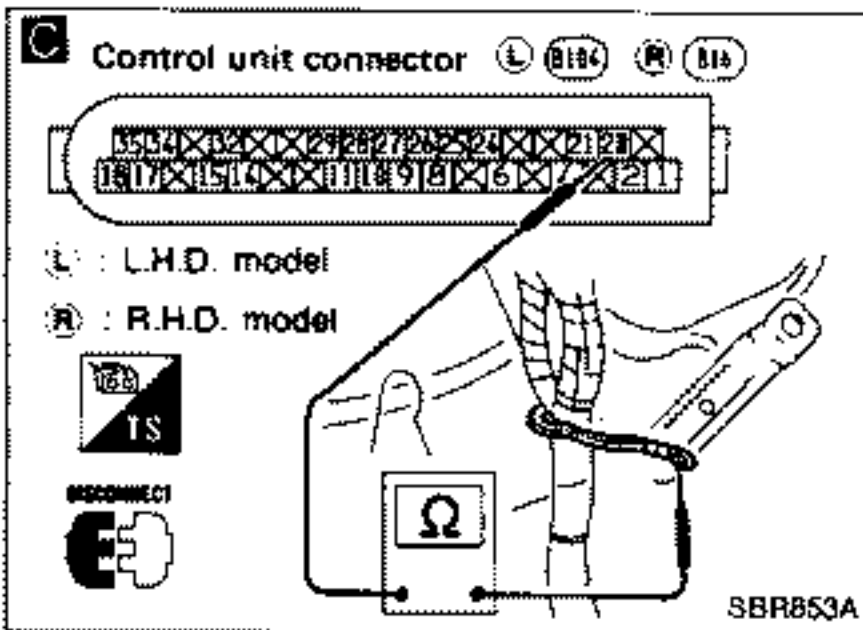
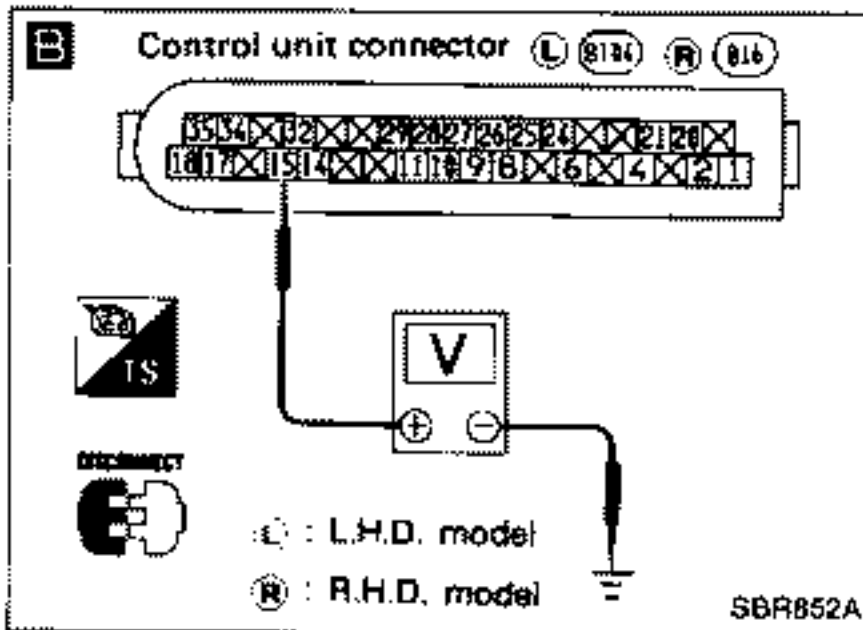
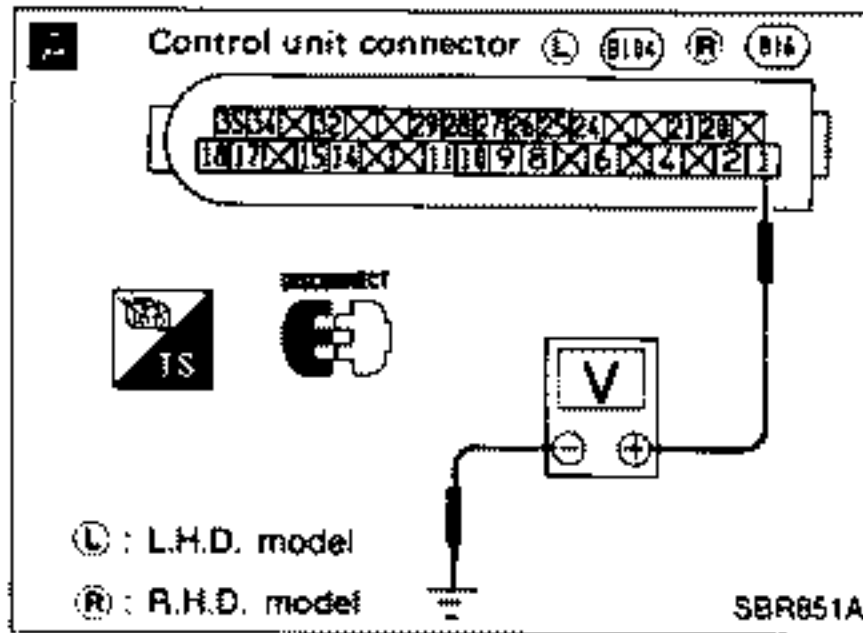

Diagnostic Procedure 11

CONTROL UNIT OR POWER SUPPLY AND GROUND CIRCUIT (Warning activates but L.E.D. comes off.)

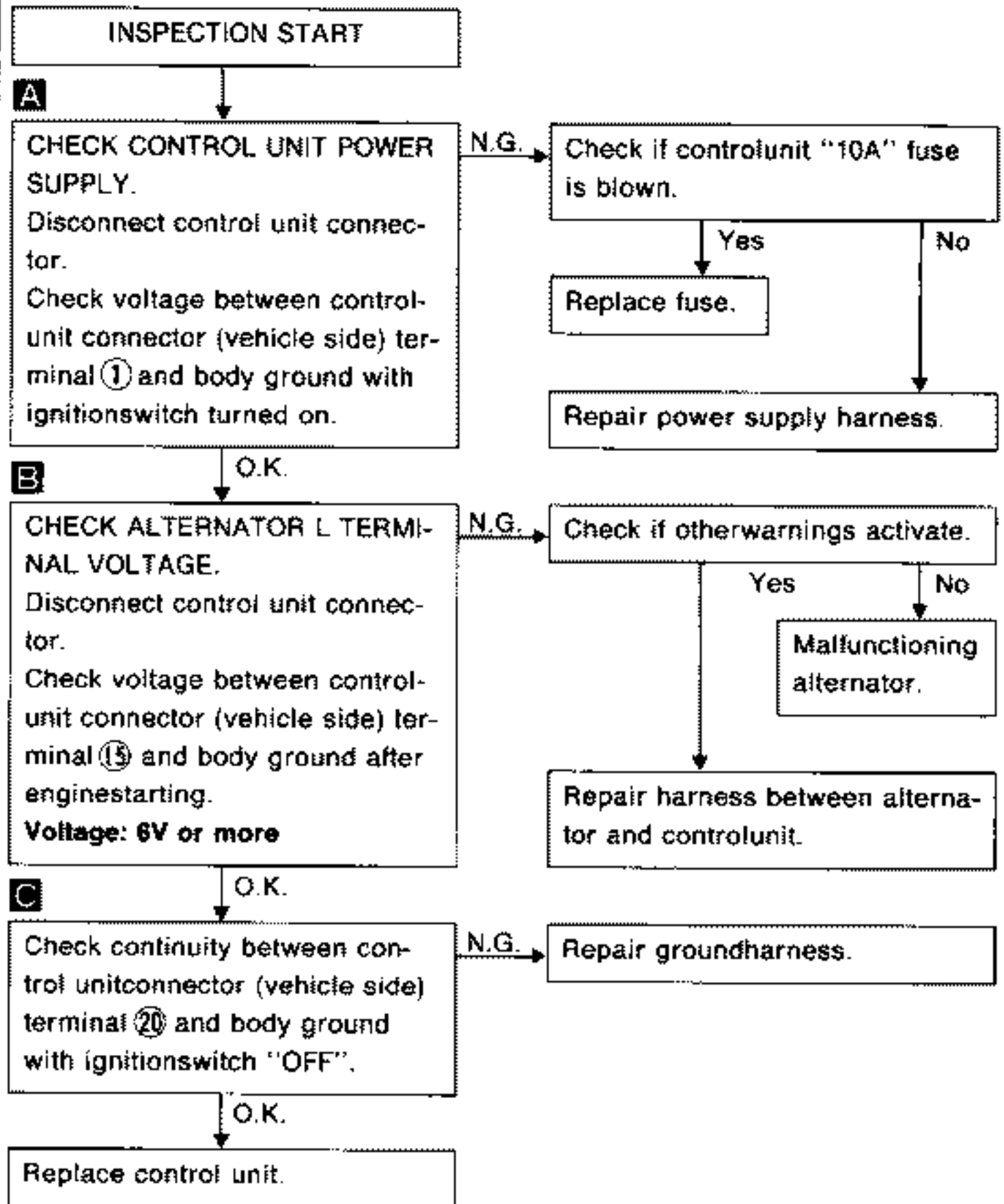

TROUBLE DIAGNOSES

Electrical Components Inspection ACTUATOR (Not self-diagnostic item)

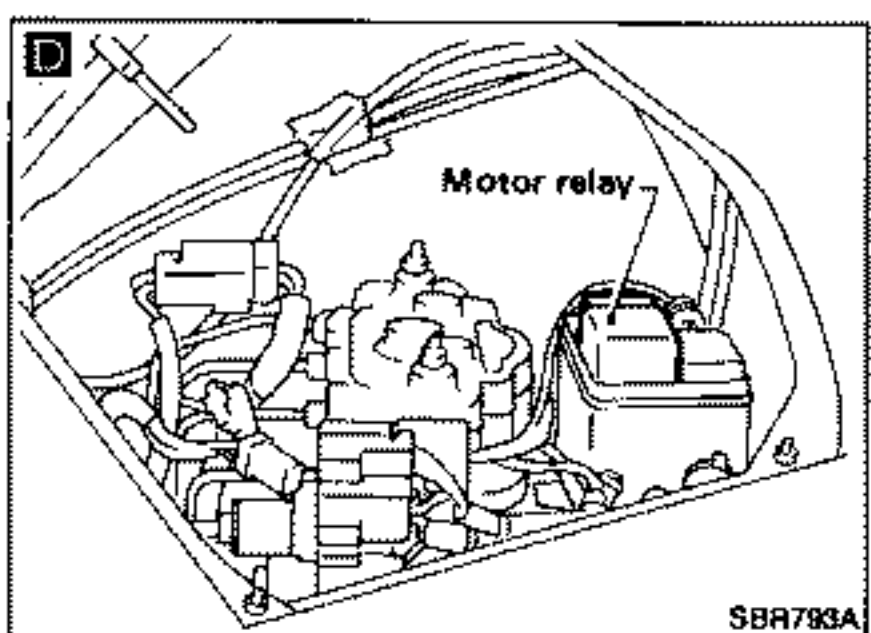
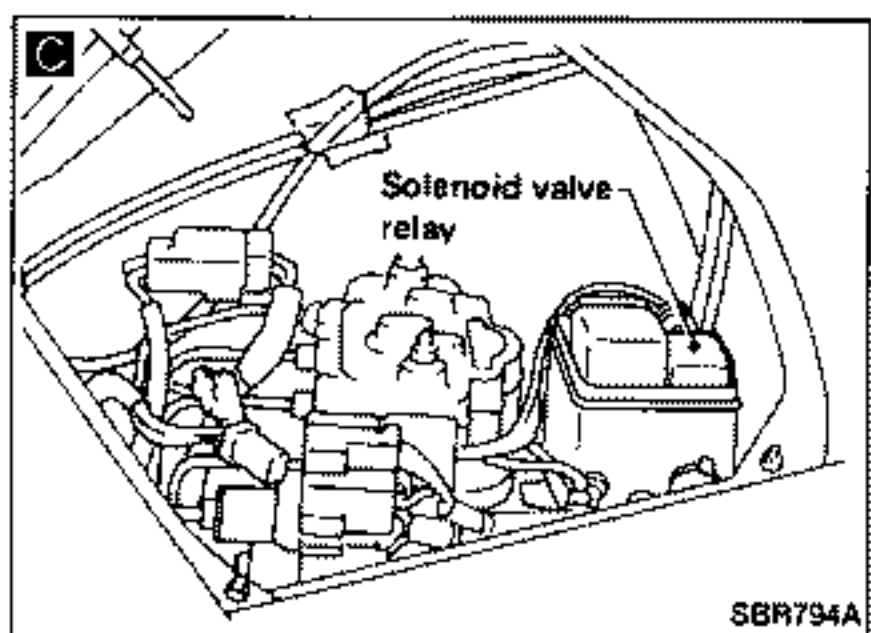
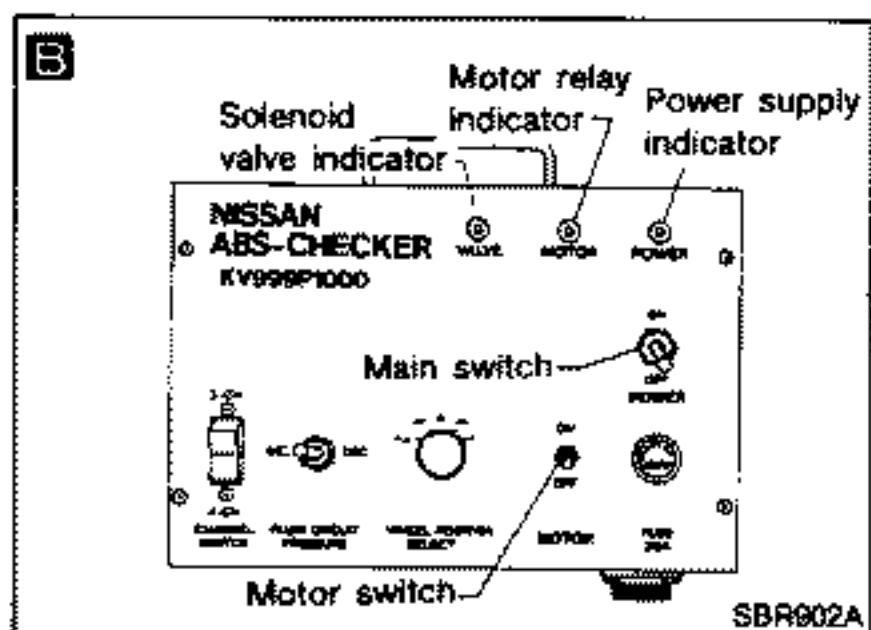
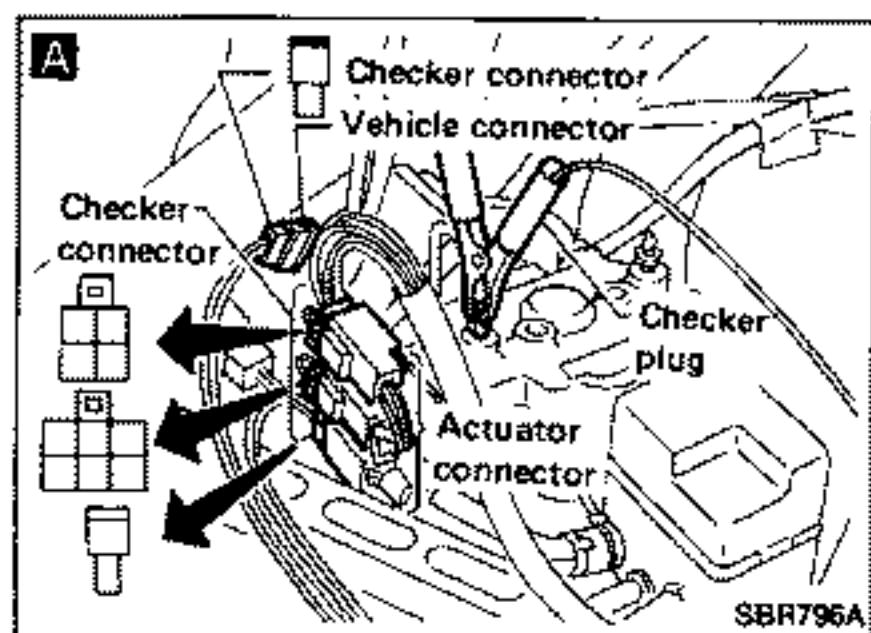

INSPECTION START

A Connect A.B.S. checker to actuator connector and vehicle harness with battery terminal connected and all checker switch turning off.
Use harness for 3 channel.
Set channel select switch to 3 channel.

B Turn checker main switch on.
Check power supply indicator for coming on.

No → Replace battery with fully charged new one, if checker connection is correct.

B Check checker valve relay indicator for coming on.

No → **C** Replace solenoid valve relay, if checker connection is correct.

B Step **A**
Select one valve — FL, FR or RR. (valves corresponding to each wheel position.)
Select brake circuit pressure decreasing position by switch then turn motor switch on.
Select pressure increasing position.

B Check motor relay indicator for coming on while motor switch is turned on.

No → **D** Replace motor relay, if checker connection is correct.

Check motor for operational sound beside the actuator in a quiet place.

No → Replace actuator as assembly, if Diagnostic Procedures 6 - 11 are already performed and checker connection is correct.

Yes → **B**

TROUBLE DIAGNOSES

Electrical Components Inspection (Cont'd)

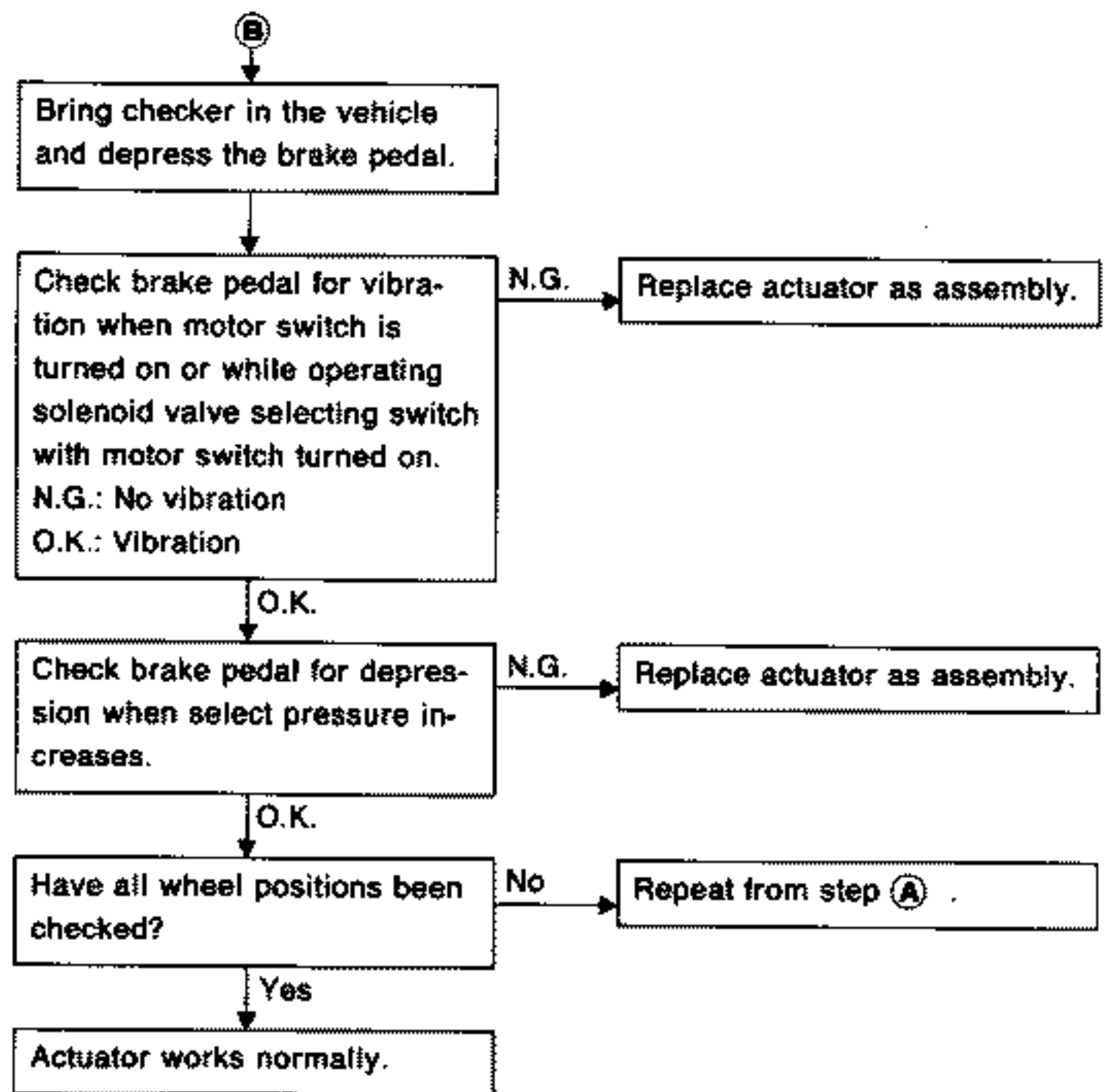

CAUTION:

Do not set checker at pressure decrease position for more than 5 seconds at a time. Actuator solenoid valve may be damaged.

SERVICE DATA AND SPECIFICATIONS (S.D.S.)

General Specifications

Applied model	Australia		Europe
	Without A.B.S.	With A.B.S.	-
Front brake			
Brake model	OPZ25V		OPF25V
Cylinder bore diameter mm (in)	40.45 (1.5925) x 4		
Pad length x width x thickness mm (in)	116 x 50 x 10 (4.57 x 1.97 x 0.39)		
Rotor outer diameter x thickness mm (in)	280 x 26 (11.02 x 1.02)	280 x 30 (11.02 x 1.18)	
Rear brake			
Brake model	OPZ11VB		
Cylinder bore diameter mm (in)	38.1 (1.500) x 2		
Pad length x width x thickness mm (in)	71.8 x 36.5 x 11.5 (2.827 x 1.437 x 0.453)		
Rotor outer diameter x thickness mm (in)	297 x 18 (11.69 x 0.71)		
Master cylinder			
Cylinder bore diameter mm (in)	23.81 (15/16)	26.99 (17/16)	
Control valve			
Valve model	Proportioning valve (within master cylinder)		
Split point x reducing ratio kPa (bar, kg/cm ² , psi)	3,432 (34.3, 35, 498) x 0.4		
Brake booster			
Booster model	M215T		
Diaphragm diameter mm (in)	Primary: 230 (9.06) Secondary: 205 (8.07)		
Brake fluid			
Recommended brake fluid	DOT 3		
Parking drum brake			
Brake model	DS17HD		
Lining			
Width x thickness x length mm (in)	154.1 x 25.0 x 3.0 (6.07 x 0.984 x 0.118)		
Drum inner diameter mm (in)	172.0 (6.77)		

SERVICE DATA AND SPECIFICATIONS (S.D.S.)

Inspection and Adjustment BRAKE PEDAL

FRONT DISC BRAKE

Unit: mm (in)

Brake model	OPZ25V	OPF25V
Pad wear limit		
Minimum thickness	2.0 (0.079)	
Rotor repair limit		
Minimum thickness	24.0 (0.945)	28.0 (1.102)
Maximum runout	0.07 (0.0028)	

Applied model

M/T

A/T

Free height

186 - 196
(7.32 - 7.72)

195 - 205
(7.68 - 8.07)

Depressed height

[under force of 490 N (50 kg,
110 lb) with engine running]

 With A.B.S.

105 (4.13)

110 (4.33)

 Without A.B.S.

95 (3.74)

105 (4.13)

Clearance between pedal stopper
and threaded end of switches

0.3 - 1.0 (0.012 - 0.039)

Pedal free play at clevis

1 - 3 (0.04 - 0.12)

PARKING BRAKE

Number of notches
[under force of 196 N
(20 kg, 44 lb)]

6 - 7

Number of notches
(when warning lamp switch
comes on)

1

REAR DISC BRAKE

Unit: mm (in)

Brake model	OPZ11VB	
Pad wear limit		
Minimum thickness	2.0 (0.079)	
Rotor repair limit		
Minimum thickness	16.0 (0.630)	
Maximum runout	0.07 (0.0028)	

PARKING DRUM BRAKE

Unit: mm (in)

Brake model	DS17HD	
Lining replacement limit		
Minimum thickness	1.5 (0.059)	
Drum repair limit		
Maximum inner diameter	173.0 (6.81)	