

SECTION **GI**

CONTENTS

PRECAUTIONS	GI- 2
HOW TO USE THIS MANUAL	GI- 6
HOW TO READ WIRING DIAGRAMS	GI- 8
HOW TO FOLLOW FLOW CHART IN TROUBLE DIAGNOSES	GI-12
CONSULT CHECKING SYSTEM	GI-16
IDENTIFICATION INFORMATION	GI-18
LIFTING POINTS AND TOW TRUCK TOWING	GI-22
TIGHTENING TORQUE OF STANDARD BOLTS	GI-25

PRECAUTIONS

Observe the following precautions to ensure safe and proper servicing. These precautions are not described in each individual section.

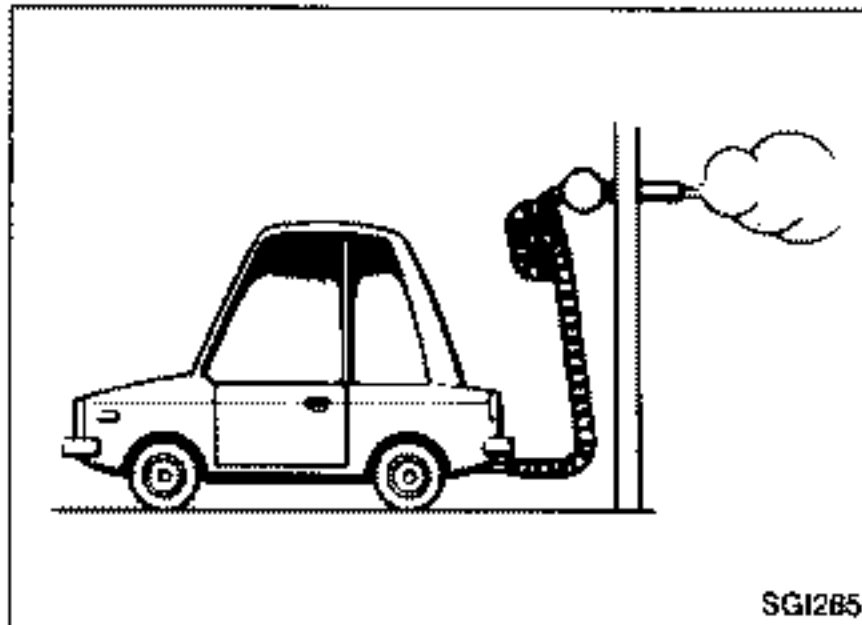

1. Do not operate the engine for an extended period of time without proper exhaust ventilation. Keep the work area well ventilated and free of any inflammable materials. Special care should be taken when handling any inflammable or poisonous materials, such as gasoline, refrigerant gas, etc. When working in a pit or other enclosed area, be sure to properly ventilate the area before working with hazardous materials. Do not smoke while working on the vehicle.

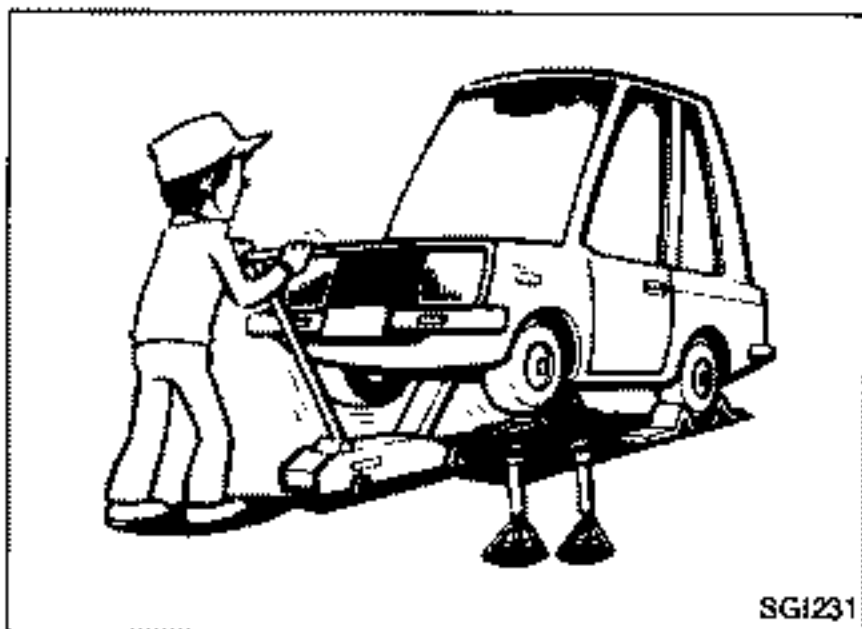

2. Before jacking up the vehicle, apply wheel chocks or other tire blocks to the wheels to prevent the vehicle from moving. After jacking up the vehicle, support the vehicle weight with safety stands at the points designated for proper lifting and towing before working on the vehicle. These operations should be done on a level surface.
3. When removing a heavy component such as the engine or transaxle/transmission, be careful not to lose your balance and drop them. Also, do not allow them to strike adjacent parts, especially the brake tubes and master cylinder.

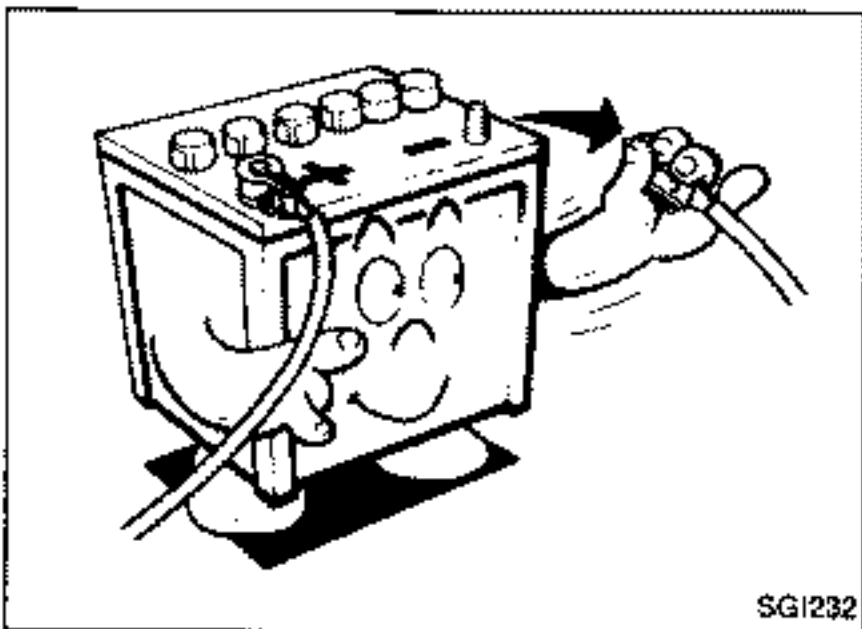

4. Before starting repairs which do not require battery power, always turn off the ignition switch, then disconnect the ground cable from the battery to prevent accidental short circuit.

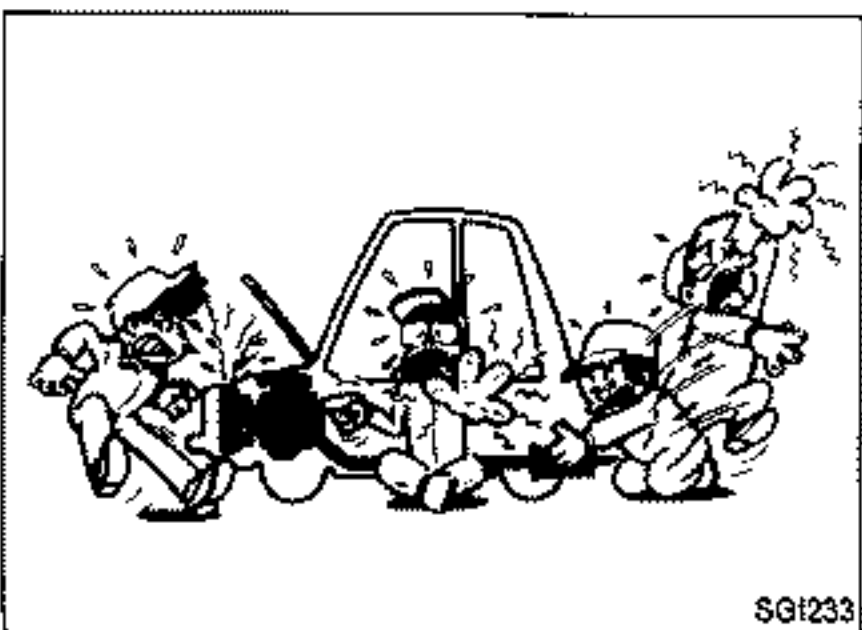

5. To prevent serious burns, avoid contact with hot metal parts such as the radiator, exhaust manifold, tail pipe and muffler. Do not remove the radiator cap when the engine is hot.

PRECAUTIONS

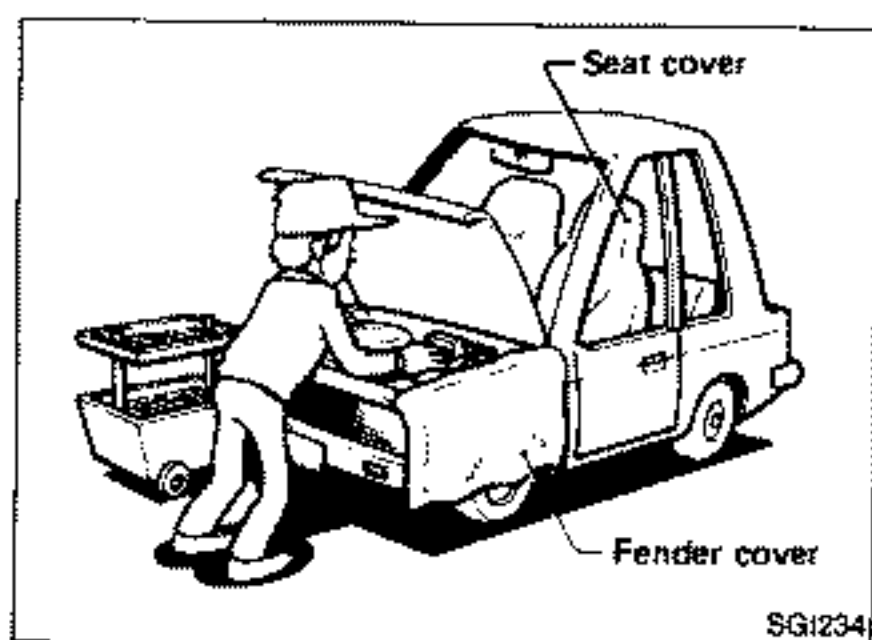

6. Before servicing the vehicle, protect fenders, upholstery and carpeting with appropriate covers. Take caution that keys, buckles or buttons on your person do not scratch the paint.

7. Clean all disassembled parts in the designated liquid or solvent prior to inspection or assembly.
8. Replace oil seals, gaskets, packings, O-rings, locking washers, cotter pins, self-locking nuts, etc. with new ones.
9. Replace inner and outer races of tapered roller bearings and needle bearings as a set.
10. Arrange the disassembled parts in accordance with their assembled locations and sequence.
11. Do not touch the terminals of electrical components which use microcomputers (such as electronic control units). Static electricity may damage internal electronic components.
12. After disconnecting vacuum or air hoses, attach a tag to indicate the proper connection.
13. Use only the lubricants specified in MA section.
14. Use approved bonding agent, sealants or their equivalents when required.
15. Use tools and recommended special tools where specified for safe and efficient service repairs.
16. When repairing the fuel, oil, water, vacuum or exhaust systems, check all affected lines for leaks.
17. Dispose of drained oil or the solvent used for cleaning parts in an appropriate manner.

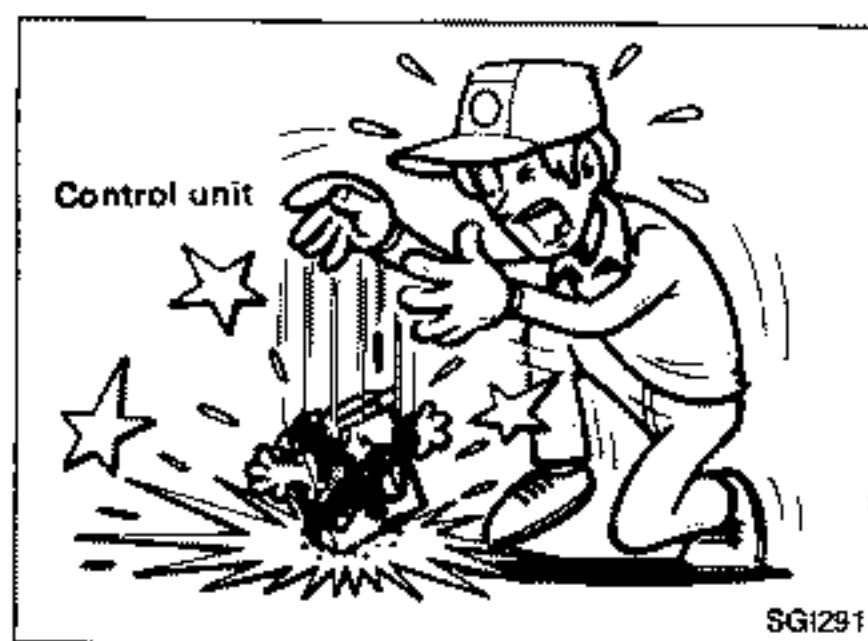

Precautions for E.F.I. or E.C.C.S. Engine

1. Before connecting or disconnecting E.F.I. or E.C.C.S. harness connector to or from any E.F.I. or E.C.C.S. control unit, be sure to turn the ignition switch to the "OFF" position and disconnect the negative battery terminal. Otherwise, there may be damage to control unit.
2. Before disconnecting pressurized fuel line from fuel pump to injectors, be sure to release fuel pressure to eliminate danger.
3. Be careful not to jar components such as control unit and air flow meter.

PRECAUTIONS

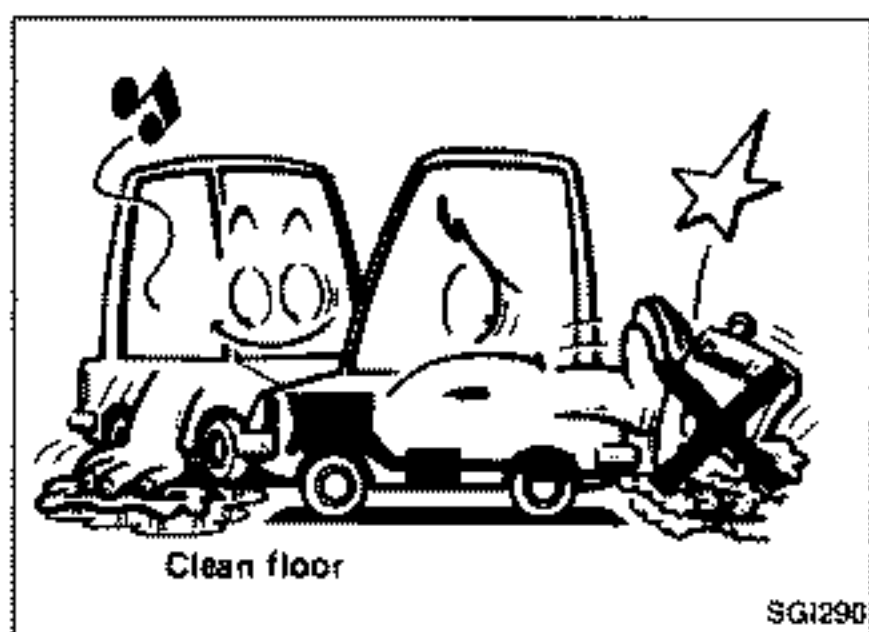

Precautions for Catalyst

If a large amount of unburned fuel flows into the converter, the converter temperature will be excessively high. To prevent this, follow the procedure below:

1. Use unleaded gasoline only. Leaded gasoline will seriously damage the catalytic converter.
2. When checking for ignition spark or measuring engine compression, make tests quickly and only when necessary.
3. Do not run engine when the fuel tank level is low, otherwise the engine may misfire causing damage to the converter.
4. Do not place the vehicle on inflammable material. Keep inflammable material off the exhaust pipe.

Precautions for Turbocharger

The turbocharger turbine revolves at extremely high speeds and becomes very hot. Therefore, it is essential to maintain a clean supply of oil flowing through the turbocharger and to follow all required maintenance instructions and operating procedures.

For proper operation of the system, follow the procedure below.

1. Always use the recommended oil. Follow the instructions for proper time to change the oil and proper oil level.
2. Avoid accelerating engine to a high rpm immediately after starting.
3. If engine had been operating at high rpm for an extended period of time, let it idle for a few minutes prior to shutting it off.

Asbestos Safety Instructions

(Based on United Kingdom and Republic of Ireland regulations)

This vehicle uses parts containing asbestos. Most are not hazardous but Brake and Clutch linings can be. Consult the manufacturer or his agent for further details. When working with these please observe the "Garage Workers' Asbestos Code" available through your Nissan Dealer, Local Authority or Health and Safety Executive. In particular, work in a well-ventilated place using, where possible, appropriate dust extraction equipment, and avoid creating dust. Dampen all asbestos/dust where possible prior to machining, cutting, cleaning, etc. Use only hand or low speed tools.

Dispose of all asbestos waste, wet rags, etc., in a closed container as directed by your local waste disposal authority.

PRECAUTIONS

Precautions for Fuel

For Australia

Unleaded gasoline of at least 91 octane (RON)

For optimum engine performance, Nissan recommends the use of premium unleaded petrol above 95 octane (RON). However if this petrol is not available, your Nissan vehicle will also operate with 91 to 93 octane (RON) fuel.

CAUTION:

Do not use leaded gasoline. Using leaded gasoline will damage the catalytic converter.

For Europe

Unleaded premium gasoline with an octane rating of at least 95 (RON) must be used.

If premium gasoline is not available, unleaded regular gasoline with an octane rating of 91 (RON) may be temporarily used, but only under the following precautions:

- Have the fuel tank filled only partially with unleaded regular gasoline, and fill up with premium unleaded gasoline as soon as possible.
- Avoid full throttle driving and abrupt acceleration.

CAUTION:

Do not use leaded gasoline. Using leaded gasoline will damage the catalytic converter.

HOW TO USE THIS MANUAL



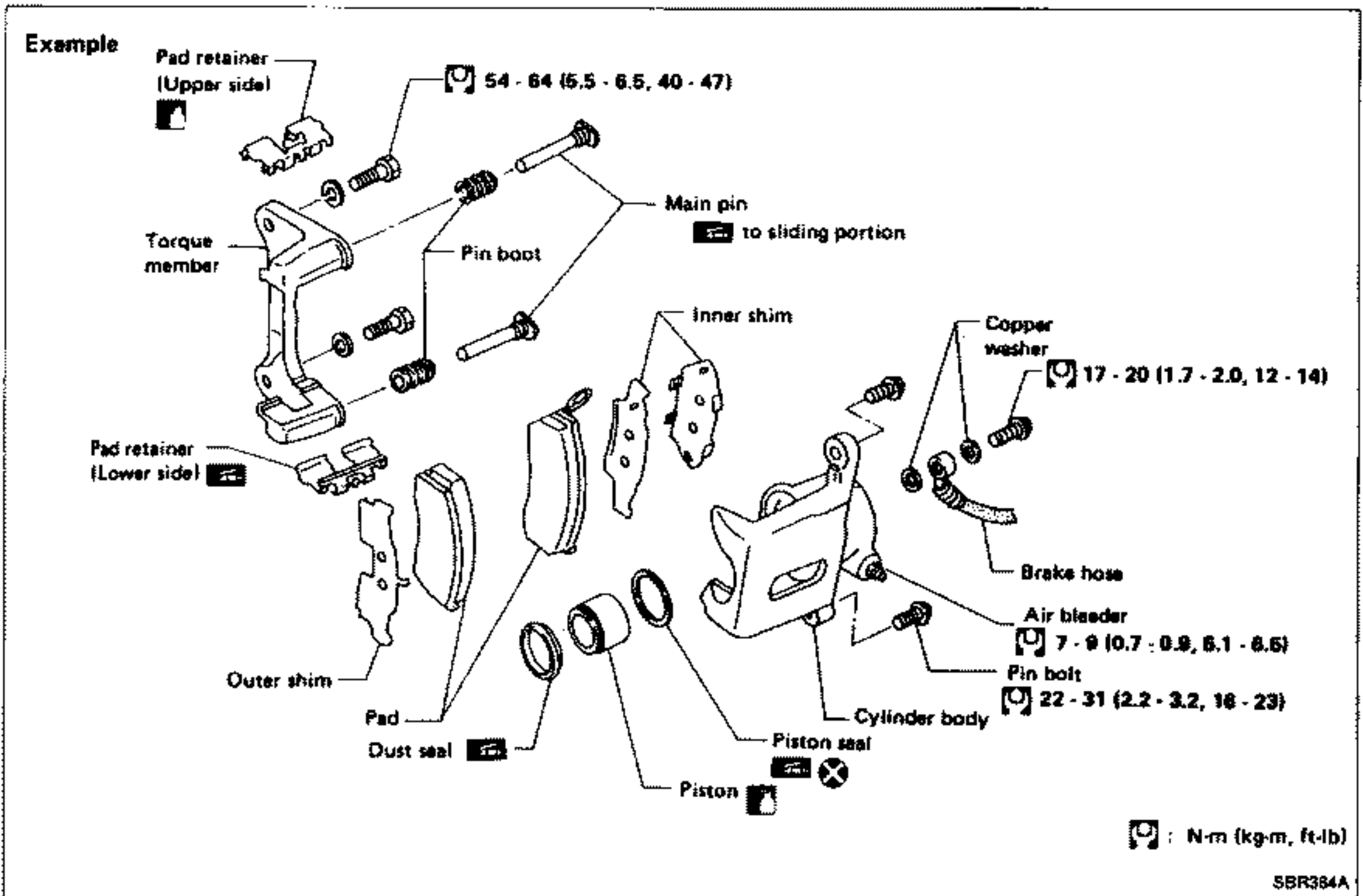





1. **A QUICK REFERENCE INDEX**, a black tab (e.g. BR) is provided on the first page. You can quickly find the first page of each section by mating it to the section's black tab.
2. **THE CONTENTS** are listed on the first page of each section.
3. **THE TITLE** is indicated on the upper portion of each page and shows the part or system.
4. **THE PAGE NUMBER** of each section consists of two letters, which designate the particular section, and a number (e.g. "BR-5").
5. **THE LARGE ILLUSTRATIONS** are exploded views (See below.) and contain tightening torques, lubrication points and other information necessary to perform repairs. The illustrations should be used in reference to service matters only. When ordering parts, refer to the appropriate **PARTS CATALOG**.



6. **THE SMALL ILLUSTRATIONS** show the important steps such as inspection, use of special tools, knacks of work and hidden or tricky steps which are not shown in the previous large illustrations. Assembly, inspection and adjustment procedures for the complicated units such as the automatic transaxle or transmission, etc. are presented in a step-by-step format where necessary.

HOW TO USE THIS MANUAL

7. The following **SYMBOLS AND ABBREVIATIONS** are used:

	: Tightening torque	A/T	: Automatic Transaxle/Transmission
	: Should be lubricated with grease. Unless otherwise indicated, use recommended multi-purpose grease.	A/C	: Air Conditioner
	: Should be lubricated with oil.	P/S	: Power Steering
	: Sealing point	S.S.T.	: Special Service Tools
	: Checking point	S.D.S.	: Service Data and Specifications
	: Always replace after every disassembly.	SAE	: Society of Automotive Engineers, Inc.
L.H., R.H.	: Left-Hand, Right-Hand	G.C.C.	: Gulf Cooperation Council
FR, RR	: Front, Rear	L.H.D.	: Left-Hand Drive
2WD	: 2-Wheel Drive	R.H.D.	: Right-Hand Drive
 (P)	: Apply petroleum jelly.	A.T.F.	: Automatic Transmission Fluid
 (ATF)	: Apply A.T.F.	D ₁	: Drive range 1st gear
★	: Select with proper thickness.	D ₂	: Drive range 2nd gear
☆	: Adjustment is required.	D ₃	: Drive range 3rd gear
M/T	: Manual Transaxle/Transmission	D ₄	: Drive range 4th gear
		O.D.	: Overdrive
		2 ₂	: 2nd range 2nd gear
		2 ₁	: 2nd range 1st gear
		1 ₂	: 1st range 2nd gear
		1 ₁	: 1st range 1st gear

8. The **UNITS** given in this manual are primarily expressed as the SI UNIT (International System of Unit), and alternatively expressed in the metric system and in the yard/pound system.

"Example"

Tightening torque:

59 - 78 N·m (6.0 - 8.0 kg·m, 43 - 58 ft·lb)

9. **TROUBLE DIAGNOSES** are included in sections dealing with complicated components.
10. **SERVICE DATA AND SPECIFICATIONS** are contained at the end of each section for quick reference of data.
11. The captions **WARNING** and **CAUTION** warn you of steps that must be followed to prevent personal injury and/or damage to some part of the vehicle.
- **WARNING** indicates the possibility of personal injury if instructions are not followed.
 - **CAUTION** indicates the possibility of component damage if instructions are not followed.
 - **BOLD TYPED STATEMENTS** except **WARNING** and **CAUTION** give you helpful information.

HOW TO READ WIRING DIAGRAMS

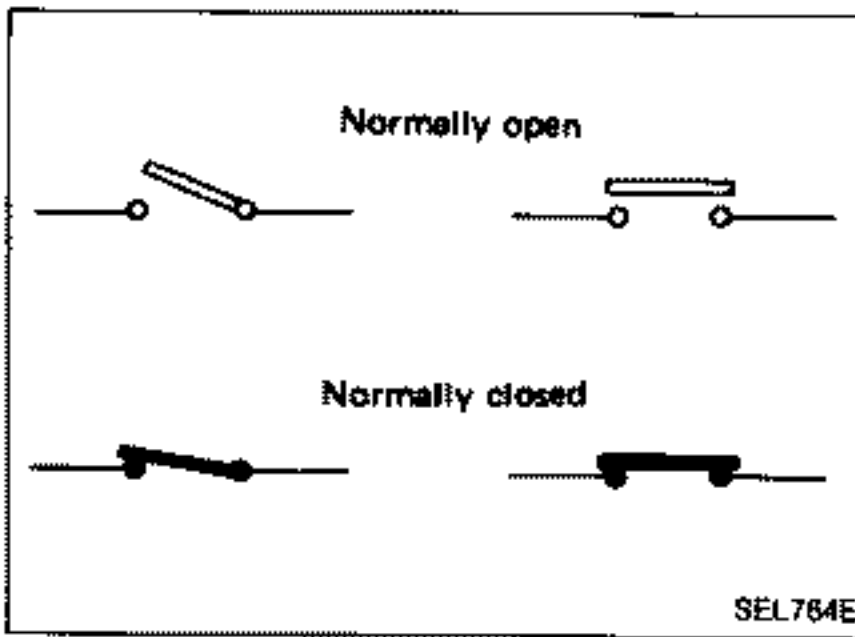

SWITCH POSITIONS

Wiring diagram switches are shown with the vehicle in the following condition.

- Ignition switch "OFF".
- Doors, hood and trunk lid/back door closed.
- Pedals are not depressed and parking brake is released.

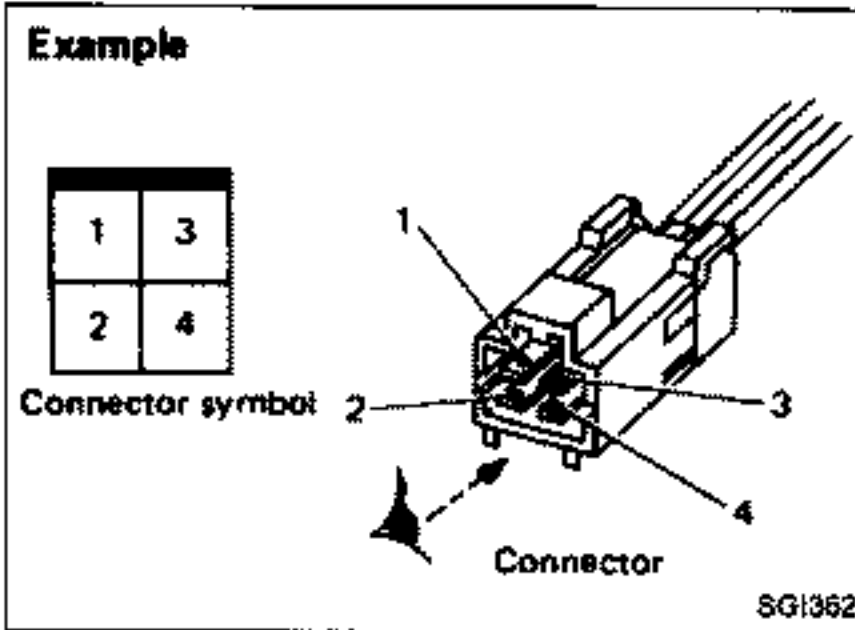

CONNECTOR SYMBOLS

- All connector symbols in wiring diagrams are shown from the terminal side.

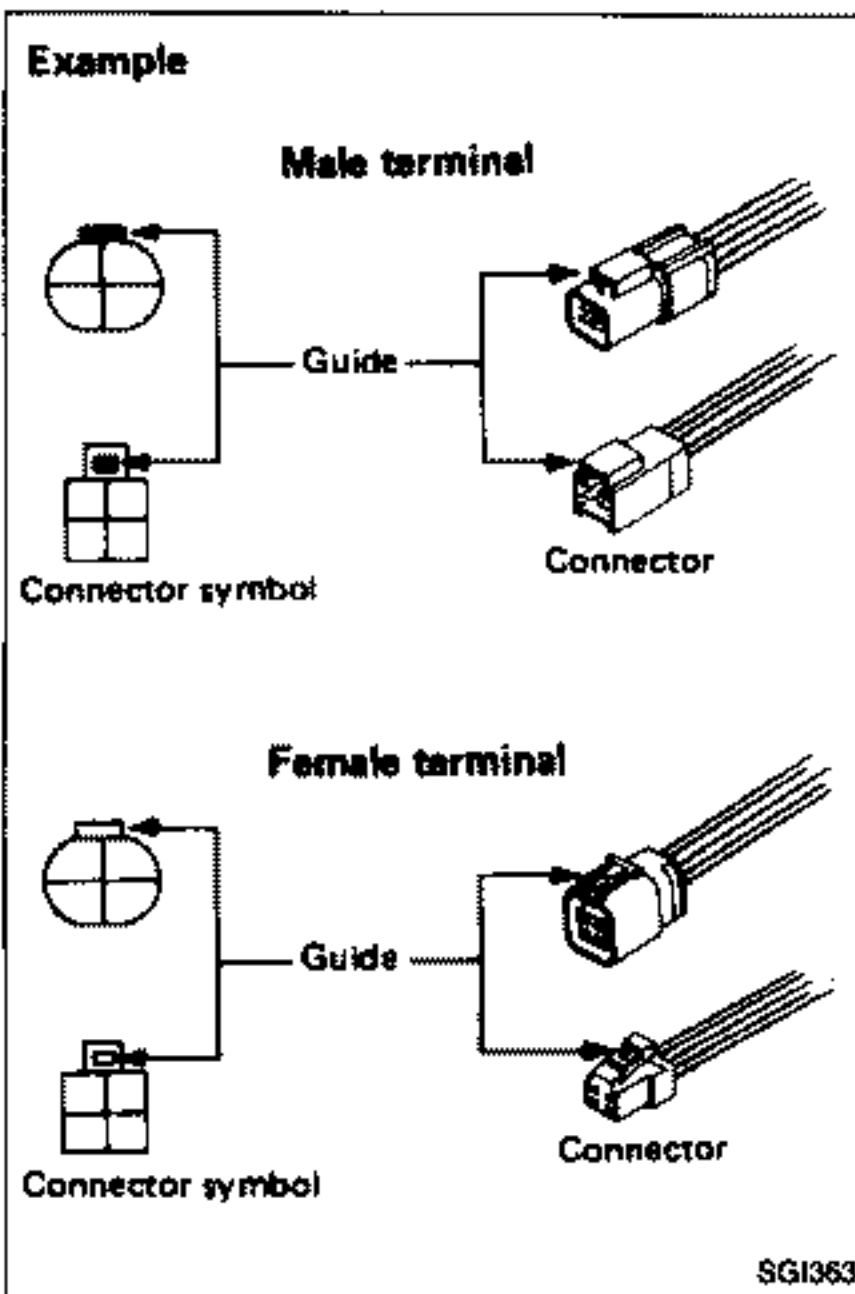

- Male and female terminals
Connector guides for male terminals are shown in black and female terminals in white in wiring diagrams.

HOW TO READ WIRING DIAGRAMS

MULTIPLE SWITCH

The continuity of the multiple switch is identified in the switch chart in wiring diagrams.

Example

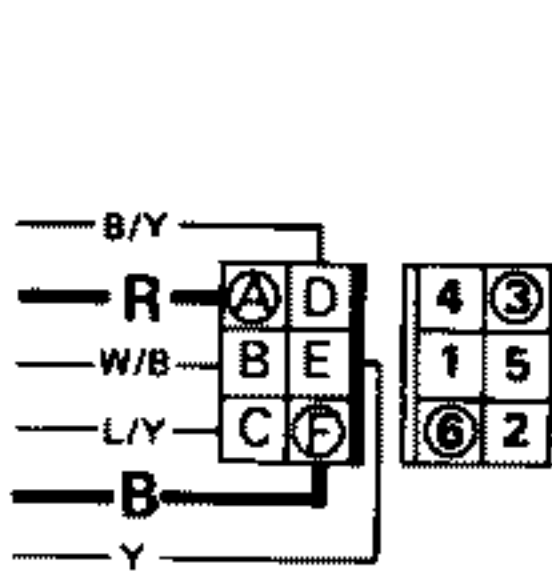

WIPER SWITCH

	OFF	INT	LO	HI	WASH
1					○
2				○	
③	○	○	●	○	
4			●		
5		○	●	○	
⑥		○	●	○	

Continuity circuit of wiper switch

SWITCH POSITION	CONTINUITY CIRCUIT
OFF	3 - 4
INT	3 - 4, 5 - 6
LO	3 - 6
HI	2 - 6
WASH	1 - 6

Example: Wiper switch in LO position

Continuity circuit: Red wire - A terminal - ③ terminal - Wiper switch (● - ● : LO) - ⑥ terminal - F terminal - Black wire

SG1365

HOW TO READ WIRING DIAGRAMS

SUPER MULTIPLE JUNCTION (S.M.J.)

- The "S.M.J." indicated in wiring diagrams is shown in a simplified form. The terminal arrangement should therefore be referred to in the foldout at the end of the Service Manual.
- The foldout should be spread to read the entire wiring diagram.

Example

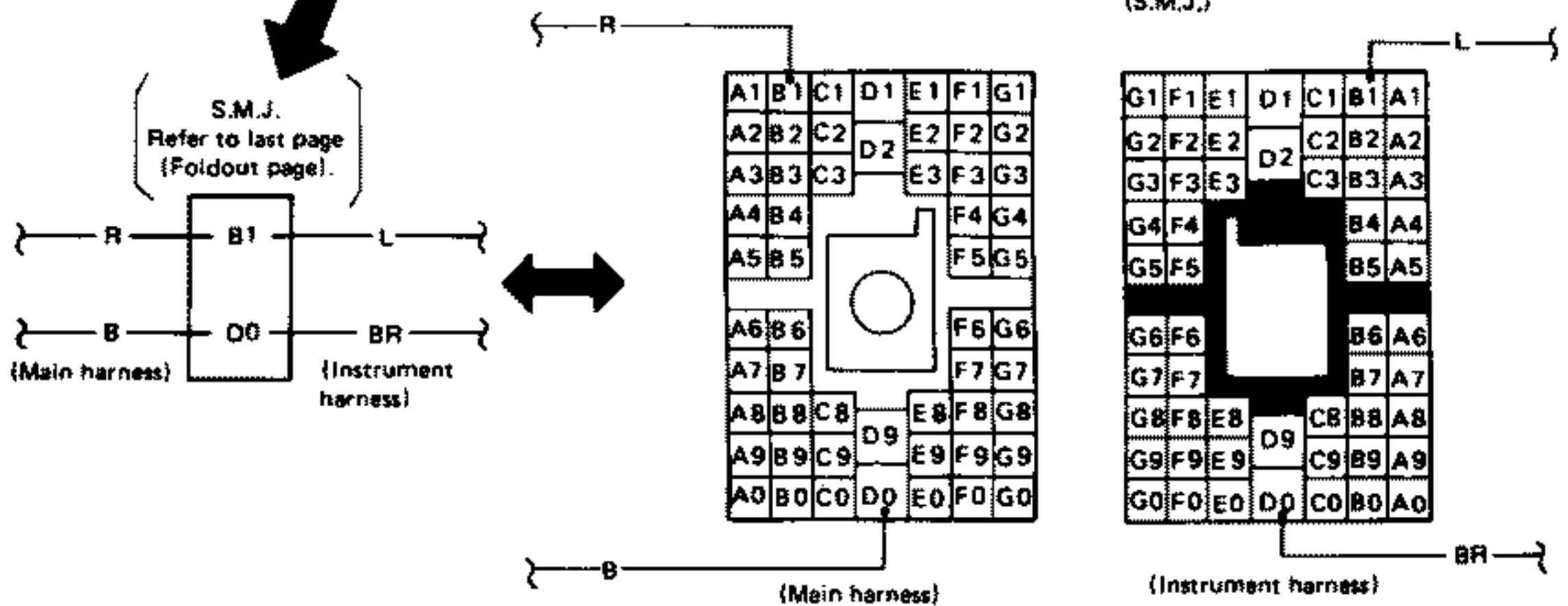
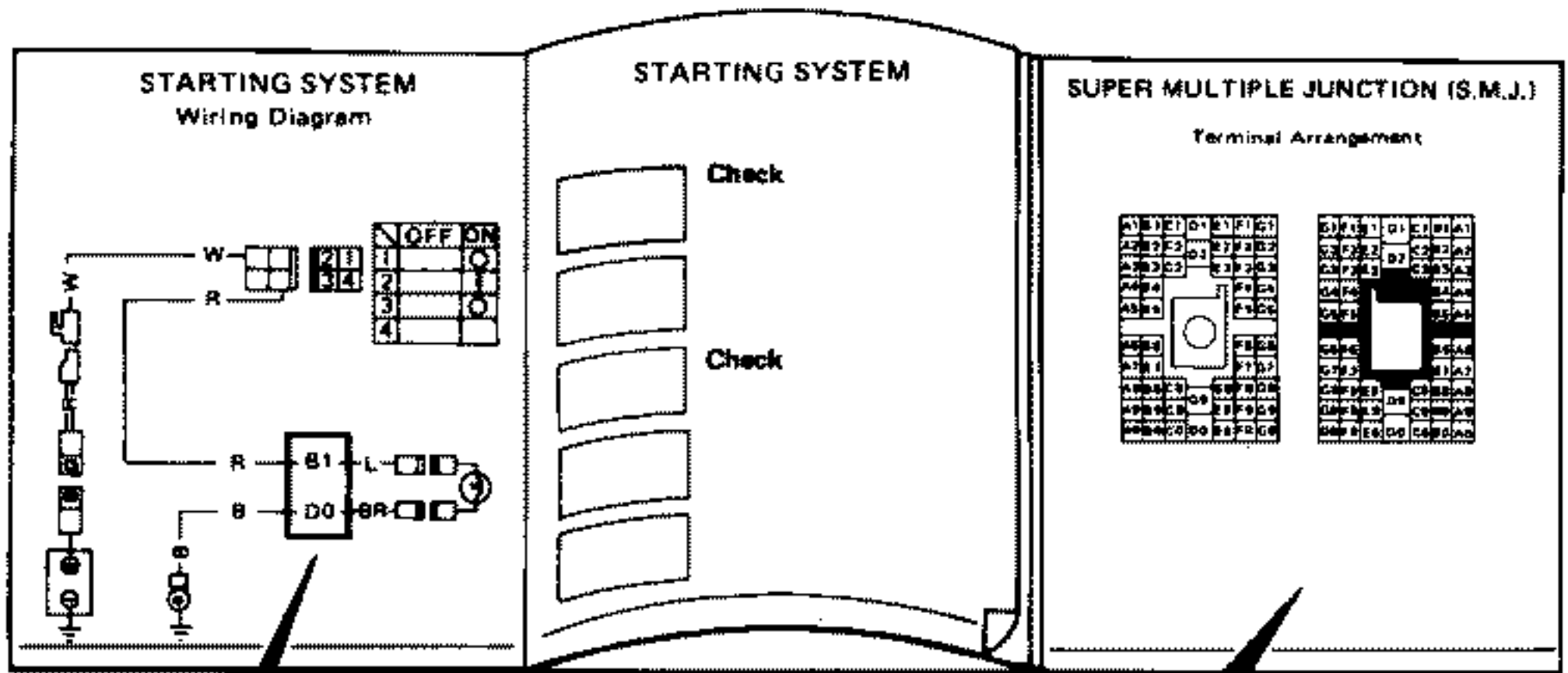

SEL653F

HOW TO FOLLOW FLOW CHART IN TROUBLE DIAGNOSES

Example

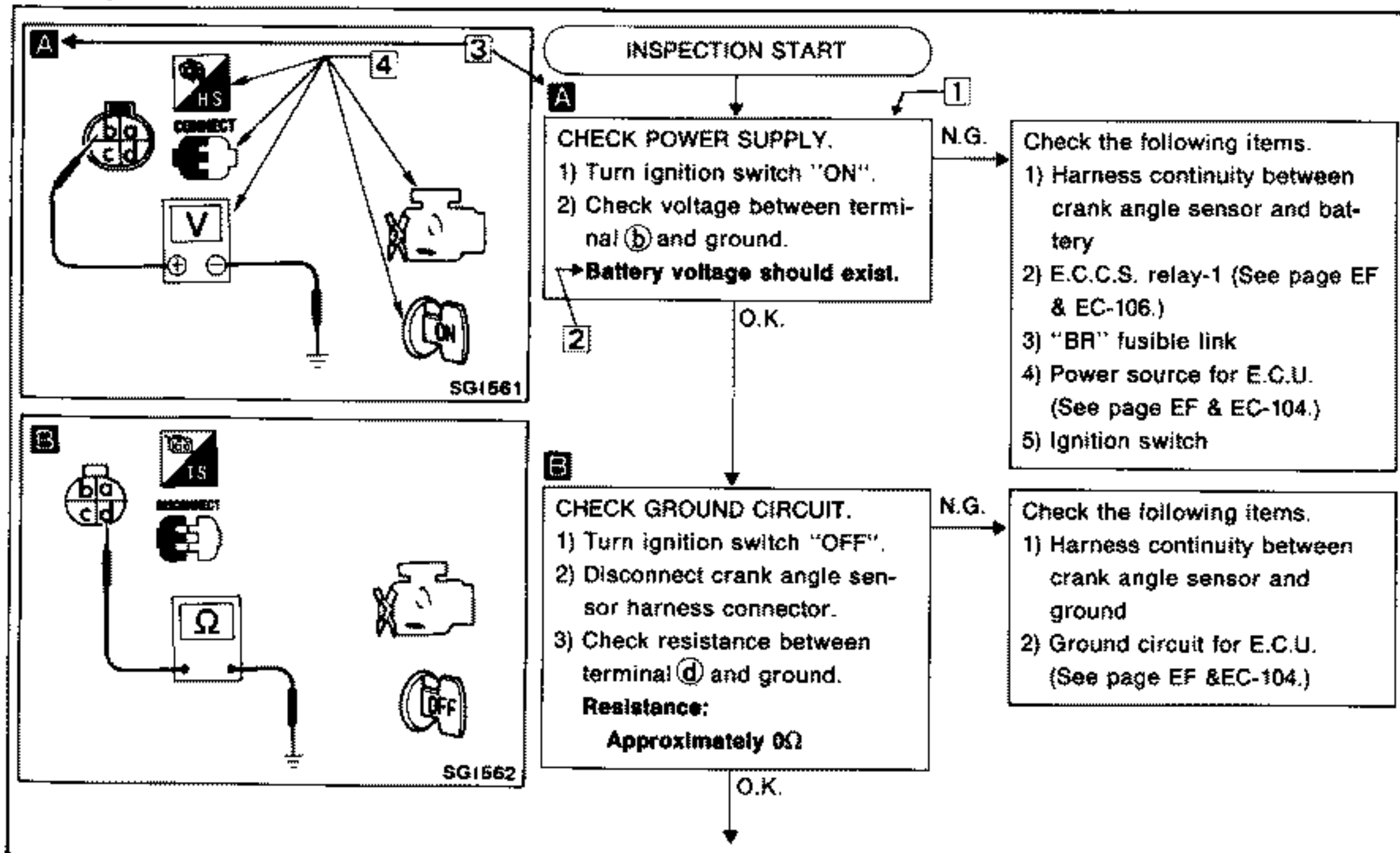

NOTICE

The flow chart indicates work procedures required to diagnose problems effectively. Observe the following instructions before diagnosing.

- 1) Use the flow chart after locating probable causes of a problem following the "Preliminary Check" or the "Symptom Chart".
- 2) After repairs, re-check that the problem has been completely eliminated.
- 3) Refer to Component Parts Location and Harness Layout for the Systems described in each section for identification/location of components and harness connectors.
- 4) Refer to the Circuit Diagram for Quick Pinpoint Check. If you must perform circuit continuity between harness connectors more detail, such as in case of sub-harness is used, refer to Wiring Diagram and Harness Layout in EL section for identification of harness connectors.
- 5) When checking circuit continuity, ignition switch should be "OFF".
- 6) Before checking voltage at connectors, check battery voltage.
- 7) After accomplishing the Diagnostic Procedures and Electrical Components Inspection, make sure that all harness connectors are reconnected as it was.

HOW TO FOLLOW FLOW CHART IN TROUBLE DIAGNOSES

HOW TO FOLLOW THIS FLOW CHART

1 Work and diagnostic procedure

Start to diagnose a problem using procedures indicated in enclosed blocks, as shown in the following example.

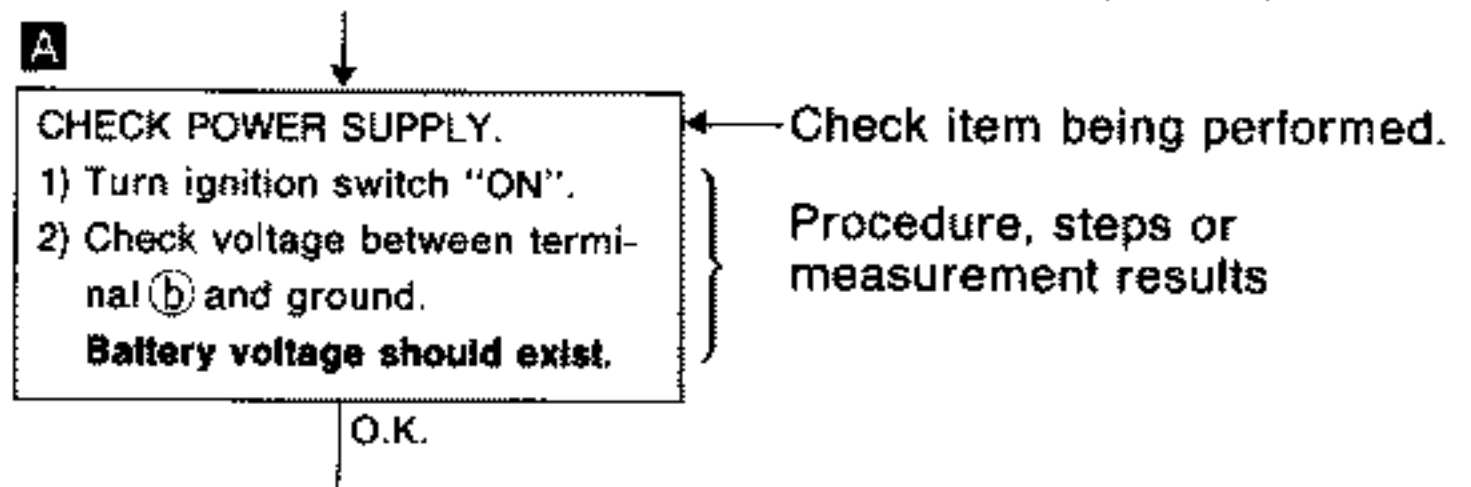

2 Measurement results

Required results are indicated in bold type in the corresponding block, as shown below:

These have the following meanings:

Battery voltage → 11 - 14V or approximately 12V

Voltage: Approximately 0V → Less than 1V

3 Cross reference of work symbols in the text and illustrations

Illustrations are provided as visual aids for work procedures. For example, symbol **A** indicated in the left upper portion of each illustration corresponds with the symbol in the flowchart for easy identification. More precisely, the procedure under the "CHECK POWER SUPPLY" outlined previously is indicated by an illustration **A**.

4 Symbols used in illustrations

Symbols included in illustrations refer to measurements or procedures. Before diagnosing a problem, familiarize yourself with each symbol.

HOW TO FOLLOW FLOW CHART IN TROUBLE DIAGNOSES

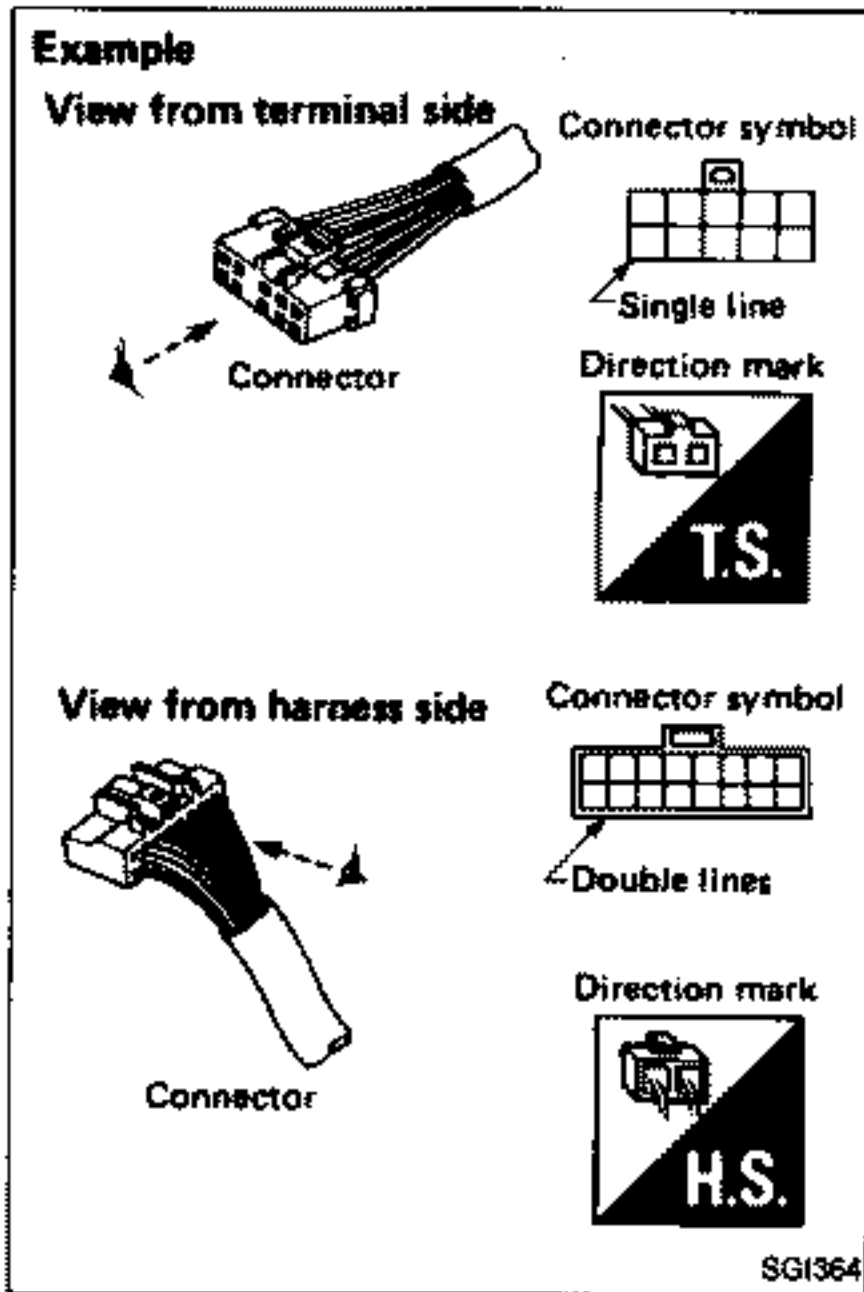

Direction mark

A direction mark is shown to clarify the side of connector (terminal side or harness side).

Direction marks are mainly used in the illustrations indicating terminal inspection.



: View from terminal side ... T.S.

- All connector symbols shown from the terminal side are enclosed by a single line.











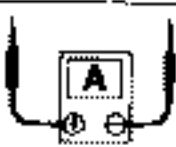









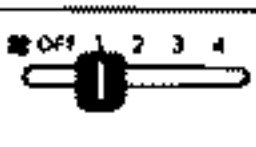

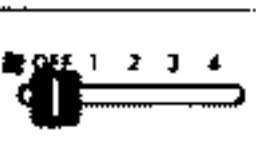

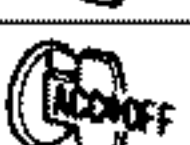

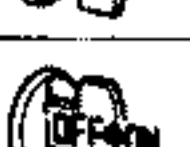

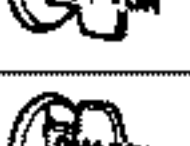



: View from harness side ... H.S.

- All connector symbols shown from the harness side are enclosed by a double line.

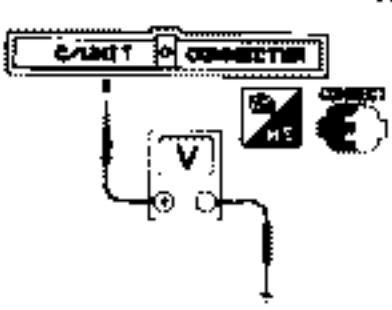
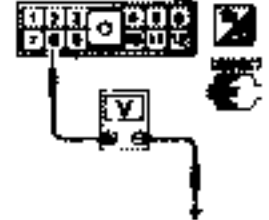
HOW TO FOLLOW FLOW CHART IN TROUBLE DIAGNOSES

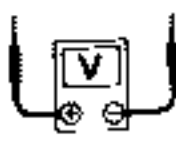
Key to symbols signifying measurements or procedures

Symbol	Symbol explanation	Symbol	Symbol explanation
	Check after disconnecting the connector to be measured.		Current should be measured with an ammeter.
	Check after connecting the connector to be measured.		Procedure with CONSULT
	Insert key into ignition switch.		Procedure without CONSULT
	Remove key from ignition switch.		A/C switch is "OFF".
	Turn ignition switch to "OFF" position.		A/C switch is "ON".
	Turn ignition switch to "ON" position.		Fan switch is "ON". (At any position except for "OFF" position)
	Turn ignition switch to "START" position.		Fan switch is "OFF".
	Turn ignition switch from "OFF" to "ACC" position.		Apply battery voltage directly to components.
	Turn ignition switch from "ACC" to "OFF" position.		Drive vehicle.
	Turn ignition switch from "OFF" to "ON" position.		Disconnect battery negative cable.
	Turn ignition switch from "ON" to "OFF" position.		Depress brake pedal.
	Do not start engine, or check with engine stopped.		Release brake pedal.
	Start engine, or check with engine running.		Depress accelerator pedal.
	Apply parking brake.		Release accelerator pedal.
	Release parking brake.	 <p>Pin terminal check for S.M.J. type E.C.U. and A/T control unit connectors. For details regarding the terminal arrangement, refer to the foldout page.</p> 	
	Check after engine is warmed up sufficiently.		
	Voltage should be measured with a voltmeter.		
	Circuit resistance should be measured with an ohmmeter.		

CONSULT CHECKING SYSTEM

Outside View

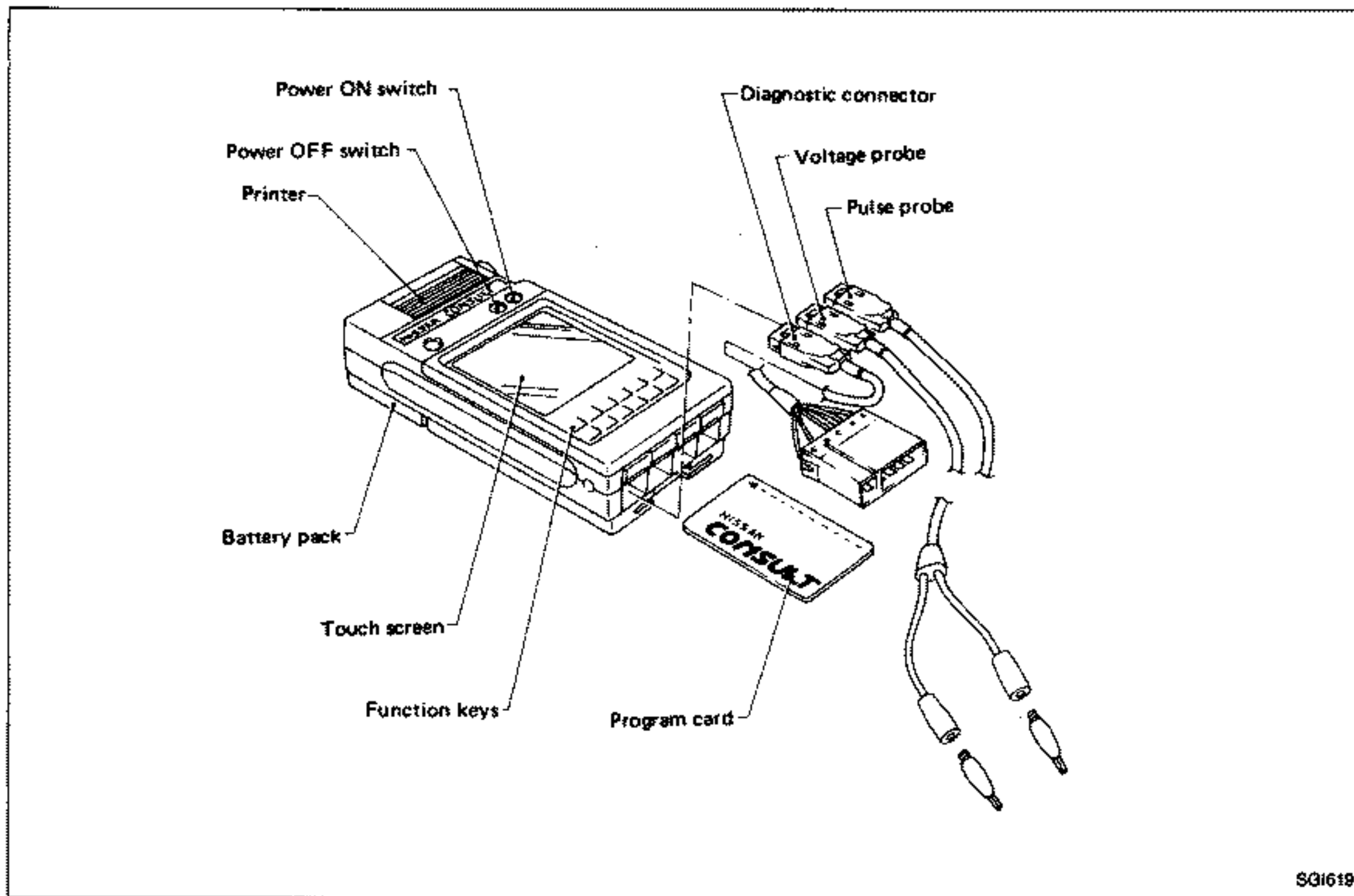

SG1619

System Application

System	E.C.C.S.	Auto A/C*	A/T	HICAS*
Diagnostic mode				
Work support	X	X	—	—
Self-diagnostic results	X	X	X	X
Data monitor	X	X	X	X
Active test	X	X	—	X
E.C.U. part number	X	—	X	X

X: Applicable

*: For Europe

CONSULT CHECKING SYSTEM

Function

Diagnostic mode	Function
Work support	This mode enables a technician to adjust some devices faster and more accurately by following the indications on CONSULT.
Self-diagnostic results	Self-diagnostic results can be read and erased quickly.
Data monitor	Input/Output data in the control unit can be read.
Active test	Mode in which CONSULT drives some actuators apart from the control units and also shifts some parameters in a specified range.
E.C.U. part number	E.C.U. part number can be read.

Checking Equipment

Tool name	Description
<p>NISSAN CONSULT kit</p> <ul style="list-style-type: none"> ① CONSULT unit and accessories ② Program card ③ Operation manuals ④ Binder ⑤ Carrying case ⑥ Thermal paper (Rolls) 	

When ordering the above equipment, contact your NISSAN distributor.

IDENTIFICATION INFORMATION

Model Variation

Body	Destination	Model		Engine	Transmission	Differential carrier
T-bar roof	Europe	2+2	KRG-JSQ	VG30DETT	RS5R30A	R230V
			KRG-JASQ		RE4R03A	
			KRLG-JSQ		RS5R30A	
			KRLG-JASQ		RE4R03A	
T-bar roof	Australia	2+2	KRG-JM	VG30DE	RS5R30A	R200V
			KRG-JAM		RE4R01A	

Prefix and suffix designations:

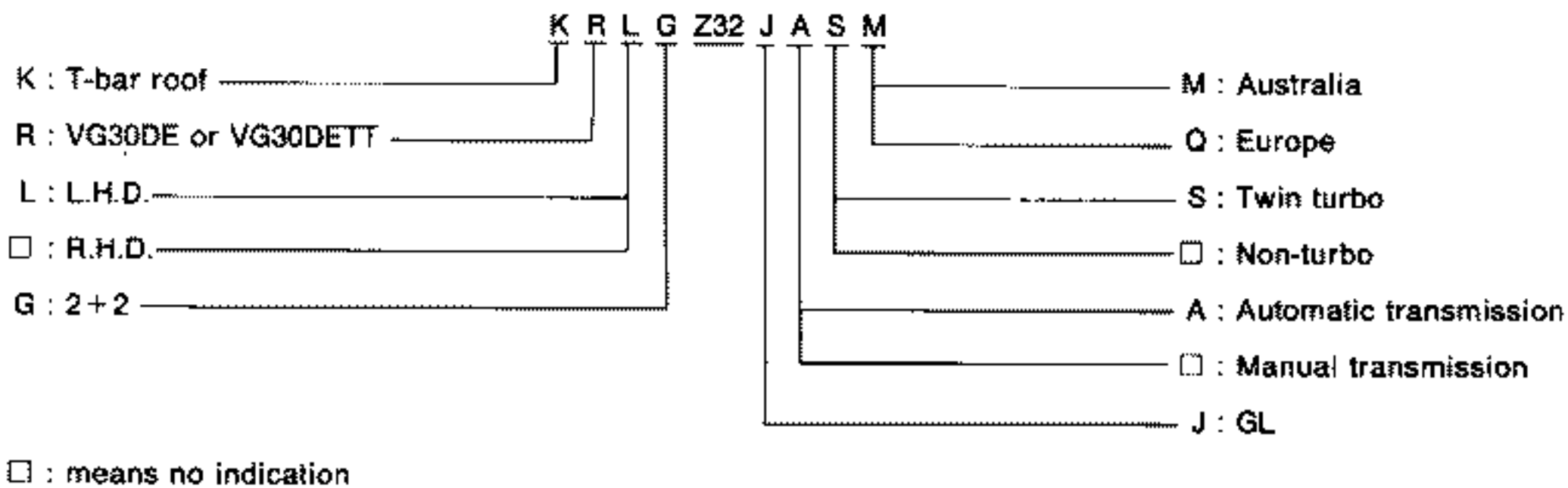

IDENTIFICATION INFORMATION

Identification Number

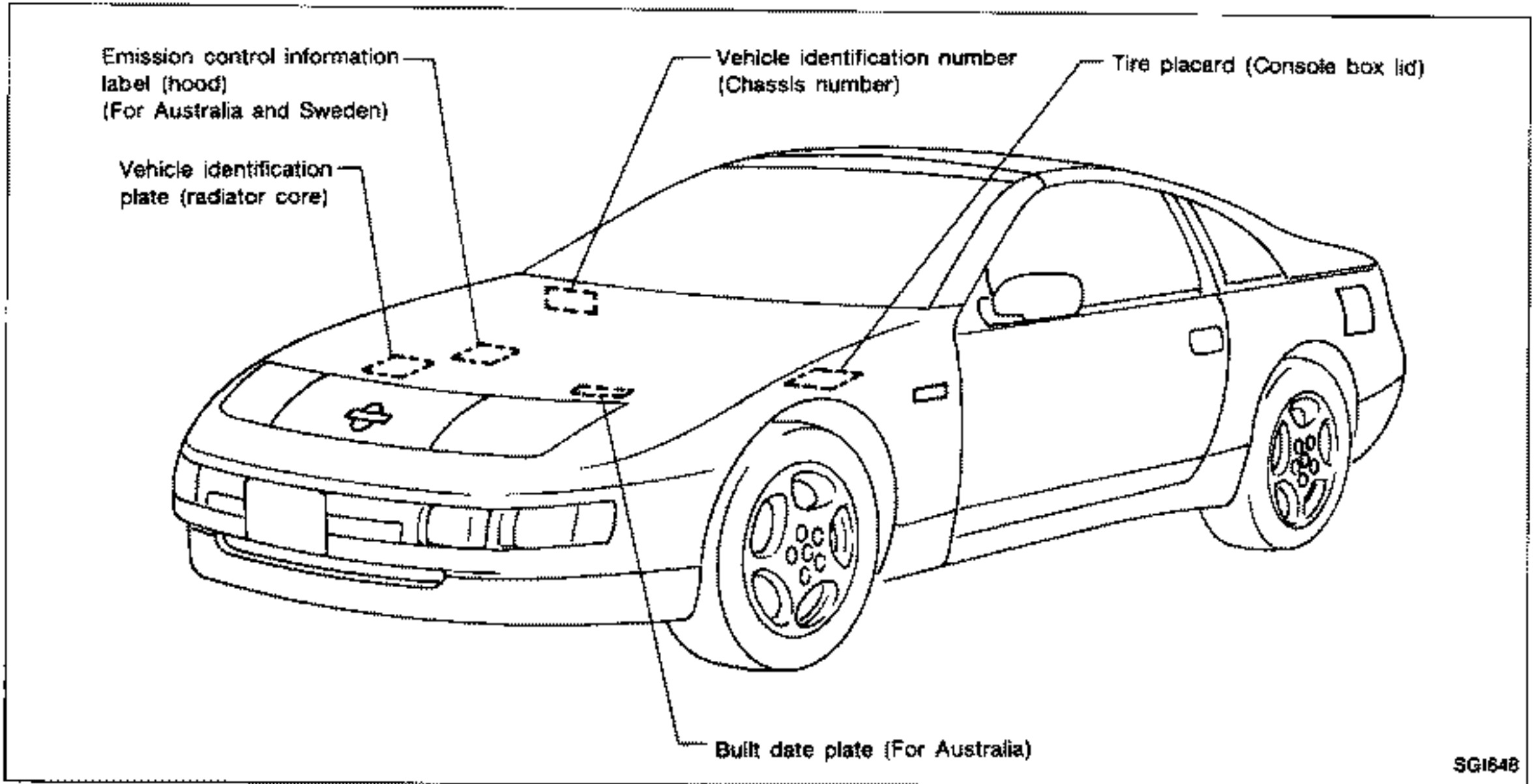

VEHICLE IDENTIFICATION NUMBER ARRANGEMENT

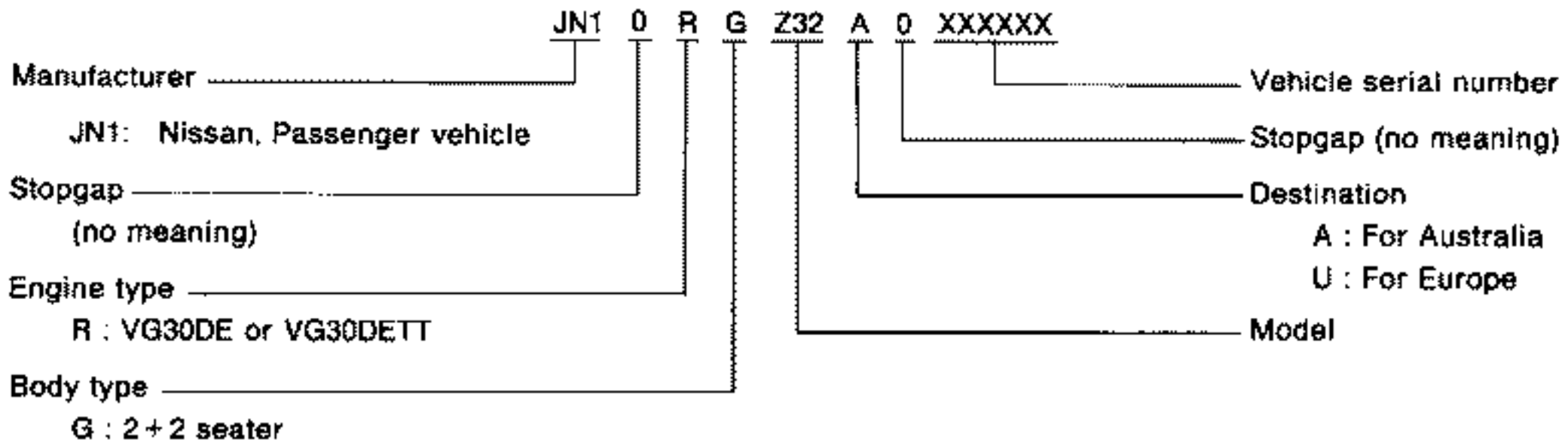

IDENTIFICATION INFORMATION

Dimensions

Unit: mm (in)

	2+2
Overall length	4,525 (178.1)
Overall width	1,800 (70.9)
Overall height (T-bar roof)	1,255 (49.4)
Front tread	1,495 (58.9)
Rear tread	1,535 (60.4)*1 1,555 (61.2)*2
Wheelbase	2,570 (101.2)

*1: For Australia

*2: For Europe

Wheels and Tires

Road wheel

	Aluminum	Steel	Offset mm (in)
Conventional	16 x 7.5JJ*1	—	45 (1.77)
	16 x 8.5JJ*2	—	35 (1.38)*1
Spare T-type	—	16 x 4T	30 (1.18)

Tire size

Conventional	P225/50R16 91V*3
	225/50ZR16*4
	245/45ZR16*5
Spare T-type	T125/90D16

*1: For Australia and front wheel for Europe

*2: Rear wheel for Europe

*3: For Australia

*4: Front tire for Europe

*5: Rear tire for Europe

LIFTING POINTS AND TOW TRUCK TOWING

Garage Jack and Safety Stand

WARNING:

- Never get under the vehicle while it is supported only by the jack. Always use safety stands to support the frame when you have to get under the vehicle.
- Place wheel chocks at both the front and rear of the wheels on the ground.

CAUTION:

Place a wooden or rubber block between safety stand and vehicle body when the supporting body is flat.

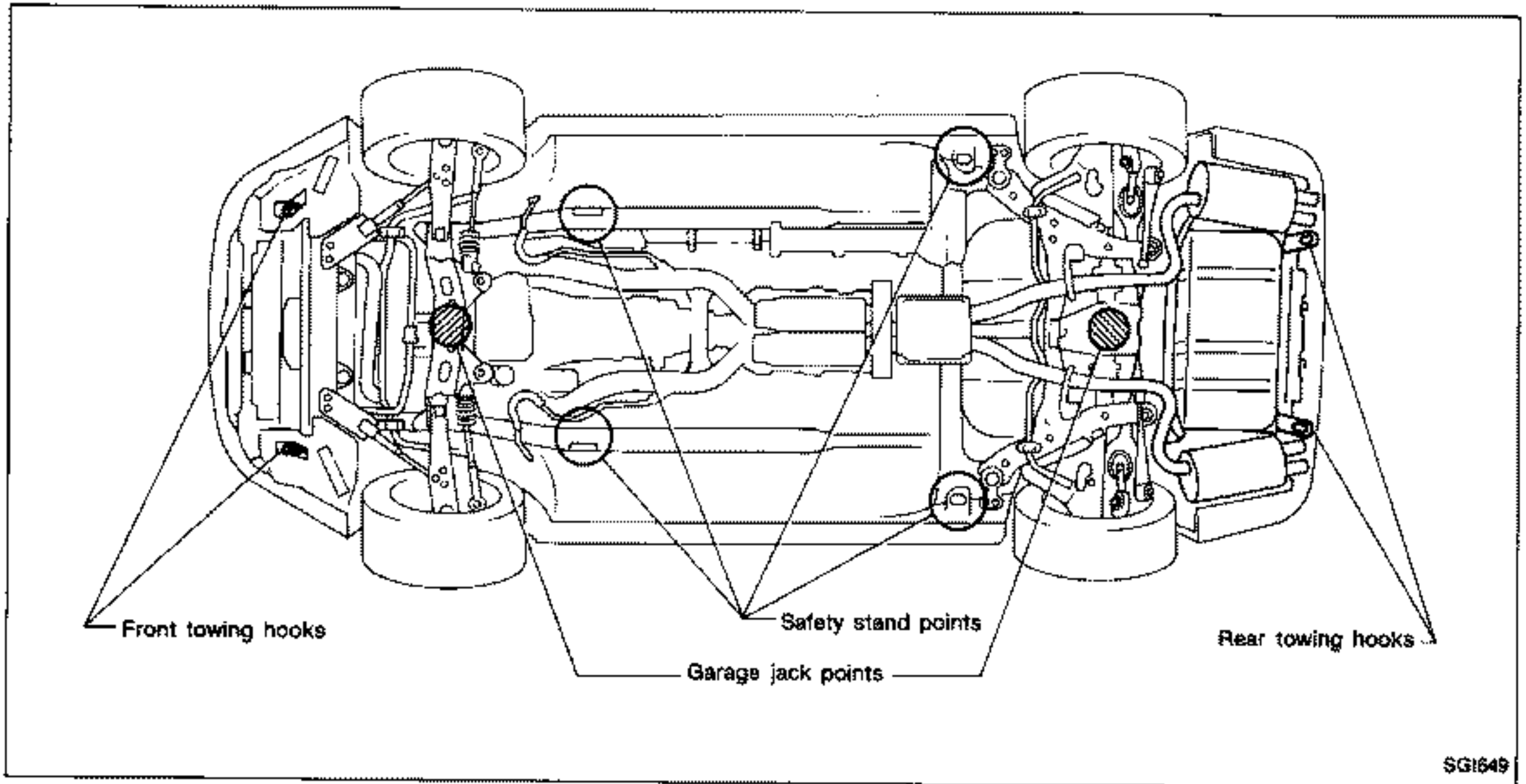

SG1649

LIFTING POINTS AND TOW TRUCK TOWING

2-pole Lift

WARNING:

When lifting the vehicle, open the lift arms as wide as possible and ensure that the front and rear of the vehicle are well balanced.

When setting the lift arm, do not allow the arm to contact the brake tubes and fuel lines.

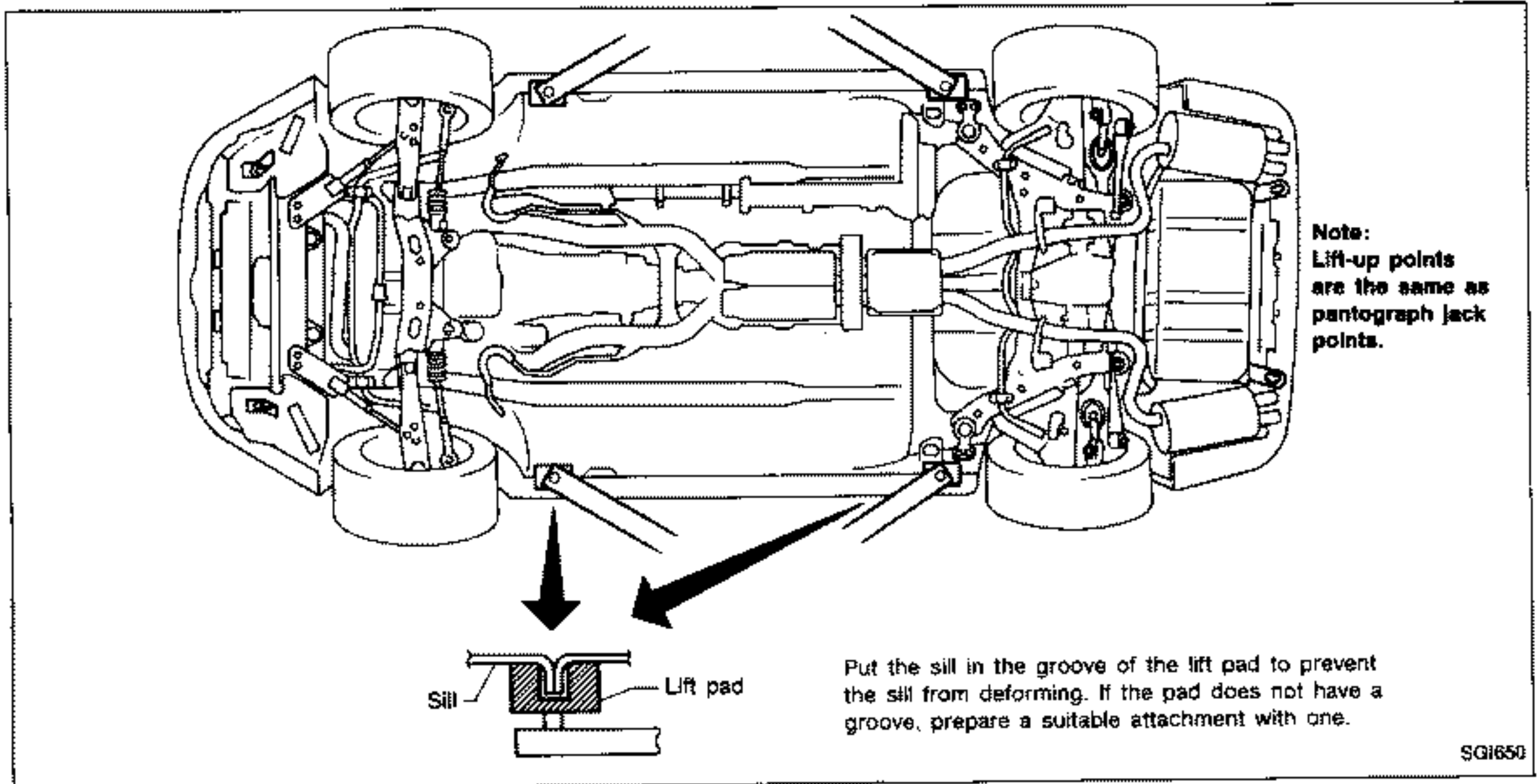

Tow Truck Towing

CAUTION:

- All applicable local laws regarding the towing operation must be obeyed.
- It is necessary to use proper towing equipment to avoid possible damage to the vehicle during towing operation. Towing is in accordance with Towing Procedure Manual at dealer.
- When towing with the rear wheels on the ground, release the parking brake and move the gearshift lever to neutral ("N" position).

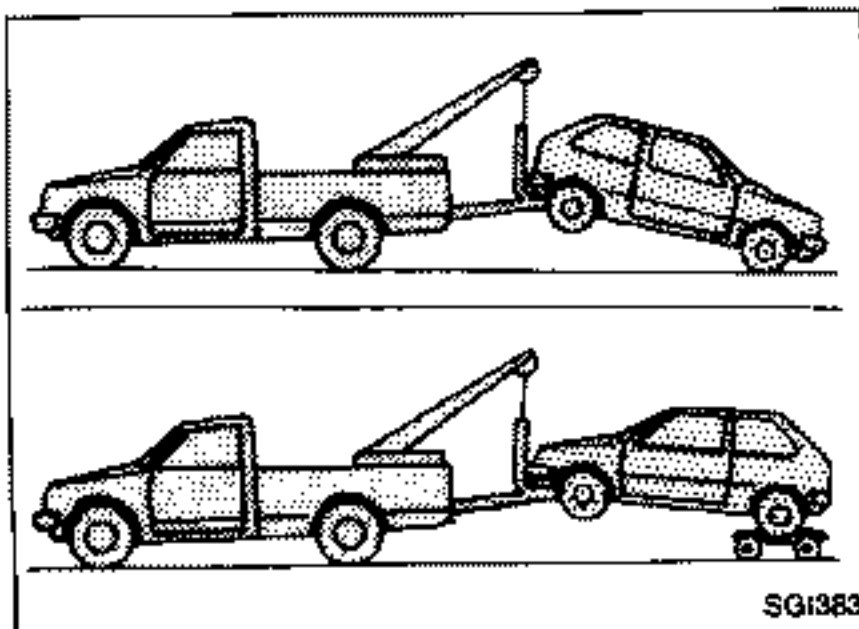

NISSAN recommends that vehicle be towed with the driving (rear) wheels off the ground as illustrated.

LIFTING POINTS AND TOW TRUCK TOWING

Tow Truck Towing (Cont'd)

TOWING AN AUTOMATIC TRANSMISSION MODEL WITH FOUR WHEELS ON GROUND OR TOWING WITH FRONT WHEELS RAISED (With rear wheels on ground)

Observe the following restricted towing speeds and distances.

Speed:

Below 50 km/h (30 MPH)

Distance:

Less than 65 km (40 miles)

If the speed or distance must necessarily be greater, remove the propeller shaft beforehand to prevent damage to the transmission.

TOWING POINT

- Always pull the cable straight out from the vehicle. Never pull on the hook at a sideways angle.
- Remove the first bolt under the front fender protector when using the front towing hooks.

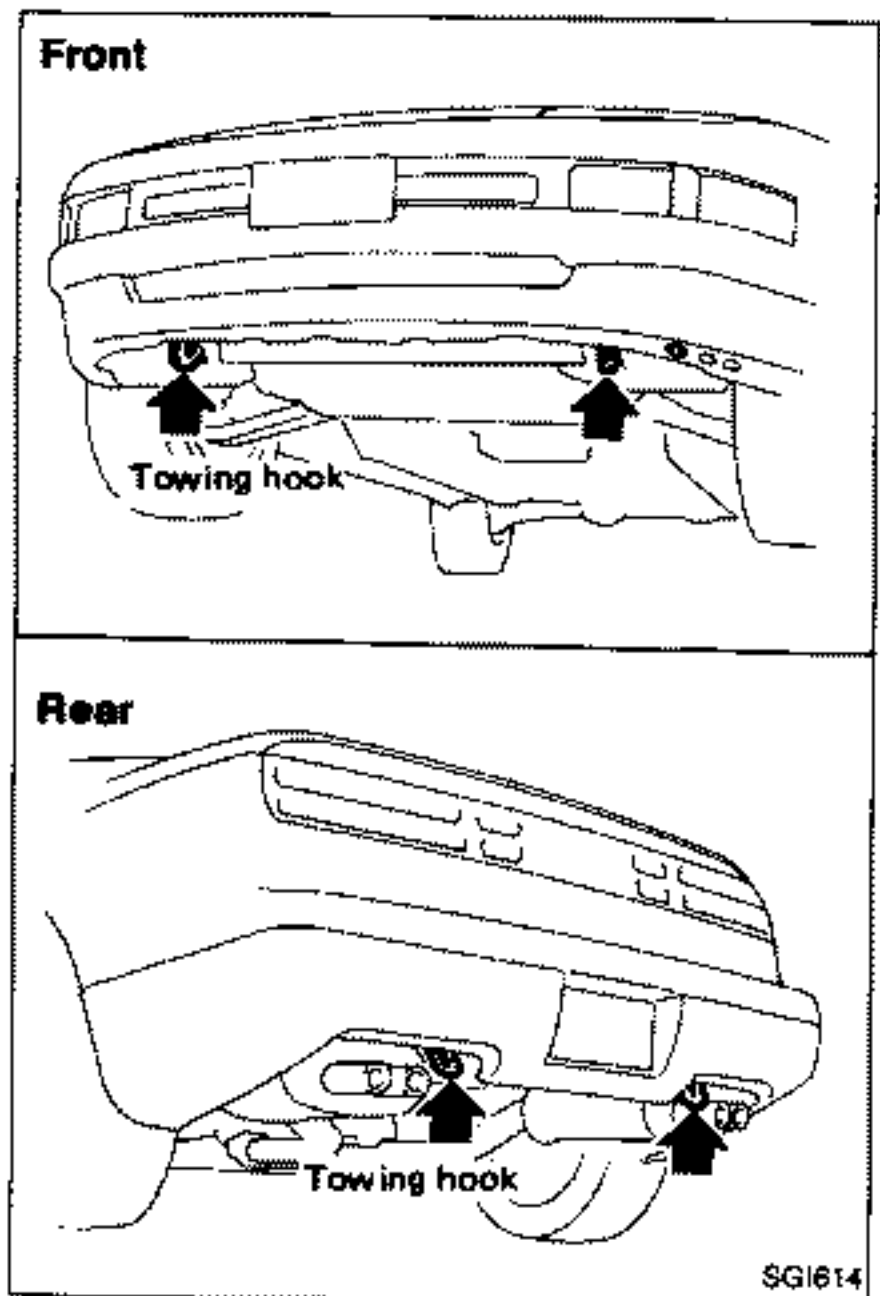

TIGHTENING TORQUE OF STANDARD BOLTS

Grade	Bolt size	Bolt diameter* mm	Pitch mm	Tightening torque (Without lubricant)					
				Hexagon head bolt			Hexagon flange bolt		
				N·m	kg·m	ft·lb	N·m	kg·m	ft·lb
4T	M6	6.0	1.0	5.1	0.52	3.8	6.1	0.62	4.5
	M8	8.0	1.25	13	1.3	9	15	1.5	11
			1.0	13	1.3	9	16	1.6	12
	M10	10.0	1.5	25	2.5	18	29	3.0	22
			1.25	25	2.6	19	30	3.1	22
	M12	12.0	1.75	42	4.3	31	51	5.2	38
			1.25	46	4.7	34	56	5.7	41
M14	14.0	1.5	74	7.5	54	88	9.0	65	
7T	M6	6.0	1.0	8.4	0.86	6.2	10	1.0	7
	M8	8.0	1.25	21	2.1	15	25	2.5	18
			1.0	22	2.2	16	26	2.7	20
	M10	10.0	1.5	41	4.2	30	48	4.9	35
			1.25	43	4.4	32	51	5.2	38
	M12	12.0	1.75	71	7.2	52	84	8.6	62
			1.25	77	7.9	57	92	9.4	68
M14	14.0	1.5	127	13.0	94	147	15.0	108	
9T	M6	6.0	1.0	12	1.2	9	15	1.5	11
	M8	8.0	1.25	29	3.0	22	35	3.6	26
			1.0	31	3.2	23	37	3.8	27
	M10	10.0	1.5	59	6.0	43	70	7.1	51
			1.25	62	6.3	46	74	7.5	54
	M12	12.0	1.75	98	10.0	72	118	12.0	87
			1.25	108	11.0	80	137	14.0	101
M14	14.0	1.5	177	18.0	130	206	21.0	152	

1. Special parts are excluded.
2. This standard is applicable to bolts having the following marks embossed on the bolt head.

Grade	Mark
4T	4
7T	7
9T	9

* : Nominal diameter

