

SECTION BF

GI
MA
EM
LC
EF &
EC
FE
CL
MT
AT
PD
FA
RA
BR
ST
BF
HA
EL
IDX

CONTENTS

GENERAL SERVICING	2	Windshield.....	57
Precautions.....	2	Side Window.....	58
Supplemental Restraint System "AIR BAG".....	2	Back Door Window.....	59
Circuit Breaker Inspection.....	2	REAR AIR SPOILER AND MIRROR	60
Clip and Fastener.....	3	Rear Air Spoiler.....	60
BODY END	5	Door Mirror.....	60
Body Front End.....	5	BODY ALIGNMENT	62
Body Rear End and Opener.....	7	Engine Compartment.....	62
DOOR	10	Underbody.....	64
Power Window.....	11	SUPPLEMENTAL RESTRAINT SYSTEM (SRS)	69
Power Door Lock.....	13	Precautions for SRS "Air Bag" Service.....	69
MULTI-REMOTE CONTROL SYSTEM	16	Special Service Tools.....	69
Wiring Diagram.....	16	Commercial Service Tools.....	69
Circuit Diagram for Quick Pinpoint Check.....	18	Description.....	70
Trouble Diagnoses Preliminary Inspection.....	19	SRS Component Parts Location and Caution	
Trouble Diagnoses.....	20	Labels.....	71
Replacing Remote Controller or Control Unit.....	26	Maintenance Items.....	74
INSTRUMENT PANEL	27	Removal and Installation — Diagnosis	
INTERIOR AND EXTERIOR	29	(Control) Unit and Sensors.....	75
Interior.....	29	Removal — Air Bag Module and Spiral Cable.....	76
Exterior.....	36	Removal — Front Passenger Air Bag Module.....	77
T-BAR ROOF	45	Installation — Air Bag Module and Spiral	
CONVERTIBLE ROOF	47	Cable.....	78
Wiring Diagram.....	47	Installation — Front Passenger Air Bag	
Storage Lid.....	49	Module.....	80
Top Cover and Headliner.....	50	Scrapping Air Bag.....	80
Linkage.....	51	TROUBLE DIAGNOSES — Supplemental	
Adjustment.....	53	Restraint System (SRS)	83
SEAT	54	Contents.....	83
WINDSHIELD AND WINDOWS	57		

When you read wiring diagrams:

- Read GI section, "HOW TO READ WIRING DIAGRAMS".
- See EL section, "POWER SUPPLY ROUTING" for power distribution circuit.

★ For conventional seat belt, refer to MA section.

Precautions

- When removing or installing various parts, place a cloth or padding onto the vehicle body to prevent scratches.
- Handle trim, molding, instruments, grille, etc. carefully during removing or installation. Be careful not to soil or damage them.
- Apply sealing compound where necessary when installing parts.
- When applying sealing compound, be careful that the sealing compound does not protrude from parts.
- When replacing any metal parts (for example body outer panel, members, etc.), be sure to take rust prevention measures.

Supplemental Restraint System "AIR BAG"

The Supplemental Restraint System "Air Bag" helps to reduce the risk or severity of injury to the driver and front passenger in a frontal collision. The Supplemental Restraint System consists of air bags (located in the center of the steering wheel and on the instrument panel on the passenger side), sensors, a diagnosis unit, warning lamp, wiring harness and spiral cable. Information necessary to service the system safely is included in the **BF section** of this Service Manual.

WARNING:

- To avoid rendering the SRS inoperative, which could lead to personal injury or death in the event of a severe frontal collision, all maintenance must be performed by an authorized NISSAN dealer.
- Improper maintenance, including incorrect removal and installation of the SRS, can lead to personal injury caused by unintentional activation of the system.
- All SRS air bag electrical wiring harnesses and connectors are covered with yellow outer insulation. Do not use electrical test equipment on any circuit related to the SRS SYSTEM.

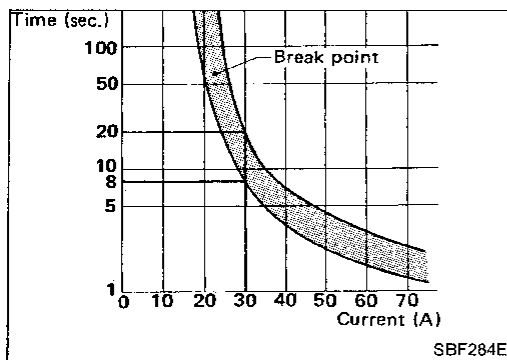

Circuit Breaker Inspection

For example, when current is 30A, the circuit is broken within 8 to 20 seconds.





Circuit breakers are used in the following systems.

- Power window & power door lock
- Power seat

GENERAL SERVICING

Clip and Fastener

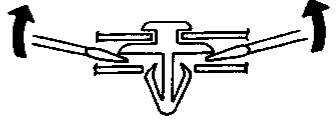
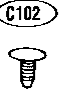
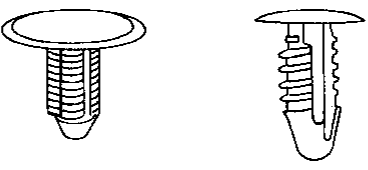
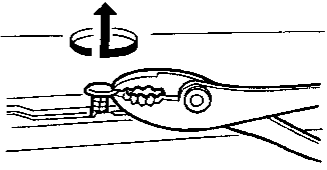
- Clips and fasteners in BF section correspond to the following numbers and symbols.
- Replace any clips and/or fasteners which are damaged during removal or installation.

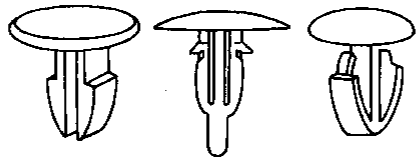
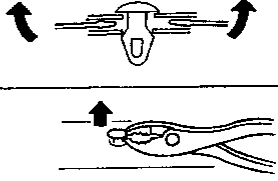
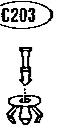
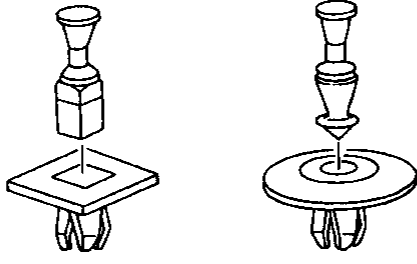
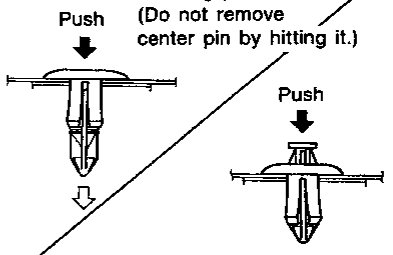
Symbol No.	Shapes	Removal & Installation
 <p>C101</p>	 <p style="text-align: right;">SBF256G</p>	<p>Removal: Remove by bending up with flat-bladed screwdrivers.</p>  <p style="text-align: right;">SBF367B</p>
 <p>C102</p>	 <p style="text-align: right;">MBF176B</p>	 <p>Removal: Pull up by rotating.</p> <p style="text-align: right;">SBF115B</p>
 <p>C103</p>	 <p style="text-align: right;">SBF257G</p>	<p>Removal: Remove with a flat-bladed screwdriver or pliers.</p>  <p style="text-align: right;">SBF292C</p>
 <p>C203</p>	 <p style="text-align: right;">SBF258G</p>	<p>Push center pin to catching position. (Do not remove center pin by hitting it.)</p>  <p>Installation:</p> <p style="text-align: right;">SBF708E</p>

GI

MA

EM

LC

EF &
EC

FE

CL

MT

AT

PD

FA

RA

BR

ST

BF









HA

EL

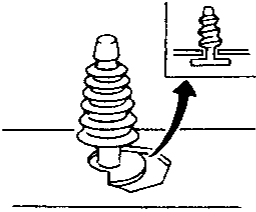
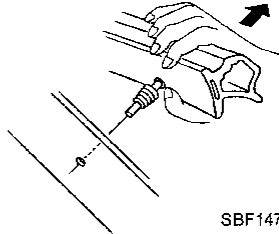
IDX

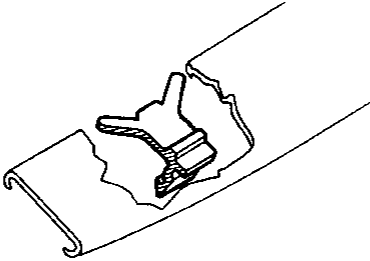
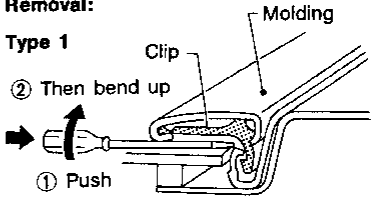
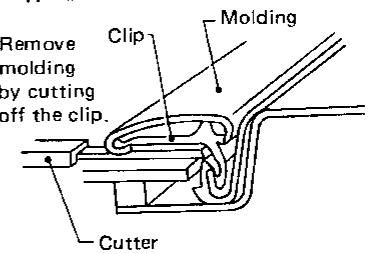
GENERAL SERVICING

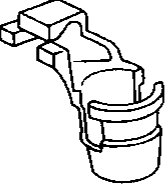
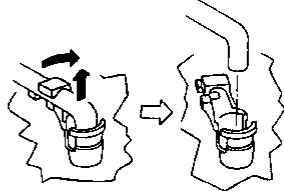
Clip and Fastener (Cont'd)

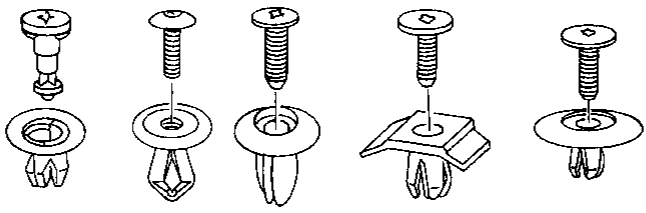
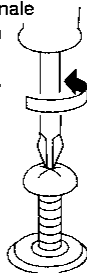
Symbol No.	Shapes	Removal & Installation
 		<p>Removal:</p>  <p style="text-align: right;">SBF104B SBF147B</p>
		<p>Removal:</p> <p>Type 1</p>  <p>② Then bend up ① Push</p> <p style="text-align: right;">SBF654B</p> <p>Type 2</p> <p>Remove molding by cutting off the clip.</p>  <p style="text-align: right;">SBF653B SBF914B</p>
		<p>Removal:</p> <p>Holder portion of clip must be spread out to remove rod.</p>  <p style="text-align: right;">SBF768B SBF770B</p>
		<p>Removal:</p> <ol style="list-style-type: none"> Screw out with a Phillips screwdriver. Remove female portion with flat-bladed screwdriver.  <p style="text-align: right;">SBF078B SBF992G</p>

Body Front End

- Hood adjustment: Adjust at hinge portion.
- Hood lock adjustment: After adjusting, check hood lock control operation. Apply a coat of grease to hood locks engaging mechanism.
- Hood opener: Do not attempt to bend cable forcibly.

Bumper shock absorber inspection

1. Check shock absorber for oil leakage, cracks or deformation.
2. Function of shock absorber;
 - (1) Place vehicle in front of a wall.
Apply parking brake and place tire stoppers securely.
 - (2) Place a jack between bumper and wall, jack is positioned squarely with bumper, directly in line with shock absorber to be checked.
 - (3) Apply pressure to compress shock absorber at least 10.0 mm (0.394 in).

Use a jack with capacity of more than 600 kg (1,323 lb).

- (4) Make sure bumper returns to its original position when jack is retracted. Replace if necessary.

CAUTION:

It is not recommended to confirm proper installation by driving into walls or other barriers as this could cause personal injury or damage to the vehicle.

When replacing shock absorbers, make sure they are of the same type and rating, and manufactured by the same maker.

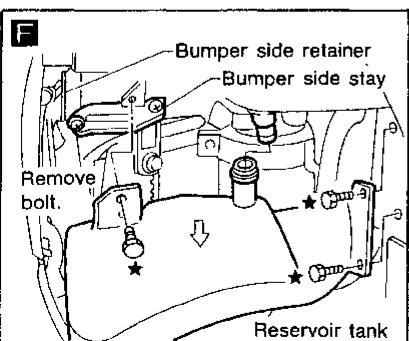
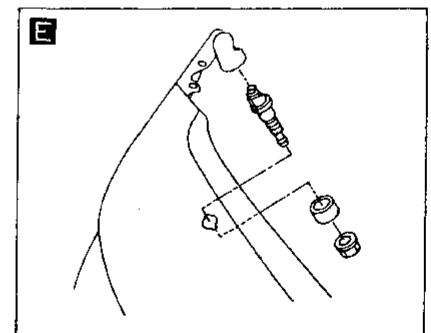
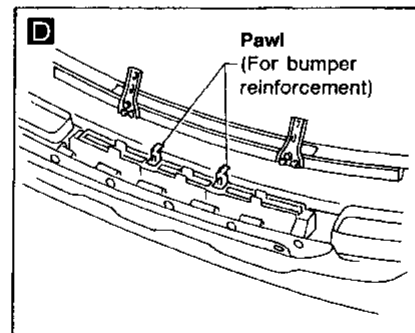
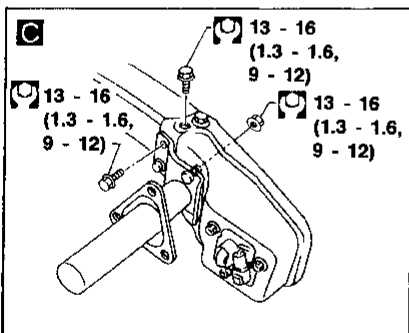
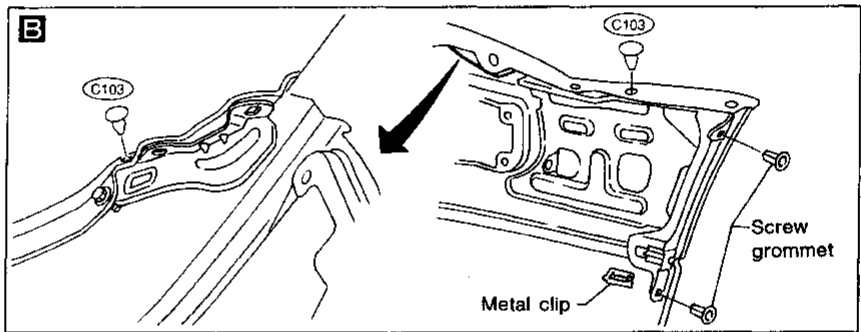
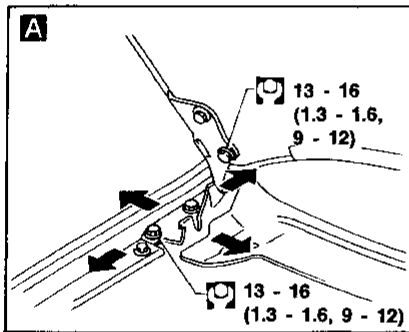

- Remove front fender protectors. Remove bolts (* in figure at left) securing reservoir tank, and slide reservoir tank downward.
- Remove bolt securing bumper side stay.

GI

MA

EM

LC

EF &
EC

FE

CL

MT

AT

PD

FA

RA

BR

ST

BF

HA

EL

IDX

BODY END

Body Front End (Cont'd)

Hood lock adjustment

- Adjust lock so that hood primary lock meshes at a position where hood is 1 to 1.5 mm (0.039 to 0.059 in) lower than fender.
- After hood lock adjustment, adjust bumper rubber.
- When securing hood lock, ensure it does not tilt. Striker must be positioned at the center of hood primary lock.
- After adjustment, ensure that hood primary and secondary lock operate properly.

Hood lock secondary latch hooking length

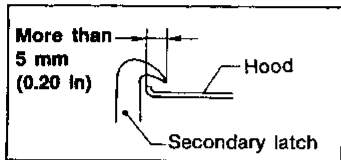

Bumper rubber adjustment

- Adjust so that hood is aligned with fender. [Bumper rubber free height is approx. 15 mm (0.59 in).]

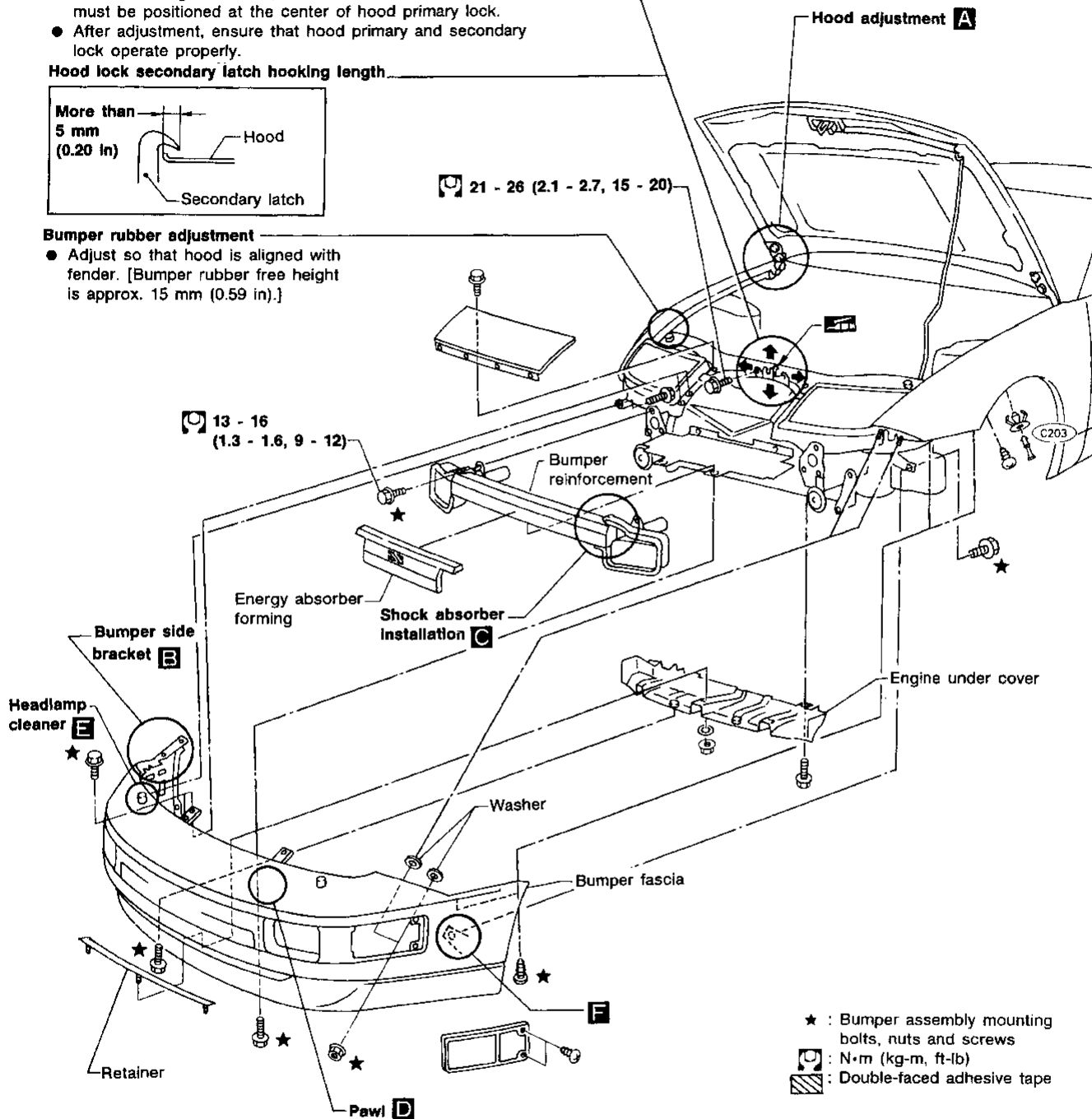

Service notice

- Be sure to enlarge hood hinge holes (hinge to hood side) less than 10 mm (0.39 in) dia. for easy hood adjustment at hood-hinge portion.
- Be sure to take rust prevention measures after enlargement of holes.

MBF333B

Body Rear End and Opener

BACK DOOR TYPE

- Back door adjustment: Adjust at hinge-body portion for proper back door fit.
- Back door lock system adjustment: Adjust lock & striker so that they are in the center. After adjustment, check back door lock operation.

WARNING:

- Be careful not to scratch back door stay when installing back door. A scratched stay may cause gas leakage.
- The contents of the back door stay are under pressure. Do not take apart, puncture, apply heat or allow fire near it.
- Opener cable: do not attempt to bend cable using excessive force.
- After installation, make sure that back door and fuel filler lid open smoothly.
- Remove washer tank (located at left of luggage compartment) before removing or installing bumper.

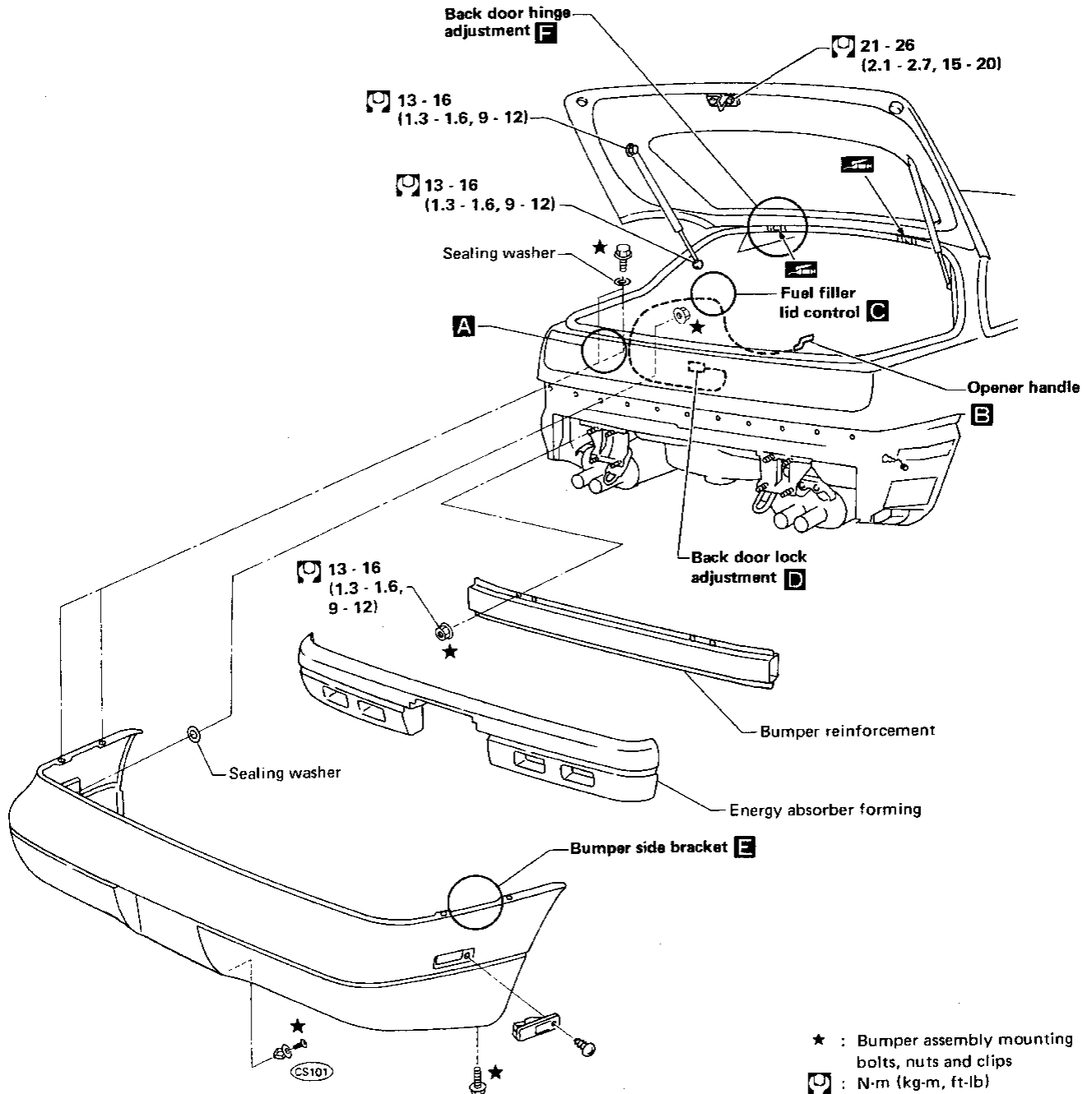

GI
MA
EM
LC
EF & EC
FE
CL
MT
AT
PD
FA
RA
BR
ST
BF
HA
EL
IDX

BODY END

Body Rear End and Opener (Cont'd)

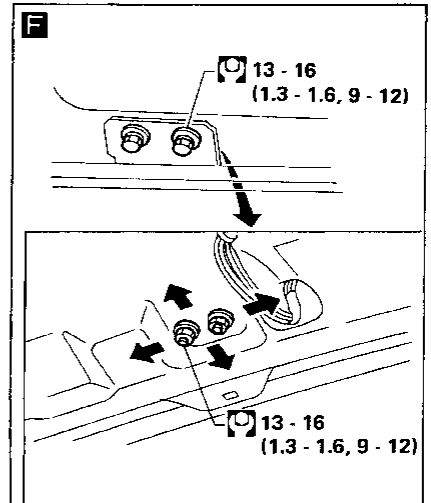
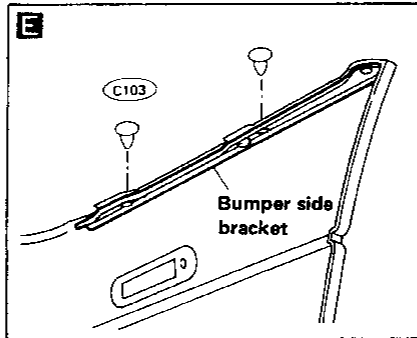
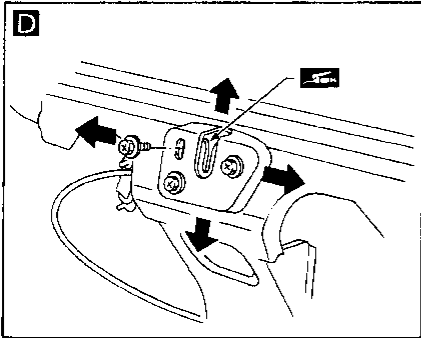
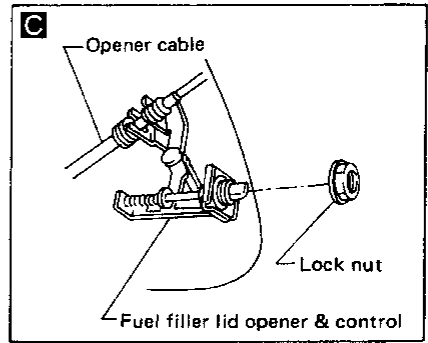
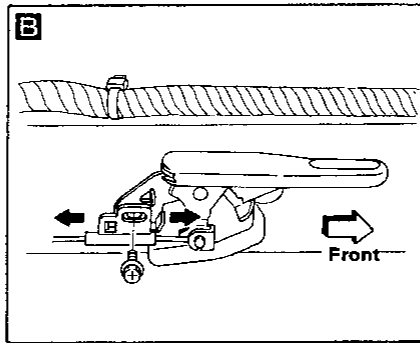
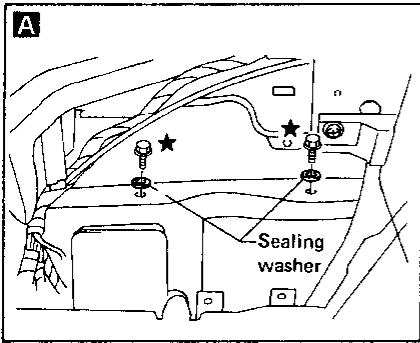

BODY END

Body Rear End and Opener (Cont'd)

TRUNK LID TYPE — Convertible model

- Trunk lid adjustment: Adjust at hinge-trunk lid portion for proper trunk lid fit.
- Trunk lid lock system adjustment: Adjust striker so that it is in the center of the lock. After adjustment, check trunk lid lock operation.
- After installing/adjusting opener, make sure that trunk lid and fuel filler lid open smoothly.

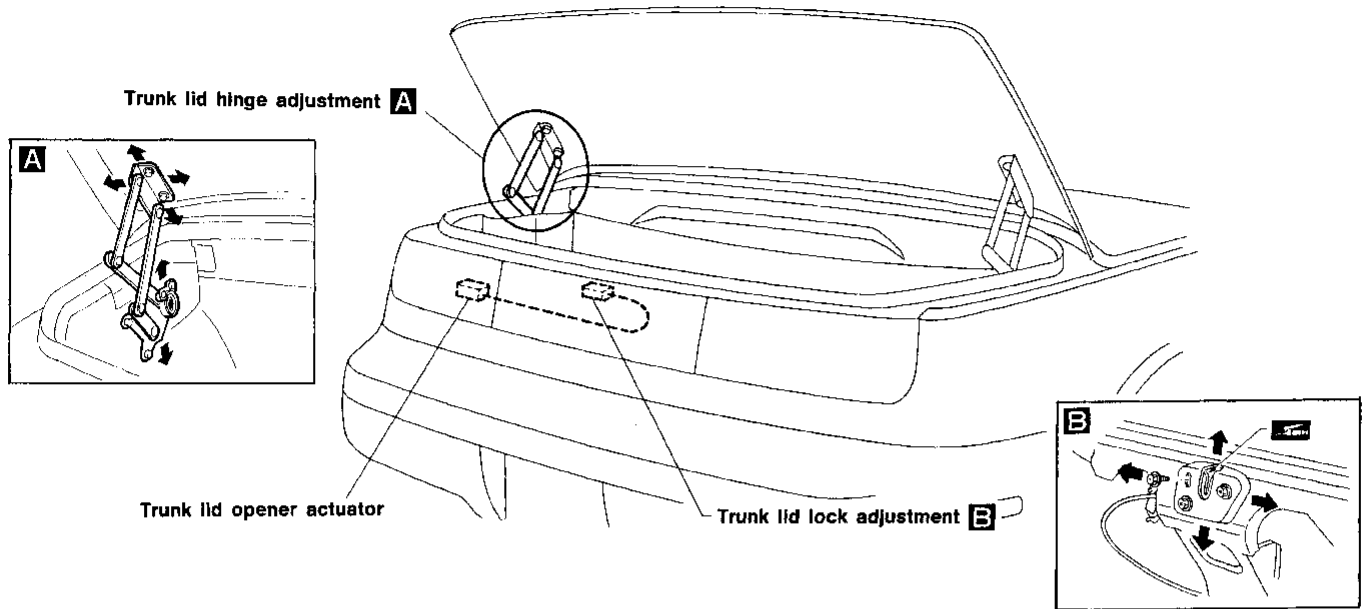

MBF696A

FUEL FILLER LID OPENER SYSTEM — WIRING DIAGRAM

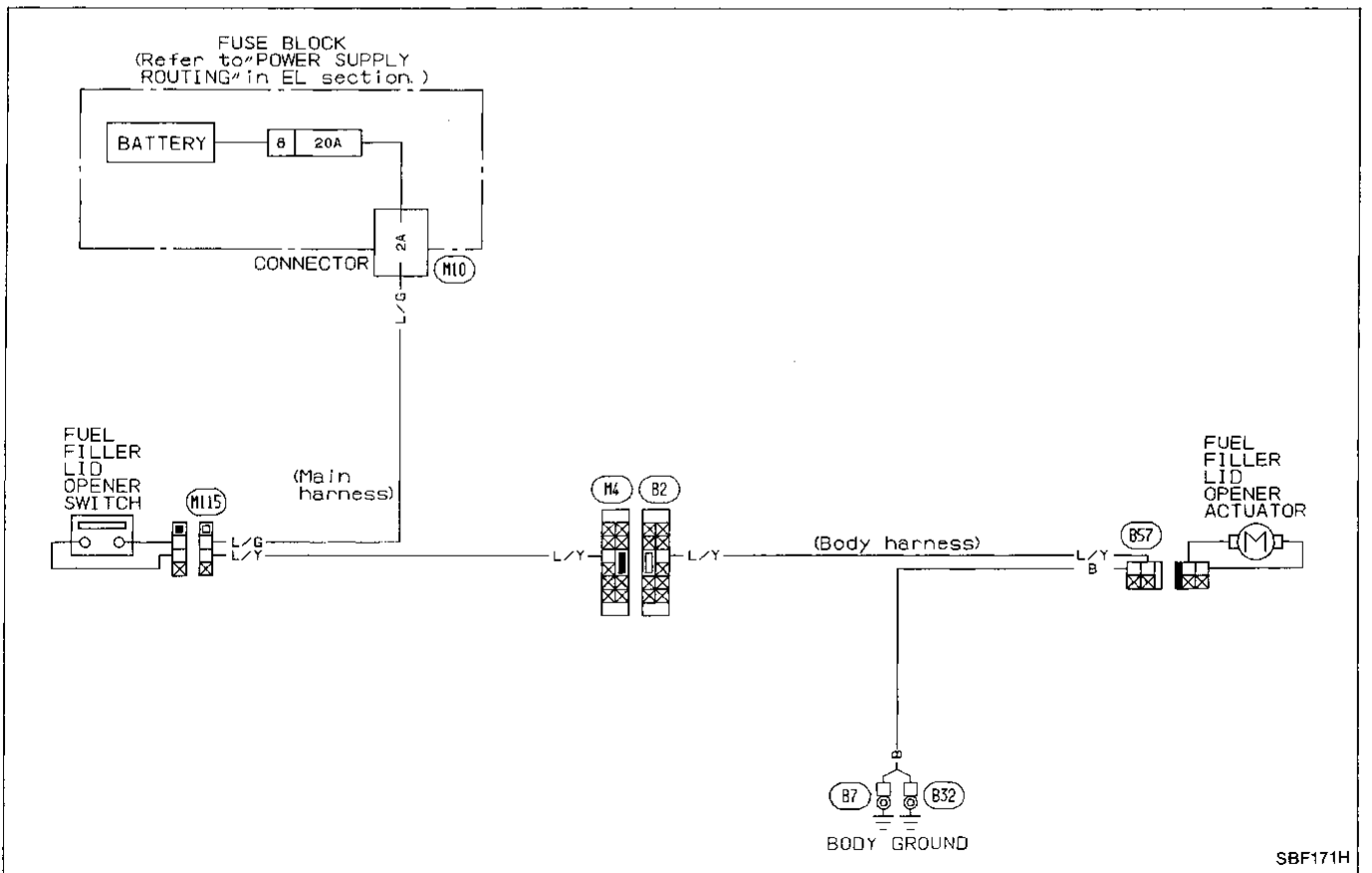

SBF171H

DOOR

- For removal of door trim, refer to "INTERIOR AND EXTERIOR" (BF-31).
- After adjusting door or door lock, check door lock operation.

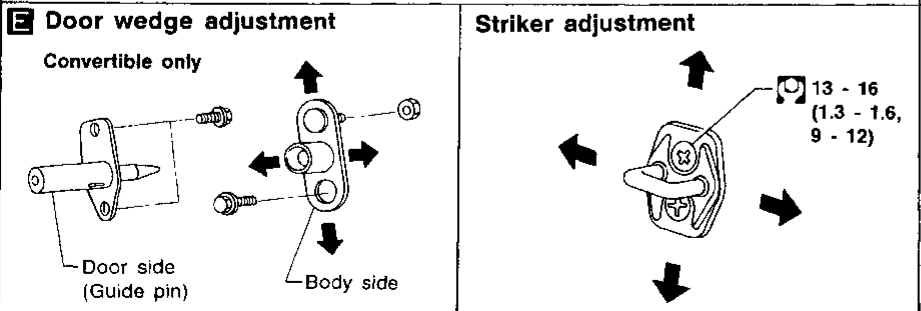
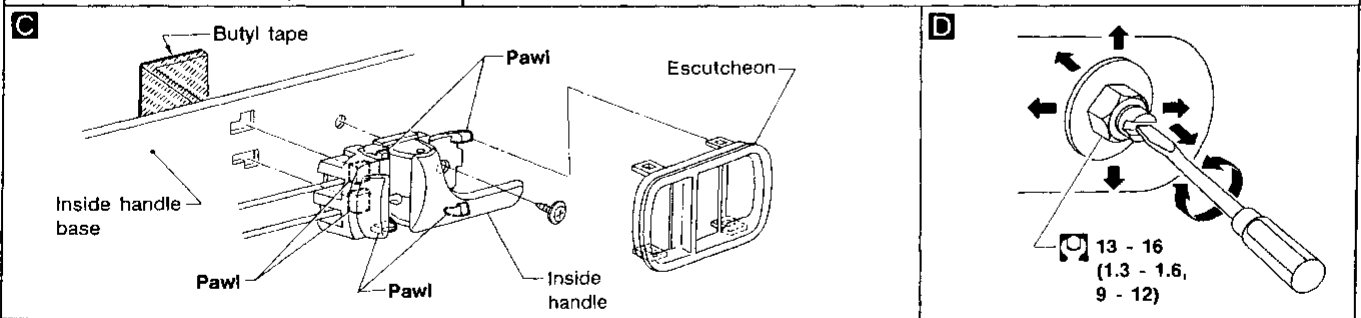
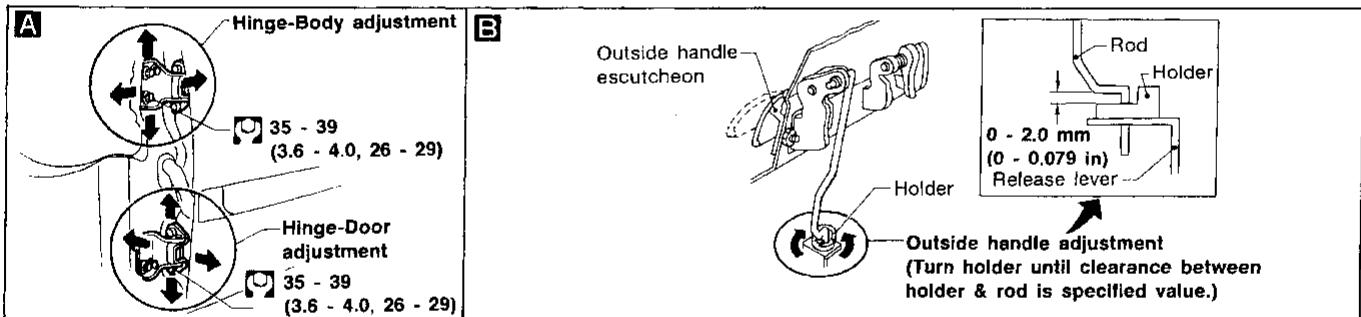
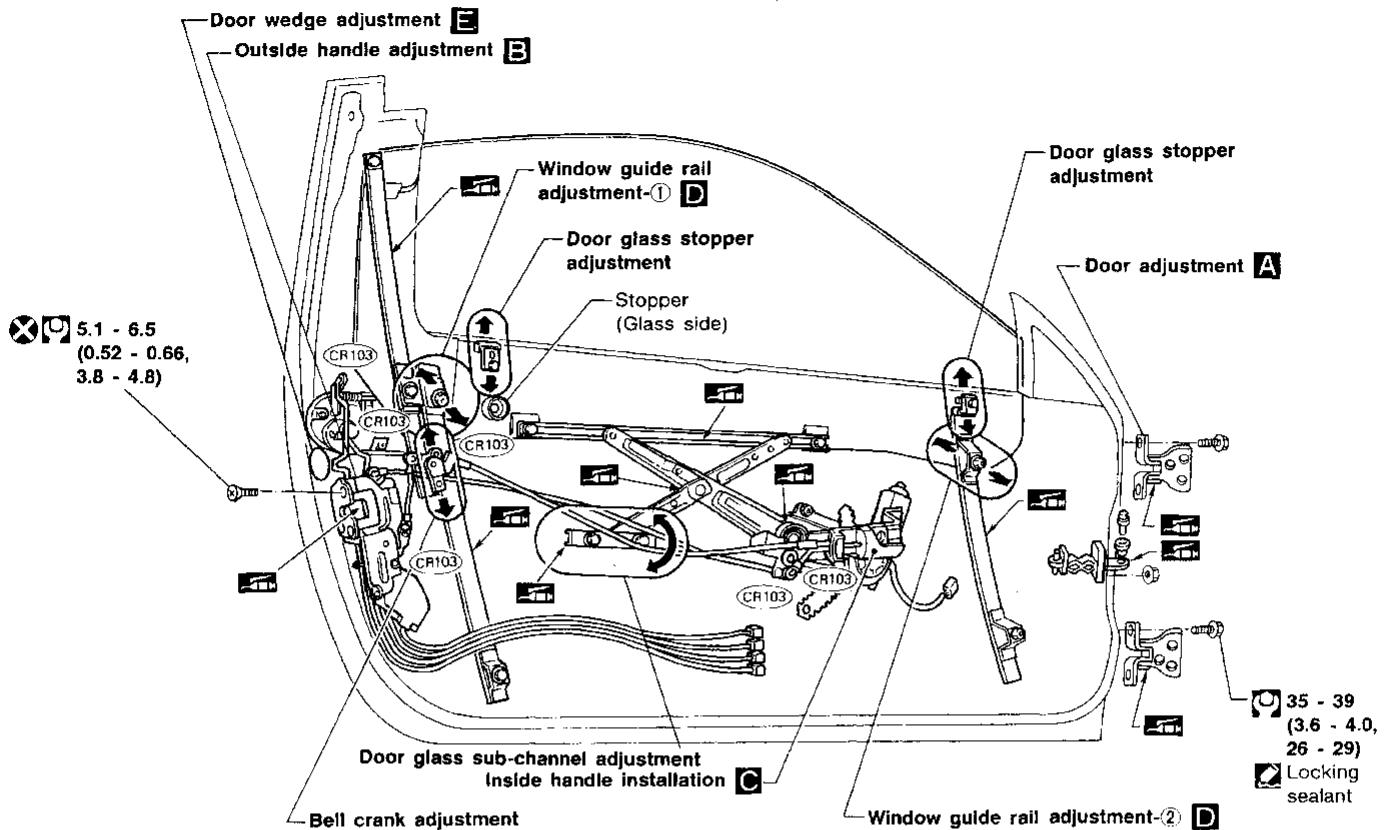

: N·m (kg·m, ft·lb)

MBF768AA

Power Window

WIRING DIAGRAM

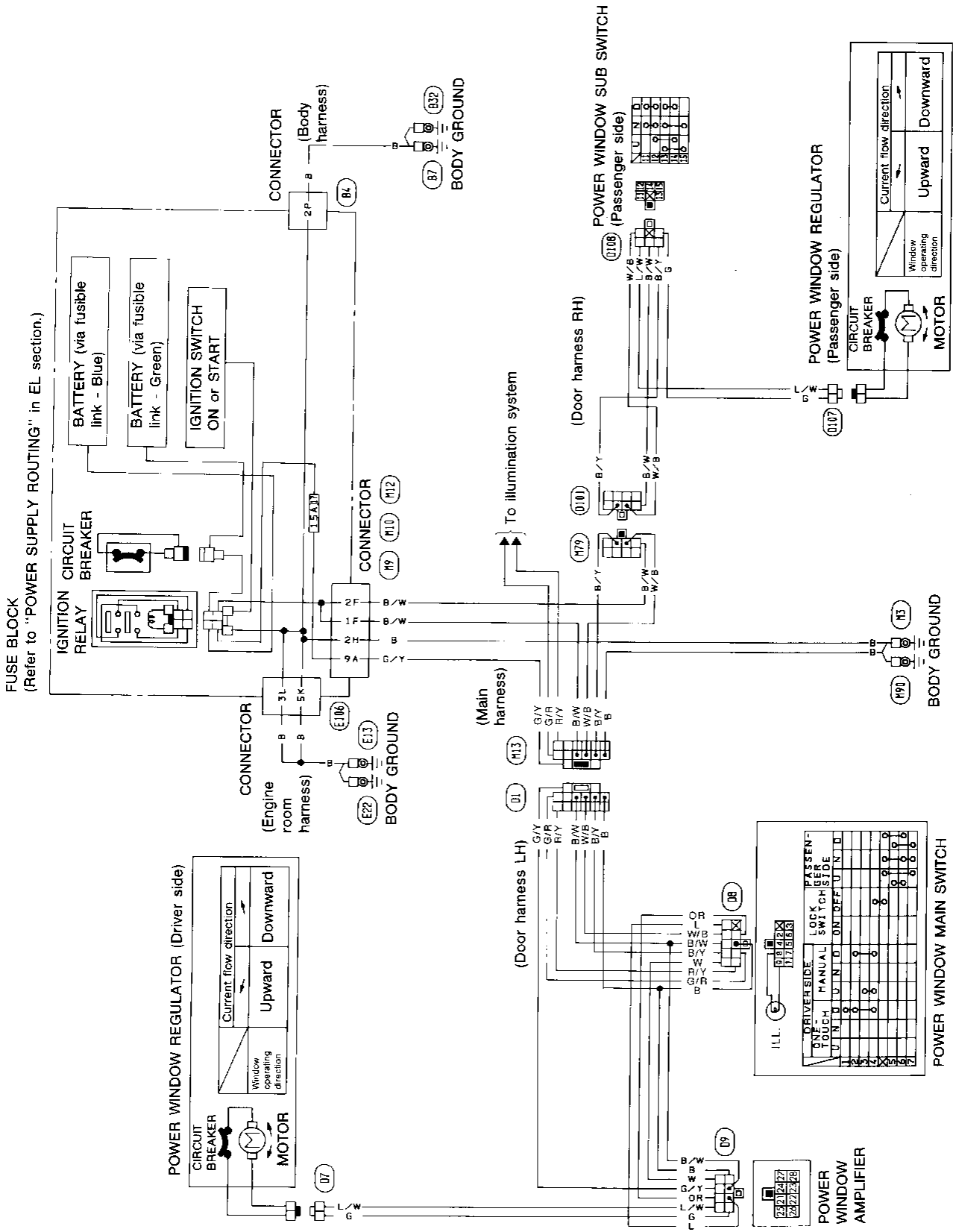

- GI
- MA
- EM
- LC
- FF
- FC
- FE
- CL
- MT
- AT
- PD
- FA
- RA
- BR
- ST
- BF**
- HA
- FL
- IDX

DOOR

Power Window (Cont'd)

POWER WINDOW AMP. INSPECTION

FRONT DRIVER SIDE POWER WINDOW SWITCH

	FR Drive side						Connections
	One-touch (Auto)			Manual			
	U	N	D	U	N	D	
1				○			From power window AMP (23)
2					○		From power window AMP (22)
3						○	From power window AMP (21)
4				○	○	○	Ground

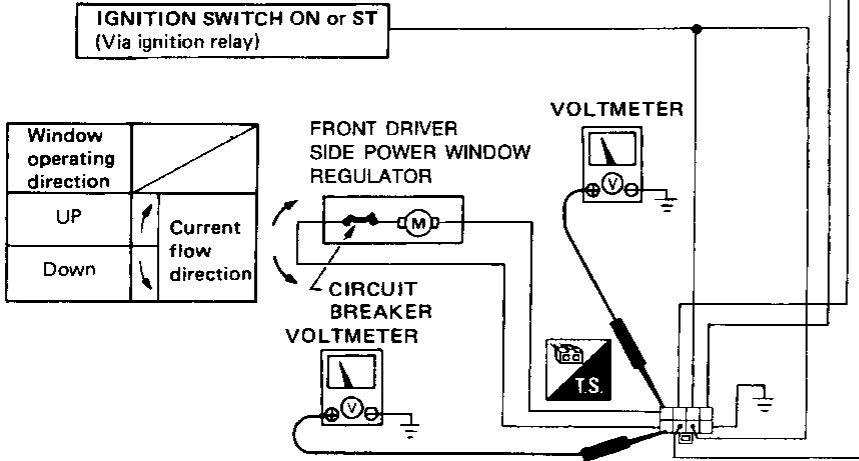

AMP. OPERATION

25 21 24 22
26 22 23 28

	Connections	Operations					
		Manual operation			One-touch (Auto) Operation		
		12V	12V	12V	12V	12V	12V
24	Power source (IGN)	12V	12V	12V	12V	12V	12V
27	Ground	Ground	Ground	Ground	Ground	Ground	Ground
23	From ignition SW (ON or ST)	ON or ST	ON or ST	ON or ST	ON or ST	ON or ST	ON or ST
28	To FR driver side power window SW (AUTO) (1)	OFF	OFF	OFF	OFF	ON	OFF
	To FR driver side power window SW (UP) (3)	OFF	ON	OFF	OFF	OFF	OFF
	To FR driver side power window SW (DOWN) (2)	OFF	OFF	ON	OFF	ON	OFF
25	FR driver side regulator ("Up" power source)	Approx. 0V	Approx. over 9V	Approx. 0V	Approx. 0V	Approx. 0V	Approx. 0V
	FR driver side regulator ("Down" power source)	Approx. 0V	Approx. 0V	Approx. over 9V	Approx. 0V	Approx. over 9V	Approx. over 9V

Regulator Operating Condition	Stop	Upward operation	Downward operation	Stop	Starting	Keeps operating until fully open, then stops automatically.
					Downward operation	

Carry out this operation check in this chart from left to right

POWER WINDOW AMP. – Front driver side door (Behind door trim)

SBF219F

DOOR

Power Door Lock (Cont'd)

DOOR LOCK TIMER INSPECTION

- Carry out the following inspections:

(1) Check power source and ground.

(2) Check input signals.

If the input signal is NG, go to ELECTRICAL COMPONENTS INSPECTION.

(3) Check output signals.

If the input signal is OK and the output signal is NG, replace the door lock timer.

If the input signal and output signal are OK, check door lock actuator in ELECTRICAL COMPONENTS INSPECTION.

Lock & unlock operation by lock knob or main switch

(The voltages are approximate values.)

	Connections	Operations			
		Lock knob switch LH		Lock knob switch RH	
		Unlock → Lock	Lock → Unlock	Unlock → Lock	Lock → Unlock
1	Power source	12V	12V	12V	12V
5	Ground	Ground	Ground	Ground	Ground
7	Key switch	Either key switch or door switches are off. (Key is not in the ignition or all doors are closed.)			
4	Door switch LH				
10	Input signals Lock knob switch LH	ON (Ground) → OFF (Open)	OFF (Open) → ON (Ground)	—	—
9	Input signals Lock knob switch RH	—	—	ON (Ground) → OFF (Open)	OFF (Open) → ON (Ground)
2	Output signals Door lock actuator (Lock power source)	0V → 12V → 0V (Approx. 1.0 sec.)	0V	0V → 12V → 0V (Approx. 1.0 sec.)	0V
3	Output signals Door lock actuator (Unlock power source)	0V	0V → 12V → 0V (Approx. 1.0 sec.)	0V	0V → 12V → 0V (Approx. 1.0 sec.)

Key reminder operation

(The voltages are approximate values.)

	Connections	Operations			
		Lock knob switch LH		Lock knob switch RH	
		Unlock → Lock	Lock → Automatically unlocked	Unlock → Lock	Lock → Automatically unlocked
1	Power source	12V		12V	
5	Ground	0V		0V	
7	Key switch	ON (12V) — Key is in the ignition.			
4	Door switch	ON (Ground) — Either door is open.			
10	Input signals Lock knob switch LH	ON (Ground) → OFF (Open)	ON (Ground)	—	
9	Input signals Lock knob switch RH	—		ON (Ground) → OFF (Open)	ON (Ground)
2	Output signals Door lock actuator (Lock power source)	0V → 12V → 0V (Approx. 0.3 sec.)		0V → 12V → 0V (Approx. 0.3 sec.)	
3	Output signals Door lock actuator (Unlock power source)	0V → 12V → 0V (Approx. 1.4 sec.)		0V → 12V → 0V (Approx. 1.4 sec.)	

DOOR

Power Door Lock (Cont'd)

ELECTRICAL COMPONENTS INSPECTION

Key switch

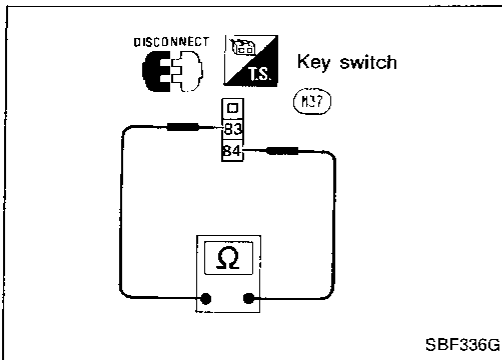

Terminals	Condition	Continuity
83 - 84	Key is in the ignition.	Yes
	Key is not in the ignition.	No

GI

MA

EM

Door switch

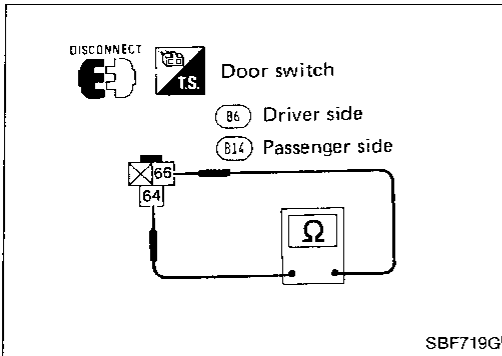

Terminals	Condition	Continuity
64 - 66	Door is closed.	No
	Door is open.	Yes

LC

EF &
EC

FE

CL

Lock knob switch (Built-in front door lock actuator)

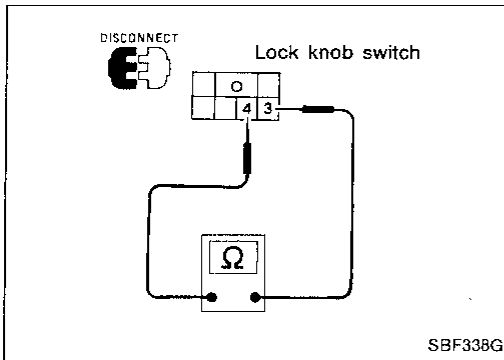

Terminals	Condition	Continuity
3 - 4	Lock	No
	Unlock	Yes

MT

AT

PD

FA

Door lock actuator

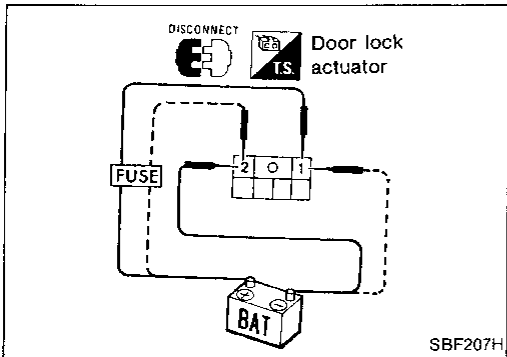

Terminals		Operation
⊕	⊖	
1	2	Lock
2	1	Unlock

RA

BR

ST

BF

HA

EL

IDX

MULTI-REMOTE CONTROL SYSTEM

Wiring Diagram

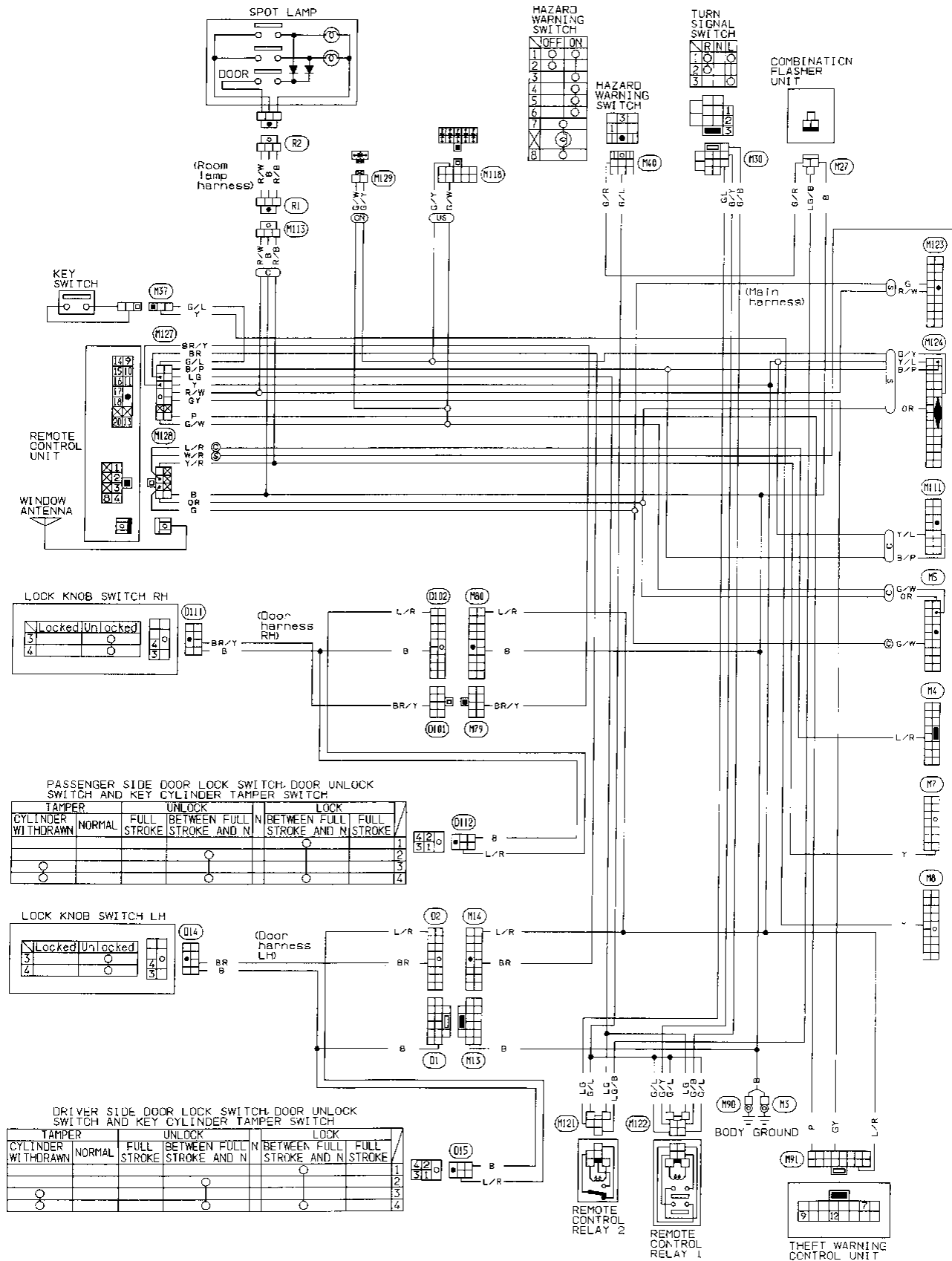

MULTI-REMOTE CONTROL SYSTEM

Wiring Diagram (Cont'd)

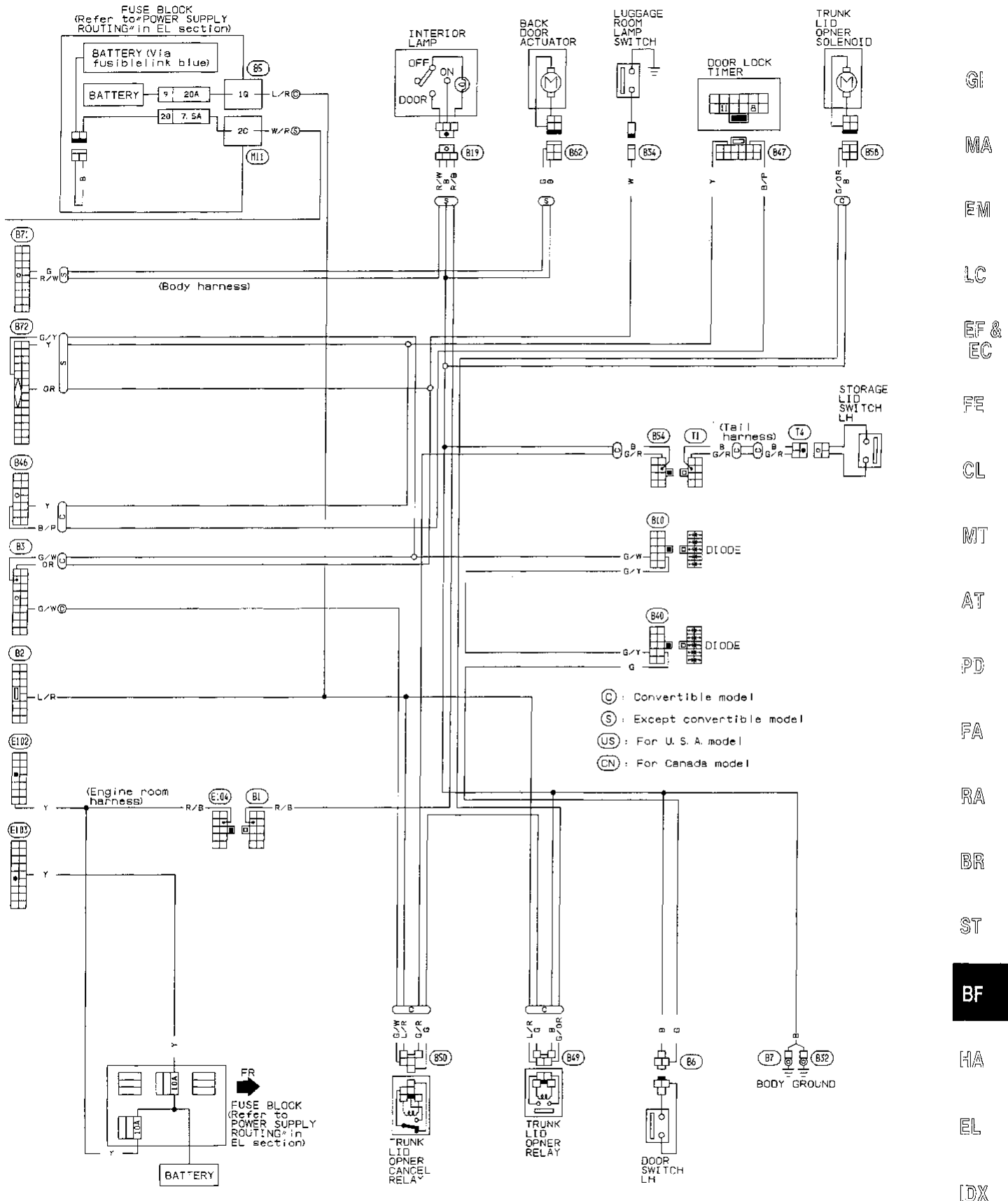

MULTI-REMOTE CONTROL SYSTEM

Circuit Diagram for Quick Pinpoint Check

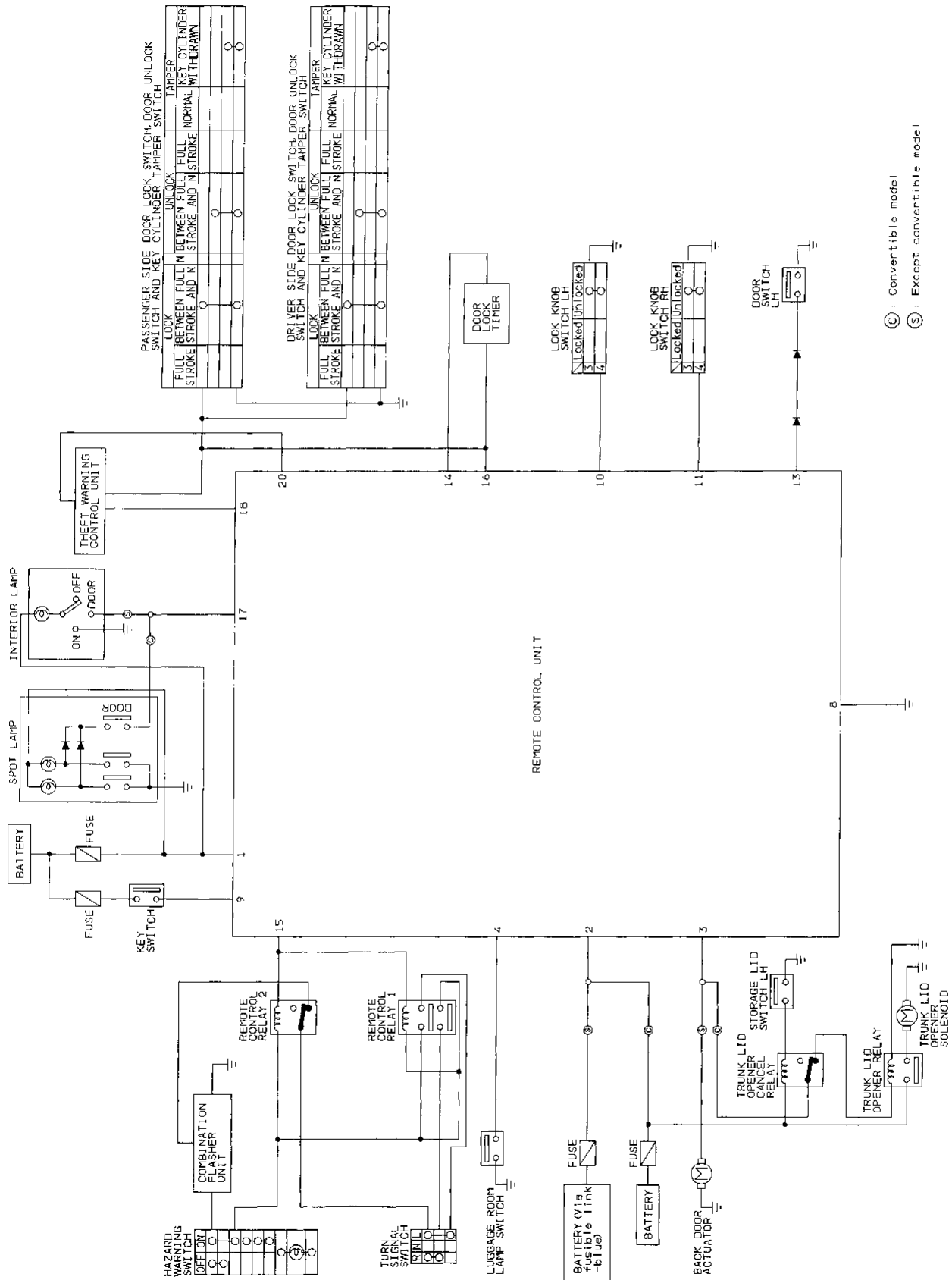

Trouble Diagnoses Preliminary Inspection

PRELIMINARY INSPECTION PROCEDURE 1

All functions of multi remote control system do not function.

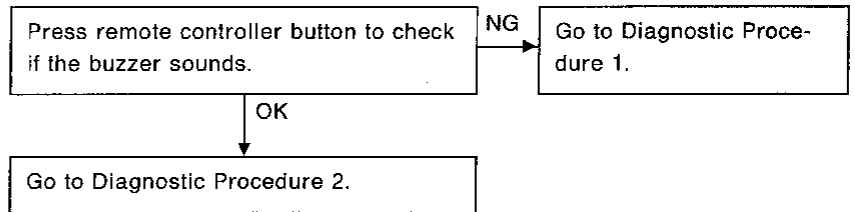

GI
MA

PRELIMINARY INSPECTION PROCEDURE 2

Door lock and unlock do not function.

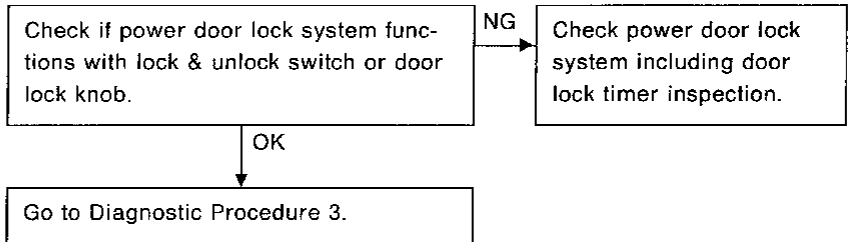

EM
LC
EF & EC

PRELIMINARY INSPECTION PROCEDURE 3

Back door or trunk lid open function does not function.

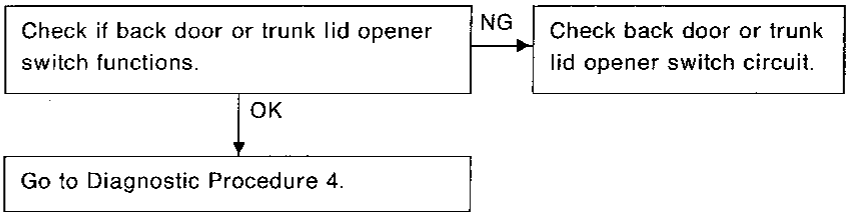

FE
CL

PRELIMINARY INSPECTION PROCEDURE 4

Interior light or spot light does not function.

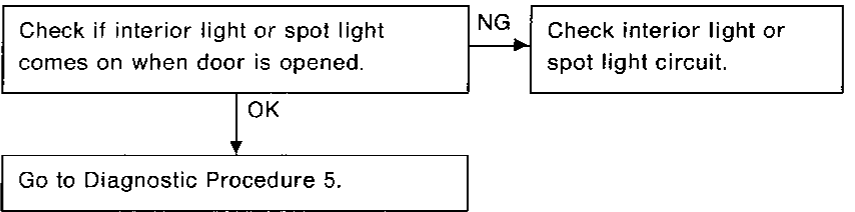

MT
AT

PRELIMINARY INSPECTION PROCEDURE 5

Panic alarm does not function.

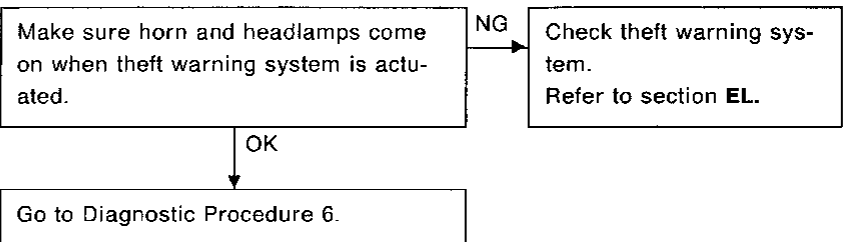

PD
FA

RA
BR
ST

BF

HA
EL

IDX

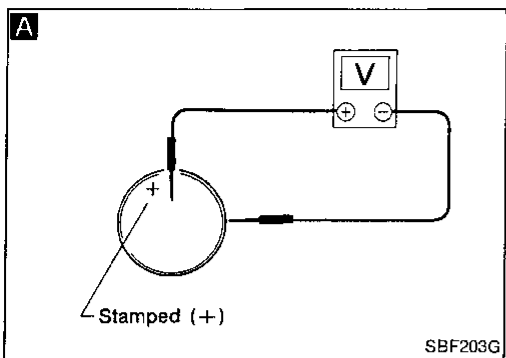

Trouble Diagnoses

DIAGNOSTIC PROCEDURE 1

Remote controller buzzer does not sound when the button is pressed.

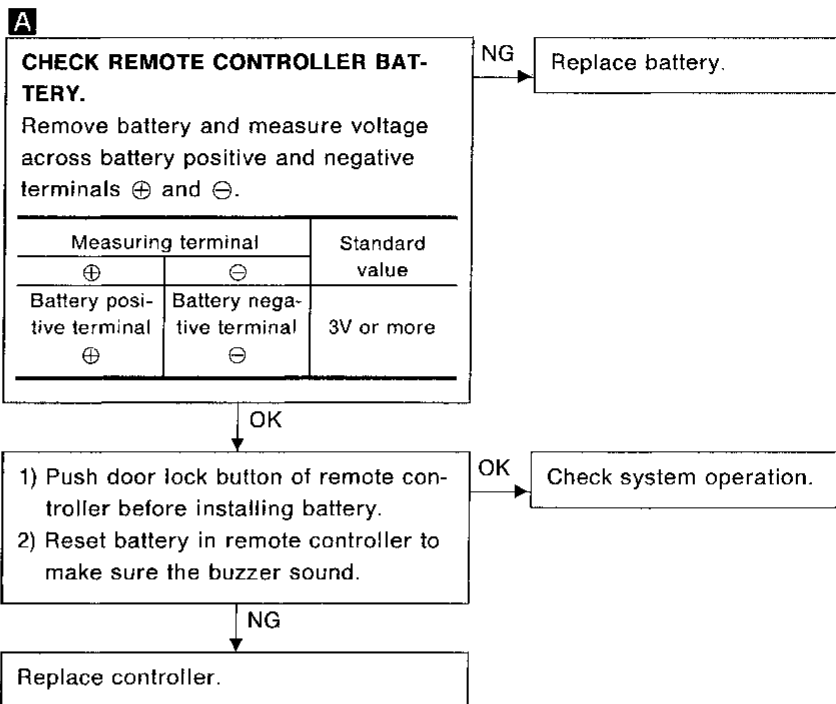

Note:

Remote controller does not function if battery is not set correctly.

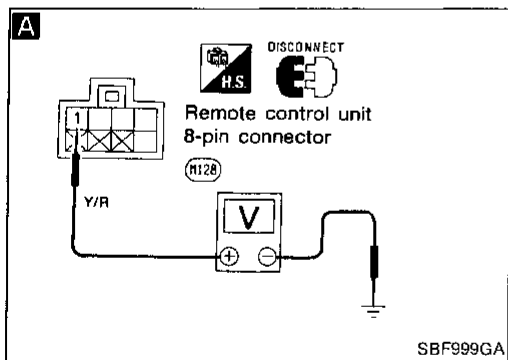

DIAGNOSTIC PROCEDURE 2

All remote controls do not function even if remote controller buzzer does sound.

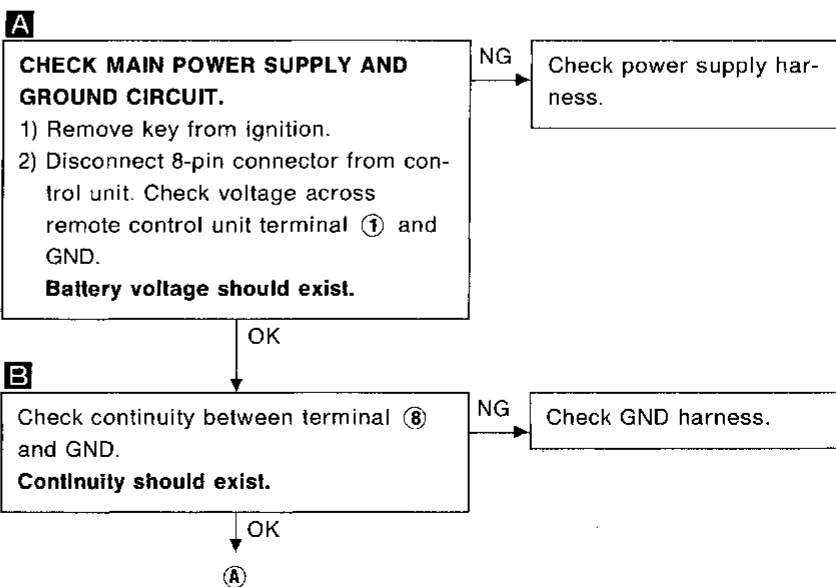
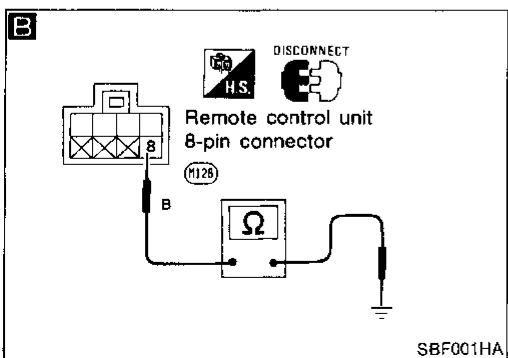

MULTI-REMOTE CONTROL SYSTEM

Trouble Diagnoses (Cont'd)

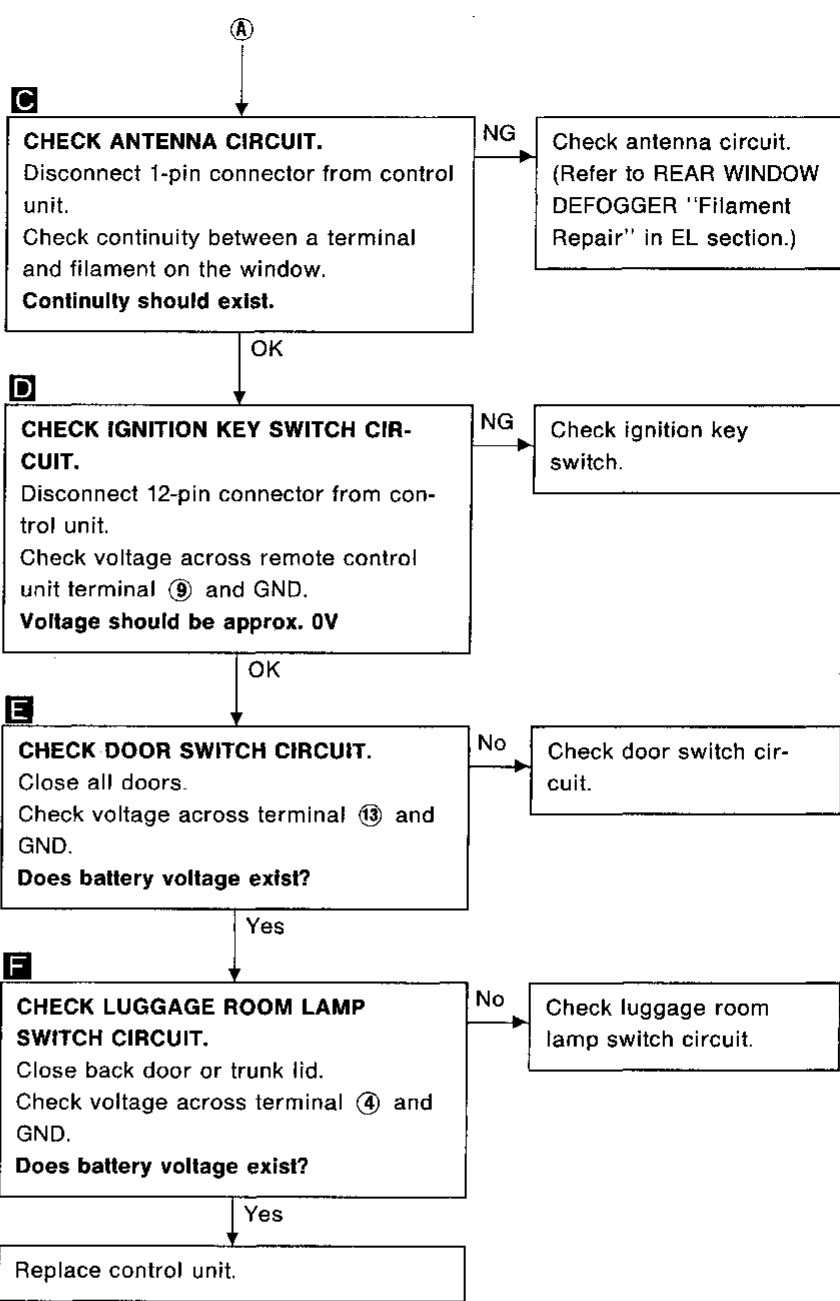
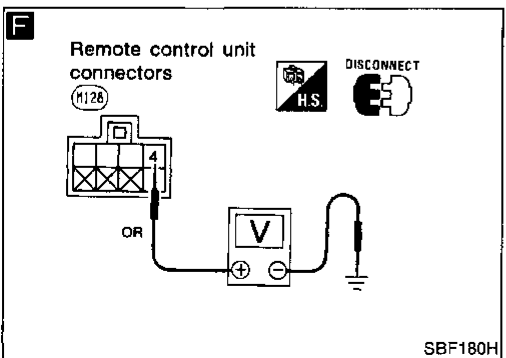
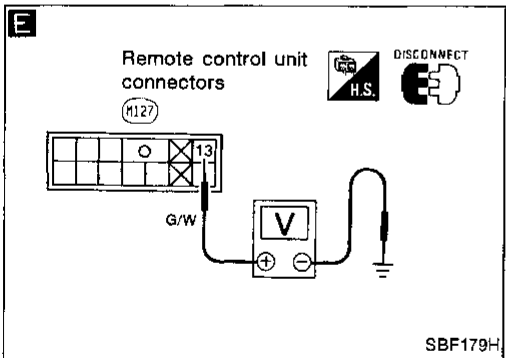
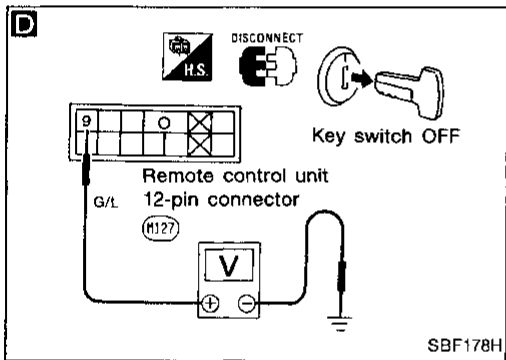
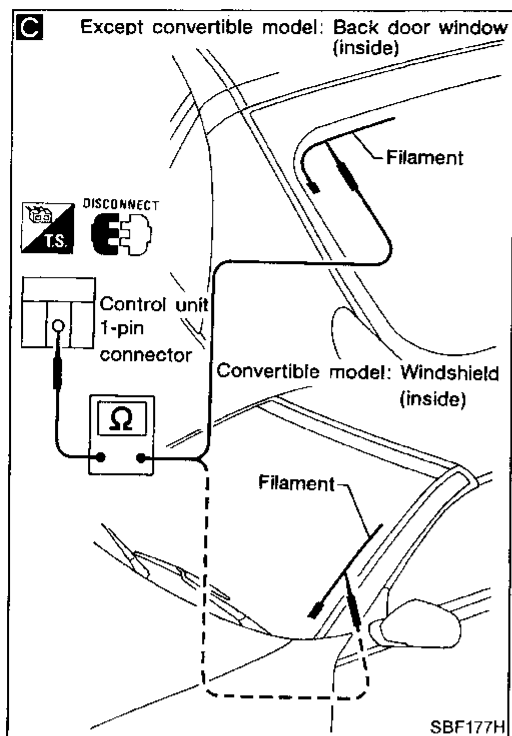

GI
MA
EM
LC
EF & EC
FE
CL
MT
AT
PD
FA
RA
BR
ST
BF
HA
EL
IDX

MULTI-REMOTE CONTROL SYSTEM

Trouble Diagnoses (Cont'd)

DIAGNOSTIC PROCEDURE 3

Door lock and unlock remote control do not function. Everything else does function.

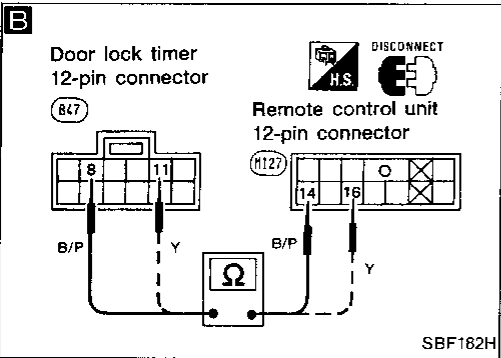
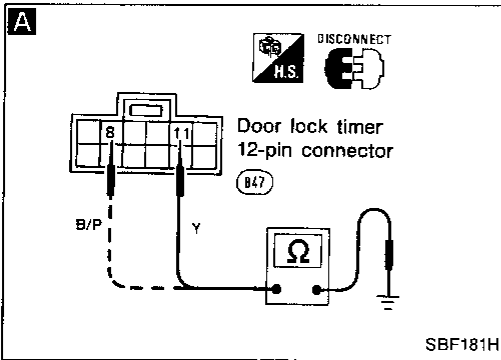

A

CHECK DOOR LOCK AND UNLOCK SIGNAL FOR DOOR LOCK TIMER.

- 1) Remove key from ignition.
- 2) Close all doors and trunk lid.
- 3) Remove door lock timer 12-pin connector.

Push remote controller buttons and check continuity between terminals ⑪ and GND, ⑧ and GND.

Terminals	Operation	Continuity
⑪ - GND	Lock	Yes
	Unlock	No
⑧ - GND	Unlock	Yes
	Lock	No

OK → Check power door lock system.

NG

Does continuity exist continually?

Yes → Repair harness. (There might be incorrect grounding.)

No →

B

Remove remote control unit 12-pin connector.

Check continuity between remote control unit terminals and door lock timer.

Terminals	
Remote control	Door lock timer
⑭	⑧
⑯	⑪

Continuity should exist.

NG → Repair harness.

OK

Replace control unit.

MULTI-REMOTE CONTROL SYSTEM

Trouble Diagnoses (Cont'd)

DIAGNOSTIC PROCEDURE 4

Trunk lid open remote control does not function. Everything else does function.

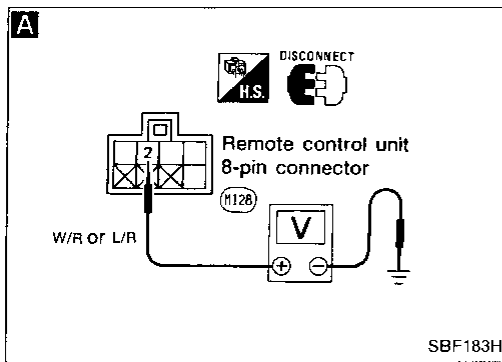

A

CHECK POWER SUPPLY CIRCUIT FOR TRUNK OPEN FUNCTION.

Disconnect 8-pin connector from remote control unit.

Check voltage between terminal ② and ground.

Battery voltage should exist.

NG

Repair harness.

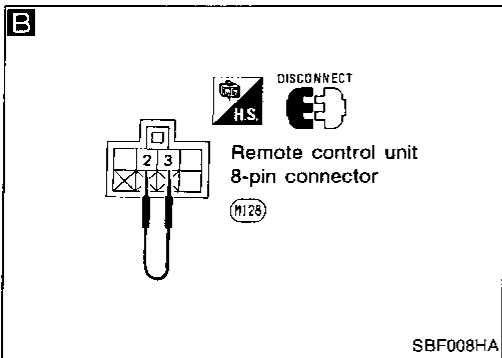

B

Connect remote control unit connector terminal ② to ③.

Does trunk lid opener function?

No

Check trunk lid opener circuit.

OK

Yes

Replace control unit.

GI

MA

EM

LC

EF & EC

FE

CL

MT

AT

PD

FA

RA

BR

ST

BF

HA

EL

IDX

DIAGNOSTIC PROCEDURE 5

Interior light or spot light (convertible model) does not function. Everything else does function.

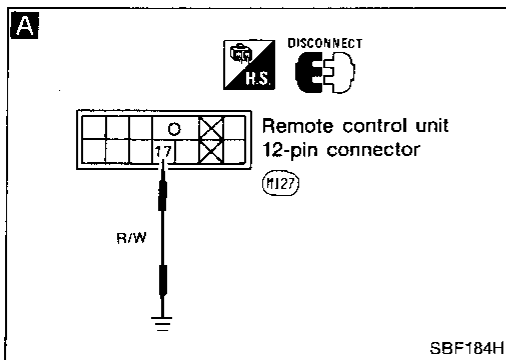

A

CHECK INTERIOR LIGHT OR SPOT LIGHT (CONVERTIBLE MODEL) CIRCUIT.

Disconnect remote control unit 12-pin connector.

Ground remote control unit connector terminal ⑰.

Does interior light or spot light (convertible model) function?

No

Check interior light or spot light (convertible model) circuit.

Yes

Replace control unit.

MULTI-REMOTE CONTROL SYSTEM

Trouble Diagnoses (Cont'd)

DIAGNOSTIC PROCEDURE 6

Panic alarm function does not function. Everything else does function.

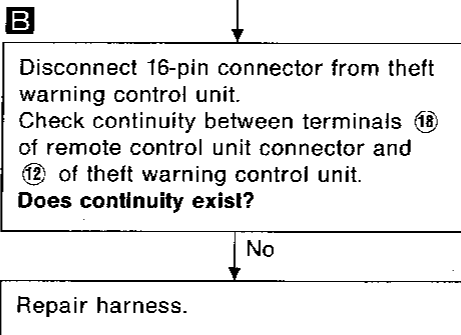
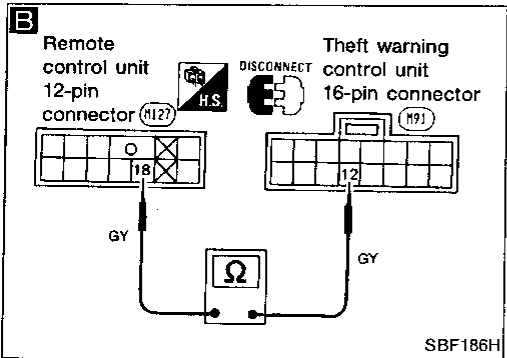
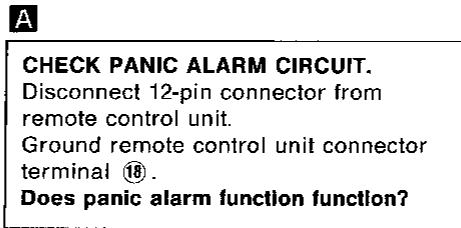
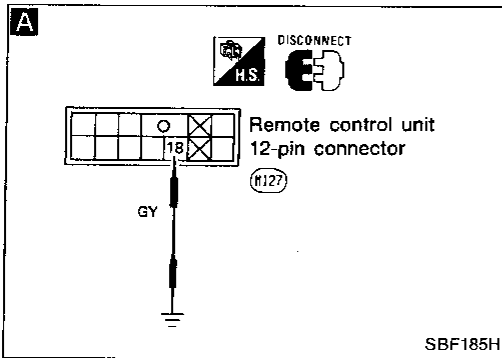

DIAGNOSTIC PROCEDURE 7

Hazard indicator flashing does not function. Everything else does function.

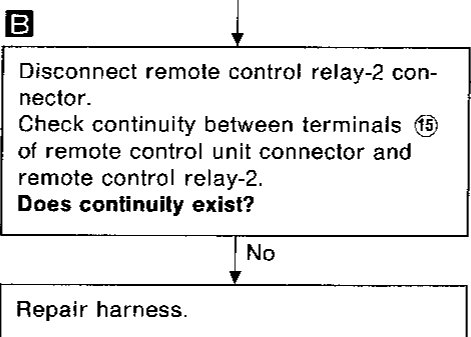
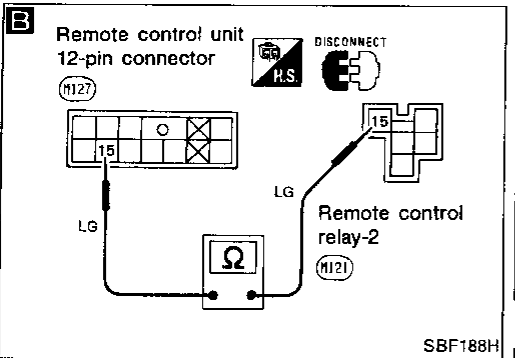
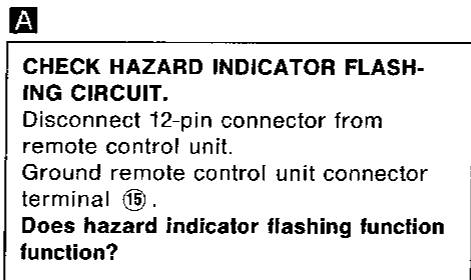
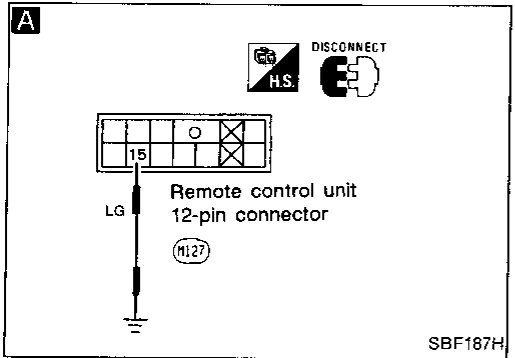

MULTI-REMOTE CONTROL SYSTEM

Trouble Diagnoses (Cont'd)

DIAGNOSTIC PROCEDURE 8

Theft warning is actuated when door is unlocked or trunk lid is opened with remote control.

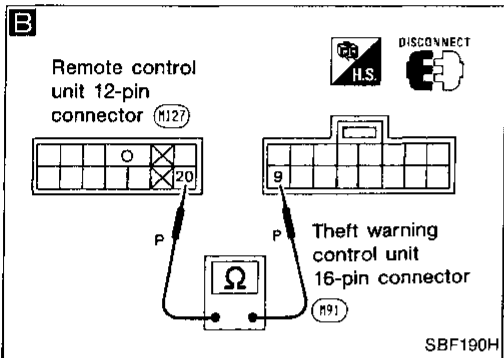
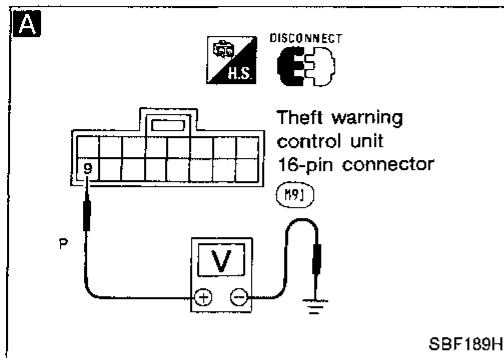

A

CHECK THEFT WARNING CANCEL SIGNAL CIRCUIT.

- 1) Disconnect theft warning control unit 16-pin connector.
- 2) Remove key from ignition.
- 3) Close all doors and back door or trunk lid.

Check voltage between terminal ⑨ and GND when door unlock remote control function is operated.

Terminal	Operation	Voltage
⑨ - GND	Door is unlocked	12V → 0V → 12V

Does voltmeter gauge move when door is unlocked?

Yes

Check theft warning system. Refer to section EL.

No

B

Disconnect 12-pin connector from remote control unit. Check continuity between terminals ⑳ of remote control unit and ⑨ of theft warning control unit. Does continuity exist?

Yes

Replace remote control unit.

No

Repair harness.

GI

MA

EM

LC

EF & EC

FE

CL

MT

AT

PD

FA

RA

BR

ST

BF

HA

EL

IDX

Replacing Remote Controller or Control Unit

If the remote controller or the control unit needs to be replaced or if an additional remote controller needs to be set, enter the Identity (ID) code manually.

ID Code Entry Procedure

To enter the ID code, follow this procedure.

“Setting mode”.

Three steps must be followed to establish the “setting mode”.

- (1) Open the trunk.
- (2) Close and lock all doors.
- (3) Insert and remove the key from the ignition more than six times within 10 seconds.

- **At this time, the original ID codes are eliminated.**

ID code entry:

- (4) Unlock and lock the driver's door inside lock lever once.
- (5) Push lock button on the new remote controller once (for example, if door is locked using the remote controller during this ID code entry enable state, a new ID code can be entered).

- **At this time, the new ID code is entered.**

- (6) If you need to enter additional remote controllers (including the original) repeat the step (4) and (5) for each additional controller.
- (7) This ID code entry enable state and setting mode remain until any one of the doors is opened.

Note

- **If the same ID code that existing in the memory is input, the entry is canceled, and no ID code will be entered.**
- **Entry of maximum four ID codes is allowed and any attempt to enter more will be ignored.**
- **Any ID codes entered after termination of the “setting” mode will not be accepted. Additionally remote control signals will be inhibited when an ID code has not been entered during the “setting” mode.**

INSTRUMENT PANEL

- When removing instrument panel assembly, remove defroster grille, combination meter, cluster lid and radio first.

CAUTION:

Never tamper with or force the air bag lid open as this may adversely affect air bag performance.

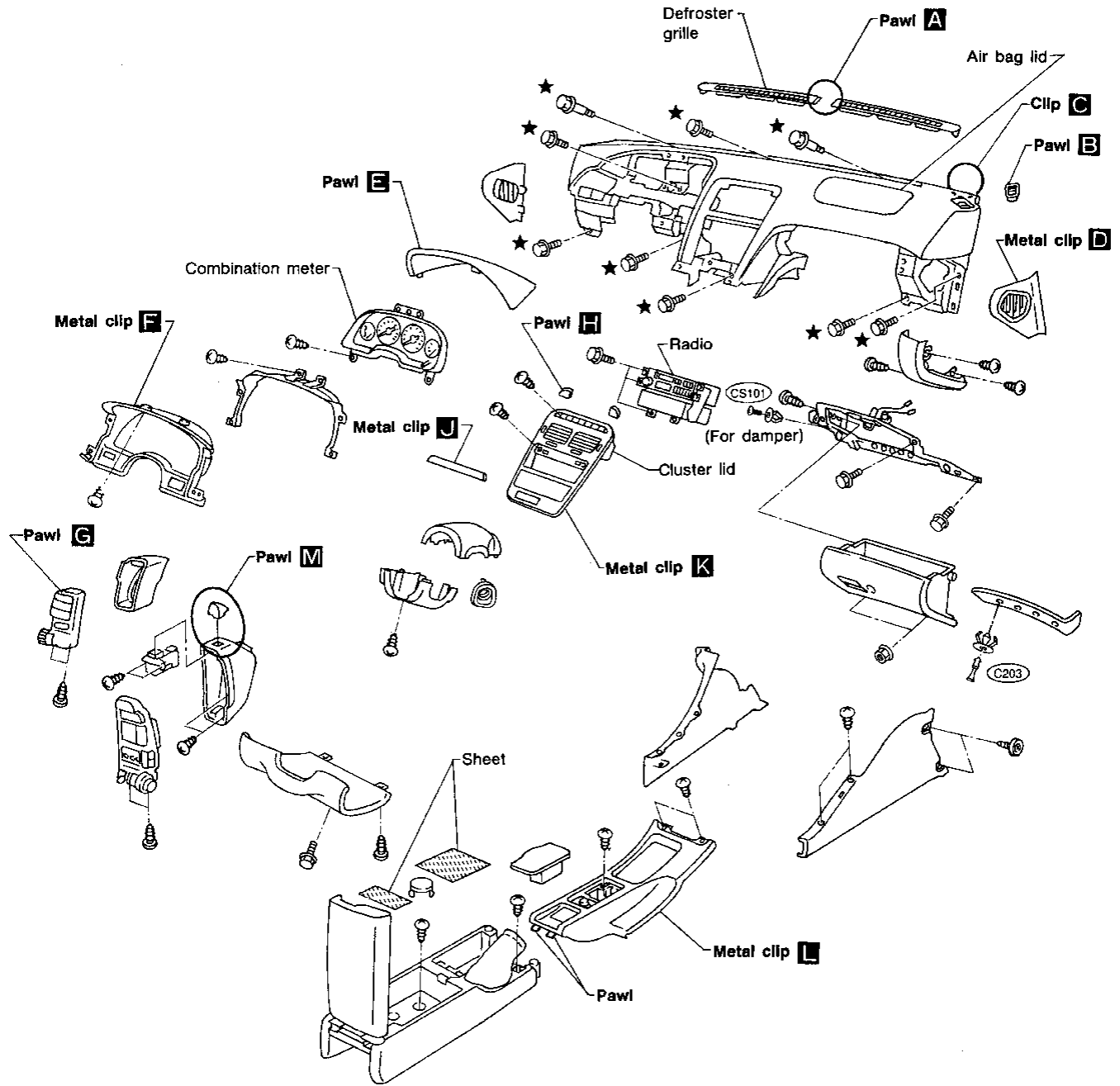

 : Double-faced adhesive tape

GI
MA
EM
LC
EF & EC
FE
CL
MT
AT
PD
FA
RA
BR
ST
BF
HA
EL
IDX

INSTRUMENT PANEL

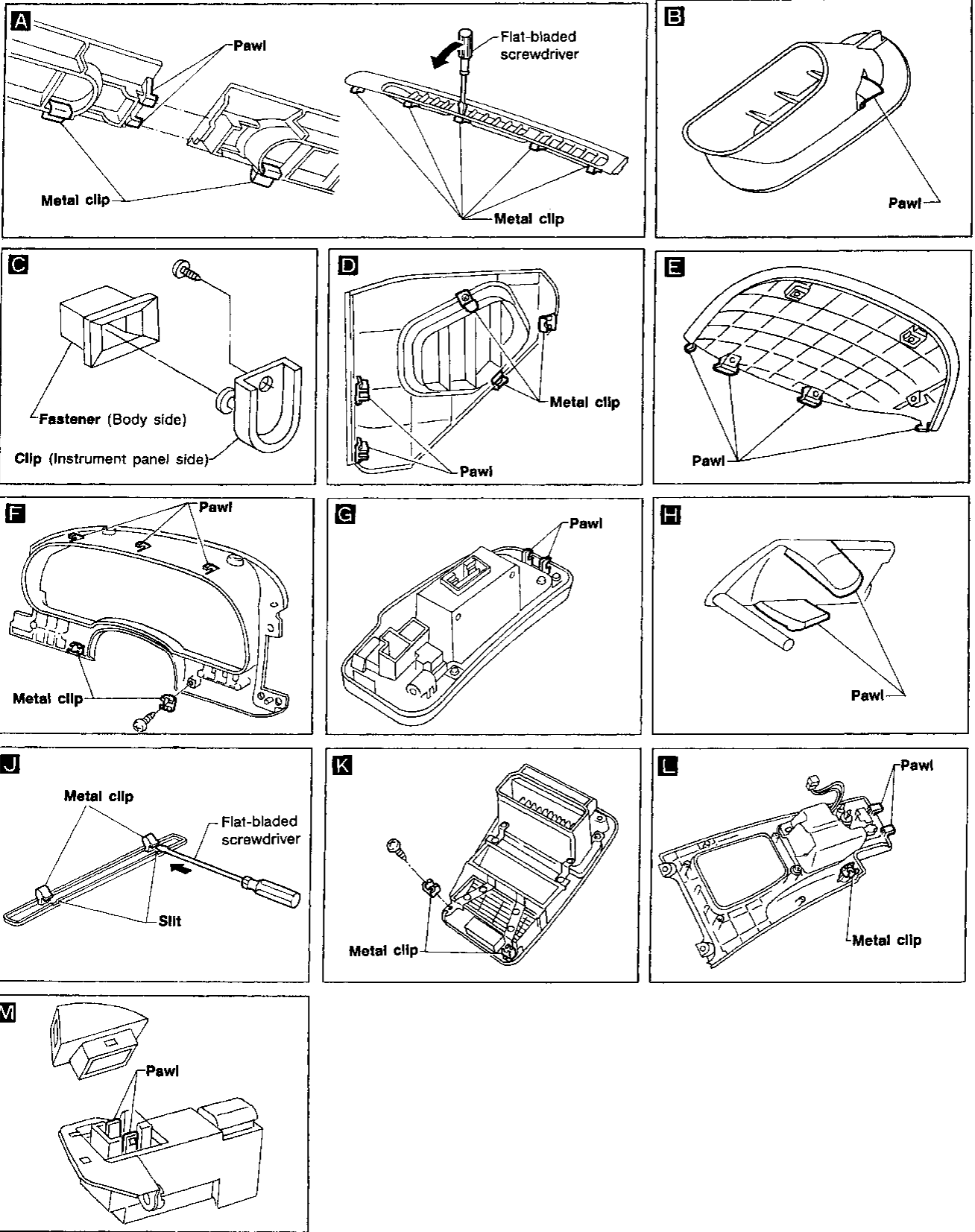

Interior

SIDE, LUGGAGE AND FLOOR TRIM

2 seater model

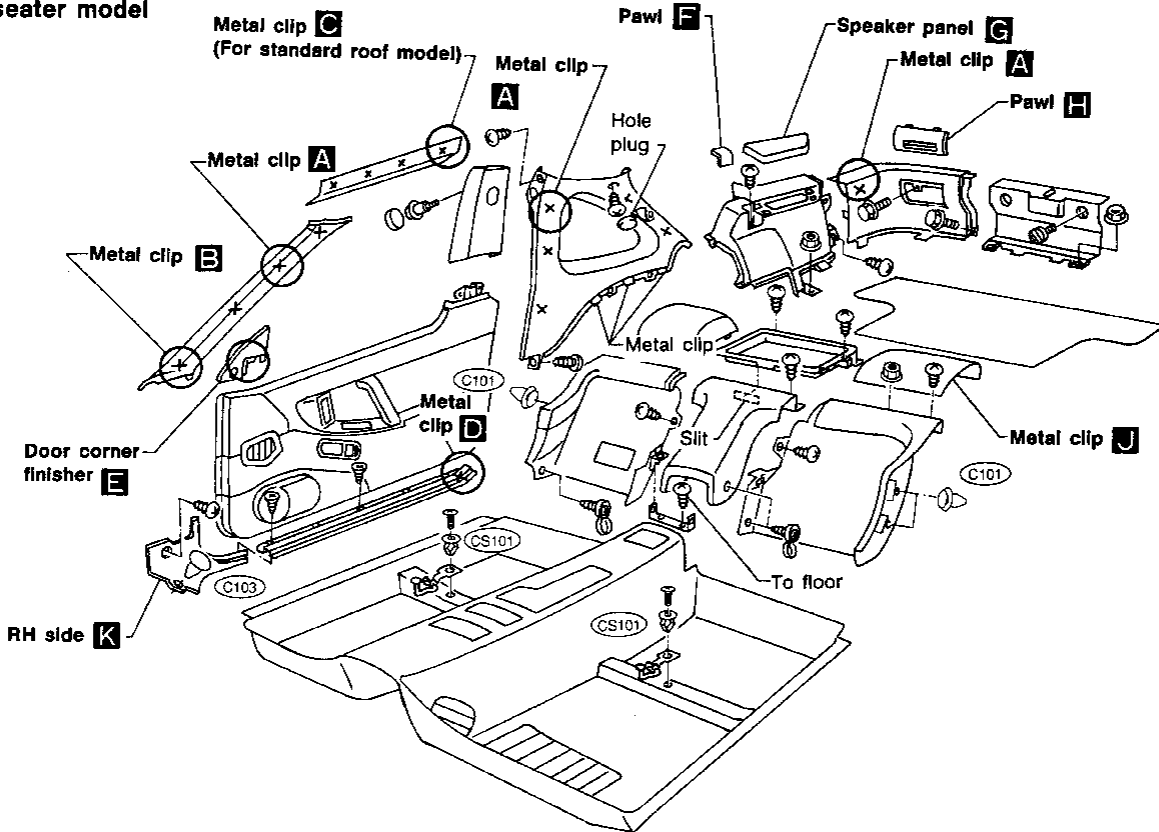

2 + 2 seater model

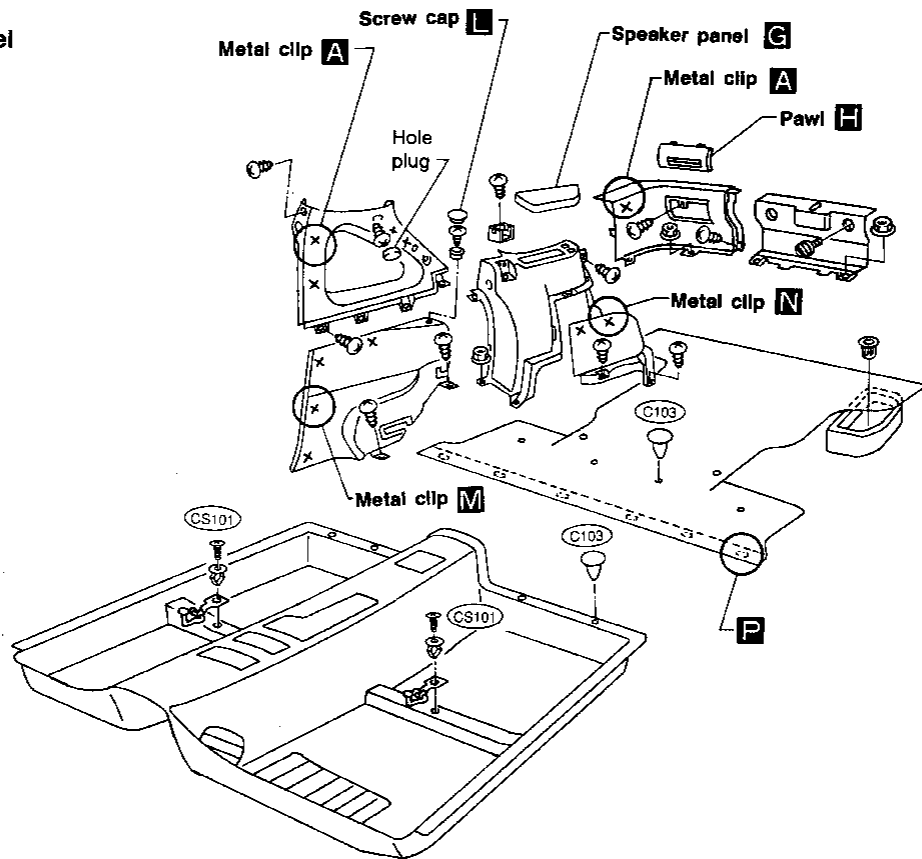

- GI
- MA
- EM
- LC
- EF & EC
- FE
- CL
- MT
- AT
- PD
- FA
- RA
- BR
- ST
- BF
- HA
- EL
- IDX

INTERIOR AND EXTERIOR

Interior (Cont'd)

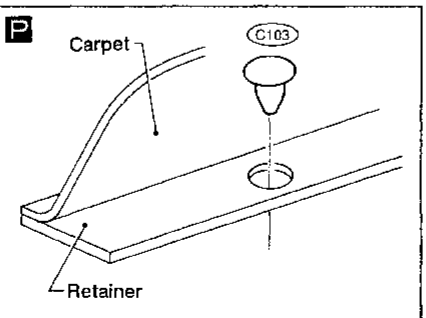
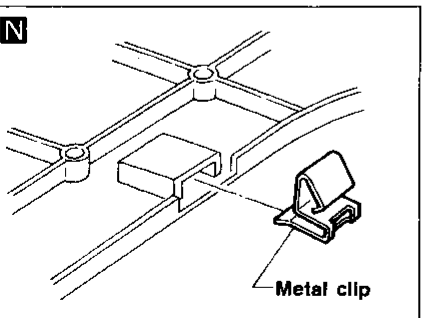
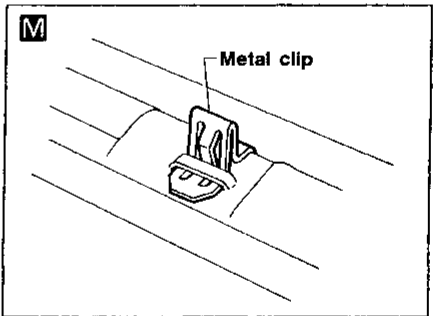
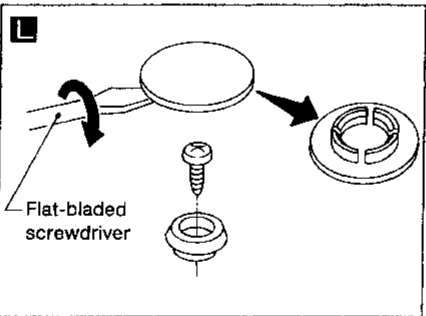
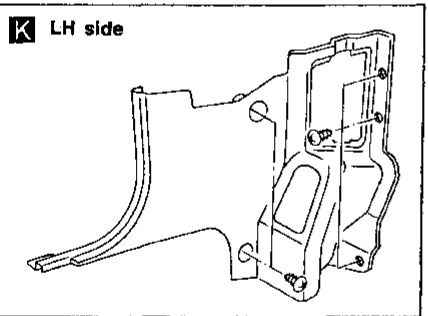
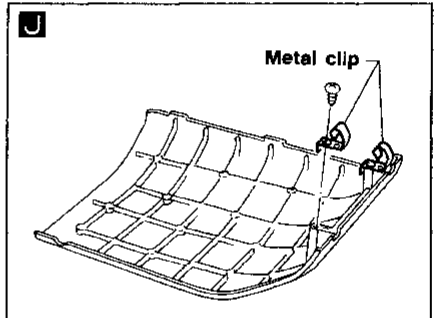
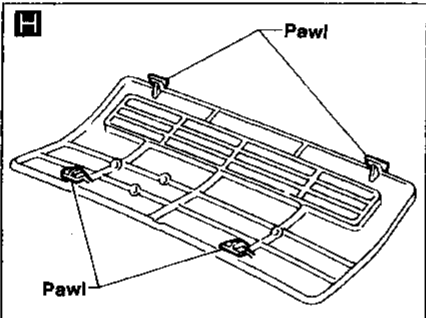
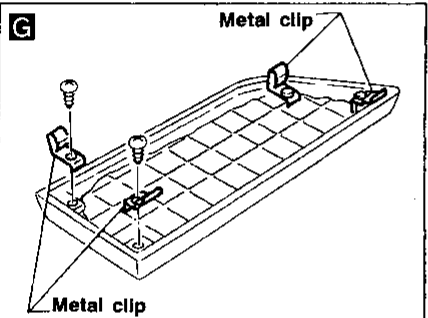
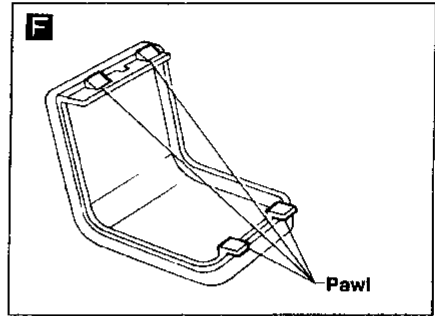
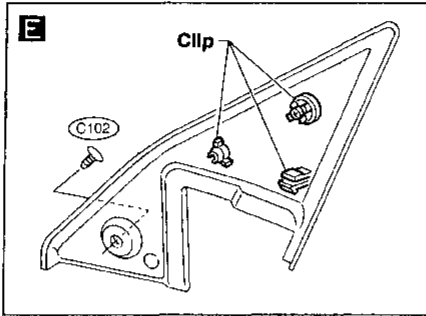
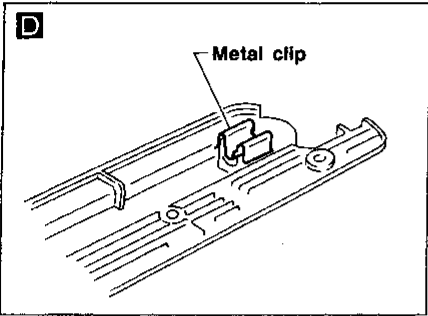
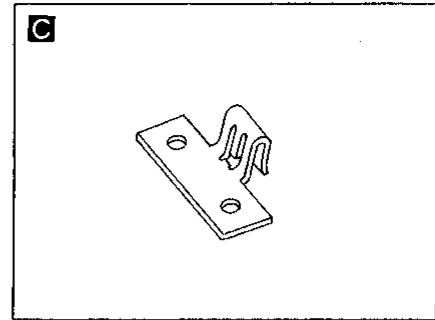
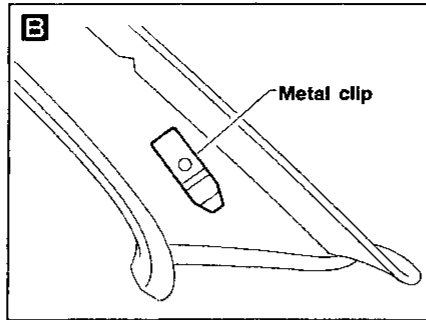
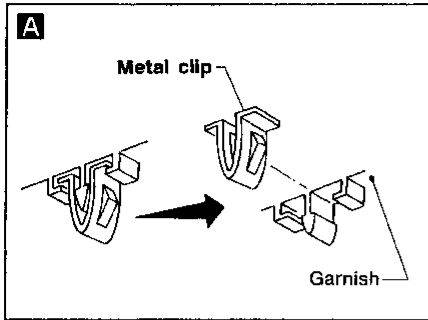

INTERIOR AND EXTERIOR

Interior (Cont'd)

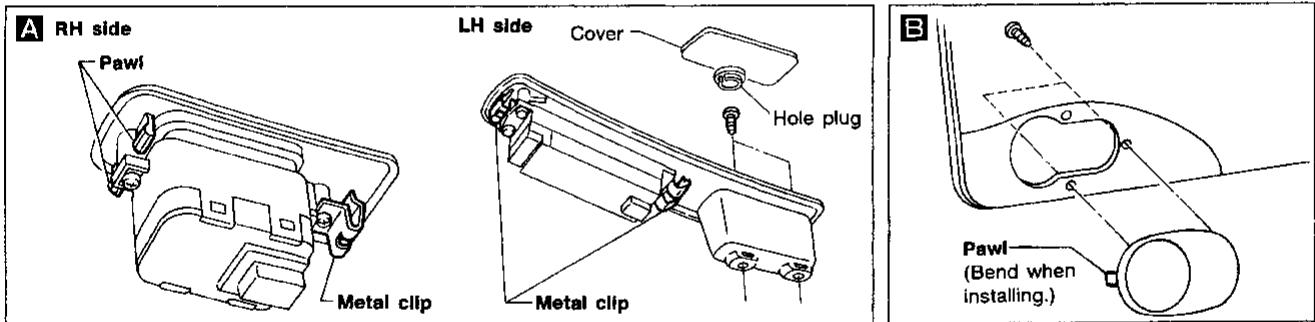
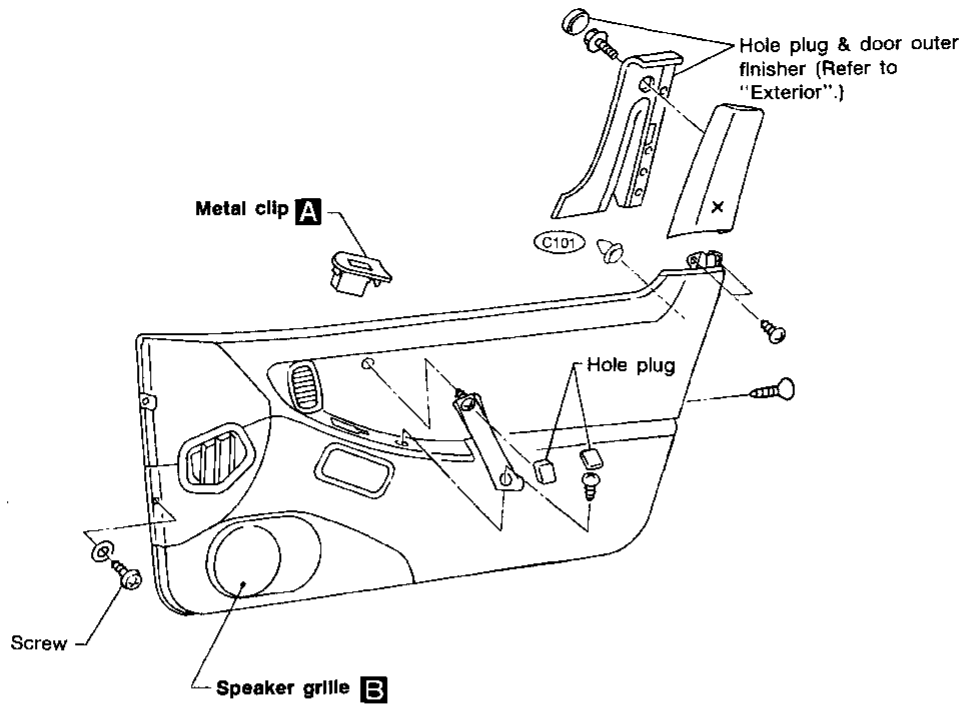

GI

VA

EM

LC

EF &
EC

FE

CL

MT

AT

PD

FA

RA

BR

ST

BF

HA

EL

IDX

INTERIOR AND EXTERIOR

Interior (Cont'd)

Convertible model

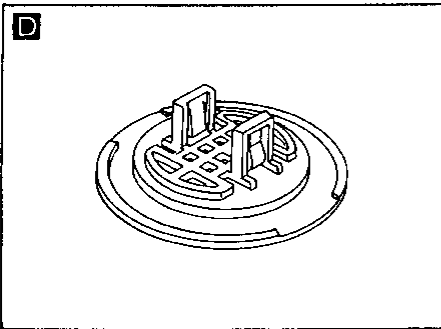
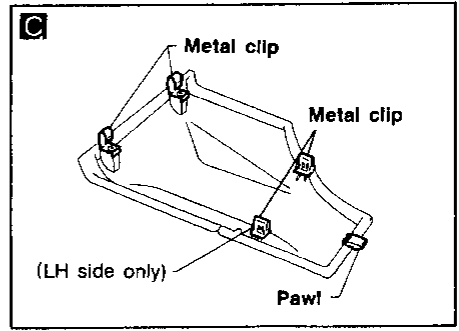
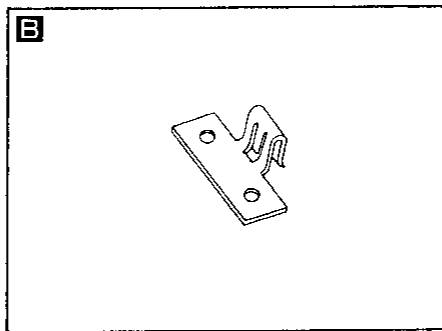
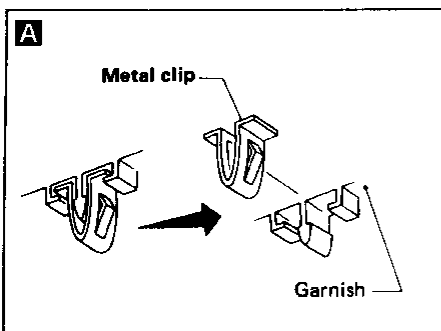
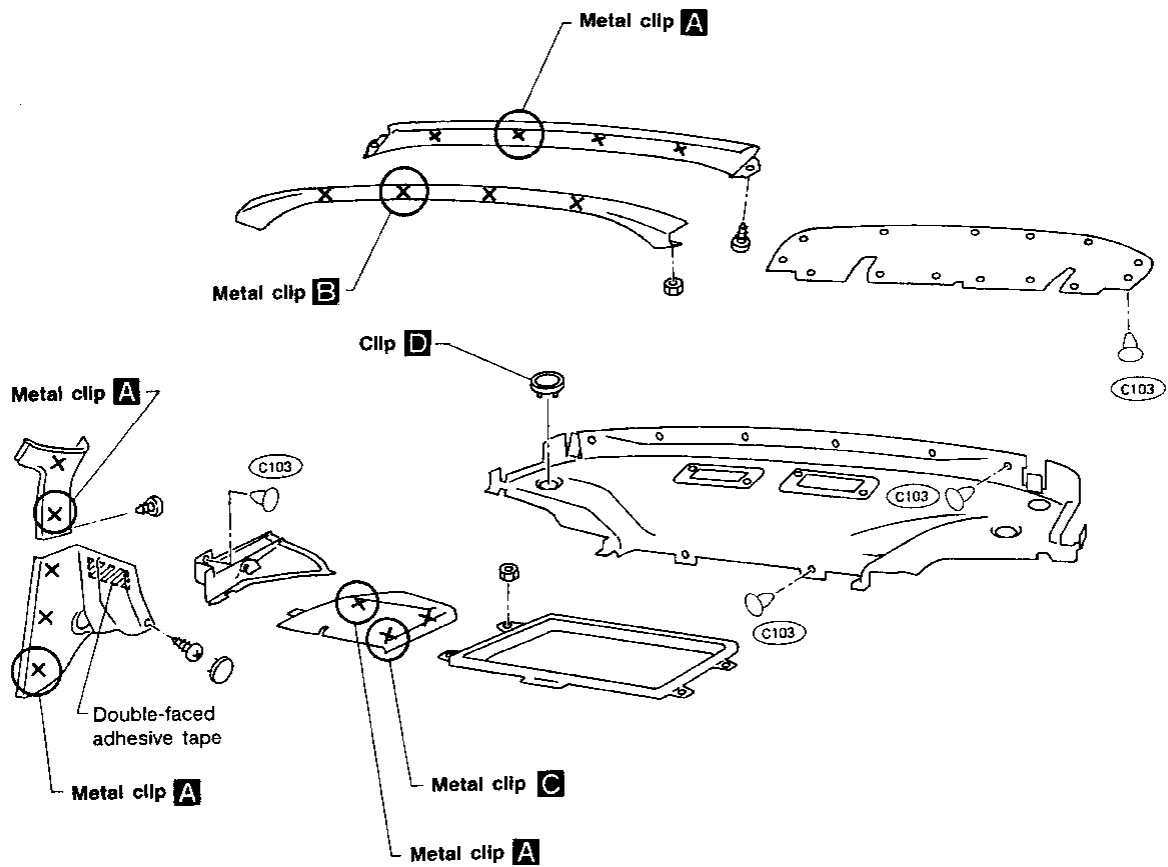

INTERIOR AND EXTERIOR

Interior (Cont'd)

BACK DOOR TRIM — Standard model

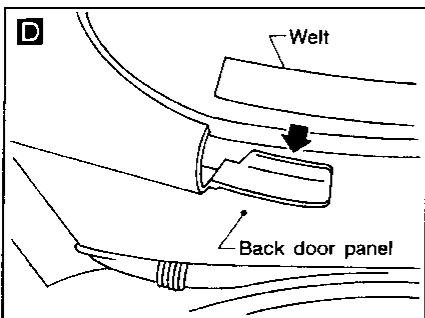
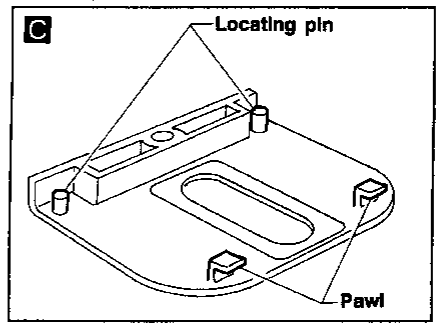
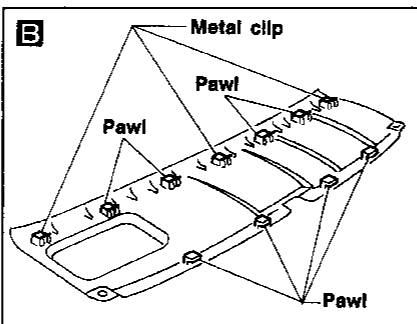
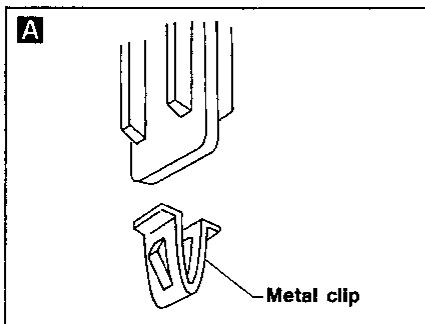
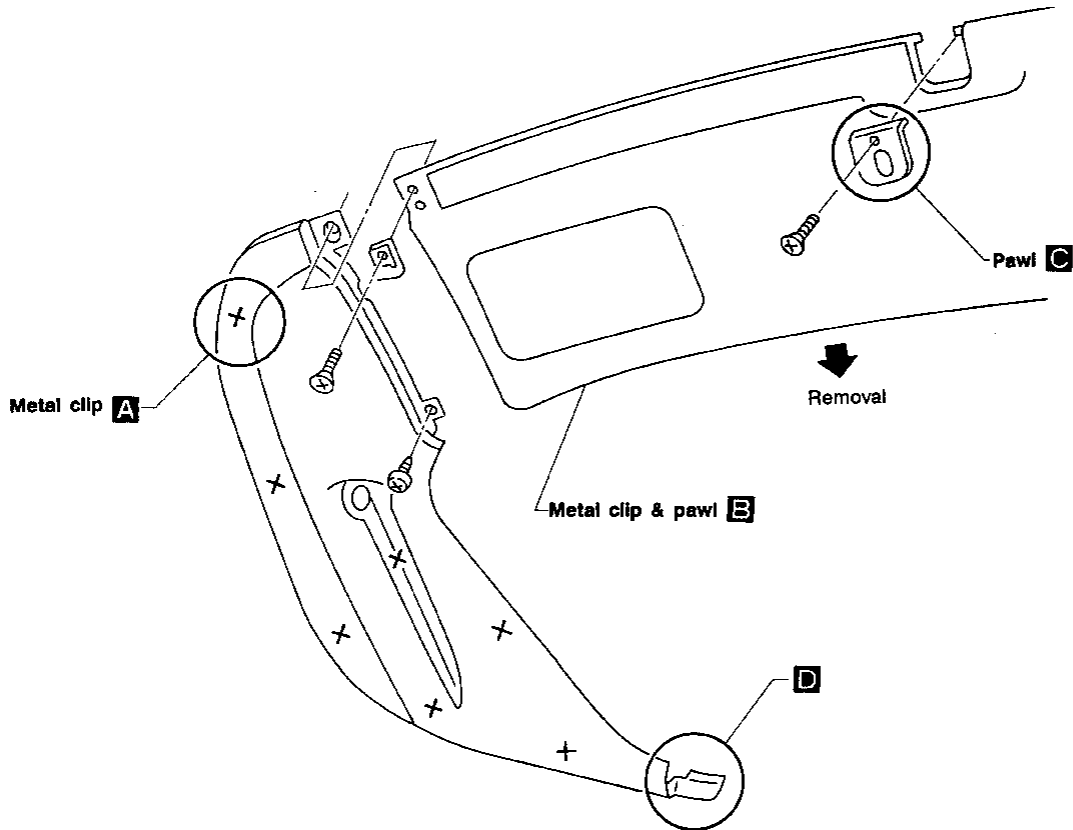

GI
MA
EM
LC
EF &
EC
FE
CL
MT
AT
PD
FA
RA
BR
ST
BF
HA
EL
IDX

INTERIOR AND EXTERIOR

Interior (Cont'd)

ROOF TRIM — T-bar roof model

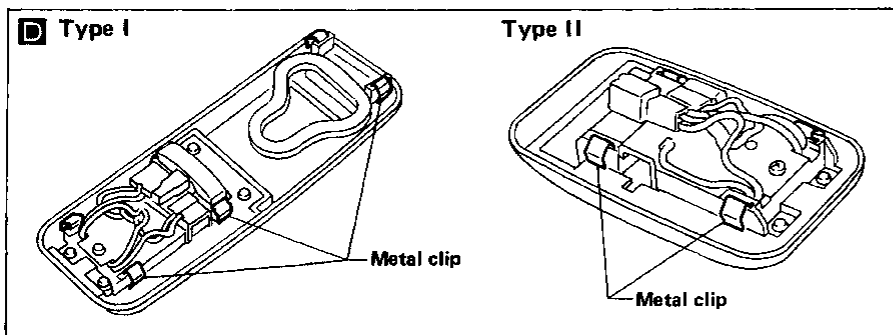
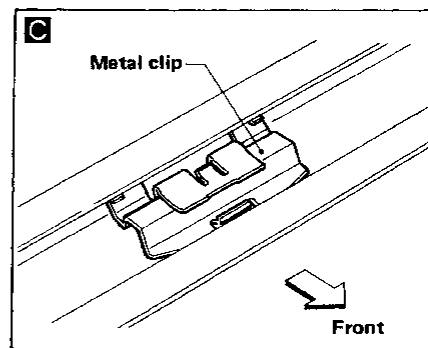
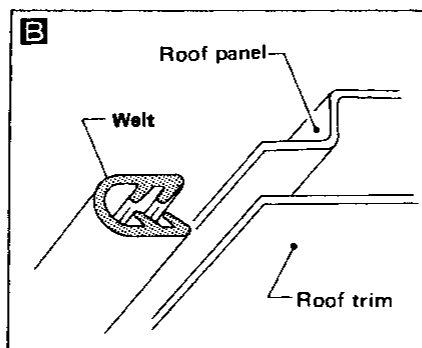
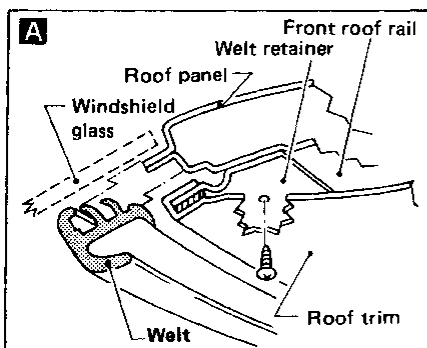
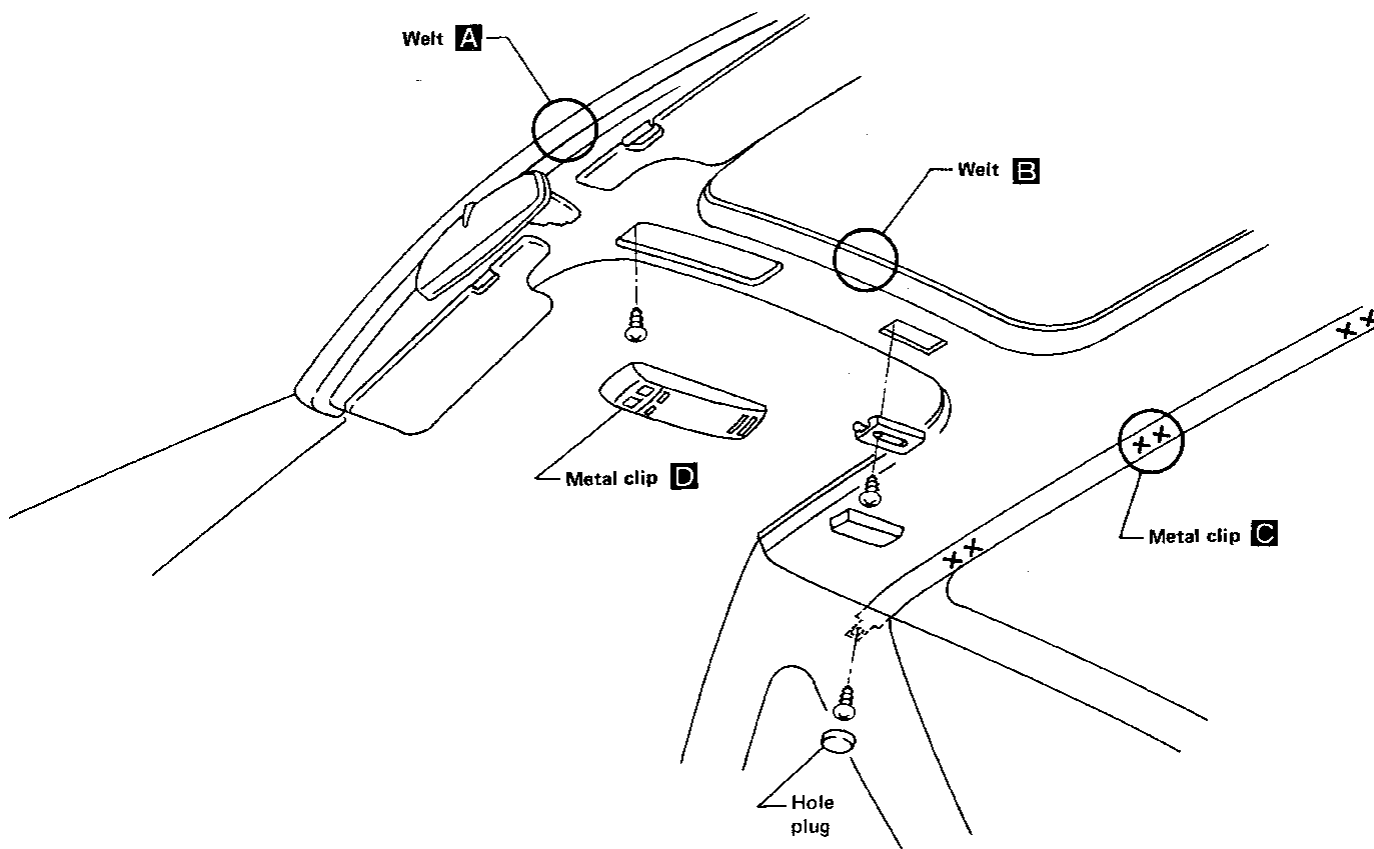

INTERIOR AND EXTERIOR

Interior (Cont'd)

TRUNK ROOM TRIM — Convertible model

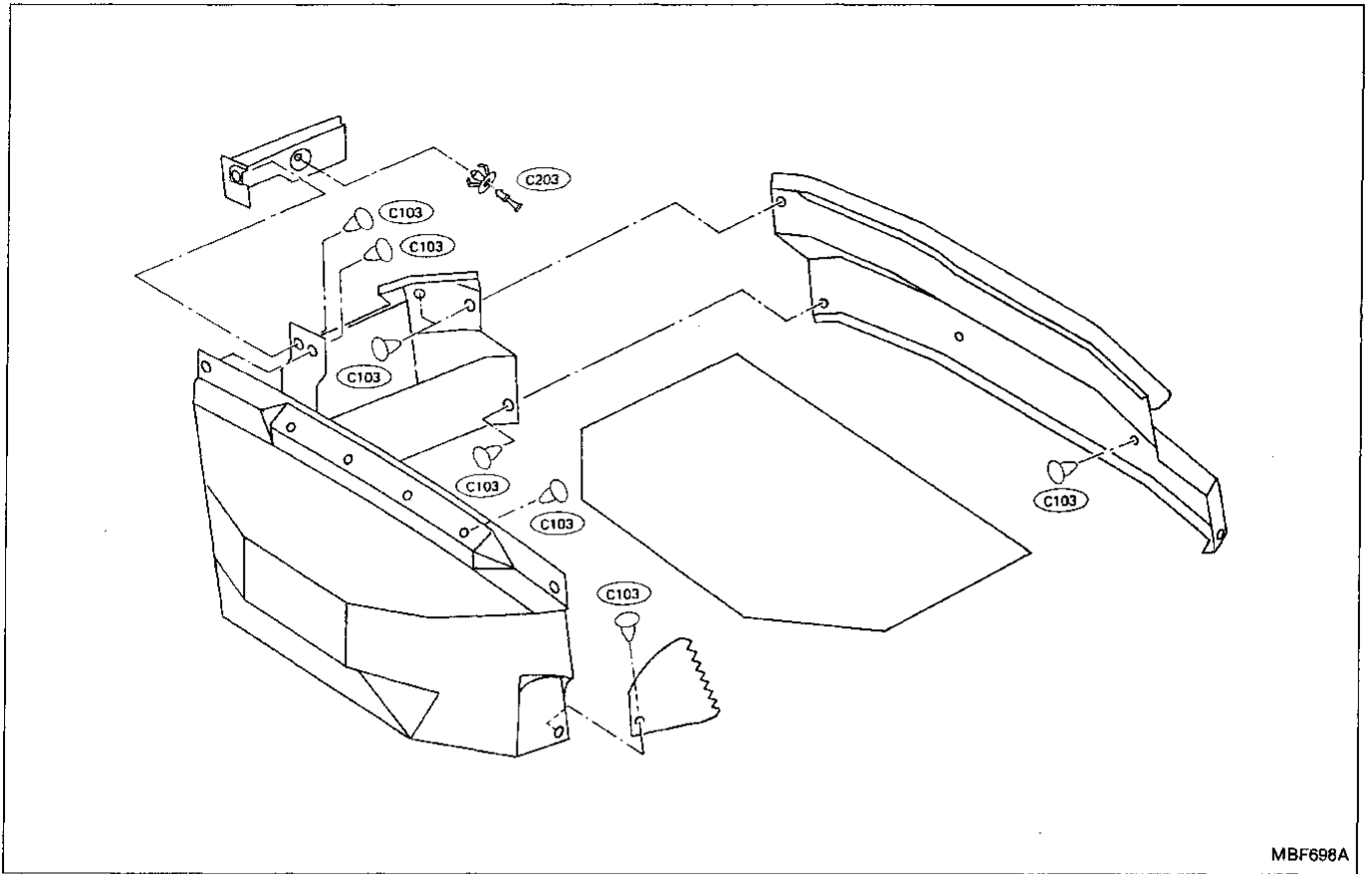

GI

MA

EM

LC

EF &
EC

FE

CL

MT

AT

PD

FA

RA

BR

ST

BF

HA

EL

IDX

Exterior

Standard model

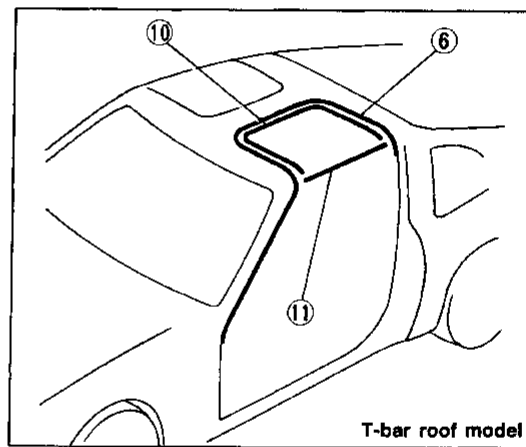
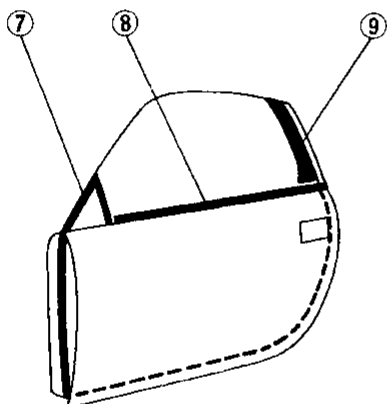
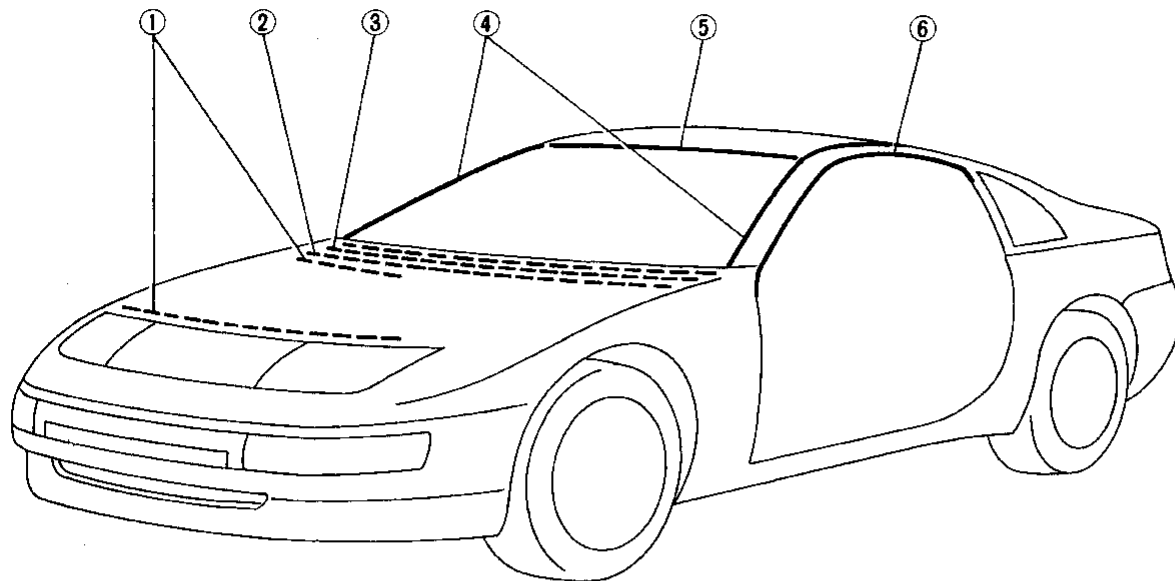

T-bar roof model

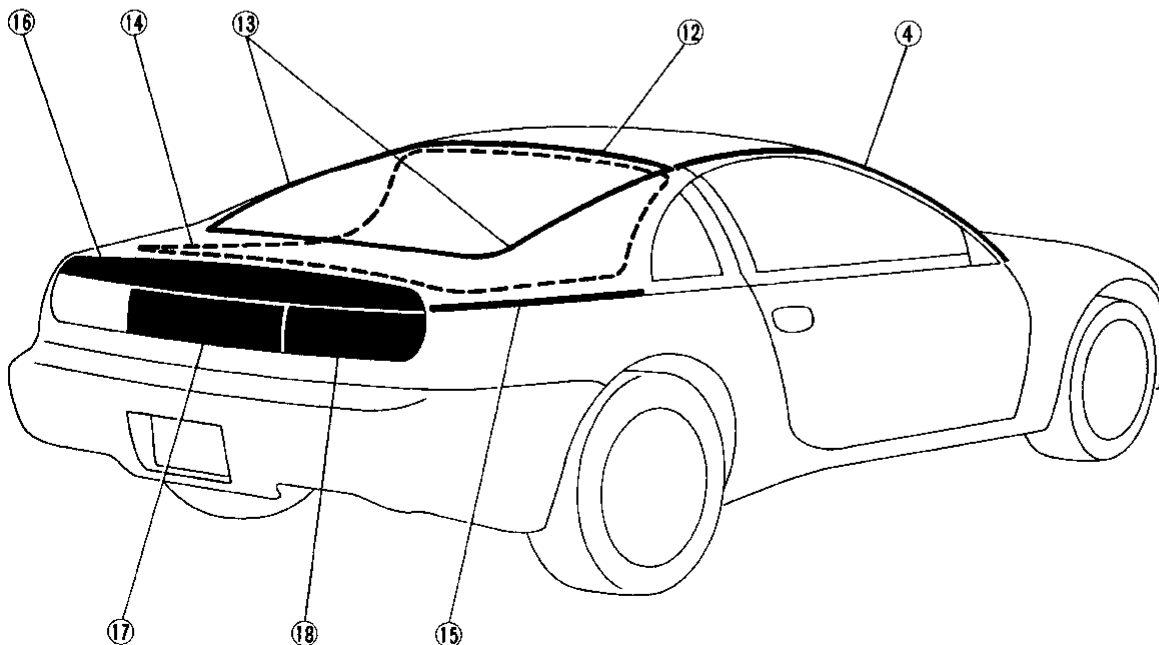

INTERIOR AND EXTERIOR

Exterior (Cont'd)

Convertible model

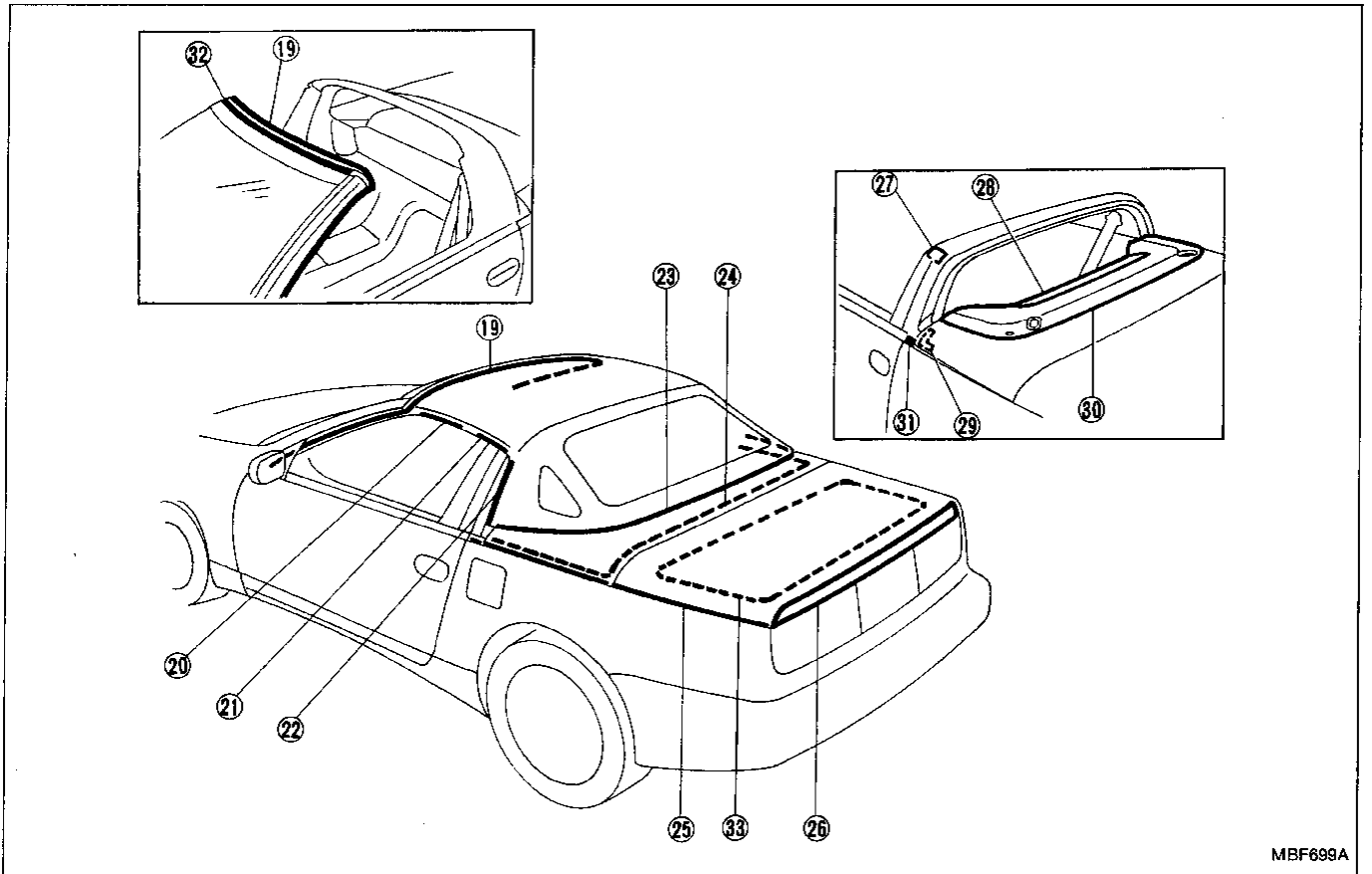

GI

MA

EM

LC

EF &
EC

FE

CL

MT

AT

PD

FA

RA

BR

ST

BF

HA

EL

IDX

INTERIOR AND EXTERIOR

Exterior (Cont'd)

① Hood front and rear seal

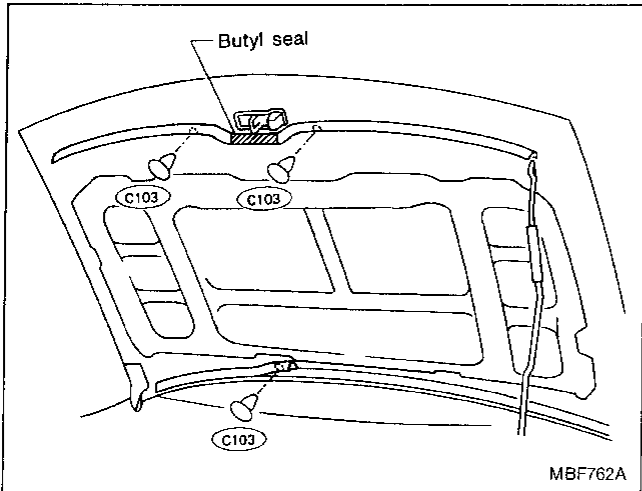

② ③ Cowl top seal and cowl top grille

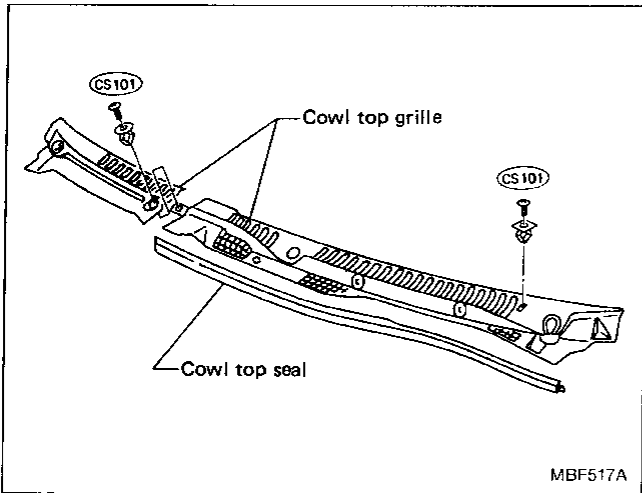

④ Windshield side molding

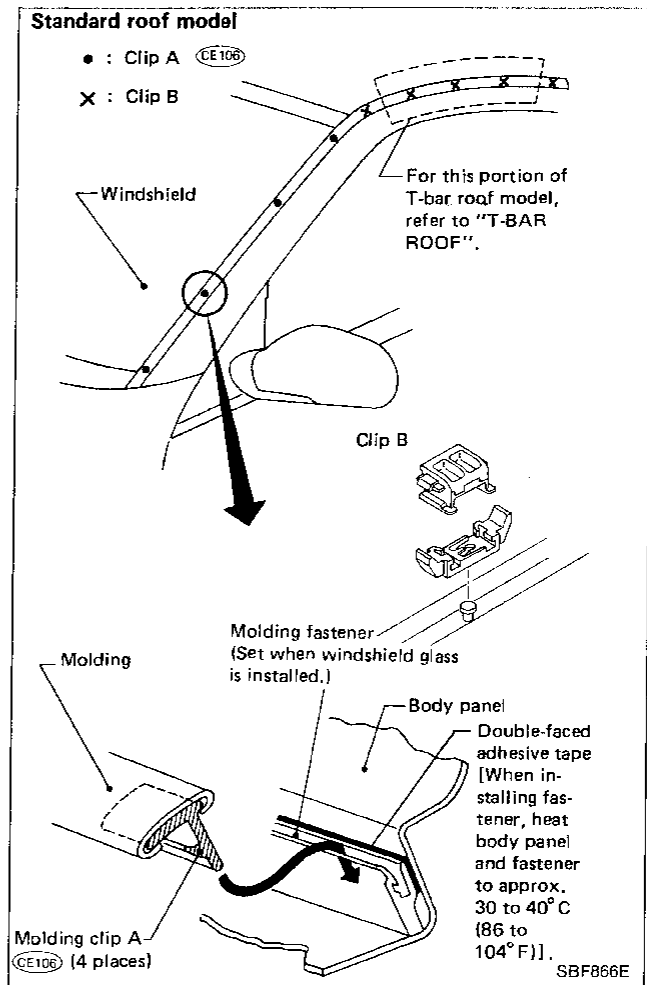

⑤ Windshield upper molding

Method 1

Cut off top portion of molding and clean glass and panel surfaces.

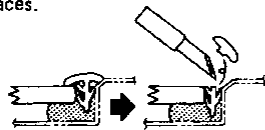

Apply sealant to top portion of molding.

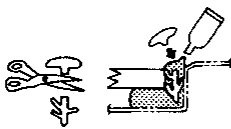

Cut off lower portion of new molding



Finish well to give it a good appearance.

Method 2

1. Cut off sealant at glass end.
2. Clean the side on which panel was mounted.
3. Set molding fastener and apply sealant & primer to body panel, and apply primer to molding.

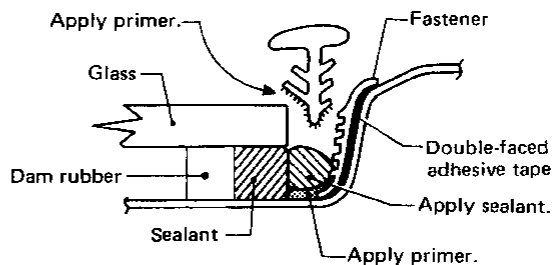

4. Install molding by aligning the molding mark located on center with vehicle center. Be sure to install tightly so that there is no gap around the corner.

MBF690A

INTERIOR AND EXTERIOR

Exterior (Cont'd)

⑥ Body side weatherstrip

T-bar roof model

Basically the same as the standard roof model

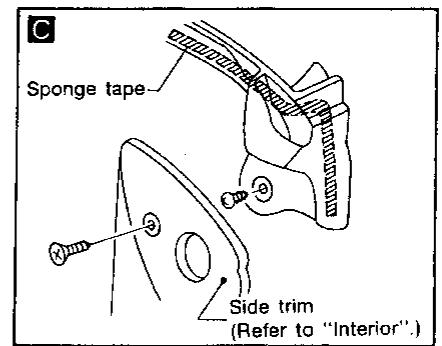
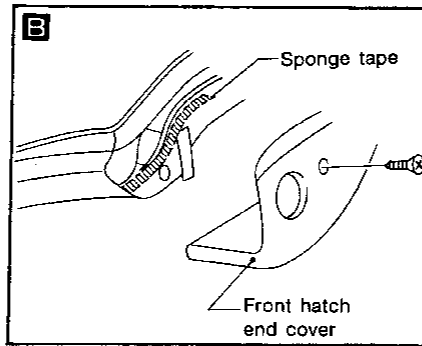
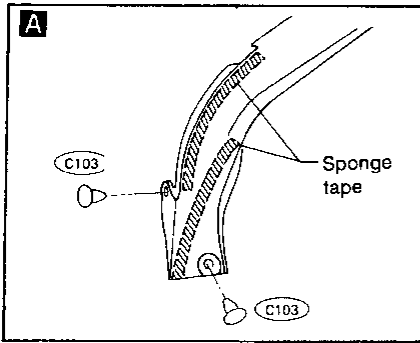
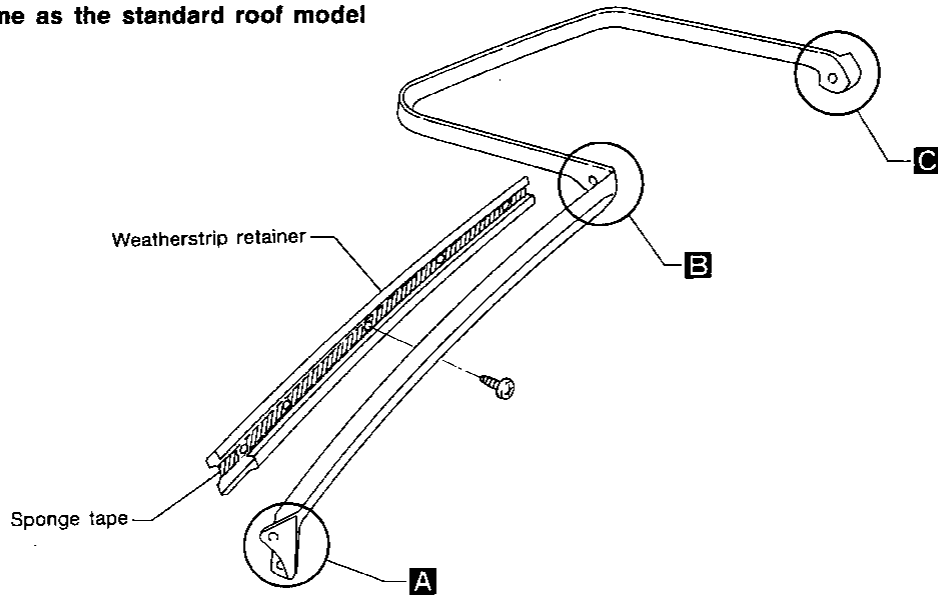

MBF763A

⑦ Door weatherstrip

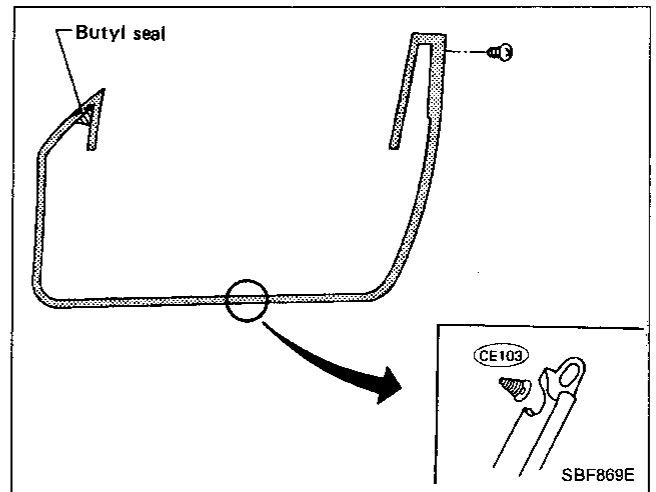

GI

MA

EM

LC

EF &
EC

FE

CL

MT

AT

PD

FA

RA

BR

ST

BF

HA

EL

IDX

INTERIOR AND EXTERIOR

Exterior (Cont'd)

⑧ Door out side molding

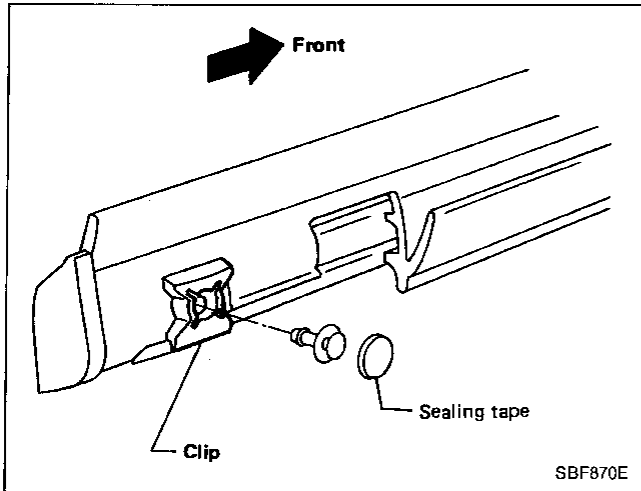

⑨ Door outer finisher

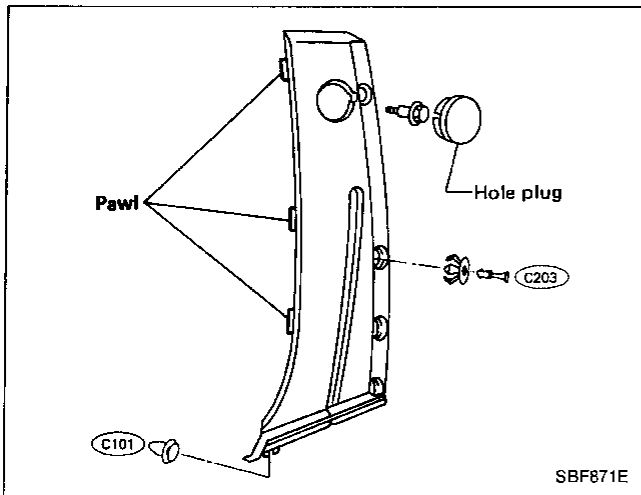

⑩ T-bar roof sash and T-bar roof weatherstrip

These are part of the T-bar roof glass and cannot be removed. (Refer to "T-BAR ROOF".) If they are damaged, replace entire T-bar roof glass assembly.

⑪ T-bar roof side weatherstrip

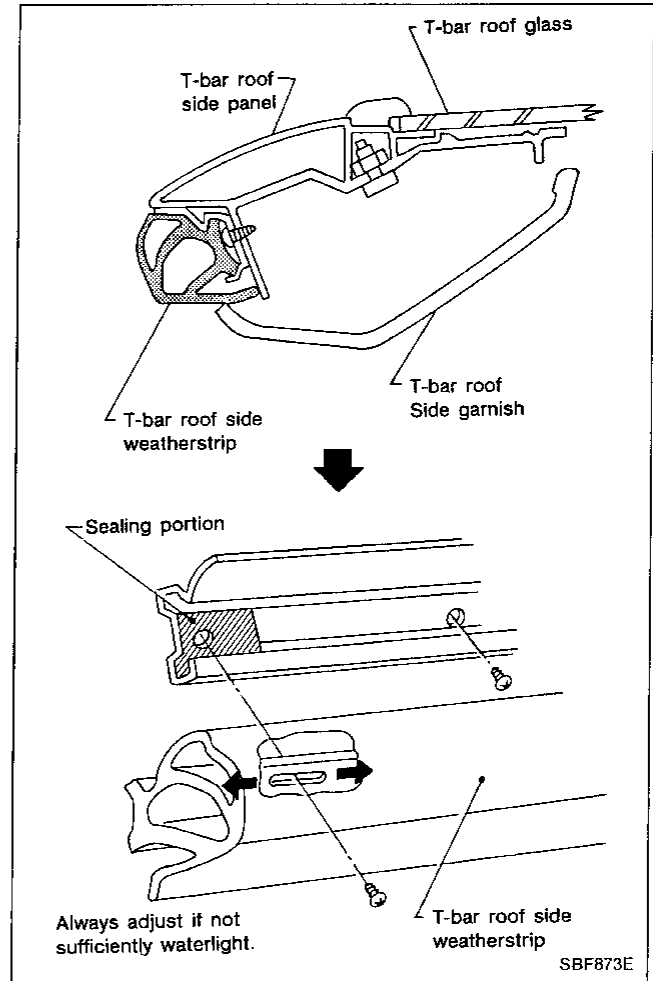

⑫ Back door glass upper molding

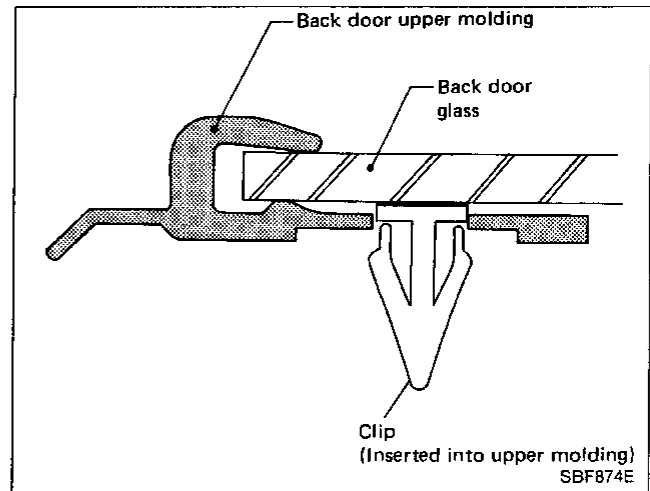

INTERIOR AND EXTERIOR

Exterior (Cont'd)

13 Back door glass side molding

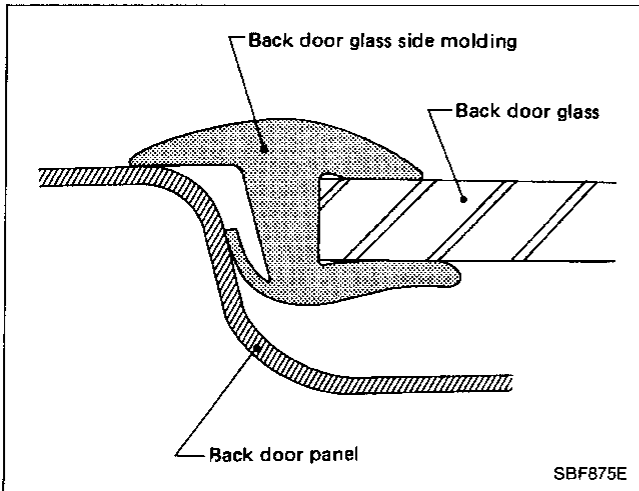

14 Back door weatherstrip

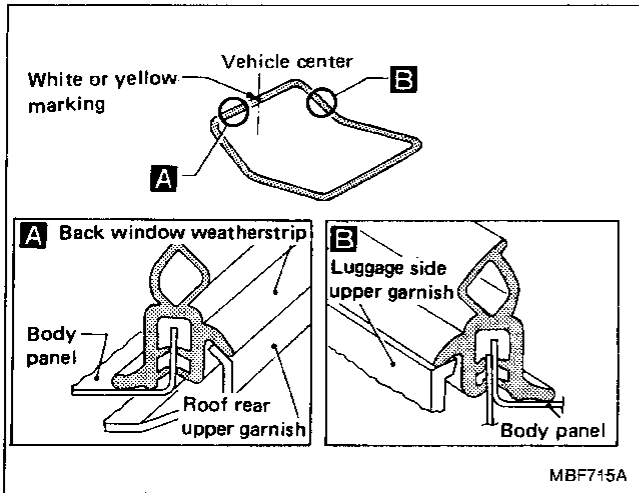

15 Back door molding

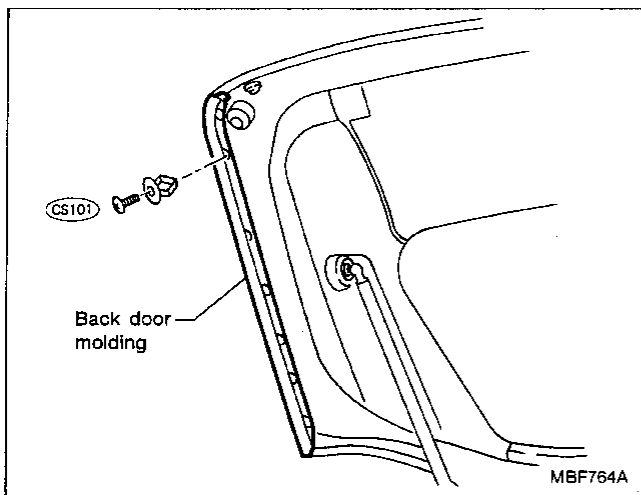

16 26 Back door finisher and trunk lid finisher

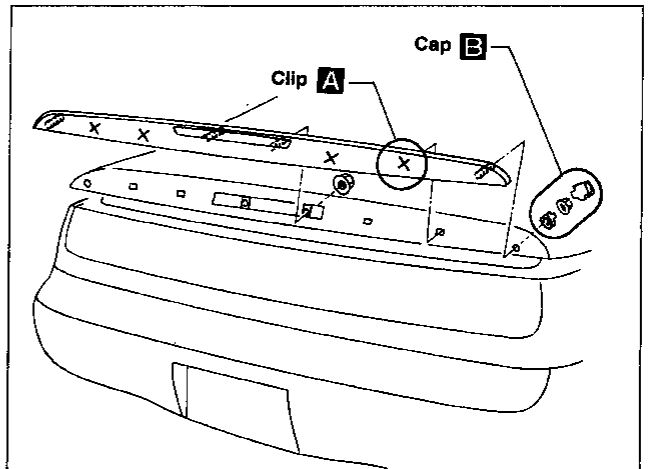

Trunk lid finisher
Basically the same as the back door finisher

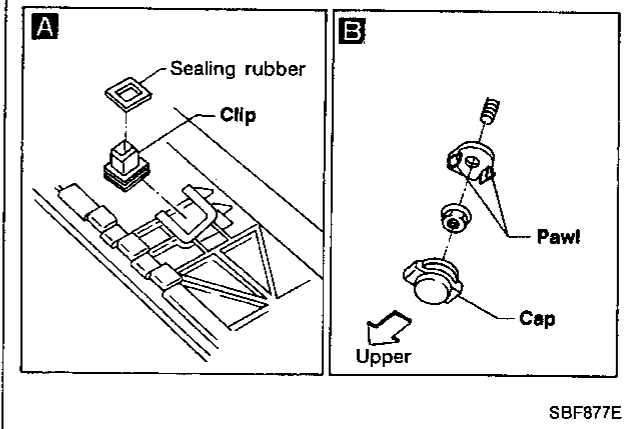

17 Rear panel finisher

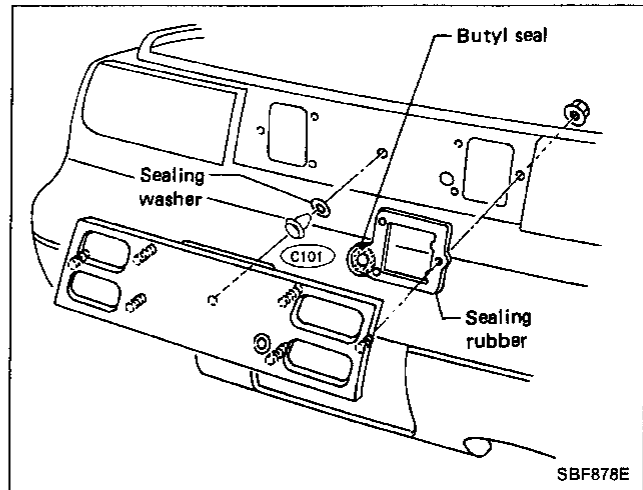

GI

MA

EM

LC

EF &
EC

FE

CL

MT

AT

PD

FA

RA

BR

ST

BF

HA

EL

IDX

INTERIOR AND EXTERIOR

Exterior (Cont'd)

18 Rear combination lamp

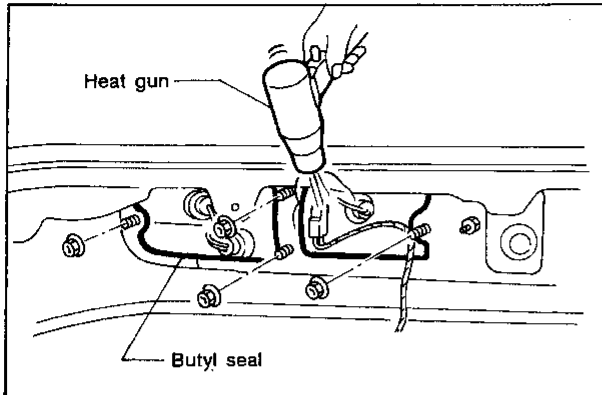

- Warm up lamp assembly area to a temperature a little below 60°C (140°F).

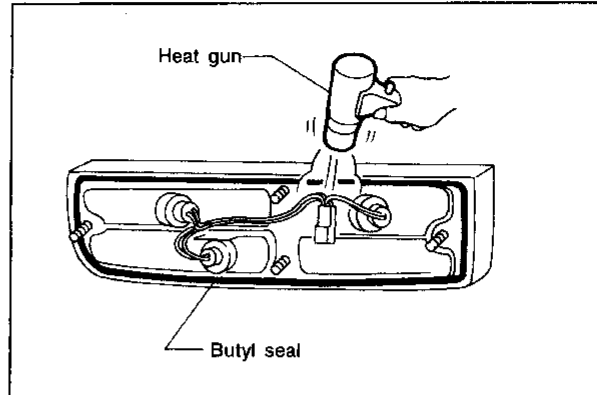

- Apply butyl seal evenly as it tends to become thin in the corners.
- Warm up lamp assembly area to a temperature a little below 60°C (140°F).

SBF886E

19 Body side weatherstrip

Convertible model

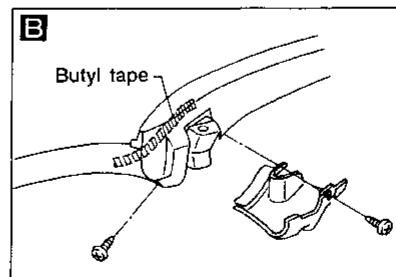
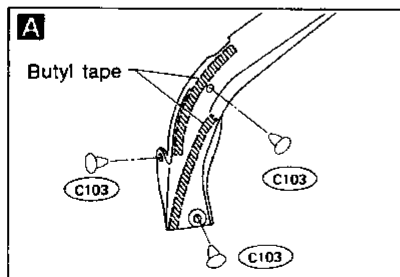
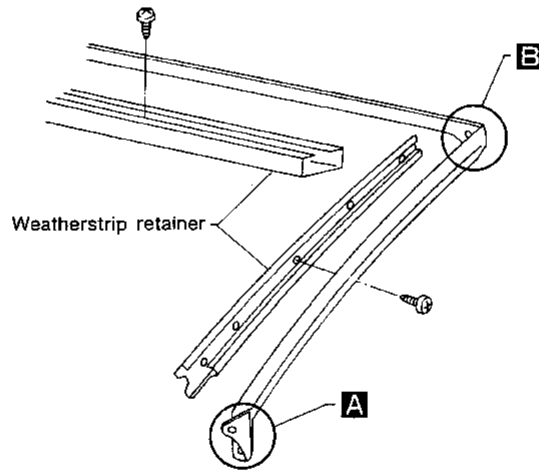

MBF700A

INTERIOR AND EXTERIOR

Exterior (Cont'd)

20 Front rail weatherstrip

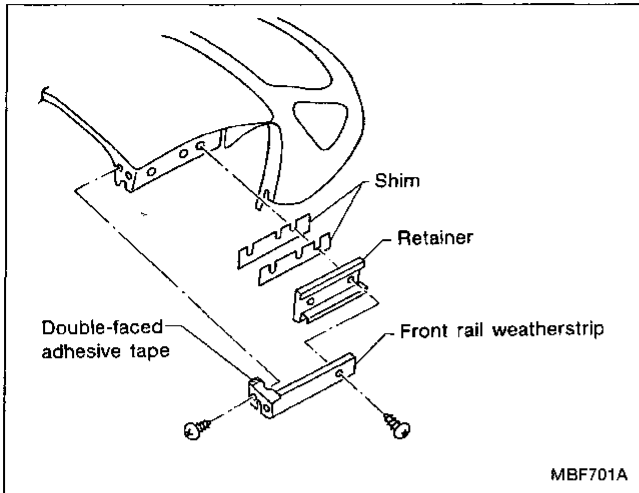

24 Storage lid weatherstrip

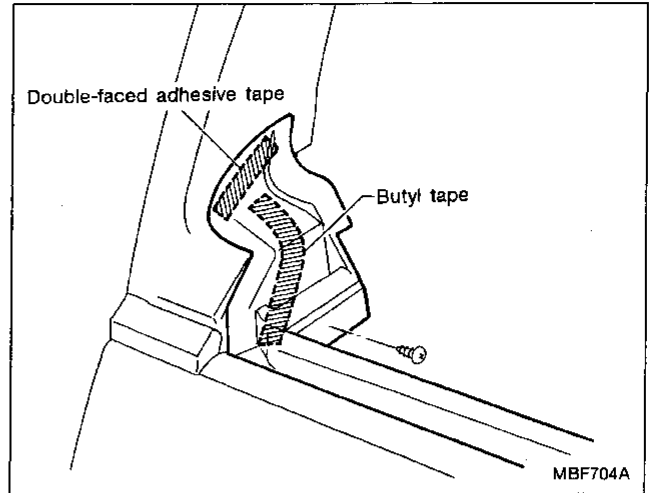

GI
MA
EM
LC
EF &
EC

21 Center rail weatherstrip

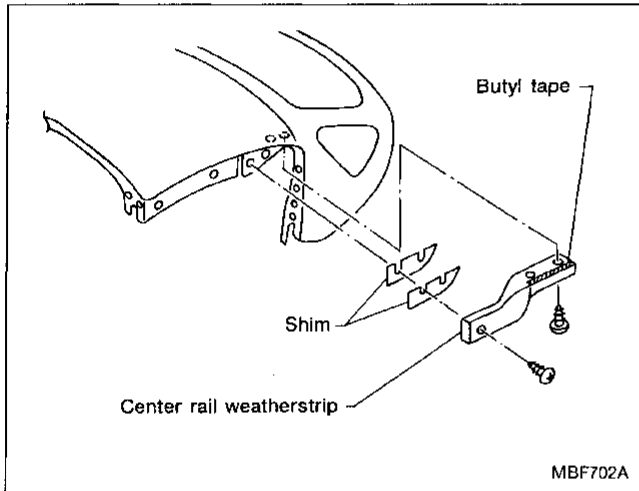

25 33 Trunk lid molding and Trunk lid weatherstrip

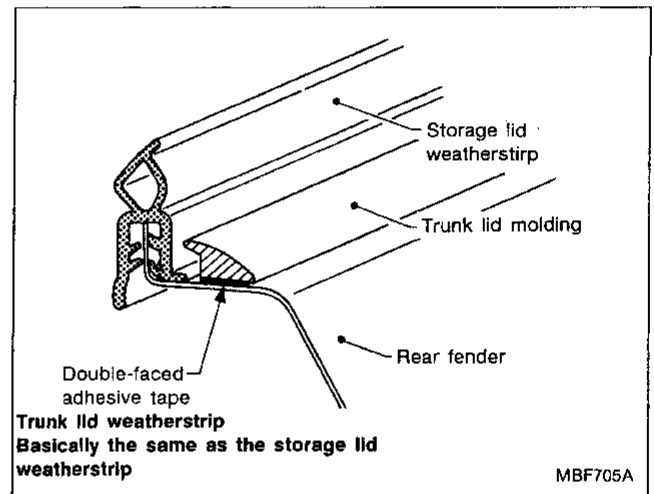

FE
CL
MT
AT
PD
FA

22 23 Rear rail weatherstrip and rear frame weatherstrip

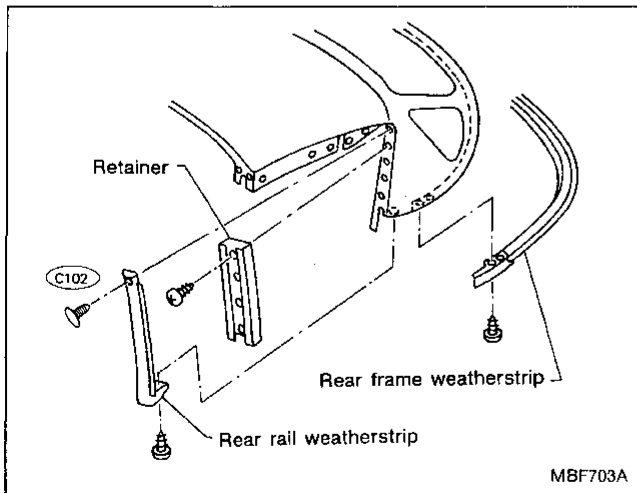

RA
BR
ST
BF
HA
EL

IDX

INTERIOR AND EXTERIOR

Exterior (Cont'd)

27 Body side rear weatherstrip

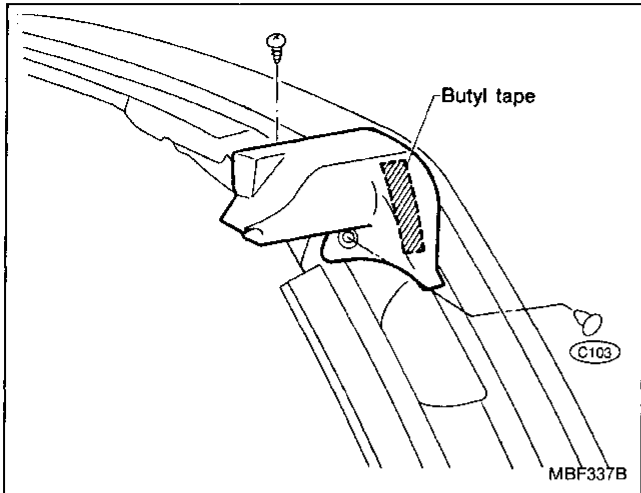

29 Storage lid corner seal

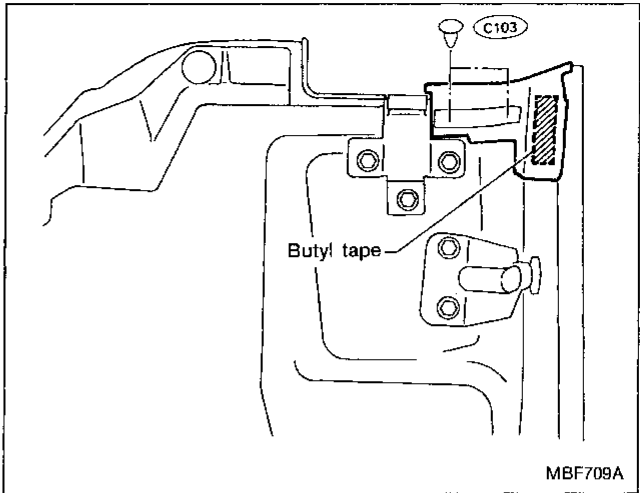

28 30 Storage lid deflector and finisher

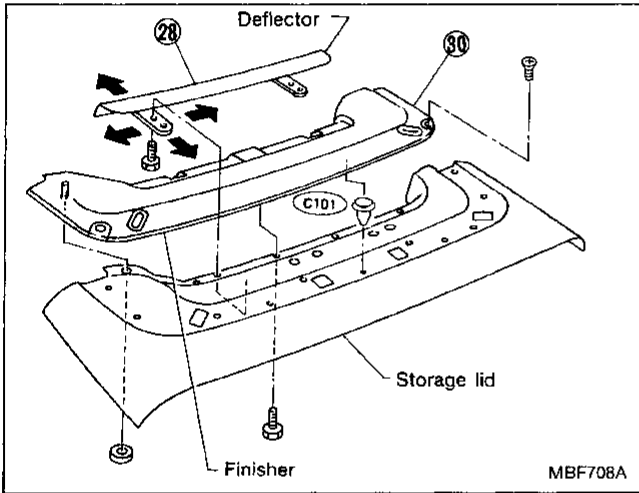

31 Center pillar molding

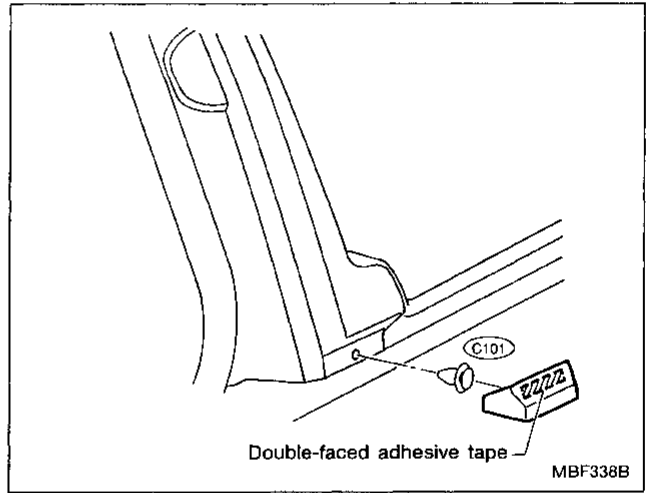

32 Front roof molding

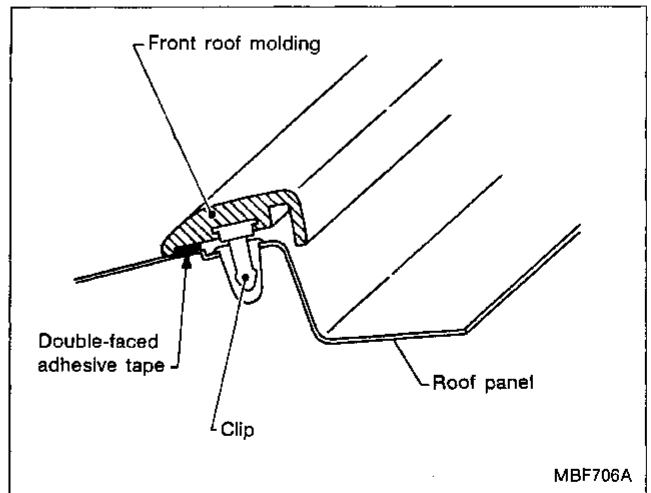

T-BAR ROOF

- Handle T-bar roof glass with care so not to damage it.
- Apply sealant to portions susceptible to water leakage if necessary.
- Side molding, sash, lock basement and glass of T-bar roof constitute one unit and cannot be disassembled.

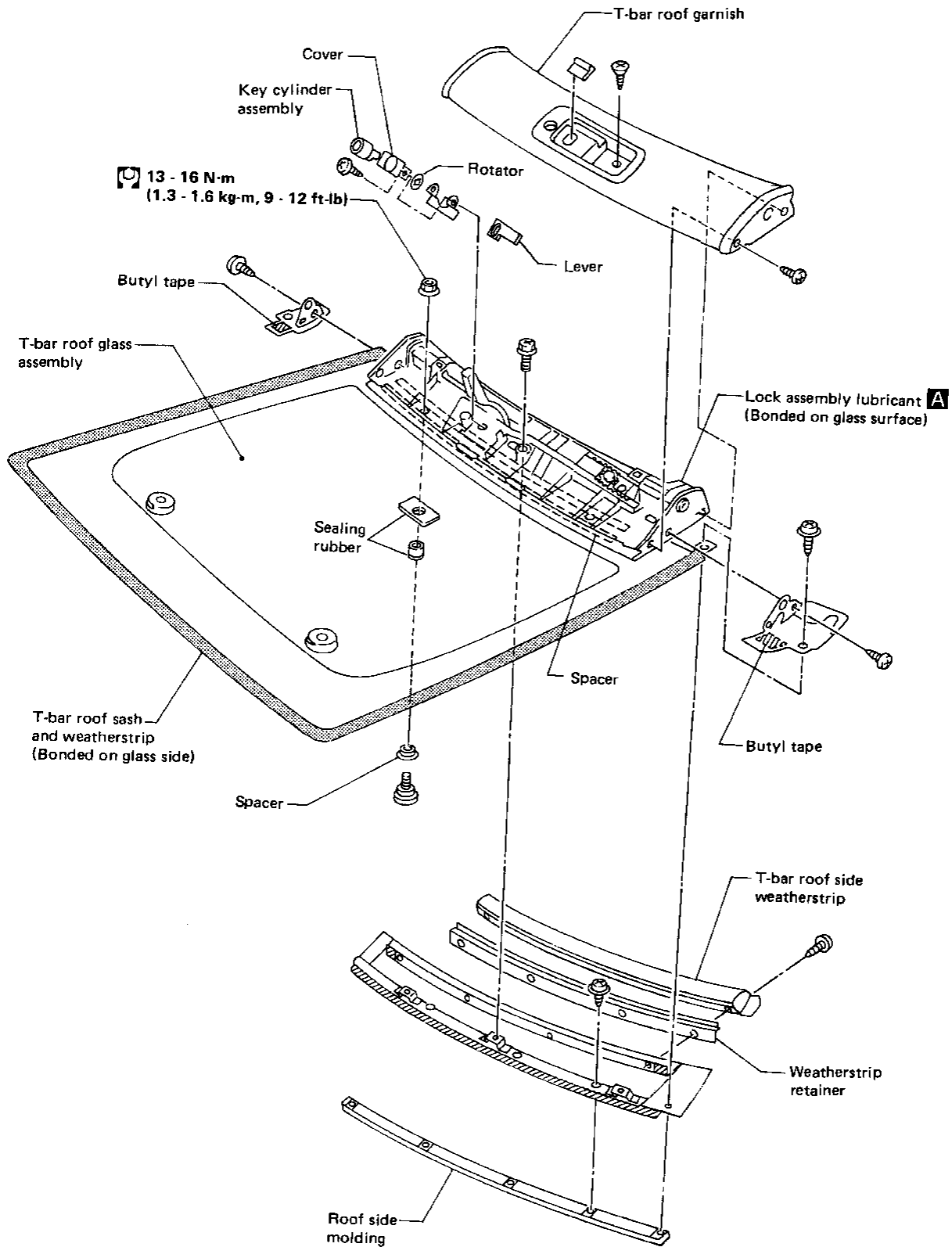

GI
MA
EM
LC
EF &
EC
FE
CL
MT
AT
PD
FA
RA
BR
ST
BF
HA
EL
IDX

T-BAR ROOF

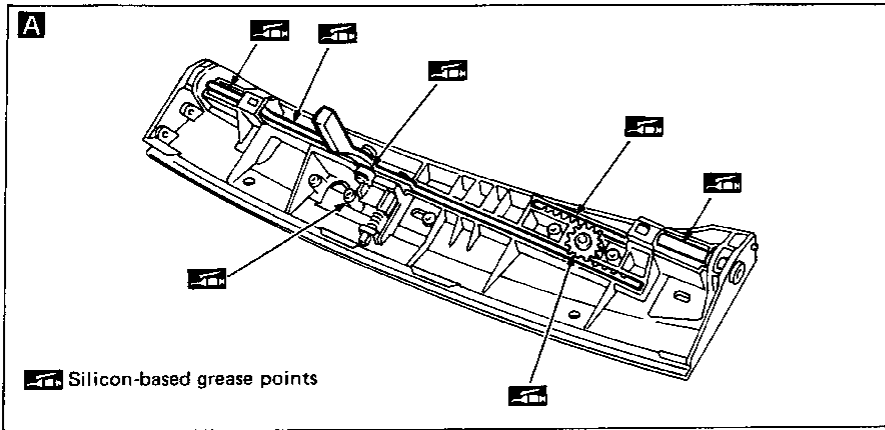

T-bar roof hook

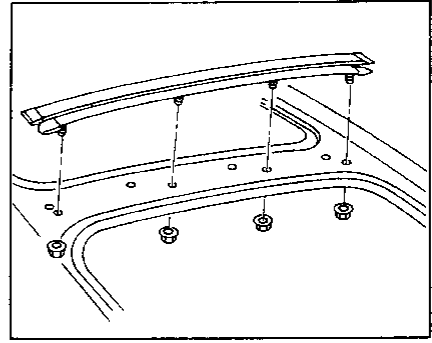

T-bar roof female lock adjustment

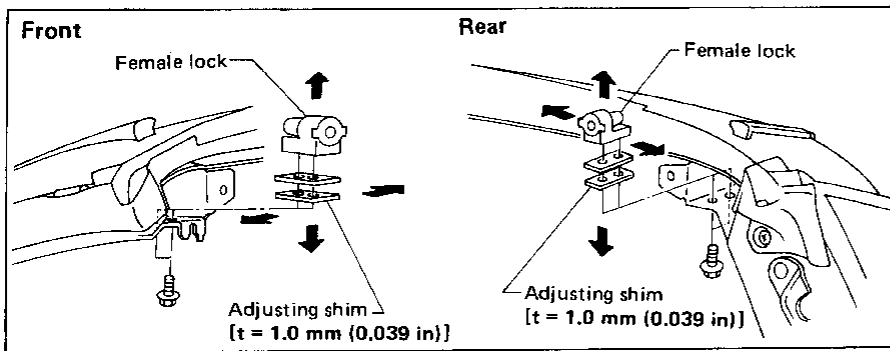

Wiring Diagram

STORAGE LID AND TRUNK LID OPENER SYSTEM

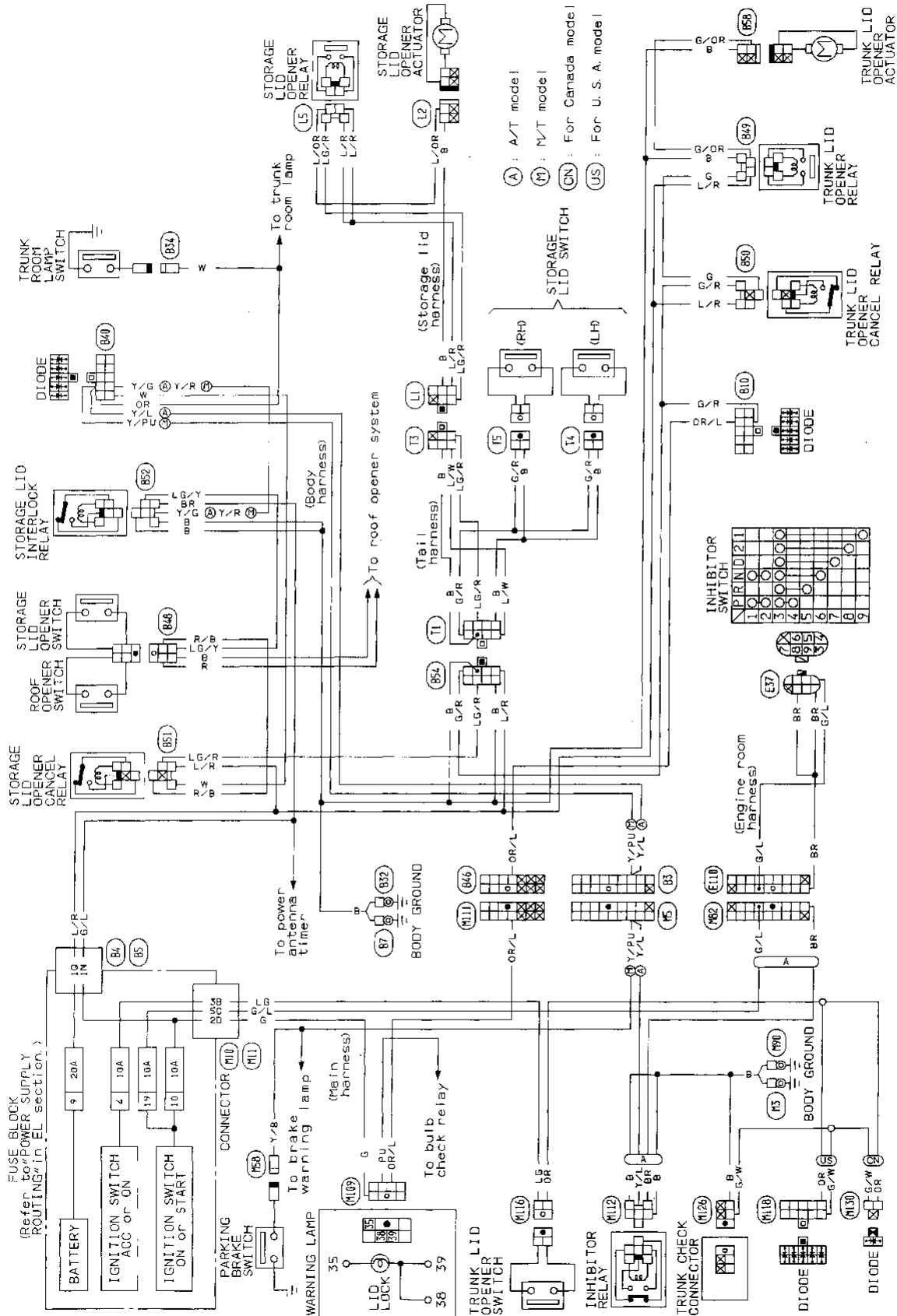

GI
MA
EM
LC
FF &
EC
FE
CL
MT
AT
PD
FA
RA
BR
ST
BF
HA
FL
IDX

CONVERTIBLE ROOF

Wiring Diagram (Cont'd)

ROOF OPENER SYSTEM

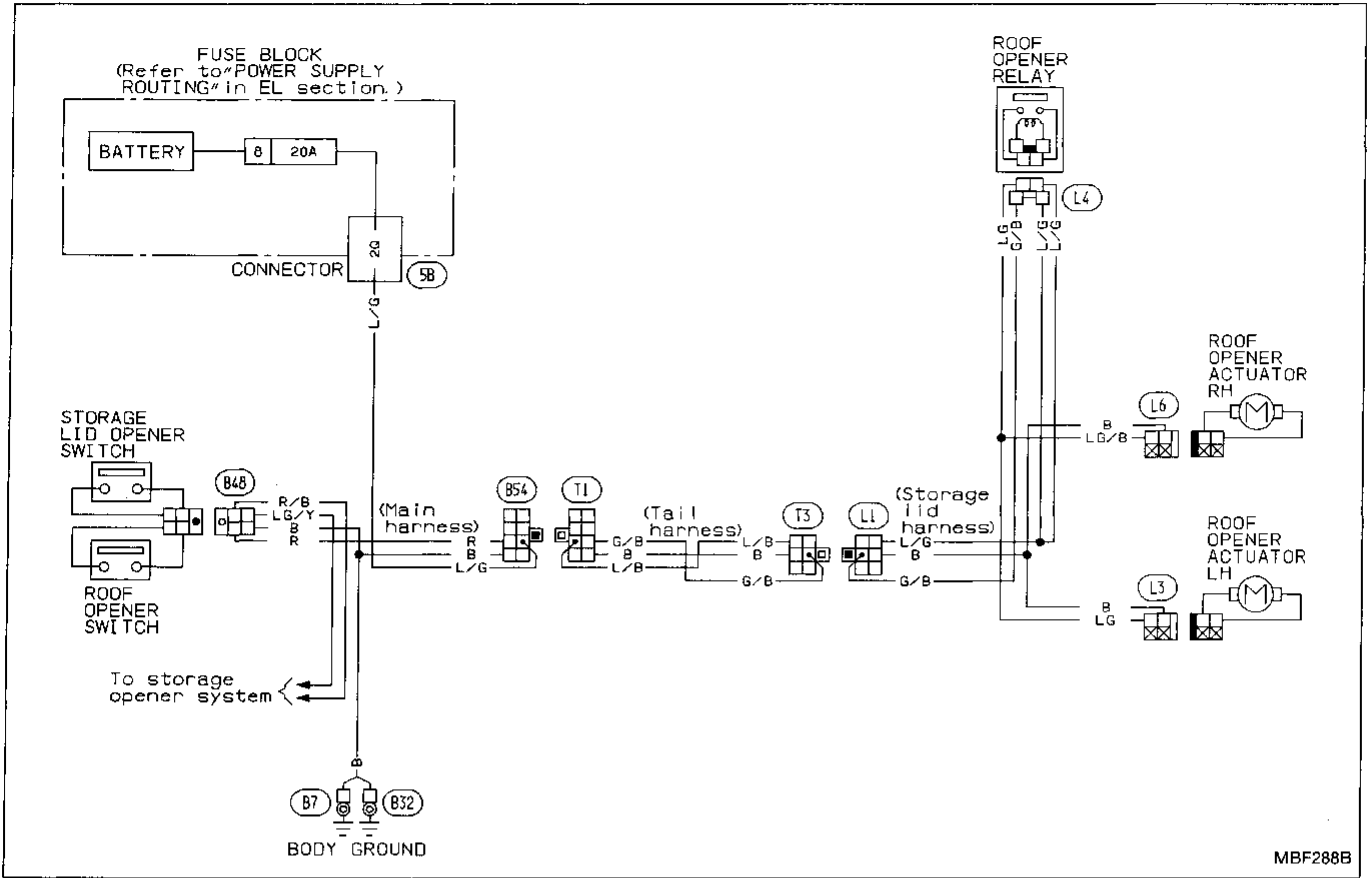

CONVERTIBLE ROOF

Storage Lid

- Storage lid adjustment: Adjust at hinge-storage lid portion for proper storage lid.
- Storage lid lock system adjustment: Adjust striker so that it is in the center of the lock. After adjustment, check storage lid lock operation.

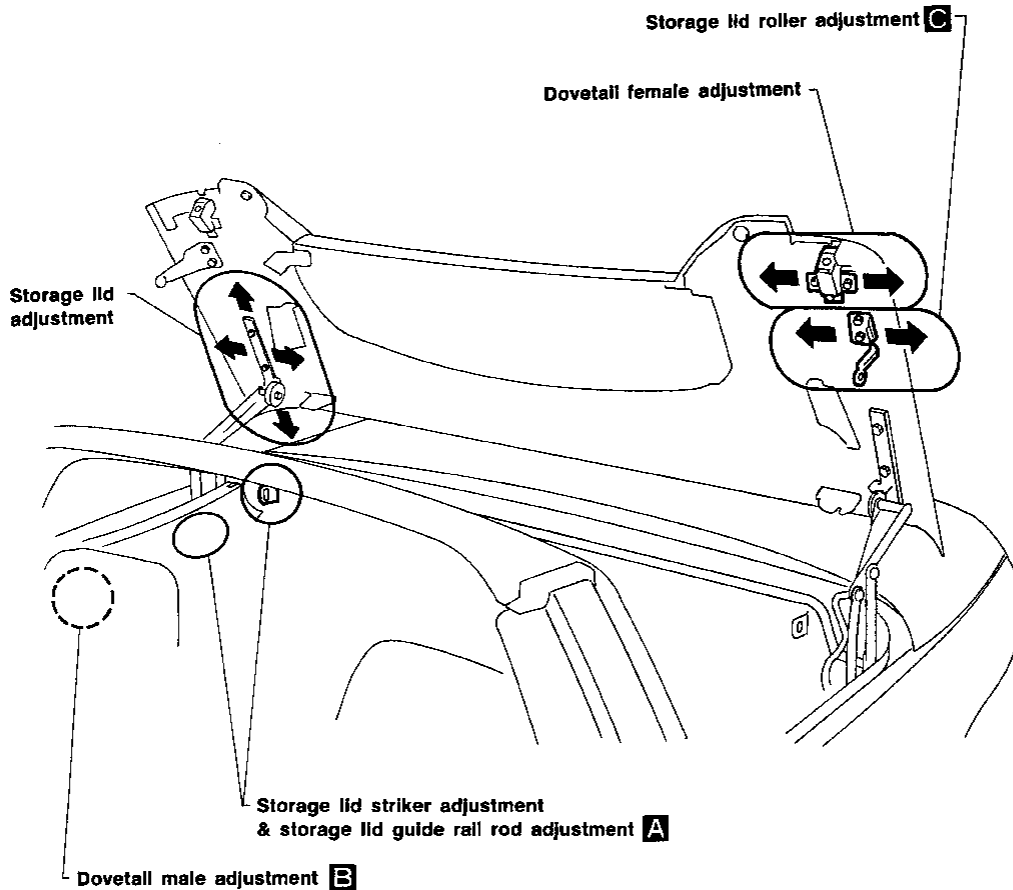

GI

MA

EM

LC

EF &
EC

FE

CL

MT

AT

PD

FA

RA

BR

ST

BF

HA

EL

IDX

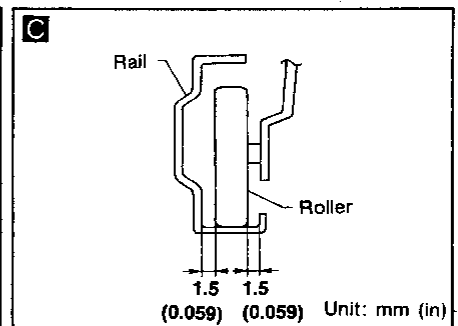
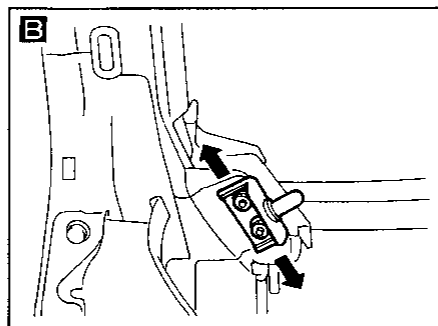
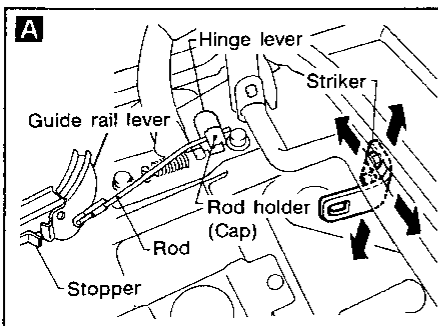

Rod length adjustment procedure

- (1) Ensure cap and rod are freed.
- (2) Lightly push rod toward front of vehicle until guide rail lever comes into contact with stopper.
- (3) Push lever (on hinge side) toward front of vehicle until it comes into contact with catch.
- (4) Push rod into rod holder and then put cap over the rod.

CONVERTIBLE ROOF

Top Cover and Headliner

- Protect vehicle interior and exterior when applying adhesive.
- Take care not to apply an excessive amount of adhesive.

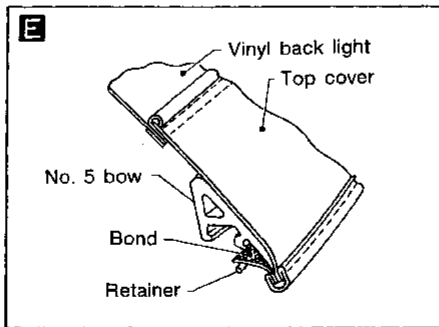
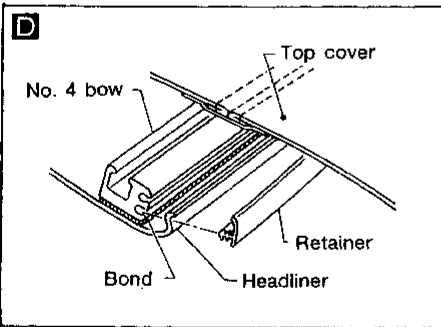
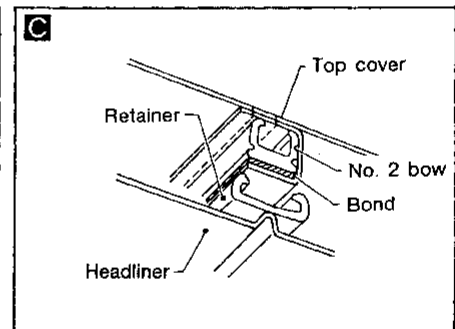
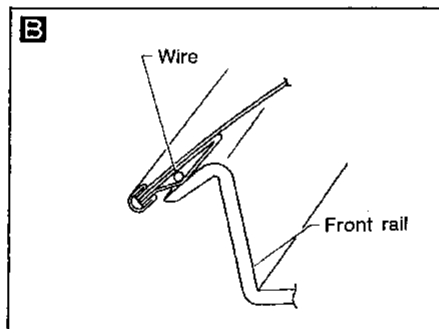
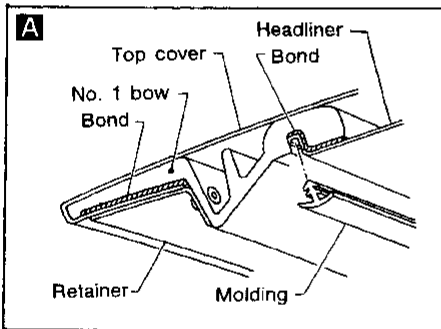
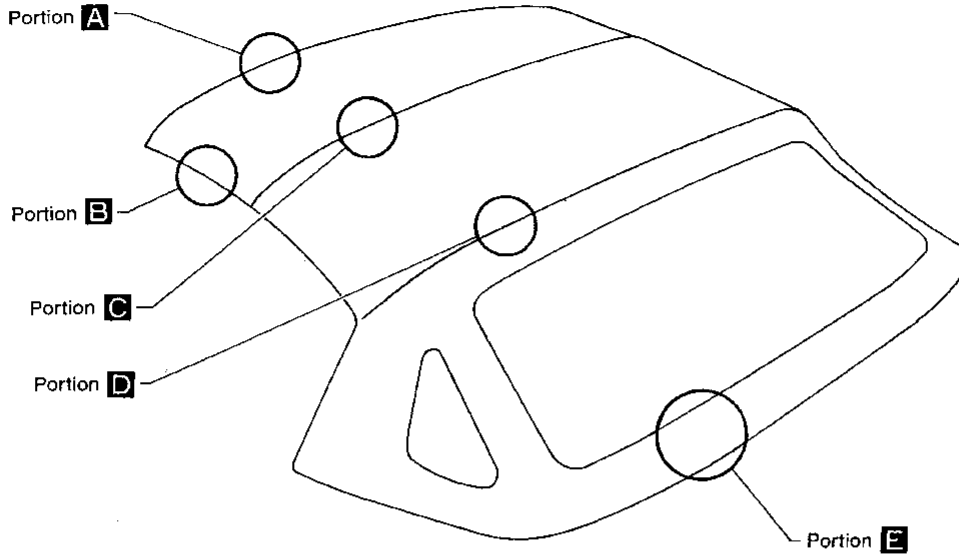

BOND ... 3M Super Weatherstrip Adhesive or equivalent

CONVERTIBLE ROOF

Linkage

Make sure of the following:

- Front and rear locks operate smoothly and securely.
- When stored, top cover is locked securely to hook and storage lid operates smoothly.
- No abnormal sound is heard during operation.
- The bolts are coated with bonding agent. Discard old ones after removal; replace with new ones.

REMOVAL — Top stack roof assembly

- ① Fully open top stack roof.
- ② Unlock the rear lock at rear frame.
- ③ Remove balance spring.
- ④ Remove bolt.

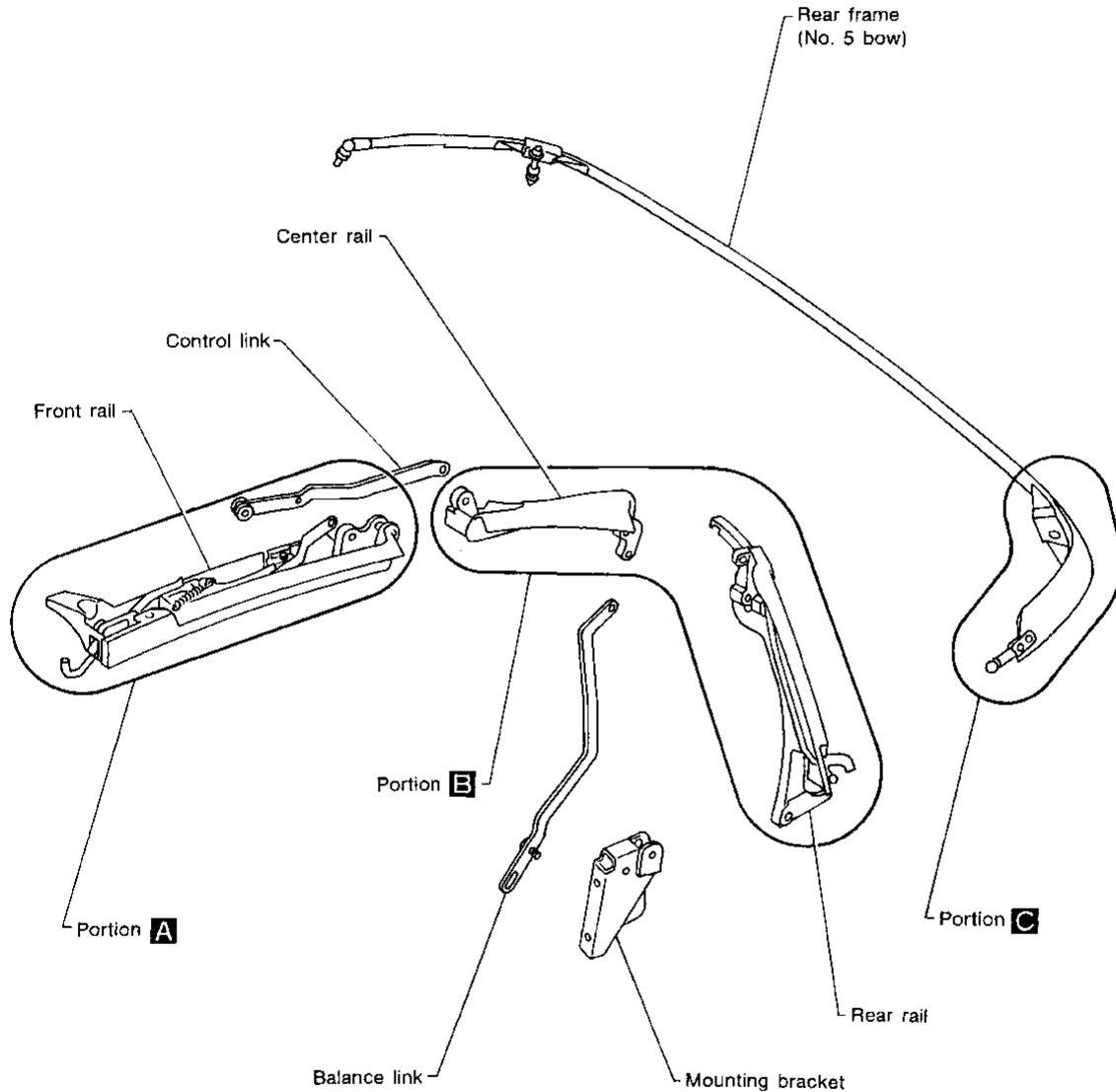

GI

MA

EM

LC

EF &
EC

FE

CL

MT

AT

PD

FA

RA

BR

ST

BF

HA

EL

IDX

CONVERTIBLE ROOF Linkage (Cont'd)

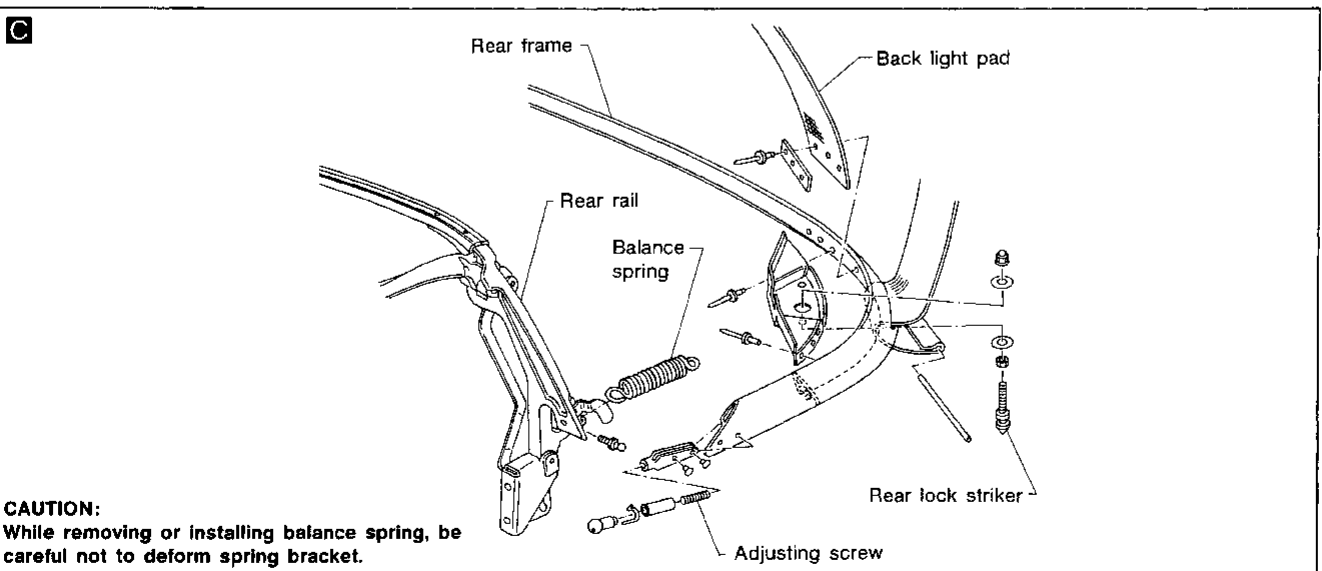
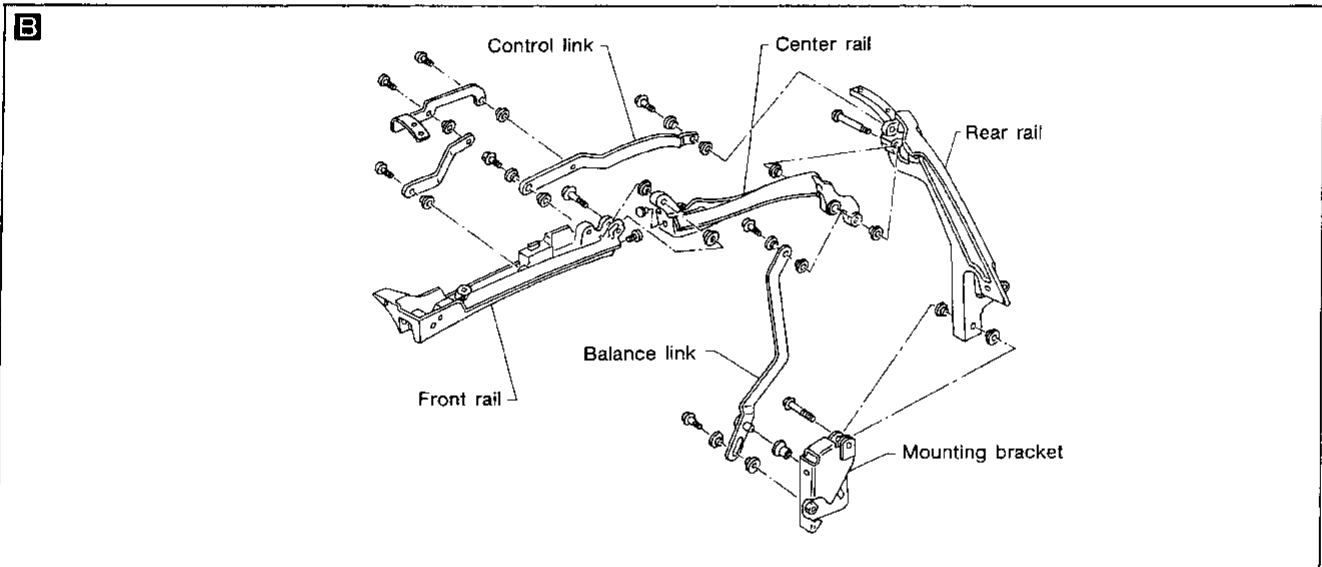
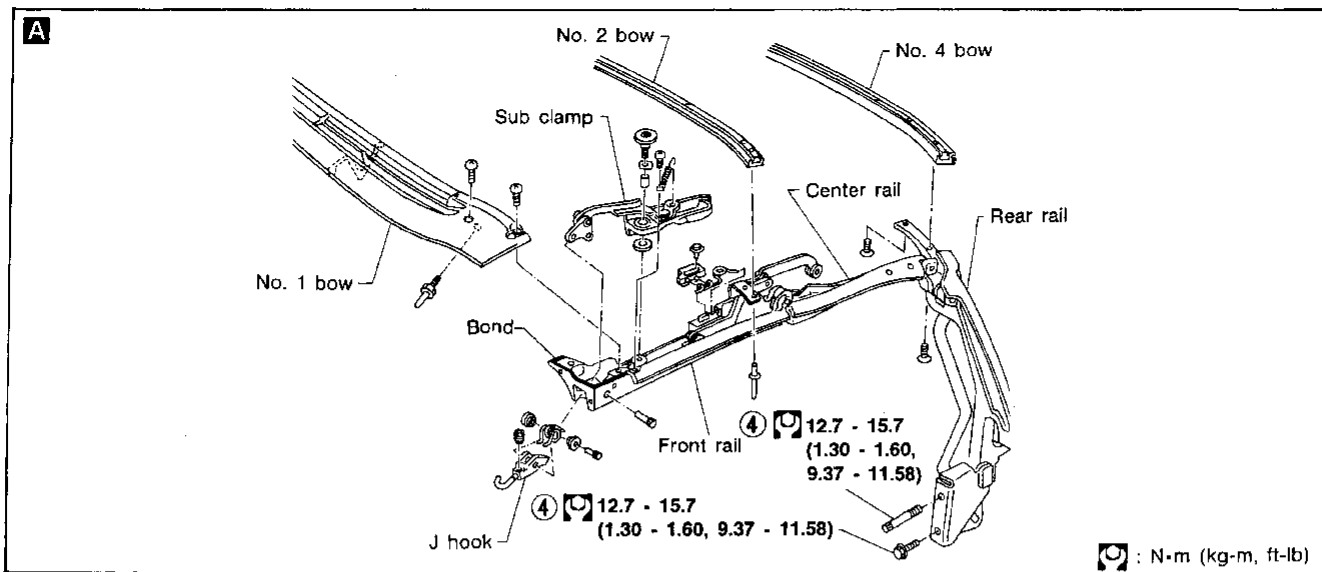

CONVERTIBLE ROOF

Adjustment

- After any adjustment, check top stack roof operation and roof alignment.

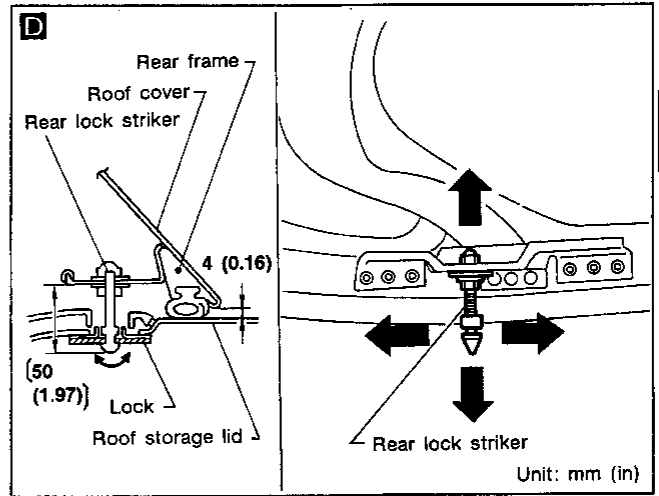
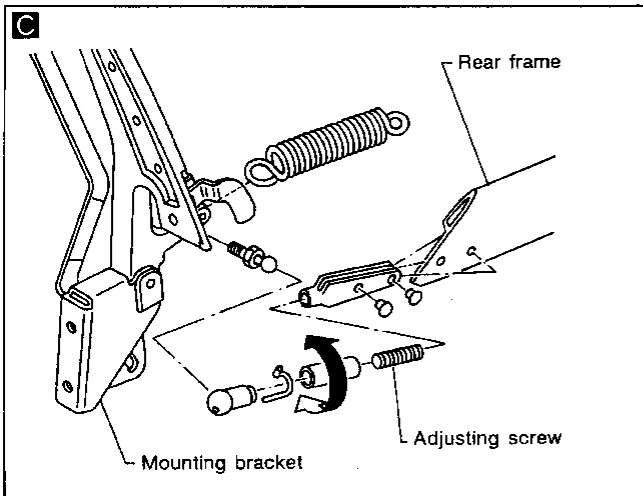
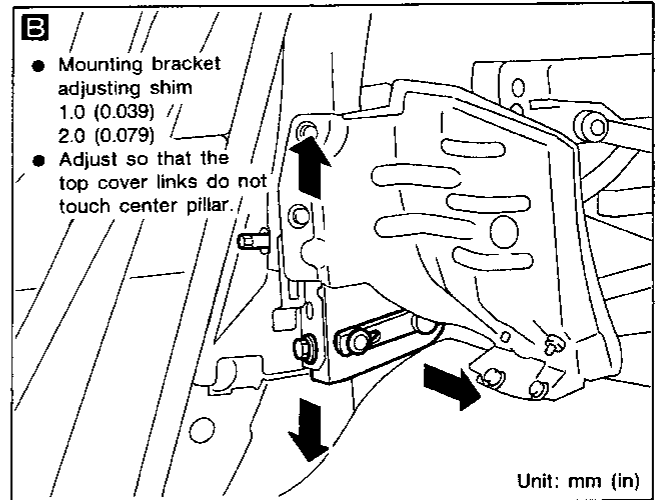
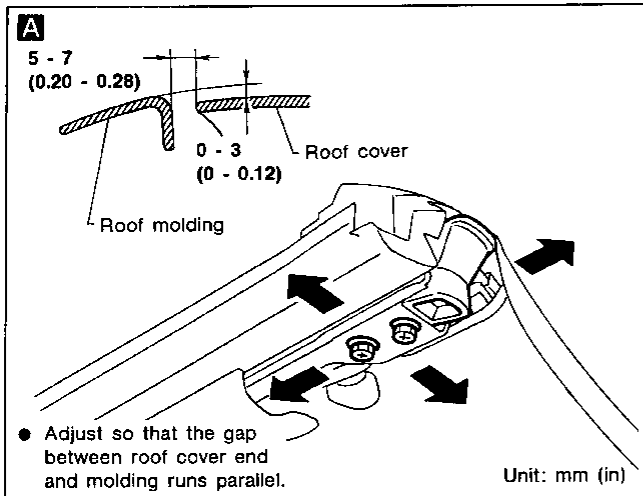
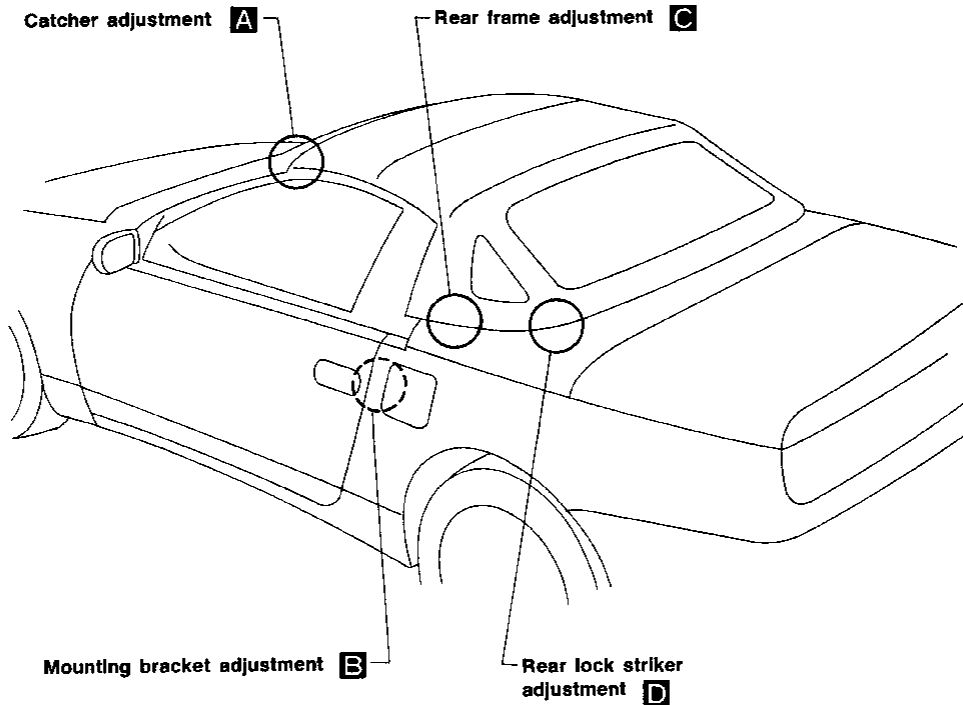

MBF714A

GI
MA
EM
LC
EF &
EC
FE
CL
MT
AT
PD
FA
RA
BR
ST
BF
HA
EL
IDX

SEAT

- When removing or installing the seat trim, handle it carefully to keep it from becoming dirty and to avoid damage.

FRONT SEAT

For power seat

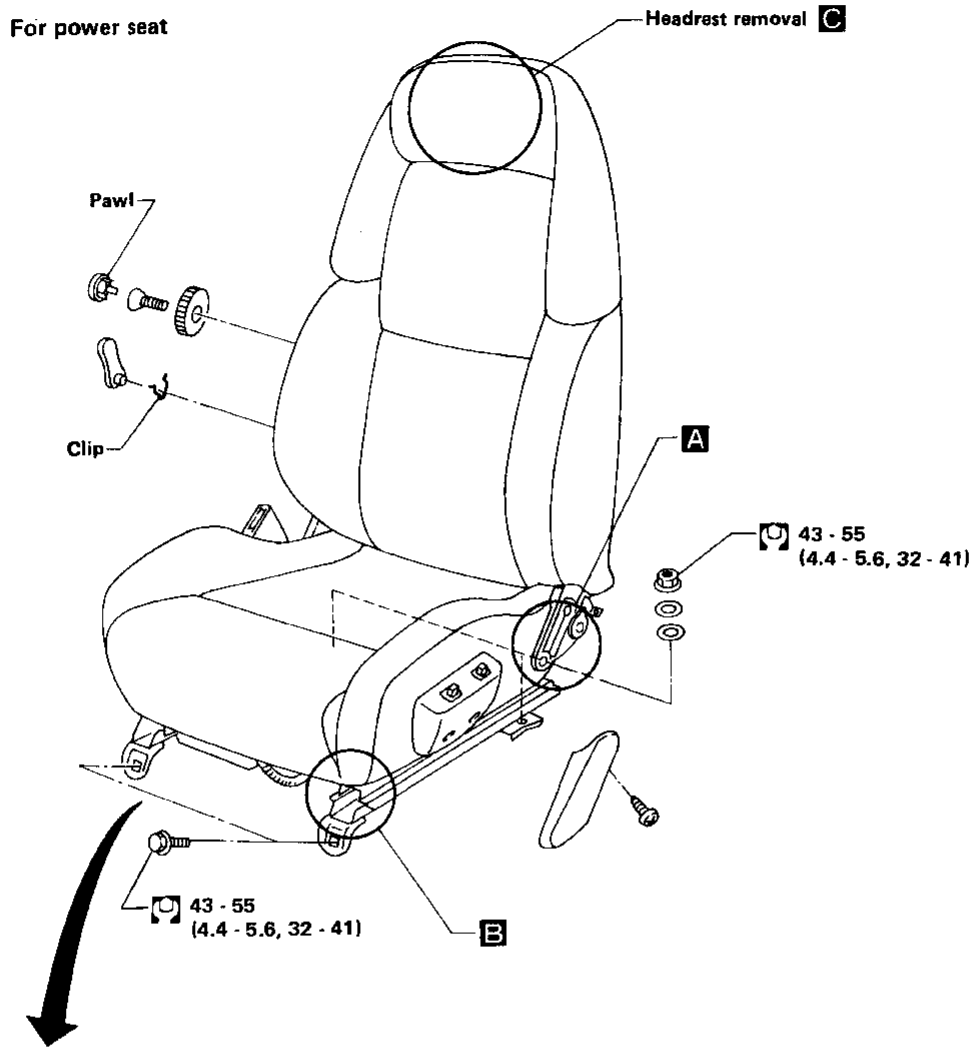

For manual seat

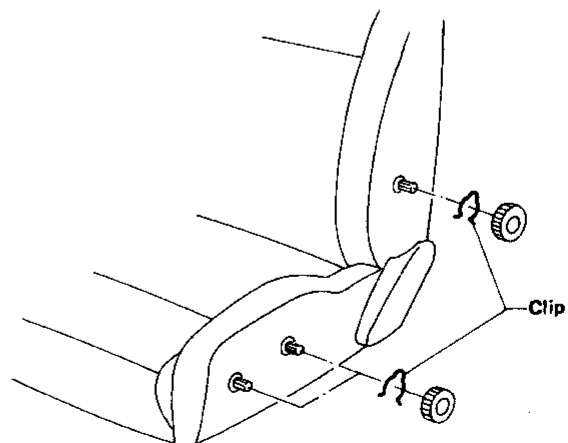
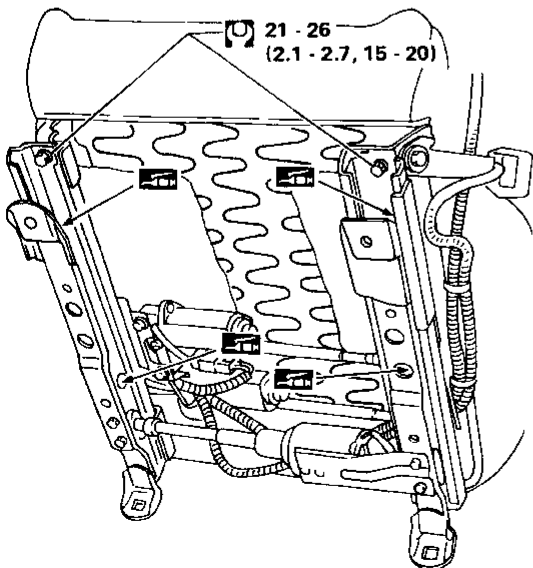

U : N·m (kg·m, ft·lb)

SEAT

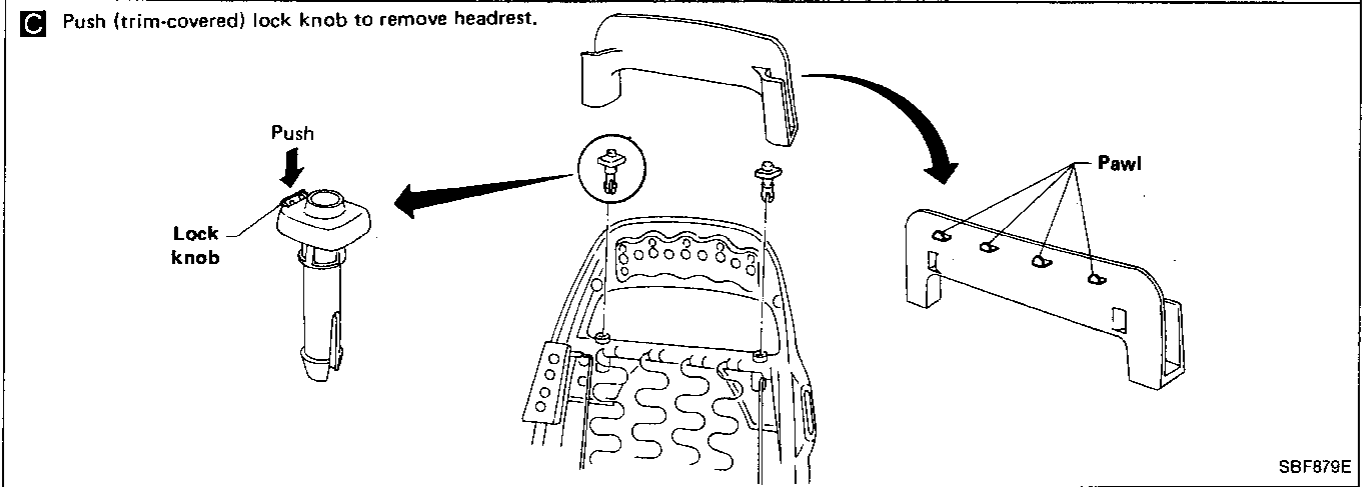
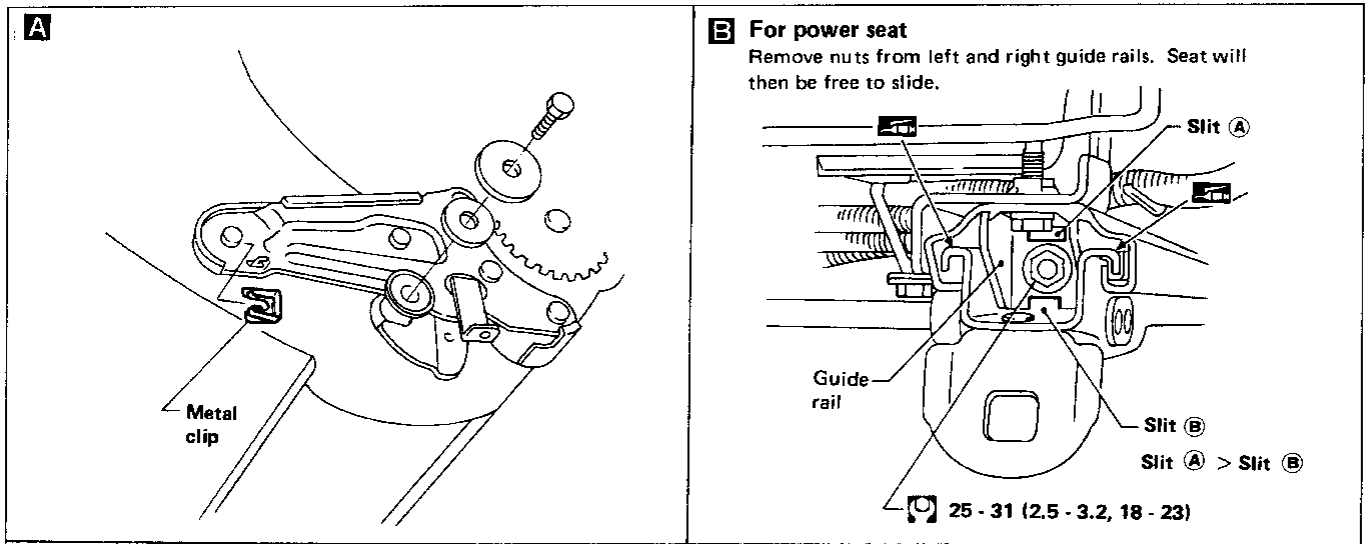

REAR SEAT

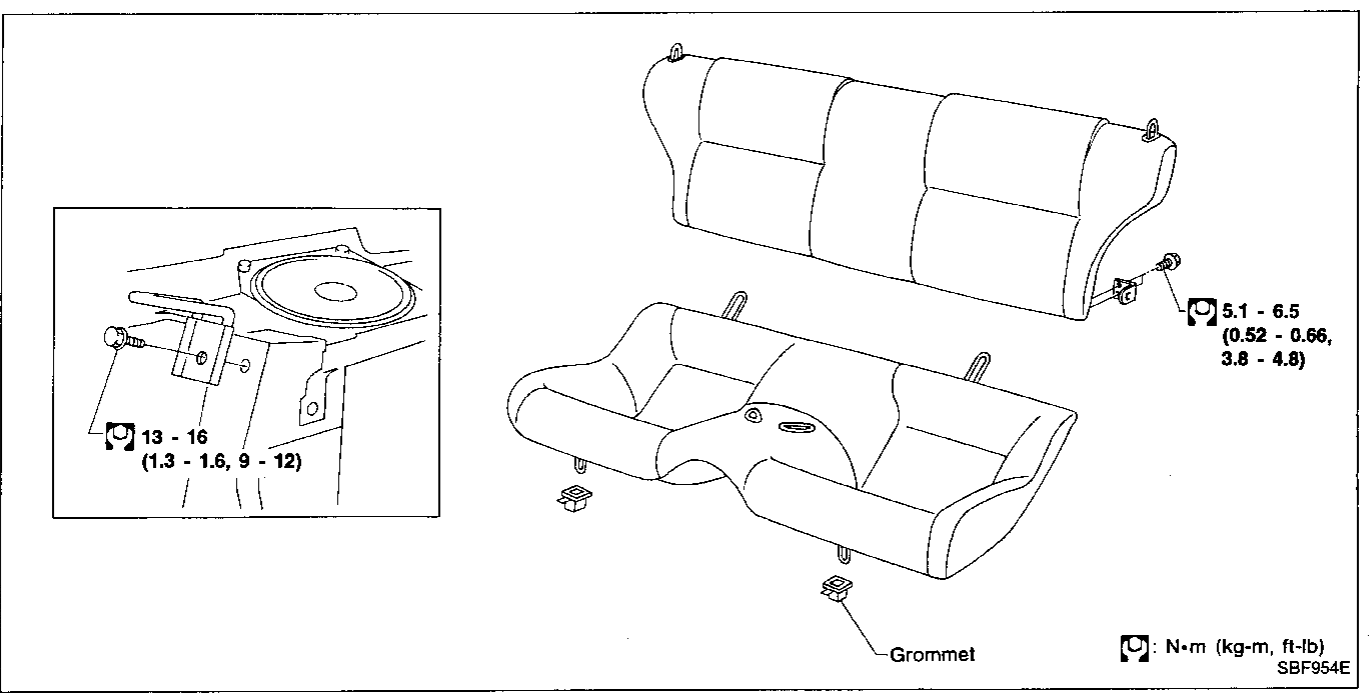

GI
MA
EM
LC
EF &
EC
FE
CL
MT
AT
PD
FA
RA
BR
ST
BF
HA
EL
IDX

POWER SEAT/WIRING DIAGRAM

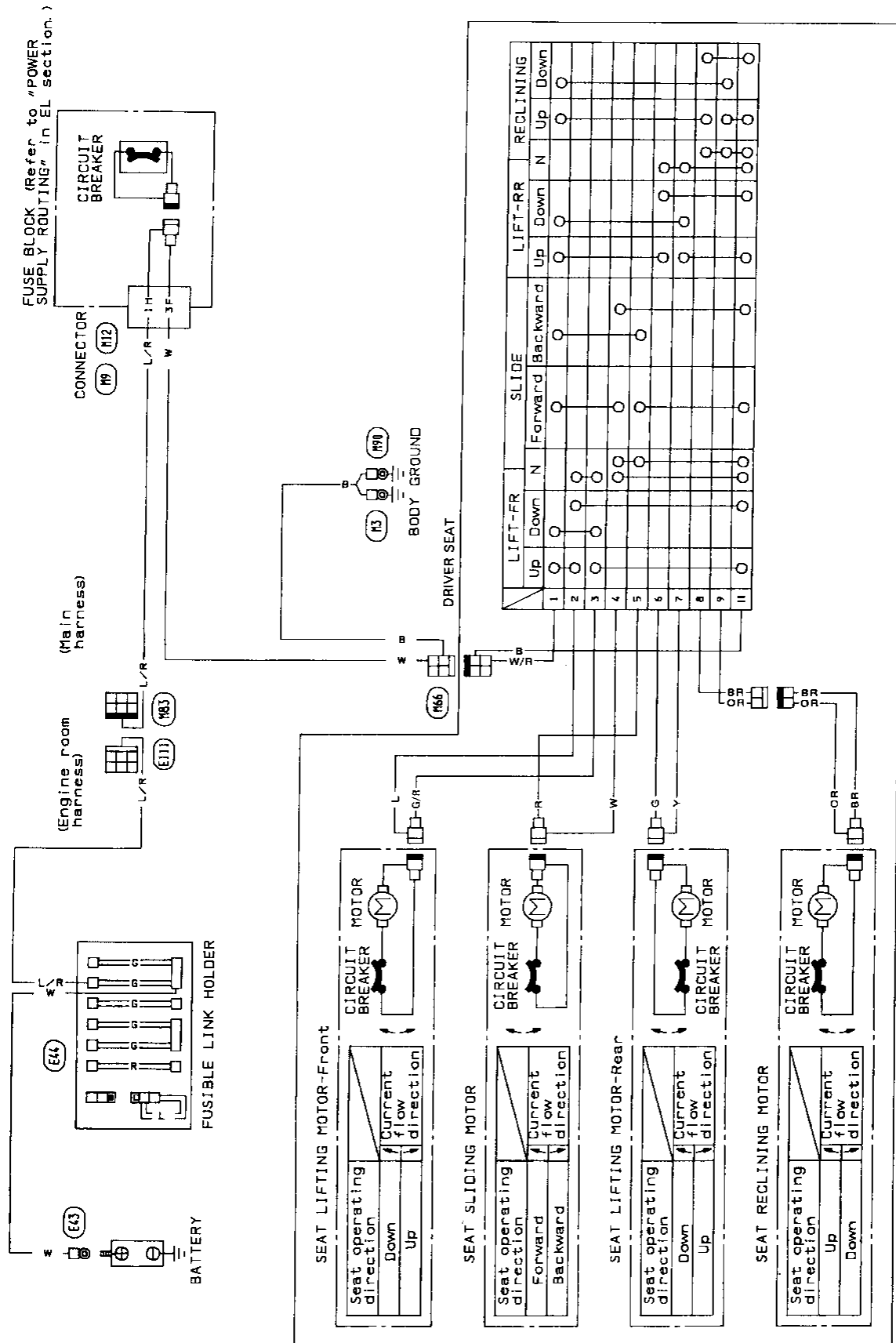

WINDSHIELD AND WINDOWS

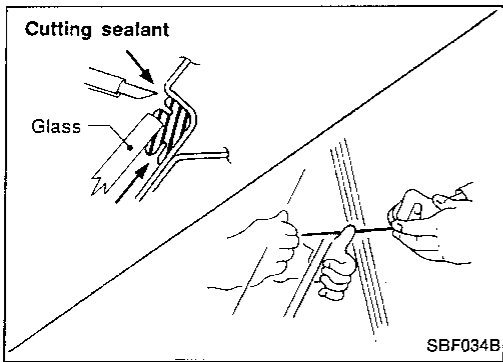

Windshield

REMOVAL

After removing moldings, remove glass.

CAUTION:

Be careful not to scratch glass when removing.

INSTALLATION

- Use genuine Nissan Sealant kit or equivalent. Follow instructions furnished with it.
- After installing the glass, the vehicle should remain stationary until the sealant hardens.

WARNING :

Keep heat and open flames away as primers are flammable.

CAUTION:

Advise the user of the fact that vehicle should not be driven on rough roads or surfaces until sealant has properly vulcanized.

- Do not use sealant which is past its usable term.
- Do not leave cartridge unattended with its cap open.
- Keep primers and sealant in a cool, dry place. Ideally, they should be stored in a refrigerator.
- Molding must be installed securely so that it is in position and leaves no gap.

GI
MA
EM
LC
EF & EC
FE
CL

<p>Body side</p> <p>Install spacers to panel with double-faced adhesive tape.</p>	<p>Glass side</p> <p>Install dam rubber & spacers with double-faced adhesive tape.</p>
<p>Install molding fastener. When installing, heat body panel and fastener to approx. 30 to 40°C (86 to 104°F).</p>	<p>Apply sealant evenly.</p>

REPAIRING WATER LEAKS FOR WINDSHIELD

Leaks can be repaired without removing and reinstalling glass.

If water is leaking between caulking material and body or between glass and caulking material, determine the extent of the leak by applying water while pushing glass outward.

To stop the leak, apply primer (if necessary) and then sealant to the leak point.

MT
AT
PD
FA
RA
BR
ST
BF
HA
EL
IDX

WINDSHIELD AND WINDOWS

Side Window

2 seater model

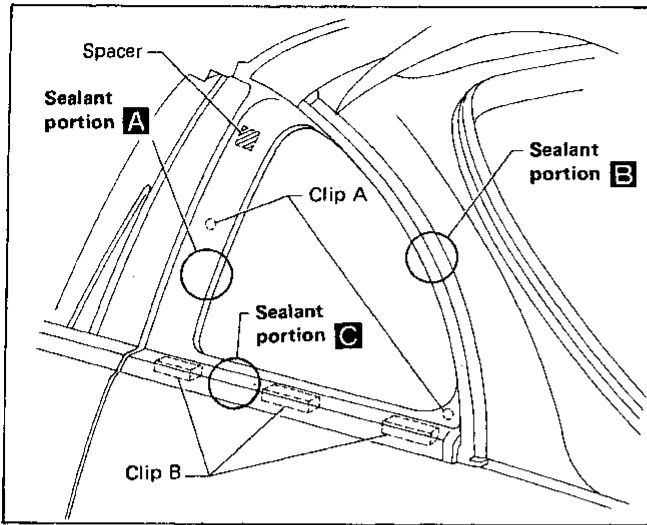

2+2 seater model

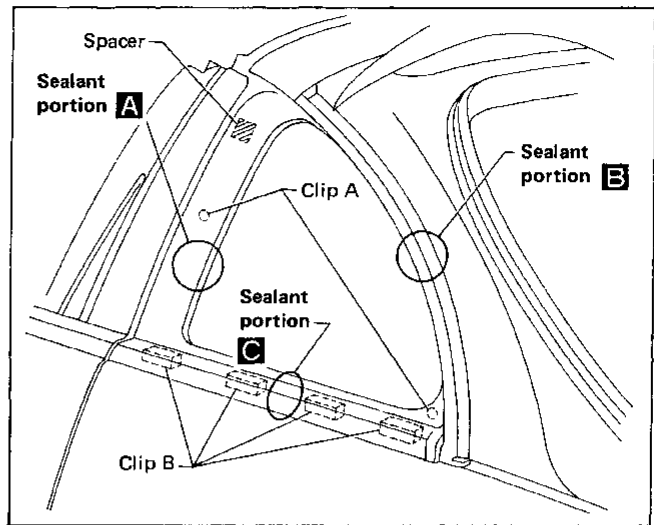

Spacer and clip portion

Unit: mm (in)

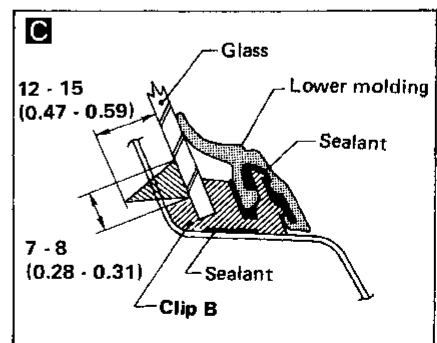
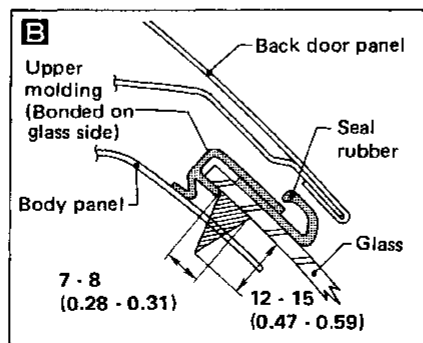
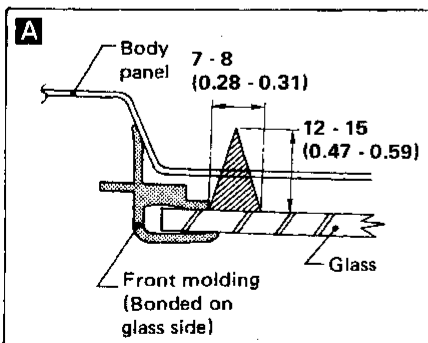
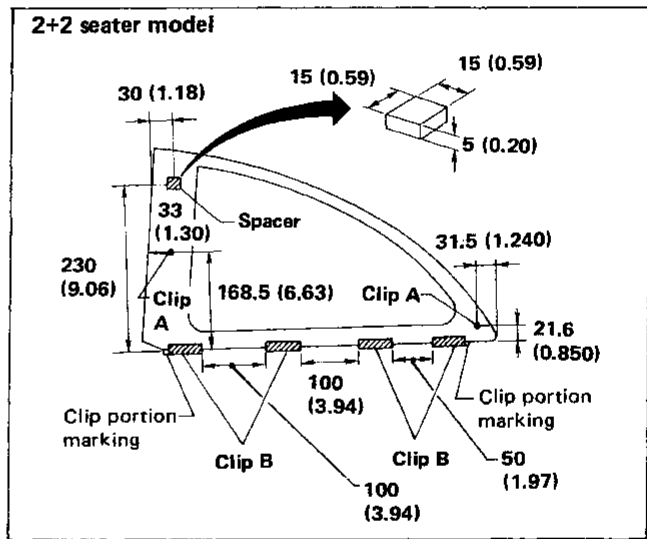
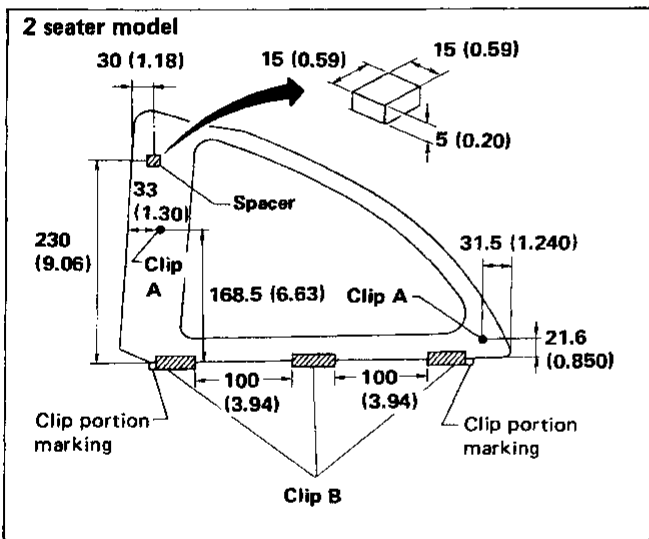

Back Door Window

- Construction and removal/reinstallation method of back door window are basically the same as those of windshield.
- For details of moldings, refer to "Exterior".

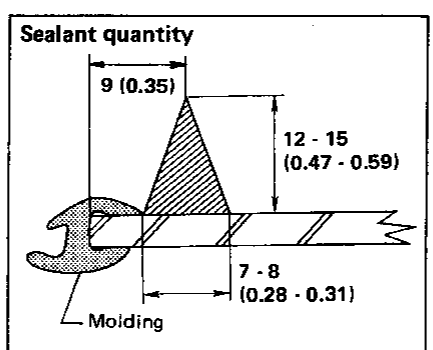
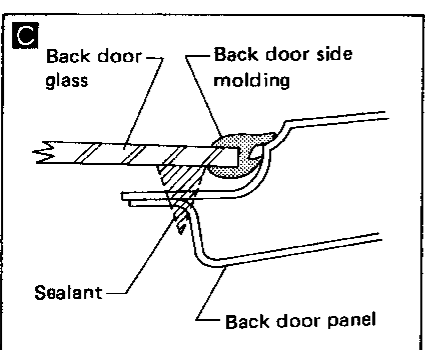
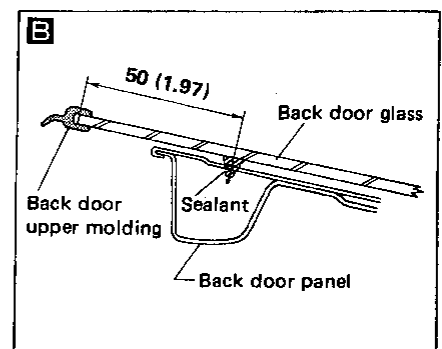
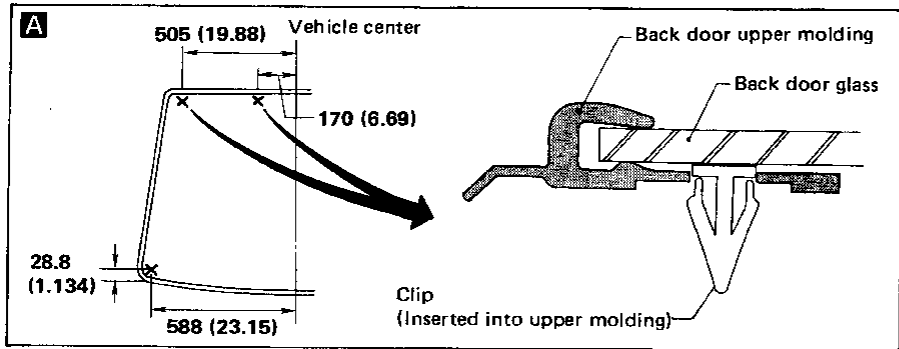
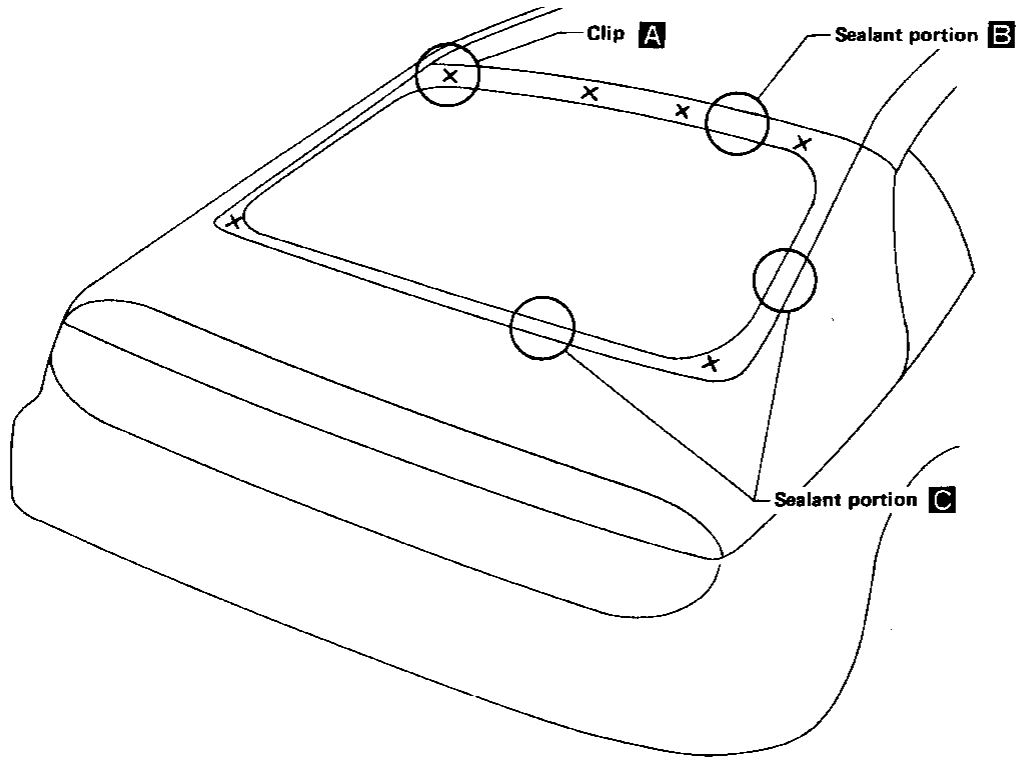

Unit: mm (in)

SBF884E

GI
 MA
 EM
 LC
 EF & EC
 FE
 CL
 MT
 AT
 PD
 FA
 RA
 BR
 ST
 BF
 HA
 EL
 IDX

REAR AIR SPOILER AND MIRROR

Rear Air Spoiler

- When installing, make sure that there are not gaps or waves at ends of air spoiler.
- Before installing spoiler, clean and remove oil from surface where spoiler will be mounted.

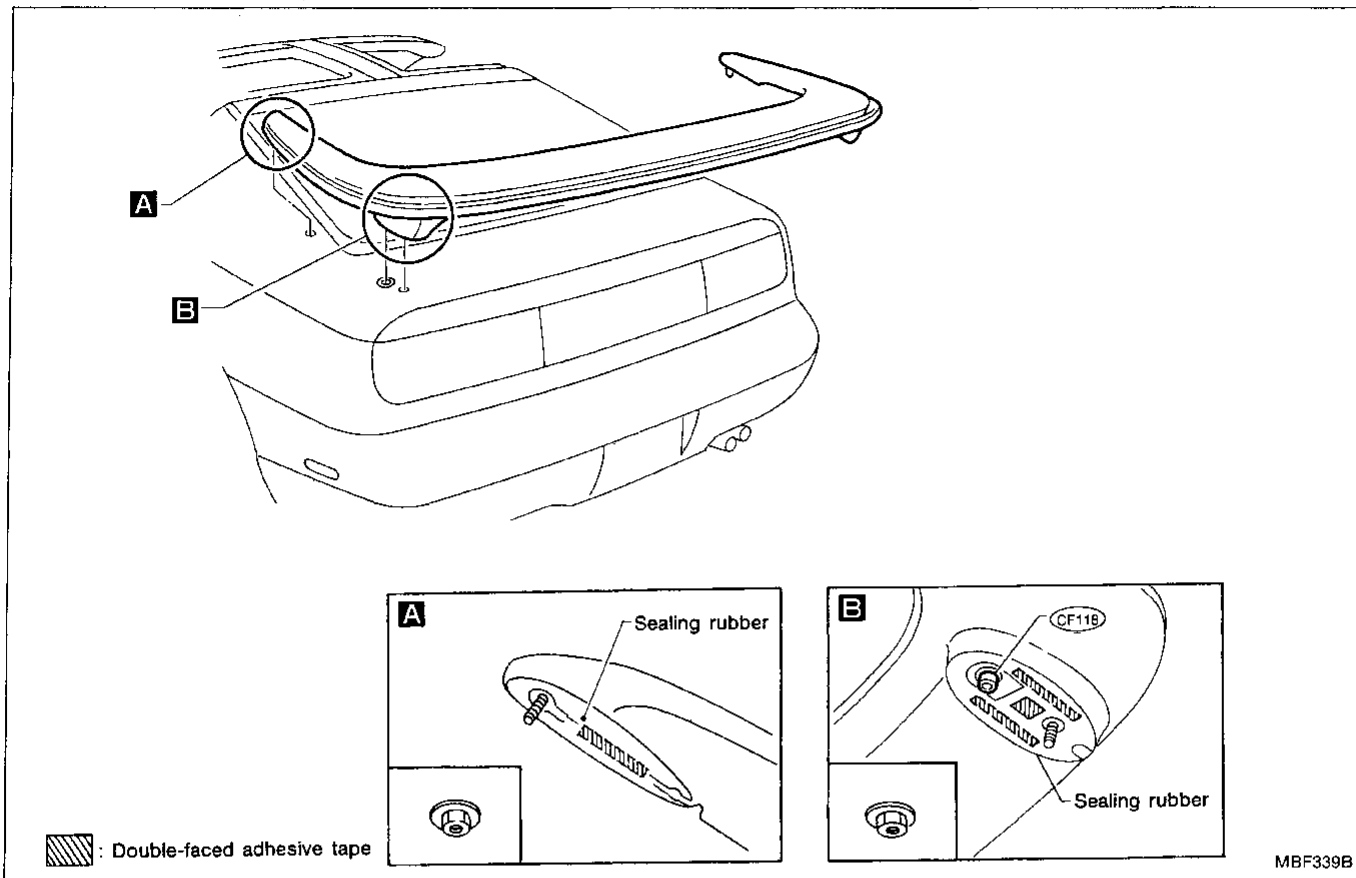

Door Mirror

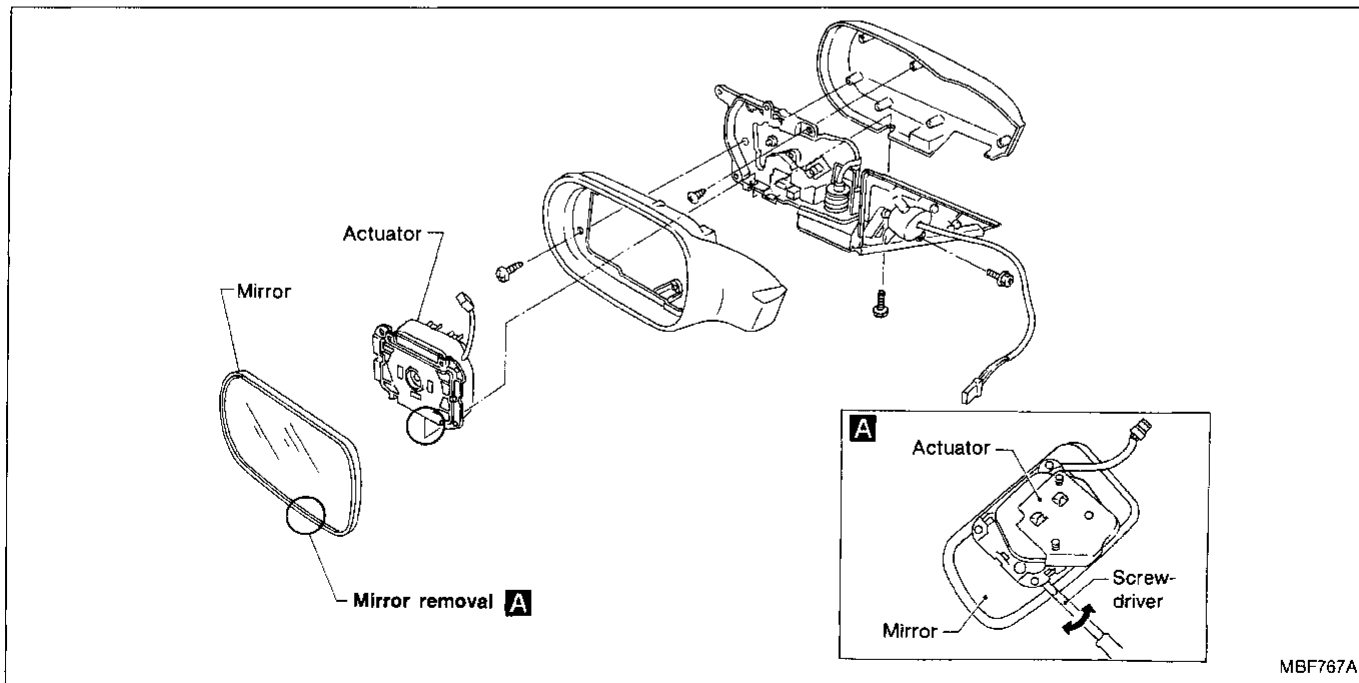

BODY ALIGNMENT

- All dimensions indicated in figures are actual ones.
- When a tram tracking gauge is used, adjust both pointers to equal length and check the pointers and gauge itself to make sure there is no free play.
- When a measuring tape is used, check to be sure there is no elongation, twisting or bending.
- Measurements should be taken at the center of the mounting holes.
- An asterisk (*) following the value at the measuring point indicates that the measuring point on the other side is symmetrically the same value.
- The coordinates of the measurement points are the distances measured from the standard line of "X", "Y" and "Z".

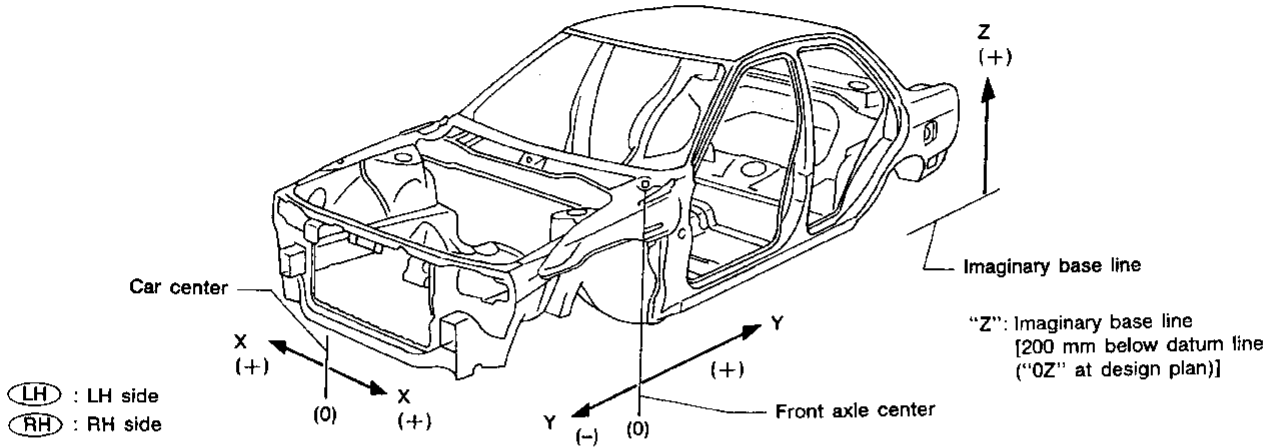

SBF874G

Engine Compartment

MEASUREMENT

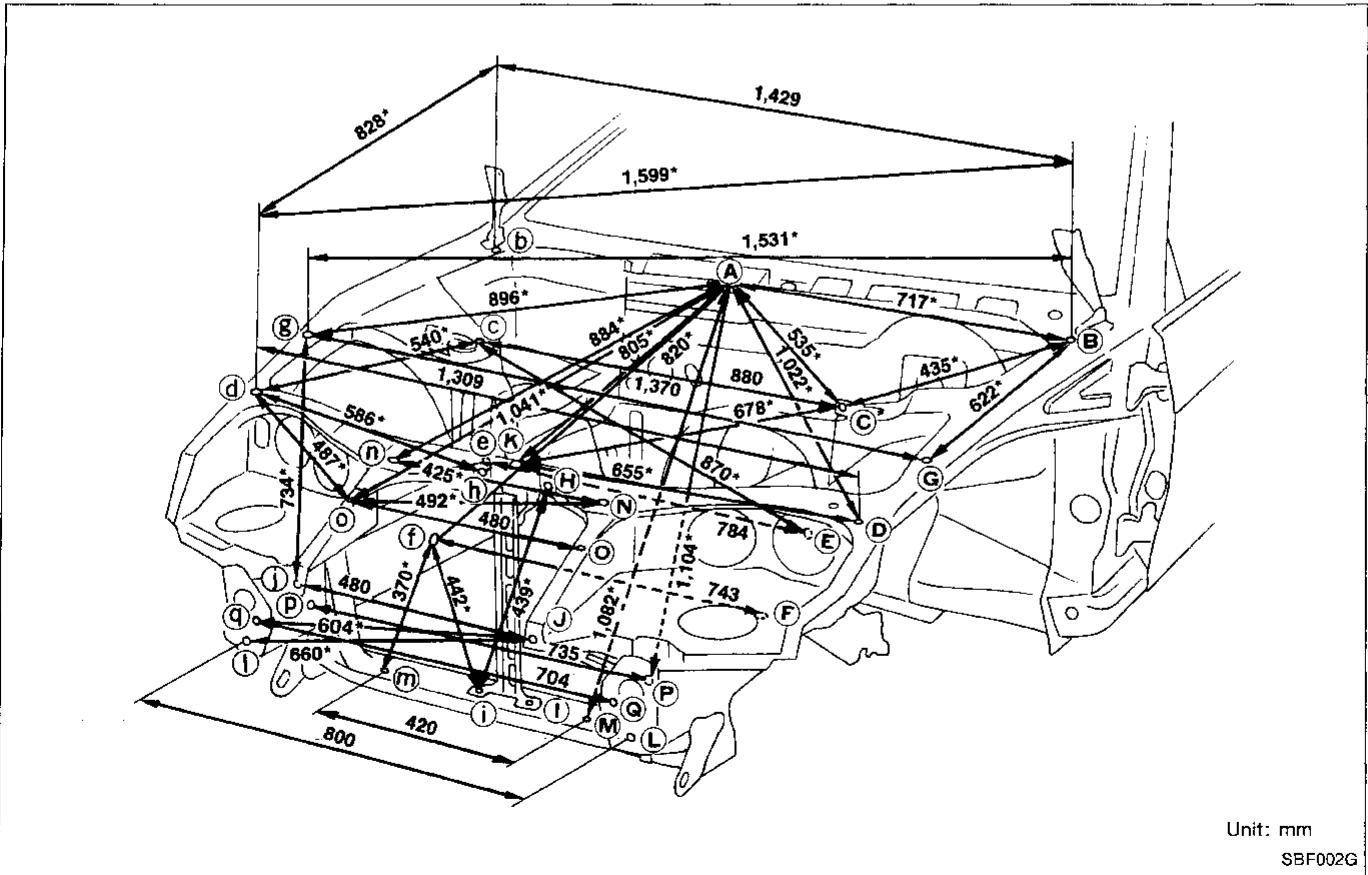

BODY ALIGNMENT

Engine Compartment (Cont'd)

MEASUREMENT POINTS

Unit: mm

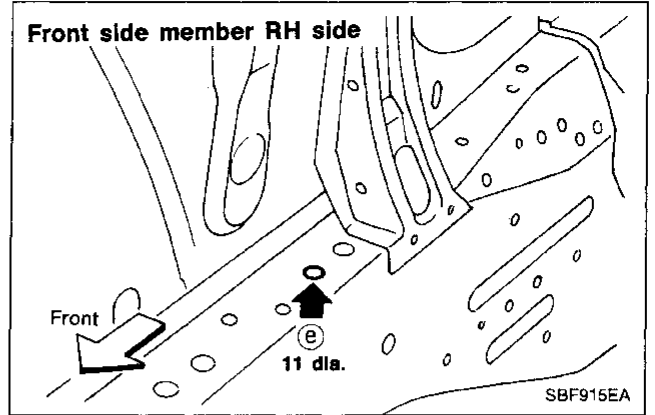
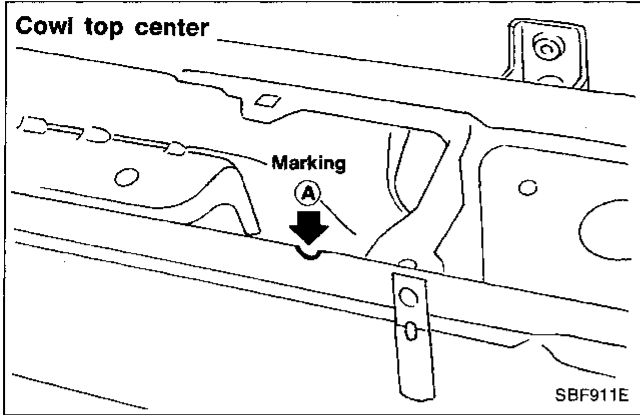

GI
MA
EM
LC

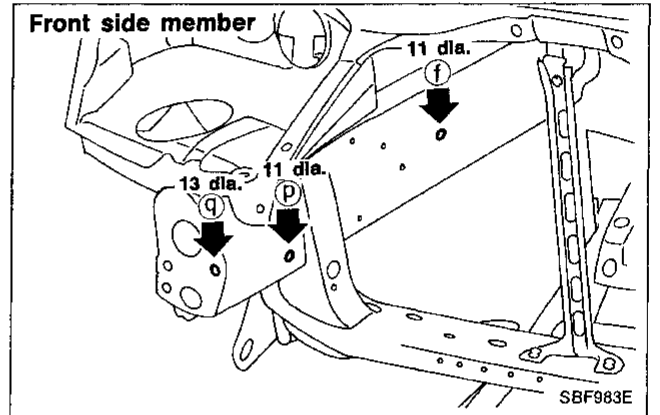
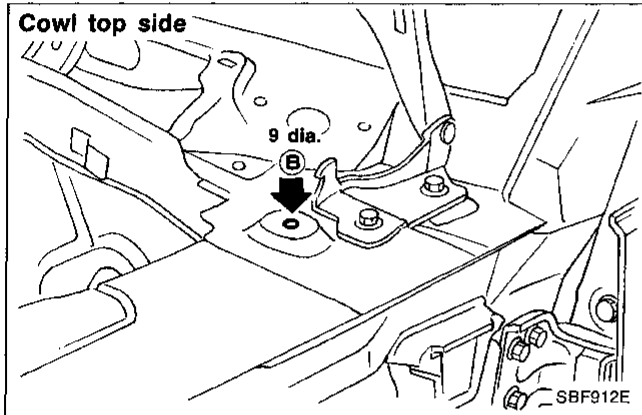

EF &
EC
FE
CL
MT
AT

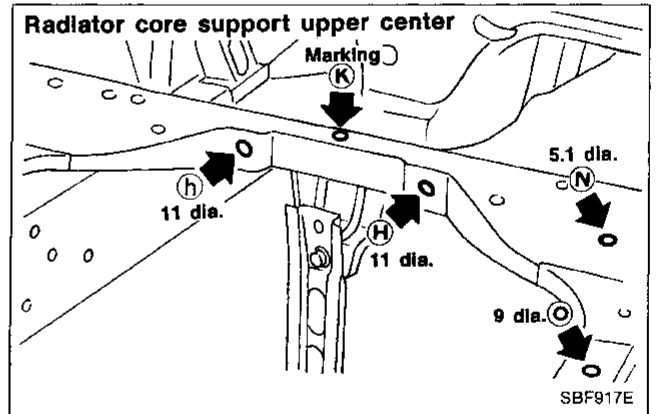
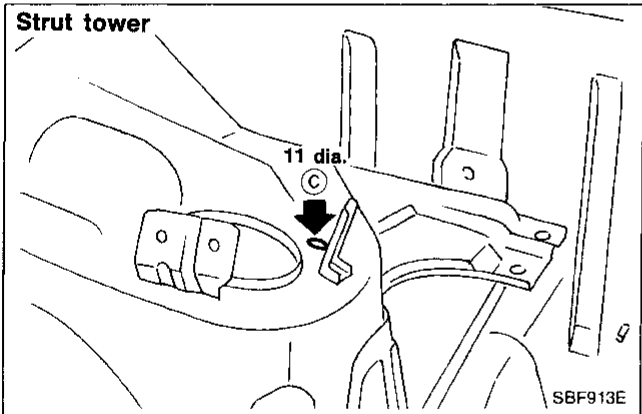

PD
FA
RA
BR

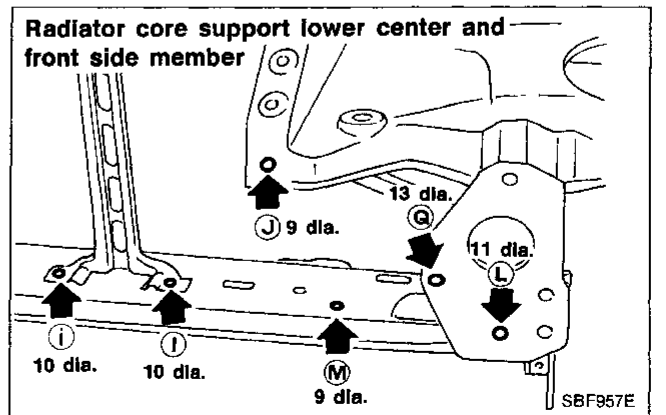
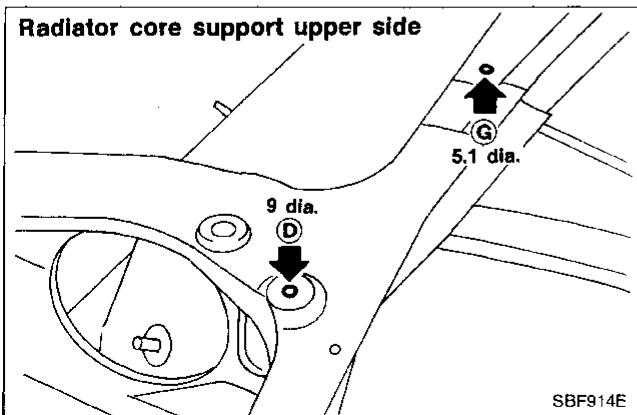

BF
HA
EL
IDX

BODY ALIGNMENT

Underbody

MEASUREMENT

2 seater model

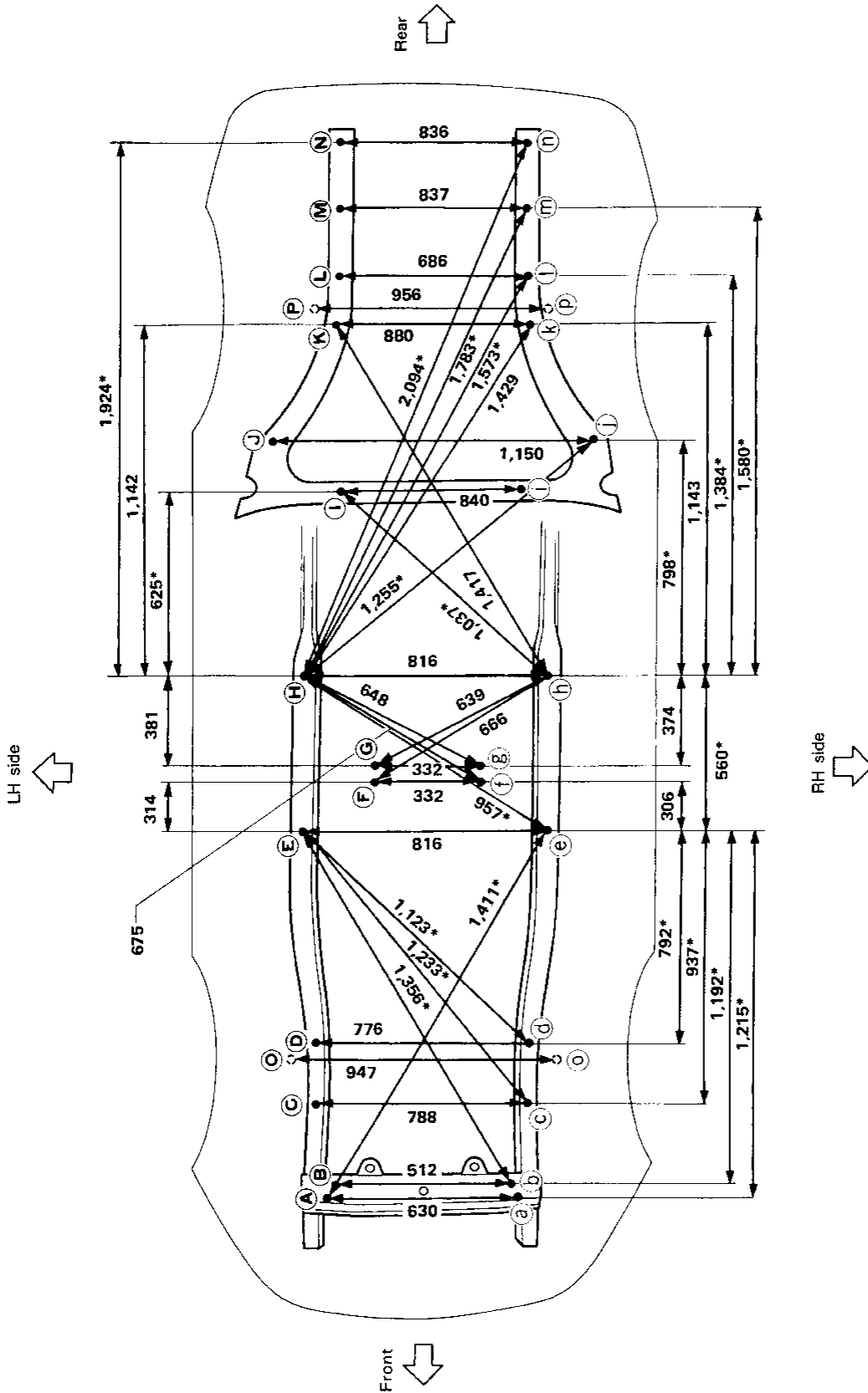

Unit: mm

All dimensions indicated in this figure are actual ones. (There are no projected dimensions.)

BODY ALIGNMENT

Underbody (Cont'd)

MEASUREMENT POINTS

2 seater model

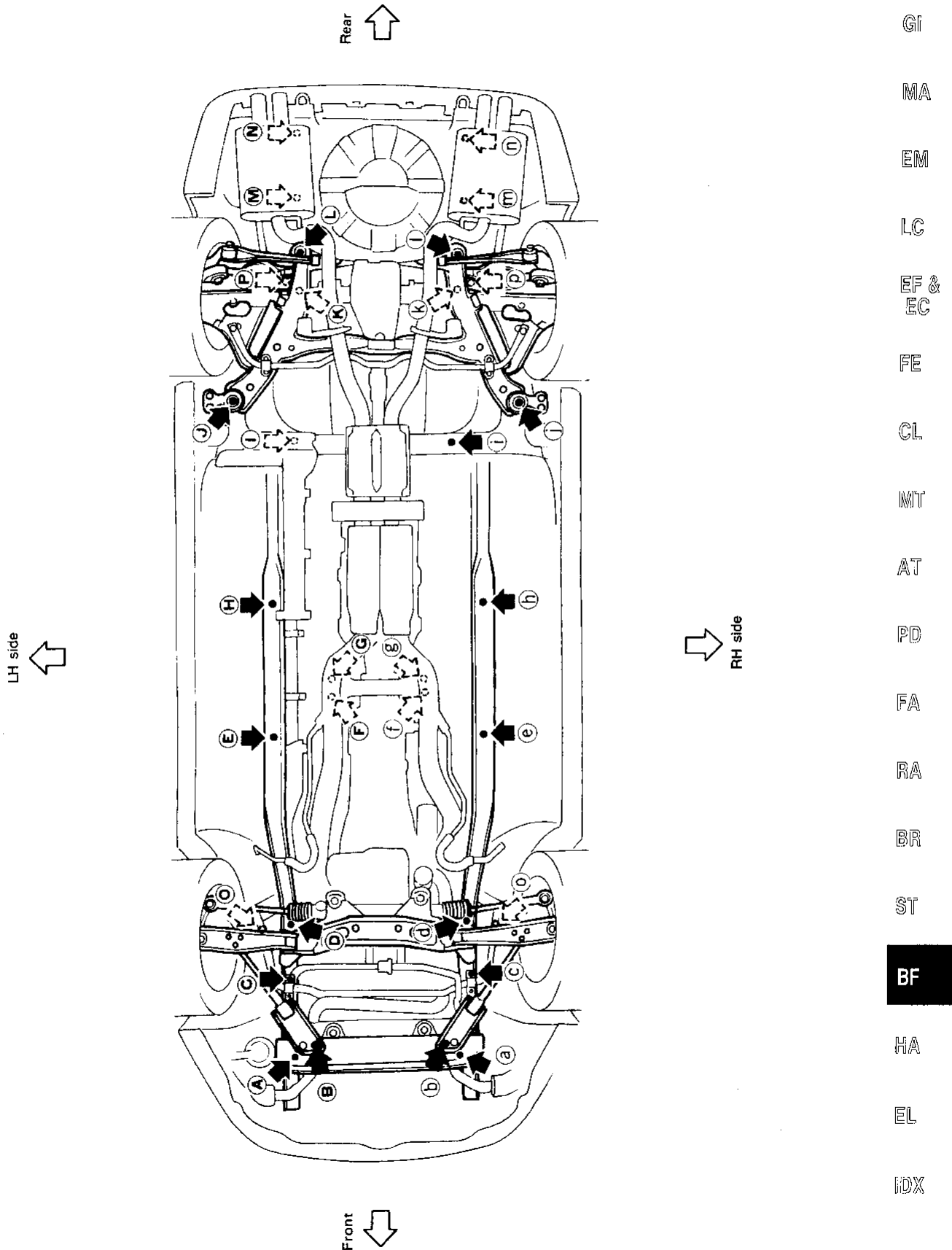

GI

MA

EM

LC

EF &
EC

FE

CL

MT

AT

PD

FA

RA

BR

ST

BF

HA

EL

FDX

BODY ALIGNMENT

Underbody (Cont'd)

MEASUREMENT

2 + 2 seater model

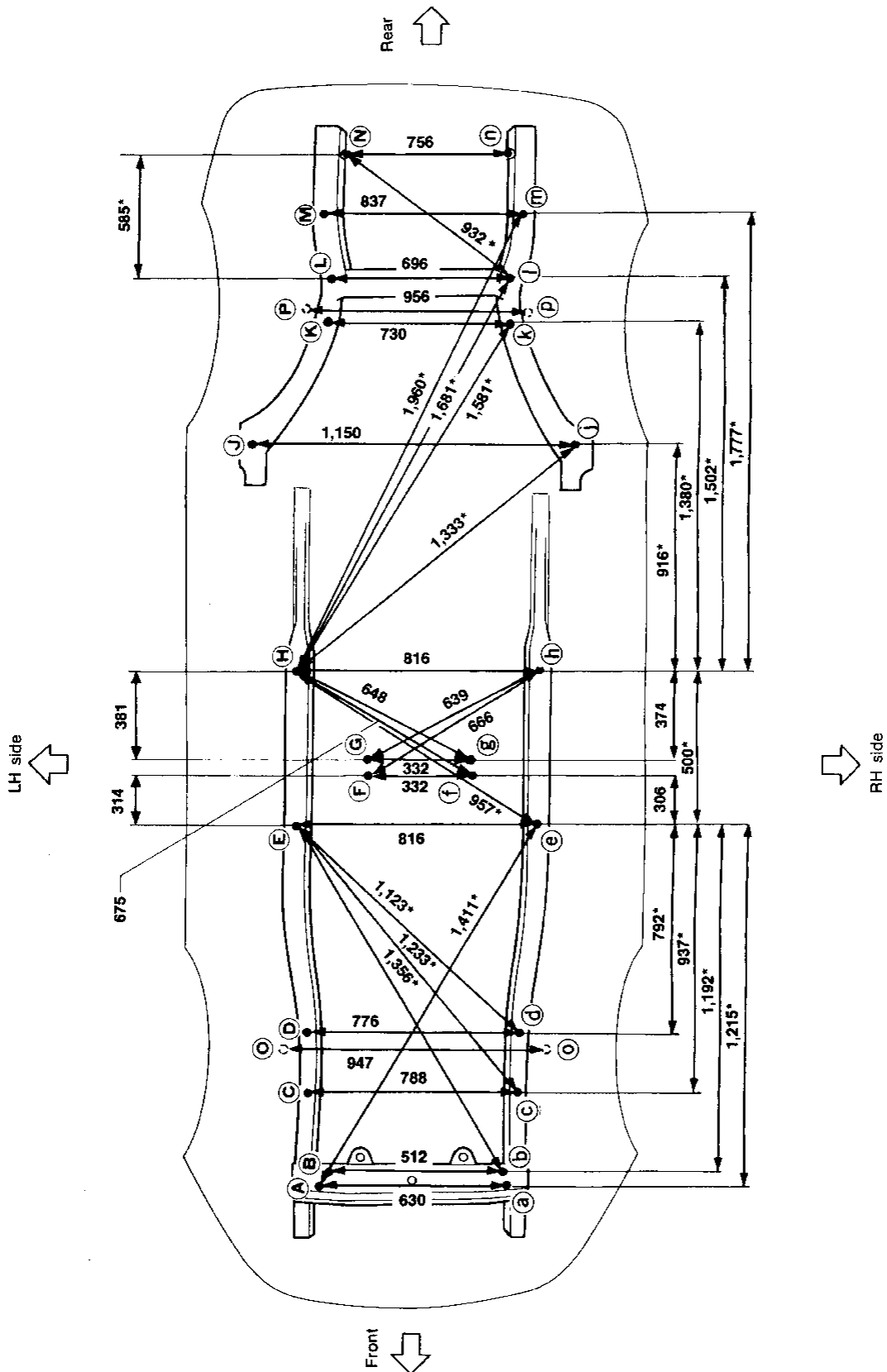

Unit: mm

All dimensions indicated in this figure are actual ones. (There are no projected dimensions.)

BODY ALIGNMENT

Underbody (Cont'd)

MEASUREMENT POINTS

2 + 2 seater model

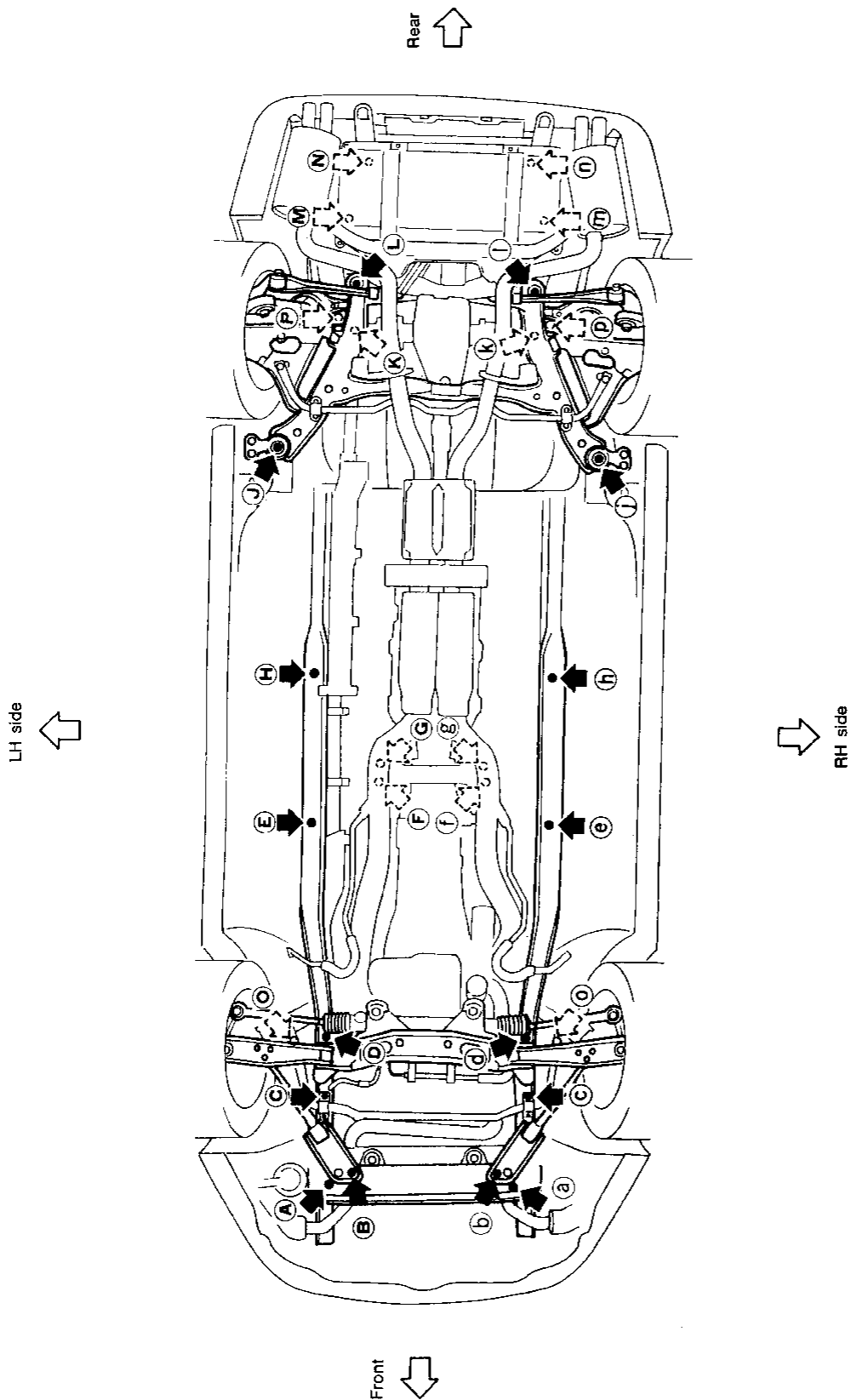

GI

MA

EM

LC

EF &
EC

FE

CL

MT

AT

PD

FA

RA

BR

ST

BF

HA

EL

IDX

BODY ALIGNMENT

Underbody (Cont'd)

Unit: mm

Front and rear strut tower centers

Coordinates:

(K), (k)

X: 473.4

Y: 52.3

Z: 727.2

(L), (l)

X: 477.9

Y: 2,489.3

(2 seater model)

2,609.3

(2+2 seater model)

Z: 727.8

Front: (K), (k) 82.6 dia.
Rear: (L), (l) 46 dia.

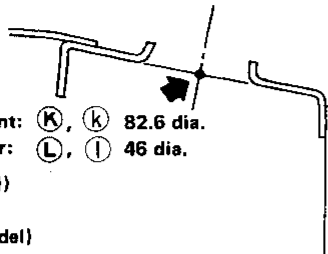

MBF052A

Front side member and front extension

Coordinates:

(A), (a)

X: 315

Y: -460

Z: 205.1

(B), (b)

X: 255.8

Y: -431

Z: 205.1

(C), (c)

X: 394

Y: -170

Z: 330

(D), (d)

X: 388

Y: -22

Z: 330

(E), (e)

X: 408.2

Y: 750

Z: 152.6

(F), (f)

Y: 161

Z: 249

(G), (g)

X: 171

Y: 917

Z: 249

(H), (h)

X: 408.2

Y: 1,250

Z: 152.6

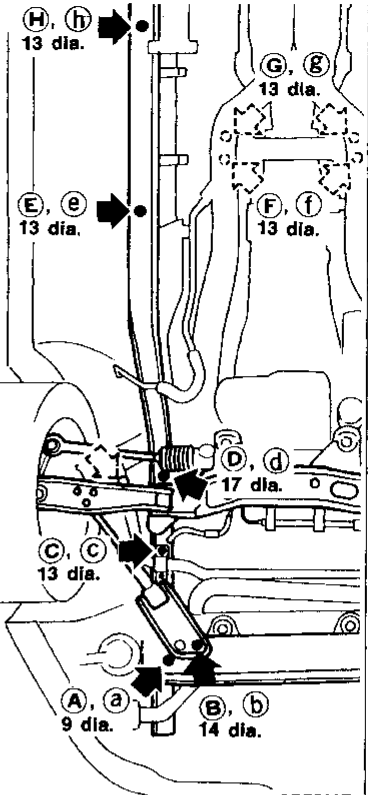

SBF566F

Rear side member and rear extension (2 seater model)

Coordinates:

(I), (i)

X: 420

Y: 1,860

Z: 286.1

(J), (j)

X: 575

Y: 2,030

Z: 179.1

(K), (k)

X: 430

Y: 2,350

Z: 459.6

(L), (l)

X: 450

Y: 2,350

Z: 459.6

(M), (m)

X: 418.5

Y: 2,800

Z: 460

(N), (n)

X: 343

Y: 2,620

Z: 334.3

(O), (o)

X: 418

Y: 3,153.1

Z: 434.1

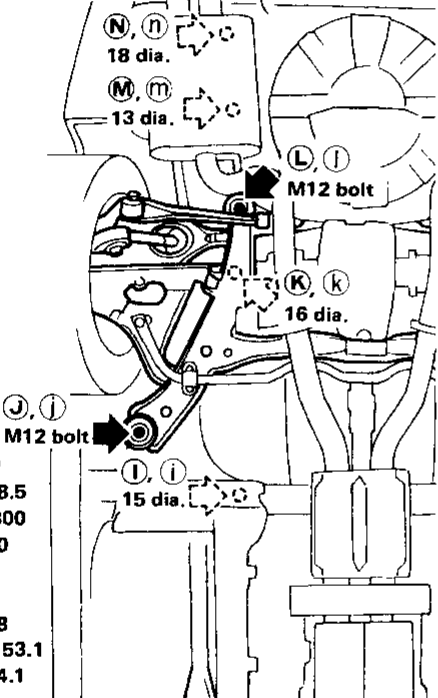

SBF963E

Rear side member and rear extension (2+2 seater model)

Coordinates:

(J), (j)

X: 575

Y: 2,150

Z: 180.7

(K), (k)

X: 365

Y: 2,625

Z: 259.6

(L), (l)

X: 348

Y: 2,740

Z: 334.3

(M), (m)

X: 418.5

Y: 3,000

Z: 459.8

(N), (n)

X: 378

Y: 3,290

Z: 530

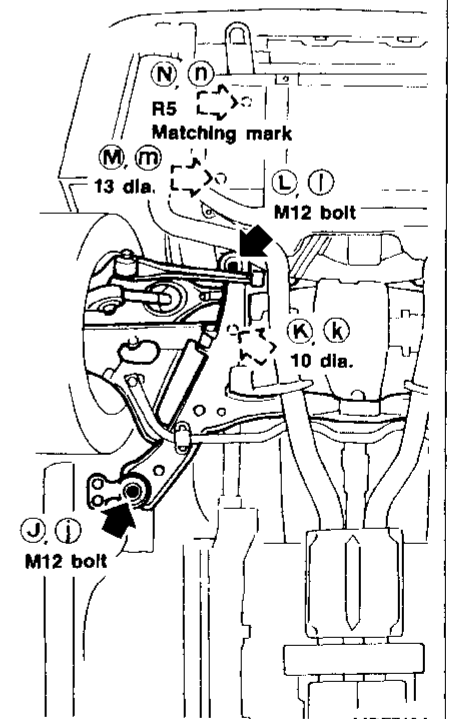

MBF718A

SUPPLEMENTAL RESTRAINT SYSTEM (SRS)

Precautions for SRS "Air Bag" Service

- Do not use a circuit tester to check SRS circuits.
- Before servicing the SRS, turn ignition switch "OFF", disconnect battery ground cable and wait for at least 10 minutes.

For approximately ten minutes after the cables are removed, it is still possible for the air bag to inflate. Therefore, do not work on any air bag system connectors or wires until at least ten minutes have passed.

- SRS sensors must always be installed with their arrow marks " ← " facing the front of the vehicle for proper operation. Also check sensors for cracks, deformities or rust before installation and replace as required.
- The spiral cable must be aligned with the neutral position since its rotations are limited. Do not attempt to turn steering wheel or column after removal of steering gear.
- Handle air bag module carefully. Always place it with the pad side facing upward.
- After removing any SRS parts, discard old bolts and replace with new ones. Conduct self-diagnosis to check entire SRS for proper function.
- If front of vehicle is damaged in a collision, always check the crash zone sensor and the wiring harness.
- After air bag inflates, the front instrument panel assembly should be replaced.

Special Service Tools

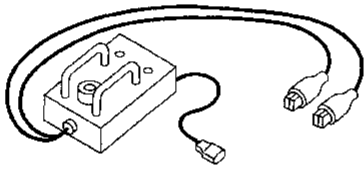
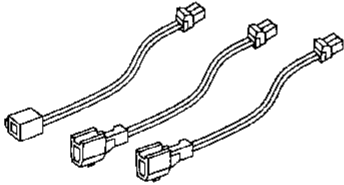
Tool number (Kent-Moore No.) Tool name	Description
KV99106400 (J38381) Deployment tool	 <p style="text-align: right;">Disposing of air bag module</p> <p>NT219</p>
KV991065S0 (J38381-30) Deployment tool adapters	 <p>NT634</p>

Commercial Service Tools

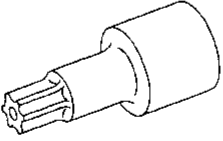
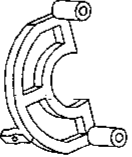
Tool name	Description
Special torx bit	 <p style="text-align: right;">Use for special bolts (tamper resistant screw)</p> <p>NT220</p>
Spiral cable stopper	 <p style="text-align: right;">Avoiding unexpected spiral cable rotation</p> <p>NT221</p>

SUPPLEMENTAL RESTRAINT SYSTEM (SRS)

Description

The air bag deploys when any of the four sensors (right crash zone sensor, center crash zone sensor, left crash zone sensor or tunnel sensor) and the safing sensor simultaneously activate while the ignition switch is "ON".

Ignition	Crash zone sensor			Tunnel sensor	Safing sensor	Air bag signal
	Right	Center	Left			
ON	ON				ON	ON
ON		ON			ON	ON
ON			ON		ON	ON
ON				ON	ON	ON

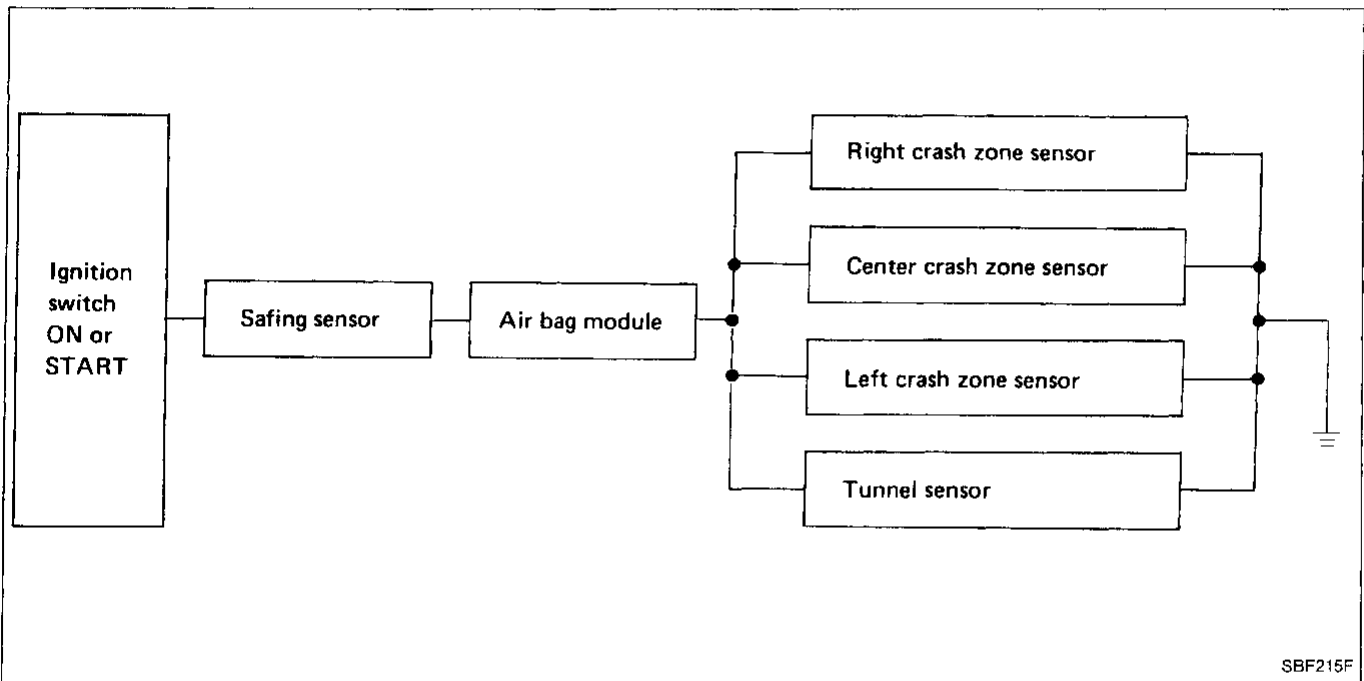

SBF215F

Self-diagnosis

The diagnosis unit (control unit) diagnoses the SRS circuit. When the ignition key is in the "ON" or "START" position, the "AIR BAG" warning lamp will illuminate for about 7 seconds and then turn off. This means that the system is operational.

SUPPLEMENTAL RESTRAINT SYSTEM (SRS)

SRS Component Parts Location and Caution Labels

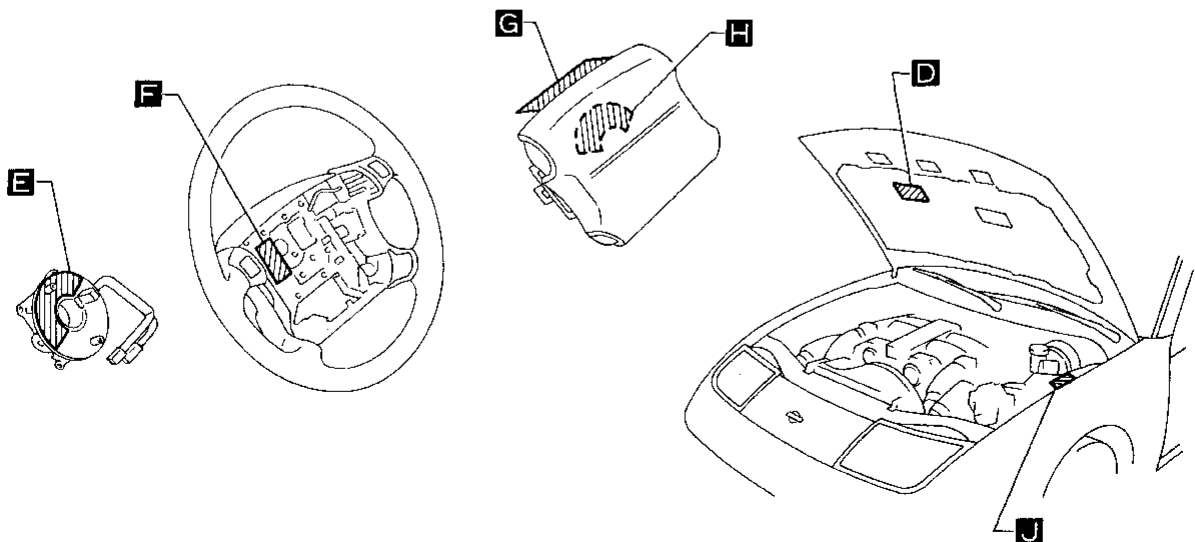
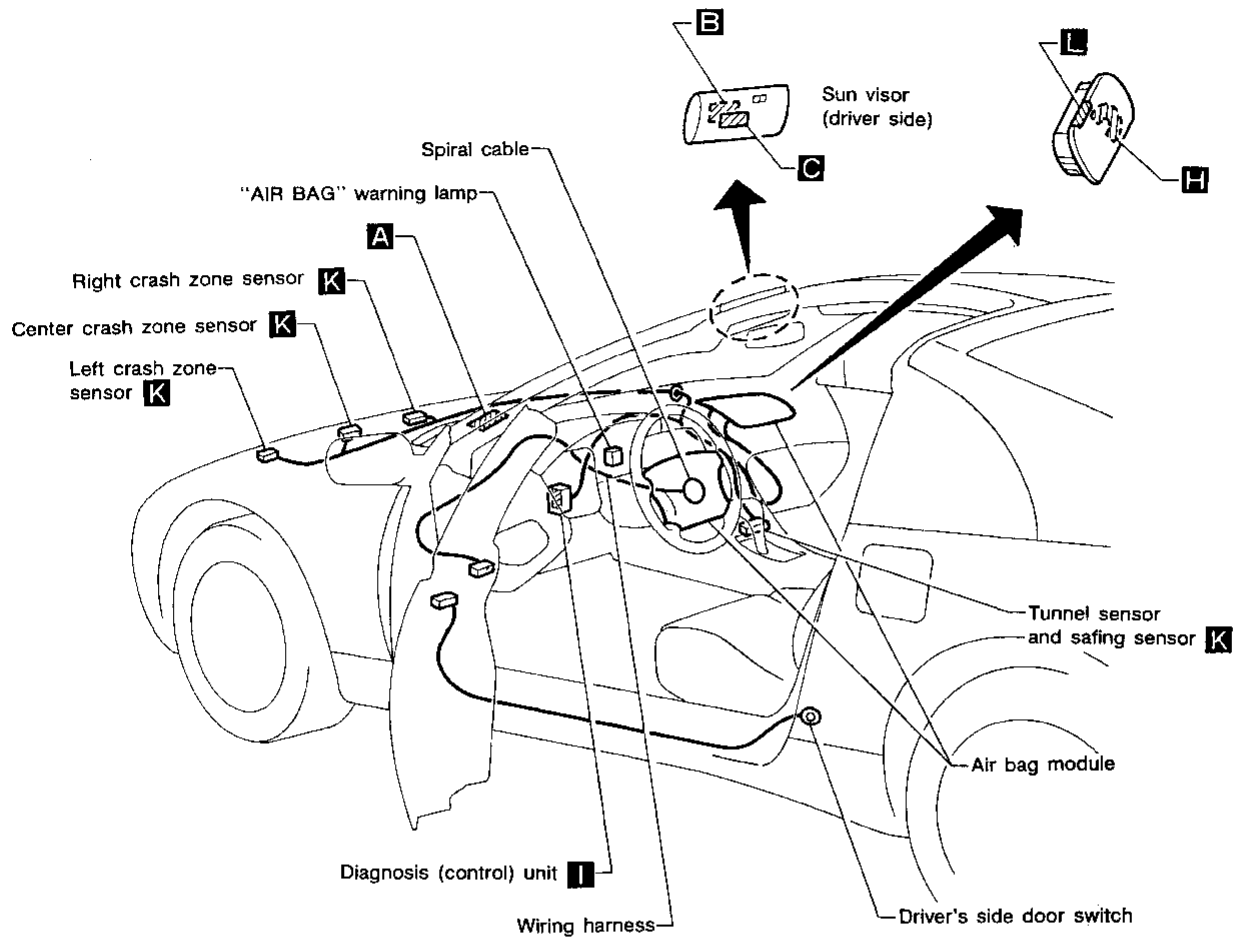

GI
MA
EM
LC
EF &
EC
FE
CL
MT
AT
PD
FA
RA
BR
ST
BF
HA
EL
IDX

SUPPLEMENTAL RESTRAINT SYSTEM (SRS)

SRS Component Parts Location and Caution Labels (Cont'd)

The CAUTION LABELS are important when servicing air bags in the field. If they are dirty or damaged, replace them with new ones.

A

DRIVER-AIRBAG

B

INFORMATION SRS AIRBAG

- THIS CAR IS EQUIPPED WITH A DRIVER AIR BAG AS A SUPPLEMENTAL RESTRAINT SYSTEM (S.R.S.) TO REDUCE INJURY TO THE DRIVER IN A FRONTAL COLLISION.
- THE SYSTEM IS DESIGNED TO SUPPLEMENT THE ACCIDENT PROTECTION PROVIDED BY THE DRIVER'S SEAT BELT. BUT IT IS NOT A SUBSTITUTE FOR THE BELT SYSTEM.
- ALWAYS WEAR YOUR SEAT BELT WHEN THE CAR IS IN USE.
- THE SYSTEM MUST BE INSPECTED 10 YEARS AFTER DATE OF MANUFACTURE, AS NOTED ON THE CERTIFICATION LABEL LOCATED ON THE LEFT FRONT DOOR.
- THE "AIRBAG" LAMP WILL LIGHT MOMENTARILY WHEN THE IGNITION KEY IS TURNED TO THE "ON" OR "START" POSITION. THIS MEANS THE SYSTEM IS OPERATIONAL.
- HOWEVER, IF ANY OF THE FOLLOWING CONDITIONS OCCUR, THE SYSTEM MUST BE SERVICED:
 1. THE "AIR BAG" LAMP DOES NOT GO ON AS DESCRIBED ABOVE.
 2. THE "AIRBAG" LAMP FLASHES INTERMITTENTLY OR REMAINS ON.
 3. ANY PORTION OF THE FRONT END OF THE CAR IS DAMAGED.
 4. THE AIR BAG HAS DEPLOYED.
- SEE YOUR OWNER'S MANUAL FOR DETAILS ABOUT THE FUNCTIONING, SERVICE, AND DISPOSAL PROCEDURES FOR THE SYSTEM.

C

NOTICE SRS AIRBAG

- THIS CAR IS EQUIPPED WITH A DRIVER AIR BAG AS A SUPPLEMENTAL RESTRAINT SYSTEM (S.R.S.)
- IT IS DESIGNED TO SUPPLEMENT THE SEAT BELT.
- ALWAYS WEAR YOUR SEAT BELT.

D

WARNING SRS AIRBAG

- THIS CAR IS EQUIPPED WITH AIR BAGS AS A SUPPLEMENTAL RESTRAINT SYSTEM (S.R.S.)
- ALL S.R.S. ELECTRICAL WIRING AND CONNECTORS ARE COLORED YELLOW.
- DO NOT USE ELECTRICAL TEST EQUIPMENT ON THESE CIRCUITS.
- TAMPERING WITH OR DISCONNECTING THE S.R.S. WIRING AND CONNECTORS COULD RESULT IN ACCIDENTAL DEPLOYMENT OF THE AIR BAG OR MAKE THE SYSTEM INOPERATIVE, WHICH MAY RESULT IN SERIOUS INJURY.

E

CAUTION SRS AIRBAG

- BEFORE ASSEMBLY;
 - LINE UP THE FRONT WHEELS STRAIGHT AHEAD.
 - ALIGN THE ARROW WITH THE YELLOW MARK ON THE SIDE GEAR.
 - READ SERVICE MANUAL.
- NO SERVICEABLE PARTS INSIDE.
- DO NOT DISASSEMBLE OR TAMPER.

F

WARNING SRS AIRBAG

- BEFORE MOUNTING STEERING WHEEL;
- MAKE SURE THAT THE FRONT WHEELS ARE IN STRAIGHT-AHEAD POSITION.
 - ALIGN THE ARROW WITH THE YELLOW MARK ON THE SIDE GEAR. (SPIRAL CABLE)
 - READ SERVICE MANUAL.

SUPPLEMENTAL RESTRAINT SYSTEM (SRS)

SRS Component Parts Location and Caution Labels (Cont'd)

G

WARNING

SRS AIRBAG

- THIS AIRBAG MODULE CANNOT BE REPAIRED.
- USE DIAGNOSTIC INSTRUCTIONS TO DETERMINE IF THE UNIT IS OPERATIONAL.
- IF NOT OPERATIONAL, REPLACE AND DISPOSE OF THE ENTIRE UNIT AS DIRECTED IN THE INSTRUCTIONS.
- UNDER NO CIRCUMSTANCES SHOULD A DIAGNOSIS BE PERFORMED USING ELECTRICALLY POWERED TEST EQUIPMENT OR PROBING DEVICES.
- TAMPERING OR MISHANDLING CAN RESULT IN PERSONAL INJURY.
- STORE THE REMOVED AIRBAG MODULE WITH THE PAD SURFACE UP.
- FOR SPECIAL HANDLING OR STORAGE REFER TO SERVICE MANUAL.

I

CAUTION SRS AIRBAG

- NO SERVICEABLE PARTS INSIDE.
- DO NOT DISASSEMBLE OR TAMPER.
- DO NOT DROP: KEEP DRY.
- WHILE REMOVED, STORE IN A CLEAN AND DRY AREA.
- IF WET CONDITION OCCURS. THIS UNIT MUST BE SERVICED.

GI

MA

EM

LC

J

CAUTION SRS AIRBAG

- TO AVOID DAMAGING THE S.R.S. SPIRAL CABLE, WHICH COULD MAKE THE SYSTEM INOPERATIVE, REMOVE THE STEERING WHEEL BEFORE REMOVING THE STEERING LOWER JOINT.

EF &
EC

FE

CL

H

DANGER POISON

- KEEP OUT OF REACH OF CHILDREN.
- CONTAINS SODIUM AZIDE AND POTASSIUM NITRATE.
- CONTENTS ARE POISONOUS AND EXTREMELY FLAMMABLE.
- CONTACT WITH ACID WATER, OR HEAVY METALS MAY PRODUCE HARMFUL AND IRRITATING GASES OR EXPLOSIVE COMPOUNDS.
- DO NOT DISMANTLE, INCINERATE, BRING INTO CONTACT WITH ELECTRICITY, OR STORE AT TEMPERATURES EXCEEDING 200°F.
- FIRST AID: IF CONTENTS ARE SWALLOWED, INDUCE VOMITING;
 - FOR EYE CONTACT, FLUSH EYES WITH WATER FOR 15 MINUTES
 - IF GASES FROM ACID OR WATER CONTACT ARE INHALED, SEEK FRESH AIR;
 - IN EVERY CASE, GET PROMPT MEDICAL ATTENTION
- FOR ADDITIONAL INFORMATION, SEE MATERIAL SAFETY DATA SHEET (MSDS) FOR THIS PRODUCT.

K

WARNING

SRS AIRBAG

- DO NOT DISASSEMBLE OR TAMPER.
- DISMANTLING AND INSTALLATION SHOULD ONLY BE PERFORMED BY TRAINED PERSONNEL.

MT

AT

PD

FA

RA

BR

ST

BF

HA

EL

LDX

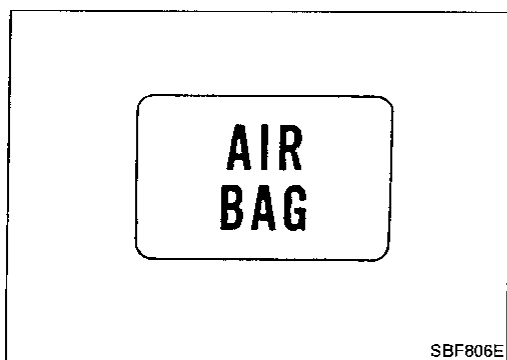

Maintenance Items

1. Check "AIR BAG" warning lamp
When the ignition key is in the "ON" or "START" position, the "AIR BAG" warning lamp will illuminate for about 7 seconds and then turn off. This means that the system is operational.
When a warning lamp flashes, check and correct cause of the problem.
2. Visually check SRS components
 - (1) Sensors
 - Check sensors to ensure the arrow marks face the front of the vehicle.
 - Check body and sensor brackets for deformities or rust.
 - Check sensor case for dents, cracks, deformities or rust.
 - Check sensor harness for binds, connector for damage, and terminals for deformities.
 - (2) Diagnosis (Control) unit — Airbag
 - Check case and bracket for dents, cracks or deformities.
 - Check connectors for damage, and terminals for deformities.
 - (3) Main harness
 - Check connectors for poor connections.
 - Check harnesses for binds, connectors for damage, and terminals deformities.
 - (4) Spiral cable
 - Visually check lock (engagement) pins and combination switch for damage.
 - Check connectors, flat cable and protective tape for damage.
 - Check steering wheel for noise, binds or difficult operation.
 - (5) Steering wheel
 - Check harness (built into steering wheel) and connectors for damage, and terminals for deformities.
 - Install air bag module to check fit or alignment with steering wheel.
 - Check steering wheel for excessive free play.
 - (6) Air bag module — Driver and passenger side
 - Check harness cover and connectors for damage, terminals for deformities, and harness for binds.
 - Install air bag module to steering wheel to check fit or alignment with the wheel.

CAUTION:

Replace previously used screws with new ones.

Removal and Installation — Diagnosis (Control) Unit and Sensors

CAUTION:

- Before servicing SRS, turn the ignition switch off, disconnect battery ground cable and wait for at least 10 minutes.
- The special bolts are coated with bonding agent. Discard old ones after removal; replace with new ones.
- Check sensors for proper installation.
- Check sensors to ensure they are free of deformities, dents, cracks or rust. If they show any visible signs of damage, replace them with new ones.
- Check sensor brackets to ensure they are free of deformities or rust.

GI

MA

EM

LC

EF &
EC

FE

CL

MT

AT

PD

FA

RA

BR

ST

BF

HA

EL

IDX

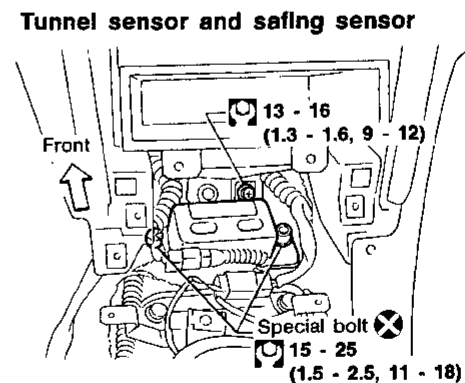
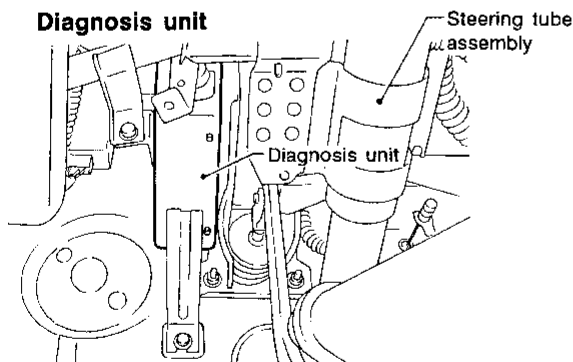
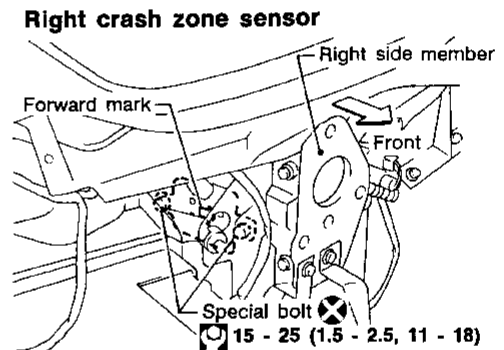
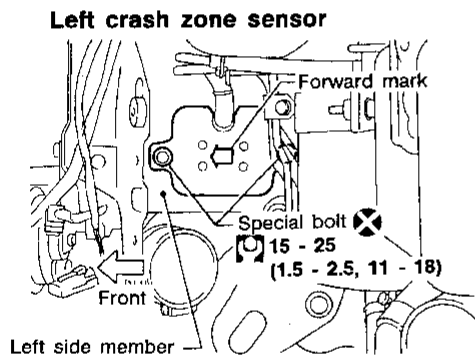
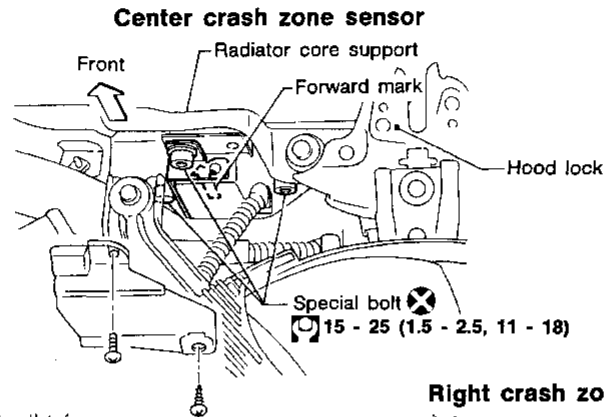

: N·m (kg-m, ft-lb)

MBF367B

SUPPLEMENTAL RESTRAINT SYSTEM (SRS)

Removal — Air Bag Module and Spiral Cable

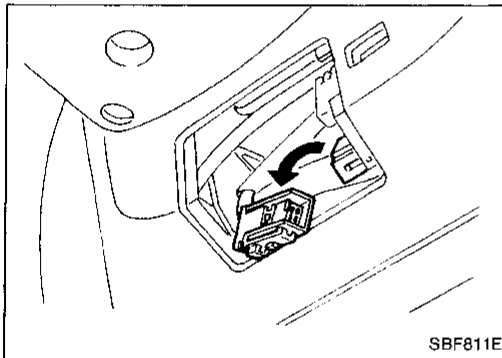
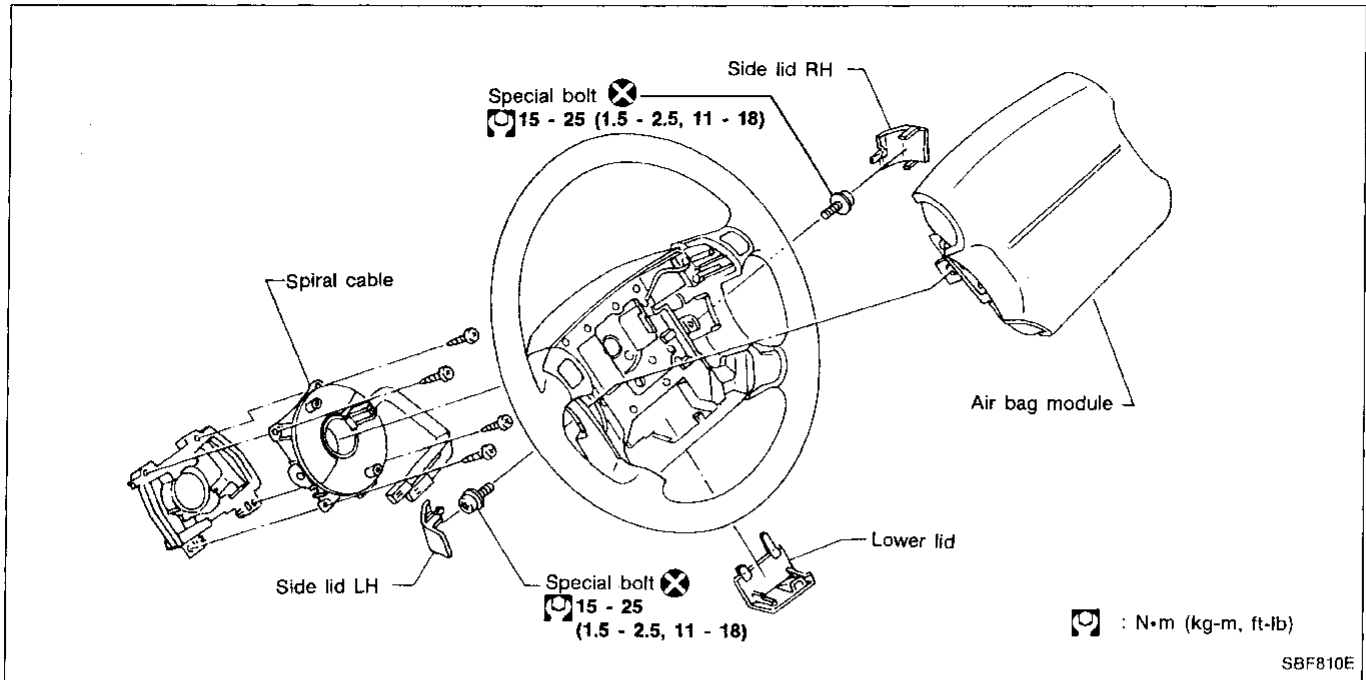

CAUTION:

Before servicing SRS, turn the ignition switch off, disconnect battery ground cable and wait for at least 10 minutes.

1. Remove lower lid from steering wheel, and disconnect air bag module connector.

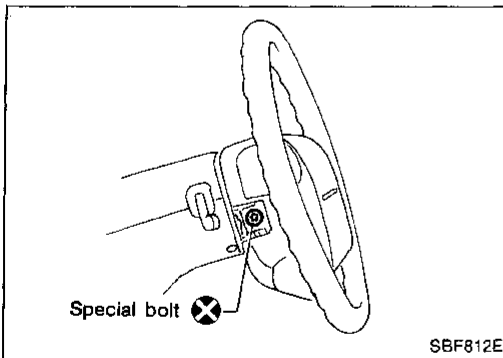

2. Remove side lid. Using the T50H torx bit, remove left and right special bolts. Air bag module can then be removed.

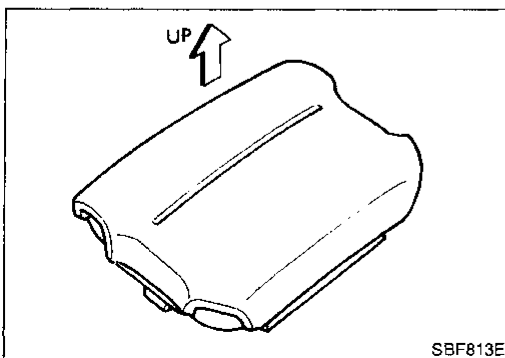

CAUTION:

- Always place air bag module with pad side facing upward.
- Do not attempt to disassemble air bag module.
- The special bolts are coated with bonding agent. Discard old ones after removal; replace with new ones.

SUPPLEMENTAL RESTRAINT SYSTEM (SRS)

Removal — Air Bag Module and Spiral Cable (Cont'd)

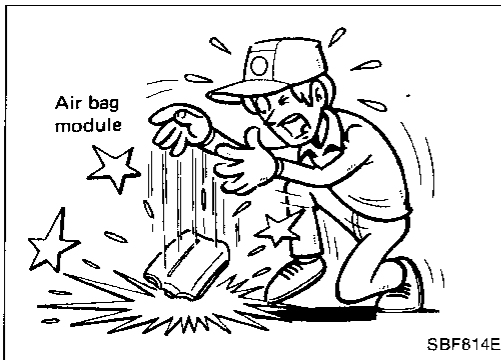

- Do not drop or impact air bag module. If any portion is deformed or cracked, replace the module.
- Do not expose the air bag module to temperatures exceeding 100°C (212°F).
- Do not allow oil, grease or water to come in contact with the air bag module.

GI

MA

EM

LC

EF &
EC

FE

CL

MT

AT

PD

FA

RA

BR

ST

BF

HA

EL

IDX

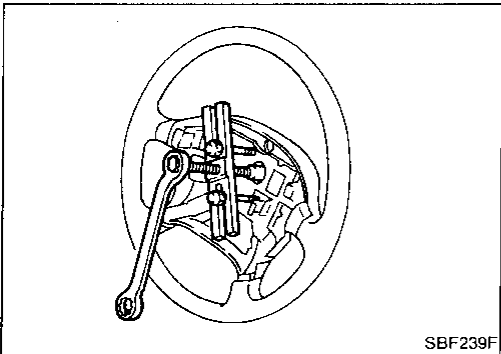

3. Set steering wheel in the neutral position.
4. Disconnect horn connector and remove nuts.
5. Using steering wheel puller, remove steering wheel. Be careful not to over-tighten puller bolt on steering wheel.

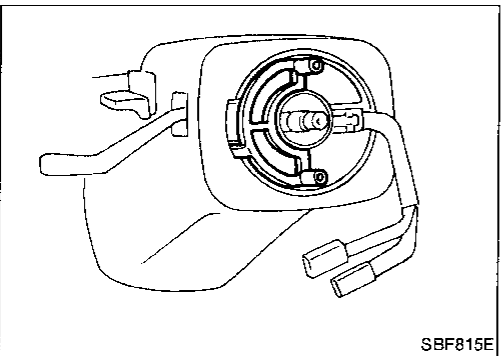

6. Attach spiral cable to stopper.
7. Remove steering column cover.
8. Disconnect connector and remove the four screws. The spiral cable can then be removed.

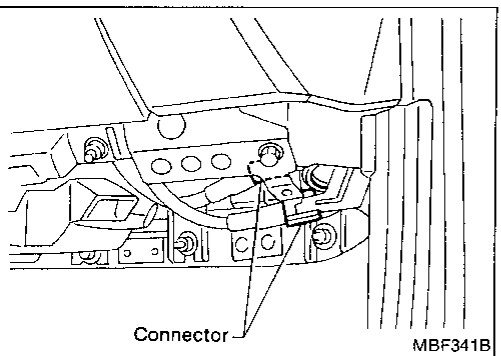

Removal — Front Passenger Air Bag Module

- For removal of instrument panel, refer to "INSTRUMENT PANEL" (BF-27).

CAUTION:

Before servicing SRS, turn the ignition switch off, disconnect battery ground cable and wait for at least 10 minutes.

1. Remove instrument lower cover on passenger side.
 2. Remove connector bracket from air bag module and disconnect inflator connector from body harness air bag connector.
 3. Remove instrument panel.
 4. Remove the special bolt from left and right sides of front passenger air bag module and remove the air bag module from the steering member.
- Air bag module is heavy and should be supported using both hands during removal.

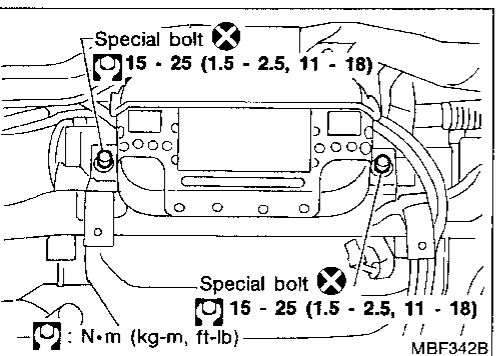

SUPPLEMENTAL RESTRAINT SYSTEM (SRS)

Removal — Front Passenger Air Bag Module (Cont'd)

CAUTION:

- Always place air bag module with pad side facing upward.
- Do not attempt to disassemble air bag module.
- The special bolts are coated with bonding agent. Discard old ones after removal; replace with new ones.

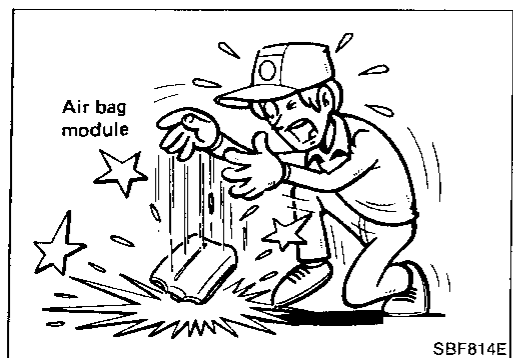
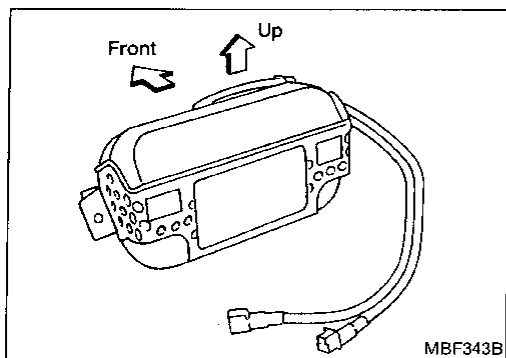

- Do not drop or impact air bag module. If any portion is deformed or cracked, replace the module.
- Do not expose the air bag module to temperatures exceeding 100°C (212°F).
- Do not allow oil, grease or water to come in contact with the air bag module.

Installation — Air Bag Module and Spiral Cable

1. Connect spiral cable connector and tighten with screws. Install steering column cover.

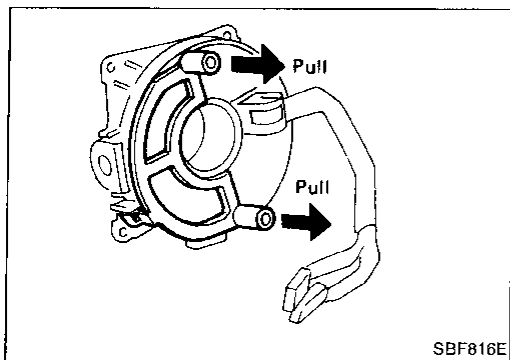

2. Remove stopper by pulling two pin guides.

SUPPLEMENTAL RESTRAINT SYSTEM (SRS)

Installation — Air Bag Module and Spiral Cable (Cont'd)

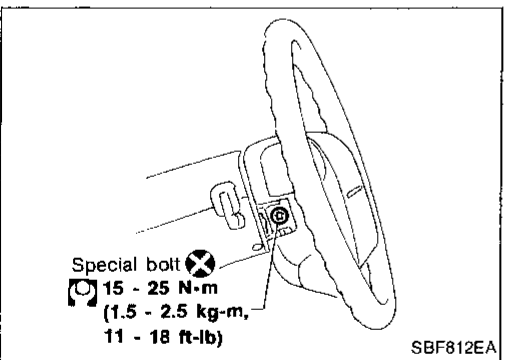
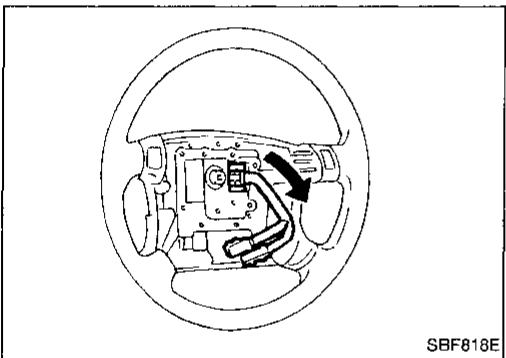
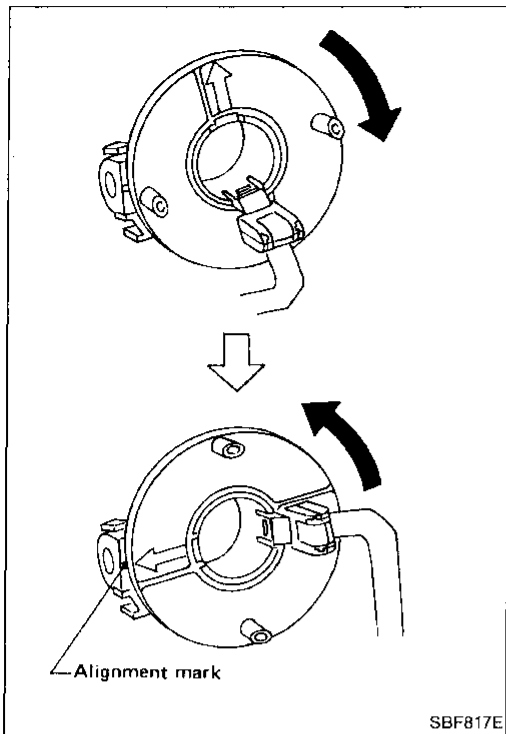

- Alignment of spiral cable with neutral position
If stopper is not used, align spiral cable with neutral position as follows:

Turn spiral cable clockwise until it catches stopper. Then, back spiral cable off approximately two turns until yellow alignment mark appears on left gear. Align arrow mark "←" of spiral cable with this yellow mark.

3. Install steering wheel setting spiral cable pin guides, and pull spiral cable through.
4. Connect horn connector and engage spiral cable with pawls in steering wheel.
5. Tighten nuts.

6. Position air bag module and tighten with new special bolts.
7. Connect air bag module connector.
8. Install all lids.

9. Conduct self-diagnosis to ensure entire SRS operates properly. (Use CONSULT or warning lamp check.)

GI

MA

EM

LC

EF &
EC

FE

CL

MT

AT

PD

FA

RA

BR

ST

BF

HA

EL

IDX

SUPPLEMENTAL RESTRAINT SYSTEM (SRS)

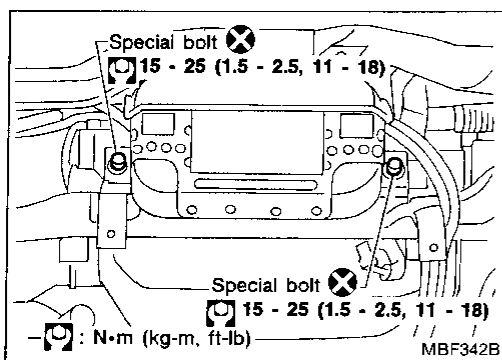

Installation — Front Passenger Air Bag Module

1. Install front passenger air bag module on steering member.
 - Ensure harness is not caught between rear of air bag module and steering member.
2. Install instrument panel.
3. Connect air bag module connector to body harness connector.
4. Install air bag module connector on connector bracket.
5. Install connector bracket on air bag module, then install instrument lower cover on passenger side.

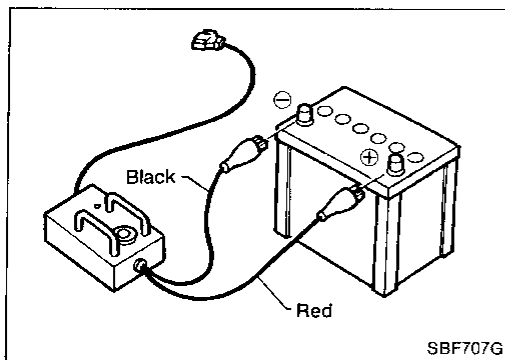
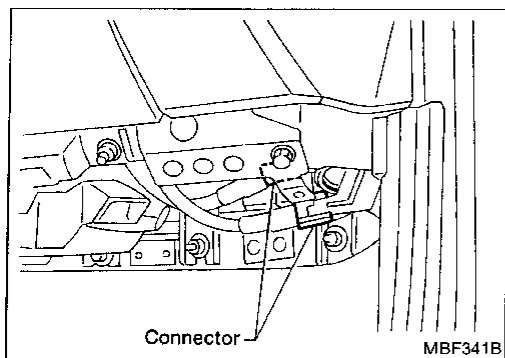

Scrapping Air Bag

Before scrapping air bag module or a vehicle equipped with an SRS system, be sure to deactivate the units or the system.

CONNECTING TO BATTERY

- Place the vehicle outdoors in such a way that it is surrounded on all sides by at least 6 m (20 ft) of open space.
- Use a voltmeter to make sure the vehicle battery is fully charged.

CAUTION:

The battery must show voltage of 9.6V or more.

Remove the battery from the vehicle and place it on dry wood blocks approximately 5 m (16 ft) away from the vehicle.

- Wait 10 to 12 minutes after the vehicle battery is disconnected before proceeding.
- Connect deployment tool to the battery.

CAUTION:

Make sure the polarity is correct. The right side lamp in the tool, marked "deployment tool power", should glow with a green light. If the right side lamp glows red, reverse the connections to the battery.

SUPPLEMENTAL RESTRAINT SYSTEM (SRS)

Scrapping Air Bag (Cont'd)

DEPLOYMENT TOOL CHECK

Press the deployment tool switch to the "ON" position. The left side lamp in the tool, marked "air bag connector voltage" should illuminate. If it does not illuminate, replace the tool.

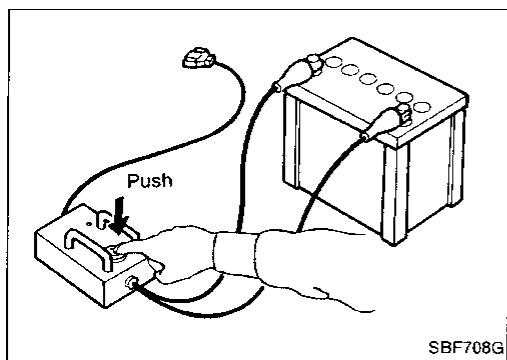

AIR BAG DEPLOYMENT TOOL LAMP ILLUMINATION CHART (Battery connected)

Switch operation	Left side lamp, green* "AIR BAG CONNecTOR VOLTAGE"	Right side lamp, green* "DEPLOYMENT TOOL POWER"
OFF	OFF	ON
ON	ON	ON

*: If this lamp glows red, the tool is connected to the battery incorrectly. Reverse the connections and make sure the lamp glows green.

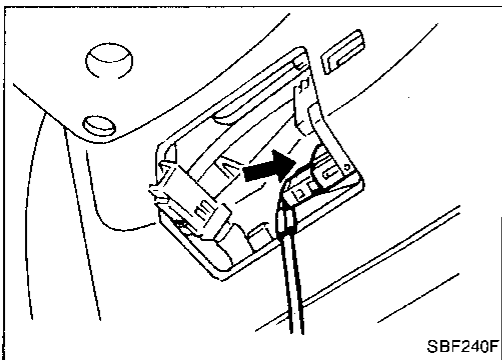

CONNECTING TO AIR BAG

- Disconnect the prepared battery cable.
- Also disconnect the vehicle battery ground cable and wait 10 minutes.
- Disconnect air bag module connector.
- Connect deployment tool connector to air bag module. For front passenger air bag, attach the adapters to the tool connector.

CAUTION:

Make sure the deployment tool is disconnected from the battery before you make this connection.

- Reconnect the battery cable to the prepared battery.
- The lamp on the right side of the tool, marked "deployment tool power", should glow green, not red.

GI

MA

EM

LC

EF &
EC

FE

CL

MT

AT

PD

FA

RA

BR

ST

BF

HA

EL

IDX

SUPPLEMENTAL RESTRAINT SYSTEM (SRS)

Scrapping Air Bag (Cont'd)

DEPLOYMENT

Press the button on the deployment tool. The left side lamp on the tool, marked "air bag connector voltage", will illuminate and the air bag will deploy.

DISPOSAL

- Remove steering wheel side lids. Use the special "torx" bit to remove the air bag module from the steering wheel. Place it into a sealed vinyl bag for disposal.

CAUTION:

- When deploying air bag, ensure vehicle is empty.
- No poisonous gas is produced upon air bag deployment. However, be careful not to inhale gas since it irritates throat and can cause choking.
- Due to heat, leave air bag module unattended for more than 30 minutes after deployment.
- Do not attempt to disassemble air bag module.
- Air bag module can not be re-used.
- Never apply water to a deployed air bag module.
- Be sure to wear gloves when handling a deployed air bag module.

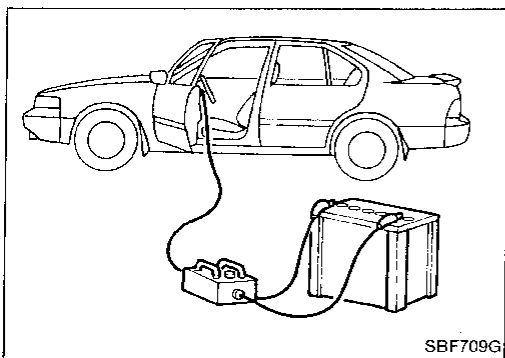

Contents

Schematic	BF-83
Wiring Diagram	BF-84
Self-diagnosis	
USING CONSULT	BF-85
USING THE WARNING LAMP	BF-88
Diagnostic Procedure 1	BF-91
SYMPTOM: Warning lamp flashes.	
Diagnostic Procedure 2	BF-91
SYMPTOM: Warning lamp does not come on.	
Diagnostic Procedure 3	BF-92
SYMPTOM: Warning lamp does not go off.	
Collision Diagnosis	BF-93

Schematic

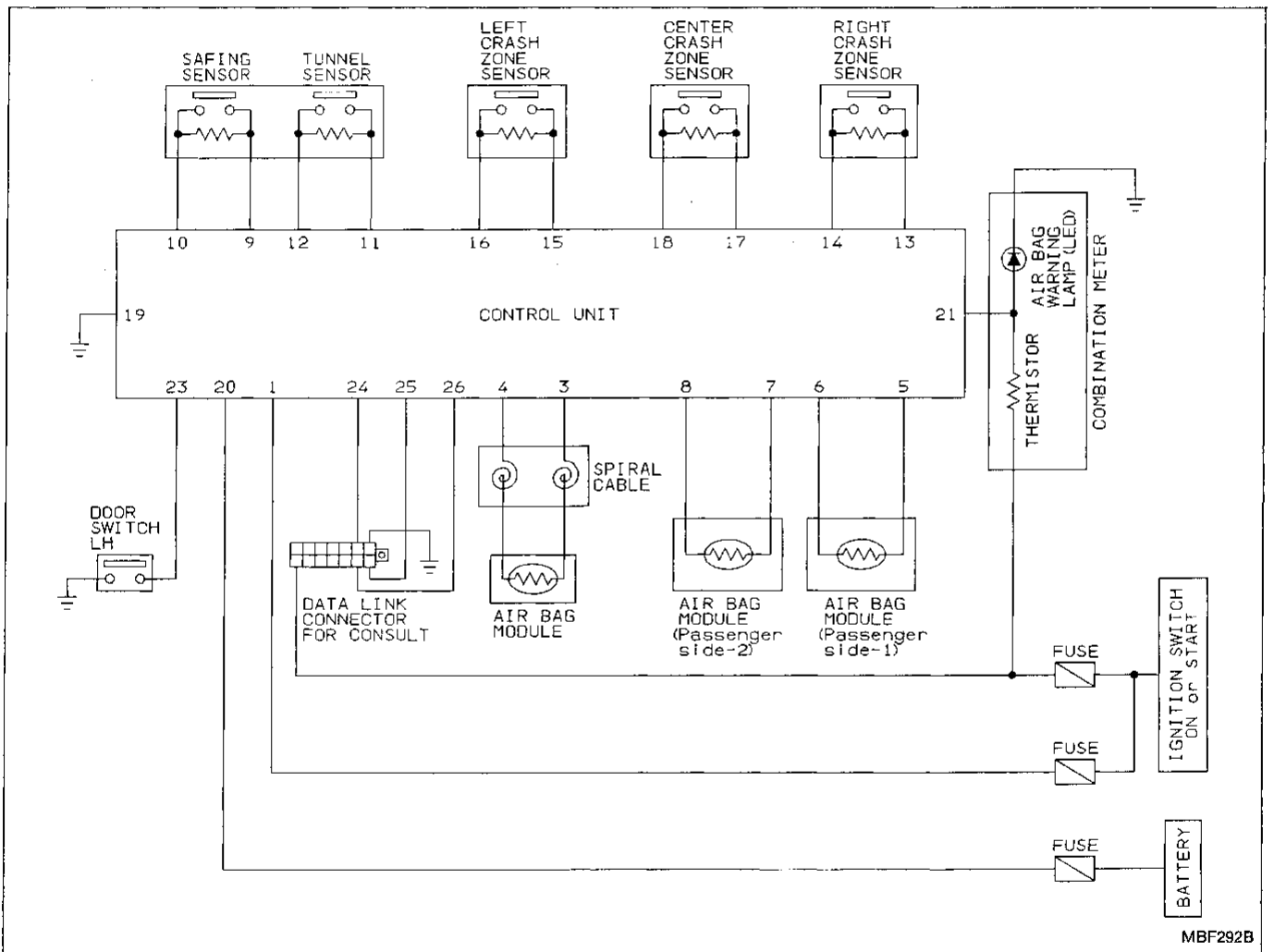

Wiring Diagram

CAUTION:

- Do not use a circuit tester to check SRS "Air Bag" harness connectors. The wiring harness and connectors have yellow outer insulation for easy identification.
- Do not attempt to repair, splice or modify the SRS "Air Bag" wiring harness. If the harness is damaged, replace it with a new one.
- Keep ground portion clean.

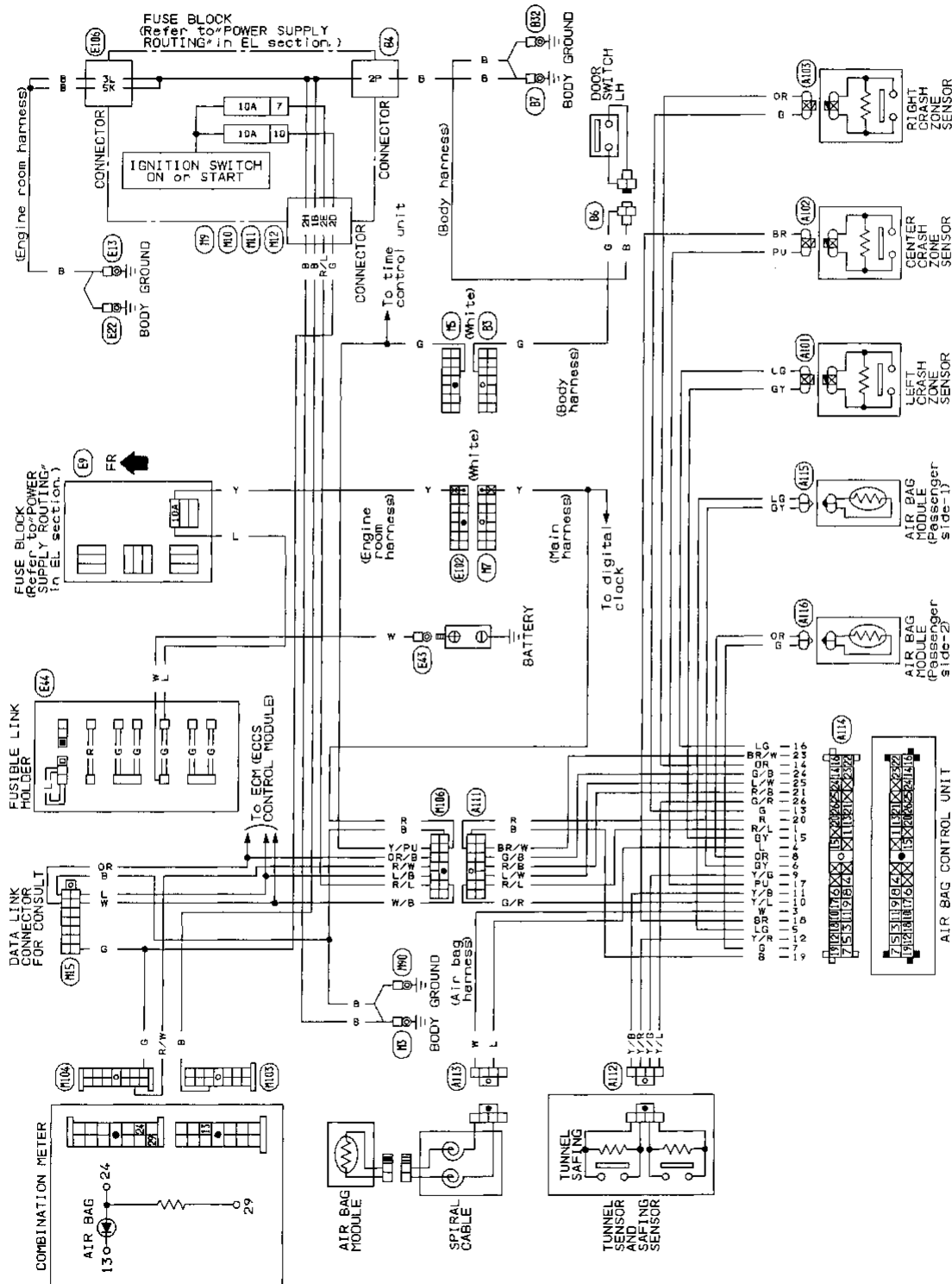

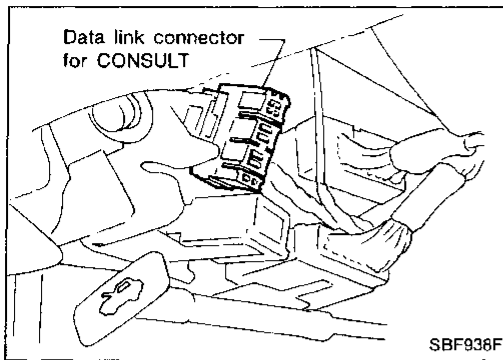

Self-diagnosis

USING CONSULT

The self-diagnosis results can be read by CONSULT, as follows:

1. Connect "CONSULT" to data link connector for CONSULT. GI



2. Turn ignition switch to "ON". (When CONSULT is connected, the "AIR BAG" warning lamp will be turned to present diagnosis mode.) MA



3. Touch "START" to operate "CONSULT". EM



4. Touch "AIR BAG" to choose air bag system. LC



5. Touch "SELF DIAG RESULTS" to read self-diagnosis results. EF & EC



6. Problem codes are displayed on "SELF DIAG RESULT 1" (first page — present mode). The problem code last indicated is displayed on "SELF DIAG RESULT 2" (second page — initial mode). FE



7. When "PRINT" is pressed, information displayed on "SELF DIAG RESULTS 1 and 2" is printed out. CL



8. After repairing malfunctioning parts, press "ERASE" to clear self-diagnosis results. MT



- After repairing malfunctioning parts, attempt to clear self-diagnosis results from memory. AT

- If malfunctioning parts are not completely repaired, self-diagnosis results remain stored in memory. PD



9. Push Back Key of CONSULT until SELECT SYSTEM mode appears to make "SELF-DIAGNOSIS" user mode. FA



10. Push the power off switch. RA



11. Turn off ignition switch. BR

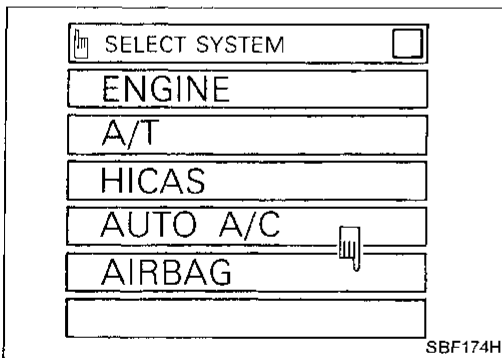

BF

HA

EL

IDX

TROUBLE DIAGNOSES — Supplemental Restraint System (SRS)

Self-diagnosis (Cont'd)

Self-diagnosis results

Diagnostic item	Explanation	Repair order * Recheck SRS at each replacement.
NO SELF DIAGNOSTIC FAILURE INDICATED.	Normal. The SRS system is in good order.	—
SAFING SENSOR [OPEN/UPR-VB-SHORT]	The circuit for the safing sensor is open or the wire from the diagnosis (control) unit (terminal No. 3) to the safing sensor is shorted to some power supply circuit.	<ol style="list-style-type: none"> 1. Visually check the wiring harness connections. 2. Replace the safing sensor. (safing sensor and tunnel sensor unit) 3. Replace the diagnosis (control) unit. 4. Replace the main harness.
SAFING SENSOR [SHORT/UPR-GND-SHORT]	Both the wires for the safing sensor are shorted or the wire from the diagnosis (control) unit (terminal No. 3) to the safing sensor is shorted to ground.	
AIRBAG MODULE [OPEN]	The circuit for driver's air bag module is open. (including the spiral cable)	<ol style="list-style-type: none"> 1. Visually check the wiring harness connections. 2. Replace the spiral cable. 3. Replace driver's air bag module. (Before disposing of it, it must be deployed.) 4. Replace the diagnosis (control) unit. 5. Replace the main harness.
AIRBAG MODULE [VB-SHORT]	The circuit for driver's air bag module is shorted to some power supply circuit. (including the spiral cable)	
AIRBAG MODULE [GND-SHORT]	The circuit for driver's air bag module is shorted to ground. (including the spiral cable)	
AIRBAG MODULE [SHORT]	The circuits for driver's air bag module are shorted to each other.	
ASSIST A/B MODULE 1 [OPEN]	The circuit for front passenger air bag module 1 is open.	<ol style="list-style-type: none"> 1. Visually check the wiring harness connections. 2. Replace front passenger air bag module. (Before disposing of it, it must be deployed.) 3. Replace the diagnosis (control) unit. 4. Replace the main harness.
ASSIST A/B MODULE 1 [VB-SHORT]	The circuit for front passenger air bag module 1 is shorted to some power supply circuit.	
ASSIST A/B MODULE 1 [GND-SHORT]	The circuit for front passenger air bag module 1 is shorted to ground.	
ASSIST A/B MODULE 1 [SHORT]	The circuits for front passenger air bag module 1 are shorted to each other.	
ASSIST A/B MODULE 2 [OPEN]	The circuit for front passenger air bag module 2 is open.	<ol style="list-style-type: none"> 1. Visually check the wiring harness connections. 2. Replace front passenger air bag module. (Before disposing of it, it must be deployed.) 3. Replace the diagnosis (control) unit. 4. Replace the main harness.
ASSIST A/B MODULE 2 [VB-SHORT]	The circuit for front passenger air bag module 2 is shorted to some power supply circuit.	
ASSIST A/B MODULE 2 [GND-SHORT]	The circuit for front passenger air bag module 2 is shorted to ground.	
ASSIST A/B MODULE 2 [SHORT]	The circuits for front passenger air bag module 2 are shorted to each other.	

TROUBLE DIAGNOSES — Supplemental Restraint System (SRS)

Self-diagnosis (Cont'd)

Diagnostic item	Explanation	Repair order * Recheck SRS at each replacement.	
TUNNEL SENSOR [OPEN/UPR-VB-SHORT]	The circuit for the tunnel sensor is open or the wire from the diagnosis (control) unit (terminal No. 6) to the tunnel sensor is shorted to some power supply circuit.	1. Visually check the wiring harness connections. 2. Replace the tunnel sensor. (safing sensor and tunnel sensor unit)	GI
TUNNEL SENSOR [SHORT/UPR-GND-SHORT]	Both the wires for the tunnel sensor are shorted or the wire from the diagnosis (control) unit (terminal No. 6) to the tunnel sensor is shorted to ground.	3. Replace the diagnosis (control) unit. 4. Replace the main harness.	MA
CRASH ZONE SEN-RH [OPEN/UPR-VB-SHORT]	The circuit for the crash zone sensor is open or the wire from the diagnosis (control) unit (terminal for the crash zone sensor RH: No. 7, LH: No. 8, CTR: No. 9) to the crash zone sensor is shorted to some power supply circuit.	1. Visually check the wiring harness connections. 2. Replace the crash zone sensor. 3. Replace the diagnosis (control) unit. 4. Replace the main harness.	EM
CRASH ZONE SEN-LH [OPEN/UPR-VB-SHORT]			LC
CRASH ZONE SEN-CTR [OPEN/UPR-VB-SHORT]			EF & EC
CRASH ZONE SEN-RH [SHORT]			FE
CRASH ZONE SEN-LH [SHORT]	The circuits for the crash zone sensor are shorted to each other.		CL
CRASH ZONE SEN-CTR [SHORT]			CL
CONTROL UNIT			MT
INDEFINITE FAILURES [AIR BAG]	A problem which cannot be specified occurs because more than two parts except seat belt pre-tensioners are out of order.	1. Visually check the wiring harness connections. 2. Replace the diagnosis (control) unit. 3. Replace all sensors, spiral cable and air bag modules and seat belts. 4. Replace the main harness.	AT PD FA

RA

BR

ST

BF

HA

EL

IOX

Self-diagnosis (Cont'd)

USING THE WARNING LAMP

Self-diagnosis results can be also read by using the "AIR BAG" warning lamp.

The "Air bag" warning lamp operates as shown below:

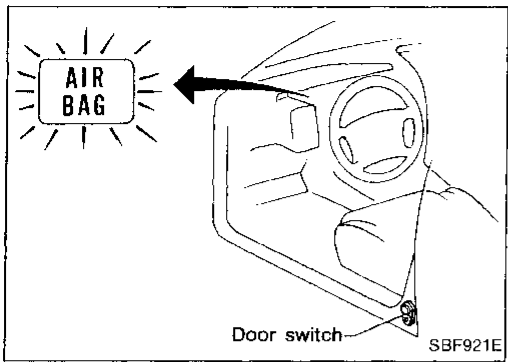

How to alternate self-diagnosis

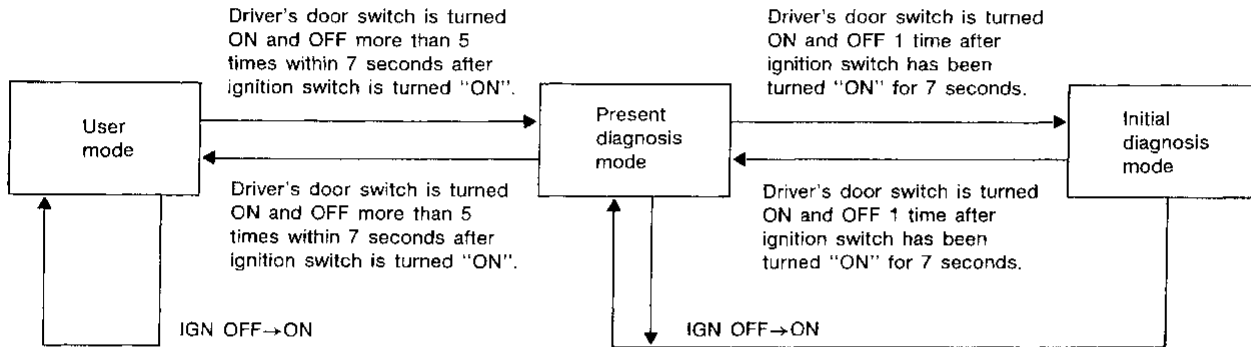

Problem codes are displayed in present diagnosis mode (self-diagnosis result 1). The problem code last indicated is displayed in initial diagnosis mode (self-diagnosis result 2).

After the malfunctioning parts have been repaired and the system is returned to the user mode, the present diagnosis mode information, displayed as self-diagnosis results, is automatically cleared from memory.

- After repairing malfunctioning part, attempt to clear self-diagnosis results from memory.
- If a malfunctioning part is not completely repaired, information stored in memory will not be cleared.

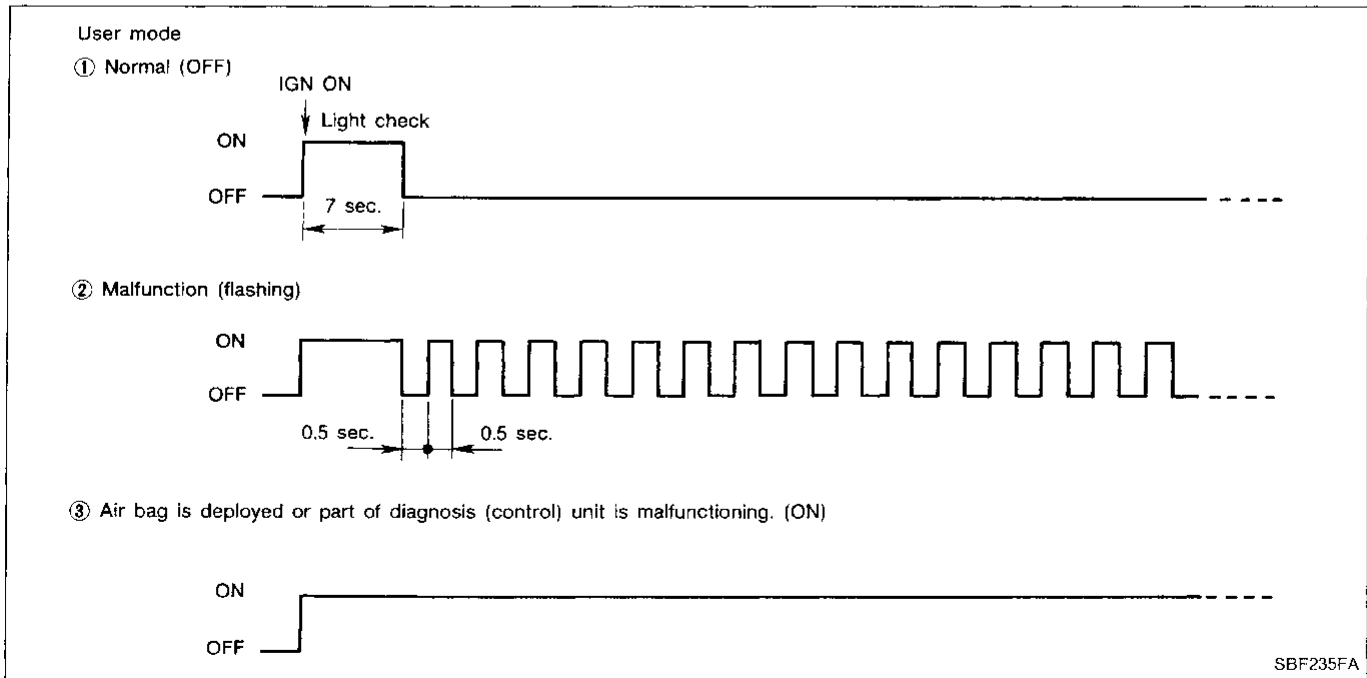

TROUBLE DIAGNOSES — Supplemental Restraint System (SRS)

Self-diagnosis (Cont'd)

Present diagnosis mode (self-diagnosis result 1)

(b) Start signal; Start signal identifies display modes.

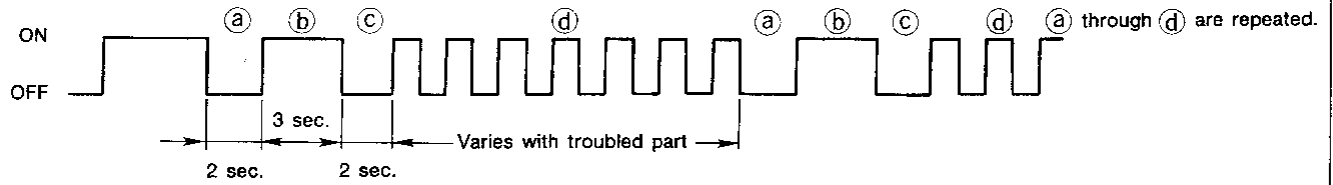

No trouble (or intermittent trouble/repair completion)

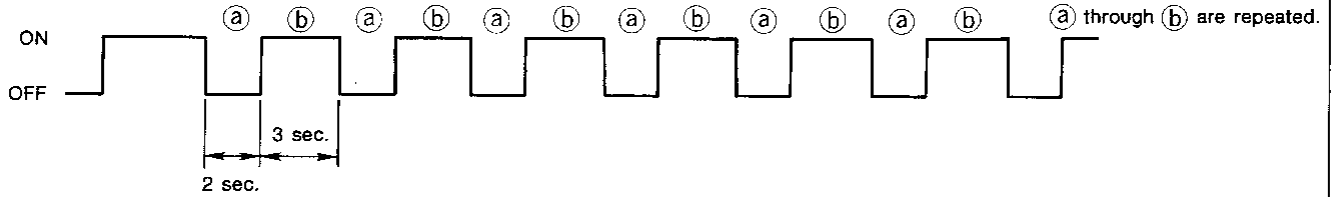

SBF236FA

Initial diagnosis mode (self-diagnosis result 2)

(b) Start signal; Start signal identifies display modes.

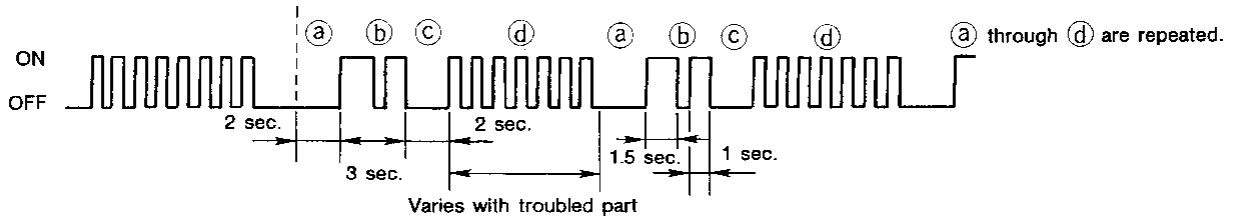

No trouble

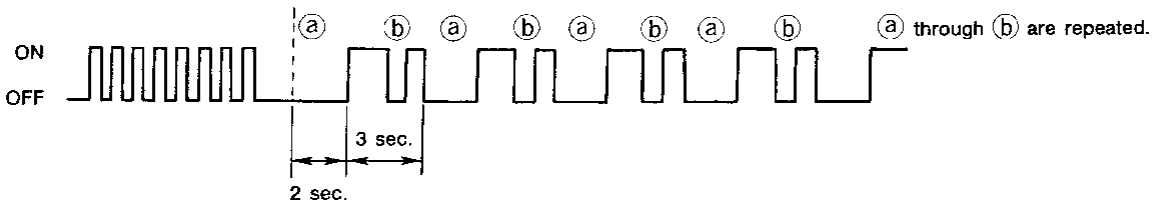

SBF237FA

Self-diagnosis results in present- and initial-diagnosis modes can be identified by number of flashes (d). Refer to Table on next page for troubled parts.

TROUBLE DIAGNOSES — Supplemental Restraint System (SRS)

Self-diagnosis (Cont'd)

Warning lamp flashing times and repair

Warning lamp	Flash code ④ (# of flashes)	Explanation	Repair order * Recheck SRS at each replacement.
"AIR BAG" warning lamp	0	Normal. The SRS "Air Bag" is in good order.	—
	1	The circuit for the safing sensor is out of order.	<ol style="list-style-type: none"> 1. Visually check the wiring harness connections. 2. Replace the safing sensor. (safing sensor and tunnel sensor unit) 3. Replace the diagnosis (control) unit. 4. Replace the main harness.
	2	The circuit for the driver's air bag module is out of order.	<ol style="list-style-type: none"> 1. Visually check the wiring harness connections. 2. Replace the spiral cable. 3. Replace the driver's air bag module. (Before disposing of it, it must be deployed.) 4. Replace the diagnosis (control) unit. 5. Replace the main harness.
	3	The circuit for the tunnel sensor is out of order.	<ol style="list-style-type: none"> 1. Visually check the wiring harness connections. 2. Replace the tunnel sensor. (safing sensor and tunnel sensor unit) 3. Replace the diagnosis (control) unit. 4. Replace the main harness.
	4	The circuit for the right crash zone sensor is out of order.	<ol style="list-style-type: none"> 1. Visually check the wiring harness connections. 2. Replace the right crash sensor. 3. Replace the diagnosis (control) unit. 4. Replace the main harness.
	5	The circuit for the left crash zone sensor is out of order.	<ol style="list-style-type: none"> 1. Visually check the wiring harness connections. 2. Replace the left crash zone sensor. 3. Replace the diagnosis (control) unit. 4. Replace the main harness.
	6	The circuit for the center crash zone sensor is out of order.	<ol style="list-style-type: none"> 1. Visually check the wiring harness connections. 2. Replace the center crash zone sensor. 3. Replace the diagnosis (control) unit. 4. Replace the main harness.
	7	The diagnosis (control) unit is out of order.	<ol style="list-style-type: none"> 1. Visually check the wiring harness connections. 2. Replace the diagnosis (control) unit. 3. Replace the main harness.
	8	The circuit for the front passenger air bag module is out of order.	<ol style="list-style-type: none"> 1. Visually check the wiring harness connections. 2. Replace the front passenger air bag module. (Before disposing of it, it must be deployed.) 3. Replace the diagnosis (control) unit. 4. Replace the main harness.
	9	More than two parts groups are out of order.	<ol style="list-style-type: none"> 1. Visually check the wiring harness connections. 2. Replace the diagnosis (control) unit. 3. Replace all sensors, spiral cable and air bag module. 4. Replace the main harness.

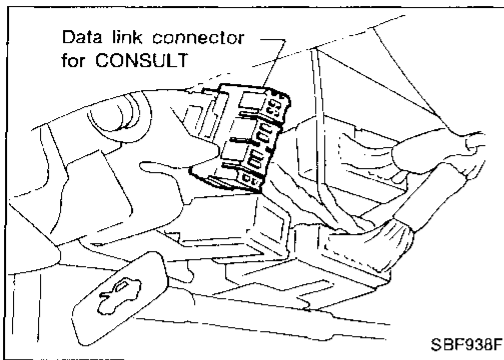

Diagnostic Procedure 1

SYMPTOM: Warning lamp flashes.

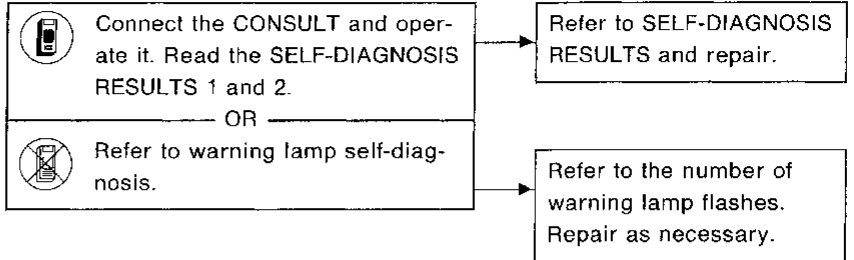

GI

WA

EM

LC

EF & EC

FE

CL

WT

AT

PD

FA

RA

BR

ST

BF

HA

EL

IDX

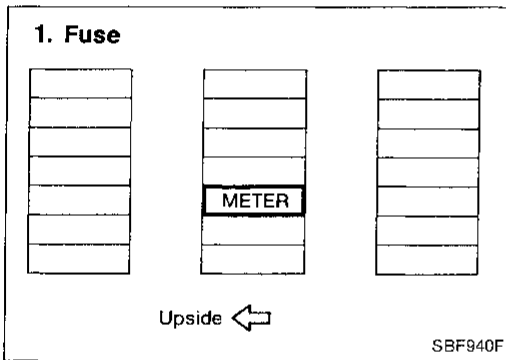

Diagnostic Procedure 2

SYMPTOM: Warning lamp does not come on.

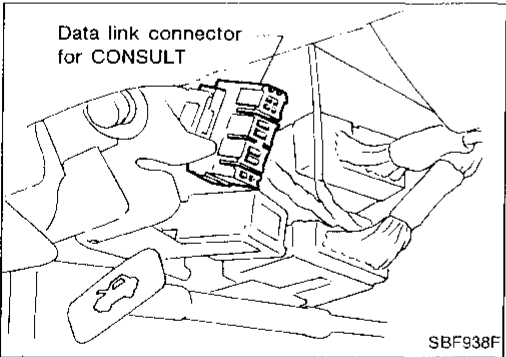
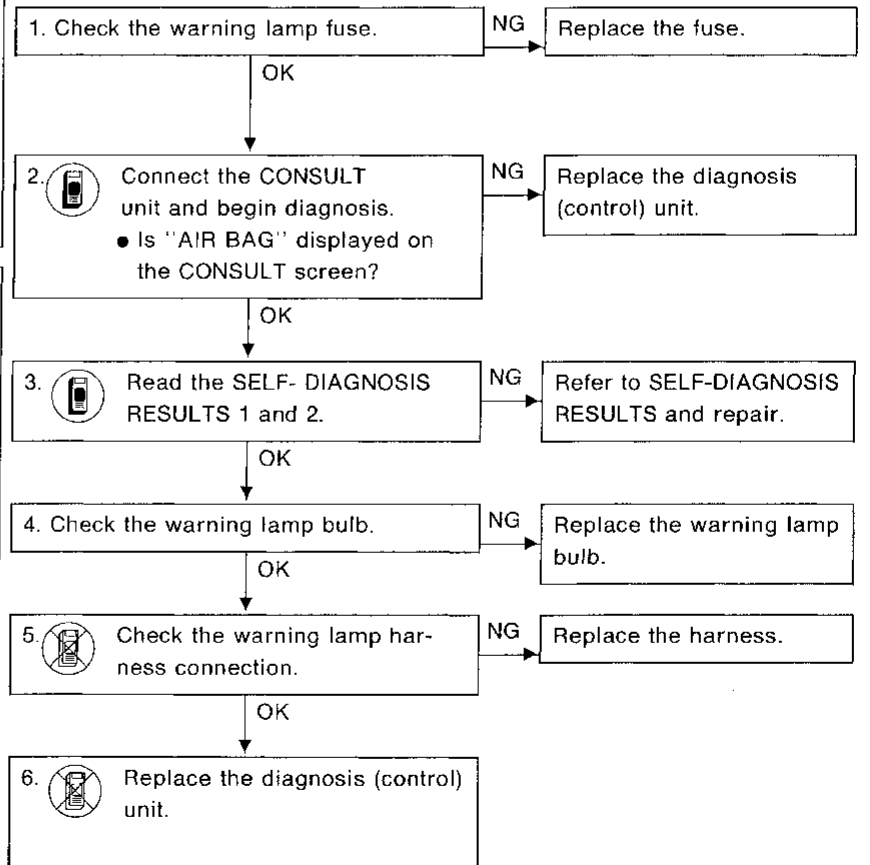

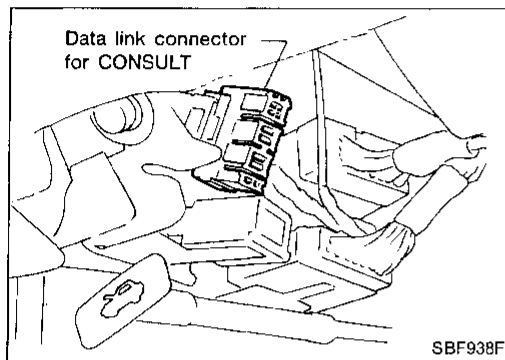
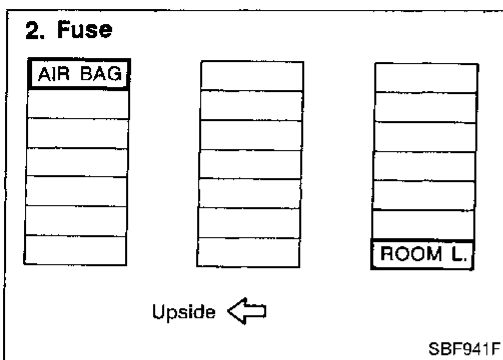

Diagnostic Procedure 3

SYMPTOM: Warning lamp does not go off.

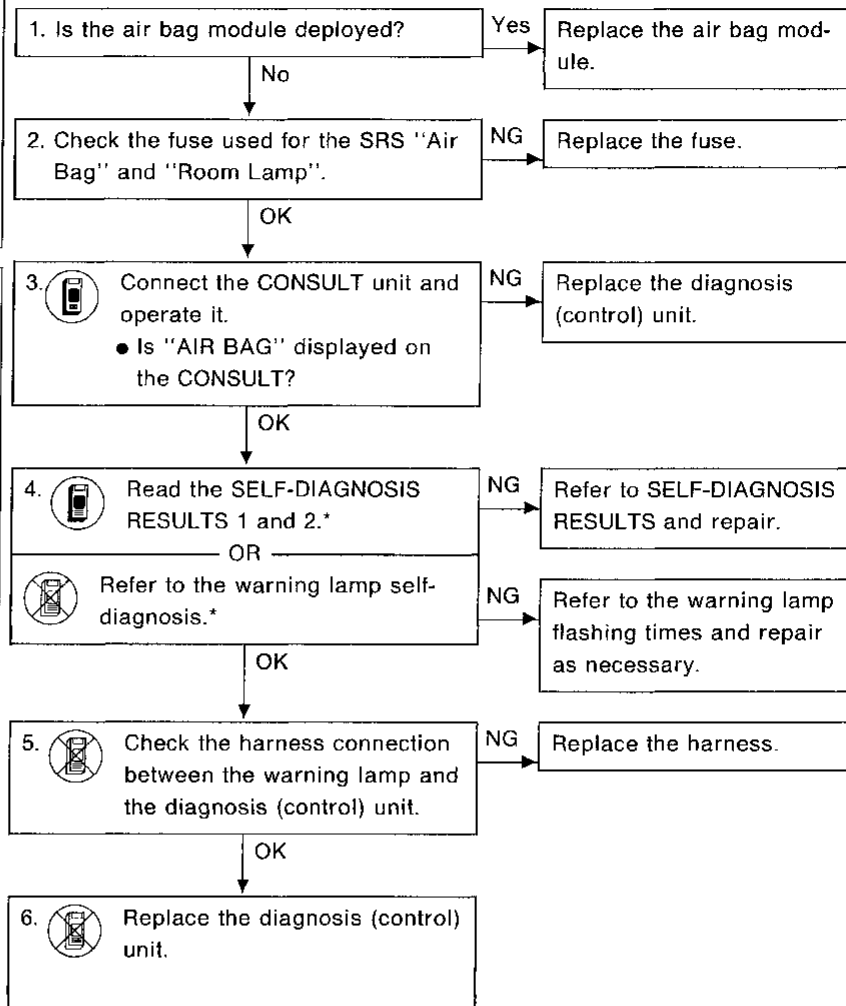

* Recheck SRS after each replacement.

Collision Diagnosis

To repair the SRS "AIR BAG", perform the following steps.

When air bag deployed in a collision:

- ① Replace the diagnosis (control) unit. GI
- ② Remove the air bag module. MA
- ③ Check the SRS components using the table shown below:
 - If the SRS components are showing any visible damage such as dents, cracks, or deformation, replace them with new ones.
- ④ Conduct self-diagnosis using CONSULT or "AIR BAG" warning lamp to ensure entire SRS operates properly except open circuits of air bag module and seat belt pre-tensioners. EM
- ⑤ Install new air bag module and seat belt pre-tensioners.
- ⑥ Conduct self-diagnosis again. LC

When air bag did not deploy in a collision:

- ① Check the SRS components using the table shown below:
 - If the SRS components are showing any visible damage such as dents, cracks, or deformation, replace them with new ones. EE & EC
- ② Conduct self-diagnosis using CONSULT or "AIR BAG" warning lamp to ensure entire SRS operates properly. FE

SRS inspection

Part	Air bag deployed	Air bag did NOT deploy	
Air bag module (driver and passenger side)	REPLACE Install with new bolts.	1. Remove air bag module. Check harness cover and connectors for damage, terminals for deformities, and harness for binding. 2. Install air bag module into the steering wheel to check fit and alignment with the wheel. 3. No damage found, reinstall with new bolts. 4. If damaged—REPLACE. Air bag must be deployed before discarding.	CL MT
Instrument panel	REPLACE Install with new bolts.	1. Check instrument panel for bending, deformities, or cracks. 2. If no damage is found, reinstall with new bolts. 3. If damaged—REPLACE.	AT
Diagnosis (Control) unit	REPLACE Install with new bolts.	1. Check case and bracket for dents, cracks or deformities. 2. Check connectors for damage, and terminals for deformities. 3. If no damage is found, reinstall with new bolts. 4. If damaged—REPLACE.	PD FA
Sensors		1. Check body and sensor brackets for deformities or rust. 2. Check sensor case for dents, cracks, scratches, deformities or rust. 3. Check sensor harness, connector, and terminals for binding, damage, or deformities. 4. If no damage is found, reinstall with new bolts. 5. If damaged—REPLACE.	RA BR
Steering wheel		1. Check harness (built into steering wheel) and connectors for damage, and terminals for deformities. 2. Install air bag module to check fit or alignment with steering wheel. 3. Check steering wheel for excessive free play. 4. If no damage is found, reinstall with new bolts. 5. If damaged—REPLACE.	ST
Spiral cable		1. Visually check lock (engagement) pins and combination switch for damage. 2. Check connectors, flat cable and protective tape for damage. 3. Check steering wheel for noise, binding or heavy operation. 4. If no damage is found, reinstall with new bolts. 5. If damaged—REPLACE.	BF
Harness and Connectors		1. Check connectors for poor connection, damage, and terminals for deformities. 2. Check harness for binding, chafing, cuts, or deformities. 3. If no damage is found, reinstall 4. Damaged—REPLACE damaged section of harness. Do not attempt to repair, splice or modify any SRS harness.	HA EL IDX