

# REAR AXLE & REAR SUSPENSION

## SECTION **RA**

GI

MA

EM

LC

EF &  
EC

## CONTENTS

<b>PRECAUTIONS AND PREPARATION</b> .....	2	Drive Shaft.....	12	FE
Precautions.....	2	<b>REAR SUSPENSION</b> .....	16	
Special Service Tools .....	2	Coil Spring and Shock Absorber .....	17	
Commercial Service Tools .....	3	Multi-link and Lower Ball Joint .....	17	CL
<b>REAR AXLE AND REAR SUSPENSION</b> .....	4	Stabilizer Bar .....	18	
<b>ON-VEHICLE SERVICE</b> .....	5	<b>ADJUSTABLE SHOCK ABSORBER</b> .....	19	MT
Rear Axle and Rear Suspension Parts.....	5	Removal and Installation.....	19	
Rear Wheel Bearing .....	5	Inspection .....	19	
Rear Wheel Alignment.....	5	Trouble Diagnosis.....	19	AT
Drive Shaft.....	7	<b>SUPER HICAS</b> .....	20	
<b>REAR AXLE AND REAR SUSPENSION</b>		Rear Wheel Alignment.....	20	
<b>ASSEMBLY</b> .....	8	Rear Axle Housing Ball Joint.....	20	PD
Removal and Installation.....	8	<b>SERVICE DATA AND SPECIFICATIONS (SDS)</b> .....	22	
<b>REAR AXLE</b> .....	9	General Specifications.....	22	FA
Wheel Hub and Axle Housing .....	9	Inspection and Adjustment.....	23	

**RA**

BR

ST

BF

HA

EL

IDX

## PRECAUTIONS AND PREPARATION

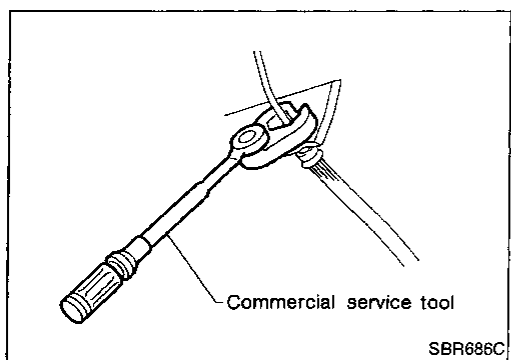

### Precautions

- When installing rubber parts, final tightening must be carried out under unladen condition\* with tires on ground.
- \* Fuel, radiator coolant and engine oil full. Spare tire, jack, hand tools and mats in designated positions.
- Use flare nut wrench when removing or installing brake lines.
- After installing removed suspension parts, check wheel alignment and adjust if necessary.
- Do not jack up at the lower arm.
- Always torque brake lines when installing.

### Special Service Tools

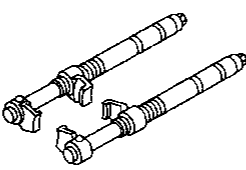
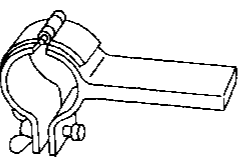
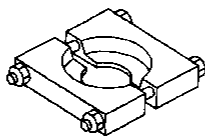
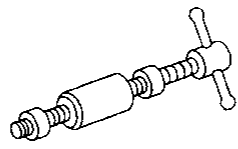
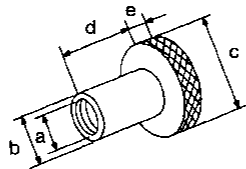
Tool number (Kent-Moore No.) Tool name	Description
HT71780000 ( — ) Spring compressor	 NT144 Removing and installing coil spring
ST35652000 ( — ) Shock absorber attachment	 NT145 Fixing strut assembly
ST30031000 (J22912-01) Bearing puller	 NT071 Removing inner race of wheel bearing
ST38280000 ( — ) Arm bushing remover	 NT157 Removing and installing bushing of rear axle housing
IM23600800 ( — ) Attachment Wheel alignment	 NT148 Measure rear wheel alignment a: Screw M24 x 1.5 b: 35 (1.38) dia. c: 65 (2.56) dia. d: 56 (2.20) e: 12 (0.47) Unit: mm (in)

# PRECAUTIONS AND PREPARATION

## Commercial Service Tools

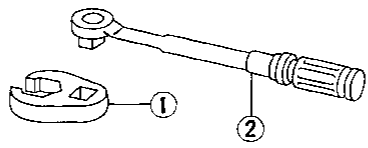
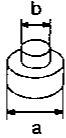
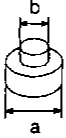
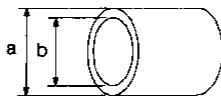
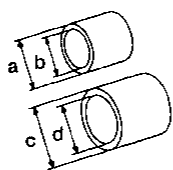
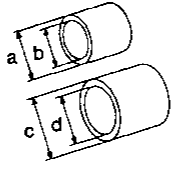
Tool name	Description
① Flare nut crows foot ② Torque wrench	<div style="display: flex; justify-content: space-between;"> <div style="width: 25%;">  </div> <div style="width: 50%;"> <p>Removing and installing each brake piping</p> </div> <div style="width: 20%; text-align: right;"> <p>GI</p> <p>MA</p> </div> </div> <p style="margin-top: 10px;">NT223</p>
Rear wheel hub drift	<div style="display: flex; justify-content: space-between;"> <div style="width: 25%;">  </div> <div style="width: 50%;"> <p>Installing bearing</p> <p style="margin-top: 10px;">a: 49 mm (1.93 in) dia. b: 41 mm (1.61 in) dia.</p> </div> <div style="width: 20%; text-align: right;"> <p>EM</p> <p>LC</p> </div> </div> <p style="margin-top: 10px;">NT635</p>
Wheel bearing drift	<div style="display: flex; justify-content: space-between;"> <div style="width: 25%;">  </div> <div style="width: 50%;"> <p>Removing rear wheel hub</p> <p style="margin-top: 10px;">a: 40 mm (1.57 in) dia. b: 26 mm (1.02 in) dia.</p> </div> <div style="width: 20%; text-align: right;"> <p>EF &amp; EC</p> <p>FE</p> </div> </div> <p style="margin-top: 10px;">NT635</p>
Rear drive shaft plug seal drift	<div style="display: flex; justify-content: space-between;"> <div style="width: 25%;">  </div> <div style="width: 50%;"> <p>Installing rear drive shaft plug seal</p> <p style="margin-top: 10px;">a: 85 mm (3.35 in) dia. b: 67 mm (2.64 in) dia.</p> </div> <div style="width: 20%; text-align: right;"> <p>CL</p> <p>MT</p> </div> </div> <p style="margin-top: 10px;">NT474</p>
Rear axle housing ball joint drift	<div style="display: flex; justify-content: space-between;"> <div style="width: 25%;">  </div> <div style="width: 50%;"> <p>Removing ball joint</p> <p style="margin-top: 5px;">a: 28 (1.10) dia. b: 20 (0.79) dia. c: 43 (1.69) dia. d: 40 (1.57) dia.</p> <p style="margin-top: 5px;">Unit: mm (in)</p> </div> <div style="width: 20%; text-align: right;"> <p>AT</p> <p>PD</p> </div> </div> <p style="margin-top: 10px;">NT164</p>
Rear axle housing ball joint drift	<div style="display: flex; justify-content: space-between;"> <div style="width: 25%;">  </div> <div style="width: 50%;"> <p>Installing ball joint</p> <p style="margin-top: 5px;">a: 43 (1.69) dia. b: 33 (1.30) dia. c: 40 (1.57) dia. d: 30 (1.18) dia.</p> <p style="margin-top: 5px;">Unit: mm (in)</p> </div> <div style="width: 20%; text-align: right;"> <p>FA</p> <p style="background-color: black; color: white; padding: 5px; font-weight: bold;">RA</p> </div> </div> <p style="margin-top: 10px;">NT164</p>

GI  
MA  
EM  
LC  
EF &  
EC  
FE  
CL  
MT  
AT  
PD  
FA  
RA  
BR  
ST  
BF  
HA  
EL  
IDX

# REAR AXLE AND REAR SUSPENSION

When installing rubber parts, final tightening must be carried out under unladen condition\* with tires on ground.

\* Fuel, radiator coolant and engine oil full.  
Spare tire, jack, hand tools and mats in designated positions.

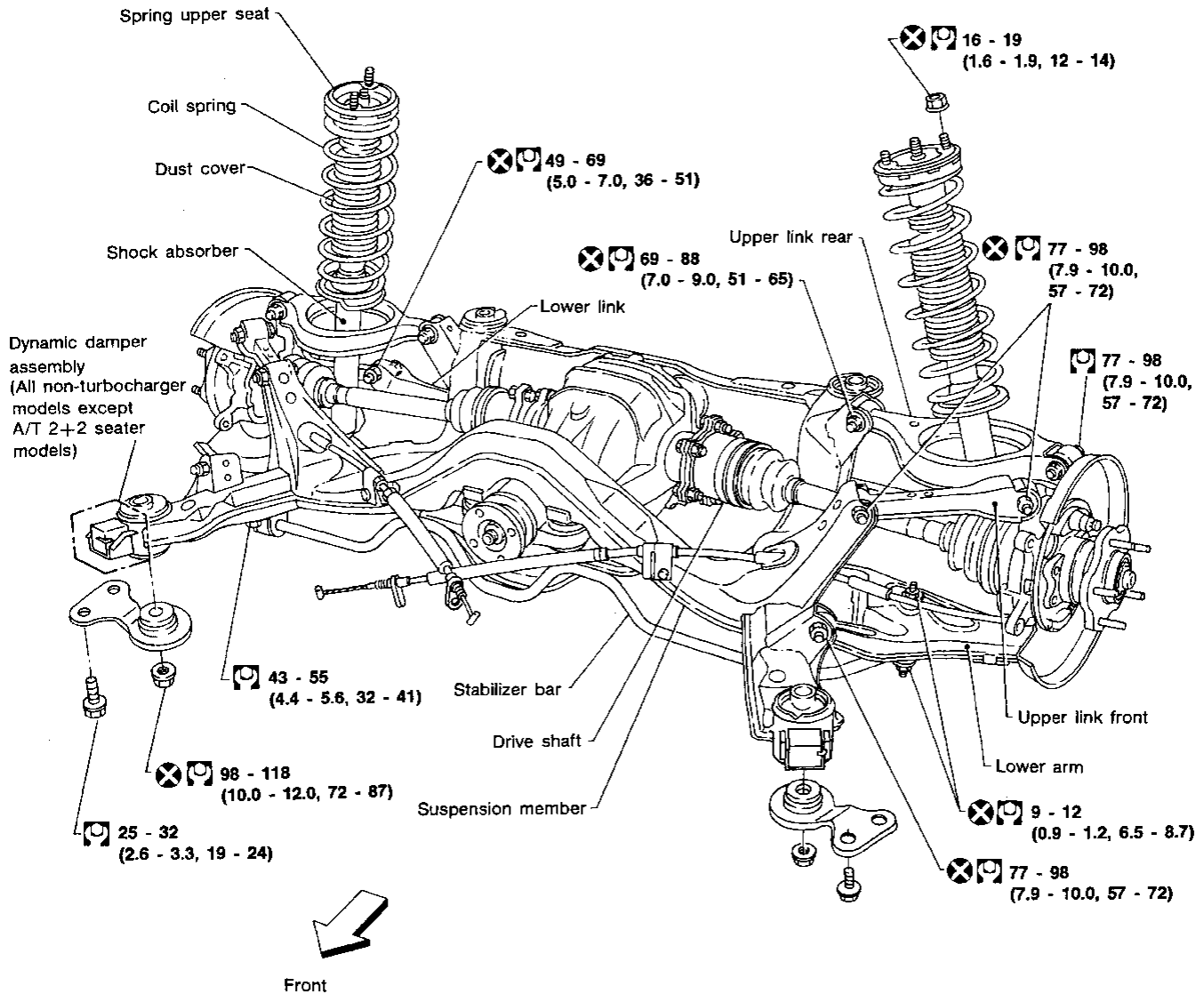

: N·m (kg-m, ft-lb)

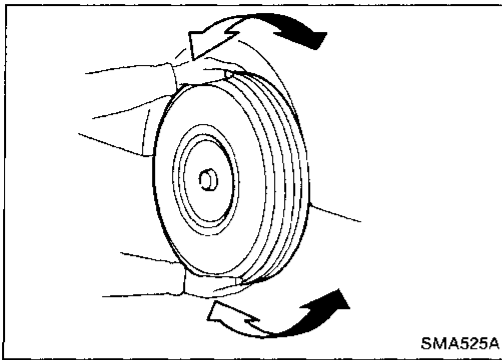

### Rear Axle and Rear Suspension Parts

Check axle and suspension parts for looseness, wear or damage.

- Shake each rear wheel to check for excessive play.
- Retighten all nuts and bolts to the specified torque.

**Tightening torque:**

Refer to **REAR SUSPENSION (RA-16)**.

- Make sure that cotter pin is inserted.
- Check rear axle and rear suspension parts for wear, cracks or other damage.

GI

MA

EM

LC

EF &  
EC

FE

CL

MT

AT

PD

FA

RA

BR

ST

BF

HA

EL

IDX

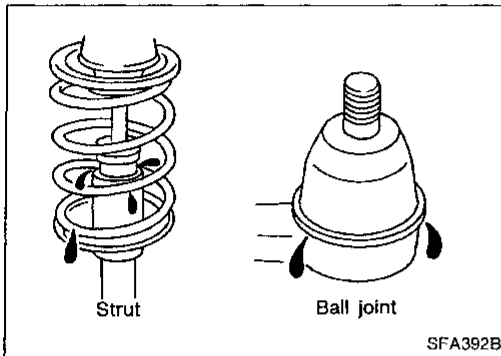

- Check shock absorber for oil leakage or other damage.
- Check wheelarch height.  
Refer to ON-VEHICLE SERVICE in FA section.
- Check suspension ball joint for grease leakage and ball joint dust cover for cracks or other damage.

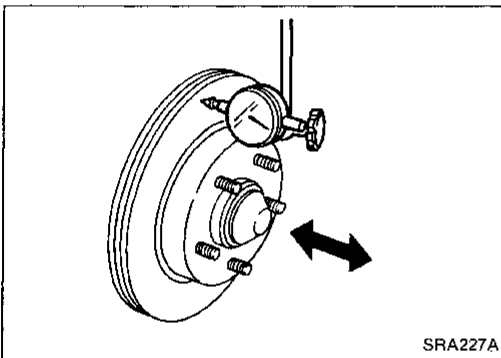

### Rear Wheel Bearing

- Check tightening torque of wheel bearing lock nut.

: 206 - 275 N·m  
(21 - 28 kg-m, 152 - 203 ft-lb)

- Check wheel bearings for smooth operation.
- Check axial end play.

**Axial end play:**  
0.05 mm (0.0020 in) or less

If axial end play is not within specification or wheel bearing does not turn smoothly, replace wheel bearing assembly. Refer to REAR AXLE — Wheel Hub and Axle Housing (RA-9).

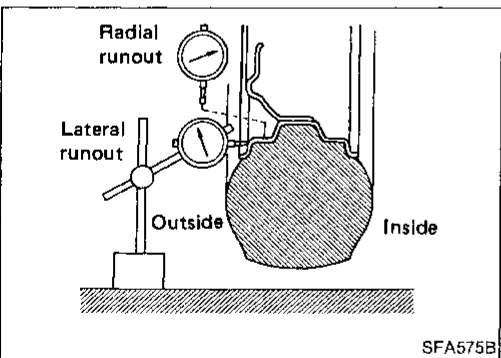

### Rear Wheel Alignment

Before checking rear wheel alignment, be sure to make a preliminary inspection.

#### PRELIMINARY INSPECTION

Make the following checks. Adjust, repair or replace if necessary.

- Check tires for wear and for improper inflation.
- Check rear wheel bearings for looseness.
- Check wheel runout.

Refer to **SDS (RA-23)**.

- Check that rear shock absorber works properly.
- Check rear axle and rear suspension parts for looseness.
- Check vehicle posture (Unladen).

("Unladen": Fuel tank, radiator and engine oil full. Spare tire, jack, hand tools and mats in designated positions.)

## ON-VEHICLE SERVICE

### Rear Wheel Alignment (Cont'd)

#### CAMBER

- Measure camber of both right and left wheels with a suitable alignment gauge and adjust in accordance with the following procedures.

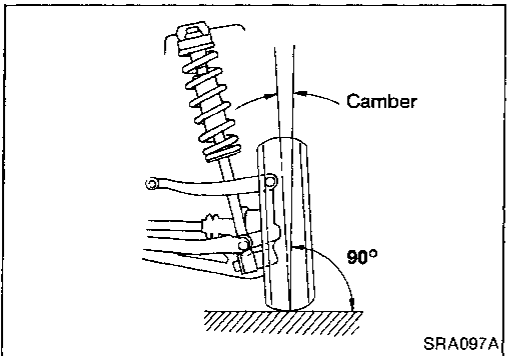
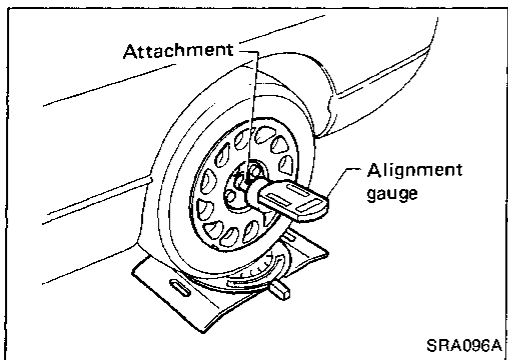

**Camber:**  
Refer to SDS (RA-23).

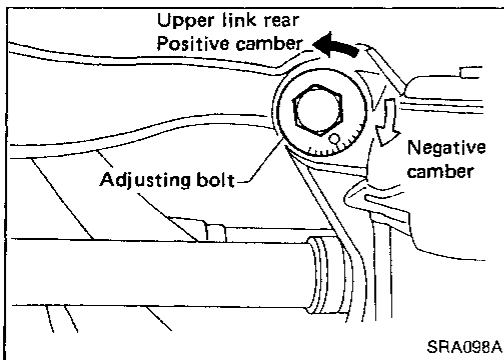

If camber is not within specification, adjust by turning the adjusting bolt.

- (1) Turn the adjusting bolt to adjust.

**Camber changes about 5' with each graduation of the adjusting bolt.**

- (2) Tighten to the specified torque.

: 69 - 88 N·m  
(7.0 - 9.0 kg-m, 51 - 65 ft-lb)

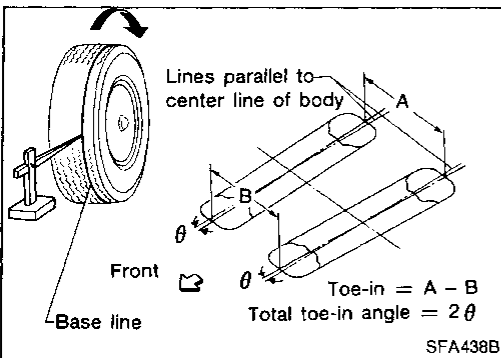

#### TOE-IN

1. Draw a base line across the tread.

**After lowering rear of vehicle, move it up and down to eliminate friction.**

2. Measure toe-in.

**Measure distance "A" and "B" at the same height as hub center.**

**Toe-in:**  
Refer to SDS (RA-23).

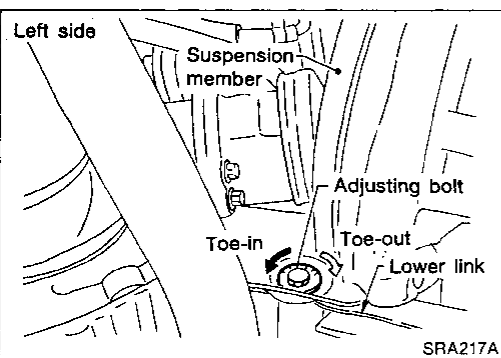

3. Adjust toe-in by turning adjusting bolts.

**Toe changes about 1.5 mm (0.059 in) [One side] with each graduation of the adjusting bolt.**

4. Tighten to the specified torque.

: 69 - 88 N·m  
(7.0 - 9.0 kg-m, 51 - 65 ft-lb)

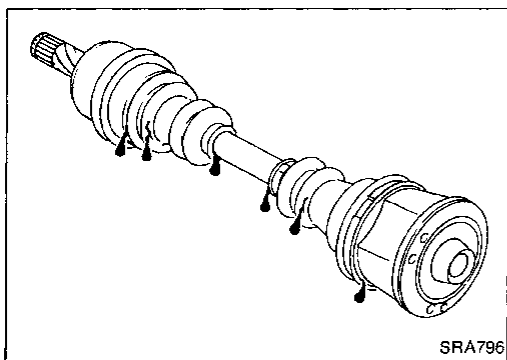

### Drive Shaft

Check boot and drive shaft for cracks, wear, damage or grease leakage.

GI

MA

EM

LC

EF &  
EC

FE

CL

MT

AT

PD

FA

**RA**

BR

ST

BF

HA

EL

IDX

# REAR AXLE AND REAR SUSPENSION ASSEMBLY

## Removal and Installation

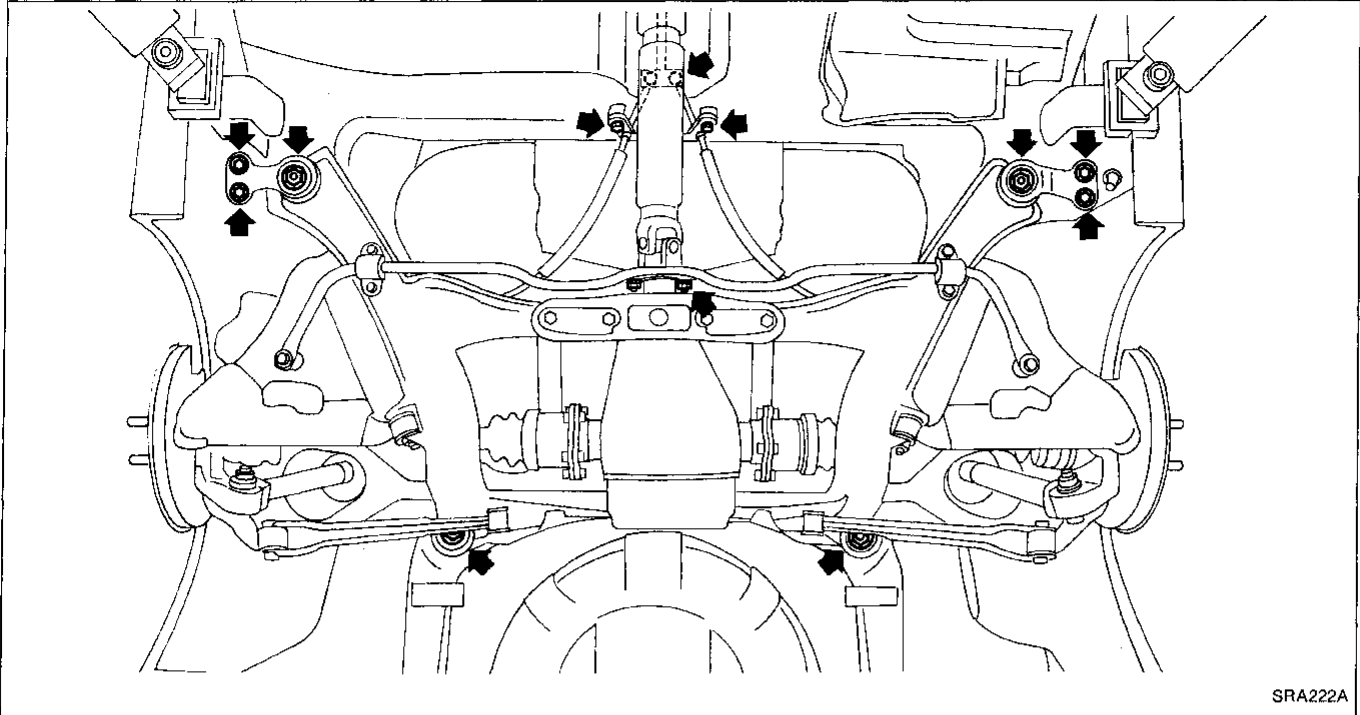

SRA222A

- Remove exhaust tube.
- Disconnect propeller shaft rear end.
- Disconnect hand brake wire front end.

### CAUTION:

**Before removing the rear axle assembly, disconnect the ABS wheel sensor from the assembly and move it away from the rear axle assembly area. Failure to do so may result in the sensor wires being damaged and the sensor becoming inoperative.**

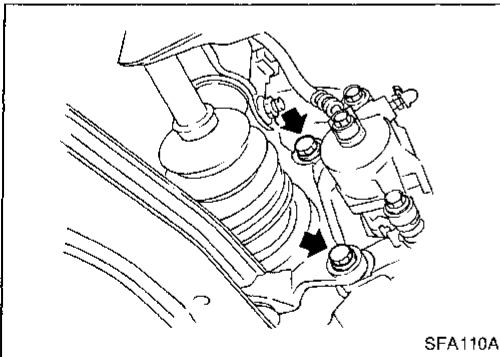

SFA110A

- Remove brake caliper assembly.  
**Brake line need not be disconnected from brake caliper. Be careful not to depress brake pedal, or piston will pop out. Make sure brake line is not twisted.**

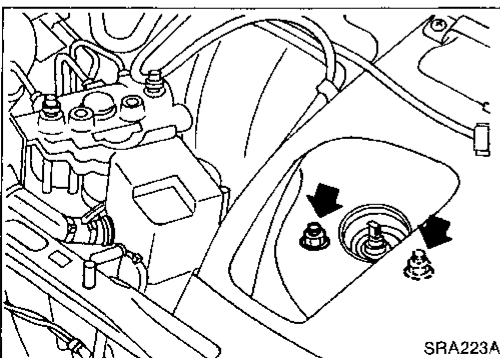

SRA223A

- Remove upper end nuts of shock absorber.  
**Do not remove piston rod lock nut.**
- Remove suspension member fixing nuts. Then draw out rear axle and rear suspension assembly.



# REAR AXLE

## Wheel Hub and Axle Housing

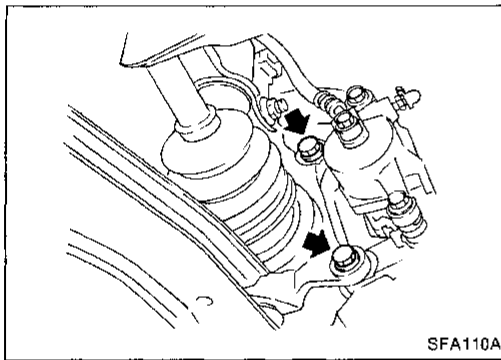
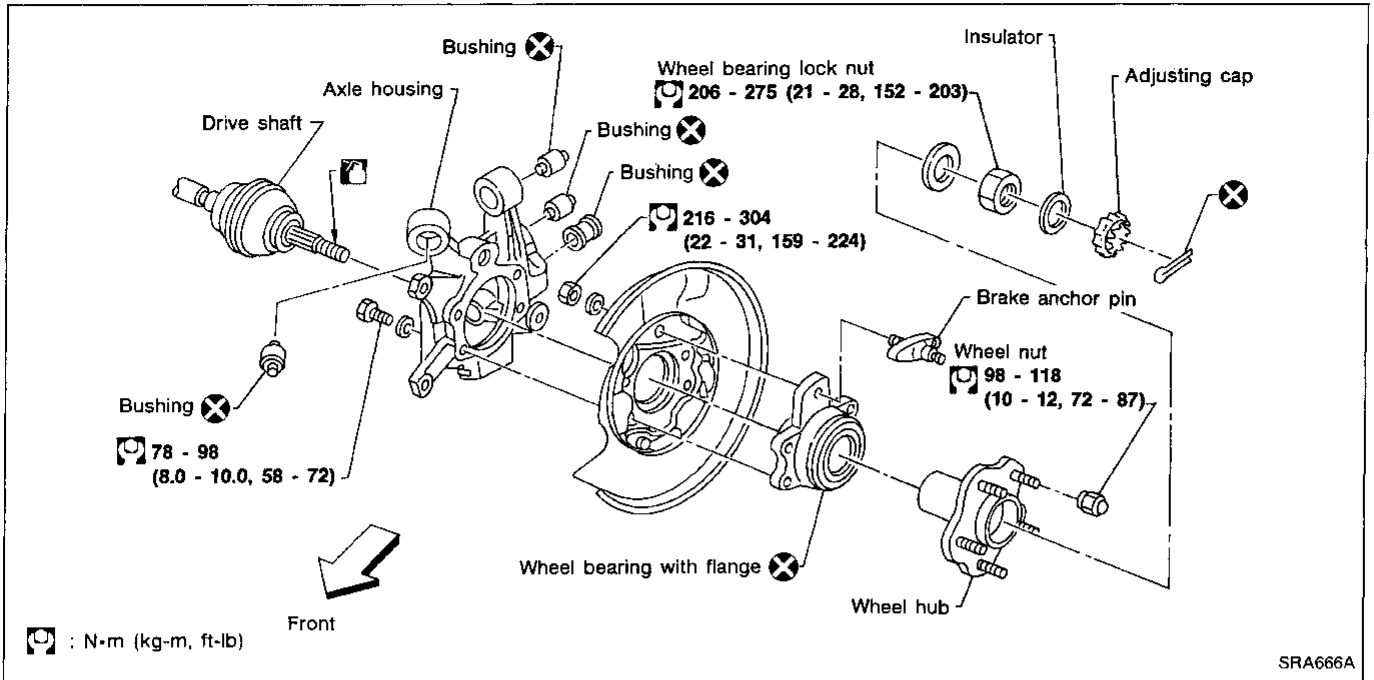

### REMOVAL

- Remove wheel bearing lock nut.
- Remove brake caliper assembly and rotor.

**Brake line need not be disconnected from brake caliper. Be careful not to depress brake pedal, or piston will pop out. Make sure brake line is not twisted.**

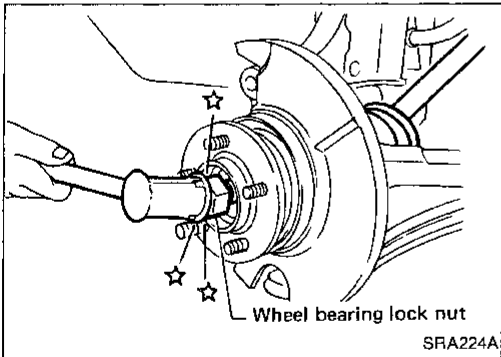

- Separate drive shaft from axle housing by slightly tapping it.

**When removing drive shaft, cover boots with shop towel to prevent them from being damaged.**

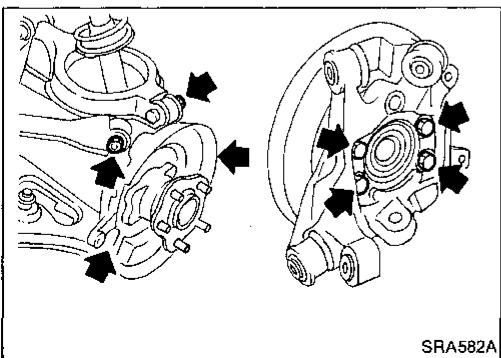

- Remove axle housing.
- Remove wheel bearing with flange, and wheel hub from axle housing.

GI  
MA  
EM  
LC  
EF & EC  
FE  
CL  
MT  
AT  
PD  
FA  
RA  
BR  
ST  
BF  
HA  
EL  
IDX

## REAR AXLE

### Wheel Hub and Axle Housing (Cont'd)

#### INSTALLATION

- Install axle housing with wheel hub.
- Tighten wheel bearing lock nut.  
☞: 206 - 275 N·m  
(21 - 28 kg-m, 152 - 203 ft-lb)

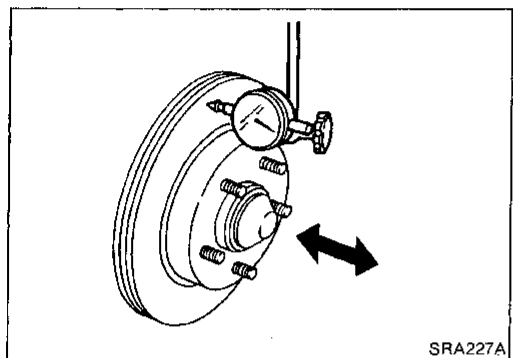
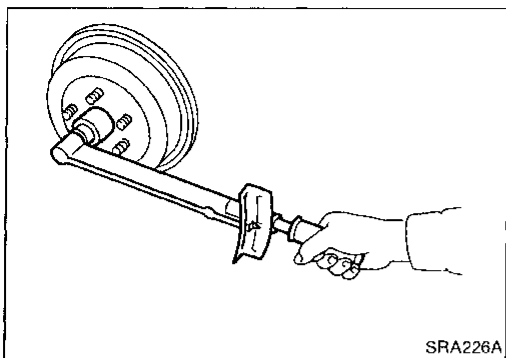

- Check wheel bearing axial end play.  
Axial end play: 0.05 mm (0.0020 in) or less

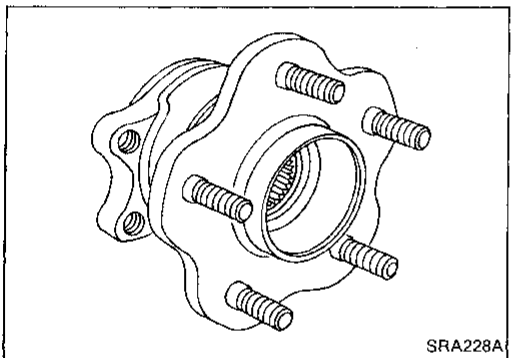

#### DISASSEMBLY

##### CAUTION:

Wheel bearing with flange usually does not require maintenance. If any of the following symptoms are noted, replace wheel bearing assembly (including flange, and inner and outer seals).

- Growling noise is emitted from wheel bearing during operation.
- Wheel bearing drags or turns roughly when hub is turned with your hand after bearing lock nut is tightened to specified torque.
- After wheel bearing is removed from hub.

##### Wheel hub

- Remove wheel bearing (with flange) and wheel hub as one unit from axle housing before disassembling.

##### Wheel bearing

- Using a press and drift as shown in figure at left, press wheel bearing out.
- Discard old wheel bearing assembly. Replace with a new wheel assembly.

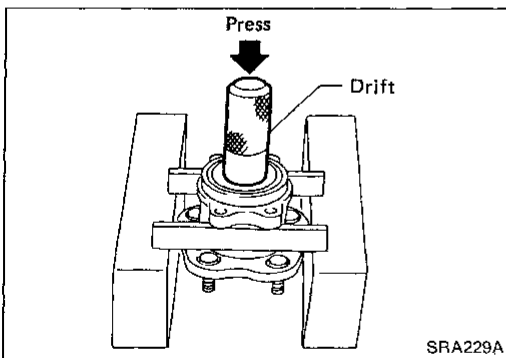

- Remove inner race from hub using a bearing replacer/puller.

##### CAUTION:

- Do not reuse old inner race although it is of the same brand as the bearing assembly.
- Do not replace grease seals as single parts.

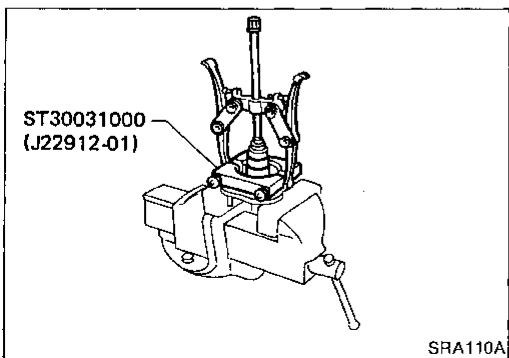

## REAR AXLE

### Wheel Hub and Axle Housing (Cont'd)

#### Axle housing

- Attach a drift on outer shell of bushing as shown in figure at left, remove bushing using arm bushing remover.

**When placing axle housing in a vise, use wooden blocks or copper plates as pads.**

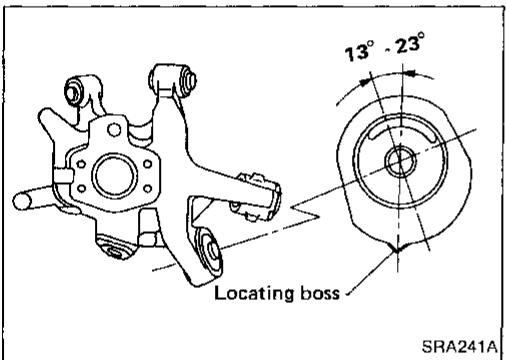
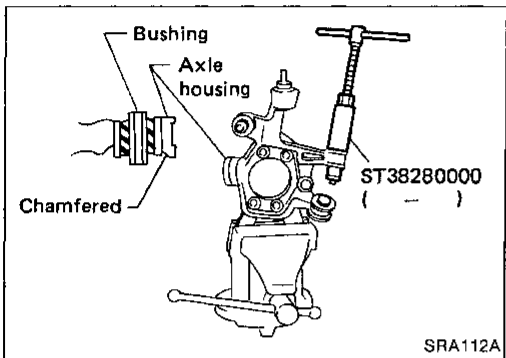
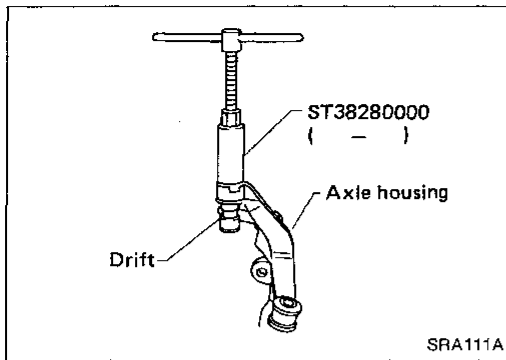

- Ensure axle housing bore is free from scratches or deformities before pressing bushing into it.
- Attach bushing to chamfered bore end of axle housing and press it until it is flush with end face of axle housing.

- When installing shock absorber bushing, make sure that it is positioned as shown.

#### INSPECTION

##### Wheel hub and axle housing

- Check wheel hub and axle housing for cracks by using a magnetic exploration or dyeing test.
- Check wheel bearing for damage, seizure, rust or rough operation.
- Check rubber bushing for wear or other damage.

**Replace if necessary.**

#### ASSEMBLY

- Place hub on a block. Attach a drift to inner race of wheel bearing and press it into hub as shown in figure at left.

**Be careful not to damage grease seal.**

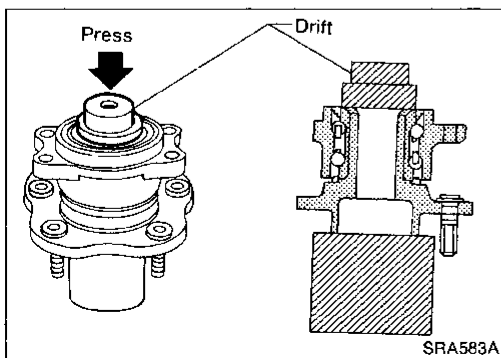

## Drive Shaft

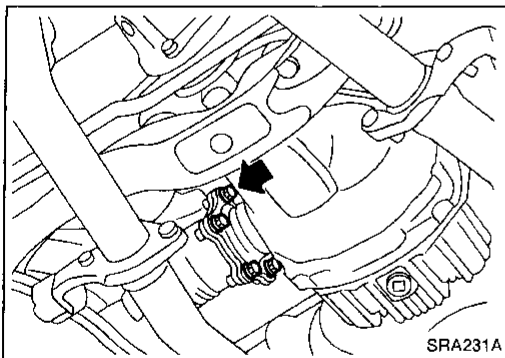
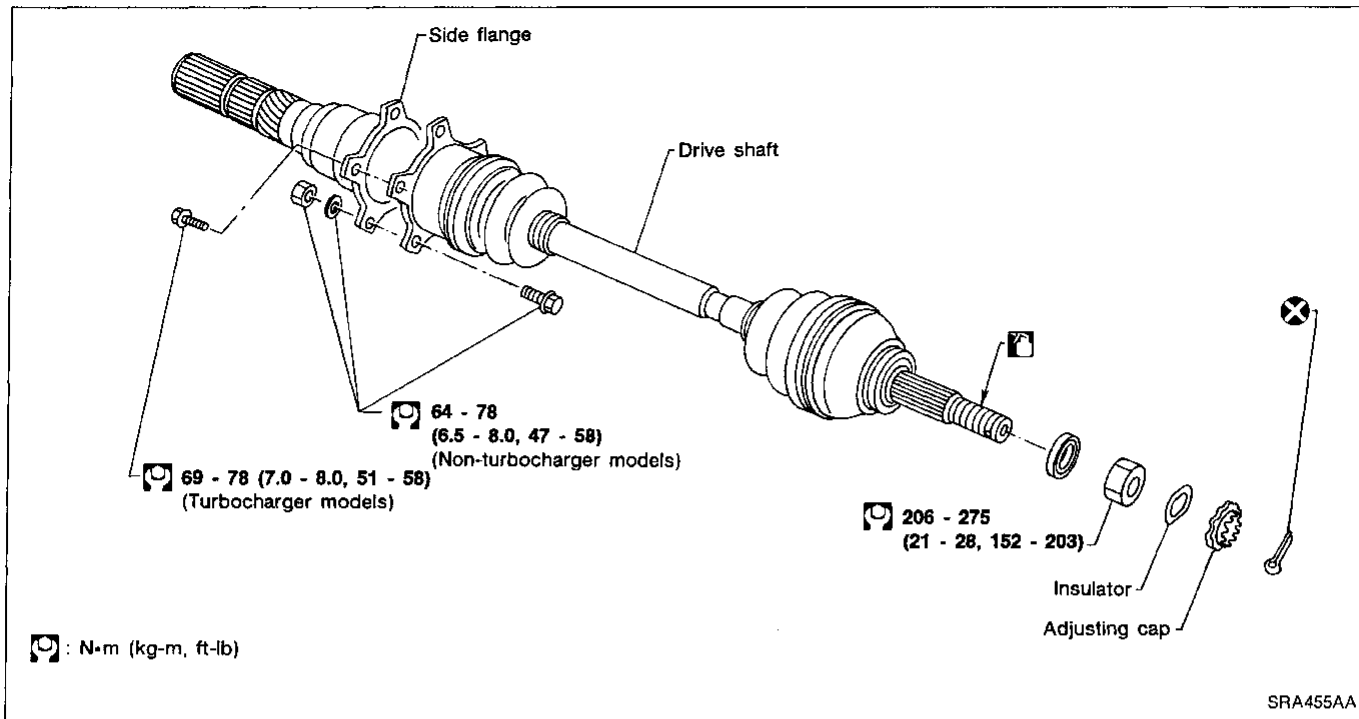

### REMOVAL

- Before removing the drive shaft assembly, disconnect the ABS wheel sensor to prevent the damage of the sensor.
- When removing drive shaft, cover boots with shop towel to prevent damage to them.

### Final drive side

- Remove side flange mounting bolt and separate shaft.

### Wheel side

- Remove drive shaft by lightly tapping it with a copper hammer.

To avoid damaging threads of drive shaft, install a nut while removing drive shaft.

### INSTALLATION

- Insert drive shaft from wheel hub and temporarily tighten wheel bearing lock nut.
- Tighten side flange mounting bolts to specified torque.
- Tighten wheel bearing lock nut to specified torque.

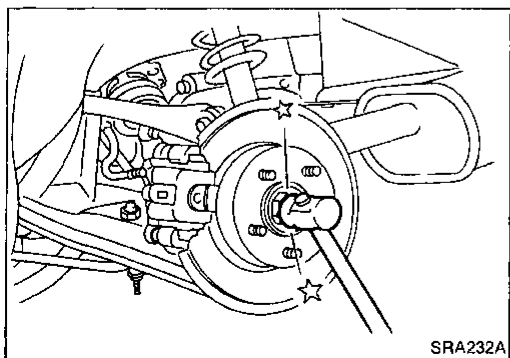

# REAR AXLE

## Drive Shaft (Cont'd)

### COMPONENTS

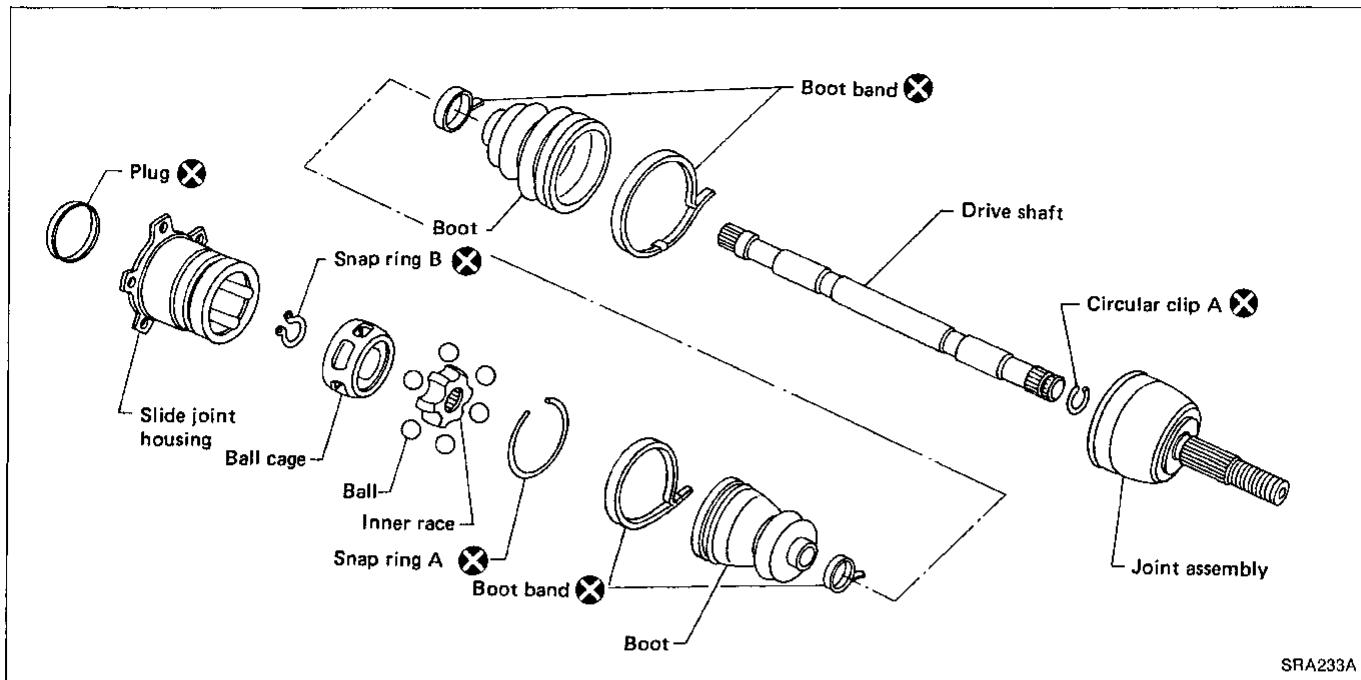

SRA233A

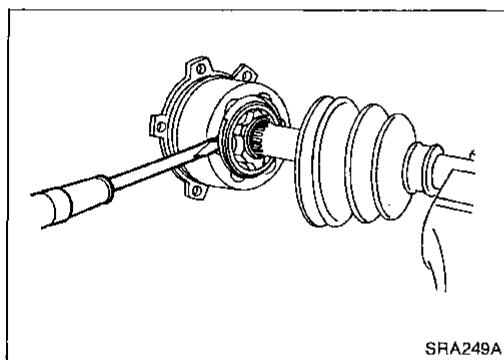

SRA249A

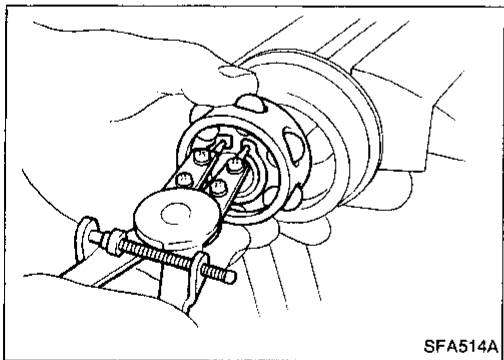

SFA514A

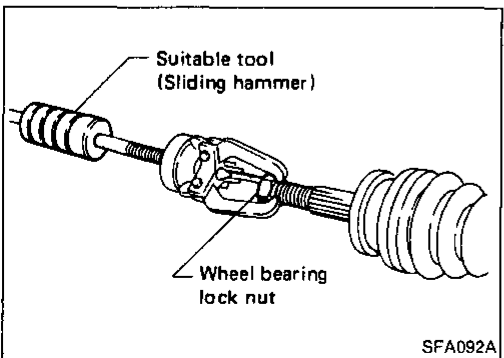

SFA092A

### DISASSEMBLY

#### Final drive side

1. Remove boot bands.
2. Put matchmarks on slide joint housing and inner race, before separating joint assembly.
3. Pry off snap ring "A" with a screwdriver, and pull out slide joint housing.

4. Put matchmarks on inner race and drive shaft.
5. Pry off snap ring "B", then remove ball cage, inner race and balls as a unit.
6. Draw out boot.

**Cover drive shaft serration with tape so as not to damage the boot.**

#### Wheel side

#### CAUTION:

**The joint on the wheel side cannot be disassembled.**

- Before separating joint assembly, put matchmarks on drive shaft and joint assembly.
- Separate joint assembly with a suitable tool.

**Be careful not to damage threads on drive shaft.**

- Remove boot bands.

GI

MA

EM

LC

EF &  
EC

FE

CL

MT

AT

PD

FA

RA

BR

ST

BF

HA

EL

IDX

## REAR AXLE

### Drive Shaft (Cont'd)

#### INSPECTION

Thoroughly clean all parts in cleaning solvent, and dry with compressed air. Check parts for evidence of deformation or other damage.

#### Drive shaft

Replace drive shaft if it is twisted or cracked.

#### Boot

Check boot for fatigue, cracks, or wear. Replace boot with new boot bands.

#### Joint assembly (Final drive side)

- Replace any parts of double offset joint which show signs of scorching, rust, wear or excessive play.
- Check serration for deformation. Replace if necessary.
- Check slide joint housing for any damage. Replace if necessary.

#### Joint assembly (Wheel side)

Replace joint assembly if it is deformed or damaged.

#### ASSEMBLY

- After drive shaft has been assembled, ensure that it moves smoothly over its entire range without binding.
- Use **NISSAN GENUINE GREASE** or equivalent after every overhaul.

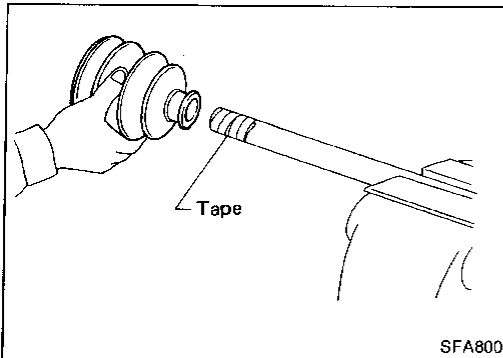

#### Wheel side

1. Install boot and new small boot band on drive shaft.

**Cover drive shaft serration with tape so as not to damage boot during installation.**

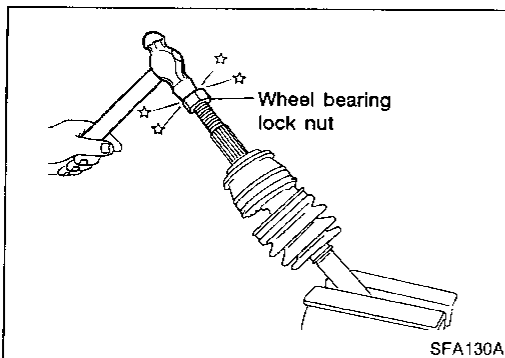

2. Set joint assembly onto drive shaft by lightly tapping it. Install joint assembly securely, ensuring marks which were made during disassembly are properly aligned.

## REAR AXLE

### Drive Shaft (Cont'd)

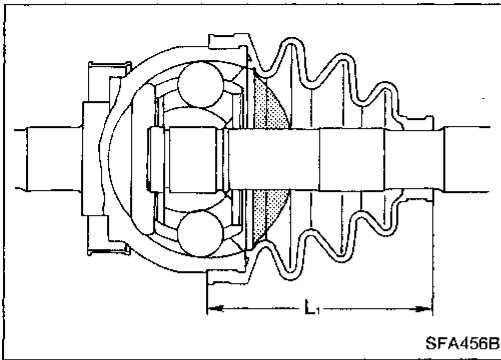

- Pack drive shaft with specified amount of grease.

**Specified amount of grease:**

**Without turbocharger 150 - 160 g (5.29 - 5.64 oz)**

**With turbocharger 170 - 190 g (6.00 - 6.70 oz)**

- Set boot so that it does not swell and deform when its length is "L<sub>1</sub>".

**Make sure that boot is properly installed on the drive shaft groove.**

**Length "L<sub>1</sub>":**

**Without turbocharger 96 - 98 mm (3.78 - 3.86 in)**

**With turbocharger 101 - 103 mm (3.98 - 4.06 in)**

GI

MA

EM

LC

EF &  
EC

FE

CL

MT

AT

PD

FA

RA

BR

ST

BF

HA

EL

IDX

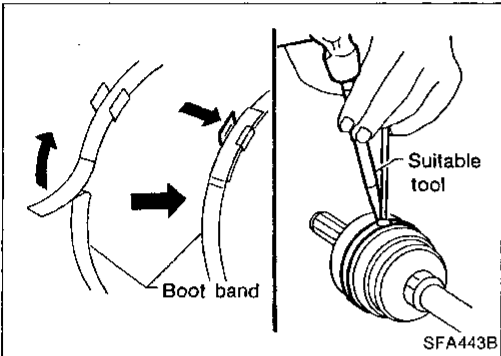

- Lock new larger and smaller boot bands securely with a suitable tool.

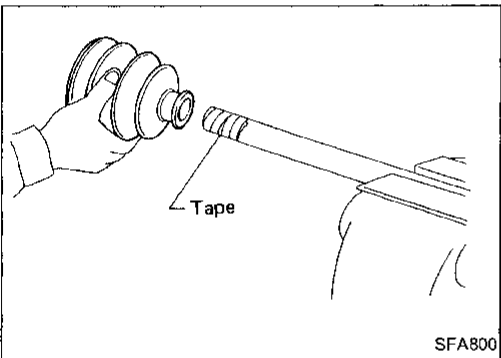

### Final drive side

- Install boot and new small boot band on drive shaft.

**Cover drive shaft serration with tape so as not to damage boot during installation.**

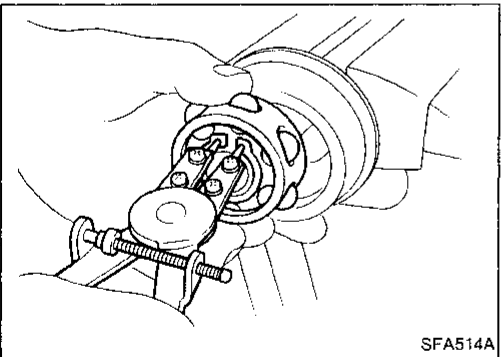

- Securely install ball cage, inner race and balls as a unit, making sure the marks which were made during disassembly are properly aligned.

- Install new snap ring "B".

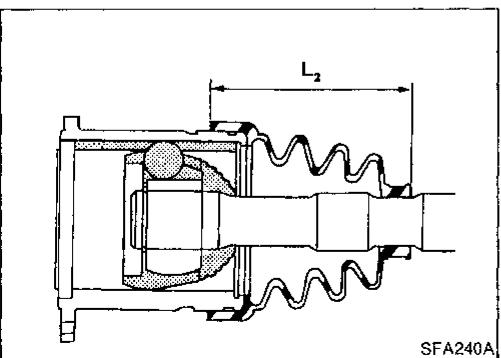

- Pack drive shaft with specified amount of grease.

**Specified amount of grease:**

**Without turbocharger 165 - 175 g (5.82 - 6.17 oz)**

**With turbocharger 180 - 200 g (6.35 - 7.05 oz)**

- Install slide joint housing, then install new snap ring "A".

- Set boot so that it does not swell and deform when its length is "L<sub>2</sub>".

**Make sure that boot is properly installed on the drive shaft groove.**

**Length "L<sub>2</sub>":**

**Without turbocharger 93 - 95 mm (3.66 - 3.74 in)**

**With turbocharger 102.5 - 104.5 mm (4.04 - 4.11 in)**

- Lock new larger and smaller boot bands securely with a suitable tool.

# REAR SUSPENSION

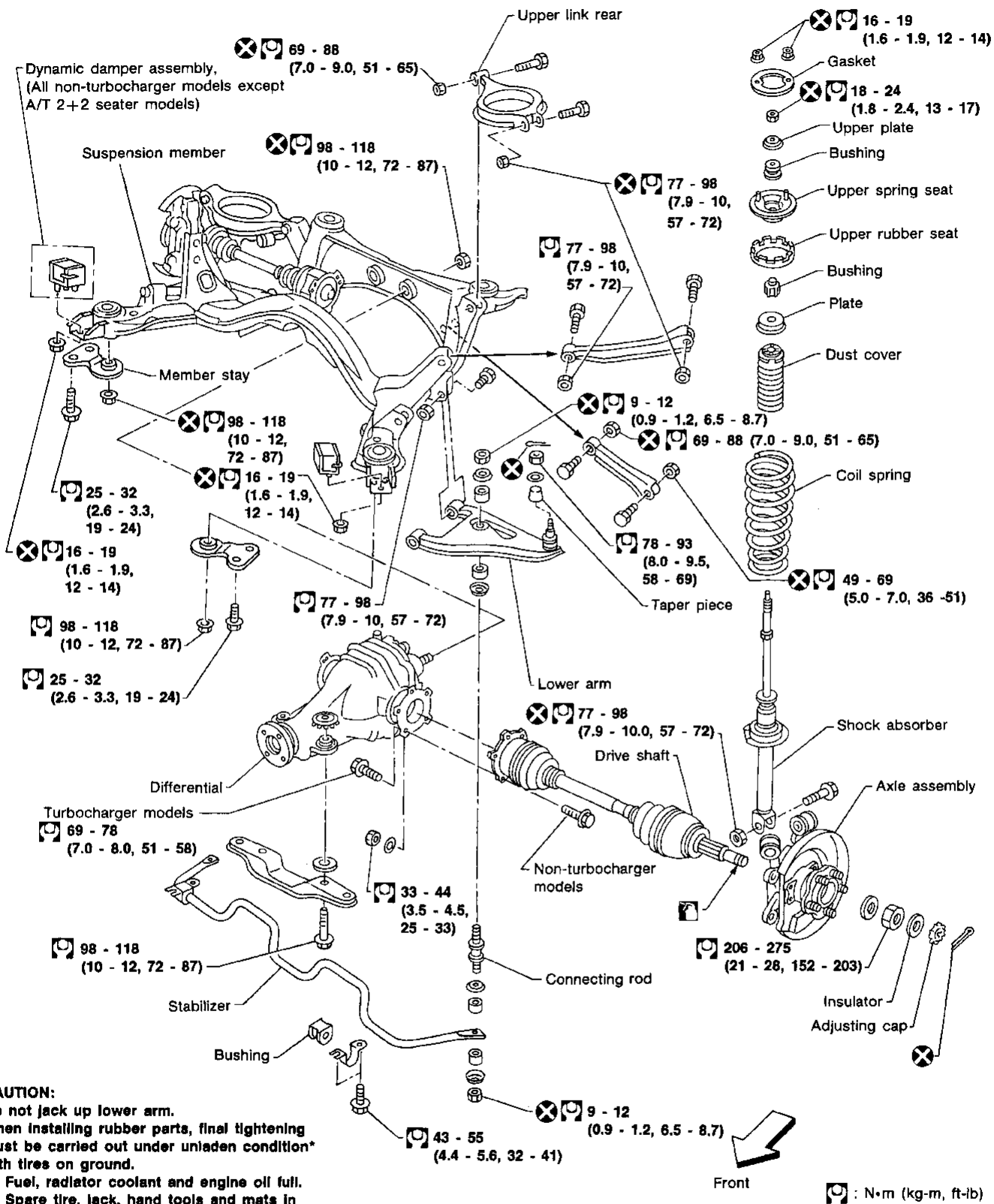



# REAR SUSPENSION

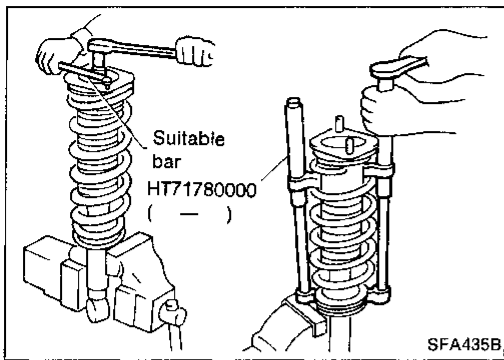

## Coil Spring and Shock Absorber

### REMOVAL

- Remove shock absorber upper and lower fixing nuts.
- **Do not remove piston rod lock nut on vehicle.**

### DISASSEMBLY

1. Set shock absorber on vise with attachment, then loosen piston rod lock nut.
- **Do not remove piston rod lock nut.**
2. Compress spring with Tool so that the strut upper spring seat can be turned by hand.
3. Remove piston rod lock nut.

### INSPECTION

#### Shock absorber assembly

- Check for smooth operation through a full stroke, both compression and extension.
- Check for oil leakage occurring on welded or gland packing portions.
- Check piston rod for cracks, deformation or other damage. Replace if necessary.

#### Upper rubber seat and bushing

- Check rubber parts for deterioration or cracks. Replace if necessary.

#### Coil spring

- Check for cracks, deformation or other damage. Replace if necessary.

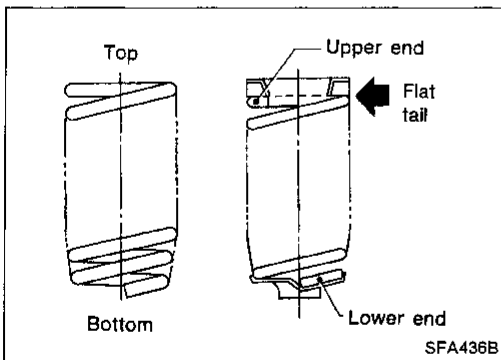

### ASSEMBLY

- When installing coil spring, be careful not to reverse top and bottom direction. (Top end is flat.)
- When installing coil spring on strut, it must be positioned as shown in figure at left.

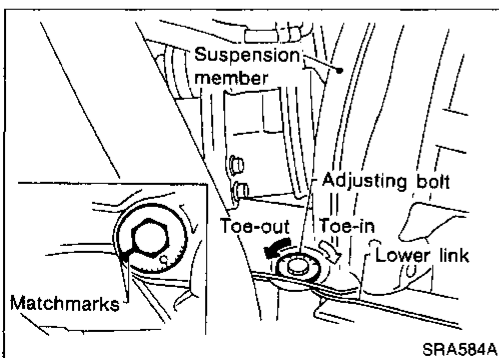

## Multi-link and Lower Ball Joint

### REMOVAL AND INSTALLATION

- Refer to "Removal and Installation" of REAR AXLE AND REAR SUSPENSION ASSEMBLY (RA-8).

#### Before removing, put matchmarks on adjusting bolt.

- When installing, final tightening must be done at curb weight with tires on ground.
- After installation, check wheel alignment. Refer to "Rear Wheel Alignment" of ON-VEHICLE SERVICE (RA-5).

GI

MA

EM

LC

EF &  
EC

FE

CL

MT

AT

PD

FA

RA

BR

ST

BF

HA

EL

IDX

## REAR SUSPENSION

### Multi-link and Lower Ball Joint (Cont'd)

#### INSPECTION

##### Rear suspension member

- Replace suspension member assembly if cracked or deformed or if any part (insulator, for example) is damaged.

##### Upper and lower links

- Replace upper or lower link as required if cracked or deformed or if bushing is damaged.

##### Suspension lower ball joint

- Measure swing force, turning torque and vertical end play in axial direction. (Use same measurement procedures as that of FA section.)
- If ball stud is worn, play in axial direction is excessive, or joint is hard to swing, replace lower arm.

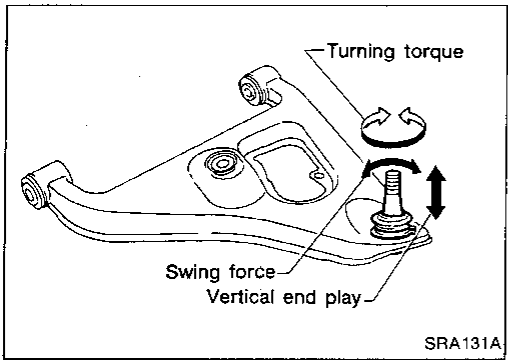

Ball joint specifications	Swing force	7.8 - 54.9 N (0.8 - 5.6 kg, 1.8 - 12.3 lb)
	Turning torque	0.5 - 3.4 N·m (5 - 35 kg-cm, 4.3 - 30.4 in-lb)
	Vertical end play	0 mm (0 in)

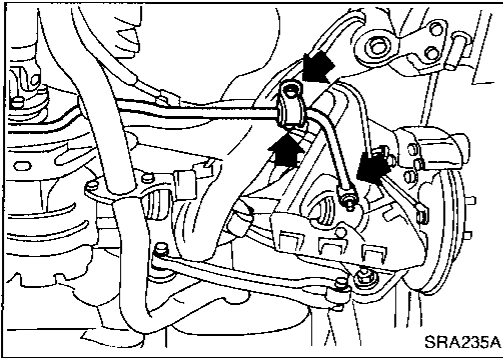

#### Stabilizer Bar

##### REMOVAL

- Remove connecting rod and clamp

##### INSPECTION

- Check stabilizer bar for deformation or cracks. Replace if necessary.
- Check rubber bushings for deterioration or cracks. Replace if necessary.

##### INSTALLATION

- When installing connecting rod, make sure direction is correct (as shown at left).

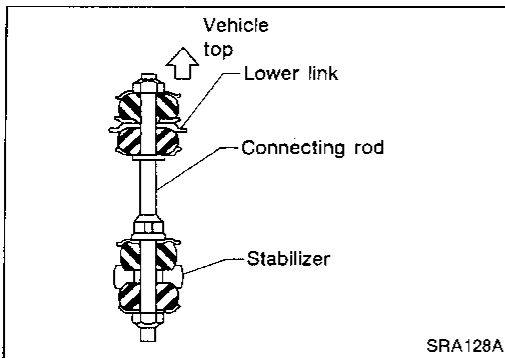

# ADJUSTABLE SHOCK ABSORBER

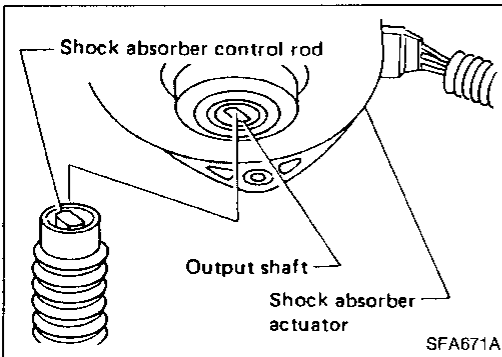
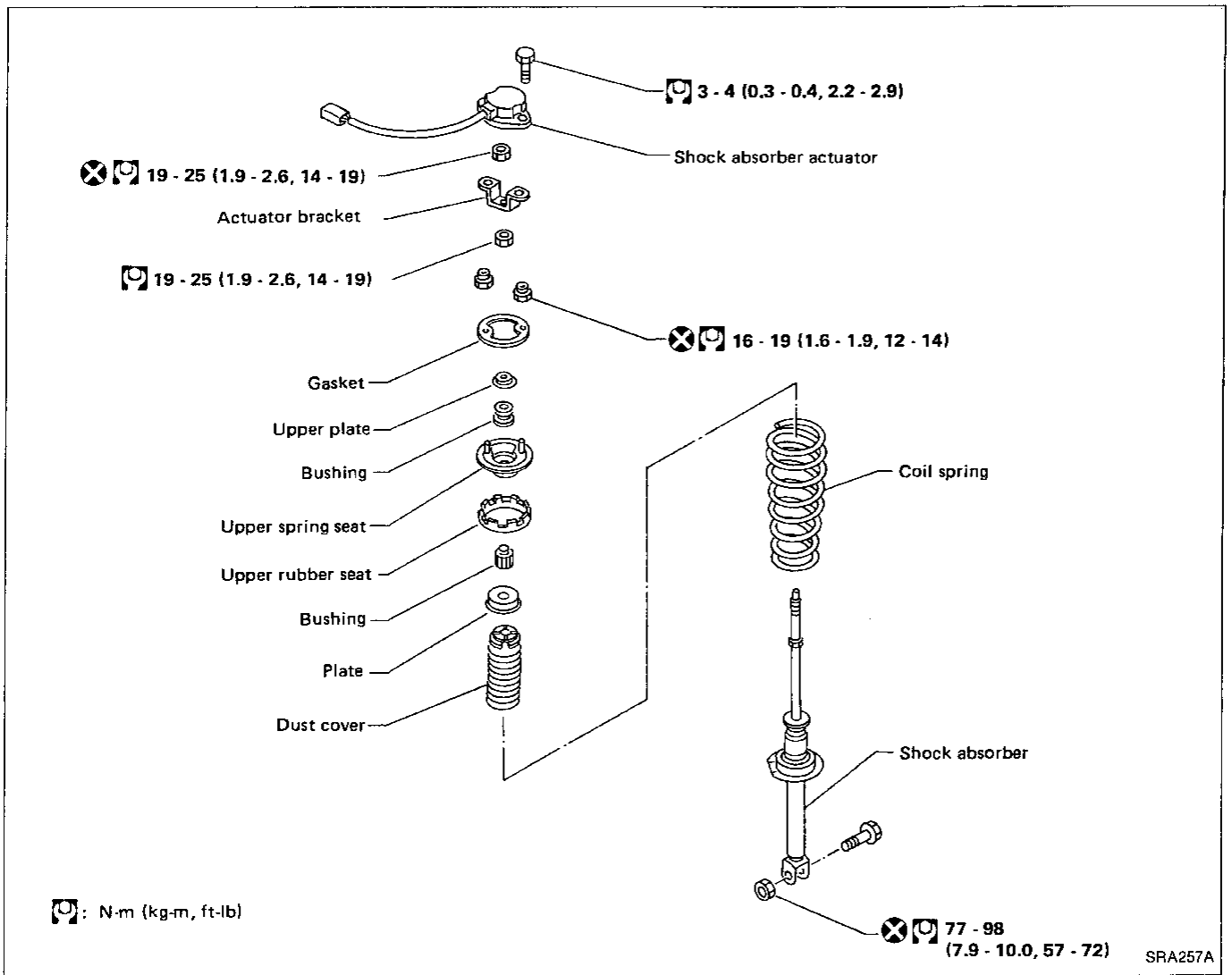

## Removal and Installation

- Remove room trim. Refer to BF section.
- Disconnect sub-harness connector.
- Remove shock absorber actuator fixing bolts.
- **Before installing actuator, ensure angle of shock absorber control rod is aligned with that of actuator output shaft. Otherwise, actuator may be damaged.**
- Refer to REAR SUSPENSION for other procedures.

## Inspection

- Replace shock absorber assembly if it is damaged. Refer to REAR SUSPENSION — Coil Spring and Shock Absorber (RA-17).

## Trouble Diagnosis

Refer to ADJUSTABLE SHOCK ABSORBER — Trouble Diagnoses in FA section.

**Rear Wheel Alignment**

**TOE-IN**

1. Draw a base line across the tread.  
**After lowering rear of vehicle, move it up and down to eliminate friction.**

2. Measure toe-in.

**Measure distance "A" and "B" at the same height as hub center.**

**Toe-in:**

**Refer to SDS (RA-23).**

3. Adjust toe-in by varying length of power cylinder lower links.

- (1) Loosen lock nuts.
- (2) Adjust toe-in by turning lower links forward or backward.

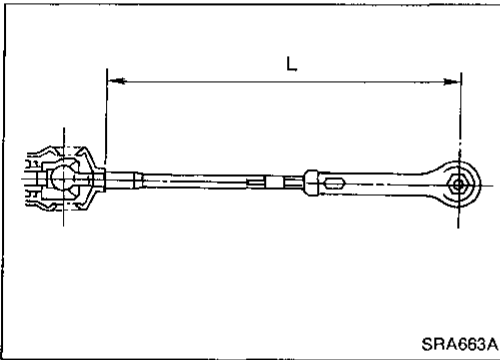
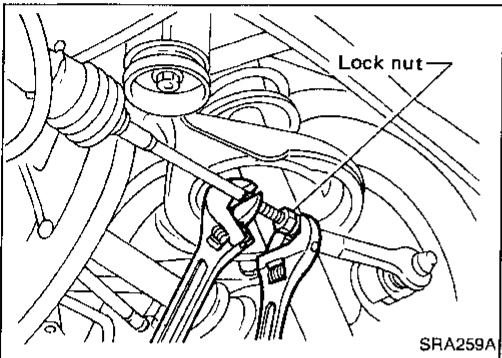
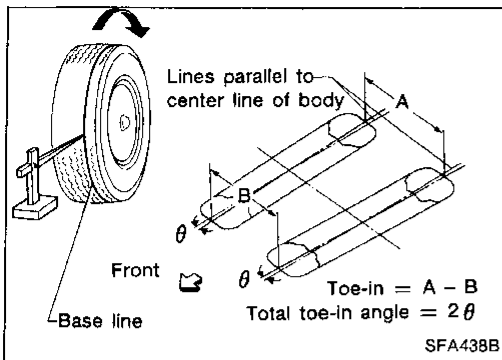

**Make sure both lower links are the same length.**

**Standard length "L":**

**290.4 mm (11.43 in)**

(3) Tighten lock nuts to the specified torque.

**⚙️: 78 - 98 N·m**

**(8 - 10 kg-m, 58 - 72 ft-lb)**

- Refer to ON-VEHICLE SERVICE for other procedures.

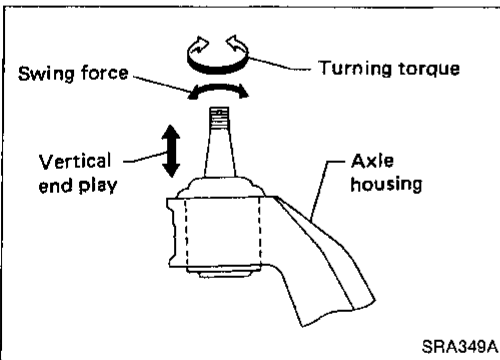

**Rear Axle Housing Ball Joint**

**INSPECTION**

- Measure swing force, turning torque and vertical end play in axial direction.
- If ball joint is worn, play in axial direction is excessive, or joint is hard to swing, replace ball joint.

Ball joint specifications	Swing force	6.9 - 68.6 N (0.7 - 7.0 kg, 1.5 - 15.4 lb)
	Turning torque	0.3 - 2.9 N·m (3 - 30 kg-cm, 2.6 - 26.0 in-lb)
	Vertical end play	0 mm (0 in)

# SUPER HICAS

## Rear Axle Housing Ball Joint (Cont'd)

### REMOVAL

- Remove ball joint snap ring.
- Press out ball joint from axle housing.

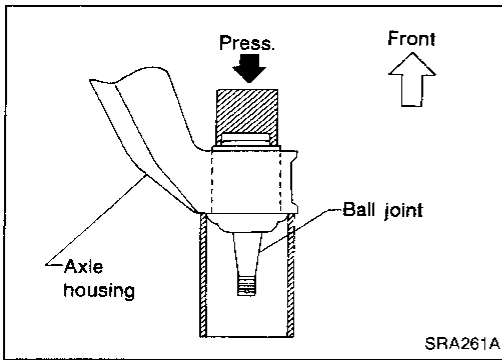

### ASSEMBLY

- Press new ball joint assembly into axle housing.
- Install snap ring into groove of ball joint.
- Refer to REAR AXLE — Wheel Hub and Axle Housing for other procedures.
- Refer to SUPER HICAS — Trouble Diagnoses in ST section.

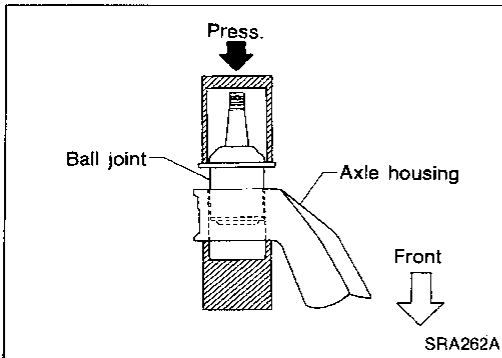

GI

MA

EM

LC

EF &  
EC

FE

CL

MT

AT

PD

FA

**RA**

BR

ST

BF

HA

EL

IDX

# SERVICE DATA AND SPECIFICATIONS (SDS)

## General Specifications

### COIL SPRING

Item		Engine		
		VG30DE		VG30DETT
		2 seater	2+2 seater, Convertible	2 seater
Wire diameter	mm (in)	11.4 (0.449)		11.2 (0.441)
Coil diameter	mm (in)	99.9 (3.933)		99.2 (3.906)
Free length	mm (in)	371.5 (14.63)	380 (14.96)	370 (14.57)
Spring constant	N/mm (kg/mm, lb/in)	21.6 (2.2, 123)		23.5 (2.4, 134)
Identification color		White x 1, Yellow x 1	Purple x 1, Pink x 1	Purple x 1, Light green x 1

### SHOCK ABSORBER

Item		Engine	
		VG30DE	VG30DETT
Piston rod diameter	mm (in)	12.5 (0.492)	14.0 (0.551)

### DRIVE SHAFT

Item	Engine	
	VG30DE	VG30DETT
Joint type		
Final drive side	DS90	DS100
Wheel side	ZF100	BF100
Diameter mm (in)		
Wheel side D <sub>1</sub>	30 (1.18)	33 (1.30)
Grease	Nissan genuine grease or equivalent	
Specified amount of grease		
g (oz)		
Final drive side	165 - 175 (5.82 - 6.17)	180 - 200 (6.35 - 7.05)
Wheel side	150 - 160 (5.29 - 5.64)	170 - 190 (6.00 - 6.70)
Boot length mm (in)		
Final drive side (L <sub>2</sub> )	93 - 95 (3.66 - 3.74)	102.5 - 104.5 (4.04 - 4.11)
Wheel side (L <sub>1</sub> )	96 - 98 (3.78 - 3.86)	101 - 103 (3.98 - 4.06)

#### Final drive side

Final drive side

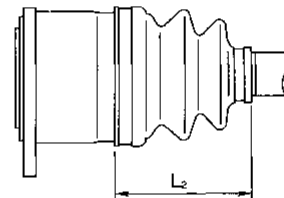

Wheel drive side

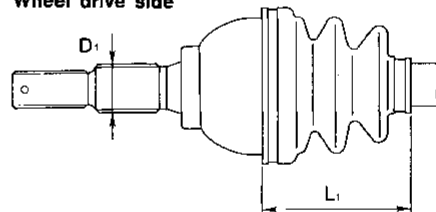

SRA668A

### REAR STABILIZER BAR

Item		Engine		
		VG30DE		VG30DETT
		2 seater Convertible	2+2 seater	
Stabilizer diameter	mm (in)			
Outer		15.9 (0.626)	21.0 (0.827)	25.4 (1.000)
Inner		12.3 (0.484)	15.8 (0.622)	19.4 (0.764)

# SERVICE DATA AND SPECIFICATIONS (SDS)

## Inspection and Adjustment

### WHEEL ALIGNMENT (Unladen\*)

Camber	degree	-1°36' to -0°36'
Toe-in		
A — B	mm (in)	0.4 - 4.4 (0.016 - 0.173)
Total angle 2θ	degree	2' - 24'

\*: Fuel, radiator coolant and engine oil full.  
Spare tire, jack, hand tools and mats in designated positions.

### WHEEL BEARING

Wheel bearing axial end play	mm (in)	0.05 (0.0020) or less
Wheel bearing lock nut		
Tightening torque	N·m (kg-m, ft-lb)	206 - 275 (21 - 28, 152 - 203)

### WHEEL RUNOUT (Radial and lateral)

Wheel type	Radial runout	Lateral runout
Aluminum wheel mm (in)	0.3 (0.012) or less	

### LOWER BALL JOINT

Swing force (Measuring point: cotter pin hole of ball stud) N (kg, lb)	7.8 - 54.9 (0.8 - 5.6, 1.8 - 12.3)
Turning torque N·m (kg-cm, in-lb)	0.5 - 3.4 (5 - 35, 4.3 - 30.4)
Vertical end play mm (in)	0 (0)

### LOWER LINK BALL JOINT (SUPER HICAS)

Swing force (at cotter pin hole) N (kg, lb)	6.9 - 68.6 (0.7 - 7.0, 1.5 - 15.4)
Turning torque N·m (kg-cm, in-lb)	0.3 - 2.9 (3 - 30, 2.6 - 26.0)
Vertical end play mm (in)	0 (0)

GF

MA

EM

LC

EF &  
EC

FE

CL

MT

AT

PD

FA

RA

BR

ST

BF

HA

EL

IDX