

# FRONT AXLE & FRONT SUSPENSION

GI

MA

EM

LC

EF &  
EC

FE

CL

MT

AT

PD

**FA**

RA

BR

ST

RS

BT

HA

EL

IDX

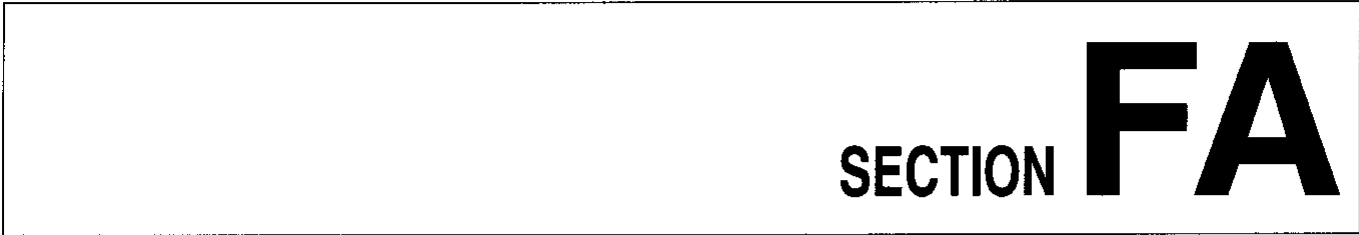

## CONTENTS

<b>PRECAUTIONS AND PREPARATION</b> .....2	<b>FRONT SUSPENSION</b> .....13
Precautions.....2	Coil Spring and Shock Absorber .....14
Special Service Tools .....2	Third Link and Upper Link.....15
Commercial Service Tools .....2	Transverse Link and Lower Ball Joint .....17
<b>FRONT AXLE AND FRONT SUSPENSION</b> .....4	Tension Rod and Stabilizer Bar.....18
<b>ON-VEHICLE SERVICE</b> .....5	<b>ADJUSTABLE SHOCK ABSORBER</b> .....19
Front Axle and Front Suspension Parts .....5	Trouble Diagnoses.....20
Front Wheel Bearing.....7	<b>SERVICE DATA AND SPECIFICATIONS (SDS)</b> .....26
Front Wheel Alignment .....7	General Specifications.....26
<b>FRONT AXLE</b> .....9	Inspection and Adjustment .....26
Wheel Hub and Steering Knuckle .....9	

## PRECAUTIONS AND PREPARATION

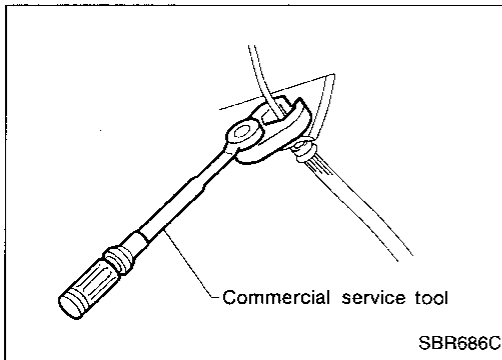

### Precautions

- When installing rubber parts, final tightening must be carried out under unladen condition\* with tires on ground.
- \* Fuel, radiator coolant and engine oil full. Spare tire, jack, hand tools and mats in designated positions.
- After installing removed suspension parts, check wheel alignment and adjust if necessary.
- Use flare nut wrench when removing or installing brake lines.
- Always torque brake lines when installing.

### Special Service Tools

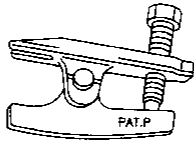
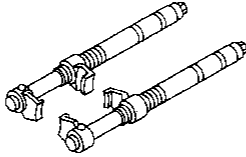
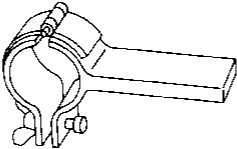
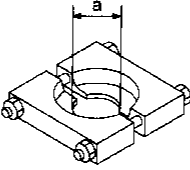
Tool number (Kent-Moore No.) Tool name	Description	
HT72750000 (J24319-01) Ball joint remover	 NT146	Removing tie-rod outer end and lower ball joint
HT71780000 ( — ) Spring compressor	 NT144	Removing and installing coil spring
ST35652000 ( — ) Shock absorber attachment	 NT145	Fixing shock absorber
ST30031000 (J22912-01) Bearing inner race puller	 NT412	Removing bearing inner race  a: 50 mm (1.97 in) dia.

### Commercial Service Tools

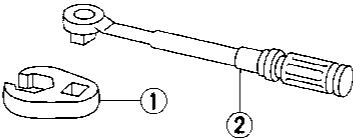
Tool name	Description	
① Flare nut crows foot ② Torque wrench	 NT223	Removing and installing each brake piping

# PRECAUTIONS AND PREPARATION

## Commercial Service Tools (Cont'd)

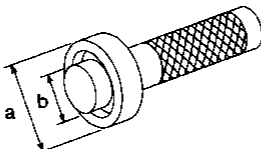
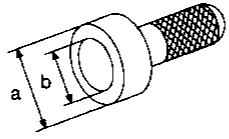
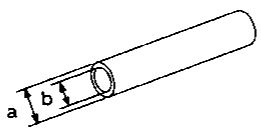
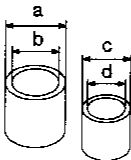
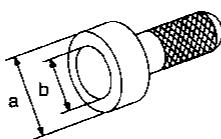
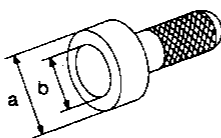
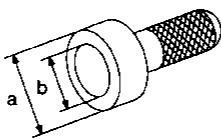
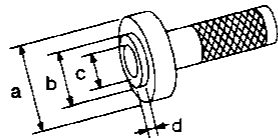
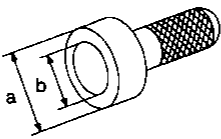
Tool name	Description	
Wheel bearing drift	 <p>NT084</p>	Removing wheel bearing  a: 60 mm (2.36 in) dia. b: 37 mm (1.46 in) dia.
Wheel bearing drift	 <p>NT115</p>	Installing wheel bearing  a: 75 mm (2.95 in) dia. b: 65 mm (2.56 in) dia.
Baffle plate drift	 <p>NT065</p>	Installing baffle plate  a: 125 mm (4.92 in) dia. b: 106 mm (4.17 in) dia.
Tension rod bushing drift	 <p>NT155</p>	Removing and installing tension rod bushing  a: 78 mm (3.07 in) dia. b: 66 mm (2.60 in) dia. c: 62 mm (2.44 in) dia. d: 25 - 55 mm (0.98 - 2.17 in) dia.
Grease seal drift	 <p>NT115</p>	Installing wheel hub grease seal  a: 86 mm (3.39 in) dia. b: 76 mm (2.99 in) dia.
Cap drift	 <p>NT115</p>	Installing king pin cap  a: 60 mm (2.36 in) dia. b: 52 mm (2.05 in) dia.
Bearing drift	 <p>NT115</p>	Installing king pin lower bearing  a: 57 mm (2.24 in) dia. b: 50 mm (1.97 in) dia.
Bearing drift	 <p>NT156</p>	Installing king pin upper bearing  a: 57 mm (2.24 in) dia. b: 46 mm (1.81 in) dia. c: 40 mm (1.57 in) dia. d: 2.5 mm (0.098 in)
Grease seal drift	 <p>NT115</p>	Installing king pin grease seal  a: 68 mm (2.68 in) dia. b: 58 mm (2.28 in) dia.

GI  
MA  
EM  
LC  
EF & EC  
FE  
CL  
MT  
AT  
PD  
FA  
RA  
BR  
ST  
RS  
BT  
HA  
EL  
IDX

# FRONT AXLE AND FRONT SUSPENSION

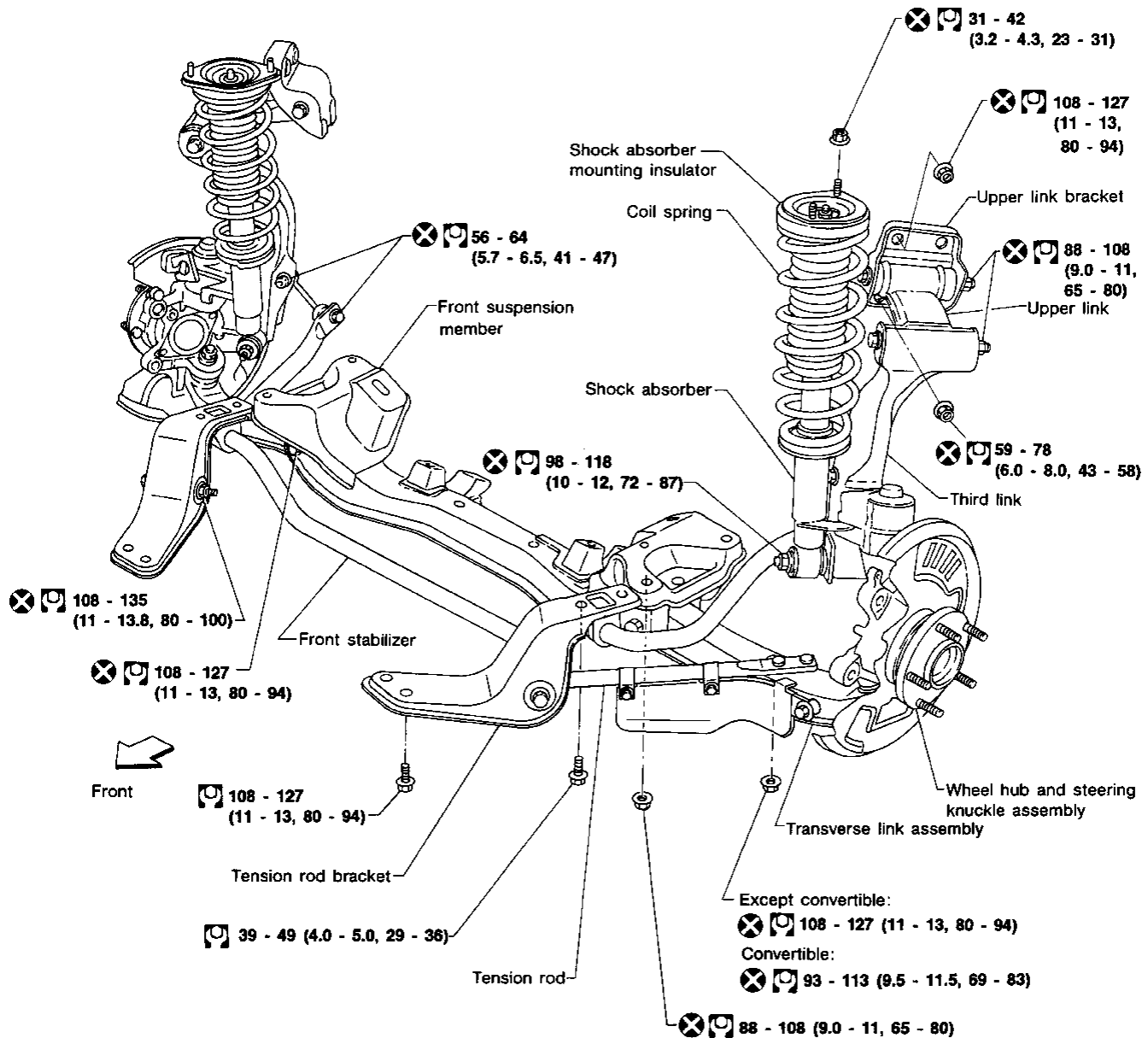

When installing rubber parts, final tightening must be carried out under unladen condition\* with tires on ground.

\* Fuel, radiator coolant and engine oil full. Spare tire, jack, hand tools and mats in designated positions.

ⓧ : N·m (kg-m, ft-lb)

## Front Axle and Front Suspension Parts

Check front axle and front suspension parts for looseness, cracks, wear or other damage.

- Retighten all nuts and bolts to the specified torque.  
**Tightening torque: Refer to FRONT SUSPENSION (FA-13).**
- Make sure that cotter pin is inserted.

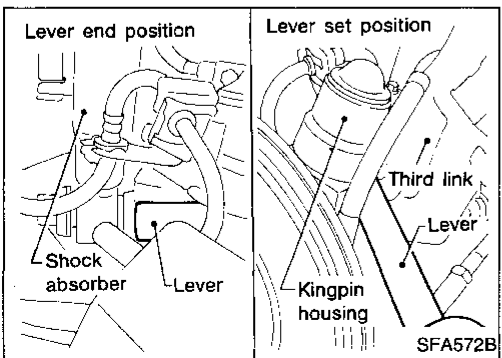
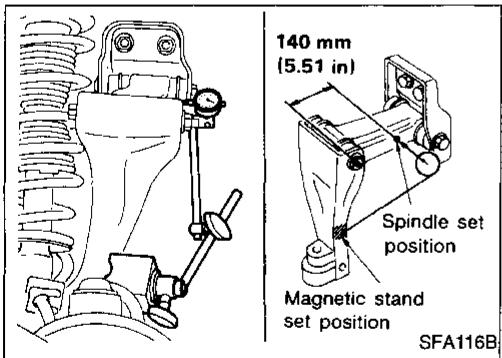
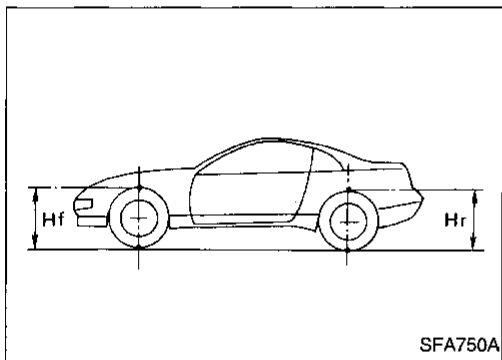
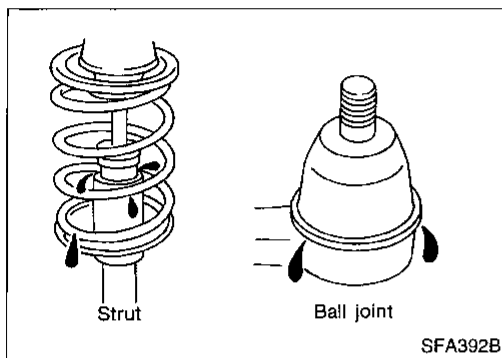

- Check suspension lower ball joint and tie-rod ball joint for grease leakage, and dust cover for cracks or other damage.
- Check shock absorber for oil leakage or other damage.

- Check spring height from top of wheelarch to ground.
- (1) Vehicle must be unladen\*, parked on a level surface, and tires checked for proper inflation and wear (tread wear indicator must not be showing).

\* Fuel, radiator coolant and engine oil full. Spare tire, jack, hand tools and mats in designated positions.

- (2) Bounce vehicle up and down several times before measuring.  
**Standard height: Refer to SDS (FA-27).**
- (3) Spring height is not adjustable. If out of specification, check for worn springs or suspension parts.

- Check upper link free play.
- (1) Jack up front of vehicle and set stands.
  - (2) Set steering wheel in the straight-forward direction and lock it using key lock.
  - (3) Remove front wheels.

### On axle side

- (4) Install dial gauge.
  - a. Install magnet stand on third link.
  - b. Set dial gauge in position.  
Set dial gauge spindle in contact with flat surface of upper link. Set at 140 mm (5.51 in) from center of upper link retaining bolt on the third link side.  
(Reset dial gauge.)
- (5) Install lever.  
Insert lever [30 mm (1.18 in) outside dia., 350 mm (13.78 in) long, approx.] between lower end of third link and kingpin location.

**Make sure lever does not interfere with splash guard, brake hoses, etc., when set in position.**

## ON-VEHICLE SERVICE

### Front Axle and Front Suspension Parts (Cont'd)

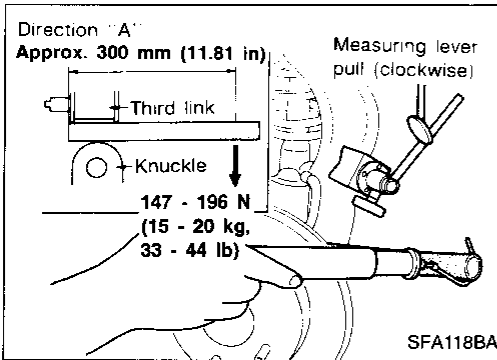

— Free play in direction "A" —

Attach spring scale to lever tip. Pull spring scale with a force of 147 to 196 N (15 to 20 kg, 33 to 44 lb) and then read dial gauge indication.

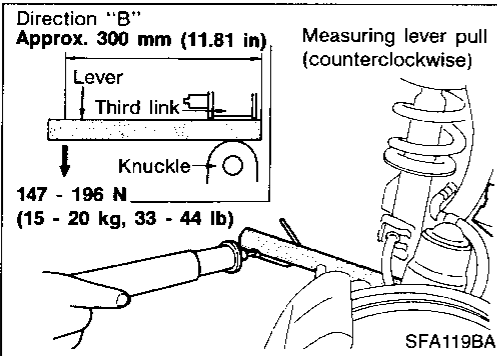

— Free play in direction "B" —

With dial gauge held in position, invert lever. Attach spring scale to lever tip. Pull spring scale with a force of 147 to 196 N (15 to 20 kg, 33 to 44 lb) and then read dial gauge indication.

Free play = (Gauge pointer deflection in direction "A") +  
(Gauge pointer deflection in direction "B")

**Allowable free play range:  
5.0 mm (0.197 in), max.**

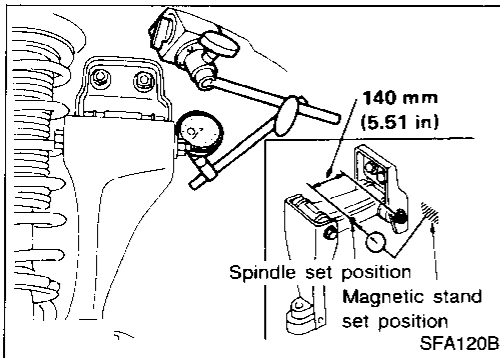
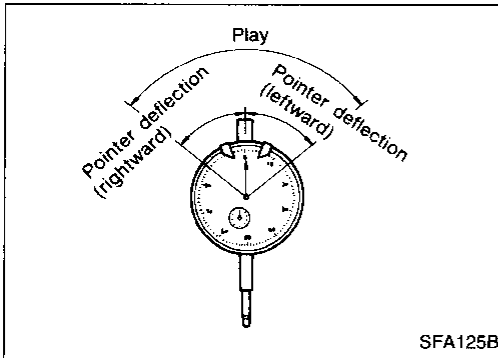

#### On body side

- (6) Install dial gauge.
  - a. Install magnet stand on hoodledge wheelhouse side.
  - b. Set dial gauge in position.  
Set dial gauge spindle in contact with flat surface of upper link. Set at 140 mm (5.51 in) from center of upper link retaining bolt on bracket side. (Reset dial gauge.)
- (7) Follow the same procedures for setting lever and measuring the free play as those outlined under "On axle side" above.  
**Allowable free play range: 5.0 mm (0.197 in), max.**
- (8) If free play exceeds specifications, replace upper link assembly.

## ON-VEHICLE SERVICE

### Front Axle and Front Suspension Parts (Cont'd)

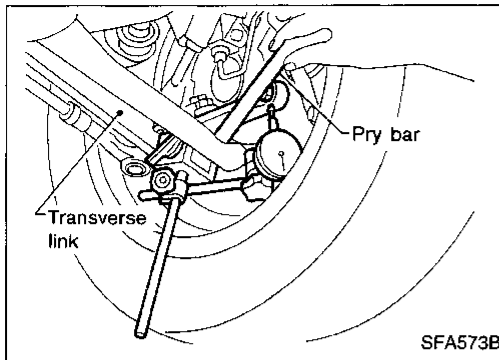

- Check suspension ball joint end play.
- (1) Jack up front of vehicle and set the stands.
- (2) Clamp dial indicator onto transverse link and place indicator tip on lower edge of brake caliper.
- (3) Make sure front wheels are straight and brake pedal is depressed.
- (4) Place a pry bar as shown in figure at left.
- (5) While pushing and releasing pry bar, observe maximum dial indicator value.

**Vertical end play: 0 mm (0 in)**

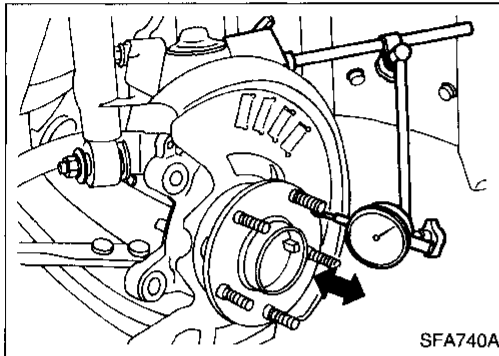

### Front Wheel Bearing

- Check tightening torque of wheel bearing lock nut.  
☞: **206 - 284 N·m**  
(21 - 29 kg-m, 152 - 210 ft-lb)
- Check wheel bearings for smooth operation.
- Check axial end play.  
**Axial end play: 0.05 mm (0.0020 in) or less**
- If out of specification or wheel bearing does not turn smoothly, replace wheel bearing assembly.  
Refer to FRONT AXLE — Wheel Hub and Steering Knuckle (FA-9).

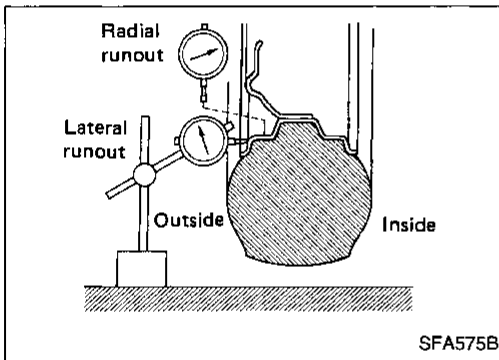

### Front Wheel Alignment

Before checking front wheel alignment, be sure to make a preliminary inspection.

#### PRELIMINARY INSPECTION

Make the following checks. Adjust, repair or replace if necessary.

- Check tires for wear and improper inflation.
- Check front wheel bearings for looseness.
- Check wheel runout.

**Refer to SDS (FA-27).**

- Check front suspension for looseness.
- Check steering linkage for looseness.
- Check that front shock absorbers work properly.
- Check vehicle posture (Unladen).  
("Unladen": Fuel, radiator coolant and engine oil full. Spare tire, jack, hand tools and mats in designated positions.)

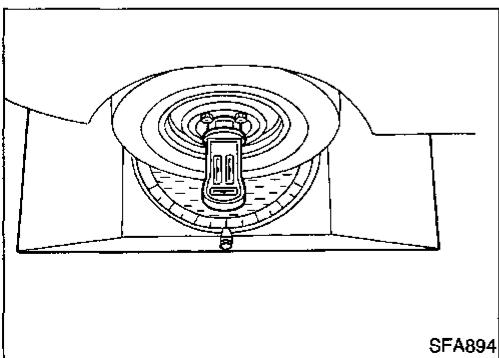

### CAMBER, CASTER AND KINGPIN INCLINATION

Camber, caster and kingpin inclination are preset at factory and cannot be adjusted.

- (1) Measure camber, caster and kingpin inclination of both right and left wheels with a suitable alignment gauge.

**Camber, Caster and Kingpin inclination:**

**Refer to SDS (FA-26).**

- (2) If camber, caster or kingpin inclination is not within specification, inspect front suspension parts. Replace damaged or worn out parts.

# ON-VEHICLE SERVICE

## Front Wheel Alignment (Cont'd)

### TOE-IN

Measure toe-in using following procedure. If out of specification, inspect and replace any damaged or worn rear suspension parts.

#### WARNING:

- Perform following procedure always on a flat surface.
- Make sure that no person is in front of the vehicle before pushing it.

1. Move rear of vehicle up and down to stabilize the posture.
2. Push the vehicle straight ahead about 5 m (196.9 in).
3. Put a mark on base line of the tread (rear side) at the same height of hub center to be a measuring point.
4. Measure distance "A" (rear side).
5. Push the vehicle slowly ahead to turn the wheels around 180 degrees.

If the wheels have passed 180 degrees, try the above procedure again from the beginning. Never push vehicle backward.

6. Measure distance "B" (front side).

Toe-in (A - B):

Refer to SDS (FA-26).

7. Adjust toe-in by varying length of steering tie-rods.
  - (1) Loosen lock nuts.
  - (2) Adjust toe-in by turning tie-rod forward or backward.

Make sure both tie-rods are the same length.

Standard length "L":

155 mm (6.10 in)

- (3) Tighten lock nuts to the specified torque.

$\square$ : 78 - 98 N·m

(8.0 - 10.0 kg-m, 58 - 72 ft-lb)

### FRONT WHEEL TURNING ANGLE

1. Set wheels in straight-ahead position. Then, move vehicle forward until front wheels rest on turning radius gauge properly.
2. Rotate steering wheel fully to the right or left; measure turning angle.

#### Wheel turning angle:

Full turn	Inside wheel: A	32°30' - 36°30'
	Outside wheel: B	26°30' - 30°30'

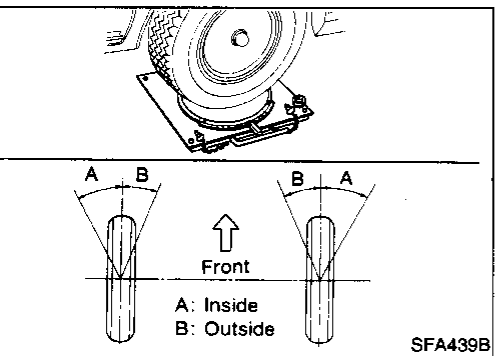
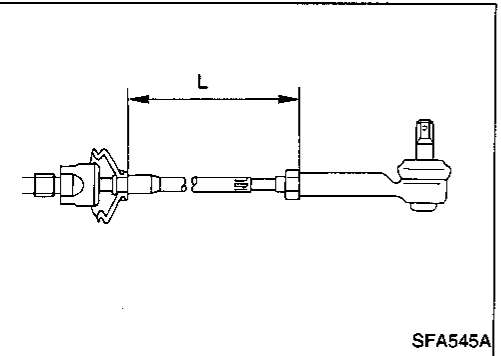
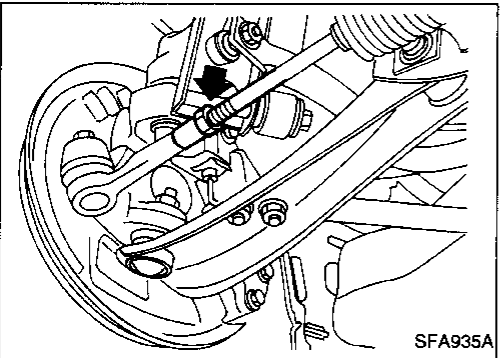
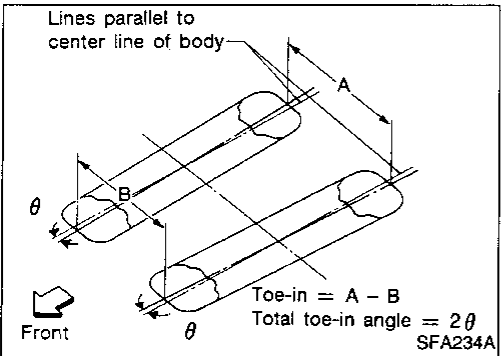
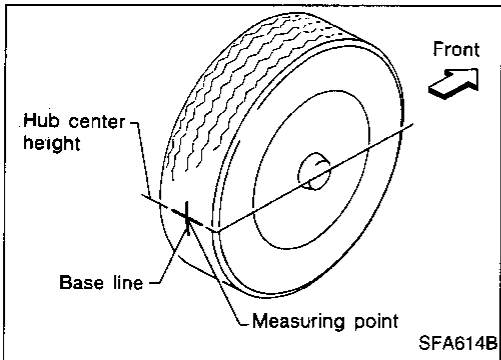



# FRONT AXLE

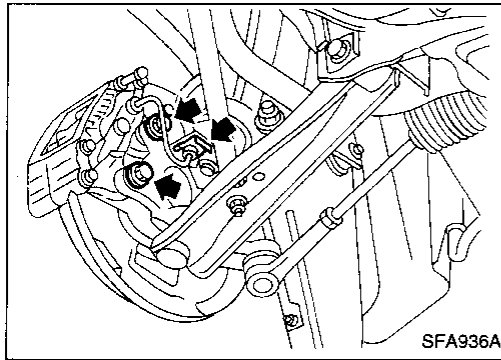
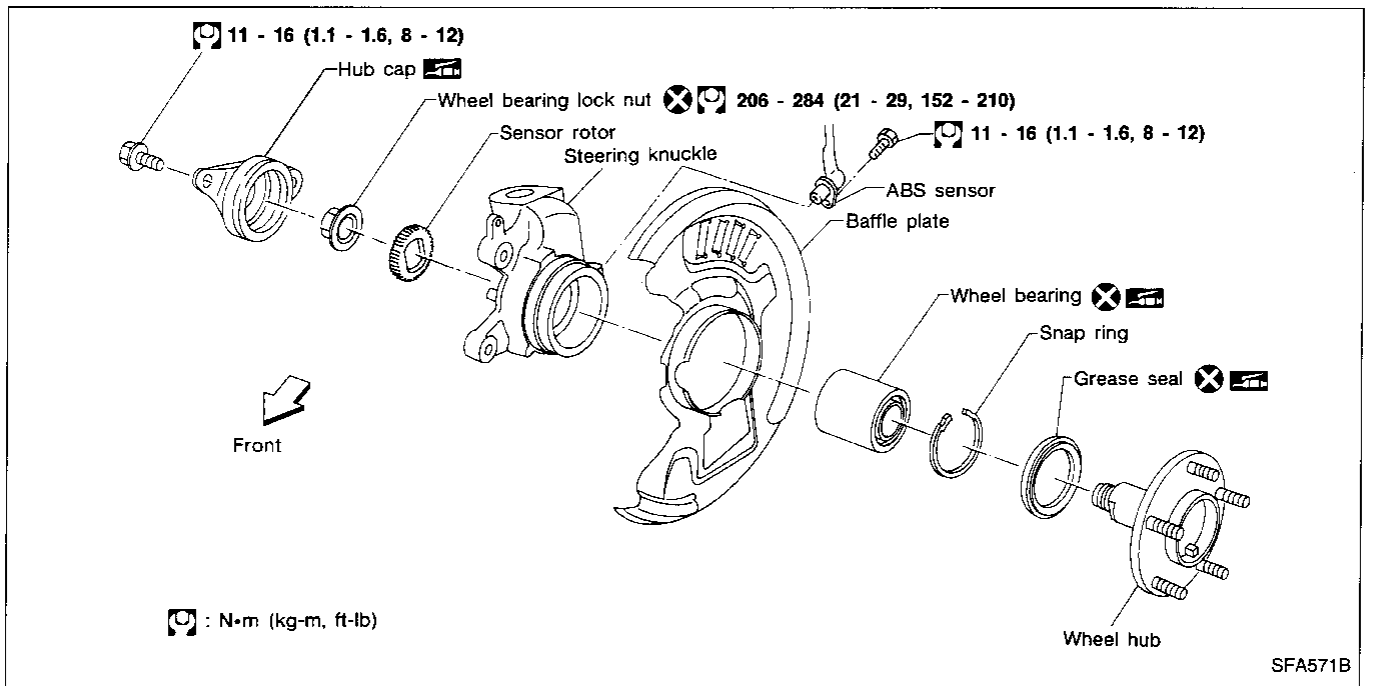

## Wheel Hub and Steering Knuckle

### REMOVAL

#### CAUTION:

Wheel bearing usually does not require maintenance. If any of the following symptoms are noted, replace wheel bearing assembly.

- Growling noise is emitted from wheel bearing during operation.
- Wheel bearing drags or turns roughly when hub is turned by hand.
- Remove brake caliper assembly and rotor.

Brake line need not be disconnected from brake caliper. Be careful not to depress brake pedal, or piston will pop out. Make sure brake line is not twisted.

- Remove ABS sensor.

Before removing the front wheel hub assembly, disconnect the ABS wheel sensor from the assembly. Then move it away from the front wheel hub assembly area. Failure to do so may result in damage to the sensor wires and the sensor becoming inoperative.

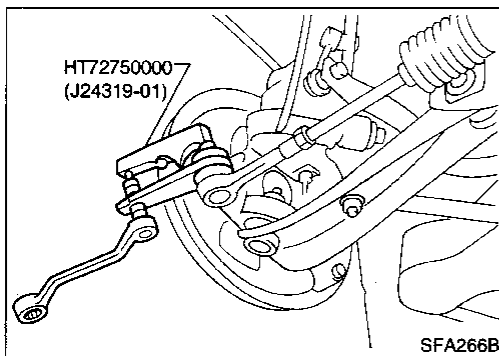

- Remove tie-rod ball joint and lower ball joint with Tool.

#### CAUTION:

Steering knuckle is made from aluminum alloy. Be careful not to hit steering knuckle.

- Remove kingpin lower nut then remove steering knuckle assembly.

GI  
MA  
EM  
LC  
EF & EC  
FE  
CL  
MT  
AT  
PD  
FA  
RA  
BR  
ST  
RS  
BT  
HA  
EL  
IDX

## FRONT AXLE

### Wheel Hub and Steering Knuckle (Cont'd)

#### INSTALLATION

- Install steering knuckle assembly.
- Apply anti-rust wax as follows:
  - Portions around lower ball joint connections
  - Portions around tie-rod ball joint connections
  - Portions around kingpin lower nut location
  - Portions around ABS sensor connection

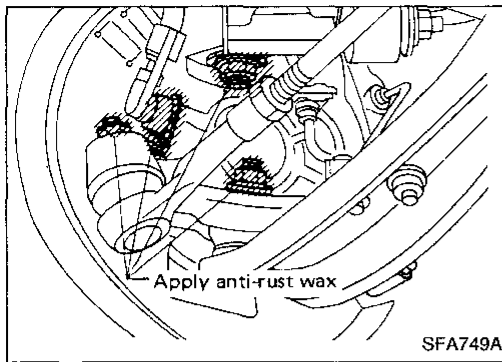

#### DISASSEMBLY

##### CAUTION:

When removing wheel bearing from steering knuckle, replace wheel bearing assembly (outer race, inner races and grease seal) with a new one.

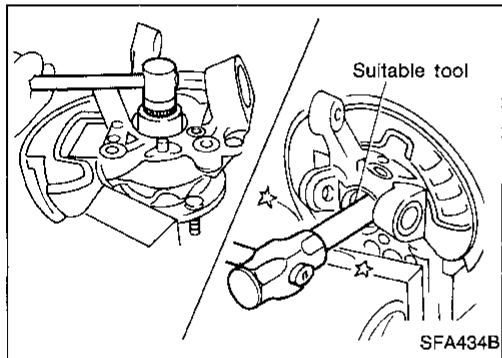

- Remove hub cap and wheel bearing lock nut.
- Remove wheel hub with a suitable tool.

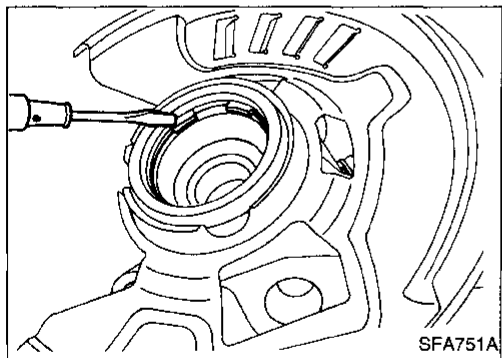

- Remove circular clip with a suitable tool.

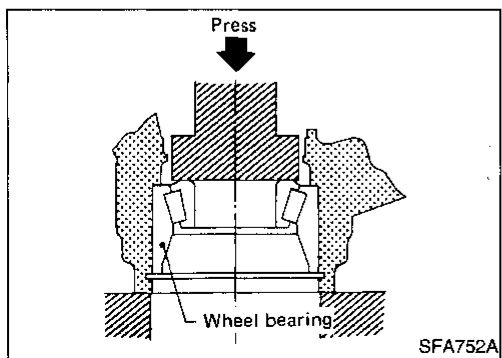

- Press out wheel bearing assembly from steering knuckle.

## FRONT AXLE

### Wheel Hub and Steering Knuckle (Cont'd)

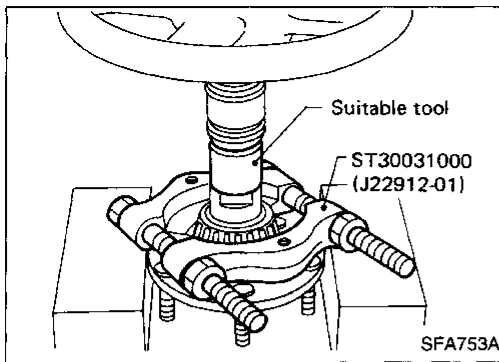

- Drive out wheel bearing inner race (to outside) from wheel hub, then remove grease seal.

GI

MA

EM

LC

EF &  
EC

FE

CL

MT

### INSPECTION

#### Wheel hub and steering knuckle

- Check wheel hub and steering knuckle for any cracks.

#### Circular clip

- Check circular clip for wear or cracks.  
Replace if necessary.

AT

PD

FA

RA

BR

ST

RS

BT

HA

EL

IDX

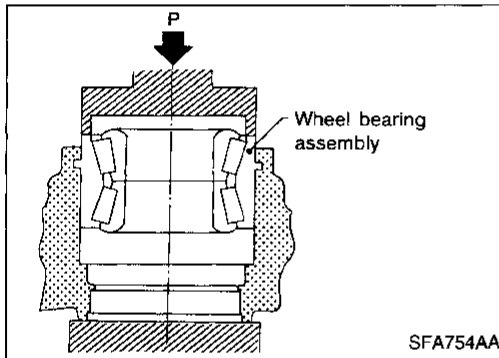

### ASSEMBLY

1. Press new wheel bearing assembly into steering knuckle from outside of steering knuckle.

**Maximum load P:**

**34.3 kN (3.5 ton, 3.9 US ton, 3.44 Imp ton)**

#### CAUTION:

- Do not press inner race of wheel bearing assembly.
- Do not apply oil or grease to mating surfaces of wheel bearing outer race and wheel hub.

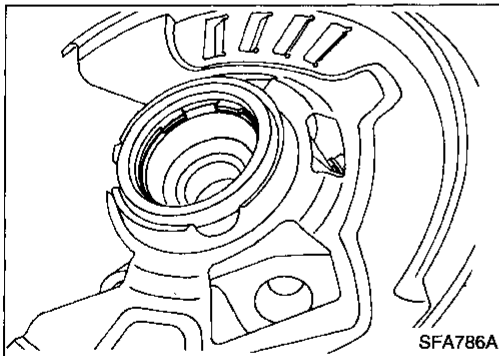

2. Install circular clip into groove of steering knuckle.

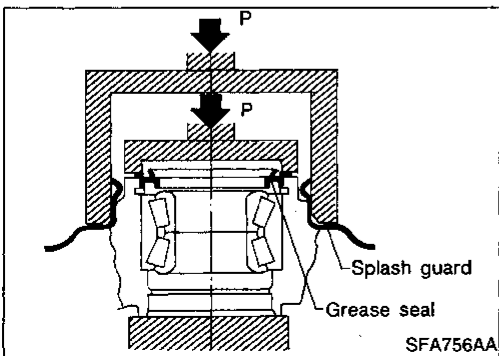

3. Apply multi-purpose grease to sealing lip.
4. Install grease seal.  
**Maximum load P:**  
**10 kN (1 ton, 1.1 US ton, 1.0 Imp ton)**
5. Install splash guard.

## FRONT AXLE

### Wheel Hub and Steering Knuckle (Cont'd)

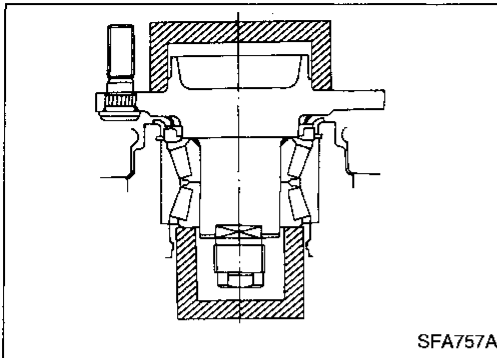

6. Press wheel hub into steering knuckle.  
**Maximum load P:**  
29 kN (3 ton, 3.3 US ton, 3.0 Imp ton)
7. Tighten wheel bearing lock nut to the specified torque.  
☐: 206 - 284 N·m (21 - 29 kg·m, 152 - 210 ft·lb)

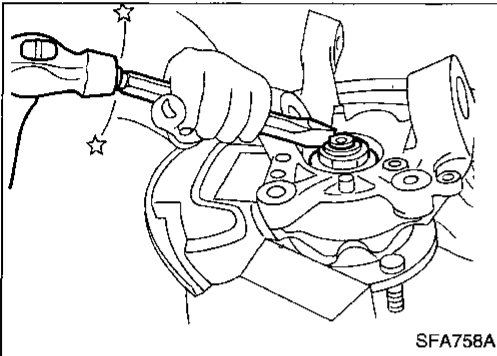

8. Stake wheel bearing lock nut.

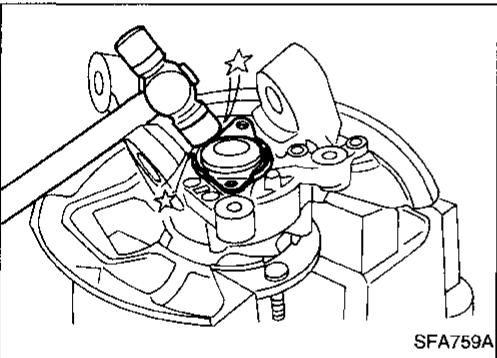

9. Install hub cap.  
Apply multi-purpose grease to packing surface of hub cap.  
Drive hub cap onto steering knuckle by lightly tapping with a plastic hammer. After hub cap is in close contact with steering knuckle, tighten bolts.

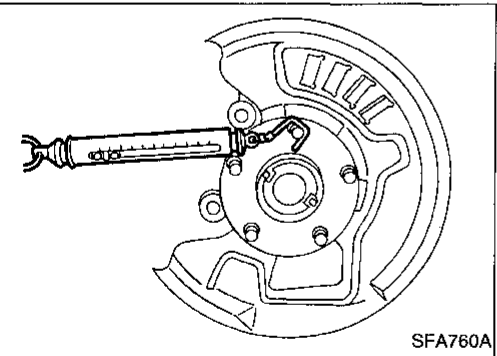

10. Check wheel bearing preload and axial end play.  
**Before checking, spin wheel hub at least 10 revolutions in both directions.**

#### Turning torque:

0.34 - 2.16 N·m (3.5 - 22.0 kg·cm, 3.0 - 19.1 in·lb)

(NSK bearing)

0.44 - 3.33 N·m (4.5 - 34.0 kg·cm, 3.9 - 29.5 in·lb)

(NTN bearing)

#### As measured at wheel hub bolt:

5.9 - 37.3 N (0.6 - 3.8 kg, 1.3 - 8.4 lb)

(NSK bearing)

7.8 - 57.9 N (0.8 - 5.9 kg, 1.8 - 13.0 lb)

(NTN bearing)

#### Axial end play:

0.05 mm (0.0020 in) or less

# FRONT SUSPENSION

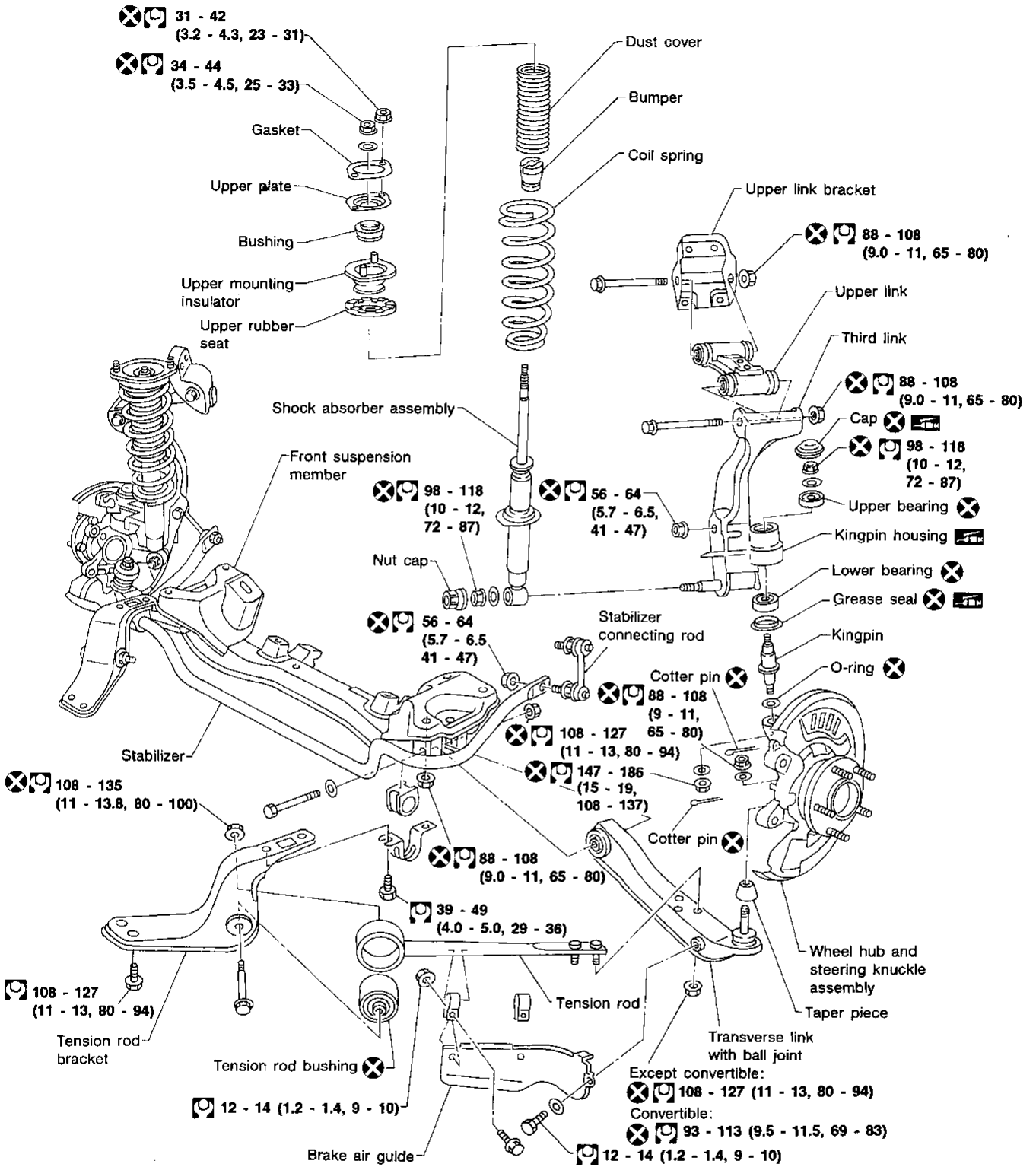

When installing rubber parts, final tightening must be carried out under unladen condition\* with tires on ground.

\* Fuel, radiator coolant and engine oil full.  
Spare tire, jack, hand tools and mats in designated positions.

: N•m (kg-m, ft-lb)

GI

MA

EM

LC

EF & EC

FE

CL

MT

AT

PD

FA

RA

BR

ST

RS

BT

HA

EL

IDX

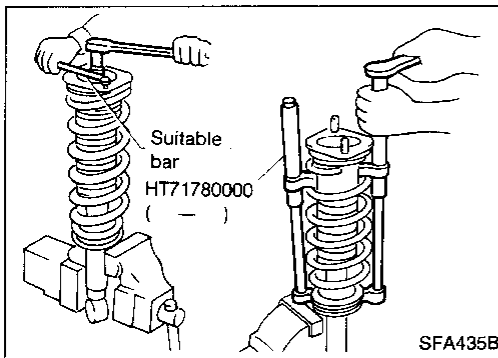
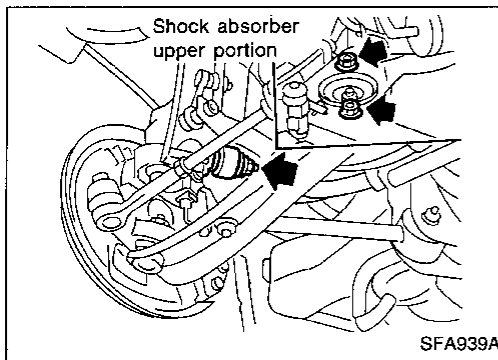

## Coil Spring and Shock Absorber

### REMOVAL

- Remove shock absorber fixing bolt and nut (to hoodledge).
- **Do not remove piston rod lock nut.**

### DISASSEMBLY

1. Set shock absorber in vise with Tool, then loosen piston rod lock nut.
- **Do not remove piston rod lock nut.**
2. Compress spring with Tool so that shock absorber mounting insulator can be turned by hand.
3. Remove piston rod lock nut.

### INSPECTION

#### Shock absorber assembly

- Check for smooth operation through a full stroke, both compression and extension.
- Check for oil leakage occurring on welded or gland packing portions.
- Check piston rod for cracks, deformation or other damage. Replace if necessary.

#### Mounting insulator and rubber parts

- Check cemented rubber-to-metal portion for separation or cracks. Check rubber parts for deterioration. Replace if necessary.

#### Coil spring

- Check for cracks, deformation or other damage. Replace if necessary.

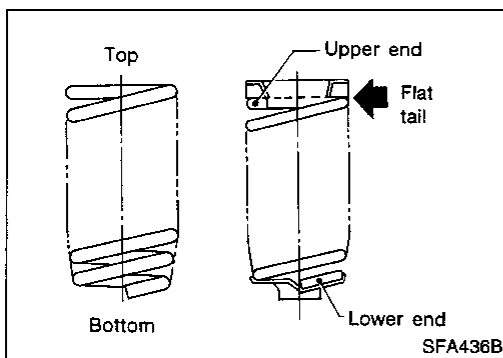

### ASSEMBLY

- When installing coil spring, be careful not to reverse top and bottom direction. (Top end is flat.)
- When installing coil spring on shock absorber, it must be positioned as shown in figure at left.

## Third Link and Upper Link

### REMOVAL

#### CAUTION:

Kingpin bearing usually does not require maintenance. If any of the following symptoms are noted, replace kingpin bearing assembly.

- Growling noise is emitted from kingpin bearing during operation.
- Kingpin bearing drags or turns roughly when steering knuckle is turned by hand.

GI

MA

EM

LC

EF &amp;

EC

FE

CL

MT

AT

PD

FA

RA

BR

ST

RS

BT

HA

EL

IDX

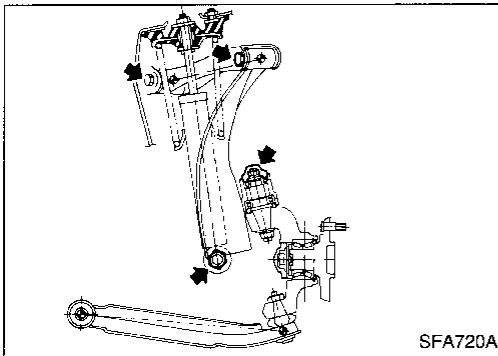

1. Remove cap and kingpin upper nut.
- **Do not remove kingpin lower nut.**
2. Remove shock absorber fixing nut and upper link fixing bolts.
3. Remove third link and upper link.

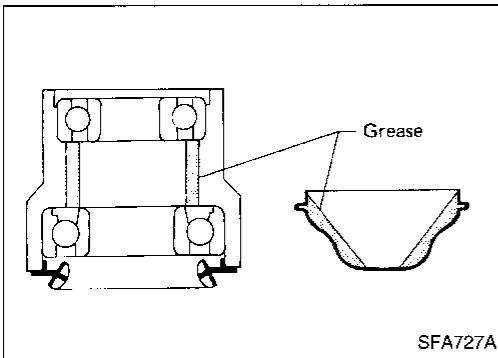

### INSTALLATION

#### Third link

- Pack kingpin housing and cap with multi-purpose grease.

#### Grease capacity:

**Kingpin housing 10 g (0.35 oz)**

**Cap 5 g (0.18 oz)**

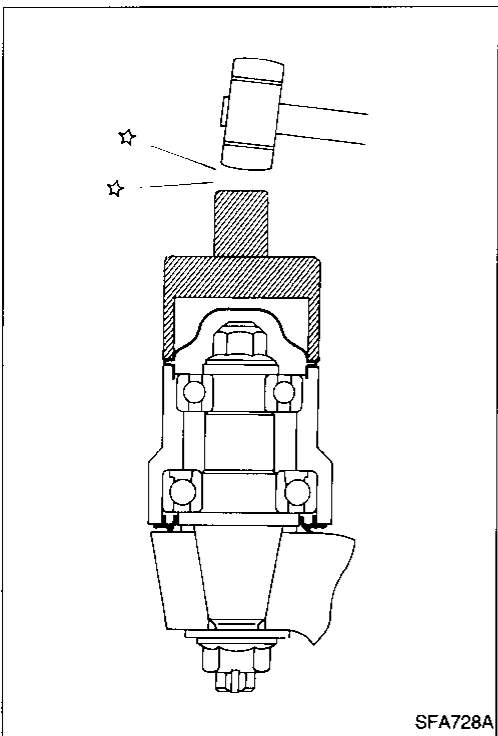

- Install third link and cap.

# FRONT SUSPENSION

## Third Link and Upper Link (Cont'd)

### Upper link

- Upper link has characters "A" and "L" (or "R") on it as shown. Always install upper link with "A" side facing axle and side without a character facing vehicle body.

**Upper link bushings cannot be disassembled.**

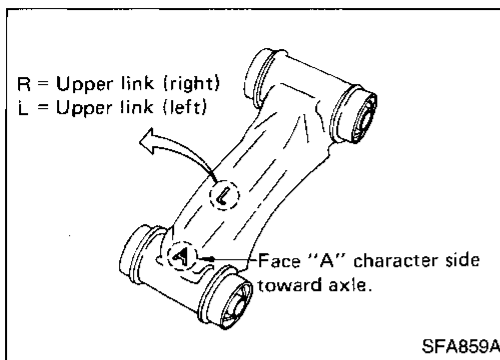

### DISASSEMBLY

- Remove upper bearing (inner race and ball).

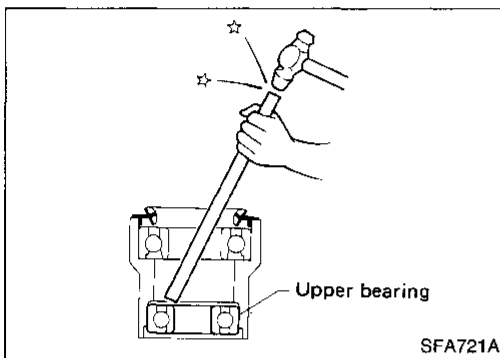

- Remove kingpin grease seal.
- Remove lower bearing (inner race and ball).

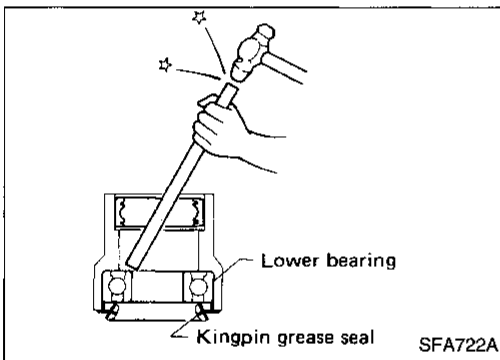

- Remove upper and lower outer race.
- **Be careful not to damage kingpin housing.**

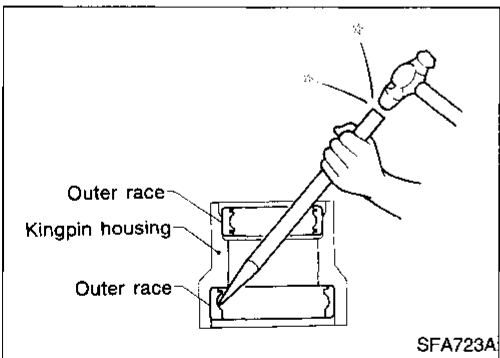

### ASSEMBLY

- Install lower bearing.

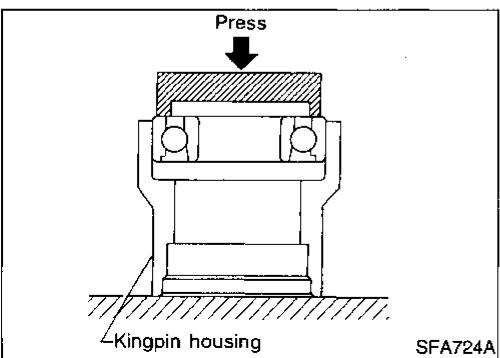



# FRONT SUSPENSION

## Third Link and Upper Link (Cont'd)

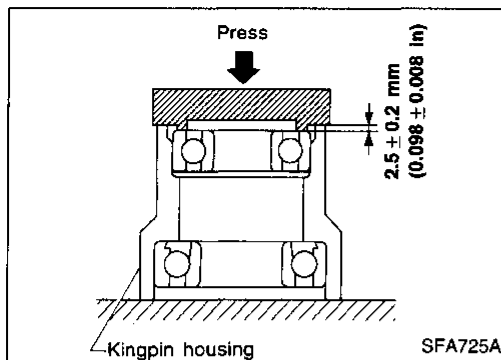

- Install upper bearing.

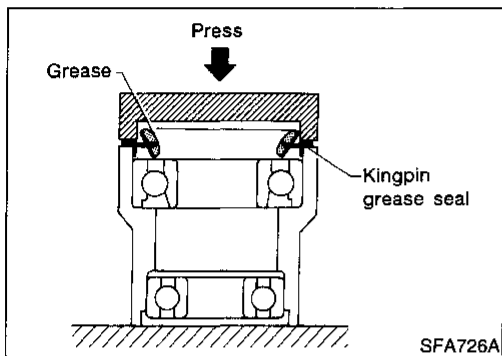

- Install lower oil seal.
- Apply multi-purpose grease to oil seal lip.

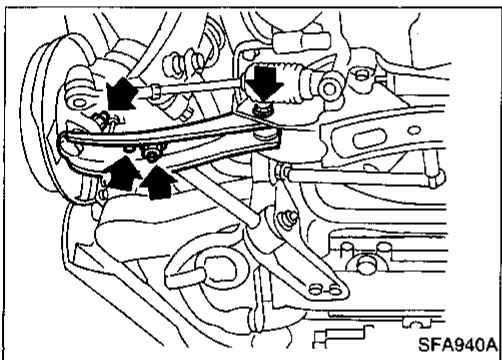

## Transverse Link and Lower Ball Joint

### REMOVAL AND INSTALLATION

- Remove tension rod, ball joint and transverse link assembly.
- During installation, final tightening must be done at curb weight with tires on ground.
- After installation, check wheel alignment. Refer to "Front Wheel Alignment" of ON-VEHICLE SERVICE (FA-7).

### INSPECTION

#### Transverse link

- Check transverse link and rubber bushing for damage, cracks or deformation. Replace if necessary.

GI

MA

EM

LC

EF &  
EC

FE

CL

MT

AT

PD

FA

RA

BR

ST

RS

BT

HA

EL

IDX

## FRONT SUSPENSION

### Transverse Link and Lower Ball Joint (Cont'd)

#### Lower ball joint

Replace transverse link assembly if any of the following cases occur: Ball stud is worn, play in axial direction is excessive or joint is hard to swing.

#### Swing force, turning torque and vertical end play

Before checking, turn ball joint at least 10 revolutions so that ball joint is properly broken in.

**Swing force "A": 7.8 - 53.0 N (0.8 - 5.4 kg, 1.8 - 11.9 lb)**

**(measuring point: cotter pin hole of ball stud)**

**Turning torque "B":**

**0.49 - 3.43 N·m (5.0 - 35 kg-cm, 4.3 - 30.4 in-lb)**

**Vertical end play limit "C": 0 mm (0 in)**

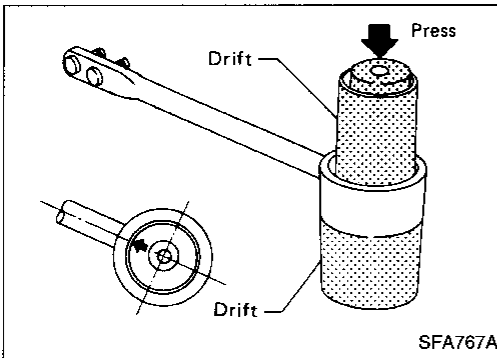
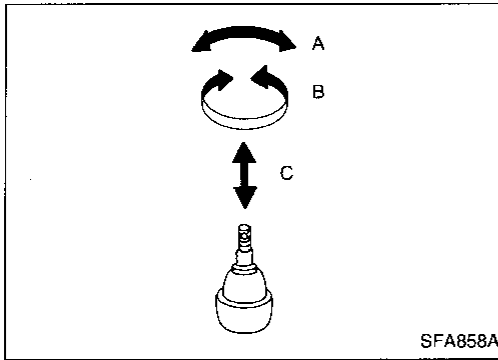

#### Tension Rod and Stabilizer Bar

##### REMOVAL AND INSTALLATION

- Remove tension rod and stabilizer bar.
- Place a drift on lower side of tension rod bushing and another on upper side, as shown. Remove tension rod bushing by pressing it out.
- Place arrow mark on bushing facing tension rod before installing bushing.

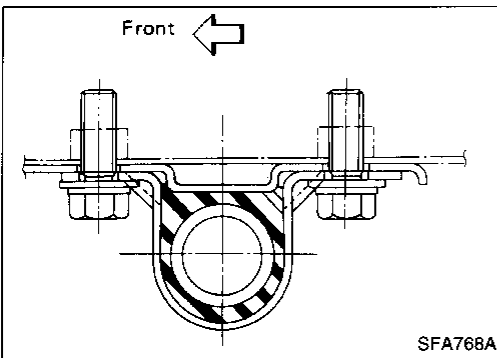

- When installing stabilizer, make sure that paint mark and clamp face in the correct direction.

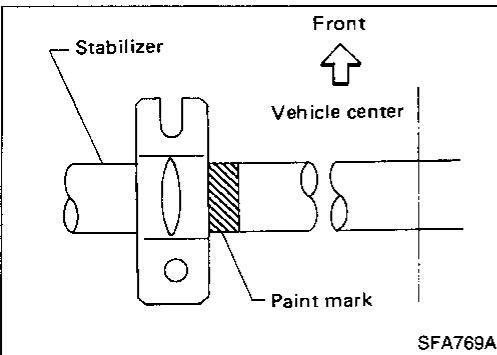

# ADJUSTABLE SHOCK ABSORBER

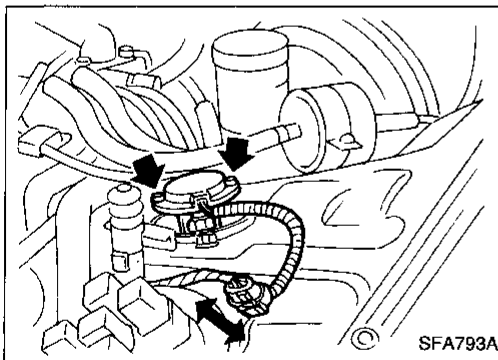
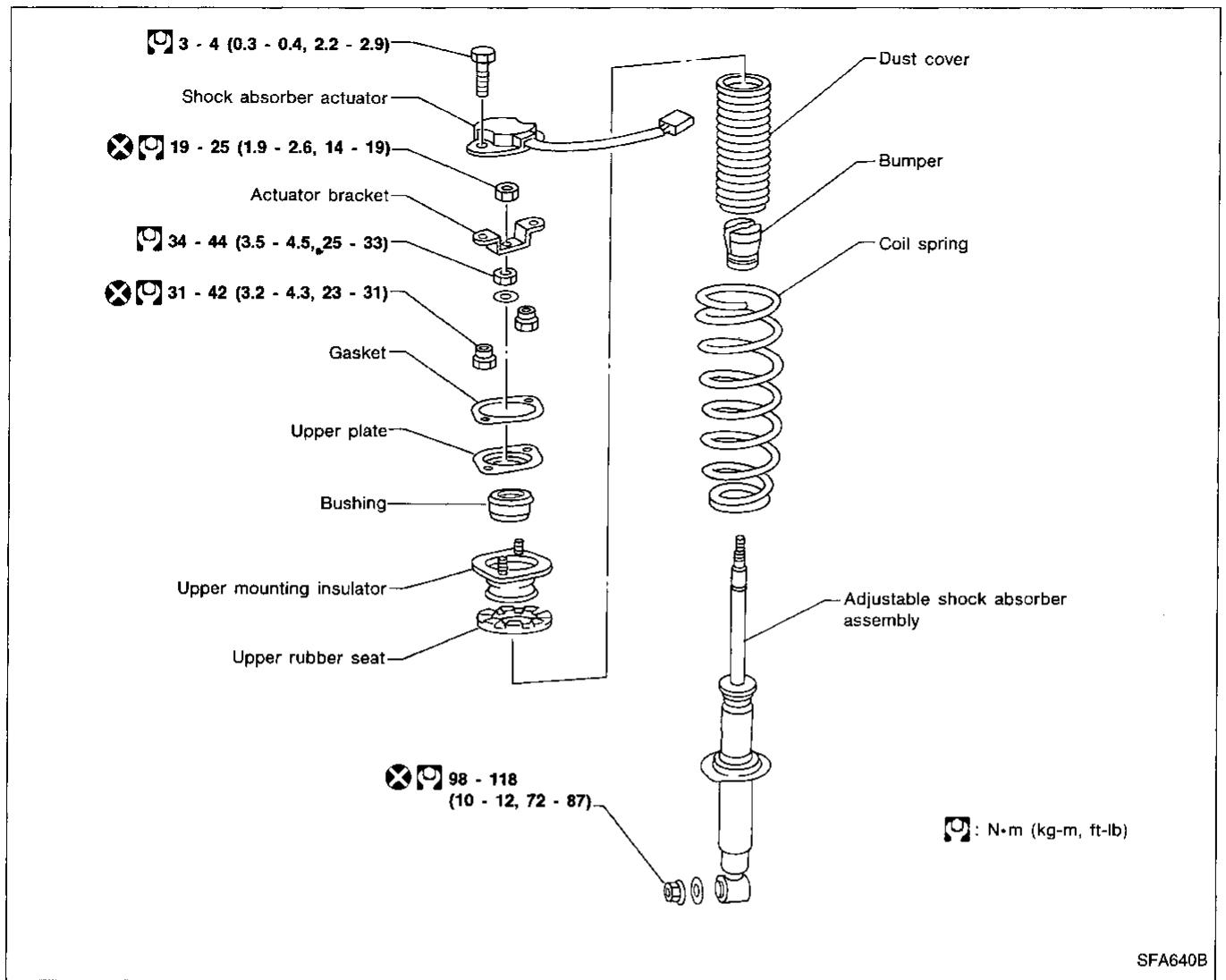

## REMOVAL AND INSTALLATION

- Disconnect sub-harness connector.
- Remove shock absorber actuator fixing bolts.

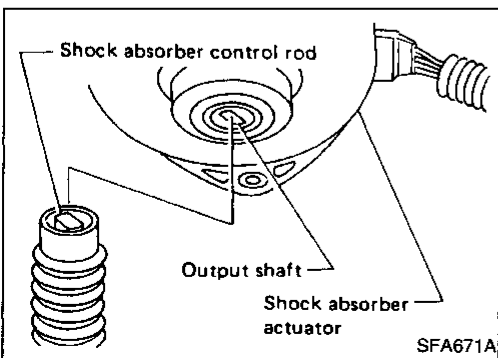

- **Before installing actuator, ensure shock absorber control rod is aligned with actuator output shaft. Otherwise, actuator may be damaged.**
- Refer to FRONT SUSPENSION for other procedures.

## INSPECTION

- Replace shock absorber assembly if it is damaged. Refer to FRONT SUSPENSION — Coil Spring and Shock Absorber (FA-14).

GI  
MA  
EM  
LC  
EF &  
EC  
FE  
CL  
MT  
AT  
PD  
FA

RA

BR

ST

RS

BT

HA

EL

IDX

# ADJUSTABLE SHOCK ABSORBER

## Trouble Diagnoses

### COMPONENT PARTS AND HARNESS CONNECTOR LOCATION

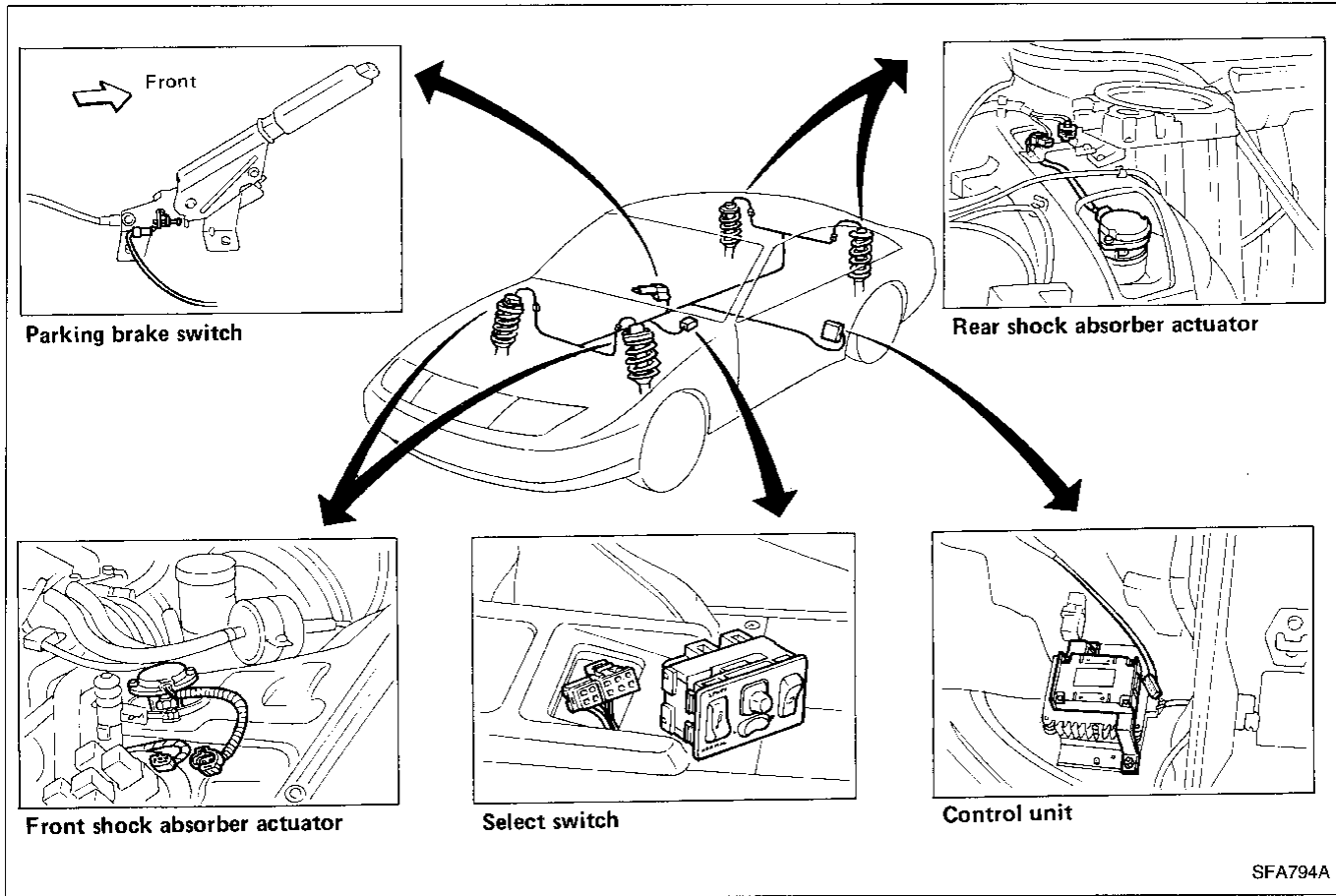

### CIRCUIT DIAGRAM FOR QUICK PINPOINT CHECK

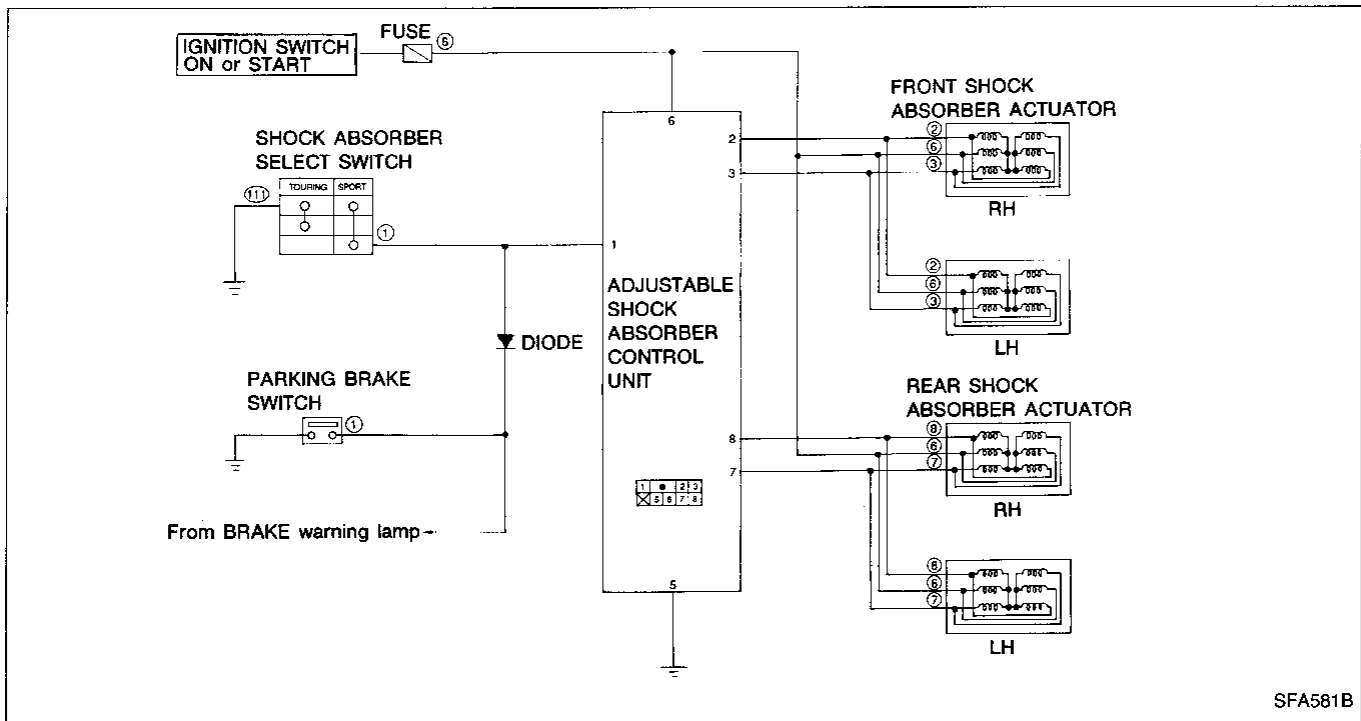

# ADJUSTABLE SHOCK ABSORBER

## Trouble Diagnoses (Cont'd) WIRING DIAGRAM

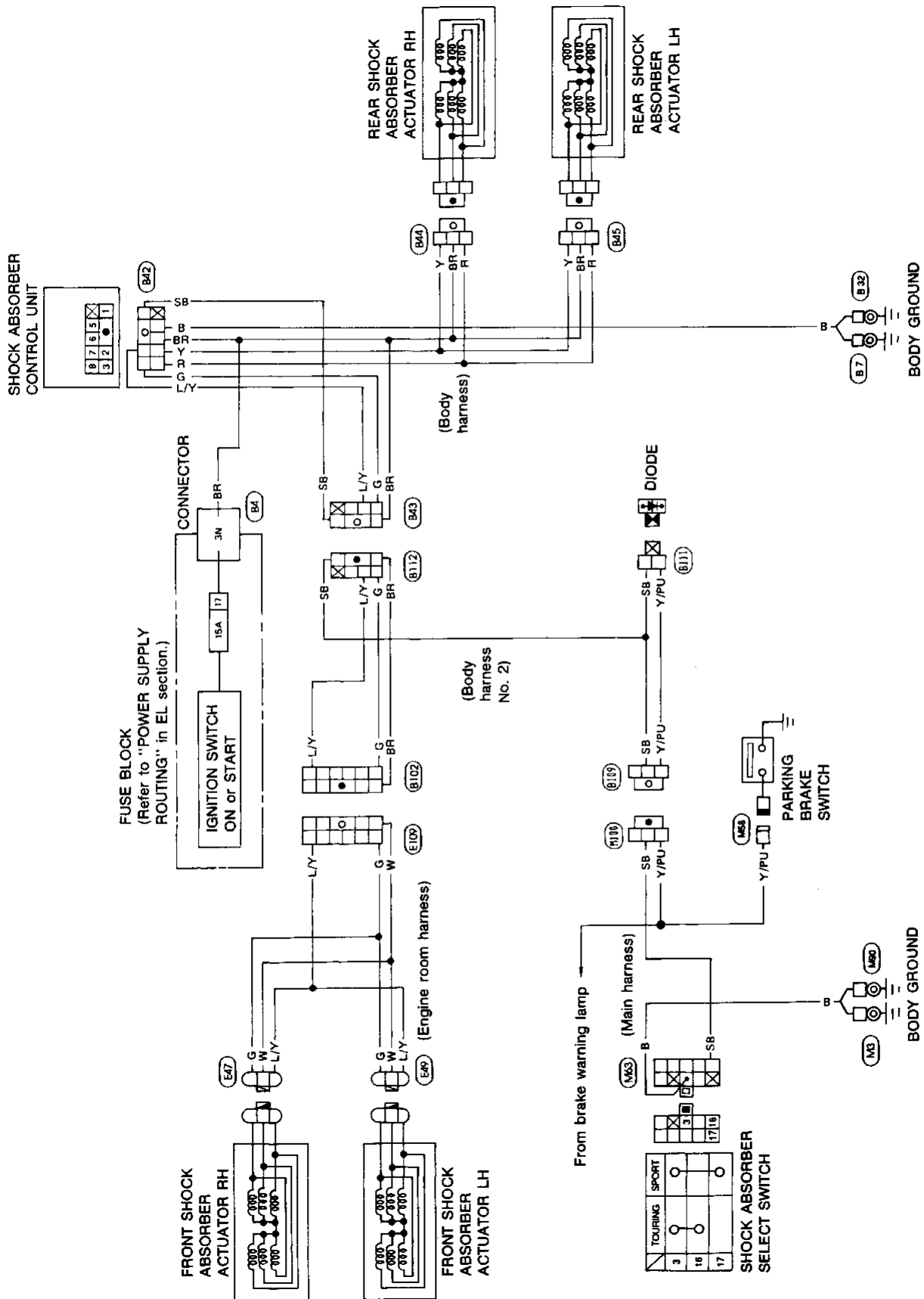

- GI
- MA
- EM
- LC
- EF & EC
- FE
- CL
- MT
- AT
- PD
- FA**
- RA
- BR
- ST
- RS
- BT
- HA
- EL
- IDX

# ADJUSTABLE SHOCK ABSORBER

## Trouble Diagnoses (Cont'd) DIAGNOSTIC PROCEDURE

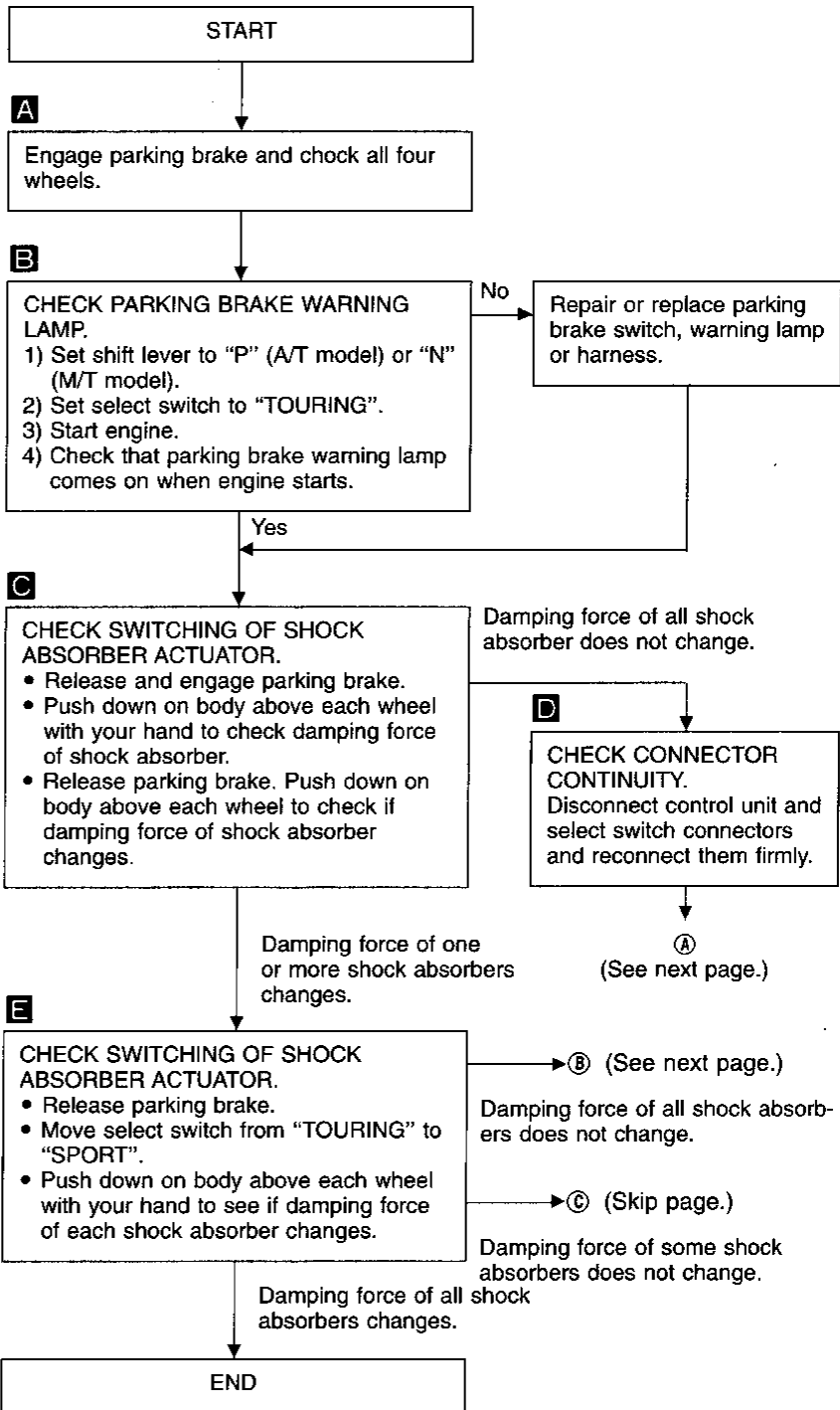
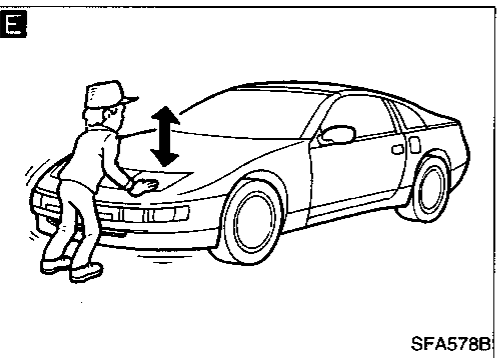
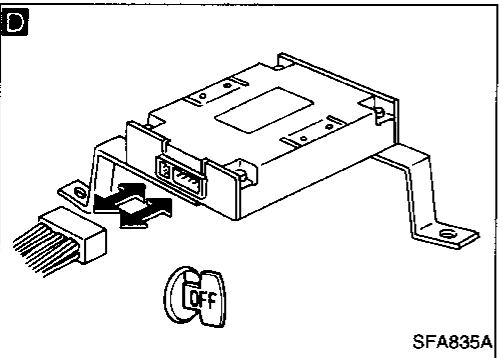
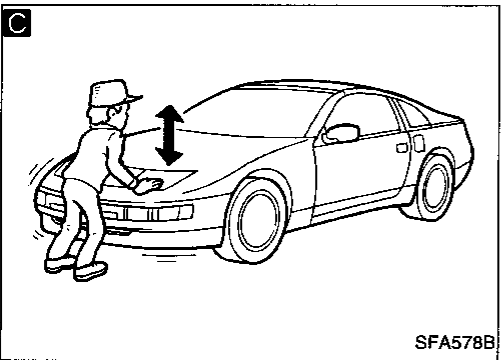
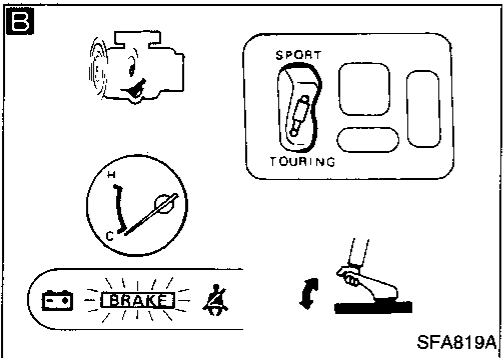
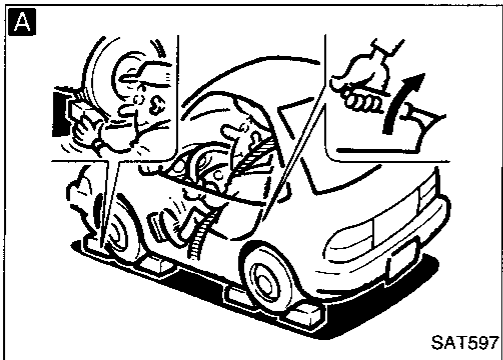

# ADJUSTABLE SHOCK ABSORBER

## Trouble Diagnoses (Cont'd)

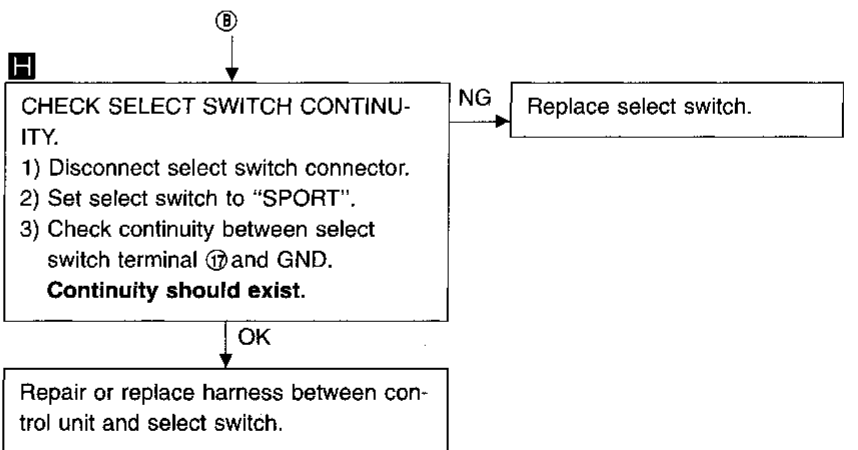
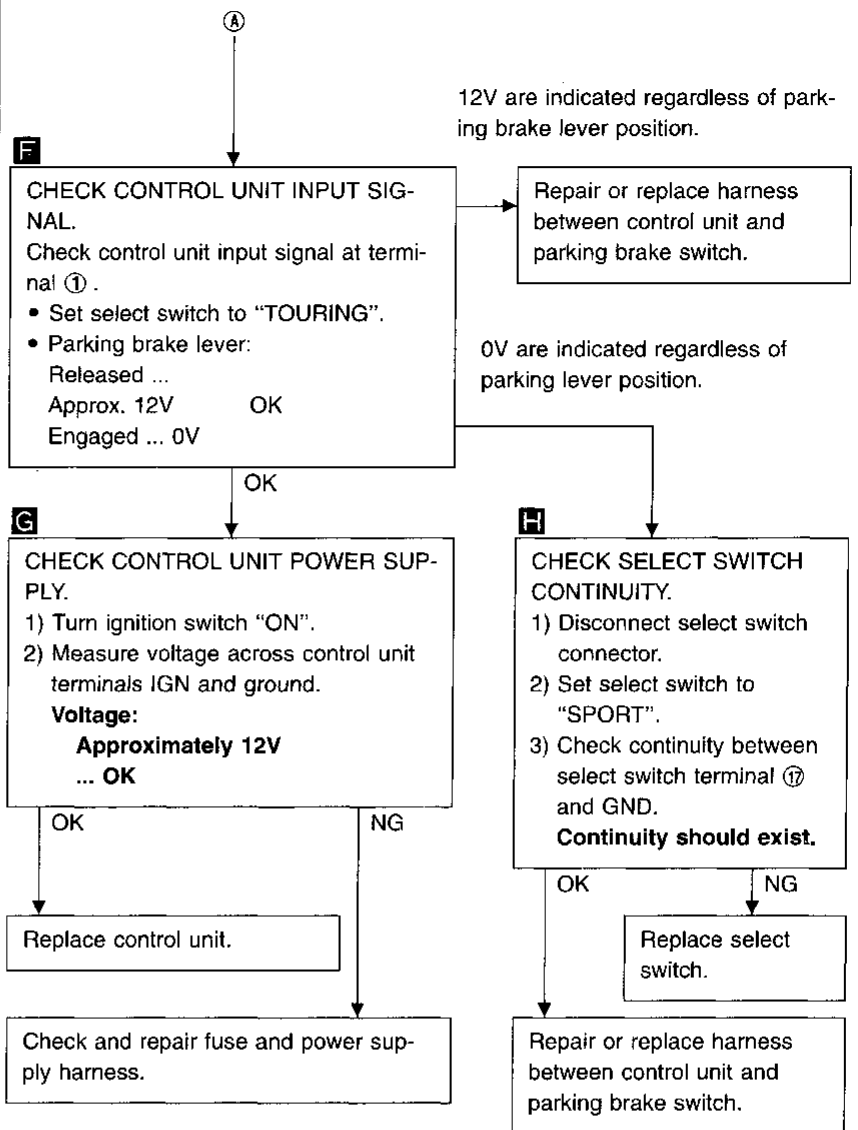
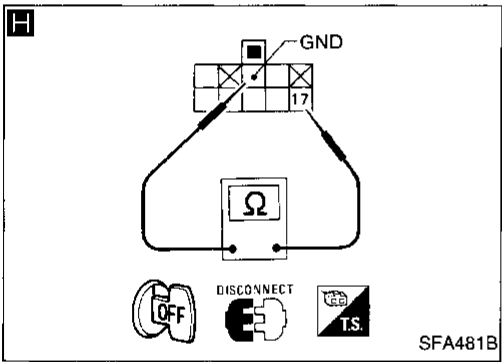
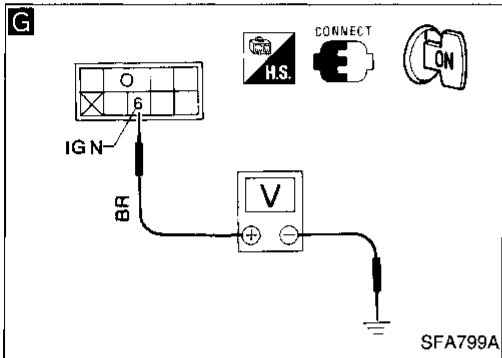
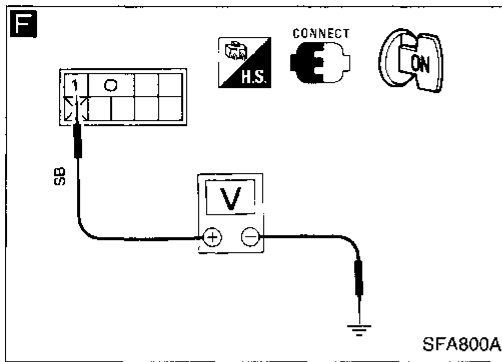

GI  
MA  
EM  
LC  
EF & EC  
FE  
CL  
MT  
AT  
PD  
FA  
RA  
BR  
ST  
RS  
BT  
HA  
EL  
IDX

# ADJUSTABLE SHOCK ABSORBER

## Trouble Diagnoses (Cont'd)

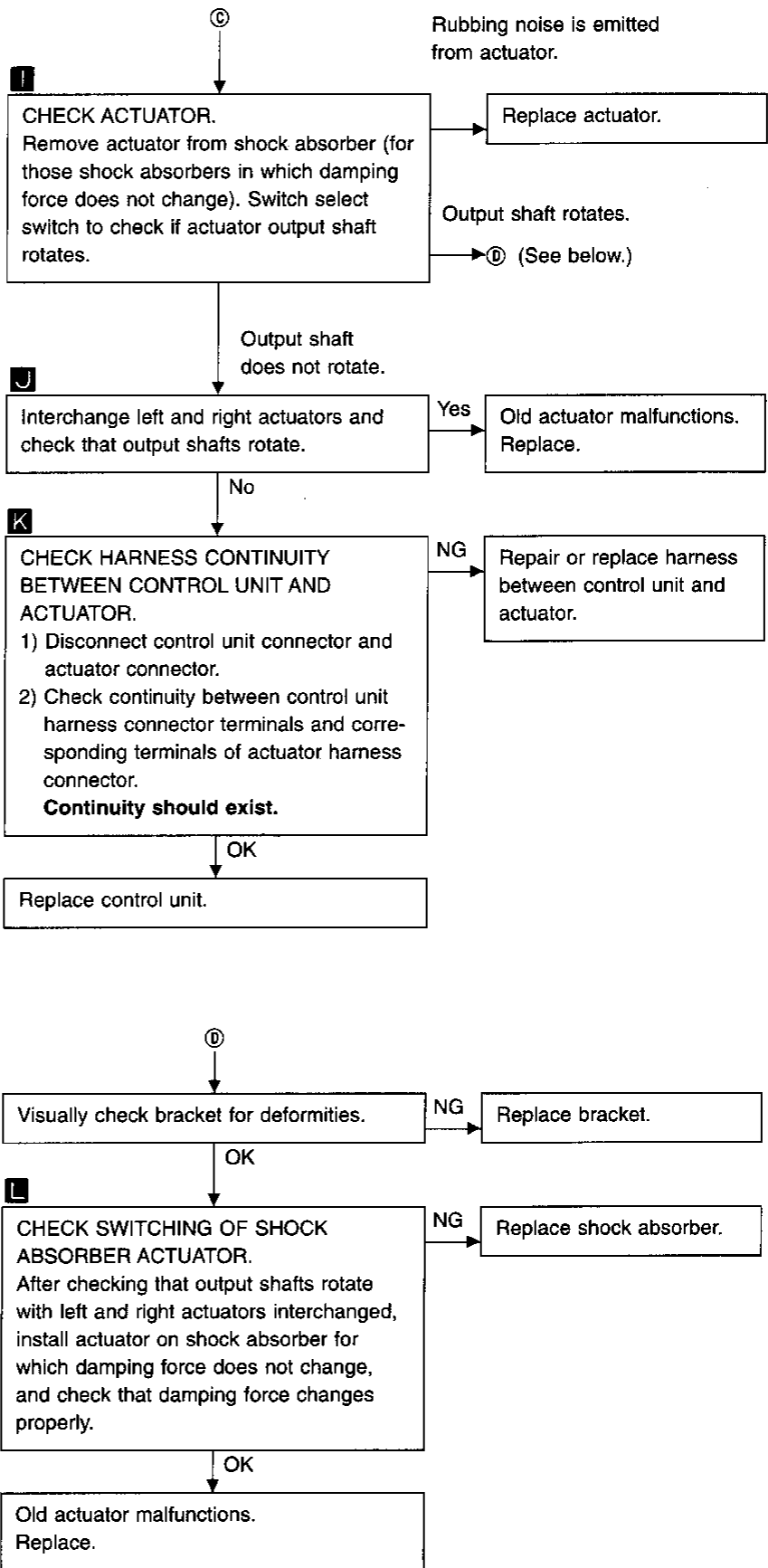
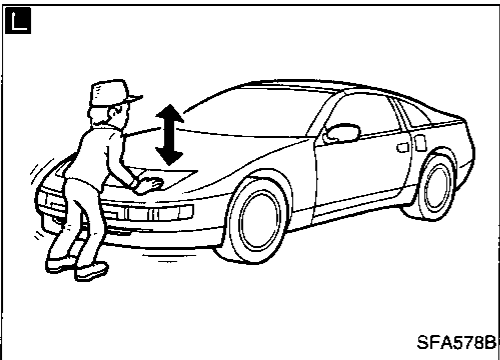
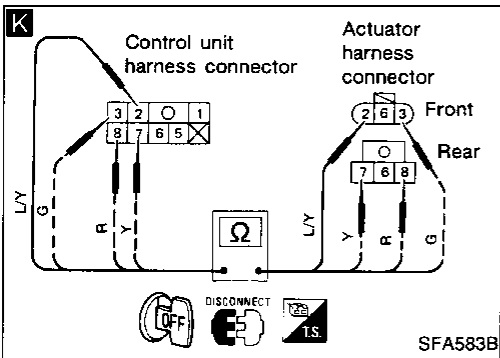
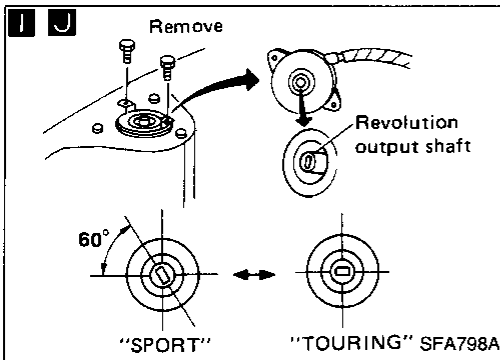



# ADJUSTABLE SHOCK ABSORBER

## Trouble Diagnoses (Cont'd)

### Control and operation of shock absorber damping force

	Select switch	
	TOURING	SPORT
Parking brake lever released	Soft	Firm
Parking brake lever engaged	Firm	Firm

### Control unit inspection table

Terminal No.	Connected to	Standard value
①	Select switch and parking brake switch	0V ("SPORT"); 12V ("TOURING") *1
		0V (parking brake lever released); *2 12V (parking brake lever engaged)
②	Front actuator "Firm"	When select signal is emitted, 12V (approx.) instantaneously drops to 2 - 3V. *1
③	Front actuator "Soft"	When select signal is emitted, 12V (approx.) instantaneously drops to 2 - 3V. *1
⑤	GND	0V
⑥	IGN	Approx. 12V
⑦	Rear actuator "Firm"	When select signal is emitted, 12V (approx.) instantaneously drops to 2 - 3V. *1
⑧	Rear actuator "Soft"	When select signal is emitted, 12V (approx.) instantaneously drops to 2 - 3V. *1

\*1: Measure with parking brake released.

\*2: Measure with select switch set to "TOURING".

# SERVICE DATA AND SPECIFICATIONS (SDS)

## General Specifications

### COIL SPRING

Model		2 seater (Non-turbocharger), Convertible	2+2 seater (Non-turbocharger)	Turbocharger
Wire diameter	mm (in)	12.1 (0.476)	11.9 (0.469)	12.1 (0.476)
Coil diameter	mm (in)	100.1 (3.94)	99.9 (3.933)	100.1 (3.94)
Free length	mm (in)	360 (14.17)	370 (14.57)	
Identification color		Light blue x 1, Pink x 1	Light blue x 2	Light blue x 1, Orange x 1

### SHOCK ABSORBER

Model		Non-turbocharger	Turbocharger
Shock absorber type		Double acting gas type	
Piston rod diameter	mm (in)	12.5 (0.492)	14.0 (0.551)
Inner cylinder bore diameter	mm (in)	25.0 (0.984)	30.0 (1.181)

### FRONT STABILIZER BAR

Applied model		2 seater	2+2 seater
Stabilizer diameter	mm (in)	27.2 (1.071)	28.6 (1.126)
Identification color		White	Purple

### TENSION ROD

Rod diameter	mm (in)	20.0 (0.787)
--------------	---------	--------------

## Inspection and Adjustment

### WHEEL ALIGNMENT (Unladen\*1)

Camber	degree	-1°35' to -0°05'
Caster	degree	8°55' - 10°25'
Toe-in		
A — B	mm (in)	0 - 2 (0 - 0.08)
Total angle 2θ	degree	0' - 11'
Kingpin inclination	degree	12°10' - 13°40'
Front wheel turning angle		
Full turn*2 inside/outside	degree	32°30' - 36°30'/26°30' - 30°30'

\*1: Fuel, radiator coolant and engine oil full. Spare tire, jack, hand tools and mats in designated positions.

\*2: On power steering models, wheel turning force (at circumference of steering wheel) of 98 to 147 N (10 to 15 kg, 22 to 33 lb) with engine idle.

### WHEEL BEARING

Wheel bearing axial end play	mm (in)	0.05 (0.0020) or less
Wheel bearing lock nut		
Tightening torque	N·m (kg·m, ft·lb)	206 - 284 (21 - 29, 152 - 210)
Wheel bearing turning resistance	N·m (kg·cm, in·lb)	
NSK bearing		0.34 - 2.16 (3.5 - 22.0, 3.0 - 19.1)
NTN bearing		0.44 - 3.33 (4.5 - 34.0, 3.9 - 29.5)
At wheel hub bolt	N (kg, lb)	
NSK bearing		5.9 - 37.3 (0.6 - 3.8, 1.3 - 8.4)
NTN bearing		7.8 - 57.9 (0.8 - 5.9, 1.8 - 13.0)

# SERVICE DATA AND SPECIFICATIONS (SDS)

## Inspection and Adjustment (Cont'd)

### LOWER BALL JOINT

Swing force (Measuring point: cotter pin hole of ball stud) N (kg, lb)	7.8 - 53.0 (0.8 - 5.4, 1.8 - 11.9)
Turning torque N·m (kg-cm, in-lb)	0.49 - 3.43 (5.0 - 35, 4.3 - 30.4)
Vertical end play mm (in)	0 (0)

### WHEEL RUNOUT (Radial and lateral)

Aluminum wheel	0.3 mm (0.012 in) or less
----------------	---------------------------

### WHEELARCH HEIGHT

Unit: mm (in)

	Non-turbocharger		Turbocharger
	2 seater	2+2 seater	2 seater
Front (Hf)	675 (26.57)	677 (26.65)	675 (26.57)
Rear (Hr)	676 (26.61)	675 (26.57)	675 (26.57)

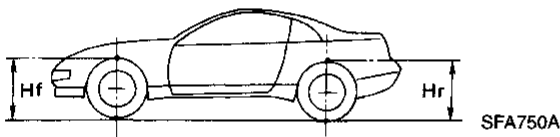

GI

MA

EM

LC

EF &  
EC

FE

CL

MT

AT

PD

**FA**

RA

BR

ST

RS

BT

HA

EL

IDX