

A
CO
C
D
E
F
G
H
I
J
K
L
M

CO

SECTION

ENGINE COOLING SYSTEM

CONTENTS

| | |
|---|---|
| PRECAUTIONS 2 | RADIATOR (ALUMINUM TYPE) 14 |
| Precautions for Battery Service 2 | Disassembly and Assembly 14 |
| Precautions for Supplemental Restraint System (SRS) "AIR BAG" and "SEAT BELT PRE-TENSIONER" 2 | PREPARATION 14 |
| Precautions for Liquid Gasket 2 | DISASSEMBLY 14 |
| REMOVAL OF LIQUID GASKET SEALING 2 | ASSEMBLY 15 |
| LIQUID GASKET APPLICATION PROCEDURE... 2 | INSPECTION 17 |
| PREPARATION 4 | COOLINGFAN 18 |
| Special Service Tools 4 | Removal and Installation 18 |
| Commercial Service Tools 4 | REMOVAL 18 |
| OVERHEATING CAUSE ANALYSIS 5 | INSTALLATION 18 |
| Troubleshooting Chart 5 | Disassembly and Assembly 18 |
| COOLING SYSTEM 7 | DISASSEMBLY 18 |
| Cooling Circuit 7 | ASSEMBLY 18 |
| ENGINE COOLANT 8 | WATER PUMP 19 |
| Inspection 8 | Removal and Installation 19 |
| LEVEL CHECK 8 | REMOVAL 19 |
| LEAK CHECK 8 | INSPECTION AFTER REMOVAL 21 |
| Changing Engine Coolant 8 | INSTALLATION 21 |
| DRAINING ENGINE COOLANT 8 | THERMOSTAT AND THERMOSTAT HOUSING 23 |
| REFILLING ENGINE COOLANT 9 | Removal and Installation 23 |
| FLUSHING COOLING SYSTEM 10 | REMOVAL 23 |
| RADIATOR 11 | INSPECTION AFTER REMOVAL 23 |
| Removal and Installation 11 | INSTALLATION 23 |
| REMOVAL 11 | WATER OUTLET AND WATER PIPING 24 |
| INSTALLATION 13 | Removal and Installation 24 |
| Checking Radiator Cap 13 | REMOVAL 24 |
| Checking Radiator 13 | INSTALLATION 24 |
| | SERVICE DATA AND SPECIFICATIONS (SDS) 25 |
| | Engine Coolant Capacity (Approximate) 25 |
| | Thermostat 25 |
| | Radiator 25 |
| | Tightening Torque 25 |

PRECAUTIONS

PRECAUTIONS

PFP:00001

Precautions for Battery Service

ABS003MG

Before disconnecting the battery, lower both the driver and passenger windows. This will prevent any interference between the window edge and the vehicle when the door is opened/closed. During normal operation, the window slightly raises and lowers automatically to prevent any window to vehicle interference. The automatic window function will not work with the battery disconnected.

Precautions for Supplemental Restraint System (SRS) “AIR BAG” and “SEAT BELT PRE-TENSIONER”

ABS0095S

The Supplemental Restraint System such as “AIR BAG” and “SEAT BELT PRE-TENSIONER”, used along with a front seat belt, helps to reduce the risk or severity of injury to the driver and front passenger for certain types of collision. This system includes seat belt switch inputs and dual stage front air bag modules. The SRS system uses the seat belt switches to determine the front air bag deployment, and may only deploy one front air bag, depending on the severity of a collision and whether the front occupants are belted or unbelted. Information necessary to service the system safely is included in the SRS and SB section of this Service Manual.

WARNING:

- To avoid rendering the SRS inoperative, which could increase the risk of personal injury or death in the event of a collision which would result in air bag inflation, all maintenance must be performed by an authorized NISSAN/INFINITI dealer.
- Improper maintenance, including incorrect removal and installation of the SRS, can lead to personal injury caused by unintentional activation of the system. For removal of Spiral Cable and Air Bag Module, see the SRS section.
- Do not use electrical test equipment on any circuit related to the SRS unless instructed to in this Service Manual. SRS wiring harnesses can be identified by yellow and/or orange harnesses or harness connectors.

Precautions for Liquid Gasket REMOVAL OF LIQUID GASKET SEALING

ABS000QL

- After removing the mounting bolts and nuts, separate the mating surface using a seal cutter (special service tool) and remove the old liquid gasket sealing.

CAUTION:

Be careful not to damage the mating surfaces.

- In areas where the seal cutter (special service tool) is difficult to use, use a plastic hammer to lightly tap (1) the seal cutter where the liquid gasket is applied. Use a plastic hammer to slide the seal cutter (2) by tapping on the side.

CAUTION:

If for some unavoidable reason a tool such as a flat-bladed screwdriver is used, be careful not to damage the mating surfaces.

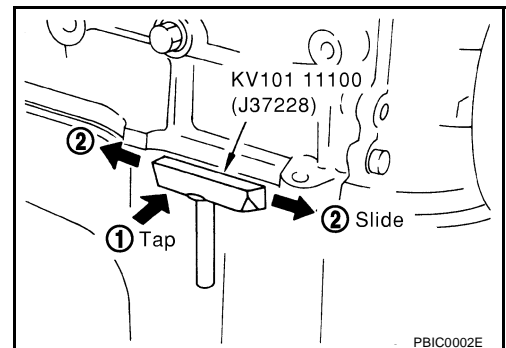

LIQUID GASKET APPLICATION PROCEDURE

1. Using a scraper, remove the old liquid gasket adhering to the gasket application surface and the mating surface.
 - Remove the liquid gasket completely from the groove of the gasket application surface, mounting bolts, and bolt holes.
2. Wipe the liquid gasket application surface and the mating surface with white gasoline (lighting and heating use) to remove adhering moisture, grease and foreign materials.

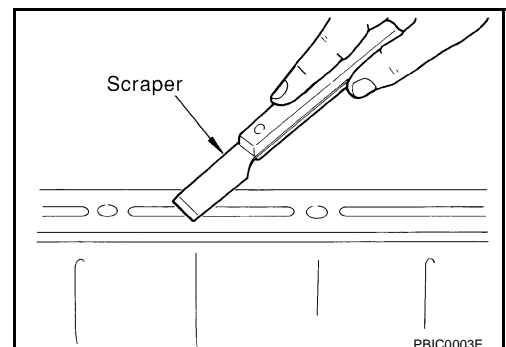

PRECAUTIONS

3. Attach the liquid gasket tube to the tube presser (special service tool).
Use Genuine RTV Silicone Sealant or equivalent. Refer to [GI-47, "RECOMMENDED CHEMICAL PRODUCTS AND SEALANTS"](#).
4. Apply the liquid gasket without breaks to the specified location with the specified dimensions.
 - If there is a groove for the liquid gasket application, apply the liquid gasket to the groove.

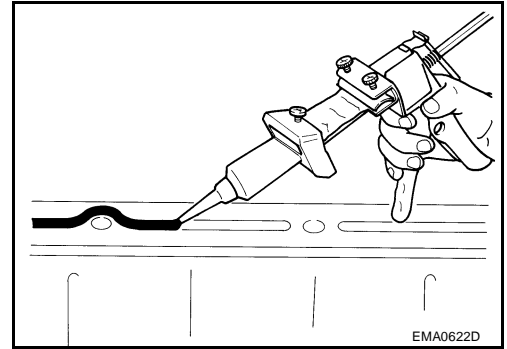

- As for the bolt holes, normally apply the liquid gasket inside the holes. Occasionally, it should be applied outside the holes. Make sure to read the text of this manual.
- Within five minutes of gasket application, install the mating component.
- If the liquid gasket protrudes, wipe it off immediately.
- Do not retighten after the installation.
- After 30 minutes or more have passed from the installation, fill the engine oil and engine coolant.

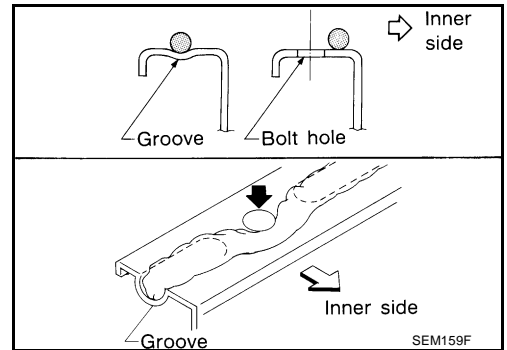

CAUTION:

If there are specific instructions in this manual, observe them.

A
CO
C
D
E
F
G
H
I
J
K
L
M

PREPARATION

PREPARATION

PFP:00002

Special Service Tools

ABS000QM

The actual shapes of Kent-Moore tools may from those of special service tools illustrated here.

| Tool number (Kent-Moore No.) Tool name | Description |
|---|--|
| WS39930000 (-) Tube pressure | Pressing the tube of liquid gasket |
| EG17650301 (J33984-A) Radiator cap tester adapter | Adapting radiator cap tester to radiator cap and radiator filler neck a: 28 (1.10) dia. b: 31.4 (1.236) dia. c: 41.3 (1.626) dia. Unit: mm (in) |
| KV99103510 (-) Radiator plate pliers A | Installing radiator upper and lower tanks |
| KV99103520 (-) Radiator plate pliers B | Removing radiator upper and lower tanks |

Commercial Service Tools

ABS000QN

| Tool name | Description |
|------------|--------------------------|
| Power tool | Loosening bolts and nuts |

OVERHEATING CAUSE ANALYSIS

OVERHEATING CAUSE ANALYSIS

PFP:00012

Troubleshooting Chart

ABS000QO

| | | Symptom | | Check items | | |
|----------------------------------|---------------------------------------|--|--|--------------------------|----|---|
| Cooling system parts malfunction | Poor heat transfer | Water pump malfunction | Worn or loose drive belt | — | CO | |
| | | Thermostat stuck closed | — | | | |
| | | Damaged fins | Dust contamination or paper clogging | | | |
| | | | Physical damage | | | |
| | | Clogged radiator cooling tube | Excess foreign material (rust, dirt, sand, etc.) | | D | |
| | Reduced air flow | Cooling fan does not operate | Fan assembly | — | E | |
| | | High resistance to fan rotation | | | | |
| | | Damaged fan blades | | | | |
| | | Damaged radiator shroud | — | — | — | F |
| | | Improper engine coolant mixture ratio | — | — | — | G |
| | | Poor engine coolant quality | — | Engine coolant viscosity | — | |
| | Insufficient engine coolant | Engine coolant leaks | Cooling hose | Loose clamp | H | |
| | | | | Cracked hose | | |
| | | | Water pump | Poor sealing | | |
| | | | Radiator cap | Loose | I | |
| Poor sealing | | | | | | |
| Radiator | | O-ring for damage, deterioration or improper fitting | J | | | |
| | | Cracked radiator tank | | | | |
| | | Cracked radiator core | | | | |
| | Reservoir tank | Cracked reservoir tank | K | | | |
| Overflowing reservoir tank | Exhaust gas leaks into cooling system | Cylinder head deterioration | L | | | |
| | | Cylinder head gasket deterioration | | | | |

A
CO
C
D
E
F
G
H
I
J
K
L
M

OVERHEATING CAUSE ANALYSIS

| | | Symptom | | Check items | |
|---|--------------------------------|--------------------------------|--|---------------------------------------|---|
| Except cooling system parts malfunction | — | Overload on engine | Abusive driving | High engine rpm under no load | — |
| | | | | Driving in low gear for extended time | |
| | | | | Driving at extremely high speed | |
| | | | Powertrain system malfunction | | |
| | | | Installed improper size wheels and tires | | |
| | | | Dragging brakes | | |
| | Blocked or restricted air flow | Blocked or restricted air flow | Blocked bumper | — | — |
| | | | Blocked radiator grille | Installed car brassiere | |
| | | | | Mud contamination or paper clogging | |
| | | | Blocked radiator | — | |
| Blocked condenser | | | Blocked air flow | | |
| Installed large fog lamp | | | | | |

COOLING SYSTEM

COOLING SYSTEM

PPF:21020

Cooling Circuit

ABS000QP

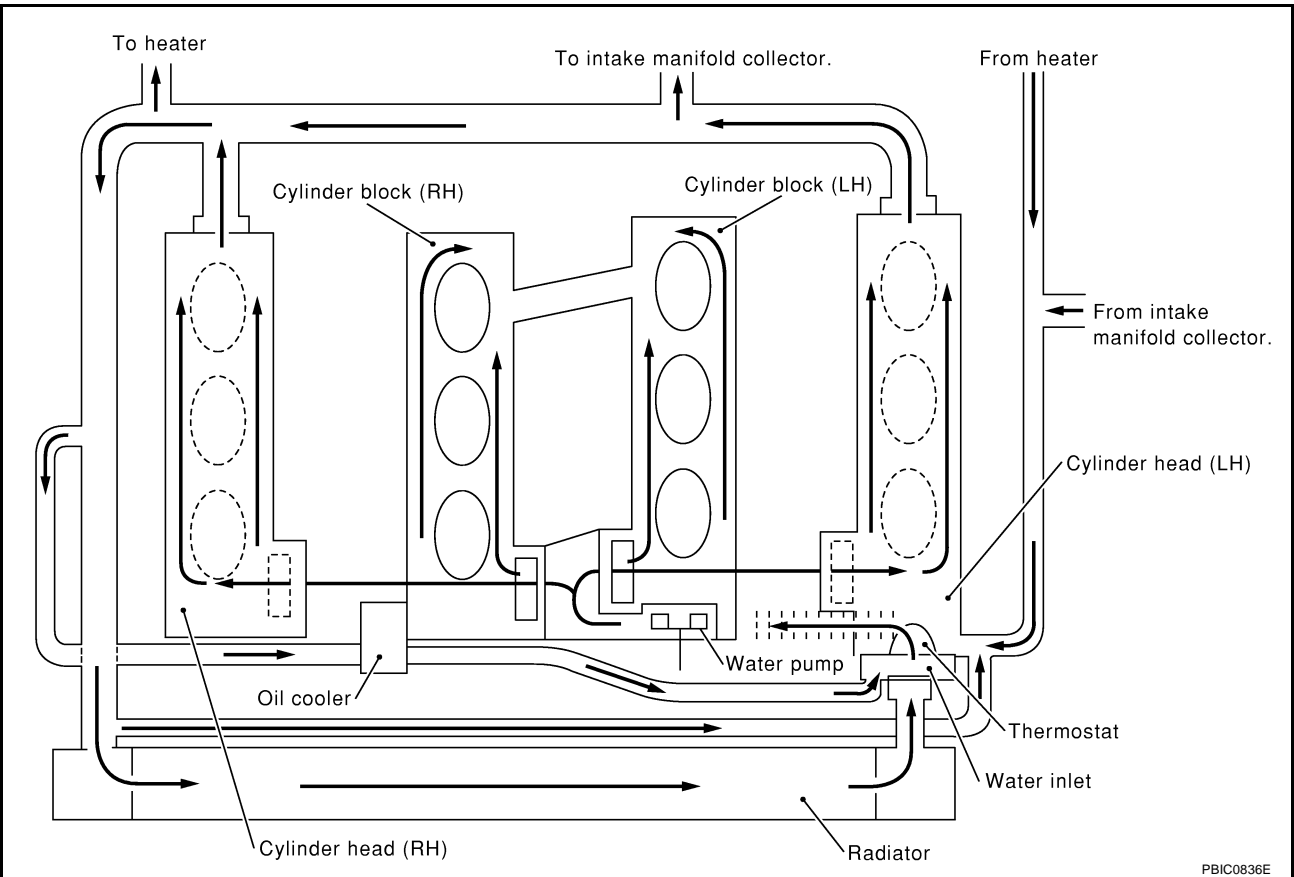

PBIC0836E

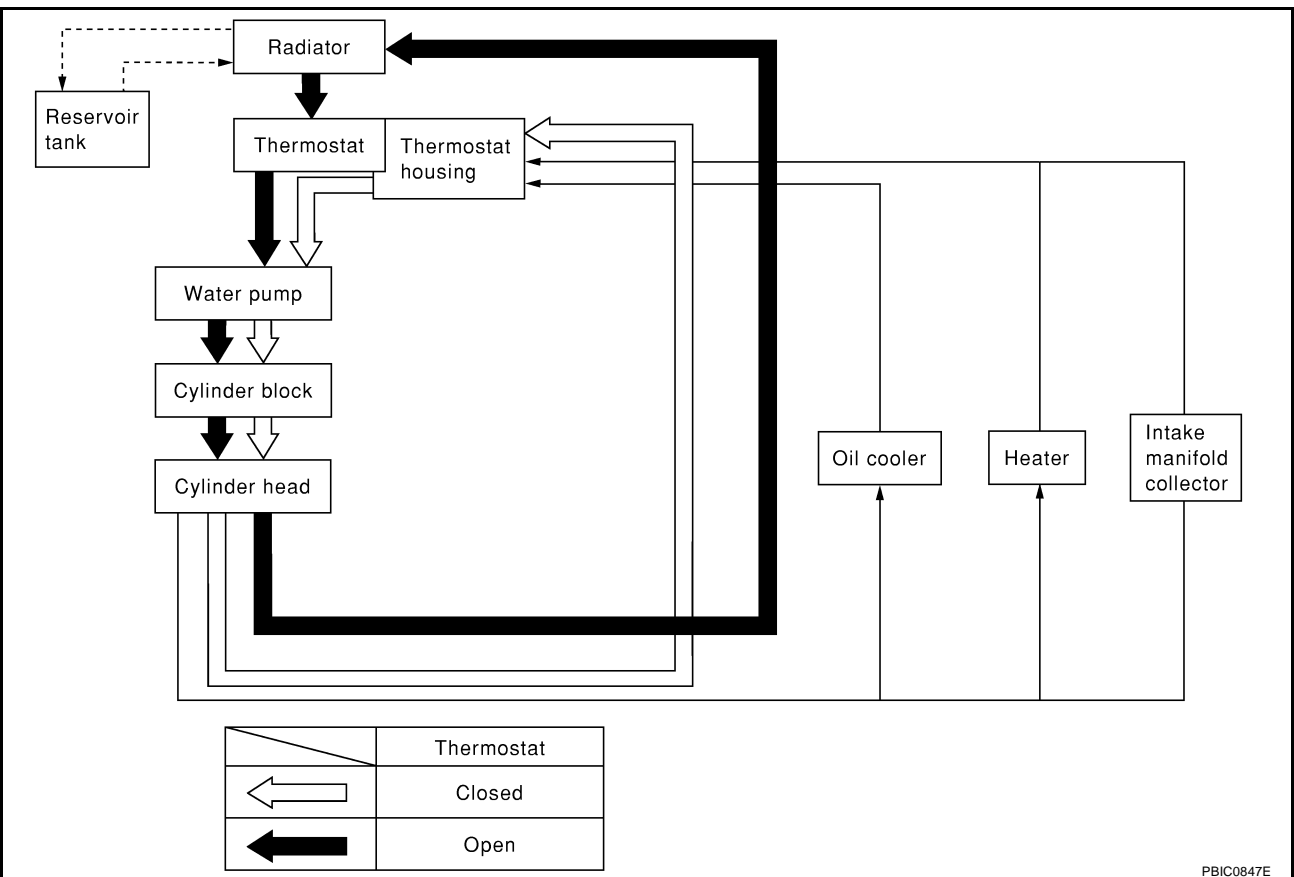

PBIC0847E

ENGINE COOLANT

ENGINE COOLANT

PFK:KQ100

Inspection LEVEL CHECK

ABS000QO

- Check if the reservoir tank engine coolant level is within the MIN to MAX range when the engine is cool.
- Adjust the engine coolant level as necessary.

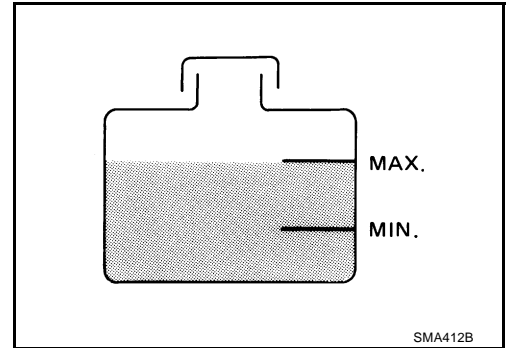

LEAK CHECK

- To check for leaks, apply pressure to the cooling system with the tester.

Testing pressure : 157 kPa (1.6 kg/cm² , 23 psi)

WARNING:

Never remove the radiator cap when the engine is hot. Serious burns could occur from high pressure engine coolant escaping from the radiator.

CAUTION:

Higher test pressure than specified may cause radiator damage.

NOTE:

In case that engine coolant decreases, replenish radiator with engine coolant.

- If anything is found, repair or replace damaged parts.

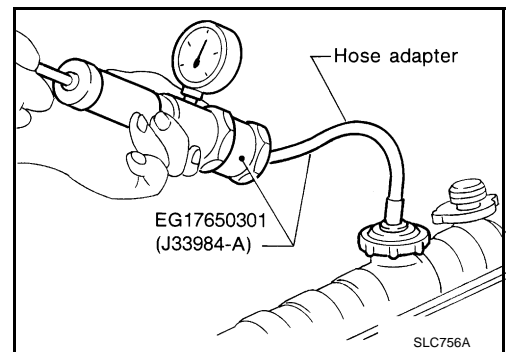

Changing Engine Coolant

ABS000QR

WARNING:

- To avoid being scalded, never change the engine coolant when the engine is hot.
- Wrap a thick cloth around cap and carefully remove the cap. First, turn the cap a quarter of a turn to release built-up pressure. Then turn the cap all the way.
- Be careful not to allow engine coolant to contact drive belts.

DRAINING ENGINE COOLANT

1. Remove engine undercover using power tool.
2. Open radiator drain plug at the bottom of radiator, and remove radiator cap.
When draining all the engine coolant in the system, also perform the following steps.
3. Remove the reservoir tank, drain the engine coolant and clean the tank before installing.

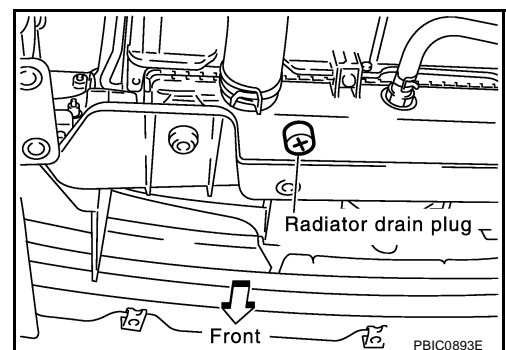

ENGINE COOLANT

4. Drain engine coolant from both sides of cylinder block at B and C in the figure and cylinder block front at A in the figure when draining all the engine coolant in the system.
5. Check drained engine coolant for contaminants such as rust, corrosion or discoloration. If contaminated, flush the engine cooling system. Refer to [CO-10, "FLUSHING COOLING SYSTEM"](#).

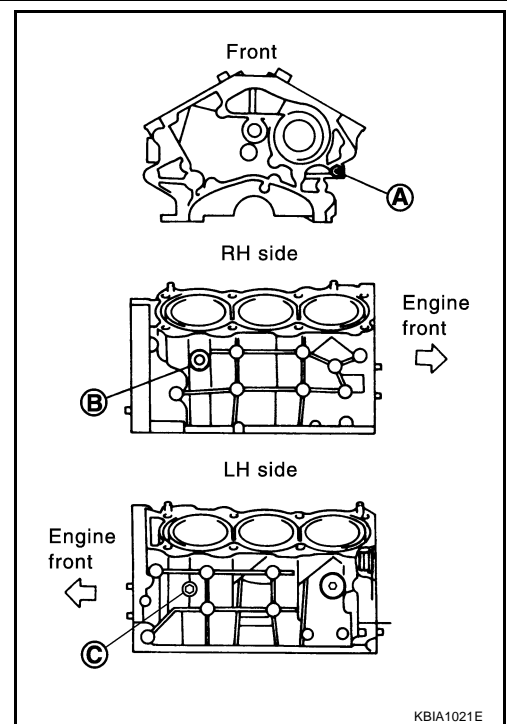

REFILLING ENGINE COOLANT

1. Install reservoir tank if removed, and radiator drain plug.
2. Close and tighten cylinder block drain plugs securely if removed.
 - **Apply sealant to the threads of cylinder block drain plugs.**
 - **Use Genuine Thread Sealant or equivalent. Refer to [GI-47, "RECOMMENDED CHEMICAL PRODUCTS AND SEALANTS"](#).**

Radiator drain plug:

: 0.78 - 1.6 N·m (0.08 - 0.16 kg-m, 7 - 14 in-lb)

Cylinder block drain plug (LH):

: 17.6 - 21.6 N·m (1.8 - 2.2 kg-m, 13 - 15 ft-lb)

Cylinder block drain plug (RH):

: 17.6 - 21.6 N·m (1.8 - 2.2 kg-m, 13 - 15 ft-lb)

Cylinder block drain plug (Front side):

: 7.8 - 11.8 N·m (0.8 - 1.2 Kg-m, 69 - 104 in-lb)

3. Remove air relief plug on heater hose.

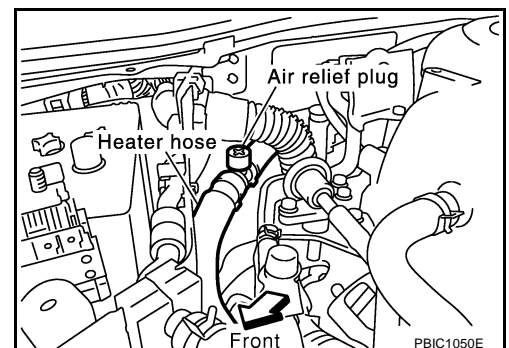

ENGINE COOLANT

4. Fill radiator and reservoir tank to specified level.

- Pour engine coolant through engine coolant filler neck slowly of less than 2 ℓ (2-1/8US qt, 1-3/4 Imp qt) a minute to allow air in system to escape.
- Use Genuine Nissan Long Life Antifreeze/ Coolant or equivalent mixed with water (distilled or demineralized). Refer to [MA-11, "RECOMMENDED FLUIDS AND LUBRICANTS"](#) .

**Engine coolant capacity
(with reservoir tank at MAX level)**

: Approximately 8.7 ℓ (9-1/4 US qt, 7-5/8 Imp qt)

Reservoir tank capacity (at MAX level)

: 0.8 ℓ (7/8 US qt, 3/4 Imp qt)

- When engine coolant overflows air relief hole on heater hose, install air relief plug with new O-ring.

Air relief plug:

 **: 0.78 - 1.6 N·m (0.08 - 0.16 kg·m, 7 - 14 in·lb)**

5. Warm up engine to normal operating temperature with radiator cap installed.

6. Run engine at 3,000 rpm for 10 seconds and return to idle speed.

- Repeat two or three times.

7. Stop engine and cool down to less than approximately 50°C (122°F).

- Cool down using a fan to reduce the time.
- If necessary, refill radiator up to filler neck with engine coolant.

8. Refill reservoir tank to MAX level line with engine coolant.

9. Repeat steps 4 through 7 two or more times with radiator cap installed until engine coolant level no longer drops.

10. Check cooling system for leaks with engine running.

11. Warm up engine, and check for sound of engine coolant flow while running engine from idle up to 3,000 rpm with heater temperature controller set at several position between COOL and WARM.

- Sound may be noticeable at heater unit.

12. Repeat step 11 three times.

13. If sound is heard, bleed air from cooling system by repeating step 4 through 7 until engine coolant level no longer drops.

- Clean excess engine coolant from engine.

FLUSHING COOLING SYSTEM

1. Fill radiator with water until water spills from the air relief hole, then close air relief plug. Fill radiator and reservoir tank with water and reinstall radiator cap.

2. Run engine and warm it up to normal operating temperature.

3. Rev engine two or three times under no-load.

4. Stop engine and wait until it cools down.

5. Drain the water from the system. Refer to [CO-8, "DRAINING ENGINE COOLANT"](#) .

6. Repeat steps 1 through 5 until clear water begins to drain from the radiator.

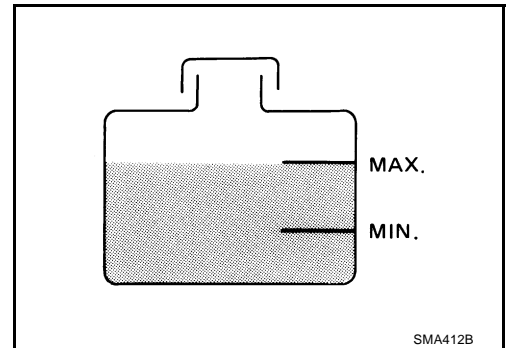
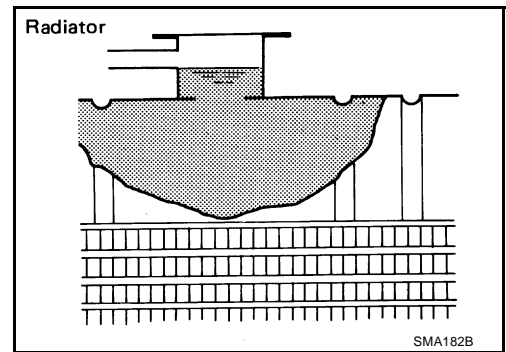

RADIATOR

PFP:21400

ABS000QS

RADIATOR

Removal and Installation

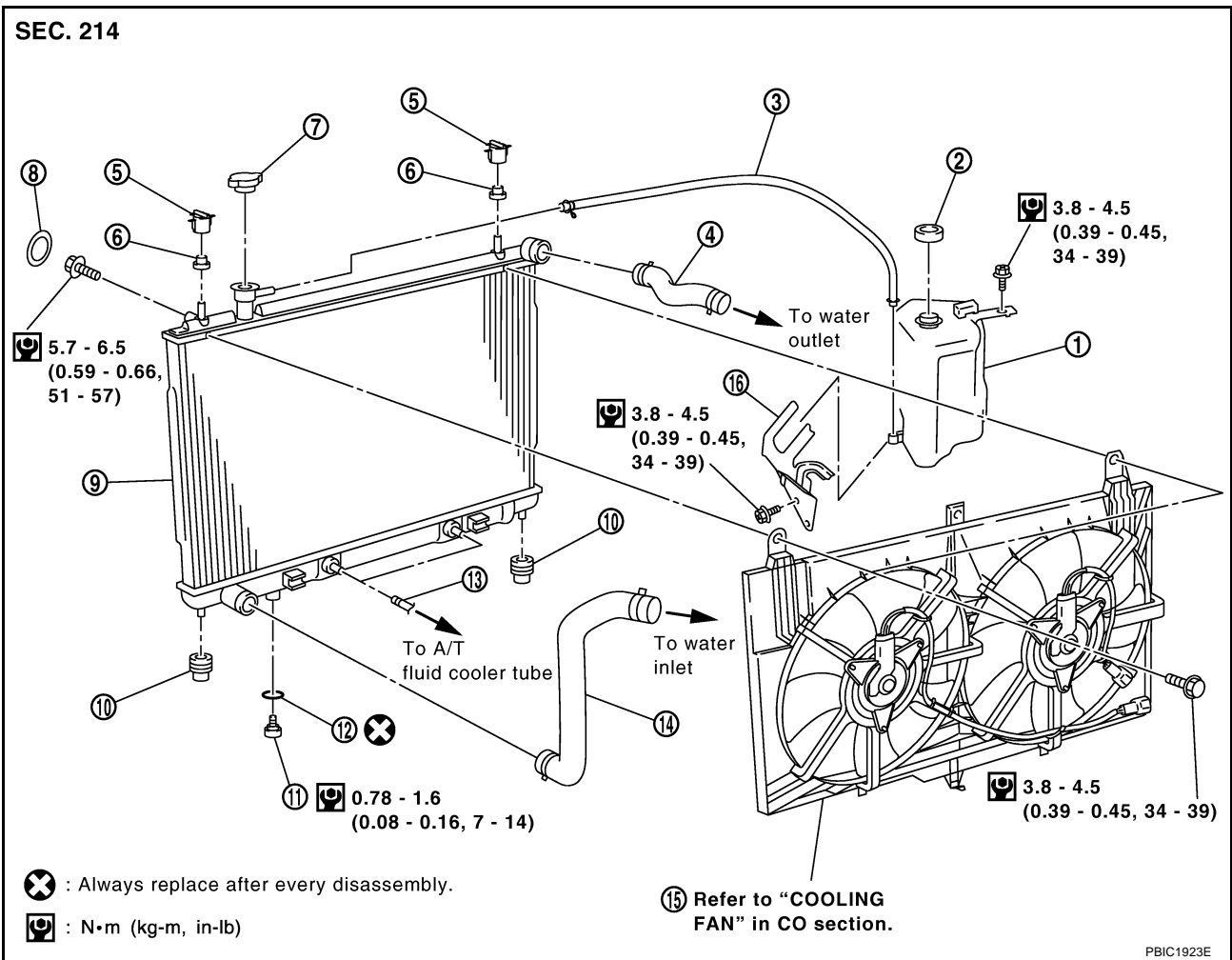

- | | | |
|-----------------------------|---------------------------|-----------------------------------|
| 1. Reservoir tank | 2. Reservoir tank hose | 3. Reservoir tank |
| 4. Radiator hose (upper) | 5. Upper mount bracket | 6. Mounting rubber (upper) |
| 7. Radiator cap | 8. Cover | 9. Radiator |
| 10. Mounting rubber (lower) | 11. Drain plug | 12. O-ring |
| 13. A/T fluid cooler hose | 14. Radiator hose (lower) | 15. Radiator cooling fan assembly |
| 16. Bracket | | |

WARNING:

Never remove radiator cap when engine is hot. Serious burns could occur from high pressure engine coolant escaping from radiator.

REMOVAL

1. Remove undercover using power tool.
2. Drain engine coolant from radiator. Refer to [CO-8, "Changing Engine Coolant"](#) .

CAUTION:

Perform when the engine is cold.

3. Remove air duct and air cleaner case assembly. Refer to [EM-15, "Removal and Installation"](#) .
4. Remove reservoir tank and bracket.
5. Disconnect A/T fluid cooler hoses.
 - Install blind plug to avoid leakage of A/T fluid.
6. Disconnect radiator upper and lower hoses.
7. Remove radiator cooling fan assembly.

RADIATOR

8. Rotate two radiator upper mount brackets 90 degrees in the direction shown in the figure, and remove them.
9. Remove bracket mounting bolt for anchoring air conditioner piping from vehicle left side, so that air conditioner piping can be moved.

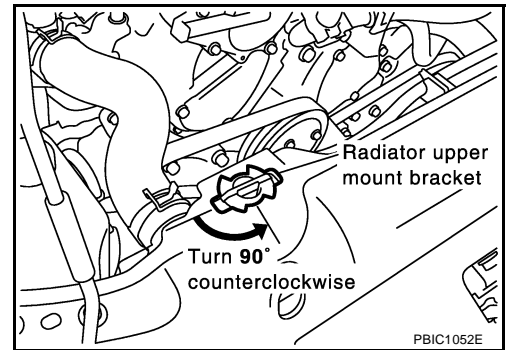

10. Remove cover, and then two A/C condenser mounting bolts located in upper part of radiator.

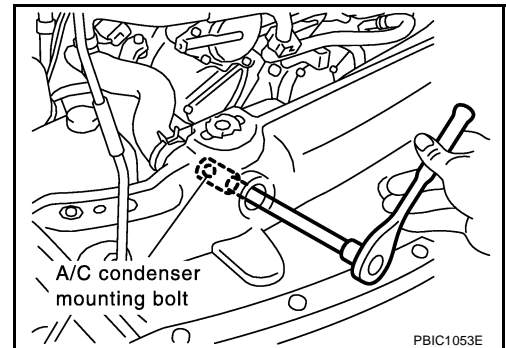

11. Lift A/C condenser up approximately 2 cm (0.79 in). Remove radiator mounting brackets.

CAUTION:

To avoid putting a load on air conditioner piping, be careful not to lift too much.

12. Lift up and remove radiator.

CAUTION:

- Do not damage or scratch A/C condenser and radiator core when removing.
- After removing radiator, fix A/C condenser on the vehicle side with a rope or similar means. This is to prevent a load being applied to A/C piping.

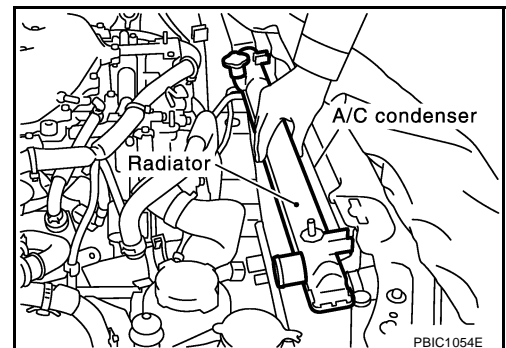

RADIATOR

INSTALLATION

- Install in the reverse order of removal.

Checking Radiator Cap

ABS008HT

1. Pull negative-pressure valve to open it and check that it closes completely when released.
 - Check that there is no dirt or damage on the valve seat of radiator cap negative-pressure valve.
 - Check that there are no unusualness in the opening and closing conditions of negative-pressure valve.

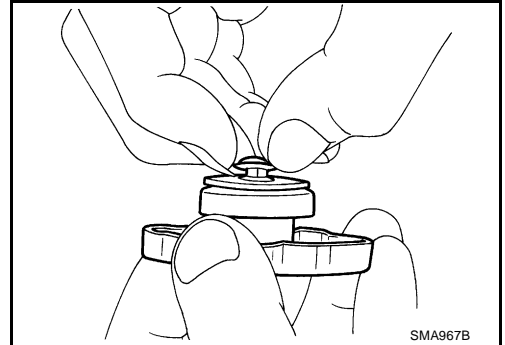

2. Check radiator cap relief pressure.

Standard:

78 - 98 kPa (0.8 - 1.0 kg/cm² , 11 - 14 psi)

Limit:

59 kPa (0.6 kg/cm² , 9 psi)

- When connecting radiator cap to the radiator cap tester adapter (special service tool) and radiator cap tester, apply engine coolant to the cap seal surface.
- Replace radiator cap if there is an unusualness in negative-pressure valve, or if the open-valve pressure is outside of the limit.

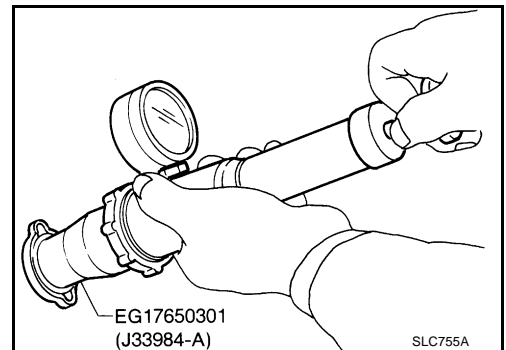

Checking Radiator

ABS008HU

Check radiator for mud or clogging. If necessary, clean radiator as follows.

- Be careful not to bend or damage the radiator fins.
 - When radiator is cleaned without removal, remove all surrounding parts such as cooling fan, radiator shroud and horns. Then tape the harness and electrical connectors to prevent water from entering.
1. Apply water by hose to the back side of radiator core vertically downward.
 2. Apply water again to all radiator core surface once per minute.
 3. Stop washing if any stains no longer flow out from radiator.
 4. Blow air into the back side of radiator core vertically downward.
 - Use compressed air lower than 490 kPa (5 kg/cm² , 71 psi) and keep distance more than 30 cm (11.8 in).
 5. Blow air again into all the radiator core surfaces once per minute until no water sprays out.

RADIATOR (ALUMINUM TYPE)

RADIATOR (ALUMINUM TYPE)

PFP:21460

Disassembly and Assembly

ABS000QT

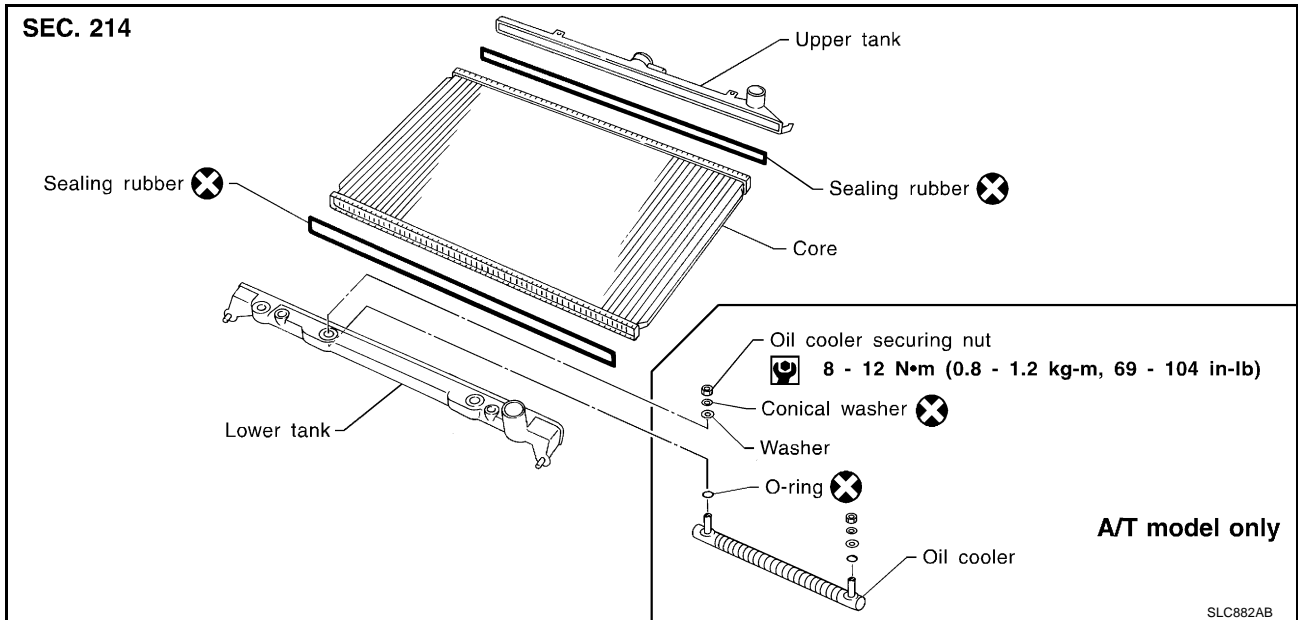

PREPARATION

1. Attach the spacer to the tip of the radiator plate pliers A. Spacer specification: 1.5 mm (0.059 in) thick x 18 mm (0.71 in) wide x 8.5 mm (0.335 in) long.
2. Make sure that when radiator plate pliers A (special service tool) are closed dimension H'' is approx. 7.6 mm (0.299 in).
3. Adjust dimension H'' with the spacer, if necessary.

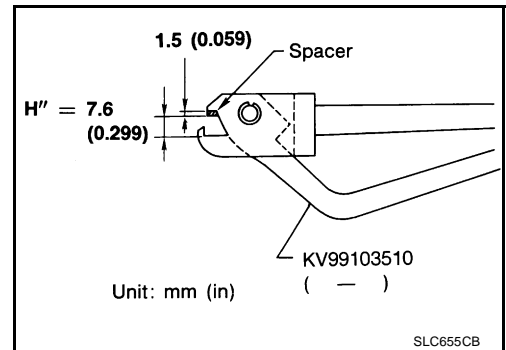

DISASSEMBLY

1. Remove upper and lower tanks with radiator plate pliers B (special service tool).

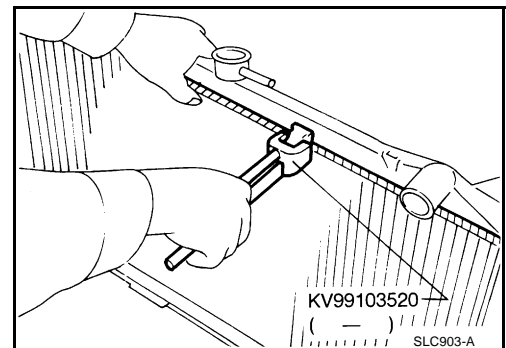

RADIATOR (ALUMINUM TYPE)

- Grip the crimped edge and bend it upwards so that radiator plate pliers B (special service tool) slips off.
Do not bend excessively.

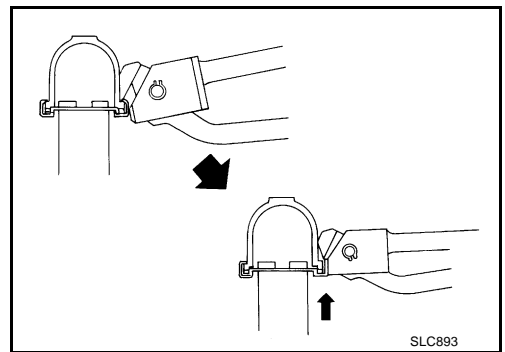

- In areas where radiator plate pliers B (special service tool) cannot be used, use a screwdriver to bend the edge up.
Be careful not to damage tank.

2. Remove sealing rubbers.

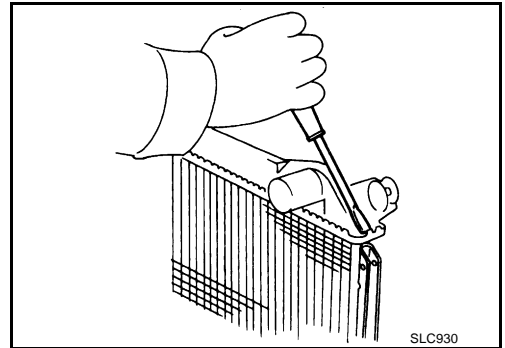

3. Make sure the edge stands straight up.
4. Remove oil cooler from tank. (A/T model)

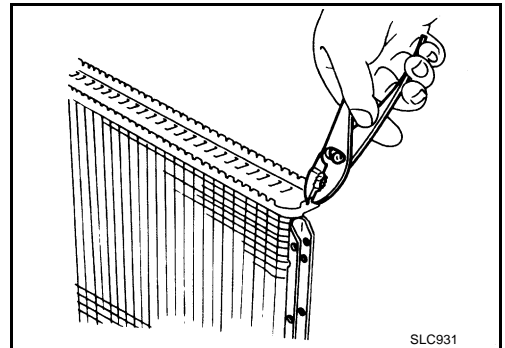

ASSEMBLY

1. Install oil cooler. (A/T model)
Pay attention to direction of conical washer.

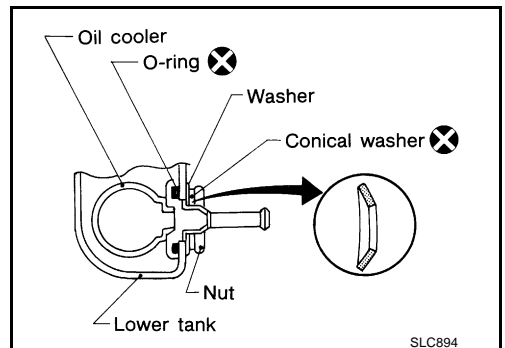

A
CO
C
D
E
F
G
H
I
J
K
L
M

RADIATOR (ALUMINUM TYPE)

2. Clean contact portion of tank.

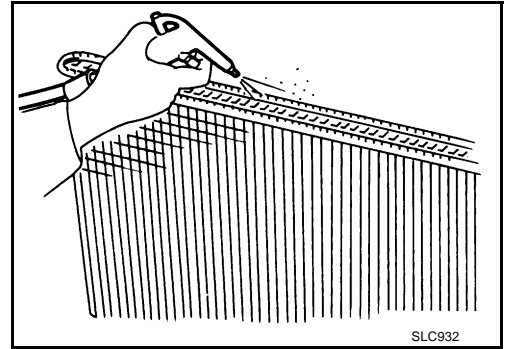

3. Install sealing rubber.
Push it in with fingers.
Be careful not to twist sealing rubber.

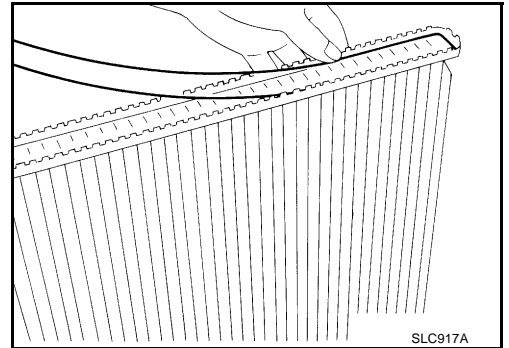

4. Caulk tank in specified sequence with radiator plate pliers A (special service tool).

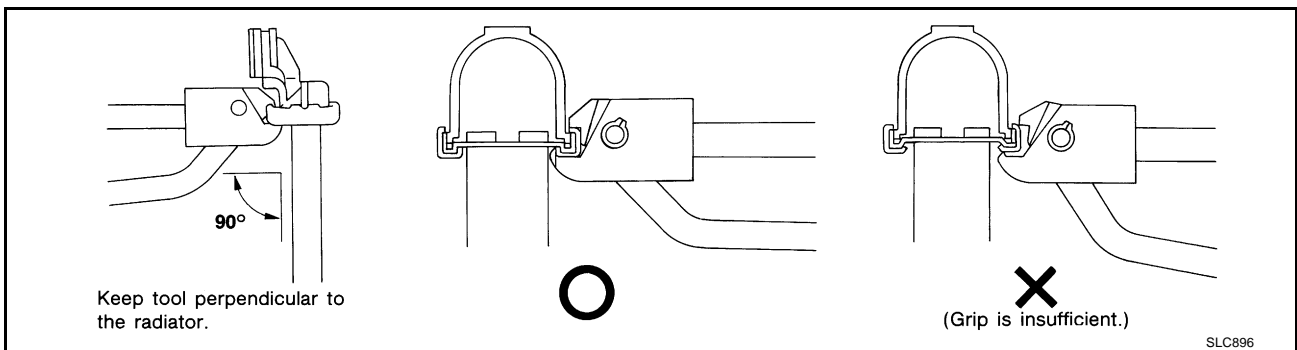
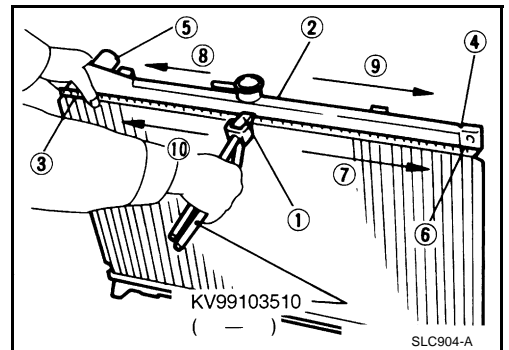

RADIATOR (ALUMINUM TYPE)

- Use pliers in the locations where radiator plate pliers A (special service tool) cannot be used.

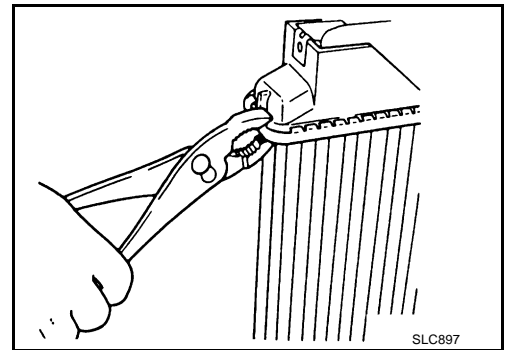

A

CO

C

D

5. Make sure that the rim is completely crimped down.

Standard height "H" : 8.0 - 8.4 mm (0.315 - 0.331 in)

6. Confirm that there is no leakage.
Refer to [CO-17, "INSPECTION"](#) .

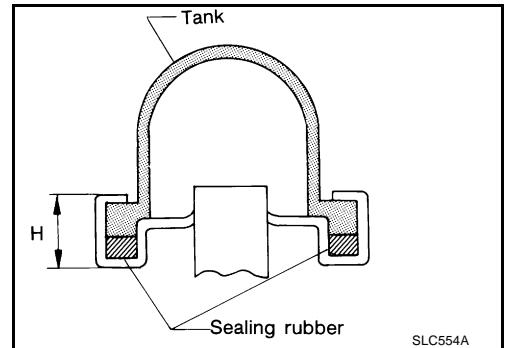

E

F

G

H

INSPECTION

1. Apply pressure with radiator cap tester adapter (special service tool) and radiator cap tester.

Specified pressure value : 157 kPa (1.6 kg/cm² , 23 psi)

WARNING:

To prevent the risk of the hose coming undone while under pressure, securely fasten it down with a hose clamp.

CAUTION:

Attach a hose to oil cooler to seal its inlet and outlet. (A/T models)

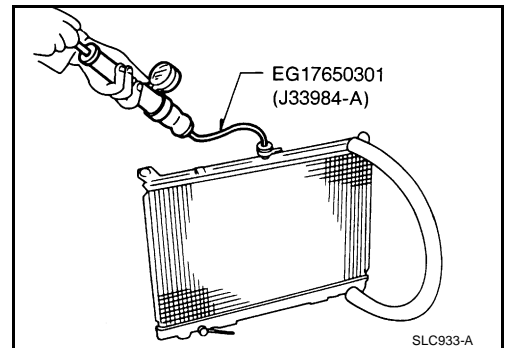

I

J

K

2. Check for leakage by soaking radiator in water container with the testing pressure applied.

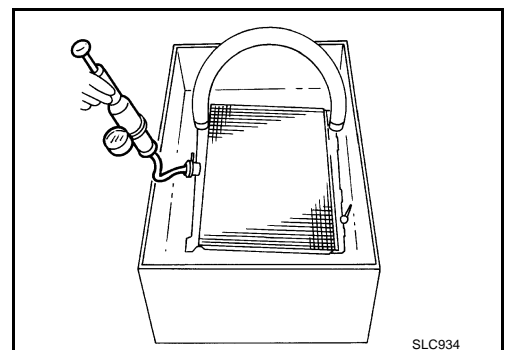

L

M

COOLINGFAN

PF21060

COOLINGFAN

Removal and Installation

ABS00814

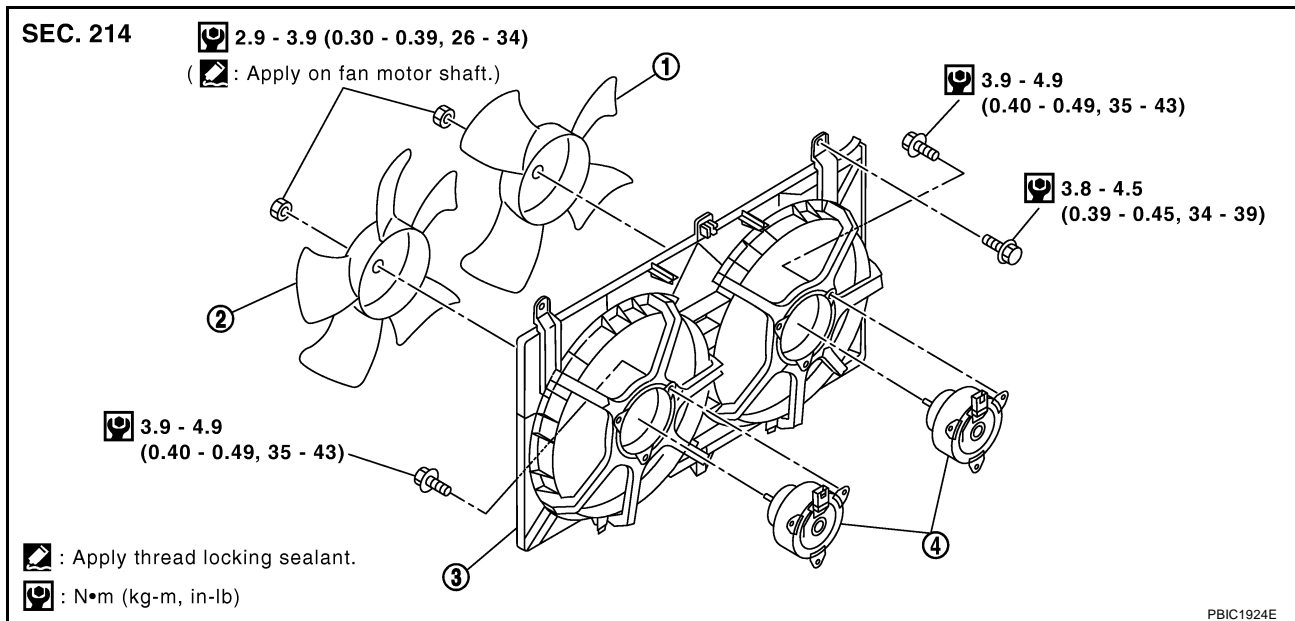

1. Cooling fan (RH)
2. Cooling fan (LH)
3. Fan shroud
4. Fan motor

REMOVAL

1. Drain engine coolant from radiator. Refer to [CO-8, "Changing Engine Coolant"](#) .

CAUTION:

Perform when engine is cold.

2. Remove air cleaner case assembly. Refer to [EM-15, "AIR CLEANER AND AIR DUCT"](#) .
3. Disconnect radiator upper hose.
4. Disconnect fan motor connectors.
5. Remove radiator cooling fan assembly.

INSTALLATION

Install in the reverse order of removal.

- Cooling fan is controlled by ECM. For details, refer to [EC-466, "DTC P1217 ENGINE OVER TEMPERATURE"](#) .

Disassembly and Assembly

DISASSEMBLY

1. Remove fans from fan motors.
2. Remove fan motors from fan shroud.

ASSEMBLY

Install in the reverse order of disassembly.

ABS00815

WATER PUMP

WATER PUMP

PF2:21020

Removal and Installation

ABS000QW

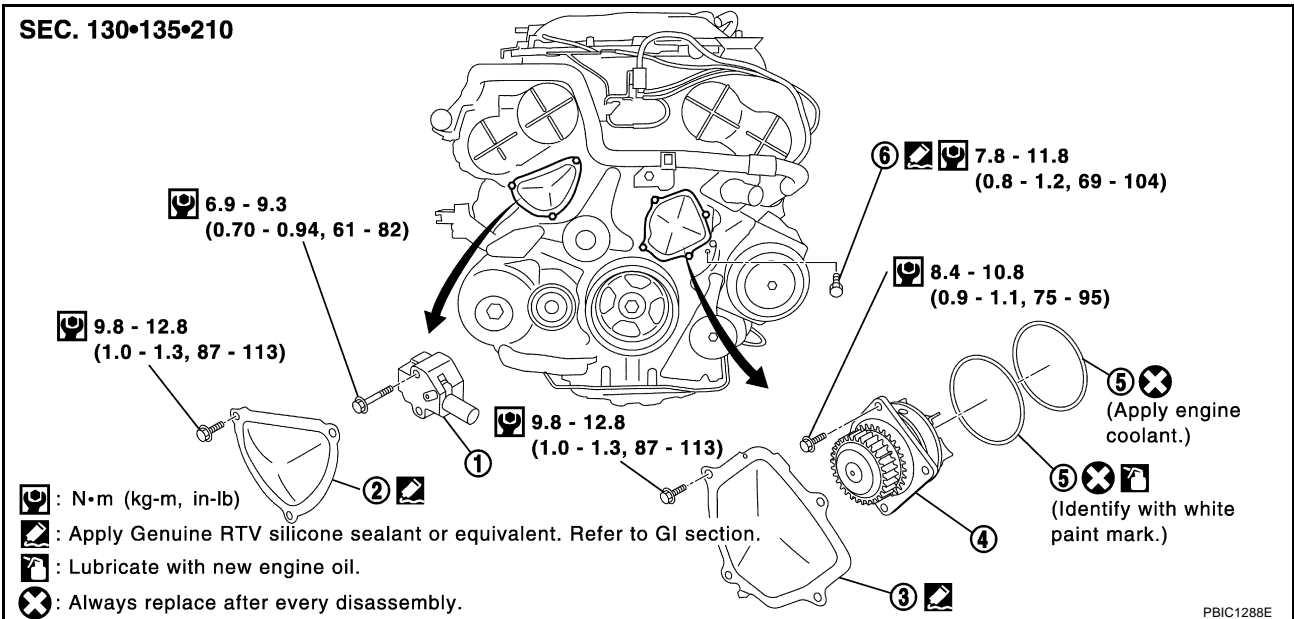

- | | | |
|--------------------|--------------------------|---------------------|
| 1. Chain tensioner | 2. Chain tensioner cover | 3. Water pump cover |
| 4. Water pump | 5. O - rings | 6. Drain plug |

CAUTION:

- When removing water pump assembly, be careful not to get engine coolant on drive belt.
- Water pump cannot be disassembled and should be replaced as a unit.
- After installing water pump, connect hose and clamp securely, then check for leaks using radiator cap tester.

REMOVAL

1. Remove undercover using power tool.
2. Remove drive belts. Refer to [EM-14, "Removal and Installation"](#).
3. Drain engine coolant from radiator. Refer to [CO-8, "Changing Engine Coolant"](#).

CAUTION:

Perform when engine is cold.

4. Remove water drain plug on water pump side of cylinder block.
5. Remove chain tensioner cover and water pump cover.
6. Remove chain tensioner assembly with the following procedure.

- a. Pull the lever down and release the plunger stopper tab.
 - Plunger stopper tab can be pushed up to release (coaxial structure with lever).

- b. Insert the stopper pin into the tensioner body hole to hold the lever and keep the stopper tab released.

NOTE:

An allen wrench [2.5 mm (0.098 in)] is used for a stopper pin as an example.

- c. Insert the plunger into the tensioner body by pressing timing chain slack guide.
- d. Keep slack guide pressed and hold the plunger in by pushing the stopper pin deeper through the lever and into the tensioner body hole.

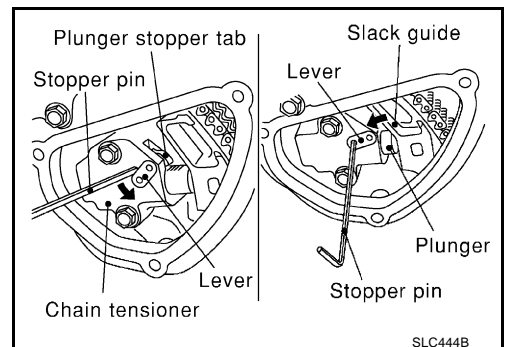
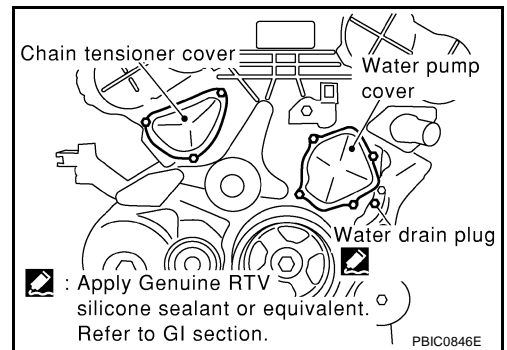

WATER PUMP

- e. Turn crankshaft pulley approximately 20° clockwise so that timing chain on the chain tensioner side is loose.

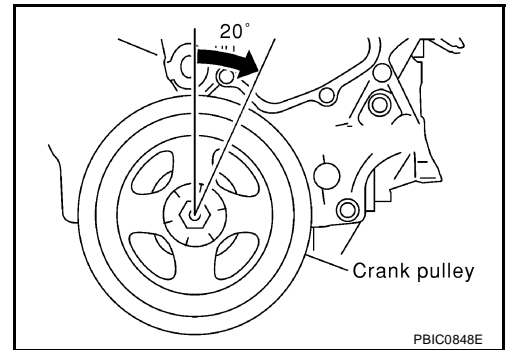

7. Remove chain tensioner.

CAUTION:

Be careful not to drop mounting bolts inside chain case.

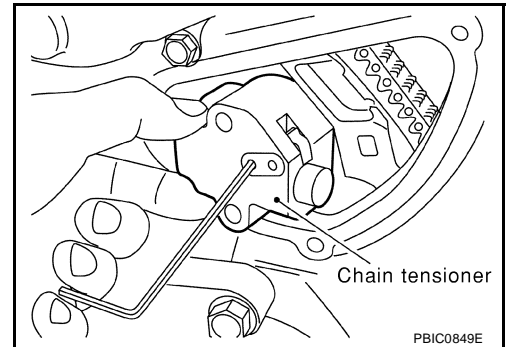

8. Remove the 3 water pump fixing bolts. Secure a gap between water pump gear and timing chain, by turning crankshaft pulley counterclockwise until timing chain looseness on water pump sprocket becomes maximum.

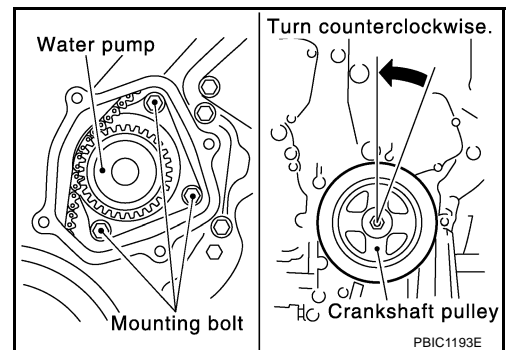

9. Screw M8 bolts [pitch: 1.25 mm (0.049 in) length: approx. 50 mm (1.97 in)] into water pumps upper and lower mounting-bolt holes until they reach timing chain case. Then, alternately tighten each bolt for a half turn, and pull out water pump.

- Pull straight out while preventing vane from contacting socket in installation area.
- Remove water pump without causing sprocket to contact timing chain.

10. Remove M8 bolts and O-rings from water pump.

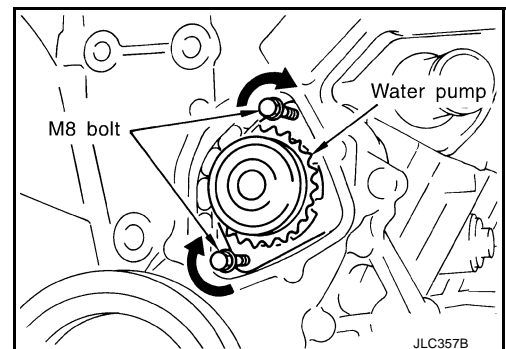

WATER PUMP

INSPECTION AFTER REMOVAL

1. Check for badly rusted or corroded water pump body assembly.
2. Check for rough operation due to excessive end play.

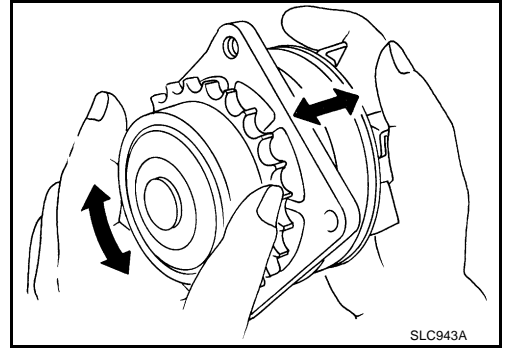

INSTALLATION

1. Install new O-rings to water pump.
2. Apply engine oil and engine coolant to O-rings as shown.
 - Locate O-ring with white paint mark to engine front side.

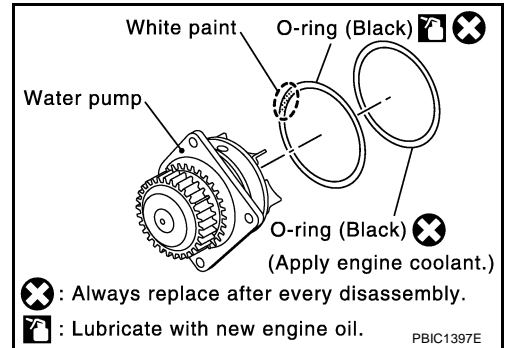

3. Install water pump.
 - **Do not allow cylinder block to nip O-rings when installing the water pump.**
 - Check that timing chain and water pump sprocket are engaged.
 - Insert water pump by tightening mounting bolts alternately and evenly.
4. Remove dust and foreign material completely from backside of chain tensioner and from installation area of rear timing chain case.
5. Turn crankshaft pulley clockwise so that timing chain on the timing chain tensioner side is loose.
 - **When installing timing chain tensioner, engine oil should be applied to the oil hole and tensioner.**
6. Install timing chain tensioner.
7. Remove the stopper pin.

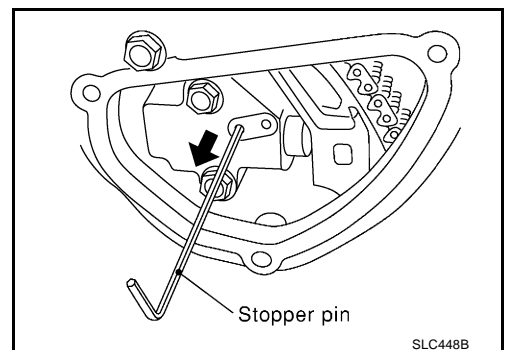
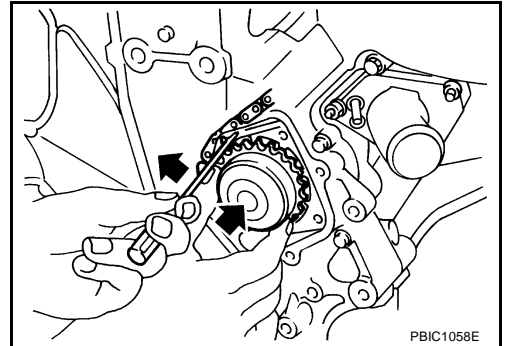

WATER PUMP

8. Install chain tensioner cover and water pump cover.
- a. Before installing, remove all traces of liquid gasket from mating surface of water pump cover and chain tensioner cover using a scraper. Also remove traces of liquid gasket from the mating surface of the front cover.

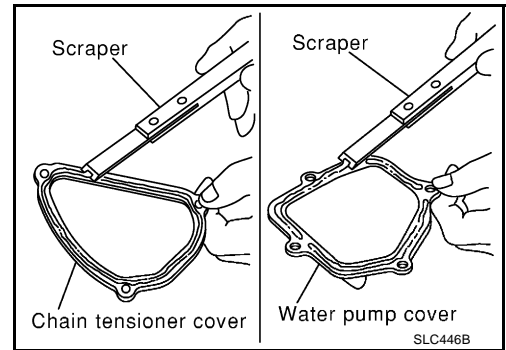

- b. Apply a continuous bead of liquid gasket to mating surface of chain tensioner cover and water pump cover.
Use Genuine RTV Silicon Sealant or equivalent. Refer to [GI-47. "RECOMMENDED CHEMICAL PRODUCTS AND SEALANTS"](#).

9. Install water drain plug on water pump side of cylinder block.
10. Installation is in the reverse order of removal for remaining parts.
 - **After starting engine, let idle for three minutes, then rev engine up to 3,000 rpm under no load to purge air from the high-pressure chamber of chain tensioner. The engine may produce a rattling noise. This indicates that air still remains in the chamber and is not a matter of concern.**

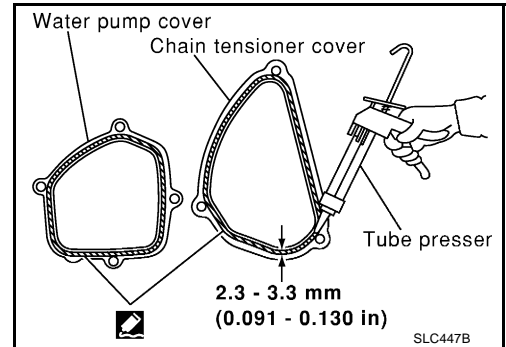

THERMOSTAT AND THERMOSTAT HOUSING

THERMOSTAT AND THERMOSTAT HOUSING

PFP:21200

Removal and Installation

ABS000QX

SEC. 210•211

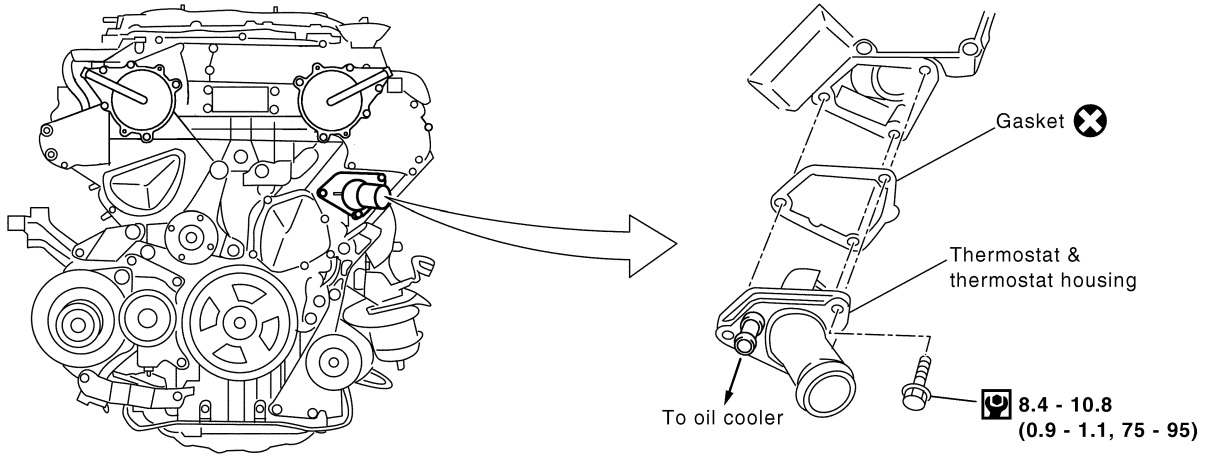

: N·m (kg-m, in-lb)

: Always replace after every disassembly.

PBIC1669E

REMOVAL

1. Remove undercover using power tool.
2. Drain engine coolant from radiator. Refer to [CO-8, "Changing Engine Coolant"](#).
3. Remove air duct and air cleaner case assembly. Refer to [EM-15, "Removal and Installation"](#).
4. Remove water drain plug on water pump side of the engine.
5. Remove radiator lower hose from thermostat and thermostat housing.
6. Remove oil cooler water hose from thermostat and thermostat housing.
7. Remove thermostat and thermostat housing.
 - **Do not disassemble thermostat and thermostat housing. Replace them as a unit, if necessary.**

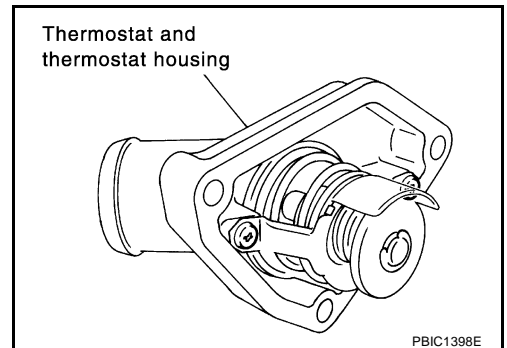

PBIC1398E

INSPECTION AFTER REMOVAL

1. Check valve seating condition at ordinary room temperatures. It should seat tightly.
2. Check valve opening temperature and maximum valve lift.

| Thermostat | Standard |
|---------------------------|----------------------------------|
| Valve opening temperature | 76.5°C (170°F) |
| Valve lift | 8.6 mm / 90°C (0.339 in / 194°F) |

3. Then check if valve closes at 5°C (9°F) below valve opening temperature.

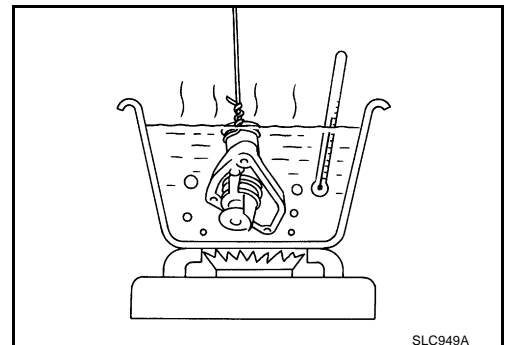

SLC949A

INSTALLATION

Install in the reverse order of removal.

SERVICE DATA AND SPECIFICATIONS (SDS)

SERVICE DATA AND SPECIFICATIONS (SDS)

PPF:00100

Engine Coolant Capacity (Approximate)

ABS000QZ

| | |
|--|------------------------------------|
| Engine coolant capacity (With reservoir tank at MAX level) | 8.7 ℓ (9-1/4 US qt, 7- 5/8 Imp qt) |
| Reservoir tank engine coolant capacity (at MAX level) | 0.8 ℓ (7/8 US qt, 3/4 Imp qt) |

Thermostat

ABS000R0

| | |
|---------------------------|----------------------------------|
| Valve opening temperature | 76.5°C (170°F) |
| Valve lift | 8.6 mm / 90°C (0.339 in / 194°F) |

Radiator

ABS000R1

Unit: kPa (kg/cm², psi)

| | | |
|-----------------------|----------|------------------------------|
| Cap relief pressure | Standard | 78 - 98 (0.8 - 1.0, 11 - 14) |
| | Limit | 59 (0.6, 9) |
| Leakage test pressure | | 157 (1.6, 23) |

Tightening Torque

ABS000R2

Unit: N·m (kg·m, ft·lb)
Unit: N·m (kg·m, in·lb)*

| | |
|--|-----------------------------------|
| Cylinder block drain plug (LH) | 17.6 - 21.6 (1.8 - 2.2, 13 - 15) |
| Cylinder block drain plug (RH) | 17.6 - 21.6 (1.8 - 2.2, 13 - 15) |
| Cylinder block drain plug (Front side) | 7.8 - 11.8 (0.8 - 1.2, 69 - 104)* |
| Air relief plug | 0.78 - 1.6 (0.08 - 0.16, 7 - 14)* |
| Radiator drain plug | 0.78 - 1.6 (0.08 - 0.16, 7 - 14)* |
| Cooling fan | 2.9 - 3.9 (0.30 - 0.39, 26 - 34)* |
| Radiator cooling fan assembly | 3.8 - 4.5 (0.39 - 0.45, 34 - 39)* |
| Fan motor | 3.9 - 4.9 (0.40 - 0.49, 35 - 43)* |
| Water pump | 8.4 - 10.8 (0.9 - 1.1, 75 - 95)* |
| Water pump cover | 9.8 - 12.8 (1.0 - 1.3, 87 - 113) |
| Chain tensioner cover | 9.8 - 12.8 (1.0 - 1.3, 87 - 113) |
| Chain tensioner | 6.9 - 9.3 (0.70 - 0.94, 61 - 82)* |
| Water outlet | 21.6 - 27.4 (2.2 - 2.7, 16 - 20) |
| Thermostat and thermostat housing | 8.4 - 10.8 (0.9 - 1.1, 75 - 95)* |
| Engine coolant temperature sensor | 19.6 - 29.4 (2.0 - 2.9, 15 - 21) |

SERVICE DATA AND SPECIFICATIONS (SDS)
