

SECTION **AT**

AUTOMATIC TRANSMISSION

A
B
AT

CONTENTS

<p>INDEX FOR DTC 5</p> <p style="padding-left: 20px;">Alphabetical Index 5</p> <p style="padding-left: 20px;">DTC No. Index 6</p> <p>PRECAUTIONS 7</p> <p style="padding-left: 20px;">Precautions for Supplemental Restraint System (SRS) "AIR BAG" and "SEAT BELT PRE-TENSIONER" 7</p> <p style="padding-left: 20px;">Precautions for Battery Service 7</p> <p style="padding-left: 20px;">Precautions for On Board Diagnostic (OBD) System of A/T and Engine 7</p> <p style="padding-left: 20px;">Precautions 8</p> <p style="padding-left: 20px;">Service Notice or Precautions 9</p> <p style="padding-left: 20px;">Wiring Diagrams and Trouble Diagnosis 9</p> <p>PREPARATION 10</p> <p style="padding-left: 20px;">Special Service Tools 10</p> <p style="padding-left: 20px;">Commercial Service Tools 11</p> <p>A/T FLUID 12</p> <p style="padding-left: 20px;">Changing A/T Fluid 12</p> <p style="padding-left: 20px;">Checking A/T Fluid 12</p> <p style="padding-left: 20px;">A/T Fluid Cooler Cleaning 14</p> <p>A/T CONTROL SYSTEM 17</p> <p style="padding-left: 20px;">Cross-Sectional View 17</p> <p style="padding-left: 20px;">Shift Mechanism 18</p> <p style="padding-left: 20px;">TCM Function 29</p> <p style="padding-left: 20px;">CAN Communication 30</p> <p style="padding-left: 20px;">Input/Output Signal of TCM 30</p> <p style="padding-left: 20px;">Line Pressure Control 31</p> <p style="padding-left: 20px;">Shift Control 32</p> <p style="padding-left: 20px;">Lock-up Control 33</p> <p style="padding-left: 20px;">Engine Brake Control 34</p> <p style="padding-left: 20px;">Control Valve 35</p> <p>ON BOARD DIAGNOSTIC (OBD) SYSTEM 37</p> <p style="padding-left: 20px;">Introduction 37</p> <p style="padding-left: 20px;">OBD-II Function for A/T System 37</p> <p style="padding-left: 20px;">One or Two Trip Detection Logic of OBD-II 37</p> <p style="padding-left: 20px;">OBD-II Diagnostic Trouble Code (DTC) 37</p> <p style="padding-left: 20px;">Malfunction Indicator Lamp (MIL) 40</p> <p>TROUBLE DIAGNOSIS 41</p> <p style="padding-left: 20px;">DTC Inspection Priority Chart 41</p> <p style="padding-left: 20px;">Fail-safe 41</p>	<p style="padding-left: 20px;">How To Perform Trouble Diagnosis For Quick and Accurate Repair 43</p> <p style="padding-left: 20px;">A/T Electrical Parts Location 48</p> <p style="padding-left: 20px;">Circuit Diagram 50</p> <p style="padding-left: 20px;">Inspections Before Trouble Diagnosis 51</p> <p style="padding-left: 20px;">Check Before Engine is Started 55</p> <p style="padding-left: 20px;">Check at Idle 55</p> <p style="padding-left: 20px;">Cruise Test - Part 1 57</p> <p style="padding-left: 20px;">Cruise Test - Part 2 59</p> <p style="padding-left: 20px;">Cruise Test - Part 3 60</p> <p style="padding-left: 20px;">Vehicle Speed When Shifting Gears 61</p> <p style="padding-left: 20px;">Vehicle Speed When Performing and Releasing Complete Lock-up 61</p> <p style="padding-left: 20px;">Vehicle Speed When Performing and Releasing Slip Lock-up 61</p> <p style="padding-left: 20px;">Symptom Chart 62</p> <p style="padding-left: 20px;">TCM Input/Output Signal Reference Values 86</p> <p style="padding-left: 20px;">CONSULT-II 87</p> <p style="padding-left: 20px;">Diagnostic Procedure Without CONSULT-II 99</p> <p>DTC U1000 CAN COMMUNICATION LINE 101</p> <p style="padding-left: 20px;">Description 101</p> <p style="padding-left: 20px;">On Board Diagnosis Logic 101</p> <p style="padding-left: 20px;">Possible Cause 101</p> <p style="padding-left: 20px;">DTC Confirmation Procedure 101</p> <p style="padding-left: 20px;">Wiring Diagram — AT — CAN 102</p> <p style="padding-left: 20px;">Diagnostic Procedure 103</p> <p>DTC P0615 START SIGNAL CIRCUIT 104</p> <p style="padding-left: 20px;">Description 104</p> <p style="padding-left: 20px;">CONSULT-II Reference Value 104</p> <p style="padding-left: 20px;">On Board Diagnosis Logic 104</p> <p style="padding-left: 20px;">Possible Cause 104</p> <p style="padding-left: 20px;">DTC Confirmation Procedure 104</p> <p style="padding-left: 20px;">Wiring Diagram — AT — STSIG 105</p> <p style="padding-left: 20px;">Diagnostic Procedure 106</p> <p>DTC P0700 TCM 108</p> <p style="padding-left: 20px;">Description 108</p> <p style="padding-left: 20px;">On Board Diagnosis Logic 108</p> <p style="padding-left: 20px;">Possible Cause 108</p> <p style="padding-left: 20px;">DTC Confirmation Procedure 108</p> <p style="padding-left: 20px;">Diagnostic Procedure 108</p>
---	--

D
E
F
G
H
I
J
K
L
M

DTC P0705 PARK/NEUTRAL POSITION SWITCH	109	DTC Confirmation Procedure	127
Description	109	Diagnostic Procedure	127
CONSULT-II Reference Value	109	DTC P1705 THROTTLE POSITION SENSOR	128
On Board Diagnosis Logic	109	Description	128
Possible Cause	109	CONSULT-II Reference Value	128
DTC Confirmation Procedure	109	On Board Diagnosis Logic	128
Wiring Diagram — AT — PNP/SW	110	Possible Cause	128
Diagnostic Procedure	111	DTC Confirmation Procedure	128
DTC P0720 VEHICLE SPEED SENSOR A/T (REVOLUTION SENSOR)	113	Diagnostic Procedure	129
Description	113	DTC P1710 A/T FLUID TEMPERATURE SENSOR CIRCUIT	131
CONSULT-II Reference Value	113	Description	131
On Board Diagnosis Logic	113	CONSULT-II Reference Value	131
Possible Cause	113	On Board Diagnosis Logic	131
DTC Confirmation Procedure	113	Possible Cause	131
Wiring Diagram — AT — VSSA/T	115	DTC Confirmation Procedure	131
Diagnostic Procedure	116	Wiring Diagram — AT — FTS	132
DTC P0725 ENGINE SPEED SIGNAL	118	Diagnostic Procedure	133
Description	118	Component Inspection	135
CONSULT-II Reference Value	118	DTC P1716 TURBINE REVOLUTION SENSOR	136
On Board Diagnosis Logic	118	Description	136
Possible Cause	118	CONSULT-II Reference Value	136
DTC Confirmation Procedure	118	On Board Diagnosis Logic	136
Diagnostic Procedure	119	Possible Cause	136
DTC P0740 TORQUE CONVERTER CLUTCH SOLENOID VALVE	120	DTC Confirmation Procedure	136
Description	120	Diagnostic Procedure	137
CONSULT-II Reference Value	120	DTC P1721 VEHICLE SPEED SENSOR MTR	138
On Board Diagnosis Logic	120	Description	138
Possible Cause	120	CONSULT-II Reference Value	138
DTC Confirmation Procedure	120	On Board Diagnosis Logic	138
Diagnostic Procedure	121	Possible Cause	138
DTC P0744 A/T TCC S/V FUNCTION (LOCK-UP)	122	DTC Confirmation Procedure	138
Description	122	Diagnostic Procedure	139
CONSULT-II Reference Value	122	DTC P1730 A/T INTERLOCK	140
On Board Diagnosis Logic	122	Description	140
Possible Cause	122	On Board Diagnosis Logic	140
DTC Confirmation Procedure	122	Possible Cause	140
Diagnostic Procedure	123	DTC Confirmation Procedure	140
DTC P0745 LINE PRESSURE SOLENOID VALVE	124	Judgement of A/T Interlock	140
Description	124	Diagnostic Procedure	141
CONSULT-II Reference Value	124	DTC P1731 A/T 1ST ENGINE BRAKING	143
On Board Diagnosis Logic	124	Description	143
Possible Cause	124	CONSULT-II Reference Value	143
DTC Confirmation Procedure	124	On Board Diagnosis Logic	143
Diagnostic Procedure	125	Possible Cause	143
DTC P1702 TRANSMISSION CONTROL MODULE (RAM)	126	DTC Confirmation Procedure	143
Description	126	Diagnostic Procedure	144
On Board Diagnosis Logic	126	DTC P1752 INPUT CLUTCH SOLENOID VALVE	145
Possible Cause	126	Description	145
DTC Confirmation Procedure	126	CONSULT-II Reference Value	145
Diagnostic Procedure	126	On Board Diagnosis Logic	145
DTC P1703 TRANSMISSION CONTROL MODULE (ROM)	127	Possible Cause	145
Description	127	DTC Confirmation Procedure	145
On Board Diagnosis Logic	127	Diagnostic Procedure	146
Possible Cause	127	DTC P1754 INPUT CLUTCH SOLENOID VALVE FUNCTION	147
		Description	147
		CONSULT-II Reference Value	147
		On Board Diagnosis Logic	147

Possible Cause	147	Description	163
DTC Confirmation Procedure	147	CONSULT-II Reference Value	163
Diagnostic Procedure	148	On Board Diagnosis Logic	163
DTC P1757 FRONT BRAKE SOLENOID VALVE .	149	Possible Cause	163
Description	149	DTC Confirmation Procedure	163
CONSULT-II Reference Value	149	Diagnostic Procedure	164
On Board Diagnosis Logic	149	DTC P1815 MANUAL MODE SWITCH	165
Possible Cause	149	Description	165
DTC Confirmation Procedure	149	CONSULT-II Reference Value in Data Monitor Mode	165
Diagnostic Procedure	150	On Board Diagnosis Logic	165
DTC P1759 FRONT BRAKE SOLENOID VALVE		Possible Cause	165
FUNCTION	151	DTC Confirmation Procedure	165
Description	151	Wiring Diagram — AT — MMSW	166
CONSULT-II Reference Value	151	Diagnostic Procedure	168
On Board Diagnosis Logic	151	Component Inspection	169
Possible Cause	151	A/T Position Indicator	169
DTC Confirmation Procedure	151	DTC P1841 ATF PRESSURE SWITCH 1	171
Diagnostic Procedure	152	Description	171
DTC P1762 DIRECT CLUTCH SOLENOID VALVE	153	CONSULT-II Reference Value	171
Description	153	On Board Diagnosis Logic	171
CONSULT-II Reference Value	153	Possible Cause	171
On Board Diagnosis Logic	153	DTC Confirmation Procedure	171
Possible Cause	153	Diagnostic Procedure	172
DTC Confirmation Procedure	153	DTC P1843 ATF PRESSURE SWITCH 3	173
Diagnostic Procedure	154	Description	173
DTC P1764 DIRECT CLUTCH SOLENOID VALVE		CONSULT-II Reference Value	173
FUNCTION	155	On Board Diagnosis Logic	173
Description	155	Possible Cause	173
CONSULT-II Reference Value	155	DTC Confirmation Procedure	173
On Board Diagnosis Logic	155	Diagnostic Procedure	174
Possible Cause	155	DTC P1845 ATF PRESSURE SWITCH 5	175
DTC Confirmation Procedure	155	Description	175
Diagnostic Procedure	156	CONSULT-II Reference Value	175
DTC P1767 HIGH AND LOW REVERSE CLUTCH		On Board Diagnosis Logic	175
SOLENOID VALVE	157	Possible Cause	175
Description	157	DTC Confirmation Procedure	175
CONSULT-II Reference Value	157	Diagnostic Procedure	176
On Board Diagnosis Logic	157	DTC P1846 ATF PRESSURE SWITCH 6	177
Possible Cause	157	Description	177
DTC Confirmation Procedure	157	CONSULT-II Reference Value	177
Diagnostic Procedure	158	On Board Diagnosis Logic	177
DTC P1769 HIGH AND LOW REVERSE CLUTCH		Possible Cause	177
SOLENOID VALVE FUNCTION	159	DTC Confirmation Procedure	177
Description	159	Diagnostic Procedure	178
CONSULT-II Reference Value	159	MAIN POWER SUPPLY AND GROUND CIRCUIT. 179	
On Board Diagnosis Logic	159	Wiring Diagram — AT — MAIN	179
Possible Cause	159	Diagnostic Procedure	180
DTC Confirmation Procedure	159	CLOSED THROTTLE POSITION AND WIDE OPEN	
Diagnostic Procedure	160	THROTTLE POSITION CIRCUIT	183
DTC P1772 LOW COAST BRAKE SOLENOID		CONSULT-II Reference Value	183
VALVE	161	Diagnostic Procedure	183
Description	161	BRAKE SIGNAL CIRCUIT	184
CONSULT-II Reference Value	161	CONSULT-II Reference Value	184
On Board Diagnosis Logic	161	Diagnostic Procedure	184
Possible Cause	161	TROUBLE DIAGNOSIS FOR SYMPTOMS	185
DTC Confirmation Procedure	161	Wiring Diagram — AT — NONDTC	185
Diagnostic Procedure	162	A/T Check Indicator Lamp Does Not Come On ...	188
DTC P1774 LOW COAST BRAKE SOLENOID		Engine Cannot Be Started in “P” or “N” Position .	188
VALVE FUNCTION	163		

A
B
AT
D
E
F
G
H
I
J
K
L
M

In "P" Position, Vehicle Moves When Pushed	189	AIR BREATHER HOSE	263
In "N" Position, Vehicle Moves	190	Removal and Installation	263
Large Shock ("N" to "D" Position)	191	TRANSMISSION ASSEMBLY	264
Vehicle Does Not Creep Backward in "R" Position	194	Removal and Installation	264
Vehicle Does Not Creep Forward in "D" Position	197	OVERHAUL	267
Vehicle Cannot Be Started From D1	199	Components	267
A/T Does Not Shift: D1 → D2	202	Oil Channel	273
A/T Does Not Shift: D2 → D3	204	Locations of Adjusting Shims, Needle Bearings, Thrust Washers and Snap Rings	274
A/T Does Not Shift: D3 → D4	207	DISASSEMBLY	275
A/T Does Not Shift: D4 → D5	209	Disassembly	275
A/T Does Not Perform Lock-up	212	REPAIR FOR COMPONENT PARTS	292
A/T Does Not Hold Lock-up Condition	214	Oil Pump	292
Lock-up Is Not Released	215	Front Sun Gear, 3rd One-way Clutch	295
Engine Speed Does Not Return to Idle	216	Front Carrier, Input Clutch, Rear Internal Gear	297
Cannot Be Changed to Manual Mode	217	Mid Sun Gear, Rear Sun Gear, High and Low Reverse Clutch Hub	302
A/T Does Not Shift: 5th gear → 4th gear	218	High and Low Reverse Clutch	307
A/T Does Not Shift: 4th gear → 3rd gear	220	Direct Clutch	309
A/T Does Not Shift: 3rd gear → 2nd gear	222	ASSEMBLY	311
A/T Does Not Shift: 2nd gear → 1st gear	224	Assembly (1)	311
Vehicle Does Not Decelerate by Engine Brake	226	Adjustment	323
SHIFT CONTROL SYSTEM	228	Assembly (2)	325
Control Device Removal and Installation	228	SERVICE DATA AND SPECIFICATIONS (SDS) ...	333
Adjustment of A/T Position	229	General Specifications	333
Checking of A/T Position	229	Vehicle Speed When Shifting Gears	333
A/T SHIFT LOCK SYSTEM	231	Vehicle Speed When Performing and Releasing Complete Lock-up	333
Description	231	Vehicle Speed When Performing and Releasing Slip Lock-up	333
Shift Lock System Electrical Parts Location	231	Stall Speed	333
Wiring Diagram — AT — SHIFT	232	Line Pressure	334
Diagnostic Procedure	233	A/T Fluid Temperature Sensor	334
KEY INTERLOCK CABLE	235	Turbine Revolution Sensor	334
Components	235	Vehicle Speed Sensor A/T (Revolution Sensor)	334
Removal and Installation	236	Reverse Brake	334
ON-VEHICLE SERVICE	238	Total End Play	334
Control Valve with TCM and A/T Fluid Temperature Sensor 2	238		
Parking Components	250		
Rear Oil Seal	257		
Revolution Sensor	258		

INDEX FOR DTC

INDEX FOR DTC

PFP:00024

Alphabetical Index

ACS000GR

NOTE:

If DTC "U1000" is displayed with other DTC, first perform the trouble diagnosis for "DTC U1000 CAN COMMUNICATION LINE". Refer to [AT-101](#).

Items (CONSULT-II screen terms)	DTC		Reference page
	OBD-II	Except OBD-II	
	CONSULT-II GST*1	CONSULT-II only "A/T"	
A/T 1ST E/BRAKING	—	P1731	AT-143
ATF PRES SW 1/CIRC	—	P1841	AT-171
ATF PRES SW 3/CIRC	—	P1843	AT-173
ATF PRES SW 5/CIRC	—	P1845	AT-175
ATF PRES SW 6/CIRC	—	P1846	AT-177
A/T INTERLOCK	P1730	P1730	AT-140
A/T TCC S/V FNCTN	P0744	P0744	AT-122
ATF TEMP SEN/CIRC	P0710	P1710	AT-131
CAN COMM CIRCUIT	U1000	U1000	AT-101
D/C SOLENOID/CIRC	P1762	P1762	AT-153
D/C SOLENOID FNCTN	P1764	P1764	AT-155
ENGINE SPEED SIG	P0725	P0725	AT-118
FR/B SOLENOID/CIRC	P1757	P1757	AT-149
FR/B SOLENOID FNCT	P1759	P1759	AT-151
HLR/C SOL/CIRC	P1767	P1767	AT-157
HLR/C SOL FNCTN	P1769	P1769	AT-159
I/C SOLENOID/CIRC	P1752	P1752	AT-145
I/C SOLENOID FNCTN	P1754	P1754	AT-147
L/PRESS SOL/CIRC	P0745	P0745	AT-124
LC/B SOLENOID/CIRC	P1772	P1772	AT-161
LC/B SOLENOID FNCT	P1774	P1774	AT-163
MANU MODE SW/CIR	—	P1815	AT-165
PNP SW/CIRC	P0705	P0705	AT-109
STARTER RELAY/CIRC	—	P0615	AT-104
TCC SOLENOID/CIRC	P0740	P0740	AT-120
TCM	P0700	P0700	AT-108
TCM-RAM	—	P1702	AT-126
TCM-ROM	—	P1703	AT-127
TP SEN/CIRC A/T	P1705	P1705	AT-128
TURBINE REV S/CIRC	P1716	P1716	AT-136
VEH SPD SE/CIR-MTR	—	P1721	AT-138
VEH SPD SEN/CIR AT	P0720	P0720	AT-113

*1: These numbers are prescribed by SAE J2012.

INDEX FOR DTC

ACS000GS

DTC No. Index

NOTE:

If DTC “U1000” is displayed with other DTC, first perform the trouble diagnosis for “DTC U1000 CAN COMMUNICATION LINE”. Refer to [AT-101](#).

DTC		Items (CONSULT-II screen terms)	Reference page
OBD-II	Except OBD-II		
CONSULT-II GST*1	CONSULT-II only “A/T”		
—	P0615	STARTER RELAY/CIRC	AT-104
P0700	P0700	TCM	AT-108
P0705	P0705	PNP SW/CIRC	AT-109
P0710	P1710	ATF TEMP SEN/CIRC	AT-131
P0720	P0720	VEH SPD SEN/CIR AT	AT-113
P0725	P0725	ENGINE SPEED SIG	AT-118
P0740	P0740	TCC SOLENOID/CIRC	AT-120
P0744	P0744	A/T TCC S/V FNCTN	AT-122
P0745	P0745	L/PRESS SOL/CIRC	AT-124
—	P1702	TCM-RAM	AT-126
—	P1703	TCM-ROM	AT-127
P1705	P1705	TP SEN/CIRC A/T	AT-128
P1716	P1716	TURBINE REV S/CIRC	AT-136
—	P1721	VEH SPD SE/CIR-MTR	AT-138
P1730	P1730	A/T INTERLOCK	AT-140
—	P1731	A/T 1ST E/BRAKING	AT-143
P1752	P1752	I/C SOLENOID/CIRC	AT-145
P1754	P1754	I/C SOLENOID FNCTN	AT-147
P1757	P1757	FR/B SOLENOID/CIRC	AT-149
P1759	P1759	FR/B SOLENOID FNCT	AT-151
P1762	P1762	D/C SOLENOID/CIRC	AT-153
P1764	P1764	D/C SOLENOID FNCTN	AT-155
P1767	P1767	HLR/C SOL/CIRC	AT-157
P1769	P1769	HLR/C SOL FNCTN	AT-159
P1772	P1772	LC/B SOLENOID/CIRC	AT-161
P1774	P1774	LC/B SOLENOID FNCT	AT-163
—	P1815	MANU MODE SW/CIRC	AT-165
—	P1841	ATF PRES SW 1/CIRC	AT-171
—	P1843	ATF PRES SW 3/CIRC	AT-173
—	P1845	ATF PRES SW 5/CIRC	AT-175
—	P1846	ATF PRES SW 6/CIRC	AT-177
U1000	U1000	CAN COMM CIRCUIT	AT-101

*1: These numbers are prescribed by SAE J2012.

PRECAUTIONS

PRECAUTIONS

PPF:00001

Precautions for Supplemental Restraint System (SRS) “AIR BAG” and “SEAT BELT PRE-TENSIONER”

ACS006FV

The Supplemental Restraint System such as “AIR BAG” and “SEAT BELT PRE-TENSIONER”, used along with a front seat belt, helps to reduce the risk or severity of injury to the driver and front passenger for certain types of collision. This system includes seat belt switch inputs and dual stage front air bag modules. The SRS system uses the seat belt switches to determine the front air bag deployment, and may only deploy one front air bag, depending on the severity of a collision and whether the front occupants are belted or unbelted. Information necessary to service the system safely is included in the SRS and SB section of this Service Manual.

WARNING:

- To avoid rendering the SRS inoperative, which could increase the risk of personal injury or death in the event of a collision which would result in air bag inflation, all maintenance must be performed by an authorized NISSAN/INFINITI dealer.
- Improper maintenance, including incorrect removal and installation of the SRS, can lead to personal injury caused by unintentional activation of the system. For removal of Spiral Cable and Air Bag Module, see the SRS section.
- Do not use electrical test equipment on any circuit related to the SRS unless instructed to in this Service Manual. SRS wiring harnesses can be identified by yellow and/or orange harnesses or harness connectors.

Precautions for Battery Service

ACS001NN

Before disconnecting the battery, lower both the driver and passenger windows. This will prevent any interference between the window edge and the vehicle when the door is opened/closed. During normal operation, the window slightly raises and lowers automatically to prevent any window to vehicle interference. The automatic window function will not work with the battery disconnected.

Precautions for On Board Diagnostic (OBD) System of A/T and Engine

ACS000GU

The ECM has an on board diagnostic system. It will light up the malfunction indicator lamp (MIL) to warn the driver of a malfunction causing emission deterioration.

CAUTION:

- Be sure to turn the ignition switch OFF and disconnect the battery cable from the negative terminal before any repair or inspection work. The open/short circuit of related switches, sensors, solenoid valves, etc. will cause the MIL to light up.
- Be sure to connect and lock the connectors securely after work. A loose (unlocked) connector will cause the MIL to light up due to an open circuit. (Be sure the connector is free from water, grease, dirt, bent terminals, etc.)
- Be sure to route and secure the harnesses properly after work. Interference of the harness with a bracket, etc. may cause the MIL to light up due to a short circuit.
- Be sure to connect rubber tubes properly after work. A misconnected or disconnected rubber tube may cause the MIL to light up due to a malfunction of the EGR system or fuel injection system, etc.
- Be sure to erase the unnecessary malfunction information (repairs completed) from the TCM and ECM before returning the vehicle to the customer.

PRECAUTIONS

Precautions

ACS000GW

- Before connecting or disconnecting the A/T assembly harness connector, turn ignition switch OFF and disconnect the battery cable from the negative terminal. Because battery voltage is applied to TCM even if ignition switch is turned OFF.

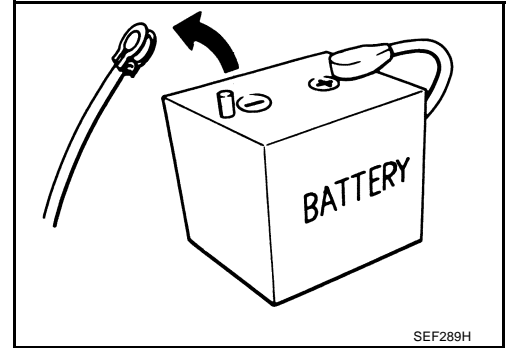

- After performing each TROUBLE DIAGNOSIS, perform "DTC (Diagnostic Trouble Code) Confirmation Procedure". If the repair is completed the DTC should not be displayed in the "DTC Confirmation Procedure".

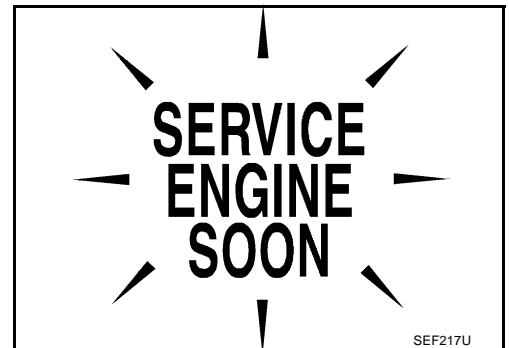

- Always use the specified brand of A/T fluid. Refer to [MA-12, "Fluids and Lubricants"](#) .
- Use paper rags not cloth rags during work.
- After replacing the A/T fluid, dispose of the waste oil using the methods prescribed by law, ordinance, etc.
- Before proceeding with disassembly, thoroughly clean the outside of the transmission. It is important to prevent the internal parts from becoming contaminated by dirt or other foreign matter.
- Disassembly should be done in a clean work area.
- Use lint-free cloth or towels for wiping parts clean. Common shop rags can leave fibers that could interfere with the operation of the transmission.
- Place disassembled parts in order for easier and proper assembly.
- All parts should be carefully cleaned with a general purpose, non-flammable solvent before inspection or reassembly.
- Gaskets, seals and O-rings should be replaced any time the transmission is disassembled.
- It is very important to perform functional tests whenever they are indicated.
- The valve body contains precision parts and requires extreme care when parts are removed and serviced. Place disassembled valve body parts in order for easier and proper assembly. Care will also prevent springs and small parts from becoming scattered or lost.
- Properly installed valves, sleeves, plugs, etc. will slide along bores in valve body under their own weight.
- Before assembly, apply a coat of recommended ATF to all parts. Apply petroleum jelly to protect O-rings and seals, or hold bearings and washers in place during assembly. Do not use grease.
- Extreme care should be taken to avoid damage to O-rings, seals and gaskets when assembling.
- Clean or replace ATF cooler if excessive foreign material is found in oil pan or clogging strainer. Refer to [AT-9, "ATF COOLER SERVICE"](#) .
- After overhaul, refill the transmission with new ATF.
- When the A/T drain plug is removed, only some of the fluid is drained. Old A/T fluid will remain in torque converter and ATF cooling system. Always follow the procedures under "Changing A/T Fluid" in the AT section when changing A/T fluid. Refer to [AT-12, "Changing A/T Fluid"](#) , [AT-12, "Checking A/T Fluid"](#) .

PRECAUTIONS

Service Notice or Precautions ATF COOLER SERVICE

ACS000GX

If A/T fluid contains frictional material (clutches, bands, etc.), or if an A/T is repaired, overhauled, or replaced, inspect and clean the A/T fluid cooler mounted in the radiator or replace the radiator. Flush cooler lines using cleaning solvent and compressed air after repair. For A/T fluid cooler cleaning procedure, refer to [AT-14, "A/T Fluid Cooler Cleaning"](#) . For radiator replacement, refer to [CO-12, "RADIATOR"](#) .

OBD-II SELF-DIAGNOSIS

- A/T self-diagnosis is performed by the TCM in combination with the ECM. The results can be read through the blinking pattern of the A/T CHECK indicator or the malfunction indicator lamp (MIL). Refer to the table on [AT-90, "SELF-DIAGNOSTIC RESULT MODE"](#) for the indicator used to display each self-diagnostic result.
- The self-diagnostic results indicated by the MIL are automatically stored in both the ECM and TCM memories.
Always perform the procedure on [AT-38, "HOW TO ERASE DTC"](#) to complete the repair and avoid unnecessary blinking of the MIL.

For details of OBD-II, refer to [EC-47, "ON BOARD DIAGNOSTIC \(OBD\) SYSTEM"](#) .

- **Certain systems and components, especially those related to OBD, may use the new style slide-locking type harness connector. For description and how to disconnect, refer to [PG-80, "HARNESS CONNECTOR"](#) .**

Wiring Diagrams and Trouble Diagnosis

ACS000GY

When you read wiring diagrams, refer to the following:

- [GI-15, "How to Read Wiring Diagrams"](#).
- [PG-4, "POWER SUPPLY ROUTING CIRCUIT"](#) for power distribution circuit.

When you perform trouble diagnosis, refer to the following:

- [GI-11, "How to Follow Trouble Diagnoses"](#).
- [GI-27, "How to Perform Efficient Diagnosis for an Electrical Incident"](#).

PREPARATION

PREPARATION

PFP:00002

Special Service Tools

ACS000GZ

The actual shapes of Kent-Moore tools may differ from those of special service tools illustrated here.

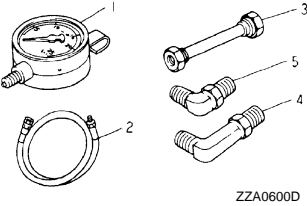
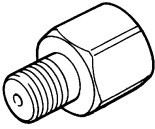
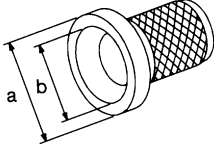
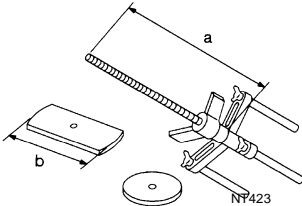
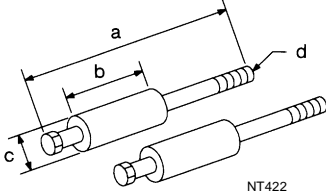
Tool number (Kent-Moore No.) Tool name	Description
ST2505S001 (J-34301-C) Oil pressure gauge set 1 ST25051001 (—) Oil pressure gauge 2 ST25052000 (—) Hose 3 ST25053000 (—) Joint pipe 4 ST25054000 (—) Adapter 5 ST25055000 (—) Adapter	Measuring line pressure <div style="text-align: center;">  <p>ZZA0600D</p> </div>
KV31103600 (J-45674) Joint pipe adapter (With ST25054000)	Measuring line pressure <div style="text-align: center;">  <p>ZZA1227D</p> </div>
ST33400001 (J-26082) Drift a: 60 mm (2.36 in) dia. b: 47 mm (1.85 in) dia.	<ul style="list-style-type: none"> ● Installing rear oil seal ● Installing oil pump housing oil seal <div style="text-align: center;">  <p>NT086</p> </div>
KV31102400 (J-34285 and J-34285-87) Clutch spring compressor a: 320 mm (12.60 in) b: 174 mm (6.85 in)	Installing reverse brake return spring retainer <div style="text-align: center;">  <p>NT423</p> </div>
ST25850000 (J-25721-A) Sliding hammer a: 179 mm (7.05 in) b: 70 mm (2.76 in) c: 40 mm (1.57 in) d: M12X1.75P	Remove oil pump assembly <div style="text-align: center;">  <p>NT422</p> </div>

PREPARATION

Commercial Service Tools

ACS000H0

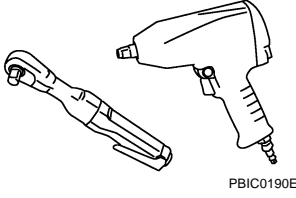
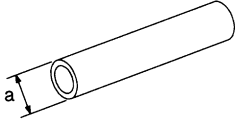
Tool name	Description
<p>Power tool</p>  <p>PBIC0190E</p>	<p>Loosening bolts and nuts</p>
<p>Drift a: 22mm (0.87 in) dia.</p>  <p>NT083</p>	<p>Installing manual shaft oil seals</p>

A
B
AT
D
E
F
G
H
I
J
K
L
M

A/T FLUID

PFP:KLE40

Changing A/T Fluid

ACS003S7

1. Warm up ATF.
2. Stop engine.
3. Loosen the level gauge bolt.
4. Drain ATF from drain plug and refill with new ATF. Always refill same volume with drained fluid.
 - To replace the ATF, pour in new fluid at the A/T fluid charging pipe with the engine idling and at the same time drain the old fluid from the radiator cooler hose return side.
 - When the color of the fluid coming out is about the same as the color of the new fluid, the replacement is complete. The amount of A/T fluid to use should be 30 to 50% increase of the stipulated amount.

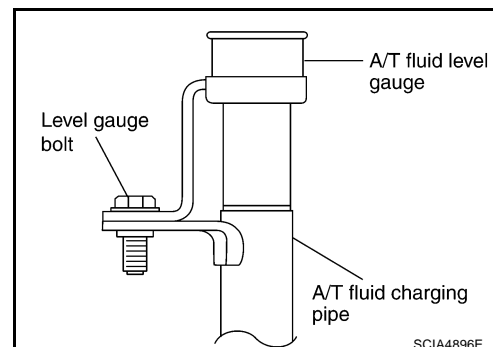

A/T fluid: Genuine NISSAN Matic J ATF

Fluid capacity: 10.3 ℓ (10-7/8 US qt, 9-1/8 Imp qt)

CAUTION:

- Use only Genuine NISSAN Matic J ATF. Do not mix with other fluid.
- Using A/T fluid other than Genuine NISSAN Matic J ATF will cause deterioration in driveability and automatic transmission durability, and may damage the automatic transmission, which is not covered by the NISSAN new vehicle limited warranty.
- When filling ATF, take care not to splash heat generating parts such as exhaust with ATF.
- Do not reuse drain plug gasket.

Drain plug:

 : 34 N·m (3.5 kg-m, 25 ft-lb)

5. Run engine at idle speed for 5 minutes.
6. Check A/T fluid level and condition. Refer to [AT-12, "Checking A/T Fluid"](#) . If A/T fluid is still dirty, repeat step 2 through 5.
7. Install the removed A/T fluid level gauge in the A/T fluid charging pipe.
8. Tighten the level gauge bolt.

Level gauge bolt:

 : 5.1 N·m (0.52 kg-m, 45 in-lb)

Checking A/T Fluid

ACS003S8

1. Warm up engine.
2. Check for fluid leakage.
3. Loosen the level gauge bolt.
4. Before driving, A/T fluid level can be checked at fluid temperatures of 30 to 50°C (86 to 122°F) using "COLD" range on A/T fluid level gauge as follows.
 - a. Park vehicle on level surface and set parking brake.
 - b. Start engine and move selector lever through each gear position. Leave selector lever in "P" position.
 - c. Check fluid level with engine idling.
 - d. Remove A/T fluid level gauge and wipe clean with lint-free paper.

CAUTION:

When wiping away the A/T fluid level gauge, always use lint-free paper, not a cloth one.

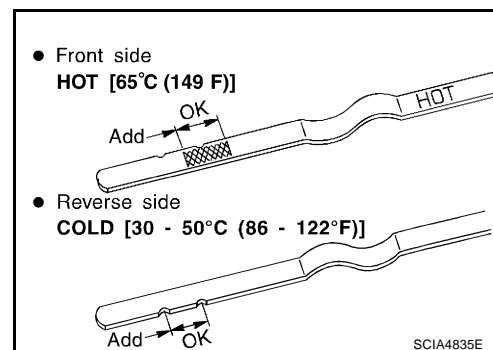

A/T FLUID

- e. Re-insert A/T fluid level gauge into A/T fluid charging pipe as far as it will go.

CAUTION:

To check A/T fluid level, insert the A/T fluid level gauge until the cap contacts the end of the A/T fluid charging pipe, with the A/T fluid level gauge reversed from the normal attachment conditions.

- f. Remove A/T fluid level gauge and note reading. If reading is at low side of range, add fluid to the A/T fluid charging pipe.

CAUTION:

Do not overfill.

5. Drive vehicle for approximately 5 minutes in urban areas.
6. Make the fluid temperature approximately 65°C (149°F).

NOTE:

Fluid level will be greatly affected by temperature as shown in the figure. Therefore, be certain to perform level check operation checking warm up condition with CONSULT-II.

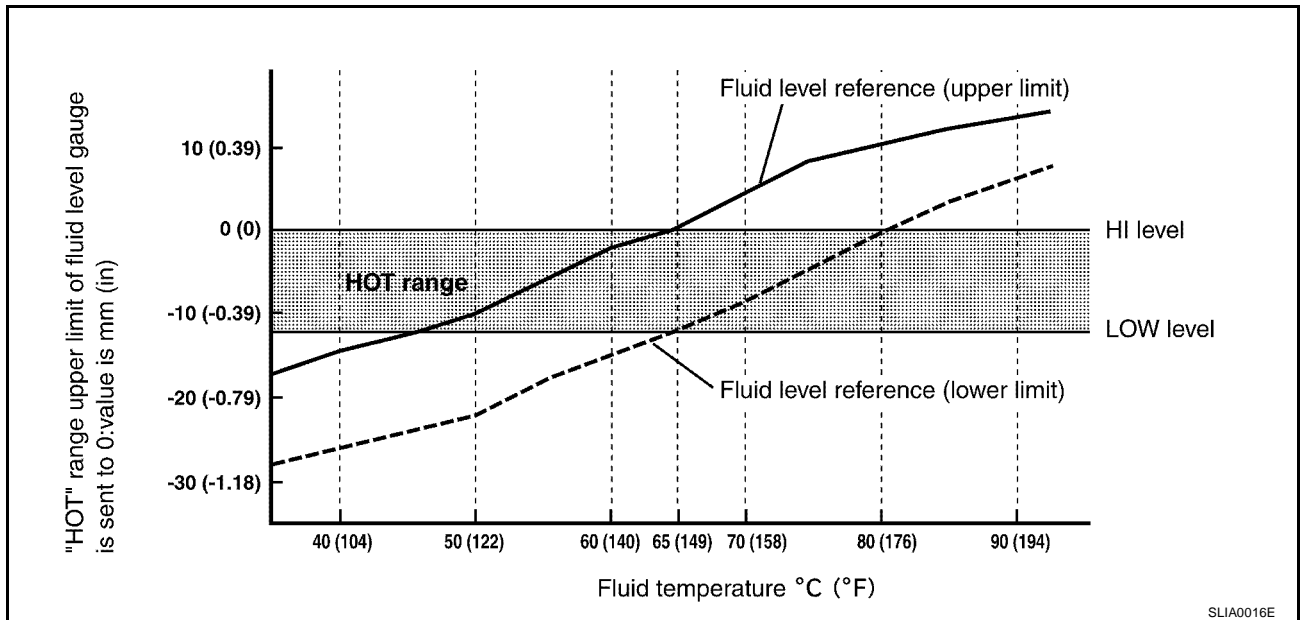

- a. Connect CONSULT-II to data link connector. Refer to [AT-89, "CONSULT-II SETTING PROCEDURE"](#).
b. Select "MAIN SIGNALS" in "DATA MONITOR" mode for "A/T" with CONSULT-II.
c. Read out the value of "ATF TEMP 1".
7. Re-check fluid level at fluid temperatures of approximately 65°C (149°F) using "HOT" range on A/T fluid level gauge.

CAUTION:

- When wiping away the A/T fluid level gauge, always use lint-free paper, not a cloth one.
- To check fluid level, insert the A/T fluid level gauge until the cap contacts the end of the A/T fluid charging pipe, with the gauge rotated from the normal attachment conditions as shown in the figure.

8. Check fluid condition.

- If fluid is very dark or smells burned, check operation of A/T. Flush cooling system after repair of A/T.
- If ATF contains frictional material (clutches, bands, etc.), replace radiator and flush cooler line using cleaning solvent and compressed air after repair of A/T. Refer to [CO-12, "RADIATOR"](#) and [AT-14, "A/T Fluid Cooler Cleaning"](#).

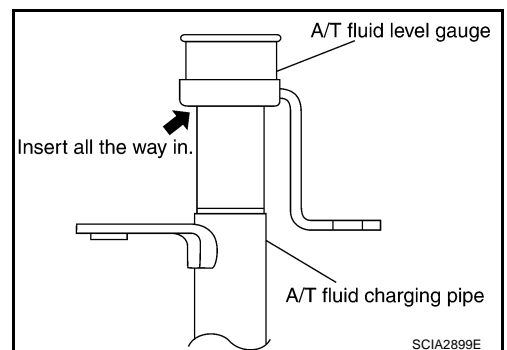

9. Install the removed A/T fluid level gauge in the A/T fluid charging pipe.

A/T FLUID

10. Tighten the level gauge bolt.

Level gauge bolt:

 : 5.1N·m (0.52 kg-m, 45 in-lb)

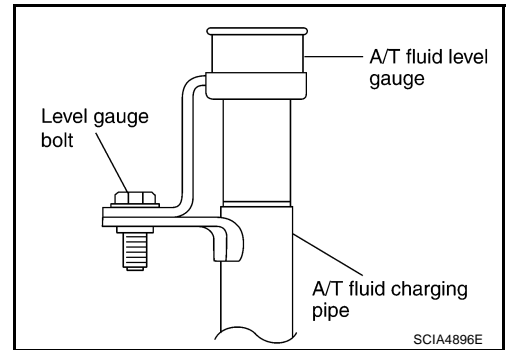

A/T Fluid Cooler Cleaning

ACS004LL

Whenever an automatic transmission is replaced, the A/T fluid cooler mounted in the radiator must be inspected and cleaned.

Metal debris and friction material, if present, can become trapped in the A/T fluid cooler. This debris can contaminate the newly serviced A/T or, in severe cases, can block or restrict the flow of A/T fluid. In either case, malfunction of the newly serviced A/T may result.

Debris, if present, may build up as A/T fluid enters the cooler inlet. It will be necessary to back flush the cooler through the cooler outlet in order to flush out any built up debris.

A/T FLUID COOLER CLEANING PROCEDURE

1. Position an oil pan under the automatic transmission's inlet and outlet cooler hoses.
2. Identify the inlet and outlet fluid cooler hoses.
3. Disconnect the fluid cooler inlet and outlet rubber hoses from the steel cooler tubes or bypass valve.

NOTE:

Replace the cooler hoses if rubber material from the hose remains on the tube fitting.

4. Allow any A/T fluid that remains in the cooler hoses to drain into the oil pan.

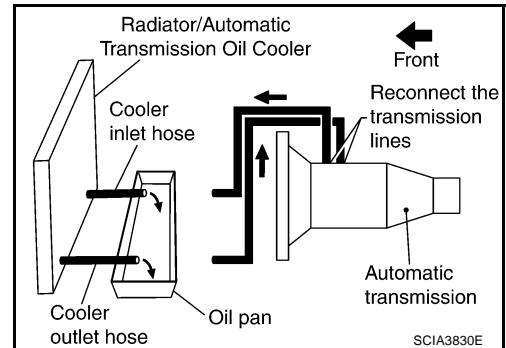

5. Insert the extension adapter hose of a can of the Transmission Cooler Cleaner (Nissan P/N 999MP-AM006) into the cooler outlet hose.

CAUTION:

- Wear safety glasses and rubber gloves when spraying the Transmission Cooler Cleaner.
- Spray the Transmission Cooler Cleaner only with adequate ventilation.
- Avoid contact with eyes and skin.
- Do not breath vapors or spray mist.

6. Hold the hose and can as high as possible and spray the Transmission Cooler Cleaner in a continuous stream into the cooler outlet hose until fluid flows out of the cooler inlet hose for 5 seconds.

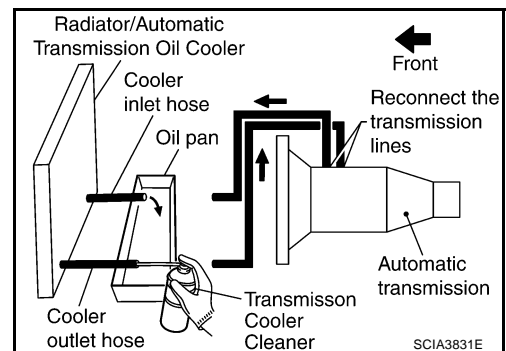

A/T FLUID

7. Insert the tip of an air gun into the end of the cooler outlet hose.
8. Wrap a shop rag around the air gun tip and of the cooler outlet hose.

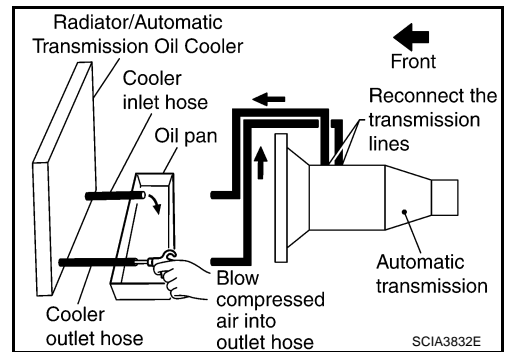

9. Blow compressed air regulated to 5 - 9 kg/cm² (70 - 130 psi) through the cooler outlet hose for 10 seconds to force out any remaining fluid.
10. Repeat steps 5 through 9 three additional times.
11. Position an oil pan under the banjo bolts that connect the fluid cooler steel lines to the transmission.
12. Remove the banjo bolts.
13. Flush each steel line from the cooler side back toward the transmission by spraying the Transmission Cooler Cleaner in a continuous stream for 5 seconds.
14. Blow compressed air regulated to 5 - 9 kg/cm² (70 - 130 psi) through each steel line from the cooler side back toward the transmission for 10 seconds to force out any remaining fluid.
15. Ensure all debris is removed from the steel cooler lines.
16. Ensure all debris is removed from the banjo bolts and fittings.
17. Perform [AT-15, "A/T FLUID COOLER DIAGNOSIS PROCEDURE"](#).

A/T FLUID COOLER DIAGNOSIS PROCEDURE

NOTE:

Insufficient cleaning of the cooler inlet hose exterior may lead to inaccurate debris identification.

1. Position an oil pan under the automatic transmission's inlet and outlet cooler hoses.
2. Clean the exterior and tip of the cooler inlet hose.
3. Insert the extension adapter hose of a can of the Transmission Cooler Cleaner (Nissan P/N 999MP-AM006) into the cooler outlet hose.

CAUTION:

- Wear safety glasses and rubber gloves when spraying the Transmission Cooler Cleaner.
- Spray the Transmission Cooler Cleaner only with adequate ventilation.
- Avoid contact with eyes and skin.
- Do not breath vapors or spray mist.

4. Hold the hose and can as high as possible and spray the Transmission Cooler Cleaner in a continuous stream into the cooler outlet hose until fluid flows out of the cooler inlet hose for 5 seconds.
5. Tie a common white, basket-type coffee filter to the end of the cooler inlet hose.

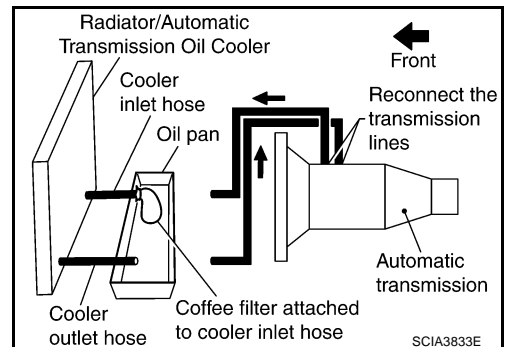
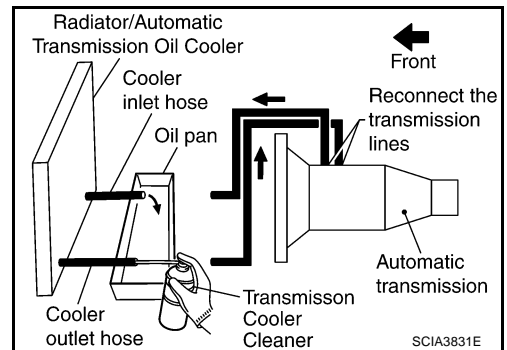

A/T FLUID

6. Insert the tip of an air gun into the end of the cooler outlet hose.
7. Wrap a shop rag around the air gun tip and end of cooler outlet hose.
8. Blow compressed air regulated to 5 - 9 kg/cm² (70 - 130 psi) through the cooler outlet hose to force any remaining A/T fluid into the coffee filter.
9. Remove the coffee filter from the end of the cooler inlet hose.
10. Perform [AT-16, "A/T FLUID COOLER INSPECTION PROCEDURE"](#).

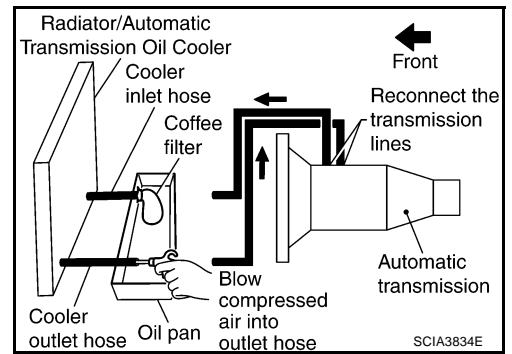

A/T FLUID COOLER INSPECTION PROCEDURE

1. Inspect the coffee filter for debris.
 - a. If small metal debris less than 1 mm (0.040 in) in size or metal powder is found in the coffee filter, this is normal. If normal debris is found, the A/T fluid cooler/radiator can be re-used and the procedure is ended.
 - b. If one or more pieces of debris are found that are over 1 mm (0.040 in) in size and/or peeled clutch facing material is found in the coffee filter, the fluid cooler is not serviceable. The A/T fluid cooler/radiator must be replaced and the inspection procedure is ended. Refer to [CO-12, "RADIATOR"](#) and [CO-16, "RADIATOR \(ALUMINUM TYPE\)"](#).

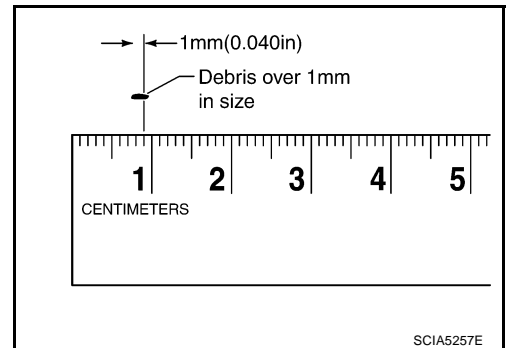
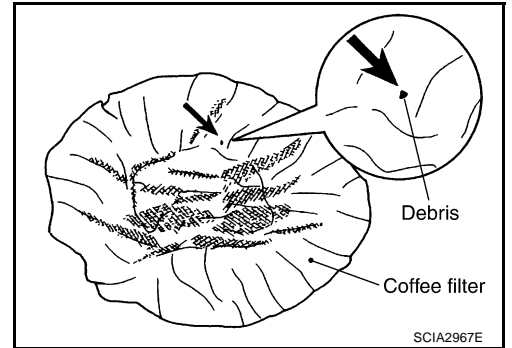

A/T FLUID COOLER FINAL INSPECTION

After performing all procedures, ensure that all remaining oil is cleaned from all components.

A/T CONTROL SYSTEM

A/T CONTROL SYSTEM

PFP:31036

Cross-Sectional View

ACS000H3

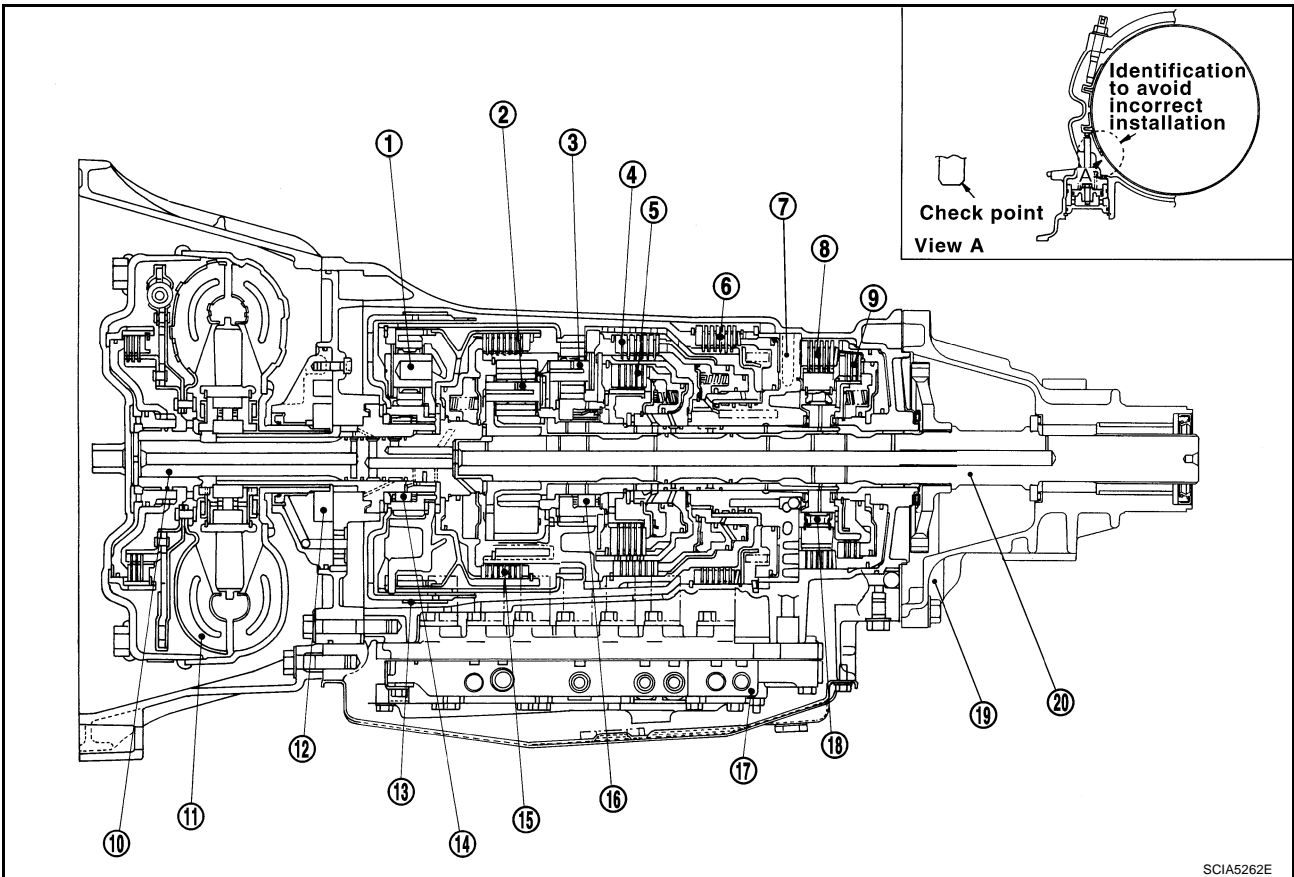

- | | | |
|-------------------------|--------------------------------|----------------------------|
| 1. Front planetary gear | 2. Mid planetary gear | 3. Rear planetary gear |
| 4. Direct clutch | 5. High and low reverse clutch | 6. Reverse brake |
| 7. Drum support | 8. Forward brake | 9. Low coast brake |
| 10. Input shaft | 11. Torque converter | 12. Oil pump |
| 13. Front brake | 14. 3rd one-way clutch | 15. Input clutch |
| 16. 1st one-way clutch | 17. Control valve with TCM | 18. Forward one-way clutch |
| 19. Rear extension | 20. Output shaft | |

SCIA5262E

A
B
AT
D
E
F
G
H
I
J
K
L
M

A/T CONTROL SYSTEM

ACS000H4

Shift Mechanism

The automatic transmission uses compact triple planetary gear systems to improve power-transmission efficiency, simplify construction and reduce weight. It also employs an optimum shift control and super wide gear ratios. They improve starting performance and acceleration during medium and high-speed operation.

CONSTRUCTION

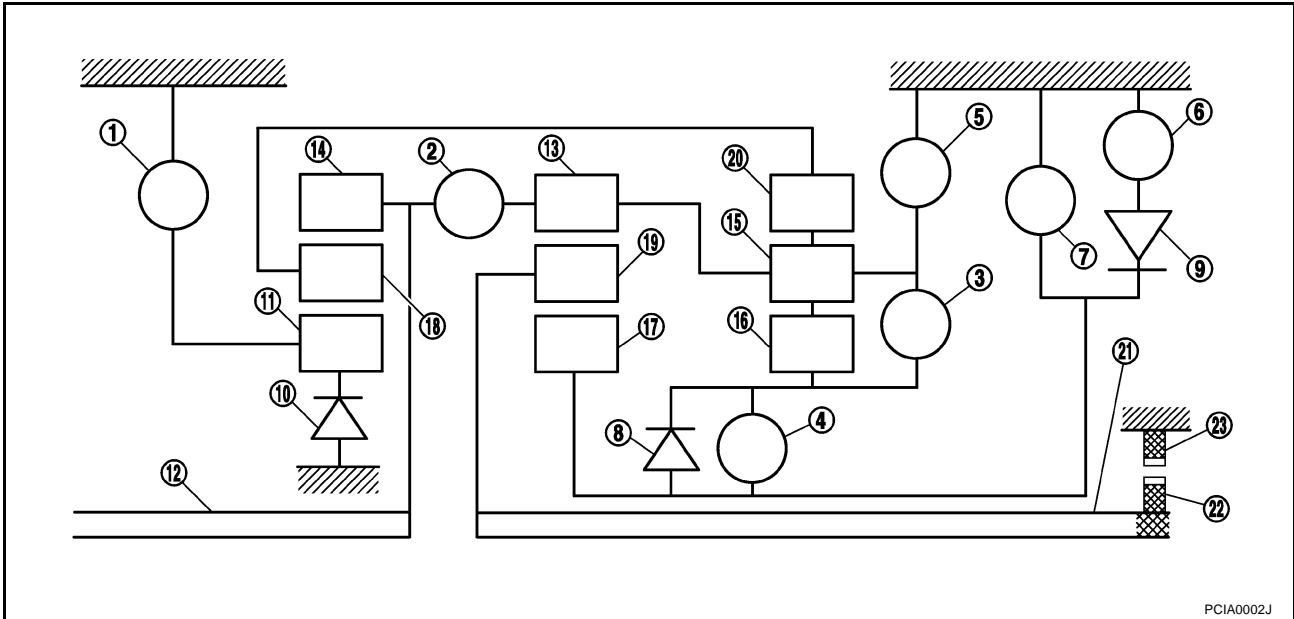

PCIA0002J

- | | | |
|--------------------------------|-------------------------|---------------------------|
| 1. Front brake | 2. Input clutch | 3. Direct clutch |
| 4. High and low reverse clutch | 5. Reverse brake | 6. Forward brake |
| 7. Low coast brake | 8. 1st one-way clutch | 9. Forward one-way clutch |
| 10. 3rd one-way clutch | 11. Front sun gear | 12. Input shaft |
| 13. Mid internal gear | 14. Front internal gear | 15. Rear carrier |
| 16. Rear sun gear | 17. Mid sun gear | 18. Front carrier |
| 19. Mid carrier | 20. Rear internal gear | 21. Output shaft |
| 22. Parking gear | 23. Parking pawl | |

FUNCTION OF CLUTCH AND BRAKE

Name of the Part	Abbreviation	Function
Front brake (1)	FR/B	Fastens the front sun gear (11).
Input clutch (2)	I/C	Connects the input shaft (12), the front internal gear (14) and the mid internal gear (13).
Direct clutch (3)	D/C	Connects the rear carrier (15) and the rear sun gear (16).
High and low reverse clutch (4)	HLR/C	Connects the mid sun gear (17) and the rear sun gear (16).
Reverse brake (5)	R/B	Fastens the rear carrier (15).
Forward brake (6)	Fwd/B	Fastens the mid sun gear (17).
Low coast brake (7)	LC/B	Fastens the mid sun gear (17).
1st one-way clutch (8)	1st/OWC	Allows the rear sun gear (16) to turn freely forward relative to the mid sun gear (17) but fastens it for reverse rotation.
Forward one-way clutch (9)	Fwd/OWC	Allows the mid sun gear (17) to turn freely in the forward direction but fastens it for reverse rotation.
3rd one-way clutch (10)	3rd/OWC	Allows the front sun gear (11) to turn freely in the forward direction but fastens it for reverse rotation.

A/T CONTROL SYSTEM

CLUTCH AND BAND CHART

Shift position	I/C	HLR/C	D/C	R/B	FR/B	LC/B	Fwd/B	1st OWC	Fwd OWC	3rd OWC	Remarks
P		△			△						PARK POSITION
R		○		○	○			◎		◎	REVERSE POSITION
N		△			△						NEUTRAL POSITION
D	1st	△ *			△	△ **	○	◎	◎	◎	Automatic shift 1↔2↔3↔4↔5
	2nd		○		△		○		◎	◎	
	3rd		○	○		○	△	◇		◎	
	4th	○	○	○			△	◇			
	5th	○	○			○	△	◇		◇	
M5	5th	○	○				△	◇		◇	Locks (held stationary) in 5th gear
M4	4th	○	○	○			△	◇			Locks (held stationary) in 4th gear
M3	3rd		○	○			○	△	◇	◎	Locks (held stationary) in 3rd gear
M2	2nd			○		○	○		◎	◎	Locks (held stationary) in 2nd gear
M1	1st		○			○	○	◎	◎	◎	Locks (held stationary) in 1st gear

- – Operates
- ◎ – Operates during “progressive” acceleration.
- ◇ – Operates and affects power transmission while coasting.
- △ – Line pressure is applied but does not affect power transmission.
- △ * – Operates under conditions shown in illustration ①.
- △ ** – Operates under conditions shown in illustration ②. Delay control is applied during D (4,3,2,1) → N shift.

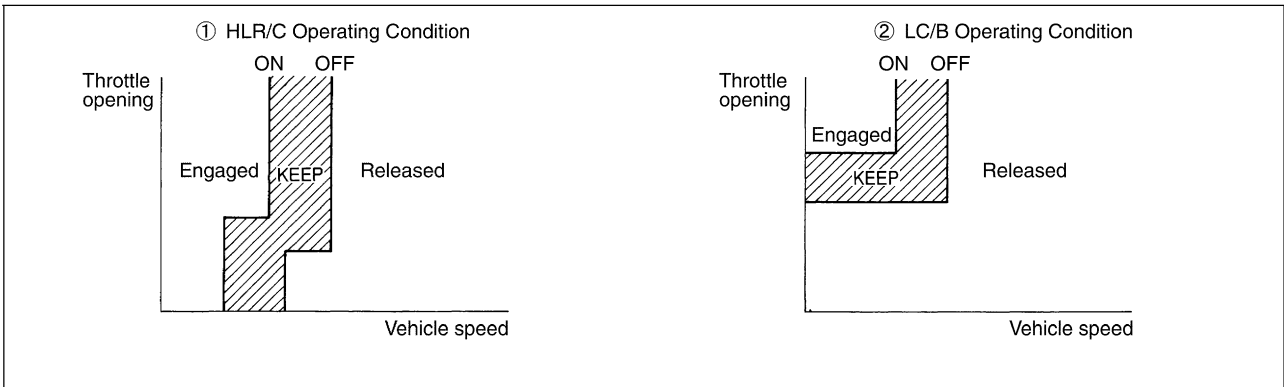

SCIA4998E

A/T CONTROL SYSTEM

POWER TRANSMISSION

“N” Position

Since both the forward brake and the reverse brake are released, torque from the input shaft drive is not transmitted to the output shaft.

“P” Position

- The same as for the “N” position, both the forward brake and the reverse brake are released, so torque from the input shaft drive is not transmitted to the output shaft.
- The parking pawl linked with the selector lever meshes with the parking gear and fastens the output shaft mechanically.

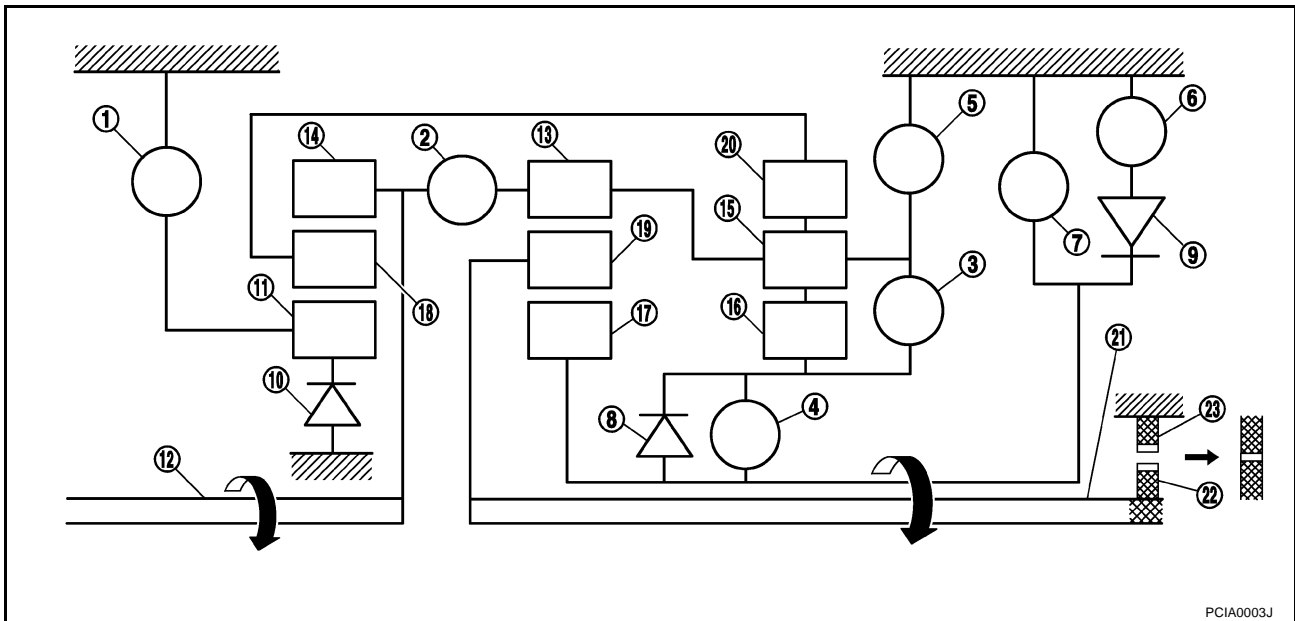

- | | | |
|--------------------------------|-------------------------|---------------------------|
| 1. Front brake | 2. Input clutch | 3. Direct clutch |
| 4. High and low reverse clutch | 5. Reverse brake | 6. Forward brake |
| 7. Low coast brake | 8. 1st one-way clutch | 9. Forward one-way clutch |
| 10. 3rd one-way clutch | 11. Front sun gear | 12. Input shaft |
| 13. Mid internal gear | 14. Front internal gear | 15. Rear carrier |
| 16. Rear sun gear | 17. Mid sun gear | 18. Front carrier |
| 19. Mid carrier | 20. Rear internal gear | 21. Output shaft |
| 22. Parking gear | 23. Parking pawl | |

A/T CONTROL SYSTEM

“D1 ” Position

- The forward brake and the forward one-way clutch regulate reverse rotation of the mid sun gear.
- The 1st one-way clutch regulates reverse rotation of the rear sun gear.
- The 3rd one-way clutch regulates reverse rotation of the front sun gear.
- During deceleration, the mid sun gear turns forward, so the forward one-way clutch idles and the engine brake is not activated.

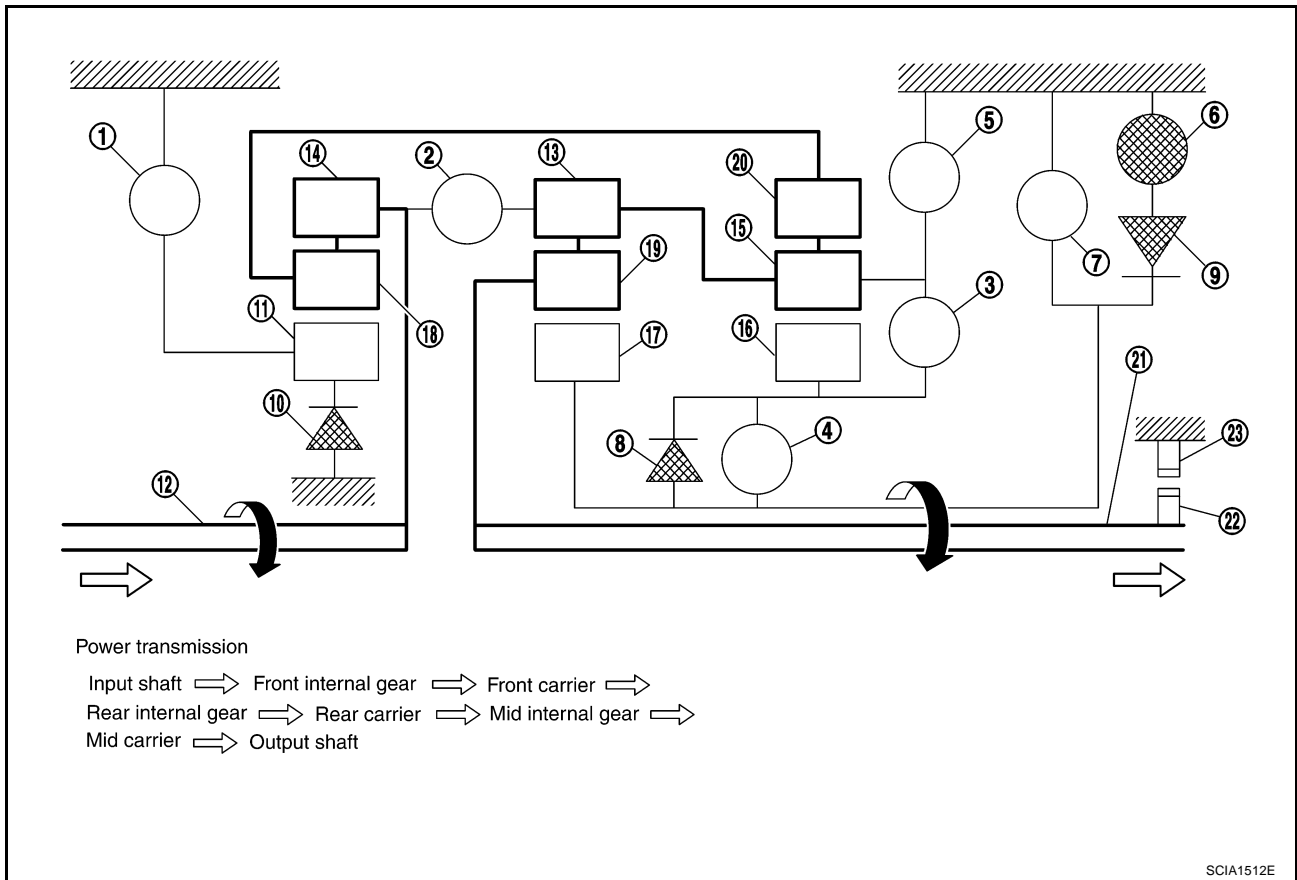

- | | | |
|--------------------------------|-------------------------|---------------------------|
| 1. Front brake | 2. Input clutch | 3. Direct clutch |
| 4. High and low reverse clutch | 5. Reverse brake | 6. Forward brake |
| 7. Low coast brake | 8. 1st one-way clutch | 9. Forward one-way clutch |
| 10. 3rd one-way clutch | 11. Front sun gear | 12. Input shaft |
| 13. Mid internal gear | 14. Front internal gear | 15. Rear carrier |
| 16. Rear sun gear | 17. Mid sun gear | 18. Front carrier |
| 19. Mid carrier | 20. Rear internal gear | 21. Output shaft |
| 22. Parking gear | 23. Parking pawl | |

A
B
AT
D
E
F
G
H
I
J
K
L
M

A/T CONTROL SYSTEM

“M1” Position

- The front brake fastens the front sun gear.
- The forward brake and the forward one-way clutch regulate reverse rotation of the mid sun gear.
- High and low reverse clutch connects the rear sun gear and the mid sun gear.
- The low coast brake fastens the mid sun gear.
- During deceleration, the low coast brake regulates forward rotation of the mid sun gear and the engine brake functions.

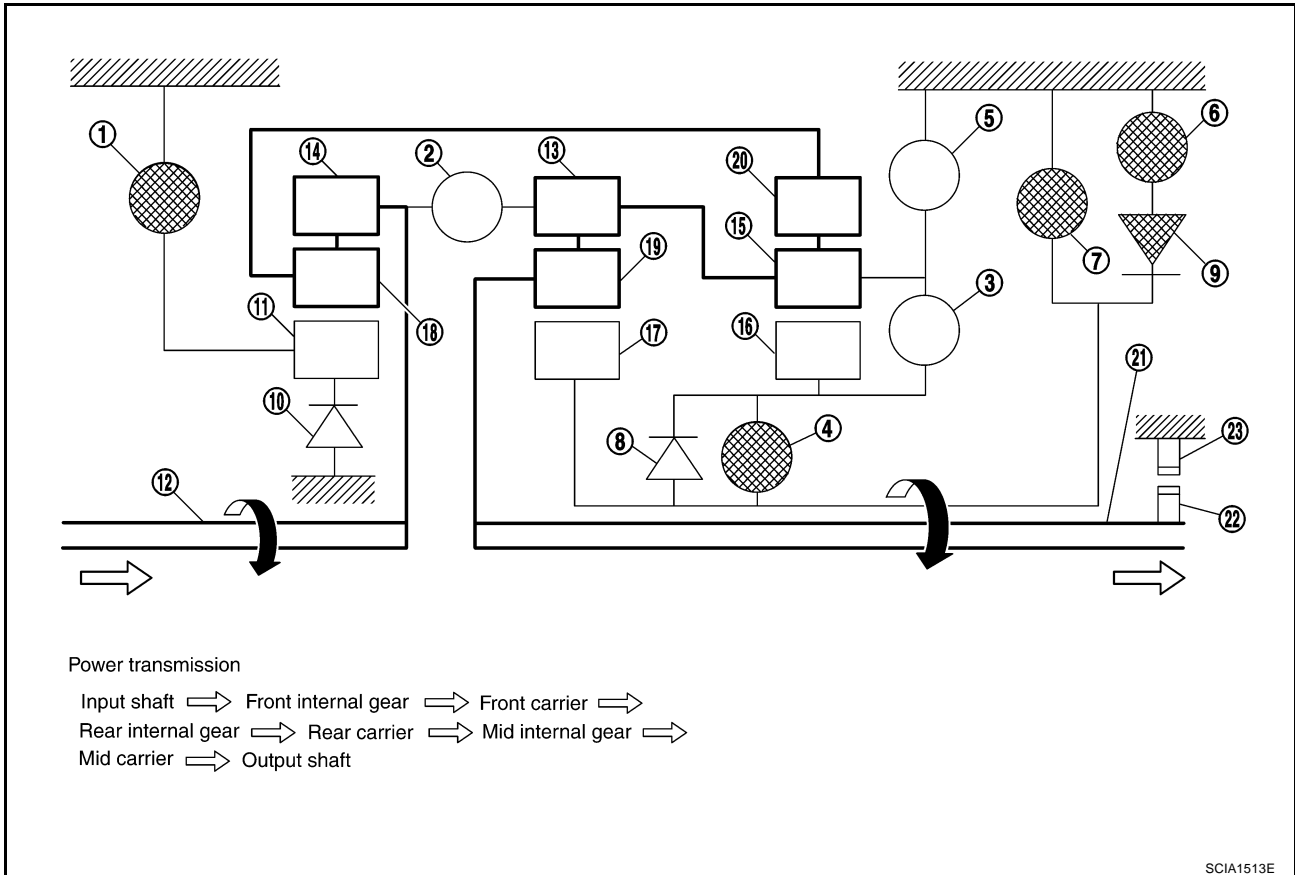

- | | | |
|--------------------------------|-------------------------|---------------------------|
| 1. Front brake | 2. Input clutch | 3. Direct clutch |
| 4. High and low reverse clutch | 5. Reverse brake | 6. Forward brake |
| 7. Low coast brake | 8. 1st one-way clutch | 9. Forward one-way clutch |
| 10. 3rd one-way clutch | 11. Front sun gear | 12. Input shaft |
| 13. Mid internal gear | 14. Front internal gear | 15. Rear carrier |
| 16. Rear sun gear | 17. Mid sun gear | 18. Front carrier |
| 19. Mid carrier | 20. Rear internal gear | 21. Output shaft |
| 22. Parking gear | 23. Parking pawl | |

A/T CONTROL SYSTEM

“D2” Position

- The forward brake and the forward one-way clutch regulate reverse rotation of the mid sun gear.
- The 3rd one-way clutch regulates reverse rotation of the front sun gear.
- The direct clutch is coupled, and the rear carrier and rear sun gear are connected.
- During deceleration, the mid sun gear turns forward, so the forward one-way clutch idles and engine brake is not activated.

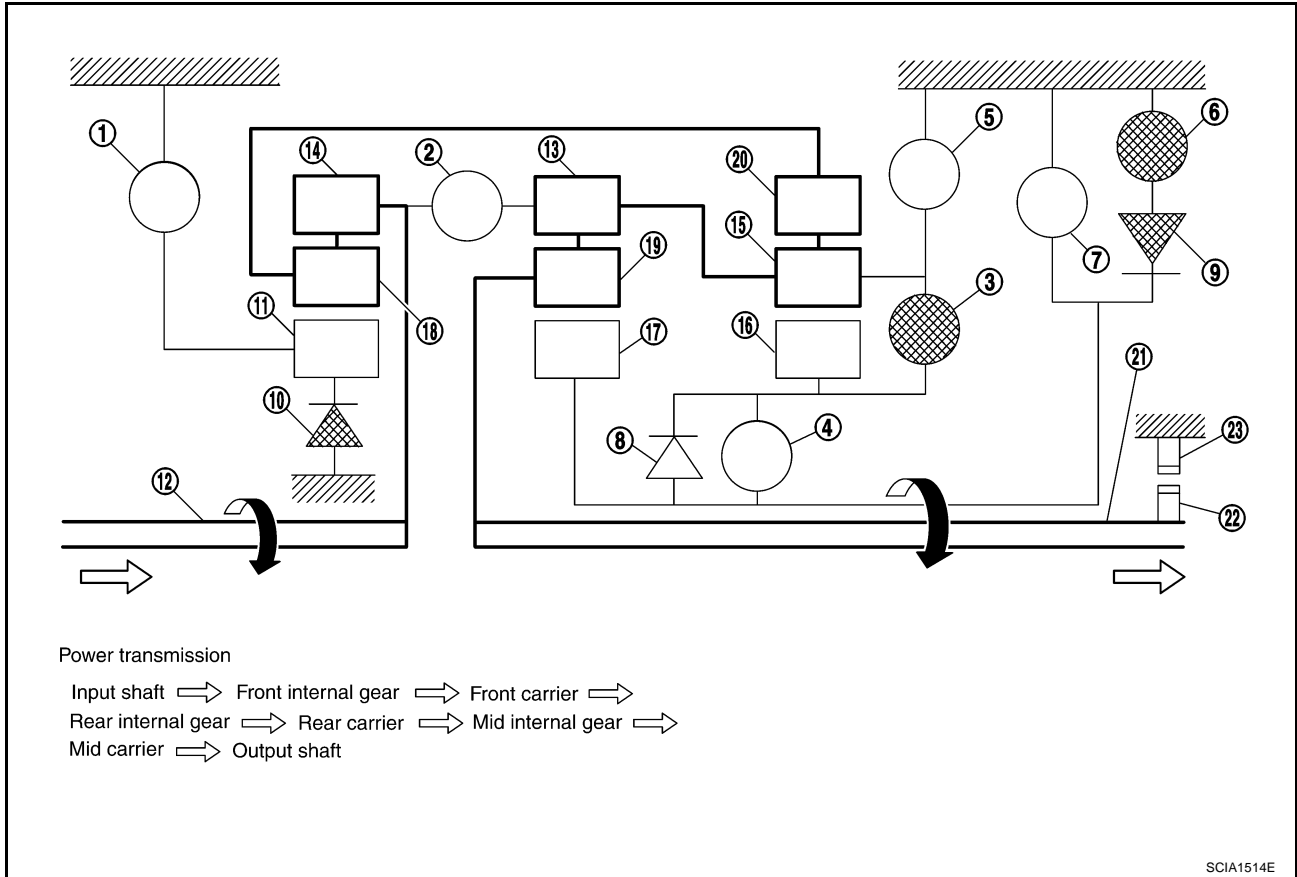

- | | | |
|--------------------------------|-------------------------|---------------------------|
| 1. Front brake | 2. Input clutch | 3. Direct clutch |
| 4. High and low reverse clutch | 5. Reverse brake | 6. Forward brake |
| 7. Low coast brake | 8. 1st one-way clutch | 9. Forward one-way clutch |
| 10. 3rd one-way clutch | 11. Front sun gear | 12. Input shaft |
| 13. Mid internal gear | 14. Front internal gear | 15. Rear carrier |
| 16. Rear sun gear | 17. Mid sun gear | 18. Front carrier |
| 19. Mid carrier | 20. Rear internal gear | 21. Output shaft |
| 22. Parking gear | 23. Parking pawl | |

A
B
AT
D
E
F
G
H
I
J
K
L
M

A/T CONTROL SYSTEM

“M2” Position

- The front brake fastens the front sun gear.
- The forward brake and the forward one-way clutch regulate reverse rotation of the mid sun gear.
- The direct clutch is coupled, and the rear carrier and rear sun gear are connected.
- The low coast brake fastens the mid sun gear.
- During deceleration, the low coast brake regulates forward rotation of the mid sun gear and the engine brake functions.

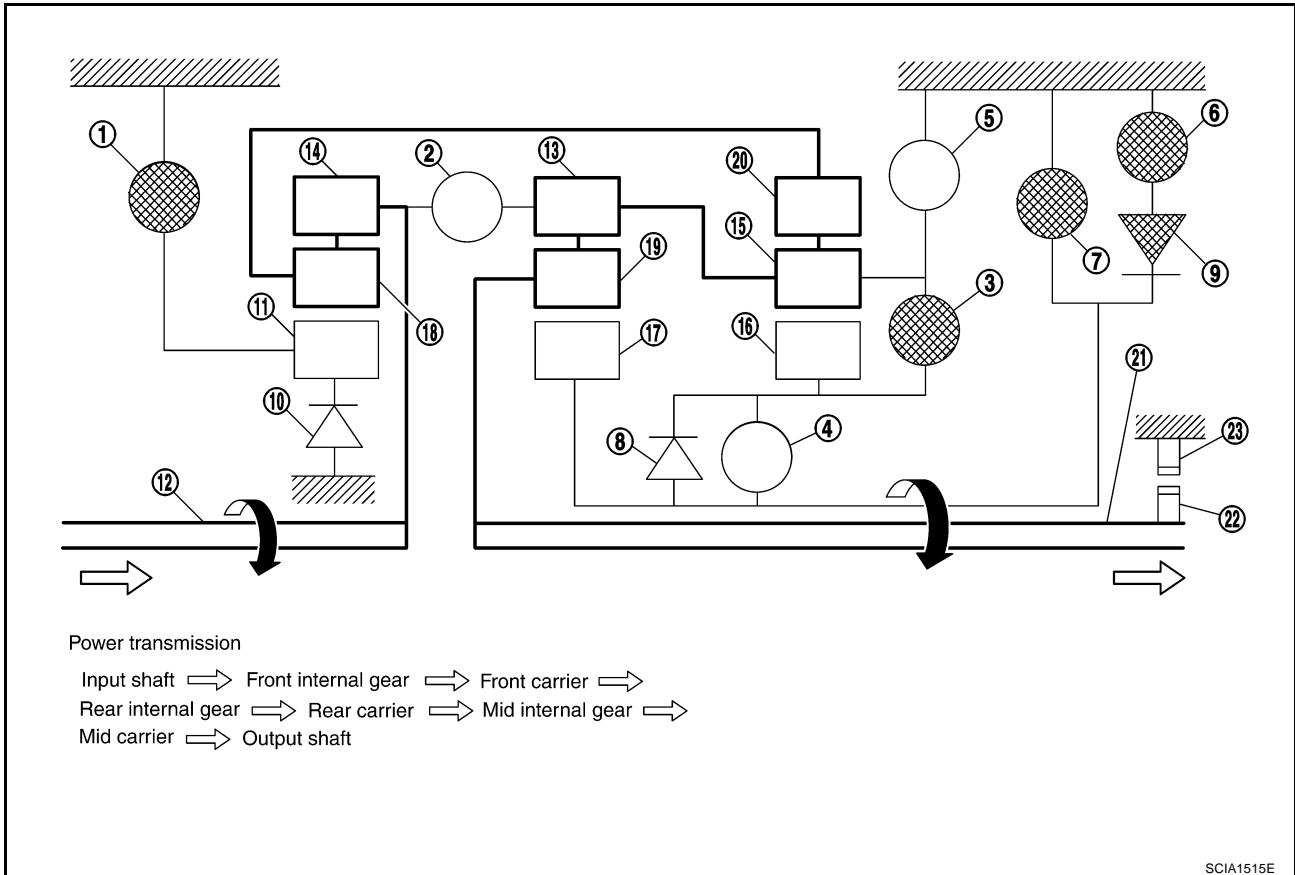

- | | | |
|--------------------------------|-------------------------|---------------------------|
| 1. Front brake | 2. Input clutch | 3. Direct clutch |
| 4. High and low reverse clutch | 5. Reverse brake | 6. Forward brake |
| 7. Low coast brake | 8. 1st one-way clutch | 9. Forward one-way clutch |
| 10. 3rd one-way clutch | 11. Front sun gear | 12. Input shaft |
| 13. Mid internal gear | 14. Front internal gear | 15. Rear carrier |
| 16. Rear sun gear | 17. Mid sun gear | 18. Front carrier |
| 19. Mid carrier | 20. Rear internal gear | 21. Output shaft |
| 22. Parking gear | 23. Parking pawl | |

A/T CONTROL SYSTEM

“D3” and “M3” Positions

- The front brake fastens the front sun gear.
- The direct clutch is coupled, and the rear carrier and rear sun gear are connected.
- The high and low reverse clutch is coupled, and the mid sun gear and rear sun gear are connected.

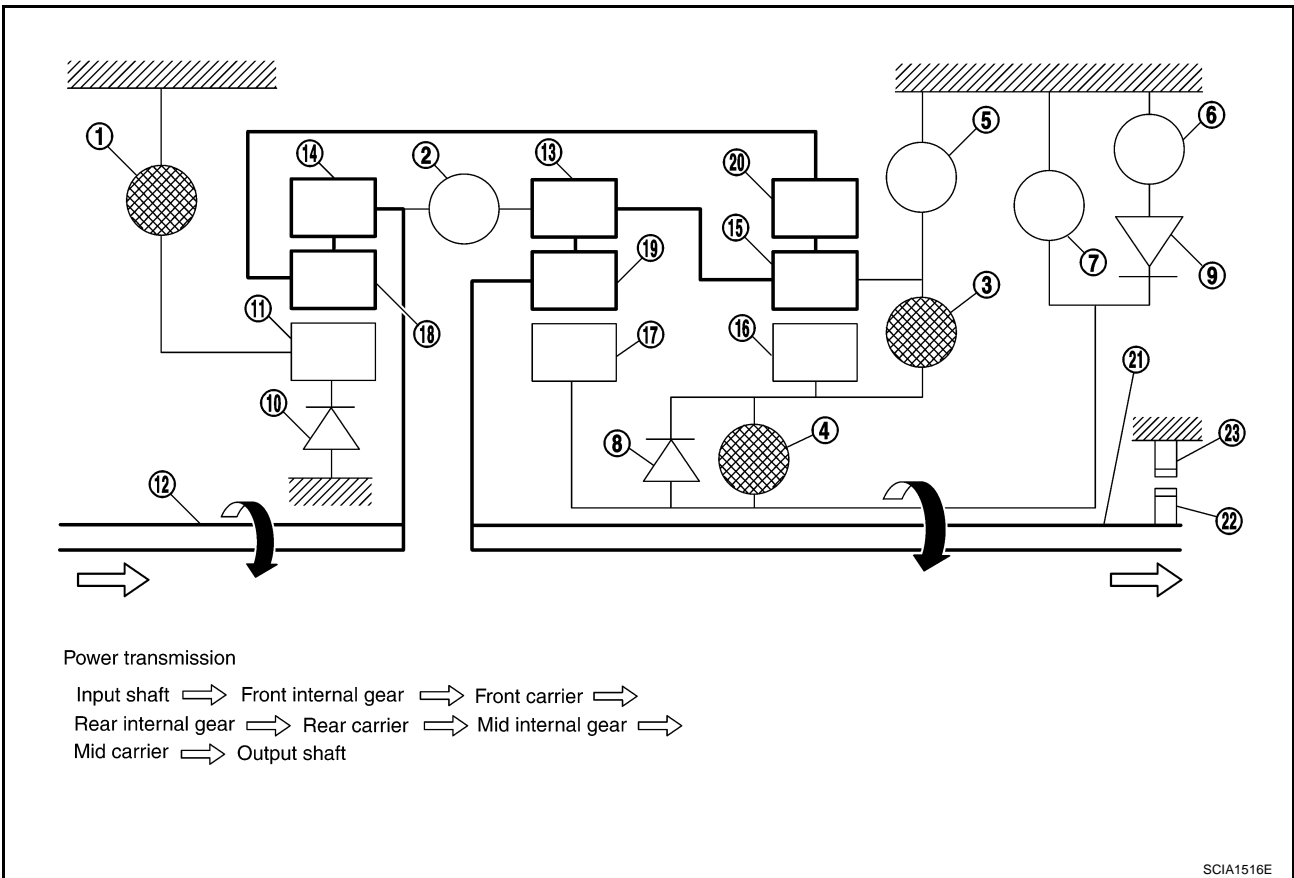

- | | | |
|--------------------------------|-------------------------|---------------------------|
| 1. Front brake | 2. Input clutch | 3. Direct clutch |
| 4. High and low reverse clutch | 5. Reverse brake | 6. Forward brake |
| 7. Low coast brake | 8. 1st one-way clutch | 9. Forward one-way clutch |
| 10. 3rd one-way clutch | 11. Front sun gear | 12. Input shaft |
| 13. Mid internal gear | 14. Front internal gear | 15. Rear carrier |
| 16. Rear sun gear | 17. Mid sun gear | 18. Front carrier |
| 19. Mid carrier | 20. Rear internal gear | 21. Output shaft |
| 22. Parking gear | 23. Parking pawl | |

A
B
AT
D
E
F
G
H
I
J
K
L
M

A/T CONTROL SYSTEM

“D4 ” and “M4” Positions

- The direct clutch is coupled, and the rear carrier and rear sun gear are connected.
- The high and low reverse clutch is coupled, and the mid sun gear and rear sun gear are connected.
- The input clutch is coupled, and the front internal gear and mid internal gear are connected.
- The drive power is conveyed to the front internal gear, mid internal gear, and rear carrier and the three planetary gears rotate forward as one unit.

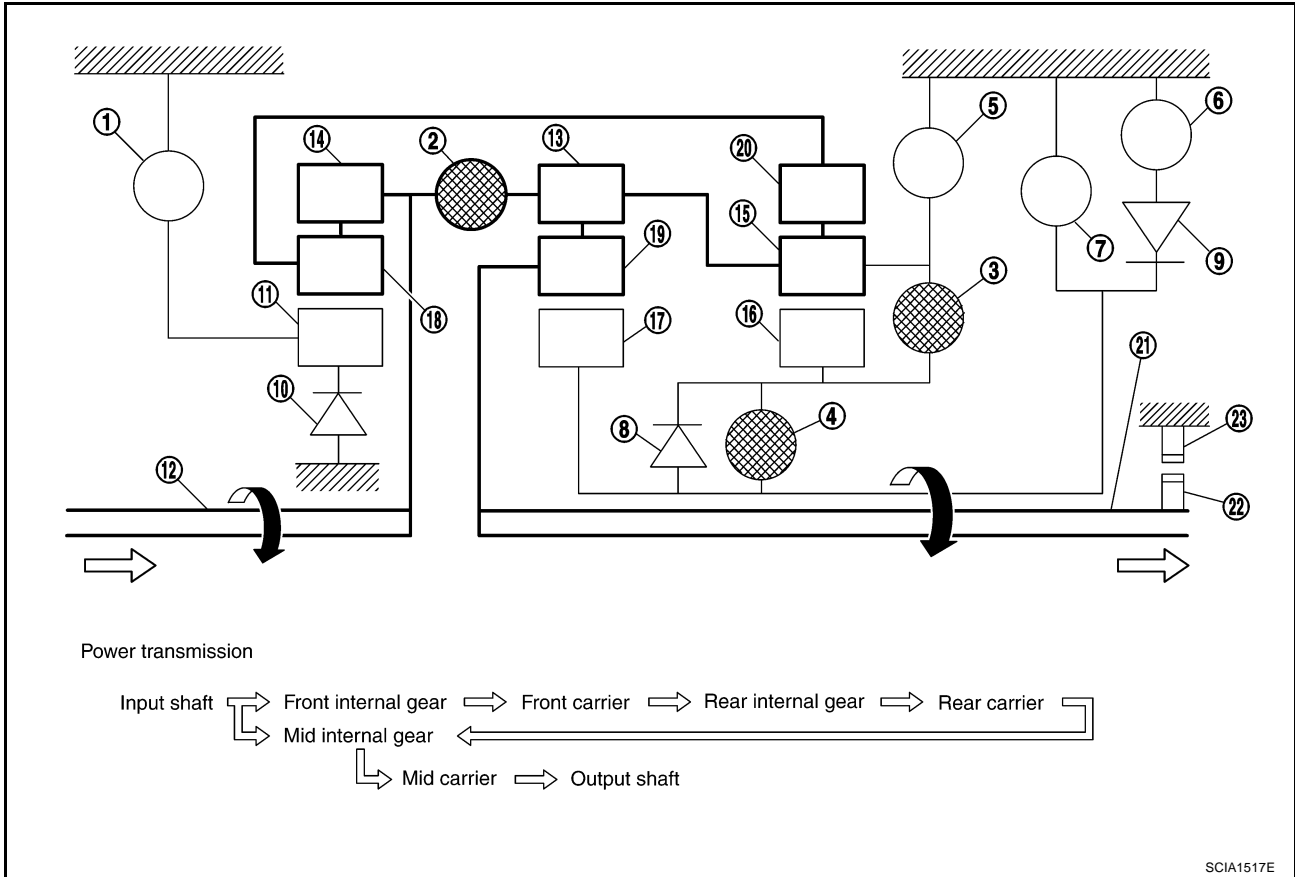

- | | | |
|--------------------------------|-------------------------|---------------------------|
| 1. Front brake | 2. Input clutch | 3. Direct clutch |
| 4. High and low reverse clutch | 5. Reverse brake | 6. Forward brake |
| 7. Low coast brake | 8. 1st one-way clutch | 9. Forward one-way clutch |
| 10. 3rd one-way clutch | 11. Front sun gear | 12. Input shaft |
| 13. Mid internal gear | 14. Front internal gear | 15. Rear carrier |
| 16. Rear sun gear | 17. Mid sun gear | 18. Front carrier |
| 19. Mid carrier | 20. Rear internal gear | 21. Output shaft |
| 22. Parking gear | 23. Parking pawl | |

A/T CONTROL SYSTEM

“D5” and “M5” Positions

- The front brake fastens the front sun gear.
- The input clutch is coupled, and the front internal gear and mid internal gear are connected.
- The high and low reverse clutch is coupled, and the mid sun gear and rear sun gear are connected.

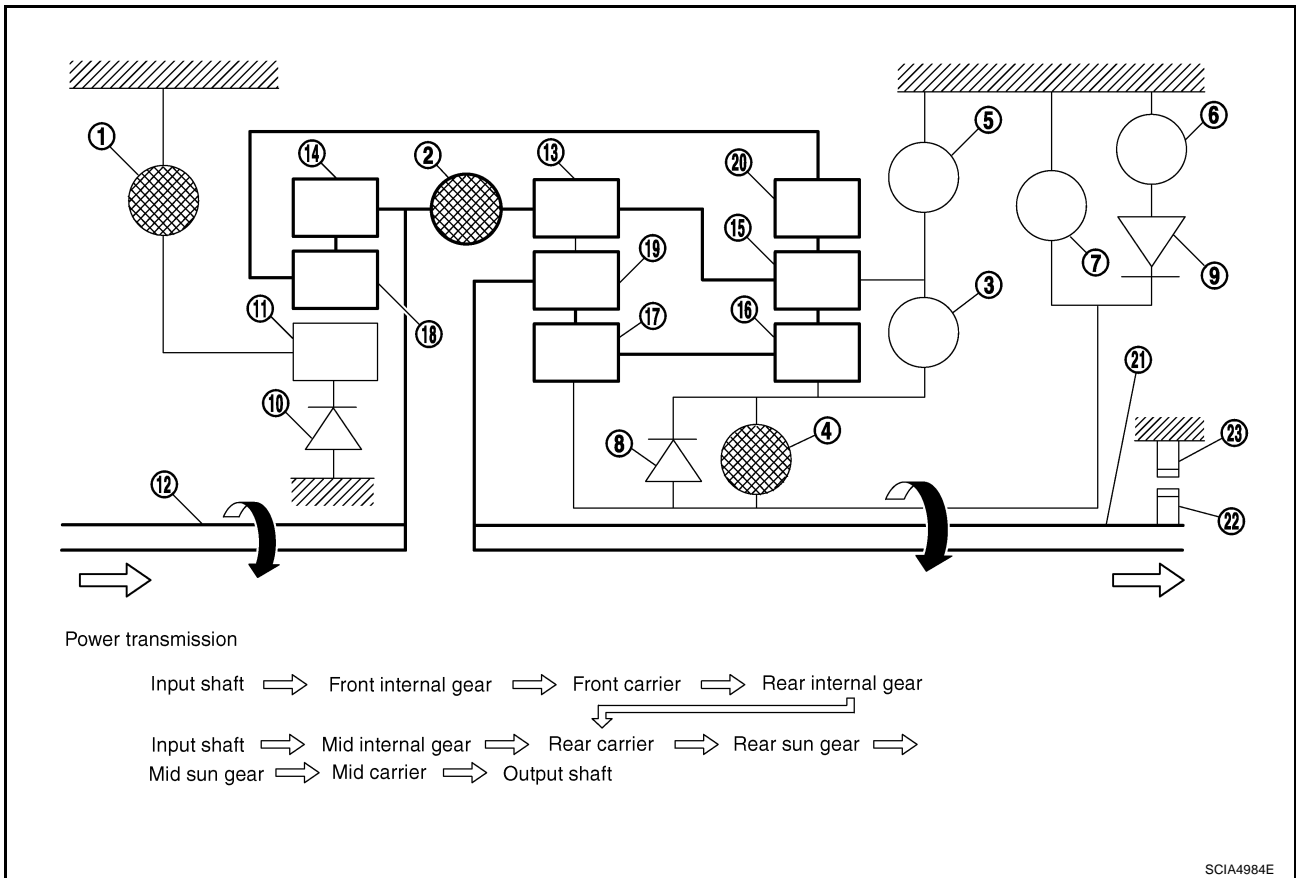

- | | | |
|--------------------------------|-------------------------|---------------------------|
| 1. Front brake | 2. Input clutch | 3. Direct clutch |
| 4. High and low reverse clutch | 5. Reverse brake | 6. Forward brake |
| 7. Low coast brake | 8. 1st one-way clutch | 9. Forward one-way clutch |
| 10. 3rd one-way clutch | 11. Front sun gear | 12. Input shaft |
| 13. Mid internal gear | 14. Front internal gear | 15. Rear carrier |
| 16. Rear sun gear | 17. Mid sun gear | 18. Front carrier |
| 19. Mid carrier | 20. Rear internal gear | 21. Output shaft |
| 22. Parking gear | 23. Parking pawl | |

A
B
AT
D
E
F
G
H
I
J
K
L
M

A/T CONTROL SYSTEM

“R” Position

- The front brake fastens the front sun gear.
- The high and low reverse clutch is coupled, and the mid sun gear and rear sun gear are connected.
- The reverse brake fastens the rear carrier.

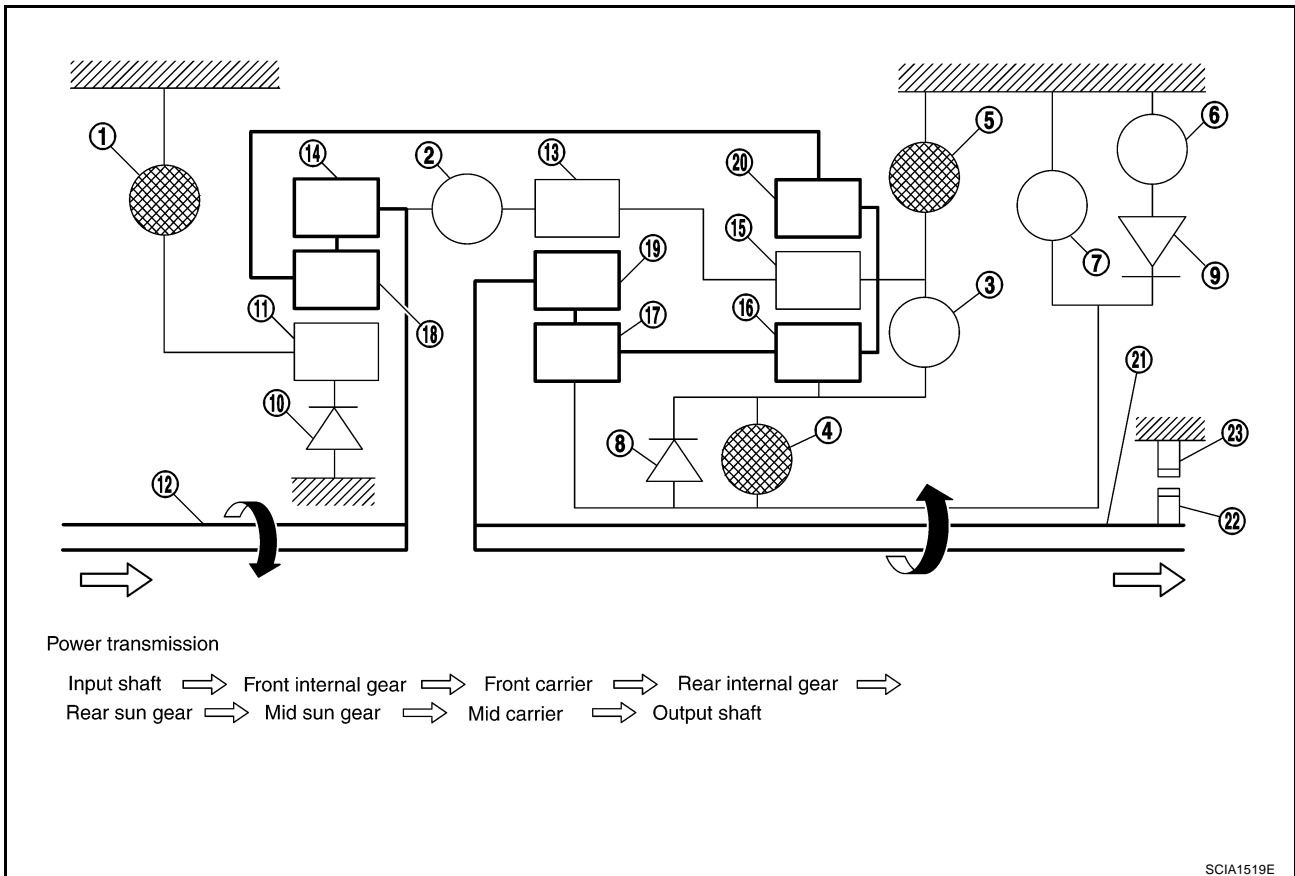

SCIA1519E

- | | | |
|--------------------------------|-------------------------|---------------------------|
| 1. Front brake | 2. Input clutch | 3. Direct clutch |
| 4. High and low reverse clutch | 5. Reverse brake | 6. Forward brake |
| 7. Low coast brake | 8. 1st one-way clutch | 9. Forward one-way clutch |
| 10. 3rd one-way clutch | 11. Front sun gear | 12. Input shaft |
| 13. Mid internal gear | 14. Front internal gear | 15. Rear carrier |
| 16. Rear sun gear | 17. Mid sun gear | 18. Front carrier |
| 19. Mid carrier | 20. Rear internal gear | 21. Output shaft |
| 22. Parking gear | 23. Parking pawl | |

A/T CONTROL SYSTEM

ACS000H5

TCM Function

The function of the TCM is to:

- Receive input signals sent from various switches and sensors.
- Determine required line pressure, shifting point, lock-up operation, and engine brake operation.
- Send required output signals to the respective solenoids.

CONTROL SYSTEM OUTLINE

The automatic transmission senses vehicle operating conditions through various sensors or signals. It always controls the optimum shift position and reduces shifting and lock-up shocks.

SENSORS (or SIGNALS)		TCM		ACTUATORS
PNP switch Accelerator pedal position signal Closed throttle position signal Wide open throttle position signal Engine speed signal A/T fluid temperature sensor Revolution sensor Vehicle speed signal Manual mode switch signal Stop lamp switch signal Turbine revolution sensor ATF pressure switch	⇒	Shift control Line pressure control Lock-up control Engine brake control Timing control Fail-safe control Self-diagnosis CONSULT-II communication line Duet-EA control CAN system	⇒	Input clutch solenoid valve Direct clutch solenoid valve Front brake solenoid valve High and low reverse clutch solenoid valve Low coast brake solenoid valve Torque converter clutch solenoid valve Line pressure solenoid valve A/T CHECK indicator lamp Starter relay Back-up lamp relay

CONTROL SYSTEM DIAGRAM

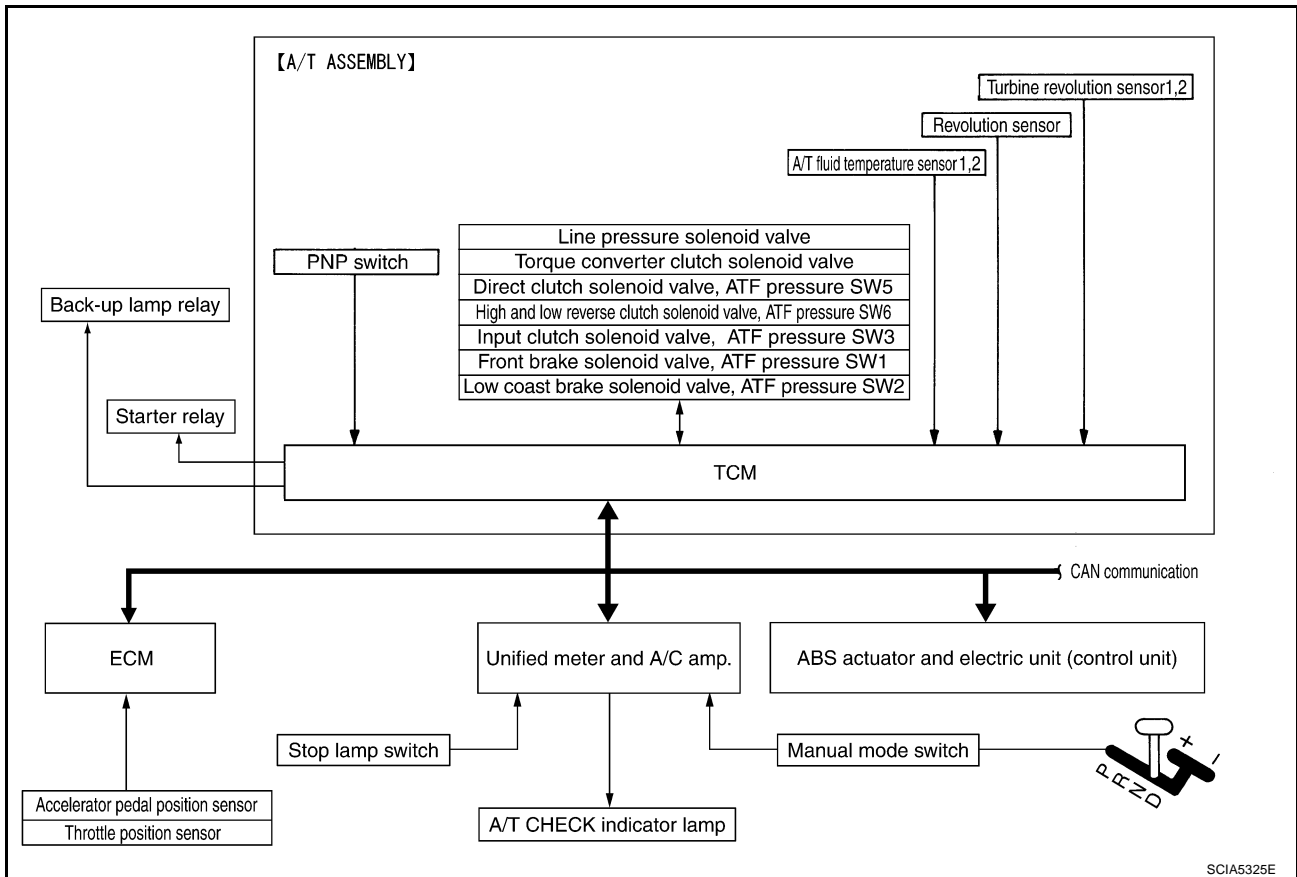

A/T CONTROL SYSTEM

CAN Communication SYSTEM DESCRIPTION

ACS000H6

CAN (Controller Area Network) is a serial communication line for real time application. It is an on-vehicle multiplex communication line with high data communication speed and excellent error detection ability. Many electronic control units are equipped onto a vehicle, and each control unit shares information and links with other control units during operation (not independent). In CAN communication, control units are connected with 2 communication lines (CAN H line, CAN L line) allowing a high rate of information transmission with less wiring. Each control unit transmits/receives data but selectively reads required data only. For details, refer to [LAN-5, "CAN Communication Unit"](#).

Input/Output Signal of TCM

ACS000H7

Control item		Line pressure control	Vehicle speed control	Shift control	Lock-up control	Engine brake control	Fail-safe function (*3)	Self-diagnostics function	
Input	Accelerator pedal position signal (*5)	X	X	X	X	X	X	X	
	Vehicle speed sensor A/T (revolution sensor)	X	X	X	X		X	X	
	Vehicle speed sensor MTR(*1) (*5)	X	X	X	X			X	
	Closed throttle position signal(*5)	(*2) X	(*2) X		X	(*2) X		(*4) X	
	Wide open throttle position signal(*5)	(*2) X	(*2) X			(*2) X		(*4) X	
	Turbine revolution sensor 1	X	X		X		X	X	
	Turbine revolution sensor 2 (for 4th speed only)	X	X		X		X	X	
	Engine speed signals(*5)				X			X	
	PNP switch	X	X	X	X	X	X	(*4) X	
	Stop lamp switch signal(*5)		X			X		(*4) X	
	A/T fluid temperature sensors 1, 2	X	X	X	X	X	X	X	
	ASCD	Operation signal(*5)		X	X	X	X		
		Overdrive cancel signal(*5)		X		X	X		
		TCM power supply voltage signal	X	X	X	X	X		X
Output	Direct clutch solenoid (ATF pressure switch 5)		X	X			X	X	
	Input clutch solenoid (ATF pressure switch 3)		X	X			X	X	
	High and low reverse clutch solenoid (ATF pressure switch 6)		X	X			X	X	
	Front brake solenoid (ATF pressure switch 1)		X	X			X	X	
	Low coast brake solenoid (ATF pressure switch 2)		X	X		X	X	X	
	Line pressure solenoid	X	X	X	X	X	X	X	
	TCC solenoid				X		X	X	
	Self-diagnostics table(*5)							X	
	Starter relay					X	X		

*1: Spare for vehicle speed sensor-A/T (revolution sensor)

*2: Spare for accelerator pedal position signal

*3: If these input and output signals are different, the TCM triggers the fail-safe function.

*4: Used as a condition for starting self-diagnostics; if self-diagnostics are not started, it is judged that there is some kind of error.

*5: CAN communications

A/T CONTROL SYSTEM

Line Pressure Control

ACS000HB

- When an input torque signal equivalent to the engine drive force is sent from the ECM to the TCM, the TCM controls the line pressure solenoid.
- This line pressure solenoid controls the pressure regulator valve as the signal pressure and adjusts the pressure of the operating oil discharged from the oil pump to the line pressure most appropriate to the driving state.

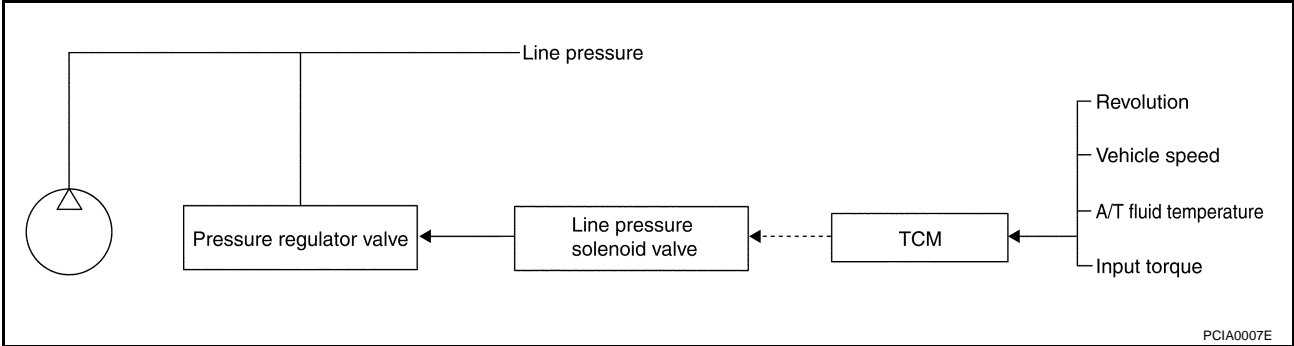

LINE PRESSURE CONTROL IS BASED ON THE TCM LINE PRESSURE CHARACTERISTIC PATTERN

- The TCM has stored in memory a number of patterns for the optimum line pressure characteristic for the driving state.
- In order to obtain the most appropriate line pressure characteristic to meet the current driving state, the TCM controls the line pressure solenoid current value and thus controls the line pressure.

Normal Control

Each clutch is adjusted to the necessary pressure to match the engine drive force.

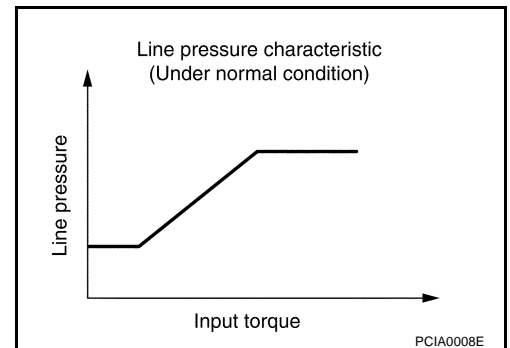

Back-up Control (Engine Brake)

When the select operation is executed during driving and the transmission is shifted down, the line pressure is set according to the vehicle speed.

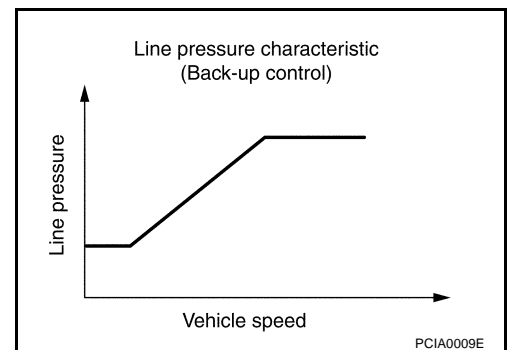

A/T CONTROL SYSTEM

During Shift Change

The necessary and adequate line pressure for shift change is set. For this reason, line pressure pattern setting corresponds to input torque and gearshift selection. Also, line pressure characteristic is set according to engine speed, during engine brake operation.

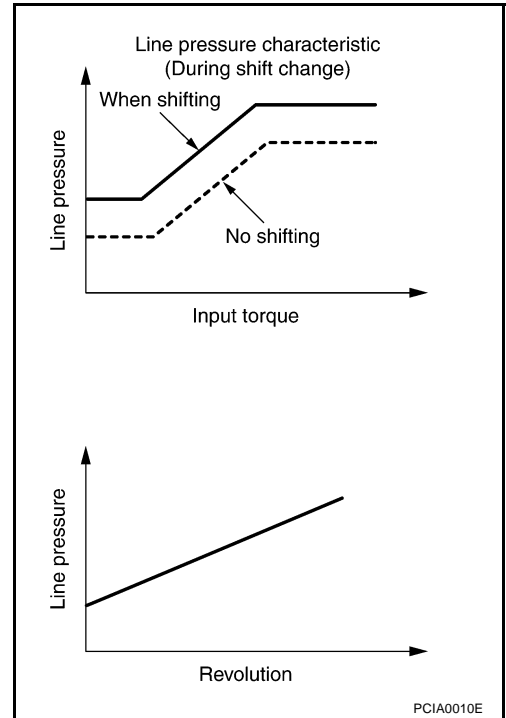

At Low Fluid Temperature

When the A/T fluid temperature drops below the prescribed temperature, in order to speed up the action of each friction element, the line pressure is set higher than the normal line pressure characteristic.

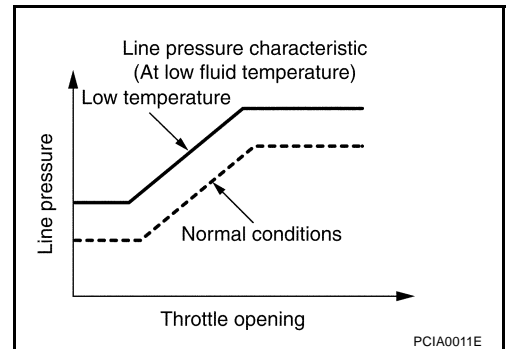

Shift Control

The clutch pressure control solenoid is controlled by the signals from the switches and sensors. Thus, the clutch pressure is adjusted to be appropriate to the engine load state and vehicle driving state. It becomes possible to finely control the clutch hydraulic pressure with high precision and a smoother shift change characteristic is attained.

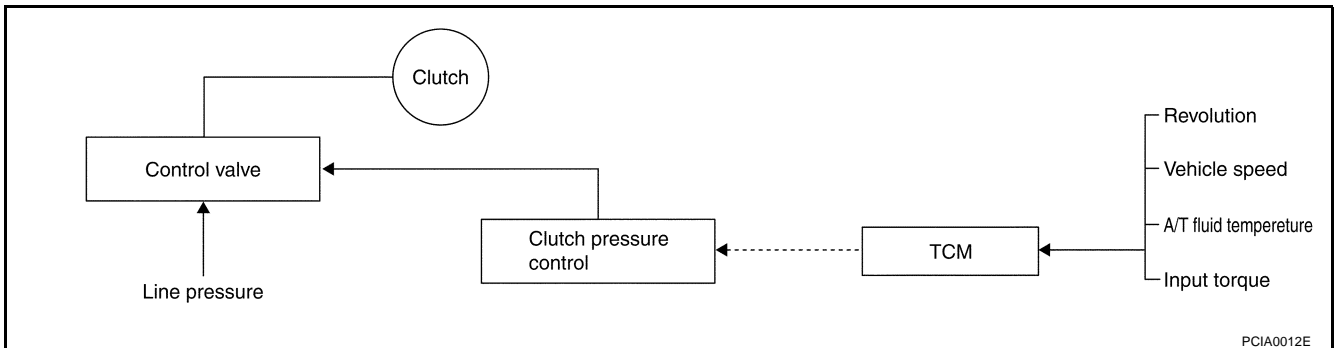

A/T CONTROL SYSTEM

SHIFT CHANGE

The clutch is controlled with the optimum timing and oil pressure by the engine speed, engine torque information, etc.

Shift Change System Diagram

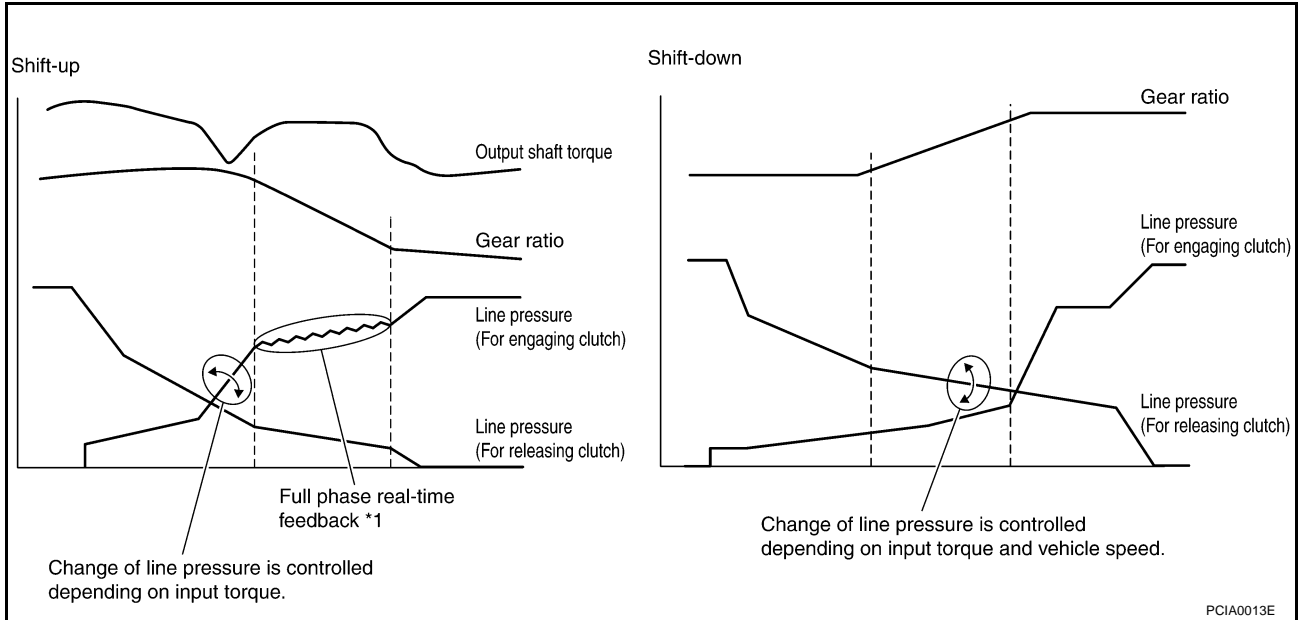

*1: Full phase real-time feedback control monitors movement of gear ratio at gear change, and controls oil pressure at real-time to achieve the best gear ratio.

Lock-up Control

ACS000HA

The torque converter clutch piston in the torque converter is engaged to eliminate torque converter slip to increase power transmission efficiency.

The torque converter clutch control valve operation is controlled by the torque converter clutch solenoid valve, which is controlled by a signal from TCM, and the torque converter clutch control valve engages or releases the torque converter clutch piston.

Lock-up Operation Condition Table

selector lever	D position		M5 position	M4 position	M3 position	M2 position
Gear position	5	4	5	4	3	2
Lock-up	×	—	×	×	×	×
Slip lock-up	×	×	—	—	—	—

TORQUE CONVERTER CLUTCH CONTROL VALVE CONTROL

Lock-up Control System Diagram

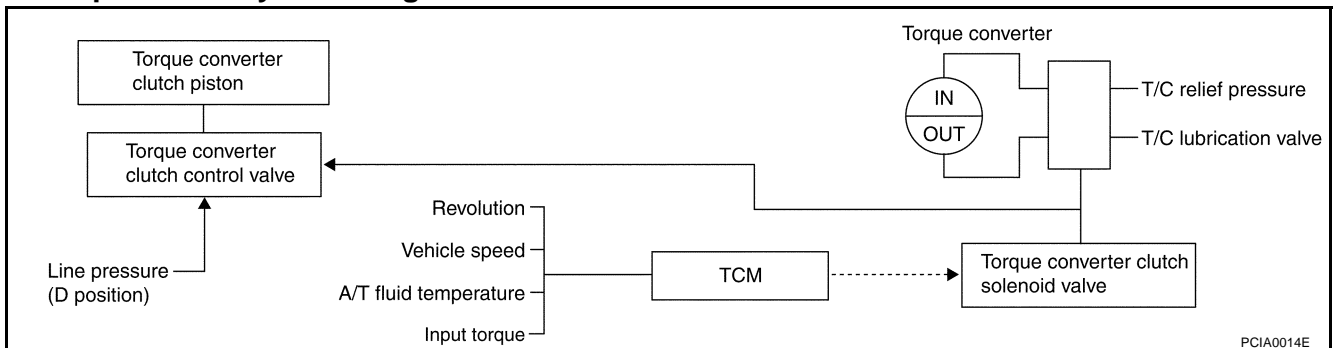

A/T CONTROL SYSTEM

Lock-up Released

- In the lock-up released state, the torque converter clutch control valve is set into the unlocked state by the torque converter clutch solenoid and the lock-up apply pressure is drained. In this way, the torque converter clutch piston is not coupled.

Lock-up Applied

- In the lock-up applied state, the torque converter clutch control valve is set into the locked state by the torque converter clutch solenoid and lock-up apply pressure is generated. In this way, the torque converter clutch piston is pressed and coupled.

SMOOTH LOCK-UP CONTROL

When shifting from the lock-up released state to the lock-up applied state, the current output to the torque converter clutch solenoid is controlled with the TCM. In this way, when shifting to the lock-up applied state, the torque converter clutch is temporarily set to the half-clutched state to reduce the shock.

Half-clutched State

- The current output from the TCM to the torque converter clutch solenoid is varied to gradually increase the torque converter clutch solenoid pressure. In this way, the lock-up apply pressure gradually rises and while the torque converter clutch piston is put into half-clutched status, the torque converter clutch piston operating pressure is increased and the coupling is completed smoothly.

Slip Lock-up Control

- In the slip region, the torque converter clutch solenoid current is controlled with the TCM to put it into the half-clutched state. This absorbs the engine torque fluctuation and lock-up operates from low speed. This raises the fuel efficiency for 4th and 5th gears at both low speed and when the accelerator has a low degree of opening.

Engine Brake Control

ACS000HB

- The forward one-way clutch transmits the drive force from the engine to the rear wheels. But the reverse drive from the rear wheels is not transmitted to the engine because the one-way clutch is idling. Therefore, the low coast brake solenoid is operated to prevent the forward one-way clutch from idling and the engine brake is operated in the same manner as conventionally.

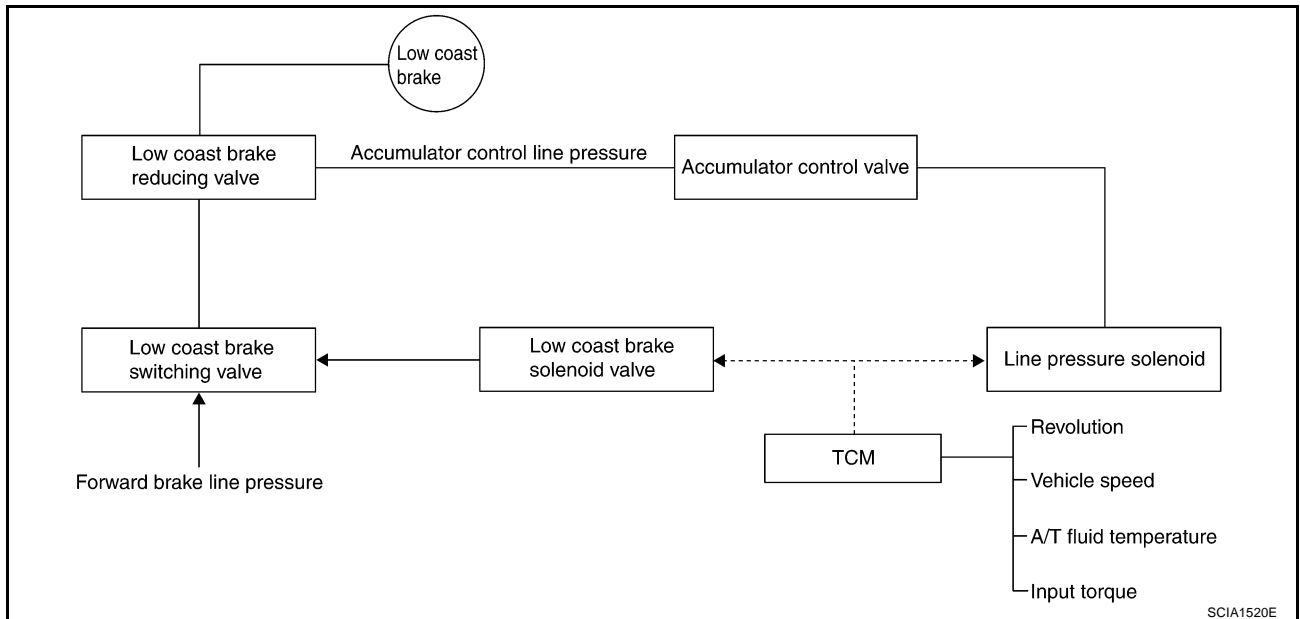

- The operation of the low coast brake solenoid switches the low coast brake switching valve and controls the coupling and releasing of the low coast brake. The low coast brake reducing valve controls the low coast brake coupling force.

A/T CONTROL SYSTEM

Control Valve FUNCTION OF CONTROL VALVE

ACS000HC

Name	Function
Torque converter regulator valve	In order to prevent the pressure supplied to the torque converter from being excessive, the line pressure is adjusted to the optimum pressure (torque converter operating pressure).
Pressure regulator valve Pressure regulator plug Pressure regulator sleeve	Adjusts the oil discharged from the oil pump to the optimum pressure (line pressure) for the driving state.
Front brake control valve	When the front brake is coupled, adjusts the line pressure to the optimum pressure (front brake pressure) and supplies it to the front brake. (In 1st, 2nd, 3rd, and 5th gears, adjusts the clutch pressure.)
Accumulator control valve	Adjusts the pressure (accumulator control pressure) acting on the accumulator piston and low coast reducing valve to the pressure appropriate to the driving state.
Pilot valve A	Adjusts the line pressure and produces the constant pressure (pilot pressure) required for line pressure control, shift change control, and lock-up control.
Pilot valve B	Adjusts the line pressure and produces the constant pressure (pilot pressure) required for shift change control.
Low coast brake switching valve	During engine braking, supplies the line pressure to the low coast brake reducing valve.
Low coast brake reducing valve	When the low coast brake is coupled, adjusts the line pressure to the optimum pressure (low coast brake pressure) and supplies it to the low coast brake.
N-R accumulator	Produces the stabilizing pressure for when N-R is selected.
Direct clutch piston switching valve	Operates in 4th gear and switches the direct clutch coupling capacity.
High and low reverse clutch control valve	When the high and low reverse clutch is coupled, adjusts the line pressure to the optimum pressure (high and low reverse clutch pressure) and supplies it to the high and low reverse clutch. (In 1st, 3rd, 4th and 5th gears, adjusts the clutch pressure.)
Input clutch control valve	When the input clutch is coupled, adjusts the line pressure to the optimum pressure (input clutch pressure) and supplies it to the input clutch. (In 4th and 5th gears, adjusts the clutch pressure.)
Direct clutch control valve	When the direct clutch is coupled, adjusts the line pressure to the optimum pressure (direct clutch pressure) and supplies it to the direct clutch. (In 2nd, 3rd, and 4th gears, adjusts the clutch pressure.)
TCC control valve TCC control plug TCC control sleeve	Switches the lock-up to operating or released. Also, by executing the lock-up operation transiently, lock-up smoothly.
Torque converter lubrication valve	Operates during lock-up to switch the torque converter, cooling, and lubrication system oil path.
Cool bypass valve	Allows excess oil to bypass cooler circuit without being fed into it.
Line pressure relief valve	Discharges excess oil from line pressure circuit.
N-D accumulator	Produces the stabilizing pressure for when N-D is selected.
Manual valve	Sends line pressure to each circuit according to the select position. The circuits to which the line pressure is not sent drain.

A
B
AT
D
E
F
G
H
I
J
K
L
M

A/T CONTROL SYSTEM

FUNCTION OF ATF PRESSURE SWITCH

Name	Function
ATF pressure switch 1 (FR/B)	Detects any malfunction in the front brake hydraulic pressure. When it detects any malfunction, it puts the system into fail-safe mode.
ATF pressure switch 2 (LC/B)	Detects any malfunction in the low coast brake hydraulic pressure. When it detects any malfunction, it puts the system into fail-safe mode.
ATF pressure switch 3 (I/C)	Detects any malfunction in the input clutch hydraulic pressure. When it detects any malfunction, it puts the system into fail-safe mode.
ATF pressure switch 5 (D/C)	Detects any malfunction in the direct clutch hydraulic pressure. When it detects any malfunction, it puts the system into fail-safe mode.
ATF pressure switch 6 (HLR/C)	Detects any malfunction in the high and low reverse clutch hydraulic pressure. When it detects any malfunction, it puts the system into fail-safe mode.

ON BOARD DIAGNOSTIC (OBD) SYSTEM

PFP:00028

Introduction

ACS000HD

The A/T system has two self-diagnostic systems.

The first is the emission-related on board diagnostic system (OBD-II) performed by the TCM in combination with the ECM. The malfunction is indicated by the MIL (malfunction indicator lamp) and is stored as a DTC in the ECM memory but not the TCM memory.

The second is the TCM original self-diagnosis indicated by the A/T CHECK indicator lamp. The malfunction is stored in the TCM memory. The detected items are overlapped with OBD-II self-diagnostic items. For detail, refer to [AT-90, "SELF-DIAGNOSTIC RESULT MODE"](#).

OBD-II Function for A/T System

ACS000HE

The ECM provides emission-related on board diagnostic (OBD-II) functions for the A/T system. One function is to receive a signal from the TCM used with OBD-related parts of the A/T system. The signal is sent to the ECM when a malfunction occurs in the corresponding OBD-related part. The other function is to indicate a diagnostic result by means of the MIL (malfunction indicator lamp) on the instrument panel. Sensors, switches and solenoid valves are used as sensing elements.

The MIL automatically illuminates in One or Two Trip Detection Logic when a malfunction is sensed in relation to A/T system parts.

One or Two Trip Detection Logic of OBD-II ONE TRIP DETECTION LOGIC

ACS000HF

If a malfunction is sensed during the first test drive, the MIL will illuminate and the malfunction will be stored in the ECM memory as a DTC. The TCM is not provided with such a memory function.

TWO TRIP DETECTION LOGIC

When a malfunction is sensed during the first test drive, it is stored in the ECM memory as a 1st trip DTC (diagnostic trouble code) or 1st trip freeze frame data. At this point, the MIL will not illuminate. — 1st Trip



If the same malfunction as that experienced during the first test drive is sensed during the second test drive, the MIL will illuminate. — 2nd Trip

The "Trip" in the "One or Two Trip Detection Logic" means a driving mode in which self-diagnosis is performed during vehicle operation.

OBD-II Diagnostic Trouble Code (DTC) HOW TO READ DTC AND 1ST TRIP DTC

ACS000HG

DTC and 1st trip DTC can be read by the following methods.

( with **CONSULT-II** or ( **GST**) CONSULT-II or GST (Generic Scan Tool) Examples: P0705, P0720 etc. These DTC are prescribed by SAE J2012.

(CONSULT-II also displays the malfunctioning component or system.)

- **1st trip DTC No. is the same as DTC No.**
- **Output of the diagnostic trouble code indicates that the indicated circuit has a malfunction. However, in case of the Mode II and GST, they do not indicate whether the malfunction is still occurring or occurred in the past and returned to normal.**
CONSULT-II can identify them as shown below, therefore, CONSULT-II (if available) is recommended.

A sample of CONSULT-II display for DTC and 1st trip DTC is shown on the next page. DTC or 1st trip DTC of a malfunction is displayed in SELF-DIAGNOSTIC RESULTS mode for "ENGINE" with CONSULT-II. Time data indicates how many times the vehicle was driven after the last detection of a DTC.

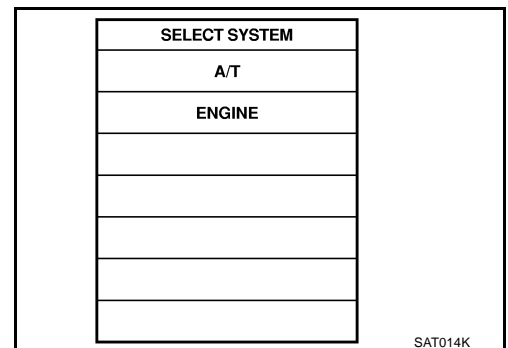

ON BOARD DIAGNOSTIC (OBD) SYSTEM

If the DTC is being detected currently, the time data will be "0".

SELF-DIAG RESULTS	
DTC RESULTS	TIME
PNP SW/CIRC [P0705]	0

SAT015K

If a 1st trip DTC is stored in the ECM, the time data will be "1 t".

SELF-DIAG RESULTS	
DTC RESULTS	TIME
PNP SW/CIRC [P0705]	1 t

SAT016K

Freeze frame data and 1st trip freeze frame data

The ECM has a memory function, which stores the driving condition such as fuel system status, calculated load value, engine coolant temperature, short term fuel trim, long term fuel trim, engine speed and vehicle speed at the moment the ECM detects a malfunction.

Data which are stored in the ECM memory, along with the 1st trip DTC, are called 1st trip freeze frame data, and the data, stored together with the DTC data, are called freeze frame data and displayed on CONSULT-II or GST. The 1st trip freeze frame data can only be displayed on the CONSULT-II screen, not on the GST. For detail, refer to [EC-103, "CONSULT-II Function \(ENGINE\)"](#).

Only one set of freeze frame data (either 1st trip freeze frame data or freeze frame data) can be stored in the ECM. 1st trip freeze frame data is stored in the ECM memory along with the 1st trip DTC. There is no priority for 1st trip freeze frame data and it is updated each time a different 1st trip DTC is detected. However, once freeze frame data (2nd trip detection/MIL on) is stored in the ECM memory, 1st trip freeze frame data is no longer stored. Remember, only one set of freeze frame data can be stored in the ECM. The ECM has the following priorities to update the data.

Priority	Items	
1	Freeze frame data	Misfire — DTC: P0300 - P0306 Fuel Injection System Function — DTC: P0171, P0172, P0174, P0175
2		Except the above items (Includes A/T related items)
3	1st trip freeze frame data	

Both 1st trip freeze frame data and freeze frame data (along with the DTC) are cleared when the ECM memory is erased.

HOW TO ERASE DTC

The diagnostic trouble code can be erased by CONSULT-II, GST or ECM DIAGNOSTIC TEST MODE as described following.

- **If the battery cable is disconnected from the terminal, the diagnostic trouble code will be lost within 24 hours.**
- **When you erase the DTC, using CONSULT-II or GST is easier and quicker than switching the mode selector on the ECM.**

The following emission-related diagnostic information is cleared from the ECM memory when erasing DTC related to OBD-II. For details, refer to [EC-48, "Emission-related Diagnostic Information"](#).

- **Diagnostic trouble codes (DTC)**
- **1st trip diagnostic trouble codes (1st trip DTC)**

ON BOARD DIAGNOSTIC (OBD) SYSTEM

- Freeze frame data
- 1st trip freeze frame data
- System readiness test (SRT) codes
- Test values

Ⓟ HOW TO ERASE DTC (WITH CONSULT-II)

- If a DTC is displayed for both ECM and TCM, it is necessary to be erased for both ECM and TCM.
1. If the ignition switch stays ON after repair work, be sure to turn ignition switch OFF once. Wait for at least 10 seconds and then turn it ON (engine stopped) again.
 2. Turn CONSULT-II "ON" and touch "A/T".
 3. Touch "SELF-DIAG RESULTS".
 4. Touch "ERASE". (The DTC in the TCM will be erased.) Then touch "BACK" twice.
 5. Touch "ENGINE".
 6. Touch "SELF-DIAG RESULTS".
 7. Touch "ERASE". (The DTC in the ECM will be erased.)

How to erase DTC (With CONSULT-II)

1. If the ignition switch stays "ON" after repair work, be sure to turn ignition switch "OFF" once. Wait at least 10 seconds and then turn it "ON" (engine stopped) again.

SELECT SYSTEM
A/T
ENGINE

2. Turn CONSULT-II "ON", and touch "A/T".

SELECT DIAG MODE
SELF-DIAG RESULTS
DATA MONITOR
CAN DIAG SUPPORT MNTR
FUNCTION TEST
DTC WORK SUPPORT
ECU PART NUMBER

3. Touch "SELF-DIAG RESULTS".

SELF-DIAG RESULTS
DTC RESULTS
TCC SOLENOID/CIRC [P0740]

4. Touch "ERASE". (The DTC in the TCM will be erased.)

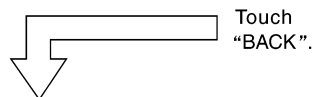

SELECT SYSTEM
A/T
ENGINE

5. Touch "ENGINE".

SELECT DIAG MODE
WORK SUPPORT
SELF-DIAG RESULTS
DATA MONITOR
DATA MONITOR(SPEC)
CAN DIAG SUPPORT MNTR
ACTIVE TEST

6. Touch "SELF-DIAG RESULTS".

SELF-DIAG RESULTS	
DTC RESULTS	TIME
TCC SOLENOID/CIRC [P0740]	0

7. Touch "ERASE". (The DTC in the TCM will be erased.)

SCIA5671E

Ⓟ HOW TO ERASE DTC (WITH GST)

1. If the ignition switch stays ON after repair work, be sure to turn ignition switch OFF once. Wait for at least 10 seconds and then turn it ON (engine stopped) again.
2. Perform "TCM SELF-DIAGNOSTIC PROCEDURE (No Tools)". Refer to [AT-99, "TCM SELF-DIAGNOSTIC PROCEDURE \(NO TOOLS\)"](#). (The engine warm-up step can be skipped when performing the diagnosis only to erase the DTC.)
3. Select Mode 4 with Generic Scan Tool (GST). For details, refer to [EC-116, "Generic Scan Tool \(GST\) Function"](#).

ON BOARD DIAGNOSTIC (OBD) SYSTEM



HOW TO ERASE DTC (NO TOOLS)

The A/T CHECK indicator lamp is located on the instrument panel.

1. If the ignition switch stays ON after repair work, be sure to turn ignition switch OFF once. Wait for at least 10 seconds and then turn it ON (engine stopped) again.
2. Perform "TCM SELF-DIAGNOSTIC PROCEDURE (No Tools)". Refer to [AT-99, "TCM SELF-DIAGNOSTIC PROCEDURE \(NO TOOLS\)"](#). (The engine warm-up step can be skipped when performing the diagnosis only to erase the DTC.)
3. Perform "OBD-II SELF-DIAGNOSTIC PROCEDURE (No tools)". Refer to [EC-61, "How to Erase DTC"](#).

Malfunction Indicator Lamp (MIL) DESCRIPTION

ACS000HH

The MIL is located on the instrument panel.

1. The MIL will light up when the ignition switch is turned ON without the engine running. This is a bulb check.
 - If the MIL does not light up, refer to [DI-62, "WARNING LAMPS"](#), or see [EC-672, "MIL AND DATA LINK CONNECTOR"](#).
2. When the engine is started, the MIL should go off. If the MIL remains on, the on board diagnostic system has detected an engine system malfunction.

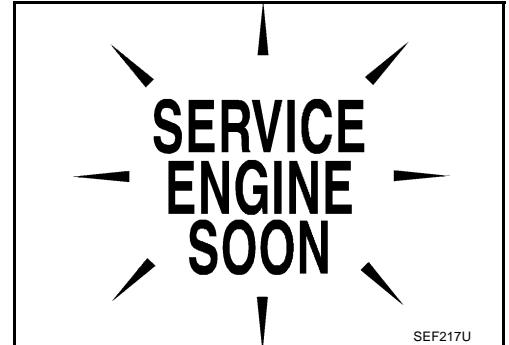

TROUBLE DIAGNOSIS

TROUBLE DIAGNOSIS

PFP:00004

DTC Inspection Priority Chart

ACS000HI

If some DTCs are displayed at the same time, perform inspections one by one based on the following priority chart.

NOTE:

If DTC “U1000” is displayed with other DTC, first perform the trouble diagnosis for “DTC U1000 CAN COMMUNICATION LINE”. Refer to [AT-101](#) .

Priority	Detected items (DTC)
1	U1000 CAN communication line
2	Except above

Fail-safe

ACS000HJ

The TCM has an electrical fail-safe mode. This mode makes it possible to operate even if there is an error in a main electronic control input/output signal circuit.

In fail-safe mode, even if the selector lever is “D” or “M” mode, the transmission is fixed in 2nd, 4th or 5th (depending on the breakdown position), so the customer should feel “slipping” or “poor acceleration”. When fail-safe mode is triggered, when the ignition switch is switched ON, the A/T CHECK indicator lamp flashes for about 8 seconds. (Refer to [AT-99, "TCM SELF-DIAGNOSTIC PROCEDURE \(NO TOOLS\)"](#)).

Even when the electronic circuits are normal, under special conditions (for example, when slamming on the brake with the wheels spinning drastically and stopping the tire rotation), the transmission can go into fail-safe mode. If this happens, switch OFF the ignition switch for 10 seconds, then switch it ON again to return to the normal shift pattern. Also, the A/T CHECK indicator lamp flashes for about 8 seconds once, then is cleared. Therefore, the customer's vehicle has returned to normal, so handle according to the “diagnostics flow” (Refer to [AT-44](#)).

FAIL-SAFE FUNCTION

If any malfunction occurs in a sensor or solenoid, this function controls the A/T to mark driving possible.

Vehicle Speed Sensor A/T (Revolution Sensor)

- Signals are input from two systems - from vehicle speed sensor A/T (revolution sensor) installed on the transmission and from combination meter so normal driving is possible even if there is a malfunction in one of the systems. And if vehicle speed sensor A/T (revolution sensor) has unusual cases, 5th gear and manual mode are prohibited.

Accelerator Pedal Position Sensor

- If there is a malfunction in one of the systems, the accelerator opening angle is controlled by ECM according to a pre-determined accelerator angle to make driving possible. And if there are malfunctions in tow systems, the engine speed is fixed by ECM to a pre-determined engine speed to make driving possible.

Throttle Position Sensor

- If there is a malfunction in one of the systems, the accelerator opening angle is controlled by ECM according to a pre-determined accelerator angle to make driving possible. And if there are malfunctions in tow systems, the accelerator opening angle is controlled by the idle signal sent from the ECM which is based on input indicating either idle condition or off-idle condition (pre-determined accelerator opening) in order to make driving possible.

PNP Switch

- In the unlikely event that a malfunction signal enters the TCM, the position indicator is switched OFF, the starter relay is switched OFF (starter starting is disabled), the back-up lamp relay switched OFF (back-up lamp is OFF) and the position is fixed to the D range to make driving possible.

Starter Relay

- The starter relay is switched OFF. (Starter starting is disabled.)

TROUBLE DIAGNOSIS

A/T Interlock

- If there is an A/T interlock judgment malfunction, the transmission is fixed in 2nd gear to make driving possible.

NOTE:

When the vehicle is driven fixed in 2nd gear a turbine revolution sensor malfunction is displayed, but this is not a turbine revolution sensor malfunction.

- When the coupling pattern below is detected, the fail-safe action corresponding to the pattern is executed.

A/T INTERLOCK COUPLING PATTERN TABLE

●: NG X: OK

Gear position		ATF pressure switch output					Fail-safe function	Clutch pressure output pattern after fail-safe function					
		SW3 (I/C)	SW6 (HLR/C)	SW5 (D/C)	SW1 (FR/B)	SW2 (LC/B)		I/C	HLR/C	D/C	FR/B	LC/B	L/U
A/T interlock coupling pattern	3rd	–	X	X	–	●	Held in 2nd gear	OFF	OFF	ON	OFF	OFF	OFF
	4th	–	X	X	–	●	Held in 2nd gear	OFF	OFF	ON	OFF	OFF	OFF
	5th	X	X	–	X	●	Held in 2nd gear	OFF	OFF	ON	OFF	OFF	OFF

A/T 1st Engine Braking

- When there is an A/T first gear engine brake judgment malfunction, the low coast brake solenoid is switched OFF to avoid the engine brake operation.

Line Pressure Solenoid

- The solenoid is switched OFF and the line pressure is set to the maximum hydraulic pressure to make driving possible.

Torque Converter Clutch Solenoid

- The solenoid is switched OFF to release the lock-up.

Low Coast Brake Solenoid

- If a malfunction (electrical or functional) occurs with the solenoid ON, the transmission is held in 2nd gear, and the solenoid OFF, the transmission is held in 4th gear to make driving possible. (engine brake is not applied in 1st and 2nd gear.)

Input Clutch Solenoid

- If a malfunction (electrical or functional) occurs with the solenoid either ON or OFF, the transmission is held in 4th gear to make driving possible.

Direct Clutch Solenoid

- If a malfunction (electrical or functional) occurs with the solenoid either ON or OFF, the transmission is held in 4th gear to make driving possible.

Front Brake Solenoid

- If a malfunction (electrical or functional) occurs with the solenoid ON, the transmission is held in 5th gear, and the solenoid OFF, the transmission is held in 4th gear to make driving possible.

High and Low Reverse Clutch Solenoid

- If a malfunction (electrical or functional) occurs with the solenoid either ON or OFF, the transmission is held in 4th gear to make driving possible.

Turbine Revolution Sensor 1 or 2

- The control is the same as if there were no turbine revolution sensors, 5th gear and manual mode are prohibited.

TROUBLE DIAGNOSIS

How To Perform Trouble Diagnosis For Quick and Accurate Repair INTRODUCTION

ACS000HK

The TCM receives a signal from the vehicle speed sensor, accelerator pedal position sensor (throttle position sensor) or PNP switch and provides shift control or lock-up control via A/T solenoid valves.

The TCM also communicates with the ECM by means of a signal sent from sensing elements used with the OBD-related parts of the A/T system for malfunction-diagnostic purposes. The TCM is capable of diagnosing malfunctioning parts while the ECM can store malfunctions in its memory.

Input and output signals must always be correct and stable in the operation of the A/T system. The A/T system must be in good operating condition and be free of valve seizure, solenoid valve malfunction, etc.

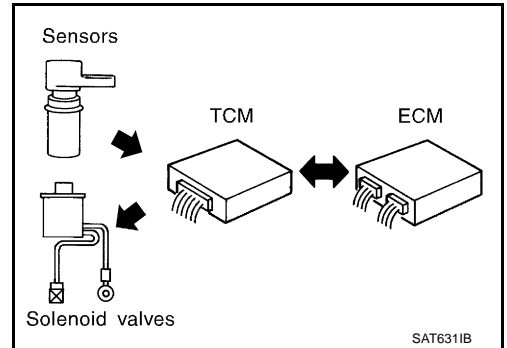

It is much more difficult to diagnose a error that occurs intermittently rather than continuously. Most intermittent errors are caused by poor electric connections or improper wiring. In this case, careful checking of suspected circuits may help prevent the replacement of good parts.

A visual check only may not find the cause of the errors. A road test with CONSULT-II (or GST) or a circuit tester connected should be performed. Follow the [AT-44, "WORK FLOW"](#) .

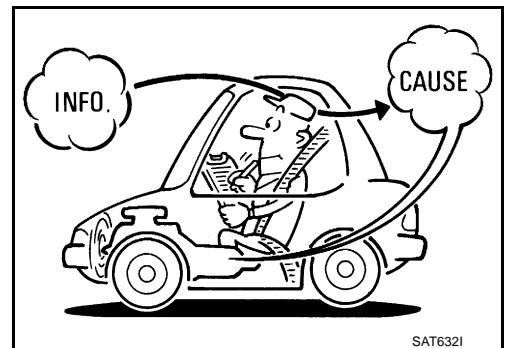

Before undertaking actual checks, take a few minutes to talk with a customer who approaches with a driveability complaint. The customer can supply good information about such errors, especially intermittent ones. Find out what symptoms are present and under what conditions they occur. A "DIAGNOSTIC WORKSHEET" as shown on the example (Refer to [AT-45](#)) should be used.

Start your diagnosis by looking for "conventional" errors first. This will help troubleshoot driveability errors on an electronically controlled engine vehicle.

Also check related Service bulletins.

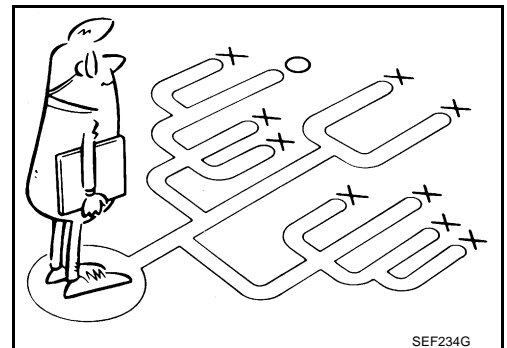

A
B
AT
D
E
F
G
H
I
J
K
L
M

TROUBLE DIAGNOSIS

WORK FLOW

A good understanding of the malfunction conditions can make troubleshooting faster and more accurate. In general, each customer feels differently about a malfunction. It is important to fully understand the symptoms or conditions for a customer's complaint. Make good use of the two sheets provided, "Information From Customer" (Refer to [AT-45](#)) and "Diagnostic Worksheet Chart" (Refer to [AT-45](#)), to perform the best troubleshooting possible.

Work Flow Chart

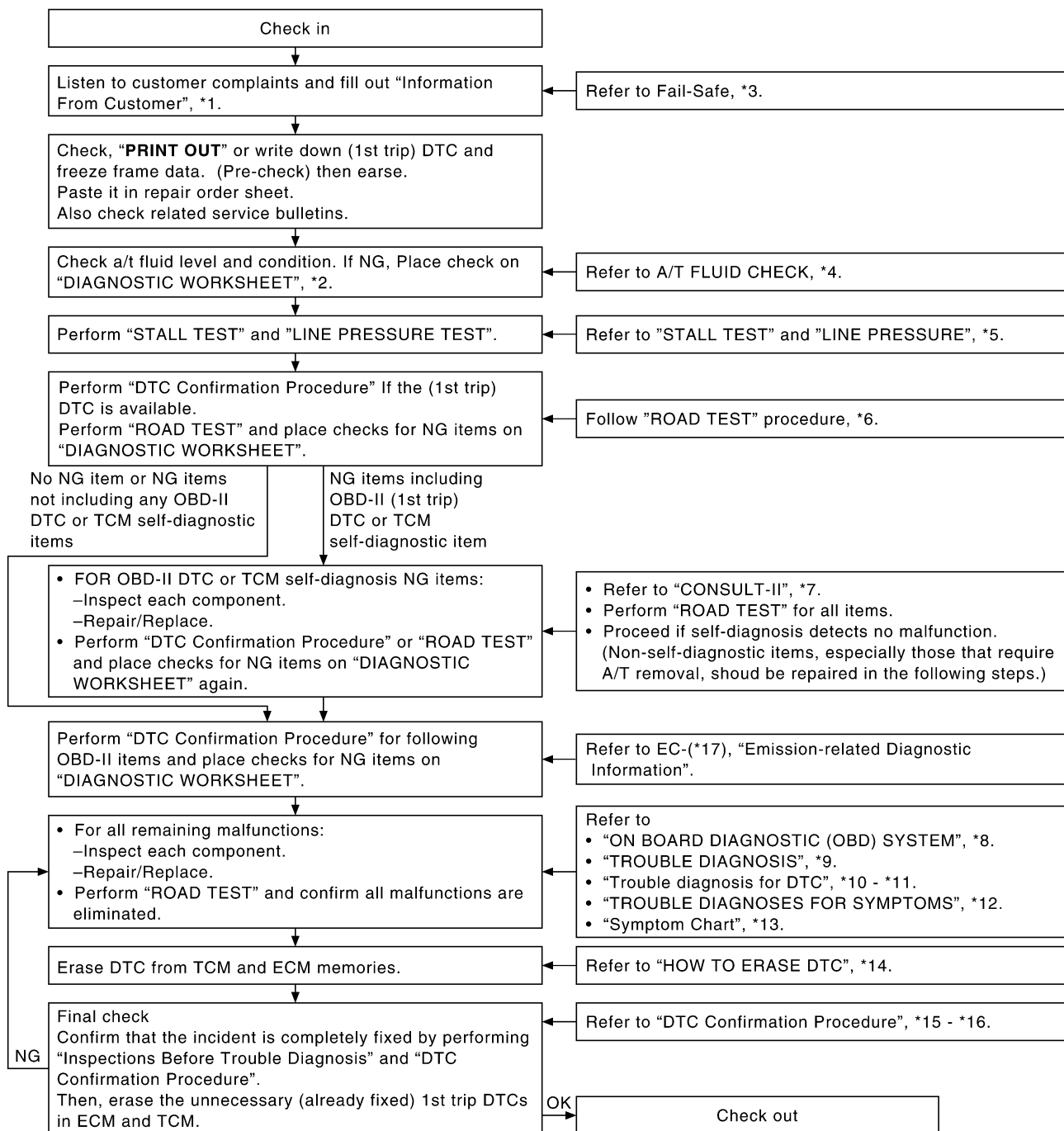

SCIA5324E

- *1. [AT-45](#)
- *4. [AT-51](#)
- *7. [AT-90](#)
- *10. [AT-101](#)
- *13. [AT-62](#)
- *16. [AT-177](#)

- *2. [AT-45](#)
- *5. [AT-51](#), [AT-52](#)
- *8. [AT-37](#)
- *11. [AT-177](#)
- *14. [AT-38](#)
- *17. [EC-48](#)

- *3. [AT-41](#)
- *6. [AT-54](#)
- *9. [AT-41](#)
- *12. [AT-185](#)
- *15. [AT-101](#)

TROUBLE DIAGNOSIS

	<input type="checkbox"/> Perform all road tests and enter checks in required inspection items.		AT-54
4	4-1.	Check before engine is started	AT-55
		<input type="checkbox"/> AT-188, "A/T Check Indicator Lamp Does Not Come On" . <input type="checkbox"/> Perform self-diagnostics. Enter checks for detected items. AT-90 , AT-99	
		<input type="checkbox"/> AT-101, "DTC U1000 CAN COMMUNICATION LINE" . <input type="checkbox"/> AT-104, "DTC P0615 START SIGNAL CIRCUIT" . <input type="checkbox"/> AT-108, "DTC P0700 TCM" . <input type="checkbox"/> AT-109, "DTC P0705 PARK/NEUTRAL POSITION SWITCH" . <input type="checkbox"/> AT-113, "DTC P0720 VEHICLE SPEED SENSOR A/T (REVOLUTION SENSOR)" . <input type="checkbox"/> AT-118, "DTC P0725 ENGINE SPEED SIGNAL" . <input type="checkbox"/> AT-120, "DTC P0740 TORQUE CONVERTER CLUTCH SOLENOID VALVE" . <input type="checkbox"/> AT-122, "DTC P0744 A/T TCC S/V FUNCTION (LOCK-UP)" . <input type="checkbox"/> AT-124, "DTC P0745 LINE PRESSURE SOLENOID VALVE" . <input type="checkbox"/> AT-126, "DTC P1702 TRANSMISSION CONTROL MODULE (RAM)" . <input type="checkbox"/> AT-127, "DTC P1703 TRANSMISSION CONTROL MODULE (ROM)" . <input type="checkbox"/> AT-128, "DTC P1705 THROTTLE POSITION SENSOR" . <input type="checkbox"/> AT-131, "DTC P1710 A/T FLUID TEMPERATURE SENSOR CIRCUIT" . <input type="checkbox"/> AT-136, "DTC P1716 TURBINE REVOLUTION SENSOR" . <input type="checkbox"/> AT-138, "DTC P1721 VEHICLE SPEED SENSOR MTR" . <input type="checkbox"/> AT-140, "DTC P1730 A/T INTERLOCK" . <input type="checkbox"/> AT-143, "DTC P1731 A/T 1ST ENGINE BRAKING" . <input type="checkbox"/> AT-145, "DTC P1752 INPUT CLUTCH SOLENOID VALVE" . <input type="checkbox"/> AT-147, "DTC P1754 INPUT CLUTCH SOLENOID VALVE FUNCTION" . <input type="checkbox"/> AT-149, "DTC P1757 FRONT BRAKE SOLENOID VALVE" . <input type="checkbox"/> AT-151, "DTC P1759 FRONT BRAKE SOLENOID VALVE FUNCTION" . <input type="checkbox"/> AT-153, "DTC P1762 DIRECT CLUTCH SOLENOID VALVE" . <input type="checkbox"/> AT-155, "DTC P1764 DIRECT CLUTCH SOLENOID VALVE FUNCTION" . <input type="checkbox"/> AT-157, "DTC P1767 HIGH AND LOW REVERSE CLUTCH SOLENOID VALVE" . <input type="checkbox"/> AT-159, "DTC P1769 HIGH AND LOW REVERSE CLUTCH SOLENOID VALVE FUNCTION" . <input type="checkbox"/> AT-161, "DTC P1772 LOW COAST BRAKE SOLENOID VALVE" . <input type="checkbox"/> AT-163, "DTC P1774 LOW COAST BRAKE SOLENOID VALVE FUNCTION" . <input type="checkbox"/> AT-165, "DTC P1815 MANUAL MODE SWITCH" . <input type="checkbox"/> AT-171, "DTC P1841 ATF PRESSURE SWITCH 1" . <input type="checkbox"/> AT-173, "DTC P1843 ATF PRESSURE SWITCH 3" . <input type="checkbox"/> AT-175, "DTC P1845 ATF PRESSURE SWITCH 5" . <input type="checkbox"/> AT-177, "DTC P1846 ATF PRESSURE SWITCH 6" .	
	4-2.	Check at Idle <input type="checkbox"/> AT-188, "Engine Cannot Be Started in "P" or "N" Position" . <input type="checkbox"/> AT-189, "In "P" Position, Vehicle Moves When Pushed" . <input type="checkbox"/> AT-190, "In "N" Position, Vehicle Moves" . <input type="checkbox"/> AT-191, "Large Shock ("N" to "D" Position)" . <input type="checkbox"/> AT-194, "Vehicle Does Not Creep Backward in "R" Position" . <input type="checkbox"/> AT-197, "Vehicle Does Not Creep Forward in "D" Position" .	AT-55
	4-3.	Cruise test Part 1 <input type="checkbox"/> AT-199, "Vehicle Cannot Be Started From D1" . <input type="checkbox"/> AT-202, "A/T Does Not Shift: D1 → D2" . <input type="checkbox"/> AT-204, "A/T Does Not Shift: D2 → D3" . <input type="checkbox"/> AT-207, "A/T Does Not Shift: D3 → D4" . <input type="checkbox"/> AT-209, "A/T Does Not Shift: D4 → D5" . <input type="checkbox"/> AT-212, "A/T Does Not Perform Lock-up" . <input type="checkbox"/> AT-214, "A/T Does Not Hold Lock-up Condition" . <input type="checkbox"/> AT-215, "Lock-up Is Not Released" . <input type="checkbox"/> AT-216, "Engine Speed Does Not Return to Idle" .	AT-57

TROUBLE DIAGNOSIS

4	4-3	Part 2 <input type="checkbox"/> AT-199, "Vehicle Cannot Be Started From D1" . <input type="checkbox"/> AT-202, "A/T Does Not Shift: D1 → D2" . <input type="checkbox"/> AT-204, "A/T Does Not Shift: D2 → D3" . <input type="checkbox"/> AT-207, "A/T Does Not Shift: D3 → D4" .	AT-59	A
		Part 3 <input type="checkbox"/> AT-217, "Cannot Be Changed to Manual Mode" . <input type="checkbox"/> AT-218, "A/T Does Not Shift: 5th gear → 4th gear" . <input type="checkbox"/> AT-220, "A/T Does Not Shift: 4th gear → 3rd gear" . <input type="checkbox"/> AT-222, "A/T Does Not Shift: 3rd gear → 2nd gear" . <input type="checkbox"/> AT-224, "A/T Does Not Shift: 2nd gear → 1st gear" . <input type="checkbox"/> AT-226, "Vehicle Does Not Decelerate by Engine Brake" . <input type="checkbox"/> Perform self-diagnostics. Enter checks for detected items. AT-90 , AT-99	AT-60	B AT D
		<input type="checkbox"/> AT-101, "DTC U1000 CAN COMMUNICATION LINE" . <input type="checkbox"/> AT-104, "DTC P0615 START SIGNAL CIRCUIT" . <input type="checkbox"/> AT-108, "DTC P0700 TCM" . <input type="checkbox"/> AT-109, "DTC P0705 PARK/NEUTRAL POSITION SWITCH" . <input type="checkbox"/> AT-113, "DTC P0720 VEHICLE SPEED SENSOR A/T (REVOLUTION SENSOR)" . <input type="checkbox"/> AT-118, "DTC P0725 ENGINE SPEED SIGNAL" . <input type="checkbox"/> AT-120, "DTC P0740 TORQUE CONVERTER CLUTCH SOLENOID VALVE" . <input type="checkbox"/> AT-122, "DTC P0744 A/T TCC S/V FUNCTION (LOCK-UP)" . <input type="checkbox"/> AT-124, "DTC P0745 LINE PRESSURE SOLENOID VALVE" . <input type="checkbox"/> AT-126, "DTC P1702 TRANSMISSION CONTROL MODULE (RAM)" . <input type="checkbox"/> AT-127, "DTC P1703 TRANSMISSION CONTROL MODULE (ROM)" . <input type="checkbox"/> AT-128, "DTC P1705 THROTTLE POSITION SENSOR" . <input type="checkbox"/> AT-131, "DTC P1710 A/T FLUID TEMPERATURE SENSOR CIRCUIT" . <input type="checkbox"/> AT-136, "DTC P1716 TURBINE REVOLUTION SENSOR" . <input type="checkbox"/> AT-138, "DTC P1721 VEHICLE SPEED SENSOR MTR" . <input type="checkbox"/> AT-140, "DTC P1730 A/T INTERLOCK" . <input type="checkbox"/> AT-143, "DTC P1731 A/T 1ST ENGINE BRAKING" . <input type="checkbox"/> AT-145, "DTC P1752 INPUT CLUTCH SOLENOID VALVE" . <input type="checkbox"/> AT-147, "DTC P1754 INPUT CLUTCH SOLENOID VALVE FUNCTION" . <input type="checkbox"/> AT-149, "DTC P1757 FRONT BRAKE SOLENOID VALVE" . <input type="checkbox"/> AT-151, "DTC P1759 FRONT BRAKE SOLENOID VALVE FUNCTION" . <input type="checkbox"/> AT-153, "DTC P1762 DIRECT CLUTCH SOLENOID VALVE" . <input type="checkbox"/> AT-155, "DTC P1764 DIRECT CLUTCH SOLENOID VALVE FUNCTION" . <input type="checkbox"/> AT-157, "DTC P1767 HIGH AND LOW REVERSE CLUTCH SOLENOID VALVE" . <input type="checkbox"/> AT-159, "DTC P1769 HIGH AND LOW REVERSE CLUTCH SOLENOID VALVE FUNCTION" . <input type="checkbox"/> AT-161, "DTC P1772 LOW COAST BRAKE SOLENOID VALVE" . <input type="checkbox"/> AT-163, "DTC P1774 LOW COAST BRAKE SOLENOID VALVE FUNCTION" . <input type="checkbox"/> AT-165, "DTC P1815 MANUAL MODE SWITCH" . <input type="checkbox"/> AT-171, "DTC P1841 ATF PRESSURE SWITCH 1" . <input type="checkbox"/> AT-173, "DTC P1843 ATF PRESSURE SWITCH 3" . <input type="checkbox"/> AT-175, "DTC P1845 ATF PRESSURE SWITCH 5" . <input type="checkbox"/> AT-177, "DTC P1846 ATF PRESSURE SWITCH 6" .		E F G H I J K L M
		<input type="checkbox"/> Inspect each system for items found to be NG in the self-diagnostics and repair or replace the malfunction parts.		
5	<input type="checkbox"/> Perform all road tests and enter the checks again for the required items.	AT-54		
6	<input type="checkbox"/> For any remaining NG items, execute the "diagnostics procedure" and repair or replace the malfunction parts. See the chart for diagnostics by symptoms. (This chart also contains other symptoms and inspection procedures.)	AT-62		
7	<input type="checkbox"/> Erase the results of the self-diagnostics from the TCM.	AT-38 , AT-100		
8				

TROUBLE DIAGNOSIS

A/T Electrical Parts Location

ACS000HL

COUPE MODEL

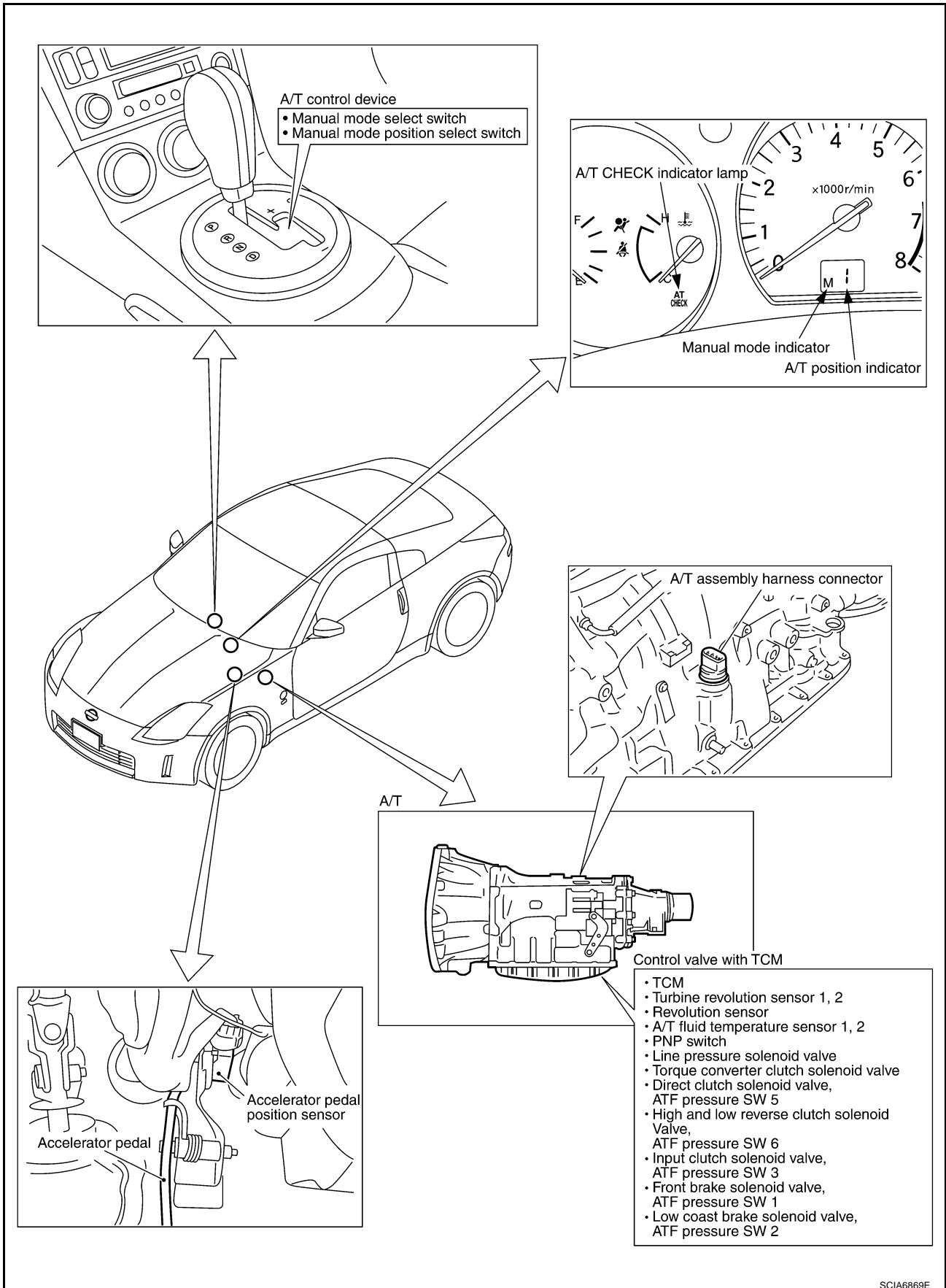

TROUBLE DIAGNOSIS

ROADSTER MODEL

A
B
AT
D
E
F
G
H
I
J
K
L
M

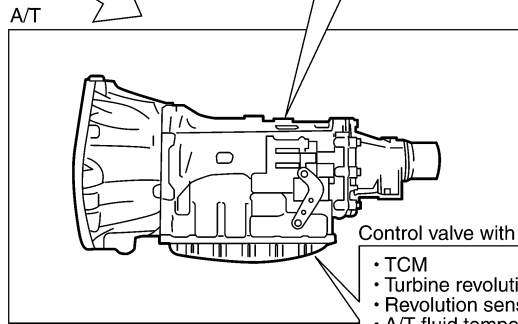
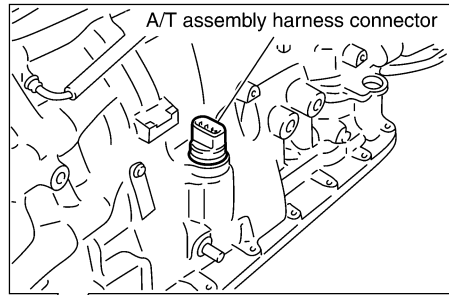
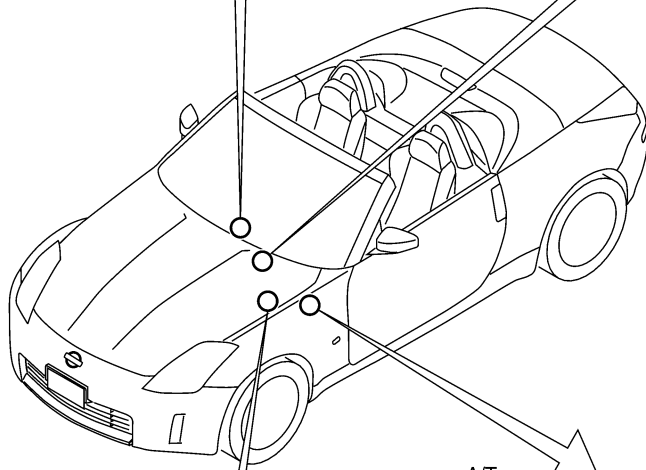
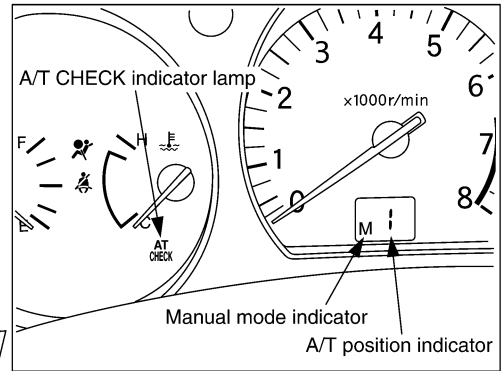
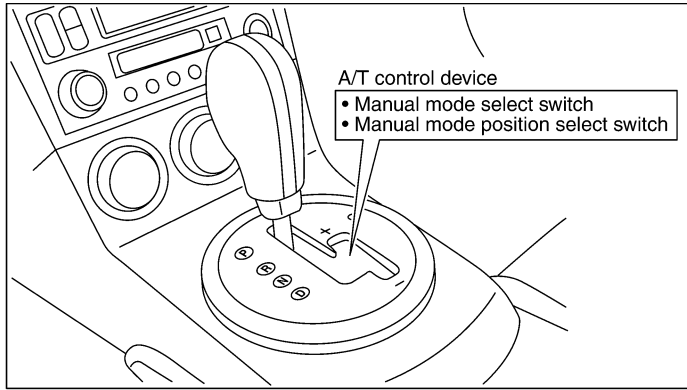

- TCM
- Turbine revolution sensor 1, 2
- Revolution sensor
- A/T fluid temperature sensor 1, 2
- PNP switch
- Line pressure solenoid valve
- Torque converter clutch solenoid valve
- Direct clutch solenoid valve, ATF pressure SW 5
- High and low reverse clutch solenoid valve, ATF pressure SW 6
- Input clutch solenoid valve, ATF pressure SW 3
- Front brake solenoid valve, ATF pressure SW 1
- Low coast brake solenoid valve, ATF pressure SW 2

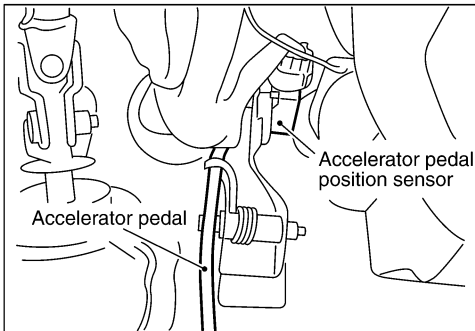

SCIA5497E

TROUBLE DIAGNOSIS

Circuit Diagram

ACS000HM

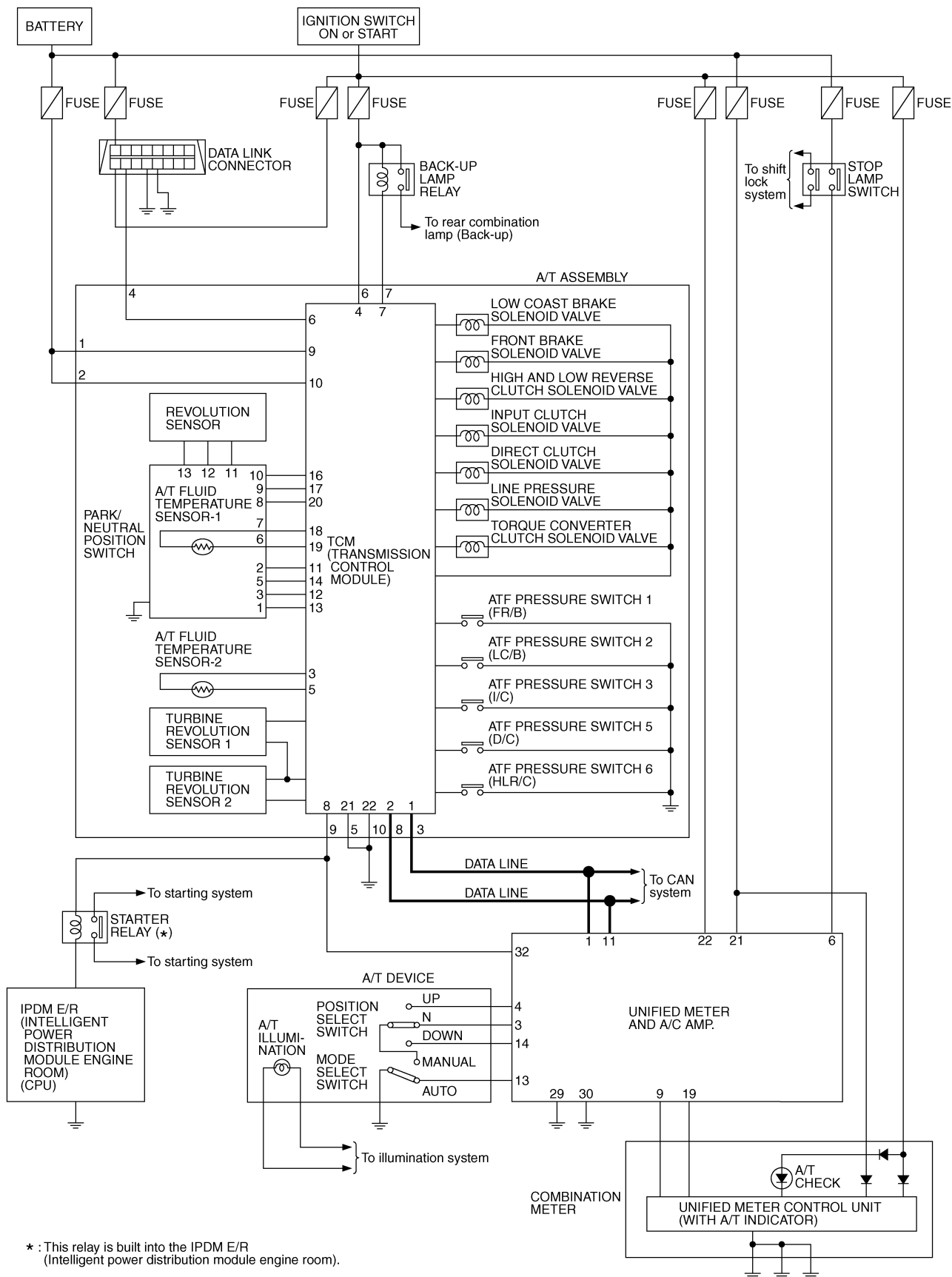

* : This relay is built into the IPDM E/R (Intelligent power distribution module engine room).

TCWM0258E

TROUBLE DIAGNOSIS

ACS000HN

Inspections Before Trouble Diagnosis

A/T FLUID CHECK

Fluid Leakage and Fluid Level Check

- Inspect for fluid leakage and check the fluid level. Refer to [AT-12, "Checking A/T Fluid"](#).

Fluid Condition Check

Inspect the fluid condition.

Fluid condition	Conceivable Cause	Required Operation
Varnished (viscous varnish state)	Clutch, brake scorched	Replace the A/T fluid and check the A/T main unit and the vehicle for malfunctions (wire harnesses, cooler pipes, etc.)
Milky white or cloudy	Water in the fluid	Replace the A/T fluid and check for places where water is getting in.
Large amount of metal powder mixed in	Unusual wear of sliding parts within A/T	Replace the A/T fluid and check for improper operation of the A/T.

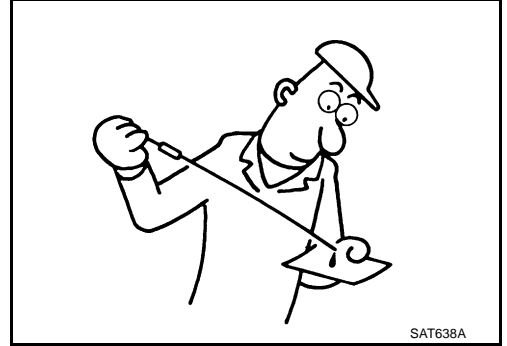

STALL TEST

Stall Test Procedure

- Inspect the amount of engine oil. Replenish the engine oil if necessary.
- Drive for about 10 minutes to warm up the vehicle so that the A/T fluid temperature is 50 to 80°C (122 to 176°F). Inspect the amount of A/T fluid. Replenish if necessary.

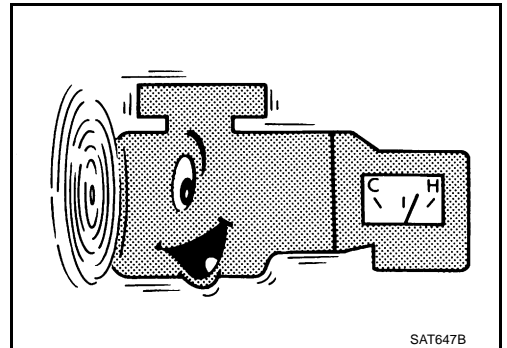

- Securely engage the parking brake so that the tires do not turn.

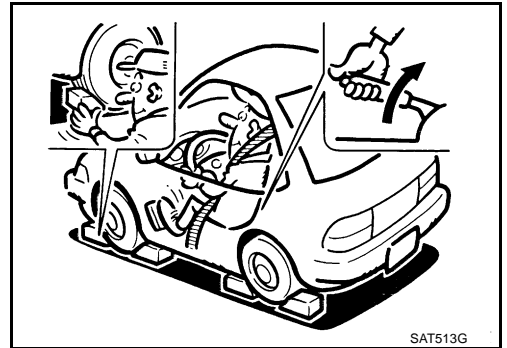

- Engine start, apply foot brake, and place selector lever in "D" position.
- While holding down the foot brake, gradually press down the accelerator pedal.
- Quickly read off the stall speed, then quickly remove your foot from the accelerator pedal.

CAUTION:

Do not hold down the accelerator pedal for more than 5 seconds during this test.

Stall speed: 2,650 - 2,950 rpm

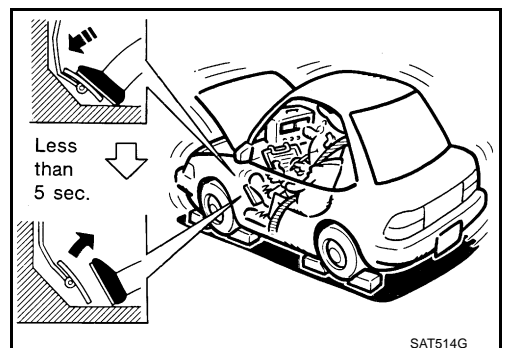

TROUBLE DIAGNOSIS

7. Move the selector lever to "N" position.
8. Cool down the A/T fluid.
CAUTION:
Run the engine at idle for at least one minute.
9. Repeat steps 5 through 8 with selector lever in "R" position.

Judgement Stall Test

	Selector lever position		Expected problem location
	"D", "M"	"R"	
Stall speed	H	O	<ul style="list-style-type: none"> ● Forward brake ● Forward one-way clutch ● 1st one-way clutch ● 3rd one-way clutch
	O	H	<ul style="list-style-type: none"> ● Reverse brake
	L	L	<ul style="list-style-type: none"> ● Engine and torque converter one-way clutch
	H	H	<ul style="list-style-type: none"> ● Line pressure low

O: Stall speed within standard value position

H: Stall speed higher than standard value

L: Stall speed lower than standard value

Stall Test Standard Value Position

Does not shift up "D", "M" position 1 → 2	Slipping in 2nd, 3rd, 4th gears	Direct clutch slippage
Does not shift up "D", "M" position 2 → 3	Slipping in 3rd, 4th, 5th gears	High and low reverse clutch slippage
Does not shift up "D", "M" position 3 → 4	Slipping in 4th, 5th gears	Input clutch slippage
Does not shift up "D", "M" position 4 → 5	Slipping in 5th gear	Front brake slippage

LINE PRESSURE TEST

Line Pressure Test Port

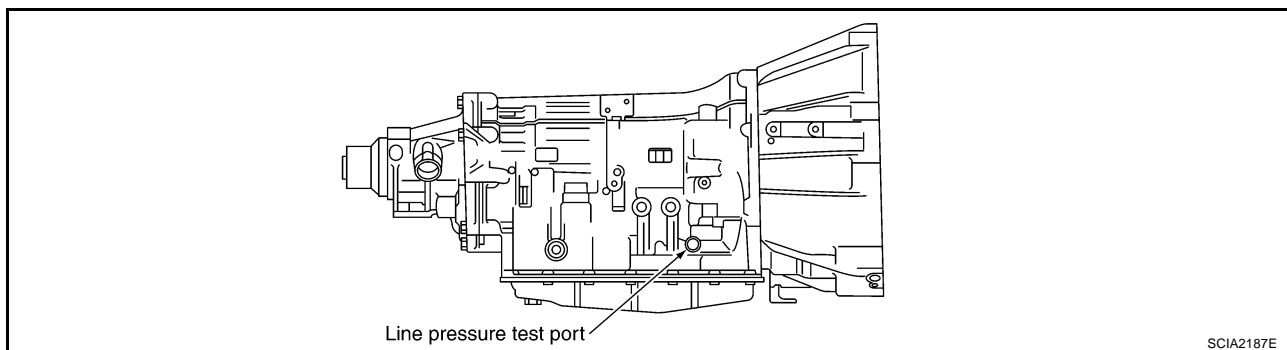

Line Pressure Test Procedure

1. Inspect the amount of engine oil and replenish if necessary.
2. Drive the car for about 10 minutes to warm it up so that the A/T fluid reaches in range of 50 to 80°C (122 to 176°F), then inspect the amount of A/T fluid and replenish if necessary.

NOTE:

The A/T fluid temperature rises in range of 50 to 80°C (122 to 176°F) during 10 minutes of driving.

TROUBLE DIAGNOSIS

3. After warming up remove the oil pressure detection plug and install the oil pressure gauge [ST2505S001(J-34301-C)].

CAUTION:

When using the oil pressure gauge, be sure to use the O-ring attached to the oil pressure detection plug.

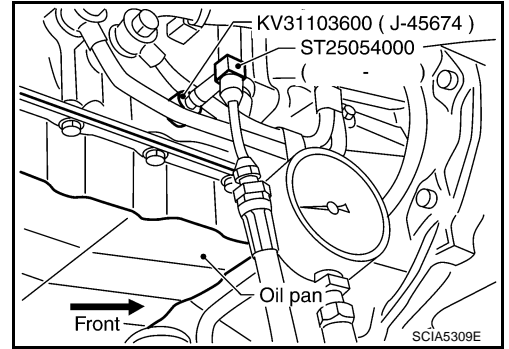

4. Securely engage the parking brake so that the tires do not turn.

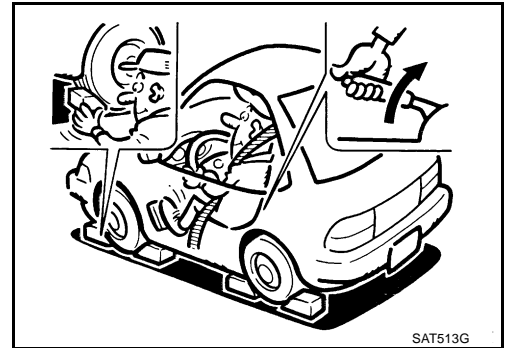

5. Start the engine, then measure the line pressure at both idle and the stall speed.

CAUTION:

- Keep the brake pedal pressed all the way down during measurement.
- When measuring the line pressure at the stall speed, refer to [AT-51, "STALL TEST"](#).

6. After the measurements are complete, install the oil pressure detection plug and tighten to the regulation torque below.

 : 7.3 N·m (0.74 kg·m, 65 in·lb)

CAUTION:

- Do not reuse O-ring.
- Apply ATF to O-ring.

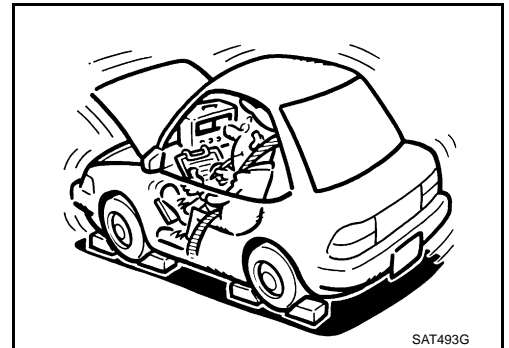

Line Pressure

Engine speed	Line pressure [kPa (kg/cm ² , psi)]	
	"R" position	"D", "M" positions
At idle speed	392 - 441 (4.0 - 4.5, 57 - 64)	373 - 422 (3.8 - 4.3, 54 - 61)
At stall speed	1,700 - 1,890 (17.3 - 19.3, 247 - 274)	1,310 - 1,500 (13.3 - 15.3, 190 - 218)

A
B
AT
D
E
F
G
H
I
J
K
L
M

TROUBLE DIAGNOSIS

Judgement of Line Pressure Test

Judgement		Possible cause
Idle speed	Low for all positions ("P", "R", "N", "D", "M")	<p>Possible causes include malfunctions in the pressure supply system and low oil pump output. For example</p> <ul style="list-style-type: none"> ● Oil pump wear ● Pressure regulator valve or plug sticking or spring fatigue ● Oil strainer ⇒ oil pump ⇒ pressure regulator valve passage oil leak ● Engine idle speed too low
	Only low for a specific position	<p>Possible causes include an oil pressure leak in a passage or device related to the position after the pressure is distributed by the manual valve.</p>
	High	<p>Possible causes include a sensor malfunction or malfunction in the line pressure adjustment function. For example</p> <ul style="list-style-type: none"> ● Accelerator pedal position signal malfunction ● ATF temperature sensor malfunction ● Line pressure solenoid malfunction (sticking in OFF state, filter clog, cut line) ● Pressure regulator valve or plug sticking
Stall speed	Oil pressure does not rise higher than the oil pressure for idle.	<p>Possible causes include a sensor malfunction or malfunction in the pressure adjustment function. For example</p> <ul style="list-style-type: none"> ● Accelerator pedal position signal malfunction ● TCM breakdown ● Line pressure solenoid malfunction (shorting, sticking in ON state) ● Pressure regulator valve or plug sticking ● Pilot valve sticking or pilot filter clogged
	The pressure rises, but does not enter the standard position.	<p>Possible causes include malfunctions in the pressure supply system and malfunction in the pressure adjustment function. For example</p> <ul style="list-style-type: none"> ● Accelerator pedal position signal malfunction ● Line pressure solenoid malfunction (sticking, filter clog) ● Pressure regulator valve or plug sticking ● Pilot valve sticking or pilot filter clogged
	Only low for a specific position	<p>Possible causes include an oil pressure leak in a passage or device related to the position after the pressure is distributed by the manual valve.</p>

ROAD TEST

Description

- The road test inspects overall performance of the A/T and analyzes possible malfunction causes.
- The road test is carried out in the following three stages.
 1. Check before engine is started. Refer to [AT-55, "Check Before Engine is Started"](#) .
 2. Check at idle. Refer to [AT-55, "Check at Idle"](#) .
 3. Cruise test
 - Inspect all the items from Cruise Test Part 1 to Part 3. Refer to [AT-57, "Cruise Test - Part 1"](#) , [AT-59, "Cruise Test - Part 2"](#) and [AT-60, "Cruise Test - Part 3"](#) .
 - Before beginning the road test, check the test procedure and inspection items.
 - Test all inspection items until the symptom is uncovered. Diagnose NG items when all road tests are complete.

TROUBLE DIAGNOSIS

Check Before Engine is Started

ACS000HO

1. CHECK A/T CHECK INDICATOR LAMP

1. Park vehicle on level surface.
2. Move selector lever to "P" position.
3. Turn ignition switch OFF and wait for at least 10 seconds.
4. Turn ignition switch ON. (Do not start engine.)

Does A/T CHECK indicator lamp light up for about 2 seconds?

YES >> GO TO 2.

NO >> Stop the road test and go to [AT-188, "A/T Check Indicator Lamp Does Not Come On"](#).

2. CHECK A/T CHECK INDICATOR LAMP

Does A/T CHECK indicator lamp flash for about 8 seconds?

YES >> For TCM fail-safe mode, perform self-diagnostics and record all NG items on the "DIAGNOSTICS WORKSHEET" ([AT-45](#)). Refer to [AT-90, "SELF-DIAGNOSTIC RESULT MODE"](#), [AT-99, "Diagnostic Procedure Without CONSULT-II"](#).

NO >> 1. Turn ignition switch OFF.

2. Perform self-diagnostics and record all NG items on the "DIAGNOSTICS WORKSHEET" ([AT-45](#)). Refer to [AT-90, "SELF-DIAGNOSTIC RESULT MODE"](#), [AT-99, "Diagnostic Procedure Without CONSULT-II"](#).

3. Go to [AT-55, "Check at Idle"](#).

Check at Idle

ACS000HP

1. CHECK STARTING THE ENGINE

1. Park vehicle on level surface.
2. Move selector lever to "P" or "N" position.
3. Turn ignition switch OFF.
4. Start the engine.

Does the engine start?

YES >> GO TO 2.

NO >> Stop the road test and go to [AT-188, "Engine Cannot Be Started in "P" or "N" Position"](#).

2. CHECK STARTING THE ENGINE

1. Turn ignition switch ON. (Do not start engine.)
2. Move selector lever in "D", "M" or "R" position.
3. Start the engine.

Does the engine start in any position?

YES >> Stop the road test and go to [AT-188, "Engine Cannot Be Started in "P" or "N" Position"](#).

NO >> GO TO 3.

TROUBLE DIAGNOSIS

3. CHECK "P" POSITION FUNCTIONS

1. Move selector lever to "P" position.
2. Turn ignition switch OFF.
3. Release the parking brake.
4. Push the vehicle forward or backward.
5. Engage the parking brake.

When you push the vehicle with disengaging the parking brake, does it move?

- YES >> Enter a check mark at "In "P" position, Vehicle Moves When Pushed" on the "DIAGNOSTICS WORKSHEET" ([AT-45](#)), then continue the road test.
- NO >> GO TO 4.

4. CHECK "N" POSITION FUNCTIONS

1. Start engine.
2. Move selector lever to "N" position.
3. Release the parking brake.

Does vehicle move forward or backward?

- YES >> Enter a check mark at "In "N" position Vehicle Moves" on the "DIAGNOSTICS WORKSHEET" ([AT-45](#)), then continue the road test.
- NO >> GO TO 5.

5. CHECK SHIFT SHOCK

1. Engage the brake.
2. Move selector lever to "D" position.

When the transmission is shifted from "N" to "D", is there an excessive shock?

- YES >> Enter a check mark at "Large Shock ("N" to "D" Position)" on the "DIAGNOSTICS WORKSHEET" ([AT-45](#)), then continue the road test.
- NO >> GO TO 6.

6. CHECK "R" POSITION FUNCTIONS

1. Engage the brake.
2. Move selector lever to "R" position.
3. Release the brake for 4 to 5 seconds.

Does the vehicle creep backward?

- YES >> GO TO 7.
- NO >> Enter a check mark at "Vehicle Does Not Creep Backward in "R" Position" on the "DIAGNOSTICS WORKSHEET" ([AT-45](#)), then continue the road test.

7. CHECK "D" POSITION FUNCTIONS

Check if whether the vehicle creeps forward when the transmission is at "D" position.

Does the vehicle creep forward in the "D" positions?

- YES >> Go to [AT-57, "Cruise Test - Part 1"](#) , [AT-59, "Cruise Test - Part 2"](#) and [AT-60, "Cruise Test - Part 3"](#)
- NO >> Enter a check mark at "Vehicle Does not Creep Forward in "D" Position" on the "DIAGNOSTICS WORKSHEET" ([AT-45](#)), then continue the road test. Go to [AT-57, "Cruise Test - Part 1"](#) , [AT-59, "Cruise Test - Part 2"](#) and [AT-60, "Cruise Test - Part 3"](#) .

Cruise Test - Part 1

1. CHECK STARTING OUT FROM D1

1. Drive the vehicle for about 10 minutes to warm up the engine oil and A/T fluid. Appropriate temperature for the A/T fluid: 50 - 80°C (122 - 176°F)
2. Park the vehicle on a level surface.
3. Move selector lever to "P" position.
4. Start the engine.
5. Move selector lever to "D" position.
6. Press the accelerator pedal about half way down to accelerate the vehicle.

Ⓟ With CONSULT-II

Read the gear position. Refer to [AT-93, "DATA MONITOR MODE"](#) .

Starts from D1?

YES >> GO TO 2.

NO >> Enter a check mark at "Vehicle Cannot Be Started From D1" on the "DIAGNOSTICS WORKSHEET" ([AT-45](#)), then continue the road test.

2. CHECK SHIFT UP D1 → D2

Press down the accelerator pedal about half way and inspect if the vehicle shifts up (D1 → D2) at the appropriate speed.

- Refer to [AT-61, "Vehicle Speed When Shifting Gears"](#) .

Ⓟ With CONSULT-II

Read the gear position, throttle position, and vehicle speed. Refer to [AT-93, "DATA MONITOR MODE"](#) .

Does the A/T shift up D1 → D2 at the correct speed?

YES >> GO TO 3.

NO >> Enter a check mark at "A/T Does Not Shift:D1 → D2" on the "DIAGNOSTICS WORKSHEET" ([AT-45](#)), then continue the road test.

3. CHECK SHIFT UP D2 → D3

Press down the accelerator pedal about half way and inspect if the vehicle shifts up (D2 → D3) at the appropriate speed.

- Refer to [AT-61, "Vehicle Speed When Shifting Gears"](#) .

Ⓟ With CONSULT-II

Read the gear position, throttle position, and vehicle speed. Refer to [AT-93, "DATA MONITOR MODE"](#) .

Does the A/T shift up D2 → D3 at the correct speed?

YES >> GO TO 4.

NO >> Enter a check mark at "A/T Does Not Shift:D2 → D3" on the "DIAGNOSTICS WORKSHEET" ([AT-45](#)), then continue the road test.

4. CHECK SHIFT UP D3 → D4

Press down the accelerator pedal about half way and inspect if the vehicle shifts up (D3 → D4) at the appropriate speed.

- Refer to [AT-61, "Vehicle Speed When Shifting Gears"](#) .

Ⓟ With CONSULT-II

Read the gear position, throttle position, and vehicle speed. Refer to [AT-93, "DATA MONITOR MODE"](#) .

Does the A/T shift up D3 → D4 at the correct speed?

YES >> GO TO 5.

NO >> Enter a check mark at "A/T Does Not Shift:D3 → D4" on the "DIAGNOSTICS WORKSHEET" ([AT-45](#)), then continue the road test.

TROUBLE DIAGNOSIS

5. CHECK SHIFT UP D4 → D5

Press down the accelerator pedal about half way and inspect if the vehicle shifts up (D4 → D5) at the appropriate speed.

- Refer to [AT-61, "Vehicle Speed When Shifting Gears"](#) .

Ⓟ With CONSULT-II

Read the gear position, throttle position, and vehicle speed. Refer to [AT-93, "DATA MONITOR MODE"](#) .

Does the A/T shift up D4 → D5 at the correct speed?

YES >> GO TO 6.

NO >> Enter a check mark at "A/T Does Not Shift:D4 → D5" on the "DIAGNOSTICS WORKSHEET" ([AT-45](#)), then continue the road test.

6. CHECK LOCK-UP

When releasing accelerator pedal from D5, check lock-up from D5 to L/U.

- Refer to [AT-61, "Vehicle Speed When Shifting Gears"](#) .

Ⓟ With CONSULT-II

Select "TCC SOL" with the "MAIN SIGNAL" mode for "A/T". Refer to [AT-87, "CONSULT-II REFERENCE VALUE"](#) .

Does it lock-up?

YES >> GO TO 7.

NO >> Enter a check mark at "A/T Does Not Perform Lock-up" on the "DIAGNOSTICS WORKSHEET" ([AT-45](#)), then continue the road test.

7. CHECK LOCK-UP HOLD

Check hold lock-up.

Ⓟ With CONSULT-II

Select "TCC SOL" with the "MAIN SIGNAL" mode for "A/T". Refer to [AT-87, "CONSULT-II REFERENCE VALUE"](#) .

Does it maintain lock-up status?

YES >> GO TO 8.

NO >> Enter a check mark at "A/T Does Not Hold Lock-up Condition" on the "DIAGNOSTICS WORKSHEET" ([AT-45](#)), then continue the road test.

8. CHECK LOCK-UP RELEASE

Check lock-up cancellation by depressing brake pedal lightly to decelerate.

Ⓟ With CONSULT-II

Select "TCC SOL" with the "MAIN SIGNAL" mode for "A/T". Refer to [AT-87, "CONSULT-II REFERENCE VALUE"](#) .

Does lock-up cancel?

YES >> GO TO 9.

NO >> Enter a check mark at "Lock-up Is Not Released" on the "DIAGNOSTICS WORKSHEET" ([AT-45](#)), then continue the road test.

TROUBLE DIAGNOSIS

9. CHECK SHIFT DOWN D5 → D4

Decelerate by pressing lightly on the brake pedal.

With CONSULT-II

Read the gear position and engine speed. [AT-93, "DATA MONITOR MODE"](#) .

When the A/T shift down D5 → D4, does the engine speed drop smoothly back to idle?

YES >> 1. Stop the vehicle.

2. Go to [AT-59, "Cruise Test - Part 2"](#) .

NO >> Enter a check mark at "Engine Speed Does Not Return to Idle" on the "DIAGNOSTICS WORKSHEET" ([AT-45](#)), then continue the road test. Go to [AT-59, "Cruise Test - Part 2"](#) .

Cruise Test - Part 2

ACS000HR

1. CHECK STARTING FROM D1

1. Move selector lever to "D" position.

2. Accelerate at half throttle.

With CONSULT-II

Read the gear position. Refer to [AT-93, "DATA MONITOR MODE"](#) .

Does it start from D1?

YES >> GO TO 2.

NO >> Enter a check mark at "Vehicle Cannot Be Started From D1" on the "DIAGNOSTICS WORKSHEET" ([AT-45](#)), then continue the road test.

2. CHECK SHIFT UP D1 → D2

Press the accelerator pedal down all the way and inspect whether or not the transmission shifts up (D1 → D2) at the correct speed.

- Refer to [AT-61, "Vehicle Speed When Shifting Gears"](#) .

With CONSULT-II

Read the gear position, throttle position and vehicle speed. Refer to [AT-93, "DATA MONITOR MODE"](#) .

Does the A/T shift up D1 → D2 at the correct speed?

YES >> GO TO 3.

NO >> Enter a check mark at "Vehicle Does Not Shift D1 → D2" on the "DIAGNOSTICS WORKSHEET" ([AT-45](#)), then continue the road test.

3. CHECK SHIFT UP D2 → D3

Press the accelerator pedal down all the way and inspect whether or not the transmission shifts up (D2 → D3) at the correct speed.

- Refer to [AT-61, "Vehicle Speed When Shifting Gears"](#) .

With CONSULT-II

Read the gear position, throttle position and vehicle speed. Refer to [AT-93, "DATA MONITOR MODE"](#) .

Does the A/T shift up D2 → D3 at the correct speed?

YES >> GO TO 4.

NO >> Enter a check mark at "Vehicle Does Not Shift D2 → D3" on the "DIAGNOSTICS WORKSHEET" ([AT-45](#)), then continue the road test.

TROUBLE DIAGNOSIS

4. CHECK SHIFT UP D3 → D4 AND ENGINE BRAKE

When the transmission changes speed D3 → D4, return the accelerator pedal.

④ **With CONSULT-II**

Read the gear position. Refer to [AT-93, "DATA MONITOR MODE"](#) .

Does the A/T shift up D3 → D4 and apply the engine brake?

YES >> 1. Stop the vehicle.

2. Go to [AT-60, "Cruise Test - Part 3"](#) .

NO >> Enter a check mark at "Vehicle Does Not Shift D3 → D4" on the "DIAGNOSTICS WORKSHEET" ([AT-45](#)), then continue the road test. Go to [AT-60, "Cruise Test - Part 3"](#) .

Cruise Test - Part 3

ACS000HS

1. MANUAL MODE FUNCTION

Move to manual mode from "D" position.

Does it switch to manual mode?

YES >> GO TO 2.

NO >> Continue road test and add check mark to "Cannot Be Changed to Manual Mode" on the "DIAGNOSTICS WORKSHEET" ([AT-45](#)).

2. CHECK SHIFT DOWN

During manual mode driving, is downshift from M5 → M4 → M3 → M2 → M1 performed?

④ **With CONSULT-II**

Read the gear position. Refer to [AT-93, "DATA MONITOR MODE"](#) .

Is downshifting correctly performed?

YES >> GO TO 2.

NO >> Enter a check mark at "Vehicle Does Not Shift" at the corresponding position (5th → 4th, 4th → 3rd, 3rd → 2nd, 2nd → 1st) on the "DIAGNOSTICS WORKSHEET" ([AT-45](#)), then continue the road test.

3. CHECK ENGINE BRAKE

Check engine brake.

Does engine braking effectively reduce speed in M1 position?

YES >> 1. Stop the vehicle.

2. Perform self-diagnostics. Refer to [AT-90, "SELF-DIAGNOSTIC RESULT MODE"](#) , [AT-99, "Diagnostic Procedure Without CONSULT-II"](#) .

NO >> Enter a check mark at "Vehicle Does Not Decelerate by Engine Brake" on the "DIAGNOSTICS WORKSHEET" ([AT-45](#)), then continue trouble diagnosis.

TROUBLE DIAGNOSIS

Vehicle Speed When Shifting Gears

ACS000HT

Throttle position	Vehicle speed km/h (MPH)							
	D1 →D2	D2 →D3	D3 →D4	D4 →D5	D5 →D4	D4 →D3	D3 →D2	D2 →D1
Full throttle	58 - 62 (36 - 39)	90 - 98 (56 - 61)	140 - 150 (87 - 93)	201 - 211 (125 - 131)	197 - 207 (122 - 129)	122 - 132 (76 - 82)	74 - 82 (46 - 51)	34 - 38 (23 - 25)
Half throttle	46 - 50 (29 - 31)	71 - 79 (44 - 49)	107 - 117 (66 - 73)	135 - 145 (84 - 90)	88 - 98 (55 - 61)	63 - 73 (39 - 45)	29 - 37 (18 - 23)	11 - 15 (7 - 9)

- At half throttle, the accelerator opening is 4/8 of the full opening.

Vehicle Speed When Performing and Releasing Complete Lock-up

ACS000HU

Throttle position	Vehicle speed km/h (MPH)	
	Lock-up "ON"	Lock-up "OFF"
Closed throttle	56 - 64 (35 - 40)	53 - 61 (33 - 38)
Half throttle	168 - 176 (104 - 109)	131 - 139 (81 - 86)

- At closed throttle, the accelerator opening is less than 1/8 condition. (Closed throttle position signal: OFF)
- At half throttle, the accelerator opening is 4/8 of the full opening.

Vehicle Speed When Performing and Releasing Slip Lock-up

ACS000HV

Throttle position	Gear position	Vehicle speed km/h (MPH)	
		Slip lock-up "ON"	Slip lock-up "OFF"
Closed throttle	4th	37 - 45 (23 - 28)	34 - 42 (21 - 26)
	5th	44 - 52 (27 - 32)	41 - 49 (25 - 30)

- At closed throttle, the accelerator opening is less than 1/8 condition. (Closed throttle position signal: OFF)

TROUBLE DIAGNOSIS

Symptom Chart

ACS00843

- The diagnostics item numbers show the sequence for inspection. Inspect in order from item 1.
- Overhaul and inspect inside the A/T only if A/T fluid condition is NG. Refer to [AT-51, "Fluid Condition Check"](#).

No.	Items	Symptom	Condition	Diagnostic Item	Reference page
1		Large shock. ("N" → "D" position) Refer to AT-191, "Large Shock ("N" to "D" Position)" .	ON vehicle	1. Engine idle speed	EC-30
				2. Engine speed signal	AT-118
				3. Accelerator pedal position sensor	AT-128
				4. Control linkage adjustment	AT-229
				5. A/T fluid temperature sensor	AT-131
				6. ATF pressure switch 1 and front brake solenoid valve	AT-171, AT-149
				7. CAN communication line	AT-101
				8. Fluid level and state	AT-51
				9. Line pressure test	AT-52
				10. Control valve with TCM	AT-238
			OFF vehicle	11. Forward brake (Parts behind drum support is impossible to perform inspection by disassembly. Refer to AT-17, "Cross-Sectional View" .)	AT-275
2	Shift Shock	Shock is too large when changing D1 → D2 or M1 → M2.	ON vehicle	1. Accelerator pedal position sensor	AT-128
				2. Control linkage adjustment	AT-229
				3. ATF pressure switch 5 and direct clutch solenoid valve	AT-175, AT-153
				4. CAN communication line	AT-101
				5. Engine speed signal	AT-118
				6. Turbine revolution sensor	AT-136
				7. Vehicle speed sensor A/T and vehicle speed sensor MTR	AT-113, AT-138
				8. Fluid level and state	AT-51
				9. Control valve with TCM	AT-238
			OFF vehicle	10. Direct clutch	AT-309
3		Shock is too large when changing D2 → D3 or M2 → M3.	ON vehicle	1. Accelerator pedal position sensor	AT-128
				2. Control linkage adjustment	AT-229
				3. ATF pressure switch 6 and high and low reverse clutch solenoid valve	AT-177, AT-157
				4. CAN communication line	AT-101
				5. Engine speed signal	AT-118
				6. Turbine revolution sensor	AT-136
				7. Vehicle speed sensor A/T and vehicle speed sensor MTR	AT-113, AT-138
				8. Fluid level and state	AT-51
				9. Control valve with TCM	AT-238
			OFF vehicle	10. High and low reverse clutch	AT-307

TROUBLE DIAGNOSIS

No.	Items	Symptom	Condition	Diagnostic Item	Reference page
4		Shock is too large when changing D3 → D4 or M3 → M4 .	ON vehicle	1. Accelerator pedal position sensor	AT-128
				2. Control linkage adjustment	AT-229
				3. ATF pressure switch 3 and input clutch solenoid valve	AT-173 , AT-145
				4. CAN communication line	AT-101
				5. Engine speed signal	AT-118
				6. Turbine revolution sensor	AT-136
				7. Vehicle speed sensor A/T and vehicle speed sensor MTR	AT-113 , AT-138
				8. Fluid level and state	AT-51
				9. Control valve with TCM	AT-238
			OFF vehicle	10. Input clutch	AT-297
5	Shift Shock	Shock is too large when changing D4 → D5 or M4 → M5 .	ON vehicle	1. Accelerator pedal position sensor	AT-128
				2. Control linkage adjustment	AT-229
				3. ATF pressure switch 1 and front brake solenoid valve	AT-171 , AT-149
				4. CAN communication line	AT-101
				5. Engine speed signal	AT-118
				6. Turbine revolution sensor	AT-136
				7. Vehicle speed sensor A/T and vehicle speed sensor MTR	AT-113 , AT-138
				8. Fluid level and state	AT-51
				9. Control valve with TCM	AT-238
			OFF vehicle	10. Front brake (brake band)	AT-267
				11. Input clutch	AT-297
6		Shock is too large for downshift when accelerator pedal is pressed.	ON vehicle	1. Accelerator pedal position sensor	AT-128
				2. Control linkage adjustment	AT-229
				3. CAN communication line	AT-101
				4. Engine speed signal	AT-118
				5. Turbine revolution sensor	AT-136
				6. Vehicle speed sensor A/T and vehicle speed sensor MTR	AT-113 , AT-138
				7. Fluid level and state	AT-51
				8. Control valve with TCM	AT-238
			OFF vehicle	9. Front brake (brake band)	AT-267
				10. Input clutch	AT-297
				11. High and low reverse clutch	AT-307
				12. Direct clutch	AT-309

A
B
AT
D
E
F
G
H
I
J
K
L
M

TROUBLE DIAGNOSIS

No.	Items	Symptom	Condition	Diagnostic Item	Reference page
7		Shock is too large for upshift when accelerator pedal is released.	ON vehicle	1. Accelerator pedal position sensor	AT-128
				2. Control linkage adjustment	AT-229
				3. Engine speed signal	AT-118
				4. CAN communication line	AT-101
				5. Turbine revolution sensor	AT-136
				6. Vehicle speed sensor A/T and vehicle speed sensor MTR	AT-113, AT-138
				7. Fluid level and state	AT-51
				8. Control valve with TCM	AT-238
			OFF vehicle	9. Front brake (brake band)	AT-267
				10. Input clutch	AT-297
				11. High and low reverse clutch	AT-307
				12. Direct clutch	AT-309
8	Shift Shock	Shock is too large for lock-up.	ON vehicle	1. Accelerator pedal position sensor	AT-128
				2. Control linkage adjustment	AT-229
				3. Engine speed signal	AT-118
				4. CAN communication line	AT-101
				5. Turbine revolution sensor	AT-136
				6. Vehicle speed sensor A/T and vehicle speed sensor MTR	AT-113, AT-138
				7. Torque converter clutch solenoid valve	AT-120
				8. Fluid level and state	AT-51
				9. Control valve with TCM	AT-238
			OFF vehicle	10. Torque converter	AT-275
9		Shock is too large during engine brake.	ON vehicle	1. Accelerator pedal position sensor	AT-128
				2. Control linkage adjustment	AT-229
				3. CAN communication line	AT-101
				4. Fluid level and state	AT-51
				5. Control valve with TCM	AT-238
			OFF vehicle	6. Front brake (brake band)	AT-267
				7. Input clutch	AT-297
				8. High and low reverse clutch	AT-307
				9. Direct clutch	AT-309

TROUBLE DIAGNOSIS

No.	Items	Symptom	Condition	Diagnostic Item	Reference page
10		Gear does not change from D1 → D2 or from M1 → M2 . Refer to AT-202, "A/T Does Not Shift: D1 → D2" .	ON vehicle	1. Fluid level and state	AT-51
				2. Vehicle speed sensor A/T and vehicle speed sensor MTR	AT-113, AT-138
				3. ATF pressure switch 5 and direct clutch solenoid valve	AT-175, AT-153
				4. Line pressure test	AT-52
				5. CAN communication line	AT-101
				6. Control valve with TCM	AT-238
			OFF vehicle	7. Direct clutch	AT-309
11		Gear does not change from D2 → D3 or from M2 → M3 . Refer to AT-204, "A/T Does Not Shift: D2 → D3" .	ON vehicle	1. Fluid level and state	AT-51
				2. Vehicle speed sensor A/T and vehicle speed sensor MTR	AT-113, AT-138
				3. ATF pressure switch 6 and high and low reverse clutch solenoid valve	AT-177, AT-157
				4. Line pressure test	AT-52
				5. CAN communication line	AT-101
				6. Control valve with TCM	AT-238
			OFF vehicle	7. High and low reverse clutch	AT-307
12	No Up Shift	Gear does not change from D3 → D4 or from M3 → M4 . Refer to AT-207, "A/T Does Not Shift: D3 → D4" .	ON vehicle	1. Fluid level and state	AT-51
				2. Vehicle speed sensor A/T and vehicle speed sensor MTR	AT-113, AT-138
				3. ATF pressure switch 3 and input clutch solenoid valve	AT-173, AT-145
				4. ATF pressure switch 1 and front brake solenoid valve	AT-171, AT-149
				5. Line pressure test	AT-52
				6. CAN communication line	AT-101
				7. Control valve with TCM	AT-238
			OFF vehicle	8. Input clutch	AT-297
13		Gear does not change from D4 → D5 or from M4 → M5 . Refer to AT-209, "A/T Does Not Shift: D4 → D5" .	ON vehicle	1. Fluid level and state	AT-51
				2. Vehicle speed sensor A/T and vehicle speed sensor MTR	AT-113, AT-138
				3. ATF pressure switch 1 and front brake solenoid valve	AT-171, AT-149
				4. ATF pressure switch 5 and direct clutch solenoid valve	AT-175, AT-153
				5. Turbine revolution sensor	AT-136
				6. Line pressure test	AT-52
				7. CAN communication line	AT-101
				8. Control valve with TCM	AT-238
			OFF vehicle	9. Front brake (brake band)	AT-275
				10. Input clutch	AT-297

TROUBLE DIAGNOSIS

No.	Items	Symptom	Condition	Diagnostic Item	Reference page
14		In "D" or "M" range, does not downshift to 4th gear. Refer to AT-218, "A/T Does Not Shift: 5th gear → 4th gear" .	ON vehicle	1. Fluid level and state	AT-51
				2. Vehicle speed sensor A/T and vehicle speed sensor MTR	AT-113, AT-138
				3. ATF pressure switch 1 and front brake solenoid valve	AT-171, AT-149
				4. ATF pressure switch 5 and direct clutch solenoid valve	AT-175, AT-153
				5. CAN communication line	AT-101
				6. Line pressure test	AT-52
				7. Control valve with TCM	AT-238
			OFF vehicle	8. Front brake (brake band)	AT-275
				9. Input clutch	AT-297
15	No Down Shift	In "D" or "M" range, does not downshift to 3rd gear. Refer to AT-220, "A/T Does Not Shift: 4th gear → 3rd gear" .	ON vehicle	1. Fluid level and state	AT-51
				2. Vehicle speed sensor A/T and vehicle speed sensor MTR	AT-113, AT-138
				3. ATF pressure switch 3 and input clutch solenoid valve	AT-173, AT-145
				4. ATF pressure switch 1 and front brake solenoid valve	AT-171, AT-149
				5. CAN communication line	AT-101
				6. Line pressure test	AT-52
				7. Control valve with TCM	AT-238
			OFF vehicle	8. Input clutch	AT-297
			16		In "D" or "M" range, does not downshift to 2nd gear. Refer to AT-222, "A/T Does Not Shift: 3rd gear → 2nd gear" .
2. Vehicle speed sensor A/T and vehicle speed sensor MTR	AT-113, AT-138				
3. ATF pressure switch 6 and high and low reverse clutch solenoid valve	AT-177, AT-157				
4. CAN communication line	AT-101				
5. Line pressure test	AT-52				
6. Control valve with TCM	AT-238				
OFF vehicle	7. High and low reverse clutch	AT-307			
17		In "D" or "M" range, does not downshift to 1st gear. Refer to AT-224, "A/T Does Not Shift: 2nd gear → 1st gear" .	ON vehicle	1. Fluid level and state	AT-51
				2. Vehicle speed sensor A/T and vehicle speed sensor MTR	AT-113, AT-138
				3. ATF pressure switch 5 and direct clutch solenoid valve	AT-175, AT-153
				4. CAN communication line	AT-101
				5. Line pressure test	AT-52
				6. Control valve with TCM	AT-238
			OFF vehicle	7. Direct clutch	AT-309

TROUBLE DIAGNOSIS

No.	Items	Symptom	Condition	Diagnostic Item	Reference page				
18		When "D" or "M" position, remains in 1st gear.	ON vehicle	1. Fluid level and state	AT-51				
				2. Vehicle speed sensor A/T and vehicle speed sensor MTR	AT-113 , AT-138				
				3. Direct clutch solenoid valve	AT-153				
				4. Line pressure test	AT-52				
				5. CAN communication line	AT-101				
				6. Control valve with TCM	AT-238				
			OFF vehicle	7. 3rd one-way clutch	AT-295				
				8. 1st one-way clutch	AT-302				
				9. Gear system	AT-267				
				10. Reverse brake	AT-275				
				11. Forward one-way clutch (Parts behind drum support is impossible to perform inspection by disassembly. Refer to AT-17 , " Cross-Sectional View " .)	AT-275				
				12. Forward brake (Parts behind drum support is impossible to perform inspection by disassembly. Refer to AT-17 , " Cross-Sectional View " .)	AT-275				
19	Slips/Will Not engage	When "D" or "M" position, remains in 2nd gear.	ON vehicle	1. Fluid level and state	AT-51				
				2. Vehicle speed sensor A/T and vehicle speed sensor MTR	AT-113 , AT-138				
				3. Low coast brake solenoid valve	AT-161				
				4. Line pressure test	AT-52				
				5. CAN communication line	AT-101				
				6. Control valve with TCM	AT-238				
			OFF vehicle	7. 3rd one-way clutch	AT-295				
				8. Gear system	AT-267				
				9. Direct clutch	AT-309				
				10. Forward brake (Parts behind drum support is impossible to perform inspection by disassembly. Refer to AT-17 , " Cross-Sectional View " .)	AT-275				
				20		When "D" or "M" position, remains in 3rd gear.	ON vehicle	1. Fluid level and state	AT-51
								2. Vehicle speed sensor A/T and vehicle speed sensor MTR	AT-113 , AT-138
3. Line pressure test	AT-52								
4. CAN communication line	AT-101								
5. Control valve with TCM	AT-238								
OFF vehicle	6. 3rd one-way clutch	AT-295							
	7. Gear system	AT-267							
	8. High and low reverse clutch	AT-307							
	9. Forward one-way clutch (Parts behind drum support is impossible to perform inspection by disassembly. Refer to AT-17 , " Cross-Sectional View " .)	AT-275							
	10. Forward brake (Parts behind drum support is impossible to perform inspection by disassembly. Refer to AT-17 , " Cross-Sectional View " .)	AT-275							

TROUBLE DIAGNOSIS

No.	Items	Symptom	Condition	Diagnostic Item	Reference page
21	Slips/Will Not engage	When "D" or "M" position, remains in 4th gear.	ON vehicle	1. Fluid level and state	AT-51
				2. Vehicle speed sensor A/T and vehicle speed sensor MTR	AT-113 , AT-138
				3. ATF pressure switch 3 and input clutch solenoid valve	AT-173 , AT-145
				4. ATF pressure switch 5 and direct clutch solenoid valve	AT-175 , AT-153
				5. ATF pressure switch 6 and high and low reverse clutch solenoid valve	AT-177 , AT-157
				6. Low coast brake solenoid valve	AT-161
				7. Front brake solenoid valve	AT-149
				8. Line pressure test	AT-52
				9. CAN communication line	AT-101
				10. Control valve with TCM	AT-238
			OFF vehicle	11. Input clutch	AT-297
				12. Gear system	AT-267
				13. High and low reverse clutch	AT-307
				14. Direct clutch	AT-309
22		When "D" or "M" position, remains in 5th gear.	ON vehicle	1. Fluid level and state	AT-51
				2. Vehicle speed sensor A/T and vehicle speed sensor MTR	AT-113 , AT-138
				3. ATF pressure switch 1 and front brake solenoid valve	AT-171 , AT-149
				4. Line pressure test	AT-52
				5. CAN communication line	AT-101
				6. Control valve with TCM	AT-238
			OFF vehicle	7. Front brake (brake band)	AT-275
				8. Input clutch	AT-297
				9. Gear system	AT-267
				10. High and low reverse clutch	AT-307

TROUBLE DIAGNOSIS

No.	Items	Symptom	Condition	Diagnostic Item	Reference page			
23		Vehicle cannot be started from D1 . Refer to AT-199 . " Vehicle Cannot Be Started From D1 " .	ON vehicle	1. Fluid level and state	AT-51			
				2. Accelerator pedal position sensor	AT-128			
				3. Line pressure test	AT-52			
				4. CAN communication line	AT-101			
				5. Control valve with TCM	AT-238			
			OFF vehicle	6. Torque converter	AT-275			
				7. Oil pump assembly	AT-292			
				8. 3rd one-way clutch	AT-295			
				9. 1st one-way clutch	AT-302			
				10. Gear system	AT-267			
				11. Reverse brake	AT-275			
				12. Forward one-way clutch (Parts behind drum support is impossible to perform inspection by disassembly. Refer to AT-17 , " Cross-Sectional View " .)	AT-275			
				13. Forward brake (Parts behind drum support is impossible to perform inspection by disassembly. Refer to AT-17 , " Cross-Sectional View " .)	AT-275			
24	Slips/Will Not Engage	Does not lock-up. Refer to AT-212 . " A/T Does Not Perform Lock-up " .	ON vehicle	1. Fluid level and state	AT-51			
				2. Line pressure test	AT-52			
				3. Engine speed signal	AT-118			
				4. Turbine revolution sensor	AT-136			
				5. Torque converter clutch solenoid valve	AT-120			
				6. CAN communication line	AT-101			
				7. Control valve with TCM	AT-238			
			OFF vehicle	8. Torque converter	AT-275			
				9. Oil pump assembly	AT-292			
			25		Does not hold lock-up condition. Refer to AT-214 , " A/T Does Not Hold Lock-up Condition " .	ON vehicle	1. Fluid level and state	AT-51
							2. Line pressure test	AT-52
							3. Engine speed signal	AT-118
							4. Turbine revolution sensor	AT-136
5. Torque converter clutch solenoid valve	AT-120							
6. CAN communication line	AT-101							
7. Control valve with TCM	AT-238							
OFF vehicle	8. Torque converter	AT-275						
	9. Oil pump assembly	AT-292						

A
B
AT
D
E
F
G
H
I
J
K
L
M

TROUBLE DIAGNOSIS

No.	Items	Symptom	Condition	Diagnostic Item	Reference page
26		Lock-up is not released. Refer to AT-215 , "Lock-up Is Not Released" .	ON vehicle	1. Fluid level and state	AT-51
				2. Line pressure test	AT-52
				3. Engine speed signal	AT-118
				4. Turbine revolution sensor	AT-136
				5. Torque converter clutch solenoid valve	AT-120
				6. CAN communication line	AT-101
				7. Control valve with TCM	AT-238
			OFF vehicle	8. Torque converter	AT-275
				9. Oil pump assembly	AT-292
27	Slips/Will Not engage	No shock at all or the clutch slips when vehicle changes speed D1 → D2 or M1 → M2 .	ON vehicle	1. Fluid level and state	AT-51
				2. Vehicle speed sensor A/T and vehicle speed sensor MTR	AT-113 , AT-138
				3. ATF pressure switch 5 and direct clutch solenoid valve	AT-175 , AT-153
				4. CAN communication line	AT-101
				5. Line pressure test	AT-52
				6. Control valve with TCM	AT-238
			OFF vehicle	7. Torque converter	AT-275
				8. Oil pump assembly	AT-292
				9. 3rd one-way clutch	AT-295
				10. Gear system	AT-267
				11. Direct clutch	AT-309
				12. Forward brake (Parts behind drum support is impossible to perform inspection by disassembly. Refer to AT-17 , "Cross-Sectional View" .)	AT-275

TROUBLE DIAGNOSIS

No.	Items	Symptom	Condition	Diagnostic Item	Reference page
28	Slips/Will Not engage	No shock at all or the clutch slips when vehicle changes speed D2 → D3 or M2 → M3 .	ON vehicle	1. Fluid level and state	AT-51
				2. Vehicle speed sensor A/T and vehicle speed sensor MTR	AT-113, AT-138
				3. ATF pressure switch 6 and high and low reverse clutch solenoid valve	AT-177, AT-157
				4. CAN communication line	AT-101
				5. Line pressure test	AT-52
				6. Control valve with TCM	AT-238
			OFF vehicle	7. Torque converter	AT-275
				8. Oil pump assembly	AT-292
				9. 3rd one-way clutch	AT-295
				10. Gear system	AT-267
				11. High and low reverse clutch	AT-307
				12. Forward one- way clutch (Parts behind drum support is impossible to perform inspection by disassembly. Refer to AT-17, "Cross-Sectional View" .)	AT-275
				13. Forward brake (Parts behind drum support is impossible to perform inspection by disassembly. Refer to AT-17, "Cross-Sectional View" .)	AT-275
29	Slips/Will Not engage	No shock at all or the clutch slips when vehicle changes speed D3 → D4 or M3 → M4 .	ON vehicle	1. Fluid level and state	AT-51
				2. Vehicle speed sensor A/T and vehicle speed sensor MTR	AT-113, AT-138
				3. ATF pressure switch 3 and input clutch solenoid valve	AT-173, AT-145
				4. ATF pressure switch 1 and front brake solenoid valve	AT-171, AT-149
				5. CAN communication line	AT-101
				6. Line pressure test	AT-52
				7. Control valve with TCM	AT-238
			OFF vehicle	8. Torque converter	AT-275
				9. Oil pump assembly	AT-292
				10. Input clutch	AT-297
				11. Gear system	AT-267
				12. High and low reverse clutch	AT-307
				13. Direct clutch	AT-309

A
B
AT
D
E
F
G
H
I
J
K
L
M

TROUBLE DIAGNOSIS

No.	Items	Symptom	Condition	Diagnostic Item	Reference page
30	Slips/Will Not engage	No shock at all or the clutch slips when vehicle changes speed D4 → D5 or M4 → M5 .	ON vehicle	1. Fluid level and state	AT-51
				2. Vehicle speed sensor A/T and vehicle speed sensor MTR	AT-113, AT-138
				3. ATF pressure switch 1 and front brake solenoid valve	AT-171, AT-149
				4. ATF pressure switch 5 and direct clutch solenoid valve	AT-175, AT-153
				5. CAN communication line	AT-101
				6. Line pressure test	AT-52
				7. Control valve with TCM	AT-238
			OFF vehicle	8. Torque converter	AT-275
				9. Oil pump assembly	AT-292
				10. Front brake (brake band)	AT-275
				11. Input clutch	AT-297
				12. Gear system	AT-267
				13. High and low reverse clutch	AT-307
31	Slips/Will Not engage	When you press the accelerator pedal and shift speed D5 → D4 or M5 → M4 the engine idles or the transmission slips.	ON vehicle	1. Fluid level and state	AT-51
				2. Vehicle speed sensor A/T and vehicle speed sensor MTR	AT-113, AT-138
				3. ATF pressure switch 1 and front brake solenoid valve	AT-171, AT-149
				4. ATF pressure switch 5 and direct clutch solenoid valve	AT-175, AT-153
				5. CAN communication line	AT-101
				6. Line pressure test	AT-52
				7. Control valve with TCM	AT-238
			OFF vehicle	8. Torque converter	AT-275
				9. Oil pump assembly	AT-292
				10. Input clutch	AT-297
				11. Gear system	AT-267
				12. High and low reverse clutch	AT-307
				13. Direct clutch	AT-309

TROUBLE DIAGNOSIS

No.	Items	Symptom	Condition	Diagnostic Item	Reference page
32	Slips/Will Not engage	When you press the accelerator pedal and shift speed D4 → D3 or M4 → M3 the engine idles or the transmission slips.	ON vehicle	1. Fluid level and state	AT-51
				2. Vehicle speed sensor A/T and vehicle speed sensor MTR	AT-113, AT-138
				3. ATF pressure switch 3 and input clutch solenoid valve	AT-173, AT-145
				4. ATF pressure switch 1 and front brake solenoid valve	AT-171, AT-149
				5. CAN communication line	AT-101
				6. Line pressure test	AT-52
				7. Control valve with TCM	AT-238
			OFF vehicle	8. Torque converter	AT-275
				9. Oil pump assembly	AT-292
				10. 3rd one-way clutch	AT-295
				11. Gear system	AT-267
				12. High and low reverse clutch	AT-307
				13. Forward one- way clutch (Parts behind drum support is impossible to perform inspection by disassembly. Refer to AT-17, "Cross-Sectional View" .)	AT-275
				14. Forward brake (Parts behind drum support is impossible to perform inspection by disassembly. Refer to AT-17, "Cross-Sectional View" .)	AT-275
33	Slips/Will Not engage	When you press the accelerator pedal and shift speed D3 → D2 or M3 → M2 the engine idles or the transmission slips.	ON vehicle	1. Fluid level and state	AT-51
				2. Vehicle speed sensor A/T and vehicle speed sensor MTR	AT-113, AT-138
				3. ATF pressure switch 6 and high and low reverse clutch solenoid valve	AT-177, AT-157
				4. ATF pressure switch 5 and direct clutch solenoid valve	AT-175, AT-153
				5. CAN communication line	AT-101
				6. Line pressure test	AT-52
				7. Control valve with TCM	AT-238
			OFF vehicle	8. Torque converter	AT-275
				9. Oil pump assembly	AT-292
				10. 3rd one-way clutch	AT-295
				11. Gear system	AT-267
				12. Direct clutch	AT-309
				13. Forward brake (Parts behind drum support is impossible to perform inspection by disassembly. Refer to AT-17, "Cross-Sectional View" .)	AT-275

A
B
AT
D
E
F
G
H
I
J
K
L
M

TROUBLE DIAGNOSIS

No.	Items	Symptom	Condition	Diagnostic Item	Reference page
34	Slips/Will Not Engage	When you press the accelerator pedal and shift speed D2 → D1 or M2 → M1 the engine idles or the transmission slips.	ON vehicle	1. Fluid level and state	AT-51
				2. Vehicle speed sensor A/T and vehicle speed sensor MTR	AT-113 , AT-138
				3. ATF pressure switch 5 and direct clutch solenoid valve	AT-175 , AT-153
				4. CAN communication line	AT-101
				5. Line pressure test	AT-52
				6. Control valve with TCM	AT-238
			OFF vehicle	7. Torque converter	AT-275
				8. Oil pump assembly	AT-292
				9. 3rd one-way clutch	AT-295
				10. 1st one-way clutch	AT-302
				11. Gear system	AT-267
				12. Reverse brake	AT-275
				13. Forward one- way clutch (Parts behind drum support is impossible to perform inspection by disassembly. Refer to AT-17 , " Cross-Sectional View " .)	AT-275
				14. Forward brake (Parts behind drum support is impossible to perform inspection by disassembly. Refer to AT-17 , " Cross-Sectional View " .)	AT-275
35	With selector lever in "D" position, acceleration is extremely poor.		ON vehicle	1. Fluid level and state	AT-51
				2. Line pressure test	AT-52
				3. Accelerator pedal position sensor	AT-128
				4. CAN communication line	AT-101
				5. PNP switch	AT-109
				6. Control linkage adjustment	AT-229
				7. Control valve with TCM	AT-238
			OFF vehicle	8. Torque converter	AT-275
				9. Oil pump assembly	AT-292
				10. 1st one-way clutch	AT-302
				11. Gear system	AT-267
				12. Reverse brake	AT-275
				13. Forward one- way clutch (Parts behind drum support is impossible to perform inspection by disassembly. Refer to AT-17 , " Cross-Sectional View " .)	AT-275
				14. Forward brake (Parts behind drum support is impossible to perform inspection by disassembly. Refer to AT-17 , " Cross-Sectional View " .)	AT-275

TROUBLE DIAGNOSIS

No.	Items	Symptom	Condition	Diagnostic Item	Reference page
36		With selector lever in "R" position, acceleration is extremely poor.	ON vehicle	1. Fluid level and state	AT-51
				2. Line pressure test	AT-52
				3. Accelerator pedal position sensor	AT-128
				4. ATF pressure switch 6 and high and low reverse clutch solenoid valve	AT-177 , AT-157
				5. CAN communication line	AT-101
				6. PNP switch	AT-109
				7. Control linkage adjustment	AT-229
				8. Control valve with TCM	AT-238
			OFF vehicle	9. Gear system	AT-267
				10. Output shaft	AT-275
				11. Reverse brake	AT-275
37	Slips/Will Not Engage	While starting off by accelerating in 1st, engine races or slippage occurs.	ON vehicle	1. Fluid level and state	AT-51
				2. Line pressure test	AT-52
				3. Accelerator pedal position sensor	AT-128
				4. CAN communication line	AT-101
				5. Control valve with TCM	AT-238
			OFF vehicle	6. Torque converter	AT-275
				7. Oil pump assembly	AT-292
				8. 3rd one-way clutch	AT-295
				9. 1st one-way clutch	AT-302
				10. Gear system	AT-267
				11. Reverse brake	AT-275
				12. Forward one- way clutch (Parts behind drum support is impossible to perform inspection by disassembly. Refer to AT-17 , " Cross-Sectional View " .)	AT-275
				13. Forward brake (Parts behind drum support is impossible to perform inspection by disassembly. Refer to AT-17 , " Cross-Sectional View " .)	AT-275

A
B
AT
D
E
F
G
H
I
J
K
L
M

TROUBLE DIAGNOSIS

No.	Items	Symptom	Condition	Diagnostic Item	Reference page
38		While accelerating in 2nd, engine races or slippage occurs.	ON vehicle	1. Fluid level and state	AT-51
				2. Line pressure test	AT-52
				3. Accelerator pedal position sensor	AT-128
				4. CAN communication line	AT-101
				5. ATF pressure switch 5 and direct clutch solenoid valve	AT-175, AT-153
				6. Control valve with TCM	AT-238
			OFF vehicle	7. Torque converter	AT-275
				8. Oil pump assembly	AT-292
				9. 3rd one-way clutch	AT-295
				10. Gear system	AT-267
				11. Direct clutch	AT-309
				12. Forward brake (Parts behind drum support is impossible to perform inspection by disassembly. Refer to AT-17, " Cross-Sectional View " .)	AT-275
39	Slips/Will Not Engage	While accelerating in 3rd, engine races or slippage occurs.	ON vehicle	1. Fluid level and state	AT-51
				2. Line pressure test	AT-52
				3. Accelerator pedal position sensor	AT-128
				4. CAN communication line	AT-101
				5. ATF pressure switch 6 and high and low reverse clutch solenoid valve	AT-177, AT-157
				6. Control valve with TCM	AT-238
			OFF vehicle	7. Torque converter	AT-275
				8. Oil pump assembly	AT-292
				9. 3rd one-way clutch	AT-295
				10. Gear system	AT-267
				11. High and low reverse clutch	AT-307
				12. Forward one- way clutch (Parts behind drum support is impossible to perform inspection by disassembly. Refer to AT-17, " Cross-Sectional View " .)	AT-275
				13. Forward brake (Parts behind drum support is impossible to perform inspection by disassembly. Refer to AT-17, " Cross-Sectional View " .)	AT-275

TROUBLE DIAGNOSIS

No.	Items	Symptom	Condition	Diagnostic Item	Reference page
40		While accelerating in 4th, engine races or slippage occurs.	ON vehicle	1. Fluid level and state	AT-51
				2. Line pressure test	AT-52
				3. Accelerator pedal position sensor	AT-128
				4. CAN communication line	AT-101
				5. ATF pressure switch 3 and input clutch solenoid valve	AT-173, AT-145
				6. Control valve with TCM	AT-238
			OFF vehicle	7. Torque converter	AT-275
				8. Oil pump assembly	AT-292
				9. Input clutch	AT-297
				10. Gear system	AT-267
				11. High and low reverse clutch	AT-307
				12. Direct clutch	AT-309
41	Slips/Will Not Engage	While accelerating in 5th, engine races or slippage occurs.	ON vehicle	1. Fluid level and state	AT-51
				2. Line pressure test	AT-52
				3. Accelerator pedal position sensor	AT-128
				4. CAN communication line	AT-101
				5. ATF pressure switch 1 and front brake solenoid valve	AT-171, AT-149
				6. Control valve with TCM	AT-238
			OFF vehicle	7. Torque converter	AT-275
				8. Oil pump assembly	AT-292
				9. Front brake (brake band)	AT-275
				10. Input clutch	AT-297
				11. Gear system	AT-267
				12. High and low reverse clutch	AT-307
42		Slips at lock-up.	ON vehicle	1. Fluid level and state	AT-51
				2. Line pressure test	AT-52
				3. Engine speed signal	AT-118
				4. Turbine revolution sensor	AT-136
				5. Torque converter clutch solenoid valve	AT-120
				6. CAN communication line	AT-101
				7. Control valve with TCM	AT-238
			8. Torque converter	AT-275	
			9. Oil pump assembly	AT-292	

A
B
AT
D
E
F
G
H
I
J
K
L
M

TROUBLE DIAGNOSIS

No.	Items	Symptom	Condition	Diagnostic Item	Reference page
43	Slips/Will Not Engage	No creep at all. Refer to AT-194 . "Vehicle Does Not Creep Backward in "R" Position" , AT-197 . "Vehicle Does Not Creep Forward in "D" Position"	ON vehicle	1. Fluid level and state	AT-51
				2. Line pressure test	AT-52
				3. Accelerator pedal position sensor	AT-128
				4. ATF pressure switch 5 and direct clutch solenoid valve	AT-175 , AT-153
				5. PNP switch	AT-109
				6. CAN communication line	AT-101
				7. Control linkage adjustment	AT-229
				8. Control valve with TCM	AT-238
			OFF vehicle	9. Torque converter	AT-275
				10. Oil pump assembly	AT-292
				11. 1st one-way clutch	AT-302
				12. Gear system	AT-267
				13. Reverse brake	AT-275
				14. Direct clutch	AT-309
				15. Forward one- way clutch (Parts behind drum support is impossible to perform inspection by disassembly. Refer to AT-17 , "Cross-Sectional View" .)	AT-275
				16. Forward brake (Parts behind drum support is impossible to perform inspection by disassembly. Refer to AT-17 , "Cross-Sectional View" .)	AT-275
44	Vehicle cannot run in all positions.		ON vehicle	1. Fluid level and state	AT-51
				2. Line pressure test	AT-52
				3. PNP switch	AT-109
				4. Control linkage adjustment	AT-229
				5. Control valve with TCM	AT-238
			OFF vehicle	6. Oil pump assembly	AT-292
				7. Gear system	AT-267
				8. Output shaft	AT-275

TROUBLE DIAGNOSIS

No.	Items	Symptom	Condition	Diagnostic Item	Reference page
45	Slips/Will Not Engage	With selector lever in "D" position, driving is not possible.	ON vehicle	1. Fluid level and state	AT-51
				2. Line pressure test	AT-52
				3. PNP switch	AT-109
				4. Control linkage adjustment	AT-229
				5. Control valve with TCM	AT-238
			OFF vehicle	6. Torque converter	AT-275
				7. Oil pump assembly	AT-292
				8. 1st one-way clutch	AT-302
				9. Gear system	AT-267
				10. Reverse brake	AT-275
				11. Forward one- way clutch (Parts behind drum support is impossible to perform inspection by disassembly. Refer to AT-17 . "Cross-Sectional View" .)	AT-275
				12. Forward brake (Parts behind drum support is impossible to perform inspection by disassembly. Refer to AT-17 . "Cross-Sectional View" .)	AT-275
46		With selector lever in "R" position, driving is not possible.	ON vehicle	1. Fluid level and state	AT-51
				2. Line pressure test	AT-52
				3. PNP switch	AT-109
				4. Control linkage adjustment	AT-229
				5. Control valve with TCM	AT-238
			OFF vehicle	6. Gear system	AT-267
				7. Output shaft	AT-275
				8. Reverse brake	AT-275
47	Does Not Change	Does not change M5 → M4.	ON vehicle	1. PNP switch	AT-109
				2. Fluid level and state	AT-51
				3. Control linkage adjustment	AT-229
				4. Manual mode switch	AT-165
				5. ATF pressure switch 1	AT-171
				6. CAN communication line	AT-101
				7. Control valve with TCM	AT-238
			OFF vehicle	8. Front brake (brake band)	AT-275

A
B
AT
D
E
F
G
H
I
J
K
L
M

TROUBLE DIAGNOSIS

No.	Items	Symptom	Condition	Diagnostic Item	Reference page	
48	Does Not Change	Does not change M4 → M3.	ON vehicle	1. PNP switch	AT-109	
				2. Fluid level and state	AT-51	
				3. Control linkage adjustment	AT-229	
				4. Manual mode switch	AT-165	
				5. ATF pressure switch 1 and ATF pressure switch 3	AT-171 , AT-173	
				6. CAN communication line	AT-101	
				7. Control valve with TCM	AT-238	
OFF vehicle		8. Front brake (brake band)	AT-275			
		9. Input clutch	AT-297			
49		Does Not Change	Does not change M3 → M2.	ON vehicle	1. PNP switch	AT-109
					2. Fluid level and state	AT-51
					3. Control linkage adjustment	AT-229
					4. Manual mode switch	AT-165
					5. ATF pressure switch 6	AT-177
	6. CAN communication line				AT-101	
	7. Control valve with TCM				AT-238	
	OFF vehicle			8. Front brake (brake band)	AT-275	
				9. Input clutch	AT-297	
				10. High and low reverse clutch	AT-307	
50	Does Not Change	Does not change M2 → M1.	ON vehicle	1. PNP switch	AT-109	
				2. Fluid level and state	AT-51	
				3. Control linkage adjustment	AT-229	
				4. Manual mode switch	AT-165	
				5. ATF pressure switch 5	AT-175	
				6. CAN communication line	AT-101	
				7. Control valve with TCM	AT-238	
			OFF vehicle	8. Input clutch	AT-297	
				9. High and low reverse clutch	AT-307	
				10. Direct clutch	AT-309	
51	Does Not Change	Cannot be changed to manual mode. Refer to AT-217 , " Cannot Be Changed to Manual Mode ".	ON vehicle	1. Manual mode switch	AT-165	
				2. Turbine revolution sensor	AT-136	
				3. CAN communication line	AT-101	
52	Others	Shift point is high in "D" position.	ON vehicle	1. Vehicle speed sensor A/T and vehicle speed sensor MTR	AT-113 , AT-138	
				2. Accelerator pedal position sensor	AT-128	
				3. CAN communication line	AT-101	
				4. A/T fluid temperature sensor	AT-131	
				5. Control valve with TCM	AT-238	

TROUBLE DIAGNOSIS

No.	Items	Symptom	Condition	Diagnostic Item	Reference page
53		Shift point is low in "D" position.	ON vehicle	1. Vehicle speed sensor A/T and vehicle speed sensor MTR	AT-113 , AT-138
				2. Accelerator pedal position sensor	AT-128
				3. CAN communication line	AT-101
				4. Control valve with TCM	AT-238
54		Judder occurs during lock-up.	ON vehicle	1. Fluid level and state	AT-51
				2. Engine speed signal	AT-118
				3. Turbine revolution sensor	AT-136
				4. Vehicle speed sensor A/T and vehicle speed sensor MTR	AT-113 , AT-138
			OFF vehicle	5. Accelerator pedal position sensor	AT-128
				6. CAN communication line	AT-101
				7. Torque converter clutch solenoid valve	AT-120
				8. Control valve with TCM	AT-238
55	Others	Strange noise in "R" position.	ON vehicle	1. Fluid level and state	AT-51
				2. Engine speed signal	AT-118
				3. CAN communication line	AT-101
				4. Control valve with TCM	AT-238
			OFF vehicle	5. Torque converter	AT-275
				6. Oil pump assembly	AT-292
				7. Gear system	AT-267
				8. High and low reverse clutch	AT-307
				9. Reverse brake	AT-275
56		Strange noise in "N" position.	ON vehicle	1. Fluid level and state	AT-51
				2. Engine speed signal	AT-118
				3. CAN communication line	AT-101
				4. Control valve with TCM	AT-238
			OFF vehicle	5. Torque converter	AT-275
				6. Oil pump assembly	AT-292
				7. Gear system	AT-267
57		Strange noise in "D" position.	ON vehicle	1. Fluid level and state	AT-51
				2. Engine speed signal	AT-118
				3. CAN communication line	AT-101
				4. Control valve with TCM	AT-238
			OFF vehicle	5. Torque converter	AT-275
				6. Oil pump assembly	AT-292
				7. Gear system	AT-267
				8. Forward brake (Parts behind drum support is impossible to perform inspection by disassembly. Refer to AT-17 , " Cross-Sectional View " .)	AT-275

TROUBLE DIAGNOSIS

No.	Items	Symptom	Condition	Diagnostic Item	Reference page
58		Vehicle does not decelerate by engine brake. Refer to AT-226 . "Vehicle Does Not Decelerate by Engine Brake" .	ON vehicle	1. PNP switch	AT-109
				2. Fluid level and state	AT-51
				3. Control linkage adjustment	AT-229
				4. Manual mode switch	AT-165
				5. ATF pressure switch 5	AT-175
				6. CAN communication line	AT-101
				7. Control valve with TCM	AT-238
			OFF vehicle	8. Input clutch	AT-297
				9. High and low reverse clutch	AT-307
				10. Direct clutch	AT-309
59		Engine brake does not work M5 → M4.	ON vehicle	1. PNP switch	AT-109
				2. Fluid level and state	AT-51
				3. Control linkage adjustment	AT-229
				4. Manual mode switch	AT-165
				5. ATF pressure switch 1	AT-171
				6. CAN communication line	AT-101
				7. Control valve with TCM	AT-238
OFF vehicle	8. Front brake (brake band)	AT-275			
60	Others	Engine brake does not work M4 → M3.	ON vehicle	1. PNP switch	AT-109
				2. Fluid level and state	AT-51
				3. Control linkage adjustment	AT-229
				4. Manual mode switch	AT-165
				5. ATF pressure switch 1 and ATF pressure switch 3	AT-171 , AT-173
				6. CAN communication line	AT-101
				7. Control valve with TCM	AT-238
			OFF vehicle	8. Front brake (brake band)	AT-275
				9. Input clutch	AT-297
				10. High and low reverse clutch	AT-307
61		Engine brake does not work M3 → M2.	ON vehicle	1. PNP switch	AT-109
				2. Fluid level and state	AT-51
				3. Control linkage adjustment	AT-229
				4. Manual mode switch	AT-165
				5. ATF pressure switch 6	AT-177
				6. CAN communication line	AT-101
				7. Control valve with TCM	AT-238
			OFF vehicle	8. Front brake (brake band)	AT-275
				9. Input clutch	AT-297
				10. High and low reverse clutch	AT-307

TROUBLE DIAGNOSIS

No.	Items	Symptom	Condition	Diagnostic Item	Reference page
62		Engine brake does not work M2 → M1.	ON vehicle	1. PNP switch	AT-109
				2. Fluid level and state	AT-51
				3. Control linkage adjustment	AT-229
				4. Manual mode switch	AT-165
				5. ATF pressure switch 5	AT-175
				6. CAN communication line	AT-101
				7. Control valve with TCM	AT-238
			OFF vehicle	8. Input clutch	AT-297
				9. High and low reverse clutch	AT-307
				10. Direct clutch	AT-309
63	Others	Maximum speed low.	ON vehicle	1. Fluid level and state	AT-51
				2. Line pressure test	AT-52
				3. Accelerator pedal position sensor	AT-128
				4. CAN communication line	AT-101
				5. Direct clutch solenoid valve	AT-153
				6. Control valve with TCM	AT-238
			OFF vehicle	7. Torque converter	AT-275
				8. Oil pump assembly	AT-292
				9. Input clutch	AT-297
				10. Gear system	AT-267
				11. High and low reverse clutch	AT-307
				12. Direct clutch	AT-309
				13. Forward one- way clutch (Parts behind drum support is impossible to perform inspection by disassembly. Refer to AT-17 , " Cross-Sectional View " .)	AT-275
				14. Forward brake (Parts behind drum support is impossible to perform inspection by disassembly. Refer to AT-17 , " Cross-Sectional View " .)	AT-275
64		Extremely large creep.	ON vehicle	1. Engine idle speed	EC-30
				2. CAN communication line	AT-101
				3. ATF pressure switch 5	AT-175
			OFF vehicle	4. Torque converter	AT-275
65		With selector lever in "P" position, vehicle does not enter parking condition or, with selector lever in another position, parking condition is not cancelled. Refer to AT-189 , " In "P" Position, Vehicle Moves When Pushed "	ON vehicle	1. PNP switch	AT-109
				2. Control linkage adjustment	AT-229
				3. Parking pawl components	AT-267

A
B
AT
D
E
F
G
H
I
J
K
L
M

TROUBLE DIAGNOSIS

No.	Items	Symptom	Condition	Diagnostic Item	Reference page
66	Others	Vehicle runs with transmission in "P" position.	ON vehicle	1. PNP switch	AT-109
				2. Fluid level and state	AT-51
				3. Control linkage adjustment	AT-229
				4. Control valve with TCM	AT-238
				5. Parking pawl components	AT-267
		OFF vehicle	6. Gear system	AT-267	
67		Vehicle runs with transmission in "N" position. Refer to AT-190. "In "N" Position, Vehicle Moves" .	ON vehicle	1. PNP switch	AT-109
				2. Fluid level and state	AT-51
				3. Control linkage adjustment	AT-229
				4. Control valve with TCM	AT-238
	OFF vehicle		5. Input clutch	AT-297	
			6. Gear system	AT-267	
			7. Direct clutch	AT-309	
			8. Reverse brake	AT-275	
			9. Forward one- way clutch (Parts behind drum support is impossible to perform inspection by disassembly. Refer to AT-17. "Cross-Sectional View" .)	AT-275	
			10. Low coast brake (Parts behind drum support is impossible to perform inspection by disassembly. Refer to AT-17. "Cross-Sectional View" .)	AT-275	
68	Engine does not start in "N" or "P" position. Refer to AT-188. "Engine Cannot Be Started in "P" or "N" Position" .	ON vehicle	1. Ignition switch and starter	PG-4, SC-10	
			2. Control linkage adjustment	AT-229	
			3. PNP switch	AT-109	
69	Engine starts in positions other than "N" or "P".	ON vehicle	1. Ignition switch and starter	PG-4, SC-10	
			2. Control linkage adjustment	AT-229	
			3. PNP switch	AT-109	
70	Engine stall.	ON vehicle	1. Fluid level and state	AT-51	
			2. Engine speed signal	AT-118	
			3. Turbine revolution sensor	AT-136	
			4. Torque converter clutch solenoid valve	AT-120	
			5. CAN communication line	AT-101	
			6. Control valve with TCM	AT-238	
		OFF vehicle	7. Torque converter	AT-275	

TROUBLE DIAGNOSIS

No.	Items	Symptom	Condition	Diagnostic Item	Reference page
71		Engine stalls when select lever shifted "N" → "D", "R".	ON vehicle	1. Fluid level and state	AT-51
				2. Engine speed signal	AT-118
				3. Turbine revolution sensor	AT-136
				4. Torque converter clutch solenoid valve	AT-120
				5. CAN communication line	AT-101
				6. Control valve with TCM	AT-238
			OFF vehicle	7. Torque converter	AT-275
72	Others	Engine speed does not return to idle. Refer to AT-216 . " Engine Speed Does Not Return to Idle ".	ON vehicle	1. Fluid level and state	AT-51
				2. ATF pressure switch 5 and direct clutch solenoid valve	AT-175 , AT-153
				3. ATF pressure switch 1 and front brake solenoid valve	AT-171 , AT-149
				4. Accelerator pedal position sensor	AT-128
				5. Vehicle speed sensor A/T and vehicle speed sensor MTR	AT-113 , AT-138
				6. CAN communication line	AT-101
				7. Control valve with TCM	AT-238
			OFF vehicle	8. Front brake (brake band)	AT-275
			9. Direct clutch	AT-309	

A
B
AT
D
E
F
G
H
I
J
K
L
M

TROUBLE DIAGNOSIS



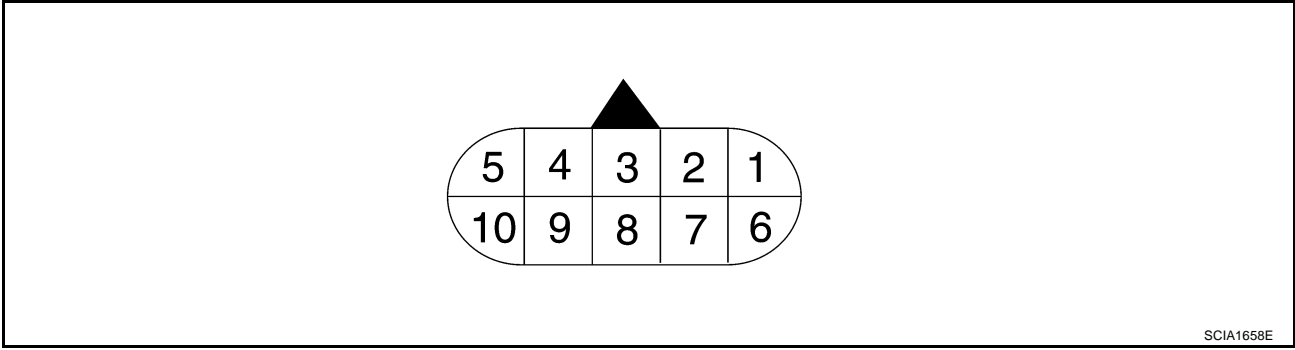

TCM Input/Output Signal Reference Values A/T ASSEMBLY HARNESS CONNECTOR TERMINAL LAYOUT

ACS000HX



TCM INSPECTION TABLE

Data are reference value and are measured between each terminal and ground.

Terminal	Wire color	Item	Condition	Data (Approx.)	
1	R/W	Power supply (Memory back-up)	Always	Battery voltage	
2	R/W	Power supply (Memory back-up)	Always	Battery voltage	
3	L	CAN-H	-	-	
4	PU/W	K-line (CONSULT-II signal)	The terminal is connected to the data link connector for CONSULT-II.		
5	B	Ground	Always	0V	
6	Y/R	Power supply		-	Battery voltage
				-	0V
7	P	Back-up lamp relay		Selector lever in "R" position.	0V
				Selector lever in other positions.	Battery voltage
8	P	CAN-L	-	-	
9	GY/R	Starter relay		Selector lever in "N", "P" positions.	Battery voltage
				Selector lever in other positions.	0V
10	B	Ground	Always	0V	

TROUBLE DIAGNOSIS

CONSULT-II

ACS000HY

After performing [AT-90, "SELF-DIAGNOSTIC RESULT MODE"](#) , place check marks for results on the [AT-45, "DIAGNOSTIC WORKSHEET"](#) . Reference pages are provided following the items.

NOTICE:

1. The CONSULT-II electrically displays shift timing and lock-up timing (that is, operation timing of each solenoid).
Check for time difference between actual shift timing and the CONSULT-II display. If the difference is noticeable, mechanical parts (except solenoids, sensors, etc.) may be malfunctioning. Check mechanical parts using applicable diagnostic procedures.
2. Shift schedule (which implies gear position) displayed on CONSULT-II and that indicated in Service Manual may differ slightly. This occurs because of the following reasons:
 - Actual shift schedule has more or less tolerance or allowance,
 - Shift schedule indicated in Service Manual refers to the point where shifts start, and
 - Gear position displayed on CONSULT-II indicates the point where shifts are completed.
3. Display of solenoid valves on CONSULT-II changes at the start of shifting, while gear position is displayed upon completion of shifting (which is computed by TCM).
4. Additional CONSULT-II information can be found in the Operation Manual supplied with the CONSULT-II unit.

FUNCTION

Diagnostic test mode	Function	Reference page
Self-diagnostic results	Self-diagnostic results can be read and erased quickly.	AT-90
Data monitor	Input/Output data in the ECM can be read.	AT-93
CAN diagnostic support monitor	The results of transmit/receive diagnosis of CAN communication can be read.	—
Function test	Conducted by CONSULT-II instead of a technician to determine whether each system is "OK" or "NG".	—
DTC work support	Select the operating condition to confirm Diagnosis Trouble Codes.	AT-96
ECU (ECM, TCM) part number	ECU (ECM, TCM) part number can be read.	—

CONSULT-II REFERENCE VALUE

Item name	Condition	Display value (Approx.)
ATF TEMP SE 1	0°C (32° F) - 20°C (68°F) - 80°C (176°F)	3.2 - 2.5 - 0.8 V
ATF TEMP SE 2		3.2 - 2.4 - 0.65 V
TCC SOLENOID	When performing slip lock-up.	0.2 - 0.4 A
	When performing lock-up.	0.4 - 0.6 A
SLCT LVR POSI	Selector lever in "N", "P" positions.	N/P
	Selector lever in "R" position.	R
	Selector lever in "D" position.	D
VHCL/S SE-A/T	During driving	Approximately matches the speedometer reading.
ENGINE SPEED	Engine running	Closely matches the tachometer reading.
LINE PRES SOL	During driving	0.2 - 0.6 A
TURBINE REV	During driving (lock-up ON)	Approximately matches the engine speed.
VHCL/S SE-MTR	During driving	Approximately matches the speedometer reading.
ATF PRES SW 1	Front brake engaged. Refer to AT-19 .	ON
	Front brake disengaged. Refer to AT-19 .	OFF
ATF PRES SW 2	Low coast brake engaged. Refer to AT-19 .	ON
	Low coast brake disengaged. Refer to AT-19 .	OFF

TROUBLE DIAGNOSIS

Item name	Condition	Display value (Approx.)
ATF PRES SW 3	Input clutch engaged. Refer to AT-19 .	ON
	Input clutch disengaged. Refer to AT-19 .	OFF
ATF PRES SW 5	Direct clutch engaged. Refer to AT-19 .	ON
	Direct clutch disengaged. Refer to AT-19 .	OFF
ATF PRES SW 6	High and low reverse clutch engaged. Refer to AT-19 .	ON
	High and low reverse clutch disengaged. Refer to AT-19 .	OFF
I/C SOLENOID	Input clutch disengaged. Refer to AT-19 .	0.6 - 0.8 A
	Input clutch engaged. Refer to AT-19 .	0 - 0.05 A
FR/B SOLENOID	Front brake engaged. Refer to AT-19 .	0.6 - 0.8 A
	Front brake disengaged. Refer to AT-19 .	0 - 0.05 A
D/C SOLENOID	Direct clutch disengaged. Refer to AT-19 .	0.6 - 0.8 A
	Direct clutch engaged. Refer to AT-19 .	0 - 0.05 A
HLR/C SOL	High and low reverse clutch disengaged. Refer to AT-19 .	0.6 - 0.8 A
	High and low reverse clutch engaged. Refer to AT-19 .	0 - 0.05 A
ON OFF SOL	Low coast brake engaged. Refer to AT-19 .	ON
	Low coast brake disengaged. Refer to AT-19 .	OFF
MANU MODE SW	Manual shift gate position (neutral).	ON
	Other than the above.	OFF
NON M-MODE SW	Manual shift gate position.	OFF
	Other than the above.	ON
UP SW LEVER	Selector lever: + side.	ON
	Other than the above.	OFF
DOWN SW LEVER	Selector lever: - side.	ON
	Other than the above.	OFF
STARTER RELAY	Selector lever in "N", "P" positions.	ON
	Selector lever in other positions.	OFF
ACCELE POSI	Released accelerator pedal.	0.0/8
	Fully depressed accelerator pedal.	8/8
CLSD THL POS	Released accelerator pedal.	ON
	Fully depressed accelerator pedal.	OFF
W/O THL POS	Fully depressed accelerator pedal.	ON
	Released accelerator pedal.	OFF
BRAKE SW	Depressed brake pedal.	ON
	Released brake pedal.	OFF

TROUBLE DIAGNOSIS

CONSULT-II SETTING PROCEDURE

CAUTION:

If CONSULT-II is used with no connection of CONSULT-II CONVERTER, malfunctions might be detected in self-diagnosis depending on control unit which perform CAN communication.

- For details, refer to the separate "CONSULT-II Operations Manual".

1. Turn ignition switch OFF.
2. Connect CONSULT-II and CONSULT-II CONVERTER to data link connector, which is located in instrument lower panel on driver side.

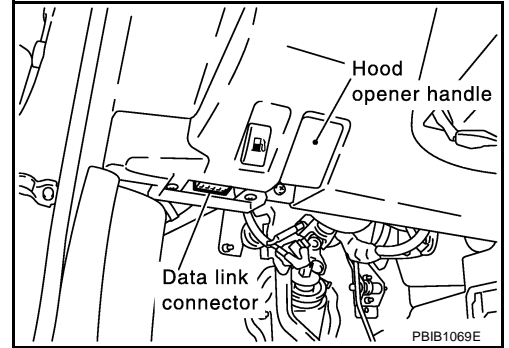

3. Turn ignition switch ON. (Do not start engine.)
4. Touch "START (NISSAN BASED VHCL)".

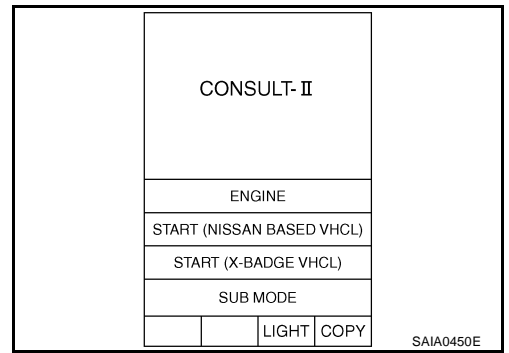

5. Touch "A/T".
If "A/T" is not indicated, go to [GI-39, "CONSULT-II Data Link Connector \(DLC\) Circuit"](#).

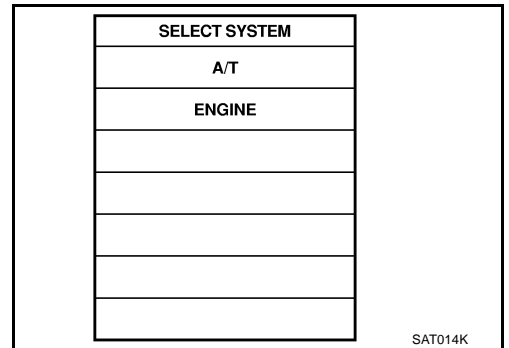

6. Perform each diagnostic test mode according to each service procedure.

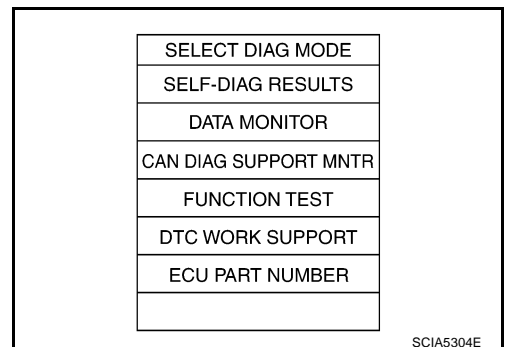

A
B
AT
D
E
F
G
H
I
J
K
L
M

TROUBLE DIAGNOSIS

SELF-DIAGNOSTIC RESULT MODE

Operation Procedure

1. Perform "CONSULT-II SETTING PROCEDURE". Refer to [AT-89, "CONSULT-II SETTING PROCEDURE"](#)
2. Touch "SELF-DIAG RESULTS".
Display shows malfunction experienced since the last erasing operation.

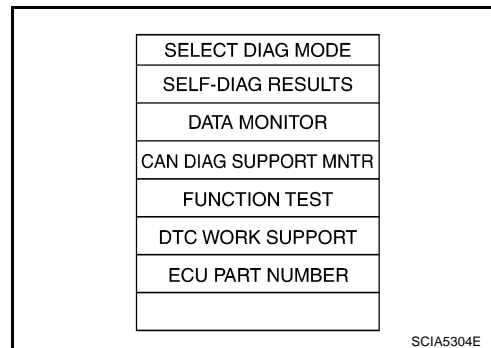

Display Items List

X: Applicable, —: Not applicable

Items (CONSULT-II screen terms)	Malfunction is detected when...	TCM self-diagnosis		OBD-II (DTC)
		A/T CHECK indicator lamp	"A/T" with CONSULT-II	MIL indicator lamp*1, "ENGINE" with CONSULT-II or GST
CAN COMM CIR-CUIT	<ul style="list-style-type: none"> When a malfunction is detected in CAN communications 	X	U1000	U1000
STARTER RELAY/CIRC	<ul style="list-style-type: none"> If this signal is ON other than in P or N position, this is judged to be a malfunction. (And if it is OFF in P or N position, this too is judged to be a malfunction.) 	X	P0615	—
TCM	<ul style="list-style-type: none"> TCM is malfunctioning 	—	P0700	P0700
PNP SW/CIRC	<ul style="list-style-type: none"> PNP switch 1-4 signals input with impossible pattern P position is detected from N position without any other position being detected in between. 	X	P0705	P0705
VEH SPD SEN/CIR AT (Revolution sensor)	<ul style="list-style-type: none"> Signal from vehicle speed sensor A/T (Revolution sensor) not input due to cut line or the like Unexpected signal input during running After ignition switch is turned ON, unexpected signal input from vehicle speed sensor MTR before the vehicle starts moving 	X	P0720	P0720
ENGINE SPEED SIG	<ul style="list-style-type: none"> TCM does not receive the CAN communication signal from the ECM. 	X	P0725	P0725
TCC SOLENOID/CIRC	<ul style="list-style-type: none"> Normal voltage not applied to solenoid due to cut line, short, or the like 	X	P0740	P0740
A/T TCC S/V FNCTN	<ul style="list-style-type: none"> A/T cannot perform lock-up even if electrical circuit is good. TCM detects as irregular by comparing difference value with slip rotation. 	X	P0744	P0744*2
L/PRESS SOL/CIRC	<ul style="list-style-type: none"> Normal voltage not applied to solenoid due to cut line, short, or the like TCM detects as irregular by comparing target value with monitor value. 	X	P0745	P0745
TCM-RAM	<ul style="list-style-type: none"> TCM memory (RAM) is malfunctioning. 	—	P1702	—
TCM-ROM	<ul style="list-style-type: none"> TCM memory (ROM) is malfunctioning. 	—	P1703	—
TP SEN/CIRC A/T	<ul style="list-style-type: none"> TCM does not receive the proper accelerator pedal position signals (input by CAN communication) from ECM. 	X	P1705	P1705

TROUBLE DIAGNOSIS

Items (CONSULT-II screen terms)	Malfunction is detected when...	TCM self-diagnosis		OBD-II (DTC)	
		A/T CHECK indicator lamp	"A/T" with CONSULT-II	MIL indicator lamp*1, "ENGINE" with CONSULT-II or GST	
ATF TEMP SEN/ CIRC	<ul style="list-style-type: none"> During running, the ATF temperature sensor signal voltage is excessively high or low 	X	P1710	P0710	A
TURBINE REV S/ CIRC	<ul style="list-style-type: none"> TCM does not receive the proper voltage signal from the sensor. TCM detects an irregularity only at position of 4th gear for turbine revolution sensor 2. 	X	P1716	P1716	B
VEH SPD SE/ CIR-MTR	<ul style="list-style-type: none"> Signal (CAN communication) from vehicle speed sensor MTR not input due to cut line or the like Unexpected signal input during running 	—	P1721	—	AT
A/T INTERLOCK	<ul style="list-style-type: none"> Except during shift change, the gear position and ATF pressure switch states are monitored and comparative judgment made. 	X	P1730	P1730	D
A/T 1ST E/BRAKING	<ul style="list-style-type: none"> Each pressure switch and solenoid current is monitored and if a pattern is detected having engine braking 1st gear other than in the M1 position, a malfunction is detected. 	X	P1731	—	E
I/C SOLENOID/ CIRC	<ul style="list-style-type: none"> Normal voltage not applied to solenoid due to functional malfunction, cut line, short, or the like TCM detects as irregular by comparing target value with monitor value. 	X	P1752	P1752	F
I/C SOLENOID FNCTN	<ul style="list-style-type: none"> TCM detects that actual gear ratio is irregular, and relation between gear position and condition of ATF pressure switch 3 is irregular during depressing accelerator pedal. (Other than during shift change) TCM detects that relation between gear position and condition of ATF pressure switch 3 is irregular during releasing accelerator pedal. (Other than during shift change) 	X	P1754	P1754*2	G
FR/B SOLENOID/ CIRC	<ul style="list-style-type: none"> Normal voltage not applied to solenoid due to functional malfunction, cut line, short, or the like TCM detects as irregular by comparing target value with monitor value. 	X	P1757	P1757	H
FR/B SOLENOID FNCT	<ul style="list-style-type: none"> TCM detects that actual gear ratio is irregular, and relation between gear position and condition of ATF pressure switch 1 is irregular during depressing accelerator pedal. (Other than during shift change) TCM detects that relation between gear position and condition of ATF pressure switch 1 is irregular during releasing accelerator pedal. (Other than during shift change) 	X	P1759	P1759*2	I
D/C SOLENOID/ CIRC	<ul style="list-style-type: none"> Normal voltage not applied to solenoid due to cut line, short, or the like TCM detects as irregular by comparing target value with monitor value. 	X	P1762	P1762	J
D/C SOLENOID FNCTN	<ul style="list-style-type: none"> TCM detects that actual gear ratio is irregular, and relation between gear position and condition of ATF pressure switch 5 is irregular during depressing accelerator pedal. (Other than during shift change) TCM detects that relation between gear position and condition of ATF pressure switch 5 is irregular during releasing accelerator pedal. (Other than during shift change) 	X	P1764	P1764*2	K

TROUBLE DIAGNOSIS

Items (CONSULT-II screen terms)	Malfunction is detected when...	TCM self-diagnosis		OBD-II (DTC)
		A/T CHECK indicator lamp	"A/T" with CONSULT-II	MIL indicator lamp*1, "ENGINE" with CONSULT-II or GST
HLR/C SOL/CIRC	<ul style="list-style-type: none"> Normal voltage not applied to solenoid due to functional malfunction, cut line, short, or the like TCM detects as irregular by comparing target value with monitor value. 	X	P1767	P1767
HLR/C SOL FNCTN	<ul style="list-style-type: none"> TCM detects that actual gear ratio is irregular, and relation between gear position and condition of ATF pressure switch 6 is irregular during depressing accelerator pedal. (Other than during shift change) TCM detects that relation between gear position and condition of ATF pressure switch 6 is irregular during releasing accelerator pedal. (Other than during shift change) 	X	P1769	P1769*2
LC/B SOLENOID/CIRC	<ul style="list-style-type: none"> Normal voltage not applied to solenoid due to functional malfunction, cut line, short, or the like 	X	P1772	P1772
LC/B SOLENOID FNCT	<ul style="list-style-type: none"> TCM detects an improper voltage drop when it tries to operate the solenoid valve. Condition of ATF pressure switch 2 is different from monitor value, and relation between gear position and actual gear ratio is irregular. 	X	P1774	P1774*2
MANU MODE SW/CIRC	<ul style="list-style-type: none"> When an impossible pattern of switch signals is detected, a malfunction is detected. 	—	P1815	—
ATF PRES SW 1/CIRC	<ul style="list-style-type: none"> TCM detects that actual gear ratio is normal, and relation between gear position and condition of ATF pressure switch 1 is irregular during depressing accelerator pedal. (Other than during shift change) 	—	P1841	—
ATF PRES SW 3/CIRC	<ul style="list-style-type: none"> TCM detects that actual gear ratio is normal, and relation between gear position and condition of ATF pressure switch 3 is irregular during depressing accelerator pedal. (Other than during shift change) 	—	P1843	—
ATF PRES SW 5/CIRC	<ul style="list-style-type: none"> TCM detects that actual gear ratio is normal, and relation between gear position and condition of ATF pressure switch 5 is irregular during depressing accelerator pedal. (Other than during shift change) 	—	P1845	—
ATF PRES SW 6/CIRC	<ul style="list-style-type: none"> TCM detects that actual gear ratio is normal, and relation between gear position and condition of ATF pressure switch 6 is irregular during depressing accelerator pedal. (Other than during shift change) 	—	P1846	—
NO DTC IS DETECTED FURTHER TESTING MAY BE REQUIRED	<ul style="list-style-type: none"> No NG item has been detected. 	—	X	X

*1: Refer to [AT-40, "Malfunction Indicator Lamp \(MIL\)"](#).

*2: These malfunctions cannot be displayed MIL if another malfunction is assigned to MIL.

TROUBLE DIAGNOSIS

How to Erase Self-diagnostic Results

1. Perform "CONSULT-II SETTING PROCEDURE". Refer to [AT-89, "CONSULT-II SETTING PROCEDURE"](#).
2. Touch "SELF-DIAG RESULTS".

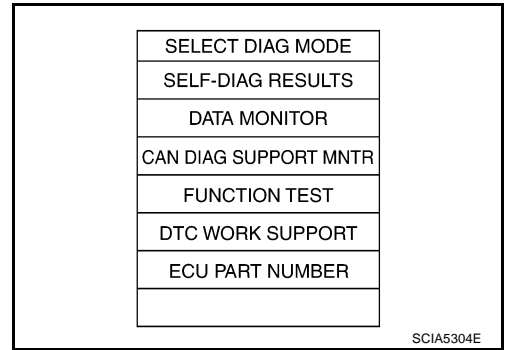

3. Touch "ERASE". (The self-diagnostic results will be erased.)

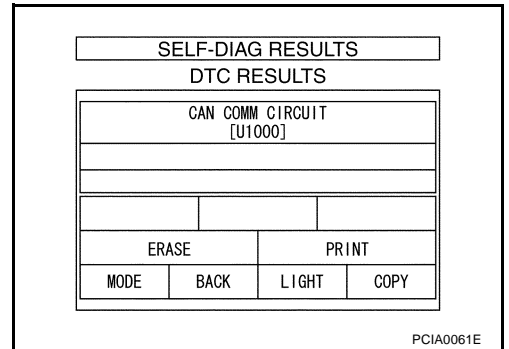

DATA MONITOR MODE

Operation Procedure

1. Perform "CONSULT-II SETTING PROCEDURE". Refer to [AT-89, "CONSULT-II SETTING PROCEDURE"](#).
2. Touch "DATA MONITOR".

NOTE:

When malfunction is detected, CONSULT-II performs "REAL-TIME DIAGNOSIS". Also, any malfunction detected while in this mode will be displayed at real time.

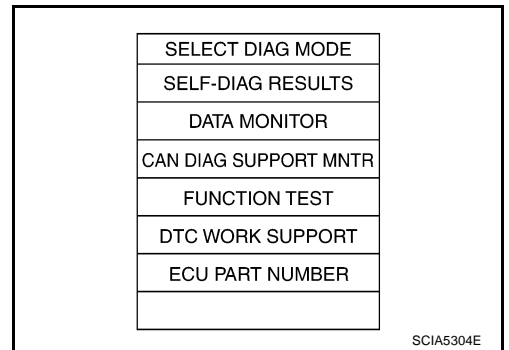

Display Items List

X: Standard, —: Not applicable

Monitored item (Unit)	Monitor Item Selection			Remarks
	ECU INPUT SIGNALS	MAIN SIGNALS	SELECTION FROM MENU	
VHCL/S SE-A/T (km/h)	X	X	X	Revolution sensor
VHCL/S SE-MTR (km/h)	X	—	X	
ACCELE POSI (0.0/8)	X	—	X	Accelerator pedal position signal
THROTTLE POSI (0.0/8)	X	X	X	Degree of opening for accelerator recognized by the TCM For fail-safe operation, the specific value used for control is displayed.
BATTERY VOLT (V)	X	—	X	

TROUBLE DIAGNOSIS

Monitored item (Unit)	Monitor Item Selection			Remarks
	ECU INPUT SIGNALS	MAIN SIGNALS	SELECTION FROM MENU	
ENGINE SPEED (rpm)	X	X	X	
TURBINE REV (rpm)	X	X	X	
ATF TEMP 1 (°C)	—	X	X	
ATF TEMP 2 (°C)	—	X	X	
OUTPUT REV (rpm)	X	X	X	
ATF TEMP SE 1 (V)	X	—	X	
ATF TEMP SE 2 (V)	X	—	X	
ATF PRES SW 1 (ON-OFF display)	X	X	X	(for FR/B solenoid)
ATF PRES SW 2 (ON-OFF display)	X	X	X	(for LC/B solenoid)
ATF PRES SW 3 (ON-OFF display)	X	X	X	(for I/C solenoid)
ATF PRES SW 5 (ON-OFF display)	X	X	X	(for D/C solenoid)
ATF PRES SW 6 (ON-OFF display)	X	X	X	(for HLR/C solenoid)
PNP SW 1 (ON-OFF display)	X	—	X	
PNP SW 2 (ON-OFF display)	X	—	X	
PNP SW 3 (ON-OFF display)	X	—	X	
PNP SW 4 (ON-OFF display)	X	—	X	
1 POSITION SW (ON-OFF display)	X	—	X	
ASCD-CRUISE (ON-OFF display)	X	—	X	
ASCD-OD CUT (ON-OFF display)	X	—	X	
OD CONT SW (ON-OFF display)	X	—	X	Not mounted but displayed.
MANU MODE SW (ON-OFF display)	X	—	X	
NON M-MODE SW (ON-OFF display)	X	—	X	
UP SW LEVER (ON-OFF display)	X	—	X	
DOWN SW LEVER (ON-OFF display)	X	—	X	
POWER SHIFT SW (ON-OFF display)	X	—	X	Not mounted but displayed.
CLSD THL POS (ON-OFF display)	X	—	X	Signal input with CAN communications.
W/O THL POS (ON-OFF display)	X	—	X	Signal input with CAN communications.
TCC SOLENOID (A)	—	X	X	
LINE PRES SOL (A)	—	X	X	
I/C SOLENOID (A)	—	X	X	
FR/B SOLENOID (A)	—	X	X	
D/C SOLENOID (A)	—	X	X	
HLR/C SOL (A)	—	X	X	
HOLD SW (ON-OFF display)	X	—	X	Not mounted but displayed.
BRAKE SW (ON-OFF display)	X	—	X	Stop lamp switch
GEAR	—	X	X	Gear position recognized by the TCM updated after gear-shifting.
GEAR RATIO	—	X	X	
SLCT LVR POSI	—	X	X	Selector lever position is recognized by the TCM. For fail safe operation, the specific value used for control is displayed.
VEHICLE SPEED (km/h)	—	X	X	Vehicle speed recognized by the TCM.

TROUBLE DIAGNOSIS

Monitored item (Unit)	Monitor Item Selection			Remarks
	ECU INPUT SIGNALS	MAIN SIGNALS	SELECTION FROM MENU	
TC SLIP SPEED (rpm)	—	X	X	Difference between engine speed and torque converter input shaft speed.
Voltage (V)	—	—	X	Displays the value measured by the voltage probe.
F SUN GR REV (rpm)	—	—	X	
F CARR GR REV (rpm)	—	—	X	
SFT UP ST SW	—	—	X	Not mounted but displayed.
SFT DOWN ST SW	—	—	X	
ABS SIGNAL	—	—	X	
ACC OD CUT	—	—	X	Not mounted but displayed.
ACC SIGNAL	—	—	X	
TCS GR/P KEEP	—	—	X	
TCS SIGNAL 2	—	—	X	
TCS SIGNAL 1	—	—	X	
ON OFF SOL (ON-OFF display)	—	—	X	LC/B solenoid
TCC SOL MON	—	—	X	
L/P SOL MON	—	—	X	
I/C SOL MON	—	—	X	
FR/B SOL MON	—	—	X	
D/C SOL MON	—	—	X	
HLR/C SOL MON	—	—	X	
ON OFF SOL MON	—	—	X	LC/B solenoid
P POSI IND	—	—	X	
R POSI IND	—	—	X	
N POSI IND	—	—	X	
D POSI IND	—	—	X	
4TH POSI IND	—	—	X	
3RD POSI IND	—	—	X	
2ND POSI IND	—	—	X	
1ST POSI IND	—	—	X	
M MODE IND	—	—	X	
POWER M LAMP	—	—	X	
F-SAFE IND/L	—	—	X	
ATF WARN LAMP	—	—	X	
BACK-UP LAMP	—	—	X	
STARTER RELAY	—	—	X	
PNP SW3 MON	—	—	X	
TRGT GR RATIO	—	—	X	
TRGT PRES TCC	—	—	X	
TRGT PRES L/P	—	—	X	
TRGT PRES I/C	—	—	X	
TRGT PRES FR/B	—	—	X	
TRGT PRES D/C	—	—	X	

A
 B
AT
 D
 E
 F
 G
 H
 I
 J
 K
 L
 M

TROUBLE DIAGNOSIS

Monitored item (Unit)	Monitor Item Selection			Remarks
	ECU INPUT SIGNALS	MAIN SIGNALS	SELECTION FROM MENU	
TRG PRE HLR/C	—	—	X	
SHIFT PATTERN	—	—	X	
C/V CLB ID1	—	—	X	
C/V CLB ID2	—	—	X	
C/V CLB ID3	—	—	X	
UNIT CLB ID1	—	—	X	
UNIT CLB ID2	—	—	X	
UNIT CLB ID3	—	—	X	
DRV CST JUDGE	—	—	X	
START RLY MON	—	—	X	
NEXT GR POSI	—	—	X	
SHIFT MODE	—	—	X	
MANU GR POSI	—	—	X	
Frequency (Hz)	—	—	X	The value measured by the pulse probe is displayed.
DUTY·HI (%)	—	—	X	
DUTY·LOW (%)	—	—	X	
PLS WIDTH·HI (ms)	—	—	X	
PLS WIDTH·LOW (ms)	—	—	X	
	—	—	X	

DTC WORK SUPPORT MODE WITH CONSULT-II

Operation Procedure

1. Perform "CONSULT-II SETTING PROCEDURE". Refer to [AT-89, "CONSULT-II SETTING PROCEDURE"](#).
2. Touch "DTC WORK SUPPORT".

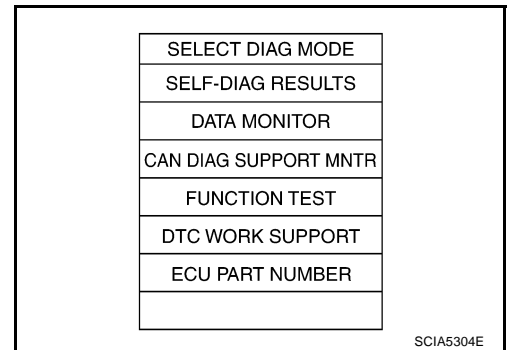

3. Touch select item menu.

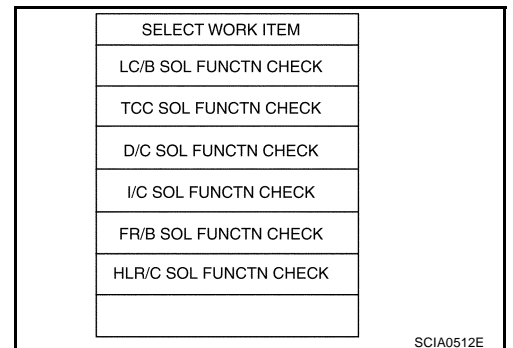

TROUBLE DIAGNOSIS

4. Touch "START".

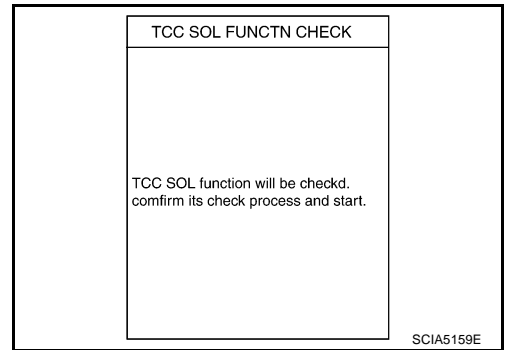

A
B
AT

5. Perform driving test according to "DTC CONFIRMATION PROCEDURE" in "TROUBLE DIAGNOSIS FOR DTC".

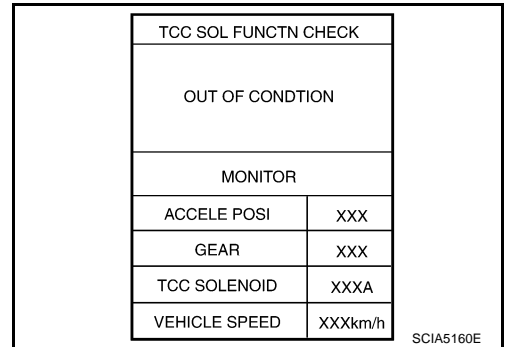

D
E
F
G

- When testing conditions are satisfied, CONSULT-II screen changes from "OUT OF CONDITION" to "TESTING".

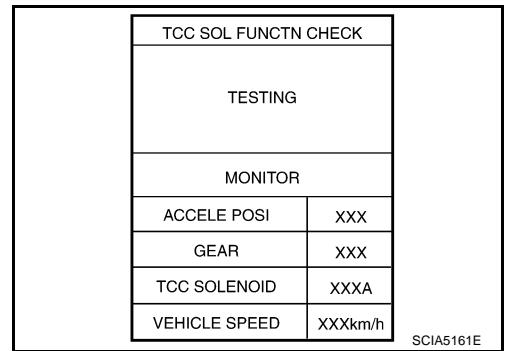

H
I
J
K

6. Stop vehicle.

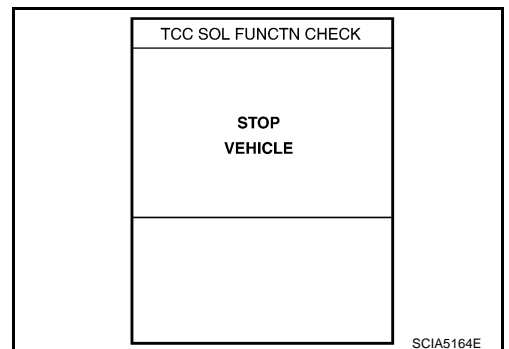

L
M

- If "NG" appears on the screen, malfunction may exist. Go to "Diagnostic Procedure".

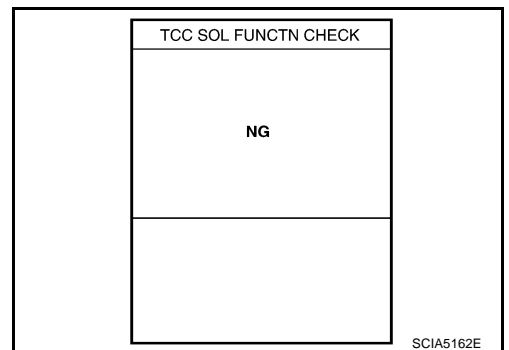

TROUBLE DIAGNOSIS

7. Perform test drive to check gear shift feeling in accordance with instructions displayed.
8. Touch "YES" or "NO".
9. CONSULT-II procedure ended.

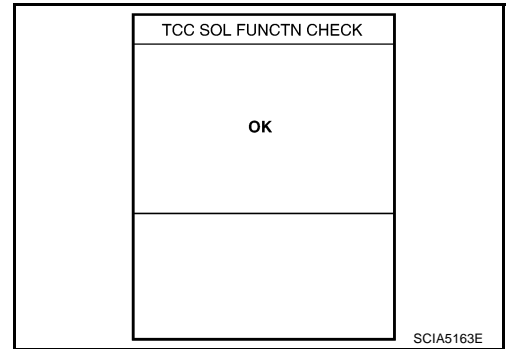

- If "NG" appears on the screen, malfunction may exist. Go to "Diagnostic Procedure".

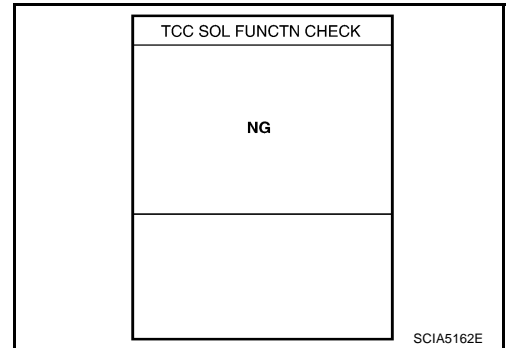

Display Items List

DTC work support item	Description	Check item
I/C SOL FUNCTN CHECK*	—	—
FR/B SOL FUNCTN CHECK*	—	—
D/C SOL FUNCTN CHECK*	—	—
HLR/C SOL FUNCTN CHECK*	—	—
LC/B SOL FUNCTN CHECK*	—	—
TCC SOL FUNCTN CHECK	Following items for "TCC solenoid function (lock-up) " can be confirmed. ● Self-diagnosis status (whether the diagnosis is being performed or not) ● Self-diagnosis result (OK or NG)	● TCC solenoid valve ● Hydraulic control circuit

*: Do not use, but displayed.

TROUBLE DIAGNOSIS

ACS000HZ

A

Diagnostic Procedure Without CONSULT-II

OBD-II SELF-DIAGNOSTIC PROCEDURE (WITH GST)

Refer to [EC-116, "Generic Scan Tool \(GST\) Function"](#) .

OBD-II SELF-DIAGNOSTIC PROCEDURE (NO TOOLS)

Refer to [EC-63, "Malfunction Indicator Lamp \(MIL\)"](#) .

TCM SELF-DIAGNOSTIC PROCEDURE (NO TOOLS)

Description

In the unlikely event of a malfunction in the electrical system, when the ignition switch is switched ON, the A/T CHECK indicator lamp lights up for 2 seconds, then flashes for 8 seconds. If there is no malfunction, when the ignition switch is turned ON, the indicator lamp lights up for 2 seconds. As a method for locating the suspect circuit, when the self-diagnostics start signal is input, the memory for the malfunction location is output and the A/T CHECK indicator lamp flashes to display the corresponding DTC.

Diagnostic Procedure

1. CHECK A/T CHECK INDICATOR LAMP

1. Start engine with selector lever in "P" position. Warm engine to normal operating temperature.
2. Turn ignition switch ON and OFF at least twice, then leave it in the OFF position.
3. Wait for 10 seconds.
4. Turn ignition switch to ON position. (Do not start engine.)

Does A/T CHECK indicator lamp come on for about 2 seconds?

YES >> GO TO 2.

NO >> GO TO [AT-188, "A/T Check Indicator Lamp Does Not Come On"](#) .

2. JUDGEMENT PROCEDURE STEP 1

1. Turn ignition switch OFF.
2. Push shift lock release button.
3. Move selector lever from "P" to "D" position.
4. Release accelerator pedal. (Set the closed throttle position signal ON.)
5. Depress brake pedal. (Stop lamp switch signal ON.)
6. Turn ignition switch ON. (Do not start engine.)
7. Wait for 3 seconds.
8. Move the selector lever to the Manual shift gate side. (Manual mode switch ON.)
9. Release brake pedal. (Stop lamp switch signal OFF.)
10. Move the selector lever to "D" position. (Manual mode switch OFF.)
11. Depress brake pedal. (Stop lamp switch signal ON.)
12. Release brake pedal. (Stop lamp switch signal OFF.)
13. Depress accelerator pedal fully and release it.

>> GO TO 3.

3. CHECK SELF-DIAGNOSIS CODE

Check A/T CHECK indicator lamp. Refer to [AT-100, "Judgement Self-diagnosis Code"](#) .

If the system does not go into self-diagnostics. Refer to [AT-109, "DTC P0705 PARK/NEUTRAL POSITION SWITCH"](#) , [AT-165, "DTC P1815 MANUAL MODE SWITCH"](#) , [AT-183, "CLOSED THROTTLE POSITION AND WIDE OPEN THROTTLE POSITION CIRCUIT"](#) , [AT-184, "BRAKE SIGNAL CIRCUIT"](#) .

>> **DIAGNOSIS END**

AT

D

E

F

G

H

I

J

K

L

M

TROUBLE DIAGNOSIS

Judgement Self-diagnosis Code

If there is a malfunction, the lamp lights up for the time corresponding to the suspect circuit.

1	Revolution sensor
2	Direct clutch solenoid valve
3	Torque converter clutch solenoid valve
4	Line pressure solenoid valve
5	Input clutch solenoid valve
6	Front brake solenoid valve
7	Low coast brake solenoid valve
8	High and low reverse clutch solenoid valve
9	PNP switch
10	A/T fluid temperature sensor
11	Turbine revolution sensor
12	A/T interlock
13	A/T 1st engine braking
14	Start signal
15	Accelerator pedal position sensor
16	Engine speed signal
17	CAN

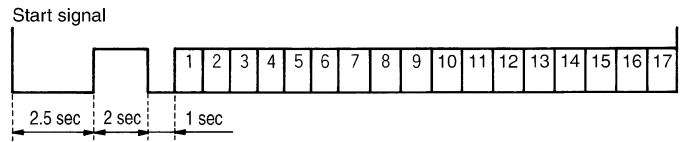

17-judgement flickers
(OK)

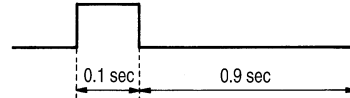

(NG)

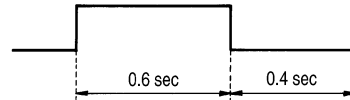

※ Solenoid valve is checked for open and short circuit, and malfunctions.

SCIA4758E

Erase Self-diagnosis

- In order to make it easier to find the cause of hard-to-duplicate malfunctions, malfunction information is stored into the control unit as necessary during use by the user. This memory is not erased no matter how many times the ignition switch is turned ON and OFF.
- However, this information is erased by turning ignition switch OFF after executing self-diagnostics or by erasing the memory using the CONSULT-II.

DTC U1000 CAN COMMUNICATION LINE

DTC U1000 CAN COMMUNICATION LINE

PFP:23710

Description

ACS003MG

CAN (Controller Area Network) is a serial communication line for real time application. It is an on-vehicle multiplex communication line with high data communication speed and excellent malfunction detection ability. Many electronic control units are equipped onto a vehicle, and each control unit shares information and links with other control units during operation (not independent). In CAN communication, control units are connected with 2 communication lines (CAN H line, CAN L line) allowing a high rate of information transmission with less wiring. Each control unit transmits/receives data but selectively reads required data only.

On Board Diagnosis Logic

ACS003MH

- This is an OBD-II self-diagnostic item.
- Diagnostic trouble code "CAN COMM CIRCUIT" with CONSULT-II or U1000 without CONSULT-II is detected when TCM cannot communicate to other control units.

Possible Cause

ACS003MI

Harness or connectors
(CAN communication line is open or shorted.)

DTC Confirmation Procedure

ACS003MJ

NOTE:

If "DTC Confirmation Procedure" has been previously performed, always turn ignition switch OFF and wait for at least 10 seconds before performing the next test.

After the repair, perform the following procedure to confirm the malfunction is eliminated.

④ WITH CONSULT-II

1. Turn ignition switch ON. (Do not start engine.)
2. Select "DATA MONITOR" mode for "ENGINE" with CONSULT-II.
3. Start engine and wait for at least 6 seconds.
4. If DTC is detected, go to [AT-103, "Diagnostic Procedure"](#).

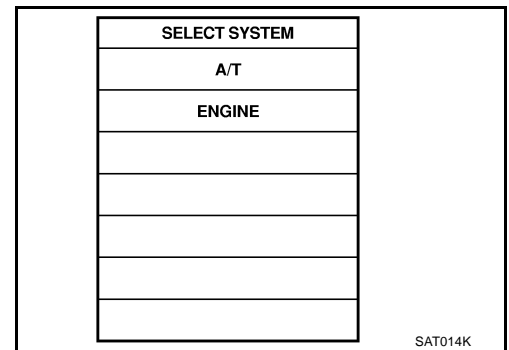

④ WITH GST

Follow the procedure "WITH CONSULT-II".

DTC U1000 CAN COMMUNICATION LINE

Wiring Diagram — AT — CAN

ACS0080J

AT-CAN-01

: DETECTABLE LINE FOR DTC
 : NON-DETECTABLE LINE FOR DTC
 : DATA LINE

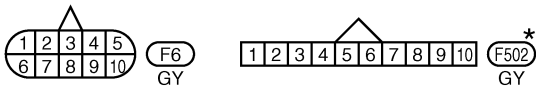
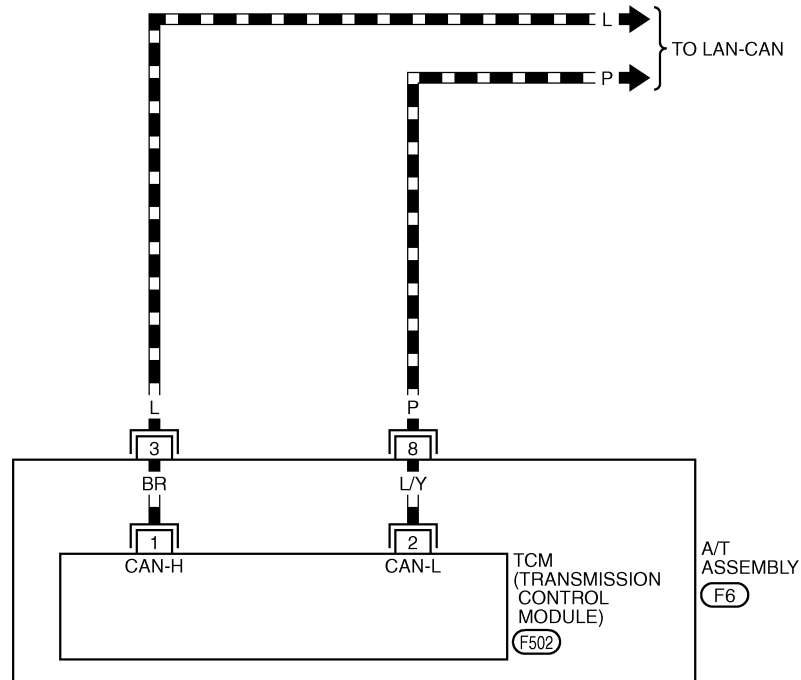

*: THIS CONNECTOR IS NOT SHOWN IN "HARNESS LAYOUT", PG SECTION.

TCWM0259E

DTC U1000 CAN COMMUNICATION LINE

TCM terminals and data are reference value. Measured between each terminal and ground.

Terminal	Wire color	Item	Condition	Data (Approx.)
3	L	CAN-H	-	-
8	P	CAN-L	-	-

Diagnostic Procedure

ACS003MK

1. CHECK CAN COMMUNICATION CIRCUIT

④ With CONSULT-II

- Turn ignition switch ON and start engine.
- Select "SELF-DIAG RESULTS" mode for "AT" with CONSULT-II.

Is any malfunction of the "CAN COMM CIRCUIT" indicated?

- YES >> Print out CONSULT-II screen, GO TO LAN section.
Refer to [LAN-3, "Precautions When Using CONSULT-II"](#)
- NO >> **INSPECTION END**

The screenshot shows the following screen layout:

- Top bar: SELF-DIAG RESULTS
- Second bar: DTC RESULTS
- Third bar: CAN COMM CIRCUIT [U1000]
- Fourth bar: (Empty)
- Fifth bar: (Empty)
- Sixth bar: (Empty)
- Bottom section:

ERASE		PRINT	
MODE	BACK	LIGHT	COPY

PCIA0061E

A
B
AT
D
E
F
G
H
I
J
K
L
M

DTC P0615 START SIGNAL CIRCUIT

DTC P0615 START SIGNAL CIRCUIT

PFP:25230

Description

ACS00016

Prohibits cranking other at "P" or "N" position.

CONSULT-II Reference Value

ACS006C0

Item name	Condition	Display value
STARTER RELAY	Selector lever in "N", "P" positions.	ON
	Selector lever in other positions.	OFF

On Board Diagnosis Logic

ACS00017

- This is not an OBD-II self-diagnostic item.
- Diagnostic trouble code "STARTER RELAY/CIRC" with CONSULT-II or 14th judgement flicker without CONSULT-II is detected when starter relay is switched ON other than at "P" or "N" position. (Or when switched OFF at "P" or "N" position).

Possible Cause

ACS00018

- Harness or connectors
(Starter relay and TCM circuit is open or shorted.)
- Starter relay circuit

DTC Confirmation Procedure

ACS00019

NOTE:

If "DTC Confirmation Procedure" has been previously conducted, always turn ignition switch OFF and wait for at least 10 seconds before conducting the next test.

After the repair, perform the following procedure to confirm the malfunction is eliminated.

④ WITH CONSULT-II

1. Turn ignition switch ON. (Do not start engine.)
2. Select "DATA MONITOR" mode for "A/T" with CONSULT-II.
3. Start engine.
4. Vehicle start for at least 2 consecutive seconds.
5. If DTC is detected, go to [AT-106, "Diagnostic Procedure"](#).

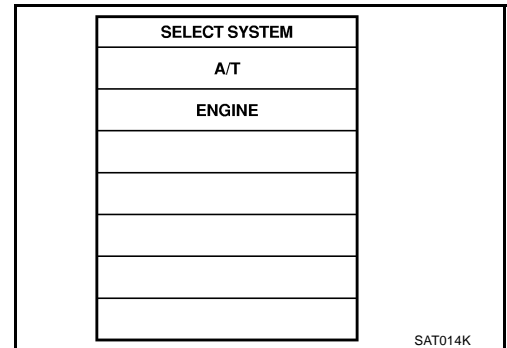

DTC P0615 START SIGNAL CIRCUIT

Wiring Diagram — AT — STSIG

ACS0080K

AT-STSIG-01

: DETECTABLE LINE FOR DTC
 : NON-DETECTABLE LINE FOR DTC

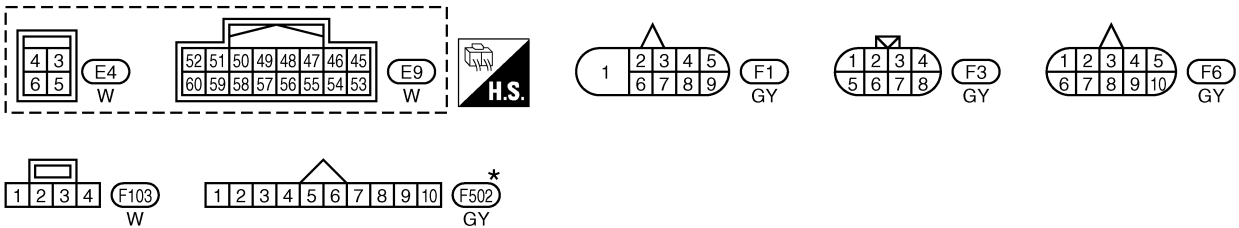
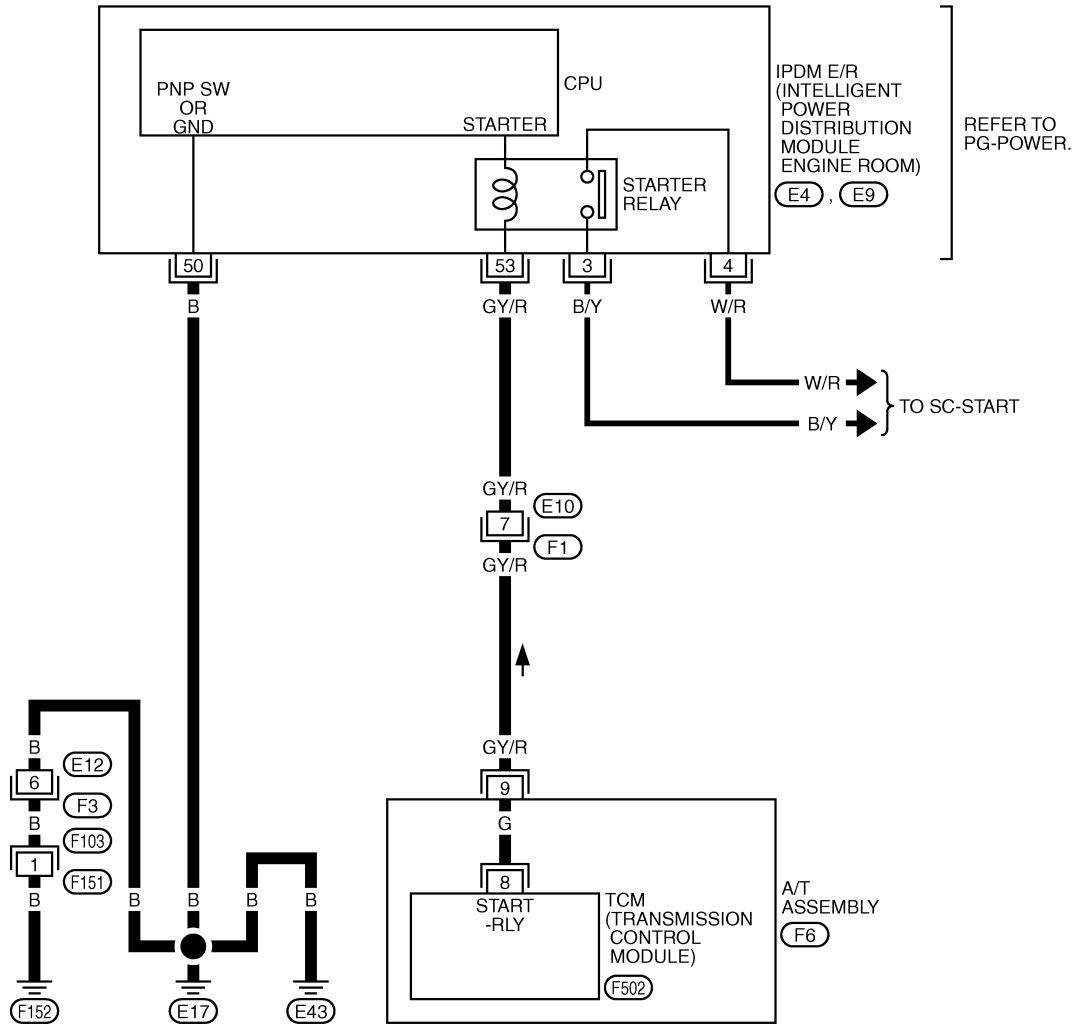

*: THIS CONNECTOR IS NOT SHOWN IN "HARNESS LAYOUT", PG SECTION.

TCWM0260E

DTC P0615 START SIGNAL CIRCUIT

TCM terminals and data are reference value. Measured between each terminal and ground.

Terminal	Wire color	Item	Condition	Data (Approx.)
9	GY/R	Starter relay	 Selector lever in "N", "P" positions.	Battery voltage
			Selector lever in other positions.	0V

Diagnostic Procedure

ACS0001B

1. CHECK STARTER RELAY

With CONSULT-II

- Turn ignition switch ON. (Do not start engine.)
- Select "SELECTION FROM MENU" in "DATA MONITOR" mode for "A/T" with CONSULT-II and check monitor "STARTER RELAY" ON/OFF.

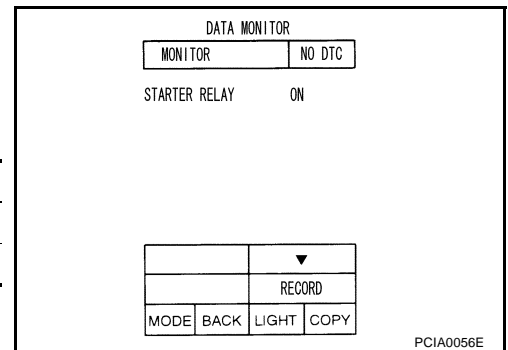

Item name	Condition	Display value
STARTER RELAY	Selector lever in "N", "P" positions.	ON
	Selector lever in other positions.	OFF

Without CONSULT-II

- Turn ignition switch ON. (Do not start engine.)
- Check voltage between the IPDM E/R connector and ground.

Item	Connector	Terminal (Wiring color)	Shift position	Voltage (Approx.)
Starter relay	E9	53 (GY/R)	Ground	Battery voltage
			"N", "P"	0V

OK or NG

- OK >> GO TO 5.
NG >> GO TO 2.

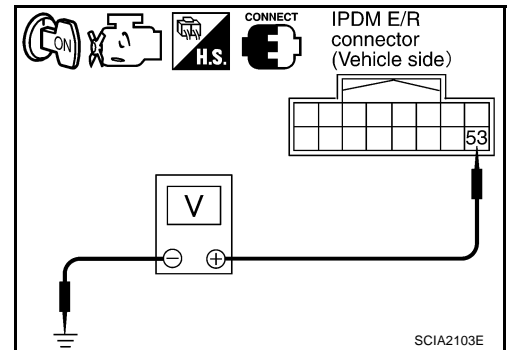

2. CHECK HARNESS BETWEEN A/T ASSEMBLY HARNESS CONNECTOR AND IPDM E/R CONNECTOR

- Turn ignition switch OFF.
- Disconnect A/T assembly harness connector and IPDM E/R connector.
- Check continuity between A/T assembly harness connector and IPDM E/R connector.

Item	Connector	Terminal (Wire color)	Continuity
A/T assembly harness connector	F6	9 (GY/R)	Yes
IPDM E/R connector	E9	53 (GY/R)	

- If OK, check harness for short to ground and short to power.
- Reinstall any part removed.

OK or NG

- OK >> GO TO 3.
NG >> Repair open circuit or short to ground or short to power in harness or connectors.

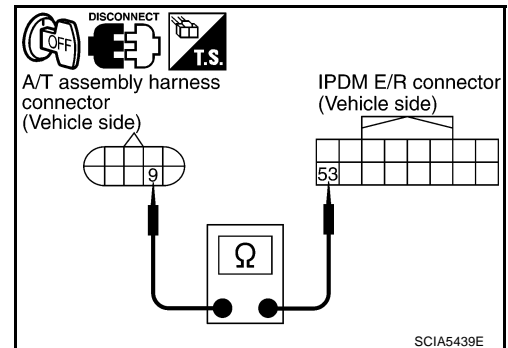

DTC P0615 START SIGNAL CIRCUIT

3. CHECK TERMINAL CORD ASSEMBLY

1. Remove control valve with TCM. Refer to [AT-238, "Control Valve with TCM and A/T Fluid Temperature Sensor 2"](#) .
2. Disconnect A/T assembly harness connector and TCM connector.
3. Check continuity between A/T assembly harness connector terminal and TCM connector terminal.

Item	Connector	Terminal (Wire color)	Continuity
A/T assembly harness connector	F6	9 (G)	Yes
TCM connector	F502	8 (G)	

4. If OK, check harness for short to ground and short to power.
5. Reinstall any part removed.

OK or NG

- OK >> GO TO 4.
- NG >> Replace open circuit or short to ground and short to power in harness or connectors.

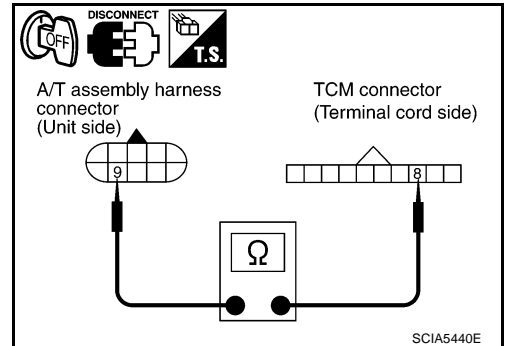

4. DETECT MALFUNCTIONING ITEM

Check the following items:

- Starter relay, refer to [SC-10, "STARTING SYSTEM"](#) .
- IPDM E/R, refer to [PG-17, "IPDM E/R \(INTELLIGENT POWER DISTRIBUTION MODULE ENGINE ROOM\)"](#) .

OK or NG

- OK >> Replace control valve with TCM. Refer to [AT-238, "Control Valve with TCM and A/T Fluid Temperature Sensor 2"](#) .
- NG >> Repair or replace damaged parts.

5. CHECK DTC

Perform "DTC Confirmation Procedure".

- Refer to [AT-104, "DTC Confirmation Procedure"](#) .

OK or NG

- OK >> **INSPECTION END**
- NG >> GO TO 2.

DTC P0700 TCM

DTC P0700 TCM

PFP:31036

Description

ACS006DL

TCM consists of a microcomputer and connectors for signal input and output and for power supply. TCM controls A/T.

On Board Diagnosis Logic

ACS006DM

- This is an OBD-II self-diagnostic item.
- Diagnostic trouble code "TCM" with CONSULT-II or P0700 without CONSULT-II is detected when TCM is malfunctioning.

Possible Cause

ACS006DN

TCM.

DTC Confirmation Procedure

ACS006DO

NOTE:

If "DTC Confirmation Procedure" has been previously performed, always turn ignition switch OFF and wait for at least 10 seconds before performing the next test.

After the repair, perform the following procedure to confirm the malfunction is eliminated.

④ WITH CONSULT-II

1. Turn ignition switch ON. (Do not start engine.)
2. Select "DATA MONITOR" mode for "A/T" with CONSULT-II.
3. Start engine.
4. Run engine for at least 2 consecutive seconds at idle speed.
5. If DTC is detected, go to [AT-108, "Diagnostic Procedure"](#).

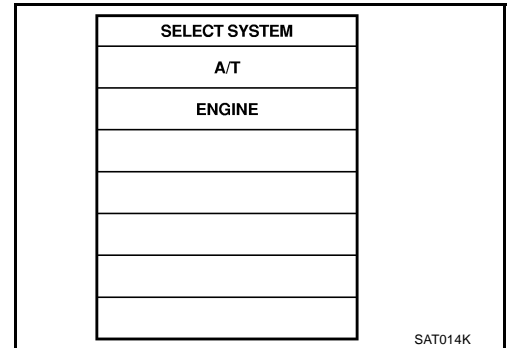

Diagnostic Procedure

ACS006DP

1. CHECK DTC

④ With CONSULT-II

1. Turn ignition switch ON. (Do not start engine.)
2. Select "SELF DIAG RESULTS" mode for "A/T" with CONSULT-II.
3. Touch "ERASE".
4. Turn ignition switch OFF and wait for at least 10 seconds.
5. Perform "DTC confirmation procedure". Refer to [AT-108, "DTC Confirmation Procedure"](#).

Is the "TCM" displayed again?

YES >> Replace control valve with TCM. Refer to [AT-238, "Control Valve with TCM and A/T Fluid Temperature Sensor 2"](#).

NO >> **INSPECTION END**

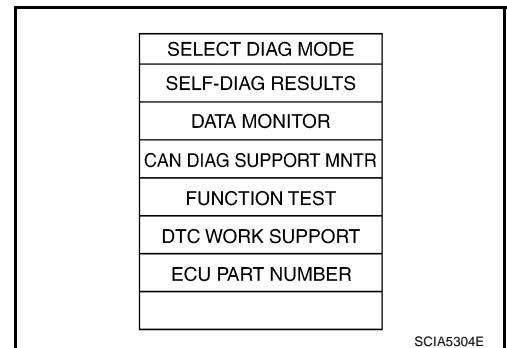

DTC P0705 PARK/NEUTRAL POSITION SWITCH

DTC P0705 PARK/NEUTRAL POSITION SWITCH

PFP:32006

Description

ACS003ML

- Park/neutral position (PNP) switch includes a transmission range switch.
- Transmission range switch detects the selector lever position and sends a signal to TCM.

CONSULT-II Reference Value

ACS003MM

Item name	Condition	Display value
SLC TLVR POSI	Selector lever in "N", "P" positions.	N/P
	Selector lever in "R" position.	R
	Selector lever in "D" position.	D

On Board Diagnosis Logic

ACS003MN

- This is an OBD-II self-diagnostic item.
- Diagnostic trouble code "PNP SW/CIRC" with CONSULT-II or P0705 without CONSULT-II is detected under the following conditions.
 - When TCM does not receive the correct voltage signal from PNP switch 1, 2, 3, 4 based on the gear position.
 - When no other position but "P" position is detected from "N" position.

Possible Cause

ACS003MO

- Harness or connectors [Park/neutral position (PNP) switch 1, 2, 3, 4 and TCM circuit is open or shorted.]
- Park/neutral position (PNP) switch 1, 2, 3, 4

DTC Confirmation Procedure

ACS003MP

CAUTION:

Always drive vehicle at a safe speed.

NOTE:

If "DTC Confirmation Procedure" has been previously performed, always turn ignition switch OFF and wait for at least 10 seconds before performing the next test.

After the repair, perform the following procedure to confirm the malfunction is eliminated.

Ⓟ WITH CONSULT-II

1. Turn ignition switch ON. (Do not start engine.)
2. Select "DATA MONITOR" mode for "ENGINE" with CONSULT-II.
3. Start engine.
4. Drive vehicle and maintain the following conditions for at least 2 consecutive seconds.
THRTL POS SEN: More than 1.2V
5. If DTC is detected, go to [AT-111, "Diagnostic Procedure"](#).

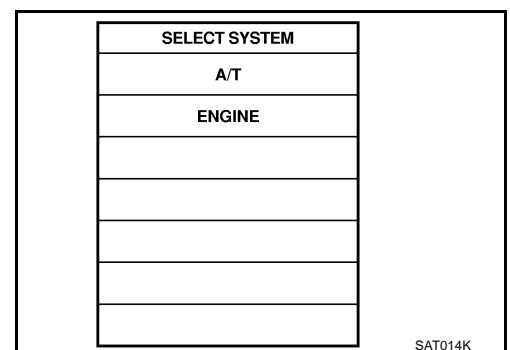

Ⓟ WITH GST

Follow the procedure "With CONSULT-II".

DTC P0705 PARK/NEUTRAL POSITION SWITCH

Wiring Diagram — AT — PNP/SW

ACS0080L

AT-PNP/SW-01

: DETECTABLE LINE FOR DTC
 : NON-DETECTABLE LINE FOR DTC

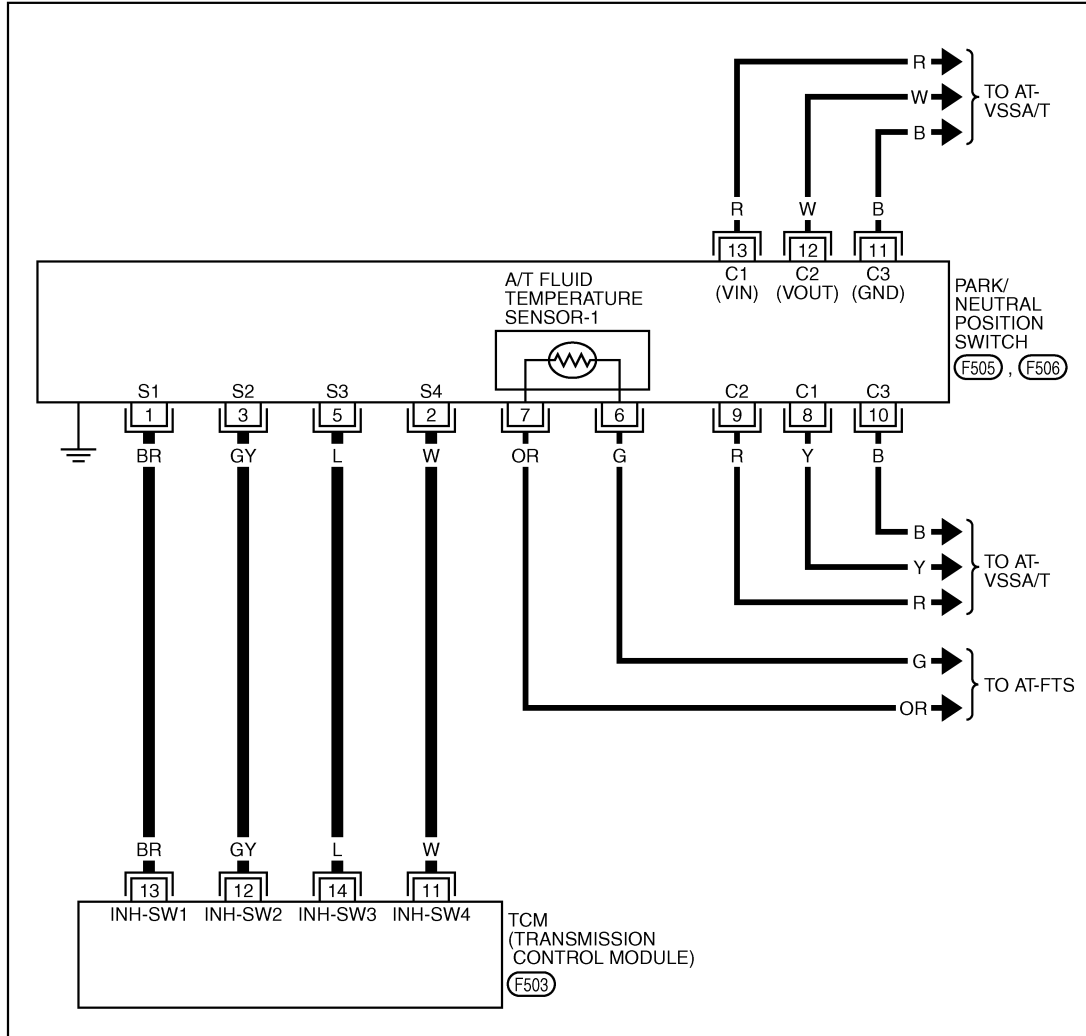

A/T ASSEMBLY

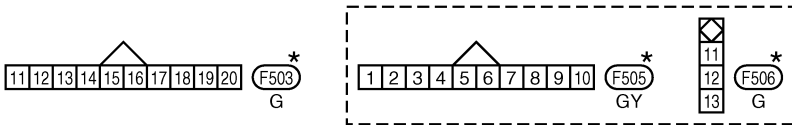

TCWM0248E

DTC P0705 PARK/NEUTRAL POSITION SWITCH

ACS003MQ

Diagnostic Procedure

1. CHECK PNP SW CIRCUIT

With CONSULT-II

1. Turn ignition switch ON. (Do not start engine.)
2. Select "SELECTION FROM MENU" in "DATA MONITOR" mode for "A/T" with CONSULT-II.
3. Check if correct selector lever position (N/P, R or D) is displayed as selector lever is moved into each position.

Item name	Condition	Display value
SLCT LVR POSI	Selector lever in "N", "P" positions.	N/P
	Selector lever in "R" position.	R
	Selector lever in "D" position.	D

DATA MONITOR			
MONITOR		NO DTC	
ATF PRES SW 2	xxx		
ATF PRES SW 3	xxx		
ATF PRES SW 5	xxx		
ATF PRES SW 6	xxx		
SLCT LVR POSI	xxx		
RECORD			
MODE	BACK	LIGHT	COPY

SCIA5296E

OK or NG

- OK >> GO TO 5.
NG >> GO TO 2.

2. CHECK TCM POWER SUPPLY AND GROUND CIRCUIT

Check TCM power supply and ground circuit. Refer to [AT-179, "MAIN POWER SUPPLY AND GROUND CIRCUIT"](#).

OK or NG

- OK >> GO TO 3.
NG >> Repair or replace damaged parts.

3. DETECT MALFUNCTIONING ITEM

Check the following items:

- A/T assembly harness connector pin terminals for damage or loose connection with harness connector.

OK or NG

- OK >> GO TO 4.
NG >> Repair or replace damaged parts.

DTC P0705 PARK/NEUTRAL POSITION SWITCH

4. CHECK SUB-HARNESS

1. Remove control valve with TCM. Refer to [AT-238, "Control Valve with TCM and A/T Fluid Temperature Sensor 2"](#) .
2. Disconnect park/neutral position switch connector and TCM connector.
3. Check continuity between park/neutral position switch connector terminals and TCM connector terminals.

Item	Connector	Terminal (Wire color)	Continuity
Park/neutral position switch connector	F505	1 (BR)	Yes
TCM connector	F503	13 (BR)	
Park/neutral position switch connector	F505	2 (W)	Yes
TCM connector	F503	11 (W)	
Park/neutral position switch connector	F505	3 (GY)	Yes
TCM connector	F503	12 (GY)	
Park/neutral position switch connector	F505	5 (L)	Yes
TCM connector	F503	14 (L)	

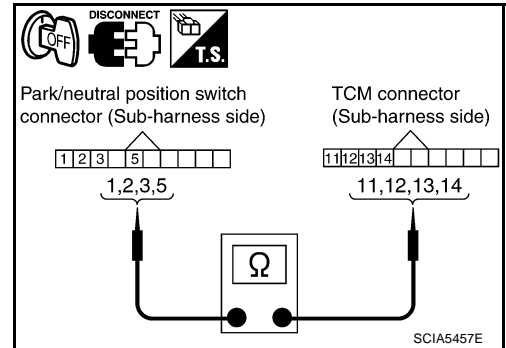

4. If OK, check harness for short to ground and short to power.
5. Reinstall any part removed.

OK or NG

- OK >> Replace control valve with TCM. Refer to [AT-238, "Control Valve with TCM and A/T Fluid Temperature Sensor 2"](#) .
- NG >> Replace open circuit or short to ground and short to power in harness or connectors.

5. CHECK DTC

Perform "DTC Confirmation Procedure".

- Refer to [AT-109, "DTC Confirmation Procedure"](#) .

OK or NG

- OK >> **INSPECTION END**
- NG >> GO TO 2.

DTC P0720 VEHICLE SPEED SENSOR A/T (REVOLUTION SENSOR)

DTC P0720 VEHICLE SPEED SENSOR A/T (REVOLUTION SENSOR)

PF:32702

Description

ACS003MR

Revolution sensor detects the revolution of the idler gear parking pawl lock gear and emits a pulse signal. The pulse signal is sent to the TCM which converts it into vehicle speed.

CONSULT-II Reference Value

ACS003MS

Item name	Condition	Display value (km/h)
VHCL/S SE·A/T	During driving	Approximately matches the speedometer reading.

On Board Diagnosis Logic

ACS003MT

- This is an OBD-II self-diagnostic item.
- Diagnostic trouble code "VEH SPD SEN/CIR AT" with CONSULT-II or P0720 without CONSULT-II is detected under the following conditions.
 - When TCM does not receive the proper voltage signal from the sensor.
 - After ignition switch is turned ON, irregular signal input from vehicle speed sensor MTR before the vehicle starts moving.

Possible Cause

ACS003MU

- Harness or connectors
(Sensor circuit is open or shorted.)
- Revolution sensor
- Vehicle speed sensor MTR

DTC Confirmation Procedure

ACS003MV

CAUTION:

- Always drive vehicle at a safe speed.
- Be careful not to rev engine into the red zone on the tachometer.

NOTE:

If "DTC Confirmation Procedure" has been previously performed, always turn ignition switch OFF and wait for at least 10 seconds before performing the next test.

After the repair, perform the following procedure to confirm the malfunction is eliminated.

WITH CONSULT-II

1. Turn ignition switch ON. (Do not start engine.)
2. Select "DATA MONITOR" mode for "A/T" with CONSULT-II.
3. Drive vehicle and check for an increase of "VHCL/S SE·A/T" value in response to "VHCL/S SE·MTR" value.
If the check result is NG, go to [AT-116, "Diagnostic Procedure"](#) .
If the check result is OK, go to following step.
4. Select "DATA MONITOR" mode for "ENGINE" with CONSULT-II.
5. Start engine and maintain the following conditions for at least 5 consecutive seconds.

VHCL SPEED SE: 30 km/h (19 MPH) or more

THRTL POS SEN: More than 1.0/8

Selector lever: "D" position

Driving location: Driving the vehicle uphill (increased engine load) will help maintain the driving conditions required for this test.

If the check result is NG, go to [AT-116, "Diagnostic Procedure"](#) .

If the check result is OK, go to following step.

6. Maintain the following conditions for at least 5 consecutive seconds.

ENGINE SPEED: 3,500 rpm or more

THRTL POS SEN: More than 1.0/8

Selector lever: "D" position

Driving location: Driving the vehicle uphill (increased engine load) will help maintain the driving conditions required for this test.

If the check result is NG, go to [AT-116, "Diagnostic Procedure"](#) .

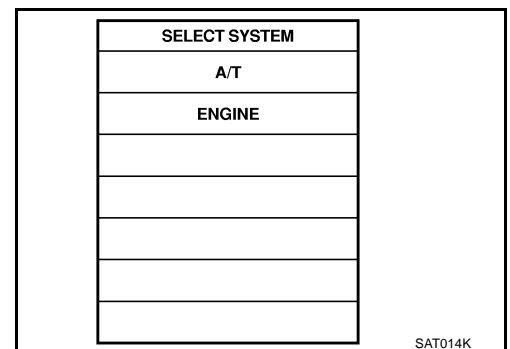

DTC P0720 VEHICLE SPEED SENSOR A/T (REVOLUTION SENSOR)

WITH GST

Follow the procedure "With CONSULT-II".

DTC P0720 VEHICLE SPEED SENSOR A/T (REVOLUTION SENSOR)

Wiring Diagram — AT — VSSA/T

ACS0080M

AT-VSSA/T-01

— : DETECTABLE LINE FOR DTC
— : NON-DETECTABLE LINE FOR DTC

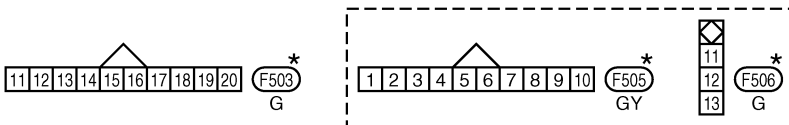
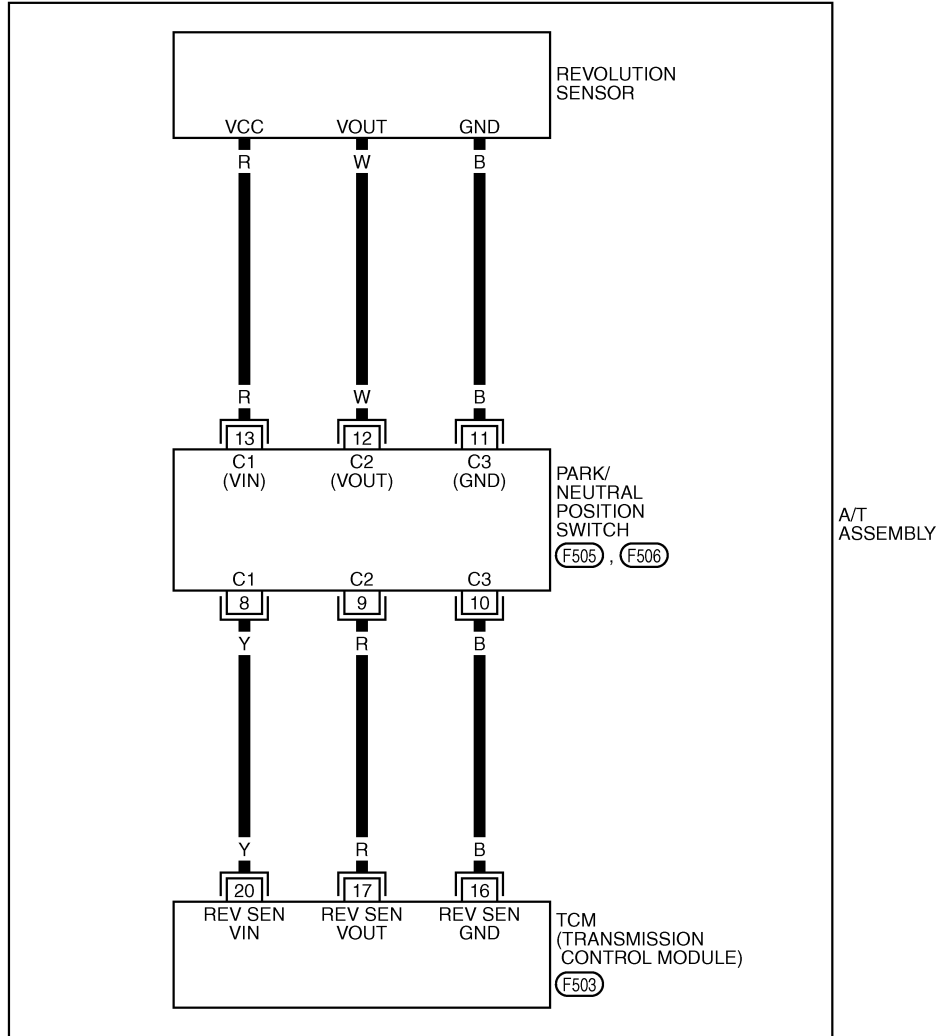

*: THIS CONNECTOR IS NOT SHOWN IN "HARNES LAYOUT", PG SECTION.

TCWM0249E

DTC P0720 VEHICLE SPEED SENSOR A/T (REVOLUTION SENSOR)

ACS003MW

Diagnostic Procedure

1. CHECK INPUT SIGNAL

With CONSULT-II

1. Turn ignition switch ON.
2. Select "ECU INPUT SIGNALS" in "DATA MONITOR" mode for "A/T" with CONSULT-II.
3. Start engine.
4. Read out the value of "VHCL/S SE-A/T" during driving.
Check the value changes according to driving speed.

Item name	Condition	Display value (km/h)
VHCL/S SE-A/T	During driving	Approximately matches the speedometer reading.

DATA MONITOR			
MONITOR	NO DTC		
VHCL/S SE-A/T	0km/h		
VHCL/S SE-MTR	0km/h		
ACCELE POSI	0.0/8		
THROTTLE POS	0.0/8		
CLSD THL POS	ON		
W/O THL POS	OFF		
	▽		
RECORD			
MODE	BACK	LIGHT	COPY

SCIA2148E

OK or NG

- OK >> GO TO 5.
NG >> GO TO 2.

2. CHECK TCM POWER SUPPLY AND GROUND CIRCUIT

Check TCM power supply and ground circuit. Refer to [AT-179, "MAIN POWER SUPPLY AND GROUND CIRCUIT"](#).

OK or NG

- OK >> GO TO 3.
NG >> Repair or replace damaged parts.

3. DETECT MALFUNCTIONING ITEM

Check the following items:

- A/T assembly harness connector pin terminals for damage or loose connection with harness connector.

OK or NG

- OK >> GO TO 4.
NG >> Repair or replace damaged parts.

DTC P0720 VEHICLE SPEED SENSOR A/T (REVOLUTION SENSOR)

4. CHECK SUB-HARNESS

1. Remove control valve with TCM. Refer to [AT-238, "Control Valve with TCM and A/T Fluid Temperature Sensor 2"](#) .
2. Disconnect park/neutral position switch connector and TCM connector.
3. Check continuity between park/neutral position switch connector terminals and TCM connector terminals.

Item	Connector	Terminal (Wire color)	Continuity
Park/neutral position switch connector	F505	8 (Y)	Yes
TCM connector	F503	20 (Y)	
Park/neutral position switch connector	F505	9 (R)	Yes
TCM connector	F503	17 (R)	
Park/neutral position switch connector	F505	10 (B)	Yes
TCM connector	F503	16 (B)	

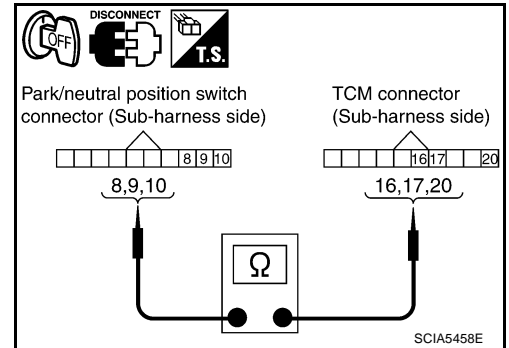

4. If OK, check harness for short to ground and short to power.
5. Reinstall any part removed.

OK or NG

- OK >> Replace control valve with TCM. Refer to [AT-238, "Control Valve with TCM and A/T Fluid Temperature Sensor 2"](#) .
- NG >> Replace open circuit or short to ground and short to power in harness or connectors.

5. CHECK DTC

Perform "DTC Confirmation Procedure".

- Refer to [AT-113, "DTC Confirmation Procedure"](#) .

OK or NG

- OK >> **INSPECTION END**
- NG >> GO TO 2.

DTC P0725 ENGINE SPEED SIGNAL

DTC P0725 ENGINE SPEED SIGNAL

PFP:24825

Description

ACS003MX

The engine speed signal is sent from the ECM to the TCM.

CONSULT-II Reference Value

ACS003MY

Item name	Condition	Display value (rpm)
ENGINE SPEED	Engine running	Closely matches the tachometer reading.

On Board Diagnosis Logic

ACS003MZ

- This is an OBD-II self-diagnostic item.
- Diagnostic trouble code "ENGINE SPEED SIG" with CONSULT-II or P0725 without CONSULT-II is detected when TCM does not receive the ignition signal from ECM during engine cranking or running.

Possible Cause

ACS003N0

Harness or connectors
(ECM to TCM circuit is open or shorted.)

DTC Confirmation Procedure

ACS003N1

CAUTION:

Always drive vehicle at a safe speed.

NOTE:

If "DTC Confirmation Procedure" has been previously performed, always turn ignition switch OFF and wait for at least 10 seconds before performing the next test.

After the repair, perform the following procedure to confirm the malfunction is eliminated.

WITH CONSULT-II

1. Turn ignition switch ON and select "DATA MONITOR" mode for "A/T" with CONSULT-II.
2. Start engine and maintain the following conditions for at least 10 consecutive seconds.
VHCL SPEED SE: 10 km/h (6 MPH) or more
ACCELE POSI: More than 1/8
Selector lever: "D" position
3. If DTC is detected, go to [AT-119, "Diagnostic Procedure"](#).

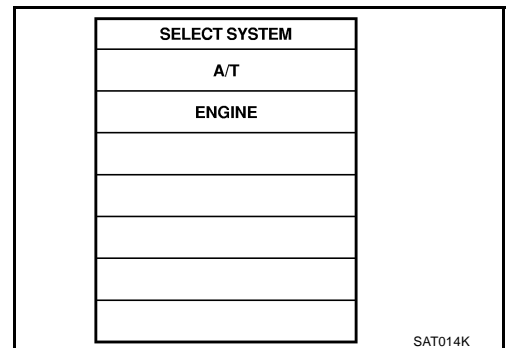

WITH GST

Follow the procedure "With CONSULT-II".

DTC P0725 ENGINE SPEED SIGNAL

ACS003N2

Diagnostic Procedure

1. CHECK CAN COMMUNICATION LINE

Perform self-diagnosis. Refer to [AT-90, "SELF-DIAGNOSTIC RESULT MODE"](#) , [AT-99, "Diagnostic Procedure Without CONSULT-II"](#) .

Is a malfunction in the CAN communication indicated in the results?

YES >> Check CAN communication line. Refer to [AT-101, "DTC U1000 CAN COMMUNICATION LINE"](#) .

NO >> GO TO 2.

2. CHECK INPUT SIGNALS

With CONSULT-II

1. Start engine.
2. Select "ECU INPUT SIGNALS" in "DATA MONITOR" mode for "A/T" with CONSULT-II.
3. While monitoring engine speed, check for engine speed change corresponding to wide-open throttle position signal.

Item name	Condition	Display value (rpm)
ENGINE SPEED	Engine running	Closely matches the tachometer reading.

DATA MONITOR			
MONITOR	NO DTC		
W/O THL POS	OFF		
BRAKE SW	OFF		
ENGINE SPEED	0 rpm		
TURBINE REV	0 rpm		
OUTPUT REV	0 rpm		
▼			
RECORD			
MODE	BACK	LIGHT	COPY

PCIA0041E

OK or NG

OK >> GO TO 3.

NG >> Check the ignition signal circuit.

- Refer to [EC-622, "IGNITION SIGNAL"](#) .

3. CHECK DTC

Perform "DTC Confirmation Procedure".

- Refer to [AT-118, "DTC Confirmation Procedure"](#) .

OK or NG

OK >> **INSPECTION END**

NG >> GO TO 4.

4. CHECK TCM POWER SUPPLY AND GROUND CIRCUIT

Check TCM power supply and ground circuit. Refer to [AT-179, "MAIN POWER SUPPLY AND GROUND CIRCUIT"](#) .

OK or NG

OK >> GO TO 5.

NG >> Repair or replace damaged parts.

5. DETECT MALFUNCTIONING ITEM

Check the following items:

- A/T assembly harness connector pin terminals for damage or loose connection with harness connector.

OK or NG

OK >> Replace control valve with TCM. Refer to [AT-238, "Control Valve with TCM and A/T Fluid Temperature Sensor 2"](#) .

NG >> Repair or replace damaged parts.

DTC P0740 TORQUE CONVERTER CLUTCH SOLENOID VALVE

DTC P0740 TORQUE CONVERTER CLUTCH SOLENOID VALVE

PFP:31940

Description

ACS003N3

- Torque converter clutch solenoid valve is activated, with the gear in D4 , D5, M2, M3, M4 and M5 by TCM in response to signals sent from the vehicle speed sensor and accelerator pedal position sensor (throttle position sensor). Torque converter clutch piston operation will then be controlled.
- Lock-up operation, however, is prohibited when A/T fluid temperature is too low.
- When the accelerator pedal is depressed (less than 1/8) in lock-up condition, the engine speed should not change abruptly. If there is a big jump in engine speed, there is no lock-up.

CONSULT-II Reference Value

ACS003N4

Item name	Condition	Display value (Approx.)
TCC SOLENOID	When performing slip lock-up	0.2 - 0.4 A
	When performing lock-up	0.4 - 0.6 A

On Board Diagnosis Logic

ACS003N5

- This is an OBD-II self-diagnostic item.
- Diagnostic trouble code "TCC SOLENOID/CIRC" with CONSULT-II or P0740 without CONSULT-II is detected under the following conditions.
 - When TCM detects an improper voltage drop when it tries to operate the solenoid valve.
 - When TCM detects as irregular by comparing target value with monitor value.

Possible Cause

ACS003N6

- Torque converter clutch solenoid valve
- Harness or connectors
(Solenoid circuit is open or shorted.)

DTC Confirmation Procedure

ACS003N7

CAUTION:

Always drive vehicle at a safe speed.

NOTE:

If "DTC Confirmation Procedure" has been previously performed, always turn ignition switch OFF and wait for at least 10 seconds before performing the next test.

After the repair, perform the following procedure to confirm the malfunction is eliminated.

④ WITH CONSULT-II

1. Turn ignition switch ON. (Do not start engine.)
2. Select "DATA MONITOR" mode for "ENGINE" with CONSULT-II.
3. Start engine and maintain the following conditions for at least 5 consecutive seconds.

VHCL SPEED SE: 80 km/h (50 MPH) or more

ACCELE POSI: 0.5/8 - 1.0/8

SELECTOR LEVER: "D" position

Driving location: Driving the vehicle uphill (increased engine load) will help maintain the driving conditions required for this test.

4. If DTC is detected go to [AT-121, "Diagnostic Procedure"](#) .

④ WITH GST

Follow the procedure "With CONSULT-II".

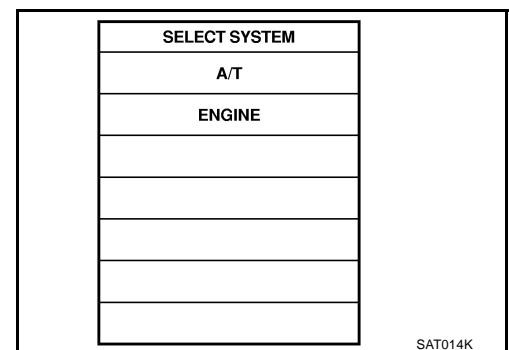

DTC P0740 TORQUE CONVERTER CLUTCH SOLENOID VALVE

Diagnostic Procedure

ACS003NB

1. CHECK INPUT SIGNAL

With CONSULT-II

1. Turn ignition switch ON.
2. Select "MAIN SIGNALS" in "DATA MONITOR" mode for "A/T" with CONSULT-II.
3. Start engine.
4. Read out the value of "TCC SOLENOID" while driving.

Item name	Condition	Display value (Approx.)
TCC SOLENOID	When performing slip lock-up	0.2 - 0.4 A
	When performing lock-up	0.4 - 0.6 A

DATA MONITOR			
MONITOR		NO DTC	
TCC SOLENOID	XXXX		
LINE PRES SOL	XXXX		
I/C SOLENOID	XXXX		
FR/B SOLENOID	XXXX		
D/C SOLENOID	XXXX		
HLR/C SOL	XXXX		
		▽	
		RECORD	
MODE	BACK	LIGHT	COPY

SCIA4793E

OK or NG

- OK >> GO TO 4.
NG >> GO TO 2.

2. CHECK TCM POWER SUPPLY AND GROUND CIRCUIT

Check TCM power supply and ground circuit. Refer to [AT-179, "MAIN POWER SUPPLY AND GROUND CIRCUIT"](#).

OK or NG

- OK >> GO TO 3.
NG >> Repair or replace damaged parts.

3. DETECT MALFUNCTIONING ITEM

Check the following items:

- A/T assembly harness connector pin terminals for damage or loose connection with harness connector.

OK or NG

- OK >> Replace control valve with TCM. Refer to [AT-238, "Control Valve with TCM and A/T Fluid Temperature Sensor 2"](#).
NG >> Repair or replace damaged parts.

4. CHECK DTC

Perform "DTC Confirmation Procedure".

- Refer to [AT-120, "DTC Confirmation Procedure"](#).

OK or NG

- OK >> **INSPECTION END**
NG >> GO TO 2.

DTC P0744 A/T TCC S/V FUNCTION (LOCK-UP)

DTC P0744 A/T TCC S/V FUNCTION (LOCK-UP)

PDF:31940

Description

ACS003N9

This malfunction is detected when A/T does not shift into 5th gear position or the torque converter clutch does not lock-up as instructed by TCM. This is not only caused by electrical malfunction (circuits open or shorted) but also by mechanical malfunction such as control valve sticking, improper solenoid valve operation, etc.

CONSULT-II Reference Value

ACS003NA

Item name	Condition	Display value (Approx.)
TCC SOLENOID	When performing slip lock-up	0.2 - 0.4 A
	When performing lock-up	0.4 - 0.6 A

On Board Diagnosis Logic

ACS003NB

- This is an OBD-II self-diagnostic item.
- Diagnostic trouble code "A/T TCC S/V FNCTN" with CONSULT-II or P0744 without CONSULT-II is detected under the following conditions.
 - When A/T cannot perform lock-up even if electrical circuit is good.
 - When TCM detects as irregular by comparing difference value with slip rotation.

Possible Cause

ACS003NC

- Harness or connectors (Solenoid circuit is open or shorted.)
- Torque converter clutch solenoid valve
- Hydraulic control circuit

DTC Confirmation Procedure

ACS003ND

CAUTION:

Always drive vehicle at a safe speed.

NOTE:

If "DTC Confirmation Procedure" has been previously performed, always turn ignition switch OFF and wait for at least 10 seconds before performing the next test.

After the repair, perform the following procedure to confirm the malfunction is eliminated.

WITH CONSULT-II

1. Start engine and Select "TCC SOL FUNCTN CHECK" of "DTC WORK SUPPORT" mode for "A/T" with CONSULT-II and touch "START".
2. Accelerate vehicle to more than 80 km/h (50 MPH) and maintain the following condition continuously until "TESTING" has turned to "COMPLETE". (It will take approximately 30 seconds after "TESTING" shows.)

ACCELE POSI: More than 1.0/8 (at all times during step 4)

TCC SOLENOID: 0.4 - 0.6 A

Selector lever: "D" position

[Reference speed: Constant speed of more than 80 km/h (50 MPH)]

- Make sure "GEAR" shows "5".
 - For shift schedule, refer to [AT-333, "Vehicle Speed When Performing and Releasing Complete Lock-up"](#).
 - If "TESTING" does not appear on CONSULT-II for a long time, select "SELF-DIAG RESULTS". In case a 1st trip DTC other than P0744 is shown, refer to applicable "TROUBLE DIAGNOSIS FOR DTC".
3. Make sure that "OK" is displayed. (If "NG" is displayed, refer to "DIAGNOSTIC PROCEDURE".) Refer to [AT-123, "Diagnostic Procedure"](#). Refer to shift schedule, [AT-333, "Vehicle Speed When Performing and Releasing Complete Lock-up"](#).

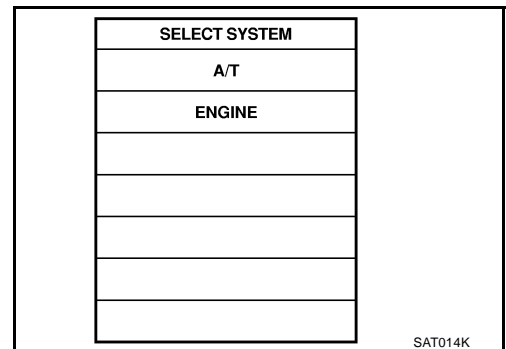

DTC P0744 A/T TCC S/V FUNCTION (LOCK-UP)

WITH GST

Follow the procedure "With CONSULT-II".

Diagnostic Procedure

ACS003NE

1. CHECK INPUT SIGNAL

With CONSULT-II

1. Turn ignition switch ON.
2. Select "MAIN SIGNALS" in "DATA MONITOR" mode for "A/T" with CONSULT-II.
3. Start engine.
4. Read out the value of "TCC SOLENOID" while driving.

Item name	Condition	Display value (Approx.)
TCC SOLENOID	When performing slip lock-up	0.2 - 0.4 A
	When performing lock-up	0.4 - 0.6 A

DATA MONITOR			
MONITOR		NO DTC	
TCC SOLENOID	XXXX		
LINE PRES SOL	XXXX		
I/C SOLENOID	XXXX		
FR/B SOLENOID	XXXX		
D/C SOLENOID	XXXX		
HLR/C SOL	XXXX		
		▽	
		RECORD	
MODE	BACK	LIGHT	COPY

SCIA4793E

OK or NG

- OK >> GO TO 4.
- NG >> GO TO 2.

2. CHECK TCM POWER SUPPLY AND GROUND CIRCUIT

Check TCM power supply and ground circuit. Refer to [AT-179, "MAIN POWER SUPPLY AND GROUND CIRCUIT"](#).

OK or NG

- OK >> GO TO 3.
- NG >> Repair or replace damaged parts.

3. DETECT MALFUNCTIONING ITEM

Check the following items:

- A/T assembly harness connector pin terminals for damage or loose connection with harness connector.

OK or NG

- OK >> Replace control valve with TCM. Refer to [AT-238, "Control Valve with TCM and A/T Fluid Temperature Sensor 2"](#).
- NG >> Repair or replace damaged parts.

4. CHECK DTC

Perform "DTC Confirmation Procedure".

- Refer to [AT-122, "DTC Confirmation Procedure"](#).

OK or NG

- OK >> **INSPECTION END**
- NG >> GO TO 2.

DTC P0745 LINE PRESSURE SOLENOID VALVE

DTC P0745 LINE PRESSURE SOLENOID VALVE

PF3:31940

Description

ACS003NF

The line pressure solenoid valve regulates oil pump discharge pressure to suit the driving condition in response to a signal sent from TCM.

CONSULT-II Reference Value

ACS003NG

Item name	Condition	Display value (Approx.)
LINE PRES SOL	During driving	0.2 - 0.6 A

On Board Diagnosis Logic

ACS003NH

- This is an OBD-II self-diagnostic item.
- Diagnostic trouble code "L/PRESS SOL/CIRC" with CONSULT-II or P0745 without CONSULT-II is detected under the following conditions.
 - When TCM detects an improper voltage drop when it tries to operate the solenoid valve.
 - When TCM detects as irregular by comparing target value with monitor value.

Possible Cause

ACS003NI

- Harness or connectors
(Solenoid circuit is open or shorted.)
- Line pressure solenoid valve

DTC Confirmation Procedure

ACS003NJ

NOTE:

If "DTC Confirmation Procedure" has been previously performed, always turn ignition switch OFF and wait for at least 10 seconds before performing the next test.

After the repair, perform the following procedure to confirm the malfunction is eliminated.

④ WITH CONSULT-II

1. Turn ignition switch ON and select "DATA MONITOR" mode for "ENGINE" with CONSULT-II.
2. Engine start and wait for at least 5 second.
3. If DTC is detected, go to ["AT-125. "Diagnostic Procedure"](#) .

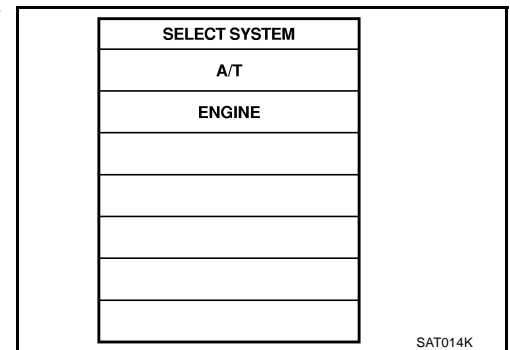

④ WITH GST

Follow the procedure "With CONSULT-II".

DTC P0745 LINE PRESSURE SOLENOID VALVE

Diagnostic Procedure

ACS003NK

1. CHECK INPUT SIGNAL

With CONSULT-II

1. Turn ignition switch ON.
2. Select "MAIN SIGNALS" in "DATA MONITOR" mode for "A/T" with CONSULT-II.
3. Start engine.
4. Read out the value of "LINE PRES SOL" during driving.

Item name	Condition	Display value (Approx.)
LINE PRES SOL	During driving	0.2 - 0.6 A

OK or NG

- OK >> GO TO 4.
NG >> GO TO 2.

DATA MONITOR			
MONITOR		NO DTC	
TCC SOLENOID	XXXX		
LINE PRES SOL	XXXX		
I/C SOLENOID	XXXX		
FR/B SOLENOID	XXXX		
D/C SOLENOID	XXXX		
HLR/C SOL	XXXX		
		▽	
		RECORD	
MODE	BACK	LIGHT	COPY

SCIA4793E

2. CHECK TCM POWER SUPPLY AND GROUND CIRCUIT

Check TCM power supply and ground circuit. Refer to [AT-179, "MAIN POWER SUPPLY AND GROUND CIRCUIT"](#).

OK or NG

- OK >> GO TO 3.
NG >> Repair or replace damaged parts.

3. DETECT MALFUNCTIONING ITEM

Check the following items:

- A/T assembly harness connector pin terminals for damage or loose connection with harness connector.

OK or NG

- OK >> Replace control valve with TCM. Refer to [AT-238, "Control Valve with TCM and A/T Fluid Temperature Sensor 2"](#).
- NG >> Repair or replace damaged parts.

4. CHECK DTC

Perform "DTC Confirmation Procedure".

- Refer to [AT-124, "DTC Confirmation Procedure"](#).

OK or NG

- OK >> **INSPECTION END**
NG >> GO TO 2.

DTC P1702 TRANSMISSION CONTROL MODULE (RAM)

DTC P1702 TRANSMISSION CONTROL MODULE (RAM)

PDF:31036

Description

ACS003NO

TCM consists of a microcomputer and connectors for signal input and output and for power supply. TCM controls A/T.

On Board Diagnosis Logic

ACS003NR

- This is not an OBD-II self-diagnostic item.
- Diagnostic trouble code "TCM-RAM" with CONSULT-II is detected when TCM memory RAM is malfunctioning.

Possible Cause

ACS003NS

TCM.

DTC Confirmation Procedure

ACS003NT

NOTE:

If "DTC Confirmation Procedure" has been previously performed, always turn ignition switch OFF and wait for at least 10 seconds before performing the next test.

After the repair, perform the following procedure to confirm the malfunction is eliminated.

WITH CONSULT-II

1. Turn ignition switch ON. (Do not start engine.)
2. Select "DATA MONITOR" mode for "A/T" with CONSULT-II.
3. Start engine.
4. Run engine for at least 2 consecutive seconds at idle speed.
5. If DTC is detected, go to [AT-126, "Diagnostic Procedure"](#).

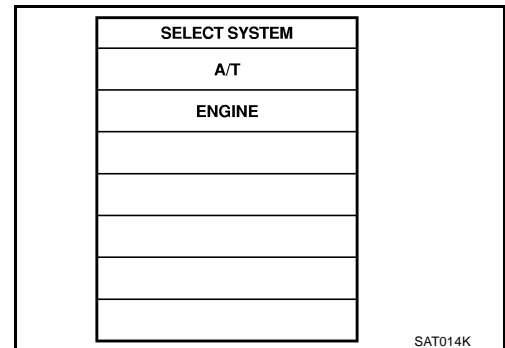

Diagnostic Procedure

ACS003NU

1. CHECK DTC

With CONSULT-II

1. Turn ignition switch ON. (Do not start engine.)
2. Select "SELF-DIAG RESULTS" mode for "A/T" with CONSULT-II.
3. Touch "ERASE".
4. Turn ignition switch OFF and wait for at least 10 seconds.
5. Perform "DTC confirmation procedure". Refer to [AT-126, "DTC Confirmation Procedure"](#).

Is the "TCM-RAM" displayed again?

YES >> Replace control valve with TCM. Refer to [AT-238, "Control Valve with TCM and A/T Fluid Temperature Sensor 2"](#).

NO >> **INSPECTION END**

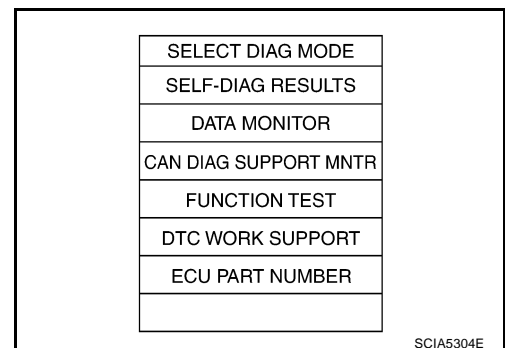

DTC P1703 TRANSMISSION CONTROL MODULE (ROM)

DTC P1703 TRANSMISSION CONTROL MODULE (ROM)

PF3:31036

Description

ACS003NV

TCM consists of a microcomputer and connectors for signal input and output and for power supply. TCM controls A/T.

On Board Diagnosis Logic

ACS003NW

- This is not an OBD-II self-diagnostic item.
- Diagnostic trouble code "TCM-ROM" with CONSULT-II is detected when TCM memory ROM is malfunctioning.

Possible Cause

ACS003NX

TCM.

DTC Confirmation Procedure

ACS003NY

NOTE:

If "DTC Confirmation Procedure" has been previously performed, always turn ignition switch OFF and wait for at least 10 seconds before performing the next test.

After the repair, perform the following procedure to confirm the malfunction is eliminated.

WITH CONSULT-II

1. Turn ignition switch to ON. (Do not start engine.)
2. Select "DATA MONITOR" mode for A/T with CONSULT-II.
3. Start engine.
4. Run engine for at least 2 consecutive seconds at idle speed.
5. If DTC is detected, go to [AT-127, "Diagnostic Procedure"](#).

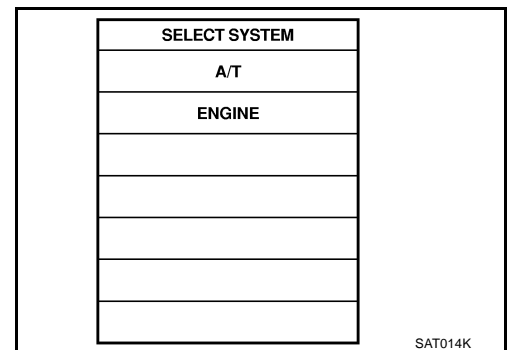

Diagnostic Procedure

ACS003NZ

1. CHECK DTC

With CONSULT-II

1. Turn ignition switch ON. (Do not start engine.)
2. Select "SELF-DIAG RESULTS" mode for "A/T" with CONSULT-II.
3. Touch "ERASE".
4. Turn ignition switch OFF and wait for at least 10 seconds.
5. Perform "DTC confirmation procedure". Refer to [AT-127, "DTC Confirmation Procedure"](#).

Is the "TCM-ROM" displayed again?

YES >> Replace control valve with TCM. Refer to [AT-238, "Control Valve with TCM and A/T Fluid Temperature Sensor 2"](#).

NO >> **INSPECTION END**

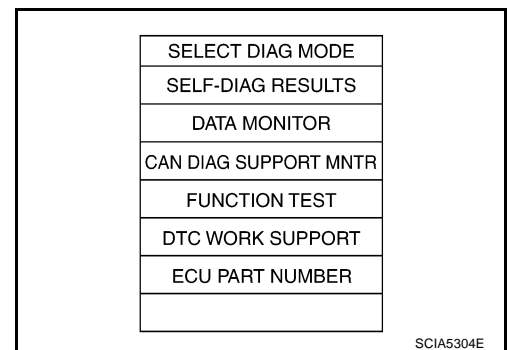

DTC P1705 THROTTLE POSITION SENSOR

DTC P1705 THROTTLE POSITION SENSOR

PFP:22620

Description

ACS00305

Electric throttle control actuator consists of throttle control motor, accelerator pedal position sensor, throttle position sensor, etc. The actuator sends a signal to the ECM, and ECM sends signals to TCM with CAN communication.

CONSULT-II Reference Value

ACS006C1

Item name	Condition	Display value (Approx.)
ACCELE POSI	Released accelerator pedal.	0.0/8
	Fully depressed accelerator pedal.	8/8

On Board Diagnosis Logic

ACS00306

- This is an OBD-II self-diagnostic item.
- Diagnostic trouble code "TP SEN/CIRC A/T" with CONSULT-II or P1705 without CONSULT-II is detected when TCM does not receive the proper accelerator pedal position signals (input by CAN communication) from ECM.

Possible Cause

ACS00307

Harness or connectors
(Sensor circuit is open or shorted.)

DTC Confirmation Procedure

ACS00308

NOTE:

If "DTC Confirmation Procedure" has been previously performed, always turn ignition switch OFF and wait for at least 10 seconds before performing the next test.

After the repair, perform the following procedure to confirm the malfunction is eliminated.

④ WITH CONSULT-II

1. Turn ignition switch ON. (Do not start engine.)
2. Select "DATA MONITOR" mode for "A/T" with CONSULT-II.
3. Start engine and let it idle for 1 second.
4. If DTC is detected, go to [AT-129, "Diagnostic Procedure"](#).

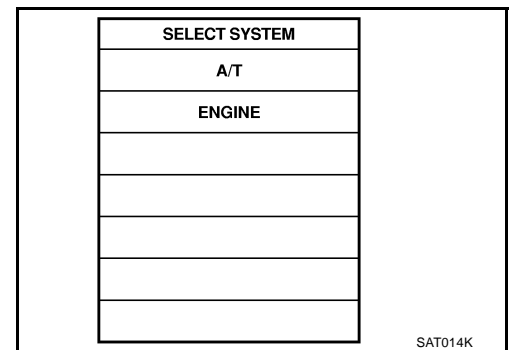

④ WITH GST

Follow the procedure "With CONSULT-II".

DTC P1705 THROTTLE POSITION SENSOR

ACS00309

Diagnostic Procedure

1. CHECK CAN COMMUNICATION LINE

Perform self-diagnosis. Refer to [AT-90, "SELF-DIAGNOSTIC RESULT MODE"](#) , [AT-99, "Diagnostic Procedure Without CONSULT-II"](#) .

Is a malfunction in the CAN communication indicated in the results?

YES >> Check CAN communication line. Refer to [AT-101, "DTC U1000 CAN COMMUNICATION LINE"](#) .

NO >> GO TO 2.

2. CHECK DTC WITH TCM

With CONSULT-II

1. Turn ignition switch ON. (Do not start engine.)
2. Select "ECU INPUT SIGNALS" in "DATA MONITOR" mode for "A/T" with CONSULT-II.
3. Depress accelerator pedal and read out the value of "ACCELE POSI".

Item name	Condition	Display value (Approx.)
ACCELE POSI	Released accelerator pedal.	0.0/8
	Fully depressed accelerator pedal.	8/8

DATA MONITOR	
MONITOR	NO DTC
ACCELE POSI	0.0/8
THROTTLE POSI	0.0/8
CLSD THL POS	ON
W/O THL POS	OFF
BRAKE SW	OFF

▼			
RECORD			
MODE	BACK	LIGHT	COPY

PCIA0070E

4. Select "SELF-DIAG RESULTS" mode for "A/T" with CONSULT-II. Refer to [AT-90, "SELF-DIAGNOSTIC RESULT MODE"](#)

OK or NG

OK >> GO TO 4.

NG >> GO TO 3.

3. CHECK DTC WITH ECM

With CONSULT-II

1. Turn ignition switch ON. (Do not start engine.)
2. Select "SELF-DIAG RESULTS" mode for "ENGINE" with CONSULT-II. Refer to [EC-103, "CONSULT-II Function \(ENGINE\)"](#) .

OK or NG

OK >> GO TO 4.

NG >> Check the DTC detected item. Refer to [EC-103, "CONSULT-II Function \(ENGINE\)"](#) .

- If CAN communication line is detected, go to [AT-101, "DTC U1000 CAN COMMUNICATION LINE"](#) .

SELECT SYSTEM
A/T
ENGINE

SAT014K

4. CHECK DTC

Perform "DTC Confirmation Procedure".

- Refer to [AT-128, "DTC Confirmation Procedure"](#) .

OK or NG

OK >> **INSPECTION END**

NG >> GO TO 5.

DTC P1705 THROTTLE POSITION SENSOR

5. CHECK TCM POWER SUPPLY AND GROUND CIRCUIT

Check TCM power supply and ground circuit. Refer to [AT-179, "MAIN POWER SUPPLY AND GROUND CIRCUIT"](#) .

OK or NG

- OK >> GO TO 6.
- NG >> Repair or replace damaged parts.

6. DETECT MALFUNCTIONING ITEM

Check the following items:

- A/T assembly harness connector pin terminals for damage or loose connection with harness connector.

OK or NG

- OK >> Replace control valve with TCM. Refer to [AT-238, "Control Valve with TCM and A/T Fluid Temperature Sensor 2"](#) .
- NG >> Repair or replace damaged parts.

DTC P1710 A/T FLUID TEMPERATURE SENSOR CIRCUIT

DTC P1710 A/T FLUID TEMPERATURE SENSOR CIRCUIT

PF3:31940

Description

ACS0030A

A/T fluid temperature sensor detects A/T fluid temperature and sends a signal to TCM.

CONSULT-II Reference Value

ACS0030B

Item name	Condition °C (°F)	Display value (Approx.)
ATF TEMP SE 1	0 (32) - 20 (68) - 80 (176)	3.2 - 2.5 - 0.8 V
ATF TEMP SE 2		3.2 - 2.4 - 0.65 V

On Board Diagnosis Logic

ACS0030C

- This is an OBD-II self-diagnostic item.
- Diagnostic trouble code "ATF TEMP SEN/CIRC" with CONSULT-II or P1710 (A/T), P0710 (ENGINE) without CONSULT-II is detected when TCM receives an excessively low or high voltage from the sensor.

Possible Cause

ACS0030D

- Harness or connectors
(Sensor circuit is open or shorted.)
- A/T fluid temperature sensors 1 and/or 2

DTC Confirmation Procedure

ACS0030E

CAUTION:

Always drive vehicle at a safe speed.

NOTE:

If "DTC Confirmation Procedure" has been previously performed, always turn ignition switch OFF and wait for at least 10 seconds before performing the next test.

After the repair, perform the following procedure to confirm the malfunction is eliminated.

WITH CONSULT-II

1. Turn ignition switch ON. (Do not start engine.)
2. Select "DATA MONITOR" mode for "ENGINE" with CONSULT-II.
3. Start engine and maintain the following conditions for at least 10 minutes (Total). (It is not necessary to maintain continuously.)
VHCL SPEED SE: 10 km/h (6 MPH) or more
THRTL POS SEN: More than 1.0/8
Selector lever: "D" position
4. If DTC is detected, go to [AT-133, "Diagnostic Procedure"](#).

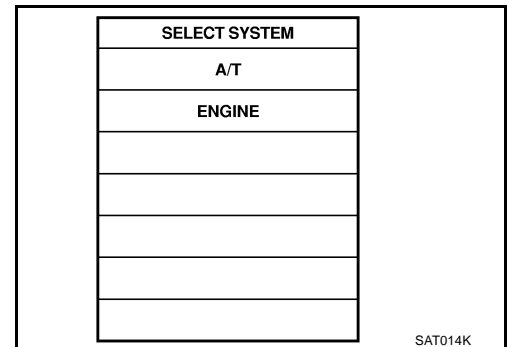

WITH GST

Follow the procedure "With CONSULT-II".

DTC P1710 A/T FLUID TEMPERATURE SENSOR CIRCUIT

Wiring Diagram — AT — FTS

ACS0080N

AT-FTS-01

: DETECTABLE LINE FOR DTC
 : NON-DETECTABLE LINE FOR DTC

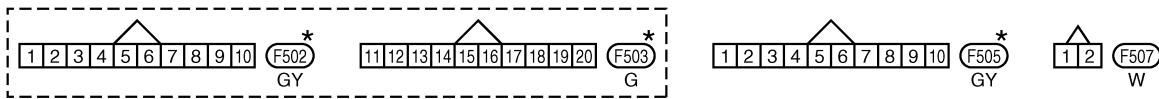
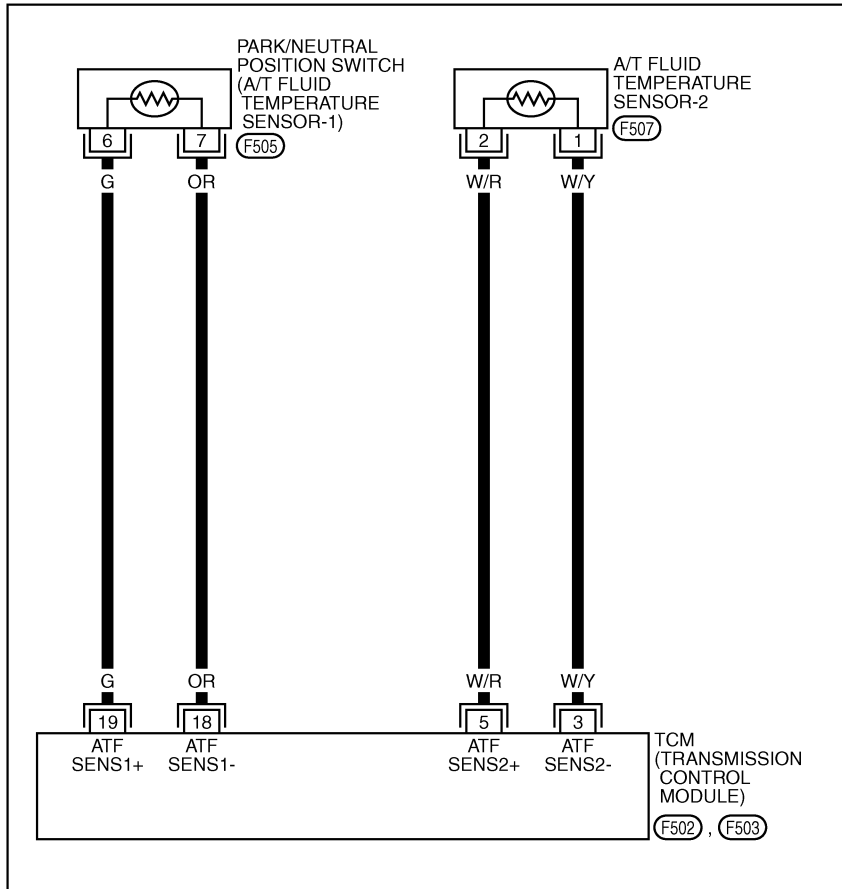

*: THIS CONNECTOR IS NOT SHOWN IN "HARNESS LAYOUT", PG SECTION.

TCWM0251E

DTC P1710 A/T FLUID TEMPERATURE SENSOR CIRCUIT

ACS0030F

Diagnostic Procedure

1. CHECK A/T FLUID TEMPERATURE SENSOR 1 SIGNAL

With CONSULT-II

1. Start engine.
2. Select "ECU INPUT SIGNALS" in "DATA MONITOR" mode for "A/T" with CONSULT-II.
3. Read out the value of "ATF TEMP SE 1".

Item name	Condition °C (°F)	Display value (Approx.)
ATF TEMP SE 1	0 (32) - 20 (68) - 80 (176)	3.2 - 2.5 - 0.8 V

OK or NG

- OK >> GO TO 2.
 NG >> GO TO 3.

DATA MONITOR	
MONITOR	NO DTC
OUTPUT REV	0 rpm
ATF TEMP SE 1	1.84 v
ATF TEMP SE 2	1.72 v
BATTERY BOLT	11.5 v
ATF PRES SW 1	OFF

Δ	▽
RECORD	
MODE	BACK
LIGHT	COPY

PCIA0039E

2. CHECK A/T FLUID TEMPERATURE SENSOR 2 SIGNAL

With CONSULT-II

1. Start engine.
2. Select "ECU INPUT SIGNALS" in "DATA MONITOR" mode for "A/T" with CONSULT-II.
3. Read out the value of "ATF TEMP SE 2".

Item name	Condition °C (°F)	Display value (Approx.)
ATF TEMP SE 2	0 (32) - 20 (68) - 80 (176)	3.2 - 2.4 - 0.65 V

OK or NG

- OK >> GO TO 8.
 NG >> GO TO 5.

DATA MONITOR	
MONITOR	NO DTC
OUTPUT REV	0 rpm
ATF TEMP SE 1	1.84 v
ATF TEMP SE 2	1.72 v
BATTERY BOLT	11.5 v
ATF PRES SW 1	OFF

Δ	▽
RECORD	
MODE	BACK
LIGHT	COPY

PCIA0039E

3. CHECK A/T FLUID TEMPERATURE SENSOR 1

Check A/T fluid temperature sensor 1. Refer to [AT-135, "A/T FLUID TEMPERATURE SENSOR 1"](#).

OK or NG

- OK >> GO TO 4.
 NG >> Replace control valve with TCM. Refer to [AT-238, "Control Valve with TCM and A/T Fluid Temperature Sensor 2"](#).

4. CHECK SUB-HARNESS

1. Disconnect park/neutral position switch connector and TCM connector.
2. Check continuity between park/neutral position switch connector terminals and TCM connector terminals.

Item	Connector	Terminal (Wire color)	Continuity
Park/neutral position switch connector	F505	6 (G)	Yes
TCM connector	F503	19 (G)	
Park/neutral position switch connector	F505	7 (OR)	Yes
TCM connector	F503	18 (OR)	

3. If OK, check harness for short to ground and short to power.

OK or NG

- OK >> GO TO 7.
 NG >> Replace open circuit or short to ground and short to power in harness or connectors.

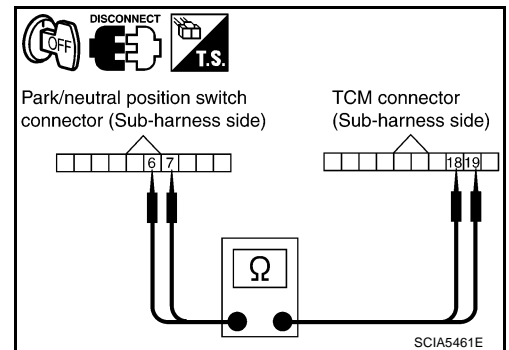

DTC P1710 A/T FLUID TEMPERATURE SENSOR CIRCUIT

5. CHECK A/T FLUID TEMPERATURE SENSOR 2

Check A/T fluid temperature sensor 2. Refer to [AT-135, "A/T FLUID TEMPERATURE SENSOR 2"](#) .

OK or NG

OK >> GO TO 6.

NG >> Replace A/T fluid temperature sensor 2. Refer to [AT-246, "A/T FLUID TEMPERATURE SENSOR 2 REMOVAL AND INSTALLATION"](#) .

6. CHECK TERMINAL CORD ASSEMBLY

1. Disconnect A/T fluid temperature sensor 2 connector and TCM connector.
2. Check continuity between A/T fluid temperature sensor 2 connector terminals and TCM connector terminals.

Item	Connector	Terminal (Wire color)	Continuity
A/T fluid temperature sensor 2 connector	F507	1 (W/Y)	Yes
TCM connector	F502	3 (W/Y)	
A/T fluid temperature sensor 2 connector	F507	2 (W/R)	Yes
TCM connector	F502	5 (W/R)	

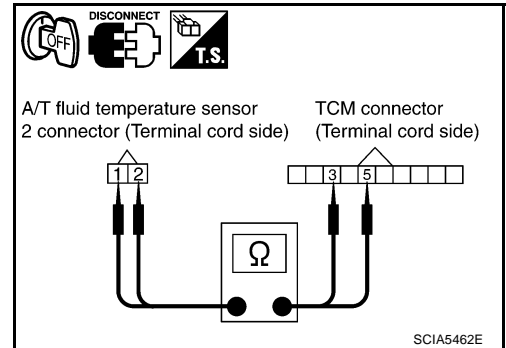

3. If OK, check harness for short to ground and short to power.

OK or NG

OK >> GO TO 7.

NG >> Replace open circuit or short to ground and short to power in harness or connectors.

7. CHECK TCM POWER SUPPLY AND GROUND CIRCUIT

1. Check TCM power supply and ground circuit. Refer to [AT-179, "MAIN POWER SUPPLY AND GROUND CIRCUIT"](#) .
2. Reinstall any part removed.

OK or NG

OK >> Replace control valve with TCM. Refer to [AT-238, "Control Valve with TCM and A/T Fluid Temperature Sensor 2"](#) .

NG >> Repair or replace damaged parts.

8. CHECK DTC

Perform "DTC Confirmation Procedure".

- Refer to [AT-131, "DTC Confirmation Procedure"](#) .

OK or NG

OK >> **INSPECTION END**

NG >> GO TO 1.

DTC P1710 A/T FLUID TEMPERATURE SENSOR CIRCUIT

ACS00864

Component Inspection

A/T FLUID TEMPERATURE SENSOR 1

1. Remove control valve with TCM. Refer to [AT-238, "Control Valve with TCM and A/T Fluid Temperature Sensor 2"](#) .
2. Check resistance between terminals.

Name	Connector	Terminal	Temperature °C (°F)	Resistance (Approx.) (kΩ)
A/T fluid temperature sensor 1	F505	6 - 7	0 (32)	15
			20 (68)	6.5
			80 (176)	0.9

3. If NG, replace control valve with TCM. Refer to [AT-238, "Control Valve with TCM and A/T Fluid Temperature Sensor 2"](#) .

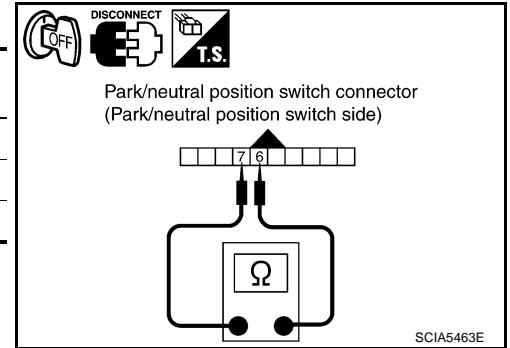

A/T FLUID TEMPERATURE SENSOR 2

1. Remove A/T fluid temperature sensor 2. Refer to [AT-246, "A/T FLUID TEMPERATURE SENSOR 2 REMOVAL AND INSTALLATION"](#) .
2. Check resistance between terminals.

Name	Connector	Terminal	Temperature °C (°F)	Resistance (Approx.) (kΩ)
A/T fluid temperature sensor 2	F507	1 - 2	0 (32)	10
			20 (68)	4
			80 (176)	0.5

3. If NG, replace A/T fluid temperature sensor 2. Refer to [AT-246, "A/T FLUID TEMPERATURE SENSOR 2 REMOVAL AND INSTALLATION"](#) .

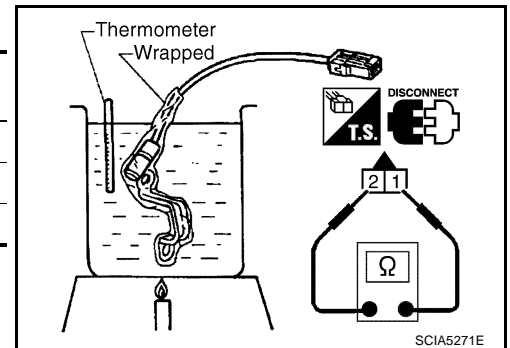

DTC P1716 TURBINE REVOLUTION SENSOR

DTC P1716 TURBINE REVOLUTION SENSOR

PFP:31935

Description

ACS0030G

Turbine revolution sensor detects input shaft rpm (revolutions per minute). It is located on the input side of automatic transmission. Monitors revolution of sensor 1 and sensor 2 for non-standard conditions.

CONSULT-II Reference Value

ACS0030H

Item name	Condition	Display value (rpm)
TURBINE REV	During driving (lock-up ON)	Approximately matches the engine speed.

On Board Diagnosis Logic

ACS0030I

- This is an OBD-II self-diagnostic item.
- Diagnostic trouble code "TURBINE REV S/CIRC" with CONSULT-II or P1716 without CONSULT-II is detected under the following conditions.
 - When TCM does not receive the proper voltage signal from the sensor.
 - When TCM detects an irregularity only at position of 4th gear for turbine revolution sensor 2.

Possible Cause

ACS0030J

- Harness or connectors
(Sensor circuit is open or shorted.)
- Turbine revolution sensor 1 and/or 2

DTC Confirmation Procedure

ACS0030K

CAUTION:

Always drive vehicle at a safe speed.

NOTE:

If "DTC Confirmation Procedure" has been previously performed, always turn ignition switch OFF and wait for at least 10 seconds before performing the next test.

After the repair, perform the following procedure to confirm the malfunction is eliminated.

④ WITH CONSULT-II

1. Turn ignition switch ON. (Do not start engine.)
2. Select "DATA MONITOR" mode for "A/T" with CONSULT-II.
3. Start engine and maintain the following conditions for at least 5 consecutive seconds.

VHCL SPEED SE: 40 km/h (25 MPH) or more

ENGINE SPEED: 1,500 rpm or more

ACCELE POSI: 0.5/8 or more

Selector lever: "D" position

Gear position (Turbine revolution sensor 1): 4th or 5th position

Gear position (Turbine revolution sensor 2): All position

Driving location: Driving the vehicle uphill (increased engine load) will help maintain the driving conditions required for this test.

4. If DTC is detected, go to [AT-137, "Diagnostic Procedure"](#).

④ WITH GST

Follow the procedure "With CONSULT-II".

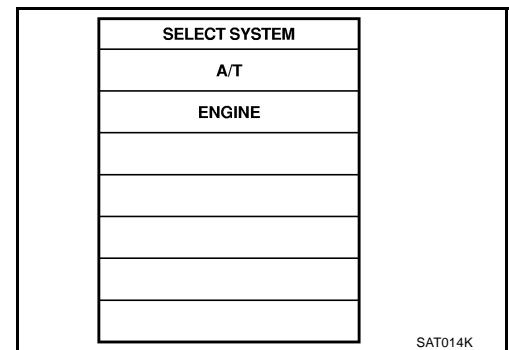

DTC P1716 TURBINE REVOLUTION SENSOR

Diagnostic Procedure

ACS003OL

1. CHECK INPUT SIGNAL

With CONSULT-II

1. Start engine.
2. Select "ECU INPUT SIGNALS" in "DATA MONITOR" mode for "A/T" with CONSULT-II.
3. Vehicle start and read out the value of "TURBINE REV".

Item name	Condition	Display value (rpm)
TURBINE REV	During driving (lock-up ON)	Approximately matches the engine speed.

OK or NG

- OK >> GO TO 4.
NG >> GO TO 2.

DATA MONITOR	
MONITOR	NO DTC
W/O THL POS	OFF
BRAKE SW	OFF
ENGINE SPEED	0 rpm
TURBINE REV	0 rpm
OUTPUT REV	0 rpm
▼	
RECORD	
MODE	BACK
LIGHT	COPY

PCIA0041E

2. CHECK TCM POWER SUPPLY AND GROUND CIRCUIT

Check TCM power supply and ground circuit. Refer to [AT-179, "MAIN POWER SUPPLY AND GROUND CIRCUIT"](#).

OK or NG

- OK >> GO TO 3.
NG >> Repair or replace damaged parts.

3. DETECT MALFUNCTIONING ITEM

Check the following items:

- A/T assembly harness connector pin terminals for damage or loose connection with harness connector.

OK or NG

- OK >> Replace control valve with TCM. Refer to [AT-238, "Control Valve with TCM and A/T Fluid Temperature Sensor 2"](#).
- NG >> Repair or replace damaged parts.

4. CHECK DTC

Perform "DTC Confirmation Procedure".

- Refer to [AT-136, "DTC Confirmation Procedure"](#).

OK or NG

- OK >> **INSPECTION END**
NG >> GO TO 2.

DTC P1721 VEHICLE SPEED SENSOR MTR

DTC P1721 VEHICLE SPEED SENSOR MTR

PFP:24814

Description

ACS0030M

Vehicle speed sensor-MTR signal is transmitted from combination meter to TCM by CAN communication line. The signal functions as an auxiliary device to revolution sensor when it is malfunctioning. TCM will then use vehicle speed sensor-MTR signal.

CONSULT-II Reference Value

ACS0030N

Item name	Condition	Display value (km/h)
VHCL/S SE-MTR	During driving	Approximately matches the speedometer reading.

On Board Diagnosis Logic

ACS0030O

- This is not an OBD-II self-diagnostic item.
- Diagnostic trouble code "VHE SPD SE/CIR-MTR" with CONSULT-II is detected when TCM does not receive the proper vehicle speed sensor MTR signal (input by CAN communication) from combination meter.

Possible Cause

ACS0030P

Harness or connectors
(Sensor circuit is open or shorted.)

DTC Confirmation Procedure

ACS0030Q

CAUTION:

Always drive vehicle at a safe speed.

NOTE:

If "DTC Confirmation Procedure" has been previously performed, always turn ignition switch OFF and wait for at least 10 seconds before performing the next test.

After the repair, perform the following procedure to confirm the malfunction is eliminated.

④ WITH CONSULT-II

1. Turn ignition switch ON. (Do not start engine.)
2. Select "DATA MONITOR" mode for "A/T" with CONSULT-II.
3. Start engine and maintain the following conditions for at least 5 consecutive seconds.
ACCELE POSI: 1/8 or less
VHCL SPEED SE: 30 km/h (17 MPH) or more
4. If DTC is detected, go to [AT-139, "Diagnostic Procedure"](#).

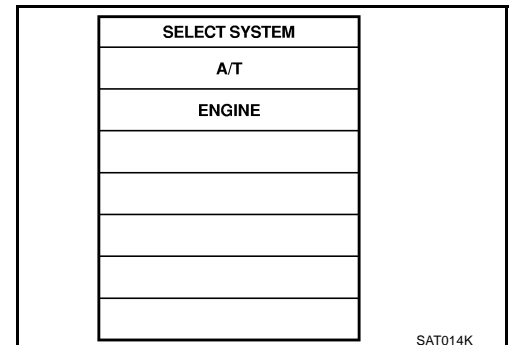

DTC P1721 VEHICLE SPEED SENSOR MTR

ACS0030R

Diagnostic Procedure

1. CHECK CAN COMMUNICATION LINE

Perform self-diagnosis. Refer to [AT-90, "SELF-DIAGNOSTIC RESULT MODE"](#) , [AT-99, "Diagnostic Procedure Without CONSULT-II"](#) .

Is malfunction in the CAN communication indicated in the result?

YES >> Check CAN communication line. Refer to [AT-101, "DTC U1000 CAN COMMUNICATION LINE"](#) .

NO >> GO TO 2.

2. CHECK INPUT SIGNAL

With CONSULT-II

1. Start engine.
2. Select "ECU INPUT SIGNALS" in "DATA MONITOR" mode for "A/T" with CONSULT-II.
3. Drive vehicle and read out the value of "VHCL/S SE-MTR".

Item name	Condition	Display value (km/h)
VHCL/S SE-MTR	During driving	Approximately matches the speedometer reading.

OK or NG

OK >> GO TO 4.

NG >> GO TO 3.

DATA MONITOR			
MONITOR	NO DTC		
VHCL/S SE-A/T	0km/h		
VHCL/S SE-MTR	0km/h		
ACCELE POSI	0.0/8		
THROTTLE POS	0.0/8		
CLSD THL POS	ON		
W/O THL POS	OFF		
▽			
RECORD			
MODE	BACK	LIGHT	COPY

SCIA2148E

3. CHECK COMBINATION METERS

Check combination meters. Refer to [DI-14, "How to Proceed with Trouble Diagnosis"](#) .

OK or NG

OK >> GO TO 4.

NG >> Repair or replace damaged parts.

4. CHECK DTC

Perform "DTC Confirmation Procedure".

- Refer to [AT-138, "DTC Confirmation Procedure"](#) .

OK or NG

OK >> **INSPECTION END**

NG >> GO TO 5.

5. CHECK TCM POWER SUPPLY AND GROUND CIRCUIT

Check TCM power supply and ground circuit. Refer to [AT-179, "MAIN POWER SUPPLY AND GROUND CIRCUIT"](#) .

OK or NG

OK >> GO TO 6.

NG >> Repair or replace damaged parts.

6. DETECT MALFUNCTIONING ITEM

Check the following items:

- A/T assembly harness connector pin terminals for damage or loose connection with harness connector.

OK or NG

OK >> Replace control valve with TCM. Refer to [AT-238, "Control Valve with TCM and A/T Fluid Temperature Sensor 2"](#) .

NG >> Repair or replace damaged parts.

DTC P1730 A/T INTERLOCK

DTC P1730 A/T INTERLOCK

PFP:00000

Description

ACS0030S

- Fail-safe function to detect interlock conditions.

On Board Diagnosis Logic

ACS0030T

- This is an OBD-II self-diagnostic item.
- Diagnostic trouble code "A/T INTERLOCK" with CONSULT-II or P1730 without CONSULT-II is detected when TCM does not receive the proper voltage signal from the sensor and switch.
- TCM monitors and compares gear position and conditions of each ATF pressure switch when gear is steady.

Possible Cause

ACS0030U

- Harness or connectors
(Solenoid and switch circuit is open or shorted.)
- Low coast brake solenoid valve
- ATF pressure switch 2

DTC Confirmation Procedure

ACS0030V

NOTE:

If "DTC Confirmation Procedure" has been previously performed, always turn ignition switch OFF and wait for at least 10 seconds before performing the next test.

After the repair, perform the following procedure to confirm the malfunction is eliminated.

④ WITH CONSULT-II

1. Turn ignition switch ON. (Do not start engine.)
2. Select "DATA MONITOR" mode for "A/T" with CONSULT-II.
3. Start engine.
4. Drive vehicle and maintain the following conditions for at least 2 consecutive seconds.
Selector lever: "D" position
5. If DTC is detected, go to [AT-141, "Diagnostic Procedure"](#).

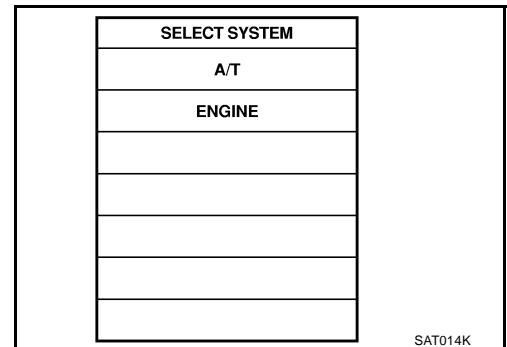

④ WITH GST

Follow the procedure "With CONSULT-II".

Judgement of A/T Interlock

ACS0030W

When A/T Interlock is judged to be malfunctioning, the vehicle should be fixed in 2nd gear, and should be set in a condition in which it can travel.

When one of the following fastening patterns is detected, the fail-safe function in correspondence with the individual pattern should be performed.

DTC P1730 A/T INTERLOCK

A/T INTERLOCK COUPLING PATTERN TABLE

●: NG, X: OK

Gear position		ATF pressure switch output					Fail-safe function	Clutch pressure output pattern after fail-safe function					
		SW3 (I/C)	SW6 (HLR/C)	SW5 (D/C)	SW1 (FR/B)	SW2 (LC/B)		I/C	HLR/C	D/C	FR/B	LC/B	L/U
A/T interlock coupling pattern	3rd	-	X	X	-	●	Held in 2nd gear	OFF	OFF	ON	OFF	OFF	OFF
	4th	-	X	X	-	●	Held in 2nd gear	OFF	OFF	ON	OFF	OFF	OFF
	5th	X	X	-	X	●	Held in 2nd gear	OFF	OFF	ON	OFF	OFF	OFF

Diagnostic Procedure

ACS0030X

1. CHECK SELF-DIAGNOSTIC RESULTS

④ With CONSULT-II

1. Drive vehicle.
2. Stop vehicle and turn ignition switch OFF.
3. Turn ignition switch ON.
4. Select "SELF-DIAG RESULTS" mode for "A/T" with CONSULT-II.

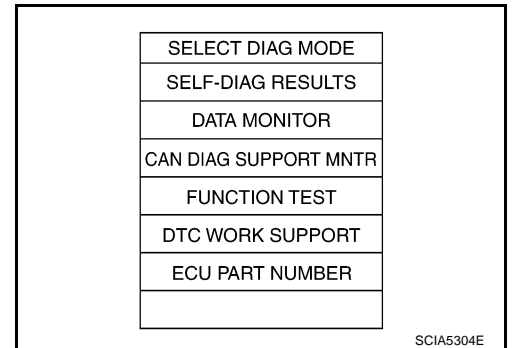

⊗ Without CONSULT-II

1. Drive vehicle.
2. Stop vehicle and turn ignition switch OFF.
3. Turn ignition switch ON. (Do not start engine.)
4. Perform self-diagnosis. Refer to [AT-99, "TCM SELF-DIAGNOSTIC PROCEDURE \(NO TOOLS\)"](#).

OK or NG

OK >> GO TO 2.

NG >> Check low coast brake solenoid valve circuit and function. Refer to [AT-161, "DTC P1772 LOW COAST BRAKE SOLENOID VALVE"](#), [AT-163, "DTC P1774 LOW COAST BRAKE SOLENOID VALVE FUNCTION"](#).

2. CHECK DTC

Perform "DTC Confirmation Procedure".

- Refer to [AT-140, "DTC Confirmation Procedure"](#).

OK or NG

OK >> **INSPECTION END**

NG >> GO TO 3.

3. CHECK TCM POWER SUPPLY AND GROUND CIRCUIT

Check TCM power supply and ground circuit. Refer to [AT-179, "MAIN POWER SUPPLY AND GROUND CIRCUIT"](#).

OK or NG

OK >> GO TO 4.

NG >> Repair or replace damaged parts.

DTC P1730 A/T INTERLOCK

4. DETECT MALFUNCTIONING ITEM

Check the following items:

- A/T assembly harness connector pin terminals for damage or loose connection with harness connector.

OK or NG

- OK >> Replace control valve with TCM. Refer to [AT-238, "Control Valve with TCM and A/T Fluid Temperature Sensor 2"](#).
- NG >> Repair or replace damaged parts.

DTC P1731 A/T 1ST ENGINE BRAKING

DTC P1731 A/T 1ST ENGINE BRAKING

PFP:00000

Description

ACS00866

Fail-safe function to prevent sudden decrease in speed by engine brake other than at M1 position.

CONSULT-II Reference Value

ACS00867

Item name	Condition	Display value
ON OFF SOL	Low coast brake engaged. Refer to AT-19 .	ON
	Low coast brake disengaged. Refer to AT-19 .	OFF
ATF PRES SW 2	Low coast brake engaged. Refer to AT-19 .	ON
	Low coast brake disengaged. Refer to AT-19 .	OFF

On Board Diagnosis Logic

ACS008D3

- This is not an OBD-II self-diagnostic item.
- Diagnostic trouble code "A/T 1ST E/BRAKING" with CONSULT-II or 13th judgement flicker without CONSULT-II is detected under the following conditions.
 - When TCM does not receive the proper voltage signal from the sensor.
 - When TCM monitors each ATF pressure switch and solenoid monitor value, and detects as irregular when engine brake of 1st gear acts other than at M1 position.

Possible Cause

ACS008D4

- Harness or connectors
(The sensor circuit is open or shorted.)
- Low coast brake solenoid valve
- ATF pressure switch 2

DTC Confirmation Procedure

ACS008D5

NOTE:

If "DTC Confirmation Procedure" has been previously preformed, always turn ignition switch OFF and wait for at least 10 seconds before performing the next test.

After the repair, perform the following procedure to confirm the malfunction is eliminated.

WITH CONSULT-II

1. Turn ignition switch ON. (Do not start engine.)
2. Select "DATA MONITOR" mode for "A/T" with CONSULT-II.
3. Start engine.
4. Drive vehicle and maintain the following conditions for at least 2 consecutive seconds.
ENGINE SPEED: 1,200 rpm
Selector lever: "M" position
Gear position: 1st gear
5. If DTC is detected, go to [AT-144](#), "Diagnostic Procedure" .

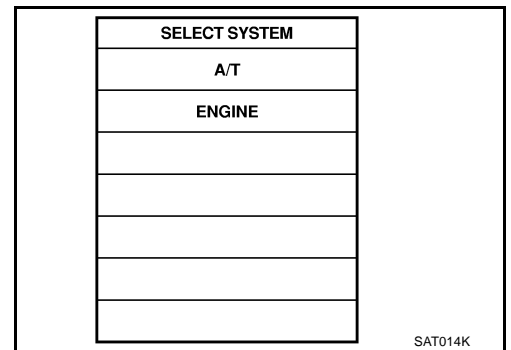

DTC P1731 A/T 1ST ENGINE BRAKING

ACS008D6

Diagnostic Procedure

1. CHECK INPUT SIGNALS

With CONSULT-II

1. Start engine.
2. Select "SELECTION FROM MENU" in "DATA MONITOR" mode for "A/T" with CONSULT-II.
3. Drive vehicle in "M" position (1st gear), and confirm the ON/OFF actuation of "ATF PRES SW 2" and "ON OFF SOL".

DATA MONITOR	
MONITOR	NO DTC
ATF PRES SW 2	xxx
ON OFF SOL	xxx
RECORD	
MODE	BACK
LIGHT	COPY

SCIA4670E

Item name	Condition	Display value
ON OFF SOL	Low coast brake engaged. Refer to AT-19 .	ON
	Low coast brake disengaged. Refer to AT-19 .	OFF
ATF PRES SW 2	Low coast brake engaged. Refer to AT-19 .	ON
	Low coast brake disengaged. Refer to AT-19 .	OFF

OK or NG

- OK >> GO TO 4.
NG >> GO TO 2.

2. CHECK TCM POWER SUPPLY AND GROUND CIRCUIT

Check TCM power supply and ground circuit. Refer to [AT-179, "MAIN POWER SUPPLY AND GROUND CIRCUIT"](#) .

OK or NG

- OK >> GO TO 3.
NG >> Repair or replace damaged parts.

3. DETECT MALFUNCTIONING ITEM

Check the following items:

- A/T assembly harness connector pin terminals for damage or loose connection with harness connector.

OK or NG

- OK >> Replace control valve with TCM. Refer to [AT-238, "Control Valve with TCM and A/T Fluid Temperature Sensor 2"](#) .
NG >> Repair or replace damaged parts.

4. CHECK DTC

Perform "DTC Confirmation Procedure".

- Refer to [AT-143, "DTC Confirmation Procedure"](#) .

OK or NG

- OK >> **INSPECTION END**
NG >> GO TO 2.

DTC P1752 INPUT CLUTCH SOLENOID VALVE

DTC P1752 INPUT CLUTCH SOLENOID VALVE

PF3:31940

Description

ACS003P4

Input clutch solenoid valve is controlled by TCM in response to signals sent from PNP switch, vehicle speed sensor and accelerator pedal position sensor (throttle position sensor). Gears will then be shifted to the optimum position.

CONSULT-II Reference Value

ACS003P5

Item name	Condition	Display value (Approx.)
I/C SOLENOID	Input clutch disengaged. Refer to AT-19 .	0.6 - 0.8 A
	Input clutch engaged. Refer to AT-19 .	0 - 0.05 A

On Board Diagnosis Logic

ACS003P6

- This is an OBD-II self-diagnostic item.
- Diagnostic trouble code "I/C SOLENOID/CIRC" with CONSULT-II or P1752 without CONSULT-II is detected under the following conditions.
 - When TCM detects an improper voltage drop when it tries to operate the solenoid valve.
 - When TCM detects as irregular by comparing target value with monitor value.

Possible Cause

ACS003P7

- Harness or connectors
(Solenoid circuit is open or shorted.)
- Input clutch solenoid valve

DTC Confirmation Procedure

ACS003P8

CAUTION:

Always drive vehicle at a safe speed.

NOTE:

If "DTC Confirmation Procedure" has been previously performed, always turn ignition switch OFF and wait for at least 10 seconds before performing the next test.

After the repair, perform the following procedure to confirm the malfunction is eliminated.

ⓑ WITH CONSULT-II

1. Turn ignition switch ON. (Do not start engine.)
2. Select "DATA MONITOR" mode for "A/T" with CONSULT-II.
3. Start engine.
4. Drive vehicle and maintain the following conditions for at least 5 consecutive seconds.

ACCELE POSI: 1.5/8 - 2.0/8

Selector lever: "D" position

Gear position: 3rd ⇒ 4th Gear (I/C ON/OFF)

Driving location: Driving the vehicle uphill (increased engine load) will help maintain the driving conditions required for this test.

5. If DTC is detected go to "[AT-146, "Diagnostic Procedure"](#) .

Ⓒ WITH GST

Follow the procedure "With CONSULT-II".

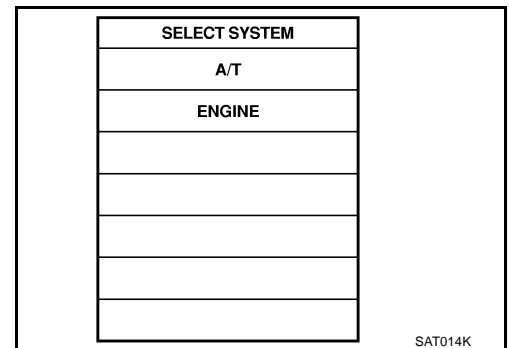

DTC P1752 INPUT CLUTCH SOLENOID VALVE

ACS003P9

Diagnostic Procedure

1. CHECK INPUT SIGNAL

With CONSULT-II

1. Turn ignition switch ON.
2. Select "MAIN SIGNALS" in "DATA MONITOR" mode for "A/T" with CONSULT-II.
3. Start engine.
4. Read out the value of "I/C SOLENOID" while driving.

Item name	Condition	Display value (Approx.)
I/C SOLENOID	Input clutch disengaged. Refer to AT-19 .	0.6 - 0.8 A
	Input clutch engaged. Refer to AT-19 .	0 - 0.05 A

DATA MONITOR	
MONITOR	NO DTC
TCC SOLENOID	XXXX
LINE PRES SOL	XXXX
I/C SOLENOID	XXXX
FR/B SOLENOID	XXXX
D/C SOLENOID	XXXX
HLR/C SOL	XXXX
	▽
	RECORD
MODE	BACK
LIGHT	COPY

SCIA4793E

OK or NG

- OK >> GO TO 4.
NG >> GO TO 2.

2. CHECK TCM POWER SUPPLY AND GROUND CIRCUIT

Check TCM power supply and ground circuit. Refer to [AT-179, "MAIN POWER SUPPLY AND GROUND CIRCUIT"](#) .

OK or NG

- OK >> GO TO 3.
NG >> Repair or replace damaged parts.

3. DETECT MALFUNCTIONING ITEM

Check the following items:

- A/T assembly harness connector pin terminals for damage or loose connection with harness connector.

OK or NG

- OK >> Replace control valve with TCM. Refer to [AT-238, "Control Valve with TCM and A/T Fluid Temperature Sensor 2"](#) .
NG >> Repair or replace damaged parts.

4. CHECK DTC

Perform "DTC Confirmation Procedure".

- Refer to [AT-145, "DTC Confirmation Procedure"](#) .

OK or NG

- OK >> **INSPECTION END**
NG >> GO TO 2.

DTC P1754 INPUT CLUTCH SOLENOID VALVE FUNCTION

DTC P1754 INPUT CLUTCH SOLENOID VALVE FUNCTION

PFP:31940

Description

ACS003PA

- Input clutch solenoid valve is controlled by TCM in response to signals sent from PNP switch, vehicle speed sensor and accelerator pedal position sensor (throttle position sensor). Gears will then be shifted to the optimum position.
- This is not only caused by electrical malfunction (circuits open or shorted) but also by mechanical malfunction such as control valve sticking, improper solenoid valve operation.

CONSULT-II Reference Value

ACS003PB

Item name	Condition	Display value (Approx.)
I/C SOLENOID	Input clutch disengaged. Refer to AT-19 .	0.6 - 0.8 A
	Input clutch engaged. Refer to AT-19 .	0 - 0.05 A
ATF PRES SW 3	Input clutch engaged. Refer to AT-19 .	ON
	Input clutch disengaged. Refer to AT-19 .	OFF

On Board Diagnosis Logic

ACS003PC

- This is an OBD-II self-diagnostic item.
- Diagnostic trouble code "I/C SOLENOID FNCTN" with CONSULT-II or P1754 without CONSULT-II is detected under the following conditions.
 - When TCM detects that actual gear ratio is irregular, and relation between gear position and condition of pressure switch 3 is irregular during depressing accelerator pedal. (Other than during shift change)
 - When TCM detects that relation between gear position and condition of ATF pressure switch 3 is irregular during releasing accelerator pedal. (Other than during shift change)

Possible Cause

ACS003PD

- Harness or connectors (Solenoid and switch circuits are open or shorted.)
- Input clutch solenoid valve
- ATF pressure switch 3

DTC Confirmation Procedure

ACS003PE

CAUTION:

Always drive vehicle at a safe speed.

NOTE:

If "DTC Confirmation Procedure" has been previously performed, always turn ignition switch OFF and wait for at least 10 seconds before performing the next test.

After the repair, perform the following procedure to confirm the malfunction is eliminated.

WITH CONSULT-II

1. Start engine.
2. Accelerate vehicle to maintain the following conditions.
ACCELE POSI: 1.5/8 - 2.0/8
Selector lever: "D" position
Gear position: 3rd ⇒ 4th Gear (I/C ON/OFF)
Driving location: Driving the vehicle uphill (increased engine load) will help maintain the driving conditions required for this test.
3. Perform step "2" again.
4. Turn ignition switch OFF, then perform step "1" to "3" again.
5. Check "SELF-DIAG RESULTS" mode for "A/T" with CONSULT-II. If DTC (P1754) is detected, refer to [AT-148, "Diagnostic Procedure"](#) .
If DTC (P1752) is detected, go to [AT-146, "Diagnostic Procedure"](#) .
If DTC (P1843) is detected, go to [AT-174, "Diagnostic Procedure"](#) .

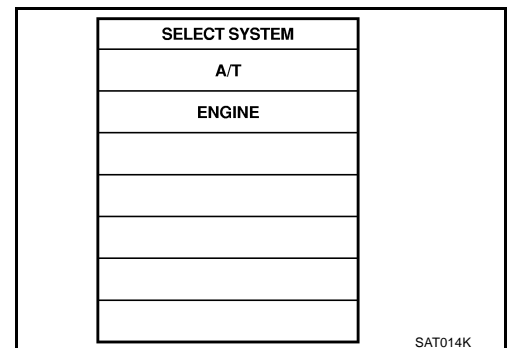

DTC P1754 INPUT CLUTCH SOLENOID VALVE FUNCTION

WITH GST

Follow the procedure "With CONSULT-II".

Diagnostic Procedure

ACS003PF

1. CHECK INPUT SIGNALS

With CONSULT-II

1. Start engine.
2. Select "SELECTION FROM MENU" in "DATA MONITOR" mode for "A/T" with CONSULT-II.
3. Drive vehicle in "D" position (3rd ⇒ 4th gear), and confirm the ON/OFF actuation of "ATF PRES SW 3" and electrical current value of "I/C SOLENOID".

DATA MONITOR			
MONITOR		NO DTC	
I/C SOLENOID		XXX A	
ATF PRES SW 3		OFF	
RECORD			
MODE	BACK	LIGHT	COPY

SCIA4795E

Item name	Condition	Display value (Approx.)
I/C SOLENOID	Input clutch disengaged. Refer to AT-19 .	0.6 - 0.8 A
	Input clutch engaged. Refer to AT-19 .	0 - 0.05 A
ATF PRES SW 3	Input clutch engaged. Refer to AT-19 .	ON
	Input clutch disengaged. Refer to AT-19 .	OFF

OK or NG

- OK >> GO TO 4.
NG >> GO TO 2.

2. CHECK TCM POWER SUPPLY AND GROUND CIRCUIT

Check TCM power supply and ground circuit. Refer to [AT-179, "MAIN POWER SUPPLY AND GROUND CIRCUIT"](#) .

OK or NG

- OK >> GO TO 3.
NG >> Repair or replace damaged parts.

3. DETECT MALFUNCTIONING ITEM

Check the following items:

- A/T assembly harness connector pin terminals for damage or loose connection with harness connector.

OK or NG

- OK >> Replace control valve with TCM. Refer to [AT-238, "Control Valve with TCM and A/T Fluid Temperature Sensor 2"](#) .
NG >> Repair or replace damaged parts.

4. CHECK DTC

Perform "DTC Confirmation Procedure".

- Refer to [AT-147, "DTC Confirmation Procedure"](#) .

OK or NG

- OK >> **INSPECTION END**
NG >> GO TO 2.

DTC P1757 FRONT BRAKE SOLENOID VALVE

DTC P1757 FRONT BRAKE SOLENOID VALVE

PFP:31940

Description

ACS003PG

Front brake solenoid valve is controlled by TCM in response to signals sent from PNP switch, vehicle speed sensor and accelerator pedal position sensor (throttle position sensor). Gears will then be shifted to the optimum position.

CONSULT-II Reference Value

ACS003PH

Item name	Condition	Display value (Approx.)
FR/B SOLENOID	Front brake engaged. Refer to AT-19 .	0.6 - 0.8 A
	Front brake disengaged. Refer to AT-19 .	0 - 0.05 A

On Board Diagnosis Logic

ACS003PI

- This is an OBD-II self-diagnostic item.
- Diagnostic trouble code "FR/B SOLENOID/CIRC" with CONSULT-II or P1757 without CONSULT-II is detected under the following conditions.
 - When TCM detects an improper voltage drop when it tries to operate the solenoid valve.
 - When TCM detects as irregular by comparing target value with monitor value.

Possible Cause

ACS003PJ

- Harness or connectors
(Solenoid circuit is open or shorted.)
- Front brake solenoid valve

DTC Confirmation Procedure

ACS003PK

CAUTION:

Always drive vehicle at a safe speed.

NOTE:

If "DTC Confirmation Procedure" has been previously performed, always turn ignition switch OFF and wait for at least 10 seconds before performing the next test.

After the repair, perform the following procedure to confirm the malfunction is eliminated.

Ⓟ WITH CONSULT-II

1. Turn ignition switch ON. (Do not start engine.)
2. Select "DATA MONITOR" mode for "A/T" with CONSULT-II.
3. Start engine.
4. Drive vehicle and maintain the following conditions for at least 5 consecutive seconds.

ACCELE POSI: 1.5/8 - 2.0/8

Selector lever: "D" position

Gear position: 3rd ⇒ 4th Gear (FR/B ON/OFF)

Driving location: Driving the vehicle uphill (increased engine load) will help maintain the driving conditions required for this test.

5. If DTC is detected go to [AT-150, "Diagnostic Procedure"](#) .

Ⓢ WITH GST

Follow the procedure "With CONSULT-II".

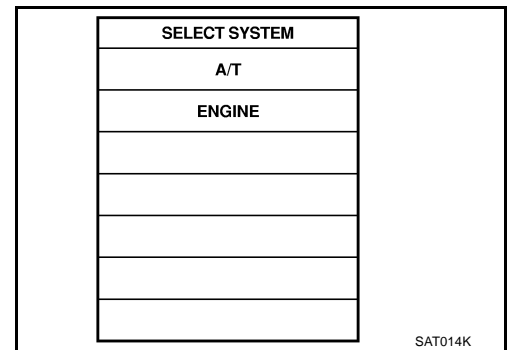

DTC P1757 FRONT BRAKE SOLENOID VALVE

ACS003PL

Diagnostic Procedure

1. CHECK INPUT SIGNAL

With CONSULT-II

1. Turn ignition switch ON.
2. Select "MAIN SIGNALS" in "DATA MONITOR" mode for "A/T" with CONSULT-II.
3. Start engine.
4. Read out the value of "FR/B SOLENOID" while driving.

Item name	Condition	Display value (Approx.)
FR/B SOLENOID	Front brake engaged. Refer to AT-19 .	0.6 - 0.8 A
	Front brake disengaged. Refer to AT-19 .	0 - 0.05 A

DATA MONITOR	
MONITOR	NO DTC
TCC SOLENOID	XXXX
LINE PRES SOL	XXXX
I/C SOLENOID	XXXX
FR/B SOLENOID	XXXX
D/C SOLENOID	XXXX
HLR/C SOL	XXXX
	▽
	RECORD
MODE	BACK
LIGHT	COPY

SCIA4793E

OK or NG

- OK >> GO TO 4.
NG >> GO TO 2.

2. CHECK TCM POWER SUPPLY AND GROUND CIRCUIT

Check TCM power supply and ground circuit. Refer to [AT-179, "MAIN POWER SUPPLY AND GROUND CIRCUIT"](#) .

OK or NG

- OK >> GO TO 3.
NG >> Repair or replace damaged parts.

3. DETECT MALFUNCTIONING ITEM

Check the following items:

- A/T assembly harness connector pin terminals for damage or loose connection with harness connector.

OK or NG

- OK >> Replace control valve with TCM. Refer to [AT-238, "Control Valve with TCM and A/T Fluid Temperature Sensor 2"](#) .
NG >> Repair or replace damaged parts.

4. CHECK DTC

Perform "DTC Confirmation Procedure".

- Refer to [AT-149, "DTC Confirmation Procedure"](#) .

OK or NG

- OK >> **INSPECTION END**
NG >> GO TO 2.

DTC P1759 FRONT BRAKE SOLENOID VALVE FUNCTION

DTC P1759 FRONT BRAKE SOLENOID VALVE FUNCTION

PFP:31940

Description

ACS003PM

- Front brake solenoid valve is controlled by TCM in response to signals sent from PNP switch, vehicle speed sensor and accelerator pedal position sensor (throttle position sensor). Gears will then be shifted to the optimum position.
- This is not only caused by electrical malfunction (circuits open or shorted) but also by mechanical malfunction such as control valve sticking, improper solenoid valve operation.

CONSULT-II Reference Value

ACS003PV

Item name	Condition	Display value (Approx.)
FR/B SOLENOID	Front brake engaged. Refer to AT-19 .	0.6 - 0.8 A
	Front brake disengaged. Refer to AT-19 .	0 - 0.05 A
ATF PRES SW 1	Front brake engaged. Refer to AT-19 .	ON
	Front brake disengaged. Refer to AT-19 .	OFF

On Board Diagnosis Logic

ACS003PO

- This is an OBD-II self-diagnostic item.
- Diagnostic trouble code "FR/B SOLENOID FNCT" with CONSULT-II or P1759 without CONSULT-II is detected under the following conditions.
 - When TCM detects that actual gear ratio is irregular, and relation between gear position and condition of ATF pressure switch 1 is irregular during depressing accelerator pedal. (Other than during shift change)
 - When TCM detects that relation between gear position and condition of ATF pressure switch 1 is irregular during releasing accelerator pedal. (Other than during shift change)

Possible Cause

ACS003PP

- Harness or connectors (Solenoid and switch circuits are open or shorted.)
- Front brake solenoid valve
- ATF pressure switch 1

DTC Confirmation Procedure

ACS003PQ

CAUTION:

Always drive vehicle at a safe speed.

NOTE:

If "DTC Confirmation Procedure" has been previously performed, always turn ignition switch OFF and wait for at least 10 seconds before performing the next test.

After the repair, perform the following procedure to confirm the malfunction is eliminated.

WITH CONSULT-II

1. Start engine.
2. Accelerate vehicle to maintain the following conditions.
ACCELE POSI: 1.5/8 - 2.0/8
Selector lever: "D" position
Gear position: 3rd ⇒ 4th Gear (FR/B ON/OFF)
Driving location: Driving the vehicle uphill (increased engine load) will help maintain the driving conditions required for this test.
3. Perform step "2" again.
4. Turn ignition switch OFF, then perform step "1" to "3" again.
5. Check "SELF-DIAG RESULTS" mode for "A/T" with CONSULT-II. If DTC (P1759) is detected, refer to [AT-152, "Diagnostic Procedure"](#) .
If DTC (P1757) is detected, go to [AT-150, "Diagnostic Procedure"](#) .
If DTC (P1841) is detected, go to [AT-172, "Diagnostic Procedure"](#) .

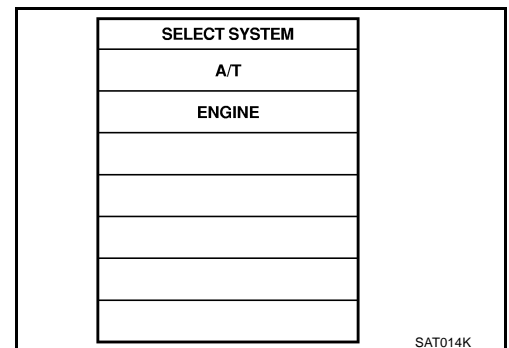

DTC P1759 FRONT BRAKE SOLENOID VALVE FUNCTION

WITH GST

Follow the procedure "With CONSULT-II".

Diagnostic Procedure

ACS003PR

1. CHECK INPUT SIGNALS

With CONSULT-II

1. Start engine.
2. Select "SELECTION FROM MENU" in "DATA MONITOR" mode for "A/T" with CONSULT-II.
3. Drive vehicle in "D" position (3rd ⇒ 4th gear), and confirm the ON/OFF actuation of the "ATF PRES SW 1" and electrical current value of "FR/B SOLENOID".

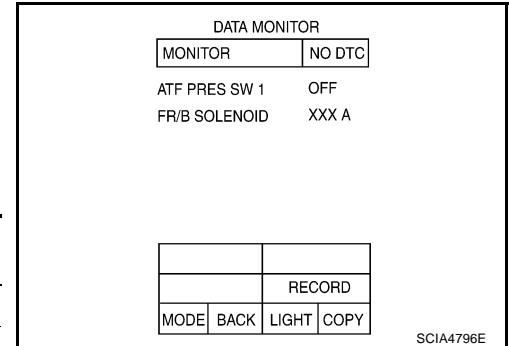

Item name	Condition	Display value (Approx.)
FR/B SOLENOID	Front brake engaged. Refer to AT-19 .	0.6 - 0.8 A
	Front brake disengaged. Refer to AT-19 .	0 - 0.05 A
ATF PRES SW 1	Front brake engaged. Refer to AT-19 .	ON
	Front brake disengaged. Refer to AT-19 .	OFF

OK or NG

- OK >> GO TO 4.
NG >> GO TO 2.

2. CHECK TCM POWER SUPPLY AND GROUND CIRCUIT

Check TCM power supply and ground circuit. Refer to [AT-179, "MAIN POWER SUPPLY AND GROUND CIRCUIT"](#) .

OK or NG

- OK >> GO TO 3.
NG >> Repair or replace damaged parts.

3. DETECT MALFUNCTIONING ITEM

Check the following items:

- A/T assembly harness connector pin terminals for damage or loose connection with harness connector.

OK or NG

- OK >> Replace control valve with TCM. Refer to [AT-238, "Control Valve with TCM and A/T Fluid Temperature Sensor 2"](#) .
NG >> Repair or replace damaged parts.

4. CHECK DTC

Perform "DTC Confirmation Procedure".

- Refer to [AT-151, "DTC Confirmation Procedure"](#) .

OK or NG

- OK >> **INSPECTION END**
NG >> GO TO 2.

DTC P1762 DIRECT CLUTCH SOLENOID VALVE

DTC P1762 DIRECT CLUTCH SOLENOID VALVE

PFP:31940

Description

ACS003PS

Direct clutch solenoid valve is controlled by TCM in response to signals sent from PNP switch, vehicle speed sensor and accelerator pedal position sensor (throttle position sensor). Gears will then be shifted to the optimum position.

CONSULT-II Reference Value

ACS003PT

Item name	Condition	Display value (Approx.)
D/C SOLENOID	Direct clutch disengaged. Refer to AT-19 .	0.6 - 0.8 A
	Direct clutch engaged. Refer to AT-19 .	0 - 0.05 A

On Board Diagnosis Logic

ACS003PU

- This is an OBD-II self-diagnostic item.
- Diagnostic trouble code "D/C SOLENOID/CIRC" with CONSULT-II or P1762 without CONSULT-II is detected under the following conditions.
 - When TCM detects an improper voltage drop when it tries to operate the solenoid valve.
 - When TCM detects as irregular by comparing target value with monitor value.

Possible Cause

ACS003PV

- Harness or connectors
(Solenoid circuit is open or shorted.)
- Direct clutch solenoid valve

DTC Confirmation Procedure

ACS003PW

NOTE:

If "DTC Confirmation Procedure" has been previously performed, always turn ignition switch OFF and wait for at least 10 seconds before performing the next test.

After the repair, perform the following procedure to confirm the malfunction is eliminated.

WITH CONSULT-II

1. Turn ignition switch ON. (Do not start engine.)
2. Select "DATA MONITOR" mode for "A/T" with CONSULT-II.
3. Start engine.
4. Drive vehicle and maintain the following conditions for at least 5 consecutive seconds.
ACCELE POSI: 1.5/8 - 2.0/8
Selector lever: "D" position
Gear position: 1st ⇒ 2nd Gear (D/C ON/OFF)
Driving location: Driving the vehicle uphill (increased engine load) will help maintain the driving conditions required for this test.
5. If DTC is detected, go to [AT-154, "Diagnostic Procedure"](#) .

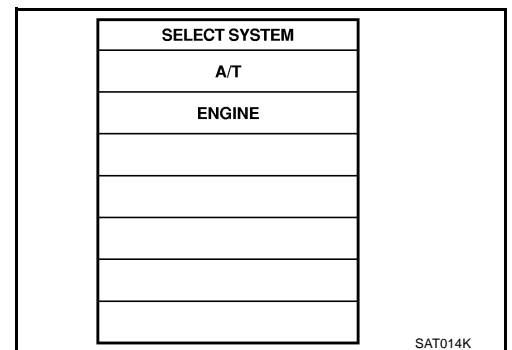

WITH GST

Follow the procedure "With CONSULT-II".

DTC P1762 DIRECT CLUTCH SOLENOID VALVE

ACS003PX

Diagnostic Procedure

1. CHECK INPUT SIGNAL

With CONSULT-II

1. Turn ignition switch ON.
2. Select "MAIN SIGNALS" in "DATA MONITOR" mode for "A/T" with CONSULT-II.
3. Start engine.
4. Read out the value of "D/C SOLENOID" while driving.

Item name	Condition	Display value (Approx.)
D/C SOLENOID	Direct clutch disengaged. Refer to AT-19 .	0.6 - 0.8 A
	Direct clutch engaged. Refer to AT-19 .	0 - 0.05 A

DATA MONITOR	
MONITOR	NO DTC
TCC SOLENOID	XXXX
LINE PRES SOL	XXXX
I/C SOLENOID	XXXX
FR/B SOLENOID	XXXX
D/C SOLENOID	XXXX
HLR/C SOL	XXXX
	▽
	RECORD
MODE	BACK
LIGHT	COPY

SCIA4793E

OK or NG

- OK >> GO TO 4.
NG >> GO TO 2.

2. CHECK TCM POWER SUPPLY AND GROUND CIRCUIT

Check TCM power supply and ground circuit. Refer to [AT-179, "MAIN POWER SUPPLY AND GROUND CIRCUIT"](#) .

OK or NG

- OK >> GO TO 3.
NG >> Repair or replace damaged parts.

3. DETECT MALFUNCTIONING ITEM

Check the following items:

- A/T assembly harness connector pin terminals for damage or loose connection with harness connector.

OK or NG

- OK >> Replace control valve with TCM. Refer to [AT-238, "Control Valve with TCM and A/T Fluid Temperature Sensor 2"](#) .
NG >> Repair or replace damaged parts.

4. CHECK DTC

Perform "DTC Confirmation Procedure".

- Refer to [AT-153, "DTC Confirmation Procedure"](#) .

OK or NG

- OK >> **INSPECTION END**
NG >> GO TO 2.

DTC P1764 DIRECT CLUTCH SOLENOID VALVE FUNCTION

DTC P1764 DIRECT CLUTCH SOLENOID VALVE FUNCTION

PFP:31940

Description

ACS003PY

- Direct clutch solenoid valve is controlled by TCM in response to signals sent from PNP switch, vehicle speed sensor and accelerator pedal position sensor (throttle position sensor). Gears will then be shifted to the optimum position.
- This is not only caused by electrical malfunction (circuits open or shorted) but also by mechanical malfunction such as control valve sticking, improper solenoid valve operation.

CONSULT-II Reference Value

ACS003PZ

Item name	Condition	Display value (Approx.)
D/C SOLENOID	Direct clutch disengaged. Refer to AT-19 .	0.6 - 0.8 A
	Direct clutch engaged. Refer to AT-19 .	0 - 0.05 A
ATF PRES SW 5	Direct clutch engaged. Refer to AT-19 .	ON
	Direct clutch disengaged. Refer to AT-19 .	OFF

On Board Diagnosis Logic

ACS003Q0

- This is an OBD-II self-diagnostic item.
- Diagnostic trouble code “D/C SOLENOID FNCTN” with CONSULT-II or P1764 without CONSULT-II is detected under the following conditions.
 - When TCM detects that actual gear ratio is irregular, and relation between gear position and condition of ATF pressure switch 5 is irregular during depressing accelerator pedal. (Other than during shift change)
 - When TCM detects that relation between gear position and condition of ATF pressure switch 5 is irregular during releasing accelerator pedal. (Other than during shift change)

Possible Cause

ACS003Q1

- Harness or connectors
(Solenoid and switch circuits are open or shorted.)
- Direct clutch solenoid valve
- ATF pressure switch 5

DTC Confirmation Procedure

ACS003Q2

NOTE:

If “DTC Confirmation Procedure” has been previously performed, always turn ignition switch OFF and wait for at least 10 seconds before performing the next test.

After the repair, perform the following procedure to confirm the malfunction is eliminated.

WITH CONSULT-II

1. Start engine.
2. Accelerate vehicle to maintain the following conditions.
ACCELE POSI: 1.5/8 - 2.0/8
Selector lever: “D” position
Gear position: 1st ⇒ 2nd Gear (D/C ON/OFF)
Driving location: Driving the vehicle uphill (increased engine load) will help maintain the driving conditions required for this test.
3. Perform step “2” again.
4. Turn ignition switch OFF, then perform step “1” to “3” again.
5. Check “SELF-DIAG RESULTS” mode for “A/T” with CONSULT-II. If DTC (P1764) is detected, refer to [AT-156, "Diagnostic Procedure"](#) .
If DTC (P1762) is detected, go to [AT-154, "Diagnostic Procedure"](#) .
If DTC (P1845) is detected, go to [AT-176, "Diagnostic Procedure"](#) .

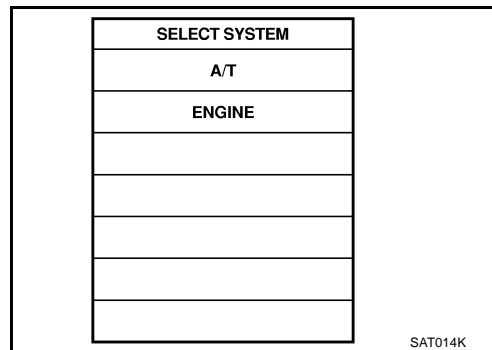

WITH GST

Follow the procedure “With CONSULT-II”.

DTC P1764 DIRECT CLUTCH SOLENOID VALVE FUNCTION

Diagnostic Procedure

ACS003Q3

1. CHECK INPUT SIGNALS

With CONSULT-II

1. Start engine.
2. Select "SELECTION FROM MENU" in "DATA MONITOR" mode for "A/T" with CONSULT-II.
3. Drive vehicle in "D" position (1st ⇒ 2nd gear), and confirm the display actuation of the "ATF PRES SW 5" and electrical current value of "D/C SOLENOID".

DATA MONITOR			
MONITOR		NO DTC	
D/C SOLENOID		XXXX	
ATF PRES SW 5		OFF	

		RECORD	
MODE	BACK	LIGHT	COPY

SCIA4797E

Item name	Condition	Display value (Approx.)
D/C SOLENOID	Direct clutch disengaged. Refer to AT-19 .	0.6 - 0.8 A
	Direct clutch engaged. Refer to AT-19 .	0 - 0.05 A
ATF PRES SW 5	Direct clutch engaged. Refer to AT-19 .	ON
	Direct clutch disengaged. Refer to AT-19 .	OFF

OK or NG

- OK >> GO TO 4.
NG >> GO TO 2.

2. CHECK TCM POWER SUPPLY AND GROUND CIRCUIT

Check TCM power supply and ground circuit. Refer to [AT-179, "MAIN POWER SUPPLY AND GROUND CIRCUIT"](#) .

OK or NG

- OK >> GO TO 3.
NG >> Repair or replace damaged parts.

3. DETECT MALFUNCTIONING ITEM

Check the following items:

- A/T assembly harness connector pin terminals for damage or loose connection with harness connector.

OK or NG

- OK >> Replace control valve with TCM. Refer to [AT-238, "Control Valve with TCM and A/T Fluid Temperature Sensor 2"](#) .
NG >> Repair or replace damaged parts.

4. CHECK DTC

Perform "DTC Confirmation Procedure".

- Refer to [AT-155, "DTC Confirmation Procedure"](#) .

OK or NG

- OK >> **INSPECTION END**
NG >> GO TO 2.

DTC P1767 HIGH AND LOW REVERSE CLUTCH SOLENOID VALVE

DTC P1767 HIGH AND LOW REVERSE CLUTCH SOLENOID VALVE

PFP:31940

Description

ACS003Q4

High and low reverse clutch solenoid valve is controlled by TCM in response to signals sent from PNP switch, vehicle speed sensor and accelerator pedal position sensor (throttle position sensor). Gears will then be shifted to the optimum position.

CONSULT-II Reference Value

ACS003Q5

Item name	Condition	Display value (Approx.)
HLR/C SOL	High and low reverse clutch disengaged. Refer to AT-19 .	0.6 - 0.8 A
	High and low reverse clutch engaged. Refer to AT-19 .	0 - 0.05 A

On Board Diagnosis Logic

ACS003Q6

- This is an OBD-II self-diagnostic item.
- Diagnostic trouble code "HLR/C SOL/CIRC" with CONSULT-II or P1767 without CONSULT-II is detected under the following conditions.
 - When TCM detects an improper voltage drop when it tries to operate the solenoid valve.
 - When TCM detects as irregular by comparing target value with monitor value.

Possible Cause

ACS003Q7

- Harness or connectors
(Solenoid circuit is open or shorted.)
- High and low reverse clutch solenoid valve

DTC Confirmation Procedure

ACS003Q8

CAUTION:

Always drive vehicle at a safe speed.

NOTE:

If "DTC Confirmation Procedure" has been previously performed, always turn ignition switch OFF and wait for at least 10 seconds before performing the next test.

After the repair, perform the following procedure to confirm the malfunction is eliminated.

Ⓟ WITH CONSULT-II

1. Turn ignition switch ON. (Do not start engine.)
2. Select "DATA MONITOR" mode for "A/T" with CONSULT-II.
3. Start engine.
4. Drive vehicle and maintain the following conditions for at least 5 consecutive seconds.

ACCELE POSI: 1.5/8 - 2.0/8

Selector lever: "D" position

Gear position: 2nd ⇒ 3rd Gear (HLR/C ON/OFF)

Driving location: Driving the vehicle uphill (increased engine load) will help maintain the driving conditions required for this test.

5. If DTC is detected, go to [AT-158, "Diagnostic Procedure"](#) .

Ⓢ WITH GST

Follow the procedure "With CONSULT-II".

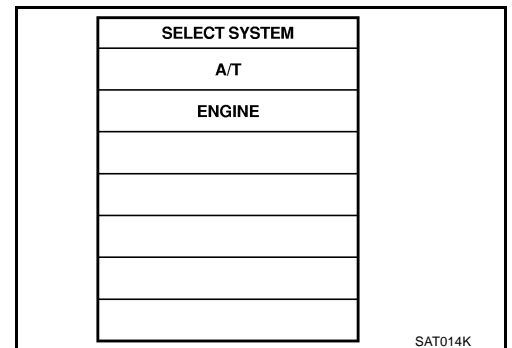

DTC P1767 HIGH AND LOW REVERSE CLUTCH SOLENOID VALVE

ACS003Q9

Diagnostic Procedure

1. CHECK INPUT SIGNAL

With CONSULT-II

1. Turn ignition switch ON.
2. Select "MAIN SIGNALS" in "DATA MONITOR" mode for "A/T" with CONSULT-II.
3. Start engine.
4. Read out the value of "HLR/C SOLENOID" while driving.

DATA MONITOR	
MONITOR	NO DTC
TCC SOLENOID	XXXX
LINE PRES SOL	XXXX
I/C SOLENOID	XXXX
FR/B SOLENOID	XXXX
D/C SOLENOID	XXXX
HLR/C SOL	XXXX
	▽
	RECORD
MODE	BACK
LIGHT	COPY

SCIA4793E

Item name	Condition	Display value (Approx.)
HLR/C SOL	High and low reverse clutch disengaged. Refer to AT-19 .	0.6 - 0.8 A
	High and low reverse clutch engaged. Refer to AT-19 .	0 - 0.05 A

OK or NG

- OK >> GO TO 4.
NG >> GO TO 2.

2. CHECK TCM POWER SUPPLY AND GROUND CIRCUIT

Check TCM power supply and ground circuit. Refer to [AT-179, "MAIN POWER SUPPLY AND GROUND CIRCUIT"](#) .

OK or NG

- OK >> GO TO 3.
NG >> Repair or replace damaged parts.

3. DETECT MALFUNCTIONING ITEM

Check the following items:

- A/T assembly harness connector pin terminals for damage or loose connection with harness connector.

OK or NG

- OK >> Replace control valve with TCM. Refer to [AT-238, "Control Valve with TCM and A/T Fluid Temperature Sensor 2"](#) .
NG >> Repair or replace damaged parts.

4. CHECK TCM

Perform "DTC Confirmation Procedure".

- Refer to [AT-157, "DTC Confirmation Procedure"](#) .

OK or NG

- OK >> **INSPECTION END**
NG >> GO TO 2.

DTC P1769 HIGH AND LOW REVERSE CLUTCH SOLENOID VALVE FUNCTION

DTC P1769 HIGH AND LOW REVERSE CLUTCH SOLENOID VALVE FUNCTION

PPF:31940

Description

ACS003QA

- High and low reverse clutch solenoid valve is controlled by TCM in response to signals sent from PNP switch, vehicle speed sensor and accelerator pedal position sensor (throttle position sensor). Gears will then be shifted to the optimum position.
- This is not only caused by electrical malfunction (circuits open or shorted) but also by mechanical malfunction such as control valve sticking, improper solenoid valve operation.

CONSULT-II Reference Value

ACS003QB

Item name	Condition	Display value (Approx.)
HLR/C SOL	High and low reverse clutch disengaged. Refer to AT-19 .	0.6 - 0.8 A
	High and low reverse clutch engaged. Refer to AT-19 .	0 - 0.05 A
ATF PRES SW 6	High and low reverse clutch engaged. Refer to AT-19 .	ON
	High and low reverse clutch disengaged. Refer to AT-19 .	OFF

On Board Diagnosis Logic

ACS003QC

- This is an OBD-II self-diagnostic item.
- Diagnostic trouble code "HLR/C SOL FNCTN" with CONSULT-II or P1769 without CONSULT-II is detected under the following conditions.
 - When TCM detects that actual gear ratio is irregular, and relation between gear position and condition of ATF pressure switch 6 is irregular during depressing accelerator pedal. (Other than during shift change)
 - When TCM detects that relation between gear position and condition of ATF pressure switch 6 is irregular during releasing accelerator pedal. (Other than during shift change)

Possible Cause

ACS003QD

- Harness or connectors (Solenoid and switch circuits are open or shorted.)
- High and low reverse clutch solenoid valve
- ATF pressure switch 6

DTC Confirmation Procedure

ACS003QE

CAUTION:

Always drive vehicle at a safe speed.

NOTE:

If "DTC Confirmation Procedure" has been previously performed, always turn ignition switch OFF and wait for at least 10 seconds before performing the next test.

After the repair, perform the following procedure to confirm the malfunction is eliminated.

Ⓟ WITH CONSULT-II

1. Start engine.
2. Accelerate vehicle to maintain the following conditions.
ACCELE POSI: 1.5/8 - 2.0/8
Selector lever: "D" position
Gear position: 2nd ⇒ 3rd Gear (HLR/C ON/OFF)
Driving location: Driving the vehicle uphill (increased engine load) will help maintain the driving conditions required for this test.
3. Perform step "2" again.
4. Turn ignition switch OFF, then perform step "1" to "3" again.
5. Check "SELF-DIAG RESULTS" mode for "A/T" with CONSULT-II. If DTC (P1769) is detected, refer to [AT-160, "Diagnostic Procedure"](#) .
 If DTC (P1767) is detected, go to [AT-158, "Diagnostic Procedure"](#) .
 If DTC (P1846) is detected, go to [AT-178, "Diagnostic Procedure"](#) .

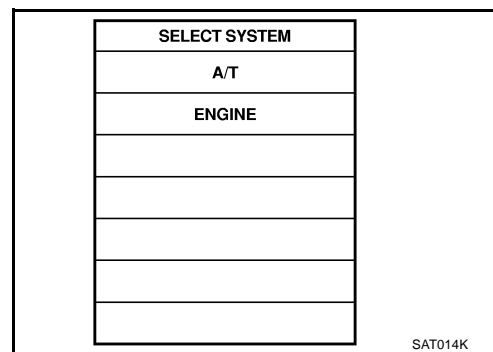

DTC P1769 HIGH AND LOW REVERSE CLUTCH SOLENOID VALVE FUNCTION

WITH GST

Follow the procedure "With CONSULT-II".

Diagnostic Procedure

ACS003QF

1. CHECK INPUT SIGNALS

With CONSULT-II

1. Start engine.
2. Select "SELECTION FROM MENU" in "DATA MONITOR" mode for "A/T" with CONSULT-II.
3. Drive vehicle in "D" position (2nd ⇒ 3rd gear), and confirm the ON/OFF actuation of the "ATF PRES SW 6" and electrical current value of "HLR/C SOL".

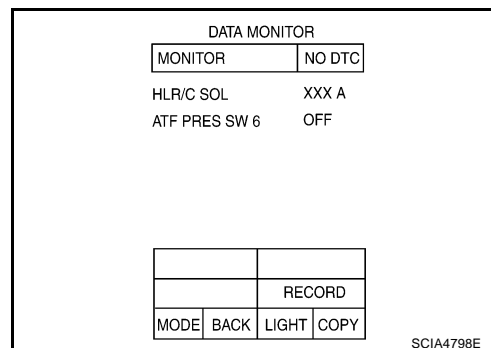

Item name	Condition	Display value (Approx.)
HLR/C SOL	High and low reverse clutch disengaged. Refer to AT-19 .	0.6 - 0.8 A
	High and low reverse clutch engaged. Refer to AT-19 .	0 - 0.05 A
ATF PRES SW 6	High and low reverse clutch engaged. Refer to AT-19 .	ON
	High and low reverse clutch disengaged. Refer to AT-19 .	OFF

OK or NG

- OK >> GO TO 4.
- NG >> GO TO 2.

2. CHECK TCM POWER SUPPLY AND GROUND CIRCUIT

Check TCM power supply and ground circuit. Refer to [AT-179, "MAIN POWER SUPPLY AND GROUND CIRCUIT"](#) .

OK or NG

- OK >> GO TO 3.
- NG >> Repair or replace damaged parts.

3. DETECT MALFUNCTIONING ITEM

Check the following items:

- A/T assembly harness connector pin terminals for damage or loose connection with harness connector.

OK or NG

- OK >> Replace control valve with TCM. Refer to [AT-238, "Control Valve with TCM and A/T Fluid Temperature Sensor 2"](#) .
- NG >> Repair or replace damaged parts.

4. CHECK DTC

Perform "DTC Confirmation Procedure".

- Refer to [AT-159, "DTC Confirmation Procedure"](#) .

OK or NG

- OK >> **INSPECTION END**
- NG >> GO TO 2.

DTC P1772 LOW COAST BRAKE SOLENOID VALVE

DTC P1772 LOW COAST BRAKE SOLENOID VALVE

PPF:31940

Description

ACS003QG

Low coast brake solenoid valve is turned ON or OFF by TCM in response to signals sent from PNP switch, vehicle speed sensor and accelerator pedal position sensor (throttle position sensor). Gears will then be shifted to the optimum position.

CONSULT-II Reference Value

ACS003QH

Item name	Condition	Display value
ON OFF SOL	Low coast brake engaged. Refer to AT-19 .	ON
	Low coast brake disengaged. Refer to AT-19 .	OFF

On Board Diagnosis Logic

ACS003QI

- This is an OBD-II self-diagnostic item.
- Diagnostic trouble code "LC/B SOLENOID/CIRC" with CONSULT-II or P1772 without CONSULT-II is detected when TCM detects an improper voltage drop when it tries to operate the solenoid valve.

Possible Cause

ACS003QJ

- Harness or connectors
(Solenoid circuit is open or shorted.)
- Low coast brake solenoid valve

DTC Confirmation Procedure

ACS003QK

NOTE:

If "DTC Confirmation Procedure" has been previously performed, always turn ignition switch OFF and wait for at least 10 seconds before performing the next test.

After the repair, perform the following procedure to confirm the malfunction is eliminated.

WITH CONSULT-II

1. Turn ignition switch ON. (Do not start engine.)
2. Select "DATA MONITOR" mode for "ENGINE" with CONSULT-II.
3. Start engine.
4. Drive vehicle and maintain the following conditions for at least 5 consecutive seconds.
Selector lever: "M" position
Gear position: "M1-1st" or "M2-2nd" gear (LC/B ON/OFF)
5. If DTC is detected, go to [AT-162, "Diagnostic Procedure"](#) .

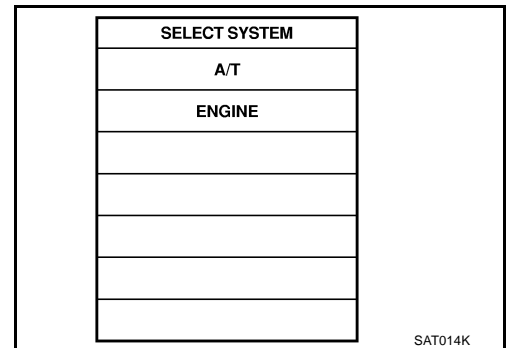

WITH GST

Follow the procedure "With CONSULT-II".

DTC P1772 LOW COAST BRAKE SOLENOID VALVE

ACS003QL

Diagnostic Procedure

1. CHECK INPUT SIGNAL

With CONSULT-II

1. Turn ignition switch ON.
2. Select "SELECTION FROM MENU" in "DATA MONITOR" mode for "A/T" with CONSULT-II.
3. Start engine.
4. Read out the value of "ON OFF SOL" while driving.

Item name	Condition	Display value
ON OFF SOL	Low coast brake engaged. Refer to AT-19 .	ON
	Low coast brake disengaged. Refer to AT-19 .	OFF

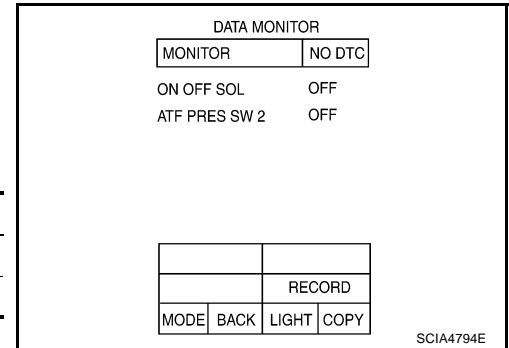

OK or NG

- OK >> GO TO 4.
NG >> GO TO 2.

2. CHECK TCM POWER SUPPLY AND GROUND CIRCUIT

Check TCM power supply and ground circuit. Refer to [AT-179, "MAIN POWER SUPPLY AND GROUND CIRCUIT"](#) .

OK or NG

- OK >> GO TO 3.
NG >> Repair or replace damaged parts.

3. DETECT MALFUNCTIONING ITEM

Check the following items:

- A/T assembly harness connector pin terminals for damage or loose connection with harness connector.

OK or NG

- OK >> Replace control valve with TCM. Refer to [AT-238, "Control Valve with TCM and A/T Fluid Temperature Sensor 2"](#) .
NG >> Repair or replace damaged parts.

4. CHECK DTC

Perform "DTC Confirmation Procedure".

- Refer to [AT-161, "DTC Confirmation Procedure"](#) .

OK or NG

- OK >> **INSPECTION END**
NG >> GO TO 2.

DTC P1774 LOW COAST BRAKE SOLENOID VALVE FUNCTION

DTC P1774 LOW COAST BRAKE SOLENOID VALVE FUNCTION

PFP:31940

Description

ACS003QM

- Low coast brake solenoid valve is turned ON or OFF by TCM in response to signals sent from PNP switch, vehicle speed sensor and accelerator pedal position sensor (throttle position sensor). Gears will then be shifted to the optimum position.
- This is not only caused by electrical malfunction (circuits open or shorted) but also by mechanical malfunction such as control valve sticking, improper solenoid valve operation.

CONSULT-II Reference Value

ACS003QN

Item name	Condition	Display value
ON OFF SOL	Low coast brake engaged. Refer to AT-19 .	ON
	Low coast brake disengaged. Refer to AT-19 .	OFF
ATF PRES SW 2	Low coast brake engaged. Refer to AT-19 .	ON
	Low coast brake disengaged. Refer to AT-19 .	OFF

On Board Diagnosis Logic

ACS008D7

- This is an OBD-II self-diagnostic item.
- Diagnostic trouble code "LC/B SOLENOID FNCT" with CONSULT-II or P1774 without CONSULT-II is detected under the following conditions.
 - When TCM detects that actual gear ratio is irregular, and relation between gear position and condition of ATF pressure switch 2 is irregular during depressing accelerator pedal. (Other than during shift change)
 - When TCM detects that relation between gear position and condition of ATF pressure switch 2 is irregular during releasing accelerator pedal. (Other than during shift change)

Possible Cause

ACS008D8

- Harness or connectors
(The solenoid and switch circuits are open or shorted.)
- Low coast brake solenoid valve
- ATF pressure switch 2

DTC Confirmation Procedure

ACS008D9

CAUTION:

Always drive vehicle at a safe speed.

NOTE:

If "DTC Confirmation Procedure" has been previously performed, always turn ignition switch OFF and wait for at least 10 seconds before performing the next test.

After the repair, perform the following procedure to confirm the malfunction is eliminated.

WITH CONSULT-II

1. Start engine.
2. Accelerate vehicle to maintain the following conditions.
Selector lever: "M" position
Gear position: "M1-1st" or "M2-2nd" gear (LC/B ON/OFF)
3. Perform step "2" again.
4. Turn ignition switch OFF, then perform step "1" to "3" again.
5. Check "SELF-DIAG RESULTS" mode for "A/T" with CONSULT-II. If DTC (P1774) is detected, refer to [AT-164, "Diagnostic Procedure"](#) .
If DTC (P1772) is detected, go to [AT-162, "Diagnostic Procedure"](#) .

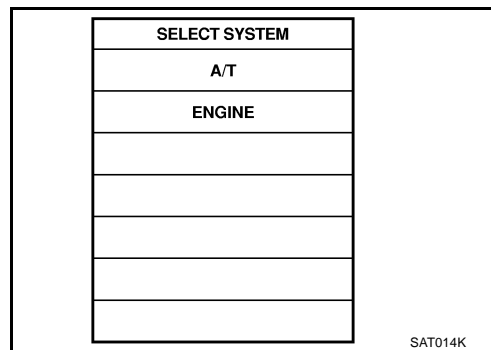

WITH GST

Follow the procedure "With CONSULT-II".

DTC P1774 LOW COAST BRAKE SOLENOID VALVE FUNCTION

ACS008DA

Diagnostic Procedure

1. CHECK INPUT SIGNALS

With CONSULT-II

1. Start engine.
2. Select "SELECTION FROM MENU" in "DATA MONITOR" mode for "A/T" with CONSULT-II.
3. Drive vehicle in the manual mode ("M1-1st" or "M2-2nd" gear), and confirm the ON/OFF actuation of the "ATF PRES SW 2" and "ON OFF SOL".

Item name	Condition	Display value
ON OFF SOL	Low coast brake engaged. Refer to AT-19 .	ON
	Low coast brake disengaged. Refer to AT-19 .	OFF
ATF PRES SW 2	Low coast brake engaged. Refer to AT-19 .	ON
	Low coast brake disengaged. Refer to AT-19 .	OFF

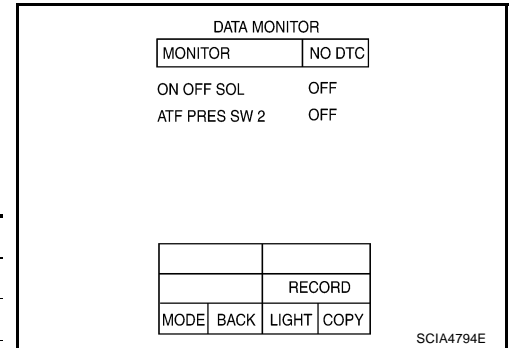

OK or NG

- OK >> GO TO 4.
NG >> GO TO 2.

2. CHECK TCM POWER SUPPLY AND GROUND CIRCUIT

Check TCM power supply and ground circuit. Refer to [AT-179, "MAIN POWER SUPPLY AND GROUND CIRCUIT"](#) .

OK or NG

- OK >> GO TO 3.
NG >> Repair or replace damaged parts.

3. DETECT MALFUNCTIONING ITEM

Check the following items:

- A/T assembly harness connector pin terminals for damage or loose connection with harness connector.

OK or NG

- OK >> Replace control valve with TCM. Refer to [AT-238, "Control Valve with TCM and A/T Fluid Temperature Sensor 2"](#) .
NG >> Repair or replace damaged parts.

4. CHECK DTC

Perform "DTC Confirmation Procedure".

- Refer to [AT-163, "DTC Confirmation Procedure"](#) .

OK or NG

- OK >> **INSPECTION END**
NG >> GO TO 2.

DTC P1815 MANUAL MODE SWITCH

DTC P1815 MANUAL MODE SWITCH

PFP:34901

Description

ACS004YC

Manual mode switch is installed in A/T device. It sends manual mode switch, shift up and shift down switch signals to TCM.

TCM sends the switch signals to unified meter and A/C amp by CAN communication line. Then manual mode switch position is indicated on the A/T position indicator. For inspection, refer to [AT-169, "A/T Position Indicator"](#).

CONSULT-II Reference Value in Data Monitor Mode

ACS003QT

Item name	Condition	Display Value
MANU MODE SW	Manual shift gate position (neutral)	ON
	Other than the above	OFF
NON M-MODE SW	Manual shift gate position	OFF
	Other than the above	ON
UP SW LEVER	Selector lever: + side	ON
	Other than the above	OFF
DOWN SW LEVER	Selector lever: - side	ON
	Other than the above	OFF

On Board Diagnosis Logic

ACS003QU

- This is not an OBD-II self-diagnostic item.
- Diagnostic trouble code "MANU MODE SW/CIR" with CONSULT-II is detected when TCM monitors Manual mode, Non manual mode, Up or Down switch signal, and detects as irregular when impossible input pattern occurs 1 second or more.

Possible Cause

ACS003QV

- Harness or connectors
(These switches circuit is open or shorted.)
- Manual mode select switch (Into control device)
- Manual mode position select switch (Into control device)

DTC Confirmation Procedure

ACS003QW

NOTE:

If "DTC Confirmation Procedure" has been previously performed, always turn ignition switch OFF and wait for at least 10 seconds before performing the next test.

After the repair, perform the following procedure to confirm the malfunction is eliminated.

WITH CONSULT-II

1. Turn ignition switch ON. (Do not start engine.)
2. Select "DATA MONITOR" mode for "A/T" with CONSULT-II.
3. Start engine.
4. Move selector lever to "M" position.
5. Drive vehicle for at least 2 consecutive seconds.
6. If DTC is detected, go to [AT-168, "Diagnostic Procedure"](#).

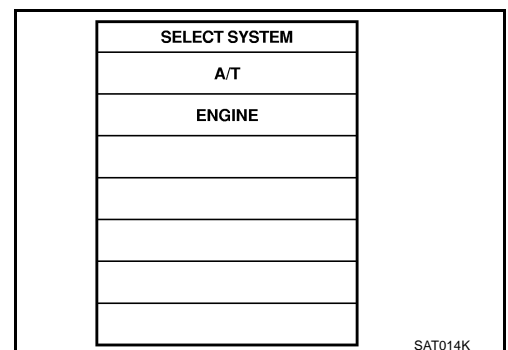

DTC P1815 MANUAL MODE SWITCH

ACS00800

Wiring Diagram — AT — MMSW

AT-MMSW-01

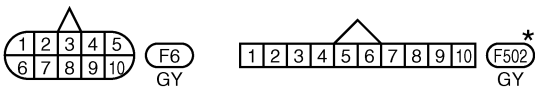
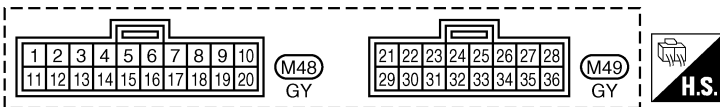
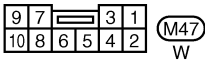
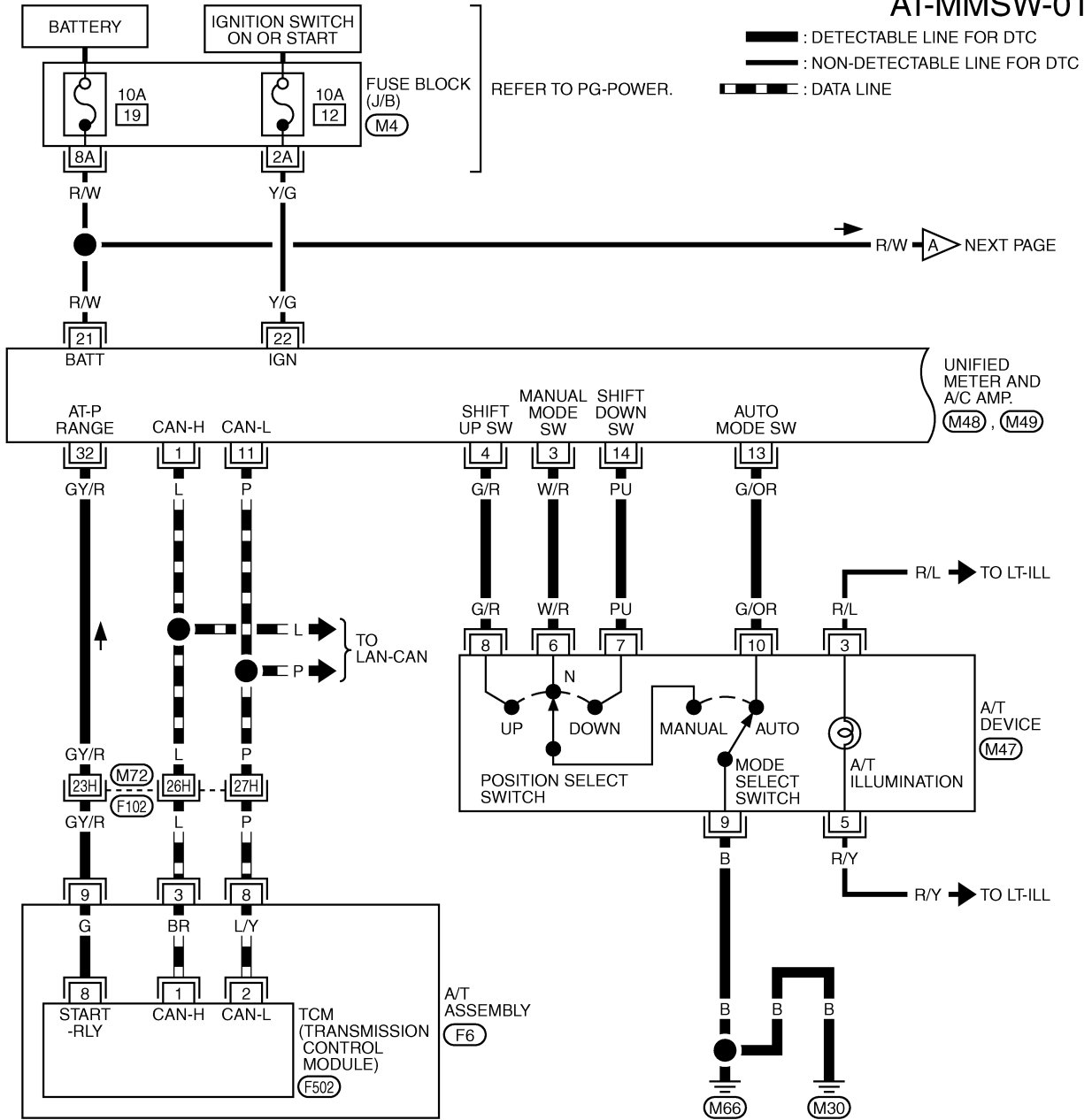

*: THIS CONNECTOR IS NOT SHOWN IN "HARNESS LAYOUT", PG SECTION.

REFER TO THE FOLLOWING.

(F102) -SUPER MULTIPLE JUNCTION (SMJ)

(M4) -FUSE BLOCK-JUNCTION BOX (J/B)

TCWM0262E

DTC P1815 MANUAL MODE SWITCH

AT-MMSW-02

: DETECTABLE LINE FOR DTC
 : NON-DETECTABLE LINE FOR DTC

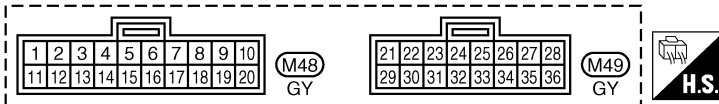
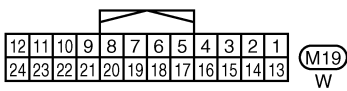
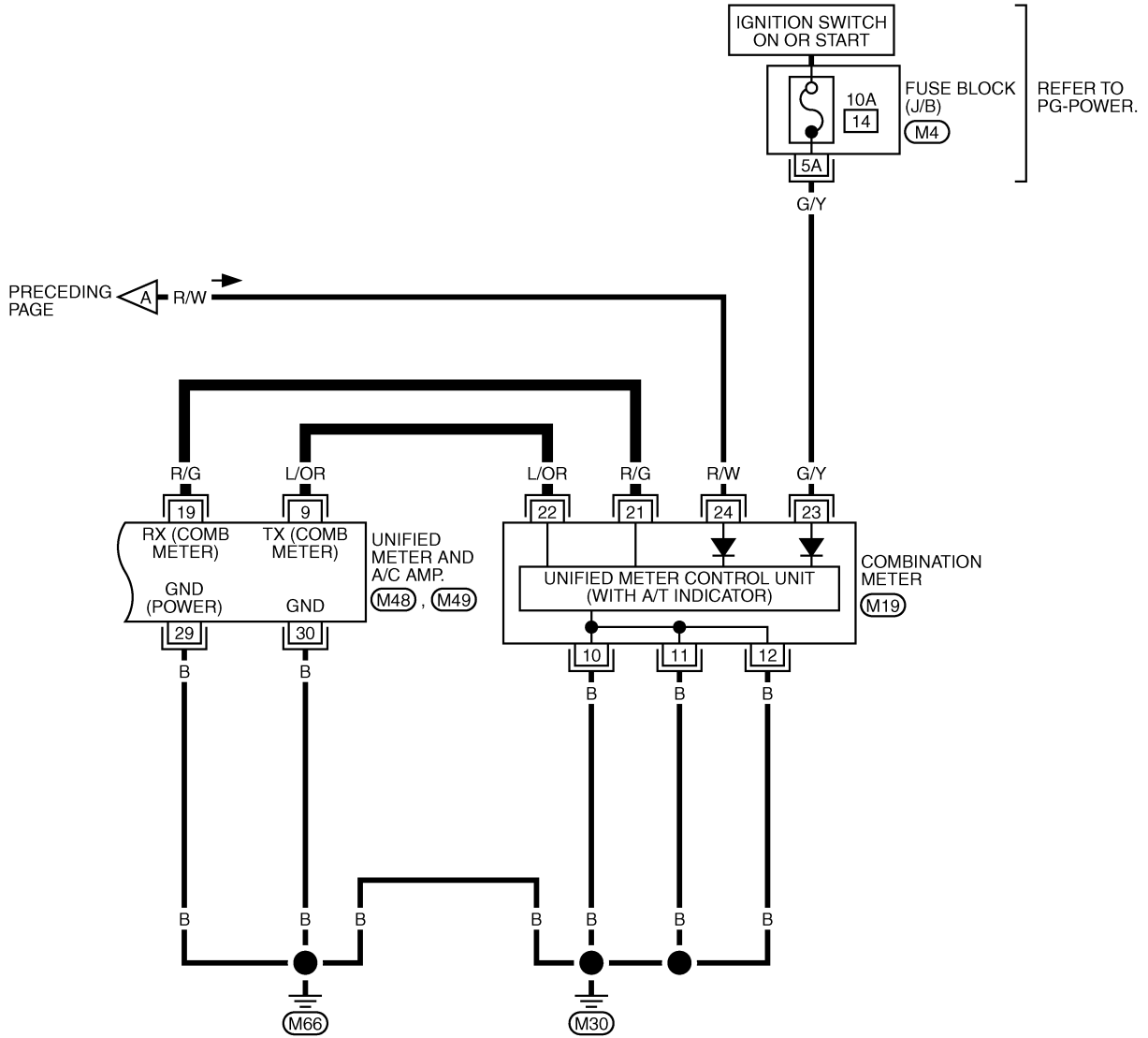

REFER TO THE FOLLOWING.
 (M4) - FUSE BLOCK-JUNCTION BOX (J/B)

TCWM0263E

DTC P1815 MANUAL MODE SWITCH

TCM terminals and data are reference value. Measured between each terminal and ground.

Terminal	Wire color	Item	Condition	Data (Approx.)
3	L	CAN-H	-	-
8	P	CAN-L	-	-
9	GY/R	Starter relay	 Selector lever in "N", "P" positions.	Battery voltage
			Selector lever in other positions.	0V

Diagnostic Procedure

ACS003QX

1. CHECK CAN COMMUNICATION LINE

Perform self-diagnosis. Refer to [AT-90, "SELF-DIAGNOSTIC RESULT MODE"](#) .

Is a malfunction in the CAN communication indicated in the results?

- YES >> Check CAN communication line. Refer to [AT-101, "DTC U1000 CAN COMMUNICATION LINE"](#) .
 NO >> GO TO 2.

2. CHECK MANUAL MODE SWITCH CIRCUIT

Ⓟ With CONSULT-II

- Turn ignition switch ON. (Do not start engine.)
- Select "ECU INPUT SIGNALS" in "DATA MONITOR" mode for "A/T" with CONSULT-II.
- Read out ON/OFF switching action of "MANU MODE SW", "NON M-MODE SW", "UP SW LEVER", "DOWN SW LEVER".

DATA MONITOR			
MONITOR		NO DTC	
MANU MODE SW	OFF	NON M-MODE SW	ON
UP SW LEVER	OFF	DOWN SW LEVER	OFF
△		RECORD	
MODE	BACK	LIGHT	COPY

SCIA4988E

Item name	Condition	Display Value
MANU MODE SW	Manual shift gate position (neutral)	ON
	Other than the above	OFF
NON M-MODE SW	Manual shift gate position	OFF
	Other than the above	ON
UP SW LEVER	Selector lever: +side	ON
	Other than the above	OFF
DOWN SW LEVER	Selector lever: -side	ON
	Other than the above	OFF

⊗ Without CONSULT-II

Drive vehicle in the manual mode, and confirm that the actual gear position and the meter's indication of the position mutually coincide when the selector lever is shifted to the "+" (up) or "-" (down) side (1st ↔ 5th gear).

OK or NG

- OK >> GO TO 4.
 NG >> GO TO 3.

3. DETECT MALFUNCTIONING ITEM

Check the following items.

- Manual mode switch. Refer to [AT-169, "Component Inspection"](#) .
- Pin terminals for damage or loose connection with harness connector.
- Open circuit or short to ground or short to power in harness or connector for A/T device (manual mode switch).
- Unified meter and A/C amp. Refer to [DI-54, "UNIFIED METER AND A/C AMP"](#) .

OK or NG

- OK >> GO TO 4.
 NG >> Repair or replace damaged parts.

DTC P1815 MANUAL MODE SWITCH

4. CHECK DTC

Perform "DTC Confirmation Procedure".

- Refer to [AT-165, "DTC Confirmation Procedure"](#).

OK or NG

- OK >> **INSPECTION END**
- NG >> GO TO 5.

5. CHECK TCM POWER SUPPLY AND GROUND CIRCUIT

Check TCM power supply and ground circuit. Refer to [AT-179, "MAIN POWER SUPPLY AND GROUND CIRCUIT"](#).

OK or NG

- OK >> GO TO 6.
- NG >> Repair or replace damaged parts.

6. DETECT MALFUNCTIONING ITEM

Check the following items:

- A/T assembly harness connector pin terminals for damage or loose connection with harness connector.

OK or NG

- OK >> Replace control valve with TCM. Refer to [AT-238, "Control Valve with TCM and A/T Fluid Temperature Sensor 2"](#).
- NG >> Repair or replace damaged parts.

Component Inspection MANUAL MODE SWITCH

ACS003QY

Check continuity between terminals.

Item	Position	Connector	Terminal (Unit side)	Continuity
Manual mode select switch	Auto	M47	9 - 10	Yes
	Manual		6 - 9	
Manual mode position select switch	UP		8 - 9	
	DOWN		7 - 9	

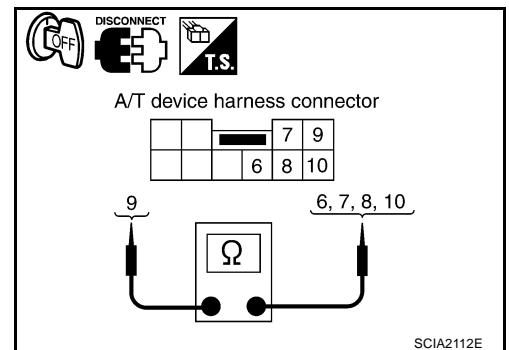

A/T Position Indicator DIAGNOSTIC PROCEDURE

ACS003OZ

1. CHECK INPUT SIGNALS

With CONSULT-II

- Start engine.
- Select "MAIN SIGNALS" in "DATA MONITOR" mode for A/T with CONSULT-II and read out the value of "GEAR".
- Drive vehicle in the manual mode, and confirm that the actual gear position and the meter's indication of the position mutually coincide when the selector lever is shifted to the "+ (up)" or "- (down)" side (1st ⇔ 5th gear).

OK or NG

- OK >> **INSPECTION END**
- NG >> Check the following items.

DATA MONITOR	
MONITOR	NO DTC
VHCL/S SE-A/T	0 km/h
THROTTLE POSI	0. 0/8
GEAR	1
ENGINE SPEED	0 rpm
TURBINE REV	0 rpm
▼	
RECORD	
MODE	BACK LIGHT COPY

PCIA0065E

DTC P1815 MANUAL MODE SWITCH

A/T Position Indicator Symptom Chart

Items	Presumed Location of Trouble
The actual gear position does not change, or shifting into the manual mode is not possible (no gear shifting in the manual mode possible). The A/T position indicator is not indicated.	Manual mode switch <ul style="list-style-type: none">● Refer to AT-165, "DTC P1815 MANUAL MODE SWITCH" . A/T main system (Fail-safe function actuated) <ul style="list-style-type: none">● Refer to AT-90, "SELF-DIAGNOSTIC RESULT MODE" .
The actual gear position changes, but the A/T position indicator is not indicated.	Perform the self-diagnosis function. <ul style="list-style-type: none">● Refer to AT-90, "SELF-DIAGNOSTIC RESULT MODE" .
The actual gear position and the indication on the A/T position indicator do not coincide.	Perform the self-diagnosis function. <ul style="list-style-type: none">● Refer to AT-90, "SELF-DIAGNOSTIC RESULT MODE" .
Only a specific position or positions is/are not indicated on the A/T position indicator.	Check the unified meter and A/C amp. <ul style="list-style-type: none">● Refer to DI-4, "COMBINATION METERS" .

DTC P1841 ATF PRESSURE SWITCH 1

DTC P1841 ATF PRESSURE SWITCH 1

PFP:25240

Description

ACS003R0

Fail-safe function to detect front brake solenoid valve condition.

CONSULT-II Reference Value

ACS003R1

Item name	Condition	Display value
ATF PRES SW 1	Front brake engaged. Refer to AT-19 .	ON
	Front brake disengaged. Refer to AT-19 .	OFF

On Board Diagnosis Logic

ACS003R2

- This is not an OBD-II self-diagnostic item.
- Diagnostic trouble code “ATF PRES SW 1/CIRC” with CONSULT-II is detected when TCM detects that actual gear ratio is normal, and relation between gear position and condition of ATF pressure switch 1 is irregular during depressing accelerator pedal. (Other than during shift change)

Possible Cause

ACS003R3

- ATF pressure switch 1
- Harness or connectors
(Switch circuit is open or shorted.)

DTC Confirmation Procedure

ACS003R4

CAUTION:

Always drive vehicle at a safe speed.

NOTE:

If “DTC Confirmation Procedure” has been previously performed, always turn ignition switch OFF and wait for at least 10 seconds before performing the next test.

After the repair, perform the following procedure to confirm the malfunction is eliminated.

Ⓟ WITH CONSULT-II

1. Start engine.
2. Accelerate vehicle to maintain the following conditions.
ACCELE POSI: 1.5/8 - 2.0/8
Selector lever: “D” position
Gear position: 3rd ⇒ 4th Gear (FR/B ON/OFF)
Driving location: Driving the vehicle uphill (increased engine load) will help maintain the driving conditions required for this test.
3. Perform step “2” again.
4. Turn ignition switch OFF, then perform step “1” to “3” again.
5. Check “SELF-DIAG RESULTS” mode for “A/T” with CONSULT-II.

If DTC (P1841) is detected, go to [AT-172. "Diagnostic Procedure"](#) .

If DTC (P1757) is detected, go to [AT-150. "Diagnostic Procedure"](#) .

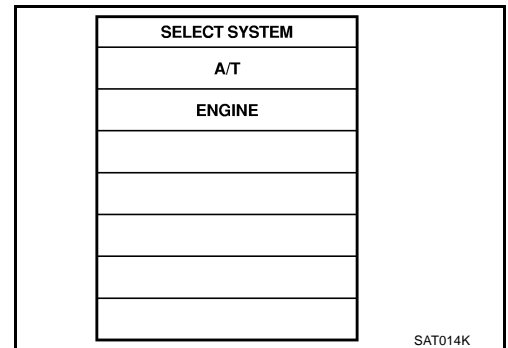

DTC P1841 ATF PRESSURE SWITCH 1

ACS003R5

Diagnostic Procedure

1. CHECK INPUT SIGNAL

With CONSULT-II

1. Start engine.
2. Select "ECU INPUT SIGNALS" or "MAIN SIGNALS" in "DATA MONITOR" mode for "A/T" with CONSULT-II.
3. Drive vehicle in "D" position (3rd ⇒ 4th gear), and confirm the ON/OFF actuation of the "ATF PRES SW 1".

Item name	Condition	Display value
ATF PRES SW 1	Front brake engaged. Refer to AT-19 .	ON
	Front brake disengaged. Refer to AT-19 .	OFF

DATA MONITOR	
MONITOR	NO. DTC
ATF PRES SW 1	OFF
ATF PRES SW 2	OFF
ATF PRES SW 3	OFF
ATF PRES SW 5	OFF
ATF PRES SW 6	OFF

△	▽		
RECORD			
MODE	BACK	LIGHT	COPY

PCIA0067E

OK or NG

- OK >> GO TO 4.
NG >> GO TO 2.

2. CHECK TCM POWER SUPPLY AND GROUND CIRCUIT

Check TCM power supply and ground circuit. Refer to [AT-179, "MAIN POWER SUPPLY AND GROUND CIRCUIT"](#) .

OK or NG

- OK >> GO TO 3.
NG >> Repair or replace damaged parts.

3. DETECT MALFUNCTIONING ITEM

Check the following items:

- A/T assembly harness connector pin terminals for damage or loose connection with harness connector.

OK or NG

- OK >> Replace control valve with TCM. Refer to [AT-238, "Control Valve with TCM and A/T Fluid Temperature Sensor 2"](#) .
NG >> Repair or replace damaged parts.

4. CHECK DTC

Perform "DTC Confirmation Procedure".

- Refer to [AT-171, "DTC Confirmation Procedure"](#) .

OK or NG

- OK >> **INSPECTION END**
NG >> GO TO 2.

DTC P1843 ATF PRESSURE SWITCH 3

DTC P1843 ATF PRESSURE SWITCH 3

PFP:25240

Description

ACS003R6

Fail-safe function to detect input clutch solenoid valve condition.

CONSULT-II Reference Value

ACS003R7

Item name	Condition	Display value
ATF PRES SW 3	Input clutch engaged. Refer to AT-19 .	ON
	Input clutch disengaged. Refer to AT-19 .	OFF

On Board Diagnosis Logic

ACS003R8

- This is not an OBD-II self-diagnostic item.
- Diagnostic trouble code “ATF PRES SW 3/CIRC” with CONSULT-II is detected when TCM detects that actual gear ratio is normal, and relation between gear position and condition of ATF pressure switch 3 is irregular during depressing accelerator pedal. (Other than during shift change)

Possible Cause

ACS003R9

- ATF pressure switch 3
- Harness or connectors
(Switch circuit is open or shorted.)

DTC Confirmation Procedure

ACS003RA

CAUTION:

Always drive vehicle at a safe speed.

NOTE:

If “DTC Confirmation Procedure” has been previously performed, always turn ignition switch OFF and wait for at least 10 seconds before performing the next test.

After the repair, perform the following procedure to confirm the malfunction is eliminated.

WITH CONSULT-II

1. Start engine.
2. Accelerate vehicle to maintain the following conditions.
ACCELE POSI: 1.5/8 - 2.0/8
Selector lever: “D” position
Gear position: 3rd ⇒ 4th Gear (I/C ON/OFF)
Driving location: Driving the vehicle uphill (increased engine load) will help maintain the driving conditions required for this test.
3. Perform step “2” again.
4. Turn ignition switch OFF, then perform step “1” to “3” again.
5. Check “SELF-DIAG RESULTS” mode for “A/T” with CONSULT-II.

If DTC (P1843) is detected, go to [AT-174. "Diagnostic Procedure"](#) .

If DTC (P1752) is detected, go to [AT-146. "Diagnostic Procedure"](#) .

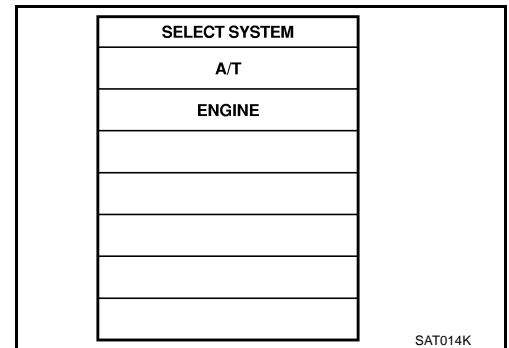

DTC P1843 ATF PRESSURE SWITCH 3

ACS003RB

Diagnostic Procedure

1. CHECK INPUT SIGNAL

With CONSULT-II

1. Start engine.
2. Select "ECU INPUT SIGNALS" or "MAIN SIGNALS" in "DATA MONITOR" mode for "A/T" with CONSULT-II.
3. Drive vehicle in "D" position (3rd ⇒ 4th gear), and confirm the ON/OFF actuation of the "ATF PRES SW 3".

DATA MONITOR	
MONITOR	NO. DTC
ATF PRES SW 1	OFF
ATF PRES SW 2	OFF
ATF PRES SW 3	OFF
ATF PRES SW 5	OFF
ATF PRES SW 6	OFF

△	▽		
RECORD			
MODE	BACK	LIGHT	COPY

PCIA0067E

Item name	Condition	Display value
ATF PRES SW 3	Input clutch engaged. Refer to AT-19 .	ON
	Input clutch disengaged. Refer to AT-19 .	OFF

OK or NG

- OK >> GO TO 4.
NG >> GO TO 2.

2. CHECK TCM POWER SUPPLY AND GROUND CIRCUIT

Check TCM power supply and ground circuit. Refer to [AT-179, "MAIN POWER SUPPLY AND GROUND CIRCUIT"](#) .

OK or NG

- OK >> GO TO 3.
NG >> Repair or replace damaged parts.

3. DETECT MALFUNCTIONING ITEM

Check the following items:

- A/T assembly harness connector pin terminals for damage or loose connection with harness connector.

OK or NG

- OK >> Replace control valve with TCM. Refer to [AT-238, "Control Valve with TCM and A/T Fluid Temperature Sensor 2"](#) .
NG >> Repair or replace damaged parts.

4. CHECK DTC

Perform "DTC Confirmation Procedure".

- Refer to [AT-173, "DTC Confirmation Procedure"](#) .

OK or NG

- OK >> **INSPECTION END**
NG >> GO TO 2.

DTC P1845 ATF PRESSURE SWITCH 5

DTC P1845 ATF PRESSURE SWITCH 5

PDF:25240

Description

ACS003RC

Fail-safe function to detect direct clutch solenoid valve condition.

CONSULT-II Reference Value

ACS003RD

Item name	Condition	Display value
ATF PRES SW 5	Direct clutch engaged. Refer to AT-19 .	ON
	Direct clutch disengaged. Refer to AT-19 .	OFF

On Board Diagnosis Logic

ACS003RE

- This is not an OBD-II self-diagnostic item.
- Diagnostic trouble code “ATF PRES SW 5/CIRC” with CONSULT-II is detected when TCM detects that actual gear ratio is normal, and relation between gear position and condition of ATF pressure switch 5 is irregular during depressing accelerator pedal. (Other than during shift change)

Possible Cause

ACS003RF

- ATF pressure switch 5
- Harness or connectors
(Switch circuit is open or shorted.)

DTC Confirmation Procedure

ACS003RG

CAUTION:

Always drive vehicle at a safe speed.

NOTE:

If “DTC Confirmation Procedure” has been previously performed, always turn ignition switch OFF and wait for at least 10 seconds before performing the next test.

After the repair, perform the following procedure to confirm the malfunction is eliminated.

Ⓟ WITH CONSULT-II

1. Start engine.
2. Accelerate vehicle to maintain the following conditions.
ACCELE POSI: 1.5/8 - 2.0/8
Selector lever: “D” position
Gear position: 1st ⇒ 2nd Gear (D/C ON/OFF)
Driving location: Driving the vehicle uphill (increased engine load) will help maintain the driving conditions required for this test.
3. Perform step “2” again.
4. Turn ignition switch OFF, then perform step “1” to “3” again.
5. Check “SELF-DIAG RESULTS” mode for “A/T” with CONSULT-II.

If DTC (P1845) is detected, go to [AT-176. "Diagnostic Procedure"](#) .

If DTC (P1762) is detected, go to [AT-154. "Diagnostic Procedure"](#) .

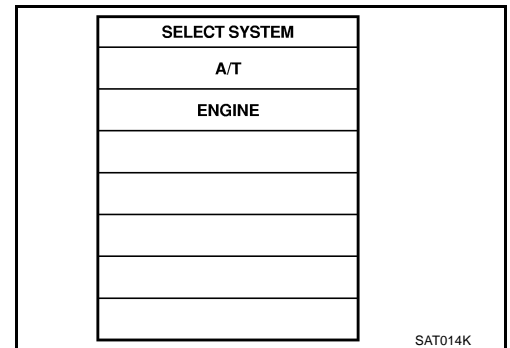

DTC P1845 ATF PRESSURE SWITCH 5

ACS003RH

Diagnostic Procedure

1. CHECK INPUT SIGNAL

With CONSULT-II

1. Start engine.
2. Select "ECU INPUT SIGNALS" or "MAIN SIGNALS" in "DATA MONITOR" mode for "A/T" with CONSULT-II.
3. Drive vehicle in "D" position (1st ⇒ 2nd gear), and confirm the ON/OFF actuation of the "ATF PRES SW 5".

Item name	Condition	Display value
ATF PRES SW 5	Direct clutch engaged. Refer to AT-19 .	ON
	Direct clutch disengaged. Refer to AT-19 .	OFF

DATA MONITOR	
MONITOR	NO. DTC
ATF PRES SW 1	OFF
ATF PRES SW 2	OFF
ATF PRES SW 3	OFF
ATF PRES SW 5	OFF
ATF PRES SW 6	OFF

Δ	▽		
RECORD			
MODE	BACK	LIGHT	COPY

PCIA0067E

OK or NG

- OK >> GO TO 4.
NG >> GO TO 2.

2. CHECK TCM POWER SUPPLY AND GROUND CIRCUIT

Check TCM power supply and ground circuit. Refer to [AT-179, "MAIN POWER SUPPLY AND GROUND CIRCUIT"](#) .

OK or NG

- OK >> GO TO 3.
NG >> Repair or replace damaged parts.

3. DETECT MALFUNCTIONING ITEM

Check the following items:

- A/T assembly harness connector pin terminals for damage or loose connection with harness connector.

OK or NG

- OK >> Replace control valve with TCM. Refer to [AT-238, "Control Valve with TCM and A/T Fluid Temperature Sensor 2"](#) .
NG >> Repair or replace damaged parts.

4. CHECK DTC

Perform "DTC Confirmation Procedure".

- Refer to [AT-175, "DTC Confirmation Procedure"](#) .

OK or NG

- OK >> **INSPECTION END**
NG >> GO TO 2.

DTC P1846 ATF PRESSURE SWITCH 6

DTC P1846 ATF PRESSURE SWITCH 6

PDF:25240

Description

ACS003RI

Fail-safe function to detect high and low reverse clutch solenoid valve condition.

CONSULT-II Reference Value

ACS003RJ

Item name	Condition	Display value
ATF PRES SW 6	High and low reverse clutch engaged. Refer to AT-19 .	ON
	High and low reverse clutch disengaged. Refer to AT-19 .	OFF

On Board Diagnosis Logic

ACS003RK

- This is not an OBD-II self-diagnostic item.
- Diagnostic trouble code "ATF PRES SW 6/CIRC" with CONSULT-II is detected when TCM detects that actual gear ratio is normal, and relation between gear position and condition of ATF pressure switch 6 is irregular during depressing accelerator pedal. (Other than during shift change)

Possible Cause

ACS003RL

- ATF pressure switch 6
- Harness or connectors
(Switch circuit is open or shorted.)

DTC Confirmation Procedure

ACS003RM

CAUTION:

Always drive vehicle at a safe speed.

NOTE:

If "DTC Confirmation Procedure" has been previously performed, always turn ignition switch OFF and wait for at least 10 seconds before performing the next test.

After the repair, perform the following procedure to confirm the malfunction is eliminated.

WITH CONSULT-II

1. Start engine.
2. Accelerate vehicle to maintain the following conditions.
ACCELE POSI: 1.5/8 - 2.0/8
Selector lever: "D" position
Gear position: 2nd ⇒ 3rd Gear (HLR/C ON/OFF)
Driving location: Driving the vehicle uphill (increased engine load) will help maintain the driving conditions required for this test.
3. Perform step "2" again.
4. Turn ignition switch OFF, then perform step "1" to "3" again.
5. Check "SELF-DIAG RESULTS" mode for "A/T" with CONSULT-II.

If DTC (P1846) is detected, go to [AT-178. "Diagnostic Procedure"](#) .

If DTC (P1767) is detected, go to [AT-158. "Diagnostic Procedure"](#) .

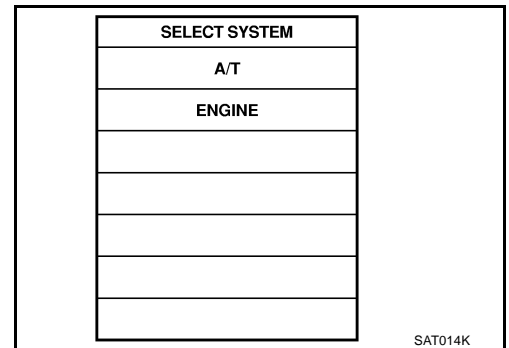

DTC P1846 ATF PRESSURE SWITCH 6

ACS003RN

Diagnostic Procedure

1. CHECK INPUT SIGNAL

With CONSULT-II

1. Start engine.
2. Select "ECU INPUT SIGNALS" or "MAIN SIGNALS" in "DATA MONITOR" mode for "A/T" with CONSULT-II.
3. Drive vehicle in "D" position (2nd ⇒ 3rd gear), and confirm the ON/OFF actuation of the "ATF PRES SW 6".

DATA MONITOR	
MONITOR	NO. DTC
ATF PRES SW 1	OFF
ATF PRES SW 2	OFF
ATF PRES SW 3	OFF
ATF PRES SW 5	OFF
ATF PRES SW 6	OFF

Δ	▽		
RECORD			
MODE	BACK	LIGHT	COPY

PCIA0067E

Item name	Condition	Display value
ATF PRES SW 6	High and low reverse clutch engaged. Refer to AT-19 .	ON
	High and low reverse clutch disengaged. Refer to AT-19 .	OFF

OK or NG

- OK >> GO TO 4.
NG >> GO TO 2.

2. CHECK TCM POWER SUPPLY AND GROUND CIRCUIT

Check TCM power supply and ground circuit. Refer to [AT-179, "MAIN POWER SUPPLY AND GROUND CIRCUIT"](#) .

OK or NG

- OK >> GO TO 3.
NG >> Repair or replace damaged parts.

3. DETECT MALFUNCTIONING ITEM

Check the following items:

- A/T assembly harness connector pin terminals for damage or loose connection with harness connector.

OK or NG

- OK >> Replace control valve with TCM. Refer to [AT-238, "Control Valve with TCM and A/T Fluid Temperature Sensor 2"](#) .
NG >> Repair or replace damaged parts.

4. CHECK DTC

Perform "DTC Confirmation Procedure".

- Refer to [AT-177, "DTC Confirmation Procedure"](#) .

OK or NG

- OK >> **INSPECTION END**
NG >> GO TO 2.

MAIN POWER SUPPLY AND GROUND CIRCUIT

MAIN POWER SUPPLY AND GROUND CIRCUIT

PPF:00100

Wiring Diagram — AT — MAIN

ACS0085Z

AT-MAIN-01

— : DETECTABLE LINE FOR DTC
 — : NON-DETECTABLE LINE FOR DTC

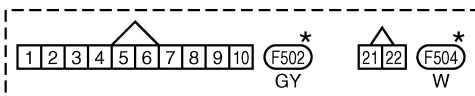
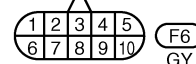
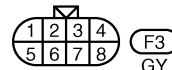
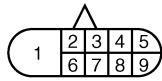
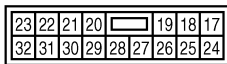
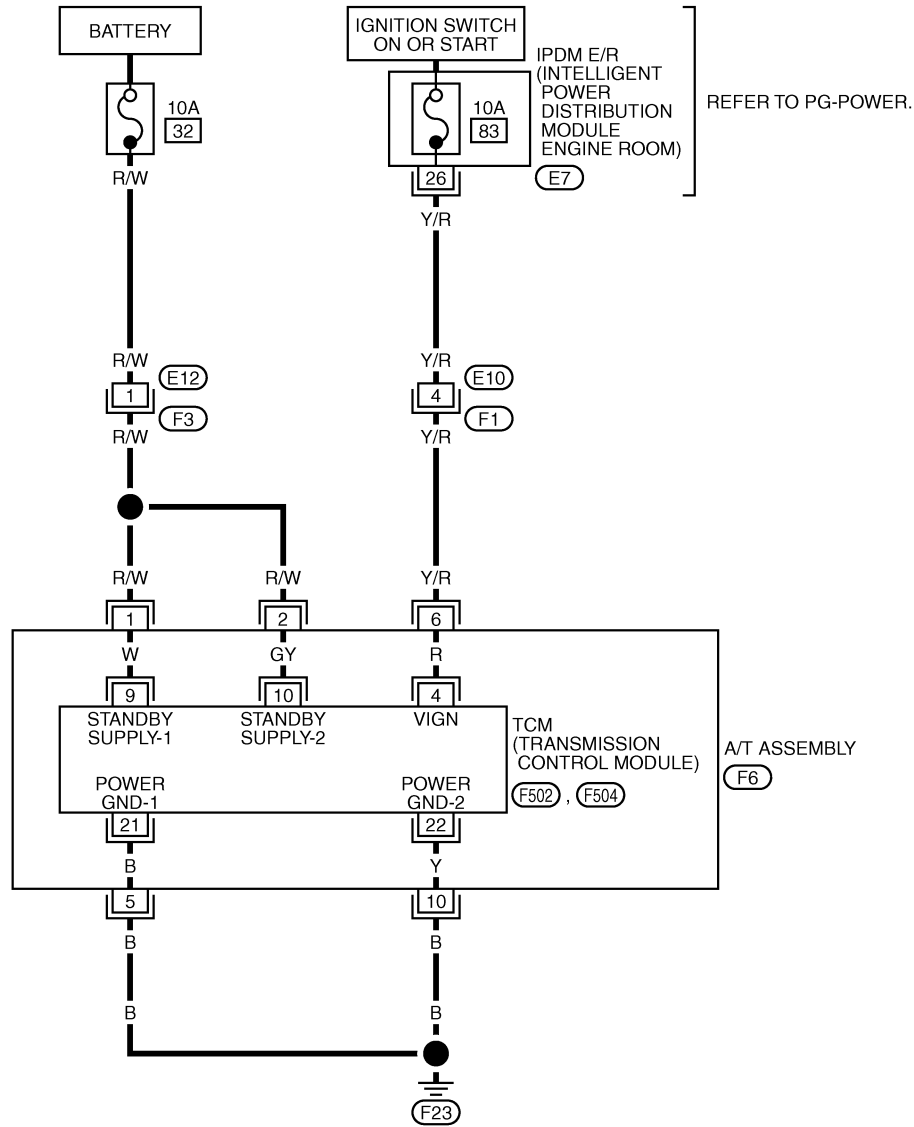



*: THIS CONNECTOR IS NOT SHOWN IN "HARNESS LAYOUT", PG SECTION.

TKWB0266E

MAIN POWER SUPPLY AND GROUND CIRCUIT

TCM terminals and data are reference value. Measured between each terminal and ground.

Terminal	Wire color	Item	Condition	Data (Approx.)
1	R/W	Power supply (Memory back-up)	Always	Battery voltage
2	R/W	Power supply (Memory back-up)	Always	Battery voltage
5	B	Ground	Always	0V
6	Y/R	Power supply		-
				-
10	B	Ground	Always	0V

Diagnostic Procedure

ACS00860

1. CHECK TCM POWER SOURCE STEP 1

- Turn ignition switch OFF.
- Disconnect A/T assembly harness connector.
- Check voltage between A/T assembly harness connector and ground.

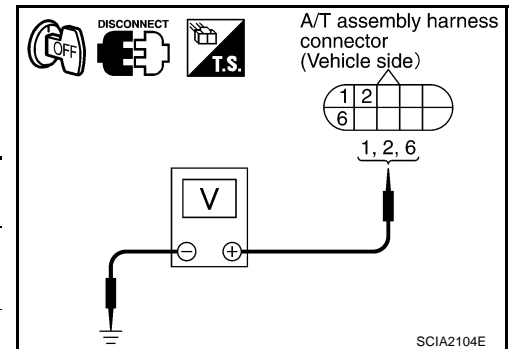

Item	Connector	Terminal (Wire color)	Voltage
TCM	F6	1 (R/W) - Ground	Battery voltage
		2 (R/W) - Ground	Battery voltage
		6 (Y/R) - Ground	0V

OK or NG

- OK >> GO TO 2.
NG >> GO TO 3.

2. CHECK TCM POWER SOURCE STEP 2

- Disconnect A/T assembly harness connector.
- Turn ignition switch ON. (Do not start engine.)
- Check voltage between A/T assembly harness connector and ground.

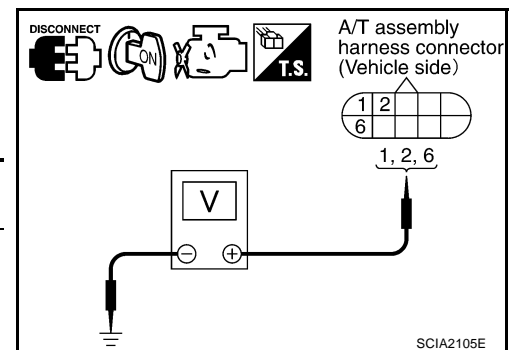

Item	Connector	Terminal (Wire color)	Voltage
TCM	F6	1 (R/W) - Ground	Battery voltage
		2 (R/W) - Ground	Battery voltage
		6 (Y/R) - Ground	Battery voltage

OK or NG

- OK >> GO TO 4.
NG >> GO TO 3.

MAIN POWER SUPPLY AND GROUND CIRCUIT

3. DETECT MALFUNCTIONING ITEM

Check the following items:

- Harness for short or open between battery and A/T assembly harness connector terminals 1, 2
- Harness for short or open between ignition switch and A/T assembly harness connector terminal 6
- 10A fuse (No.32, located in the fuse and fusible link block) and 10A fuse (No.83, located in the IPDM E/R)
- Ignition switch, Refer to [PG-4, "POWER SUPPLY ROUTING CIRCUIT"](#) .

OK or NG

- OK >> GO TO 4.
NG >> Repair or replace damaged parts.

4. CHECK TCM GROUND CIRCUIT

1. Turn ignition switch OFF.
2. Disconnect A/T assembly harness connector.
3. Check continuity between A/T assembly harness connector terminals and ground.

Continuity should exist.

If OK, check harness for short to ground and short to power.

OK or NG

- OK >> GO TO 5.
NG >> Repair open circuit or short to ground or short to power in harness or connectors.

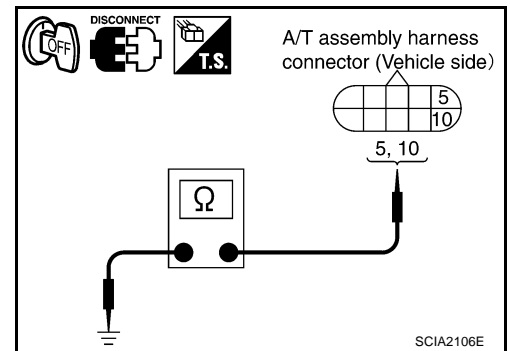

5. DETECT MALFUNCTIONING ITEM

Check the following items:

- The A/T assembly harness connector terminals for damage or loose connection with harness connector.

OK or NG

- OK >> GO TO 6.
NG >> Repair or replace damaged parts.

6. PERFORM SELF-DIAGNOSIS

Perform self-diagnosis. Refer to [AT-90, "SELF-DIAGNOSTIC RESULT MODE"](#) .

OK or NG

- OK >> **INSPECTION END**
NG-1 >> Self-diagnosis does not activate: GO TO 7.
NG-2 >> DTC is displayed: Check the malfunctioning system. Refer to [AT-90, "SELF-DIAGNOSTIC RESULT MODE"](#) .

MAIN POWER SUPPLY AND GROUND CIRCUIT

7. CHECK TERMINAL CORD ASSEMBLY

1. Remove control valve with TCM. Refer to [AT-238, "Control Valve with TCM and A/T Fluid Temperature Sensor 2"](#) .
2. Disconnect A/T assembly harness connector and TCM connector.
3. Check continuity between A/T assembly harness connector terminals and TCM connector terminals.

Item	Connector	Terminal (Wire color)	Continuity
A/T assembly harness connector	F6	1 (W)	Yes
TCM connector	F502	9 (W)	
A/T assembly harness connector	F6	2 (GY)	Yes
TCM connector	F502	10 (GY)	
A/T assembly harness connector	F6	6 (R)	Yes
TCM connector	F502	4 (R)	

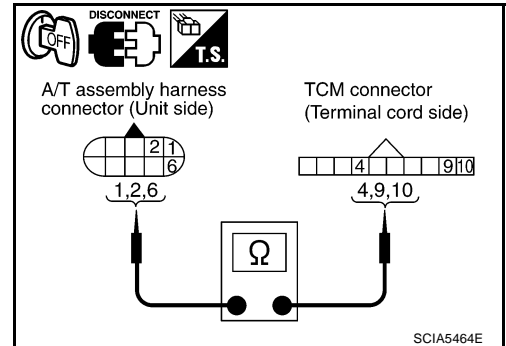

4. Check continuity between A/T assembly harness connector terminals and TCM connector terminals.

Item	Connector	Terminal (Wire color)	Continuity
A/T assembly harness connector	F6	5 (B)	Yes
TCM connector	F504	21 (B)	
A/T assembly harness connector	F6	10 (Y)	Yes
TCM connector	F504	22 (Y)	

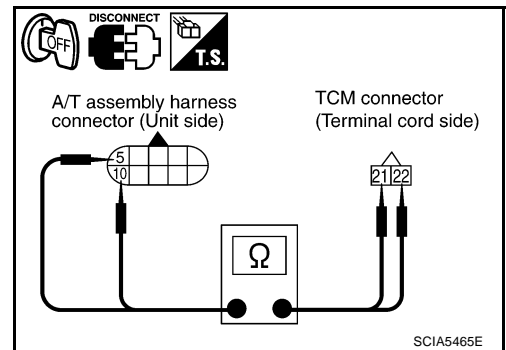

5. If OK, check harness for short to ground and short to power.

OK or NG

- OK >> Replace control valve with TCM. Refer to [AT-238, "Control Valve with TCM and A/T Fluid Temperature Sensor 2"](#) .
- NG >> Replace open circuit or short to ground and short to power in harness or connectors.

CLOSED THROTTLE POSITION AND WIDE OPEN THROTTLE POSITION CIRCUIT

CLOSED THROTTLE POSITION AND WIDE OPEN THROTTLE POSITION CIRCUIT

PFP:18002

CONSULT-II Reference Value

ACS006C2

Item name	Condition	Display value
CLSD THL POS	Released accelerator pedal.	ON
	Fully depressed accelerator pedal.	OFF
W/O THL POS	Fully depressed accelerator pedal.	ON
	Released accelerator pedal.	OFF

Diagnostic Procedure

ACS003R0

1. CHECK CAN COMMUNICATION LINE

Perform self-diagnosis. Refer to [AT-90, "SELF-DIAGNOSTIC RESULT MODE"](#) , [AT-99, "TCM SELF-DIAGNOSTIC PROCEDURE \(NO TOOLS\)"](#) .

Is a malfunction in the CAN communication indicated in the results?

- YES >> Check CAN communication line. Refer to [AT-101, "DTC U1000 CAN COMMUNICATION LINE"](#) .
 NO >> GO TO 2.

2. CHECK THROTTLE POSITION SIGNAL CIRCUIT

With CONSULT-II

- Turn ignition switch ON. (Do not start engine.)
- Select "ECU INPUT SIGNALS" in "DATA MONITOR" mode for "A/T" with CONSULT-II.
- Depress accelerator pedal and read out the value of "CLSD THL POS" and "W/O THL POS".

Accelerator Pedal Operation	Monitor Item	
	CLSD THL POS	W/O THL POS
Released	ON	OFF
Fully depressed	OFF	ON

DATA MONITOR	
MONITOR	NO DTC
ACCELE POSI	0.0/8
THROTTLE POSI	0.0/8
CLSD THL POS	ON
W/O THL POS	OFF
BRAKE SW	OFF
▼	
RECORD	
MODE	BACK
LIGHT	COPY

PCIA0070E

OK or NG

OK >> **INSPECTION END**

NG >> Check the following items. If NG, repair or replace damaged parts.

- Perform self-diagnosis for "ENGINE" with CONSULT-II. Refer to [EC-103, "CONSULT-II Function \(ENGINE\)"](#) .
- Open circuit or short to ground or short to power in harness or connectors.
- Pin terminals for damage or loose connection with harness connector.

BRAKE SIGNAL CIRCUIT

BRAKE SIGNAL CIRCUIT

PFP:25320

CONSULT-II Reference Value

ACS006C3

Item name	Condition	Display value
BRAKE SW	Depressed brake pedal.	ON
	Released brake pedal.	OFF

Diagnostic Procedure

ACS003RP

1. CHECK CAN COMMUNICATION LINE

Perform self-diagnosis. Refer to [AT-90, "SELF-DIAGNOSTIC RESULT MODE"](#) , [AT-99, "TCM SELF-DIAGNOSTIC PROCEDURE \(NO TOOLS\)"](#) .

Is a malfunction in the CAN communication indicated in the results?

- YES >> Check CAN communication line. Refer to [AT-101, "DTC U1000 CAN COMMUNICATION LINE"](#) .
 NO >> GO TO 2.

2. CHECK STOP LAMP SWITCH CIRCUIT

With CONSULT-II

- Turn ignition switch ON. (Do not start engine.)
- Select "ECU INPUT SIGNALS" in "DATA MONITOR" mode for "A/T" with CONSULT-II.
- Read out ON/OFF switching action of the "BRAKE SW".

Item name	Condition	Display value
BRAKE SW	Depressed brake pedal.	ON
	Released brake pedal.	OFF

OK or NG

- OK >> **INSPECTION END**
 NG >> GO TO 3.

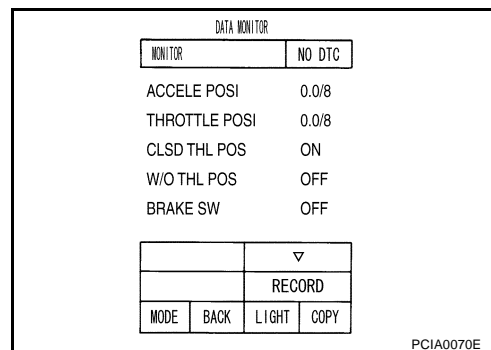

3. CHECK STOP LAMP SWITCH

Check continuity between stop lamp switch harness connector E11 terminals 1 and 2. Refer to [AT-185, "Wiring Diagram — AT — NON-DTC"](#) .

Condition	Continuity
When brake pedal is depressed	Yes
When brake pedal is released	No

Check stop lamp switch after adjusting brake pedal — refer to [BR-6, "BRAKE PEDAL"](#) .

OK or NG

- OK >> Check the following items. If NG, repair or replace damaged parts.
- Harness for short or open between battery and stop lamp switch.
 - Harness for short or open between stop lamp switch and unified meter and A/C amp.
- NG >> Repair or replace the stop lamp switch.

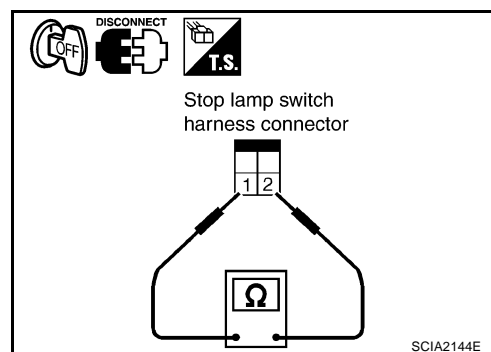

TROUBLE DIAGNOSIS FOR SYMPTOMS

TROUBLE DIAGNOSIS FOR SYMPTOMS

PFP:00007

Wiring Diagram — AT — NONDTC

ACS00844

AT-NONDTC-01

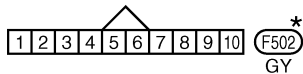
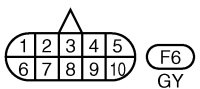
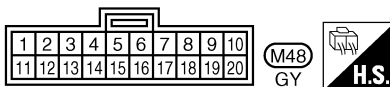
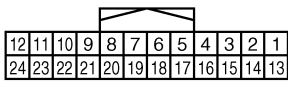
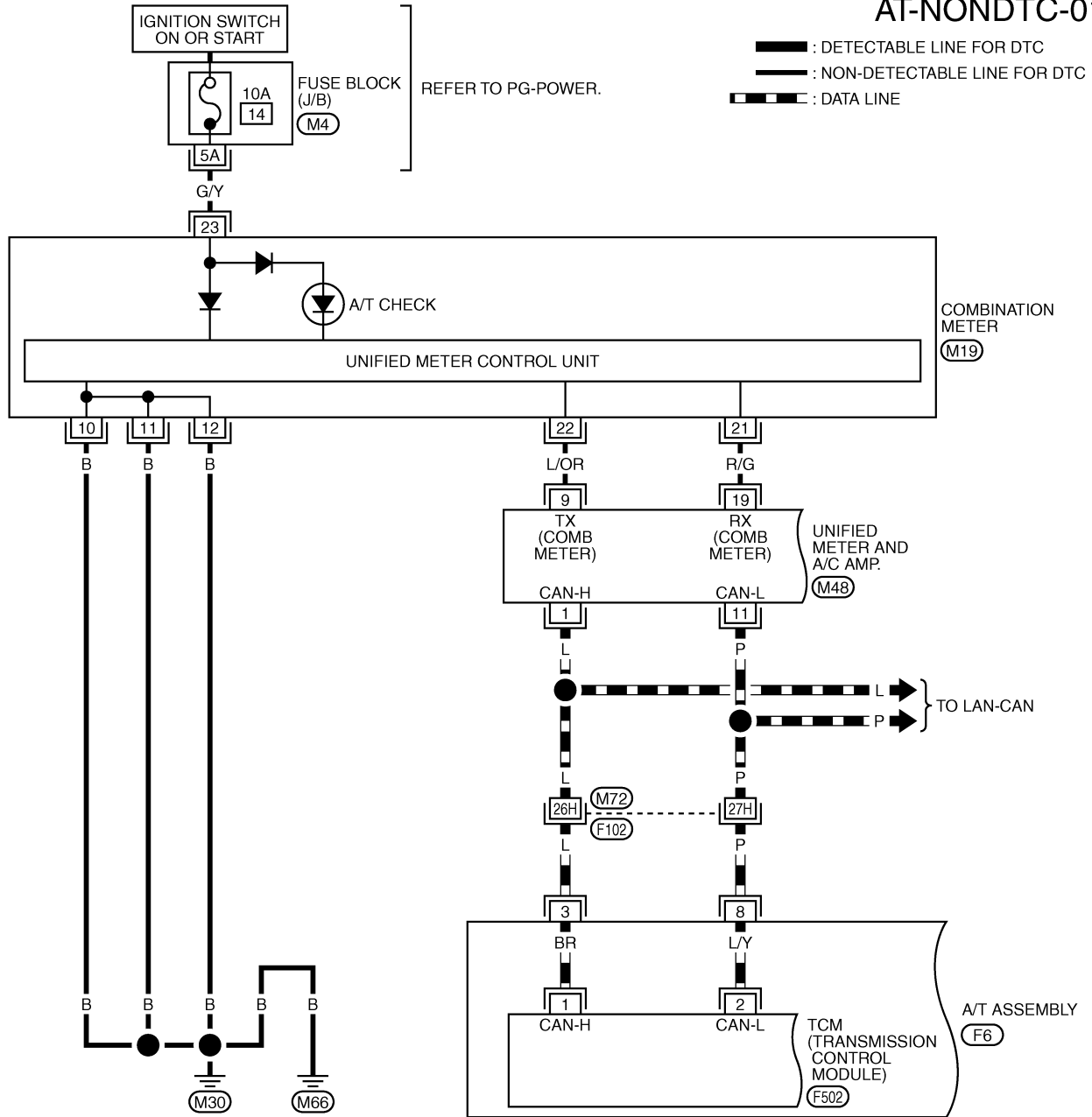

*: THIS CONNECTOR IS NOT SHOWN IN "HARNESS LAYOUT", PG SECTION.

REFER TO THE FOLLOWING.

(F102) -SUPER MULTIPLE JUNCTION (SMJ)

(M4) -FUSE BLOCK-JUNCTION BOX (J/B)

TCWM0264E

TROUBLE DIAGNOSIS FOR SYMPTOMS

AT-NONDTC-02

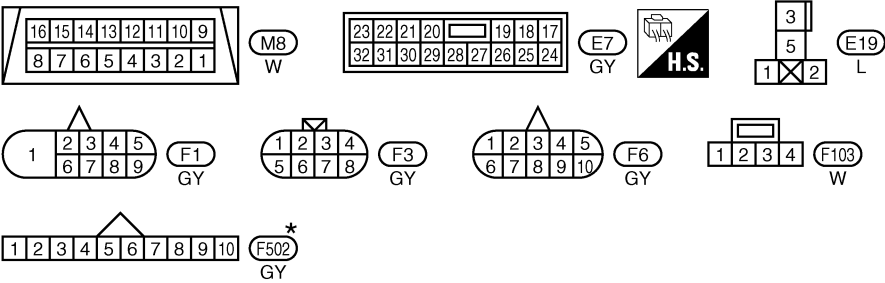
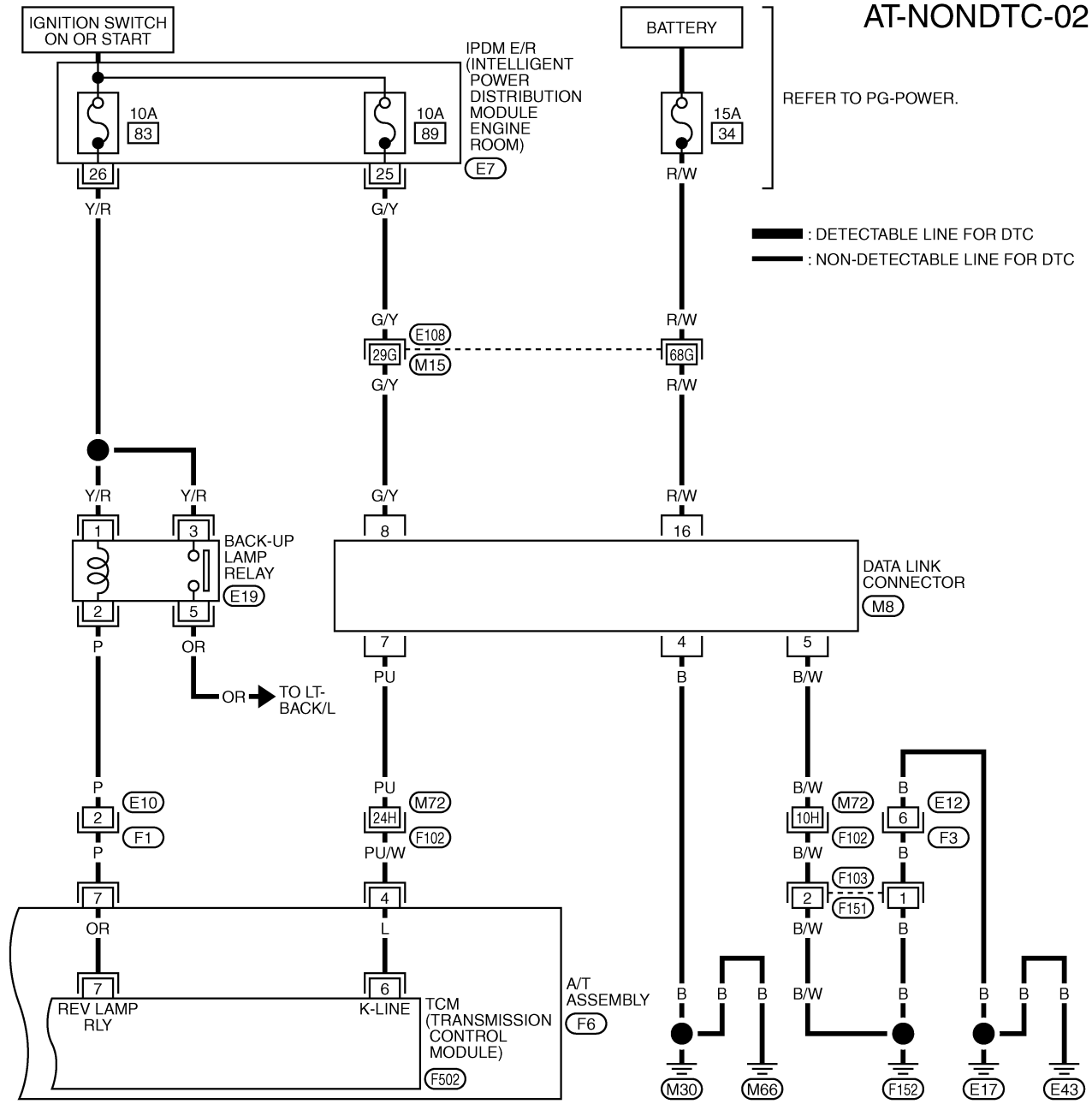

*: THIS CONNECTOR IS NOT SHOWN IN "HARNESS LAYOUT", PG SECTION.

REFER TO THE FOLLOWING.
 (E108), (F102) -SUPER MULTIPLE JUNCTION (SMJ)

TCWM0265E

TROUBLE DIAGNOSIS FOR SYMPTOMS

AT-NONDTC-03

: DETECTABLE LINE FOR DTC
 : NON-DETECTABLE LINE FOR DTC

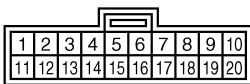
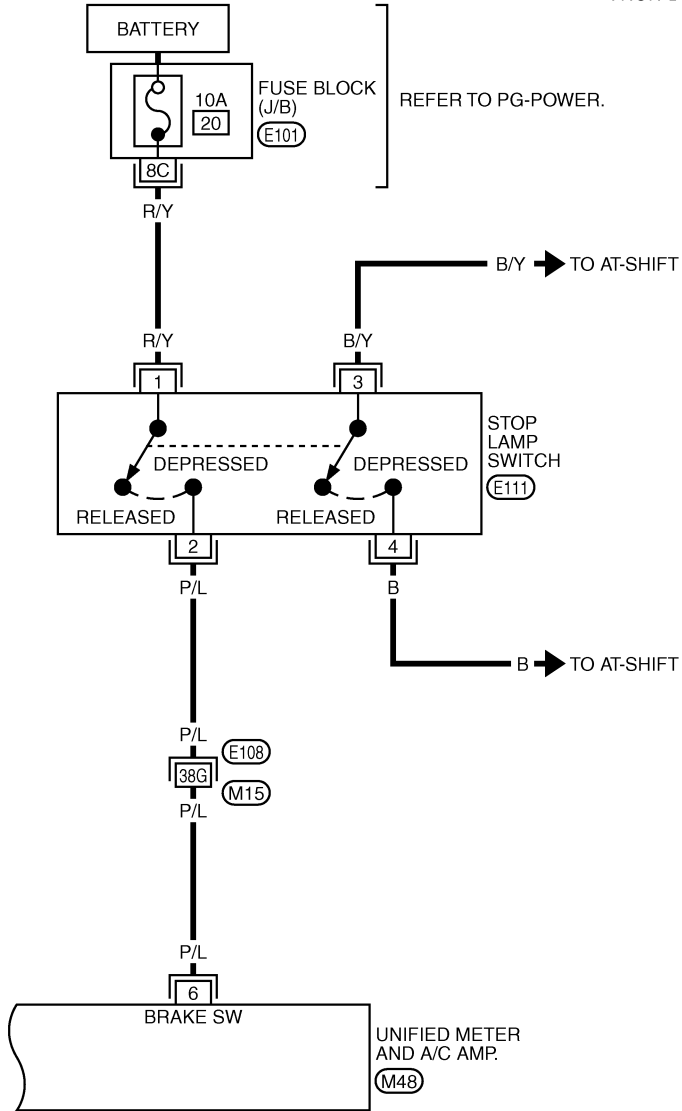

M48
GY

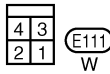

E111
W

REFER TO THE FOLLOWING.

(E108) -SUPER MULTIPLE JUNCTION (SMJ)

(E101) -FUSE BLOCK-JUNCTION BOX (J/B)

TCWM0266E

TROUBLE DIAGNOSIS FOR SYMPTOMS

TCM terminals and data are reference value. Measured between each terminal and ground.

Terminal	Wire color	Item	Condition	Data (Approx.)
3	L	CAN-H	–	–
4	PU/W	K-line (CONSULT-II signal)	The terminal is connected to the data link connector for CONSULT-II.	
7	P	Back-up lamp relay	 Selector lever in "R" position.	0V
			Selector lever in other positions.	Battery voltage
8	P	CAN-L	–	–

A/T Check Indicator Lamp Does Not Come On

ACS00845

SYMPTOM:

A/T CHECK indicator lamp does not come on for about 2 seconds when turning ignition switch to ON.

DIAGNOSTIC PROCEDURE

1. CHECK CAN COMMUNICATION LINE

Perform self-diagnosis. Refer to [AT-90, "SELF-DIAGNOSTIC RESULT MODE"](#) , [AT-99, "TCM SELF-DIAGNOSTIC PROCEDURE \(NO TOOLS\)"](#) .

Is a malfunction in the CAN communication indicated in the results?

- YES >> Check CAN communication line. Refer to [AT-101, "DTC U1000 CAN COMMUNICATION LINE"](#) .
 NO >> GO TO 2.

2. CHECK A/T CHECK INDICATOR LAMP CIRCUIT

Check combination meter. Refer to [DI-4, "COMBINATION METERS"](#) .

OK or NG

- OK >> GO TO 3.
 NG >> Repair or replace damaged parts.

3. CHECK TCM POWER SUPPLY AND GROUND CIRCUIT

Check TCM power supply and ground circuit. Refer to [AT-179, "MAIN POWER SUPPLY AND GROUND CIRCUIT"](#) .

OK or NG

- OK >> **INSPECTION END**
 NG >> Repair or replace damaged parts.

Engine Cannot Be Started in "P" or "N" Position

ACS00846

SYMPTOM:

- Engine cannot be started with selector lever in "P" or "N" position.
- Engine can be started with selector lever in "D" or "R" position.

DIAGNOSTIC PROCEDURE

1. CHECK PNP SWITCH CIRCUIT

Perform self-diagnosis. Refer to [AT-90, "SELF-DIAGNOSTIC RESULT MODE"](#) , [AT-99, "TCM SELF-DIAGNOSTIC PROCEDURE \(NO TOOLS\)"](#) .

Do the self-diagnosis results indicate PNP switch?

- YES >> Check the malfunctioning system. Refer to [AT-109, "DTC P0705 PARK/NEUTRAL POSITION SWITCH"](#) .
 NO >> GO TO 2.

TROUBLE DIAGNOSIS FOR SYMPTOMS

2. CHECK CONTROL LINKAGE

Check control linkage.

- Refer to [AT-229, "Checking of A/T Position"](#).

OK or NG

OK >> GO TO 3.

NG >> Adjust control linkage. Refer to [AT-229, "Adjustment of A/T Position"](#).

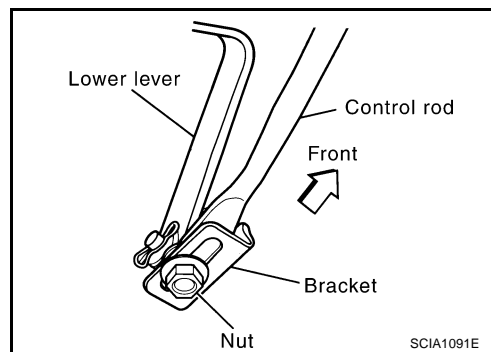

3. CHECK STARTING SYSTEM

Check starting system. Refer to [SC-10, "STARTING SYSTEM"](#).

OK or NG

OK >> **INSPECTION END**

NG >> Repair or replace damaged parts.

In "P" Position, Vehicle Moves When Pushed SYMPTOM:

ACS00847

Even though the selector lever is set in "P" position, the parking mechanism is not actuated, allowing the vehicle to be moved when it is pushed.

DIAGNOSTIC PROCEDURE

1. CHECK PNP SWITCH CIRCUIT

Perform self-diagnosis. Refer to [AT-90, "SELF-DIAGNOSTIC RESULT MODE"](#), [AT-99, "TCM SELF-DIAGNOSTIC PROCEDURE \(NO TOOLS\)"](#).

Do the self-diagnosis results indicate PNP switch?

YES >> Check the malfunctioning system. Refer to [AT-109, "DTC P0705 PARK/NEUTRAL POSITION SWITCH"](#).

NO >> GO TO 2.

2. CHECK CONTROL LINKAGE

Check control linkage.

- Refer to [AT-229, "Checking of A/T Position"](#).

OK or NG

OK >> GO TO 3.

NG >> Adjust control linkage. Refer to [AT-229, "Adjustment of A/T Position"](#).

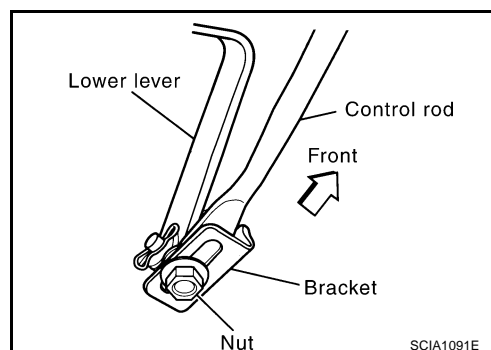

3. CHECK PARKING COMPONENTS

Check parking components. Refer to [AT-250, "Parking Components"](#).

OK or NG

OK >> GO TO 4

NG >> Repair or replace damaged parts.

TROUBLE DIAGNOSIS FOR SYMPTOMS

4. CHECK A/T FLUID CONDITION

1. Remove oil pan. Refer to [AT-238, "Control Valve with TCM and A/T Fluid Temperature Sensor 2"](#) .
2. Check A/T fluid condition. Refer to [AT-51, "Fluid Condition Check"](#) .

OK or NG

OK >> **INSPECTION END**

NG >> Check the malfunction items. If any items are damaged, repair or replace damaged parts. Refer to [AT-62, "Symptom Chart"](#) (Symptom No.65).

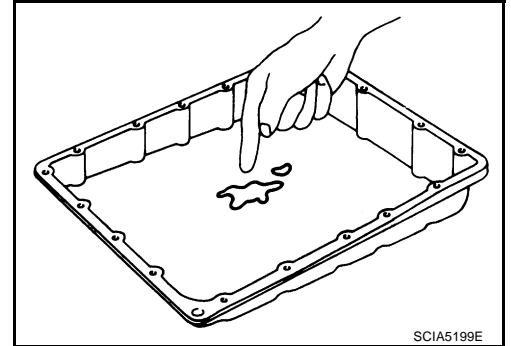

ACS00848

In "N" Position, Vehicle Moves SYMPTOM:

Vehicle moves forward or backward when selecting "N" position.

DIAGNOSTIC PROCEDURE

1. CHECK PNP SWITCH CIRCUIT

Perform self-diagnosis. Refer to [AT-90, "SELF-DIAGNOSTIC RESULT MODE"](#) , [AT-99, "TCM SELF-DIAGNOSTIC PROCEDURE \(NO TOOLS\)"](#) .

Do the self-diagnostic results indicate PNP switch?

YES >> Check the malfunctioning system. Refer to [AT-109, "DTC P0705 PARK/NEUTRAL POSITION SWITCH"](#) .

NO >> GO TO 2.

2. CHECK CONTROL LINKAGE

Check control linkage.

- Refer to [AT-229, "Checking of A/T Position"](#) .

OK or NG

OK >> GO TO 3.

NG >> Adjust control linkage. Refer to [AT-229, "Adjustment of A/T Position"](#) .

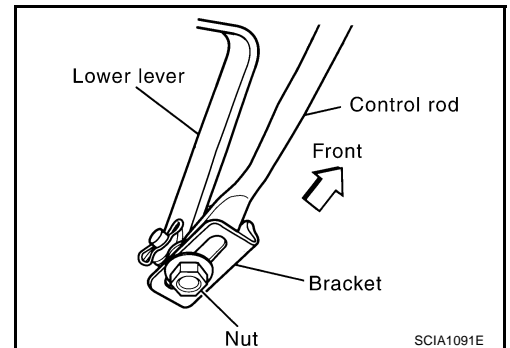

3. CHECK A/T FLUID LEVEL

Check A/T fluid level. Refer to [AT-12, "Checking A/T Fluid"](#) .

OK or NG

OK >> GO TO 4.

NG >> Refill ATF.

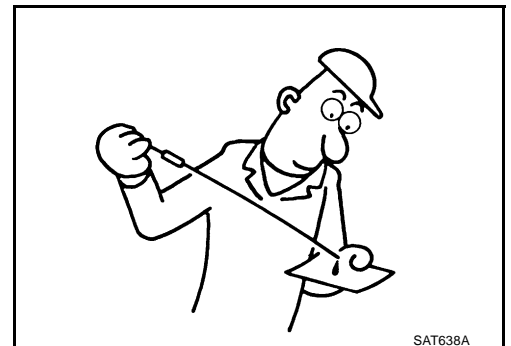

TROUBLE DIAGNOSIS FOR SYMPTOMS

4. CHECK A/T FLUID CONDITION

1. Remove oil pan. Refer to [AT-238, "Control Valve with TCM and A/T Fluid Temperature Sensor 2"](#) .
2. Check A/T fluid condition. Refer to [AT-51, "Fluid Condition Check"](#) .

OK or NG

- OK >> GO TO 5.
NG >> Check the malfunction items. If any items are damaged, repair or replace damaged parts. Refer to [AT-62, "Symptom Chart"](#) (Symptom No.67).

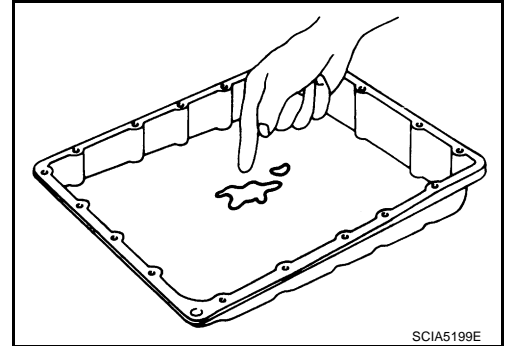

5. CHECK SYMPTOM

Check again. Refer to [AT-55, "Check at Idle"](#) .

OK or NG

- OK >> **INSPECTION END**
NG >> GO TO 6.

6. CHECK TCM

1. Check TCM input/output signals. Refer to [AT-86, "TCM Input/Output Signal Reference Values"](#) .
2. If NG, recheck A/T assembly harness connector terminals for damage or loose connection with harness connector.

OK or NG

- OK >> **INSPECTION END**
NG >> Repair or replace damaged parts.

Large Shock ("N" to "D" Position) SYMPTOM:

ACS00849

A noticeable shock occurs when the selector lever is shifted from "N" to "D" position.

DIAGNOSTIC PROCEDURE

1. CHECK SELF-DIAGNOSTIC RESULTS

Perform self-diagnosis. Refer to [AT-90, "SELF-DIAGNOSTIC RESULT MODE"](#) .

Do the self-diagnostic results indicate A/T fluid temperature sensor, engine speed signal, accelerator pedal position sensor, ATF pressure switch 1, front brake solenoid valve, CAN communication?

- YES >> Check the malfunctioning system. Refer to [AT-131, "DTC P1710 A/T FLUID TEMPERATURE SENSOR CIRCUIT"](#) , [AT-118, "DTC P0725 ENGINE SPEED SIGNAL"](#) , [AT-128, "DTC P1705 THROTTLE POSITION SENSOR"](#) , [AT-171, "DTC P1841 ATF PRESSURE SWITCH 1"](#) , [AT-149, "DTC P1757 FRONT BRAKE SOLENOID VALVE"](#) , [AT-101, "DTC U1000 CAN COMMUNICATION LINE"](#) .

- NO >> GO TO 2.

2. ENGINE IDLE SPEED

Check engine idle speed. Refer to [EC-30, "Idle Speed and Ignition Timing Check"](#) .

OK or NG

- OK >> GO TO 3.
NG >> Repair.

TROUBLE DIAGNOSIS FOR SYMPTOMS

3. CHECK CONTROL LINKAGE

Check control linkage.

- Refer to [AT-229, "Checking of A/T Position"](#) .

OK or NG

OK >> GO TO 4.

NG >> Adjust control linkage. Refer to [AT-229, "Adjustment of A/T Position"](#) .

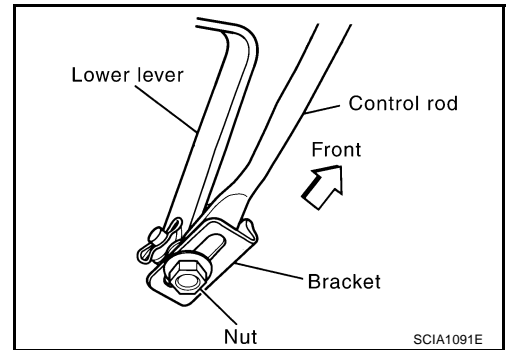

4. CHECK A/T FLUID LEVEL

Check A/T fluid level. Refer to [AT-12, "Checking A/T Fluid"](#) .

OK or NG

OK >> GO TO 5.

NG >> Refill ATF.

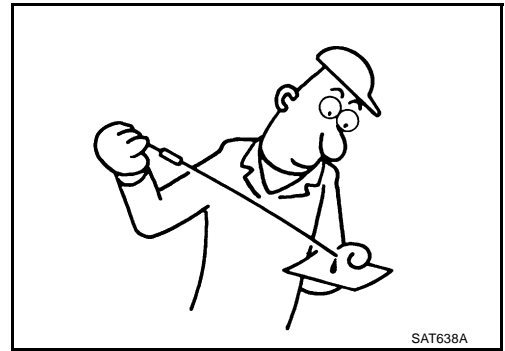

5. CHECK LINE PRESSURE

Check line pressure at idle with selector lever in "D" position. Refer to [AT-52, "LINE PRESSURE TEST"](#) .

OK or NG

OK >> GO TO 8.

NG - 1 >> Line pressure high: GO TO 6.

NG - 2 >> Line pressure low: GO TO 7.

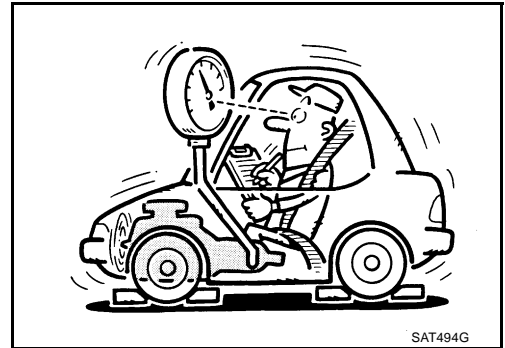

6. DETECT MALFUNCTIONING ITEM

1. Check control valve with TCM. Refer to [AT-238, "Control Valve with TCM and A/T Fluid Temperature Sensor 2"](#) .

2. Disassemble A/T. Refer to [AT-275, "DISASSEMBLY"](#) .

3. Check the following items:

- Oil pump assembly. Refer to [AT-292, "Oil Pump"](#) .

OK or NG

OK >> GO TO 8.

NG >> Repair or replace damaged parts.

TROUBLE DIAGNOSIS FOR SYMPTOMS

7. DETECT MALFUNCTIONING ITEM

1. Check control valve with TCM. Refer to [AT-238, "Control Valve with TCM and A/T Fluid Temperature Sensor 2"](#) .
2. Disassemble A/T. Refer to [AT-275, "DISASSEMBLY"](#) .
3. Check the following items:
 - Oil pump assembly. Refer to [AT-292, "Oil Pump"](#) .
 - Power train system. Refer to [AT-275, "DISASSEMBLY"](#) .
 - Transmission case. Refer to [AT-275, "DISASSEMBLY"](#) .

OK or NG

- OK >> GO TO 8.
NG >> Repair or replace damaged parts.

8. CHECK A/T FLUID CONDITION

1. Remove oil pan. Refer to [AT-238, "Control Valve with TCM and A/T Fluid Temperature Sensor 2"](#) .
2. Check A/T fluid condition. Refer to [AT-51, "Fluid Condition Check"](#) .

OK or NG

- OK >> GO TO 10.
NG >> GO TO 9.

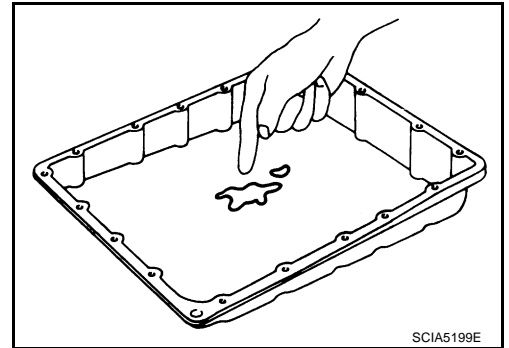

9. DETECT MALFUNCTIONING ITEM

- Check the malfunction items. If any items are damaged, repair or replace damaged parts. Refer to [AT-62, "Symptom Chart"](#) (Symptom No.1).

OK or NG

- OK >> GO TO 10.
NG >> Repair or replace damaged parts.

10. CHECK SYMPTOM

Check again. Refer to [AT-55, "Check at Idle"](#) .

OK or NG

- OK >> **INSPECTION END**
NG >> GO TO 11.

11. CHECK TCM

1. Check TCM input/output signals. Refer to [AT-86, "TCM Input/Output Signal Reference Values"](#) .
2. If NG, recheck A/T assembly harness connector terminals for damage or loose connection with harness connector.

OK or NG

- OK >> **INSPECTION END**
NG >> Repair or replace damaged parts.

TROUBLE DIAGNOSIS FOR SYMPTOMS

ACS0084A

Vehicle Does Not Creep Backward in "R" Position

SYMPTOM:

The vehicle does not creep in "R" position. Or an extreme lack of acceleration is observed.

DIAGNOSTIC PROCEDURE

1. CHECK SELF-DIAGNOSTIC RESULTS

Perform self-diagnosis. Refer to [AT-90, "SELF-DIAGNOSTIC RESULT MODE"](#) .

Do the self-diagnostic results indicate accelerator pedal position sensor, ATF pressure switch 6, high and low reverse clutch solenoid valve, CAN communication, PNP switch?

YES >> Check the malfunctioning system. Refer to [AT-128, "DTC P1705 THROTTLE POSITION SENSOR"](#) , [AT-177, "DTC P1846 ATF PRESSURE SWITCH 6"](#) , [AT-157, "DTC P1767 HIGH AND LOW REVERSE CLUTCH SOLENOID VALVE"](#) , [AT-101, "DTC U1000 CAN COMMUNICATION LINE"](#) , [AT-109, "DTC P0705 PARK/NEUTRAL POSITION SWITCH"](#) .

NO >> GO TO 2.

2. CHECK CONTROL LINKAGE

Check control linkage.

- Refer to [AT-229, "Checking of A/T Position"](#) .

OK or NG

OK >> GO TO 3.

NG >> Adjust control linkage. Refer to [AT-229, "Adjustment of A/T Position"](#) .

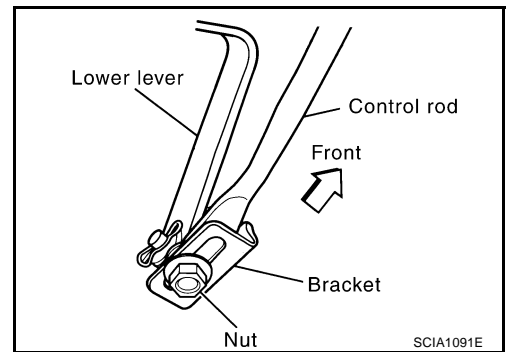

3. CHECK A/T FLUID LEVEL

Check A/T fluid level. Refer to [AT-12, "Checking A/T Fluid"](#) .

OK or NG

OK >> GO TO 4.

NG >> Refill ATF.



4. CHECK STALL TEST

Check stall revolution with selector lever in "M" and "R" positions.

Refer to [AT-51, "STALL TEST"](#) .

OK or NG

OK >> GO TO 6.

OK in "M" position, NG in "R" position>>GO TO 5.

NG in both "M" and "R" positions>>GO TO 8.

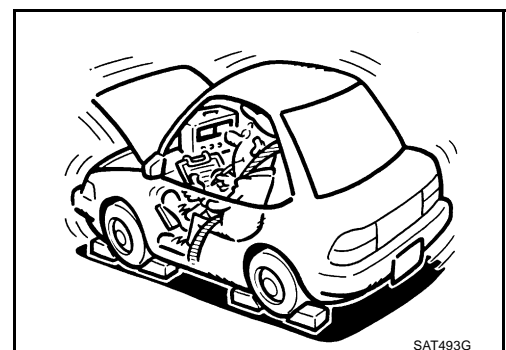

TROUBLE DIAGNOSIS FOR SYMPTOMS

5. DETECT MALFUNCTIONING ITEM

1. Disassemble A/T. Refer to [AT-275, "DISASSEMBLY"](#) .
2. Check the following items:
 - Reverse brake. Refer to [AT-275, "Disassembly"](#) .

OK or NG

- OK >> GO TO 9.
NG >> Repair or replace damaged parts.

6. CHECK LINE PRESSURE

Check line pressure with the engine idling. Refer to [AT-52, "LINE PRESSURE TEST"](#) .

OK or NG

- OK >> GO TO 9.
NG - 1 >> Line pressure high. GO TO 7.
NG - 2 >> Line pressure low. GO TO 8.

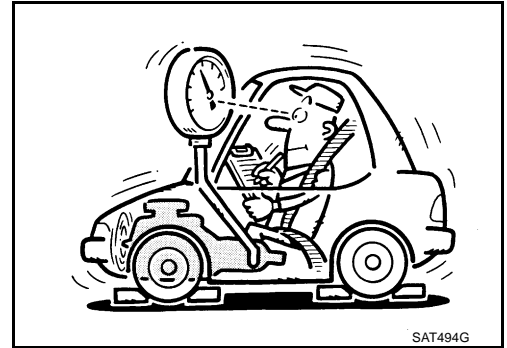

7. DETECT MALFUNCTIONING ITEM

1. Check control valve with TCM. Refer to [AT-238, "Control Valve with TCM and A/T Fluid Temperature Sensor 2"](#) .
2. Disassemble A/T. Refer to [AT-275, "DISASSEMBLY"](#) .
3. Check the following items:
 - Oil pump assembly. Refer to [AT-292, "Oil Pump"](#) .

OK or NG

- OK >> GO TO 9.
NG >> Repair or replace damaged parts.

8. DETECT MALFUNCTIONING ITEM

1. Check control valve with TCM. Refer to [AT-238, "Control Valve with TCM and A/T Fluid Temperature Sensor 2"](#) .
2. Disassemble A/T. Refer to [AT-275, "DISASSEMBLY"](#) .
3. Check the following items:
 - Oil pump assembly. Refer to [AT-292, "Oil Pump"](#) .
 - Power train system. Refer to [AT-275, "DISASSEMBLY"](#) .
 - Transmission case. Refer to [AT-275, "DISASSEMBLY"](#) .

OK or NG

- OK >> GO TO 9.
NG >> Repair or replace damaged parts.

A
B
AT
D
E
F
G
H
I
J
K
L
M

TROUBLE DIAGNOSIS FOR SYMPTOMS

9. CHECK A/T FLUID CONDITION

1. Remove oil pan. Refer to [AT-238, "Control Valve with TCM and A/T Fluid Temperature Sensor 2"](#) .
2. Check A/T fluid condition. Refer to [AT-51, "Fluid Condition Check"](#) .

OK or NG

- OK >> GO TO 10.
NG >> GO TO 13.

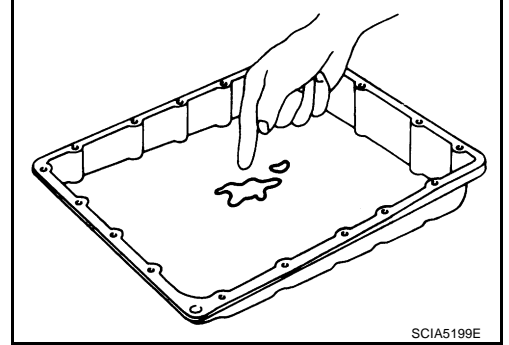

10. DETECT MALFUNCTIONING ITEM

- Check the malfunction items. If any items are damaged, repair or replace damaged parts. Refer to [AT-62, "Symptom Chart"](#) (Symptom No.43).

OK or NG

- OK >> GO TO 11.
NG >> Repair or replace damaged parts.

11. CHECK SYMPTOM

Check again. Refer to [AT-55, "Check at Idle"](#) .

OK or NG

- OK >> **INSPECTION END**
NG >> GO TO 12.

12. CHECK TCM

1. Check TCM input/output signals. Refer to [AT-86, "TCM Input/Output Signal Reference Values"](#) .
2. If NG, recheck A/T assembly harness connector terminals for damage or loose connection with harness connector.

OK or NG

- OK >> **INSPECTION END**
NG >> Repair or replace damaged parts.

13. DETECT MALFUNCTIONING ITEM

- Check the malfunction items. If any items are damaged, repair or replace damaged parts. Refer to [AT-62, "Symptom Chart"](#) (Symptom No.43).

OK or NG

- OK >> GO TO 11.
NG >> Repair or replace damaged parts.

TROUBLE DIAGNOSIS FOR SYMPTOMS

ACS0084B

Vehicle Does Not Creep Forward in "D" Position

SYMPTOM:

Vehicle does not creep forward when selecting "D" position.

DIAGNOSTIC PROCEDURE

1. CHECK SELF-DIAGNOSTIC RESULTS

Perform self-diagnosis. Refer to [AT-90, "SELF-DIAGNOSTIC RESULT MODE"](#) , [AT-99, "TCM SELF-DIAGNOSTIC PROCEDURE \(NO TOOLS\)"](#) .

Do the self-diagnostic results indicate accelerator pedal position sensor, CAN communication, PNP switch?

YES >> Check the malfunctioning system. Refer to [AT-128, "DTC P1705 THROTTLE POSITION SENSOR"](#) , [AT-101, "DTC U1000 CAN COMMUNICATION LINE"](#) , [AT-109, "DTC P0705 PARK/NEUTRAL POSITION SWITCH"](#) .

NO >> GO TO 2.

2. CHECK CONTROL LINKAGE

Check control linkage.

- Refer to [AT-229, "Checking of A/T Position"](#) .

OK or NG

OK >> GO TO 3.

NG >> Adjust control linkage. Refer to [AT-229, "Adjustment of A/T Position"](#) .

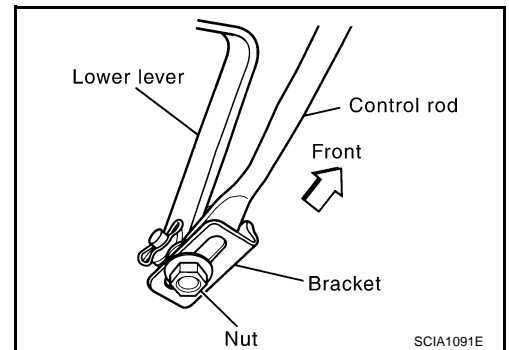

3. CHECK A/T FLUID LEVEL

Check A/T fluid level. Refer to [AT-12, "Checking A/T Fluid"](#) .

OK or NG

OK >> GO TO 4.

NG >> Refill ATF.

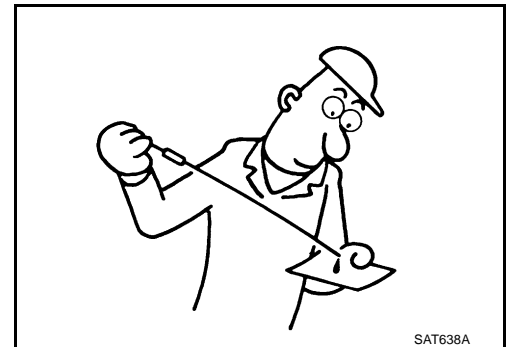

4. CHECK STALL TEST

Check stall revolution with selector lever in "D" position. Refer to [AT-51, "STALL TEST"](#) .

OK or NG

OK >> GO TO 5.

NG >> GO TO 7.

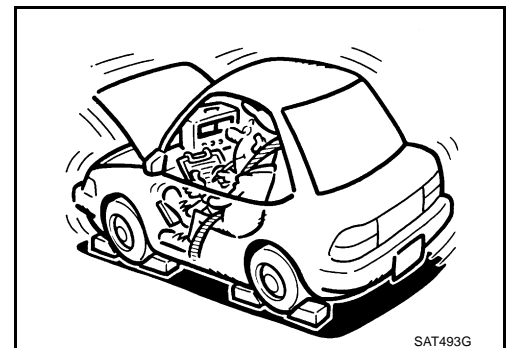

TROUBLE DIAGNOSIS FOR SYMPTOMS

5. CHECK LINE PRESSURE

Check line pressure at idle with selector lever in "D" position. Refer to [AT-52, "LINE PRESSURE TEST"](#) .

OK or NG

- OK >> GO TO 8.
- NG - 1 >> Line pressure high. GO TO 6.
- NG - 2 >> Line pressure low. GO TO 7.

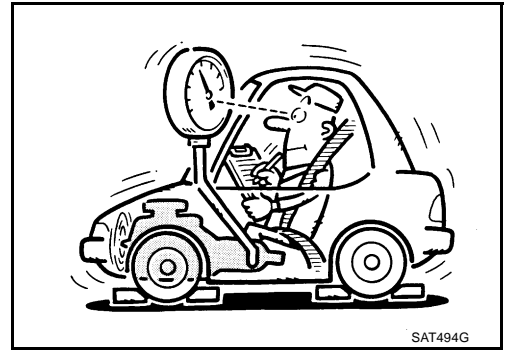

6. DETECT MALFUNCTIONING ITEM

1. Check control valve with TCM. Refer to [AT-238, "Control Valve with TCM and A/T Fluid Temperature Sensor 2"](#) .
2. Disassemble A/T. Refer to [AT-275, "DISASSEMBLY"](#) .
3. Check the following items:
 - Oil pump assembly. Refer to [AT-292, "Oil Pump"](#) .

OK or NG

- OK >> GO TO 8.
- NG >> Repair or replace damaged parts.

7. DETECT MALFUNCTIONING ITEM

1. Check control valve with TCM. Refer to [AT-238, "Control Valve with TCM and A/T Fluid Temperature Sensor 2"](#) .
2. Disassemble A/T. Refer to [AT-275, "DISASSEMBLY"](#) .
3. Check the following items:
 - Oil pump assembly. Refer to [AT-292, "Oil Pump"](#) .
 - Power train system. Refer to [AT-275, "DISASSEMBLY"](#) .
 - Transmission case. Refer to [AT-275, "DISASSEMBLY"](#) .

OK or NG

- OK >> GO TO 8.
- NG >> Repair or replace damaged parts.

8. CHECK A/T FLUID CONDITION

1. Remove oil pan. Refer to [AT-238, "Control Valve with TCM and A/T Fluid Temperature Sensor 2"](#) .
2. Check A/T fluid condition. Refer to [AT-51, "Fluid Condition Check"](#) .

OK or NG

- OK >> GO TO 9.
- NG >> GO TO 12.

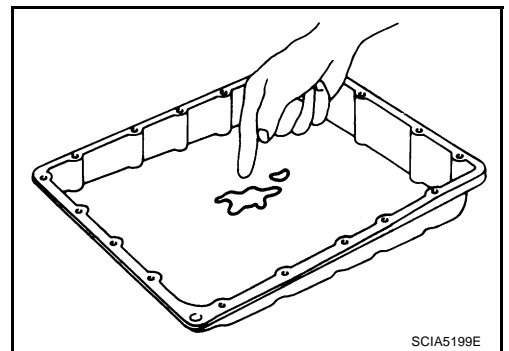

TROUBLE DIAGNOSIS FOR SYMPTOMS

9. DETECT MALFUNCTIONING ITEM

- Check the malfunction items. If any items are damaged, repair or replace damaged parts. Refer to [AT-62, "Symptom Chart"](#) (Symptom No.43).

OK or NG

- OK >> GO TO 10.
NG >> Repair or replace damaged parts.

10. CHECK SYMPTOM

Check again. Refer to [AT-55, "Check at Idle"](#) .

OK or NG

- OK >> **INSPECTION END**
NG >> GO TO 11.

11. CHECK TCM

1. Check TCM input/output signals. Refer to [AT-86, "TCM Input/Output Signal Reference Values"](#) .
2. If NG, recheck A/T assembly harness connector terminals for damage or loose connection with harness connector.

OK or NG

- OK >> **INSPECTION END**
NG >> Repair or replace damaged parts.

12. DETECT MALFUNCTIONING ITEM

- Check the malfunction items. If any items are damaged, repair or replace damaged parts. Refer to [AT-62, "Symptom Chart"](#) (Symptom No.43).

OK or NG

- OK >> GO TO 10.
NG >> Repair or replace damaged parts.

Vehicle Cannot Be Started From D1

ACS0084C

SYMPTOM:

Vehicle cannot be started from D1 on cruise test - Part 1 and Part 2.

DIAGNOSTIC PROCEDURE

1. CONFIRM THE SYMPTOM

Check if vehicle creep in "R" position.

OK or NG

- OK >> GO TO 2.
NG >> Refer to [AT-194, "Vehicle Does Not Creep Backward in "R" Position"](#) .

2. CHECK SELF-DIAGNOSTIC RESULTS

Perform self-diagnosis. Refer to [AT-90, "SELF-DIAGNOSTIC RESULT MODE"](#) , [AT-99, "TCM SELF-DIAGNOSTIC PROCEDURE \(NO TOOLS\)"](#)

Is any malfunction detected by self-diagnostic results?

- YES >> Check the malfunctioning system. Refer to [AT-90, "SELF-DIAGNOSTIC RESULT MODE"](#) , [AT-100, "Judgement Self-diagnosis Code"](#) .
NO >> GO TO 3.

TROUBLE DIAGNOSIS FOR SYMPTOMS

3. CHECK ACCELERATOR PEDAL POSITION (APP) SENSOR

Check accelerator pedal position (APP) sensor. Refer to [AT-128, "DTC P1705 THROTTLE POSITION SENSOR"](#)

OK or NG

OK >> GO TO 4.

NG >> Repair or replace accelerator pedal position (APP) sensor.

4. CHECK A/T FLUID LEVEL

Check A/T fluid level. Refer to [AT-12, "Checking A/T Fluid"](#) .

OK or NG

OK >> GO TO 5.

NG >> Refill ATF.



5. CHECK LINE PRESSURE

Check line pressure at the engine stall point. Refer to [AT-52, "LINE PRESSURE TEST"](#) .

OK or NG

OK >> GO TO 8.

NG - 1 >> Line pressure high. GO TO 6.

NG - 2 >> Line pressure low. GO TO 7.

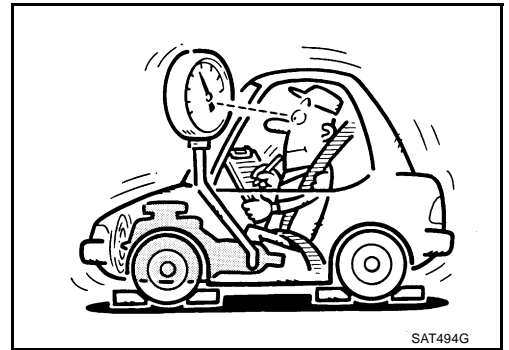

6. DETECT MALFUNCTIONING ITEM

1. Check control valve with TCM. Refer to [AT-238, "Control Valve with TCM and A/T Fluid Temperature Sensor 2"](#) .

2. Disassemble A/T. Refer to [AT-275, "DISASSEMBLY"](#) .

3. Check the following items:

- Oil pump assembly. Refer to [AT-292, "Oil Pump"](#) .

OK or NG

OK >> GO TO 8.

NG >> Repair or replace damaged parts.

TROUBLE DIAGNOSIS FOR SYMPTOMS

7. DETECT MALFUNCTIONING ITEM

1. Check control valve with TCM. Refer to [AT-238, "Control Valve with TCM and A/T Fluid Temperature Sensor 2"](#) .
2. Disassemble A/T. Refer to [AT-275, "DISASSEMBLY"](#) .
3. Check the following items:
 - Oil pump assembly. Refer to [AT-292, "Oil Pump"](#) .
 - Power train system. Refer to [AT-275, "DISASSEMBLY"](#) .
 - Transmission case. Refer to [AT-275, "DISASSEMBLY"](#) .

OK or NG

- OK >> GO TO 8.
NG >> Repair or replace damaged parts.

8. CHECK A/T FLUID CONDITION

1. Remove oil pan. Refer to [AT-238, "Control Valve with TCM and A/T Fluid Temperature Sensor 2"](#) .
2. Check A/T fluid condition. Refer to [AT-51, "Fluid Condition Check"](#) .

OK or NG

- OK >> GO TO 9.
NG >> GO TO 12.

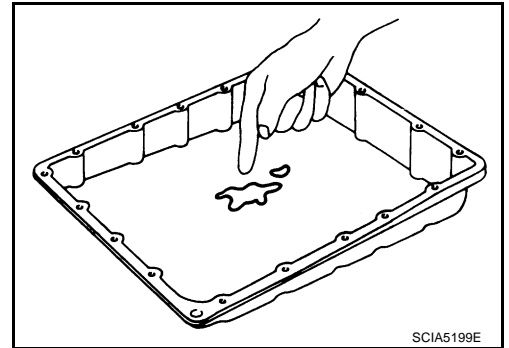

9. DETECT MALFUNCTIONING ITEM

- Check the malfunction items. If any items are damaged, repair or replace damaged parts. Refer to [AT-62, "Symptom Chart"](#) (Symptom No.23).

OK or NG

- OK >> GO TO 10.
NG >> Repair or replace damaged parts.

10. CHECK SYMPTOM

Check again. Refer to [AT-57, "Cruise Test - Part 1"](#) , [AT-59, "Cruise Test - Part 2"](#) .

OK or NG

- OK >> **INSPECTION END**
NG >> GO TO 11.

11. CHECK TCM

1. Check TCM input/output signals. Refer to [AT-86, "TCM Input/Output Signal Reference Values"](#) .
2. If NG, recheck A/T assembly harness connector terminals for damage or loose connection with harness connector.

OK or NG

- OK >> **INSPECTION END**
NG >> Repair or replace damaged parts.

TROUBLE DIAGNOSIS FOR SYMPTOMS

12. DETECT MALFUNCTIONING ITEM

- Check the malfunction items. If any items are damaged, repair or replace damaged parts. Refer to [AT-62, "Symptom Chart"](#) (Symptom No.23).

OK or NG

- OK >> GO TO 10.
NG >> Repair or replace damaged parts.

A/T Does Not Shift: D1 → D2

ACS0084D

SYMPTOM:

The vehicle does not shift-up from D1 to D2 gear at the specified speed.

DIAGNOSTIC PROCEDURE

1. CONFIRM THE SYMPTOM

Check if vehicle creep forward in "D" position and vehicle can be started from D1.

OK or NG

- OK >> GO TO 2.
NG >> Refer to [AT-197, "Vehicle Does Not Creep Forward in "D" Position"](#) , [AT-199, "Vehicle Cannot Be Started From D1"](#) .

2. CHECK SELF-DIAGNOSTIC RESULTS

Perform self-diagnosis. Refer to [AT-90, "SELF-DIAGNOSTIC RESULT MODE"](#) .

Do the self-diagnostic results indicate ATF pressure switch 5, direct clutch solenoid valve, accelerator pedal position sensor, vehicle speed sensor A/T (revolution sensor) and vehicle speed sensor MTR?

- YES >> Check the malfunctioning system. Refer to [AT-175, "DTC P1845 ATF PRESSURE SWITCH 5"](#) , [AT-153, "DTC P1762 DIRECT CLUTCH SOLENOID VALVE"](#) , [AT-128, "DTC P1705 THROTTLE POSITION SENSOR"](#) , [AT-113, "DTC P0720 VEHICLE SPEED SENSOR A/T \(REVOLUTION SENSOR\)"](#) , [AT-138, "DTC P1721 VEHICLE SPEED SENSOR MTR"](#) .
NO >> GO TO 3.

3. CHECK A/T FLUID LEVEL

Check A/T fluid level. Refer to [AT-12, "Checking A/T Fluid"](#) .

OK or NG

- OK >> GO TO 4.
NG >> Refill ATF.

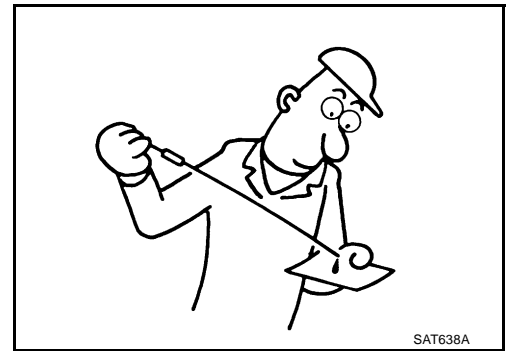

TROUBLE DIAGNOSIS FOR SYMPTOMS

4. CHECK LINE PRESSURE

Check line pressure at the engine stall point. Refer to [AT-52, "LINE PRESSURE TEST"](#) .

OK or NG

- OK >> GO TO 7.
- NG - 1 >> Line pressure high. GO TO 5.
- NG - 2 >> Line pressure low. GO TO 6.

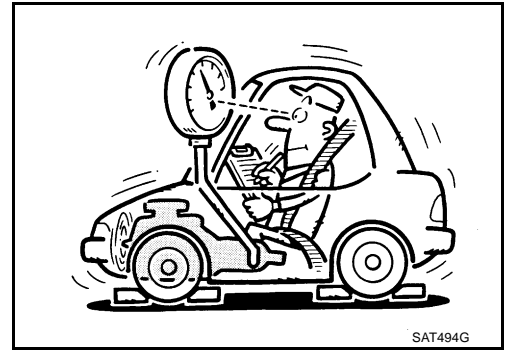

5. DETECT MALFUNCTIONING ITEM

1. Check control valve with TCM. Refer to [AT-238, "Control Valve with TCM and A/T Fluid Temperature Sensor 2"](#) .
2. Disassemble A/T. Refer to [AT-275, "DISASSEMBLY"](#) .
3. Check the following items:
 - Oil pump assembly. Refer to [AT-292, "Oil Pump"](#) .

OK or NG

- OK >> GO TO 7.
- NG >> Repair or replace damaged parts.

6. DETECT MALFUNCTIONING ITEM

1. Check control valve with TCM. Refer to [AT-238, "Control Valve with TCM and A/T Fluid Temperature Sensor 2"](#) .
2. Disassemble A/T. Refer to [AT-275, "DISASSEMBLY"](#) .
3. Check the following items:
 - Oil pump assembly. Refer to [AT-292, "Oil Pump"](#) .
 - Power train system. Refer to [AT-275, "DISASSEMBLY"](#) .
 - Transmission case. Refer to [AT-275, "DISASSEMBLY"](#) .

OK or NG

- OK >> GO TO 7.
- NG >> Repair or replace damaged parts.

7. CHECK A/T FLUID CONDITION

1. Remove oil pan. Refer to [AT-238, "Control Valve with TCM and A/T Fluid Temperature Sensor 2"](#) .
2. Check A/T fluid condition. Refer to [AT-51, "Fluid Condition Check"](#) .

OK or NG

- OK >> GO TO 8.
- NG >> GO TO 11.

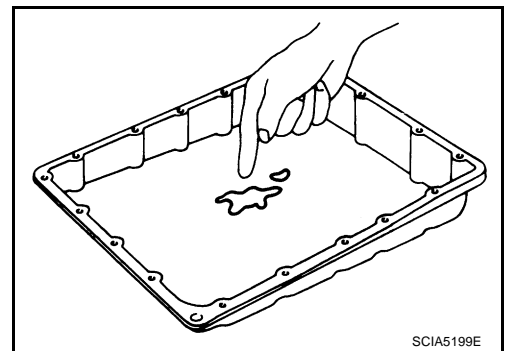

TROUBLE DIAGNOSIS FOR SYMPTOMS

8. DETECT MALFUNCTIONING ITEM

- Check the malfunction items. If any items are damaged, repair or replace damaged parts. Refer to [AT-62, "Symptom Chart"](#) (Symptom No.10).

OK or NG

- OK >> GO TO 9.
NG >> Repair or replace damaged parts.

9. CHECK SYMPTOM

Check again. Refer to [AT-57, "Cruise Test - Part 1"](#) , [AT-59, "Cruise Test - Part 2"](#) .

OK or NG

- OK >> **INSPECTION END**
NG >> GO TO 10.

10. CHECK TCM

1. Check TCM input/output signals. Refer to [AT-86, "TCM Input/Output Signal Reference Values"](#) .
2. If NG, recheck A/T assembly harness connector terminals for damage or loose connection with harness connector.

OK or NG

- OK >> **INSPECTION END**
NG >> Repair or replace damaged parts.

11. DETECT MALFUNCTIONING ITEM

- Check the malfunction items. If any items are damaged, repair or replace damaged parts. Refer to [AT-62, "Symptom Chart"](#) (Symptom No.10).

OK or NG

- OK >> GO TO 9.
NG >> Repair or replace damaged parts.

A/T Does Not Shift: D2 → D3

ACS0084E

SYMPTOM:

The vehicle does not shift-up from D2 to D3 gear at the specified speed.

DIAGNOSTIC PROCEDURE

1. CONFIRM THE SYMPTOM

Check if vehicle creep forward in "D" position and vehicle can be started from D1.

OK or NG

- OK >> GO TO 2.
NG >> Refer to [AT-197, "Vehicle Does Not Creep Forward in "D" Position"](#) , [AT-199, "Vehicle Cannot Be Started From D1"](#) .

2. CHECK SELF-DIAGNOSTIC RESULTS

Perform self-diagnosis. Refer to [AT-90, "SELF-DIAGNOSTIC RESULT MODE"](#) .

Do the self-diagnostic results indicate ATF pressure switch 6, high and low reverse clutch solenoid valve, accelerator pedal position sensor, vehicle speed sensor A/T (revolution sensor) and vehicle speed sensor MTR?

- YES >> Check the malfunctioning system. Refer to [AT-177, "DTC P1846 ATF PRESSURE SWITCH 6"](#) , [AT-157, "DTC P1767 HIGH AND LOW REVERSE CLUTCH SOLENOID VALVE"](#) , [AT-128, "DTC P1705 THROTTLE POSITION SENSOR"](#) , [AT-113, "DTC P0720 VEHICLE SPEED SENSOR A/T \(REVOLUTION SENSOR\)"](#) , [AT-138, "DTC P1721 VEHICLE SPEED SENSOR MTR"](#) .
- NO >> GO TO 3.

TROUBLE DIAGNOSIS FOR SYMPTOMS

3. CHECK A/T FLUID LEVEL

Check A/T fluid level. Refer to [AT-12, "Checking A/T Fluid"](#) .

OK or NG

- OK >> GO TO 4.
- NG >> Refill ATF.

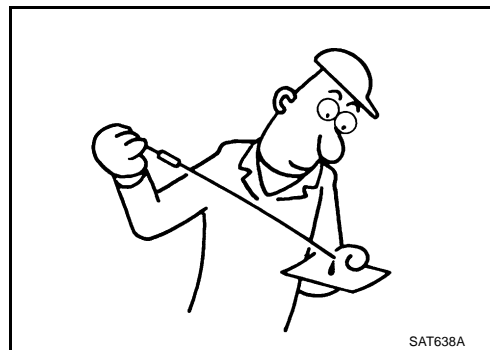

4. CHECK LINE PRESSURE

Check line pressure at the engine stall point. Refer to [AT-52, "LINE PRESSURE TEST"](#) .

OK or NG

- OK >> GO TO 7.
- NG - 1 >> Line pressure high. GO TO 5.
- NG - 2 >> Line pressure low. GO TO 6.

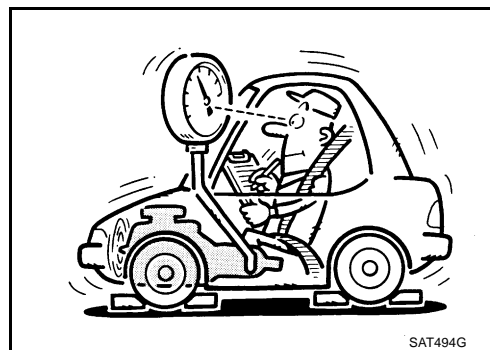

5. DETECT MALFUNCTIONING ITEM

1. Check control valve with TCM. Refer to [AT-238, "Control Valve with TCM and A/T Fluid Temperature Sensor 2"](#) .
2. Disassemble A/T. Refer to [AT-275, "DISASSEMBLY"](#) .
3. Check the following items:
 - Oil pump assembly. Refer to [AT-292, "Oil Pump"](#) .

OK or NG

- OK >> GO TO 7.
- NG >> Repair or replace damaged parts.

6. DETECT MALFUNCTIONING ITEM

1. Check control valve with TCM. Refer to [AT-238, "Control Valve with TCM and A/T Fluid Temperature Sensor 2"](#) .
2. Disassemble A/T. Refer to [AT-275, "DISASSEMBLY"](#) .
3. Check the following items:
 - Oil pump assembly. Refer to [AT-292, "Oil Pump"](#) .
 - Power train system. Refer to [AT-275, "DISASSEMBLY"](#) .
 - Transmission case. Refer to [AT-275, "DISASSEMBLY"](#) .

OK or NG

- OK >> GO TO 7.
- NG >> Repair or replace damaged parts.

A
B
AT
D
E
F
G
H
I
J
K
L
M

TROUBLE DIAGNOSIS FOR SYMPTOMS

7. CHECK A/T FLUID CONDITION

1. Remove oil pan. Refer to [AT-238, "Control Valve with TCM and A/T Fluid Temperature Sensor 2"](#) .
2. Check A/T fluid condition. Refer to [AT-51, "Fluid Condition Check"](#) .

OK or NG

- OK >> GO TO 8.
NG >> GO TO 11.

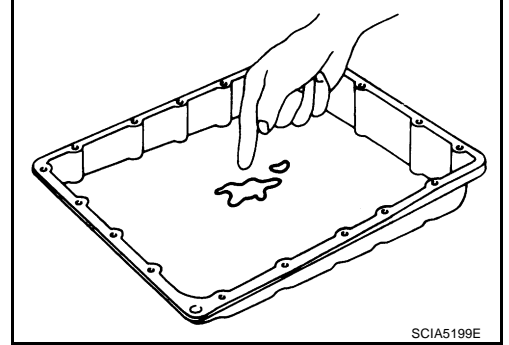

8. DETECT MALFUNCTIONING ITEM

- Check the malfunction items. If any items are damaged, repair or replace damaged parts. Refer to [AT-62, "Symptom Chart"](#) (Symptom No.11).

OK or NG

- OK >> GO TO 9.
NG >> Repair or replace damaged parts.

9. CHECK SYMPTOM

Check again. Refer to [AT-57, "Cruise Test - Part 1"](#) , [AT-59, "Cruise Test - Part 2"](#) .

OK or NG

- OK >> **INSPECTION END**
NG >> GO TO 10.

10. CHECK TCM

1. Check TCM input/output signals. Refer to [AT-86, "TCM Input/Output Signal Reference Values"](#) .
2. If NG, recheck A/T assembly harness connector terminals for damage or loose connection with harness connector.

OK or NG

- OK >> **INSPECTION END**
NG >> Repair or replace damaged parts.

11. DETECT MALFUNCTIONING ITEM

- Check the malfunction items. If any items are damaged, repair or replace damaged parts. Refer to [AT-62, "Symptom Chart"](#) (Symptom No.11).

OK or NG

- OK >> GO TO 9.
NG >> Repair or replace damaged parts.

TROUBLE DIAGNOSIS FOR SYMPTOMS

ACS0084F

A/T Does Not Shift: D3 → D4

SYMPTOM:

- The vehicle does not shift-up from D3 to D4 gear at the specified speed.

DIAGNOSTIC PROCEDURE

1. CONFIRM THE SYMPTOM

Check if vehicle creep forward in "D" position and vehicle can be started from D1.

OK or NG

OK >> GO TO 2.

NG >> Refer to [AT-197, "Vehicle Does Not Creep Forward in "D" Position"](#) , [AT-199, "Vehicle Cannot Be Started From D1"](#) .

2. CHECK SELF-DIAGNOSTIC RESULTS

Perform self-diagnosis. Refer to [AT-90, "SELF-DIAGNOSTIC RESULT MODE"](#) .

Do the self-diagnostic results indicate ATF pressure switch 1, ATF pressure switch 3, front brake solenoid valve, input clutch solenoid valve, accelerator pedal position sensor, vehicle speed sensor A/T (revolution sensor) and vehicle speed sensor MTR?

YES >> Check the malfunctioning system. Refer to [AT-171, "DTC P1841 ATF PRESSURE SWITCH 1"](#) , [AT-173, "DTC P1843 ATF PRESSURE SWITCH 3"](#) , [AT-145, "DTC P1752 INPUT CLUTCH SOLENOID VALVE"](#) , [AT-149, "DTC P1757 FRONT BRAKE SOLENOID VALVE"](#) , [AT-128, "DTC P1705 THROTTLE POSITION SENSOR"](#) , [AT-113, "DTC P0720 VEHICLE SPEED SENSOR A/T \(REVOLUTION SENSOR\)"](#) , [AT-138, "DTC P1721 VEHICLE SPEED SENSOR MTR"](#) .

NO >> GO TO 3.

3. CHECK A/T FLUID LEVEL

Check A/T fluid level. Refer to [AT-12, "Checking A/T Fluid"](#) .

OK or NG

OK >> GO TO 4.

NG >> Refill ATF.

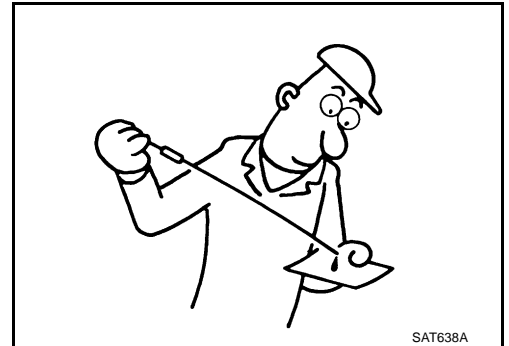

SAT638A

4. CHECK LINE PRESSURE

Check line pressure at the engine stall point. Refer to [AT-52, "LINE PRESSURE TEST"](#) .

OK or NG

OK >> GO TO 7.

NG - 1 >> Line pressure high. GO TO 5.

NG - 2 >> Line pressure low. GO TO 6.

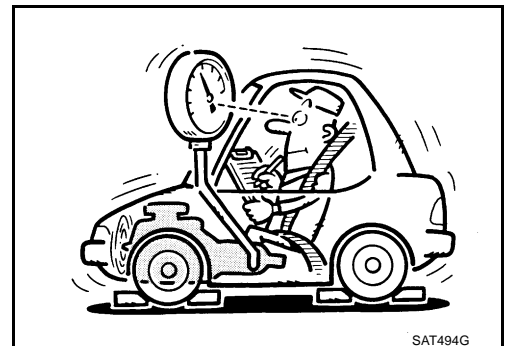

SAT494G

TROUBLE DIAGNOSIS FOR SYMPTOMS

5. DETECT MALFUNCTIONING ITEM

1. Check control valve with TCM. Refer to [AT-238, "Control Valve with TCM and A/T Fluid Temperature Sensor 2"](#) .
2. Disassemble A/T. Refer to [AT-275, "DISASSEMBLY"](#) .
3. Check the following items:
 - Oil pump assembly. Refer to [AT-292, "Oil Pump"](#) .

OK or NG

- OK >> GO TO 7.
- NG >> Repair or replace damaged parts.

6. DETECT MALFUNCTIONING ITEM

1. Check control valve with TCM. Refer to [AT-238, "Control Valve with TCM and A/T Fluid Temperature Sensor 2"](#) .
2. Disassemble A/T. Refer to [AT-275, "DISASSEMBLY"](#) .
3. Check the following items:
 - Oil pump assembly. Refer to [AT-292, "Oil Pump"](#) .
 - Power train system. Refer to [AT-275, "DISASSEMBLY"](#) .
 - Transmission case. Refer to [AT-275, "DISASSEMBLY"](#) .

OK or NG

- OK >> GO TO 7.
- NG >> Repair or replace damaged parts.

7. CHECK A/T FLUID CONDITION

1. Remove oil pan. Refer to [AT-238, "Control Valve with TCM and A/T Fluid Temperature Sensor 2"](#) .
2. Check A/T fluid condition. Refer to [AT-51, "Fluid Condition Check"](#) .

OK or NG

- OK >> GO TO 8.
- NG >> GO TO 11.

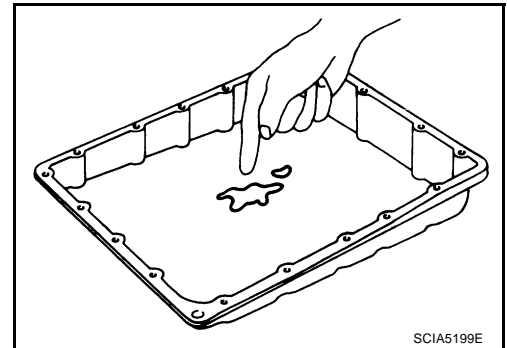

8. DETECT MALFUNCTIONING ITEM

- Check the malfunction items. If any items are damaged, repair or replace damaged parts. Refer to [AT-62, "Symptom Chart"](#) (Symptom No.12).

OK or NG

- OK >> GO TO 9.
- NG >> Repair or replace damaged parts.

9. CHECK SYMPTOM

Check again. Refer to [AT-57, "Cruise Test - Part 1"](#) , [AT-59, "Cruise Test - Part 2"](#) .

OK or NG

- OK >> **INSPECTION END**
- NG >> GO TO 10.

TROUBLE DIAGNOSIS FOR SYMPTOMS

10. CHECK TCM

1. Check TCM input/output signals. Refer to [AT-86, "TCM Input/Output Signal Reference Values"](#) .
2. If NG, recheck A/T assembly harness connector terminals for damage or loose connection with harness connector.

OK or NG

- OK >> **INSPECTION END**
NG >> Repair or replace damaged parts.

11. DETECT MALFUNCTIONING ITEM

- Check the malfunction items. If any items are damaged, repair or replace damaged parts. Refer to [AT-62, "Symptom Chart"](#) (Symptom No.12).

OK or NG

- OK >> GO TO 9.
NG >> Repair or replace damaged parts.

A/T Does Not Shift: D4 → D5 SYMPTOM:

ACS0084G

The vehicle does not shift-up from D4 to D5 gear at the specified speed.

DIAGNOSTIC PROCEDURE

1. CONFIRM THE SYMPTOM

Check if vehicle creep forward in "D" position and vehicle can be started from D1.

OK or NG

- OK >> GO TO 2.
NG >> Refer to [AT-197, "Vehicle Does Not Creep Forward in "D" Position"](#) , [AT-199, "Vehicle Cannot Be Started From D1"](#) .

2. CHECK SELF-DIAGNOSTIC RESULTS

Perform self-diagnosis. Refer to [AT-90, "SELF-DIAGNOSTIC RESULT MODE"](#) .

Do the self-diagnostic results indicate ATF pressure switch 1, ATF pressure switch 5, front brake solenoid valve, direct clutch solenoid valve, accelerator pedal position sensor, turbine revolution sensor, vehicle speed sensor A/T (revolution sensor) and vehicle speed sensor MTR?

- YES >> Check the malfunctioning system. Refer to [AT-171, "DTC P1841 ATF PRESSURE SWITCH 1"](#) , [AT-175, "DTC P1845 ATF PRESSURE SWITCH 5"](#) , [AT-149, "DTC P1757 FRONT BRAKE SOLENOID VALVE"](#) , [AT-153, "DTC P1762 DIRECT CLUTCH SOLENOID VALVE"](#) , [AT-128, "DTC P1705 THROTTLE POSITION SENSOR"](#) , [AT-136, "DTC P1716 TURBINE REVOLUTION SENSOR"](#) , [AT-113, "DTC P0720 VEHICLE SPEED SENSOR A/T \(REVOLUTION SENSOR\)"](#) , [AT-138, "DTC P1721 VEHICLE SPEED SENSOR MTR"](#) .

- NO >> GO TO 3.

3. CHECK A/T FLUID LEVEL

Check A/T fluid level. Refer to [AT-12, "Checking A/T Fluid"](#) .

OK or NG

- OK >> GO TO 4.
NG >> Refill ATF.

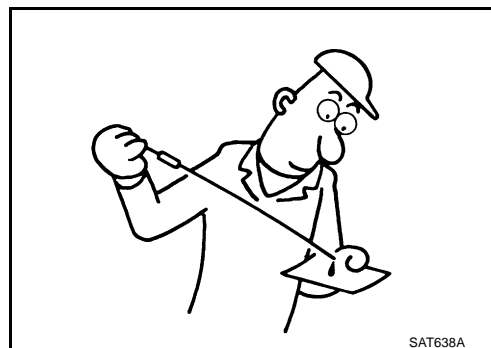

TROUBLE DIAGNOSIS FOR SYMPTOMS

4. CHECK LINE PRESSURE

Check line pressure at the engine stall point. Refer to [AT-52, "LINE PRESSURE TEST"](#) .

OK or NG

- OK >> GO TO 7.
- NG - 1 >> Line pressure high. GO TO 5.
- NG - 2 >> Line pressure low. GO TO 6.

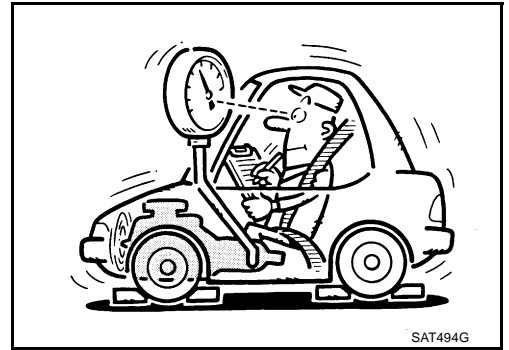

5. DETECT MALFUNCTIONING ITEM

1. Check control valve with TCM. Refer to [AT-238, "Control Valve with TCM and A/T Fluid Temperature Sensor 2"](#) .
2. Disassemble A/T. Refer to [AT-275, "DISASSEMBLY"](#) .
3. Check the following items:
 - Oil pump assembly. Refer to [AT-292, "Oil Pump"](#) .

OK or NG

- OK >> GO TO 7.
- NG >> Repair or replace damaged parts.

6. DETECT MALFUNCTIONING ITEM

1. Check control valve with TCM. Refer to [AT-238, "Control Valve with TCM and A/T Fluid Temperature Sensor 2"](#) .
2. Disassemble A/T. Refer to [AT-275, "DISASSEMBLY"](#) .
3. Check the following items:
 - Oil pump assembly. Refer to [AT-292, "Oil Pump"](#) .
 - Power train system. Refer to [AT-275, "DISASSEMBLY"](#) .
 - Transmission case. Refer to [AT-275, "DISASSEMBLY"](#) .

OK or NG

- OK >> GO TO 7.
- NG >> Repair or replace damaged parts.

7. CHECK A/T FLUID CONDITION

1. Remove oil pan. Refer to [AT-238, "Control Valve with TCM and A/T Fluid Temperature Sensor 2"](#) .
2. Check A/T fluid condition. Refer to [AT-51, "Fluid Condition Check"](#) .

OK or NG

- OK >> GO TO 8.
- NG >> GO TO 11.

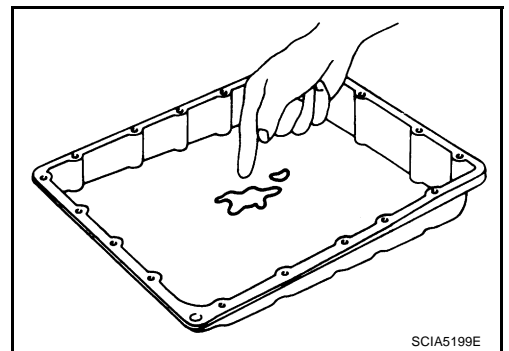

TROUBLE DIAGNOSIS FOR SYMPTOMS

8. DETECT MALFUNCTIONING ITEM

- Check the malfunction items. If any items are damaged, repair or replace damaged parts. Refer to [AT-62, "Symptom Chart"](#) (Symptom No.13).

OK or NG

- OK >> GO TO 9.
NG >> Repair or replace damaged parts.

9. CHECK SYMPTOM

Check again. Refer to [AT-57, "Cruise Test - Part 1"](#) .

OK or NG

- OK >> **INSPECTION END**
NG >> GO TO 10.

10. CHECK TCM

1. Check TCM input/output signals. Refer to [AT-86, "TCM Input/Output Signal Reference Values"](#) .
2. If NG, recheck A/T assembly harness connector terminals for damage or loose connection with harness connector.

OK or NG

- OK >> **INSPECTION END**
NG >> Repair or replace damaged parts.

11. DETECT MALFUNCTIONING ITEM

- Check the malfunction items. If any items are damaged, repair or replace damaged parts. Refer to [AT-62, "Symptom Chart"](#) (Symptom No.13).

OK or NG

- OK >> GO TO 9.
NG >> Repair or replace damaged parts.

A
B
AT
D
E
F
G
H
I
J
K
L
M

TROUBLE DIAGNOSIS FOR SYMPTOMS

ACS0084H

A/T Does Not Perform Lock-up

SYMPTOM:

A/T does not perform lock-up at the specified speed.

DIAGNOSTIC PROCEDURE

1. CHECK SELF-DIAGNOSTIC RESULTS

Perform self-diagnosis. Refer to [AT-90, "SELF-DIAGNOSTIC RESULT MODE"](#) , [AT-99, "TCM SELF-DIAGNOSTIC PROCEDURE \(NO TOOLS\)"](#) .

Do the self-diagnostic results indicate torque converter clutch solenoid valve, engine speed signal, turbine revolution sensor, accelerator pedal position sensor, CAN communication?

YES >> Check the malfunctioning system. Refer to [AT-120, "DTC P0740 TORQUE CONVERTER CLUTCH SOLENOID VALVE"](#) , [AT-118, "DTC P0725 ENGINE SPEED SIGNAL"](#) , [AT-136, "DTC P1716 TURBINE REVOLUTION SENSOR"](#) , [AT-128, "DTC P1705 THROTTLE POSITION SENSOR"](#) , [AT-101, "DTC U1000 CAN COMMUNICATION LINE"](#) .

NO >> GO TO 2.

2. CHECK A/T FLUID LEVEL

Check A/T fluid level. Refer to [AT-12, "Checking A/T Fluid"](#) .

OK or NG

OK >> GO TO 3.

NG >> Refill ATF.

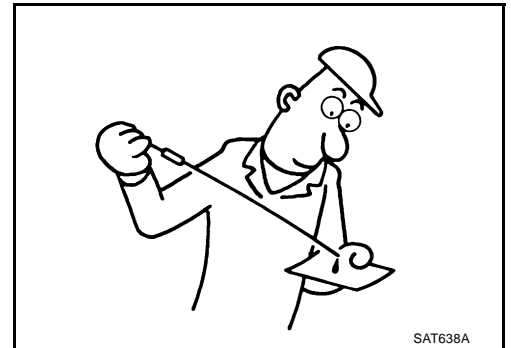

3. CHECK LINE PRESSURE

Check line pressure at the engine stall point. Refer to [AT-52, "LINE PRESSURE TEST"](#) .

OK or NG

OK >> GO TO 6.

NG - 1 >> Line pressure high. GO TO 4.

NG - 2 >> Line pressure low. GO TO 5.

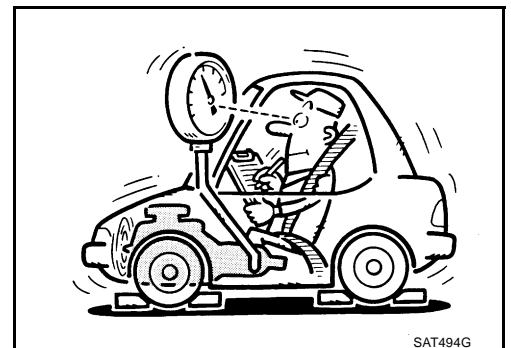

4. DETECT MALFUNCTIONING ITEM

1. Check control valve with TCM. Refer to [AT-238, "Control Valve with TCM and A/T Fluid Temperature Sensor 2"](#) .

2. Disassemble A/T. Refer to [AT-275, "DISASSEMBLY"](#) .

3. Check the following items:

- Oil pump assembly. Refer to [AT-292, "Oil Pump"](#) .

OK or NG

OK >> GO TO 6.

NG >> Repair or replace damaged parts.

TROUBLE DIAGNOSIS FOR SYMPTOMS

5. DETECT MALFUNCTIONING ITEM

1. Check control valve with TCM. Refer to [AT-238, "Control Valve with TCM and A/T Fluid Temperature Sensor 2"](#) .
2. Disassemble A/T. Refer to [AT-275, "DISASSEMBLY"](#) .
3. Check the following items:
 - Oil pump assembly. Refer to [AT-292, "Oil Pump"](#) .
 - Power train system. Refer to [AT-275, "DISASSEMBLY"](#) .
 - Transmission case. Refer to [AT-275, "DISASSEMBLY"](#) .

OK or NG

- OK >> GO TO 6.
NG >> Repair or replace damaged parts.

6. CHECK A/T FLUID CONDITION

1. Remove oil pan. Refer to [AT-238, "Control Valve with TCM and A/T Fluid Temperature Sensor 2"](#) .
2. Check A/T fluid condition. Refer to [AT-51, "Fluid Condition Check"](#) .

OK or NG

- OK >> GO TO 7.
NG >> GO TO 10.

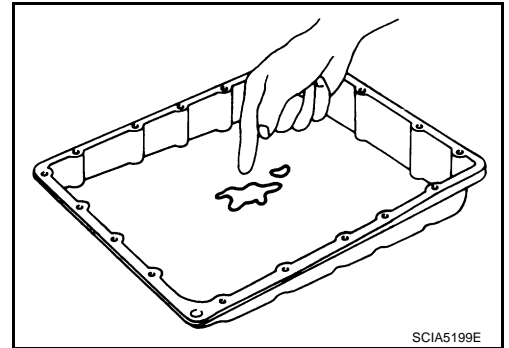

7. DETECT MALFUNCTIONING ITEM

- Check the malfunction items. If any items are damaged, repair or replace damaged parts. Refer to [AT-62, "Symptom Chart"](#) (Symptom No.24).

OK or NG

- OK >> GO TO 8.
NG >> Repair or replace damaged parts.

8. CHECK SYMPTOM

Check again. Refer to [AT-57, "Cruise Test - Part 1"](#) .

OK or NG

- OK >> **INSPECTION END**
NG >> GO TO 9.

9. CHECK TCM

1. Check TCM input/output signals. Refer to [AT-86, "TCM Input/Output Signal Reference Values"](#) .
2. If NG, recheck A/T assembly harness connector terminals for damage or loose connection with harness connector.

OK or NG

- OK >> **INSPECTION END**
NG >> Repair or replace damaged parts.

TROUBLE DIAGNOSIS FOR SYMPTOMS

10. DETECT MALFUNCTIONING ITEM

- Check the malfunction items. If any items are damaged, repair or replace damaged parts. Refer to [AT-62, "Symptom Chart"](#) (Symptom No.24).

OK or NG

- OK >> GO TO 8.
NG >> Repair or replace damaged parts.

A/T Does Not Hold Lock-up Condition SYMPTOM:

ACS0084I

The lock-up condition cannot be maintained for more than 30 seconds.

DIAGNOSTIC PROCEDURE

1. CHECK SELF-DIAGNOSTIC RESULTS

Perform self-diagnosis. Refer to [AT-90, "SELF-DIAGNOSTIC RESULT MODE"](#) , [AT-99, "TCM SELF-DIAGNOSTIC PROCEDURE \(NO TOOLS\)"](#) .

Do the self-diagnostic results indicate torque converter clutch solenoid valve, engine speed signal, turbine revolution sensor, CAN communication?

- YES >> Check the malfunctioning system. Refer to [AT-120, "DTC P0740 TORQUE CONVERTER CLUTCH SOLENOID VALVE"](#) , [AT-118, "DTC P0725 ENGINE SPEED SIGNAL"](#) , [AT-136, "DTC P1716 TURBINE REVOLUTION SENSOR"](#) , [AT-101, "DTC U1000 CAN COMMUNICATION LINE"](#) .

- NO >> GO TO 2.

2. CHECK A/T FLUID LEVEL

Check A/T fluid level. Refer to [AT-12, "Checking A/T Fluid"](#) .

OK or NG

- OK >> GO TO 3.
NG >> Refill ATF.

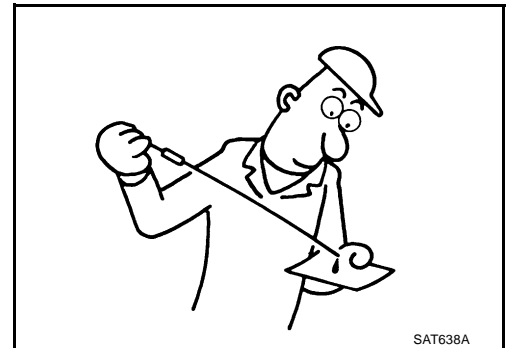

3. CHECK A/T FLUID CONDITION

1. Remove oil pan. Refer to [AT-238, "Control Valve with TCM and A/T Fluid Temperature Sensor 2"](#) .
2. Check A/T fluid condition. Refer to [AT-51, "Fluid Condition Check"](#) .

OK or NG

- OK >> GO TO 4.
NG >> GO TO 7.

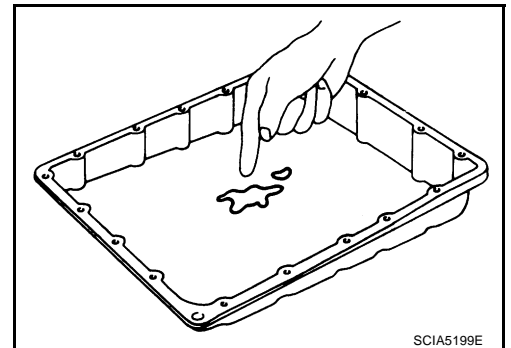

TROUBLE DIAGNOSIS FOR SYMPTOMS

4. DETECT MALFUNCTIONING ITEM

- Check the malfunction items. If any items are damaged, repair or replace damaged parts. Refer to [AT-62, "Symptom Chart"](#) (Symptom No.25).

OK or NG

- OK >> GO TO 5.
NG >> Repair or replace damaged parts.

5. CHECK SYMPTOM

Check again. Refer to [AT-57, "Cruise Test - Part 1"](#) .

OK or NG

- OK >> **INSPECTION END**
NG >> GO TO 6.

6. CHECK TCM

1. Check TCM input/output signals. Refer to [AT-86, "TCM Input/Output Signal Reference Values"](#) .
2. If NG, recheck A/T assembly harness connector terminals for damage or loose connection with harness connector.

OK or NG

- OK >> **INSPECTION END**
NG >> Repair or replace damaged parts.

7. DETECT MALFUNCTIONING ITEM

- Check the malfunction items. If any items are damaged, repair or replace damaged parts. Refer to [AT-62, "Symptom Chart"](#) (Symptom No.25).

OK or NG

- OK >> GO TO 5.
NG >> Repair or replace damaged parts.

Lock-up Is Not Released

SYMPTOM:

ACS0084J

The lock-up condition cannot be cancelled even after releasing the accelerator pedal.

DIAGNOSTIC PROCEDURE

1. CHECK SELF-DIAGNOSTIC RESULTS

Perform self-diagnosis. Refer to [AT-90, "SELF-DIAGNOSTIC RESULT MODE"](#) , [AT-99, "TCM SELF-DIAGNOSTIC PROCEDURE \(NO TOOLS\)"](#) .

Do the self-diagnostic results indicate torque converter clutch solenoid valve, engine speed signal, turbine revolution sensor, CAN communication?

- YES >> Check the malfunctioning system. Refer to [AT-120, "DTC P0740 TORQUE CONVERTER CLUTCH SOLENOID VALVE"](#) , [AT-118, "DTC P0725 ENGINE SPEED SIGNAL"](#) , [AT-136, "DTC P1716 TURBINE REVOLUTION SENSOR"](#) , [AT-101, "DTC U1000 CAN COMMUNICATION LINE"](#) .
- NO >> GO TO 2.

2. CHECK SYMPTOM

Check again. Refer to [AT-57, "Cruise Test - Part 1"](#) .

OK or NG

- OK >> **INSPECTION END**
NG >> GO TO 3.

TROUBLE DIAGNOSIS FOR SYMPTOMS

3. CHECK TCM

1. Check TCM input/output signals. Refer to [AT-86, "TCM Input/Output Signal Reference Values"](#) .
2. If NG, recheck A/T assembly harness connector terminals for damage or loose connection with harness connector.

OK or NG

- OK >> **INSPECTION END**
NG >> Repair or replace damaged parts.

Engine Speed Does Not Return to Idle SYMPTOM:

ACS0084K

When a shift-down is performed, the engine speed does not smoothly return to the idling speed.

DIAGNOSTIC PROCEDURE

1. CHECK A/T FLUID LEVEL

Check A/T fluid level. Refer to [AT-12, "Checking A/T Fluid"](#) .

OK or NG

- OK >> GO TO 2.
NG >> Refill ATF.

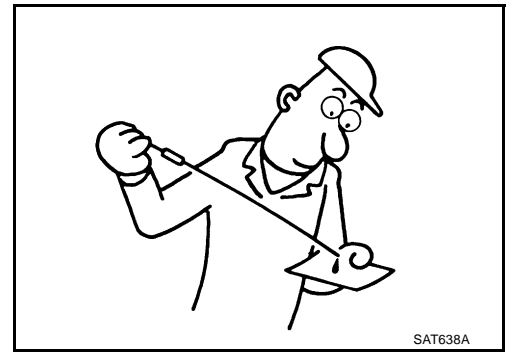

SAT638A

2. CHECK SELF-DIAGNOSTIC RESULTS

Perform self-diagnosis. Refer to [AT-90, "SELF-DIAGNOSTIC RESULT MODE"](#) .

Do the self-diagnostic results indicate front brake solenoid valve, direct clutch solenoid valve, ATF pressure switch 1, ATF pressure switch 5, accelerator pedal position sensor, vehicle speed sensor A/T (revolution sensor) and vehicle speed sensor MTR?

- YES >> Check the malfunctioning system. Refer to [AT-149, "DTC P1757 FRONT BRAKE SOLENOID VALVE"](#) , [AT-153, "DTC P1762 DIRECT CLUTCH SOLENOID VALVE"](#) , [AT-171, "DTC P1841 ATF PRESSURE SWITCH 1"](#) , [AT-175, "DTC P1845 ATF PRESSURE SWITCH 5"](#) , [AT-128, "DTC P1705 THROTTLE POSITION SENSOR"](#) , [AT-113, "DTC P0720 VEHICLE SPEED SENSOR A/T \(REVOLUTION SENSOR\)"](#) , [AT-138, "DTC P1721 VEHICLE SPEED SENSOR MTR"](#) .

NO >> GO TO 3.

3. CHECK A/T FLUID CONDITION

1. Remove oil pan. Refer to [AT-238, "Control Valve with TCM and A/T Fluid Temperature Sensor 2"](#) .
2. Check A/T fluid condition. Refer to [AT-51, "Fluid Condition Check"](#) .

OK or NG

- OK >> GO TO 4.
NG >> GO TO 7.

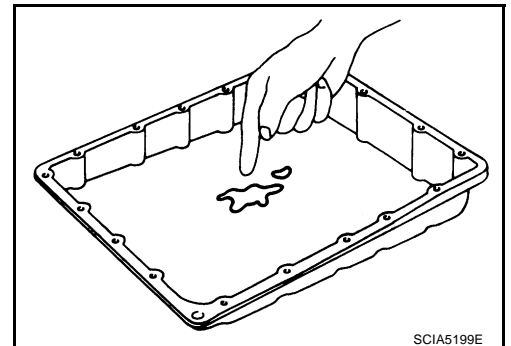

SCIA5199E

TROUBLE DIAGNOSIS FOR SYMPTOMS

4. DETECT MALFUNCTIONING ITEM

- Check the malfunction items. If any items are damaged, repair or replace damaged parts. Refer to [AT-62, "Symptom Chart"](#) (Symptom No.72).

OK or NG

- OK >> GO TO 5.
NG >> Repair or replace damaged parts.

5. CHECK SYMPTOM

Check again. Refer to [AT-57, "Cruise Test - Part 1"](#) .

OK or NG

- OK >> **INSPECTION END**
NG >> GO TO 6.

6. CHECK TCM

1. Check TCM input/output signals. Refer to [AT-86, "TCM Input/Output Signal Reference Values"](#) .
2. If NG, recheck A/T assembly harness connector terminals for damage or loose connection with harness connector.

OK or NG

- OK >> **INSPECTION END**
NG >> Repair or replace damaged parts.

7. DETECT MALFUNCTIONING ITEM

- Check the malfunction items. If any items are damaged, repair or replace damaged parts. Refer to [AT-62, "Symptom Chart"](#) (Symptom No.72).

OK or NG

- OK >> GO TO 5.
NG >> Repair or replace damaged parts.

Cannot Be Changed to Manual Mode

SYMPTOM:

Does not change to manual mode when manual shift gate is used.

DIAGNOSTIC PROCEDURE

1. MANUAL MODE SWITCH

Check manual mode switch. Refer to [AT-165, "DTC P1815 MANUAL MODE SWITCH"](#) .

OK or NG

- OK >> GO TO 2.
NG >> Repair or replace damaged parts.

2. CHECK SELF-DIAGNOSIS RESULTS

Perform self-diagnosis. Refer to [AT-90, "SELF-DIAGNOSTIC RESULT MODE"](#) .

Do the self-diagnosis results indicate turbine revolution sensor?

- YES >> Check the malfunctioning system. Refer to [AT-136, "DTC P1716 TURBINE REVOLUTION SENSOR"](#) .
NO >> **INSPECTION END**

TROUBLE DIAGNOSIS FOR SYMPTOMS

ACS0084M

A/T Does Not Shift: 5th gear → 4th gear

SYMPTOM:

When shifted from M5 to M4 position in manual mode, does not downshift from 5th to 4th gear.

DIAGNOSTIC PROCEDURE

1. CHECK SELF-DIAGNOSTIC RESULTS

Perform self-diagnosis. Refer to [AT-90, "SELF-DIAGNOSTIC RESULT MODE"](#) .

Do the self-diagnostic results indicate PNP switch, ATF pressure switch 1?

YES >> Check the malfunctioning system. Refer to [AT-109, "DTC P0705 PARK/NEUTRAL POSITION SWITCH"](#) , [AT-171, "DTC P1841 ATF PRESSURE SWITCH 1"](#) .

NO >> GO TO 2.

2. CHECK A/T FLUID LEVEL

Check A/T fluid level. Refer to [AT-12, "Checking A/T Fluid"](#) .

OK or NG

OK >> GO TO 3.

NG >> Refill ATF.

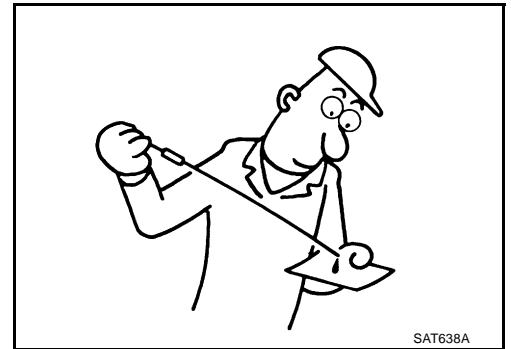

3. CHECK CONTROL LINKAGE

Check control linkage.

- Refer to [AT-229, "Checking of A/T Position"](#) .

OK or NG

OK >> GO TO 4.

NG >> Adjust control linkage. Refer to [AT-229, "Adjustment of A/T Position"](#) .

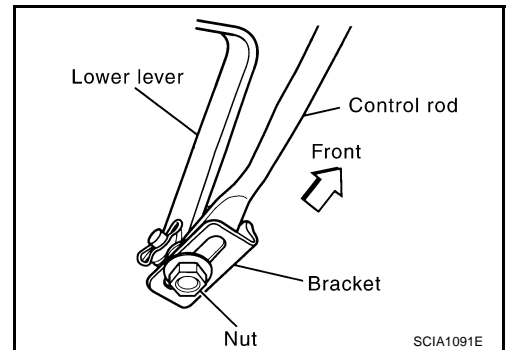

4. MANUAL MODE SWITCH

Check manual mode switch. Refer to [AT-165, "DTC P1815 MANUAL MODE SWITCH"](#) .

OK or NG

OK >> GO TO 5.

NG >> Repair or replace damaged parts.

TROUBLE DIAGNOSIS FOR SYMPTOMS

5. CHECK A/T FLUID CONDITION

1. Remove oil pan. Refer to [AT-238, "Control Valve with TCM and A/T Fluid Temperature Sensor 2"](#) .
2. Check A/T fluid condition. Refer to [AT-51, "Fluid Condition Check"](#) .

OK or NG

- OK >> GO TO 6.
- NG >> GO TO 9.

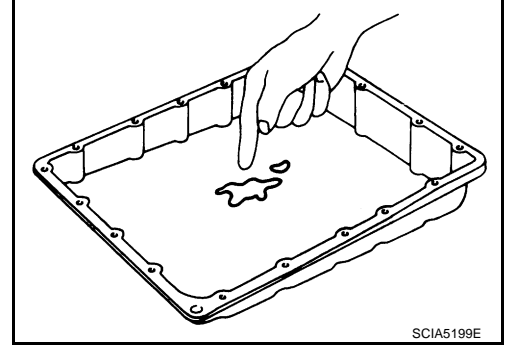

6. DETECT MALFUNCTIONING ITEM

- Check the malfunction items. If any items are damaged, repair or replace damaged parts. Refer to [AT-62, "Symptom Chart"](#) (Symptom No.14).

OK or NG

- OK >> GO TO 7.
- NG >> Repair or replace damaged parts.

7. CHECK SYMPTOM

Check again. Refer to [AT-60, "Cruise Test - Part 3"](#) .

OK or NG

- OK >> **INSPECTION END**
- NG >> GO TO 8.

8. CHECK TCM

1. Check TCM input/output signals. Refer to [AT-86, "TCM Input/Output Signal Reference Values"](#) .
2. If NG, recheck A/T assembly harness connector terminals for damage or loose connection with harness connector.

OK or NG

- OK >> **INSPECTION END**
- NG >> Repair or replace damaged parts.

9. DETECT MALFUNCTIONING ITEM

- Check the malfunction items. If any items are damaged, repair or replace damaged parts. Refer to [AT-62, "Symptom Chart"](#) (Symptom No.14).

OK or NG

- OK >> GO TO 7.
- NG >> Repair or replace damaged parts.

TROUBLE DIAGNOSIS FOR SYMPTOMS

ACS0084N

A/T Does Not Shift: 4th gear → 3rd gear

SYMPTOM:

When shifted from M4 to M3 position in manual mode, does not downshift from 4th to 3rd gear.

DIAGNOSTIC PROCEDURE

1. CHECK SELF-DIAGNOSTIC RESULTS

Perform self-diagnosis. Refer to [AT-90, "SELF-DIAGNOSTIC RESULT MODE"](#) .

Do the self-diagnostic results indicate PNP switch, ATF pressure switch 1, ATF pressure switch 3?

YES >> Check the malfunctioning system. Refer to [AT-109, "DTC P0705 PARK/NEUTRAL POSITION SWITCH"](#) , [AT-171, "DTC P1841 ATF PRESSURE SWITCH 1"](#) , [AT-173, "DTC P1843 ATF PRES-SURE SWITCH 3"](#) .

NO >> GO TO 2.

2. CHECK A/T FLUID LEVEL

Check A/T fluid level. Refer to [AT-12, "Checking A/T Fluid"](#) .

OK or NG

OK >> GO TO 3.

NG >> Refill ATF.

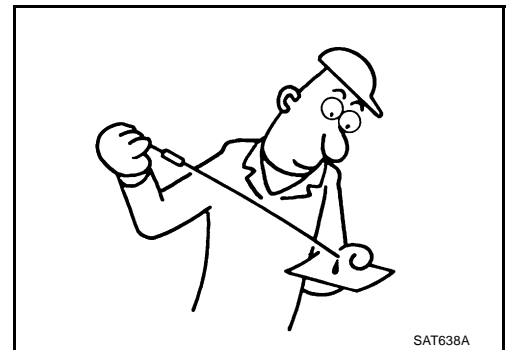

3. CHECK CONTROL LINKAGE

Check control linkage.

- Refer to [AT-229, "Checking of A/T Position"](#) .

OK or NG

OK >> GO TO 4.

NG >> Adjust control linkage. Refer to [AT-229, "Adjustment of A/T Position"](#) .

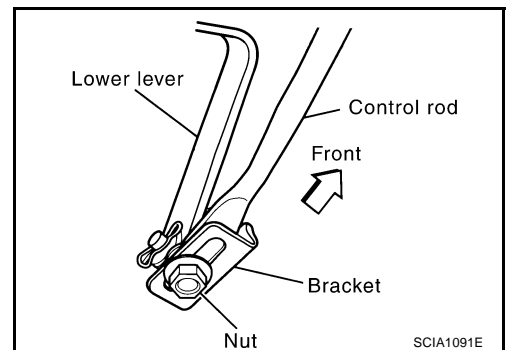

4. MANUAL MODE SWITCH

Check manual mode switch. Refer to [AT-165, "DTC P1815 MANUAL MODE SWITCH"](#) .

OK or NG

OK >> GO TO 5.

NG >> Repair or replace damaged parts.

TROUBLE DIAGNOSIS FOR SYMPTOMS

5. CHECK A/T FLUID CONDITION

1. Remove oil pan. Refer to [AT-238, "Control Valve with TCM and A/T Fluid Temperature Sensor 2"](#) .
2. Check A/T fluid condition. Refer to [AT-51, "Fluid Condition Check"](#) .

OK or NG

- OK >> GO TO 6.
- NG >> GO TO 9.

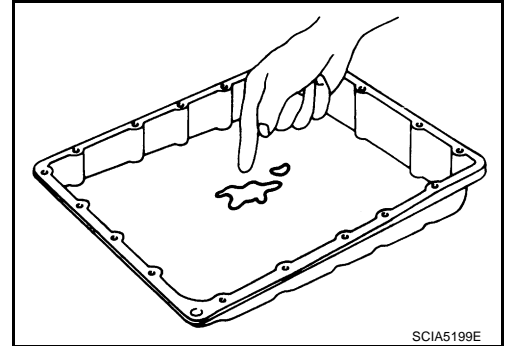

6. DETECT MALFUNCTIONING ITEM

- Check the malfunction items. If any items are damaged, repair or replace damaged parts. Refer to [AT-62, "Symptom Chart"](#) (Symptom No.15).

OK or NG

- OK >> GO TO 7.
- NG >> Repair or replace damaged parts.

7. CHECK SYMPTOM

Check again. Refer to [AT-60, "Cruise Test - Part 3"](#) .

OK or NG

- OK >> **INSPECTION END**
- NG >> GO TO 8.

8. CHECK TCM

1. Check TCM input/output signals. Refer to [AT-86, "TCM Input/Output Signal Reference Values"](#) .
2. If NG, recheck A/T assembly harness connector terminals for damage or loose connection with harness connector.

OK or NG

- OK >> **INSPECTION END**
- NG >> Repair or replace damaged parts.

9. DETECT MALFUNCTIONING ITEM

- Check the malfunction items. If any items are damaged, repair or replace damaged parts. Refer to [AT-62, "Symptom Chart"](#) (Symptom No.15).

OK or NG

- OK >> GO TO 7.
- NG >> Repair or replace damaged parts.

TROUBLE DIAGNOSIS FOR SYMPTOMS

ACS00840

A/T Does Not Shift: 3rd gear → 2nd gear

SYMPTOM:

When shifted from M3 to M2 position in manual mode, does not downshift from 3rd to 2nd gear.

DIAGNOSTIC PROCEDURE

1. CHECK SELF-DIAGNOSTIC RESULTS

Perform self-diagnosis. Refer to [AT-90, "SELF-DIAGNOSTIC RESULT MODE"](#) .

Do the self-diagnostic results indicate PNP switch, ATF pressure switch 6?

YES >> Check the malfunctioning system. Refer to [AT-109, "DTC P0705 PARK/NEUTRAL POSITION SWITCH"](#) , [AT-177, "DTC P1846 ATF PRESSURE SWITCH 6"](#) .

NO >> GO TO 2.

2. CHECK A/T FLUID LEVEL

Check A/T fluid level. Refer to [AT-12, "Checking A/T Fluid"](#) .

OK or NG

OK >> GO TO 3.

NG >> Refill ATF.

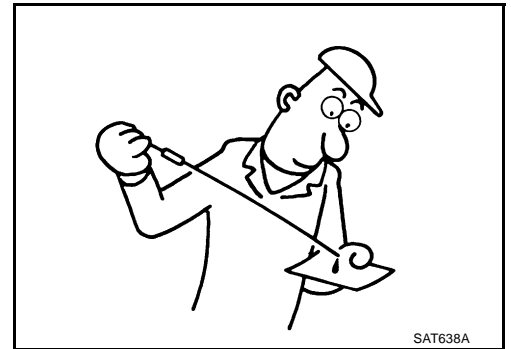

3. CHECK CONTROL LINKAGE

Check control linkage.

- Refer to [AT-229, "Checking of A/T Position"](#) .

OK or NG

OK >> GO TO 4.

NG >> Adjust control linkage. Refer to [AT-229, "Adjustment of A/T Position"](#) .

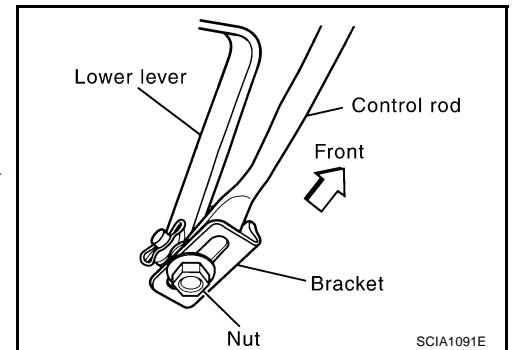

4. MANUAL MODE SWITCH

Check manual mode switch. Refer to [AT-165, "DTC P1815 MANUAL MODE SWITCH"](#) .

OK or NG

OK >> GO TO 5.

NG >> Repair or replace damaged parts.

TROUBLE DIAGNOSIS FOR SYMPTOMS

5. CHECK A/T FLUID CONDITION

1. Remove oil pan. Refer to [AT-238, "Control Valve with TCM and A/T Fluid Temperature Sensor 2"](#) .
2. Check A/T fluid condition. Refer to [AT-51, "Fluid Condition Check"](#) .

OK or NG

- OK >> GO TO 6.
- NG >> GO TO 9.

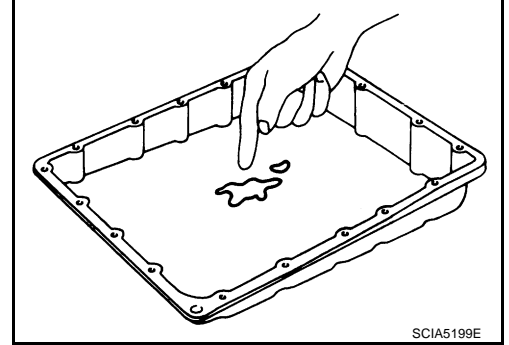

6. DETECT MALFUNCTIONING ITEM

- Check the malfunction items. If any items are damaged, repair or replace damaged parts. Refer to [AT-62, "Symptom Chart"](#) (Symptom No.16).

OK or NG

- OK >> GO TO 7.
- NG >> Repair or replace damaged parts.

7. CHECK SYMPTOM

Check again. Refer to [AT-60, "Cruise Test - Part 3"](#) .

OK or NG

- OK >> **INSPECTION END**
- NG >> GO TO 8.

8. CHECK TCM

1. Check TCM input/output signals. Refer to [AT-86, "TCM Input/Output Signal Reference Values"](#) .
2. If NG, recheck A/T assembly harness connector terminals for damage or loose connection with harness connector.

OK or NG

- OK >> **INSPECTION END**
- NG >> Repair or replace damaged parts.

9. DETECT MALFUNCTIONING ITEM

- Check the malfunction items. If any items are damaged, repair or replace damaged parts. Refer to [AT-62, "Symptom Chart"](#) (Symptom No.16).

OK or NG

- OK >> GO TO 7.
- NG >> Repair or replace damaged parts.

TROUBLE DIAGNOSIS FOR SYMPTOMS

ACS0084P

A/T Does Not Shift: 2nd gear → 1st gear

SYMPTOM:

When shifted from M2 to M1 position in manual mode, does not downshift from 2nd to 1st gear.

DIAGNOSTIC PROCEDURE

1. CHECK SELF-DIAGNOSTIC RESULTS

Perform self-diagnosis. Refer to [AT-90, "SELF-DIAGNOSTIC RESULT MODE"](#) .

Do the self-diagnostic results indicate PNP switch, ATF pressure switch 5?

YES >> Check the malfunctioning system. Refer to [AT-109, "DTC P0705 PARK/NEUTRAL POSITION SWITCH"](#) , [AT-175, "DTC P1845 ATF PRESSURE SWITCH 5"](#) .

NO >> GO TO 2.

2. CHECK A/T FLUID LEVEL

Check A/T fluid level. Refer to [AT-12, "Checking A/T Fluid"](#) .

OK or NG

OK >> GO TO 3.

NG >> Refill ATF.

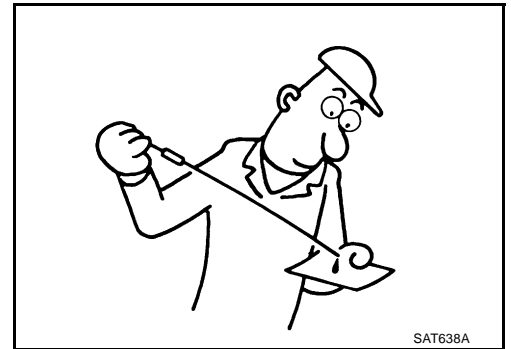

3. CHECK CONTROL LINKAGE

Check control linkage.

- Refer to [AT-229, "Checking of A/T Position"](#) .

OK or NG

OK >> GO TO 4.

NG >> Adjust control linkage. Refer to [AT-229, "Adjustment of A/T Position"](#) .

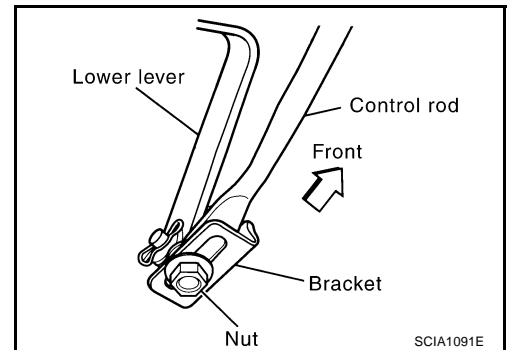

4. MANUAL MODE SWITCH

Check manual mode switch. Refer to [AT-165, "DTC P1815 MANUAL MODE SWITCH"](#) .

OK or NG

OK >> GO TO 5.

NG >> Repair or replace damaged parts.

TROUBLE DIAGNOSIS FOR SYMPTOMS

5. CHECK A/T FLUID CONDITION

1. Remove oil pan. Refer to [AT-238, "Control Valve with TCM and A/T Fluid Temperature Sensor 2"](#) .
2. Check A/T fluid condition. Refer to [AT-51, "Fluid Condition Check"](#) .

OK or NG

- OK >> GO TO 6.
- NG >> GO TO 9.

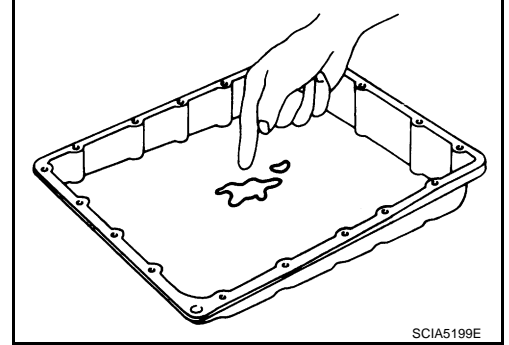

6. DETECT MALFUNCTIONING ITEM

- Check the malfunction items. If any items are damaged, repair or replace damaged parts. Refer to [AT-62, "Symptom Chart"](#) (Symptom No.17).

OK or NG

- OK >> GO TO 7.
- NG >> Repair or replace damaged parts.

7. CHECK SYMPTOM

Check again. Refer to [AT-60, "Cruise Test - Part 3"](#) .

OK or NG

- OK >> **INSPECTION END**
- NG >> GO TO 8.

8. CHECK TCM

1. Check TCM input/output signals. Refer to [AT-86, "TCM Input/Output Signal Reference Values"](#) .
2. If NG, recheck A/T assembly harness connector terminals for damage or loose connection with harness connector.

OK or NG

- OK >> **INSPECTION END**
- NG >> Repair or replace damaged parts.

9. DETECT MALFUNCTIONING ITEM

- Check the malfunction items. If any items are damaged, repair or replace damaged parts. Refer to [AT-62, "Symptom Chart"](#) (Symptom No.17).

OK or NG

- OK >> GO TO 7.
- NG >> Repair or replace damaged parts.

TROUBLE DIAGNOSIS FOR SYMPTOMS

ACS0084Q

Vehicle Does Not Decelerate by Engine Brake

SYMPTOM:

No engine brake is applied when the gear is shifted from the 2nd to 1st gear.

DIAGNOSTIC PROCEDURE

1. CHECK SELF-DIAGNOSTIC RESULTS

Perform self-diagnosis. Refer to [AT-90, "SELF-DIAGNOSTIC RESULT MODE"](#) .

Do the self-diagnostic results indicate PNP switch, ATF pressure switch 5?

YES >> Check the malfunctioning system. Refer to [AT-109, "DTC P0705 PARK/NEUTRAL POSITION SWITCH"](#) , [AT-175, "DTC P1845 ATF PRESSURE SWITCH 5"](#) .

NO >> GO TO 2.

2. CHECK A/T FLUID LEVEL

Check A/T fluid level. Refer to [AT-12, "Checking A/T Fluid"](#) .

OK or NG

OK >> GO TO 3.

NG >> Refill ATF.

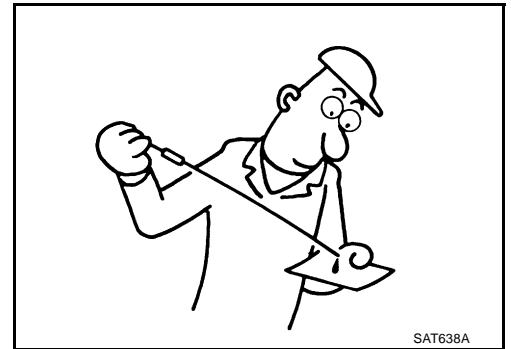

3. CHECK CONTROL LINKAGE

Check control linkage.

● Refer to [AT-229, "Checking of A/T Position"](#) .

OK or NG

OK >> GO TO 4.

NG >> Adjust control linkage. Refer to [AT-229, "Adjustment of A/T Position"](#) .

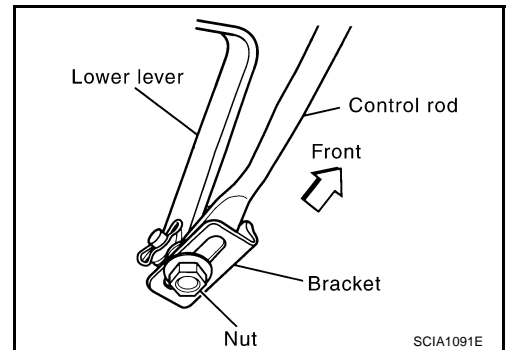

4. MANUAL MODE SWITCH

Check manual mode switch. Refer to [AT-165, "DTC P1815 MANUAL MODE SWITCH"](#) .

OK or NG

OK >> GO TO 5.

NG >> Repair or replace damaged parts.

TROUBLE DIAGNOSIS FOR SYMPTOMS

5. CHECK A/T FLUID CONDITION

1. Remove oil pan. Refer to [AT-238, "Control Valve with TCM and A/T Fluid Temperature Sensor 2"](#) .
2. Check A/T fluid condition. Refer to [AT-51, "Fluid Condition Check"](#) .

OK or NG

- OK >> GO TO 6.
- NG >> GO TO 9.

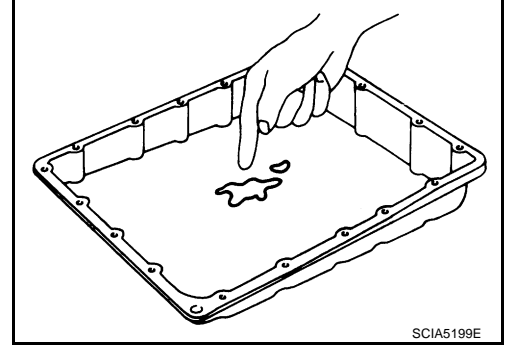

6. DETECT MALFUNCTIONING ITEM

- Check the malfunction items. If any items are damaged, repair or replace damaged parts. Refer to [AT-62, "Symptom Chart"](#) (Symptom No.58).

OK or NG

- OK >> GO TO 7.
- NG >> Repair or replace damaged parts.

7. CHECK SYMPTOM

Check again. Refer to [AT-60, "Cruise Test - Part 3"](#) .

OK or NG

- OK >> **INSPECTION END**
- NG >> GO TO 8.

8. CHECK TCM

1. Check TCM input/output signals. Refer to [AT-86, "TCM Input/Output Signal Reference Values"](#) .
2. If NG, recheck A/T assembly harness connector terminals for damage or loose connection with harness connector.

OK or NG

- OK >> **INSPECTION END**
- NG >> Repair or replace damaged parts.

9. DETECT MALFUNCTIONING ITEM

- Check the malfunction items. If any items are damaged, repair or replace damaged parts. Refer to [AT-62, "Symptom Chart"](#) (Symptom No.58).

OK or NG

- OK >> GO TO 7.
- NG >> Repair or replace damaged parts.

SHIFT CONTROL SYSTEM

SHIFT CONTROL SYSTEM

PFP:34901

Control Device Removal and Installation

ACS00006

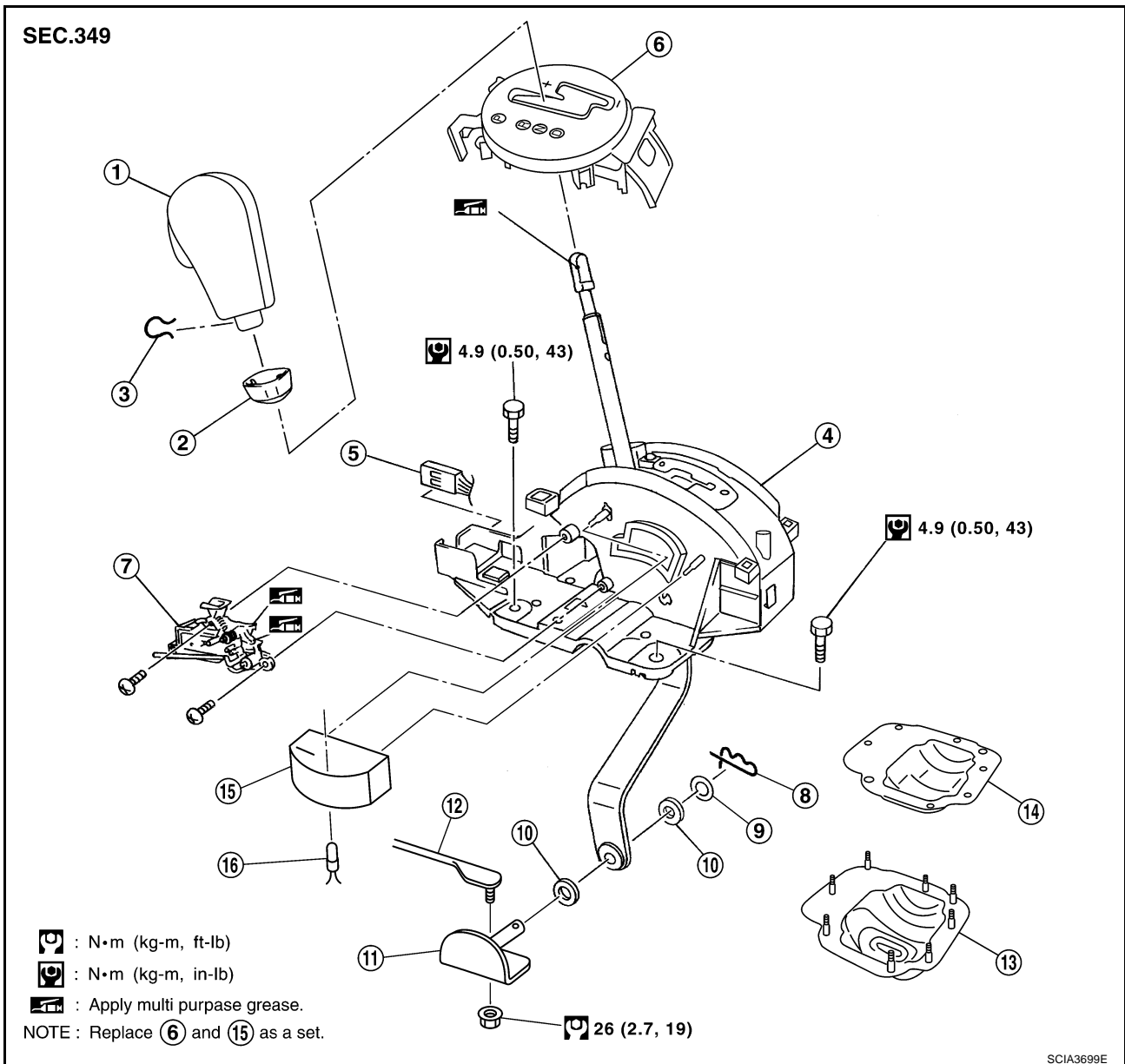

- | | | |
|--|---------------------------------|-----------------------------|
| 1. Selector lever knob | 2. Knob cover | 3. Lock pin |
| 4. Control device assembly | 5. A/T device harness connector | 6. Position indicator plate |
| 7. Shift lock solenoid and park position switch assembly | 8. Snap pin | 9. Conical washer |
| 10. Plain washer | 11. Bracket | 12. Control rod |
| 13. Dust cover | 14. Dust cover plate | 15. Bulb case |
| 16. Position lamp | | |

SHIFT CONTROL SYSTEM

REMOVAL

1. Disconnect lower lever of control device and control rod.
2. Remove knob cover below selector lever downward.
3. Pull lock pin out of selector lever knob.
4. Remove selector lever knob.
5. Remove console finisher (A/T ring) and console finisher.
 - Refer to [IP-10, "Component Parts Drawing"](#) .
6. Remove center console.
 - Refer to [IP-10, "Component Parts Drawing"](#) .
7. Remove key interlock cable from control device.
 - Refer to [AT-236, "Removal and Installation"](#) .
8. Disconnect A/T device harness connector.
9. Remove control device assembly.

CAUTION:

Do not impact, or damage propeller shaft tube.

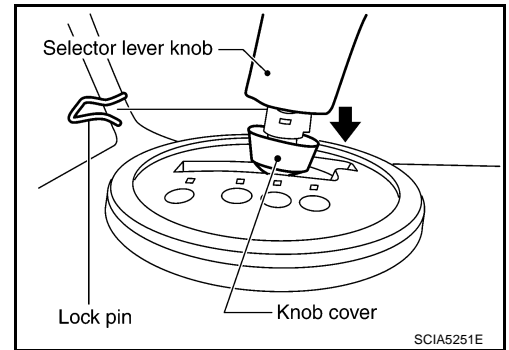

INSTALLATION

Install in reverse order of removal. Be careful of the following:

- After installation is completed, adjust and check A/T position.

Adjustment of A/T Position

1. Loosen nut of control rod.
2. Place PNP switch and selector lever in "P" position.
3. While pressing lower lever toward rear of vehicle (in "P" position direction), tighten nut to specified torque.

 : 26 N·m (2.7 kg·m, 19 ft·lb)

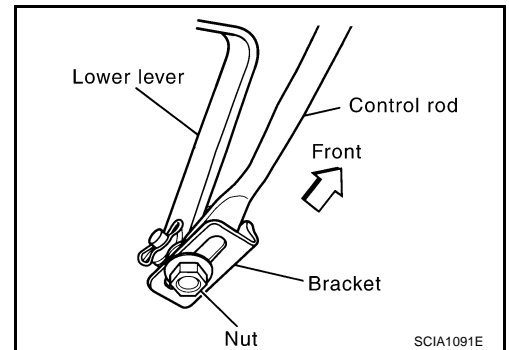

Checking of A/T Position

1. Place selector lever in "P" position, and turn ignition switch ON (engine stop).
2. Check that selector lever can be shifted to other than "P" position when brake pedal is depressed. Also check that selector lever can be shifted from "P" position only when brake pedal is depressed.
3. Move the selector lever and check for excessive effort, sticking, noise or rattle.
4. Confirm the selector lever stops at each position with the feel of engagement when it is moved through all the positions. Check whether or not the actual position the selector lever is in matches the position shown by the shift position indicator and the transmission body.
5. The method of operating the lever to individual positions correctly should be as shown in the figure.
6. When selector button is pressed in "P", "R" or "N" position without applying forward/backward force to selector lever, check button operation for sticking.
7. Confirm the back-up lamps illuminate only when lever is placed in "R" position. Confirm the back-up lamps does not illuminate when selector lever is pushed against "R" position in "P" or "N" position.
8. Confirm the engine can only be started with the selector lever in "P" and "N" positions. (With selector lever in "P" position, engine can be started even when selector lever is moved forward and backward.)
9. Check that transmission is locked completely in "P" position.

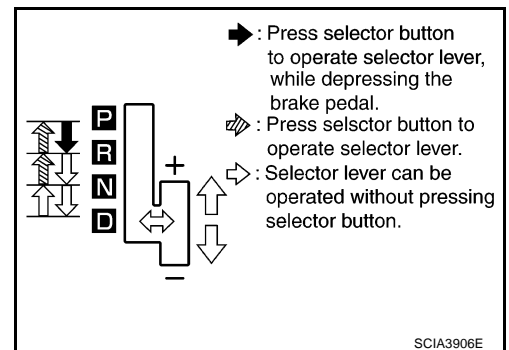

SHIFT CONTROL SYSTEM

10. When selector lever is set to manual shift gate, check that manual mode is displayed on combination meter.
Shift selector lever to “+” and “-” sides, and check that set shift position changes.

A/T SHIFT LOCK SYSTEM

A/T SHIFT LOCK SYSTEM

PFP:34950

Description

ACS00009

- The mechanical key interlock mechanism also operates as a shift lock:
With the ignition switch turned to ON, the selector lever cannot be shifted from "P" (parking) to any other position unless the brake pedal is depressed.
With the key removed, the selector lever cannot be shifted from "P" to any other position.
The key cannot be removed unless the selector lever is placed in "P".
- The shift lock and key interlock mechanisms are controlled by the ON-OFF operation of the shift lock solenoid and by the operation of the rotator and slider located inside the key cylinder.

Shift Lock System Electrical Parts Location

ACS0000A

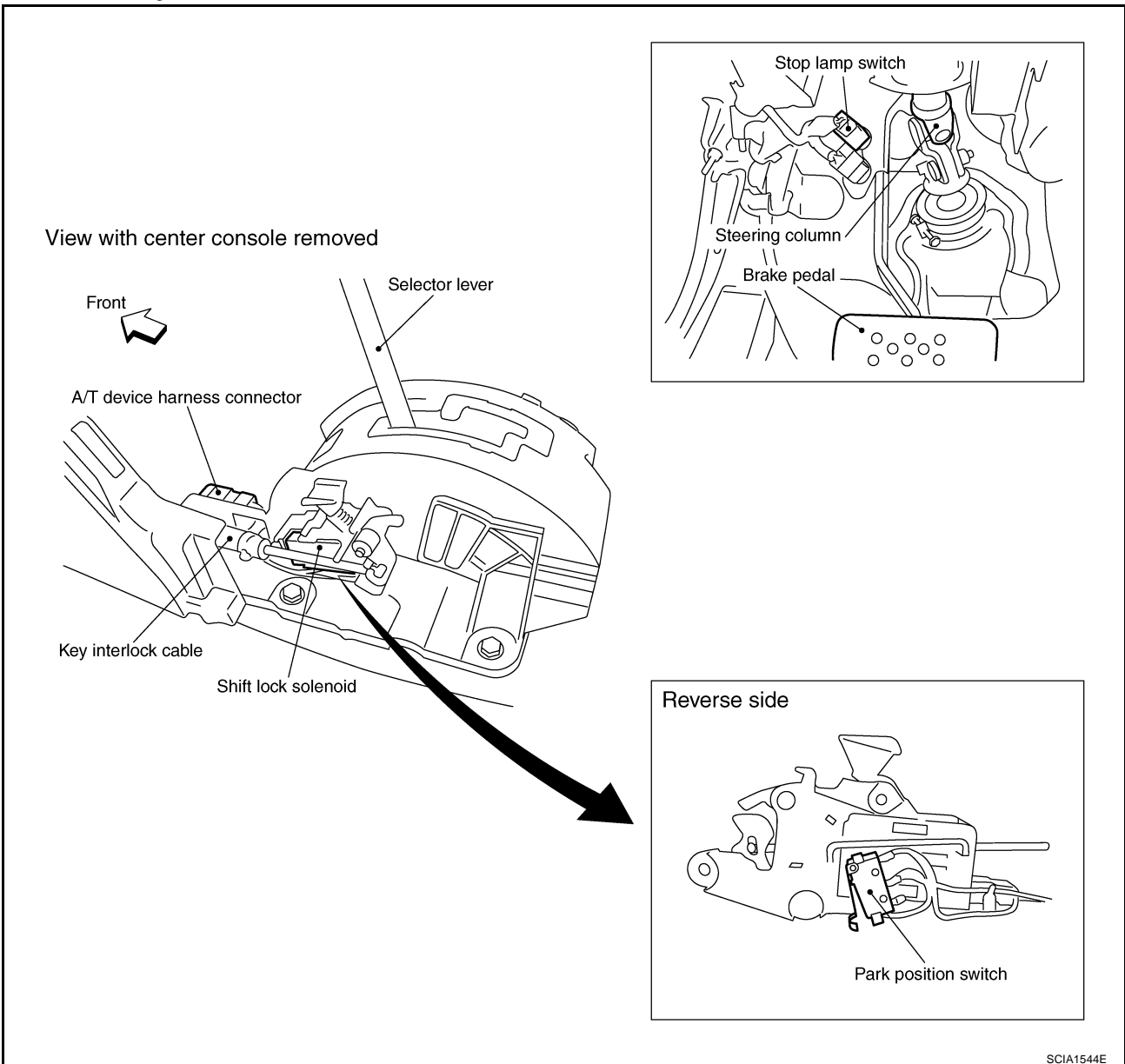

A/T SHIFT LOCK SYSTEM

ACS001LG

Wiring Diagram — AT — SHIFT

AT-SHIFT-01

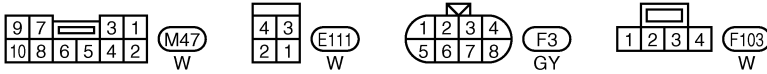
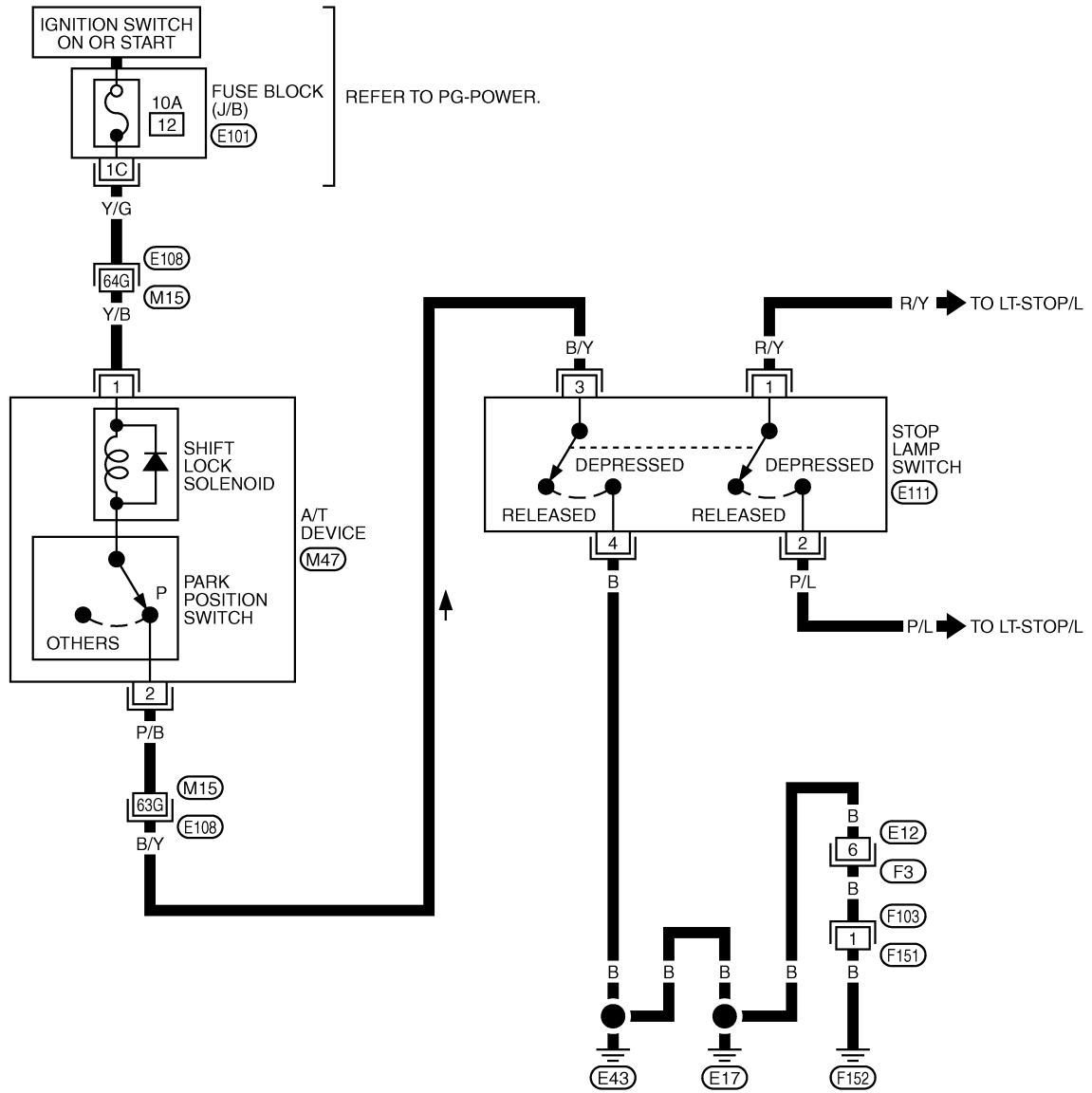

REFER TO THE FOLLOWING.

- (E108) -SUPER MULTIPLE JUNCTION (SMJ)
- (E101) -FUSE BLOCK-JUNCTION BOX (J/B)

TCWT0202E

A/T SHIFT LOCK SYSTEM

ACS003RQ

Diagnostic Procedure

SYMPTOM 1:

- Selector lever cannot be moved from “P” position with key in ON position and brake pedal applied.
- Selector lever can be moved from “P” position with key in ON position and brake pedal released.
- Selector lever can be moved from “P” position when key is removed from key cylinder.

SYMPTOM 2:

- Ignition key cannot be removed when selector lever is set to “P” position.
- Ignition key can be removed when selector lever is set to any position except “P” position.

1. CHECK KEY INTERLOCK CABLE

Check the key interlock cable for damage.

OK or NG

- OK >> GO TO 2.
- NG >> Replace key interlock cable. Refer to [AT-235, "KEY INTERLOCK CABLE"](#) .

2. CHECK SELECTOR LEVER POSITION

Check the selector lever position for damage. Refer to [AT-229, "Checking of A/T Position"](#) .

OK or NG

- OK >> GO TO 3.
- NG >> Check selector lever. Refer to [AT-229, "Adjustment of A/T Position"](#) .

3. CHECK SHIFT LOCK SOLENOID AND PARK POSITION SWITCH

1. Connect A/T device harness connector.
2. Turn ignition switch ON. (Do not start engine.)
3. Selector lever is set in “P” position.
4. Check operation.

Condition	Brake pedal	Operation
When ignition switch is turned to ON position and selector lever is set in “P” position.	Depressed	Yes
	Released	No

OK or NG

- OK >> **INSPECTION END**
- NG >> GO TO 4.

4. CHECK POWER SOURCE

1. Turn ignition switch ON. (Do not start engine.)
2. Check voltage between A/T device harness connector M47 terminal 1 (Y/B) and ground. Refer to [AT-232, "Wiring Diagram — AT — SHIFT"](#) .

Voltage: Battery voltage

OK or NG

- OK >> GO TO 5.
- NG >> GO TO 6.

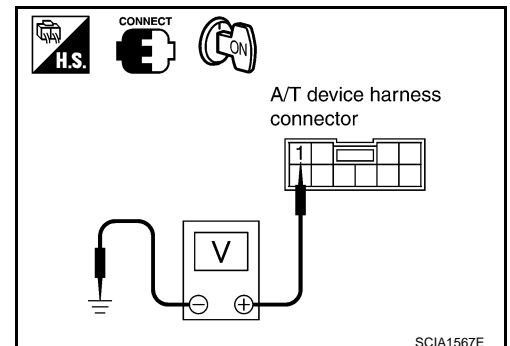

A/T SHIFT LOCK SYSTEM

5. CHECK STOP LAMP SWITCH

Check continuity between stop lamp switch harness connector E111 terminals 3 and 4. Refer to [AT-232, "Wiring Diagram — AT — SHIFT"](#) .

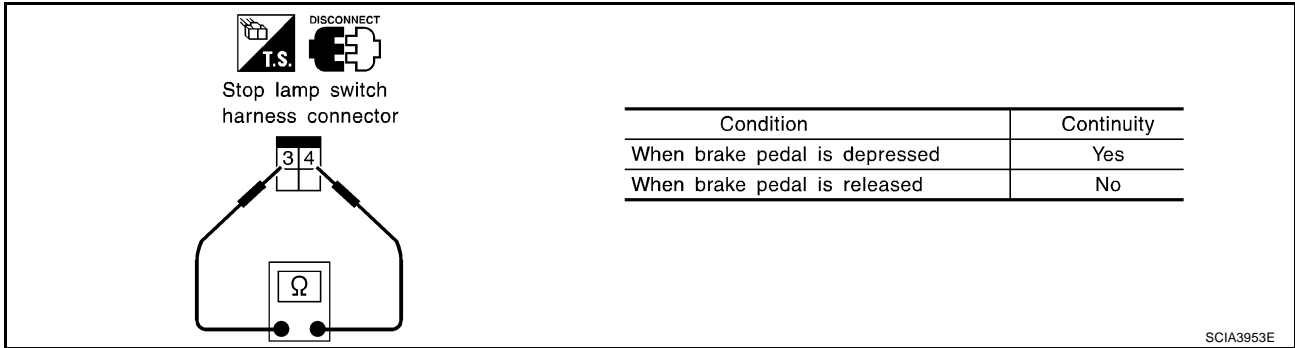

Check stop lamp switch after adjusting brake pedal — refer to [BR-6, "BRAKE PEDAL"](#) .

OK or NG

- OK >> GO TO 7.
- NG >> Repair or replace damaged parts.

6. DETECT MALFUNCTIONING ITEM

Check the following items. If any items are damaged, repair or replace damaged parts.

1. Harness for short or open between ignition switch and A/T device harness connector terminal 1
2. 10A fuse [No.12, located in the fuse block (J/B)]
3. Ignition switch (Refer to [PG-4, "POWER SUPPLY ROUTING CIRCUIT"](#) .)

OK or NG

- OK >> **INSPECTION END**
- NG >> Repair or replace damaged parts.

7. CHECK GROUND CIRCUIT

1. Turn ignition switch OFF.
2. Disconnect stop lamp switch harness connector.
3. Check continuity between stop lamp switch harness connector E111 terminal 4 (B) and ground. Refer to [AT-232, "Wiring Diagram — AT — SHIFT"](#) .

Continuity should exist.

If OK, check harness for short to ground and short to power.

4. Connect stop lamp switch harness connector.

OK or NG

- OK >> GO TO 8.
- NG >> Repair open circuit or short to ground or short to power in harness or connectors.

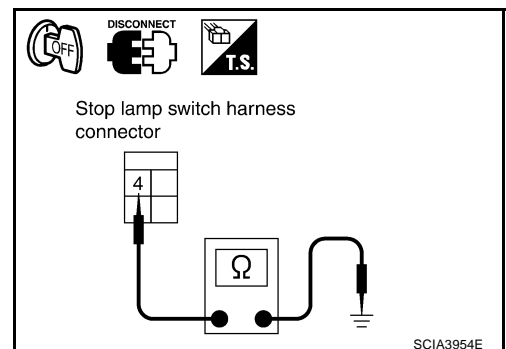

8. DETECT MALFUNCTIONING ITEM

Check the following items. If any items are damaged, repair or replace damaged parts.

- Harness for short or open between A/T device harness connector M47 terminal 2 (P/B) and stop lamp switch harness connector E111 terminal 3 (B/Y). Refer to [AT-232, "Wiring Diagram — AT — SHIFT"](#) .

OK or NG

- OK >> Replace shift lock solenoid or park position switch.
- NG >> Repair or replace damaged parts.

KEY INTERLOCK CABLE

KEY INTERLOCK CABLE

PFP:34908

Components

ACS0000D

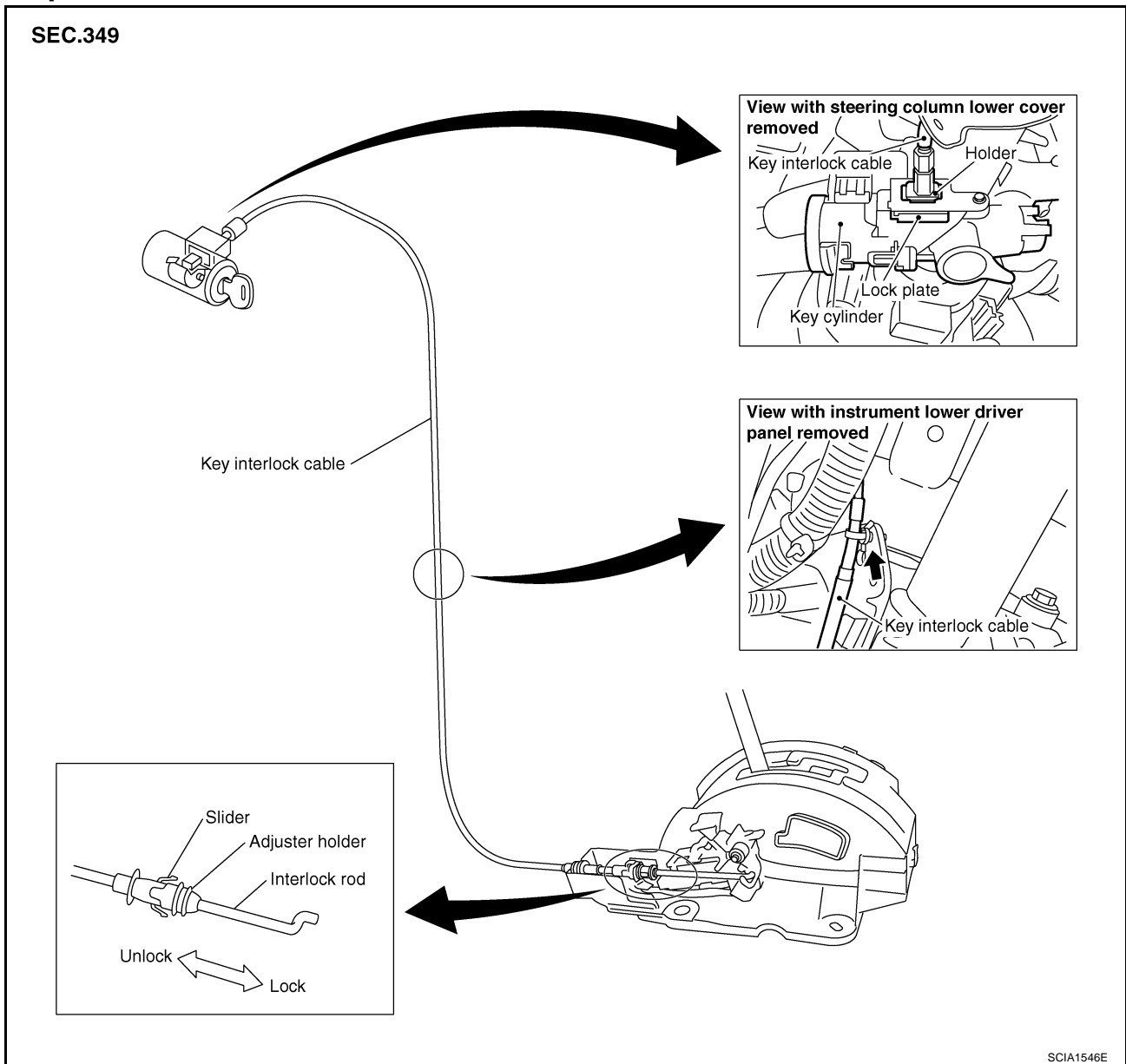

CAUTION:

- Install key interlock cable in such a way that it will not be damaged by sharp bends, twists or interference with adjacent parts.
- After installing key interlock cable to control device, make sure that casing cap and bracket are firmly secured in their positions. If casing cap be removed with an external load of less than 39.2 N (4.0 kg, 8.8 lb), replace key interlock cable with new one.

A
B
AT
D
E
F
G
H
I
J
K
L
M

KEY INTERLOCK CABLE

ACS0000E

Removal and Installation

REMOVAL

1. Unlock slider by squeezing lock tabs on slider from adjuster holder.
2. Remove casing cap from bracket of control device assembly and remove interlock rod from adjuster holder.

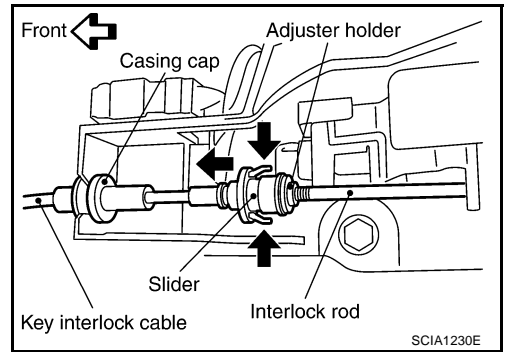

3. Remove lock plate from key cylinder.
4. Remove holder from key cylinder and remove key interlock cable.

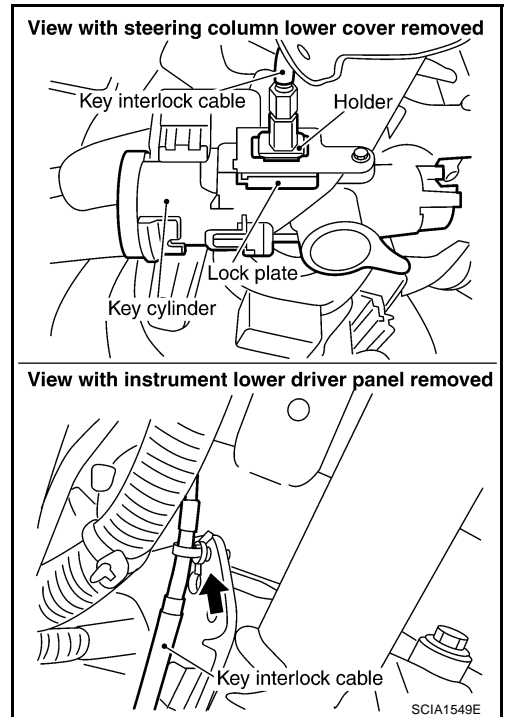

KEY INTERLOCK CABLE

INSTALLATION

1. Set holder of key interlock cable to key cylinder and install lock plate.

CAUTION:

Do not reuse the lock plate

2. Clamp key interlock cable and fix to key interlock cable with band.
3. Turn ignition key to lock position.
4. Set selector lever to "P" position.

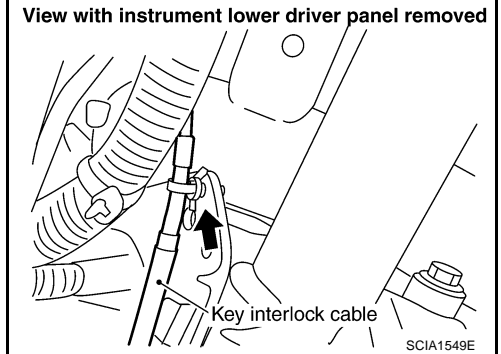
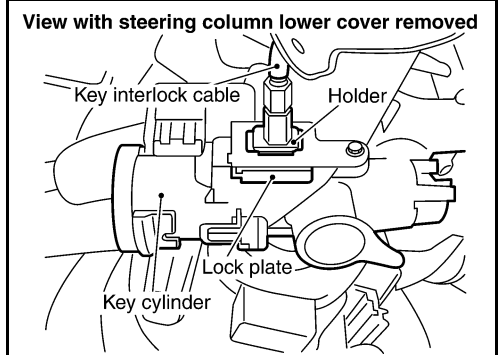

5. Insert interlock rod into adjuster holder.
6. Install casing cap to bracket.
7. Move slider in order to fix adjuster holder to interlock rod.

CAUTION:

Do not touch any parts except slider. Do not add any force to slider except force toward slider.

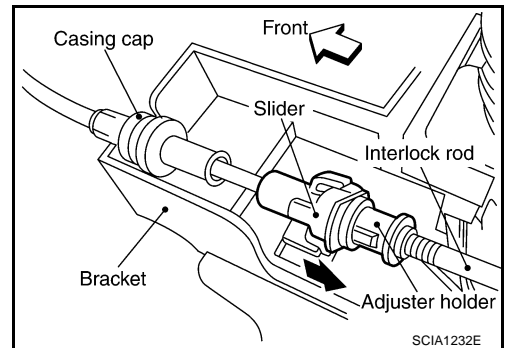

A
B
AT
D
E
F
G
H
I
J
K
L
M

ON-VEHICLE SERVICE

PFP:00000

Control Valve with TCM and A/T Fluid Temperature Sensor 2 COMPONENTS

ACS0084R

SEC.313 · 314 · 315 · 316 · 317 · 319

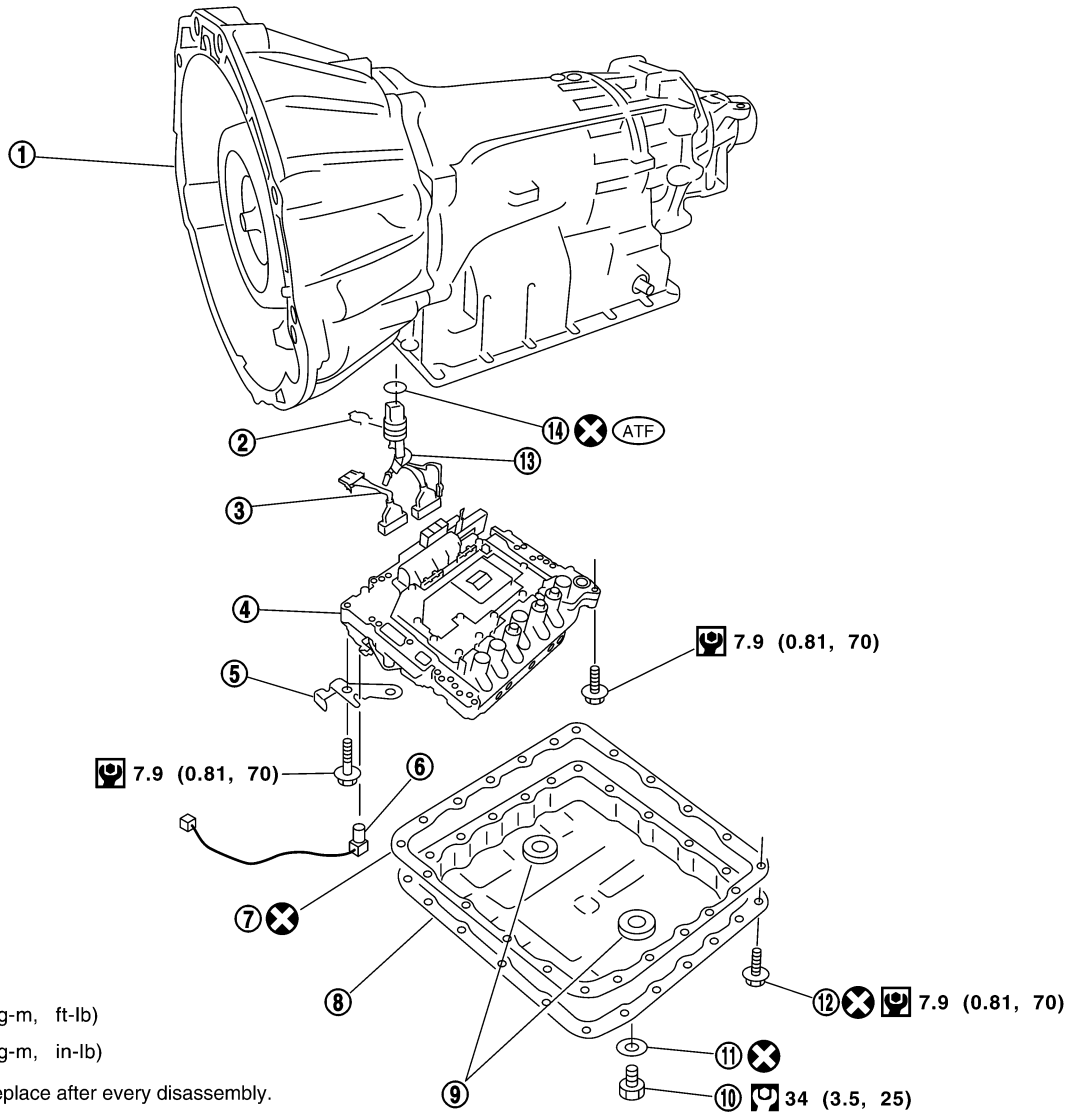

: N·m (kg-m, ft-lb)

: N·m (kg-m, in-lb)

: Always replace after every disassembly.

: Apply ATF.

SCIA5445E

- | | | |
|----------------------------|-----------------------|-----------------------------------|
| 1. Transmission | 2. Snap ring | 3. Sub-harness |
| 4. Control valve with TCM | 5. Bracket | 6. A/T fluid temperature sensor 2 |
| 7. Oil pan gasket | 8. Oil pan | 9. Magnet |
| 10. Drain plug | 11. Drain plug gasket | 12. Oil pan mounting bolt |
| 13. Terminal cord assembly | 14. O-ring | |

CONTROL VALVE WITH TCM REMOVAL AND INSTALLATION

Removal

1. Disconnect the battery cable from the negative terminal.
2. Disconnect heated oxygen sensor 2 harness connector.
3. Drain ATF through drain plug.
4. Disconnect A/T assembly harness connector.

ON-VEHICLE SERVICE

5. Remove snap ring from A/T assembly harness connector.

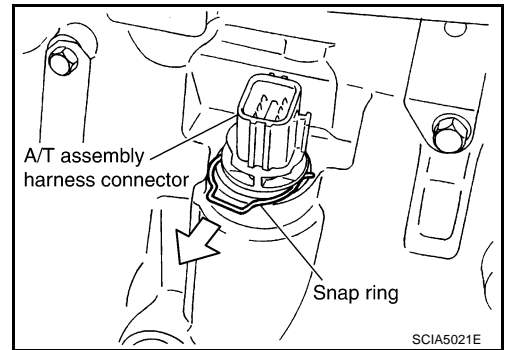

6. Push A/T assembly harness connector.

CAUTION:
Be careful not to damage connector.

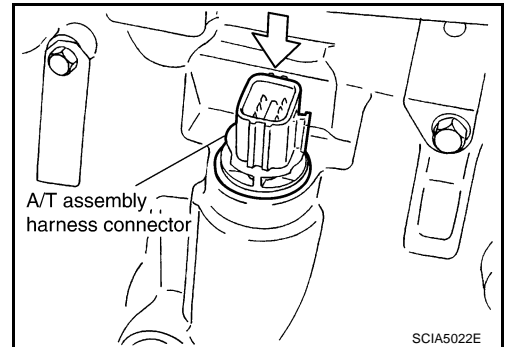

7. Remove oil pan and oil pan gasket.

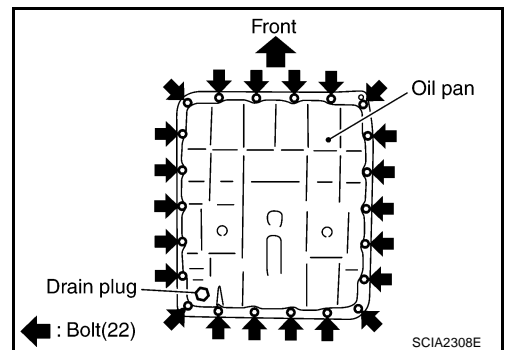

8. Check foreign materials in oil pan to help determine causes of malfunction. If the A/T fluid is very dark, smells burned, or contains foreign particles, the frictional material (clutches, band) may need replacement. A tacky film that will not wipe clean indicates varnish build up. Varnish can cause valves, servo, and clutches to stick and can inhibit pump pressure.

● If frictional material is detected, perform A/T fluid cooler cleaning. Refer to [AT-14, "A/T Fluid Cooler Cleaning"](#).

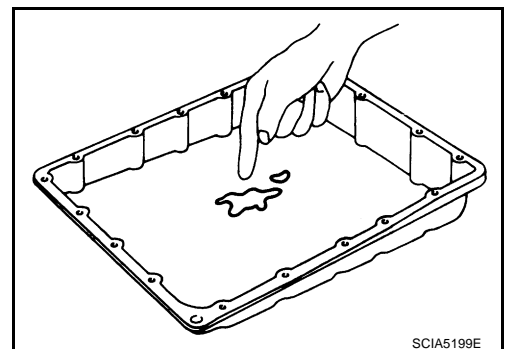

9. Remove magnets from oil pan.

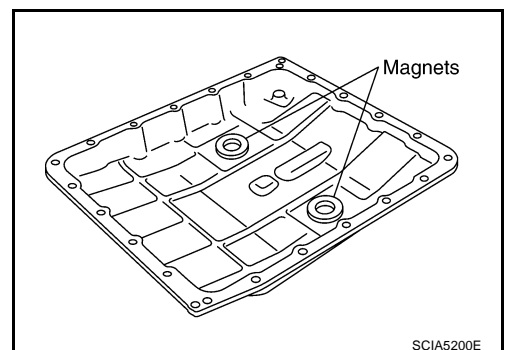

A
B
AT
D
E
F
G
H
I
J
K
L
M

ON-VEHICLE SERVICE

10. Disconnect A/T fluid temperature sensor 2 connector.

CAUTION:
Be careful not to damage connector.

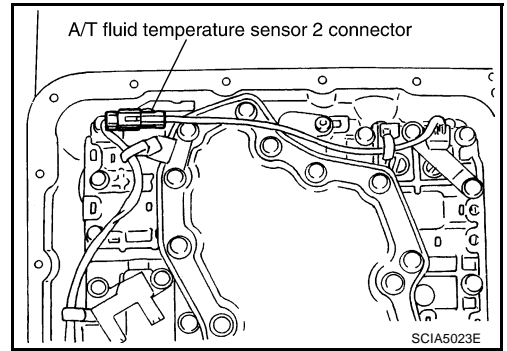

11. Straighten terminal clips to free terminal cord assembly and A/T fluid temperature sensor 2 harness.

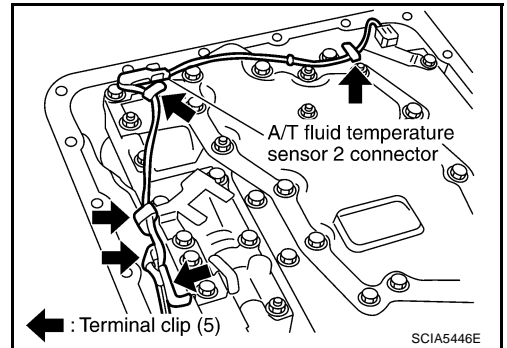

12. Disconnect revolution sensor connector.

CAUTION:
Be careful not to damage connector.

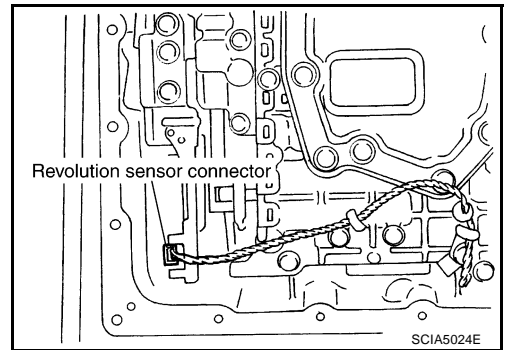

13. Straighten terminal clips to free revolution sensor harness.

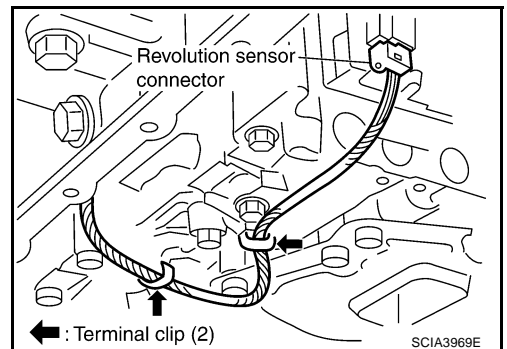

14. Remove bolts A, B and C from control valve with TCM.

Bolt symbol	Length mm (in)	Number of bolts
A	42 (1.65)	5
B	55 (2.17)	6
C	40 (1.57)	1

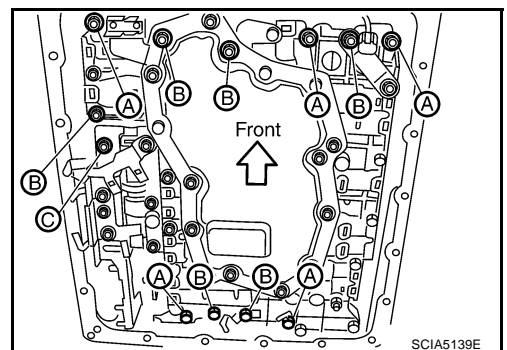

ON-VEHICLE SERVICE

15. Remove control valve with TCM from transmission case.

CAUTION:

When removing, be careful with the manual valve notch and manual plate height. Remove it vertically.

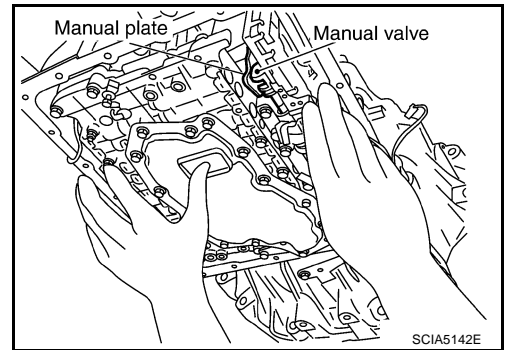

16. Remove A/T fluid temperature sensor 2 with bracket from control valve with TCM.

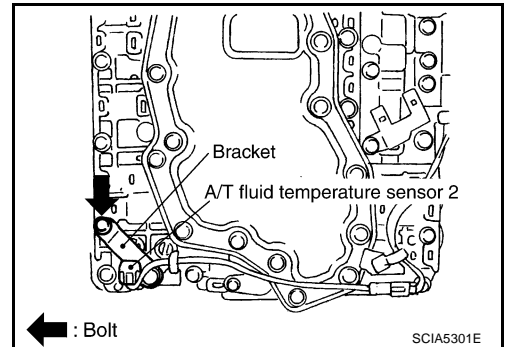

17. Remove bracket from A/T fluid temperature sensor 2.

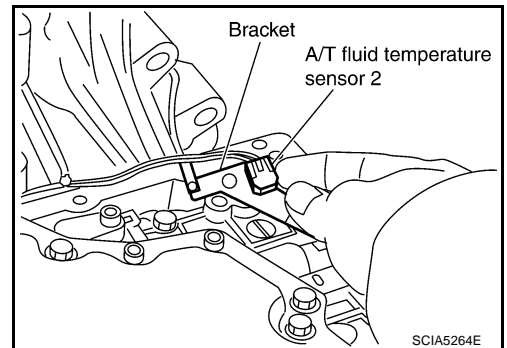

18. Remove O-ring from A/T assembly harness connector.

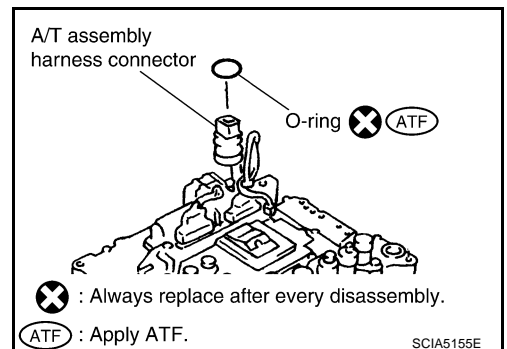

19. Disconnect TCM connectors.

CAUTION:

Be careful not to damage connectors.

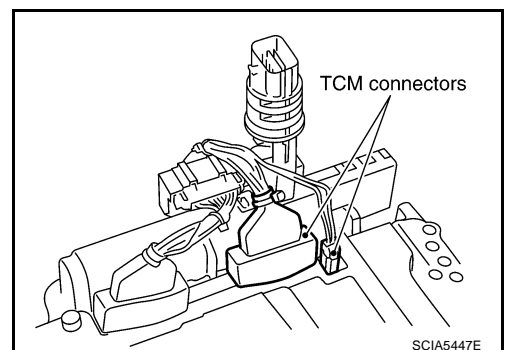

A
B
AT
D
E
F
G
H
I
J
K
L
M

ON-VEHICLE SERVICE

20. Remove A/T assembly harness connector from control valve with TCM using a flat-bladed screwdriver.

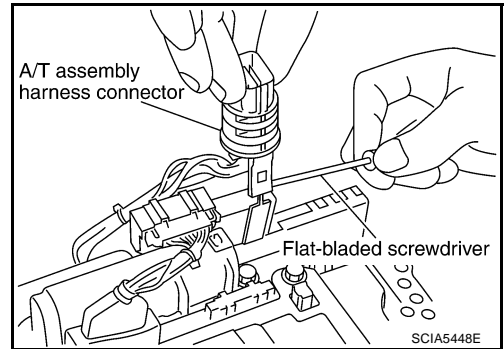

21. Disconnect TCM connector and park/neutral position switch connector.

CAUTION:

Be careful not to damage connectors.

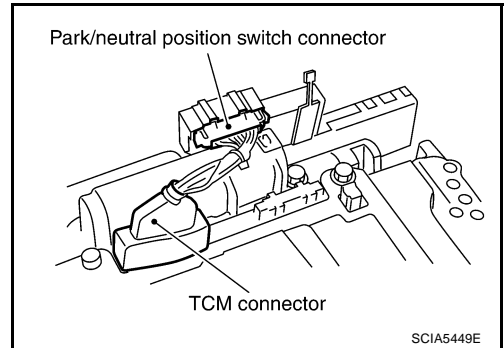

Installation

CAUTION:

After completing installation, check A/T fluid leakage and fluid level. Refer to [AT-12, "Changing A/T Fluid"](#) , [AT-12, "Checking A/T Fluid"](#) .

1. Connect TCM connector and park/neutral position switch connector.

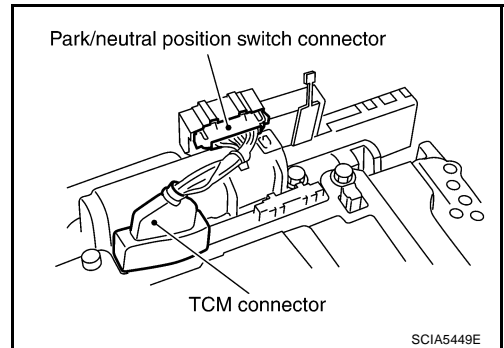

2. Install A/T assembly harness connector from control valve with TCM.

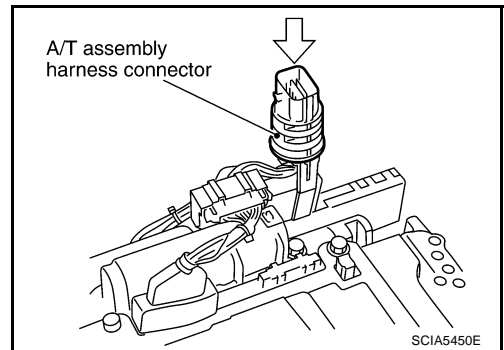

ON-VEHICLE SERVICE

3. Connect TCM connectors.

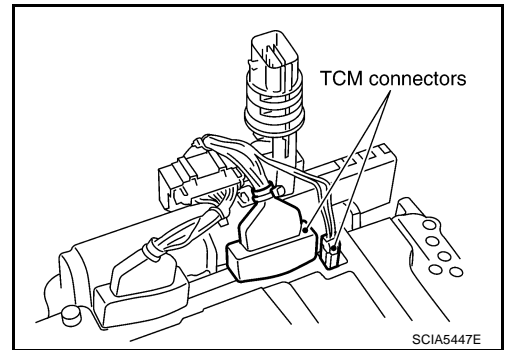

4. Install O-ring in A/T assembly harness connector.

CAUTION:

- Do not reuse O-ring.
- Apply ATF to O-ring.

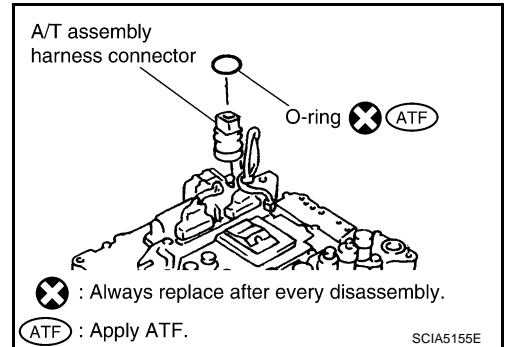

5. Install A/T fluid temperature sensor 2 to bracket.

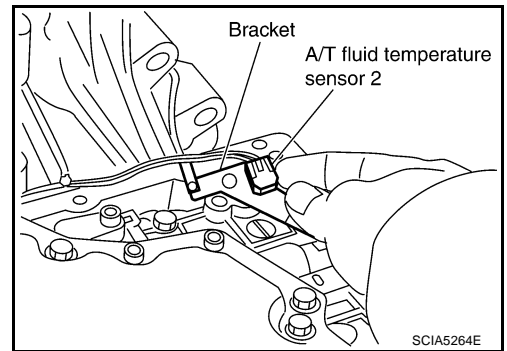

6. Install A/T fluid temperature sensor 2 (with bracket) in control valve with TCM.

CAUTION:

Adjust bolt hole of bracket to bolt hole of control valve with TCM.

: 7.9 N·m (0.81 kg-m, 70 in-lb)

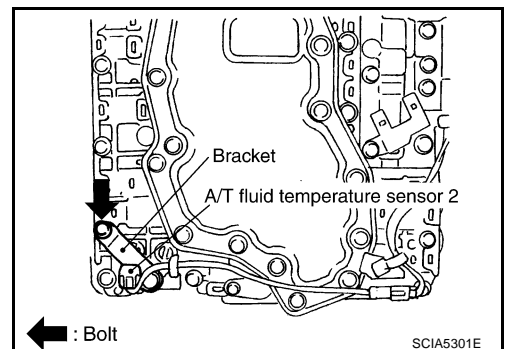

7. Install control valve with TCM in transmission case.

CAUTION:

- Make sure that turbine revolution sensor securely installs turbine revolution sensor hole.
- Hang down revolution sensor harness toward outside so as not to disturb installation of control valve with TCM.
- Adjust A/T assembly harness connector of control valve with TCM to terminal hole of transmission case.

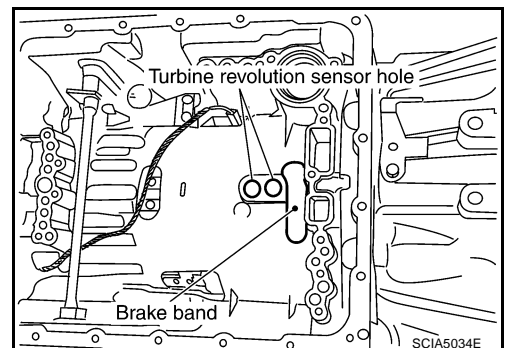

A
B
AT
D
E
F
G
H
I
J
K
L
M

ON-VEHICLE SERVICE

- Assemble it so that manual valve cutout is engaged with manual plate projection.

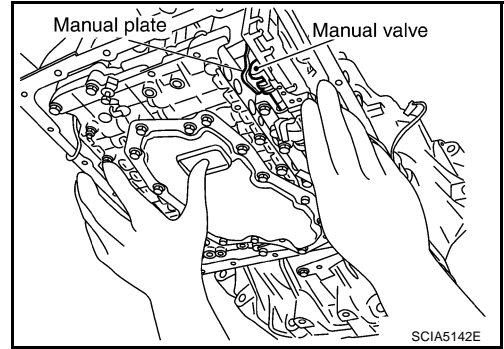

8. Install bolts A, B and C in control valve with TCM.

Bolt symbol	Length mm (in)	Number of bolts
A	42 (1.65)	5
B	55 (2.17)	6
C	40 (1.57)	1

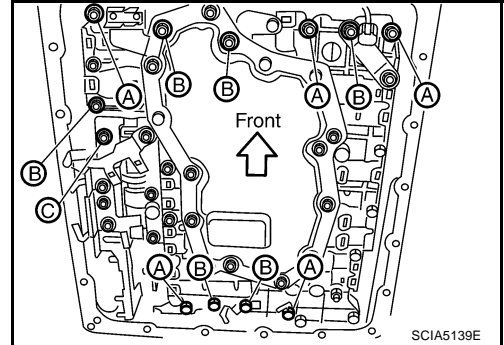

9. Tighten bolt 1, 2 and 3 temporarily to prevent dislocation. After that tighten them in order (1 → 2 → 3), and then tighten other bolts.

 : 7.9 N-m (0.81 kg-m, 70 in-lb)

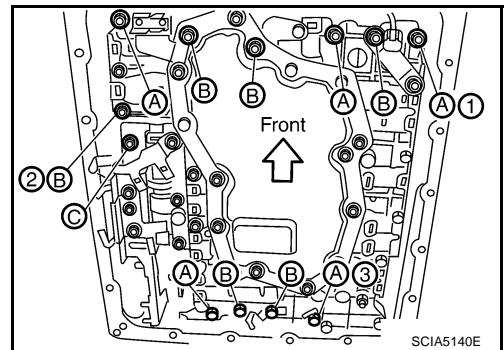

10. Connect A/T fluid temperature sensor 2 connector.

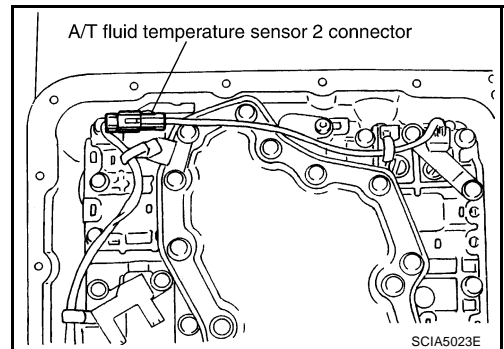

11. Securely fasten terminal cord assembly and A/T fluid temperature sensor 2 harness with terminal clips.

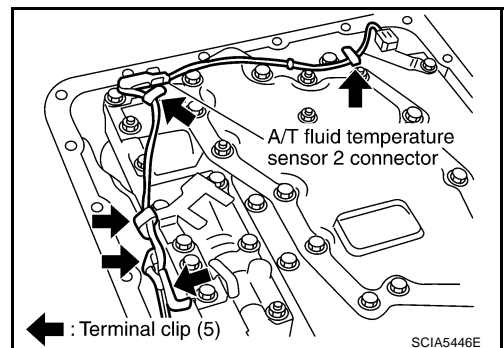

ON-VEHICLE SERVICE

12. Connect revolution sensor connector.

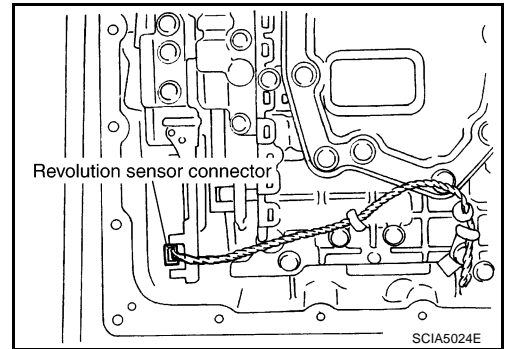

13. Securely fasten revolution sensor harness with terminal clips.

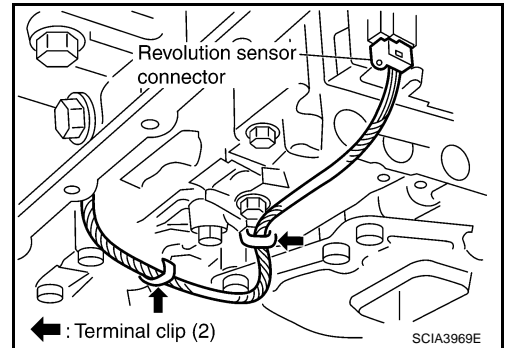

14. Install magnets in oil pan.

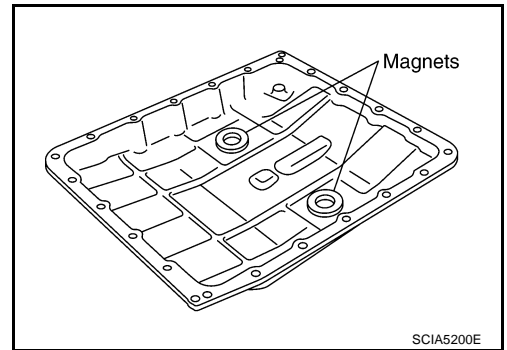

15. Install oil pan to transmission case.

a. Install oil pan gasket to oil pan.

CAUTION:

- Do not reuse oil pan gasket.
- Install it in the direction to align hole positions.
- Completely remove all moisture, oil and old gasket, etc. from oil pan gasket mounting surface.

b. Install oil pan (with oil pan gasket) to transmission case.

CAUTION:

- Install it so that drain plug comes to the position as shown in the figure.
- Be careful not to pinch harnesses.
- Completely remove all moisture, oil and old gasket, etc. from oil pan mounting surface.

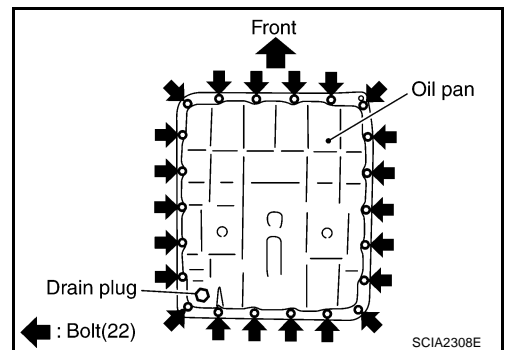

A
B
AT
D
E
F
G
H
I
J
K
L
M

ON-VEHICLE SERVICE

- c. Tighten oil pan mounting bolts to the specified torque in numerical order as shown in the figure after temporarily tightening them.

CAUTION:

Do not reuse oil pan mounting bolts.

 : 7.9 N·m (0.81 kg·m, 70 in·lb)

16. Install drain plug to oil pan.

CAUTION:

Do not reuse drain plug gasket.

 : 34 N·m (3.5 kg·m, 25 ft·lb)

17. Pull up A/T assembly harness connector.

CAUTION:

Be careful not to damage connector.

18. Install snap ring to A/T assembly harness connector.
 19. Connect A/T assembly harness connector.
 20. Connect heated oxygen sensor 2 harness connector.
 21. Pour ATF into transmission assembly. Refer to [AT-12, "Changing A/T Fluid"](#) .
 22. Connect the battery cable to the negative terminal.

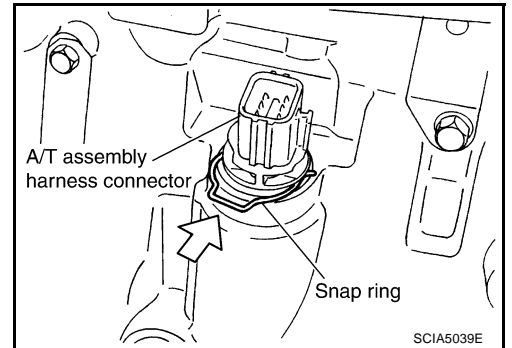
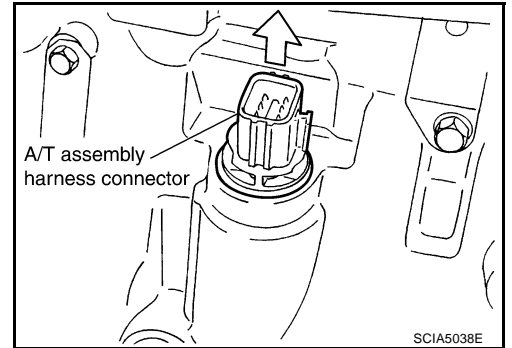
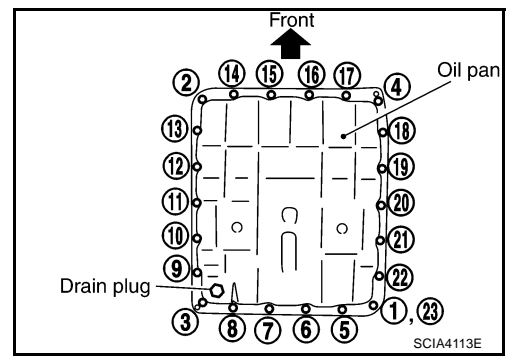

A/T FLUID TEMPERATURE SENSOR 2 REMOVAL AND INSTALLATION

Removal

1. Disconnect the battery cable from the negative terminal.
2. Disconnect heated oxygen sensor 2 harness connector.
3. Drain ATF through drain plug.
4. Remove oil pan and oil pan gasket.

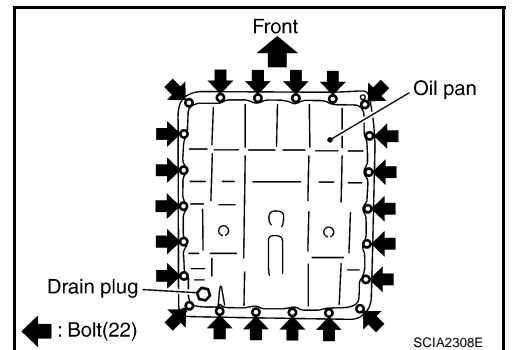

ON-VEHICLE SERVICE

5. Check foreign materials in oil pan to help determine causes of malfunction. If the A/T fluid is very dark, smells burned, or contains foreign particles, the frictional material (clutches, band) may need replacement. A tacky film that will not wipe clean indicates varnish build up. Varnish can cause valves, servo, and clutches to stick and can inhibit pump pressure.

- If frictional material is detected, perform A/T fluid cooler cleaning. Refer to [AT-14, "A/T Fluid Cooler Cleaning"](#).

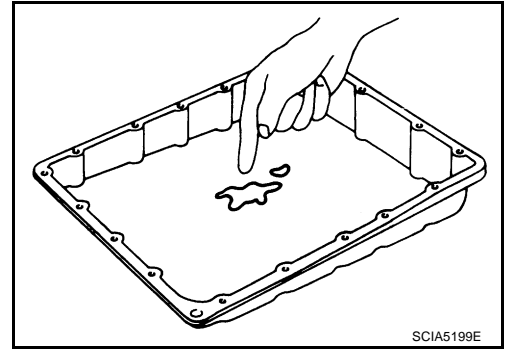

6. Disconnect A/T fluid temperature sensor 2 connector.

CAUTION:
Be careful not to damage connector.

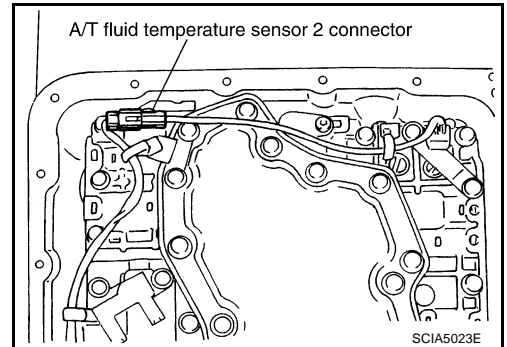

7. Straighten terminal clip to free A/T fluid temperature sensor 2 harness.

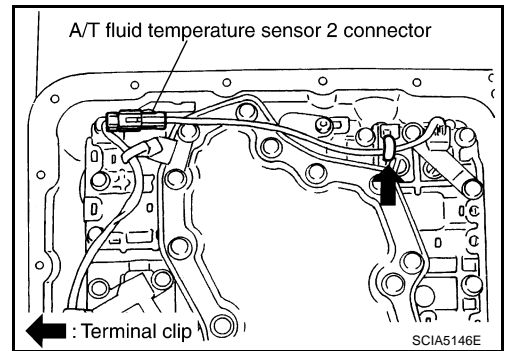

8. Remove A/T fluid temperature sensor 2 with bracket from control valve with TCM.

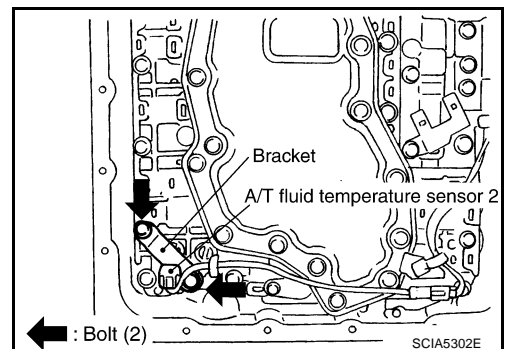

9. Remove bracket from A/T fluid temperature sensor 2.

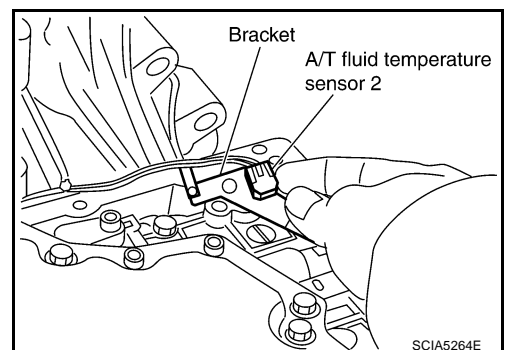

A
B
AT
D
E
F
G
H
I
J
K
L
M

ON-VEHICLE SERVICE

Installation

CAUTION:

After completing installation, check A/T fluid leakage and fluid level. Refer to [AT-12, "Changing A/T Fluid"](#) , [AT-12, "Checking A/T Fluid"](#) .

1. Install A/T fluid temperature sensor 2 to bracket.

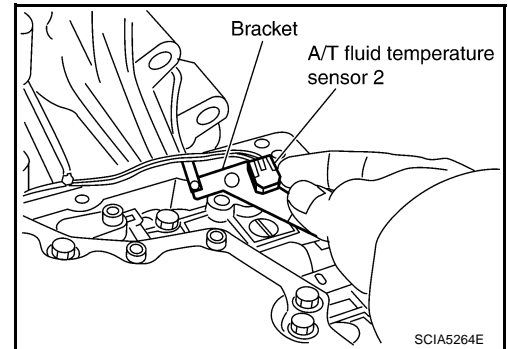

2. Install A/T fluid temperature sensor 2 (with bracket) in control valve with TCM.

 : 7.9 N-m (0.81 kg-m, 70 in-lb)

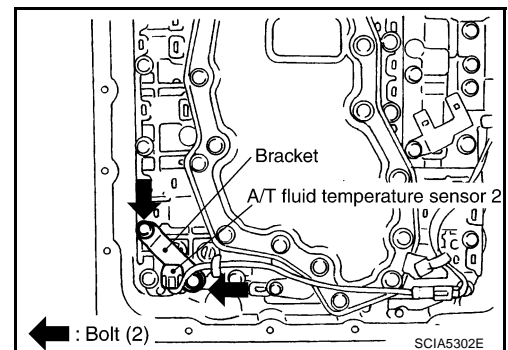

3. Connect A/T fluid temperature sensor 2 connector.

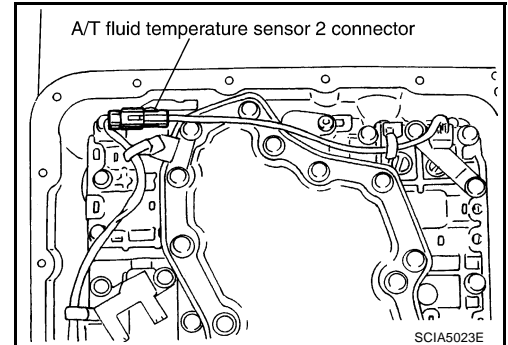

4. Securely fasten A/T fluid temperature sensor 2 harness with terminal clip.

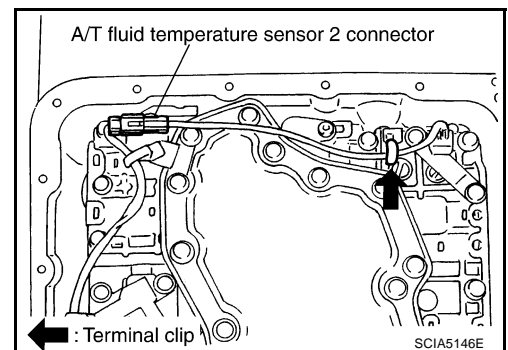

5. Install oil pan to transmission case.

- a. Install oil pan gasket to oil pan.

CAUTION:

- Do not reuse oil pan gasket.
- Install it in the direction to align hole positions.
- Completely remove all moisture, oil and old gasket, etc. from oil pan gasket mounting surface.

ON-VEHICLE SERVICE

- b. Install oil pan (with oil pan gasket) to transmission case.

CAUTION:

- Install it so that drain plug comes to the position as shown in the figure.
- Be careful not to pinch harnesses.
- Completely remove all moisture, oil and old gasket, etc. from oil pan mounting surface.

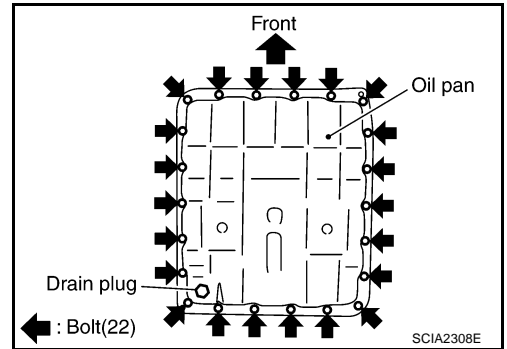

- c. Tighten oil pan mounting bolts to the specified torque in numerical order as shown in the figure after temporarily tightening them.

CAUTION:

Do not reuse oil pan mounting bolts.

 : 7.9 N·m (0.81 kg-m, 70 in-lb)

6. Install drain plug to oil pan.

CAUTION:

Do not reuse drain plug gasket.

 : 34 N·m (3.5 kg-m, 25 ft-lb)

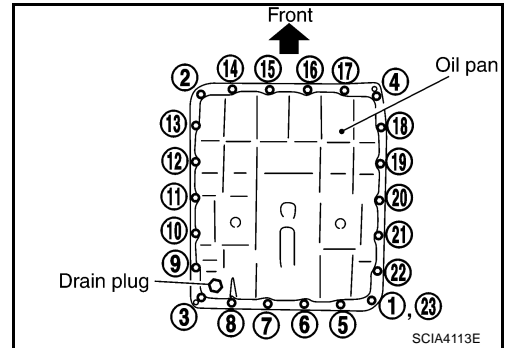

7. Connect heated oxygen sensor 2 harness connector.
8. Pour ATF into transmission assembly. Refer to [AT-12. "Changing A/T Fluid"](#).
9. Connect the battery cable to the negative terminal.

A
B
AT
D
E
F
G
H
I
J
K
L
M

Parking Components COMPONENTS

ACS0084S

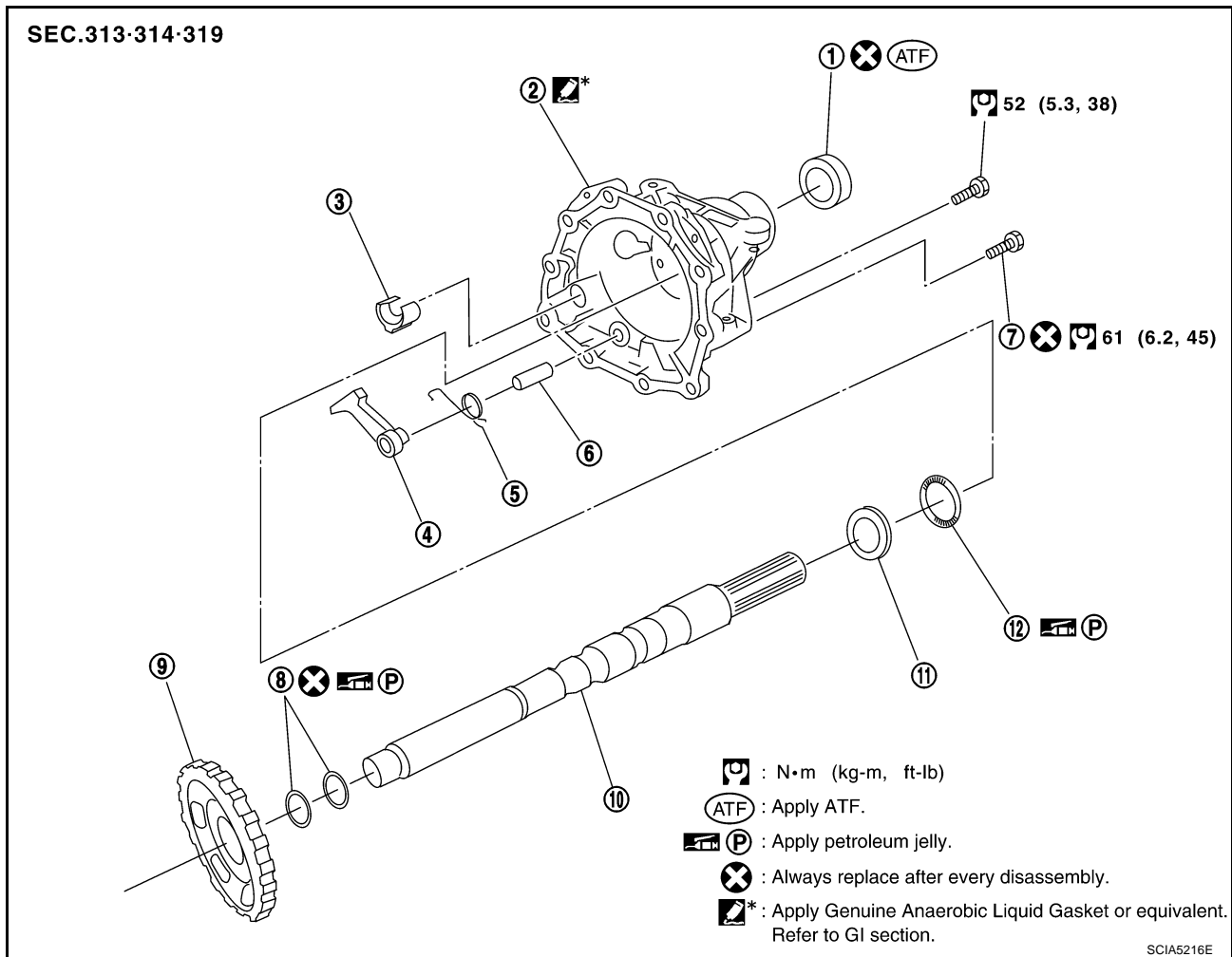

- | | | |
|----------------------|-------------------|-----------------------------|
| 1. Rear oil seal | 2. Rear extension | 3. Parking actuator support |
| 4. Parking pawl | 5. Return spring | 6. Pawl shaft |
| 7. Self-sealing bolt | 8. Seal ring | 9. Parking gear |
| 10. Output shaft | 11. Bearing race | 12. Needle bearing |

REMOVAL

1. Drain ATF through drain plug.
2. Remove exhaust front tube and center muffler with a power tool. Refer to [EX-3, "Removal and Installation"](#).
3. Remove rear propeller shaft. Refer to [PR-7, "Removal and Installation"](#).
CAUTION:
Do not impact or damage propeller shaft tube.
4. Remove control rod. Refer to [AT-228, "SHIFT CONTROL SYSTEM"](#).
5. Support transmission assembly with a transmission jack.
CAUTION:
When setting the transmission jack, be careful not to allow it to collide against the drain plug.
6. Remove engine rear member with a power tool. Refer to [AT-264, "Removal and Installation"](#).
7. Remove insulator. Refer to [AT-264, "Removal and Installation"](#).

ON-VEHICLE SERVICE

8. Remove tightening bolts for rear extension assembly and transmission case.

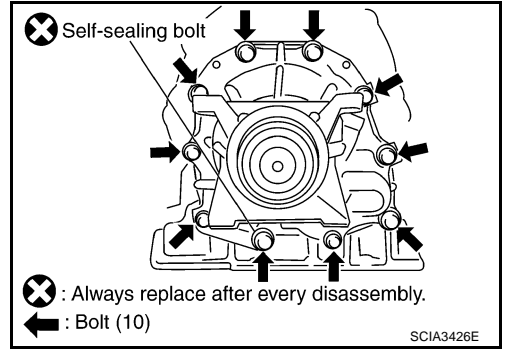

9. Tap rear extension assembly with a soft hammer.

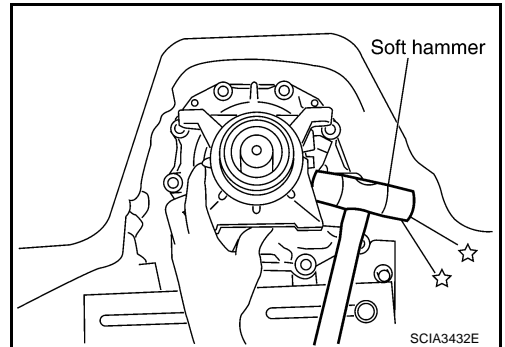

10. Remove rear extension assembly from transmission case. (With needle bearing.)

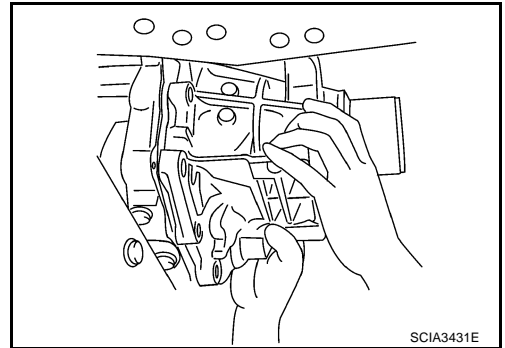

11. Remove bearing race from output shaft.

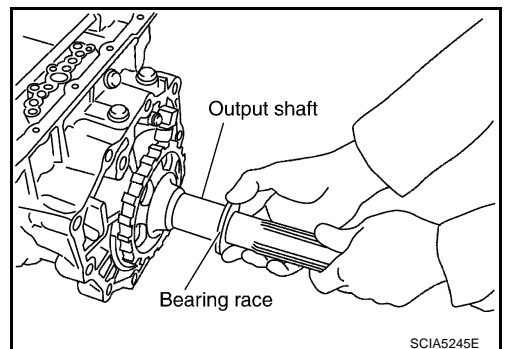

12. Remove output shaft from transmission case by rotating left/right.

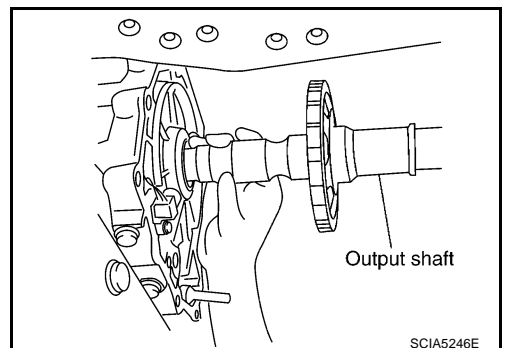

A
B
AT
D
E
F
G
H
I
J
K
L
M

ON-VEHICLE SERVICE

13. Remove parking gear from output shaft.

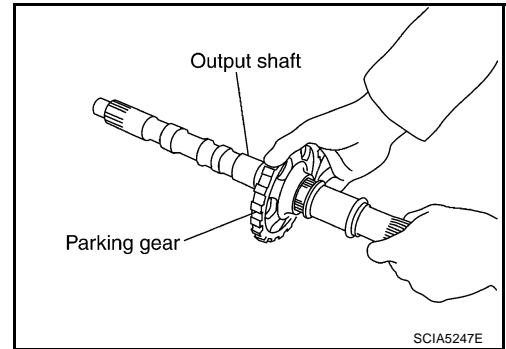

14. Remove seal rings from output shaft.

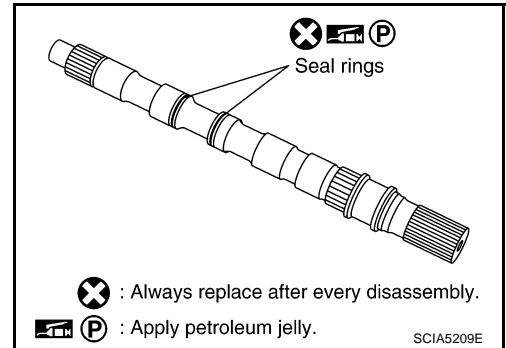

15. Remove needle bearing from rear extension.

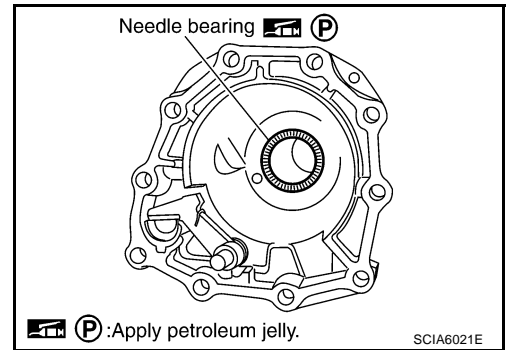

16. Remove parking actuator support from rear extension.

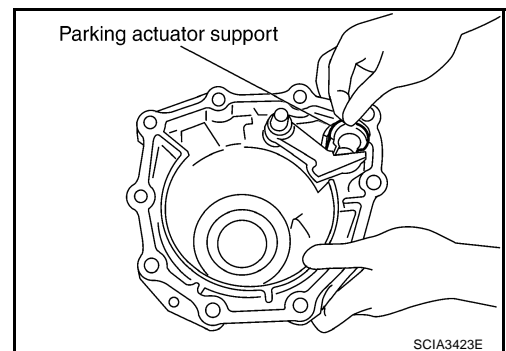

17. Remove parking pawl (with return spring) and pawl shaft from rear extension.

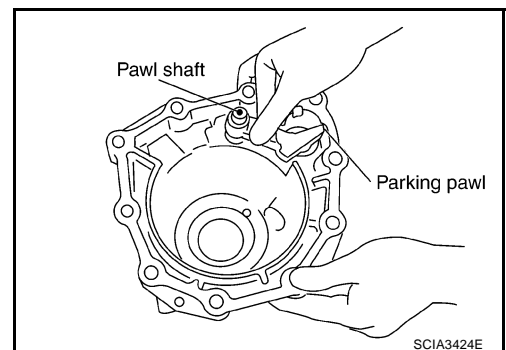

ON-VEHICLE SERVICE

18. Remove return spring from parking pawl.

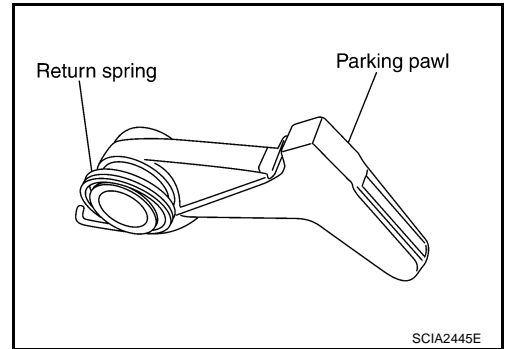

19. Remove rear oil seal from rear extension using a flat-bladed screwdriver.

CAUTION:

Be careful not to scratch rear extension.

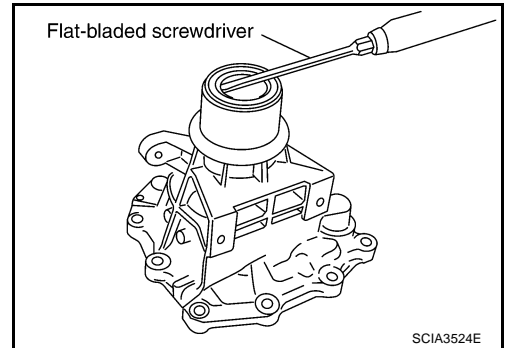

INSPECTION

- If the contact surface on parking actuator support, parking pawl, etc. has excessive wear, abrasion, bend, or any other damage, replace the components.

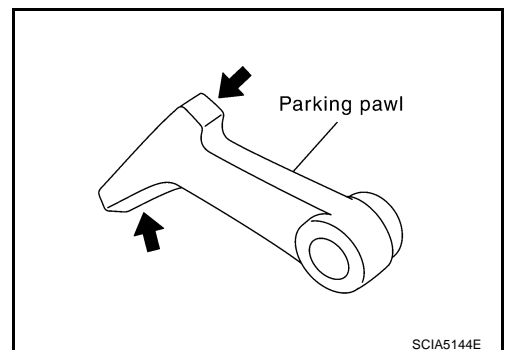
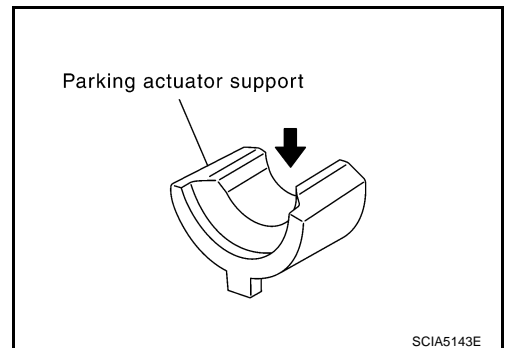

A
B
AT
D
E
F
G
H
I
J
K
L
M

ON-VEHICLE SERVICE

INSTALLATION

CAUTION:

After completing installation, check A/T fluid leakage and fluid level. Refer to [AT-12, "Changing A/T Fluid"](#) , [AT-12, "Checking A/T Fluid"](#) .

1. As shown in the right figure, use the drift to drive rear oil seal into the rear extension until it is flush.

CAUTION:

- Apply ATF to rear oil seal.
- Do not reuse rear oil seal.

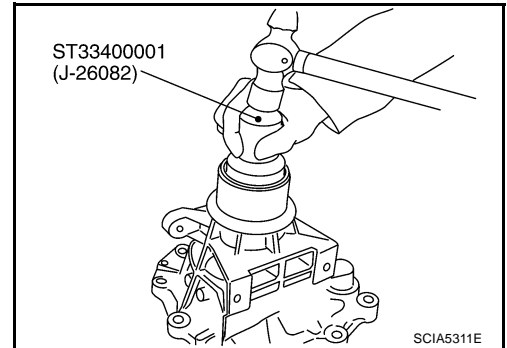

2. Install return spring to parking pawl.

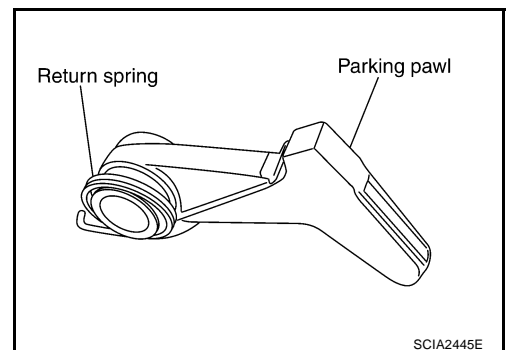

3. Install parking pawl (with return spring) and pawl shaft to rear extension.

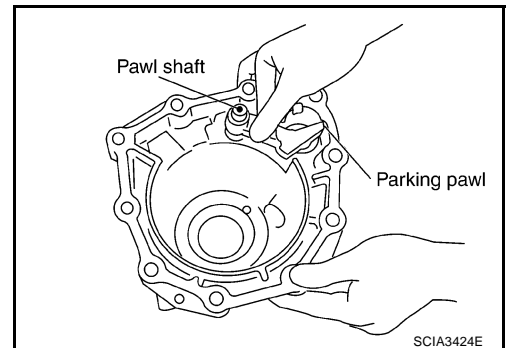

4. Install parking actuator support to rear extension.

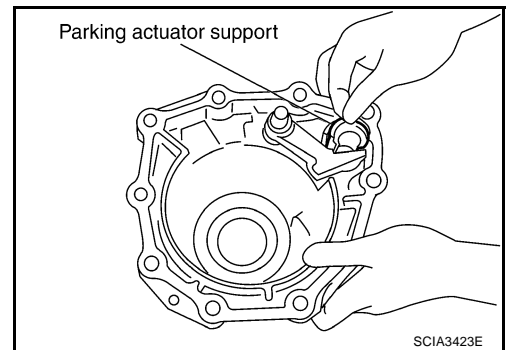

ON-VEHICLE SERVICE

5. Install needle bearing to rear extension.

CAUTION:

Apply petroleum jelly to needle bearing.

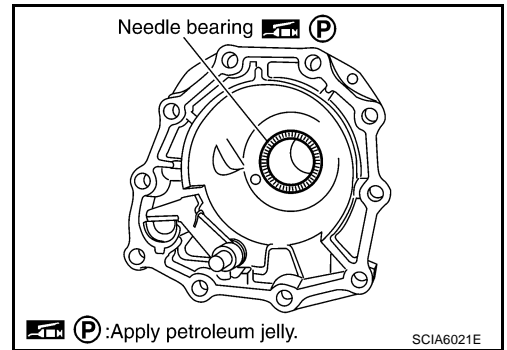

6. Install seal rings in output shaft.

CAUTION:

- Do not reuse seal rings.
- Apply petroleum jelly to seal rings.

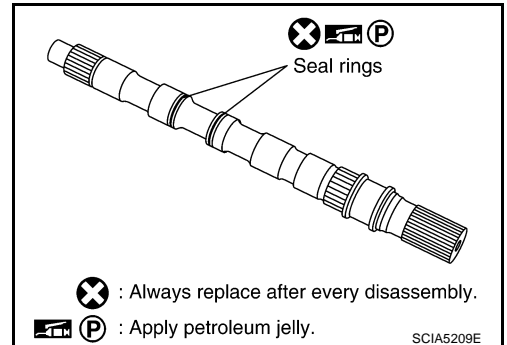

7. Install parking gear to output shaft.

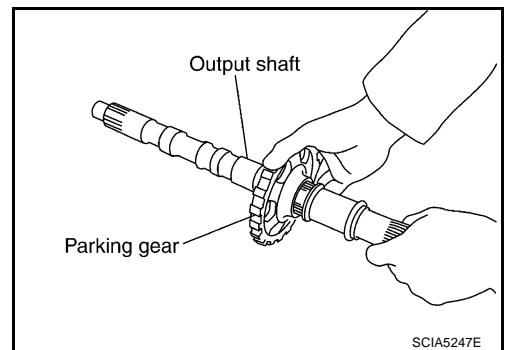

8. Install output shaft to transmission case.

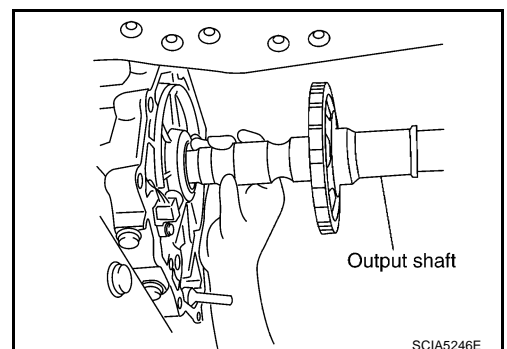

9. Install bearing race to output shaft.

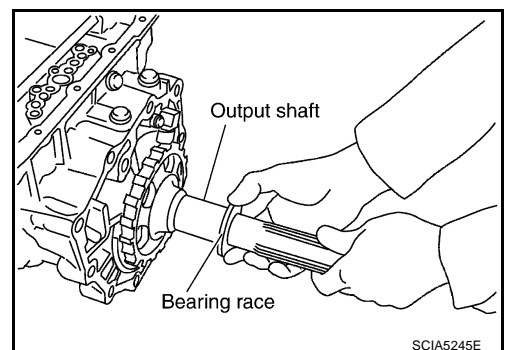

A
B
AT
D
E
F
G
H
I
J
K
L
M

ON-VEHICLE SERVICE

10. Apply recommended sealant (Genuine Anaerobic Liquid Gasket or equivalent. Refer to [GI-47, "Recommended Chemical Products and Sealants"](#) .) to rear extension assembly as shown in the figure.

CAUTION:

Completely remove all moisture, oil and old sealant, etc. from the transmission case and rear extension assembly mounting surfaces.

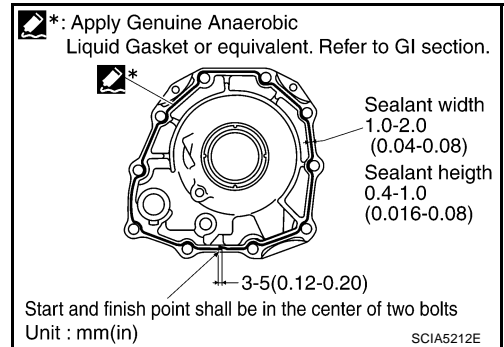

11. Install rear extension assembly to transmission case. (With needle bearing.)

CAUTION:

Insert the tip of parking rod between the parking pawl and the parking actuator support when assembling the rear extension assembly.

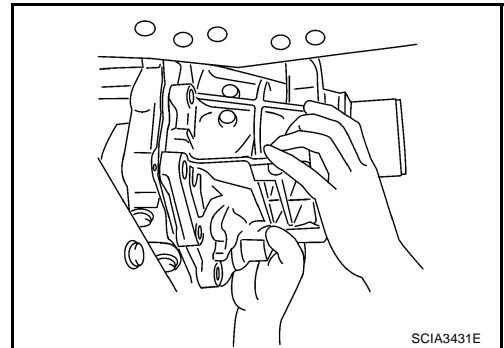

12. Tighten rear extension assembly mounting bolts to specified torque.

CAUTION:

Do not reuse self-sealing bolt.

Rear extension assembly mounting bolt:

: 52 N·m (5.3 Kg·m, 38 ft·lb)

Self-sealing bolt:

: 61 N·m (6.2 Kg·m, 45 ft·lb)

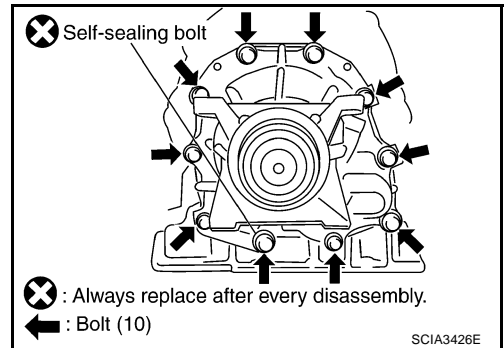

13. Install insulator. Refer to [AT-264, "Removal and Installation"](#) .
14. Install engine rear member. Refer to [AT-264, "Removal and Installation"](#) .
15. Install control rod. Refer to [AT-228, "SHIFT CONTROL SYSTEM"](#) .
16. Install rear propeller shaft. Refer to [PR-7, "Removal and Installation"](#) .

CAUTION:

Do not impact or damage propeller shaft tube.

17. Install exhaust front tube and center muffler. Refer to [EX-3, "Removal and Installation"](#) .
18. Install drain plug in oil pan.

CAUTION:

Do not reuse drain plug gasket.

: 34 N·m (3.5 kg·m, 25 ft·lb)

19. Pour ATF into transmission assembly. Refer to [AT-12, "Changing A/T Fluid"](#) .

ON-VEHICLE SERVICE

ACS0084T

Rear Oil Seal REMOVAL

1. Remove exhaust front tube and center muffler with a power tool. Refer to [EX-3, "Removal and Installation"](#).
2. Remove rear propeller shaft. Refer to [PR-7, "Removal and Installation"](#).

CAUTION:

Do not impact or damage propeller shaft tube.

3. Remove rear oil seal using a flat-bladed screwdriver.

CAUTION:

Be careful not to scratch rear extension assembly.

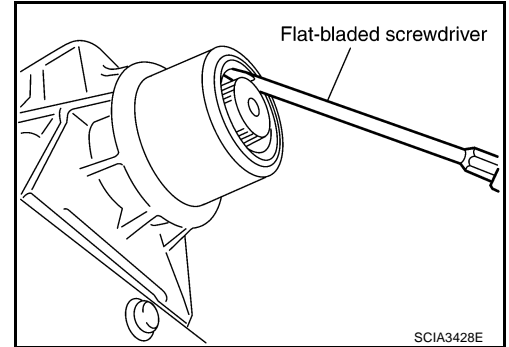

INSTALLATION

CAUTION:

After completing installation, check fluid leakage and fluid level. Refer to [AT-12, "Changing A/T Fluid"](#), [AT-12, "Checking A/T Fluid"](#).

1. As shown in the right figure, use the drift to drive rear oil seal into rear extension assembly until it is flush.

CAUTION:

- Apply ATF to rear oil seal.
- Do not reuse rear oil seal.

2. Install rear propeller shaft. Refer to [PR-7, "Removal and Installation"](#).

CAUTION:

Do not impact or damage propeller shaft tube.

3. Install exhaust front tube and center muffler. Refer to [EX-3, "Removal and Installation"](#).

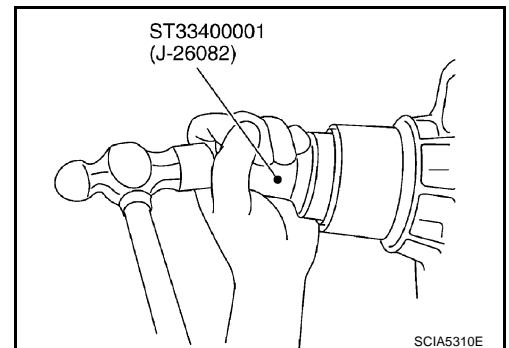

ON-VEHICLE SERVICE

ACS0084U

Revolution Sensor COMPONENTS

SEC. 313·314·319

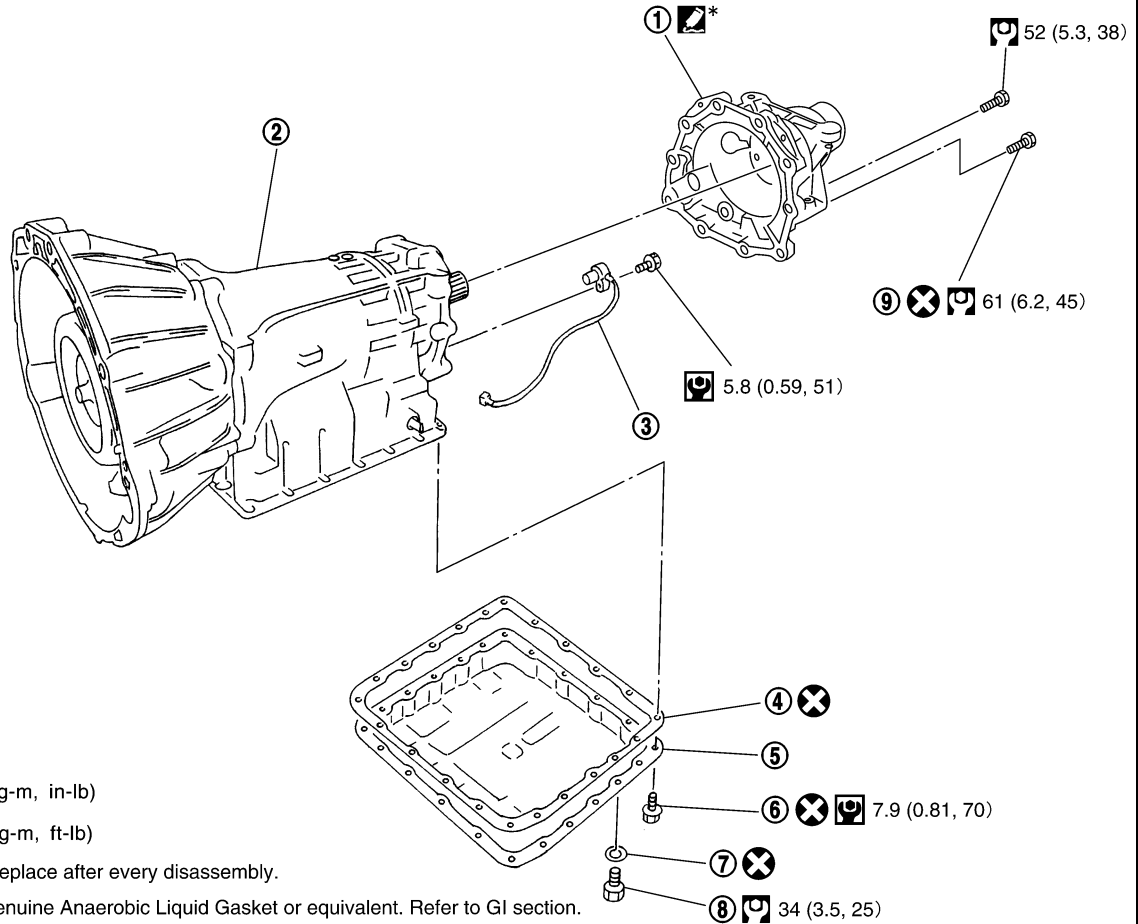

SCIA5145E

- | | | |
|----------------------|-----------------|--------------------------|
| 1. Rear extension | 2. Transmission | 3. Revolution sensor |
| 4. Oil pan gasket | 5. Oil pan | 6. Oil pan mounting bolt |
| 7. Drain plug gasket | 8. Drain plug | 9. Self-sealing bolt |

REMOVAL

1. Disconnect the battery cable from the negative terminal.
2. Drain ATF through drain plug.
3. Remove exhaust front tube and center muffler with a power tool. Refer to [EX-3, "Removal and Installation"](#).
4. Remove rear propeller shaft. Refer to [PR-7, "Removal and Installation"](#).

CAUTION:

Do not impact or damage propeller shaft tube.

5. Remove control rod. Refer to [AT-228, "SHIFT CONTROL SYSTEM"](#).
6. Remove oil pan and oil pan gasket.

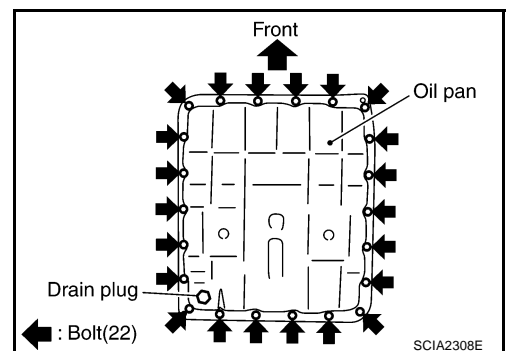

SCIA2308E

ON-VEHICLE SERVICE

7. Check foreign materials in oil pan to help determine causes of malfunction. If the A/T fluid is very dark, smells burned, or contains foreign particles, the frictional material (clutches, band) may need replacement. A tacky film that will not wipe clean indicates varnish build up. Varnish can cause valves, servo, and clutches to stick and can inhibit pump pressure.

- If frictional material is detected, perform A/T fluid cooler cleaning. Refer to [AT-14, "A/T Fluid Cooler Cleaning"](#).

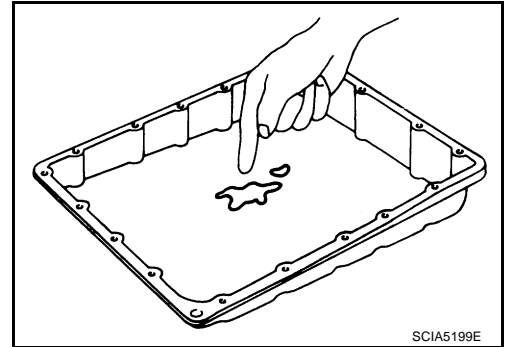

8. Support transmission assembly with a transmission jack.

CAUTION:

When setting the transmission jack, place wooden blocks to prevent from damaging control valve with TCM and transmission case.

9. Remove engine rear member with a power tool. Refer to [AT-264, "Removal and Installation"](#).
10. Remove tightening bolts for rear extension assembly and transmission case.

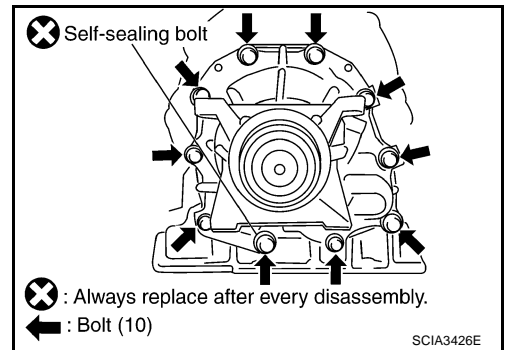

11. Tap rear extension assembly with a soft hammer.

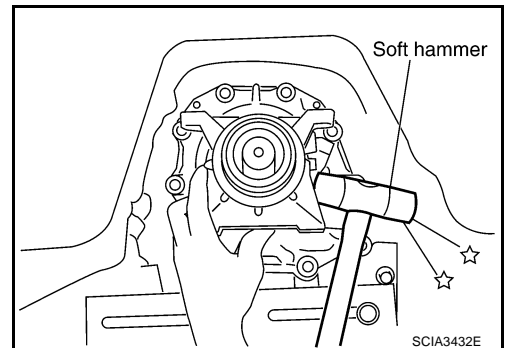

12. Remove rear extension assembly from transmission case. (With needle bearing.)

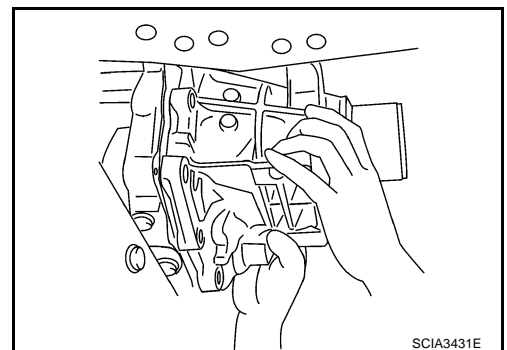

A
B
AT
D
E
F
G
H
I
J
K
L
M

ON-VEHICLE SERVICE

13. Disconnect revolution sensor connector.

CAUTION:

Be careful not to damage connector.

14. Straighten terminal clips to free revolution sensor harness.

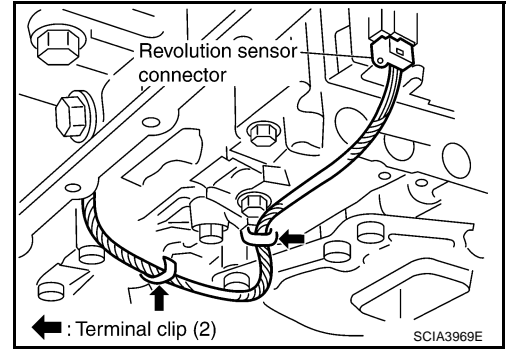

15. Remove revolution sensor from transmission case.

CAUTION:

- Do not subject it to impact by dropping or hitting it.
- Do not disassemble.
- Do not allow metal filings, etc. to get on the sensor's front edge magnetic area.
- Do not place in an area affected by magnetism.

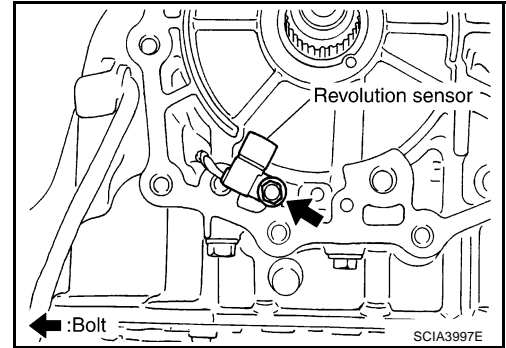

INSTALLATION

CAUTION:

After completing installation, check A/T fluid leakage and fluid level. Refer to [AT-12. "Changing A/T Fluid"](#) , [AT-12. "Checking A/T Fluid"](#) .

1. Install revolution sensor in transmission case.

CAUTION:

- Do not subject it to impact by dropping or hitting it.
- Do not disassemble.
- Do not allow metal filings, etc. to get on the sensor's front edge magnetic area.
- Do not place in an area affected by magnetism.

 : 5.8 N-m (0.59 kg-m, 51 in-lb)

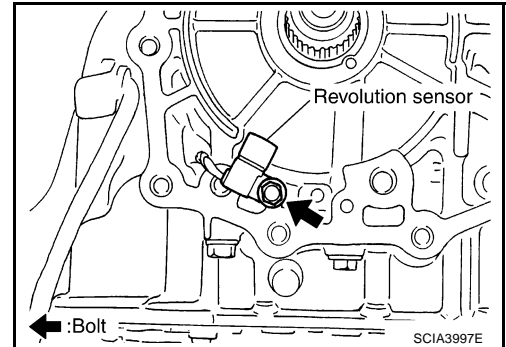

2. Connect revolution sensor connector.

3. Securely fasten revolution sensor harness with clips.

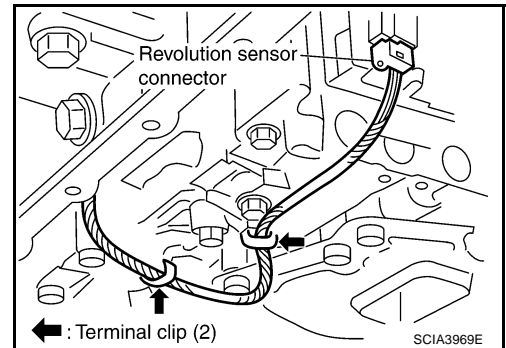

ON-VEHICLE SERVICE

4. Apply recommended sealant (Genuine Anaerobic Liquid Gasket or equivalent. Refer to [GI-47, "Recommended Chemical Products and Sealants"](#) .) to rear extension assembly as shown in the figure.

CAUTION:

Completely remove all moisture, oil and old sealant, etc. from transmission case and rear extension assembly mounting surfaces.

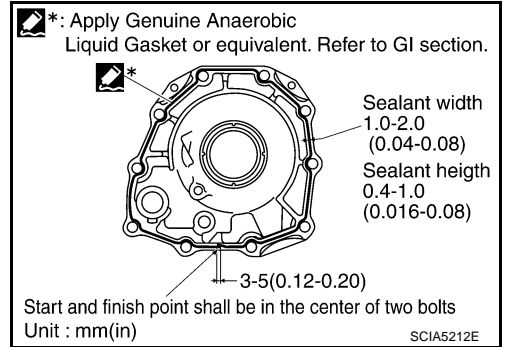

5. Install rear extension assembly to transmission case. (With needle bearing.)

CAUTION:

Insert the tip of parking rod between the parking pawl and the parking actuator support when assembling the rear extension assembly.

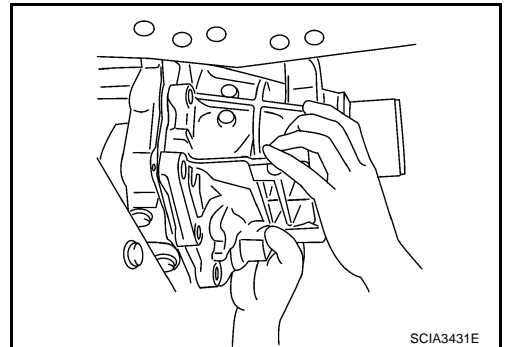

6. Tighten rear extension assembly mounting bolts to specified torque.

CAUTION:

Do not reuse self-sealing bolt.

Rear extension assembly mounting bolt:

: 52 N·m (5.3 Kg·m, 38 ft·lb)

Self-sealing bolt:

: 61 N·m (6.2 Kg·m, 45 ft·lb)

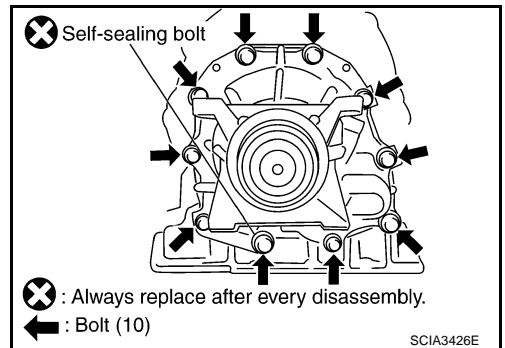

7. Install engine rear member. Refer to [AT-264, "Removal and Installation"](#) .

8. Install oil pan to transmission case.

- a. Install oil pan gasket to oil pan.

CAUTION:

- Do not reuse oil pan gasket.
- Install it in the direction to align hole positions.
- Completely remove all moisture, oil and old gasket, etc. from oil pan gasket mounting surface.

- b. Install oil pan (with oil pan gasket) to transmission case.

CAUTION:

- Install it so that drain plug comes to the position as shown in the figure.
- Be careful not to pinch harnesses.
- Completely remove all moisture, oil and old gasket, etc. from oil pan mounting surface.

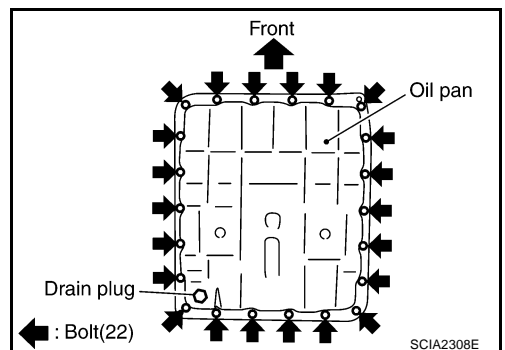

A
B
AT
D
E
F
G
H
I
J
K
L
M

ON-VEHICLE SERVICE

- c. Tighten oil pan mounting bolts to the specified torque in numerical order as shown in the figure after temporarily tightening them.

CAUTION:

Do not reuse oil pan mounting bolts.

 : 7.9 N·m (0.81 kg·m, 70 in·lb)

9. Install drain plug to oil pan.

CAUTION:

Do not reuse drain plug gasket.

 : 34 N·m (3.5 kg·m, 25 ft·lb)

10. Install control rod. Refer to [AT-228, "SHIFT CONTROL SYSTEM"](#) .
11. Install rear propeller shaft. Refer to [PR-7, "Removal and Installation"](#) .

CAUTION:

Do not impact or damage propeller shaft tube.

12. Install exhaust front tube and center muffler. Refer to [EX-3, "Removal and Installation"](#) .
13. Pour ATF into transmission assembly. Refer to [AT-12, "Changing A/T Fluid"](#) .
14. Connect the battery cable to the negative terminal.

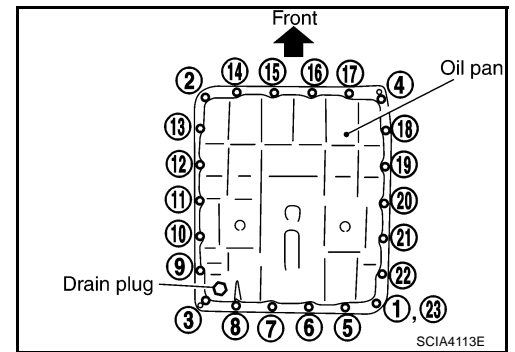

AIR BREATHER HOSE

AIR BREATHER HOSE

PF3:31098

Removal and Installation

ACS0000G

Refer to the figure below for air breather hose removal and installation procedure.

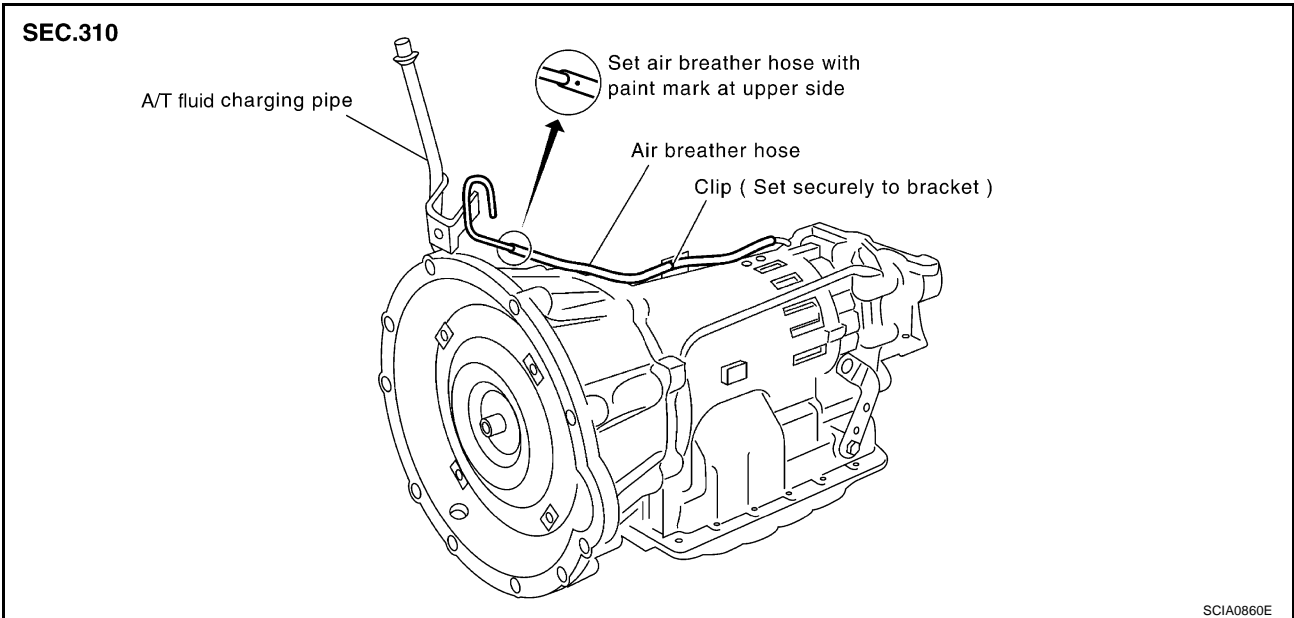

CAUTION:

- When installing an air breather hose, be careful not to be crushed or blocked by folding or bending the hose.
- When inserting a hose to the transmission tube, be sure to insert it fully until its end reaches the tube bend R portion.

A
B
AT
D
E
F
G
H
I
J
K
L
M

TRANSMISSION ASSEMBLY

PFP:31020

TRANSMISSION ASSEMBLY

Removal and Installation

ACS0000H

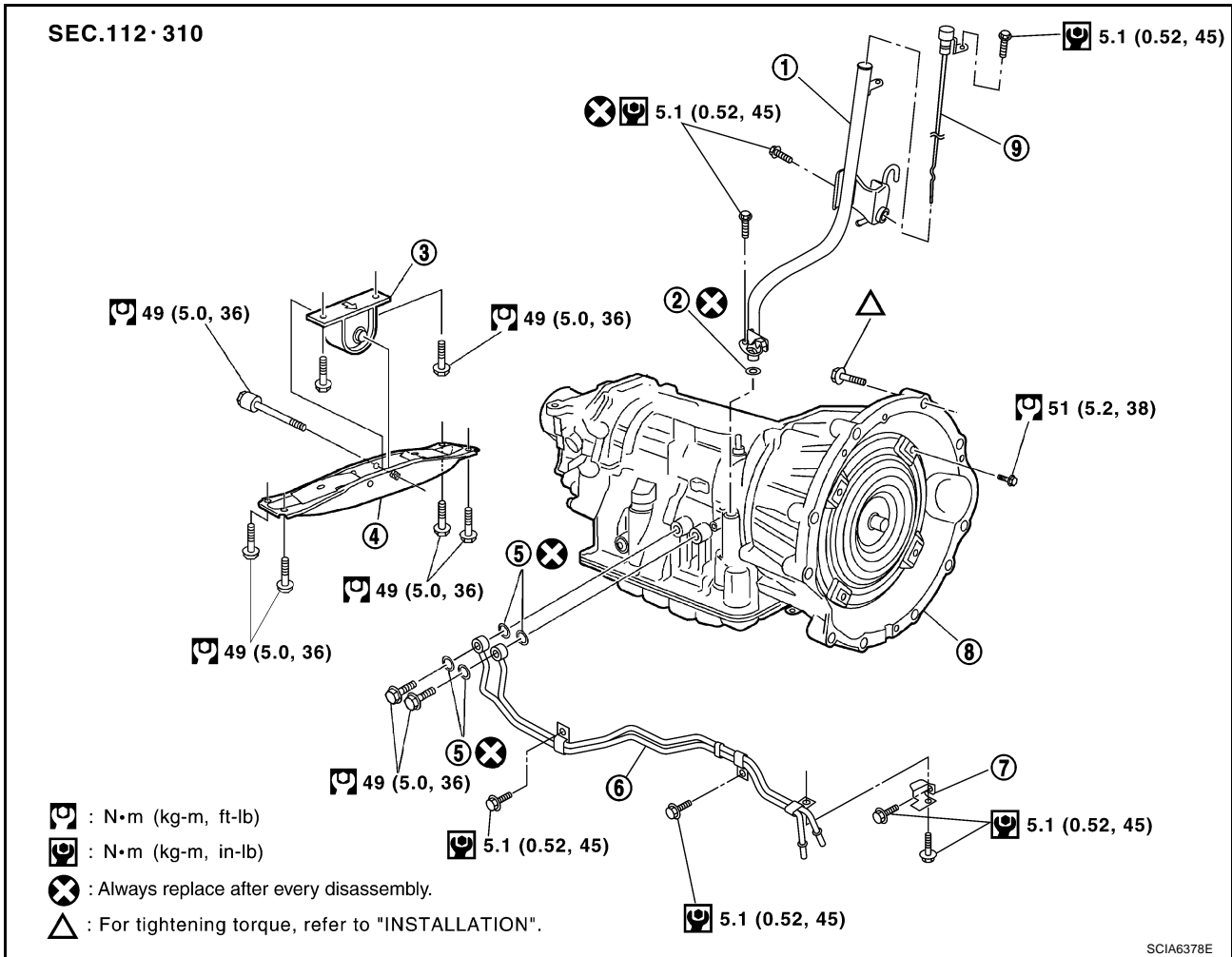

- | | | |
|----------------------------|--------------------------|--------------------------|
| 1. A/T fluid charging pipe | 2. O-ring | 3. Insulator |
| 4. Rear member | 5. Copper washer | 6. Fluid cooler tube |
| 7. Bracket | 8. Transmission assembly | 9. A/T fluid level gauge |

REMOVAL

CAUTION:

When removing the A/T assembly from engine, first remove the crankshaft position sensor (POS) from the A/T assembly.

Be careful not to damage sensor edge.

1. Disconnect the battery cable from the negative terminal.
2. Remove tower bar with a power tool. Refer to [FSU-20, "Removal and Installation"](#).
3. Remove engine under cover with a power tool.
4. Remove front cross bar with a power tool. Refer to [FSU-8, "Components"](#).
5. Remove exhaust front tube and center muffler with a power tool. Refer to [EX-3, "Removal and Installation"](#).
6. Remove three way catalyst. Refer to [EM-23, "Removal and Installation"](#).
7. Remove rear propeller shaft. Refer to [PR-7, "Removal and Installation"](#).

CAUTION:

Do not impact, or damage propeller shaft tube.

8. Remove control rod. Refer to [AT-228, "SHIFT CONTROL SYSTEM"](#).
9. Disconnect A/T assembly harness connector.

TRANSMISSION ASSEMBLY

10. Remove crankshaft position sensor (POS). Refer to [EM-27, "Removal and Installation"](#) .

CAUTION:

- Do not subject it to impact by dropping or hitting it.
- Do not disassemble.
- Do not allow metal filings, etc. to get on the sensor's front edge magnetic area.
- Do not place in an area affected by magnetism.

11. Remove fluid cooler tube and A/T fluid charging pipe.

12. Plug up openings such as the fluid charging pipe hole, etc.

13. Remove air breather hose. Refer to [AT-263, "Removal and Installation"](#) .

14. Remove starter motor with a power tool. Refer to [SC-19, "Removal and Installation"](#) .

15. Remove rear cover plate. Refer to [EM-27, "Removal and Installation"](#) .

16. Remove rear plate from converter housing part. Refer to [EM-27, "Removal and Installation"](#) .

17. Turn crankshaft, and remove the four tightening bolts for drive plate and torque converter.

CAUTION:

When turning crankshaft, turn it clockwise as viewed from the front of the engine.

18. Support transmission assembly with a transmission jack.

CAUTION:

When setting the transmission jack, be careful not to allow it to collide against the drain plug.

19. Remove engine rear member with a power tool.

20. Remove bolts fixing transmission assembly to engine with a power tool.

21. Remove transmission assembly from vehicle with a transmission jack.

- Secure torque converter to prevent it from dropping.
- Secure transmission assembly to the transmission jack.

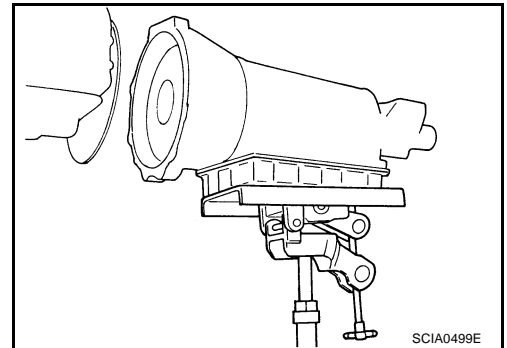
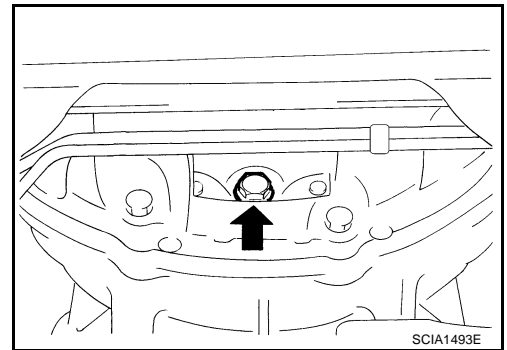
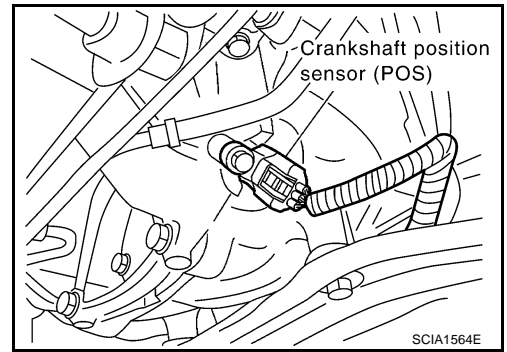

INSPECTION

Installation and Inspection of Torque Converter

- After inserting a torque converter to a transmission, be sure to check distance "A" to ensure it is within the reference value limit.

Distance "A" : 25.0 mm (0.98 in) or more

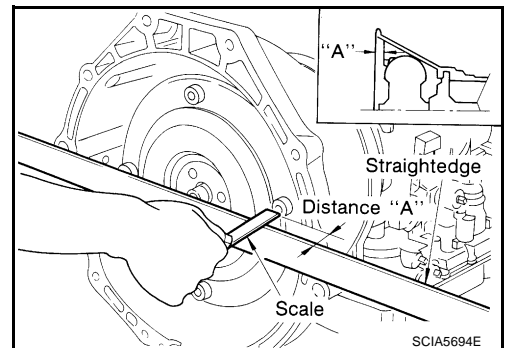

TRANSMISSION ASSEMBLY

INSTALLATION

Install the removed parts in the reverse order of the removal, while paying attention to the following work.

- When installing transmission assembly to the engine, attach the fixing bolts in accordance with the following standard.

Bolt No.	1	2	3	4
Number of bolts	1	5	2	2
Bolt length "ℓ"mm (in)	55 (2.17)	65 (2.56)	56 (2.20)	35 (1.38)
Tightening torque N-m (kg-m, ft-lb)	75 (7.7, 55)		55 (5.6, 41)	47 (4.8, 35)

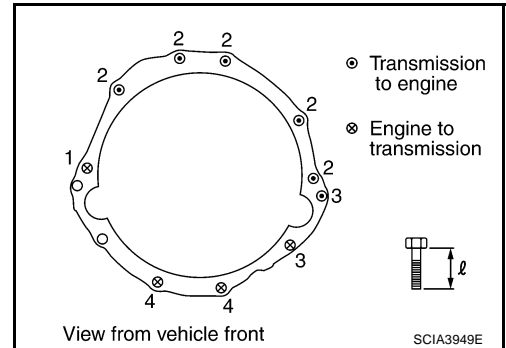

- Align the positions of tightening bolts for drive plate with those of the torque converter, and temporarily tighten the bolts. Then tighten the bolts with the specified torque.

 : 5.1 N·m (5.2 kg-m, 38 ft-lb)

CAUTION:

- When turning crankshaft, turn it clockwise as viewed from the front of the engine.
- When tightening the tightening bolts for the torque converter after fixing the crankshaft pulley bolts, be sure to confirm the tightening torque of the crankshaft pulley mounting bolts.
- After converter is installed to drive plate, rotate crankshaft several turns and check to be sure that transmission rotates freely without binding.
- Install crankshaft position sensor (POS). Refer to [EM-27, "Removal and Installation"](#).
- After completing installation, check fluid leakage, fluid level, and the A/T positions of A/T. Refer to [AT-12, "Checking A/T Fluid"](#), [AT-229, "Adjustment of A/T Position"](#), [AT-229, "Checking of A/T Position"](#).

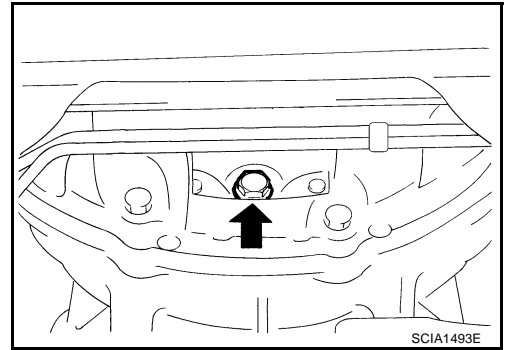

OVERHAUL

OVERHAUL Components

PF0:0000

ACS0084V

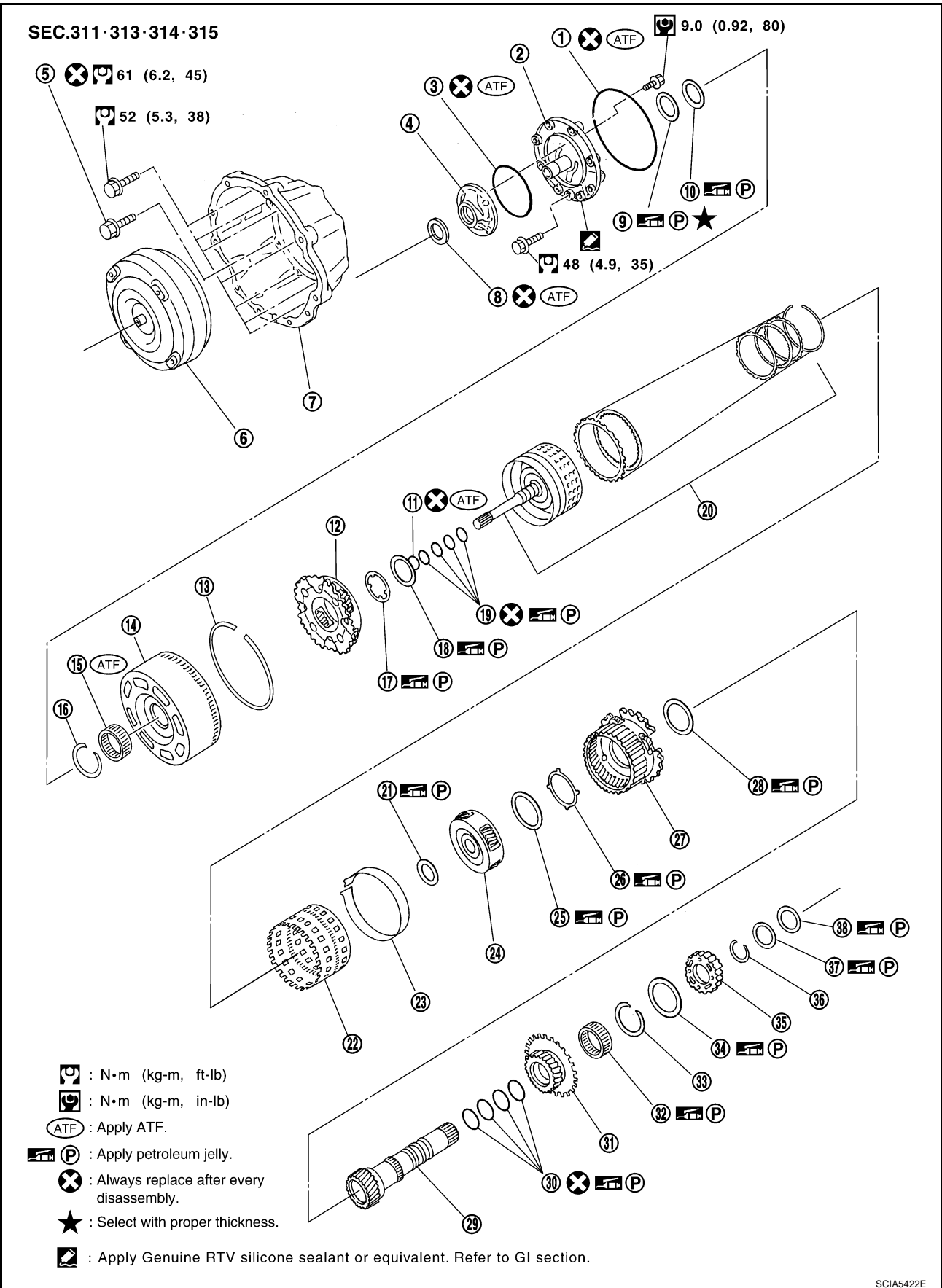

A
B
AT
D
E
F
G
H
I
J
K
L
M

SCIA5422E

OVERHAUL

- | | | |
|------------------------|-------------------------------------|----------------------------|
| 1. O-ring | 2. Oil pump cover | 3. O-ring |
| 4. Oil pump housing | 5. Self-sealing bolt | 6. Torque converter |
| 7. Converter housing | 8. Oil pump housing oil seal | 9. Bearing race |
| 10. Needle bearing | 11. O-ring | 12. Front carrier assembly |
| 13. Snap ring | 14. Front sun gear | 15. 3rd one-way clutch |
| 16. Snap ring | 17. Bearing race | 18. Needle bearing |
| 19. Seal ring | 20. Input clutch assembly | 21. Needle bearing |
| 22. Rear internal gear | 23. Brake band | 24. Mid carrier assembly |
| 25. Needle bearing | 26. Bearing race | 27. Rear carrier assembly |
| 28. Needle bearing | 29. Mid sun gear | 30. Seal ring |
| 31. Rear sun gear | 32. 1st one-way clutch | 33. Snap ring |
| 34. Needle bearing | 35. High and low reverse clutch hub | 36. Snap ring |
| 37. Bearing race | 38. Needle bearing | |

OVERHAUL

SEC.315-316

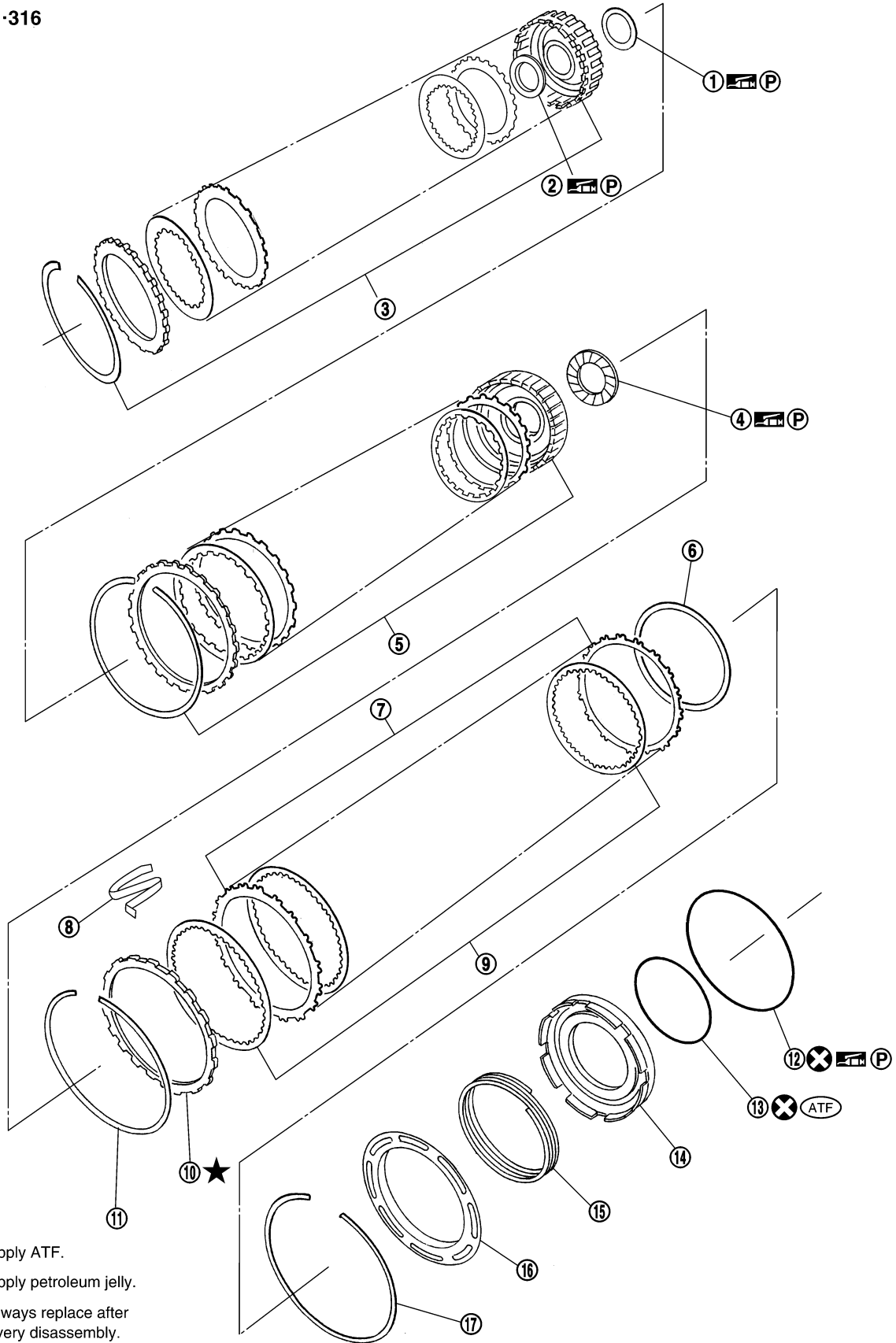

- : Apply ATF.
- : Apply petroleum jelly.
- : Always replace after every disassembly.
- : Select with proper thickness.

- | | | |
|-------------------|---------------------------|---|
| 1. Needle bearing | 2. Bearing race | 3. High and low reverse clutch assembly |
| 4. Needle bearing | 5. Direct clutch assembly | 6. Reverse brake dish plate |

A
B
AT
D
E
F
G
H
I
J
K
L
M

SCIA5043E

OVERHAUL

- | | | |
|-----------------------------------|--------------------------|------------------------------|
| 7. Reverse brake driven plate | 8. N-spring | 9. Reverse brake drive plate |
| 10. Reverse brake retaining plate | 11. Snap ring | 12. Lip seal |
| 13. D-ring | 14. Reverse brake piston | 15. Return spring |
| 16. Spring retainer | 17. Snap ring | |

OVERHAUL

SEC.313 · 314 · 315 · 316 · 317 · 319

A
B
AT
D
E
F
G
H
I
J
K
L
M

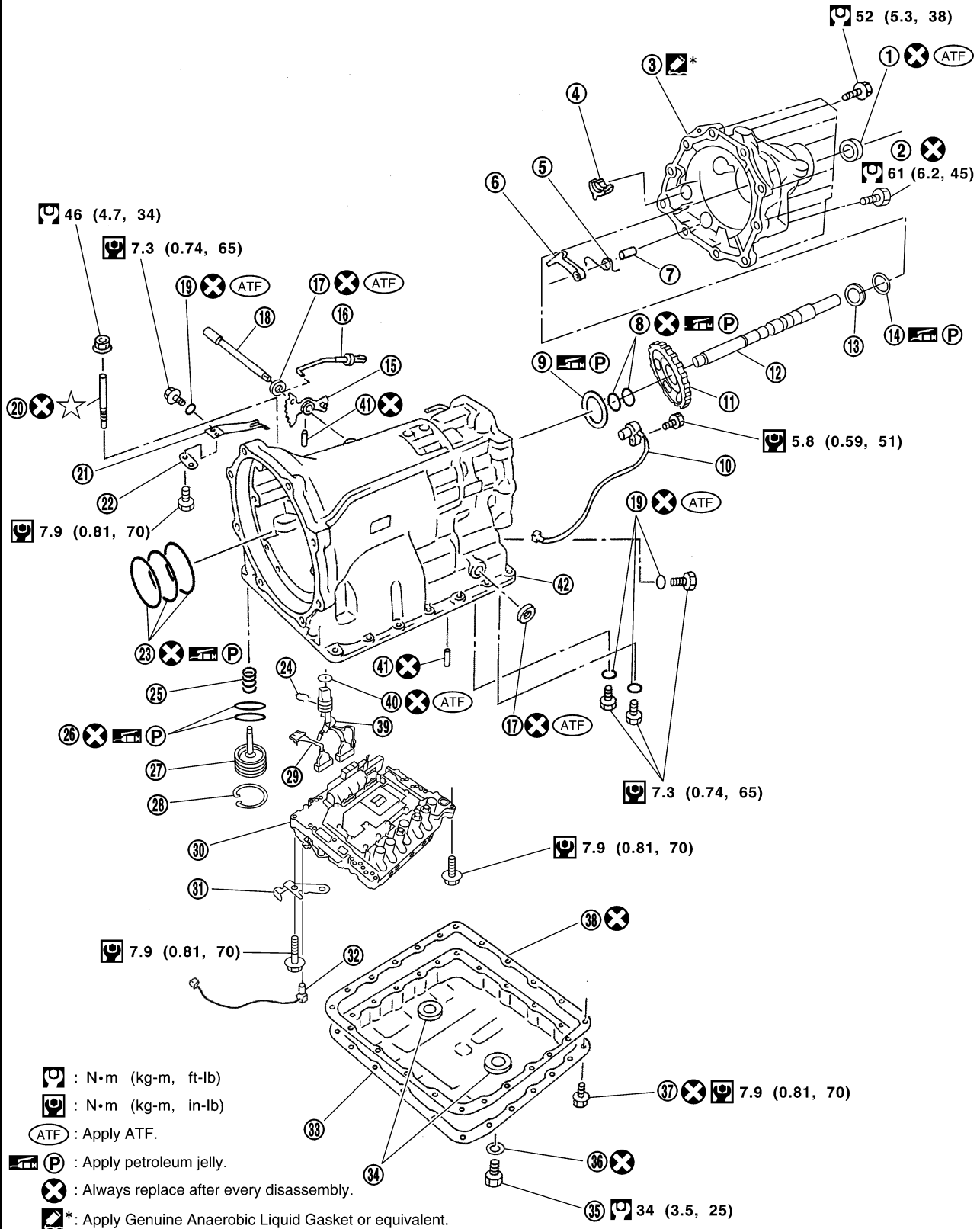

SCIA5444E

- | | | |
|-----------------------------|----------------------|-------------------|
| 1. Rear oil seal | 2. Self-sealing bolt | 3. Rear extension |
| 4. Parking actuator support | 5. Return spring | 6. Parking pawl |
| 7. Pawl shaft | 8. Seal ring | 9. Needle bearing |

OVERHAUL

- | | | |
|---------------------------|------------------------------------|----------------------------|
| 10. Revolution sensor | 11. Parking gear | 12. Output shaft |
| 13. Bearing race | 14. Needle bearing | 15. Manual plate |
| 16. Parking rod | 17. Manual shaft oil seal | 18. Manual shaft |
| 19. O-ring | 20. Band servo anchor end pin | 21. Detent spring |
| 22. Spacer | 23. Seal ring | 24. Snap ring |
| 25. Return spring | 26. O-ring | 27. Servo assembly |
| 28. Snap ring | 29. Sub-harness | 30. Control valve with TCM |
| 31. Bracket | 32. A/T fluid temperature sensor 2 | 33. Oil pan |
| 34. Magnet | 35. Drain plug | 36. Drain plug gasket |
| 37. Oil pan mounting bolt | 38. Oil pan gasket | 39. Terminal cord assembly |
| 40. O-ring | 41. Retaining pin | 42. Transmission case |

OVERHAUL

Oil Channel

ACS0084W

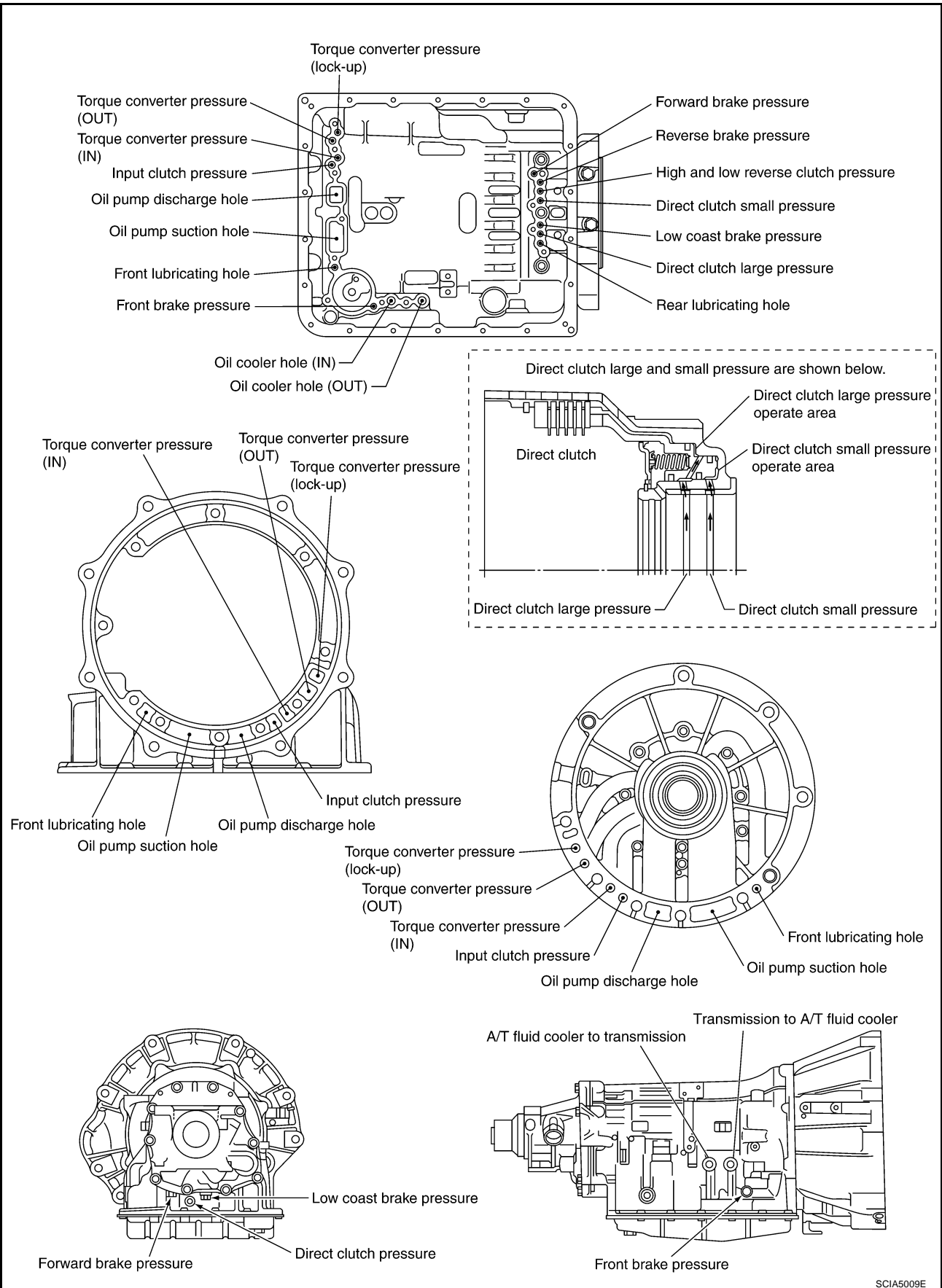

A
B
AT
D
E
F
G
H
I
J
K
L
M

SCIA5009E

OVERHAUL

Locations of Adjusting Shims, Needle Bearings, Thrust Washers and Snap Rings

ACS0084X

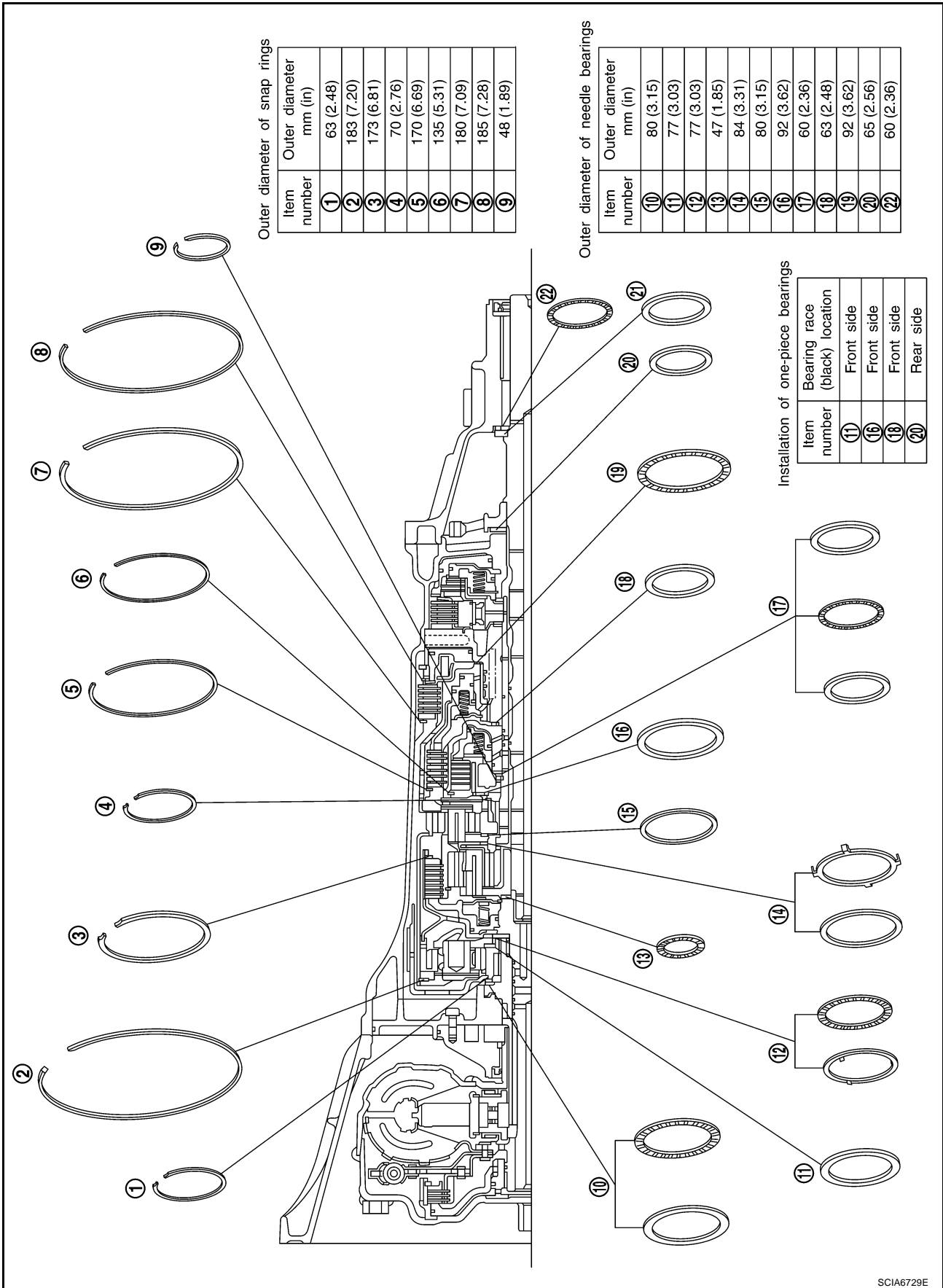

SCIA6729E

DISASSEMBLY

PFP:31020

Disassembly

ACS0084Y

CAUTION:

Do not disassemble parts behind Drum Support. Refer to [AT-17, "Cross-Sectional View"](#) .

1. Drain ATF through drain plug.
2. Remove torque converter by holding it firmly and turing while pulling straight out.

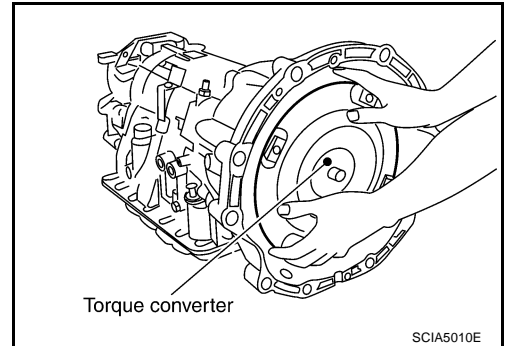

3. Check torque converter one-way clutch using a check tool as shown in the figure.
 - a. Insert a check tool into the groove of bearing support built into one-way clutch outer race.
 - b. When fixing bearing support with a check tool, rotate one-way clutch spline using a screwdriver.
 - c. Check that inner race rotates clockwise only. If not, replace torque converter assembly.

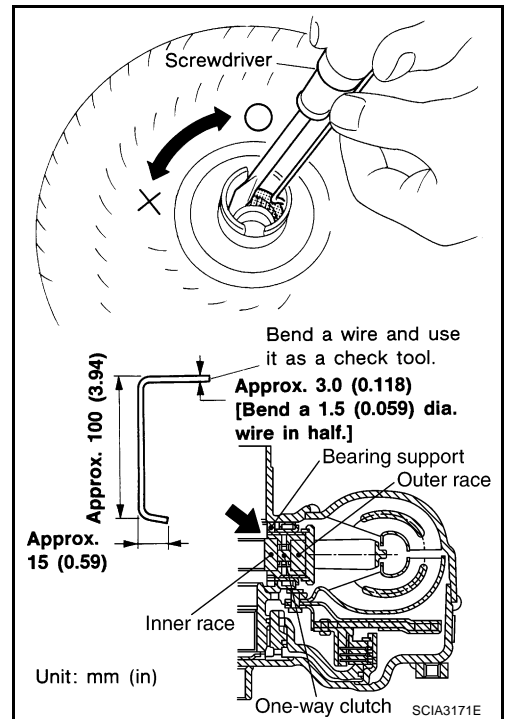

4. Remove converter housing from transmission case.

CAUTION:

Be careful not to scratch converter housing.

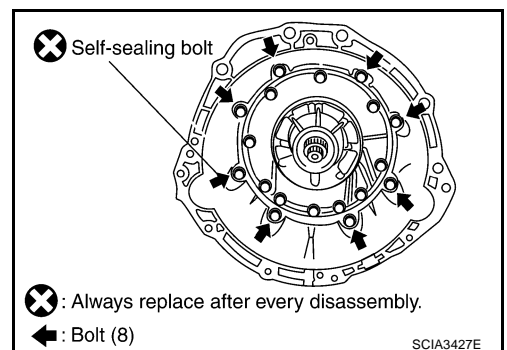

DISASSEMBLY

5. Remove O-ring from input clutch assembly.

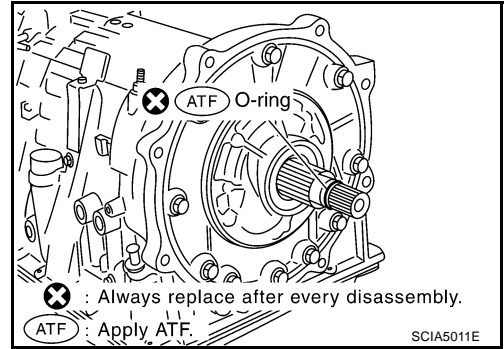

6. Remove tightening bolts for oil pump assembly and transmission case.

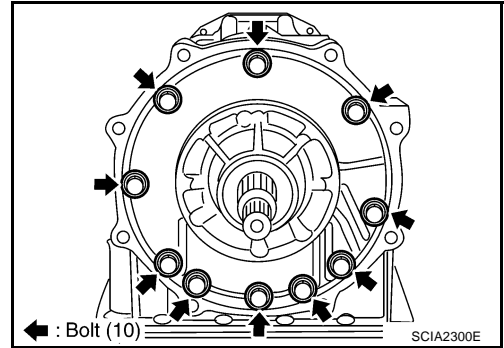

7. Attach the sliding hammers to oil pump assembly and extract it evenly from transmission case.

CAUTION:

- Fully tighten the sliding hammer screws.
- Make sure that bearing race is installed to the oil pump assembly edge surface.

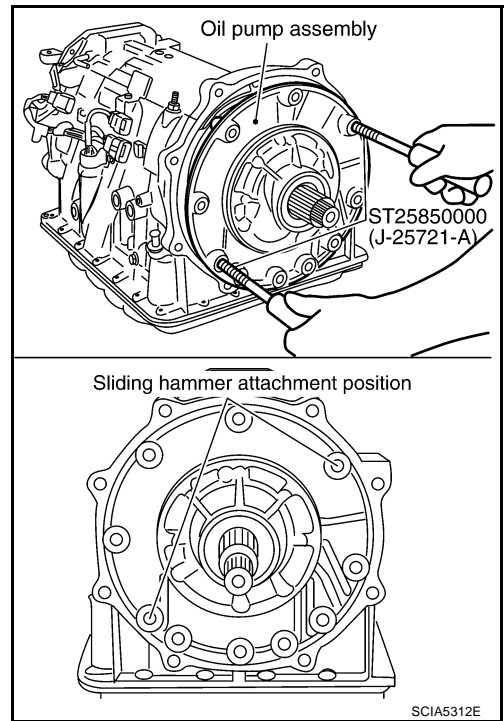

8. Remove O-ring from oil pump assembly.

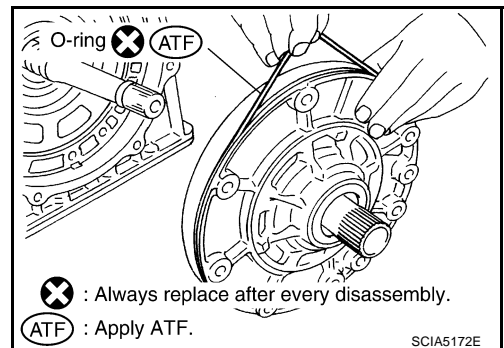

DISASSEMBLY

9. Remove bearing race from oil pump assembly.

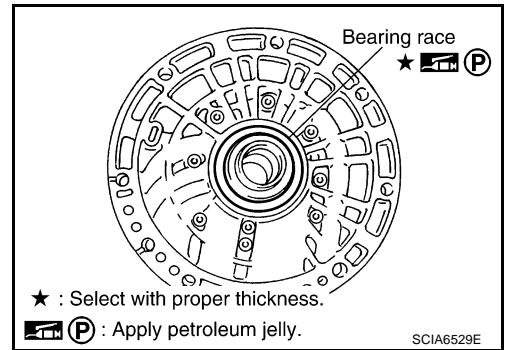

10. Remove needle bearing from front sun gear.

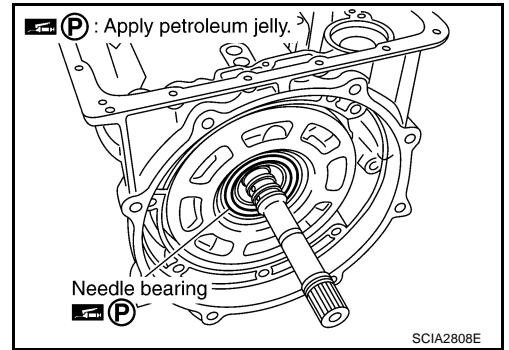

11. Remove front sun gear assembly from front carrier assembly.

NOTE:
Remove front sun gear by rotating left/right.

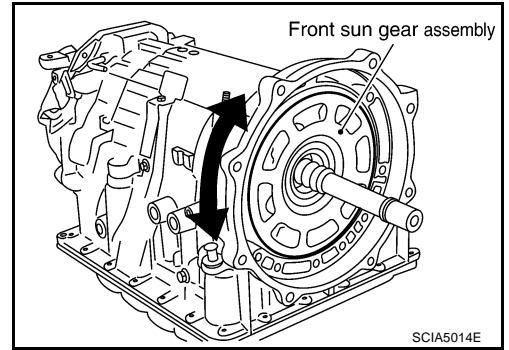

12. Remove seal rings from input clutch assembly.

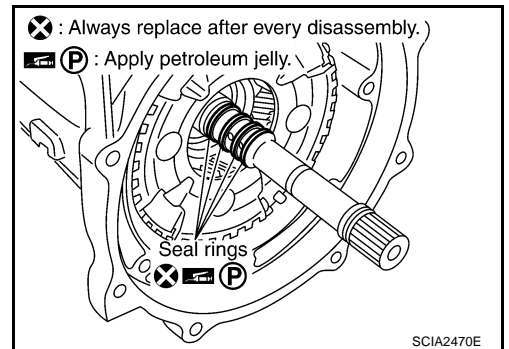

13. Remove front carrier assembly from rear carrier assembly. (With input clutch assembly and rear internal gear.)

CAUTION:
Be careful to remove it with needle bearing.

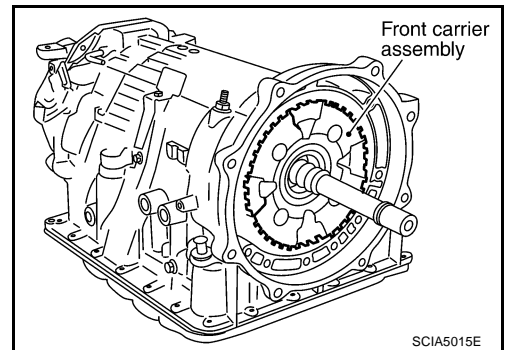

A
B
AT
D
E
F
G
H
I
J
K
L
M

DISASSEMBLY

14. Loosen lock nut and remove band servo anchor end pin from transmission case.

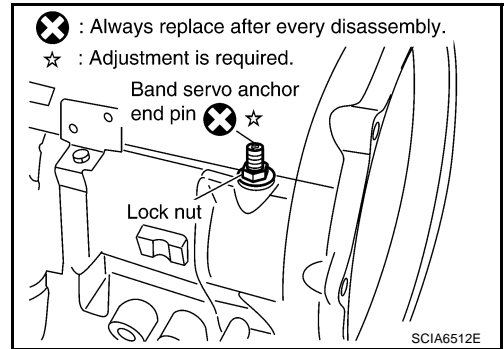

15. Remove brake band from transmission case.

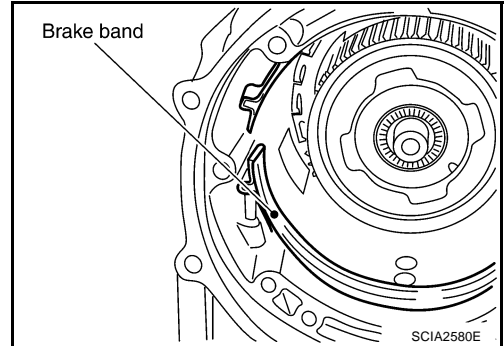

- To prevent brake linings from cracking or peeling, do not stretch the flexible band unnecessarily. When removing the brake band, always secure it with a clip as shown in the figure at right. Leave the clip in position after removing the brake band.
- Check brake band facing for damage, cracks, wear or burns.

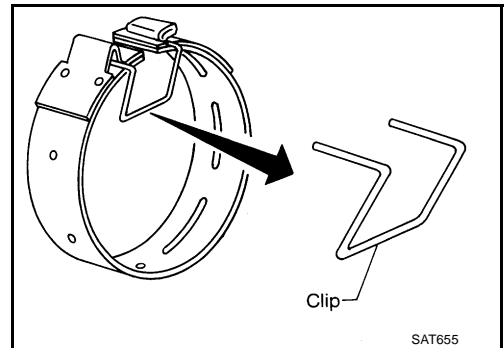

16. Remove mid carrier assembly and rear carrier assembly as a unit.

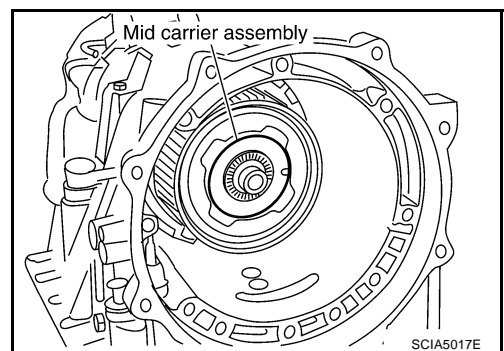

17. Remove mid carrier assembly from rear carrier assembly.

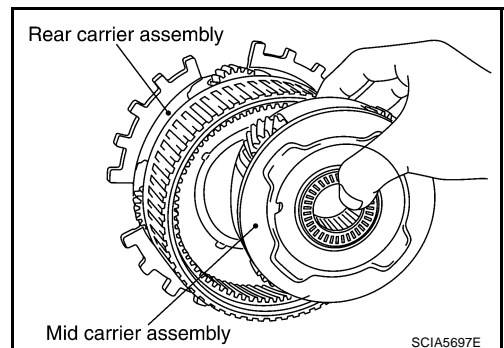

DISASSEMBLY

18. Remove needle bearing (front side) from mid carrier assembly.

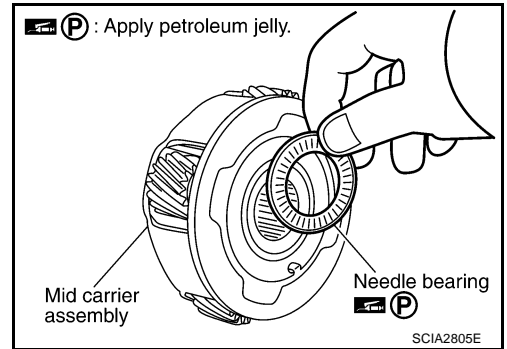

19. Remove needle bearing (rear side) from mid carrier assembly.

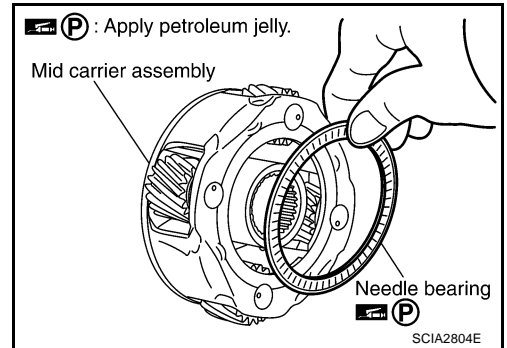

20. Remove bearing race from rear carrier assembly.

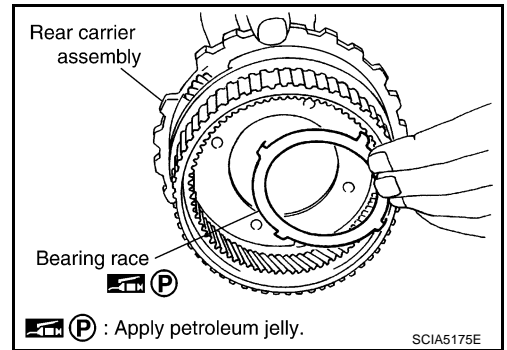

21. Remove needle bearing from rear carrier assembly.

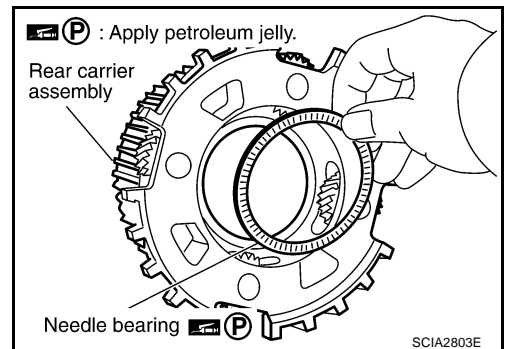

22. Remove mid sun gear assembly, rear sun gear assembly and high and low reverse clutch hub as a unit.

CAUTION:

Be careful to remove them with bearing race and needle bearing.

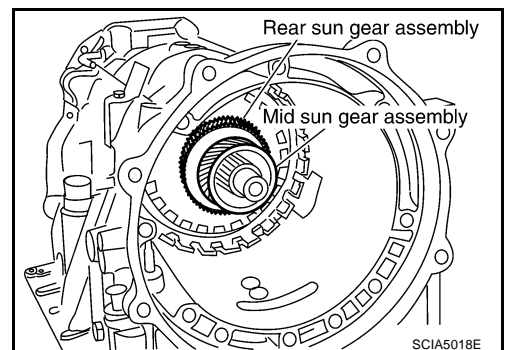

A
B
AT
D
E
F
G
H
I
J
K
L
M

DISASSEMBLY

23. Remove high and low reverse clutch assembly from direct clutch assembly.

CAUTION:

Make sure that needle bearing is installed to the high and low reverse clutch assembly edge surface.

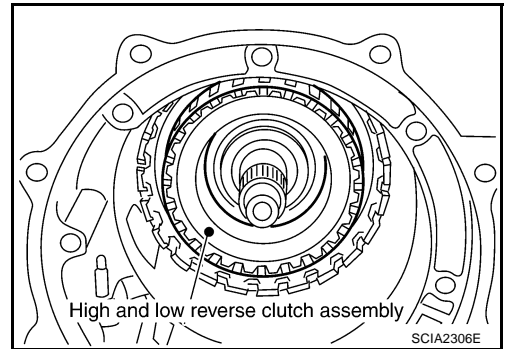

24. Remove direct clutch assembly from transmission case.

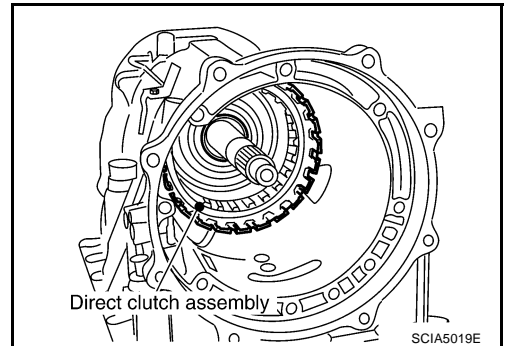

25. Remove needle bearing from drum support edge surface.

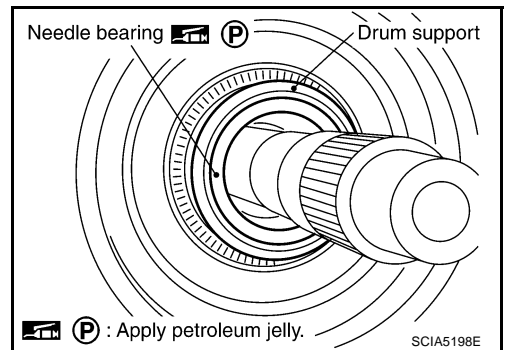

26. Remove snap ring from A/T assembly harness connector.

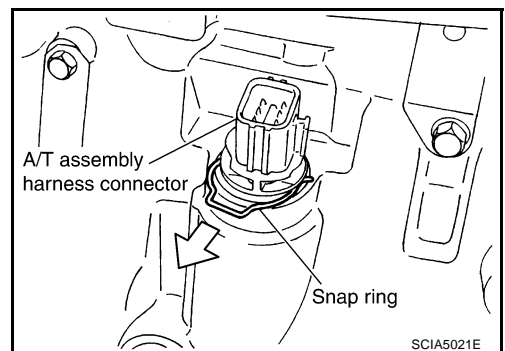

27. Push A/T assembly harness connector.

CAUTION:

Be careful not to damage connector.

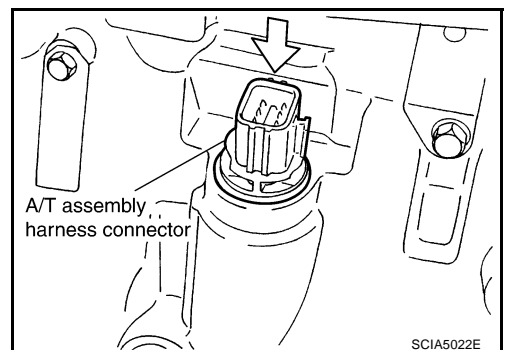

DISASSEMBLY

28. Remove oil pan and oil pan gasket.

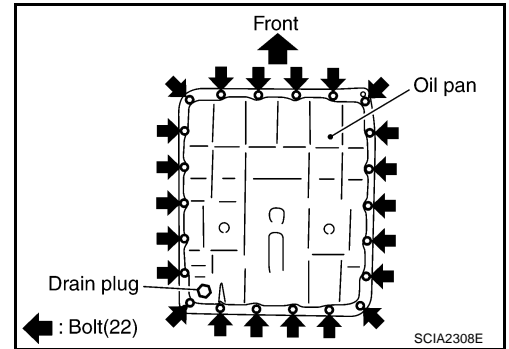

29. Check foreign materials in oil pan to help determine causes of malfunction. If the A/T fluid is very dark, smells burned, or contains foreign particles, the frictional material (clutches, band) may need replacement. A tacky film that will not wipe clean indicates varnish build up. Varnish can cause valves, servo, and clutches to stick and can inhibit pump pressure.

- If frictional material is detected, perform A/T fluid cooler cleaning. Refer to [AT-14, "A/T Fluid Cooler Cleaning"](#).

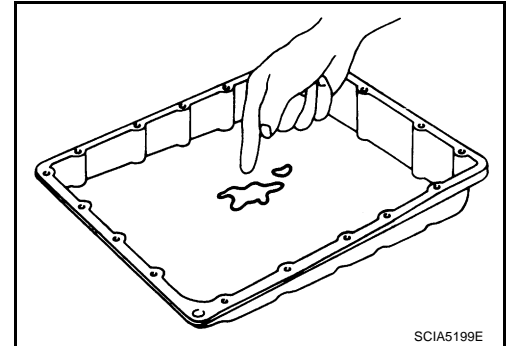

30. Remove magnets from oil pan.

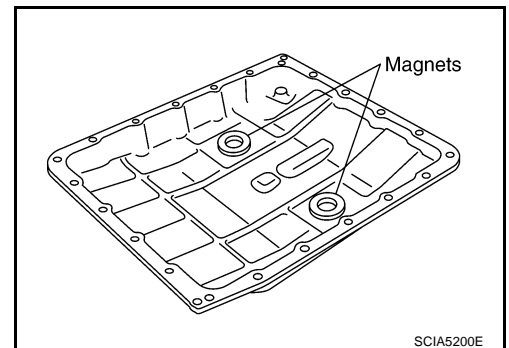

31. Disconnect A/T fluid temperature sensor 2 connector.

- CAUTION:**
Be careful not to damage connector.

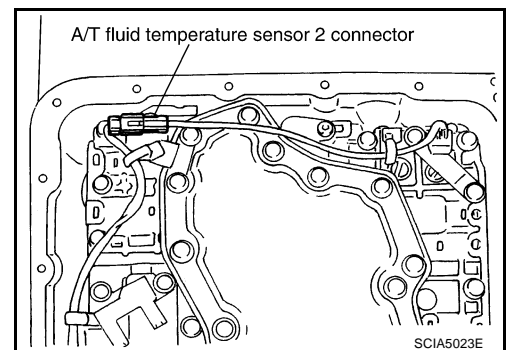

A
B
AT
D
E
F
G
H
I
J
K
L
M

DISASSEMBLY

32. Straighten terminal clips to free terminal cord assembly and A/T fluid temperature sensor 2 harness.

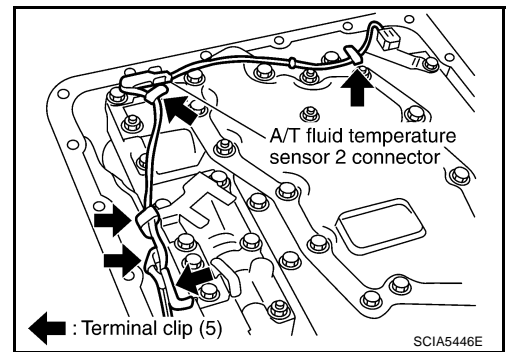

33. Disconnect revolution sensor connector.

CAUTION:
Be careful not to damage connector.

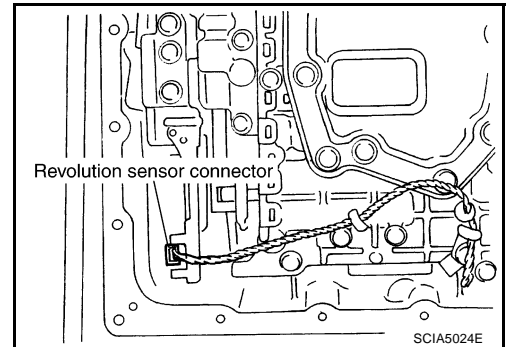

34. Straighten terminal clips to free revolution sensor harness.

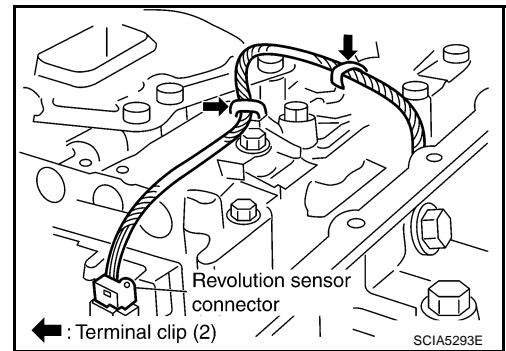

35. Remove bolts A, B and C from control valve with TCM.

Bolt symbol	Length mm (in)	Number of bolts
A	42 (1.65)	5
B	55 (2.17)	6
C	40 (1.57)	1

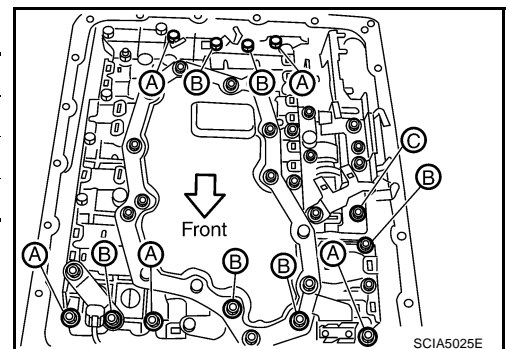

36. Remove control valve with TCM from transmission case.

CAUTION:
When removing, be careful with the manual valve notch and manual plate height. Remove it vertically.

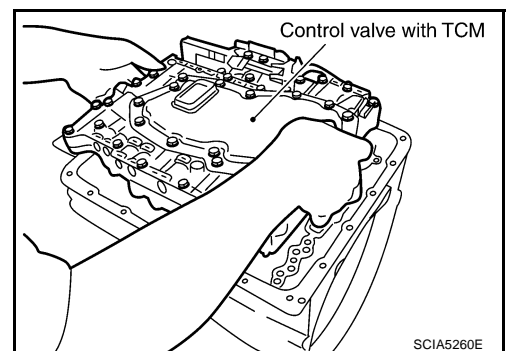

DISASSEMBLY

37. Remove A/T fluid temperature sensor 2 with bracket from control valve with TCM.

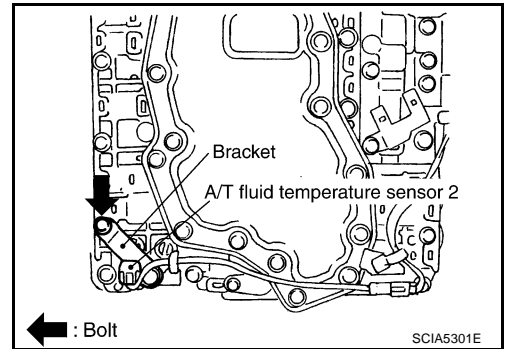

38. Remove bracket from A/T fluid temperature sensor 2.

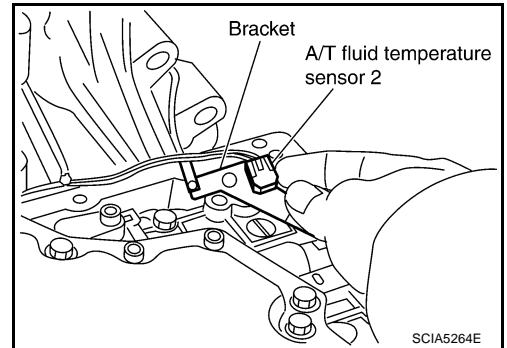

39. Remove O-ring from A/T assembly harness connector.

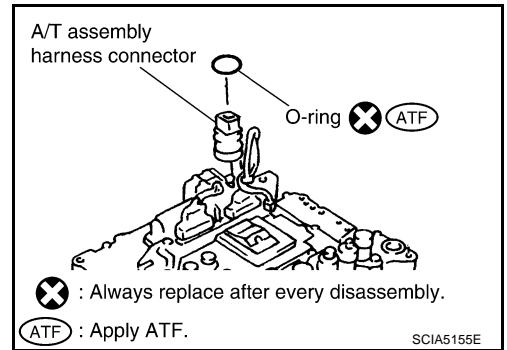

40. Disconnect TCM connectors.

CAUTION:
Be careful not to damage connectors.

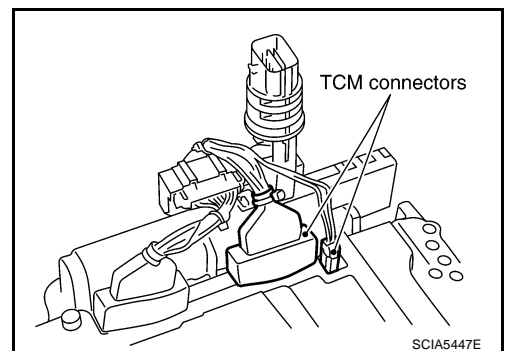

41. Remove A/T assembly harness connector from control valve with TCM using a flat-bladed screwdriver.

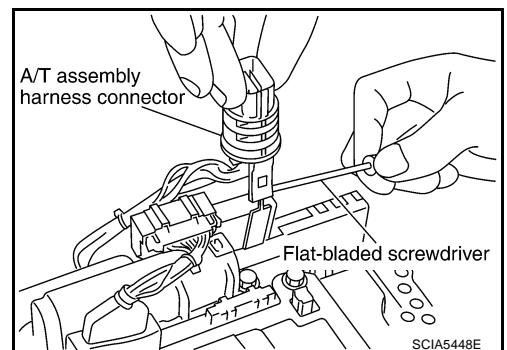

A
B
AT
D
E
F
G
H
I
J
K
L
M

DISASSEMBLY

42. Disconnect TCM connector and park/neutral position switch connector.

CAUTION:

Be careful not to damage connectors.

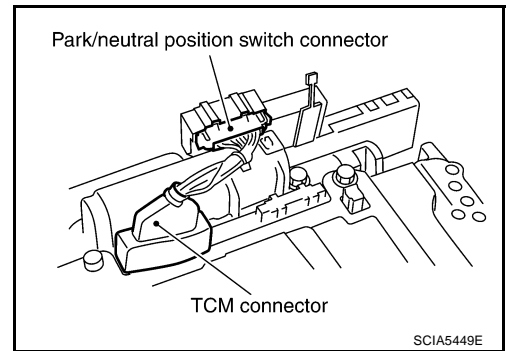

43. Remove tightening bolts for rear extension assembly and transmission case.

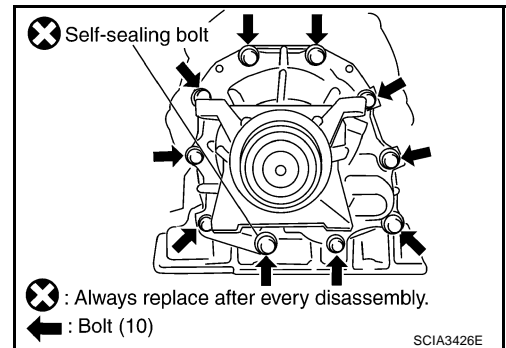

44. Tap rear extension assembly with a soft hammer.

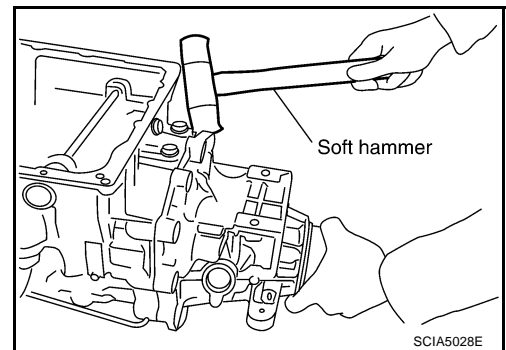

45. Remove rear extension assembly from transmission case.

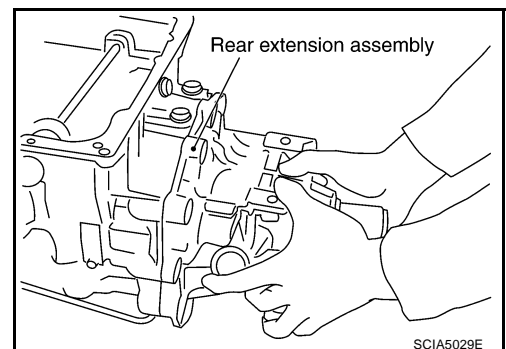

46. Remove bearing race from output shaft.

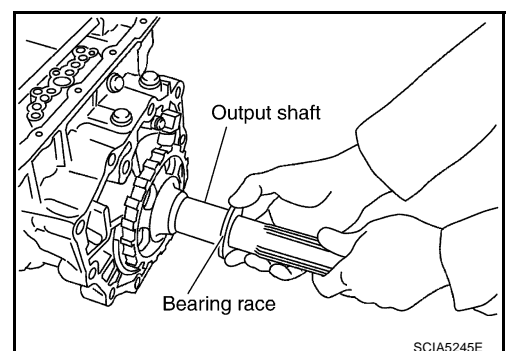

DISASSEMBLY

47. Remove output shaft from transmission case by rotating left/right.

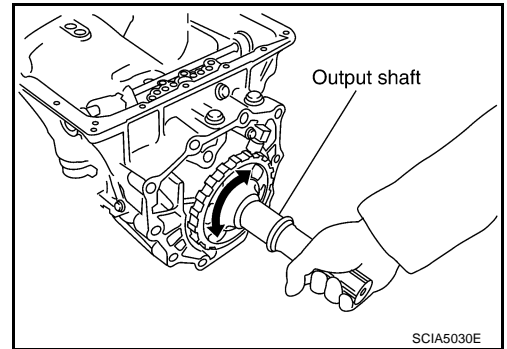

48. Remove parking gear from output shaft.

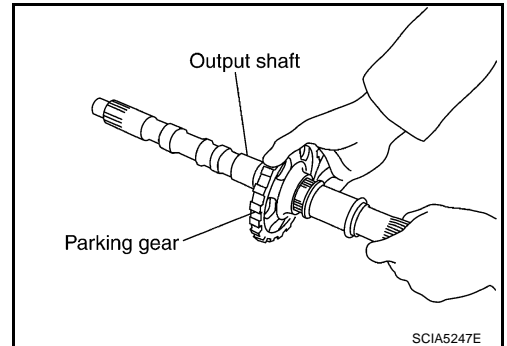

49. Remove seal rings from output shaft.

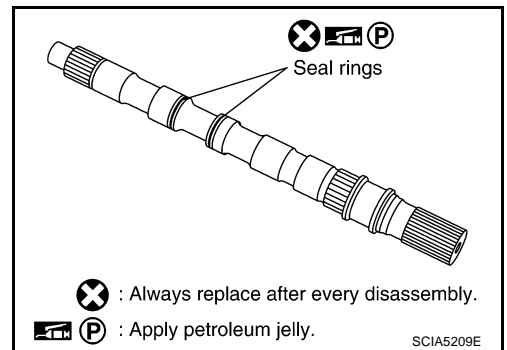

50. Remove needle bearing from transmission case.

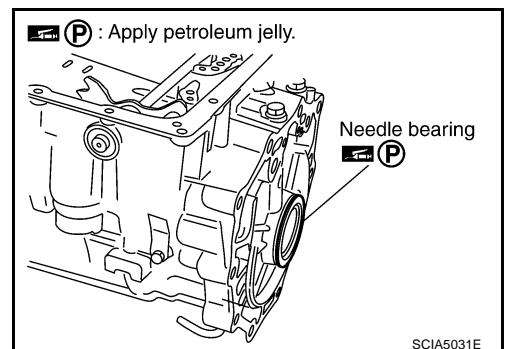

51. Remove revolution sensor from transmission case.

CAUTION:

- Do not subject it to impact by dropping or hitting it.
- Do not disassemble.
- Do not allow metal filings, etc. to get on the sensor's front edge magnetic area.
- Do not place in an area affected by magnetism.

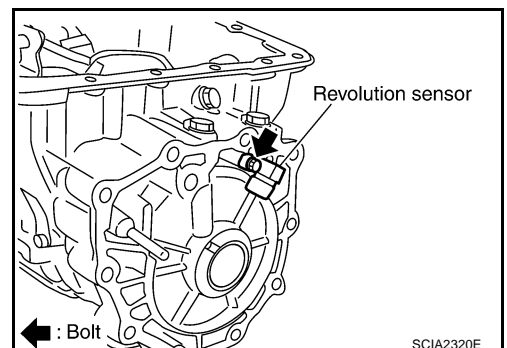

A
B
AT
D
E
F
G
H
I
J
K
L
M

DISASSEMBLY

52. Remove reverse brake snap ring (fixing plate) using 2 flat-bladed screwdrivers.

NOTE:

Press out snap ring from the transmission case oil pan side gap using a flat-bladed screwdriver, and remove it using another screwdriver.

53. Remove reverse brake retaining plate from transmission case.
- Check facing for burns, cracks or damage. If necessary, replace the plate.

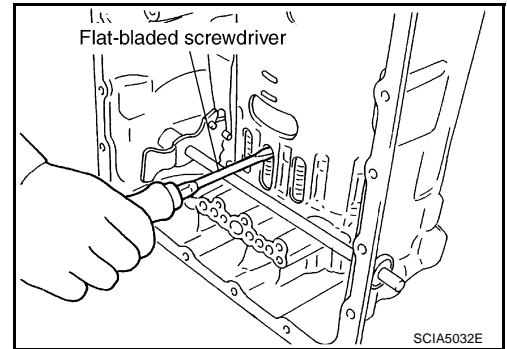

54. Remove N-spring from transmission case.

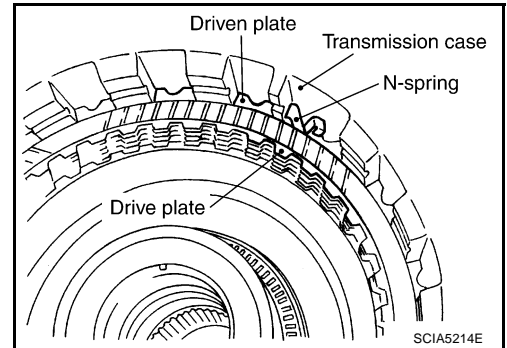

55. Remove reverse brake, drive plates, driven plates and dish plate from transmission case.

- Check facing for burns, cracks or damage. If necessary, replace the plate.

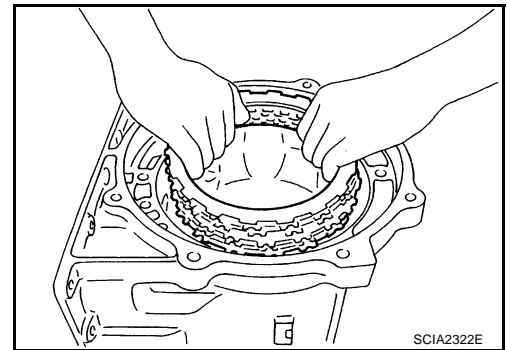

56. Remove snap ring (fixing spring retainer) using a flat-bladed screwdriver.

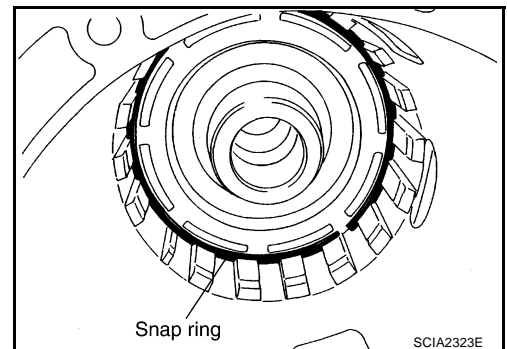

57. Remove spring retainer and return spring from transmission case.

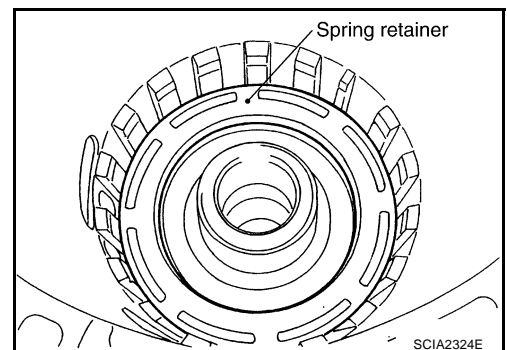

DISASSEMBLY

58. Remove seal rings from drum support.

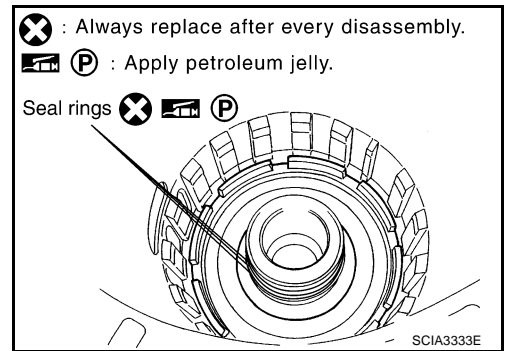

59. Remove needle bearing from drum support.

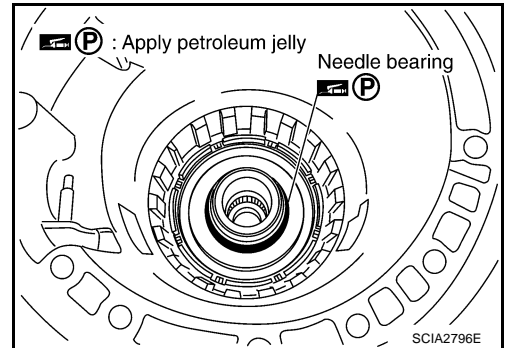

60. Remove reverse brake piston from transmission case with compressed air. Refer to [AT-273, "Oil Channel"](#).

CAUTION:

Care should be taken not to abruptly blow air. It makes pistons incline, as the result, it becomes hard to disassemble the pistons.

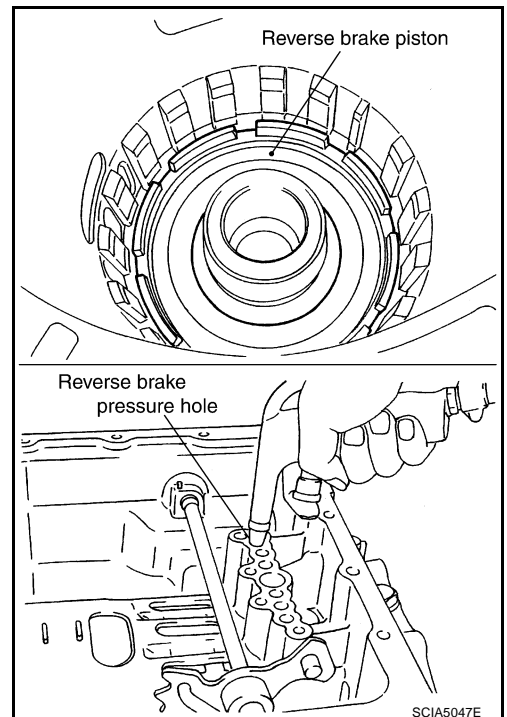

61. Remove lip seal and D-ring from reverse brake piston.

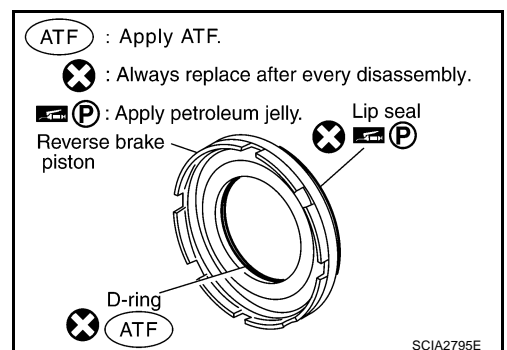

A
B
AT
D
E
F
G
H
I
J
K
L
M

DISASSEMBLY

62. Use a pin punch (4mm dia. commercial service tool) to knock out retaining pin.

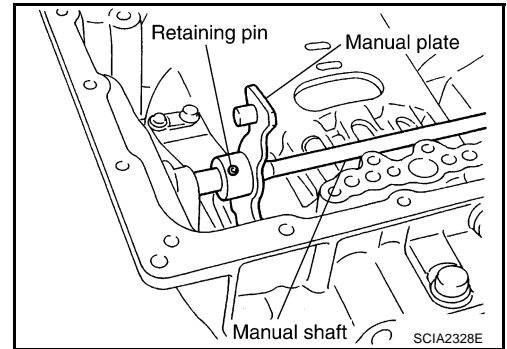

63. Remove manual shaft retaining pin with a pair of nippers.

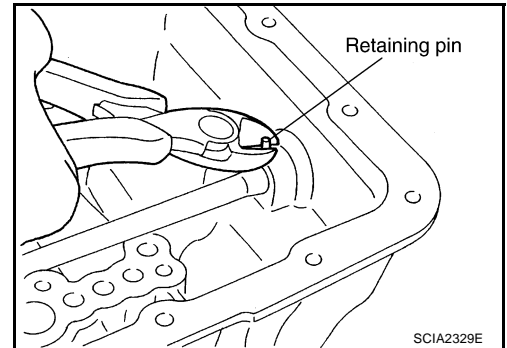

64. Remove manual plate (with parking rod) from manual shaft.

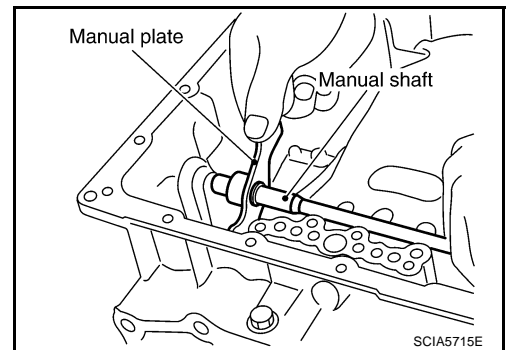

65. Remove parking rod from manual plate.

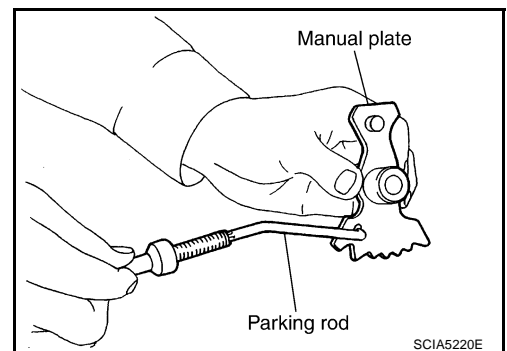

66. Remove manual shaft from transmission case.

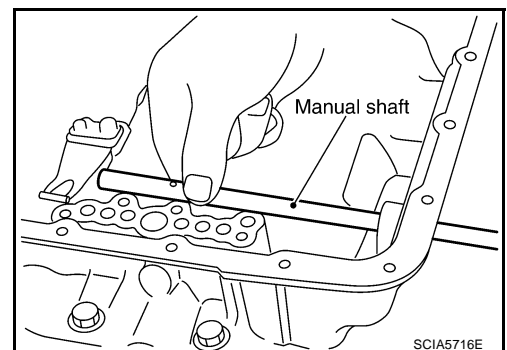

DISASSEMBLY

67. Remove manual shaft oil seals using a flat-bladed screwdriver.

CAUTION:
Be careful not to scratch transmission case.

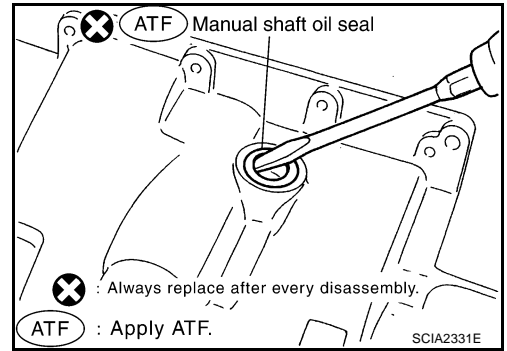

68. Remove detent spring and spacer from transmission case.

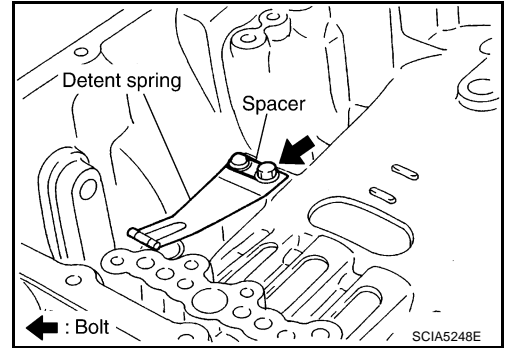

69. Using a pair of snap ring pliers, remove snap ring from transmission case.

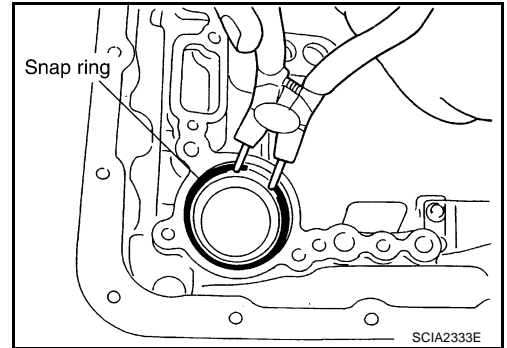

70. Remove servo assembly (with return spring) from transmission case.

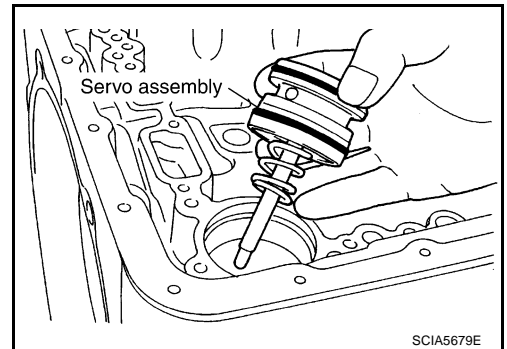

71. Remove return spring from servo assembly.

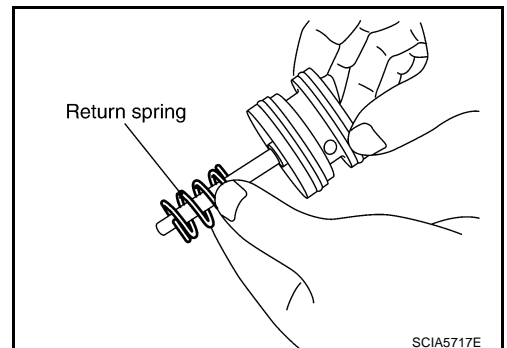

A
B
AT
D
E
F
G
H
I
J
K
L
M

DISASSEMBLY

72. Remove O-rings from servo assembly.

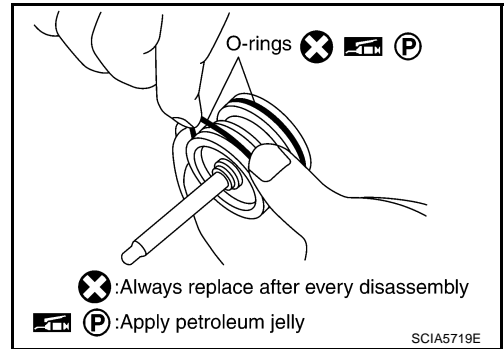

73. Remove needle bearing from rear extension.

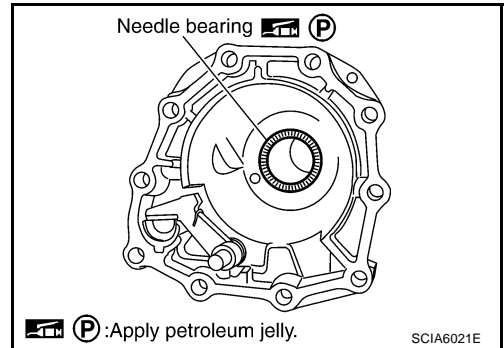

74. Remove parking actuator support from rear extension.

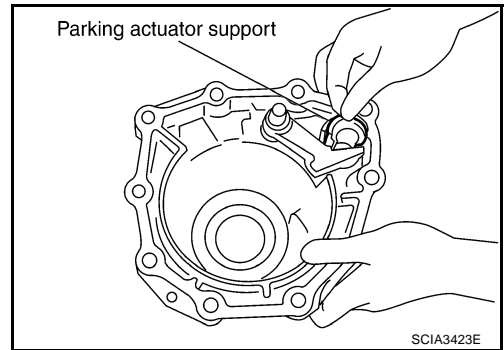

75. Remove parking pawl (with return spring) and pawl shaft from rear extension.

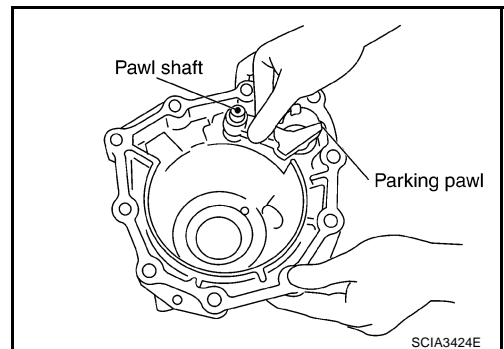

76. Remove return spring from parking pawl.

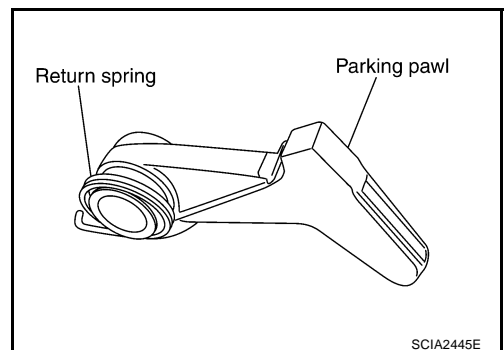

DISASSEMBLY

77. Remove rear oil seal from rear extension using a flat-bladed screwdriver.

CAUTION:
Be careful not to scratch rear extension.

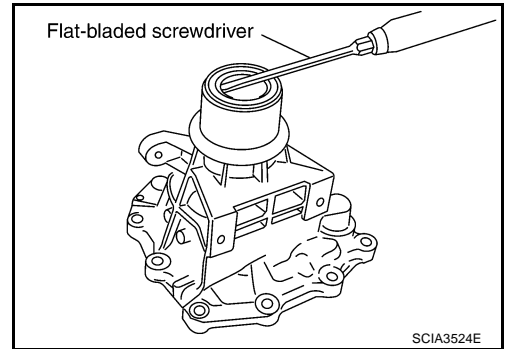

A

B

AT

D

E

F

G

H

I

J

K

L

M

REPAIR FOR COMPONENT PARTS

REPAIR FOR COMPONENT PARTS

PFP:00000

Oil Pump COMPONENTS

ACS0084Z

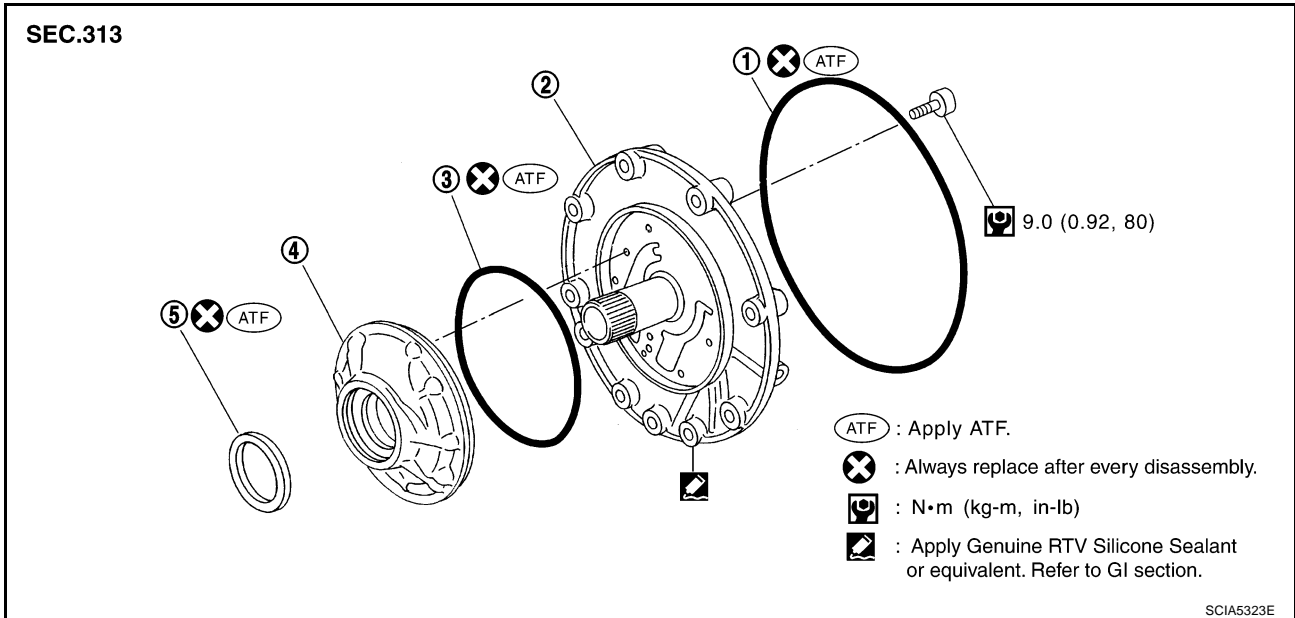

DISASSEMBLY

1. Remove oil pump housing from oil pump cover.

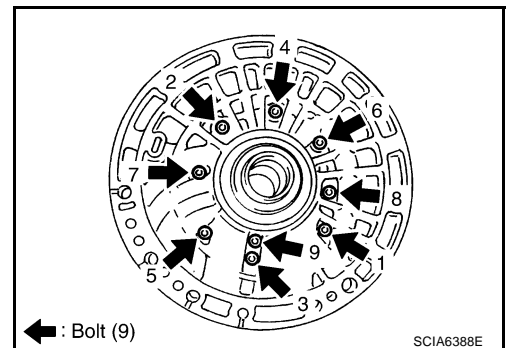

2. Remove oil pump housing oil seal using a flat-bladed screwdriver.

CAUTION:

Be careful not to scratch oil pump housing.

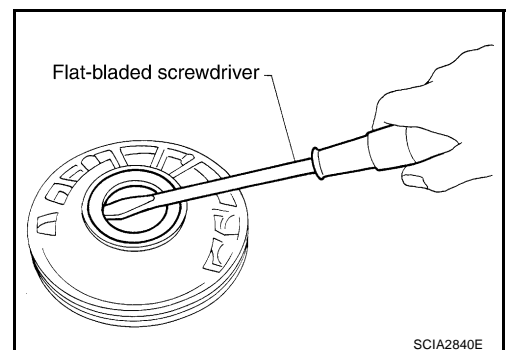

REPAIR FOR COMPONENT PARTS

3. Remove O-ring from oil pump housing.

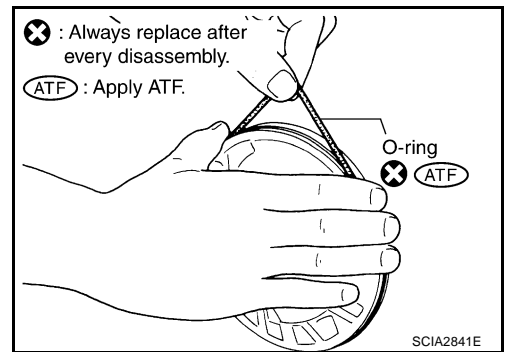

4. Remove O-ring from oil pump cover.

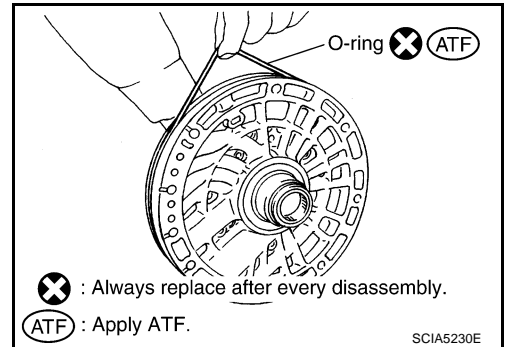

ASSEMBLY

1. Install O-ring to oil pump cover.

CAUTION:

- Do not reuse O-ring.
- Apply ATF to O-ring.



2. Install O-ring to oil pump housing.

CAUTION:

- Do not reuse O-ring.
- Apply ATF to O-ring.

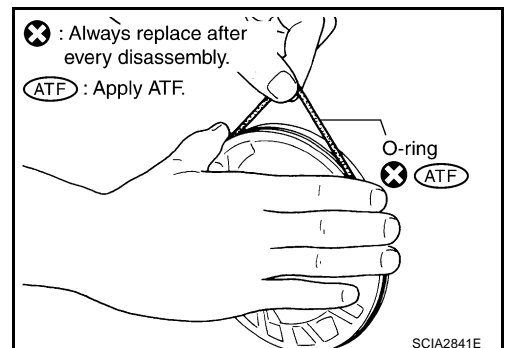

A
B
AT
D
E
F
G
H
I
J
K
L
M

REPAIR FOR COMPONENT PARTS

- Using the drift, install oil pump housing oil seal to the oil pump housing until it is flush.

CAUTION:

- Do not reuse oil seal.
- Apply ATF to oil seal.

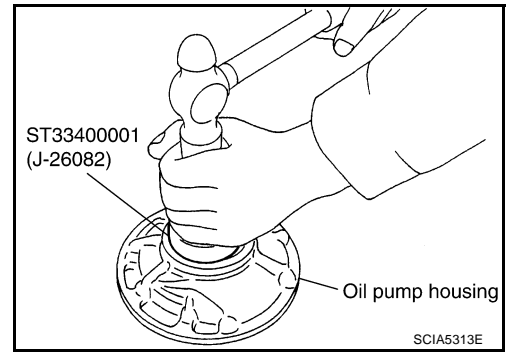

- Install oil pump housing to oil pump cover.
- Tighten bolts to the specified torque in numerical order as show in the figure after temporarily tightening them.

 : 9.0 N·m (0.92 kg-m, 80 in-lb.)

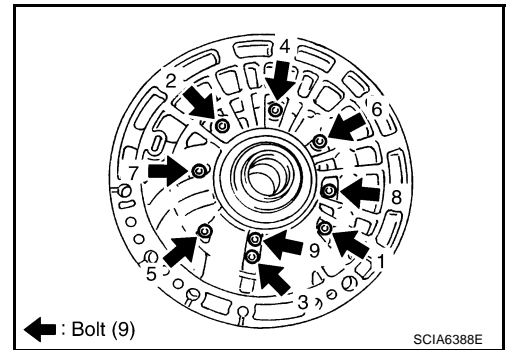

REPAIR FOR COMPONENT PARTS

ACS00850

Front Sun Gear, 3rd One-way Clutch COMPONENTS

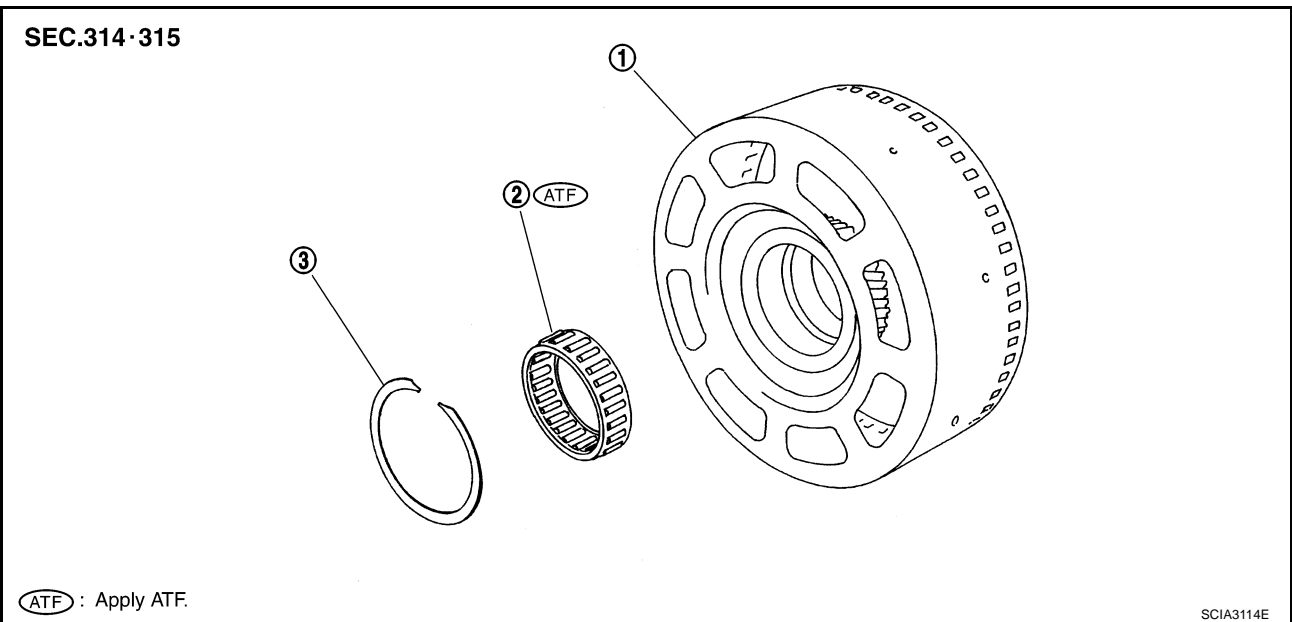

1. Front sun gear

2. 3rd one-way clutch

3. Snap ring

DISASSEMBLY

1. Using a flat-bladed screwdriver, remove snap ring from front sun gear.

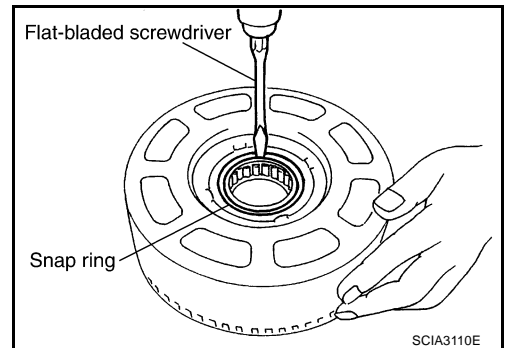

2. Remove 3rd one-way clutch from front sun gear.

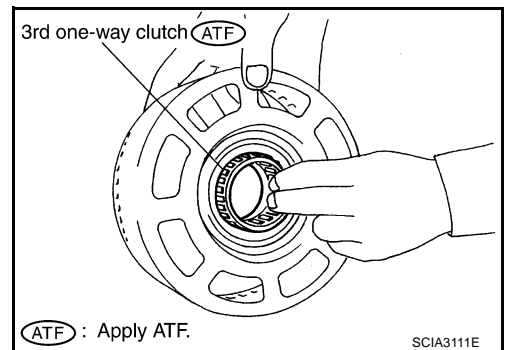

INSPECTION

3rd One-way Clutch

- Check frictional surface for wear or damage.

CAUTION:

If necessary, replace the 3rd one-way clutch.

Front Sun Gear Snap Ring

- Check for deformation, fatigue or damage.

A
B
AT
D
E
F
G
H
I
J
K
L
M

REPAIR FOR COMPONENT PARTS

CAUTION:

If necessary, replace the snap ring.

Front Sun Gear

- Check for deformation, fatigue or damage.

CAUTION:

If necessary, replace the front sun gear.

ASSEMBLY

1. Install 3rd one-way clutch in front sun gear.

CAUTION:

Apply ATF to 3rd one-way clutch.

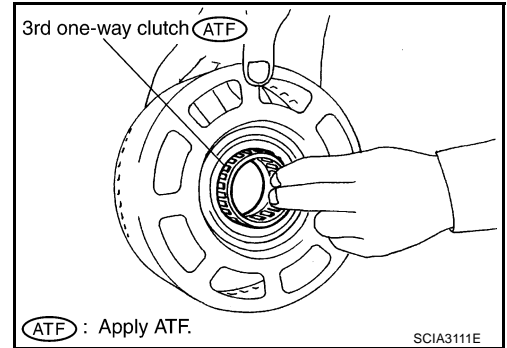

2. Using a flat-bladed screwdriver, install snap ring in front sun gear.

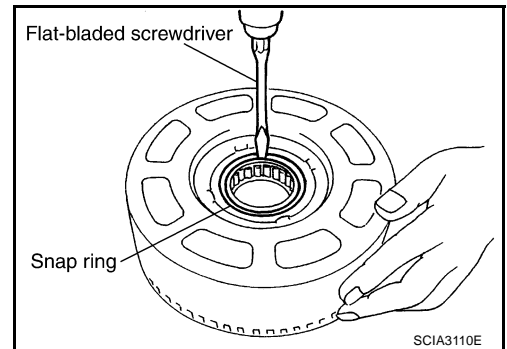

3. Check operation of 3rd one-way clutch.
 - a. Hold oil pump assembly and turn front sun gear.
 - b. Check 3rd one-way clutch for correct locking and unlocking directions.

CAUTION:

If not as shown in the figure, check installation direction of 3rd one-way clutch.

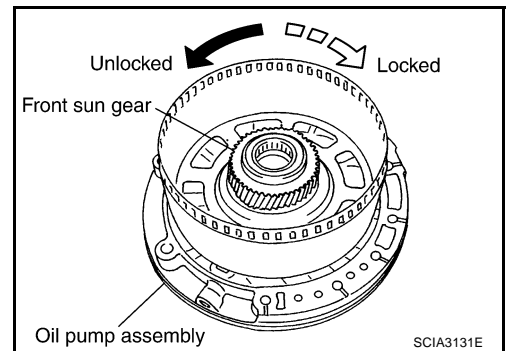

REPAIR FOR COMPONENT PARTS

ACS00851

Front Carrier, Input Clutch, Rear Internal Gear COMPONENTS

A
B
AT
D
E
F
G
H
I
J
K
L
M

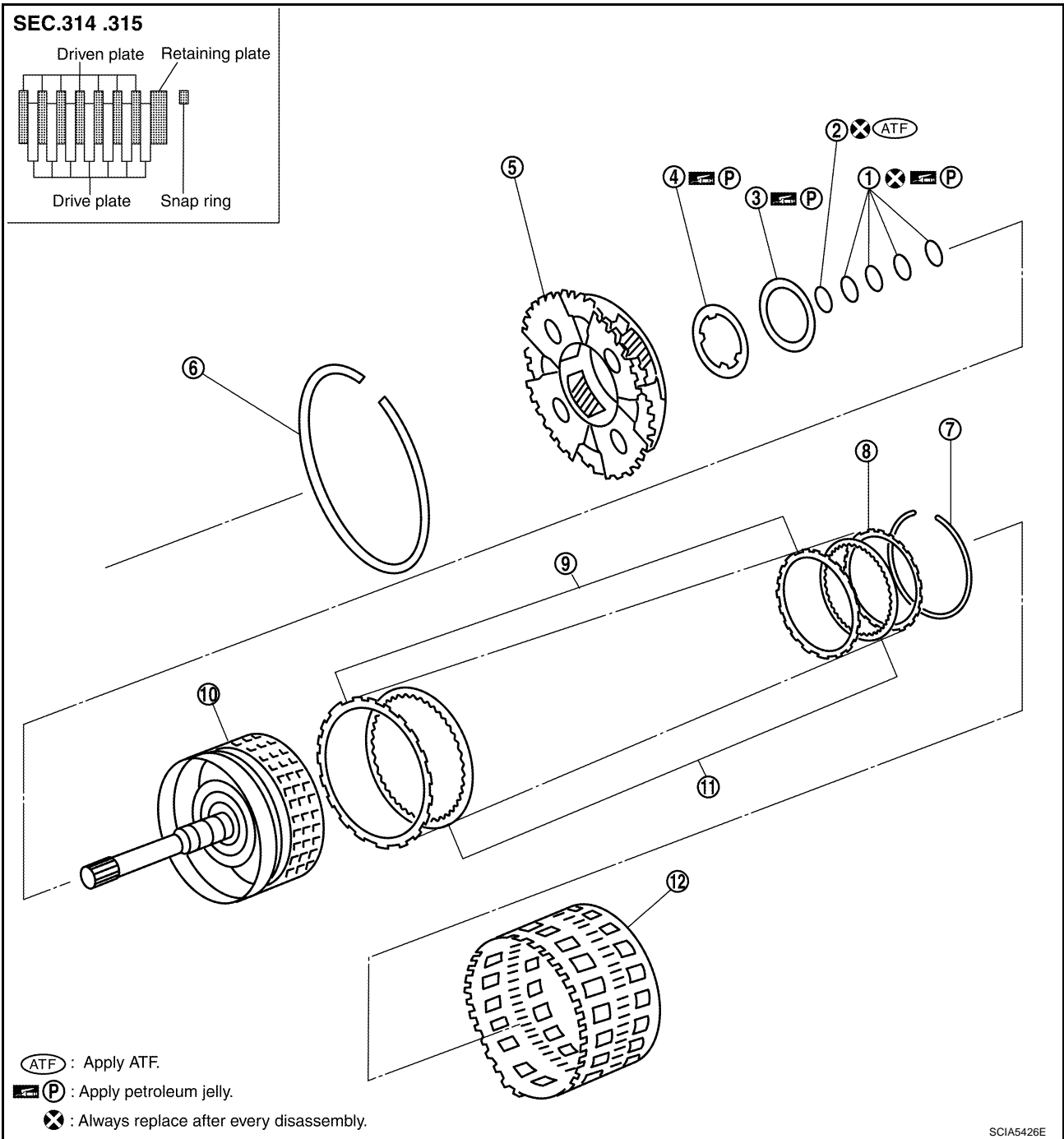

- | | | |
|-----------------------|---------------------------|------------------------|
| 1. Seal ring | 2. O-ring | 3. Needle bearing |
| 4. Bearing race | 5. Front carrier assembly | 6. Snap ring |
| 7. Snap ring | 8. Retaining plate | 9. Driven plate |
| 10. Input clutch drum | 11. Drive plate | 12. Rear internal gear |

REPAIR FOR COMPONENT PARTS

DISASSEMBLY

1. Compress snap ring using 2 flat-bladed screwdrivers.
2. Remove front carrier assembly and input clutch assembly from rear internal gear.
3. Remove front carrier assembly from input clutch assembly.

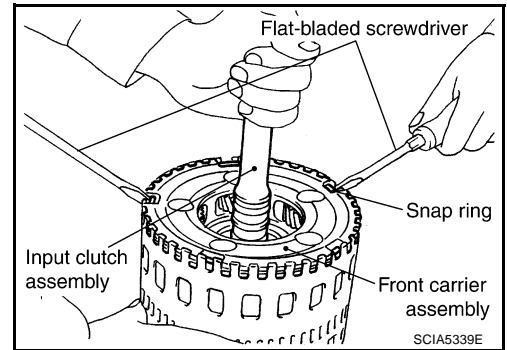

- a. Remove bearing race from front carrier assembly.

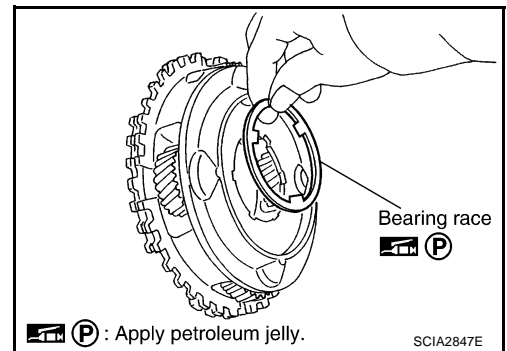

- b. Remove snap ring from front carrier assembly.

CAUTION:
Do not expand snap ring excessively.

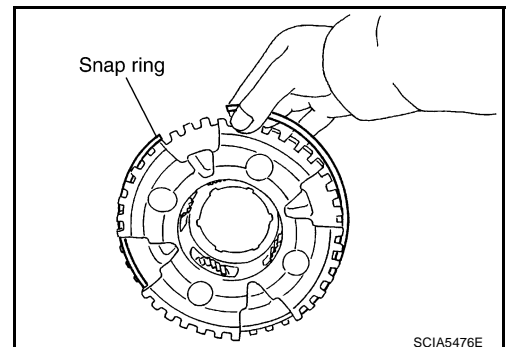

4. Disassemble input clutch assembly.

- a. Remove O-ring and seal rings from input clutch assembly.

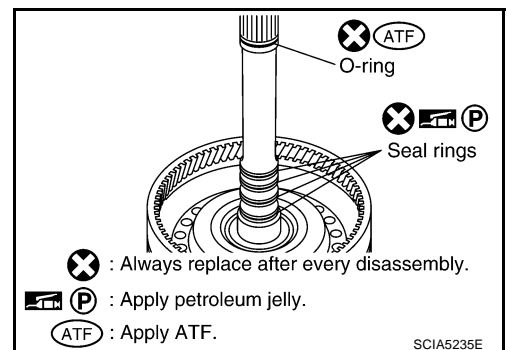

REPAIR FOR COMPONENT PARTS

- b. Remove needle bearing from input clutch assembly.

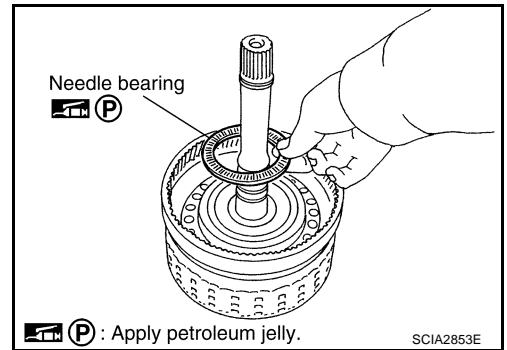

- c. Using a flat-bladed screwdriver, remove snap ring from input clutch drum.
- d. Remove drive plates, driven plates and retaining plate from input clutch drum.

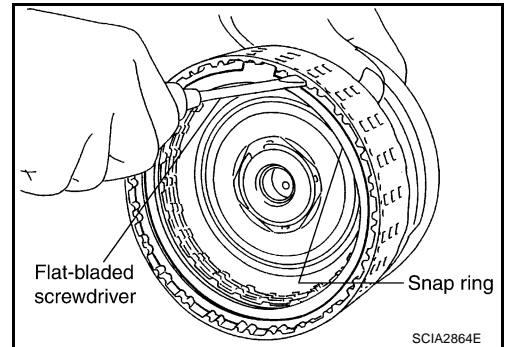

INSPECTION

Front Carrier Snap Ring

- Check for deformation, fatigue or damage.

CAUTION:

If necessary, replace the snap ring.

Input Clutch Snap Ring

- Check for deformation, fatigue or damage.

CAUTION:

If necessary, replace the input clutch assembly.

Input Clutch Drum

- Check for deformation, fatigue or damage or burns.

CAUTION:

If necessary, replace the input clutch assembly.

Input Clutch Drive Plates

- Check facing for burns, cracks or damage.

CAUTION:

If necessary, replace the input clutch assembly.

Input Clutch Retaining Plate and Driven Plates

- Check facing for burns, cracks or damage.

CAUTION:

If necessary, replace the input clutch assembly.

Front Carrier

- Check for deformation, fatigue or damage.

CAUTION:

If necessary, replace the front carrier assembly.

Rear Internal Gear

- Check for deformation, fatigue or damage.

CAUTION:

If necessary, replace the rear internal gear.

REPAIR FOR COMPONENT PARTS

ASSEMBLY

1. Install input clutch.
 - a. Install drive plates, driven plates and retaining plate in input clutch drum.

CAUTION:

Take care with order of plates.

- b. Using a flat-bladed screwdriver, install snap ring in input clutch drum.

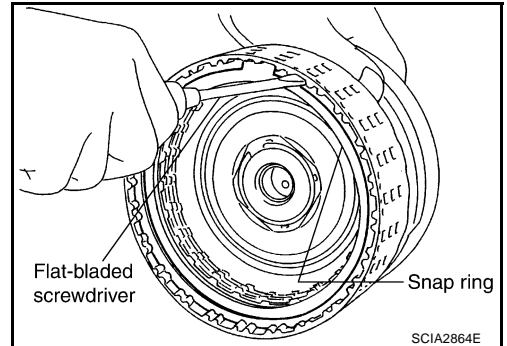

- c. Install needle bearing in input clutch assembly.

CAUTION:

Apply petroleum jelly to needle bearing.

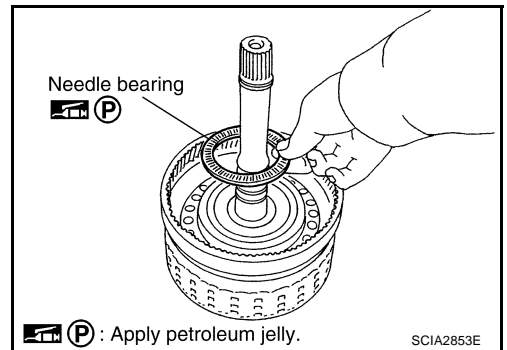

- d. Install O-ring and seal rings in input clutch assembly.

CAUTION:

- Do not reuse O-ring and seal rings.
- Apply ATF to O-ring.
- Apply petroleum jelly to seal rings.

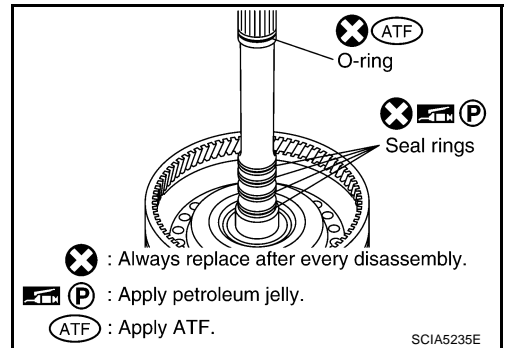

2. Install front carrier assembly.

- a. Install snap ring to front carrier assembly.

CAUTION:

Do not expand snap ring excessively.

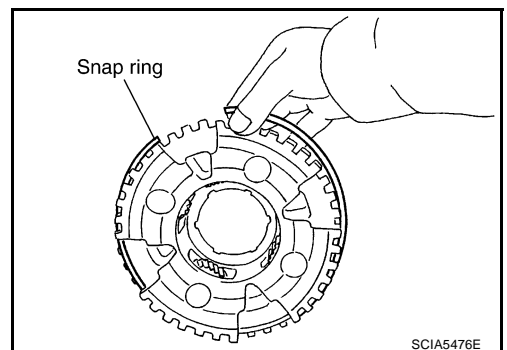

REPAIR FOR COMPONENT PARTS

- b. Install bearing race in front carrier assembly.
CAUTION:
Apply petroleum jelly to bearing race.
- c. Install front carrier assembly to input clutch assembly.

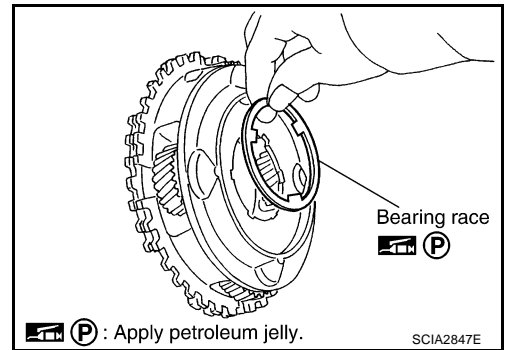

3. Compress snap ring using 2 flat-bladed screwdrivers.
4. Install front carrier assembly and input clutch assembly to rear internal gear.

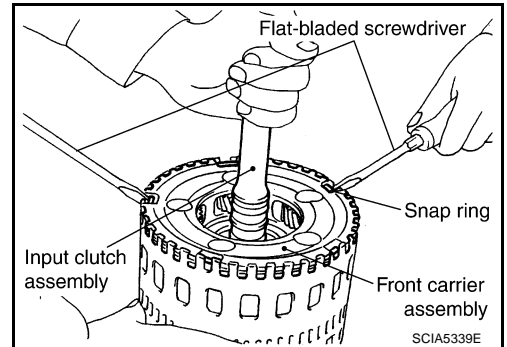

A
B
AT
D
E
F
G
H
I
J
K
L
M

REPAIR FOR COMPONENT PARTS

Mid Sun Gear, Rear Sun Gear, High and Low Reverse Clutch Hub COMPONENTS

ACS00852

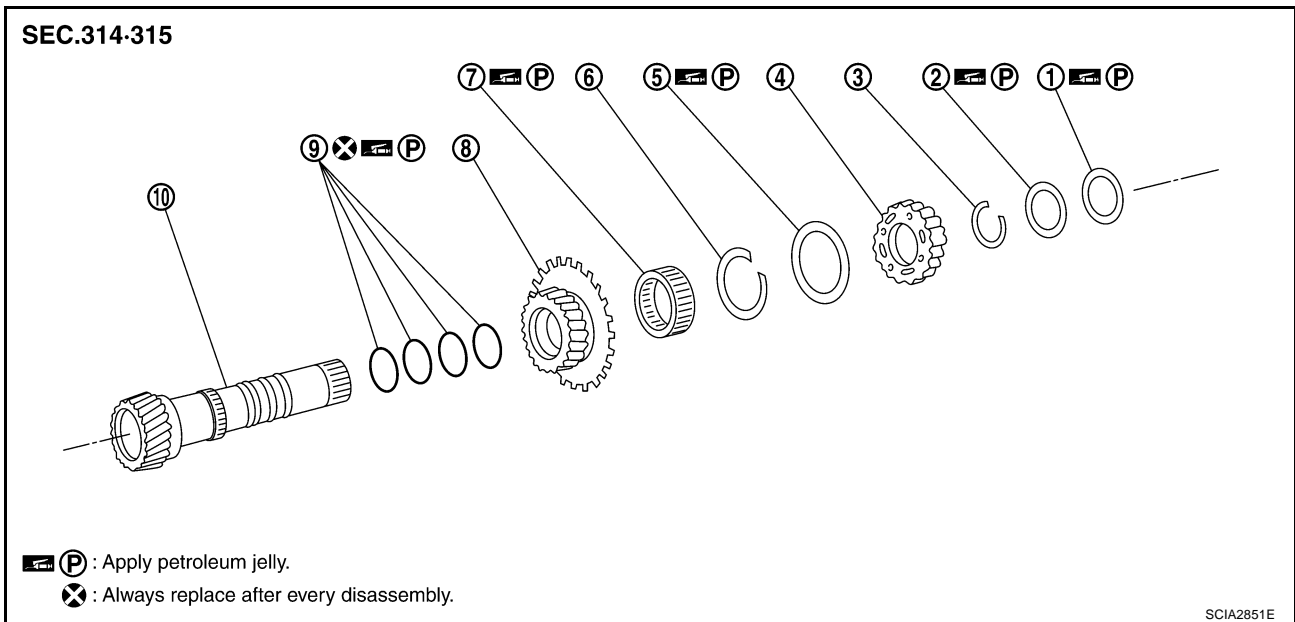

- | | | |
|------------------------------------|-------------------|--------------|
| 1. Needle bearing | 2. Bearing race | 3. Snap ring |
| 4. High and low reverse clutch hub | 5. Needle bearing | 6. Snap ring |
| 7. 1st one-way clutch | 8. Rear sun gear | 9. Seal ring |
| 10. Mid sun gear | | |

DISASSEMBLY

1. Remove needle bearing and bearing race from high and low reverse clutch hub.

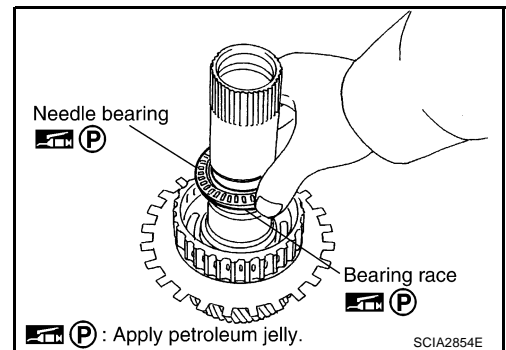

2. Using a pair of snap ring pliers, remove snap ring from mid sun gear assembly.

CAUTION:
Do not expand snap ring excessively.

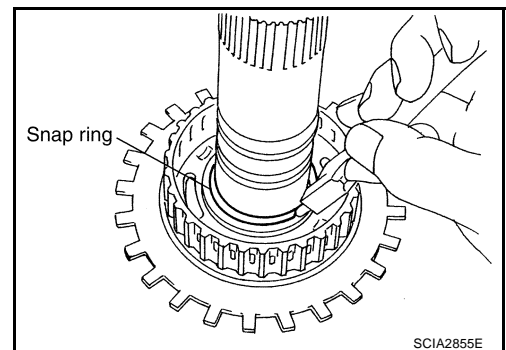

REPAIR FOR COMPONENT PARTS

3. Remove high and low reverse clutch hub from mid sun gear assembly.

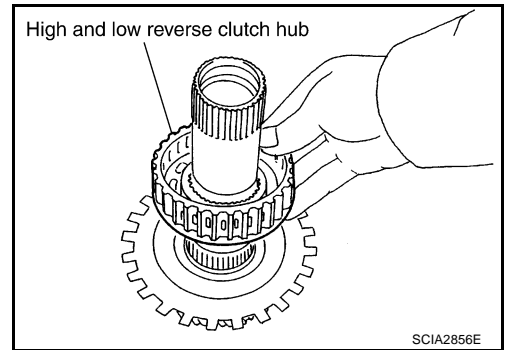

A
B
AT

- a. Remove needle bearing from high and low reverse clutch hub.

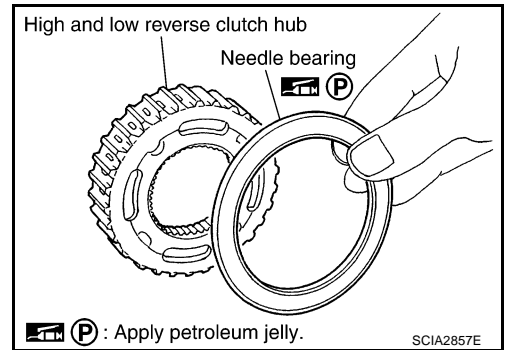

D
E
F
G

4. Remove rear sun gear assembly from mid sun gear assembly.

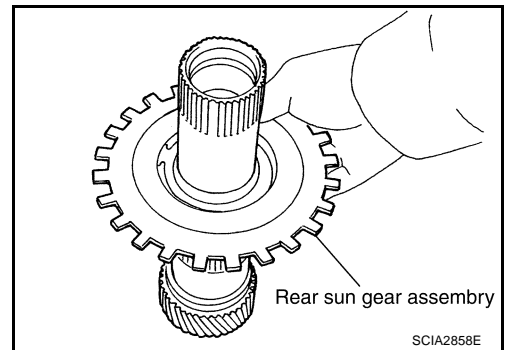

H
I
J
K

- a. Using a flat-bladed screwdriver, remove snap ring from rear sun gear.

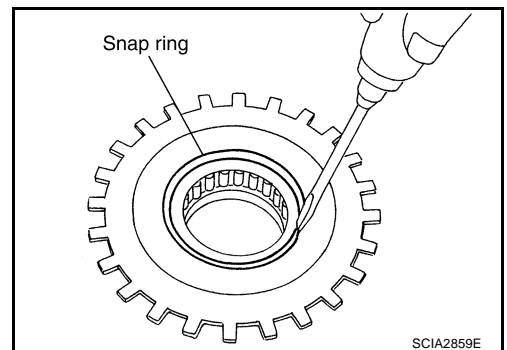

L
M

REPAIR FOR COMPONENT PARTS

- b. Remove 1st one-way clutch from rear sun gear.

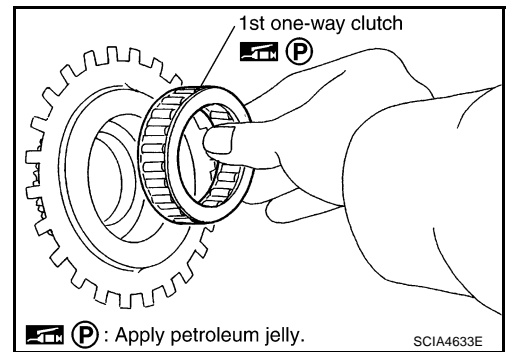

5. Remove seal rings from mid sun gear.

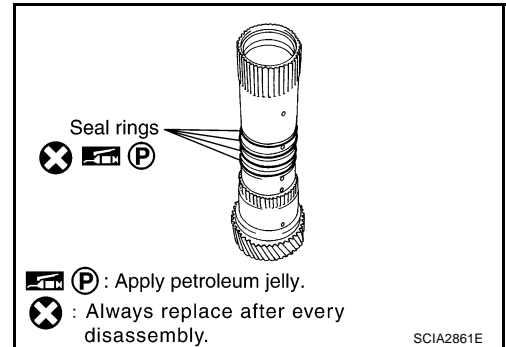

INSPECTION

High and Low Reverse Clutch Hub Snap Ring, Rear Sun Gear Snap Ring

- Check for deformation, fatigue or damage.

CAUTION:

If necessary, replace the snap ring.

1st One-way Clutch

- Check frictional surface for wear or damage.

CAUTION:

If necessary, replace the 1st one-way clutch.

Mid Sun Gear

- Check for deformation, fatigue or damage.

CAUTION:

If necessary, replace the mid sun gear.

Rear Sun Gear

- Check for deformation, fatigue or damage.

CAUTION:

If necessary, replace the rear sun gear.

High and Low Reverse Clutch Hub

- Check for deformation, fatigue or damage.

CAUTION:

If necessary, replace the high and low reverse clutch hub.

REPAIR FOR COMPONENT PARTS

ASSEMBLY

1. Install seal rings to mid sun gear.

CAUTION:

- Do not reuse seal rings.
- Apply petroleum jelly to seal rings.

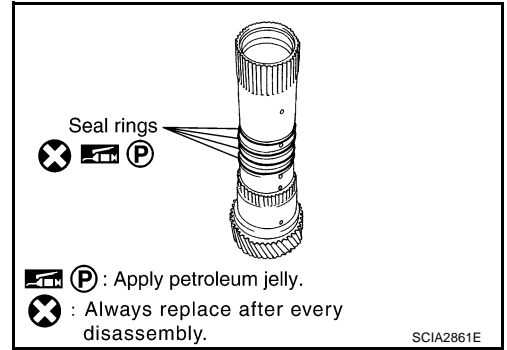

2. Install 1st one-way clutch to rear sun gear.

CAUTION:

- Apply petroleum jelly to 1st one-way clutch.

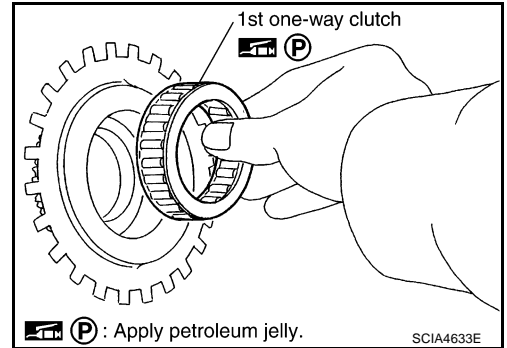

3. Using a flat-bladed screwdriver, install snap ring to rear sun gear.

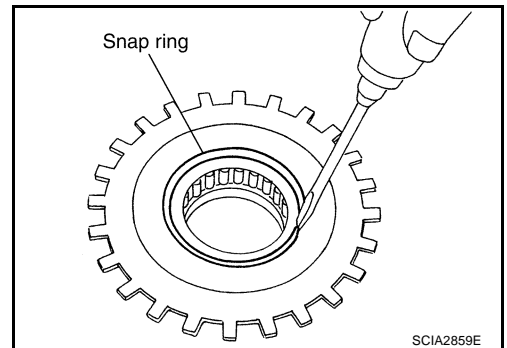

4. Install rear sun gear assembly to mid sun gear assembly.

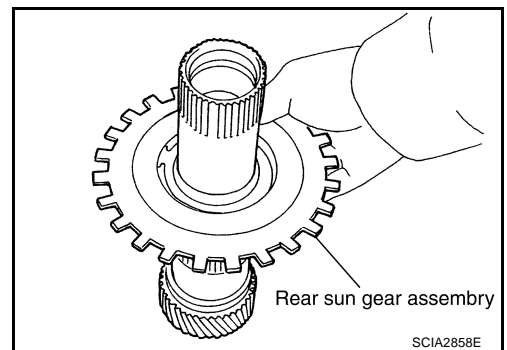

A
B
AT
D
E
F
G
H
I
J
K
L
M

REPAIR FOR COMPONENT PARTS

5. Install needle bearing to high and low reverse clutch hub.

CAUTION:

Apply petroleum jelly to needle bearing.

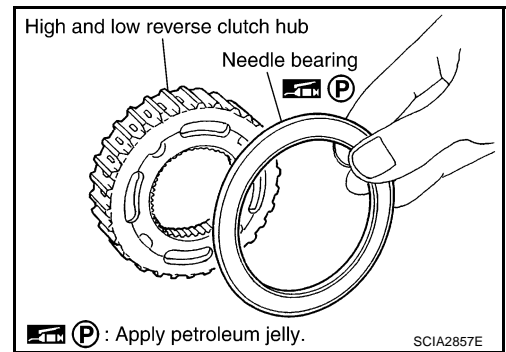

6. Install high and low reverse clutch hub to mid sun gear assembly.

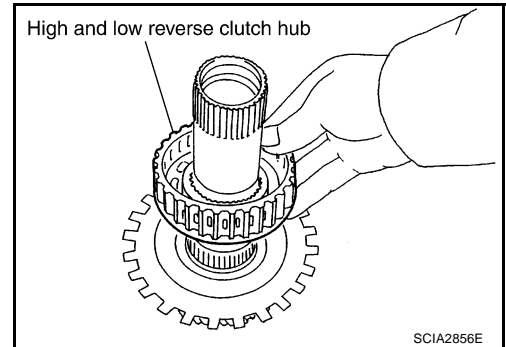

7. Using a pair of snap ring pliers, install snap ring to mid sun gear assembly.

CAUTION:

Do not expand snap ring excessively.

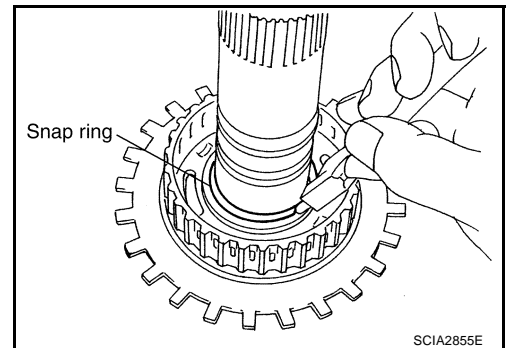

8. Check operation of 1st one-way clutch.

- a. Hold mid sun gear and turn rear sun gear.

- b. Check 1st one-way clutch for correct locking and unlocking directions.

CAUTION:

If not as shown in the figure, check installation direction of 1st one-way clutch.

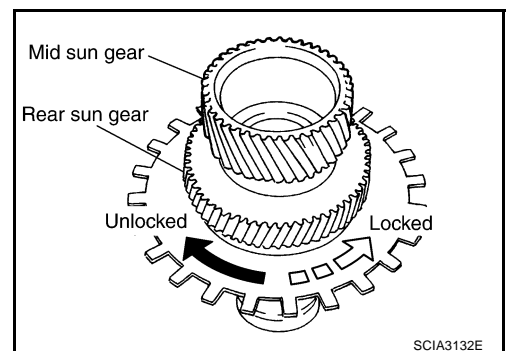

9. Install needle bearing and bearing race to high and low reverse clutch hub.

CAUTION:

Apply petroleum jelly to needle bearing and bearing race.

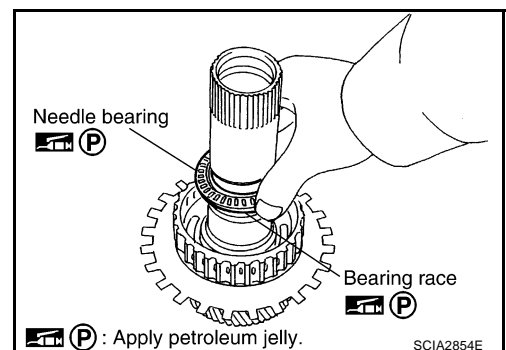

REPAIR FOR COMPONENT PARTS

ACS00853

High and Low Reverse Clutch COMPONENTS

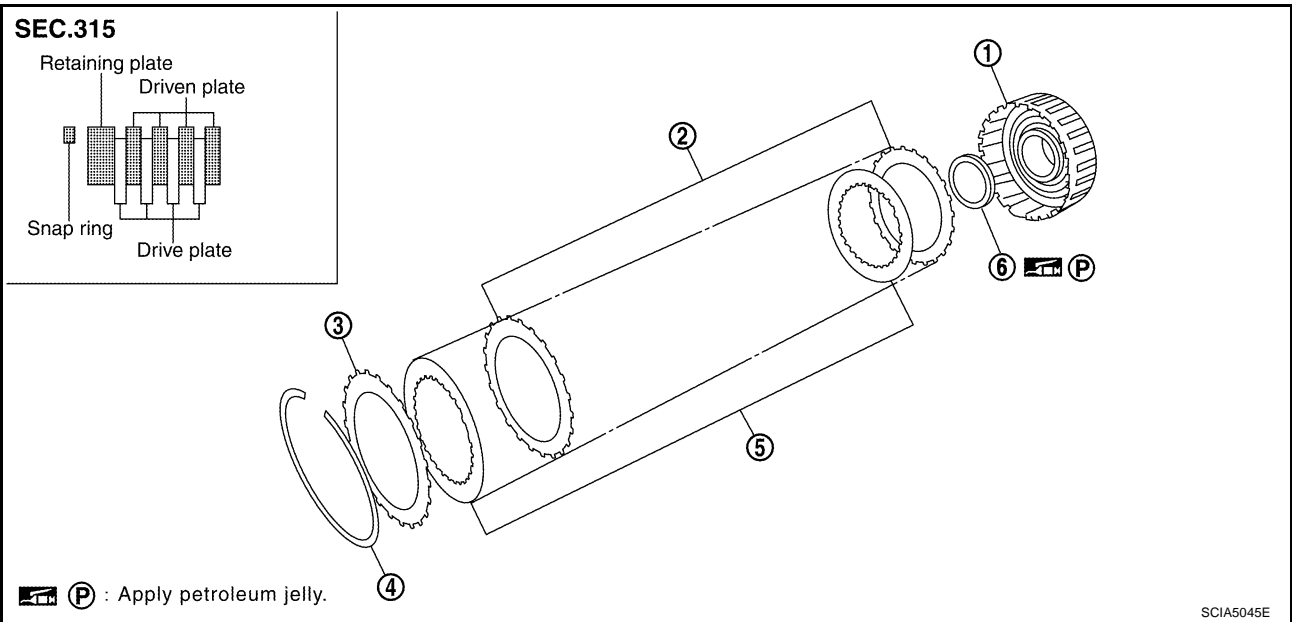

- | | | |
|-------------------------------------|-----------------|--------------------|
| 1. High and low reverse clutch drum | 2. Driven plate | 3. Retaining plate |
| 4. Snap ring | 5. Drive plate | 6. Bearing race |

DISASSEMBLY

1. Remove bearing race from high and low reverse clutch drum.

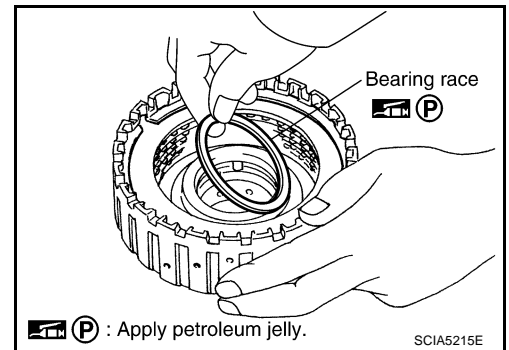

2. Using a flat-bladed screwdriver, remove snap ring from high and low reverse clutch drum.
3. Remove drive plates, driven plates and retaining plate from high and low reverse clutch drum.

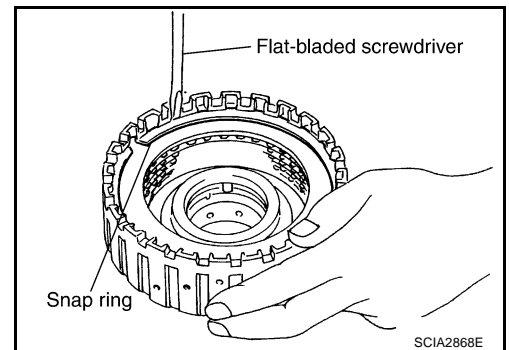

A
B
AT
D
E
F
G
H
I
J
K
L
M

REPAIR FOR COMPONENT PARTS

INSPECTION

- Check the following, and replace high and low reverse clutch assembly if necessary.

High and Low Reverse Clutch Snap Ring

- Check for deformation, fatigue or damage.

High and Low Reverse Clutch Drive Plates

- Check facing for burns, cracks or damage.

High and Low Reverse Clutch Retaining Plate and Driven Plates

- Check facing for burns, cracks or damage.

ASSEMBLY

1. Install drive plates, driven plates and retaining plate in high and low reverse clutch drum.

CAUTION:

Take care with order of plates.

2. Using a flat-bladed screwdriver, install snap ring in high and low reverse clutch drum.

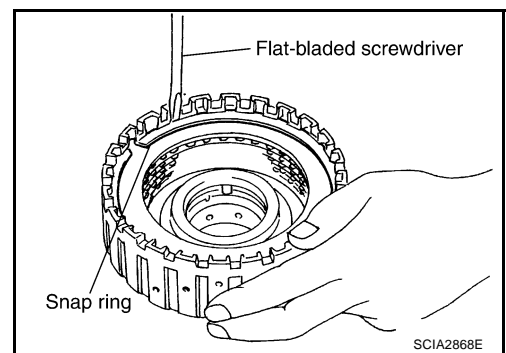

3. Install bearing race to high and low reverse clutch drum.

CAUTION:

Apply petroleum jelly to bearing race.

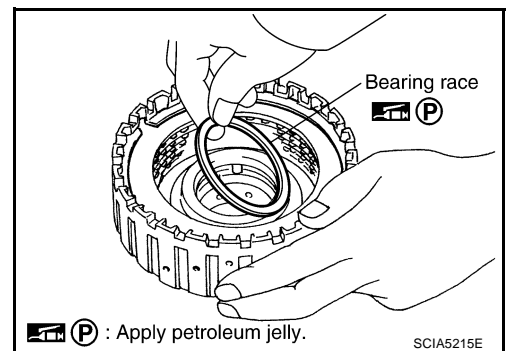

REPAIR FOR COMPONENT PARTS

Direct Clutch COMPONENTS

ACS00854

A

B

AT

D

E

F

G

H

I

J

K

L

M

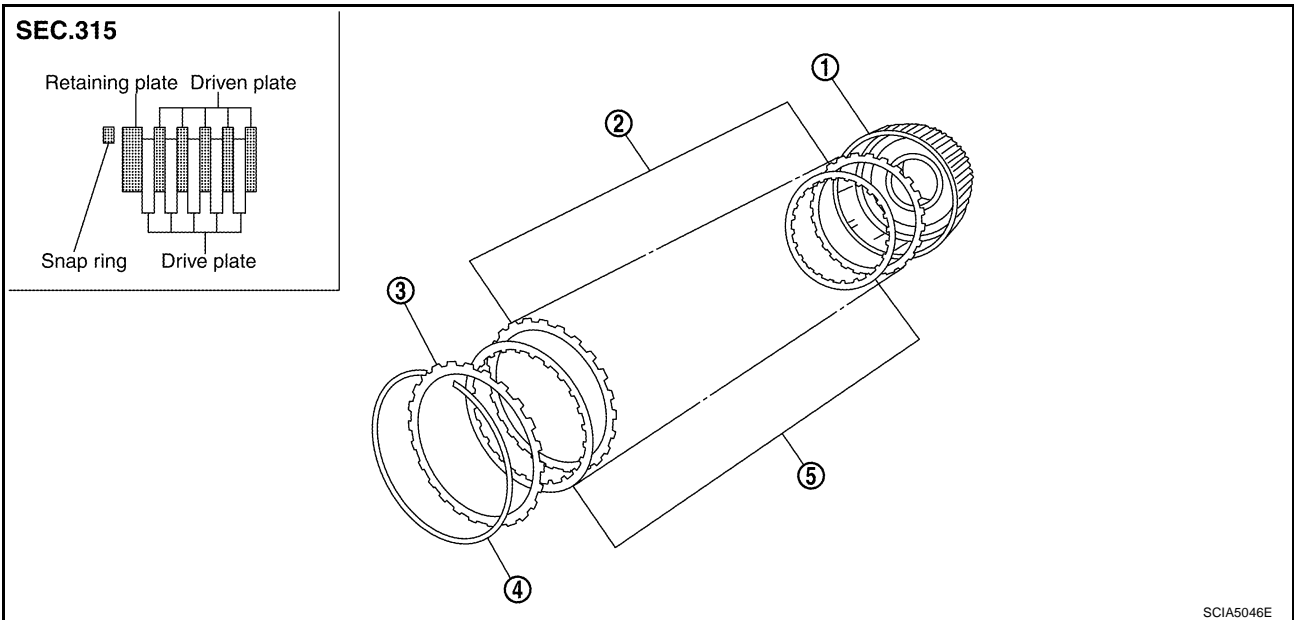

DISASSEMBLY

1. Using a flat-bladed screwdriver, remove snap ring from direct clutch drum.
2. Remove drive plates, driven plates and retaining plate from direct clutch drum.

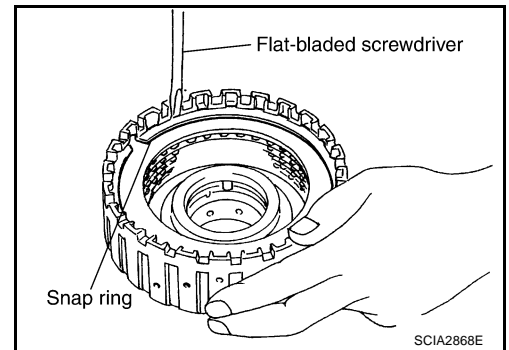

INSPECTION

- Check the following, and replace direct clutch assembly if necessary.

Direct Clutch Snap Ring

- Check for deformation, fatigue or damage.

Direct Clutch Drive Plates

- Check facing for burns, cracks or damage.

Direct Clutch Retaining Plate and Driven Plates

- Check facing for burns, cracks or damage.

REPAIR FOR COMPONENT PARTS

ASSEMBLY

1. Install drive plates, driven plates and retaining plate in direct clutch drum.

CAUTION:

Take care with order of plates.

2. Using a flat-bladed screwdriver, install snap ring in direct clutch drum.

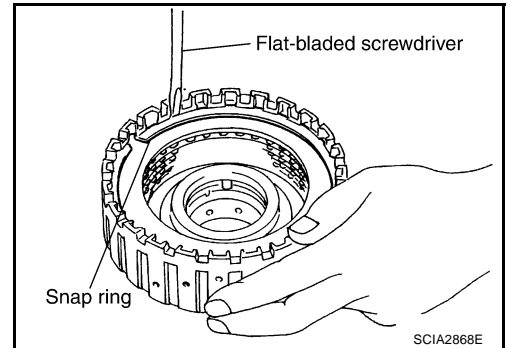

ASSEMBLY

ASSEMBLY

PF0:00000

Assembly (1)

ACS00855

1. As shown in the right figure, use a drift [commercial service tool $\phi 22$ mm (0.87 in)] to drive manual shaft oil seals into the transmission case until it is flush.

CAUTION:

- Apply ATF to manual shaft oil seals.
- Do not reuse manual shaft oil seals.

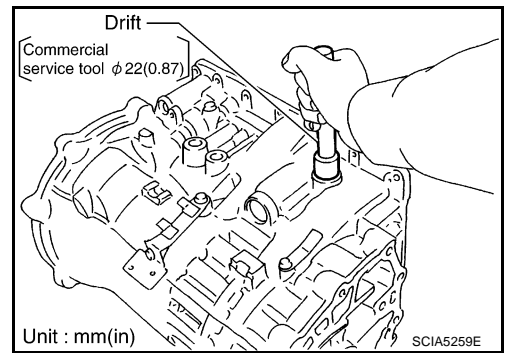

2. Install detent spring and spacer in transmission case.

 : 7.9 N·m (0.81 kg-m, 70 in-lb)

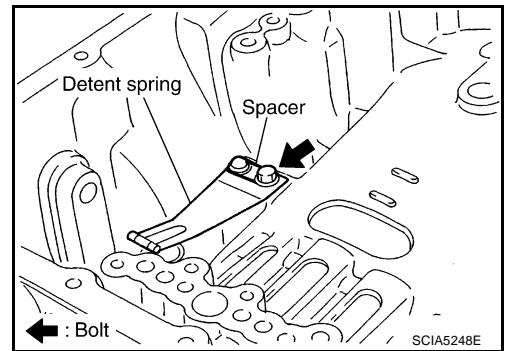

3. Install manual shaft to transmission case.

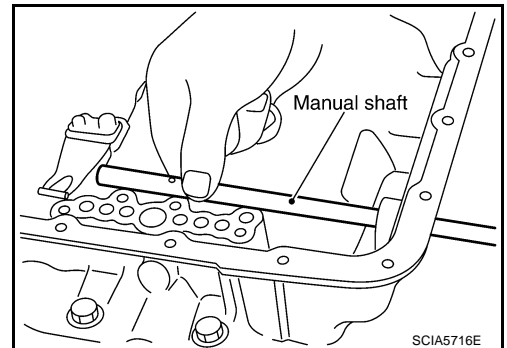

4. Install parking rod to manual plate.

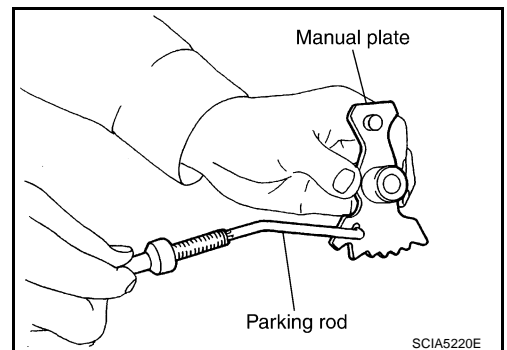

A
B
AT
D
E
F
G
H
I
J
K
L
M

ASSEMBLY

5. Install manual plate (with parking rod) to manual shaft.

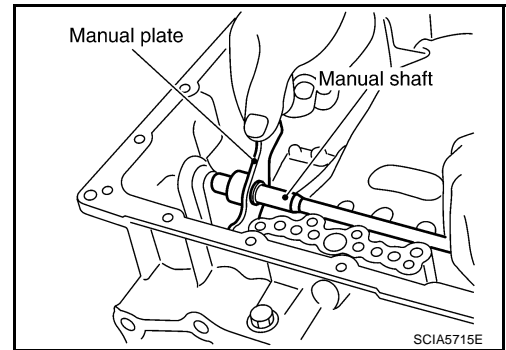

6. Install retaining pin into the manual plate and manual shaft.
a. Fit pinhole of the manual plate to pinhole of the manual shaft with a pin punch.
b. Use a hammer to tap the retaining pin into the manual plate.

CAUTION:

- Drive retaining pin to 2 ± 0.5 mm (0.08 ± 0.020 in) over the manual plate.
- Do not reuse retaining pin.

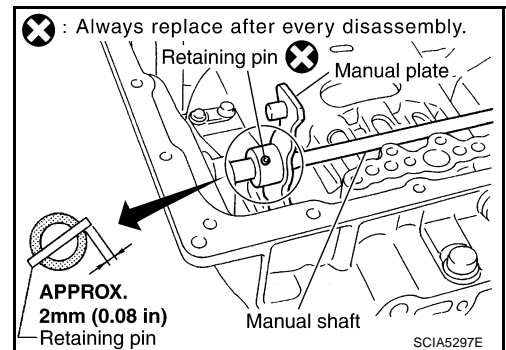

7. Install retaining pin into the transmission case and manual shaft.
a. Fit pinhole of the transmission case to pinhole of the manual shaft with a pin punch.
b. Use a hammer to tap the retaining pin into the transmission case.

CAUTION:

- Drive retaining pin to 5 ± 1 mm (0.20 ± 0.04 in) over the transmission case.
- Do not reuse retaining pin.

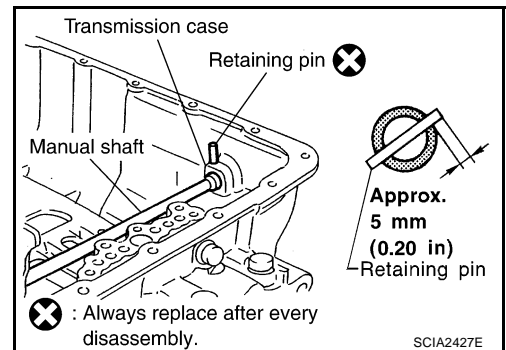

8. Install O-rings to servo assembly.

CAUTION:

- Do not reuse O-rings.
- Apply petroleum jelly to O-rings.

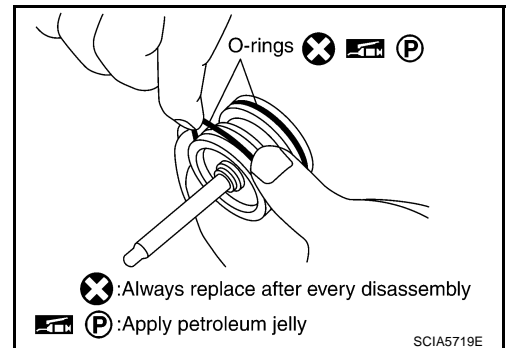

ASSEMBLY

9. Install return spring to servo assembly.

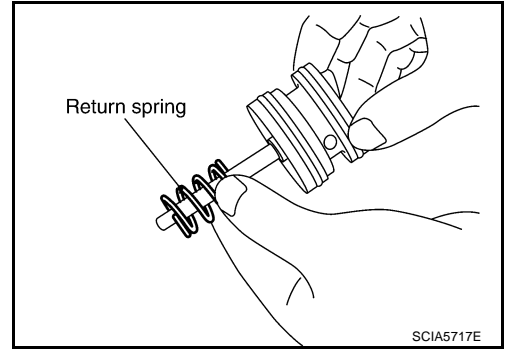

10. Install servo assembly in transmission case.

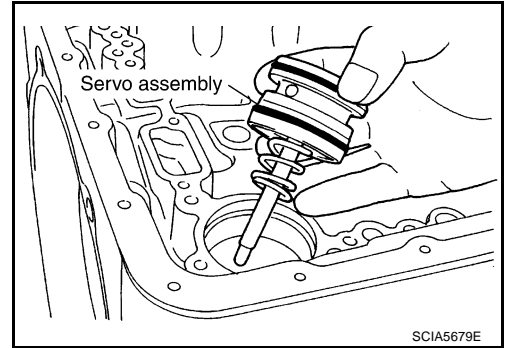

11. Using a pair of snap ring pliers, install snap ring to transmission case.

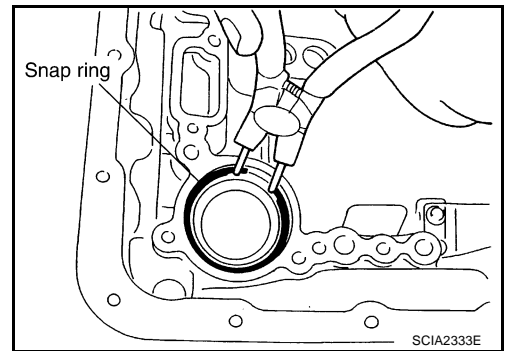

12. Install lip seal and D-ring in reverse brake piston.

CAUTION:

- Do not reuse lip seal and D-ring.
- Apply petroleum jelly to lip seal.
- Apply ATF to D-ring.

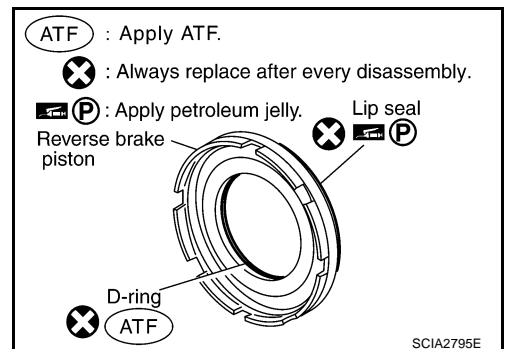

13. Install reverse brake piston in transmission case.

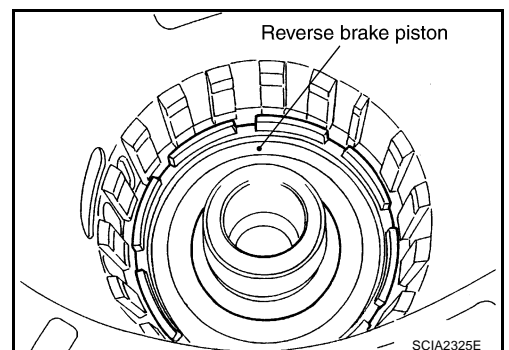

A
B
AT
D
E
F
G
H
I
J
K
L
M

ASSEMBLY

14. Install needle bearing to drum support edge surface.

CAUTION:

Apply petroleum jelly to needle bearing.

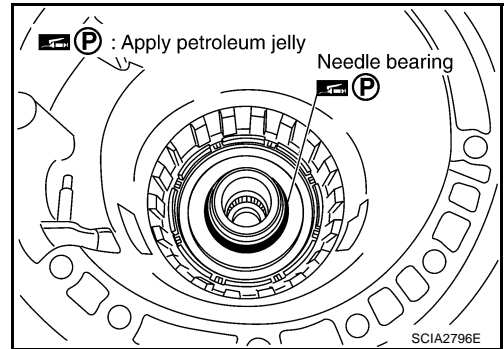

15. Install seal rings to drum support.

CAUTION:

- Do not reuse seal rings.
- Apply petroleum jelly to seal rings.

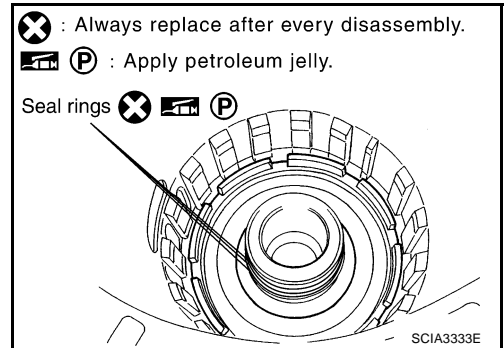

16. Install spring retainer and return spring in transmission case.

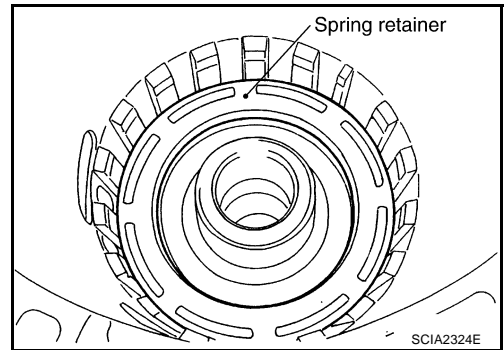

17. Set the SST on spring retainer and install snap ring (fixing spring retainer) in transmission case while compressing return spring.

CAUTION:

Securely assemble them using a flat-bladed screwdriver so that snap ring tension is slightly weak.

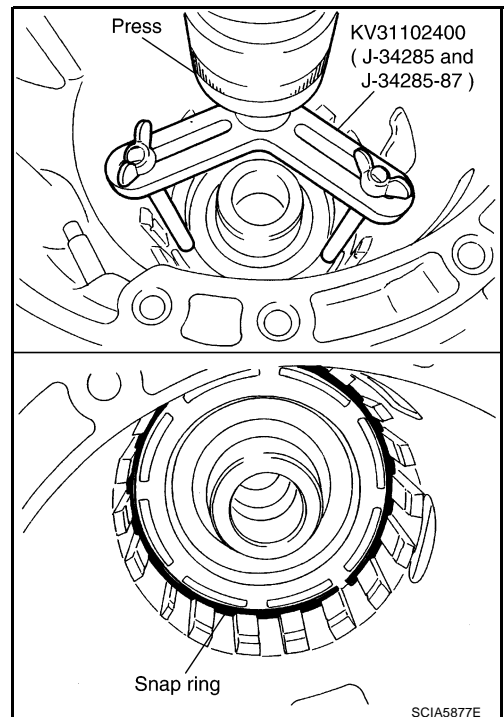

ASSEMBLY

18. Install reverse brake drive plates, driven plates and dish plate in transmission case.

CAUTION:

Take care with order of plates.

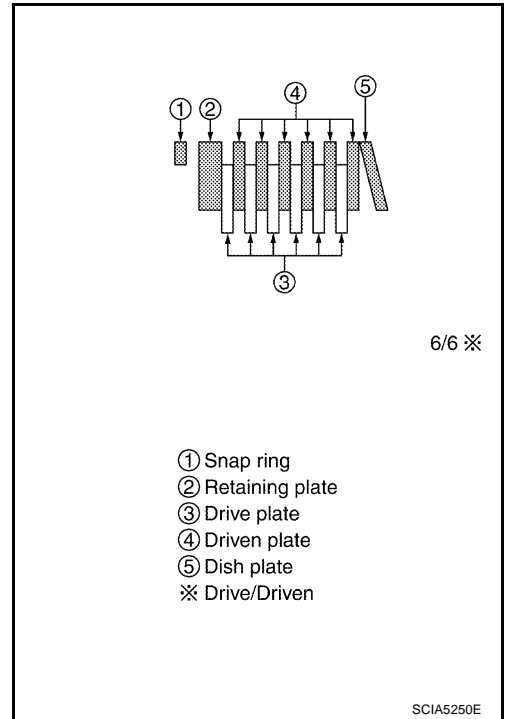

19. Assemble N-spring.

20. Install reverse brake retaining plate in transmission case.

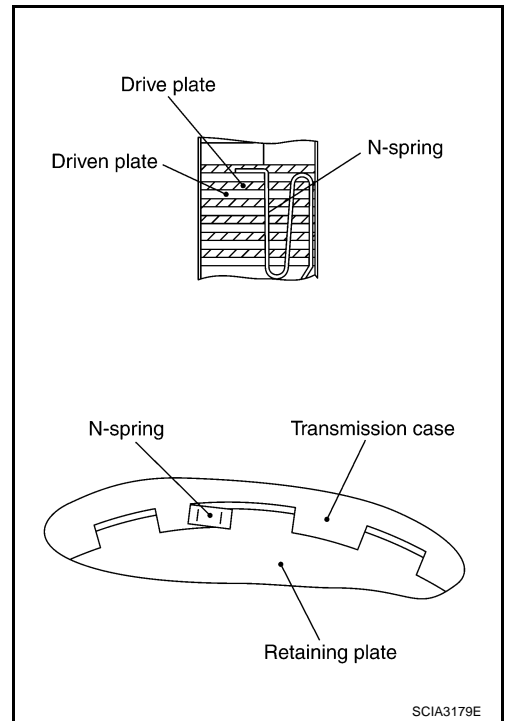

21. Install snap ring in transmission case.

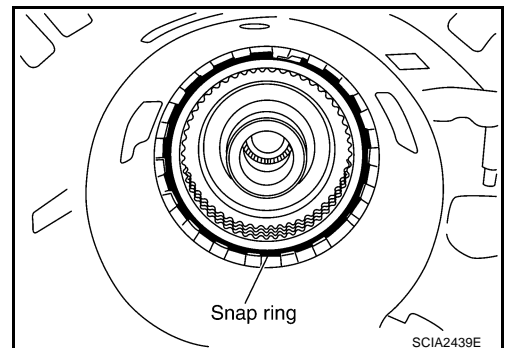

A
B
AT
D
E
F
G
H
I
J
K
L
M

ASSEMBLY

22. Measure clearance between retaining plate and snap ring. If not within specified clearance, select proper retaining plate.

Specified clearance "A":

Standard: 0.7 - 1.1mm (0.028 - 0.043 in)

Retaining plate:

Refer to [AT-334, "Reverse Brake"](#) .

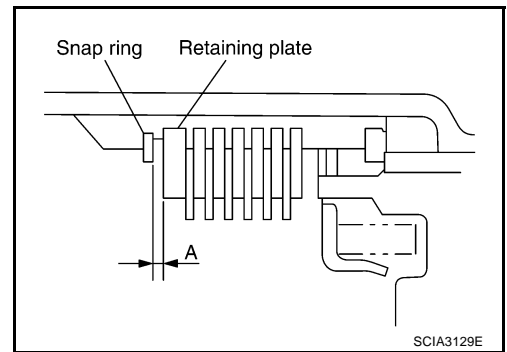

23. Install needle bearing to transmission case.

CAUTION:

- Apply petroleum jelly to needle bearing.

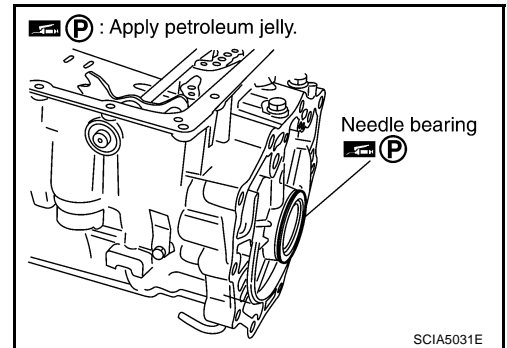

24. Install revolution sensor to transmission case.

CAUTION:

- Do not subject it to impact by dropping or hitting it.
- Do not disassemble.
- Do not allow metal filings, etc. to get on the sensor's front edge magnetic area.
- Do not place in an area affected by magnetism.

 : 5.8 N·m (0.59 kg-m, 51 in-lb)

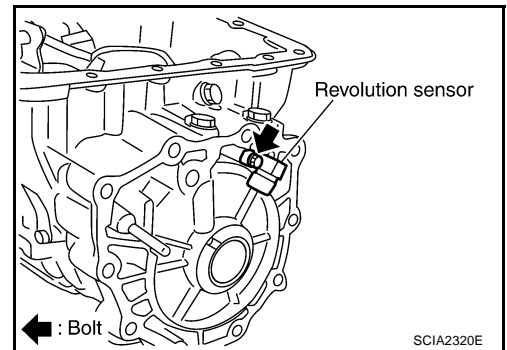

25. As shown in the right figure, use the drift to drive rear oil seal into the rear extension until it is flush.

CAUTION:

- Apply ATF to rear oil seal.
- Do not reuse rear oil seal.

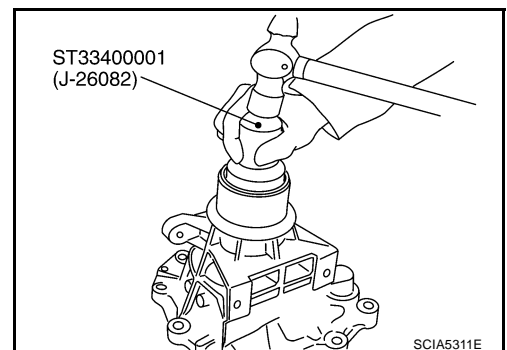

26. Install return spring to parking pawl.

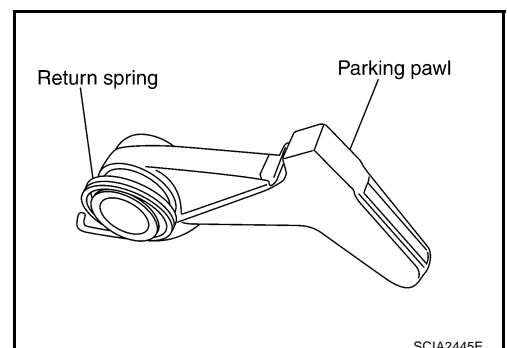

ASSEMBLY

27. Install parking pawl (with return spring) and pawl shaft to rear extension.

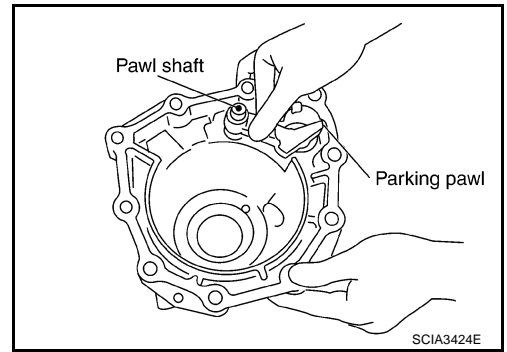

28. Install parking actuator support to rear extension.

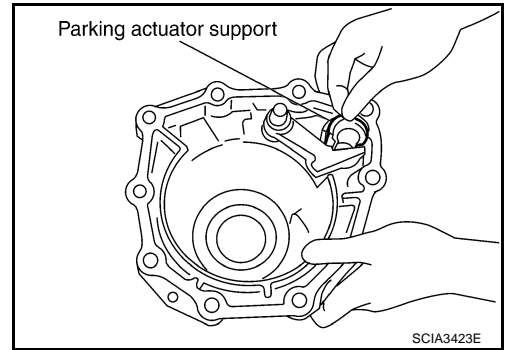

29. Install needle bearing to rear extension.

CAUTION:
Apply petroleum jelly to needle bearing.

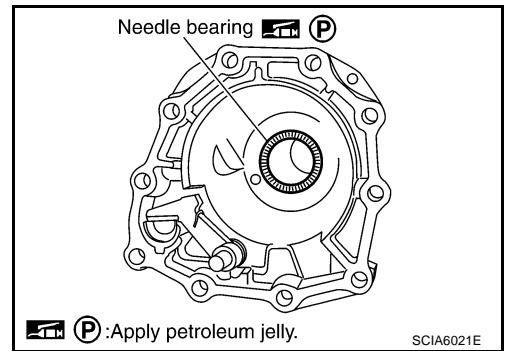

30. Install seal rings to output shaft.

CAUTION:

- Do not reuse seal rings.
- Apply petroleum jelly to seal rings.

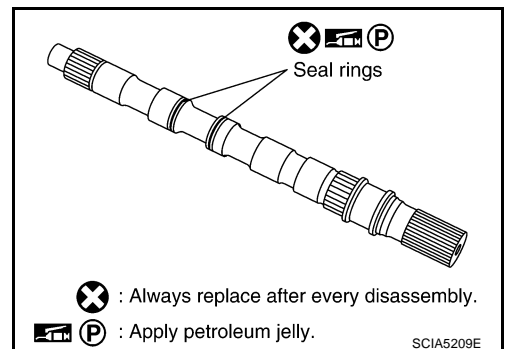

31. Install parking gear to output shaft.

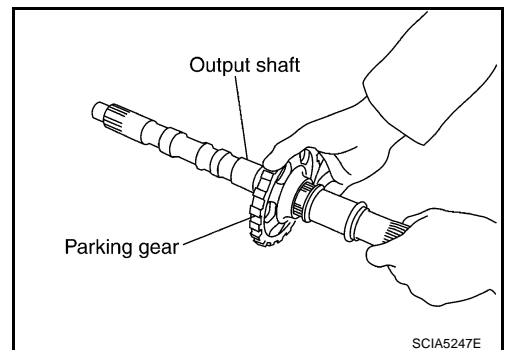

A
B
AT
D
E
F
G
H
I
J
K
L
M

ASSEMBLY

32. Install output shaft in transmission case.

CAUTION:

Be careful not to mistake front for rear because both sides looks similar. (Thinner end is front side.)

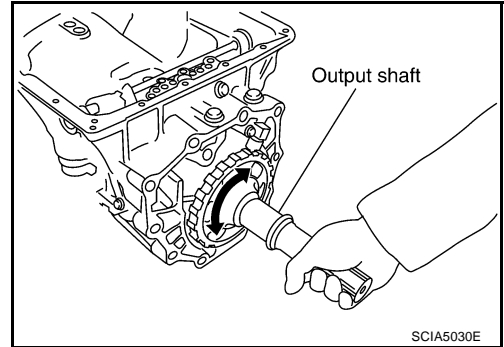

33. Install bearing race to output shaft.

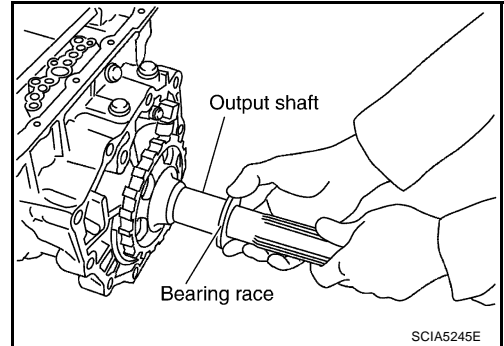

34. Apply recommended sealant (Genuine Anaerobic Liquid Gasket or equivalent. Refer to [GI-47, "Recommended Chemical Products and Sealants"](#) .) to rear extension assembly as shown in the figure.

CAUTION:

Completely remove all moisture, oil and old sealant, etc. from the transmission case and rear extension assembly mounting surfaces.

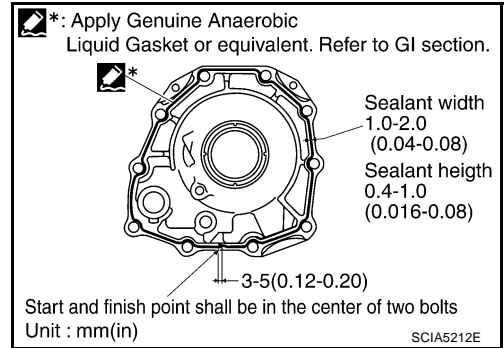

35. Install rear extension assembly to transmission case.

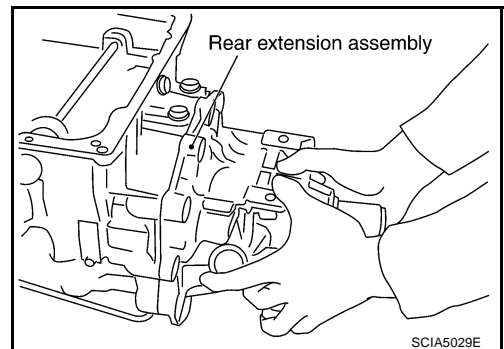

36. Tighten rear extension assembly mounting bolts to specified torque.

CAUTION:

Do not reuse self-sealing bolt.

Rear extension assembly mounting bolt:

: 52 N·m (5.3 kg-m, 38 ft-lb)

Self-sealing bolt:

: 61 N·m (6.2 kg-m, 45 ft-lb)

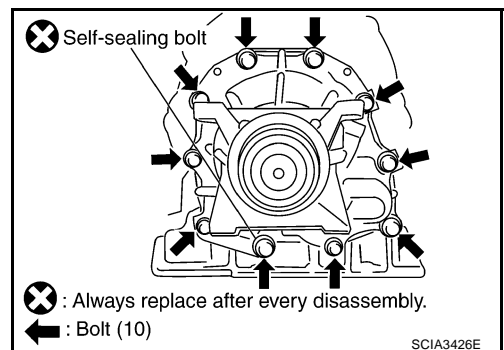

ASSEMBLY

37. Install needle bearing in drum support.

CAUTION:
Apply petroleum jelly to needle bearing.

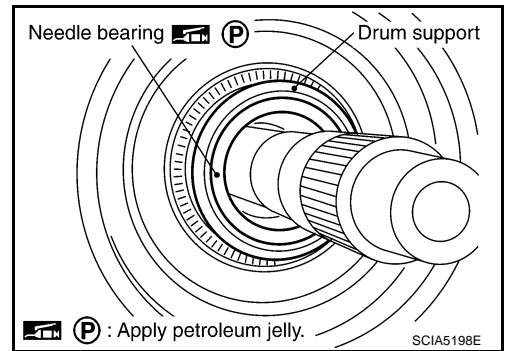

38. Install direct clutch assembly in reverse brake.

CAUTION:
Make sure that drum support edge surface and direct clutch inner boss edge surface come to almost same place.

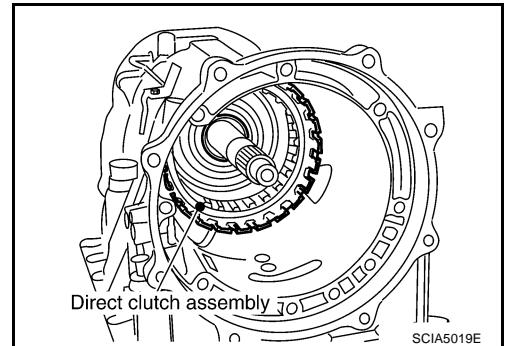

39. Install high and low reverse clutch assembly in direct clutch.

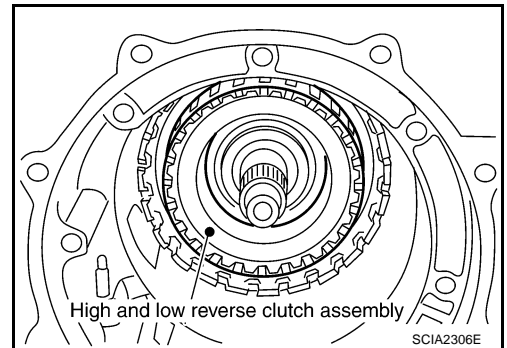

40. Using a flat-bladed screwdriver, align the drive plates.

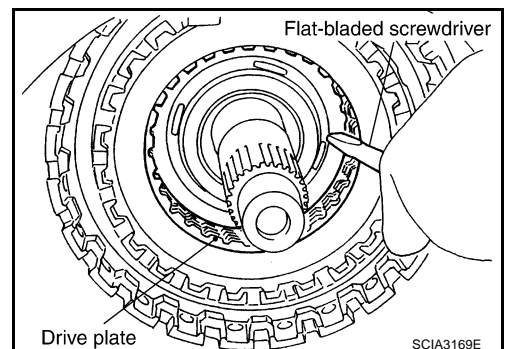

41. Install high and low reverse clutch hub, mid sun gear assembly and rear sun gear assembly as a unit.

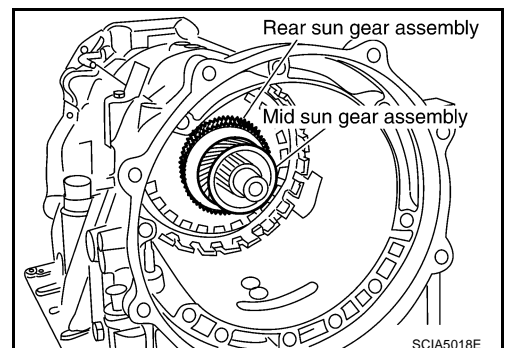

A
B
AT
D
E
F
G
H
I
J
K
L
M

ASSEMBLY

CAUTION:

Check that portion "A" of high and low reverse clutch drum protrudes approximately 2 mm (0.08 in) beyond portion "B" of rear sun gear.

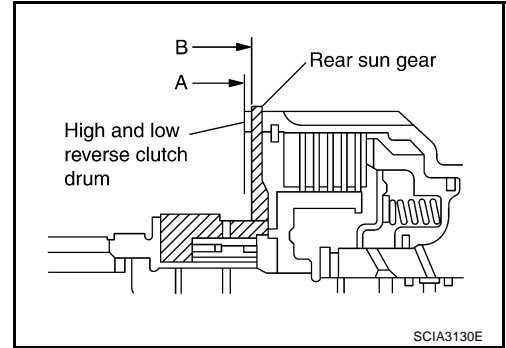

42. Install needle bearing in rear carrier assembly.

CAUTION:

Apply petroleum jelly to needle bearing.

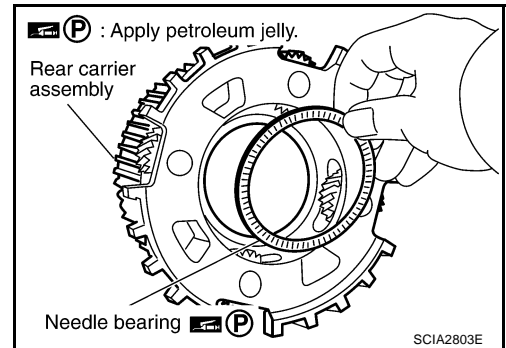

43. Install bearing race in rear carrier assembly.

CAUTION:

Apply petroleum jelly to bearing race.

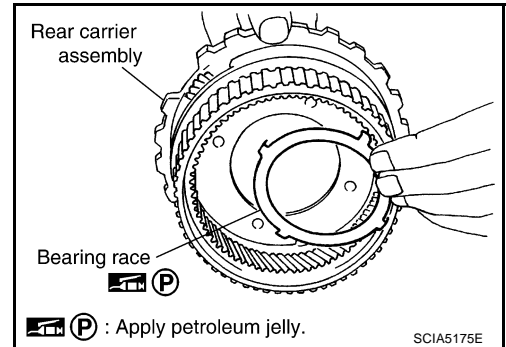

44. Install rear carrier assembly in direct clutch drum.

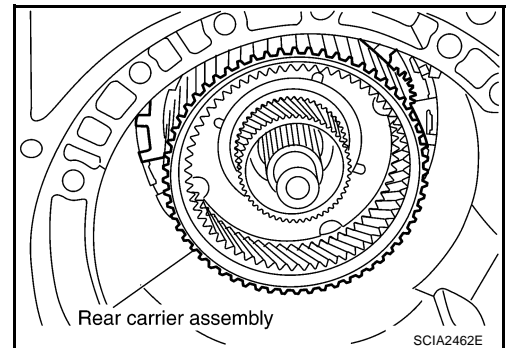

ASSEMBLY

45. Install needle bearing (rear side) to mid carrier assembly.

CAUTION:

Apply petroleum jelly to needle bearing.

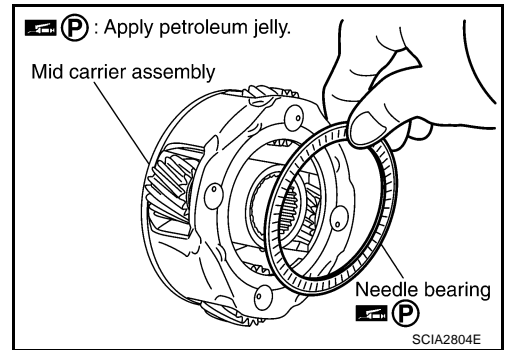

46. Install needle bearing (front side) to mid carrier assembly.

CAUTION:

Apply petroleum jelly to needle bearing.

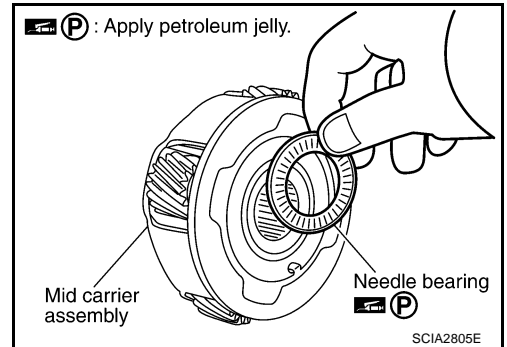

47. Install mid carrier assembly in rear carrier assembly.

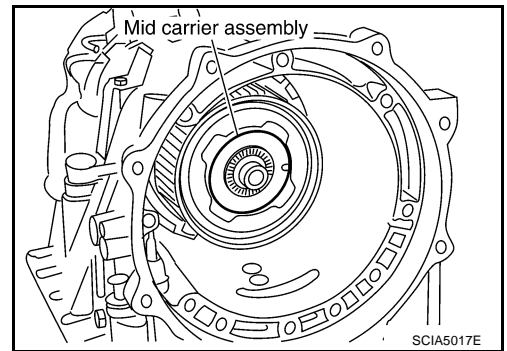

48. Install front carrier assembly (With input clutch assembly and rear internal gear.) to rear carrier assembly.

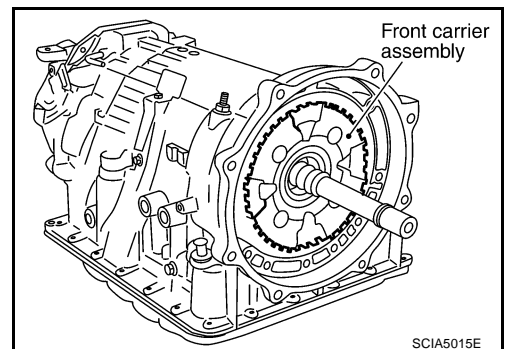

49. Install seal rings in input clutch assembly.

CAUTION:

- Do not reuse seal rings.
- Apply petroleum jelly to seal rings.

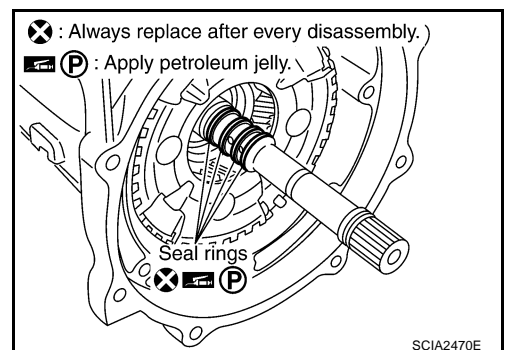

A
B
AT
D
E
F
G
H
I
J
K
L
M

ASSEMBLY

50. Install band servo anchor end pin and lock nut in transmission case.

CAUTION:

Do not reuse band servo anchor end pin.

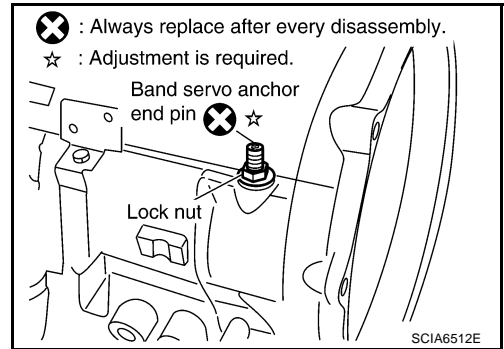

51. Install brake band in transmission case.

CAUTION:

Assemble it so that identification to avoid incorrect installation faces servo side.

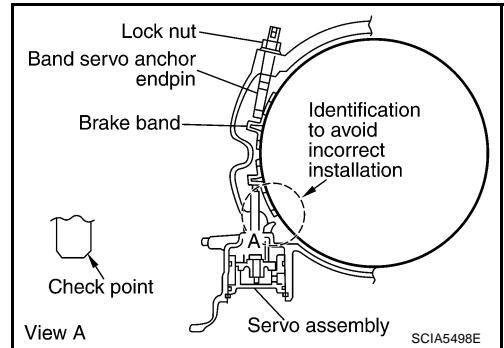

52. Install front sun gear to front carrier assembly.

CAUTION:

Apply ATF to front sun gear bearing and 3rd one-way clutch end bearing.

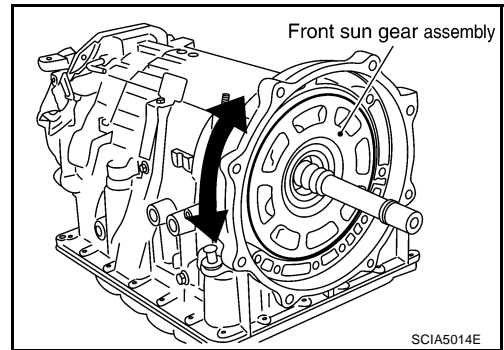

53. Install needle bearing to front sun gear.

CAUTION:

Apply petroleum jelly to needle bearing.

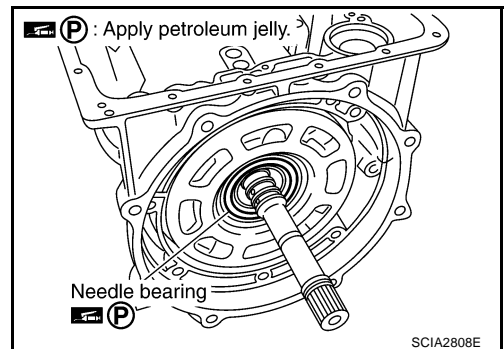

54. Adjust brake band tilting using a clip so that brake band contacts front sun gear drum evenly.

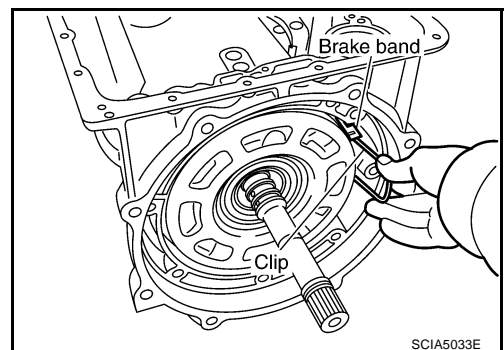

ASSEMBLY

55. Adjust brake band.

- a. Loosen lock nut.
- b. Tighten band servo anchor end pin to specified torque.

 : 5.0 N·m (0.51 kg·m, 44 in·lb)

- c. Back of band servo anchor end pin three turns.
- d. Holding band servo anchor end pin, tighten lock nut to specified torque.

 : 46 N·m (4.7 kg·m, 34 ft·lb)

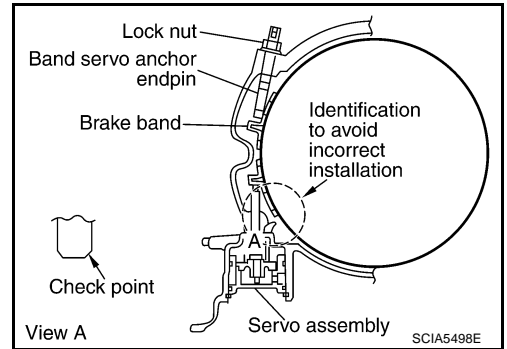

ACS00856

Adjustment TOTAL END PLAY

- Measure clearance between front sun gear and bearing race for oil pump cover.
- Select proper thickness of bearing race so that end play is within specifications.

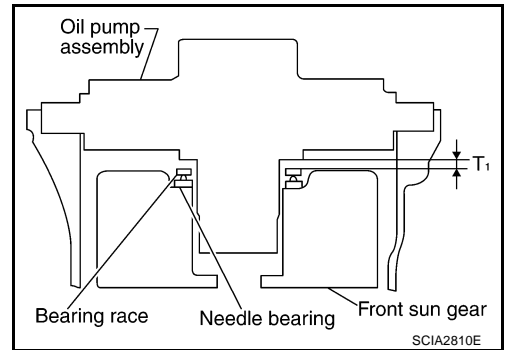

1. Measure dimensions "K" and "L" and then calculate dimension "J".

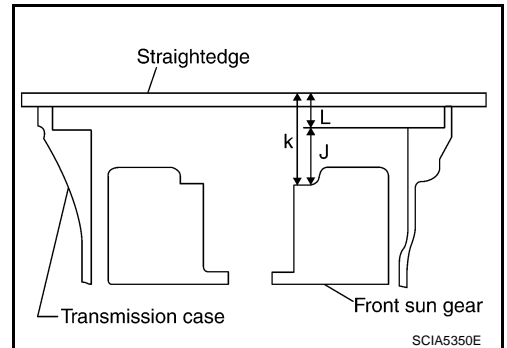

- a. Measure dimension "K".

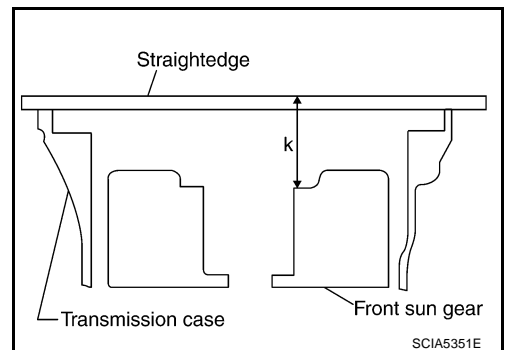

ASSEMBLY

- b. Measure dimension "L".
- c. Calculate dimension "J".

"J": Distance between oil pump fitting surface of transmission case and needle bearing mating surface of front sun gear.

$$J = K - L$$

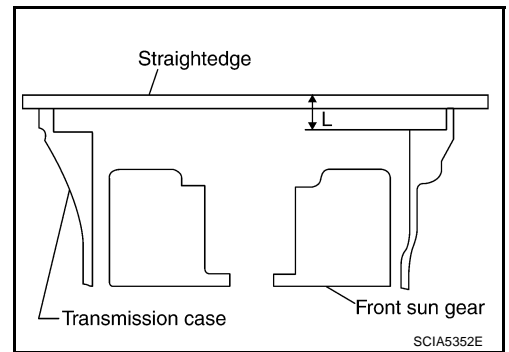

- 2. Measure dimensions "M1" and "M2" and then calculate dimension "M".

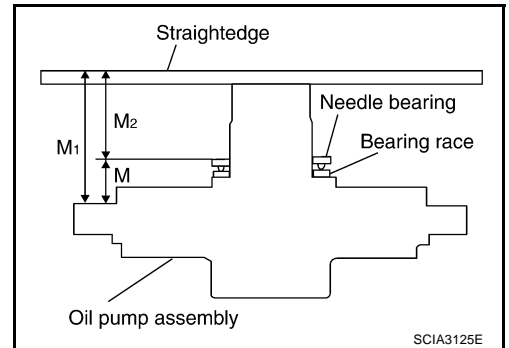

- a. Place bearing race and needle bearing on oil pump assembly.

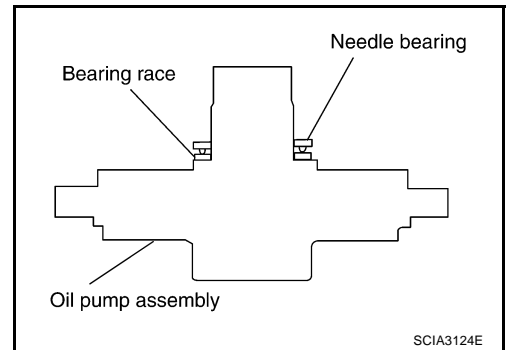

- b. Measure dimension "M1".

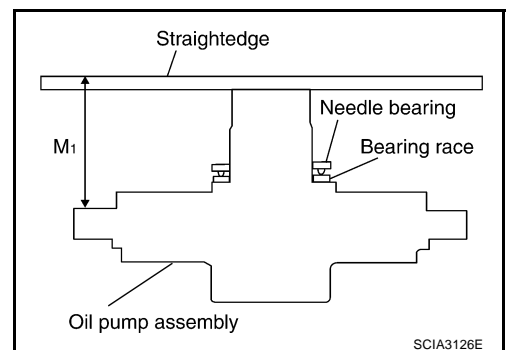

- c. Measure dimension "M2".

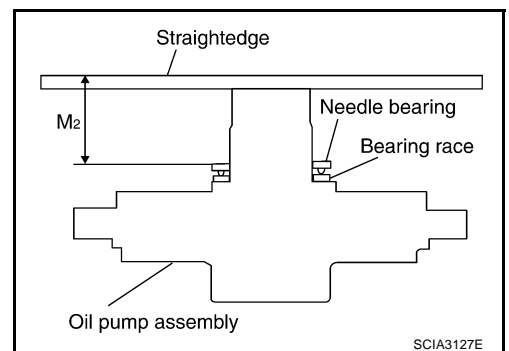

ASSEMBLY

d. Calculate dimension "M".

"M": Distance between transmission case fitting surface of oil pump and needle bearing on oil pump.

$$M = M_1 - M_2$$

3. Adjust total end play "T1".

$$T_1 = J - M$$

Total end play "T1":

0.25 - 0.55 mm (0.0098 - 0.0217 in)

- Select proper thickness of bearing race so that total end play is within specifications.

Bearing races: Refer to [AT-334, "BEARING RACE FOR ADJUSTING TOTAL END PLAY"](#).

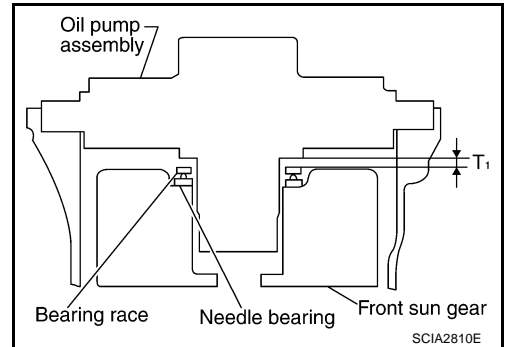
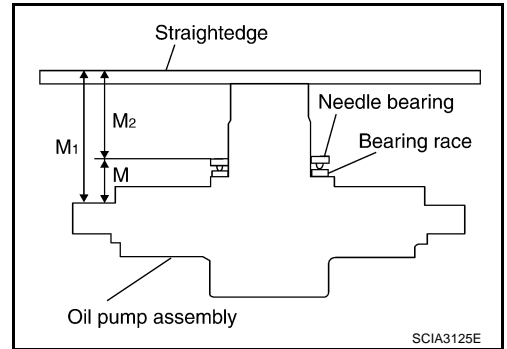

Assembly (2)

1. Install O-ring to oil pump assembly.

CAUTION:

- Do not reuse O-ring.
- Apply ATF to O-ring.

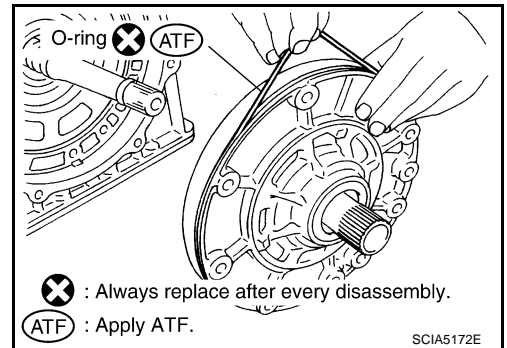

2. Install bearing race to oil pump assembly.

CAUTION:

Apply petroleum jelly to bearing race.

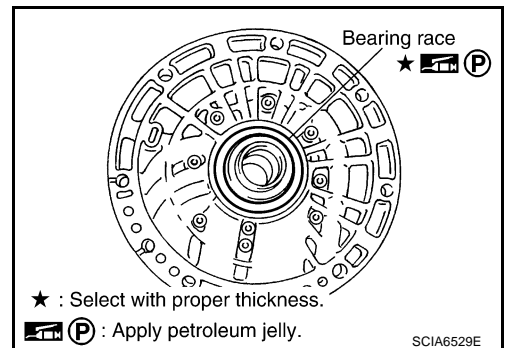

A
B
AT
D
E
F
G
H
I
J
K
L
M

ASSEMBLY

3. Install oil pump assembly in transmission case.

CAUTION:

Apply ATF to oil pump bearing.

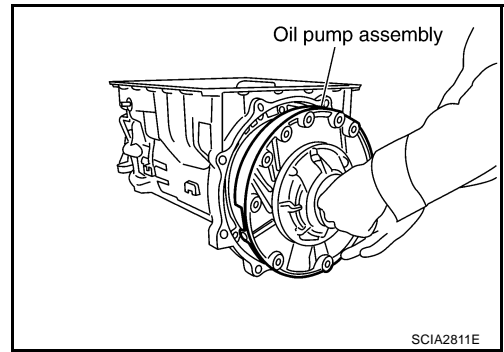

4. Apply recommended sealant (Genuine RTV Silicone Sealant or equivalent. Refer to [GI-47, "Recommended Chemical Products and Sealants"](#) .) to oil pump assembly as shown in the figure.

CAUTION:

Completely remove all moisture, oil and old sealant, etc. from the oil pump mounting bolts and oil pump mounting bolt mounting surfaces.

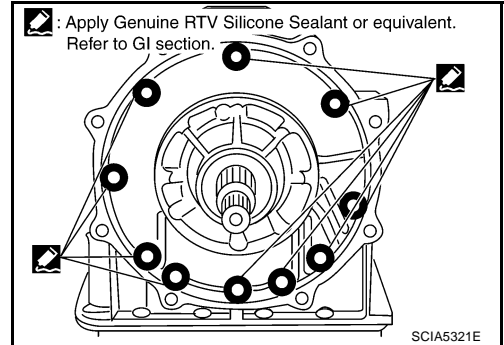

5. Tighten oil pump mounting bolts to specified torque.

CAUTION:

Apply ATF to oil pump bushing.

: 48 N·m (4.9 kg·m, 35 ft·lb)

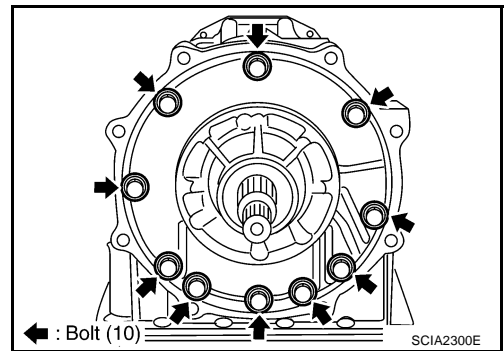

6. Install O-ring to input clutch assembly.

CAUTION:

- Do not reuse O-ring.
- Apply ATF to O-ring.

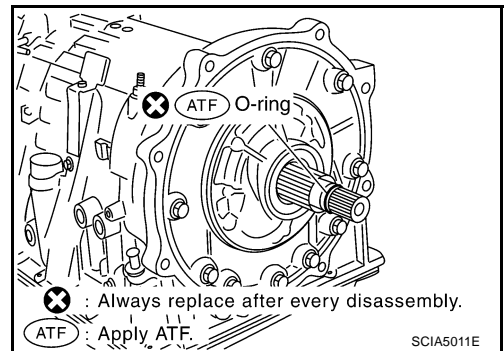

7. Install converter housing to transmission case.

CAUTION:

Do not reuse self-sealing bolt.

Converter housing mounting bolt:

: 52 N·m (5.3 kg·m, 38 ft·lb)

Self-sealing bolt:

: 61 N·m (6.2 kg·m, 45 ft·lb)

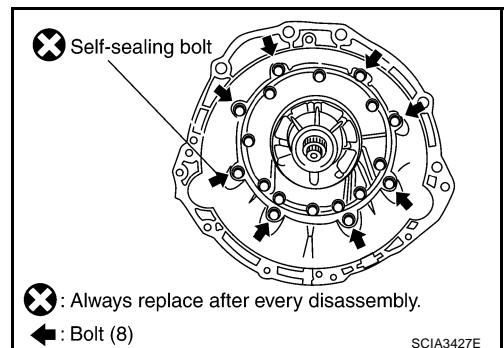

ASSEMBLY

8. Make sure that brake band does not close turbine revolution sensor hole.

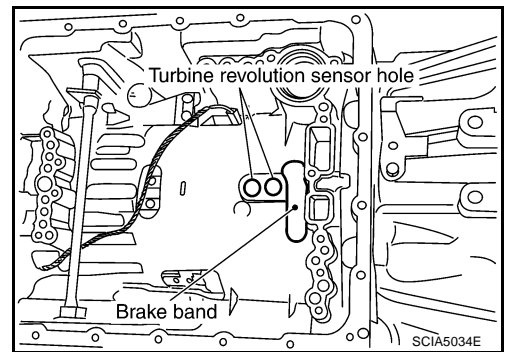

A
B
AT

9. Install control valve with TCM.

- a. Connect TCM connector and park/neutral position switch connector.

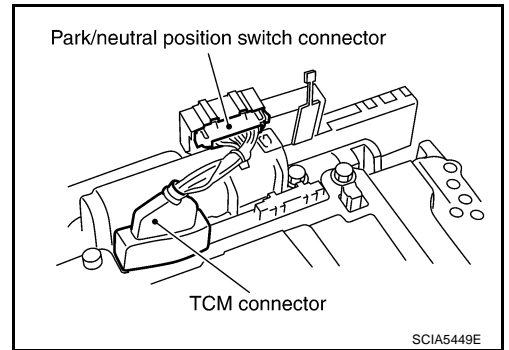

D
E
F
G

- b. Install A/T assembly harness connector from control valve with TCM.

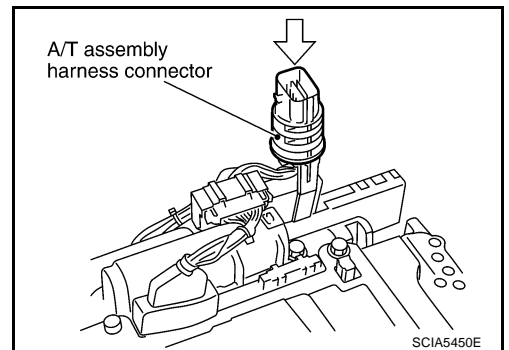

H
I
J
K

- c. Connect TCM connectors.

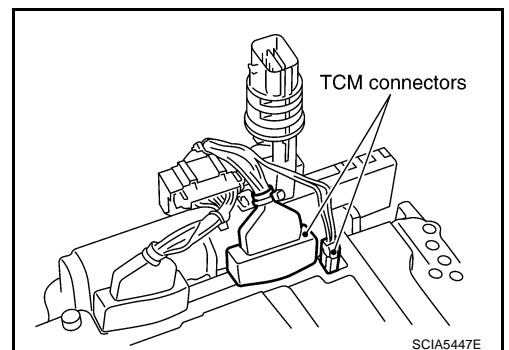

L
M

ASSEMBLY

d. Install O-ring to A/T assembly harness connector.

CAUTION:

- Do not reuse O-ring.
- Apply ATF to O-ring.

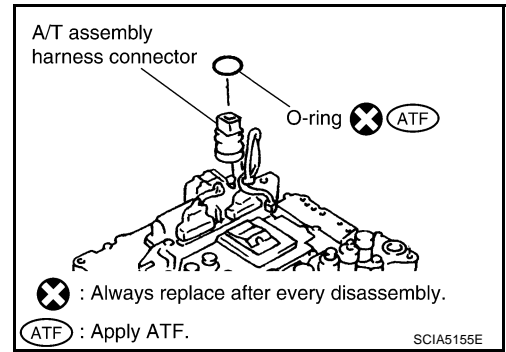

e. Install A/T fluid temperature sensor 2 to bracket.

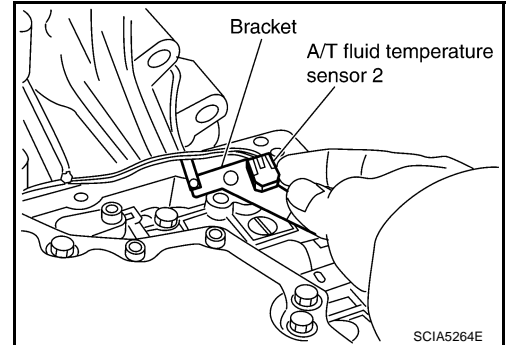

f. Install A/T fluid temperature sensor 2 (with bracket) in control valve with TCM.

CAUTION:

Adjust bolt hole of bracket to bolt hole of control valve.

 : 7.9 N-m (0.81 kg-m, 70 in-lb)

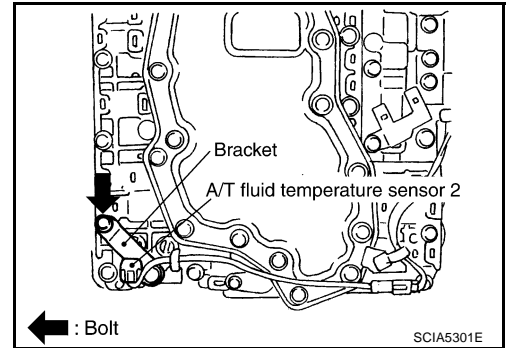

g. Install control valve with TCM in transmission case.

CAUTION:

- Make sure that turbine revolution sensor securely installs turbine revolution sensor hole.
- Hang down revolution sensor harness toward outside so as not to disturb installation of control valve with TCM.
- Adjust A/T assembly harness connector of control valve with TCM to terminal hole of transmission case.

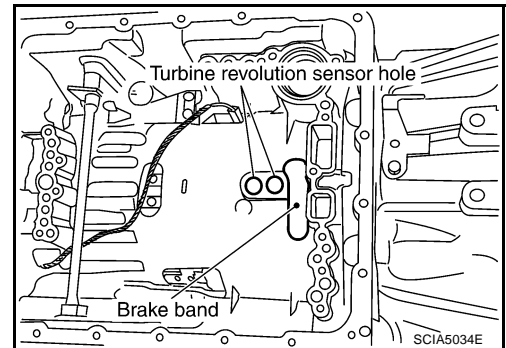

ASSEMBLY

- Assemble it so that manual valve cutout is engaged with manual plate projection.

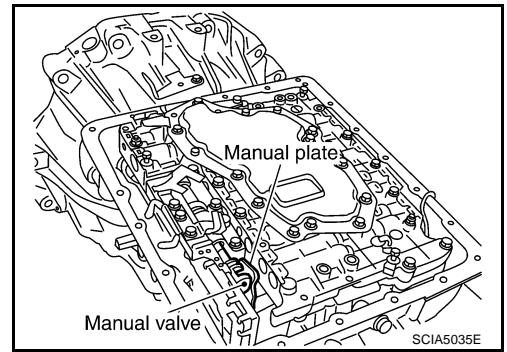

A
B
AT

h. Install bolts A, B and C to control valve with TCM.

Bolt symbol	Length mm (in)	Number of bolts
A	42 (1.65)	5
B	55 (2.17)	6
C	40 (1.57)	1

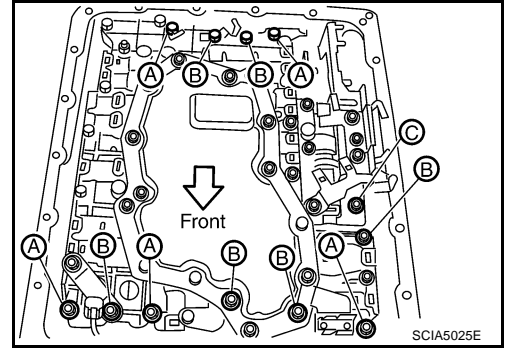

D
E
F
G

i. Tighten bolt 1, 2 and 3 temporarily to prevent dislocation. After that tighten them in order (1 → 2 → 3), and then tighten other bolts.

 : 7.9 N·m (0.81 kg-m, 70 in-lb)

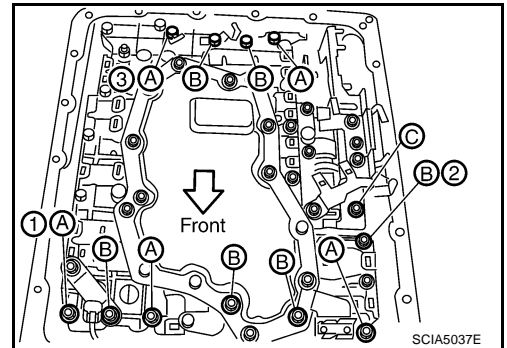

H
I
J
K

10. Connect A/T fluid temperature sensor 2 connector.

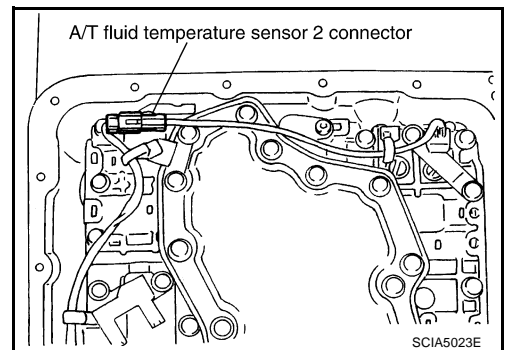

L
M

ASSEMBLY

11. Securely fasten terminal cord assembly and A/T fluid temperature sensor 2 harness with terminal clips.

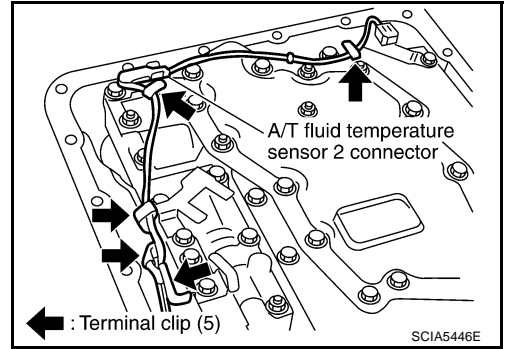

12. Connect revolution sensor connector.

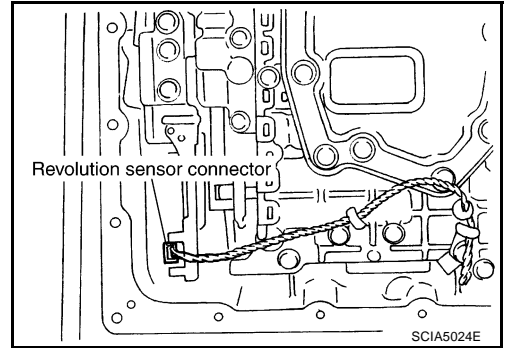

13. Securely fasten revolution sensor harness with terminal clips.

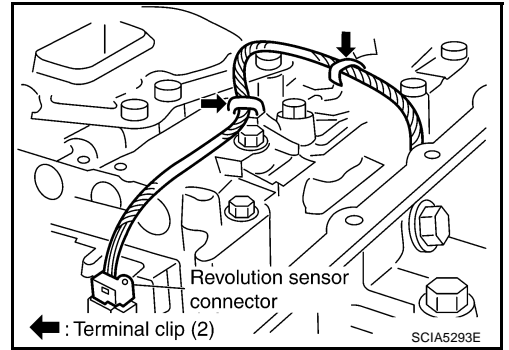

14. Pull down A/T assembly harness connector.

CAUTION:
Be careful not to damage connector.

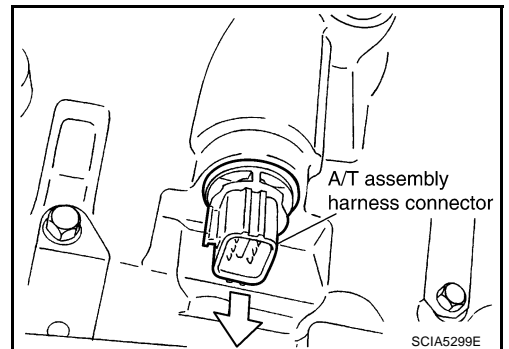

15. Install snap ring to A/T assembly harness connector.

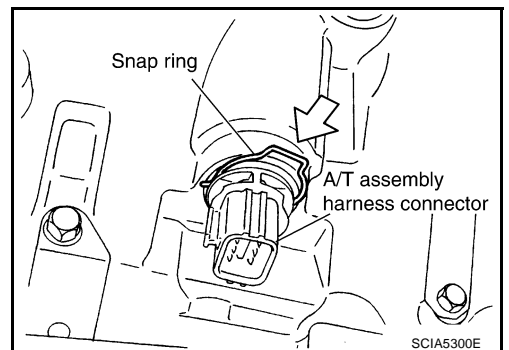

ASSEMBLY

16. Install magnets in oil pan.

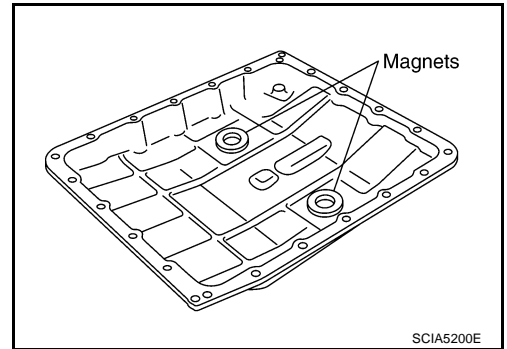

17. Install oil pan to transmission case.

a. Install oil pan gasket to oil pan.

CAUTION:

- Do not reuse oil pan gasket.
- Install it in the direction to align hole positions.
- Completely remove all moisture, oil and old gasket, etc. from oil pan gasket mounting surface.

b. Install oil pan (with oil pan gasket) to transmission case.

CAUTION:

- Install it so that drain plug comes to the position as shown in the figure.
- Be careful not to pinch harnesses.
- Completely remove all moisture, oil and old gasket, etc. from oil pan mounting surface.

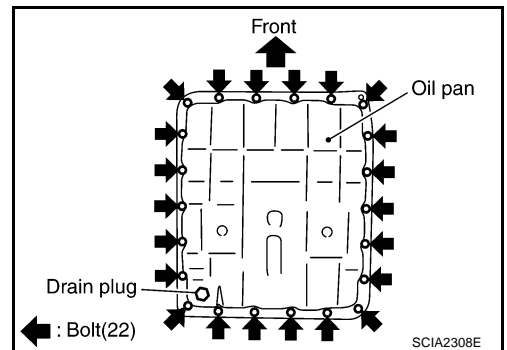

c. Tighten oil pan mounting bolts to the specified torque in numerical order as shown in the figure after temporarily tightening them.

CAUTION:

Do not reuse oil pan mounting bolts.

 : 7.9 N·m (0.81 kg·m, 70 in·lb)

18. Install drain plug to oil pan.

CAUTION:

Do not reuse drain plug gasket.

 : 34 N·m (3.5 kg·m, 25 ft·lb)

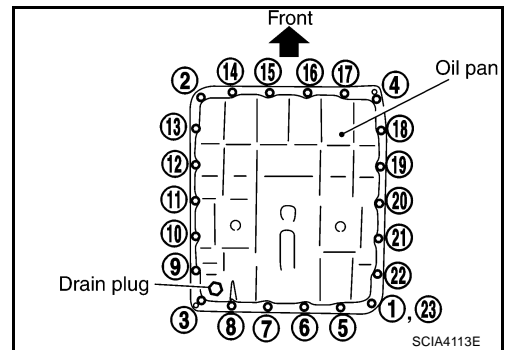

19. Install torque converter.

a. Pour ATF into torque converter.

- Approximately 2 liter (2-1/8 US qt, 1-3/4 Imp qt) of fluid is required for a new torque converter.
- When reusing old torque converter, add the same amount of fluid as was drained.

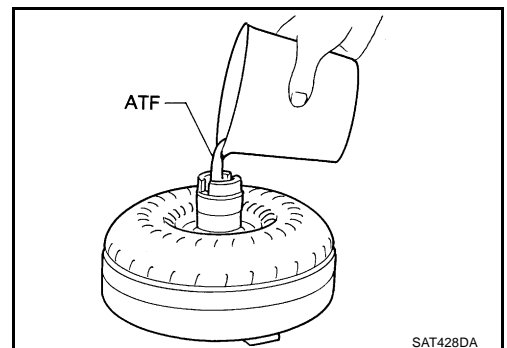

A
B
AT
D
E
F
G
H
I
J
K
L
M

ASSEMBLY

- b. Install torque converter while aligning notches of torque converter with notches of oil pump.

CAUTION:

Install torque converter while rotating it.

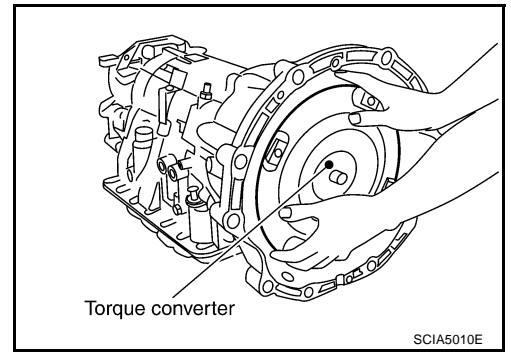

- c. Measure distance "A" to check that torque converter is in proper position.

Distance "A": 25.0 mm (0.98 in) or more

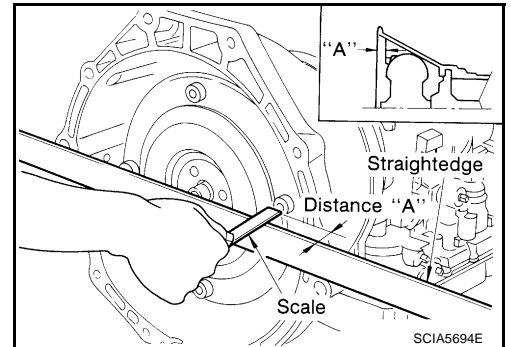

SERVICE DATA AND SPECIFICATIONS (SDS)

SERVICE DATA AND SPECIFICATIONS (SDS)

PPF:00030

General Specifications

ACS0000I

Applied model	VQ35DE engine	
Automatic transmission model	RE5R05A	
Transmission model code number	92X01	
Stall torque ratio	2.0: 1	
Transmission gear ratio	1st	3.540
	2nd	2.264
	3rd	1.471
	4th	1.000
	5th	0.834
	Reverse	2.370
Recommended fluid	Genuine NISSAN Matic J ATF*1	
Fluid capacity	10.3 liter (10-7/8 US qt, 9-1/8 Imp qt)	

CAUTION:

- Use only Genuine NISSAN Matic J ATF. Do not mix with other fluid.
- Using automatic transmission fluid other than Genuine NISSAN Matic J ATF will deteriorate in driveability and automatic transmission durability, and may damage the automatic transmission, which is not covered by the NISSAN new vehicle limited warranty.

*1: Refer to [MA-12, "Fluids and Lubricants"](#).

Vehicle Speed When Shifting Gears

ACS0000J

Throttle position	Vehicle speed km/h (MPH)							
	D1 →D2	D2 →D3	D3 →D4	D4 →D5	D5 →D4	D4 →D3	D3 →D2	D2 →D1
Full throttle	58 - 62 (36 - 39)	90 - 98 (56 - 61)	140 - 150 (87 - 93)	201 - 211 (125 - 131)	197 - 207 (122 - 129)	122 - 132 (76 - 82)	74 - 82 (46 - 51)	34 - 38 (23 - 25)
Half throttle	46 - 50 (29 - 31)	71 - 79 (44 - 49)	107 - 117 (66 - 73)	135 - 145 (84 - 90)	88 - 98 (55 - 61)	63 - 73 (39 - 45)	29 - 37 (18 - 23)	11 - 15 (7 - 9)

- At half throttle, the accelerator opening is 4/8 of the full opening.

Vehicle Speed When Performing and Releasing Complete Lock-up

ACS0000K

Throttle position	Vehicle speed km/h (MPH)	
	Lock-up ON	Lock-up OFF
Closed throttle	56 - 64 (35 - 40)	53 - 61 (33 - 38)
Half throttle	168 - 176 (104 - 109)	131 - 139 (81 - 86)

- At closed throttle, the accelerator opening is less than 1/8 condition. (Closed throttle position signal: OFF)
- At half throttle, the accelerator opening is 4/8 of the full opening.

Vehicle Speed When Performing and Releasing Slip Lock-up

ACS0000L

Throttle position	Gear position	Vehicle speed km/h (MPH)	
		Slip lock-up ON	Slip lock-up OFF
Closed throttle	4th	37 - 45 (23 - 28)	34 - 42 (21 - 26)
	5th	44 - 52 (27 - 32)	41 - 49 (25 - 30)

- At closed throttle, the accelerator opening is less than 1/8 condition. (Closed throttle position signal: OFF)

Stall Speed

ACS0000M

Stall speed	2,650 - 2,950 rpm
-------------	-------------------

SERVICE DATA AND SPECIFICATIONS (SDS)

Line Pressure

ACS0000N

Engine speed	Line pressure [kPa (kg/cm ² , psi)]	
	"R" position	"D", "M" positions
At idle speed	392 - 441 (4.0 - 4.5, 57 - 64)	373 - 422 (3.8 - 4.3, 54 - 61)
At stall speed	1,700 - 1,890 (17.3 - 19.3, 247 - 274)	1,310 - 1,500 (13.3 - 15.3, 190 - 218)

A/T Fluid Temperature Sensor

ACS0080E

Name	Condition	CONSULT-II "DATA MONITOR" (Approx.) (V)	Resistance (Approx.) (kΩ)
A/T fluid temperature sensor 1	0°C (32°F)	3.2	15
	20°C (68°F)	2.5	6.5
	80°C (176°F)	0.8	0.9
A/T fluid temperature sensor 2	0°C (32°F)	3.2	10
	20°C (68°F)	2.4	4
	80°C (176°F)	0.65	0.5

Turbine Revolution Sensor

ACS0080F

Name	Condition	Data (Approx.) (kHz)
Turbine revolution sensor 1	When running at 50 km/h (31 MPH) in 4th speed with the closed throttle position switch "OFF".	1.3
Turbine revolution sensor 2	When running at 20 km/h (12 MPH) in 1st speed with the closed throttle position switch "OFF".	

Vehicle Speed Sensor A/T (Revolution Sensor)

ACS0080G

Name	Condition	Data (Approx.) (Hz)
Revolution sensor	When running at 20 km/h (12 MPH).	185

Reverse Brake

ACS0080H

	Thickness mm (in)	Part number*
Thickness of retaining plates	4.2 (0.165)	31667 90X14
	4.4 (0.173)	31667 90X15
	4.6 (0.181)	31667 90X16
	4.8 (0.189)	31667 90X17
	5.0 (0.197)	31667 90X18
	5.2 (0.205)	31667 90X19

*: Always check with the Parts Department for the latest parts information.

Total End Play

ACS0080I

Total end play mm (in)	0.25 - 0.55 (0.0098 - 0.0217)
------------------------	-------------------------------

BEARING RACE FOR ADJUSTING TOTAL END PLAY

Thickness mm (in)	Part number*
1.2 (0.047)	31435 90X02
1.4 (0.055)	31435 90X03
1.6 (0.063)	31435 90X04
1.8 (0.071)	31435 90X05
2.0 (0.079)	31435 90X06

*: Always check with the Parts Department for the latest parts information.