

SECTION **ATC**

AUTOMATIC AIR CONDITIONER

A
B
C

CONTENTS

D
E

<p>PRECAUTIONS 4</p> <p>Precautions for Supplemental Restraint System (SRS) "AIR BAG" and "SEAT BELT PRE-TENSIONER" 4</p> <p>Precautions for Battery Service 4</p> <p>Precautions for Working with HFC-134a (R-134a)..... 5</p> <p style="padding-left: 20px;">CONTAMINATED REFRIGERANT 5</p> <p>General Refrigerant Precautions 6</p> <p>Lubricant Precautions 6</p> <p>Precautions for Refrigerant Connection 6</p> <p style="padding-left: 20px;">ABOUT ONE-TOUCH JOINT 7</p> <p style="padding-left: 20px;">FEATURES OF NEW TYPE REFRIGERANT CONNECTION 9</p> <p style="padding-left: 20px;">O-RING AND REFRIGERANT CONNECTION... 10</p> <p>Precautions for Servicing Compressor 11</p> <p>Precautions for Service Equipment 12</p> <p style="padding-left: 20px;">RECOVERY/RECYCLING EQUIPMENT 12</p> <p style="padding-left: 20px;">ELECTRONIC LEAK DETECTOR 12</p> <p style="padding-left: 20px;">VACUUM PUMP 12</p> <p style="padding-left: 20px;">MANIFOLD GAUGE SET 12</p> <p style="padding-left: 20px;">SERVICE HOSES 13</p> <p style="padding-left: 20px;">SERVICE COUPLERS 13</p> <p style="padding-left: 20px;">REFRIGERANT WEIGHT SCALE 13</p> <p style="padding-left: 20px;">CHARGING CYLINDER 13</p> <p>Precautions for Leak Detection Dye 14</p> <p style="padding-left: 20px;">IDENTIFICATION 14</p> <p style="padding-left: 20px;">IDENTIFICATION LABEL FOR VEHICLE 14</p> <p>Wiring Diagrams and Trouble Diagnosis 14</p> <p>PREPARATION 15</p> <p>Special Service Tools 15</p> <p>HFC-134a (R-134a) Service Tools and Equipment.. 16</p> <p>Commercial Service Tools 18</p> <p>REFRIGERATION SYSTEM 19</p> <p>Refrigerant Cycle 19</p> <p style="padding-left: 20px;">REFRIGERANT FLOW 19</p> <p style="padding-left: 20px;">FREEZE PROTECTION 19</p> <p>Refrigerant System Protection 19</p> <p style="padding-left: 20px;">REFRIGERANT PRESSURE SENSOR 19</p> <p style="padding-left: 20px;">PRESSURE RELIEF VALVE 19</p> <p>V-6 Variable Displacement Compressor 20</p>	<p>GENERAL INFORMATION 20</p> <p>DESCRIPTION 21</p> <p>Component Layout 23</p> <p>LUBRICANT 24</p> <p>Maintenance of Lubricant Quantity in Compressor.. 24</p> <p style="padding-left: 20px;">LUBRICANT 24</p> <p style="padding-left: 20px;">LUBRICANT RETURN OPERATION 24</p> <p style="padding-left: 20px;">LUBRICANT ADJUSTING PROCEDURE FOR COMPONENTS REPLACEMENT EXCEPT COMPRESSOR 25</p> <p style="padding-left: 20px;">LUBRICANT ADJUSTING PROCEDURE FOR COMPRESSOR REPLACEMENT 25</p> <p>AIR CONDITIONER CONTROL 27</p> <p>Description of Air Conditioner LAN Control System.. 27</p> <p>System Construction 27</p> <p>OPERATION 28</p> <p>TRANSMISSION DATA AND TRANSMISSION ORDER 28</p> <p>AIR MIX DOOR CONTROL (AUTOMATIC TEMPERATURE CONTROL) 29</p> <p>FAN SPEED CONTROL 29</p> <p>INTAKE DOOR CONTROL 29</p> <p>OUTLET DOOR CONTROL 29</p> <p>MAGNET CLUTCH CONTROL 30</p> <p>SELF-DIAGNOSTIC SYSTEM 30</p> <p>Description of Control System 31</p> <p>Control Operation 32</p> <p style="padding-left: 20px;">TEMPERATURE CONTROL DIAL (POTENTIAL TEMPERATURE CONTROL) 32</p> <p style="padding-left: 20px;">INTAKE SWITCH 32</p> <p style="padding-left: 20px;">REAR WINDOW DEFOGGER SWITCH 32</p> <p style="padding-left: 20px;">A/C SWITCH 32</p> <p style="padding-left: 20px;">MODE CONTROL DIAL 32</p> <p style="padding-left: 20px;">FAN CONTROL DIAL 32</p> <p>Discharge Air Flow 33</p> <p>System Description 34</p> <p style="padding-left: 20px;">SWITCHES AND THEIR CONTROL FUNCTION.. 34</p> <p>CAN Communication System Description 35</p> <p>TROUBLE DIAGNOSIS 36</p> <p>CONSULT-II 36</p>
--	---

F
G

H
I

ATC

K
L

M

CONSULT-II INSPECTION PROCEDURE	36	DOOR MOTOR	74
DATA MONITOR	37	Blower Motor Circuit	75
How to Perform Trouble Diagnoses for Quick and		INSPECTION FLOW	75
Accurate Repair	38	SYSTEM DESCRIPTION	76
WORK FLOW	38	COMPONENT DESCRIPTION	77
SYMPTOM TABLE	38	DIAGNOSTIC PROCEDURE FOR BLOWER	
Component Parts and Harness Connector Location..	39	MOTOR	77
ENGINE COMPARTMENT	39	COMPONENT INSPECTION	79
PASSENGER COMPARTMENT	40	Magnet Clutch Circuit	80
Schematic	41	INSPECTION FLOW	80
Wiring Diagram —A/C—	42	SYSTEM DESCRIPTION	81
Auto Amp. Terminals and Reference Value	47	DIAGNOSTIC PROCEDURE FOR MAGNET	
PIN CONNECTOR TERMINAL LAYOUT	47	CLUTCH	81
TERMINALS AND REFERENCE VALUE FOR		COMPONENT INSPECTION	86
UNIFIED METER AND A/C AMP.	47	Insufficient Cooling	87
Self-diagnosis Function	49	INSPECTION FLOW	87
DESCRIPTION	49	PERFORMANCE TEST DIAGNOSIS	89
FUNCTION CONFIRMATION PROCEDURE	51	PERFORMANCE CHART	91
AUXILIARY MECHANISM: TEMPERATURE		TROUBLE DIAGNOSIS FOR UNUSUAL PRES-	
SETTING TRIMMER	55	SURE	92
AUXILIARY MECHANISM: FOOT POSITION		Insufficient Heating	95
SETTING TRIMMER	56	INSPECTION FLOW	95
AUXILIARY MECHANISM: INLET PORT MEM-		Noise	96
ORY FUNCTION	56	INSPECTION FLOW	96
Operational Check	57	Self-diagnosis	97
CHECKING BLOWER	57	INSPECTION FLOW	97
CHECKING DISCHARGE AIR	57	Ambient Sensor Circuit	98
CHECKING INTAKE DOOR	57	COMPONENT DESCRIPTION	98
CHECKING TEMPERATURE DECREASE	58	AMBIENT TEMPERATURE INPUT PROCESS...	98
CHECKING TEMPERATURE INCREASE	58	DIAGNOSTIC PROCEDURE FOR AMBIENT	
CHECKING A/C SWITCH	58	SENSOR	98
Power Supply and Ground Circuit for Auto Amp. ...	59	COMPONENT INSPECTION	100
INSPECTION FLOW	59	In-vehicle Sensor Circuit	100
COMPONENT DESCRIPTION	59	COMPONENT DESCRIPTION	100
DIAGNOSTIC PROCEDURE FOR A/C SYSTEM..	60	DIAGNOSTIC PROCEDURE FOR IN-VEHICLE	
LAN System Circuit	61	SENSOR	101
DIAGNOSTIC PROCEDURE FOR LAN CIR-		COMPONENT INSPECTION	102
CUIT	61	Sunload Sensor Circuit	103
Mode Door Motor Circuit	65	COMPONENT DESCRIPTION	103
INSPECTION FLOW	65	SUNLOAD INPUT PROCESS	103
SYSTEM DESCRIPTION	66	DIAGNOSTIC PROCEDURE FOR SUNLOAD	
COMPONENT DESCRIPTION	67	SENSOR	103
DIAGNOSTIC PROCEDURE FOR MODE		COMPONENT INSPECTION	105
DOOR MOTOR	67	Intake Sensor Circuit	106
Air Mix Door Motor Circuit	68	COMPONENT DESCRIPTION	106
INSPECTION FLOW	68	DIAGNOSTIC PROCEDURE FOR INTAKE SEN-	
SYSTEM DESCRIPTION	70	SOR	106
COMPONENT DESCRIPTION	71	COMPONENT INSPECTION	107
DIAGNOSTIC PROCEDURE FOR AIR MIX		A/C CONTROLLER	108
DOOR	71	Removal and Installation	108
Air Mix Door Motor PBR Circuit	71	REMOVAL	108
DIAGNOSTIC PROCEDURE FOR AIR MIX		INSTALLATION	108
DOOR PBR	71	AUTO AMP	109
Intake Door Motor Circuit	72	Removal and Installation of Unified Meter and A/C	
INSPECTION FLOW	72	Amp.	109
SYSTEM DESCRIPTION	73	REMOVAL	109
COMPONENT DESCRIPTION	74	INSTALLATION	109
DIAGNOSTIC PROCEDURE FOR INTAKE			

AMBIENT SENSOR	110	Components	131
Removal and Installation	110	Removal and Installation of Compressor	131
REMOVAL	110	REMOVAL	131
INSTALLATION	110	INSTALLATION	132
IN-VEHICLE SENSOR	111	Removal and Installation of Compressor Clutch	132
Removal and Installation	111	REMOVAL	132
REMOVAL	111	INSTALLATION	134
INSTALLATION	111	Removal and Installation of Low-pressure Flexible	
SUNLOAD SENSOR	112	Hose	136
Removal and Installation	112	REMOVAL	136
REMOVAL	112	INSTALLATION	137
INSTALLATION	112	Removal and Installation of High-pressure Flexible	
INTAKE SENSOR	113	Hose	137
Removal and Installation	113	REMOVAL	137
REMOVAL	113	INSTALLATION	138
INSTALLATION	113	Removal and Installation of High-pressure Pipe 1	
BLOWER UNIT	114	(Engine Compartment)	138
Removal and Installation	114	REMOVAL	138
REMOVAL	114	INSTALLATION	139
INSTALLATION	114	Removal and Installation of Low-pressure Pipe and	
Disassembly and Assembly	115	High-pressure Pipe 2	139
BLOWER MOTOR	116	REMOVAL	139
Removal and Installation	116	INSTALLATION	140
REMOVAL	116	Removal and Installation of Liquid Tank	141
INSTALLATION	116	REMOVAL	141
INTAKE DOOR MOTOR	117	INSTALLATION	141
Removal and Installation	117	Removal and Installation of Condenser	142
REMOVAL	117	REMOVAL	142
INSTALLATION	117	INSTALLATION	143
HEATER & COOLING UNIT ASSEMBLY	118	Removal and Installation of Refrigerant Pressure	
Removal and Installation	118	Sensor	143
REMOVAL	118	REMOVAL	143
INSTALLATION	119	INSTALLATION	144
Disassembly and Assembly	120	Removal and Installation of Evaporator	144
MODE DOOR MOTOR	122	REMOVAL	144
Removal and Installation	122	INSTALLATION	144
REMOVAL	122	Removal and Installation of Expansion Valve	145
INSTALLATION	122	REMOVAL	145
AIR MIX DOOR MOTOR	123	INSTALLATION	145
Removal and Installation	123	Checking for Refrigerant Leaks	146
REMOVAL	123	Checking System for Leaks Using the Fluorescent	
INSTALLATION	123	Leak Detector	146
HEATER CORE	124	Dye Injection	146
Removal and Installation	124	Electronic Refrigerant Leak Detector	147
REMOVAL	124	PRECAUTIONS FOR HANDLING LEAK	
INSTALLATION	124	DETECTOR	147
DUCTS AND GRILLES	125	CHECKING PROCEDURE	148
Removal and Installation	125	SERVICE DATA AND SPECIFICATIONS (SDS) ...	150
REMOVAL	125	Compressor	150
INSTALLATION	128	Lubricant	150
REFRIGERANT LINES	129	Refrigerant	150
HFC-134a (R-134a) Service Procedure	129	Engine Idling Speed	150
SETTING OF SERVICE TOOLS AND EQUIP-		Belt Tension	150
MENT	129		

A
B
C
D
E
F
G
H
I
K
L
M

ATC

PRECAUTIONS

PRECAUTIONS

PFP:00001

Precautions for Supplemental Restraint System (SRS) “AIR BAG” and “SEAT BELT PRE-TENSIONER”

AJS001FF

The Supplemental Restraint System such as “AIR BAG” and “SEAT BELT PRE-TENSIONER”, used along with a front seat belt, helps to reduce the risk or severity of injury to the driver and front passenger for certain types of collision. This system includes seat belt switch inputs and dual stage front air bag modules. The SRS system uses the seat belt switches to determine the front air bag deployment, and may only deploy one front air bag, depending on the severity of a collision and whether the front occupants are belted or unbelted. Information necessary to service the system safely is included in the SRS and SB section of this Service Manual.

WARNING:

- To avoid rendering the SRS inoperative, which could increase the risk of personal injury or death in the event of a collision which would result in air bag inflation, all maintenance must be performed by an authorized NISSAN/INFINITI dealer.
- Improper maintenance, including incorrect removal and installation of the SRS, can lead to personal injury caused by unintentional activation of the system. For removal of Spiral Cable and Air Bag Module, see the SRS section.
- Do not use electrical test equipment on any circuit related to the SRS unless instructed to in this Service Manual. SRS wiring harnesses can be identified by yellow and/or orange harnesses or harness connectors.

Precautions for Battery Service

AJS000S7

Before disconnecting the battery, lower both the driver and passenger windows. This will prevent any interference between the window edge and the vehicle when the door is opened/closed. During normal operation, the window slightly raises and lowers automatically to prevent any window to vehicle interference. The automatic window function will not work with the battery disconnected.

PRECAUTIONS

Precautions for Working with HFC-134a (R-134a)

AJS0009G

WARNING:

- CFC-12 (R-12) refrigerant and HFC-134a (R-134a) refrigerant are not compatible. If the refrigerants are mixed and compressor malfunction is likely to occur, refer to “CONTAMINATED REFRIGERANT” below. To determine the purity of HFC-134a (R-134a) in the vehicle and recovery tank, use Refrigerant Recovery/Recycling Recharging equipment and Refrigerant Identifier.
- Use only specified lubricant for the HFC-134a (R-134a) A/C system and HFC-134a (R-134a) components. If lubricant other than that specified is used, compressor malfunction is likely to occur.
- The specified HFC-134a (R-134a) lubricant rapidly absorbs moisture from the atmosphere. The following handling precautions must be observed:
 - When removing refrigerant components from a vehicle, immediately cap (seal) the component to minimize the entry of moisture from the atmosphere.
 - When installing refrigerant components to a vehicle, do not remove the caps (unseal) until just before connecting the components. Connect all refrigerant loop components as quickly as possible to minimize the entry of moisture into system.
 - Only use the specified lubricant from a sealed container. Immediately reseal containers of lubricant. Without proper sealing, lubricant will become moisture saturated and should not be used.
 - Avoid breathing A/C refrigerant and lubricant vapor or mist. Exposure may irritate eyes, nose and throat. Remove HFC-134a (R-134a) from the A/C system, using certified service equipment meeting requirements of SAE J2210 HFC-134a (R-134a) recycling equipment, or J2209 HFC-134a (R-134a) recovery equipment. If accidental system discharge occurs, ventilate work area before resuming service. Additional health and safety information may be obtained from refrigerant and lubricant manufacturers.
 - Do not allow lubricant (Nissan A/C System Oil Type S) to come in contact with styrofoam parts. Damage may result.

CONTAMINATED REFRIGERANT

If a refrigerant other than pure HFC-134a (R-134a) is identified in a vehicle, your options are:

- Explain to the customer that environmental regulations prohibit the release of contaminated refrigerant into the atmosphere.
- Explain that recovery of the contaminated refrigerant could damage your service equipment and refrigerant supply.
- Suggest the customer return the vehicle to the location of previous service where the contamination may have occurred.
- If you choose to perform the repair, recover the refrigerant using only **dedicated equipment and containers. Do not recover contaminated refrigerant into your existing service equipment.** If your facility does not have dedicated recovery equipment, you may contact a local refrigerant product retailer for available service. This refrigerant must be disposed of in accordance with all federal and local regulations. In addition, replacement of all refrigerant system components on the vehicle is recommended.
- If the vehicle is within the warranty period, the air conditioner warranty is void. Please contact Nissan Customer Affairs for further assistance.

PRECAUTIONS

General Refrigerant Precautions

AJS0009H

WARNING:

- Do not release refrigerant into the air. Use approved recovery/recycling equipment to capture the refrigerant every time an air conditioning system is discharged.
- Always wear eye and hand protection (goggles and gloves) when working with any refrigerant or air conditioning system.
- Do not store or heat refrigerant containers above 52°C (125°F).
- Do not heat a refrigerant container with an open flame; if container warming is required, place the bottom of the container in a warm pail of water.
- Do not intentionally drop, puncture, or incinerate refrigerant containers.
- Keep refrigerant away from open flames: poisonous gas will be produced if refrigerant burns.
- Refrigerant will displace oxygen, therefore be certain to work in well ventilated areas to prevent suffocation.
- Do not pressure test or leak test HFC-134a (R-134a) service equipment and/or vehicle air conditioning systems with compressed air during repair. Some mixtures of air and HFC-134a (R-134a) have been shown to be combustible at elevated pressures. These mixtures, if ignited, may cause injury or property damage. Additional health and safety information may be obtained from refrigerant manufacturers.

Lubricant Precautions

AJS0009I

- Use only specified lubricant for the HFC-134a (R-134a) A/C system and HFC-134a (R-134a) components. If lubricant other than that specified is used, compressor malfunction is likely to occur.
- The specified HFC-134a (R-134a) lubricant rapidly absorbs moisture from the atmosphere. The following handling precautions must be observed:
 - When removing refrigerant components from a vehicle, immediately cap (seal) the component to minimize the entry of moisture from the atmosphere.
 - When installing refrigerant components to a vehicle, do not remove the caps (unseal) until just before connecting the components. Connect all refrigerant loop components as quickly as possible to minimize the entry of moisture into system.
 - Only use the specified lubricant from a sealed container. Immediately reseal containers of lubricant. Without proper sealing, lubricant will become moisture saturated and should not be used.
- Avoid breathing A/C refrigerant and lubricant vapor or mist. Exposure may irritate eyes, nose and throat. Remove HFC-134a (R-134a) from the A/C system, using certified service equipment meeting requirements of SAE J2210 HFC-134a (R-134a) recycling equipment, or J2209 HFC-134a (R-134a) recovery equipment. If accidental system discharge occurs, ventilate work area before resuming service. Additional health and safety information may be obtained from refrigerant and lubricant manufacturers.
- Do not allow lubricant (Nissan A/C System Oil Type S) to come in contact with styrofoam parts. Damage may result.

Precautions for Refrigerant Connection

AJS0009J

A new type refrigerant connection has been introduced to all refrigerant lines except the following location.

- Expansion valve to evaporator
- Refrigerant pressure sensor to liquid tank

PRECAUTIONS

ABOUT ONE-TOUCH JOINT

Description

- One-touch joints are pipe joints which do not require tools during piping connection.
- Unlike conventional connection methods using union nuts and flanges, controlling tightening torque at connection point is not necessary.
- When removing a pipe joint, use a disconnecter.

COMPONENT PARTS

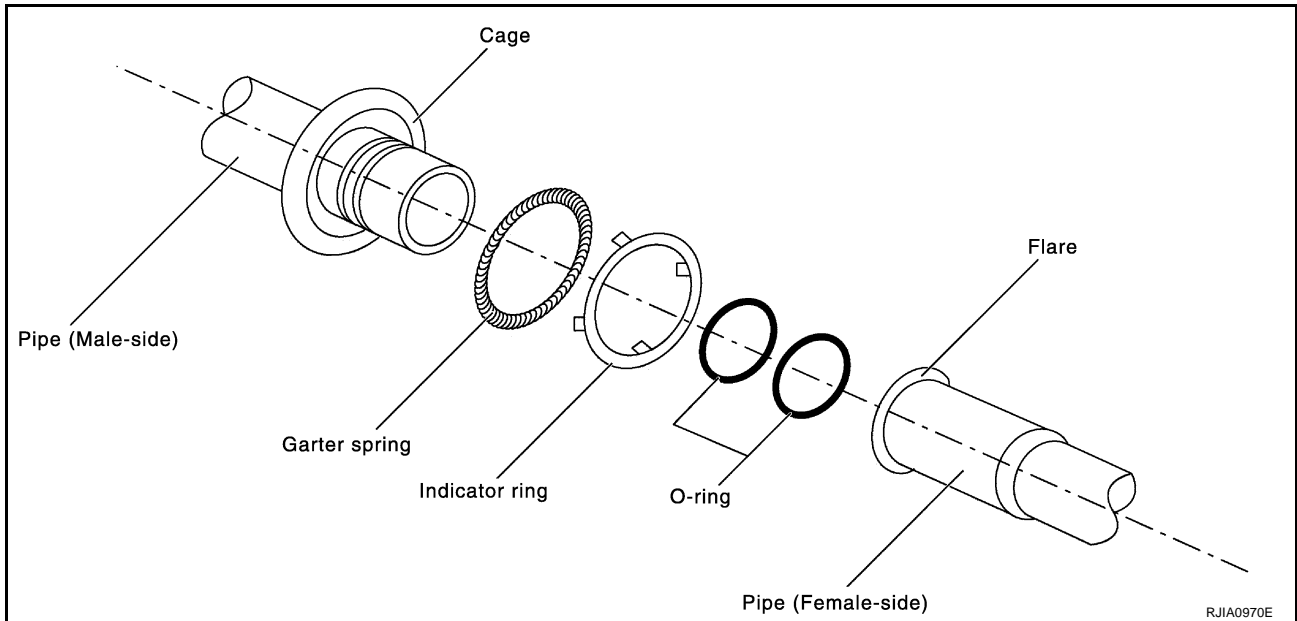

FUNCTIONS OF COMPONENT PARTS

Pipe (Male side)	<ul style="list-style-type: none"> ● Retains O-rings. ● Retains garter spring in cage.
Garter spring	Anchors female side piping.
Indicator ring	When connection is made properly, this is ejected from male-side piping. (This part is no longer necessary after connection.)
O-ring	Seals connection point. (Not reusable)
Pipe (Female side)	<ul style="list-style-type: none"> ● Seals connection by compressing O-rings. ● Anchors piping connection using flare and garter spring.

NOTE:

- Garter spring cannot be removed from cage of male-side piping.
- Indicator ring remains near piping connection point, however, this is not a malfunction. (This is to check piping connection during factory assembly.)

A
B
C
D
E
F
G
H
I
K
L
M

ATC

PRECAUTIONS

REMOVAL

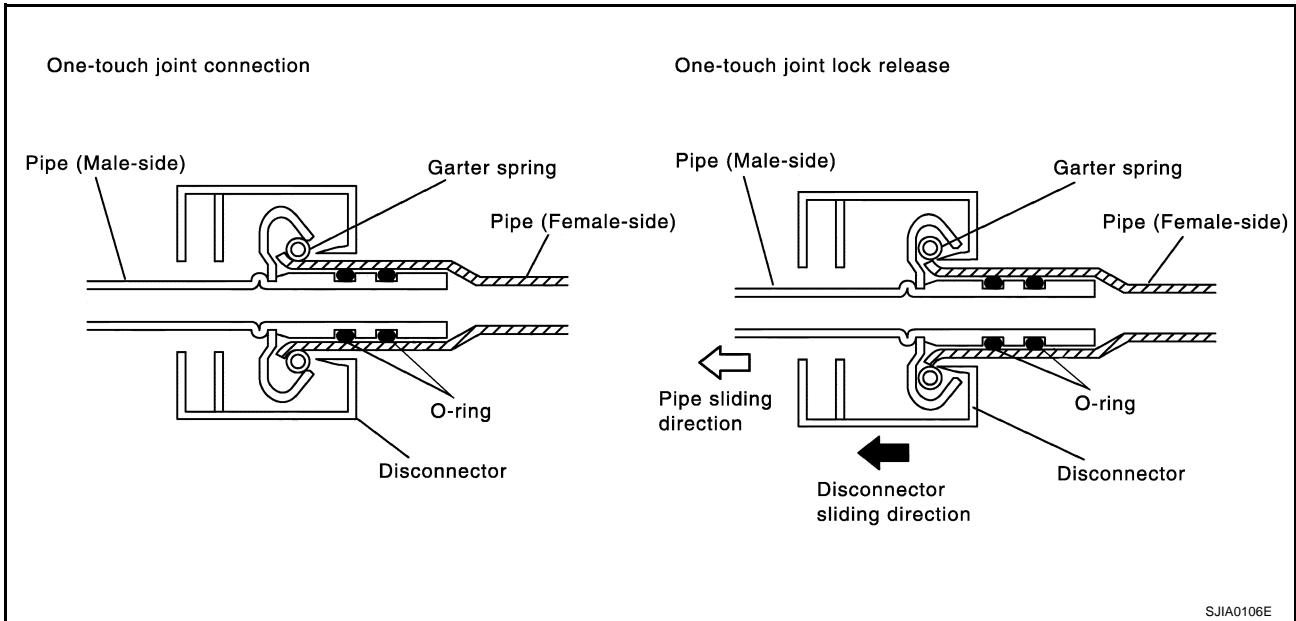

1. Clean piping connection point, and set a disconnecter.
2. Slide disconnecter in axial direction of piping, and stretch garter spring with tapered point of disconnecter.
3. Slide disconnecter farther so that inside diameter of garter spring becomes larger than outside diameter of female-side piping flare. Then male-side piping can be disconnected.

INSTALLATION

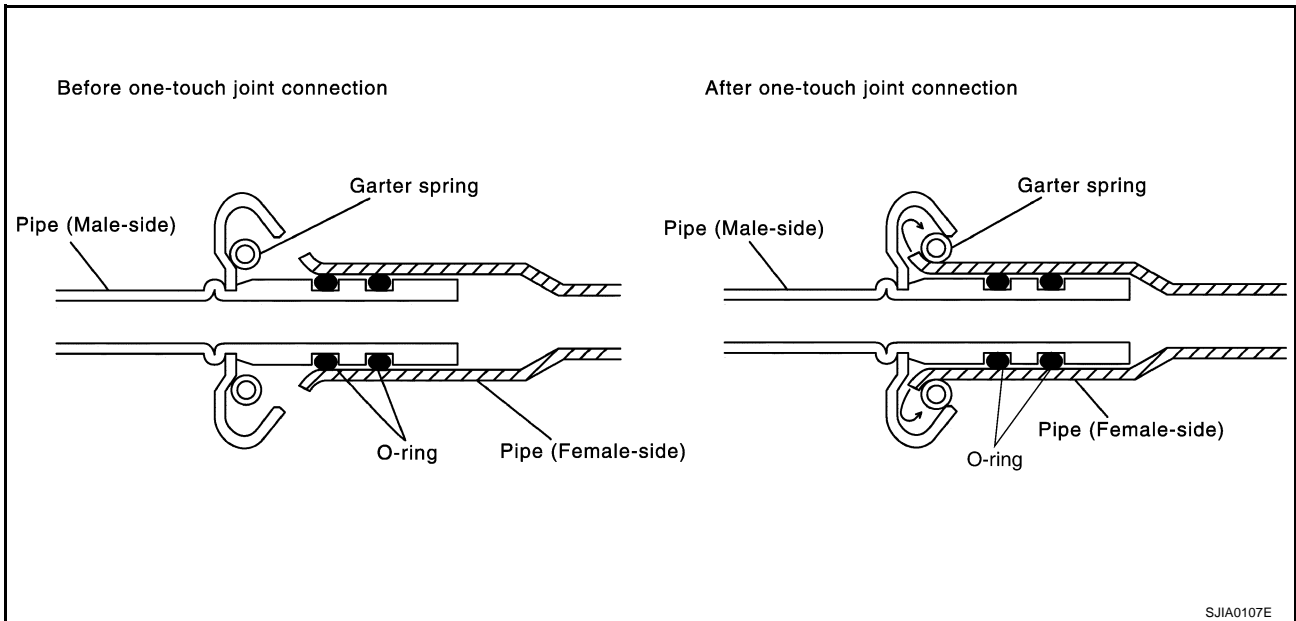

1. Clean piping connection points, and insert male-side piping into female-side piping.
2. Push inserted male-side piping harder so that female-side piping flare stretches garter spring.
3. If inside diameter of garter spring becomes larger than outside diameter of female-side piping flare, garter spring seats on flare. Then, it fits in between male-side piping cage and female-side piping flare to anchor piping connection point.

NOTICE:

When garter spring seats on flare, and fits in between male-side piping cage and female-side piping flare, it clicks.

CAUTION:

- Female-side piping connection point is thin. So, when inserting male-side piping, take care not to deform female-side piping. Slowly insert it in axial direction.
- Insert piping securely until a click is heard.

PRECAUTIONS

- After piping connection is completed, pull male-side piping by hand to make sure connection does not come loose.

NOTE:

One-touch joint connection is used in points below.

- Low-pressure flexible hose to evaporator (O-ring size: 16)
- High-pressure flexible hose to condenser (O-ring size: 12)
- High-pressure pipe 1 to evaporator (O-ring size: 8)
- High-pressure pipe 1 to condenser (O-ring size: 8)

FEATURES OF NEW TYPE REFRIGERANT CONNECTION

- The O-ring has been relocated. It has also been provided with a groove for proper installation. This eliminates the chance of the O-ring being caught in, or damaged by, the mating part. The sealing direction of the O-ring is now set vertically in relation to the contacting surface of the mating part to improve sealing characteristics.
- The reaction force of the O-ring will not occur in the direction that causes the joint to pull out, thereby facilitating piping connections.

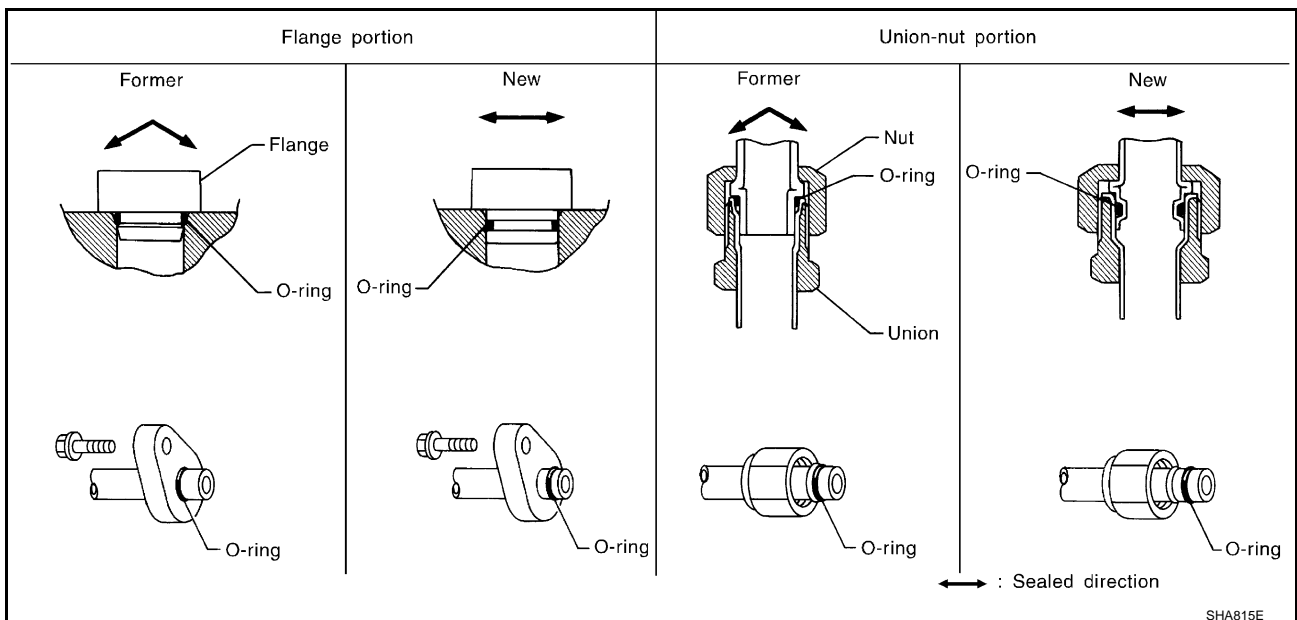

A
B
C
D
E
F
G
H
I
K
L
M

ATC

PRECAUTIONS

O-RING AND REFRIGERANT CONNECTION

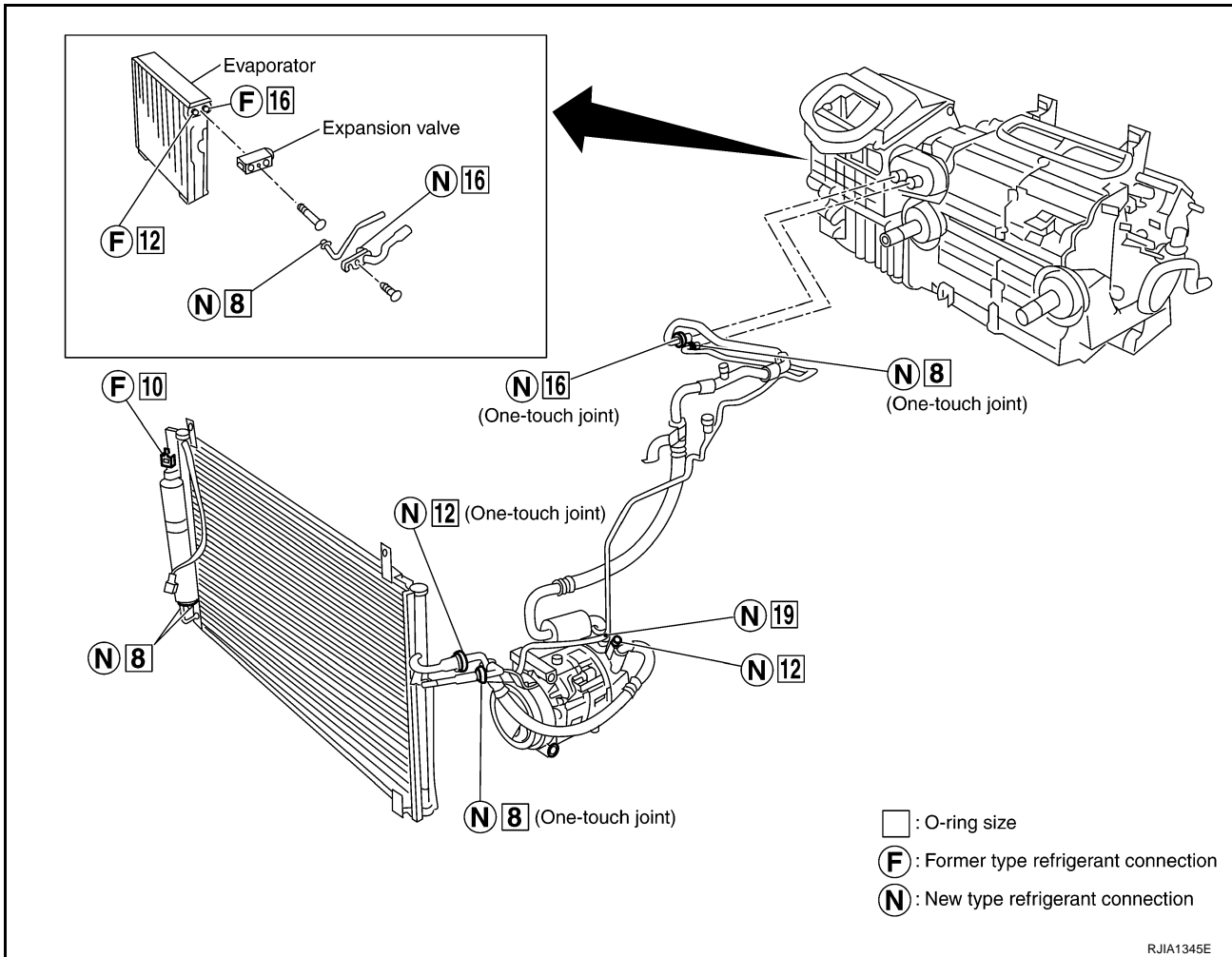

CAUTION:

The new and former refrigerant connections use different O-ring configurations. Do not confuse O-rings since they are not interchangeable. If a wrong O-ring is installed, refrigerant will leak at, or around, the connection.

O-Ring Part Numbers and Specifications

Connection type	Piping connection point		Part number	QTY	O-ring size	
New	Low-pressure flexible hose to low-pressure pipe (One-touch joint)		92473 N8221	2	16	
	High-pressure pipe 1 to high-pressure pipe 2 (One-touch joint)		92471 N8221	2	8	
	Condenser to high-pressure flexible hose (One-touch joint)		92472 N8221	2	12	
	Condenser to high-pressure pipe 1 (One-touch joint)		92471 N8221	2	8	
	Low-pressure pipe to expansion valve		92473 N8210	1	16	
	High-pressure pipe 2 to expansion valve		92471 N8210	1	8	
	Compressor to low-pressure flexible hose		92474 N8210	1	19	
	Compressor to high-pressure flexible hose		92472 N8210	1	12	
	Liquid tank to condenser pipe		92471 N8210	Inlet	1	8
		Outlet		1		
Former	Refrigerant pressure sensor to liquid tank		J2476 89956	1	10	
	Expansion valve to evaporator		Inlet	92475 71L00	1	12
			Outlet	92475 72L00	1	16

PRECAUTIONS

WARNING:

Make sure all refrigerant is discharged into the recycling equipment and the pressure in the system is less than atmospheric pressure. Then gradually loosen the discharge side hose fitting and remove it.

CAUTION:

When replacing or cleaning refrigerant cycle components, observe the following.

- When the compressor is removed, store it in the same position as it is when mounted on the car. Malfunction to do so will cause lubricant to enter the low pressure chamber.
- When connecting tubes, always use a torque wrench and a back-up wrench.
- After disconnecting tubes, immediately plug all openings to prevent entry of dirt and moisture.
- When installing an air conditioner in the vehicle, connect the pipes as the final stage of the operation. Do not remove the seal caps of pipes and other components until just before required for connection.
- Allow components stored in cool areas to warm to working area temperature before removing seal caps. This prevents condensation from forming inside A/C components.
- Thoroughly remove moisture from the refrigeration system before charging the refrigerant.
- Always replace used O-rings.
- When connecting tube, apply lubricant to circle of the O-rings shown in illustration. Be careful not to apply lubricant to threaded portion.
Lubricant name: Nissan A/C System Oil Type S
Part number: KLH00-PAGS0
- O-ring must be closely attached to dented portion of tube.
- When replacing the O-ring, be careful not to damage O-ring and tube.
- Connect tube until you hear it click, then tighten the nut or bolt by hand until snug. Make sure that the O-ring is installed to tube correctly.
- After connecting line, conduct leak test and make sure that there is no leakage from connections. When the gas leaking point is found, disconnect that line and replace the O-ring. Then tighten connections of seal seat to the specified torque.

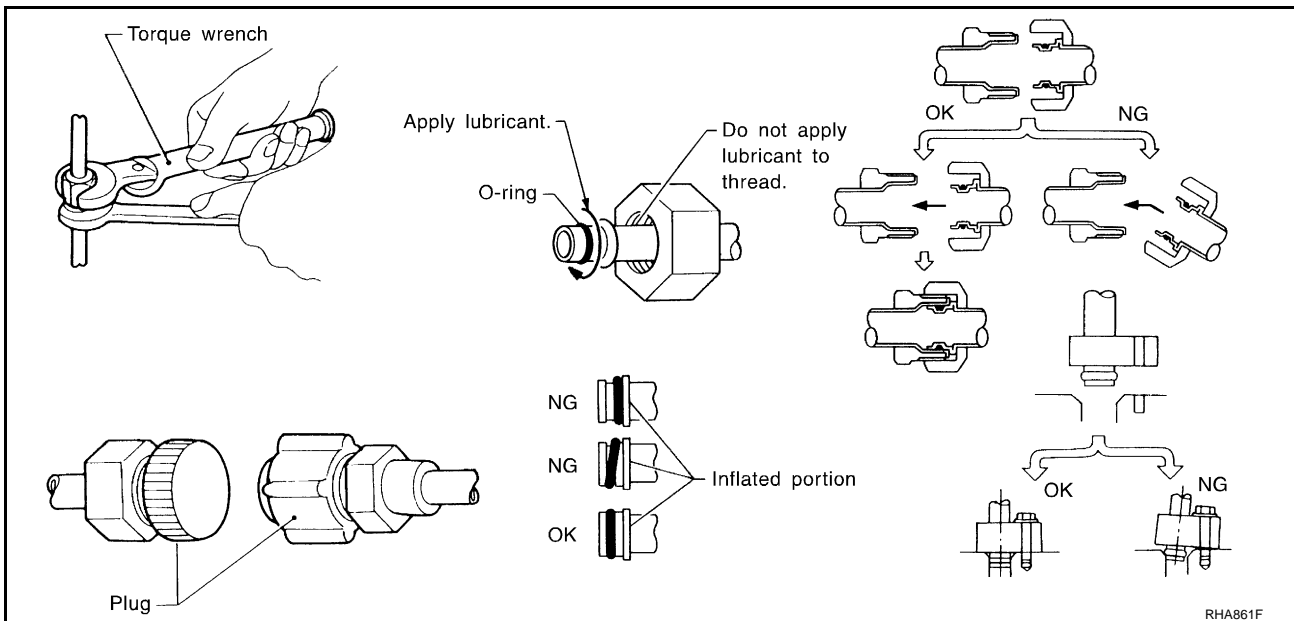

Precautions for Servicing Compressor

AJS009K

- Plug all openings to prevent moisture and foreign matter from entering.
- When the compressor is removed, store it in the same position as it is when mounted on the car.
- When replacing or repairing compressor, follow "Maintenance of Lubricant Quantity in Compressor" exactly. Refer to [ATC-24, "Maintenance of Lubricant Quantity in Compressor"](#).
- Keep friction surfaces between clutch and pulley clean. If the surface is contaminated, with lubricant, wipe it off by using a clean waste cloth moistened with thinner.

PRECAUTIONS

- After compressor service operation, turn the compressor shaft by hand more than five turns in both directions. This will equally distribute lubricant inside the compressor. After the compressor is installed, let the engine idle and operate the compressor for one hour.
- After replacing the compressor magnet clutch, apply voltage to the new one and check for usual operation.

Precautions for Service Equipment RECOVERY/RECYCLING EQUIPMENT

AJS0009L

Be certain to follow the manufacturer's instructions for machine operation and machine maintenance. Never introduce any refrigerant other than that specified into the machine.

ELECTRONIC LEAK DETECTOR

Be certain to follow the manufacturer's instructions for tester operation and tester maintenance.

VACUUM PUMP

The lubricant contained inside the vacuum pump is not compatible with the specified lubricant for HFC-134a (R-134a) A/C systems. The vent side of the vacuum pump is exposed to atmospheric pressure. So the vacuum pump lubricant may migrate out of the pump into the service hose. This is possible when the pump is switched off after evacuation (vacuuming) and hose is connected to it.

To prevent this migration, use a manual valve placed near the hose-to-pump connection, as follows.

- Usually vacuum pumps have a manual isolator valve as part of the pump. Close this valve to isolate the service hose from the pump.
- For pumps without an isolator, use a hose equipped with a manual shut-off valve near the pump end. Close the valve to isolate the hose from the pump.
- If the hose has an automatic shut-off valve, disconnect the hose from the pump. As long as the hose is connected, the valve is open and lubricating oil may migrate.

Some one-way valves open when vacuum is applied and close under a no vacuum condition. Such valves may restrict the pump's ability to pull a deep vacuum and are not recommended.

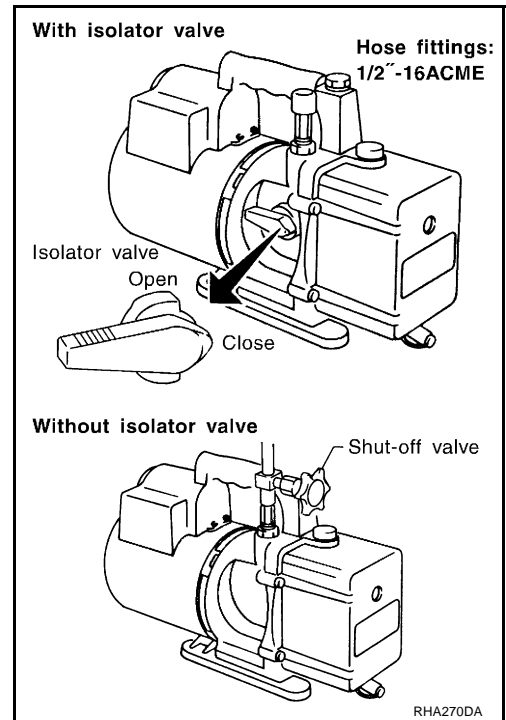

MANIFOLD GAUGE SET

Be certain that the gauge face indicates HFC-134a or R-134a. Be sure the gauge set has 1/2\"-16 ACME threaded connections for service hoses. Confirm the set has been used only with refrigerant HFC-134a (R-134a) and specified lubricants.

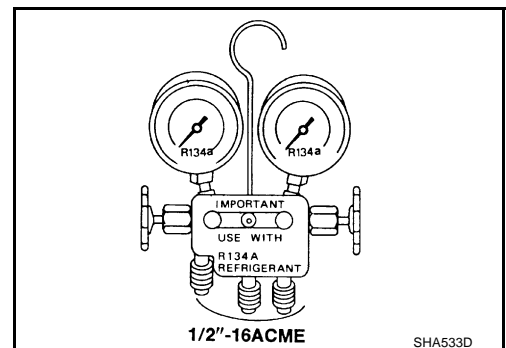

PRECAUTIONS

SERVICE HOSES

Be certain that the service hoses display the markings described (colored hose with black stripe). All hoses must include positive shut-off devices (either manual or automatic) near the end of the hoses opposite the manifold gauge.

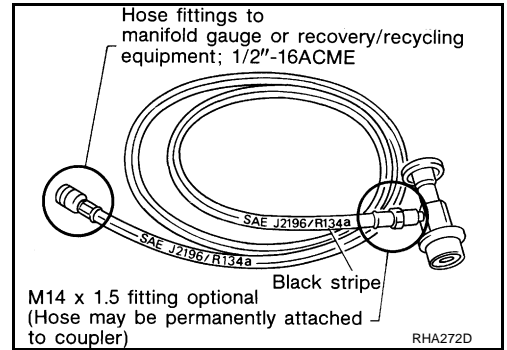

SERVICE COUPLERS

Never attempt to connect HFC-134a (R-134a) service couplers to a CFC-12 (R-12) A/C system. The HFC-134a (R-134a) couplers will not properly connect to the CFC-12 (R-12) system. However, if an improper connection is attempted, discharging and contamination may occur.

Shut-off valve rotation	A/C service valve
Clockwise	Open
Counterclockwise	Close

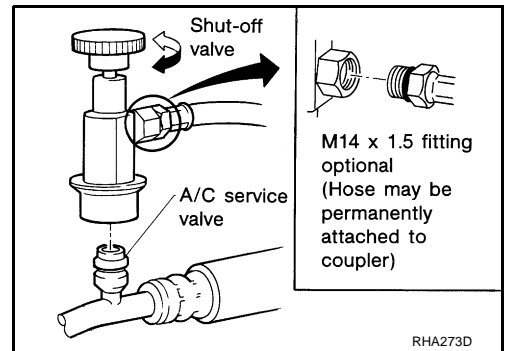

REFRIGERANT WEIGHT SCALE

Verify that no refrigerant other than HFC-134a (R-134a) and specified lubricants have been used with the scale. If the scale controls refrigerant flow electronically, the hose fitting must be 1/2"-16 ACME.

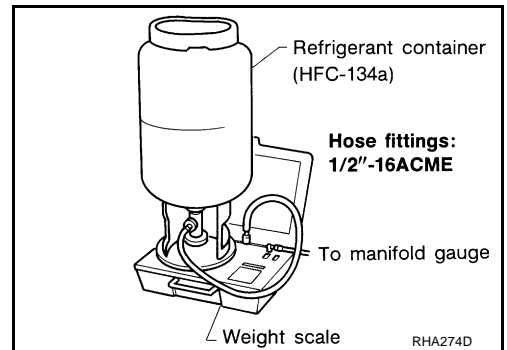

CHARGING CYLINDER

Using a charging cylinder is not recommended. Refrigerant may be vented into air from cylinder's top valve when filling the cylinder with refrigerant. Also, the accuracy of the cylinder is generally less than that of an electronic scale or of quality recycle/recharge equipment.

A
B
C
D
E
F
G
H
I
K
L
M

ATC

PRECAUTIONS

AJS0009M

Precautions for Leak Detection Dye

- The A/C system contains a fluorescent leak detection dye used for locating refrigerant leaks. An ultraviolet (UV) lamp is required to illuminate the dye when inspecting for leaks.
- Always wear fluorescence enhancing UV safety goggles to protect your eyes and enhance the visibility of the fluorescent dye.
- The fluorescent dye leak detector is not a replacement for an electronic refrigerant leak detector. The fluorescent dye leak detector should be used in conjunction with an electronic refrigerant leak detector to (J-41995) pin-point refrigerant leaks.
- For your safety and your customer's satisfaction, read and follow all manufacturer's operating instructions and precautions prior to performing the work.
- A compressor shaft seal should not be repaired because of dye seepage. The compressor shaft seal should only be repaired after confirming the leak with an electronic refrigerant leak detector (J-41995).
- Always remove any remaining dye from the leak area after repairs are complete to avoid a misdiagnosis during a future service.
- Do not allow dye to come into contact with painted body panels or interior components. If dye is spilled, clean immediately with the approved dye cleaner. Fluorescent dye left on a surface for an extended period of time cannot be removed.
- Do not spray the fluorescent dye cleaning agent on hot surfaces (engine exhaust manifold, etc.).
- Do not use more than one refrigerant dye bottle (1/4 ounce /7.4 cc) per A/C system.
- Leak detection dyes for HFC-134a (R-134a) and CFC-12 (R-12) A/C systems are different. Do not use HFC-134a (R-134a) leak detection dye in CFC-12 (R-12) A/C system or CFC-12 (R-12) leak detector dye in HFC-134a (R-134a) A/C system or A/C system damage may result.
- The fluorescent properties of the dye will remain for over three (3) years unless a compressor malfunction occurs.

IDENTIFICATION

NOTE:

Vehicles with factory installed fluorescent dye have a green label.
Vehicles without factory installed fluorescent dye have a blue label.

IDENTIFICATION LABEL FOR VEHICLE

Vehicles with factory installed fluorescent dye have this identification label on the front side of hood.

AIR CONDITIONER NISSAN		
	REFRIGERANT	COMPRESSOR LUBRICANT
TYPE (PART NO.)	HFC134a (R134a)	Nissan UV Luminous Oil Type S [KLHOO-PAGSO]
AMOUNT		

CAUTION PRECAUTION

- REFRIGERANT UNDER HIGH PRESSURE.
- SYSTEM TO BE SERVICED BY QUALIFIED PERSONNEL.
- IMPROPER SERVICE METHODS MAY CAUSE PERSONAL INJURY.
- CONSULT SERVICE MANUAL.
- THIS AIR CONDITIONER SYSTEM COMPLIES WITH SAE J-639.

Nissan Motor Co., Ltd., TOKYO, Japan

27090 6P102

SHA436FA

Wiring Diagrams and Trouble Diagnosis

AJS0009N

When you read wiring diagrams, refer to the following:

- [GI-15, "How to Read Wiring Diagrams"](#) in GI section.
- [PG-5, "Wiring Diagram — POWER —"](#) in PG section.

When you perform trouble diagnosis, refer to the following:

- [GI-11, "How to Follow Trouble Diagnoses"](#) in GI section.
- [GI-27, "How to Perform Efficient Diagnosis for an Electrical Incident"](#) in GI section.

PREPARATION



PREPARATION

PPF:00002

Special Service Tools

AJS00090

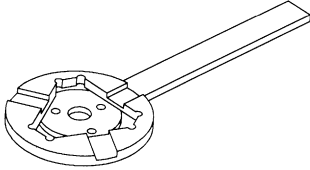
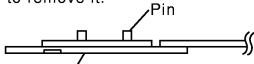
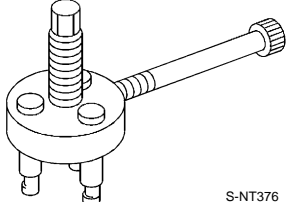
The actual shapes of Kent-Moore tools may differ from those of special service tools illustrated here.

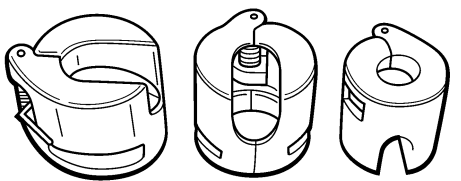
Tool number (Kent-Moore No.) Tool name	Description
<p>KV99106100 (J-41260) Clutch disc wrench</p>  <p style="text-align: right;">S-NT232</p> <p>When replacing the magnetic clutch in the above compressor, use a clutch disc wrench with the pin side on the clutch disc to remove it.</p>  <p style="text-align: right;">RJIA0194E</p>	<p>Removing shaft nut and clutch disc</p>
<p>KV99232340 (J-38874) or KV992T0001 (-) Clutch disc puller</p>  <p style="text-align: right;">S-NT376</p>	<p>Removing clutch disc</p>
<p>KV99106200 (J-41261) Pulley installer</p>  <p style="text-align: right;">S-NT235</p>	<p>Installing pulley</p>
<p>92530 89908 (for high-pressure pipe 1) (-) 92530 89912 (for high-pressure flexible hose) (-) 92530 89916 (for low-pressure pipe 1 and low-pressure flexible hose) (-) Disconnecter tool set (J-45815)</p>  <p style="text-align: center;">92530 89916 (16 mm) 92530 89912 (12 mm) 92530 89908 (8 mm)</p> <p style="text-align: center;">Disconnecter tool set : J-45815</p> <p style="text-align: right;">SJIA0285E</p>	<p>Disconnect one-touch joint connection</p>

A
B
C
D
E
F
G
H
I
ATC
K
L
M

PREPARATION

HFC-134a (R-134a) Service Tools and Equipment



AJS0009P

Never mix HFC-134a (R-134a) refrigerant and/or its specified lubricant with CFC-12 (R-12) refrigerant and/or its lubricant.



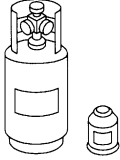

Separate and non-interchangeable service equipment must be used for handling each type of refrigerant/lubricant.

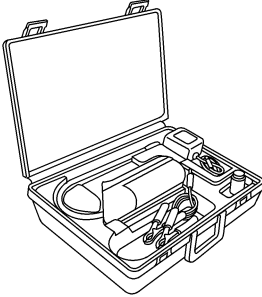
Refrigerant container fittings, service hose fittings and service equipment fittings (equipment which handles refrigerant and/or lubricant) are different between CFC-12 (R-12) and HFC-134a (R-134a). This is to avoid mixed use of the refrigerants/lubricant.

Adapters that convert one size fitting to another must never be used: refrigerant/lubricant contamination will occur and compressor malfunction will result.

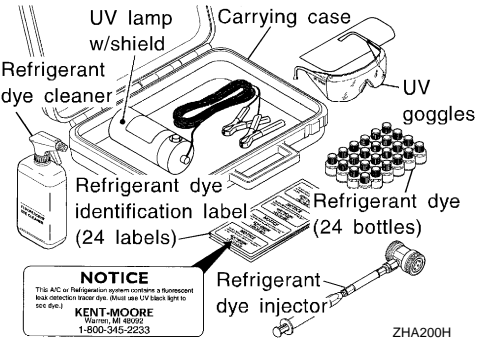
Tool number (Kent-Moore No.) Tool name	Description
<p>HFC-134a (R-134a) refrigerant</p> <div style="text-align: center;">  <p>S-NT196</p> </div>	<p>Container color: Light blue Container marking: HFC-134a (R-134a) Fitting size: Thread size</p> <ul style="list-style-type: none"> ● Large container 1/2"-16 ACME
<p>KLH00-PAGS0 (-) Nissan A/C System Oil Type S (DH-PS)</p> <div style="text-align: center;">  <p>S-NT197</p> </div>	<p>Type: Poly alkylene glycol oil (PAG), type S (DH-PS) Application: HFC-134a (R-134a) wobble (swash) plate compressors (Nissan only) Lubricity: 40 m ℓ (1.4 US fl oz, 1.4 Imp fl oz)</p>
<p>(J-43600) Recovery/Recycling/ Recharging equipment (ACR2000)</p> <div style="text-align: center;">  <p>WJIA0293E</p> </div>	<p>Function: Refrigerant recovery and recycling and recharging</p>
<p>(J-41995) Electrical leak detector</p> <div style="text-align: center;">  <p>AHA281A</p> </div>	<p>Power supply:</p> <ul style="list-style-type: none"> ● DC 12V (Cigarette lighter)

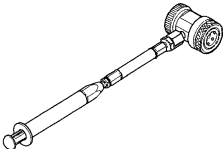
PREPARATION

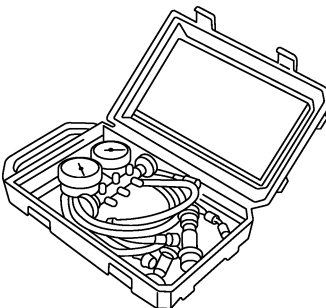
Tool number (Kent-Moore No.) Tool name	Description	A
(J-43926) Refrigerant dye leak detection kit Kit includes: (J-42220) UV lamp and UV safety goggles (J-41459) HFC-134a (R-134a) dye injector Use with J-41447, 1/4 ounce bottle (J-41447) HFC-134a (R-134a) fluorescent leak detection dye (Box of 24, 1/4 ounce bottles) (J-43872) Refrigerant dye cleaner	 <p style="text-align: right;">Power supply: DC 12V (Battery terminal)</p>	B C D E
(J-42220) UV lamp and UV safety goggles	 <p style="text-align: right;">Power supply: DC 12V (Battery terminal) For checking refrigerant leak when fluorescent dye is installed in A/C system Includes: UV lamp and UV safety goggles</p>	F G
(J-41447) HFC-134a (R-134a) fluorescent leak detection dye (Box of 24, 1/4 ounce bottles)	 <p style="text-align: right;">Application: For HFC-134a (R-134a) PAG oil Container: 1/4 ounce (7.4 cc) bottle (Includes self-adhesive dye identification labels for affixing to vehicle after charging system with dye.)</p>	H I ATC
(J-41459) HFC-134a (R-134a) dye injector Use with J-41447, 1/4 ounce bottle	 <p style="text-align: right;">For injecting 1/4 ounce of fluorescent leak detection dye into A/C system</p>	K L
(J-43872) Refrigerant dye cleaner	 <p style="text-align: right;">For cleaning dye spills</p>	M
(J-39183) Manifold gauge set (with hoses and couplers)	 <p style="text-align: right;">Identification: ● The gauge face indicates HFC-134a (R-134a). Fitting size: Thread size ● 1/2"-16 ACME</p>	RJA0196E

PREPARATION

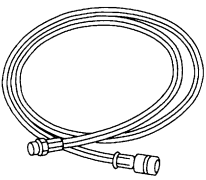
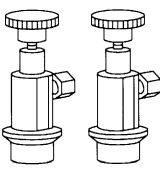
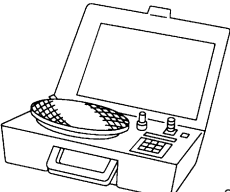
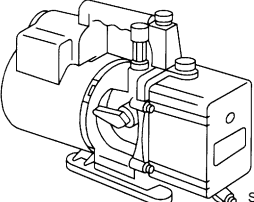
Tool number (Kent-Moore No.) Tool name	Description
<p>Service hoses</p> <ul style="list-style-type: none"> ● High-pressure side hose (J-39501-72) ● Low-pressure side hose (J-39502-72) ● Utility hose (J-39476-72) 	 <p style="text-align: right; margin-right: 50px;">S-NT201</p> <p>Hose color:</p> <ul style="list-style-type: none"> ● Low hose: Blue with black stripe ● High hose: Red with black stripe ● Utility hose: Yellow with black stripe or green with black stripe <p>Hose fitting to gauge:</p> <ul style="list-style-type: none"> ● 1/2"-16 ACME
<p>Service couplers</p> <ul style="list-style-type: none"> ● High-pressure side coupler (J-39500-20) ● Low-pressure side coupler (J-39500-24) 	 <p style="text-align: right; margin-right: 50px;">S-NT202</p> <p>Hose fitting to service hose:</p> <ul style="list-style-type: none"> ● M14 x 1.5 fitting is optional or permanently attached.
<p>(J-39650) Refrigerant weight scale</p>	 <p style="text-align: right; margin-right: 50px;">S-NT200</p> <p>For measuring of refrigerant Fitting size: Thread size</p> <ul style="list-style-type: none"> ● 1/2"-16 ACME
<p>(J-39649) Vacuum pump (Including the isolator valve)</p>	 <p style="text-align: right; margin-right: 50px;">S-NT203</p> <p>Capacity:</p> <ul style="list-style-type: none"> ● Air displacement: 4 CFM ● Micron rating: 20 microns ● Oil capacity: 482 g (17 oz) <p>Fitting size: Thread size</p> <ul style="list-style-type: none"> ● 1/2"-16 ACME

Commercial Service Tools

AJS0009Q

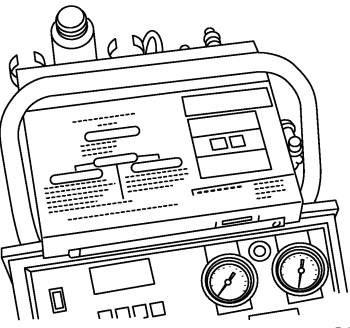
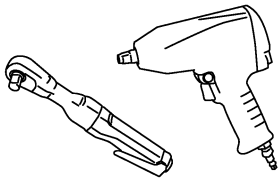
Tool name	Description
<p>Refrigerant identifier equipment</p>	 <p style="text-align: right; margin-right: 50px;">RJIA0197E</p> <p>Checking for refrigerant purity and system contamination</p>
<p>Power tool</p>	 <p style="text-align: right; margin-right: 50px;">PBIC0190E</p> <p>For loosening bolts and nuts</p>

REFRIGERATION SYSTEM

REFRIGERATION SYSTEM

PFP:KA990

Refrigerant Cycle REFRIGERANT FLOW

AJS0009R

The refrigerant flows in the standard pattern, that is, through the compressor, the condenser with liquid tank, through the evaporator, and back to the compressor. The refrigerant evaporation through the evaporator coil is controlled by an externally equalized expansion valve, located inside the evaporator case.

FREEZE PROTECTION

Under normal operating conditions, when the A/C is switched on, the compressor runs continuously, and the evaporator pressure, and therefore, temperature is controlled by the V-6 variable displacement compressor to prevent freeze up.

Refrigerant System Protection REFRIGERANT PRESSURE SENSOR

AJS000JD

The refrigerant system is protected against excessively high- or low-pressures by the refrigerant pressure sensor, located on the liquid tank. If the system pressure rises above, or falls below the specifications, the refrigerant pressure sensor detects the pressure inside the refrigerant line and sends the voltage signal to the ECM. ECM makes the A/C relay go OFF and stops the compressor when pressure on the high-pressure side detected by refrigerant pressure sensor is over about 2,746 kPa (28 kg/cm², 398 psi), or below about 134 kPa (1.4 kg/cm², 20 psi).

PRESSURE RELIEF VALVE

The refrigerant system is also protected by a pressure relief valve, located in the rear head of the compressor. When the pressure of refrigerant in the system increases to an unusual level [more than 3,727 kPa (38 kg/cm², 540 psi)], the release port on the pressure relief valve automatically opens and releases refrigerant into the atmosphere.

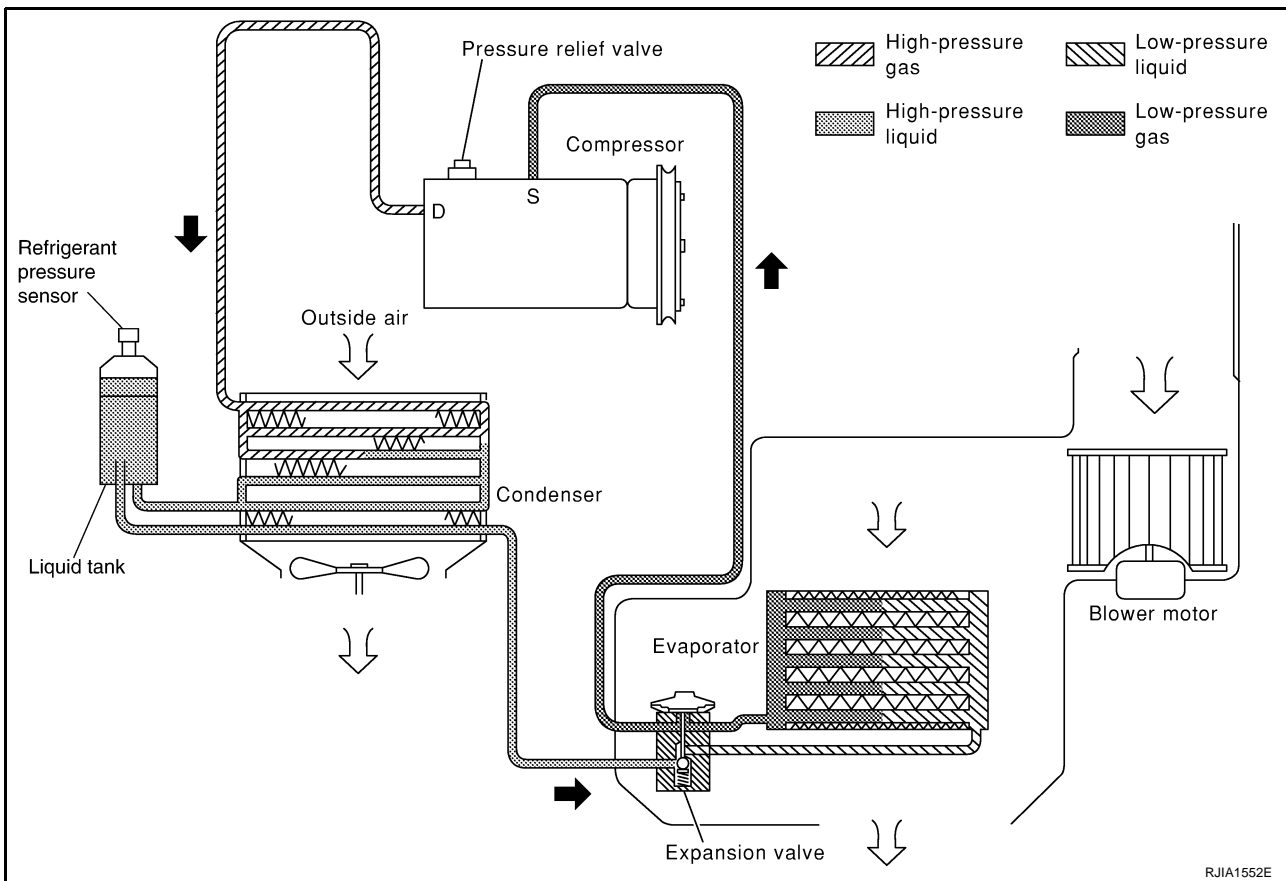

ATC

REFRIGERATION SYSTEM

V-6 Variable Displacement Compressor

AJS000MV

GENERAL INFORMATION

1. The V-6 variable compressor differs from previous units. The vent temperatures of the V-6 variable compressor do not drop too far below 5°C (41°F) when:
Evaporator intake air temperature is less than 20°C (68°F).
Engine is running at speeds less than 1,500 rpm.
This is because the V-6 compressor provides a means of “capacity” control.
2. The V-6 variable compressor provides refrigerant control under varying conditions. During cold winters, it may not produce high refrigerant pressure discharge (compared to previous units) when used with air conditioning systems.
3. A “clanking” sound may occasionally be heard during refrigerant charge. The sound indicates that the tilt angle of the wobble (swash) plate has changed and is not a malfunction.
4. For air conditioning systems with the V-6 compressor, the clutch remains engaged unless: the system main switch, fan switch or ignition switch is turned OFF. When ambient (outside) temperatures are low or when the amount of refrigerant is insufficient, the clutch is disengaged to protect the compressor.
5. A constant range of suction pressure is maintained when engine speed is greater than a certain value. It normally ranges from 147 to 177 kPa (1.5 to 1.8 kg/cm², 21 to 26 psi) under varying conditions. In previous compressors, however, suction pressure was reduced with increases in engine speed.

REFRIGERATION SYSTEM

DESCRIPTION

General

The variable compressor is basically a swash plate type that changes piston stroke in response to the required cooling capacity.

The tilt of the wobble (swash) plate allows the piston's stroke to change so that refrigerant discharge can be continuously changed from 13.5 to 146 cm³ (0.824 to 8.91 cu in).

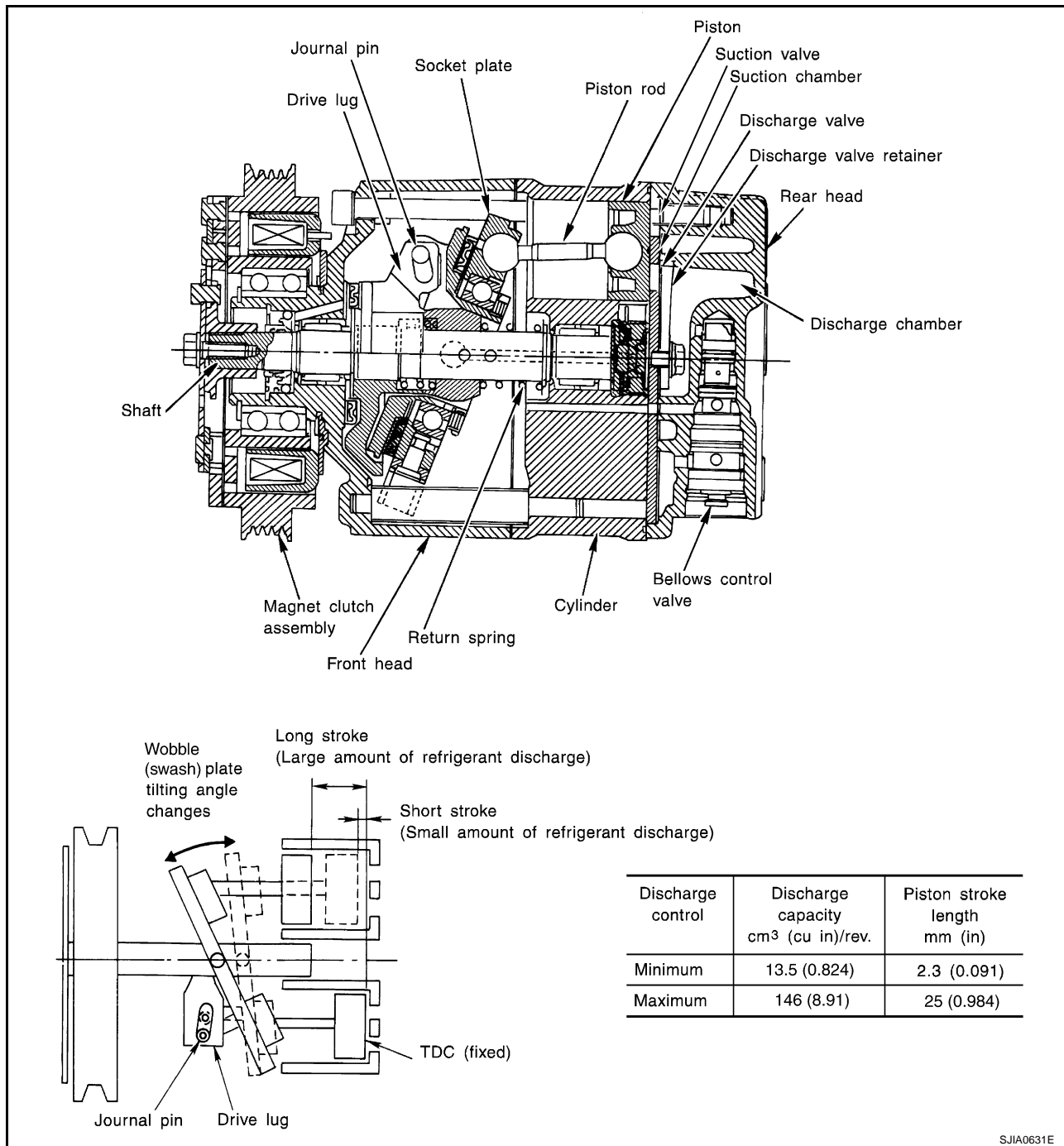

Operation

1. Operation Control Valve

Operation control valve is located in the suction port (low-pressure) side, and opens or closes in response to changes in refrigerant suction pressure.

Operation of the valve controls the internal pressure of the crankcase.

The angle of the wobble (swash) plate is controlled between the crankcase's internal pressure and the piston cylinder pressure.

REFRIGERATION SYSTEM

2. Maximum Cooling

Refrigerant pressure on the low-pressure side increases with an increase in heat loads. When this occurs, the control valve's bellows compress to open the low-pressure side valve and close the high-pressure side valve.

This causes the following pressure changes:

The crankcase's internal pressure to equal the pressure on the low-pressure side.

The cylinder's internal pressure to be greater than the crankcase's internal pressure.

Under this condition, the wobble (swash) plate is set to the maximum stroke position.

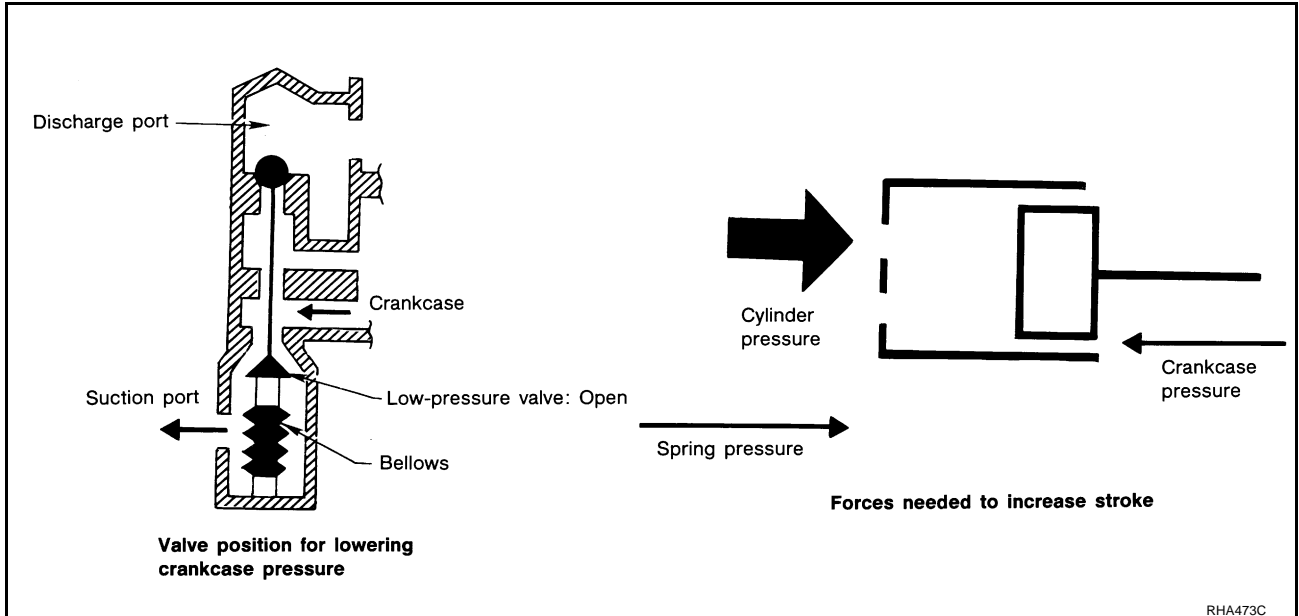

3. Capacity Control

- Refrigerant pressure on suction side is low during high speed driving or when ambient or interior temperature is low.
- The bellows expands when refrigerant pressure on the suction pressure side drops below approximately 177 kPa (1.8 kg/cm², 26 psi).
- The force acts around the journal pin are located where the piston generates the highest pressure. Piston pressure is between suction pressure P_s and discharge pressure P_d , which is near suction pressure P_s . If crankcase pressure P_c rises due to capacity control, the force around the journal pin makes the wobble (swash) plate angle decrease and also the piston stroke decrease. In other words, crankcase pressure increase triggers pressure difference between the piston and the crankcase. The pressure difference changes the angle of the wobble (swash) plate.

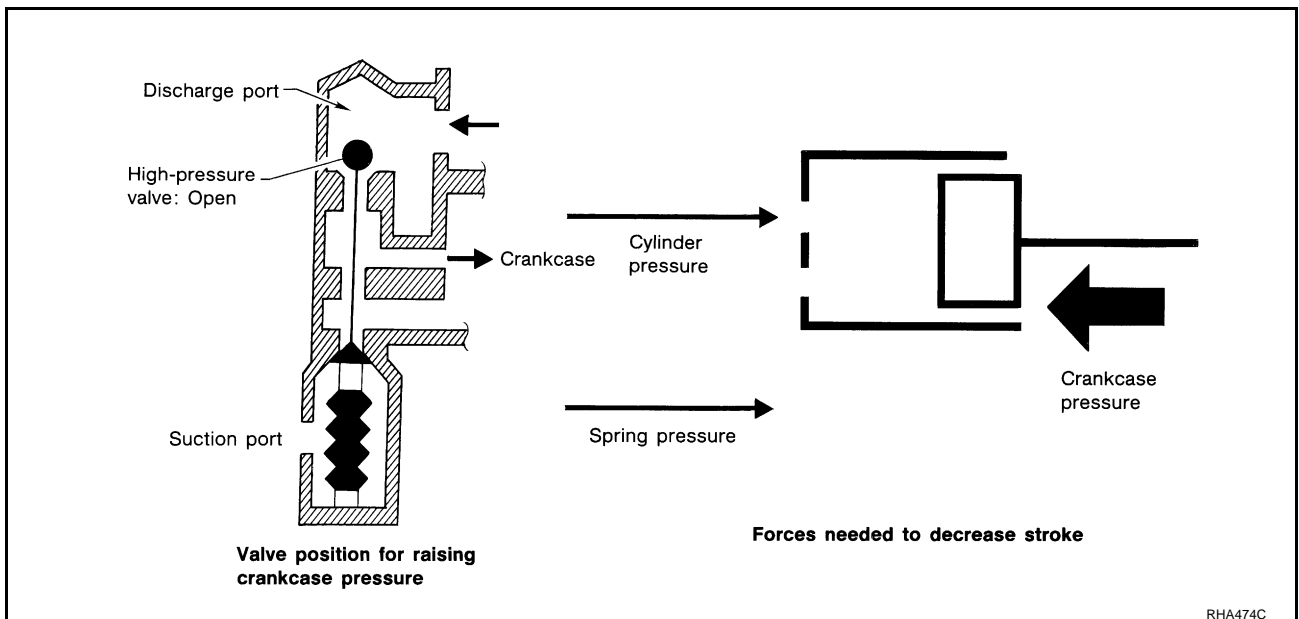

REFRIGERATION SYSTEM

Component Layout

AJS000JF

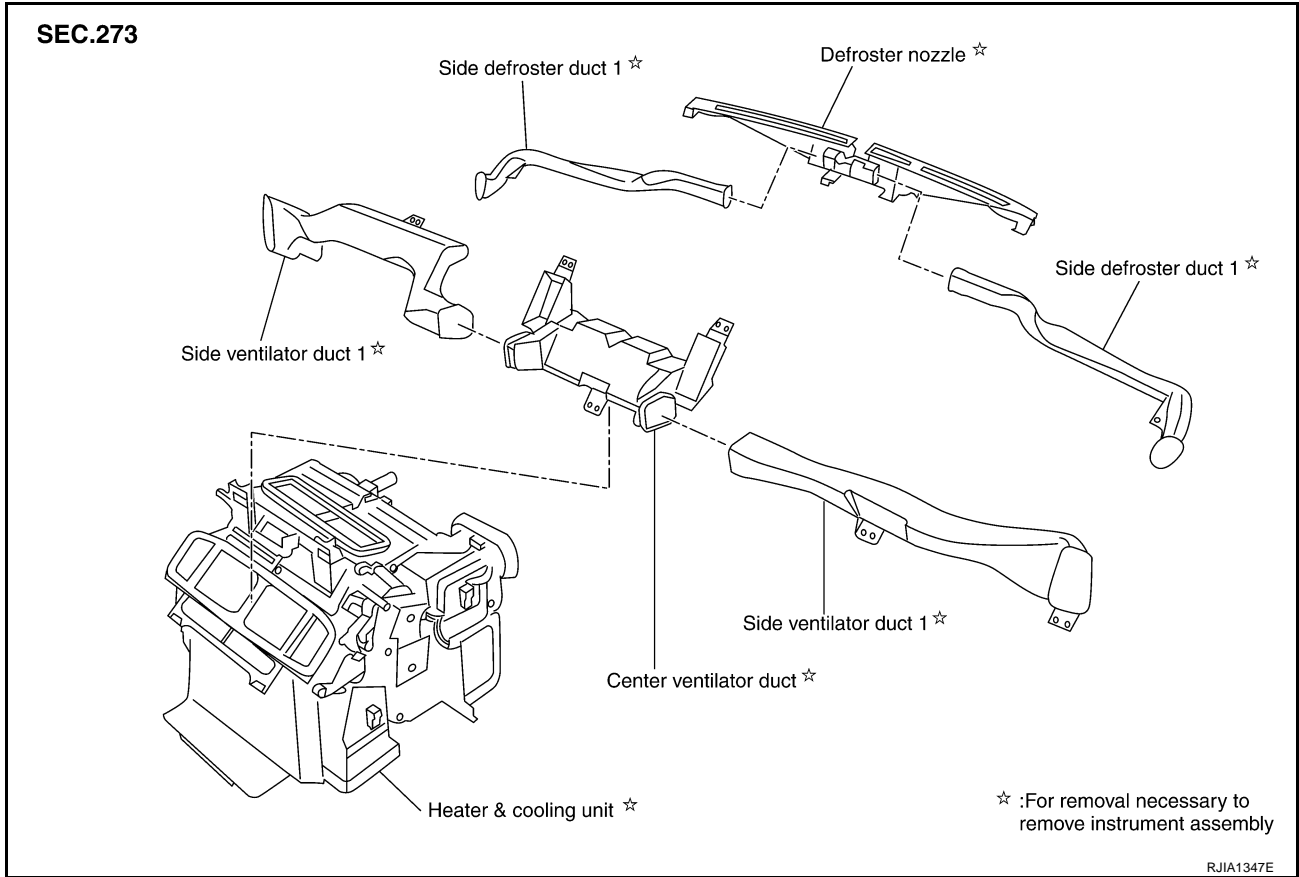

A
B
C
D
E
F
G
H
I
K
L
M

ATC

LUBRICANT

LUBRICANT

PFPP:KLG00

Maintenance of Lubricant Quantity in Compressor

AJS0009V

The lubricant in the compressor circulates through the system with the refrigerant. Add lubricant to compressor when replacing any component or after a large refrigerant leakage occurred. It is important to maintain the specified amount.

If lubricant quantity is not maintained properly, the following malfunctions may result:

- Lack of lubricant: May lead to a seized compressor.
- Excessive lubricant: Inadequate cooling (thermal exchange interference)

LUBRICANT

Name	:Nissan A/C System Oil Type S
Part number	:KLH00-PAGS0

LUBRICANT RETURN OPERATION

Adjust the lubricant quantity according to the test group shown below.

1. CHECK LUBRICANT RETURN OPERATION

Can lubricant return operation be performed?

- A/C system works properly.
- There is no evidence of a large amount of lubricant leakage.

CAUTION:

If excessive lubricant leakage is noted, do not perform the lubricant return operation.

OK or NG

- OK >> GO TO 2.
NG >> GO TO 3.

2. PERFORM LUBRICANT RETURN OPERATION, PROCEEDING AS FOLLOWS:

1. Start engine, and set the following conditions:
 - Test condition
 - Engine speed: Idling to 1,200 rpm
 - A/C switch: ON
 - Blower speed: Max. position
 - Temp. control: Optional [Set so that intake air temperature is 25 to 30°C (77 to 86°F).]
 - Intake position: Recirculation (REC)
2. Perform lubricant return operation for about 10 minutes.
3. Stop engine.

>> GO TO 3.

3. CHECK REPLACEMENT PART

Should the compressor be replaced?

- YES >> GO TO [ATC-25, "LUBRICANT ADJUSTING PROCEDURE FOR COMPRESSOR REPLACEMENT"](#).
- NO >> GO TO [ATC-25, "LUBRICANT ADJUSTING PROCEDURE FOR COMPONENTS REPLACEMENT EXCEPT COMPRESSOR"](#).

LUBRICANT

LUBRICANT ADJUSTING PROCEDURE FOR COMPONENTS REPLACEMENT EXCEPT COMPRESSOR

After replacing any of the following major components, add the correct amount of lubricant to the system.
Amount of lubricant to be added

Part replaced	Lubricant to be added to system	Remarks
	Amount of lubricant m ℓ (US fl oz, Imp fl oz)	
Evaporator	75 (2.5, 2.6)	-
Condenser	35 (1.2, 1.2)	-
Liquid tank	10 (0.3, 0.4)	-
In case of refrigerant leak	30 (1.0, 1.1)	Large leak
	-	Small leak *1

*1: If refrigerant leak is small, no addition of lubricant is needed.

LUBRICANT ADJUSTING PROCEDURE FOR COMPRESSOR REPLACEMENT

1. Before connecting recovery/recycling recharging equipment to vehicle, check recovery/recycling recharging equipment gauges. No refrigerant pressure should be displayed. If NG, recover refrigerant from equipment lines.
2. Connect recovery/recycling recharging equipment to vehicle. Confirm refrigerant purity in supply tank using recovery/recycling recharging equipment and refrigerant identifier. If NG, refer to [ATC-5, "CONTAMINATED REFRIGERANT"](#).
3. Confirm refrigerant purity in vehicle A/C system using recovery/recycling recharging equipment and refrigerant identifier. If NG, refer to [ATC-5, "CONTAMINATED REFRIGERANT"](#).
4. Discharge refrigerant into the refrigerant recovery/recycling equipment. Measure lubricant discharged into the recovery/recycling equipment.
5. Drain the lubricant from the old (removed) compressor into a graduated container and recover the amount of lubricant drained.
6. Drain the lubricant from the new compressor into a separate, clean container.
7. Measure an amount of new lubricant installed equal to amount drained from old compressor. Add this lubricant to new compressor through the suction port opening.
8. Measure an amount of new lubricant equal to the amount recovered during discharging. Add this lubricant to new compressor through the suction port opening.
9. If the liquid tank also needs to be replaced, add an additional 5 m ℓ (0.2 US fl oz, 0.2 Imp fl oz) of lubricant at this time.
Do not add this 5 m ℓ (0.2 US fl oz, 0.2 Imp fl oz) of lubricant if only replacing the compressor.

LUBRICANT

Lubricant adjusting procedure for compressor replacement

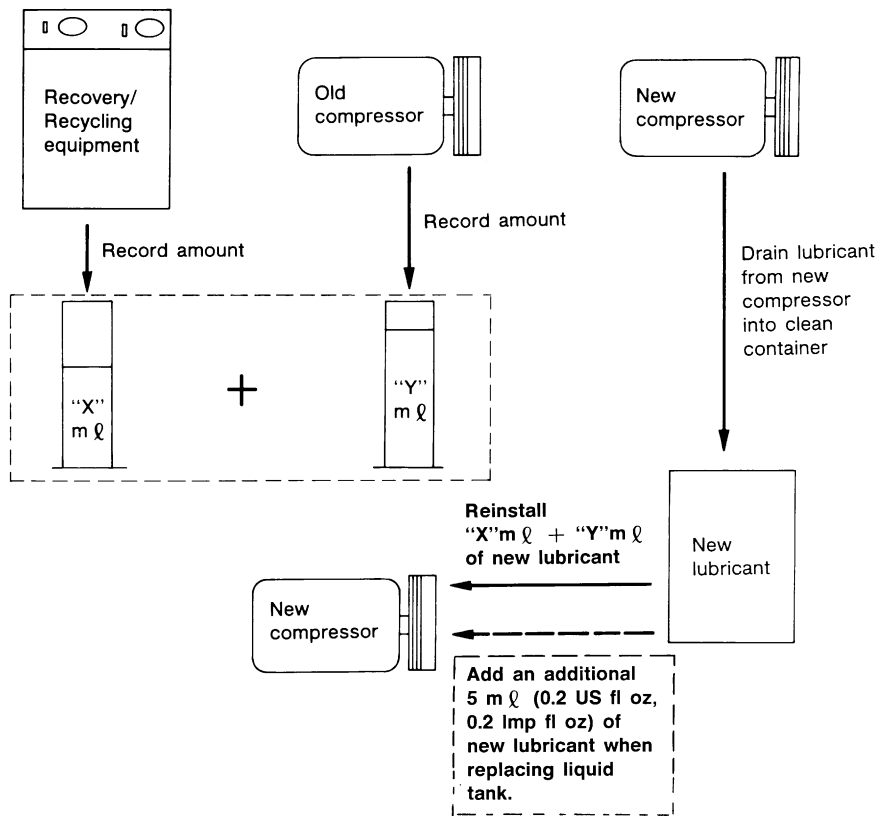

RHA065DD

AIR CONDITIONER CONTROL

AIR CONDITIONER CONTROL

PFP:27500

Description of Air Conditioner LAN Control System

AJS0009W

The LAN (Local Area Network) system consists of unified meter and A/C amp., mode door motor, air mix door motor and intake door motor.

A configuration of these components is shown in the diagram below.

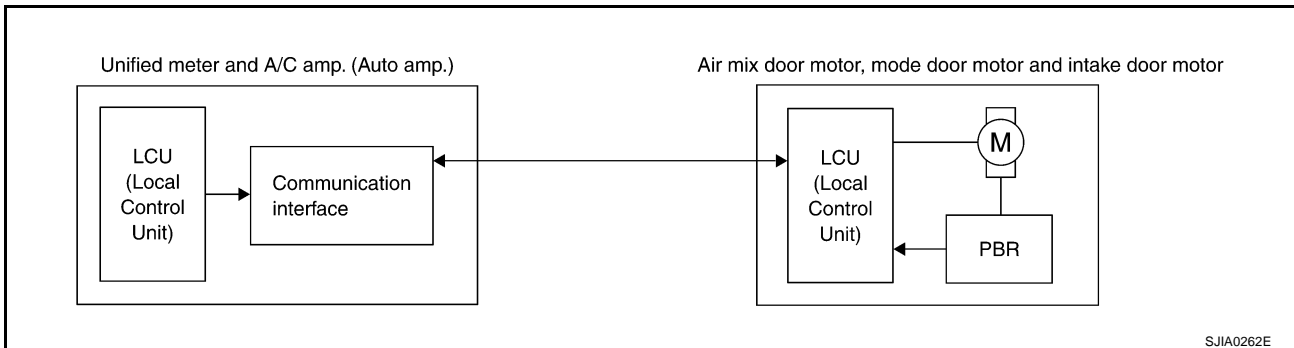

System Construction

AJS0009X

A small network is constructed between unified meter and A/C amp., air mix door motor, mode door motor and intake door motor. The unified meter and A/C amp. and motors are connected by data transmission lines and motor power supply lines. The LAN network is built through the ground circuits of each door motor.

Addresses, motor opening angle signals, motor stop signals and error checking messages are all transmitted through the data transmission lines connecting the unified meter and A/C amp. and each door motor.

The following functions are contained in LCUs built into the air mix door motor, mode door motor and intake door motor.

- Address
- Motor opening angle signals
- Data transmission
- Motor stop and drive decision
- Opening angle sensor (PBR function)
- Comparison
- Decision (Unified meter and A/C amp. indicated value and motor opening angle comparison)

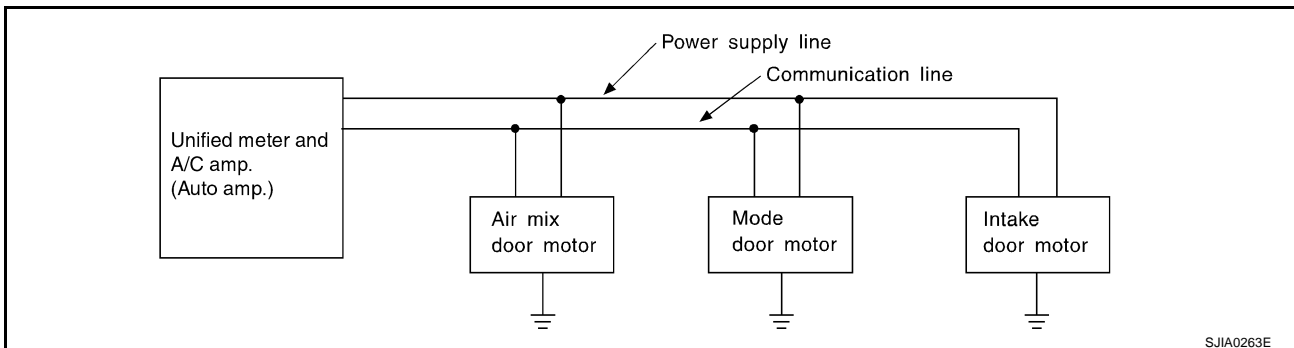

A
B
C
D
E
F
G
H
I
K
L
M

ATC

AIR CONDITIONER CONTROL

OPERATION

The unified meter and A/C amp. receives data from each of the sensors. The unified meter and A/C amp. sends mode door, air mix door and intake door opening angle data to the mode door motor LCU, air mix door motor LCU and intake door motor LCU.

The mode door motor, air mix door motor and intake door motor read their respective signals according to the address signal. Opening angle indication signals received from the unified meter and A/C amp. and each of the motor position sensors is compared by the LCUs in each motor with the existing decision and opening angles. Subsequently, HOT/COLD, DEFROST/VENT or FRESH/RECIRCULATION operation is selected. The new selection data is returned to the unified meter and A/C amp.

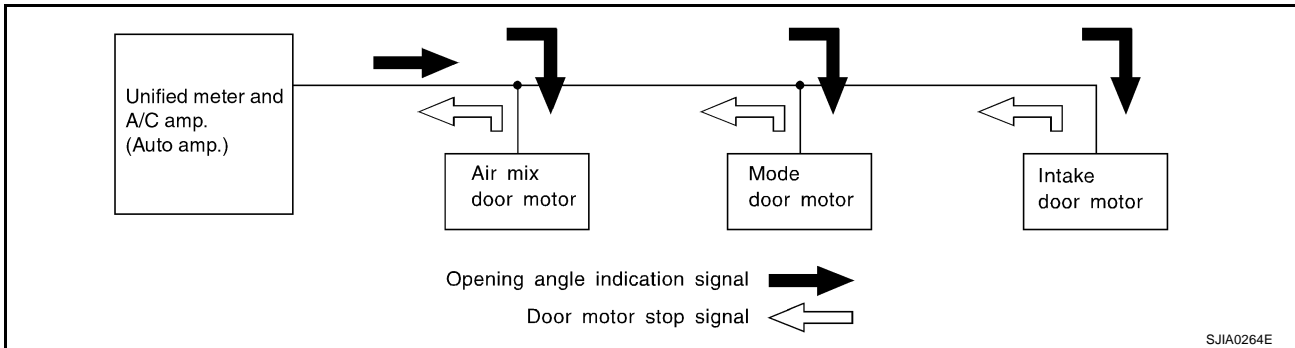

TRANSMISSION DATA AND TRANSMISSION ORDER

Unified meter and A/C amp. data is transmitted consecutively to each of the door motors following the form shown in figure below.

Start:

Initial compulsory signal sent to each of the door motors.

Address:

Data sent from the unified meter and A/C amp. is selected according to data-based decisions made by the air mix door motor, mode door motor and intake door motor.

If the addresses are identical, the opening angle data and error check signals are received by the door motor LCUs. The LCUs then make the appropriate error decision. If the opening angle data is usual, door control begins.

If an error exists, the received data is rejected and corrected data received. Finally, door control is based upon the corrected opening angle data.

Opening Angle:

Data that shows the indicated door opening angle of each door motor.

Error Check:

Procedure by which sent and received data is checked for errors. Error data is then compiled. The error check prevents corrupted data from being used by the air mix door motor, mode door motor and intake door motor. Error data can be related to the following symptoms.

- Unusual electrical frequency
- Poor electrical connections
- Signal leakage from transmission lines
- Signal level fluctuation

AIR CONDITIONER CONTROL

Stop Signal:

At the end of each transmission, a stop operation, in-operation, or internal error message is delivered to the unified meter and A/C amp. This completes one data transmission and control cycle.

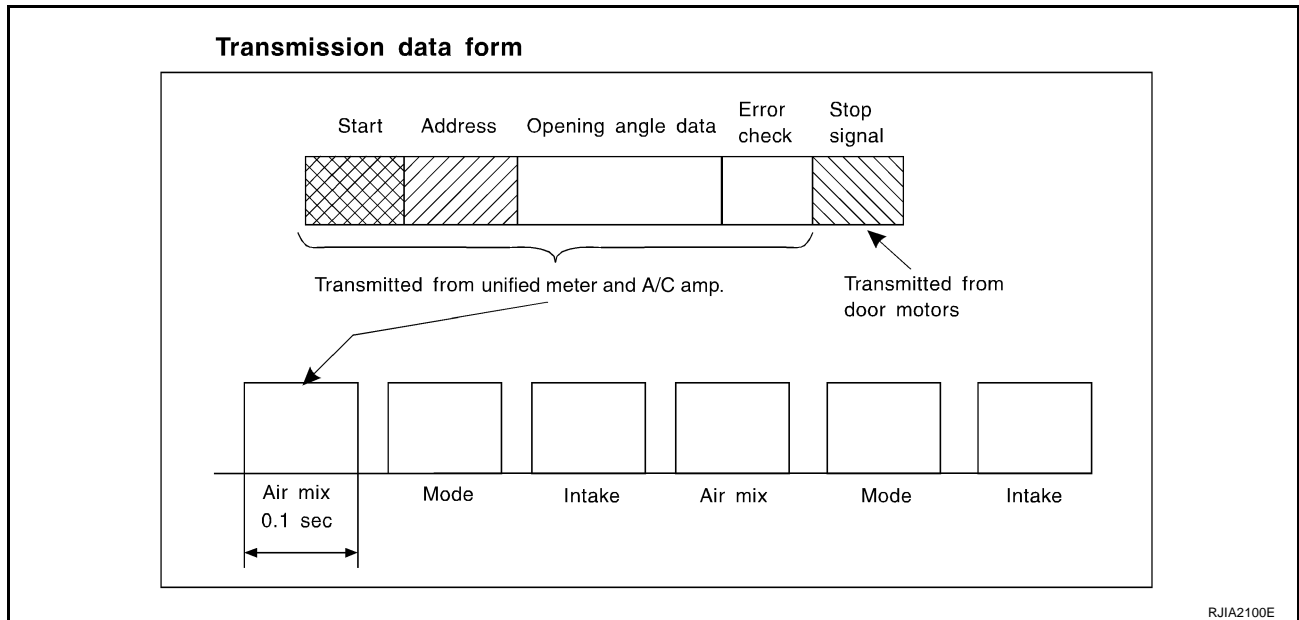

AIR MIX DOOR CONTROL (AUTOMATIC TEMPERATURE CONTROL)

The air mix door is automatically controlled so that in-vehicle temperature is maintained at a predetermined value by the temperature setting, ambient temperature, in-vehicle temperature and amount of sunload.

FAN SPEED CONTROL

Blower speed is automatically controlled by the temperature setting, ambient temperature, in-vehicle temperature, intake temperature, amount of sunload and air mix door position.

With FAN control dial set to AUTO, the blower motor starts to gradually increase air flow volume.

When engine coolant temperature is low, the blower motor operation is delayed to prevent cool air from flowing.

INTAKE DOOR CONTROL

The intake doors are automatically controlled by the temperature setting, ambient temperature, in-vehicle temperature, intake temperature, amount of sunload and ON-OFF operation of the compressor.

OUTLET DOOR CONTROL

The outlet door is automatically controlled by the temperature setting, ambient temperature, in-vehicle temperature, intake temperature and amount of sunload.

A
B
C
D
E
F
G
H
I
K
L
M

ATC

AIR CONDITIONER CONTROL

MAGNET CLUTCH CONTROL

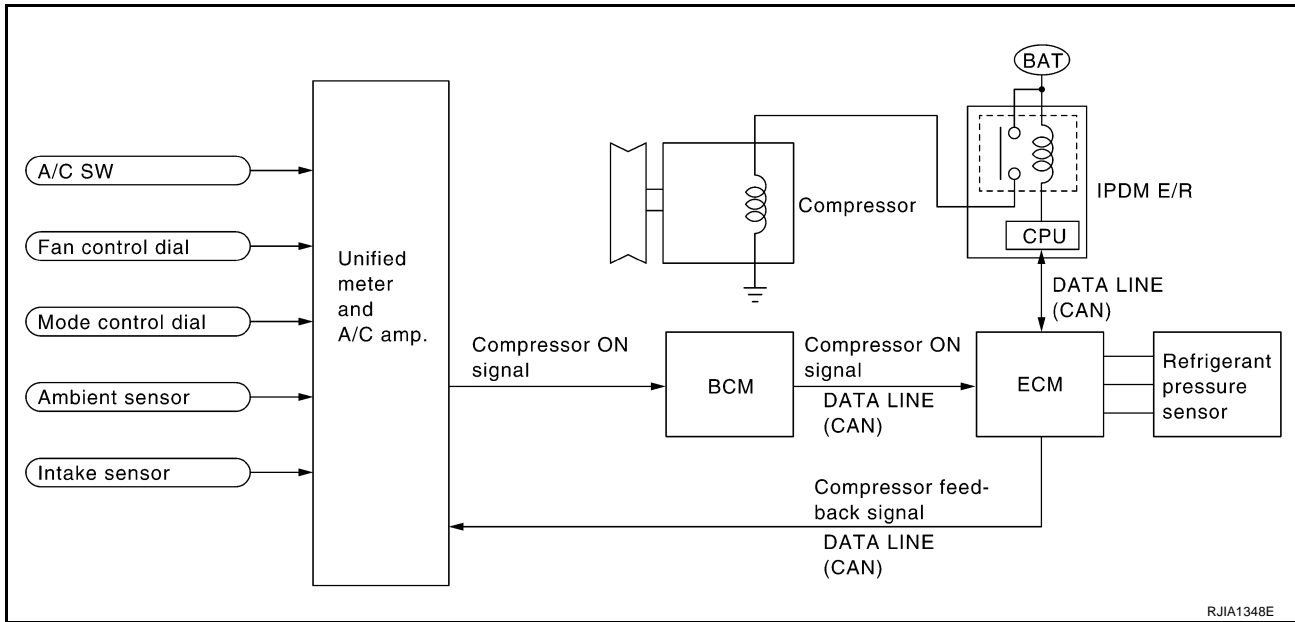

When A/C switch is pressed, turn fan control dial to ON or set mode control dial to D/F, D/F2 or DEF position, unified meter and A/C amp. inputs compressor ON signal to BCM.

BCM sends compressor ON signal to ECM, via CAN communication line.

ECM judges whether compressor can be turned ON, based on each sensor status (refrigerant-pressure sensor signal, throttle angle, etc.). If it judges compressor can be turned ON, it sends compressor ON signal to IPDM E/R, via CAN communication line.

Upon receipt of compressor ON signal from ECM, IPDM E/R turns air conditioner relay ON to operate compressor.

When sending compressor ON signal to IPDM E/R via CAN communication line, ECM simultaneously sends compressor feedback signal to unified meter and A/C amp. via CAN communication line.

Unified meter and A/C amp., then, uses input compressor feedback signal to control air inlet.

SELF-DIAGNOSTIC SYSTEM

The self-diagnostic system is built into the unified meter and A/C amp. to quickly locate the cause of symptoms.

AIR CONDITIONER CONTROL

AJS0009Y

Description of Control System

The control system consists of input sensors, switches, unified meter and A/C amp. (microcomputer) and outputs.

The relationship of these components is shown in the diagram below:

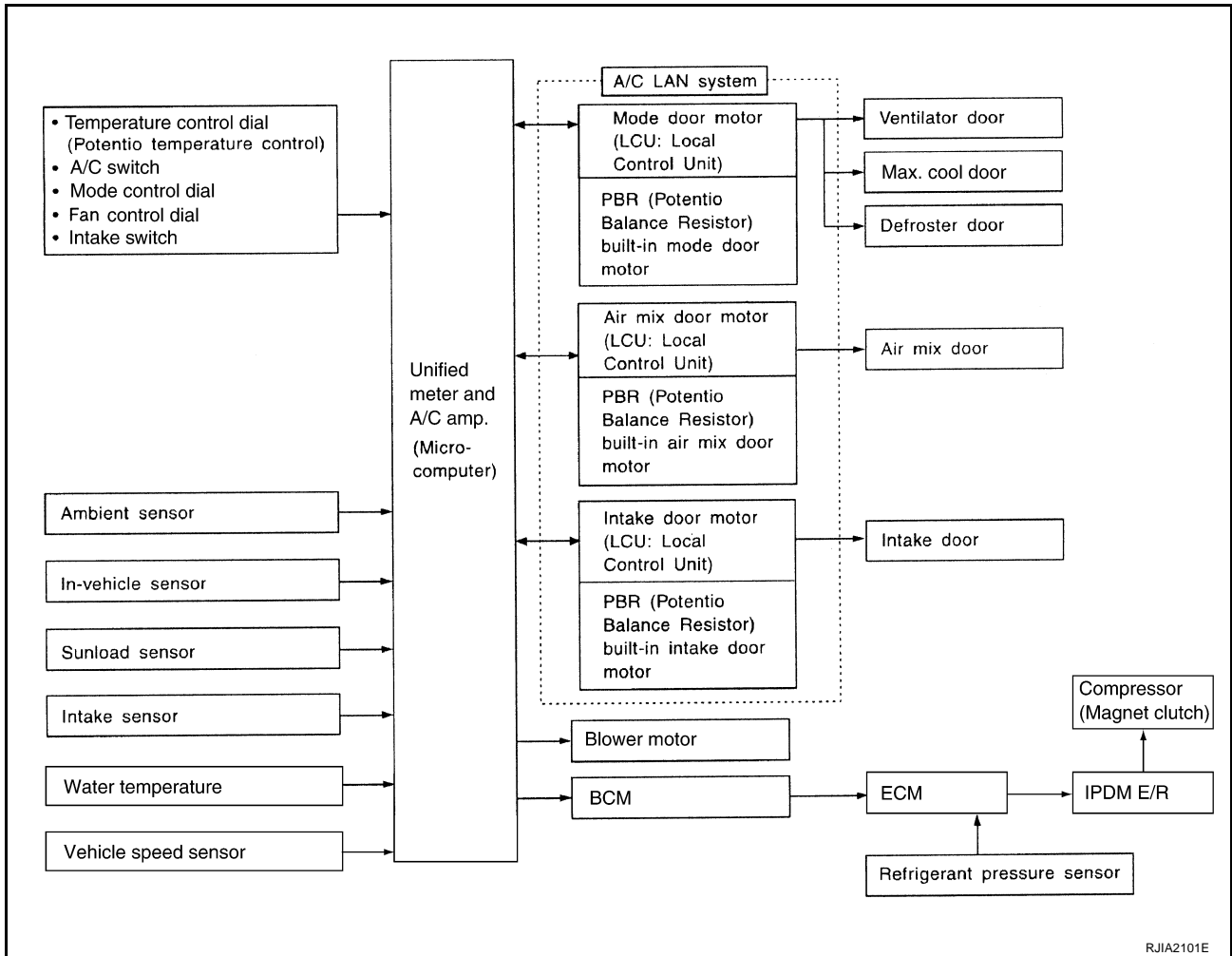

A
B
C
D
E
F
G
H
I
J
K
L
M

ATC

AIR CONDITIONER CONTROL

Control Operation

AJS0009Z

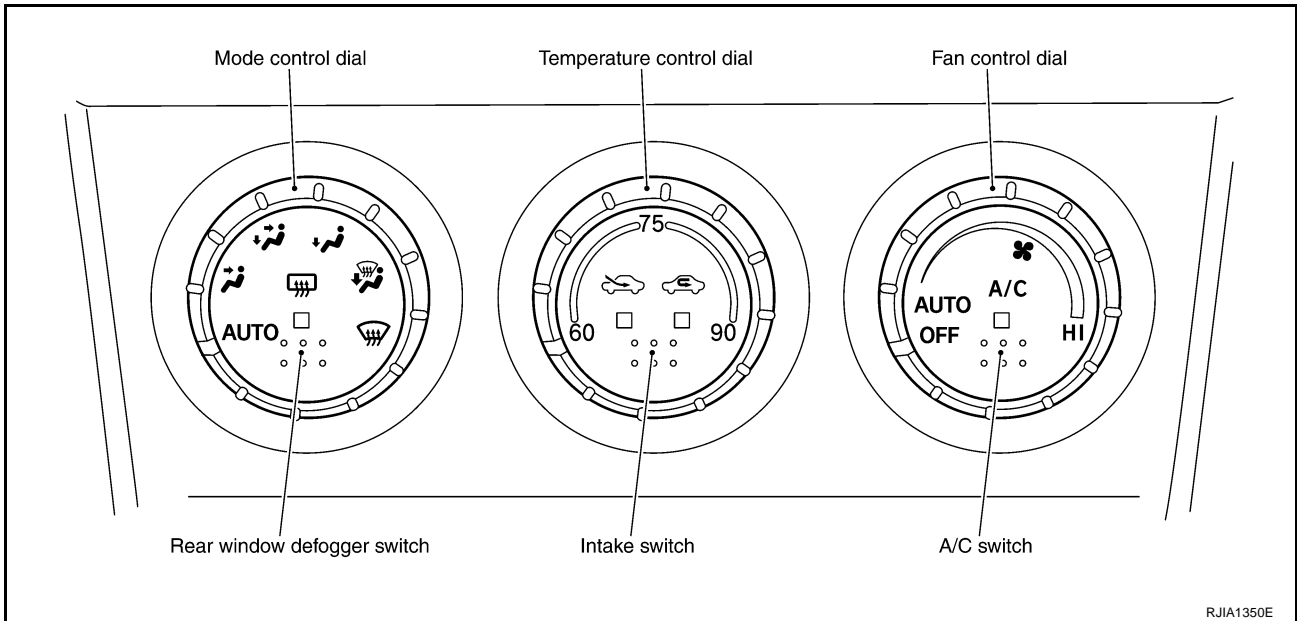

TEMPERATURE CONTROL DIAL (POTENTIO TEMPERATURE CONTROL)

Increases or decreases the set temperature.

INTAKE SWITCH

- When intake switch is ON, REC indicator turns ON, and air inlet is fixed to REC.
- Press intake switch again, FRE indicator turns ON, and air inlet is fixed to FRE.
- When intake switch is pressed for approximately 1.5 seconds or longer, REC and FRE indicators blink twice. Then, automatic control mode is entered. Inlet status is displayed even during automatic control.
- When FRE indicator is turned ON, shifting mode control dial to D/F or DEF, or when compressor is turned from ON to OFF, intake switch is automatically turned OFF (fixed to FRE mode). REC mode can be re-entered by pressing intake switch again. (Except D/F, D/F2 or DEF position)

REAR WINDOW DEFOGGER SWITCH

When illumination is ON, rear window is defogged.

A/C SWITCH

The compressor is ON or OFF.

(Pressing the A/C switch when the fan control dial is ON will turn off the A/C switch and compressor.)

MODE CONTROL DIAL

Controls the air discharge outlets.

Positions the air outlet doors to the defrost position. Also positions the intake doors to the outside air position. When shifting mode control dial to D/F, D/F2 or DEF position under the following conditions, compressor is turned ON. (A/C LED ON)

- FAN: ON
- A/C: OFF

FAN CONTROL DIAL

Automatically or manually control the blower speed. Twenty five speeds are available for manual control. Shifting fan control dial to AUTO, compressor is turned ON automatically.

AIR CONDITIONER CONTROL

Discharge Air Flow

AJS000A1

A
B
C
D
E
F
G
H
I
ATC
K
L
M

①: Ventilation ②: Foot ③: Defroster

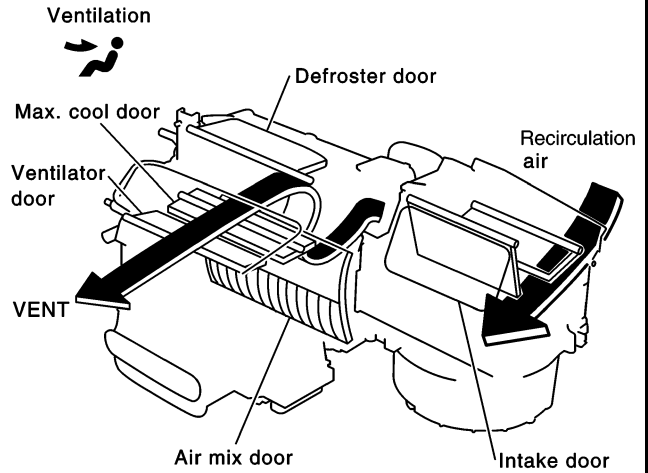
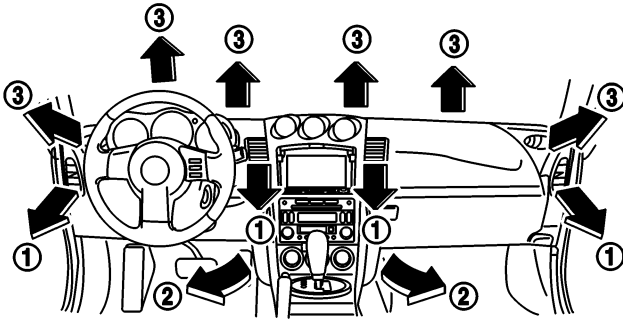

Bi-level

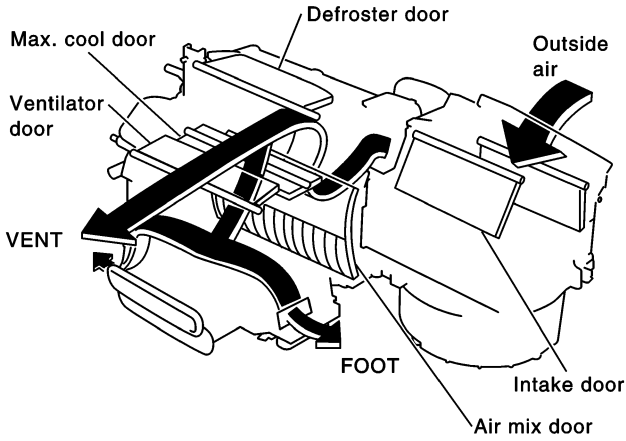

Foot

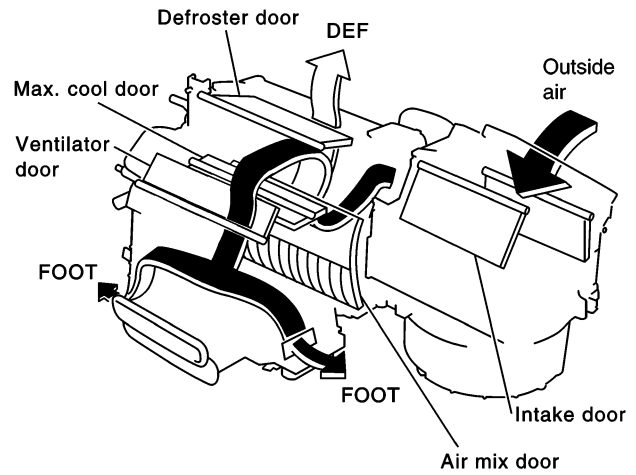

Defroster and foot

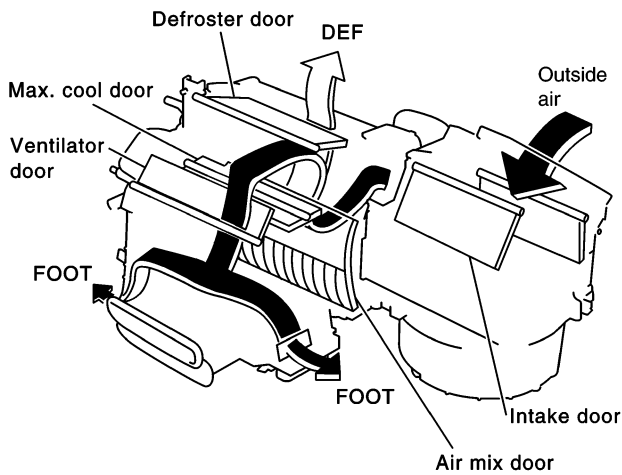

Defroster

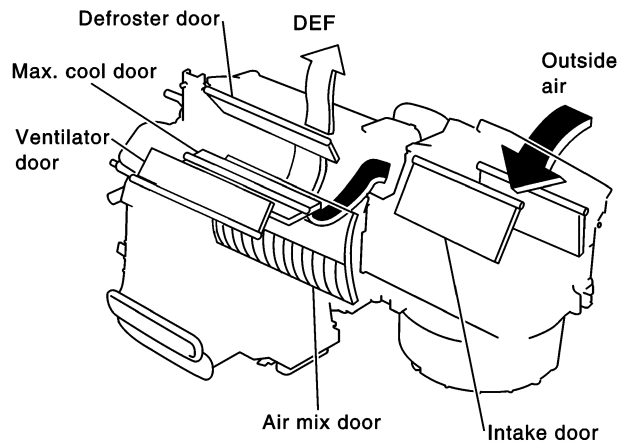

RJIA1351E

AIR CONDITIONER CONTROL

AJS000R5

System Description SWITCHES AND THEIR CONTROL FUNCTION

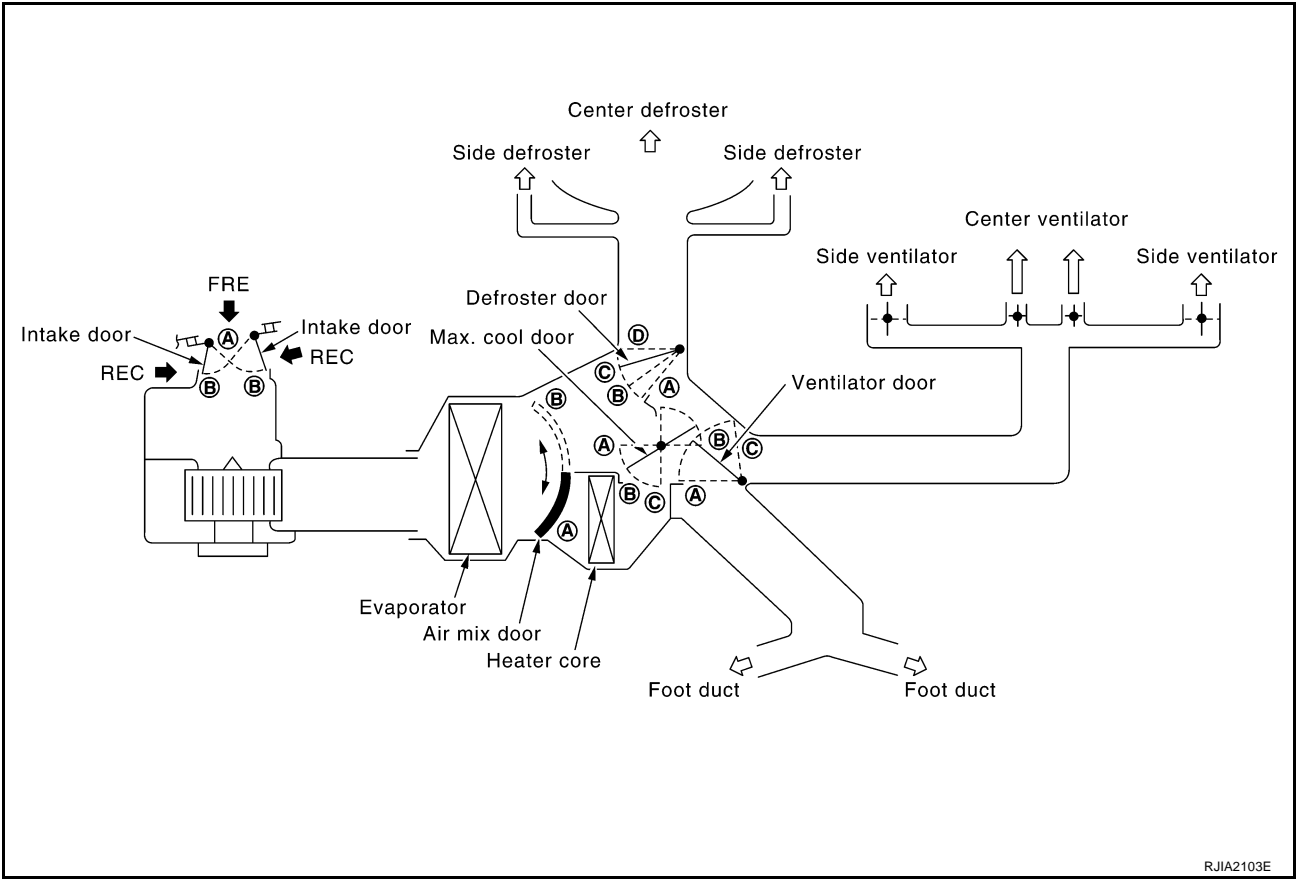

RJIA2103E

Position or switch	MODE control dial						Intake SW		Temperature control dial			
	VENT	B/L	FOOT	D/F	DEF	AUTO						
Door						—				18°C (60°F)	~	32°C (90°F)
Ventilator door	(A)	(B)	(C)	(C)	(C)	AUTO	—	—	—	—		
Max. cool door	(A)	(B)	(B)	(B)	(C)		—	—	—	—		
Defroster door	(D)	(D)	(D) or (C) ^{*1}	(B)	(A)		—	—	—	—		
Intake door	—			(B)	(B)	—	(A) ^{*2}	(B) ^{*2}	—			
Air mix door	—						—	—	(A)	AUTO	(B)	

*1: This position is selected only when the mode door is automatically controlled.

*2: Inlet status is displayed even during automatic control.

RJIA2447E

AIR CONDITIONER CONTROL

CAN Communication System Description

AJS000R2

CAN (Controller Area Network) is a serial communication line for real time application. It is an on-vehicle multiplex communication line with high data communication speed and excellent error detection ability. Many electronic control units are equipped onto a vehicle, and each control unit shares information and links with other control units during operation (not independent). In CAN communication, control units are connected with 2 communication lines (CAN H line, CAN L line) allowing a high rate of information transmission with less wiring. Each control unit transmits/receives data but selectively reads required data only. For details, refer to [LAN-5, "CAN Communication Unit"](#).

A

B

C

D

E

F

G

H

I

ATC

K

L

M

TROUBLE DIAGNOSIS

TROUBLE DIAGNOSIS

PFP:00004

CONSULT-II

AJS001F5

CONSULT-II performs the following functions communicating with BCM.

System part	Check item, diagnosis mode	Description
BCM	Data monitor	Displays BCM input data in real time.

CONSULT-II INSPECTION PROCEDURE

CAUTION:

If CONSULT-II is used with no connection of CONSULT-II CONVERTER, malfunctions might be detected in self-diagnosis depending on control unit which carry out CAN communication.

1. With the ignition switch OFF, connect CONSULT-II and CONSULT-II CONVERTER to the data link connector, then turn the ignition switch ON.

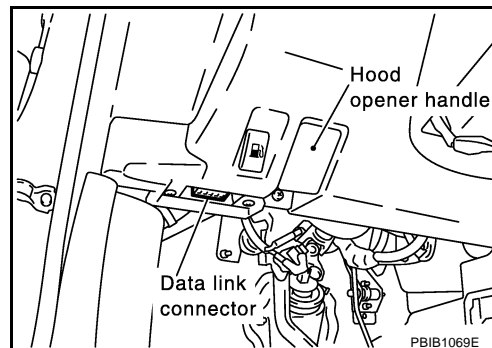

2. Touch "START (NISSAN BASED VHCL)".

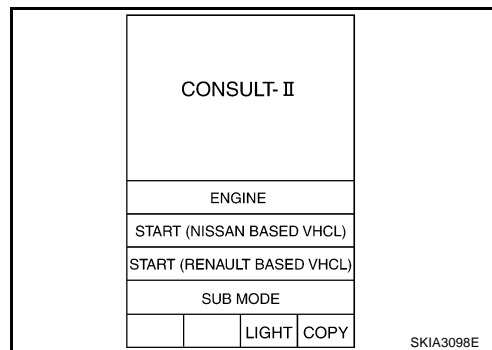

3. Touch "BCM" on "SELECT SYSTEM" screen. If "BCM" is not indicated, refer to [GI-39, "CONSULT-II Data Link Connector \(DLC\) Circuit"](#).

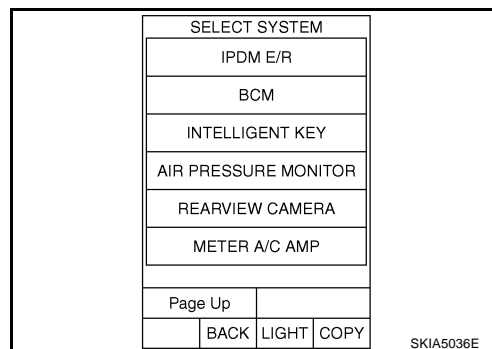

TROUBLE DIAGNOSIS

DATA MONITOR

Operation Procedure

1. Touch "AIR CONDITIONER" on "SELECT TEST ITEM" screen.

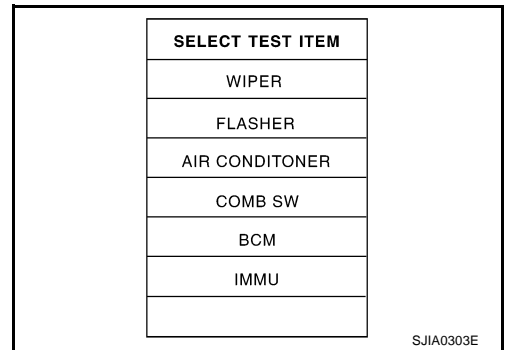

2. Touch "DATA MONITOR" on "SELECT DIAG MODE" screen.

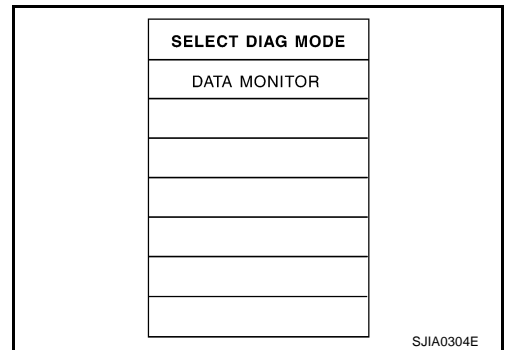

3. Touch either "ALL SIGNALS" or "SELECTION FROM MENU" on "DATA MONITOR" screen.

All signals	Monitors all the items.
Selection from menu	Selects and monitors the individual item selected.

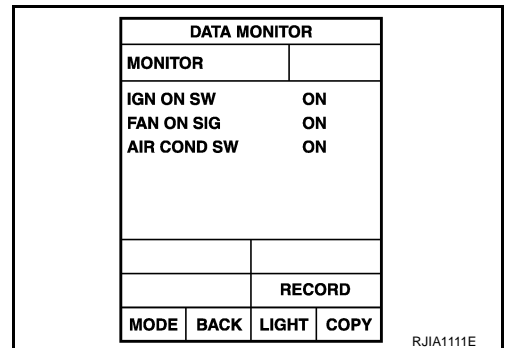

4. Touch "START".

5. When "SELECTION FROM MENU" is selected, touch items to be monitored. When "ALL SIGNALS" is selected, all the items will be monitored.

6. Touch "RECORD" while monitoring, then the status of the monitored item can be recorded. To stop recording, touch "STOP".

Display Item List

Monitor item name "operation or unit"	Contents
IGN ON SW "ON/OFF"	Displays "IGN Position (ON)/OFF, ACC Position (OFF)" status as judged from ignition switch signal.
FAN ON SIG "ON/OFF"	Displays "FAN (ON)/FAN (OFF)" status as judged from blower fan motor switch signal.
AIR COND SW "ON/OFF"	Displays "COMP (ON)/COMP (OFF)" status as judged from air conditioner switch signal.

A
B
C
D
E
F
G
H
I
K
L
M

ATC

TROUBLE DIAGNOSIS

How to Perform Trouble Diagnoses for Quick and Accurate Repair WORK FLOW

AJS000A3

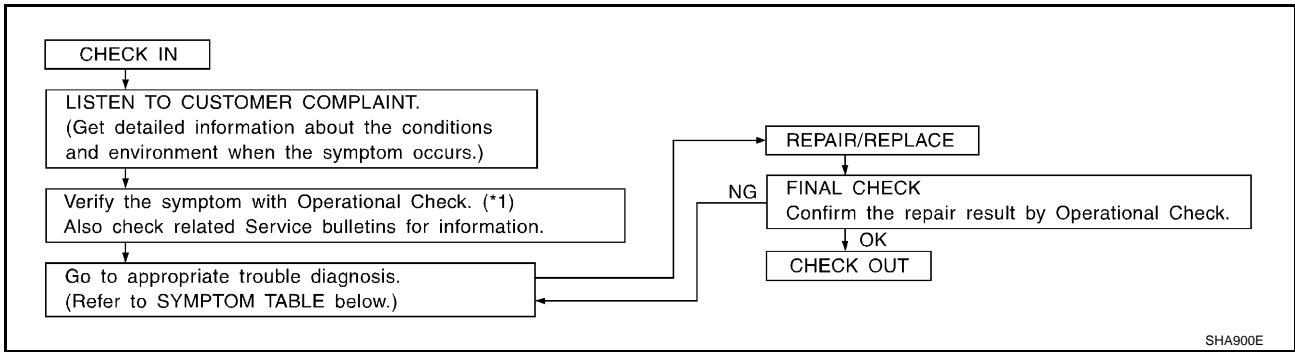

SHA900E

*1 [ATC-57. "Operational Check"](#).

SYMPTOM TABLE

Symptom	Reference Page	
A/C system does not come on.	Go to Trouble Diagnosis Procedure for A/C system.	ATC-59. "Power Supply and Ground Circuit for Auto Amp."
Air outlet does not change.	Go to Trouble Diagnosis Procedure for Mode Door Motor. (LAN)	ATC-65. "Mode Door Motor Circuit"
Mode door motor does not operate normally.		
Discharge air temperature does not change.	Go to Trouble Diagnosis Procedure for Air Mix Door Motor. (LAN)	ATC-68. "Air Mix Door Motor Circuit"
Air mix door motor does not operate normally.		
Intake door does not change.	Go to Trouble Diagnosis Procedure for Intake Door Motor. (LAN)	ATC-72. "Intake Door Motor Circuit"
Intake door motor does not operate normally.		
Blower motor operation is malfunctioning.	Go to Trouble Diagnosis Procedure for Blower Motor.	ATC-75. "Blower Motor Circuit"
Blower motor operation is malfunctioning under out of starting fan speed control.		
Magnet clutch does not engage.	Go to Trouble Diagnosis Procedure for Magnet Clutch.	ATC-80. "Magnet Clutch Circuit"
Insufficient cooling	Go to Trouble Diagnosis Procedure for Insufficient Cooling.	ATC-87. "Insufficient Cooling"
Insufficient heating	Go to Trouble Diagnosis Procedure for Insufficient Heating.	ATC-95. "Insufficient Heating"
Noise	Go to Trouble Diagnosis Procedure for Noise.	ATC-96. "Noise"
Self-diagnosis cannot be performed.	Go to Trouble Diagnosis Procedure for Self-diagnosis.	ATC-97. "Self-diagnosis"

TROUBLE DIAGNOSIS

Component Parts and Harness Connector Location ENGINE COMPARTMENT

AJS000A4

A
B
C
D
E
F
G
H
I
ATC
K
L
M

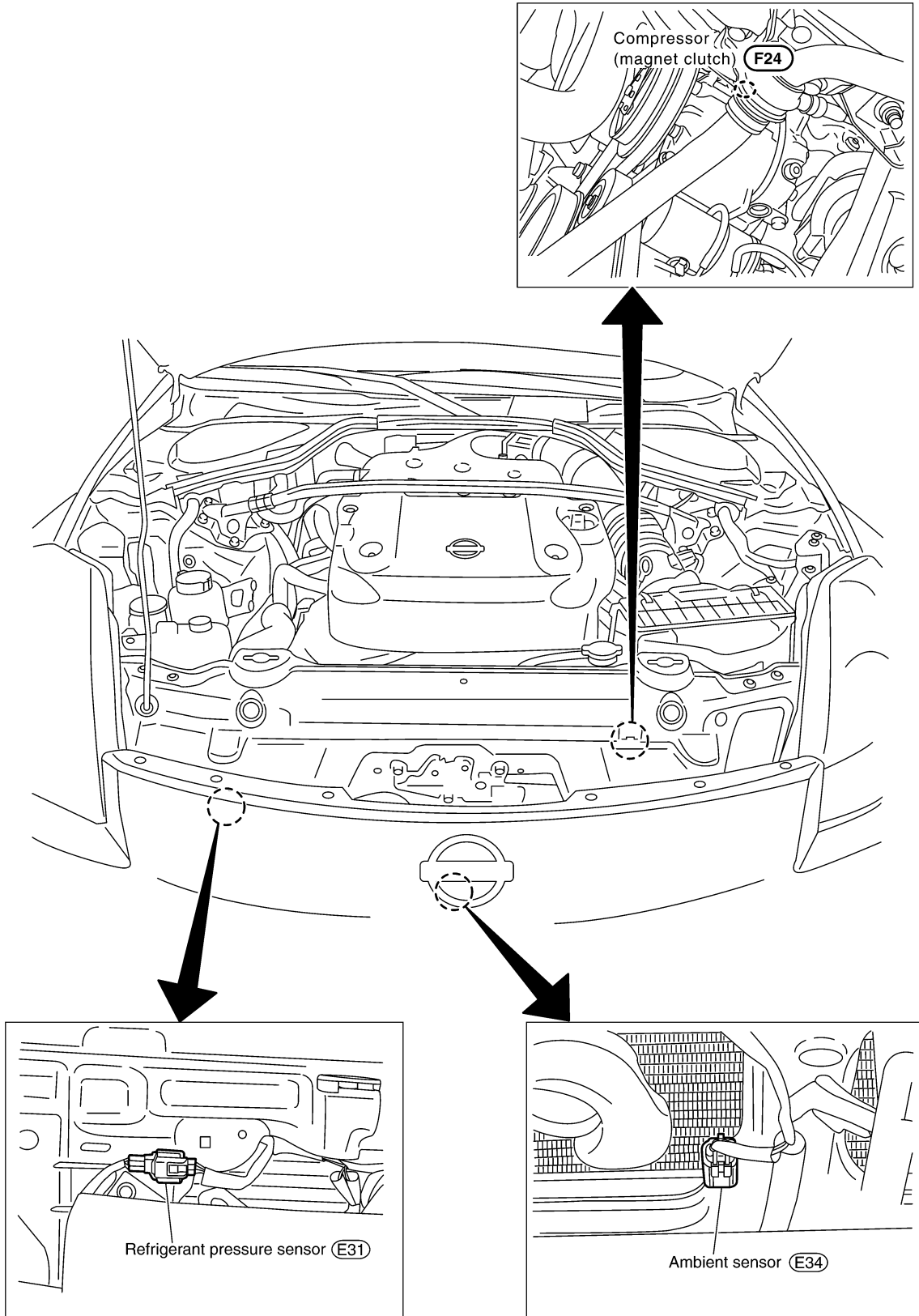

RJIA1354E

TROUBLE DIAGNOSIS

PASSENGER COMPARTMENT

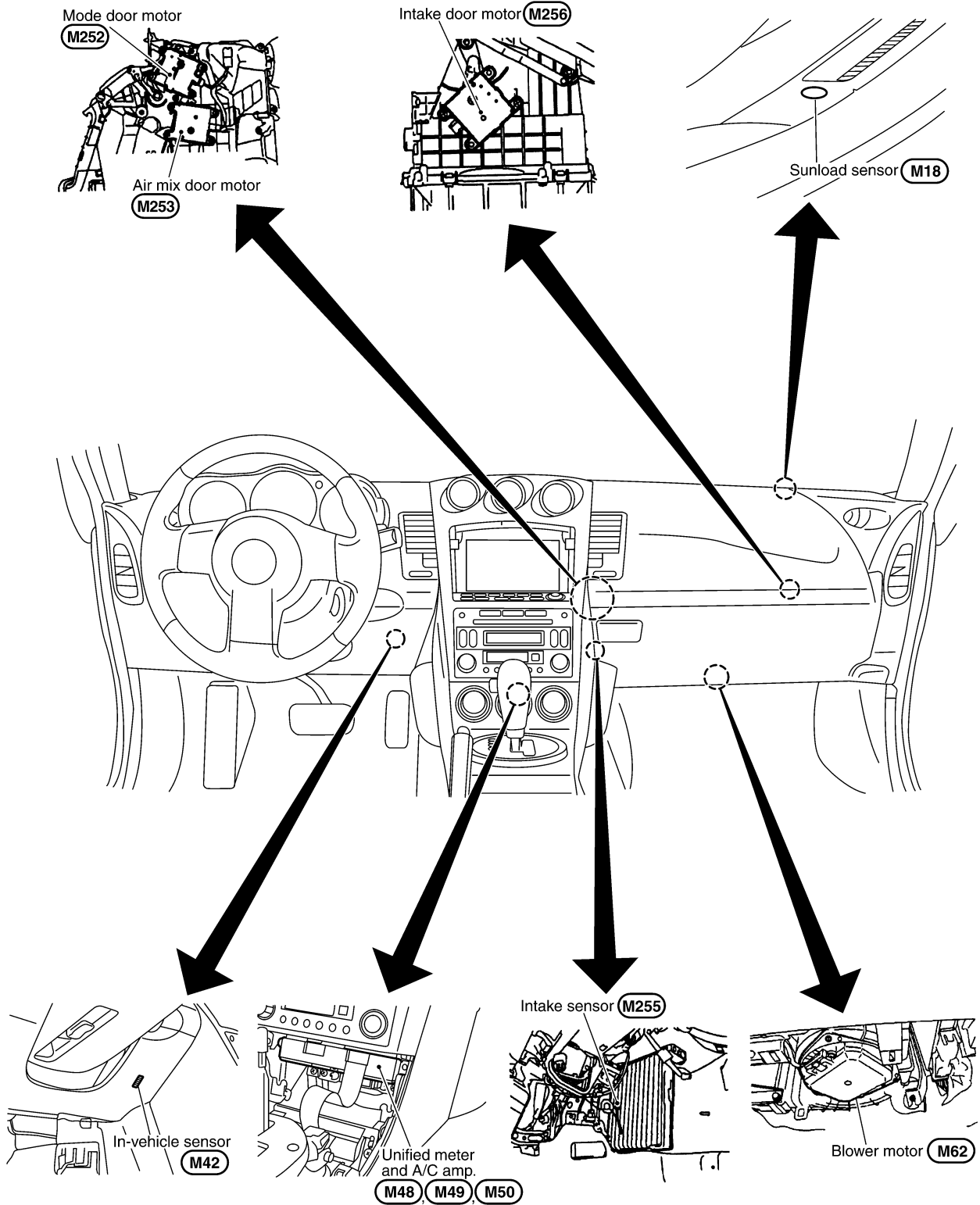

RJA1355E

TROUBLE DIAGNOSIS

Schematic

AJS000A5

A
B
C
D
E
F
G
H
I
K
L
M

ATC

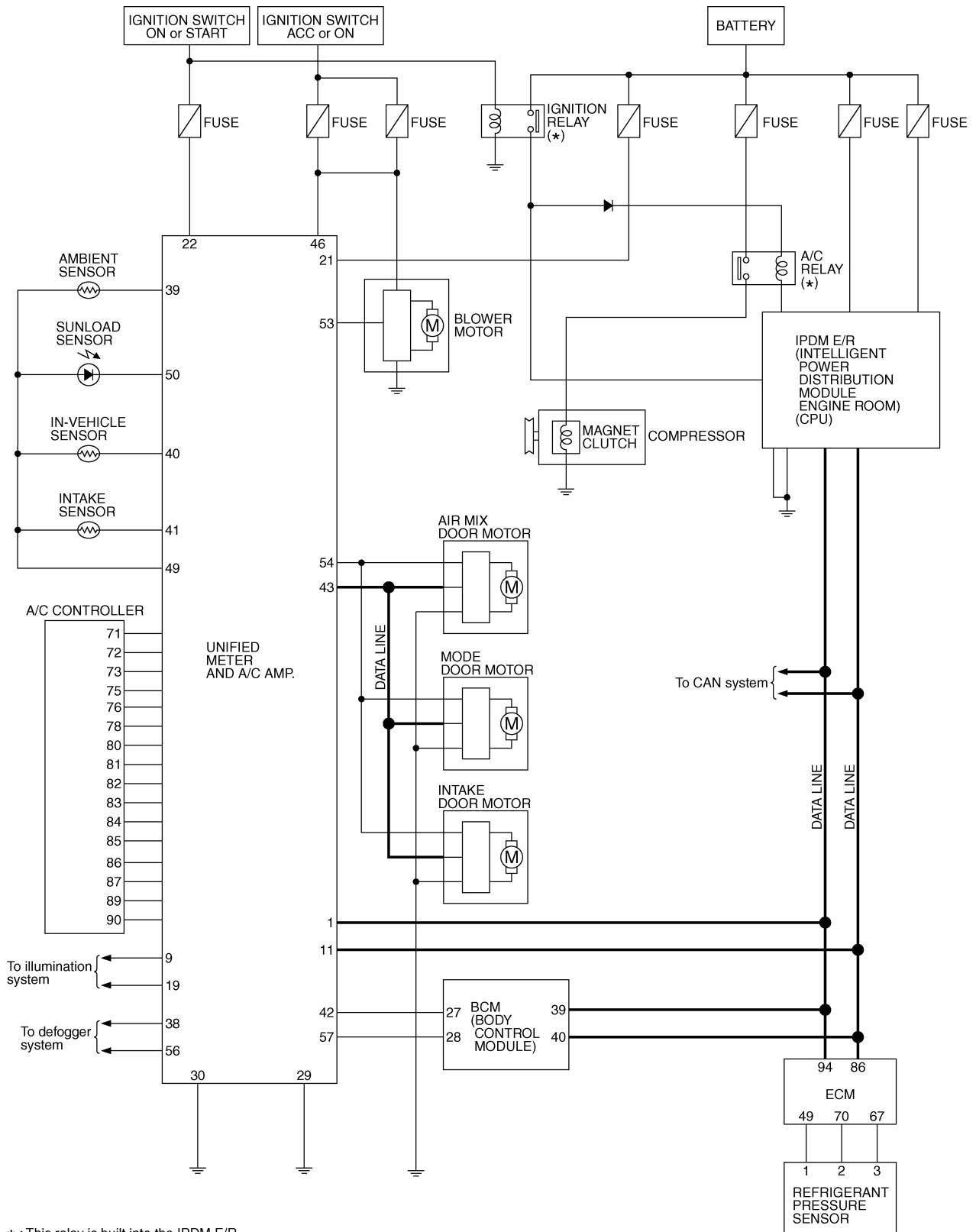

* : This relay is built into the IPDM E/R (Intelligent power distribution module engine room).

TJW0101E

TROUBLE DIAGNOSIS

Wiring Diagram —A/C—

AJS000A6

ATC-A/C-01

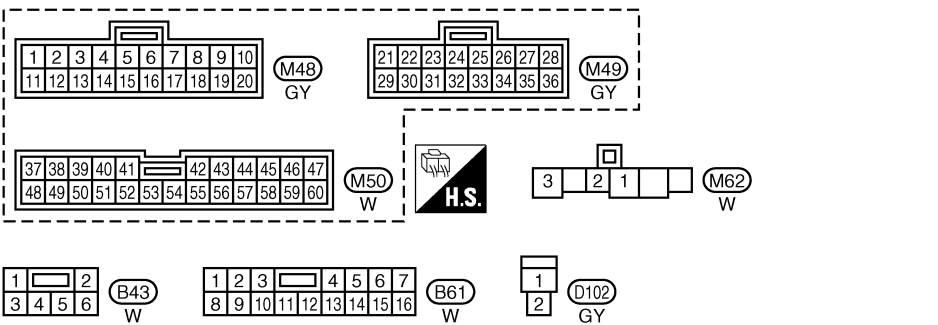
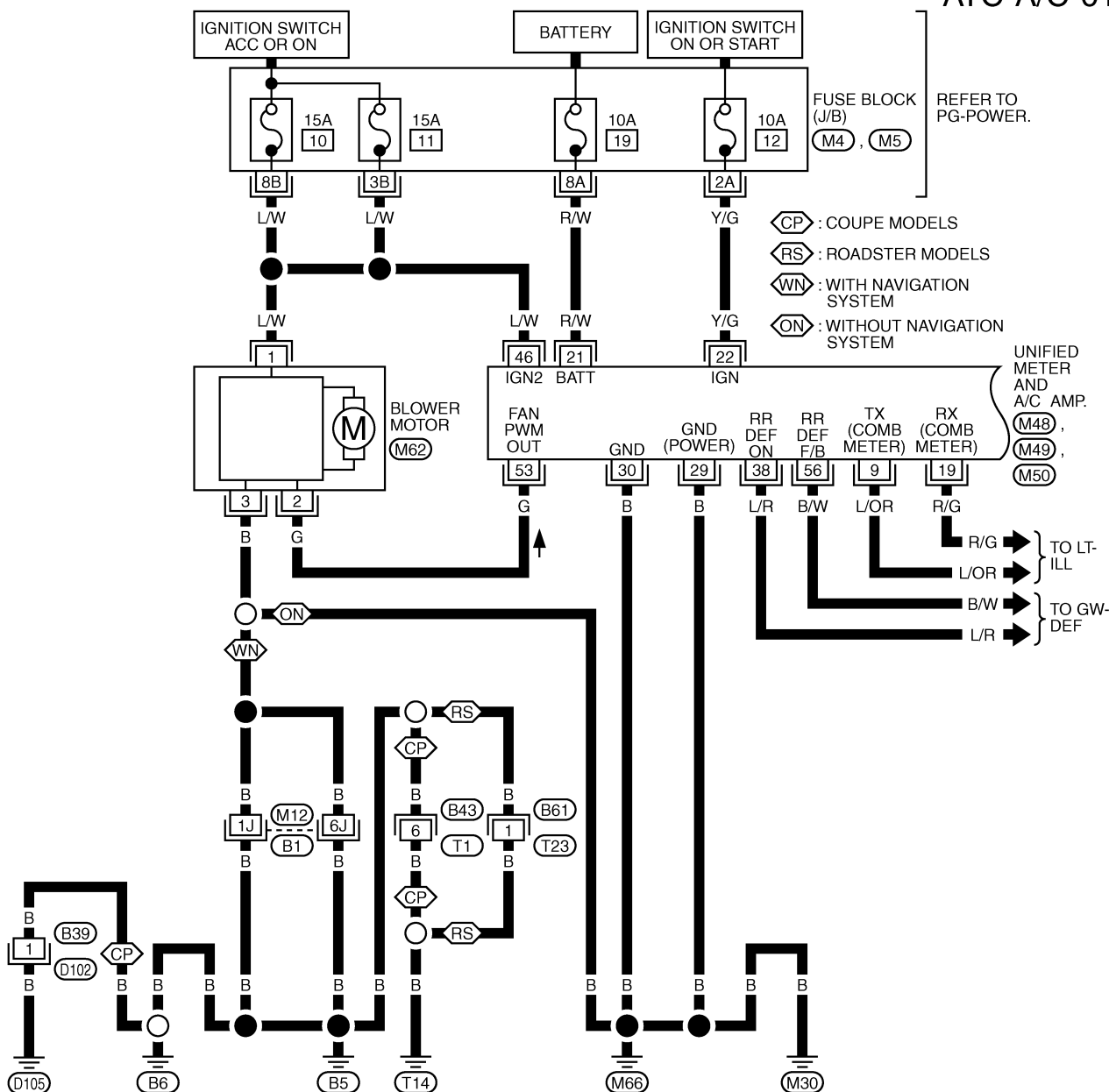

REFER TO THE FOLLOWING.
 (B1) -SUPER MULTIPLE JUNCTION (SMJ)
 (M4), (M5) -FUSE BLOCK-JUNCTION BOX (J/B)

TJWT0092E

TROUBLE DIAGNOSIS

ATC-A/C-02

A
B
C
D
E
F
G
H
I
K
L
M

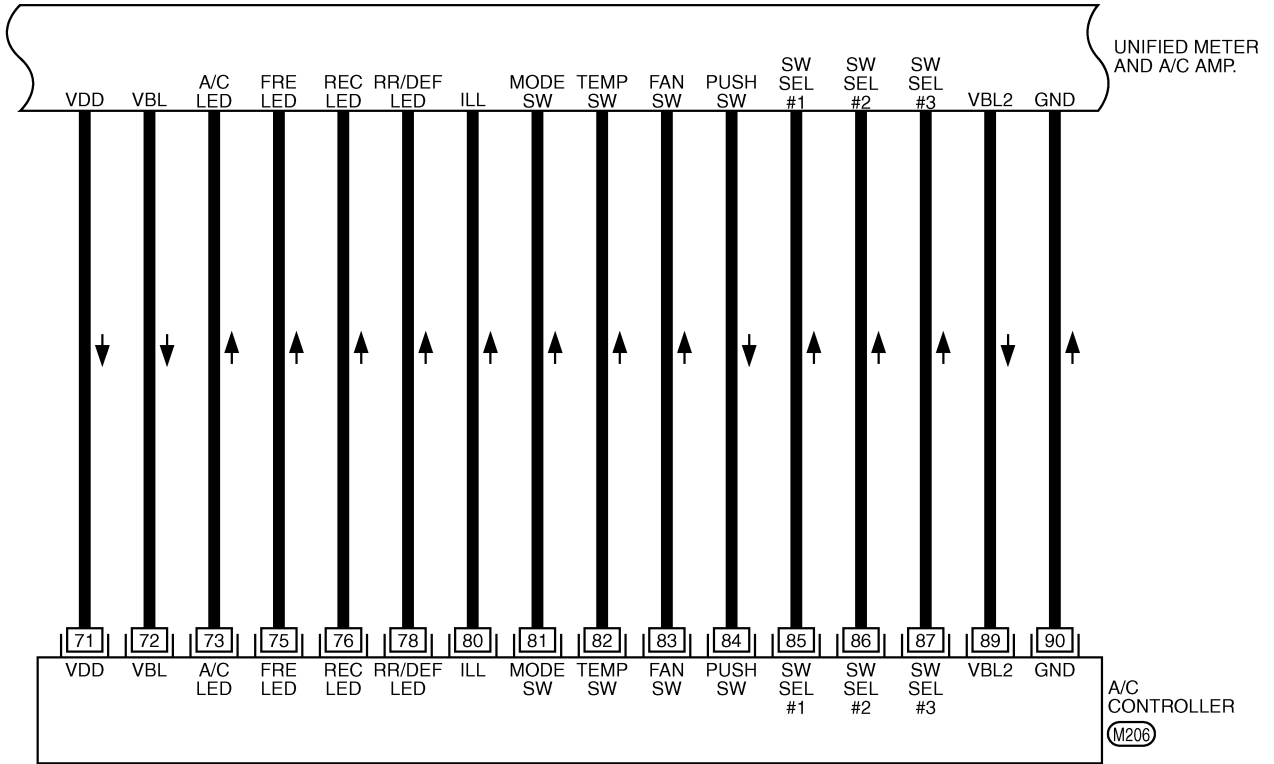

ATC

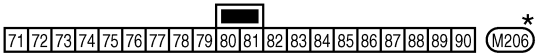

*: THIS CONNECTOR IS NOT SHOWN IN "HARNESS LAYOUT", PG SECTION.

TJWT0032E

TROUBLE DIAGNOSIS

ATC-A/C-03

▬ : DATA LINE

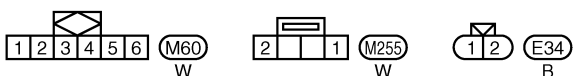
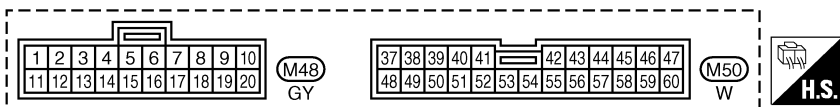
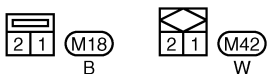
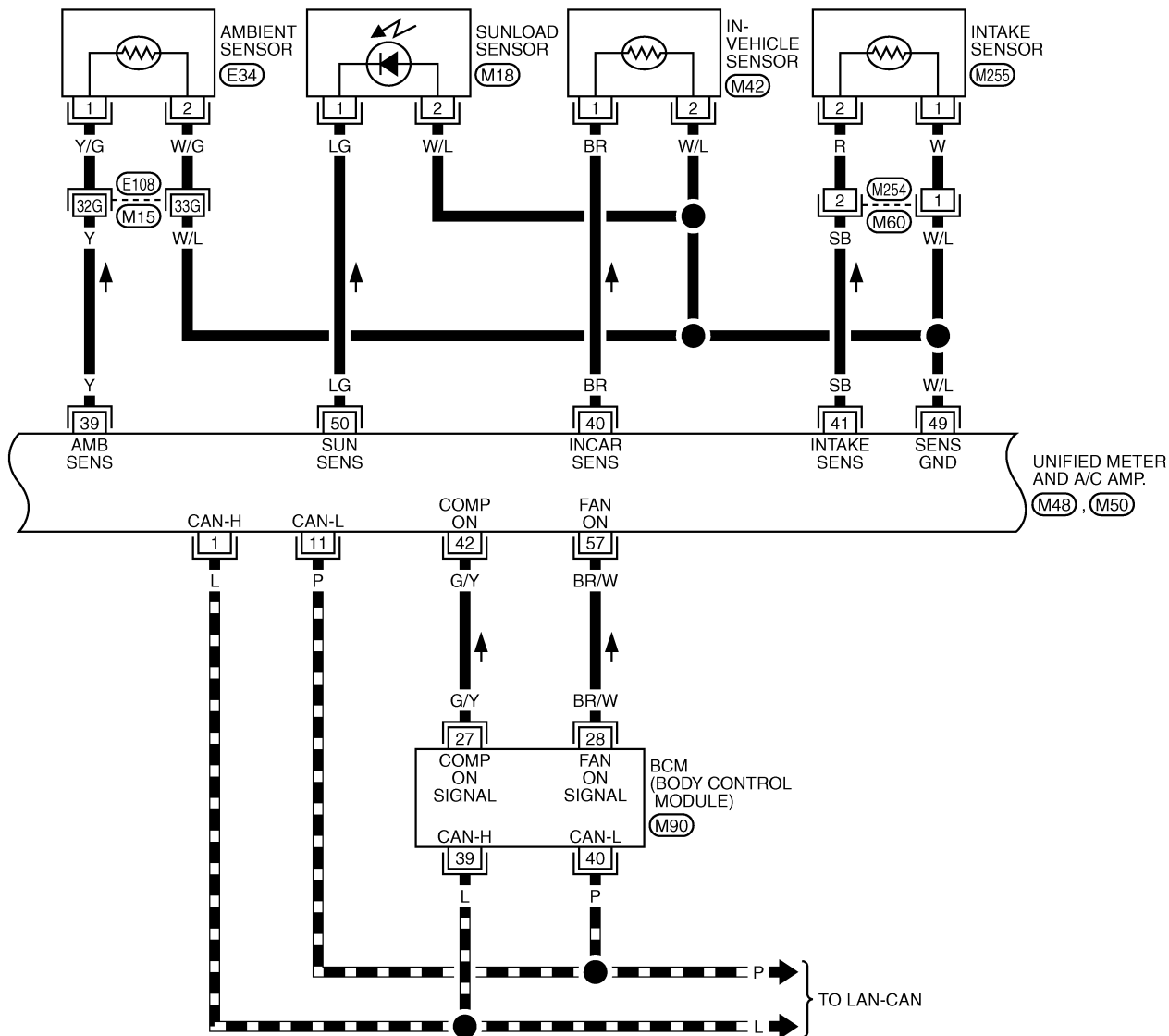

REFER TO THE FOLLOWING.

(E108) -SUPER MULTIPLE JUNCTION (SMJ)

(M90) -ELECTRICAL UNITS

TJWT0102E

TROUBLE DIAGNOSIS

ATC-A/C-04

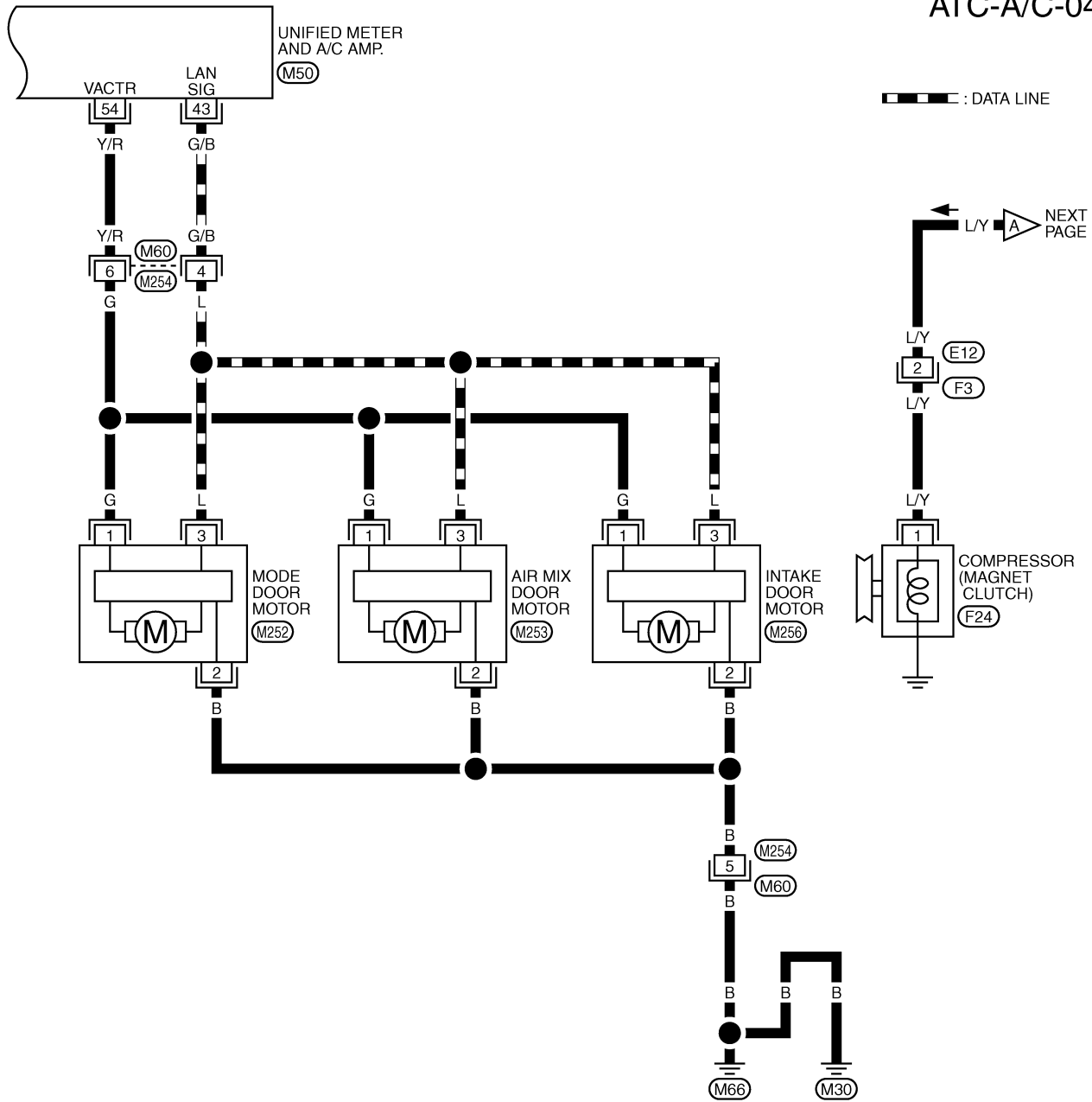

A
B
C
D
E
F
G
H
I
ATC
K
L
M

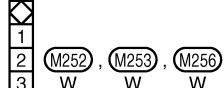
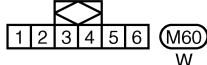

TJWT0103E

TROUBLE DIAGNOSIS

ATC-A/C-05

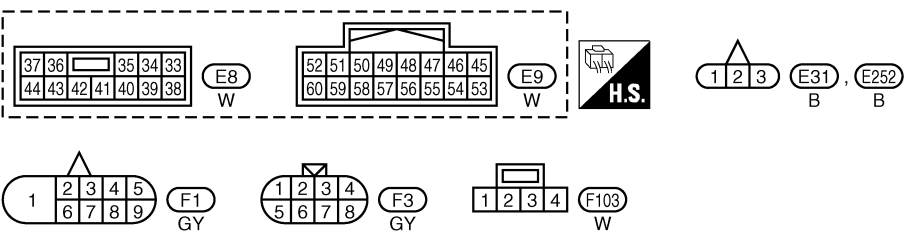
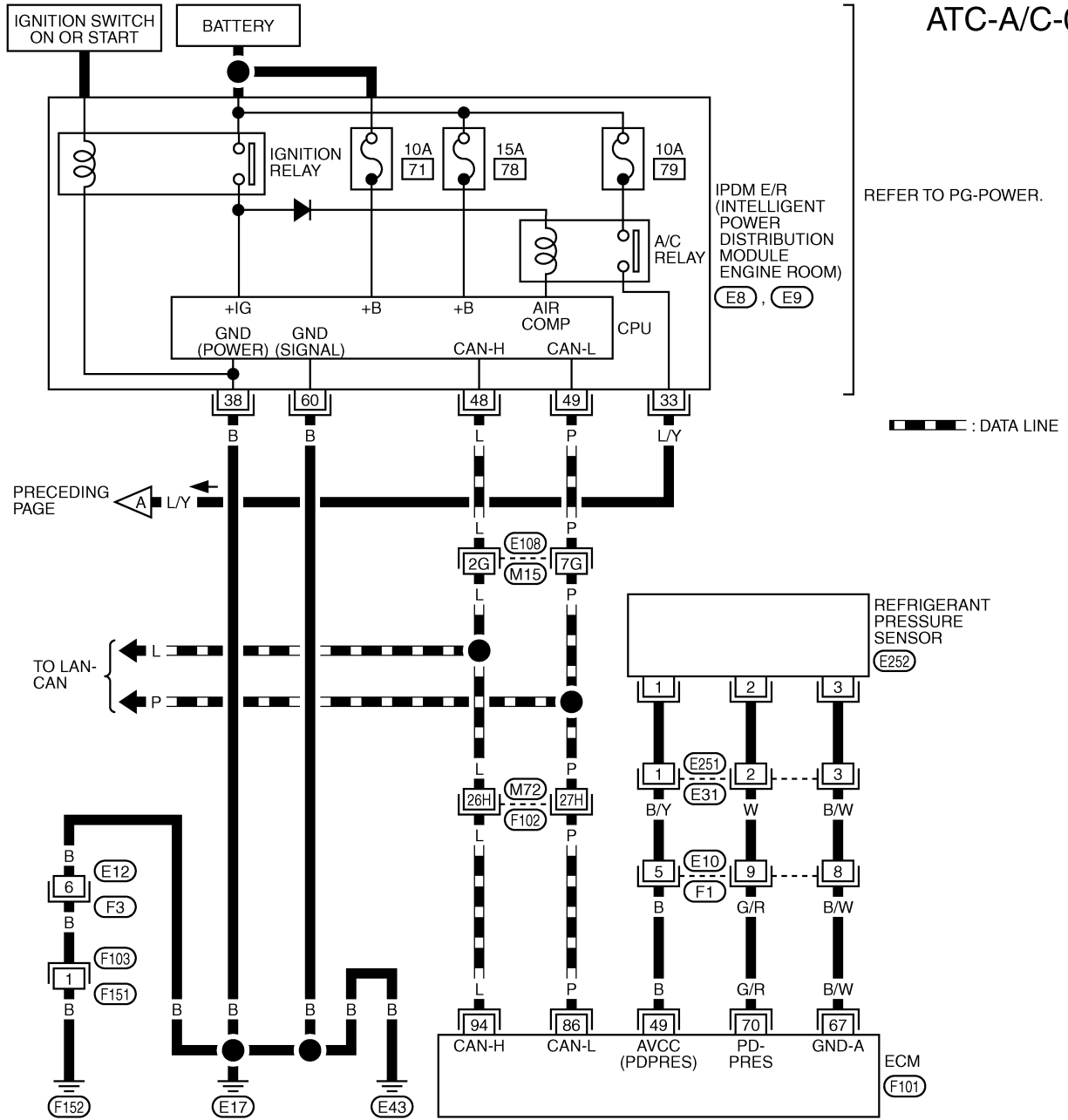

REFER TO THE FOLLOWING.

(E108), (F102) -SUPER MULTIPLE JUNCTION (SMJ)

(F101) -ELECTRICAL UNITS

TROUBLE DIAGNOSIS

Auto Amp. Terminals and Reference Value

AJS000JI

Measure voltage between each terminal and ground by following terminals and reference value for unified meter and A/C amp.

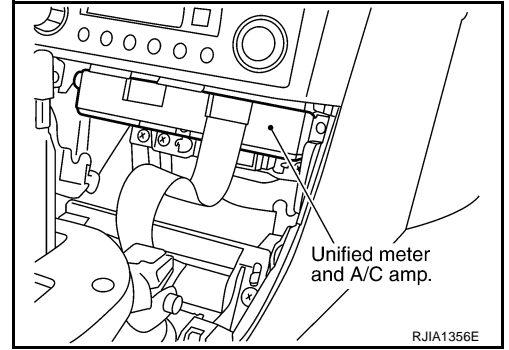

PIN CONNECTOR TERMINAL LAYOUT

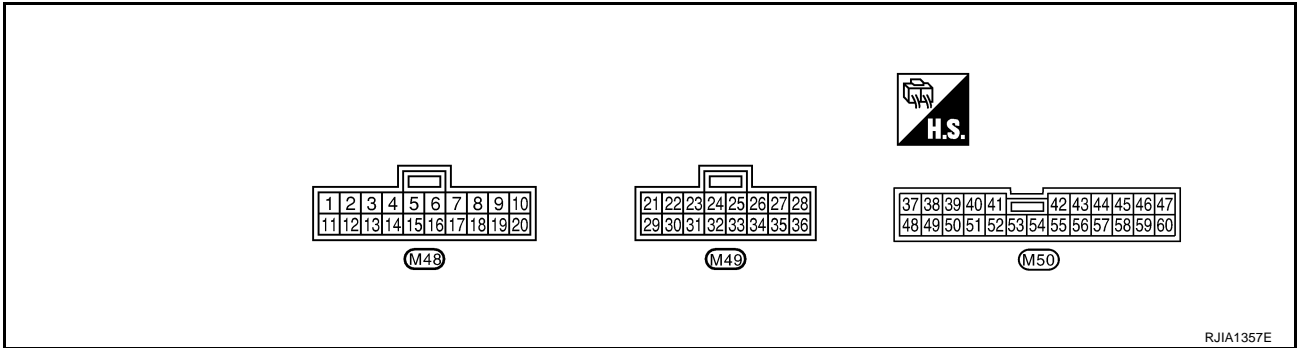

TERMINALS AND REFERENCE VALUE FOR UNIFIED METER AND A/C AMP.

Terminal No.	Wire color	Item	Ignition switch	Condition	Voltage (V)
1	L	CAN-H	-	-	-
9	L/OR	Multiplex communication signal (Tx)	-	-	-
11	P	CAN-L	-	-	-
19	R/G	Multiplex communication signal (Rx)	-	-	-
21	R/W	Power supply for BAT	OFF	-	Battery voltage
22	Y/G	Power supply for IGN	ON	-	Battery voltage
29	B	Ground (Power)	ON	-	Approx. 0
30	B	Ground	ON	-	Approx. 0
38	L/R	Rear window defogger ON signal	ON	Rear window defogger switch: Press ON	Approx. 0
				Rear window defogger switch: OFF	Approx. 12
39	Y	Ambient sensor	-	-	-
40	BR	In-vehicle sensor	-	-	-
41	SB	Intake sensor	-	-	-
42	G/Y	Compressor ON signal	ON	Compressor: ON	Approx. 0
				Compressor: OFF	Approx. 5
43	G/B	A/C LAN signal	ON	-	

HAK0652D

A
B
C
D
E
F
G
H
I
K
L
M

ATC

TROUBLE DIAGNOSIS

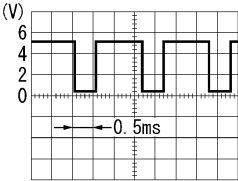
Terminal No.	Wire color	Item	Ignition switch	Condition	Voltage (V)
46	L/W	Power supply for IGN2	ACC or ON	-	Battery voltage
49	W/L	Sensor ground	ON	-	Approx. 0
50	LG	Sunload sensor	-	-	-
53	G	Blower motor control signal	ON	Blower speed: 1st step	 <p style="text-align: right; font-size: small;">SJIA0116J</p>
54	Y/R	Power supply for each door motor	ON	-	Battery voltage
56	B/W	Rear window defogger feedback signal	ON	Rear window defogger switch: ON	Approx. 12
				Rear window defogger switch: OFF	Approx. 0
57	BR/W	Blower motor ON signal	ON	Fan control dial: ON (A/C system operates)	Approx. 0
				Fan control dial: OFF	Approx. 5

TROUBLE DIAGNOSIS

Self-diagnosis Function

AJS000JJ

DESCRIPTION

The self-diagnostic system diagnoses sensors, door motors, blower motor, etc. by system line. Self-diagnosis is step-1 to 7. There are two ways of changing method during self-diagnosis.

- Switching to self-diagnosis step-1 to 4.
Shifting from usual control to the self-diagnostic system is accomplished by starting the engine (turning the ignition switch from OFF to ON) and pressing A/C switch for at least 5 seconds. The A/C switch must be pressed within 10 seconds after starting the engine (ignition switch is turned ON). This system will be canceled by either pressing intake switch or turning the ignition switch OFF. Shifting from one step to another is accomplished by means of turning fan control dial, as required.
- Switching to self diagnosis step-5 to 7 (Auxiliary mechanism).
Shifting from usual control to the self-diagnostic system is accomplished by starting the engine (turning the ignition switch from OFF to ON) and pressing intake switch for at least 5 seconds. The intake switch must be pressed within 10 seconds after starting the engine (ignition switch is turned ON). This system will be canceled by either pressing A/C switch or turning the ignition switch OFF. Shifting from one step to another is accomplished by means of turning fan control dial, as required.

A

B

C

D

E

F

G

H

I

ATC

K

L

M

TROUBLE DIAGNOSIS

STEP 1 to 4

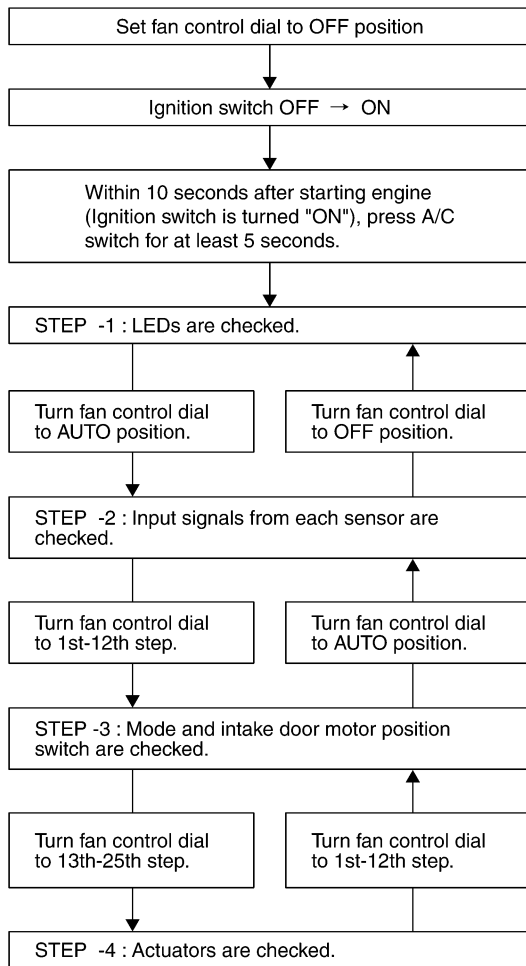

STEP 5 to 7 (Auxiliary mechanism)

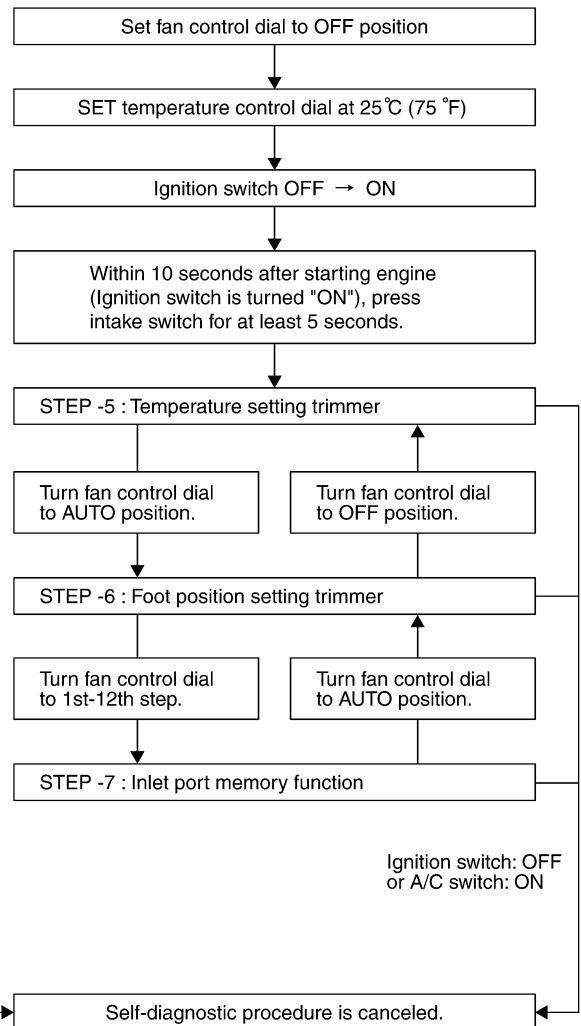

Ignition switch: OFF
or Intake switch: ON

Ignition switch: OFF
or A/C switch: ON

RJIA1358E

TROUBLE DIAGNOSIS

FUNCTION CONFIRMATION PROCEDURE

1. SET IN SELF-DIAGNOSTIC MODE (STEP-1 TO 4)

1. Set the fan control dial to OFF position.
2. Turn ignition switch ON.
3. Set in self-diagnostic mode as follows. Within 10 seconds after starting engine (ignition switch is turned ON.), press A/C switch for at least 5 seconds.

CAUTION:

If battery voltage drops below 12V during diagnosis step-3, actuator speed becomes slower and as a result, the system may generate an error even when operation is usual. To avoid this, start engine before performing this diagnosis.

>> GO TO 2.

2. STEP-1:LEDS ARE CHECKED

Check intake and A/C switch LEDs illumination.

OK or NG

OK >> GO TO 3.

NG >> Refer to [ATC-97, "Self-diagnosis"](#).

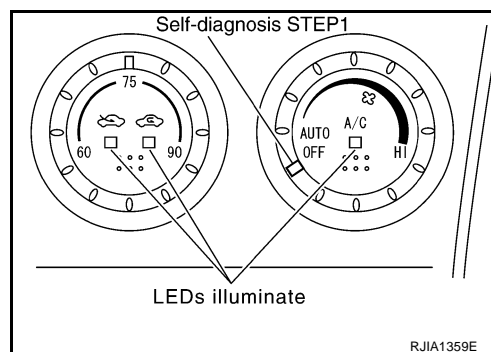

3. CHECK TO ADVANCE SELF-DIAGNOSIS STEP-2

1. Turn fan control dial to AUTO position.

CAUTION:

When switched to STEP-2, LED of REC position blinks for approximately 25 seconds.

2. Advance to self-diagnosis STEP-2?

Check A/C LED illumination.

YES >> GO TO 4.

NO >> Replace A/C controller. (Fan control dial malfunctioning.)

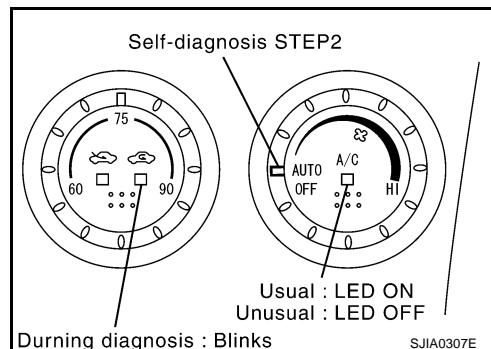

4. CHECK TO RETURN SELF-DIAGNOSIS STEP-1

Turn fan control dial to OFF position.

Return to self-diagnosis STEP-1?

YES >> GO TO 5.

NO >> Replace A/C controller. (Fan control dial malfunctioning.)

TROUBLE DIAGNOSIS

5. STEP-2: SENSOR CIRCUITS ARE CHECKED FOR OPEN OR SHORT CIRCUIT

1. Turn fan control dial to AUTO position.
2. Turn mode control dial to AUTO position.

CAUTION:

When switched to STEP-2, LED of REC position blinks for approximately 25 seconds.

3. Check A/C switch LED is illuminate.

OK or NG

- OK >> GO TO 6.
NG >> GO TO 9.

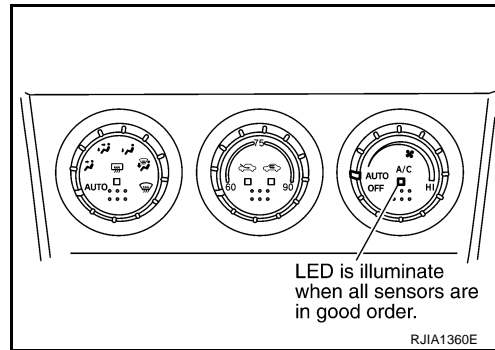

6. STEP-3: MODE DOOR AND INTAKE DOOR POSITIONS ARE CHECKED

1. Turn fan control dial to 1st–12th speed.
2. Check A/C switch LED is illuminate.

OK or NG

- OK >> GO TO 7.
NG >> GO TO 10.

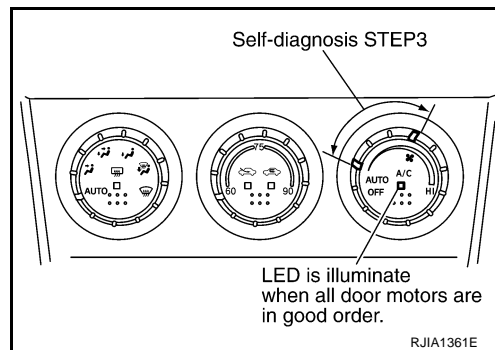

7. STEP-4: OPERATION OF EACH ACTUATOR IS CHECKED

1. Turn fan control dial to 13th–25th speed.
2. Change operation status of air conditioner by changing mode control dial position.

>> GO TO 8.

TROUBLE DIAGNOSIS

8. CHECK ACTUATORS

Refer to the following chart and confirm discharge air flow, air temperature, blower motor duty ratio and compressor operation.

Discharge air flow			
Mode door position	Air outlet/distribution		
	Vent	Foot	Defroster
	100%	-	-
	54%	46%	-
	-	76% (100%)	24% (-)
	-	57%	43%
	-	-	100%

() : Manually control RJIA2110E

STEP No. *1	Mode control dial position					
	STEP-41	STEP-42	STEP-43	STEP-44	STEP-45	STEP-46
Mode control dial position	AUTO	VENT	B/L	FOOT or FOOT2	D/F or D/F2	DEF
Mode door position	VENT	VENT2	B/L	FOOT *2	D/F	DEF
Intake door position	REC	REC	REC	FRE	FRE	FRE
Air mix door position	FULL COLD	FULL COLD	FULL COLD	FULL HOT	FULL HOT	FULL HOT
Blower motor duty ratio	25%	25%	41%	57%	75%	91%
Compressor	ON	ON	OFF	OFF	ON	OFF

Checks must be made visually, by listening to any noise, or by touching air outlets with your hand, etc. for improper operation.

*1: Step No. 41 to 46 are for differentiation and will not be displayed.

*2: FOOT position during automatic control. Refer to [ATC-56, "AUXILIARY MECHANISM: FOOT POSITION SETTING TRIMMER"](#) .

OK or NG

OK >> 1. Turn ignition switch OFF or intake switch ON.

2. INSPECTION END

NG >> ● Air outlet does not change.

Go to Mode Door Motor Circuit. Refer to [ATC-65, "Mode Door Motor Circuit"](#) .

● Intake door does not change.

Go to Intake Door Motor Circuit. Refer to [ATC-72, "Intake Door Motor Circuit"](#) .

● Blower motor operation is malfunctioning.

Go to Blower Motor Circuit. Refer to [ATC-75, "Blower Motor Circuit"](#) .

● Magnet clutch does not engage.

Go to Magnet Clutch Circuit. Refer to [ATC-80, "Magnet Clutch Circuit"](#) .

● Discharge air temperature does not change.

Go to Air Mix Door Motor Circuit. Refer to [ATC-68, "Air Mix Door Motor Circuit"](#) .

TROUBLE DIAGNOSIS

9. CHECK MALFUNCTIONING SENSOR

Refer to the following chart.

*1: Conduct self-diagnosis STEP-2 under sunshine.

When conducting indoors, aim a light (more than 60W) at sunload sensor, otherwise LED of A/C switch will not indicate despite that sunload sensor is functioning properly.

CAUTION:

When switched to STEP-2, LED of REC position blinks for approximately 25 seconds.

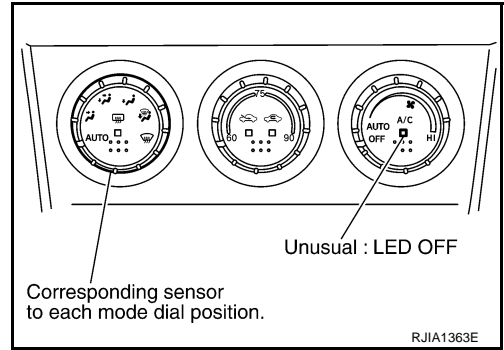

Mode control dial position	Unusual	Malfunctioning sensor (Including circuits)	Reference page
VENT	A/C LED: OFF	Ambient sensor	*2
B/L		In-vehicle sensor	*3
FOOT or FOOT2		Sunload sensor *1	*4
D/F or D/F2		Intake sensor	*5
DEF		Air mix door motor (LCU) PBR	*6

*2: [ATC-98, "DIAGNOSTIC PROCEDURE FOR AMBIENT SENSOR"](#) .

*3: [ATC-101, "DIAGNOSTIC PROCEDURE FOR IN-VEHICLE SENSOR"](#) .

*4: [ATC-103, "DIAGNOSTIC PROCEDURE FOR SUNLOAD SENSOR"](#) .

*5: [ATC-106, "DIAGNOSTIC PROCEDURE FOR INTAKE SENSOR"](#) .

*6: [ATC-61, "DIAGNOSTIC PROCEDURE FOR LAN CIRCUIT"](#) .

>> INSPECTION END

10. CHECK MALFUNCTIONING DOOR MOTOR POSITION SWITCH

Mode and/or intake door motor PBR(s) is/are malfunctioning.

CAUTION:

When switched to STEP-3, LED of REC position blinks for approximately 25 seconds.

Unusual	Mode or intake door position	Reference page
REC LED: ON	Mode door motor	*1
FRE LED: ON	Intake door motor	*2

*1: [ATC-67, "DIAGNOSTIC PROCEDURE FOR MODE DOOR MOTOR"](#) .

*2: [ATC-74, "DIAGNOSTIC PROCEDURE FOR INTAKE DOOR MOTOR"](#) .

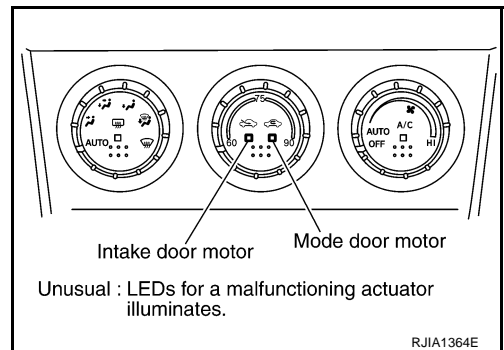

>> INSPECTION END

TROUBLE DIAGNOSIS

AUXILIARY MECHANISM: TEMPERATURE SETTING TRIMMER

The trimmer compensates for differences in range of $\pm 3^{\circ}\text{C}$ ($\pm 6^{\circ}\text{F}$) between temperature setting (Temperature control dial position) and temperature felt by driver.

Operating procedures for this trimmer are as follows:

1. Set temperature at 25°C (75°F).
2. Set fan control dial to OFF.
3. Turn ignition switch ON.
4. Set in self-diagnostic mode as follows. Within 10 seconds after starting engine (ignition switch is turned ON.), press intake switch for at least 5 seconds.
5. Turn temperature control dial as desired. temperature will change at a rate of 1°C (2.0°F) each time a dial is turned.

Setting temperature	LED status of each switch		
	FRE	REC	A/C
-3°C (-6°F)	ON	ON	ON
-2°C (-4°F)	ON	ON	OFF
-1°C (-2°F)	ON	OFF	ON
0°C (0°F) (Initial setting)	OFF	OFF	OFF
1°C (2°F)	OFF	OFF	ON
2°C (4°F)	OFF	ON	OFF
3°C (6°F)	OFF	ON	ON

When battery cable is disconnected, trimmer operation is canceled. Temperature set becomes that of initial condition, i.e. 0°C (0°F).

A

B

C

D

E

F

G

H

I

ATC

K

L

M

TROUBLE DIAGNOSIS

AUXILIARY MECHANISM: FOOT POSITION SETTING TRIMMER

Wind distribution ratio in FOOT mode can be set.

Operating procedures for this trimmer are as follows:

1. Set temperature at 25°C (75°F).
2. Set fan control dial to AUTO.
3. Turn ignition switch ON.
4. Set in self-diagnostic mode as follows. Within 10 seconds after starting engine (ignition switch is turned ON.), press intake switch for at least 5 seconds.
5. Turn temperature control dial as desired.

Type	Discharge air flow			
	Automatically controls the mode door		Manually controls the mode door	
	FOOT	DEF	FOOT	DEF
Type-A (initial setting)	76%	24%	100%	—
Type-B	76%	24%	100%	—
Type-C	100%	—	100%	—
Type-D	100%	—	100%	—

RJIA1365E

Type	LED status of each switch		
	FRE	REC	A/C
Type-A (Initial setting)	OFF	OFF	ON
Type-B	OFF	ON	OFF
Type-C	OFF	ON	ON
Type-D	ON	OFF	OFF

AUXILIARY MECHANISM: INLET PORT MEMORY FUNCTION

When ignition key is turned from OFF to ON, inlet port can be set to AUTO or manual.

Operating procedures for this trimmer are as follows:

1. Set fan control dial to 1st-25th speed.
2. Turn ignition switch ON.
3. Set in self-diagnostic mode as follows. Within 10 seconds after starting engine (ignition switch is turned ON.), press intake switch for at least 5 seconds.
4. Press the intake switch as desired.

LED status of FRE	LED status of REC	Setting status		Setting changeover method
		FRE	REC	
OFF	OFF	AUTO control	AUTO control	Intake SW: ON
OFF	ON	AUTO control (Initial setting)	Manual REC status is memorized. (Initial setting)	
ON	OFF	Manual FRE status is memorized.	AUTO control	
ON	ON	Manual FRE status is memorized.	Manual REC status is memorized.	

TROUBLE DIAGNOSIS

AJS000A9

Operational Check

The purpose of the operational check is to confirm that the system operates properly.

Conditions : Engine running at usual operating temperature

CHECKING BLOWER

1. Turn fan control dial to 1st speed. Blower should operate on low speed.
2. Turn fan control dial to 2nd speed, and continue checking blower speed until all speeds are checked.
3. Leave blower on Max. speed.

If NG, go to trouble diagnosis procedure for [ATC-75, "Blower Motor Circuit"](#).

If OK, continue the check.

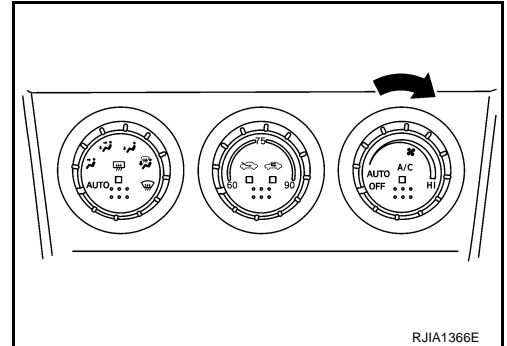

RJIA1366E

CHECKING DISCHARGE AIR

1. Turn mode control dial to each position.

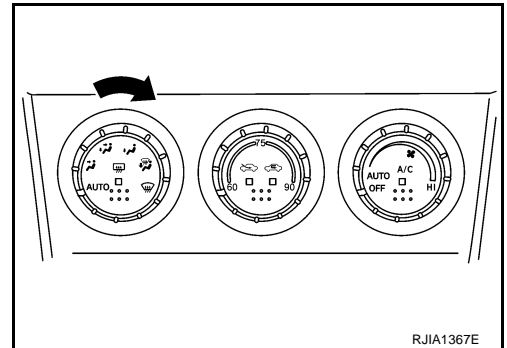

RJIA1367E

2. Confirm that discharge air comes out according to the air distribution table. Refer to [ATC-33, "Discharge Air Flow"](#).

Mode door position is checked in the next step.

If NG, go to trouble diagnosis procedure for [ATC-65, "Mode Door Motor Circuit"](#).

If OK, continue the check.

NOTE:

Confirm that the compressor clutch is engaged (sound or visual inspection) and intake door position is at FRESH when the D/F, D/F2 or DEF position are selected.

Discharge air flow

Mode door position	Air outlet/distribution		
	Vent	Foot	Defroster
	100%	-	-
	54%	46%	-
	-	76% (100%)	24% (-)
	-	57%	43%
	-	-	100%

() : Manually control

RJIA2110E

CHECKING INTAKE DOOR

1. Press intake switch. Recirculation indicator should illuminate.
2. Press intake switch again. Fresh indicator should illuminate.
3. Listen for intake door position change (you should hear blower sound change slightly).

If NG, go to trouble diagnosis procedure for [ATC-72, "Intake Door Motor Circuit"](#).

If OK, continue the check.

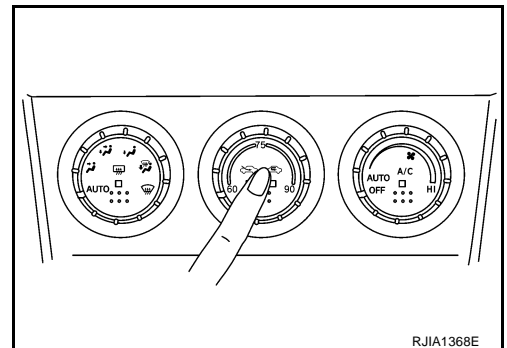

RJIA1368E

A
B
C
D
E
F
G
H
I
K
L
M

ATC

TROUBLE DIAGNOSIS

CHECKING TEMPERATURE DECREASE

1. Turn temperature control dial until 18°C (60°F).
2. Check for cold air at discharge air outlets.

If NG, go to trouble diagnosis procedure for [ATC-87, "Insufficient Cooling"](#).

If OK, continue the check.

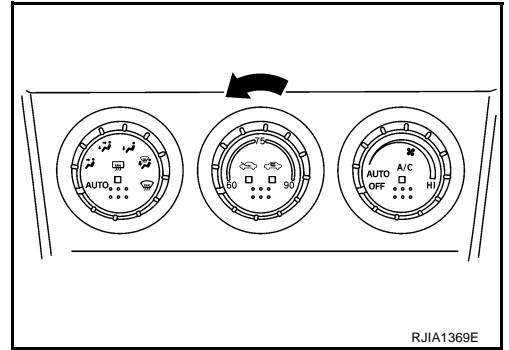

CHECKING TEMPERATURE INCREASE

1. Turn temperature control dial until 32°C (90°F).
2. Check for hot air at discharge air outlets.

If NG, go to trouble diagnosis procedure for [ATC-95, "Insufficient Heating"](#).

If OK, continue the check.

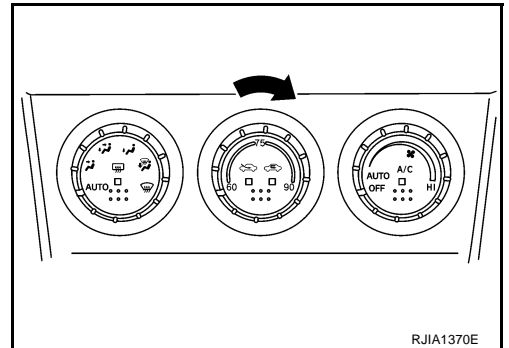

CHECKING A/C SWITCH

Turn fan control dial to AUTO position. (Compressor is turned ON automatically.)

- Confirm that the compressor clutch engages (sound or visual inspection). (Discharge air and blower speed will depend on ambient, in-vehicle, and set temperatures.)

If NG, go to trouble diagnosis procedure for [ATC-59, "Power Supply and Ground Circuit for Auto Amp."](#), then if necessary, trouble diagnosis procedure for [ATC-80, "Magnet Clutch Circuit"](#).

If all operational checks are OK (symptom cannot be duplicated), go to Incident Simulation Tests in [GI-27, "How to Perform Efficient Diagnosis for an Electrical Incident"](#) and perform tests as outlined to simulate driving conditions environment. If symptom appears, refer to [ATC-38, "SYMPTOM TABLE"](#) and perform applicable trouble diagnosis procedures.

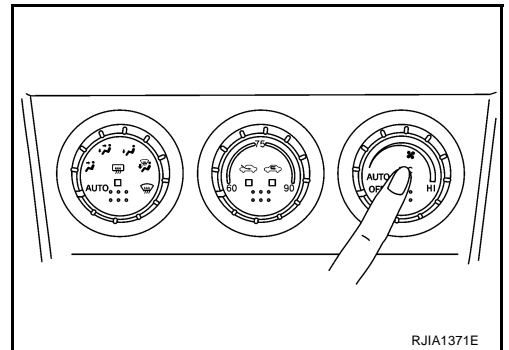

TROUBLE DIAGNOSIS

Power Supply and Ground Circuit for Auto Amp.

AJS000JK

SYMPTOM: A/C system does not come on.

INSPECTION FLOW

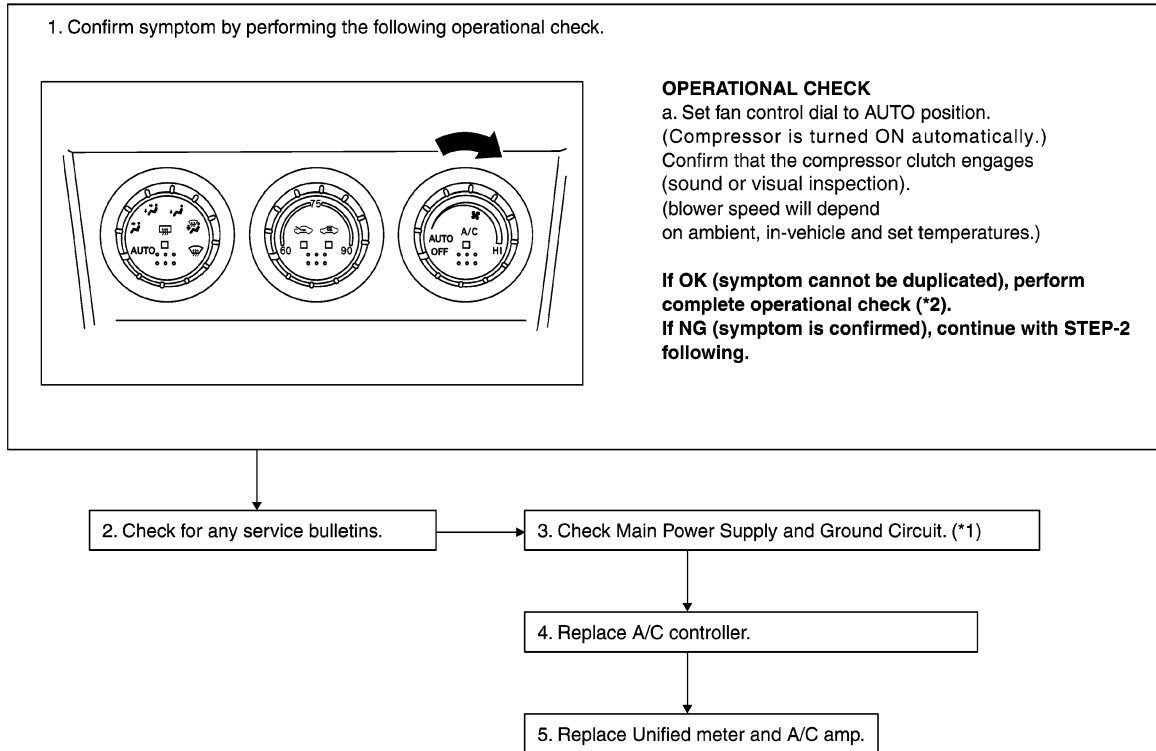

*1 [ATC-60. "DIAGNOSTIC PROCEDURE FOR A/C SYSTEM"](#).

*2 [ATC-57. "Operational Check"](#).

RJIA1372E

ATC

COMPONENT DESCRIPTION

Unified meter and A/C amp. (Automatic Amplifier)

The unified meter and A/C amp. has a built-in microcomputer which processes information sent from various sensors needed for air conditioner operation. The air mix door motor, mode door motor, intake door motor, blower motor and compressor are then controlled.

The unified meter and A/C amp. is unitized with control mechanisms. When the various switches and temperature control dial are operated, data is input to the auto amp. from the A/C controller using multiplex communication.

Self-diagnostic functions are also built into unified meter and A/C amp. to provide quick check of malfunctions in the auto air conditioner system.

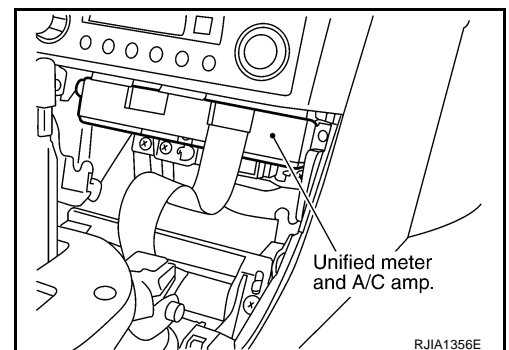

TROUBLE DIAGNOSIS

Potential Temperature Control (PTC)

The PTC is built into the A/C controller. It can be set at an interval of 1°C (2.0°F) in the 18°C (60°F) to 32°C (90°F) temperature range by turning the temperature control dial.

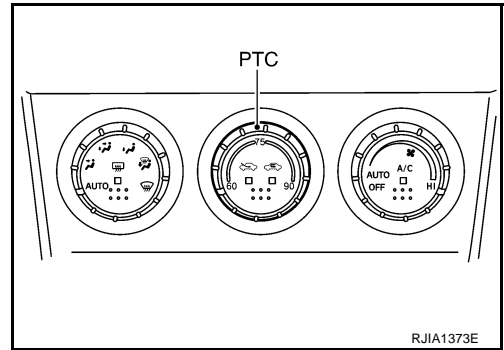

DIAGNOSTIC PROCEDURE FOR A/C SYSTEM

SYMPTOM: A/C system does not come on.

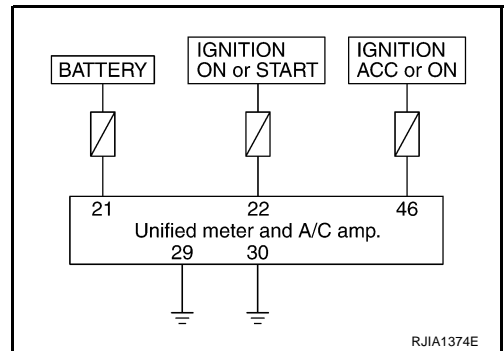

1. CHECK POWER SUPPLY CIRCUIT FOR UNIFIED METER AND A/C AMP.

1. Disconnect unified meter and A/C amp. connector.
2. Turn ignition switch ON.
3. Check voltage between unified meter and A/C amp. harness connector M49 terminal 21 (R/W) and 22 (Y/G), unified meter and A/C amp. harness connector M50 terminal 46 (L/W) and ground.

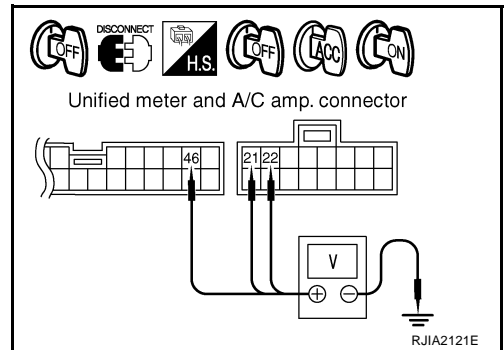

Terminals		(-)	Ignition switch position		
(+)	Terminal No. (wire color)		OFF	ACC	ON
Unified meter and A/C amp. connector					
M49	21 (R/W)	Ground	Battery voltage	Battery voltage	Battery voltage
M49	22 (Y/G)		Approx. 0V	Approx. 0V	Battery voltage
M50	46 (L/W)		Approx. 0V	Battery voltage	Battery voltage

OK or NG

OK >> GO TO 2.

NG >> Check 10A and 15A fuses [Nos. 10, 11, 12 and 19, located in the fuse block (J/B)]. Refer to [PG-88, "FUSE BLOCK - JUNCTION BOX \(J/B\)"](#).

- If fuses are OK, check harness for open circuit. Repair or replace if necessary.
- If fuses are NG, replace fuse and check harness for short circuit. Repair or replace if necessary.

TROUBLE DIAGNOSIS

2. CHECK GROUND CIRCUIT FOR UNIFIED METER AND A/C AMP.

1. Turn ignition switch OFF.
2. Check continuity between unified meter and A/C amp. harness connector M49 terminal 29 (B), 30 (B) and ground.

29, 30 – Ground : Continuity should exist.

OK or NG

- OK >> Replace unified meter and A/C amp.
 NG >> Repair or replace harness.

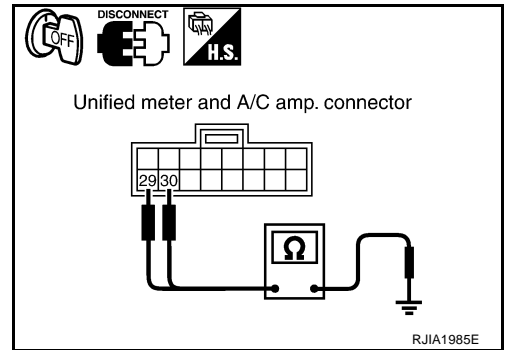

LAN System Circuit

AJS000AB

SYMPTOM: Mode door motor, intake door motor and/or air mix door motor(s) does not operate normally.

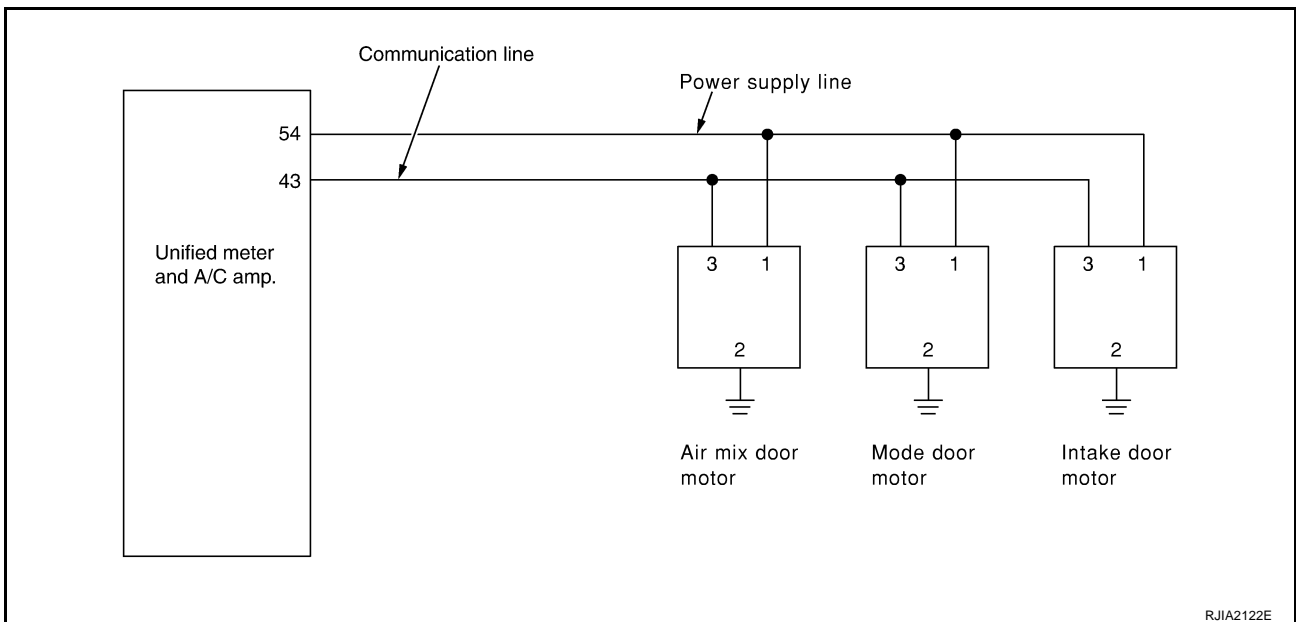

DIAGNOSTIC PROCEDURE FOR LAN CIRCUIT

1. CHECK POWER SUPPLY FOR UNIFIED METER AND A/C AMP.

1. Turn ignition switch ON.
2. Check voltage between unified meter and A/C amp. harness connector M50 terminal 54 (Y/R) and ground.

54 – Ground : Battery voltage

OK or NG

- OK >> GO TO 2.
 NG >> Replace unified meter and A/C amp.

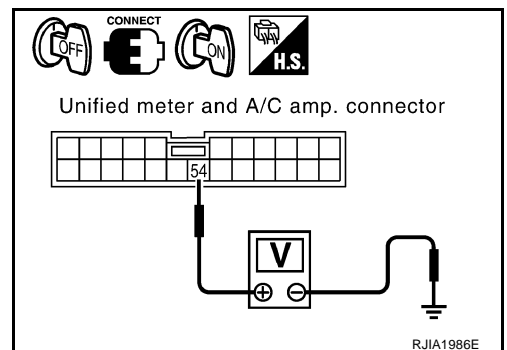

TROUBLE DIAGNOSIS

2. CHECK SIGNAL FOR UNIFIED METER AND A/C AMP.

Confirm A/C LAN signal between unified meter and A/C amp. harness connector M50 terminal 43 (G/B) and ground using an oscilloscope.

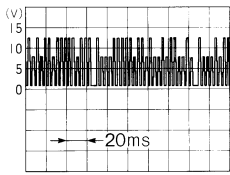
Terminals			Voltage
(+)		(-)	
Unified meter and A/C amp. connector	Terminal No. (wire color)		
M50	43 (G/B)	Ground	 <p style="text-align: right;">HAK0652D</p>

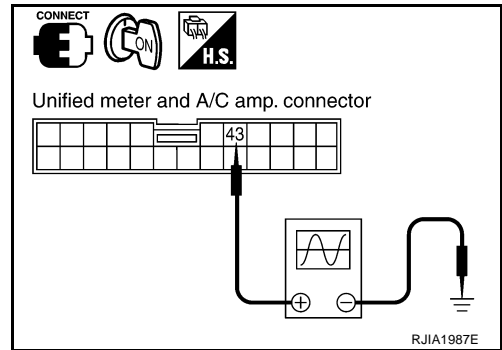

OK or NG

- OK >> GO TO 3.
- NG >> Replace unified meter and A/C amp.

3. CHECK POWER SUPPLY FOR MOTOR

Check voltage between mode door motor harness connector M252 terminal 1 (G), air mix door motor harness connector M253 terminal 1 (G), intake door motor connector M256 terminal 1 (G) and ground.

1 – Ground : Battery voltage

OK or NG

- OK >> GO TO 4.
- NG >> Replace harness or connector.

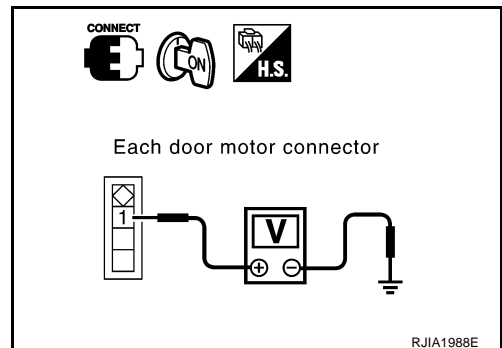

4. CHECK SIGNAL FOR MOTOR

Confirm A/C LAN signal between mode door motor harness connector M252 terminal 3 (L), air mix door motor harness connector M253 terminal 3 (L), intake door motor harness connector M256 terminal 3 (L) and ground using an oscilloscope.

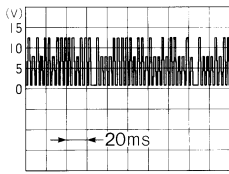
Door motor	Terminals		(-)	Voltage
	(+)			
	Connector	Terminal No. (wire color)		
Mode	M252	3 (L)	Ground	 <p style="text-align: right;">HAK0652D</p>
Air mix	M253	3 (L)		
Intake	M256	3 (L)		

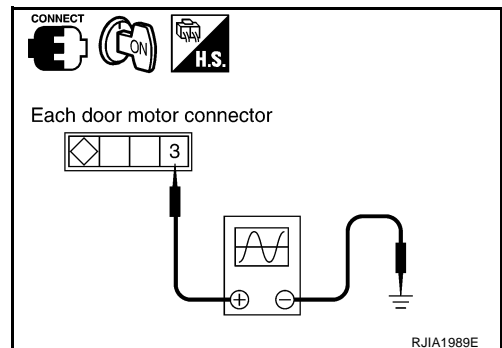

OK or NG

- OK >> GO TO 5.
- NG >> Replace harness or connector.

TROUBLE DIAGNOSIS

5. CHECK MOTOR GROUND CIRCUIT

1. Turn ignition switch OFF.
2. Disconnect door motor connector.
3. Check continuity between mode door motor harness connector M252 terminal 2 (B), air mix door motor harness connector M253 terminal 2 (B), intake door motor harness connector M256 terminal 2 (B) and ground.

2 – Ground : Continuity should exist.

OK or NG

- OK >> GO TO 6.
NG >> Replace harness or connector.

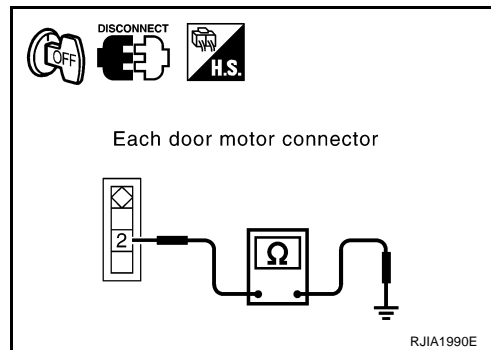

6. CHECK MOTOR OPERATION

1. Turn ignition switch OFF.
2. Disconnect each door motor connector.
3. Reconnect each door motor connector.
4. Turn ignition switch ON.
5. Confirm each door motor operation.

OK or NG

- OK >> (Return to operate normally.)
- Poor contacting the motor connector
- NG >> (Does not operate normally.)
- GO TO 7.

7. CHECK AIR MIX AND INTAKE DOOR MOTORS OPERATION

1. Turn ignition switch OFF.
2. Disconnect mode, air mix and intake door motor connectors.
3. Reconnect air mix and intake door motor connector.
4. Turn ignition switch ON.
5. Confirm air mix and intake door motors operation.

OK or NG

- OK >> (Air mix and intake door motors operate normally.)
- Replace mode door motor.
- NG >> (Air mix and intake door motors does not operate normally.)
- GO TO 8.

8. CHECK MODE AND INTAKE DOOR MOTORS OPERATION

1. Turn ignition switch OFF.
2. Disconnect air mix door motor connector.
3. Reconnect mode door motor connector.
4. Turn ignition switch ON.
5. Confirm mode and intake door motors operation.

OK or NG

- OK >> (Mode and intake door motors operate normally.)
- Replace air mix door motor.
- NG >> (Mode and intake door motor does not operate normally.)
- GO TO 9.

A
B
C
D
E
F
G
H
I
K
L
M

ATC

TROUBLE DIAGNOSIS

9. CHECK MODE AND AIR MIX DOOR MOTORS OPERATION

1. Turn ignition switch OFF.
2. Disconnect intake door motor connector.
3. Reconnect air mix door motor connector.
4. Turn ignition switch ON.
5. Confirm mode and air mix door motors operation.

OK or NG

- OK >> (Mode and air mix door motors operate normally.)
- Replace intake door motor.
- NG >> (Mode and air mix door motors does not operate normally.)
- Replace unified meter and A/C amp.

TROUBLE DIAGNOSIS

AJS000AC

Mode Door Motor Circuit

SYMPTOM:

- Air outlet does not change.
- Mode door motor does not operate normally.

INSPECTION FLOW

1. Confirm symptom by performing the following operational check.

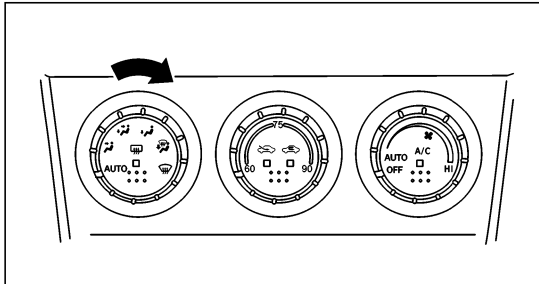

OPERATIONAL CHECK – Discharge air

a. Turn mode control dial to each position.

b. Confirm that discharge air comes out according to the air distribution table at left.
Refer to “Discharge Air Flow” (*1).

Discharge air flow

Mode door position	Air outlet/distribution		
	Face	Foot	Defroster
	100%	–	–
	54%	46%	–
	–	76%	24%
	–	57%	43%
	–	–	100%

NOTE:

- If OK (symptom cannot be duplicated), perform complete operational check (*2).
- If NG (symptom is confirmed), continue with STEP-2 following.
- Confirm that the compressor clutch is engaged (Sound or visual inspection) and intake door position is at FRESH when D/F, D/F2 or DEF is selected. Intake door position is checked in the next step.

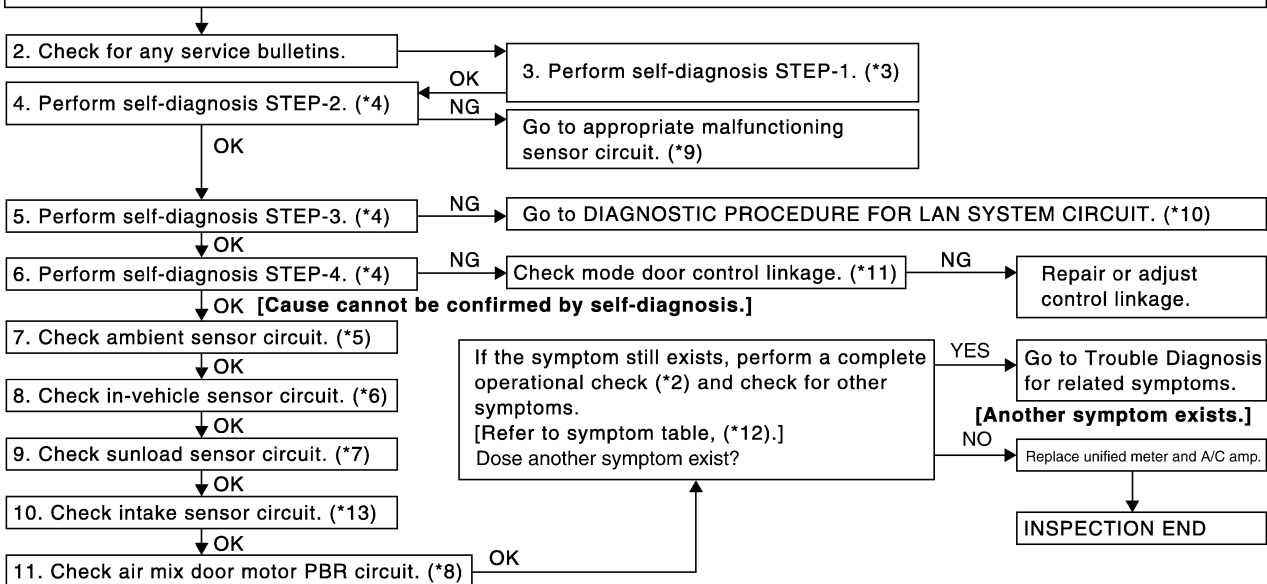

*1 [ATC-33, "Discharge Air Flow".](#)

*2 [ATC-57, "Operational Check".](#)

*3 [ATC-51, "FUNCTION CONFIRMATION PROCEDURE",](#) see No. 1.

*4 [ATC-51, "FUNCTION CONFIRMATION PROCEDURE",](#) see No. 5 to 7.

*5 [ATC-98, "Ambient Sensor Circuit".](#)

*6 [ATC-100, "In-vehicle Sensor Circuit".](#)

*7 [ATC-103, "Sunload Sensor Circuit".](#)

*8 [ATC-71, "Air Mix Door Motor PBR Circuit".](#)

*9 [ATC-51, "FUNCTION CONFIRMATION PROCEDURE",](#) see No. 9.

RJA2449E

TROUBLE DIAGNOSIS

- *10 [ATC-61, "DIAGNOSTIC PROCEDURE FOR LAN CIRCUIT"](#).
- *13 [ATC-106, "Intake Sensor Circuit"](#).

*11 [ATC-122, "MODE DOOR MOTOR"](#).

*12 [ATC-38, "SYMPTOM TABLE"](#).

SYSTEM DESCRIPTION

Component Parts

Mode door control system components are:

- Unified meter and A/C amp.
- Mode door motor (LCU)
- A/C LAN system (PBR built-in mode door motor, air mix door motor and intake door motor)
- In-vehicle sensor
- Ambient sensor
- Sunload sensor
- Intake sensor

System Operation

The unified meter and A/C amp. receives data from each of the sensors. The unified meter and A/C amp. sends air mix door, mode door and intake door opening angle data to the air mix door motor LCU, mode door motor LCU and intake door motor LCU.

The air mix door motor, mode door motor and intake door motor read their respective signals according to the address signal. Opening angle indication signals received from the unified meter and A/C amp. and each of the motor position sensors are compared by the LCUs in each motor with the existing decision and opening angles. Subsequently, HOT/COLD or DEFROST/VENT or FRESH/RECIRCULATION operation is selected. The new selection data is returned to the unified meter and A/C amp.

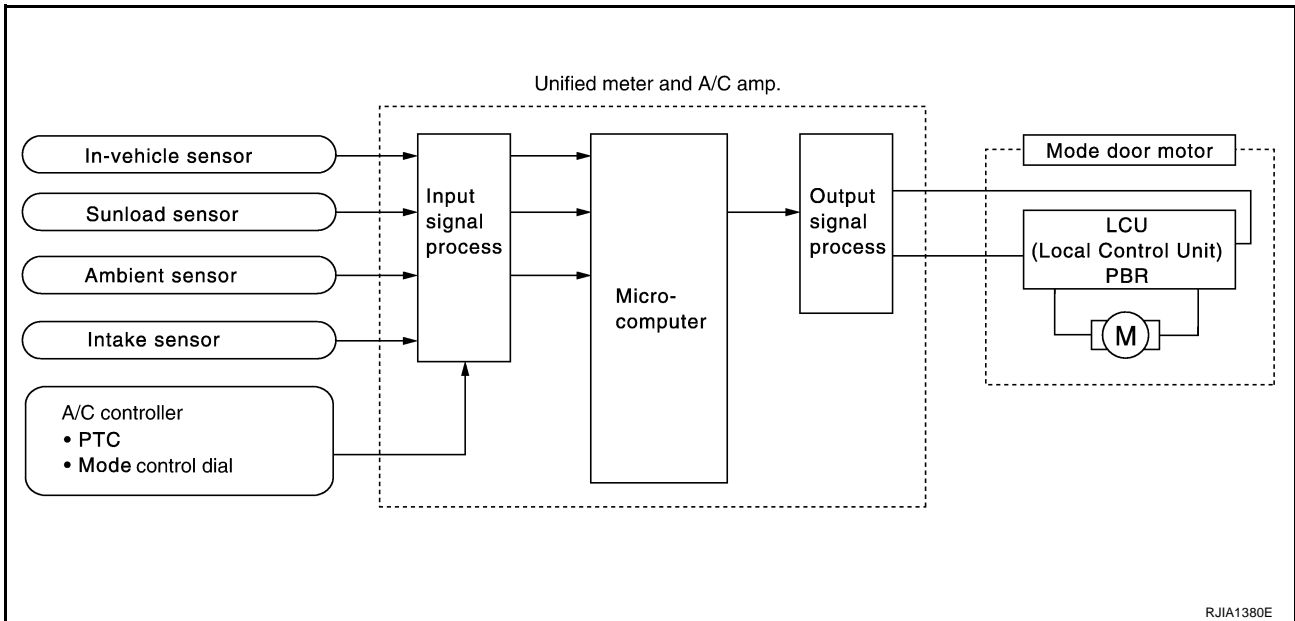

Mode Door Control Specification

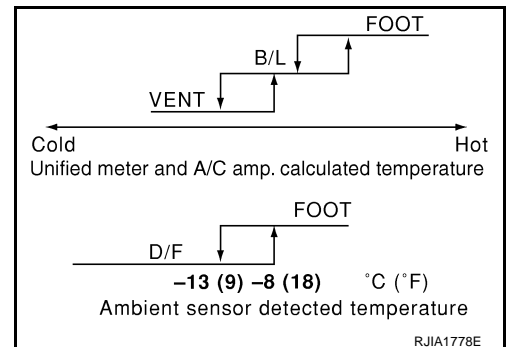

TROUBLE DIAGNOSIS

COMPONENT DESCRIPTION

Mode Door Motor

The mode door motor is attached to the heater & cooling unit. It rotates so that air is discharged from the outlet set by the unified meter and A/C amp. Motor rotation is conveyed to a link which activates the mode door.

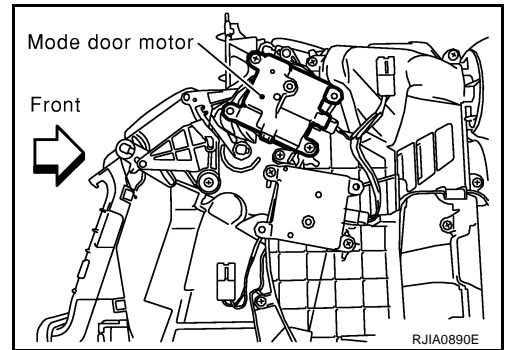

DIAGNOSTIC PROCEDURE FOR MODE DOOR MOTOR

SYMPTOM: Mode door motor does not operate normally.

Perform diagnostic procedure for [ATC-61, "DIAGNOSTIC PROCEDURE FOR LAN CIRCUIT"](#) .

A
B
C
D
E
F
G
H
I
K
L
M

ATC

TROUBLE DIAGNOSIS

AJS000AD

Air Mix Door Motor Circuit

SYMPTOM:

- Discharge air temperature does not change.
- Air mix door motor does not operate.

INSPECTION FLOW

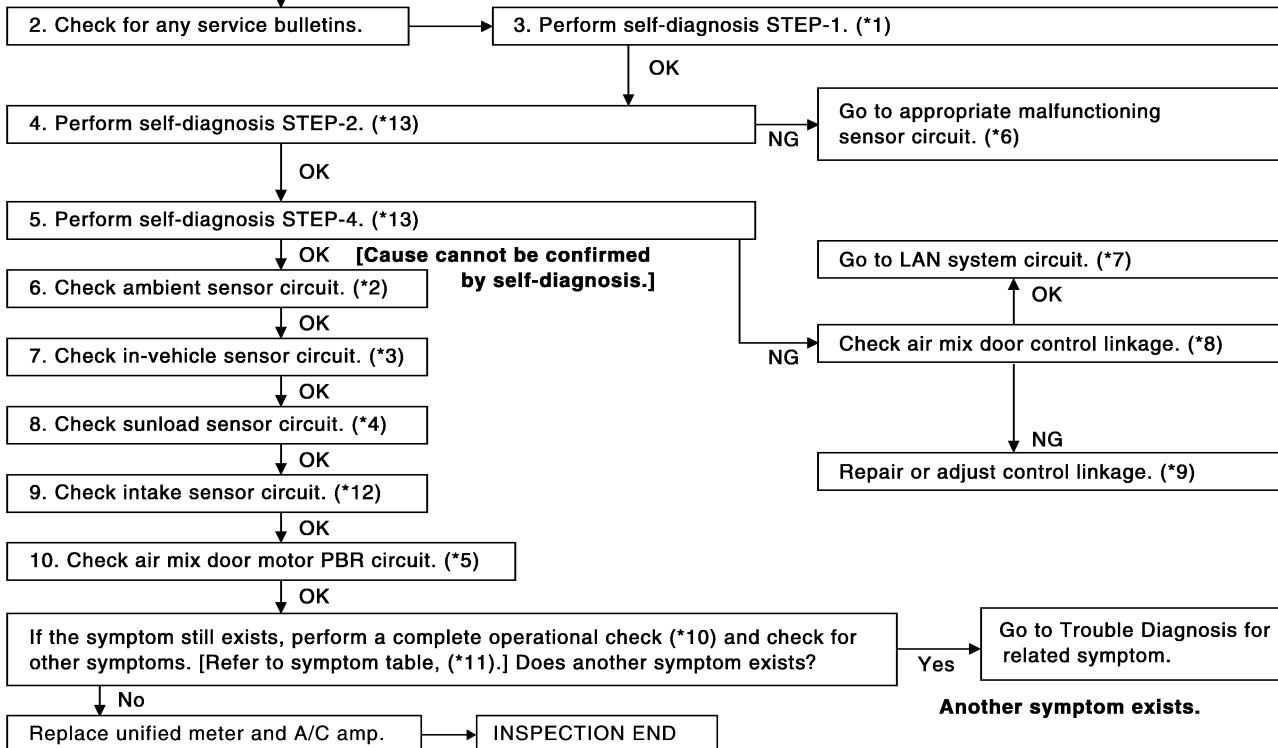
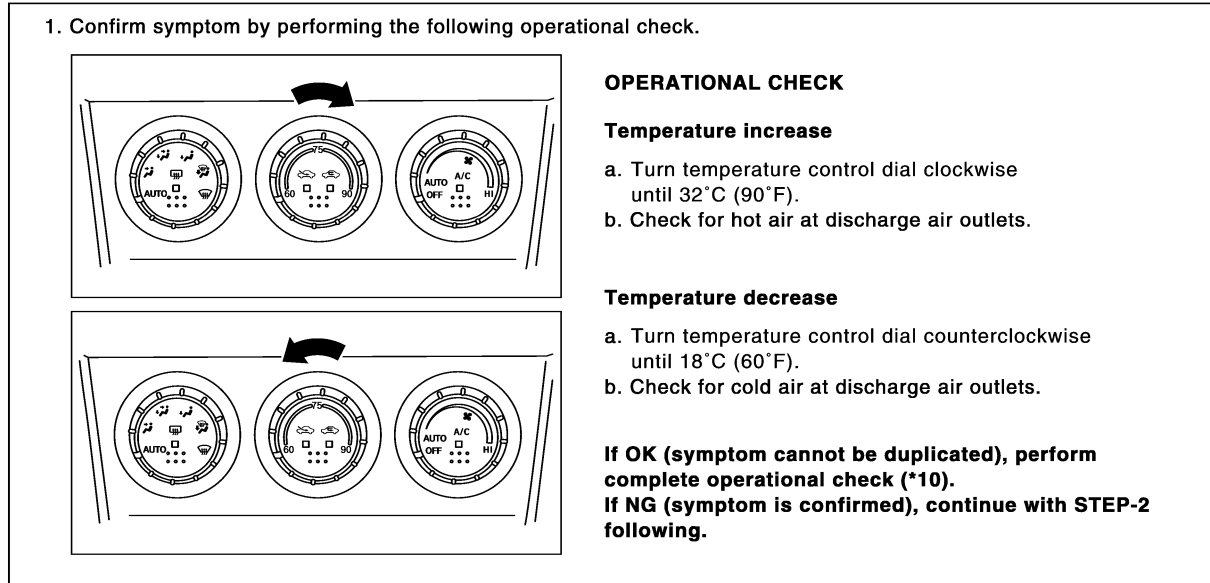

Another symptom exists.

RJIA1381E

*1 [ATC-51, "FUNCTION CONFIRMATION PROCEDURE"](#), see No.1.

*2 [ATC-98, "Ambient Sensor Circuit"](#).

*3 [ATC-100, "In-vehicle Sensor Circuit"](#).

*4 [ATC-103, "Sunload Sensor Circuit"](#)

*5 [ATC-71, "Air Mix Door Motor PBR Circuit"](#).

*6 [ATC-51, "FUNCTION CONFIRMATION PROCEDURE"](#), see No. 9.

*7 [ATC-61, "LAN System Circuit"](#).

*8 [ATC-71, "Air Mix Door Motor"](#).

*9 [ATC-123, "AIR MIX DOOR MOTOR"](#).

TROUBLE DIAGNOSIS

*10 [ATC-57, "Operational Check"](#).

*11 [ATC-38, "SYMPTOM TABLE"](#).

*12 [ATC-106, "Intake Sensor Circuit"](#).

*13 [ATC-51, "FUNCTION CONFIRMATION PROCEDURE"](#), see No. 5 to 7.

A

B

C

D

E

F

G

H

I

ATC

K

L

M

TROUBLE DIAGNOSIS

SYSTEM DESCRIPTION

Component Parts

Air mix door control system components are:

- Unified meter and A/C amp.
- Air mix door motor (LCU)
- A/C LAN system (PBR built-in mode door motor, air mix door motor and intake door motor)
- In-vehicle sensor
- Ambient sensor
- Sunload sensor
- Intake sensor

System Operation

The unified meter and A/C amp. receives data from each of the sensors. The unified meter and A/C amp. sends air mix door, mode door and intake door opening angle data to the air mix door motor LCU, mode door motor LCU and intake door motor LCU.

The air mix door motor, mode door motor and intake door motor read their respective signals according to the address signal. Opening angle indication signals received from the unified meter and A/C amp. and each of the motor position sensors are compared by the LCUs in each motor with the existing decision and opening angles. Subsequently, HOT/COLD or DEFROST/VENT or FRESH/RECIRCULATION operation is selected. The new selection data is returned to the unified meter and A/C amp.

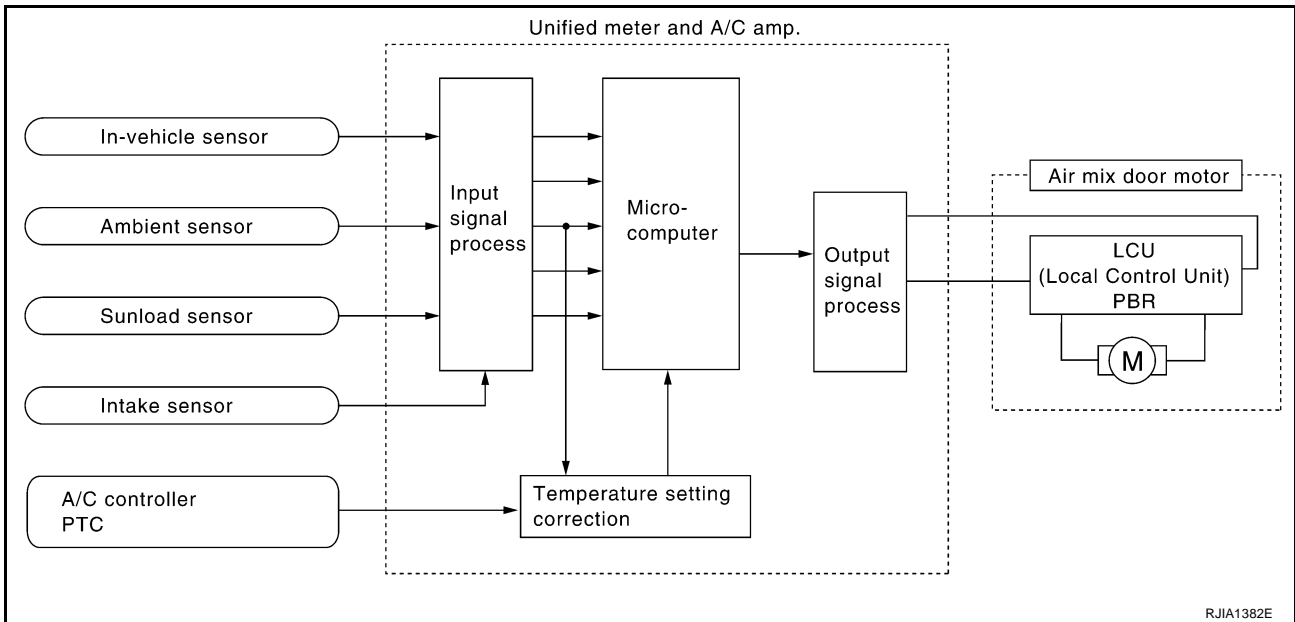

TROUBLE DIAGNOSIS

Air Mix Door Control Specification

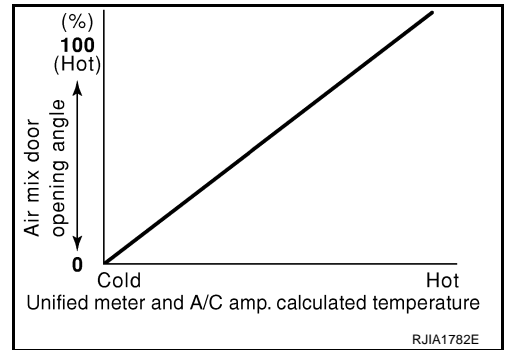

COMPONENT DESCRIPTION

Air Mix Door Motor

The air mix door motor is attached to the heater & cooling unit. It rotates so that the air mix door is opened or closed to a position set by the unified meter and A/C amp. Motor rotation is conveyed through a shaft and the air mix door position is then fed back to the unified meter and A/C amp. by PBR built-in air mix door motor.

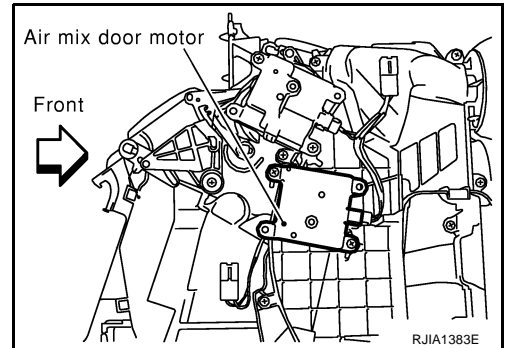

DIAGNOSTIC PROCEDURE FOR AIR MIX DOOR

SYMPTOM: Discharge air temperature does not change.

Perform diagnostic procedure for [ATC-61, "DIAGNOSTIC PROCEDURE FOR LAN CIRCUIT"](#) .

Air Mix Door Motor PBR Circuit

AJS000QW

SYMPTOM:

- Discharge air temperature does not change.
- PBR circuit is open or shorted.

DIAGNOSTIC PROCEDURE FOR AIR MIX DOOR PBR

Perform diagnostic procedure for [ATC-61, "DIAGNOSTIC PROCEDURE FOR LAN CIRCUIT"](#) .

A
B
C
D
E
F
G
H
I
K
L
M

ATC

TROUBLE DIAGNOSIS

AJS000AE

Intake Door Motor Circuit

SYMPTOM:

- Intake door does not change.
- Intake door motor does not operate normally.

INSPECTION FLOW

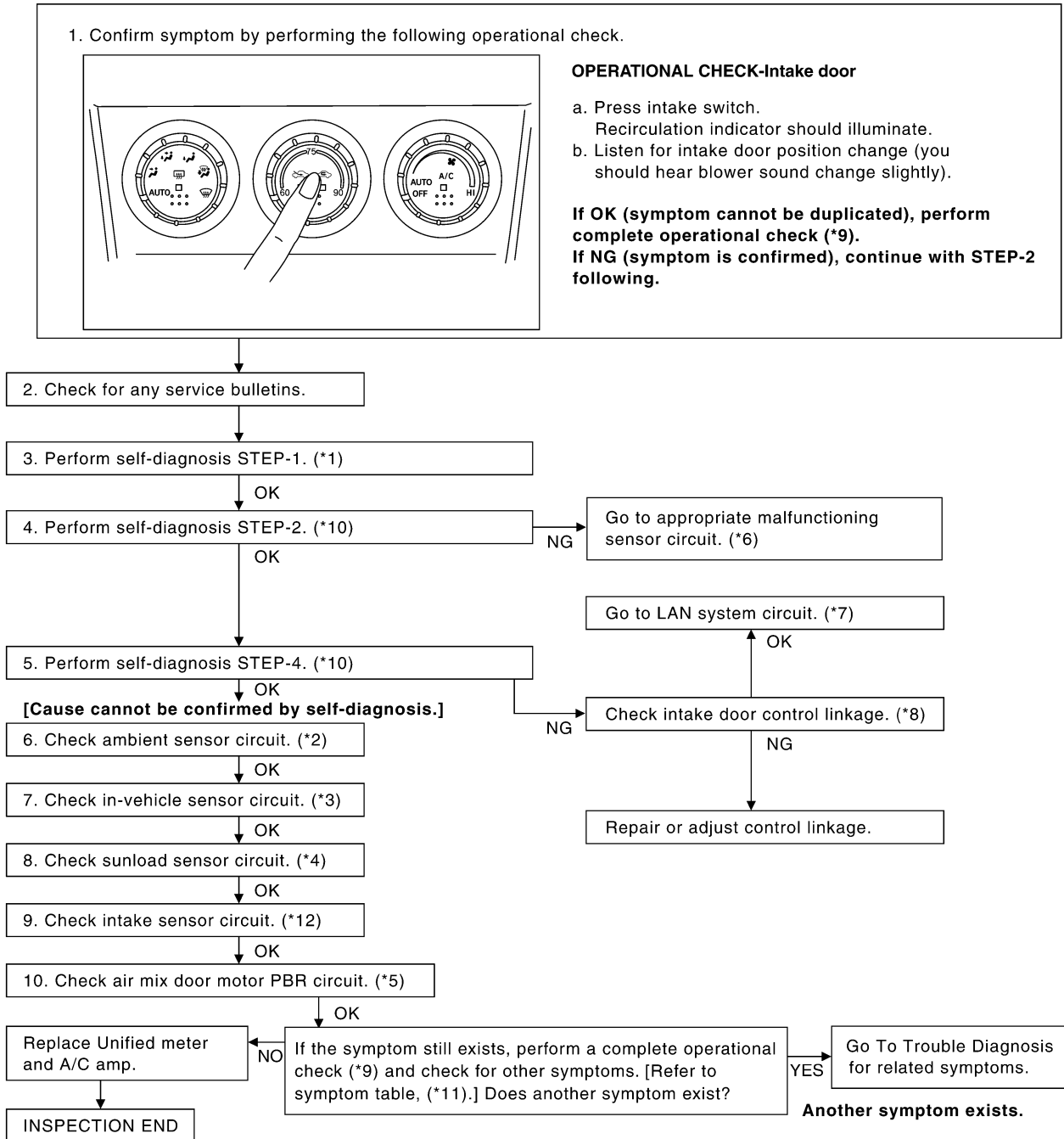

RJIA1384E

- | | | |
|--|---|---|
| <p>*1 ATC-51, "FUNCTION CONFIRMATION PROCEDURE", see No.1.</p> <p>*4 ATC-103, "Sunload Sensor Circuit".</p> <p>*7 ATC-61, "LAN System Circuit".</p> <p>*10 ATC-51, "FUNCTION CONFIRMATION PROCEDURE", see No.5 to 7.</p> | <p>*2 ATC-98, "Ambient Sensor Circuit".</p> <p>*5 ATC-71, "Air Mix Door Motor PBR Circuit".</p> <p>*8 ATC-117, "INTAKE DOOR MOTOR".</p> <p>*11 ATC-38, "SYMPTOM TABLE".</p> | <p>*3 ATC-100, "In-vehicle Sensor Circuit".</p> <p>*6 ATC-51, "FUNCTION CONFIRMATION PROCEDURE", see No. 9.</p> <p>*9 ATC-57, "Operational Check".</p> <p>*12 ATC-106, "Intake Sensor Circuit".</p> |
|--|---|---|

TROUBLE DIAGNOSIS

SYSTEM DESCRIPTION

Component Parts

Intake door control system components are:

- Unified meter and A/C amp.
- Intake door motor (LCU)
- A/C LAN system (PBR built-in mode door motor, air mix door motor and intake door motor)
- In-vehicle sensor
- Ambient sensor
- Sunload sensor
- Intake sensor

System Operation

The intake door control determines intake door position based on the ambient temperature, the intake air temperature and the in-vehicle temperature. When set mode control dial to D/F, D/F2 or DEF position, or OFF switch is pushed, the unified meter and A/C amp. sets the intake door at the FRESH position.

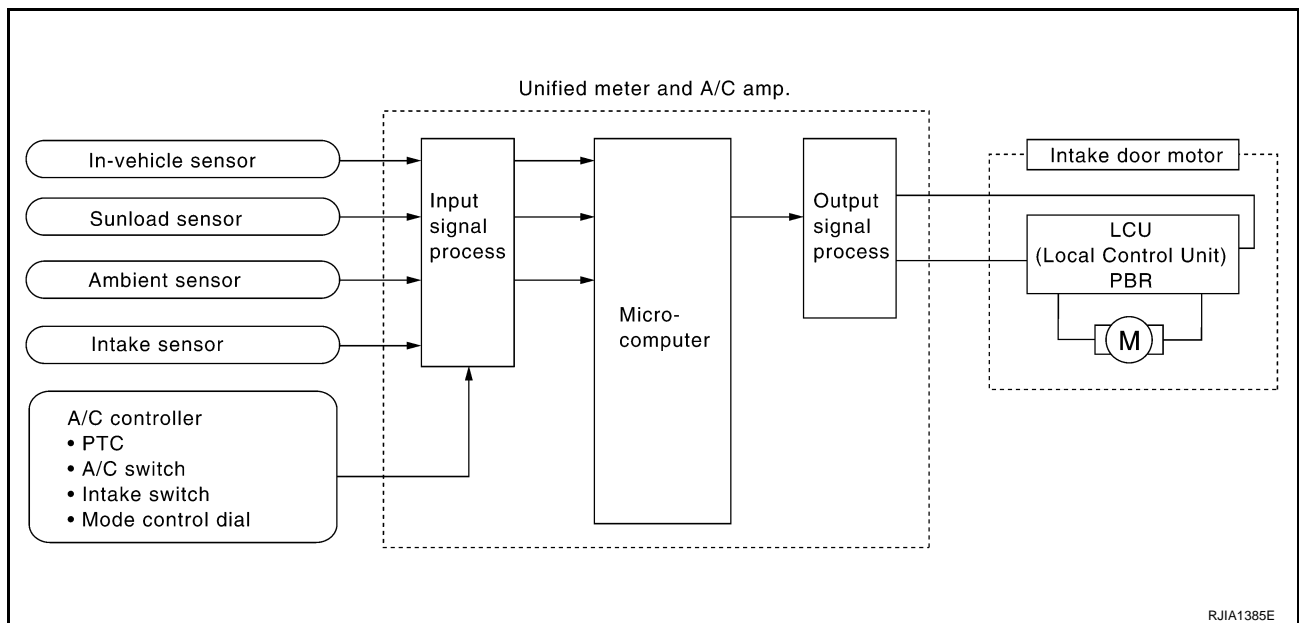

Intake Door Control Specification

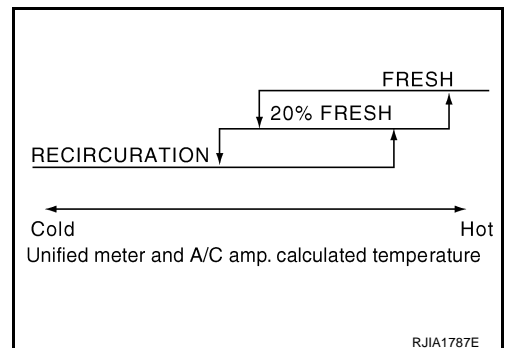

TROUBLE DIAGNOSIS

COMPONENT DESCRIPTION

Intake Door Motor

The intake door motor is attached to the blower unit. It rotates so that air is drawn from inlets set by the unified meter and A/C amp. Motor rotation is conveyed to a lever which activates the intake door.

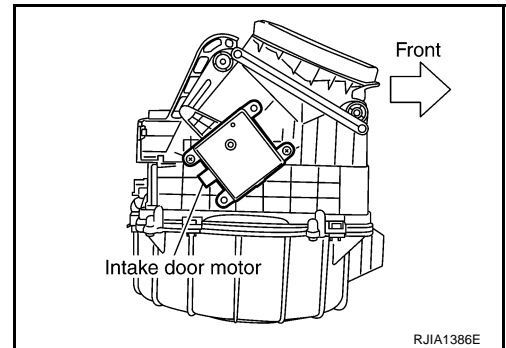

DIAGNOSTIC PROCEDURE FOR INTAKE DOOR MOTOR

SYMPTOM: Intake door motor does not operate normally.

Perform diagnostic procedure for [ATC-61, "DIAGNOSTIC PROCEDURE FOR LAN CIRCUIT"](#) .

TROUBLE DIAGNOSIS

AJS000AF

Blower Motor Circuit

SYMPTOM:

- Blower motor operation is malfunctioning.
- Blower motor operation is malfunctioning under out of starting fan speed control.

INSPECTION FLOW

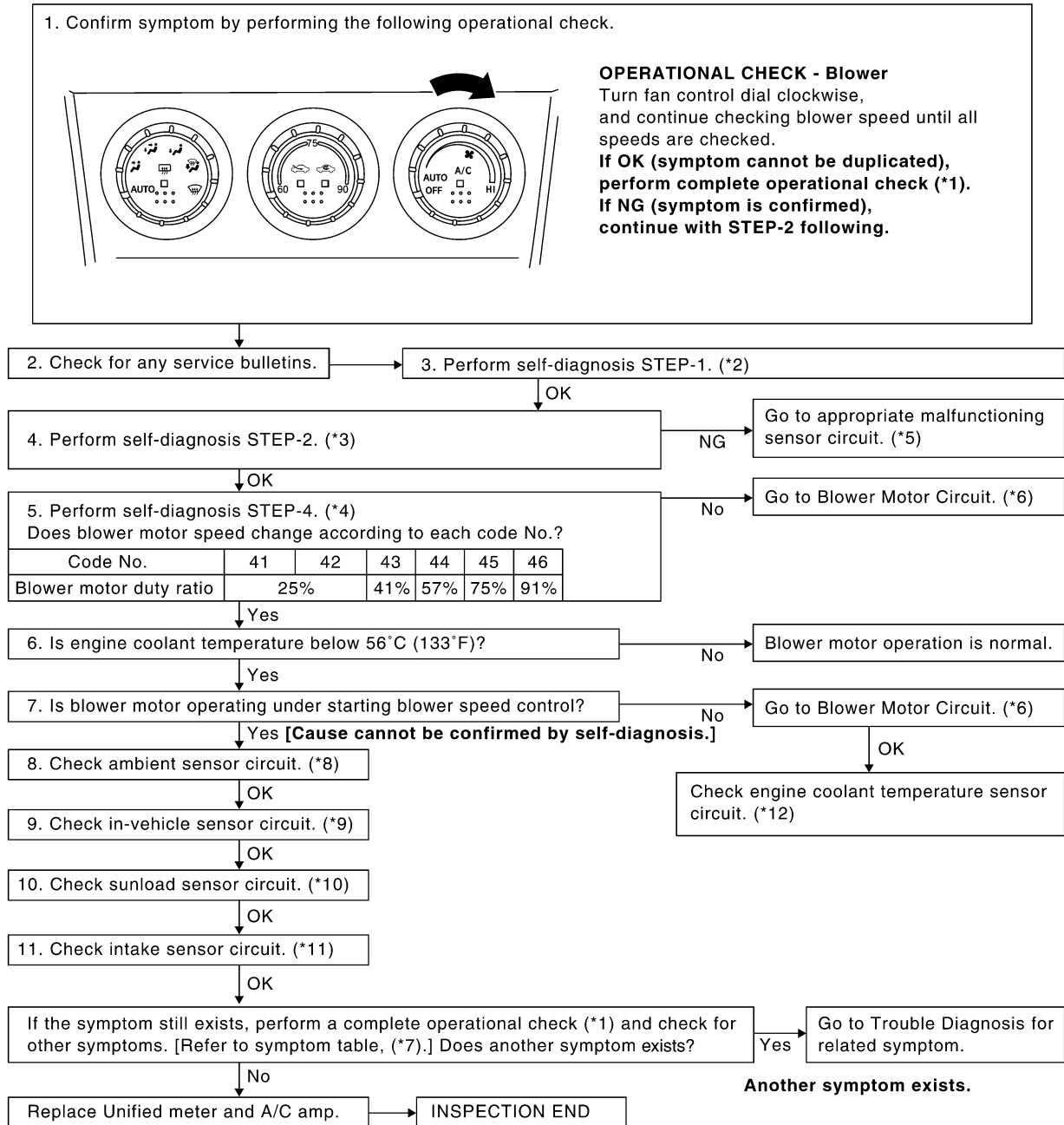

*1 [ATC-57, "Operational Check".](#)

*2 [ATC-51, "FUNCTION CONFIRMATION PROCEDURE",](#) see No.1.

*3 [ATC-51, "FUNCTION CONFIRMATION PROCEDURE",](#) see No.5.

*4 [ATC-51, "FUNCTION CONFIRMATION PROCEDURE",](#) see No.7.

*5 [ATC-51, "FUNCTION CONFIRMATION PROCEDURE",](#) see No.9.

*6 [ATC-77, "DIAGNOSTIC PROCEDURE FOR BLOWER MOTOR".](#)

*7 [ATC-38, "SYMPTOM TABLE".](#)

*8 [ATC-98, "Ambient Sensor Circuit".](#)

*9 [ATC-100, "In-vehicle Sensor Circuit".](#)

*10 [ATC-103, "Sunload Sensor Circuit".](#)

*11 [ATC-106, "Intake Sensor Circuit".](#)

*12 [EC-178, "DTC P0117, P0118 ECT SENSOR".](#)

RJIA1387E

TROUBLE DIAGNOSIS

SYSTEM DESCRIPTION

Component Parts

Fan speed control system components are:

- Unified meter and A/C amp.
- A/C LAN system (PBR built-in mode door motor, air mix door motor and intake door motor)
- In-vehicle sensor
- Ambient sensor
- Sunload sensor
- Intake sensor

System Operation

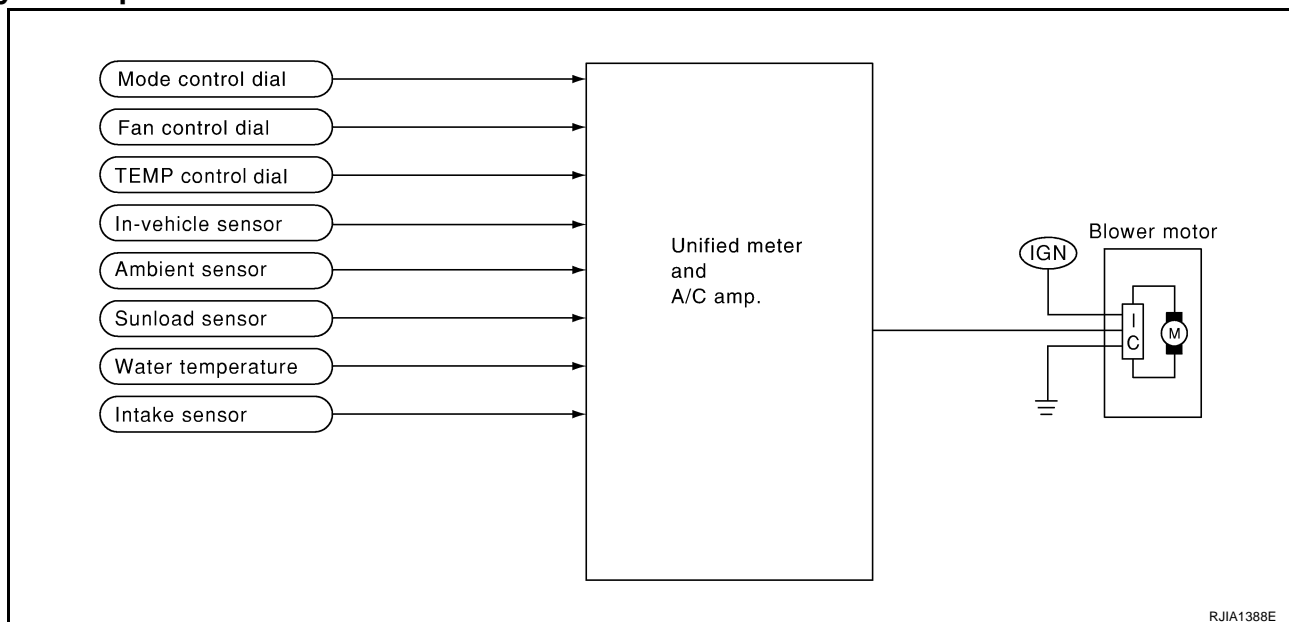

Automatic Mode

In the automatic mode, the blower motor speed is calculated by the unified meter and A/C amp. based on input from the PBR, in-vehicle sensor, sunload sensor, intake sensor and ambient sensor.

When the air flow is increased, the duty ratio of the blower fan motor's drive signal is changed at 8%/sec. to prevent a sudden increase in air flow.

In addition to manual air flow control and the usual automatic air flow control, starting air flow control, low water temperature starting control and high passenger compartment temperature starting control are available.

Starting Fan Speed Control

Start Up from COLD SOAK Condition (Automatic mode)

In a cold start up condition where the engine coolant temperature is below 56°C (133°F), the blower will not operate for a short period of time (up to 150 seconds). The exact start delay time varies depending on the ambient and engine coolant temperature.

In the most extreme case (very low ambient) the blower starting delay will be 150 seconds as described above. After this delay, the blower will operate at low speed until the engine coolant temperature rises above 56°C (133°F), at which time the blower speed will increase to the objective speed.

Start Up from Usual or HOT SOAK Condition (Automatic mode)

The blower will begin operation momentarily after the A/C switch is pushed. The blower speed will gradually rise to the objective speed over a time period of 3 seconds or less (actual time depends on the objective blower speed).

TROUBLE DIAGNOSIS

Blower Speed Compensation

Sunload

When the in-vehicle temperature and the set temperature are very close, the blower will be operating at low speed. The low speed will vary depending on the sunload. During conditions of low or no sunload, the blower low speed is usual low speed (duty ratio 25%). During high sunload conditions, the unified meter and A/C amp. causes the blower fan speed to increase. (duty ratio 49%).

Fan Speed Control Specification

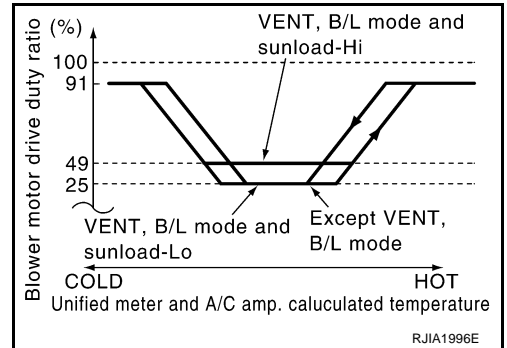

COMPONENT DESCRIPTION

Brush-less Motor

The blower motor utilizes a brush-less motor with a rotating magnet. Quietness is improved over previous motors where the brush was the point of contact and the coil rotated.

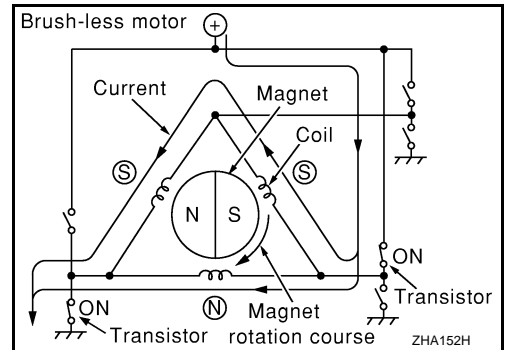

DIAGNOSTIC PROCEDURE FOR BLOWER MOTOR

SYMPTOM: Blower motor operation is malfunctioning under starting fan speed control.

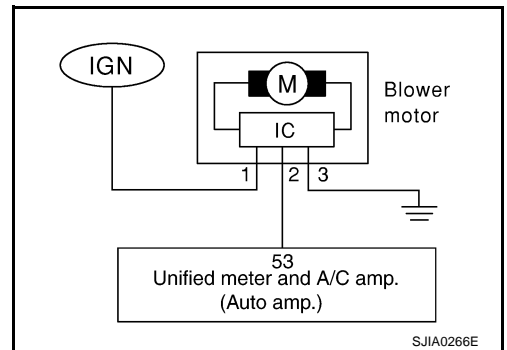

TROUBLE DIAGNOSIS

1. CHECK POWER SUPPLY FOR BLOWER MOTOR

1. Disconnect blower motor connector.
2. Turn ignition switch ON.
3. Check voltage between blower motor harness connector M62 terminal 1 (L/W) and ground.

1 – Ground : **Battery voltage**

OK or NG

OK >> GO TO 2.

NG >> Check power supply circuit and 15A fuses [Nos. 10 and 11, located in the fuse block (J/B)]. Refer to [PG-88](#), "[FUSE BLOCK - JUNCTION BOX \(J/B\)](#)".

- If OK, check for open circuit in wiring harness. Repair or replace if necessary.
- If NG, replace fuse and check wiring harness for short circuit. Repair or replace if necessary.

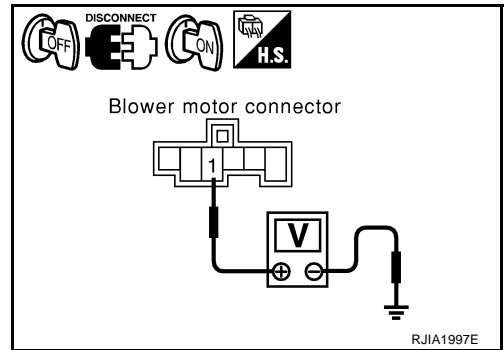

2. CHECK GROUND CIRCUIT FOR BLOWER MOTOR

1. Turn ignition switch OFF.
2. Check continuity between blower motor harness connector M62 terminal 3 (B) and ground.

3 – Ground : **Continuity should exist.**

OK or NG

OK >> GO TO 3.

NG >> Repair harness or connector.

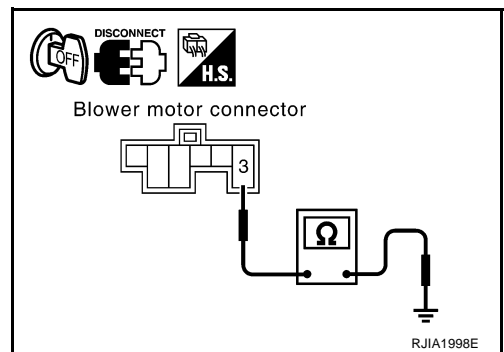

3. CHECK CIRCUIT CONTINUITY BLOWER MOTOR AND UNIFIED METER AND A/C AMP.

1. Disconnect unified meter and A/C amp. connector.
2. Check continuity between blower motor harness connector M62 terminal 2 (G) and unified meter and A/C amp. harness connector M50 terminal 53 (G).

2 – 53 : **Continuity should exist.**

OK or NG

OK >> GO TO 4.

NG >> Repair harness or connector.

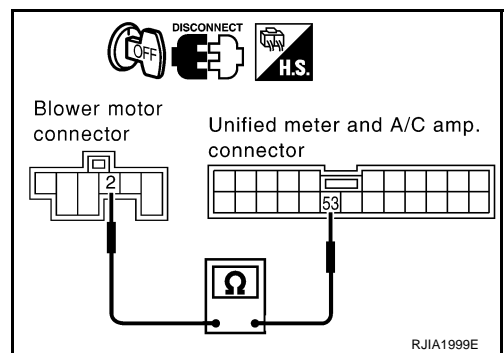

TROUBLE DIAGNOSIS

4. CHECK FOR UNIFIED METER AND A/C AMP. OUTPUT

1. Reconnect blower motor connector and unified meter and A/C amp. connector.
2. Turn ignition switch ON.
3. Vary the fan speed between Lo and Hi and confirm the blower motor connector M62 terminal 2 (G) and ground duty ratios using an oscilloscope. Usual terminal 2 (G) drive signal duty ratios are shown in the table below.

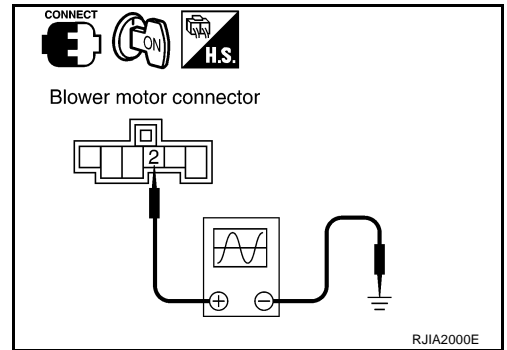

Blower fan speed	1st	5th	10th	15th	20th	25th
Blower motor connector M62 Terminal No. 2 (Oscilloscope)						
Duty ratio	Approx. 29%	Approx. 37%	Approx. 47%	Approx. 57%	Approx. 71%	Approx. 91%

NOTE: Duty ratio = $\frac{T_x}{\text{Approx. } 1.6 \text{ ms}} \times 100 (\%)$

RJA1390E

OK or NG

- OK >> GO TO 5.
- NG >> Replace unified meter and A/C amp.

5. CHECK BLOWER MOTOR DRIVE SIGNAL

If the fan air flow does not change, usual terminal 2 (G) drive signal duty ratios are shown in the table above.

OK or NG

- OK >> Replace blower motor.
- NG >> INSPECTION END

COMPONENT INSPECTION

Blower Motor

Confirm smooth rotation of the blower motor.

- Ensure that there are no foreign particles inside the blower unit.

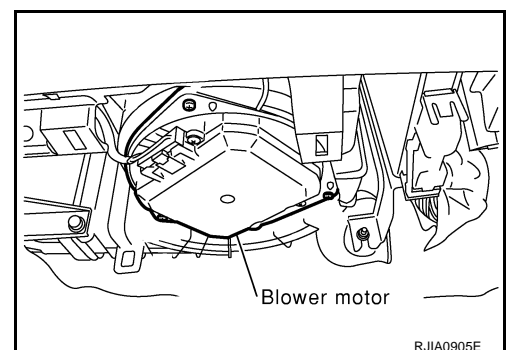

A
B
C
D
E
F
G
H
I
K
L
M

ATC

TROUBLE DIAGNOSIS

AJS000AG

Magnet Clutch Circuit

SYMPTOM: Magnet clutch does not engage.

INSPECTION FLOW

1. Confirm symptom by performing operational check.

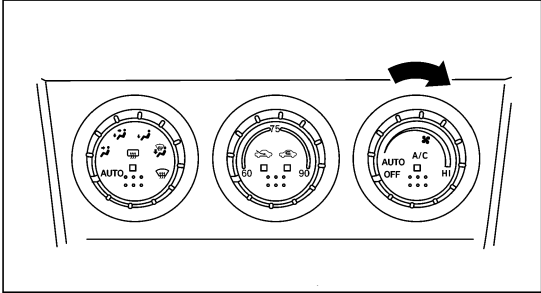

OPERATIONAL CHECK

a. Turn fan control dial to ON.
(Compressor is turned ON automatically.)
Confirm that the compressor clutch engages (sound or visual inspection).
(Discharge air and blower speed will depend on ambient, in-vehicle and set temperatures.)

If OK (symptom cannot be duplicated), perform complete operational check (*6).
If NG (symptom is confirmed), continue with STEP-2 following.

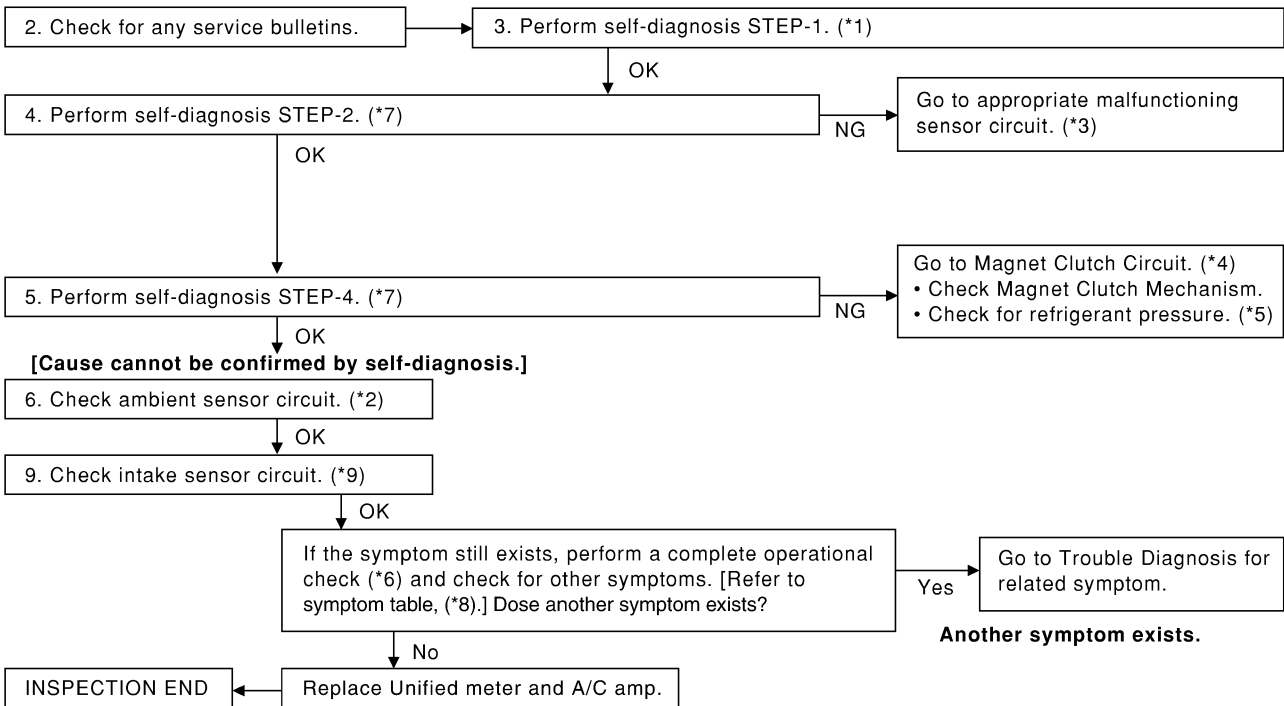

*1 [ATC-51, "FUNCTION CONFIRMATION PROCEDURE"](#), see No.1.

*2 [ATC-98, "Ambient Sensor Circuit"](#).

*3 [ATC-51, "FUNCTION CONFIRMATION PROCEDURE"](#), see No. 9.

*4 [ATC-81, "DIAGNOSTIC PROCEDURE FOR MAGNET CLUTCH"](#).

*5 [ATC-92, "TROUBLE DIAGNOSIS FOR UNUSUAL PRESSURE"](#).

*6 [ATC-57, "Operational Check"](#).

*7 [ATC-51, "FUNCTION CONFIRMATION PROCEDURE"](#), see No.5 to 7.

*8 [ATC-38, "SYMPTOM TABLE"](#).

*9 [ATC-106, "Intake Sensor Circuit"](#).

RJIA1391E

TROUBLE DIAGNOSIS

SYSTEM DESCRIPTION

Unified meter and A/C amp. controls compressor operation by ambient temperature, intake air temperature and signal from ECM.

Low Temperature Protection Control

Unified meter and A/C amp. will turn compressor ON or OFF as determined by a signal detected by ambient sensor and intake sensor.

When ambient temperatures are higher than -2°C (28°F), the compressor turns ON. The compressor turns OFF when ambient temperatures are lower than -5°C (23°F).

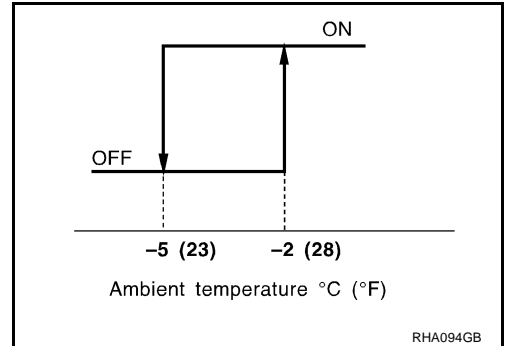

When intake air temperatures are higher than 1°C (34°F), the compressor turns ON. The compressor turns OFF when intake air temperatures are lower than -5°C (23°F).

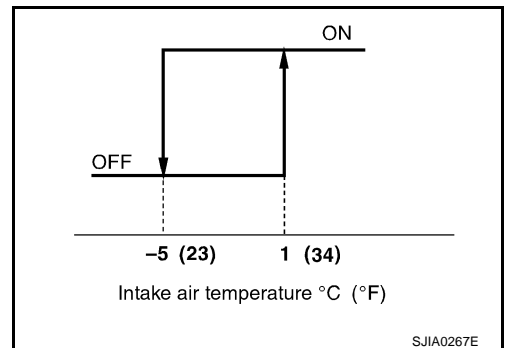

DIAGNOSTIC PROCEDURE FOR MAGNET CLUTCH

SYMPTOM: Magnet clutch does not engage when A/C switch is ON.

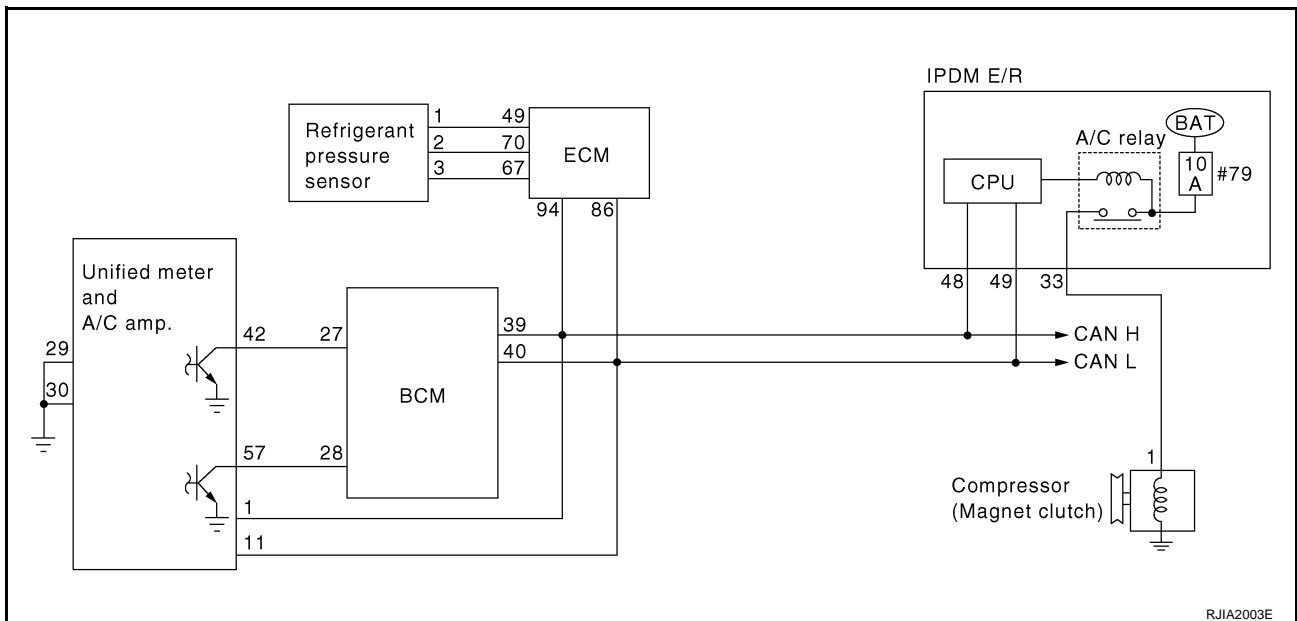

TROUBLE DIAGNOSIS

1. CHECK AMBIENT SENSOR CIRCUIT AND INTAKE SENSOR CIRCUIT

Check ambient sensor and intake sensor. Refer to [ATC-51, "FUNCTION CONFIRMATION PROCEDURE"](#) , see No. 9.

OK or NG

OK >> GO TO 2.

- NG >> ● Malfunctioning ambient sensor: Refer to [ATC-98, "Ambient Sensor Circuit"](#) .
● Malfunctioning intake sensor: Refer to [ATC-106, "Intake Sensor Circuit"](#) .

2. PERFORM AUTO ACTIVE TEST

Refer to [PG-24, "Auto Active Test"](#) .

Does the magnet clutch operate?

YES >> ●  WITH CONSULT-II
GO TO 5.

-  WITHOUT CONSULT-II
GO TO 6.

NO >> Check 10A fuse (No. 79, located in IPDM E/R), and GO TO 3.

3. CHECK CIRCUIT CONTINUITY BETWEEN IPDM E/R AND COMPRESSOR

1. Turn ignition switch OFF.
2. Disconnect IPDM E/R connector and compressor (magnet clutch) connector.
3. Check continuity between IPDM E/R harness connector E8 terminal 33 (L/Y) and compressor (magnet clutch) harness connector F24 terminal 1 (L/Y).

33 – 1 : Continuity should exist.

OK or NG

OK >> GO TO 4.

NG >> Repair harness or connector.

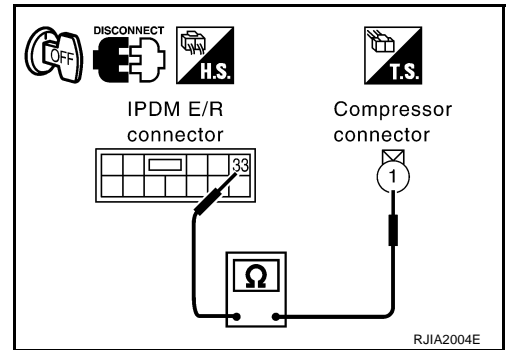

4. CHECK MAGNET CLUTCH CIRCUIT

Check operation sound when applying battery voltage direct current to terminal.

OK or NG

OK >> Replace IPDM E/R.

NG >> Replace magnet clutch. Refer to [ATC-132, "Removal and Installation of Compressor Clutch"](#) .

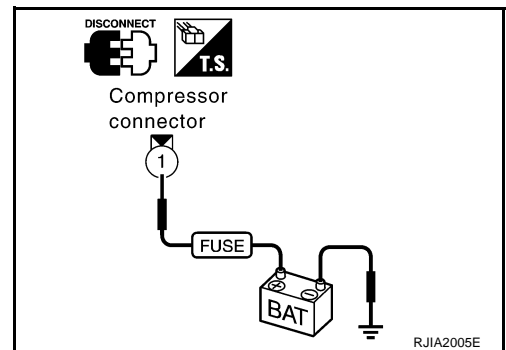

TROUBLE DIAGNOSIS

5. CHECK BCM INPUT (COMPRESSOR ON) SIGNAL

Check compressor ON/OFF signal. Refer to [ATC-36, "CONSULT-II"](#) .

A/C SW ON : AIR COND SW ON
A/C SW OFF : AIR COND SW OFF

OK or NG

OK >> GO TO 8.
 NG >> GO TO 6.

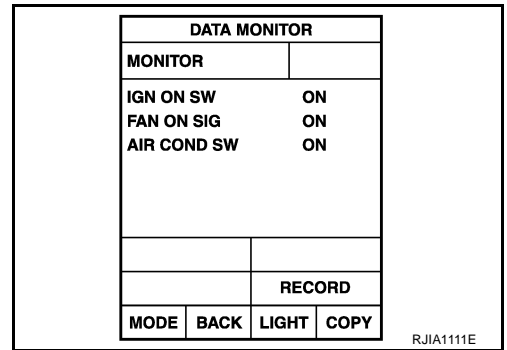

6. CHECK CIRCUIT CONTINUITY BETWEEN BCM AND UNIFIED METER AND A/C AMP.

1. Turn ignition switch OFF.
2. Disconnect BCM connector and unified meter and A/C amp. connector.
3. Check continuity between BCM harness connector M90 terminal 27 (G/Y) and unified meter and A/C amp. harness connector M50 terminal 42 (G/Y).

27 – 42 : Continuity should exist.

OK or NG

OK >> GO TO 7.
 NG >> Repair harness or connector.

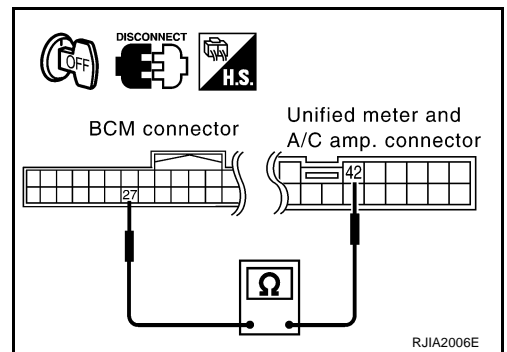

7. CHECK VOLTAGE FOR UNIFIED METER AND A/C AMP. (COMPRESSOR ON SIGNAL)

1. Reconnect BCM connector and unified meter and A/C amp. connector.
2. Turn ignition switch ON.
3. Check voltage between unified meter and A/C amp. harness connector M50 terminal 42 (G/Y) and ground.

Terminals			Condition	Voltage
(+)		(-)		
Unified meter and A/C amp. connector	Terminal No. (wire color)			
M50	42 (G/Y)	Ground	A/C switch: ON	Approx. 0V
			A/C switch: OFF	Approx. 5V

OK or NG

OK >> GO TO 8.
 NG-1 >> If the voltage is approx. 5V when A/C switch is ON: Replace unified meter and A/C amp.
 NG-2 >> If the voltage is approx. 0V when A/C switch is OFF: Replace BCM.

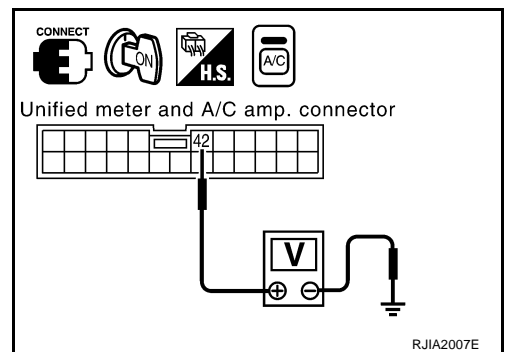

A
B
C
D
E
F
G
H
I
K
L
M

ATC

TROUBLE DIAGNOSIS

8. CHECK REFRIGERANT PRESSURE SENSOR

④ WITH CONSULT-II

1. Start the engine.
2. Check voltage of refrigerant pressure sensor. Refer to [EC-119, "CONSULT-II Reference Value in Data Monitor"](#).

⊗ WITHOUT CONSULT-II

1. Start the engine.
2. Check voltage between ECM harness connector F101 terminal 70 (G/R) and ground.

Terminals		(-)	Condition	Voltage	
(+)	Terminal No. (wire color)				
ECM connector	F101	70 (G/R)	Ground	A/C switch: ON	Approx. 1 - 4V

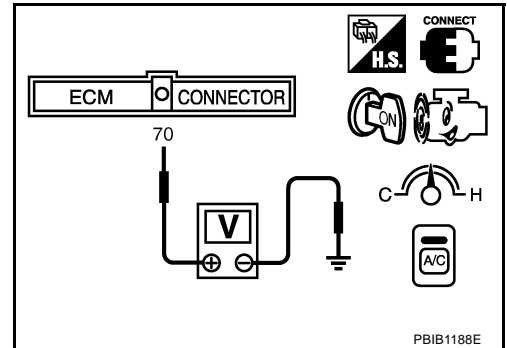

OK or NG

OK >> ● ④ WITH CONSULT-II
GO TO 9.

- ⊗ WITHOUT CONSULT-II
GO TO 10.

NG >> Refer to [EC-647, "REFRIGERANT PRESSURE SENSOR"](#).

9. CHECK BCM INPUT (FAN ON) SIGNAL

Check FAN ON/OFF signal. Refer to [ATC-36, "CONSULT-II"](#).

FAN SW ON

: FAN ON SIG ON

FAN SW OFF

: FAN ON SIG OFF

OK or NG

OK >> GO TO 12.

NG >> GO TO 10.

DATA MONITOR	
MONITOR	
IGN ON SW	ON
FAN ON SIG	ON
AIR COND SW	ON
RECORD	
MODE	BACK
LIGHT	COPY

10. CHECK CIRCUIT CONTINUITY BETWEEN BCM AND UNIFIED METER AND A/C AMP.

1. Turn ignition switch OFF.
2. Disconnect BCM connector and unified meter and A/C amp. connector.
3. Check continuity between BCM harness connector M60 terminal 28 (BR/W) and unified meter and A/C amp. harness connector M50 terminal 57 (BR/W).

28 - 57

: Continuity should exist.

OK or NG

OK >> GO TO 11.

NG >> Repair harness or connector.

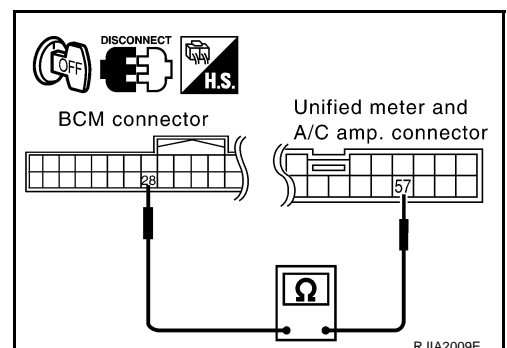

TROUBLE DIAGNOSIS

11. CHECK VOLTAGE FOR UNIFIED METER AND A/C AMP. (FAN ON SIGNAL)

1. Reconnect BCM connector and unified meter and A/C amp. connector.
2. Turn ignition switch ON.
3. Check voltage between unified meter and A/C amp. harness connector M50 terminal 57 (BR/W) and ground.

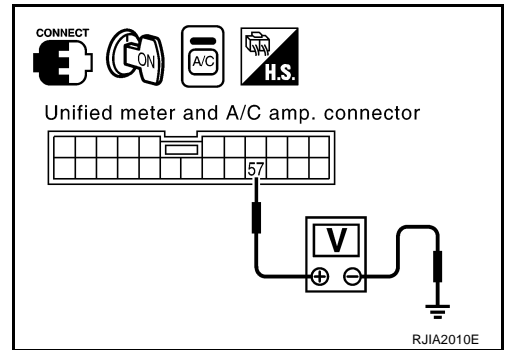

Terminals		(-)	Condition	Voltage
(+)				
Unified meter and A/C amp. connector	Terminal No. (wire color)			
M50	57 (BR/W)	Ground	Fan control dial: ON (Blower motor operates.)	Approx. 0V
			Fan control dial: OFF	Approx. 5V

OK or NG

OK >> GO TO 12.

NG-1 >> If the voltage is approx. 5V when blower motor is ON: Replace unified meter and A/C amp.

NG-2 >> If the voltage is approx. 0V when blower motor is OFF: Replace BCM. Refer to [BCS-17, "Removal and Installation of BCM"](#).

12. CHECK CAN COMMUNICATION

Check CAN communication. Refer to [BCS-16, "CAN Communication Inspection Using CONSULT-II \(Self-Diagnosis\)"](#).

- BCM – ECM
- ECM – IPDM E/R
- ECM – Unified meter and A/C amp.

OK or NG

OK >> INSPECTION END

NG >> Repair or replace malfunctioning part(s).

A
B
C
D
E
F
G
H
I
K
L
M

ATC

TROUBLE DIAGNOSIS

COMPONENT INSPECTION

Refrigerant Pressure Sensor

The refrigerant pressure sensor is attached to the liquid tank. Make sure that the A/C refrigerant pressure and the sensor output voltage are within the specified range as shown in the A/C operating condition figure. Refer to [EC-647, "REFRIGERANT PRESSURE SENSOR"](#).

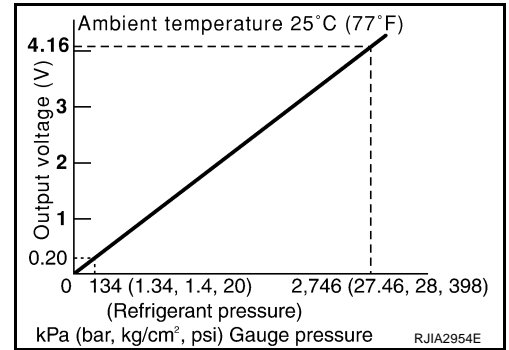
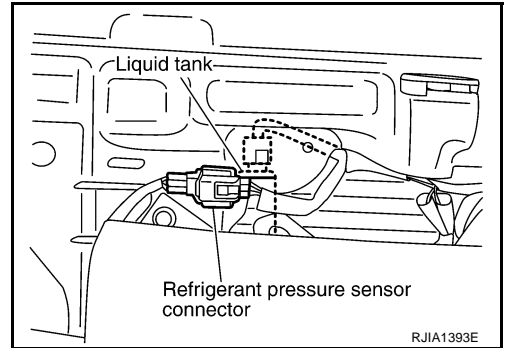

TROUBLE DIAGNOSIS

AJS000AH

Insufficient Cooling

SYMPTOM: Insufficient cooling.

INSPECTION FLOW

1. Confirm symptom by performing the following operational check.

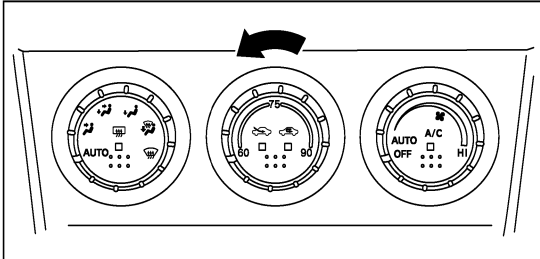

OPERATIONAL CHECK – Temperature decrease

- Turn temperature control dial counterclockwise until 18°C (60°F).
- Check for cold air at discharge air outlets.

If OK (symptom cannot be duplicated), perform complete operational check (*10).
If NG (symptom is confirmed), continue with STEP-2 following.

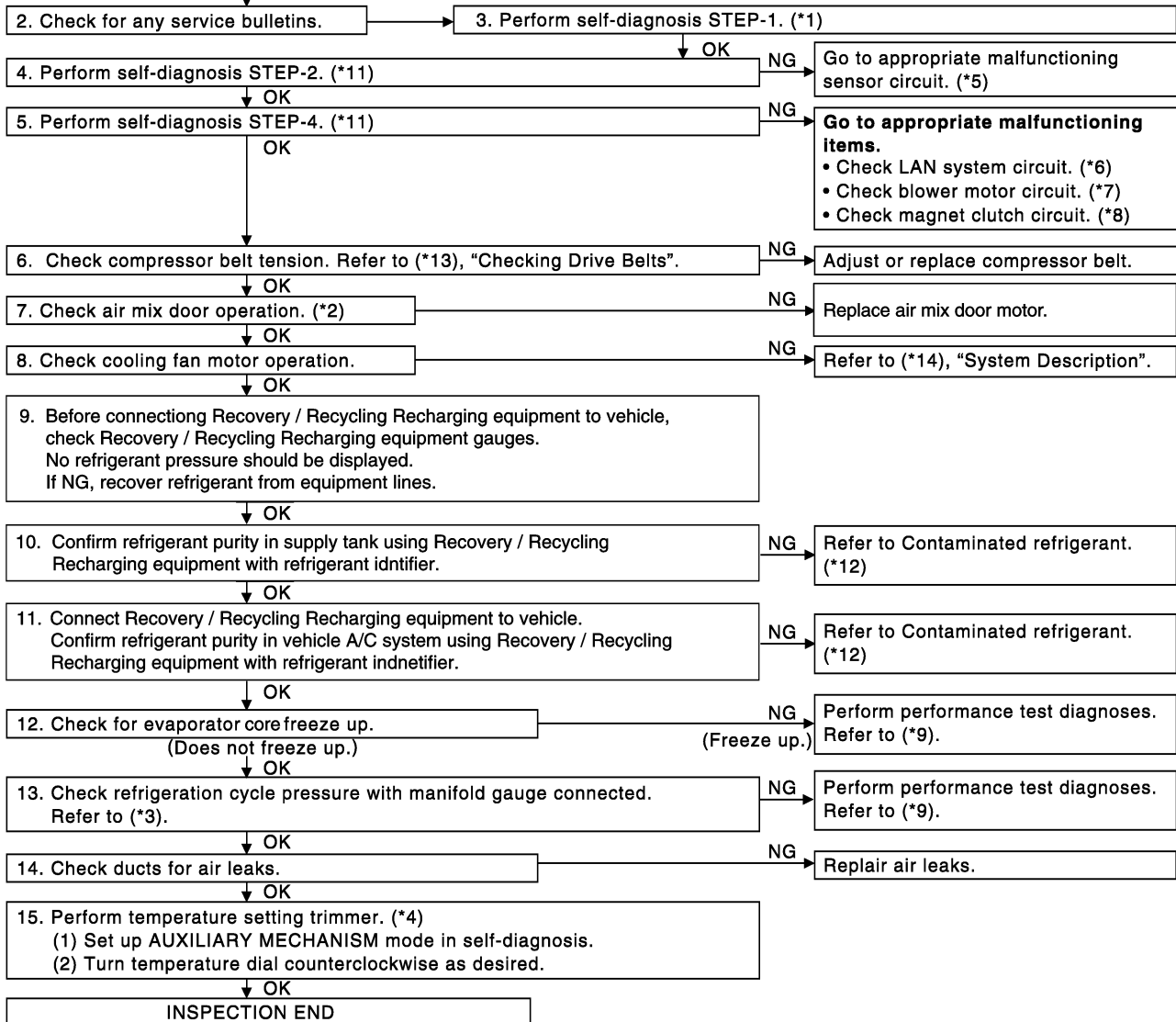

A
B
C
D
E
F
G
H
I
K
L
M

ATC

RJIA3007E

TROUBLE DIAGNOSIS

- *1 [ATC-51, "FUNCTION CONFIRMATION PROCEDURE"](#), see No.1.
- *2 [ATC-68, "Air Mix Door Motor Circuit"](#).
- *3 [ATC-91, "Test Reading"](#).
- *4 [ATC-55, "AUXILIARY MECHANISM: TEMPERATURE SETTING TRIMMER"](#).
- *5 [ATC-51, "FUNCTION CONFIRMATION PROCEDURE"](#), see No. 9.
- *6 [ATC-61, "LAN System Circuit"](#).
- *7 [ATC-75, "Blower Motor Circuit"](#).
- *8 [ATC-80, "Magnet Clutch Circuit"](#).
- *9 [ATC-89, "PERFORMANCE TEST DIAGNOSIS"](#).
- *10 [ATC-57, "Operational Check"](#).
- *11 [ATC-51, "FUNCTION CONFIRMATION PROCEDURE"](#), see No.5 to 7.
- *12 [ATC-5, "CONTAMINATED REFRIGERANT"](#).
- *13 [EM-12, "Checking Drive Belts"](#).
- *14 [EC-439, "SYSTEM DESCRIPTION"](#).

TROUBLE DIAGNOSIS

PERFORMANCE TEST DIAGNOSIS

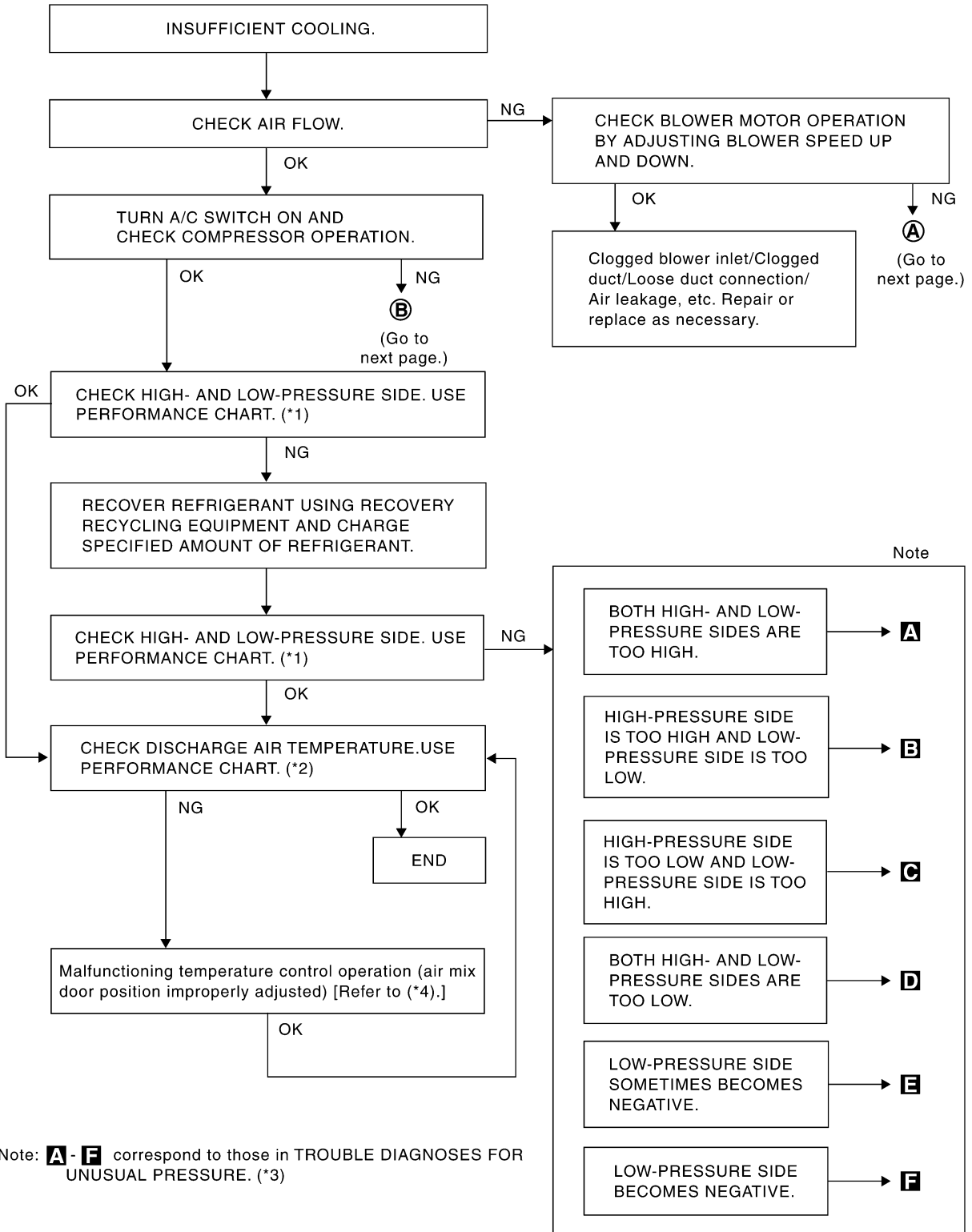

Note: **A - F** correspond to those in TROUBLE DIAGNOSES FOR UNUSUAL PRESSURE. (*3)

*1 [ATC-91, "PERFORMANCE CHART"](#).

*2 [ATC-91, "PERFORMANCE CHART"](#).

*3 [ATC-92, "TROUBLE DIAGNOSIS FOR UNUSUAL PRESSURE"](#).

*4 [ATC-68, "Air Mix Door Motor Circuit"](#).

RJIA1601E

TROUBLE DIAGNOSIS

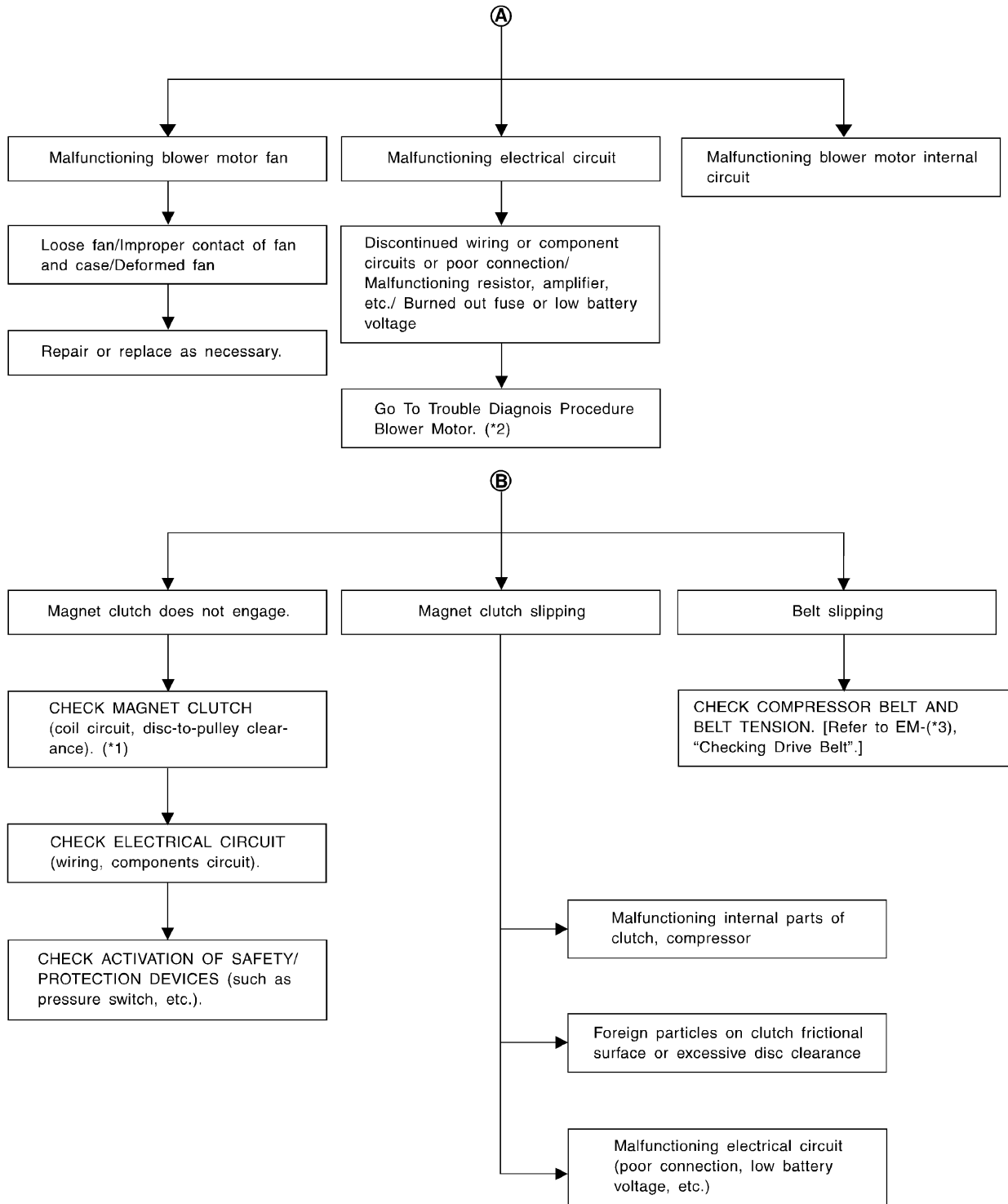

RJIA1595E

*1 [ATC-132, "Removal and Installation of Compressor Clutch"](#).

*2 [ATC-75, "Blower Motor Circuit"](#).



*3 [EM-12, "Checking Drive Belts"](#)

TROUBLE DIAGNOSIS

PERFORMANCE CHART

Test Condition

Testing must be performed as follows:

Vehicle location	Indoors or in the shade (in a well-ventilated place)
Doors	Closed
Door window	Open
Hood	Open
TEMP.	Max. COLD
Mode control dial	 (Ventilation) set
Intake switch	 (Recirculation) set
 Fan (blower) speed	Max. speed set
Engine speed	Idle speed

Operate the air conditioning system for 10 minutes before taking measurements.

Test Reading

Recirculating-to-discharge Air Temperature Table

Inside air (Recirculating air) at blower assembly inlet		Discharge air temperature at center ventilator °C (°F)
Relative humidity %	Air temperature °C (°F)	
50 - 60	15 (59)	2.8 - 3.9 (37.0 - 39.0)
	20 (68)	5.3 - 7.7 (41.5 - 45.9)
	25 (77)	8.9 - 12.0 (48.0 - 53.6)
	30 (86)	13.0 - 16.7 (55.4 - 62.1)
	35 (95)	18.2 - 22.0 (64.8 - 71.6)
60 - 70	15 (59)	3.9 - 6.0 (39.0 - 42.8)
	20 (68)	7.7 - 10.0 (45.9 - 50.0)
	25 (77)	12.0 - 14.4 (53.6 - 57.9)
	30 (86)	16.7 - 19.8 (62.1 - 67.6)
	35 (95)	22.0 - 26.0 (71.6 - 78.8)

Ambient Air Temperature-to-operating Pressure Table

Ambient air		High-pressure (Discharge side) kPa (kg/cm ² , psi)	Low-pressure (Suction side) kPa (kg/cm ² , psi)
Relative humidity %	Air temperature °C (°F)		
50 - 70	15 (59)	600 - 770 (6.12 - 7.86, 87.0 - 111.7)	165 - 220 (1.68 - 2.24, 23.9 - 31.9)
	20 (68)	640 - 840 (6.53 - 8.57, 92.8 - 121.8)	170 - 235 (1.73 - 2.40, 24.7 - 34.1)
	25 (77)	790 - 1,030 (8.06 - 10.5, 114.6 - 149.4)	185 - 255 (1.89- 2.60, 26.8 - 37.0)
	30 (86)	1,050 - 1,340 (10.7 - 13.7, 152.3 - 194.3)	205 - 290 (2.10 - 2.96, 29.7 - 42.1)
	35 (95)	1,055 - 1,345 (10.8 - 13.7, 153.0 - 195.0)	240 - 335 (2.45 - 3.42, 34.8 - 48.6)

TROUBLE DIAGNOSIS

TROUBLE DIAGNOSIS FOR UNUSUAL PRESSURE

Whenever system's high and/or low side pressure(s) is/are unusual, diagnose using a manifold gauge. The marker above the gauge scale in the following tables indicates the standard (usual) pressure range. Since the standard (usual) pressure, however, differs from vehicle to vehicle, refer to above table (Ambient air temperature-to-operating pressure table).

Both High- and Low-pressure Sides are Too High

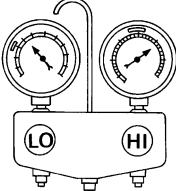
Gauge indication	Refrigerant cycle	Probable cause	Corrective action
<p>Both high- and low-pressure sides are too high.</p>  <p style="text-align: right; font-size: small;">AC359A</p>	Pressure is reduced soon after water is splashed on condenser.	Excessive refrigerant charge in refrigeration cycle	Reduce refrigerant until specified pressure is obtained.
	Air suction by cooling fan is insufficient.	Insufficient condenser cooling performance ↓ 1. Condenser fins are clogged. 2. Improper fan rotation of cooling fan	<ul style="list-style-type: none"> ● Clean condenser. ● Check and repair cooling fan as necessary.
	<ul style="list-style-type: none"> ● Low-pressure pipe is not cold. ● When compressor is stopped high-pressure value quickly drops by approximately 196 kPa (2 kg/cm², 28 psi). It then decreases gradually thereafter. 	Poor heat exchange in condenser (After compressor operation stops, high-pressure decreases too slowly.) ↓ Air in refrigeration cycle	Evacuate repeatedly and recharge system.
	Engine tends to overheat.	Engine cooling systems malfunction.	Check and repair each engine cooling system.
	<ul style="list-style-type: none"> ● An area of the low-pressure pipe is colder than areas near the evaporator outlet. ● Plates are sometimes covered with frost. 	<ul style="list-style-type: none"> ● Excessive liquid refrigerant on low-pressure side ● Excessive refrigerant discharge flow ● Expansion valve is open a little compared with the specification. ↓ Improper expansion valve adjustment	Replace expansion valve.

High-pressure Side is Too High and Low-pressure Side is Too Low

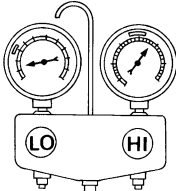
Gauge indication	Refrigerant cycle	Probable cause	Corrective action
<p>High-pressure side is too high and low-pressure side is too low.</p>  <p style="text-align: right; font-size: small;">AC360A</p>	Upper side of condenser and high-pressure side are hot, however, liquid tank is not so hot.	High-pressure tube or parts located between compressor and condenser are clogged or crushed.	<ul style="list-style-type: none"> ● Check and repair or replace malfunctioning parts. ● Check lubricant for contamination.

TROUBLE DIAGNOSIS

High-pressure Side is Too Low and Low-pressure Side is Too High

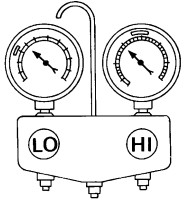
Gauge indication	Refrigerant cycle	Probable cause	Corrective action
<p>High-pressure side is too low and low-pressure side is too high.</p>  <p style="text-align: right; font-size: small;">AC356A</p>	<p>High- and low-pressure sides become equal soon after compressor operation stops.</p>	<p>Compressor pressure operation is improper. ↓ Damaged inside compressor packings</p>	<p>Replace compressor.</p>
	<p>No temperature difference between high- and low-pressure sides</p>	<p>Compressor pressure operation is improper. ↓ Damaged inside compressor packings.</p>	<p>Replace compressor.</p>

Both High- and Low-pressure Sides are Too Low

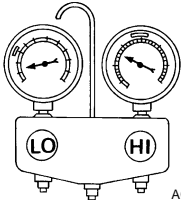
Gauge indication	Refrigerant cycle	Probable cause	Corrective action
<p>Both high- and low-pressure sides are too low.</p>  <p style="text-align: right; font-size: small;">AC353A</p>	<ul style="list-style-type: none"> There is a big temperature difference between receiver drier outlet and inlet. Outlet temperature is extremely low. Liquid tank inlet and expansion valve are frosted. 	<p>Liquid tank inside is slightly clogged.</p>	<ul style="list-style-type: none"> Replace liquid tank. Check lubricant for contamination.
	<ul style="list-style-type: none"> Temperature of expansion valve inlet is extremely low as compared with areas near liquid tank. Expansion valve inlet may be frosted. Temperature difference occurs somewhere in high-pressure side. 	<p>High-pressure pipe located between receiver drier and expansion valve is clogged.</p>	<ul style="list-style-type: none"> Check and repair malfunctioning parts. Check lubricant for contamination.
	<p>Expansion valve and liquid tank are warm or only cool when touched.</p>	<p>Low refrigerant charge ↓ Leaking fittings or components</p>	<p>Check refrigerant for leaks. Refer to ATC-146, "Checking for Refrigerant Leaks".</p>
	<p>There is a big temperature difference between expansion valve inlet and outlet while the valve itself is frosted.</p>	<p>Expansion valve closes a little compared with the specification. ↓ 1. Improper expansion valve adjustment. 2. Malfunctioning expansion valve. 3. Outlet and inlet may be clogged.</p>	<ul style="list-style-type: none"> Remove foreign particles by using compressed air. Check lubricant for contamination.
	<p>An area of the low-pressure pipe is colder than areas near the evaporator outlet.</p>	<p>Low-pressure pipe is clogged or crushed.</p>	<ul style="list-style-type: none"> Check and repair malfunctioning parts. Check lubricant for contamination.
	<p>Air flow volume is not enough or is too low.</p>	<p>Evaporator is frozen.</p>	<ul style="list-style-type: none"> Check intake sensor circuit. Refer to ATC-106, "Intake Sensor Circuit". Replace compressor.

TROUBLE DIAGNOSIS

Low-pressure Side Sometimes Becomes Negative

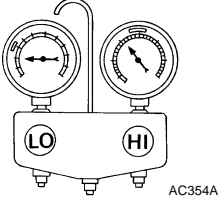
Gauge indication	Refrigerant cycle	Probable cause	Corrective action
<p>Low-pressure side sometimes becomes negative.</p> 	<ul style="list-style-type: none"> ● Air conditioning system does not function and does not cyclically cool the compartment air. ● The system constantly functions for a certain period of time after compressor is stopped and restarted. 	<p>Refrigerant does not discharge cyclically.</p> <p>↓</p> <p>Moisture is frozen at expansion valve outlet and inlet.</p> <p>↓</p> <p>Water is mixed with refrigerant.</p>	<ul style="list-style-type: none"> ● Drain water from refrigerant or replace refrigerant. ● Replace liquid tank.

Low-pressure Side Becomes Negative

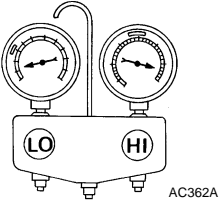
Gauge indication	Refrigerant cycle	Probable cause	Corrective action
<p>Low-pressure side becomes negative.</p> 	<p>Liquid tank or front/rear side of expansion valve's pipe is frosted or dewed.</p>	<p>High-pressure side is closed and refrigerant does not flow.</p> <p>↓</p> <p>Expansion valve or liquid tank is frosted.</p>	<p>Leave the system at rest until no frost is present. Start it again to check whether or not the problem is caused by water or foreign particles.</p> <ul style="list-style-type: none"> ● If water is the cause, initially cooling is okay. Then the water freezes causing a blockage. Drain water from refrigerant or replace refrigerant. ● If due to foreign particles, remove expansion valve and remove the particles with dry and compressed air (not shop air). ● If either of the above methods cannot correct the problem, replace expansion valve. ● Replace liquid tank. ● Check lubricant for contamination.

TROUBLE DIAGNOSIS

AJS000AI

Insufficient Heating

SYMPTOM: Insufficient heating

INSPECTION FLOW

1. Confirm symptom by performing the following operational check.

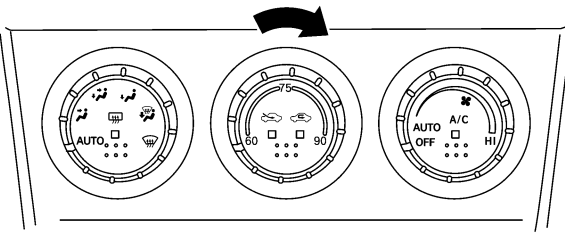

OPERATIONAL CHECK – Temperature increase

- Turn temperature dial clockwise until 32°C (90°F) .
- Check for hot air at discharge air outlets.

If OK (symptom cannot be duplicated), perform complete operational check (*1).
If NG (symptom is confirmed), continue with STEP-2 following.

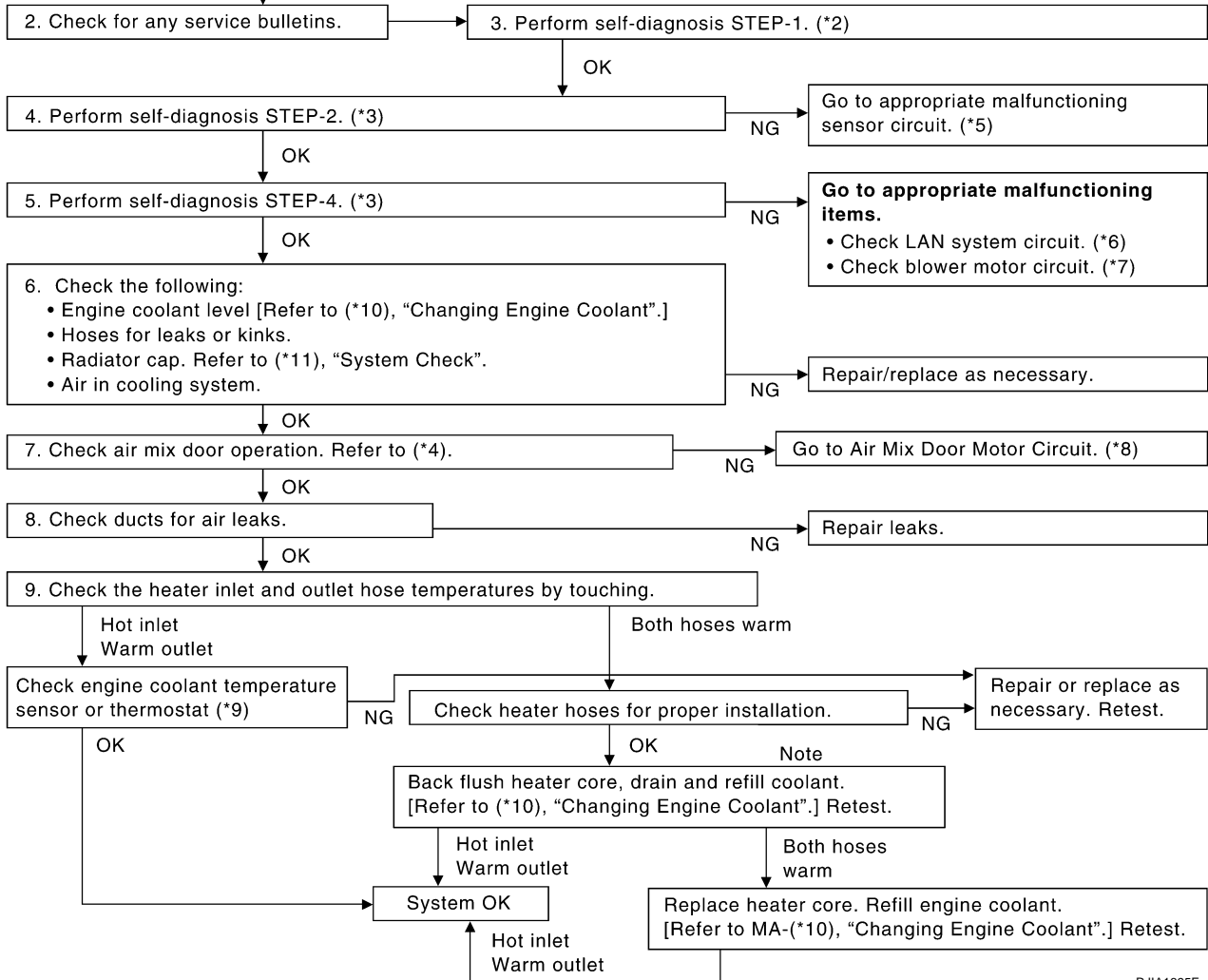

*1 [ATC-57, "Operational Check".](#)

*2 [ATC-51, "FUNCTION CONFIRMATION PROCEDURE",](#) see No. 1.

*3 [ATC-51, "FUNCTION CONFIRMATION PROCEDURE",](#) see No. 5 to 7.

*4 [ATC-68, "Air Mix Door Motor Circuit".](#)

*5 [ATC-51, "FUNCTION CONFIRMATION PROCEDURE",](#) see No. 9.

*6 [ATC-61, "LAN System Circuit".](#)

*7 [ATC-75, "Blower Motor Circuit".](#)

*8 [ATC-68, "Air Mix Door Motor Circuit".](#)

*9 [EC-178, "DTC P0117, P0118 ECT SENSOR".](#)

*10 [CO-9, "Changing Engine Coolant".](#)

*11 [CO-14, "Checking Radiator Cap".](#)

RJIA1395E

TROUBLE DIAGNOSIS

AJS000AJ

Noise

SYMPTOM: Noise

INSPECTION FLOW

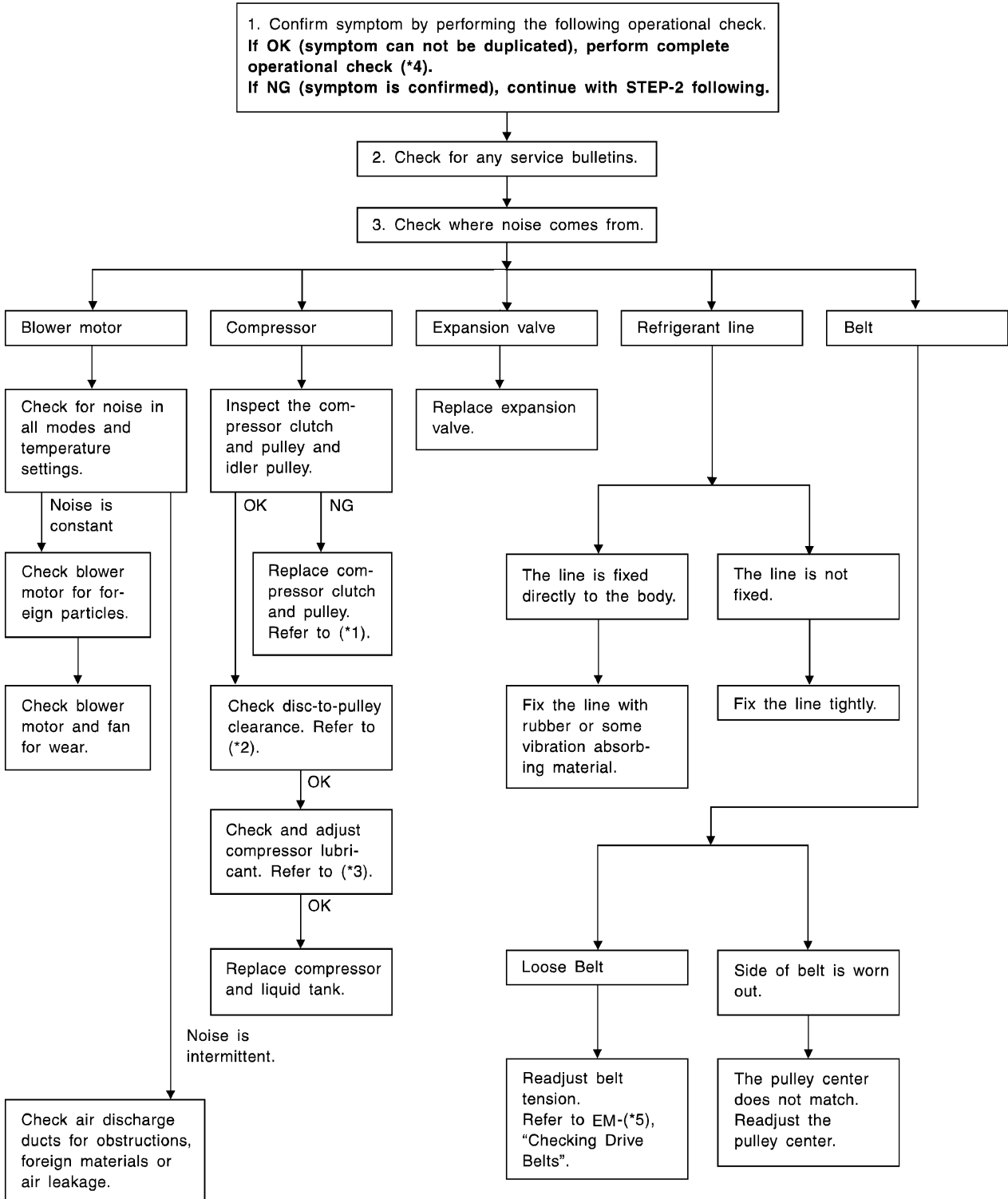

RJIA1596E

*1 Compressor Clutch, [ATC-132. "REMOVAL"](#) .

*2 Compressor Clutch, [ATC-134. "INSTALLATION"](#) .

*3 [ATC-24. "Maintenance of Lubricant Quantity in Compressor"](#).

*4 [ATC-57. "Operational Check"](#).

*5 [EM-12. "Checking Drive Belts"](#).

TROUBLE DIAGNOSIS

AJS000AK

Self-diagnosis

SYMPTOM: Self-diagnosis cannot be performed.

INSPECTION FLOW

1. Confirm symptom by performing operational check.

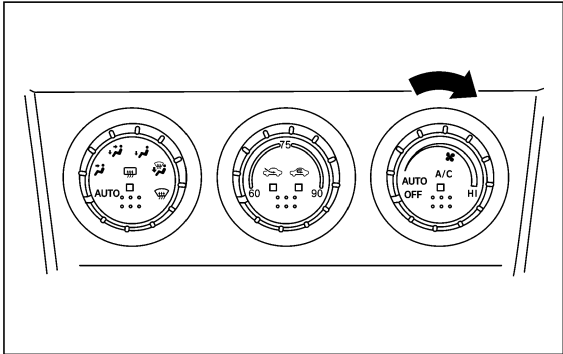

OPERATIONAL CHECK

a. Set mode control dial and fan control dial to AUTO position.
(Compressor is turned ON automatically.)
Confirm that the compressor clutch engages (sound or visual inspection).
(Discharge air and blower speed will depend on ambient, in-vehicle and set temperatures.)

**If OK (symptom cannot be duplicated), perform complete operational check (*2).
If NG (symptom is confirmed), continue with STEP-2 following.**

2. Check for any service bulletins.

3. Check Main Power Supply and Ground Circuit. (*1)

OK

Cause cannot be confirmed by self-diagnosis.

If the symptom still exists, perform a complete operational check (*2) and check for other symptoms. [Refer to symptom table, (*3).]
Does another symptom exist?

No

OK

Replace A/C controller.

NG

Replace Unified meter and A/C amp.

INSPECTION END

Yes

Go to Trouble Diagnosis for related symptom.

Another symptom exists.

*1 [ATC-59. "Power Supply and Ground Circuit for Auto Amp."](#)

*2 [ATC-57. "Operational Check"](#).

*3 [ATC-38. "SYMPTOM TABLE"](#).

RJIA1396E

A
B
C
D
E
F
G
H
I
K
L
M

ATC

TROUBLE DIAGNOSIS

AJS000AM

Ambient Sensor Circuit COMPONENT DESCRIPTION

Ambient Sensor

The ambient sensor is attached on the hood lock stay. It detects ambient temperature and converts it into a resistance value which is then input into the unified meter and A/C amp.

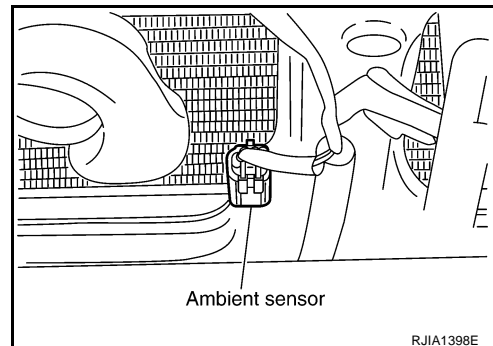

AMBIENT TEMPERATURE INPUT PROCESS

The unified meter and A/C amp. includes a processing circuit for the ambient sensor input. However, when the temperature detected by the ambient sensor increases quickly, the processing circuit retards the unified meter and A/C amp. function. It only allows the auto amp. to recognize an ambient temperature increase of 0.33°C (0.6°F) per 100 seconds.

As an example, consider stopping for a few minutes after high speed driving. Although the actual ambient temperature has not changed, the temperature detected by the ambient sensor will increase. This is because the heat from the engine compartment can radiate to the front grille area, location of the ambient sensor.

DIAGNOSTIC PROCEDURE FOR AMBIENT SENSOR

SYMPTOM: Ambient sensor circuit is open or shorted.

LED of A/C switch does not illuminate as a result of performing self-diagnosis STEP-2.

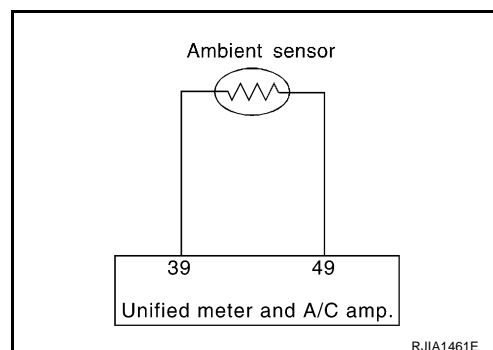

1. CHECK VOLTAGE BETWEEN AMBIENT SENSOR AND GROUND

1. Disconnect ambient sensor connector.
2. Turn ignition switch ON.
3. Check voltage between ambient sensor harness connector E34 terminal 1 (Y/G) and ground.

1 – Ground

: Approx. 5V

OK or NG

OK >> GO TO 2.

NG >> GO TO 4.

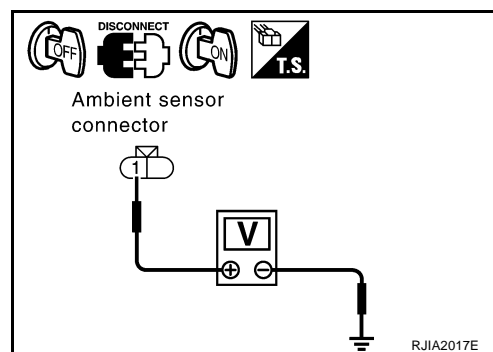

TROUBLE DIAGNOSIS

2. CHECK CIRCUIT CONTINUITY BETWEEN AMBIENT SENSOR AND UNIFIED METER AND A/C AMP.

1. Turn ignition switch OFF.
2. Disconnect unified meter and A/C amp. connector.
3. Check continuity between ambient sensor harness connector E34 terminal 2 (W/G) and unified meter and A/C amp. harness connector M50 terminal 49 (W/L).

2 – 49 : Continuity should exist.

OK or NG

OK >> GO TO 3.

NG >> Repair harness or connector.

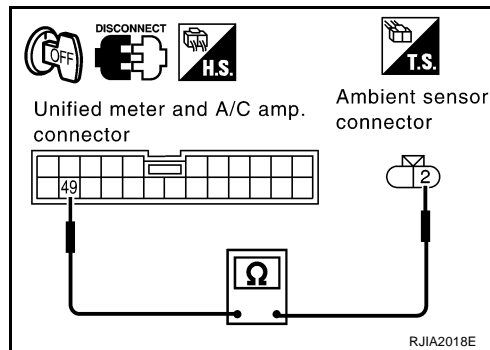

3. CHECK AMBIENT SENSOR

Refer to [ATC-100, "Ambient Sensor"](#) .

OK or NG

OK >> 1. Replace unified meter and A/C amp.

2. Go to self-diagnosis [ATC-51, "FUNCTION CONFIRMATION PROCEDURE"](#) and perform self-diagnosis STEP-2.

NG >> 1. Replace ambient sensor.

2. Go to self-diagnosis [ATC-51, "FUNCTION CONFIRMATION PROCEDURE"](#) and perform self-diagnosis STEP-2.

4. CHECK CIRCUIT CONTINUITY BETWEEN AMBIENT SENSOR AND UNIFIED METER AND A/C AMP.

1. Turn ignition switch OFF.
2. Disconnect unified meter and A/C amp. connector.
3. Check continuity between ambient sensor harness connector E34 terminal 1 (Y/G) and unified meter and A/C amp. harness connector M50 terminal 39 (Y).

1 – 39 : Continuity should exist.

4. Check continuity between ambient sensor harness connector E34 terminal 1 (Y/G) and ground.

1 – Ground : Continuity should not exist.

OK or NG

OK >> 1. Replace unified meter and A/C amp.

2. Go to self-diagnosis [ATC-51, "FUNCTION CONFIRMATION PROCEDURE"](#) and perform self-diagnosis STEP-2.

NG >> Repair harness or connector.

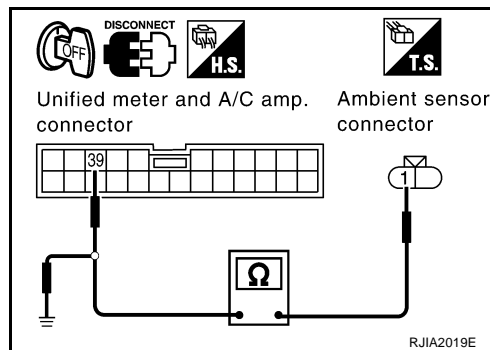

TROUBLE DIAGNOSIS

COMPONENT INSPECTION

Ambient Sensor

After disconnecting ambient sensor connector E34, measure resistance between terminals 2 and 1 at sensor side, using the table below.

Temperature °C (°F)	Resistance kΩ
-15 (5)	12.73
-10 (14)	9.92
-5 (23)	7.80
0 (32)	6.19
5 (41)	4.95
10 (50)	3.99
15 (59)	3.24
20 (68)	2.65
25 (77)	2.19
30 (86)	1.81
35 (95)	1.51
40 (104)	1.27
45 (113)	1.07

If NG, replace ambient sensor.

In-vehicle Sensor Circuit COMPONENT DESCRIPTION

In-vehicle Sensor

The in-vehicle sensor is located on instrument lower panel. It converts variations in temperature of compartment air drawn from the aspirator into a resistance value. It is then input into the unified meter and A/C amp.

Aspirator

The aspirator is located on driver's side of heater & cooling unit. It produces vacuum pressure due to air discharged from the heater & cooling unit, continuously taking compartment air in the aspirator.

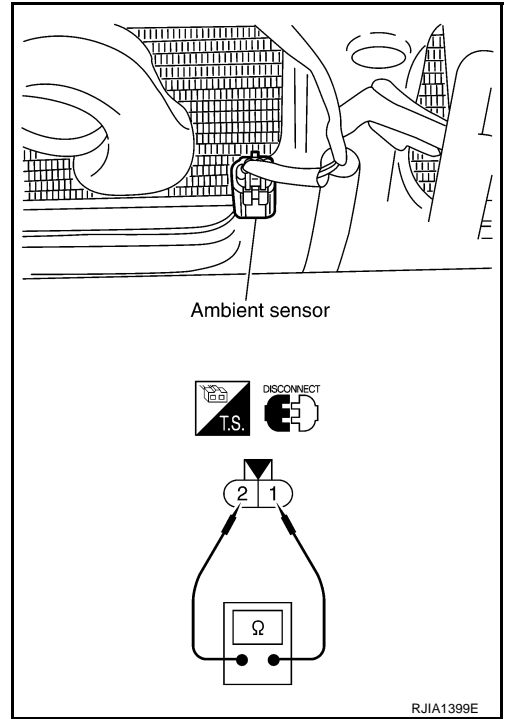

AJS000AN

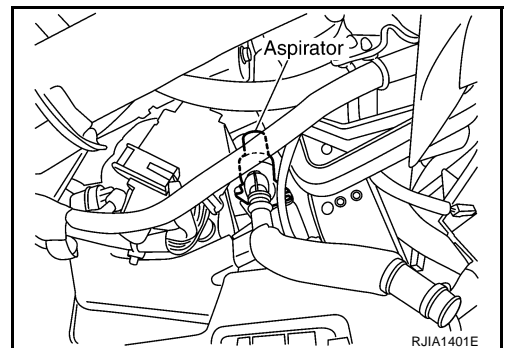
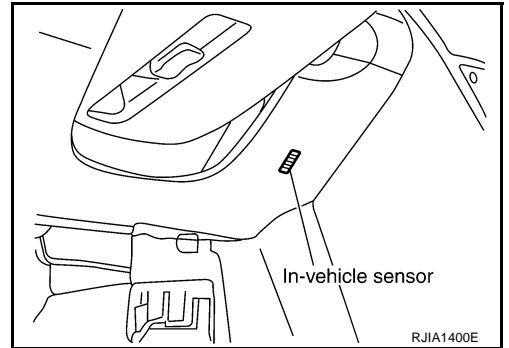

TROUBLE DIAGNOSIS

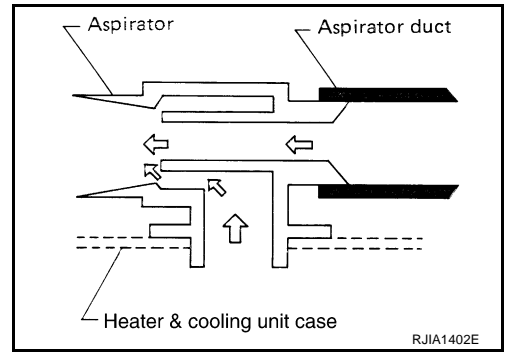

A
B
C
D
E
F
G
H
I
K
L
M

DIAGNOSTIC PROCEDURE FOR IN-VEHICLE SENSOR

SYMPTOM: In-vehicle sensor circuit is open or shorted.
LED of A/C switch does not illuminate as a result of performing self-diagnosis STEP-2.

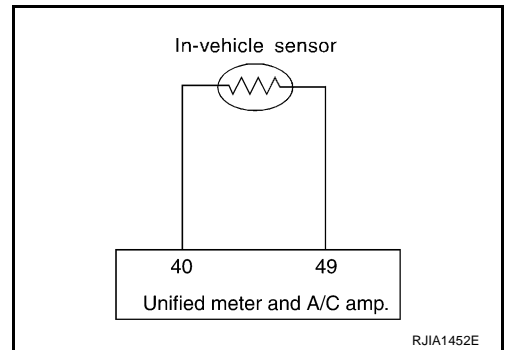

1. CHECK VOLTAGE BETWEEN IN-VEHICLE SENSOR AND GROUND

1. Disconnect in-vehicle sensor connector.
2. Turn ignition switch ON.
3. Check voltage between in-vehicle sensor harness connector M42 terminal 1 (BR) and ground.

1 – Ground : Approx. 5V

OK or NG

- OK >> GO TO 2.
NG >> GO TO 4.

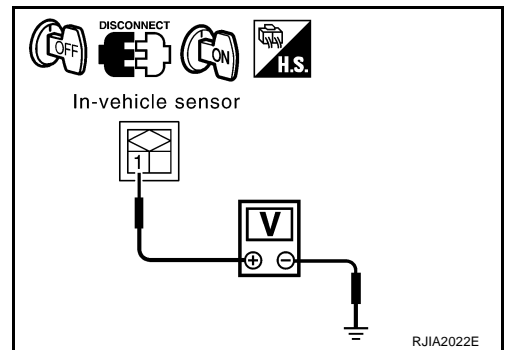

ATC

2. CHECK CIRCUIT CONTINUITY BETWEEN IN-VEHICLE SENSOR AND UNIFIED METER AND A/C AMP.

1. Turn ignition switch OFF.
2. Disconnect unified meter and A/C amp. connector.
3. Check continuity between in-vehicle sensor harness connector M42 terminal 2 (W/L) and unified meter and A/C amp. harness connector M50 terminal 49 (W/L).

2 – 49 : Continuity should exist.

OK or NG

- OK >> GO TO 3.
NG >> Repair harness or connector.

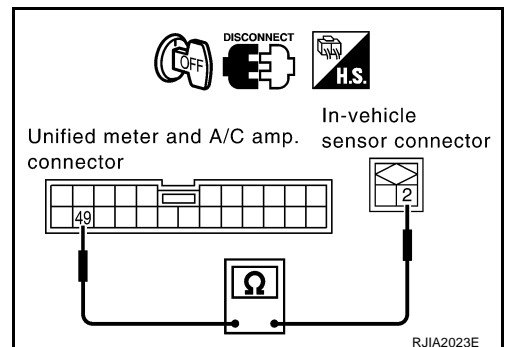

TROUBLE DIAGNOSIS

3. CHECK IN-VEHICLE SENSOR

Refer to [ATC-102, "In-vehicle Sensor"](#) .

OK or NG

- OK >> 1. Replace unified meter and A/C amp.
 2. Go to self-diagnosis [ATC-51, "FUNCTION CONFIRMATION PROCEDURE"](#) and perform self-diagnosis STEP-2.
- NG >> 1. Replace in-vehicle sensor.
 2. Go to self-diagnosis [ATC-51, "FUNCTION CONFIRMATION PROCEDURE"](#) and perform self-diagnosis STEP-2.

4. CHECK CIRCUIT CONTINUITY BETWEEN IN-VEHICLE SENSOR AND UNIFIED METER AND A/C AMP.

- Turn ignition switch OFF.
- Disconnect unified meter and A/C amp. connector.
- Check continuity between in-vehicle sensor harness connector M42 terminal 1 (BR) and unified meter and A/C amp. harness connector M50 terminal 40 (BR).

1 – 40 : Continuity should exist.

- Check continuity between in-vehicle sensor harness connector M42 terminal 1 (BR) and ground.

1 – Ground : Continuity should not exist.

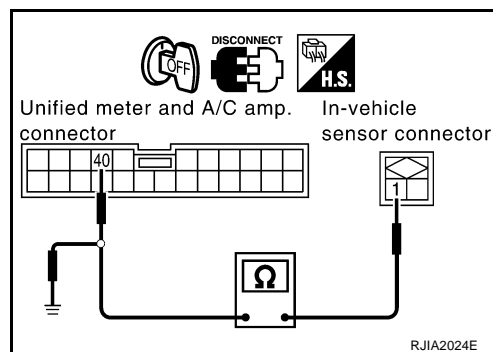

OK or NG

- OK >> 1. Replace unified meter and A/C amp.
 2. Go to self-diagnosis [ATC-51, "FUNCTION CONFIRMATION PROCEDURE"](#) and perform self-diagnosis STEP-2.
- NG >> Repair harness or connector.

COMPONENT INSPECTION

In-vehicle Sensor

After disconnecting in-vehicle sensor connector M42, measure resistance between terminals 1 and 2 at sensor side, using the table below.

Temperature °C (°F)	Resistance kΩ
-15 (5)	12.73
-10 (14)	9.92
-5 (23)	7.80
0 (32)	6.19
5 (41)	4.95
10 (50)	3.99
15 (59)	3.24
20 (68)	2.65
25 (77)	2.19
30 (86)	1.81
35 (95)	1.51
40 (104)	1.27
45 (113)	1.07

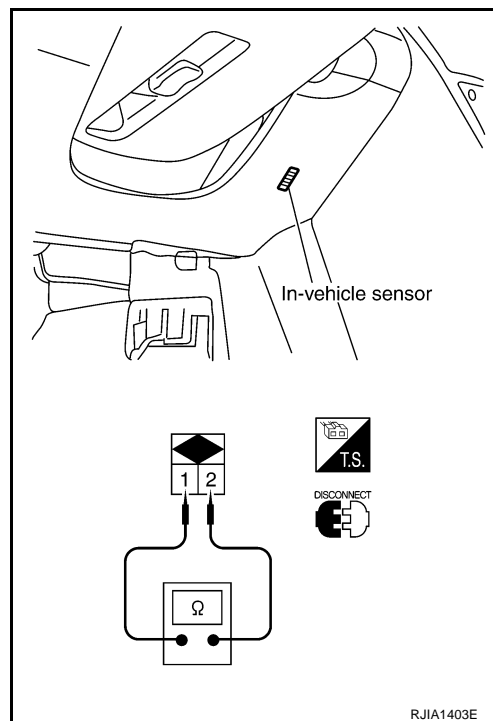

If NG, replace in-vehicle sensor.

TROUBLE DIAGNOSIS

Sunload Sensor Circuit COMPONENT DESCRIPTION

AJS000AO

The sunload sensor is located on the passenger's side defroster grille. It detects sunload entering through windshield by means of a photo diode. The sensor converts the sunload into a current value which is then input into the unified meter and A/C amp.

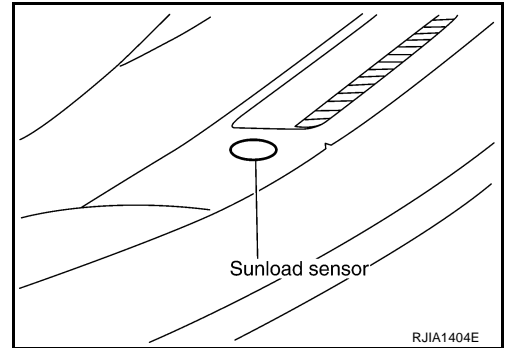

SUNLOAD INPUT PROCESS

The unified meter and A/C amp. also includes a processing circuit which averages the variations in detected sunload over a period of time. This prevents drastic swings in the ATC system operation due to small or quick variations in detected sunload.

For example, consider driving along a road bordered by an occasional group of large trees. The sunload detected by the sunload sensor will vary whenever the trees obstruct the sunlight. The processing circuit averages the detected sunload over a period of time, so that the (insignificant) effect of the trees momentarily obstructing the sunlight does not cause any change in the ATC system operation. On the other hand, shortly after entering a long tunnel, the system will recognize the change in sunload, and the system will react accordingly.

DIAGNOSTIC PROCEDURE FOR SUNLOAD SENSOR

SYMPTOM: Sunload sensor circuit is open or shorted.
LED of A/C switch does not illuminate as a result of performing self-diagnosis STEP-2.

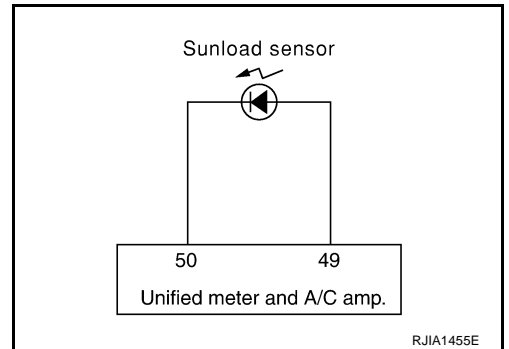

1. CHECK VOLTAGE BETWEEN SUNLOAD SENSOR AND GROUND

1. Disconnect sunload sensor connector.
2. Turn ignition switch ON.
3. Check voltage between sunload sensor harness connector M18 terminal 1 (LG) and ground.

1 – Ground : **Approx. 5V**

OK or NG

- OK >> GO TO 2.
NG >> GO TO 4.

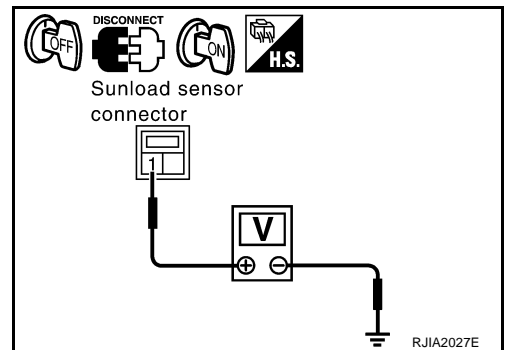

TROUBLE DIAGNOSIS

2. CHECK CIRCUIT CONTINUITY BETWEEN SUNLOAD SENSOR AND UNIFIED METER AND A/C AMP.

1. Turn ignition switch OFF.
2. Disconnect unified meter and A/C amp. connector.
3. Check continuity between sunload sensor harness connector M18 terminal 2 (W/L) and unified meter and A/C amp. harness connector M50 terminal 49 (W/L).

2 – 49

: Continuity should exist.

OK or NG

OK >> GO TO 3.

NG >> Repair harness or connector.

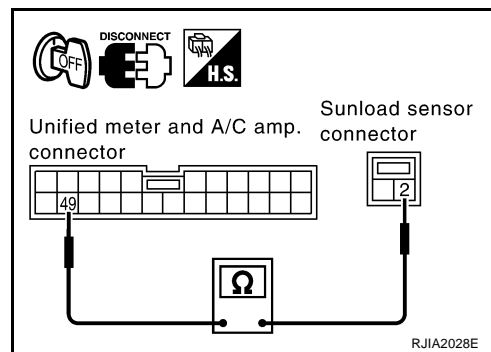

3. CHECK SUNLOAD SENSOR

1. Reconnect sunload sensor connector and unified meter and A/C amp. connector.
2. Refer to [ATC-105, "Sunload Sensor"](#).

OK or NG

OK >> 1. Replace unified meter and A/C amp.

2. Go to self-diagnosis [ATC-51, "FUNCTION CONFIRMATION PROCEDURE"](#) and perform self-diagnosis STEP-2.

NG >> 1. Replace sunload sensor.

2. Go to self-diagnosis [ATC-51, "FUNCTION CONFIRMATION PROCEDURE"](#) and perform self-diagnosis STEP-2.

4. CHECK CIRCUIT CONTINUITY BETWEEN SUNLOAD SENSOR AND UNIFIED METER AND A/C AMP.

1. Turn ignition switch OFF.
2. Disconnect unified meter and A/C amp. connector.
3. Check continuity between sunload sensor harness connector M18 terminal 1 (LG) and unified meter and A/C amp. harness connector M50 terminal 50 (LG).

1 – 50

: Continuity should exist.

4. Check continuity between sunload sensor harness connector M18 terminal 1 (LG) and ground.

1 – Ground

: Continuity should not exist.

OK or NG

OK >> 1. Replace unified meter and A/C amp.

2. Go to self-diagnosis [ATC-51, "FUNCTION CONFIRMATION PROCEDURE"](#) and perform self-diagnosis STEP-2.

NG >> Repair harness or connector.

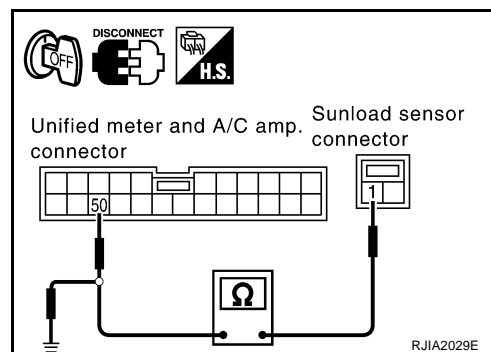

TROUBLE DIAGNOSIS

COMPONENT INSPECTION

Sunload Sensor

Measure voltage between unified meter and A/C amp. harness connector M50 terminal 50 (LG) and ground.
If NG, replace sunload sensor.

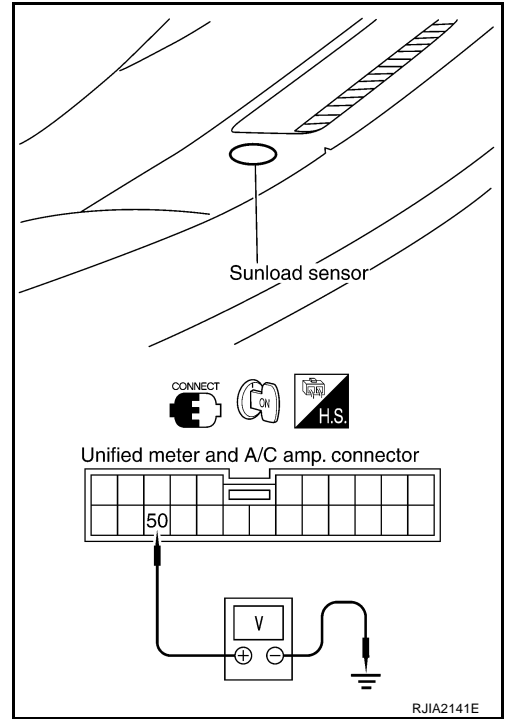

- When checking sunload sensor, select a place where sun shines directly on it.

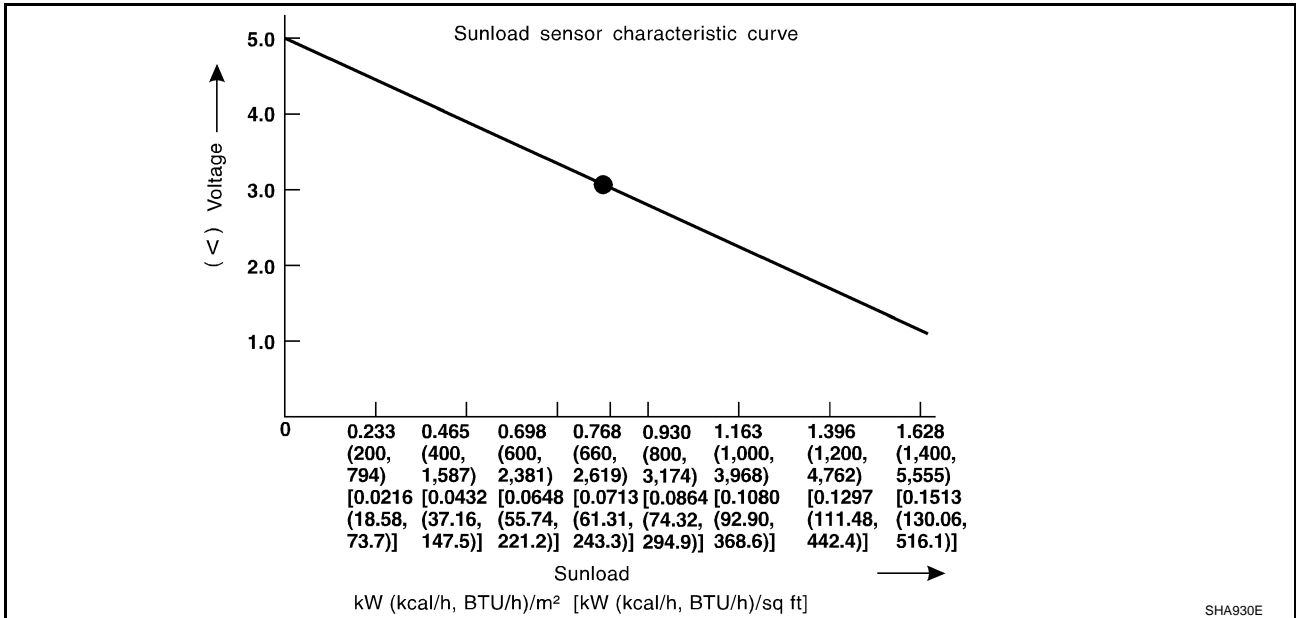

TROUBLE DIAGNOSIS

AJS000JL

Intake Sensor Circuit COMPONENT DESCRIPTION

Intake Sensor

The intake sensor is located on the heater & cooling unit. It converts temperature of air after it passes through the evaporator into a resistance value which is then input to the unified meter and A/C amp.

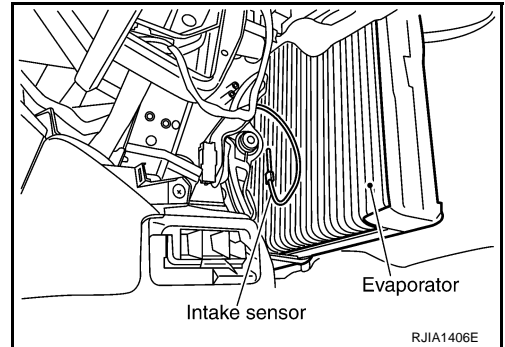

DIAGNOSTIC PROCEDURE FOR INTAKE SENSOR

SYMPTOM: Intake sensor circuit is open or shorted.

LED of A/C switch does not illuminate as a result of performing self-diagnosis STEP-2.

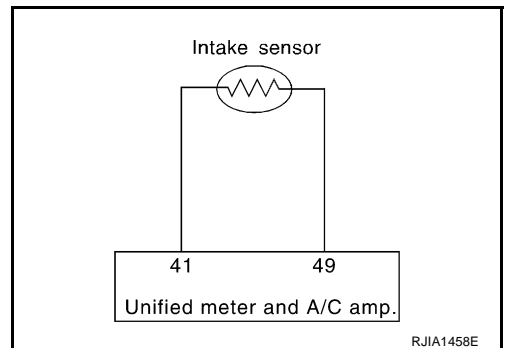

1. CHECK VOLTAGE BETWEEN INTAKE SENSOR AND GROUND

1. Disconnect intake sensor connector.
2. Turn ignition switch ON.
3. Check voltage between intake sensor harness connector M255 terminal 2 (R) and ground.

2 – Ground : **Approx. 5V**

OK or NG

- OK >> GO TO 2.
NG >> GO TO 4.

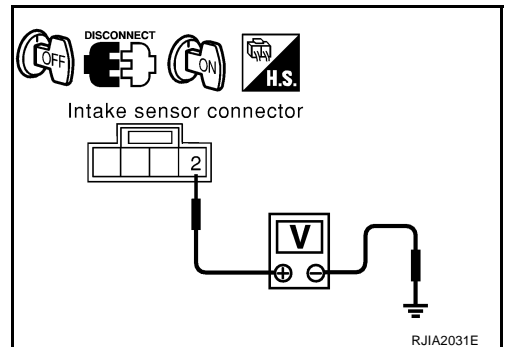

2. CHECK CIRCUIT CONTINUITY BETWEEN INTAKE SENSOR AND UNIFIED METER AND A/C AMP.

1. Turn ignition switch OFF.
2. Disconnect unified meter and A/C amp. connector.
3. Check continuity between intake sensor harness connector M255 terminal 1 (W) and unified meter and A/C amp. harness connector M50 terminal 49 (W/L).

1 – 49 : **Continuity should exist.**

OK or NG

- OK >> GO TO 3.
NG >> Repair harness or connector.

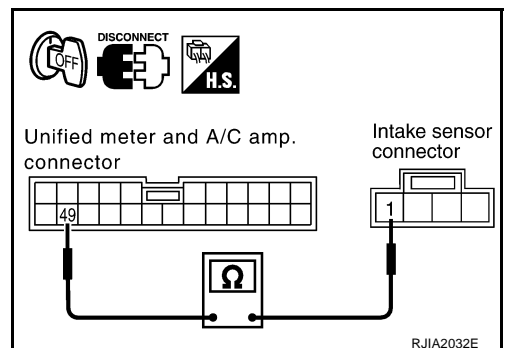

TROUBLE DIAGNOSIS

3. CHECK INTAKE SENSOR

Refer to [ATC-107, "Intake Sensor"](#) .

OK or NG

- OK >> 1. Replace unified meter and A/C amp.
 2. Go to self-diagnosis [ATC-51, "FUNCTION CONFIRMATION PROCEDURE"](#) and perform self-diagnosis STEP-2.
- NG >> 1. Replace intake sensor.
 2. Go to self-diagnosis [ATC-51, "FUNCTION CONFIRMATION PROCEDURE"](#) and perform self-diagnosis STEP-2.

4. CHECK CIRCUIT CONTINUITY BETWEEN INTAKE SENSOR AND UNIFIED METER AND A/C AMP.

- Turn ignition switch OFF.
- Disconnect unified meter and A/C amp. connector.
- Check continuity between intake sensor harness connector M255 terminal 2 (R) and unified meter and A/C amp. harness connector M50 terminal 41 (SB).

2 – 41 : Continuity should exist.

- Check continuity between intake sensor harness connector M255 terminal 2 (R) and ground.

2 – Ground : Continuity should not exist.

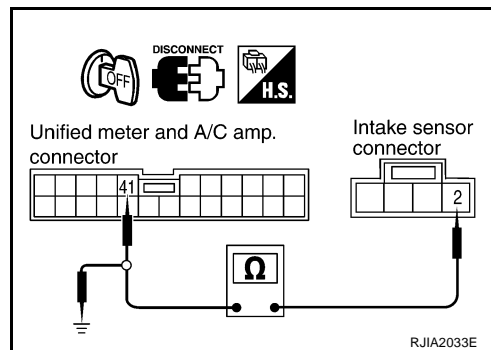

OK or NG

- OK >> 1. Replace unified meter and A/C amp.
 2. Go to self-diagnosis [ATC-51, "FUNCTION CONFIRMATION PROCEDURE"](#) and perform self-diagnosis STEP-2.
- NG >> Repair harness or connector.

COMPONENT INSPECTION

Intake Sensor

After disconnecting intake sensor connector M255, measure resistance between terminals 1 and 2 at sensor side, using the table below.

Temperature °C (°F)	Resistance kΩ
-15 (5)	12.34
-10 (14)	9.62
-5 (23)	7.56
0 (32)	6.00
5 (41)	4.80
10 (50)	3.87
15 (59)	3.15
20 (68)	2.57
25 (77)	2.12
30 (86)	1.76
35 (95)	1.47
40 (104)	1.23
45 (113)	1.04

If NG, replace intake sensor.

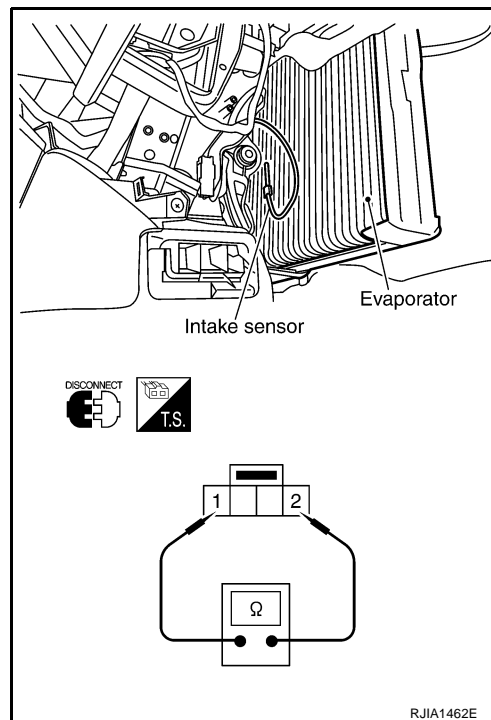

A/C CONTROLLER

A/C CONTROLLER

PFP:27500

Removal and Installation

AJS000JG

REMOVAL

1. Remove console finisher (A/T) or console boot (M/T). Refer to [IP-11, "Removal and Installation"](#).
2. Remove A/C controller from console finisher (A/T) or console boot (M/T).

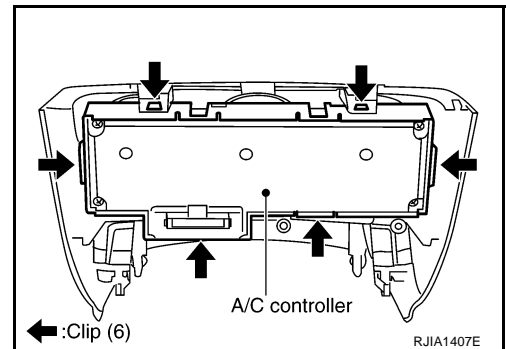

INSTALLATION

Installation is basically the reverse order of removal.

AUTO AMP

AUTO AMP

PFP:27760

Removal and Installation of Unified Meter and A/C Amp.

AJS000AT

REMOVAL

1. Remove the console finisher (A/T) or console boot (M/T). Refer to [IP-11, "Removal and Installation"](#).
2. Remove the fixing screws, and then remove the unified meter and A/C amp.

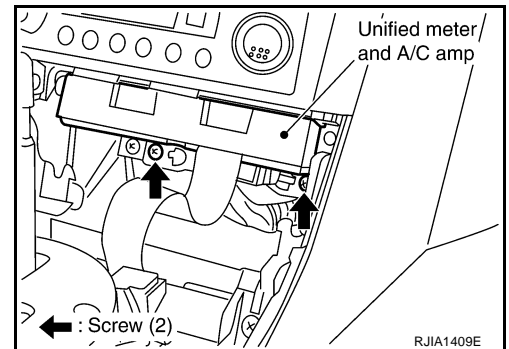

INSTALLATION

Installation is basically the reverse order of removal.

A
B
C
D
E
F
G
H
I

ATC

K
L
M

AMBIENT SENSOR

AMBIENT SENSOR

PFP:27722

Removal and Installation

AJS000AV

REMOVAL

1. Remove the engine under cover, using power tools.
2. Disconnect ambient sensor connector.
3. Remove ambient sensor.

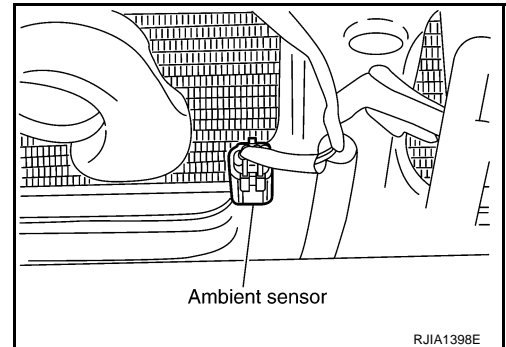

INSTALLATION

Installation is basically the reverse order of removal.

IN-VEHICLE SENSOR

IN-VEHICLE SENSOR

PFP:27720

Removal and Installation

AJS000AW

REMOVAL

1. Remove instrument driver panel lower. Refer to [IP-11, "Removal and Installation"](#) .
2. Remove mounting screw, and then remove in-vehicle sensor.

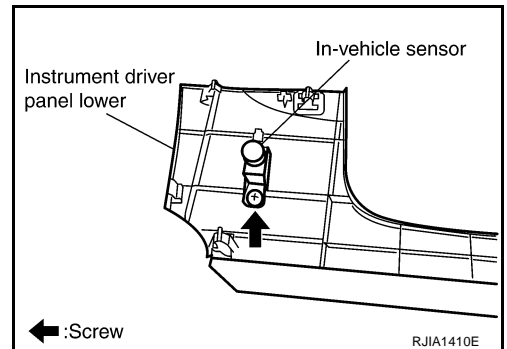

INSTALLATION

Installation is basically the reverse order of removal.

A
B
C
D
E
F
G
H
I
K
L
M

ATC

SUNLOAD SENSOR

SUNLOAD SENSOR

PFP:27721

Removal and Installation

AJS000AX

REMOVAL

1. Pull out sunload sensor from instrument panel.
2. Disconnect sunload sensor connector, and then remove sunload sensor.

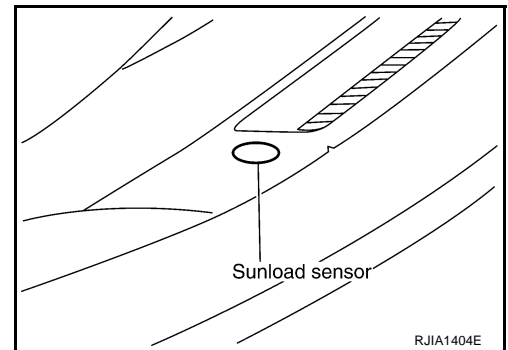

INSTALLATION

Installation is basically the reverse order of removal.

INTAKE SENSOR

INTAKE SENSOR

PFP:27723

Removal and Installation

AJS001C5

REMOVAL

1. Set the temperature control dial at 18°C (60°F).
2. Open the driver and front passenger window, and then disconnect the battery negative cable.

CAUTION:

After the battery cables are disconnected, do not open/close the driver and/or front passenger door with the window in the full up position. The automatic window adjusting function will not work and the side roof panel may be damaged.

3. Use a refrigerant collecting equipment (for HFC-134a) to discharge the refrigerant.
4. Remove low-pressure pipe and high-pressure pipe 2. Refer to [ATC-139, "Removal and Installation of Low-pressure Pipe and High-pressure Pipe 2"](#).

CAUTION:

Cap or wrap the joint of the pipe with suitable material such as vinyl tape to avoid the entry of air.

5. Slide the evaporator to passenger side, and then remove the intake sensor.

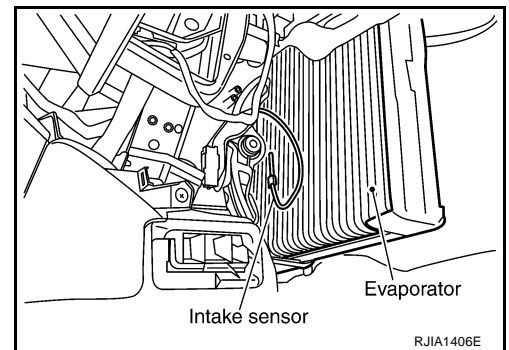

INSTALLATION

Installation is basically the reverse order of removal.

CAUTION:

- Replace O-rings for A/C piping with new ones. Before installing, apply compressor oil to them.
- Connection point for female-side piping is thin. So, when inserting male-side piping, take care not to deform female-side piping. Slowly insert in axial direction.
- Insert one-touch joint connection point securely until it clicks.
- After piping has been connected, pull male-side piping by hand to make sure piping does not come off.
- When recharging refrigerant, check for leaks.

ATC

K

L

M

BLOWER UNIT

PFP:27200

AJS000B0

BLOWER UNIT

Removal and Installation

REMOVAL

1. Remove instrument passenger panel lower. Refer to [IP-11, "Removal and Installation"](#).
2. Remove ECM with bracket attached.
3. Disconnect intake door motor connector and blower fan motor connector.
4. Remove fixing bolt (1) and screws (2), and then remove blower unit.

CAUTION:

Move blower unit rightward, and remove locating pin (1) and joint. Then remove blower unit downward.

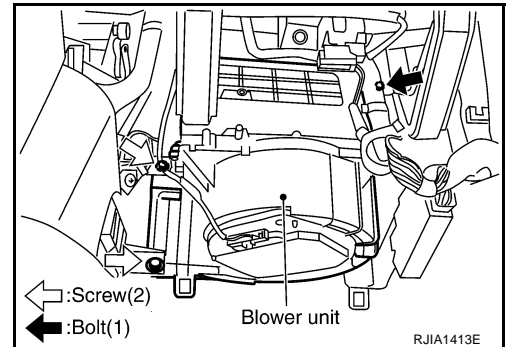

5. Remove blower unit.

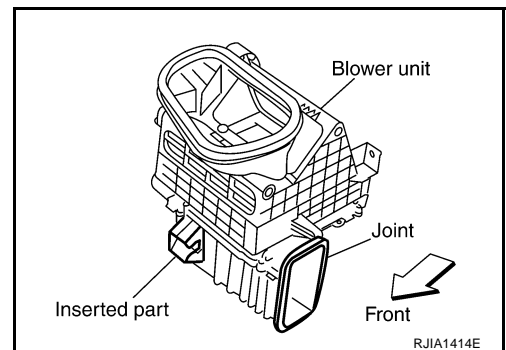

INSTALLATION

Installation is basically the reverse order of removal.

CAUTION:

Make sure locating pin (1) and joint are securely inserted.

BLOWER UNIT

Disassembly and Assembly

AJS000B1

A
B
C
D
E
F
G
H
I
K
L
M

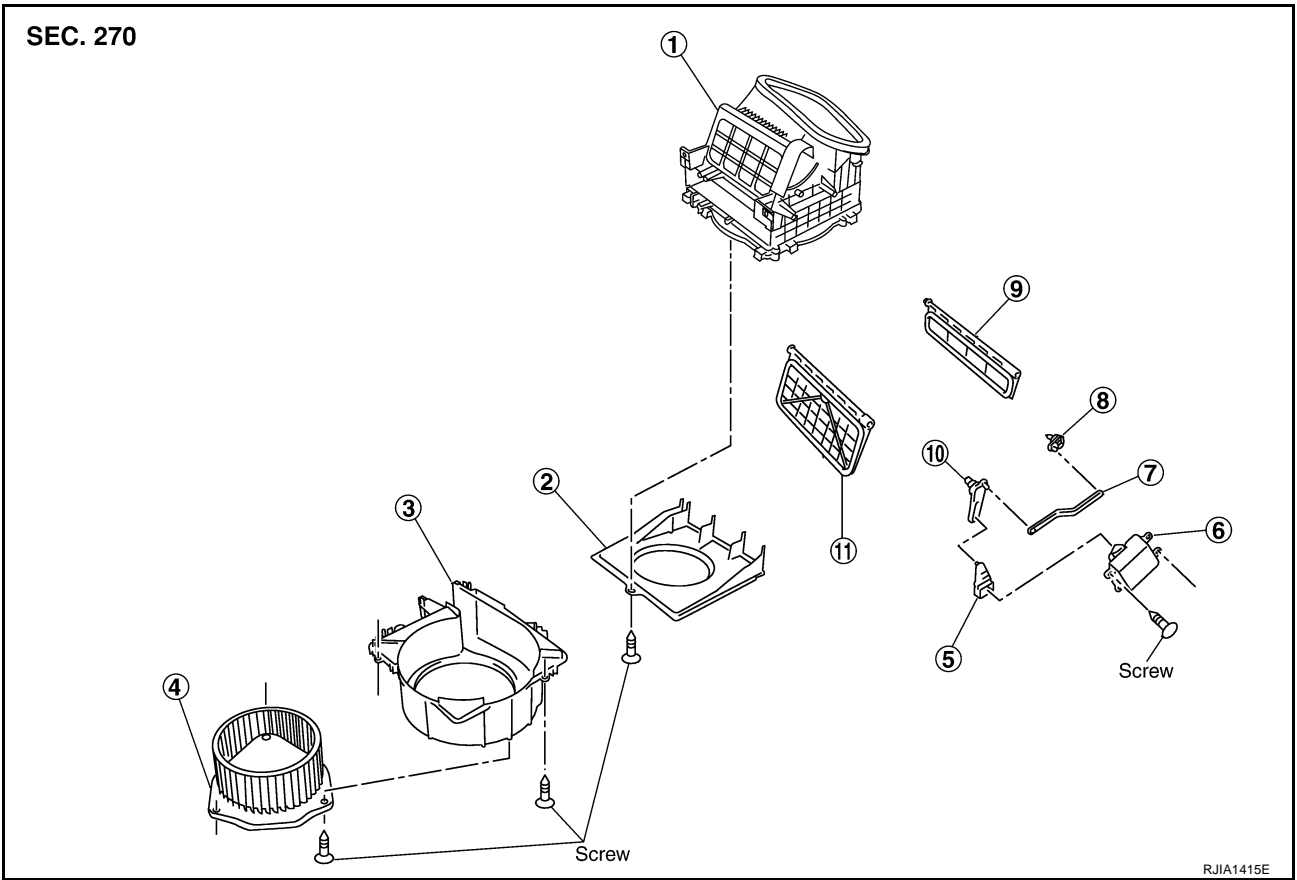

- | | | |
|--------------------------|------------------------|----------------------|
| 1. Intake upper case | 2. Intake bell mouth | 3. Intake lower case |
| 4. Blower motor assembly | 5. Intake door lever 2 | 6. Intake door motor |
| 7. Intake door link | 8. Intake door lever 3 | 9. Intake door 2 |
| 10. Intake door lever 1 | 11. Intake door 1 | |

ATC

BLOWER MOTOR

BLOWER MOTOR

PFP:27226

Removal and Installation

AJS000B2

REMOVAL

1. Disconnect blower motor connector.
2. Remove screws from blower motor, and then remove it.

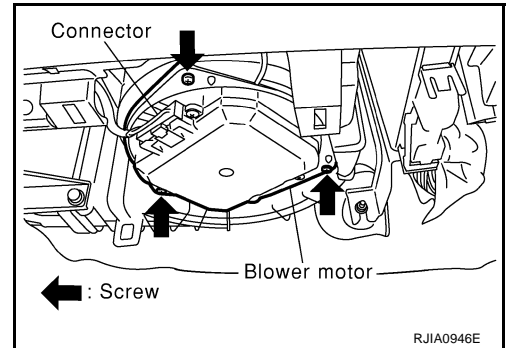

INSTALLATION

Installation is basically the reverse order of removal.

INTAKE DOOR MOTOR

INTAKE DOOR MOTOR

PFP:27730

Removal and Installation

AJS000B3

1. Remove blower unit. Refer to [ATC-114, "BLOWER UNIT"](#) .
2. Remove intake door motor from the blower unit.

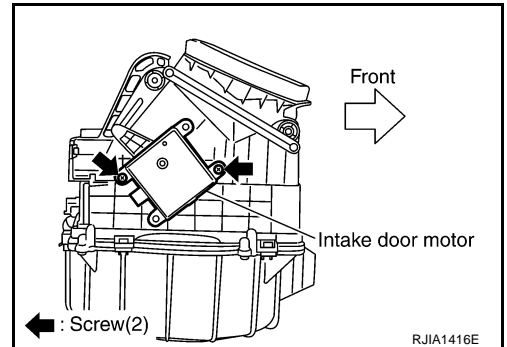

INSTALLATION

Installation is basically the reverse order of removal.

A
B
C
D
E
F
G
H
I
K
L
M

ATC

HEATER & COOLING UNIT ASSEMBLY

PFP:27110

HEATER & COOLING UNIT ASSEMBLY

Removal and Installation REMOVAL

AJS000B5

1. Use a refrigerant collecting equipment (for HFC-134a) to discharge refrigerant.
2. Drain coolant from cooling system. Refer to [CO-9, "Changing Engine Coolant"](#) .
3. Remove cowl top cover. Refer to [EI-20, "COWL TOP"](#) .
4. Disconnect low-pressure flexible hose and high-pressure pipe 1 from evaporator.
 - a. Set a disconnecter (low-pressure side: 92530-89916, high-pressure side: 92530-89908) on A/C piping.
 - b. Slide a disconnecter toward vehicle front until it clicks.
 - c. Slide A/C piping toward vehicle front and disconnect it.

CAUTION:

Cap or wrap the joint of the pipe with suitable material such as vinyl tape to avoid the entry of air.

5. Remove air hose and electronic control throttle assembly. Refer to [EM-16, "INTAKE MANIFOLD COLLECTOR"](#) .
6. Disconnect two heater hoses from heater core.

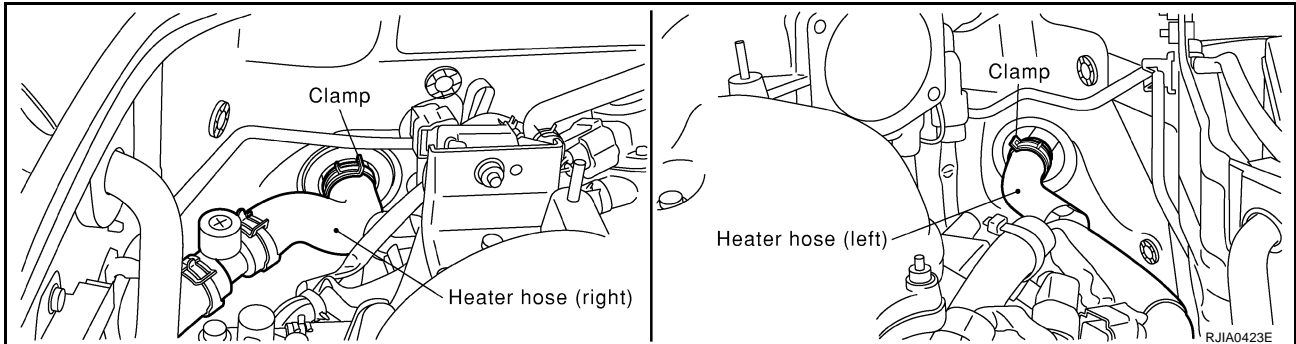
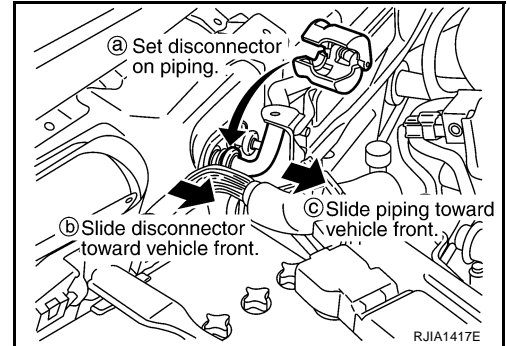

7. Remove instrument panel assembly. Refer to [IP-11, "Removal and Installation"](#) .
8. Remove blower unit. Refer to [ATC-114, "BLOWER UNIT"](#) .
9. Remove clips of vehicle harness from steering member.
10. Remove instrument stays (left and right).

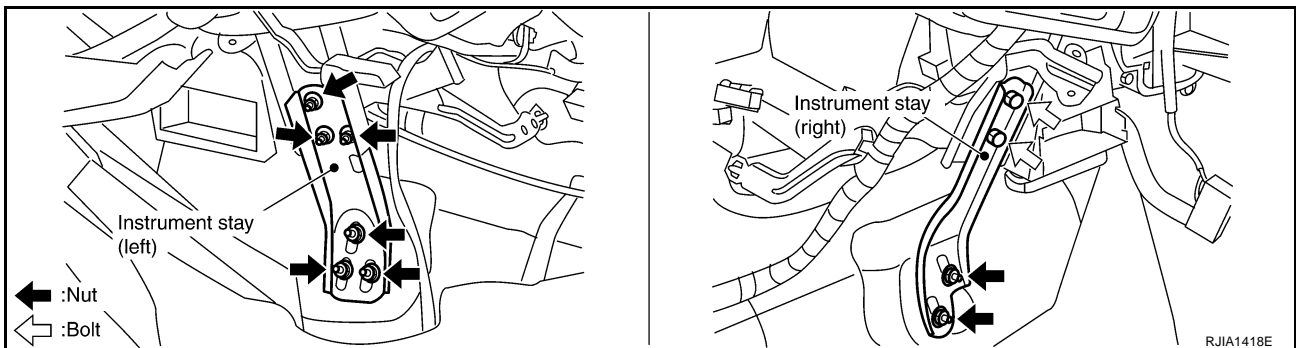

11. Remove defroster nozzle and ventilator ducts.

HEATER & COOLING UNIT ASSEMBLY

12. Remove mounting bolts from heater & cooling unit.

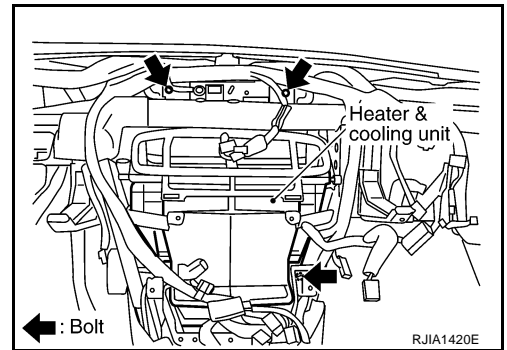

13. Remove the steering member.

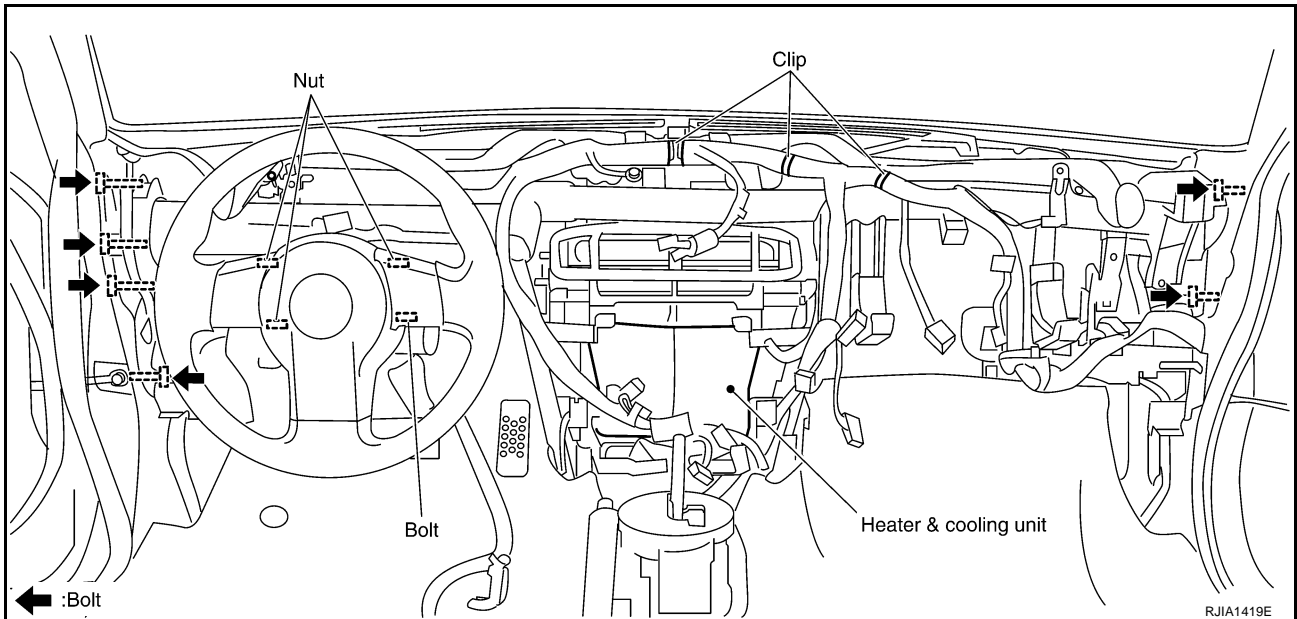

14. Remove heater & cooling unit.

INSTALLATION

Installation is basically the reverse order of removal.

CAUTION:

- Replace O-rings for A/C piping with new one, then apply compressor oil to it when installing it.
- Connection point for female-side piping is thin. So, when inserting male-side piping, take care not to deform female-side piping. Slowly insert in axial direction.
- Insert one-touch joint connection point securely until it clicks.
- After piping has been connected, pull male-side piping by hand to make sure piping does not come off.
- When recharging refrigerant, check for leaks.

NOTE:

- When filling radiator with coolant, refer to [CO-9. "Changing Engine Coolant"](#) .
- Recharge the refrigerant.

Heater & cooling unit mounting bolt

Tightening torque : 6.9 N·m (0.7 kg-m, 61 in-lb)

Steering member mounting nut and bolt

Tightening torque : 12 N·m (1.25 kg-m, 9 ft-lb)

A
B
C
D
E
F
G
H
I
K
L
M

HEATER & COOLING UNIT ASSEMBLY

AJS000B6

Disassembly and Assembly

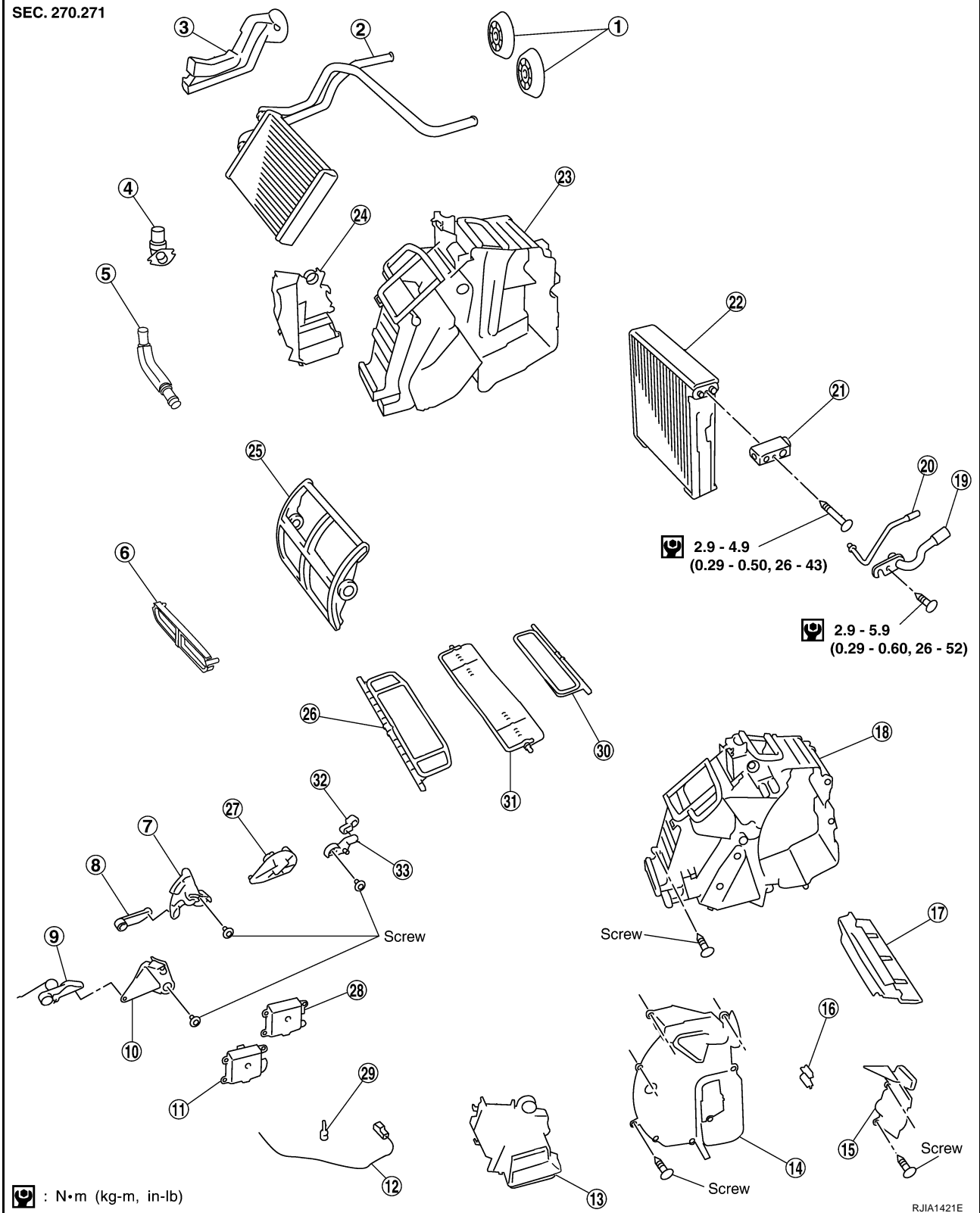

- | | | |
|--------------------------|-------------------------|------------------------------|
| 1. Heater pipe grommet | 2. Heater core | 3. Heater pipe cover |
| 4. Aspirator | 5. Aspirator duct | 6. Rear foot cover |
| 7. Max. cool door link | 8. Max. cool door lever | 9. Ventilator door lever |
| 10. Ventilator door link | 11. Air mix door motor | 12. Intake sensor |
| 13. Foot duct (right) | 14. Evaporator cover | 15. Evaporator cover adapter |
| 16. Heater pipe bracket | 17. Insulator | 18. Heater case (right) |

HEATER & COOLING UNIT ASSEMBLY

- | | | |
|-------------------------------|---------------------------|-------------------------|
| 19. Low-pressure pipe | 20. High-pressure pipe 2 | 21. Expansion valve |
| 22. Evaporator | 23. Heater case (left) | 24. Foot duct (left) |
| 25. Air mix door (slide door) | 26. Ventilator door | 27. Side link |
| 28. Mode door motor | 29. Intake sensor bracket | 30. Defroster door |
| 31. Max. cool door | 32. Defroster door lever | 33. Defroster door link |

A

B

C

D

E

F

G

H

I

ATC

K

L

M

MODE DOOR MOTOR

MODE DOOR MOTOR

PFP:27731

Removal and Installation

AJS000B7

REMOVAL

1. Remove blower unit. Refer to [ATC-114, "BLOWER UNIT"](#) .
2. Remove mounting screws from mode door motor.
3. Disconnect mode door connector.
4. Remove mode door motor.

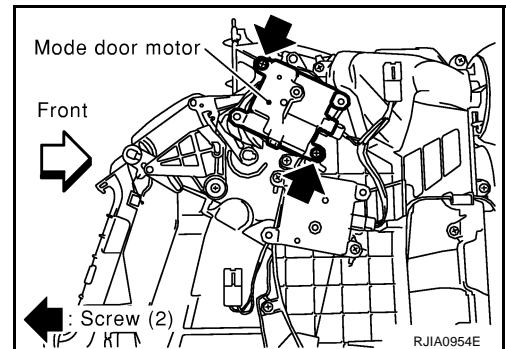

INSTALLATION

Installation is basically the reverse order of removal.

AIR MIX DOOR MOTOR

AIR MIX DOOR MOTOR

PFP:27732

Removal and Installation

AJS000JM

REMOVAL

1. Set the temperature control dial at 18°C (60°F).
2. Open the driver and front passenger window, and then disconnect the battery negative cable.

CAUTION:

After the battery cables are disconnected, do not open/close the driver and/or front passenger door with the window in the full up position. The automatic window adjusting function will not work and the side roof panel may be damaged.

3. Remove blower unit. Refer to [ATC-114, "BLOWER UNIT"](#).
4. Disconnect air mix door motor connector.
5. Remove air mix door motor.

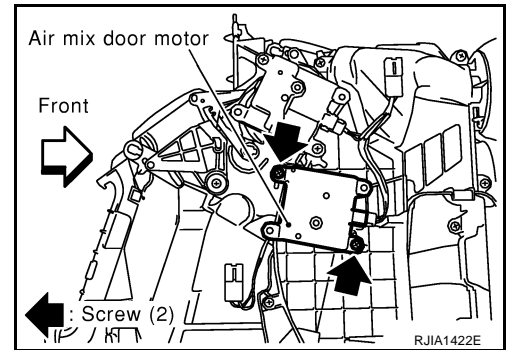

INSTALLATION

Installation is basically the reverse order of removal.

A
B
C
D
E
F
G
H
I
K
L
M

ATC

HEATER CORE

HEATER CORE

PF27140

Removal and Installation

AJS001C7

REMOVAL

1. Remove heater & cooling unit. Refer to [ATC-118, "HEATER & COOLING UNIT ASSEMBLY"](#) .
2. Remove foot duct (left). Refer to [ATC-128, "Removal of Foot Ducts"](#) .

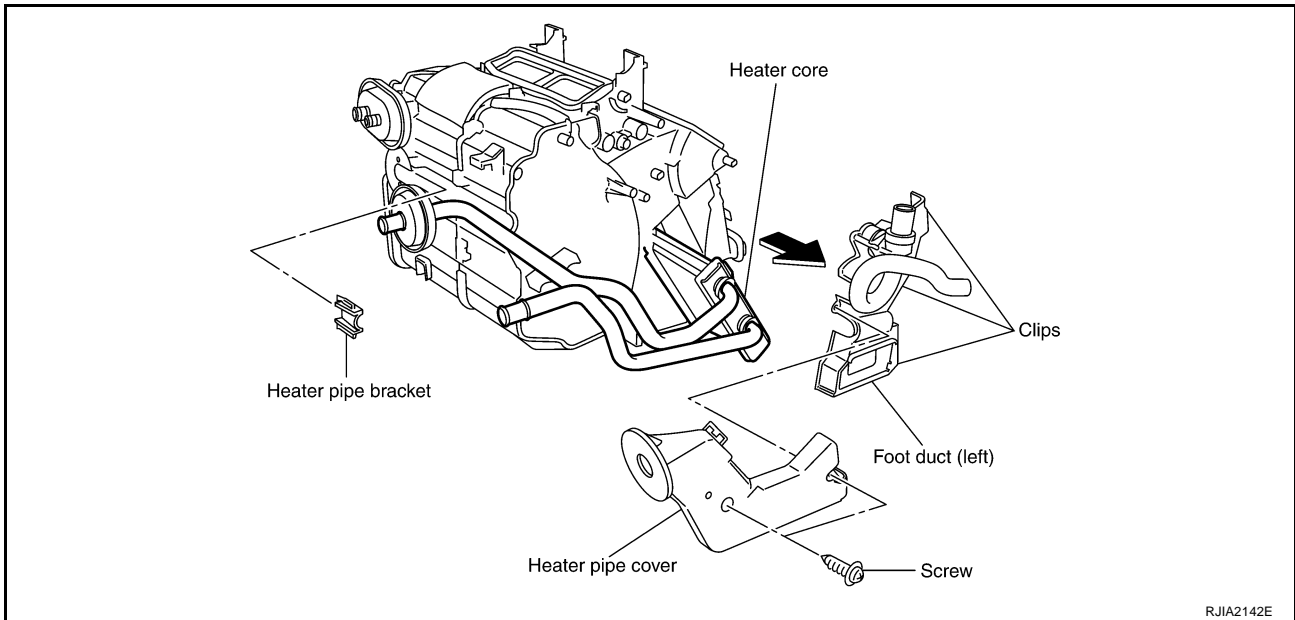

3. Remove heater pipe cover.
4. Remove heater pipe support and heater pipe grommet.
5. Slide heater core to driver side.

INSTALLATION

Installation is basically the reverse order of removal.

DUCTS AND GRILLES

DUCTS AND GRILLES

PPF:27860

Removal and Installation REMOVAL

AJS000B9

A
B
C
D
E
F
G
H
I
K
L
M

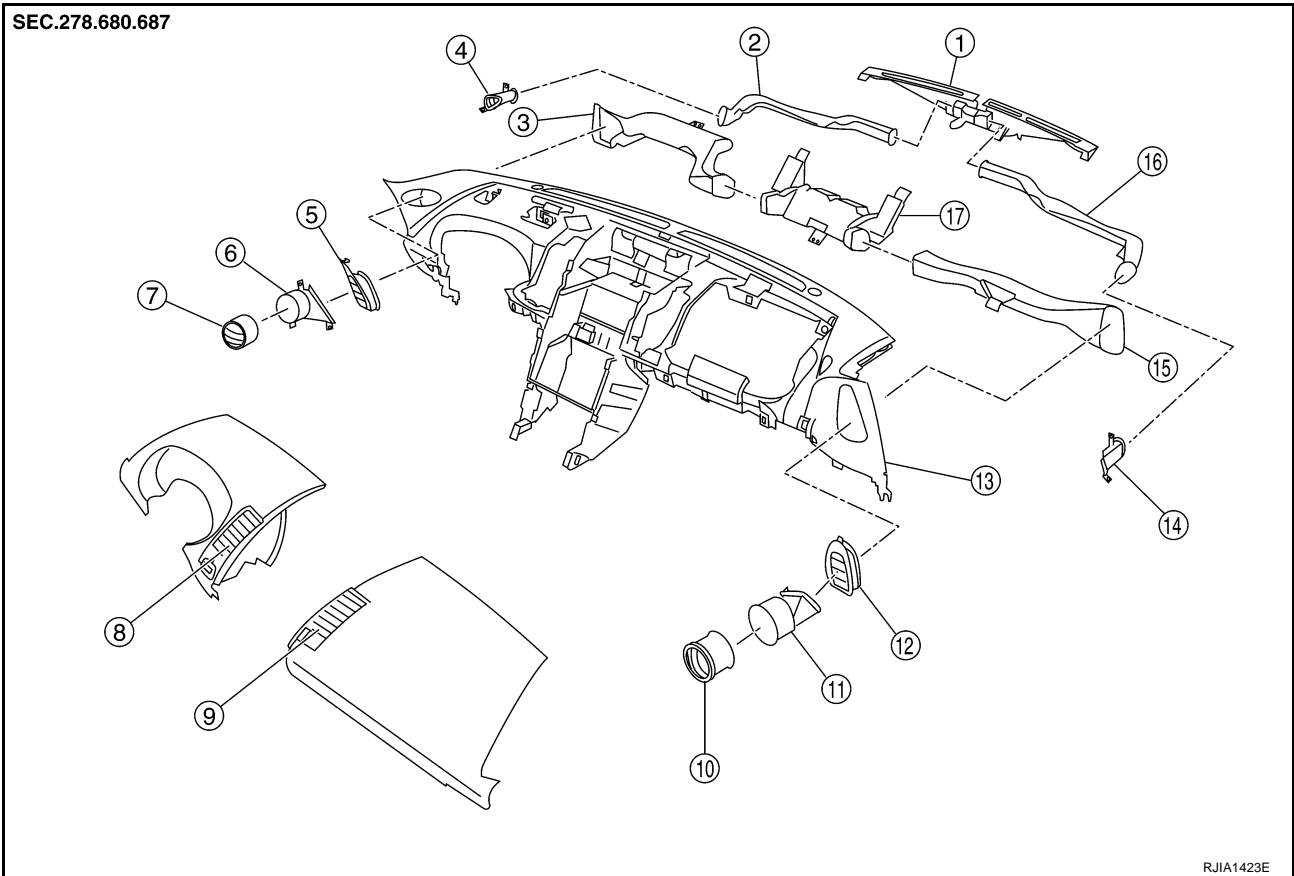

- | | | |
|------------------------------------|------------------------------------|--------------------------------------|
| 1. Defroster nozzle | 2. Side defroster duct 1 (left) | 3. Side ventilator duct 1 (left) |
| 4. Side defroster duct 2 | 5. Instrument side finisher (left) | 6. Side ventilator duct 2 (left) |
| 7. Side ventilator grille (left) | 8. Center ventilator grille (left) | 9. Side ventilator grille (right) |
| 10. Side ventilator grille (right) | 11. Side ventilator duct 2 (right) | 12. Instrument side finisher (right) |
| 13. Instrument panel | 14. Side defroster duct 2 (right) | 15. Side ventilator duct 1 (right) |
| 16. Side defroster duct 1 (right) | 17. Center ventilator duct | |

ATC

Removal of Center Ventilator Grille

1. Remove instrument driver and passenger panel upper. Refer to [IP-11, "Removal and Installation"](#).
2. Remove mounting screws, and then remove center ventilator grille.

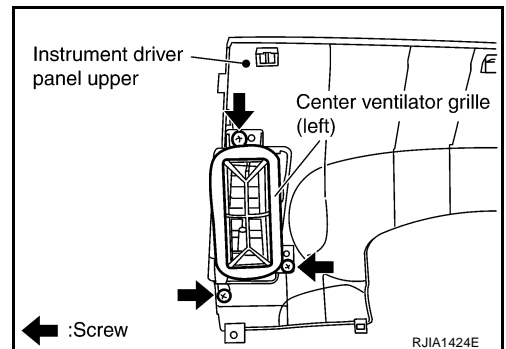

DUCTS AND GRILLES

Removal of Side Ventilator Duct 2 and Grille

1. Remove door finisher. Refer to [EI-33, "DOOR FINISHER"](#) .
2. Remove mounting screws, and then remove side ventilator duct 2.

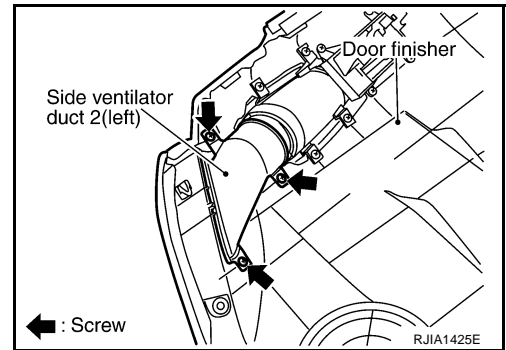

3. Remove mounting clips, and then remove side ventilator grille.

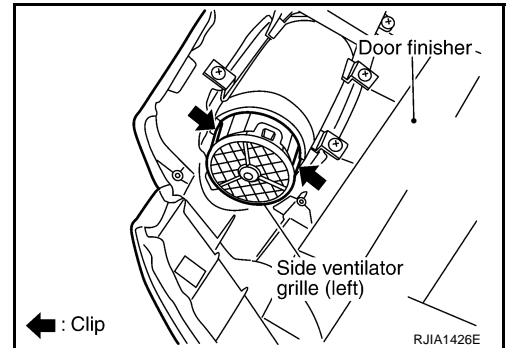

Removal of Instrument Side Finisher

Remove mounting clips, and then remove instrument side finisher.

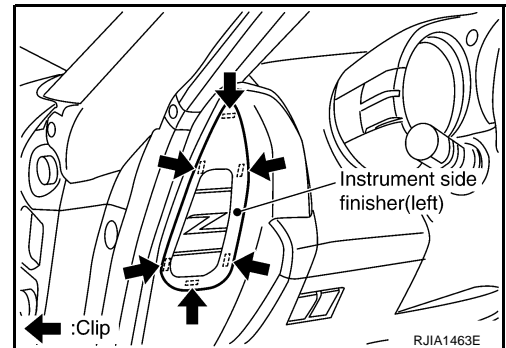

DUCTS AND GRILLES

Removal of Defroster Nozzle, Ducts and Ventilator Ducts

1. Remove instrument panel. Refer to [IP-11, "Removal and Installation"](#).
2. Remove mounting screws, and then remove side defroster duct 1.
3. Remove steering member, and then remove defroster nozzle.

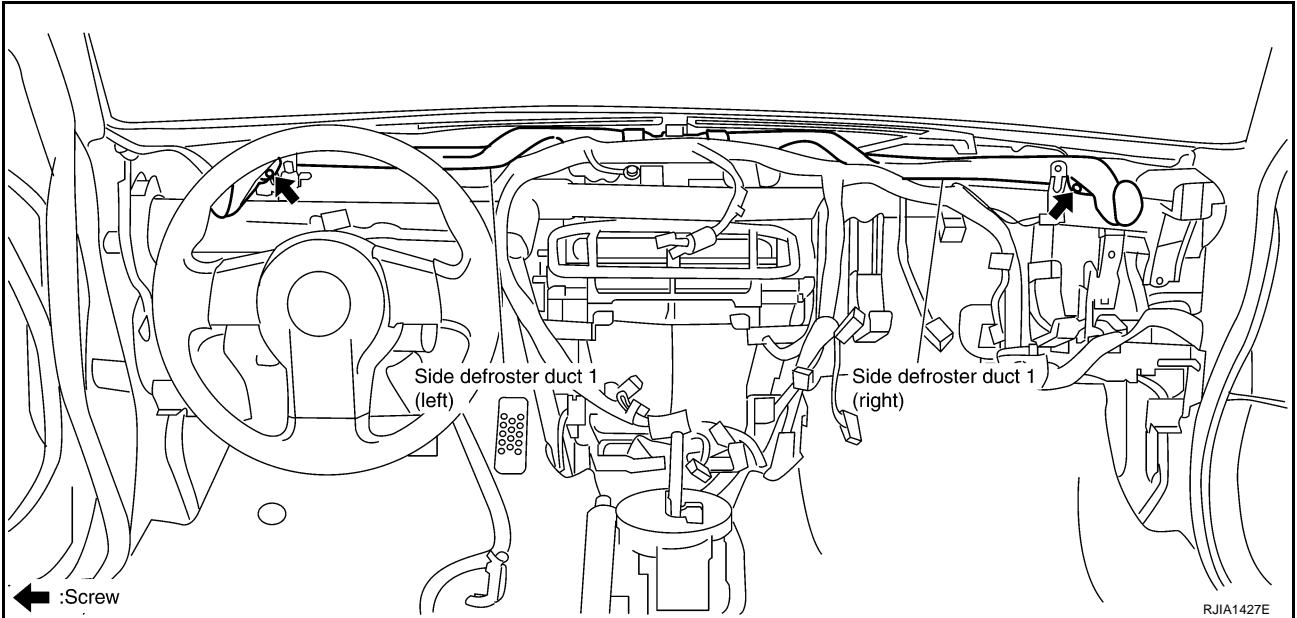

4. Remove mounting screws, and then remove side ventilator duct 1 and center ventilator duct from instrument panel.

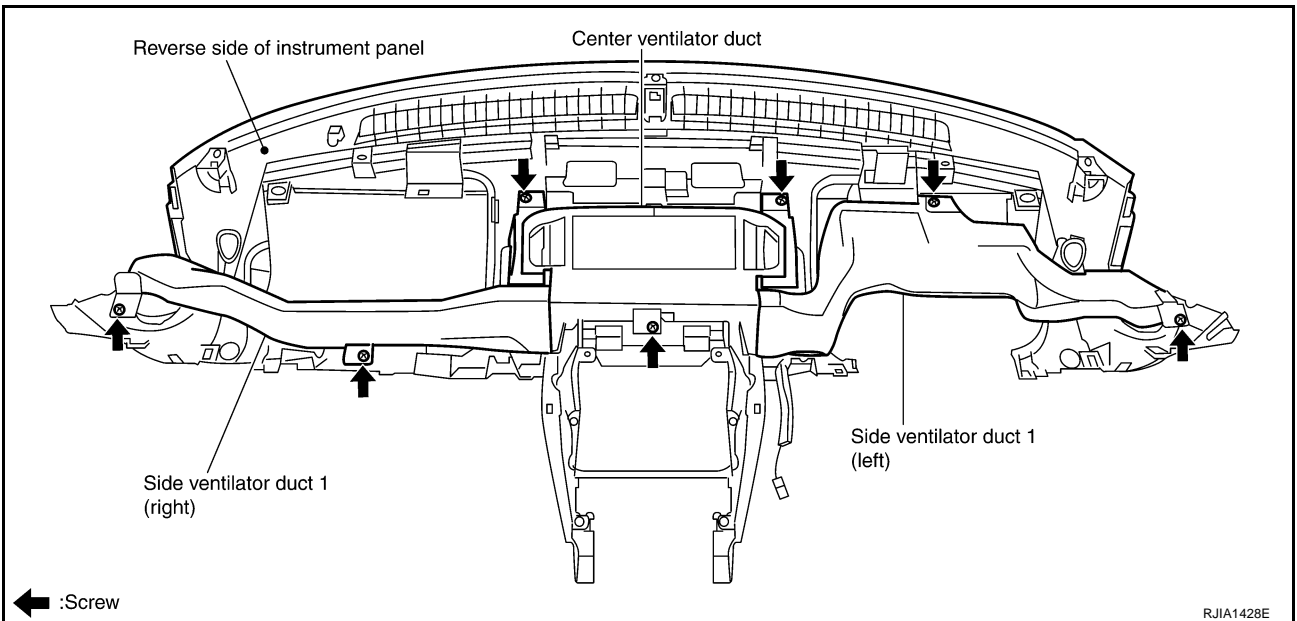

5. Remove mounting screws, and then remove side defroster duct 2.

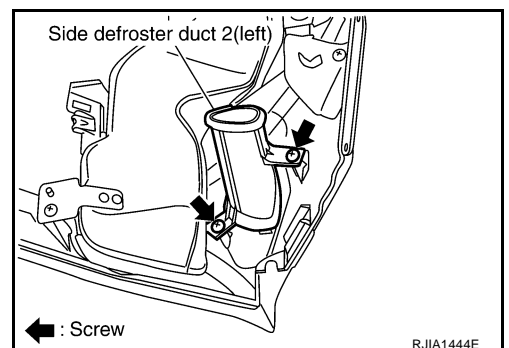

A
B
C
D
E
F
G
H
I
K
L
M

ATC

DUCTS AND GRILLES

Removal of Foot Ducts

1. Remove heater & cooling unit. Refer to [ATC-118, "HEATER & COOLING UNIT ASSEMBLY"](#) .
2. Remove evaporator cover, and then remove the foot duct (right).
3. Remove aspirator and heater pipe cover.
4. Remove foot duct (left).

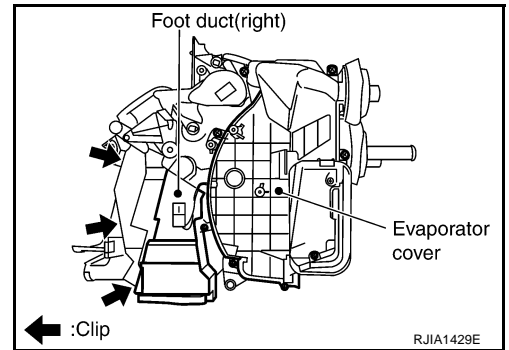

INSTALLATION

Installation is basically the reverse order of removal.

REFRIGERANT LINES

REFRIGERANT LINES

PFP:92600

HFC-134a (R-134a) Service Procedure SETTING OF SERVICE TOOLS AND EQUIPMENT

AJS000BA

Discharging Refrigerant

WARNING:

Avoid breathing A/C refrigerant and lubricant vapor or mist. Exposure may irritate eyes, nose and throat. Remove HFC-134a (R-134a) from A/C system using certified service equipment meeting requirements of SAE J2210 HFC-134a (R-134a) recycling equipment or J2201 HFC-134a (R-134a) recovery equipment. If accidental system discharge occurs, ventilate work area before resuming service. Additional health and safety information may be obtained from refrigerant and lubricant manufacturers.

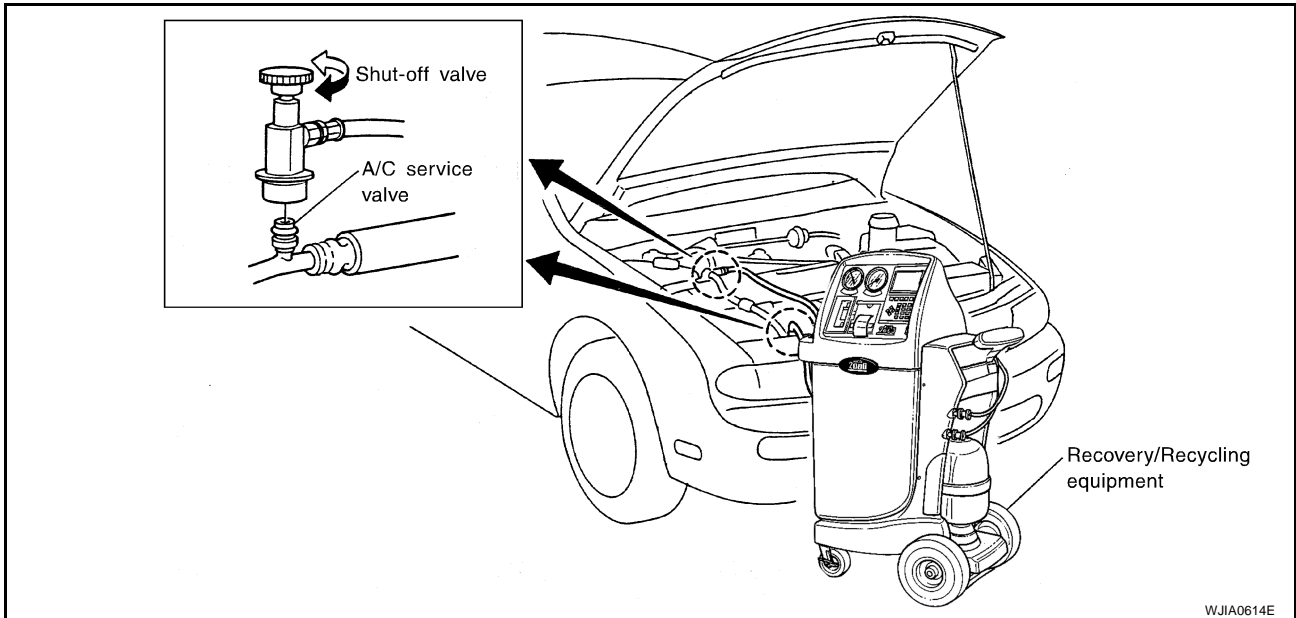

A
B
C
D
E
F
G
H
I

ATC

Evacuating System and Charging Refrigerant

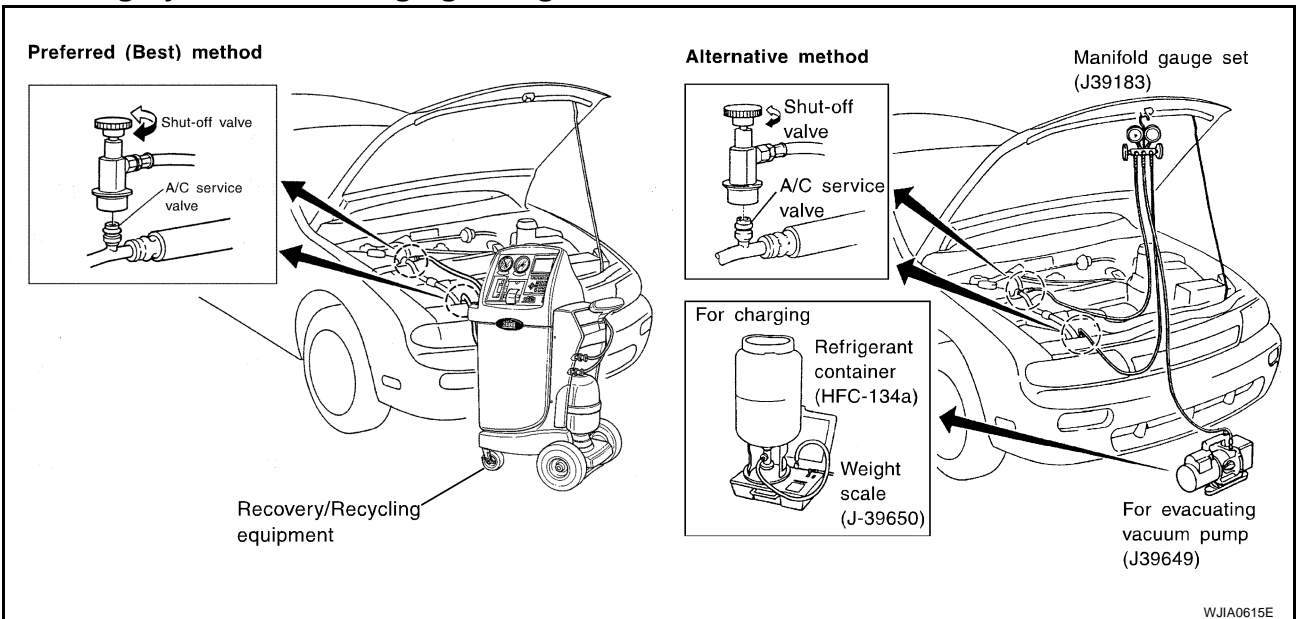

K
L
M

REFRIGERANT LINES

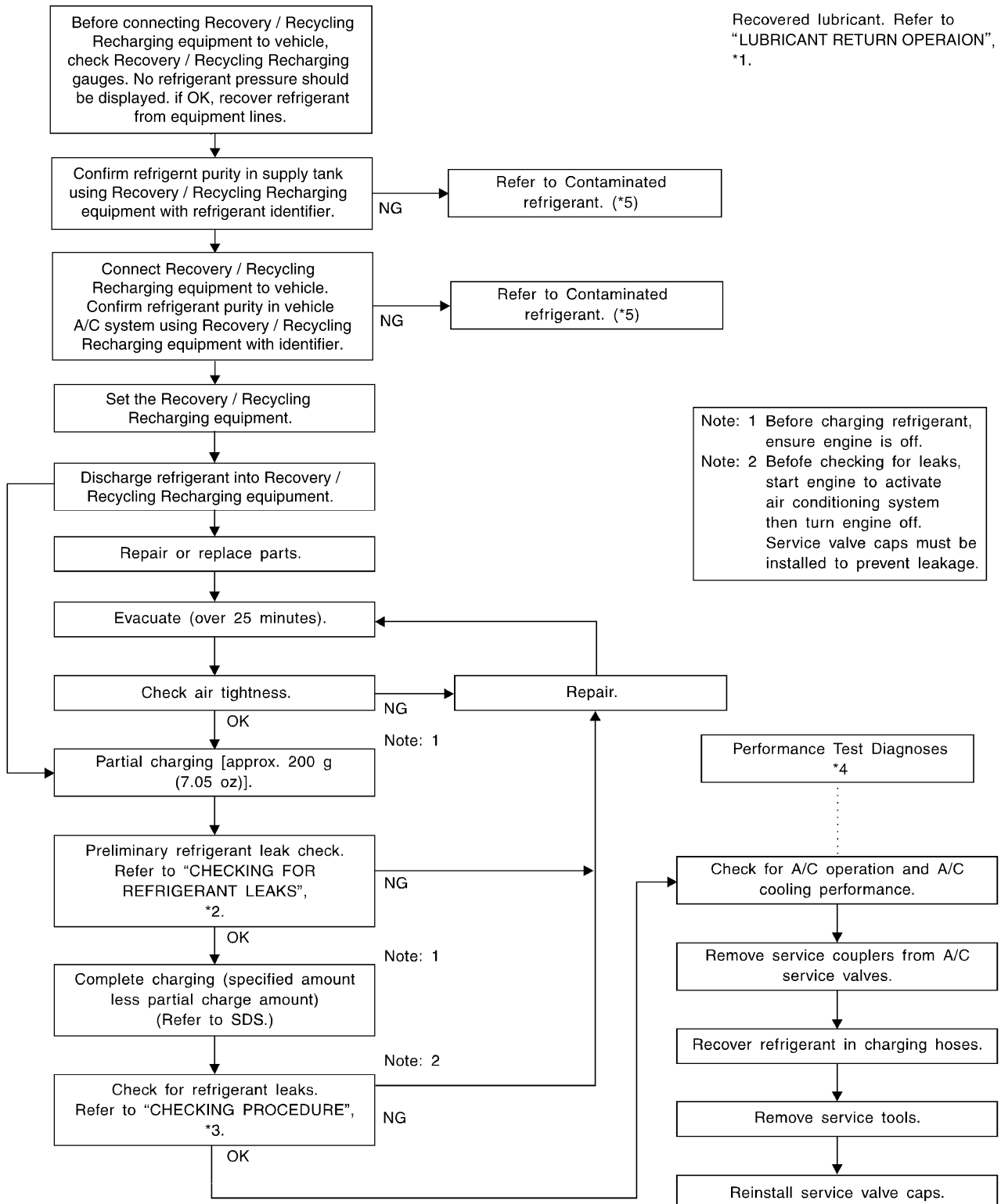

*1 [ATC-24, "LUBRICANT RETURN OPERATION"](#).

*4 [ATC-89, "PERFORMANCE TEST DIAGNOSIS"](#).

*2 [ATC-146, "Checking for Refrigerant Leaks"](#).

*5 [ATC-5, "CONTAMINATED REFRIGERANT"](#).

*3 [ATC-148, "CHECKING PROCEDURE"](#).

RJIA3006E

REFRIGERANT LINES

AJS000BB

Components

Refer to [ATC-6, "Precautions for Refrigerant Connection"](#).

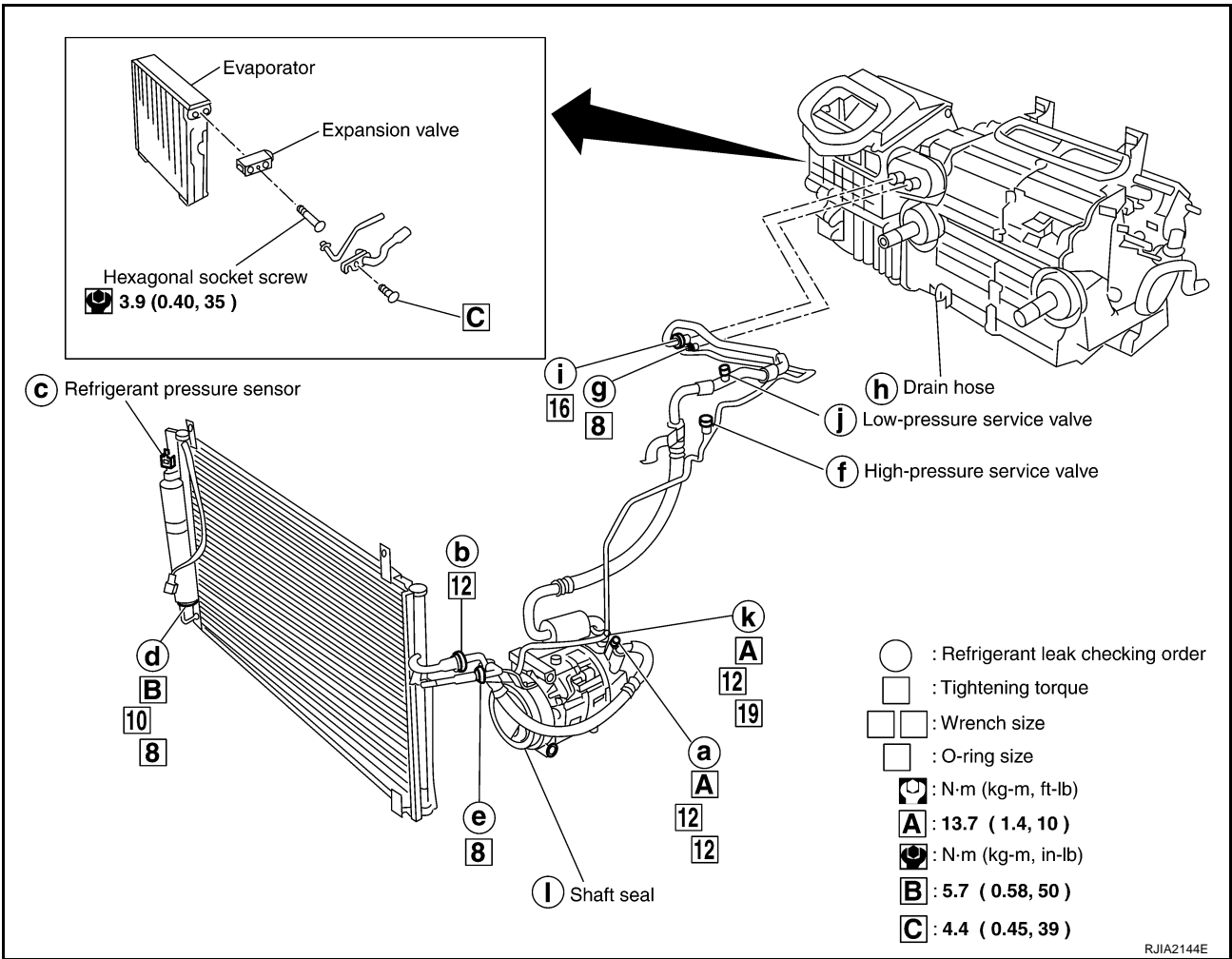

RJIA2144E

Removal and Installation of Compressor

REMOVAL

AJS000BC

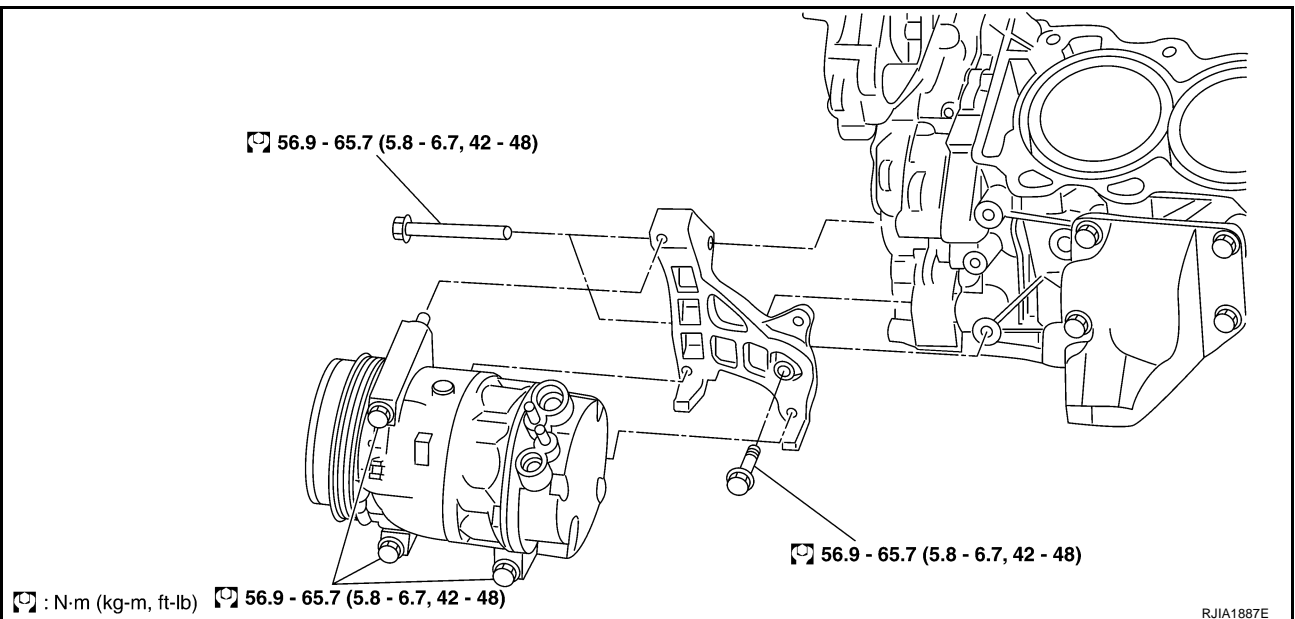

RJIA1887E

REFRIGERANT LINES

1. Use a refrigerant collecting equipment (for HFC-134a) to discharge the refrigerant.
2. Remove air cleaner assembly and air duct. Refer to [EM-14, "AIR CLEANER AND AIR DUCT"](#).
3. Remove engine under cover, using power tools.

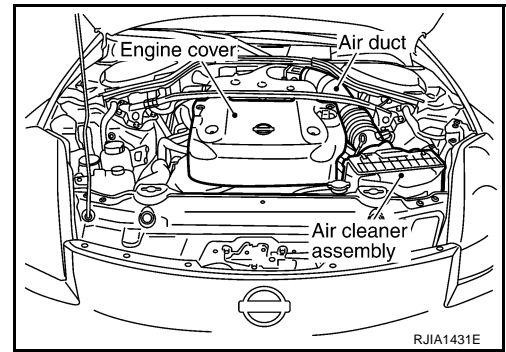

4. Remove mounting nuts from low-pressure and high-pressure flexible hose.

CAUTION:

Cap or wrap the joint of the pipe with suitable material such as vinyl tape to avoid the entry of air.

5. Disconnect compressor connector.
6. Remove the A/C compressor belt. Refer to [EM-12, "DRIVE BELTS"](#).

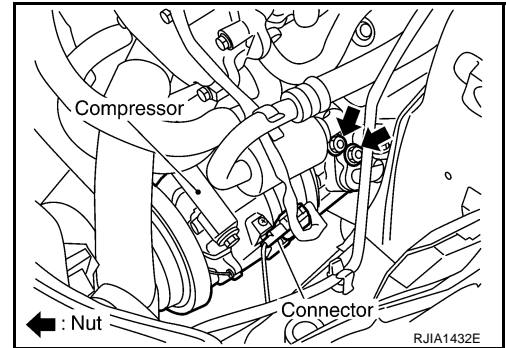

7. Remove mounting bolts from compressor, using power tools.
8. Remove compressor from the lower side of the vehicle.

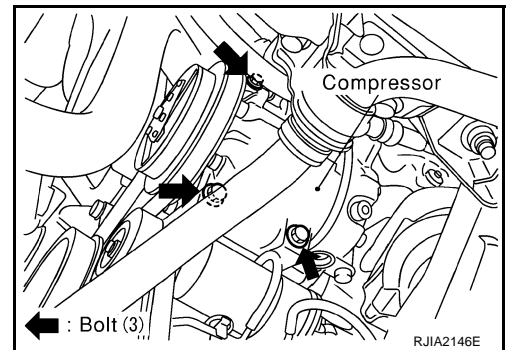

INSTALLATION

Installation is basically the reverse order of removal.

CAUTION:

- Replace the O-ring of the low-pressure flexible hose and high-pressure flexible hose with a new one, then apply compressor oil to it when installing it.
- When recharging refrigerant, check for leaks.

Removal and Installation of Compressor Clutch

REMOVAL

Overhaul

1. When removing center bolt, hold clutch disc with wrench.

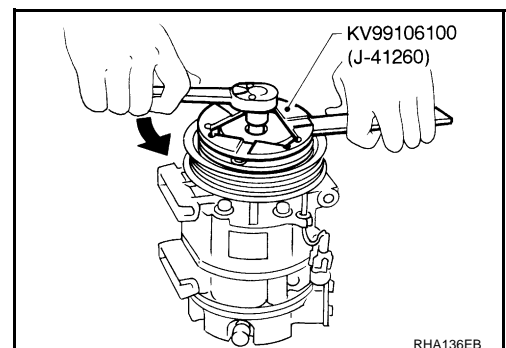

REFRIGERANT LINES

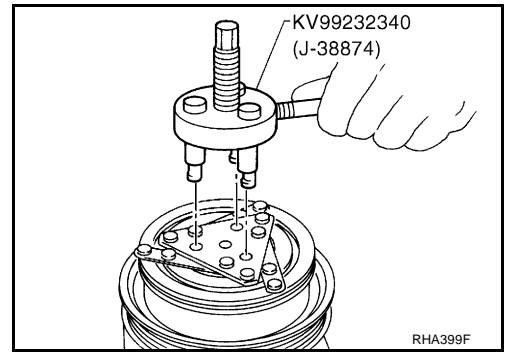

2. Remove the clutch disc using the clutch disc puller.

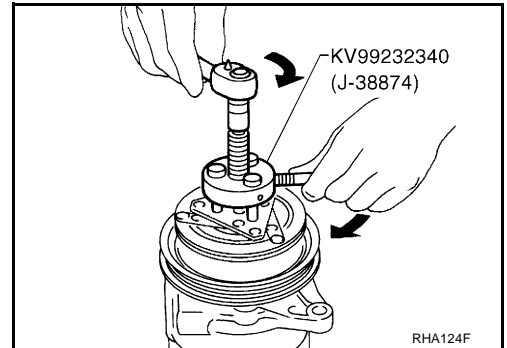

3. Remove the snap ring using external snap ring pliers.

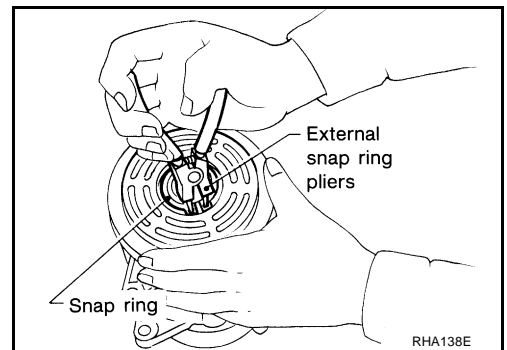

4. Position the center pulley puller on the end of the drive shaft, and remove the pulley assembly using any commercially available pulley puller. To prevent the pulley groove from being deformed, the puller claws should be positioned into the edge of the pulley assembly.

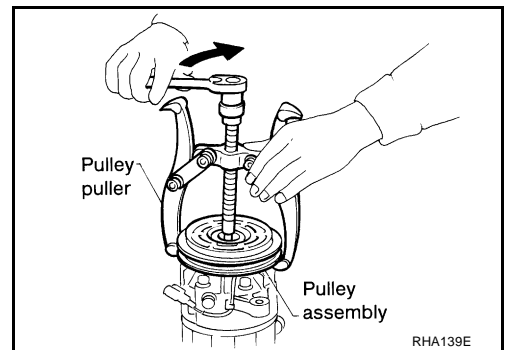

A
B
C
D
E
F
G
H
I
K
L
M

ATC

REFRIGERANT LINES

5. Remove the field coil harness clip using a pair of pliers.

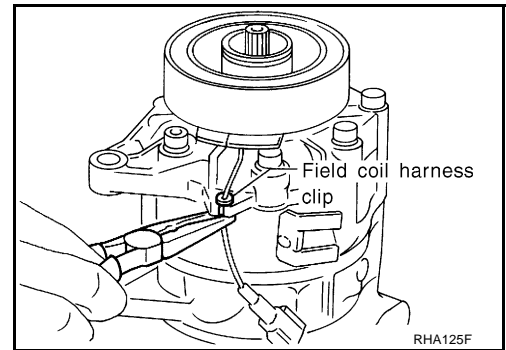

6. Remove the snap ring using external snap ring pliers.

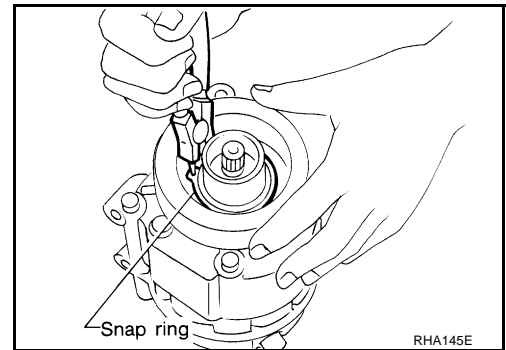

Inspection

Clutch disc

If the contact surface shows signs of damage due to excessive heat, replace clutch disc and pulley.

Pulley

Check the appearance of the pulley assembly. If the contact surface of pulley shows signs of excessive grooving, replace clutch disc and pulley. The contact surfaces of the pulley assembly should be cleaned with a suitable solvent before reinstallation.

Coil

Check coil for loose connection or cracked insulation.

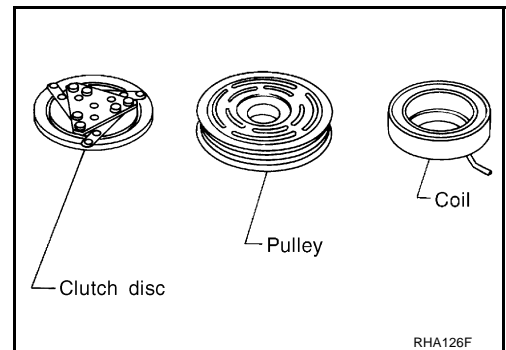

INSTALLATION

1. Install the field coil.
Be sure to align the coil's pin with the hole in the compressor's front head.
2. Install the field coil harness clip using a screwdriver.

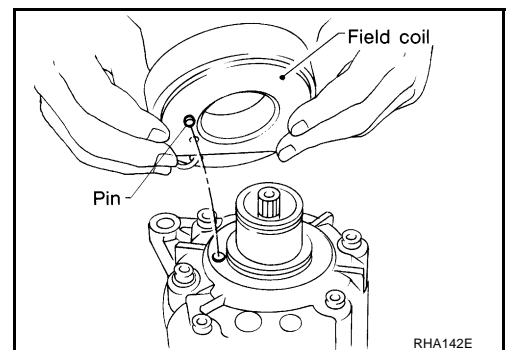

REFRIGERANT LINES

3. Install the pulley assembly using the installer and a hand press, and then install the snap ring using snap ring pliers.

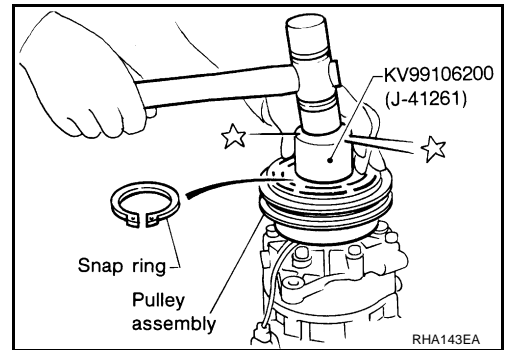

4. Install the clutch disc on the drive shaft, together with the original shim(s). Press the clutch disc down by hand.

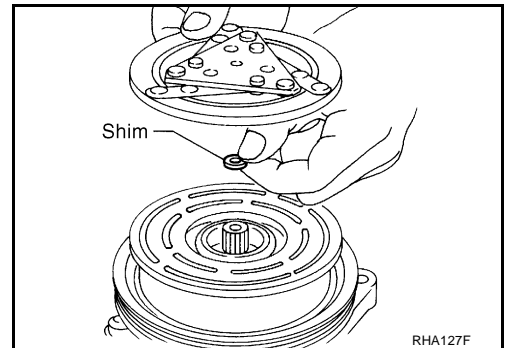

5. Using the holder to prevent clutch disc rotation, tighten the bolt to 14 N·m (1.4 kg-m, 10 ft-lb) torque. After tightening the bolt, make sure the pulley rotates smoothly.

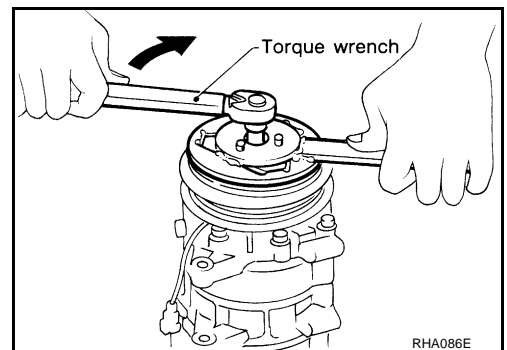

6. Check clearance around the entire periphery of clutch disc.

Disc to pulley clearance : 0.25 - 0.60 mm (0.010 - 0.024 in)

If the specified clearance is not obtained, replace adjusting spacer and readjust.

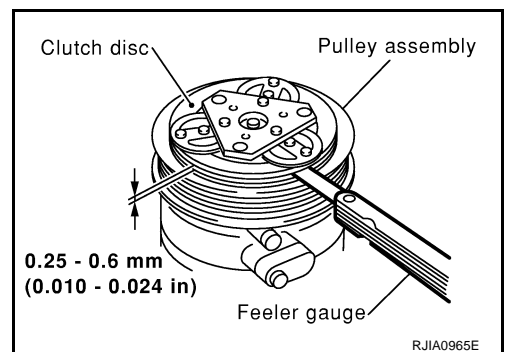

Break-in Operation

When replacing compressor clutch assembly, always carry out the break-in operation. This is done by engaging and disengaging the clutch about thirty times. Break-in operation raises the level of transmitted torque.

A
B
C
D
E
F
G
H
I
K
L
M

ATC

REFRIGERANT LINES

AJS000BE

Removal and Installation of Low-pressure Flexible Hose

REMOVAL

1. Use a refrigerant collecting equipment (for HFC-134a) to discharge the refrigerant.
2. Remove cowl top cover. Refer to [EI-20, "COWL TOP"](#).
3. Remove air cleaner assembly and air duct. Refer to [EM-14, "AIR CLEANER AND AIR DUCT"](#).

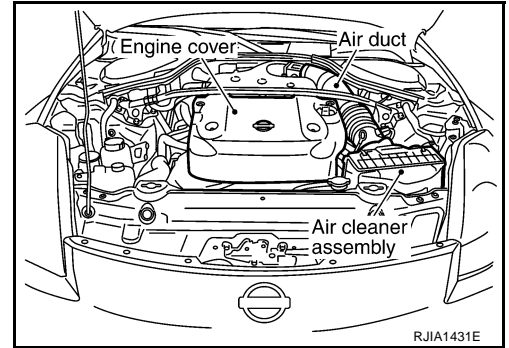

4. Remove mounting bolt for low-pressure flexible hose bracket.
5. Remove clip from high-pressure pipe 1.

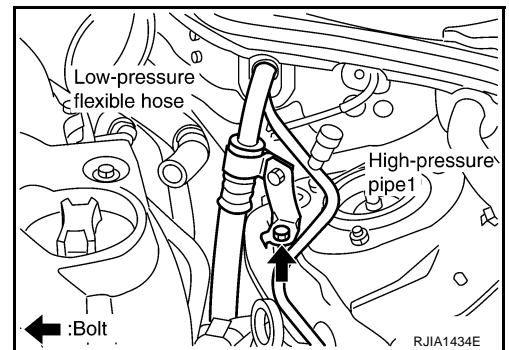

6. Disconnect one-touch joint between low-pressure flexible hose and low-pressure pipe.
 - a. Set a disconnecter (92530-89916) on A/C piping.
 - b. Slide a disconnecter toward vehicle front until it clicks.
 - c. Slide A/C piping toward vehicle front and disconnect it.

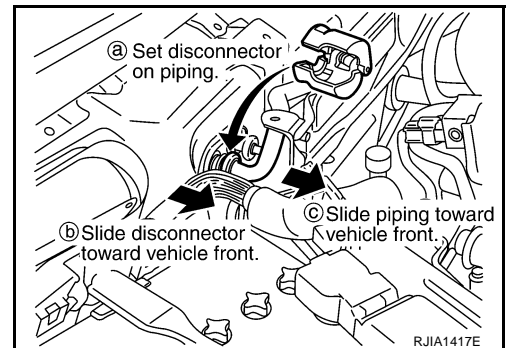

7. Remove mounting nut from low-pressure flexible hose. (Compressor side)

CAUTION:

Cap or wrap the joint of the pipe with suitable material such as vinyl tape to avoid the entry of air.

8. Remove low-pressure flexible hose.

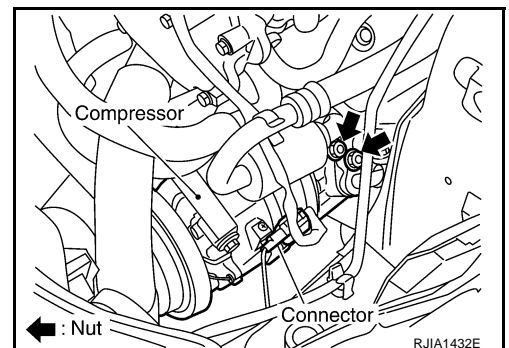

REFRIGERANT LINES

INSTALLATION

Installation is basically the reverse order of removal.

CAUTION:

- Replace O-rings for A/C piping with new one, then apply compressor oil to it when installing it.
- Connection point for female-side piping is thin. So, when inserting male-side piping, take care not to deform female-side piping. Slowly insert in axial direction.
- Insert one-touch joint connection point securely until it clicks.
- After piping has been connected, pull male-side piping by hand to make sure piping does not come off.
- When recharging refrigerant, check for leaks.

Bolt mounting the low-pressure flexible hose bracket

Tightening torque : 4.2 N·m (0.43 kg-m, 37 in-lb)

Removal and Installation of High-pressure Flexible Hose

AJS000BF

REMOVAL

1. Use a refrigerant collecting equipment (for HFC-134a) to discharge the refrigerant.
2. Remove air cleaner assembly and air duct. Refer to [EM-14](#), "[AIR CLEANER AND AIR DUCT](#)".

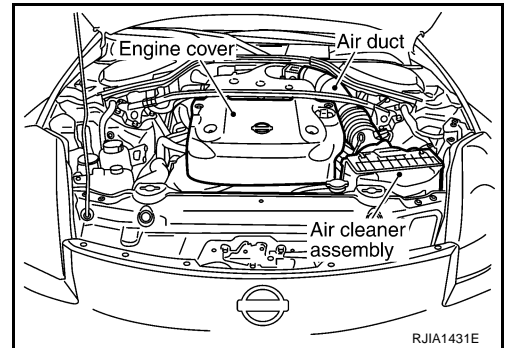

3. Remove mounting bolt for high-pressure flexible hose bracket.

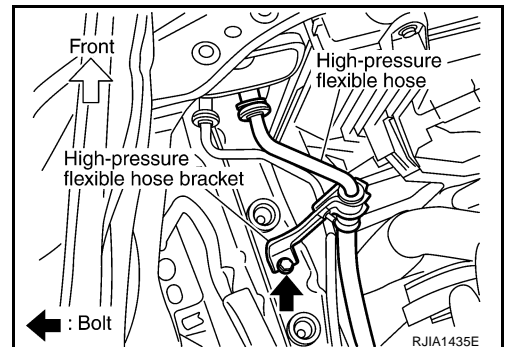

4. Disconnect the one-touch joint between high-pressure flexible hose and condenser.
 - a. Set a disconnecter (92530-89912) on A/C piping.
 - b. Slide a disconnecter backward until it clicks.
 - c. Slide A/C piping backward and disconnect it.

CAUTION:

Cap or wrap the joint of the pipe with suitable material such as vinyl tape to avoid the entry of air.

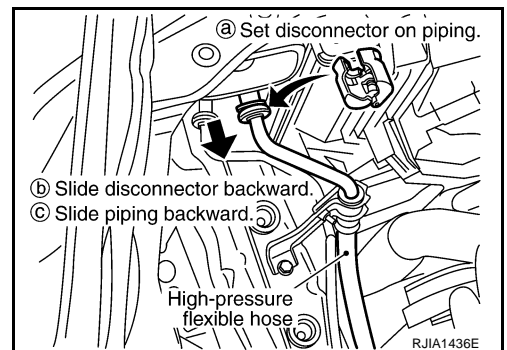

REFRIGERANT LINES

- Remove the mounting nut for high-pressure flexible hose, and then remove the high-pressure flexible hose.

CAUTION:

Cap or wrap the joint of the pipe with suitable material such as vinyl tape to avoid the entry of air.

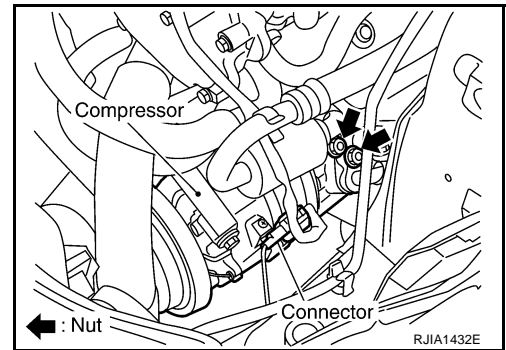

INSTALLATION

Installation is basically the reverse order of removal.

CAUTION:

- Replace the O-ring of the high-pressure flexible hose with a new one, then apply compressor oil to it when installing it.
- Connection point for female-side piping is thin. So, when inserting male-side piping, take care not to deform female-side piping. Slowly insert in axial direction.
- Insert one-touch joint connection point securely until it clicks.
- After piping has been connected, pull male-side piping by hand to make sure piping does not come off.
- When recharging refrigerant, check for leaks.

Bolt mounting high-pressure flexible hose bracket

Tightening torque : 4.2 N·m (0.43 kg·m, 37 in-lb)

Removal and Installation of High-pressure Pipe 1 (Engine Compartment)

AJS000BH

REMOVAL

- Use a refrigerant collecting equipment (for HFC-134a) to discharge the refrigerant.
- Remove cowl top cover. Refer to [EI-20, "COWL TOP"](#).
- Remove air cleaner assembly and air duct. Refer to [EM-14, "AIR CLEANER AND AIR DUCT"](#).
- Remove tower bar. Refer to [FSU-20, "TOWER BAR"](#).
- Remove low-pressure flexible hose. Refer to [ATC-136, "Removal and Installation of Low-pressure Flexible Hose"](#).
- Remove high-pressure flexible hose bracket. Refer to [ATC-137, "Removal and Installation of High-pressure Flexible Hose"](#).

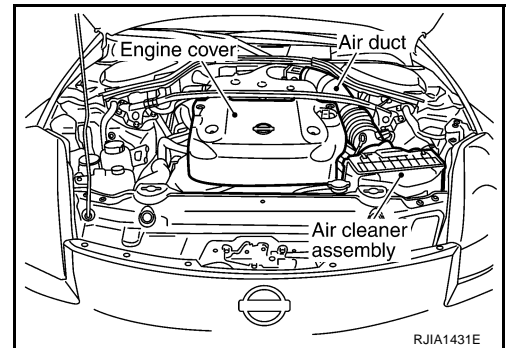

- Remove the high-pressure flexible hose from vehicle clips.
- Disconnect the one-touch joints of high-pressure pipe.
 - Set a disconnecter (92530-89908) on A/C piping.

REFRIGERANT LINES

- b. Slide a disconnecter toward vehicle front (or backward) until it clicks.

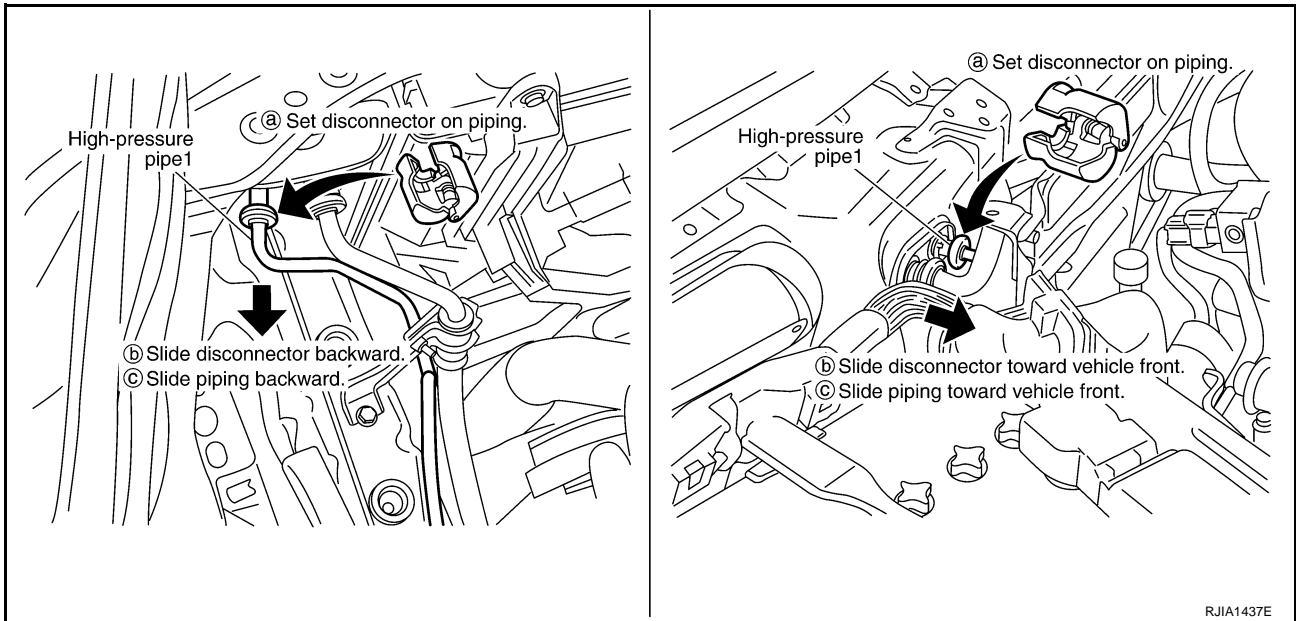

- c. Slide A/C piping toward vehicle front (or backward) and disconnect it.

CAUTION:

Cap or wrap the joint of the pipe with suitable material such as vinyl tape to avoid the entry of air.

9. Remove the high-pressure pipe 1.

INSTALLATION

Installation is basically the reverse order of removal.

CAUTION:

- Replace the O-ring of the high-pressure pipe with a new one, then apply compressor oil to it when installing it.
- Connection point for female-side piping is thin. So, when inserting male-side piping, take care not to deform female-side piping. Slowly insert in axial direction.
- Insert one-touch joint connection point securely until it clicks.
- After piping has been connected, pull male-side piping by hand to make sure piping does not come off.
- When recharging refrigerant, check for leaks.

Removal and Installation of Low-pressure Pipe and High-pressure Pipe 2

AJS000BI

REMOVAL

1. Set the temperature control dial at 18°C (60°F).
2. Open the driver and front passenger window, and then disconnect the battery negative cable.

CAUTION:

After the battery cables are disconnected, do not open/close the driver and/or front passenger door with the window in the full up position. The automatic window adjusting function will not work and the side roof panel may be damaged.

3. Use a refrigerant collecting equipment (for HFC-134a) to discharge the refrigerant.
4. Remove cowl top cover. Refer to [EI-20, "COWL TOP"](#) .

A
B
C
D
E
F
G
H
I
K
L
M

ATC

REFRIGERANT LINES

5. Remove mounting bolt for low-pressure flexible hose bracket.
6. Remove high-pressure pipe 1 from vehicle clips.

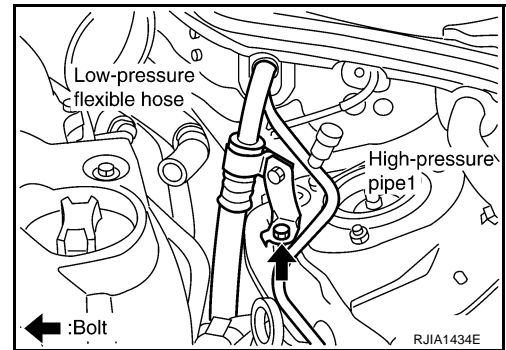

7. Disconnect one-touch joints.
 - a. Set a disconnecter (high-pressure side: 92530-89908, low-pressure side: 92530-89916) on A/C piping.
 - b. Slide a disconnecter toward vehicle front until it clicks.
 - c. Slide A/C piping toward vehicle front and disconnect it.

CAUTION:

Cap or wrap the joint of the pipe with suitable material such as vinyl tape to avoid the entry of air.

8. Remove instrument passenger panel lower. Refer to [IP-11, "Removal and Installation"](#).
9. Remove blower unit. Refer to [ATC-114, "BLOWER UNIT"](#).
10. Remove air mix door motor and mode door motor.
11. Remove evaporator cover.

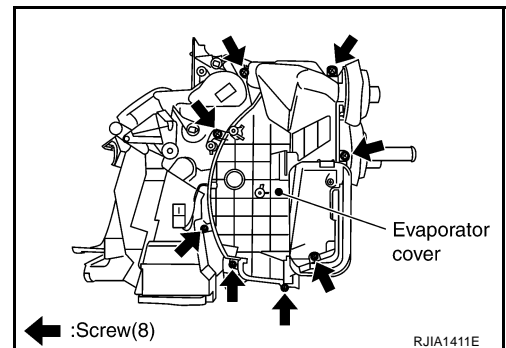
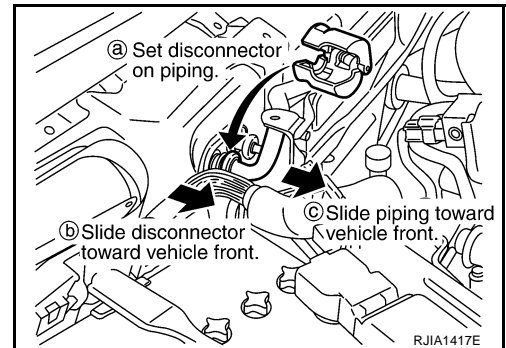

12. Remove mounting bolt, and then remove low-pressure pipe and high-pressure pipe 2.

CAUTION:

Cap or wrap the joint of the pipe with suitable material such as vinyl tape to avoid the entry of air.

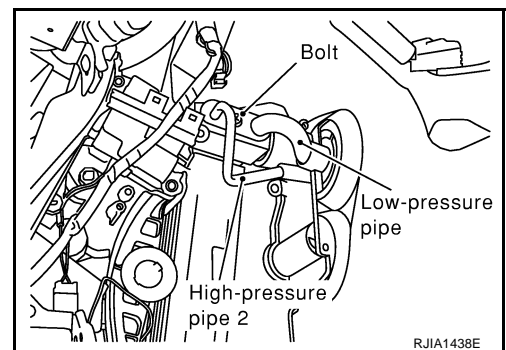

INSTALLATION

Installation is basically the reverse order of removal.

CAUTION:

- Replace O-rings for A/C piping with new ones, then apply compressor oil to it when installing it.
- Connection point for female-side piping is thin. So, when inserting male-side piping, take care not to deform female-side piping. Slowly insert in axial direction.
- Insert one-touch joint connection point securely until it clicks.
- After piping has been connected, pull male-side piping by hand to make sure piping does not come off.

REFRIGERANT LINES

- When recharging refrigerant, check for leaks.

Bolt mounting low-pressure flexible hose bracket

Tightening torque : 4.2 N·m (0.43 kg·m, 37 in·lb)

Removal and Installation of Liquid Tank

AJS000BJ

REMOVAL

1. Use a refrigerant collecting equipment (for HFC-134a) to discharge the refrigerant.
2. Remove the condenser. Refer to [ATC-142, "Removal and Installation of Condenser"](#).
3. Clean liquid tank and its surrounding area, and remove dirt and rust from liquid tank.

CAUTION:

Be sure to clean carefully.

4. Remove mounting bolt for liquid tank.

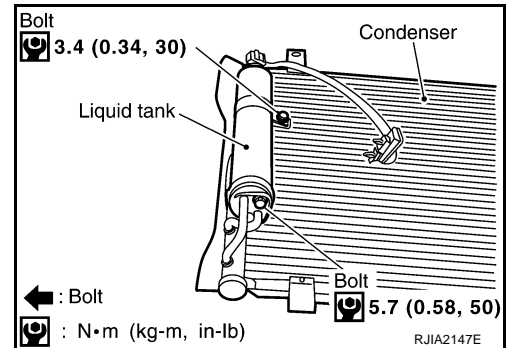

5. Lift liquid tank upwards. Remove bracket from protruding part of condenser.
6. Slide liquid tank upward, and then remove liquid tank.

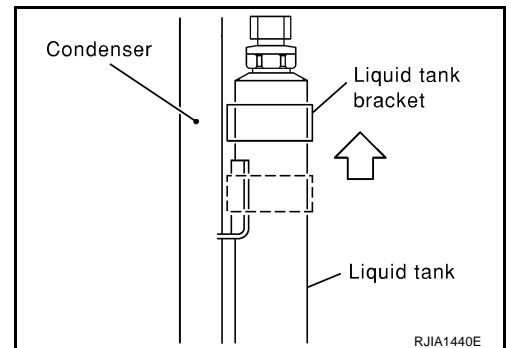

INSTALLATION

Installation is basically the reverse order of removal.

CAUTION:

- **Make sure liquid tank bracket is securely installed at protrusion of condenser. (Make sure liquid tank bracket does not move to a position below center of liquid tank.)**
- **Replace O-rings for A/C piping with new ones, then apply compressor oil to it when installing it.**
- **When recharging refrigerant, check for leaks.**

Bolt mounting liquid tank bracket (upper side)

Tightening torque : 3.4 N·m (0.34 kg·m, 30 in·lb)

Bolt mounting liquid tank bracket (lower side)

Tightening torque : 5.7 N·m (0.58 kg·m, 50 in·lb)

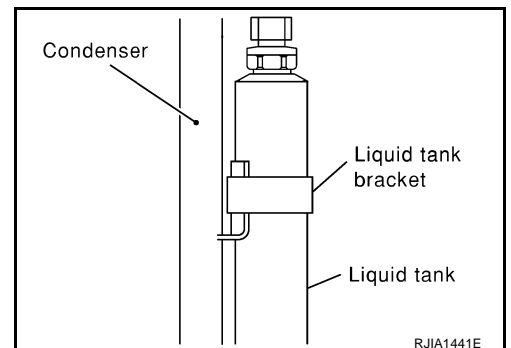

REFRIGERANT LINES

AJS000BK

Removal and Installation of Condenser REMOVAL

1. Use a refrigerant collecting equipment (for HFC-134a) to discharge the refrigerant.
2. Remove engine under cover, using power tools.
3. Drain engine coolant. Refer to [CO-9, "Changing Engine Coolant"](#) .
4. Remove cover for condenser mounting bolt.

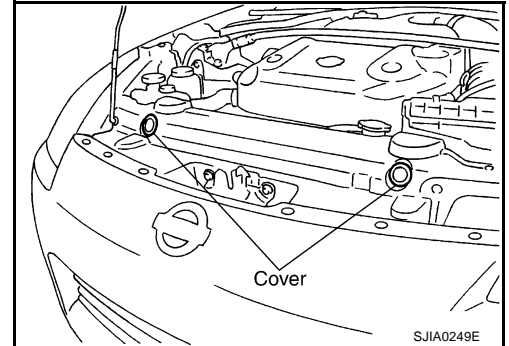

5. Remove engine cover, air cleaner assembly and air duct. Refer to [EM-16, "INTAKE MANIFOLD COLLECTOR"](#) and [EM-14, "AIR CLEANER AND AIR DUCT"](#) .
6. Remove radiator fan shroud after removing radiator upper hose.

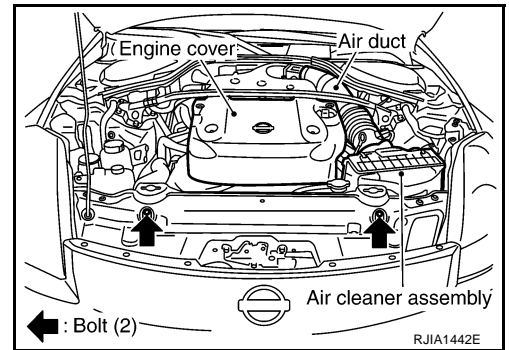

7. Remove mounting bolt for high-pressure flexible hose bracket.

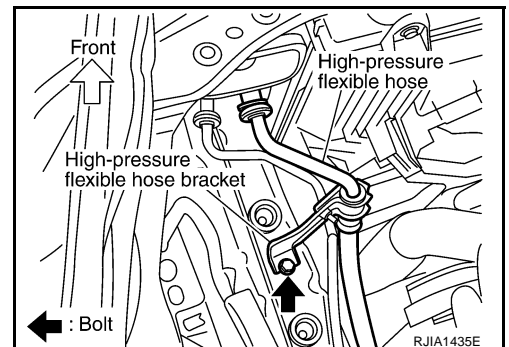

8. Disconnect high-pressure flexible hose and high-pressure pipe 1 from condenser.
 - a. Set a disconnecter (condenser outlet: 92530-89908, condenser inlet: 92530-89912) on A/C piping.
 - b. Slide a disconnecter backward until it clicks.
 - c. Slide A/C piping backward and disconnect it.

CAUTION:

Cap or wrap the joint of the pipe with suitable material such as vinyl tape to avoid the entry of air.

9. Remove mounting bolt for condenser.
10. Remove radiator upper mount, move radiator and condenser to the engine side.
11. Disconnect refrigerant pressure sensor connector.

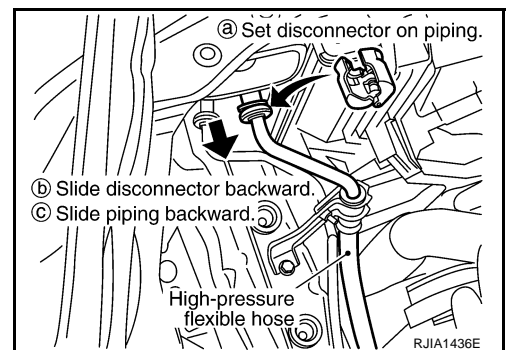

REFRIGERANT LINES

12. Lift condenser up slightly and tilt it toward front of vehicle. (This is because condenser lower bracket is on bottom of radiator tank.)

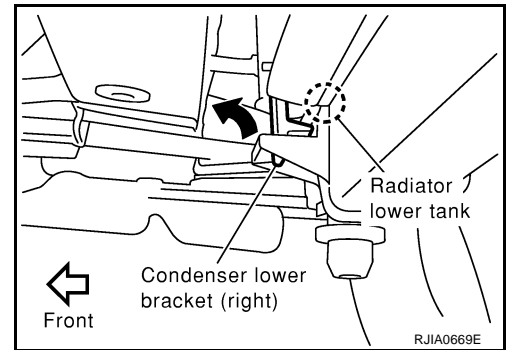

13. Pull condenser forward at an angle. Remove condenser from radiator.

CAUTION:

Be careful not to damage the core surface of the condenser and the radiator.

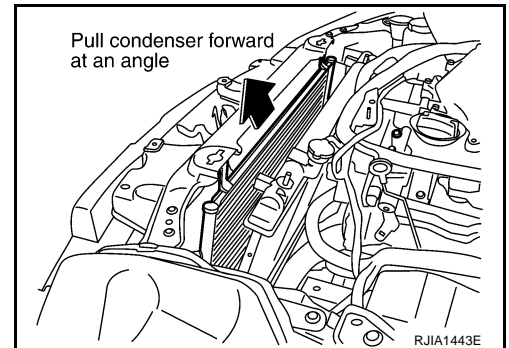

INSTALLATION

Installation is basically the reverse order of removal.

CAUTION:

- Replace O-rings for A/C piping with new ones, then apply compressor oil to it when installing it.
- Connection point for female-side piping is thin. So, when inserting male-side piping, take care not to deform female-side piping. Slowly insert in axial direction.
- Insert one-touch joint connection point securely until it clicks.
- After piping has been connected, pull male-side piping by hand to make sure piping does not come off.
- When recharging refrigerant, check for leaks.

Bolt mounting the condenser

Tightening torque : 6.1 N·m (0.62 kg·m, 54 in·lb)

Removal and Installation of Refrigerant Pressure Sensor

AJS000BL

REMOVAL

1. Remove the liquid tank. Refer to [ATC-141, "Removal and Installation of Liquid Tank"](#).
2. Using a vise, secure liquid tank, and remove refrigerant pressure sensor.

CAUTION:

When working, be careful not to damage the condenser fins.

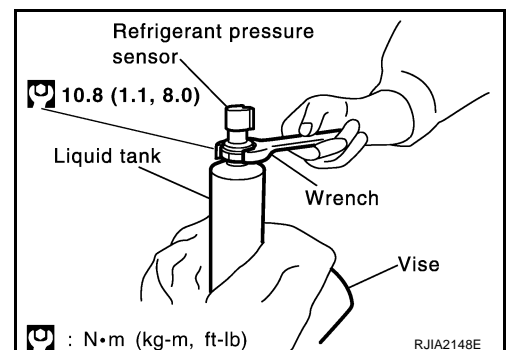

REFRIGERANT LINES

INSTALLATION

Installation is basically the reverse order of removal.

CAUTION:

Apply compressor oil to the O-ring of the refrigerant pressure sensor when installing it.

Removal and Installation of Evaporator REMOVAL

AJS000BM

1. Set the temperature control dial at 18°C (60°F).
2. Open the driver and front passenger window, and then disconnect the battery negative cable.

CAUTION:

After the battery cables are disconnected, do not open/close the driver and/or front passenger door with the window in the full up position. The automatic window adjusting function will not work and the side roof panel may be damaged.

3. Use a refrigerant collecting equipment (for HFC-134a) to discharge the refrigerant.
4. Remove the low-pressure pipe and high-pressure pipe 2. Refer to [ATC-139, "Removal and Installation of Low-pressure Pipe and High-pressure Pipe 2"](#).

CAUTION:

Cap or wrap the joint of the pipe with suitable material such as vinyl tape to avoid the entry of air.

5. Slide evaporator, and then remove it from heater & cooling unit.
6. Remove intake sensor from evaporator, and then remove evaporator.

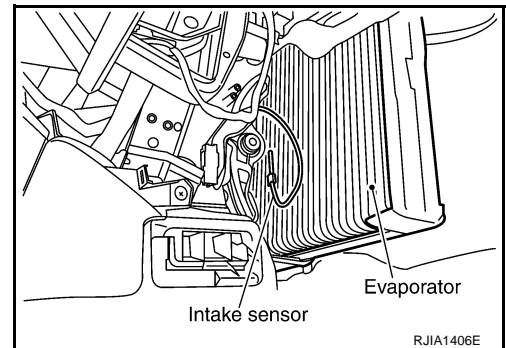

INSTALLATION

Installation is basically the reverse order of removal.

CAUTION:

- Replace O-rings for A/C piping with new ones, then apply compressor oil to it when installing it.
- Connection point for female-side piping is thin. So, when inserting male-side piping, take care not to deform female-side piping. Slowly insert in axial direction.
- Insert one-touch joint connection point securely until it clicks.
- After piping has been connected, pull male-side piping by hand to make sure piping does not come off.
- The O-rings are different from low-pressure flexible hose (high-pressure pipe 1) and low-pressure pipe (high-pressure pipe 2).
- Mark the mounting position of the intake sensor bracket.
- When recharging refrigerant, check for leaks.

Bolt mounting low-pressure flexible hose bracket

Tightening torque : 4.2 N·m (0.43 kg·m, 37 in·lb)

REFRIGERANT LINES

AJS000BN

Removal and Installation of Expansion Valve

REMOVAL

1. Set the temperature control dial at 18°C (60°F).
2. Open the driver and front passenger window, and then disconnect the battery negative cable.

CAUTION:

After the battery cables are disconnected, do not open/close the driver and/or front passenger door with the window in the full up position. The automatic window adjusting function will not work and the side roof panel may be damaged.

3. Use a refrigerant collecting equipment (for HFC-134a) to discharge the refrigerant.
4. Remove the low-pressure pipe and high-pressure pipe 2. Refer to [ATC-139, "Removal and Installation of Low-pressure Pipe and High-pressure Pipe 2"](#).

CAUTION:

Cap or wrap the joint of the pipe with suitable material such as vinyl tape to avoid the entry of air.

5. Remove mounting bolts, and then remove expansion valve.

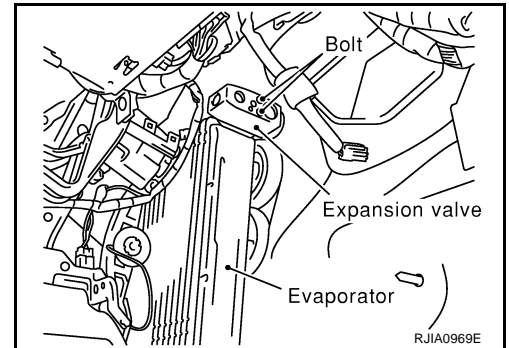

INSTALLATION

Installation is basically the reverse order of removal.

CAUTION:

- Replace O-rings with new ones, then apply compressor oil to them when installing them.
- The O-rings are different from low-pressure flexible hose (high-pressure pipe 1) and low-pressure pipe (high-pressure pipe 2).
- When recharging refrigerant, check for leaks.

Bolts mounting expansion valve

Tightening torque : 3.9 N·m (0.40 kg·m, 35 in·lb)

A
B
C
D
E
F
G
H
I
K
L
M

ATC

REFRIGERANT LINES

Checking for Refrigerant Leaks

AJS000B0

Perform a visual inspection of all refrigeration parts, fittings, hoses and components for signs of A/C lubricant leakage, damage and corrosion. A/C lubricant leakage may indicate an area of refrigerant leakage. Allow extra inspection time in these areas when using either an electronic refrigerant leak detector or fluorescent dye leak detector.

If dye is observed, confirm the leak with an electronic refrigerant leak detector. It is possible a prior leak was repaired and not properly cleaned.

When searching for leaks, do not stop when one leak is found but continue to check for additional leaks at all system components and connections.

When searching for refrigerant leaks using an electronic leak detector, move the probe along the suspected leak area at 1 to 2 inches per second and no further than 1/4 inch from the component.

CAUTION:

Moving the electronic leak detector probe slower and closer to the suspected leak area will improve the chances of finding a leak.

Checking System for Leaks Using the Fluorescent Leak Detector

AJS000BP

1. Check A/C system for leaks using the UV lamp and safety goggles (J-42220) in a low sunlight area (area without windows preferable). Illuminate all components, fittings and lines. The dye will appear as a bright green/yellow area at the point of leakage. Fluorescent dye observed at the evaporator drain opening indicates an evaporator core assembly (tubes, core or expansion valve) leak.
2. If the suspected area is difficult to see, use an adjustable mirror or wipe the area with a clean shop rag or cloth, with the UV lamp for dye residue.
3. After the leak is repaired, remove any residual dye using dye cleaner (J-43872) to prevent future misdiagnosis.
4. Perform a system performance check and verify the leak repair with an approved electronic refrigerant leak detector.

NOTE:

Other gases in the work area or substances on the A/C components, for example, anti-freeze, windshield washer fluid, solvents and lubricants, may falsely trigger the leak detector. Make sure the surfaces to be checked are clean.

Clean with a dry cloth or blow off with shop air.

Do not allow the sensor tip of the detector to contact with any substance. This can also cause false readings and may damage the detector.

Dye Injection

AJS000BQ

(This procedure is only necessary when recharging the system or when the compressor has seized and was replaced.)

1. Check A/C system static (at rest) pressure. Pressure must be at least 345 kPa (3.52kg/cm² , 50 psi).
2. Pour one bottle (1/4 ounce / 7.4 cc) of the A/C refrigerant dye into the injector tool (J-41459).
3. Connect the injector tool to the A/C LOW PRESSURE side service fitting.
4. Start engine and switch A/C ON.
5. When the A/C operating (compressor running), inject one bottle (1/4 ounce / 7.4 cc) of fluorescent dye through the low-pressure service valve using dye injector tool J-41459 (refer to the manufacture's operating instructions).
6. With the engine still running, disconnect the injector tool from the service fitting.

CAUTION:

Be careful the A/C system or replacing a component, pour the dye directly into the open system connection and proceed with the service procedures.

7. Operate the A/C system for a minimum of 20 minutes to mix the dye with the system oil. Depending on the leak size, operating conditions and location of the leak, it may take from minutes to days for the dye to penetrate a leak and become visible.

REFRIGERANT LINES

Electronic Refrigerant Leak Detector PRECAUTIONS FOR HANDLING LEAK DETECTOR

AJS000BR

When performing a refrigerant leak check, use a J-41995 A/C leak detector or equivalent. Ensure that the instrument is calibrated and set properly per the operating instructions.

The leak detector is a delicate device. In order to use the leak detector properly, read the operating instructions and perform any specified maintenance.

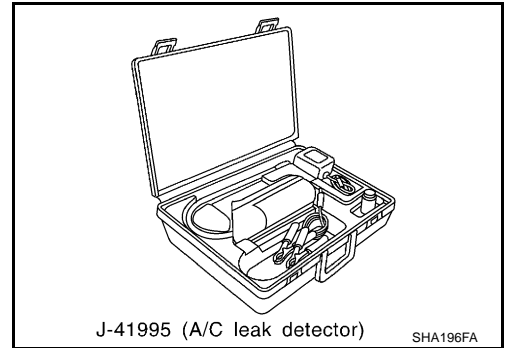

1. Position probe approximately 5 mm (3/16 in) away from point to be checked.

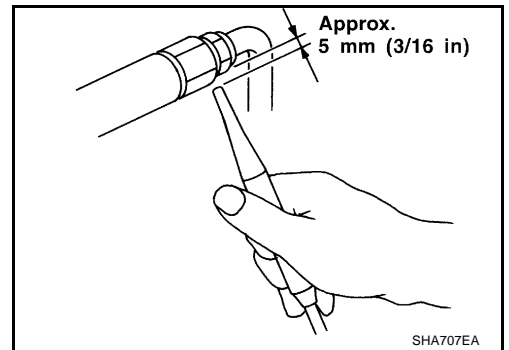

2. When testing, circle each fitting completely with probe.

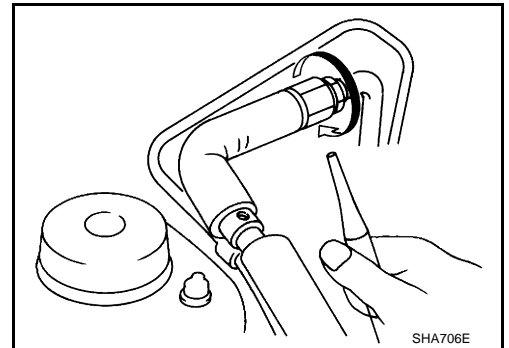

3. Move probe along component approximately 25 to 50 mm (1 to 2 in)/sec.

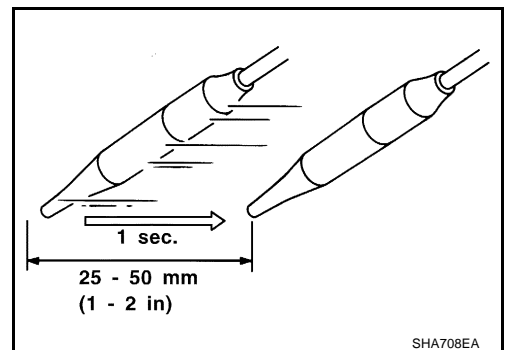

A
B
C
D
E
F
G
H
I
ATC
K
L
M

REFRIGERANT LINES

CHECKING PROCEDURE

To prevent inaccurate or false readings, make sure there is no refrigerant vapor, shop chemicals, or cigarette smoke in the vicinity of the vehicle. Perform the leak test in calm area (low air/wind movement) so that the leaking refrigerant is not dispersed.

1. Turn engine OFF.
2. Connect a suitable A/C manifold gauge set to the A/C service ports.
3. Check if the A/C refrigerant pressure is at least 345 kPa (3.52 kg/cm², 50 psi) above 16°C (61°F). If less than specification, recover/evacuate and recharge the system with the specified amount of refrigerant.

NOTE:

At temperatures below 16°C (61°F), leaks may not be detected since the system may not reach 345 kPa (3.52 kg/cm², 50 psi).

4. Perform the leak test from the high-pressure side (compressor discharge a to evaporator inlet g) to the low-pressure side (evaporator drain hose h to shaft seal l). Refer to [ATC-131, "Components"](#). Perform a leak check for the following areas carefully. Clean the component to be checked and move the leak detected probe completely around the connection/component.

Compressor

Check the fitting of high- and low-pressure hoses, relief valve and shaft seal.

Liquid tank

Check the refrigerant pressure sensor.

Service valves

Check all around the service valves. Ensure service valve caps are secured on the service valves (to prevent leaks).

NOTE:

After removing A/C manifold gauge set from service valves, wipe any residue from valves to prevent any false readings by leak detector.

Cooling unit (Evaporator)

With engine OFF, turn blower fan on "High" for at least 15 seconds to dissipate any refrigerant trace in the cooling unit. Wait a minimum of 10 minutes accumulation time (refer to the manufacturer's recommended procedure for actual wait time) before inserting the leak detector probe into the drain hose.

Keep the probe inserted for at least 10 seconds. Use caution not to contaminate the probe tip with water or dirt that may be in the drain hose.

5. If a leak detector detects a leak, verify at least once by blowing compressed air into area of suspected leak, then repeat check as outlined above.
6. Do not stop when one leak is found. Continue to check for additional leaks at all system components. If no leaks are found, perform steps 7 - 10.
7. Start engine.
8. Set the heater A/C control as follows;
 - a. A/C switch: ON
 - b. Air outlet: Ventilation (VENT)
 - c. Intake position: Recirculation
 - d. Max cold temperature
 - e. Fan speed: High
9. Run engine at 1,500 rpm for at least 2 minutes.
10. Turn engine off and perform leak check again following steps 4 through 6 above.

Refrigerant leaks should be checked immediately after stopping the engine. Begin with the leak detector at the compressor. The pressure on the high-pressure side will gradually drop after refrigerant circulation stops and pressure on the low-pressure side will gradually rise, as shown in the graph. Some leaks are more easily detected when pressure is high.

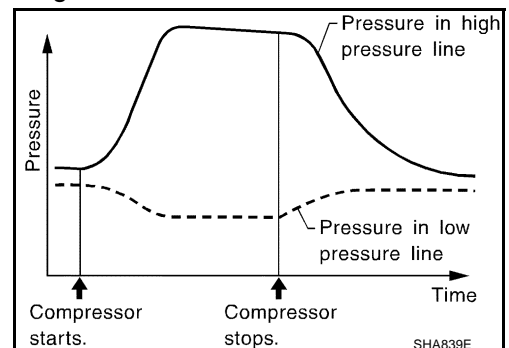

REFRIGERANT LINES

-
11. Before connecting recovery/recycling/recharging equipment to vehicle, check recovery/recycling/recharging equipment gauges. No refrigerant pressure should be displayed. If pressure is displayed, recover refrigerant from equipment lines and then check refrigerant purity. A
 12. Confirm refrigerant purity in supply tank using recovery/recycling/recharging equipment and refrigerant identifier. B
 13. Confirm refrigerant purity in vehicle A/C system using recovery/recycling/recharging equipment and refrigerant identifier. C
 14. Discharge A/C system using approved refrigerant recovery equipment. Repair the leaking fitting or component if necessary. C
 15. Evacuate and recharge A/C system and perform the leak test to confirm no refrigerant leaks. D
 16. Perform A/C performance test to ensure system works properly. D

E

F

G

H

I

ATC

K

L

M

SERVICE DATA AND SPECIFICATIONS (SDS)

SERVICE DATA AND SPECIFICATIONS (SDS)

PFP:00030

Compressor

AJS000BS

Model	Calsonic Kansei make CWV-615M	
Type	V-6 variable displacement	
Displacement cm ³ (cu in)/rev	Max.	146 (8.91)
	Min.	13.5 (0.824)
Cylinder bore × stroke mm (in)	35.2 (1.386) × [2.3 - 25 (0.091 - 0.98)]	
Direction of rotation	Clockwise (viewed from drive end)	
Drive belt	Poly V	

Lubricant

AJS000BT

Model	Calsonic Kansei make CWV-615M	
Name	Nissan A/C System Oil Type S (DH-PS)	
Part number	KLH00-PAGS0	
Capacity m ℓ (US fl oz, Imp fl oz)	Total in system	180 (6.0, 6.3)
	Compressor (Service part) charging amount	180 (6.0, 6.3)

Refrigerant

AJS000BU

Type	HFC-134a (R-134a)	
Capacity kg (lb)	0.55 (1.21)	

Engine Idling Speed

AJS000BV

Refer to [EC-30, "Idle Speed and Ignition Timing Check"](#) .

Belt Tension

AJS000BW

Refer to [EM-12, "DRIVE BELTS"](#) .