

SECTION **CL**
CLUTCH

A
B
CL

D

E

CONTENTS

| | | | | |
|---|-----------|--|-----------|---|
| PRECAUTIONS | 2 | Removal and Installation | 11 | F |
| Precautions for Battery Service | 2 | REMOVAL | 11 | |
| Caution | 2 | INSTALLATION | 11 | |
| PREPARATION | 3 | Disassembly and Assembly | 11 | G |
| Special Service Tools | 3 | DISASSEMBLY | 11 | |
| Commercial Service Tools | 3 | INSPECTION AFTER DISASSEMBLY | 11 | |
| NOISE, VIBRATION AND HARSHNESS (NVH) | | ASSEMBLY | 11 | H |
| TROUBLESHOOTING | 4 | CLUTCH PIPING | 12 | |
| NVH Troubleshooting Chart | 4 | Removal and Installation | 12 | I |
| CLUTCH | 4 | CLUTCH RELEASE MECHANISM | 13 | |
| CLUTCH PEDAL | 5 | Removal and Installation | 13 | J |
| On-Vehicle Inspection and Adjustment | 5 | REMOVAL | 13 | |
| Removal and Installation | 6 | INSPECTION AFTER REMOVAL | 13 | |
| REMOVAL | 6 | INSTALLATION | 14 | K |
| INSPECTION AFTER REMOVAL | 6 | CLUTCH DISC, CLUTCH COVER | 15 | |
| INSTALLATION | 6 | Removal and Installation | 15 | L |
| CLUTCH FLUID | 7 | REMOVAL | 15 | |
| Bleeding | 7 | INSPECTION AND ADJUSTMENT AFTER | | M |
| CLUTCH MASTER CYLINDER | 8 | REMOVAL | 15 | |
| Removal and Installation | 8 | INSTALLATION | 16 | |
| REMOVAL | 8 | SERVICE DATA AND SPECIFICATIONS (SDS) | 17 | |
| INSTALLATION | 8 | Clutch Control System | 17 | |
| Disassembly and Assembly | 9 | Clutch Master Cylinder | 17 | |
| DISASSEMBLY | 9 | Clutch Operating Cylinder | 17 | |
| INSPECTION AFTER DISASSEMBLY | 10 | Clutch Disc | 17 | |
| ASSEMBLY | 10 | Clutch Cover | 17 | |
| OPERATING CYLINDER | 11 | Clutch Pedal | 17 | |

PRECAUTIONS

PRECAUTIONS

PFP:00001

Precautions for Battery Service

ACS006FW

Before disconnecting the battery, lower both the driver and passenger windows. This will prevent any interference between the window edge and the vehicle when the door is opened/closed. During normal operation, the window slightly raises and lowers automatically to prevent any window to vehicle interference. The automatic window function will not work with the battery disconnected.

Caution

ACS004MV

- Recommended fluid is brake fluid "DOT 3".
- Never reuse drained brake fluid.
- Be careful not to splash brake fluid on painted areas.
- When removing and installing clutch piping, use Tool.
- Use new brake fluid to clean or wash all parts of master cylinder and operating cylinder.
- Never use mineral oils such as gasoline or kerosene. It will ruin the rubber parts of the hydraulic system.

WARNING:

After cleaning clutch disc, wipe it with a dust collector. Do not use compressed air.

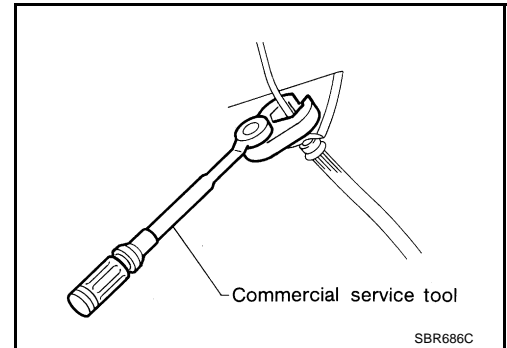

PREPARATION

PREPARATION

PF0:00002

Special Service Tools

ACS004MW

The actual shapes of Kent-Moore tool may differ from those of special service tools illustrated here.

| Tool number (Kent-Moore No.) Tool name | Description |
|--|--|
| KV30101400 (—) a: 51 mm (2.01 in) dia. b: 44 mm (1.73 in) dia. Drift | Installing release bearing |
| ST20050240 (—) Diaphragm adjusting wrench | Adjusting unevenness of diaphragm spring of clutch cover |
| ST20670000 (—) a: 15 mm (0.59 in) dia. b: 23 mm (0.91 in) dia. Clutch aligning bar | Installing clutch disc |

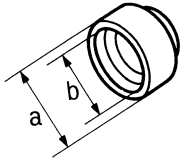

ZZA0838D



ZZA0508D

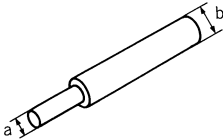

ZZA1178D

Commercial Service Tools

ACS004MX

| Tool name | Description |
|---|--|
| Pin punch Tip diameter: 4.5 mm (0.177 in) dia. | Removing and installing master cylinder spring pin |
| Power tool | Loosening bolts and nuts |
| 1. Flare nut crowfoot 2. Torque wrench a: 10 mm (0.39 in) | Removing and installing clutch piping |



ZZA0515D

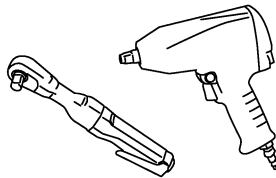

PBIC0190E

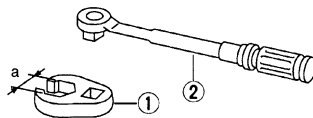

S-NT360

NOISE, VIBRATION AND HARSHNESS (NVH) TROUBLESHOOTING

NOISE, VIBRATION AND HARSHNESS (NVH) TROUBLESHOOTING

PF0:00003

NVH Troubleshooting Chart

ACS004MY

Use the chart below to help you find the cause of the symptom. The numbers indicate the order of the inspection. If necessary, repair or replace these parts.

CLUTCH

| Reference page | | CL-5 | CL-7 | CL-9 | CL-11 | EM-103 | CL-13 | CL-15 | CL-15 | CL-15 | CL-15 | CL-15 | CL-15 | CL-15 | CL-15 | CL-15 | EM-13Z | | |
|----------------------------------|---------------------------|--|---------------------------|--------------------------------------|---|-------------------------|--|---------------------------|-----------------------------------|-----------------------------|-------------------------------|-----------------------|------------------------|------------------------|-------------------------------------|----------------------------|---|-----------------------------|-----------------------|
| SUSPECTED PARTS (Possible cause) | | CLUTCH PEDAL (Free play out of adjustment) | CLUTCH LINE (Air in line) | MASTER CYLINDER PISTON CUP (Damaged) | OPERATING CYLINDER PISTON CUP (Damaged) | ENGINE MOUNTING (Loose) | RELEASE BEARING (Worn, dirty or damaged) | CLUTCH DISC (Out of true) | CLUTCH DISC (Runout is excessive) | CLUTCH DISC (Lining broken) | CLUTCH DISC (Dirty or burned) | CLUTCH DISC (Oily) | CLUTCH DISC (Worn out) | CLUTCH DISC (Hardened) | CLUTCH DISC (Lack of spline grease) | DIAPHRAGM SPRING (Damaged) | DIAPHRAGM SPRING (Out of tip alignment) | PRESSURE PLATE (Distortion) | FLYWHEEL (Distortion) |
| Symptom | Clutch grabs/chatters | | | | | 1 | | | 2 | | | 2 | 2 | 2 | | | 2 | | |
| | Clutch pedal spongy | | 1 | 2 | 2 | | | | | | | | | | | | | | |
| | Clutch noisy | | | | | | 1 | | | | | | | | | | | | |
| | Clutch slips | 1 | | | | | | | | | | 2 | 2 | | | 3 | | 4 | 5 |
| | Clutch does not disengage | 1 | 2 | 3 | 4 | | | 5 | 5 | 5 | 5 | 5 | | | 5 | 6 | 6 | 7 | |

CLUTCH PEDAL

CLUTCH PEDAL

PF4:46540

On-Vehicle Inspection and Adjustment

ACS004MZ

1. Check to see if the clevis pin floats freely in the bore of the clutch pedal. It should not be bound by the clevis or clutch pedal.
 - a. If the clevis pin is not free, check that the ASCD clutch switch is not applying pressure to the clutch pedal causing the clevis pin to bind. To adjust, loosen lock nut and turn ASCD clutch switch.
 - b. Tighten the lock nut.
 - c. Verify that the clevis pin floats in the bore of the clutch pedal. It should not be bound by the clutch pedal.
 - d. If the clevis pin is still not free, remove the clevis pin and check for deformation or damage. Replace clevis pin if necessary. Leave pin removed for step 2.
2. Check clutch pedal stroke for free range of movement.
 - a. With the clevis pin removed, manually move the clutch pedal up and down to determine if it moves freely.
 - b. If any sticking is noted, replace the related parts (clutch pedal bracket, assist spring, bushing etc.). Re-assemble the clutch pedal and re-verify that the clevis pin floats freely in the bore of the clutch pedal.
3. Adjust clearance "C" while depressing clutch pedal fully.(With clutch interlock switch)

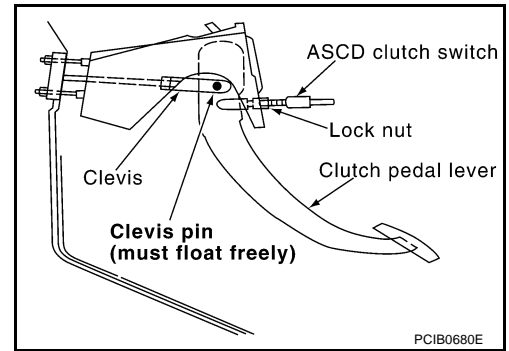

PCIB0680E

Clearance C : 0.1 - 1.0mm (0.004 - 0.039 in)

4. Check clutch hydraulic and system components (clutch master cylinder, clutch operating cylinder, clutch withdrawal lever, clutch release bearing, etc.) for sticking or binding.
 - a. If any sticking or binding noted, repair or replace related parts as necessary.
 - b. If hydraulic system repair was necessary, bleed the clutch hydraulic system. Refer to [CL-7, "Bleeding"](#).

NOTE:

Do not use a vacuum assist or any other type of power bleeder on this system. Use of a vacuum assist or power bleeder will not purge all the air from the system.

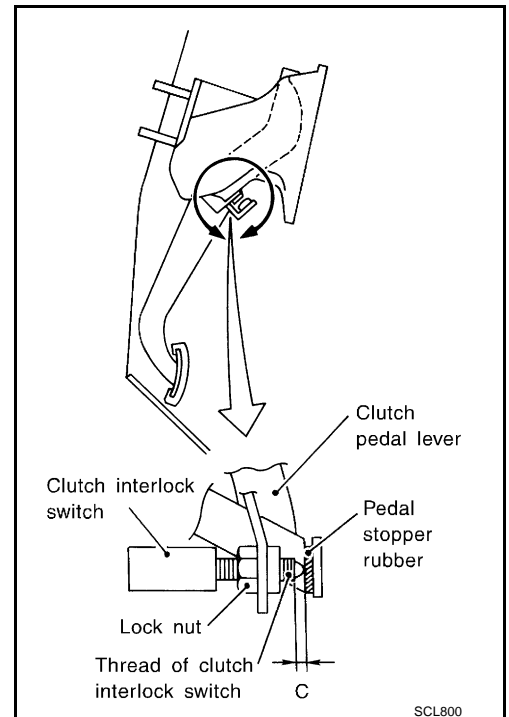

SCL800

CLUTCH PEDAL

ACS004N0

Removal and Installation

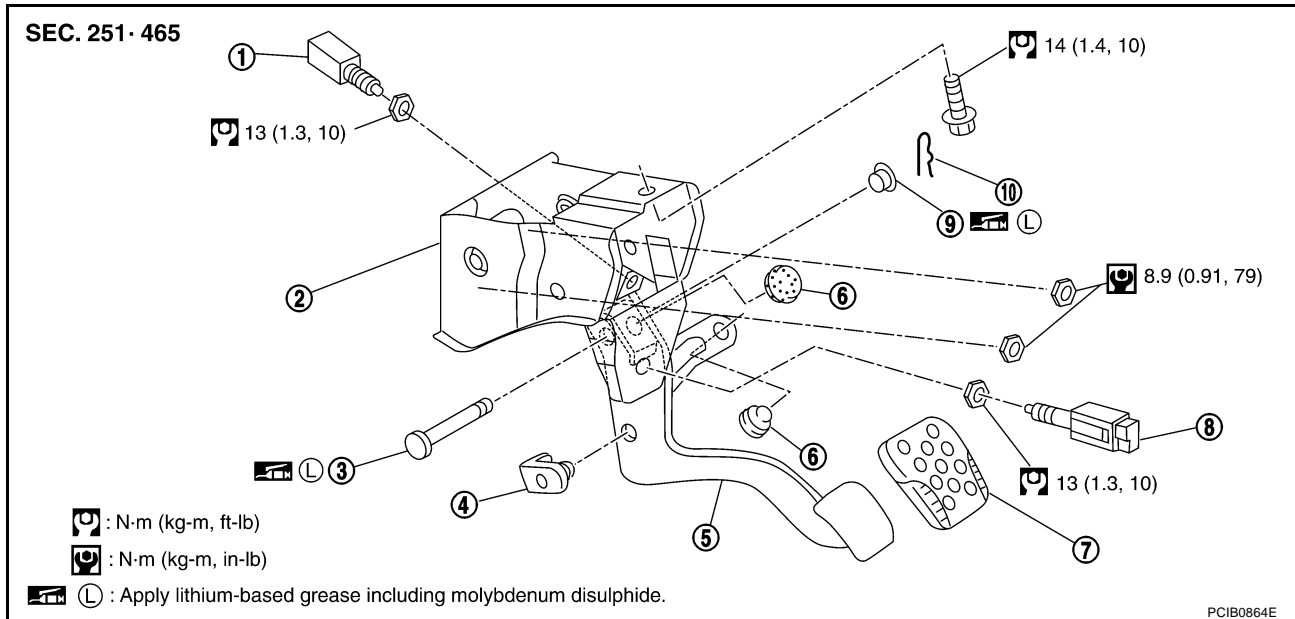

- | | | |
|----------------------------|-----------------------|-------------------|
| 1. Clutch interlock switch | 2. Bracket | 3. Clevis pin |
| 4. Pedal stopper rubber | 5. Clutch pedal | 6. Stopper rubber |
| 7. Pedal pad | 8. ASCD clutch switch | 9. Bushing |
| 10. Snap pin | | |

REMOVAL

1. Remove kicking plate. Refer to [EI-37, "Removal and Installation \(for Roadster Models\)"](#) .
2. Remove footrest. Refer to [EI-43, "Removal and Installation"](#) .
3. Remove dash side finisher (LH). Refer to [IP-11, "Removal and Installation"](#) .
4. Remove instrument driver panel lower. Refer to [IP-11, "Removal and Installation"](#) .
5. Remove VDC/TCS/ABS control unit. (VDC/TCS/ABS model) Refer to [BRC-144, "Removal and Installation"](#) .
6. Remove the clutch interlock switch and ASCD clutch switch connector and harness.
7. Remove the snap pin and clevis pin.
8. Remove the pedal bracket mounting bolt and nuts and then remove the clutch pedal assembly.

INSPECTION AFTER REMOVAL

- Check clutch pedal for bend, damage, or a cracked weld. If bend, damage, or a cracked weld is found, replace the clutch pedal assembly.

INSTALLATION

To install, reverse the removal procedure, following the cautions below:

- Install clutch pedal assembly and adjust the pedal height. Tighten ASCD clutch switch lock nut to the specified torque.
- After installing the clutch interlock switch, adjust the switch position.

NOTE:

Tighten the ASCD clutch switch lock nut to the specified torque after installing the clutch pedal assembly in the vehicle and adjusting the pedal height.

CLUTCH FLUID

CLUTCH FLUID

PFP:00017

Bleeding

ACS004N1

CAUTION:

- Monitor fluid level in the reservoir tank to make sure it does not empty.
- Do not spill clutch fluid onto painted surfaces. If it spills, wipe up immediately and wash the affected area with water.

1. Fill the master cylinder reservoir tank with new clutch fluid.
2. Connect a transparent vinyl hose to the air bleeder.
3. Depress the clutch pedal quickly and fully a few times and hold it.
4. With clutch pedal depressed, open air bleeder.
5. Close air bleeder.
6. Release clutch pedal and wait for 5 seconds.
7. Repeat steps 3 to 6 until no bubbles can be observed in the brake fluid.
8. Tighten air bleeder to the specified torque. Refer to [CL-11, "Removal and Installation"](#).

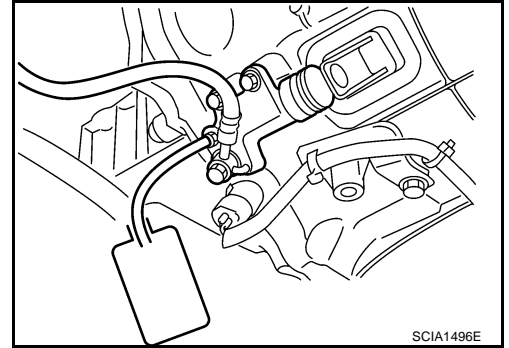

A

B

CL

D

E

F

G

H

I

J

K

L

M

CLUTCH MASTER CYLINDER

PFP:30610

CLUTCH MASTER CYLINDER

Removal and Installation

ACS004N2

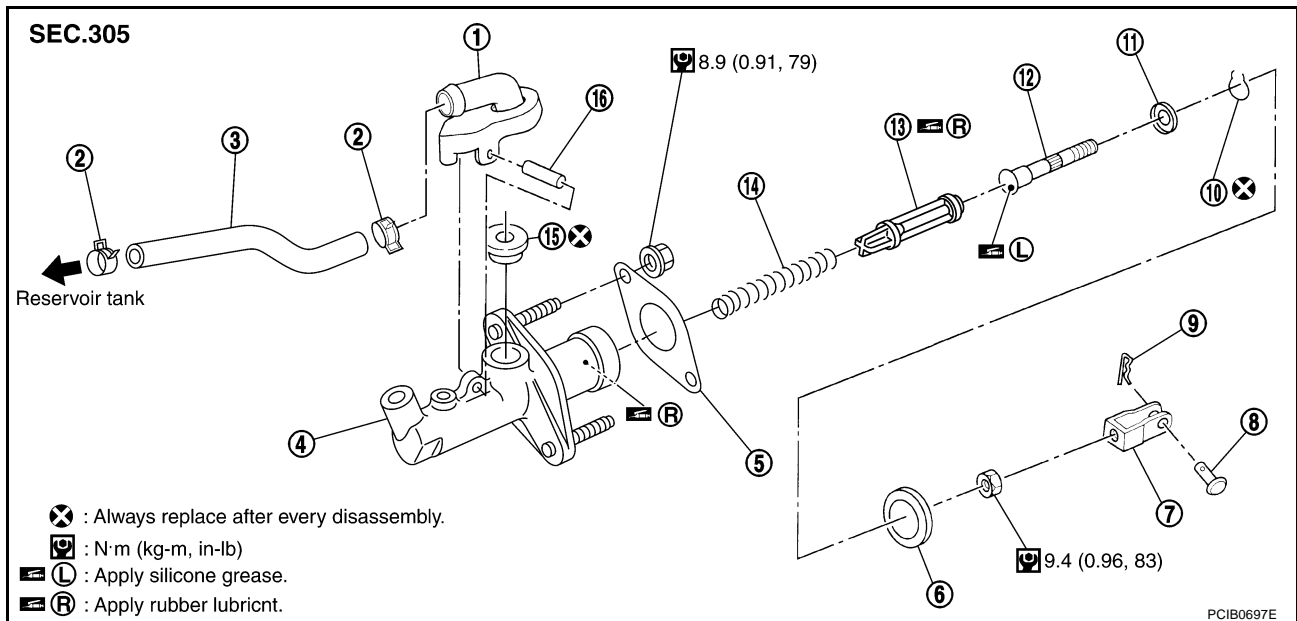

- | | | |
|---------------------|-------------------|--------------------|
| 1. Nipple | 2. Clamp | 3. Reservoir hose |
| 4. Cylinder body | 5. Packing | 6. Seat |
| 7. Clevis | 8. Clevis pin | 9. Snap pin |
| 10. Stopper ring | 11. Stopper | 12. Push rod |
| 13. Piston assembly | 14. Return spring | 15. Reservoir seal |
| 16. Spring pin | | |

REMOVAL

1. Remove kicking plate. Refer to [EI-37, "Removal and Installation \(for Roadster Models\)"](#) .
2. Remove footrest. Refer to [EI-43, "Removal and Installation"](#) .
3. Remove dash side finisher. Refer to [IP-11, "Removal and Installation"](#) .
4. Remove instrument driver panel lower. Refer to [IP-11, "Removal and Installation"](#) .
5. Remove VDC/TCS/ABS control unit. (VDC/TCS/ABS model) Refer to [BRC-144, "Removal and Installation"](#) .
6. Remove snap pin and clevis pin from the clevis, and separate it from clutch pedal.
7. Remove clips, and remove hoodledge cover.
8. Drain clutch fluid in the reservoir tank and remove reservoir hose from nipple.

CAUTION:

Do not spill clutch fluid onto painted surfaces. If it spills, wipe up immediately and wash the affected area with water.

9. Remove the reservoir tank mounting nuts and then remove the reservoir tank.
10. Using a flare nut wrench, remove clutch tube.
11. First remove nuts on master cylinder assembly, and then master cylinder assembly from the vehicle.

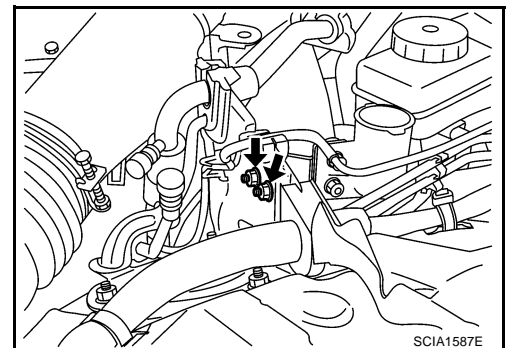

INSTALLATION

1. Connect clutch tube to master cylinder assembly and temporarily tighten flare nut.

CLUTCH MASTER CYLINDER

2. Install master cylinder assembly and tighten mounting nuts to the specified torque. Refer to [CL-8, "Removal and Installation"](#) .
3. Using a flare nut torque wrench, tighten clutch tube flare nut to the specified torque. Refer to [CL-12, "Removal and Installation"](#) .
4. Install clevis to the clutch pedal, and fix clevis with clevis pin.
5. Install snap pin to the clevis pin.
6. Install reservoir hose to the nipple. Install the reservoir tank to the vehicle, and then tighten mounting nuts to the specified torque.

: **5.8 N·m (0.59 Kg-m, 51 in-lb)**

7. After completing this procedure, inspect and adjust pedal height and then bleed the clutch tube. Refer to [CL-5, "On-Vehicle Inspection and Adjustment"](#) and [CL-7, "Bleeding"](#) .
8. Install hoodledge cover.
9. Install instrument driver panel lower. Refer to [IP-11, "Removal and Installation"](#) .
10. Install dash side finisher. Refer to [IP-11, "Removal and Installation"](#) .
11. Install footrest. Refer to [EI-43, "FLOOR TRIM"](#) .
12. Install kicking plate. Refer to [EI-37, "Removal and Installation \(for Roadster Models\)"](#) .

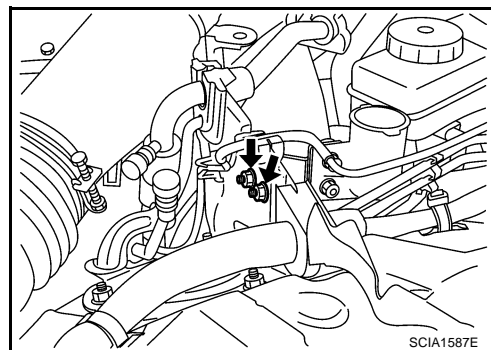

Disassembly and Assembly

DISASSEMBLY

ACS004N3

1. Using a pin punch, remove spring pin, nipple and reservoir seal from the cylinder body.

Tool number : **Commercial service tool**

2. Loosen push rod lock nut. Remove clevis and lock nut.
3. Remove the seat from the cylinder body.
4. Remove the stopper ring and stopper, and then remove the push rod, piston assembly, and return spring from the cylinder body.

CAUTION:

Restrain the push rod while doing this because there is a danger the piston assembly will fly out of the cylinder body.

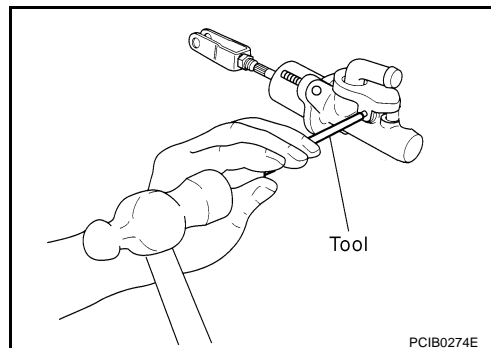

CLUTCH MASTER CYLINDER

INSPECTION AFTER DISASSEMBLY

Check for any of the conditions shown below. If any malfunction is found, replace the part concerned.

- Damaged cylinder internal wall, foreign matter, wear, corrosion, or pin hole
- Damaged or deformed nipple or reservoir tank
- Settling of the spring
- Cracked and deformed seat

ASSEMBLY

1. Apply rubber lubricant to internal surface of the cylinder body, sliding surface of piston assembly, and the piston cup. Insert return spring and piston assembly to the cylinder body.
2. Apply silicone grease to the push rod and install the stopper before installing the stopper ring.

CAUTION:

Restrain the push rod while doing this because there is a danger the piston assembly will fly out of the master cylinder.

3. Install seat to the cylinder body.
4. Install clevis to the push rod and tighten lock nut to the specified torque. Refer to [CL-8, "Removal and Installation"](#).
5. Install reservoir seal and nipple to the cylinder body. Using a pin punch, install spring pin.

CLUTCH PIPING

CLUTCH PIPING

PFP:30650

Removal and Installation

ACS004N6

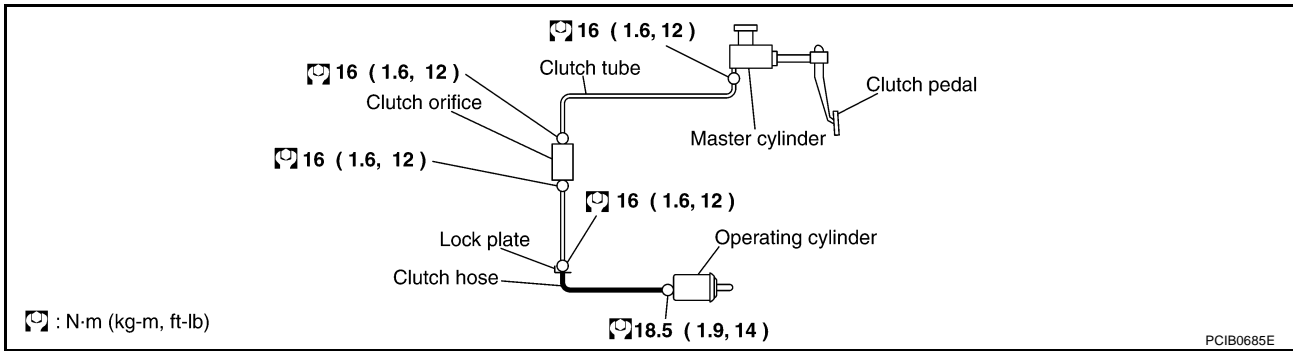

Carefully observe the following steps during clutch tube removal and installation.

- Do not spill clutch fluid onto painted surfaces. If it spills, wipe up immediately and wash the affected area with water.
- When fixing clutch hose to bracket, align clutch hose metal fittings with bracket positioning emboss and lock plate to secure. At this time, prevent twisting or damage of clutch hose. In addition, be careful not to damage clutch hose.
- Tighten clutch tube flare nut to the specified torque.
CAUTION:
Be careful not to damage flare nut and clutch tube.
- Tighten the union bolt to the specified torque. Refer to [CL-11, "Removal and Installation"](#).
- **CAUTION:**
Do not reuse the copper washer.
- After installation, bleed the clutch tube. Refer to [CL-7, "Bleeding"](#).

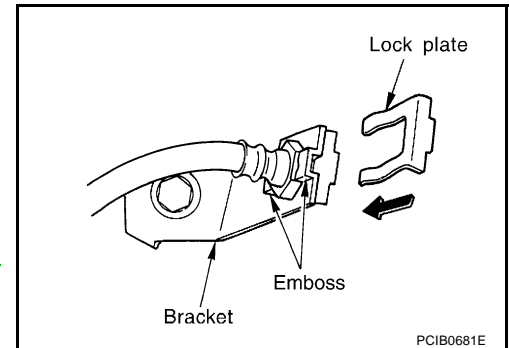

CLUTCH RELEASE MECHANISM

CLUTCH RELEASE MECHANISM

PFP:30502

Removal and Installation

ACS004N7

SEC.321

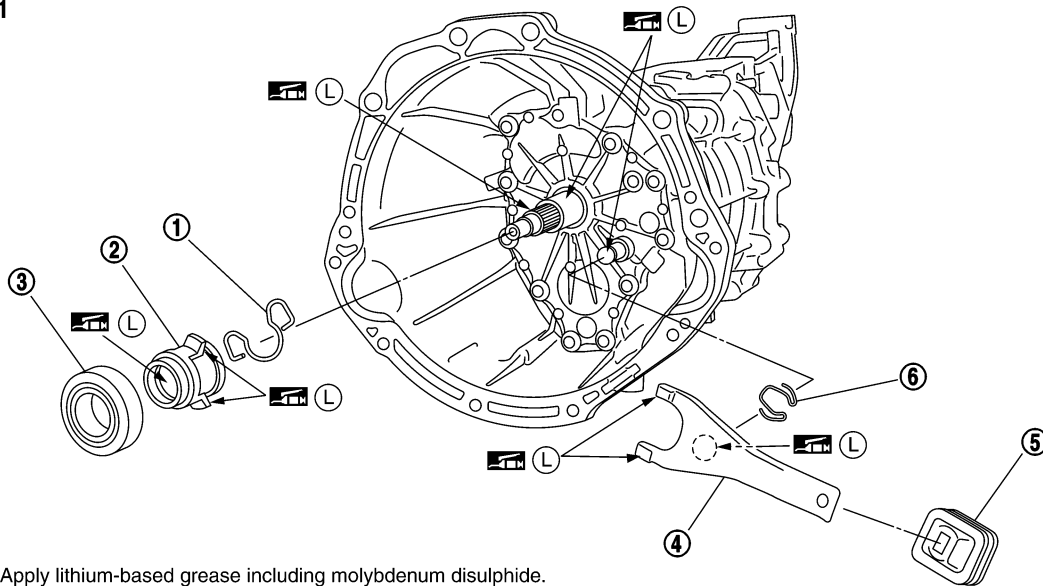

(L) : Apply lithium-based grease including molybdenum disulfide.

PCIB0810E

- | | | |
|---------------------|---------------------------|--------------------|
| 1. Holder spring | 2. Release bearing sleeve | 3. Release bearing |
| 4. Withdrawal lever | 5. Dust cover | 6. Snap spring |

REMOVAL

1. Remove manual transmission from the vehicle. Refer to [MT-19, "Removal and Installation from Vehicle"](#).
2. Remove release bearing sleeve assembly, holder spring, and withdrawal lever from inside the clutch housing.
3. Remove dust cover.
4. Remove snap spring from withdrawal lever.
5. Using a puller as shown in the figure, remove release bearing from release bearing sleeve.

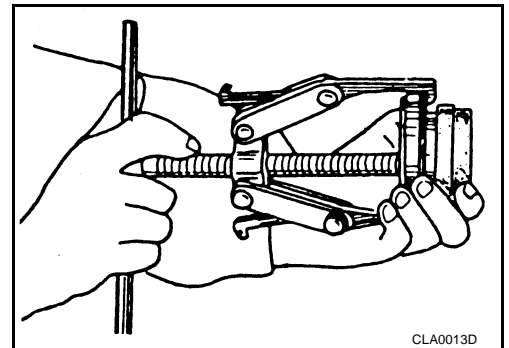

CLA0013D

INSPECTION AFTER REMOVAL

- If release bearing is seized, damaged, not properly centered or does not rotate smoothly, replace it.
- If contact surface of withdrawal lever is excessively worn out, replace it.
- If dust cover is cracked or deformed, replace it.

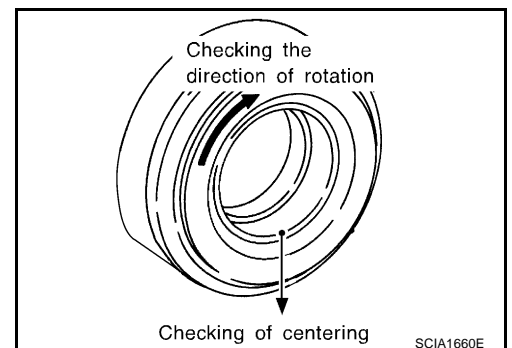

SCIA1660E

CLUTCH RELEASE MECHANISM

INSTALLATION

CAUTION:

- Be sure to apply grease to the points specified. Otherwise, noise, poor disengagement, or damage to the clutch may result. Excessive grease may cause slip or quiver. Wipe off any grease oozing from the parts.
 - Be careful not to bring any grease into contact with the clutch disc facing, pressure plate surface, or flywheel surface.
1. Using a drift, install release bearing to release bearing sleeve.

Tool number : KV 30101400 (—)

CAUTION:

Press bearing inner race by pushing with a drift.

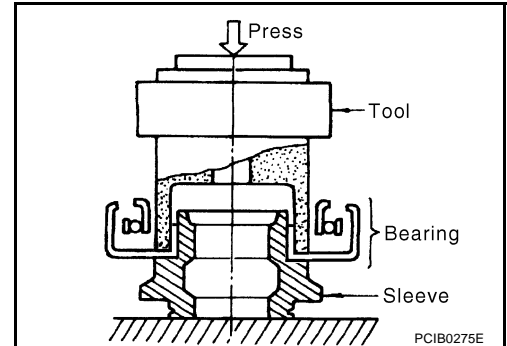

2. Following the instructions below, apply grease to the specified points.

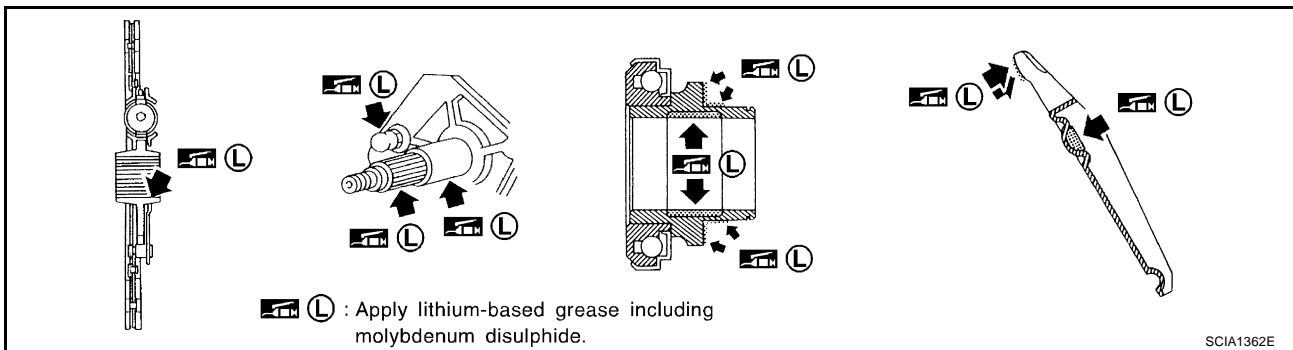

CAUTION:

Wipe off any old grease, debris, or powdery residue left on the surfaces.

- Evenly apply a 1 mm thick coating of recommended grease to withdrawal lever and release bearing sleeve or holder spring sliding surface.
 - Apply recommended grease to ball pin contact surface of the withdrawal lever and inner slots of the release bearing. The grease surface should be level with the surrounding area.
 - Evenly apply a thin coat of recommended grease to the release bearing sliding surface. Install release bearing. Wipe off any excess grease that oozes from the parts and then remove release bearing.
3. To install, reverse the removal procedure, following the cautions below.

CAUTION:

- Before installing manual transmission to the vehicle, check that each sliding surface slides smoothly by operating withdrawal lever.
- When assembling, make sure that both ends of snap spring touch the end face of withdrawal lever.
- Be careful with the orientation of installation.

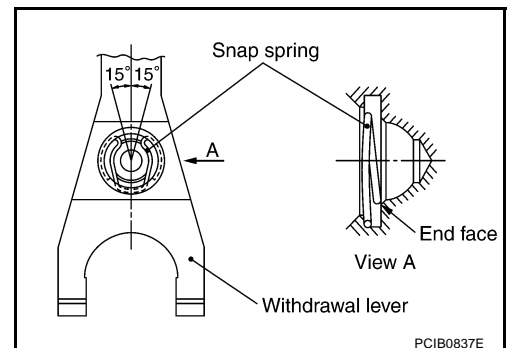

CLUTCH DISC, CLUTCH COVER

CLUTCH DISC, CLUTCH COVER

PFP:30100

Removal and Installation

ACS004N8

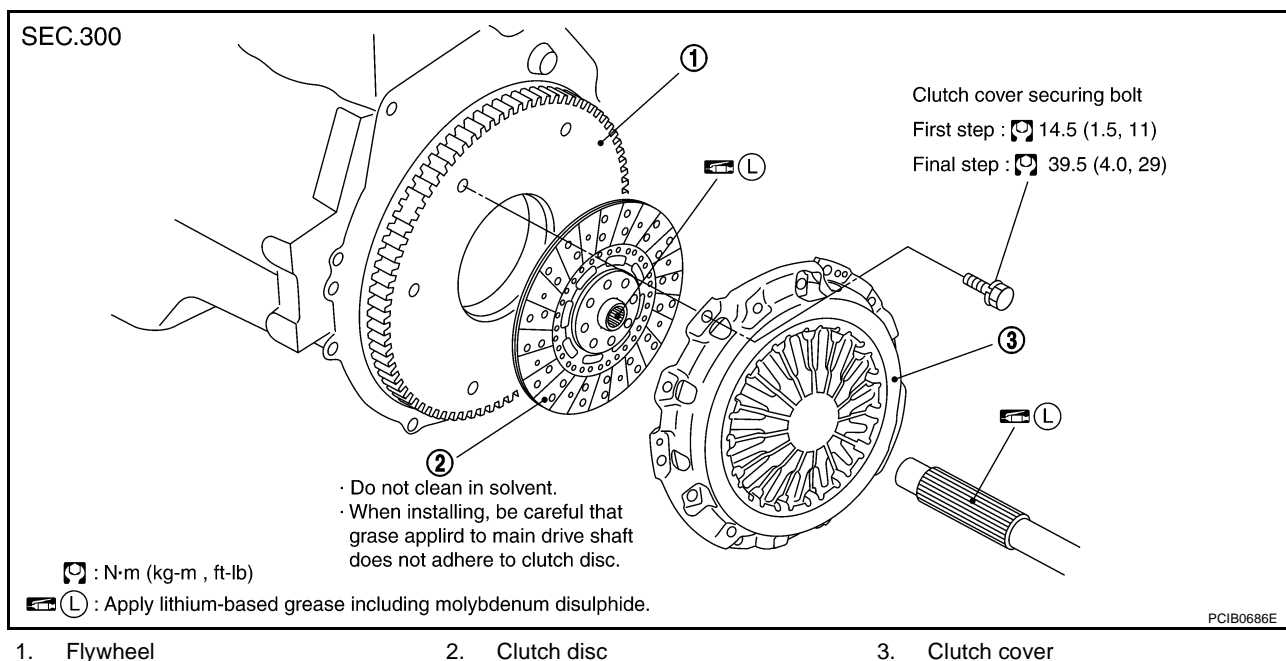

CAUTION:

- Be careful not to bring any grease into contact with the clutch disc facing, pressure plate surface, or flywheel surface.
- If flywheel is removed, align dowel pin with the smallest hole of flywheel. Refer to [EM-115, "ASSEMBLY"](#).

REMOVAL

1. Remove manual transmission from the vehicle. Refer to [MT-19, "Removal and Installation from Vehicle"](#).
2. Loosen clutch cover mounting bolts with power tool. Remove clutch cover and clutch disc.

INSPECTION AND ADJUSTMENT AFTER REMOVAL

Clutch Disc

- Measure circumference runout relative to the clutch disc center spline. If it is outside the specification, replace the clutch disc.

Runout limit/diameter of the area to be measured:

0.7 mm (0.028 in) or less/240 mm (9.45 in) dia.

- Measure backlash for clutch disc spline and main drive shaft spline at the circumference of the disc. If it is outside the specified range, replace the clutch disc.

Maximum backlash of spline:

1.0 mm (0.039 in)

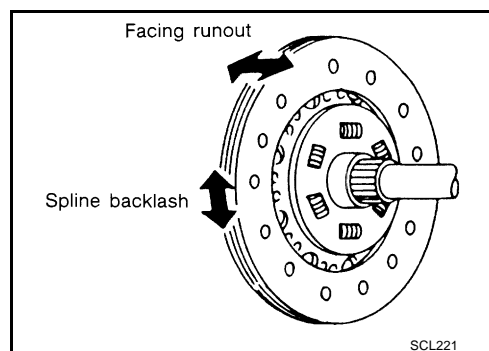

CLUTCH DISC, CLUTCH COVER

- Using calipers, measure the depth to the clutch disc facing rivet heads. If it exceeds the allowable wear limit, replace the clutch disc.

**Facing wear limit (depth to the rivet head):
0.3 mm (0.012 in)**

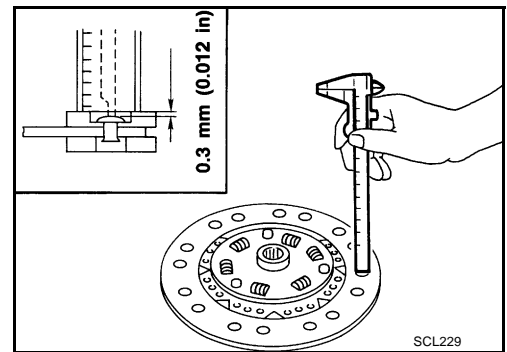

Clutch Cover

Check diaphragm spring lever claws for unevenness with the lever still on the vehicle. If they exceed the tolerance, adjust lever height using a diaphragm adjusting wrench.

Tool number : ST20050240

**Tolerance for diaphragm spring lever unevenness:
0.5mm (0.020 in)**

- Check clutch cover thrust ring for wear or breakage. If wear or breakage is found, replace clutch cover assembly.

NOTE:

- Worn thrust ring will generate a beating noise when tapped at the rivet with a hammer.
- Broken thrust ring will make a clinking sound when cover is shaken up and down.
- If a trace of burn or discoloration is found on the clutch cover pressure plate to clutch disc contact surface, repair the surface with sandpaper. If surface is damaged or distorted, replace the assembly.

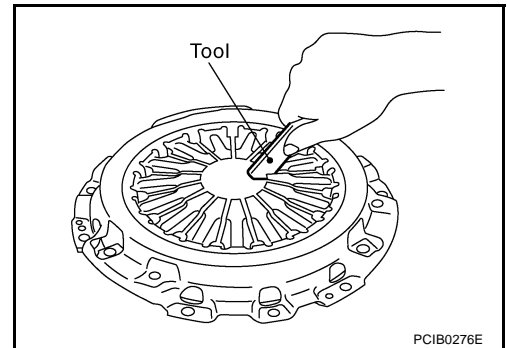

INSTALLATION

- Apply recommended grease to clutch disc and main drive shaft spline.

CAUTION:

Be sure to apply grease to the points specified. Otherwise, noise, poor disengagement, or damage to the clutch may result. Excessive grease may cause slip or quiver. Wipe off any grease oozing from the parts.

- Install clutch disc and clutch cover. Pre-tighten mounting bolts and install clutch aligning bar.

Tool number : ST20670000

- Tighten clutch cover attaching bolts evenly in two steps in the order shown in the figure. Refer to [CL-15, "Removal and Installation"](#).
- Install manual transmission. Refer to [MT-19, "Removal and Installation from Vehicle"](#).

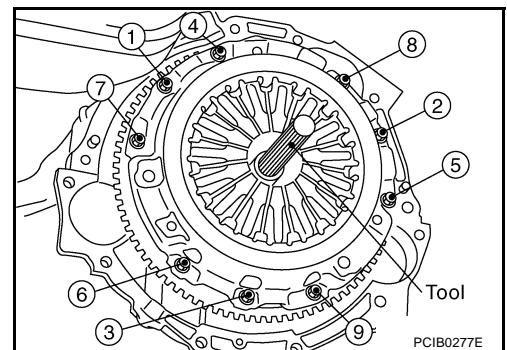

SERVICE DATA AND SPECIFICATIONS (SDS)

SERVICE DATA AND SPECIFICATIONS (SDS)

PPF:00030

Clutch Control System

ACS004N9

| | |
|------------------------|-----------|
| Type of clutch control | Hydraulic |
|------------------------|-----------|

Clutch Master Cylinder

ACS004NA

Unit: mm (in)

| | |
|----------------|-------------|
| Inner diameter | 15.87 (5/8) |
|----------------|-------------|

Clutch Operating Cylinder

ACS004NB

Unit: mm (in)

| | |
|----------------|-------------|
| Inner diameter | 19.05 (3/4) |
|----------------|-------------|

Clutch Disc

ACS004NC

Unit: mm (in)

| | |
|---|---------------------------------------|
| Engine model | VQ35DE |
| Model | 250 |
| Facing size (Outer dia. × inner dia. × thickness) | 250 × 170 × 3.2 (9.84 × 6.69 × 0.126) |
| Wear limit (depth to the rivet head) | 0.3 (0.012) |
| Runout limit/diameter of the area to be measured | 0.7 (0.028) or less/240 (9.45) dia. |
| Maximum backlash of spline (at outer edge disc) | 1.0 (0.039) |

Clutch Cover

ACS004ND

Unit: mm (in)

| | |
|---|-----------------------------|
| Engine model | VQ35DE |
| Model | 250 |
| Set-load | 8,630 N (880 kg) |
| Diaphragm spring lever height | 39.5 - 41.5 (1.555 - 1.634) |
| Uneven limit of diaphragm spring toe height | 0.5 (0.020) |

Clutch Pedal

ACS004NE

Unit: mm (in)

| | |
|--|---------------------------|
| Clearance "C" between pedal stopper rubber and clutch interlock switch threaded while clutch pedal is fully depressed. | 0.1 - 1.0 (0.004 - 0.039) |
|--|---------------------------|

SERVICE DATA AND SPECIFICATIONS (SDS)
