

A  
EC  
C  
D  
E  
F  
G  
H  
I  
J  
K  
L  
M

# SECTION EC

## ENGINE CONTROL SYSTEM

### CONTENTS

<p><b>INDEX FOR DTC</b> ..... 8</p> <p>    Alphabetical Index ..... 8</p> <p>    DTC No. Index ..... 12</p> <p><b>PRECAUTIONS</b> ..... 16</p> <p>    Precautions for Supplemental Restraint System (SRS) "AIR BAG" and "SEAT BELT PRE-TENSIONER" ..... 16</p> <p>    Precautions for Battery Service ..... 16</p> <p>    On Board Diagnostic (OBD) System of Engine and A/T ..... 16</p> <p>    Precaution ..... 17</p> <p>    Wiring Diagrams and Trouble Diagnosis ..... 19</p> <p><b>PREPARATION</b> ..... 20</p> <p>    Special Service Tools ..... 20</p> <p>    Commercial Service Tools ..... 21</p> <p><b>ENGINE CONTROL SYSTEM</b> ..... 22</p> <p>    System Diagram ..... 22</p> <p>    Vacuum Hose Drawing ..... 23</p> <p>    System Chart ..... 24</p> <p>    Multiport Fuel Injection (MFI) System ..... 25</p> <p>    Electronic Ignition (EI) System ..... 27</p> <p>    Air Conditioning Cut Control ..... 28</p> <p>    Fuel Cut Control (at No Load and High Engine Speed) ..... 28</p> <p>    CAN communication ..... 29</p> <p><b>BASIC SERVICE PROCEDURE</b> ..... 30</p> <p>    Idle Speed and Ignition Timing Check ..... 30</p> <p>    Idle Speed/Ignition Timing/Idle Mixture Ratio Adjustment ..... 31</p> <p>    VIN Registration ..... 42</p> <p>    Accelerator Pedal Released Position Learning ..... 42</p> <p>    Throttle Valve Closed Position Learning ..... 42</p> <p>    Idle Air Volume Learning ..... 43</p> <p>    Fuel Pressure Check ..... 45</p> <p><b>ON BOARD DIAGNOSTIC (OBD) SYSTEM</b> ..... 47</p> <p>    Introduction ..... 47</p> <p>    Two Trip Detection Logic ..... 47</p> <p>    Emission-related Diagnostic Information ..... 48</p> <p>    NVIS (Nissan Vehicle Immobilizer System—NATS) ..... 63</p>	<p>    Malfunction Indicator Lamp (MIL) ..... 63</p> <p>    OBD System Operation Chart ..... 66</p> <p><b>TROUBLE DIAGNOSIS</b> ..... 72</p> <p>    Trouble Diagnosis Introduction ..... 72</p> <p>    DTC Inspection Priority Chart ..... 75</p> <p>    Fail-safe Chart ..... 77</p> <p>    Basic Inspection ..... 78</p> <p>    Symptom Matrix Chart ..... 83</p> <p>    Engine Control Component Parts Location ..... 87</p> <p>    Circuit Diagram ..... 93</p> <p>    ECM Harness Connector Terminal Layout ..... 95</p> <p>    ECM Terminals and Reference Value ..... 95</p> <p>    CONSULT-II Function (ENGINE) ..... 103</p> <p>    Generic Scan Tool (GST) Function ..... 116</p> <p>    CONSULT-II Reference Value in Data Monitor ... 119</p> <p>    Major Sensor Reference Graph in Data Monitor Mode ..... 123</p> <p><b>TROUBLE DIAGNOSIS - SPECIFICATION VALUE</b> 125</p> <p>    Description ..... 125</p> <p>    Testing Condition ..... 125</p> <p>    Inspection Procedure ..... 125</p> <p>    Diagnostic Procedure ..... 126</p> <p><b>TROUBLE DIAGNOSIS FOR INTERMITTENT INCIDENT</b> ..... 129</p> <p>    Description ..... 129</p> <p>    Diagnostic Procedure ..... 129</p> <p><b>POWER SUPPLY AND GROUND CIRCUIT</b> ..... 130</p> <p>    Wiring Diagram ..... 130</p> <p>    Diagnostic Procedure ..... 133</p> <p>    Ground Inspection ..... 138</p> <p><b>DTC U1000, U1001 CAN COMMUNICATION LINE</b> 139</p> <p>    Description ..... 139</p> <p>    On Board Diagnosis Logic ..... 139</p> <p>    DTC Confirmation Procedure ..... 139</p> <p>    Wiring Diagram ..... 140</p> <p>    Diagnostic Procedure ..... 141</p> <p><b>DTC P0011, P0021 IVT CONTROL</b> ..... 142</p> <p>    Description ..... 142</p> <p>    CONSULT-II Reference Value in Data Monitor Mode ..... 142</p>
--	--

On Board Diagnosis Logic .....	143	Component Inspection .....	191
DTC Confirmation Procedure .....	143	Removal and Installation .....	191
Diagnostic Procedure .....	144	<b>DTC P0125 ECT SENSOR .....</b>	<b>192</b>
<b>DTC P0037, P0038, P0057, P0058 HO2S2 HEATER 145</b>		Component Description .....	192
Description .....	145	On Board Diagnosis Logic .....	192
CONSULT-II Reference Value in Data Monitor Mode .....	145	DTC Confirmation Procedure .....	193
On Board Diagnosis Logic .....	145	Diagnostic Procedure .....	194
DTC Confirmation Procedure .....	146	Component Inspection .....	195
Wiring Diagram .....	147	Removal and Installation .....	195
Diagnostic Procedure .....	150	<b>DTC P0127 IAT SENSOR .....</b>	<b>196</b>
Component Inspection .....	152	Component Description .....	196
Removal and Installation .....	152	On Board Diagnosis Logic .....	196
<b>DTC P0101 MAF SENSOR .....</b>	<b>153</b>	DTC Confirmation Procedure .....	196
Component Description .....	153	Diagnostic Procedure .....	197
CONSULT-II Reference Value in Data Monitor Mode .....	153	Component Inspection .....	198
On Board Diagnosis Logic .....	153	Removal and Installation .....	198
DTC Confirmation Procedure .....	154	<b>DTC P0128 THERMOSTAT FUNCTION .....</b>	<b>199</b>
Overall Function Check .....	155	On Board Diagnosis Logic .....	199
Wiring Diagram .....	156	DTC Confirmation Procedure .....	199
Diagnostic Procedure .....	157	Diagnostic Procedure .....	199
Component Inspection .....	161	Component Inspection .....	200
Removal and Installation .....	162	Removal and Installation .....	200
<b>DTC P0102, P0103 MAF SENSOR .....</b>	<b>163</b>	<b>DTC P0138, P0158 HO2S2 .....</b>	<b>201</b>
Component Description .....	163	Component Description .....	201
CONSULT-II Reference Value in Data Monitor Mode .....	163	CONSULT-II Reference Value in Data Monitor Mode .....	201
On Board Diagnosis Logic .....	163	On Board Diagnosis Logic .....	201
DTC Confirmation Procedure .....	164	DTC Confirmation Procedure .....	202
Wiring Diagram .....	165	Wiring Diagram .....	203
Diagnostic Procedure .....	166	Diagnostic Procedure .....	206
Component Inspection .....	170	Component Inspection .....	208
Removal and Installation .....	171	Removal and Installation .....	209
<b>DTC P0112, P0113 IAT SENSOR .....</b>	<b>172</b>	<b>DTC P0139, P0159 HO2S2 .....</b>	<b>210</b>
Component Description .....	172	Component Description .....	210
On Board Diagnosis Logic .....	172	CONSULT-II Reference Value in Data Monitor Mode .....	210
DTC Confirmation Procedure .....	172	On Board Diagnosis Logic .....	210
Wiring Diagram .....	174	DTC Confirmation Procedure .....	211
Diagnostic Procedure .....	175	Overall Function Check .....	211
Component Inspection .....	177	Wiring Diagram .....	213
Removal and Installation .....	177	Diagnostic Procedure .....	216
<b>DTC P0117, P0118 ECT SENSOR .....</b>	<b>178</b>	Component Inspection .....	219
Component Description .....	178	Removal and Installation .....	220
On Board Diagnosis Logic .....	178	<b>DTC P0171, P0174 FUEL INJECTION SYSTEM</b>	
DTC Confirmation Procedure .....	179	<b>FUNCTION .....</b>	<b>221</b>
Wiring Diagram .....	180	On Board Diagnosis Logic .....	221
Diagnostic Procedure .....	181	DTC Confirmation Procedure .....	221
Component Inspection .....	183	Wiring Diagram .....	223
Removal and Installation .....	183	Diagnostic Procedure .....	225
<b>DTC P0122, P0123 TP SENSOR .....</b>	<b>184</b>	<b>DTC P0172, P0175 FUEL INJECTION SYSTEM</b>	
Component Description .....	184	<b>FUNCTION .....</b>	<b>230</b>
CONSULT-II Reference Value in Data Monitor Mode .....	184	On Board Diagnosis Logic .....	230
On Board Diagnosis Logic .....	184	DTC Confirmation Procedure .....	230
DTC Confirmation Procedure .....	185	Wiring Diagram .....	232
Wiring Diagram .....	186	Diagnostic Procedure .....	234
Diagnostic Procedure .....	188	<b>DTC P0181 FTT SENSOR .....</b>	<b>238</b>
		Component Description .....	238
		On Board Diagnosis Logic .....	238
		DTC Confirmation Procedure .....	238

Wiring Diagram .....	240	Overall Function Check .....	284
Diagnostic Procedure .....	241	Diagnostic Procedure .....	285
Component Inspection .....	242	<b>DTC P0441 EVAP CONTROL SYSTEM .....</b>	<b>287</b>
Removal and Installation .....	242	System Description .....	287
<b>DTC P0182, P0183 FTT SENSOR .....</b>	<b>243</b>	On Board Diagnosis Logic .....	287
Component Description .....	243	DTC Confirmation Procedure .....	287
On Board Diagnosis Logic .....	243	Overall Function Check .....	288
DTC Confirmation Procedure .....	243	Diagnostic Procedure .....	289
Wiring Diagram .....	244	<b>DTC P0442 EVAP CONTROL SYSTEM .....</b>	<b>292</b>
Diagnostic Procedure .....	245	On Board Diagnosis Logic .....	292
Component Inspection .....	246	DTC Confirmation Procedure .....	293
Removal and Installation .....	246	Diagnostic Procedure .....	294
<b>DTC P0222, P0223 TP SENSOR .....</b>	<b>247</b>	<b>DTC P0444, P0445 EVAP CANISTER PURGE VOL-</b>	<b>301</b>
Component Description .....	247	<b>UME CONTROL SOLENOID VALVE .....</b>	<b>301</b>
CONSULT-II Reference Value in Data Monitor Mode	247	Description .....	301
On Board Diagnosis Logic .....	247	CONSULT-II Reference Value in Data Monitor Mode	301
DTC Confirmation Procedure .....	248	On Board Diagnosis Logic .....	302
Wiring Diagram .....	249	DTC Confirmation Procedure .....	302
Diagnostic Procedure .....	251	Wiring Diagram .....	303
Component Inspection .....	254	Diagnostic Procedure .....	305
Removal and Installation .....	254	Component Inspection .....	306
<b>DTC P0300 - P0306 MULTIPLE CYLINDER MIS-</b>	<b>255</b>	Removal and Installation .....	307
<b>FIRE, NO. 1 - 6 CYLINDER MISFIRE .....</b>	<b>255</b>	<b>DTC P0447 EVAP CANISTER VENT CONTROL</b>	<b>308</b>
On Board Diagnosis Logic .....	255	<b>VALVE .....</b>	<b>308</b>
DTC Confirmation Procedure .....	255	Component Description .....	308
Diagnostic Procedure .....	256	CONSULT-II Reference Value in Data Monitor Mode	308
<b>DTC P0327, P0328 KS .....</b>	<b>262</b>	On Board Diagnosis Logic .....	308
Component Description .....	262	DTC Confirmation Procedure .....	309
On Board Diagnosis Logic .....	262	Wiring Diagram .....	310
DTC Confirmation Procedure .....	262	Diagnostic Procedure .....	313
Wiring Diagram .....	263	Component Inspection .....	315
Diagnostic Procedure .....	264	<b>DTC P0451 EVAP CONTROL SYSTEM PRESSURE</b>	<b>317</b>
Component Inspection .....	266	<b>SENSOR .....</b>	<b>317</b>
Removal and Installation .....	266	Component Description .....	317
<b>DTC P0335 CKP SENSOR (POS) .....</b>	<b>267</b>	CONSULT-II Reference Value in Data Monitor Mode	317
Component Description .....	267	On Board Diagnosis Logic .....	317
CONSULT-II Reference Value in Data Monitor Mode	267	DTC Confirmation Procedure .....	318
On Board Diagnosis Logic .....	267	Diagnostic Procedure .....	318
DTC Confirmation Procedure .....	267	Component Inspection .....	319
Wiring Diagram .....	268	<b>DTC P0452 EVAP CONTROL SYSTEM PRESSURE</b>	<b>320</b>
Diagnostic Procedure .....	270	<b>SENSOR .....</b>	<b>320</b>
Component Inspection .....	273	Component Description .....	320
Removal and Installation .....	273	CONSULT-II Reference Value in Data Monitor Mode	320
<b>DTC P0340, P0345 CMP SENSOR (PHASE) .....</b>	<b>274</b>	On Board Diagnosis Logic .....	320
Component Description .....	274	DTC Confirmation Procedure .....	321
CONSULT-II Reference Value in Data Monitor Mode	274	Wiring Diagram .....	322
On Board Diagnosis Logic .....	274	Diagnostic Procedure .....	325
DTC Confirmation Procedure .....	274	Component Inspection .....	328
Wiring Diagram .....	275	<b>DTC P0453 EVAP CONTROL SYSTEM PRESSURE</b>	<b>329</b>
Diagnostic Procedure .....	278	<b>SENSOR .....</b>	<b>329</b>
Component Inspection .....	282	Component Description .....	329
Removal and Installation .....	282	CONSULT-II Reference Value in Data Monitor Mode	329
<b>DTC P0420, P0430 THREE WAY CATALYST FUNC-</b>	<b>283</b>	On Board Diagnosis Logic .....	329
<b>TION .....</b>	<b>283</b>	DTC Confirmation Procedure .....	330
On Board Diagnosis Logic .....	283		
DTC Confirmation Procedure .....	283		

Wiring Diagram .....	331	DTC Confirmation Procedure .....	374
Diagnostic Procedure .....	334	Diagnostic Procedure .....	375
Component Inspection .....	338	<b>DTC P1031, P1032, P1051, P1052 A/F SENSOR 1</b>	
<b>DTC P0455 EVAP CONTROL SYSTEM .....</b>	<b>339</b>	<b>HEATER .....</b>	<b>377</b>
On Board Diagnosis Logic .....	339	Description .....	377
DTC Confirmation Procedure .....	340	CONSULT-II Reference Value in Data Monitor Mode	
Diagnostic Procedure .....	341		377
<b>DTC P0456 EVAP CONTROL SYSTEM .....</b>	<b>347</b>	On Board Diagnosis Logic .....	377
On Board Diagnosis Logic .....	347	DTC Confirmation Procedure .....	377
DTC Confirmation Procedure .....	348	Wiring Diagram .....	378
Overall Function Check .....	349	Diagnostic Procedure .....	381
Diagnostic Procedure .....	350	Component Inspection .....	383
<b>DTC P0460 FUEL LEVEL SENSOR .....</b>	<b>357</b>	Removal and Installation .....	383
Component Description .....	357	<b>DTC P1065 ECM POWER SUPPLY .....</b>	<b>384</b>
On Board Diagnosis Logic .....	357	Component Description .....	384
DTC Confirmation Procedure .....	357	On Board Diagnosis Logic .....	384
Diagnostic Procedure .....	358	DTC Confirmation Procedure .....	384
Removal and Installation .....	358	Wiring Diagram .....	385
<b>DTC P0461 FUEL LEVEL SENSOR .....</b>	<b>359</b>	Diagnostic Procedure .....	386
Component Description .....	359	<b>DTC P1111, P1136 IVT CONTROL SOLENOID</b>	
On Board Diagnosis Logic .....	359	<b>VALVE .....</b>	<b>388</b>
Overall Function Check .....	359	Component Description .....	388
Diagnostic Procedure .....	360	CONSULT-II Reference Value in Data Monitor Mode	
Removal and Installation .....	360		388
<b>DTC P0462, P0463 FUEL LEVEL SENSOR .....</b>	<b>361</b>	On Board Diagnosis Logic .....	388
Component Description .....	361	DTC Confirmation Procedure .....	388
On Board Diagnosis Logic .....	361	Wiring Diagram .....	389
DTC Confirmation Procedure .....	361	Diagnostic Procedure .....	392
Diagnostic Procedure .....	362	Component Inspection .....	394
Removal and Installation .....	362	Removal and Installation .....	394
<b>DTC P0500 VSS .....</b>	<b>363</b>	<b>DTC P1121 ELECTRIC THROTTLE CONTROL</b>	
Description .....	363	<b>ACTUATOR .....</b>	<b>395</b>
On Board Diagnosis Logic .....	363	Component Description .....	395
DTC Confirmation Procedure .....	363	On Board Diagnosis Logic .....	395
Overall Function Check .....	364	DTC Confirmation Procedure .....	395
Diagnostic Procedure .....	364	Diagnostic Procedure .....	396
<b>DTC P0506 ISC SYSTEM .....</b>	<b>365</b>	<b>DTC P1122 ELECTRIC THROTTLE CONTROL</b>	
Description .....	365	<b>FUNCTION .....</b>	<b>397</b>
On Board Diagnosis Logic .....	365	Description .....	397
DTC Confirmation Procedure .....	365	On Board Diagnosis Logic .....	397
Diagnostic Procedure .....	366	DTC Confirmation Procedure .....	397
<b>DTC P0507 ISC SYSTEM .....</b>	<b>367</b>	Wiring Diagram .....	398
Description .....	367	Diagnostic Procedure .....	400
On Board Diagnosis Logic .....	367	Component Inspection .....	403
DTC Confirmation Procedure .....	367	Removal and Installation .....	403
Diagnostic Procedure .....	368	<b>DTC P1124, P1126 THROTTLE CONTROL MOTOR</b>	
<b>DTC P0550 PSP SENSOR .....</b>	<b>369</b>	<b>RELAY .....</b>	<b>404</b>
Component Description .....	369	Component Description .....	404
CONSULT-II Reference Value in Data Monitor Mode		CONSULT-II Reference Value in Data Monitor Mode	
	369		404
On Board Diagnosis Logic .....	369	On Board Diagnosis Logic .....	404
DTC Confirmation Procedure .....	369	DTC Confirmation Procedure .....	404
Wiring Diagram .....	370	Wiring Diagram .....	406
Diagnostic Procedure .....	371	Diagnostic Procedure .....	407
Component Inspection .....	373	<b>DTC P1128 THROTTLE CONTROL MOTOR .....</b>	<b>409</b>
Removal and Installation .....	373	Component Description .....	409
<b>DTC P0605 ECM .....</b>	<b>374</b>	On Board Diagnosis Logic .....	409
Component Description .....	374	DTC Confirmation Procedure .....	409
On Board Diagnosis Logic .....	374	Wiring Diagram .....	410

Diagnostic Procedure .....	412	<b>DTC P1229 SENSOR POWER SUPPLY .....</b>	<b>456</b>	
Component Inspection .....	413	On Board Diagnosis Logic .....	456	A
Removal and Installation .....	413	DTC Confirmation Procedure .....	456	
<b>DTC P1146, P1166 HO2S2 .....</b>	<b>414</b>	Wiring Diagram .....	457	
Component Description .....	414	Diagnostic Procedure .....	458	EC
CONSULT-II Reference Value in Data Monitor Mode		<b>DTC P1271, P1281 A/F SENSOR 1 .....</b>	<b>461</b>	
	414	Component Description .....	461	C
On Board Diagnosis Logic .....	414	CONSULT-II Reference Value in Data Monitor Mode		
DTC Confirmation Procedure .....	415		461	
Overall Function Check .....	415	On Board Diagnosis Logic .....	461	
Wiring Diagram .....	417	DTC Confirmation Procedure .....	461	D
Diagnostic Procedure .....	420	Wiring Diagram .....	463	
Component Inspection .....	423	Diagnostic Procedure .....	466	
Removal and Installation .....	424	Removal and Installation .....	469	
<b>DTC P1147, P1167 HO2S2 .....</b>	<b>425</b>	<b>DTC P1272, P1282 A/F SENSOR 1 .....</b>	<b>470</b>	E
Component Description .....	425	Component Description .....	470	
CONSULT-II Reference Value in Data Monitor Mode		CONSULT-II Reference Value in Data Monitor Mode		
	425		470	F
On Board Diagnosis Logic .....	425	On Board Diagnosis Logic .....	470	
DTC Confirmation Procedure .....	426	DTC Confirmation Procedure .....	470	
Overall Function Check .....	426	Wiring Diagram .....	472	G
Wiring Diagram .....	428	Diagnostic Procedure .....	475	
Diagnostic Procedure .....	431	Removal and Installation .....	478	
Component Inspection .....	434	<b>DTC P1273, P1283 A/F SENSOR 1 .....</b>	<b>479</b>	H
Removal and Installation .....	435	Component Description .....	479	
<b>DTC P1148, P1168 CLOSED LOOP CONTROL ...</b>	<b>436</b>	CONSULT-II Reference Value in Data Monitor Mode		
On Board Diagnosis Logic .....	436		479	
<b>DTC P1211 TCS CONTROL UNIT .....</b>	<b>437</b>	On Board Diagnosis Logic .....	479	I
Description .....	437	DTC Confirmation Procedure .....	479	
On Board Diagnosis Logic .....	437	Wiring Diagram .....	481	J
DTC Confirmation Procedure .....	437	Diagnostic Procedure .....	484	
Diagnostic Procedure .....	437	Removal and Installation .....	488	
<b>DTC P1212 TCS COMMUNICATION LINE .....</b>	<b>438</b>	<b>DTC P1274, P1284 A/F SENSOR 1 .....</b>	<b>489</b>	K
Description .....	438	Component Description .....	489	
On Board Diagnosis Logic .....	438	CONSULT-II Reference Value in Data Monitor Mode		
DTC Confirmation Procedure .....	438		489	
Diagnostic Procedure .....	438	On Board Diagnosis Logic .....	489	L
<b>DTC P1217 ENGINE OVER TEMPERATURE .....</b>	<b>439</b>	DTC Confirmation Procedure .....	489	
Description .....	439	Wiring Diagram .....	491	
CONSULT-II Reference Value in Data Monitor Mode		Diagnostic Procedure .....	494	
	440	Removal and Installation .....	498	M
On Board Diagnosis Logic .....	440	<b>DTC P1276, P1286 A/F SENSOR 1 .....</b>	<b>499</b>	
Overall Function Check .....	441	Component Description .....	499	
Wiring Diagram .....	443	CONSULT-II Reference Value in Data Monitor Mode		
Diagnostic Procedure .....	445		499	
Main 12 Causes of Overheating .....	451	On Board Diagnosis Logic .....	499	
Component Inspection .....	451	DTC Confirmation Procedure .....	499	
<b>DTC P1225 TP SENSOR .....</b>	<b>452</b>	Overall Function Check .....	500	
Component Description .....	452	Wiring Diagram .....	502	
On Board Diagnosis Logic .....	452	Diagnostic Procedure .....	505	
DTC Confirmation Procedure .....	452	Removal and Installation .....	508	
Diagnostic Procedure .....	453	<b>DTC P1278, P1288 A/F SENSOR 1 .....</b>	<b>509</b>	
Removal and Installation .....	453	Component Description .....	509	
<b>DTC P1226 TP SENSOR .....</b>	<b>454</b>	CONSULT-II Reference Value in Data Monitor Mode		
Component Description .....	454		509	
On Board Diagnosis Logic .....	454	On Board Diagnosis Logic .....	509	
DTC Confirmation Procedure .....	454	DTC Confirmation Procedure .....	510	
Diagnostic Procedure .....	455	Wiring Diagram .....	512	
Removal and Installation .....	455			

Diagnostic Procedure .....	515	On Board Diagnosis Logic .....	576
Removal and Installation .....	520	DTC Confirmation Procedure .....	576
<b>DTC P1279, P1289 A/F SENSOR 1 .....</b>	<b>521</b>	Overall Function Check .....	577
Component Description .....	521	Wiring Diagram .....	578
CONSULT-II Reference Value in Data Monitor Mode		Diagnostic Procedure .....	581
	521	<b>DTC P1805 BRAKE SWITCH .....</b>	<b>584</b>
On Board Diagnosis Logic .....	521	Description .....	584
DTC Confirmation Procedure .....	522	CONSULT-II Reference Value in Data Monitor Mode	
Wiring Diagram .....	524		584
Diagnostic Procedure .....	527	On Board Diagnosis Logic .....	584
Removal and Installation .....	532	DTC Confirmation Procedure .....	584
<b>DTC P1444 EVAP CANISTER PURGE VOLUME</b>		Wiring Diagram .....	585
<b>CONTROL SOLENOID VALVE .....</b>	<b>533</b>	Diagnostic Procedure .....	586
Description .....	533	Component Inspection .....	588
CONSULT-II Reference Value in Data Monitor Mode		<b>DTC P2122, P2123 APP SENSOR .....</b>	<b>589</b>
	533	Component Description .....	589
On Board Diagnosis Logic .....	534	CONSULT-II Reference Value in Data Monitor Mode	
DTC Confirmation Procedure .....	534		589
Wiring Diagram .....	535	On Board Diagnosis Logic .....	589
Diagnostic Procedure .....	537	DTC Confirmation Procedure .....	590
Component Inspection .....	540	Wiring Diagram .....	591
Removal and Installation .....	540	Diagnostic Procedure .....	593
<b>DTC P1446 EVAP CANISTER VENT CONTROL</b>		Component Inspection .....	595
<b>VALVE .....</b>	<b>541</b>	Removal and Installation .....	596
Component Description .....	541	<b>DTC P2127, P2128 APP SENSOR .....</b>	<b>597</b>
CONSULT-II Reference Value in Data Monitor Mode		Component Description .....	597
	541	CONSULT-II Reference Value in Data Monitor Mode	
On Board Diagnosis Logic .....	541		597
DTC Confirmation Procedure .....	542	On Board Diagnosis Logic .....	597
Wiring Diagram .....	543	DTC Confirmation Procedure .....	598
Diagnostic Procedure .....	546	Wiring Diagram .....	599
Component Inspection .....	548	Diagnostic Procedure .....	601
<b>DTC P1564 ASCD STEERING SWITCH .....</b>	<b>550</b>	Component Inspection .....	604
Component Description .....	550	Removal and Installation .....	604
CONSULT-II Reference Value in Data Monitor Mode		<b>DTC P2135 TP SENSOR .....</b>	<b>605</b>
	550	Component Description .....	605
On Board Diagnosis Logic .....	550	CONSULT-II Reference Value in Data Monitor Mode	
DTC Confirmation Procedure .....	551		605
Wiring Diagram .....	552	On Board Diagnosis Logic .....	605
Diagnostic Procedure .....	554	DTC Confirmation Procedure .....	606
Component Inspection .....	557	Wiring Diagram .....	607
<b>DTC P1572 ASCD BRAKE SWITCH .....</b>	<b>558</b>	Diagnostic Procedure .....	609
Component Description .....	558	Component Inspection .....	612
CONSULT-II Reference Value in Data Monitor Mode		Removal and Installation .....	612
	558	<b>DTC P2138 APP SENSOR .....</b>	<b>613</b>
On Board Diagnosis Logic .....	558	Component Description .....	613
DTC Confirmation Procedure .....	559	CONSULT-II Reference Value in Data Monitor Mode	
Wiring Diagram .....	560		613
Diagnostic Procedure .....	563	On Board Diagnosis Logic .....	613
Component Inspection .....	573	DTC Confirmation Procedure .....	614
<b>DTC P1574 ASCD VEHICLE SPEED SENSOR ....</b>	<b>574</b>	Wiring Diagram .....	615
Component Description .....	574	Diagnostic Procedure .....	617
On Board Diagnosis Logic .....	574	Component Inspection .....	621
DTC Confirmation Procedure .....	574	Removal and Installation .....	621
Diagnostic Procedure .....	575	<b>IGNITION SIGNAL .....</b>	<b>622</b>
<b>DTC P1706 PNP SWITCH .....</b>	<b>576</b>	Component Description .....	622
Component Description .....	576	Wiring Diagram .....	623
CONSULT-II Reference Value in Data Monitor Mode		Diagnostic Procedure .....	628
	576		

Component Inspection .....	633	CONSULT-II Reference Value in Data Monitor Mode .....	669	A
Removal and Installation .....	633	Wiring Diagram .....	670	
<b>INJECTOR CIRCUIT .....</b>	<b>634</b>	Diagnostic Procedure .....	671	
Component Description .....	634	<b>MIL AND DATA LINK CONNECTOR .....</b>	<b>672</b>	EC
CONSULT-II Reference Value in Data Monitor Mode .....	634	Wiring Diagram .....	672	
Wiring Diagram .....	635	<b>EVAPORATIVE EMISSION SYSTEM .....</b>	<b>674</b>	
Diagnostic Procedure .....	636	Description .....	674	C
Component Inspection .....	639	Component Inspection .....	677	
Removal and Installation .....	639	Removal and Installation .....	678	
<b>FUEL PUMP CIRCUIT .....</b>	<b>640</b>	How to Detect Fuel Vapor Leakage .....	678	
Description .....	640	<b>ON BOARD REFUELING VAPOR RECOVERY (ORVR) .....</b>	<b>681</b>	D
CONSULT-II Reference Value in Data Monitor Mode .....	640	System Description .....	681	
Wiring Diagram .....	641	Diagnostic Procedure .....	682	E
Diagnostic Procedure .....	642	Component Inspection .....	684	
Component Inspection .....	646	<b>POSITIVE CRANKCASE VENTILATION .....</b>	<b>686</b>	F
Removal and Installation .....	646	Description .....	686	
<b>REFRIGERANT PRESSURE SENSOR .....</b>	<b>647</b>	Component Inspection .....	686	
Component Description .....	647	<b>AUTOMATIC SPEED CONTROL DEVICE (ASCD) .....</b>	<b>688</b>	G
Wiring Diagram .....	648	System Description .....	688	
Diagnostic Procedure .....	649	Component Description .....	689	
Removal and Installation .....	652	<b>SERVICE DATA AND SPECIFICATIONS (SDS) ...</b>	<b>690</b>	
<b>ELECTRICAL LOAD SIGNAL .....</b>	<b>653</b>	Fuel Pressure .....	690	H
Description .....	653	Idle Speed and Ignition Timing .....	690	
CONSULT-II Reference Value in Data Monitor Mode .....	653	Calculated Load Value .....	690	
Diagnostic Procedure .....	653	Mass Air Flow Sensor .....	690	I
<b>ASCD BRAKE SWITCH .....</b>	<b>654</b>	Intake Air Temperature Sensor .....	690	
Component Description .....	654	Engine Coolant Temperature Sensor .....	690	J
CONSULT-II Reference Value in Data Monitor Mode .....	654	Air Fuel Ratio (A/F) Sensor 1 Heater .....	690	
Wiring Diagram .....	655	Heated Oxygen sensor 2 Heater .....	690	
Diagnostic Procedure .....	658	Crankshaft Position Sensor (POS) .....	690	K
Component Inspection .....	668	Camshaft Position Sensor (PHASE) .....	691	
<b>ASCD INDICATOR .....</b>	<b>669</b>	Throttle Control Motor .....	691	
Component Description .....	669	Injector .....	691	
		Fuel Pump .....	691	L
				M

# INDEX FOR DTC

## INDEX FOR DTC

PFP:00024

### Alphabetical Index

ABS009A9

**NOTE:**

If DTC U1000 or U1001 is displayed with other DTC, first perform the trouble diagnosis for DTC U1000, U1001. Refer to [EC-139, "DTC U1000, U1001 CAN COMMUNICATION LINE"](#) .

×:Applicable —: Not applicable

Items (CONSULT-II screen terms)	DTC*1		Trip	MIL lighting up	Reference page
	CONSULT-II GST*2	ECM*3			
A/F SENSOR1 (B1)	P1271	1271	2	×	<a href="#">EC-461</a>
A/F SENSOR1 (B1)	P1272	1272	2	×	<a href="#">EC-470</a>
A/F SENSOR1 (B1)	P1273	1273	2	×	<a href="#">EC-479</a>
A/F SENSOR1 (B1)	P1274	1274	2	×	<a href="#">EC-489</a>
A/F SENSOR1 (B1)	P1276	1276	2	×	<a href="#">EC-499</a>
A/F SENSOR1 (B1)	P1278	1278	2	×	<a href="#">EC-509</a>
A/F SENSOR1 (B1)	P1279	1279	2	×	<a href="#">EC-521</a>
A/F SENSOR1 (B2)	P1281	1281	2	×	<a href="#">EC-461</a>
A/F SENSOR1 (B2)	P1282	1282	2	×	<a href="#">EC-470</a>
A/F SENSOR1 (B2)	P1283	1283	2	×	<a href="#">EC-479</a>
A/F SENSOR1 (B2)	P1284	1284	2	×	<a href="#">EC-489</a>
A/F SENSOR1 (B2)	P1286	1286	2	×	<a href="#">EC-499</a>
A/F SENSOR1 (B2)	P1288	1288	2	×	<a href="#">EC-509</a>
A/F SENSOR1 (B2)	P1289	1289	2	×	<a href="#">EC-521</a>
A/F SEN1 HTR (B1)	P1031	1031	2	×	<a href="#">EC-377</a>
A/F SEN1 HTR (B1)	P1032	1032	2	×	<a href="#">EC-377</a>
A/F SEN1 HTR (B2)	P1051	1051	2	×	<a href="#">EC-377</a>
A/F SEN1 HTR (B2)	P1052	1052	2	×	<a href="#">EC-377</a>
A/T INTERLOCK	P1730	1730	1	×	<a href="#">AT-140</a>
A/T TCC S/V FNCTN	P0744	0744	2	×	<a href="#">AT-122</a>
APP SEN 1/CIRC	P2122	2122	1	×	<a href="#">EC-589</a>
APP SEN 1/CIRC	P2123	2123	1	×	<a href="#">EC-589</a>
APP SEN 2/CIRC	P2127	2127	1	×	<a href="#">EC-597</a>
APP SEN 2/CIRC	P2128	2128	1	×	<a href="#">EC-597</a>
APP SENSOR	P2138	2138	1	×	<a href="#">EC-613</a>
ASCD BRAKE SW	P1572	1572	1	—	<a href="#">EC-558</a>
ASCD SW	P1564	1564	1	—	<a href="#">EC-550</a>
ASCD VHL SPD SEN	P1574	1574	1	—	<a href="#">EC-574</a>
ATF TEMP SEN/CIRC	P0710	0710	2	×	<a href="#">AT-131</a>
BRAKE SW/CIRCUIT	P1805	1805	2	—	<a href="#">EC-584</a>
CAN COMM CIRCUIT	U1000	1000*4	1 (A/T) 2 (M/T)	×	<a href="#">EC-139</a>
CAN COMM CIRCUIT	U1001	1001*4	2	—	<a href="#">EC-139</a>
CKP SEN/CIRCUIT	P0335	0335	2	×	<a href="#">EC-267</a>
CLOSED LOOP-B1	P1148	1148	1	×	<a href="#">EC-436</a>
CLOSED LOOP-B2	P1168	1168	1	×	<a href="#">EC-436</a>
CMP SEN/CIRC-B1	P0340	0340	2	×	<a href="#">EC-274</a>



# INDEX FOR DTC

Items (CONSULT-II screen terms)	DTC*1		Trip	MIL lighting up	Reference page
	CONSULT-II GST*2	ECM*3			
CMP SEN/CIRC-B2	P0345	0345	2	×	<a href="#">EC-274</a>
CTP LEARNING	P1225	1225	2	—	<a href="#">EC-452</a>
CTP LEARNING	P1226	1226	2	—	<a href="#">EC-454</a>
CYL 1 MISFIRE	P0301	0301	2	×	<a href="#">EC-255</a>
CYL 2 MISFIRE	P0302	0302	2	×	<a href="#">EC-255</a>
CYL 3 MISFIRE	P0303	0303	2	×	<a href="#">EC-255</a>
CYL 4 MISFIRE	P0304	0304	2	×	<a href="#">EC-255</a>
CYL 5 MISFIRE	P0305	0305	2	×	<a href="#">EC-255</a>
CYL 6 MISFIRE	P0306	0306	2	×	<a href="#">EC-255</a>
D/C SOLENOID/CIRC	P1762	1762	1	×	<a href="#">AT-153</a>
D/C SOLENOID FNCTN	P1764	1764	1	×	<a href="#">AT-155</a>
ECM	P0605	0605	1 or 2	× or —	<a href="#">EC-374</a>
ECM BACK UP/CIRCUIT	P1065	1065	2	×	<a href="#">EC-384</a>
ECT SEN/CIRC	P0117	0117	1	×	<a href="#">EC-178</a>
ECT SEN/CIRC	P0118	0118	1	×	<a href="#">EC-178</a>
ECT SENSOR	P0125	0125	1	×	<a href="#">EC-192</a>
ENG OVER TEMP	P1217	1217	1	×	<a href="#">EC-439</a>
ENGINE SPEED SIG	P0725	0725	2	×	<a href="#">AT-118</a>
ETC ACTR	P1121	1121	1	×	<a href="#">EC-395</a>
ETC FUNCTION/CIRC	P1122	1122	1	×	<a href="#">EC-397</a>
ETC MOT	P1128	1128	1	×	<a href="#">EC-409</a>
ETC MOT PWR	P1124	1124	1	×	<a href="#">EC-404</a>
ETC MOT PWR	P1126	1126	1	×	<a href="#">EC-404</a>
EVAP GROSS LEAK	P0455	0455	2	×	<a href="#">EC-339</a>
EVAP PURG FLOW/MON	P0441	0441	2	×	<a href="#">EC-287</a>
EVAP SMALL LEAK	P0442	0442	2	×	<a href="#">EC-292</a>
EVAP SYS PRES SEN	P0451	0451	2	×	<a href="#">EC-317</a>
EVAP SYS PRES SEN	P0452	0452	2	×	<a href="#">EC-320</a>
EVAP SYS PRES SEN	P0453	0453	2	×	<a href="#">EC-329</a>
EVAP VERY SML LEAK	P0456	0456	2	×	<a href="#">EC-347</a>
FR/B SOLENOID/CIRC	P1757	1757	1	×	<a href="#">AT-149</a>
FR/B SOLENOID FNCT	P1759	1759	1	×	<a href="#">AT-151</a>
FTT SEN/CIRCUIT	P0182	0182	2	×	<a href="#">EC-243</a>
FTT SEN/CIRCUIT	P0183	0183	2	×	<a href="#">EC-243</a>
FTT SENSOR	P0181	0181	2	×	<a href="#">EC-238</a>
FUEL LEV SEN SLOSH	P0460	0460	2	×	<a href="#">EC-357</a>
FUEL LEVEL SENSOR	P0461	0461	2	×	<a href="#">EC-359</a>
FUEL LEVL SEN/CIRC	P0462	0462	2	×	<a href="#">EC-361</a>
FUEL LEVL SEN/CIRC	P0463	0463	2	×	<a href="#">EC-361</a>
FUEL SYS-LEAN-B1	P0171	0171	2	×	<a href="#">EC-221</a>
FUEL SYS-LEAN-B2	P0174	0174	2	×	<a href="#">EC-221</a>
FUEL SYS-RICH-B1	P0172	0172	2	×	<a href="#">EC-230</a>

# INDEX FOR DTC

Items (CONSULT-II screen terms)	DTC*1		Trip	MIL lighting up	Reference page
	CONSULT-II GST*2	ECM*3			
FUEL SYS-RICH-B2	P0175	0175	2	×	<a href="#">EC-230</a>
HLR/C SOL FNCTN	P1769	1769	1	×	<a href="#">AT-159</a>
HLR/C SOL/CIRC	P1767	1767	1	×	<a href="#">AT-157</a>
HO2S2 (B1)	P0138	0138	2	×	<a href="#">EC-201</a>
HO2S2 (B1)	P0139	0139	2	×	<a href="#">EC-210</a>
HO2S2 (B1)	P1146	1146	2	×	<a href="#">EC-414</a>
HO2S2 (B1)	P1147	1147	2	×	<a href="#">EC-425</a>
HO2S2 (B2)	P0158	0158	2	×	<a href="#">EC-201</a>
HO2S2 (B2)	P0159	0159	2	×	<a href="#">EC-210</a>
HO2S2 (B2)	P1166	1166	2	×	<a href="#">EC-414</a>
HO2S2 (B2)	P1167	1167	2	×	<a href="#">EC-425</a>
HO2S2 HTR (B1)	P0037	0037	2	×	<a href="#">EC-145</a>
HO2S2 HTR (B1)	P0038	0038	2	×	<a href="#">EC-145</a>
HO2S2 HTR (B2)	P0057	0057	2	×	<a href="#">EC-145</a>
HO2S2 HTR (B2)	P0058	0058	2	×	<a href="#">EC-145</a>
I/C SOLENOID/CIRC	P1752	1752	1	×	<a href="#">AT-145</a>
I/C SOLENOID FNCTN	P1754	1754	1	×	<a href="#">AT-147</a>
IAT SEN/CIRCUIT	P0112	0112	2	×	<a href="#">EC-172</a>
IAT SEN/CIRCUIT	P0113	0113	2	×	<a href="#">EC-172</a>
IAT SENSOR	P0127	0127	2	×	<a href="#">EC-196</a>
INT/V TIM CONT-B1	P0011	0011	2	×	<a href="#">EC-142</a>
INT/V TIM CONT-B2	P0021	0021	2	×	<a href="#">EC-142</a>
INT/V TIM V/CIR-B1	P1111	1111	2	×	<a href="#">EC-388</a>
INT/V TIM V/CIR-B2	P1136	1136	2	×	<a href="#">EC-388</a>
ISC SYSTEM	P0506	0506	2	×	<a href="#">EC-365</a>
ISC SYSTEM	P0507	0507	2	×	<a href="#">EC-367</a>
KNOCK SEN/CIRC-B1	P0327	0327	2	—	<a href="#">EC-262</a>
KNOCK SEN/CIRC-B1	P0328	0328	2	—	<a href="#">EC-262</a>
L/PRESS SOL/CIRC	P0745	0745	2	×	<a href="#">AT-124</a>
LC/B SOLENOID FNCT	P1774	1774	1	×	<a href="#">AT-163</a>
LC/B SOLENOID/CIRC	P1772	1772	1	×	<a href="#">AT-161</a>
MAF SEN/CIRCUIT	P0101	0101	1	×	<a href="#">EC-153</a>
MAF SEN/CIRCUIT	P0102	0102	1	×	<a href="#">EC-163</a>
MAF SEN/CIRCUIT	P0103	0103	1	×	<a href="#">EC-163</a>
MULTI CYL MISFIRE	P0300	0300	2	×	<a href="#">EC-255</a>
NATS MALFUNCTION	P1610 - P1615	1610 - 1615	2	—	<a href="#">EC-63</a>
NO DTC IS DETECTED. FURTHER TESTING MAY BE REQUIRED.	No DTC	Flashing	—	Flashing	<a href="#">EC-64</a>
<b>NO DTC IS DETECTED. FURTHER TESTING MAY BE REQUIRED.</b>	<b>P0000</b>	<b>0000</b>	—	—	—
P-N POS SW/CIRCUIT	P1706	1706	2	×	<a href="#">EC-576</a>
PNP SW/CIRC	P0705	0705	2	×	<a href="#">AT-109</a>

# INDEX FOR DTC

Items (CONSULT-II screen terms)	DTC*1		Trip	MIL lighting up	Reference page
	CONSULT-II GST*2	ECM*3			
PURG VOLUME CONT/V	P0444	0444	2	×	<a href="#">EC-301</a>
PURG VOLUME CONT/V	P0445	0445	2	×	<a href="#">EC-301</a>
PURG VOLUME CONT/V	P1444	1444	2	×	<a href="#">EC-533</a>
PW ST P SEN/CIRC	P0550	0550	2	—	<a href="#">EC-369</a>
SENSOR POWER/CIRC	P1229	1229	1	×	<a href="#">EC-456</a>
TCC SOLENOID/CIRC	P0740	0740	2	×	<a href="#">AT-120</a>
TCM	P0700	0700	1	×	<a href="#">AT-108</a>
TCS C/U FUNCTN	P1211	1211	2	—	<a href="#">EC-437</a>
TCS/CIRC	P1212	1212	2	—	<a href="#">EC-438</a>
THERMSTAT FNCTN	P0128	0128	2	×	<a href="#">EC-199</a>
TP SEN 1/CIRC	P0222	0222	1	×	<a href="#">EC-247</a>
TP SEN 1/CIRC	P0223	0223	1	×	<a href="#">EC-247</a>
TP SEN 2/CIRC	P0122	0122	1	×	<a href="#">EC-184</a>
TP SEN 2/CIRC	P0123	0123	1	×	<a href="#">EC-184</a>
TP SEN/CIRC A/T	P1705	1705	1	×	<a href="#">AT-128</a>
TP SENSOR	P2135	2135	1	×	<a href="#">EC-605</a>
TURBINE REV S/CIRC	P1716	1716	2	×	<a href="#">AT-136</a>
TW CATALYST SYS-B1	P0420	0420	2	×	<a href="#">EC-283</a>
TW CATALYST SYS-B2	P0430	0430	2	×	<a href="#">EC-283</a>
VEH SPD SEN/CIR AT*5	P0720	0720	2	×	<a href="#">AT-113</a>
VEH SPEED SEN/CIRC*5	P0500	0500	2	×	<a href="#">EC-363</a>
VENT CONTROL VALVE	P0447	0447	2	×	<a href="#">EC-308</a>
VENT CONTROL VALVE	P1446	1446	2	×	<a href="#">EC-541</a>

\*1: 1st trip DTC No. is the same as DTC No.

\*2: This number is prescribed by SAE J2012.

\*3: In Diagnostic Test Mode II (Self-diagnostic results), this number is controlled by NISSAN.

\*4: The troubleshooting for this DTC needs CONSULT-II.

\*5: When the fail-safe operations for both self-diagnoses occur, the MIL illuminates.

# INDEX FOR DTC

## DTC No. Index

ABS009AA

**NOTE:**

If DTC U1000 or U1001 is displayed with other DTC, first perform the trouble diagnosis for DTC U1000, U1001. Refer to [EC-139, "DTC U1000, U1001 CAN COMMUNICATION LINE"](#).

x:Applicable —: Not applicable

DTC*1		Items (CONSULT-II screen terms)	Trip	MIL lighting up	Reference page
CONSULT-II GST*2	ECM*3				
No DTC	Flashing	NO DTC IS DETECTED. FURTHER TESTING MAY BE REQUIRED.	—	Flashing	<a href="#">EC-64</a>
U1000	1000*4	CAN COMM CIRCUIT	1 (A/T) 2 (M/T)	× —	<a href="#">EC-139</a>
U1001	1001*4	CAN COMM CIRCUIT	2	—	<a href="#">EC-139</a>
<b>P0000</b>	<b>0000</b>	<b>NO DTC IS DETECTED. FURTHER TESTING MAY BE REQUIRED.</b>	—	—	—
P0011	0011	INT/V TIM CONT-B1	2	×	<a href="#">EC-142</a>
P0021	0021	INT/V TIM CONT-B2	2	×	<a href="#">EC-142</a>
P0037	0037	HO2S2 HTR (B1)	2	×	<a href="#">EC-145</a>
P0038	0038	HO2S2 HTR (B1)	2	×	<a href="#">EC-145</a>
P0057	0057	HO2S2 HTR (B2)	2	×	<a href="#">EC-145</a>
P0058	0058	HO2S2 HTR (B2)	2	×	<a href="#">EC-145</a>
P0101	0101	MAF SEN/CIRCUIT	1	×	<a href="#">EC-153</a>
P0102	0102	MAF SEN/CIRCUIT	1	×	<a href="#">EC-163</a>
P0103	0103	MAF SEN/CIRCUIT	1	×	<a href="#">EC-163</a>
P0112	0112	IAT SEN/CIRCUIT	2	×	<a href="#">EC-172</a>
P0113	0113	IAT SEN/CIRCUIT	2	×	<a href="#">EC-172</a>
P0117	0117	ECT SEN/CIRC	1	×	<a href="#">EC-178</a>
P0118	0118	ECT SEN/CIRC	1	×	<a href="#">EC-178</a>
P0122	0122	TP SEN 2/CIRC	1	×	<a href="#">EC-184</a>
P0123	0123	TP SEN 2/CIRC	1	×	<a href="#">EC-184</a>
P0125	0125	ECT SENSOR	1	×	<a href="#">EC-192</a>
P0127	0127	IAT SENSOR	2	×	<a href="#">EC-196</a>
P0128	0128	THERMSTAT FNCTN	2	×	<a href="#">EC-199</a>
P0138	0138	HO2S2 (B1)	2	×	<a href="#">EC-201</a>
P0139	0139	HO2S2 (B1)	2	×	<a href="#">EC-210</a>
P0158	0158	HO2S2 (B2)	2	×	<a href="#">EC-201</a>
P0159	0159	HO2S2 (B2)	2	×	<a href="#">EC-210</a>
P0171	0171	FUEL SYS-LEAN-B1	2	×	<a href="#">EC-221</a>
P0172	0172	FUEL SYS-RICH-B1	2	×	<a href="#">EC-230</a>
P0174	0174	FUEL SYS-LEAN-B2	2	×	<a href="#">EC-221</a>
P0175	0175	FUEL SYS-RICH-B2	2	×	<a href="#">EC-230</a>
P0181	0181	FTT SENSOR	2	×	<a href="#">EC-238</a>
P0182	0182	FTT SEN/CIRCUIT	2	×	<a href="#">EC-243</a>
P0183	0183	FTT SEN/CIRCUIT	2	×	<a href="#">EC-243</a>
P0222	0222	TP SEN 1/CIRC	1	×	<a href="#">EC-247</a>
P0223	0223	TP SEN 1/CIRC	1	×	<a href="#">EC-247</a>

# INDEX FOR DTC

DTC*1		Items (CONSULT-II screen terms)	Trip	MIL lighting up	Reference page
CONSULT-II GST*2	ECM*3				
P0300	0300	MULTI CYL MISFIRE	2	×	<a href="#">EC-255</a>
P0301	0301	CYL 1 MISFIRE	2	×	<a href="#">EC-255</a>
P0302	0302	CYL 2 MISFIRE	2	×	<a href="#">EC-255</a>
P0303	0303	CYL 3 MISFIRE	2	×	<a href="#">EC-255</a>
P0304	0304	CYL 4 MISFIRE	2	×	<a href="#">EC-255</a>
P0305	0305	CYL 5 MISFIRE	2	×	<a href="#">EC-255</a>
P0306	0306	CYL 6 MISFIRE	2	×	<a href="#">EC-255</a>
P0327	0327	KNOCK SEN/CIRC-B1	2	—	<a href="#">EC-262</a>
P0328	0328	KNOCK SEN/CIRC-B1	2	—	<a href="#">EC-262</a>
P0335	0335	CKP SEN/CIRCUIT	2	×	<a href="#">EC-267</a>
P0340	0340	CMP SEN/CIRC-B1	2	×	<a href="#">EC-274</a>
P0345	0345	CMP SEN/CIRC-B2	2	×	<a href="#">EC-274</a>
P0420	0420	TW CATALYST SYS-B1	2	×	<a href="#">EC-283</a>
P0430	0430	TW CATALYST SYS-B2	2	×	<a href="#">EC-283</a>
P0441	0441	EVAP PURG FLOW/MON	2	×	<a href="#">EC-287</a>
P0442	0442	EVAP SMALL LEAK	2	×	<a href="#">EC-292</a>
P0444	0444	PURG VOLUME CONT/V	2	×	<a href="#">EC-301</a>
P0445	0445	PURG VOLUME CONT/V	2	×	<a href="#">EC-301</a>
P0447	0447	VENT CONTROL VALVE	2	×	<a href="#">EC-308</a>
P0451	0451	EVAP SYS PRES SEN	2	×	<a href="#">EC-317</a>
P0452	0452	EVAP SYS PRES SEN	2	×	<a href="#">EC-320</a>
P0453	0453	EVAP SYS PRES SEN	2	×	<a href="#">EC-329</a>
P0455	0455	EVAP GROSS LEAK	2	×	<a href="#">EC-339</a>
P0456	0456	EVAP VERY SML LEAK	2	×	<a href="#">EC-347</a>
P0460	0460	FUEL LEV SEN SLOSH	2	×	<a href="#">EC-357</a>
P0461	0461	FUEL LEVEL SENSOR	2	×	<a href="#">EC-359</a>
P0462	0462	FUEL LEVL SEN/CIRC	2	×	<a href="#">EC-361</a>
P0463	0463	FUEL LEVL SEN/CIRC	2	×	<a href="#">EC-361</a>
P0500	0500	VEH SPEED SEN/CIRC*5	2	×	<a href="#">EC-363</a>
P0506	0506	ISC SYSTEM	2	×	<a href="#">EC-365</a>
P0507	0507	ISC SYSTEM	2	×	<a href="#">EC-367</a>
P0550	0550	PW ST P SEN/CIRC	2	—	<a href="#">EC-369</a>
P0605	0605	ECM	1 or 2	× or —	<a href="#">EC-374</a>
P0700	0700	TCM	1	×	<a href="#">AT-108</a>
P0705	0705	PNP SW/CIRC	2	×	<a href="#">AT-109</a>
P0710	0710	ATF TEMP SEN/CIRC	2	×	<a href="#">AT-131</a>
P0720	0720	VEH SPD SEN/CIR AT*5	2	×	<a href="#">AT-113</a>
P0725	0725	ENGINE SPEED SIG	2	×	<a href="#">AT-118</a>
P0740	0740	TCC SOLENOID/CIRC	2	×	<a href="#">AT-120</a>
P0744	0744	A/T TCC S/V FNCTN	2	×	<a href="#">AT-122</a>
P0745	0745	L/PRESS SOL/CIRC	2	×	<a href="#">AT-124</a>
P1031	1031	A/F SEN1 HTR (B1)	2	×	<a href="#">EC-377</a>

# INDEX FOR DTC

DTC*1		Items (CONSULT-II screen terms)	Trip	MIL lighting up	Reference page
CONSULT-II GST*2	ECM*3				
P1032	1032	A/F SEN1 HTR (B1)	2	×	<a href="#">EC-377</a>
P1051	1051	A/F SEN1 HTR (B2)	2	×	<a href="#">EC-377</a>
P1052	1052	A/F SEN1 HTR (B2)	2	×	<a href="#">EC-377</a>
P1065	1065	ECM BACK UP/CIRCUIT	2	×	<a href="#">EC-384</a>
P1111	1111	INT/V TIM V/CIR-B1	2	×	<a href="#">EC-388</a>
P1121	1121	ETC ACTR	1	×	<a href="#">EC-395</a>
P1122	1122	ETC FUNCTION/CIRC	1	×	<a href="#">EC-397</a>
P1124	1124	ETC MOT PWR	1	×	<a href="#">EC-404</a>
P1126	1126	ETC MOT PWR	1	×	<a href="#">EC-404</a>
P1128	1128	ETC MOT	1	×	<a href="#">EC-409</a>
P1136	1136	INT/V TIM V/CIR-B2	2	×	<a href="#">EC-388</a>
P1146	1146	HO2S2 (B1)	2	×	<a href="#">EC-414</a>
P1147	1147	HO2S2 (B1)	2	×	<a href="#">EC-425</a>
P1148	1148	CLOSED LOOP-B1	1	×	<a href="#">EC-436</a>
P1166	1166	HO2S2 (B2)	2	×	<a href="#">EC-414</a>
P1167	1167	HO2S2 (B2)	2	×	<a href="#">EC-425</a>
P1168	1168	CLOSED LOOP-B2	1	×	<a href="#">EC-436</a>
P1211	1211	TCS C/U FUNCTN	2	—	<a href="#">EC-437</a>
P1212	1212	TCS/CIRC	2	—	<a href="#">EC-438</a>
P1217	1217	ENG OVER TEMP	1	×	<a href="#">EC-439</a>
P1225	1225	CTP LEARNING	2	—	<a href="#">EC-452</a>
P1226	1226	CTP LEARNING	2	—	<a href="#">EC-454</a>
P1229	1229	SENSOR POWER/CIRC	1	×	<a href="#">EC-456</a>
P1271	1271	A/F SENSOR 1 (B1)	2	×	<a href="#">EC-461</a>
P1272	1272	A/F SENSOR 1 (B1)	2	×	<a href="#">EC-470</a>
P1273	1273	A/F SENSOR 1 (B1)	2	×	<a href="#">EC-479</a>
P1274	1274	A/F SENSOR 1 (B1)	2	×	<a href="#">EC-489</a>
P1276	1276	A/F SENSOR 1 (B1)	2	×	<a href="#">EC-499</a>
P1278	1278	A/F SENSOR 1 (B1)	2	×	<a href="#">EC-509</a>
P1279	1279	A/F SENSOR 1 (B1)	2	×	<a href="#">EC-521</a>
P1281	1281	A/F SENSOR 1 (B2)	2	×	<a href="#">EC-461</a>
P1282	1282	A/F SENSOR 1 (B2)	2	×	<a href="#">EC-470</a>
P1283	1283	A/F SENSOR 1 (B2)	2	×	<a href="#">EC-479</a>
P1284	1284	A/F SENSOR 1 (B2)	2	×	<a href="#">EC-489</a>
P1286	1286	A/F SENSOR 1 (B2)	2	×	<a href="#">EC-499</a>
P1288	1288	A/F SENSOR 1 (B2)	2	×	<a href="#">EC-509</a>
P1289	1289	A/F SENSOR 1 (B2)	2	×	<a href="#">EC-521</a>
P1444	1444	PURG VOLUME CONT/V	2	×	<a href="#">EC-533</a>
P1446	1446	VENT CONTROL VALVE	2	×	<a href="#">EC-541</a>
P1564	1564	ASCD SW	1	—	<a href="#">EC-550</a>
P1572	1572	ASCD BRAKE SW	1	—	<a href="#">EC-558</a>
P1574	1574	ASCD VHL SPD SEN	1	—	<a href="#">EC-574</a>

# INDEX FOR DTC

DTC*1		Items (CONSULT-II screen terms)	Trip	MIL lighting up	Reference page
CONSULT-II GST*2	ECM*3				
P1610 - P1615	1610 - 1615	NATS MALFUNCTION	2	—	<a href="#">EC-63</a>
P1705	1705	TP SEN/CIRC A/T	1	×	<a href="#">AT-128</a>
P1706	1706	P-N POS SW/CIRCUIT	2	×	<a href="#">EC-576</a>
P1716	1716	TURBINE REV S/CIRC	2	×	<a href="#">AT-136</a>
P1730	1730	A/T INTERLOCK	1	×	<a href="#">AT-140</a>
P1752	1752	I/C SOLENOID/CIRC	1	×	<a href="#">AT-145</a>
P1754	1754	I/C SOLENOID FNCTN	1	×	<a href="#">AT-147</a>
P1757	1757	FR/B SOLENOID/CIRC	1	×	<a href="#">AT-149</a>
P1759	1759	FR/B SOLENOID FNCT	1	×	<a href="#">AT-151</a>
P1762	1762	D/C SOLENOID/CIRC	1	×	<a href="#">AT-153</a>
P1764	1764	D/C SOLENOID FNCTN	1	×	<a href="#">AT-155</a>
P1767	1767	HLR/C SOL/CIRC	1	×	<a href="#">AT-157</a>
P1769	1769	HLR/C SOL FNCTN	1	×	<a href="#">AT-159</a>
P1772	1772	LC/B SOLENOID/CIRC	1	×	<a href="#">AT-161</a>
P1774	1774	LC/B SOLENOID FNCT	1	×	<a href="#">AT-163</a>
P1805	1805	BRAKE SW/CIRCUIT	2	—	<a href="#">EC-584</a>
P2122	2122	APP SEN 1/CIRC	1	×	<a href="#">EC-589</a>
P2123	2123	APP SEN 1/CIRC	1	×	<a href="#">EC-589</a>
P2127	2127	APP SEN 2/CIRC	1	×	<a href="#">EC-597</a>
P2128	2128	APP SEN 2/CIRC	1	×	<a href="#">EC-597</a>
P2135	2135	TP SENSOR	1	×	<a href="#">EC-605</a>
P2138	2138	APP SENSOR	1	×	<a href="#">EC-613</a>

\*1: 1st trip DTC No. is the same as DTC No.

\*2: This number is prescribed by SAE J2012.

\*3: In Diagnostic Test Mode II (Self-diagnostic results), this number is controlled by NISSAN.

\*4: The troubleshooting for this DTC needs CONSULT-II.

\*5: When the fail-safe operations for both self-diagnoses occur, the MIL illuminates.

# PRECAUTIONS

## PRECAUTIONS

PFP:00001

### Precautions for Supplemental Restraint System (SRS) “AIR BAG” and “SEAT BELT PRE-TENSIONER”

ABS009AB

The Supplemental Restraint System such as “AIR BAG” and “SEAT BELT PRE-TENSIONER”, used along with a front seat belt, helps to reduce the risk or severity of injury to the driver and front passenger for certain types of collision. This system includes seat belt switch inputs and dual stage front air bag modules. The SRS system uses the seat belt switches to determine the front air bag deployment, and may only deploy one front air bag, depending on the severity of a collision and whether the front occupants are belted or unbelted. Information necessary to service the system safely is included in the SRS and SB section of this Service Manual.

#### **WARNING:**

- To avoid rendering the SRS inoperative, which could increase the risk of personal injury or death in the event of a collision which would result in air bag inflation, all maintenance must be performed by an authorized NISSAN/INFINITI dealer.
- Improper maintenance, including incorrect removal and installation of the SRS, can lead to personal injury caused by unintentional activation of the system. For removal of Spiral Cable and Air Bag Module, see the SRS section.
- Do not use electrical test equipment on any circuit related to the SRS unless instructed to in this Service Manual. SRS wiring harnesses can be identified by yellow and/or orange harnesses or harness connectors.

### Precautions for Battery Service

ABS009AC

Before disconnecting the battery, lower both the driver and passenger windows. This will prevent any interference between the window edge and the vehicle when the door is opened/closed. During normal operation, the window slightly raises and lowers automatically to prevent any window to vehicle interference. The automatic window function will not work with the battery disconnected.

### On Board Diagnostic (OBD) System of Engine and A/T

ABS009AD

The ECM has an on board diagnostic system. It will light up the malfunction indicator lamp (MIL) to warn the driver of a malfunction causing emission deterioration.

#### **CAUTION:**

- Be sure to turn the ignition switch OFF and disconnect the negative battery cable before any repair or inspection work. The open/short circuit of related switches, sensors, solenoid valves, etc. will cause the MIL to light up.
- Be sure to connect and lock the connectors securely after work. A loose (unlocked) connector will cause the MIL to light up due to the open circuit. (Be sure the connector is free from water, grease, dirt, bent terminals, etc.)
- Certain systems and components, especially those related to OBD, may use a new style slide-locking type harness connector. For description and how to disconnect, refer to [PG-80, "HARNESS CONNECTOR"](#).
- Be sure to route and secure the harnesses properly after work. The interference of the harness with a bracket, etc. may cause the MIL to light up due to the short circuit.
- Be sure to connect rubber tubes properly after work. A misconnected or disconnected rubber tube may cause the MIL to light up due to the malfunction of the EVAP system or fuel injection system, etc.
- Be sure to erase the unnecessary malfunction information (repairs completed) from the ECM and TCM (Transmission control module) before returning the vehicle to the customer.



# PRECAUTIONS

## Precaution

- Always use a 12 volt battery as power source.
- Do not attempt to disconnect battery cables while engine is running.
- Before connecting or disconnecting the ECM harness connector, turn ignition switch OFF and disconnect battery ground cable. Failure to do so may damage the ECM because battery voltage is applied to ECM even if ignition switch is turned OFF.
- Before removing parts, turn ignition switch OFF and then disconnect battery ground cable.

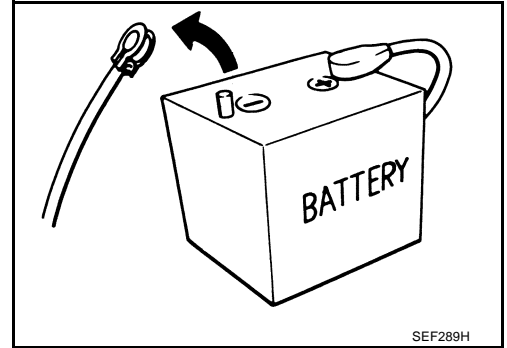

- Do not disassemble ECM.
- If a battery cable is disconnected, the memory will return to the ECM value. The ECM will now start to self-control at its initial value. Engine operation can vary slightly when the terminal is disconnected. However, this is not an indication of a malfunction. Do not replace parts because of a slight variation.

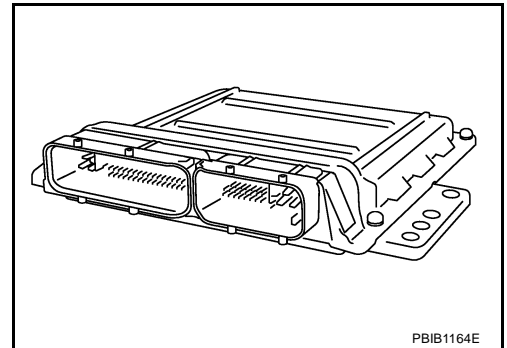

- When connecting ECM harness connector, fasten it securely with a lever as far as it will go as shown in the figure.

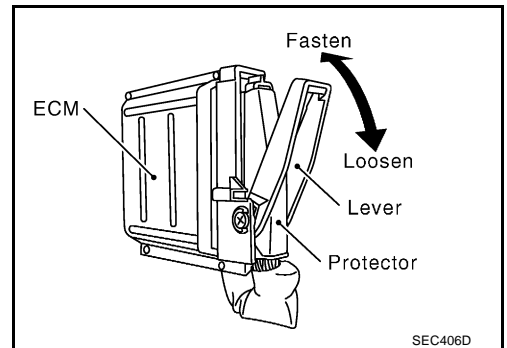

- When connecting or disconnecting pin connectors into or from ECM, take care not to damage pin terminals (bend or break). Make sure that there are not any bends or breaks on ECM pin terminal, when connecting pin connectors.
- Securely connect ECM harness connectors. A poor connection can cause an extremely high (surge) voltage to develop in coil and condenser, thus resulting in damage to ICs.
- Keep engine control system harness at least 10 cm (4 in) away from adjacent harness, to prevent engine control system malfunctions due to receiving external noise, degraded operation of ICs, etc.
- Keep engine control system parts and harness dry.

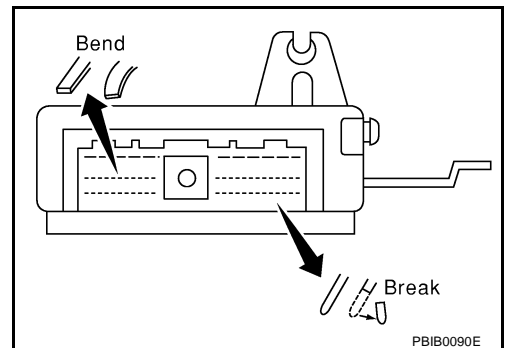

A  
EC  
C  
D  
E  
F  
G  
H  
I  
J  
K  
L  
M

## PRECAUTIONS

- Before replacing ECM, perform ECM Terminals and Reference Value inspection and make sure ECM functions properly. Refer to [EC-95](#).
- Handle mass air flow sensor carefully to avoid damage.
- Do not disassemble mass air flow sensor.
- Do not clean mass air flow sensor with any type of detergent.
- Do not disassemble electric throttle control actuator.
- Even a slight leak in the air intake system can cause serious incidents.
- Do not shock or jar the camshaft position sensor (PHASE), crankshaft position sensor (POS).
- After performing each TROUBLE DIAGNOSIS, perform DTC Confirmation Procedure or Overall Function Check. The DTC should not be displayed in the DTC Confirmation Procedure if the repair is completed. The Overall Function Check should be a good result if the repair is completed.

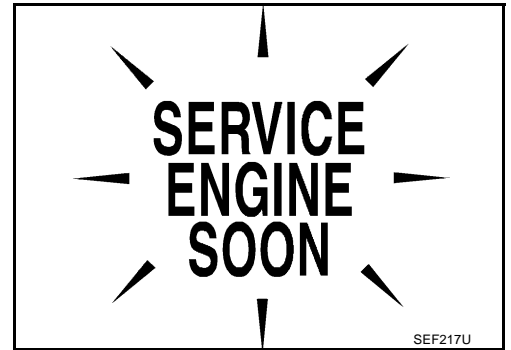
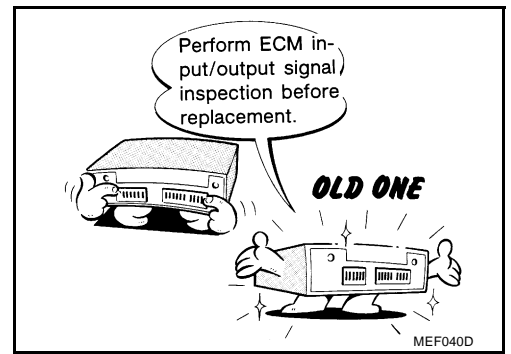

- When measuring ECM signals with a circuit tester, never allow the two tester probes to contact. Accidental contact of probes will cause a short circuit and damage the ECM power transistor.
- Do not use ECM ground terminals when measuring input/output voltage. Doing so may result in damage to the ECM's transistor. Use a ground other than ECM terminals, such as the ground.

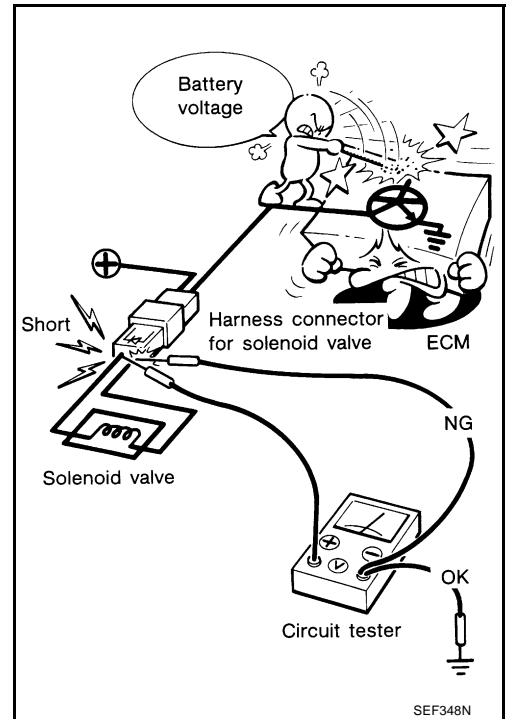

# PRECAUTIONS

- B1 indicates the bank 1, B2 indicates the bank 2 as shown in the figure.

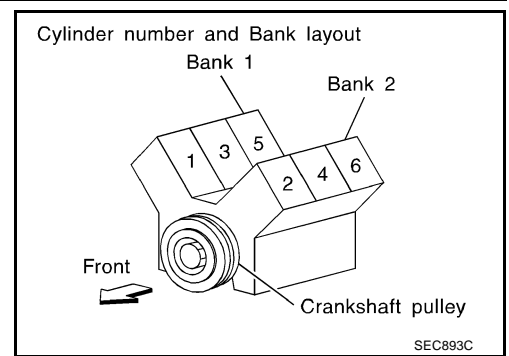

- Do not operate fuel pump when there is no fuel in lines.
- Tighten fuel hose clamps to the specified torque.

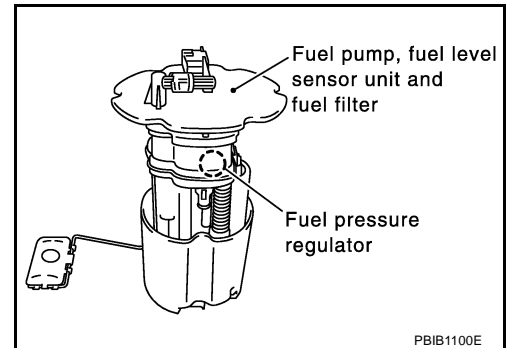

- Do not depress accelerator pedal when starting.
- Immediately after starting, do not rev up engine unnecessarily.
- Do not rev up engine just prior to shutdown.

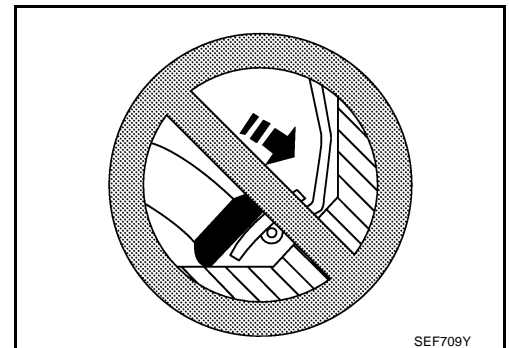

- When installing C.B. ham radio or a mobile phone, be sure to observe the following as it may adversely affect electronic control systems depending on installation location.
  - Keep the antenna as far as possible from the electronic control units.
  - Keep the antenna feeder line more than 20 cm (8 in) away from the harness of electronic controls. Do not let them run parallel for a long distance.
  - Adjust the antenna and feeder line so that the standing-wave ratio can be kept smaller.
  - Be sure to ground the radio to vehicle body.

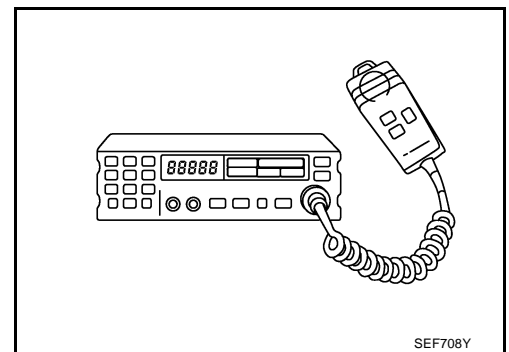

## Wiring Diagrams and Trouble Diagnosis

ABS009AF

When you read wiring diagrams, refer to the following:

- [GI-15, "How to Read Wiring Diagrams"](#)
- [PG-4, "POWER SUPPLY ROUTING CIRCUIT"](#) for power distribution circuit

When you perform trouble diagnosis, refer to the following:

- [GI-11, "HOW TO FOLLOW TEST GROUPS IN TROUBLE DIAGNOSES"](#)
- [GI-27, "How to Perform Efficient Diagnosis for an Electrical Incident"](#)

A  
EC  
C  
D  
E  
F  
G  
H  
I  
J  
K  
L  
M

# PREPARATION

## PREPARATION

PFP:00002

### Special Service Tools

ABS009AG

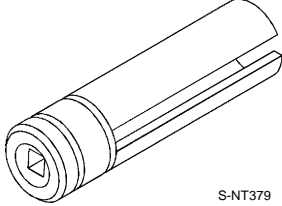
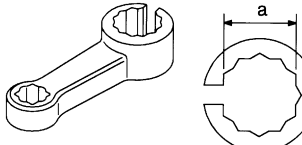
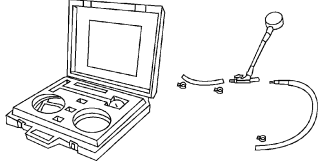
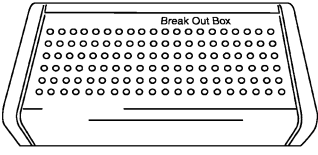
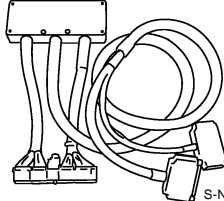
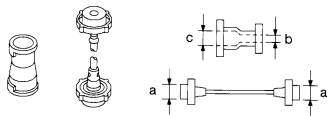

The actual shapes of Kent-Moore tools may differ from those of special service tools illustrated here.

Tool number (Kent-Moore No.) Tool name	Description
KV10117100 (J-36471-A) Heated oxygen sensor wrench   S-NT379	Loosening or tightening heated oxygen sensor with 22 mm (0.87 in) hexagon nut
KV10114400 (J-38365) Heated oxygen sensor wrench   S-NT636	Loosening or tightening heated oxygen sensor <b>a: 22 mm (0.87 in)</b>
(J-44321) Fuel pressure gauge kit   LEC642	Checking fuel pressure
KV109E0010 (J-46209) Break-out box   S-NT825	Measuring the ECM signals with a circuit tester
KV109E0080 (J-45819) Y-cable adapter   S-NT826	Measuring the ECM signals with a circuit tester
EG17650301 (J-33984-A) Radiator cap tester adapter   S-NT564	Adapting radiator cap tester to radiator cap and radiator filler neck <b>a: 28 (1.10) dia.</b> <b>b: 31.4 (1.236) dia.</b> <b>c: 41.3 (1.626) dia.</b> Unit: mm (in)

# PREPARATION

## Commercial Service Tools

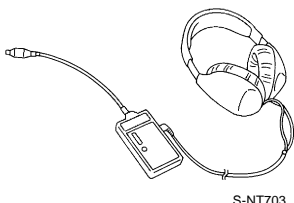
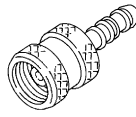
ABS009AH

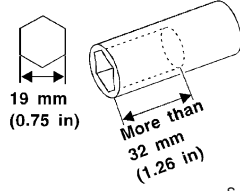
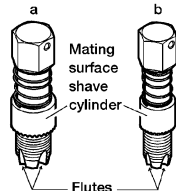
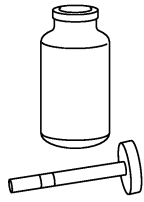
Tool name (Kent-Moore No.)	Description
Leak detector i.e.: (J-41416) <div style="text-align: center;">  <p>S-NT703</p> </div>	Locating the EVAP leak
EVAP service port adapter i.e.: (J-41413-OBD) <div style="text-align: center;">  <p>S-NT704</p> </div>	Applying positive pressure through EVAP service port
Fuel filler cap adapter i.e.: (MLR-8382) <div style="text-align: center;">  <p>S-NT815</p> </div>	Checking fuel tank vacuum relief valve opening pressure
Socket wrench <div style="text-align: center;">  <p>19 mm (0.75 in)</p> <p>More than 32 mm (1.26 in)</p> <p>S-NT705</p> </div>	Removing and installing engine coolant temperature sensor
Oxygen sensor thread cleaner i.e.: (J-43897-18) (J-43897-12) <div style="text-align: center;">  <p>a</p> <p>b</p> <p>Mating surface shave cylinder</p> <p>Flutes</p> <p>AEM488</p> </div>	Reconditioning the exhaust system threads before installing a new oxygen sensor. Use with anti-seize lubricant shown below. <b>a: 18 mm diameter with pitch 1.5 mm for Zirconia Oxygen Sensor</b> <b>b: 12 mm diameter with pitch 1.25 mm for Titania Oxygen Sensor</b>
Anti-seize lubricant i.e.: (Permatex™ 133AR or equivalent meeting MIL specification MIL-A- 907) <div style="text-align: center;">  <p>S-NT779</p> </div>	Lubricating oxygen sensor thread cleaning tool when reconditioning exhaust system threads.

A  
EC  
C  
D  
E  
F  
G  
H  
I  
J  
K  
L  
M

# ENGINE CONTROL SYSTEM

## ENGINE CONTROL SYSTEM

PFP:23710

### System Diagram

ABS009AI

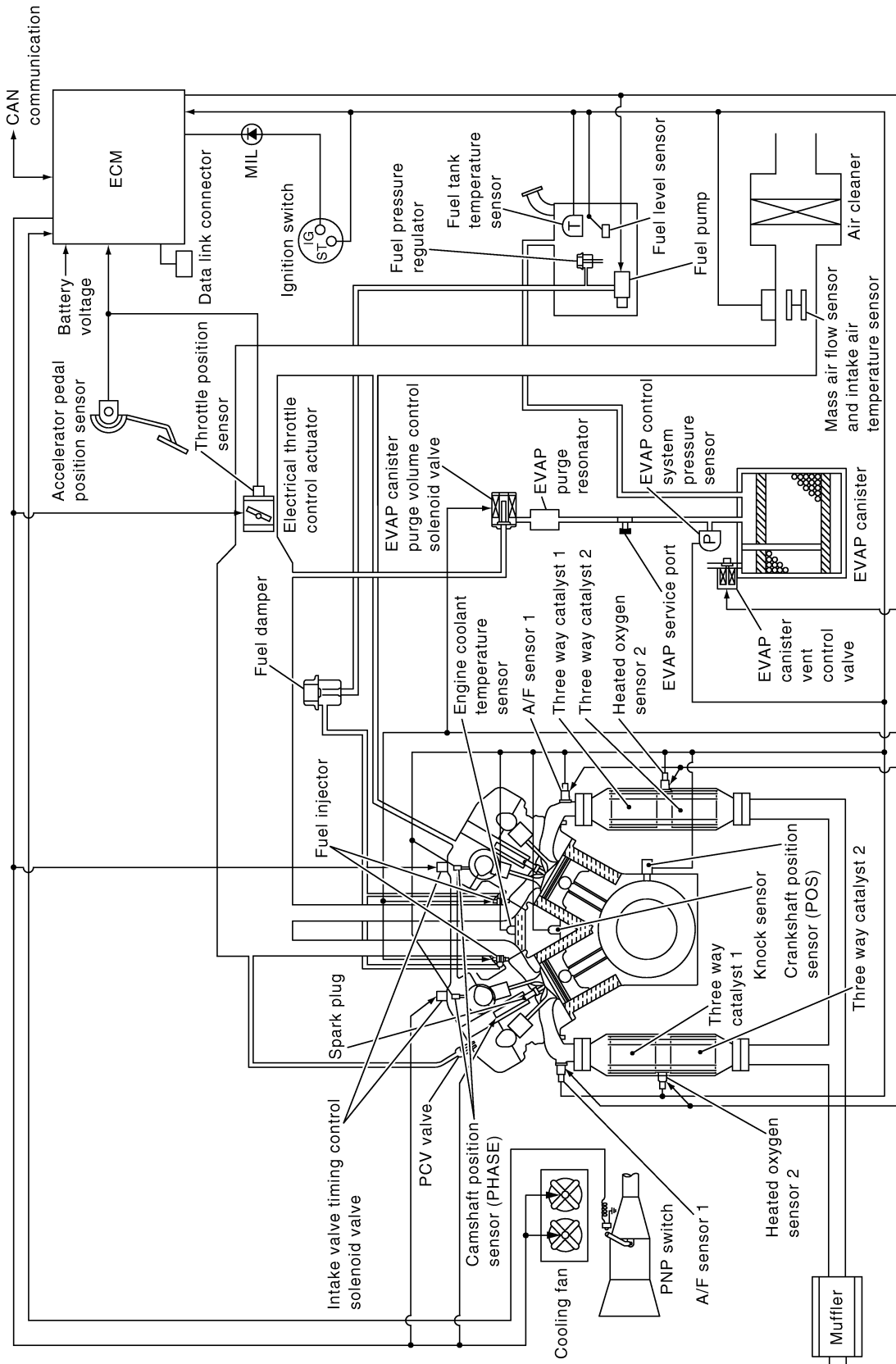

PBIB2283E

# ENGINE CONTROL SYSTEM

## Vacuum Hose Drawing

ABS009AJ

A

EC

C

D

E

F

G

H

I

J

K

L

M

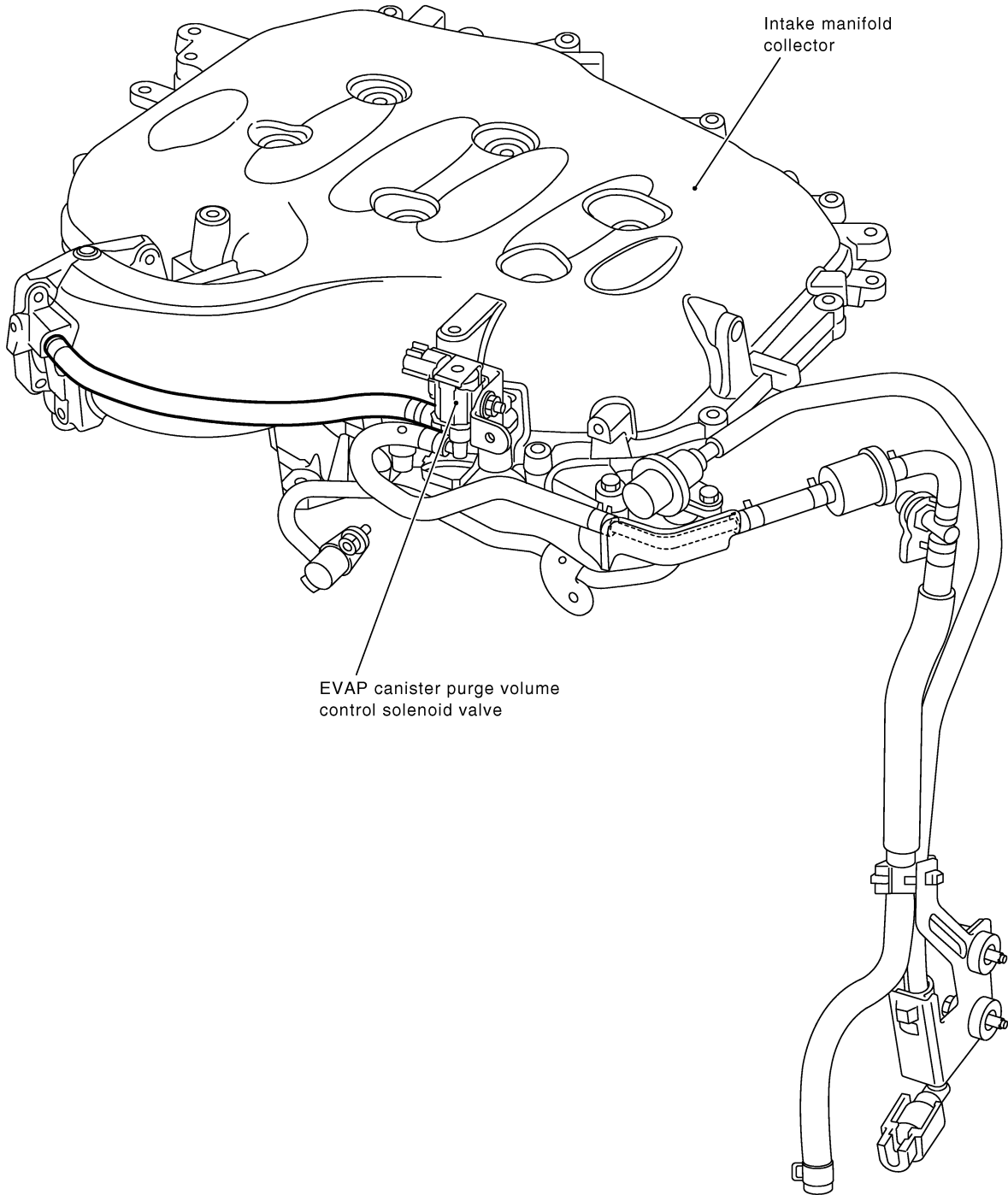

**NOTE:** Do not use soapy water or any type of solvent while installing vacuum hose or purge hoses.

Refer to [EC-22. "System Diagram"](#) for Vacuum Control System.

PBIB2095E

# ENGINE CONTROL SYSTEM

## System Chart

ABS009AK

Input (Sensor)	ECM Function	Output (Actuator)
● Camshaft position sensor (PHASE)	Fuel injection & mixture ratio control	Fuel injector
● Crankshaft position sensor (POS)	Electronic ignition system	Power transistor
● Mass air flow sensor	Fuel pump control	Fuel pump relay
● Engine coolant temperature sensor	ASCD vehicle speed control	Electric throttle control actuator
● Air fuel ratio (A/F) sensor 1	On board diagnostic system	MIL (On the instrument panel)*4
● Throttle position sensor	Air fuel ratio (A/F) sensor 1 heater control	Air fuel ratio (A/F) sensor 1 heater
● Accelerator pedal position sensor	Heated oxygen sensor 2 heater control	Heated oxygen sensor 2 heater
● Park/neutral position (PNP) switch	EVAP canister purge flow control	EVAP canister purge volume control solenoid valve
● Intake air temperature sensor	Air conditioning cut control	Air conditioner relay*4
● Power steering pressure sensor	Cooling fan control	Cooling fan relay*4
● Ignition switch		
● Battery voltage		
● Knock sensor		
● Refrigerant pressure sensor		
● Stop lamp switch		
● ASCD steering switch		
● ASCD brake switch		
● ASCD clutch switch		
● Fuel level sensor*1 *3		
● EVAP control system pressure sensor		
● Fuel tank temperature sensor*1	ON BOARD DIAGNOSIS for EVAP system	EVAP canister vent control valve
● Heated oxygen sensor 2*2		
● TCM (Transmission control module)*3		
● Air conditioner switch*3		
● Wheel sensor*3		
● Electrical load signal*3		
● VDC/TCS/ABS control unit (with VDC models)		
● ABS actuator and electric unit (control unit) (without VDC models)		

\*1: This sensor is not used to control the engine system. This is used only for the on board diagnosis.

\*2: This sensor is not used to control the engine system under normal conditions.

\*3: This input signal is sent to the ECM through CAN communication line.

\*4: This output signal is sent from the ECM through CAN communication line.



# ENGINE CONTROL SYSTEM

## Multipoint Fuel Injection (MFI) System INPUT/OUTPUT SIGNAL CHART

ABS009AL

Sensor	Input Signal to ECM	ECM function	Actuator
Crankshaft position sensor (POS)	Engine speed* <sup>3</sup>	Fuel injection & mixture ratio control	Fuel injector
Camshaft position sensor (PHASE)	Piston position		
Mass air flow sensor	Amount of intake air		
Engine coolant temperature sensor	Engine coolant temperature		
Air fuel ratio (A/F) sensor 1	Density of oxygen in exhaust gas		
Throttle position sensor	Throttle position		
Accelerator pedal position sensor	Accelerator pedal position		
Park/neutral position (PNP) switch	Gear position		
Knock sensor	Engine knocking condition		
Battery	Battery voltage* <sup>3</sup>		
Power steering pressure sensor	Power steering operation		
Heated oxygen sensor 2* <sup>1</sup>	Density of oxygen in exhaust gas		
Air conditioner switch* <sup>2</sup>	Air conditioner operation		
Wheel sensor* <sup>2</sup>	Vehicle speed		

\*1: This sensor is not used to control the engine system under normal conditions.

\*2: This signal is sent to the ECM through CAN communication line.

\*3: ECM determines the start signal status by the signals of engine speed and battery voltage.

### SYSTEM DESCRIPTION

The amount of fuel injected from the fuel injector is determined by the ECM. The ECM controls the length of time the valve remains open (injection pulse duration). The amount of fuel injected is a program value in the ECM memory. The program value is preset by engine operating conditions. These conditions are determined by input signals (for engine speed and intake air) from both the crankshaft position sensor and the mass air flow sensor.

### VARIOUS FUEL INJECTION INCREASE/DECREASE COMPENSATION

In addition, the amount of fuel injected is compensated to improve engine performance under various operating conditions as listed below.

<Fuel increase>

- During warm-up
- When starting the engine
- During acceleration
- Hot-engine operation
- When selector lever is changed from N to D (A/T models)
- High-load, high-speed operation

<Fuel decrease>

- During deceleration
- During high engine speed operation

# ENGINE CONTROL SYSTEM

## MIXTURE RATIO FEEDBACK CONTROL (CLOSED LOOP CONTROL)

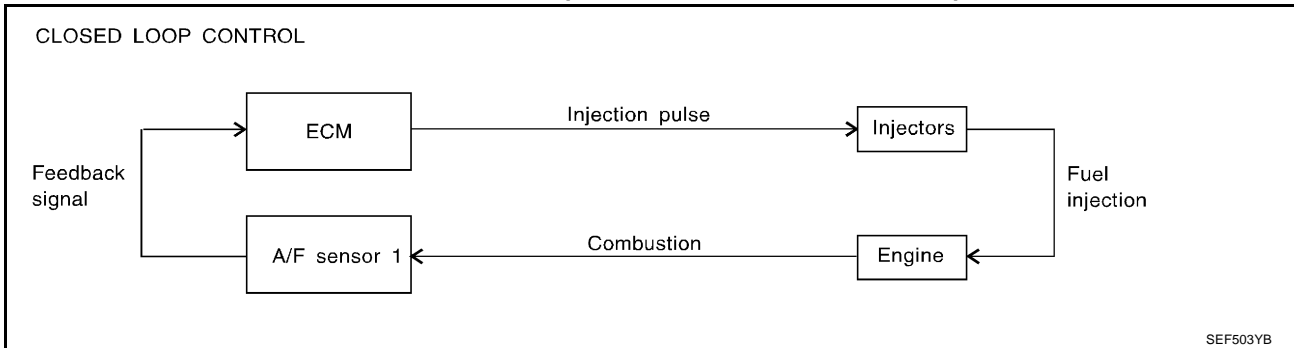

The mixture ratio feedback system provides the best air-fuel mixture ratio for driveability and emission control. The three way catalyst 1 can then better reduce CO, HC and NO<sub>x</sub> emissions. This system uses air fuel ratio (A/F) sensor 1 in the exhaust manifold to monitor whether the engine operation is rich or lean. The ECM adjusts the injection pulse width according to the sensor voltage signal. For more information about air fuel ratio (A/F) sensor 1, refer to [EC-461](#). This maintains the mixture ratio within the range of stoichiometric (ideal air-fuel mixture).

This stage is referred to as the closed loop control condition.

Heated oxygen sensor 2 is located downstream of the three way catalyst 1. Even if the switching characteristics of air fuel ratio (A/F) sensor 1 shift, the air-fuel ratio is controlled to stoichiometric by the signal from heated oxygen sensor 2.

### Open Loop Control

The open loop system condition refers to when the ECM detects any of the following conditions. Feedback control stops in order to maintain stabilized fuel combustion.

- Deceleration and acceleration
- High-load, high-speed operation
- Malfunction of air fuel ratio (A/F) sensor 1 or its circuit
- Insufficient activation of air fuel ratio (A/F) sensor 1 at low engine coolant temperature
- High engine coolant temperature
- During warm-up
- After shifting from N to D (A/T models)
- When starting the engine

### MIXTURE RATIO SELF-LEARNING CONTROL

The mixture ratio feedback control system monitors the mixture ratio signal transmitted from air fuel ratio (A/F) sensor 1. This feedback signal is then sent to the ECM. The ECM controls the basic mixture ratio as close to the theoretical mixture ratio as possible. However, the basic mixture ratio is not necessarily controlled as originally designed. Both manufacturing differences (i.e., mass air flow sensor hot wire) and characteristic changes during operation (i.e., injector clogging) directly affect mixture ratio.

Accordingly, the difference between the basic and theoretical mixture ratios is monitored in this system. This is then computed in terms of "injection pulse duration" to automatically compensate for the difference between the two ratios.

"Fuel trim" refers to the feedback compensation value compared against the basic injection duration. Fuel trim includes short term fuel trim and long term fuel trim.

"Short term fuel trim" is the short-term fuel compensation used to maintain the mixture ratio at its theoretical value. The signal from air fuel ratio (A/F) sensor 1 indicates whether the mixture ratio is RICH or LEAN compared to the theoretical value. The signal then triggers a reduction in fuel volume if the mixture ratio is rich, and an increase in fuel volume if it is lean.

"Long term fuel trim" is overall fuel compensation carried out long-term to compensate for continual deviation of the short term fuel trim from the central value. Such deviation will occur due to individual engine differences, wear over time and changes in the usage environment.

# ENGINE CONTROL SYSTEM

## FUEL INJECTION TIMING

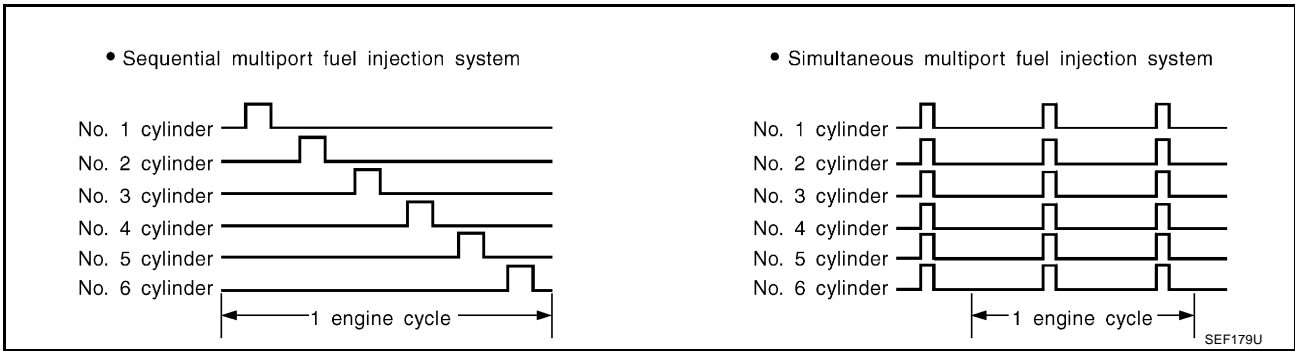

Two types of systems are used.

### Sequential Multiport Fuel Injection System

Fuel is injected into each cylinder during each engine cycle according to the firing order. This system is used when the engine is running.

### Simultaneous Multiport Fuel Injection System

Fuel is injected simultaneously into all six cylinders twice each engine cycle. In other words, pulse signals of the same width are simultaneously transmitted from the ECM.

The six injectors will then receive the signals two times for each engine cycle.

This system is used when the engine is being started and/or if the fail-safe system (CPU) is operating.

## FUEL SHUT-OFF

Fuel to each cylinder is cut off during deceleration or operation of the engine at excessively high speeds or operation of the vehicle at excessively high speeds.

## Electronic Ignition (EI) System

### INPUT/OUTPUT SIGNAL CHART

ABS009AM

Sensor	Input Signal to ECM	ECM function	Actuator
Crankshaft position sensor (POS)	Engine speed*2 Piston position	Ignition timing control	Power transistor
Camshaft position sensor (PHASE)			
Mass air flow sensor	Amount of intake air		
Engine coolant temperature sensor	Engine coolant temperature		
Throttle position sensor	Throttle position		
Accelerator pedal position sensor	Accelerator pedal position		
Knock sensor	Engine knocking		
Park/neutral position (PNP) switch	Gear position		
Battery	Battery voltage*2		
Wheel sensor*1	Vehicle speed		

\*1: This signal is sent to the ECM through CAN communication line.

\*2: ECM determines the start signal status by the signals of engine speed and battery voltage.

## SYSTEM DESCRIPTION

The ignition timing is controlled by the ECM to maintain the best air-fuel ratio for every running condition of the engine. The ignition timing data is stored in the ECM. This data forms the map shown.

The ECM receives information such as the injection pulse width and camshaft position sensor signal. Computing this information, ignition signals are transmitted to the power transistor.

e.g., N: 1,800 rpm, Tp: 1.50 msec

A °BTDC

During the following conditions, the ignition timing is revised by the ECM according to the other data stored in the ECM.

- At starting
- During warm-up

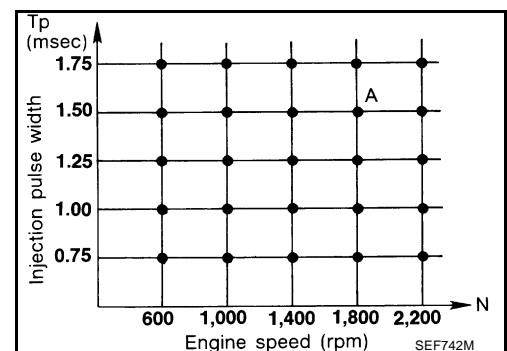

# ENGINE CONTROL SYSTEM

- At idle
- At low battery voltage
- During acceleration

The knock sensor retard system is designed only for emergencies. The basic ignition timing is programmed within the anti-knocking zone, if recommended fuel is used under dry conditions. The retard system does not operate under normal driving conditions. If engine knocking occurs, the knock sensor monitors the condition. The signal is transmitted to the ECM. The ECM retards the ignition timing to eliminate the knocking condition.

## Air Conditioning Cut Control INPUT/OUTPUT SIGNAL CHART

ABS009AN

Sensor	Input Signal to ECM	ECM function	Actuator
Air conditioner switch* <sup>1</sup>	Air conditioner ON signal	Air conditioner cut control	Air conditioner relay
Throttle position sensor	Throttle position		
Accelerator pedal position sensor	Accelerator pedal position		
Crankshaft position sensor (POS) Camshaft position sensor (PHASE)	Engine speed* <sup>2</sup>		
Engine coolant temperature sensor	Engine coolant temperature		
Battery	Battery voltage* <sup>2</sup>		
Refrigerant pressure sensor	Refrigerant pressure		
Power steering pressure sensor	Power steering operation		
Wheel sensor* <sup>1</sup>	Vehicle speed		

\*1: This signal is sent to the ECM through CAN communication line.

\*2: ECM determines the start signal status by the signals of engine speed and battery voltage.

## SYSTEM DESCRIPTION

This system improves engine operation when the air conditioner is used. Under the following conditions, the air conditioner is turned OFF.

- When the accelerator pedal is fully depressed.
- When cranking the engine.
- At high engine speeds.
- When the engine coolant temperature becomes excessively high.
- When operating power steering during low engine speed or low vehicle speed.
- When engine speed is excessively low.
- When refrigerant pressure is excessively low or high.

## Fuel Cut Control (at No Load and High Engine Speed) INPUT/OUTPUT SIGNAL CHART

ABS009AO

Sensor	Input Signal to ECM	ECM function	Actuator
Park/neutral position (PNP) switch	Neutral position	Fuel cut control	Fuel injector
Accelerator pedal position sensor	Accelerator pedal position		
Engine coolant temperature sensor	Engine coolant temperature		
Crankshaft position sensor (POS) Camshaft position sensor (PHASE)	Engine speed		
Wheel sensor*	Vehicle speed		

\*: This signal is sent to the ECM through CAN communication line.

## SYSTEM DESCRIPTION

If the engine speed is above 1,800 rpm under no load (for example, the shift position is neutral and engine speed is over 1,800 rpm) fuel will be cut off after some time. The exact time when the fuel is cut off varies based on engine speed.

Fuel cut will be operated until the engine speed reaches 1,500 rpm, then fuel cut will be cancelled.

# ENGINE CONTROL SYSTEM

---

**NOTE:**

This function is different from deceleration control listed under Multiport Fuel Injection (MFI) System, [EC-25](#) .

**CAN communication  
SYSTEM DESCRIPTION**ABS009AP

CAN (Controller Area Network) is a serial communication line for real time application. It is an on-vehicle multiplex communication line with high data communication speed and excellent error detection ability. Many electronic control units are equipped onto a vehicle, and each control unit shares information and links with other control units during operation (not independent). In CAN communication, control units are connected with 2 communication lines (CAN H line, CAN L line) allowing a high rate of information transmission with less wiring. Each control unit transmits/receives data but selectively reads required data only.

Refer to [LAN-5. "CAN Communication Unit"](#) , about CAN communication for detail.

A

EC

C

D

E

F

G

H

I

J

K

L

M

# BASIC SERVICE PROCEDURE

## BASIC SERVICE PROCEDURE

PFP:00018

### Idle Speed and Ignition Timing Check IDLE SPEED

ABS009A0

#### With CONSULT-II

Check idle speed in "DATA MONITOR" mode with CONSULT-II.

DATA MONITOR	
MONITOR	NO DTC
ENG SPEED	XXX rpm

SEF058Y

#### With GST

Check idle speed with GST.

### IGNITION TIMING

Any of following two methods may be used.

#### Method A

1. Attach timing light to loop wire as shown.
2. Check ignition timing.

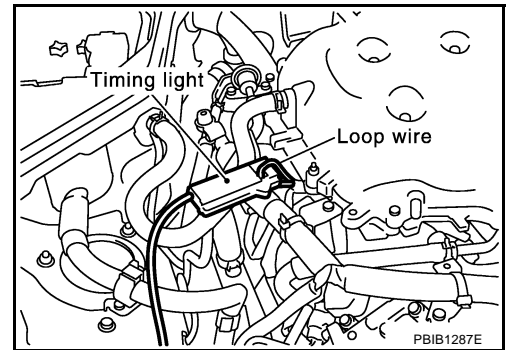

#### Method B

1. Remove No. 1 ignition coil.

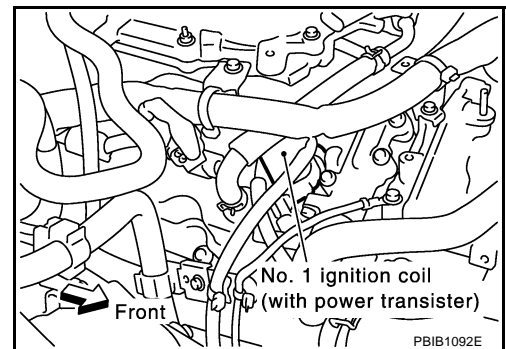

2. Connect No. 1 ignition coil and No. 1 spark plug with suitable high-tension wire as shown, and attach timing light clamp to this wire.

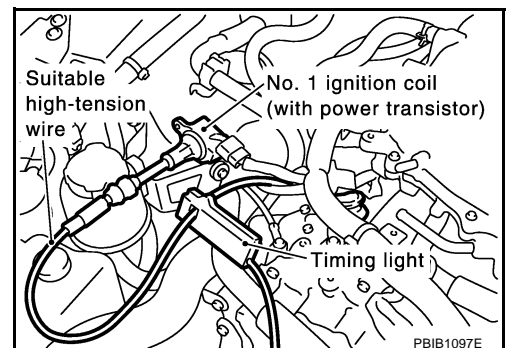

# BASIC SERVICE PROCEDURE

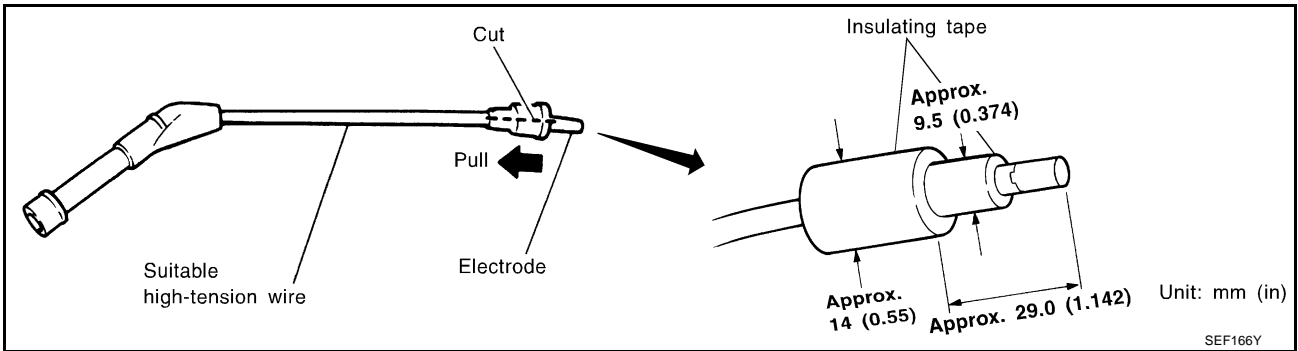

3. Check ignition timing.

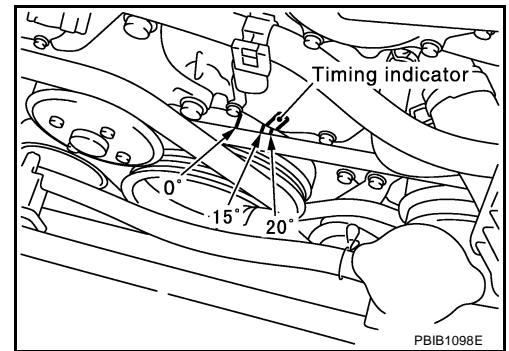

## Idle Speed/Ignition Timing/Idle Mixture Ratio Adjustment

ABS009AR

### PREPARATION

1. Make sure that the following parts are in good order.
  - Battery
  - Ignition system
  - Engine oil and coolant levels
  - Fuses
  - ECM harness connector
  - Vacuum hoses
  - Air intake system  
(Oil filler cap, oil level gauge, etc.)
  - Fuel pressure
  - Engine compression
  - Throttle valve
  - Evaporative emission system
2. On air conditioner equipped models, checks should be carried out while the air conditioner is OFF.
3. On automatic transmission equipped models, when checking idle rpm, ignition timing and mixture ratio, checks should be carried out while selector lever is in P or N position.
4. When measuring CO percentage, insert probe more than 40 cm (15.7 in) into tail pipe.
5. Turn OFF headlamp, heater blower, rear window defogger.
6. Keep front wheels pointed straight ahead.

# BASIC SERVICE PROCEDURE

## OVERALL INSPECTION SEQUENCE

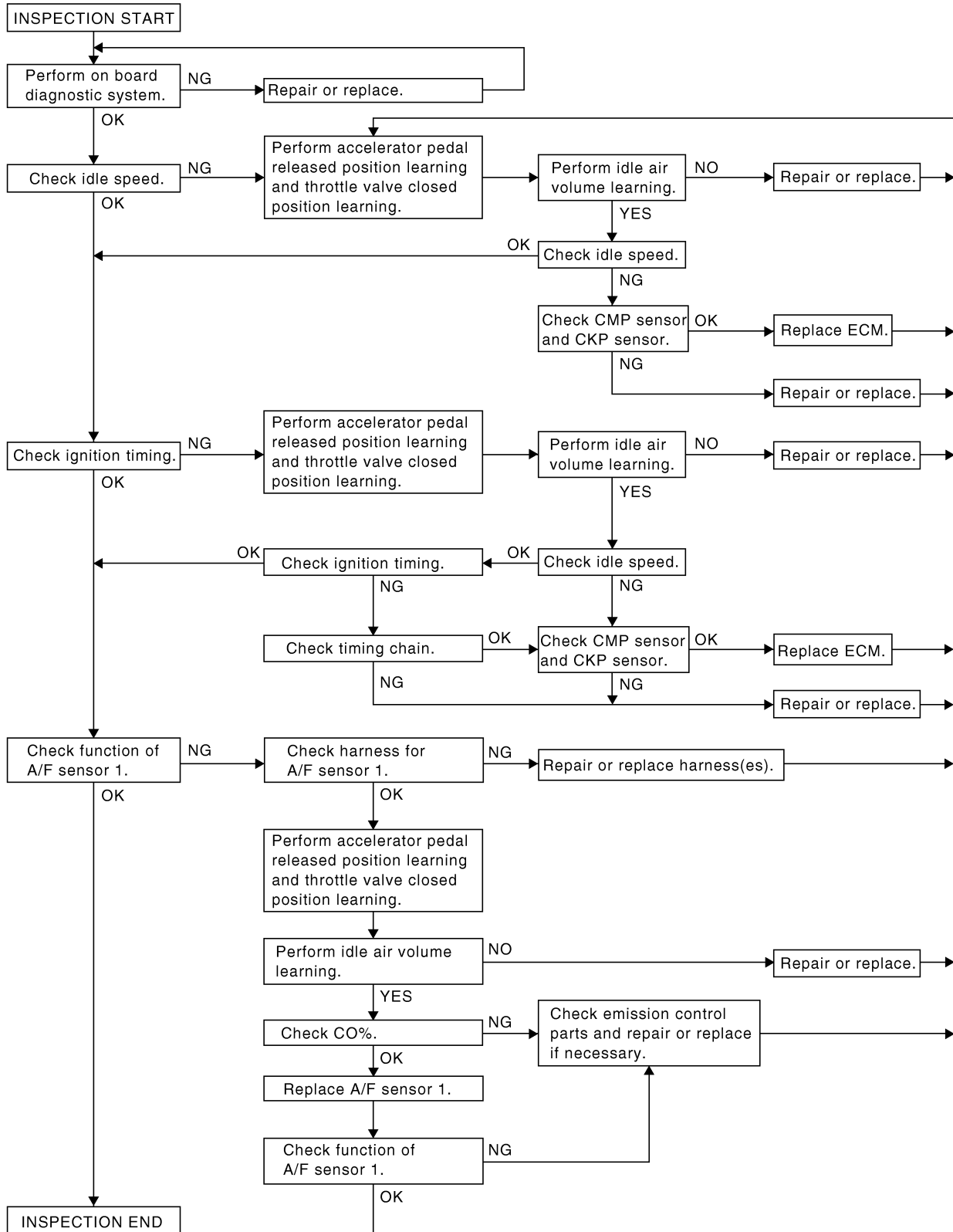

**NOTE:**

If a vehicle contains a part which is operating outside of design specifications with no MIL illumination, the part shall not be replaced prior to emission testing unless it is determined that the part has been tampered with or abused in such a way that the diagnostic system cannot reasonably be expected to detect the resulting malfunction.

PBIB2086E



# BASIC SERVICE PROCEDURE

## INSPECTION PROCEDURE

### 1. INSPECTION START

1. Check service records for any recent repairs that may indicate a related malfunction, or a current need for scheduled maintenance.
2. Open engine hood and check the following:
  - Harness connectors for improper connections
  - Wiring harness for improper connections, pinches and cut
  - Vacuum hoses for splits, kinks and improper connections
  - Hoses and ducts for leaks
  - Air cleaner clogging
  - Gasket
3. Confirm that electrical or mechanical loads are not applied.
  - Head lamp switch is OFF.
  - Air conditioner switch is OFF.
  - Rear window defogger switch is OFF.
  - Steering wheel is in the straight-ahead position, etc.
4. Start engine and warm it up until engine coolant temperature indicator points the middle of gauge.  
Ensure engine stays below 1,000 rpm.

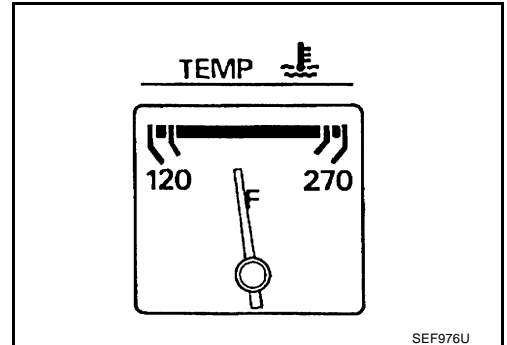
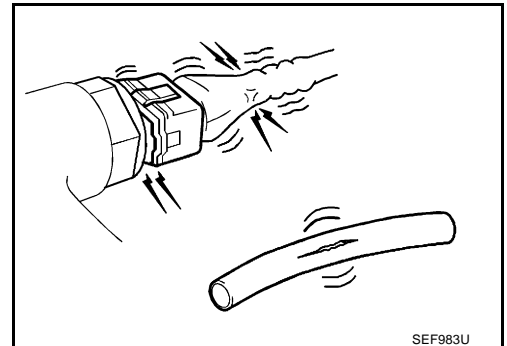

5. Run engine at about 2,000 rpm for about 2 minutes under no-load.
6. Make sure that no DTC is displayed with CONSULT-II or GST.

#### OK or NG

- OK >> GO TO 3.  
NG >> GO TO 2.

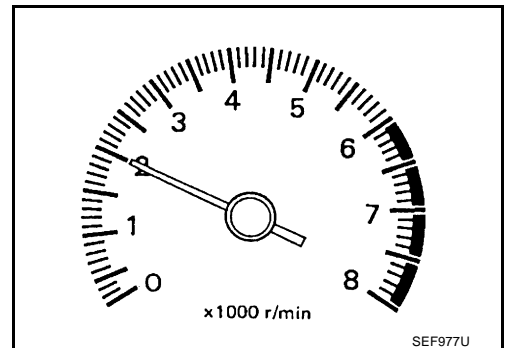

### 2. REPAIR OR REPLACE

Repair or replace components as necessary according to corresponding Diagnostic Procedure.

>> GO TO 3.

A  
EC  
C  
D  
E  
F  
G  
H  
I  
J  
K  
L  
M

# BASIC SERVICE PROCEDURE

## 3. CHECK TARGET IDLE SPEED

### ④ With CONSULT-II

1. Run engine at about 2,000 rpm for about 2 minutes under no-load.
2. Rev engine (2,000 to 3,000 rpm) two or three times under no-load, then run engine at idle speed for about 1 minute.

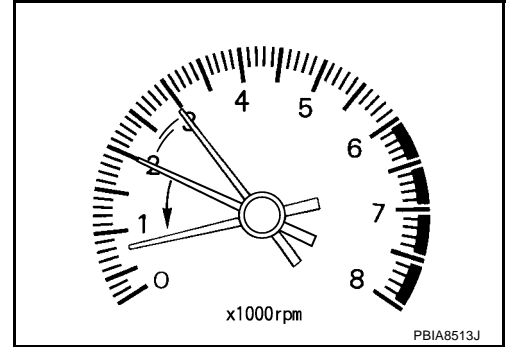

3. Read idle speed in "DATA MONITOR" mode with CONSULT-II.

**A/T: 650 ± 50 rpm (in P or N position)**

**M/T: 650 ± 50 rpm (in Neutral position)**

DATA MONITOR	
MONITOR	NO DTC
ENG SPEED	XXX rpm

SEF058Y

### ⊗ Without CONSULT-II

1. Run engine at about 2,000 rpm for about 2 minutes under no-load.
2. Rev engine (2,000 to 3,000 rpm) two or three times under no-load, then run engine at idle speed for about 1 minute.
3. Check idle speed.

**A/T: 650 ± 50 rpm (in P or N position)**

**M/T: 650 ± 50 rpm (in Neutral position)**

### OK or NG

OK >> GO TO 10.

NG >> GO TO 4.

## 4. PERFORM ACCELERATOR PEDAL RELEASED POSITION LEARNING

1. Stop engine.
2. Perform [EC-42, "Accelerator Pedal Released Position Learning"](#) .

>> GO TO 5.

## 5. PERFORM THROTTLE VALVE CLOSED POSITION LEARNING

Perform [EC-42, "Throttle Valve Closed Position Learning"](#) .

>> GO TO 6.

# BASIC SERVICE PROCEDURE

## 6. PERFORM IDLE AIR VOLUME LEARNING

Perform [EC-43, "Idle Air Volume Learning"](#) .

Is Idle Air Volume Learning carried out successfully?

Yes or No

Yes >> GO TO 7.

No >> 1. Follow the instruction of Idle Air Volume Learning.  
2. GO TO 4.

## 7. CHECK TARGET IDLE SPEED AGAIN

### With CONSULT-II

1. Start engine and warm it up to normal operating temperature.
2. Read idle speed in "DATA MONITOR" mode with CONSULT-II.

**A/T: 650 ± 50 rpm (in P or N position)**

**M/T: 650 ± 50 rpm (in Neutral position)**

### Without CONSULT-II

1. Start engine and warm it up to normal operating temperature.
2. Check idle speed.

**A/T: 650 ± 50 rpm (in P or N position)**

**M/T: 650 ± 50 rpm (in Neutral position)**

DATA MONITOR	
MONITOR	NO DTC
ENG SPEED	XXX rpm
COOLAN TEMP/S	XXX °C

SEP174Y

OK or NG

OK >> GO TO 10.

NG >> GO TO 8.

## 8. DETECT MALFUNCTIONING PART

Check the following.

- Check camshaft position sensor (PHASE) and circuit. Refer to [EC-274](#) .
- Check crankshaft position sensor (POS) and circuit. Refer to [EC-267](#) .

OK or NG

OK >> GO TO 9.

NG >> 1. Repair or replace.  
2. GO TO 4.

## 9. CHECK ECM FUNCTION

1. Substitute another known-good ECM to check ECM function. (ECM may be the cause of an incident, but this is a rare case.)
2. Perform initialization of NVIS (NATS) system and registration of all NVIS (NATS) ignition key IDs. Refer to [BL-160, "ECM Re-communicating Function"](#) .

>> GO TO 4.

# BASIC SERVICE PROCEDURE

## 10. CHECK IGNITION TIMING

1. Run engine at idle.
2. Check ignition timing with a timing light.

**A/T:**  $15 \pm 5^\circ$  BTDC (in P or N position)

**M/T:**  $15 \pm 5^\circ$  BTDC (in Neutral position)

OK or NG

OK (With CONSULT-II)>>GO TO 19.

OK (Without CONSULT-II)>>GO TO 20.

NG >> GO TO 11.

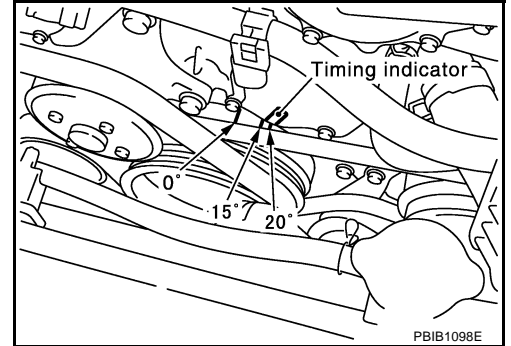

## 11. PERFORM ACCELERATOR PEDAL RELEASED POSITION LEARNING

1. Stop engine.
2. Perform [EC-42, "Accelerator Pedal Released Position Learning"](#) .

>> GO TO 12.

## 12. PERFORM THROTTLE VALVE CLOSED POSITION LEARNING

Perform [EC-42, "Throttle Valve Closed Position Learning"](#) .

>> GO TO 13.

## 13. PERFORM IDLE AIR VOLUME LEARNING

Perform [EC-43, "Idle Air Volume Learning"](#) .

**Is Idle Air Volume Learning carried out successfully?**

Yes or No

Yes >> GO TO 14.

No >> 1. Follow the instruction of Idle Air Volume Learning.  
2. GO TO 4.

## 14. CHECK TARGET IDLE SPEED AGAIN

**With CONSULT-II**

1. Start engine and warm it up to normal operating temperature.
2. Read idle speed in "DATA MONITOR" mode with CONSULT-II.

**A/T:**  $650 \pm 50$  rpm (in P or N position)

**M/T:**  $650 \pm 50$  rpm (in Neutral position)

**Without CONSULT-II**

1. Start engine and warm it up to normal operating temperature.
2. Check idle speed.

**A/T:**  $650 \pm 50$  rpm (in P or N position)

**M/T:**  $650 \pm 50$  rpm (in Neutral position)

OK or NG

OK >> GO TO 15.

NG >> GO TO 17.

DATA MONITOR	
MONITOR	NO DTC
ENG SPEED	XXX rpm
COOLAN TEMP/S	XXX °C

SEF174Y

# BASIC SERVICE PROCEDURE

## 15. CHECK IGNITION TIMING AGAIN

1. Run engine at idle.
2. Check ignition timing with a timing light.

**A/T:  $15 \pm 5^\circ$  BTDC (in P or N position)**

**M/T:  $15 \pm 5^\circ$  BTDC (in Neutral position)**

OK or NG

OK (With CONSULT-II)>>GO TO 19.

OK (Without CONSULT-II)>>GO TO 20.

NG >> GO TO 16.

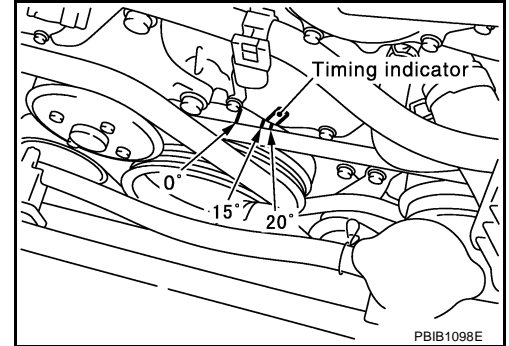

## 16. CHECK TIMING CHAIN INSTALLATION

Check timing chain installation. Refer to [EM-55, "TIMING CHAIN"](#) .

OK or NG

OK >> GO TO 17.

NG >> 1. Repair the timing chain installation.  
2. GO TO 4.

## 17. DETECT MALFUNCTIONING PART

Check the following.

- Check camshaft position sensor (PHASE) and circuit. Refer to [EC-274](#) .
- Check crankshaft position sensor (POS) and circuit. Refer to [EC-267](#) .

OK or NG

OK >> GO TO 18.

NG >> 1. Repair or replace.  
2. GO TO 4.

## 18. CHECK ECM FUNCTION

1. Substitute another known-good ECM to check ECM function. (ECM may be the cause of an incident, but this is a rare case.)
2. Perform initialization of NVIS (NATS) system and registration of all NVIS (NATS) ignition key IDs. Refer to [BL-160, "ECM Re-communicating Function"](#) .

>> GO TO 4.

# BASIC SERVICE PROCEDURE

---

## 19. CHECK AIR FUEL RATIO (A/F) SENSOR 1 FUNCTION

---

### With CONSULT-II

1. Turn ignition switch OFF and wait at a least 10 seconds.
2. Start engine and warm it up to normal operating temperature.
3. Drive the vehicle at a speed of 80 km/h (50 MPH) for a few minutes in D position (A/T models) or 5th position (M/T models).

**NOTE:**

Keep the accelerator pedal as steady as possible during the cruising.

4. Release the accelerator pedal fully until the vehicle speed decreases to 50 km/h (30 MPH).

**NOTE:**

Never apply brake during releasing the accelerator pedal.

5. Repeat steps 3 to 4 for five times.
6. Stop the vehicle and connect CONSULT-II to the vehicle.
7. Make sure that no (1st trip) DTC is displayed in "SELF-DIAG RESULTS" mode.

### OK or NG

OK >> **INSPECTION END**

NG >> GO TO 21.

---

## 20. CHECK AIR FUEL RATIO (A/F) SENSOR 1 FUNCTION

---

### Without CONSULT-II

1. Turn ignition switch OFF and wait at a least 10 seconds.
2. Start engine and warm it up to normal operating temperature.
3. Drive the vehicle at a speed of 80 km/h (50 MPH) for a few minutes in D position (A/T models) or 5th position (M/T models).

**NOTE:**

Keep the accelerator pedal as steady as possible during the cruising.

4. Release the accelerator pedal fully until the vehicle speed decreases to 50 km/h (30 MPH).

**NOTE:**

Never apply brake during releasing the accelerator pedal.

5. Repeat steps 3 to 4 for five times.
6. Stop the vehicle and connect GST to the vehicle.
7. Make sure that no (1st trip) DTC is displayed.

### OK or NG

OK >> **INSPECTION END**

NG >> GO TO 21.

# BASIC SERVICE PROCEDURE

## 21. CHECK AIR FUEL RATIO (A/F) SENSOR 1 HARNESS

1. Turn ignition switch OFF and disconnect battery ground cable.
2. Disconnect ECM harness connector.
3. Disconnect A/F sensor 1 harness connector.
4. Check harness continuity between the following terminals. Refer to [EC-463, "Wiring Diagram"](#) .

	A/F sensor 1 terminal	ECM terminal
Bank1	1	16
	2	75
	4	2
	5	35
	6	56
Bank 2	1	76
	2	77
	4	24
	5	57
	6	58

**Continuity should exist.**

5. Also check harness for short to ground and short to power.

OK or NG

OK >> GO TO 22.

NG >> 1. Repair open circuit or short to ground or short to power in harness or connectors.  
2. GO TO 4.

## 22. PERFORM ACCELERATOR PEDAL RELEASED POSITION LEARNING

1. Reconnect ECM harness connector.
2. Perform [EC-42, "Accelerator Pedal Released Position Learning"](#) .

>> GO TO 23.

## 23. PERFORM THROTTLE VALVE CLOSED POSITION LEARNING

Perform [EC-42, "Throttle Valve Closed Position Learning"](#) .

>> GO TO 24.

## 24. PERFORM IDLE AIR VOLUME LEARNING

Refer to [EC-43, "Idle Air Volume Learning"](#) .

**Is Idle Air Volume Learning carried out successfully?**

Yes or No

Yes (With CONSULT-II)>>GO TO 25.

Yes (Without CONSULT-II)>>GO TO 26.

No >> 1. Follow the instruction of Idle Air Volume Learning.  
2. GO TO 4.

# BASIC SERVICE PROCEDURE

## 25. CHECK CO%

### With CONSULT-II

1. Start engine and warm it up until engine coolant temperature indicator points the middle of gauge.
2. Turn ignition switch OFF, wait at least 10 seconds and then turn ON.
3. Select "ENG COOLANT TEMP" in "ACTIVE TEST" mode.
4. Set "ENG COOLANT TEMP" to 5°C (41°F) by touching "DOWN" and "Qd".
5. Start engine and rev it (2,000 to 3,000 rpm) two or three times under no-load, then run engine at idle speed.
6. Check CO%.

**Idle CO: 0.7 – 9.9% and engine runs smoothly.**

### OK or NG

- OK >> GO TO 28.  
NG >> GO TO 27.

ACTIVE TEST	
ENG COOLANT TEMP	XXX °C
MONITOR	
ENG SPEED	XXX rpm
INJ PULSE-B1	XXX msec
IGN TIMING	XXX BTDC

SEF172Y

## 26. CHECK CO%

### Without CONSULT-II

1. Start engine and warm it up until engine coolant temperature indicator points to the middle of gauge.
2. Turn ignition switch OFF.
3. Disconnect engine coolant temperature sensor harness connector.
4. Connect a resistor (4.4 kΩ) between terminals of engine coolant temperature sensor harness connector.
5. Start engine and rev it (2,000 to 3,000 rpm) two or three times under no-load, then run engine at idle speed.
6. Check CO%.

**Idle CO: 0.7 – 9.9% and engine runs smoothly.**

7. After checking CO%, turn ignition switch OFF, disconnect the resistor from the terminals of engine coolant temperature sensor harness connector, and then connect engine coolant temperature sensor harness connector to engine coolant temperature sensor.

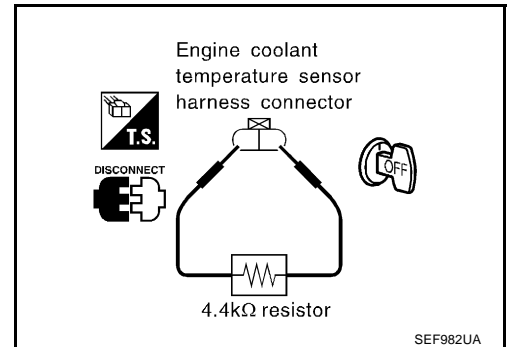

### OK or NG

- OK >> GO TO 28.  
NG >> GO TO 27.

## 27. RECONNECT AIR FUEL RATIO (A/F) SENSOR 1 HARNESS CONNECTOR

1. Turn ignition switch OFF.
2. Reconnect A/F sensor 1 harness connector.

>> GO TO 31.

## 28. REPLACE AIR FUEL RATIO (A/F) SENSOR 1

1. Stop engine.
2. Replace A/F sensor 1 on the malfunctioning bank.

With CONSULT-II>>GO TO 29.  
Without CONSULT-II>>GO TO 30.



# BASIC SERVICE PROCEDURE

## 29. CHECK AIR FUEL RATIO (A/F) SENSOR 1 FUNCTION

### With CONSULT-II

1. Turn ignition switch OFF and wait at a least 10 seconds.
2. Start engine and warm it up to normal operating temperature.
3. Drive the vehicle at a speed of 80 km/h (50 MPH) for a few minutes in D position (A/T models) or 5th position (M/T models).

#### **NOTE:**

Keep the accelerator pedal as steady as possible during the cruising.

4. Release the accelerator pedal fully until the vehicle speed decreases to 50 km/h (30 MPH).

#### **NOTE:**

Never apply brake during releasing the accelerator pedal.

5. Repeat steps 3 to 4 for five times.
6. Stop the vehicle and connect CONSULT-II to the vehicle.
7. Make sure that no (1st trip) DTC is displayed in "SELF-DIAG RESULTS" mode.

### OK or NG

- OK >> GO TO 4.  
NG >> GO TO 31.

## 30. CHECK AIR FUEL RATIO (A/F) SENSOR 1 FUNCTION

### Without CONSULT-II

1. Turn ignition switch OFF and wait at a least 10 seconds.
2. Start engine and warm it up to normal operating temperature.
3. Drive the vehicle at a speed of 80 km/h (50 MPH) for a few minutes in D position (A/T models) or 5th position (M/T models).

#### **NOTE:**

Keep the accelerator pedal as steady as possible during the cruising.

4. Release the accelerator pedal fully until the vehicle speed decreases to 50 km/h (30 MPH).

#### **NOTE:**

Never apply brake during releasing the accelerator pedal.

5. Repeat steps 3 to 4 for five times.
6. Stop the vehicle and connect GST to the vehicle.
7. Make sure that no (1st trip) DTC is displayed.

### OK or NG

- OK >> GO TO 4.  
NG >> GO TO 31.

## 31. DETECT MALFUNCTIONING PART

Check the following.

- Check fuel pressure regulator and repair or replace if necessary. Refer to [EC-45, "Fuel Pressure Check"](#) .
- Check mass air flow sensor and its circuit, and repair or replace if necessary. Refer to [EC-153](#) and [EC-163](#) .
- Check injector and its circuit, and repair or replace if necessary. Refer to [EC-634](#) .
- Check engine coolant temperature sensor and its circuit, and repair or replace if necessary. Refer to [EC-178](#) and [EC-192](#) .

### OK or NG

- OK >> GO TO 33.  
NG >> 1. Repair or replace.  
2. GO TO 32.

# BASIC SERVICE PROCEDURE

## 32. ERASE UNNECESSARY DTC

After this inspection, unnecessary DTC might be displayed.

Erase the stored memory in ECM and TCM. Refer to [EC-61, "HOW TO ERASE EMISSION-RELATED DIAGNOSTIC INFORMATION"](#) and [AT-38, "HOW TO ERASE DTC"](#) .

>> GO TO 4.

## 33. CHECK ECM FUNCTION

1. Substitute another known-good ECM to check ECM function. (ECM may be the cause of an incident, but this is a rare case.)
2. Perform initialization of NVIS (NATS) system and registration of all NVIS (NATS) ignition key IDs. Refer to [BL-160, "ECM Re-communicating Function"](#) .

>> GO TO 4.

### VIN Registration DESCRIPTION

ABS00B4Q

VIN Registration is an operation to registering VIN in ECM. It must be performed each time ECM is replaced.

#### NOTE:

Accurate VIN which is registered in ECM may be required for Inspection & Maintenance (I/M).

#### OPERATION PROCEDURE

##### With CONSULT-II

1. Check the VIN of the vehicle and note it. Refer to [GI-48, "IDENTIFICATION INFORMATION"](#) .
2. Turn ignition switch ON and engine stopped.
3. Select "VIN REGISTRATION" in "WORK SUPPORT" mode.
4. Follow the instruction of CONSULT-II display.

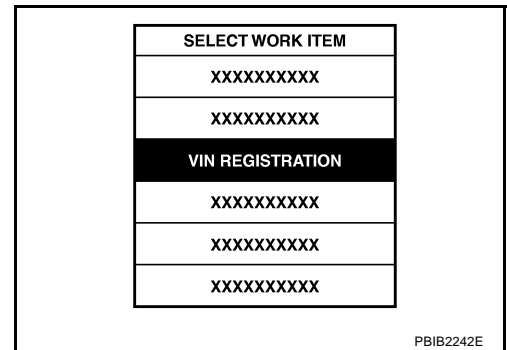

### Accelerator Pedal Released Position Learning DESCRIPTION

ABS009AS

Accelerator Pedal Released Position Learning is an operation to learn the fully released position of the accelerator pedal by monitoring the accelerator pedal position sensor output signal. It must be performed each time harness connector of accelerator pedal position sensor or ECM is disconnected.

#### OPERATION PROCEDURE

1. Make sure that accelerator pedal is fully released.
2. Turn ignition switch ON and wait at least 2 seconds.
3. Turn ignition switch OFF and wait at least 10 seconds.
4. Turn ignition switch ON and wait at least 2 seconds.
5. Turn ignition switch OFF and wait at least 10 seconds.

### Throttle Valve Closed Position Learning DESCRIPTION

ABS009AT

Throttle Valve Closed Position Learning is an operation to learn the fully closed position of the throttle valve by monitoring the throttle position sensor output signal. It must be performed each time harness connector of electric throttle control actuator or ECM is disconnected.

# BASIC SERVICE PROCEDURE

## OPERATION PROCEDURE

1. Make sure that accelerator pedal is fully released.
2. Turn ignition switch ON.
3. Turn ignition switch OFF and wait at least 10 seconds.  
Make sure that throttle valve moves during above 10 seconds by confirming the operating sound.

## Idle Air Volume Learning DESCRIPTION

ABS009AU

Idle Air Volume Learning is an operation to learn the idle air volume that keeps each engine within the specific range. It must be performed under any of the following conditions:

- Each time electric throttle control actuator or ECM is replaced.
- Idle speed or ignition timing is out of specification.

## PREPARATION

Before performing Idle Air Volume Learning, make sure that all of the following conditions are satisfied. Learning will be cancelled if any of the following conditions are missed for even a moment.

- Battery voltage: More than 12.9V (At idle)
- Engine coolant temperature: 70 - 100°C (158 - 212°F)
- Park/neutral position (PNP) switch: ON
- Electric load switch: OFF  
(Air conditioner, headlamp, rear window defogger)  
**On vehicles equipped with daytime light systems, if the parking brake is applied before the engine is started, the headlamp will not be illuminated.**
- Steering wheel: Neutral (Straight-ahead position)
- Vehicle speed: Stopped
- Transmission: Warmed-up  
For A/T models with CONSULT-II, drive vehicle until "ATF TEMP SE 1" in "DATA MONITOR" mode of "A/T" system indicates less than 0.9V.  
For A/T models without CONSULT-II and M/T models, drive vehicle for 10 minutes.

## OPERATION PROCEDURE

### ④ With CONSULT-II

1. Perform [EC-42, "Accelerator Pedal Released Position Learning"](#).
2. Perform [EC-42, "Throttle Valve Closed Position Learning"](#).
3. Start engine and warm it up to normal operating temperature.
4. Check that all items listed under the topic PREPARATION (previously mentioned) are in good order.
5. Select "IDLE AIR VOL LEARN" in "WORK SUPPORT" mode.

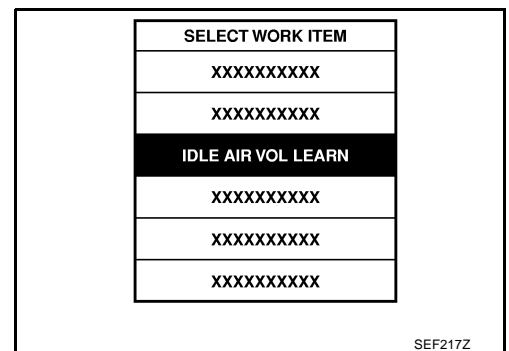

# BASIC SERVICE PROCEDURE

6. Touch "START" and wait 20 seconds.

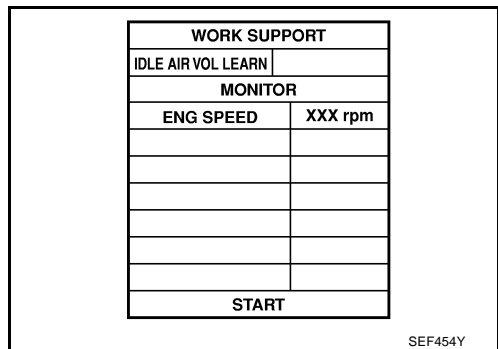

7. Make sure that "CMPLT" is displayed on CONSULT-II screen. If "CMPLT" is not displayed, Idle Air Volume Learning will not be carried out successfully. In this case, find the cause of the incident by referring to the DIAGNOSIS PROCEDURE below.
8. Rev up the engine two or three times and make sure that idle speed and ignition timing are within the specifications.

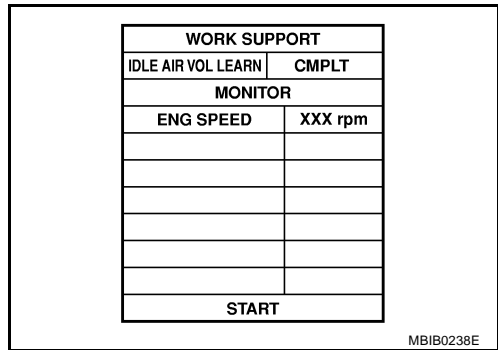

ITEM	SPECIFICATION
Idle speed	A/T: 650±50 rpm (in P or N position) M/T: 650±50 rpm (in Neutral position)
Ignition timing	A/T: 15±5° BTDC (in P or N position) M/T: 15±5° BTDC (in Neutral position)

## ⊗ Without CONSULT-II

### NOTE:

- It is better to count the time accurately with a clock.
  - It is impossible to switch the diagnostic mode when an accelerator pedal position sensor circuit has a malfunction.
1. Perform [EC-42, "Accelerator Pedal Released Position Learning"](#) .
  2. Perform [EC-42, "Throttle Valve Closed Position Learning"](#) .
  3. Start engine and warm it up to normal operating temperature.
  4. Check that all items listed under the topic PREPARATION (previously mentioned) are in good order.
  5. Turn ignition switch OFF and wait at least 10 seconds.
  6. Confirm that accelerator pedal is fully released, turn ignition switch ON and wait 3 seconds.
  7. Repeat the following procedure quickly five times within 5 seconds.
    - a. Fully depress the accelerator pedal.
    - b. Fully release the accelerator pedal.
  8. Wait 7 seconds, fully depress the accelerator pedal and keep it for approx. 20 seconds until the MIL stops blinking and turned ON.
  9. Fully release the accelerator pedal within 3 seconds after the MIL turned ON.
  10. Start engine and let it idle.
  11. Wait 20 seconds.

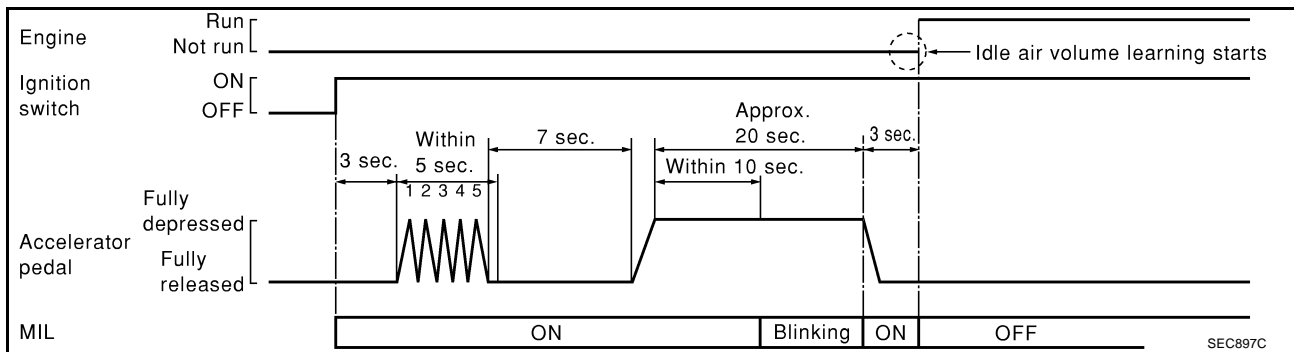

# BASIC SERVICE PROCEDURE

12. Rev up the engine two or three times and make sure that idle speed and ignition timing are within the specifications.

ITEM	SPECIFICATION
Idle speed	A/T: 650±50 rpm (in P or N position) M/T: 650±50 rpm (in Neutral position)
Ignition timing	A/T: 15±5° BTDC (in P or N position) M/T: 15±5° BTDC (in Neutral position)

13. If idle speed and ignition timing are not within the specification, Idle Air Volume Learning will not be carried out successfully. In this case, find the cause of the incident by referring to the DIAGNOSTIC PROCEDURE below.

## DIAGNOSTIC PROCEDURE

If idle air volume learning cannot be performed successfully, proceed as follows:

1. Check that throttle valve is fully closed.
2. Check PCV valve operation.
3. Check that downstream of throttle valve is free from air leakage.
4. When the above three items check out OK, engine component parts and their installation condition are questionable. Check and eliminate the cause of the incident. It is useful to perform **EC-125, "TROUBLE DIAGNOSIS - SPECIFICATION VALUE"**.
5. If any of the following conditions occur after the engine has started, eliminate the cause of the incident and perform Idle Air Volume Learning all over again:
  - Engine stalls.
  - Erroneous idle.

## Fuel Pressure Check FUEL PRESSURE RELEASE

ABS009AV

### With CONSULT-II

1. Turn ignition switch ON.
2. Perform "FUEL PRESSURE RELEASE" in "WORK SUPPORT" mode with CONSULT-II.
3. Start engine.
4. After engine stalls, crank it two or three times to release all fuel pressure.
5. Turn ignition switch OFF.

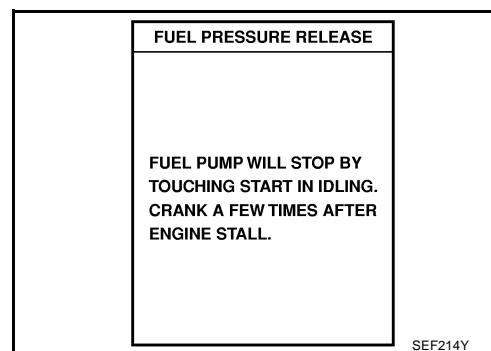

### Without CONSULT-II

1. Remove fuel pump fuse located in IPDM E/R.
2. Start engine.
3. After engine stalls, crank it two or three times to release all fuel pressure.
4. Turn ignition switch OFF.
5. Reinstall fuel pump fuse after servicing fuel system.

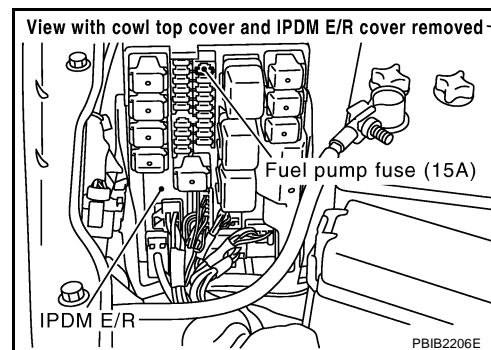

## FUEL PRESSURE CHECK

### CAUTION:

Before disconnecting fuel line, release fuel pressure from fuel line to eliminate danger.

## BASIC SERVICE PROCEDURE

### NOTE:

Prepare pans or saucers under the disconnected fuel line because the fuel may spill out. The fuel pressure cannot be completely released because Z33 models do not have fuel return system.

Use Fuel Pressure Gauge Kit (J-44321) to check fuel pressure.

1. Release fuel pressure to zero. Refer to [EC-45, "FUEL PRESSURE RELEASE"](#).
2. Install the inline fuel quick disconnected fitting between fuel damper and injector tube.
3. Connect the fuel pressure test gauge (quick connector adapter hose) to the inline fuel quick disconnected fitting.
4. Turn ignition switch ON and check for fuel leakage.
5. Start engine and check for fuel leakage.
6. Read the indication of fuel pressure gauge.

**At idling: Approximately 350 kPa (3.57 kg/cm<sup>2</sup> , 51 psi)**

7. If result is unsatisfactory, go to next step.
8. Check the following.
  - Fuel hoses and fuel tubes for clogging
  - Fuel filter for clogging
  - Fuel pump
  - Fuel pressure regulator for cloggingIf OK, replace fuel pressure regulator.  
If NG, repair or replace.

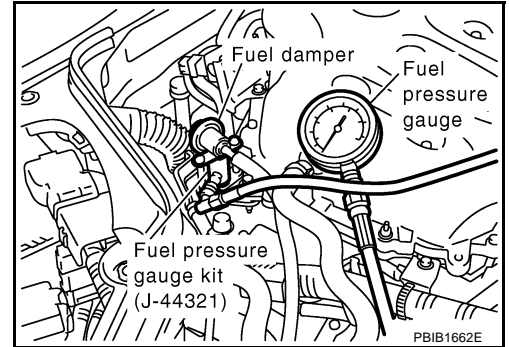

# ON BOARD DIAGNOSTIC (OBD) SYSTEM

## ON BOARD DIAGNOSTIC (OBD) SYSTEM

PPF:00028

### Introduction

ABS009AW

The ECM has an on board diagnostic system, which detects malfunctions related to engine sensors or actuators. The ECM also records various emission-related diagnostic information including:

Emission-related diagnostic information	SAE Mode
Diagnostic Trouble Code (DTC)	Mode 3 of SAE J1979
Freeze Frame data	Mode 2 of SAE J1979
System Readiness Test (SRT) code	Mode 1 of SAE J1979
1st Trip Diagnostic Trouble Code (1st Trip DTC)	Mode 7 of SAE J1979
1st Trip Freeze Frame data	
Test values and Test limits	Mode 6 of SAE J1979
Calibration ID	Mode 9 of SAE J1979

The above information can be checked using procedures listed in the table below.

×: Applicable —: Not applicable

	DTC	1st trip DTC	Freeze Frame data	1st trip Freeze Frame data	SRT code	Test value
CONSULT-II	×	×	×	×	×	—
GST	×	×	×	—	×	×
ECM	×	×	—	—	—	—

\*: When DTC and 1st trip DTC simultaneously appear on the display, they cannot be clearly distinguished from each other.

The malfunction indicator lamp (MIL) on the instrument panel lights up when the same malfunction is detected in two consecutive trips (Two trip detection logic), or when the ECM enters fail-safe mode. (Refer to [EC-77](#).)

### Two Trip Detection Logic

ABS009AX

When a malfunction is detected for the first time, 1st trip DTC and 1st trip Freeze Frame data are stored in the ECM memory. The MIL will not light up at this stage. <1st trip>

If the same malfunction is detected again during the next drive, the DTC and Freeze Frame data are stored in the ECM memory, and the MIL lights up. The MIL lights up at the same time when the DTC is stored. <2nd trip> The “trip” in the “Two Trip Detection Logic” means a driving mode in which self-diagnosis is performed during vehicle operation. Specific on board diagnostic items will cause the ECM to light up or blink the MIL, and store DTC and Freeze Frame data, even in the 1st trip, as shown below.

×: Applicable —: Not applicable

Items	MIL				DTC		1st trip DTC	
	1st trip		2nd trip		1st trip displaying	2nd trip displaying	1st trip displaying	2nd trip displaying
	Blinking	Lighting up	Blinking	Lighting up				
Misfire (Possible three way catalyst damage) — DTC: P0300 - P0306 is being detected	×	—	—	—	—	—	×	—
Misfire (Possible three way catalyst damage) — DTC: P0300 - P0306 is being detected	—	—	×	—	—	×	—	—
One trip detection diagnoses (Refer to <a href="#">EC-8</a> .)	—	×	—	—	×	—	—	—
Except above	—	—	—	×	—	×	×	—

When there is an open circuit on MIL circuit, the ECM cannot warn the driver by lighting up MIL when there is malfunction on engine control system.

Therefore, when electrical controlled throttle and part of ECM related diagnoses are continuously detected as NG for 5 trips, ECM warns the driver that engine control system malfunctions and MIL circuit is open by means of operating fail-safe function.

# ON BOARD DIAGNOSTIC (OBD) SYSTEM

The fail-safe function also operates when above diagnoses except MIL circuit are detected and demands the driver to repair the malfunction.

Engine operating condition in fail-safe mode

Engine speed will not rise more than 2,500 rpm due to the fuel cut

## Emission-related Diagnostic Information EMISSION-RELATED DIAGNOSTIC INFORMATION ITEMS

ABS009AY

Items (CONSULT-II screen terms)	DTC*1		SRT code	Test value/ Test limit (GST only)	1st trip DTC	Reference page
	CONSULT-II GST*2	ECM*3				
CAN COMM CIRCUIT	U1000	1000*5	—	—	— (A/T) × (M/T)	<a href="#">EC-139</a>
CAN COMM CIRCUIT	U1001	1001*5	—	—	×	<a href="#">EC-139</a>
<b>NO DTC IS DETECTED. FURTHER TESTING MAY BE REQUIRED.</b>	<b>P0000</b>	<b>0000</b>	—	—	—	—
INT/V TIM CONT-B1	P0011	0011	—	—	×	<a href="#">EC-142</a>
INT/V TIM CONT-B2	P0021	0021	—	—	×	<a href="#">EC-142</a>
HO2S2 HTR (B1)	P0037	0037	×	×	×	<a href="#">EC-145</a>
HO2S2 HTR (B1)	P0038	0038	×	×	×	<a href="#">EC-145</a>
HO2S2 HTR (B2)	P0057	0057	×	×	×	<a href="#">EC-145</a>
HO2S2 HTR (B2)	P0058	0058	×	×	×	<a href="#">EC-145</a>
MAF SEN/CIRCUIT	P0101	0101	—	—	—	<a href="#">EC-153</a>
MAF SEN/CIRCUIT	P0102	0102	—	—	—	<a href="#">EC-163</a>
MAF SEN/CIRCUIT	P0103	0103	—	—	—	<a href="#">EC-163</a>
IAT SEN/CIRCUIT	P0112	0112	—	—	×	<a href="#">EC-172</a>
IAT SEN/CIRCUIT	P0113	0113	—	—	×	<a href="#">EC-172</a>
ECT SEN/CIRC	P0117	0117	—	—	—	<a href="#">EC-178</a>
ECT SEN/CIRC	P0118	0118	—	—	—	<a href="#">EC-178</a>
TP SEN 2/CIRC	P0122	0122	—	—	—	<a href="#">EC-184</a>
TP SEN 2/CIRC	P0123	0123	—	—	—	<a href="#">EC-184</a>
ECT SENSOR	P0125	0125	—	—	—	<a href="#">EC-192</a>
IAT SENSOR	P0127	0127	—	—	×	<a href="#">EC-196</a>
THERMSTAT FNCTN	P0128	0128	—	—	×	<a href="#">EC-199</a>
HO2S2 (B1)	P0138	0138	—	×	×	<a href="#">EC-201</a>
HO2S2 (B1)	P0139	0139	×	×	×	<a href="#">EC-210</a>
HO2S2 (B2)	P0158	0158	—	×	×	<a href="#">EC-201</a>
HO2S2 (B2)	P0159	0159	×	×	×	<a href="#">EC-210</a>
FUEL SYS-LEAN-B1	P0171	0171	—	—	×	<a href="#">EC-221</a>
FUEL SYS-RICH-B1	P0172	0172	—	—	×	<a href="#">EC-230</a>
FUEL SYS-LEAN-B2	P0174	0174	—	—	×	<a href="#">EC-221</a>
FUEL SYS-RICH-B2	P0175	0175	—	—	×	<a href="#">EC-230</a>
FTT SENSOR	P0181	0181	—	—	×	<a href="#">EC-238</a>
FTT SEN/CIRCUIT	P0182	0182	—	—	×	<a href="#">EC-243</a>
FTT SEN/CIRCUIT	P0183	0183	—	—	×	<a href="#">EC-243</a>
TP SEN 1/CIRC	P0222	0222	—	—	—	<a href="#">EC-247</a>
TP SEN 1/CIRC	P0223	0223	—	—	—	<a href="#">EC-247</a>
MULTI CYL MISFIRE	P0300	0300	—	—	×	<a href="#">EC-255</a>



# ON BOARD DIAGNOSTIC (OBD) SYSTEM

Items (CONSULT-II screen terms)	DTC*1		SRT code	Test value/ Test limit (GST only)	1st trip DTC	Reference page
	CONSULT-II GST*2	ECM*3				
CYL 1 MISFIRE	P0301	0301	—	—	×	<a href="#">EC-255</a>
CYL 2 MISFIRE	P0302	0302	—	—	×	<a href="#">EC-255</a>
CYL 3 MISFIRE	P0303	0303	—	—	×	<a href="#">EC-255</a>
CYL 4 MISFIRE	P0304	0304	—	—	×	<a href="#">EC-255</a>
CYL 5 MISFIRE	P0305	0305	—	—	×	<a href="#">EC-255</a>
CYL 6 MISFIRE	P0306	0306	—	—	×	<a href="#">EC-255</a>
KNOCK SEN/CIRC-B1	P0327	0327	—	—	×	<a href="#">EC-262</a>
KNOCK SEN/CIRC-B1	P0328	0328	—	—	×	<a href="#">EC-262</a>
CKP SEN/CIRCUIT	P0335	0335	—	—	×	<a href="#">EC-267</a>
CMP SEN/CIRC-B1	P0340	0340	—	—	×	<a href="#">EC-274</a>
CMP SEN/CIRC-B2	P0345	0345	—	—	×	<a href="#">EC-274</a>
TW CATALYST SYS-B1	P0420	0420	×	×	×	<a href="#">EC-283</a>
TW CATALYST SYS-B2	P0430	0430	×	×	×	<a href="#">EC-283</a>
EVAP PURG FLOW/MON	P0441	0441	×	×	×	<a href="#">EC-287</a>
EVAP SMALL LEAK	P0442	0442	×	×	×	<a href="#">EC-292</a>
PURG VOLUME CONT/V	P0444	0444	—	—	×	<a href="#">EC-301</a>
PURG VOLUME CONT/V	P0445	0445	—	—	×	<a href="#">EC-301</a>
VENT CONTROL VALVE	P0447	0447	—	—	×	<a href="#">EC-308</a>
EVAP SYS PRES SEN	P0451	0451	—	—	×	<a href="#">EC-317</a>
EVAP SYS PRES SEN	P0452	0452	—	—	×	<a href="#">EC-320</a>
EVAP SYS PRES SEN	P0453	0453	—	—	×	<a href="#">EC-329</a>
EVAP GROSS LEAK	P0455	0455	—	—	×	<a href="#">EC-339</a>
EVAP VERY SML LEAK	P0456	0456	×*4	×	×	<a href="#">EC-347</a>
FUEL LEV SEN SLOSH	P0460	0460	—	—	×	<a href="#">EC-357</a>
FUEL LEVEL SENSOR	P0461	0461	—	—	×	<a href="#">EC-359</a>
FUEL LEVL SEN/CIRC	P0462	0462	—	—	×	<a href="#">EC-361</a>
FUEL LEVL SEN/CIRC	P0463	0463	—	—	×	<a href="#">EC-361</a>
VEH SPEED SEN/CIRC*6	P0500	0500	—	—	×	<a href="#">EC-363</a>
ISC SYSTEM	P0506	0506	—	—	×	<a href="#">EC-365</a>
ISC SYSTEM	P0507	0507	—	—	×	<a href="#">EC-367</a>
PW ST P SEN/CIRC	P0550	0550	—	—	×	<a href="#">EC-369</a>
ECM	P0605	0605	—	—	× or —	<a href="#">EC-374</a>
TCM	P0700	0700	—	—	—	<a href="#">AT-108</a>
PNP SW/CIRC	P0705	0705	—	—	×	<a href="#">AT-109</a>
ATF TEMP SEN/CIRC	P0710	0710	—	—	×	<a href="#">AT-131</a>
VEH SPD SEN/CIR AT*6	P0720	0720	—	—	×	<a href="#">AT-113</a>
ENGINE SPEED SIG	P0725	0725	—	—	×	<a href="#">AT-118</a>
TCC SOLENOID/CIRC	P0740	0740	—	—	×	<a href="#">AT-120</a>
A/T TCC S/V FNCTN	P0744	0744	—	—	×	<a href="#">AT-122</a>
L/PRESS SOL/CIRC	P0745	0745	—	—	×	<a href="#">AT-124</a>
A/F SEN1 HTR (B1)	P1031	1031	×	×	×	<a href="#">EC-377</a>
A/F SEN1 HTR (B1)	P1032	1032	×	×	×	<a href="#">EC-377</a>

A  
EC  
C  
D  
E  
F  
G  
H  
I  
J  
K  
L  
M

## ON BOARD DIAGNOSTIC (OBD) SYSTEM

Items (CONSULT-II screen terms)	DTC*1		SRT code	Test value/ Test limit (GST only)	1st trip DTC	Reference page
	CONSULT-II GST*2	ECM*3				
A/F SEN1 HTR (B2)	P1051	1051	×	×	×	<a href="#">EC-377</a>
A/F SEN1 HTR (B2)	P1052	1052	×	×	×	<a href="#">EC-377</a>
ECM BACK UP/CIRC	P1065	1065	—	—	×	<a href="#">EC-384</a>
INT/V TIM V/CIR-B1	P1111	1111	—	—	×	<a href="#">EC-388</a>
ETC ACTR	P1121	1121	—	—	—	<a href="#">EC-395</a>
ETC FUNCTION/CIRC	P1122	1122	—	—	—	<a href="#">EC-397</a>
ETC MOT PWR	P1124	1124	—	—	—	<a href="#">EC-404</a>
ETC MOT PWR	P1126	1126	—	—	—	<a href="#">EC-404</a>
ETC MOT	P1128	1128	—	—	—	<a href="#">EC-409</a>
INT/V TIM V/CIR-B2	P1136	1136	—	—	×	<a href="#">EC-388</a>
HO2S2 (B1)	P1146	1146	×	×	×	<a href="#">EC-414</a>
HO2S2 (B1)	P1147	1147	×	×	×	<a href="#">EC-425</a>
CLOSED LOOP-B1	P1148	1148	—	—	—	<a href="#">EC-436</a>
HO2S2 (B2)	P1166	1166	×	×	×	<a href="#">EC-414</a>
HO2S2 (B2)	P1167	1167	×	×	×	<a href="#">EC-425</a>
CLOSED LOOP-B2	P1168	1168	—	—	—	<a href="#">EC-436</a>
TCS C/U FUNCTN	P1211	1211	—	—	×	<a href="#">EC-437</a>
TCS/CIRC	P1212	1212	—	—	×	<a href="#">EC-438</a>
ENG OVER TEMP	P1217	1217	—	—	—	<a href="#">EC-439</a>
CTP LEARNING	P1225	1225	—	—	×	<a href="#">EC-452</a>
CTP LEARNING	P1226	1226	—	—	×	<a href="#">EC-454</a>
SENSOR POWER/CIRC	P1229	1229	—	—	—	<a href="#">EC-456</a>
A/F SENSOR1 (B1)	P1271	1271	—	—	×	<a href="#">EC-461</a>
A/F SENSOR1 (B1)	P1272	1272	—	—	×	<a href="#">EC-470</a>
A/F SENSOR1 (B1)	P1273	1273	—	—	×	<a href="#">EC-479</a>
A/F SENSOR1 (B1)	P1274	1274	—	—	×	<a href="#">EC-489</a>
A/F SENSOR1 (B1)	P1276	1276	—	—	×	<a href="#">EC-499</a>
A/F SENSOR1 (B1)	P1278	1278	×	×	×	<a href="#">EC-509</a>
A/F SENSOR1 (B1)	P1279	1279	×	×	×	<a href="#">EC-521</a>
A/F SENSOR1 (B2)	P1281	1281	—	—	×	<a href="#">EC-461</a>
A/F SENSOR1 (B2)	P1282	1282	—	—	×	<a href="#">EC-470</a>
A/F SENSOR1 (B2)	P1283	1283	—	—	×	<a href="#">EC-479</a>
A/F SENSOR1 (B2)	P1284	1284	—	—	×	<a href="#">EC-489</a>
A/F SENSOR1 (B2)	P1286	1286	—	—	×	<a href="#">EC-499</a>
A/F SENSOR1 (B2)	P1288	1288	×	×	×	<a href="#">EC-509</a>
A/F SENSOR1 (B2)	P1289	1289	×	×	×	<a href="#">EC-521</a>
PURG VOLUME CONT/V	P1444	1444	—	—	×	<a href="#">EC-533</a>
VENT CONTROL VALVE	P1446	1446	—	—	×	<a href="#">EC-541</a>
ASCD SW	P1564	1564	—	—	—	<a href="#">EC-550</a>
ASCD BRAKE SW	P1572	1572	—	—	—	<a href="#">EC-558</a>
ASCD VHL SPD SEN	P1574	1574	—	—	—	<a href="#">EC-574</a>
NATS MALFUNCTION	P1610 - P1615	1610 - 1615	—	—	×	<a href="#">EC-63</a>

# ON BOARD DIAGNOSTIC (OBD) SYSTEM

Items (CONSULT-II screen terms)	DTC*1		SRT code	Test value/ Test limit (GST only)	1st trip DTC	Reference page
	CONSULT-II GST*2	ECM*3				
TPV SEN/CIRC A/T	P1705	1705	—	—	—	<a href="#">AT-128</a>
P-N POS SW/CIRCUIT	P1706	1706	—	—	×	<a href="#">EC-576</a>
TURBINE REV S/CIRC	P1716	1716	—	—	×	<a href="#">AT-136</a>
A/T INTERLOCK	P1730	1730	—	—	—	<a href="#">AT-140</a>
I/C SOLENOID/CIRC	P1752	1752	—	—	—	<a href="#">AT-145</a>
I/C SOLENOID FNCTN	P1754	1754	—	—	—	<a href="#">AT-147</a>
FR/B SOLENOID/CIRC	P1757	1757	—	—	—	<a href="#">AT-149</a>
FR/B SOLENOID/CIRC	P1759	1759	—	—	—	<a href="#">AT-151</a>
D/C SOLENOID/CIRC	P1762	1762	—	—	—	<a href="#">AT-153</a>
D/C SOLENOID FNCTN	P1764	1764	—	—	—	<a href="#">AT-155</a>
HLR/C SOL/CIRC	P1767	1767	—	—	—	<a href="#">AT-157</a>
HLR/C SOL FNCTN	P1769	1769	—	—	—	<a href="#">AT-159</a>
LC/B SOLENOID/CIRC	P1772	1772	—	—	—	<a href="#">AT-161</a>
LC/B SOLENOID FNCT	P1774	1774	—	—	—	<a href="#">AT-163</a>
BRAKE SW/CIRCUIT	P1805	1805	—	—	×	<a href="#">EC-584</a>
APP SEN 1/CIRC	P2122	2122	—	—	—	<a href="#">EC-589</a>
APP SEN 1/CIRC	P2123	2123	—	—	—	<a href="#">EC-589</a>
APP SEN 2/CIRC	P2127	2127	—	—	—	<a href="#">EC-597</a>
APP SEN 2/CIRC	P2128	2128	—	—	—	<a href="#">EC-597</a>
TP SENSOR	P2135	2135	—	—	—	<a href="#">EC-605</a>
APP SENSOR	P2138	2138	—	—	—	<a href="#">EC-613</a>

\*1: 1st trip DTC No. is the same as DTC No.

\*2: This number is prescribed by SAE J2012.

\*3: In Diagnostic Test Mode II (Self-diagnostic results), this number is controlled by NISSAN.

\*4: SRT code will not be set if the self-diagnostic result is NG.

\*5: The troubleshooting for this DTC needs CONSULT-II.

\*6: When the fail-safe operations for both self-diagnoses occur at the same time, the MIL illuminates.

## DTC AND 1ST TRIP DTC

The 1st trip DTC (whose number is the same as the DTC number) is displayed for the latest self-diagnostic result obtained. If the ECM memory was cleared previously, and the 1st trip DTC did not reoccur, the 1st trip DTC will not be displayed.

If a malfunction is detected during the 1st trip, the 1st trip DTC is stored in the ECM memory. The MIL will not light up (two trip detection logic). If the same malfunction is not detected in the 2nd trip (meeting the required driving pattern), the 1st trip DTC is cleared from the ECM memory. If the same malfunction is detected in the 2nd trip, both the 1st trip DTC and DTC are stored in the ECM memory and the MIL lights up. In other words, the DTC is stored in the ECM memory and the MIL lights up when the same malfunction occurs in two consecutive trips. If a 1st trip DTC is stored and a non-diagnostic operation is performed between the 1st and 2nd trips, only the 1st trip DTC will continue to be stored. For malfunctions that blink or light up the MIL during the 1st trip, the DTC and 1st trip DTC are stored in the ECM memory.

Procedures for clearing the DTC and the 1st trip DTC from the ECM memory are described in [EC-61, "HOW TO ERASE EMISSION-RELATED DIAGNOSTIC INFORMATION"](#).

For malfunctions in which 1st trip DTCs are displayed, refer to [EC-48, "EMISSION-RELATED DIAGNOSTIC INFORMATION ITEMS"](#). These items are required by legal regulations to continuously monitor the system/component. In addition, the items monitored non-continuously are also displayed on CONSULT-II.

1st trip DTC is specified in Mode 7 of SAE J1979. 1st trip DTC detection occurs without lighting up the MIL and therefore does not warn the driver of a malfunction. However, 1st trip DTC detection will not prevent the vehicle from being tested, for example during Inspection/Maintenance (I/M) tests.

When a 1st trip DTC is detected, check, print out or write down and erase (1st trip) DTC and Freeze Frame data as specified in Work Flow procedure Step II, refer to [EC-73, "WORK FLOW"](#). Then perform DTC Confir-

# ON BOARD DIAGNOSTIC (OBD) SYSTEM

mation Procedure or Overall Function Check to try to duplicate the malfunction. If the malfunction is duplicated, the item requires repair.

## How to Read DTC and 1st Trip DTC

DTC and 1st trip DTC can be read by the following methods.

 **With CONSULT-II**

 **With GST**

CONSULT-II or GST (Generic Scan Tool) Examples: P0340, P1148, P1706, etc.

These DTCs are prescribed by SAE J2012.

(CONSULT-II also displays the malfunctioning component or system.)

 **No Tools**

The number of blinks of the MIL in the Diagnostic Test Mode II (Self-Diagnostic Results) indicates the DTC. Example: 0340, 1148, 1706, etc.

These DTCs are controlled by NISSAN.

- **1st trip DTC No. is the same as DTC No.**
- **Output of a DTC indicates a malfunction. However, GST or the Diagnostic Test Mode II do not indicate whether the malfunction is still occurring or has occurred in the past and has returned to normal. CONSULT-II can identify malfunction status as shown below. Therefore, using CONSULT-II (if available) is recommended.**

A sample of CONSULT-II display for DTC and 1st trip DTC is shown below. DTC or 1st trip DTC of a malfunction is displayed in “SELF-DIAGNOSTIC RESULTS” mode of CONSULT-II. Time data indicates how many times the vehicle was driven after the last detection of a DTC.

If the DTC is being detected currently, the time data will be [0].

If a 1st trip DTC is stored in the ECM, the time data will be [1t].

DTC display	SELF DIAG RESULTS		1st trip DTC display	SELF DIAG RESULTS	
	DTC RESULTS			TIME	
	CKP SEN/CIRCUIT [P0335]	0		CKP SEN/CIRCUIT [P0335]	1t

PBIB0911E

## FREEZE FRAME DATA AND 1ST TRIP FREEZE FRAME DATA

The ECM records the driving conditions such as fuel system status, calculated load value, engine coolant temperature, short term fuel trim, long term fuel trim, engine speed, vehicle speed, base fuel schedule and intake air temperature at the moment a malfunction is detected.

Data which are stored in the ECM memory, along with the 1st trip DTC, are called 1st trip freeze frame data. The data, stored together with the DTC data, are called freeze frame data and displayed on CONSULT-II or GST. The 1st trip freeze frame data can only be displayed on the CONSULT-II screen, not on the GST. For details, see [EC-108, "Freeze Frame Data and 1st Trip Freeze Frame Data"](#).

Only one set of freeze frame data (either 1st trip freeze frame data or freeze frame data) can be stored in the ECM. 1st trip freeze frame data is stored in the ECM memory along with the 1st trip DTC. There is no priority for 1st trip freeze frame data and it is updated each time a different 1st trip DTC is detected. However, once freeze frame data (2nd trip detection/MIL on) is stored in the ECM memory, 1st trip freeze frame data is no longer stored. Remember, only one set of freeze frame data can be stored in the ECM. The ECM has the following priorities to update the data.

Priority	Items	
1	Freeze frame data	Misfire — DTC: P0300 - P0306 Fuel Injection System Function — DTC: P0171, P0172, P0174, P0175
2		Except the above items (Includes A/T related items)
3	1st trip freeze frame data	

For example, the EGR malfunction (Priority: 2) was detected and the freeze frame data was stored in the 2nd trip. After that when the misfire (Priority: 1) is detected in another trip, the freeze frame data will be updated from the EGR malfunction to the misfire. The 1st trip freeze frame data is updated each time a different mal-

# ON BOARD DIAGNOSTIC (OBD) SYSTEM

function is detected. There is no priority for 1st trip freeze frame data. However, once freeze frame data is stored in the ECM memory, 1st trip freeze data is no longer stored (because only one freeze frame data or 1st trip freeze frame data can be stored in the ECM). If freeze frame data is stored in the ECM memory and freeze frame data with the same priority occurs later, the first (original) freeze frame data remains unchanged in the ECM memory.

Both 1st trip freeze frame data and freeze frame data (along with the DTCs) are cleared when the ECM memory is erased. Procedures for clearing the ECM memory are described in [EC-61, "HOW TO ERASE EMISSION-RELATED DIAGNOSTIC INFORMATION"](#).

## SYSTEM READINESS TEST (SRT) CODE

System Readiness Test (SRT) code is specified in Mode 1 of SAE J1979.

As part of an enhanced emissions test for Inspection & Maintenance (I/M), certain states require the status of SRT be used to indicate whether the ECM has completed self-diagnosis of major emission systems and components. Completion must be verified in order for the emissions inspection to proceed.

If a vehicle is rejected for a State emissions inspection due to one or more SRT items indicating "INCMP", use the information in this Service Manual to set the SRT to "CMPLT".

In most cases the ECM will automatically complete its self-diagnosis cycle during normal usage, and the SRT status will indicate "CMPLT" for each application system. Once set as "CMPLT", the SRT status remains "CMPLT" until the self-diagnosis memory is erased.

Occasionally, certain portions of the self-diagnostic test may not be completed as a result of the customer's normal driving pattern; the SRT will indicate "INCMP" for these items.

### NOTE:

The SRT will also indicate "INCMP" if the self-diagnosis memory is erased for any reason or if the ECM memory power supply is interrupted for several hours.

If, during the state emissions inspection, the SRT indicates "CMPLT" for all test items, the inspector will continue with the emissions test. However, if the SRT indicates "INCMP" for one or more of the SRT items the vehicle is returned to the customer untested.

### NOTE:

If MIL is ON during the state emissions inspection, the vehicle is also returned to the customer untested even though the SRT indicates "CMPLT" for all test items. Therefore, it is important to check SRT ("CMPLT") and DTC (No DTCs) before the inspection.

# ON BOARD DIAGNOSTIC (OBD) SYSTEM

## SRT Item

The table below shows required self-diagnostic items to set the SRT to "CMPLT".

SRT item (CONSULT-II indication)	Performance Priority*	Required self-diagnostic items to set the SRT to "CMPLT"	Corresponding DTC No.
CATALYST	2	Three way catalyst function	P0420, P0430
EVAP SYSTEM	1	EVAP control system	P0442
	2	EVAP control system	P0456
	2	EVAP control system purge flow monitoring	P0441
HO2S	2	Air fuel ratio (A/F) sensor 1	P1278, P1279
		Air fuel ratio (A/F) sensor 1	P1288, P1289
		Heated oxygen sensor 2	P0139, P0159
		Heated oxygen sensor 2	P1146, P1166
		Heated oxygen sensor 2	P1147, P1167
HO2S HTR	2	Air fuel ratio (A/F) sensor 1 heater	P1031, P1032, P1051, P1052
		Heated oxygen sensor 2 heater	P0037, P0038, P0057, P0058

\*: If completion of several SRTs is required, perform driving patterns (DTC confirmation procedure), one by one based on the priority for models with CONSULT-II.

## SRT Set Timing

SRT is set as "CMPLT" after self-diagnosis has been performed one or more times. Completion of SRT is done regardless of whether the result is OK or NG. The set timing is different between OK and NG results and is shown in the table below.

Self-diagnosis result		Example						
		Diagnosis	Ignition cycle					
			← ON →	OFF	← ON →	OFF	← ON →	OFF
All OK	Case 1	P0400	OK (1)	— (1)	OK (2)	— (2)		
		P0402	OK (1)	— (1)	— (1)	OK (2)		
		P1402	OK (1)	OK (2)	— (2)	— (2)		
		SRT of EGR	"CMPLT"	"CMPLT"	"CMPLT"	"CMPLT"		
	Case 2	P0400	OK (1)	— (1)	— (1)	— (1)		
		P0402	— (0)	— (0)	OK (1)	— (1)		
		P1402	OK (1)	OK (2)	— (2)	— (2)		
		SRT of EGR	"INCMP"	"INCMP"	"CMPLT"	"CMPLT"		
NG exists	Case 3	P0400	OK	OK	—	—		
		P0402	—	—	—	—		
		P1402	NG	—	NG	NG	NG (Consecutive NG)	
		(1st trip) DTC	1st trip DTC	—	1st trip DTC	DTC (= MIL "ON")		
		SRT of EGR	"INCMP"	"INCMP"	"INCMP"	"CMPLT"		

OK: Self-diagnosis is carried out and the result is OK.

NG: Self-diagnosis is carried out and the result is NG.

—: Self-diagnosis is not carried out.

When all SRT related self-diagnoses showed OK results in a single cycle (Ignition OFF-ON-OFF), the SRT will indicate "CMPLT". → Case 1 above

When all SRT related self-diagnoses showed OK results through several different cycles, the SRT will indicate "CMPLT" at the time the respective self-diagnoses have at least one OK result. → Case 2 above

# ON BOARD DIAGNOSTIC (OBD) SYSTEM

If one or more SRT related self-diagnoses showed NG results in 2 consecutive cycles, the SRT will also indicate "CMPLT". → Case 3 above

The table above shows that the minimum number of cycles for setting SRT as "INCMP" is one (1) for each self-diagnosis (Case 1 & 2) or two (2) for one of self-diagnoses (Case 3). However, in preparation for the state emissions inspection, it is unnecessary for each self-diagnosis to be executed twice (Case 3) for the following reasons:

- The SRT will indicate "CMPLT" at the time the respective self-diagnoses have one (1) OK result.
- The emissions inspection requires "CMPLT" of the SRT only with OK self-diagnosis results.
- When, during SRT driving pattern, 1st trip DTC (NG) is detected prior to "CMPLT" of SRT, the self-diagnosis memory must be erased from ECM after repair.
- If the 1st trip DTC is erased, all the SRT will indicate "INCMP".

**NOTE:**

SRT can be set as "CMPLT" together with the DTC(s). Therefore, DTC check must always be carried out prior to the state emission inspection even though the SRT indicates "CMPLT".

## SRT Service Procedure

If a vehicle has failed the state emissions inspection due to one or more SRT items indicating "INCMP", review the flowchart diagnostic sequence on the next page.

A  
EC  
C  
D  
E  
F  
G  
H  
I  
J  
K  
L  
M

# ON BOARD DIAGNOSTIC (OBD) SYSTEM

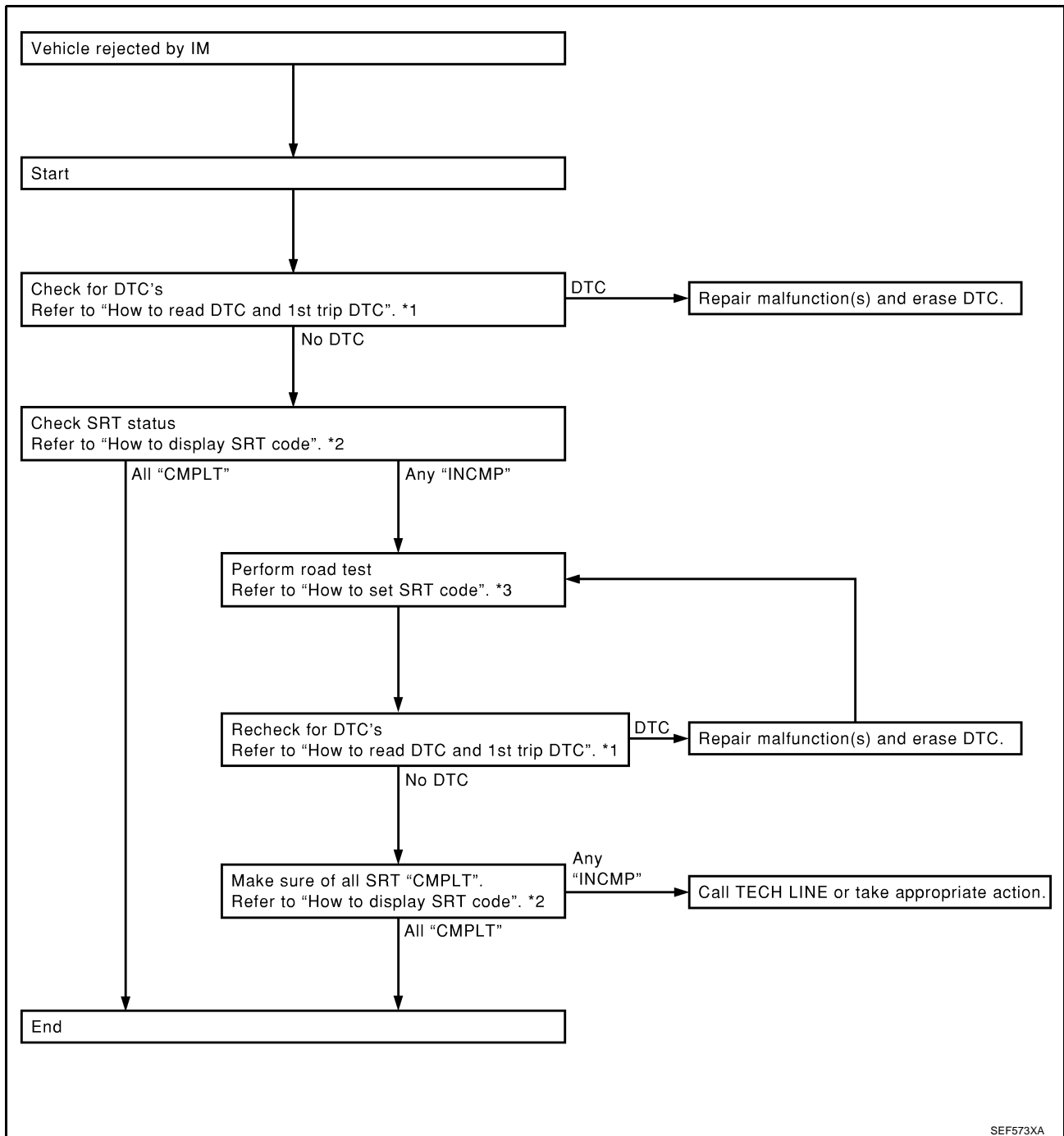

\*1 [EC-52](#)

\*2 [EC-56](#)

\*3 [EC-57](#)

SEF573XA

## How to Display SRT Code

### WITH CONSULT-II

Selecting "SRT STATUS" in "DTC CONFIRMATION" mode with CONSULT-II.

For items whose SRT codes are set, a "CMPLT" is displayed on the CONSULT-II screen; for items whose SRT codes are not set, "INCMP" is displayed.

A sample of CONSULT-II display for SRT code is shown at right.

"INCMP" means the self-diagnosis is incomplete and SRT is not set.

"CMPLT" means the self-diagnosis is complete and SRT is set.

### WITH GST

Selecting Mode 1 with GST (Generic Scan Tool)

SRT STATUS	
CATALYST	CMPLT
EVAP SYSTEM	INCMP
HO2S HTR	CMPLT
HO2S	CMPLT

SEF935Z



# ON BOARD DIAGNOSTIC (OBD) SYSTEM

## How to Set SRT Code

To set all SRT codes, self-diagnosis for the items indicated above must be performed one or more times. Each diagnosis may require a long period of actual driving under various conditions.

### **WITH CONSULT-II**

Perform corresponding DTC Confirmation Procedure one by one based on Performance Priority in the table on [EC-54. "SRT Item"](#).

### **WITHOUT CONSULT-II**

The most efficient driving pattern in which SRT codes can be properly set is explained on the next page. The driving pattern should be performed one or more times to set all SRT codes.

A  
EC  
C  
D  
E  
F  
G  
H  
I  
J  
K  
L  
M

# ON BOARD DIAGNOSTIC (OBD) SYSTEM

## Driving Pattern

**Note: Always drive vehicle in safe manner according to traffic conditions and obey all traffic laws. Refer to next page for more information and explanation of chart.**

### Driving pattern

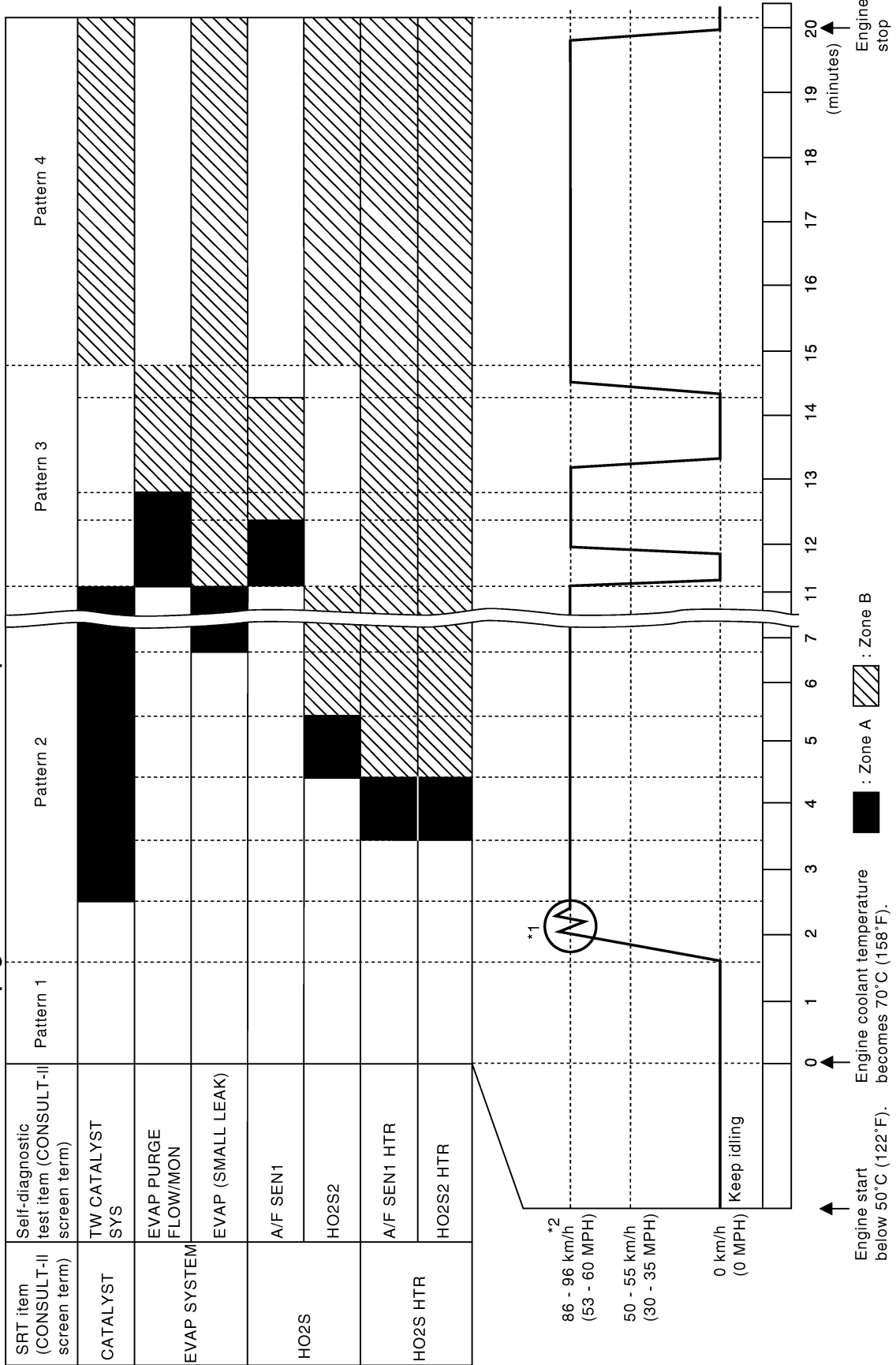

PBIB2243E

# ON BOARD DIAGNOSTIC (OBD) SYSTEM

- The time required for each diagnosis varies with road surface conditions, weather, altitude, individual driving habits, etc.  
Zone A refers to the range where the time, required for the diagnosis under normal conditions\*, is the shortest.  
Zone B refers to the range where the diagnosis can still be performed if the diagnosis is not completed within zone A.

\*: Normal conditions refer to the following:

- Sea level
- Flat road
- Ambient air temperature: 20 - 30°C (68 - 86°F)
- Diagnosis is performed as quickly as possible under normal conditions.  
Under different conditions [For example: ambient air temperature other than 20 - 30°C (68 - 86°F)], diagnosis may also be performed.

Pattern 1:

- **The engine is started at the engine coolant temperature of -10 to 35°C (14 to 95°F) (where the voltage between the ECM terminal 73 and ground is 3.0 - 4.3V).**
- **The engine must be operated at idle speed until the engine coolant temperature is greater than 70°C (158°F) (where the voltage between the ECM terminal 73 and ground is lower than 1.4V).**
- **The engine is started at the fuel tank temperature of warmer than 0°C (32°F) (where the voltage between the ECM terminal 107 and ground is less than 4.1V).**

Pattern 2:

- When steady-state driving is performed again even after it is interrupted, each diagnosis can be conducted. In this case, the time required for diagnosis may be extended.

Pattern 3:

- Operate vehicle following the driving pattern shown in the figure.
- Release the accelerator pedal during decelerating vehicle speed from 90 km/h (56 MPH) to 0 km/h (0 MPH).

Pattern 4:

- The accelerator pedal must be held very steady during steady-state driving.
- If the accelerator pedal is moved, the test must be conducted all over again.

\*1: Depress the accelerator pedal until vehicle speed is 90 km/h (56 MPH), then release the accelerator pedal and keep it released for more than 10 seconds. Depress the accelerator pedal until vehicle speed is 90 km/h (56 MPH) again.

\*2: Checking the vehicle speed with GST is advised.

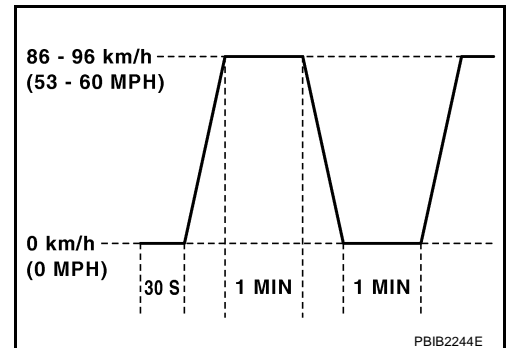

## Suggested Transmission Gear Position

Set the selector lever in the D position.

## Suggested Upshift Speeds for M/T Models

Shown below are suggested vehicle speeds for shifting into a higher gear. These suggestions relate to fuel economy and vehicle performance. Actual upshift speeds will vary according to road conditions, the weather and individual driving habits.

Gear change	For normal acceleration in low altitude areas [less than 1,219 m (4,000 ft)]:		For quick acceleration in low altitude areas and high altitude areas [over 1,219 m (4,000 ft)]:
	ACCEL shift point km/h (MPH)	CRUISE shift point km/h (MPH)	km/h (MPH)
1st to 2nd	21 (13)	13 (8)	24 (15)
2nd to 3rd	37 (23)	26 (16)	40 (25)
3rd to 4th	48 (30)	40 (25)	64 (40)
4th to 5th	60 (37)	45 (28)	72 (45)
6th	68 (42)	53 (33)	80 (50)

# ON BOARD DIAGNOSTIC (OBD) SYSTEM

## Suggested Maximum Speed in Each Gear

Downshift to a lower gear if the engine is not running smoothly, or if you need to accelerate.

Do not exceed the maximum suggested speed (shown below) in any gear. For level road driving, use the highest gear suggested for that speed. Always observe posted speed limits and drive according to the road conditions to ensure safe operation. Do not over-rev the engine when shifting to a lower gear as it may cause engine damage or loss of vehicle control.

Gear	km/h (MPH)
1st	56 (35)
2nd	96 (60)
3rd	136 (85)
4th	—
5th	—
6th	—

## TEST VALUE AND TEST LIMIT (GST ONLY — NOT APPLICABLE TO CONSULT-II)

The following is the information specified in Mode 6 of SAE J1979.

The test value is a parameter used to determine whether a system/circuit diagnostic test is OK or NG while being monitored by the ECM during self-diagnosis. The test limit is a reference value which is specified as the maximum or minimum value and is compared with the test value being monitored.

These data (test value and test limit) are specified by Test ID (TID) and Component ID (CID) and can be displayed on the GST screen.

Item	Self-diagnostic test item	DTC	Test value (GST display)		Test limit	Conversion
			TID	CID		
CATALYST	Three way catalyst function (Bank 1)	P0420	01H	01H	Max.	1/128
		P0420	02H	81H	Min.	1
	Three way catalyst function (Bank 2)	P0430	03H	02H	Max.	1/128
		P0430	04H	82H	Min.	1
EVAP SYSTEM	EVAP control system (Small leak)	P0442	05H	03H	Max.	1/128 mm <sup>2</sup>
	EVAP control system purge flow monitoring	P0441	06H	83H	Min.	20 mV
	EVAP control system (Very small leak)	P0456	07H	03H	Max.	1/128 mm <sup>2</sup>

# ON BOARD DIAGNOSTIC (OBD) SYSTEM

Item	Self-diagnostic test item	DTC	Test value (GST display)		Test limit	Conversion	
			TID	CID			
HO2S	A/F sensor 1 (Bank 1)	P1271	41H	8EH	Min.	5mV	
		P1272	42H	0EH	Max.	5mV	
		P1273	43H	0EH	Max.	0.002	
		P1274	44H	8EH	Min.	0.002	
		P1278	45H	8EH	Min.	0.004	
		P1276	46H	0EH	Max.	5mV	
		P1276	47H	8EH	Min.	5mV	
		P1279	48H	8EH	Min.	0.004	
	A/F sensor 1 (Bank 2)	P1281	4CH	8FH	Min.	5mV	
		P1282	4DH	0FH	Max	5mV	
		P1283	4EH	0FH	Max.	0.002	
		P1284	4FH	8FH	Min	0.002	
		P1288	50H	8FH	Min.	0.004	
		P1286	51H	0FH	Max.	5mV	
		P1286	52H	8FH	Min	5mV	
		P1289	53H	8FH	Min.	0.004	
	Heated oxygen sensor 2 (Bank 1)	P0138	1CH	06H	Max.	10mV	
		P0139	19H	86H	Min.	10mV/500 ms	
		P1147	1AH	86H	Min.	10 mV	
		P1146	1BH	06H	Max.	10 mV	
	Heated oxygen sensor 2 (Bank 2)	P0158	24H	07H	Max	10mV	
		P0159	21H	87H	Min.	10 mV/500 ms	
		P1167	22H	87H	Min.	10 mV	
		P1166	23H	07H	Max.	10 mV	
	HO2S HEATER	A/F sensor 1 heater (Bank 1)	P1032	57H	10H	Max.	5 mV
			P1031	58H	90H	Max.	5 mV
		A/F sensor 1 heater (Bank 2)	P1052	59H	11H	Max.	5 mV
			P1051	5AH	91H	Max.	5 mV
Heated oxygen sensor 2 heater (Bank 1)		P0038	2DH	0AH	Max.	20 mV	
		P0037	2EH	8AH	Min.	20 mV	
Heated oxygen sensor 2 heater (Bank 2)		P0058	2FH	0BH	Max.	20 mV	
		P0057	30H	8BH	Min.	20 mV	

## HOW TO ERASE EMISSION-RELATED DIAGNOSTIC INFORMATION

### How to Erase DTC

#### WITH CONSULT-II

The emission related diagnostic information in the ECM can be erased by selecting “ERASE” in the “SELF-DIAG RESULTS” mode with CONSULT-II.

If DTCs are displayed for both ECM and TCM (Transmission control module), they need to be erased individually from the ECM and TCM (Transmission control module).

#### NOTE:

**If the DTC is not for A/T related items (see EC-8 ), skip steps 2 through 4.**

1. If the ignition switch stays ON after repair work, be sure to turn ignition switch OFF once. Wait at least 10 seconds and then turn it ON (engine stopped) again.
2. Turn CONSULT-II ON and touch “A/T”.
3. Touch “SELF-DIAG RESULTS”.

# ON BOARD DIAGNOSTIC (OBD) SYSTEM

4. Touch "ERASE". [The DTC in the TCM (Transmission control module) will be erased.] Then touch "BACK" twice.
5. Touch "ENGINE".
6. Touch "SELF-DIAG RESULTS".
7. Touch "ERASE". (The DTC in the ECM will be erased.)

## How to erase DTC (With CONSULT-II)

1. If the ignition switch stays "ON" after repair work, be sure to turn ignition switch "OFF" once. Wait at least 10 seconds and then turn it "ON" (engine stopped) again.

SELECT SYSTEM
A/T
ENGINE

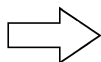

SELECT DIAG MODE
SELF-DIAG RESULTS
DATE MONITOR
CAN DIAG SUPPORT MNTR
DTC WORK SUPPORT
ECU PART NUMBER

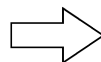

SELF-DIAG RESULTS
DTC RESULTS
TCC SOLENOID/CIRC [P0740]

2. Turn CONSULT-II "ON", and touch "A/T".

3. Touch "SELF-DIAG RESULTS".

4. Touch "ERASE". (The DTC in the TCM will be erased.)

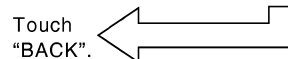
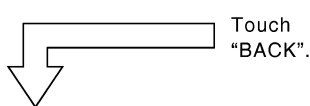

SELECT SYSTEM
A/T
ENGINE

SELECT DIAG MODE
WORK SUPPORT
SELF-DIAG RESULTS
DATA MONITOR
DATA MONITOR(SPEC)
CAN DIAG SUPPORT MNTR
ACTIVE TEST

SELF-DIAG RESULTS	
DTC RESULTS	TIME
TCC SOLENOID/CIRC [P0740]	0

5. Touch "ENGINE".

6. Touch "SELF-DIAG RESULTS".

7. Touch "ERASE". (The DTC in the ECM will be erased.)

SCIA5334E

## WITH GST

The emission related diagnostic information in the ECM can be erased by selecting Mode 4 with GST.

### NOTE:

If the DTC is not for A/T related items (see [EC-8](#)), skip step 2.

1. If the ignition switch stays ON after repair work, be sure to turn ignition switch OFF once. Wait at least 10 seconds and then turn it ON (engine stopped) again.
2. Perform [AT-39. "HOW TO ERASE DTC \(WITH GST\)"](#). (The DTC in the TCM will be erased.)
3. Select Mode 4 with GST (Generic Scan Tool).

## NO TOOLS

### NOTE:

If the DTC is not for A/T related items (see [EC-8](#)), skip step 2.

1. If the ignition switch stays ON after repair work, be sure to turn ignition switch OFF once. Wait at least 10 seconds and then turn it ON (engine stopped) again.
2. Perform [AT-40. "HOW TO ERASE DTC \(NO TOOLS\)"](#). (The DTC in the TCM will be erased.)
3. Change the diagnostic test mode from Mode II to Mode I by depressing the accelerator pedal. Refer to [EC-64. "HOW TO SWITCH DIAGNOSTIC TEST MODE"](#).
  - If the battery is disconnected, the emission-related diagnostic information will be lost within 24 hours.
  - The following data are cleared when the ECM memory is erased.

# ON BOARD DIAGNOSTIC (OBD) SYSTEM

- Diagnostic trouble codes
- 1st trip diagnostic trouble codes
- Freeze frame data
- 1st trip freeze frame data
- System readiness test (SRT) codes
- Test values
- Others

Actual work procedures are explained using a DTC as an example. Be careful so that not only the DTC, but all of the data listed above, are cleared from the ECM memory during work procedures.

## NVIS (Nissan Vehicle Immobilizer System — NATS)

ABS009AZ

- If the security indicator lights up with the ignition switch in the ON position or “NATS MALFUNCTION” is displayed on “SELF-DIAG RESULTS” screen, perform self-diagnostic results mode with CONSULT-II using NATS program card. Refer to [BL-158, "NVIS \(NISSAN VEHICLE IMMOBILIZER SYSTEM-NATS\)"](#) .
- Confirm no self-diagnostic results of NVIS (NATS) is displayed before touching “ERASE” in “SELF-DIAG RESULTS” mode with CONSULT-II.
- When replacing ECM, initialization of NVIS (NATS) system and registration of all NVIS (NATS) ignition key IDs must be carried out with CONSULT-II using NATS program card.

SELF DIAG RESULTS	
DTC RESULTS	TIME
NATS MALFUNCTION [P1610]	0

SEF543X

Therefore, be sure to receive all keys from vehicle owner. Regarding the procedures of NVIS (NATS) initialization and all NVIS (NATS) ignition key ID registration, refer to CONSULT-II Operation Manual, IVIS/NVIS.

## Malfunction Indicator Lamp (MIL)

### DESCRIPTION

ABS009B0

The MIL is located on the instrument panel.



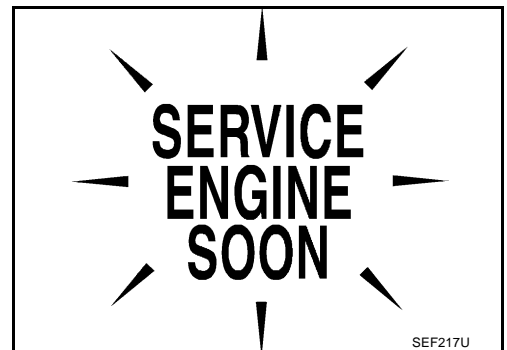

1. The MIL will light up when the ignition switch is turned ON without the engine running. This is a bulb check. If the MIL does not light up, refer to [DI-62, "WARNING LAMPS"](#) , or see [EC-672](#) .
2. When the engine is started, the MIL should go off. If the MIL remains on, the on board diagnostic system has detected an engine system malfunction.



# ON BOARD DIAGNOSTIC (OBD) SYSTEM

## ON BOARD DIAGNOSTIC SYSTEM FUNCTION

The on board diagnostic system has the following three functions.

Diagnostic Test Mode	KEY and ENG. Status	Function	Explanation of Function
Mode I	Ignition switch in ON position  Engine stopped 	BULB CHECK	This function checks the MIL bulb for damage (blown, open circuit, etc.). If the MIL does not come on, check MIL circuit.
	Engine running 	MALFUNCTION WARNING	This is a usual driving condition. When a malfunction is detected twice in two consecutive driving cycles (two trip detection logic), the MIL will light up to inform the driver that a malfunction has been detected. The following malfunctions will light up or blink the MIL in the 1st trip. <ul style="list-style-type: none"> <li>● Misfire (Possible three way catalyst damage)</li> <li>● One trip detection diagnoses</li> </ul>
Mode II	Ignition switch in ON position  Engine stopped 	SELF-DIAGNOSTIC RESULTS	This function allows DTCs and 1st trip DTCs to be read.

When there is an open circuit on MIL circuit, the ECM cannot warn the driver by lighting up MIL when there is malfunction on engine control system.

Therefore, when electrical controlled throttle and part of ECM related diagnoses are continuously detected as NG for 5 trips, ECM warns the driver that engine control system malfunctions and MIL circuit is open by means of operating fail-safe function.

The fail-safe function also operates when above diagnoses except MIL circuit are detected and demands the driver to repair the malfunction.

Engine operating condition in fail-safe mode

Engine speed will not rise more than 2,500 rpm due to the fuel cut

### MIL Flashing Without DTC

If the ECM is in Diagnostic Test Mode II, MIL may flash when engine is running. In this case, check ECM diagnostic test mode. [EC-64, "HOW TO SWITCH DIAGNOSTIC TEST MODE"](#) .

How to switch the diagnostic test (function) modes, and details of the above functions are described later. [EC-64, "HOW TO SWITCH DIAGNOSTIC TEST MODE"](#) .

The following emission-related diagnostic information is cleared when the ECM memory is erased.

- Diagnostic trouble codes
- 1st trip diagnostic trouble codes
- Freeze frame data
- 1st trip freeze frame data
- System readiness test (SRT) codes
- Test values
- Others

### HOW TO SWITCH DIAGNOSTIC TEST MODE

#### NOTE:

- It is better to count the time accurately with a clock.



# ON BOARD DIAGNOSTIC (OBD) SYSTEM

- It is impossible to switch the diagnostic mode when an accelerator pedal position sensor circuit has a malfunction.
- Always ECM returns to Diagnostic Test Mode I after ignition switch is turned OFF.

## How to Set Diagnostic Test Mode II (Self-diagnostic Results)

1. Confirm that accelerator pedal is fully released, turn ignition switch ON and wait 3 seconds.
2. Repeat the following procedure quickly five times within 5 seconds.
  - a. Fully depress the accelerator pedal.
  - b. Fully release the accelerator pedal.
3. Wait 7 seconds, fully depress the accelerator pedal and keep it for approx. 10 seconds until the MIL starts blinking.
4. Fully release the accelerator pedal.  
ECM has entered to Diagnostic Test Mode II (Self-diagnostic results).

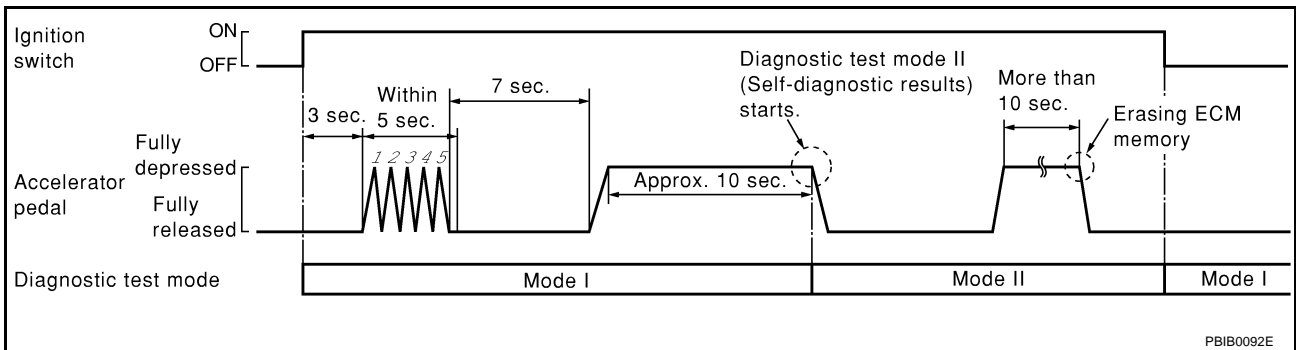

## How to Erase Diagnostic Test Mode II (Self-diagnostic Results)

1. Set ECM in Diagnostic Test Mode II (Self-diagnostic results). Refer to [EC-65, "How to Set Diagnostic Test Mode II \(Self-diagnostic Results\)"](#).
2. Fully depress the accelerator pedal and keep it for more than 10 seconds.  
The emission-related diagnostic information has been erased from the backup memory in the ECM.
3. Fully release the accelerator pedal, and confirm the DTC 0000 is displayed.

## DIAGNOSTIC TEST MODE I — BULB CHECK

In this mode, the MIL on the instrument panel should stay ON. If it remains OFF, check the bulb. Refer to [DI-62, "WARNING LAMPS"](#) or see [EC-672](#).

## DIAGNOSTIC TEST MODE I — MALFUNCTION WARNING

MIL	Condition
ON	When the malfunction is detected.
OFF	No malfunction.

These DTC numbers are clarified in Diagnostic Test Mode II (SELF-DIAGNOSTIC RESULTS)

# ON BOARD DIAGNOSTIC (OBD) SYSTEM

## DIAGNOSTIC TEST MODE II — SELF-DIAGNOSTIC RESULTS

In this mode, the DTC and 1st trip DTC are indicated by the number of blinks of the MIL as shown below. The DTC and 1st trip DTC are displayed at the same time. If the MIL does not illuminate in diagnostic test mode I (Malfunction warning), all displayed items are 1st trip DTCs. If only one code is displayed when the MIL illuminates in diagnostic test mode II (SELF-DIAGNOSTIC RESULTS), it is a DTC; if two or more codes are displayed, they may be either DTCs or 1st trip DTCs. DTC No. is same as that of 1st trip DTC. These unidentified codes can be identified by using the CONSULT-II or GST. A DTC will be used as an example for how to read a code.

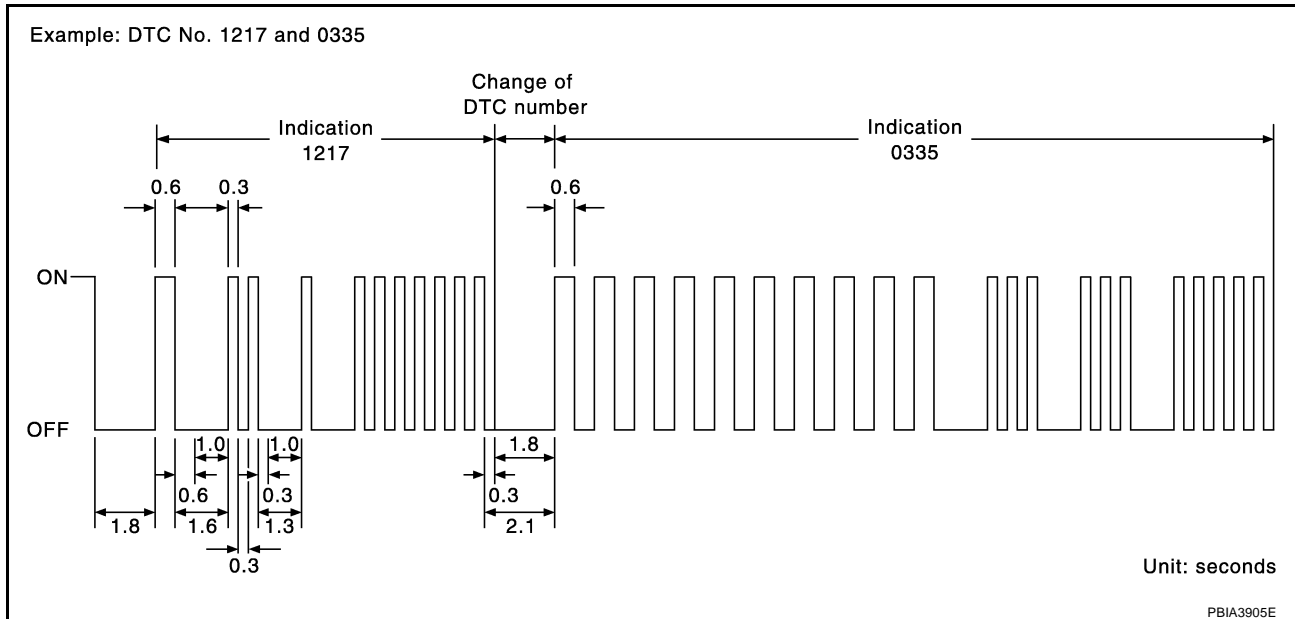

A particular trouble code can be identified by the number of four-digit numeral flashes. The “zero” is indicated by the number of ten flashes. The length of time the 1,000th-digit numeral flashes on and off is 1.2 seconds consisting of an ON (0.6-second) - OFF (0.6-second) cycle.

The 100th-digit numeral and lower digit numerals consist of a 0.3-second ON and 0.3-second OFF cycle.

A change from one digit numeral to another occurs at an interval of 1.0-second OFF. In other words, the later numeral appears on the display 1.3 seconds after the former numeral has disappeared.

A change from one trouble code to another occurs at an interval of 1.8-second OFF.

In this way, all the detected malfunctions are classified by their DTC numbers. The DTC 0000 refers to no malfunction. (See [EC-8, "INDEX FOR DTC"](#) )

### How to Erase Diagnostic Test Mode II (Self-diagnostic Results)

The DTC can be erased from the back up memory in the ECM by depressing accelerator pedal. Refer to [EC-65, "How to Erase Diagnostic Test Mode II \(Self-diagnostic Results\)"](#) .

- If the battery is disconnected, the DTC will be lost from the backup memory within 24 hours.
- Be careful not to erase the stored memory before starting trouble diagnoses.

### OBD System Operation Chart

ABS009B1

#### RELATIONSHIP BETWEEN MIL, 1ST TRIP DTC, DTC, AND DETECTABLE ITEMS

- When a malfunction is detected for the first time, the 1st trip DTC and the 1st trip freeze frame data are stored in the ECM memory.
- When the same malfunction is detected in two consecutive trips, the DTC and the freeze frame data are stored in the ECM memory, and the MIL will come on. For details, refer to [EC-47, "Two Trip Detection Logic"](#) .
- The MIL will go off after the vehicle is driven 3 times (driving pattern B) with no malfunction. The drive is counted only when the recorded driving pattern is met (as stored in the ECM). If another malfunction occurs while counting, the counter will reset.
- The DTC and the freeze frame data will be stored until the vehicle is driven 40 times (driving pattern A) without the same malfunction recurring (except for Misfire and Fuel Injection System). For Misfire and Fuel Injection System, the DTC and freeze frame data will be stored until the vehicle is driven 80 times (driving pattern C) without the same malfunction recurring. The “TIME” in “SELF-DIAGNOSTIC RESULTS” mode of CONSULT-II will count the number of times the vehicle is driven.

# ON BOARD DIAGNOSTIC (OBD) SYSTEM

- The 1st trip DTC is not displayed when the self-diagnosis results in OK for the 2nd trip.

## SUMMARY CHART

Items	Fuel Injection System	Misfire	Other
MIL (goes off)	3 (pattern B)	3 (pattern B)	3 (pattern B)
DTC, Freeze Frame Data (no display)	80 (pattern C)	80 (pattern C)	40 (pattern A)
1st Trip DTC (clear)	1 (pattern C), *1	1 (pattern C), *1	1 (pattern B)
1st Trip Freeze Frame Data (clear)	*1, *2	*1, *2	1 (pattern B)

For details about patterns B and C under “Fuel Injection System” and “Misfire”, see [EC-69](#) .

For details about patterns A and B under “Other”, see [EC-71](#)

\*1: Clear timing is at the moment OK is detected.

\*2: Clear timing is when the same malfunction is detected in the 2nd trip.

A  
EC  
C  
D  
E  
F  
G  
H  
I  
J  
K  
L  
M

# ON BOARD DIAGNOSTIC (OBD) SYSTEM

## RELATIONSHIP BETWEEN MIL, DTC, 1ST TRIP DTC AND DRIVING PATTERNS FOR "MISFIRE" <EXHAUST QUALITY DETERIORATION>, "FUEL INJECTION SYSTEM"

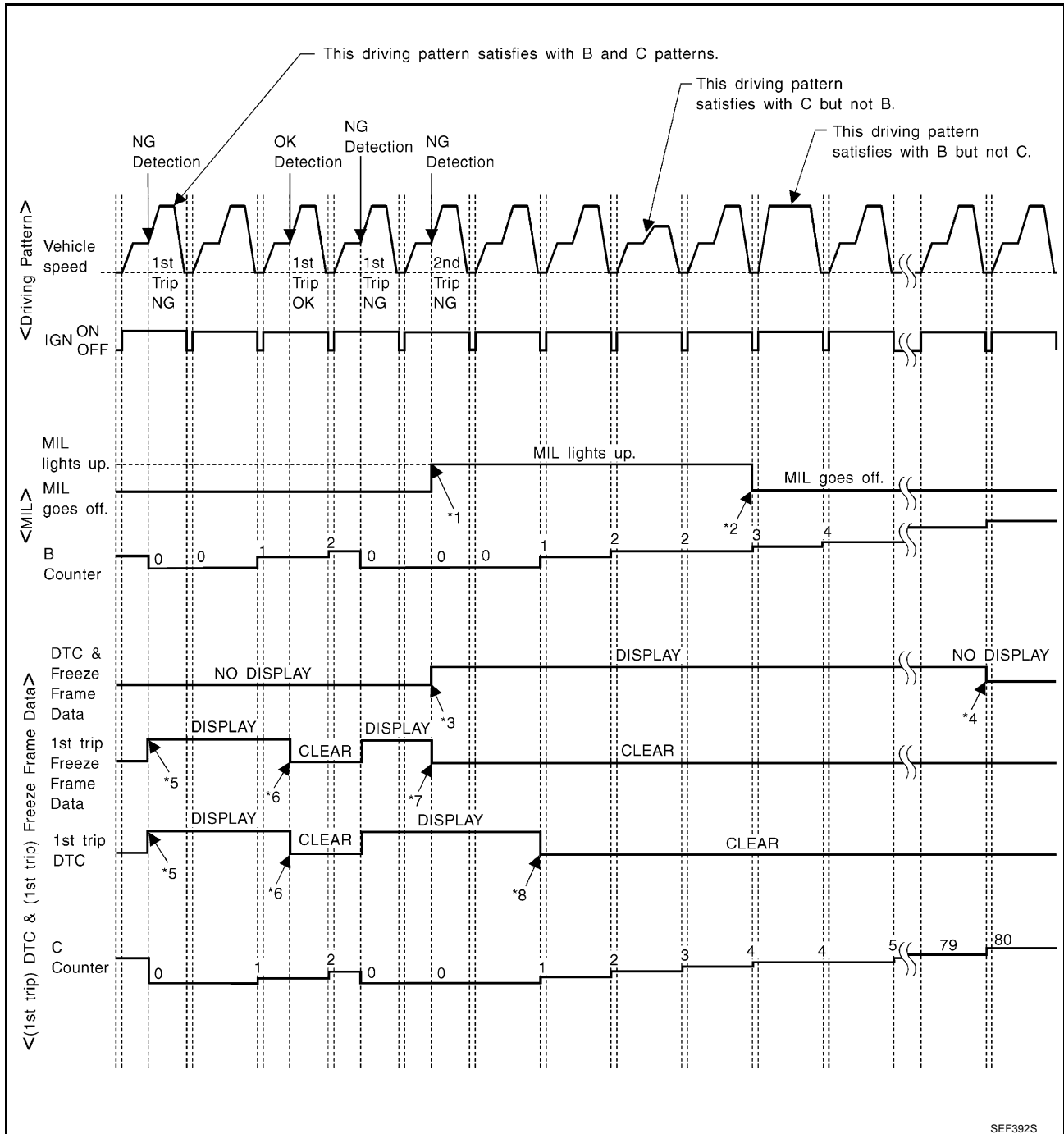

\*1: When the same malfunction is detected in two consecutive trips, MIL will light up.

\*2: MIL will go off after vehicle is driven 3 times (pattern B) without any malfunctions.

\*3: When the same malfunction is detected in two consecutive trips, the DTC and the freeze frame data will be stored in ECM.

\*4: The DTC and the freeze frame data will not be displayed any longer after vehicle is driven 80 times (pattern C) without the same malfunction. (The DTC and the freeze frame data still remain in ECM.)

\*5: When a malfunction is detected for the first time, the 1st trip DTC and the 1st trip freeze frame data will be stored in ECM.

\*6: The 1st trip DTC and the 1st trip freeze frame data will be cleared at the moment OK is detected.

\*7: When the same malfunction is detected in the 2nd trip, the 1st trip freeze frame data will be cleared.

\*8: 1st trip DTC will be cleared when vehicle is driven once (pattern C) without the same malfunction after DTC is stored in ECM.

# ON BOARD DIAGNOSTIC (OBD) SYSTEM

## EXPLANATION FOR DRIVING PATTERNS FOR “MISFIRE <EXHAUST QUALITY DETERIORATION>”, “FUEL INJECTION SYSTEM”

### <Driving Pattern B>

Driving pattern B means the vehicle operation as follows:

All components and systems should be monitored at least once by the OBD system.

- The B counter will be cleared when the malfunction is detected once regardless of the driving pattern.
- The B counter will be counted up when driving pattern B is satisfied without any malfunction.
- The MIL will go off when the B counter reaches 3. (\*2 in OBD SYSTEM OPERATION CHART)

### <Driving Pattern C>

Driving pattern C means the vehicle operation as follows:

The following conditions should be satisfied at the same time:

Engine speed: (Engine speed in the freeze frame data)  $\pm 375$  rpm

Calculated load value: (Calculated load value in the freeze frame data)  $\times (1 \pm 0.1)$  [%]

Engine coolant temperature (T) condition:

- When the freeze frame data shows lower than 70°C (158°F), T should be lower than 70°C (158°F).
- When the freeze frame data shows higher than or equal to 70°C (158°F), T should be higher than or equal to 70°C (158°F).

Example:

If the stored freeze frame data is as follows:

Engine speed: 850 rpm, Calculated load value: 30%, Engine coolant temperature: 80°C (176°F)

To be satisfied with driving pattern C, the vehicle should run under the following conditions:

Engine speed: 475 - 1,225 rpm, Calculated load value: 27 - 33%, Engine coolant temperature: more than 70°C (158°F)

- The C counter will be cleared when the malfunction is detected regardless of vehicle conditions above.
- The C counter will be counted up when vehicle conditions above is satisfied without the same malfunction.
- The DTC will not be displayed after C counter reaches 80.
- The 1st trip DTC will be cleared when C counter is counted once without the same malfunction after DTC is stored in ECM.

# ON BOARD DIAGNOSTIC (OBD) SYSTEM

## RELATIONSHIP BETWEEN MIL, DTC, 1ST TRIP DTC AND DRIVING PATTERNS EXCEPT FOR "MISFIRE <EXHAUST QUALITY DETERIORATION>", "FUEL INJECTION SYSTEM"

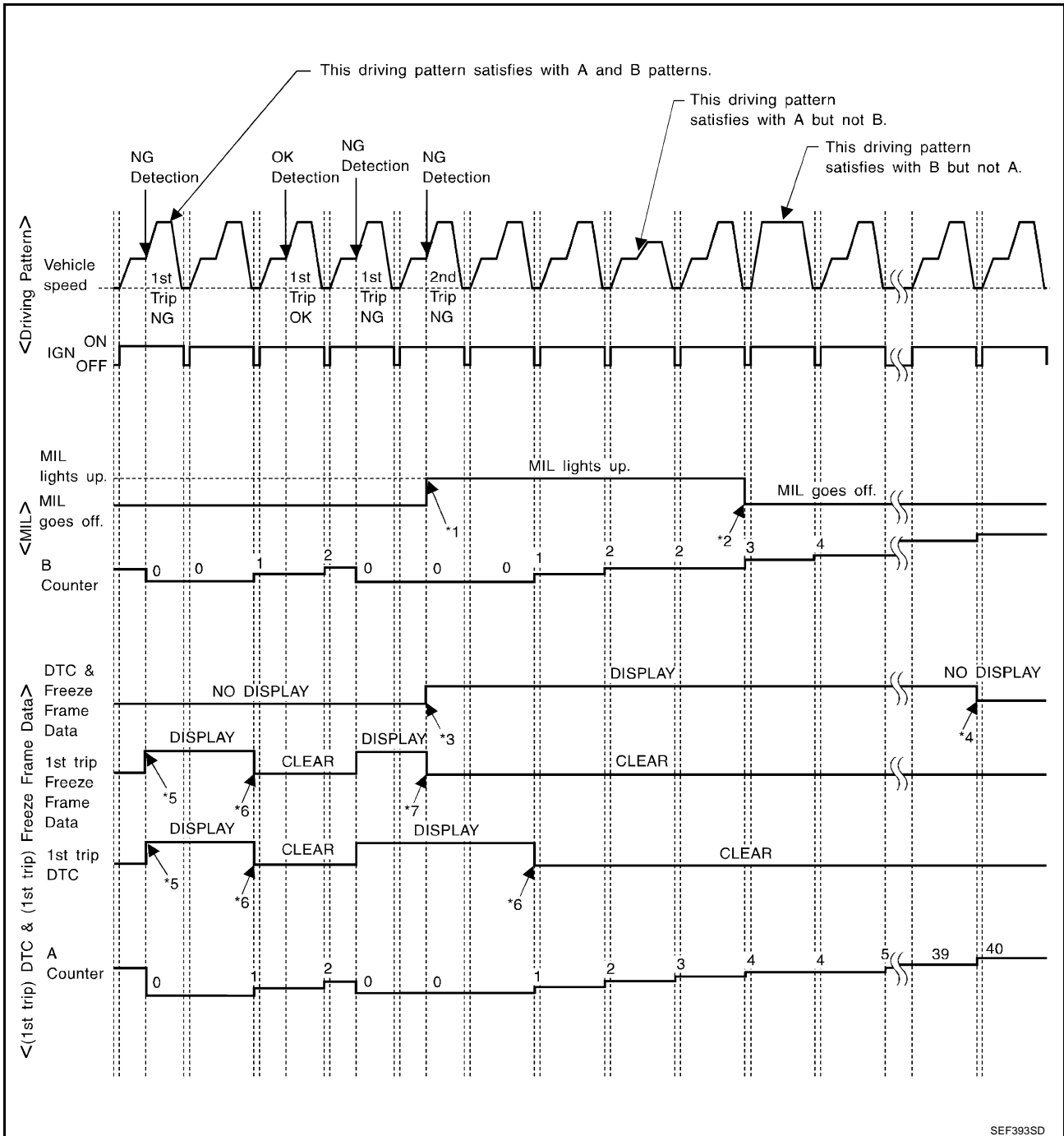

\*1: When the same malfunction is detected in two consecutive trips, MIL will light up.

\*2: MIL will go off after vehicle is driven 3 times (pattern B) without any malfunctions.

\*3: When the same malfunction is detected in two consecutive trips, the DTC and the freeze frame data will be stored in ECM.

\*4: The DTC and the freeze frame data will not be displayed any longer after vehicle is driven 40 times (pattern A) without the same malfunction. (The DTC and the freeze frame data still remain in ECM.)

\*5: When a malfunction is detected for the first time, the 1st trip DTC and the 1st trip freeze frame data will be stored in ECM.

\*6: 1st trip DTC will be cleared after vehicle is driven once (pattern B) without the same malfunction.

\*7: When the same malfunction is detected in the 2nd trip, the 1st trip freeze frame data will be cleared.

# ON BOARD DIAGNOSTIC (OBD) SYSTEM

## EXPLANATION FOR DRIVING PATTERNS EXCEPT FOR "MISFIRE <EXHAUST QUALITY DETERIORATION>", "FUEL INJECTION SYSTEM"

### <Driving Pattern A>

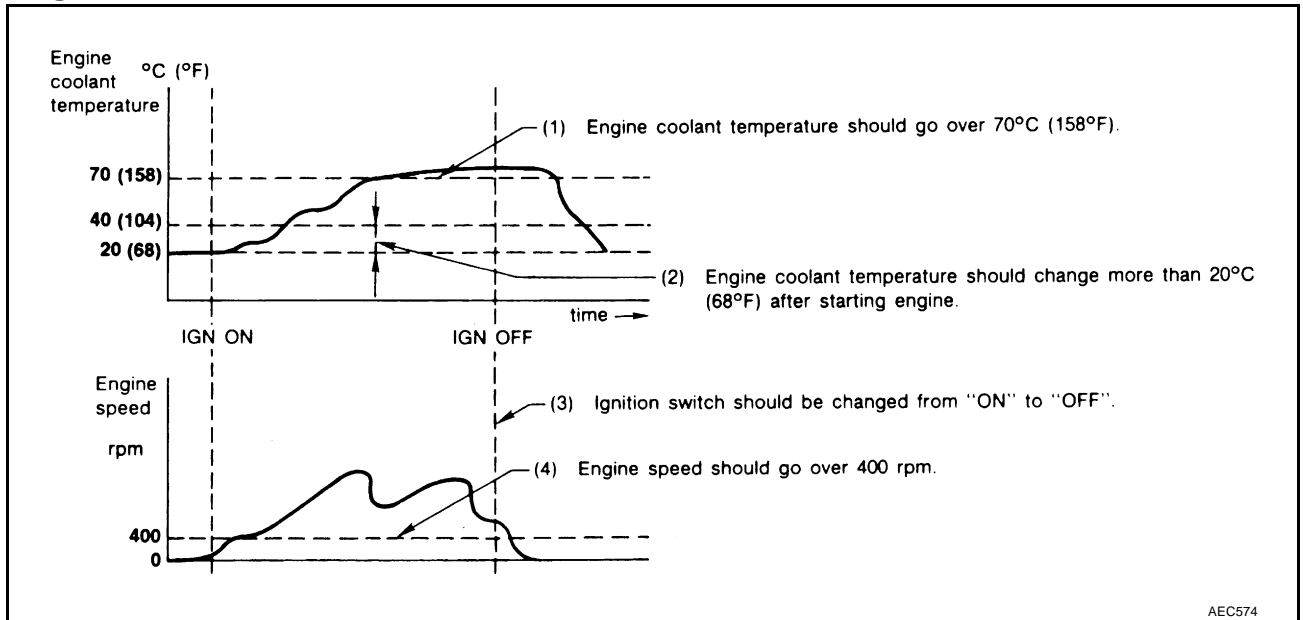

- The A counter will be cleared when the malfunction is detected regardless of (1) - (4).
- The A counter will be counted up when (1) - (4) are satisfied without the same malfunction.
- The DTC will not be displayed after the A counter reaches 40.

### <Driving Pattern B>

Driving pattern B means the vehicle operation as follows:

All components and systems should be monitored at least once by the OBD system.

- The B counter will be cleared when the malfunction is detected once regardless of the driving pattern.
- The B counter will be counted up when driving pattern B is satisfied without any malfunctions.
- The MIL will go off when the B counter reaches 3 (\*2 in OBD SYSTEM OPERATION CHART).

## TROUBLE DIAGNOSIS

PFP:00004

### Trouble Diagnosis Introduction INTRODUCTION

ABS009B2

The engine has an ECM to control major systems such as fuel control, ignition control, idle air control system, etc. The ECM accepts input signals from sensors and instantly drives actuators. It is essential that both input and output signals are proper and stable. At the same time, it is important that there are no malfunctions such as vacuum leaks, fouled spark plugs, or other malfunctions with the engine.

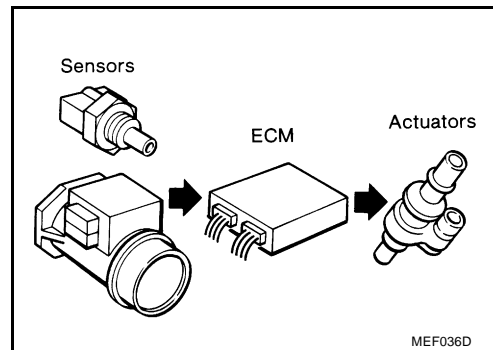

It is much more difficult to diagnose an incident that occurs intermittently rather than continuously. Most intermittent incidents are caused by poor electric connections or improper wiring. In this case, careful checking of suspected circuits may help prevent the replacement of good parts.

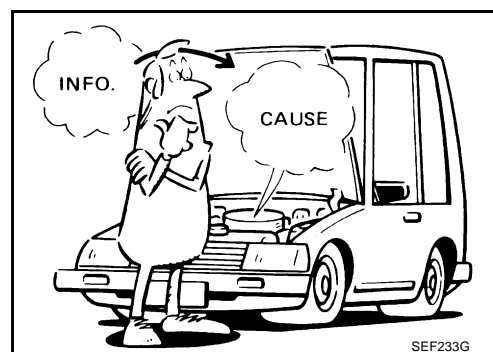

A visual check only may not find the cause of the incidents. A road test with CONSULT-II (or GST) or a circuit tester connected should be performed. Follow the Work Flow on [EC-73](#).

Before undertaking actual checks, take a few minutes to talk with a customer who approaches with a driveability complaint. The customer can supply good information about such incidents, especially intermittent ones. Find out what symptoms are present and under what conditions they occur. A Diagnostic Worksheet like the example on [EC-75](#) should be used.

Start your diagnosis by looking for conventional malfunctions first. This will help troubleshoot driveability malfunctions on an electronically controlled engine vehicle.

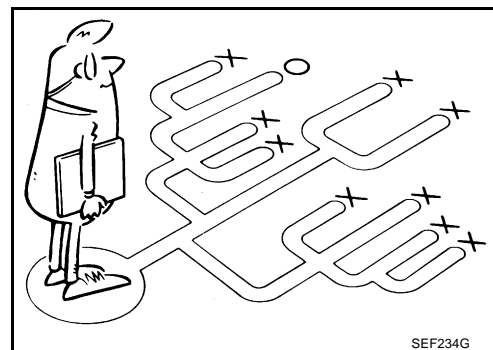



# TROUBLE DIAGNOSIS

## WORK FLOW

### Flow Chart

A

EC

C

D

E

F

G

H

I

J

K

L

M

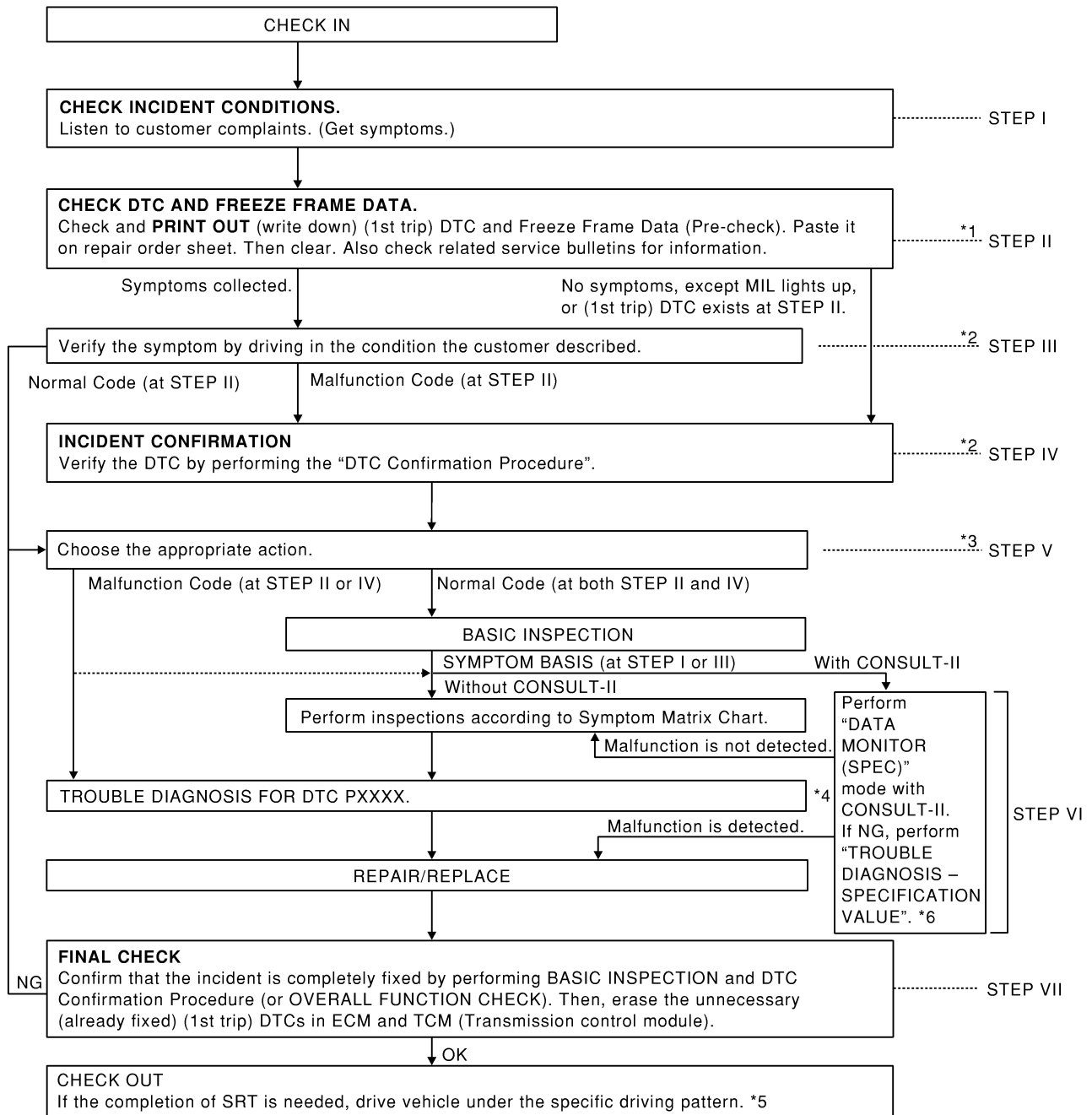

\*1 If time data of "SELF-DIAG RESULTS" is other than [0] or [1t], perform [EC-129. "TROUBLE DIAGNOSIS FOR INTERMITTENT INCIDENT"](#).

\*4 If malfunctioning part cannot be detected, perform [EC-129. "TROUBLE DIAGNOSIS FOR INTERMITTENT INCIDENT"](#).

\*2 If the incident cannot be verified, perform [EC-129. "TROUBLE DIAGNOSIS FOR INTERMITTENT INCIDENT"](#).

\*5 [EC-58](#)

\*3 If the on board diagnostic system cannot be performed, check main power supply and ground circuit. Refer to [EC-130. "POWER SUPPLY AND GROUND CIRCUIT"](#).

\*6 [EC-125](#)

PBIB1043E

# TROUBLE DIAGNOSIS

## Description for Work Flow

STEP	DESCRIPTION
STEP I	Get detailed information about the conditions and the environment when the incident/symptom occurred using the DIAGNOSTIC WORK SHEET, <a href="#">EC-74</a> .
STEP II	Before confirming the concern, check and write down (print out using CONSULT-II or GST) the (1st trip) DTC and the (1st trip) freeze frame data, then erase the DTC and the data. (Refer to <a href="#">EC-61</a> .) The (1st trip) DTC and the (1st trip) freeze frame data can be used when duplicating the incident at STEP III & IV. If the incident cannot be verified, perform <a href="#">EC-129. "TROUBLE DIAGNOSIS FOR INTERMITTENT INCIDENT"</a> . Study the relationship between the cause, specified by (1st trip) DTC, and the symptom described by the customer. (The Symptom Matrix Chart will be useful. See <a href="#">EC-83</a> .) Also check related service bulletins for information.
STEP III	Try to confirm the symptom and under what conditions the incident occurs. The DIAGNOSTIC WORK SHEET and the freeze frame data are useful to verify the incident. Connect CONSULT-II to the vehicle in DATA MONITOR (AUTO TRIG) mode and check real time diagnosis results. If the incident cannot be verified, perform <a href="#">EC-129. "TROUBLE DIAGNOSIS FOR INTERMITTENT INCIDENT"</a> . If the malfunction code is detected, skip STEP IV and perform STEP V.
STEP IV	Try to detect the (1st trip) DTC by driving in (or performing) the DTC Confirmation Procedure. Check and read the (1st trip) DTC and (1st trip) freeze frame data by using CONSULT-II or GST. During the (1st trip) DTC verification, be sure to connect CONSULT-II to the vehicle in DATA MONITOR (AUTO TRIG) mode and check real time diagnosis results. If the incident cannot be verified, perform <a href="#">EC-129. "TROUBLE DIAGNOSIS FOR INTERMITTENT INCIDENT"</a> . In case the DTC Confirmation Procedure is not available, perform the Overall Function Check instead. The (1st trip) DTC cannot be displayed by this check, however, this simplified check is an effective alternative. The NG result of the Overall Function Check is the same as the (1st trip) DTC detection.
STEP V	Take the appropriate action based on the results of STEP I through IV. If the malfunction code is indicated, proceed to TROUBLE DIAGNOSIS FOR DTC PXXXX. If the normal code is indicated, proceed to the BASIC INSPECTION. (Refer to <a href="#">EC-78</a> .) Then perform inspections according to the Symptom Matrix Chart. (Refer to <a href="#">EC-83</a> .)
STEP VI	Identify where to begin diagnosis based on the relationship study between symptom and possible causes. Inspect the system for mechanical binding, loose connectors or wiring damage using (tracing) Harness Layouts. Gently shake the related connectors, components or wiring harness with CONSULT-II set in "DATA MONITOR (AUTO TRIG)" mode. Check the voltage of the related ECM terminals or monitor the output data from the related sensors with CONSULT-II. Refer to <a href="#">EC-95</a> , <a href="#">EC-119</a> . The Diagnostic Procedure in EC section contains a description based on open circuit inspection. A short circuit inspection is also required for the circuit check in the Diagnostic Procedure. For details, refer to Circuit Inspection in <a href="#">GI-27. "How to Perform Efficient Diagnosis for an Electrical Incident"</a> . Repair or replace the malfunction parts. If malfunctioning part cannot be detected, perform <a href="#">EC-129. "TROUBLE DIAGNOSIS FOR INTERMITTENT INCIDENT"</a> .
STEP VII	Once you have repaired the circuit or replaced a component, you need to run the engine in the same conditions and circumstances which resulted in the customer's initial complaint. Perform the DTC Confirmation Procedure and confirm the normal code [DTC No. P0000] is detected. If the incident is still detected in the final check, perform STEP VI by using a method different from the previous one. Before returning the vehicle to the customer, be sure to erase the unnecessary (already fixed) (1st trip) DTC in ECM and TCM (Transmission control module). (Refer to <a href="#">EC-61. "HOW TO ERASE EMISSION-RELATED DIAGNOSTIC INFORMATION"</a> and <a href="#">AT-38. "HOW TO ERASE DTC"</a> .)

## DIAGNOSTIC WORKSHEET

### Description

There are many operating conditions that lead to the malfunction of engine components. A good grasp of such conditions can make troubleshooting faster and more accurate.

In general, each customer feels differently about a incident. It is important to fully understand the symptoms or conditions for a customer complaint.

Utilize a diagnostic worksheet like the one on the next page in order to organize all the information for troubleshooting.

Some conditions may cause the MIL to come on steady or blink and DTC to be detected. Examples:

- Vehicle ran out of fuel, which caused the engine to misfire.

### KEY POINTS

**WHAT** ..... Vehicle & engine model  
**WHEN** ..... Date, Frequencies  
**WHERE**..... Road conditions  
**HOW** ..... Operating conditions,  
 Weather conditions,  
 Symptoms

SEF907L

# TROUBLE DIAGNOSIS

- Fuel filler cap was left off or incorrectly screwed on, allowing fuel to evaporate into the atmosphere.

## Worksheet Sample

Customer name MR/MS		Model & Year	VIN
Engine #		Trans.	Mileage
Incident Date		Manuf. Date	In Service Date
Fuel and fuel filler cap		<input type="checkbox"/> Vehicle ran out of fuel causing misfire <input type="checkbox"/> Fuel filler cap was left off or incorrectly screwed on.	
Symptoms	<input type="checkbox"/> Startability	<input type="checkbox"/> Impossible to start <input type="checkbox"/> No combustion <input type="checkbox"/> Partial combustion <input type="checkbox"/> Partial combustion affected by throttle position <input type="checkbox"/> Partial combustion NOT affected by throttle position <input type="checkbox"/> Possible but hard to start <input type="checkbox"/> Others [                          ]	
	<input type="checkbox"/> Idling	<input type="checkbox"/> No fast idle <input type="checkbox"/> Unstable <input type="checkbox"/> High idle <input type="checkbox"/> Low idle <input type="checkbox"/> Others [                          ]	
	<input type="checkbox"/> Driveability	<input type="checkbox"/> Stumble <input type="checkbox"/> Surge <input type="checkbox"/> Knock <input type="checkbox"/> Lack of power <input type="checkbox"/> Intake backfire <input type="checkbox"/> Exhaust backfire <input type="checkbox"/> Others [                          ]	
	<input type="checkbox"/> Engine stall	<input type="checkbox"/> At the time of start <input type="checkbox"/> While idling <input type="checkbox"/> While accelerating <input type="checkbox"/> While decelerating <input type="checkbox"/> Just after stopping <input type="checkbox"/> While loading	
Incident occurrence		<input type="checkbox"/> Just after delivery <input type="checkbox"/> Recently <input type="checkbox"/> In the morning <input type="checkbox"/> At night <input type="checkbox"/> In the daytime	
Frequency		<input type="checkbox"/> All the time <input type="checkbox"/> Under certain conditions <input type="checkbox"/> Sometimes	
Weather conditions		<input type="checkbox"/> Not affected	
		Weather	<input type="checkbox"/> Fine <input type="checkbox"/> Raining <input type="checkbox"/> Snowing <input type="checkbox"/> Others [                          ]
		Temperature	<input type="checkbox"/> Hot <input type="checkbox"/> Warm <input type="checkbox"/> Cool <input type="checkbox"/> Cold <input type="checkbox"/> Humid                          °F
Engine conditions		<input type="checkbox"/> Cold <input type="checkbox"/> During warm-up <input type="checkbox"/> After warm-up Engine speed <div style="text-align: center;"> </div>	
Road conditions		<input type="checkbox"/> In town <input type="checkbox"/> In suburbs <input type="checkbox"/> Highway <input type="checkbox"/> Off road (up/down)	
Driving conditions		<input type="checkbox"/> Not affected <input type="checkbox"/> At starting <input type="checkbox"/> While idling <input type="checkbox"/> At racing <input type="checkbox"/> While accelerating <input type="checkbox"/> While cruising <input type="checkbox"/> While decelerating <input type="checkbox"/> While turning (RH/LH) Vehicle speed <div style="text-align: center;"> </div>	
Malfunction indicator lamp		<input type="checkbox"/> Turned on <input type="checkbox"/> Not turned on	

MTBL0017

## DTC Inspection Priority Chart

ABS009B3

If some DTCs are displayed at the same time, perform inspections one by one based on the following priority chart.

**NOTE:**

**If DTC U1000 and/or U1001 is displayed with other DTC, first perform the trouble diagnosis for DTC U1000, U1001. Refer to [EC-139](#).**

# TROUBLE DIAGNOSIS

Priority	Detected items (DTC)
1	<ul style="list-style-type: none"> <li>● U1000 U1001 CAN communication line</li> <li>● P0101 P0102 P0103 Mass air flow sensor</li> <li>● P0112 P0113 P0127 Intake air temperature sensor</li> <li>● P0117 P0118 P0125 Engine coolant temperature sensor</li> <li>● P0128 Thermostat function</li> <li>● P0122 P0123 P0222 P0223 P1225 P1226 P2135 Throttle position sensor</li> <li>● P0181 P0182 P0183 Fuel tank temperature sensor</li> <li>● P0327 P0328 Knock sensor</li> <li>● P0335 Crankshaft position sensor (POS)</li> <li>● P0340 P0345 Camshaft position sensor (PHASE)</li> <li>● P0460 P0461 P0462 P0463 Fuel level sensor</li> <li>● P0500 Vehicle speed sensor</li> <li>● P0605 ECM</li> <li>● P0700 TCM</li> <li>● P0705 Park/Neutral position (PNP) switch</li> <li>● P1229 Sensor power supply</li> <li>● P1610 - P1615 NATS</li> <li>● P1706 Park/Neutral position (PNP) switch</li> <li>● P2122 P2123 P2127 P2128 P2138 Accelerator pedal position sensor</li> </ul>
2	<ul style="list-style-type: none"> <li>● P0037 P0038 P0057 P0058 Heated oxygen sensor 2 heater</li> <li>● P0138 P0139 P0158 P0159 P1146 P1147 P1166 P1167 Heated oxygen sensor 2</li> <li>● P0441 EVAP control system purge flow monitoring</li> <li>● P0444 P0445 P1444 EVAP canister purge volume control solenoid valve</li> <li>● P0447 P1446 EVAP canister vent control valve</li> <li>● P0451 P0452 P0453 EVAP control system pressure sensor</li> <li>● P0550 Power steering pressure sensor</li> <li>● P0710 P0720 P0725 P0740 P0744 P0745 P1705 P1716 P1730 P1752 P1754 P1757 P1759 P1762 P1764 P1767 P1769 P1772 P1774 A/T related sensors, solenoid valves and switches</li> <li>● P1031 P1032 P1051 P1052 A/F sensor 1 heater</li> <li>● P1065 ECM power supply</li> <li>● P1111 P1136 Intake valve timing control solenoid valve</li> <li>● P1122 Electric throttle control function</li> <li>● P1124 P1126 P1128 Electric throttle control actuator</li> <li>● P1217 Engine over temperature (OVERHEAT)</li> <li>● P1271 P1272 P1273 P1274 P1276 P1278 P1279 P1281 P1282 P1283 P1284 P1286 P1288 P1289 A/F sensor 1</li> <li>● P1805 Brake switch</li> </ul>
3	<ul style="list-style-type: none"> <li>● P0011 P0021 Intake valve timing control</li> <li>● P0171 P0172 P0174 P0175 Fuel injection system function</li> <li>● P0300 - P0306 Misfire</li> <li>● P0420 P0430 Three way catalyst function</li> <li>● P0442 P0455 P0456 EVAP control system</li> <li>● P0506 P0507 Idle speed control system</li> <li>● P1121 Electric throttle control actuator</li> <li>● P1148 P1168 Closed loop control</li> <li>● P1211 TCS control unit</li> <li>● P1212 TCS communication line</li> <li>● P1564 ASCD steering switch</li> <li>● P1572 ASCD brake switch</li> <li>● P1574 ASCD vehicle speed sensor</li> </ul>

# TROUBLE DIAGNOSIS

## Fail-safe Chart

ABS009B4

When the DTC listed below is detected, the ECM enters fail-safe mode and the MIL lights up.

DTC No.	Detected items	Engine operating condition in fail-safe mode	
P0102 P0103	Mass air flow sensor circuit	Engine speed will not rise more than 2,400 rpm due to the fuel cut.	
P0117 P0118	Engine coolant temperature sensor circuit	Engine coolant temperature will be determined by ECM based on the time after turning ignition switch ON or START. CONSULT-II displays the engine coolant temperature decided by ECM.	
		Condition	Engine coolant temperature decided (CONSULT-II display)
		Just as ignition switch is turned ON or START	40°C (104°F)
		More than approx. 4 minutes after ignition ON or START	80°C (176°F)
		Except as shown above	40 - 80°C (104 - 176°F) (Depends on the time)
		When the fail-safe system for engine coolant temperature sensor is activated, the cooling fan operates while engine is running.	
P0122 P0123 P0222 P0223 P2135	Throttle position sensor	The ECM controls the electric throttle control actuator in regulating the throttle opening in order for the idle position to be within +10 degrees. The ECM regulates the opening speed of the throttle valve to be slower than the normal condition. So, the acceleration will be poor.	
P1121	Electric throttle control actuator	(When electric throttle control actuator does not function properly due to the return spring malfunction:) ECM controls the electric throttle actuator by regulating the throttle opening around the idle position. The engine speed will not rise more than 2,000 rpm.	
		(When throttle valve opening angle in fail-safe mode is not in specified range:) ECM controls the electric throttle control actuator by regulating the throttle opening to 20 degrees or less.	
		(When ECM detects the throttle valve is stuck open:) While the vehicle is driving, it slows down gradually by fuel cut. After the vehicle stops, the engine stalls. The engine can restart in N or P (A/T), Neutral (M/T) position, and engine speed will not exceed 1,000 rpm or more.	
P1122	Electric throttle control function	ECM stops the electric throttle control actuator control, throttle valve is maintained at a fixed opening (approx. 5 degrees) by the return spring.	
P1124 P1126	Throttle control motor relay	ECM stops the electric throttle control actuator control, throttle valve is maintained at a fixed opening (approx. 5 degrees) by the return spring.	
P1128	Throttle control motor	ECM stops the electric throttle control actuator control, throttle valve is maintained at a fixed opening (approx. 5 degrees) by the return spring.	
P1229	Sensor power supply	ECM stops the electric throttle control actuator control, throttle valve is maintained at a fixed opening (approx. 5 degrees) by the return spring.	
P2122 P2123 P2127 P2128 P2138	Accelerator pedal position sensor	The ECM controls the electric throttle control actuator in regulating the throttle opening in order for the idle position to be within +10 degrees. The ECM regulates the opening speed of the throttle valve to be slower than the normal condition. So, the acceleration will be poor.	

- When there is an open circuit on MIL circuit, the ECM cannot warn the driver by lighting up MIL when there is malfunction on engine control system.  
Therefore, when electrical controlled throttle and part of ECM related diagnoses are continuously detected as NG for 5 trips, ECM warns the driver that engine control system malfunctions and MIL circuit is open by means of operating fail-safe function.  
The fail-safe function also operates when above diagnoses except MIL circuit are detected and demands the driver to repair the malfunction.

Engine operating condition in fail-safe mode	Engine speed will not rise more than 2,500 rpm due to the fuel cut
--	--

# TROUBLE DIAGNOSIS

ABS009B5

## Basic Inspection

### 1. INSPECTION START

1. Check service records for any recent repairs that may indicate a related malfunction, or a current need for scheduled maintenance.
2. Open engine hood and check the following:
  - Harness connectors for improper connections
  - Wiring harness for improper connections, pinches and cut
  - Vacuum hoses for splits, kinks and improper connections
  - Hoses and ducts for leaks
  - Air cleaner clogging
  - Gasket
3. Confirm that electrical or mechanical loads are not applied.
  - Headlamp switch is OFF.
  - Air conditioner switch is OFF.
  - Rear window defogger switch is OFF.
  - Steering wheel is in the straight-ahead position, etc.
4. Start engine and warm it up until engine coolant temperature indicator points the middle of gauge. Ensure engine stays below 1,000 rpm.

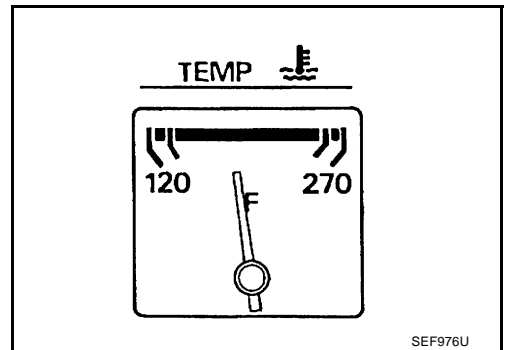
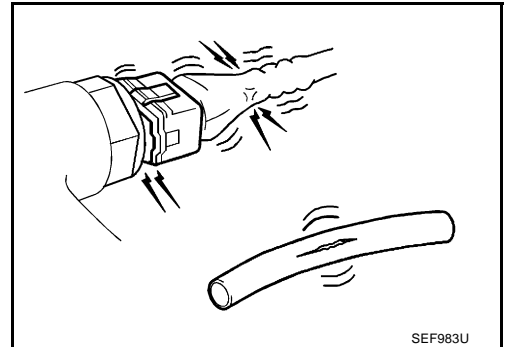

5. Run engine at about 2,000 rpm for about 2 minutes under no-load.
6. Make sure that no DTC is displayed with CONSULT-II or GST.

#### OK or NG

- OK >> GO TO 3.  
NG >> GO TO 2.

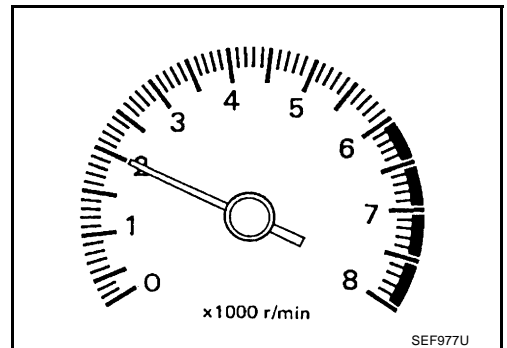

### 2. REPAIR OR REPLACE

Repair or replace components as necessary according to corresponding Diagnostic Procedure.

>> GO TO 3.

# TROUBLE DIAGNOSIS

## 3. CHECK TARGET IDLE SPEED

### With CONSULT-II

1. Run engine at about 2,000 rpm for about 2 minutes under no-load.
2. Rev engine (2,000 to 3,000 rpm) two or three times under no-load, then run engine at idle speed for about 1 minute.

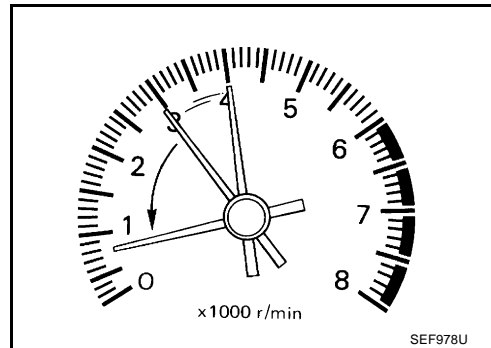

3. Read idle speed in "DATA MONITOR" mode with CONSULT-II.

**A/T:** 650 ± 50 rpm (in P or N position)

**M/T:** 650 ± 50 rpm (in Neutral position)

DATA MONITOR	
MONITOR	NO DTC
ENG SPEED	XXX rpm

### Without CONSULT-II

1. Run engine at about 2,000 rpm for about 2 minutes under no-load.
2. Rev engine (2,000 to 3,000 rpm) two or three times under no-load, then run engine at idle speed for about 1 minute.
3. Check idle speed.

**A/T:** 650 ± 50 rpm (in P or N position)

**M/T:** 650 ± 50 rpm (in Neutral position)

### OK or NG

OK >> GO TO 10.

NG >> GO TO 4.

## 4. PERFORM ACCELERATOR PEDAL RELEASED POSITION LEARNING

1. Stop engine.
2. Perform [EC-42, "Accelerator Pedal Released Position Learning"](#).

>> GO TO 5.

## 5. PERFORM THROTTLE VALVE CLOSED POSITION LEARNING

Perform [EC-42, "Throttle Valve Closed Position Learning"](#).

>> GO TO 6.

# TROUBLE DIAGNOSIS

## 6. PERFORM IDLE AIR VOLUME LEARNING

Refer to [EC-43, "Idle Air Volume Learning"](#) .

Is Idle Air Volume Learning carried out successfully?

Yes or No

Yes >> GO TO 7.

No >> 1. Follow the instruction of Idle Air Volume Learning.

2. GO TO 4.

## 7. CHECK TARGET IDLE SPEED AGAIN

### With CONSULT-II

1. Start engine and warm it up to normal operating temperature.
2. Read idle speed in "DATA MONITOR" mode with CONSULT-II.

**A/T: 650 ± 50 rpm (in P or N position)**

**M/T: 650 ± 50 rpm (in Neutral position)**

### Without CONSULT-II

1. Start engine and warm it up to normal operating temperature.
2. Check idle speed.

**A/T: 650 ± 50 rpm (in P or N position)**

**M/T: 650 ± 50 rpm (in Neutral position)**

DATA MONITOR	
MONITOR	NO DTC
ENG SPEED	XXX rpm
COOLANT TEMP/S	XXX °C

SEF174Y

OK or NG

OK >> GO TO 10.

NG >> GO TO 8.

## 8. DETECT MALFUNCTIONING PART

Check the following.

- Check camshaft position sensor (PHASE) and circuit. Refer to [EC-274](#) .
- Check crankshaft position sensor (POS) and circuit. Refer to [EC-267](#) .

OK or NG

OK >> GO TO 9.

NG >> 1. Repair or replace.

2. GO TO 4.

## 9. CHECK ECM FUNCTION

1. Substitute another known-good ECM to check ECM function. (ECM may be the cause of an incident, but this is a rare case.)
2. Perform initialization of NVIS (NATS) system and registration of all NVIS (NATS) ignition key IDs. Refer to [EC-63, "NVIS \(Nissan Vehicle Immobilizer System — NATS\)"](#) .

>> GO TO 4.



# TROUBLE DIAGNOSIS

## 10. CHECK IGNITION TIMING

1. Run engine at idle.
2. Check ignition timing with a timing light.

**A/T:** 15 ± 5° BTDC (in P or N position)  
**M/T:** 15 ± 5° BTDC (in Neutral position)

OK or NG

- OK >> GO TO 19.  
NG >> GO TO 11.

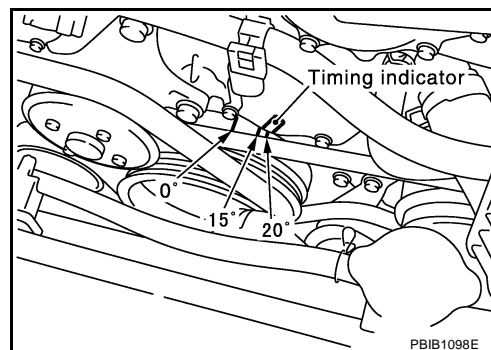

## 11. PERFORM ACCELERATOR PEDAL RELEASED POSITION LEARNING

1. Stop engine.
2. Perform [EC-42, "Accelerator Pedal Released Position Learning"](#).

>> GO TO 12.

## 12. PERFORM THROTTLE VALVE CLOSED POSITION LEARNING

Perform [EC-42, "Throttle Valve Closed Position Learning"](#).

>> GO TO 13.

## 13. PERFORM IDLE AIR VOLUME LEARNING

Refer to [EC-43, "Idle Air Volume Learning"](#).

**Is Idle Air Volume Learning carried out successfully?**

Yes or No

- Yes >> GO TO 14.  
No >> 1. Follow the instruction of Idle Air Volume Learning.  
2. GO TO 4.

## 14. CHECK TARGET IDLE SPEED AGAIN

 **With CONSULT-II**

1. Start engine and warm it up to normal operating temperature.
2. Read idle speed in "DATA MONITOR" mode with CONSULT-II.

**A/T:** 650 ± 50 rpm (in P or N position)  
**M/T:** 650 ± 50 rpm (in Neutral position)

 **Without CONSULT-II**

1. Start engine and warm it up to normal operating temperature.
2. Check idle speed.

**A/T:** 650 ± 50 rpm (in P or N position)  
**M/T:** 650 ± 50 rpm (in Neutral position)

OK or NG

- OK >> GO TO 15.  
NG >> GO TO 17.

DATA MONITOR	
MONITOR	NO DTC
ENG SPEED	XXX rpm
COOLAN TEMP/S	XXX °C

SEF174Y

# TROUBLE DIAGNOSIS

## 15. CHECK IGNITION TIMING AGAIN

1. Run engine at idle.
2. Check ignition timing with a timing light.

**A/T: 15 ± 5° BTDC (in P or N position)**

**M/T: 15 ± 5° BTDC (in Neutral position)**

OK or NG

OK >> GO TO 19.

NG >> GO TO 16.

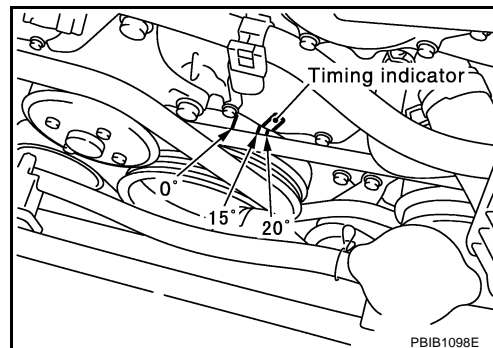

## 16. CHECK TIMING CHAIN INSTALLATION

Check timing chain installation. Refer to [EM-55, "TIMING CHAIN"](#) .

OK or NG

OK >> GO TO 17.

NG >> 1. Repair the timing chain installation.

2. GO TO 4.

## 17. DETECT MALFUNCTIONING PART

Check the following.

- Check camshaft position sensor (PHASE) and circuit. Refer to [EC-274](#) .
- Check crankshaft position sensor (POS) and circuit. Refer to [EC-267](#) .

OK or NG

OK >> GO TO 18.

NG >> 1. Repair or replace.

2. GO TO 4.

## 18. CHECK ECM FUNCTION

1. Substitute another known-good ECM to check ECM function. (ECM may be the cause of an incident, but this is a rare case.)
2. Perform initialization of NVIS (NATS) system and registration of all NVIS (NATS) ignition key IDs. Refer to [EC-63, "NVIS \(Nissan Vehicle Immobilizer System — NATS\)"](#) .

>> GO TO 4.

## 19. INSPECTION END

Did you replace the ECM, referring this Basic Inspection procedure?

Yes or No

Yes >> 1. Perform [EC-42, "VIN Registration"](#) .

2. **INSPECTION END**

No >> **INSPECTION END**

# TROUBLE DIAGNOSIS

## Symptom Matrix Chart SYSTEM — BASIC ENGINE CONTROL SYSTEM

ABS009B6

		SYMPTOM												Reference page	
		HARD/NO START/RESTART (EXCP. HA)	ENGINE STALL	HESITATION/SURGING/FLAT SPOT	SPARK KNOCK/DETONATION	LACK OF POWER/POOR ACCELERATION	HIGH IDLE/LOW IDLE	ROUGH IDLE/HUNTING	IDLING VIBRATION	SLOW/NO RETURN TO IDLE	OVERHEATS/WATER TEMPERATURE HIGH	EXCESSIVE FUEL CONSUMPTION	EXCESSIVE OIL CONSUMPTION		BATTERY DEAD (UNDER CHARGE)
Warranty symptom code		AA	AB	AC	AD	AE	AF	AG	AH	AJ	AK	AL	AM	HA	
Fuel	Fuel pump circuit	1	1	2	3	2		2	2			3		2	<a href="#">EC-640</a>
	Fuel pressure regulator system	3	3	4	4	4	4	4	4	4		4			<a href="#">EC-45</a>
	Injector circuit	1	1	2	3	2		2	2			2			<a href="#">EC-634</a>
	Evaporative emission system	3	3	4	4	4	4	4	4	4	4	4			<a href="#">EC-674</a>
Air	Positive crankcase ventilation system	3	3	4	4	4	4	4	4	4		4	1		<a href="#">EC-686</a>
	Incorrect idle speed adjustment						1	1	1	1		1			<a href="#">EC-31</a>
	Electric throttle control actuator	1	1	2	3	3	2	2	2	2		2		2	<a href="#">EC-395</a> , <a href="#">EC-397</a>
Ignition	Incorrect ignition timing adjustment	3	3	1	1	1		1	1			1			<a href="#">EC-31</a>
	Ignition circuit	1	1	2	2	2		2	2			2			<a href="#">EC-622</a>
Main power supply and ground circuit		2	2	3	3	3		3	3		2	3			<a href="#">EC-130</a>
Mass air flow sensor circuit		1			2										<a href="#">EC-153</a> , <a href="#">EC-163</a>
Engine coolant temperature sensor circuit					3										
Air fuel ratio (A/F) sensor 1 circuit			1	2	3	2		2	2			2			<a href="#">EC-377</a> , <a href="#">EC-461</a> , <a href="#">EC-470</a> , <a href="#">EC-479</a> , <a href="#">EC-489</a> , <a href="#">EC-499</a> , <a href="#">EC-509</a> , <a href="#">EC-521</a>
Throttle position sensor circuit							2			2					<a href="#">EC-184</a> , <a href="#">EC-247</a> , <a href="#">EC-452</a> , <a href="#">EC-454</a> , <a href="#">EC-605</a>
Accelerator pedal position sensor circuit				3	2	1									<a href="#">EC-456</a> , <a href="#">EC-589</a> , <a href="#">EC-597</a> , <a href="#">EC-613</a>
Knock sensor circuit				2								3			<a href="#">EC-262</a>
Crankshaft position sensor (POS) circuit		2	2												<a href="#">EC-267</a>
Camshaft position sensor (PHASE) circuit		3	2												<a href="#">EC-274</a>

# TROUBLE DIAGNOSIS

	SYMPTOM													Reference page
	HARD/NO START/RESTART (EXCP. HA)	ENGINE STALL	HESITATION/SURGING/FLAT SPOT	SPARK KNOCK/DETONATION	LACK OF POWER/POOR ACCELERATION	HIGH IDLE/LOW IDLE	ROUGH IDLE/HUNTING	IDLING VIBRATION	SLOW/NO RETURN TO IDLE	OVERHEATS/WATER TEMPERATURE HIGH	EXCESSIVE FUEL CONSUMPTION	EXCESSIVE OIL CONSUMPTION	BATTERY DEAD (UNDER CHARGE)	
Warranty symptom code	AA	AB	AC	AD	AE	AF	AG	AH	AJ	AK	AL	AM	HA	
Vehicle speed signal circuit		2	3		3						3			<a href="#">EC-363</a>
Power steering pressure sensor circuit		2					3	3						<a href="#">EC-369</a>
ECM	2	2	3	3	3	3	3	3	3	3	3			<a href="#">EC-374</a> , <a href="#">EC-384</a>
Intake valve timing control solenoid valve circuit		3	2		1	3	2	2	3		3			<a href="#">EC-388</a>
Park/neutral position (PNP) switch circuit			3		3		3	3			3			<a href="#">EC-576</a>
Refrigerant pressure sensor circuit		2				3			3		4			<a href="#">EC-647</a>
Electrical load signal circuit							3							<a href="#">EC-653</a>
Air conditioner circuit	2	2	3	3	3	3	3	3	3		3		2	<a href="#">ATC-36</a>
VDC/TCS/ABS control unit ABS actuator and electric unit (control unit)			4											<a href="#">BRC-94</a> , <a href="#">BRC-46</a>

1 - 6: The numbers refer to the order of inspection.  
(continued on next page)

# TROUBLE DIAGNOSIS

## SYSTEM — ENGINE MECHANICAL & OTHER

		SYMPTOM												Reference page															
		HARD/NO START/RESTART (EXCP. HA)	ENGINE STALL	HESITATION/SURGING/FLAT SPOT	SPARK KNOCK/DETONATION	LACK OF POWER/POOR ACCELERATION	HIGH IDLE/LOW IDLE	ROUGH IDLE/HUNTING	IDLING VIBRATION	SLOW/NO RETURN TO IDLE	OVERHEATS/WATER TEMPERATURE HIGH	EXCESSIVE FUEL CONSUMPTION	EXCESSIVE OIL CONSUMPTION		BATTERY DEAD (UNDER CHARGE)														
Warranty symptom code		AA	AB	AC	AD	AE	AF	AG	AH	AJ	AK	AL	AM	HA															
Fuel	Fuel tank	5	5												<a href="#">FL-10</a>														
	Fuel piping			5	5	5		5	5			5			<a href="#">EM-36</a>														
	Vapor lock															—													
	Valve deposit															—													
	Poor fuel (Heavy weight gasoline, Low octane)	5			5	5	5		5	5			5			—													
Air	Air duct		5	5	5	5	5	5	5	5	5	5	5	5	<a href="#">EM-14</a>														
	Air cleaner																									<a href="#">EM-14</a>			
	Air leakage from air duct (Mass air flow sensor — electric throttle control actuator)	5														5	5	5	5	5	5	5	5	5	5		<a href="#">EM-14</a>		
	Electric throttle control actuator															5		5				5					<a href="#">EM-16</a>		
	Air leakage from intake manifold/Collector/Gasket																										<a href="#">EM-16</a> , <a href="#">EM-21</a>		
Cranking	Battery	1	1	1	1	1	1	1	1	1	1	1	1	1	<a href="#">SC-4</a>														
	Generator circuit																										<a href="#">SC-21</a>		
	Starter circuit	3										1			<a href="#">SC-10</a>														
	Signal plate	6													<a href="#">EM-109</a>														
	Park/neutral position (PNP) switch	4													<a href="#">MT-12</a> or <a href="#">AT-109</a>														
Engine	Cylinder head	5	5	5	5	5	5	5	5	5	5	5	5	5	5	<a href="#">EM-90</a>													
	Cylinder head gasket																												
	Cylinder block																												
	Piston													4															
	Piston ring	6	6	6	6	6	6	6	6	6	6	6	6	6	6	<a href="#">EM-109</a>													
	Connecting rod																												
	Bearing																												
	Crankshaft																												

A  
EC  
C  
D  
E  
F  
G  
H  
I  
J  
K  
L  
M

# TROUBLE DIAGNOSIS

		SYMPTOM												Reference page	
		HARD/NO START/RESTART (EXCP. HA)	ENGINE STALL	HESITATION/SURGING/FLAT SPOT	SPARK KNOCK/DETONATION	LACK OF POWER/POOR ACCELERATION	HIGH IDLE/LOW IDLE	ROUGH IDLE/HUNTING	IDLING VIBRATION	SLOW/NO RETURN TO IDLE	OVERHEATS/WATER TEMPERATURE HIGH	EXCESSIVE FUEL CONSUMPTION	EXCESSIVE OIL CONSUMPTION		BATTERY DEAD (UNDER CHARGE)
Warranty symptom code		AA	AB	AC	AD	AE	AF	AG	AH	AJ	AK	AL	AM	HA	
Valve mecha- nism	Timing chain														<a href="#">EM-55</a>
	Camshaft														<a href="#">EM-75</a>
	Intake valve timing control	5	5	5	5	5		5	5			5			<a href="#">EM-55</a>
	Intake valve												3		<a href="#">EM-90</a>
	Exhaust valve														
Exhaust	Exhaust manifold/Tube/Muffler/ Gasket	5	5	5	5	5		5	5			5			<a href="#">EM-23, EX-3</a>
	Three way catalyst														
Lubrica- tion	Oil pan/Oil strainer/Oil pump/Oil filter/Oil gallery/Oil cooler	5	5	5	5	5		5	5			5			<a href="#">EM-27, LU-12, LU-9, LU-10</a>
	Oil level (Low)/Filthy oil														<a href="#">LU-6</a>
Cooling	Radiator/Hose/Radiator filler cap														<a href="#">CO-12, CO-16</a>
	Thermostat									5					<a href="#">CO-26</a>
	Water pump														<a href="#">CO-22</a>
	Water gallery	5	5	5	5	5		5	5		4	5			<a href="#">CO-28</a>
	Cooling fan									5					<a href="#">CO-20</a>
	Coolant level (Low)/Contami- nated coolant														<a href="#">CO-9</a>
NVIS (NISSAN Vehicle Immobilizer System — NATS)		1	1												<a href="#">EC-63</a> or <a href="#">BL-158</a>

1 - 6: The numbers refer to the order of inspection.

# TROUBLE DIAGNOSIS

## Engine Control Component Parts Location

ABS009B7

A  
EC  
C  
D  
E  
F  
G  
H  
I  
J  
K  
L  
M

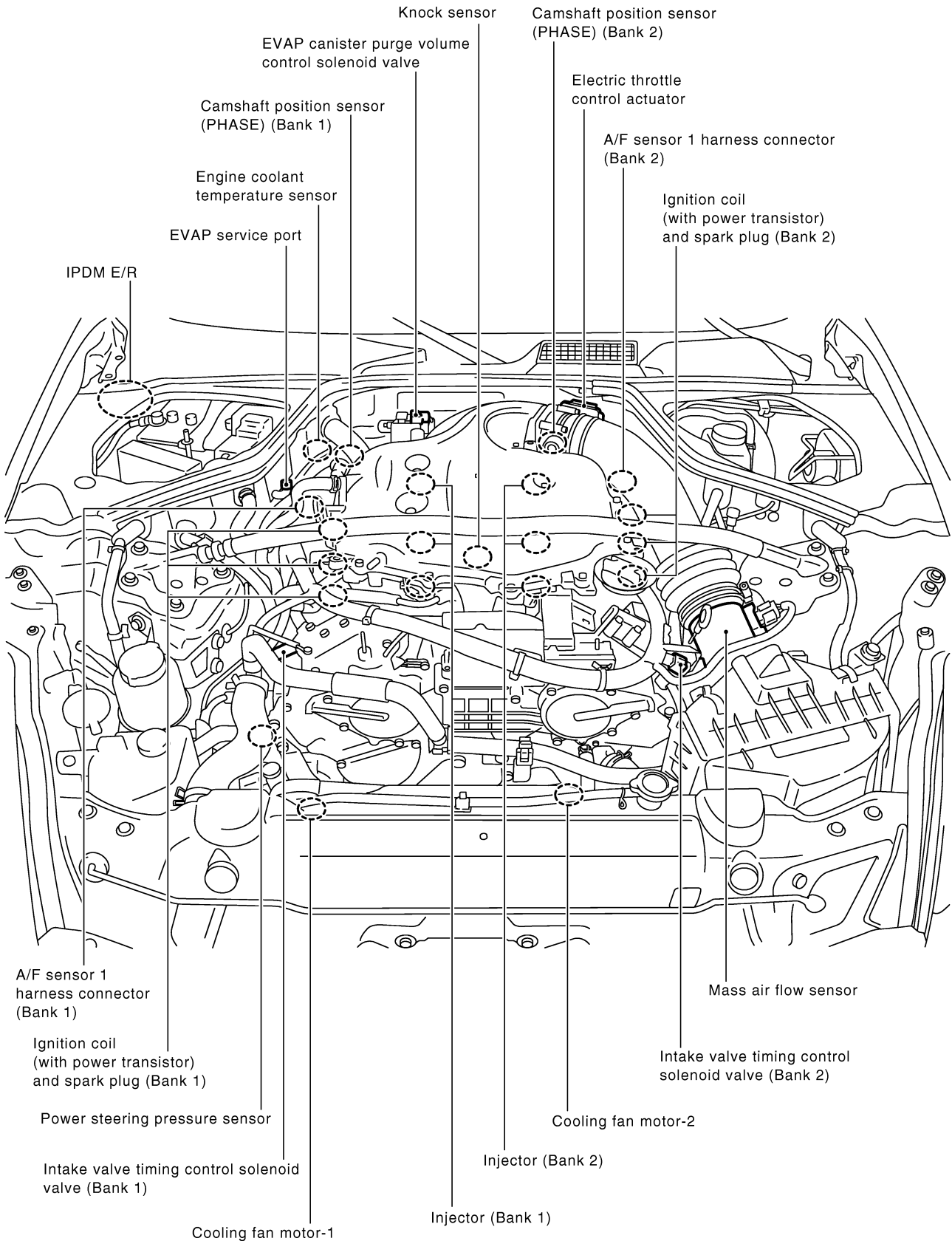

PBIB2205E

# TROUBLE DIAGNOSIS

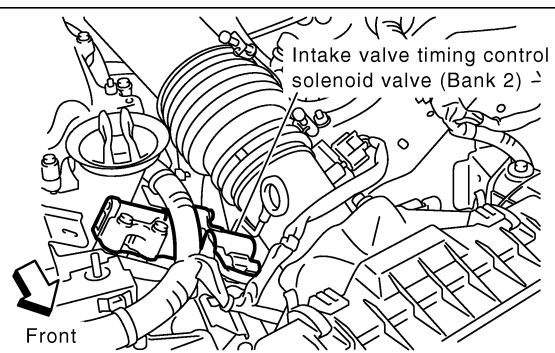
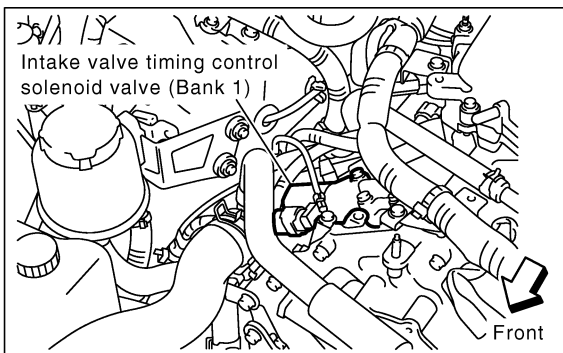
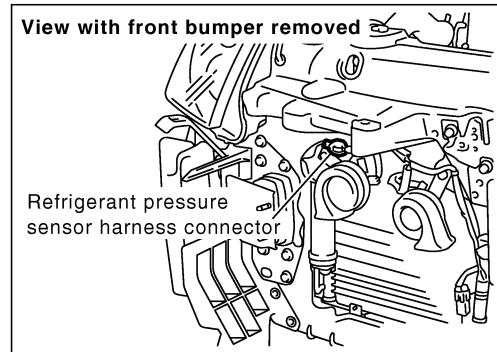
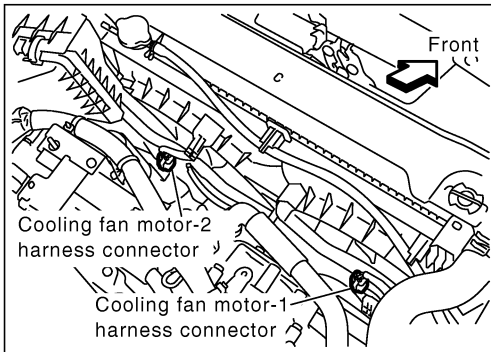
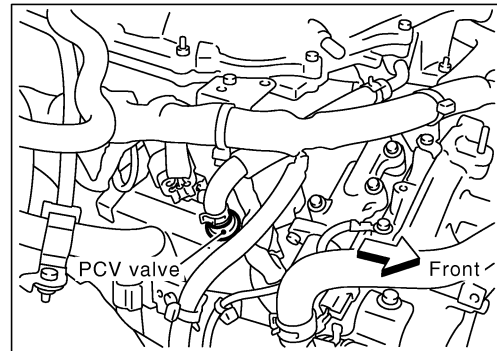
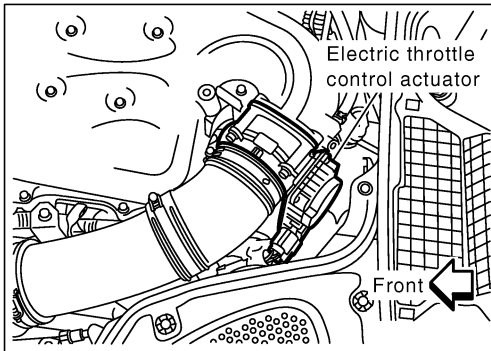
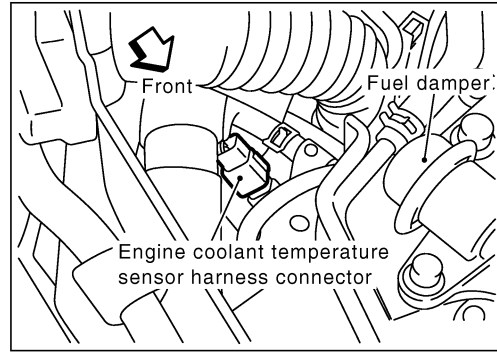
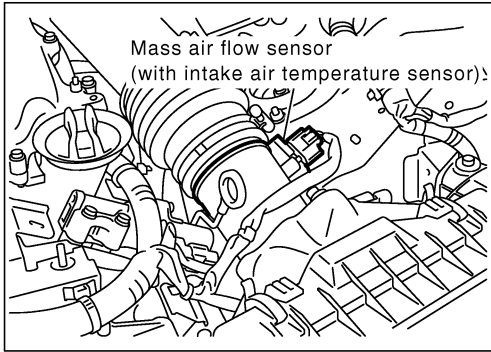

PBIB2211E



# TROUBLE DIAGNOSIS

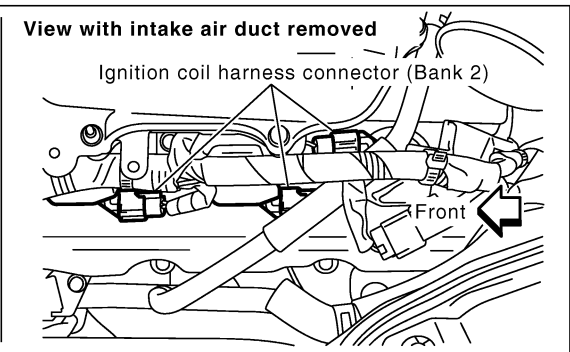
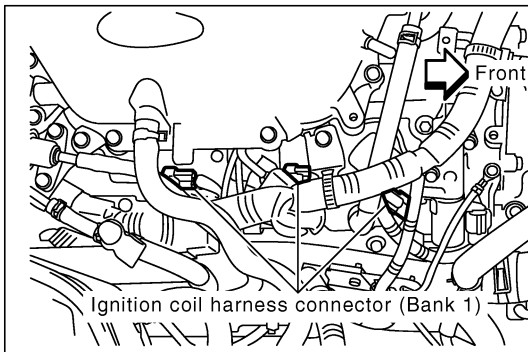
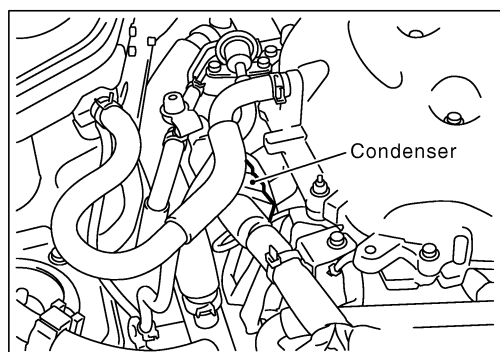
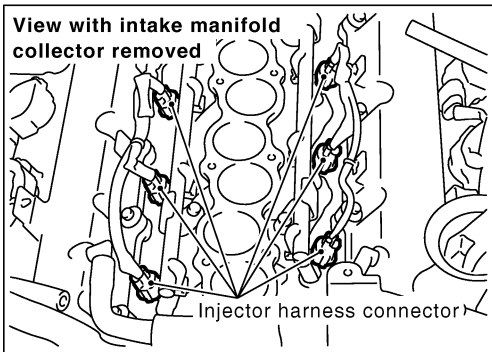
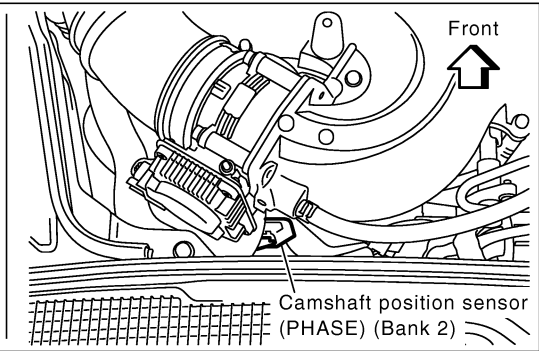
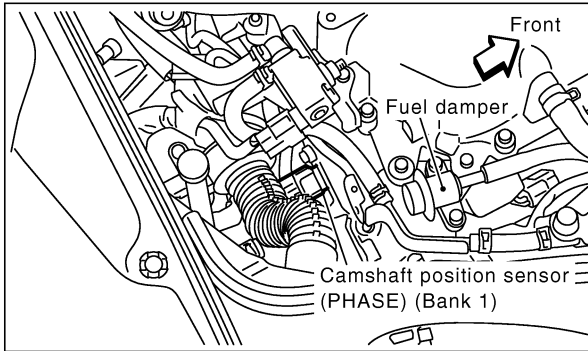
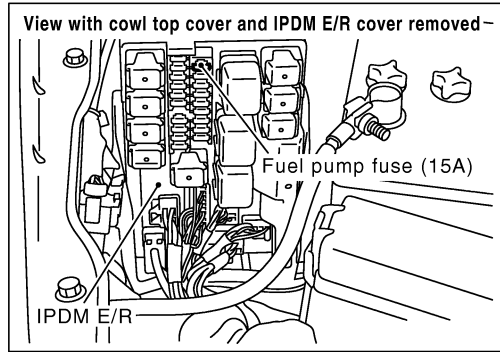
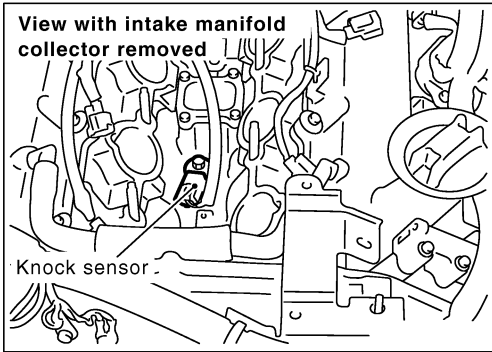

PBIB2212E

A  
EC  
C  
D  
E  
F  
G  
H  
I  
J  
K  
L  
M

# TROUBLE DIAGNOSIS

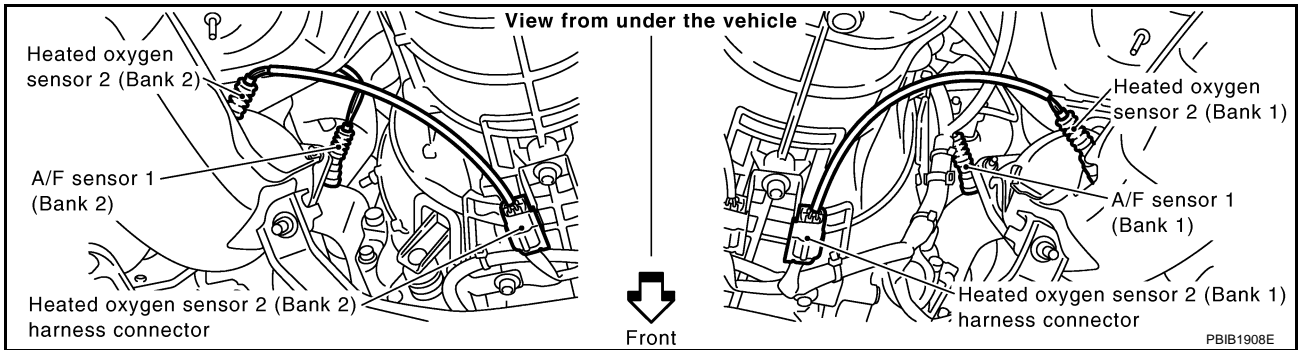
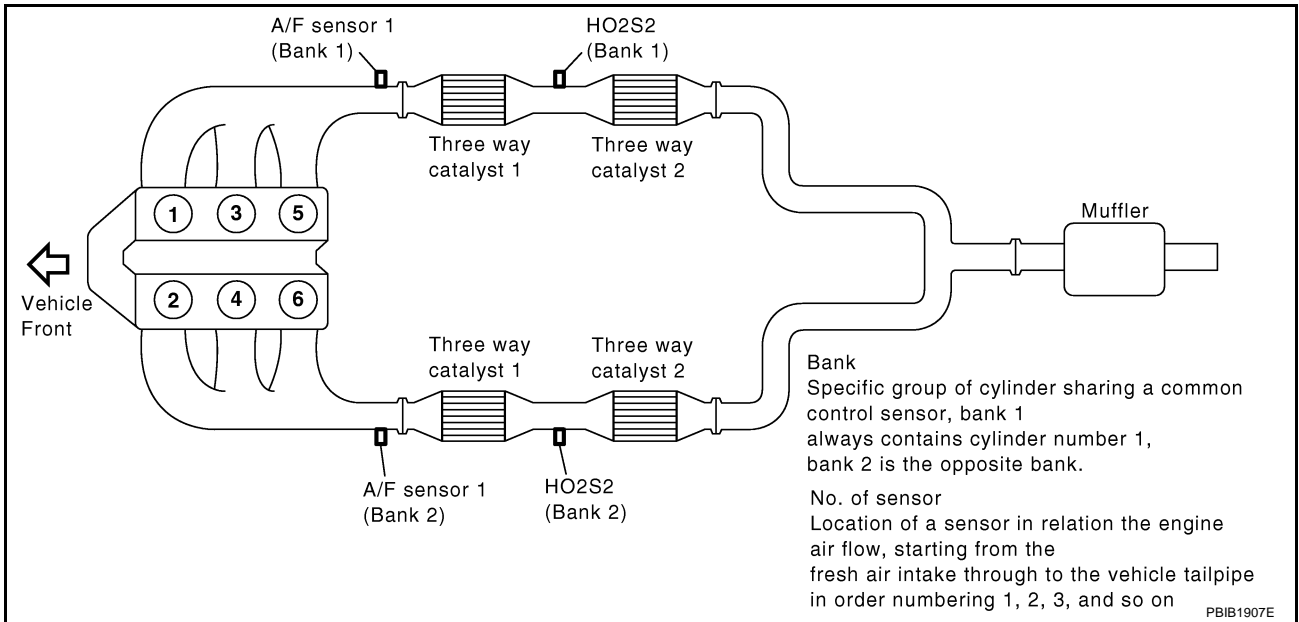

# TROUBLE DIAGNOSIS

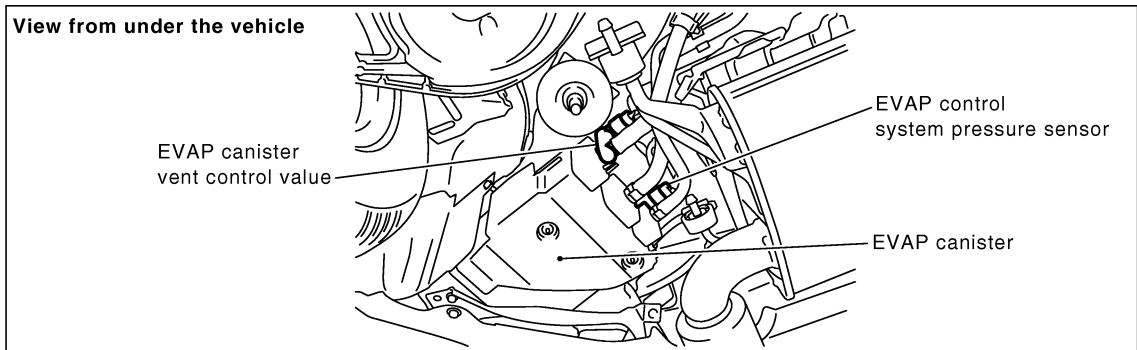
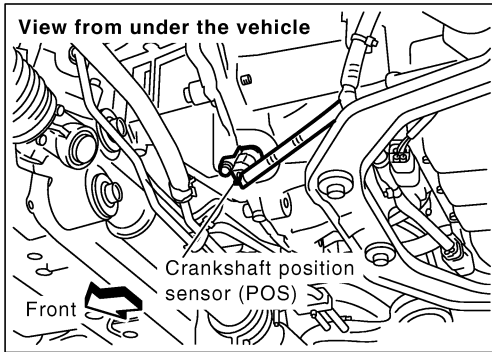
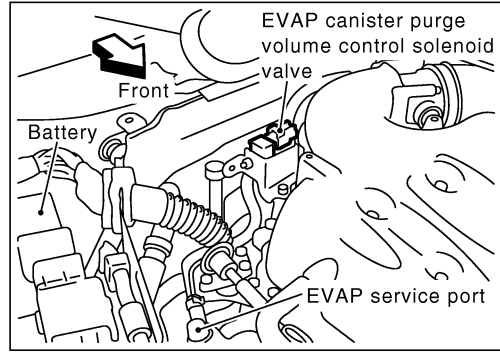
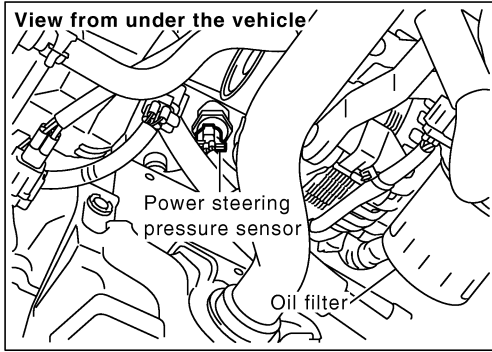

A  
EC  
C  
D  
E  
F  
G  
H  
I  
J  
K  
L  
M

# TROUBLE DIAGNOSIS

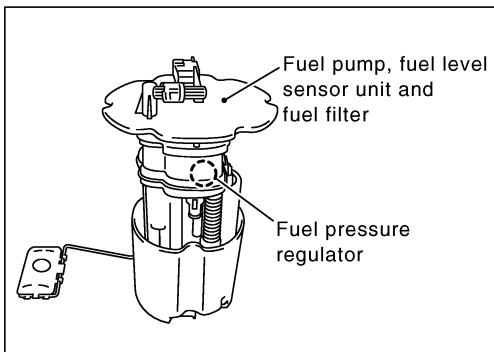
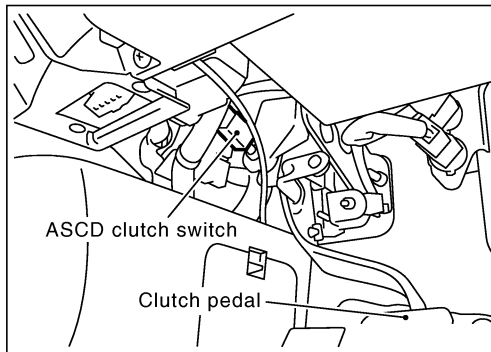
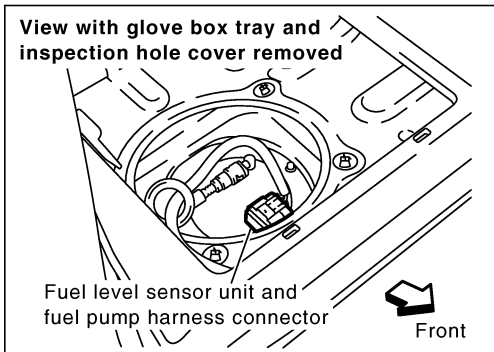
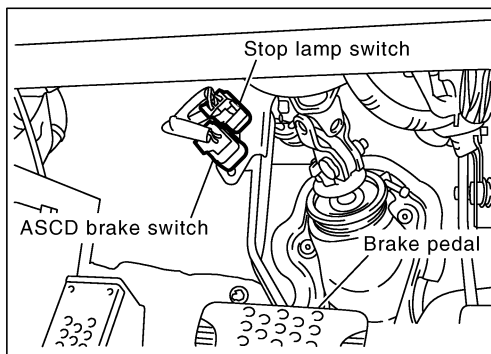
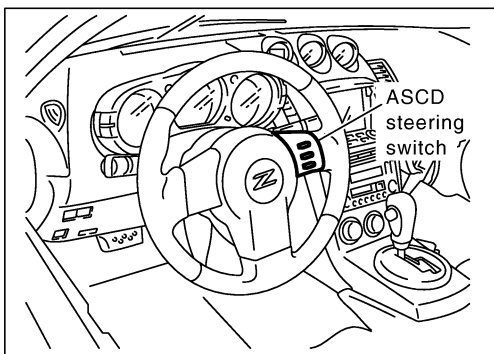
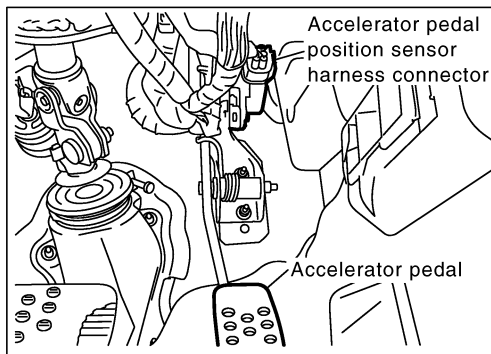
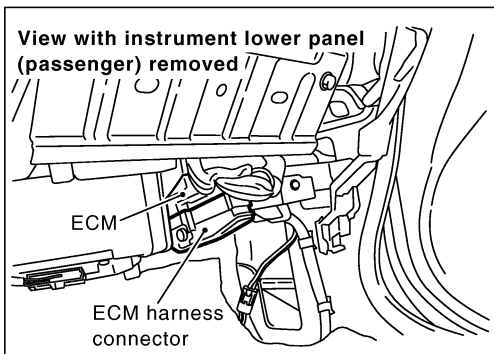

PBIB1664E

# TROUBLE DIAGNOSIS

## Circuit Diagram

ABS009B8

A  
EC  
C  
D  
E  
F  
G  
H  
I  
J  
K  
L  
M

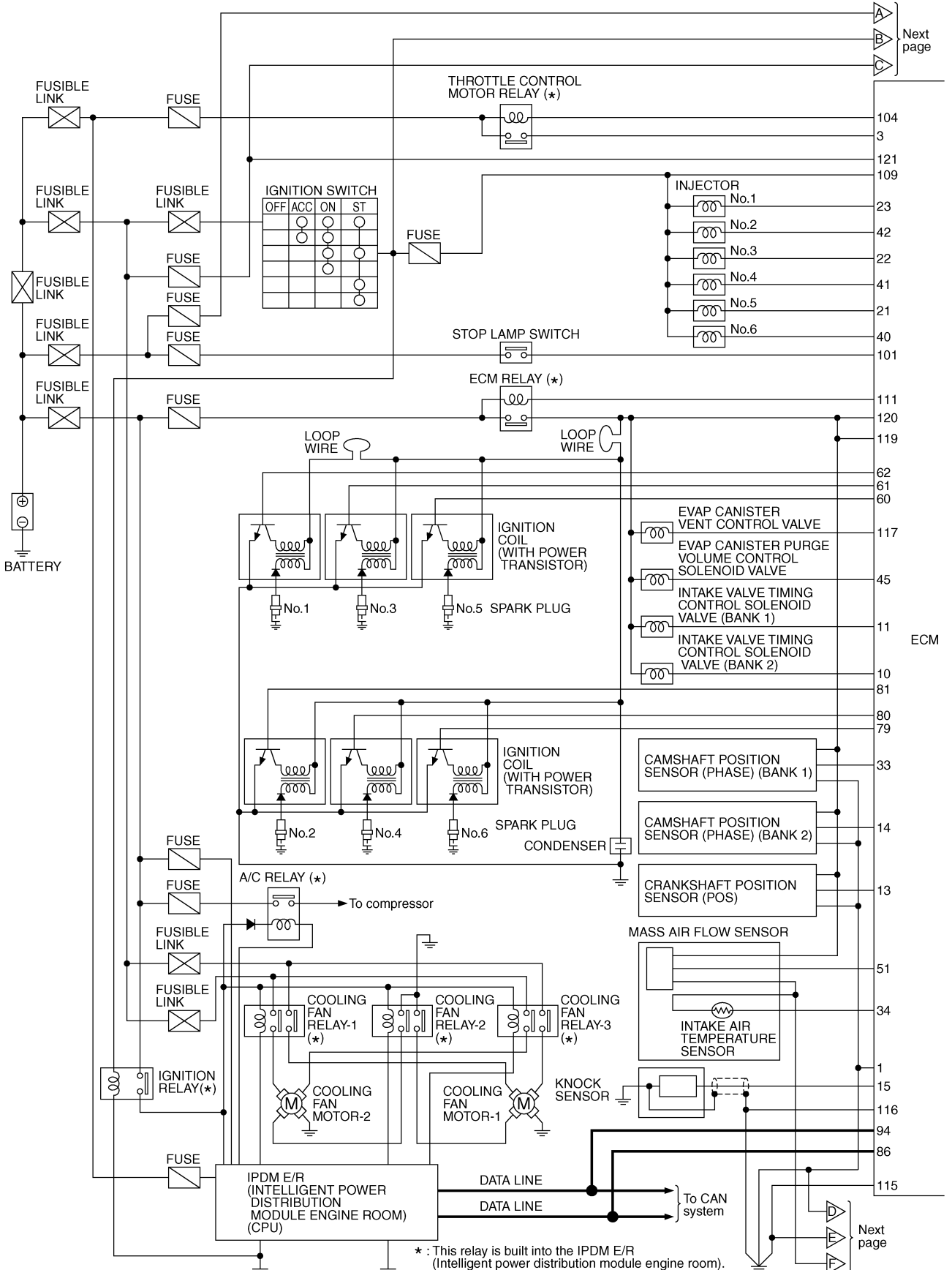

Next page  
A  
B  
C

Next page  
A  
B  
C

TBWT0611E

# TROUBLE DIAGNOSIS

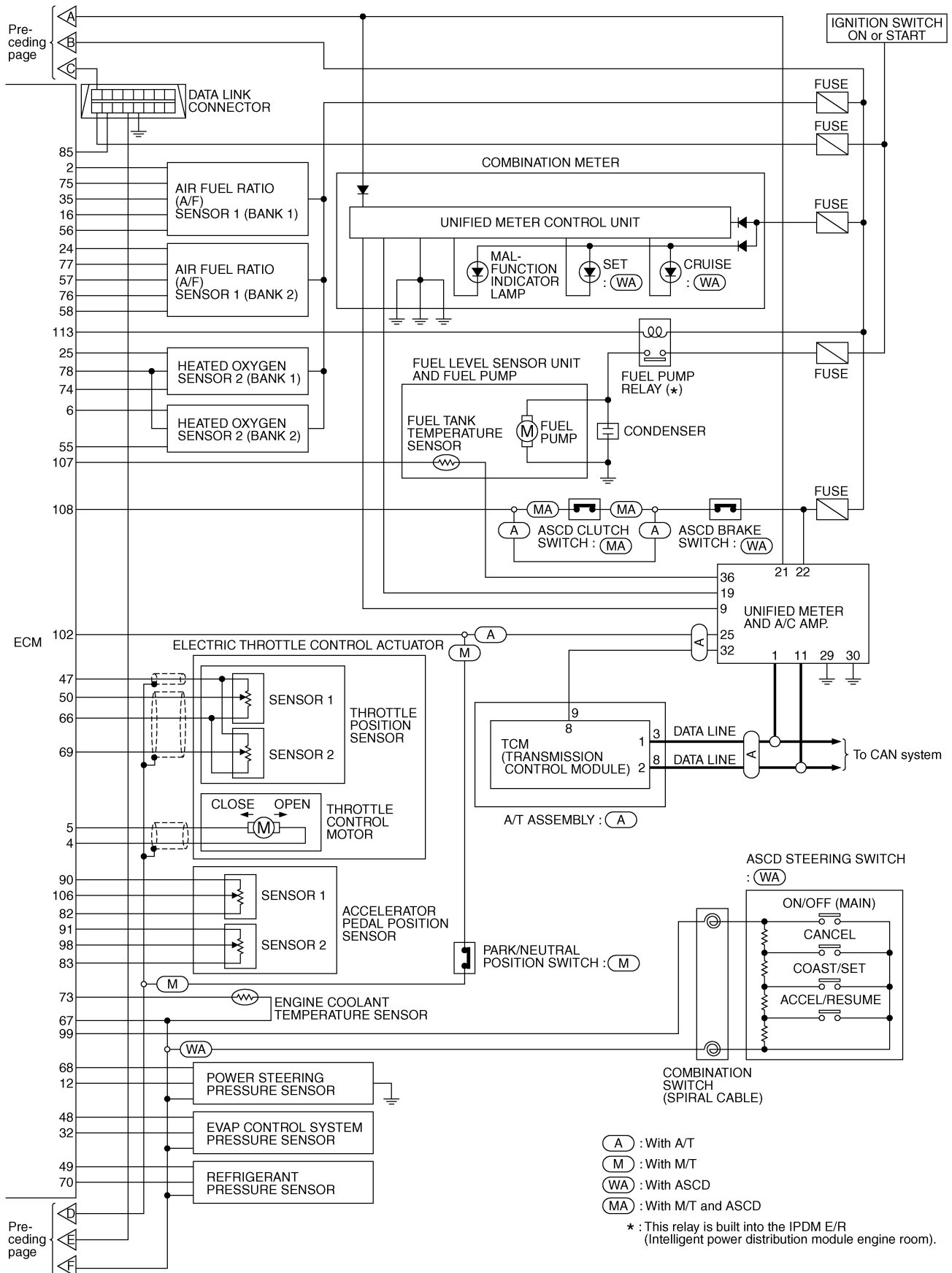

TBWM0595E

# TROUBLE DIAGNOSIS

## ECM Harness Connector Terminal Layout

ABS009B9

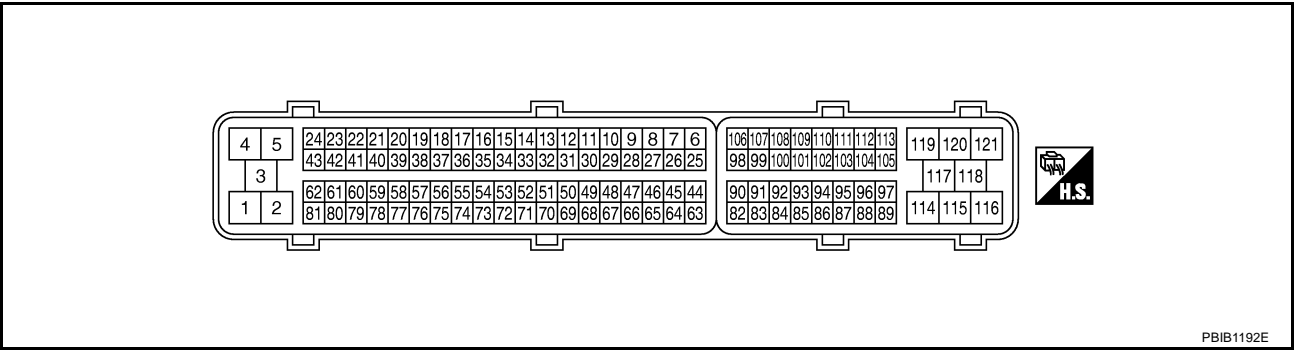

## ECM Terminals and Reference Value PREPARATION

ABS009BA

1. ECM is located behind the passenger side instrument lower panel. For this inspection, remove passenger side instrument lower panel.
2. Remove ECM harness connector.

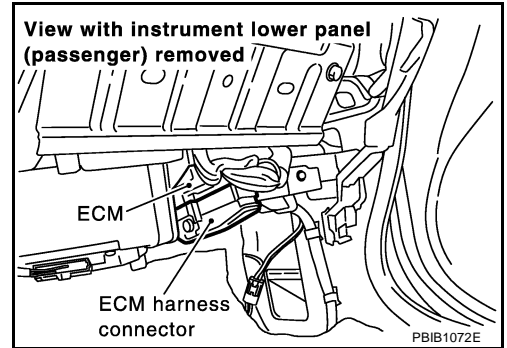

3. When disconnecting ECM harness connector, loosen it with levers as far as they will go as shown in the figure.
4. Connect a break-out box (SST) and Y-cable adapter (SST) between the ECM and ECM harness connector.
  - Use extreme care not to touch 2 pins at one time.
  - Data is for comparison and may not be exact.

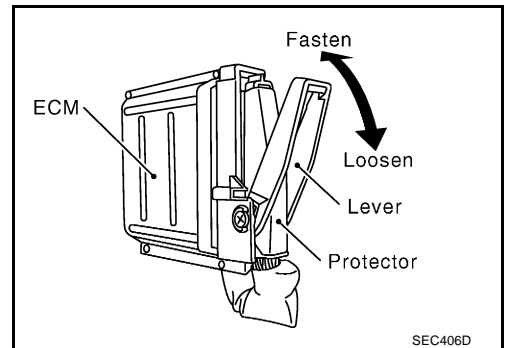

## ECM INSPECTION TABLE

Specification data are reference values and are measured between each terminal and ground. Pulse signal is measured by CONSULT-II.

### CAUTION:

Do not use ECM ground terminals when measuring input/output voltage. Doing so may result in damage to the ECMs transistor. Use a ground other than ECM terminals, such as the ground.

TER-MINAL NO.	WIRE COLOR	ITEM	CONDITION	DATA (DC Voltage)
1	B	ECM ground	<b>[Engine is running]</b> ● Idle speed	Body ground
2	GY/R	A/F sensor 1 heater (bank 1)	<b>[Engine is running]</b> ● Warm-up condition ● Idle speed	Approximately 5V★  10.0V/Div 10 ms/Div

PBIB1584E

# TROUBLE DIAGNOSIS

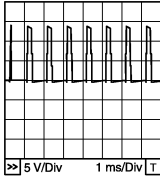
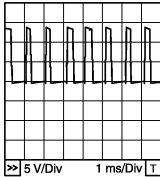
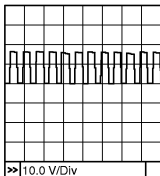
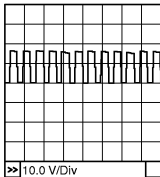
TER-MINAL NO.	WIRE COLOR	ITEM	CONDITION	DATA (DC Voltage)
3	G	Throttle control motor relay power supply	<b>[Ignition switch: ON]</b>	BATTERY VOLTAGE (11 - 14V)
4	L/B	Throttle control motor (Close)	<b>[Ignition switch: ON]</b> <ul style="list-style-type: none"> <li>● Engine stopped</li> <li>● Shift lever: D (A/T) or 1st (M/T)</li> <li>● Accelerator pedal is fully released</li> </ul>	0 - 14V★  <small>PBIB1104E</small>
5	L/Y	Throttle control motor (Open)	<b>[Ignition switch: ON]</b> <ul style="list-style-type: none"> <li>● Engine stopped</li> <li>● Shift lever: D (A/T) or 1st (M/T)</li> <li>● Accelerator pedal is fully depressed</li> </ul>	0 - 14V★  <small>PBIB1105E</small>
6	P/L	Heated oxygen sensor 2 heater (bank 2)	<b>[Engine is running]</b> <ul style="list-style-type: none"> <li>● Engine speed is below 3,600 rpm after the following conditions are met.               <ul style="list-style-type: none"> <li>- Engine: after warming up</li> <li>- Keeping the engine speed between 3,500 and 4,000 rpm for 1 minute and at idle for 1 minute under no load.</li> </ul> </li> </ul>	0 - 1.0V
			<b>[Ignition switch: ON]</b> <ul style="list-style-type: none"> <li>● Engine stopped</li> </ul> <b>[Engine is running]</b> <ul style="list-style-type: none"> <li>● Engine speed is above 3,600 rpm.</li> </ul>	BATTERY VOLTAGE (11 - 14V)
10	W/G	Intake valve timing control solenoid valve (bank 2)	<b>[Engine is running]</b> <ul style="list-style-type: none"> <li>● Warm-up condition</li> <li>● Idle speed</li> </ul>	BATTERY VOLTAGE (11 - 14V)
			<b>[Engine is running]</b> <ul style="list-style-type: none"> <li>● Warm-up condition</li> <li>● When revving engine up to 2,000 rpm quickly</li> </ul>	7 - 12V★  <small>PBIB1790E</small>
11	P	Intake valve timing control solenoid valve (bank 1)	<b>[Engine is running]</b> <ul style="list-style-type: none"> <li>● Warm-up condition</li> <li>● Idle speed</li> </ul>	BATTERY VOLTAGE (11 - 14V)
			<b>[Engine is running]</b> <ul style="list-style-type: none"> <li>● Warm-up condition</li> <li>● When revving engine up to 2,000 rpm quickly</li> </ul>	7 - 12V★  <small>PBIB1790E</small>

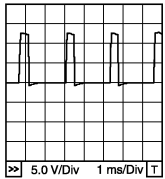
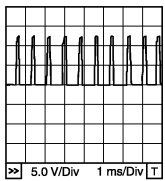
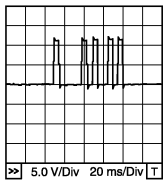
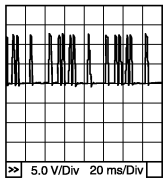

# TROUBLE DIAGNOSIS

TER-MINAL NO.	WIRE COLOR	ITEM	CONDITION	DATA (DC Voltage)
12	L/W	Power steering pressure sensor	<b>[Engine is running]</b> ● Steering wheel is being turned.	0.5 - 4.5V
			<b>[Engine is running]</b> ● Steering wheel is not being turned.	0.4 - 0.8V
13	W/L	Crankshaft position sensor (POS)	<b>[Engine is running]</b> ● <b>Warm-up condition</b> ● Idle speed <b>NOTE:</b> The pulse cycle changes depending on rpm at idle.	Approximately 1.6V★  PBIB1041E
			<b>[Engine is running]</b> ● Engine speed is 2,000 rpm.	Approximately 1.4V★  PBIB1042E
14	R/L	Camshaft position sensor (PHASE) (bank 2)	<b>[Engine is running]</b> ● <b>Warm-up condition</b> ● Idle speed <b>NOTE:</b> The pulse cycle changes depending on rpm at idle.	1.0 - 4.0V★  PBIB1039E
			<b>[Engine is running]</b> ● Engine speed is 2,000 rpm.	1.0 - 4.0V★  PBIB1040E
15	W	Knock sensor	<b>[Engine is running]</b> ● Idle speed	Approximately 2.5V
16	LG/B	A/F sensor 1 (Bank 1)	<b>[Engine is running]</b> ● <b>Warm-up condition</b> ● Idle speed	Approximately 3.1V
35	L/W			Approximately 2.6V
56	W/L			Approximately 2.3V
75	P/B			Approximately 2.3V

A  
EC  
C  
D  
E  
F  
G  
H  
I  
J  
K  
L  
M

# TROUBLE DIAGNOSIS

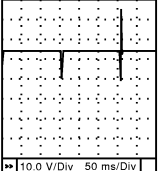
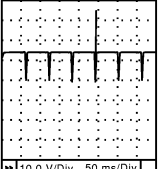
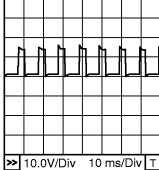
TER-MINAL NO.	WIRE COLOR	ITEM	CONDITION	DATA (DC Voltage)
21 22 23	SB R/Y R/B	Injector No. 5 Injector No. 3 Injector No. 1	<p><b>[Engine is running]</b></p> <ul style="list-style-type: none"> <li>● Warm-up condition</li> <li>● Idle speed</li> </ul> <p><b>NOTE:</b> The pulse cycle changes depending on rpm at idle.</p>	<p>BATTERY VOLTAGE (11 - 14V)★</p>  <p style="text-align: right;">SEC984C</p>
			<p><b>[Engine is running]</b></p> <ul style="list-style-type: none"> <li>● Warm-up condition</li> <li>● Engine speed is 2,000 rpm.</li> </ul>	<p>BATTERY VOLTAGE (11 - 14V)★</p>  <p style="text-align: right;">SEC985C</p>
24	G/Y	A/F sensor 1 heater (bank 2)	<p><b>[Engine is running]</b></p> <ul style="list-style-type: none"> <li>● Warm-up condition</li> <li>● Idle speed</li> </ul>	<p>Approximately 5V★</p>  <p style="text-align: right;">PBIB1584E</p>
25	P/B	Heated oxygen sensor 2 heater (bank 1)	<p><b>[Engine is running]</b></p> <ul style="list-style-type: none"> <li>● Engine speed is below 3,600 rpm after the following conditions are met.                             <ul style="list-style-type: none"> <li>- Engine: after warming up</li> <li>- Keeping the engine speed between 3,500 and 4,000 rpm for 1 minute and at idle for 1 minute under no load.</li> </ul> </li> </ul>	0 - 1.0V
			<p><b>[Ignition switch: ON]</b></p> <ul style="list-style-type: none"> <li>● Engine stopped</li> </ul> <p><b>[Engine is running]</b></p> <ul style="list-style-type: none"> <li>● Engine speed is above 3,600 rpm.</li> </ul>	BATTERY VOLTAGE (11 - 14V)
32	BR/W	EVAP control system pressure sensor	<b>[Ignition switch: ON]</b>	Approximately 1.8 - 4.8V

# TROUBLE DIAGNOSIS

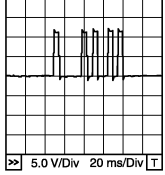
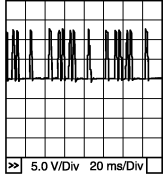
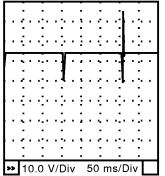
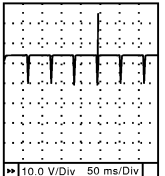
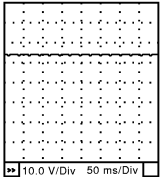
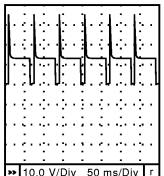
TER-MINAL NO.	WIRE COLOR	ITEM	CONDITION	DATA (DC Voltage)
33	R	Camshaft position sensor (PHASE) (bank 1)	<p><b>[Engine is running]</b></p> <ul style="list-style-type: none"> <li>● Warm-up condition</li> <li>● Idle speed</li> </ul> <p><b>NOTE:</b> The pulse cycle changes depending on rpm at idle.</p>	<p>1.0 - 4.0V★</p>  <p style="text-align: right; font-size: small;">PBIB1039E</p>
			<p><b>[Engine is running]</b></p> <ul style="list-style-type: none"> <li>● Engine speed is 2,000 rpm.</li> </ul>	<p>1.0 - 4.0V★</p>  <p style="text-align: right; font-size: small;">PBIB1040E</p>
34	Y/G	Intake air temperature sensor	<p><b>[Engine is running]</b></p>	<p>Approximately 0 - 4.8V Output voltage varies with intake air temperature.</p>
40 41 42	LG W/B B/R	Injector No. 6 Injector No. 4 Injector No. 2	<p><b>[Engine is running]</b></p> <ul style="list-style-type: none"> <li>● Warm-up condition</li> <li>● Idle speed</li> </ul> <p><b>NOTE:</b> The pulse cycle changes depending on rpm at idle.</p>	<p>BATTERY VOLTAGE (11 - 14V)★</p>  <p style="text-align: right; font-size: small;">SEC984C</p>
			<p><b>[Engine is running]</b></p> <ul style="list-style-type: none"> <li>● Warm-up condition</li> <li>● Engine speed is 2,000 rpm</li> </ul>	<p>BATTERY VOLTAGE (11 - 14V)★</p>  <p style="text-align: right; font-size: small;">SEC985C</p>
45	G/W	EVAP canister purge volume control solenoid valve	<p><b>[Engine is running]</b></p> <ul style="list-style-type: none"> <li>● Idle speed</li> <li>● Accelerator pedal is not depressed even slightly, after engine starting.</li> </ul>	<p>BATTERY VOLTAGE (11 - 14V)★</p>  <p style="text-align: right; font-size: small;">SEC990C</p>
			<p><b>[Engine is running]</b></p> <ul style="list-style-type: none"> <li>● Engine speed is about 2,000 rpm (More than 100 seconds after starting engine).</li> </ul>	<p>BATTERY VOLTAGE (11 - 14V)★</p>  <p style="text-align: right; font-size: small;">SEC991C</p>

A  
EC  
C  
D  
E  
F  
G  
H  
I  
J  
K  
L  
M

# TROUBLE DIAGNOSIS

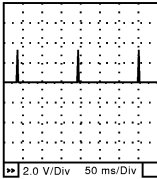
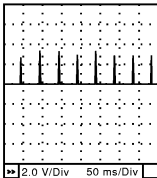
TERMINAL NO.	WIRE COLOR	ITEM	CONDITION	DATA (DC Voltage)
47	W/R	Sensor power supply (Throttle position sensor)	[Ignition switch: ON]	Approximately 5V
48	PU	Sensor power supply (EVAP control system pressure sensor)	[Ignition switch: ON]	Approximately 5V
49	B	Sensor power supply (Refrigerant pressure sensor)	[Ignition switch: ON]	Approximately 5V
50	G	Throttle position sensor 1	[Ignition switch: ON] ● Engine stopped ● Shift lever: D (A/T) or 1st (M/T) ● Accelerator pedal is fully released	More than 0.36V
			[Ignition switch: ON] ● Engine stopped ● Shift lever: D (A/T) or 1st (M/T) ● Accelerator pedal is fully depressed	Less than 4.75V
51	OR	Mass air flow sensor	[Engine is running] ● Warm-up condition ● Idle speed	0.9 - 1.2V
			[Engine is running] ● Warm-up condition ● Engine speed is 2,500 rpm.	1.6 - 1.9V
55	L/B	Heated oxygen sensor 2 (bank 2)	[Engine is running] ● Warm-up condition ● Revving engine from idle to 3,000 rpm quickly after the following conditions are met. – After keeping the engine speed between 3,500 and 4,000 rpm for 1 minute and at idle for 1 minute under no load.	0 - Approximately 1.0V
57	L	A/F sensor 1 (Bank 2)	[Engine is running] ● Warm-up condition ● Idle speed	Approximately 2.6V
58	W			Approximately 2.3V
76	LG			Approximately 3.1V
77	P			Approximately 2.3V
60 61 62	PU/W L/R Y/R	Ignition signal No. 5 Ignition signal No. 3 Ignition signal No. 1	[Engine is running] ● Warm-up condition ● Idle speed <b>NOTE:</b> The pulse cycle changes depending on rpm at idle.	0 - 0.2V★  SEC986C
			[Engine is running] ● Warm-up condition ● Engine speed is 2,500 rpm.	0.1 - 0.4V★  SEC987C

# TROUBLE DIAGNOSIS

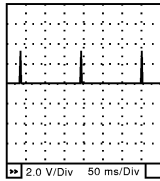
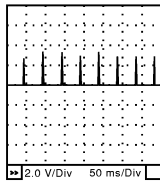
TER-MINAL NO.	WIRE COLOR	ITEM	CONDITION	DATA (DC Voltage)	A
66	L	Sensor ground (Throttle position sensor)	<b>[Engine is running]</b> ● Warm-up condition ● Idle speed	Approximately 0V	EC
67	B/W	Sensor ground	<b>[Engine is running]</b> ● Warm-up condition ● Idle speed	Approximately 0V	C
68	R/W	Sensor power supply (Power steering pressure sensor)	<b>[Ignition switch: ON]</b>	Approximately 5V	D
69	Y	Throttle position sensor 2	<b>[Ignition switch: ON]</b> ● Engine stopped ● Shift lever: D (A/T) or 1st (M/T) ● Accelerator pedal is fully released	Less than 4.75V	E
			<b>[Ignition switch: ON]</b> ● Engine stopped ● Shift lever: D (A/T) or 1st (M/T) ● Accelerator pedal is fully depressed	More than 0.36V	F
70	G/R	Refrigerant pressure sensor	<b>[Engine is running]</b> ● Warm-up condition ● Both A/C switch and blower switch are ON. (Compressor operates.)	1.0 - 4.0V	G
73	BR/Y	Engine coolant temperature sensor	<b>[Engine is running]</b>	Approximately 0 - 4.8V Output voltage varies with engine coolant temperature.	H
74	OR	Heated oxygen sensor 2 (bank 1)	<b>[Engine is running]</b> ● Warm-up condition ● Revving engine from idle to 3,000 rpm quickly after the following conditions are met. - After keeping the engine speed between 3,500 and 4,000 rpm for 1 minute and at idle for 1 minute under no load.	0 - Approximately 1.0V	I
78	B/Y	Sensor ground (Heated oxygen sensor)	<b>[Engine is running]</b> ● Warm-up condition ● Idle speed	Approximately 0V	J
79 80 81	GY/R GY G/B	Ignition signal No. 6 Ignition signal No. 4 Ignition signal No. 2	<b>[Engine is running]</b> ● Warm-up condition ● Idle speed <b>NOTE:</b> The pulse cycle changes depending on rpm at idle.	0 - 0.2V★  SEC986C	K
			<b>[Engine is running]</b> ● Warm-up condition ● Engine speed is 2,500 rpm.	0.1 - 0.4V★  SEC987C	L
					M

## TROUBLE DIAGNOSIS

TER-MINAL NO.	WIRE COLOR	ITEM	CONDITION	DATA (DC Voltage)
82	G/Y	Sensor ground (APP sensor 1)	<b>[Engine is running]</b> ● Warm-up condition ● Idle speed	Approximately 0V
83	G/R	Sensor ground (APP sensor 2)	<b>[Engine is running]</b> ● Warm-up condition ● Idle speed	Approximately 0V
85	LG	Data link connector	<b>[Ignition switch: ON]</b> ● CONSULT-II or GST is disconnected.	Approximately 5V - Battery voltage (11 - 14V)
86	P	CAN communication line	<b>[Ignition switch: ON]</b>	Approximately 1.1 - 2.3V Output voltage varies with the communication status.
90	LG	Sensor power supply (APP sensor 1)	<b>[Ignition switch: ON]</b>	Approximately 5V
91	B/OR	Sensor power supply (APP sensor 2)	<b>[Ignition switch: ON]</b>	Approximately 5V
94	L	CAN communication line	<b>[Ignition switch: ON]</b>	Approximately 2.6 - 3.2V Output voltage varies with the communication status.
98	G/B	Accelerator pedal position sensor 2	<b>[Ignition switch: ON]</b> ● Engine stopped ● Accelerator pedal is fully released	0.15 - 0.60V
			<b>[Ignition switch: ON]</b> ● Engine stopped ● Accelerator pedal is fully depressed	1.95 - 2.40V
99	G/Y	ASCD steering switch	<b>[Ignition switch: ON]</b> ● ASCD steering switch: OFF	Approximately 4V
			<b>[Ignition switch: ON]</b> ● ON/OFF (MAIN) switch: Pressed	Approximately 0V
			<b>[Ignition switch: ON]</b> ● CANCEL switch: Pressed	Approximately 1V
			<b>[Ignition switch: ON]</b> ● ACCEL/RESUME switch: Pressed	Approximately 3V
			<b>[Ignition switch: ON]</b> ● COAST/SET switch: Pressed	Approximately 2V
101	L/OR	Stop lamp switch	<b>[Ignition switch: OFF]</b> ● Brake pedal is fully released	Approximately 0V
			<b>[Ignition switch: OFF]</b> ● Brake pedal is slightly depressed	BATTERY VOLTAGE (11 - 14V)
102	BR/Y	PNP switch	<b>[Ignition switch: ON]</b> ● Shift lever: P or N (A/T), Neutral (M/T)	Approximately 0V
			<b>[Ignition switch: ON]</b> ● Except above position	BATTERY VOLTAGE (11 - 14V)
104	SB	Throttle control motor relay	<b>[Ignition switch: OFF]</b>	BATTERY VOLTAGE (11 - 14V)
			<b>[Ignition switch: ON]</b>	0 - 1.0V

# TROUBLE DIAGNOSIS

TERMINAL NO.	WIRE COLOR	ITEM	CONDITION	DATA (DC Voltage)	
106	G/OR	Accelerator pedal position sensor 1	<b>[Ignition switch: ON]</b> ● Engine stopped ● Accelerator pedal is fully released	0.5 - 1.0V	A EC
			<b>[Ignition switch: ON]</b> ● Engine stopped ● Accelerator pedal is fully depressed	3.9 - 4.7V	C
107	GY/R	Fuel tank temperature sensor	<b>[Engine is running]</b>	Approximately 0 - 4.8V Output voltage varies with fuel tank temperature.	D
108	B/R	ASCD brake switch	<b>[Ignition switch: ON]</b> ● Brake pedal is slightly depressed (A/T) ● Brake pedal and/or clutch pedal are slightly depressed (M/T)	Approximately 0V	E
			<b>[Ignition switch: ON]</b> ● Brake pedal is fully released (A/T) ● Brake pedal and clutch pedal are fully released (M/T)	BATTERY VOLTAGE (11 - 14V)	F
109	W/B	Ignition switch	<b>[Ignition switch: OFF]</b>	0V	G
			<b>[Ignition switch: ON]</b>	BATTERY VOLTAGE (11 - 14V)	H
111	GY/L	ECM relay (Self shut-off)	<b>[Engine is running]</b> <b>[Ignition switch: OFF]</b> ● A few seconds after turning ignition switch OFF	0 - 1.5V	I
			<b>[Ignition switch: OFF]</b> ● More than a few seconds after turning ignition switch OFF	BATTERY VOLTAGE (11 - 14V)	J
113	LG/B	Fuel pump relay	<b>[Ignition switch: ON]</b> ● For 1 second after turning ignition switch ON	0 - 1.5V	K
			<b>[Ignition switch: ON]</b> ● More than 1 second after turning ignition switch ON.	BATTERY VOLTAGE (11 - 14V)	L
115 116	B/W B/R	ECM ground	<b>[Engine is running]</b> ● Idle speed	Body ground	M
117	G/W	EVAP canister vent control valve	<b>[Ignition switch: ON]</b>	BATTERY VOLTAGE (11 - 14V)	
119 120	R/W P	Power supply for ECM	<b>[Ignition switch: ON]</b>	BATTERY VOLTAGE (11 - 14V)	
121	R/W	Power supply for ECM (Back-up)	<b>[Ignition switch: OFF]</b>	BATTERY VOLTAGE (11 - 14V)	

★: Average voltage for pulse signal (Actual pulse signal can be confirmed by oscilloscope.)

## CONSULT-II Function (ENGINE) FUNCTION

ABS009BB

Diagnostic test mode	Function
Work support	This mode enables a technician to adjust some devices faster and more accurately by following the indications on the CONSULT-II unit.
Self-diagnostic results	Self-diagnostic results such as 1st trip DTC, DTCs and 1st trip freeze frame data or freeze frame data can be read and erased quickly.*

# TROUBLE DIAGNOSIS

Diagnostic test mode	Function
Data monitor	Input/Output data in the ECM can be read.
Data monitor (SPEC)	Input/Output of the specification for Basic fuel schedule, AFM, A/F feedback control value and the other data monitor items can be read.
CAN diagnostic support monitor	The results of transmit/receive diagnosis of CAN communication can be read.
Active test	Diagnostic Test Mode in which CONSULT-II drives some actuators apart from the ECMs and also shifts some parameters in a specified range.
DTC & SRT confirmation	The status of system monitoring tests and the self-diagnosis status/result can be confirmed.
Function test	This mode is used to inform customers when their vehicle condition requires periodic maintenance.
ECM part number	ECM part number can be read.

\*: The following emission-related diagnostic information is cleared when the ECM memory is erased.

- Diagnostic trouble codes
- 1st trip diagnostic trouble codes
- Freeze frame data
- 1st trip freeze frame data
- System readiness test (SRT) codes
- Test values
- Others



# TROUBLE DIAGNOSIS

## ENGINE CONTROL COMPONENT PARTS/CONTROL SYSTEMS APPLICATION

Item		DIAGNOSTIC TEST MODE							
		WORK SUP-PORT	SELF-DIAGNOSTIC RESULTS		DATA MONI-TOR	DATA MONI-TOR (SPEC)	ACTIVE TEST	DTC & SRT CONFIRMATION	
			DTC*1	FREEZE FRAME DATA*2				SRT STATUS	DTC WORK SUP-PORT
ENGINE CONTROL COMPONENT PARTS INPUT	Crankshaft position sensor (POS)		×	×	×	×			A
	Camshaft position sensor (PHASE)		×	×	×	×			B
	Mass air flow sensor		×		×	×			C
	Engine coolant temperature sensor		×	×	×	×	×		D
	Air fuel ratio (A/F) sensor 1		×		×	×		×	E
	Heated oxygen sensor 2		×		×	×		×	F
	Vehicle speed sensor		×	×	×	×			G
	Accelerator pedal position sensor		×		×	×			H
	Throttle position sensor		×		×	×			I
	Fuel tank temperature sensor		×		×	×	×		J
	EVAP control system pressure sensor		×		×	×			K
	Intake air temperature sensor		×	×	×	×			L
	Knock sensor		×						M
	Refrigerant pressure sensor				×	×			N
	Closed throttle position switch (accelerator pedal position sensor signal)				×	×			O
	Air conditioner switch				×	×			P
	Park/neutral position (PNP) switch		×		×	×			Q
	Stop lamp switch		×		×	×			R
	Power steering pressure sensor		×		×	×			S
	Battery voltage				×	×			T
Load signal				×	×			U	
Fuel level sensor		×		×	×			V	
ASCD steering switch		×		×	×			W	
ASCD brake switch		×		×	×			X	
ASCD clutch switch		×		×	×			Y	

# TROUBLE DIAGNOSIS

Item		DIAGNOSTIC TEST MODE							
		WORK SUP-PORT	SELF-DIAGNOSTIC RESULTS		DATA MONI-TOR	DATA MONI-TOR (SPEC)	ACTIVE TEST	DTC & SRT CONFIRMATION	
			DTC*1	FREEZE FRAME DATA*2				SRT STATUS	DTC WORK SUP-PORT
ENGINE CONTROL COMPONENT PARTS OUTPUT	Injector				×	×	×		
	Power transistor (Ignition timing)				×	×	×		
	Throttle control motor relay		×		×	×			
	Throttle control motor		×						
	EVAP canister purge volume control solenoid valve		×		×	×	×		×
	Air conditioner relay				×	×			
	Fuel pump relay	×			×	×	×		
	Cooling fan relay		×		×	×	×		
	Air fuel ratio (A/F) sensor 1 heater		×		×	×		×	
	Heated oxygen sensor 2 heater		×		×	×		×	
	EVAP canister vent control valve	×	×		×	×	×		
	Intake valve timing control solenoid valve		×		×	×	×		
Calculated load value			×	×	×				

X: Applicable

\*1: This item includes 1st trip DTCs.

\*2: This mode includes 1st trip freeze frame data or freeze frame data. The items appear on CONSULT-II screen in freeze frame data mode only if a 1st trip DTC or DTC is detected. For details, refer to [EC-52](#).

## INSPECTION PROCEDURE

### CAUTION:

If CONSULT-II is used with no connection of CONSULT-II CONVERTER, malfunctions might be detected in self-diagnosis depending on control unit which carry out CAN communication.

1. Turn ignition switch OFF.
2. Connect "CONSULT-II" and "CONSULT-II CONVERTER" to data link connector, which is located under LH dash panel near the hood opener handle.
3. Turn ignition switch ON.

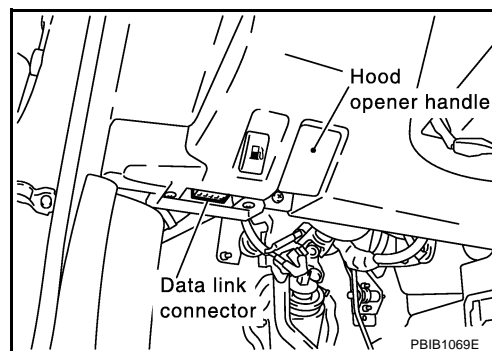

4. Touch "START (NISSAN BASED VHCL)".

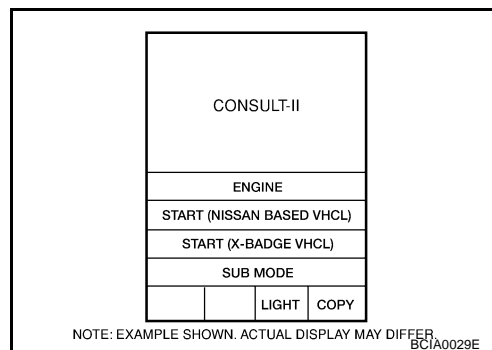

# TROUBLE DIAGNOSIS

5. Touch "ENGINE".  
If "ENGINE" is not indicated, go to [GI-39, "CONSULT-II Data Link Connector \(DLC\) Circuit"](#).

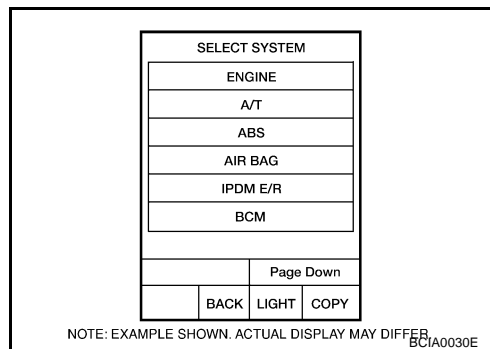

6. Perform each diagnostic test mode according to each service procedure.  
**For further information, see the CONSULT-II Operation Manual.**

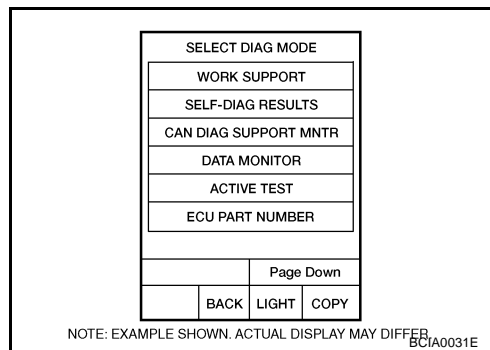

## WORK SUPPORT MODE

### Work Item

WORK ITEM	CONDITION	USAGE
FUEL PRESSURE RELEASE	<ul style="list-style-type: none"> <li>FUEL PUMP WILL STOP BY TOUCHING "START" DURING IDLING.</li> <li>CRANK A FEW TIMES AFTER ENGINE STALLS.</li> </ul>	When releasing fuel pressure from fuel line
IDLE AIR VOL LEARN	<ul style="list-style-type: none"> <li>THE IDLE AIR VOLUME THAT KEEPS THE ENGINE WITHIN THE SPECIFIED RANGE IS MEMORIZED IN ECM.</li> </ul>	When learning the idle air volume
SELF-LEARNING CONT	<ul style="list-style-type: none"> <li>THE COEFFICIENT OF SELF-LEARNING CONTROL MIXTURE RATIO RETURNS TO THE ORIGINAL COEFFICIENT.</li> </ul>	When clearing the coefficient of self-learning control value
EVAP SYSTEM CLOSE	<p>CLOSE THE EVAP CANISTER VENT CONTROL VALVE IN ORDER TO MAKE EVAP SYSTEM CLOSE UNDER THE FOLLOWING CONDITIONS.</p> <ul style="list-style-type: none"> <li>IGN SW ON</li> <li>ENGINE NOT RUNNING</li> <li>AMBIENT TEMPERATURE IS ABOVE 0°C (32°F).</li> <li>NO VACUUM AND NO HIGH PRESSURE IN EVAP SYSTEM</li> <li>FUEL TANK TEMP. IS MORE THAN 0°C (32°F).</li> <li>WITHIN 10 MINUTES AFTER STARTING "EVAP SYSTEM CLOSE"</li> <li>WHEN TRYING TO EXECUTE "EVAP SYSTEM CLOSE" UNDER THE CONDITION EXCEPT ABOVE, CONSULT-II WILL DISCONTINUE IT AND DISPLAY APPROPRIATE INSTRUCTION.</li> </ul> <p><b>NOTE:</b> <b>WHEN STARTING ENGINE, CONSULT-II MAY DISPLAY "BATTERY VOLTAGE IS LOW. CHARGE BATTERY", EVEN IN USING CHARGED BATTERY.</b></p>	When detecting EVAP vapor leak point of EVAP system
VIN REGISTRATION	<ul style="list-style-type: none"> <li>VIN IS REGISTERED IN ECM.</li> </ul>	When registering VIN in ECM

# TROUBLE DIAGNOSIS

WORK ITEM	CONDITION	USAGE
TARGET IDLE RPM ADJ*	● IDLE CONDITION	When setting target idle speed
TARGET IGN TIM ADJ*	● IDLE CONDITION	When adjusting target ignition timing

\*: This function is not necessary in the usual service procedure.

## SELF-DIAG RESULTS MODE

### Self Diagnostic Item

Regarding items of DTC and 1st trip DTC, refer to [EC-8, "INDEX FOR DTC"](#) .

### Freeze Frame Data and 1st Trip Freeze Frame Data

Freeze frame data item*	Description
DIAG TROUBLE CODE [PXXXX]	● The engine control component part/control system has a trouble code, it is displayed as PXXXX. (Refer to <a href="#">EC-8, "INDEX FOR DTC"</a> .)
FUEL SYS-B1	● "Fuel injection system status" at the moment a malfunction is detected is displayed.
FUEL SYS-B2	● One mode in the following is displayed. Mode2: Open loop due to detected system malfunction Mode3: Open loop due to driving conditions (power enrichment, deceleration enrichment) Mode4: Closed loop - using oxygen sensor(s) as feedback for fuel control Mode5: Open loop - has not yet satisfied condition to go to closed loop
CAL/LD VALUE [%]	● The calculated load value at the moment a malfunction is detected is displayed.
COOLANT TEM [°C] or [°F]	● The engine coolant temperature at the moment a malfunction is detected is displayed.
L-FUEL TRM-B1 [%]	● "Long-term fuel trim" at the moment a malfunction is detected is displayed.
L-FUEL TRM-B2 [%]	● The long-term fuel trim indicates much more gradual feedback compensation to the base fuel schedule than short-term fuel trim.
S-FUEL TRM-B1 [%]	● "Short-term fuel trim" at the moment a malfunction is detected is displayed.
S-FUEL TRM-B2 [%]	● The short-term fuel trim indicates dynamic or instantaneous feedback compensation to the base fuel schedule.
ENGINE SPEED [rpm]	● The engine speed at the moment a malfunction is detected is displayed.
VEHICL SPEED [km/h] or [mph]	● The vehicle speed at the moment a malfunction is detected is displayed.
B/FUEL SCHDL [msec]	● The base fuel schedule at the moment a malfunction is detected is displayed.
INT/A TEMP SE [°C] or [°F]	● The intake air temperature at the moment a malfunction is detected is displayed.

\*: The items are the same as those of 1st trip freeze frame data.

## DATA MONITOR MODE

### Monitored Item

×: Applicable

Monitored item [Unit]	ECM INPUT SIGNALS	MAIN SIGNALS	Description	Remarks
ENG SPEED [rpm]	×	×	● Indicates the engine speed computed from the signals of the crankshaft position sensor (POS) and camshaft position sensor (PHASE).	● Accuracy becomes poor if engine speed drops below the idle rpm. ● If the signal is interrupted while the engine is running, an abnormal value may be indicated.
MAS A/F SE-B1 [V]	×	×	● The signal voltage of the mass air flow sensor is displayed.	● When the engine is stopped, a certain value is indicated.

# TROUBLE DIAGNOSIS

Monitored item [Unit]	ECM INPUT SIGNALS	MAIN SIGNALS	Description	Remarks
B/FUEL SCHDL [msec]		×	<ul style="list-style-type: none"> <li>“Base fuel schedule” indicates the fuel injection pulse width programmed into ECM, prior to any learned on board correction.</li> </ul>	
A/F ALPHA-B1 [%]		×	<ul style="list-style-type: none"> <li>The mean value of the air-fuel ratio feedback correction factor per cycle is indicated.</li> </ul>	<ul style="list-style-type: none"> <li>When the engine is stopped, a certain value is indicated.</li> <li>This data also includes the data for the air-fuel ratio learning control.</li> </ul>
A/F ALPHA-B2 [%]		×		
COOLAN TEMP/S [°C] or [°F]	×	×	<ul style="list-style-type: none"> <li>The engine coolant temperature (determined by the signal voltage of the engine coolant temperature sensor) is displayed.</li> </ul>	<ul style="list-style-type: none"> <li>When the engine coolant temperature sensor is open or short-circuited, ECM enters fail-safe mode. The engine coolant temperature determined by the ECM is displayed.</li> </ul>
A/F SEN1 (B1) [V]	×	×	<ul style="list-style-type: none"> <li>The A/F signal computed from the input signal of the A/F sensor 1 is displayed.</li> </ul>	
A/F SEN1 (B2) [V]	×			
HO2S2 (B1) [V]	×		<ul style="list-style-type: none"> <li>The signal voltage of the heated oxygen sensor 2 is displayed.</li> </ul>	
HO2S2 (B2) [V]	×			
HO2S2 MNTR (B1) [RICH/LEAN]	×		<ul style="list-style-type: none"> <li>Display of heated oxygen sensor 2 signal: RICH: Means the amount of oxygen after three way catalyst is relatively small. LEAN: Means the amount of oxygen after three way catalyst is relatively large.</li> </ul>	<ul style="list-style-type: none"> <li>When the engine is stopped, a certain value is indicated.</li> </ul>
HO2S2 MNTR (B2) [RICH/LEAN]	×			
VHCL SPEED SE [km/h] or [mph]	×	×	<ul style="list-style-type: none"> <li>The vehicle speed computed from the vehicle speed signal sent from combination meter is displayed.</li> </ul>	
BATTERY VOLT [V]	×	×	<ul style="list-style-type: none"> <li>The power supply voltage of ECM is displayed.</li> </ul>	
ACCEL SEN 1 [V]	×	×	<ul style="list-style-type: none"> <li>The accelerator pedal position sensor signal voltage is displayed.</li> </ul>	<ul style="list-style-type: none"> <li>ACCEL SEN 2 signal is converted by ECM internally. Thus, it differ from ECM terminal voltage signal.</li> </ul>
ACCEL SEN 2 [V]	×			
THRTL SEN 1 [V]	×	×	<ul style="list-style-type: none"> <li>The throttle position sensor signal voltage is displayed.</li> </ul>	<ul style="list-style-type: none"> <li>THRTL SEN 2 signal is converted by ECM internally. Thus, it differ from ECM terminal voltage signal.</li> </ul>
THRTL SEN 2 [V]	×			
FUEL T/TEMP SE [°C] or [°F]	×		<ul style="list-style-type: none"> <li>The fuel temperature (determined by the signal voltage of the fuel tank temperature sensor) is displayed.</li> </ul>	
INT/A TEMP SE [°C] or [°F]	×	×	<ul style="list-style-type: none"> <li>The intake air temperature (determined by the signal voltage of the intake air temperature sensor) is indicated.</li> </ul>	
EVAP SYS PRES [V]	×		<ul style="list-style-type: none"> <li>The signal voltage of EVAP control system pressure sensor is displayed.</li> </ul>	
FUEL LEVEL SE [V]	×		<ul style="list-style-type: none"> <li>The signal voltage of the fuel level sensor is displayed.</li> </ul>	
START SIGNAL [ON/OFF]	×	×	<ul style="list-style-type: none"> <li>Indicates start signal status [ON/OFF] computed by the ECM according to the signals of engine speed and battery voltage.</li> </ul>	<ul style="list-style-type: none"> <li>After starting the engine, [OFF] is displayed regardless of the starter signal.</li> </ul>
CLSD THL POS [ON/OFF]	×	×	<ul style="list-style-type: none"> <li>Indicates idle position [ON/OFF] computed by ECM according to the accelerator pedal position sensor signal.</li> </ul>	
AIR COND SIG [ON/OFF]	×	×	<ul style="list-style-type: none"> <li>Indicates [ON/OFF] condition of the air conditioner switch as determined by the air conditioner signal.</li> </ul>	

## TROUBLE DIAGNOSIS

Monitored item [Unit]	ECM INPUT SIGNALS	MAIN SIGNALS	Description	Remarks
P/N POSI SW [ON/OFF]	×	×	<ul style="list-style-type: none"> <li>Indicates [ON/OFF] condition from the park/neutral position (PNP) switch signal.</li> </ul>	
PW/ST SIGNAL [ON/OFF]	×	×	<ul style="list-style-type: none"> <li>[ON/OFF] condition of the power steering system (determined by the signal voltage of the power steering pressure sensor signal) is indicated.</li> </ul>	
LOAD SIGNAL [ON/OFF]	×	×	<ul style="list-style-type: none"> <li>Indicates [ON/OFF] condition from the electrical load signal.</li> <li>ON: Rear window defogger switch is ON and/or lighting switch is in 2nd position.</li> <li>OFF: Both rear window defogger switch and lighting switch are OFF.</li> </ul>	
IGNITION SW [ON/OFF]	×		<ul style="list-style-type: none"> <li>Indicates [ON/OFF] condition from ignition switch signal.</li> </ul>	
HEATER FAN SW [ON/OFF]	×		<ul style="list-style-type: none"> <li>Indicates [ON/OFF] condition from the heater fan switch signal.</li> </ul>	
BRAKE SW [ON/OFF]	×		<ul style="list-style-type: none"> <li>Indicates [ON/OFF] condition from the stop lamp switch signal.</li> </ul>	
INJ PULSE-B1 [msec]		×	<ul style="list-style-type: none"> <li>Indicates the actual fuel injection pulse width compensated by ECM according to the input signals.</li> </ul>	<ul style="list-style-type: none"> <li>When the engine is stopped, a certain computed value is indicated.</li> </ul>
INJ PULSE-B2 [msec]				
IGN TIMING [BTDC]		×	<ul style="list-style-type: none"> <li>Indicates the ignition timing computed by ECM according to the input signals.</li> </ul>	<ul style="list-style-type: none"> <li>When the engine is stopped, a certain value is indicated.</li> </ul>
CAL/LD VALUE [%]			<ul style="list-style-type: none"> <li>"Calculated load value" indicates the value of the current air flow divided by peak air flow.</li> </ul>	
MASS AIRFLOW [g-m/s]			<ul style="list-style-type: none"> <li>Indicates the mass air flow computed by ECM according to the signal voltage of the mass air flow sensor.</li> </ul>	
PURG VOL C/V [%]			<ul style="list-style-type: none"> <li>Indicates the EVAP canister purge volume control solenoid valve control value computed by the ECM according to the input signals.</li> <li>The opening becomes larger as the value increases.</li> </ul>	
INT/V TIM (B1) [°CA]			<ul style="list-style-type: none"> <li>Indicates [°CA] of intake camshaft advanced angle.</li> </ul>	
INT/V TIM (B2) [°CA]				
INT/V SOL (B1) [%]			<ul style="list-style-type: none"> <li>The control value of the intake valve timing control solenoid valve (determined by ECM according to the input signals) is indicated.</li> <li>The advance angle becomes larger as the value increases.</li> </ul>	
INT/V SOL (B2) [%]				
AIR COND RLY [ON/OFF]		×	<ul style="list-style-type: none"> <li>The air conditioner relay control condition (determined by ECM according to the input signals) is indicated.</li> </ul>	
FUEL PUMP RLY [ON/OFF]		×	<ul style="list-style-type: none"> <li>Indicates the fuel pump relay control condition determined by ECM according to the input signals.</li> </ul>	

# TROUBLE DIAGNOSIS

Monitored item [Unit]	ECM INPUT SIGNALS	MAIN SIGNALS	Description	Remarks	
VENT CONT/V [ON/OFF]			<ul style="list-style-type: none"> <li>The control condition of the EVAP canister vent control valve (determined by ECM according to the input signals) is indicated. ON: Closed OFF: Open</li> </ul>		A EC
THRTL RELAY [ON/OFF]		×	<ul style="list-style-type: none"> <li>Indicates the throttle control motor relay control condition determined by the ECM according to the input signals.</li> </ul>		C D
COOLING FAN [HI/LOW/OFF]		×	<ul style="list-style-type: none"> <li>The control condition of the cooling fan (determined by ECM according to the input signals) is indicated. HI: High speed operation LOW: Low speed operation OFF: Stop</li> </ul>		E
HO2S2 HTR (B1) [ON/OFF]			<ul style="list-style-type: none"> <li>Indicates [ON/OFF] condition of heated oxygen sensor 2 heater determined by ECM according to the input signals.</li> </ul>		F
HO2S2 HTR (B2) [ON/OFF]				G	
I/P PULLY SPD [rpm]			<ul style="list-style-type: none"> <li>Indicates the engine speed computed from the turbine revolution sensor signal.</li> </ul>		H
VEHICLE SPEED [km/h] or [MPH]			<ul style="list-style-type: none"> <li>The vehicle speed computed from the vehicle speed signal sent from TCM or combination meter is displayed.</li> </ul>		I
IDL A/V LEARN [YET/CMPLT]			<ul style="list-style-type: none"> <li>Display the condition of idle air volume learning YET: Idle Air Volume Learning has not been performed yet. CMPLT: Idle Air Volume Learning has already been performed successfully.</li> </ul>		J
TRVL AFTER MIL [km] or [mile]			<ul style="list-style-type: none"> <li>Distance traveled while MIL is activated.</li> </ul>		K
A/F S1 HTR (B1) [%]			<ul style="list-style-type: none"> <li>Indicates A/F sensor 1 heater control value computed by ECM according to the input signals.</li> <li>The current flow to the heater becomes larger as the value increases.</li> </ul>		L
A/F S1 HTR (B2) [%]				M	
AC PRESS SEN [V]			<ul style="list-style-type: none"> <li>The signal voltage from the refrigerant pressure sensor is displayed.</li> </ul>		
VHCL SPEED SE [km/h] or [mph]			<ul style="list-style-type: none"> <li>The vehicle speed computed from the vehicle speed signal sent from combination meter is displayed.</li> </ul>		
SET VHCL SPD [km/h] or [mph]			<ul style="list-style-type: none"> <li>The preset vehicle speed is displayed.</li> </ul>		
MAIN SW [ON/OFF]			<ul style="list-style-type: none"> <li>Indicates [ON/OFF] condition from ON/OFF (MAIN) switch signal.</li> </ul>		
CANCEL SW [ON/OFF]			<ul style="list-style-type: none"> <li>Indicates [ON/OFF] condition from CANCEL switch signal.</li> </ul>		
RESUME/ACC SW [ON/OFF]			<ul style="list-style-type: none"> <li>Indicates [ON/OFF] condition from ACCEL/RESUME switch signal.</li> </ul>		
SET SW [ON/OFF]			<ul style="list-style-type: none"> <li>Indicates [ON/OFF] condition from COAST/SET switch signal.</li> </ul>		

## TROUBLE DIAGNOSIS

Monitored item [Unit]	ECM INPUT SIGNALS	MAIN SIGNALS	Description	Remarks
BRAKE SW1 [ON/OFF]			<ul style="list-style-type: none"> <li>Indicates [ON/OFF] condition from ASCD brake switch signal, and ASCD clutch switch signal (M/T models).</li> </ul>	
BRAKE SW2 [ON/OFF]			<ul style="list-style-type: none"> <li>Indicates [ON/OFF] condition of stop lamp switch signal.</li> </ul>	
VHCL SPD CUT [NON/CUT]			<ul style="list-style-type: none"> <li>Indicates the vehicle cruise condition. NON: Vehicle speed is maintained at the ASCD set speed. CUT: Vehicle speed increased to excessively high compared with the ASCD set speed, and ASCD operation is cut off.</li> </ul>	
LO SPEED CUT [NON/CUT]			<ul style="list-style-type: none"> <li>Indicates the vehicle cruise condition. NON: Vehicle speed is maintained at the ASCD set speed. CUT: Vehicle speed decreased to excessively low compared with the ASCD set speed, and ASCD operation is cut off.</li> </ul>	
AT OD MONITOR [ON/OFF]			<ul style="list-style-type: none"> <li>Indicates [ON/OFF] condition of A/T O/D according to the input signal from the TCM.</li> </ul>	<ul style="list-style-type: none"> <li>For M/T models always "OFF" is displayed.</li> </ul>
AT OD CANCEL [ON/OFF]			<ul style="list-style-type: none"> <li>Indicates [ON/OFF] condition of A/T O/D cancel signal sent from the TCM.</li> </ul>	<ul style="list-style-type: none"> <li>For M/T models always "OFF" is displayed.</li> </ul>
CRUISE LAMP [ON/OFF]			<ul style="list-style-type: none"> <li>Indicates [ON/OFF] condition of CRUISE lamp determined by the ECM according to the input signals.</li> </ul>	
SET LAMP [ON/OFF]			<ul style="list-style-type: none"> <li>Indicates [ON/OFF] condition of SET lamp determined by the ECM according to the input signals.</li> </ul>	
Voltage [V]			<ul style="list-style-type: none"> <li>Voltage, frequency, duty cycle or pulse width measured by the probe.</li> </ul>	<ul style="list-style-type: none"> <li>Only "#" is displayed if item is unable to be measured.</li> <li>Figures with "#"s are temporary ones. They are the same figures as an actual piece of data which was just previously measured.</li> </ul>
Frequency [msec], [Hz] or [%]				
DUTY-HI				
DUTY-LOW				
PLS WIDTH-HI				
PLS WIDTH-LOW				

**NOTE:**

Any monitored item that does not match the vehicle being diagnosed is deleted from the display automatically.

### DATA MONITOR (SPEC) MODE

#### Monitored Item

Monitored item [Unit]	ECM INPUT SIGNALS	MAIN SIGNALS	Description	Remarks
ENG SPEED [rpm]	×	×	<ul style="list-style-type: none"> <li>Indicates the engine speed computed from the signals of the crankshaft position sensor (POS) and camshaft position sensor (PHASE).</li> </ul>	
MAS A/F SE-B1 [V]	×	×	<ul style="list-style-type: none"> <li>The signal voltage of the mass air flow sensor specification is displayed.</li> </ul>	<ul style="list-style-type: none"> <li>When engine is running specification range is indicated.</li> </ul>



# TROUBLE DIAGNOSIS

Monitored item [Unit]	ECM INPUT SIGNALS	MAIN SIGNALS	Description	Remarks
B/FUEL SCHDL [msec]		×	<ul style="list-style-type: none"> <li>“Base fuel schedule” indicates the fuel injection pulse width programmed into ECM, prior to any learned on board correction.</li> </ul>	<ul style="list-style-type: none"> <li>When engine is running specification range is indicated.</li> </ul>
A/F ALPHA-B1 [%] A/F ALPHA-B2 [%]		×	<ul style="list-style-type: none"> <li>The mean value of the air-fuel ratio feedback correction factor per cycle is indicated.</li> </ul>	<ul style="list-style-type: none"> <li>When engine is running specification range is indicated.</li> <li>This data also includes the data for the air-fuel ratio learning control.</li> </ul>

**NOTE:**

Any monitored item that does not match the vehicle being diagnosed is deleted from the display automatically.

## ACTIVE TEST MODE

### Test Item

TEST ITEM	CONDITION	JUDGEMENT	CHECK ITEM (REMEDY)
FUEL INJECTION	<ul style="list-style-type: none"> <li>Engine: Return to the original trouble condition</li> <li>Change the amount of fuel injection using CONSULT-II.</li> </ul>	If trouble symptom disappears, see CHECK ITEM.	<ul style="list-style-type: none"> <li>Harness and connectors</li> <li>Fuel injectors</li> <li>Air fuel ratio (A/F) sensor 1</li> </ul>
IGNITION TIMING	<ul style="list-style-type: none"> <li>Engine: Return to the original trouble condition</li> <li>Timing light: Set</li> <li>Retard the ignition timing using CONSULT-II.</li> </ul>	If trouble symptom disappears, see CHECK ITEM.	<ul style="list-style-type: none"> <li>Perform Idle Air Volume Learning.</li> </ul>
POWER BALANCE	<ul style="list-style-type: none"> <li>Engine: After warming up, idle the engine.</li> <li>A/C switch OFF</li> <li>Shift lever: N (A/T), Neutral (M/T)</li> <li>Cut off each injector signal one at a time using CONSULT-II.</li> </ul>	Engine runs rough or dies.	<ul style="list-style-type: none"> <li>Harness and connectors</li> <li>Compression</li> <li>Fuel injector</li> <li>Power transistor</li> <li>Spark plug</li> <li>Ignition coil</li> </ul>
COOLING FAN*	<ul style="list-style-type: none"> <li>Ignition switch: ON</li> <li>Turn the cooling fan “HI”, “LOW” and “OFF” using CONSULT-II.</li> </ul>	Cooling fan moves and stops.	<ul style="list-style-type: none"> <li>Harness and connectors</li> <li>Cooling fan motor</li> <li>IPDM E/R</li> </ul>
ENG COOLANT TEMP	<ul style="list-style-type: none"> <li>Engine: Return to the original trouble condition</li> <li>Change the engine coolant temperature using CONSULT-II.</li> </ul>	If trouble symptom disappears, see CHECK ITEM.	<ul style="list-style-type: none"> <li>Harness and connectors</li> <li>Engine coolant temperature sensor</li> <li>Fuel injectors</li> </ul>
FUEL PUMP RELAY	<ul style="list-style-type: none"> <li>Ignition switch: ON (Engine stopped)</li> <li>Turn the fuel pump relay “ON” and “OFF” using CONSULT-II and listen to operating sound.</li> </ul>	Fuel pump relay makes the operating sound.	<ul style="list-style-type: none"> <li>Harness and connectors</li> <li>Fuel pump relay</li> </ul>
PURG VOL CONT/V	<ul style="list-style-type: none"> <li>Engine: After warming up, run engine at 1,500 rpm.</li> <li>Change the EVAP canister purge volume control solenoid valve opening percent using CONSULT-II.</li> </ul>	Engine speed changes according to the opening percent.	<ul style="list-style-type: none"> <li>Harness and connectors</li> <li>Solenoid valve</li> </ul>
FUEL/T TEMP SEN	<ul style="list-style-type: none"> <li>Change the fuel tank temperature using CONSULT-II.</li> </ul>		

# TROUBLE DIAGNOSIS

TEST ITEM	CONDITION	JUDGEMENT	CHECK ITEM (REMEDY)
VENT CONTROL/V	<ul style="list-style-type: none"> <li>● Ignition switch: ON (Engine stopped)</li> <li>● Turn solenoid valve "ON" and "OFF" with the CONSULT-II and listen to operating sound.</li> </ul>	Solenoid valve makes an operating sound.	<ul style="list-style-type: none"> <li>● Harness and connectors</li> <li>● Solenoid valve</li> </ul>
V/T ASSIGN ANGLE	<ul style="list-style-type: none"> <li>● Engine: Return to the original trouble condition</li> <li>● Change intake valve timing using CONSULT-II.</li> </ul>	If trouble symptom disappears, see CHECK ITEM.	<ul style="list-style-type: none"> <li>● Harness and connectors</li> <li>● Intake valve timing control solenoid valve</li> </ul>

\*: Leaving cooling fan "OFF" with CONSULT-II while engine is running may cause the engine to overheat.

## DTC & SRT CONFIRMATION MODE

### SRT STATUS Mode

For details, refer to [EC-53, "SYSTEM READINESS TEST \(SRT\) CODE"](#) .

### SRT Work Support Mode

This mode enables a technician to drive a vehicle to set the SRT while monitoring the SRT status.

### DTC Work Support Mode

Test mode	Test item	Condition	Reference page		
EVAPORATIVE SYSTEM	PURGE FLOW P0441	Refer to corresponding trouble diagnosis for DTC.	<a href="#">EC-287</a>		
	EVAP SML LEAK P0442/P1442*		<a href="#">EC-292</a>		
	EVAP V/S SML LEAK P0456/P1456*		<a href="#">EC-347</a>		
	PURG VOL CN/V P1444		<a href="#">EC-533</a>		
A/F SEN1	A/F SEN1 (B1) P1276		Refer to corresponding trouble diagnosis for DTC.	<a href="#">EC-499</a>	
	A/F SEN1 (B1) P1278/P1279			<a href="#">EC-509, EC-521</a>	
	A/F SEN1 (B2) P1286			<a href="#">EC-499</a>	
	A/F SEN1 (B2) P1288/P1289			<a href="#">EC-509, EC-521</a>	
HO2S2	HO2S2 (B1) P0139			Refer to corresponding trouble diagnosis for DTC.	<a href="#">EC-210</a>
	HO2S2 (B1) P1146				<a href="#">EC-414</a>
	HO2S2 (B1) P1147				<a href="#">EC-425</a>
	HO2S2 (B2) P0159				<a href="#">EC-210</a>
	HO2S2 (B2) P1166	<a href="#">EC-414</a>			
	HO2S2 (B2) P1167	<a href="#">EC-425</a>			

\*: DTC P1442 and P1456 does not apply to Z33 models but appears in DTC Work Support Mode screens.

# TROUBLE DIAGNOSIS

## REAL TIME DIAGNOSIS IN DATA MONITOR MODE (RECORDING VEHICLE DATA)

### Description

CONSULT-II has two kinds of triggers and they can be selected by touching "SETTING" in "DATA MONITOR" mode.

#### 1. "AUTO TRIG" (Automatic trigger):

- The malfunction will be identified on the CONSULT-II screen in real time.

In other words, DTC/1st trip DTC and malfunction item will be displayed if the malfunction is detected by ECM.

At the moment a malfunction is detected by ECM, "MONITOR" in "DATA MONITOR" screen is changed to "Recording Data... xx%" as shown at right, and the data after the malfunction detection is recorded. Then when the percentage reached 100%, "REAL-TIME DIAG" screen is displayed. If "STOP" is touched on the screen during "Recording Data... xx%", "REAL-TIME DIAG" screen is also displayed.

The recording time after the malfunction detection and the recording speed can be changed by "TRIGGER POINT" and "Recording Speed". Refer to CONSULT-II Operation Manual.

#### 2. "MANU TRIG" (Manual trigger):

- DTC/1st trip DTC and malfunction item will not be displayed automatically on CONSULT-II screen even though a malfunction is detected by ECM. DATA MONITOR can be performed continuously even though a malfunction is detected.

DATA MONITOR	
Recording Data...11%	NO DTC
ENG SPEED	XXX rpm
MAS A/F SE-B1	XXX V
COOLAN TEMP/S	XXX °C
A/F SEN1 (B1)	XXX V
VHCL SPEED SE	XXX km/h

PBIB1593E

SET RECORDING CONDITION						
AUTO TRIG						
MANU TRIG						
TRIGGER POINT						
<table border="1"> <tr> <td>0%</td> <td>20%</td> <td>40%</td> <td>60%</td> <td>80%</td> <td>100%</td> </tr> </table>	0%	20%	40%	60%	80%	100%
0%	20%	40%	60%	80%	100%	
RECORDING SPEED						
<table border="1"> <tr> <td>MIN</td> <td>MAX</td> </tr> <tr> <td>/64</td> <td>/32 /16 /8 /4 /2 FULL</td> </tr> </table>	MIN	MAX	/64	/32 /16 /8 /4 /2 FULL		
MIN	MAX					
/64	/32 /16 /8 /4 /2 FULL					

SEF707X

A  
EC  
C  
D  
E  
F  
G  
H  
I  
J  
K  
L  
M

# TROUBLE DIAGNOSIS

## Operation

### 1. "AUTO TRIG"

- While trying to detect the DTC/1st trip DTC by performing the DTC Confirmation Procedure, be sure to select to "DATA MONITOR (AUTO TRIG)" mode. You can confirm the malfunction at the moment it is detected.
- While narrowing down the possible causes, CONSULT-II should be set in "DATA MONITOR (AUTO TRIG)" mode, especially in case the incident is intermittent. When you are inspecting the circuit by gently shaking (or twisting) the suspicious connectors, components and harness in the DTC Confirmation Procedure, the moment a malfunction is found the DTC/1st trip DTC will be displayed. (Refer to INCIDENT SIMULATION TESTS in [GI-27, "How to Perform Efficient Diagnosis for an Electrical Incident"](#) .)

### 2. "MANU TRIG"

- If the malfunction is displayed as soon as "DATA MONITOR" is selected, reset CONSULT-II to "MANU TRIG". By selecting "MANU TRIG" you can monitor and store the data. The data can be utilized for further diagnosis, such as a comparison with the value for the normal operating condition.

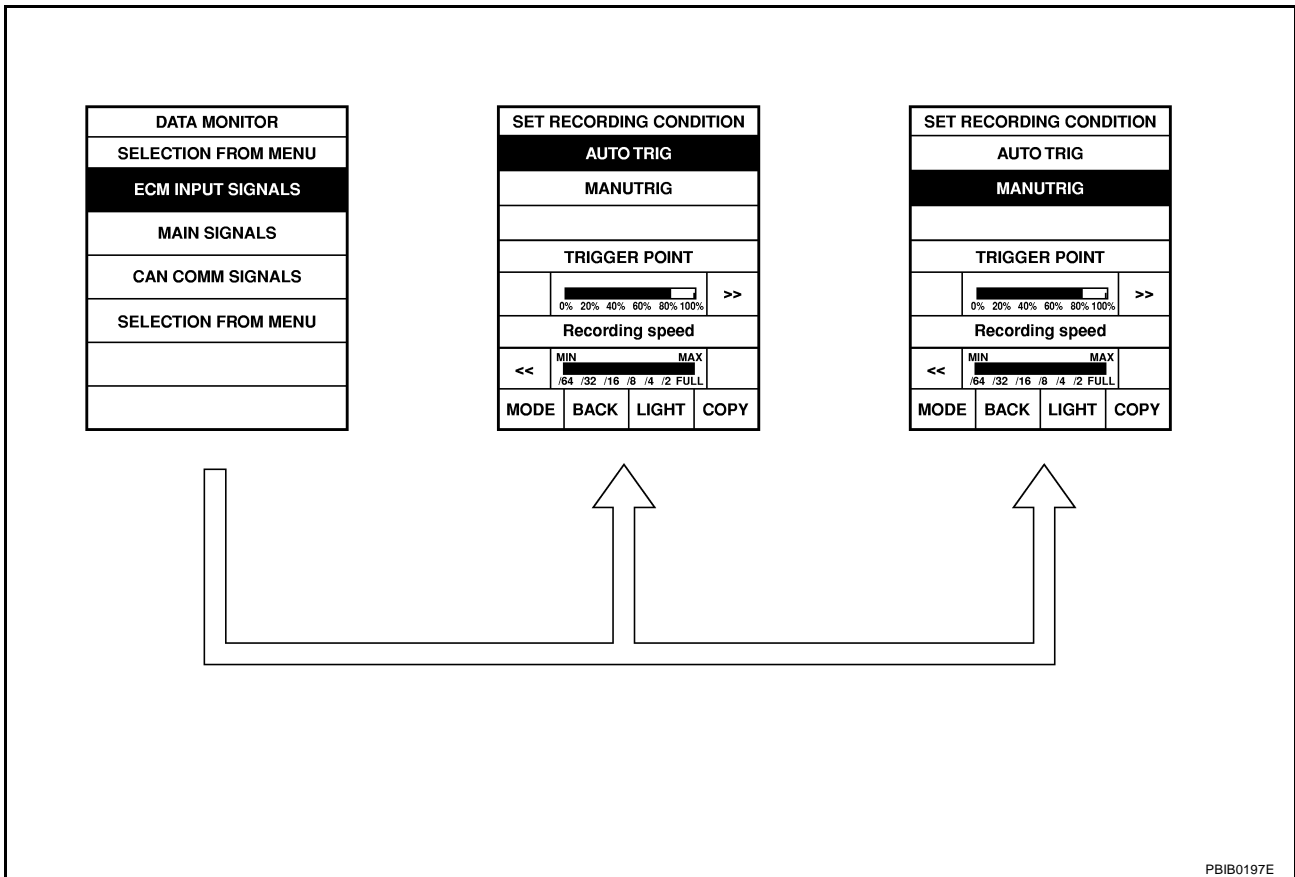

## Generic Scan Tool (GST) Function DESCRIPTION

ABS009BC

Generic Scan Tool (OBDII scan tool) complying with SAE J1978 has 8 different functions explained below. ISO9141 is used as the protocol. The name "GST" or "Generic Scan Tool" is used in this service manual.

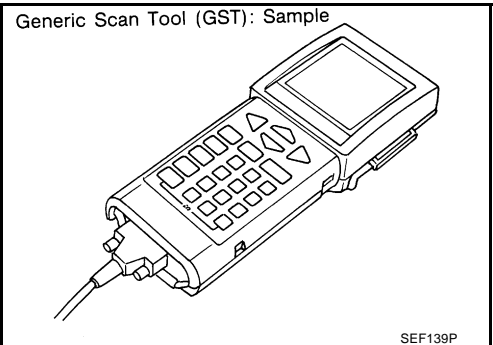

# TROUBLE DIAGNOSIS

## FUNCTION

Diagnostic test mode		Function
MODE 1	READINESS TESTS	This mode gains access to current emission-related data values, including analog inputs and outputs, digital inputs and outputs, and system status information.
MODE 2	(FREEZE DATA)	This mode gains access to emission-related data value which were stored by ECM during the freeze frame. For details, refer to <a href="#">EC-52, "FREEZE FRAME DATA AND 1ST TRIP FREEZE FRAME DATA"</a> .
MODE 3	DTCs	This mode gains access to emission-related power train trouble codes which were stored by ECM.
MODE 4	CLEAR DIAG INFO	This mode can clear all emission-related diagnostic information. This includes: <ul style="list-style-type: none"> <li>● Clear number of diagnostic trouble codes (MODE 1)</li> <li>● Clear diagnostic trouble codes (MODE 3)</li> <li>● Clear trouble code for freeze frame data (MODE 1)</li> <li>● Clear freeze frame data (MODE 2)</li> <li>● Reset status of system monitoring test (MODE 1)</li> <li>● Clear on board monitoring test results (MODE 6 and 7)</li> </ul>
MODE 6	(ON BOARD TESTS)	This mode accesses the results of on board diagnostic monitoring tests of specific components/systems that are not continuously monitored.
MODE 7	(ON BOARD TESTS)	This mode enables the off board test drive to obtain test results for emission-related powertrain components/systems that are continuously monitored during normal driving conditions.
MODE 8	—	This mode can close EVAP system in ignition switch ON position (Engine stopped). When this mode is performed, EVAP canitser vent control valve can be closed. In the following conditions, this mode cannot function. <ul style="list-style-type: none"> <li>● Low ambient temperature</li> <li>● Low battery voltage</li> <li>● Engine running</li> <li>● Ignition switch OFF</li> <li>● Low fuel temperature</li> <li>● Too much pressure is applied to EVAP system</li> </ul>
MODE 9	(CALIBRATION ID)	This mode enables the off-board test device to request specific vehicle information such as Vehicle Identification Number (VIN) and Calibration IDs.

## INSPECTION PROCEDURE

1. Turn ignition switch OFF.
2. Connect "GST" to data link connector, which is located under LH dash panel near the hood opener handle.

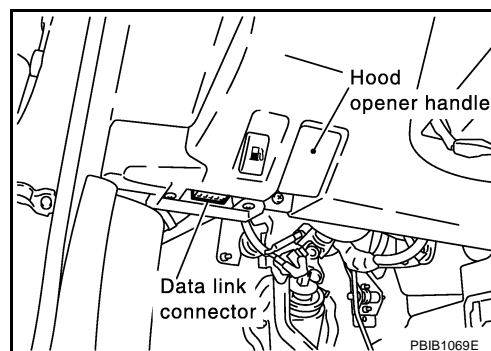

# TROUBLE DIAGNOSIS

3. Turn ignition switch ON.
4. Enter the program according to instruction on the screen or in the operation manual.  
(\*: Regarding GST screens in this section, sample screens are shown.)

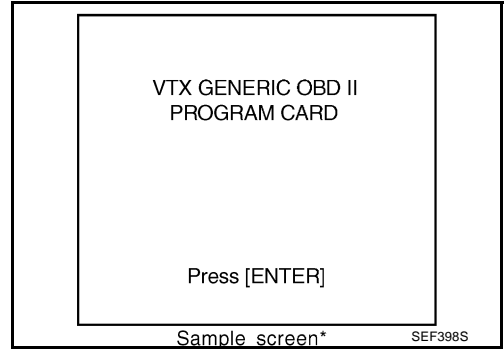

5. Perform each diagnostic mode according to each service procedure.  
**For further information, see the GST Operation Manual of the tool maker.**

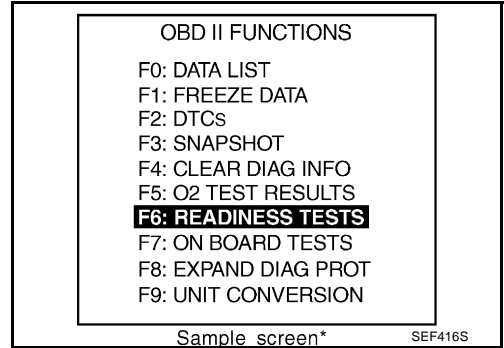

# TROUBLE DIAGNOSIS

## CONSULT-II Reference Value in Data Monitor

ABS009BD

**Remarks:**

- Specification data are reference values.
- Specification data are output/input values which are detected or supplied by the ECM at the connector.
- \* Specification data may not be directly related to their components signals/values/operations.  
i.e. Adjust ignition timing with a timing light before monitoring IGN TIMING, because the monitor may show the specification data in spite of the ignition timing not being adjusted to the specification data. This IGN TIMING monitors the data calculated by the ECM according to the signals input from the camshaft position sensor and other ignition timing related sensors.

MONITOR ITEM	CONDITION		SPECIFICATION
ENG SPEED	● Run engine and compare CONSULT-II value with the tachometer indication.		Almost the same speed as the tachometer indication
MAS A/F SE-B1	See <a href="#">EC-125, "TROUBLE DIAGNOSIS - SPECIFICATION VALUE"</a> .		
B/FUEL SCHDL	See <a href="#">EC-125, "TROUBLE DIAGNOSIS - SPECIFICATION VALUE"</a> .		
A/F ALPHA-B1 A/F ALPHA-B2	See <a href="#">EC-125, "TROUBLE DIAGNOSIS - SPECIFICATION VALUE"</a> .		
COOLAN TEMP/S	● Engine: After warming up		More than 70°C (158°F)
A/F SEN1 (B1) A/F SEN1 (B2)	● Engine: After warming up	Maintaining engine speed at 2,000 rpm	Fluctuates around 1.5V
HO2S2 (B1) HO2S2 (B2)	● Warm-up condition ● After keeping engine speed between 3,500 and 4,000 rpm for 1 minute and at idle for 1 minute under no load.	Revving engine from idle to 3,000 rpm quickly.	0 - 0.3V ↔ Approx. 0.6 - 1.0V
HO2S2 MNTR (B1) HO2S2 MNTR (B2)	● Warm-up condition ● After keeping engine speed between 3,500 and 4,000 rpm for 1 minute and at idle for 1 minute under no load.	Revving engine from idle to 3,000 rpm quickly.	LEAN ↔ RICH
VHCL SPEED SE	● Turn drive wheels and compare CONSULT-II value with the speedometer indication.		Almost the same speed as the speedometer indication
BATTERY VOLT	● Ignition switch: ON (Engine stopped)		11 - 14V
ACCEL SEN 1	● Ignition switch: ON (Engine stopped)	Accelerator pedal: Fully released	0.5 - 1.0V
		Accelerator pedal: Fully depressed	4.0 - 4.8V
ACCEL SEN 2*	● Ignition switch: ON (Engine stopped)	Accelerator pedal: Fully released	0.3 - 1.2V
		Accelerator pedal: Fully depressed	3.9 - 4.8V
THRTL SEN 1 THRTL SEN 2*	● Ignition switch: ON (Engine stopped) ● Shift lever: D (A/T), 1st (M/T)	Accelerator pedal: Fully released	More than 0.36V
		Accelerator pedal: Fully depressed	Less than 4.75V
EVAP SYS PRES	● Ignition switch: ON		Approx. 1.8 - 4.8V
START SIGNAL	● Ignition switch: ON → START → ON		OFF → ON → OFF
CLSD THL POS	● Ignition switch: ON (Engine stopped)	Accelerator pedal: Fully released	ON
		Accelerator pedal: Slightly depressed	OFF
AIR COND SIG	● Engine: After warming up, idle the engine	Air conditioner switch: OFF	OFF
		Air conditioner switch: ON (Compressor operates.)	ON
P/N POSI SW	● Ignition switch: ON	Shift lever: P or N (A/T), Neutral (M/T)	ON
		Shift lever: Except above	OFF
PW/ST SIGNAL	● Engine: After warming up, idle the engine	Steering wheel is being not turned. (Forward direction)	OFF
		Steering wheel is being turned.	ON

# TROUBLE DIAGNOSIS

MONITOR ITEM	CONDITION	SPECIFICATION
LOAD SIGNAL	<ul style="list-style-type: none"> <li>● Ignition switch: ON</li> </ul>	Rear window defogger switch is ON and/or lighting switch is in 2nd. ON
		Rear window defogger switch is OFF and lighting switch is OFF. OFF
IGNITION SW	<ul style="list-style-type: none"> <li>● Ignition switch: ON → OFF → ON</li> </ul>	ON → OFF → ON
HEATER FAN SW	<ul style="list-style-type: none"> <li>● Engine: After warming up, idle the engine</li> </ul>	Heater fan is operating. ON
		Heater fan is not operating OFF
BRAKE SW	<ul style="list-style-type: none"> <li>● Ignition switch: ON</li> </ul>	Brake pedal: Fully released OFF
		Brake pedal: Slightly depressed ON
INJ PULSE-B1 INJ PULSE-B2	<ul style="list-style-type: none"> <li>● Engine: After warming up</li> <li>● Shift lever: P or N (A/T), Neutral (M/T)</li> <li>● Air conditioner switch: OFF</li> <li>● No-load</li> </ul>	Idle 2.0 - 3.0 msec
		2,000 rpm 1.9 - 2.9 msec
IGN TIMING	<ul style="list-style-type: none"> <li>● Engine: After warming up</li> <li>● Shift lever: P or N (A/T), Neutral (M/T)</li> <li>● Air conditioner switch: OFF</li> <li>● No-load</li> </ul>	Idle 13° - 18° BTDC
		2,000 rpm 25° - 45° BTDC
CAL/LD VALUE	<ul style="list-style-type: none"> <li>● Engine: After warming up</li> <li>● Shift lever: P or N (A/T), Neutral (M/T)</li> <li>● Air conditioner switch: OFF</li> <li>● No-load</li> </ul>	Idle 5% - 35%
		2,500 rpm 5% - 35%
MASS AIRFLOW	<ul style="list-style-type: none"> <li>● Engine: After warming up</li> <li>● Shift lever: P or N (A/T), Neutral (M/T)</li> <li>● Air conditioner switch: OFF</li> <li>● No-load</li> </ul>	Idle 2.0 - 6.0 g-m/s
		2,500 rpm 7.0 - 20.0 g-m/s
PURG VOL C/V	<ul style="list-style-type: none"> <li>● Engine: After warming up</li> <li>● Shift lever: P or N (A/T), Neutral (M/T)</li> <li>● Air conditioner switch: OFF</li> <li>● No-load</li> </ul>	Idle (Accelerator pedal is not depressed even slightly, after engine starting) 0%
		2,000 rpm —
INT/V TIM (B1) INT/V TIM (B2)	<ul style="list-style-type: none"> <li>● Engine: After warming up</li> <li>● Shift lever: P or N (A/T), Neutral (M/T)</li> <li>● Air conditioner switch: OFF</li> <li>● No-load</li> </ul>	Idle -5° - 5°CA
		When revving engine up to 2,000 rpm quickly Approx. 0° - 30°CA
INT/V SOL (B1) INT/V SOL (B2)	<ul style="list-style-type: none"> <li>● Engine: After warming up</li> <li>● Shift lever: N (A/T), Neutral (M/T)</li> <li>● Air conditioner switch: OFF</li> <li>● No-load</li> </ul>	Idle 0% - 2%
		When revving engine up to 2,000 rpm quickly Approx. 0% - 50%
AIR COND RLY	<ul style="list-style-type: none"> <li>● Engine: After warming up, idle the engine</li> </ul>	Air conditioner switch: OFF OFF
		Air conditioner switch: ON (Compressor operates) ON
FUEL PUMP RLY	<ul style="list-style-type: none"> <li>● For 1 second after turning ignition switch ON</li> <li>● Engine running or cranking</li> </ul>	ON
		<ul style="list-style-type: none"> <li>● Except above conditions</li> </ul> OFF



# TROUBLE DIAGNOSIS

MONITOR ITEM	CONDITION		SPECIFICATION
VENT CONT/V	● Ignition switch: ON		OFF
THRTL RELAY	● Ignition switch: ON		ON
COOLING FAN	● Engine: After warming up, idle the engine ● Air conditioner switch: OFF	Engine coolant temperature is 94°C (201°F) or less	OFF
		Engine coolant temperature is between 95°C (203°F) and 99°C (210°F)	LOW
		Engine coolant temperature is 100°C (212°F) or more	HI
HO2S2 HTR (B1) HO2S2 HTR (B2)	● Engine speed is below 3,600 rpm after the following conditions are met. – Engine: After warming up – Keeping the engine speed between 3,500 and 4,000 rpm for 1 minute and at idle for 1 minute under no load		ON
	● Engine speed: Above 3,600 rpm		OFF
I/P PULLY SPD	● Vehicle speed: More than 20 km/h (12 MPH)		Almost the same speed as the tachometer indication
VEHICLE SPEED	● Turn drive wheels and compare CONSULT-II value with the speedometer indication.		Almost the same speed as the speedometer indication
TRVL AFTER MIL	● Ignition switch: ON	Vehicle has traveled after MIL has turned ON.	0 - 65,535 km (0 - 40,723 mile)
A/F S1 HTR (B1) A/F S1 HTR (B2)	● Engine: After warming up, idle the engine		0 - 100%
AC PRESS SEN	● Engine: Idle ● Both A/C switch and blower switch are ON. (Compressor operates.)		1.0 - 4.0V
VHCL SPEED SE	● Turn drive wheels and compare CONSULT-II value with the speedometer indication.		Almost the same speed as the speedometer indication
SET VHCL SPD	● Engine: Running	ASCD: Operating.	The preset vehicle speed is displayed.
MAIN SW	● Ignition switch: ON	ON/OFF (MAIN) switch: Pressed	ON
		ON/OFF (MAIN) switch: Released	OFF
CANCEL SW	● Ignition switch: ON	CANCEL switch: Pressed	ON
		CANCEL switch: Released	OFF
RESUME/ACC SW	● Ignition switch: ON	ACCEL/RESUME switch: Pressed	ON
		ACCEL/RESUME switch: Released	OFF
SET SW	● Ignition switch: ON	COAST/SET switch: Pressed	ON
		COAST/SET switch: Released	OFF
BRAKE SW1	● Ignition switch: ON	Clutch pedal (M/T) and brake pedal: Fully released	ON
		Clutch pedal (M/T) and/or brake pedal: Slightly depressed	OFF
BRAKE SW2	● Ignition switch: ON	Brake pedal: Fully released	OFF
		Brake pedal: Slightly depressed	ON
CRUISE LAMP	● Ignition switch: ON	ON/OFF (MAIN) switch: Pressed at the 1st time → at the 2nd time	ON → OFF
SET LAMP	● ON/OFF (MAIN) switch: ON ● When vehicle speed is between 40 km/h (25 MPH) and 144 km/h (89MPH)	ASCD: Operating	ON
		ASCD: Not operating	OFF

## TROUBLE DIAGNOSIS

---

\*: Accelerator pedal position sensor 2 signal and throttle position sensor 2 signal are converted by ECM internally. Thus, they differ from ECM terminals voltage signal.

# TROUBLE DIAGNOSIS

## Major Sensor Reference Graph in Data Monitor Mode

ABS009BE

The following are the major sensor reference graphs in "DATA MONITOR" mode.

### CLSD THL POS, ACCEL SEN 1, THRTL SEN 1

Below is the data for "CLSD THL POS", "ACCEL SEN 1" and "THRTL SEN 1" when depressing the accelerator pedal with the ignition switch ON and with shift lever in D position (A/T), 1st position (M/T).

The signal of "ACCEL SEN 1" and "THRTL SEN 1" should rise gradually without any intermittent drop or rise after "CLSD THL POS" is changed from "ON" to "OFF".

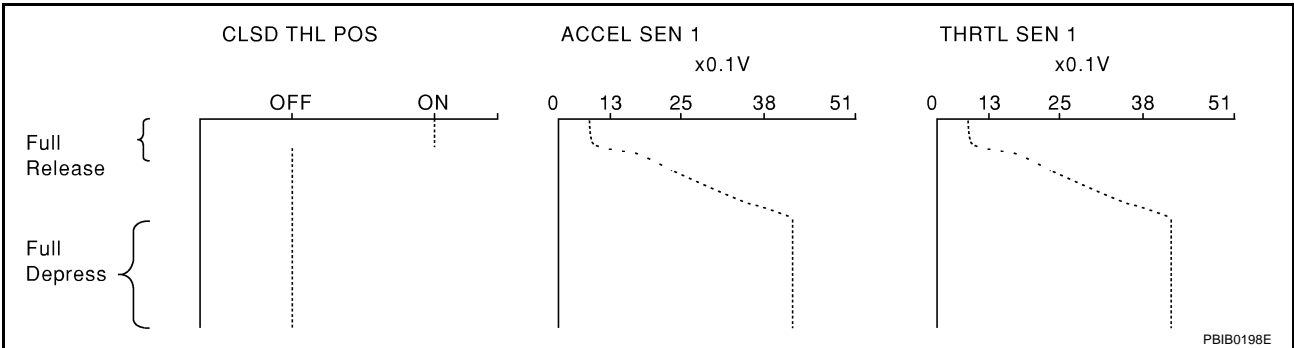

### ENG SPEED, MAS A/F SE-B1, THRTL SEN 1, HO2S2 (B1), INJ PULSE-B1

Below is the data for "ENG SPEED", "MAS A/F SE-B1", "THRTL SEN 1", "HO2S2 (B1)" and "INJ PULSE-B1" when revving engine quickly up to 4,800 rpm under no load after warming up engine sufficiently.

Each value is for reference, the exact value may vary.

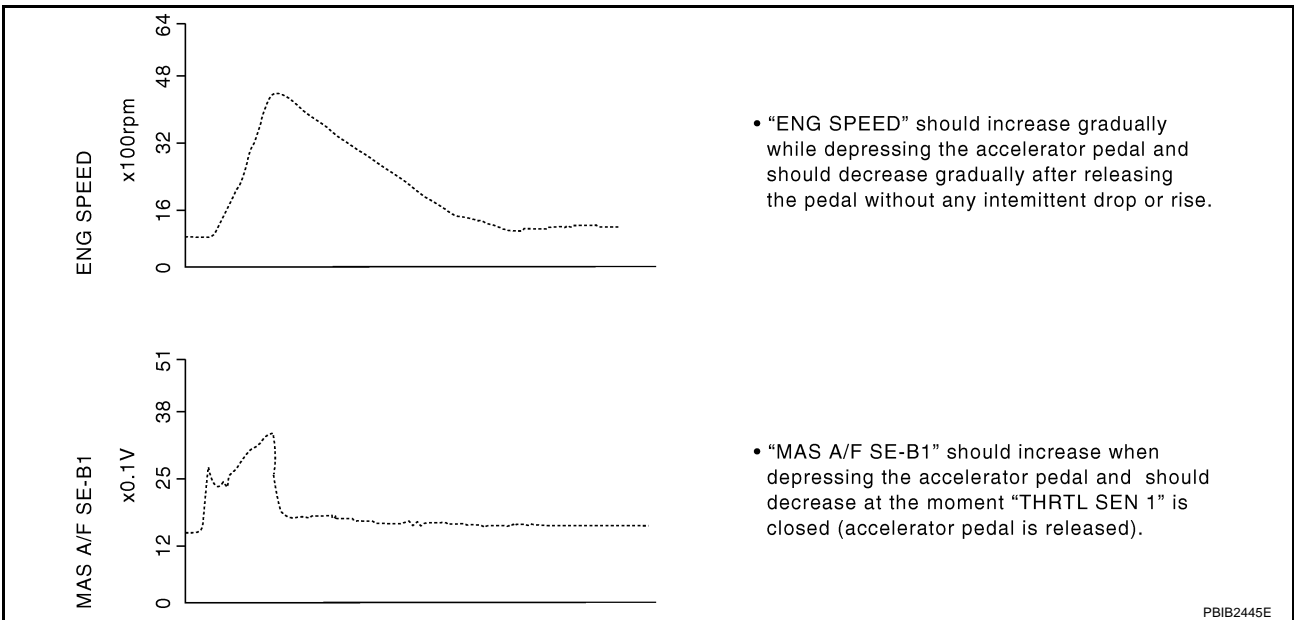

# TROUBLE DIAGNOSIS

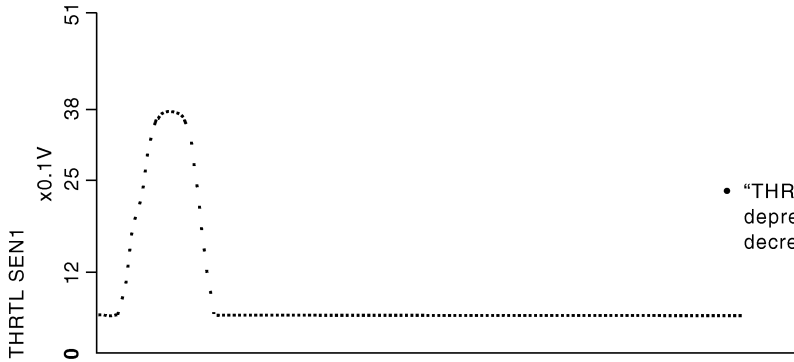

- "THRTL SEN1" should increase while depressing the accelerator pedal and should decrease while releasing it.



- "HO2S2 (B1)" may increase immediately after depressing the accelerator pedal and may decrease after releasing the pedal.

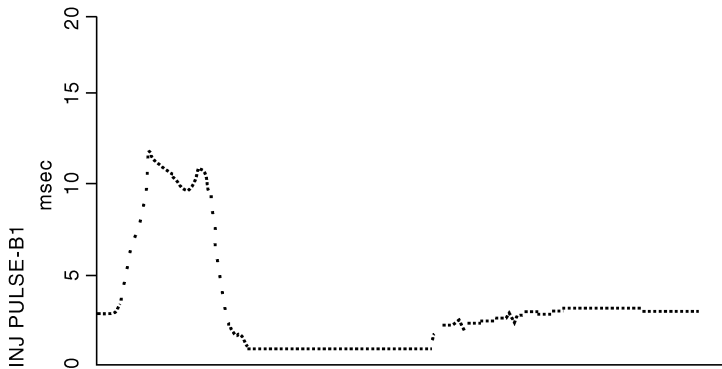

- "INJ PULSE-B1" should increase when depressing the accelerator pedal and should decrease when the pedal is released.

PBIB2099E

# TROUBLE DIAGNOSIS - SPECIFICATION VALUE

## TROUBLE DIAGNOSIS - SPECIFICATION VALUE

PFP:00031

### Description

ABS009BF

The specification (SP) value indicates the tolerance of the value that is displayed in "DATA MONITOR (SPEC)" mode of CONSULT-II during normal operation of the Engine Control System. When the value in "DATA MONITOR (SPEC)" mode is within the SP value, the Engine Control System is confirmed OK. When the value in "DATA MONITOR (SPEC)" mode is NOT within the SP value, the Engine Control System may have one or more malfunctions.

The SP value is used to detect malfunctions that may affect the Engine Control System, but will not light the MIL.

The SP value will be displayed for the following three items:

- B/FUEL SCHDL (The fuel injection pulse width programmed into ECM prior to any learned on board correction)
- A/F ALPHA-B1/B2 (The mean value of air-fuel ratio feedback correction factor per cycle)
- MAS A/F SE-B1 (The signal voltage of the mass air flow sensor)

### Testing Condition

ABS009BG

- Vehicle driven distance: More than 5,000 km (3,017 miles)
- Barometric pressure: 98.3 - 104.3 kPa (1.003 - 1.064 kg/cm<sup>2</sup>, 14.25 - 15.12 psi)
- Atmospheric temperature: 20 - 30°C (68 - 86°F)
- Engine coolant temperature: 75 - 95°C (167 - 203°F)
- Transmission: Warmed-up\*<sup>1</sup>
- Electrical load: Not applied\*<sup>2</sup>
- Engine speed: Idle

\*1: For A/T models, after the engine is warmed up to normal operating temperature, drive vehicle until "ATF TEMP 1" (A/T fluid temperature sensor signal) indicates more than 60°C (140°F).

For M/T models, after the engine is warmed up to normal operating temperature, drive vehicle for 5 minutes.

\*2: Rear window defogger switch, air conditioner switch, lighting switch are OFF. Steering wheel is straight ahead.

### Inspection Procedure

ABS009BH

#### NOTE:

Perform "DATA MONITOR (SPEC)" mode in maximum scale display.

1. Perform [EC-78, "Basic Inspection"](#).
2. Confirm that the testing conditions indicated above are met.
3. Select "B/FUEL SCHDL", "A/F ALPHA-B1", "A/F ALPHA-B2" and "MAS A/F SE-B1" in "DATA MONITOR (SPEC)" mode with CONSULT-II.
4. Make sure that monitor items are within the SP value.
5. If NG, go to [EC-126, "Diagnostic Procedure"](#).

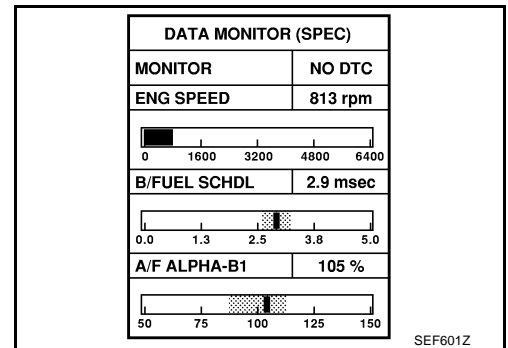

# TROUBLE DIAGNOSIS - SPECIFICATION VALUE

## Diagnostic Procedure

ABS009BI

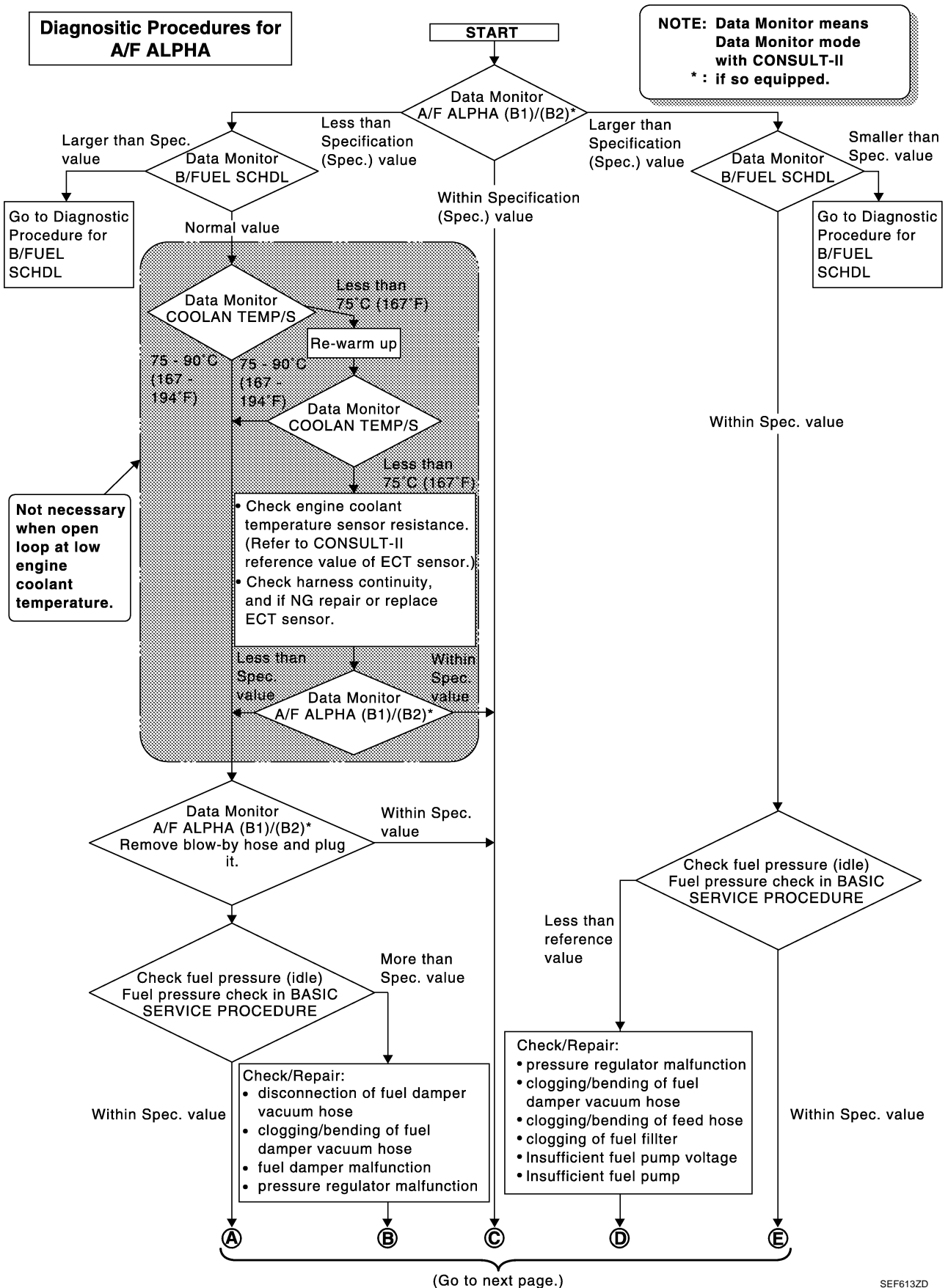

SEF613ZD

# TROUBLE DIAGNOSIS - SPECIFICATION VALUE

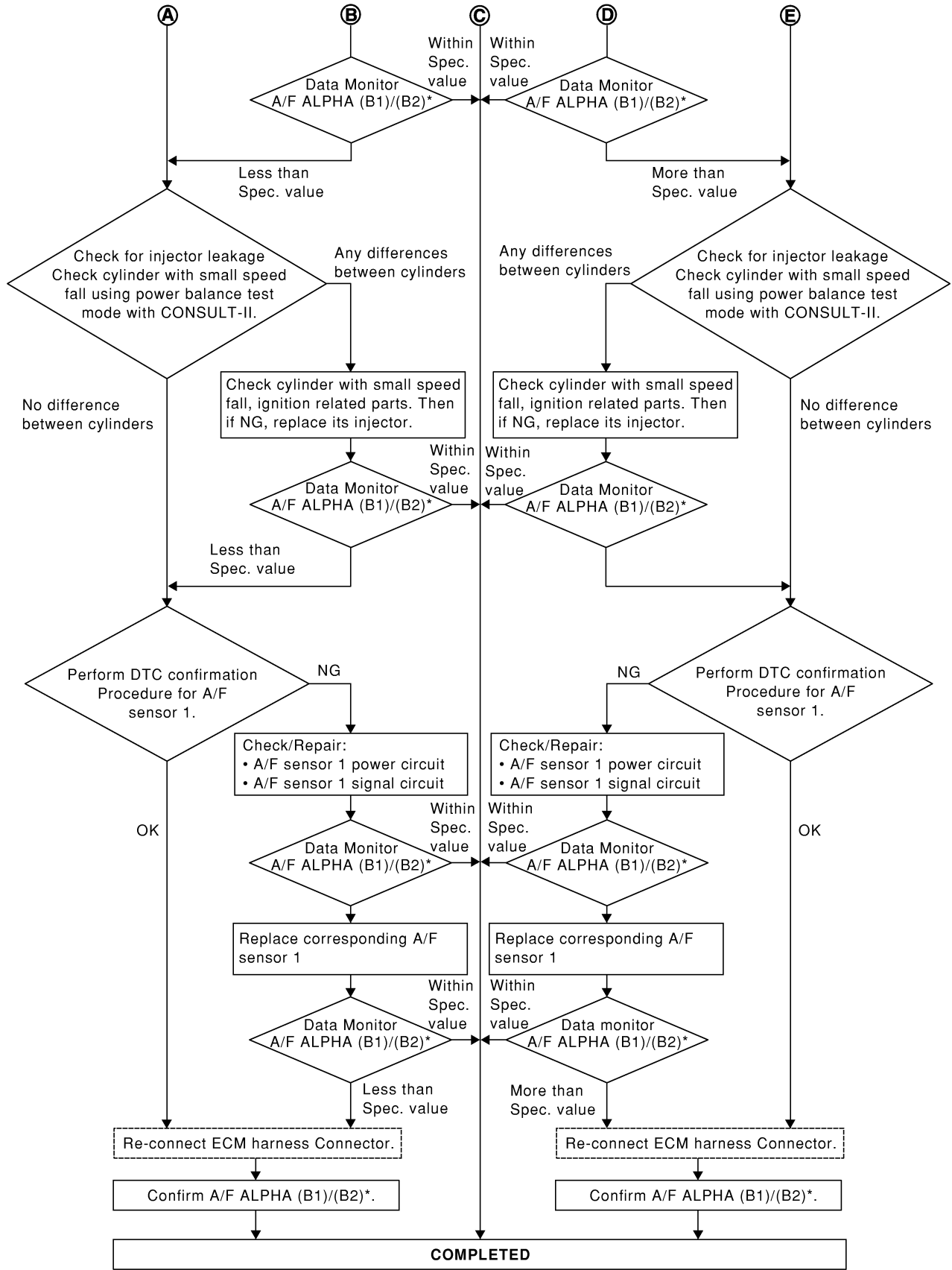

A  
EC  
C  
D  
E  
F  
G  
H  
I  
J  
K  
L  
M

SEF614Z

# TROUBLE DIAGNOSIS - SPECIFICATION VALUE

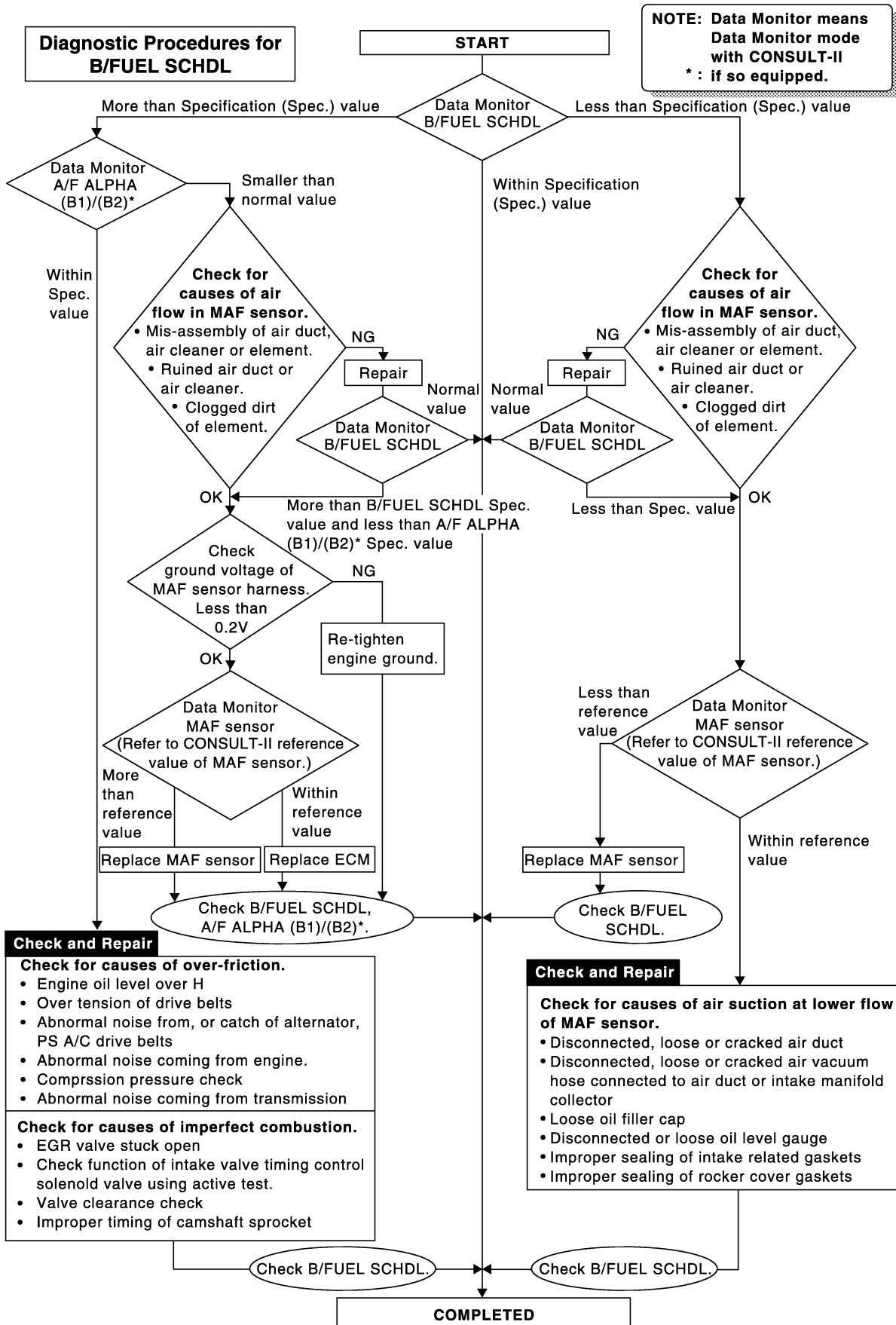

SEF615ZA



# TROUBLE DIAGNOSIS FOR INTERMITTENT INCIDENT

## TROUBLE DIAGNOSIS FOR INTERMITTENT INCIDENT

PFP:00006

### Description

ABS009BJ

Intermittent incidents may occur. In many cases, the malfunction resolves itself (the part or circuit function returns to normal without intervention). It is important to realize that the symptoms described in the customer's complaint often do not recur on (1st trip) DTC visits. Realize also that the most frequent cause of I/I occurrences is poor electrical connections. Because of this, the conditions under which the incident occurred may not be clear. Therefore, circuit checks made as part of the standard diagnostic procedure may not indicate the specific malfunctioning area.

### Common Intermittent Incident Report Situations

STEP in Work Flow	Situation
II	The CONSULT-II is used. The SELF-DIAG RESULTS screen shows time data other than [0] or [1t].
III	The symptom described by the customer does not recur.
IV	(1st trip) DTC does not appear during the DTC Confirmation Procedure.
VI	The Diagnostic Procedure for PXXXX does not indicate the malfunctioning area.

### Diagnostic Procedure

ABS009BK

#### 1. INSPECTION START

Erase (1st trip) DTCs. Refer to [EC-61, "HOW TO ERASE EMISSION-RELATED DIAGNOSTIC INFORMATION"](#).

>> GO TO 2.

#### 2. CHECK GROUND TERMINALS

Check ground terminals for corroding or loose connection.

Refer to [EC-138, "Ground Inspection"](#).

OK or NG

OK >> GO TO 3.

NG >> Repair or replace.

#### 3. SEARCH FOR ELECTRICAL INCIDENT

Perform [GI-27, "How to Perform Efficient Diagnosis for an Electrical Incident"](#), "INCIDENT SIMULATION TESTS".

OK or NG

OK >> GO TO 4.

NG >> Repair or replace.

#### 4. CHECK CONNECTOR TERMINALS

Refer to [GI-24, "How to Check Terminal"](#), "HOW TO PROBE CONNECTORS", "How to Check Enlarged Contact Spring of Terminal".

OK or NG

OK >> **INSPECTION END**

NG >> Repair or replace connector.

# POWER SUPPLY AND GROUND CIRCUIT

## POWER SUPPLY AND GROUND CIRCUIT

PFP:24110

### Wiring Diagram

ABS009BL

## EC-MAIN-01

: DETECTABLE LINE FOR DTC  
 : NON-DETECTABLE LINE FOR DTC

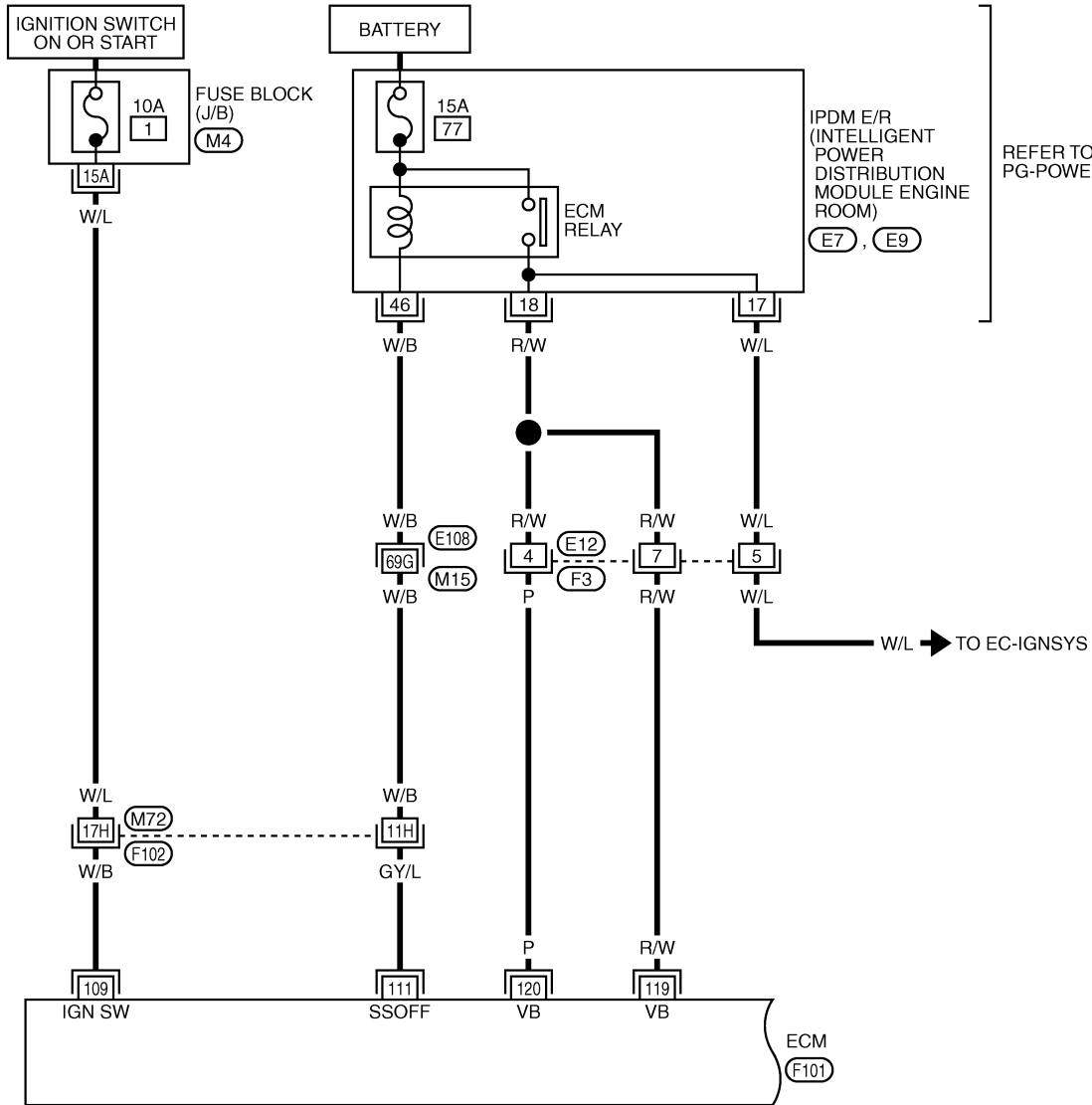

REFER TO PG-POWER.

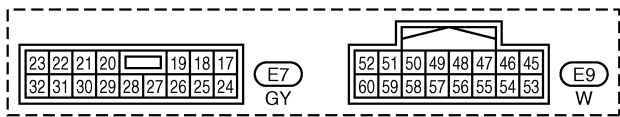

REFER TO THE FOLLOWING.  
 (E108), (F102) -SUPER MULTIPLE JUNCTION (SMJ)  
 (M4) -FUSE BLOCK-JUNCTION BOX (J/B)

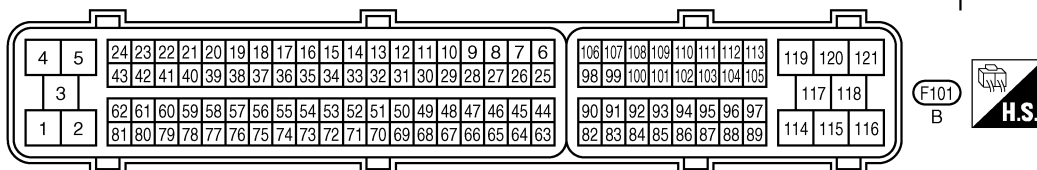

TBWT0612E

## POWER SUPPLY AND GROUND CIRCUIT

Specification data are reference values and are measured between each terminal and ground.

**CAUTION:**



**Do not use ECM ground terminals when measuring input/output voltage. Doing so may result in damage to the ECM's transistor. Use a ground other than ECM terminals, such as the ground.**

TER-MINAL NO.	WIRE COLOR	ITEM	CONDITION	DATA (DC Voltage)
109	W/B	Ignition switch	<b>[Ignition switch: OFF]</b>	0V
			<b>[Ignition switch: ON]</b>	BATTERY VOLTAGE (11 - 14V)
111	GY/L	ECM relay (Self shut-off)	<b>[Engine is running]</b> <b>[Ignition switch: OFF]</b> <ul style="list-style-type: none"> <li>● A few seconds after turning ignition switch OFF</li> </ul>	0 - 1.5V
			<b>[Ignition switch: OFF]</b> <ul style="list-style-type: none"> <li>● More than a few seconds after turning ignition switch OFF</li> </ul>	BATTERY VOLTAGE (11 - 14V)
119 120	R/W P	Power supply for ECM	<b>[Ignition switch: ON]</b>	BATTERY VOLTAGE (11 - 14V)

A  
EC  
C  
D  
E  
F  
G  
H  
I  
J  
K  
L  
M

# POWER SUPPLY AND GROUND CIRCUIT

EC-MAIN-02

 : DETECTABLE LINE FOR DTC  
 : NON-DETECTABLE LINE FOR DTC

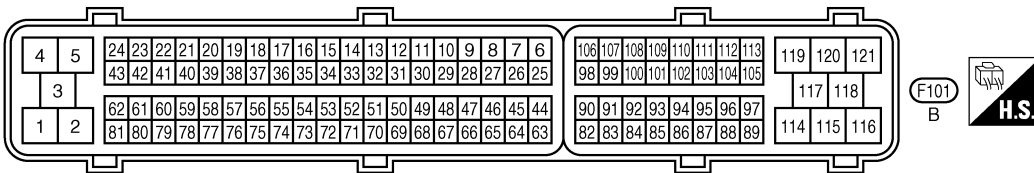
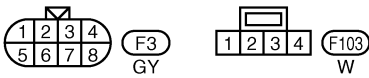
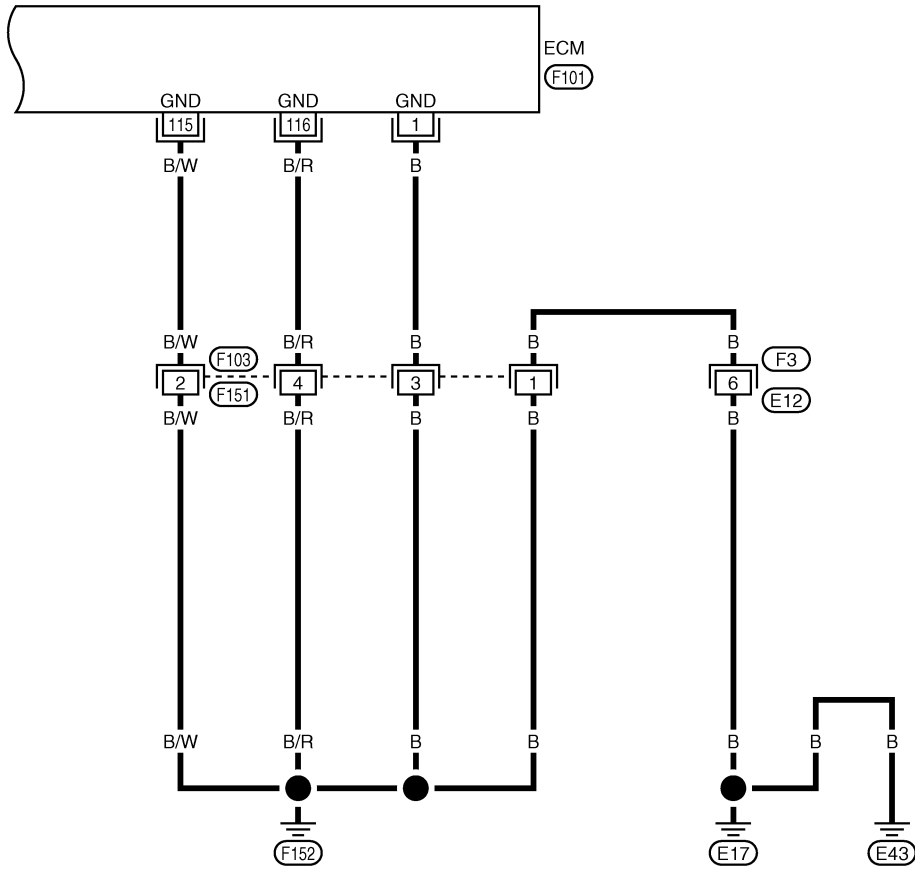

TBWT0471E

# POWER SUPPLY AND GROUND CIRCUIT

Specification data are reference values and are measured between each terminal and ground.

**CAUTION:**

Do not use ECM ground terminals when measuring input/output voltage. Doing so may result in damage to the ECM's transistor. Use a ground other than ECM terminals, such as the ground.

TER-MINAL NO.	WIRE COLOR	ITEM	CONDITION	DATA (DC Voltage)
1	B	ECM ground	<b>[Engine is running]</b> ● Idle speed	Body ground
115 116	B/W B/R	ECM ground	<b>[Engine is running]</b> ● Idle speed	Body ground

## Diagnostic Procedure

ABS009BM

### 1. INSPECTION START

Start engine.

**Is engine running?**

Yes or No

Yes >> GO TO 8.

No >> GO TO 2.

### 2. CHECK ECM POWER SUPPLY CIRCUIT-I

1. Turn ignition switch OFF and then ON.
2. Check voltage between ECM terminal 109 and ground with CONSULT-II or tester.

**Voltage: Battery voltage**

OK or NG

OK >> GO TO 4.

NG >> GO TO 3.

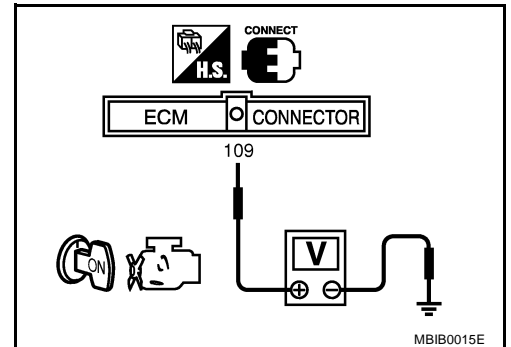

### 3. DETECT MALFUNCTIONING PART

Check the following.

- Harness connectors M72, F102
- Fuse block (J/B) connector M4
- 10A fuse
- Harness for open or short between ECM and fuse

>> Repair open circuit or short to ground or short to power in harness or connectors.

# POWER SUPPLY AND GROUND CIRCUIT

## 4. CHECK GROUND CONNECTIONS

1. Turn ignition switch OFF.
2. Loosen and retighten three ground screws on the body. Refer to [EC-138, "Ground Inspection"](#) .

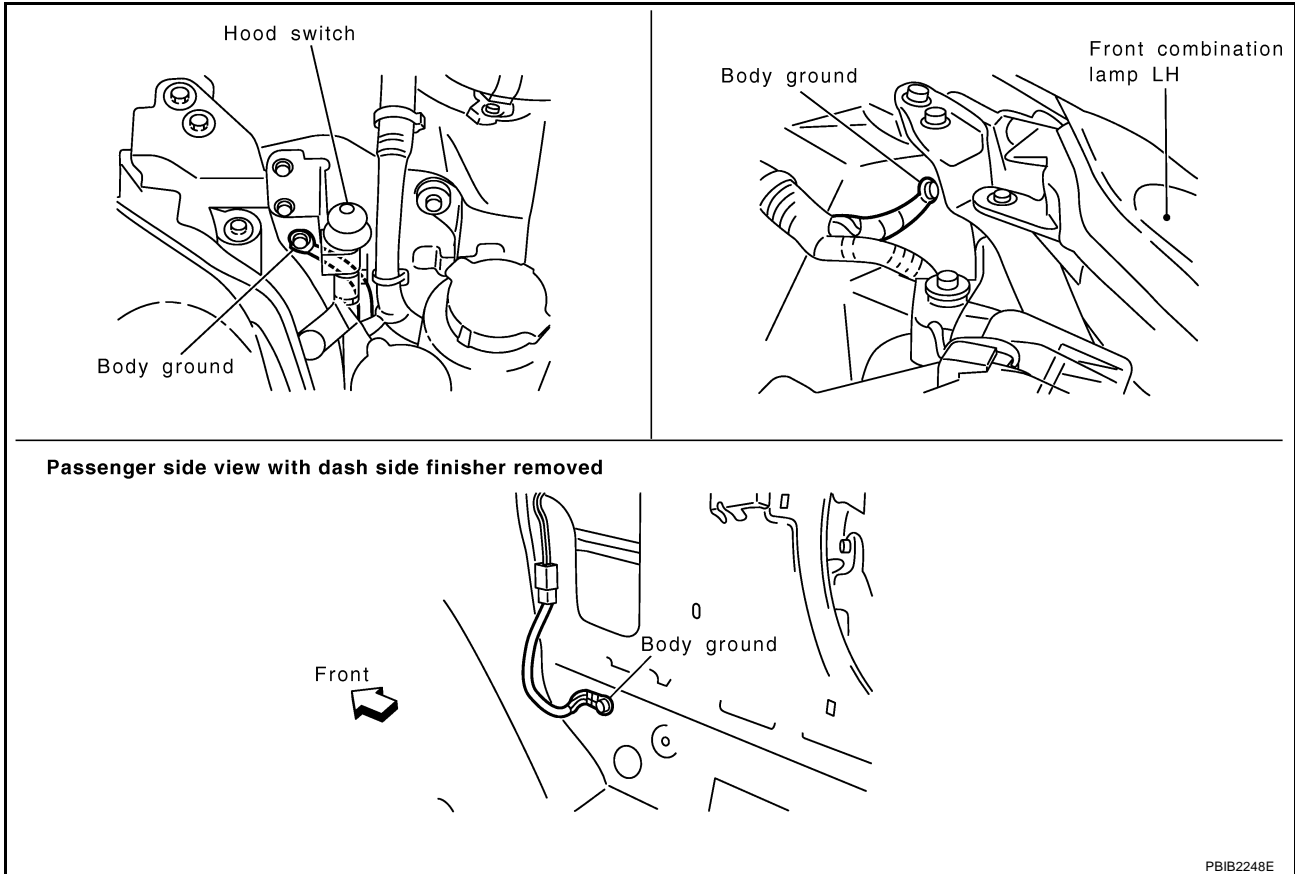

OK or NG

- OK >> GO TO 5.  
NG >> Repair or replace ground connections.

## 5. CHECK ECM GROUND CIRCUIT FOR OPEN AND SHORT-I

1. Disconnect ECM harness connector.
2. Check harness continuity between ECM terminals 1, 115, 116 and ground. Refer to Wiring Diagram.

**Continuity should exist.**

3. Also check harness for short to power.

OK or NG

- OK >> GO TO 7.  
NG >> GO TO 6.

## 6. DETECT MALFUNCTIONING PART

Check the following.

- Harness connectors F103, F151
- Harness connectors F3, E12
- Harness for open or short between ECM and ground

>> Repair open circuit or short to power in harness or connectors.

# POWER SUPPLY AND GROUND CIRCUIT

## 7. CHECK ECM POWER SUPPLY CIRCUIT-II

1. Reconnect ECM harness connector.
2. Turn ignition switch ON.
3. Check voltage between IPDM E/R terminal 17 and ground with CONSULT-II or tester.

**Voltage: Battery voltage**

OK or NG

- OK >> Go to [EC-622, "IGNITION SIGNAL"](#) .  
NG >> GO TO 8.

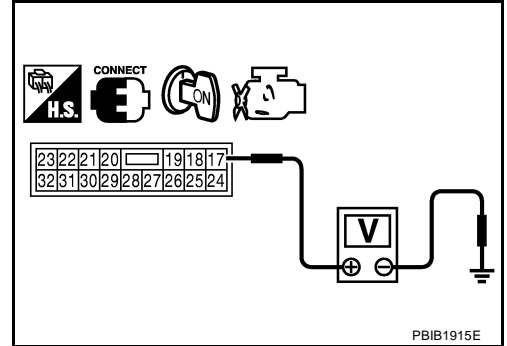

## 8. CHECK ECM POWER SUPPLY CIRCUIT-III

1. Turn ignition switch ON and then OFF and wait at least 10 seconds.
2. Check voltage between ECM terminals 119, 120 and ground with CONSULT-II or tester.

**Voltage: After turning ignition switch OFF, battery voltage will exist for a few seconds, then drop approximately 0V.**

OK or NG

- OK >> GO TO 15.  
NG (Battery voltage does not exist.)>>GO TO 9.  
NG (Battery voltage exists for more than a few seconds.)>>GO TO 12.

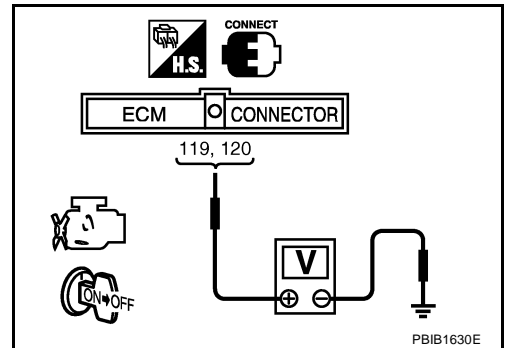

## 9. CHECK ECM POWER SUPPLY CIRCUIT-IV

1. Turn ignition switch OFF and wait at least 10 seconds.
2. Check voltage between ECM terminal 111 and ground with CONSULT-II or tester.

**Voltage: Battery voltage**

OK or NG

- OK >> GO TO 10.  
NG >> GO TO 12.

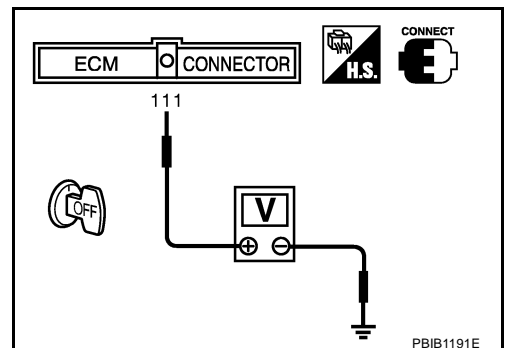

## 10. CHECK ECM POWER SUPPLY CIRCUIT-V

1. Disconnect ECM harness connector.
2. Disconnect IPDM E/R harness connector E7.
3. Check harness continuity between ECM terminals 119, 120 and IPDM E/R terminal 18. Refer to Wiring Diagram.

**Continuity should exist.**

4. Also check harness for short to ground and short to power.

OK or NG

- OK >> GO TO 18.  
NG >> GO TO 11.

# POWER SUPPLY AND GROUND CIRCUIT

---

## 11. DETECT MALFUNCTIONING PART

---

Check the following.

- Harness or connectors E12, F3
- Harness for open or short between ECM and IPDM E/R

>> Repair open circuit or short to ground or short to power in harness or connectors.

## 12. CHECK ECM POWER SUPPLY CIRCUIT-VI

---

1. Disconnect ECM harness connector.
2. Disconnect IPDM E/R harness connector E9.
3. Check harness continuity between ECM terminal 111 and IPDM E/R terminal 46.  
Refer to Wiring Diagram.

**Continuity should exist.**

4. Also check harness for short to ground and short to power.

OK or NG

- OK >> GO TO 14.  
NG >> GO TO 13.

## 13. DETECT MALFUNCTIONING PART

---

Check the following.

- Harness or connectors E108, M15
- Harness or connectors M72, F102
- Harness for open or short between ECM and IPDM E/R

>> Repair open circuit or short to ground or short to power in harness or connectors.

## 14. CHECK 15A FUSE

---

1. Disconnect 15A fuse from IPDM E/R.
2. Check 15A fuse.

OK or NG

- OK >> GO TO 18.  
NG >> Replace 15A fuse.



# POWER SUPPLY AND GROUND CIRCUIT

## 15. CHECK GROUND CONNECTIONS

Loosen and retighten three ground screws on the body. Refer to [EC-138, "Ground Inspection"](#) .

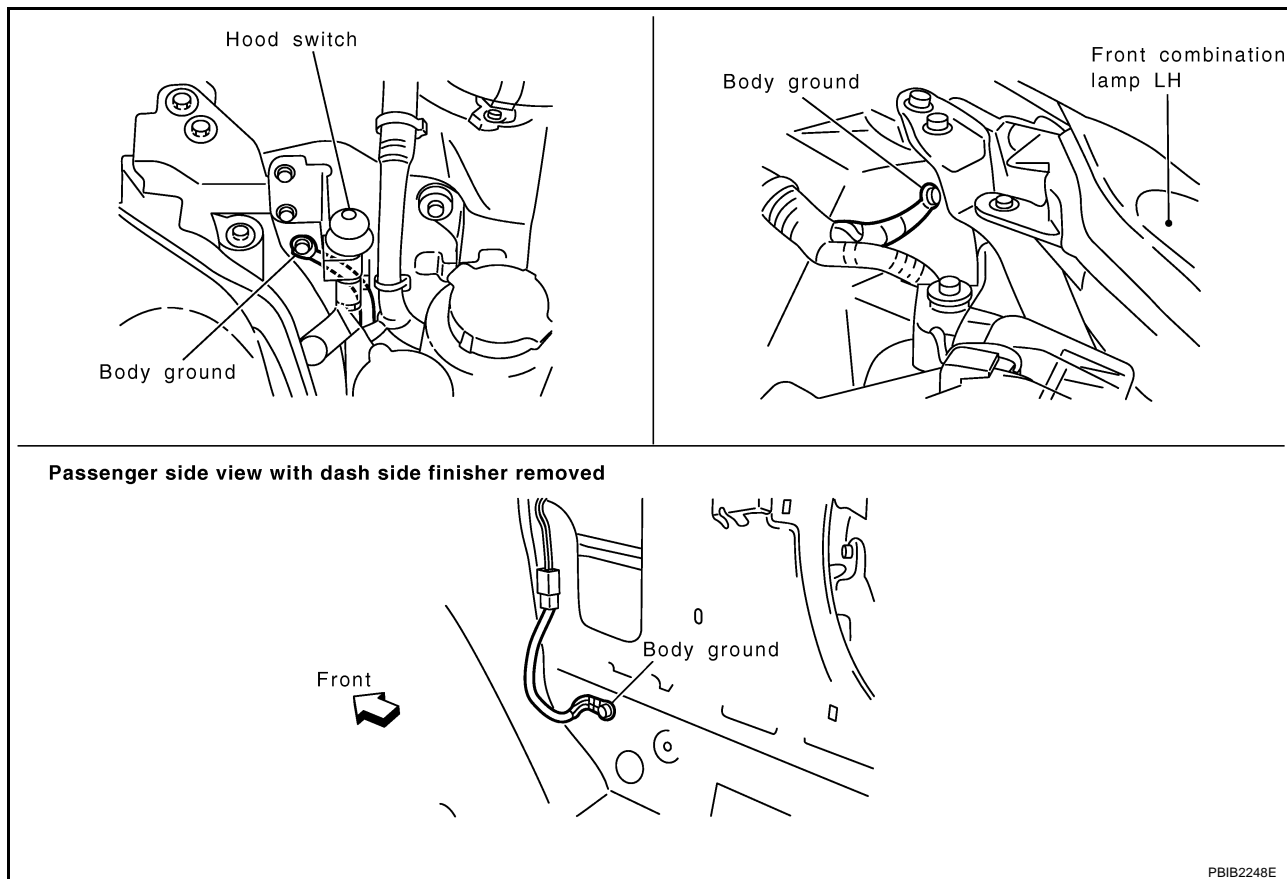

OK or NG

OK >> GO TO 16.

NG >> Repair or replace ground connections.

## 16. CHECK ECM GROUND CIRCUIT FOR OPEN AND SHORT-II

1. Disconnect ECM harness connector.
2. Check harness continuity between ECM terminals 1, 115, 116 and ground.  
Refer to Wiring Diagram.

**Continuity should exist.**

3. Also check harness for short to power.

OK or NG

OK >> GO TO 18.

NG >> GO TO 17.

## 17. DETECT MALFUNCTIONING PART

Check the following.

- Harness or connectors F103, F151
- Harness or connectors F3, E12
- Harness for open or short between ECM and ground.

>> Repair open circuit or short to power in harness or connectors.

# POWER SUPPLY AND GROUND CIRCUIT

## 18. CHECK INTERMITTENT INCIDENT

Refer to [EC-129, "TROUBLE DIAGNOSIS FOR INTERMITTENT INCIDENT"](#) .

### OK or NG

- OK >> Replace IPDM E/R. Refer to [PG-17, "IPDM E/R \(INTELLIGENT POWER DISTRIBUTION MODULE ENGINE ROOM\)"](#) .
- NG >> Repair open circuit or short to ground or short to power in harness or connectors.

### Ground Inspection

ABS00AN2

Ground connections are very important to the proper operation of electrical and electronic circuits. Ground connections are often exposed to moisture, dirt and other corrosive elements. The corrosion (rust) can become an unwanted resistance. This unwanted resistance can change the way a circuit works.

Electronically controlled circuits are very sensitive to proper grounding. A loose or corroded ground can drastically affect an electronically controlled circuit. A poor or corroded ground can easily affect the circuit. Even when the ground connection looks clean, there can be a thin film of rust on the surface.

When inspecting a ground connection follow these rules:

- Remove the ground bolt or screw.
- Inspect all mating surfaces for tarnish, dirt, rust, etc.
- Clean as required to assure good contact.
- Reinstall bolt or screw securely.
- Inspect for "add-on" accessories which may be interfering with the ground circuit.
- If several wires are crimped into one ground eyelet terminal, check for proper crimps. Make sure all of the wires are clean, securely fastened and providing a good ground path. If multiple wires are cased in one eyelet make sure no ground wires have excess wire insulation.

For detailed ground distribution information, refer to [PG-31, "Ground Distribution"](#) .

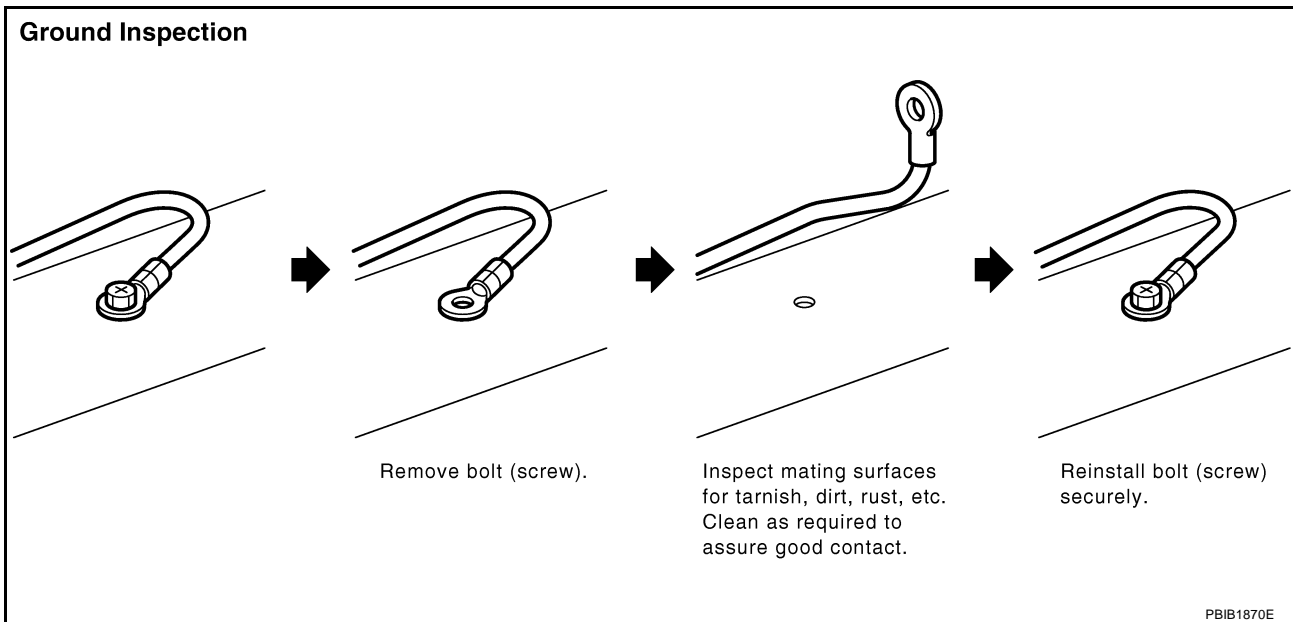

# DTC U1000, U1001 CAN COMMUNICATION LINE

## DTC U1000, U1001 CAN COMMUNICATION LINE

PF2:23710

### Description

ABS009BN

CAN (Controller Area Network) is a serial communication line for real time application. It is an on-vehicle multiplex communication line with high data communication speed and excellent error detection ability. Many electronic control units are equipped onto a vehicle, and each control unit shares information and links with other control units during operation (not independent). In CAN communication, control units are connected with 2 communication lines (CAN H line, CAN L line) allowing a high rate of information transmission with less wiring. Each control unit transmits/receives data but selectively reads required data only.

### On Board Diagnosis Logic

ABS009B0

DTC No.	Trouble diagnosis name	DTC detecting condition	Possible cause
U1000*1 1000*1	CAN communication line	<ul style="list-style-type: none"><li>● ECM cannot communicate to other control units.</li><li>● ECM cannot communicate for more than the specified time.</li></ul>	<ul style="list-style-type: none"><li>● Harness or connectors (CAN communication line is open or shorted)</li></ul>
U1001*2 1001*2			

\*1: This self-diagnosis has the one trip detection logic (A/T models).

The MIL will not light up for this diagnosis (M/T models).

\*2: The MIL will not light up for this diagnosis.

### DTC Confirmation Procedure

ABS009BP



1. Turn ignition switch ON and wait at least 3 seconds.
2. Select "DATA MONITOR" mode with CONSULT-II.
3. If 1st trip DTC is detected, go to [EC-141, "Diagnostic Procedure"](#).

# DTC U1000, U1001 CAN COMMUNICATION LINE

ABS009BQ

## Wiring Diagram

### EC-CAN-01

-  : DETECTABLE LINE FOR DTC
-  : NON-DETECTABLE LINE FOR DTC
-  : DATA LINE

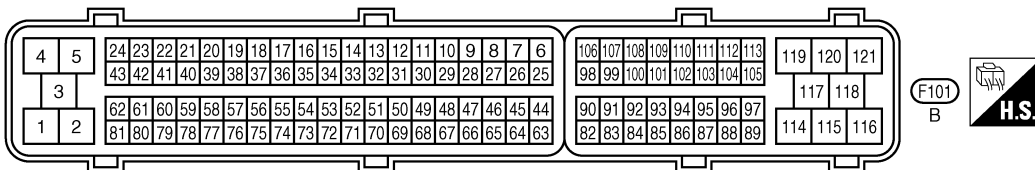
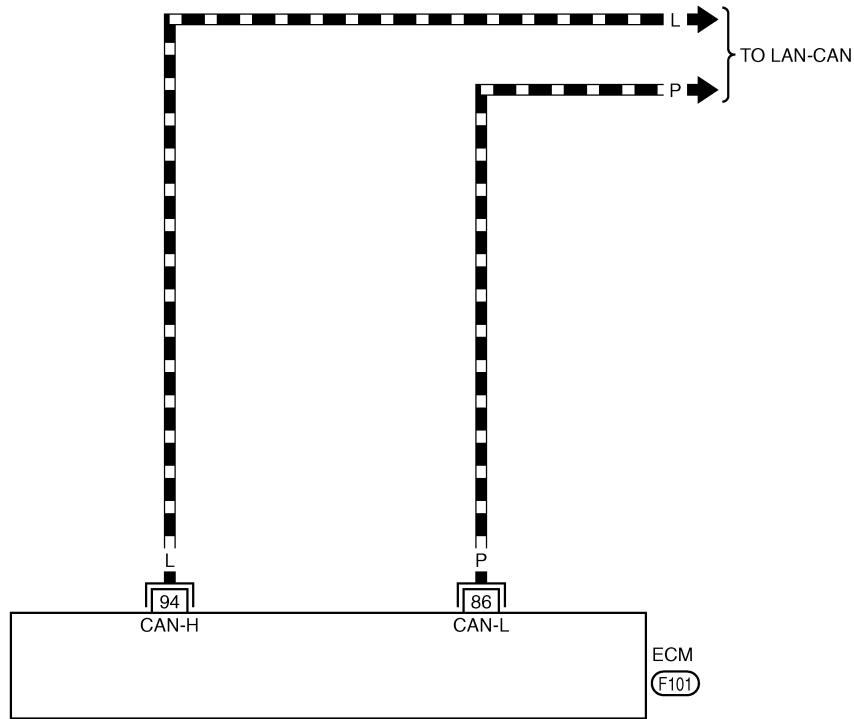

TBWT0698E

# DTC U1000, U1001 CAN COMMUNICATION LINE

## Diagnostic Procedure

ABS009BR

Go to [LAN-3, "Precautions When Using CONSULT-II"](#) .

A

EC

C

D

E

F

G

H

I

J

K

L

M

# DTC P0011, P0021 IVT CONTROL

## DTC P0011, P0021 IVT CONTROL

PFP:23796

### Description SYSTEM DESCRIPTION

ABS009BS

Sensor	Input signal to ECM	ECM function	Actuator
Crankshaft position sensor (POS)	Engine speed and piston position	Intake valve timing control	Intake valve timing control solenoid valve
Camshaft position sensor (PHASE)			
Engine coolant temperature sensor	Engine coolant temperature		
Wheel sensor*	Vehicle speed		

\*: This signal is sent to ECM through CAN communication line.

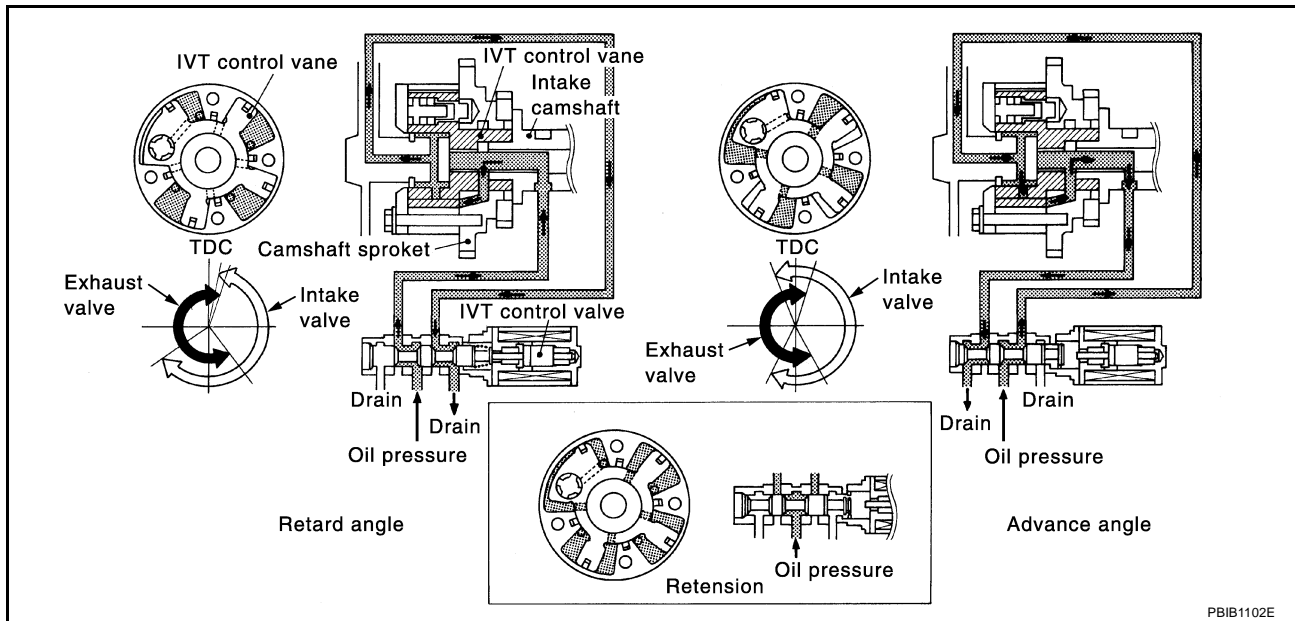

This mechanism hydraulically controls cam phases continuously with the fixed operating angle of the intake valve.

The ECM receives signals such as crankshaft position, camshaft position, engine speed, and engine coolant temperature. Then, the ECM sends ON/OFF pulse duty signals to the intake valve timing control solenoid valve depending on driving status. This makes it possible to control the shut/open timing of the intake valve to increase engine torque in low/mid speed range and output in high-speed range.

### CONSULT-II Reference Value in Data Monitor Mode

ABS009BT

Specification data are reference values.

MONITOR ITEM	CONDITION	SPECIFICATION
INT/V TIM (B1) INT/V TIM (B2)	● Engine: After warming up ● Shift lever: P or N (A/T), Neutral (M/T) ● Air conditioner switch: OFF ● No-load	Idle -5° - 5°C
	When revving engine up to 2,000 rpm quickly	Approx. 0° - 30°C
INT/V SOL (B1) INT/V SOL (B2)	● Engine: After warming up ● Shift lever: P or N (A/T), Neutral (M/T) ● Air conditioner switch: OFF ● No-load	Idle 0% - 2%
	When revving engine up to 2,000 rpm quickly	Approx. 0% - 50%

# DTC P0011, P0021 IVT CONTROL

## On Board Diagnosis Logic

ABS009BU

DTC No.	Trouble diagnosis name	Detecting condition	Possible cause
P0011 0011 (Bank 1)	Intake valve timing control performance	There is a gap between angle of target and phase-control angle degree.	<ul style="list-style-type: none"> <li>● Crankshaft position sensor (POS)</li> <li>● Camshaft position sensor (PHASE)</li> <li>● Accumulation of debris to the signal pick-up portion of the camshaft</li> </ul>
P0021 0021 (Bank 2)			

### FAIL-SAFE MODE

When the malfunction is detected, the ECM enters fail-safe mode.

Detected items	Engine operating condition in fail-safe mode
Intake valve timing control	The signal is not energized to the solenoid valve and the valve control does not function.

### DTC Confirmation Procedure

ABS009BV

#### CAUTION:

Always drive at a safe speed.

#### NOTE:

- If DTC P0011 or P0021 is displayed with DTC P1111 or P1136, first perform trouble diagnosis for DTC P1111 or P1136. Refer to [EC-388](#).
- If DTC Confirmation Procedure has been previously conducted, always turn ignition switch OFF and wait at least 10 seconds before conducting the next test.

#### TESTING CONDITION:

Before performing the following procedure, confirm that battery voltage is between 10V and 16V at idle.

#### Ⓟ WITH CONSULT-II

1. Turn ignition switch ON and select "DATA MONITOR" mode with CONSULT-II.
2. Start engine and warm it up to the normal operating temperature.
3. Maintain the following conditions for at least 6 consecutive seconds.  
Hold the accelerator pedal as steady as possible.

VHCL SPEED SE	100 - 120 km/h (63 - 75 MPH)
ENG SPEED	2,000 - 4,000 rpm
COOLAN TEMP/S	60 - 120°C (140 - 248°F)
B/FUEL SCHDL	More than 7.26 msec
Shift lever	A/T models: D position M/T models: 5th position

DATA MONITOR	
MONITOR	NO DTC
ENG SPEED	XXX rpm
COOLAN TEMP/S	XXX °C
VHCL SPEED SE	XXX km/h
B/FUEL SCHDL	XXX msec

PBIB0164E

4. Stop vehicle with engine running and let engine idle for 10 seconds.
5. If 1st trip DTC is detected, go to [EC-144, "Diagnostic Procedure"](#).  
If 1st trip DTC is not detected, go to next step.
6. Maintain the following conditions for at least 20 consecutive seconds.

ENG SPEED	1,700 - 3,175 rpm (A constant rotation is maintained.)
COOLAN TEMP/S	70 - 105°C (158 - 221°F)
Shift lever	1st or 2nd position
Driving location uphill	Driving vehicle uphill (Increased engine load will help maintain the driving conditions required for this test.)

7. If the 1st trip DTC is detected, go to [EC-144, "Diagnostic Procedure"](#).

# DTC P0011, P0021 IVT CONTROL

## WITH GST

Follow the procedure "WITH CONSULT-II" above.

### Diagnostic Procedure

ABS009BW

#### 1. CHECK CRANKSHAFT POSITION SENSOR (POS)

Refer to [EC-273, "Component Inspection"](#) .

OK or NG

- OK >> GO TO 2.
- NG >> Replace crankshaft position sensor (POS).

#### 2. CHECK CAMSHAFT POSITION SENSOR (PHASE)

Refer to [EC-282, "Component Inspection"](#) .

OK or NG

- OK >> GO TO 3.
- NG >> Replace camshaft position sensor (PHASE).

#### 3. CHECK CAMSHAFT (INTAKE)

Check the following.

- Accumulation of debris to the signal plate of camshaft rear end
- Chipping signal plate of camshaft rear end

OK or NG

- OK >> GO TO 4.
- NG >> Remove debris and clean the signal plate of camshaft rear end or replace camshaft.

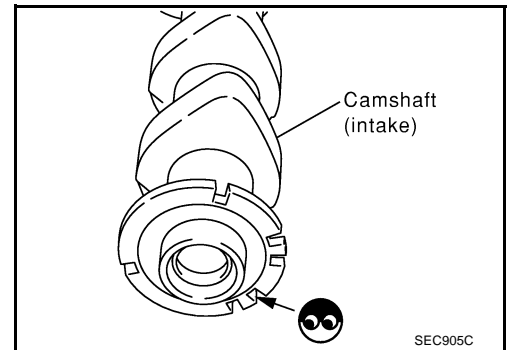

#### 4. CHECK INTERMITTENT INCIDENT

Refer to [EC-129, "TROUBLE DIAGNOSIS FOR INTERMITTENT INCIDENT"](#) .

For wiring diagram, refer to [EC-268](#) for CKP sensor (POS), [EC-275](#) and [EC-277](#) for CMP sensor (PHASE).

>> INSPECTION END



# DTC P0037, P0038, P0057, P0058 HO2S2 HEATER

## DTC P0037, P0038, P0057, P0058 HO2S2 HEATER

PFP:226A0

### Description SYSTEM DESCRIPTION

ABS009C5

Sensor	Input signal to ECM	ECM function	Actuator
Camshaft position sensor (PHASE)	Engine speed	Heated oxygen sensor 2 heater control	Heated oxygen sensor 2 heater
Crankshaft position sensor (POS)			
Engine coolant temperature sensor	Engine coolant temperature		
Mass air flow sensor	Amount of intake air		

The ECM performs ON/OFF control of the heated oxygen sensor 2 heater corresponding to the engine speed, amount of intake air and engine coolant temperature.

### OPERATION

Engine speed rpm	Heated oxygen sensor 2 heater
Above 3,600	OFF
Below 3,600 rpm after the following conditions are met.	ON
<ul style="list-style-type: none"> <li>● Engine: After warming up</li> <li>● Keeping the engine speed between 3,500 and 4,000 rpm for 1 minute and at idle for 1 minute under no load</li> </ul>	

### CONSULT-II Reference Value in Data Monitor Mode

ABS009C6

Specification data are reference values.

MONITOR ITEM	CONDITION	SPECIFICATION
HO2S2 HTR (B1) HO2S2 HTR (B2)	<ul style="list-style-type: none"> <li>● Engine speed is below 3,600 rpm after the following conditions are met.                             <ul style="list-style-type: none"> <li>- Engine: After warming up</li> <li>- Keeping the engine speed between 3,500 and 4,000 rpm for 1 minute and at idle for 1 minute under no load</li> </ul> </li> </ul>	ON
	<ul style="list-style-type: none"> <li>● Engine speed: Above 3,600 rpm</li> </ul>	OFF

### On Board Diagnosis Logic

ABS009C7

DTC No.	Trouble diagnosis name	DTC detecting condition	Possible cause
P0037 0037 (Bank 1)	Heated oxygen sensor 2 heater control circuit low	The current amperage in the heated oxygen sensor 2 heater circuit is out of the normal range. (An excessively low voltage signal is sent to ECM through the heated oxygen sensor 2 heater.)	<ul style="list-style-type: none"> <li>● Harness or connectors (The heated oxygen sensor 2 heater circuit is open or shorted.)</li> <li>● Heater oxygen sensor 2 heater</li> </ul>
P0057 0057 (Bank 2)			
P0038 0038 (Bank 1)	Heated oxygen sensor 2 heater control circuit high	The current amperage in the heated oxygen sensor 2 heater circuit is out of the normal range. (An excessively high voltage signal is sent to ECM through the heated oxygen sensor 2 heater.)	<ul style="list-style-type: none"> <li>● Harness or connectors (The heated oxygen sensor 2 heater circuit is shorted.)</li> <li>● Heater oxygen sensor 2 heater</li> </ul>
P0058 0058 (Bank 2)			

# DTC P0037, P0038, P0057, P0058 HO2S2 HEATER

ABS009C8

## DTC Confirmation Procedure

### NOTE:

If DTC Confirmation Procedure has been previously conducted, always turn ignition switch OFF and wait at least 10 seconds before conducting the next test.

### TESTING CONDITION:

Before performing the following procedure, confirm that battery voltage is between 10.5V and 16V at idle.

### WITH CONSULT-II

1. Turn ignition switch ON and select "DATA MONITOR" mode with CONSULT-II.
2. Start engine and warm it up to the normal operating temperature.
3. Turn ignition switch OFF and wait at least 10 seconds.
4. Start the engine and keep the engine speed between 3,500 rpm and 4,000 rpm for at least 1 minute under no load.
5. Let engine idle for 1 minute.
6. If 1st trip DTC is detected, go to [EC-150, "Diagnostic Procedure"](#).

DATA MONITOR	
MONITOR	NO DTC
COOLAN TEMP/S	XXX °C
VHCL SPEED SE	XXX km/h

SEF176Y

### WITH GST

Follow the procedure "WITH CONSUT-II" above.

# DTC P0037, P0038, P0057, P0058 HO2S2 HEATER

ABS009C9

## Wiring Diagram BANK 1

### EC-O2H2B1-01

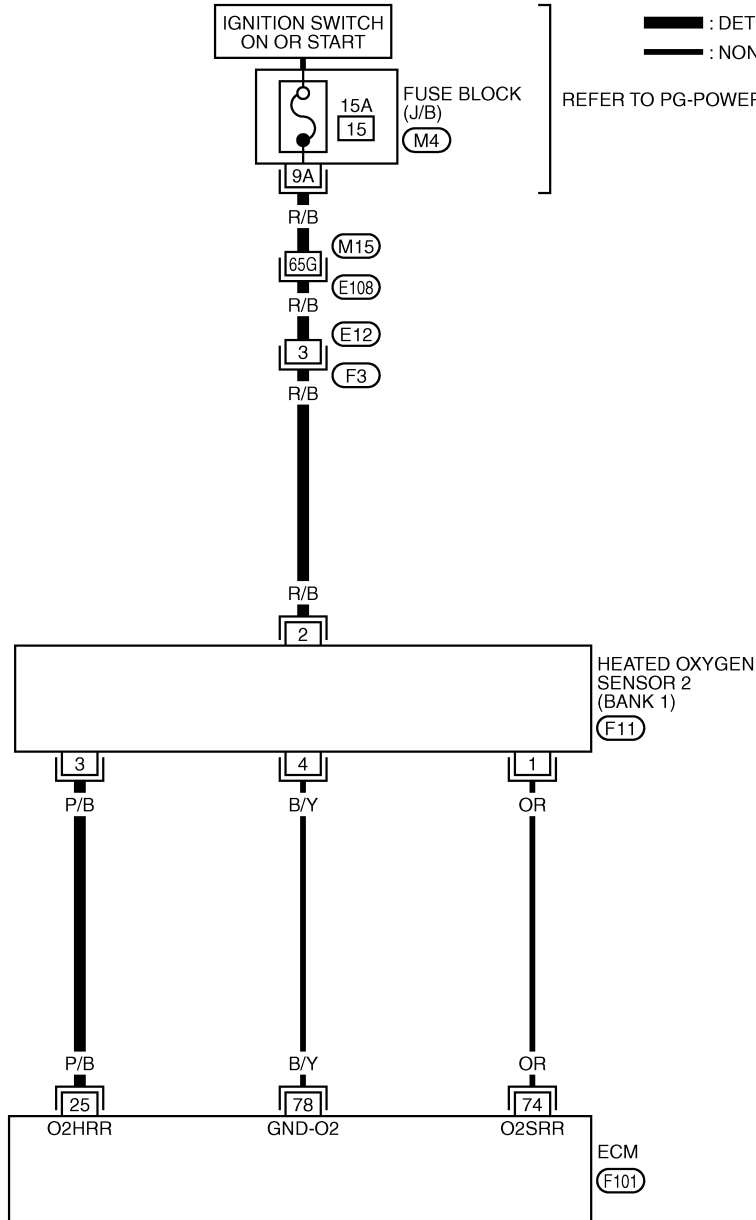

REFER TO THE FOLLOWING.

E108 -SUPER MULTIPLE JUNCTION (SMJ)

M4 -FUSE BLOCK-JUNCTION BOX (J/B)

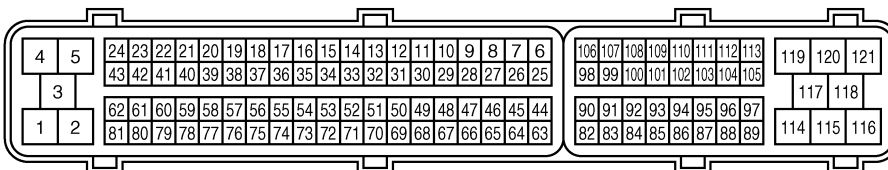

TBWT0474E

## DTC P0037, P0038, P0057, P0058 HO2S2 HEATER

Specification data are reference values and are measured between each terminal and ground.

**CAUTION:**

**Do not use ECM ground terminals when measuring input/output voltage. Doing so may result in damage to the ECM's transistor. Use a ground other than ECM terminals, such as the ground.**

TER-MINAL NO.	WIRE COLOR	ITEM	CONDITION	DATA (DC Voltage)
25	P/B	Heated oxygen sensor 2 heater (bank 1)	<b>[Engine is running]</b> <ul style="list-style-type: none"> <li>● Engine speed is below 3,600 rpm after the following conditions are met.                             <ul style="list-style-type: none"> <li>- Engine: after warming up</li> <li>- Keeping the engine speed between 3,500 and 4,000 rpm for 1 minute and at idle for 1 minute under no load.</li> </ul> </li> </ul>	0 - 1.0V
			<b>[Ignition switch: ON]</b> <ul style="list-style-type: none"> <li>● Engine stopped</li> </ul> <b>[Engine is running]</b> <ul style="list-style-type: none"> <li>● Engine speed is above 3,600 rpm.</li> </ul>	BATTERY VOLTAGE (11 - 14V)

# DTC P0037, P0038, P0057, P0058 HO2S2 HEATER

**BANK 2**

**EC-O2H2B2-01**

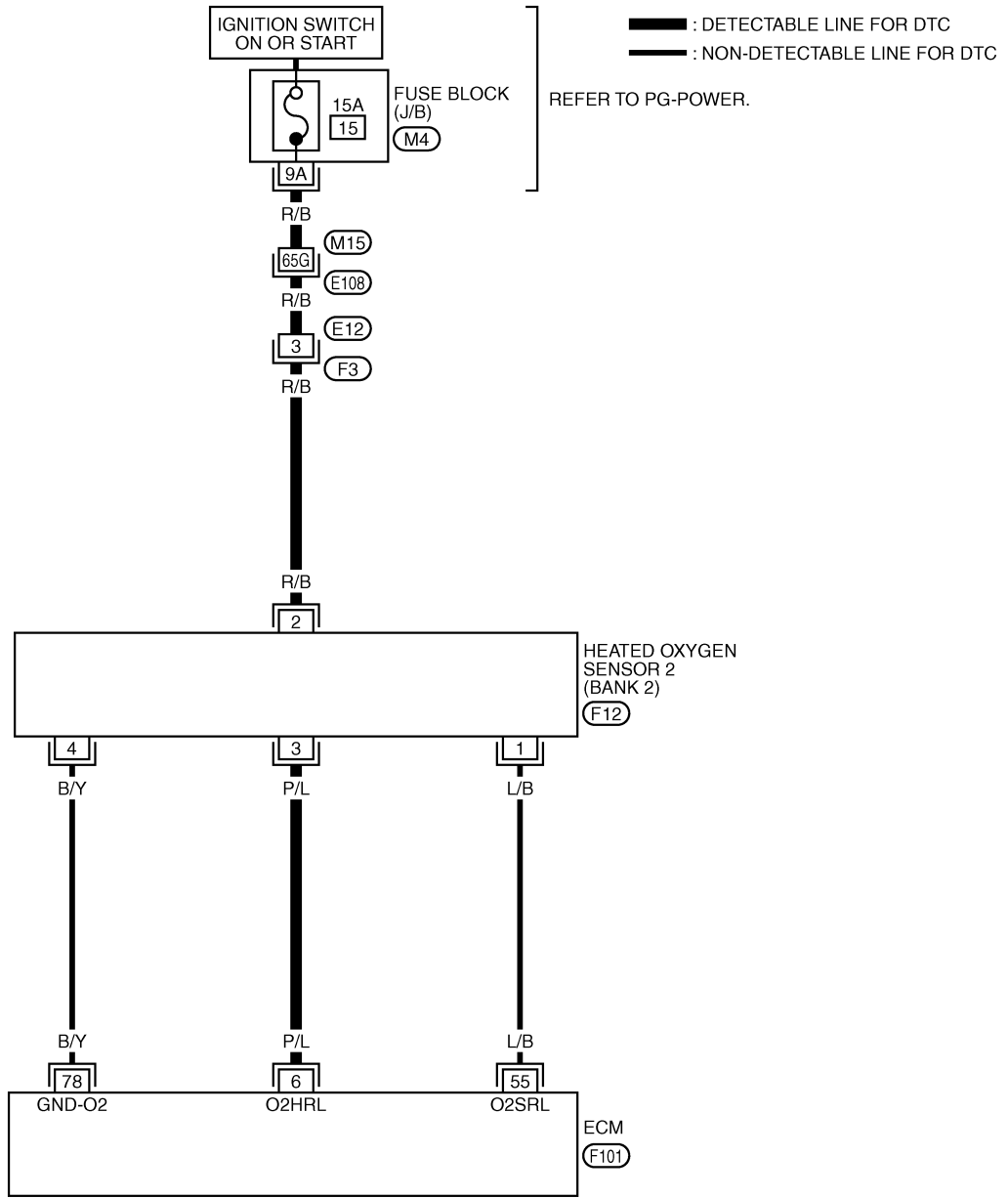

REFER TO THE FOLLOWING.

E108 -SUPER MULTIPLE JUNCTION (SMJ)

M4 -FUSE BLOCK-JUNCTION BOX (J/B)

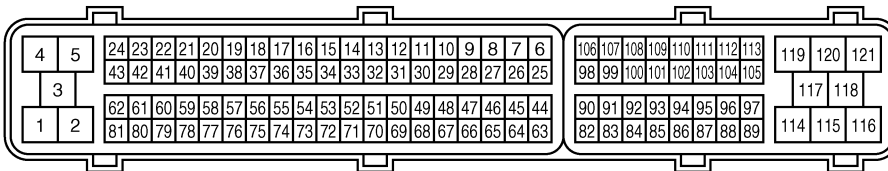

TBWT0475E

# DTC P0037, P0038, P0057, P0058 HO2S2 HEATER

Specification data are reference values and are measured between each terminal and ground.

**CAUTION:**

Do not use ECM ground terminals when measuring input/output voltage. Doing so may result in damage to the ECM's transistor. Use a ground other than ECM terminals, such as the ground.

TER-MINAL NO.	WIRE COLOR	ITEM	CONDITION	DATA (DC Voltage)
6	P/L	Heated oxygen sensor 2 heater (bank 2)	<b>[Engine is running]</b> <ul style="list-style-type: none"> <li>● Engine speed is below 3,600 rpm after the following conditions are met.                             <ul style="list-style-type: none"> <li>- Engine: after warming up</li> <li>- Keeping the engine speed between 3,500 and 4,000 rpm for 1 minute and at idle for 1 minute under no load.</li> </ul> </li> </ul>	0 - 1.0V
			<b>[Ignition switch: ON]</b> <ul style="list-style-type: none"> <li>● Engine stopped</li> </ul> <b>[Engine is running]</b> <ul style="list-style-type: none"> <li>● Engine speed is above 3,600 rpm.</li> </ul>	BATTERY VOLTAGE (11 - 14V)

## Diagnostic Procedure

ABS009CA

### 1. CHECK GROUND CONNECTIONS

1. Turn ignition switch OFF.
2. Loosen and retighten three ground screws on the body. Refer to [EC-138, "Ground Inspection"](#).

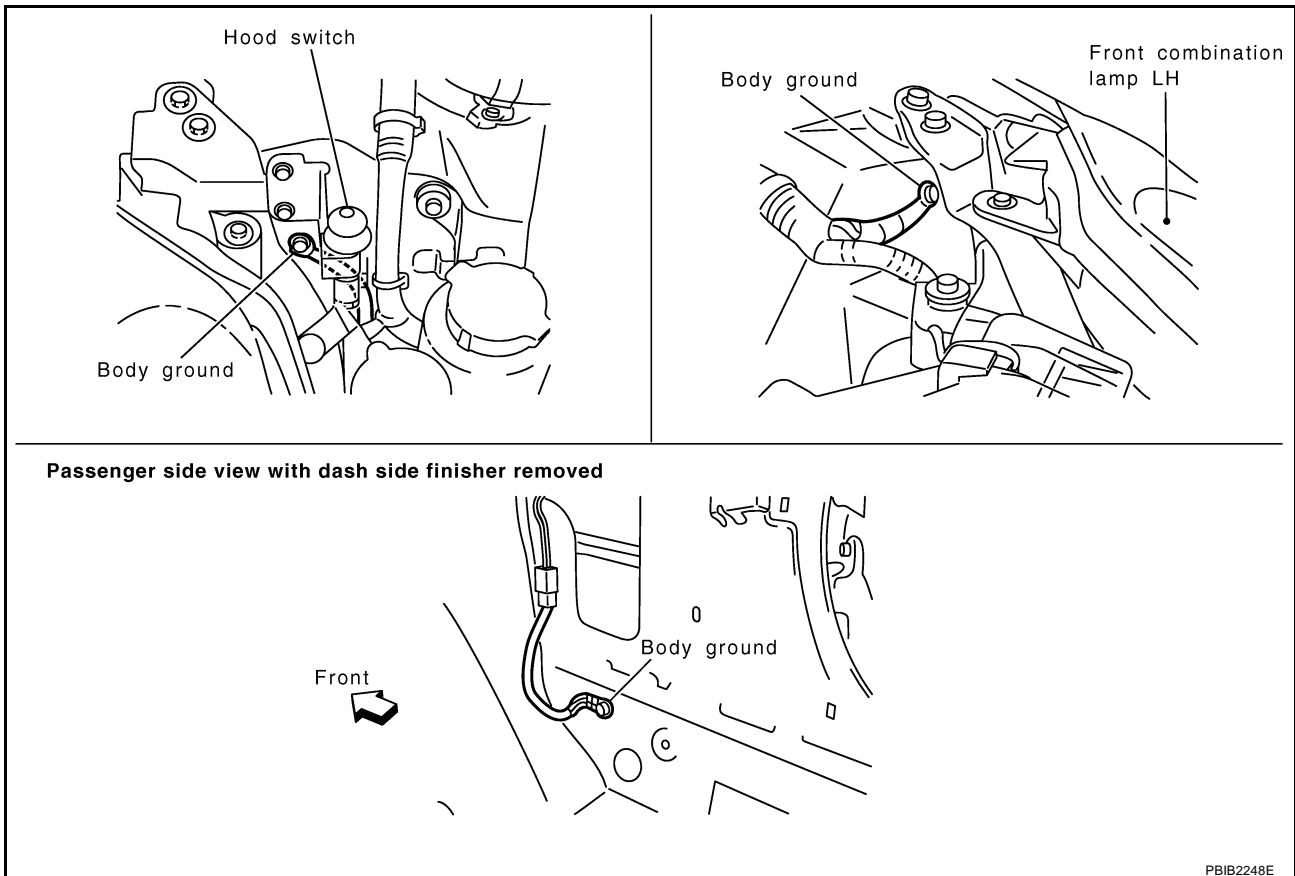

PBIB2248E

**OK or NG**

- OK >> GO TO 2.
- NG >> Repair or replace ground connections.

# DTC P0037, P0038, P0057, P0058 HO2S2 HEATER

## 2. CHECK HO2S2 POWER SUPPLY CIRCUIT

1. Disconnect heated oxygen sensor 2 harness connector.

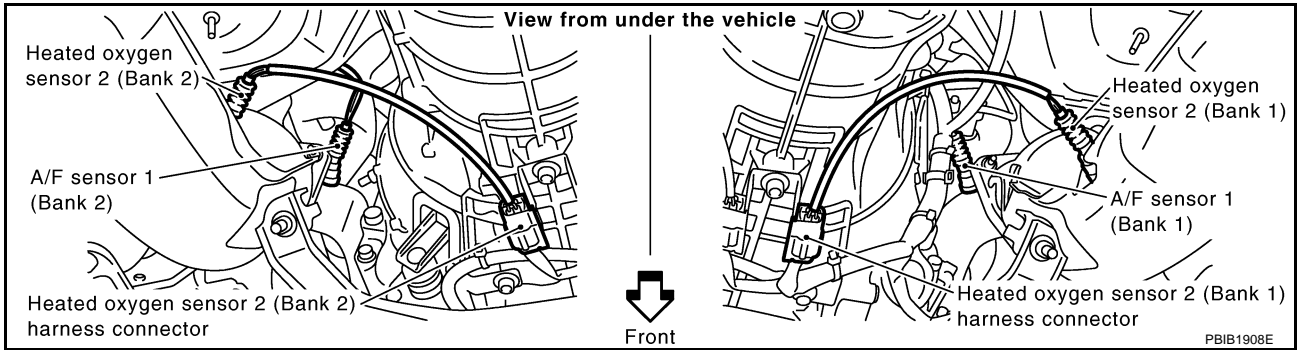

2. Turn ignition switch ON.
3. Check voltage between HO2S2 terminal 2 and ground with CONSULT-II or tester.

**Voltage: Battery voltage**

OK or NG

- OK >> GO TO 4.
- NG >> GO TO 3.

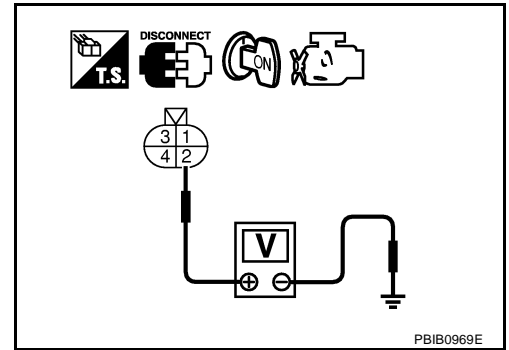

## 3. DETECT MALFUNCTIONING PART

Check the following.

- Harness connectors M15, E108
- Harness connectors E12, F3
- Fuse block (J/B) connector M4
- 15A fuse
- Harness for open or short between heated oxygen sensor 2 and fuse

>> Repair open circuit or short to ground or short to power in harness or connectors.

## 4. CHECK HO2S2 OUTPUT SIGNAL CIRCUIT FOR OPEN AND SHORT

1. Turn ignition switch OFF.
2. Disconnect ECM harness connector.
3. Check harness continuity between ECM terminal and HO2S2 terminal as follows. Refer to Wiring Diagram.

DTC	Terminals		Bank
	ECM	Sensor	
P0037, P0038	25	3	1
P0057, P0058	6	3	2

**Continuity should exist.**

4. Also check harness for short to ground and short to power.

OK or NG

- OK >> GO TO 5.
- NG >> Repair open circuit or short to ground or short to power in harness or connectors.

# DTC P0037, P0038, P0057, P0058 HO2S2 HEATER

## 5. CHECK HEATED OXYGEN SENSOR 2 HEATER

Refer to [EC-152, "Component Inspection"](#) .

OK or NG

- OK >> GO TO 6.
- NG >> Replace malfunctioning heated oxygen sensor 2.

## 6. CHECK INTERMITTENT INCIDENT

Refer to [EC-129, "TROUBLE DIAGNOSIS FOR INTERMITTENT INCIDENT"](#) .

>> INSPECTION END

### Component Inspection HEATED OXYGEN SENSOR 2 HEATER

ABS009CB

1. Check resistance between HO2S2 terminals as follows.

Terminal No.	Resistance
2 and 3	5.0 - 7.0 $\Omega$ [at 25°C (77°F)]
1 and 2, 3, 4	$\infty \Omega$
4 and 1, 2, 3	(Continuity should not exist)

2. If NG, replace heated oxygen sensor 2.

#### CAUTION:

- Discard any heated oxygen sensor which has been dropped from a height of more than 0.5 m (19.7 in) onto a hard surface such as a concrete floor; use a new one.
- Before installing new oxygen sensor, clean exhaust system threads using Oxygen Sensor Thread Cleaner tool J-43897-18 or J-43897-12 and approved anti-seize lubricant.

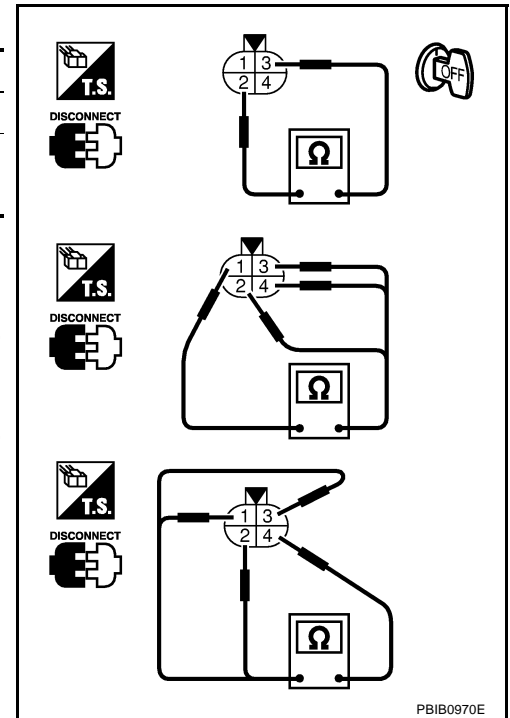

### Removal and Installation HEATED OXYGEN SENSOR 2

ABS009CC

Refer to [EM-23, "EXHAUST MANIFOLD AND THREE WAY CATALYST"](#) .



# DTC P0101 MAF SENSOR

## DTC P0101 MAF SENSOR

PF2:22680

### Component Description

ABS009CD

The mass air flow sensor is placed in the stream of intake air. It measures the intake flow rate by measuring a part of the entire intake flow. The mass air flow control the temperature of the hot wire is to a certain amount. The heat generated by the hot wire is reduced as the intake air flows around it. The more air, the greater the heat loss. Therefore, the electric current supplied to hot wire is changed to maintain the temperature of the hot wire as air flow increases. The ECM detects the air flow by means of this current change.

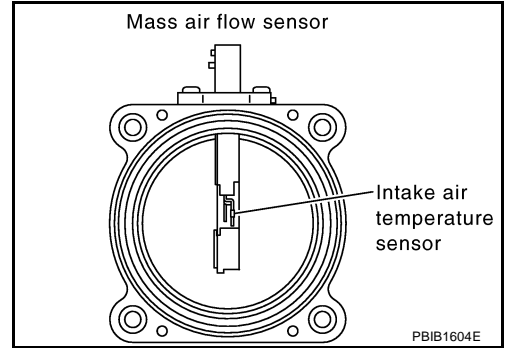

### CONSULT-II Reference Value in Data Monitor Mode

ABS009CE

Specification data are reference values.

MONITOR ITEM	CONDITION		SPECIFICATION
MAS A/F SE-B1	See <a href="#">EC-125</a> , "TROUBLE DIAGNOSIS - SPECIFICATION VALUE".		
CAL/LD VALUE	<ul style="list-style-type: none"> <li>● Engine: After warming up</li> <li>● Shift lever: P or N (A/T), Neutral (M/T)</li> <li>● Air conditioner switch: OFF</li> <li>● No-load</li> </ul>	Idle	5% - 35%
		2,500 rpm	5% - 35%
MASS AIRFLOW	<ul style="list-style-type: none"> <li>● Engine: After warming up</li> <li>● Shift lever: P or N (A/T), Neutral (M/T)</li> <li>● Air conditioner switch: OFF</li> <li>● No-load</li> </ul>	Idle	2.0 - 6.0 g-m/s
		2,500 rpm	7.0 - 20.0 g-m/s

### On Board Diagnosis Logic

ABS009CF

This self-diagnosis has the one trip detection logic.

DTC No.	Trouble diagnosis name	DTC detecting condition		Possible cause
P0101 0101	Mass air flow sensor circuit range/performance problem	A)	A high voltage from the sensor is sent to ECM under light load driving condition.	<ul style="list-style-type: none"> <li>● Harness or connectors (The sensor circuit is open or shorted.)</li> <li>● Mass air flow sensor</li> </ul>
		B)	A low voltage from the sensor is sent to ECM under heavy load driving condition.	<ul style="list-style-type: none"> <li>● Harness or connectors (The sensor circuit is open or shorted.)</li> <li>● Intake air leaks</li> <li>● Mass air flow sensor</li> </ul>

# DTC P0101 MAF SENSOR

ABS009CG

## DTC Confirmation Procedure

Perform **PROCEDURE FOR MALFUNCTION A** first.

If the DTC cannot be confirmed, perform **PROCEDURE FOR MALFUNCTION B**.

### NOTE:

If DTC Confirmation Procedure has been previously conducted, always turn ignition switch OFF and wait at least 10 seconds before conducting the next test.

### PROCEDURE FOR MALFUNCTION A

#### NOTE:

If engine will not start or stops soon, wait at least 10 seconds with engine stopped (Ignition switch ON) instead of running engine at idle speed.

#### With CONSULT-II

1. Turn ignition switch ON.
2. Select "DATA MONITOR" mode with CONSULT-II.
3. Start engine and warm it up to normal operating temperature.
4. Run engine for at least 10 seconds at idle speed.
5. If DTC is detected, go to [EC-157, "Diagnostic Procedure"](#).

DATA MONITOR	
MONITOR	NO DTC
ENG SPEED	XXX rpm
COOLANT TEMP/S	XXX °C

SEF174Y

#### With GST

Follow the procedure "With CONSULT-II" above.

### PROCEDURE FOR MALFUNCTION B

#### CAUTION:

Always drive vehicle at a safe speed.

#### With CONSULT-II

1. Turn ignition switch ON.
2. Start engine and warm it up to normal operating temperature.  
If engine cannot be started, go to [EC-157, "Diagnostic Procedure"](#).
3. Select "DATA MONITOR" mode with CONSULT-II.
4. Check the voltage of "MAS A/F SE-B1" with "DATA MONITOR".
5. Increases engine speed to about 4,000 rpm.
6. Monitor the linear voltage rise in response to engine speed increases.  
If NG, go to [EC-157, "Diagnostic Procedure"](#).  
If OK, go to following step.

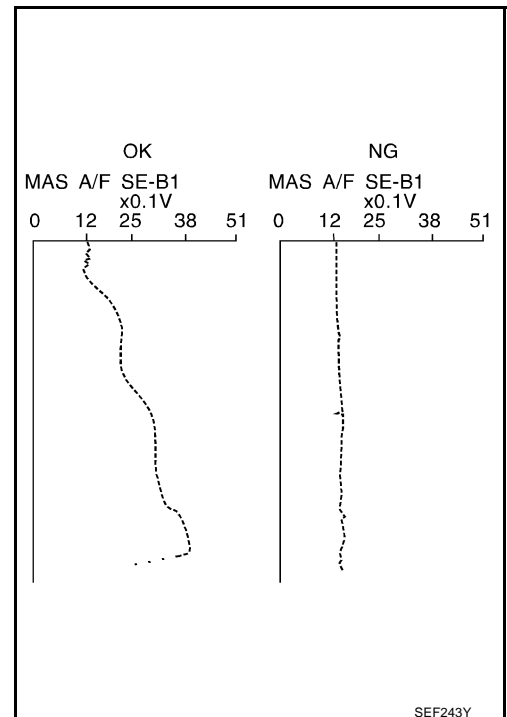

# DTC P0101 MAF SENSOR

7. Maintain the following conditions for at least 10 consecutive seconds.

ENG SPEED	More than 2,000 rpm
THRTL SEN 1	More than 3V
THRTL SEN 2	More than 3V
Shift lever	Suitable position
Driving location	Driving vehicle uphill (Increased engine load) will help maintain the driving conditions required for this test.

DATA MONITOR	
MONITOR	NO DTC
ENG SPEED	XXX rpm
VHCL SPEED SE	XXX km/h
THRTL SEN 1	XXX V
THRTL SEN 2	XXX V

PBIB0199E

8. If DTC is detected, go to [EC-157, "Diagnostic Procedure"](#) .

## Overall Function Check PROCEDURE FOR MALFUNCTION B

ABS009CH

Use this procedure to check the overall function of the mass air flow sensor circuit. During this check, a DTC might not be confirmed.

### With GST

1. Start engine and warm it up to normal operating temperature.
2. Select "MODE 1" with GST.
3. Check the mass air flow sensor signal with "MODE 1".
4. Check for linear mass air flow sensor signal value rise in response to increases to about 4,000 rpm in engine speed.
5. If NG, go to [EC-157, "Diagnostic Procedure"](#) .

CALC LOAD	20%
COOLANT TEMP	95°C
SHORT FT #1	2%
LONG FT #1	0%
SHORT FT #2	4%
LONG FT #2	0%
ENGINE SPD	2637RPM
VEHICLE SPD	0MPH
IGN ADVANCE	41.0°
INTAKE AIR	41°C
<b>MAF</b>	<b>14.1gm/sec</b>
THROTTLE POS	3%

SEF534P

# DTC P0101 MAF SENSOR

## Wiring Diagram

ABS009CI

### EC-MAFS-01

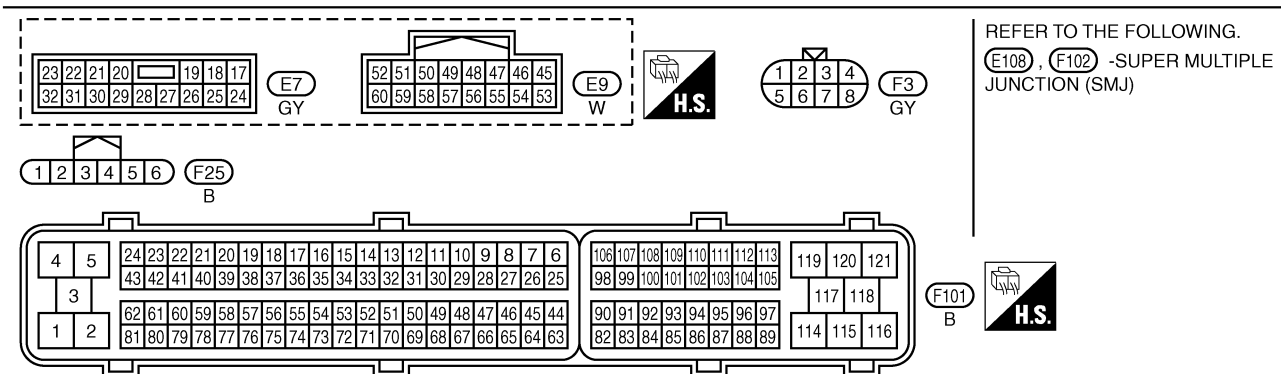
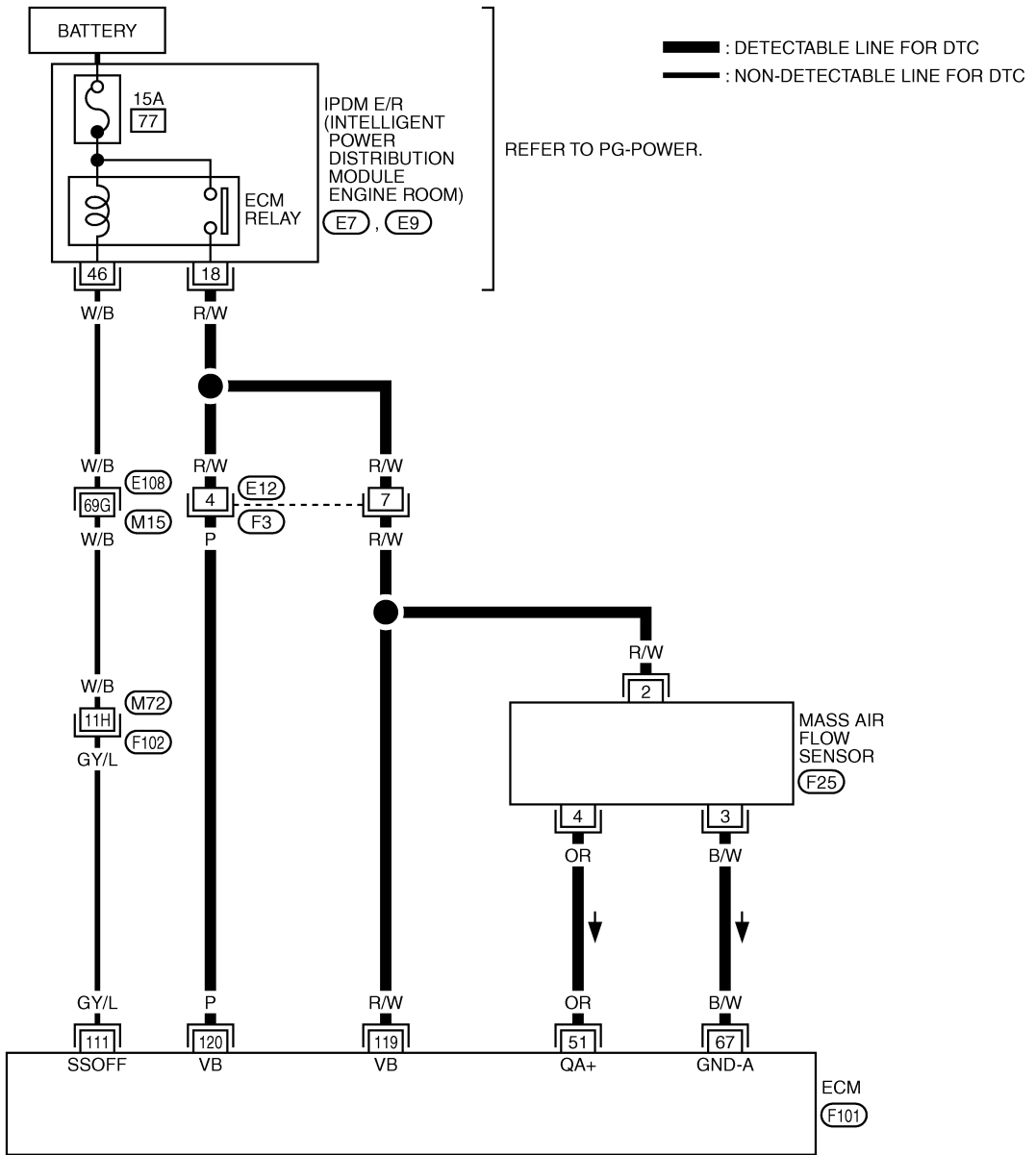

TBWT0613E

# DTC P0101 MAF SENSOR

Specification data are reference values and are measured between each terminal and ground.

**CAUTION:**

**Do not use ECM ground terminals when measuring input/output voltage. Doing so may result in damage to the ECM's transistor. Use a ground other than ECM terminals, such as the ground.**

TER-MINAL NO.	WIRE COLOR	ITEM	CONDITION	DATA (DC Voltage)
51	OR	Mass air flow sensor	<b>[Engine is running]</b> ● Warm-up condition ● Idle speed	0.9 - 1.2V
			<b>[Engine is running]</b> ● Warm-up condition ● Engine speed is 2,500 rpm.	1.6 - 1.9V
67	B/W	Sensor ground	<b>[Engine is running]</b> ● Warm-up condition ● Idle speed	Approximately 0V
111	GY/L	ECM relay (Self shut-off)	<b>[Engine is running]</b> <b>[Ignition switch: OFF]</b> ● For a few seconds after turning ignition switch OFF	0 - 1.5V
			<b>[Ignition switch: OFF]</b> ● More than a few seconds after turning ignition switch OFF	BATTERY VOLTAGE (11 - 14V)
119 120	R/W P	Power supply for ECM	<b>[Ignition switch: ON]</b>	BATTERY VOLTAGE (11 - 14V)

## Diagnostic Procedure

ABS009CJ

### 1. INSPECTION START

Which malfunction (A or B) is duplicated?

A or B

- A >> GO TO 3.
- B >> GO TO 2.

### 2. CHECK INTAKE SYSTEM

Check the following for connection.

- Air duct
- Vacuum hoses
- Intake air passage between air duct and intake manifold

OK or NG

- OK >> GO TO 3.
- NG >> Reconnect the parts.

## DTC P0101 MAF SENSOR

### 3. CHECK GROUND CONNECTIONS

1. Turn ignition switch OFF.
2. Loosen and retighten three ground screws on the body. Refer to [EC-138, "Ground Inspection"](#).

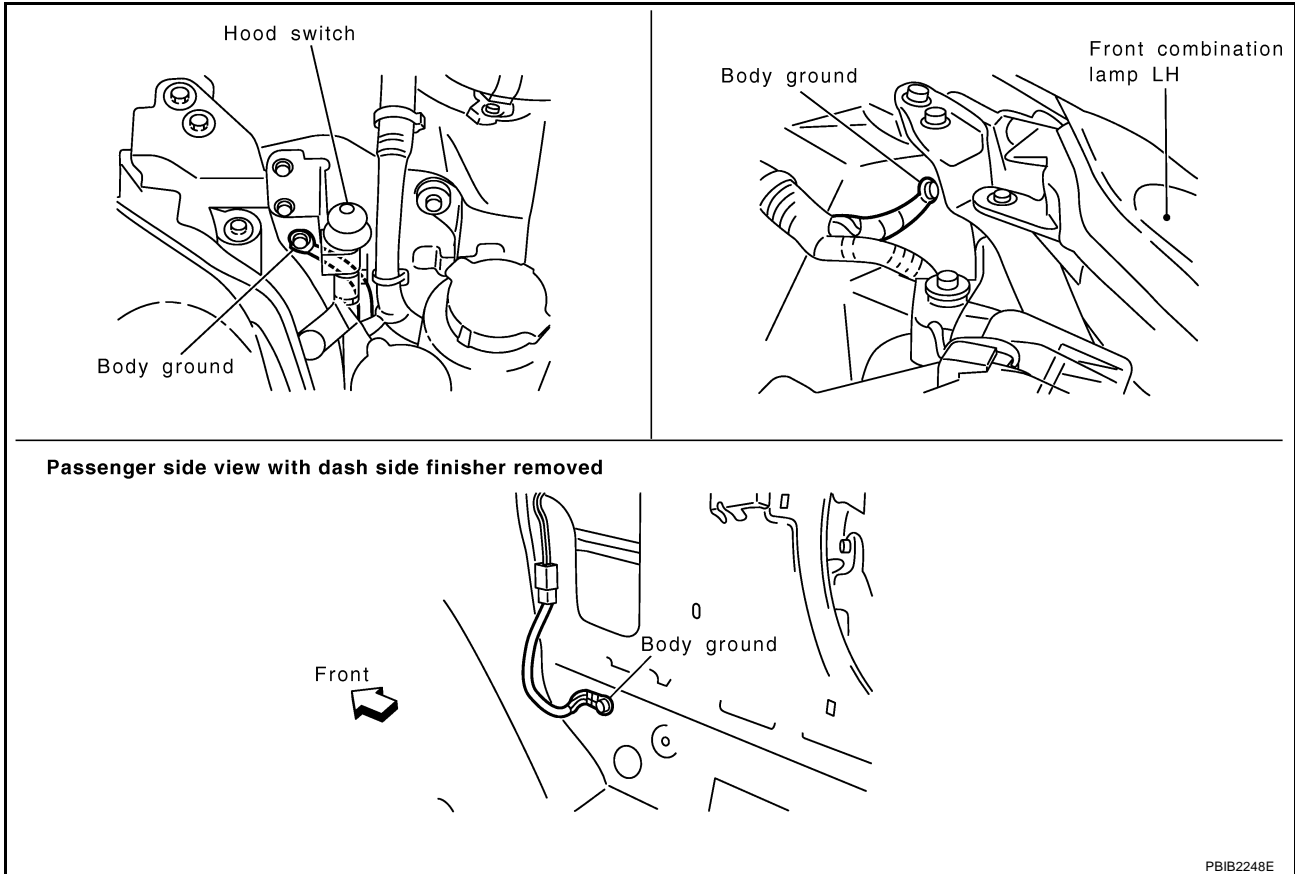

#### OK or NG

- OK >> GO TO 4.  
NG >> Repair or replace ground connections.

# DTC P0101 MAF SENSOR

## 4. CHECK MAF SENSOR POWER SUPPLY CIRCUIT

1. Disconnect mass air flow (MAF) sensor harness connector.
2. Turn ignition switch ON.

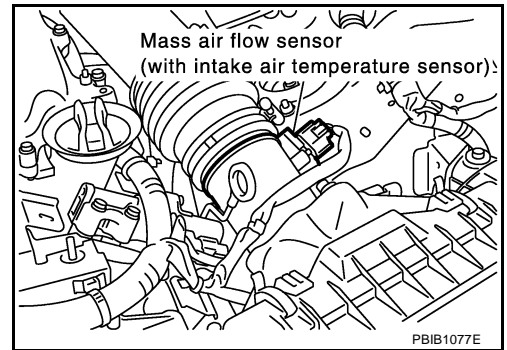

3. Check voltage between MAF sensor terminal 2 and ground with CONSULT-II or tester.

**Voltage: Battery voltage**

OK or NG

- OK >> GO TO 6.  
NG >> GO TO 5.

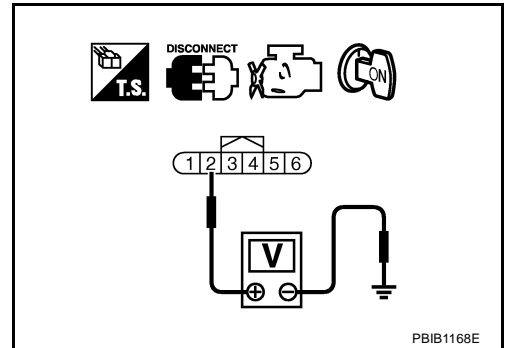

## 5. DETECT MALFUNCTIONING PART

Check the following.

- Harness connectors E12, F3
- Harness for open or short between IPDM E/R and mass air flow sensor
- Harness for open or short between mass air flow sensor and ECM

>> Repair open circuit or short to ground or short to power in harness or connectors.

## 6. CHECK MAF SENSOR GROUND CIRCUIT FOR OPEN AND SHORT

1. Turn ignition switch OFF.
2. Disconnect ECM harness connector.
3. Check harness continuity between MAF sensor terminal 3 and ECM terminal 67.  
Refer to Wiring Diagram.

**Continuity should exist.**

4. Also check harness for short to ground and short to power.

OK or NG

- OK >> GO TO 7.  
NG >> Repair open circuit or short to ground or short to power in harness or connectors.

## DTC P0101 MAF SENSOR

---

### 7. CHECK MAF SENSOR INPUT SIGNAL CIRCUIT FOR OPEN AND SHORT

---

1. Check harness continuity between MAF sensor terminal 4 and ECM terminal 51.  
Refer to Wiring Diagram.

**Continuity should exist.**

2. Also check harness for short to ground and short to power.

OK or NG

OK >> GO TO 8.

NG >> Repair open circuit or short to ground or short to power in harness or connectors.

### 8. CHECK MASS AIR FLOW SENSOR

---

Refer to [EC-161, "Component Inspection"](#) .

OK or NG

OK >> GO TO 9.

NG >> Replace mass air flow sensor.

### 9. CHECK INTERMITTENT INCIDENT

---

Refer to [EC-129, "TROUBLE DIAGNOSIS FOR INTERMITTENT INCIDENT"](#) .

**>> INSPECTION END**



# DTC P0101 MAF SENSOR

ABS009CK

## Component Inspection MASS AIR FLOW SENSOR

### ① With CONSULT-II

1. Reconnect all harness connectors disconnected.
2. Start engine and warm it up to normal operating temperature.
3. Connect CONSULT-II and select "DATA MONITOR" mode.
4. Select "MAS A/F SE-B1" and check indication under the following conditions.

Condition	MAS A/F SE-B1 (V)
Ignition switch ON (Engine stopped.)	Approx. 0.4
Idle (Engine is warmed-up to normal operating temperature.)	0.9 - 1.2
2,500 rpm (Engine is warmed-up to normal operating temperature.)	1.5 - 1.9
Idle to about 4,000 rpm	0.9 - 1.2 to Approx. 2.4*

\*: Check for linear voltage rise in response to engine being increased to about 4,000 rpm.

5. If the voltage is out of specification, proceed the following.
  - a. Check for the cause of uneven air flow through mass air flow sensor. Refer to following.
    - Crushed air ducts
    - Malfunctioning seal of air cleaner element
    - Uneven dirt of air cleaner element
    - Improper specification of intake air system parts
  - b. If NG, repair or replace malfunctioning part and perform step 2 to 4 again. If OK, go to next step.
6. Turn ignition switch OFF.
7. Disconnect mass air flow sensor harness connector and reconnect it again.
8. Perform step 2 to 4 again.
9. If NG, clean or replace mass air flow sensor.

### ⊗ Without CONSULT-II

1. Reconnect all harness connectors disconnected.
2. Start engine and warm it up to normal operating temperature.
3. Check voltage between ECM terminal 51 (Mass air flow sensor signal) and ground.

Condition	Voltage V
Ignition switch ON (Engine stopped.)	Approx. 0.4
Idle (Engine is warmed-up to normal operating temperature.)	0.9 - 1.2
2,500 rpm (Engine is warmed-up to normal operating temperature.)	1.5 - 1.9
Idle to about 4,000 rpm	0.9 - 1.2 to Approx. 2.4*

\*: Check for linear voltage rise in response to engine being increased to about 4,000 rpm.

4. If the voltage is out of specification, proceed the following.
  - a. Check for the cause of uneven air flow through mass air flow sensor. Refer to following.
    - Crushed air ducts
    - Malfunctioning seal of air cleaner element
    - Uneven dirt of air cleaner element
    - Improper specification of intake air system parts

DATA MONITOR	
MONITOR	NO DTC
ENG SPEED	XXX rpm
MAS A/F SE-B1	XXX V
COOLAN TEMP/S	XXX °C

SEF178Y

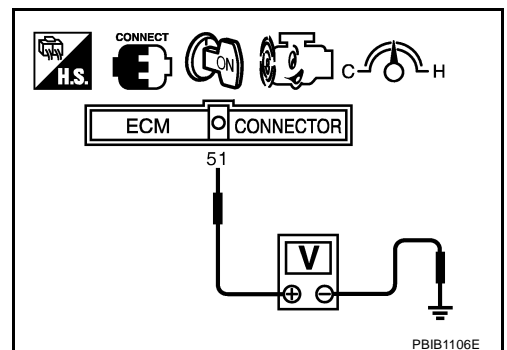

## DTC P0101 MAF SENSOR

---

- b. If NG, repair or replace malfunctioning part and perform step 2 to 3 again.  
If OK, go to next step.
5. Turn ignition switch OFF.
6. Disconnect mass air flow sensor harness connector and reconnect it again.
7. Perform step 2 and 3 again.
8. If NG, clean or replace mass air flow sensor.

### **Removal and Installation** **MASS AIR FLOW SENSOR**

ABS009CL

Refer to [EM-14, "AIR CLEANER AND AIR DUCT"](#) .

# DTC P0102, P0103 MAF SENSOR

## DTC P0102, P0103 MAF SENSOR

PFP:22680

### Component Description

ABS009CM

The mass air flow sensor is placed in the stream of intake air. It measures the intake flow rate by measuring a part of the entire intake flow. The mass air flow control the temperature of the hot wire is to a certain amount. The heat generated by the hot wire is reduced as the intake air flows around it. The more air, the greater the heat loss. Therefore, the electric current supplied to hot wire is changed to maintain the temperature of the hot wire as air flow increases. The ECM detects the air flow by means of this current change.

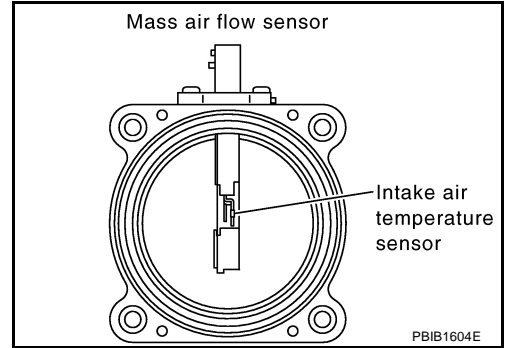

### CONSULT-II Reference Value in Data Monitor Mode

ABS009CN

Specification data are reference values.

MONITOR ITEM	CONDITION		SPECIFICATION
MAS A/F SE-B1	See <a href="#">EC-125</a> , "TROUBLE DIAGNOSIS - SPECIFICATION VALUE".		
CAL/LD VALUE	<ul style="list-style-type: none"> <li>● Engine: After warming up</li> <li>● Shift lever: P or N (A/T), Neutral (M/T)</li> <li>● Air conditioner switch: OFF</li> <li>● No-load</li> </ul>	Idle	5% - 35%
		2,500 rpm	5% - 35%
MASS AIRFLOW	<ul style="list-style-type: none"> <li>● Engine: After warming up</li> <li>● Shift lever: P or N (A/T), Neutral (M/T)</li> <li>● Air conditioner switch: OFF</li> <li>● No-load</li> </ul>	Idle	2.0 - 6.0 g-m/s
		2,500 rpm	7.0 - 20.0 g-m/s

### On Board Diagnosis Logic

ABS009CO

These self-diagnoses have the one trip detection logic.

DTC No.	Trouble diagnosis name	DTC detecting condition	Possible cause
P0102 0102	Mass air flow sensor circuit low input	An excessively low voltage from the sensor is sent to ECM.	<ul style="list-style-type: none"> <li>● Harness or connectors (The sensor circuit is open or shorted.)</li> <li>● Intake air leaks</li> <li>● Mass air flow sensor</li> </ul>
P0103 0103	Mass air flow sensor circuit high input	An excessively high voltage from the sensor is sent to ECM.	<ul style="list-style-type: none"> <li>● Harness or connectors (The sensor circuit is open or shorted.)</li> <li>● Mass air flow sensor</li> </ul>

### FAIL-SAFE MODE

When the malfunction is detected, the ECM enters fail-safe mode and the MIL lights up.

Detected items	Engine operating condition in fail-safe mode
Mass air flow sensor circuit	Engine speed will not rise more than 2,400 rpm due to the fuel cut.

# DTC P0102, P0103 MAF SENSOR

ABS009CP

## DTC Confirmation Procedure

### NOTE:

If DTC Confirmation Procedure has been previously conducted, always turn ignition switch OFF and wait at least 10 seconds before conducting the next test.

### PROCEDURE FOR DTC P0102

#### With CONSULT-II

1. Turn ignition switch ON.
2. Select "DATA MONITOR" mode with CONSULT-II.
3. Start engine and wait at least 5 seconds.
4. If DTC is detected, go to [EC-166, "Diagnostic Procedure"](#) .

DATA MONITOR	
MONITOR	NO DTC
ENG SPEED	XXX rpm

SEF058Y

#### With GST

Follow the procedure "With CONSULT-II" above.

### PROCEDURE FOR DTC P0103

#### With CONSULT-II

1. Turn ignition switch ON.
2. Select "DATA MONITOR" mode with CONSULT-II.
3. Wait at least 5 seconds.
4. If DTC is detected, go to [EC-166, "Diagnostic Procedure"](#) .  
If DTC is not detected, go to next step.
5. Start engine and wait at least 5 seconds.
6. If DTC is detected, go to [EC-166, "Diagnostic Procedure"](#) .

DATA MONITOR	
MONITOR	NO DTC
ENG SPEED	XXX rpm

SEF058Y

#### With GST

Follow the procedure "With CONSULT-II" above.

# DTC P0102, P0103 MAF SENSOR

## Wiring Diagram

ABS009CQ

### EC-MAFS-01

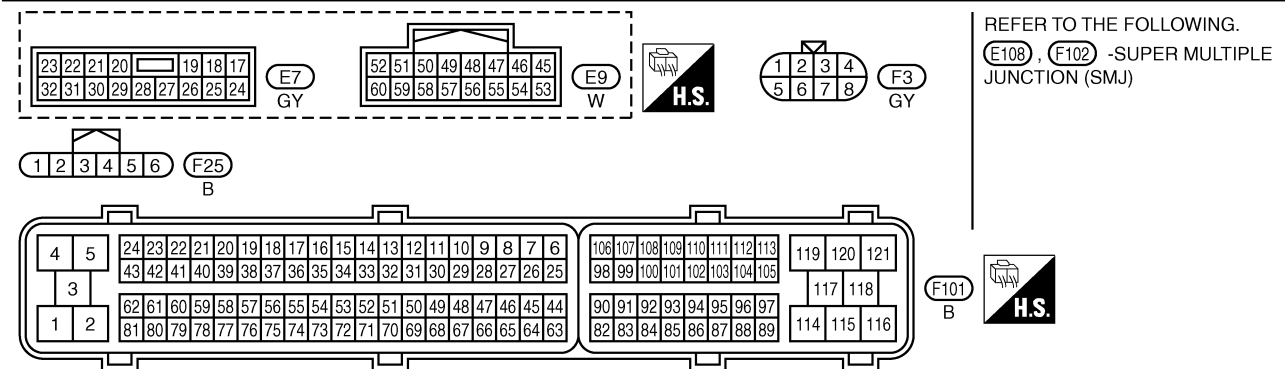
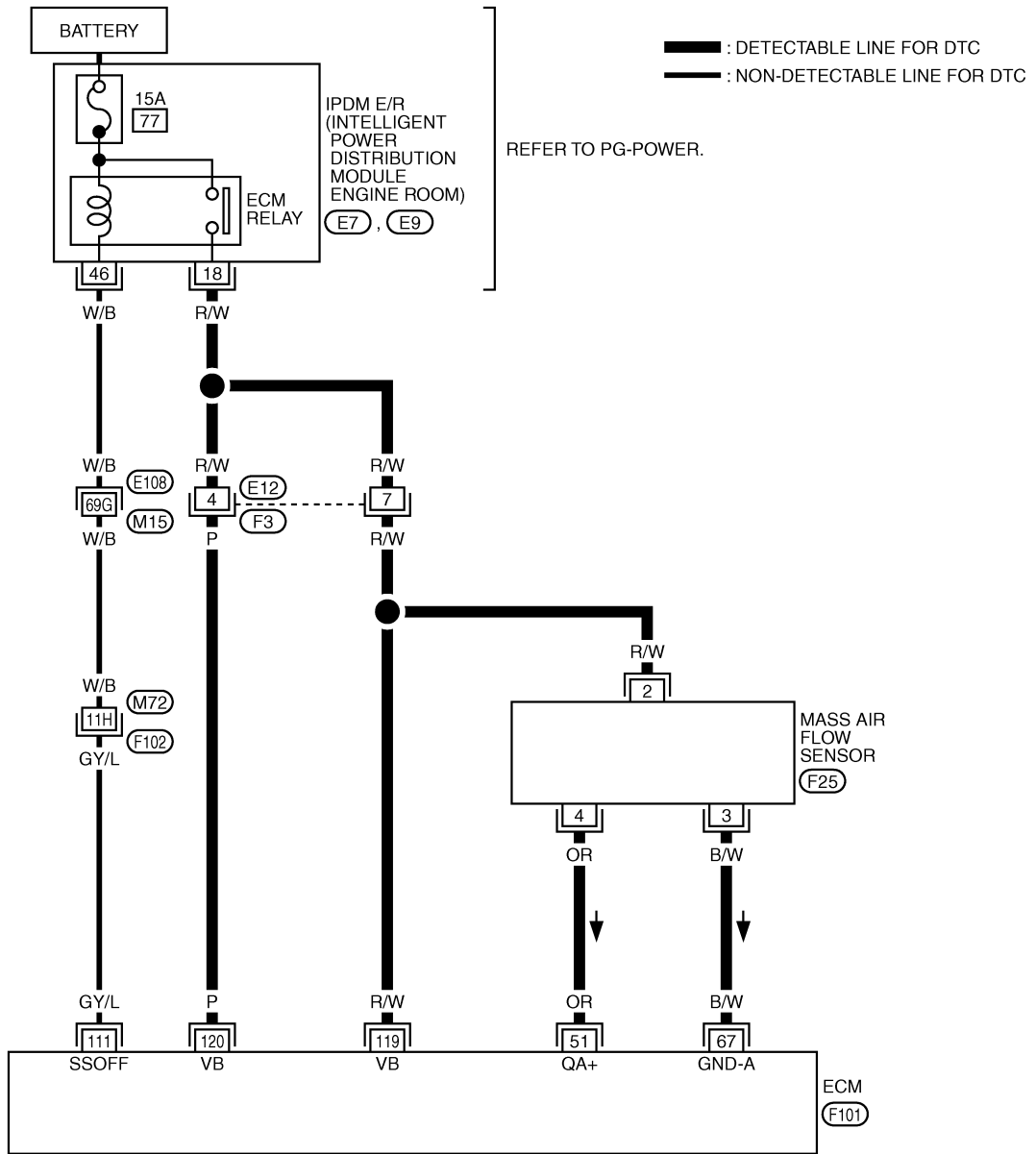

TBWT0613E

## DTC P0102, P0103 MAF SENSOR

Specification data are reference values and are measured between each terminal and ground.

**CAUTION:**

**Do not use ECM ground terminals when measuring input/output voltage. Doing so may result in damage to the ECM's transistor. Use a ground other than ECM terminals, such as the ground.**

TER-MINAL NO.	WIRE COLOR	ITEM	CONDITION	DATA (DC Voltage)
51	OR	Mass air flow sensor	[Engine is running] ● Warm-up condition ● Idle speed	0.9 - 1.2V
			[Engine is running] ● Warm-up condition ● Engine speed is 2,500 rpm.	1.6 - 1.9V
67	B/W	Sensor ground	[Engine is running] ● Warm-up condition ● Idle speed	Approximately 0V
111	GY/L	ECM relay (Self shut-off)	[Engine is running] [Ignition switch: OFF] ● A few seconds after turning ignition switch OFF	0 - 1.5V
			[Ignition switch: OFF] ● More than a few seconds after turning ignition switch OFF	BATTERY VOLTAGE (11 - 14V)
119 120	R/W P	Power supply for ECM	[Ignition switch: ON]	BATTERY VOLTAGE (11 - 14V)

### Diagnostic Procedure

ABS009CR

#### 1. INSPECTION START

Which malfunction (P0102 or P0103) is duplicated?

P0102 or P0103

P0102 >> GO TO 2.

P0103 >> GO TO 3.

#### 2. CHECK INTAKE SYSTEM

Check the following for connection.

- Air duct
- Vacuum hoses
- Intake air passage between air duct and intake manifold

OK or NG

OK >> GO TO 3.

NG >> Reconnect the parts.

# DTC P0102, P0103 MAF SENSOR

## 3. CHECK GROUND CONNECTIONS

1. Turn ignition switch OFF.
2. Loosen and retighten three ground screws on the body. Refer to [EC-138, "Ground Inspection"](#).

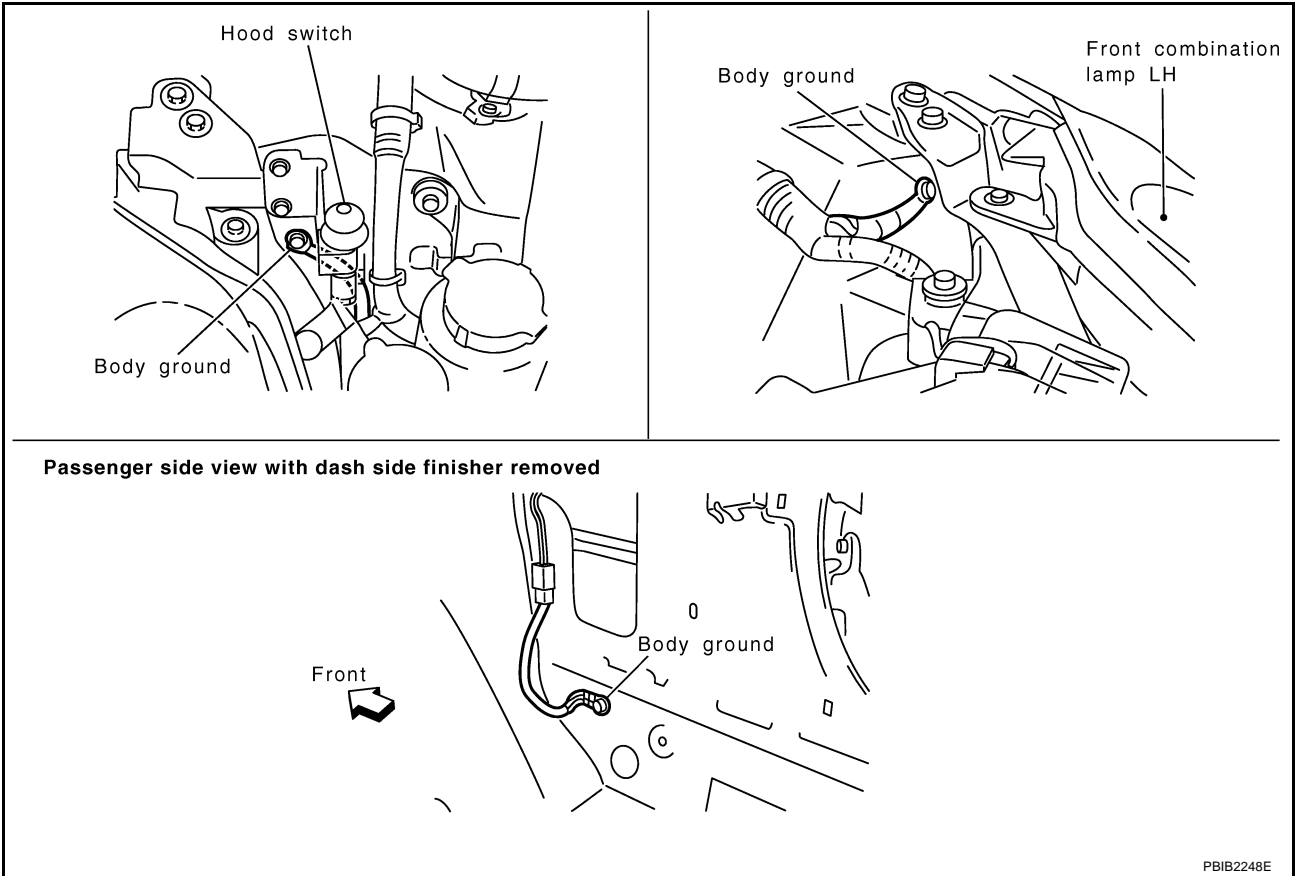

### OK or NG

- OK >> GO TO 4.
- NG >> Repair or replace ground connections.

A  
EC  
C  
D  
E  
F  
G  
H  
I  
J  
K  
L  
M

## DTC P0102, P0103 MAF SENSOR

### 4. CHECK MAF SENSOR POWER SUPPLY CIRCUIT

1. Disconnect mass air flow (MAF) sensor harness connector.
2. Turn ignition switch ON.

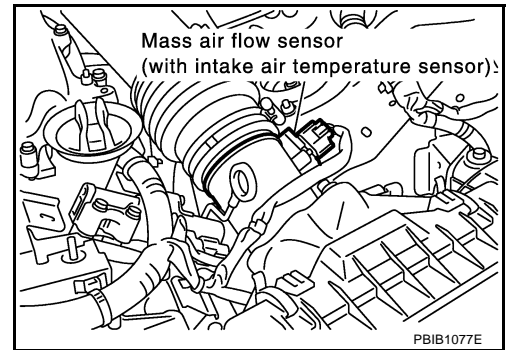

3. Check voltage between MAF sensor terminal 2 and ground with CONSULT-II or tester.

**Voltage: Battery voltage**

OK or NG

- OK >> GO TO 6.  
NG >> GO TO 5.

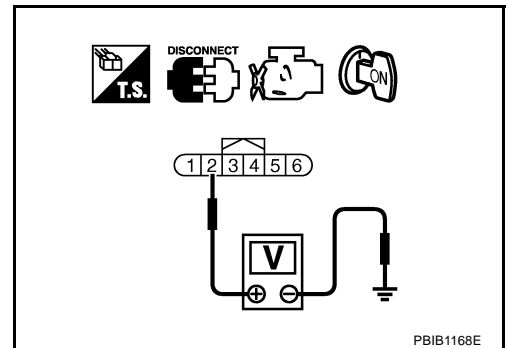

### 5. DETECT MALFUNCTIONING PART

Check the following.

- Harness connectors E12, F3
- Harness for open or short between IPDM E/R and mass air flow sensor
- Harness for open or short between mass air flow sensor and ECM

>> Repair open circuit or short to ground or short to power in harness or connectors.

### 6. CHECK MAF SENSOR GROUND CIRCUIT FOR OPEN AND SHORT

1. Turn ignition switch OFF.
2. Disconnect ECM harness connector.
3. Check harness continuity between MAF sensor terminal 3 and ECM terminal 67.  
Refer to Wiring Diagram.

**Continuity should exist.**

4. Also check harness for short to ground and short to power.

OK or NG

- OK >> GO TO 7.  
NG >> Repair open circuit or short to ground or short to power in harness or connectors.



# DTC P0102, P0103 MAF SENSOR

---

## 7. CHECK MAF SENSOR INPUT SIGNAL CIRCUIT FOR OPEN AND SHORT

---

1. Check harness continuity between MAF sensor terminal 4 and ECM terminal 51.  
Refer to Wiring Diagram.

**Continuity should exist.**

2. Also check harness for short to ground and short to power.

OK or NG

OK >> GO TO 8.

NG >> Repair open circuit or short to ground or short to power in harness or connectors.

---

## 8. CHECK MASS AIR FLOW SENSOR

---

Refer to [EC-170, "Component Inspection"](#) .

OK or NG

OK >> GO TO 9.

NG >> Replace mass air flow sensor.

---

## 9. CHECK INTERMITTENT INCIDENT

---

Refer to [EC-129, "TROUBLE DIAGNOSIS FOR INTERMITTENT INCIDENT"](#) .

**>> INSPECTION END**

A

EC

C

D

E

F

G

H

I

J

K

L

M

# DTC P0102, P0103 MAF SENSOR

ABS009CS

## Component Inspection MASS AIR FLOW SENSOR

### With CONSULT-II

1. Reconnect all harness connectors disconnected.
2. Start engine and warm it up to normal operating temperature.
3. Connect CONSULT-II and select "DATA MONITOR" mode.
4. Select "MAS A/F SE-B1" and check indication under the following conditions.

Condition	MAS A/F SE-B1 (V)
Ignition switch ON (Engine stopped.)	Approx. 0.4
Idle (Engine is warmed-up to normal operating temperature.)	0.9 - 1.2
2,500 rpm (Engine is warmed-up to normal operating temperature.)	1.5 - 1.9
Idle to about 4,000 rpm	0.9 - 1.2 to Approx. 2.4*

\*: Check for linear voltage rise in response to engine being increased to about 4,000 rpm.

5. If the voltage is out of specification, proceed the following.
  - a. Check for the cause of uneven air flow through mass air flow sensor. Refer to following.
    - Crushed air ducts
    - Malfunctioning seal of air cleaner element
    - Uneven dirt of air cleaner element
    - Improper specification of intake air system parts
  - b. If NG, repair or replace malfunctioning part and perform step 2 to 4 again. If OK, go to next step.
6. Turn ignition switch OFF.
7. Disconnect mass air flow sensor harness connector and reconnect it again.
8. Perform step 2 to 4 again.
9. If NG, clean or replace mass air flow sensor.

### Without CONSULT-II

1. Reconnect all harness connectors disconnected.
2. Start engine and warm it up to normal operating temperature.
3. Check voltage between ECM terminal 51 (Mass air flow sensor signal) and ground.

Condition	Voltage V
Ignition switch ON (Engine stopped.)	Approx. 0.4
Idle (Engine is warmed-up to normal operating temperature.)	0.9 - 1.2
2,500 rpm (Engine is warmed-up to normal operating temperature.)	1.5 - 1.9
Idle to about 4,000 rpm	0.9 - 1.2 to Approx. 2.4*

\*: Check for linear voltage rise in response to engine being increased to about 4,000 rpm.

4. If the voltage is out of specification, proceed the following.
  - a. Check for the cause of uneven air flow through mass air flow sensor. Refer to following.
    - Crushed air ducts
    - Malfunctioning seal of air cleaner element
    - Uneven dirt of air cleaner element
    - Improper specification of intake air system parts

DATA MONITOR	
MONITOR	NO DTC
ENG SPEED	XXX rpm
MAS A/F SE-B1	XXX V
COOLAN TEMP/S	XXX °C

SEF178Y

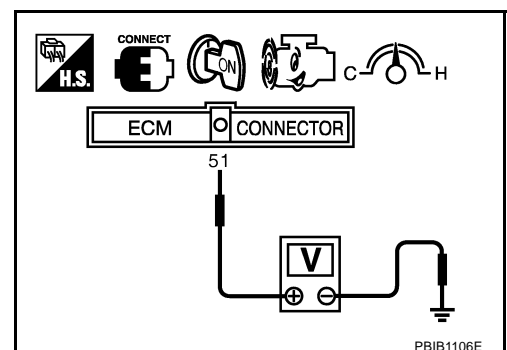

## DTC P0102, P0103 MAF SENSOR

- 
- b. If NG, repair or replace malfunctioning part and perform step 2 to 3 again.  
If OK, go to next step.
  5. Turn ignition switch OFF.
  6. Disconnect mass air flow sensor harness connector and reconnect it again.
  7. Perform step 2 and 3 again.
  8. If NG, clean or replace mass air flow sensor.

### Removal and Installation MASS AIR FLOW SENSOR

Refer to [EM-14, "AIR CLEANER AND AIR DUCT"](#) .

A

EC

ABS009CT

C

D

E

F

G

H

I

J

K

L

M

# DTC P0112, P0113 IAT SENSOR

PFP:22630

## DTC P0112, P0113 IAT SENSOR

### Component Description

ABS009CU

The intake air temperature sensor is built-into mass air flow sensor. The sensor detects intake air temperature and transmits a signal to the ECM.

The temperature sensing unit uses a thermistor which is sensitive to the change in temperature. Electrical resistance of the thermistor decreases in response to the temperature rise.

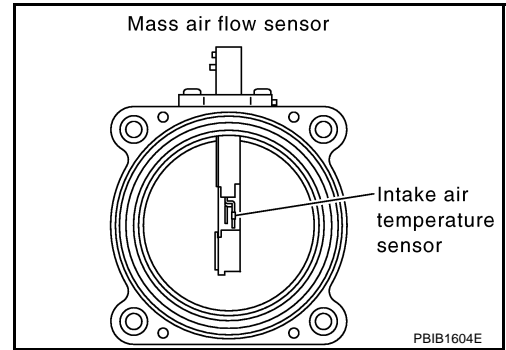

### <Reference data>

Intake air temperature °C (°F)	Voltage* V	Resistance kΩ
25 (77)	3.32	1.94 - 2.06
80 (176)	1.23	0.295 - 0.349

\*: This data is reference values and is measured between ECM terminal 34 (Intake air temperature sensor) and ground.

### CAUTION:

**Do not use ECM ground terminals when measuring input/output voltage. Doing so may result in damage to the ECM's transistor. Use a ground other than ECM terminals, such as the ground.**

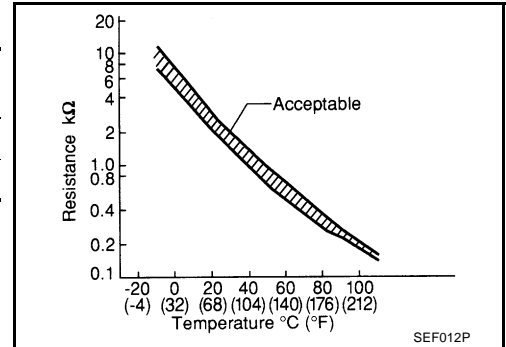

### On Board Diagnosis Logic

ABS009CV

DTC No.	Trouble diagnosis name	DTC detecting condition	Possible cause
P0112 0112	Intake air temperature sensor circuit low input	An excessively low voltage from the sensor is sent to ECM.	<ul style="list-style-type: none"> <li>● Harness or connectors (The sensor circuit is open or shorted.)</li> <li>● Intake air temperature sensor</li> </ul>
P0113 0113	Intake air temperature sensor circuit high input	An excessively high voltage from the sensor is sent to ECM.	

### DTC Confirmation Procedure

ABS009CW

#### NOTE:

If DTC Confirmation Procedure has been previously conducted, always turn ignition switch OFF and wait at least 10 seconds before conducting the next test.

#### Ⓟ WITH CONSULT-II

1. Turn ignition switch ON.
2. Select "DATA MONITOR" mode with CONSULT-II.
3. Wait at least 5 seconds.
4. If 1st trip DTC is detected, go to [EC-175. "Diagnostic Procedure"](#)

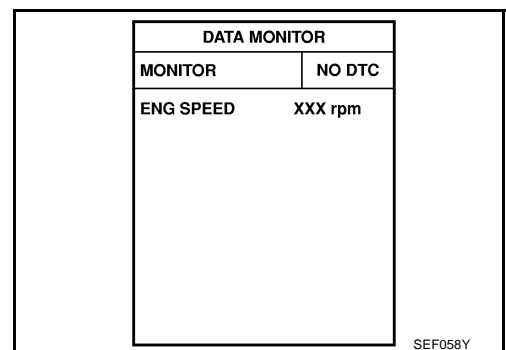

# DTC P0112, P0113 IAT SENSOR

---

 **WITH GST**

Follow the procedure "WITH CONSULT-II" above.

A

**EC**

C

D

E

F

G

H

I

J

K

L

M

# DTC P0112, P0113 IAT SENSOR

ABS009CX

## EC-IATS-01

### Wiring Diagram

: DETECTABLE LINE FOR DTC  
 : NON-DETECTABLE LINE FOR DTC

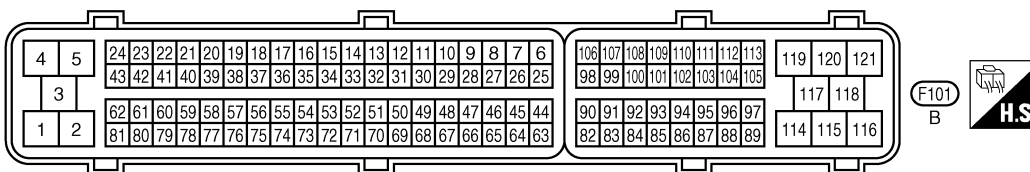
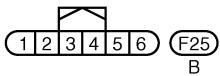
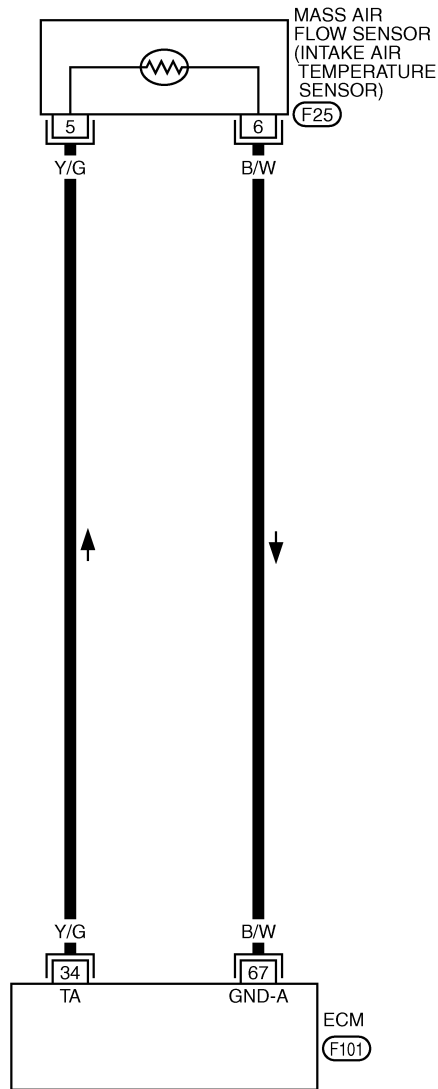

TBWT0477E

# DTC P0112, P0113 IAT SENSOR

ABS009CY

## Diagnostic Procedure

### 1. CHECK GROUND CONNECTIONS

1. Turn ignition switch OFF.
2. Loosen and retighten three ground screws on the body. Refer to [EC-138, "Ground Inspection"](#).

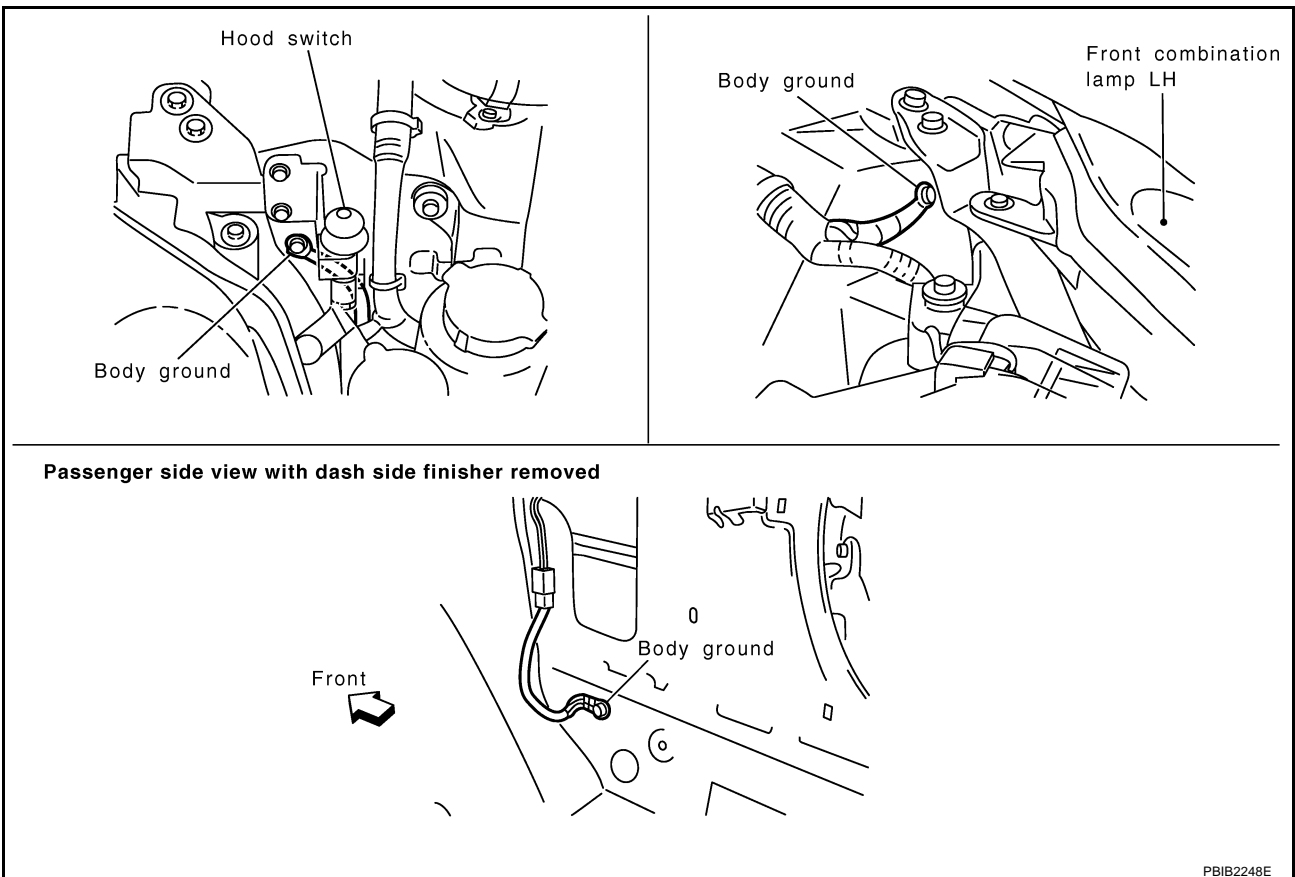

#### OK or NG

- OK >> GO TO 2.
- NG >> Repair or replace ground connections.

A  
EC  
C  
D  
E  
F  
G  
H  
I  
J  
K  
L  
M

# DTC P0112, P0113 IAT SENSOR

## 2. CHECK INTAKE AIR TEMPERATURE SENSOR POWER SUPPLY CIRCUIT

1. Disconnect mass air flow sensor (intake air temperature sensor is built-into) harness connector.
2. Turn ignition switch ON.

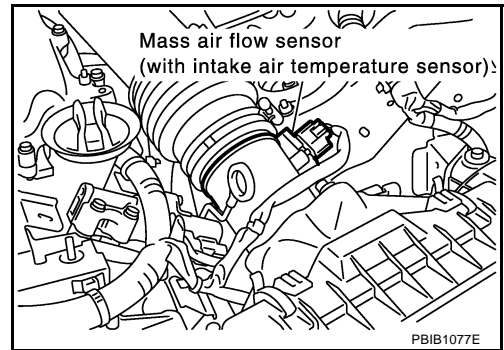

3. Check voltage between mass air flow sensor terminal 5 and ground.

**Voltage: Approximately 5V**

OK or NG

OK >> GO TO 3.

NG >> Repair open circuit or short to ground or short to power in harness or connectors.

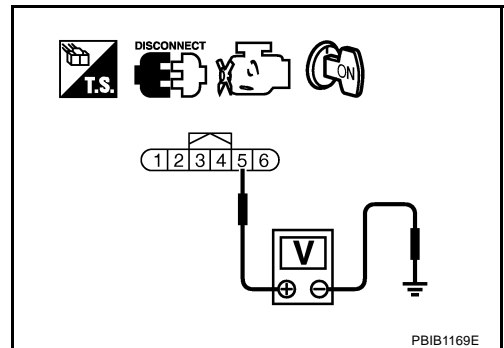

## 3. CHECK INTAKE AIR TEMPERATURE SENSOR GROUND CIRCUIT FOR OPEN AND SHORT

1. Turn ignition switch OFF.
2. Disconnect ECM harness connector.
3. Check harness continuity between mass air flow sensor terminal 6 and ECM terminal 67. Refer to Wiring Diagram.

**Continuity should exist.**

4. Also check harness for short to ground and short to power.

OK or NG

OK >> GO TO 4.

NG >> Repair open circuit or short to ground or short to power in harness or connectors.

## 4. CHECK INTAKE AIR TEMPERATURE SENSOR

Refer to [EC-177, "Component Inspection"](#) .

OK or NG

OK >> GO TO 5.

NG >> Replace mass air flow sensor (with intake air temperature sensor).

## 5. CHECK INTERMITTENT INCIDENT

Refer to [EC-129, "TROUBLE DIAGNOSIS FOR INTERMITTENT INCIDENT"](#) .

>> **INSPECTION END**



# DTC P0112, P0113 IAT SENSOR

## Component Inspection INTAKE AIR TEMPERATURE SENSOR

ABS009CZ

1. Check resistance between mass air flow sensor terminals 5 and 6 under the following conditions.

Intake air temperature °C (°F)	Resistance kΩ
25 (77)	1.94 - 2.06

2. If NG, replace mass air flow sensor (with intake air temperature sensor).

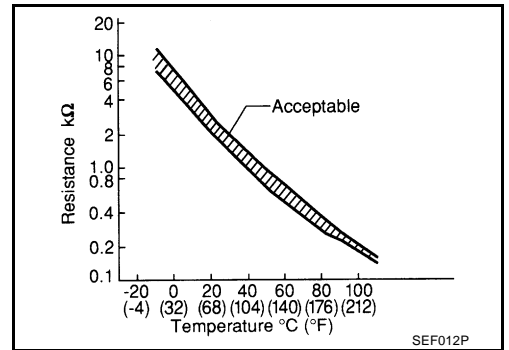
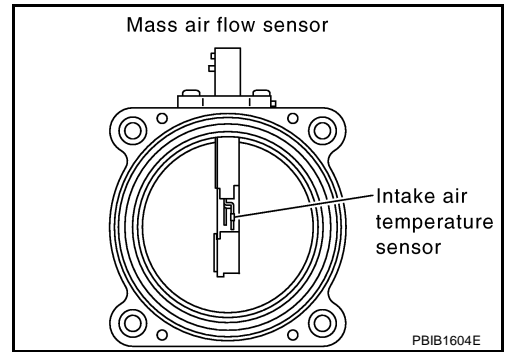

## Removal and Installation MASS AIR FLOW SENSOR

ABS009D0

Refer to [EM-14, "AIR CLEANER AND AIR DUCT"](#) .

A  
EC  
C  
D  
E  
F  
G  
H  
I  
J  
K  
L  
M

# DTC P0117, P0118 ECT SENSOR

## DTC P0117, P0118 ECT SENSOR

PFP:22630

### Component Description

ABS009D1

The engine coolant temperature sensor is used to detect the engine coolant temperature. The sensor modifies a voltage signal from the ECM. The modified signal returns to the ECM as the engine coolant temperature input. The sensor uses a thermistor which is sensitive to the change in temperature. The electrical resistance of the thermistor decreases as temperature increases.

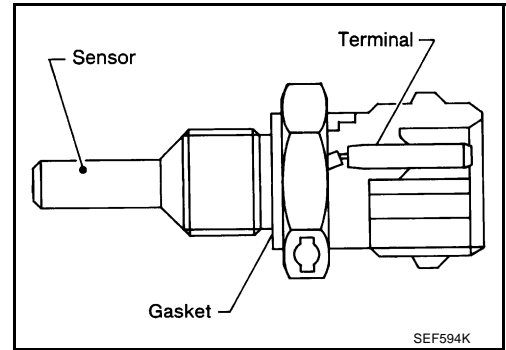

### <Reference data>

Engine coolant temperature °C (°F)	Voltage* V	Resistance kΩ
-10 (14)	4.4	7.0 - 11.4
20 (68)	3.5	2.1 - 2.9
50 (122)	2.2	0.68 - 1.00
90 (194)	0.9	0.236 - 0.260

\*: This data is reference values and is measured between ECM terminal 73 (Engine coolant temperature sensor) and ground.

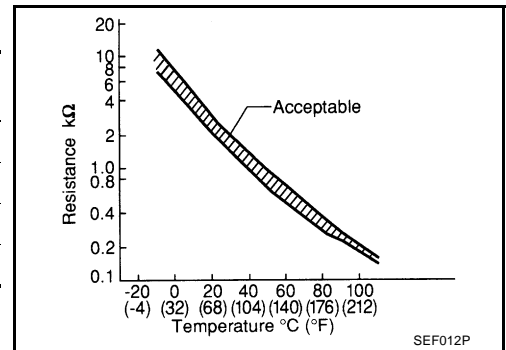

### CAUTION:

Do not use ECM ground terminals when measuring input/output voltage. Doing so may result in damage to the ECM's transistor. Use a ground other than ECM terminals, such as the ground.

### On Board Diagnosis Logic

ABS009D2

These self-diagnoses have the one trip detection logic.

DTC No.	Trouble Diagnosis Name	DTC Detecting Condition	Possible Cause
P0117 0117	Engine coolant temperature sensor circuit low input	An excessively low voltage from the sensor is sent to ECM.	<ul style="list-style-type: none"> <li>● Harness or connectors (The sensor circuit is open or shorted.)</li> <li>● Engine coolant temperature sensor</li> </ul>
P0118 0118	Engine coolant temperature sensor circuit high input	An excessively high voltage from the sensor is sent to ECM.	

### FAIL-SAFE MODE

When the malfunction is detected, the ECM enters fail-safe mode and the MIL lights up.

Detected items	Engine operating condition in fail-safe mode	
Engine coolant temperature sensor circuit	Engine coolant temperature will be determined by ECM based on the time after turning ignition switch ON or START. CONSULT-II displays the engine coolant temperature decided by ECM.	
	Condition	Engine coolant temperature decided (CONSULT-II display)
	Just as ignition switch is turned ON or START	40°C (104°F)
	More than approx. 4 minutes after ignition ON or START	80°C (176°F)
	Except as shown above	40 - 80°C (104 - 176°F) (Depends on the time)
When the fail-safe system for engine coolant temperature sensor is activated, the cooling fan operates while engine is running.		

# DTC P0117, P0118 ECT SENSOR

ABS009D3

## DTC Confirmation Procedure

### NOTE:

If DTC Confirmation Procedure has been previously conducted, always turn ignition switch OFF and wait at least 10 seconds before conducting the next test.

### ④ WITH CONSULT-II

1. Turn ignition switch ON.
2. Select "DATA MONITOR" mode with CONSULT-II.
3. Wait at least 5 seconds.
4. If DTC is detected, go to [EC-181, "Diagnostic Procedure"](#) .

DATA MONITOR	
MONITOR	NO DTC
ENG SPEED	XXX rpm

SEF058Y

### ④ WITH GST

Follow the procedure "WITH CONSULT-II" above.

A  
EC  
C  
D  
E  
F  
G  
H  
I  
J  
K  
L  
M

# DTC P0117, P0118 ECT SENSOR

## Wiring Diagram

ABS009D4

### EC-ECTS-01

: DETECTABLE LINE FOR DTC  
 : NON-DETECTABLE LINE FOR DTC

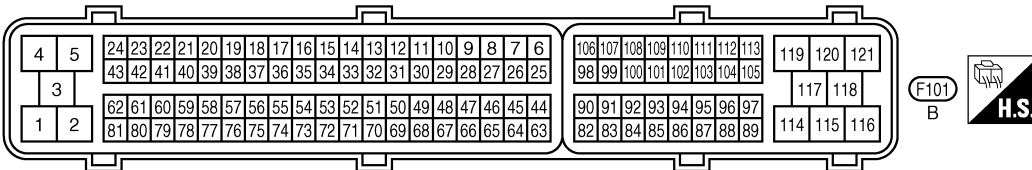
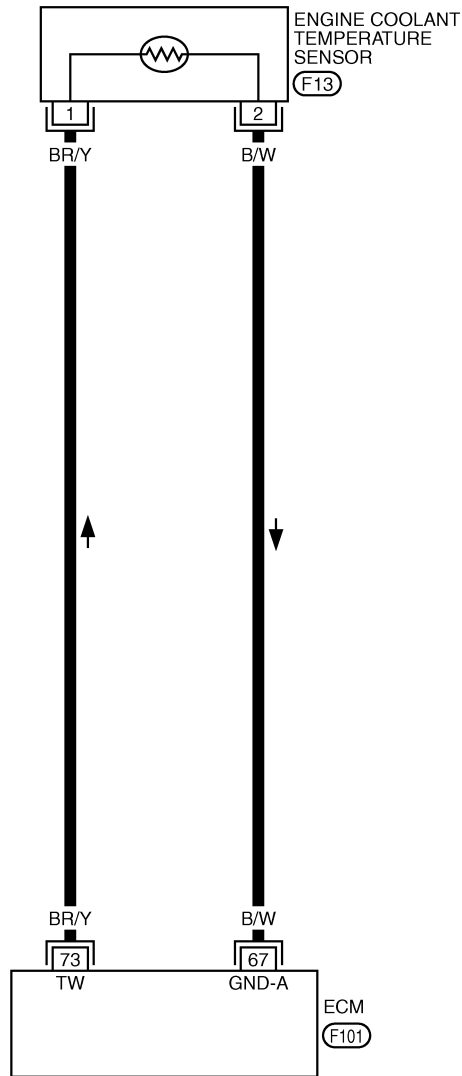

TBWT0478E

# DTC P0117, P0118 ECT SENSOR

ABS009D5

## Diagnostic Procedure

### 1. CHECK GROUND CONNECTIONS

1. Turn ignition switch OFF.
2. Loosen and retighten three ground screws on the body. Refer to [EC-138, "Ground Inspection"](#).

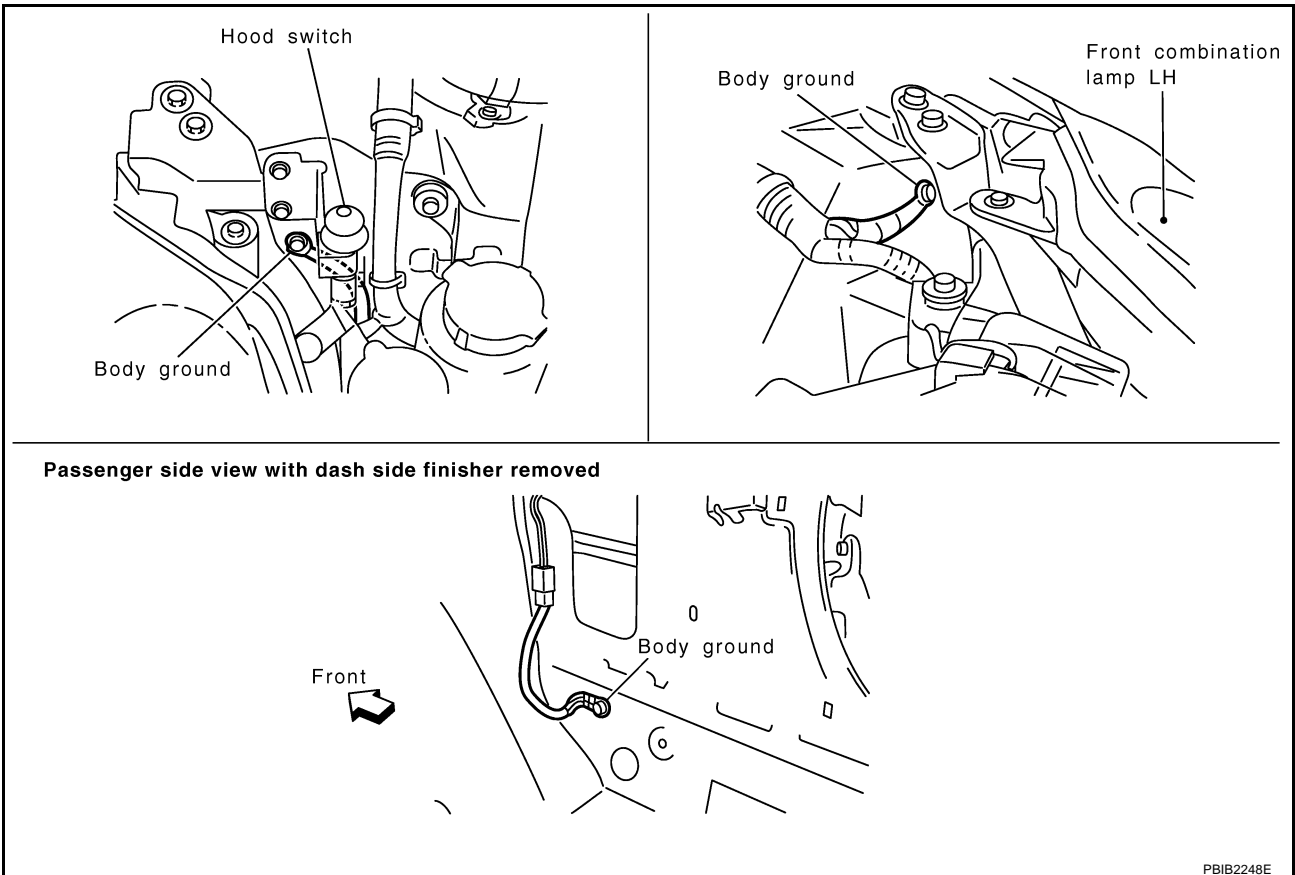

#### OK or NG

- OK >> GO TO 2.
- NG >> Repair or replace ground connections.

A  
EC  
C  
D  
E  
F  
G  
H  
I  
J  
K  
L  
M

# DTC P0117, P0118 ECT SENSOR

## 2. CHECK ECT SENSOR POWER SUPPLY CIRCUIT

1. Disconnect engine coolant temperature (ECT) sensor harness connector.
2. Turn ignition switch ON.

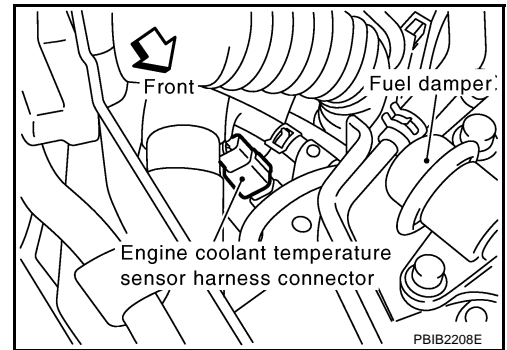

3. Check voltage between ECT sensor terminal 1 and ground with CONSULT-II or tester.

**Voltage: Approximately 5V**

OK or NG

OK >> GO TO 3.

NG >> Repair open circuit or short to ground or short to power in harness or connectors.

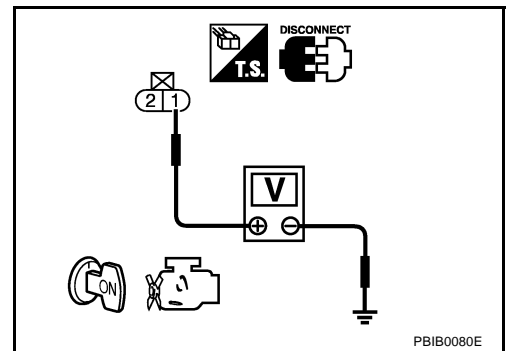

## 3. CHECK ECT SENSOR GROUND CIRCUIT FOR OPEN AND SHORT

1. Turn ignition switch OFF.
2. Disconnect ECM harness connector.
3. Check harness continuity between ECT sensor terminal 2 and ECM terminal 67. Refer to Wiring Diagram.

**Continuity should exist.**

4. Also check harness for short to ground and short to power.

OK or NG

OK >> GO TO 4.

NG >> Repair open circuit or short to ground or short to power in harness or connectors.

## 4. CHECK ENGINE COOLANT TEMPERATURE SENSOR

Refer to [EC-183, "Component Inspection"](#) .

OK or NG

OK >> GO TO 5.

NG >> Replace engine coolant temperature sensor.

## 5. CHECK INTERMITTENT INCIDENT

Refer to [EC-129, "TROUBLE DIAGNOSIS FOR INTERMITTENT INCIDENT"](#) .

>> INSPECTION END

# DTC P0117, P0118 ECT SENSOR

## Component Inspection ENGINE COOLANT TEMPERATURE SENSOR

ABS009D6

1. Check resistance between engine coolant temperature sensor terminals 1 and 2 as shown in the figure.

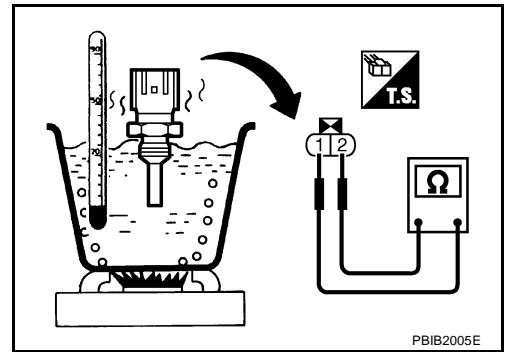

### <Reference data>

Engine coolant temperature °C (°F)	Resistance kΩ
20 (68)	2.1 - 2.9
50 (122)	0.68 - 1.00
90 (194)	0.236 - 0.260

2. If NG, replace engine coolant temperature sensor.

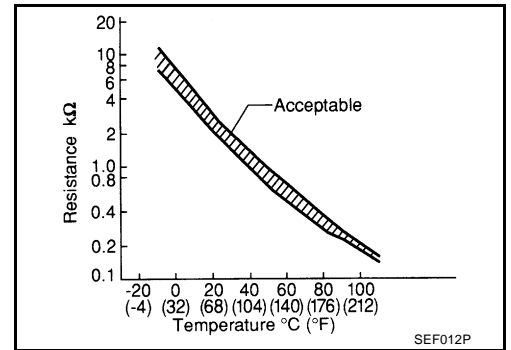

## Removal and Installation ENGINE COOLANT TEMPERATURE SENSOR

ABS009D7

Refer to [CO-28, "WATER OUTLET AND WATER PIPING"](#) .

# DTC P0122, P0123 TP SENSOR

PFP:16119

## DTC P0122, P0123 TP SENSOR

### Component Description

ABS009D8

Electric throttle control actuator consists of throttle control motor, throttle position sensor, etc. The throttle position sensor responds to the throttle valve movement.

The throttle position sensor has the two sensors. These sensors are a kind of potentiometers which transform the throttle valve position into output voltage, and emit the voltage signal to the ECM. In addition, these sensors detect the opening and closing speed of the throttle valve and feed the voltage signals to the ECM. The ECM judges the current opening angle of the throttle valve from these signals and the ECM controls the throttle control motor to make the throttle valve opening angle properly in response to driving condition.

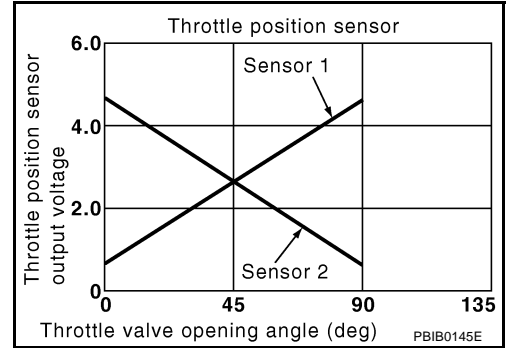

### CONSULT-II Reference Value in Data Monitor Mode

ABS009D9

Specification data are reference values.

MONITOR ITEM	CONDITION		SPECIFICATION
THRTL SEN 1 THRTL SEN 2*	<ul style="list-style-type: none"> <li>Ignition switch: ON (Engine stopped)</li> <li>Shift lever: D (A/T), 1st (M/T)</li> </ul>	Accelerator pedal: Fully released	More than 0.36V
		Accelerator pedal: Fully depressed	Less than 4.75V

\*: Throttle position sensor 2 signal is converted by ECM internally. Thus, it differs from ECM terminal voltage signal.

### On Board Diagnosis Logic

ABS009DA

These self-diagnoses have the one trip detection logic.

DTC No.	Trouble diagnosis name	DTC detecting condition	Possible cause
P0122 0122	Throttle position sensor 2 circuit low input	An excessively low voltage from the TP sensor 2 is sent to ECM.	<ul style="list-style-type: none"> <li>Harness or connectors (The TP sensor 2 circuit is open or shorted.) (APP sensor 2 circuit is shorted.)</li> <li>Electric throttle control actuator (TP sensor 2)</li> <li>Accelerator pedal position sensor (APP sensor 2)</li> </ul>
P0123 0123	Throttle position sensor 2 circuit high input	An excessively high voltage from the TP sensor 2 is sent to ECM.	

### FAIL-SAFE MODE

When the malfunction is detected, ECM enters fail-safe mode and the MIL lights up.

#### Engine operation condition in fail-safe mode

The ECM controls the electric throttle control actuator in regulating the throttle opening in order for the idle position to be within +10 degrees.

The ECM regulates the opening speed of the throttle valve to be slower than the normal condition.

So, the acceleration will be poor.



# DTC P0122, P0123 TP SENSOR

ABS009DB

## DTC Confirmation Procedure

### NOTE:

If DTC Confirmation Procedure has been previously conducted, always turn ignition switch OFF and wait at least 10 seconds before conducting the next test.

### TESTING CONDITION:

Before performing the following procedure, confirm that battery voltage is more than 10V at idle.

### WITH CONSULT-II

1. Turn ignition switch ON.
2. Select "DATA MONITOR" mode with CONSULT-II.
3. Start engine and let it idle for 1 second.
4. If DTC is detected, go to [EC-188, "Diagnostic Procedure"](#) .

DATA MONITOR	
MONITOR	NO DTC
ENG SPEED	XXX rpm

SEF058Y

### WITH GST

Follow the procedure "WITH CONSULT-II" above.

A

EC

C

D

E

F

G

H

I

J

K

L

M

# DTC P0122, P0123 TP SENSOR

ABS009DC

## Wiring Diagram

### EC-TPS2-01

**——** : DETECTABLE LINE FOR DTC  
**——** : NON-DETECTABLE LINE FOR DTC

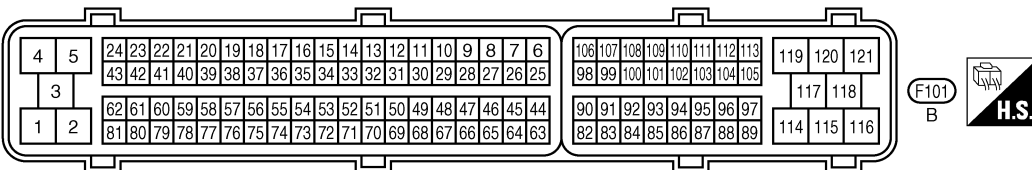
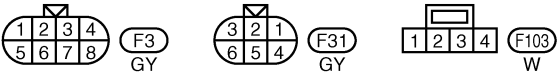
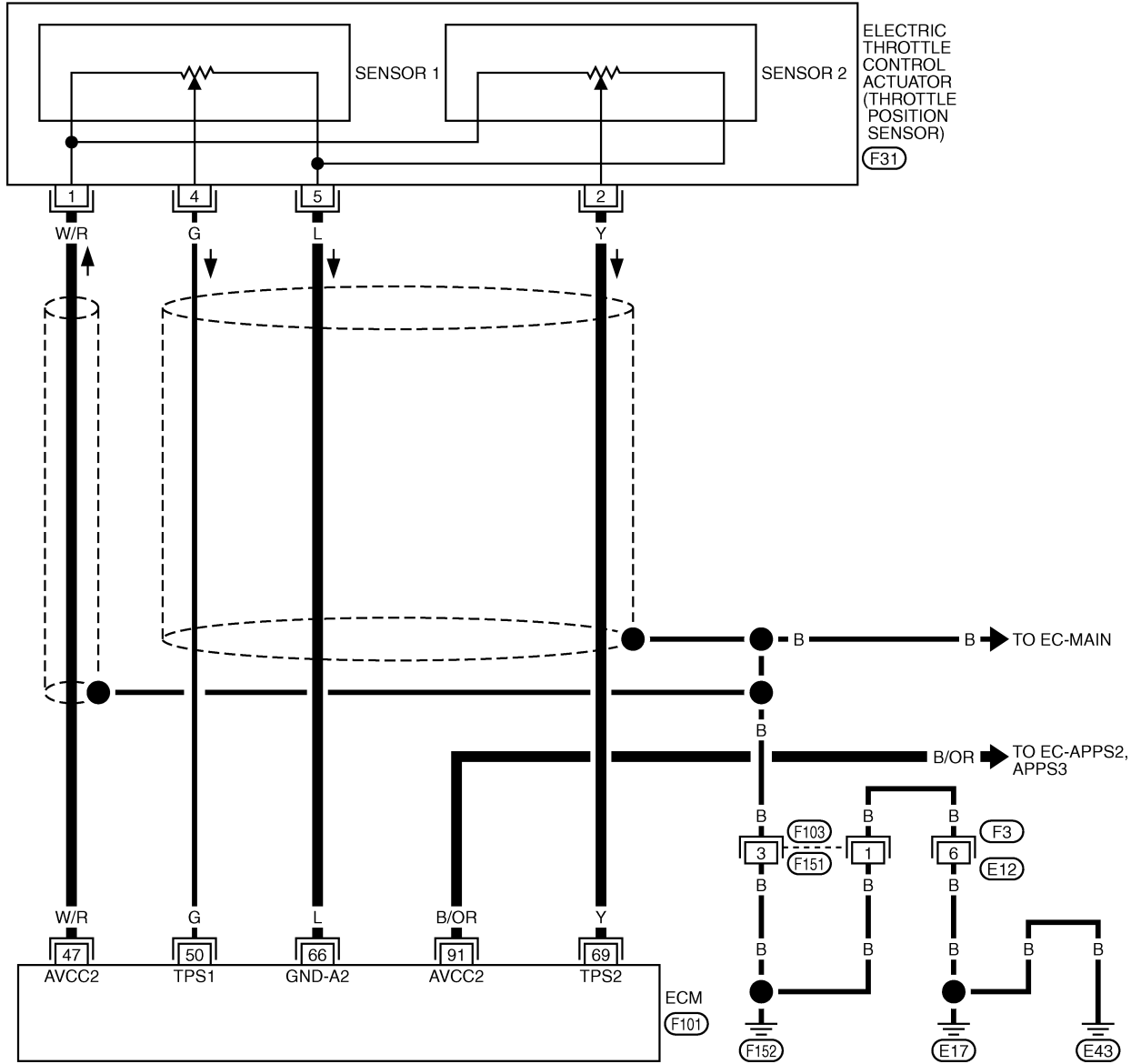

TBWT0781E

## DTC P0122, P0123 TP SENSOR

Specification data are reference values and are measured between each terminal and ground.

**CAUTION:**

**Do not use ECM ground terminals when measuring input/output voltage. Doing so may result in damage to the ECM's transistor. Use a ground other than ECM terminals, such as the ground.**

TER-MINAL NO.	WIRE COLOR	ITEM	CONDITION	DATA (DC Voltage)
47	W/R	Sensor power supply (Throttle position sensor)	<b>[Ignition switch: ON]</b>	Approximately 5V
50	G	Throttle position sensor 1	<b>[Ignition switch: ON]</b> <ul style="list-style-type: none"> <li>● Engine stopped</li> <li>● Shift lever: D (A/T) or 1st (M/T)</li> <li>● Accelerator pedal is fully released</li> </ul>	More than 0.36V
			<b>[Ignition switch: ON]</b> <ul style="list-style-type: none"> <li>● Engine stopped</li> <li>● Shift lever: D (A/T) or 1st (M/T)</li> <li>● Accelerator pedal is fully depressed</li> </ul>	Less than 4.75V
66	L	Sensor ground (Throttle position sensor)	<b>[Engine is running]</b> <ul style="list-style-type: none"> <li>● Warm-up condition</li> <li>● Idle speed</li> </ul>	Approximately 0V
69	Y	Throttle position sensor 2	<b>[Ignition switch: ON]</b> <ul style="list-style-type: none"> <li>● Engine stopped</li> <li>● Shift lever: D (A/T) or 1st (M/T)</li> <li>● Accelerator pedal is fully released</li> </ul>	Less than 4.75V
			<b>[Ignition switch: ON]</b> <ul style="list-style-type: none"> <li>● Engine stopped</li> <li>● Shift lever: D (A/T) or 1st (M/T)</li> <li>● Accelerator pedal is fully depressed</li> </ul>	More than 0.36V
91	B/OR	Sensor power supply (APP sensor 2)	<b>[Ignition switch: ON]</b>	Approximately 5V

A  
EC  
C  
D  
E  
F  
G  
H  
I  
J  
K  
L  
M

# DTC P0122, P0123 TP SENSOR

ABS009DD

## Diagnostic Procedure

### 1. CHECK GROUND CONNECTIONS

1. Turn ignition switch OFF.
2. Loosen and retighten three ground screws on the body. Refer to [EC-138, "Ground Inspection"](#).

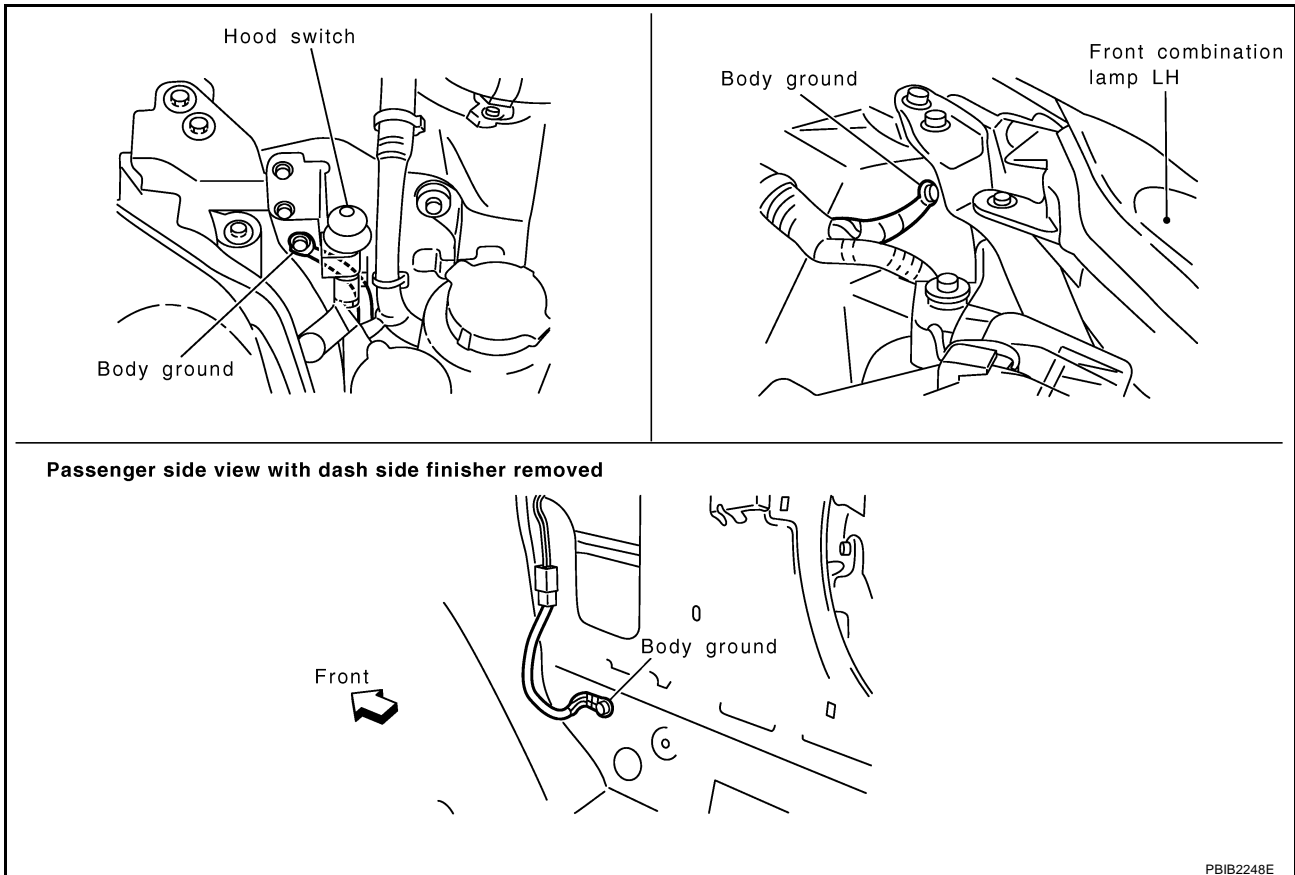

#### OK or NG

- OK >> GO TO 2.
- NG >> Repair or replace ground connections.

# DTC P0122, P0123 TP SENSOR

## 2. CHECK THROTTLE POSITION SENSOR 2 POWER SUPPLY CIRCUIT-I

1. Disconnect electric throttle control actuator harness connector.
2. Turn ignition switch ON.

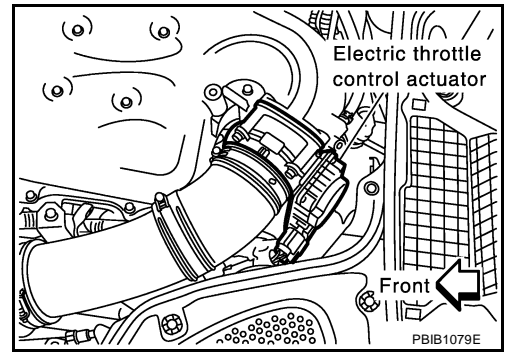

3. Check voltage between electric throttle control actuator terminal 1 and ground with CONSULT-II or tester.

**Voltage: Approximately 5V**

OK or NG

- OK >> GO TO 3.  
 NG >> Repair open circuit or short to ground or short to power in harness or connectors.

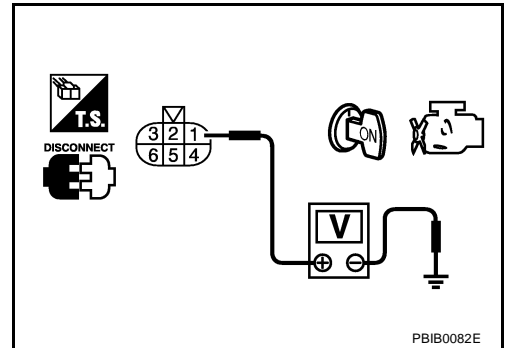

## 3. CHECK THROTTLE POSITION SENSOR 2 POWER SUPPLY CIRCUIT-II

1. Turn ignition switch OFF.
2. Disconnect ECM harness connector.
3. Check harness continuity between electric throttle control actuator terminal 1 and ECM terminal 47. Refer to Wiring Diagram.

**Continuity should exist.**

OK or NG

- OK >> GO TO 4.  
 NG >> Repair or replace open circuit.

## 4. CHECK THROTTLE POSITION SENSOR 2 POWER SUPPLY CIRCUIT-III

Check harness for short to power and short to ground, between the following terminals.

ECM terminal	Sensor terminal	Reference Wiring Diagram
47	Electric throttle control actuator terminal 1	<a href="#">EC-186</a>
91	APP sensor terminal 4	<a href="#">EC-599</a>

OK or NG

- OK >> GO TO 5.  
 NG >> Repair short to ground or short to power in harness or connectors.

## 5. CHECK APP SENSOR

Refer to [EC-604, "Component Inspection"](#) .

OK or NG

- OK >> GO TO 11.  
 NG >> GO TO 6.

## DTC P0122, P0123 TP SENSOR

---

### 6. REPLACE ACCELERATOR PEDAL ASSEMBLY

---

1. Replace accelerator pedal assembly.
2. Perform [EC-42, "Accelerator Pedal Released Position Learning"](#) .
3. Perform [EC-42, "Throttle Valve Closed Position Learning"](#) .
4. Perform [EC-43, "Idle Air Volume Learning"](#) .

>> INSPECTION END

---

### 7. CHECK THROTTLE POSITION SENSOR 2 GROUND CIRCUIT FOR OPEN AND SHORT

---

1. Turn ignition switch OFF.
2. Disconnect ECM harness connector.
3. Check harness continuity between electric throttle control actuator terminal 5 and ECM terminal 66.  
Refer to Wiring Diagram.

**Continuity should exist.**

4. Also check harness for short to ground and short to power.

OK or NG

OK >> GO TO 8.

NG >> Repair open circuit or short to ground or short to power in harness or connectors.

---

### 8. CHECK THROTTLE POSITION SENSOR 2 INPUT SIGNAL CIRCUIT FOR OPEN AND SHORT

---

1. Check harness continuity between ECM terminal 69 and electric throttle control actuator terminal 2.  
Refer to Wiring Diagram.

**Continuity should exist.**

2. Also check harness for short to ground and short to power.

OK or NG

OK >> GO TO 9.

NG >> Repair open circuit or short to ground or short to power in harness or connectors.

---

### 9. CHECK THROTTLE POSITION SENSOR

---

Refer to [EC-191, "Component Inspection"](#) .

OK or NG

OK >> GO TO 11.

NG >> GO TO 10.

---

### 10. REPLACE ELECTRIC THROTTLE CONTROL ACTUATOR

---

1. Replace the electric throttle control actuator.
2. Perform [EC-42, "Throttle Valve Closed Position Learning"](#) .
3. Perform [EC-43, "Idle Air Volume Learning"](#) .

>> INSPECTION END

---

### 11. CHECK INTERMITTENT INCIDENT

---

Refer to [EC-129, "TROUBLE DIAGNOSIS FOR INTERMITTENT INCIDENT"](#) .

>> INSPECTION END

# DTC P0122, P0123 TP SENSOR

ABS009DE

## Component Inspection THROTTLE POSITION SENSOR

1. Reconnect all harness connectors disconnected.
2. Perform [EC-42, "Throttle Valve Closed Position Learning"](#) .
3. Turn ignition switch ON.
4. Set shift lever to D (A/T) or 1st (M/T) position.
5. Check voltage between ECM terminals 50 (TP sensor 1 signal), 69 (TP sensor 2 signal) and ground under the following conditions.

Terminal	Accelerator pedal	Voltage
50 (Throttle position sensor 1)	Fully released	More than 0.36V
	Fully depressed	Less than 4.75V
69 (Throttle position sensor 2)	Fully released	Less than 4.75V
	Fully depressed	More than 0.36V

6. If NG, replace electric throttle control actuator and go to the next step.
7. Perform [EC-42, "Throttle Valve Closed Position Learning"](#) .
8. Perform [EC-43, "Idle Air Volume Learning"](#) .

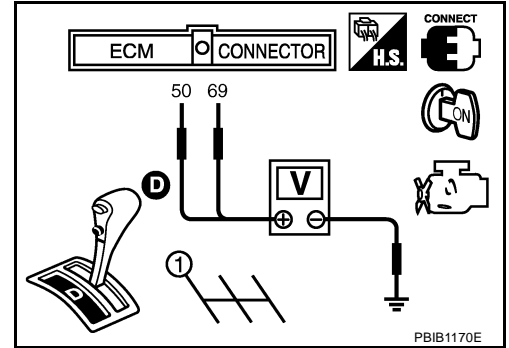

## Removal and Installation ELECTRIC THROTTLE CONTROL ACTUATOR

ABS009DF

Refer to [EM-16, "INTAKE MANIFOLD COLLECTOR"](#) .

# DTC P0125 ECT SENSOR

PFP:22630

## DTC P0125 ECT SENSOR

### Component Description

ABS009DG

#### NOTE:

If DTC P0125 is displayed with P0117 or P0118, first perform the trouble diagnosis for DTC P0117 or P0118. Refer to [EC-178](#).

The engine coolant temperature sensor is used to detect the engine coolant temperature. The sensor modifies a voltage signal from the ECM. The modified signal returns to the ECM as the engine coolant temperature input. The sensor uses a thermistor which is sensitive to the change in temperature. The electrical resistance of the thermistor decreases as temperature increases.

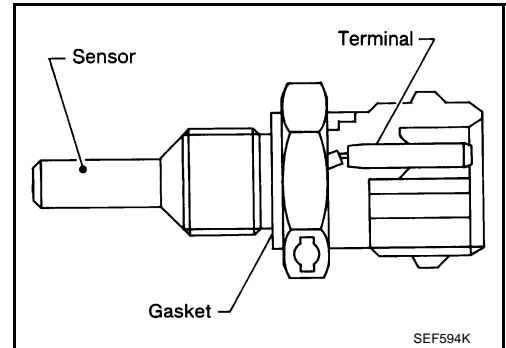

#### <Reference data>

Engine coolant temperature °C (°F)	Voltage* V	Resistance kΩ
-10 (14)	4.4	7.0 - 11.4
20 (68)	3.5	2.1 - 2.9
50 (122)	2.2	0.68 - 1.00
90 (194)	0.9	0.236 - 0.260

\*: This data is reference values and is measured between ECM terminal 73 (Engine coolant temperature sensor) and ground.

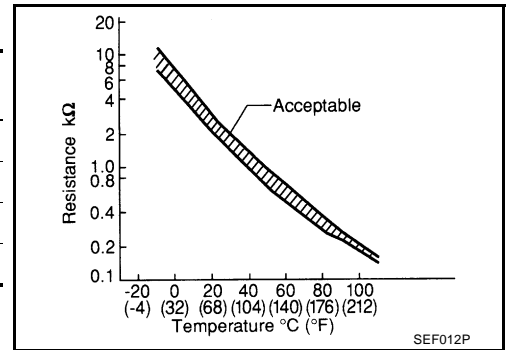

#### CAUTION:

Do not use ECM ground terminals when measuring input/output voltage. Doing so may result in damage to the ECM's transistor. Use a ground other than ECM terminals, such as the ground.

### On Board Diagnosis Logic

ABS009DH

This self-diagnosis has the one trip detection logic.

DTC No.	Trouble diagnosis name	DTC detecting condition	Possible cause
P0125 0125	Insufficient engine coolant temperature for closed loop fuel control	<ul style="list-style-type: none"> <li>● Voltage sent to ECM from the sensor is not practical, even when some time has passed after starting the engine.</li> <li>● Engine coolant temperature is insufficient for closed loop fuel control.</li> </ul>	<ul style="list-style-type: none"> <li>● Harness or connectors (High resistance in the circuit)</li> <li>● Engine coolant temperature sensor</li> <li>● Thermostat</li> </ul>



# DTC P0125 ECT SENSOR

ABS009DI

## DTC Confirmation Procedure

### CAUTION:

Be careful not to overheat engine.

### NOTE:

If DTC Confirmation Procedure has been previously conducted, always turn ignition switch OFF and wait at least 10 seconds before conducting the next test.

### WITH CONSULT-II

1. Turn ignition switch ON.
2. Select "DATA MONITOR" mode with CONSULT-II.
3. Check that "COOLAN TEMP/S" is above 10°C (50°F).  
**If it is above 10°C (50°F), the test result will be OK.**  
**If it is below 10°C (50°F), go to following step.**
4. Start engine and run it for 65 minutes at idle speed.  
**If "COOLAN TEMP/S" increases to more than 10°C (50°F) within 65 minutes, stop engine because the test result will be OK.**
5. If DTC is detected, go to [EC-194, "Diagnostic Procedure"](#).

DATA MONITOR	
MONITOR	NO DTC
ENG SPEED	XXX rpm
COOLAN TEMP/S	XXX °C

SEF174Y

### WITH GST

Follow the procedure "WITH CONSULT-II" above.

# DTC P0125 ECT SENSOR

ABS009DJ

## Diagnostic Procedure

### 1. CHECK GROUND CONNECTIONS

1. Turn ignition switch OFF.
2. Loosen and retighten three ground screws on the body. Refer to [EC-138, "Ground Inspection"](#).

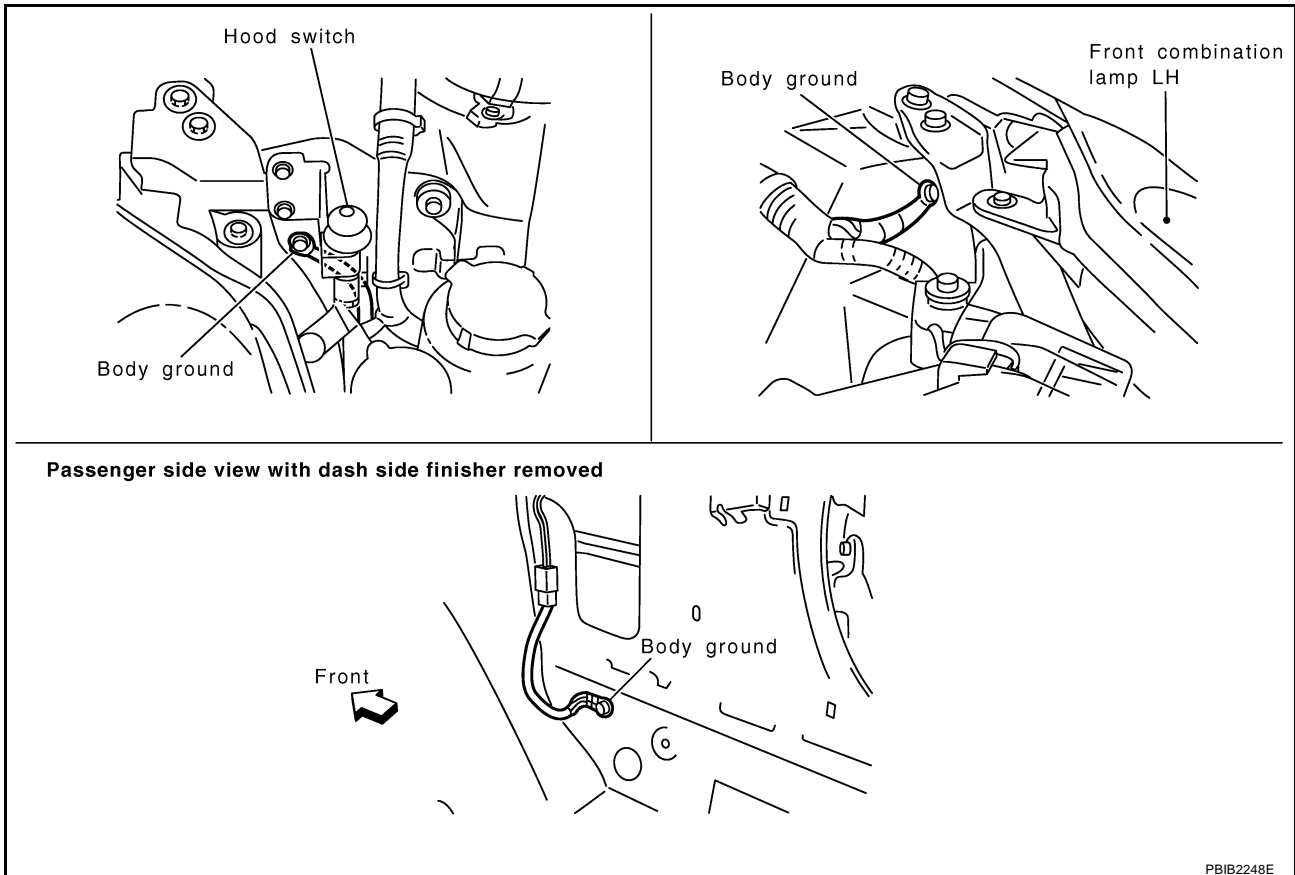

OK or NG

- OK >> GO TO 2.
- NG >> Repair or replace ground connections.

### 2. CHECK ENGINE COOLANT TEMPERATURE SENSOR

Refer to [EC-195, "Component Inspection"](#).

OK or NG

- OK >> GO TO 3.
- NG >> Replace engine coolant temperature sensor.

### 3. CHECK THERMOSTAT OPERATION

When the engine is cold [lower than 70°C (158°F)] condition, grasp lower radiator hose and confirm the engine coolant does not flow.

OK or NG

- OK >> GO TO 4.
- NG >> Repair or replace thermostat. Refer to [CO-26, "WATER INLET AND THERMOSTAT ASSEMBLY"](#)

# DTC P0125 ECT SENSOR

## 4. CHECK INTERMITTENT INCIDENT

Refer to [EC-129, "TROUBLE DIAGNOSIS FOR INTERMITTENT INCIDENT"](#) .  
Refer to [EC-180, "Wiring Diagram"](#) .

>> INSPECTION END

### Component Inspection ENGINE COOLANT TEMPERATURE SENSOR

1. Check resistance between engine coolant temperature sensor terminals 1 and 2 as shown in the figure.

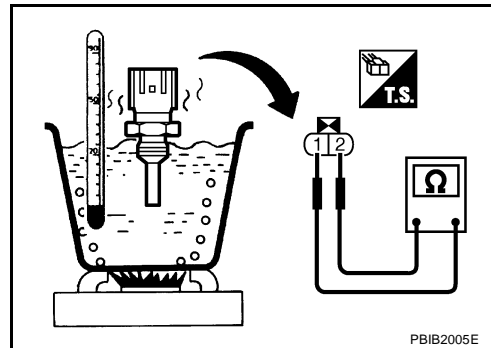

#### <Reference data>

Engine coolant temperature °C (°F)	Resistance kΩ
20 (68)	2.1 - 2.9
50 (122)	0.68 - 1.00
90 (194)	0.236 - 0.260

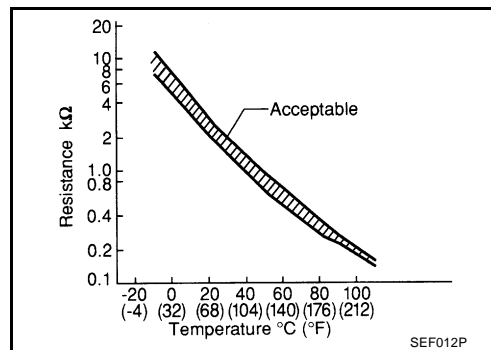

2. If NG, replace engine coolant temperature sensor.

### Removal and Installation ENGINE COOLANT TEMPERATURE SENSOR

Refer to [CO-28, "WATER OUTLET AND WATER PIPING"](#) .

# DTC P0127 IAT SENSOR

## DTC P0127 IAT SENSOR

PFP:22630

### Component Description

ABS009DM

The intake air temperature sensor is built into mass air flow sensor. The sensor detects intake air temperature and transmits a signal to the ECM.

The temperature sensing unit uses a thermistor which is sensitive to the change in temperature. Electrical resistance of the thermistor decreases in response to the temperature rise.

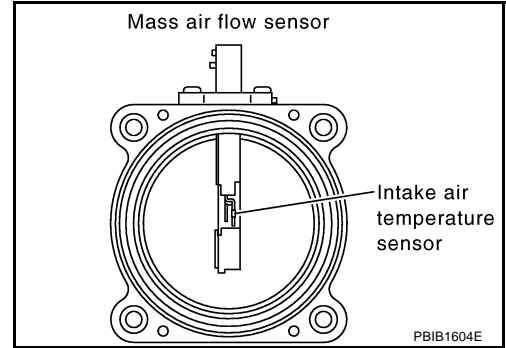

### <Reference data>

Intake air temperature °C (°F)	Voltage* V	Resistance kΩ
25 (77)	3.32	1.94 - 2.06
80 (176)	1.23	0.295 - 0.349

\*: This data is reference values and is measured between ECM terminal 34 (Intake air temperature sensor) and ground.

### CAUTION:

**Do not use ECM ground terminals when measuring input/output voltage. Doing so may result in damage to the ECM's transistor. Use a ground other than ECM terminals, such as the ground.**

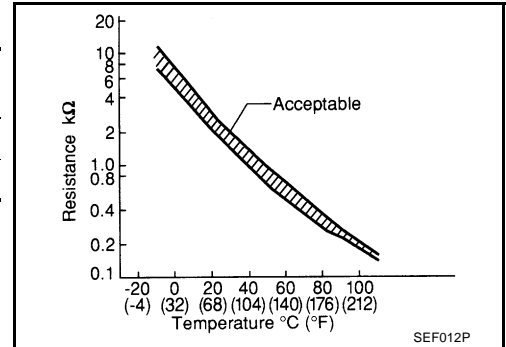

### On Board Diagnosis Logic

ABS009DN

DTC No.	Trouble diagnosis name	DTC detecting condition	Possible cause
P0127 0127	Intake air temperature too high	Rationally incorrect voltage from the sensor is sent to ECM, compared with the voltage signal from engine coolant temperature sensor.	<ul style="list-style-type: none"> <li>● Harness or connectors (The sensor circuit is open or shorted)</li> <li>● Intake air temperature sensor</li> </ul>

### DTC Confirmation Procedure

ABS009DO

#### NOTE:

If DTC Confirmation Procedure has been previously conducted, always turn ignition switch OFF and wait at least 10 seconds before conducting the next test.

#### CAUTION:

**Always drive vehicle at a safe speed.**

#### TESTING CONDITION:

**This test may be conducted with the drive wheels lifted in the shop or by driving the vehicle. If a road test is expected to be easier, it is unnecessary to lift the vehicle.**

#### Ⓜ WITH CONSULT-II

1. Wait until engine coolant temperature is less than 90°C (194°F)
  - a. Turn ignition switch ON.

# DTC P0127 IAT SENSOR

- b. Select "DATA MONITOR" mode with CONSULT-II.
- c. Check the engine coolant temperature.
- d. If the engine coolant temperature is not less than 90°C (194°F), turn ignition switch OFF and cool down engine.
  - Perform the following steps before engine coolant temperature is above 90°C (194°F).
2. Turn ignition switch ON.
3. Select "DATA MONITOR" mode with CONSULT-II.
4. Start engine.
5. Hold vehicle speed at more than 70 km/h (43 MPH) for 100 consecutive seconds.
6. If 1st trip DTC is detected, go to [EC-197, "Diagnostic Procedure"](#).

DATA MONITOR	
MONITOR	NO DTC
ENG SPEED	XXX rpm
COOLAN TEMP/S	XXX °C
VHCL SPEED SE	XXX km/h
B/FUEL SCHDL	XXX msec

SEF189Y

## WITH GST

Follow the procedure "WITH CONSULT-II" above.

## Diagnostic Procedure

ABS009DP

### 1. CHECK GROUND CONNECTIONS

1. Turn ignition switch OFF.
2. Loosen and retighten three ground screws on the body. Refer to [EC-138, "Ground Inspection"](#).

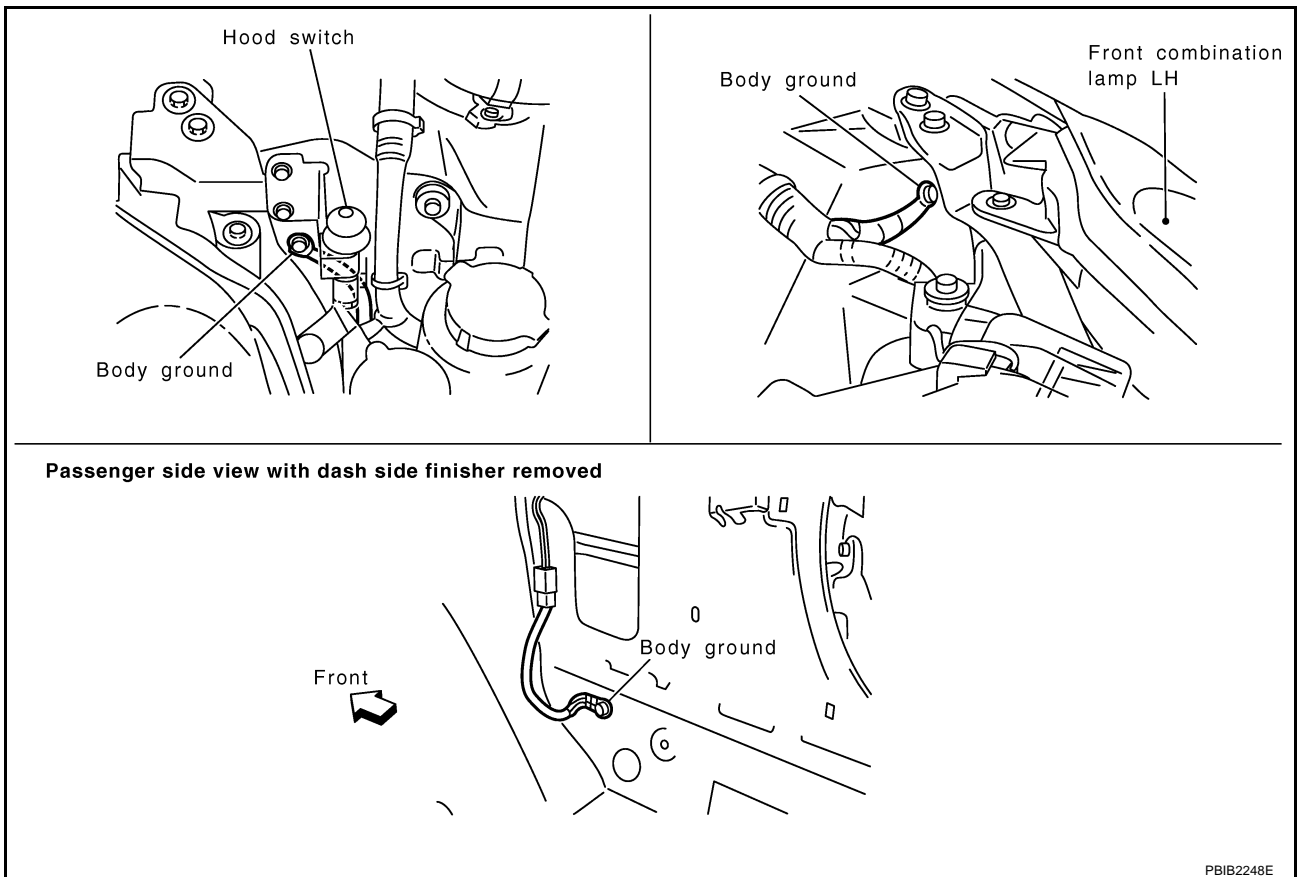

### OK or NG

- OK >> GO TO 2.
- NG >> Repair or replace ground connections.

# DTC P0127 IAT SENSOR

## 2. CHECK INTAKE AIR TEMPERATURE SENSOR

Refer to [EC-177, "Component Inspection"](#) .

OK or NG

OK >> GO TO 3.

NG >> Replace mass air flow sensor (with intake air temperature sensor).

## 3. CHECK INTERMITTENT INCIDENT

Refer to [EC-129, "TROUBLE DIAGNOSIS FOR INTERMITTENT INCIDENT"](#) .

Refer to [EC-174, "Wiring Diagram"](#) .

>> INSPECTION END

### Component Inspection INTAKE AIR TEMPERATURE SENSOR

ABS009DQ

1. Check resistance between intake air temperature sensor terminals 5 and 6 under the following conditions.

Intake air temperature °C (°F)	Resistance kΩ
25 (77)	1.94 - 2.06

2. If NG, replace mass air flow sensor (with intake air temperature sensor).

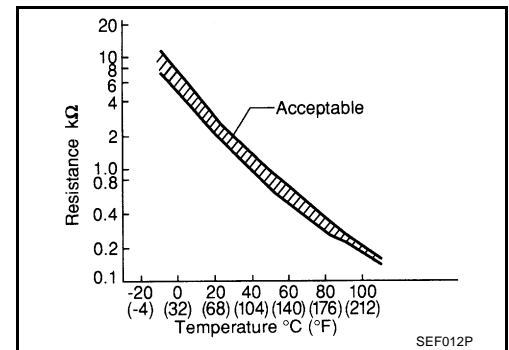
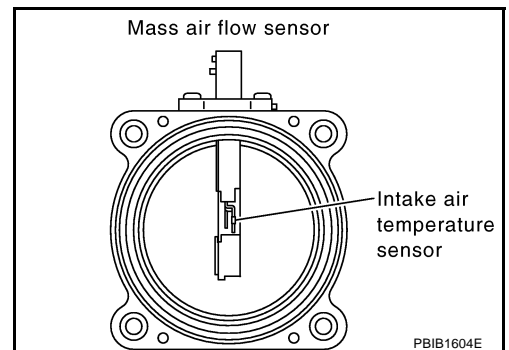

### Removal and Installation MASS AIR FLOW SENSOR

ABS009DR

Refer to [EM-14, "AIR CLEANER AND AIR DUCT"](#) .

# DTC P0128 THERMOSTAT FUNCTION

## DTC P0128 THERMOSTAT FUNCTION

PPF:21200

### On Board Diagnosis Logic

ABS009DS

Engine coolant temperature has not risen enough to open the thermostat even though the engine has run long enough.

This is due to a leak in the seal or the thermostat stuck open.

DTC No.	Trouble diagnosis name	DTC detecting condition	Possible cause
P0128 0128	Thermostat function	The engine coolant temperature does not reach to specified temperature even though the engine has run long enough.	<ul style="list-style-type: none"> <li>● Thermostat</li> <li>● Leakage from sealing portion of thermostat</li> <li>● Engine coolant temperature sensor</li> </ul>

### DTC Confirmation Procedure

ABS009DT

#### NOTE:

If DTC Confirmation Procedure has been previously conducted, always turn ignition switch OFF and wait at least 10 seconds before conducting the next test.

#### TESTING CONDITION:

- For best results, perform at ambient temperature of  $-10^{\circ}\text{C}$  ( $14^{\circ}\text{F}$ ) or higher.
- For best results, perform at engine coolant temperature of  $-10^{\circ}\text{C}$  ( $14^{\circ}\text{F}$ ) to  $60^{\circ}\text{C}$  ( $140^{\circ}\text{F}$ ).

#### WITH CONSULT-II

1. Replace thermostat with new one. Refer to [CO-26, "WATER INLET AND THERMOSTAT ASSEMBLY"](#). Use only a genuine NISSAN thermostat as a replacement. If an incorrect thermostat is used, the MIL may come on.
2. Turn ignition switch ON.
3. Select "COOLAN TEMP/S" in "DATA MONITOR" mode with CONSULT-II.
4. Check that the "COOLAN TEMP/S" is above  $60^{\circ}\text{C}$  ( $140^{\circ}\text{F}$ ).  
If it is below  $60^{\circ}\text{C}$  ( $140^{\circ}\text{F}$ ), go to following step.  
If it is above  $60^{\circ}\text{C}$  ( $140^{\circ}\text{F}$ ), cool down the engine to less than  $60^{\circ}\text{C}$  ( $140^{\circ}\text{F}$ ), then retry from step 1.
5. Drive vehicle for 10 consecutive minutes under the following conditions.

VHCL SPEED SE	80 - 120 km/h (50 - 75 MPH)
---------------	-----------------------------

If 1st trip DTC is detected, go to [EC-199, "Diagnostic Procedure"](#).

DATA MONITOR	
MONITOR	NO DTC
ENG SPEED	XXX rpm
COOLAN TEMP/S	XXX °C
VHCL SPEED SE	XXX km/h

PBIB1917E

#### WITH GST

1. Follow the procedure "WITH CONSULT-II" above.

### Diagnostic Procedure

ABS009DU

#### 1. CHECK ENGINE COOLANT TEMPERATURE SENSOR

Refer to [EC-200, "Component Inspection"](#).

#### OK or NG

- OK >> **INSPECTION END**  
 NG >> Replace engine coolant temperature sensor.

# DTC P0128 THERMOSTAT FUNCTION

ABS009DV

## Component Inspection

### ENGINE COOLANT TEMPERATURE SENSOR

1. Check resistance between engine coolant temperature sensor terminals 1 and 2 as shown in the figure.

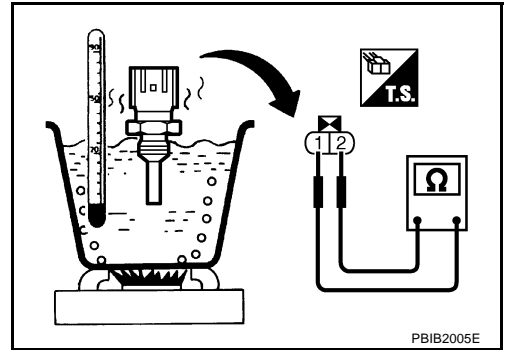

#### <Reference data>

Engine coolant temperature °C (°F)	Resistance kΩ
20 (68)	2.1 - 2.9
50 (122)	0.68 - 1.00
90 (194)	0.236 - 0.260

2. If NG, replace engine coolant temperature sensor.

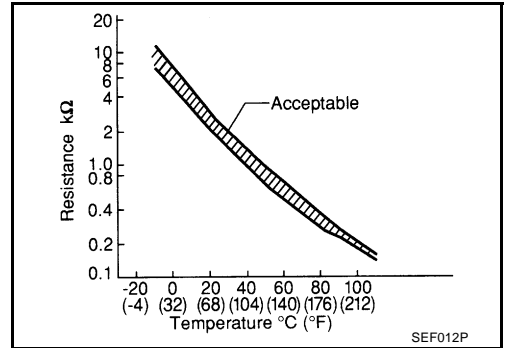

## Removal and Installation

### ENGINE COOLANT TEMPERATURE SENSOR

Refer to [CO-28, "WATER OUTLET AND WATER PIPING"](#) .

ABS009DW



**DTC P0138, P0158 HO2S2**

**Component Description**

The heated oxygen sensor 2, after three way catalyst 1, monitors the oxygen level in the exhaust gas on each bank. Even if switching characteristics of the air fuel ratio (A/F) sensor 1 are shifted, the air-fuel ratio is controlled to stoichiometric, by the signal from the heated oxygen sensor 2. This sensor is made of ceramic zirconia. The zirconia generates voltage from approximately 1V in richer conditions to 0V in leaner conditions. Under normal conditions the heated oxygen sensor 2 is not used for engine control operation.

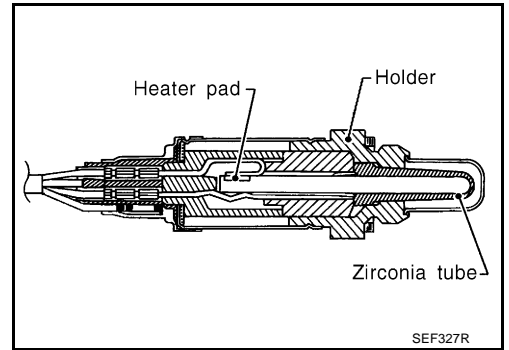

ABS009EN

A

EC

C

D

**CONSULT-II Reference Value in Data Monitor Mode**

ABS009EO

Specification data are reference values.

MONITOR ITEM	CONDITION		SPECIFICATION
HO2S2 (B1) HO2S2 (B2)	<ul style="list-style-type: none"> <li>Warm-up condition</li> <li>After keeping engine speed between 3,500 and 4,000 rpm for 1 minute and at idle for 1 minute under no load.</li> </ul>	Revving engine from idle to 3,000 rpm quickly.	0 - 0.3V ↔ Approx. 0.6 - 1.0V
HO2S2 MNTR (B1) HO2S2 MNTR (B2)			LEAN ↔ RICH

E

F

G

**On Board Diagnosis Logic**

ABS009EP

The heated oxygen sensor 2 has a much longer switching time between rich and lean than the air fuel ratio (A/F) sensor 1. The oxygen storage capacity before the three way catalyst causes the longer switching time. To judge the malfunctions of heated oxygen sensor 2, ECM monitors whether the voltage is unusually high during the various driving condition such as fuel cut.

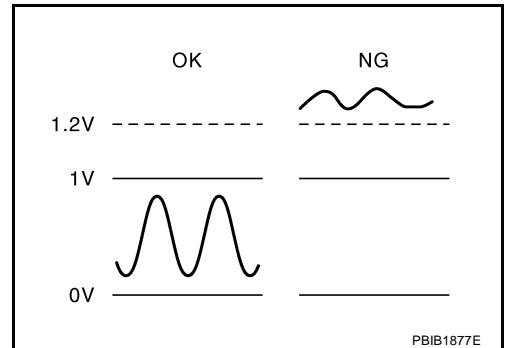

H

I

J

K

L

DTC No.	Trouble diagnosis name	DTC detecting condition	Possible cause
P0138 0138 (Bank 1)	Heated oxygen sensor 2 circuit high voltage	An excessively high voltage from the sensor is sent to ECM.	<ul style="list-style-type: none"> <li>Harness or connectors (The sensor circuit is open or shorted)</li> <li>Heated oxygen sensor 2</li> </ul>
P0158 0158 (Bank 2)			

M

## DTC Confirmation Procedure

### NOTE:

If DTC Confirmation Procedure has been previously conducted, always turn ignition switch OFF and wait at least 10 seconds before conducting the next test.

### WITH CONSULT-II

1. Turn ignition switch ON and select "DATA MONITOR" mode with CONSULT-II.
2. Start engine and warm it up to the normal operating temperature.
3. Turn ignition switch OFF and wait at least 10 seconds.
4. Start engine and keep the engine speed between 3,500 and 4,000 rpm for at least 1 minute under no load.
5. Let engine idle for 2 minutes.
6. If 1st trip DTC is detected, go to [EC-206, "Diagnostic Procedure"](#)

DATA MONITOR	
MONITOR	NO DTC
ENG SPEED	XXX rpm
COOLANTEMP/S	XXX °C

SEF174Y

### WITH GST

Follow the procedure "WITH CONSUT-II" above.

# DTC P0138, P0158 HO2S2

ABS009ER

## Wiring Diagram BANK 1

### EC-O2S2B1-01

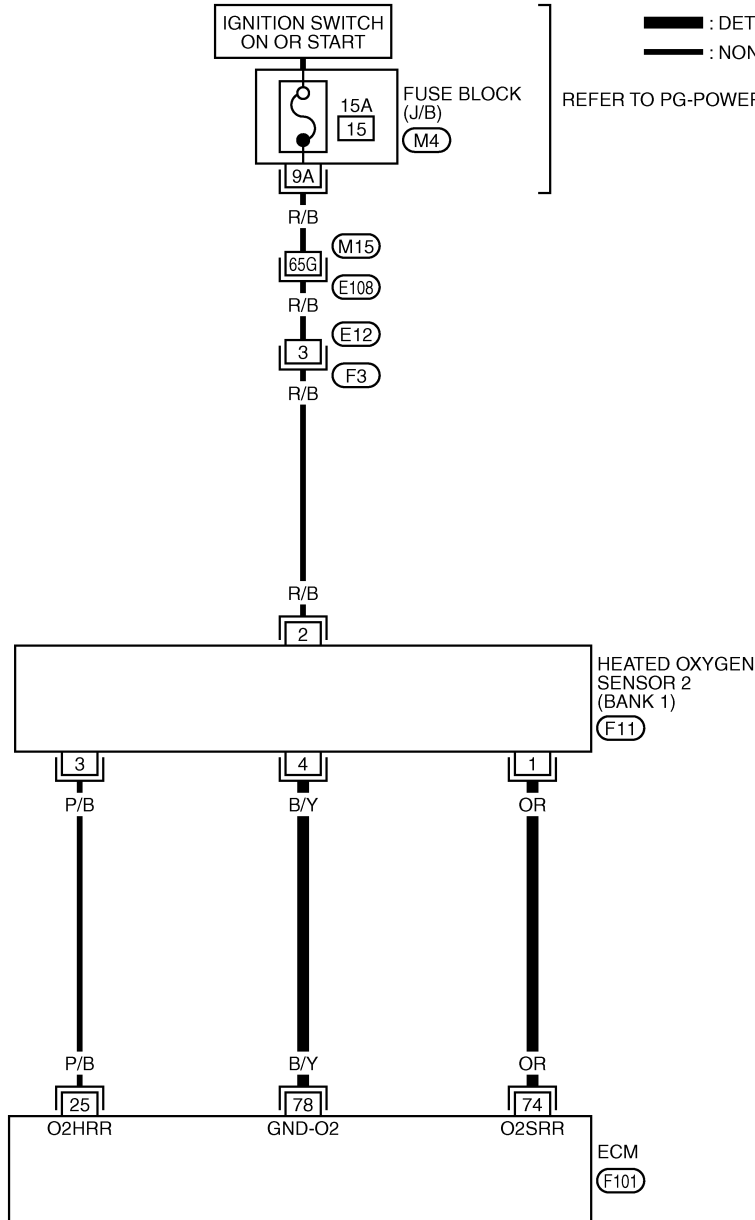

REFER TO THE FOLLOWING.

- E108 -SUPER MULTIPLE JUNCTION (SMJ)
- M4 -FUSE BLOCK-JUNCTION BOX (J/B)

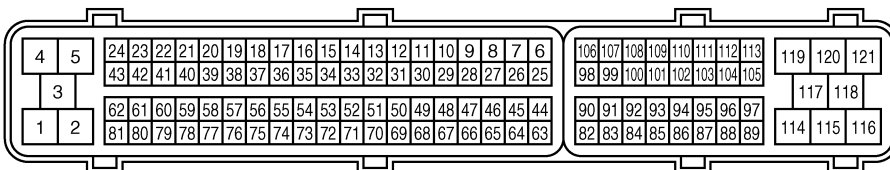

TBWT0482E

## DTC P0138, P0158 HO2S2

Specification data are reference values and are measured between each terminal and ground.

**CAUTION:**

**Do not use ECM ground terminals when measuring input/output voltage. Doing so may result in damage to the ECM's transistor. Use a ground other than ECM terminals, such as the ground.**

TER-MINAL NO.	WIRE COLOR	ITEM	CONDITION	DATA (DC Voltage)
74	OR	Heated oxygen sensor 2 (bank 1)	<b>[Engine is running]</b> <ul style="list-style-type: none"><li>● <b>Warm-up condition</b></li><li>● Revving engine from idle to 3,000 rpm quickly after the following conditions are met.</li><li>– After keeping the engine speed between 3,500 and 4,000 rpm for 1 minute and at idle for 1 minute under no load.</li></ul>	0 - Approximately 1.0V
78	B/Y	Sensor ground (Heated oxygen sensor)	<b>[Engine is running]</b> <ul style="list-style-type: none"><li>● <b>Warm-up condition</b></li><li>● Idle speed</li></ul>	Approximately 0V

# DTC P0138, P0158 HO2S2

**BANK 2**

**EC-O2S2B2-01**

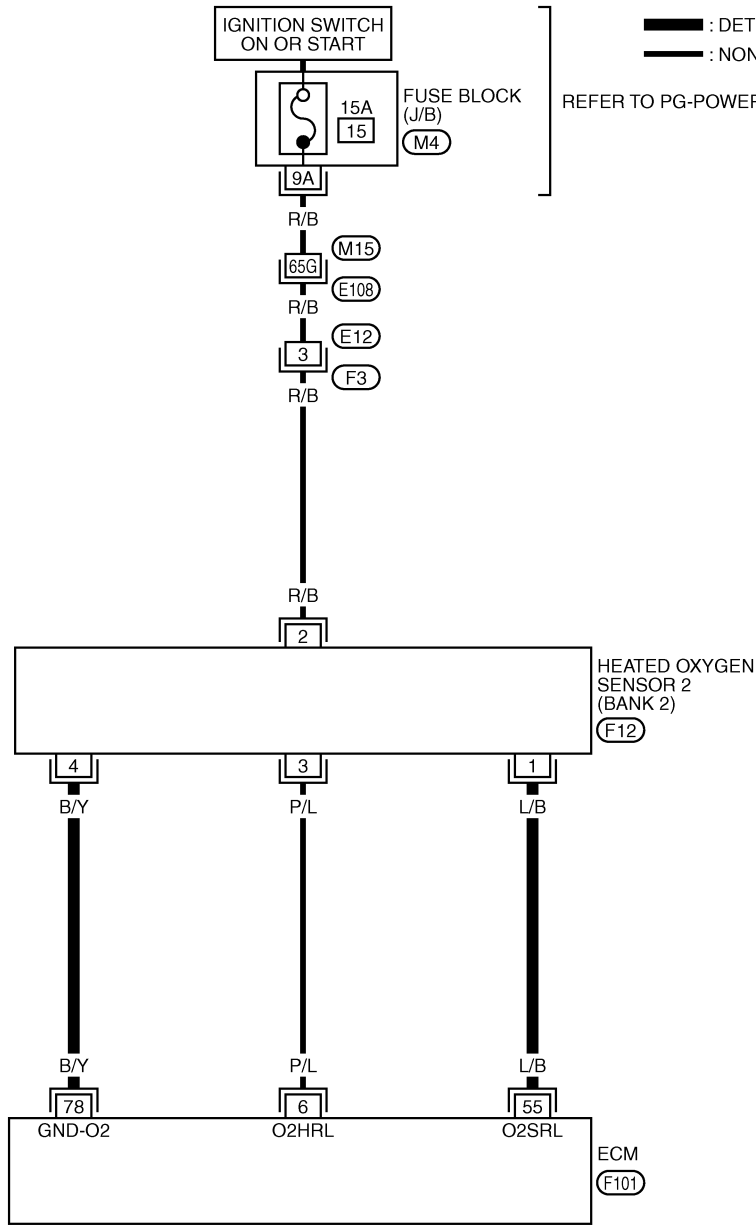

REFER TO THE FOLLOWING.

- E108 -SUPER MULTIPLE JUNCTION (SMJ)
- M4 -FUSE BLOCK-JUNCTION BOX (J/B)

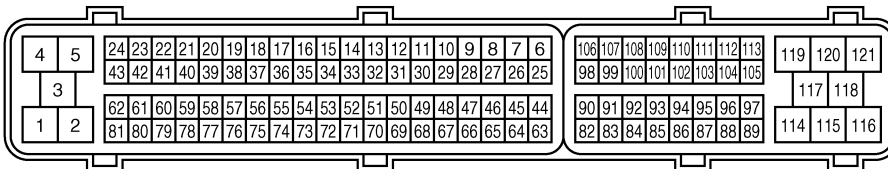

TBWT0483E

# DTC P0138, P0158 HO2S2

Specification data are reference values and are measured between each terminal and ground.

**CAUTION:**

Do not use ECM ground terminals when measuring input/output voltage. Doing so may result in damage to the ECM's transistor. Use a ground other than ECM terminals, such as the ground.

TER-MINAL NO.	WIRE COLOR	ITEM	CONDITION	DATA (DC Voltage)
55	L/B	Heated oxygen sensor 2 (bank 2)	<p>[Engine is running]</p> <ul style="list-style-type: none"> <li>● Warm-up condition</li> <li>● Revving engine from idle to 3,000 rpm quickly after the following conditions are met.</li> <li>– After keeping the engine speed between 3,500 and 4,000 rpm for 1 minute and at idle for 1 minute under no load.</li> </ul>	0 - Approximately 1.0V
78	B/Y	Sensor ground (Heated oxygen sensor)	<p>[Engine is running]</p> <ul style="list-style-type: none"> <li>● Warm-up condition</li> <li>● Idle speed</li> </ul>	Approximately 0V

## Diagnostic Procedure

ABS009ES

### 1. CHECK GROUND CONNECTIONS

1. Turn ignition switch OFF.
2. Loosen and retighten three ground screws on the body. Refer to [EC-138, "Ground Inspection"](#) .

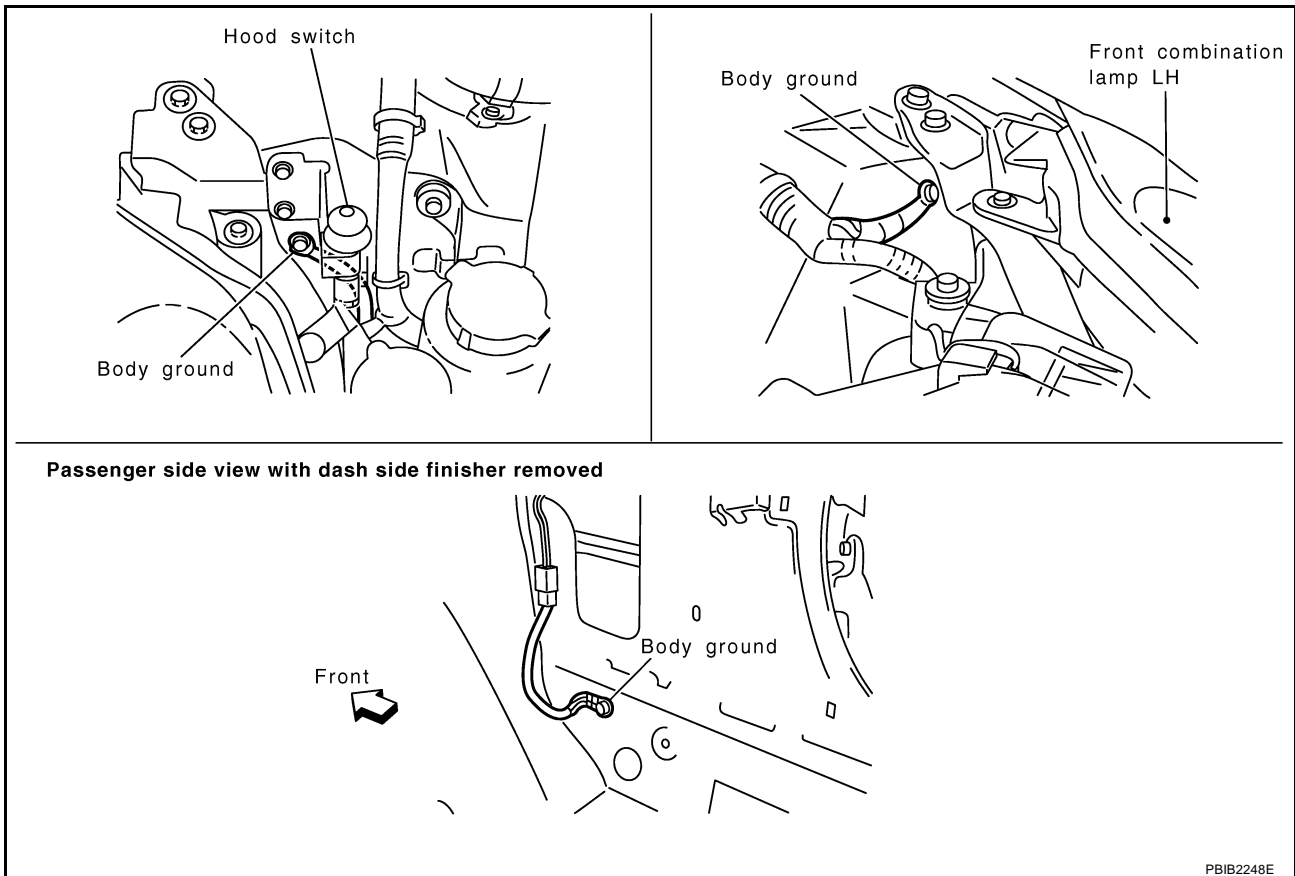

OK or NG

- OK >> GO TO 2.
- NG >> Repair or replace ground connections.

## DTC P0138, P0158 HO2S2

### 2. CHECK HO2S2 GROUND CIRCUIT FOR OPEN AND SHORT

1. Disconnect ECM harness connector.
2. Disconnect heated oxygen sensor 2 harness connector.

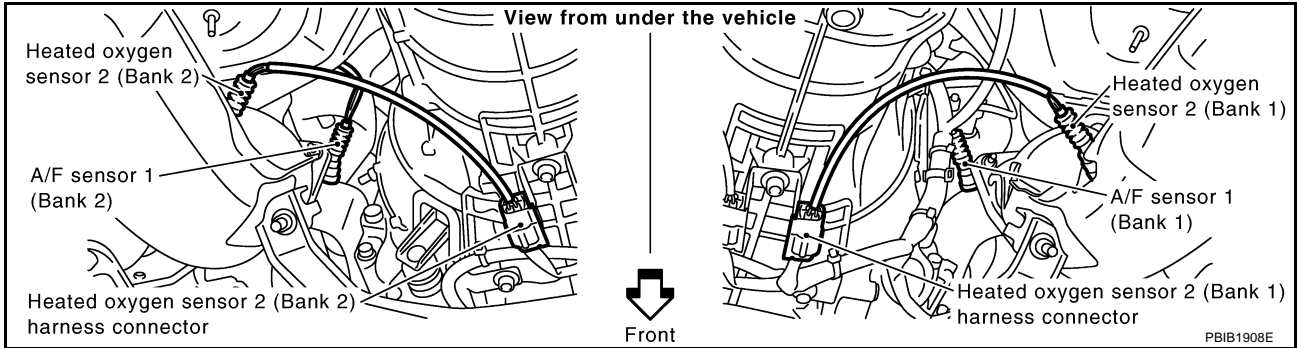

3. Check harness continuity between HO2S2 terminal 4 and ECM terminal 78. Refer to Wiring Diagram.

**Continuity should exist.**

4. Also check harness for short to ground and short to power.

OK or NG

OK >> GO TO 3.

NG >> Repair open circuit or short to ground or short to power in harness or connectors.

### 3. CHECK HO2S2 INPUT SIGNAL CIRCUIT FOR OPEN AND SHORT

1. Check harness continuity between ECM terminal and HO2S2 terminal as follows. Refer to Wiring Diagram.

DTC	Terminals		Bank
	ECM	Sensor	
P0138	74	1	1
P0158	55	1	2

**Continuity should exist.**

2. Check harness continuity between the following terminals and ground. Refer to Wiring Diagram.

DTC	Terminals		Bank
	ECM	Sensor	
P0138	74	1	1
P0158	55	1	2

**Continuity should not exist.**

3. Also check harness for short to power.

OK or NG

OK >> GO TO 4.

NG >> Repair open circuit or short to ground or short to power in harness or connectors.

#### 4. CHECK HO2S2 CONNECTOR FOR WATER

Check connectors for water.

**Water should not exist.**

OK or NG

- OK >> GO TO 5.
- NG >> Repair or replace harness or connectors.

#### 5. CHECK HEATED OXYGEN SENSOR 2

Refer to [EC-208, "Component Inspection"](#) .

OK or NG

- OK >> GO TO 6.
- NG >> Replace malfunctioning heated oxygen sensor 2.

#### 6. CHECK INTERMITTENT INCIDENT

Refer to [EC-129, "TROUBLE DIAGNOSIS FOR INTERMITTENT INCIDENT"](#) .

>> INSPECTION END

### Component Inspection HEATED OXYGEN SENSOR 2

ABS009ET

#### ④ With CONSULT-II

1. Turn ignition switch ON and select "DATA MONITOR" mode with CONSULT-II.
  2. Start engine and warm it up to the normal operating temperature.
  3. Turn ignition switch OFF and wait at least 10 seconds.
  4. Start engine and keep the engine speed between 3,500 and 4,000 rpm for at least 1 minute under no load.
  5. Let engine idle for 1 minute.
- 
6. Select "FUEL INJECTION" in "ACTIVE TEST" mode, and select "HO2S2 (B1)/(B2)" as the monitor item with CONSULT-II.

DATA MONITOR	
MONITOR	NO DTC
ENG SPEED	XXX rpm
COOLAN TEMP/S	XXX °C

SEF174Y

ACTIVE TEST	
FUEL INJECTION	25 %
MONITOR	
ENG SPEED	XXX rpm
HO2S2 (B1)	XXX V
HO2S2 (B2)	XXX V

PBIB1672E



## DTC P0138, P0158 HO2S2

7. Check "HO2S2 (B1)/(B2)" at idle speed when adjusting "FUEL INJECTION" to  $\pm 25\%$ .

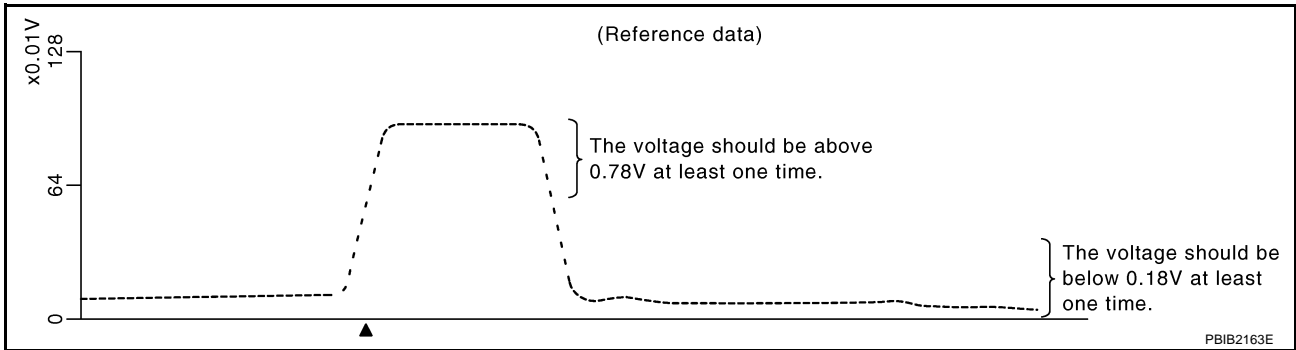

"HO2S2 (B1)/(B2)" should be above 0.78V at least once when the "FUEL INJECTION" is +25%.  
"HO2S2 (B1)/(B2)" should be below 0.18V at least once when the "FUEL INJECTION" is -25%.

### CAUTION:

- Discard any heated oxygen sensor which has been dropped from a height of more than 0.5 m (19.7 in) onto a hard surface such as a concrete floor; use a new one.
- Before installing new oxygen sensor, clean exhaust system threads using Oxygen Sensor Thread Cleaner tool J-43897-18 or J-43897-12 and approved anti-seize lubricant.

### ⊗ Without CONSULT-II

1. Start engine and warm it up to the normal operating temperature.
2. Turn ignition switch OFF and wait at least 10 seconds.
3. Start engine and keep the engine speed between 3,500 and 4,000 rpm for at least 1 minute under no load.
4. Let engine idle for 1 minute.
5. Set voltmeter probes between ECM terminal 74 [HO2S2 (B1) signal] or 55 [HO2S2 (B2) signal] and ground.
6. Check the voltage when revving up to 4,000 rpm under no load at least 10 times.  
(Depress and release accelerator pedal as soon as possible.)  
**The voltage should be above 0.78V at least once during this procedure.**  
**If the voltage is above 0.78V at step 6, step 7 is not necessary.**
7. Keep vehicle at idling for 10 minutes, then check voltage. Or check the voltage when coasting from 80 km/h (50 MPH) in D position (A/T), 4th gear position (M/T).  
**The voltage should be below 0.18V at least once during this procedure.**
8. If NG, replace heated oxygen sensor 2.

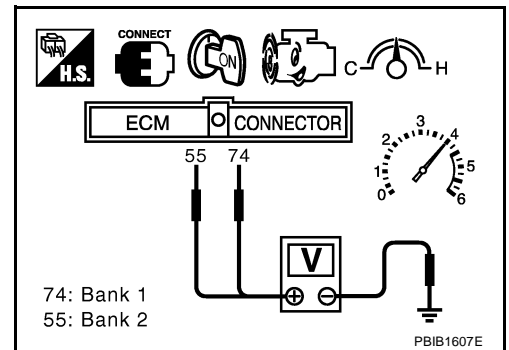

### CAUTION:

- Discard any heated oxygen sensor which has been dropped from a height of more than 0.5 m (19.7 in) onto a hard surface such as a concrete floor; use a new one.
- Before installing new oxygen sensor, clean exhaust system threads using Oxygen Sensor Thread Cleaner tool J-43897-18 or J-43897-12 and approved anti-seize lubricant.

## Removal and Installation HEATED OXYGEN SENSOR 2

ABS009EU

Refer to [EM-23, "EXHAUST MANIFOLD AND THREE WAY CATALYST"](#) .

## DTC P0139, P0159 HO2S2

PFP:226A0

### Component Description

ABS009EV

The heated oxygen sensor 2, after three way catalyst 1, monitors the oxygen level in the exhaust gas on each bank.

Even if switching characteristics of the air fuel ratio (A/F) sensor 1 are shifted, the air-fuel ratio is controlled to stoichiometric, by the signal from the heated oxygen sensor 2.

This sensor is made of ceramic zirconia. The zirconia generates voltage from approximately 1V in richer conditions to 0V in leaner conditions.

Under normal conditions the heated oxygen sensor 2 is not used for engine control operation.

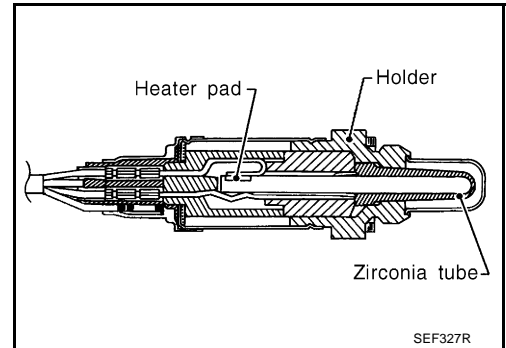

### CONSULT-II Reference Value in Data Monitor Mode

ABS009EV

Specification data are reference values.

MONITOR ITEM	CONDITION		SPECIFICATION
HO2S2 (B1) HO2S2 (B2)	<ul style="list-style-type: none"> <li>● Warm-up condition</li> <li>● After keeping engine speed between 3,500 and 4,000 rpm for 1 minute and at idle for 1 minute under no load.</li> </ul>	Revsing engine from idle to 3,000 rpm quickly.	0 - 0.3V ↔ Approx. 0.6 - 1.0V
HO2S2 MNTR (B1) HO2S2 MNTR (B2)			LEAN ↔ RICH

### On Board Diagnosis Logic

ABS009EX

The heated oxygen sensor 2 has a much longer switching time between rich and lean than the air fuel ratio (A/F) sensor 1. The oxygen storage capacity before the three way catalyst causes the longer switching time. To judge the malfunctions of heated oxygen sensor 2, ECM monitors whether the switching response of the sensor's voltage is faster than specified during the various driving condition such as fuel-cut.

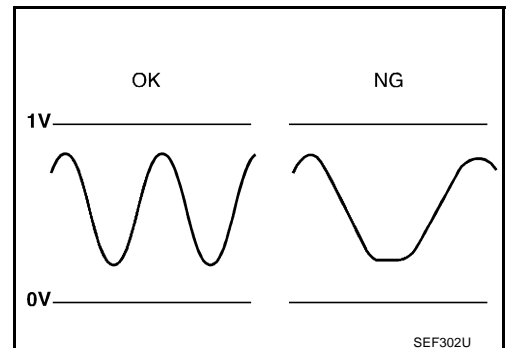

DTC No.	Trouble diagnosis name	DTC detecting condition	Possible cause
P0139 0139 (Bank 1)	Heated oxygen sensor 2 circuit slow response	It takes more time for the sensor to respond between rich and lean than the specified time.	<ul style="list-style-type: none"> <li>● Harness or connectors (The sensor circuit is open or shorted)</li> <li>● Heated oxygen sensor 2</li> <li>● Fuel pressure</li> <li>● Fuel injector</li> <li>● Intake air leaks</li> </ul>
P0159 0159 (Bank 2)			

## DTC Confirmation Procedure

### NOTE:

If DTC Confirmation Procedure has been previously conducted, always turn ignition switch OFF and wait at least 10 seconds before conducting the next test.

### Ⓟ WITH CONSULT-II

#### TESTING CONDITION:

For better results, perform "DTC WORK SUPPORT" at a temperature of 0 to 30 °C (32 to 86 °F).

1. Turn ignition switch ON and select "DATA MONITOR" mode with CONSULT-II.
2. Start engine and warm it up to the normal operating temperature.
3. Turn ignition switch OFF and wait at least 10 seconds.
4. Start engine and keep the engine speed between 3,500 and 4,000 rpm for at least 1 minute under no load.
5. Let engine idle for 1 minute.
6. Make sure that "COOLAN TEMP/S" indicates more than 70°C (158°F).  
If not, warm up engine and go to next step when "COOLAN TEMP/S" indication reaches to 70°C (158°F).
7. Select "HO2S2 (B1) P0139" or "HO2S2 (B2) P0159" of "HO2S2" in "DTC WORK SUPPORT" mode with CONSULT-II.
8. Start engine and following the instruction of CONSULT-II.

DATA MONITOR	
MONITOR	NO DTC
ENG SPEED	XXX rpm
COOLAN TEMP/S	XXX °C

SEF174Y

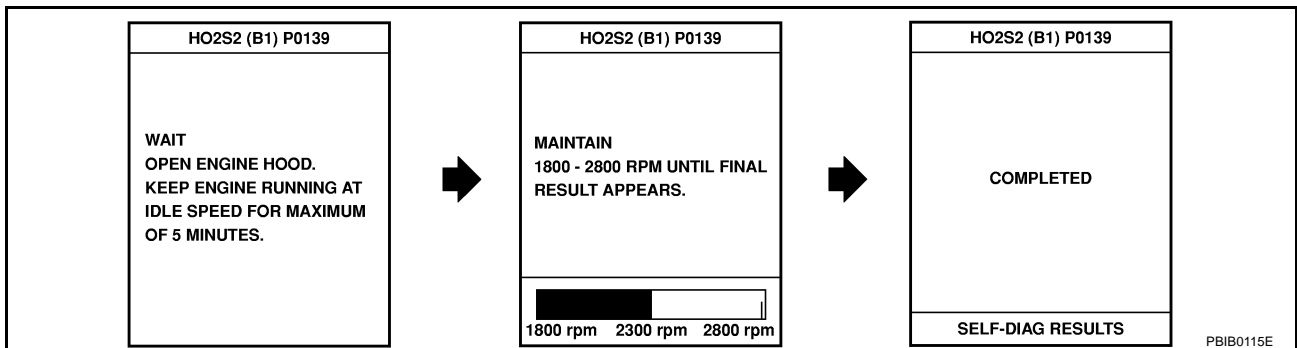

9. Make sure that "OK" is displayed after touching "SELF-DIAG RESULTS".  
If "NG" is displayed, refer to [EC-216, "Diagnostic Procedure"](#).  
If "CAN NOT BE DIAGNOSED" is displayed, perform the following.
  - a. Turn ignition switch OFF and leave the vehicle in a cool place (soak the vehicle).
  - b. Return to step 1.

## Overall Function Check

Use this procedure to check the overall function of the heated oxygen sensor 2 circuit. During this check, a 1st trip DTC might not be confirmed.

### Ⓟ WITH GST

1. Start engine and warm it up to the normal operating temperature.
2. Turn ignition switch OFF and wait at least 10 seconds.
3. Start engine and keep the engine speed between 3,500 and 4,000 rpm for at least 1 minute under no load.
4. Let engine idle for 1 minute.
5. Set voltmeter probes between ECM terminal 74 [HO2S2 (B1) signal] or 55 [HO2S2 (B2) signal] and ground.

## DTC P0139, P0159 HO2S2

6. Check the voltage when revving up to 4,000 rpm under no load at least 10 times.  
(Depress and release accelerator pedal as soon as possible.)  
**A change of voltage should be more than 0.06V for 1 second during this procedure.**  
**If the voltage can be confirmed in step 6, step 7 is not necessary.**
7. Keep vehicle at idling for 10 minutes, then check the voltage. Or check the voltage when coasting from 80 km/h (50 MPH) in D position (A/T), 4th gear position (M/T).  
**A change of voltage should be more than 0.06V for 1 second during this procedure.**
8. If NG, go to [EC-216. "Diagnostic Procedure"](#).

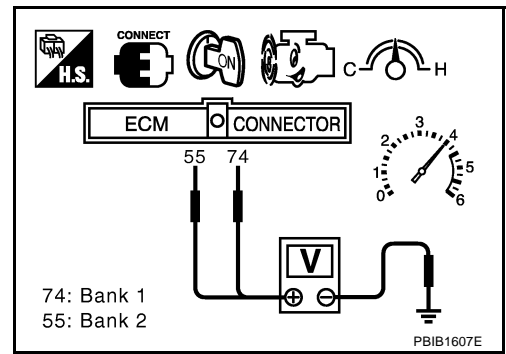

# DTC P0139, P0159 HO2S2

## Wiring Diagram BANK 1

ABS009F0

### EC-O2S2B1-01

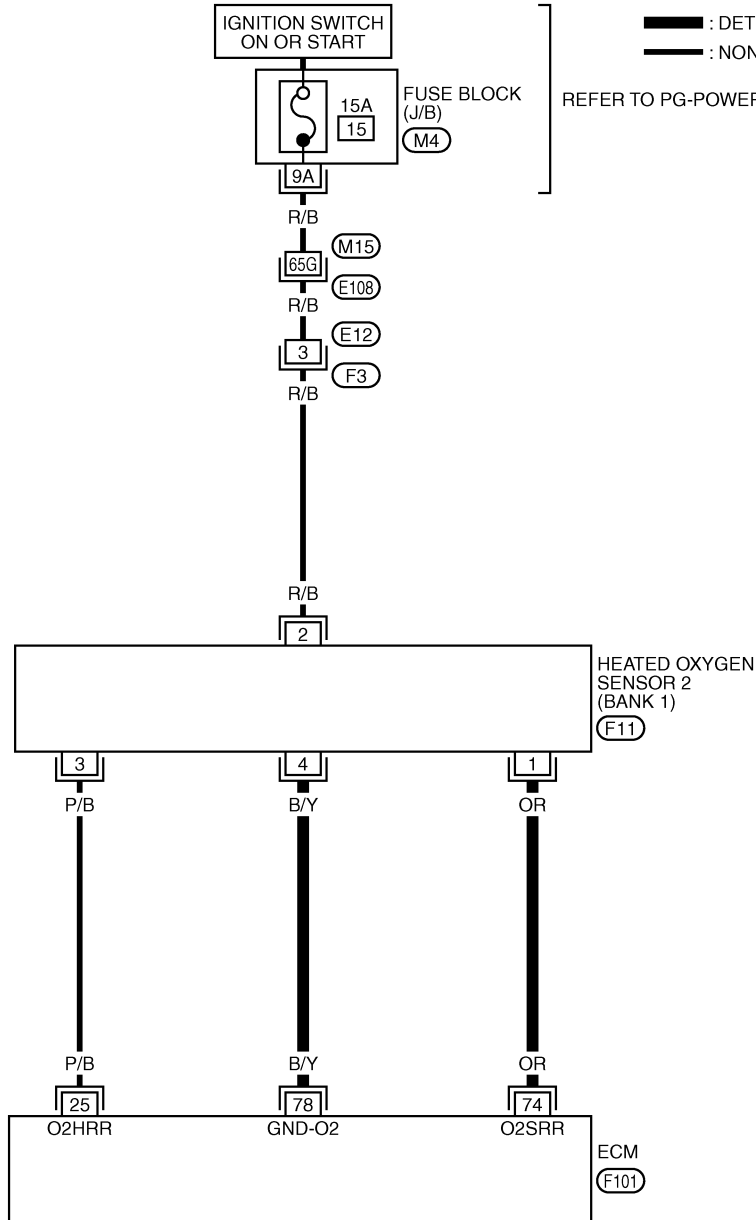

REFER TO THE FOLLOWING.

- E108 -SUPER MULTIPLE JUNCTION (SMJ)
- M4 -FUSE BLOCK-JUNCTION BOX (J/B)

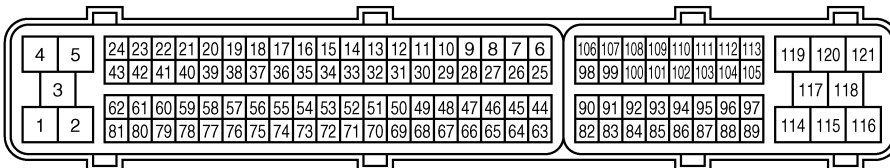

TBWT0482E

## DTC P0139, P0159 HO2S2

Specification data are reference values and are measured between each terminal and ground.

**CAUTION:**

**Do not use ECM ground terminals when measuring input/output voltage. Doing so may result in damage to the ECM's transistor. Use a ground other than ECM terminals, such as the ground.**

TER-MINAL NO.	WIRE COLOR	ITEM	CONDITION	DATA (DC Voltage)
74	OR	Heated oxygen sensor 2 (bank 1)	<b>[Engine is running]</b> <ul style="list-style-type: none"><li>● <b>Warm-up condition</b></li><li>● Revving engine from idle to 3,000 rpm quickly after the following conditions are met.</li><li>– After keeping the engine speed between 3,500 and 4,000 rpm for 1 minute and at idle for 1 minute under no load.</li></ul>	0 - Approximately 1.0V
78	B/Y	Sensor ground (Heated oxygen sensor)	<b>[Engine is running]</b> <ul style="list-style-type: none"><li>● <b>Warm-up condition</b></li><li>● Idle speed</li></ul>	Approximately 0V

# DTC P0139, P0159 HO2S2

**BANK 2**

**EC-O2S2B2-01**

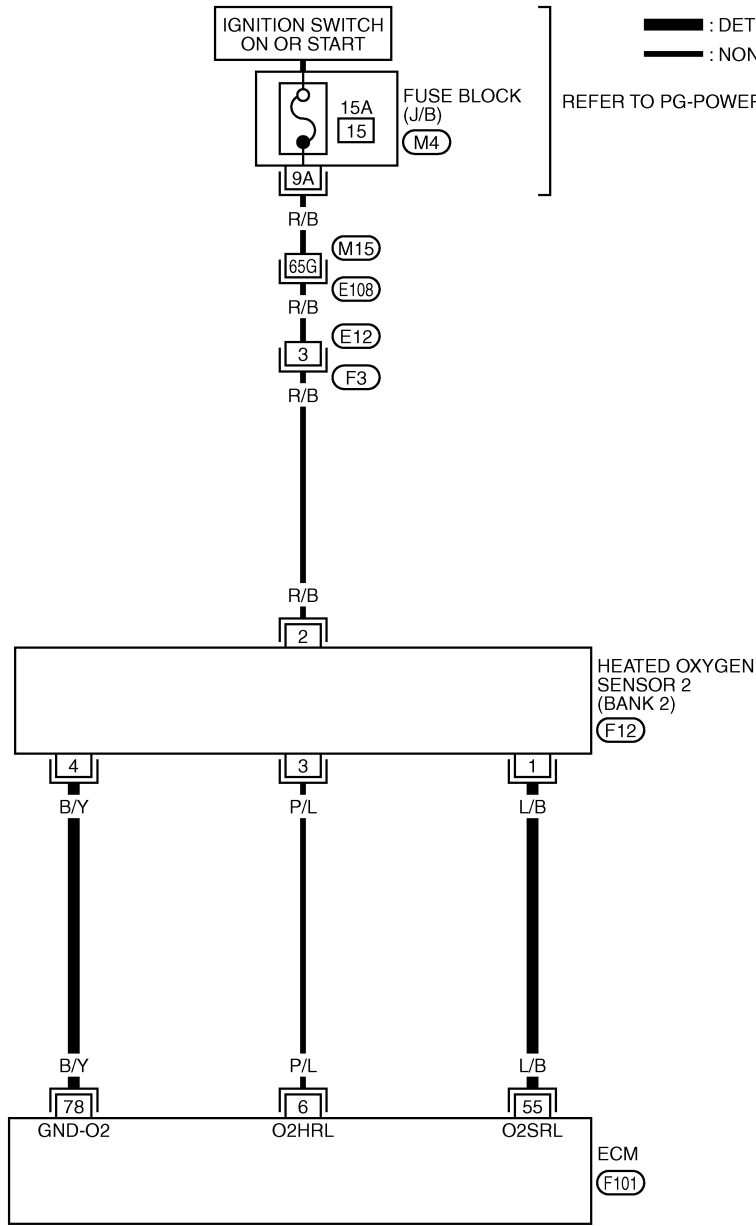

REFER TO THE FOLLOWING.

- E108 -SUPER MULTIPLE JUNCTION (SMJ)
- M4 -FUSE BLOCK-JUNCTION BOX (J/B)

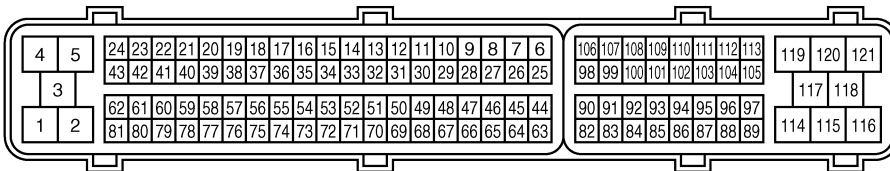

TBWT0483E

# DTC P0139, P0159 HO2S2

Specification data are reference values and are measured between each terminal and ground.

**CAUTION:**

Do not use ECM ground terminals when measuring input/output voltage. Doing so may result in damage to the ECM's transistor. Use a ground other than ECM terminals, such as the ground.

TER-MINAL NO.	WIRE COLOR	ITEM	CONDITION	DATA (DC Voltage)
55	L/B	Heated oxygen sensor 2 (bank 2)	<p>[Engine is running]</p> <ul style="list-style-type: none"> <li>● Warm-up condition</li> <li>● Revving engine from idle to 3,000 rpm quickly after the following conditions are met.</li> <li>– After keeping the engine speed between 3,500 and 4,000 rpm for 1 minute and at idle for 1 minute under no load.</li> </ul>	0 - Approximately 1.0V
78	B/Y	Sensor ground (Heated oxygen sensor)	<p>[Engine is running]</p> <ul style="list-style-type: none"> <li>● Warm-up condition</li> <li>● Idle speed</li> </ul>	Approximately 0V

## Diagnostic Procedure

ABS009F1

### 1. CHECK GROUND CONNECTIONS

1. Turn ignition switch OFF.
2. Loosen and retighten three ground screws on the body. Refer to [EC-138, "Ground Inspection"](#) .

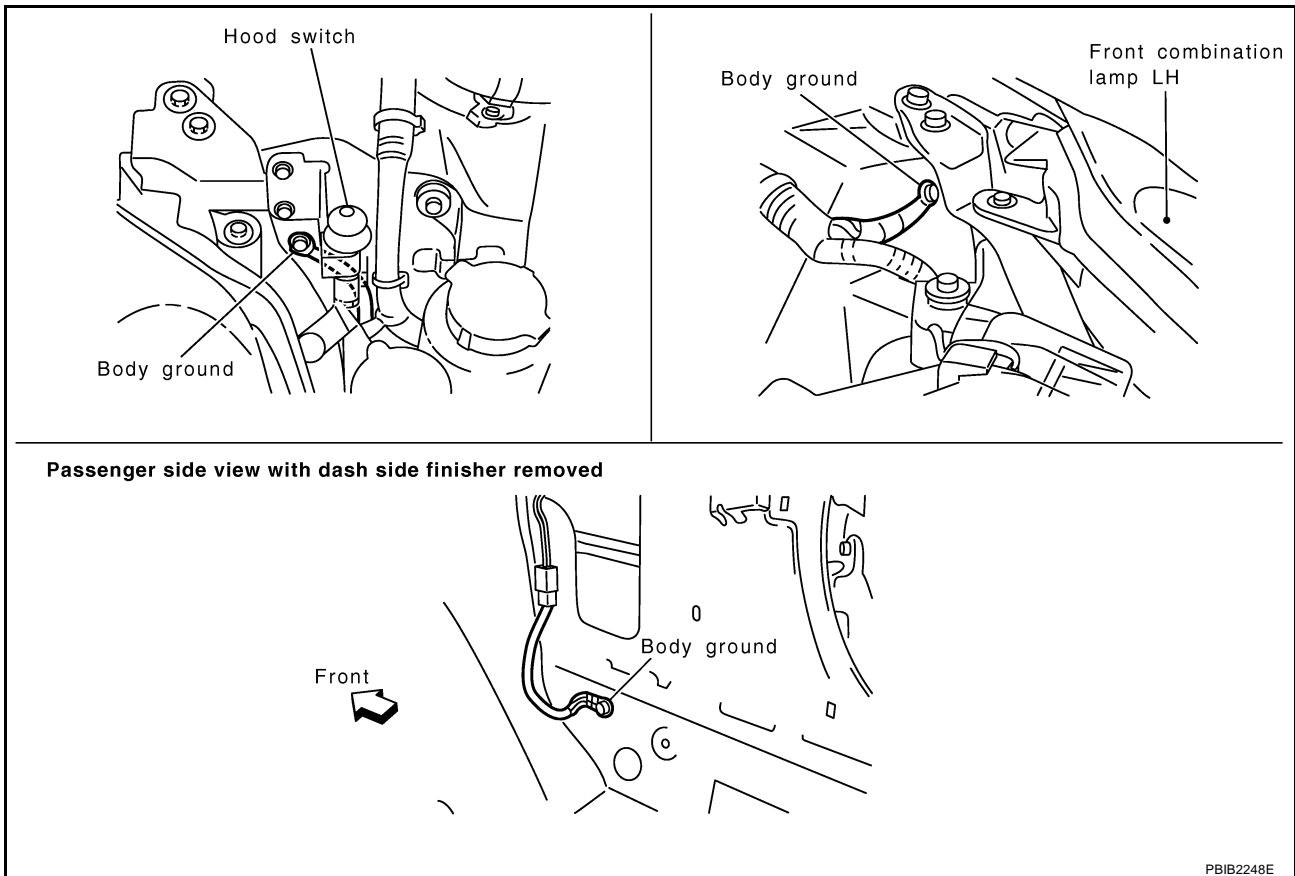

OK or NG

- OK >> GO TO 2.
- NG >> Repair or replace ground connections.



## 2. CLEAR THE SELF-LEARNING DATA

### With CONSULT-II

1. Start engine and warm it up to normal operating temperature.
2. Select "SELF-LEARNING CONT" in "WORK SUPPORT" mode with CONSULT-II.
3. Clear the self-learning control coefficient by touching "CLEAR".
4. Run engine for at least 10 minutes at idle speed.  
**Is the 1st trip DTC P0171, P0172, P0174 or P0175 detected?  
 Is it difficult to start engine?**

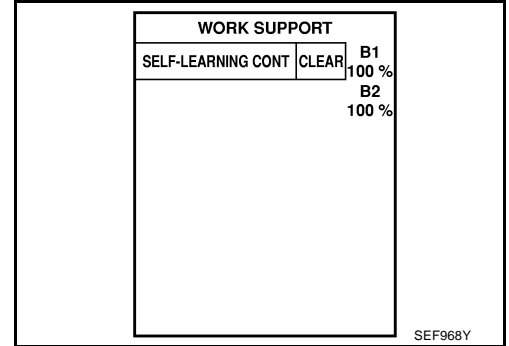

### Without CONSULT-II

1. Start engine and warm it up to normal operating temperature.
2. Turn ignition switch OFF.
3. Disconnect mass air flow sensor harness connector, and restart and run engine for at least 5 seconds at idle speed.
4. Stop engine and reconnect mass air flow sensor harness connector.
5. Make sure DTC P0102 is displayed.
6. Erase the DTC memory. Refer to [EC-61, "HOW TO ERASE EMISSION-RELATED DIAGNOSTIC INFORMATION"](#).
7. Make sure DTC P0000 is displayed.
8. Run engine for at least 10 minutes at idle speed.  
**Is the 1st trip DTC P0171, P0172, P0174 or P0175 detected?  
 Is it difficult to start engine?**

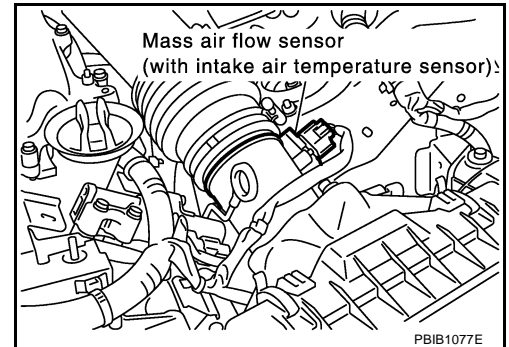

#### Yes or No

- Yes >> Perform trouble diagnosis for DTC P0171, P0174 or P0172, P0175. Refer to [EC-221](#) or [EC-230](#).
- No >> GO TO 3.

## DTC P0139, P0159 HO2S2

### 3. CHECK HO2S2 GROUND CIRCUIT FOR OPEN AND SHORT

1. Turn ignition switch OFF.
2. Disconnect ECM harness connector.
3. Disconnect heated oxygen sensor 2 harness connector.

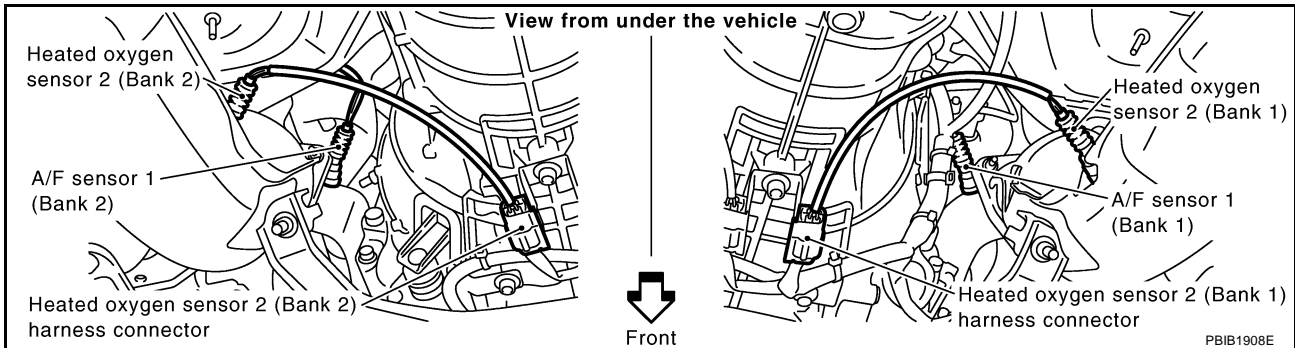

4. Check harness continuity between HO2S2 terminal 4 and ECM terminal 78.  
Refer to Wiring Diagram.

**Continuity should exist.**

5. Also check harness for short to ground and short to power.

**OK or NG**

OK >> GO TO 4.

NG >> Repair open circuit or short to ground or short to power in harness or connectors.

### 4. CHECK HO2S2 INPUT SIGNAL CIRCUIT FOR OPEN AND SHORT

1. Check harness continuity between ECM terminal and HO2S2 terminal as follows.  
Refer to Wiring Diagram.

DTC	Terminals		Bank
	ECM	Sensor	
P0139	74	1	1
P0159	55	1	2

**Continuity should exist.**

2. Check harness continuity between the following terminals and ground.  
Refer to Wiring Diagram.

DTC	Terminals		Bank
	ECM	Sensor	
P0139	74	1	1
P0159	55	1	2

**Continuity should not exist.**

3. Also check harness for short to power.

**OK or NG**

OK >> GO TO 5.

NG >> Repair open circuit or short to ground or short to power in harness or connectors.

**5. CHECK HEATED OXYGEN SENSOR 2**

Refer to [EC-219, "Component Inspection"](#) .

OK or NG

- OK >> GO TO 6.
- NG >> Replace malfunctioning heated oxygen sensor 2.

**6. CHECK INTERMITTENT INCIDENT**

Refer to [EC-129, "TROUBLE DIAGNOSIS FOR INTERMITTENT INCIDENT"](#) .

>> INSPECTION END

**Component Inspection  
HEATED OXYGEN SENSOR 2**

ABS009F2

Ⓟ With CONSULT-II

1. Turn ignition switch ON and select "DATA MONITOR" mode with CONSULT-II.
2. Start engine and warm it up to the normal operating temperature.
3. Turn ignition switch OFF and wait at least 10 seconds.
4. Start engine and keep the engine speed between 3,500 and 4,000 rpm for at least 1 minute under no load.
5. Let engine idle for 1 minute.
6. Select "FUEL INJECTION" in "ACTIVE TEST" mode, and select "HO2S2 (B1)/(B2)" as the monitor item with CONSULT-II.

DATA MONITOR	
MONITOR	NO DTC
ENG SPEED	XXX rpm
COOLAN TEMP/S	XXX °C

SEF174Y

ACTIVE TEST	
FUEL INJECTION	25 %
MONITOR	
ENG SPEED	XXX rpm
HO2S2 (B1)	XXX V
HO2S2 (B2)	XXX V

PBIB1672E

7. Check "HO2S2 (B1)/(B2)" at idle speed when adjusting "FUEL INJECTION" to ±25%.

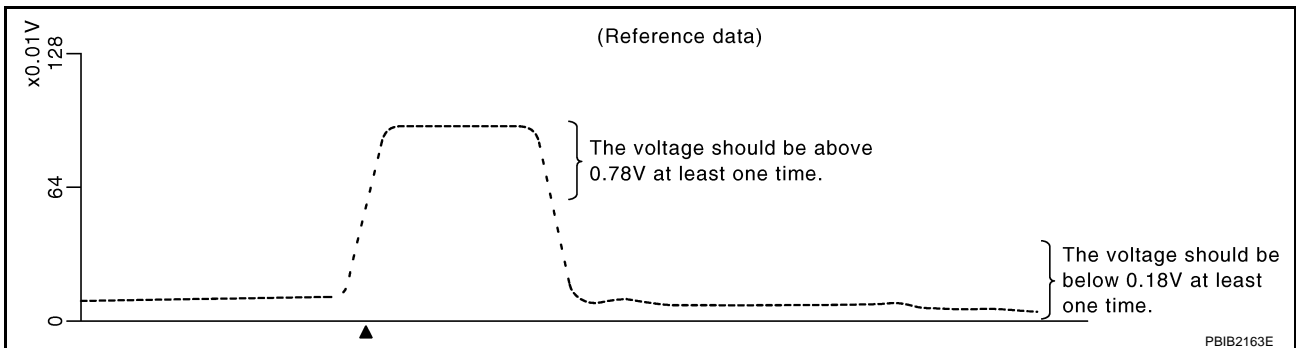

"HO2S2 (B1)/(B2)" should be above 0.78V at least once when the "FUEL INJECTION" is +25%.  
 "HO2S2 (B1)/(B2)" should be below 0.18V at least once when the "FUEL INJECTION" is -25%.

**CAUTION:**

- Discard any heated oxygen sensor which has been dropped from a height of more than 0.5 m (19.7 in) onto a hard surface such as a concrete floor; use a new one.

## DTC P0139, P0159 HO2S2

- Before installing new oxygen sensor, clean exhaust system threads using Oxygen Sensor Thread Cleaner tool J-43897-18 or J-43897-12 and approved anti-seize lubricant.

### ⊗ Without CONSULT-II

1. Start engine and warm it up to the normal operating temperature.
2. Turn ignition switch OFF and wait at least 10 seconds.
3. Start engine and keep the engine speed between 3,500 and 4,000 rpm for at least 1 minute under no load.
4. Let engine idle for 1 minute.
5. Set voltmeter probes between ECM terminal 74 [HO2S2 (B1) signal] or 55 [HO2S2 (B2) signal] and ground.
6. Check the voltage when revving up to 4,000 rpm under no load at least 10 times.  
(Depress and release accelerator pedal as soon as possible.)  
**The voltage should be above 0.78V at least once during this procedure.**  
**If the voltage is above 0.78V at step 6, step 7 is not necessary.**
7. Keep vehicle at idling for 10 minutes, then check voltage. Or check the voltage when coasting from 80 km/h (50 MPH) in D position (A/T), 4th gear position (M/T).  
**The voltage should be below 0.18V at least once during this procedure.**
8. If NG, replace heated oxygen sensor 2.

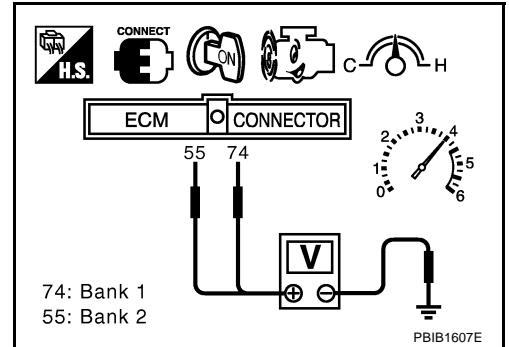

### CAUTION:

- Discard any heated oxygen sensor which has been dropped from a height of more than 0.5 m (19.7 in) onto a hard surface such as a concrete floor; use a new one.
- Before installing new oxygen sensor, clean exhaust system threads using Oxygen Sensor Thread Cleaner tool J-43897-18 or J-43897-12 and approved anti-seize lubricant.

## Removal and Installation HEATED OXYGEN SENSOR 2

ABS009F3

Refer to [EM-23, "EXHAUST MANIFOLD AND THREE WAY CATALYST"](#) .

# DTC P0171, P0174 FUEL INJECTION SYSTEM FUNCTION

## DTC P0171, P0174 FUEL INJECTION SYSTEM FUNCTION

PF16600

### On Board Diagnosis Logic

ABS009F4

With the Air/Fuel Mixture Ratio Self-Learning Control, the actual mixture ratio can be brought closely to the theoretical mixture ratio based on the mixture ratio feedback signal from the air fuel ratio (A/F) sensors 1. The ECM calculates the necessary compensation to correct the offset between the actual and the theoretical ratios.

In case the amount of the compensation value is extremely large (The actual mixture ratio is too lean.), the ECM judges the condition as the fuel injection system malfunction and lights up the MIL (2 trip detection logic).

Sensor	Input signal to ECM	ECM function	Actuator
Air fuel ratio (A/F) sensor 1	Density of oxygen in exhaust gas (Mixture ratio feedback signal)	Fuel injection control	Fuel injector

DTC No.	Trouble diagnosis name	DTC detecting condition	Possible cause
P0171 0171 (Bank 1)	Fuel injection system too lean	<ul style="list-style-type: none"> <li>Fuel injection system does not operate properly.</li> <li>The amount of mixture ratio compensation is too large. (The mixture ratio is too lean.)</li> </ul>	<ul style="list-style-type: none"> <li>Intake air leaks</li> <li>Air fuel ratio (A/F) sensor 1</li> <li>Fuel injector</li> <li>Exhaust gas leaks</li> <li>Incorrect fuel pressure</li> <li>Lack of fuel</li> <li>Mass air flow sensor</li> <li>Incorrect PCV hose connection</li> </ul>
P0174 0174 (Bank 2)			

### DTC Confirmation Procedure

ABS009F5

#### CAUTION:

Always drive vehicle at a safe speed.

#### NOTE:

If DTC Confirmation Procedure has been previously conducted, always turn ignition switch OFF and wait at least 10 seconds before conducting the next test.

#### WITH CONSULT-II

- Start engine and warm it up to normal operating temperature.
- Turn ignition switch OFF and wait at least 10 seconds.
- Turn ignition switch ON and select "SELF-LEARNING CONT" in "WORK SUPPORT" mode with CONSULT-II.
- Clear the self-learning control coefficient by touching "CLEAR".
- Select "DATA MONITOR" mode with CONSULT-II.
- Start engine again and let it idle for at least 10 minutes. The 1st trip DTC P0171 or P0174 should be detected at this stage, if a malfunction exists. If so, go to [EC-225, "Diagnostic Procedure"](#).

#### NOTE:

If 1st trip DTC is not detected during above procedure, performing the following procedure is advised.

- Turn ignition switch OFF and wait at least 10 seconds.
- Start engine and drive the vehicle under the similar conditions to (1st trip) Freeze Frame Data for 10 minutes. Refer to the table below.

**Hold the accelerator pedal as steady as possible.**

WORK SUPPORT		
SELF-LEARNING CONT	CLEAR	B1 100 %
		B2 100 %

SEF968Y

The similar conditions to (1st trip) Freeze Frame Data means the vehicle operation that the following conditions should be satisfied at the same time.

Engine speed	Engine speed in the freeze frame data $\pm$ 400 rpm
Vehicle speed	Vehicle speed in the freeze frame data $\pm$ 10 km/h (6 MPH)

# DTC P0171, P0174 FUEL INJECTION SYSTEM FUNCTION

Engine coolant temperature (T) condition	When the freeze frame data shows lower than 70 °C (158 °F), T should be lower than 70 °C (158 °F).
	When the freeze frame data shows higher than or equal to 70 °C (158 °F), T should be higher than or equal to 70 °C (158 °F).

7. If it is difficult to start engine at step 6, the fuel injection system has a malfunction, too.
8. Crank engine while depressing accelerator pedal. If engine starts, go to [EC-225, "Diagnostic Procedure"](#) . If engine does not start, check exhaust and intake air leak visually.

## WITH GST

1. Start engine and warm it up to normal operating temperature.
2. Turn ignition switch OFF and wait at least 10 seconds.
3. Disconnect mass air flow sensor harness connector.
4. Restart engine and let it idle for at least 5 seconds.
5. Stop engine and reconnect mass air flow sensor harness connector.
6. Select MODE 3 with GST. Make sure DTC P0102 is detected.
7. Select MODE 4 with GST and erase the DTC P0102.
8. Start engine again and let it idle for at least 10 minutes.
9. Select MODE 7 with GST. The 1st trip DTC P0171 or P0174 should be detected at this stage, if a malfunction exists. If so, go to [EC-225, "Diagnostic Procedure"](#) .

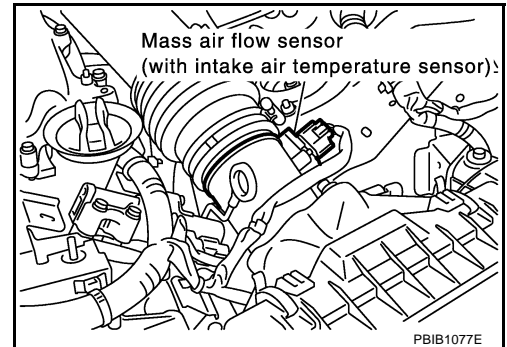

### NOTE:

If 1st trip DTC is not detected during above procedure, performing the following procedure is advised.

- a. Turn ignition switch OFF and wait at least 10 seconds.
- b. Start engine and drive the vehicle under the similar conditions to (1st trip) Freeze Frame Data for 10 minutes. Refer to the table below.

**Hold the accelerator pedal as steady as possible.**

The similar conditions to (1st trip) Freeze Frame Data means the vehicle operation that the following conditions should be satisfied at the same time.

Engine speed	Engine speed in the freeze frame data $\pm$ 400 rpm
Vehicle speed	Vehicle speed in the freeze frame data $\pm$ 10 km/h (6 MPH)
Engine coolant temperature (T) condition	When the freeze frame data shows lower than 70 °C (158 °F), T should be lower than 70 °C (158 °F).
	When the freeze frame data shows higher than or equal to 70 °C (158 °F), T should be higher than or equal to 70 °C (158 °F).

10. If it is difficult to start engine at step 8, the fuel injection system has a malfunction.
11. Crank engine while depressing accelerator pedal. If engine starts, go to [EC-225, "Diagnostic Procedure"](#) . If engine does not start, check exhaust and intake air leak visually.

# DTC P0171, P0174 FUEL INJECTION SYSTEM FUNCTION

## Wiring Diagram BANK 1

ABS009F6

EC-FUELB1-01

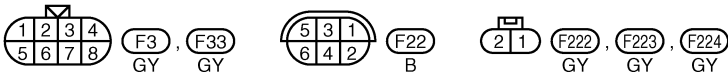
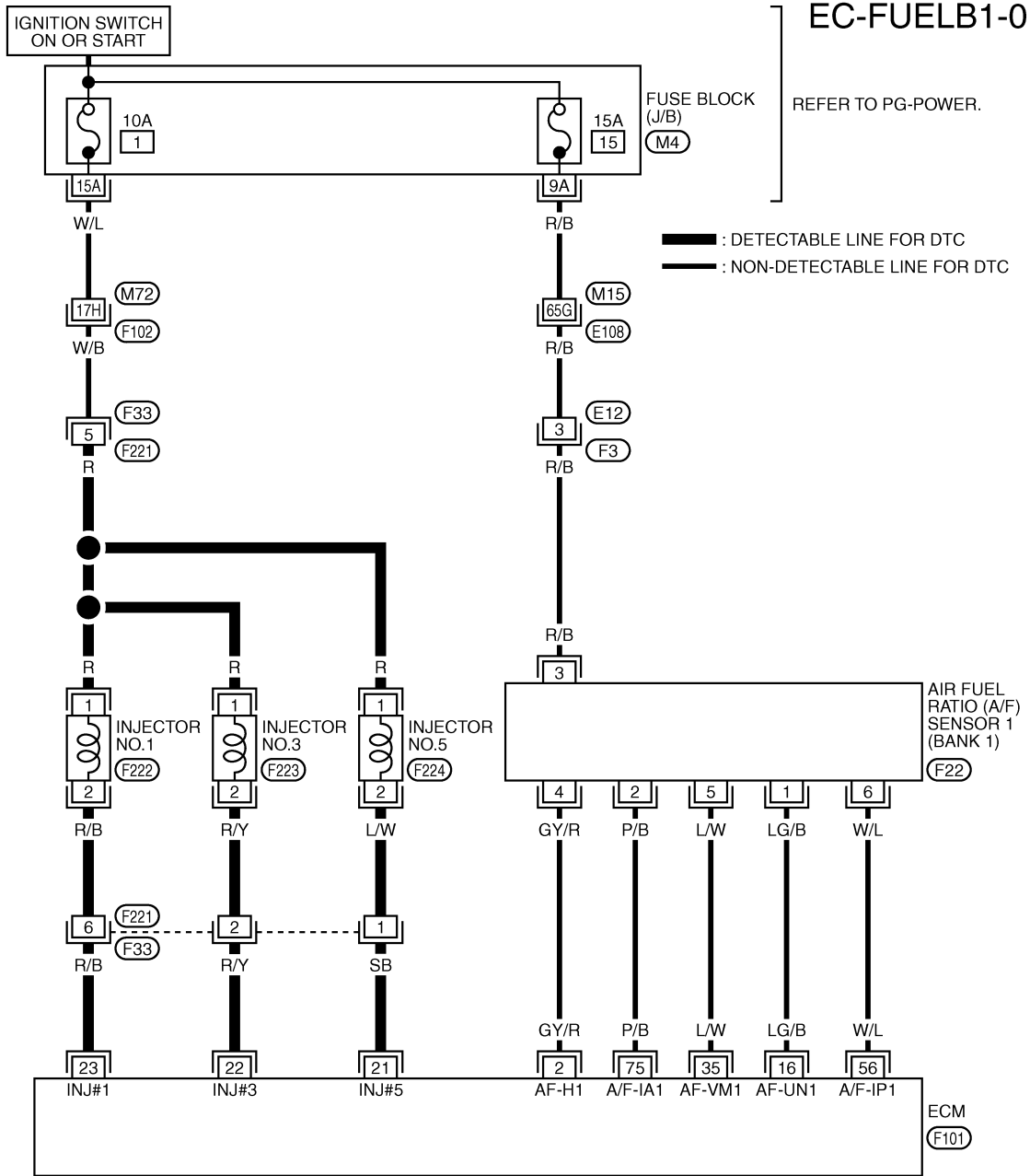

REFER TO THE FOLLOWING.

- E108, F102 -SUPER MULTIPLE JUNCTION (SMJ)
- M4 -FUSE BLOCK-JUNCTION BOX (J/B)

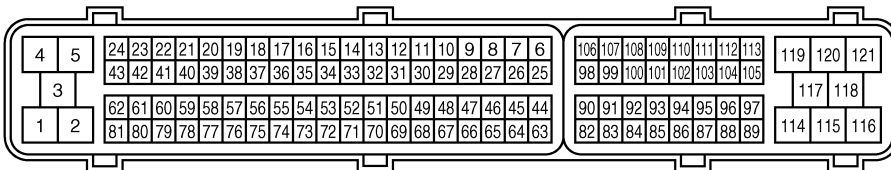

TBWT0702E

# DTC P0171, P0174 FUEL INJECTION SYSTEM FUNCTION

## BANK 2

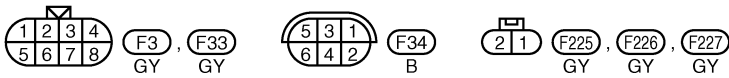
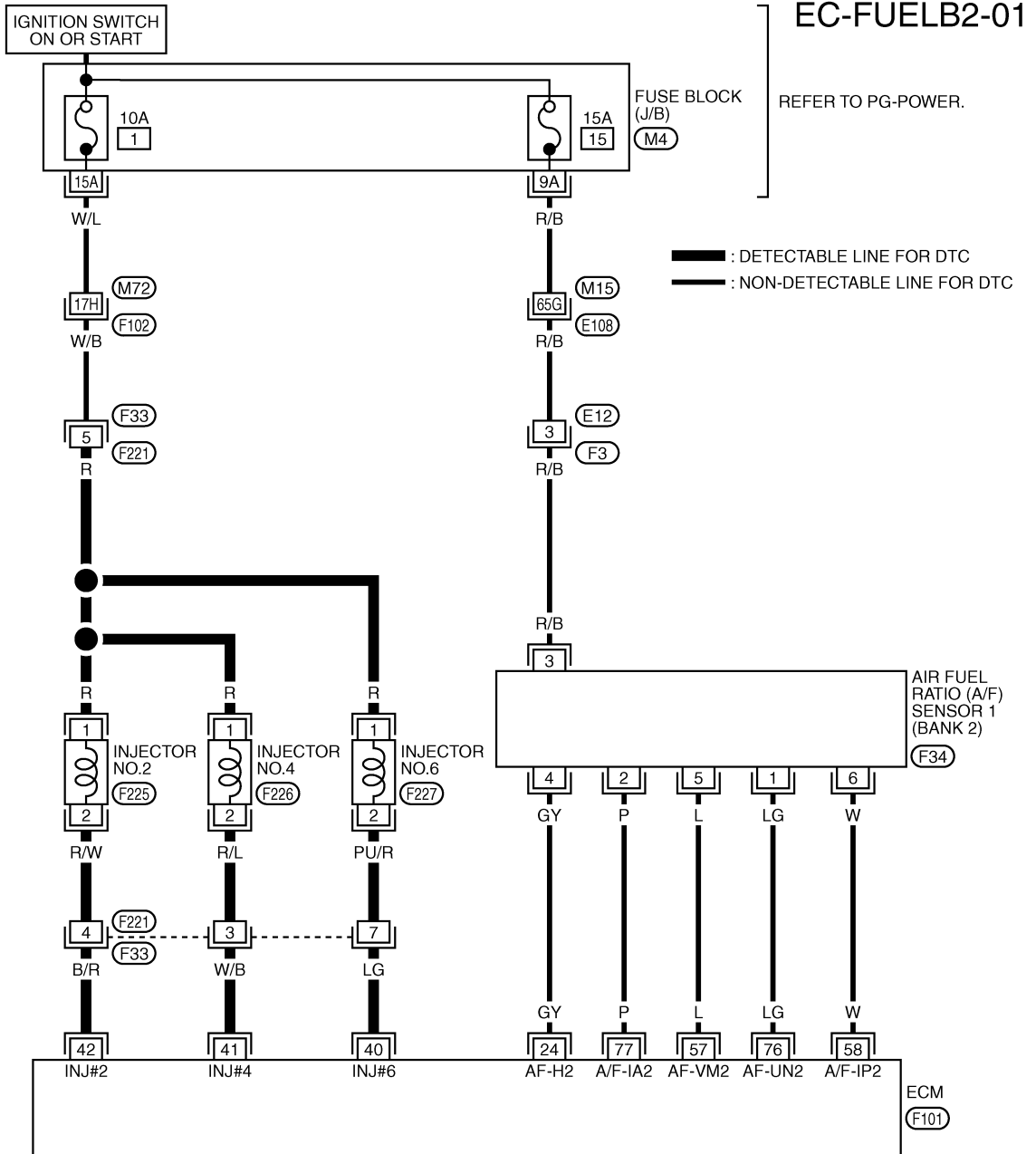

REFER TO THE FOLLOWING.

- (E108), (F102) -SUPER MULTIPLE JUNCTION (SMJ)
- (M4) -FUSE BLOCK-JUNCTION BOX (J/B)

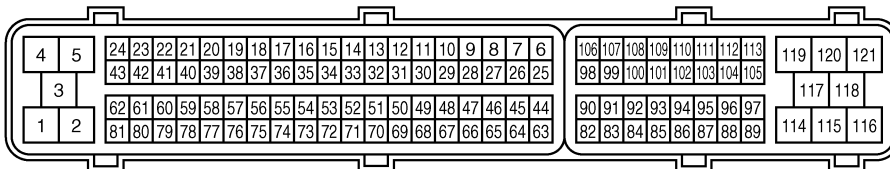

TBWT0703E



# DTC P0171, P0174 FUEL INJECTION SYSTEM FUNCTION

## Diagnostic Procedure

ABS009F7

### 1. CHECK EXHAUST GAS LEAK

1. Start engine and run it at idle.
2. Listen for an exhaust gas leak before three way catalyst 1.

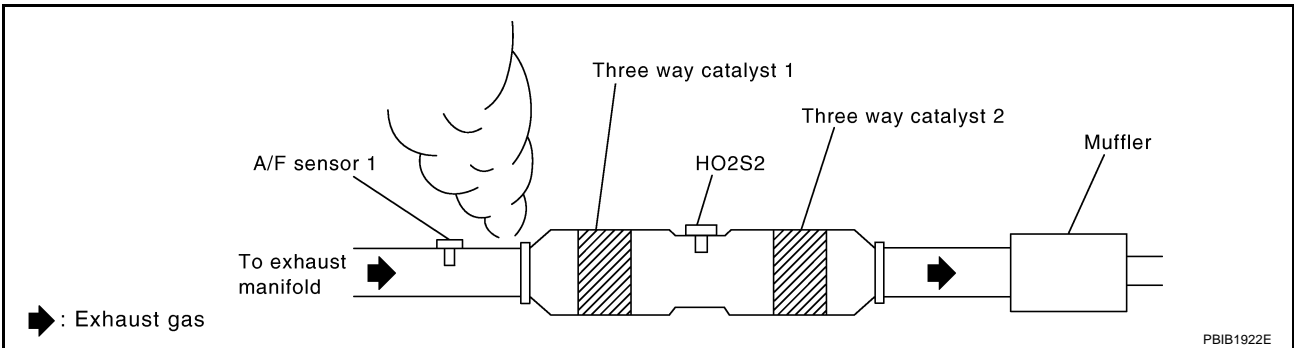

#### OK or NG

- OK >> GO TO 2.
- NG >> Repair or replace.

### 2. CHECK FOR INTAKE AIR LEAK

1. Listen for an intake air leak after the mass air flow sensor.
2. Check PCV hose connection.

#### OK or NG

- OK >> GO TO 3.
- NG >> Repair or replace.

# DTC P0171, P0174 FUEL INJECTION SYSTEM FUNCTION

## 3. CHECK A/F SENSOR 1 CIRCUIT FOR OPEN AND SHORT

1. Turn ignition switch OFF.
2. Disconnect corresponding A/F sensor 1 harness connector.

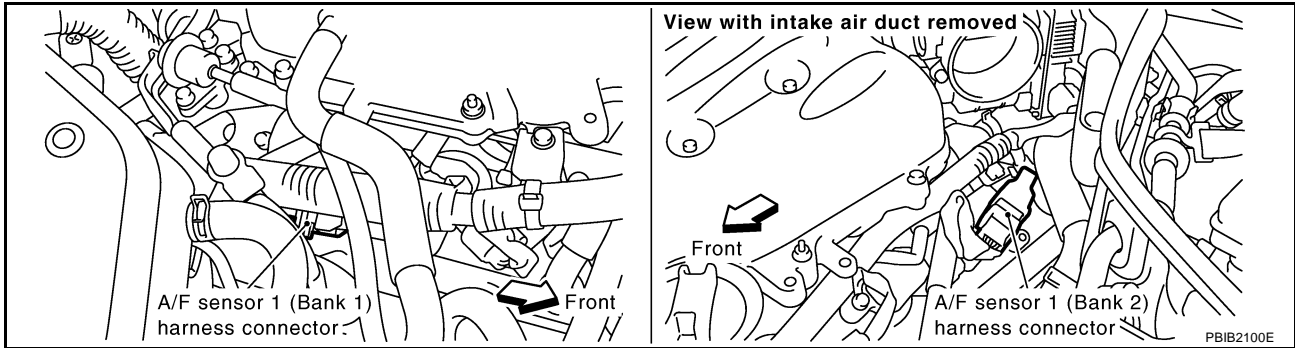

3. Disconnect ECM harness connector.
4. Check harness continuity between the following terminals. Refer to Wiring Diagram.

	A/F sensor 1 terminal	ECM terminal
Bank1	1	16
	2	75
	5	35
	6	56
Bank 2	1	76
	2	77
	5	57
	6	58

**Continuity should exist.**

5. Check harness continuity between the following terminals and ground. Refer to Wiring Diagram.

Bank 1		Bank 2	
A/F sensor 1 terminal	ECM terminal	A/F sensor 1 terminal	ECM terminal
1	16	1	76
2	75	2	77
5	35	5	57
6	56	6	58

**Continuity should not exist.**

6. Also check harness for short to power.

**OK or NG**

OK >> GO TO 4.

NG >> Repair open circuit or short to ground or short to power in harness or connectors.

# DTC P0171, P0174 FUEL INJECTION SYSTEM FUNCTION

## 4. CHECK FUEL PRESSURE

1. Release fuel pressure to zero. Refer to [EC-45, "FUEL PRESSURE RELEASE"](#) .
2. Install fuel pressure gauge and check fuel pressure. Refer to [EC-45, "FUEL PRESSURE CHECK"](#) .

**At idling: 350 kPa (3.57 kg/cm<sup>2</sup> , 51 psi)**

OK or NG

- OK >> GO TO 6.  
NG >> GO TO 5.

## 5. DETECT MALFUNCTIONING PART

Check the following.

- Fuel pump and circuit (Refer to [EC-640](#) .)
- Fuel pressure regulator (Refer to [EC-45](#) .)
- Fuel lines (Refer to [FL-3, "Checking Fuel Lines"](#) .)
- Fuel filter for clogging

>> Repair or replace.

## 6. CHECK MASS AIR FLOW SENSOR

 **With CONSULT-II**

1. Install all removed parts.
2. Check "MASS AIR FLOW" in "DATA MONITOR" mode with CONSULT-II.

**2.0 - 6.0 g-m/sec: at idling**  
**7.0 - 20.0 g-m/sec: at 2,500 rpm**

 **With GST**

1. Install all removed parts.
2. Check mass air flow sensor signal in "MODE 1" with GST.

**2.0 - 6.0 g-m/sec: at idling**  
**7.0 - 20.0 g-m/sec: at 2,500 rpm**

OK or NG

- OK >> GO TO 7.  
NG >> Check connectors for rusted terminals or loose connections in the mass air flow sensor circuit or ground. Refer to [EC-153, "DTC P0101 MAF SENSOR"](#) .

# DTC P0171, P0174 FUEL INJECTION SYSTEM FUNCTION

## 7. CHECK FUNCTION OF INJECTORS

### ④ With CONSULT-II

1. Start engine.
2. Perform "POWER BALANCE" in "ACTIVE TEST" mode with CONSULT-II.
3. Make sure that each circuit produces a momentary engine speed drop.

ACTIVE TEST	
POWER BALANCE	
MONITOR	
ENG SPEED	XXX rpm
MAS A/F SE-B1	XXX V

PBIB0133E

### ⊗ Without CONSULT-II

1. Start engine.
2. Listen to each injector operating sound.

**Clicking noise should be heard.**

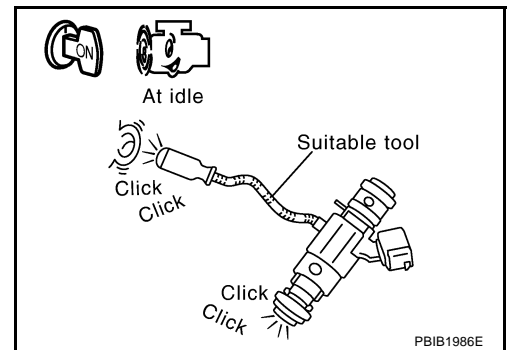

### OK or NG

OK >> GO TO 8.

NG >> Perform trouble diagnosis for [EC-634, "INJECTOR CIRCUIT"](#) .

## 8. CHECK INJECTOR

1. Confirm that the engine is cooled down and there are no fire hazards near the vehicle.
2. Turn ignition switch OFF.
3. Disconnect all injector harness connectors.
4. Remove injector gallery assembly. Refer to [EM-36, "FUEL INJECTOR AND FUEL TUBE"](#) .  
Keep fuel hose and all injectors connected to injector gallery.
5. For DTC P0171, reconnect injector harness connectors on bank 1.  
For DTC P0174, reconnect injector harness connectors on bank 2.
6. Disconnect all ignition coil harness connectors.
7. Prepare pans or saucers under each injector.
8. Crank engine for about 3 seconds.  
For DTC P0171, make sure that fuel sprays out from injectors on bank1.  
For DTC P0174, make sure that fuel sprays out from injectors on bank 2.

**Fuel should be sprayed evenly for each injector.**

### OK or NG

OK >> GO TO 9.

NG >> Replace injectors from which fuel does not spray out.  
Always replace O-ring with new ones.

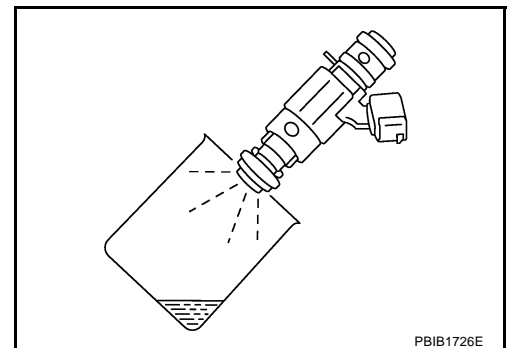

# DTC P0171, P0174 FUEL INJECTION SYSTEM FUNCTION

---

## 9. CHECK INTERMITTENT INCIDENT

---

Refer to [EC-129, "TROUBLE DIAGNOSIS FOR INTERMITTENT INCIDENT"](#) .

>> INSPECTION END

A

EC

C

D

E

F

G

H

I

J

K

L

M

# DTC P0172, P0175 FUEL INJECTION SYSTEM FUNCTION

## DTC P0172, P0175 FUEL INJECTION SYSTEM FUNCTION

PF16600

### On Board Diagnosis Logic

ABS009F8

With the Air/Fuel Mixture Ratio Self-Learning Control, the actual mixture ratio can be brought closely to the theoretical mixture ratio based on the mixture ratio feedback signal from the air fuel ratio (A/F) sensors 1. The ECM calculates the necessary compensation to correct the offset between the actual and the theoretical ratios.

In case the amount of the compensation value is extremely large (The actual mixture ratio is too rich.), the ECM judges the condition as the fuel injection system malfunction and lights up the MIL (2 trip detection logic).

Sensor	Input signal to ECM	ECM function	Actuator
Air fuel ratio (A/F) sensor 1	Density of oxygen in exhaust gas (Mixture ratio feedback signal)	Fuel injection control	Fuel injector

DTC No.	Trouble diagnosis name	DTC detecting condition	Possible cause
P0172 0172 (Bank 1)	Fuel injection system too rich	<ul style="list-style-type: none"> <li>Fuel injection system does not operate properly.</li> <li>The amount of mixture ratio compensation is too large. (The mixture ratio is too rich.)</li> </ul>	<ul style="list-style-type: none"> <li>Air fuel ratio (A/F) sensor 1</li> <li>Fuel injector</li> <li>Exhaust gas leaks</li> <li>Incorrect fuel pressure</li> <li>Mass air flow sensor</li> </ul>
P0175 0175 (Bank 2)			

### DTC Confirmation Procedure

ABS009F9

#### CAUTION:

Always drive vehicle at a safe speed.

#### NOTE:

If DTC Confirmation Procedure has been previously conducted, always turn ignition switch OFF and wait at least 10 seconds before conducting the next test.

#### WITH CONSULT-II

- Start engine and warm it up to normal operating temperature.
- Turn ignition switch OFF and wait at least 10 seconds.
- Turn ignition switch ON and select "SELF-LEARNING CONT" in "WORK SUPPORT" mode with CONSULT-II.
- Clear the self-learning control coefficient by touching "CLEAR".
- Select "DATA MONITOR" mode with CONSULT-II.
- Start engine again and let it idle for at least 10 minutes. The 1st trip DTC P0172, P0175 should be detected at this stage, if a malfunction exists. If so, go to [EC-234, "Diagnostic Procedure"](#).

#### NOTE:

If 1st trip DTC is not detected during above procedure, performing the following procedure is advised.

- Turn ignition switch OFF and wait at least 10 seconds.
- Start engine and drive the vehicle under the similar conditions to (1st trip) Freeze Frame Data for a certain time. Refer to the table below. **Hold the accelerator pedal as steady as possible.**

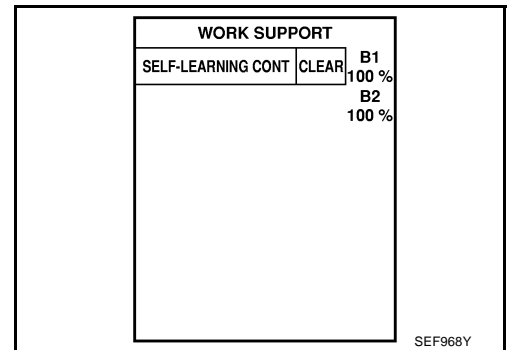

The similar conditions to (1st trip) Freeze Frame Data means the vehicle operation that the following conditions should be satisfied at the same time.

Engine speed	Engine speed in the freeze frame data $\pm$ 400 rpm
Vehicle speed	Vehicle speed in the freeze frame data $\pm$ 10 km/h (6 MPH)

# DTC P0172, P0175 FUEL INJECTION SYSTEM FUNCTION

Engine coolant temperature (T) condition	When the freeze frame data shows lower than 70 °C (158 °F), T should be lower than 70 °C (158 °F).
	When the freeze frame data shows higher than or equal to 70 °C (158 °F), T should be higher than or equal to 70 °C (158 °F).

7. If it is difficult to start engine at step 6, the fuel injection system has a malfunction, too.
8. Crank engine while depressing accelerator pedal.  
If engine starts, go to [EC-234, "Diagnostic Procedure"](#) . If engine does not start, remove ignition plugs and check for fouling, etc.

## WITH GST

1. Start engine and warm it up to normal operating temperature.
2. Turn ignition switch OFF and wait at least 10 seconds.
3. Disconnect mass air flow sensor harness connector. Then restart and run engine for at least 5 seconds at idle speed.
4. Stop engine and reconnect mass air flow sensor harness connector.
5. Select MODE 3 with GST. Make sure DTC P0102 is detected.
6. Select MODE 4 with GST and erase the DTC P0102.
7. Start engine again and let it idle for at least 10 minutes.
8. Select MODE 7 with GST. The 1st trip DTC P0172 or P0175 should be detected at this stage, if a malfunction exists. If so, go to [EC-234, "Diagnostic Procedure"](#) .

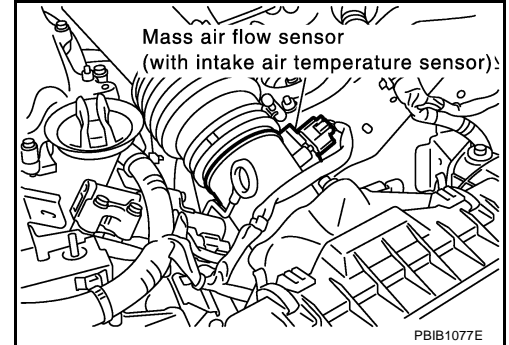

### NOTE:

If 1st trip DTC is not detected during above procedure, performing the following procedure is advised.

- a. Turn ignition switch OFF and wait at least 10 seconds.
- b. Start engine and drive the vehicle under the similar conditions to (1st trip) Freeze Frame Data for a certain time. Refer to the table below.

**Hold the accelerator pedal as steady as possible.**

The similar conditions to (1st trip) Freeze Frame Data means the vehicle operation that the following conditions should be satisfied at the same time.

Engine speed	Engine speed in the freeze frame data $\pm$ 400 rpm
Vehicle speed	Vehicle speed in the freeze frame data $\pm$ 10 km/h (6 MPH)
Engine coolant temperature (T) condition	When the freeze frame data shows lower than 70 °C (158 °F), T should be lower than 70 °C (158 °F).
	When the freeze frame data shows higher than or equal to 70 °C (158 °F), T should be higher than or equal to 70 °C (158 °F).

9. If it is difficult to start engine at step 7, the fuel injection system has a malfunction.
10. Crank engine while depressing accelerator pedal.  
If engine starts, go to [EC-234, "Diagnostic Procedure"](#) . If engine does not start, remove ignition plugs and check for fouling, etc.

# DTC P0172, P0175 FUEL INJECTION SYSTEM FUNCTION

ABS009FA

## Wiring Diagram BANK 1

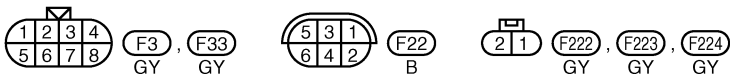
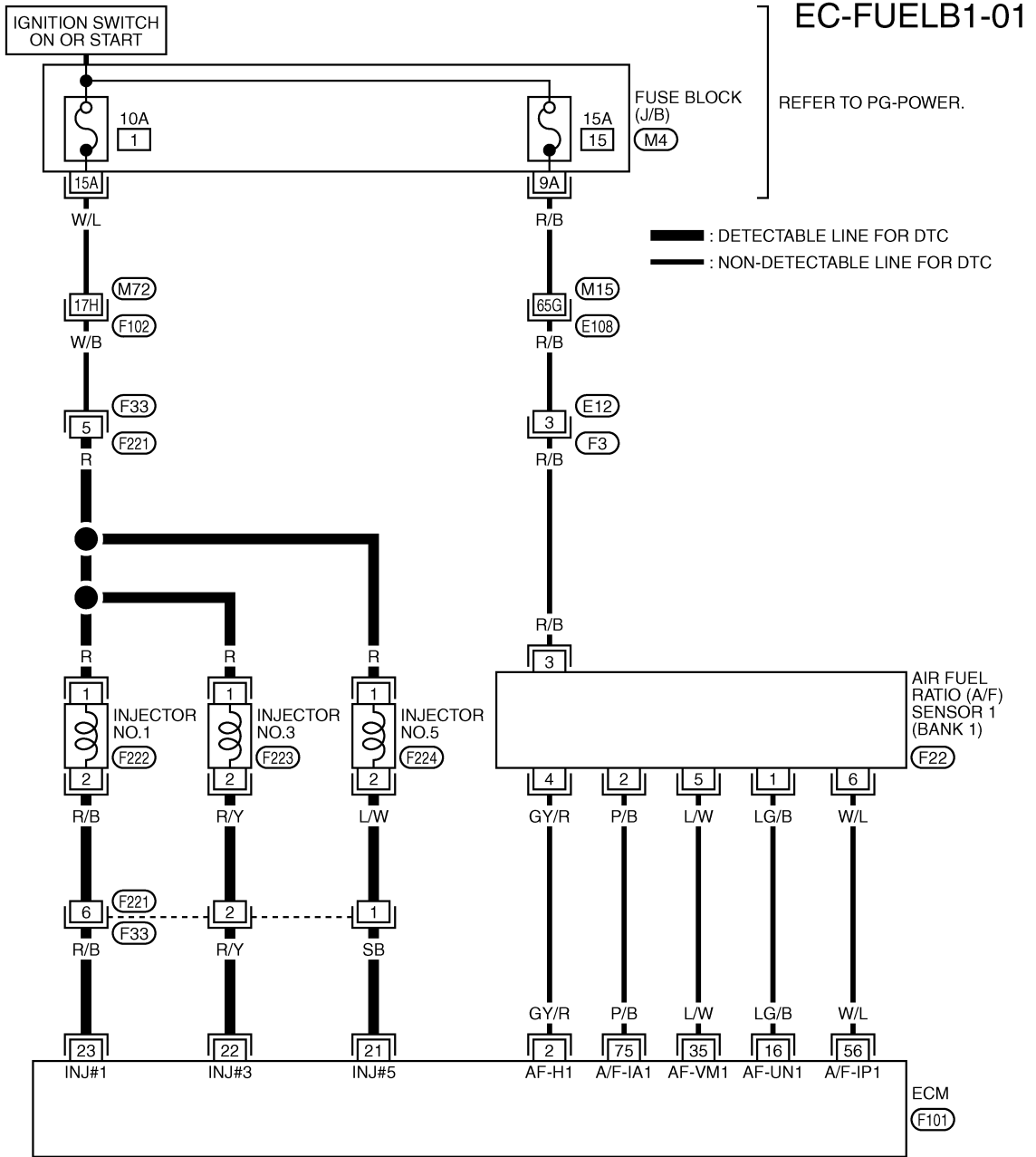

REFER TO THE FOLLOWING.

- (E108), (F102) -SUPER MULTIPLE JUNCTION (SMJ)
- (M4) -FUSE BLOCK-JUNCTION BOX (J/B)

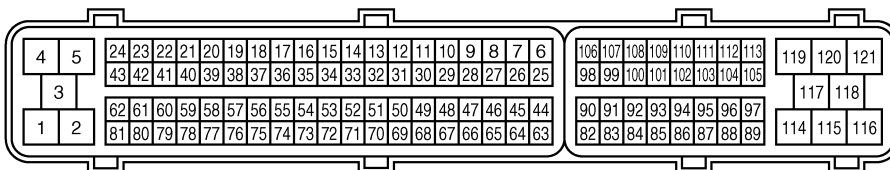

TBWT0702E



# DTC P0172, P0175 FUEL INJECTION SYSTEM FUNCTION

## BANK 2

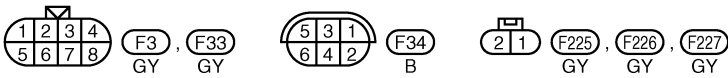
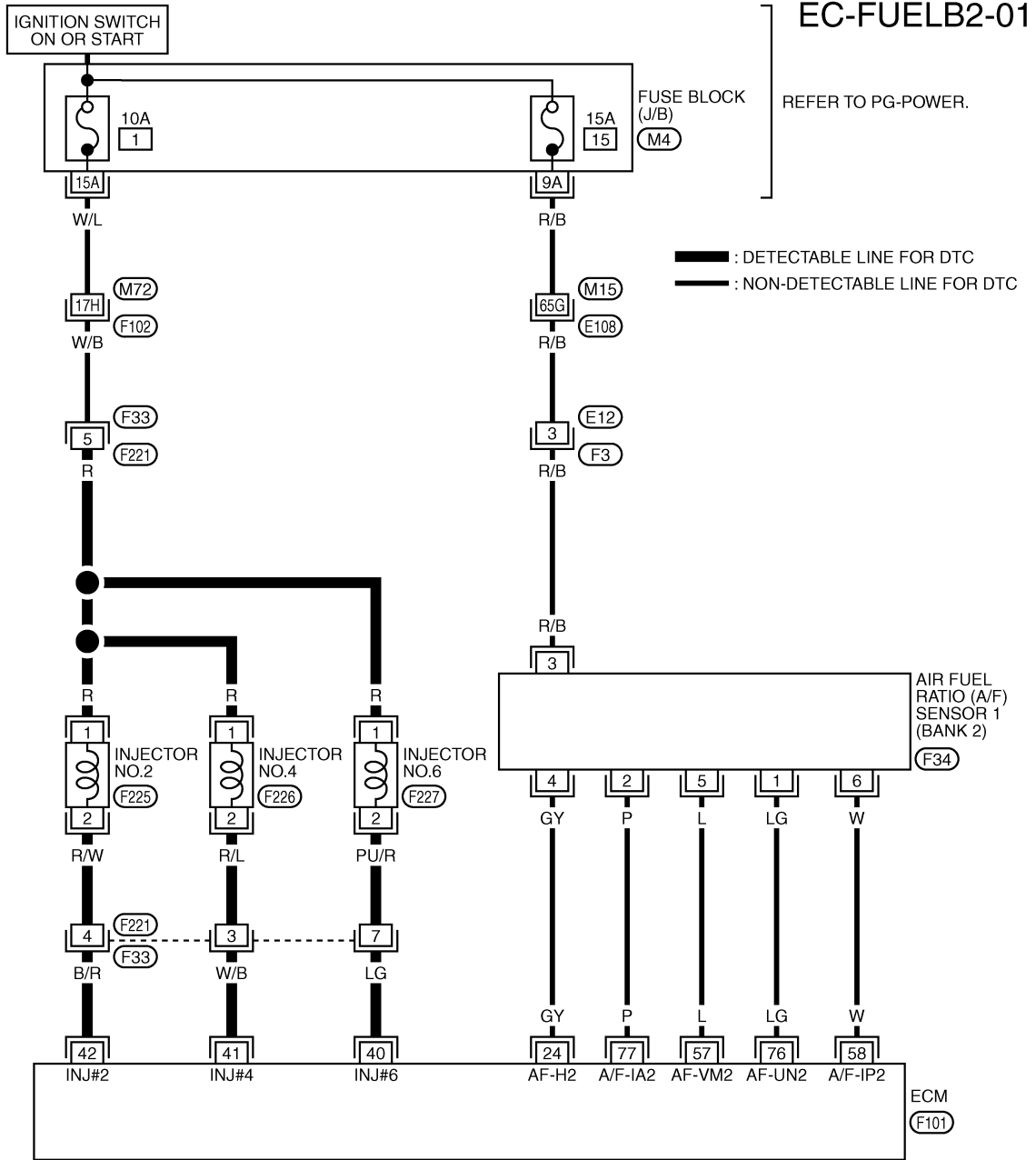

REFER TO THE FOLLOWING.  
**E108**, **F102** -SUPER MULTIPLE JUNCTION (SMJ)  
**M4** -FUSE BLOCK-JUNCTION BOX (J/B)

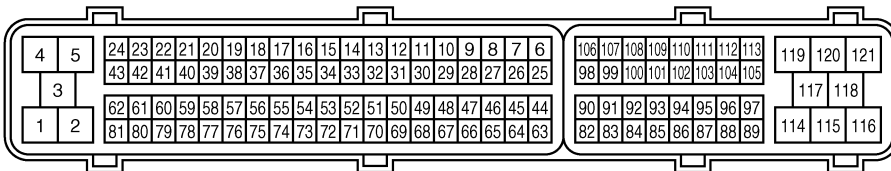

TBWT0703E

# DTC P0172, P0175 FUEL INJECTION SYSTEM FUNCTION

ABS009FB

## Diagnostic Procedure

### 1. CHECK EXHAUST GAS LEAK

1. Start engine and run it at idle.
2. Listen for an exhaust gas leak before three way catalyst 1.

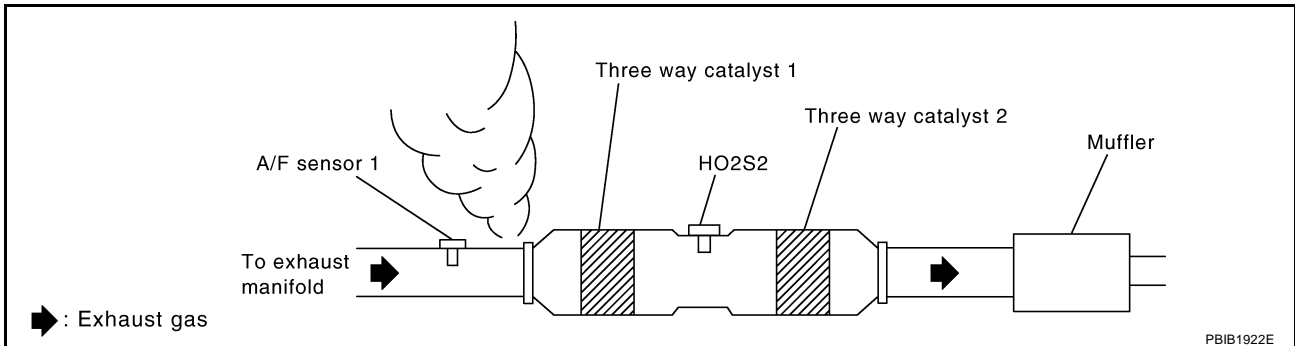

OK or NG

- OK >> GO TO 2.
- NG >> Repair or replace.

### 2. CHECK FOR INTAKE AIR LEAK

Listen for an intake air leak after the mass air flow sensor.

OK or NG

- OK >> GO TO 3.
- NG >> Repair or replace.

# DTC P0172, P0175 FUEL INJECTION SYSTEM FUNCTION

## 3. CHECK A/F SENSOR 1 CIRCUIT FOR OPEN AND SHORT

1. Turn ignition switch OFF.
2. Disconnect corresponding A/F sensor 1 harness connector.

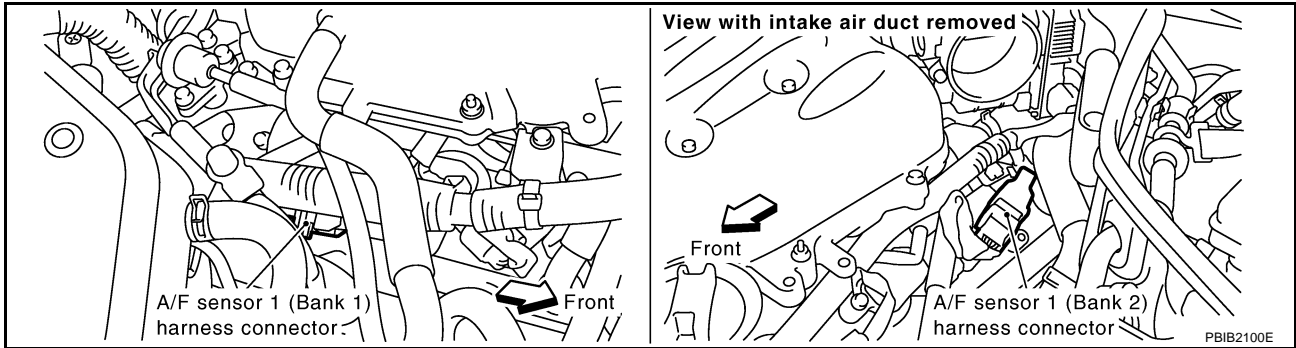

3. Disconnect ECM harness connector.
4. Check harness continuity between the following terminals. Refer to Wiring Diagram.

	A/F sensor 1 terminal	ECM terminal
Bank1	1	16
	2	75
	5	35
	6	56
Bank 2	1	76
	2	77
	5	57
	6	58

**Continuity should exist.**

5. Check harness continuity between the following terminals and ground. Refer to Wiring Diagram.

Bank 1		Bank 2	
A/F sensor 1 terminal	ECM terminal	A/F sensor 1 terminal	ECM terminal
1	16	1	76
2	75	2	77
5	35	5	57
6	56	6	58

**Continuity should not exist.**

6. Also check harness for short to power.

OK or NG

OK >> GO TO 4.

NG >> Repair open circuit or short to ground or short to power in harness or connectors.

# DTC P0172, P0175 FUEL INJECTION SYSTEM FUNCTION

---

## 4. CHECK FUEL PRESSURE

---

1. Release fuel pressure to zero. Refer to [EC-45, "FUEL PRESSURE RELEASE"](#) .
2. Install fuel pressure gauge and check fuel pressure. Refer to [EC-45, "FUEL PRESSURE CHECK"](#) .

**At idling: 350 kPa (3.57 kg/cm<sup>2</sup> , 51 psi)**

OK or NG

- OK >> GO TO 6.  
NG >> GO TO 5.

---

## 5. DETECT MALFUNCTIONING PART

---

Check the following.

- Fuel pump and circuit (Refer to, [EC-640](#) .)
- Fuel pressure regulator (Refer to [EC-45](#) .)

>> Repair or replace.

---

## 6. CHECK MASS AIR FLOW SENSOR

---

 **With CONSULT-II**

1. Install all removed parts.
2. Check "MASS AIR FLOW" in "DATA MONITOR" mode with CONSULT-II.

**2.0 - 6.0 g-m/sec: at idling**  
**7.0 - 20.0 g-m/sec: at 2,500 rpm**

 **With GST**

1. Install all removed parts.
2. Check mass air flow sensor signal in "MODE 1" with GST.

**2.0 - 6.0 g-m/sec: at idling**  
**7.0 - 20.0 g-m/sec: at 2,500 rpm**

OK or NG

- OK >> GO TO 7.  
NG >> Check connectors for rusted terminals or loose connections in the mass air flow sensor circuit or ground. Refer to [EC-153, "DTC P0101 MAF SENSOR"](#) .

# DTC P0172, P0175 FUEL INJECTION SYSTEM FUNCTION

## 7. CHECK FUNCTION OF INJECTORS

### ④ With CONSULT-II

1. Start engine.
2. Perform "POWER BALANCE" in "ACTIVE TEST" mode with CONSULT-II.
3. Make sure that each circuit produces a momentary engine speed drop.

ACTIVE TEST	
POWER BALANCE	
MONITOR	
ENG SPEED	XXX rpm
MAS A/F SE-B1	XXX V

PBIB0133E

### ⊗ Without CONSULT-II

1. Start engine.
2. Listen to each injector operating sound.

**Clicking noise should be heard.**

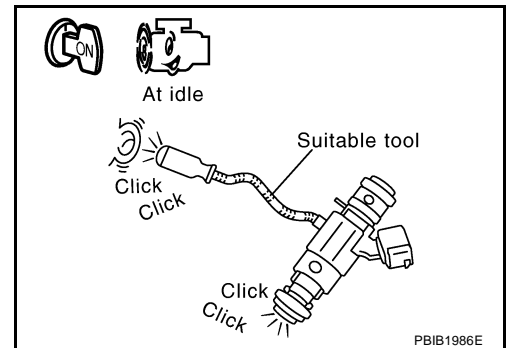

### OK or NG

OK >> GO TO 8.

NG >> Perform trouble diagnosis for [EC-634, "INJECTOR CIRCUIT"](#).

## 8. CHECK INJECTOR

1. Remove injector assembly. Refer to [EM-36, "FUEL INJECTOR AND FUEL TUBE"](#).  
Keep fuel hose and all injectors connected to injector gallery.
2. Confirm that the engine is cooled down and there are no fire hazards near the vehicle.
3. Disconnect all injector harness connectors.
4. Disconnect all ignition coil harness connectors.
5. Prepare pans or saucers under each injectors.
6. Crank engine for about 3 seconds.  
Make sure fuel does not drip from injector.

### OK or NG

OK (Does not drip.)>>GO TO 9.

NG (Drips.)>>Replace the injectors from which fuel is dripping. Always replace O-ring with new one.

## 9. CHECK INTERMITTENT INCIDENT

Refer to [EC-129, "TROUBLE DIAGNOSIS FOR INTERMITTENT INCIDENT"](#).

>> INSPECTION END

# DTC P0181 FTT SENSOR

## DTC P0181 FTT SENSOR

PFP:22630

### Component Description

ABS009FC

The fuel tank temperature sensor is used to detect the fuel temperature inside the fuel tank. The sensor modifies a voltage signal from the ECM. The modified signal returns to the ECM as the fuel temperature input. The sensor uses a thermistor which is sensitive to the change in temperature. The electrical resistance of the thermistor decreases as temperature increases.

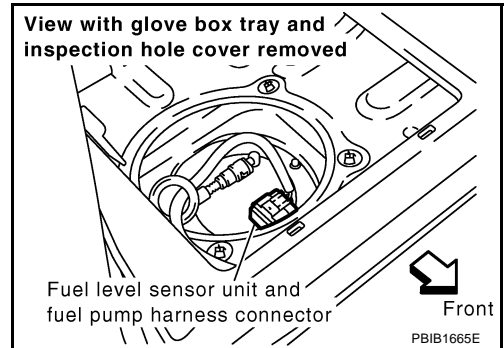

### <Reference data>

Fluid temperature °C (°F)	Voltage* V	Resistance kΩ
20 (68)	3.5	2.3 - 2.7
50 (122)	2.2	0.79 - 0.90

\*: This data is reference values and is measured between ECM terminal 107 (Fuel tank temperature sensor) and ground.

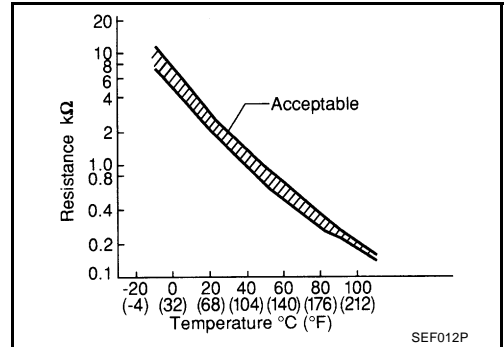

### CAUTION:

**Do not use ECM ground terminals when measuring input/output voltage. Doing so may result in damage to the ECM's transistor. Use a ground other than ECM terminals, such as the ground.**

### On Board Diagnosis Logic

ABS009FD

DTC No.	Trouble diagnosis name	DTC detecting condition	Possible cause
P0181 0181	Fuel tank temperature sensor circuit range/performance	Rationally incorrect voltage from the sensor is sent to ECM, compared with the voltage signals from engine coolant temperature sensor and intake air temperature sensor.	<ul style="list-style-type: none"> <li>● Harness or connectors (The sensor circuit is open or shorted)</li> <li>● Fuel tank temperature sensor</li> </ul>

### DTC Confirmation Procedure

ABS009FE

#### NOTE:

If DTC Confirmation Procedure has been previously conducted, always turn ignition switch OFF and wait at least 10 seconds before conducting the next test.

#### WITH CONSULT-II

1. Turn ignition switch ON.
2. Select "DATA MONITOR" mode with CONSULT-II.
3. Wait at least 10 seconds.  
If the result is NG, go to [EC-241, "Diagnostic Procedure"](#).  
If the result is OK, go to following step.
4. Check "COOLAN TEMP/S" value.  
If "COOLAN TEMP/S" is less than 60°C (140°F), the result will be OK.  
If "COOLAN TEMP/S" is above 60°C (140°F), go to the following step.
5. Cool engine down until "COOLAN TEMP/S" is less than 60°C (140°F).
6. Wait at least 10 seconds.
7. If 1st trip DTC is detected, go to [EC-241, "Diagnostic Procedure"](#).

# DTC P0181 FTT SENSOR

---

 **WITH GST**

Follow the procedure "WITH CONSULT-II" above.

A

**EC**

C

D

E

F

G

H

I

J

K

L

M

# DTC P0181 FTT SENSOR

ABS009FF

## EC-FTTS-01

### Wiring Diagram

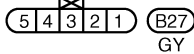
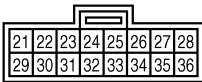
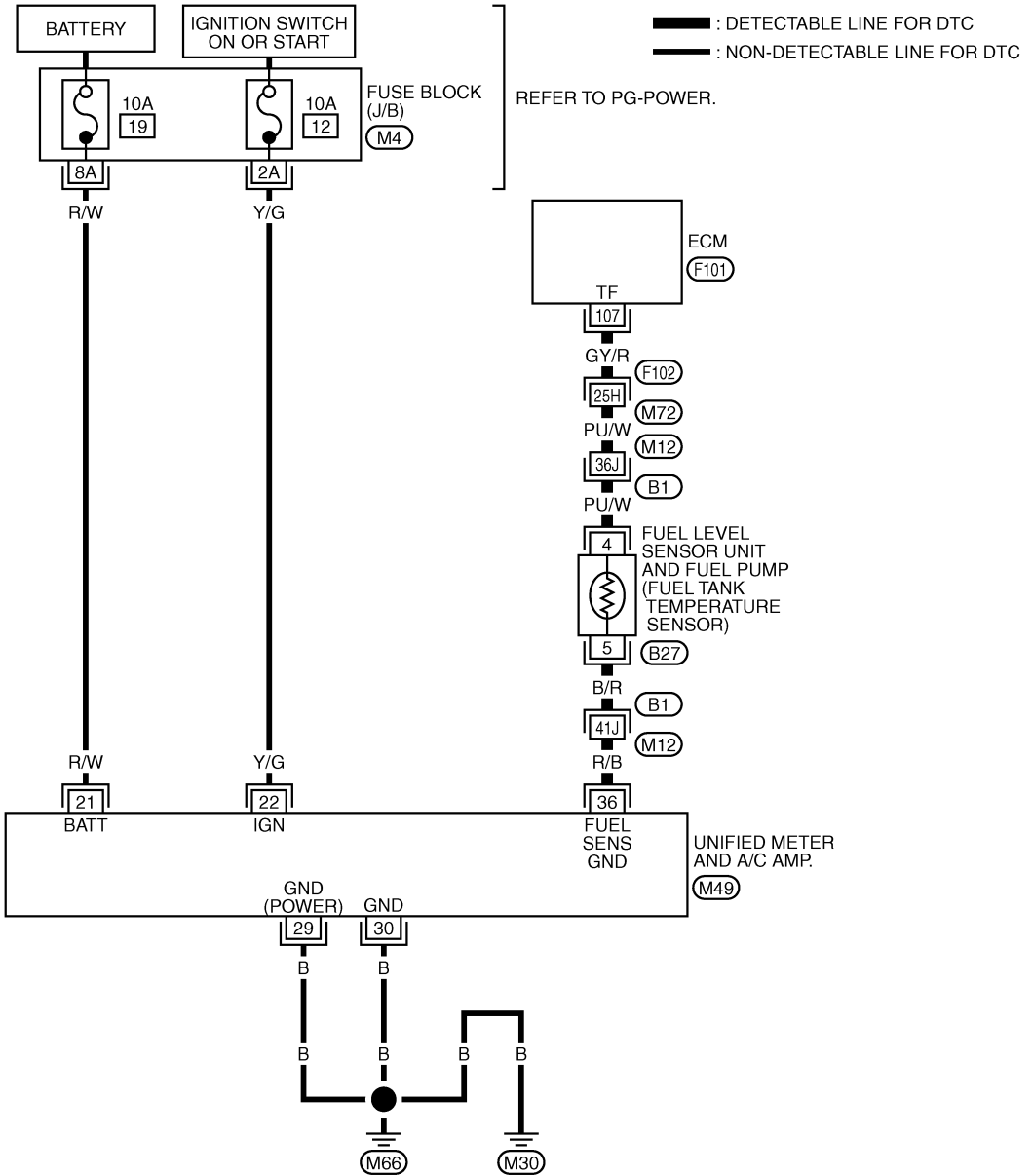

REFER TO THE FOLLOWING.  
 (F102), (B1) -SUPER MULTIPLE JUNCTION (SMJ)  
 (M4) -FUSE BLOCK-JUNCTION BOX (J/B)

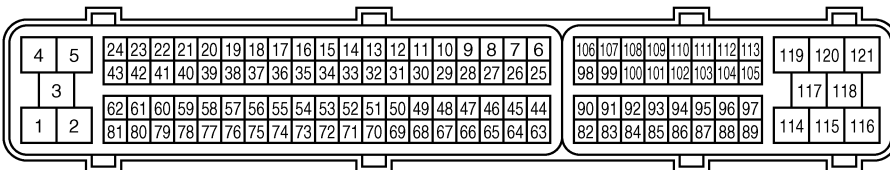



# DTC P0181 FTT SENSOR

ABS009FG

## Diagnostic Procedure

### 1. CHECK DTC WITH "UNIFIED METER AND A/C AMP."

Refer to [DI-59, "SELF-DIAGNOSIS RESULTS"](#).

OK or NG

OK >> GO TO 2.

NG >> Go to [DI-21, "Fuel Level Sensor Signal Inspection"](#).

### 2. CHECK FUEL TANK TEMPERATURE SENSOR POWER SUPPLY CIRCUIT

1. Disconnect "fuel level sensor unit and fuel pump" harness connector.
2. Turn ignition switch ON.

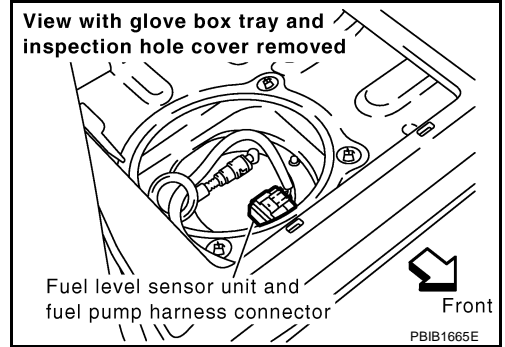

3. Check voltage between "fuel level sensor unit and fuel pump" terminal 4 and ground with CONSULT-II or tester.

**Voltage: Approximately 5V**

OK or NG

OK >> GO TO 4.

NG >> GO TO 3.

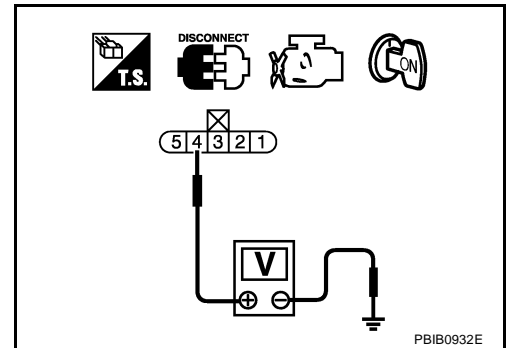

### 3. DETECT MALFUNCTIONING PART

Check the following.

- Harness connectors M72, F102
- Harness connectors B1, M12
- Harness for open or short between ECM and "fuel level sensor unit and fuel pump"

>> Repair open circuit or short to ground or short to power in harness or connector.

### 4. CHECK FUEL TANK TEMPERATURE SENSOR GROUND CIRCUIT FOR OPEN AND SHORT

1. Turn ignition switch OFF.
2. Disconnect "unified meter and A/C amp." harness connector M49.
3. Check harness continuity between "fuel level sensor unit and fuel pump" terminal 5 and "unified meter and A/C amp." terminal 36. Refer to Wiring Diagram.

**Continuity should exist.**

4. Also check harness for short to power.

OK or NG

OK >> GO TO 6.

NG >> GO TO 5.

# DTC P0181 FTT SENSOR

## 5. DETECT MALFUNCTIONING PART

Check the following.

- Harness connectors B1, M12
- Harness for open or short between “fuel level sensor unit and fuel pump” and “unified meter and A/C amp.”

>> Repair open circuit or short to ground or short to power in harness or connector.

## 6. CHECK FUEL TANK TEMPERATURE SENSOR

Refer to [EC-242, "Component Inspection"](#) .

OK or NG

OK >> GO TO 7.

NG >> Replace fuel level sensor unit.

## 7. CHECK INTERMITTENT INCIDENT

Refer to [EC-129, "TROUBLE DIAGNOSIS FOR INTERMITTENT INCIDENT"](#) .

>> INSPECTION END

### Component Inspection FUEL TANK TEMPERATURE SENSOR

ABS009FH

1. Remove fuel level sensor unit.
2. Check resistance between “fuel level sensor unit and fuel pump” terminals 4 and 5 by heating with hot water or heat gun as shown in the figure.

Temperature °C (°F)	Resistance kΩ
20 (68)	2.3 - 2.7
50 (122)	0.79 - 0.90

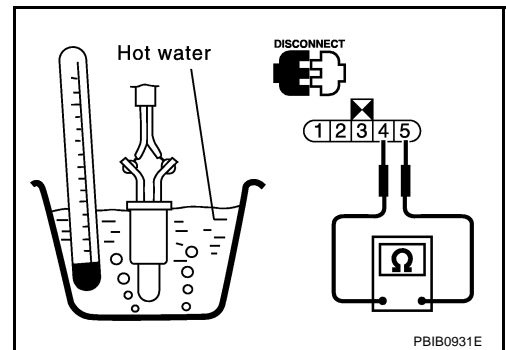

PBIB0931E

### Removal and Installation FUEL TANK TEMPERATURE SENSOR

ABS009FI

Refer to [FL-4, "FUEL LEVEL SENSOR UNIT, FUEL FILTER AND FUEL PUMP ASSEMBLY"](#) .

# DTC P0182, P0183 FTT SENSOR

## DTC P0182, P0183 FTT SENSOR

PFP:22630

### Component Description

ABS009FJ

The fuel tank temperature sensor is used to detect the fuel temperature inside the fuel tank. The sensor modifies a voltage signal from the ECM. The modified signal returns to the ECM as the fuel temperature input. The sensor uses a thermistor which is sensitive to the change in temperature. The electrical resistance of the thermistor decreases as temperature increases.

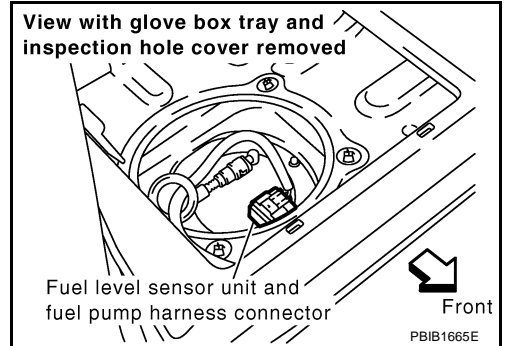

### <Reference data>

Fluid temperature °C (°F)	Voltage* V	Resistance kΩ
20 (68)	3.5	2.3 - 2.7
50 (122)	2.2	0.79 - 0.90

\*: This data is reference values and is measured between ECM terminal 107 (Fuel tank temperature sensor) and ground.

### CAUTION:

**Do not use ECM ground terminals when measuring input/output voltage. Doing so may result in damage to the ECM's transistor. Use a ground other than ECM terminals, such as the ground.**

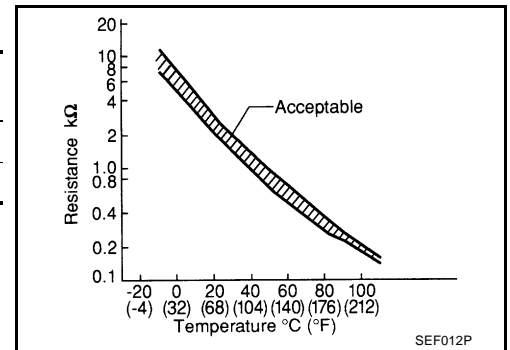

### On Board Diagnosis Logic

ABS009FK

DTC No.	Trouble diagnosis name	DTC detecting condition	Possible cause
P0182 0182	Fuel tank temperature sensor circuit low input	An excessively low voltage from the sensor is sent to ECM.	<ul style="list-style-type: none"> <li>● Harness or connectors (The sensor circuit is open or shorted.)</li> <li>● Fuel tank temperature sensor</li> </ul>
P0183 0183	Fuel tank temperature sensor circuit high input	An excessively high voltage from the sensor is sent to ECM.	

### DTC Confirmation Procedure

ABS009FL

#### NOTE:

If DTC Confirmation Procedure has been previously conducted, always turn ignition switch OFF and wait at least 10 seconds before conducting the next test.

#### WITH CONSULT-II

1. Turn ignition switch ON.
2. Select "DATA MONITOR" mode with CONSULT-II.
3. Wait at least 5 seconds.
4. If 1st trip DTC is detected, go to [EC-245, "Diagnostic Procedure"](#)

#### WITH GST

Follow the procedure "WITH CONSULT-II" above.

# DTC P0182, P0183 FTT SENSOR

ABS009FM

## EC-FTTS-01

### Wiring Diagram

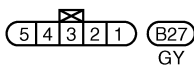
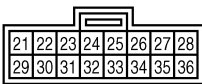
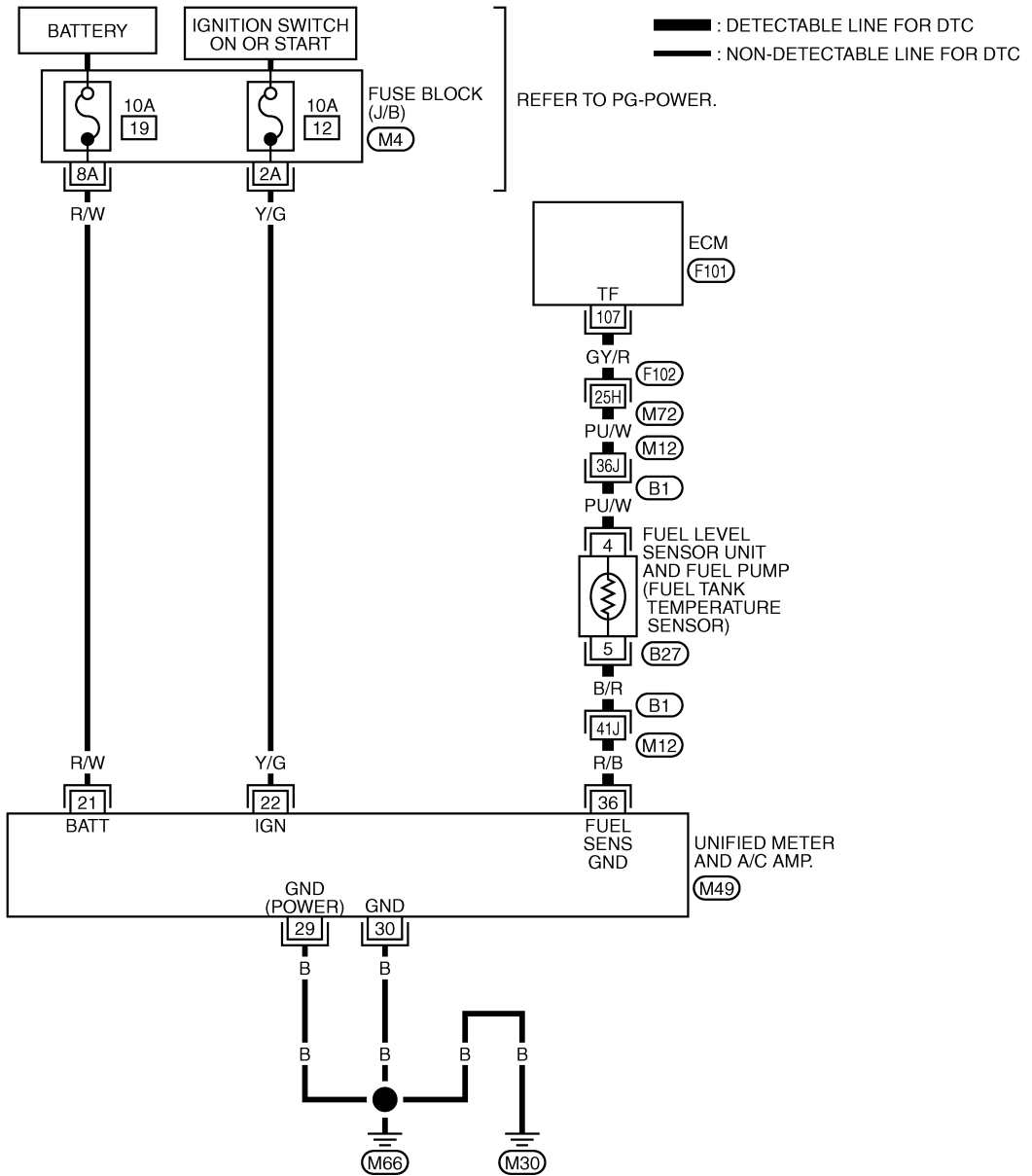

REFER TO THE FOLLOWING.  
 (F102), (B1) -SUPER MULTIPLE JUNCTION (SMJ)  
 (M4) -FUSE BLOCK-JUNCTION BOX (J/B)

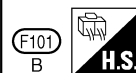
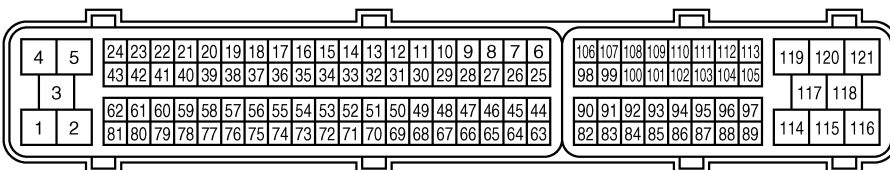

TBWT0209E

# DTC P0182, P0183 FTT SENSOR

ABS009FN

## Diagnostic Procedure

### 1. CHECK DTC WITH "UNIFIED METER AND A/C AMP."

Refer to [DI-59, "SELF-DIAGNOSIS RESULTS"](#).

OK or NG

OK >> GO TO 2.

NG >> Go to [DI-21, "Fuel Level Sensor Signal Inspection"](#).

### 2. CHECK FUEL TANK TEMPERATURE SENSOR POWER SUPPLY CIRCUIT

1. Disconnect "fuel level sensor unit and fuel pump" harness connector.
2. Turn ignition switch ON.

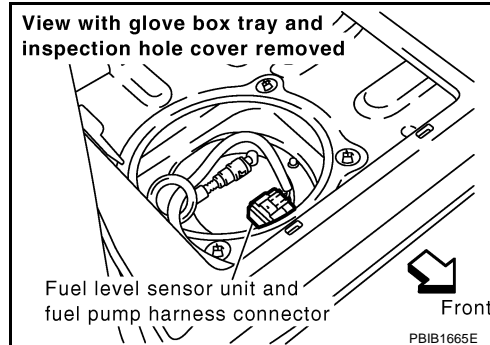

3. Check voltage between "fuel level sensor unit and fuel pump" terminal 4 and ground with CONSULT-II or tester.

**Voltage: Approximately 5V**

OK or NG

OK >> GO TO 4.

NG >> GO TO 3.

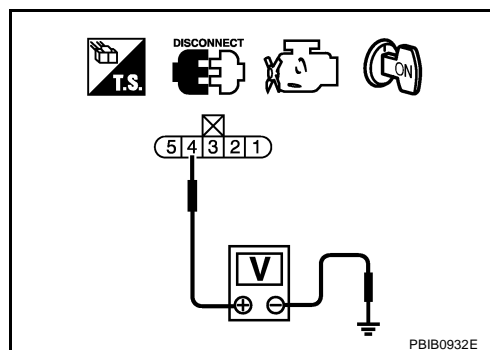

### 3. DETECT MALFUNCTIONING PART

Check the following.

- Harness connectors M72, F102
- Harness connectors B1, M12
- Harness for open or short between ECM and "fuel level sensor unit and fuel pump"

>> Repair open circuit or short to ground or short to power in harness or connector.

### 4. CHECK FUEL TANK TEMPERATURE SENSOR GROUND CIRCUIT FOR OPEN AND SHORT

1. Turn ignition switch OFF.
2. Disconnect "unified meter and A/C amp." harness connector M49.
3. Check harness continuity between "fuel level sensor unit and fuel pump" terminal 5 and "unified meter and A/C amp." terminal 36. Refer to Wiring Diagram.

**Continuity should exist.**

4. Also check harness for short to power.

OK or NG

OK >> GO TO 6.

NG >> GO TO 5.

# DTC P0182, P0183 FTT SENSOR

## 5. DETECT MALFUNCTIONING PART

Check the following.

- Harness connectors B1, M12
- Harness for open or short between “fuel level sensor unit and fuel pump” and “unified meter and A/C amp.”

>> Repair open circuit short to ground or short to power in harness or connector.

## 6. CHECK FUEL TANK TEMPERATURE SENSOR

Refer to [EC-242, "Component Inspection"](#) .

OK or NG

OK >> GO TO 7.

NG >> Replace fuel level sensor unit.

## 7. CHECK INTERMITTENT INCIDENT

Refer to [EC-129, "TROUBLE DIAGNOSIS FOR INTERMITTENT INCIDENT"](#) .

>> INSPECTION END

### Component Inspection FUEL TANK TEMPERATURE SENSOR

ABS009FO

1. Remove fuel level sensor unit.
2. Check resistance between “fuel level sensor unit and fuel pump” terminals 4 and 5 by heating with hot water or heat gun as shown in the figure.

Temperature °C (°F)	Resistance kΩ
20 (68)	2.3 - 2.7
50 (122)	0.79 - 0.90

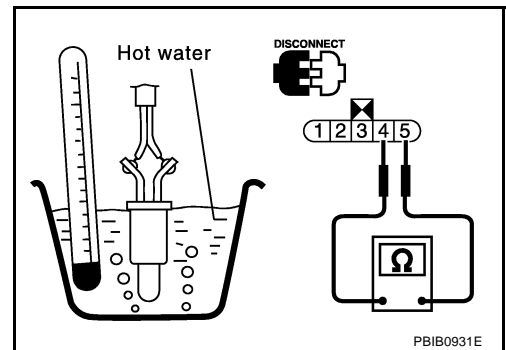

### Removal and Installation FUEL TANK TEMPERATURE SENSOR

ABS009FP

Refer to [FL-4, "FUEL LEVEL SENSOR UNIT, FUEL FILTER AND FUEL PUMP ASSEMBLY"](#) .

# DTC P0222, P0223 TP SENSOR

## DTC P0222, P0223 TP SENSOR

PF161119

### Component Description

ABS009FQ

Electric throttle control actuator consists of throttle control motor, throttle position sensor, etc. The throttle position sensor responds to the throttle valve movement.

The throttle position sensor has the two sensors. These sensors are a kind of potentiometers which transform the throttle valve position into output voltage, and emit the voltage signal to the ECM. In addition, these sensors detect the opening and closing speed of the throttle valve and feed the voltage signals to the ECM. The ECM judges the current opening angle of the throttle valve from these signals and the ECM controls the throttle control motor to make the throttle valve opening angle properly in response to driving condition.

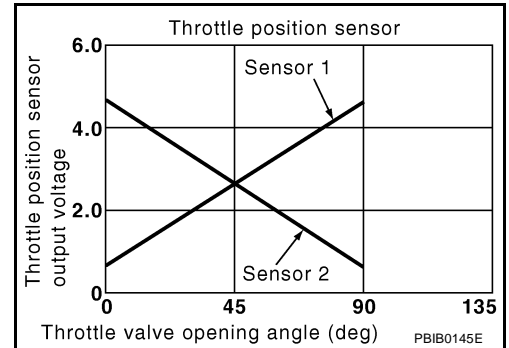

### CONSULT-II Reference Value in Data Monitor Mode

ABS009FR

Specification data are reference values.

MONITOR ITEM	CONDITION		SPECIFICATION
THRTL SEN 1 THRTL SEN 2*	<ul style="list-style-type: none"> <li>Ignition switch: ON (Engine stopped)</li> <li>Shift lever: D (A/T), 1st (M/T)</li> </ul>	Accelerator pedal: Fully released	More than 0.36V
		Accelerator pedal: Fully depressed	Less than 4.75V

\*: Throttle position sensor 2 signal is converted by ECM internally. Thus, it differs from ECM terminal voltage signal.

### On Board Diagnosis Logic

ABS009FS

These self-diagnoses have the one trip detection logic.

DTC No.	Trouble diagnosis name	DTC detecting condition	Possible cause
P0222 0222	Throttle position sensor 1 circuit low input	An excessively low voltage from the TP sensor 1 is sent to ECM.	<ul style="list-style-type: none"> <li>Harness or connectors (The TP sensor 1 circuit is open or shorted.) (APP sensor 2 circuit is shorted.)</li> <li>Electric throttle control actuator (TP sensor 1)</li> <li>Accelerator pedal position sensor (APP sensor 2)</li> </ul>
P0223 0223	Throttle position sensor 1 circuit high input	An excessively high voltage from the TP sensor 1 is sent to ECM.	

### FAIL-SAFE MODE

When the malfunction is detected, ECM enters fail-safe mode and the MIL lights up.

#### Engine operation condition in fail-safe mode

The ECM controls the electric throttle control actuator in regulating the throttle opening in order for the idle position to be within +10 degrees.

The ECM regulates the opening speed of the throttle valve to be slower than the normal condition.

So, the acceleration will be poor.

# DTC P0222, P0223 TP SENSOR

ABS009FT

## DTC Confirmation Procedure

### NOTE:

If DTC Confirmation Procedure has been previously conducted, always turn ignition switch OFF and wait at least 10 seconds before conducting the next test.

### TESTING CONDITION:

Before performing the following procedure, confirm that battery voltage is more than 10V at idle.

#### WITH CONSULT-II

1. Turn ignition switch ON.
2. Select "DATA MONITOR" mode with CONSULT-II.
3. Start engine and let it idle for 1 second.
4. If DTC is detected, go to [EC-251, "Diagnostic Procedure"](#) .

DATA MONITOR	
MONITOR	NO DTC
ENG SPEED	XXX rpm

SEF058Y

#### WITH GST

Follow the procedure "WITH CONSULT-II" above.



# DTC P0222, P0223 TP SENSOR

## Wiring Diagram

ABS009FU

### EC-TPS1-01

: DETECTABLE LINE FOR DTC  
 : NON-DETECTABLE LINE FOR DTC

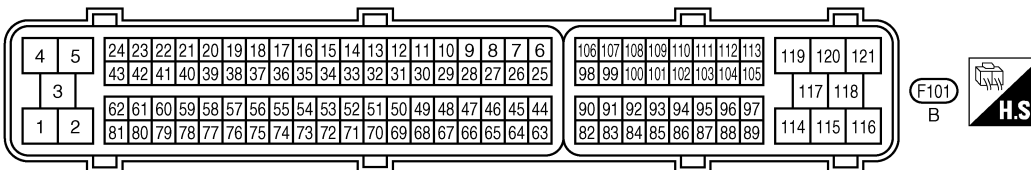
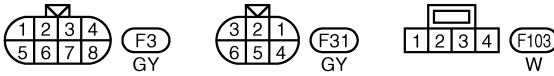
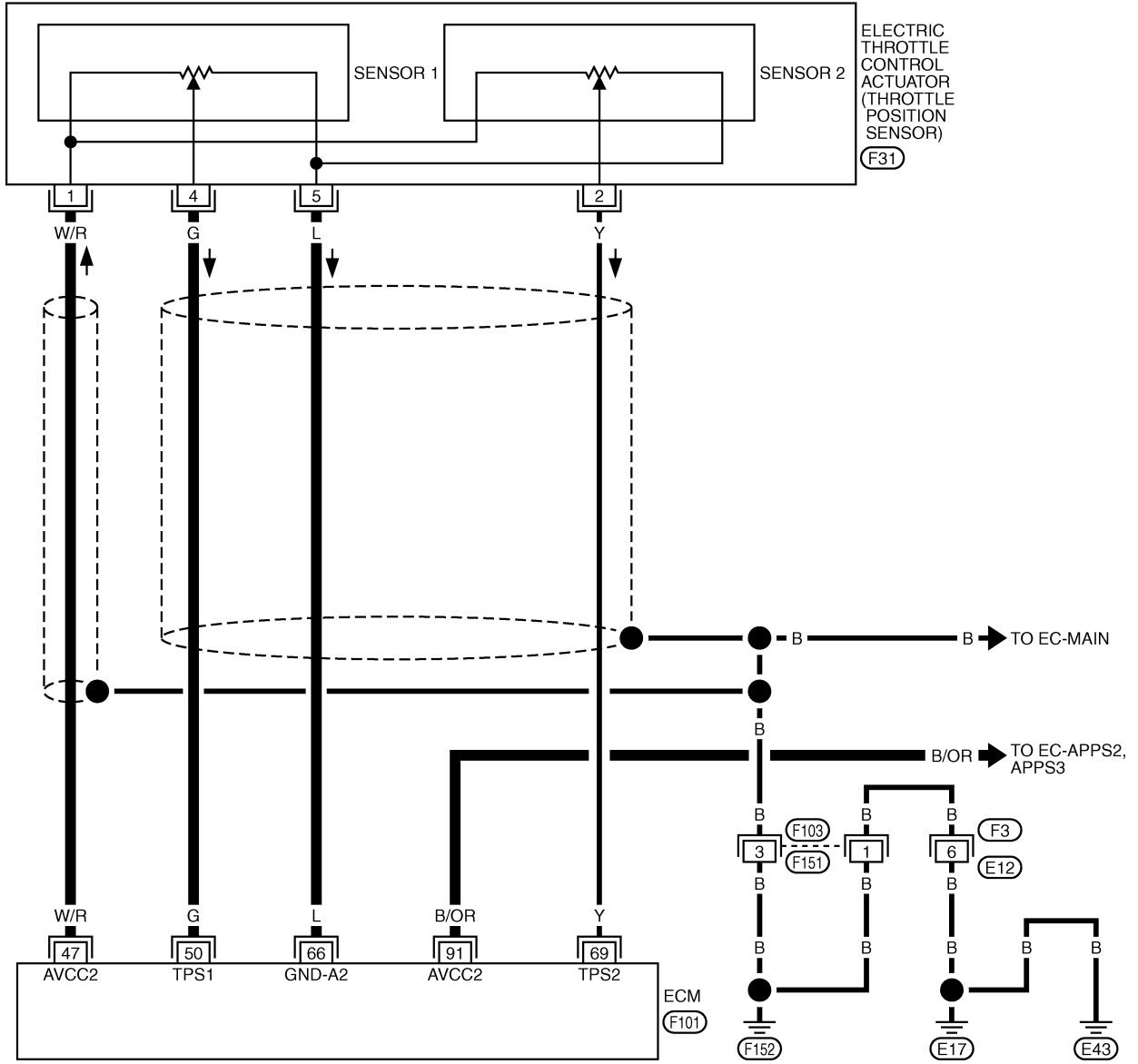

TBWT0782E

## DTC P0222, P0223 TP SENSOR

Specification data are reference values and are measured between each terminal and ground.

**CAUTION:**

**Do not use ECM ground terminals when measuring input/output voltage. Doing so may result in damage to the ECM's transistor. Use a ground other than ECM terminals, such as the ground.**

TER-MINAL NO.	WIRE COLOR	ITEM	CONDITION	DATA (DC Voltage)
47	W/R	Sensor power supply (Throttle position sensor)	<b>[Ignition switch: ON]</b>	Approximately 5V
50	G	Throttle position sensor 1	<b>[Ignition switch: ON]</b> <ul style="list-style-type: none"> <li>● Engine stopped</li> <li>● Shift lever: D (A/T) or 1st (M/T)</li> <li>● Accelerator pedal is fully released</li> </ul>	More than 0.36V
			<b>[Ignition switch: ON]</b> <ul style="list-style-type: none"> <li>● Engine stopped</li> <li>● Shift lever: D (A/T) or 1st (M/T)</li> <li>● Accelerator pedal is fully depressed</li> </ul>	Less than 4.75V
66	L	Sensor ground (Throttle position sensor)	<b>[Engine is running]</b> <ul style="list-style-type: none"> <li>● <b>Warm-up condition</b></li> <li>● Idle speed</li> </ul>	Approximately 0V
69	Y	Throttle position sensor 2	<b>[Ignition switch: ON]</b> <ul style="list-style-type: none"> <li>● Engine stopped</li> <li>● Shift lever: D (A/T) or 1st (M/T)</li> <li>● Accelerator pedal is fully released</li> </ul>	Less than 4.75V
			<b>[Ignition switch: ON]</b> <ul style="list-style-type: none"> <li>● Engine stopped</li> <li>● Shift lever: D (A/T) or 1st (M/T)</li> <li>● Accelerator pedal is fully depressed</li> </ul>	More than 0.36V
91	B/OR	Sensor power supply (APP sensor 2)	<b>[Ignition switch: ON]</b>	Approximately 5V

# DTC P0222, P0223 TP SENSOR

ABS009FV

## Diagnostic Procedure

### 1. CHECK GROUND CONNECTIONS

1. Turn ignition switch OFF.
2. Loosen and retighten three ground screws on the body. Refer to [EC-138, "Ground Inspection"](#).

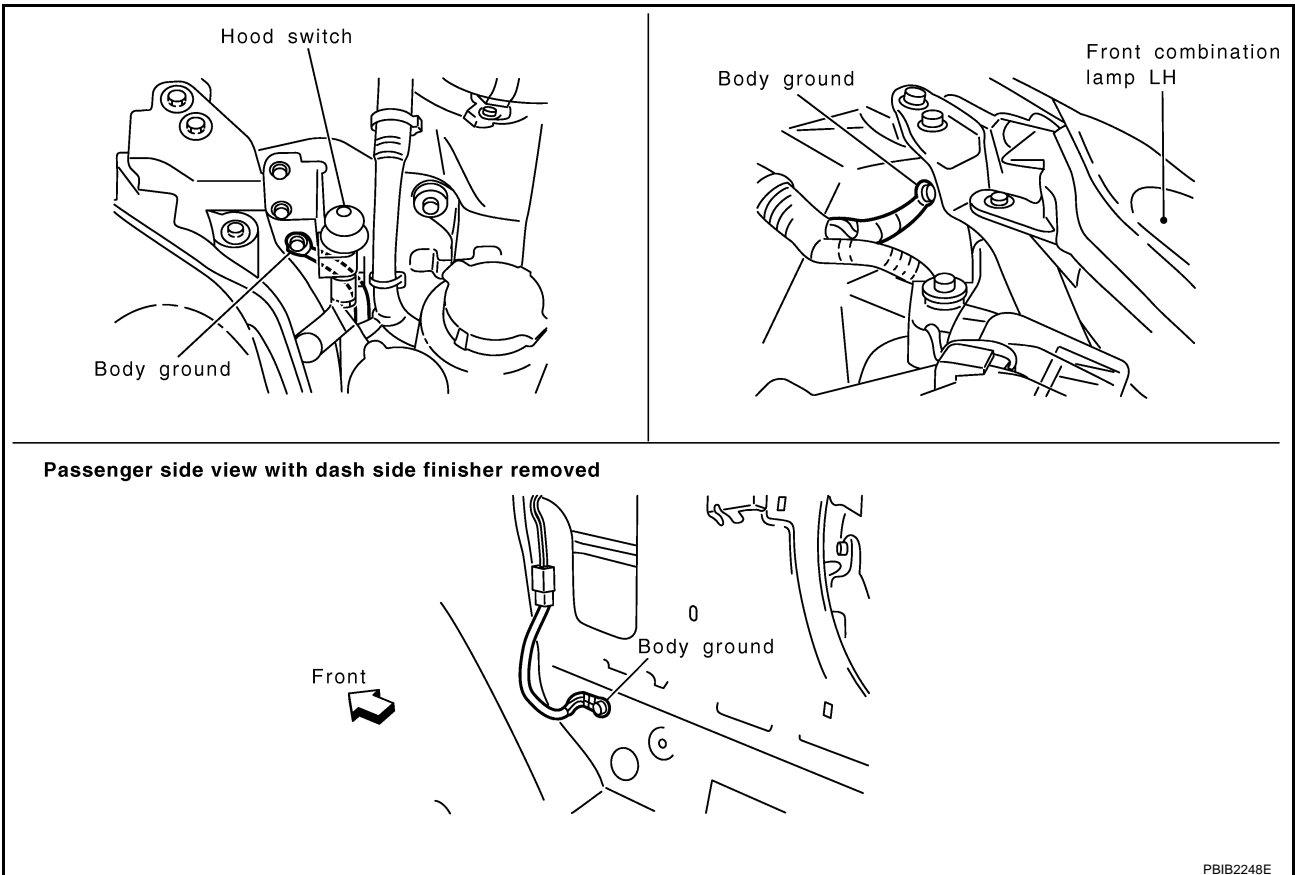

#### OK or NG

- OK >> GO TO 2.
- NG >> Repair or replace ground connections.

A  
EC  
C  
D  
E  
F  
G  
H  
I  
J  
K  
L  
M

# DTC P0222, P0223 TP SENSOR

## 2. CHECK THROTTLE POSITION SENSOR 1 POWER SUPPLY CIRCUIT-I

1. Disconnect electric throttle control actuator harness connector.
2. Turn ignition switch ON.

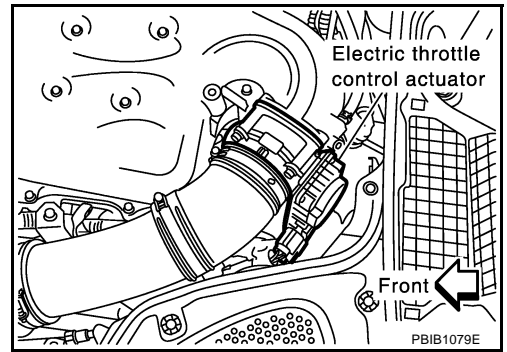

3. Check voltage between electric throttle control actuator terminal 1 and ground with CONSULT-II or tester.

**Voltage: Approximately 5V**

OK or NG

- OK >> GO TO 3.  
NG >> GO TO 7.

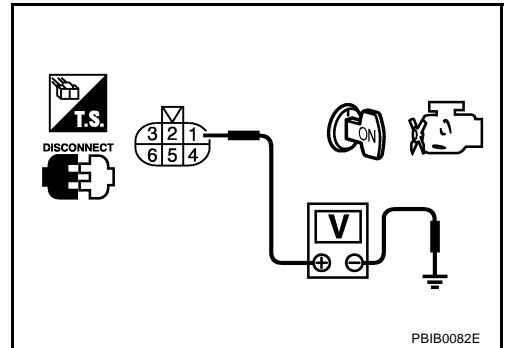

## 3. CHECK THROTTLE POSITION SENSOR 1 POWER SUPPLY CIRCUIT-II

1. Turn ignition switch OFF.
2. Disconnect ECM harness connector.
3. Check harness continuity between electric throttle control actuator terminal 1 and ECM terminal 47. Refer to Wiring Diagram.

**Continuity should exist.**

OK or NG

- OK >> GO TO 4.  
NG >> Repair or replace open circuit.

## 4. CHECK THROTTLE POSITION SENSOR 1 POWER SUPPLY CIRCUIT-III

Check harness for short to power and short to ground, between the following terminals.

ECM terminal	Sensor terminal	Reference Wiring Diagram
47	Electric throttle control actuator terminal 1	<a href="#">EC-249</a>
91	APP sensor terminal 4	<a href="#">EC-599</a>

OK or NG

- OK >> GO TO 5.  
NG >> Repair short to ground or short to power in harness or connectors.

## 5. CHECK APP SENSOR

Refer to [EC-604, "Component Inspection"](#).

OK or NG

- OK >> GO TO 11.  
NG >> GO TO 6.

## DTC P0222, P0223 TP SENSOR

---

### 6. REPLACE ACCELERATOR PEDAL ASSEMBLY

---

1. Replace accelerator pedal assembly.
2. Perform [EC-42, "Accelerator Pedal Released Position Learning"](#) .
3. Perform [EC-42, "Throttle Valve Closed Position Learning"](#) .
4. Perform [EC-43, "Idle Air Volume Learning"](#) .

>> INSPECTION END

---

### 7. CHECK THROTTLE POSITION SENSOR 1 GROUND CIRCUIT FOR OPEN AND SHORT

---

1. Turn ignition switch OFF.
2. Disconnect ECM harness connector.
3. Check harness continuity between electric throttle control actuator terminal 5 and ECM terminal 66.  
Refer to Wiring Diagram.

**Continuity should exist.**

4. Also check harness for short to ground and short to power.

OK or NG

OK >> GO TO 8.

NG >> Repair open circuit or short to ground or short to power in harness or connectors.

---

### 8. CHECK THROTTLE POSITION SENSOR 1 INPUT SIGNAL CIRCUIT FOR OPEN AND SHORT

---

1. Check harness continuity between ECM terminal 50 and electric throttle control actuator terminal 4.  
Refer to Wiring Diagram.

**Continuity should exist.**

2. Also check harness for short to ground and short to power.

OK or NG

OK >> GO TO 9.

NG >> Repair open circuit or short to ground or short to power in harness or connectors.

---

### 9. CHECK THROTTLE POSITION SENSOR

---

Refer to [EC-254, "Component Inspection"](#) .

OK or NG

OK >> GO TO 11.

NG >> GO TO 10.

---

### 10. REPLACE ELECTRIC THROTTLE CONTROL ACTUATOR

---

1. Replace the electric throttle control actuator.
2. Perform [EC-42, "Throttle Valve Closed Position Learning"](#) .
3. Perform [EC-43, "Idle Air Volume Learning"](#) .

>> INSPECTION END

---

### 11. CHECK INTERMITTENT INCIDENT

---

Refer to [EC-129, "TROUBLE DIAGNOSIS FOR INTERMITTENT INCIDENT"](#) .

>> INSPECTION END

# DTC P0222, P0223 TP SENSOR

ABS009FW

## Component Inspection THROTTLE POSITION SENSOR

1. Reconnect all harness connectors disconnected.
2. Perform [EC-42, "Throttle Valve Closed Position Learning"](#) .
3. Turn ignition switch ON.
4. Set shift lever to D (A/T) or 1st (M/T) position.
5. Check voltage between ECM terminals 50 (TP sensor 1 signal), 69 (TP sensor 2 signal) and ground under the following conditions.

Terminal	Accelerator pedal	Voltage
50 (Throttle position sensor 1)	Fully released	More than 0.36V
	Fully depressed	Less than 4.75V
69 (Throttle position sensor 2)	Fully released	Less than 4.75V
	Fully depressed	More than 0.36V

6. If NG, replace electric throttle control actuator and go to the next step.
7. Perform [EC-42, "Throttle Valve Closed Position Learning"](#) .
8. Perform [EC-43, "Idle Air Volume Learning"](#) .

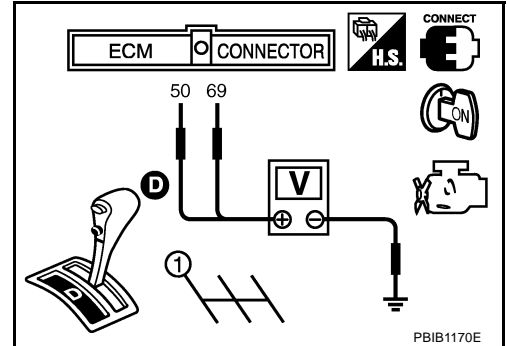

## Removal and Installation ELECTRIC THROTTLE CONTROL ACTUATOR

ABS009FX

Refer to [EM-16, "INTAKE MANIFOLD COLLECTOR"](#) .

# DTC P0300 - P0306 MULTIPLE CYLINDER MISFIRE, NO. 1 - 6 CYLINDER MISFIRE

## DTC P0300 - P0306 MULTIPLE CYLINDER MISFIRE, NO. 1 - 6 CYLINDER MISFIRE

PF0:00000

### On Board Diagnosis Logic

ABS009FY

When a misfire occurs, engine speed will fluctuate. If the engine speed fluctuates enough to cause the crankshaft position (CKP) sensor (POS) signal to vary, ECM can determine that a misfire is occurring.

Sensor	Input Signal to ECM	ECM function
Crankshaft position sensor (POS)	Engine speed	On board diagnosis of misfire

The misfire detection logic consists of the following two conditions.

- One Trip Detection Logic (Three Way Catalyst Damage)**  
 On the first trip that a misfire condition occurs that can damage the three way catalyst (TWC) due to overheating, the MIL will blink.  
 When a misfire condition occurs, the ECM monitors the CKP sensor signal every 200 engine revolutions for a change.  
 When the misfire condition decreases to a level that will not damage the TWC, the MIL will turn off.  
 If another misfire condition occurs that can damage the TWC on a second trip, the MIL will blink.  
 When the misfire condition decreases to a level that will not damage the TWC, the MIL will remain on.  
 If another misfire condition occurs that can damage the TWC, the MIL will begin to blink again.
- Two Trip Detection Logic (Exhaust quality deterioration)**  
 For misfire conditions that will not damage the TWC (but will affect vehicle emissions), the MIL will only light when the misfire is detected on a second trip. During this condition, the ECM monitors the CKP sensor signal every 1,000 engine revolutions.  
 A misfire malfunction can be detected on any one cylinder or on multiple cylinders.

DTC No.	Trouble diagnosis name	DTC detecting condition	Possible cause
P0300 0300	Multiple cylinder misfire detected	Multiple cylinder misfire.	<ul style="list-style-type: none"> <li>● Improper spark plug</li> <li>● Insufficient compression</li> <li>● Incorrect fuel pressure</li> <li>● The injector circuit is open or shorted</li> <li>● Fuel injector</li> <li>● Intake air leak</li> <li>● The ignition signal circuit is open or shorted</li> <li>● Lack of fuel</li> <li>● Signal plate</li> <li>● Air fuel ratio (A/F) sensor 1</li> <li>● Incorrect PCV hose connection</li> </ul>
P0301 0301	No.1 cylinder misfire detected	No. 1 cylinder misfires.	
P0302 0302	No. 2 cylinder misfire detected	No. 2 cylinder misfires.	
P0303 0303	No. 3 cylinder misfire detected	No. 3 cylinder misfires.	
P0304 0304	No. 4 cylinder misfire detected	No. 4 cylinder misfires.	
P0305 0305	No. 5 cylinder misfire detected	No. 5 cylinder misfires.	
P0306 0306	No. 6 cylinder misfire detected	No. 6 cylinder misfires.	

### DTC Confirmation Procedure

ABS009FZ

#### CAUTION:

Always drive vehicle at a safe speed.

#### NOTE:

If DTC Confirmation Procedure has been previously conducted, always turn ignition switch OFF and wait at least 10 seconds before conducting the next test.

# DTC P0300 - P0306 MULTIPLE CYLINDER MISFIRE, NO. 1 - 6 CYLINDER MISFIRE

## WITH CONSULT-II

1. Turn ignition switch ON, and select "DATA MONITOR" mode with CONSULT-II.
2. Start engine and warm it up to normal operating temperature.
3. Turn ignition switch OFF and wait at least 10 seconds.
4. Restart engine and let it idle for about 15 minutes.
5. If 1st trip DTC is detected, go to [EC-256, "Diagnostic Procedure"](#)

DATA MONITOR	
MONITOR	NO DTC
ENG SPEED	XXX rpm
COOLAN TEMP/S	XXX °C
VHCL SPEED SE	XXX km/h
B/FUEL SCHDL	XXX msec

PBIB0164E

### NOTE:

If 1st trip DTC is not detected during above procedure, performing the following procedure is advised.

1. Turn ignition switch OFF and wait at least 10 seconds.
2. Start engine and drive the vehicle under the similar conditions to (1st trip) Freeze Frame Data for a certain time. Refer to the table below.

**Hold the accelerator pedal as steady as possible.**

The similar conditions to (1st trip) Freeze Frame Data means the vehicle operation that the following conditions should be satisfied at the same time.

Engine speed	Engine speed in the freeze frame data $\pm$ 400 rpm
Vehicle speed	Vehicle speed in the freeze frame data $\pm$ 10 km/h (6 MPH)
Engine coolant temperature (T) condition	When the freeze frame data shows lower than 70 °C (158 °F), T should be lower than 70 °C (158 °F).
	When the freeze frame data shows higher than or equal to 70 °C (158 °F), T should be higher than or equal to 70 °C (158 °F).

The time to driving varies according to the engine speed in the freeze frame data.

Engine speed	Time
Around 1,000 rpm	Approximately 10 minutes
Around 2,000 rpm	Approximately 5 minutes
More than 3,000 rpm	Approximately 3.5 minutes

## WITH GST

Follow the procedure "WITH CONSULT-II" above.

### Diagnostic Procedure

ABS009G0

#### 1. CHECK FOR INTAKE AIR LEAK AND PCV HOSE

1. Start engine and run it at idle speed.
2. Listen for the sound of the intake air leak.
3. Check PCV hose connection.

#### OK or NG

- OK >> GO TO 2.  
 NG >> Discover air leak location and repair.

#### 2. CHECK FOR EXHAUST SYSTEM CLOGGING

Stop engine and visually check exhaust tube, three way catalyst and muffler for dents.

#### OK or NG

- OK >> GO TO 3.  
 NG >> Repair or replace it.



# DTC P0300 - P0306 MULTIPLE CYLINDER MISFIRE, NO. 1 - 6 CYLINDER MISFIRE

## 3. PERFORM POWER BALANCE TEST

### With CONSULT-II

1. Perform "POWER BALANCE" in "ACTIVE TEST" mode.
2. Is there any cylinder which does not produce a momentary engine speed drop?

ACTIVE TEST	
POWER BALANCE	
MONITOR	
ENG SPEED	XXX rpm
MAS A/F SE-B1	XXX V

PBIB0133E

### Without CONSULT-II

When disconnecting each injector harness connector one at a time, is there any cylinder which does not produce a momentary engine speed drop?

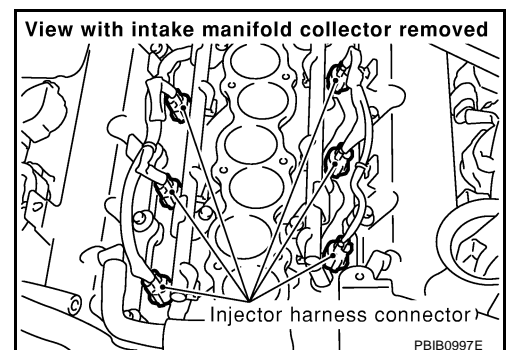

### Yes or No

- Yes >> GO TO 4.  
No >> GO TO 7.

## 4. CHECK INJECTOR

Does each injector make an operating sound at idle?

### Yes or No

- Yes >> GO TO 5.  
No >> Check injector(s) and circuit(s). Refer to [EC-634](#), "[INJECTOR CIRCUIT](#)".

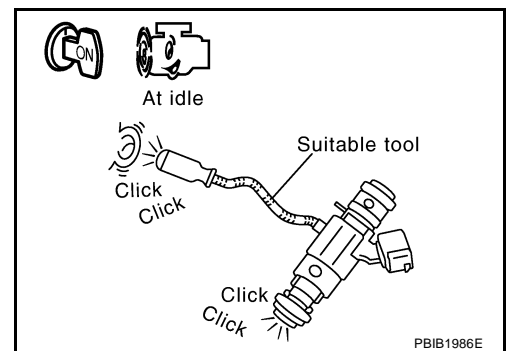

# DTC P0300 - P0306 MULTIPLE CYLINDER MISFIRE, NO. 1 - 6 CYLINDER MISFIRE

## 5. CHECK IGNITION SPARK

1. Turn ignition switch OFF.
2. Remove ignition coil assembly from rocker cover.
3. Remove spark plug from ignition coil assembly
4. Connect a known-good spark plug to the ignition coil.
5. Disconnect all injector harness connectors.
6. Place end of spark plug against a suitable ground and crank engine.
7. Check for spark.

### OK or NG

- OK >> GO TO 6.  
NG >> Check ignition coil, power transistor and their circuits.  
Refer to [EC-622, "IGNITION SIGNAL"](#) .

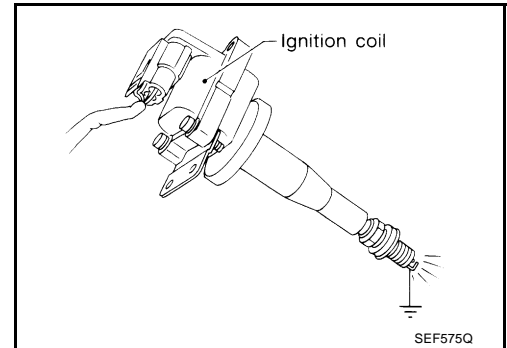

## 6. CHECK SPARK PLUGS

Remove the spark plugs and check for fouling, etc.

### OK or NG

- OK >> GO TO 7.  
NG >> Repair or replace spark plug(s) with standard type one(s). For spark plug type, refer to, [MA-20, "Changing Spark Plugs \(Platinum-Tipped Type\)"](#) .

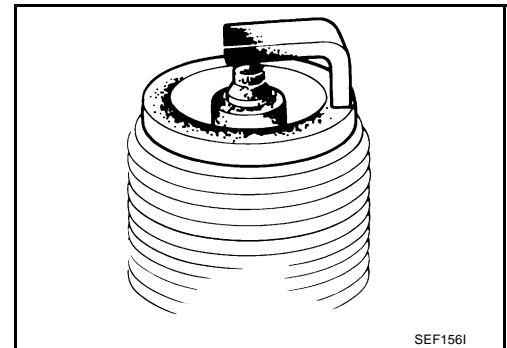

## 7. CHECK COMPRESSION PRESSURE

Check compression pressure. Refer to [EM-90, "CHECKING COMPRESSION PRESSURE"](#) .

<b>Standard:</b>	<b>1,275 kPa (13.0 kg/cm<sup>2</sup> , 185 psi)/300 rpm</b>
<b>Minimum:</b>	<b>981 kPa (10.0 kg/cm<sup>2</sup> , 142 psi)/300 rpm</b>
<b>Difference between each cylinder:</b>	<b>98 kPa (1.0 kg/cm<sup>2</sup> , 14 psi)/300 rpm</b>

### OK or NG

- OK >> GO TO 8.  
NG >> Check pistons, piston rings, valves, valve seats and cylinder head gaskets.

## 8. CHECK FUEL PRESSURE

1. Install all removed parts.
2. Release fuel pressure to zero. Refer to [EC-45, "FUEL PRESSURE RELEASE"](#) .
3. Install fuel pressure gauge and check fuel pressure. Refer to [EC-45, "FUEL PRESSURE CHECK"](#) .

**At idle: Approx. 350 kPa (3.57 kg/cm<sup>2</sup> , 51 psi)**

### OK or NG

- OK >> GO TO 10.  
NG >> GO TO 9.

# DTC P0300 - P0306 MULTIPLE CYLINDER MISFIRE, NO. 1 - 6 CYLINDER MISFIRE

## 9. DETECT MALFUNCTIONING PART

Check the following.

- Fuel pump and circuit (Refer to [EC-640, "FUEL PUMP CIRCUIT"](#) .)
- Fuel pressure regulator (Refer to [EC-45, "FUEL PRESSURE CHECK"](#) .)
- Fuel lines (Refer to [FL-3, "Checking Fuel Lines"](#) )
- Fuel filter for clogging

>> Repair or replace.

## 10. CHECK IGNITION TIMING

Check the following items. Refer to [EC-78, "Basic Inspection"](#) .

Items	Specifications	
Target idle speed	A/T	650 ± 50 rpm (in P or N position)
	M/T	650 ± 50 rpm (in Neutral position)
Ignition timing	A/T	15 ± 5° BTDC (in P or N position)
	M/T	15 ± 5° BTDC (in Neutral position)

### OK or NG

OK >> GO TO 11.

NG >> Follow the [EC-78, "Basic Inspection"](#) .

A

EC

C

D

E

F

G

H

I

J

K

L

M

# DTC P0300 - P0306 MULTIPLE CYLINDER MISFIRE, NO. 1 - 6 CYLINDER MISFIRE

## 11. CHECK A/F SENSOR 1 CIRCUIT FOR OPEN AND SHORT

1. Turn ignition switch OFF.
2. Disconnect corresponding A/F sensor 1 harness connector.

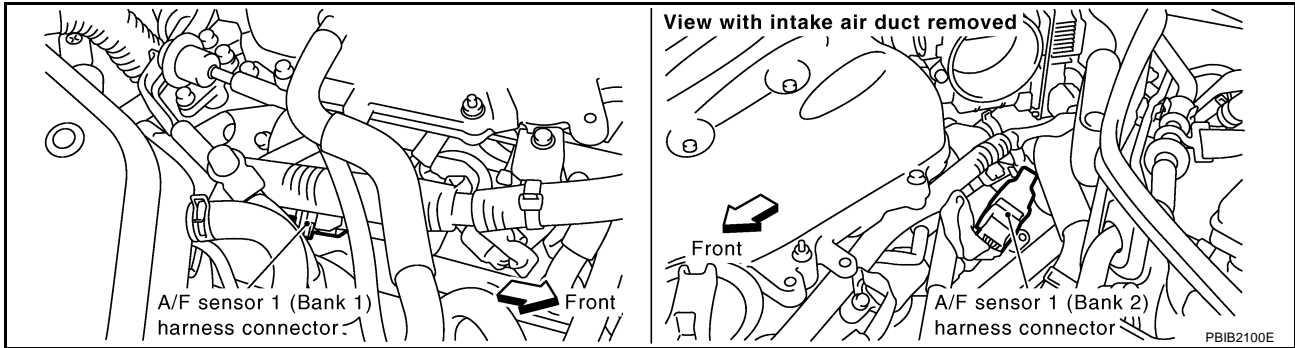

3. Disconnect ECM harness connector.
4. Check harness continuity between the following terminals. Refer to Wiring Diagram.

	A/F sensor 1 terminal	ECM terminal
Bank1	1	16
	2	75
	5	35
	6	56
Bank 2	1	76
	2	77
	5	57
	6	58

**Continuity should exist.**

5. Check harness continuity between the following terminals and ground. Refer to Wiring Diagram.

Bank 1		Bank 2	
A/F sensor 1 terminal	ECM terminal	A/F sensor 1 terminal	ECM terminal
1	16	1	76
2	75	2	77
5	35	5	57
6	56	6	58

**Continuity should not exist.**

6. Also check harness for short to power.

**OK or NG**

OK >> GO TO 4.

NG >> Repair open circuit or short to ground or short to power in harness or connectors.

## 12. CHECK A/F SENSOR 1 HEATER

Refer to [EC-383, "Component Inspection"](#).

**OK or NG**

OK >> GO TO 13.

NG >> Replace (malfunctioning) A/F sensor 1.

# DTC P0300 - P0306 MULTIPLE CYLINDER MISFIRE, NO. 1 - 6 CYLINDER MISFIRE

## 13. CHECK MASS AIR FLOW SENSOR

### With CONSULT-II

Check mass air flow sensor signal in "DATA MONITOR" mode with CONSULT-II.

**2.0 - 6.0 g-m/sec: at idling**  
**7.0 - 20.0 g-m/sec: at 2,500 rpm**

### With GST

Check mass air flow sensor signal in MODE 1 with GST.

**2.0 - 6.0 g-m/sec: at idling**  
**7.0 - 20.0 g-m/sec: at 2,500 rpm**

OK or NG

OK >> GO TO 14.

NG >> Check connectors for rusted terminals or loose connections in the mass air flow sensor circuit or ground. Refer to [EC-153, "DTC P0101 MAF SENSOR"](#) .

## 14. CHECK SYMPTOM MATRIX CHART

Check items on the rough idle symptom in [EC-83, "Symptom Matrix Chart"](#) .

OK or NG

OK >> GO TO 15.

NG >> Repair or replace.

## 15. ERASE THE 1ST TRIP DTC

Some tests may cause a 1st trip DTC to be set.

Erase the 1st trip DTC from the ECM memory after performing the tests. Refer to [EC-61, "HOW TO ERASE EMISSION-RELATED DIAGNOSTIC INFORMATION"](#) .

>> GO TO 16.

## 16. CHECK INTERMITTENT INCIDENT

Refer to [EC-129, "TROUBLE DIAGNOSIS FOR INTERMITTENT INCIDENT"](#) .

>> INSPECTION END

A

EC

C

D

E

F

G

H

I

J

K

L

M

# DTC P0327, P0328 KS

PF2:22060

## DTC P0327, P0328 KS

### Component Description

ABS009G1

The knock sensor is attached to the cylinder block. It senses engine knocking using a piezoelectric element. A knocking vibration from the cylinder block is sensed as vibrational pressure. This pressure is converted into a voltage signal and sent to the ECM.

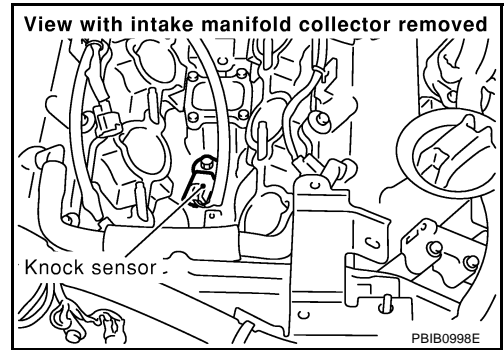

### On Board Diagnosis Logic

ABS009G2

The MIL will not light up for these diagnoses.

DTC No.	Trouble diagnosis name	DTC detected condition	Possible cause
P0327 0327	Knock sensor circuit low input	An excessively low voltage from the sensor is sent to ECM.	<ul style="list-style-type: none"> <li>● Harness or connectors (The sensor circuit is open or shorted.)</li> <li>● Knock sensor</li> </ul>
P0328 0328	Knock sensor circuit high input	An excessively high voltage from the sensor is sent to ECM.	

### DTC Confirmation Procedure

ABS009G3

#### NOTE:

If DTC Confirmation Procedure has been previously conducted, always turn ignition switch OFF and wait at least 10 seconds before conducting the next test.

#### TESTING CONDITION:

Before performing the following procedure, confirm that battery voltage is more than 10V at idle.

#### WITH CONSULT-II

1. Turn ignition switch ON and select "DATA MONITOR" mode with CONSULT-II.
2. Start engine and run it for at least 5 seconds at idle speed.
3. If 1st trip DTC is detected, go to [EC-264, "Diagnostic Procedure"](#)

DATA MONITOR	
MONITOR	NO DTC
ENG SPEED	XXX rpm

SEF058Y

#### WITH GST

Follow the procedure "WITH CONSULT-II" above.

# DTC P0327, P0328 KS

## Wiring Diagram

ABS009G4

EC-KS-01

A  
EC  
C  
D  
E  
F  
G  
H  
I  
J  
K  
L  
M

**—** : DETECTABLE LINE FOR DTC  
**—** : NON-DETECTABLE LINE FOR DTC

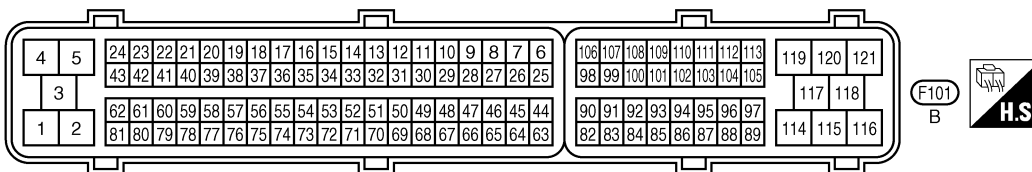
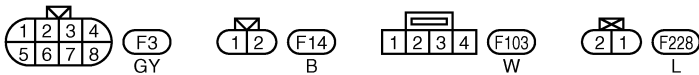
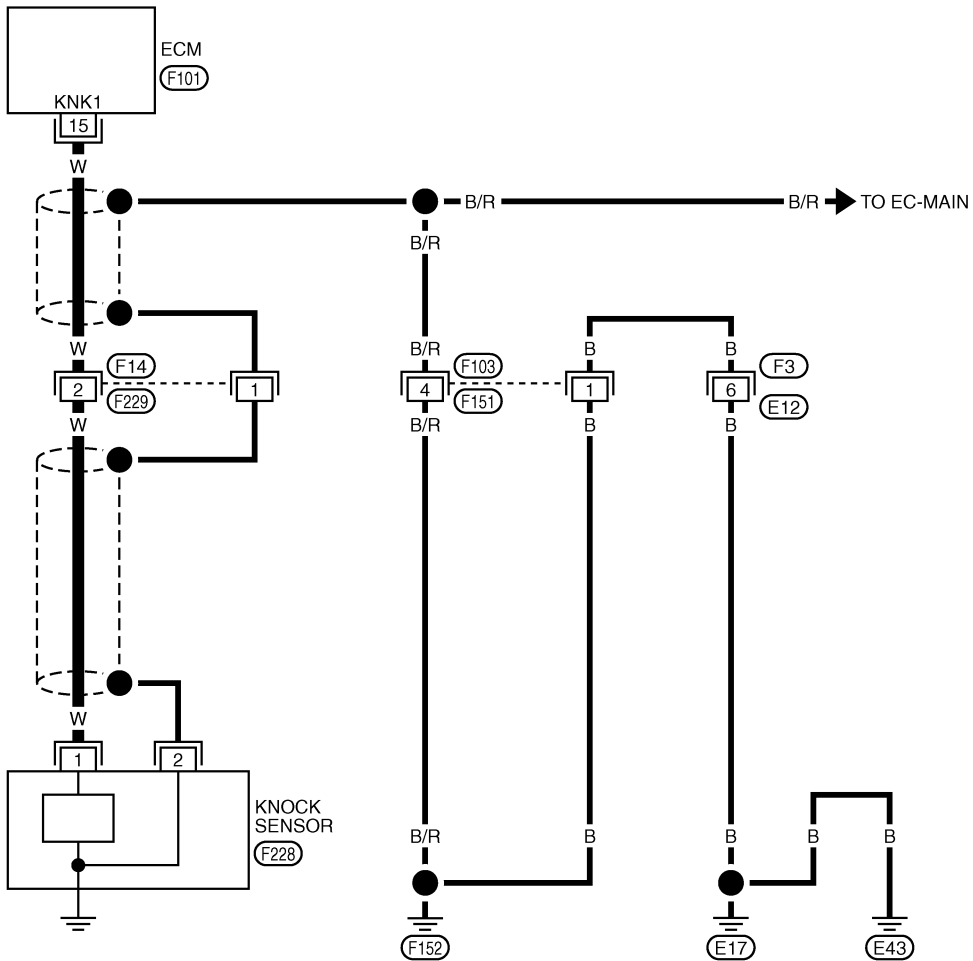

TBWT0487E

# DTC P0327, P0328 KS

Specification data are reference values and are measured between each terminal and ground.

## CAUTION:

Do not use ECM ground terminals when measuring input/output voltage. Doing so may result in damage to the ECM's transistor. Use a ground other than ECM terminals, such as the ground.

TER-MINAL NO.	WIRE COLOR	ITEM	CONDITION	DATA (DC Voltage)
15	W	Knock sensor	[Engine is running] ● Idle speed	Approximately 2.5V

## Diagnostic Procedure

ABS009G5

### 1. CHECK KNOCK SENSOR INPUT SIGNAL CIRCUIT FOR OPEN AND SHORT-I

1. Turn ignition switch OFF.
2. Disconnect ECM harness connector.
3. Check resistance between ECM terminal 15 and ground. Refer to Wiring Diagram.

#### NOTE:

It is necessary to use an ohmmeter which can measure more than 10 M $\Omega$ .

**Resistance: Approximately 532 - 588 k $\Omega$  [at 20°C (68°F)]**

4. Also check harness for short to ground and short to power.

OK or NG

- OK >> GO TO 4.  
NG >> GO TO 2.

### 2. CHECK KNOCK SENSOR INPUT SIGNAL CIRCUIT FOR OPEN AND SHORT-II

1. Disconnect knock sensor harness connector.
2. Check harness continuity between ECM terminal 15 and knock sensor terminal 1. Refer to Wiring Diagram.

**Continuity should exist.**

3. Also check harness for short to ground and short to power.

OK or NG

- OK >> GO TO 4.  
NG >> GO TO 3.

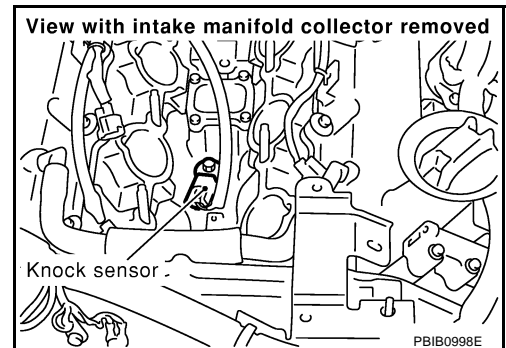

### 3. DETECT MALFUNCTIONING PART

Check the following.

- Harness connectors F14, F229
- Harness for open or short between ECM and knock sensor

>> Repair open circuit or short to ground or short to power in harness or connectors.

### 4. CHECK KNOCK SENSOR

Refer to [EC-266, "Component Inspection"](#).

OK or NG

- OK >> GO TO 5.  
NG >> Replace knock sensor.



## 5. CHECK GROUND CONNECTIONS

Loosen and retighten three ground screws on the body. Refer to [EC-138, "Ground Inspection"](#) .

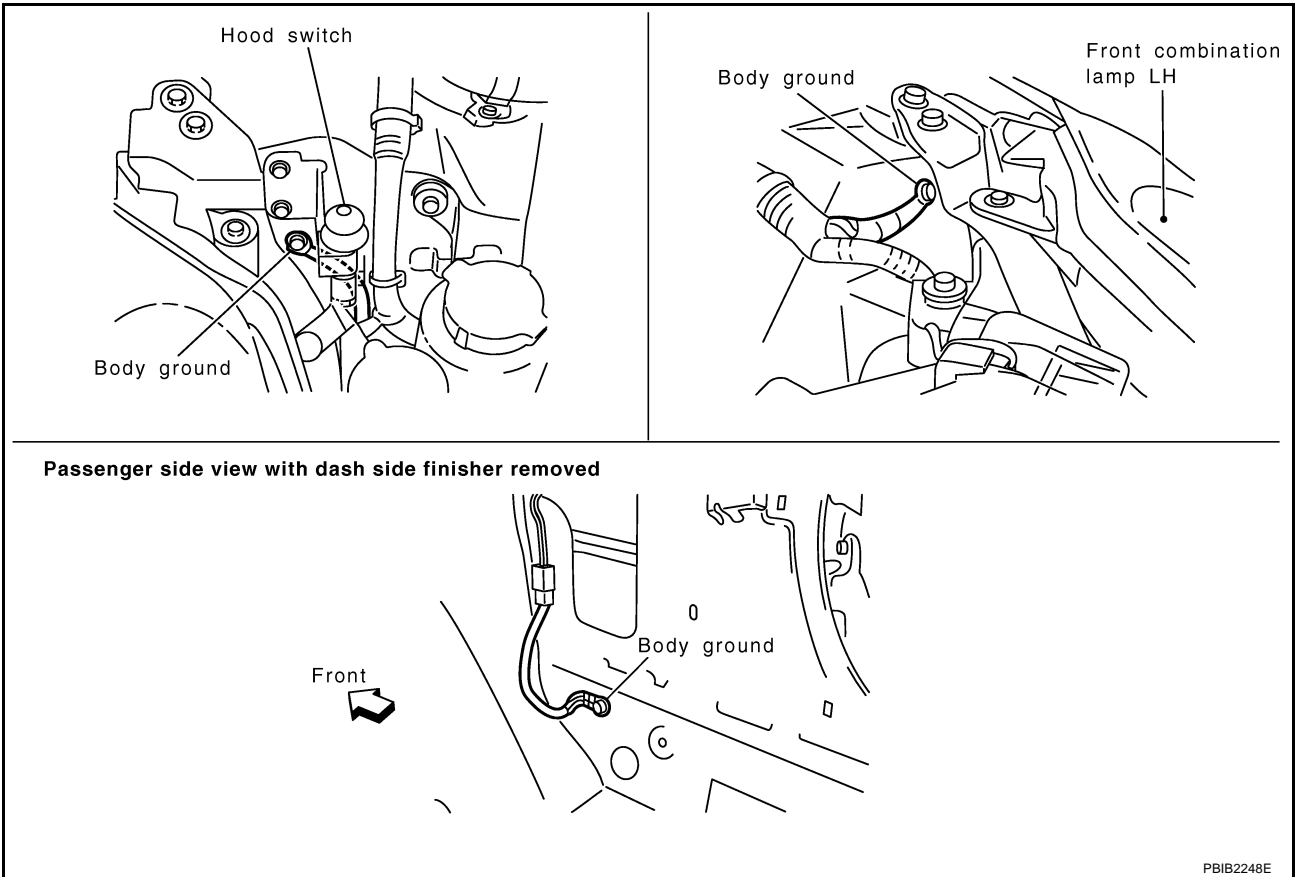

OK or NG

OK >> GO TO 6.

NG >> Repair or replace ground connections.

## 6. CHECK KNOCK SENSOR SHIELD CIRCUIT FOR OPEN AND SHORT

1. Disconnect knock sensor harness connector.
2. Check harness continuity between knock sensor terminal 2 and ground. Refer to Wiring Diagram.

**Continuity should exist.**

3. Also check harness for short to power.

OK or NG

OK >> GO TO 8.

NG >> GO TO 7.

## 7. DETECT MALFUNCTIONING PART

Check the following.

- Harness connectors F14, F229
- Harness connectors F103, F151
- Harness connectors F3, E12
- Harness for open or short between knock sensor terminal 2 and ground

>> Repair open circuit or short power in harness or connectors.

## 8. CHECK INTERMITTENT INCIDENT

Refer to [EC-129, "TROUBLE DIAGNOSIS FOR INTERMITTENT INCIDENT"](#) .

>> INSPECTION END

### Component Inspection KNOCK SENSOR

ABS009G6

Check resistance between knock sensor terminal 1 and ground.

#### NOTE:

It is necessary to use an ohmmeter which can measure more than 10 M $\Omega$ .

**Resistance: Approximately 532 - 588 k $\Omega$  [at 20°C (68°F)]**

#### CAUTION:

Do not use any knock sensors that have been dropped or physically damaged. Use only new ones.

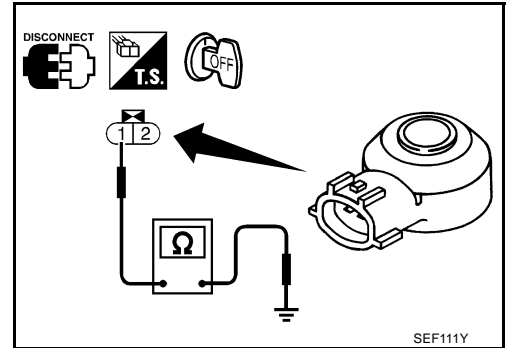

ABS009G7

### Removal and Installation KNOCK SENSOR

Refer to [EM-109, "CYLINDER BLOCK"](#) .

# DTC P0335 CKP SENSOR (POS)

## DTC P0335 CKP SENSOR (POS)

PFP:23731

### Component Description

ABS009G8

The crankshaft position sensor (POS) is located on the oil pan facing the gear teeth (cogs) of the signal plate. It detects the fluctuation of the engine revolution.

The sensor consists of a permanent magnet and Hall IC.

When the engine is running, the high and low parts of the teeth cause the gap with the sensor to change.

The changing gap causes the magnetic field near the sensor to change.

Due to the changing magnetic field, the voltage from the sensor changes.

The ECM receives the voltage signal and detects the fluctuation of the engine revolution.

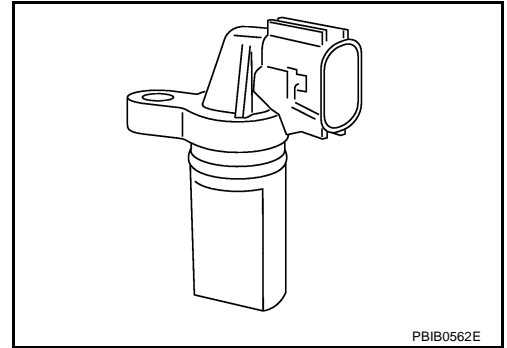

PBIB0562E

### CONSULT-II Reference Value in Data Monitor Mode

ABS009G9

Specification data are reference values.

MONITOR ITEM	CONDITION	SPECIFICATION
ENG SPEED	<ul style="list-style-type: none"> <li>Run engine and compare CONSULT-II value with the tachometer indication.</li> </ul>	Almost the same speed as the tachometer indication.

### On Board Diagnosis Logic

ABS009GA

DTC No.	Trouble diagnosis name	DTC detecting condition	Possible cause
P0335 0335	Crankshaft position sensor (POS) circuit	<ul style="list-style-type: none"> <li>The crankshaft position sensor (POS) signal is not detected by the ECM during the first few seconds of engine cranking.</li> <li>The proper pulse signal from the crankshaft position sensor (POS) is not sent to ECM while the engine is running.</li> <li>The crankshaft position sensor (POS) signal is not in the normal pattern during engine running.</li> </ul>	<ul style="list-style-type: none"> <li>Harness or connectors (The sensor circuit is open or shorted)</li> <li>Crankshaft position sensor (POS)</li> <li>Signal plate</li> </ul>

### DTC Confirmation Procedure

ABS009GB

#### NOTE:

If DTC Confirmation Procedure has been previously conducted, always turn ignition switch OFF and wait at least 10 seconds before conducting the next test.

#### TESTING CONDITION:

Before performing the following procedure, confirm that battery voltage is more than 10.5V with ignition switch ON.

#### WITH CONSULT-II

- Turn ignition switch ON and select "DATA MONITOR" mode with CONSULT-II.
- Crank engine for at least 2 seconds and run it for at least 5 seconds at idle speed.
- If 1st trip DTC is detected, go to [EC-270, "Diagnostic Procedure"](#)

DATA MONITOR	
MONITOR	NO DTC
ENG SPEED	XXX rpm

SEF058Y

#### WITH GST

Follow the procedure "WITH CONSULT-II" above.



# DTC P0335 CKP SENSOR (POS)

Specification data are reference values and are measured between each terminal and ground.  
Pulse signal is measured by CONSULT-II.

**CAUTION:**

**Do not use ECM ground terminals when measuring input/output voltage. Doing so may result in damage to the ECM's transistor. Use a ground other than ECM terminals, such as the ground.**

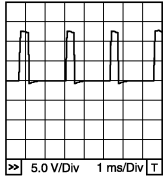
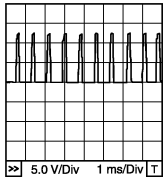
TER-MINAL NO.	WIRE COLOR	ITEM	CONDITION	DATA (DC Voltage)
13	W/L	Crankshaft position sensor (POS)	<p><b>[Engine is running]</b></p> <ul style="list-style-type: none"> <li>● Warm-up condition</li> <li>● Idle speed</li> </ul> <p><b>NOTE:</b> The pulse cycle changes depending on rpm at idle.</p>	<p>Approximately 1.6V★</p>  <p>PBIB1041E</p>
			<p><b>[Engine is running]</b></p> <ul style="list-style-type: none"> <li>● Engine speed is 2,000 rpm.</li> </ul>	<p>Approximately 1.4V★</p>  <p>PBIB1042E</p>

★: Average voltage for pulse signal (Actual pulse signal can be confirmed by oscilloscope.)

A  
EC  
C  
D  
E  
F  
G  
H  
I  
J  
K  
L  
M

# DTC P0335 CKP SENSOR (POS)

ABS009GD

## Diagnostic Procedure

### 1. CHECK GROUND CONNECTIONS

1. Turn ignition switch OFF.
2. Loosen and retighten three ground screws on the body. Refer to [EC-138, "Ground Inspection"](#).

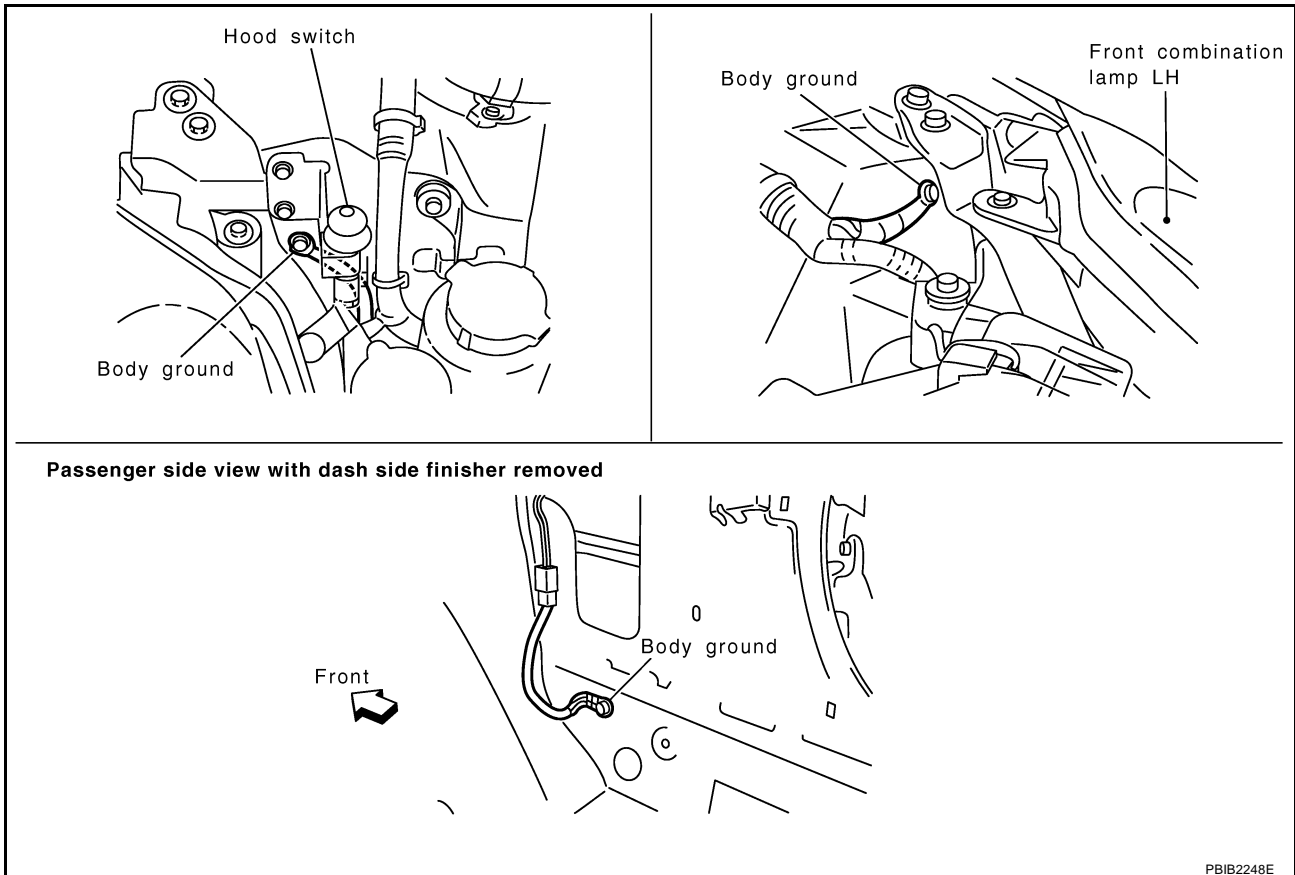

#### OK or NG

- OK >> GO TO 2.
- NG >> Repair or replace ground connections.

# DTC P0335 CKP SENSOR (POS)

## 2. CHECK CRANKSHAFT POSITION (CKP) SENSOR (POS) POWER SUPPLY CIRCUIT

1. Disconnect crankshaft position (CKP) sensor (POS) harness connector.
2. Turn ignition switch ON.

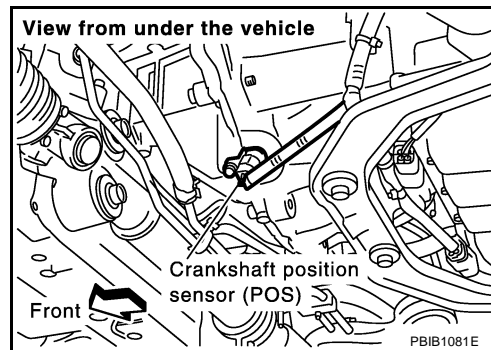

3. Check voltage between CKP sensor (POS) terminal 1 and ground with CONSULT-II or tester.

**Voltage: Battery voltage**

OK or NG

- OK >> GO TO 4.
- NG >> GO TO 3.

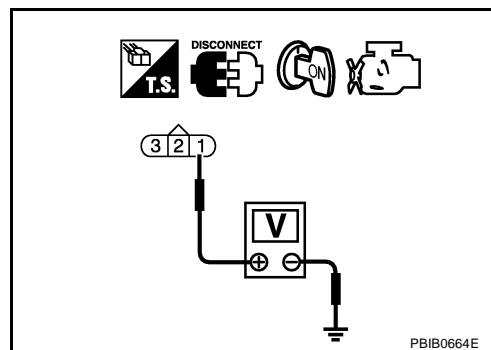

## 3. DETECT MALFUNCTIONING PART

Check the following.

- Harness connectors E12, F3
- Harness for open or short between crankshaft position sensor (POS) and ECM
- Harness for open or short between crankshaft position sensor (POS) and IPDM E/R

>> Repair open circuit or short to ground or short to power in harness or connectors.

## 4. CHECK CKP SENSOR (POS) GROUND CIRCUIT FOR OPEN AND SHORT

1. Turn ignition switch OFF.
2. Check harness continuity between CKP sensor (POS) terminal 3 and ground. Refer to Wiring Diagram.

**Continuity should exist.**

3. Also check harness for short to power.

OK or NG

- OK >> GO TO 6.
- NG >> GO TO 5.

## 5. DETECT MALFUNCTIONING PART

Check the following.

- Harness connectors E12, F3
- Harness connectors F103, F151
- Harness for open or short between crankshaft position sensor (POS) and ground

>> Repair open circuit or short to power in harness or connectors.

## DTC P0335 CKP SENSOR (POS)

---

### 6. CHECK CKP SENSOR (POS) INPUT SIGNAL CIRCUIT FOR OPEN AND SHORT

---

1. Disconnect ECM harness connector.
2. Check harness continuity between ECM terminal 13 and CKP sensor (POS) terminal 2.  
Refer to Wiring Diagram.

**Continuity should exist.**

3. Also check harness for short to ground and short to power.

OK or NG

OK >> GO TO 7.

NG >> Repair open circuit or short to ground or short to power in harness or connectors.

---

### 7. CHECK CRANKSHAFT POSITION SENSOR (POS)

---

Refer to [EC-273, "Component Inspection"](#) .

OK or NG

OK >> GO TO 8.

NG >> Replace crankshaft position sensor (POS).

---

### 8. CHECK GEAR TOOTH

---

Visually check for chipping signal plate gear tooth.

OK or NG

OK >> GO TO 9.

NG >> Replace the signal plate.

---

### 9. CHECK INTERMITTENT INCIDENT

---

Refer to [EC-129, "TROUBLE DIAGNOSIS FOR INTERMITTENT INCIDENT"](#) .

**>> INSPECTION END**



# DTC P0335 CKP SENSOR (POS)

ABS009GE

## Component Inspection CRANKSHAFT POSITION SENSOR (POS)

1. Loosen the fixing bolt of the sensor.
2. Disconnect crankshaft position sensor (POS) harness connector.
3. Remove the sensor.
4. Visually check the sensor for chipping.

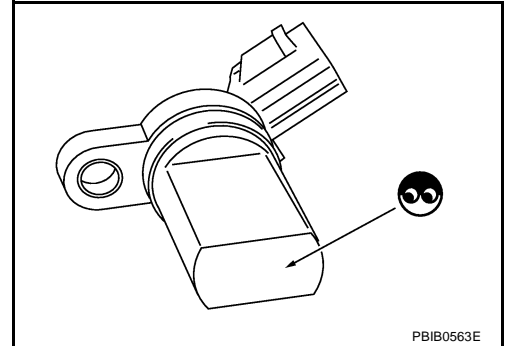

5. Check resistance as shown in the figure.

Terminal No. (Polarity)	Resistance $\Omega$ [at 25°C (77°F)]
1 (+) - 2 (-)	Except 0 or $\infty$
1 (+) - 3 (-)	
2 (+) - 3 (-)	

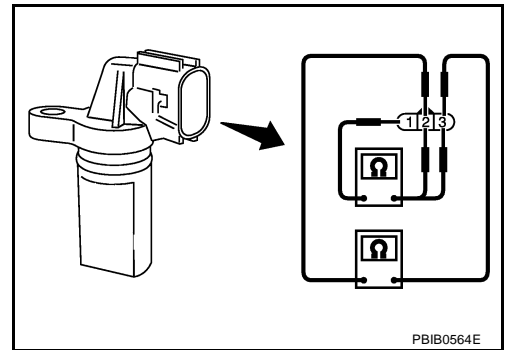

## Removal and Installation CRANKSHAFT POSITION SENSOR (POS)

Refer to [EM-27, "OIL PAN AND OIL STRAINER"](#) .

ABS009GF

# DTC P0340, P0345 CMP SENSOR (PHASE)

PFP:23731

## DTC P0340, P0345 CMP SENSOR (PHASE)

### Component Description

ABS009GG

The camshaft position sensor (PHASE) senses the retraction of intake valve camshaft to identify a particular cylinder. The camshaft position sensor (PHASE) senses the piston position.

When the crankshaft position sensor (POS) system becomes inoperative, the camshaft position sensor (PHASE) provides various controls of engine parts instead, utilizing timing of cylinder identification signals.

The sensor consists of a permanent magnet and Hall IC.

When engine is running, the high and low parts of the teeth cause the gap with the sensor to change.

The changing gap causes the magnetic field near the sensor to change.

Due to the changing magnetic field, the voltage from the sensor changes.

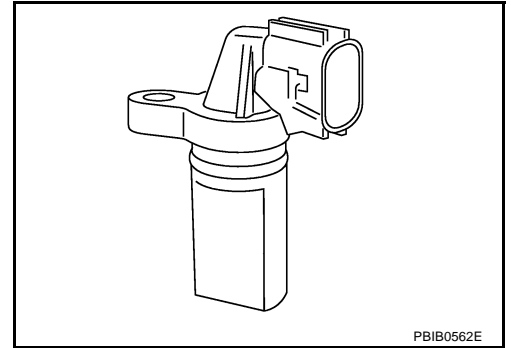

### CONSULT-II Reference Value in Data Monitor Mode

ABS009GH

Specification data are reference values.

MONITOR ITEM	CONDITION	SPECIFICATION
ENG SPEED	<ul style="list-style-type: none"> <li>Run engine and compare CONSULT-II value with the tachometer indication.</li> </ul>	Almost the same speed as the tachometer indication.

### On Board Diagnosis Logic

ABS009GI

DTC No.	Trouble diagnosis name	DTC detecting condition	Possible cause
P0340 0340 (Bank 1)	Camshaft position sensor (PHASE) circuit	<ul style="list-style-type: none"> <li>The cylinder No. signal is not sent to ECM for the first few seconds during engine cranking.</li> </ul>	<ul style="list-style-type: none"> <li>Harness or connectors (The sensor circuit is open or shorted)</li> <li>Camshaft position sensor (PHASE)</li> </ul>
P0345 0345 (Bank 2)		<ul style="list-style-type: none"> <li>The cylinder No. signal is not sent to ECM during engine running.</li> <li>The cylinder No. signal is not in the normal pattern during engine running.</li> </ul>	<ul style="list-style-type: none"> <li>Camshaft (Intake)</li> <li>Starter motor (Refer to <a href="#">SC-10</a>.)</li> <li>Starting system circuit (Refer to <a href="#">SC-10</a>.)</li> <li>Dead (Weak) battery</li> </ul>

### DTC Confirmation Procedure

ABS009GJ

#### NOTE:

If DTC Confirmation Procedure has been previously conducted, always turn ignition switch OFF and wait at least 10 seconds before conducting the next test.

#### TESTING CONDITION:

Before performing the following procedure, confirm that battery voltage is more than 10.5V with ignition switch ON.

#### WITH CONSULT-II

- Turn ignition switch ON.
- Select "DATA MONITOR" mode with CONSULT-II.
- Crank engine for at least 2 seconds and run it for at least 5 seconds at idle speed.
- If 1st trip DTC is detected, go to [EC-278, "Diagnostic Procedure"](#).  
If 1st trip DTC is not detected, go to next step.
- Maintaining engine speed at more than 800 rpm for at least 5 seconds.
- If 1st trip DTC is detected, go to [EC-278, "Diagnostic Procedure"](#).

DATA MONITOR	
MONITOR	NO DTC
ENG SPEED	XXX rpm

SEF058Y

#### WITH GST

Follow the procedure "WITH CONSULT-II" above.

# DTC P0340, P0345 CMP SENSOR (PHASE)

ABS009GK

## Wiring Diagram BANK 1

EC-PHSB1-01

A  
EC  
C  
D  
E  
F  
G  
H  
I  
J  
K  
L  
M

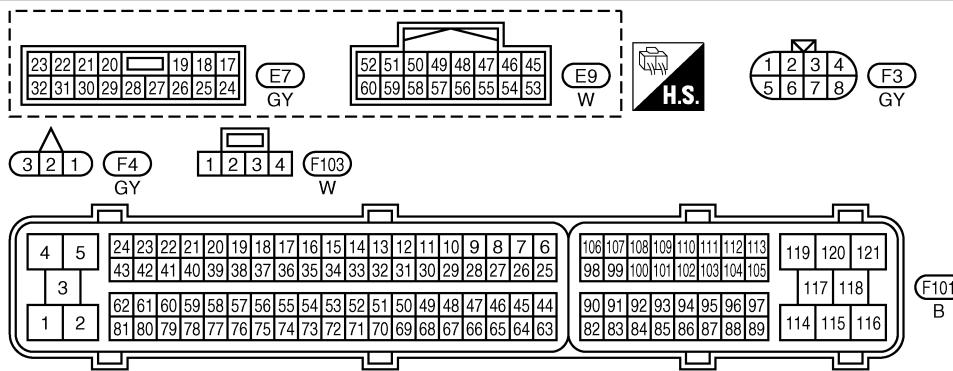
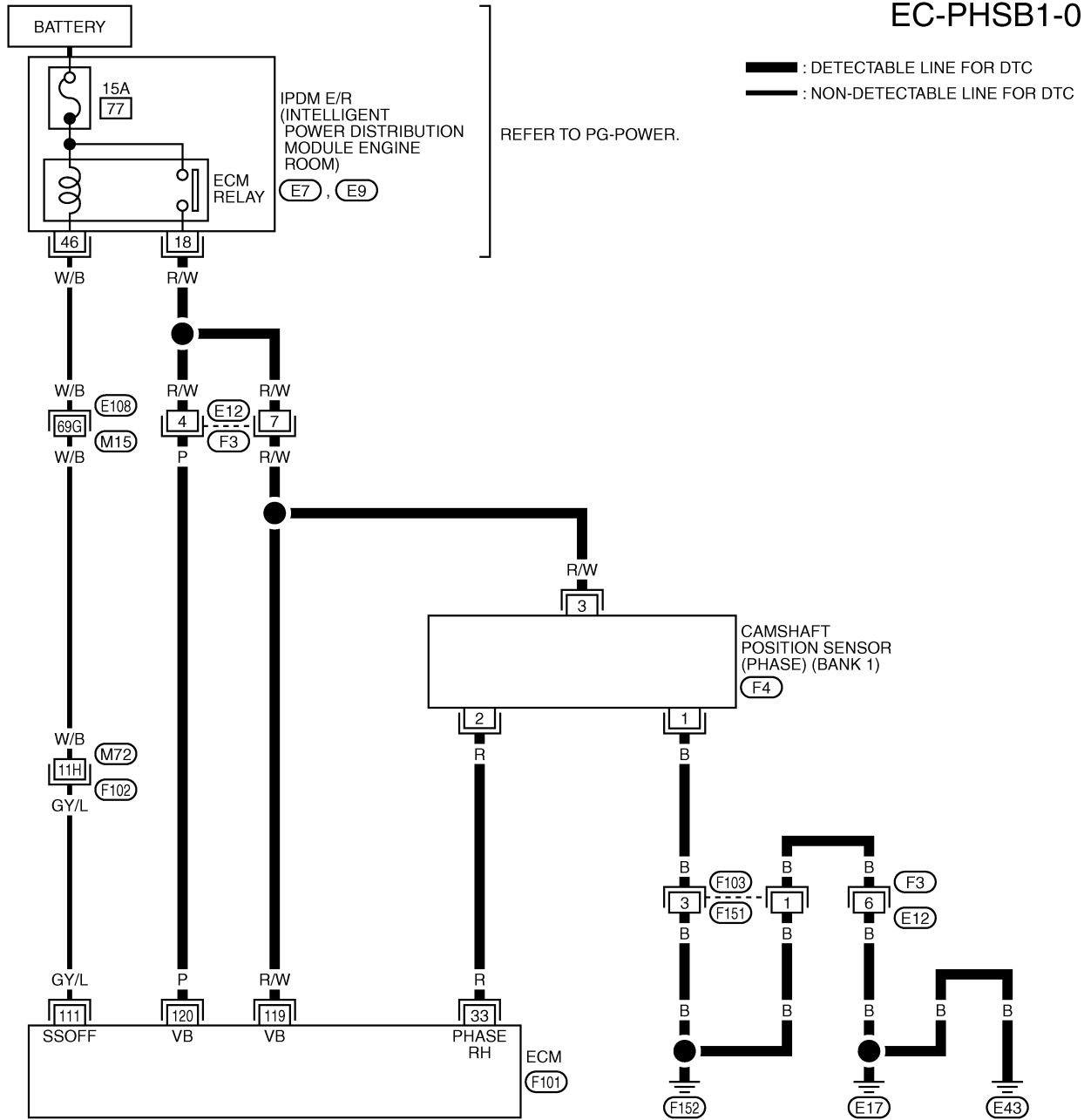

REFER TO THE FOLLOWING.  
 E108, F102 -SUPER MULTIPLE JUNCTION (SMJ)

TBWT0617E

## DTC P0340, P0345 CMP SENSOR (PHASE)

Specification data are reference values and are measured between each terminal and ground.  
Pulse signal is measured by CONSULT-II.

**CAUTION:**

**Do not use ECM ground terminals when measuring input/output voltage. Doing so may result in damage to the ECM's transistor. Use a ground other than ECM terminals, such as the ground.**

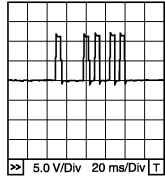
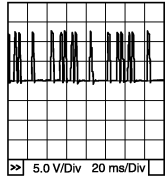
TER-MINAL NO.	WIRE COLOR	ITEM	CONDITION	DATA (DC Voltage)
33	R	Camshaft position sensor (PHASE) (bank 1)	<p><b>[Engine is running]</b></p> <ul style="list-style-type: none"> <li>● Warm-up condition</li> <li>● Idle speed</li> </ul> <p><b>NOTE:</b> The pulse cycle changes depending on rpm at idle.</p>	<p>1.0 - 4.0V★</p>  <p style="text-align: right; font-size: small;">PBIB1039E</p>
			<p><b>[Engine is running]</b></p> <ul style="list-style-type: none"> <li>● Engine speed is 2,000 rpm.</li> </ul>	<p>1.0 - 4.0V★</p>  <p style="text-align: right; font-size: small;">PBIB1040E</p>

★: Average voltage for pulse signal (Actual pulse signal can be confirmed by oscilloscope.)

# DTC P0340, P0345 CMP SENSOR (PHASE)

## BANK 2

## EC-PHSB2-01

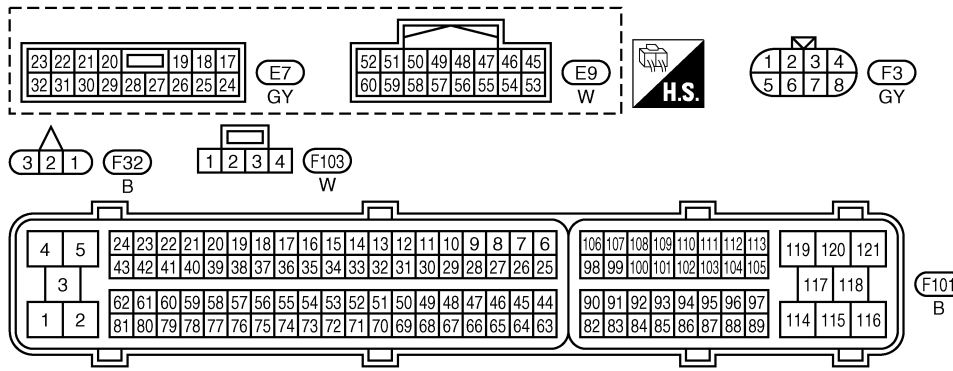
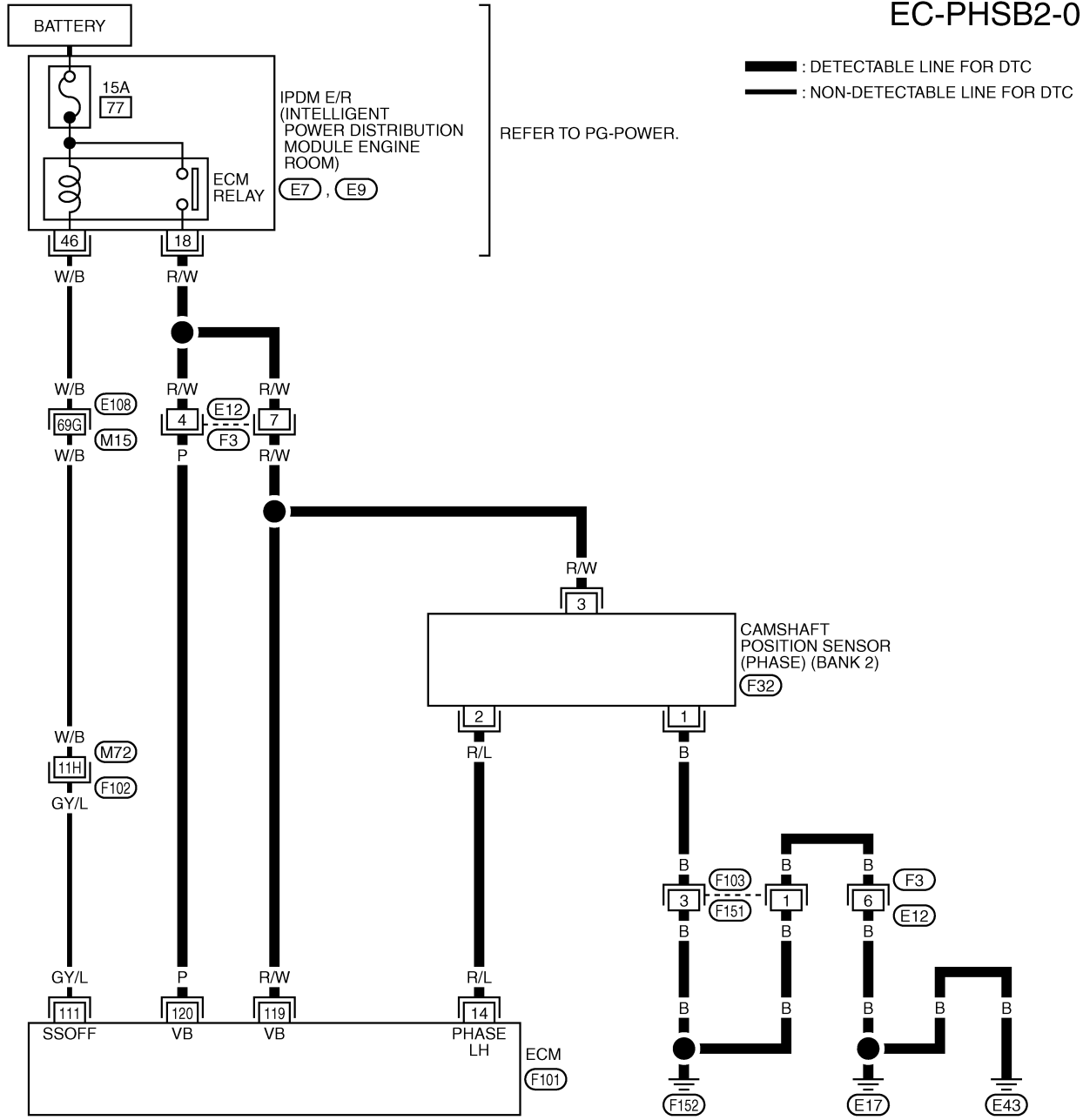

TBWT0618E

# DTC P0340, P0345 CMP SENSOR (PHASE)

Specification data are reference values and are measured between each terminal and ground.  
Pulse signal is measured by CONSULT-II.

**CAUTION:**

**Do not use ECM ground terminals when measuring input/output voltage. Doing so may result in damage to the ECM's transistor. Use a ground other than ECM terminals, such as the ground.**

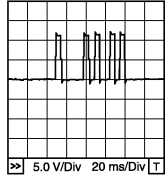
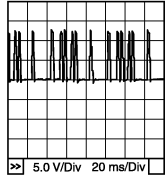
TER-MINAL NO.	WIRE COLOR	ITEM	CONDITION	DATA (DC Voltage)
14	R/L	Camshaft position sensor (PHASE) (bank 2)	<p><b>[Engine is running]</b></p> <ul style="list-style-type: none"> <li>● Warm-up condition</li> <li>● Idle speed</li> </ul> <p><b>NOTE:</b> The pulse cycle changes depending on rpm at idle.</p>	<p>1.0 - 4.0V★</p>  <p style="text-align: right;">PBIB1039E</p>
			<p><b>[Engine is running]</b></p> <ul style="list-style-type: none"> <li>● Engine speed is 2,000 rpm.</li> </ul>	<p>1.0 - 4.0V★</p>  <p style="text-align: right;">PBIB1040E</p>

★: Average voltage for pulse signal (Actual pulse signal can be confirmed by oscilloscope.)

## Diagnostic Procedure

ABS009GL

### 1. CHECK STARTING SYSTEM

Turn ignition switch to START position.

**Does the engine turn over?**

**Does the starter motor operate?**

Yes or No

Yes >> GO TO 2.

No >> Check starting system. (Refer to [SC-10, "STARTING SYSTEM"](#) .)

## DTC P0340, P0345 CMP SENSOR (PHASE)

### 2. CHECK GROUND CONNECTIONS

1. Turn ignition switch OFF.
2. Loosen and retighten three ground screws on the body. Refer to [EC-138, "Ground Inspection"](#).

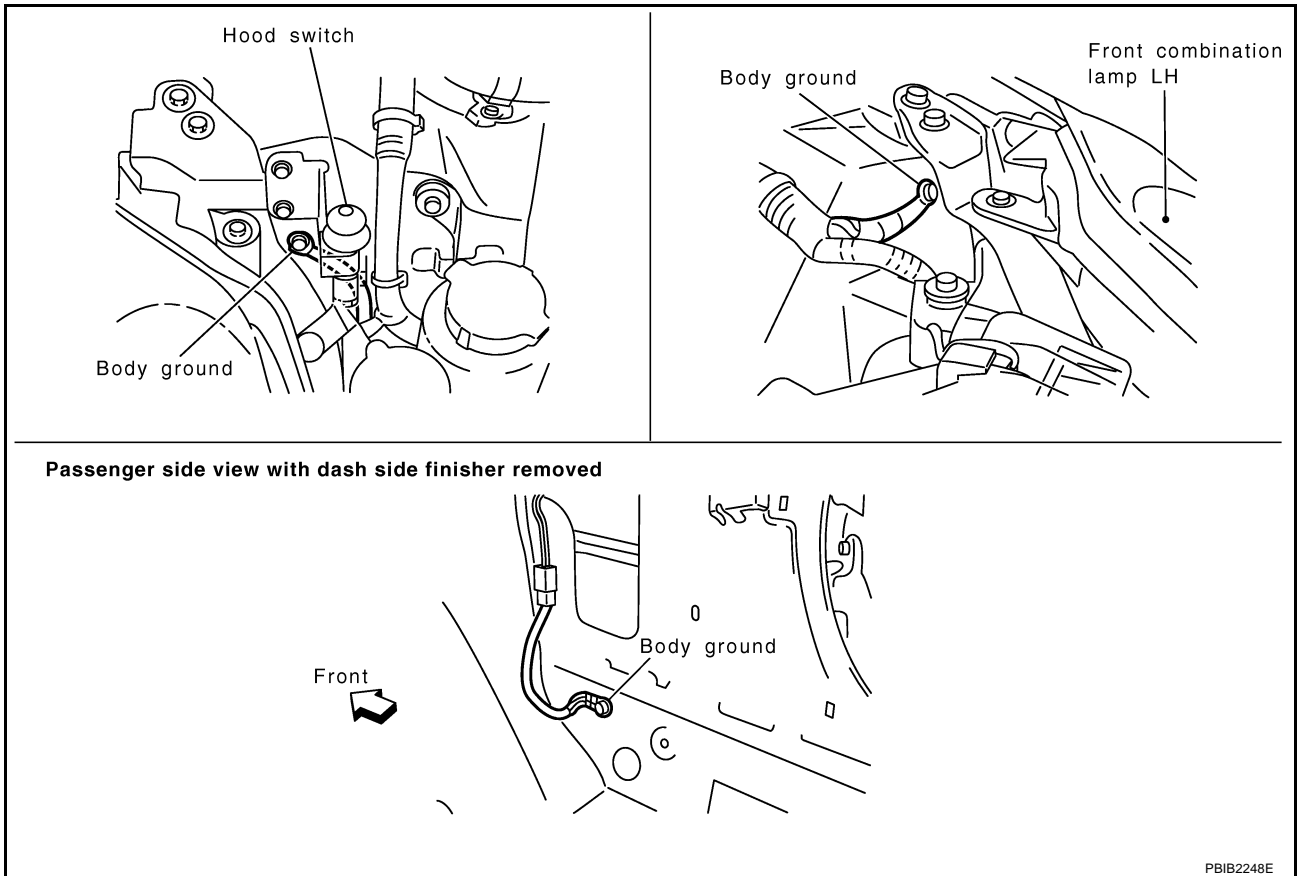

#### OK or NG

- OK >> GO TO 3.  
NG >> Repair or replace ground connections.

A  
EC  
C  
D  
E  
F  
G  
H  
I  
J  
K  
L  
M

## DTC P0340, P0345 CMP SENSOR (PHASE)

### 3. CHECK CAMSHAFT POSITION (CMP) SENSOR (PHASE) POWER SUPPLY CIRCUIT

1. Disconnect camshaft position (CMP) sensor (PHASE) harness connector.

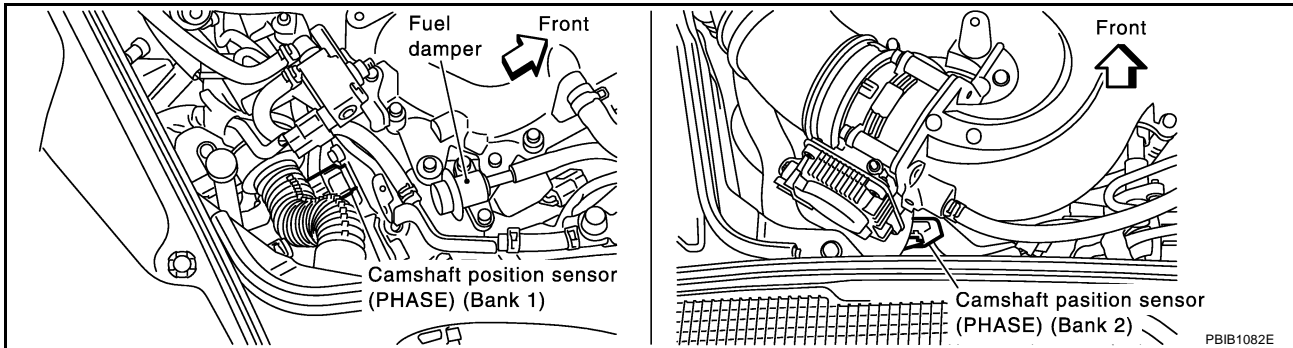

2. Turn ignition switch ON.
3. Check voltage between CMP sensor (PHASE) terminal 3 and ground with CONSULT-II or tester.

**Voltage: Battery voltage**

OK or NG

- OK >> GO TO 5.
- NG >> GO TO 4.

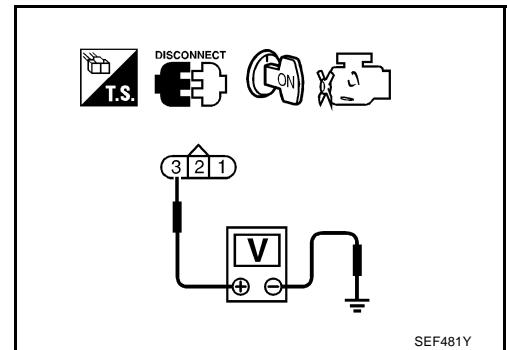

### 4. DETECT MALFUNCTIONING PART

Check the following.

- Harness connectors E12, F3
- Harness for open or short between camshaft position sensor (PHASE) and ECM
- Harness for open or short between camshaft position sensor (PHASE) and IPDM E/R

>> Repair open circuit or short to ground or short to power in harness or connectors.

### 5. CHECK CMP SENSOR (PHASE) GROUND CIRCUIT FOR OPEN AND SHORT

1. Turn ignition switch OFF.
2. Check harness continuity between CMP sensor (PHASE) terminal 1 and ground.

**Continuity should exist.**

3. Also check harness for short to power.

OK or NG

- OK >> GO TO 7.
- NG >> GO TO 6.

### 6. DETECT MALFUNCTIONING PART

Check the following.

- Harness connectors F103, F151
- Harness connectors E12, F3
- Harness for open or short between CMP sensor (PHASE) and ground

>> Repair open circuit or short to power in harness or connectors.



## DTC P0340, P0345 CMP SENSOR (PHASE)

### 7. CHECK CMP SENSOR (PHASE) INPUT SIGNAL CIRCUIT FOR OPEN AND SHORT

1. Disconnect ECM harness connector.
2. Check harness continuity between ECM terminal 33 (Bank 1) or 14 (Bank 2) and CMP sensor (PHASE) terminal 2.  
Refer to Wiring Diagram.

**Continuity should exist.**

3. Also check harness for short to ground and short to power.

OK or NG

OK >> GO TO 8.

NG >> Repair open circuit or short to ground or short to power in harness or connectors.

### 8. CHECK CAMSHAFT POSITION SENSOR (PHASE)

Refer to [EC-282, "Component Inspection"](#) .

OK or NG

OK >> GO TO 9.

NG >> Replace camshaft position sensor (PHASE).

### 9. CHECK CAMSHAFT (INTAKE)

Check the following.

- Accumulation of debris to the signal plate of camshaft rear end
- Chipping signal plate of camshaft rear end

OK or NG

OK >> GO TO 10.

NG >> Remove debris and clean the signal plate of camshaft rear end or replace camshaft.

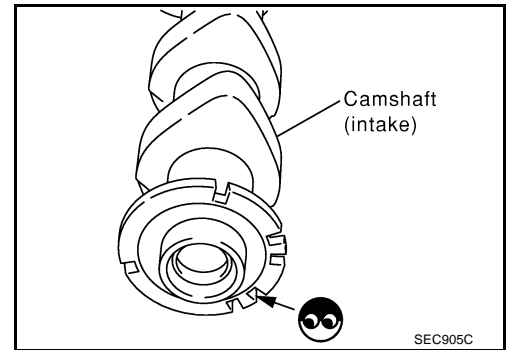

### 10. CHECK INTERMITTENT INCIDENT

Refer to [EC-129, "TROUBLE DIAGNOSIS FOR INTERMITTENT INCIDENT"](#) .

>> INSPECTION END

# DTC P0340, P0345 CMP SENSOR (PHASE)

ABS009GM

## Component Inspection CAMSHAFT POSITION SENSOR (PHASE)

1. Loosen the fixing bolt of the sensor.
2. Disconnect camshaft position sensor (PHASE) harness connector.
3. Remove the sensor.
4. Visually check the sensor for chipping.

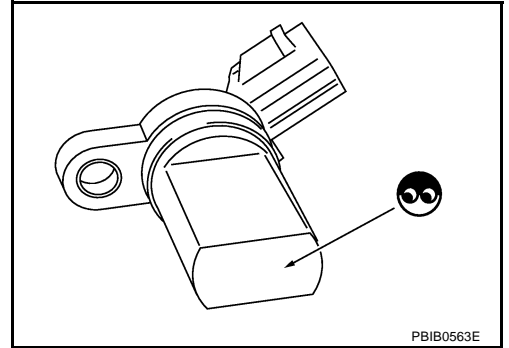

5. Check resistance as shown in the figure.

Terminal No. (Polarity)	Resistance $\Omega$ [at 25°C (77°F)]
1 (+) - 2 (-)	Except 0 or $\infty$
1 (+) - 3 (-)	
2 (+) - 3 (-)	

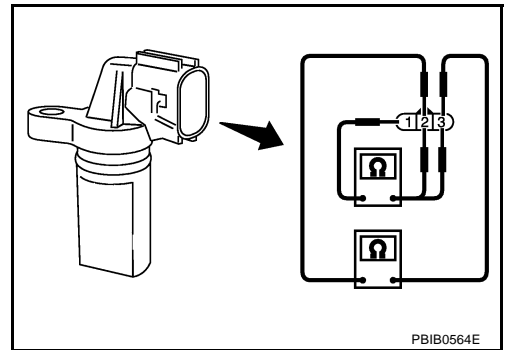

## Removal and Installation CAMSHAFT POSITION SENSOR (PHASE)

ABS009GN

Refer to [EM-75, "CAMSHAFT"](#) .

# DTC P0420, P0430 THREE WAY CATALYST FUNCTION

## DTC P0420, P0430 THREE WAY CATALYST FUNCTION

PF0:20905

### On Board Diagnosis Logic

ABS009GO

The ECM monitors the switching frequency ratio of air fuel ratio (A/F) sensor 1 and heated oxygen sensor 2. A three way catalyst 1 with high oxygen storage capacity will indicate a low switching frequency of heated oxygen sensor 2. As oxygen storage capacity decreases, the heated oxygen sensor 2 switching frequency will increase.

When the frequency ratio of air fuel ratio (A/F) sensor 1 and heated oxygen sensor 2 approaches a specified limit value, the three way catalyst 1 malfunction is diagnosed.

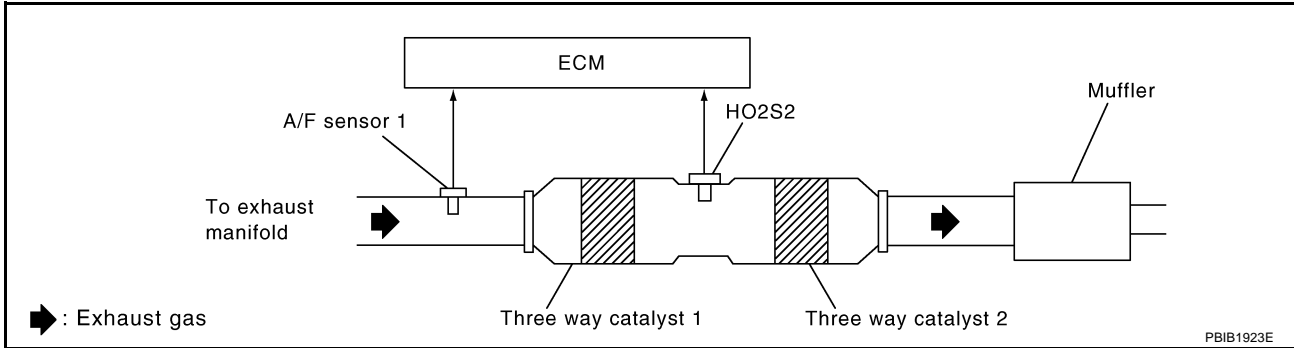

DTC No.	Trouble diagnosis name	DTC detecting condition	Possible cause
P0420 0420 (Bank 1)	Catalyst system efficiency below threshold	<ul style="list-style-type: none"> <li>• Three way catalyst 1 does not operate properly.</li> <li>• Three way catalyst 1 does not have enough oxygen storage capacity.</li> </ul>	<ul style="list-style-type: none"> <li>• Three way catalyst 1</li> <li>• Exhaust tube</li> <li>• Intake air leaks</li> <li>• Fuel injector</li> <li>• Fuel injector leaks</li> <li>• Spark plug</li> <li>• Improper ignition timing</li> </ul>
P0430 0430 (Bank 2)			

### DTC Confirmation Procedure

ABS009GP

#### NOTE:

If DTC Confirmation Procedure has been previously conducted, always turn ignition switch OFF and wait at least 10 seconds before conducting the next test.

#### WITH CONSULT-II

#### TESTING CONDITION:

Do not hold engine speed for more than the specified minutes below.

1. Turn ignition switch ON and select "DATA MONITOR" mode with CONSULT-II.
2. Start engine and warm it up to the normal operating temperature.
3. Turn ignition switch OFF and wait at least 10 seconds.
4. Start engine and keep the engine speed between 3,500 and 4,000 rpm for at least 1 minute under no load.
5. Let engine idle for 1 minute.
6. Make sure that "COOLAN TEMP/S" indicates more than 70°C (158°F).  
If not, warm up engine and go to next step when "COOLAN TEMP/S" indication reaches to 70°C (158°F).
7. Open engine hood.

DATA MONITOR	
MONITOR	NO DTC
ENG SPEED	XXX rpm
COOLAN TEMP/S	XXX °C
VHCL SPEED SE	XXX km/h
B/FUEL SCHDL	XXX msec

SEF189Y

# DTC P0420, P0430 THREE WAY CATALYST FUNCTION

8. Select "DTC & SRT CONFIRMATION" then "SRT WORK SUPPORT" mode with CONSULT-II.
9. Rev engine up to 2,000 to 3,000 rpm and hold it for 3 consecutive minutes then release the accelerator pedal completely. If "INCMP" of "CATALYST" changed to "CMPLT", go to step 12.
10. Wait 5 seconds at idle.

SRT WORK SUPPORT	
CATALYST	INCMP
EVAP SYSTEM	INCMP
HO2S HTR	CMPLT
HO2S	INCMP
MONITOR	
ENG SPEED	XXX rpm
MAS A/F SE-B1	XXX V
B/FUEL SCHDL	XXX msec
A/F ALPHA-B1	XXX V
COOLAN TEMP/S	XX °C
A/F SEN1 (B1)	XXX V

PBIB1784E

11. Rev engine up to 2,000 to 3,000 rpm and maintain it until "INCMP" of "CATALYST" changes to "CMPLT" (It will take approximately 5 minutes). If not "CMPLT", stop engine and cool it down to less than 70°C (158°F) and then retest from step 1.

SRT WORK SUPPORT	
CATALYST	CMPLT
EVAP SYSTEM	INCMP
HO2S HTR	CMPLT
HO2S	INCMP
MONITOR	
ENG SPEED	XXX rpm
MAS A/F SE-B1	XXX V
B/FUEL SCHDL	XXX msec
A/F ALPHA-B1	XXX V
COOLAN TEMP/S	XX °C
A/F SEN1 (B1)	XXX V

PBIB1785E

12. Select "SELF-DIAG RESULTS" mode with CONSULT-II.
13. Confirm that the 1st trip DTC is not detected. If the 1st trip DTC is detected, go to [EC-285, "Diagnostic Procedure"](#).

SELF DIAG RESULTS	
DTC RESULTS	TIME
NO DTC IS DETECTED. FURTHER TESTING MAY BE REQUIRED.	

SEF535Z

## Overall Function Check

ABS009GQ

Use this procedure to check the overall function of the three way catalyst 1. During this check, a 1st trip DTC might not be confirmed.

### WITH GST

1. Start engine and warm it up to the normal operating temperature.
  2. Turn ignition switch OFF and wait at least 10 seconds.
  3. Start engine and keep the engine speed between 3,500 and 4,000 rpm for at least 1 minute under no load.
  4. Let engine idle for 1minute.
  5. Open engine hood.
  6. Set voltmeters probes between ECM terminal 74 [HO2S2 (bank 1) signal], 55 [HO2S2 (bank 2) signal] and ground.
  7. Keep engine speed at 2,500 rpm constant under no load.
  8. Make sure that the voltage does not vary for more than 5 seconds. If the voltage fluctuation cycle take less than 5 seconds. Go to [EC-285, "Diagnostic Procedure"](#).
- 1cycle: 0.6 - 1.0 → 0 - 0.3 → 0.6 - 1.0

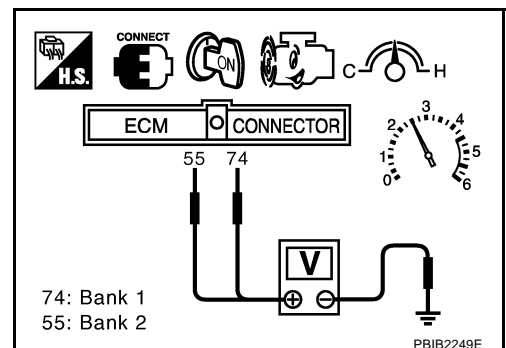

# DTC P0420, P0430 THREE WAY CATALYST FUNCTION

ABS009GR

## Diagnostic Procedure

### 1. CHECK EXHAUST SYSTEM

Visually check exhaust tubes and muffler for dent.

OK or NG

OK >> GO TO 2.

NG >> Repair or replace.

### 2. CHECK EXHAUST GAS LEAK

1. Start engine and run it at idle.
2. Listen for an exhaust gas leak before the three way catalyst 1.

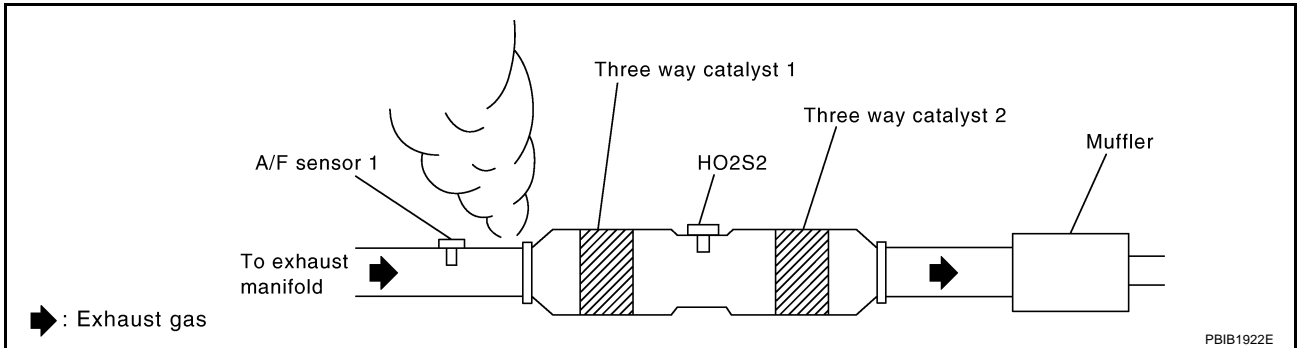

OK or NG

OK >> GO TO 3.

NG >> Repair or replace.

### 3. CHECK INTAKE AIR LEAK

Listen for an intake air leak after the mass air flow sensor.

OK or NG

OK >> GO TO 4.

NG >> Repair or replace.

### 4. CHECK IGNITION TIMING

Check the following items. Refer to [EC-78, "Basic Inspection"](#) .

Items	Specifications	
Target idle speed	A/T	650 ± 50 rpm (in P or N position)
	M/T	650 ± 50 rpm (in Neutral position)
Ignition timing	A/T	15 ± 5° BTDC (in P or N position)
	M/T	15 ± 5° BTDC (in Neutral position)

OK or NG

OK >> GO TO 5.

NG >> Follow the [EC-78, "Basic Inspection"](#) .

# DTC P0420, P0430 THREE WAY CATALYST FUNCTION

## 5. CHECK INJECTORS

1. Stop engine and then turn ignition switch ON.
2. Check voltage between ECM terminals 21, 22, 23, 40, 41, 42 and ground with CONSULT-II or tester.  
Refer to Wiring Diagram for Injectors, [EC-635](#) .

**Voltage: Battery voltage.**

OK or NG

- OK >> GO TO 6.  
NG >> Perform [EC-636, "Diagnostic Procedure"](#) .

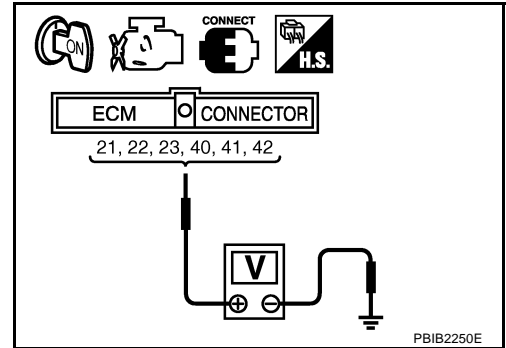

## 6. CHECK IGNITION SPARK

1. Turn ignition switch OFF.
2. Disconnect ignition coil assembly from rocker cover.
3. Connect a known-good spark plug to the ignition coil assembly.
4. Disconnect all injector harness connectors.
5. Place end of spark plug against a suitable ground and crank engine.
6. Check for spark.

OK or NG

- OK >> GO TO 7.  
NG >> Check ignition coil with power transistor and their circuit.  
Refer to [EC-622, "IGNITION SIGNAL"](#) .

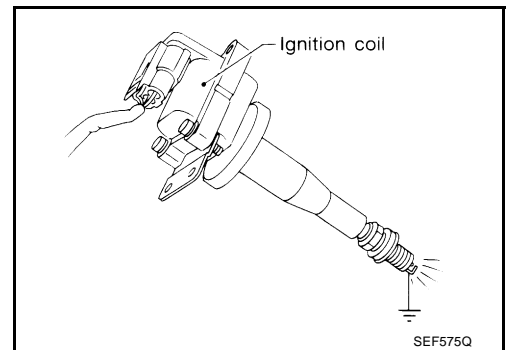

## 7. CHECK INJECTOR

1. Turn ignition switch OFF.
2. Remove injector assembly.  
Refer to [EM-36, "FUEL INJECTOR AND FUEL TUBE"](#) .  
Keep fuel hose and all injectors connected to injector gallery.
3. Disconnect all ignition coil harness connectors.
4. Reconnect injector harness connectors.
5. Turn ignition switch ON.  
Make sure fuel does not drip from injector.

OK or NG

- OK (Does not drip.)>>GO TO 8.  
NG (Drips.)>>Replace the injector(s) from which fuel is dripping.

## 8. CHECK INTERMITTENT INCIDENT

Refer to [EC-129, "TROUBLE DIAGNOSIS FOR INTERMITTENT INCIDENT"](#) .

Trouble is fixed.>>**INSPECTION END**

Trouble is not fixed.>>Replace three way catalyst assembly.

# DTC P0441 EVAP CONTROL SYSTEM

## DTC P0441 EVAP CONTROL SYSTEM

PFP:14950

### System Description

ABS009GS

**NOTE:**

If DTC P0441 is displayed with other DTC such as P2122, P2123, P2127, P2128 or P2138, first perform trouble diagnosis for other DTC.

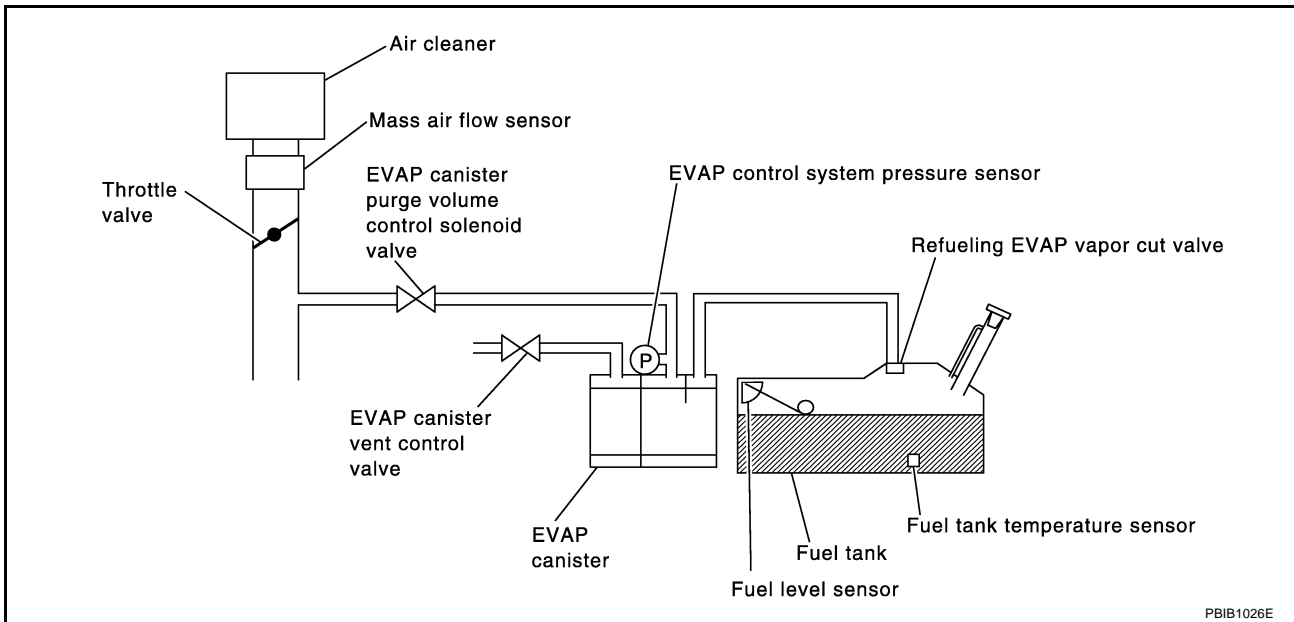

In this evaporative emission (EVAP) control system, purge flow occurs during non-closed throttle conditions. Purge volume is related to air intake volume. Under normal purge conditions (non-closed throttle), the EVAP canister purge volume control solenoid valve is open to admit purge flow. Purge flow exposes the EVAP control system pressure sensor to intake manifold vacuum.

### On Board Diagnosis Logic

ABS009GT

Under normal conditions (non-closed throttle), sensor output voltage indicates if pressure drop and purge flow are adequate. If not, a malfunction is determined.

DTC No.	Trouble diagnosis name	DTC detecting condition	Possible cause
P0441 0441	EVAP control system incorrect purge flow	EVAP control system does not operate properly, EVAP control system has a leak between intake manifold and EVAP control system pressure sensor.	<ul style="list-style-type: none"> <li>● EVAP canister purge volume control solenoid valve stuck closed</li> <li>● EVAP control system pressure sensor and the circuit</li> <li>● Loose, disconnected or improper connection of rubber tube</li> <li>● Blocked rubber tube</li> <li>● Cracked EVAP canister</li> <li>● EVAP canister purge volume control solenoid valve circuit</li> <li>● Accelerator pedal position sensor</li> <li>● Blocked purge port</li> <li>● EVAP canister vent control valve</li> </ul>

### DTC Confirmation Procedure

ABS009GU

**CAUTION:**

Always drive vehicle at a safe speed.

**NOTE:**

If DTC Confirmation Procedure has been previously conducted, always turn ignition switch OFF and wait at least 10 seconds before conducting the next test.

**TESTING CONDITION:**

Always perform test at a temperature of 5°C (41°F) or more.

# DTC P0441 EVAP CONTROL SYSTEM

## WITH CONSULT-II

1. Start engine and warm it up to normal operating temperature.
2. Turn ignition switch OFF and wait at least 10 seconds.
3. Start engine and let it idle for at least 70 seconds.
4. Select "PURG FLOW P0441" of "EVAPORATIVE SYSTEM" in "DTC CONFIRMATION" mode with CONSULT-II.
5. Touch "START".  
If "COMPLETED" is displayed, go to step 7.
6. When the following conditions are met, "TESTING" will be displayed on the CONSULT-II screen. Maintain the conditions continuously until "TESTING" changes to "COMPLETED". (It will take at least 35 seconds.)

Shift lever	Suitable position
VHCL SPEED SE	32 - 120 km/h (20 - 75 MPH)
ENG SPEED	500 - 3,000 rpm
B/FUEL SCHDL	1.3 - 9.0 msec
COOLAN TEMP/S	70 - 100°C (158 - 212°F)

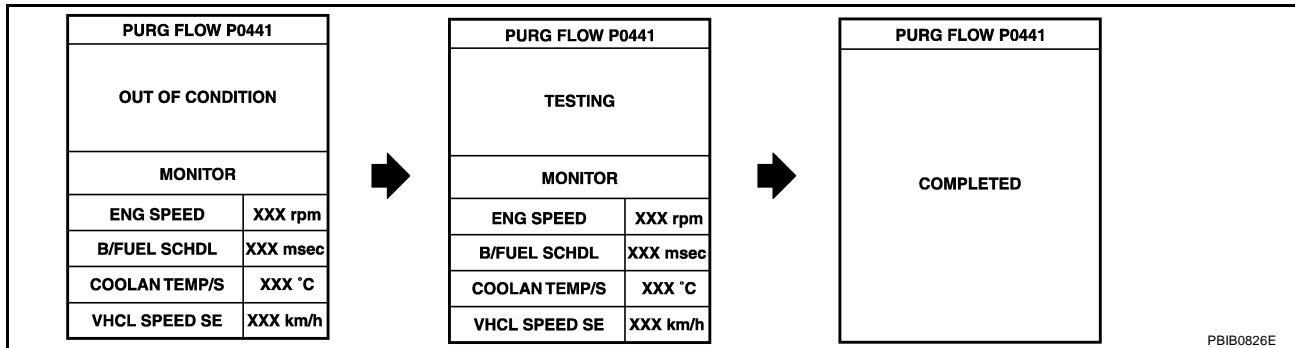

If "TESTING" is not changed for a long time, retry from step 2.

7. Make sure that "OK" is displayed after touching "SELF-DIAG RESULTS". If "NG" is displayed, refer to [EC-289, "Diagnostic Procedure"](#).

## Overall Function Check

ABS009GV

Use this procedure to check the overall monitoring function of the EVAP control system purge flow monitoring. During this check, a 1st trip DTC might not be confirmed.

## WITH GST

1. Lift up drive wheels.
2. Start engine (VDC switch or TCS switch OFF) and warm it up to normal operating temperature.
3. Turn ignition switch OFF, wait at least 10 seconds.
4. Start engine and wait at least 70 seconds.
5. Set voltmeter probes to ECM terminals 32 (EVAP control system pressure sensor signal) and ground.
6. Check EVAP control system pressure sensor value at idle speed and note it.
7. Establish and maintain the following conditions for at least 1 minute.

Air conditioner switch	ON
Headlamp switch	ON
Rear window defogger switch	ON
Engine speed	Approx. 3,000 rpm
Gear position	Any position other than P, N or R

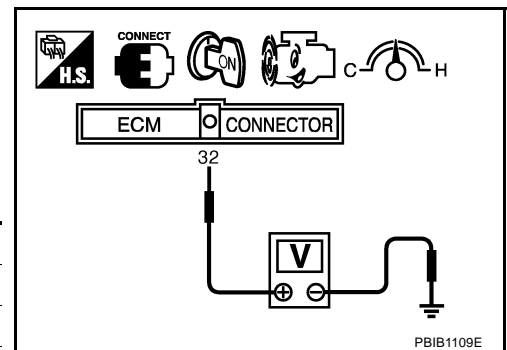

8. Verify that EVAP control system pressure sensor value stays 0.1V less than the value at idle speed (measured at step 6) for at least 1 second.



# DTC P0441 EVAP CONTROL SYSTEM

9. If NG, go to [EC-289, "Diagnostic Procedure"](#).

## Diagnostic Procedure

ABS009GW

### 1. CHECK EVAP CANISTER

1. Turn ignition switch OFF.
2. Check EVAP canister for cracks.

#### OK or NG

- OK (With CONSULT-II)>>GO TO 2.  
OK (Without CONSULT-II)>>GO TO 3.  
NG >> Replace EVAP canister.

### 2. CHECK PURGE FLOW

#### Ⓟ With CONSULT-II

1. Disconnect vacuum hose connected to EVAP canister purge volume control solenoid valve at EVAP service port and install vacuum gauge. For the location of EVAP service port, refer to [EC-675, "EVAPORATIVE EMISSION LINE DRAWING"](#).
2. Start engine and let it idle.
3. Select "PURG VOL CONT/V" in "ACTIVE TEST" mode with CONSULT-II.
4. Rev engine up to 2,000 rpm.
5. Touch "Qd" and "Qu" on CONSULT-II screen to adjust "PURG VOL CONT/V" opening and check vacuum existence.

PURG VOL CONT/V	Vacuum
100%	Should exist.
0%	Should not exist.

#### OK or NG

- OK >> GO TO 7.  
NG >> GO TO 4.

ACTIVE TEST	
PURG VOL CONT/V	XXX %
MONITOR	
ENG SPEED	XXX rpm
A/F ALPHA-B1	XX %
A/F ALPHA-B2	XX %

PBIB1678E

### 3. CHECK PURGE FLOW

#### ⓧ Without CONSULT-II

1. Start engine and warm it up to normal operating temperature.
2. Stop engine.
3. Disconnect vacuum hose connected to EVAP canister purge volume control solenoid valve at EVAP service port and install vacuum gauge. For the location of EVAP service port, refer to [EC-675, "EVAPORATIVE EMISSION LINE DRAWING"](#).
4. Start engine and let it idle.

**Do not depress accelerator pedal even slightly**

5. Check vacuum gauge indication before 60 seconds passed after starting engine.

**Vacuum should not exist.**

6. Revving engine up to 2,000 rpm after 100 seconds passed after starting engine.

**Vacuum should exist.**

#### OK or NG

- OK >> GO TO 7.  
NG >> GO TO 4.

# DTC P0441 EVAP CONTROL SYSTEM

## 4. CHECK EVAP PURGE LINE

1. Turn ignition switch OFF.
2. Check EVAP purge line for improper connection or disconnection.  
Refer to [EC-675, "EVAPORATIVE EMISSION LINE DRAWING"](#) .

OK or NG

- OK >> GO TO 5.  
NG >> Repair it.

## 5. CHECK EVAP PURGE HOSE AND PURGE PORT

1. Disconnect purge hoses connected to EVAP service port **A** and EVAP canister purge volume control solenoid valve **B** .
2. Blow air into each hose and EVAP purge port **C** .

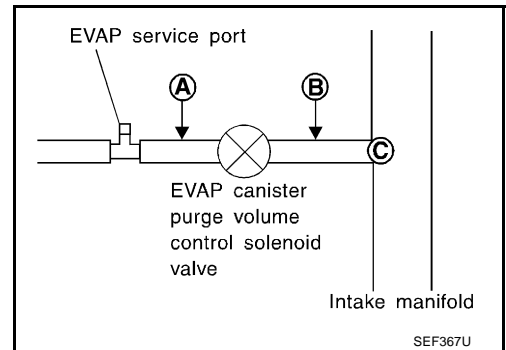

3. Check that air flows freely.

OK or NG

- OK (With CONSULT-II)>>GO TO 6.  
OK (Without CONSULT-II)>>GO TO 7.  
NG >> Repair or clean hoses and/or purge port.

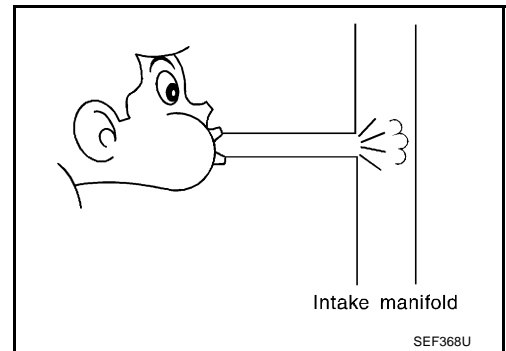

## 6. CHECK EVAP CANISTER PURGE VOLUME CONTROL SOLENOID VALVE

**With CONSULT-II**

1. Start engine.
2. Perform "PURG VOL CONT/V" in "ACTIVE TEST" mode with CONSULT-II. Check that engine speed varies according to the valve opening.

OK or NG

- OK >> GO TO 8.  
NG >> GO TO 7.

ACTIVE TEST	
PURG VOL CONT/V	XXX %
MONITOR	
ENG SPEED	XXX rpm
A/F ALPHA-B1	XX %
A/F ALPHA-B2	XX %

PBIB1678E

## 7. CHECK EVAP CANISTER PURGE VOLUME CONTROL SOLENOID VALVE

Refer to [EC-306, "Component Inspection"](#) .

OK or NG

- OK >> GO TO 8.  
NG >> Replace EVAP canister purge volume control solenoid valve.

# DTC P0441 EVAP CONTROL SYSTEM

---

## 8. CHECK EVAP CONTROL SYSTEM PRESSURE SENSOR CONNECTOR

---

1. Disconnect EVAP control system pressure sensor harness connector.
2. Check connectors for water.

**Water should not exist.**

OK or NG

- OK >> GO TO 9.  
NG >> Replace EVAP control system pressure sensor.

---

## 9. CHECK EVAP CONTROL SYSTEM PRESSURE SENSOR FUNCTION

---

Refer to DTC Confirmation Procedure for DTC P0452 [EC-321](#) , P0453 [EC-330](#) .

OK or NG

- OK >> GO TO 10.  
NG >> Replace EVAP control system pressure sensor.

---

## 10. CHECK RUBBER TUBE FOR CLOGGING

---

1. Disconnect rubber tube connected to EVAP canister vent control valve.
2. Check the rubber tube for clogging.

OK or NG

- OK >> GO TO 11.  
NG >> Clean the rubber tube using an air blower.

---

## 11. CHECK EVAP CANISTER VENT CONTROL VALVE

---

Refer to [EC-315, "Component Inspection"](#) .

OK or NG

- OK >> GO TO 12.  
NG >> Replace EVAP canister vent control valve.

---

## 12. CHECK EVAP PURGE LINE

---

Inspect EVAP purge line (pipe and rubber tube). Check for evidence of leaks.  
Refer to [EC-675, "EVAPORATIVE EMISSION LINE DRAWING"](#) .

OK or NG

- OK >> GO TO 13.  
NG >> Replace it.

---

## 13. CLEAN EVAP PURGE LINE

---

Clean EVAP purge line (pipe and rubber tube) using air blower.

>> GO TO 14.

---

## 14. CHECK INTERMITTENT INCIDENT

---

Refer to [EC-129, "TROUBLE DIAGNOSIS FOR INTERMITTENT INCIDENT"](#) .

>> INSPECTION END

A

EC

C

D

E

F

G

H

I

J

K

L

M

# DTC P0442 EVAP CONTROL SYSTEM

## DTC P0442 EVAP CONTROL SYSTEM

PF14950

### On Board Diagnosis Logic

ABS009GX

This diagnosis detects leaks in the EVAP purge line using engine intake manifold vacuum. If pressure does not increase, the ECM will check for leaks in the line between the fuel tank and EVAP canister purge volume control solenoid valve, under the following Vacuum test conditions. The EVAP canister vent control valve is closed to shut the EVAP purge line off. The EVAP canister purge volume control solenoid valve will then be opened to depressurize the EVAP purge line using intake manifold vacuum. After this occurs, the EVAP canister purge volume control solenoid valve will be closed.

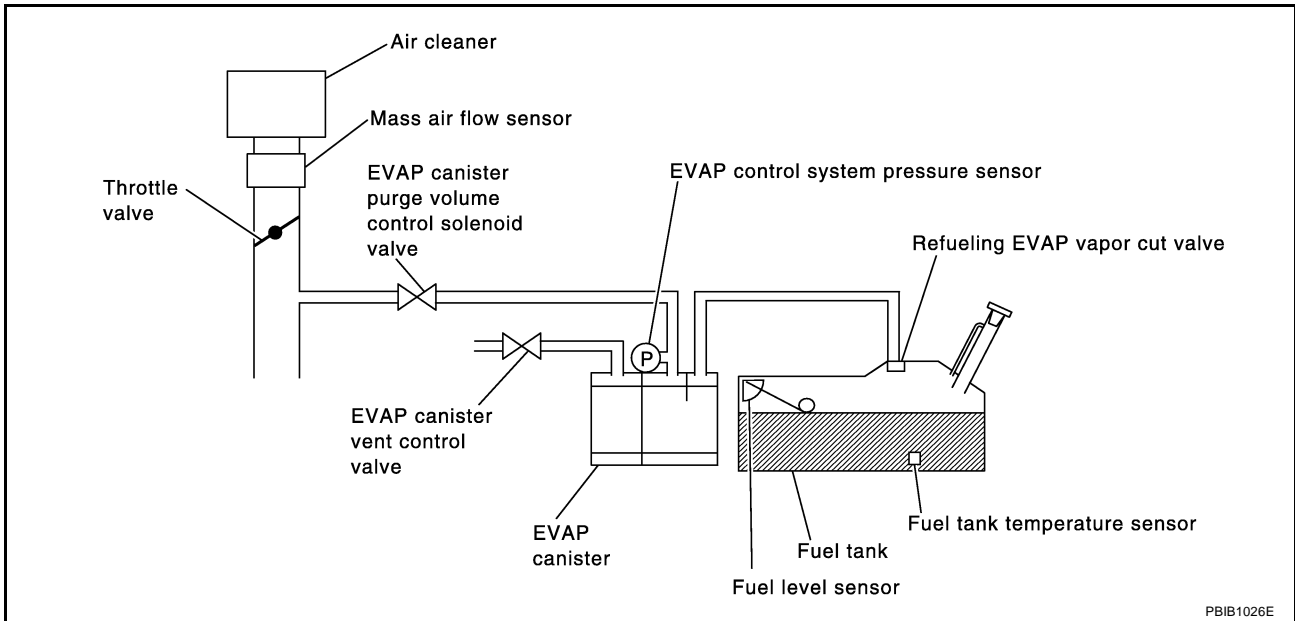

PBIB1026E

DTC No.	Trouble diagnosis name	DTC detecting condition	Possible cause
P0442 0442	EVAP control system small leak detected (negative pressure)	EVAP control system has a leak, EVAP control system does not operate properly.	<ul style="list-style-type: none"> <li>● Incorrect fuel tank vacuum relief valve</li> <li>● Incorrect fuel filler cap used</li> <li>● Fuel filler cap remains open or fails to close.</li> <li>● Foreign matter caught in fuel filler cap.</li> <li>● Leak is in line between intake manifold and EVAP canister purge volume control solenoid valve.</li> <li>● Foreign matter caught in EVAP canister vent control valve.</li> <li>● EVAP canister or fuel tank leaks</li> <li>● EVAP purge line (pipe and rubber tube) leaks</li> <li>● EVAP purge line rubber tube bent</li> <li>● Loose or disconnected rubber tube</li> <li>● EVAP canister vent control valve and the circuit</li> <li>● EVAP canister purge volume control solenoid valve and the circuit</li> <li>● Fuel tank temperature sensor</li> <li>● O-ring of EVAP canister vent control valve is missing or damaged</li> <li>● EVAP canister is saturated with water</li> <li>● EVAP control system pressure sensor</li> <li>● Fuel level sensor and the circuit</li> <li>● Refueling EVAP vapor cut valve</li> <li>● ORVR system leaks</li> </ul>

# DTC P0442 EVAP CONTROL SYSTEM

## CAUTION:

- Use only a genuine NISSAN fuel filler cap as a replacement. If an incorrect fuel filler cap is used, the MIL may come on.
- If the fuel filler cap is not tightened properly, the MIL may come on.
- Use only a genuine NISSAN rubber tube as a replacement.

## DTC Confirmation Procedure

ABS009GY

### NOTE:

- If DTC Confirmation Procedure has been previously conducted, always turn ignition switch OFF and wait at least 10 seconds before conducting the next test.

### TESTING CONDITION:

- Perform "DTC WORK SUPPORT" when the fuel level is between 1/4 and 3/4 full, and vehicle is placed on flat level surface.
- Always perform test at a temperature of 0 to 30°C (32 to 86°F).

### WITH CONSULT-II

1. Turn ignition switch ON.
2. Turn ignition switch OFF and wait at least 10 seconds.
3. Turn ignition switch ON and select "DATA MONITOR" mode with CONSULT-II.
4. Make sure that the following conditions are met.  
**COOLAN TEMP/S: 0 - 70°C (32 - 158°F)**  
**INT/A TEMP SE: 0 - 30°C (32 - 86°F)**

DATA MONITOR	
MONITOR	DTC
ENG SPEED	XXX rpm
COOLAN TEMP/S	XXX °C
INT/A TEMP SE	XXX °C

PBIB2869E

5. Select "EVAP SML LEAK P0442/P1442" of "EVAPORATIVE SYSTEM" in "DTC WORK SUPPORT" mode with CONSULT-II.  
Follow the instruction displayed.

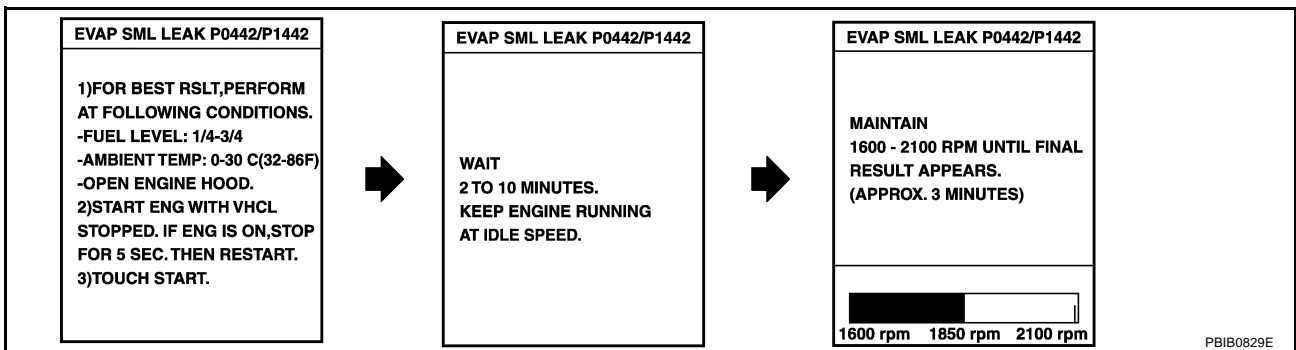

### NOTE:

If the engine speed cannot be maintained within the range displayed on the CONSULT-II screen, go to [EC-78, "Basic Inspection"](#).

## DTC P0442 EVAP CONTROL SYSTEM

6. Make sure that "OK" is displayed.  
If "NG" is displayed, refer to [EC-294, "Diagnostic Procedure"](#).

**NOTE:**

**Make sure that EVAP hoses are connected to EVAP canister purge volume control solenoid valve properly.**

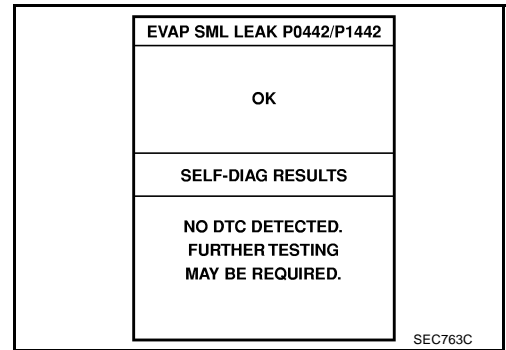

 **WITH GST**

**NOTE:**

Be sure to read the explanation of [EC-58, "Driving Pattern"](#) before driving vehicle.

1. Start engine.
2. Drive vehicle according to [EC-58, "Driving Pattern"](#).
3. Stop vehicle.
4. Turn ignition switch OFF, wait at least 10 seconds and then turn ON.
5. Select "MODE 7" with GST.
  - If P0442 is displayed on the screen, go to [EC-294, "Diagnostic Procedure"](#).
  - If P0441 is displayed on the screen, go to Diagnostic Procedure for DTC P0441, [EC-289](#).

### Diagnostic Procedure

ABS009GZ

#### 1. CHECK FUEL FILLER CAP DESIGN

1. Turn ignition switch OFF.
2. Check for genuine NISSAN fuel filler cap design.

OK or NG

- OK >> GO TO 2.  
NG >> Replace with genuine NISSAN fuel filler cap.

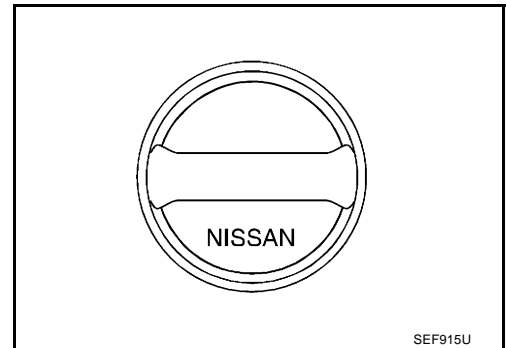

#### 2. CHECK FUEL FILLER CAP INSTALLATION

Check that the cap is tightened properly by rotating the cap clockwise.

OK or NG

- OK >> GO TO 3.  
NG >> 1. Open fuel filler cap, then clean cap and fuel filler neck threads using air blower.  
2. Retighten until ratcheting sound is heard.

#### 3. CHECK FUEL FILLER CAP FUNCTION

Check for air releasing sound while opening the fuel filler cap.

OK or NG

- OK >> GO TO 5.  
NG >> GO TO 4.

# DTC P0442 EVAP CONTROL SYSTEM

## 4. CHECK FUEL TANK VACUUM RELIEF VALVE

Refer to [EC-677, "FUEL TANK VACUUM RELIEF VALVE \(BUILT INTO FUEL FULLER CAP\)"](#) .

OK or NG

OK >> GO TO 5.

NG >> Replace fuel filler cap with a genuine one.

## 5. INSTALL THE PRESSURE PUMP

To locate the EVAP leak, install EVAP service port adapter and pressure pump to EVAP service port securely. For the location of EVAP service port, refer to [EC-675, "EVAPORATIVE EMISSION LINE DRAWING"](#) .

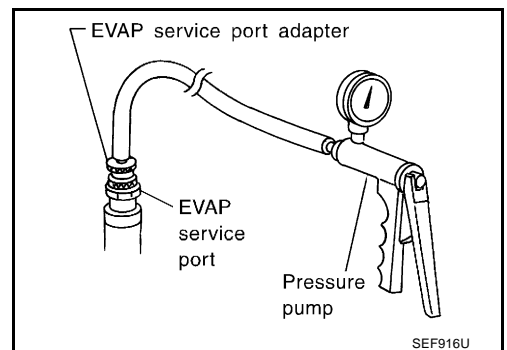
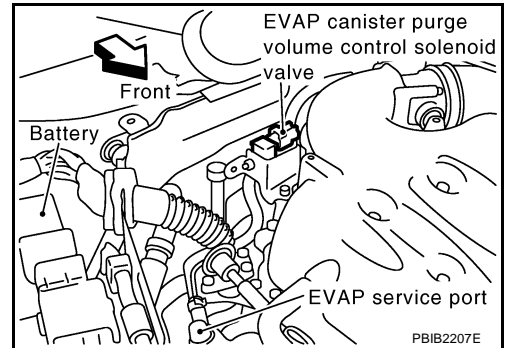

### NOTE:

Improper installation of the EVAP service port adapter to the EVAP service port may cause leaking.

With CONSULT-II>>GO TO 6.

Without CONSULT-II>>GO TO 7.

## DTC P0442 EVAP CONTROL SYSTEM

### 6. CHECK FOR EVAP LEAK

#### With CONSULT-II

1. Turn ignition switch ON.
2. Select "EVAP SYSTEM CLOSE" of "WORK SUPPORT" mode with CONSULT-II.
3. Touch "START" and apply pressure into the EVAP line until the pressure indicator reaches the middle of the bar graph.

#### CAUTION:

- Never use compressed air or a high pressure pump.
- Do not exceed 4.12 kPa (0.042 kg/cm<sup>2</sup> , 0.6 psi) of pressure in the system.

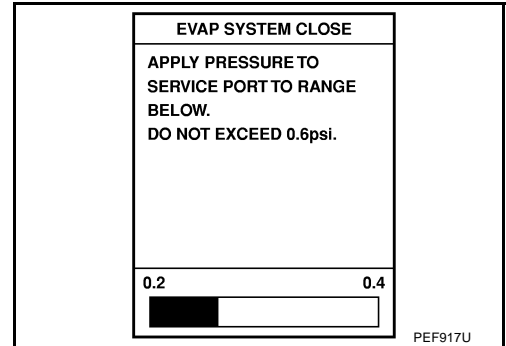

4. Using EVAP leak detector, locate the EVAP leak. For the leak detector, refer to the instruction manual for more details. Refer to [EC-675, "EVAPORATIVE EMISSION LINE DRAWING"](#)

#### OK or NG

- OK >> GO TO 8.  
NG >> Repair or replace.

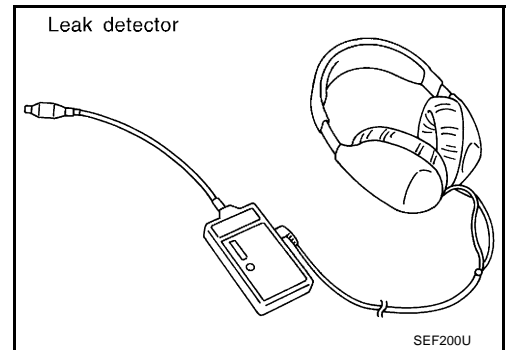



# DTC P0442 EVAP CONTROL SYSTEM

## 7. CHECK FOR EVAP LEAK

### ⊗ Without CONSULT-II

1. Turn ignition switch OFF.
2. Apply 12 volts DC to EVAP canister vent control valve. The valve will close. (Continue to apply 12 volts until the end of test.)

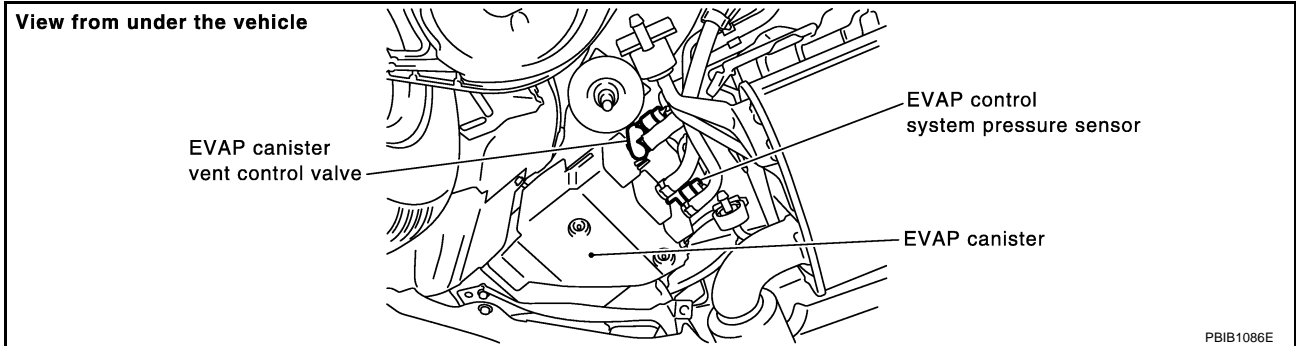

3. Pressurize the EVAP line using pressure pump with 1.3 to 2.7 kPa (10 to 20 mmHg, 0.39 to 0.79 inHg), then remove pump and EVAP service port adapter.

### CAUTION:

- Never use compressed air or a high pressure pump.
  - Do not exceed 4.12 kPa (0.042 kg/cm<sup>2</sup>, 0.6 psi) of pressure in the system.
4. Using EVAP leak detector, locate the EVAP leak. For the leak detector, refer to the instruction manual for more details. Refer to [EC-675, "EVAPORATIVE EMISSION LINE DRAWING"](#).

### OK or NG

- OK >> GO TO 8.  
NG >> Repair or replace.

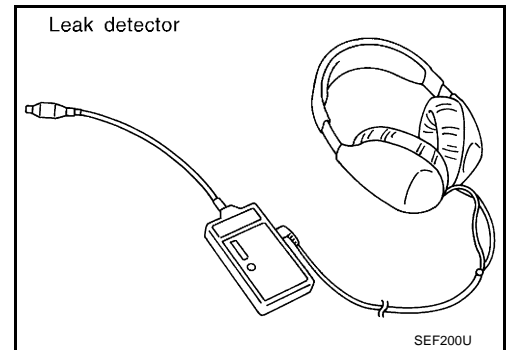

## 8. CHECK EVAP CANISTER VENT CONTROL VALVE

Check the following.

- EVAP canister vent control valve is installed properly. Refer to [EC-678, "Removal and Installation"](#).
- EVAP canister vent control valve. Refer to [EC-315, "Component Inspection"](#).

### OK or NG

- OK >> GO TO 9.  
NG >> Repair or replace EVAP canister vent control valve and O-ring.

# DTC P0442 EVAP CONTROL SYSTEM

## 9. CHECK IF EVAP CANISTER SATURATED WITH WATER

1. Remove EVAP canister with EVAP canister vent control valve and EVAP control system pressure sensor attached.
2. Does water drain from the EVAP canister?

Yes or No

- Yes >> GO TO 10.  
No (With CONSULT-II)>>GO TO 12.  
No (Without CONSULT-II)>>GO TO 13.

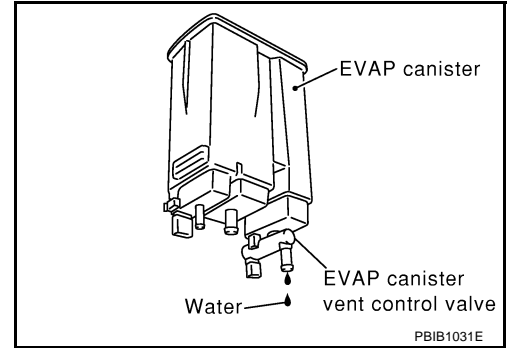

## 10. CHECK EVAP CANISTER

Weigh the EVAP canister with the EVAP canister vent control valve and EVAP control system pressure sensor attached.

**The weight should be less than 2.2 kg (4.9 lb).**

OK or NG

- OK (With CONSULT-II)>>GO TO 12.  
OK (Without CONSULT-II)>>GO TO 13.  
NG >> GO TO 11.

## 11. DETECT MALFUNCTIONING PART

Check the following.

- EVAP canister for damage
- EVAP hose between EVAP canister and vehicle frame for clogging or poor connection

>> Repair hose or replace EVAP canister.

## 12. CHECK EVAP CANISTER PURGE VOLUME CONTROL SOLENOID VALVE OPERATION

Ⓟ With CONSULT-II

1. Disconnect vacuum hose to EVAP canister purge volume control solenoid valve at EVAP service port.
2. Start engine.
3. Perform "PURG VOL CONT/V" in "ACTIVE TEST" mode.
4. Touch "Qu" on CONSULT-II screen to increase "PURG VOL CONT/V" opening to 100%.
5. Check vacuum hose for vacuum when revving engine up to 2,000 rpm.

OK or NG

- OK >> GO TO 15.  
NG >> GO TO 14.

ACTIVE TEST	
PURG VOL CONT/V	XXX %
MONITOR	
ENG SPEED	XXX rpm
A/F ALPHA-B1	XX %
A/F ALPHA-B2	XX %

PBIB1678E

# DTC P0442 EVAP CONTROL SYSTEM

---

## 13. CHECK EVAP CANISTER PURGE VOLUME CONTROL SOLENOID VALVE OPERATION

---

⊗ Without CONSULT-II

1. Start engine and warm it up to normal operating temperature.
2. Stop engine.
3. Disconnect vacuum hose to EVAP canister purge volume control solenoid valve at EVAP service port.
4. Start engine and let it idle for at least 80 seconds.
5. Check vacuum hose for vacuum when revving engine up to 2,000 rpm.

OK or NG

- OK >> GO TO 16.  
NG >> GO TO 14.

---

## 14. CHECK VACUUM HOSE

---

Check vacuum hoses for clogging or disconnection. Refer to [EC-23, "Vacuum Hose Drawing"](#) .

OK or NG

- OK >> GO TO 15.  
NG >> Repair or reconnect the hose.

---

## 15. CHECK EVAP CANISTER PURGE VOLUME CONTROL SOLENOID VALVE

---

Refer to [EC-306, "Component Inspection"](#) .

OK or NG

- OK >> GO TO 16.  
NG >> Replace EVAP canister purge volume control solenoid valve.

---

## 16. CHECK FUEL TANK TEMPERATURE SENSOR

---

Refer to [EC-242, "Component Inspection"](#) .

OK or NG

- OK >> GO TO 17.  
NG >> Replace fuel level sensor unit.

---

## 17. CHECK EVAP CONTROL SYSTEM PRESSURE SENSOR

---

Refer to [EC-328, "Component Inspection"](#) .

OK or NG

- OK >> GO TO 18.  
NG >> Replace EVAP control system pressure sensor.

---

## 18. CHECK EVAP PURGE LINE

---

Check EVAP purge line (pipe, rubber tube, fuel tank and EVAP canister) for cracks or improper connection. Refer to [EC-675, "EVAPORATIVE EMISSION LINE DRAWING"](#) .

OK or NG

- OK >> GO TO 19.  
NG >> Repair or reconnect the hose.

---

## 19. CLEAN EVAP PURGE LINE

---

Clean EVAP purge line (pipe and rubber tube) using air blower.

>> GO TO 20.

A

EC

C

D

E

F

G

H

I

J

K

L

M

# DTC P0442 EVAP CONTROL SYSTEM

---

## 20. CHECK EVAP/ORVR LINE

---

Check EVAP/ORVR line between EVAP canister and fuel tank for clogging, kink, looseness and improper connection. For location, refer to [EC-681, "ON BOARD REFUELING VAPOR RECOVERY \(ORVR\)"](#) .

OK or NG

OK >> GO TO 21.

NG >> Repair or replace hoses and tubes.

## 21. CHECK RECIRCULATION LINE

---

Check recirculation line between filler neck tube and fuel tank for clogging, kink, cracks, looseness and improper connection.

OK or NG

OK >> GO TO 22.

NG >> Repair or replace hose, tube or filler neck tube.

## 22. CHECK REFUELING EVAP VAPOR CUT VALVE

---

Refer to [EC-684, "REFUELING EVAP VAPOR CUT VALVE"](#) .

OK or NG

OK >> GO TO 23.

NG >> Replace refueling EVAP vapor cut valve with fuel tank.

## 23. CHECK FUEL LEVEL SENSOR

---

Refer to [DI-27, "FUEL LEVEL SENSOR UNIT CHECK"](#) .

OK or NG

OK >> GO TO 24.

NG >> Replace fuel level sensor unit.

## 24. CHECK INTERMITTENT INCIDENT

---

Refer to [EC-129, "TROUBLE DIAGNOSIS FOR INTERMITTENT INCIDENT"](#) .

>> **INSPECTION END**

# DTC P0444, P0445 EVAP CANISTER PURGE VOLUME CONTROL SOLENOID VALVE

## DTC P0444, P0445 EVAP CANISTER PURGE VOLUME CONTROL SOLENOID VALVE

PFP:14920

### Description SYSTEM DESCRIPTION

ABS009H0

Sensor	Input Signal to ECM	ECM function	Actuator
Crankshaft position sensor (POS) Camshaft position sensor (PHASE)	Engine speed*1	EVAP canister purge flow control	EVAP canister purge vol- ume control solenoid valve
Mass air flow sensor	Amount of intake air		
Engine coolant temperature sensor	Engine coolant temperature		
Battery	Battery voltage*1		
Throttle position sensor	Throttle position		
Accelerator pedal position sensor	Accelerator pedal position		
Air fuel ratio (A/F) sensor 1	Density of oxygen in exhaust gas (Mixture ratio feedback signal)		
Fuel tank temperature sensor	Fuel temperature in fuel tank		
Wheel sensor*2	Vehicle speed		

\*1: ECM determines the start signal status by the signals of engine speed and battery voltage.

\*2: This signal is sent to the ECM through CAN communication line.

This system controls flow rate of fuel vapor from the EVAP canister. The opening of the vapor by-pass passage in the EVAP canister purge volume control solenoid valve changes to control the flow rate. The EVAP canister purge volume control solenoid valve repeats ON/OFF operation according to the signal sent from the ECM. The opening of the valve varies for optimum engine control. The optimum value stored in the ECM is determined by considering various engine conditions. When the engine is operating, the flow rate of fuel vapor from the EVAP canister is regulated as the air flow changes.

### COMPONENT DESCRIPTION

The EVAP canister purge volume control solenoid valve uses a ON/OFF duty to control the flow rate of fuel vapor from the EVAP canister. The EVAP canister purge volume control solenoid valve is moved by ON/OFF pulses from the ECM. The longer the ON pulse, the greater the amount of fuel vapor that will flow through the valve.

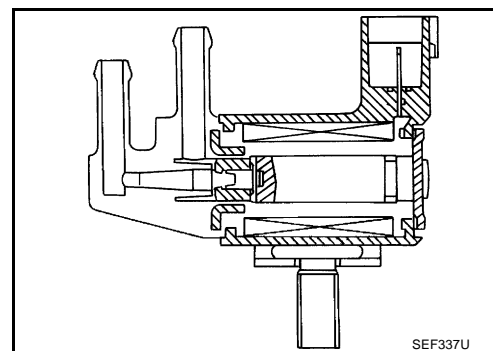

### CONSULT-II Reference Value in Data Monitor Mode

ABS009H1

Specification data are reference values.

MONITOR ITEM	CONDITION	SPECIFICATION
PURG VOL C/V	● Engine: After warming up ● Shift lever: P or N (A/T), Neutral (M/T) ● Air conditioner switch: OFF ● No-load	Idle
	2,000 rpm	0%
		—

# DTC P0444, P0445 EVAP CANISTER PURGE VOLUME CONTROL SOLENOID VALVE

## On Board Diagnosis Logic

ABS009H2

DTC No.	Trouble diagnosis name	DTC detecting condition	Possible cause
P0444 0444	EVAP canister purge volume control solenoid valve circuit open	An excessively low voltage signal is sent to ECM through the valve	<ul style="list-style-type: none"> <li>● Harness or connectors (The solenoid valve circuit is open or shorted.)</li> <li>● EVAP canister purge volume control solenoid valve</li> </ul>
P0445 0445	EVAP canister purge volume control solenoid valve circuit shorted	An excessively high voltage signal is sent to ECM through the valve	<ul style="list-style-type: none"> <li>● Harness or connectors (The solenoid valve circuit is shorted.)</li> <li>● EVAP canister purge volume control solenoid valve</li> </ul>

## DTC Confirmation Procedure

ABS009H3

### NOTE:

If DTC Confirmation Procedure has been previously conducted, always turn ignition switch OFF and wait at least 10 seconds before conducting the next test.

### TESTING CONDITION:

**Before performing the following procedure, confirm battery voltage is more than 11V at idle.**

### WITH CONSULT-II

1. Turn ignition switch ON.
2. Select "DATA MONITOR" mode with CONSULT-II.
3. Start engine and let it idle for at least 13 seconds.
4. If 1st trip DTC is detected, go to [EC-305, "Diagnostic Procedure"](#)

DATA MONITOR	
MONITOR	NO DTC
ENG SPEED	XXX rpm

SEF058Y

### WITH GST

Follow the procedure "WITH CONSULT-II" above.

# DTC P0444, P0445 EVAP CANISTER PURGE VOLUME CONTROL SOLENOID VALVE

## Wiring Diagram

ABS009H4

EC-PGC/V-01

A  
EC  
C  
D  
E  
F  
G  
H  
I  
J  
K  
L  
M

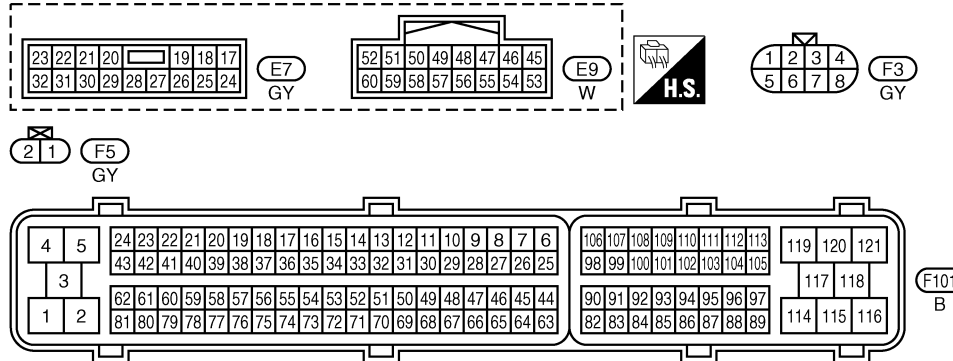
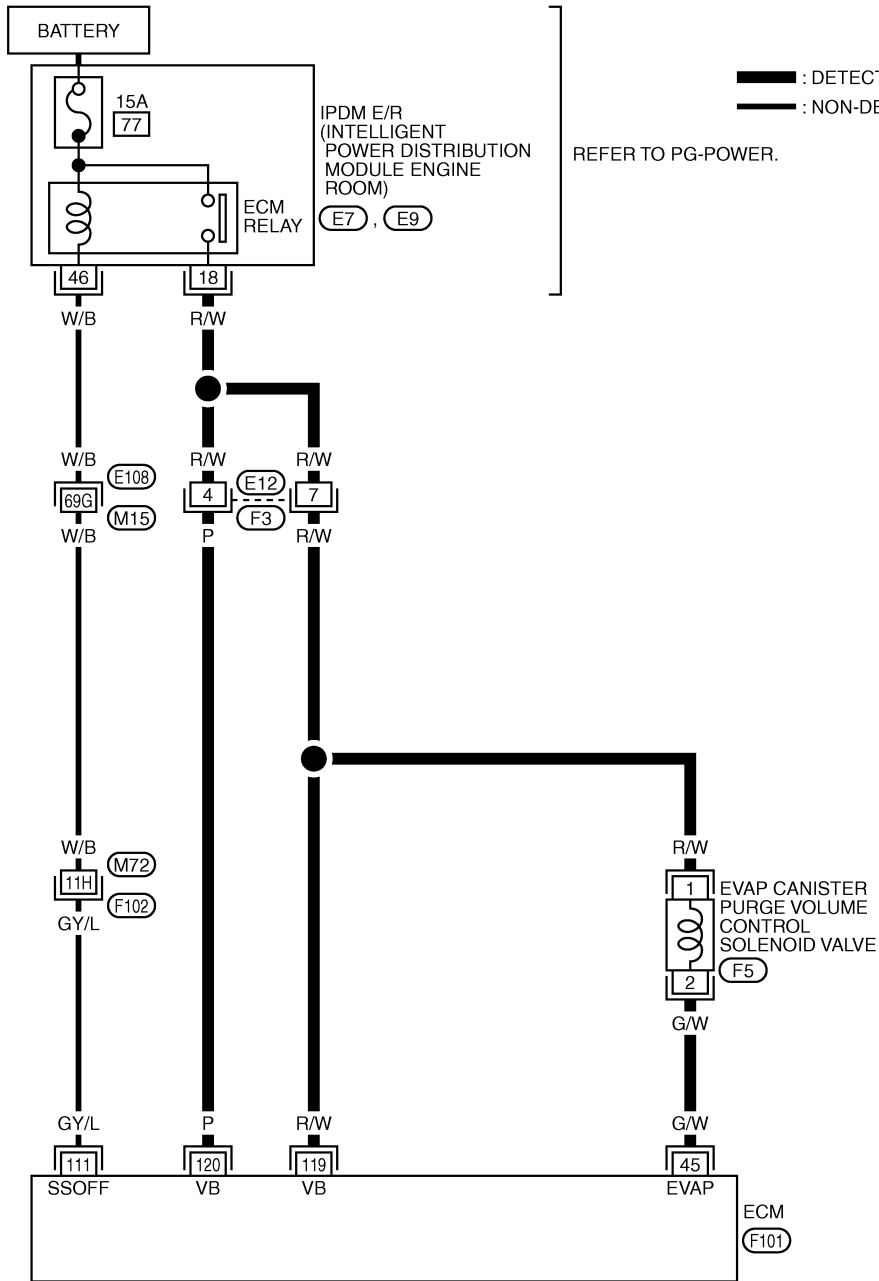

TBWT0619E

# DTC P0444, P0445 EVAP CANISTER PURGE VOLUME CONTROL SOLENOID VALVE

Specification data are reference values and are measured between each terminal and ground.  
Pulse signal is measured by CONSULT-II.

**CAUTION:**

**Do not use ECM ground terminals when measuring input/output voltage. Doing so may result in damage to the ECM's transistor. Use a ground other than ECM terminals, such as the ground.**

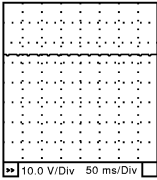
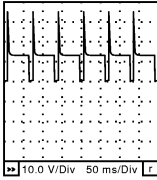
TER-MINAL NO.	WIRE COLOR	ITEM	CONDITION	DATA (DC Voltage)
45	G/W	EVAP canister purge volume control solenoid valve	<p><b>[Engine is running]</b></p> <ul style="list-style-type: none"> <li>● Idle speed</li> <li>● Accelerator pedal is not depressed even slightly, after engine starting.</li> </ul>	<p>BATTERY VOLTAGE (11 - 14V)★</p>  <p style="text-align: right;">SEC990C</p>
			<p><b>[Engine is running]</b></p> <ul style="list-style-type: none"> <li>● Engine speed is about 2,000 rpm (More than 100 seconds after starting engine).</li> </ul>	<p>BATTERY VOLTAGE (11 - 14V)★</p>  <p style="text-align: right;">SEC991C</p>
111	GY/L	ECM relay (Self shut-off)	<p><b>[Engine is running]</b> <b>[Ignition switch: OFF]</b></p> <ul style="list-style-type: none"> <li>● A few seconds after turning ignition switch OFF</li> </ul>	0 - 1.5V
			<p><b>[Ignition switch: OFF]</b></p> <ul style="list-style-type: none"> <li>● More than a few seconds after turning ignition switch OFF</li> </ul>	BATTERY VOLTAGE (11 - 14V)
119 120	R/W P	Power supply for ECM	<b>[Ignition switch: ON]</b>	BATTERY VOLTAGE (11 - 14V)

★: Average voltage for pulse signal (Actual pulse signal can be confirmed by oscilloscope.)



# DTC P0444, P0445 EVAP CANISTER PURGE VOLUME CONTROL SOLENOID VALVE

## Diagnostic Procedure

ABS009H5

### 1. CHECK EVAP CANISTER PURGE VOLUME CONTROL SOLENOID VALVE POWER SUPPLY CIRCUIT

1. Turn ignition switch OFF.
2. Disconnect EVAP canister purge volume control solenoid valve harness connector.
3. Turn ignition switch ON.

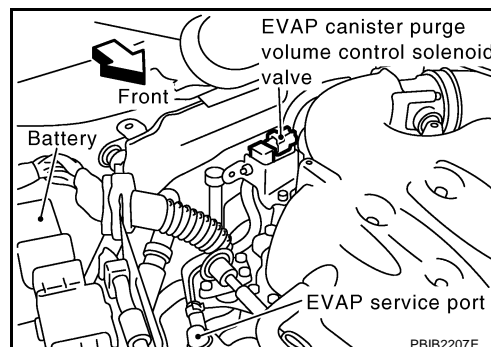

4. Check voltage between EVAP canister purge volume control solenoid valve terminal 1 and ground with CONSULT-II or tester.

**Voltage: Battery voltage**

OK or NG

- OK >> GO TO 3.
- NG >> GO TO 2.

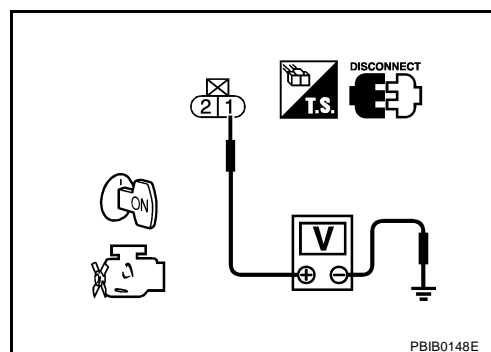

### 2. DETECT MALFUNCTIONING PART

Check the following.

- Harness connectors E12, F3
- IPDM E/R harness connector E8
- 15A fuse
- Harness for open or short between EVAP canister purge volume control solenoid valve and IPDM E/R
- Harness for open or short between EVAP canister purge volume control solenoid valve and ECM

>> Repair open circuit or short to ground or short to power in harness or connectors.

### 3. CHECK EVAP CANISTER PURGE VOLUME CONTROL SOLENOID VALVE OUTPUT SIGNAL CIRCUIT FOR OPEN AND SHORT

1. Turn ignition switch OFF.
2. Disconnect ECM harness connector.
3. Check harness continuity between ECM terminal 45 and EVAP canister purge volume control solenoid valve terminal 2. Refer to Wiring Diagram.

**Continuity should exist.**

4. Also check harness for short to ground and short to power.

OK or NG

- OK (With CONSULT-II)>>GO TO 4.
- OK (Without CONSULT-II)>>GO TO 5.
- NG >> Repair open circuit or short to ground or short to power in harness or connectors.

# DTC P0444, P0445 EVAP CANISTER PURGE VOLUME CONTROL SOLENOID VALVE

## 4. CHECK EVAP CANISTER PURGE VOLUME CONTROL SOLENOID VALVE OPERATION

### With CONSULT-II

1. Reconnect all harness connectors disconnected.
2. Start engine.
3. Perform "PURG VOL CONT/V" in "ACTIVE TEST" mode with CONSULT-II. Check that engine speed varies according to the valve opening.

### OK or NG

- OK >> GO TO 6.  
 NG >> GO TO 5.

ACTIVE TEST	
PURG VOL CONT/V	XXX %
MONITOR	
ENG SPEED	XXX rpm
A/F ALPHA-B1	XX %
A/F ALPHA-B2	XX %

PBIB1678E

## 5. CHECK EVAP CANISTER PURGE VOLUME CONTROL SOLENOID VALVE

Refer to [EC-306, "Component Inspection"](#) .

### OK or NG

- OK >> GO TO 6.  
 NG >> Replace EVAP canister purge volume control solenoid valve.

## 6. CHECK INTERMITTENT INCIDENT

Refer to [EC-129, "TROUBLE DIAGNOSIS FOR INTERMITTENT INCIDENT"](#) .

>> INSPECTION END

## Component Inspection EVAP CANISTER PURGE VOLUME CONTROL SOLENOID VALVE

ABS009H6

### With CONSULT-II

Check air passage continuity of EVAP canister purge volume control solenoid valve under the following conditions.

Condition (PURG VOL CONT/V value)	Air passage continuity between A and B
100%	Yes
0%	No

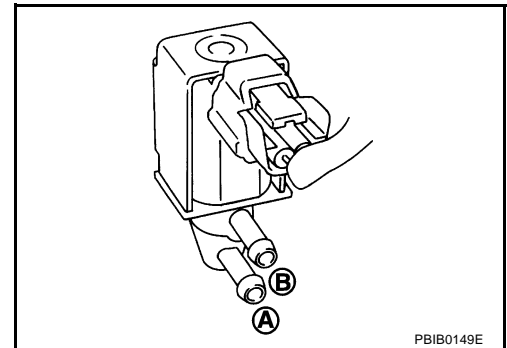

### Without CONSULT-II

Check air passage continuity of EVAP canister purge volume control solenoid valve under the following conditions.

Condition	Air passage continuity between A and B
12V direct current supply between terminals 1 and 2	Yes
No supply	No

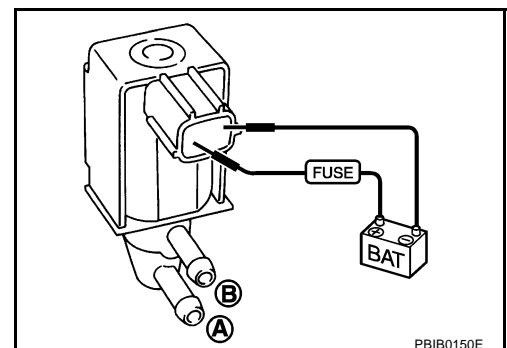

# DTC P0444, P0445 EVAP CANISTER PURGE VOLUME CONTROL SOLENOID VALVE

## Removal and Installation

### EVAP CANISTER PURGE VOLUME CONTROL SOLENOID VALVE

ABS009H7

Refer to [EM-16, "INTAKE MANIFOLD COLLECTOR"](#) .

A

EC

C

D

E

F

G

H

I

J

K

L

M

# DTC P0447 EVAP CANISTER VENT CONTROL VALVE

## DTC P0447 EVAP CANISTER VENT CONTROL VALVE

PF1:14935

### Component Description

ABS009H8

The EVAP canister vent control valve is located on the EVAP canister and is used to seal the canister vent.

This solenoid valve responds to signals from the ECM. When the ECM sends an ON signal, the coil in the solenoid valve is energized. A plunger will then move to seal the canister vent. The ability to seal the vent is necessary for the on board diagnosis of other evaporative emission control system components.

This solenoid valve is used only for diagnosis, and usually remains opened.

When the vent is closed, under normal purge conditions, the evaporative emission control system is depressurized and allows "EVAP Control System" diagnosis.

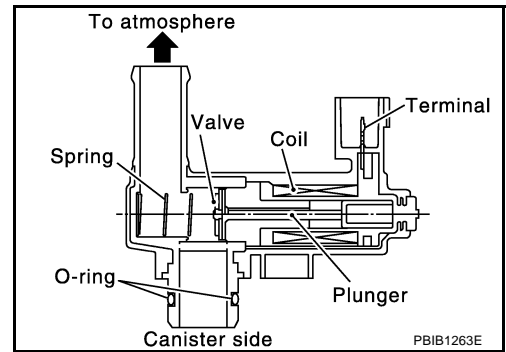

### View from under the vehicle

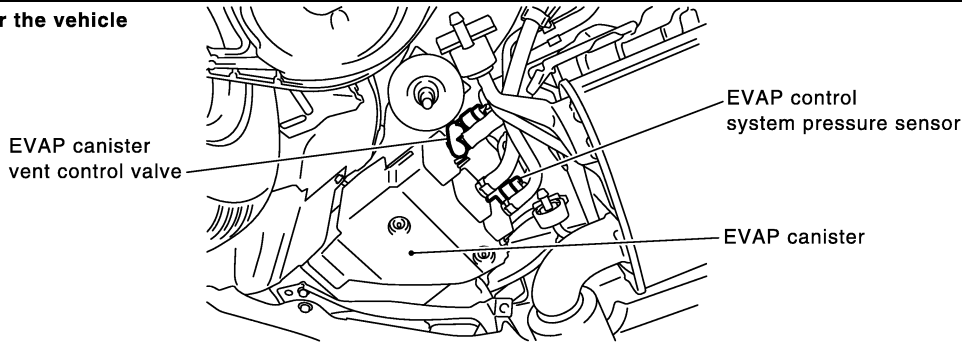

## CONSULT-II Reference Value in Data Monitor Mode

ABS009H9

Specification data are reference values.

MONITOR ITEM	CONDITION	SPECIFICATION
VENT CONT/V	● Ignition switch: ON	OFF

## On Board Diagnosis Logic

ABS009HA

DTC No.	Trouble diagnosis name	DTC detecting condition	Possible cause
P0447 0447	EVAP canister vent control valve circuit open	An improper voltage signal is sent to ECM through EVAP canister vent control valve.	<ul style="list-style-type: none"> <li>● Harness or connectors (The valve circuit is open or shorted.)</li> <li>● EVAP canister vent control valve</li> </ul>

# DTC P0447 EVAP CANISTER VENT CONTROL VALVE

ABS009HB

## DTC Confirmation Procedure

### NOTE:

If DTC Confirmation Procedure has been previously conducted, always turn ignition switch OFF and wait at least 10 seconds before conducting the next test.

### TESTING CONDITION:

Before performing the following procedure, confirm battery voltage is more than 11V at idle.

### ④ WITH CONSULT-II

1. Turn ignition switch ON.
2. Select "DATA MONITOR" mode with CONSULT-II.
3. Start engine and wait at least 8 seconds.
4. If 1st trip DTC is detected, go to [EC-313, "Diagnostic Procedure"](#)

DATA MONITOR	
MONITOR	NO DTC
ENG SPEED	XXX rpm

SEF058Y

### ④ WITH GST

Follow the procedure "WITH CONSULT-II" above.

A

EC

C

D

E

F

G

H

I

J

K

L

M

# DTC P0447 EVAP CANISTER VENT CONTROL VALVE

ABS009HC

## Wiring Diagram COUPE MODELS

## EC-VENT/V-01

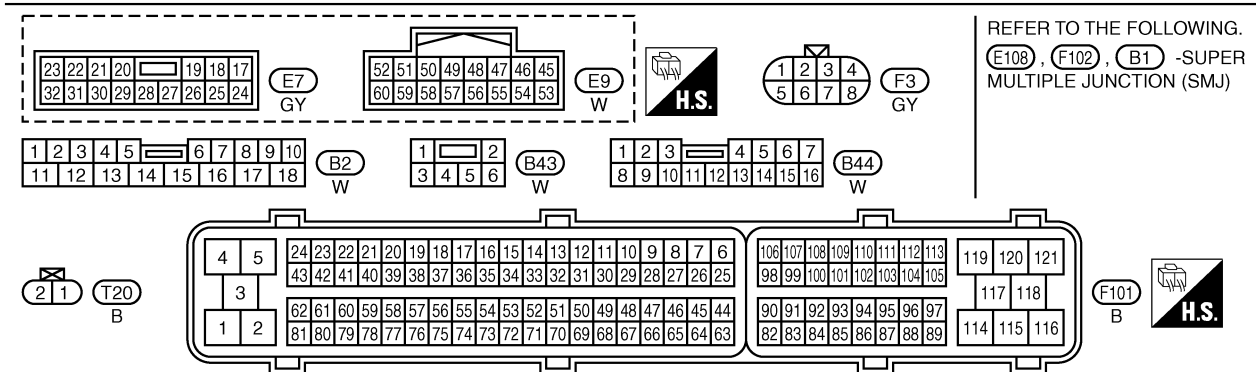
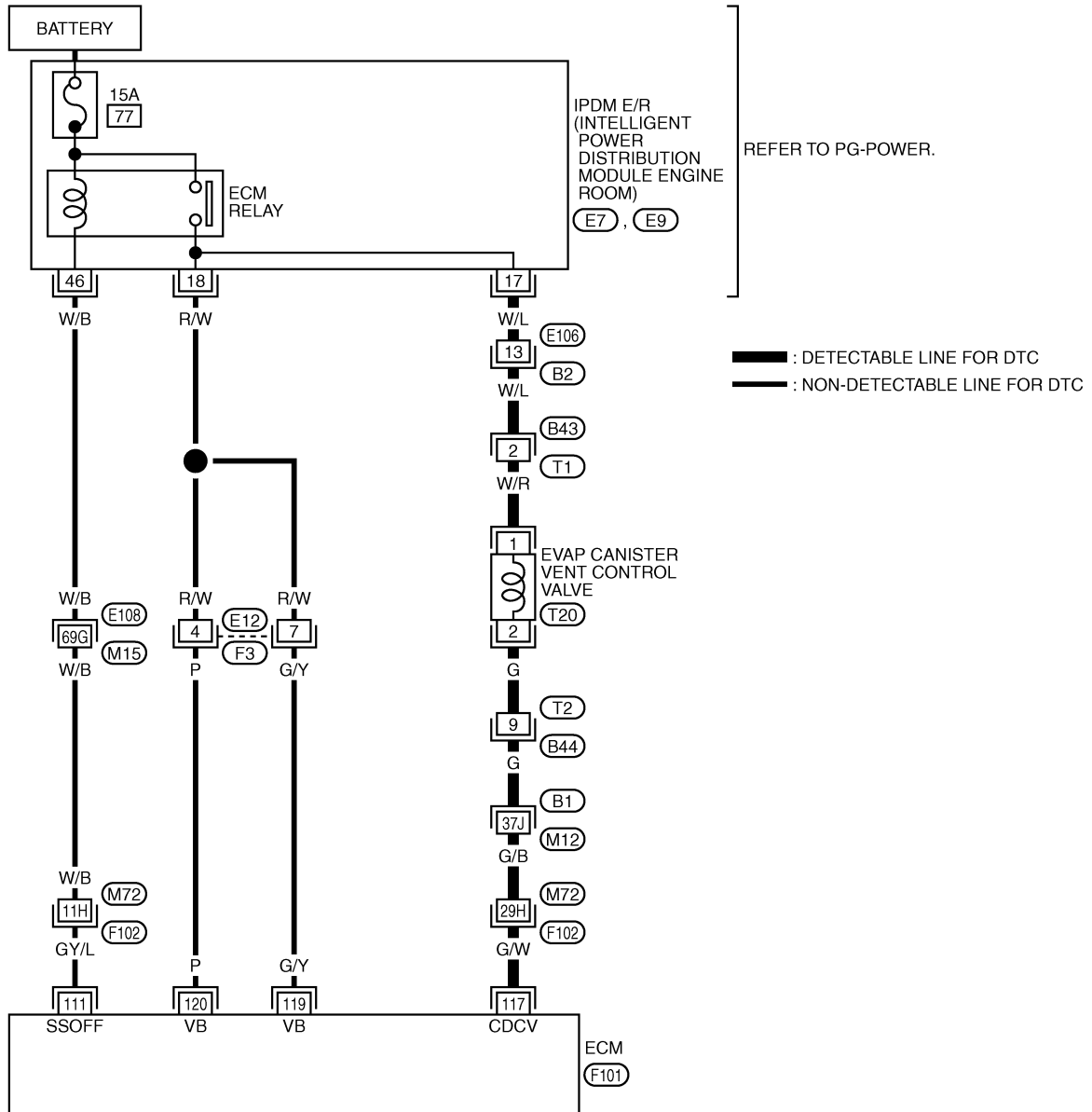

TBWT0620E

# DTC P0447 EVAP CANISTER VENT CONTROL VALVE

Specification data are reference values and are measured between each terminal and ground.

**CAUTION:**

**Do not use ECM ground terminals when measuring input/output voltage. Doing so may result in damage to the ECM's transistor. Use a ground other than ECM terminals, such as the ground.**

TER-MINAL NO.	WIRE COLOR	ITEM	CONDITION	DATA (DC Voltage)
111	GY/L	ECM relay (Self shut-off)	<b>[Engine is running]</b> <b>[Ignition switch: OFF]</b> ● A few seconds after turning ignition switch OFF	0 - 1.5V
			<b>[Ignition switch: OFF]</b> ● More than a few seconds after turning ignition switch OFF	BATTERY VOLTAGE (11 - 14V)
117	G/W	EVAP canister vent control valve	<b>[Ignition switch: ON]</b>	BATTERY VOLTAGE (11 - 14V)
119 120	R/W P	Power supply for ECM	<b>[Ignition switch: ON]</b>	BATTERY VOLTAGE (11 - 14V)

A  
EC  
C  
D  
E  
F  
G  
H  
I  
J  
K  
L  
M

# DTC P0447 EVAP CANISTER VENT CONTROL VALVE

## ROADSTER MODELS

## EC-VENT/V-02

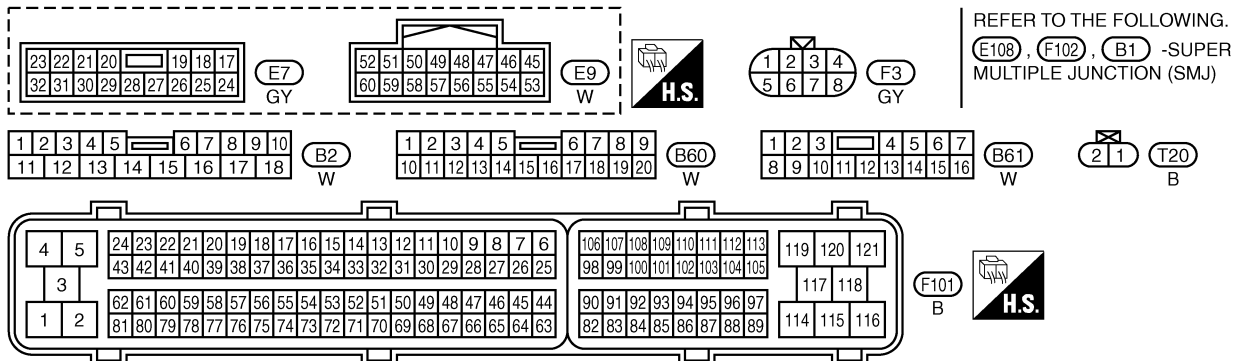
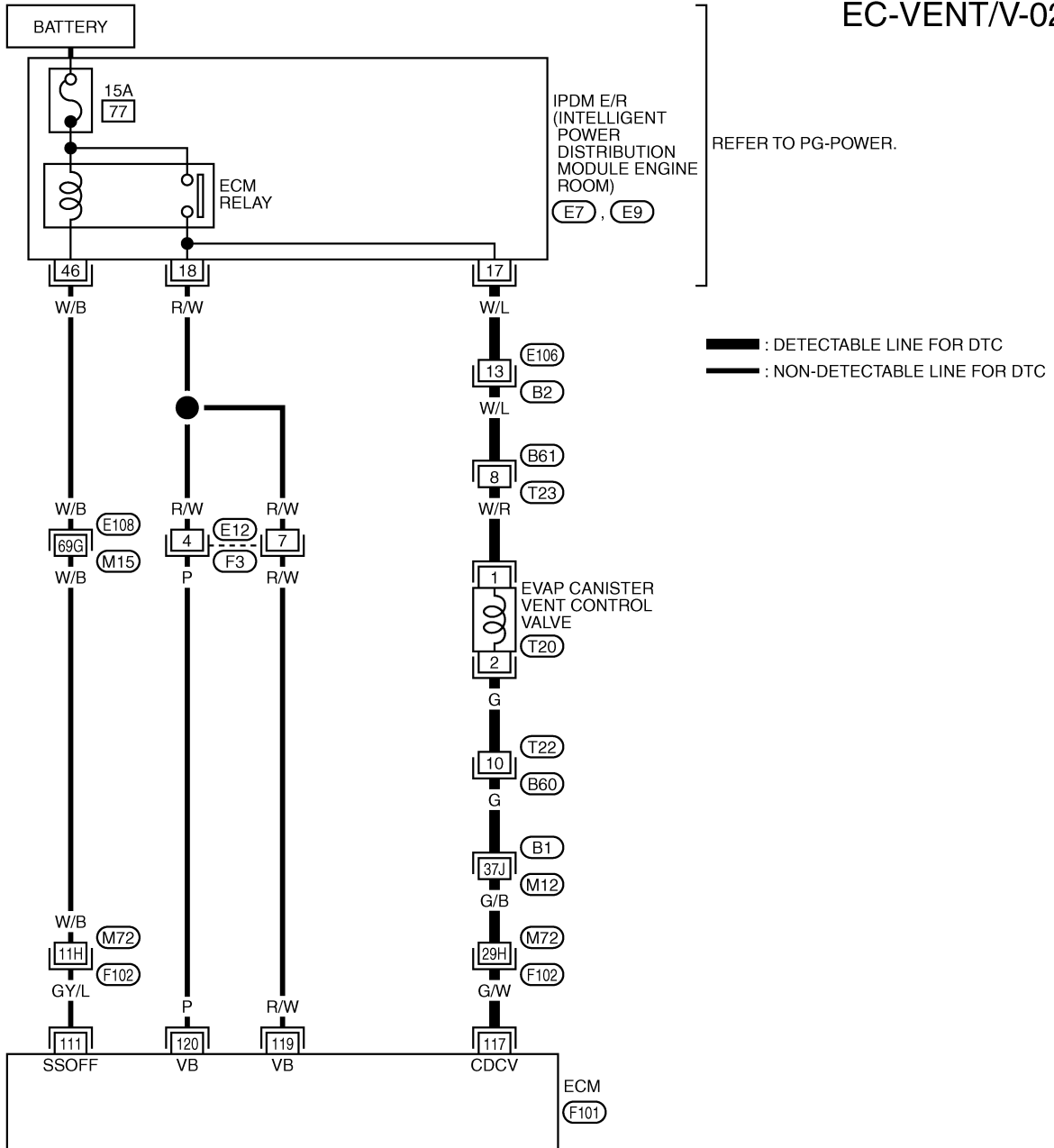

TBWT0621E



# DTC P0447 EVAP CANISTER VENT CONTROL VALVE

Specification data are reference values and are measured between each terminal and ground.

**CAUTION:**

Do not use ECM ground terminals when measuring input/output voltage. Doing so may result in damage to the ECM's transistor. Use a ground other than ECM terminals, such as the ground.

TER-MINAL NO.	WIRE COLOR	ITEM	CONDITION	DATA (DC Voltage)
111	GY/L	ECM relay (Self shut-off)	[Engine is running] [Ignition switch: OFF] ● A few seconds after turning ignition switch OFF	0 - 1.5V
			[Ignition switch: OFF] ● More than a few seconds after turning ignition switch OFF	BATTERY VOLTAGE (11 - 14V)
117	G/W	EVAP canister vent control valve	[Ignition switch: ON]	BATTERY VOLTAGE (11 - 14V)
119 120	R/W P	Power supply for ECM	[Ignition switch: ON]	BATTERY VOLTAGE (11 - 14V)

## Diagnostic Procedure

ABS009HD

### 1. INSPECTION START

Do you have CONSULT-II?

Yes or No

- Yes >> GO TO 2.
- No >> GO TO 3.

### 2. CHECK EVAP CANISTER VENT CONTROL VALVE CIRCUIT

 With CONSULT-II

1. Turn ignition switch OFF and then turn ON.
2. Select "VENT CONTROL/V" in "ACTIVE TEST" mode with CONSULT-II.
3. Touch "ON/OFF" on CONSULT-II screen.
4. Check for operating sound of the valve.  
**Clicking noise should be heard.**

OK or NG

- OK >> GO TO 7.
- NG >> GO TO 3.

ACTIVE TEST	
VENT CONTROL/V	OFF
MONITOR	
ENG SPEED	XXX rpm
A/F ALPHA-B1	XXX %
A/F ALPHA-B2	XXX %

PBIB1679E

# DTC P0447 EVAP CANISTER VENT CONTROL VALVE

## 3. CHECK EVAP CANISTER VENT CONTROL VALVE POWER SUPPLY CIRCUIT

1. Turn ignition switch OFF.
2. Disconnect EVAP canister vent control valve harness connector.

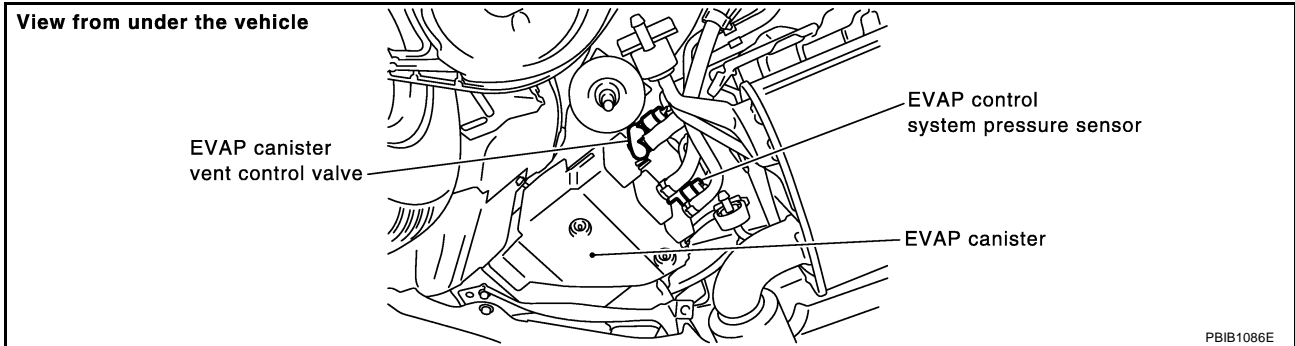

3. Turn ignition switch ON.
4. Check voltage between EVAP canister vent control valve terminal 1 and ground with CONSULT-II or tester.

**Voltage: Battery voltage**

OK or NG

- OK >> GO TO 5.
- NG >> GO TO 4.

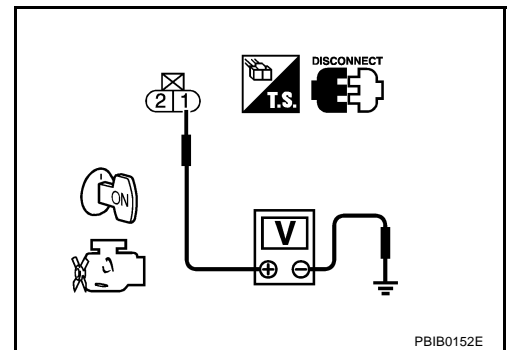

## 4. DETECT MALFUNCTIONING PART

Check the following.

- Harness connectors E106, B2
- Harness connectors B43, T1 (Coupe models)
- Harness connectors B61, T23 (Roadster models)
- IPDM E/R harness connector E8
- 15A fuse
- Harness for open or short between EVAP canister vent control valve and IPDM E/R

>> Repair open circuit or short to ground or short to power in harness or connectors.

## 5. CHECK EVAP CANISTER VENT CONTROL VALVE OUTPUT SIGNAL CIRCUIT FOR OPEN AND SHORT

1. Turn ignition switch OFF.
2. Disconnect ECM harness connector.
3. Check harness continuity between ECM terminal 117 and EVAP canister vent control valve terminal 2. Refer to Wiring Diagram.

**Continuity should exist.**

4. Also check harness for short to ground and short to power.

OK or NG

- OK >> GO TO 7.
- NG >> GO TO 6.

# DTC P0447 EVAP CANISTER VENT CONTROL VALVE

## 6. DETECT MALFUNCTIONING PART

Check the following.

- Harness connectors T2, B44 (Coupe models)
- Harness connectors T22, B60 (Roadster models)
- Harness connectors B1, M12
- Harness connectors M72, F102
- Harness for open or short between EVAP canister vent control valve and ECM

>> Repair open circuit or short to ground or short to power in harness or connectors.

## 7. CHECK RUBBER TUBE FOR CLOGGING

1. Disconnect rubber tube connected to EVAP canister vent control valve.
2. Check the rubber tube for clogging.

OK or NG

- OK >> GO TO 8.
- NG >> Clean the rubber tube using an air blower.

## 8. CHECK EVAP CANISTER VENT CONTROL VALVE

Refer to [EC-315, "Component Inspection"](#) .

OK or NG

- OK >> GO TO 9.
- NG >> Replace EVAP canister vent control valve.

## 9. CHECK INTERMITTENT INCIDENT

Refer to [EC-129, "TROUBLE DIAGNOSIS FOR INTERMITTENT INCIDENT"](#) .

>> INSPECTION END

### Component Inspection EVAP CANISTER VENT CONTROL VALVE

ABS009HE

④ **With CONSULT-II**

1. Remove EVAP canister vent control valve from EVAP canister.
2. Check portion **B** of EVAP canister vent control valve for being rusted.  
If NG, replace EVAP canister vent control valve.  
If OK, go to next step.
3. Reconnect harness connectors disconnected.
4. Turn ignition switch ON.

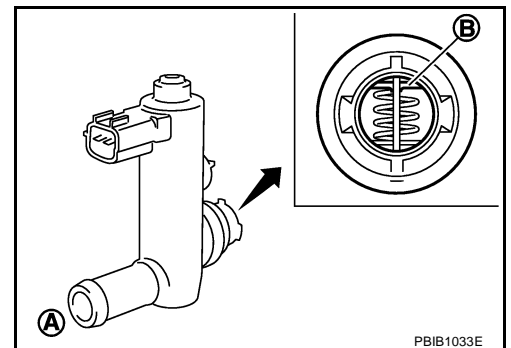

# DTC P0447 EVAP CANISTER VENT CONTROL VALVE

- Perform "VENT CONTROL/V" in "ACTIVE TEST" mode.
- Check air passage continuity and operation delay time.  
**Make sure new O-ring is installed properly.**

Condition VENT CONTROL/V	Air passage continuity between A and B
ON	No
OFF	Yes

**Operation takes less than 1 second.**

If NG, replace EVAP canister vent control valve.  
If OK, go to next step.

- Clean the air passage (Portion **A** to **B**) of EVAP canister vent control valve using an air blower.
- Perform step 6 again.

## ⊗ Without CONSULT-II

- Remove EVAP canister vent control valve from EVAP canister.
- Check portion **B** of EVAP canister vent control valve for being rusted.

- Check air passage continuity and operation delay time under the following conditions.  
**Make sure new O-ring is installed properly.**

Condition	Air passage continuity between A and B
12V direct current supply between terminals 1 and 2	No
OFF	Yes

**Operation takes less than 1 second.**

If NG, replace EVAP canister vent control valve.  
If OK, go to next step.

- Clean the air passage (Portion **A** to **B**) of EVAP canister vent control valve using an air blower.
- Perform step 3 again.

ACTIVE TEST	
VENT CONTROL/V	OFF
MONITOR	
ENG SPEED	XXX rpm
A/F ALPHA-B1	XXX %
A/F ALPHA-B2	XXX %
HO2S1 (B1)	XXX V
HO2S1 (B2)	XXX V

PBIB0151E

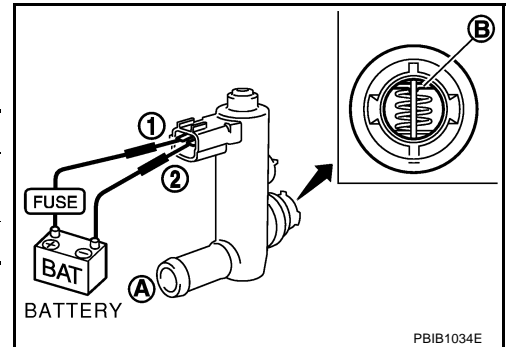
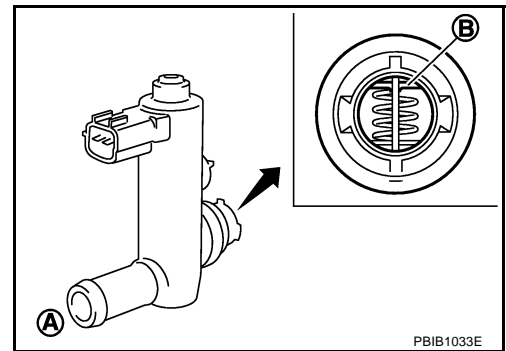

# DTC P0451 EVAP CONTROL SYSTEM PRESSURE SENSOR

## DTC P0451 EVAP CONTROL SYSTEM PRESSURE SENSOR

PF2:22365

### Component Description

ABS009HF

The EVAP control system pressure sensor detects pressure in the purge line. The sensor output voltage to the ECM increases as pressure increases.

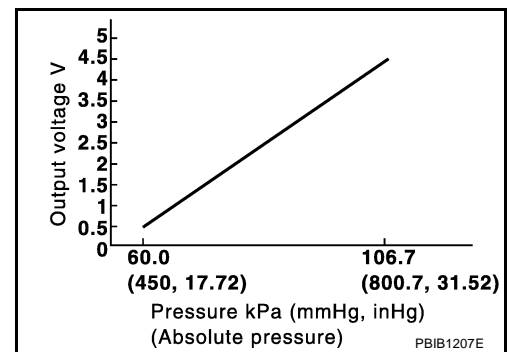
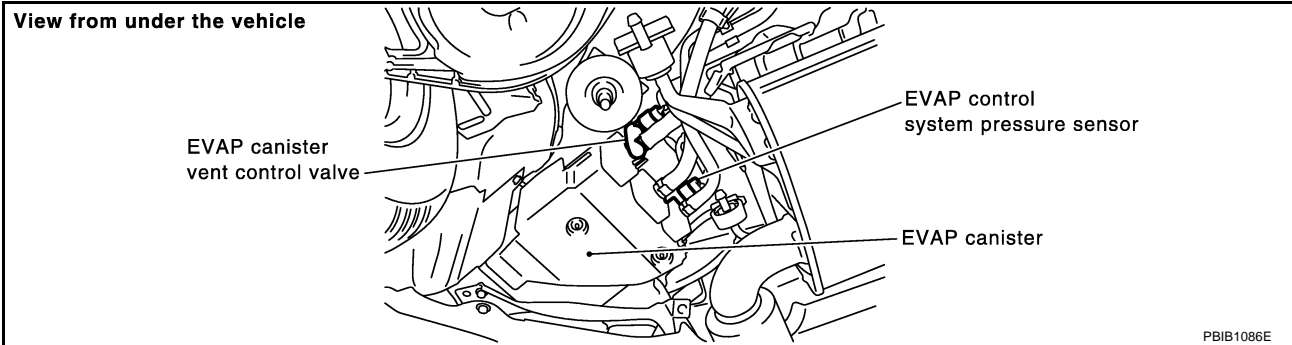

### CONSULT-II Reference Value in Data Monitor Mode

ABS009HG

Specification data are reference values.

MONITOR ITEM	CONDITION	SPECIFICATION
EVAP SYS PRES	● Ignition switch: ON	Approx. 1.8 - 4.8V

### On Board Diagnosis Logic

ABS009HH

#### NOTE:

If DTC P0451 is displayed with DTC P1229, first perform the trouble diagnosis for DTC P1229.

Refer to [EC-456](#).

DTC No.	Trouble diagnosis name	DTC detecting condition	Possible cause
P0451 0451	EVAP control system pressure sensor performance	ECM detects a sloshing signal from the EVAP control system pressure sensor	<ul style="list-style-type: none"> <li>● Harness or connectors</li> <li>● EVAP control system pressure sensor</li> </ul>

# DTC P0451 EVAP CONTROL SYSTEM PRESSURE SENSOR

ABS009HI

## DTC Confirmation Procedure

### NOTE:

If DTC Confirmation Procedure has been previously conducted, always turn ignition switch OFF and wait at least 10 seconds before conducting the next test.

### ④ WITH CONSULT-II

1. Turn ignition switch OFF and wait at least 10 seconds.
2. Turn ignition switch ON and select "DATA MONITOR" mode with CONSULT-II.
3. Start engine and wait at least 40 seconds.

### NOTE:

**Do not depress accelerator pedal even slightly.**

If 1st trip DTC is detected, go to [EC-318, "Diagnostic Procedure"](#)

DATA MONITOR	
MONITOR	NO DTC
ENG SPEED	XXX rpm
COOLAN TEMP/S	XXX °C
FUEL T/TMP SE	XXX °C

SEF194Y

### ④ WITH GST

Follow the procedure "WITH CONSULT-II" above.

## Diagnostic Procedure

ABS009HJ

### 1. CHECK GROUND CONNECTIONS

1. Turn ignition switch OFF.
2. Loosen and retighten three ground screws on the body. Refer to [EC-138, "Ground Inspection"](#) .

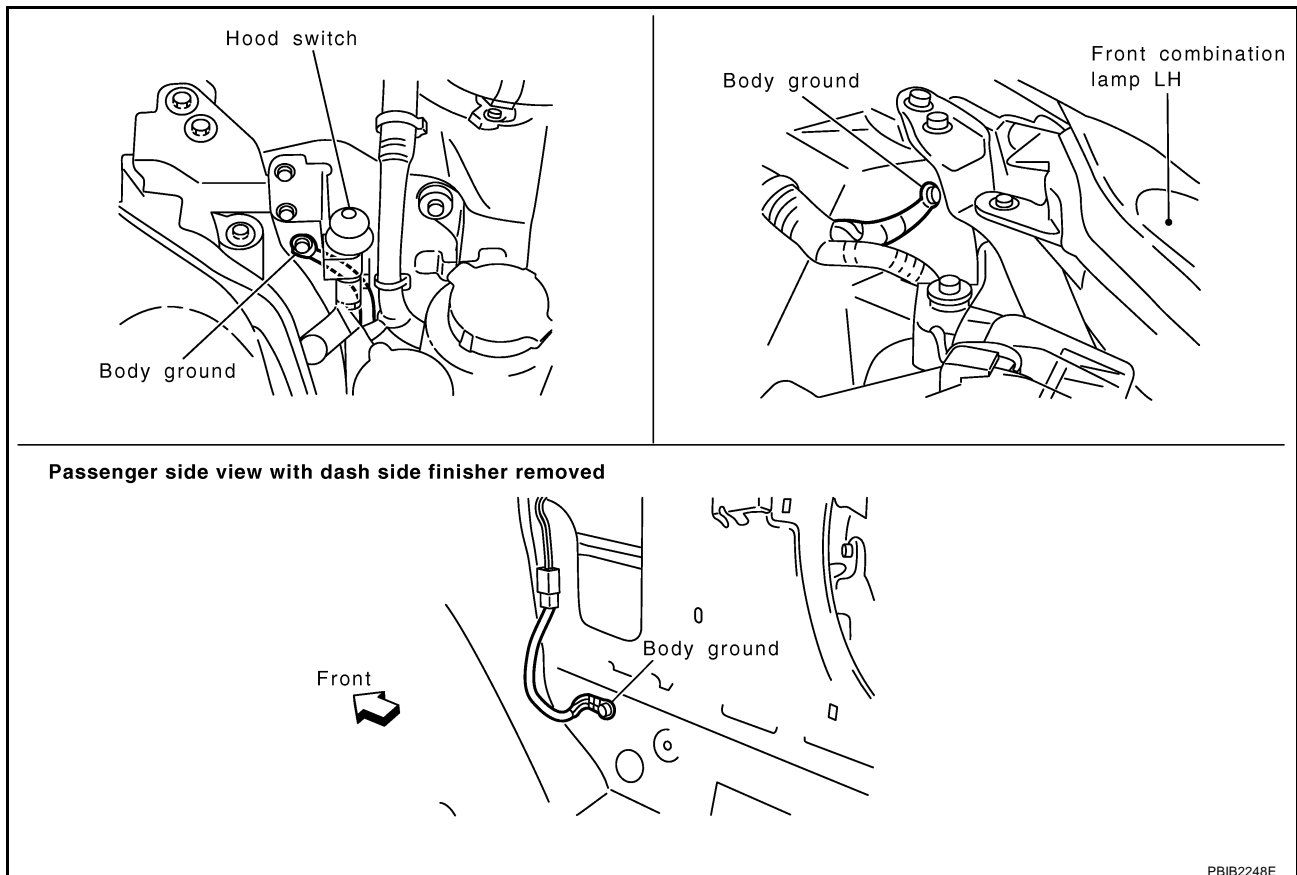

### OK or NG

OK >> GO TO 2.

NG >> Repair or replace ground connections.

# DTC P0451 EVAP CONTROL SYSTEM PRESSURE SENSOR

## 2. CHECK EVPA CONTROL SYSTEM PRESSURE SENSOR CONNECTOR FOR WATER

1. Disconnect EVAP control system pressure sensor harness connector.

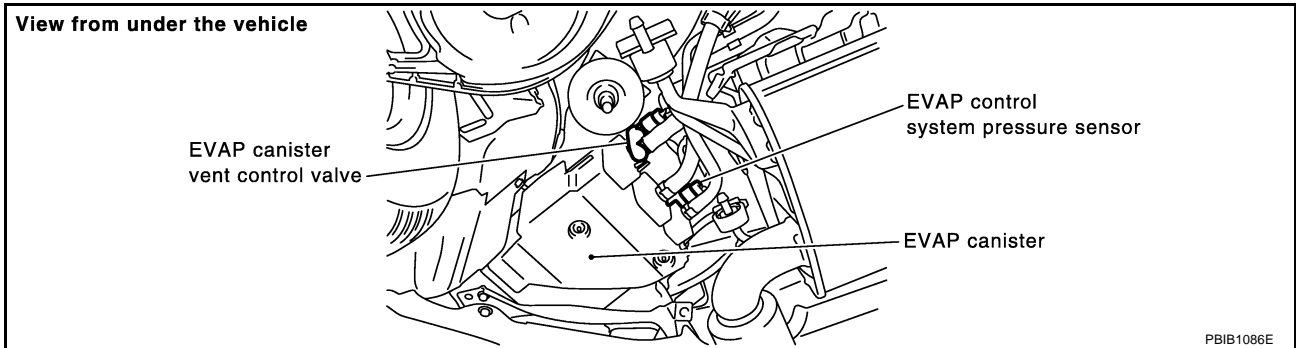

2. Check sensor harness connector for water.

**Water should not exist.**

OK or NG

- OK >> GO TO 3.
- NG >> Repair or replace harness connector.

## 3. CHECK EVAP CONTROL SYSTEM PRESSURE SENSOR

Refer to [EC-319, "Component Inspection"](#) .

OK or NG

- OK >> GO TO 4.
- NG >> Replace EVAP control system pressure sensor.

## 4. CHECK INTERMITTENT INCIDENT

Refer to [EC-129, "TROUBLE DIAGNOSIS FOR INTERMITTENT INCIDENT"](#) .

For wiring diagram, refer to [EC-322](#) .

>> INSPECTION END

### Component Inspection EVAP CONTROL SYSTEM PRESSURE SENSOR

ABS009HK

1. Remove EVAP control system pressure sensor with its harness connector connected from EVAP canister.  
**Always replace O-ring with a new one.**
2. Install a vacuum pump to EVAP control system pressure sensor.
3. Turn ignition switch ON and check output voltage between ECM terminal 32 and ground under the following conditions.

Applied vacuum kPa (mmHg, inHg)	Voltage V
Not applied	1.8 - 4.8
-26.7 (-200, -7.87)	2.1 to 2.5V lower than above value

**CAUTION:**

- Always calibrate the vacuum pump gauge when using it.
  - Do not apply below -93.3 kPa (-700 mmHg, -27.56 inHg) or pressure over 101.3 kPa (760 mmHg, 29.92 inHg).
4. If NG, replace EVAP control system pressure sensor.

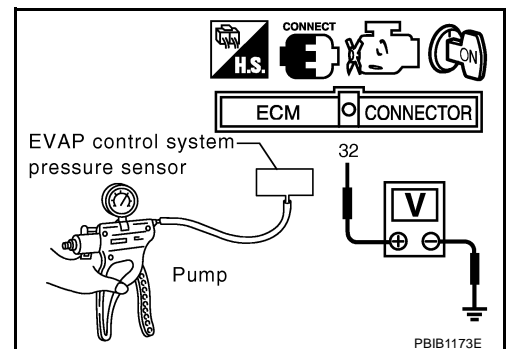

# DTC P0452 EVAP CONTROL SYSTEM PRESSURE SENSOR

## DTC P0452 EVAP CONTROL SYSTEM PRESSURE SENSOR

PFP:25085

### Component Description

ABS009HL

The EVAP control system pressure sensor detects pressure in the purge line. The sensor output voltage to the ECM increases as pressure increases.

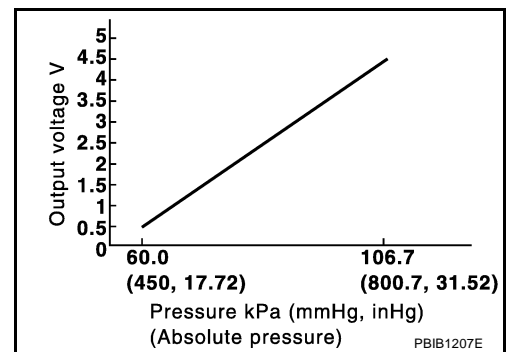
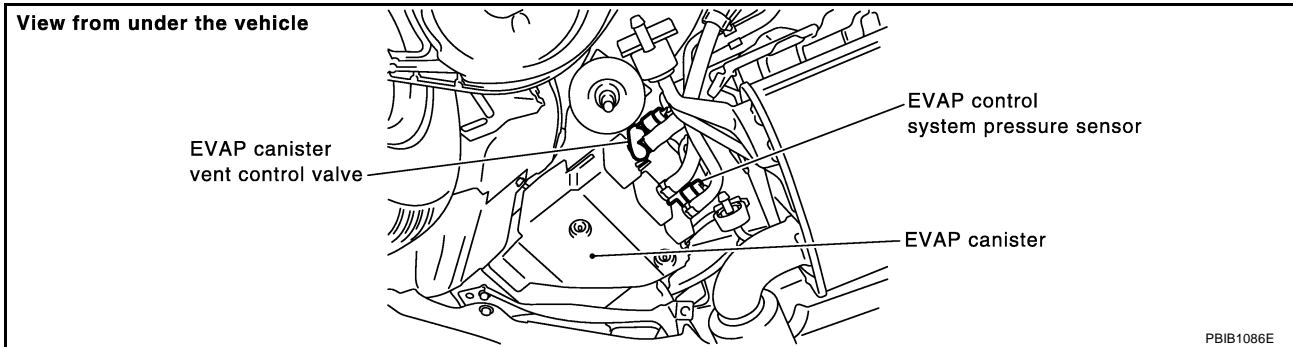

### CONSULT-II Reference Value in Data Monitor Mode

ABS009HM

Specification data are reference values.

MONITOR ITEM	CONDITION	SPECIFICATION
EVAP SYS PRES	● Ignition switch: ON	Approx. 1.8 - 4.8V

### On Board Diagnosis Logic

ABS009HM

#### NOTE:

If DTC P0452 is displayed with DTC P1229, first perform the trouble diagnosis for DTC P1229.

Refer to [EC-456](#).

DTC No.	Trouble diagnosis name	DTC detecting condition	Possible cause
P0452 0452	EVAP control system pressure sensor low input	An excessively low voltage from the sensor is sent to ECM.	<ul style="list-style-type: none"> <li>● Harness or connectors (The sensor circuit is open or shorted.)</li> <li>● EVAP control system pressure sensor</li> </ul>



# DTC P0452 EVAP CONTROL SYSTEM PRESSURE SENSOR

ABS009HO

## DTC Confirmation Procedure

### NOTE:

If DTC Confirmation Procedure has been previously conducted, always turn ignition switch OFF and wait at least 10 seconds before conducting the next test.

### TESTING CONDITION:

Always perform test at a temperature of 5°C (41°F) or more.

### WITH CONSULT-II

1. Start engine and warm it up to normal operating temperature.
2. Turn ignition switch OFF and wait at least 10 seconds.
3. Turn ignition switch ON.
4. Select "DATA MONITOR" mode with CONSULT-II.
5. Make sure that "FUEL T/TEMP SE" is more than 0°C (32°F).
6. Start engine and wait at least 20 seconds.  
If 1st trip DTC is detected, go to [EC-325, "Diagnostic Procedure"](#)

DATA MONITOR	
MONITOR	NO DTC
ENG SPEED	XXX rpm
COOLAN TEMP/S	XXX °C
FUEL T/TMP SE	XXX °C

SEF194Y

### WITH GST

1. Start engine and warm it up to normal operating temperature.
2. Check that voltage between ECM terminal 107 (Fuel tank temperature sensor signal) and ground is less than 4.2V.
3. Turn ignition switch OFF and wait at least 10 seconds.
4. Start engine and wait at least 20 seconds.
5. Select "MODE 7" with GST.  
If 1st trip DTC is detected, go to [EC-325, "Diagnostic Procedure"](#)

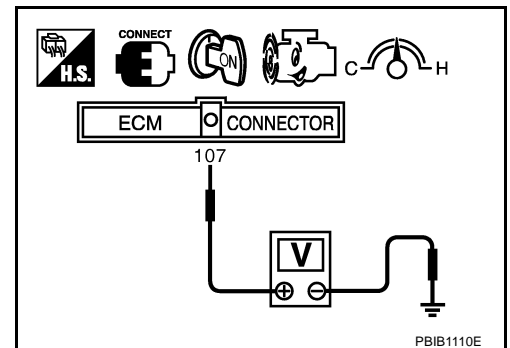

# DTC P0452 EVAP CONTROL SYSTEM PRESSURE SENSOR

ABS009HP

## Wiring Diagram COUPE MODELS

EC-PRE/SE-01

: DETECTABLE LINE FOR DTC  
 : NON-DETECTABLE LINE FOR DTC

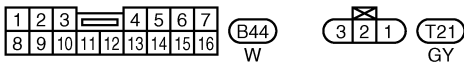
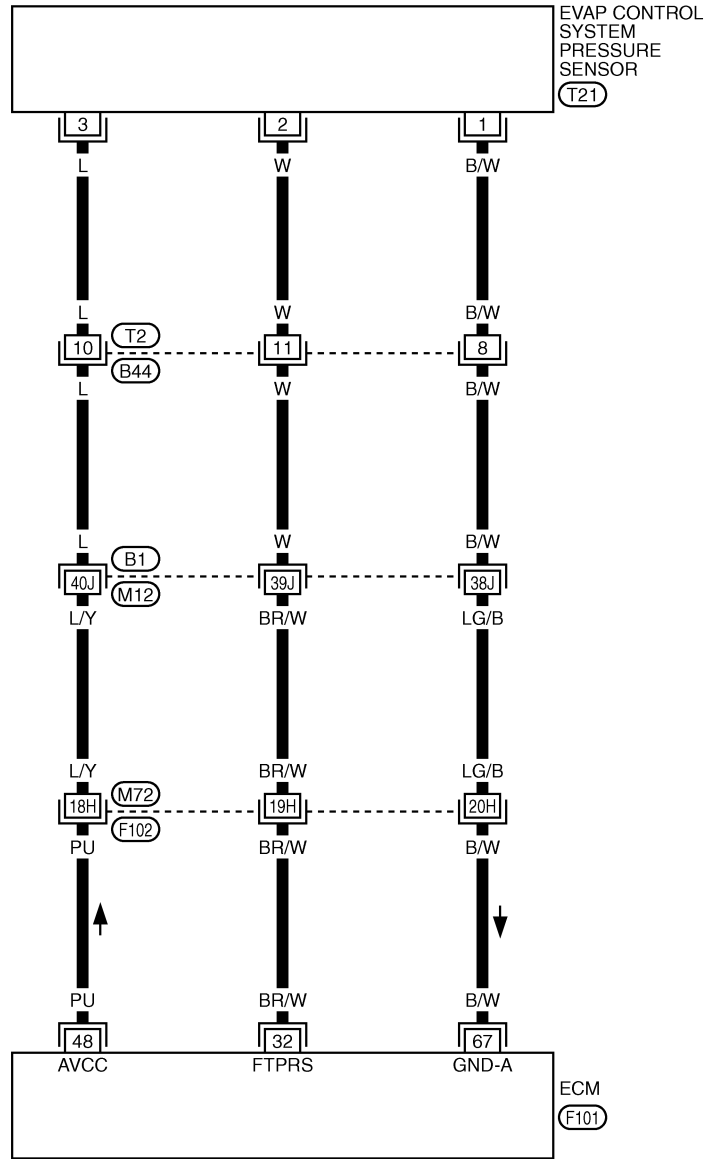

REFER TO THE FOLLOWING.  
 (F102), (B1) -SUPER MULTIPLE JUNCTION (SMJ)

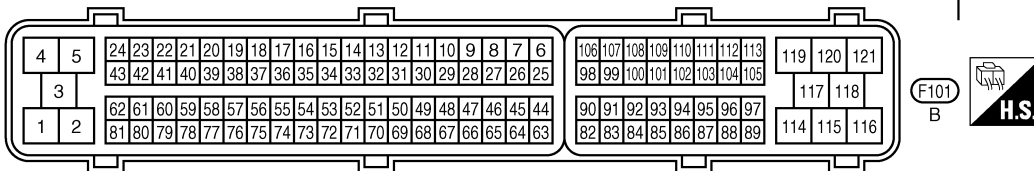

TBWT0622E

## DTC P0452 EVAP CONTROL SYSTEM PRESSURE SENSOR

Specification data are reference values and are measured between each terminal and ground.

**CAUTION:**

**Do not use ECM ground terminals when measuring input/output voltage. Doing so may result in damage to the ECM's transistor. Use a ground other than ECM terminals, such as the ground.**

TER-MINAL NO.	WIRE COLOR	ITEM	CONDITION	DATA (DC Voltage)
32	BR/W	EVAP control system pressure sensor	<b>[Ignition switch: ON]</b>	Approximately 1.8 - 4.8V
48	PU	Sensor power supply (EVAP control system pressure sensor)	<b>[Ignition switch: ON]</b>	Approximately 5V
67	B/W	Sensor ground	<b>[Engine is running]</b> <ul style="list-style-type: none"><li>● Warm-up condition</li><li>● Idle speed</li></ul>	Approximately 0V

A

EC

C

D

E

F

G

H

I

J

K

L

M

# DTC P0452 EVAP CONTROL SYSTEM PRESSURE SENSOR

## ROADSTER MODELS

### EC-PRE/SE-02

: DETECTABLE LINE FOR DTC  
 : NON-DETECTABLE LINE FOR DTC

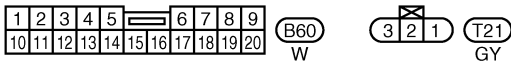
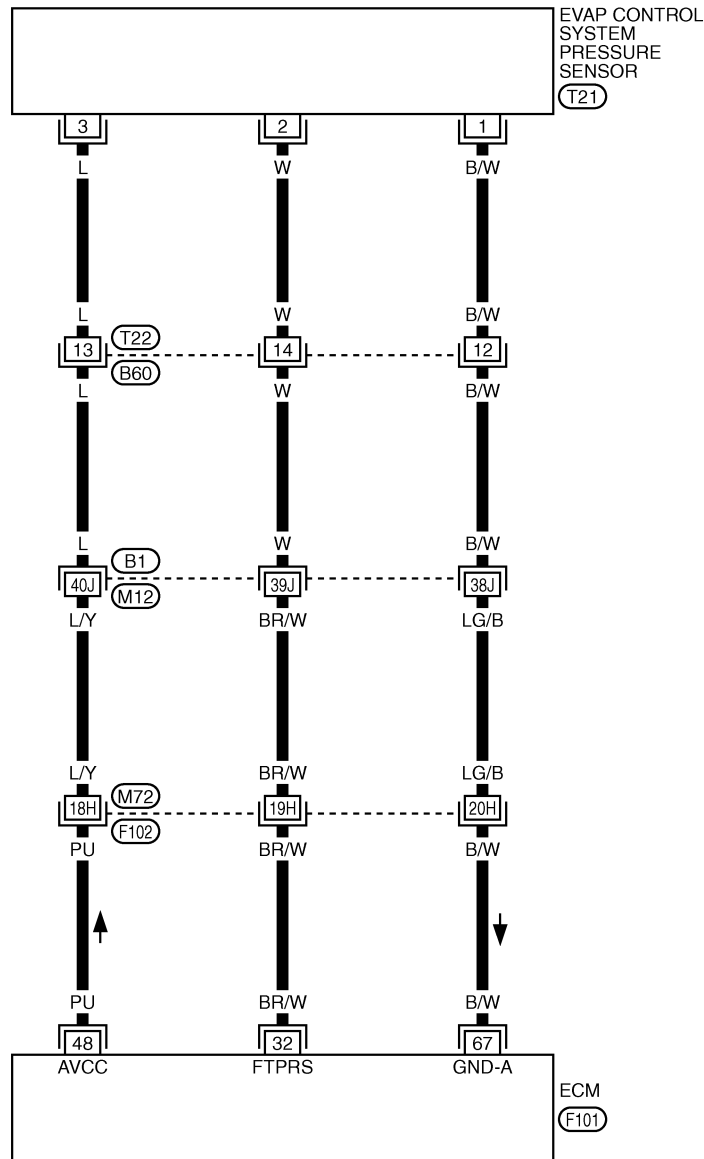

REFER TO THE FOLLOWING.  
 F102, B1 -SUPER MULTIPLE JUNCTION (SMJ)

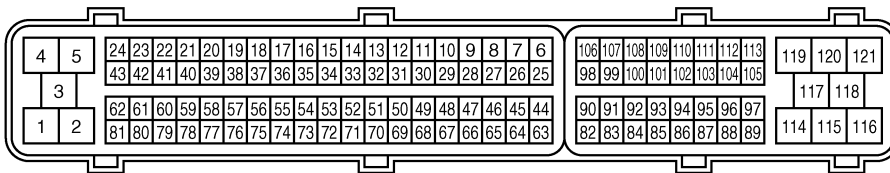

TBWT0623E

# DTC P0452 EVAP CONTROL SYSTEM PRESSURE SENSOR

Specification data are reference values and are measured between each terminal and ground.

**CAUTION:**

Do not use ECM ground terminals when measuring input/output voltage. Doing so may result in damage to the ECM's transistor. Use a ground other than ECM terminals, such as the ground.

TER-MINAL NO.	WIRE COLOR	ITEM	CONDITION	DATA (DC Voltage)
32	BR/W	EVAP control system pressure sensor	[Ignition switch: ON]	Approximately 1.8 - 4.8V
48	PU	Sensor power supply (EVAP control system pressure sensor)	[Ignition switch: ON]	Approximately 5V
67	B/W	Sensor ground	[Engine is running] ● Warm-up condition ● Idle speed	Approximately 0V

## Diagnostic Procedure

ABS009HQ

### 1. CHECK GROUND CONNECTIONS

1. Turn ignition switch OFF.
2. Loosen and retighten three ground screws on the body. Refer to [EC-138, "Ground Inspection"](#).

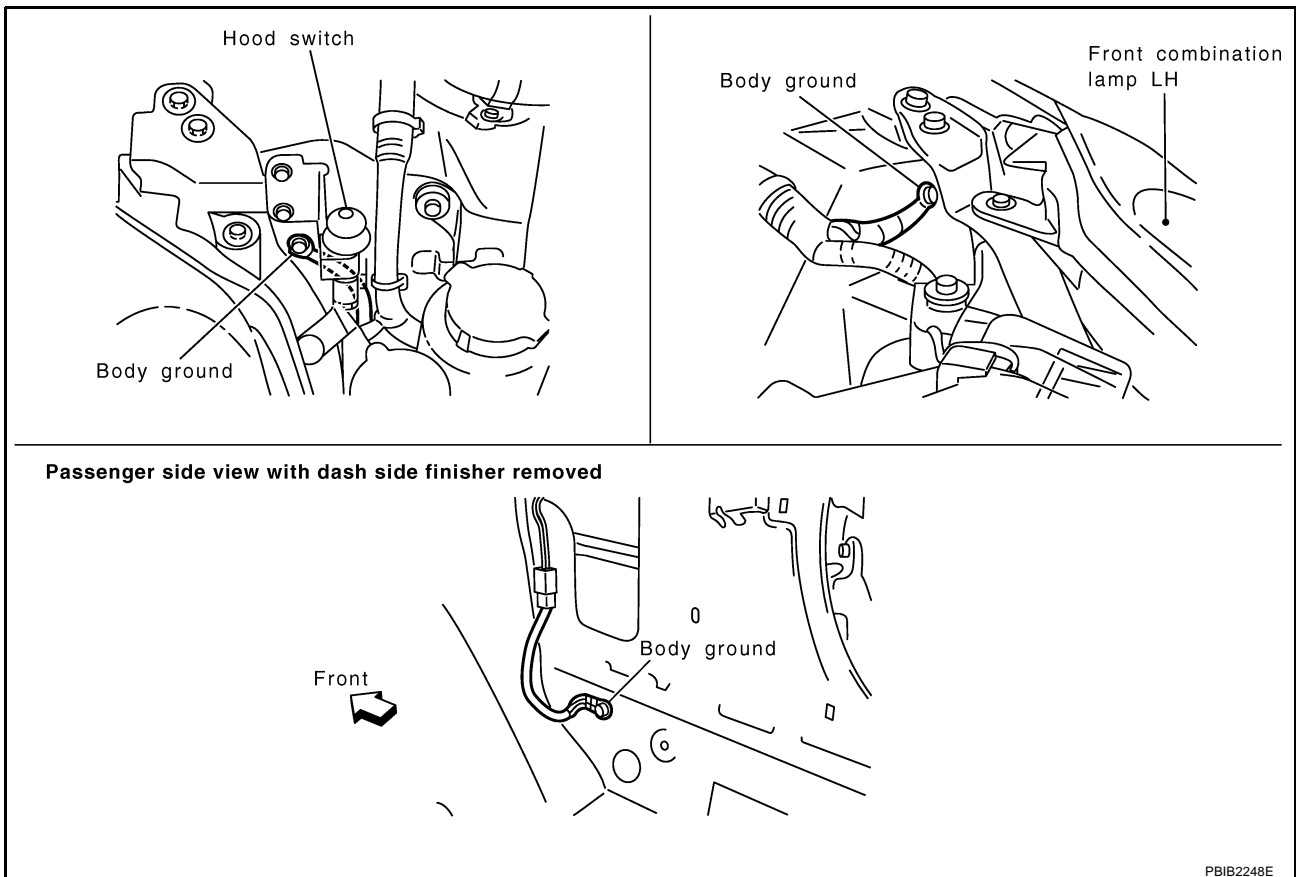

PBIB2248E

**OK or NG**

- OK >> GO TO 2.
- NG >> Repair or replace ground connections.

# DTC P0452 EVAP CONTROL SYSTEM PRESSURE SENSOR

## 2. CHECK CONNECTOR

1. Disconnect EVAP control system pressure sensor harness connector.

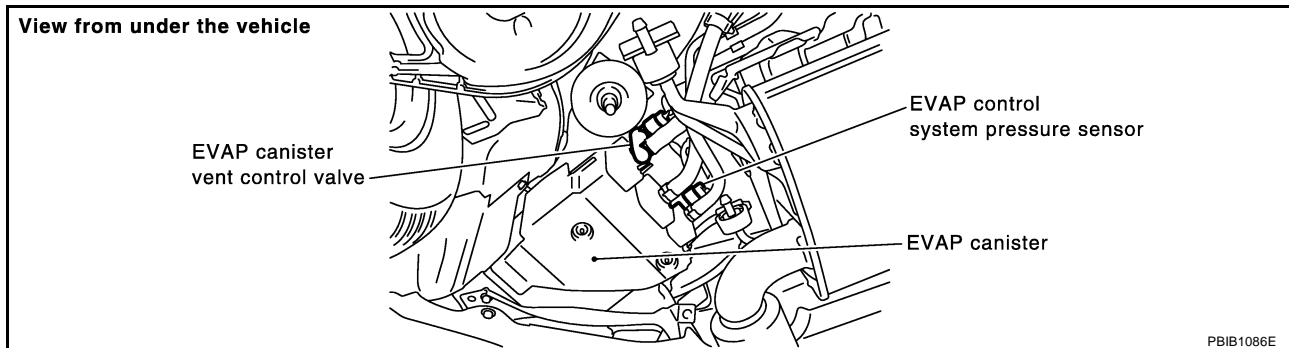

2. Check sensor harness connector for water.

**Water should not exist.**

OK or NG

OK >> GO TO 3.

NG >> Repair or replace harness connector.

## 3. CHECK EVAP CONTROL SYSTEM PRESSURE SENSOR POWER SUPPLY CIRCUIT

1. Turn ignition switch ON.
2. Check voltage between EVAP control system pressure sensor terminal 3 and ground with CONSULT-II or tester.

**Voltage: Approximately 5V**

OK or NG

OK >> GO TO 5.

NG >> GO TO 4.

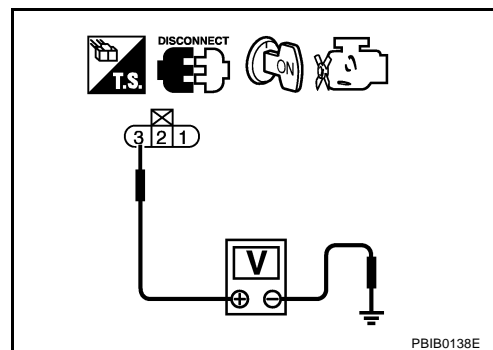

## 4. DETECT MALFUNCTIONING PART

Check the following.

- Harness connectors T2, B44 (Coupe models)
- Harness connectors T22, B60 (Roadster models)
- Harness connectors B1, M12
- Harness connectors M72, F102
- Harness for open or short between EVAP control system pressure sensor and ECM

>> Repair open circuit or short to ground or short to power in harness or connectors.

# DTC P0452 EVAP CONTROL SYSTEM PRESSURE SENSOR

---

## 5. CHECK EVAP CONTROL SYSTEM PRESSURE SENSOR GROUND CIRCUIT FOR OPEN AND SHORT

---

A

1. Turn ignition switch OFF.
2. Disconnect ECM harness connector.
3. Check harness continuity between EVAP control system pressure sensor terminal 1 and ECM terminal 67.  
Refer to Wiring Diagram.

EC

**Continuity should exist.**

C

4. Also check harness for short to ground and short to power.

D

OK or NG

- OK >> GO TO 7.  
NG >> GO TO 6.

E

---

## 6. DETECT MALFUNCTIONING PART

---

Check the following.

F

- Harness connectors T2, B44 (Coupe models)
- Harness connectors T22, B60 (Roadster models)
- Harness connectors B1, M12
- Harness connectors M72, F102
- Harness for open or short between EVAP control system pressure sensor and ECM

G

H

>> Repair open circuit or short to ground or short to power in harness or connectors.

---

## 7. CHECK EVAP CONTROL SYSTEM PRESSURE SENSOR INPUT SIGNAL CIRCUIT FOR OPEN AND SHORT

---

I

1. Check harness continuity between ECM terminal 32 and EVAP control system pressure sensor terminal 2.  
Refer to Wiring Diagram.

J

**Continuity should exist.**

K

2. Also check harness for short to ground and short to power.

OK or NG

- OK >> GO TO 9.  
NG >> GO TO 8.

L

---

## 8. DETECT MALFUNCTIONING PART

---

M

Check the following.

- Harness connectors T2, B44 (Coupe models)
- Harness connectors T22, B60 (Roadster models)
- Harness connectors B1, M12
- Harness connectors M72, F102
- Harness for open or short between EVAP control system pressure sensor and ECM

>> Repair open circuit or short to ground or short to power in harness or connectors.

# DTC P0452 EVAP CONTROL SYSTEM PRESSURE SENSOR

## 9. CHECK EVAP CONTROL SYSTEM PRESSURE SENSOR

Refer to [EC-328, "Component Inspection"](#) .

OK or NG

- OK >> GO TO 10.
- NG >> Replace EVAP control system pressure sensor.

## 10. CHECK INTERMITTENT INCIDENT

Refer to [EC-129, "TROUBLE DIAGNOSIS FOR INTERMITTENT INCIDENT"](#) .

>> INSPECTION END

### Component Inspection EVAP CONTROL SYSTEM PRESSURE SENSOR

ABS009HR

1. Remove EVAP control system pressure sensor with its harness connector connected from EVAP canister. **Always replace O-ring with a new one.**
2. Install a vacuum pump to EVAP control system pressure sensor.
3. Turn ignition switch ON and check output voltage between ECM terminal 32 and ground under the following conditions.

Applied vacuum kPa (mmHg, inHg)	Voltage V
Not applied	1.8 - 4.8
-26.7 (-200, -7.87)	2.1 to 2.5V lower than above value

**CAUTION:**

- Always calibrate the vacuum pump gauge when using it.
  - Do not apply below -93.3 kPa (-700 mmHg, -27.56 inHg) or pressure over 101.3 kPa (760 mmHg, 29.92 inHg).
4. If NG, replace EVAP control system pressure sensor.

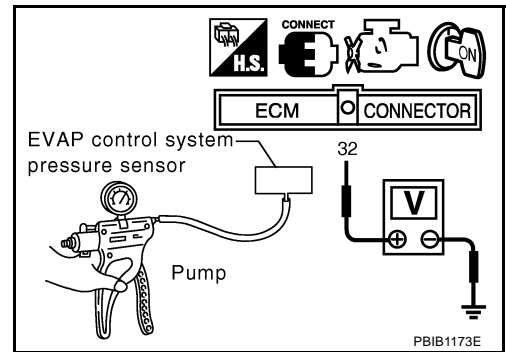



# DTC P0453 EVAP CONTROL SYSTEM PRESSURE SENSOR

## DTC P0453 EVAP CONTROL SYSTEM PRESSURE SENSOR

PF25085

### Component Description

ABS009HS

The EVAP control system pressure sensor detects pressure in the purge line. The sensor output voltage to the ECM increases as pressure increases.

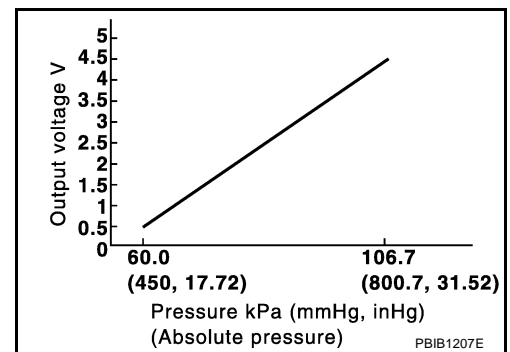
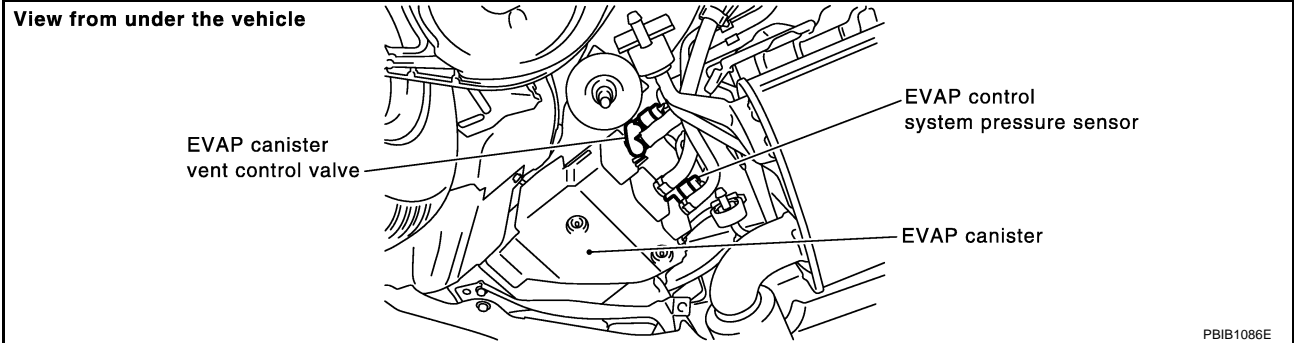

### CONSULT-II Reference Value in Data Monitor Mode

ABS009HT

Specification data are reference values.

MONITOR ITEM	CONDITION	SPECIFICATION
EVAP SYS PRES	● Ignition switch: ON	Approx. 1.8 - 4.8V

### On Board Diagnosis Logic

ABS009HU

#### NOTE:

If DTC P0453 is displayed with DTC P1229, first perform the trouble diagnosis for DTC P1229.

Refer to [EC-456](#).

DTC No.	Trouble diagnosis name	DTC detecting condition	Possible cause
P0453 0453	EVAP control system pressure sensor high input	An excessively high voltage from the sensor is sent to ECM.	<ul style="list-style-type: none"> <li>● Harness or connectors (The sensor circuit is open or shorted.)</li> <li>● EVAP control system pressure sensor</li> <li>● EVAP canister vent control valve</li> <li>● EVAP canister</li> <li>● Rubber hose from EVAP canister vent control valve to vehicle frame</li> </ul>

# DTC P0453 EVAP CONTROL SYSTEM PRESSURE SENSOR

ABS009HV

## DTC Confirmation Procedure

### NOTE:

If DTC Confirmation Procedure has been previously conducted, always turn ignition switch OFF and wait at least 10 seconds before conducting the next test.

### TESTING CONDITION:

Always perform test at a temperature of 5°C (41°F) or more.

#### WITH CONSULT-II

1. Start engine and warm it up to normal operating temperature.
2. Turn ignition switch OFF and wait at least 10 seconds.
3. Turn ignition switch ON.
4. Select "DATA MONITOR" mode with CONSULT-II.
5. Make sure that "FUEL T/TEMP SE" is more than 0°C (32°F).
6. Start engine and wait at least 20 seconds.
7. If 1st trip DTC is detected, go to [EC-334, "Diagnostic Procedure"](#)

DATA MONITOR	
MONITOR	NO DTC
ENG SPEED	XXX rpm
COOLAN TEMP/S	XXX °C
FUEL T/TMP SE	XXX °C

SEF194Y

#### WITH GST

1. Start engine and warm it up to normal operating temperature.
2. Check that voltage between ECM terminal 107 (Fuel tank temperature sensor signal) and ground is less than 4.2V.
3. Turn ignition switch OFF and wait at least 10 seconds.
4. Start engine and wait at least 20 seconds.
5. Select "MODE 7" with GST.  
If 1st trip DTC is detected, go to [EC-334, "Diagnostic Procedure"](#)

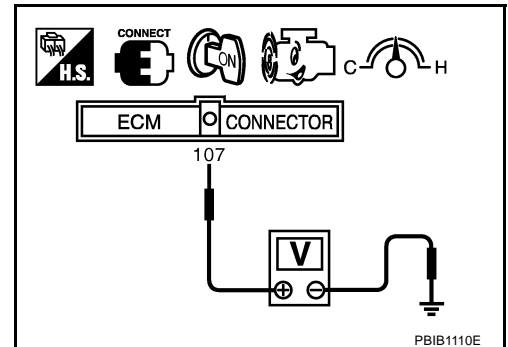

# DTC P0453 EVAP CONTROL SYSTEM PRESSURE SENSOR

## Wiring Diagram COUPE MODELS

ABS009HW

EC-PRE/SE-01

— : DETECTABLE LINE FOR DTC  
 — : NON-DETECTABLE LINE FOR DTC

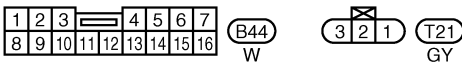
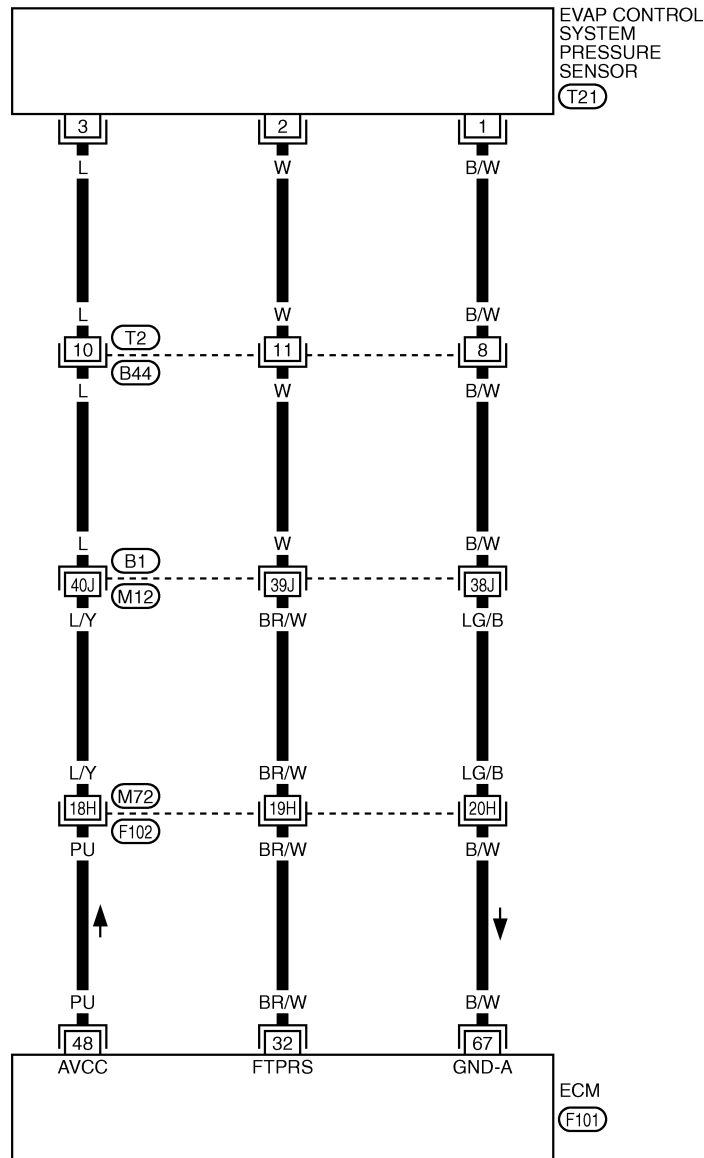

REFER TO THE FOLLOWING.  
 (F102), (B1) -SUPER MULTIPLE JUNCTION (SMJ)

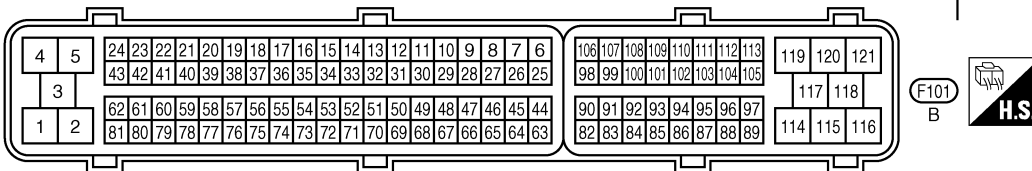

TBWT0622E

## DTC P0453 EVAP CONTROL SYSTEM PRESSURE SENSOR

Specification data are reference values and are measured between each terminal and ground.

**CAUTION:**

**Do not use ECM ground terminals when measuring input/output voltage. Doing so may result in damage to the ECM's transistor. Use a ground other than ECM terminals, such as the ground.**

TER-MINAL NO.	WIRE COLOR	ITEM	CONDITION	DATA (DC Voltage)
32	BR/W	EVAP control system pressure sensor	<b>[Ignition switch: ON]</b>	Approximately 1.8 - 4.8V
48	PU	Sensor power supply (EVAP control system pressure sensor)	<b>[Ignition switch: ON]</b>	Approximately 5V
67	B/W	Sensor ground	<b>[Engine is running]</b> <ul style="list-style-type: none"><li>● Warm-up condition</li><li>● Idle speed</li></ul>	Approximately 0V

# DTC P0453 EVAP CONTROL SYSTEM PRESSURE SENSOR

## ROADSTER MODELS

### EC-PRE/SE-02

: DETECTABLE LINE FOR DTC  
 : NON-DETECTABLE LINE FOR DTC

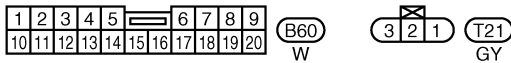
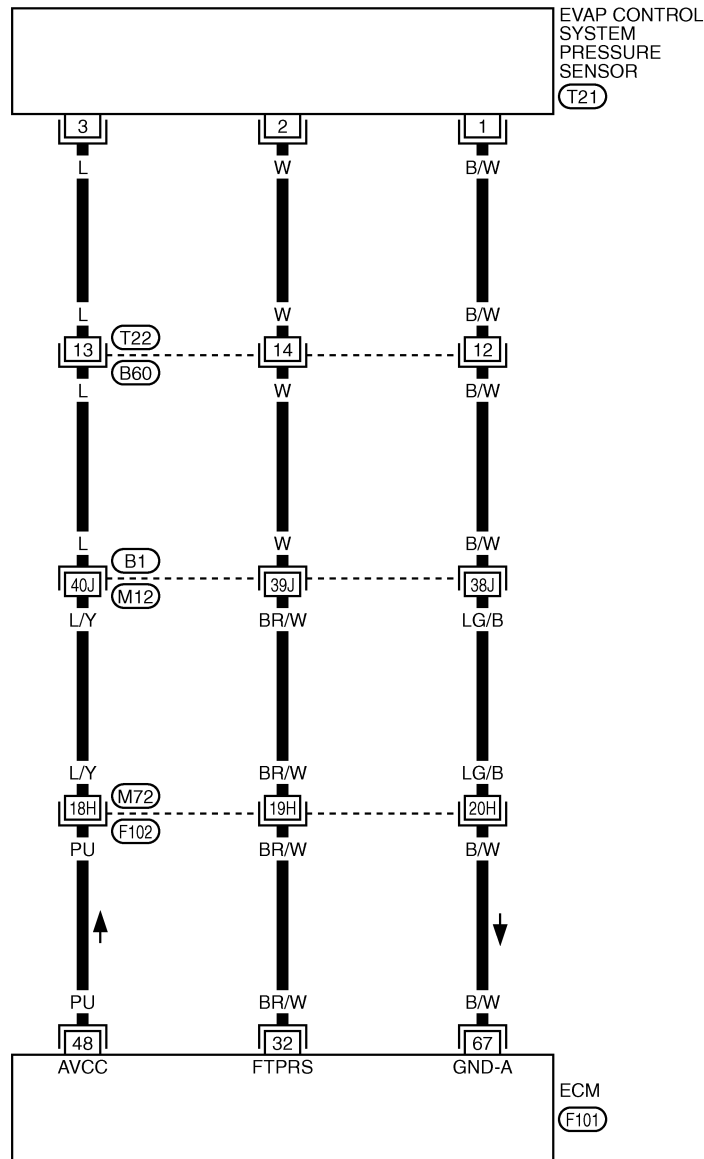

REFER TO THE FOLLOWING.  
 F102, B1 -SUPER MULTIPLE JUNCTION (SMJ)

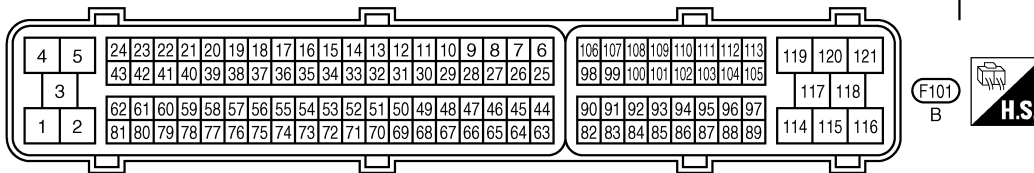

TBWT0623E

# DTC P0453 EVAP CONTROL SYSTEM PRESSURE SENSOR

Specification data are reference values and are measured between each terminal and ground.

**CAUTION:**

Do not use ECM ground terminals when measuring input/output voltage. Doing so may result in damage to the ECM's transistor. Use a ground other than ECM terminals, such as the ground.

TER-MINAL NO.	WIRE COLOR	ITEM	CONDITION	DATA (DC Voltage)
32	BR/W	EVAP control system pressure sensor	[Ignition switch: ON]	Approximately 1.8 - 4.8V
48	PU	Sensor power supply (EVAP control system pressure sensor)	[Ignition switch: ON]	Approximately 5V
67	B/W	Sensor ground	[Engine is running] ● Warm-up condition ● Idle speed	Approximately 0V

## Diagnostic Procedure

ABS009HX

### 1. CHECK GROUND CONNECTIONS

1. Turn ignition switch OFF.
2. Loosen and retighten three ground screws on the body. Refer to [EC-138, "Ground Inspection"](#).

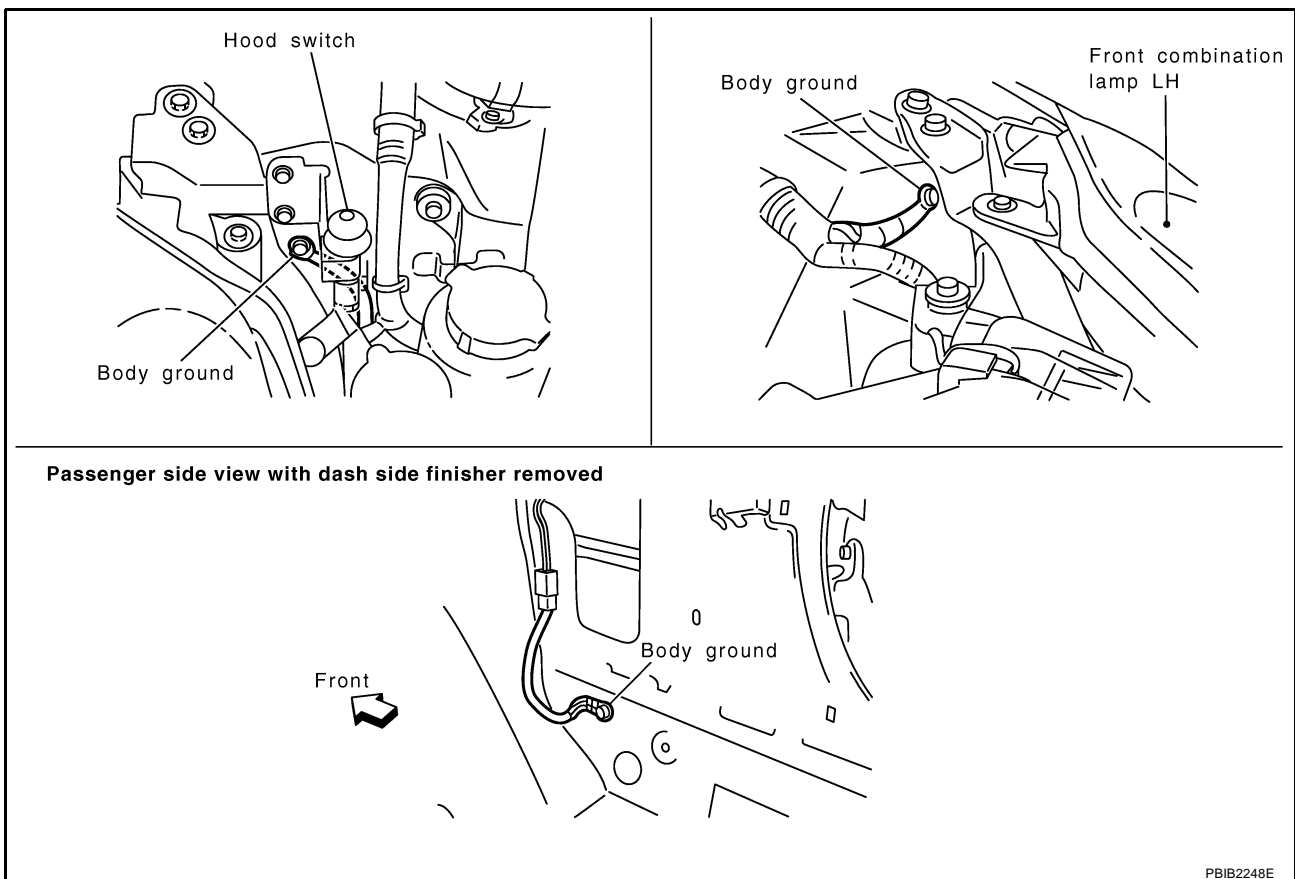

OK or NG

- OK >> GO TO 2.
- NG >> Repair or replace ground connections.

# DTC P0453 EVAP CONTROL SYSTEM PRESSURE SENSOR

## 2. CHECK CONNECTOR

1. Disconnect EVAP control system pressure sensor harness connector.

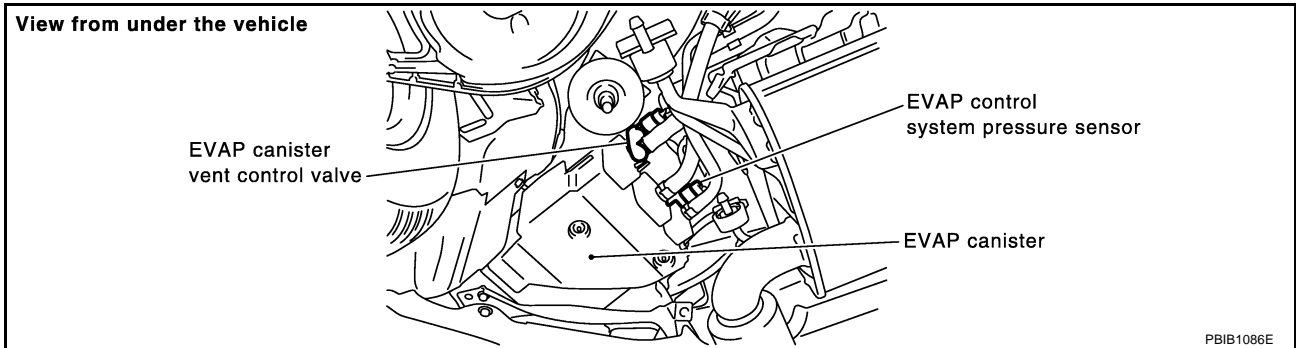

2. Check sensor harness connector for water.

**Water should not exist.**

OK or NG

- OK >> GO TO 3.
- NG >> Repair or replace harness connector.

## 3. CHECK EVAP CONTROL SYSTEM PRESSURE SENSOR POWER SUPPLY CIRCUIT

1. Turn ignition switch ON.
2. Check voltage between EVAP control system pressure sensor terminal 3 and ground with CONSULT-II or tester.

**Voltage: Approximately 5V**

OK or NG

- OK >> GO TO 5.
- NG >> GO TO 4.

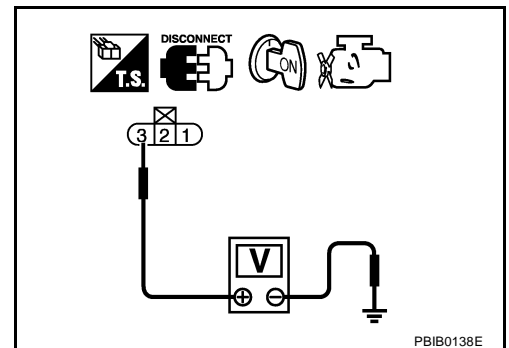

## 4. DETECT MALFUNCTIONING PART

Check the following.

- Harness connectors T2, B44 (Coupe models)
- Harness connectors T22, B60 (Roadster models)
- Harness connectors B1, M12
- Harness connectors M72, F102
- Harness for open or short between EVAP control system pressure sensor and ECM

>> Repair open circuit or short to ground or short to power in harness or connectors.

# DTC P0453 EVAP CONTROL SYSTEM PRESSURE SENSOR

---

## 5. CHECK EVAP CONTROL SYSTEM PRESSURE SENSOR GROUND CIRCUIT FOR OPEN AND SHORT

---

1. Turn ignition switch OFF.
2. Disconnect ECM harness connector.
3. Check harness continuity between EVAP control system pressure sensor terminal 1 and ECM terminal 67.  
Refer to Wiring Diagram.

**Continuity should exist.**

4. Also check harness for short to ground and short to power.

OK or NG

- OK >> GO TO 7.  
NG >> GO TO 6.

---

## 6. DETECT MALFUNCTIONING PART

---

Check the following.

- Harness connectors T2, B44 (Coupe models)
- Harness connectors T22, B60 (Roadster models)
- Harness connectors B1, M12
- Harness connectors M72, F102
- Harness for open or short between EVAP control system pressure sensor and ECM

>> Repair open circuit or short to ground or short to power in harness or connectors.

---

## 7. CHECK EVAP CONTROL SYSTEM PRESSURE SENSOR INPUT SIGNAL CIRCUIT FOR OPEN AND SHORT

---

1. Check harness continuity between ECM terminal 32 and EVAP control system pressure sensor terminal 2.  
Refer to Wiring Diagram.

**Continuity should exist.**

2. Also check harness for short to ground and short to power.

OK or NG

- OK >> GO TO 9.  
NG >> GO TO 8.

---

## 8. DETECT MALFUNCTIONING PART

---

Check the following.

- Harness connectors T2, B44 (Coupe models)
- Harness connectors T22, B60 (Roadster models)
- Harness connectors B1, M12
- Harness connectors M72, F102
- Harness for open or short between EVAP control system pressure sensor and ECM

>> Repair open circuit or short to ground or short to power in harness or connectors.



# DTC P0453 EVAP CONTROL SYSTEM PRESSURE SENSOR

## 9. CHECK RUBBER TUBE

1. Disconnect rubber tube connected to EVAP canister vent control valve.
2. Check the rubber tube for clogging, vent and kinked.

OK or NG

- OK >> GO TO 10.  
NG >> Clean the rubber tube using an air blower.

## 10. CHECK EVAP CANISTER VENT CONTROL VALVE

Refer to [EC-315, "Component Inspection"](#) .

OK or NG

- OK >> GO TO 11.  
NG >> Replace EVAP canister vent control valve.

## 11. CHECK EVAP CONTROL SYSTEM PRESSURE SENSOR

Refer to [EC-338, "Component Inspection"](#) .

OK or NG

- OK >> GO TO 12.  
NG >> Replace EVAP control system pressure sensor.

## 12. CHECK IF EVAP CANISTER SATURATED WITH WATER

1. Remove EVAP canister with EVAP canister vent control valve and EVAP control system pressure sensor attached.
2. Check if water will drain from the EVAP canister.

Yes or No

- Yes >> GO TO 13.  
No >> GO TO 15.

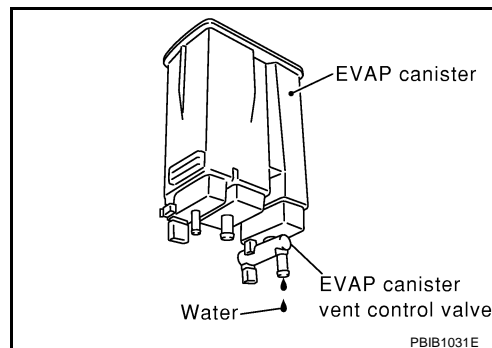

## 13. CHECK EVAP CANISTER

Weigh the EVAP canister with the EVAP canister vent control valve and EVAP control system pressure sensor attached.

**The weight should be less than 2.2 kg (4.9 lb).**

OK or NG

- OK >> GO TO 15.  
NG >> GO TO 14.

## 14. DETECT MALFUNCTIONING PART

Check the following.

- EVAP canister for damage
- EVAP hose between EVAP canister and vehicle frame for clogging or poor connection

>> Repair hose or replace EVAP canister.

# DTC P0453 EVAP CONTROL SYSTEM PRESSURE SENSOR

## 15. CHECK INTERMITTENT INCIDENT

Refer to [EC-129, "TROUBLE DIAGNOSIS FOR INTERMITTENT INCIDENT"](#) .

>> INSPECTION END

### Component Inspection EVAP CONTROL SYSTEM PRESSURE SENSOR

ABS009HY

1. Remove EVAP control system pressure sensor with its harness connector connected from EVAP canister.  
**Always replace O-ring with a new one.**
2. Install a vacuum pump to EVAP control system pressure sensor.
3. Turn ignition switch ON and check output voltage between ECM terminal 32 and ground under the following conditions.

Applied vacuum kPa (mmHg, inHg)	Voltage V
Not applied	1.8 - 4.8
-26.7 (-200, -7.87)	2.1 to 2.5V lower than above value

**CAUTION:**

- Always calibrate the vacuum pump gauge when using it.
  - Do not apply below -93.3 kPa (-700 mmHg, -27.56 inHg) or pressure over 101.3 kPa (760 mmHg, 29.92 inHg).
4. If NG, replace EVAP control system pressure sensor.

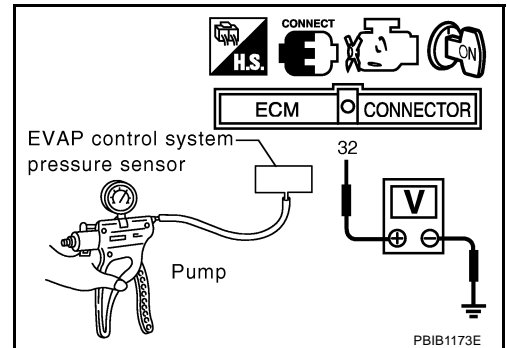

PBIB1173E

# DTC P0455 EVAP CONTROL SYSTEM

## DTC P0455 EVAP CONTROL SYSTEM

PF14950

### On Board Diagnosis Logic

ABS009HZ

This diagnosis detects a very large leak (fuel filler cap fell off etc.) in EVAP system between the fuel tank and EVAP canister purge volume control solenoid valve.

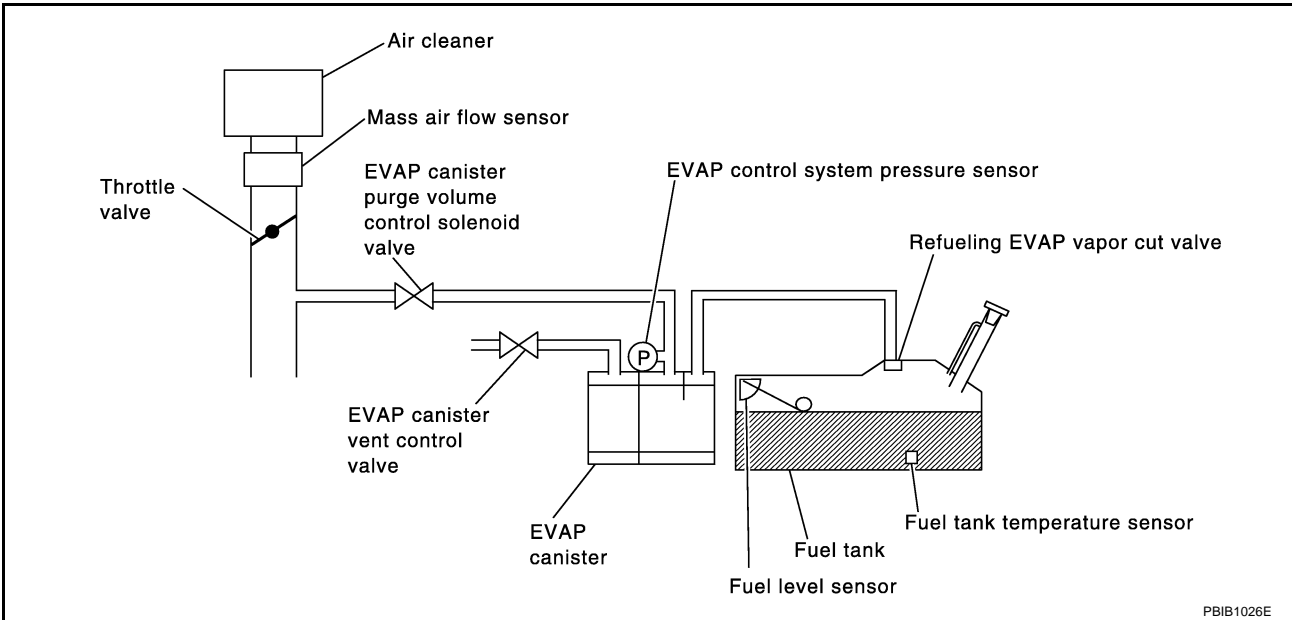

DTC No.	Trouble diagnosis name	DTC detecting condition	Possible cause
P0455 0455	EVAP control system gross leak detected	EVAP control system has a very large leak such as fuel filler cap fell off, EVAP control system does not operate properly.	<ul style="list-style-type: none"> <li>● Fuel filler cap remains open or fails to close.</li> <li>● Incorrect fuel tank vacuum relief valve</li> <li>● Incorrect fuel filler cap used</li> <li>● Foreign matter caught in fuel filler cap.</li> <li>● Leak is in line between intake manifold and EVAP canister purge volume control solenoid valve.</li> <li>● Foreign matter caught in EVAP canister vent control valve.</li> <li>● EVAP canister or fuel tank leaks</li> <li>● EVAP purge line (pipe and rubber tube) leaks</li> <li>● EVAP purge line rubber tube bent.</li> <li>● Loose or disconnected rubber tube</li> <li>● EVAP canister vent control valve and the circuit</li> <li>● EVAP canister purge volume control solenoid valve and the circuit</li> <li>● Fuel tank temperature sensor</li> <li>● O-ring of EVAP canister vent control valve is missing or damaged.</li> <li>● EVAP control system pressure sensor</li> <li>● Refueling EVAP vapor cut valve</li> <li>● ORVR system leaks</li> </ul>

#### CAUTION:

- Use only a genuine NISSAN fuel filler cap as a replacement. If an incorrect fuel filler cap is used, the MIL may come on.
- If the fuel filler cap is not tightened properly, the MIL may come on.

# DTC P0455 EVAP CONTROL SYSTEM

- Use only a genuine NISSAN rubber tube as a replacement.

## DTC Confirmation Procedure

ABS00910

### CAUTION:

Never remove fuel filler cap during the DTC Confirmation Procedure.

### NOTE:

- Make sure that EVAP hoses are connected to EVAP canister purge volume control solenoid valve properly.
- If DTC Confirmation Procedure has been previously conducted, always turn ignition switch OFF and wait at least 10 seconds before conducting the next test.

### TESTING CONDITION:

- Perform "DTC WORK SUPPORT" when the fuel level is between 1/4 and 3/4 full, and vehicle is placed on flat level surface.
- Open engine hood before conducting the following procedures.

### WITH CONSULT-II

1. Tighten fuel filler cap securely until ratcheting sound is heard.
2. Turn ignition switch ON.
3. Turn ignition switch OFF and wait at least 10 seconds.
4. Turn ignition switch ON and select "DATA MONITOR" mode with CONSULT-II.
5. Make sure that the following conditions are met.

**COOLAN TEMP/S: 0 - 70°C (32 - 158°F)**

**INT/A TEMP SE: 0 - 60°C (32 - 140°F)**

DATA MONITOR	
MONITOR	DTC
ENG SPEED	XXX rpm
COOLAN TEMP/S	XXX °C
INT/A TEMP SE	XXX °C

PBIB2869E

6. Select "EVAP SML LEAK P0442/P1442" of "EVAPORATIVE SYSTEM" in "DTC WORK SUPPORT" mode with CONSULT-II.  
Follow the instruction displayed.

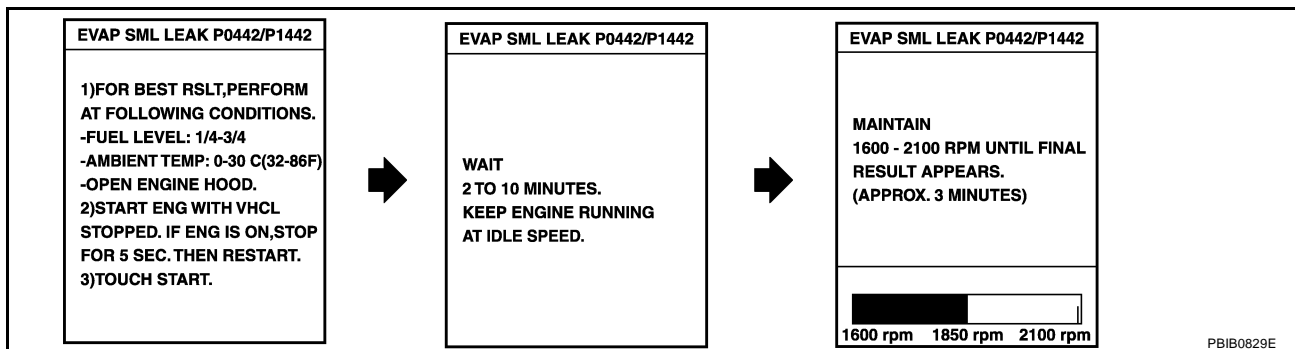

### NOTE:

If the engine speed cannot be maintained within the range displayed on the CONSULT-II screen, go to [EC-78, "Basic Inspection"](#).

# DTC P0455 EVAP CONTROL SYSTEM

7. Make sure that "OK" is displayed.  
If "NG" is displayed, select "SELF-DIAG RESULTS" mode and make sure that "EVAP GROSS LEAK [P0455]" is displayed. If it is displayed, refer to [EC-341, "Diagnostic Procedure"](#) .  
If P0442 is displayed, perform Diagnostic Procedure for DTC P0442 [EC-294, "Diagnostic Procedure"](#) .

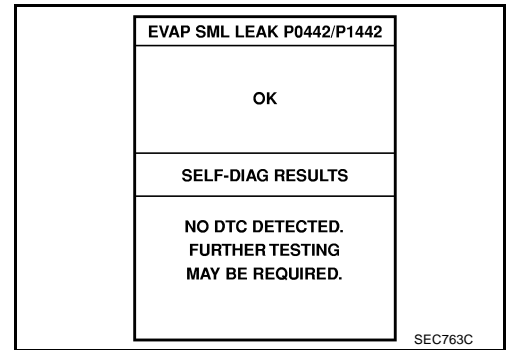

## WITH GST

### NOTE:

Be sure to read the explanation of [EC-58, "Driving Pattern"](#) before driving vehicle.

1. Start engine.
2. Drive vehicle according to [EC-58, "Driving Pattern"](#) .
3. Stop vehicle.
4. Turn ignition switch OFF and wait at least 10 seconds.
5. Select "MODE 7" with GST.
  - If P0455 is displayed on the screen, go to [EC-341, "Diagnostic Procedure"](#) .
  - If P0442 is displayed on the screen, go to Diagnostic Procedure for DTC P0442, [EC-294](#) .
  - If P0441 is displayed on the screen, go to Diagnostic Procedure for DTC P0441, [EC-289](#) .

## Diagnostic Procedure

ABS009/1

### 1. CHECK FUEL FILLER CAP DESIGN

1. Turn ignition switch OFF.
2. Check for genuine NISSAN fuel filler cap design.

#### OK or NG

- OK >> GO TO 2.  
NG >> Replace with genuine NISSAN fuel filler cap.

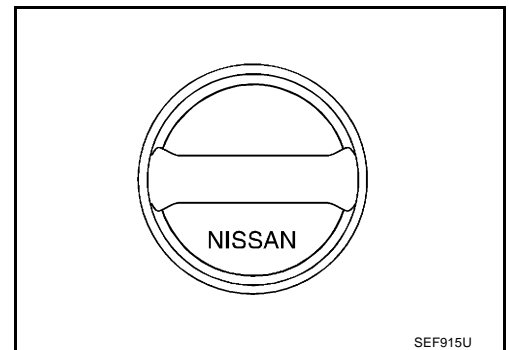

### 2. CHECK FUEL FILLER CAP INSTALLATION

Check that the cap is tightened properly by rotating the cap clockwise.

#### OK or NG

- OK >> GO TO 3.  
NG >> 1. Open fuel filler cap, then clean cap and fuel filler neck threads using air blower.  
2. Retighten until ratcheting sound is heard.

### 3. CHECK FUEL FILLER CAP FUNCTION

Check for air releasing sound while opening the fuel filler cap.

#### OK or NG

- OK >> GO TO 5.  
NG >> GO TO 4.

# DTC P0455 EVAP CONTROL SYSTEM

---

## 4. CHECK FUEL TANK VACUUM RELIEF VALVE

---

Refer to [EC-677, "FUEL TANK VACUUM RELIEF VALVE \(BUILT INTO FUEL FULLER CAP\)"](#) .

OK or NG

- OK >> GO TO 5.
- NG >> Replace fuel filler cap with a genuine one.

## 5. CHECK EVAP PURGE LINE

---

Check EVAP purge line (pipe, rubber tube, fuel tank and EVAP canister) for cracks, improper connection or disconnection.

Refer to [EC-675, "EVAPORATIVE EMISSION LINE DRAWING"](#) .

OK or NG

- OK >> GO TO 6.
- NG >> Repair or reconnect the hose.

## 6. CLEAN EVAP PURGE LINE

---

Clean EVAP purge line (pipe and rubber tube) using air blower.

>> GO TO 7.

## 7. CHECK EVAP CANISTER VENT CONTROL VALVE

---

Check the following.

- EVAP canister vent control valve is installed properly.  
Refer to [EC-678, "Removal and Installation"](#) .
- EVAP canister vent control valve.  
Refer to [EC-315, "Component Inspection"](#) .

OK or NG

- OK >> GO TO 8.
- NG >> Repair or replace EVAP canister vent control valve and O-ring.

# DTC P0455 EVAP CONTROL SYSTEM

## 8. INSTALL THE PRESSURE PUMP

To locate the EVAP leak, install EVAP service port adapter and pressure pump to EVAP service port securely.

**NOTE:**

**Improper installation of the EVAP service port adapter to the EVAP service port may cause leaking.**

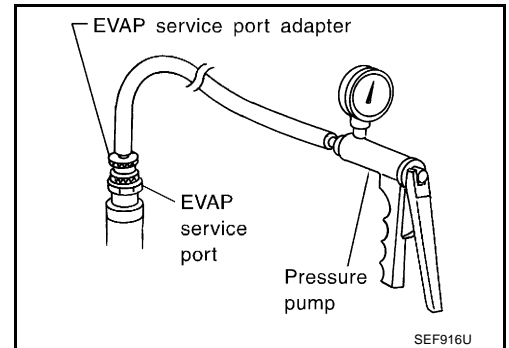
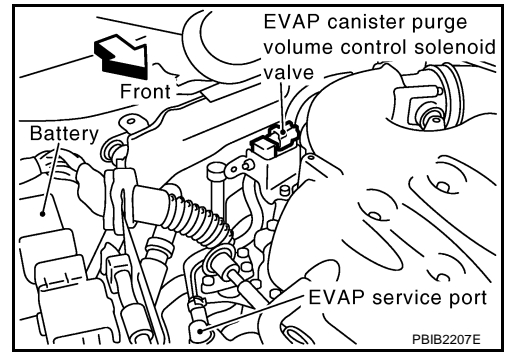

With CONSULT-II>>GO TO 9.  
Without CONSULT-II>>GO TO 10.

## 9. CHECK FOR EVAP LEAK

**With CONSULT-II**

1. Turn ignition switch ON.
2. Select "EVAP SYSTEM CLOSE" of "WORK SUPPORT" mode with CONSULT-II.
3. Touch "START" and apply pressure into the EVAP line until the pressure indicator reaches the middle of the bar graph.

**CAUTION:**

- Never use compressed air or a high pressure pump.
- Do not exceed 4.12 kPa (0.042 kg/cm<sup>2</sup>, 0.6 psi) of pressure in the system.

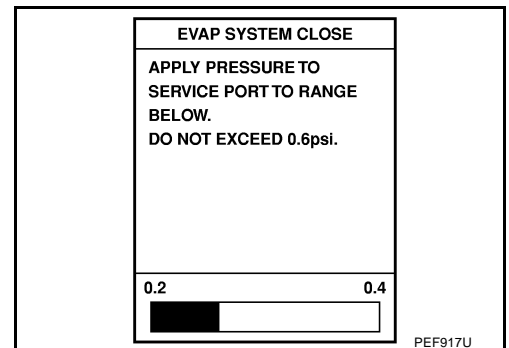

4. Using EVAP leak detector, locate the EVAP leak. For the leak detector, refer to the instruction manual for more details. Refer to [EC-675, "EVAPORATIVE EMISSION LINE DRAWING"](#)

**OK or NG**

- OK >> GO TO 11.  
NG >> Repair or replace.

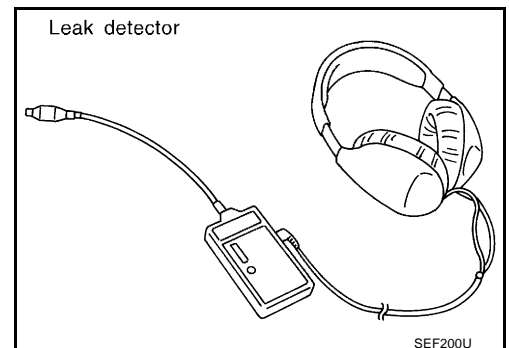

# DTC P0455 EVAP CONTROL SYSTEM

## 10. CHECK FOR EVAP LEAK

### ⊗ Without CONSULT-II

1. Turn ignition switch OFF.
2. Apply 12 volts DC to EVAP canister vent control valve. The valve will close. (Continue to apply 12 volts until the end of test.)

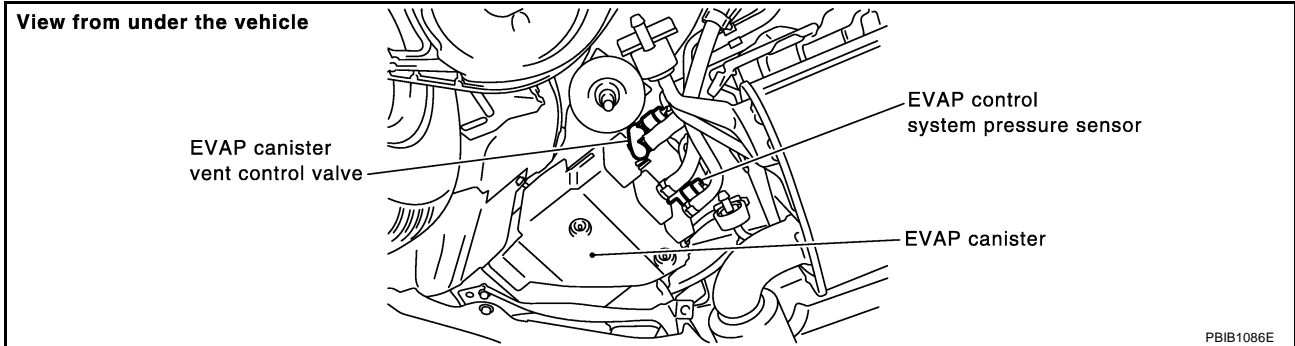

3. Pressurize the EVAP line using pressure pump with 1.3 to 2.7 kPa (10 to 20 mmHg, 0.39 to 0.79 inHg), then remove pump and EVAP service port adapter.

### CAUTION:

- Never use compressed air or a high pressure pump.
- Do not exceed 4.12 kPa (0.042 kg/cm<sup>2</sup>, 0.6 psi) of pressure in the system.

4. Using EVAP leak detector, locate the EVAP leak. For the leak detector, refer to the instruction manual for more details. Refer to [EC-675, "EVAPORATIVE EMISSION LINE DRAWING"](#).

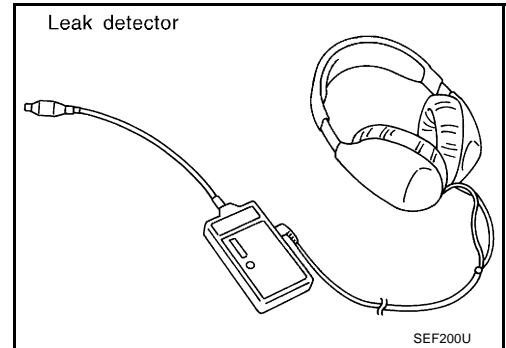

### OK or NG

- OK >> GO TO 12.  
 NG >> Repair or replace.

## 11. CHECK EVAP CANISTER PURGE VOLUME CONTROL SOLENOID VALVE OPERATION

### Ⓟ With CONSULT-II

1. Disconnect vacuum hose to EVAP canister purge volume control solenoid valve at EVAP service port.
2. Start engine.
3. Perform "PURG VOL CONT/V" in "ACTIVE TEST" mode.
4. Touch "Qu" on CONSULT-II screen to increase "PURG VOL CONT/V" opening to 100%.
5. Check vacuum hose for vacuum when revving engine up to 2,000 rpm.

### OK or NG

- OK >> GO TO 14.  
 NG >> GO TO 13.

ACTIVE TEST	
PURG VOL CONT/V	XXX %
MONITOR	
ENG SPEED	XXX rpm
A/F ALPHA-B1	XX %
A/F ALPHA-B2	XX %

PBIB1678E



# DTC P0455 EVAP CONTROL SYSTEM

## 12. CHECK EVAP CANISTER PURGE VOLUME CONTROL SOLENOID VALVE OPERATION

### ⊗ Without CONSULT-II

1. Start engine and warm it up to normal operating temperature.
2. Stop engine.
3. Disconnect vacuum hose to EVAP canister purge volume control solenoid valve at EVAP service port.
4. Start engine and let it idle for at least 80 seconds.
5. Check vacuum hose for vacuum when revving engine up to 2,000 rpm.

#### OK or NG

- OK >> GO TO 15.  
NG >> GO TO 13.

## 13. CHECK VACUUM HOSE

Check vacuum hoses for clogging or disconnection. Refer to [EC-23, "Vacuum Hose Drawing"](#).

#### OK or NG

- OK (With CONSULT-II)>>GO TO 14.  
OK (Without CONSULT-II)>>GO TO 15.  
NG >> Repair or reconnect the hose.

## 14. CHECK EVAP CANISTER PURGE VOLUME CONTROL SOLENOID VALVE

### Ⓟ With CONSULT-II

1. Start engine.
2. Perform "PURG VOL CONT/V" in "ACTIVE TEST" mode with CONSULT-II. Check that engine speed varies according to the valve opening.

#### OK or NG

- OK >> GO TO 16.  
NG >> GO TO 15.

ACTIVE TEST	
PURG VOL CONT/V	XXX %
MONITOR	
ENG SPEED	XXX rpm
A/F ALPHA-B1	XX %
A/F ALPHA-B2	XX %

PBIB1678E

## 15. CHECK EVAP CANISTER PURGE VOLUME CONTROL SOLENOID VALVE

Refer to [EC-306, "Component Inspection"](#).

#### OK or NG

- OK >> GO TO 16.  
NG >> Replace EVAP canister purge volume control solenoid valve.

## 16. CHECK FUEL TANK TEMPERATURE SENSOR

Refer to [EC-242, "Component Inspection"](#).

#### OK or NG

- OK >> GO TO 17.  
NG >> Replace fuel level sensor unit.

## 17. CHECK EVAP CONTROL SYSTEM PRESSURE SENSOR

Refer to [EC-328, "Component Inspection"](#).

#### OK or NG

- OK >> GO TO 18.  
NG >> Replace EVAP control system pressure sensor.

## DTC P0455 EVAP CONTROL SYSTEM

---

### 18. CHECK EVAP/ORVR LINE

---

Check EVAP/ORVR line between EVAP canister and fuel tank for clogging, kink, looseness and improper connection. For location, refer to [EC-681, "ON BOARD REFUELING VAPOR RECOVERY \(ORVR\)"](#) .

OK or NG

OK >> GO TO 19.

NG >> Repair or replace hoses and tubes.

### 19. CHECK RECIRCULATION LINE

---

Check recirculation line between filler neck tube and fuel tank for clogging, kink, cracks, looseness and improper connection.

OK or NG

OK >> GO TO 20.

NG >> Repair or replace hose, tube or filler neck tube.

### 20. CHECK REFUELING EVAP VAPOR CUT VALVE

---

Refer to [EC-684, "REFUELING EVAP VAPOR CUT VALVE"](#) .

OK or NG

OK >> GO TO 21.

NG >> Replace refueling EVAP vapor cut valve with fuel tank.

### 21. CHECK INTERMITTENT INCIDENT

---

Refer to [EC-129, "TROUBLE DIAGNOSIS FOR INTERMITTENT INCIDENT"](#) .

>> **INSPECTION END**

# DTC P0456 EVAP CONTROL SYSTEM

## DTC P0456 EVAP CONTROL SYSTEM

PFP:14950

### On Board Diagnosis Logic

ABS009I2

This diagnosis detects very small leaks in the EVAP line between fuel tank and EVAP canister purge volume control solenoid valve, using the intake manifold vacuum in the same way as conventional EVAP small leak diagnosis.

If ECM judges a leak which corresponds to a very small leak, the very small leak P0456 will be detected.

If ECM judges a leak equivalent to a small leak, EVAP small leak P0442 will be detected.

If ECM judges there are no leaks, the diagnosis will be OK.

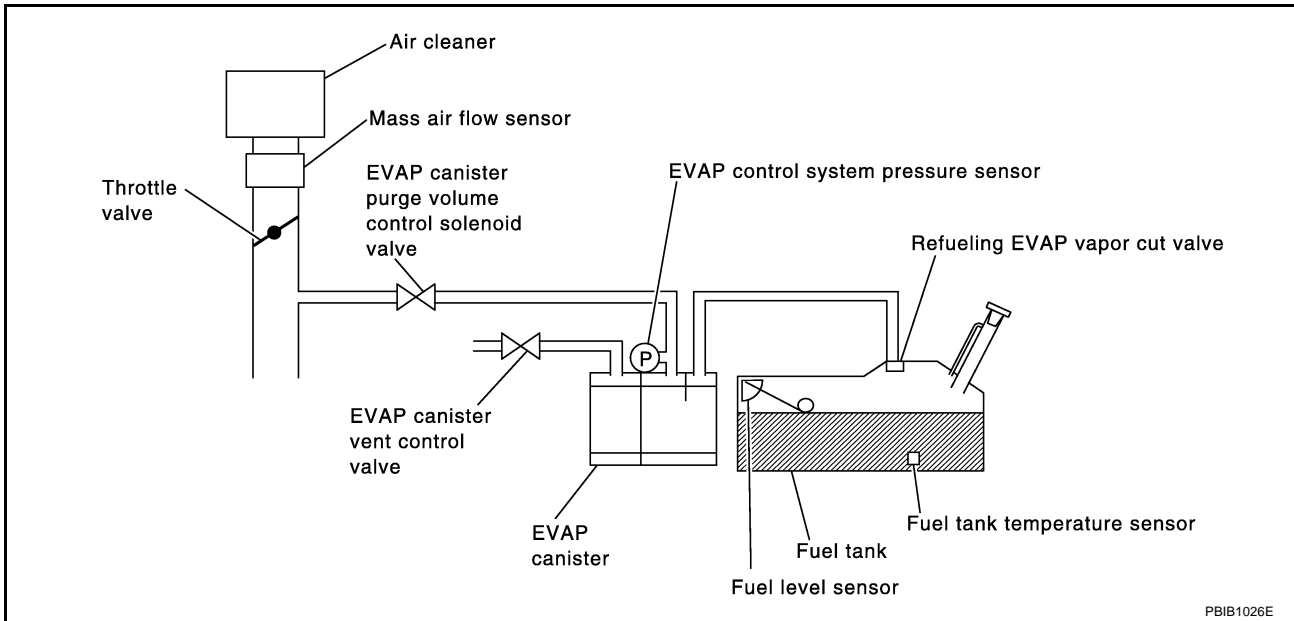

PBIB1026E

DTC No.	Trouble diagnosis name	DTC detecting condition	Possible cause
P0456 0456	Evaporative emission control system very small leak (negative pressure check)	<ul style="list-style-type: none"> <li>● EVAP system has a very small leak.</li> <li>● EVAP system does not operate properly.</li> </ul>	<ul style="list-style-type: none"> <li>● Incorrect fuel tank vacuum relief valve</li> <li>● Incorrect fuel filler cap used</li> <li>● Fuel filler cap remains open or fails to close.</li> <li>● Foreign matter caught in fuel filler cap.</li> <li>● Leak is in line between intake manifold and EVAP canister purge volume control solenoid valve.</li> <li>● Foreign matter caught in EVAP canister vent control valve.</li> <li>● EVAP canister or fuel tank leaks</li> <li>● EVAP purge line (pipe and rubber tube) leaks</li> <li>● EVAP purge line rubber tube bent</li> <li>● Loose or disconnected rubber tube</li> <li>● EVAP canister vent control valve and the circuit</li> <li>● EVAP canister purge volume control solenoid valve and the circuit</li> <li>● Fuel tank temperature sensor</li> <li>● O-ring of EVAP canister vent control valve is missing or damaged</li> <li>● EVAP canister is saturated with water</li> <li>● EVAP control system pressure sensor</li> <li>● Refueling EVAP vapor cut valve</li> <li>● ORVR system leaks</li> <li>● Fuel level sensor and the circuit</li> <li>● Foreign matter caught in EVAP canister purge volume control solenoid valve</li> </ul>

# DTC P0456 EVAP CONTROL SYSTEM

## CAUTION:

- Use only a genuine NISSAN fuel filler cap as a replacement. If an incorrect fuel filler cap is used, the MIL may come on.
- If the fuel filler cap is not tightened properly, the MIL may come on.
- Use only a genuine NISSAN rubber tube as a replacement.

## DTC Confirmation Procedure

ABS009/3

### NOTE:

- If DTC P0456 is displayed with P0442, first perform trouble diagnosis for DTC P0456.
- After repair, make sure that the hoses and clips are installed properly.
- If DTC Confirmation Procedure has been previously conducted, always turn ignition switch OFF and wait at least 10 seconds before conducting the next test.

### TESTING CONDITION:

- Open engine hood before conducting following procedure.
- If any of following conditions are met just before the DTC confirmation procedure, leave the vehicle for more than 1 hour.
  - Fuel filler cap is removed.
  - Refilled or drained the fuel.
  - EVAP component parts is/are removed.
- Before performing the following procedure, confirm that battery voltage is more than 11V at idle.

### WITH CONSULT-II

1. Turn ignition switch ON and select "DATA MONITOR" mode with CONSULT-II.

2. Make sure the following conditions are met.

**FUEL LEVEL SE: 0.25 - 1.4V**

**COOLAN TEMP/S: 0 - 32°C (32 - 90°F)**

**FUEL T/TMP SE: 0 - 35°C (32 - 95°F)**

**INT/A TEMP SE: More than 0°C (32°F)**

If NG, turn ignition switch OFF and leave the vehicle in a cool place (soak the vehicle) or refilling/draining fuel until the output voltage condition of the "FUEL LEVEL SE" meets within the range above and leave the vehicle for more than 1 hour. Then start from step 1).

DATA MONITOR	
MONITOR	DTC
ENG SPEED	XXX rpm
COOLAN TEMP/S	XXX °C
INT/A TEMP SE	XXX °C
FUEL LEVEL SE	XXX V
FUEL T/TEMP SE	XXX °C

PBIB2870E

3. Turn ignition switch OFF and wait at least 10 seconds.

4. Turn ignition switch ON.

5. Select "EVAP V/S LEAK P0456/P1456" of "EVAPORATIVE SYSTEM" in "DTC WORK SUPPORT" mode with CONSULT-II.

Follow the instruction displayed.

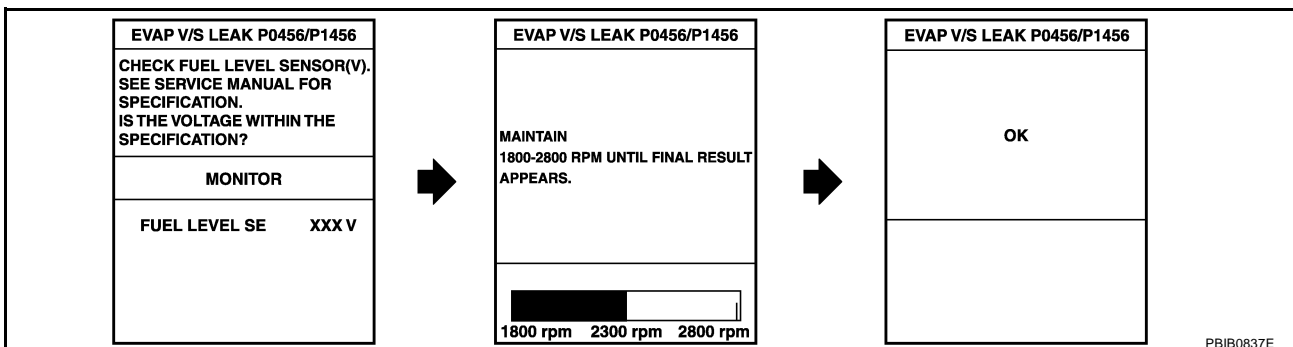

6. Make sure that "OK" is displayed. If "NG" is displayed, refer to [EC-350, "Diagnostic Procedure"](#).

### NOTE:

- If the engine speed cannot be maintained within the range displayed on CONSULT-II screen, go to [EC-78, "Basic Inspection"](#).

# DTC P0456 EVAP CONTROL SYSTEM

- Make sure that EVAP hoses are connected to EVAP canister purge volume control solenoid valve properly.

## Overall Function Check

ABS009/4

### WITH GST

Use this procedure to check the overall function of the EVAP very small leak function. During this check, a 1st trip DTC might not be confirmed.

#### CAUTION:

- Never use compressed air, doing so may damage the EVAP system.
- Do not start engine.
- Do not exceeded 4.12 kPa (0.042 kg/cm<sup>2</sup> , 0.6 psi).

1. Attach the EVAP service port adapter securely to the EVAP service port.

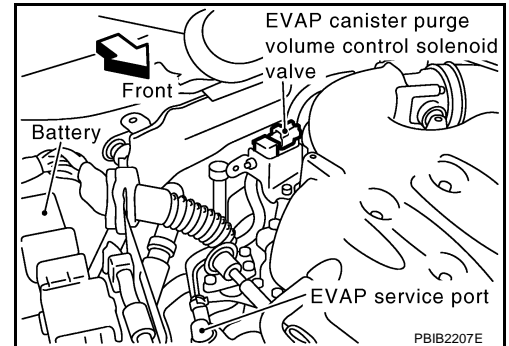

2. Set the pressure pump and a hose.
3. Also set a vacuum gauge via 3-way connector and a hose.
4. Turn ignition switch ON.
5. Connect GST and select "MODE 8".
6. Using "MODE 8" control the EVAP canister vent control valve (close).
7. Apply pressure and make sure the following conditions are satisfied.

**Pressure to be applied: 2.7 kPa (20 mmHg, 0.79 inHg)**

**Time to be waited after the pressure drawn in to the EVAP system and the pressure to be dropped: 60 seconds and the pressure should not be dropped more than 0.4 kPa (3 mmHg, 0.12 inHg).**

If NG, go to [EC-350, "Diagnostic Procedure"](#) .

If OK, go to next step.

8. Disconnect GST.
9. Start engine and warm it up to normal operating temperature.
10. Turn ignition switch OFF and wait at least 10 seconds.
11. Restart engine and let it idle for 90 seconds.
12. Keep engine speed at 2,000 rpm for 30 seconds.
13. Turn ignition switch OFF.

#### NOTE:

**For more information, refer to GST instruction manual.**

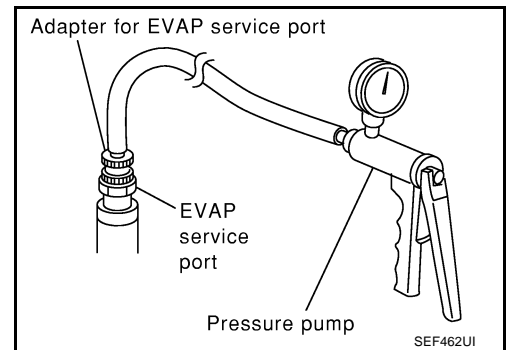

# DTC P0456 EVAP CONTROL SYSTEM

## Diagnostic Procedure

ABS009/5

### 1. CHECK FUEL FILLER CAP DESIGN

1. Turn ignition switch OFF.
2. Check for genuine NISSAN fuel filler cap design.

#### OK or NG

- OK >> GO TO 2.  
NG >> Replace with genuine NISSAN fuel filler cap.

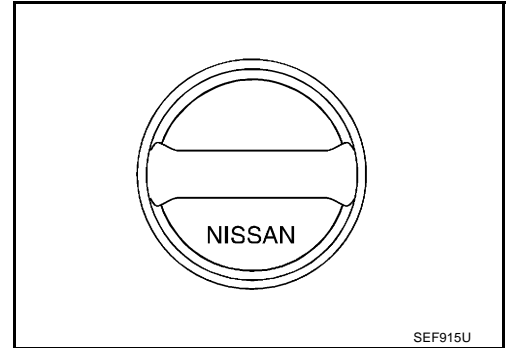

### 2. CHECK FUEL FILLER CAP INSTALLATION

Check that the cap is tightened properly by rotating the cap clockwise.

#### OK or NG

- OK >> GO TO 3.  
NG >> 1. Open fuel filler cap, then clean cap and fuel filler neck threads using air blower.  
2. Retighten until ratcheting sound is heard.

### 3. CHECK FUEL FILLER CAP FUNCTION

Check for air releasing sound while opening the fuel filler cap.

#### OK or NG

- OK >> GO TO 5.  
NG >> GO TO 4.

### 4. CHECK FUEL TANK VACUUM RELIEF VALVE

Refer to [EC-677, "FUEL TANK VACUUM RELIEF VALVE \(BUILT INTO FUEL FULLER CAP\)"](#).

#### OK or NG

- OK >> GO TO 5.  
NG >> Replace fuel filler cap with a genuine one.

# DTC P0456 EVAP CONTROL SYSTEM

## 5. INSTALL THE PRESSURE PUMP

To locate the EVAP leak, install EVAP service port adapter and pressure pump to EVAP service port securely. For the location of EVAP service port, refer to [EC-675, "EVAPORATIVE EMISSION LINE DRAWING"](#).

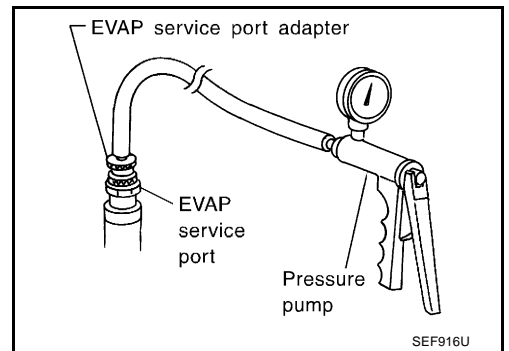
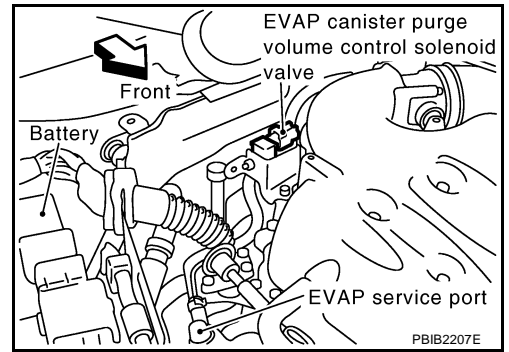

**NOTE:**

**Improper installation of the EVAP service port adapter to the EVAP service port may cause leaking.**

With CONSULT-II>>GO TO 6.  
Without CONSULT-II>>GO TO 7.

A  
EC  
C  
D  
E  
F  
G  
H  
I  
J  
K  
L  
M

# DTC P0456 EVAP CONTROL SYSTEM

## 6. CHECK FOR EVAP LEAK

### With CONSULT-II

1. Turn ignition switch ON.
2. Select "EVAP SYSTEM CLOSE" of "WORK SUPPORT" mode with CONSULT-II.
3. Touch "START" and apply pressure into the EVAP line until the pressure indicator reaches the middle of the bar graph.

#### CAUTION:

- Never use compressed air or a high pressure pump.
- Do not exceed 4.12 kPa (0.042 kg/cm<sup>2</sup> , 0.6 psi) of pressure in the system.

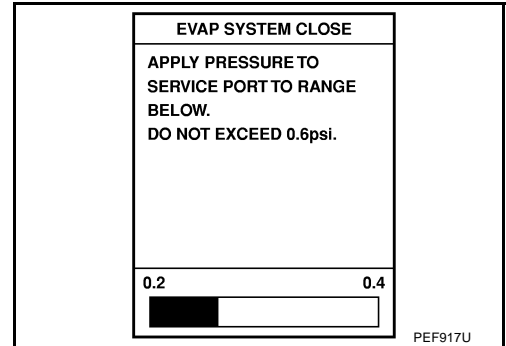

4. Using EVAP leak detector, locate the EVAP leak. For the leak detector, refer to the instruction manual for more details. Refer to [EC-675, "EVAPORATIVE EMISSION LINE DRAWING"](#)

#### OK or NG

- OK >> GO TO 8.  
NG >> Repair or replace.

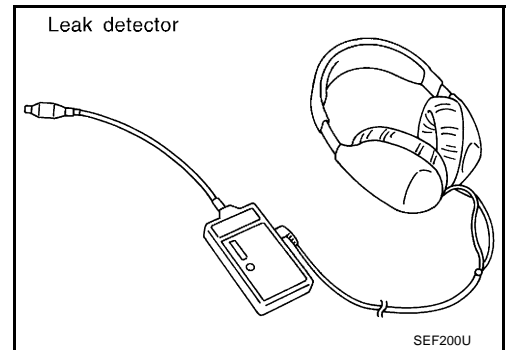



# DTC P0456 EVAP CONTROL SYSTEM

## 7. CHECK FOR EVAP LEAK

### ⊗ Without CONSULT-II

1. Turn ignition switch OFF.
2. Apply 12 volts DC to EVAP canister vent control valve. The valve will close. (Continue to apply 12 volts until the end of test.)

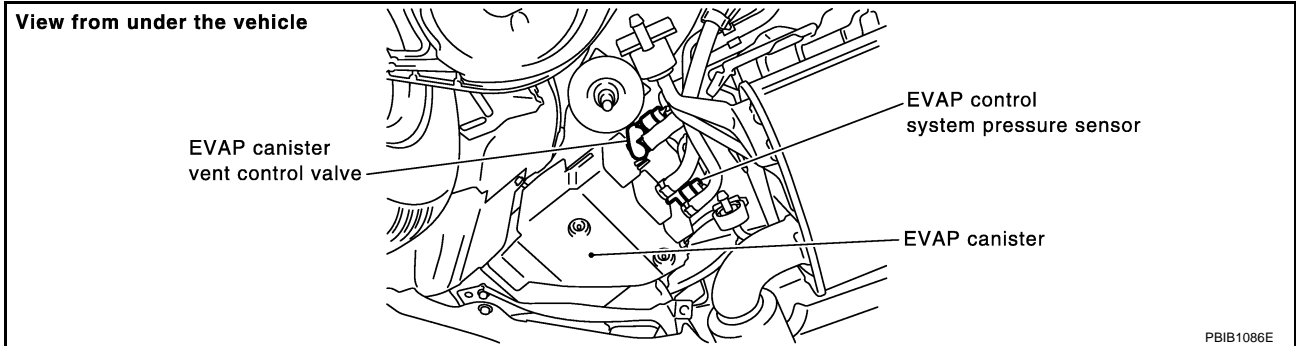

3. Pressurize the EVAP line using pressure pump with 1.3 to 2.7 kPa (10 to 20 mmHg, 0.39 to 0.79 inHg), then remove pump and EVAP service port adapter.

### CAUTION:

- Never use compressed air or a high pressure pump.
  - Do not exceed 4.12 kPa (0.042 kg/cm<sup>2</sup>, 0.6 psi) of pressure in the system.
4. Using EVAP leak detector, locate the EVAP leak. For the leak detector, refer to the instruction manual for more details. Refer to [EC-675, "EVAPORATIVE EMISSION LINE DRAWING"](#).

### OK or NG

- OK >> GO TO 8.  
NG >> Repair or replace.

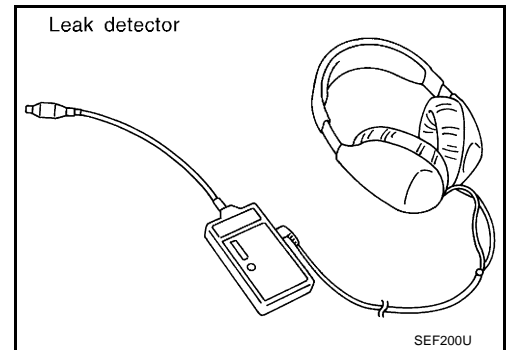

## 8. CHECK EVAP CANISTER VENT CONTROL VALVE

Check the following.

- EVAP canister vent control valve is installed properly. Refer to [EC-678, "Removal and Installation"](#).
- EVAP canister vent control valve. Refer to [EC-315, "Component Inspection"](#).

### OK or NG

- OK >> GO TO 9.  
NG >> Repair or replace EVAP canister vent control valve and O-ring.

# DTC P0456 EVAP CONTROL SYSTEM

## 9. CHECK IF EVAP CANISTER SATURATED WITH WATER

1. Remove EVAP canister with EVAP canister vent control valve and EVAP control system pressure sensor attached.
2. Does water drain from the EVAP canister?

Yes or No

Yes >> GO TO 10.

No (With CONSULT-II)>>GO TO 12.

No (Without CONSULT-II)>>GO TO 13.

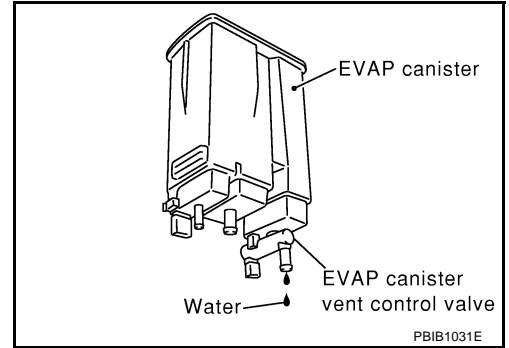

## 10. CHECK EVAP CANISTER

Weigh the EVAP canister with the EVAP canister vent control valve and EVAP control system pressure sensor attached.

**The weight should be less than 2.2 kg (4.9 lb).**

OK or NG

OK (With CONSULT-II)>>GO TO 12.

OK (Without CONSULT-II)>>GO TO 13.

NG >> GO TO 11.

## 11. DETECT MALFUNCTIONING PART

Check the following.

- EVAP canister for damage
- EVAP hose between EVAP canister and vehicle frame for clogging or poor connection

>> Repair hose or replace EVAP canister.

## 12. CHECK EVAP CANISTER PURGE VOLUME CONTROL SOLENOID VALVE OPERATION

Ⓟ With CONSULT-II

1. Disconnect vacuum hose to EVAP canister purge volume control solenoid valve at EVAP service port.
2. Start engine.
3. Perform "PURG VOL CONT/V" in "ACTIVE TEST" mode.
4. Touch "Qu" on CONSULT-II screen to increase "PURG VOL CONT/V" opening to 100%.
5. Check vacuum hose for vacuum when revving engine up to 2,000 rpm.

OK or NG

OK >> GO TO 15.

NG >> GO TO 14.

ACTIVE TEST	
PURG VOL CONT/V	XXX %
MONITOR	
ENG SPEED	XXX rpm
A/F ALPHA-B1	XX %
A/F ALPHA-B2	XX %

PBIB1678E

# DTC P0456 EVAP CONTROL SYSTEM

---

## 13. CHECK EVAP CANISTER PURGE VOLUME CONTROL SOLENOID VALVE OPERATION

---

⊗ Without CONSULT-II

1. Start engine and warm it up to normal operating temperature.
2. Stop engine.
3. Disconnect vacuum hose to EVAP canister purge volume control solenoid valve at EVAP service port.
4. Start engine and let it idle for at least 80 seconds.
5. Check vacuum hose for vacuum when revving engine up to 2,000 rpm.

OK or NG

OK >> GO TO 16.

NG >> GO TO 14.

---

## 14. CHECK VACUUM HOSE

---

Check vacuum hoses for clogging or disconnection. Refer to [EC-23, "Vacuum Hose Drawing"](#) .

OK or NG

OK >> GO TO 15.

NG >> Repair or reconnect the hose.

---

## 15. CHECK EVAP CANISTER PURGE VOLUME CONTROL SOLENOID VALVE

---

Refer to [EC-306, "Component Inspection"](#) .

OK or NG

OK >> GO TO 16.

NG >> Replace EVAP canister purge volume control solenoid valve.

---

## 16. CHECK FUEL TANK TEMPERATURE SENSOR

---

Refer to [EC-242, "Component Inspection"](#) .

OK or NG

OK >> GO TO 17.

NG >> Replace fuel level sensor unit.

---

## 17. CHECK EVAP CONTROL SYSTEM PRESSURE SENSOR

---

Refer to [EC-328, "Component Inspection"](#) .

OK or NG

OK >> GO TO 18.

NG >> Replace EVAP control system pressure sensor.

---

## 18. CHECK EVAP PURGE LINE

---

Check EVAP purge line (pipe, rubber tube, fuel tank and EVAP canister) for cracks or improper connection. Refer to [EC-675, "EVAPORATIVE EMISSION LINE DRAWING"](#) .

OK or NG

OK >> GO TO 19.

NG >> Repair or reconnect the hose.

---

## 19. CLEAN EVAP PURGE LINE

---

Clean EVAP purge line (pipe and rubber tube) using air blower.

>> GO TO 20.

A

EC

C

D

E

F

G

H

I

J

K

L

M

# DTC P0456 EVAP CONTROL SYSTEM

---

## 20. CHECK EVAP/ORVR LINE

---

Check EVAP/ORVR line between EVAP canister and fuel tank for clogging, kink, looseness and improper connection. For location, refer to [EC-681, "ON BOARD REFUELING VAPOR RECOVERY \(ORVR\)"](#) .

OK or NG

OK >> GO TO 21.

NG >> Repair or replace hoses and tubes.

## 21. CHECK RECIRCULATION LINE

---

Check recirculation line between filler neck tube and fuel tank for clogging, kink, cracks, looseness and improper connection.

OK or NG

OK >> GO TO 22.

NG >> Repair or replace hose, tube or filler neck tube.

## 22. CHECK REFUELING EVAP VAPOR CUT VALVE

---

Refer to [EC-684, "Component Inspection"](#) .

OK or NG

OK >> GO TO 23.

NG >> Replace refueling EVAP vapor cut valve with fuel tank.

## 23. CHECK FUEL LEVEL SENSOR

---

Refer to [DI-27, "FUEL LEVEL SENSOR UNIT CHECK"](#) .

OK or NG

OK >> GO TO 24.

NG >> Replace fuel level sensor unit.

## 24. CHECK INTERMITTENT INCIDENT

---

Refer to [EC-129, "TROUBLE DIAGNOSIS FOR INTERMITTENT INCIDENT"](#) .

>> **INSPECTION END**

# DTC P0460 FUEL LEVEL SENSOR

## DTC P0460 FUEL LEVEL SENSOR

PFP:25060

### Component Description

ABS00916

The fuel level sensor is mounted in the fuel level sensor unit. The sensor detects a fuel level in the fuel tank and transmits a signal to the “unified meter and A/C amp.”. The “unified meter and A/C amp.” sends the fuel level sensor signal to the ECM through CAN communication line.

It consists of two parts, one is mechanical float and the other is variable resistor. Fuel level sensor output voltage changes depending on the movement of the fuel mechanical float.

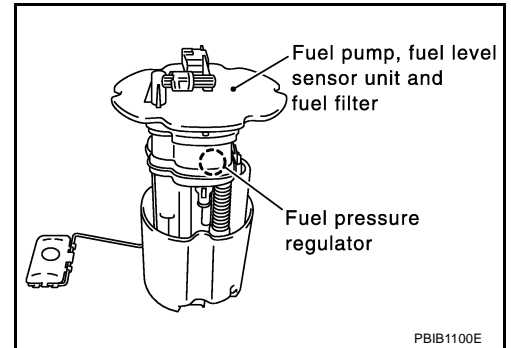

### On Board Diagnosis Logic

ABS00917

#### NOTE:

If DTC P0460 is displayed with DTC U1000 or U1001, first perform the trouble diagnosis for DTC U1000, U1001. Refer to [EC-139, "DTC U1000, U1001 CAN COMMUNICATION LINE"](#).

When the vehicle is parked, naturally the fuel level in the fuel tank is stable. It means that output signal of the fuel level sensor does not change. If ECM senses sloshing signal from the sensor, fuel level sensor malfunction is detected.

DTC No.	Trouble diagnosis name	DTC detecting condition	Possible cause
P0460 0460	Fuel level sensor circuit noise	Even though the vehicle is parked, a signal being varied is sent from the fuel level sensor to ECM.	<ul style="list-style-type: none"> <li>● Harness or connectors (The CAN communication line is open or shorted)</li> <li>● Harness or connectors (The sensor circuit is open or shorted)</li> <li>● Unified meter and A/C amp.</li> <li>● Fuel level sensor</li> </ul>

### DTC Confirmation Procedure

ABS00918

#### NOTE:

If DTC Confirmation Procedure has been previously conducted, always turn ignition switch OFF and wait at least 10 seconds before conducting the next test.

#### ① WITH CONSULT-II

1. Turn ignition switch ON.
2. Select “DATA MONITOR” mode with CONSULT-II.
3. Start engine and wait maximum of 2 consecutive minutes.
4. If 1st trip DTC is detected, go to [EC-358, "Diagnostic Procedure"](#)

DATA MONITOR	
MONITOR	NO DTC
FUEL T/TMP SE	XXX °C
FUEL LEVEL SE	XXX V

SEF195Y

#### ② WITH GST

Follow the procedure “WITH CONSULT-II” above.

# DTC P0460 FUEL LEVEL SENSOR

---

## Diagnostic Procedure

ABS00919

### 1. CHECK FUEL GAUGE OPERATION

---

Refer to [DI-13, "Meter/Gauges Operation and Odo/Trip Meter"](#) .

OK or NG

OK >> GO TO 2.

NG >> Follow the instruction of [DI-13, "Meter/Gauges Operation and Odo/Trip Meter"](#) .

### 2. CHECK FUEL LEVEL SENSOR AND CIRCUIT

---

Refer to [DI-21, "Fuel Level Sensor Signal Inspection"](#) .

OK or NG

OK >> GO TO 3.

NG >> Repair or replace malfunctioning parts.

### 3. CHECK INTERMITTENT INCIDENT

---

Refer to [EC-129, "TROUBLE DIAGNOSIS FOR INTERMITTENT INCIDENT"](#) .

>> INSPECTION END

## Removal and Installation FUEL LEVEL SENSOR

ABS0091A

Refer to [FL-4, "FUEL LEVEL SENSOR UNIT, FUEL FILTER AND FUEL PUMP ASSEMBLY"](#) .

# DTC P0461 FUEL LEVEL SENSOR

## DTC P0461 FUEL LEVEL SENSOR

PFP:25060

### Component Description

ABS0091B

The fuel level sensor is mounted in the fuel level sensor unit. The sensor detects a fuel level in the fuel tank and transmits a signal to the “unified meter and A/C amp.”. The “unified meter and A/C amp.” sends the fuel level sensor signal to the ECM through CAN communication line.

It consists of two parts, one is mechanical float and the other is variable resistor. Fuel level sensor output voltage changes depending on the movement of the fuel mechanical float.

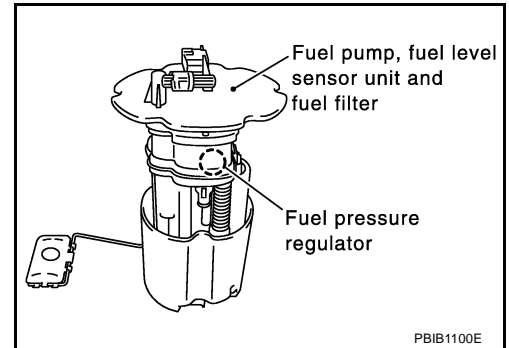

### On Board Diagnosis Logic

ABS0091C

#### NOTE:

If DTC P0461 is displayed with DTC U1000 or U1001, first perform the trouble diagnosis for DTC U1000, U1001. Refer to [EC-139, "DTC U1000, U1001 CAN COMMUNICATION LINE"](#).

Driving long distances naturally affect fuel gauge level.

This diagnosis detects the fuel gauge malfunction of the gauge not moving even after a long distance has been driven.

DTC No.	Trouble diagnosis name	DTC detecting condition	Possible cause
P0461 0461	Fuel level sensor circuit range/performance	The output signal of the fuel level sensor does not change within the specified range even though the vehicle has been driven a long distance.	<ul style="list-style-type: none"><li>● Harness or connectors (The CAN communication line is open or shorted)</li><li>● Harness or connectors (The sensor circuit is open or shorted)</li><li>● Unified meter and A/C amp.</li><li>● Fuel level sensor</li></ul>

### Overall Function Check

ABS0091D

Use this procedure to check the overall function of the fuel level sensor function. During this check, a 1st trip DTC might not be confirmed.

#### WARNING:

When performing following procedure, be sure to observe the handling of the fuel. Refer to [FL-10, "FUEL TANK"](#).

#### TESTING CONDITION:

Before starting overall function check, preparation of draining fuel and refilling fuel is required.

#### ⓘ WITH CONSULT-II

#### NOTE:

Start from step 10, if it is possible to confirm that the fuel cannot be drained by 30 ℓ (7-7/8 US gal, 6-5/8 Imp gal) in advance.

1. Prepare a fuel container and a spare hose.
2. Release fuel pressure from fuel line, refer to [EC-45, "FUEL PRESSURE RELEASE"](#).
3. Remove the fuel feed hose on the fuel level sensor unit.
4. Connect a spare fuel hose where the fuel feed hose was removed.
5. Turn ignition switch OFF and wait at least 10 seconds then turn ON.
6. Select “FUEL LEVEL SE” in “DATA MONITOR” mode with CONSULT-II.

# DTC P0461 FUEL LEVEL SENSOR

7. Check "FUEL LEVEL SE" output voltage and note it.
8. Select "FUEL PUMP" in "ACTIVE TEST" mode with CONSULT-II.
9. Touch "ON" and drain fuel approximately 30 ℓ (7-7/8 US gal, 6-5/8 Imp gal) and stop it.
10. Check "FUEL LEVEL SE" output voltage and note it.
11. Fill fuel into the fuel tank for 30 ℓ (7-7/8 US gal, 6-5/8 Imp gal).
12. Check "FUEL LEVEL SE" output voltage and note it.
13. Confirm whether the voltage changes more than 0.03V during step 7 to 10 and 10 to 12.  
If NG, go to [EC-360, "Diagnostic Procedure"](#).

DATA MONITOR	
MONITOR	NO DTC
FUEL T/TMP SE	XXX °C
FUEL LEVEL SE	XXX V

SEF195Y

## WITH GST

### NOTE:

Start from step 8, if it is possible to confirm that the fuel cannot be drained by 30 ℓ (7-7/8 US gal, 6-5/8 Imp gal) in advance.

1. Prepare a fuel container and a spare hose.
2. Release fuel pressure from fuel line. Refer to [EC-45, "FUEL PRESSURE RELEASE"](#).
3. Remove the fuel feed hose on the fuel level sensor unit.
4. Connect a spare fuel hose where the fuel feed hose was removed.
5. Turn ignition switch ON.
6. Drain fuel by 30 ℓ (7-7/8 US gal, 6-5/8 Imp gal) from the fuel tank using proper equipment.
7. Confirm that the fuel gauge indication varies.
8. Fill fuel into the fuel tank for 30 ℓ (7-7/8 US gal, 6-5/8 Imp gal).
9. Confirm that the fuel gauge indication varies.
10. If NG, go to [EC-360, "Diagnostic Procedure"](#).

## Diagnostic Procedure

ABS009IE

### 1. CHECK FUEL GAUGE OPERATION

Refer to [DI-13, "Meter/Gauges Operation and Odo/Trip Meter"](#).

OK or NG

OK >> GO TO 2.

NG >> Follow the instruction of [DI-13, "Meter/Gauges Operation and Odo/Trip Meter"](#).

### 2. CHECK FUEL LEVEL SENSOR AND CIRCUIT

Refer to [DI-21, "Fuel Level Sensor Signal Inspection"](#).

OK or NG

OK >> GO TO 3.

NG >> Repair or replace malfunctioning parts.

### 3. CHECK INTERMITTENT INCIDENT

Refer to [EC-129, "TROUBLE DIAGNOSIS FOR INTERMITTENT INCIDENT"](#).

>> INSPECTION END

## Removal and Installation FUEL LEVEL SENSOR

ABS009IF

Refer to [FL-4, "FUEL LEVEL SENSOR UNIT, FUEL FILTER AND FUEL PUMP ASSEMBLY"](#)



# DTC P0462, P0463 FUEL LEVEL SENSOR

## DTC P0462, P0463 FUEL LEVEL SENSOR

PF2:25060

### Component Description

ABS00ALW

The fuel level sensor is mounted in the fuel level sensor unit. The sensor detects a fuel level in the fuel tank and transmits a signal to the combination meter. The combination meter sends the fuel level sensor signal to the ECM through CAN communication line. It consists of two parts, one is mechanical float and the other is variable resistor. Fuel level sensor output voltage changes depending on the movement of the fuel mechanical float.

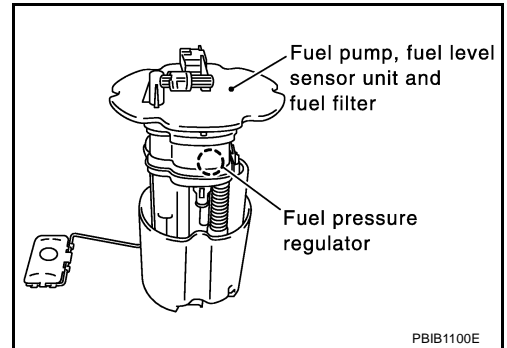

### On Board Diagnosis Logic

ABS00ALW

#### NOTE:

If DTC P0462 or P0463 is displayed with DTC U1000 or U1001, first perform the trouble diagnosis for DTC U1000, U1001. Refer to [EC-139, "DTC U1000, U1001 CAN COMMUNICATION LINE"](#).

This diagnosis indicates the former, to detect open or short circuit malfunction.

DTC No.	Trouble diagnosis name	DTC detecting condition	Possible cause
P0462 0462	Fuel level sensor circuit low input	An excessively low voltage is sent from the sensor is sent to ECM.	<ul style="list-style-type: none"> <li>● Harness or connectors (The CAN communication line is open or shorted)</li> <li>● Harness or connectors (The sensor circuit is open or shorted)</li> <li>● Unified meter and A/C amp.</li> <li>● Fuel level sensor</li> </ul>
P0463 0463	Fuel level sensor circuit high input	An excessively high voltage is sent from the sensor is sent to ECM.	

### DTC Confirmation Procedure

ABS00ALX

#### NOTE:

If DTC Confirmation Procedure has been previously conducted, always turn ignition switch OFF and wait at least 10 seconds before conducting the next test.

#### TESTING CONDITION:

Before performing the following procedure, confirm that battery voltage is more than 11V at ignition switch ON.

#### WITH CONSULT-II

1. Turn ignition switch ON.
2. Select "DATA MONITOR" mode with CONSULT-II.
3. Wait at least 5 seconds.
4. If 1st trip DTC is detected, go to [EC-362, "Diagnostic Procedure"](#).

DATA MONITOR	
MONITOR	NO DTC
FUEL T/TMP SE	XXX °C
FUEL LEVEL SE	XXX V

SEF195Y

#### WITH GST

Follow the procedure "WITH CONSULT-II" above.

# DTC P0462, P0463 FUEL LEVEL SENSOR

---

## Diagnostic Procedure

ABS00ALY

### 1. CHECK FUEL GAUGE OPERATION

---

Refer to [DI-13, "Meter/Gauges Operation and Odo/Trip Meter"](#) .

OK or NG

OK >> GO TO 2.

NG >> Follow the instruction of [DI-13, "Meter/Gauges Operation and Odo/Trip Meter"](#) .

### 2. CHECK FUEL LEVEL SENSOR AND CIRCUIT

---

Refer to [DI-21, "Fuel Level Sensor Signal Inspection"](#) .

OK or NG

OK >> GO TO 3.

NG >> Repair or replace malfunctioning parts.

### 3. CHECK INTERMITTENT INCIDENT

---

Refer to [EC-129, "TROUBLE DIAGNOSIS FOR INTERMITTENT INCIDENT"](#) .

>> INSPECTION END

## Removal and Installation FUEL LEVEL SENSOR

ABS00ALZ

Refer to [FL-4, "FUEL LEVEL SENSOR UNIT, FUEL FILTER AND FUEL PUMP ASSEMBLY"](#) .

# DTC P0500 VSS

## DTC P0500 VSS

PF3:32702

### Description

ABS009IL

#### NOTE:

If DTC P0500 is displayed with DTC U1000 or U1001, first perform the trouble diagnosis for DTC U1000, U1001. Refer to [EC-139, "DTC U1000, U1001 CAN COMMUNICATION LINE"](#).

The vehicle speed signal is sent to the "unified meter and A/C amp". from the VDC/TCS/ABS control unit (models with VDC) or "ABS actuator and electric unit (control unit)" by CAN communication line. The unified meter and A/C amp. then sends the signal to the ECM by CAN communication line.

### On Board Diagnosis Logic

ABS009IM

DTC No.	Trouble diagnosis name	DTC detecting condition	Possible cause
P0500 0500	Vehicle speed sensor	The almost 0 km/h (0 MPH) signal from vehicle speed sensor is sent to ECM even when vehicle is being driven.	<ul style="list-style-type: none"> <li>● Harness or connectors (The CAN communication line is open or shorted)</li> <li>● Harness or connectors (The vehicle speed signal circuit is open or shorted)</li> <li>● Wheel sensor</li> <li>● Unified meter and A/C amp.</li> <li>● VDC/TCS/ABS control unit (models with VDC)</li> <li>● ABS actuator and electric unit (control unit) (models without VDC)</li> </ul>

### DTC Confirmation Procedure

ABS009IN

#### CAUTION:

Always drive vehicle at a safe speed.

#### NOTE:

If DTC Confirmation Procedure has been previously conducted, always turn ignition switch OFF and wait at least 10 seconds before conducting the next test.

#### TESTING CONDITION:

Steps 1 and 2 may be conducted with the drive wheels lifted in the shop or by driving the vehicle. If a road test is expected to be easier, it is unnecessary to lift the vehicle.

#### WITH CONSULT-II

1. Start engine (VDC switch or TCS switch OFF).
2. Read "VHCL SPEED SE" in "DATA MONITOR" mode with CONSULT-II. The vehicle speed on CONSULT-II should exceed 10 km/h (6 MPH) when rotating wheels with suitable gear position.  
If NG, go to [EC-364, "Diagnostic Procedure"](#).  
If OK, go to following step.
3. Select "DATA MONITOR" mode with CONSULT-II.
4. Warm engine up to normal operating temperature.
5. Maintain the following conditions for at least 60 consecutive seconds.

ENG SPEED	1,600 - 6,000 rpm
COOLAN TEMP/S	More than 70°C (158°F)
B/FUEL SCHDL	5.5 - 31.8 msec
Shift lever	Except P or N position (A/T), Neutral position (M/T)
PW/ST SIGNAL	OFF

6. If 1st trip DTC is detected, go to [EC-364, "Diagnostic Procedure"](#)

DATA MONITOR	
MONITOR	NO DTC
ENG SPEED	XXX rpm
COOLAN TEMP/S	XXX °C
B/FUEL SCHDL	XXX msec
PW/ST SIGNAL	OFF
VHCL SPEED SE	XXX km/h

SEF196Y

---

## Overall Function Check

ABS00910

Use this procedure to check the overall function of the vehicle speed sensor circuit. During this check, a 1st trip DTC might not be confirmed.

### WITH GST

1. Lift up drive wheels.
2. Start engine.
3. Read vehicle speed sensor signal in "MODE 1" with GST.  
The vehicle speed sensor on GST should be able to exceed 10 km/h (6 MPH) when rotating wheels with suitable gear position.
4. If NG, go to [EC-364, "Diagnostic Procedure"](#) .

## Diagnostic Procedure

ABS0091P

### 1. CHECK DTC WITH "VDC/TCS/ABS CONTROL UNIT (MODELS WITH VDC)" OR "ABS ACTUATOR AND ELECTRIC UNIT (CONTROL UNIT) (MODELS WITHOUT VDC)"

Refer to [BRC-94, "TROUBLE DIAGNOSIS"](#) (models with VDC) or refer to [BRC-46, "TROUBLE DIAGNOSIS"](#) (models without VDC).

OK or NG

- OK >> GO TO 2.  
NG >> Repair or replace.

### 2. CHECK DTC WITH UNIFIED METER AND A/C AMP.

Refer to [DI-4, "COMBINATION METERS"](#) .

>> INSPECTION END

# DTC P0506 ISC SYSTEM

## DTC P0506 ISC SYSTEM

PFP:23781

### Description

ABS009IQ

#### NOTE:

If DTC P0506 is displayed with other DTC, first perform the trouble diagnosis for the other DTC.

The ECM controls the engine idle speed to a specified level through the fine adjustment of the air, which is let into the intake manifold, by operating the electric throttle control actuator. The operating of the throttle valve is varied to allow for optimum control of the engine idling speed. The crankshaft position sensor (POS) detects the actual engine speed and sends a signal to the ECM.

The ECM controls the electric throttle control actuator so that the engine speed coincides with the target value memorized in the ECM. The target engine speed is the lowest speed at which the engine can operate steadily. The optimum value stored in the ECM is determined by taking into consideration various engine conditions, such as during warming up, deceleration, and engine load (air conditioner, power steering and cooling fan operation, etc.).

### On Board Diagnosis Logic

ABS009IR

DTC No.	Trouble diagnosis name	DTC detecting condition	Possible cause
P0506 0506	Idle speed control system RPM lower than expected	The idle speed is less than the target idle speed by 100 rpm or more.	<ul style="list-style-type: none"><li>● Electric throttle control actuator</li><li>● Intake air leak</li></ul>

### DTC Confirmation Procedure

ABS009IS

#### NOTE:

- If DTC Confirmation Procedure has been previously conducted, always turn ignition switch OFF and wait at least 10 seconds before conducting the next test.
- If the target idle speed is out of the specified value, perform [EC-43, "Idle Air Volume Learning"](#), before conducting DTC Confirmation Procedure. For the target idle speed, refer to [EC-690, "SERVICE DATA AND SPECIFICATIONS \(SDS\)"](#).

#### TESTING CONDITION:

- Before performing the following procedure, confirm that battery voltage is more than 11V at idle.
- Always perform the test at a temperature above  $-10^{\circ}\text{C}$  ( $14^{\circ}\text{F}$ ).

#### WITH CONSULT-II

1. Open engine hood.
2. Start engine and warm it up to normal operating temperature.
3. Turn ignition switch OFF and wait at least 10 seconds.
4. Turn ignition switch ON again and select "DATA MONITOR" mode with CONSULT-II.
5. Start engine and run it for at least 1 minute at idle speed.
6. If 1st trip DTC is detected, go to [EC-366, "Diagnostic Procedure"](#)

DATA MONITOR	
MONITOR	NO DTC
ENG SPEED	XXX rpm
COOLAN TEMP/S	XXX °C

SEP174Y

#### WITH GST

Follow the procedure "WITH CONSULT-II" above.

# DTC P0506 ISC SYSTEM

---

## Diagnostic Procedure

ABS009IT

### 1. CHECK INTAKE AIR LEAK

---

1. Start engine and let it idle.
2. Listen for an intake air leak after the mass air flow sensor.

OK or NG

- OK >> GO TO 2.
- NG >> Discover air leak location and repair.

### 2. REPLACE ECM

---

1. Stop engine.
2. Replace ECM.
3. Perform initialization of NVIS (NATS) system and registration of all NVIS (NATS) ignition key IDs. Refer to [BL-160, "ECM Re-communicating Function"](#) .
4. Perform [EC-42, "VIN Registration"](#) .
5. Perform [EC-42, "Accelerator Pedal Released Position Learning"](#) .
6. Perform [EC-42, "Throttle Valve Closed Position Learning"](#) .
7. Perform [EC-43, "Idle Air Volume Learning"](#) .

>> INSPECTION END

# DTC P0507 ISC SYSTEM

## DTC P0507 ISC SYSTEM

PF:23781

### Description

ABS009IU

#### NOTE:

If DTC P0507 is displayed with other DTC, first perform the trouble diagnosis for the other DTC.

The ECM controls the engine idle speed to a specified level through the fine adjustment of the air, which is let into the intake manifold, by operating the electric throttle control actuator. The operating of the throttle valve is varied to allow for optimum control of the engine idling speed. The crankshaft position sensor (POS) detects the actual engine speed and sends a signal to the ECM.

The ECM controls the electric throttle control actuator so that the engine speed coincides with the target value memorized in the ECM. The target engine speed is the lowest speed at which the engine can operate steadily. The optimum value stored in the ECM is determined by taking into consideration various engine conditions, such as during warming up, deceleration, and engine load (air conditioner, power steering and cooling fan operation, etc.).

### On Board Diagnosis Logic

ABS009IV

DTC No.	Trouble diagnosis name	DTC detecting condition	Possible cause
P0507 0507	Idle speed control system RPM higher than expected	The idle speed is more than the target idle speed by 200 rpm or more.	<ul style="list-style-type: none"> <li>● Electric throttle control actuator</li> <li>● Intake air leak</li> <li>● PCV system</li> </ul>

### DTC Confirmation Procedure

ABS009IW

#### NOTE:

- If DTC Confirmation Procedure has been previously conducted, always turn ignition switch OFF and wait at least 10 seconds before conducting the next test.
- If the target idle speed is out of the specified value, perform [EC-43, "Idle Air Volume Learning"](#), before conducting DTC Confirmation Procedure. For the target idle speed, refer to [EC-690, "SERVICE DATA AND SPECIFICATIONS \(SDS\)"](#).

#### TESTING CONDITION:

- Before performing the following procedure, confirm that battery voltage is more than 11V at idle.
- Always perform the test at a temperature above  $-10^{\circ}\text{C}$  ( $14^{\circ}\text{F}$ ).

#### WITH CONSULT-II

1. Open engine hood.
2. Start engine and warm it up to normal operating temperature.
3. Turn ignition switch OFF and wait at least 10 seconds.
4. Turn ignition switch ON again and select "DATA MONITOR" mode with CONSULT-II.
5. Start engine and run it for at least 1 minute at idle speed.
6. If 1st trip DTC is detected, go to [EC-368, "Diagnostic Procedure"](#).

DATA MONITOR	
MONITOR	NO DTC
ENG SPEED	XXX rpm
COOLAN TEMP/S	XXX °C

SEP174Y

#### WITH GST

Follow the procedure "WITH CONSULT-II" above.

---

## Diagnostic Procedure

ABS009IX

### 1. CHECK PCV HOSE CONNECTION

---

Confirm that PCV hose is connected correctly.

OK or NG

OK >> GO TO 2.

NG >> Repair or replace.

### 2. CHECK INTAKE AIR LEAK

---

1. Start engine and let it idle.
2. Listen for an intake air leak after the mass air flow sensor.

OK or NG

OK >> GO TO 3.

NG >> Discover air leak location and repair.

### 3. REPLACE ECM

---

1. Stop engine.
2. Replace ECM.
3. Perform initialization of NVIS (NATS) system and registration of all NVIS (NATS) ignition key IDs. Refer to [BL-160, "ECM Re-communicating Function"](#) .
4. Perform [EC-42, "VIN Registration"](#) .
5. Perform [EC-42, "Accelerator Pedal Released Position Learning"](#) .
6. Perform [EC-42, "Throttle Valve Closed Position Learning"](#) .
7. Perform [EC-43, "Idle Air Volume Learning"](#) .

>> **INSPECTION END**



# DTC P0550 PSP SENSOR

## DTC P0550 PSP SENSOR

PFP:49763

### Component Description

ABS0091Y

Power steering pressure (PSP) sensor is installed to the power steering high-pressure tube and detects a power steering load. This sensor is a potentiometer which transforms the power steering load into output voltage, and emits the voltage signal to the ECM. The ECM controls the electric throttle control actuator and adjusts the throttle valve opening angle to increase the engine speed and adjusts the idle speed for the increased load.

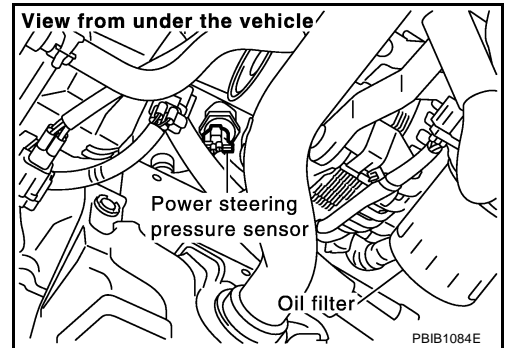

### CONSULT-II Reference Value in Data Monitor Mode

ABS0091Z

Specification data are reference values.

MONITOR ITEM	CONDITION		SPECIFICATION
PW/ST SIGNAL	<ul style="list-style-type: none"> <li>Engine: After warming up, idle the engine</li> </ul>	Steering wheel is being not turned. (Forward direction)	OFF
		Steering wheel is being turned.	ON

### On Board Diagnosis Logic

ABS00910

The MIL will not light up for this diagnosis.

#### NOTE:

If DTC P0550 is displayed with DTC P1229, first perform the trouble diagnosis for DTC P1229.

Refer to [EC-456](#).

DTC No.	Trouble diagnosis name	DTC detecting condition	Possible cause
P0550 0550	Power steering pressure sensor circuit	An excessively low or high voltage from the sensor is sent to ECM.	<ul style="list-style-type: none"> <li>Harness or connectors (The sensor circuit is open or shorted)</li> <li>Power steering pressure sensor</li> </ul>

### DTC Confirmation Procedure

ABS00911

#### NOTE:

If DTC Confirmation Procedure has been previously conducted, always turn ignition switch OFF and wait at least 10 seconds before conducting the next test.

#### Ⓟ WITH CONSULT-II

- Turn ignition switch ON.
- Select "DATA MONITOR" mode with CONSULT-II.
- Start engine and let it idle for at least 5 seconds.
- If 1st trip DTC is detected, go to [EC-371, "Diagnostic Procedure"](#).

#### Ⓢ WITH GST

Follow the procedure "WITH CONSULT-II" above.

# DTC P0550 PSP SENSOR

## Wiring Diagram

ABS009J2

### EC-PS/SEN-01

: DETECTABLE LINE FOR DTC  
 : NON-DETECTABLE LINE FOR DTC

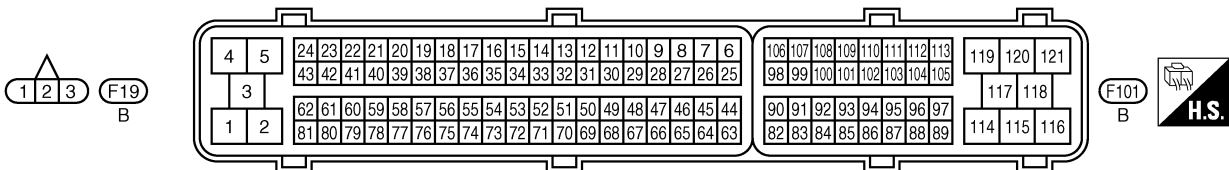
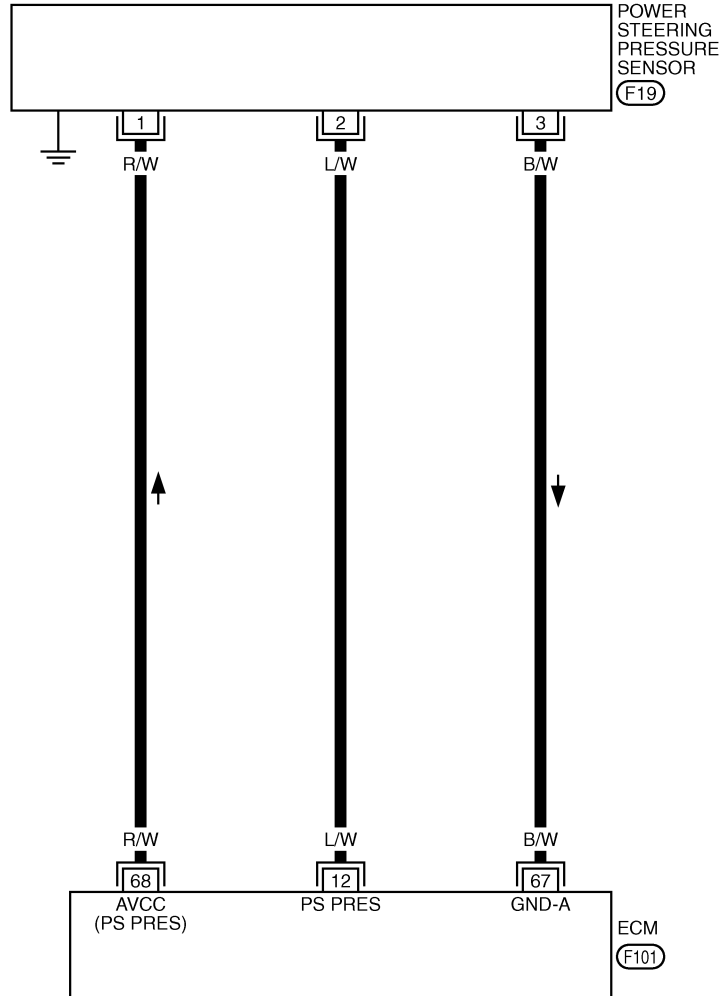

TBWT0494E

# DTC P0550 PSP SENSOR

Specification data are reference values and are measured between each terminal and ground.

**CAUTION:**

Do not use ECM ground terminals when measuring input/output voltage. Doing so may result in damage to the ECM's transistor. Use a ground other than ECM terminals, such as the ground.

TER-MINAL NO.	WIRE COLOR	ITEM	CONDITION	DATA (DC Voltage)
12	L/W	Power steering pressure sensor	[Engine is running] ● Steering wheel is being turned.	0.5 - 4.5V
			[Engine is running] ● Steering wheel is not being turned.	0.4 - 0.8V
67	B/W	Sensor ground	[Engine is running] ● Warm-up condition ● Idle speed	Approximately 0V
68	R/W	Sensor power supply (Power steering pressure sensor)	[Ignition switch: ON]	Approximately 5V

## Diagnostic Procedure

ABS009J3

### 1. CHECK GROUND CONNECTIONS

1. Turn ignition switch OFF.
2. Loosen and retighten three ground screws on the body. Refer to [EC-138, "Ground Inspection"](#).

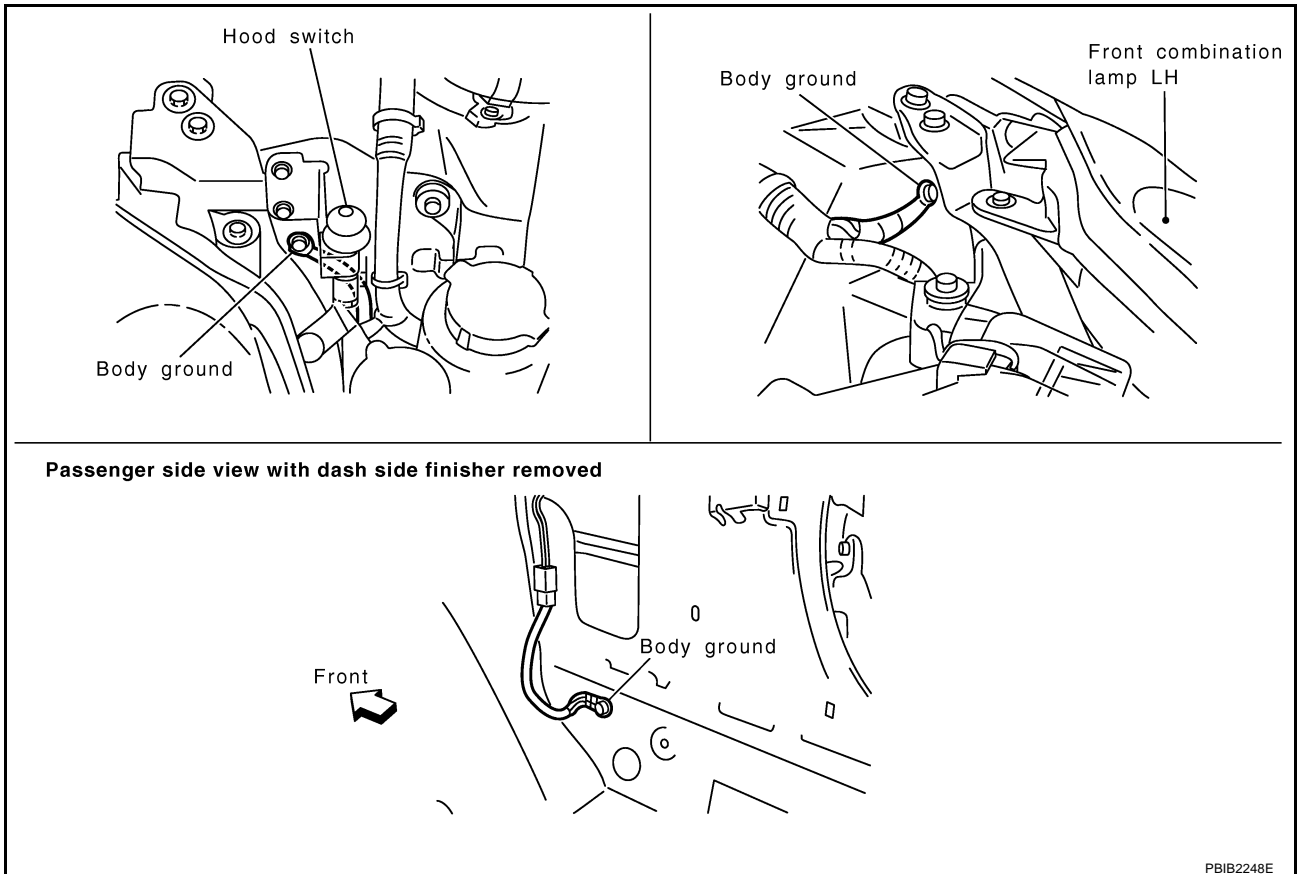

**OK or NG**

- OK >> GO TO 2.
- NG >> Repair or replace ground connections.

# DTC P0550 PSP SENSOR

## 2. CHECK PSP SENSOR POWER SUPPLY CIRCUIT

1. Disconnect power steering pressure (PSP) sensor harness connector.
2. Turn ignition switch ON.

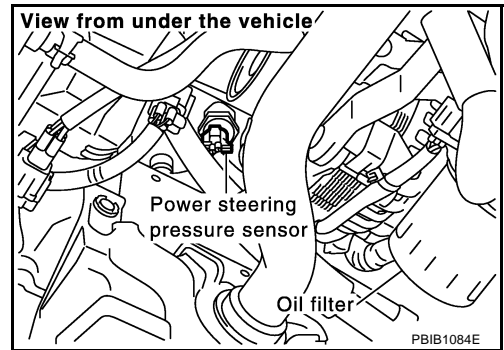

3. Check voltage between PSP sensor terminal 1 and ground with CONSULT-II or tester.

**Voltage: Approximately 5V**

OK or NG

OK >> GO TO 3.

NG >> Repair open circuit or short to ground or short to power in harness or connectors.

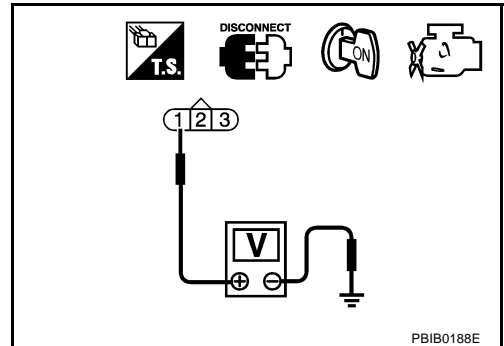

## 3. CHECK PSP SENSOR GROUND CIRCUIT FOR OPEN AND SHORT

1. Turn ignition switch OFF.
2. Disconnect ECM harness connector.
3. Check harness continuity between PSP sensor terminal 3 and ECM terminal 67. Refer to Wiring Diagram.

**Continuity should exist.**

4. Also check harness for short to ground and short to power.

OK or NG

OK >> GO TO 4.

NG >> Repair open circuit or short to ground or short to power in harness or connectors.

## 4. CHECK PSP SENSOR INPUT SIGNAL CIRCUIT FOR OPEN AND SHORT

1. Check harness continuity between ECM terminal 12 and PSP sensor terminal 2.

**Continuity should exist.**

2. Also check harness for short to ground and short to power.

OK or NG

OK >> GO TO 5.

NG >> Repair open circuit or short to ground or short to power in harness or connectors.

## 5. CHECK PSP SENSOR

Refer to [EC-373, "Component Inspection"](#).

OK or NG

OK >> GO TO 6.

NG >> Replace PSP sensor.

# DTC P0550 PSP SENSOR

## 6. CHECK INTERMITTENT INCIDENT

Refer to [EC-129, "TROUBLE DIAGNOSIS FOR INTERMITTENT INCIDENT"](#) .

>> INSPECTION END

### Component Inspection POWER STEERING PRESSURE SENSOR

ABS009J4

1. Reconnect all harness connectors disconnected.
2. Start engine and let it idle.
3. Check voltage between ECM terminal 12 and ground under the following conditions.

Condition	Voltage
Steering wheel is being turned.	0.5 - 4.5V
Steering wheel is not being turned.	0.4 - 0.8V

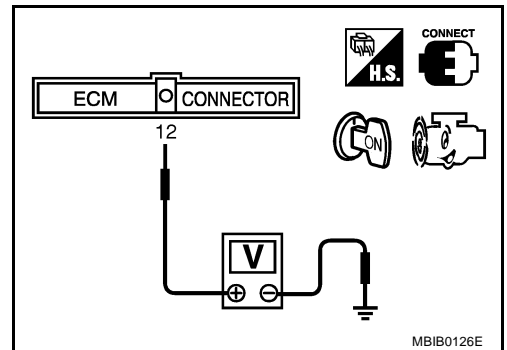

ABS00B3F

### Removal and Installation POWER STEERING PRESSURE SENSOR

Refer to [PS-34, "HYDRAULIC LINE"](#) .

# DTC P0605 ECM

## DTC P0605 ECM

PFP:23710

### Component Description

ABS009J5

The ECM consists of a microcomputer and connectors for signal input and output and for power supply. The ECM controls the engine.

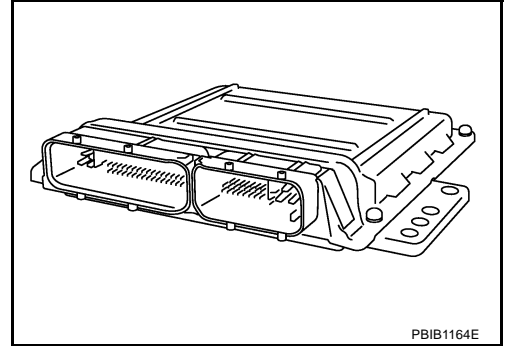

### On Board Diagnosis Logic

ABS009J6

This self-diagnosis has one or two trip detection logic.

DTC No.	Trouble diagnosis name	DTC detecting condition		Possible cause
P0605 0605	Engine control module	A)	ECM calculation function is malfunctioning.	● ECM
		B)	ECM EEPROM system is malfunctioning.	
		C)	ECM self shut-off function is malfunctioning.	

### FAIL-SAFE MODE

ECM enters fail-safe mode when the malfunction A is detected.

Detected items	Engine operation condition in fail-safe mode
Malfunction A	<ul style="list-style-type: none"> <li>● ECM stops the electric throttle control actuator control, throttle valve is maintained at a fixed opening (approx. 5 degrees) by the return spring.</li> <li>● ECM deactivates ASCD operation.</li> </ul>

### DTC Confirmation Procedure

ABS009J7

Perform **PROCEDURE FOR MALFUNCTION A** first. If the 1st trip DTC cannot be confirmed, perform **PROCEDURE FOR MALFUNCTION B**. If there is no malfunction on **PROCEDURE FOR MALFUNCTION B**, perform **PROCEDURE FOR MALFUNCTION C**.

#### NOTE:

If DTC Confirmation Procedure has been previously conducted, always turn ignition switch OFF and wait at least 10 seconds before conducting the next test.

#### PROCEDURE FOR MALFUNCTION A

##### ④ With CONSULT-II

1. Turn ignition switch ON.
2. Select "DATA MONITOR" mode with CONSULT-II.
3. If 1st trip DTC is detected, go to [EC-375, "Diagnostic Procedure"](#)

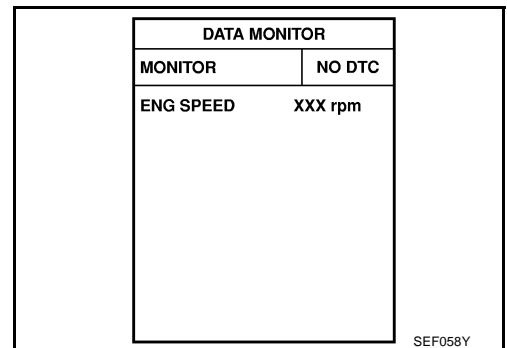

##### ④ With GST

Follow the procedure "With CONSULT-II" above.

## PROCEDURE FOR MALFUNCTION B

### With CONSULT-II

1. Turn ignition switch ON and wait at least 1 second.
2. Select "DATA MONITOR" mode with CONSULT-II.
3. Turn ignition switch OFF, wait at least 10 seconds, and then turn ON.
4. If 1st trip DTC is detected, go to [EC-375, "Diagnostic Procedure"](#)

DATA MONITOR	
MONITOR	NO DTC
ENG SPEED	XXX rpm

SEF058Y

### With GST

Follow the procedure "With CONSULT-II" above.

## PROCEDURE FOR MALFUNCTION C

### With CONSULT-II

1. Turn ignition switch ON and wait at least 1 second.
2. Select "DATA MONITOR" mode with CONSULT-II.
3. Turn ignition switch OFF, wait at least 10 seconds, and then turn ON.
4. Repeat step 3 procedure, 32 times.
5. If 1st trip DTC is detected, go to [EC-375, "Diagnostic Procedure"](#)

DATA MONITOR	
MONITOR	NO DTC
ENG SPEED	XXX rpm

SEF058Y

### With GST

Follow the procedure "With CONSULT-II" above.

## Diagnostic Procedure

ABS009J8

### 1. INSPECTION START

#### With CONSULT-II

1. Turn ignition switch ON.
2. Select "SELF DIAG RESULTS" mode with CONSULT-II.
3. Touch "ERASE".
4. **Perform DTC Confirmation Procedure.**  
See [EC-374](#) .
5. Is the 1st trip DTC P0605 displayed again?

#### With GST

1. Turn ignition switch ON.
2. Select "MODE 4" with GST.
3. Touch "ERASE".
4. **Perform DTC Confirmation Procedure.**  
See [EC-374](#) .
5. Is the 1st trip DTC P0605 displayed again?

Yes or No

Yes >> GO TO 2.

No >> **INSPECTION END**

### 2. REPLACE ECM

---

1. Replace ECM.
2. Perform initialization of NVIS (NATS) system and registration of all NVIS (NATS) ignition key IDs. Refer to [BL-160, "ECM Re-communicating Function"](#) .
3. Perform [EC-42, "VIN Registration"](#) .
4. Perform [EC-42, "Accelerator Pedal Released Position Learning"](#) .
5. Perform [EC-42, "Throttle Valve Closed Position Learning"](#) .
6. Perform [EC-43, "Idle Air Volume Learning"](#) .

>> INSPECTION END



# DTC P1031, P1032, P1051, P1052 A/F SENSOR 1 HEATER

## DTC P1031, P1032, P1051, P1052 A/F SENSOR 1 HEATER

PPF:22693

### Description SYSTEM DESCRIPTION

ABS00A7Z

Sensor	Input Signal to ECM	ECM function	Actuator
Camshaft position sensor (PHASE) Crankshaft position sensor (POS)	Engine speed	Air fuel ratio (A/F) sensor 1 heater control	Air fuel ratio (A/F) sensor 1 heater
Mass air flow sensor	Amount of intake air		

The ECM performs ON/OFF duty control of the A/F sensor 1 heater corresponding to the engine operating condition to keep the temperature of A/F sensor 1 element at the specified range.

### CONSULT-II Reference Value in Data Monitor Mode

ABS00A80

Specification data are reference values.

MONITOR ITEM	CONDITION	SPECIFICATION
A/F S1 HTR (B1) A/F S1 HTR (B2)	● Engine: After warming up, idle the engine	0 - 100%

### On Board Diagnosis Logic

ABS00A81

DTC No.	Trouble diagnosis name	DTC detecting condition	Possible cause
P1031 1031 (Bank 1)	Air fuel ratio (A/F) sensor 1 heater control circuit low	The current amperage in the air fuel ratio (A/F) sensor 1 heater circuit is out of the normal range. (An excessively low voltage signal is sent to ECM through the air fuel ratio (A/F) sensor 1 heater.)	<ul style="list-style-type: none"> <li>● Harness or connectors (The A/F sensor 1 heater circuit is open or shorted.)</li> <li>● A/F sensor 1 heater</li> </ul>
P1051 1051 (Bank 2)			
P1032 1032 (Bank 1)	Air fuel ratio (A/F) sensor 1 heater control circuit high	The current amperage in the air fuel ratio (A/F) sensor 1 heater circuit is out of the normal range. (An excessively high voltage signal is sent to ECM through the air fuel ratio (A/F) sensor 1 heater.)	<ul style="list-style-type: none"> <li>● Harness or connectors (The A/F sensor 1 heater circuit is shorted.)</li> <li>● A/F sensor 1 heater</li> </ul>
P1052 1052 (Bank 2)			

### DTC Confirmation Procedure

ABS00A82

#### NOTE:

If DTC Confirmation Procedure has been previously conducted, always turn ignition switch OFF and wait at least 10 seconds before conducting the next test.

#### TESTING CONDITION:

Before performing the following procedure, confirm that battery voltage is between 10.5V and 16V at idle.

#### WITH CONSULT-II

1. Turn ignition switch ON and select "DATA MONITOR" mode with CONSULT-II.
2. Start engine and let it idle for at least 10 seconds.
3. If 1st trip DTC is detected, go to [EC-381, "Diagnostic Procedure"](#)

DATA MONITOR	
MONITOR	NO DTC
ENG SPEED	XXX rpm

SEF058Y

#### WITH GST

Follow the procedure "WITH CONSULT-II" above.

# DTC P1031, P1032, P1051, P1052 A/F SENSOR 1 HEATER

ABS00A83

## Wiring Diagram BANK 1

EC-AF1HB1-01

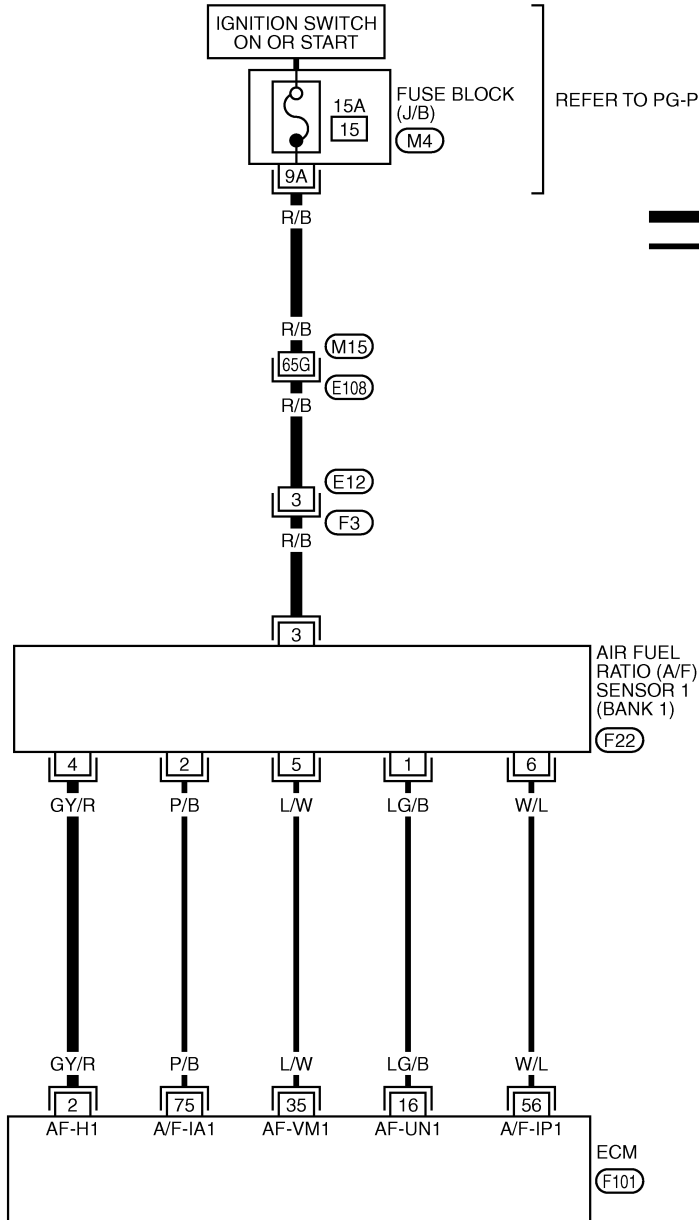

— : DETECTABLE LINE FOR DTC  
— : NON-DETECTABLE LINE FOR DTC

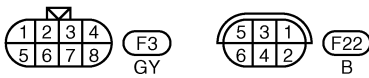

REFER TO THE FOLLOWING.

- (E108) -SUPER MULTIPLE JUNCTION (SMJ)
- (M4) -FUSE BLOCK-JUNCTION BOX (J/B)

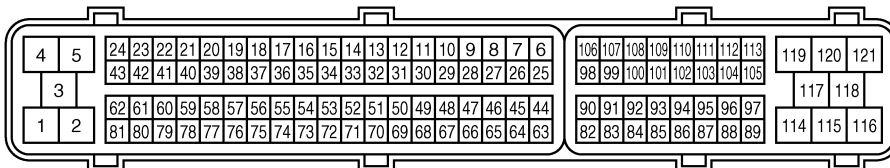

TBWT0704E

# DTC P1031, P1032, P1051, P1052 A/F SENSOR 1 HEATER

Specification data are reference values and are measured between each terminal and ground.  
Pulse signal is measured by CONSULT-II.

**CAUTION:**

**Do not use ECM ground terminals when measuring input/output voltage. Doing so may result in damage to the ECM's transistor. Use a ground other than ECM terminals, such as the ground.**

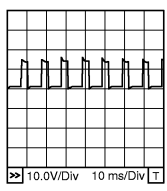
TER-MINAL NO.	WIRE COLOR	ITEM	CONDITION	DATA (DC Voltage)
2	GY/R	A/F sensor 1 heater (Bank 1)	<p><b>[Engine is running]</b></p> <ul style="list-style-type: none"> <li>● Warm-up condition</li> <li>● Idle speed</li> </ul>	<p>Approximately 5V★</p>  <p style="text-align: right; font-size: small;">PBIB1584E</p>

★: Average voltage for pulse signal (Actual pulse signal can be confirmed by oscilloscope.)

A  
EC  
C  
D  
E  
F  
G  
H  
I  
J  
K  
L  
M

# DTC P1031, P1032, P1051, P1052 A/F SENSOR 1 HEATER

**BANK 2**

**EC-AF1HB2-01**

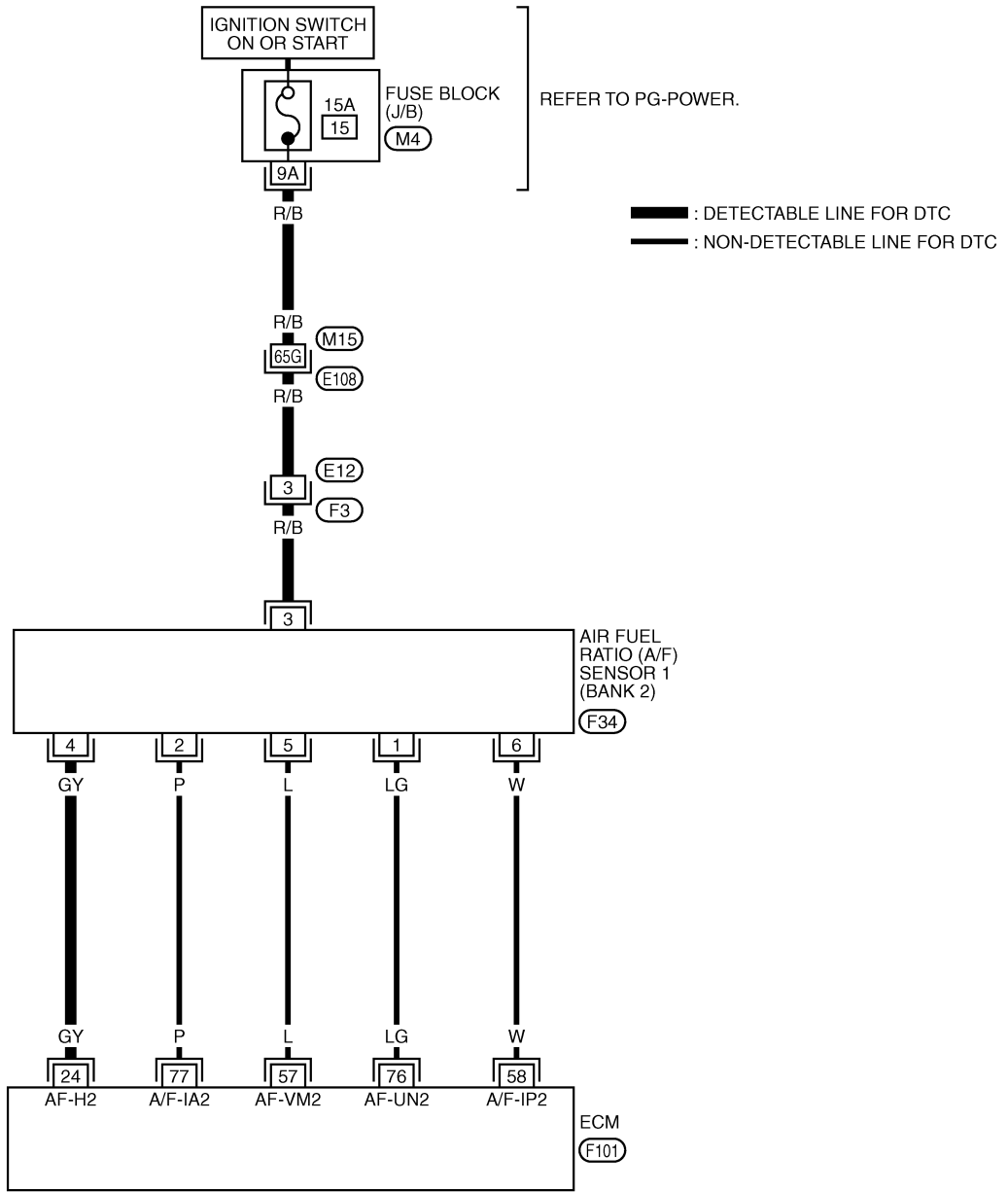

REFER TO THE FOLLOWING.

(E108) -SUPER MULTIPLE JUNCTION (SMJ)

(M4) -FUSE BLOCK-JUNCTION BOX (J/B)

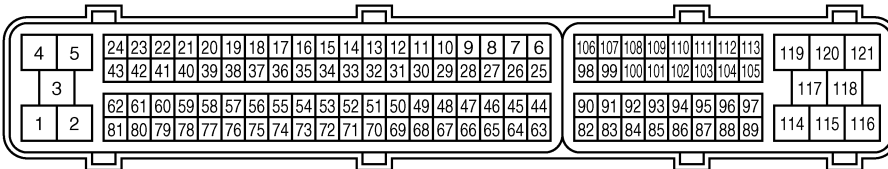

TBWT0705E

# DTC P1031, P1032, P1051, P1052 A/F SENSOR 1 HEATER

Specification data are reference values and are measured between each terminal and ground.  
Pulse signal is measured by CONSULT-II.

**CAUTION:**

**Do not use ECM ground terminals when measuring input/output voltage. Doing so may result in damage to the ECM's transistor. Use a ground other than ECM terminals, such as the ground.**

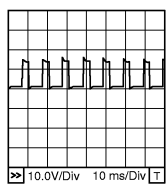
TER-MINAL NO.	WIRE COLOR	ITEM	CONDITION	DATA (DC Voltage)
24	GY	A/F sensor 1 heater (Bank 2)	<p>[Engine is running]</p> <ul style="list-style-type: none"> <li>● Warm-up condition</li> <li>● Idle speed</li> </ul>	<p>Approximately 5V★</p>  <p>PBIB1584E</p>

★: Average voltage for pulse signal (Actual pulse signal can be confirmed by oscilloscope.)

## Diagnostic Procedure

ABS00A84

### 1. CHECK GROUND CONNECTIONS

1. Turn ignition switch OFF.
2. Loosen and retighten three ground screws on the body. Refer to [EC-138, "Ground Inspection"](#).

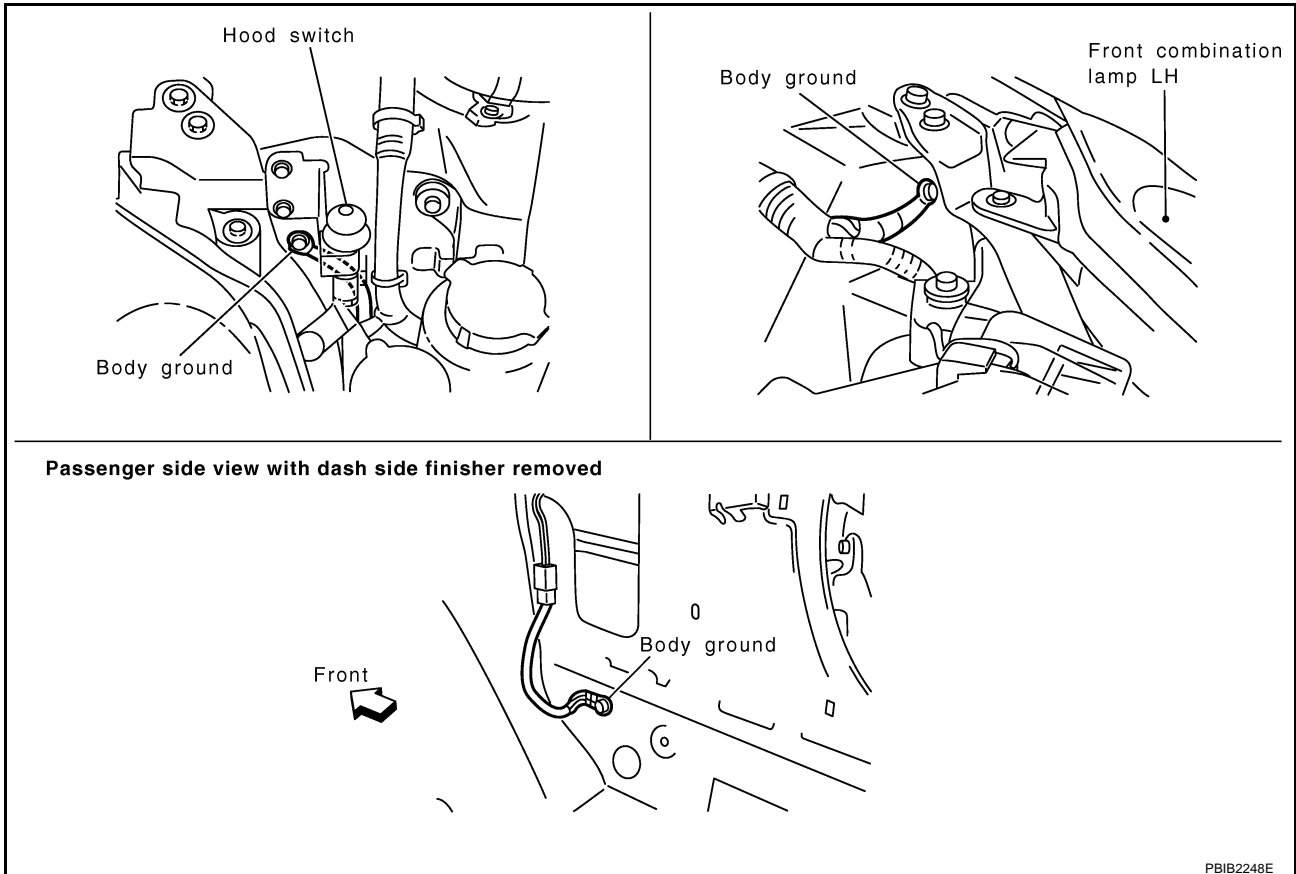

OK or NG

- OK >> GO TO 2.
- NG >> Repair or replace ground connections.

# DTC P1031, P1032, P1051, P1052 A/F SENSOR 1 HEATER

## 2. CHECK AIR FUEL RATIO (A/F) SENSOR 1 POWER SUPPLY CIRCUIT

1. Disconnect air fuel ratio (A/F) sensor 1 harness connector.

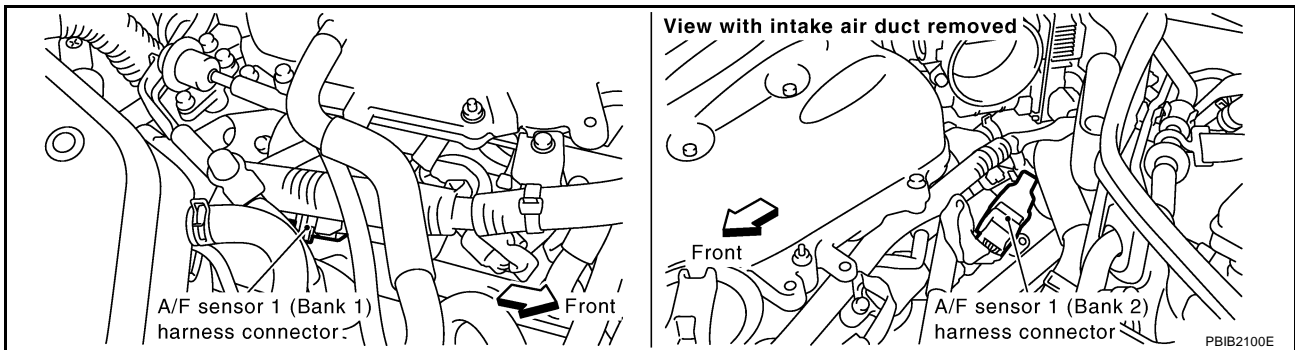

2. Turn ignition switch ON.
3. Check voltage between A/F sensor 1 terminal 3 and ground with CONSULT-II or tester.

**Voltage: Battery voltage**

OK or NG

- OK >> GO TO 4.
- NG >> GO TO 3.

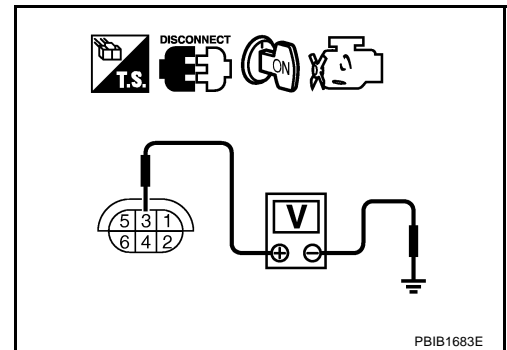

## 3. DETECT MALFUNCTIONING PART

Check the following.

- Harness connectors M15, E108
- Harness connectors E12, F3
- Fuse block (J/B) connector M4
- 15A fuse
- Harness for open or short between A/F sensor 1 and fuse

>> Repair or replace harness or connectors.

## 4. CHECK A/F SENSOR 1 HEATER OUTPUT SIGNAL CIRCUIT

1. Turn ignition switch OFF.
2. Disconnect ECM harness connector.
3. Check harness continuity between ECM terminal 2 (bank 1) or 24 (bank 2) and A/F sensor 1 terminal 4. Refer to Wiring Diagram.

**Continuity should exist.**

4. Also check harness for short to ground or short to power.

OK or NG

- OK >> GO TO 5.
- NG >> Repair open circuit or short to ground or short to power in harness or connectors.

# DTC P1031, P1032, P1051, P1052 A/F SENSOR 1 HEATER

## 5. CHECK A/F SENSOR 1 HEATER

Refer to [EC-383, "Component Inspection"](#) .

OK or NG

- OK >> GO TO 6.
- NG >> GO TO 7.

## 6. CHECK INTERMITTENT INCIDENT

Perform [EC-129, "TROUBLE DIAGNOSIS FOR INTERMITTENT INCIDENT"](#) .

OK or NG

- OK >> GO TO 7.
- NG >> Repair or replace.

## 7. REPLACE AIR FUEL RATIO (A/F) SENSOR 1

Replace A/F sensor 1.

### CAUTION:

- Discard any A/F sensor which has been dropped from a height of more than 0.5 m (19.7 in) onto a hard surface such as a concrete floor; use a new one.
- Before installing new A/F sensor, clean exhaust system threads (using Oxygen Sensor Thread Cleaner tool J-43897-18 or J-43897-12) and approved anti-seize lubricant.

>> INSPECTION END

## Component Inspection AIR FUEL RATIO (A/F) SENSOR 1 HEATER

ABS00A85

Check resistance between terminals 3 and 4.

**Resistance: 2.3 - 4.3Ω [at 25°C (77°F)]**

Check continuity between terminals 3 and 1, 2, 5, 6, terminals 4 and 1, 2, 5, 6.

**Continuity should not exist.**

If NG, replace the A/F sensor 1.

### CAUTION:

- Discard any A/F sensor which has been dropped from a height of more than 0.5 m (19.7 in) onto a hard surface such as a concrete floor; use a new one.
- Before installing new A/F sensor, clean exhaust system threads using Heated Oxygen Sensor Thread Cleaner tool J-43897-18 or J-43897-12 and approved anti-seize lubricant.

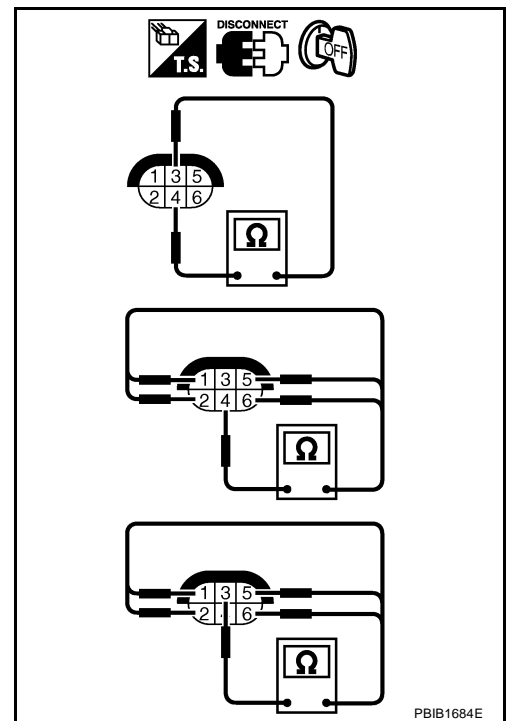

PBIB1684E

## Removal and Installation AIR FUEL RATIO (A/F) SENSOR 1

ABS00A86

Refer to [EM-23, "EXHAUST MANIFOLD AND THREE WAY CATALYST"](#) .

# DTC P1065 ECM POWER SUPPLY

## DTC P1065 ECM POWER SUPPLY

PFP:23710

### Component Description

ABS009J9

Battery voltage is supplied to the ECM even when the ignition switch is turned OFF for the ECM memory function of the DTC memory, the air-fuel ratio feedback compensation value memory, the idle air volume learning value memory, etc.

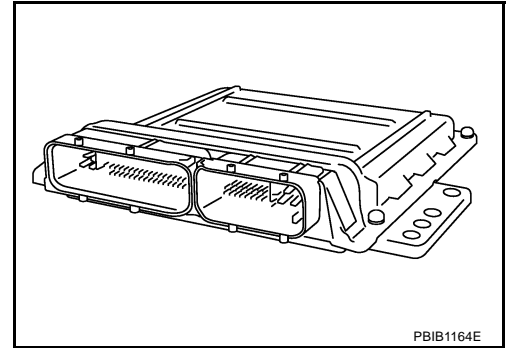

### On Board Diagnosis Logic

ABS009JA

DTC No.	Trouble diagnosis name	DTC detecting condition	Possible cause
P1065 1065	ECM power supply circuit	ECM back-up RAM system does not function properly.	<ul style="list-style-type: none"><li>● Harness or connectors [ECM power supply (back-up) circuit is open or shorted.]</li><li>● ECM</li></ul>

### DTC Confirmation Procedure

ABS009JB

#### NOTE:

If DTC Confirmation Procedure has been previously conducted, always turn ignition switch OFF and wait at least 10 seconds before conducting the next test.

#### WITH CONSULT-II

1. Turn ignition switch ON and wait at least 1 second.
2. Select "DATA MONITOR" mode with CONSULT-II.
3. Start engine and let it idle for 1 second.
4. Turn ignition switch OFF, wait at least 10 seconds, and then turn ON.
5. Repeat steps 3 and 4 for four times.
6. If 1st trip DTC is detected, go to [EC-386. "Diagnostic Procedure"](#)

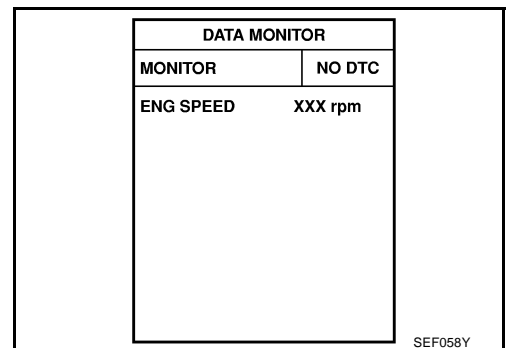

#### WITH GST

Follow the procedure "WITH CONSULT-II" above.



# DTC P1065 ECM POWER SUPPLY

## Wiring Diagram

ABS009JC

### EC-ECM/PW-01

: DETECTABLE LINE FOR DTC  
 : NON-DETECTABLE LINE FOR DTC

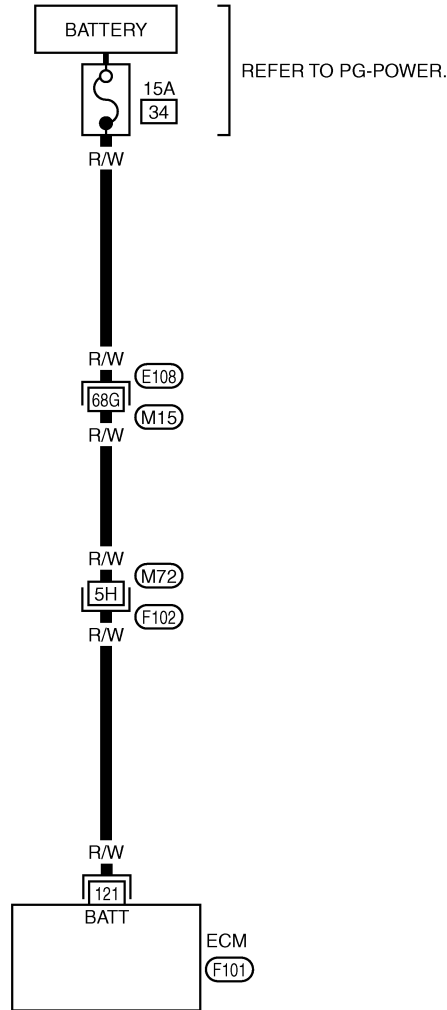

REFER TO THE FOLLOWING.  
 (E108), (F102) -SUPER MULTIPLE JUNCTION (SMJ)

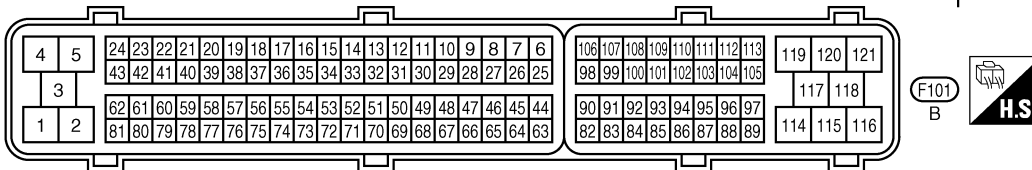

TBWT0225E

# DTC P1065 ECM POWER SUPPLY

Specification data are reference values and are measured between each terminal and ground.

## CAUTION:

Do not use ECM ground terminals when measuring input/output voltage. Doing so may result in damage to the ECM's transistor. Use a ground other than ECM terminals, such as the ground.

TER-MINAL NO.	WIRE COLOR	ITEM	CONDITION	DATA (DC Voltage)
121	R/W	Power supply for ECM (Back-up)	[Ignition switch: OFF]	BATTERY VOLTAGE (11 - 14V)

## Diagnostic Procedure

ABS009JD

### 1. CHECK ECM POWER SUPPLY

1. Turn ignition switch OFF.
2. Disconnect ECM harness connector.
3. Check voltage between ECM terminal 121 and ground with CONSULT-II or tester.

**Voltage: Battery voltage**

OK or NG

- OK >> GO TO 3.
- NG >> GO TO 2.

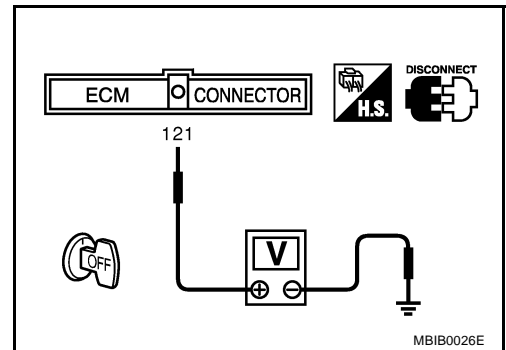

MBIB0026E

### 2. DETECT MALFUNCTIONING PART

Check the following.

- Harness connectors E108, M15
- Harness connectors M72, F102
- 15A fuse
- Harness for open or short between ECM and battery

>> Repair or replace harness or connectors.

### 3. CHECK INTERMITTENT INCIDENT

Refer to [EC-129, "TROUBLE DIAGNOSIS FOR INTERMITTENT INCIDENT"](#).

OK or NG

- OK >> GO TO 4.
- NG >> Repair or replace harness or connectors.

# DTC P1065 ECM POWER SUPPLY

## 4. PERFORM DTC CONFIRMATION PROCEDURE

### With CONSULT-II

1. Turn ignition switch ON.
2. Select "SELF DIAG RESULTS" mode with CONSULT-II.
3. Touch "ERASE".
4. **Perform DTC Confirmation Procedure.**  
See [EC-384](#) .
5. Is the 1st trip DTC P1065 displayed again?

### With GST

1. Turn ignition switch ON.
2. Select "MODE 4" with GST.
3. Touch "ERASE".
4. **Perform DTC Confirmation Procedure.**  
See [EC-384](#) .
5. Is the 1st trip DTC P1065 displayed again?

Yes or No

Yes >> GO TO 5.

No >> **INSPECTION END**

## 5. REPLACE ECM

1. Replace ECM.
2. Perform initialization of NVIS (NATS) system and registration of all NVIS (NATS) ignition key IDs. Refer to [BL-160, "ECM Re-communicating Function"](#) .
3. Perform [EC-42, "VIN Registration"](#) .
4. Perform [EC-42, "Accelerator Pedal Released Position Learning"](#) .
5. Perform [EC-42, "Throttle Valve Closed Position Learning"](#) .
6. Perform [EC-43, "Idle Air Volume Learning"](#) .

>> **INSPECTION END**

# DTC P1111, P1136 IVT CONTROL SOLENOID VALVE

## DTC P1111, P1136 IVT CONTROL SOLENOID VALVE

PF2:23796

### Component Description

ABS009JE

Intake valve timing control solenoid valve is activated by ON/OFF pulse duty (ratio) signals from the ECM.

The intake valve timing control solenoid valve changes the oil amount and direction of flow through intake valve timing control unit or stops oil flow.

The longer pulse width advances valve angle.

The shorter pulse width retards valve angle.

When ON and OFF pulse widths become equal, the solenoid valve stops oil pressure flow to fix the intake valve angle at the control position.

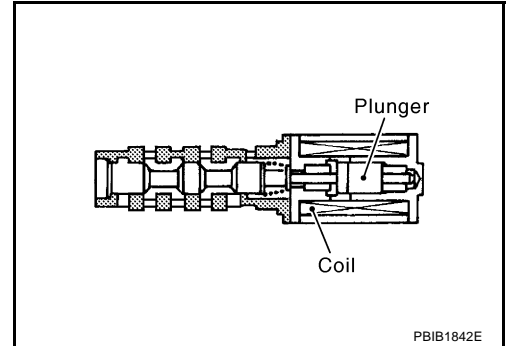

### CONSULT-II Reference Value in Data Monitor Mode

ABS009JF

Specification data are reference values.

MONITOR ITEM	CONDITION		SPECIFICATION
INT/V SOL (B1) INT/V SOL (B2)	<ul style="list-style-type: none"> <li>● Engine: After warming up</li> <li>● Shift lever: P or N (A/T), Neutral (M/T)</li> <li>● Air conditioner switch: OFF</li> <li>● No-load</li> </ul>	Idle	0% - 2%
		When revving engine up to 2,000 rpm quickly	Approx. 0% - 50%

### On Board Diagnosis Logic

ABS009JG

DTC No.	Trouble diagnosis name	DTC detecting condition	Possible cause
P1111 1111 (Bank 1)	Intake valve timing control solenoid valve circuit	An improper voltage is sent to the ECM through intake valve timing control solenoid valve.	<ul style="list-style-type: none"> <li>● Harness or connectors (Intake valve timing control solenoid valve circuit is open or shorted.)</li> <li>● Intake valve timing control solenoid valve</li> </ul>
P1136 1136 (Bank 2)			

### DTC Confirmation Procedure

ABS009JH

#### NOTE:

If DTC Confirmation Procedure has been previously conducted, always turn ignition switch OFF and wait at least 10 seconds before conducting the next test.

#### WITH CONSULT-II

1. Turn ignition switch ON.
2. Select "DATA MONITOR" mode with CONSULT-II.
3. Start engine and let it idle for 5 seconds.
4. If 1st trip DTC is detected, go to [EC-392, "Diagnostic Procedure"](#)

DATA MONITOR	
MONITOR	NO DTC
ENG SPEED	XXX rpm

SEF058Y

#### WITH GST

Following the procedure "WITH CONSULT-II" above.

# DTC P1111, P1136 IVT CONTROL SOLENOID VALVE

ABS009JI

## Wiring Diagram BANK 1

EC-IVCB1-01

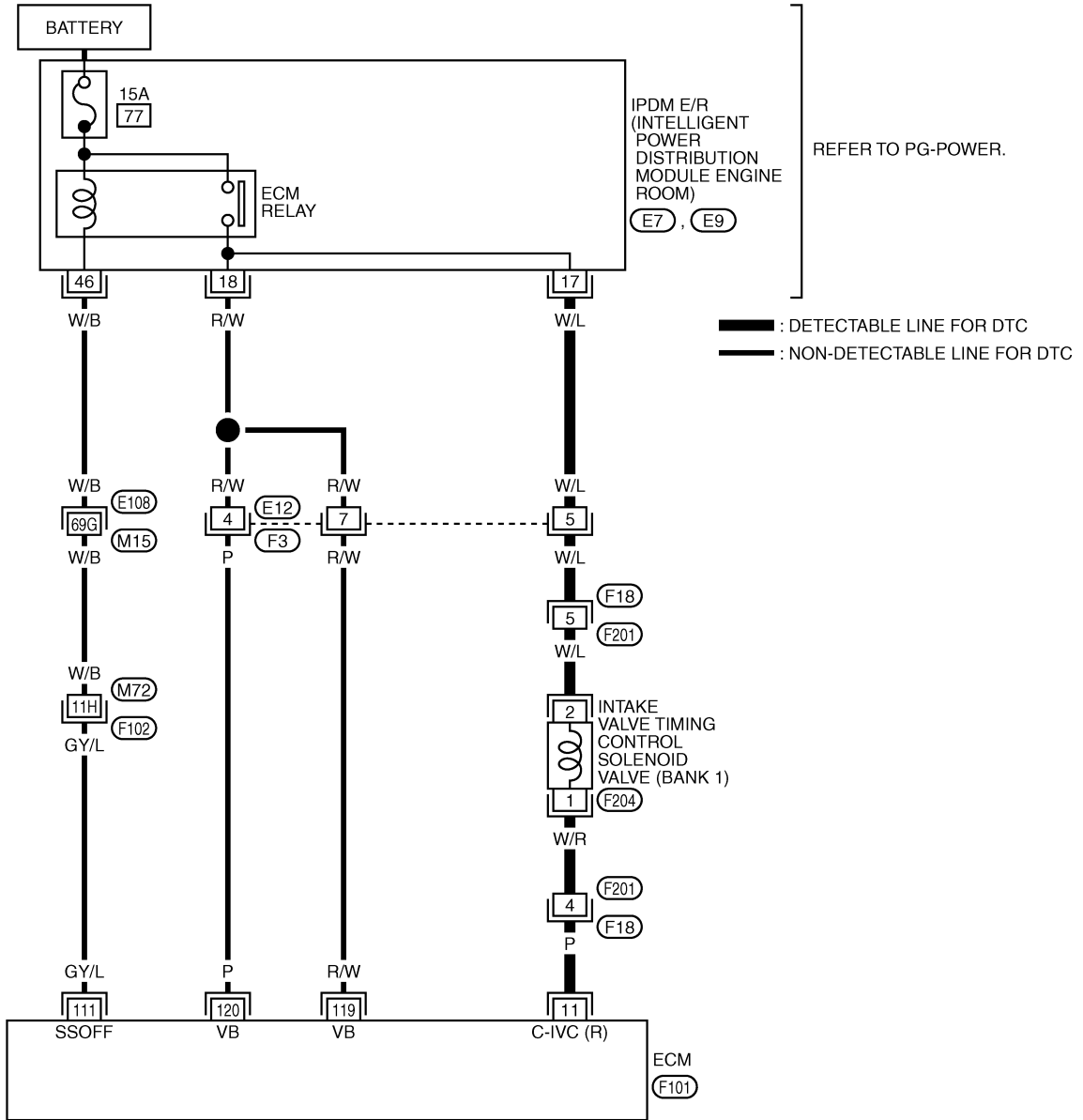

A  
EC  
C  
D  
E  
F  
G  
H  
I  
J  
K  
L  
M

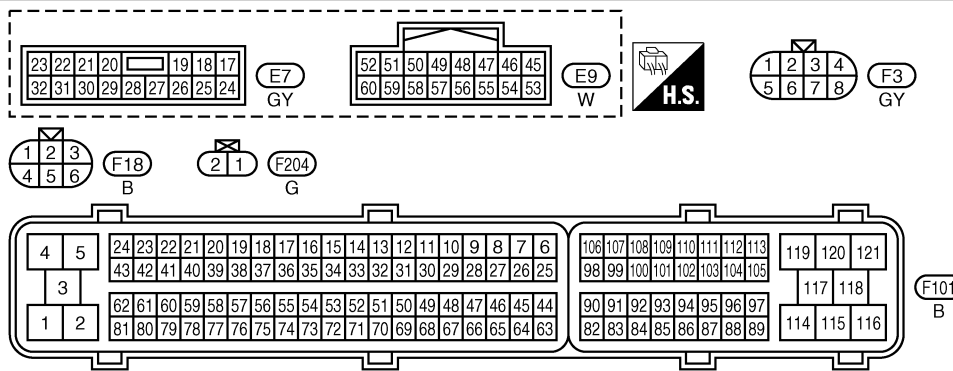

REFER TO THE FOLLOWING.  
(E108), (F102) -SUPER MULTIPLE JUNCTION (SMJ)

## DTC P1111, P1136 IVT CONTROL SOLENOID VALVE

Specification data are reference values and are measured between each terminal and ground.  
Pulse signal is measured by CONSULT-II.

**CAUTION:**

**Do not use ECM ground terminals when measuring input/output voltage. Doing so may result in damage to the ECM's transistor. Use a ground other than ECM terminals, such as the ground.**

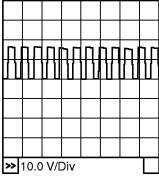
TER-MINAL NO.	WIRE COLOR	ITEM	CONDITION	DATA (DC Voltage)
11	P	Intake valve timing control solenoid valve (bank 1)	<b>[Engine is running]</b> <ul style="list-style-type: none"> <li>● Warm-up condition</li> <li>● Idle speed</li> </ul>	BATTERY VOLTAGE (11 - 14V)
			<b>[Engine is running]</b> <ul style="list-style-type: none"> <li>● Warm-up condition</li> <li>● When revving engine up to 2,000 rpm quickly</li> </ul>	7 - 12V★ 

PBIB1790E

★: Average voltage for pulse signal (Actual pulse signal can be confirmed by oscilloscope.)

# DTC P1111, P1136 IVT CONTROL SOLENOID VALVE

BANK 2

EC-IVCB2-01

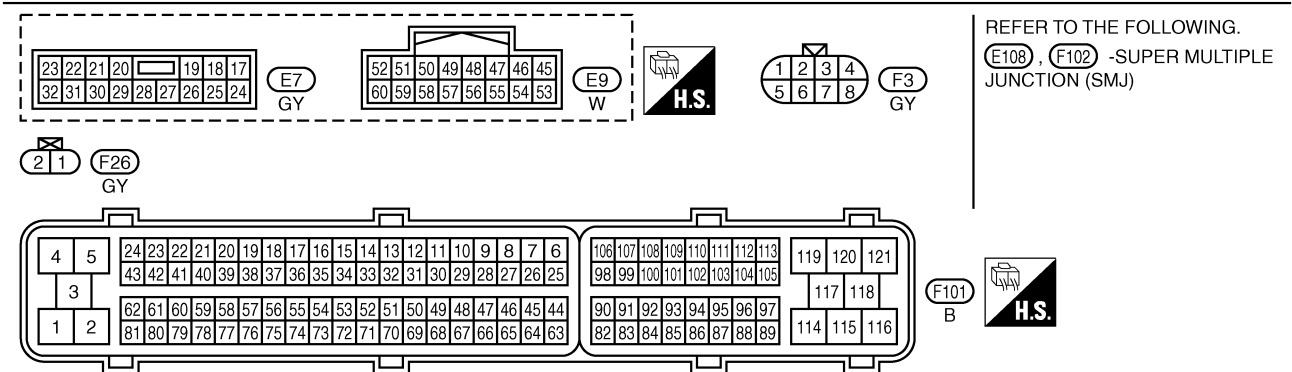
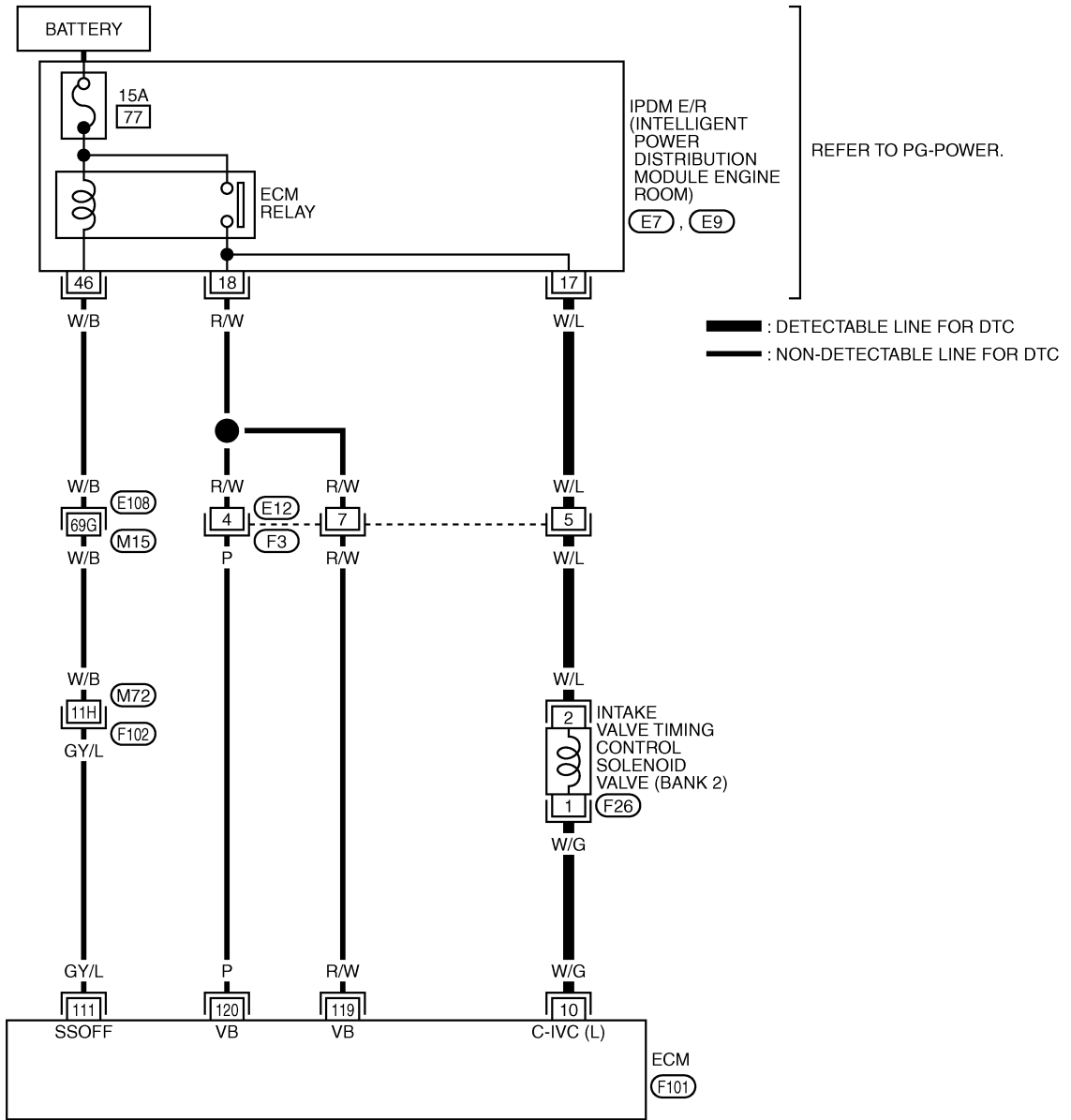

TBWT0625E

# DTC P1111, P1136 IVT CONTROL SOLENOID VALVE

Specification data are reference values and are measured between each terminal and ground.  
Pulse signal is measured by CONSULT-II.

## CAUTION:

Do not use ECM ground terminals when measuring input/output voltage. Doing so may result in damage to the ECM's transistor. Use a ground other than ECM terminals, such as the ground.

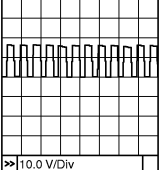
TER-MINAL NO.	WIRE COLOR	ITEM	CONDITION	DATA (DC Voltage)
10	W/G	Intake valve timing control solenoid valve (bank 2)	[Engine is running] ● Warm-up condition ● Idle speed	BATTERY VOLTAGE (11 - 14V)
			[Engine is running] ● Warm-up condition ● When revving engine up to 2,000 rpm quickly	7 - 12V★  PBIB1790E

★: Average voltage for pulse signal (Actual pulse signal can be confirmed by oscilloscope.)

## Diagnostic Procedure

ABS009JJ

### 1. CHECK INTAKE VALVE TIMING CONTROL SOLENOID VALVE POWER SUPPLY CIRCUIT

1. Turn ignition switch OFF.
2. Disconnect intake valve timing control solenoid valve harness connector.

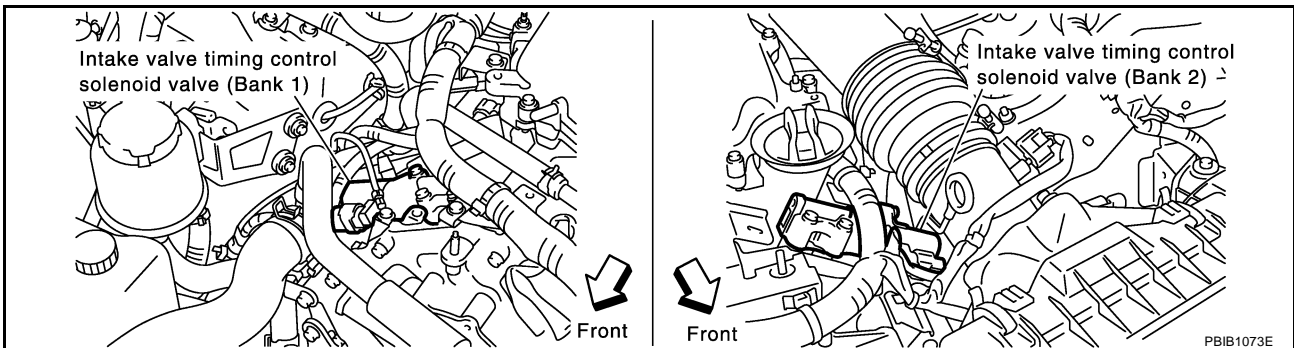

3. Turn ignition switch ON.
4. Check voltage between intake valve timing control solenoid valve terminal 2 and ground with CONSULT-II or tester.

**Voltage: Battery voltage**

OK or NG

- OK >> GO TO 3.  
NG >> GO TO 2.

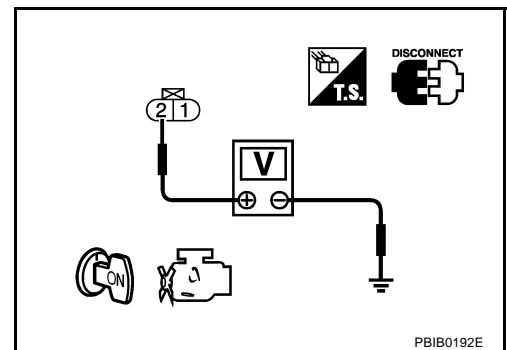



# DTC P1111, P1136 IVT CONTROL SOLENOID VALVE

---

## 2. DETECT MALFUNCTIONING PART

---

Check the following.

- Harness connectors E12, F3
- Harness connectors F18, F201 (Bank 1)
- IPDM E/R harness connector E7
- Harness for open or short between intake valve timing control solenoid valve and IPDM E/R

>> Repair open circuit or short to ground or short to power in harness or connectors.

---

## 3. CHECK INTAKE VALVE TIMING CONTROL SOLENOID VALVE OUTPUT SIGNAL CIRCUIT FOR OPEN AND SHORT

---

1. Turn ignition switch OFF.
2. Disconnect ECM harness connector.
3. Check harness continuity between ECM terminal 11 (bank 1) or 10 (bank 2) and intake valve timing control solenoid valve terminal 1. Refer to Wiring Diagram.

**Continuity should exist.**

4. Also check harness for short to ground and short to power.

OK or NG

- OK >> GO TO 5.
- NG >> GO TO 4.

---

## 4. DETECT MALFUNCTIONING PART

---

Check the following.

- Harness connectors F18, F201 (Bank 1)
- Harness for open and short between ECM and intake valve timing control solenoid valve

>> Repair open circuit or short to ground or short to power in harness or connectors.

---

## 5. CHECK INTAKE VALVE TIMING CONTROL SOLENOID VALVE

---

Refer to [EC-394, "Component Inspection"](#) .

OK or NG

- OK >> GO TO 6.
- NG >> Replace intake valve timing control solenoid valve.

---

## 6. CHECK INTERMITTENT INCIDENT

---

Refer to [EC-129, "TROUBLE DIAGNOSIS FOR INTERMITTENT INCIDENT"](#) .

For wiring diagram, refer to [EC-268](#) for CKP sensor (POS), [EC-275](#) and [EC-277](#) for CMP sensor (PHASE).

>> **INSPECTION END**

# DTC P1111, P1136 IVT CONTROL SOLENOID VALVE

ABS009JK

## Component Inspection INTAKE VALVE TIMING CONTROL SOLENOID VALVE

1. Disconnect intake valve timing control solenoid valve harness connector.
2. Check resistance between intake valve timing control solenoid valve terminals as follows.

Terminals	Resistance
1 and 2	7.0 - 7.5Ω [at 20°C (68°F)]
1 or 2 and ground	$\infty\Omega$ (Continuity should not exist)

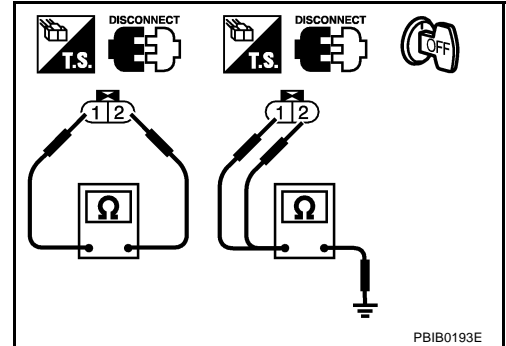

ABS009JL

## Removal and Installation INTAKE VALVE TIMING CONTROL SOLENOID VALVE

Refer to [EM-55, "TIMING CHAIN"](#) .

# DTC P1121 ELECTRIC THROTTLE CONTROL ACTUATOR

## DTC P1121 ELECTRIC THROTTLE CONTROL ACTUATOR

PFP:16119

### Component Description

ABS009JM

Electric throttle control actuator consists of throttle control motor, throttle position sensor, etc. The throttle control motor is operated by the ECM and it opens and closes the throttle valve. The throttle position sensor detects the throttle valve position, and the opening and closing speed of the throttle valve and feeds the voltage signals to the ECM. The ECM judges the current opening angle of the throttle valve from these signals and the ECM controls the throttle control motor to make the throttle valve opening angle properly in response to driving condition.

### On Board Diagnosis Logic

ABS009JN

This self-diagnosis has the one trip detection logic.

DTC No.	Trouble diagnosis name	DTC detecting condition		Possible cause
P1121 1121	Electric throttle control actuator	A)	Electric throttle control actuator does not function properly due to the return spring malfunction.	● Electric throttle control actuator
		B)	Throttle valve opening angle in fail-safe mode is not in specified range.	
		C)	ECM detects the throttle valve is stuck open.	

### FAIL-SAFE MODE

When the malfunction is detected, ECM enters fail-safe mode and the MIL lights up.

Detected items	Engine operating condition in fail-safe mode
Malfunction A	ECM controls the electric throttle actuator by regulating the throttle opening around the idle position. The engine speed will not rise more than 2,000 rpm.
Malfunction B	ECM controls the electric throttle control actuator by regulating the throttle opening to 20 degrees or less.
Malfunction C	While the vehicle is driving, it slows down gradually by fuel cut. After the vehicle stops, the engine stalls. The engine can restart in N or P position, and engine speed will not exceed 1,000 rpm or more.

### DTC Confirmation Procedure

ABS009JO

#### NOTE:

- Perform PROCEDURE FOR MALFUNCTION A AND B first. If the DTC cannot be confirmed, perform PROCEDURE FOR MALFUNCTION C.
- If DTC Confirmation Procedure has been previously conducted, always turn ignition switch OFF and wait at least 10 seconds before conducting the next test.

#### PROCEDURE FOR MALFUNCTION A AND B

##### With CONSULT-II

1. Turn ignition switch ON and wait at least 1 second.
2. Select "DATA MONITOR" mode with CONSULT-II.
3. Set shift lever to D position (A/T) or 1st position (M/T), and wait at least 3 seconds.
4. Set shift lever to P position (A/T) or Neutral position (M/T).
5. Turn ignition switch OFF and wait at least 10 seconds.
6. Turn ignition switch ON and wait at least 1 second.
7. Set shift lever to D position (A/T) or 1st position (M/T), and wait at least 3 seconds.
8. Set shift lever to P position (A/T) or Neutral position (M/T).
9. Turn ignition switch OFF, wait at least 10 seconds, and then turn ON.
10. If DTC is detected, go to [EC-396, "Diagnostic Procedure"](#).

DATA MONITOR	
MONITOR	NO DTC
ENG SPEED	XXX rpm

SEF058Y

##### With GST

Follow the procedure "With CONSULT-II" above.

# DTC P1121 ELECTRIC THROTTLE CONTROL ACTUATOR

## PROCEDURE FOR MALFUNCTION C

### ① With CONSULT-II

1. Turn ignition switch ON and wait at least 1 second.
2. Select "DATA MONITOR" mode with CONSULT-II.
3. Set shift lever to D position (A/T) or 1st position (M/T) and wait at least 3 seconds.
4. Set shift lever to N, P position (A/T) or Neutral (M/T) position.
5. Start engine and let it idle for 3 seconds.
6. If DTC is detected, go to [EC-396, "Diagnostic Procedure"](#) .

DATA MONITOR	
MONITOR	NO DTC
ENG SPEED	XXX rpm

SEF058Y

### ② With GST

Follow the procedure "With CONSULT-II" above.

## Diagnostic Procedure

ABS009JP

### 1. CHECK ELECTRIC THROTTLE CONTROL ACTUATOR VISUALLY

1. Remove the intake air duct.
2. Check if a foreign matter is caught between the throttle valve and the housing.

#### OK or NG

- OK >> GO TO 2.  
NG >> Remove the foreign matter and clean the electric throttle control actuator inside.

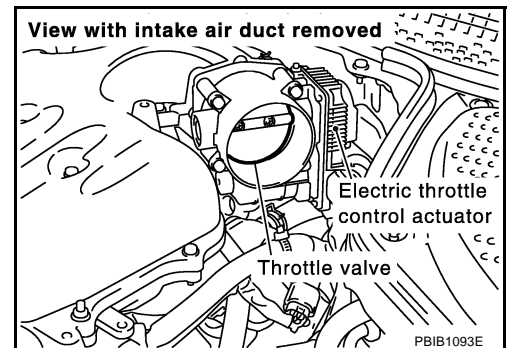

### 2. REPLACE ELECTRIC THROTTLE CONTROL ACTUATOR

1. Replace the electric throttle control actuator.
2. Perform [EC-42, "Throttle Valve Closed Position Learning"](#) .
3. Perform [EC-43, "Idle Air Volume Learning"](#) .

>> INSPECTION END

# DTC P1122 ELECTRIC THROTTLE CONTROL FUNCTION

## DTC P1122 ELECTRIC THROTTLE CONTROL FUNCTION

PF16119

### Description

ABS009JQ

#### NOTE:

If DTC P1122 is displayed with DTC P1121 or 1126, first perform the trouble diagnosis for DTC P1121 or P1126. Refer to [EC-395](#) or [EC-404](#).

Electric throttle control actuator consists of throttle control motor, throttle position sensor, etc.

The throttle control motor is operated by the ECM and it opens and closes the throttle valve.

The current opening angle of the throttle valve is detected by the throttle position sensor and it provides feedback to the ECM to control the throttle control motor to make the throttle valve opening angle properly in response to driving condition.

### On Board Diagnosis Logic

ABS009JR

This self-diagnosis has the one trip detection logic.

DTC No.	Trouble diagnosis name	DTC detecting condition	Possible cause
P1122 1122	Electric throttle control performance problem	Electric throttle control function does not operate properly.	<ul style="list-style-type: none"><li>● Harness or connectors (Throttle control motor circuit is open or shorted)</li><li>● Electric throttle control actuator</li></ul>

### FAIL-SAFE MODE

When the malfunction is detected, ECM enters fail-safe mode and the MIL lights up.

Engine operating condition in fail-safe mode

ECM stops the electric throttle control actuator control, throttle valve is maintained at a fixed opening (approx. 5 degrees) by the return spring.

### DTC Confirmation Procedure

ABS009JS

#### NOTE:

If DTC Confirmation Procedure has been previously conducted, always turn ignition switch OFF and wait at least 10 seconds before conducting the next test.

#### TESTING CONDITION:

Before performing the following procedure, confirm that battery voltage is more than 11V when engine is running.

#### WITH CONSULT-II

1. Turn ignition switch ON and wait at least 2 seconds.
2. Select "DATA MONITOR" mode with CONSULT-II.
3. Start engine and let it idle for 5 seconds.
4. If DTC is detected, go to [EC-400, "Diagnostic Procedure"](#).

DATA MONITOR	
MONITOR	NO DTC
ENG SPEED	XXX rpm

SEF058Y

#### WITH GST

Follow the procedure "WITH CONSULT-II" above.

# DTC P1122 ELECTRIC THROTTLE CONTROL FUNCTION

ABS009JT

## Wiring Diagram

EC-ETC1-01

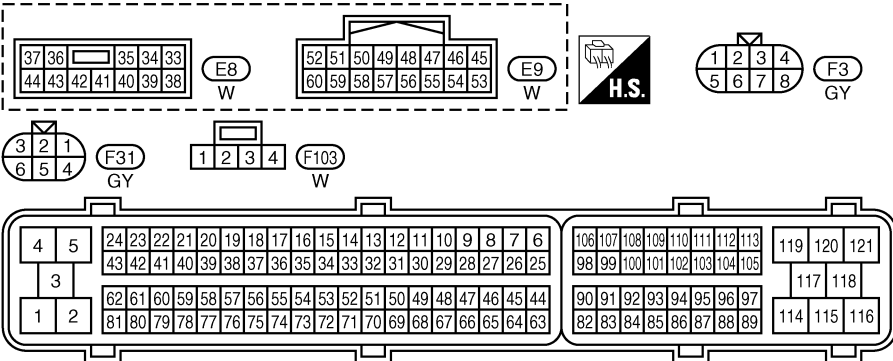
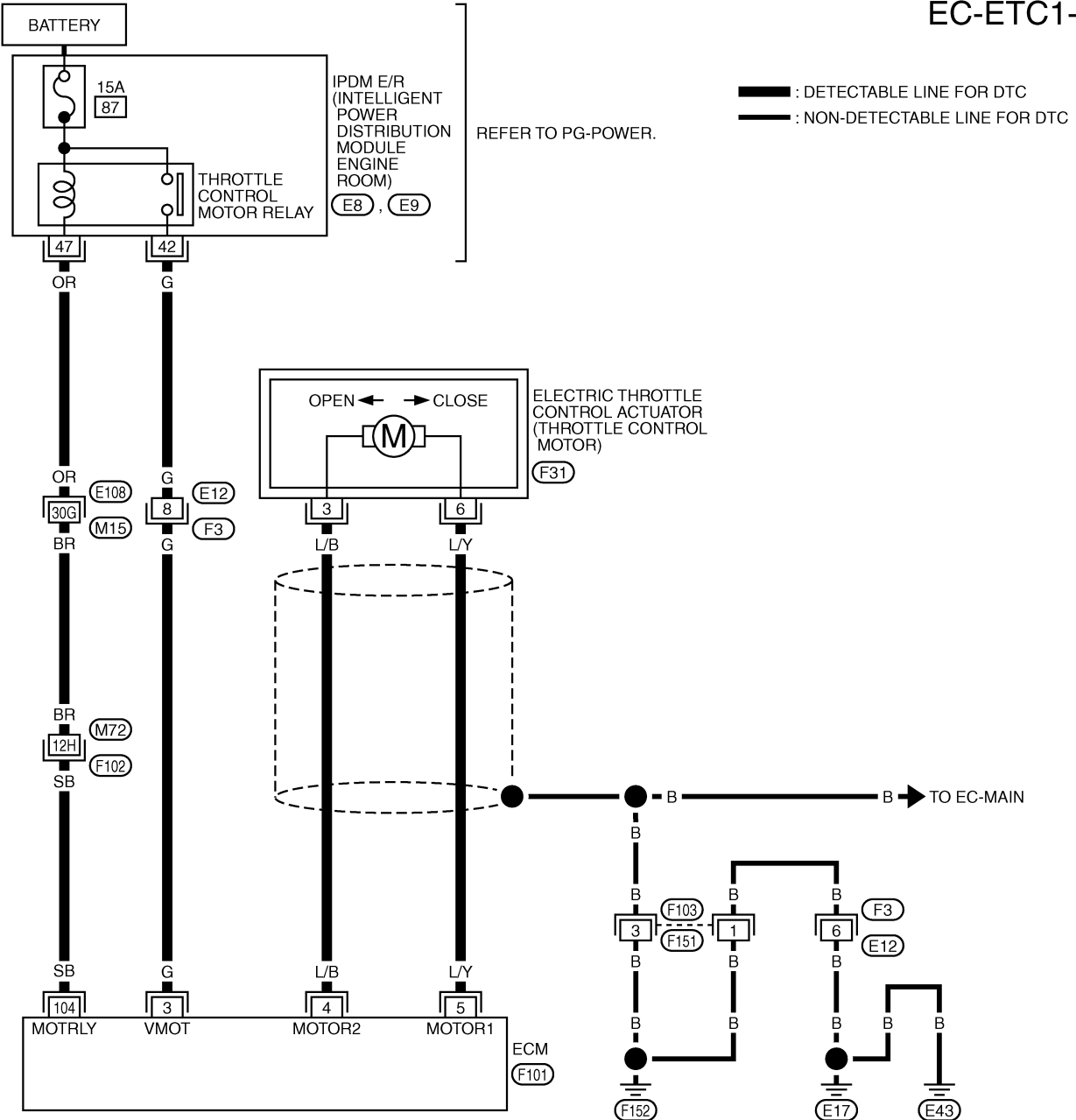

REFER TO THE FOLLOWING.  
 (E108), (F102) -SUPER MULTIPLE JUNCTION (SMJ)



TBWT0626E

# DTC P1122 ELECTRIC THROTTLE CONTROL FUNCTION

Specification data are reference values and are measured between each terminal and ground.  
Pulse signal is measured by CONSULT-II.

**CAUTION:**

**Do not use ECM ground terminals when measuring input/output voltage. Doing so may result in damage to the ECM's transistor. Use a ground other than ECM terminals, such as the ground.**

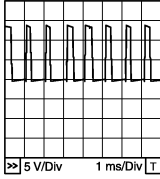
TER-MINAL NO.	WIRE COLOR	ITEM	CONDITION	DATA (DC Voltage)
3	G	Throttle control motor relay power supply	<b>[Ignition switch: ON]</b>	BATTERY VOLTAGE (11 - 14V)
4	L/B	Throttle control motor (Close)	<b>[Ignition switch: ON]</b> <ul style="list-style-type: none"> <li>● Engine stopped</li> <li>● Shift lever: D (A/T) or 1st (M/T)</li> <li>● Accelerator pedal is fully released</li> </ul>	0 - 14V★ 
5	L/Y	Throttle control motor (Open)	<b>[Ignition switch: ON]</b> <ul style="list-style-type: none"> <li>● Engine stopped</li> <li>● Shift lever: D (A/T) or 1st (M/T)</li> <li>● Accelerator pedal is fully depressed</li> </ul>	0 - 14V★ 
104	SB	Throttle control motor relay	<b>[Ignition switch: OFF]</b>	BATTERY VOLTAGE (11 - 14V)
			<b>[Ignition switch: ON]</b>	0 - 1.0V

★: Average voltage for pulse signal (Actual pulse signal can be confirmed by oscilloscope.)

A  
EC  
C  
D  
E  
F  
G  
H  
I  
J  
K  
L  
M

# DTC P1122 ELECTRIC THROTTLE CONTROL FUNCTION

ABS009JU

## Diagnostic Procedure

### 1. CHECK GROUND CONNECTIONS

1. Turn ignition switch OFF.
2. Loosen and retighten three ground screws on the body. Refer to [EC-138, "Ground Inspection"](#).

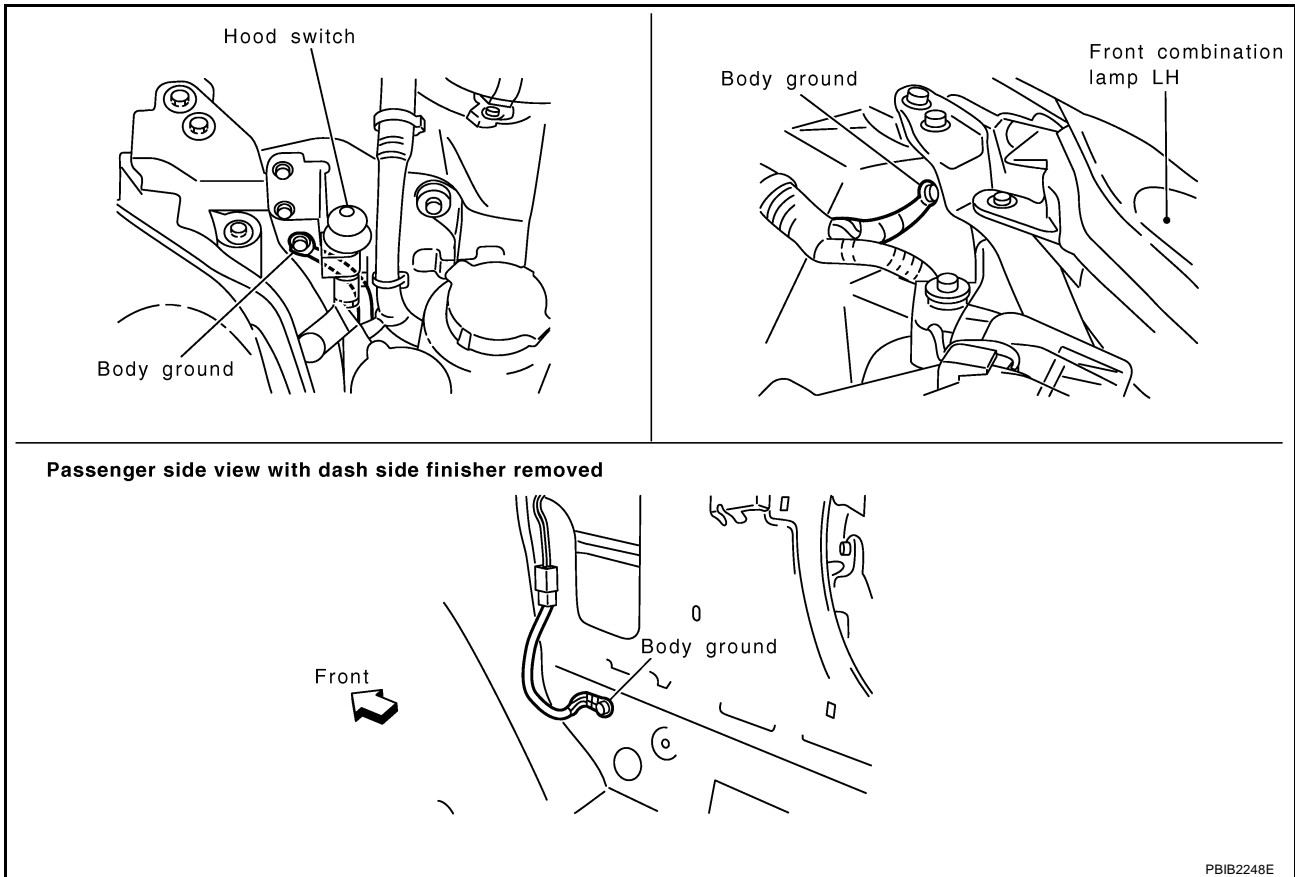

OK or NG

- OK >> GO TO 2.  
 NG >> Repair or replace ground connections.

### 2. CHECK THROTTLE CONTROL MOTOR RELAY INPUT SIGNAL CIRCUIT-I

Check voltage between ECM terminal 3 and ground under the following conditions with CONSULT-II or tester.

Ignition switch	Voltage
OFF	Approximately 0V
ON	Battery voltage (11 - 14V)

OK or NG

- OK >> GO TO 10.  
 NG >> GO TO 3.

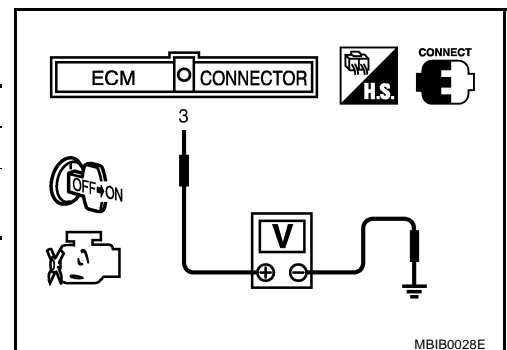



# DTC P1122 ELECTRIC THROTTLE CONTROL FUNCTION

## 3. CHECK THROTTLE CONTROL MOTOR RELAY INPUT SIGNAL CIRCUIT-II

1. Turn ignition switch OFF.
2. Disconnect ECM harness connector.
3. Disconnect IPDM E/R harness connector E8.
4. Check continuity between ECM terminal 3 and IPDM E/R terminal 42.  
Refer to Wiring Diagram.

**Continuity should exist.**

5. Also check harness for short to ground and short to power.

OK or NG

- OK >> GO TO 5.  
NG >> GO TO 4.

## 4. DETECT MALFUNCTIONING PART

Check the following.

- Harness connectors E12, F3
- Harness for open or short between ECM and IPDM E/R

>> Repair open circuit or short to ground or short to power in harness or connectors.

## 5. CHECK THROTTLE CONTROL MOTOR RELAY POWER SUPPLY CIRCUIT-I

1. Turn ignition switch ON.
2. Reconnect all harness connectors disconnected.
3. Check voltage between ECM terminal 104 and ground with CONSULT-II or tester.

**Voltage: Battery voltage**

OK or NG

- OK >> GO TO 9.  
NG >> GO TO 6.

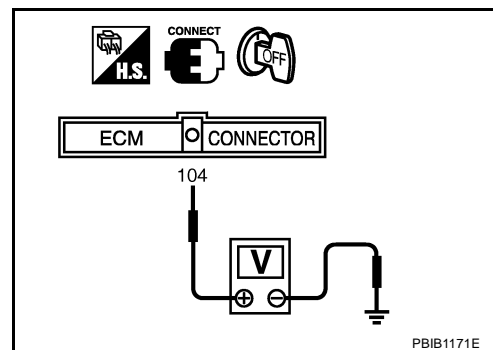

## 6. CHECK THROTTLE CONTROL MOTOR RELAY POWER SUPPLY CIRCUIT-II

1. Disconnect ECM harness connector.
2. Disconnect IPDM E/R harness connector E9.
3. Check continuity between ECM terminal 104 and IPDM E/R terminal 47.  
Refer to Wiring Diagram.

**Continuity should exist.**

4. Also check harness for short to ground and short to power.

OK or NG

- OK >> GO TO 8.  
NG >> GO TO 7.

# DTC P1122 ELECTRIC THROTTLE CONTROL FUNCTION

## 7. DETECT MALFUNCTIONING PART

Check the following.

- Harness connectors E108, M15
- Harness connectors M72, F102
- Harness for open or short between ECM and IPDM E/R

>> Repair open circuit or short to ground or short to power in harness or connectors.

## 8. CHECK FUSE

1. Disconnect 15A fuse.
2. Check 15A fuse for blown.

OK or NG

OK >> GO TO 9.

NG >> Replace 15A fuse.

## 9. CHECK INTERMITTENT INCIDENT

Refer to [EC-129, "TROUBLE DIAGNOSIS FOR INTERMITTENT INCIDENT"](#) .

OK or NG

OK >> Replace IPDM E/R. Refer to [PG-17, "IPDM E/R \(INTELLIGENT POWER DISTRIBUTION MODULE ENGINE ROOM\)"](#) .

NG >> Repair or replace harness or connectors.

## 10. CHECK THROTTLE CONTROL MOTOR OUTPUT SIGNAL CIRCUIT FOR OPEN OR SHORT

1. Turn ignition switch OFF.
2. Disconnect electric throttle control actuator harness connector.
3. Disconnect ECM harness connector.
4. Check harness continuity between the following terminals. Refer to Wiring Diagram.

Electric throttle control actuator terminal	ECM terminal	Continuity
3	5	Should not exist
	4	Should exist
6	5	Should exist
	4	Should not exist

5. Also check harness for short to ground and short to power.

OK or NG

OK >> GO TO 11.

NG >> Repair or replace.

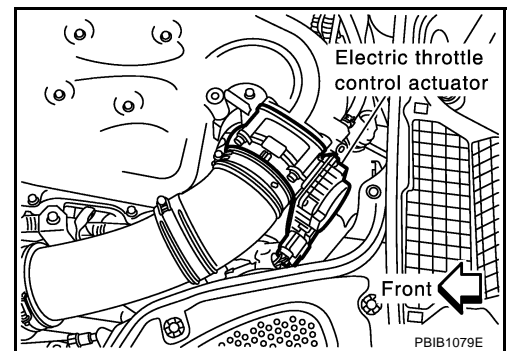

# DTC P1122 ELECTRIC THROTTLE CONTROL FUNCTION

## 11. CHECK ELECTRIC THROTTLE CONTROL ACTUATOR VISUALLY

1. Remove the intake air duct.
2. Check if foreign matter is caught between the throttle valve and the housing.

OK or NG

OK >> GO TO 12.

NG >> Remove the foreign matter and clean the electric throttle control actuator inside.

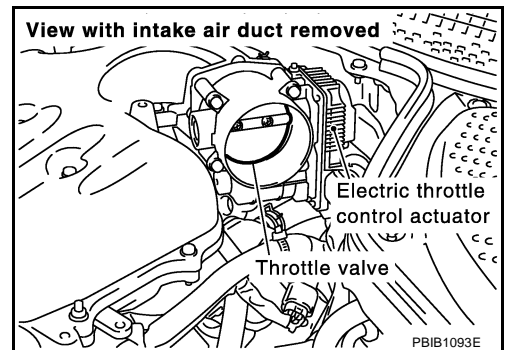

## 12. CHECK THROTTLE CONTROL MOTOR

Refer to [EC-403, "Component Inspection"](#) .

OK or NG

OK >> GO TO 13.

NG >> GO TO 14.

## 13. CHECK INTERMITTENT INCIDENT

Refer to [EC-129, "TROUBLE DIAGNOSIS FOR INTERMITTENT INCIDENT"](#) .

OK or NG

OK >> GO TO 14.

NG >> Repair or replace harness or connectors.

## 14. REPLACE ELECTRIC THROTTLE CONTROL ACTUATOR

1. Replace the electric throttle control actuator.
2. Perform [EC-42, "Throttle Valve Closed Position Learning"](#) .
3. Perform [EC-43, "Idle Air Volume Learning"](#) .

>> INSPECTION END

### Component Inspection THROTTLE CONTROL MOTOR

ABS009JV

1. Disconnect electric throttle control actuator harness connector.
2. Check resistance between terminals 3 and 6.

**Resistance: Approximately 1 - 15  $\Omega$  [at 25 °C (77°F)]**

3. If NG, replace electric throttle control actuator and go to next step.
4. Perform [EC-42, "Throttle Valve Closed Position Learning"](#) .
5. Perform [EC-43, "Idle Air Volume Learning"](#) .

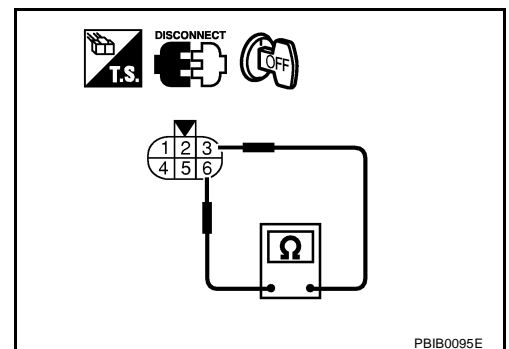

ABS009JW

### Removal and Installation ELECTRIC THROTTLE CONTROL ACTUATOR

Refer to [EM-16, "INTAKE MANIFOLD COLLECTOR"](#) .

# DTC P1124, P1126 THROTTLE CONTROL MOTOR RELAY

## DTC P1124, P1126 THROTTLE CONTROL MOTOR RELAY

PFP:16119

### Component Description

ABS009JX

Power supply for the throttle control motor is provided to the ECM via throttle control motor relay. The throttle control motor relay is ON/OFF controlled by the ECM. When the ignition switch is turned ON, the ECM sends an ON signal to throttle control motor relay and battery voltage is provided to the ECM. When the ignition switch is turned OFF, the ECM sends an OFF signal to throttle control motor relay and battery voltage is not provided to the ECM.

### CONSULT-II Reference Value in Data Monitor Mode

ABS009JY

Specification data are reference values.

MONITOR ITEM	CONDITION	SPECIFICATION
THRTL RELAY	● Ignition switch: ON	ON

### On Board Diagnosis Logic

ABS009JZ

These self-diagnoses have the one trip detection logic.

DTC No.	Trouble diagnosis name	DTC detecting condition	Possible cause
P1124 1124	Throttle control motor relay circuit short	ECM detect the throttle control motor relay is stuck ON.	<ul style="list-style-type: none"><li>● Harness or connectors (Throttle control motor relay circuit is shorted)</li><li>● Throttle control motor relay</li></ul>
P1126 1126	Throttle control motor relay circuit open	ECM detects a voltage of power source for throttle control motor is excessively low.	<ul style="list-style-type: none"><li>● Harness or connectors (Throttle control motor relay circuit is open)</li><li>● Throttle control motor relay</li></ul>

### FAIL-SAFE MODE

When the malfunction is detected, ECM enters fail-safe mode and the MIL lights up.

Engine operating condition in fail-safe mode

ECM stops the electric throttle control actuator control, throttle valve is maintained at a fixed opening (approx. 5 degrees) by the return spring.

### DTC Confirmation Procedure

ABS009K0

#### NOTE:

If DTC Confirmation Procedure has been previously conducted, always turn ignition switch OFF and wait at least 10 seconds before conducting the next test.

#### PROCEDURE FOR DTC P1124

##### TESTING CONDITION:

Before performing the following procedure, confirm that battery voltage is more than 8V.

##### ☑ With CONSULT-II

1. Turn ignition switch ON and wait at least 1 second.
2. Select "DATA MONITOR" mode with CONSULT-II.
3. If DTC is detected, go to [EC-407, "Diagnostic Procedure"](#).

DATA MONITOR	
MONITOR	NO DTC
ENG SPEED	XXX rpm

SEF058Y

# DTC P1124, P1126 THROTTLE CONTROL MOTOR RELAY

## With GST

Follow the procedure "With CONSULT-II" above.

### PROCEDURE FOR DTC P1126

#### With CONSULT-II

1. Turn ignition switch ON and wait at least 2 seconds.
2. Select "DATA MONITOR" mode with CONSULT-II.
3. Start engine and let it idle for 5 seconds.
4. If DTC is detected, go to [EC-407, "Diagnostic Procedure"](#) .

DATA MONITOR	
MONITOR	NO DTC
ENG SPEED	XXX rpm

SEF058Y

## With GST

Follow the procedure "With CONSULT-II" above.

A

EC

C

D

E

F

G

H

I

J

K

L

M



# DTC P1124, P1126 THROTTLE CONTROL MOTOR RELAY

Specification data are reference values and are measured between each terminal and ground.

## CAUTION:

Do not use ECM ground terminals when measuring input/output voltage. Doing so may result in damage to the ECM's transistor. Use a ground other than ECM terminals, such as the ground.

TER-MINAL NO.	WIRE COLOR	ITEM	CONDITION	DATA (DC Voltage)
3	G	Throttle control motor relay power supply	[Ignition switch: ON]	BATTERY VOLTAGE (11 - 14V)
104	SB	Throttle control motor relay	[Ignition switch: OFF]	BATTERY VOLTAGE (11 - 14V)
			[Ignition switch: ON]	0 - 1.0V

## Diagnostic Procedure

ABS009K2

### 1. CHECK THROTTLE CONTROL MOTOR RELAY POWER SUPPLY CIRCUIT-I

1. Turn ignition switch OFF.
2. Check voltage between ECM terminal 104 and ground with CONSULT-II or tester.

**Voltage: Battery voltage**

OK or NG

- OK >> GO TO 5.  
NG >> GO TO 2.

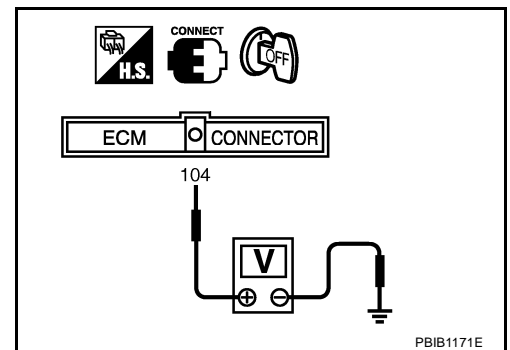

### 2. CHECK THROTTLE CONTROL MOTOR RELAY POWER SUPPLY CIRCUIT-II

1. Disconnect ECM harness connector.
2. Disconnect IPDM E/R harness connector E9.
3. Check continuity between ECM terminal 104 and IPDM E/R terminal 47. Refer to Wiring Diagram.

**Continuity should exist.**

4. Also check harness for short to ground and short to power.

OK or NG

- OK >> GO TO 4.  
NG >> GO TO 3.

### 3. DETECT MALFUNCTIONING PART

Check the following.

- Harness connectors E108, M15
- Harness connectors M72, F102
- Harness for open or short between ECM and IPDM E/R

>> Repair open circuit or short to ground or short to power in harness or connectors.

# DTC P1124, P1126 THROTTLE CONTROL MOTOR RELAY

## 4. CHECK FUSE

1. Disconnect 15A fuse.
2. Check 15A fuse for blown.

OK or NG

- OK >> GO TO 8.  
NG >> Replace 15A fuse.

## 5. CHECK THROTTLE CONTROL MOTOR RELAY INPUT SIGNAL CIRCUIT-I

1. Turn ignition switch ON.
2. Check voltage between ECM terminal 3 and ground under the following conditions with CONSULT-II or tester.

Ignition switch	Voltage
OFF	Approximately 0V
ON	Battery voltage (11 - 14V)

OK or NG

- OK >> GO TO 8.  
NG >> GO TO 6.

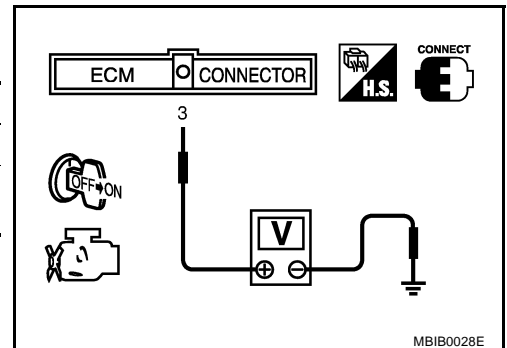

## 6. CHECK THROTTLE CONTROL MOTOR RELAY INPUT SIGNAL CIRCUIT-II

1. Turn ignition switch OFF.
2. Disconnect ECM harness connector.
3. Disconnect IPDM E/R harness connector E8.
4. Check continuity between ECM terminal 3 and IPDM E/R terminal 42. Refer to Wiring Diagram.

**Continuity should exist.**

5. Also check harness for short to ground and short to power.

OK or NG

- OK >> GO TO 8.  
NG >> GO TO 7.

## 7. DETECT MALFUNCTIONING PART

Check the following.

- Harness connectors E12, F3
- Harness for open or short between ECM and IPDM E/R

>> Repair open circuit or short to ground or short to power in harness or connectors.

## 8. CHECK INTERMITTENT INCIDENT

Refer to [EC-129, "TROUBLE DIAGNOSIS FOR INTERMITTENT INCIDENT"](#) .

OK or NG

- OK >> Replace IPDM E/R. Refer to [PG-17, "IPDM E/R \(INTELLIGENT POWER DISTRIBUTION MODULE ENGINE ROOM\)"](#) .  
NG >> Repair or replace harness or connectors.



# DTC P1128 THROTTLE CONTROL MOTOR

## DTC P1128 THROTTLE CONTROL MOTOR

PF16119

### Component Description

ABS009K3

The throttle control motor is operated by the ECM and it opens and closes the throttle valve. The current opening angle of the throttle valve is detected by the throttle position sensor and it provides feedback to the ECM to control the throttle control motor to make the throttle valve opening angle properly in response to driving condition.

### On Board Diagnosis Logic

ABS009K4

This self-diagnosis has the one trip detection logic.

DTC No.	Trouble diagnosis name	DTC detecting condition	Possible cause
P1128 1128	Throttle control motor circuit short	ECM detects short in both circuits between ECM and throttle control motor.	<ul style="list-style-type: none"><li>● Harness or connectors (Throttle control motor circuit is shorted.)</li><li>● Electric throttle control actuator (Throttle control motor)</li></ul>

### FAIL-SAFE MODE

When the malfunction is detected, the ECM enters fail-safe mode and the MIL lights up.

Engine operating condition in fail-safe mode

ECM stops the electric throttle control actuator control, throttle valve is maintained at a fixed opening (approx. 5 degrees) by the return spring.

### DTC Confirmation Procedure

ABS009K5

#### NOTE:

If DTC Confirmation Procedure has been previously conducted, always turn ignition switch OFF and wait at least 10 seconds before conducting the next test.

#### WITH CONSULT-II

1. Turn ignition switch ON and wait at least 2 seconds.
2. Select "DATA MONITOR" mode with CONSULT-II.
3. Start engine and let it idle for 5 seconds.
4. If DTC is detected, go to [EC-412. "Diagnostic Procedure"](#).

DATA MONITOR	
MONITOR	NO DTC
ENG SPEED	XXX rpm

SEF058Y

#### WITH GST

Follow the procedure "WITH CONSULT-II" above.

# DTC P1128 THROTTLE CONTROL MOTOR

ABS009K6

EC-ETC3-01

## Wiring Diagram

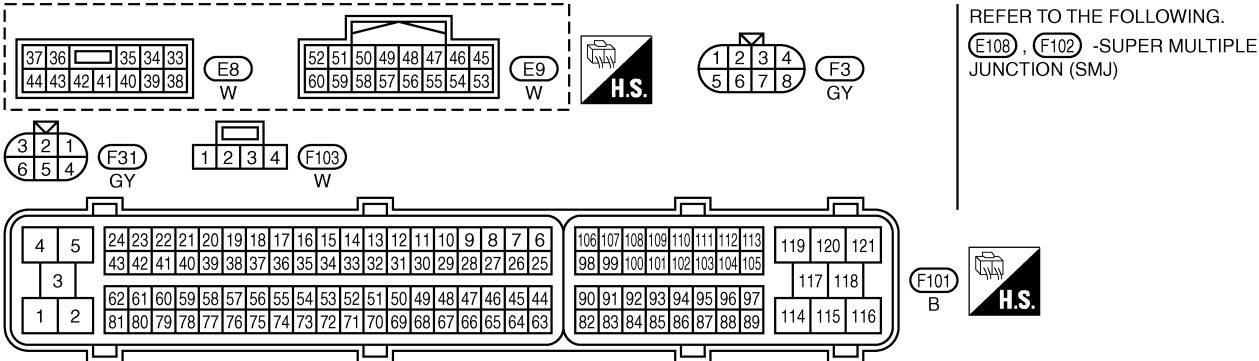
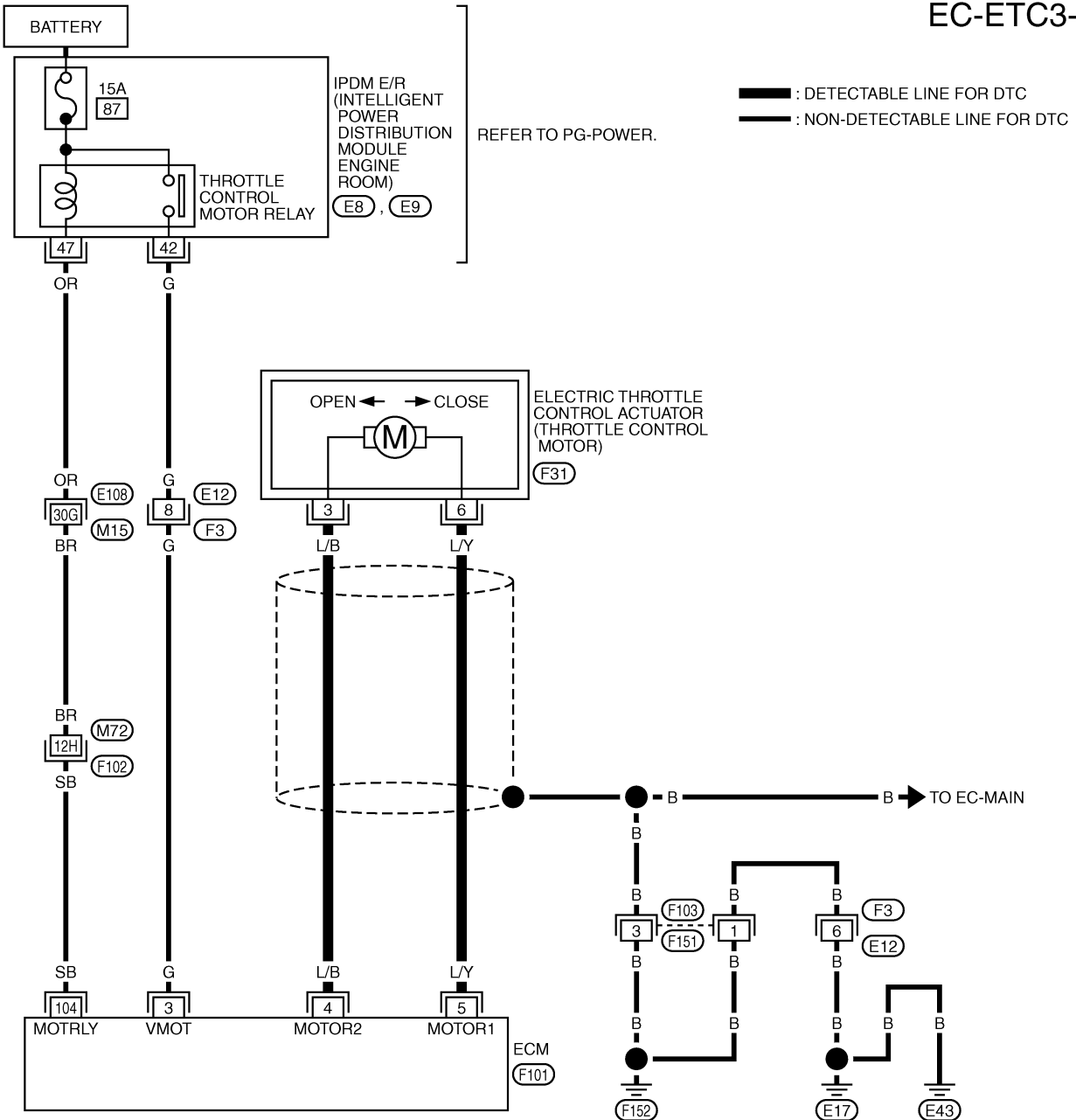

TBWT0626E

# DTC P1128 THROTTLE CONTROL MOTOR

Specification data are reference values and are measured between each terminal and ground.  
Pulse signal is measured by CONSULT-II.

**CAUTION:**

**Do not use ECM ground terminals when measuring input/output voltage. Doing so may result in damage to the ECM's transistor. Use a ground other than ECM terminals, such as the ground.**

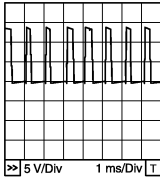
TER-MINAL NO.	WIRE COLOR	ITEM	CONDITION	DATA (DC Voltage)
4	L/B	Throttle control motor (Close)	<p><b>[Ignition switch: ON]</b></p> <ul style="list-style-type: none"> <li>● Engine stopped</li> <li>● Shift lever: D (A/T) or 1st (M/T)</li> <li>● Accelerator pedal is fully released</li> </ul>	<p>0 - 14V★</p>  <p style="text-align: right; font-size: small;">PBIB1104E</p>
5	L/Y	Throttle control motor (Open)	<p><b>[Ignition switch: ON]</b></p> <ul style="list-style-type: none"> <li>● Engine stopped</li> <li>● Shift lever: D (A/T) or 1st (M/T)</li> <li>● Accelerator pedal is fully depressed</li> </ul>	<p>0 - 14V★</p>  <p style="text-align: right; font-size: small;">PBIB1105E</p>

★: Average voltage for pulse signal (Actual pulse signal can be confirmed by oscilloscope.)

A  
EC  
C  
D  
E  
F  
G  
H  
I  
J  
K  
L  
M

# DTC P1128 THROTTLE CONTROL MOTOR

ABS009K7

## Diagnostic Procedure

### 1. CHECK GROUND CONNECTIONS

1. Turn ignition switch OFF.
2. Loosen and retighten three ground screws on the body. Refer to [EC-138, "Ground Inspection"](#).

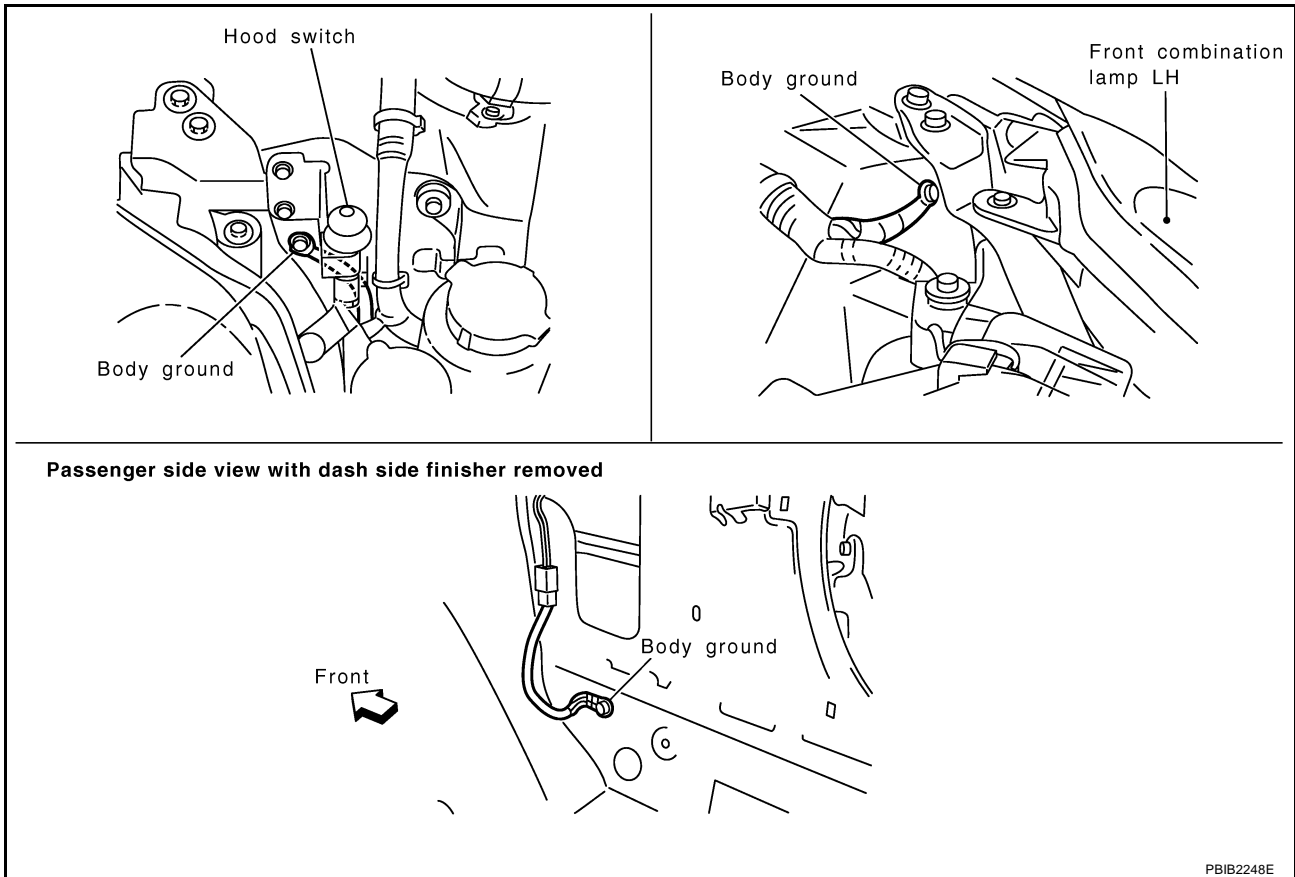

OK or NG

- OK >> GO TO 2.  
 NG >> Repair or replace ground connections.

### 2. CHECK THROTTLE CONTROL MOTOR OUTPUT SIGNAL CIRCUIT FOR OPEN OR SHORT

1. Turn ignition switch OFF.
2. Disconnect electric throttle control actuator harness connector.
3. Disconnect ECM harness connector.
4. Check harness continuity between the following terminals. Refer to Wiring Diagram.

Electric throttle control actuator terminal	ECM terminal	Continuity
3	5	Should not exist
	4	Should exist
6	5	Should exist
	4	Should not exist

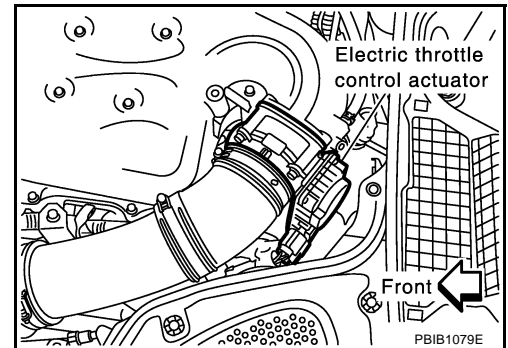

5. Also check harness for short to ground and short to power.

OK or NG

- OK >> GO TO 3.  
 NG >> Repair or replace.

# DTC P1128 THROTTLE CONTROL MOTOR

## 3. CHECK THROTTLE CONTROL MOTOR

Refer to [EC-413, "Component Inspection"](#) .

OK or NG

- OK >> GO TO 4.
- NG >> GO TO 5.

## 4. CHECK INTERMITTENT INCIDENT

Refer to [EC-129, "TROUBLE DIAGNOSIS FOR INTERMITTENT INCIDENT"](#) .

OK or NG

- OK >> GO TO 5.
- NG >> Repair or replace harness or connectors.

## 5. REPLACE ELECTRIC THROTTLE CONTROL ACTUATOR

1. Replace the electric throttle control actuator.
2. Perform [EC-42, "Throttle Valve Closed Position Learning"](#) .
3. Perform [EC-43, "Idle Air Volume Learning"](#) .

>> INSPECTION END

### Component Inspection THROTTLE CONTROL MOTOR

ABS009K8

1. Disconnect electric throttle control actuator harness connector.
2. Check resistance between terminals 3 and 6.

**Resistance: Approximately 1 - 15  $\Omega$  [at 25 °C (77°F)]**

3. If NG, replace electric throttle control actuator and go to next step.
4. Perform [EC-42, "Throttle Valve Closed Position Learning"](#) .
5. Perform [EC-43, "Idle Air Volume Learning"](#) .

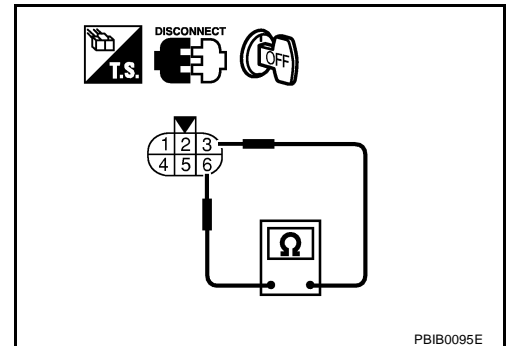

PBIB0095E

### Removal and Installation ELECTRIC THROTTLE CONTROL ACTUATOR

ABS009K9

Refer to [EM-16, "INTAKE MANIFOLD COLLECTOR"](#) .

**DTC P1146, P1166 HO2S2**

**Component Description**

ABS009KO

The heated oxygen sensor 2, after three way catalyst 1, monitors the oxygen level in the exhaust gas on each bank.

Even if switching characteristics of the air fuel ratio (A/F) sensor 1 are shifted, the air-fuel ratio is controlled to stoichiometric, by the signal from the heated oxygen sensor 2.

This sensor is made of ceramic zirconia. The zirconia generates voltage from approximately 1V in richer conditions to 0V in leaner conditions.

Under normal conditions the heated oxygen sensor 2 is not used for engine control operation.

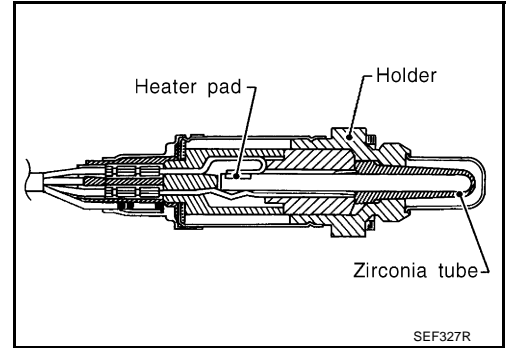

**CONSULT-II Reference Value in Data Monitor Mode**

ABS009KS

Specification data are reference values.

MONITOR ITEM	CONDITION		SPECIFICATION
HO2S2 (B1) HO2S2 (B2)	<ul style="list-style-type: none"> <li>● Warm-up condition</li> <li>● After keeping engine speed between 3,500 and 4,000 rpm for 1 minute and at idle for 1 minute under no load.</li> </ul>	Revsing engine from idle to 3,000 rpm quickly.	0 - 0.3V ↔ Approx. 0.6 - 1.0V
HO2S2 MNTR (B1) HO2S2 MNTR (B2)			LEAN ↔ RICH

**On Board Diagnosis Logic**

ABS009KS

The heated oxygen sensor 2 has a much longer switching time between rich and lean than the air fuel ratio (A/F) sensor 1. The oxygen storage capacity of the three way catalyst causes the longer switching time. To judge the malfunctions of heated oxygen sensor 2, ECM monitors whether the minimum voltage of sensor is sufficiently low during the various driving condition such as fuel-cut.

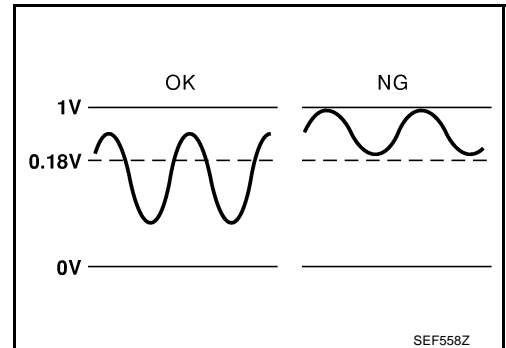

DTC No.	Trouble diagnosis name	DTC detecting condition	Possible cause
P1146 1146 (Bank 1)	Heated oxygen sensor 2 minimum voltage monitoring	The minimum voltage from the sensor is not reached to the specified voltage.	<ul style="list-style-type: none"> <li>● Harness or connectors (The sensor circuit is open or shorted)</li> <li>● Heated oxygen sensor 2</li> <li>● Fuel pressure</li> <li>● Fuel injector</li> </ul>
P1166 1166 (Bank 2)			

# DTC P1146, P1166 HO2S2

ABS009KT

## DTC Confirmation Procedure

### NOTE:

If DTC confirmation Procedure has been previously conducted, always turn ignition switch OFF and wait at least 10 seconds before conducting the next test.

### Ⓟ WITH CONSULT-II

#### TESTING CONDITION:

For better results, perform "DTC WORK SUPPORT" at a temperature of 0 to 30 °C (32 to 86 °F).

1. Turn ignition switch ON and select "DATA MONITOR" mode with CONSULT-II.
2. Start engine and warm it up to the normal operating temperature.
3. Turn ignition switch OFF and wait at least 10 seconds.
4. Start engine and keep the engine speed between 3,500 and 4,000 rpm for at least 1 minute under no load.
5. Let engine idle for 1 minute.
6. Make sure that "COOLAN TEMP/S" indicates more than 70°C (158°F).  
If not, warm up engine and go to next step when "COOLAN TEMP/S" indication reaches to 70°C (158°F).
7. Open engine hood.
8. Select "HO2S2 (B1) P1146" or "HO2S2 (B2) P1166" of "HO2S2" in "DTC WORK SUPPORT" mode with CONSULT-II.
9. Start engine and following the instruction of CONSULT-II.

DATA MONITOR	
MONITOR	NO DTC
ENG SPEED	XXX rpm
COOLAN TEMP/S	XXX °C

SEF174Y

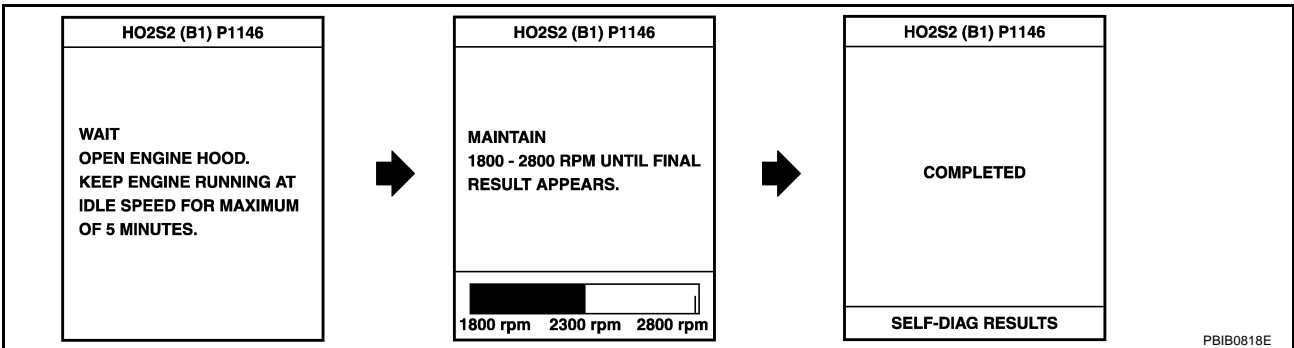

10. Make sure that "OK" is displayed after touching "SELF-DIAG RESULTS".  
If "NG" is displayed, refer to [EC-420, "Diagnostic Procedure"](#).  
If "CAN NOT BE DIAGNOSED" is displayed, perform the following.
  - a. Turn ignition switch OFF and leave the vehicle in a cool place (soak the vehicle).
  - b. Return to step 1.

## Overall Function Check

ABS009KU

Use this procedure to check the overall function of the heated oxygen sensor 2 circuit. During this check, a 1st trip DTC might not be confirmed.

### Ⓟ WITH GST

1. Start engine and warm it up to the normal operating temperature.
2. Turn ignition switch OFF and wait at least 10 seconds.
3. Start engine and keep the engine speed between 3,500 and 4,000 rpm for at least 1 minute under no load.
4. Let engine idle for 1 minute.
5. Set voltmeter probes between ECM terminal 74 [HO2S2 (B1) signal] or 55 [HO2S2 (B2) signal] and ground.

## DTC P1146, P1166 HO2S2

6. Check the voltage when revving up to 4,000 rpm under no load at least 10 times.  
(Depress and release accelerator pedal as soon as possible.)  
**The voltage should be below 0.18V at least once during this procedure.**  
**If the voltage can be confirmed in step 6, step 7 is not necessary.**
7. Keep vehicle at idling for 10 minutes, then check the voltage. Or check the voltage when coasting from 80 km/h (50 MPH) in D position (A/T), 4th gear (M/T).  
**The voltage should be below 0.18V at least once during this procedure.**
8. If NG, go to [EC-420, "Diagnostic Procedure"](#).

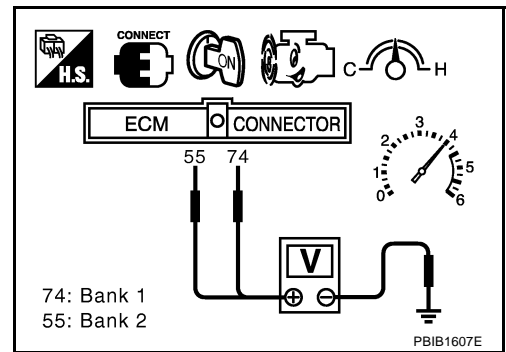



# DTC P1146, P1166 HO2S2

ABS009KV

## Wiring Diagram BANK 1

### EC-O2S2B1-01

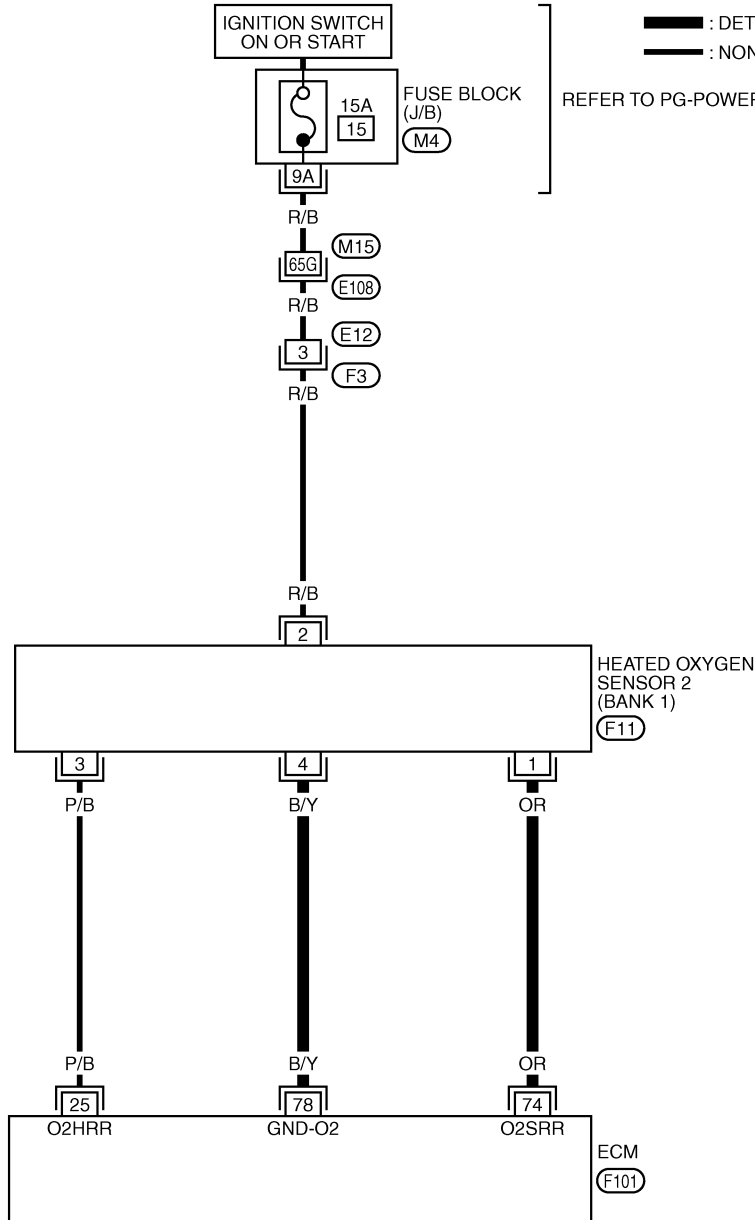

REFER TO THE FOLLOWING.

- E108 -SUPER MULTIPLE JUNCTION (SMJ)
- M4 -FUSE BLOCK-JUNCTION BOX (J/B)

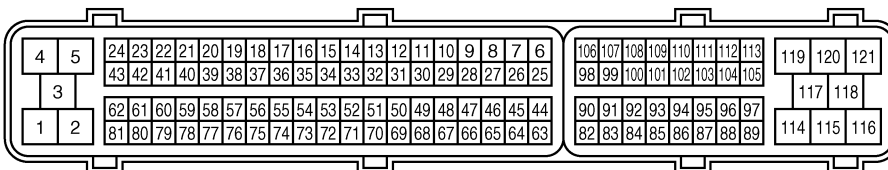

TBWT0482E

## DTC P1146, P1166 HO2S2

Specification data are reference values and are measured between each terminal and ground.

**CAUTION:**

**Do not use ECM ground terminals when measuring input/output voltage. Doing so may result in damage to the ECM's transistor. Use a ground other than ECM terminals, such as the ground.**

TER-MINAL NO.	WIRE COLOR	ITEM	CONDITION	DATA (DC Voltage)
74	OR	Heated oxygen sensor 2 (bank 1)	<b>[Engine is running]</b> <ul style="list-style-type: none"><li>● <b>Warm-up condition</b></li><li>● Revving engine from idle to 3,000 rpm quickly after the following conditions are met.</li><li>– After keeping the engine speed between 3,500 and 4,000 rpm for 1 minute and at idle for 1 minute under no load.</li></ul>	0 - Approximately 1.0V
78	B/Y	Sensor ground (Heated oxygen sensor)	<b>[Engine is running]</b> <ul style="list-style-type: none"><li>● <b>Warm-up condition</b></li><li>● Idle speed</li></ul>	Approximately 0V

# DTC P1146, P1166 HO2S2

**BANK 2**

**EC-O2S2B2-01**

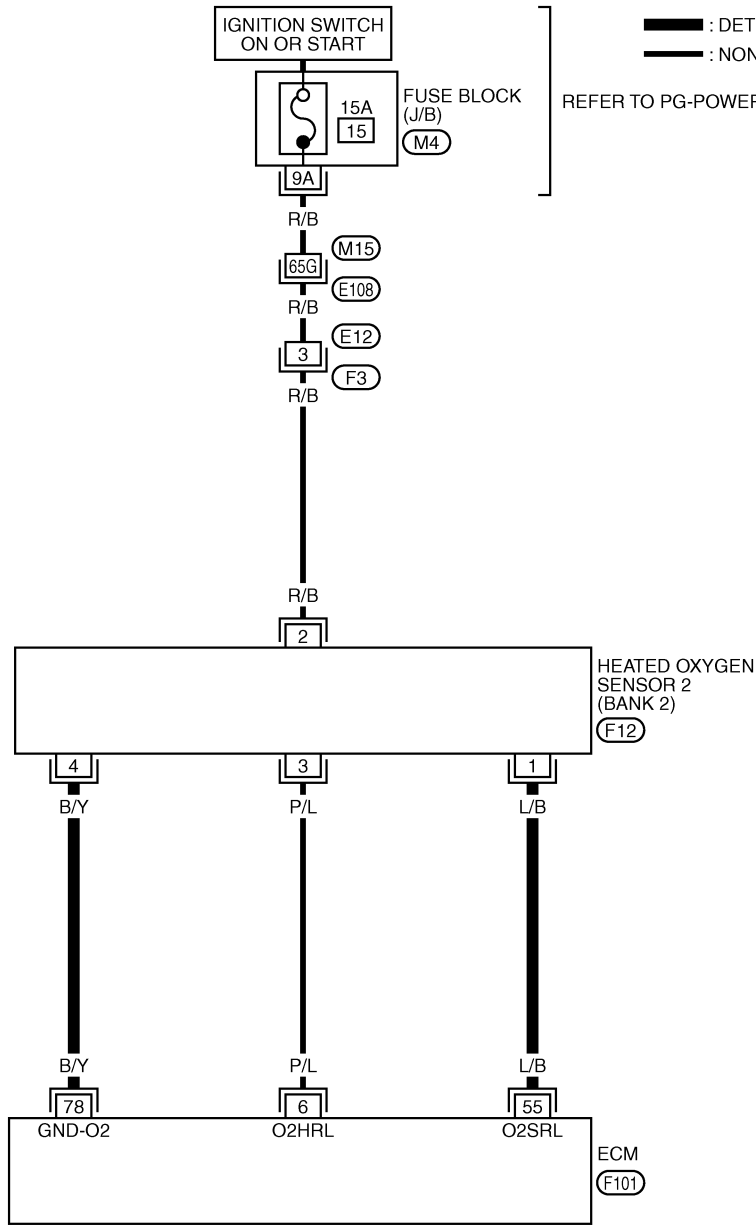

: DETECTABLE LINE FOR DTC  
 : NON-DETECTABLE LINE FOR DTC

REFER TO PG-POWER.



REFER TO THE FOLLOWING.

- E108** -SUPER MULTIPLE JUNCTION (SMJ)
- M4** -FUSE BLOCK-JUNCTION BOX (J/B)

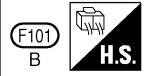
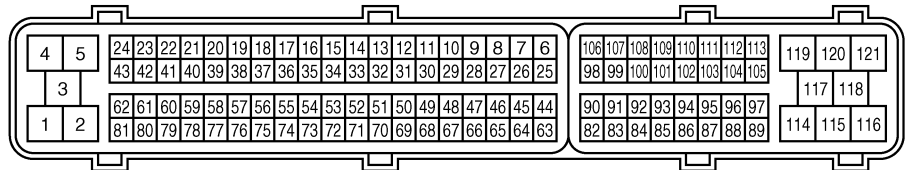

TBWT0483E

# DTC P1146, P1166 HO2S2

Specification data are reference values and are measured between each terminal and ground.

**CAUTION:**

Do not use ECM ground terminals when measuring input/output voltage. Doing so may result in damage to the ECM's transistor. Use a ground other than ECM terminals, such as the ground.

TER-MINAL NO.	WIRE COLOR	ITEM	CONDITION	DATA (DC Voltage)
55	L/B	Heated oxygen sensor 2 (bank 2)	<p>[Engine is running]</p> <ul style="list-style-type: none"> <li>● Warm-up condition</li> <li>● Revving engine from idle to 3,000 rpm quickly after the following conditions are met.</li> <li>– After keeping the engine speed between 3,500 and 4,000 rpm for 1 minute and at idle for 1 minute under no load.</li> </ul>	0 - Approximately 1.0V
78	B/Y	Sensor ground (Heated oxygen sensor)	<p>[Engine is running]</p> <ul style="list-style-type: none"> <li>● Warm-up condition</li> <li>● Idle speed</li> </ul>	Approximately 0V

## Diagnostic Procedure

ABS009KW

### 1. CHECK GROUND CONNECTIONS

1. Turn ignition switch OFF.
2. Loosen and retighten three ground screws on the body. Refer to [EC-138, "Ground Inspection"](#) .

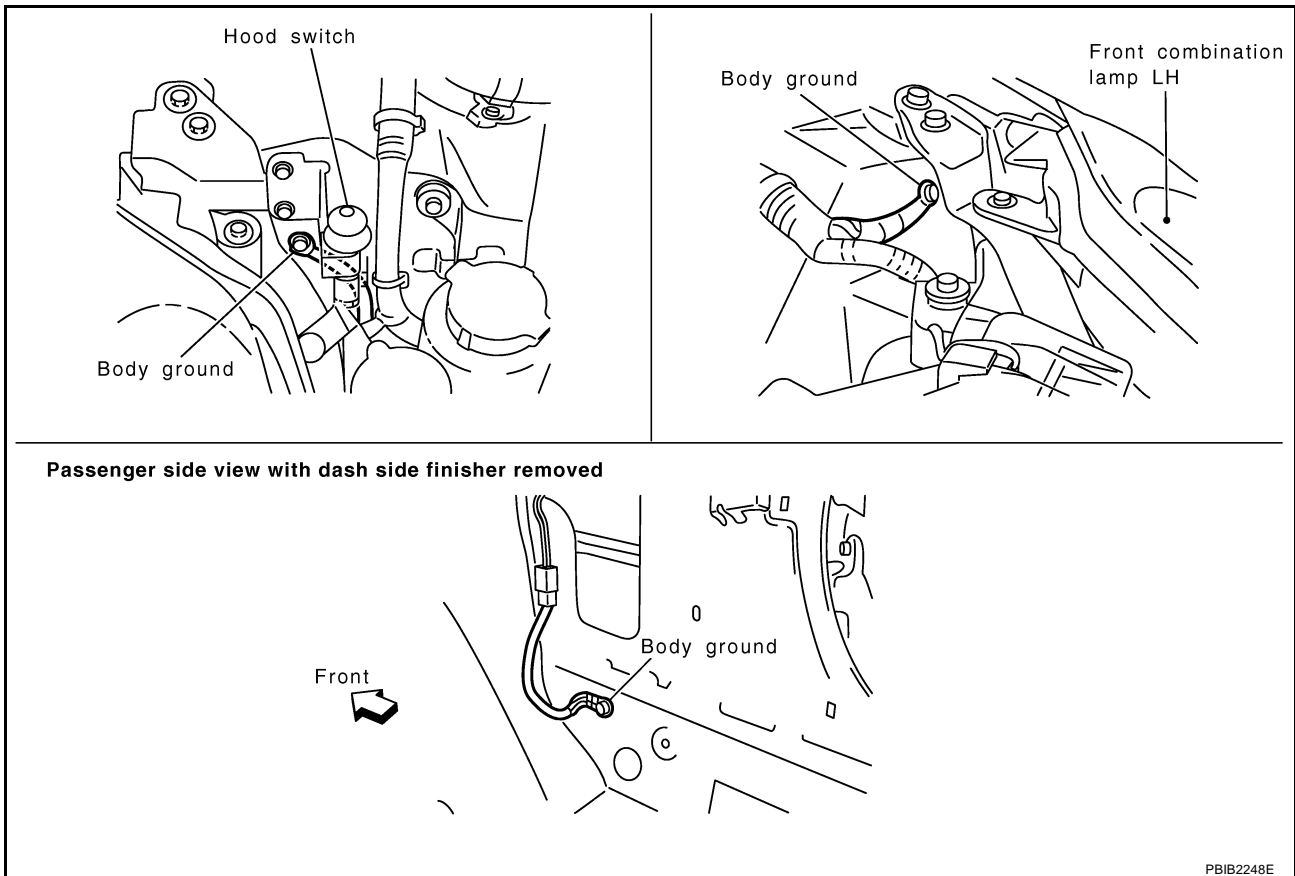

OK or NG

- OK >> GO TO 2.
- NG >> Repair or replace ground connections.

**2. CLEAR THE SELF-LEARNING DATA**

**☑ With CONSULT-II**

1. Start engine and warm it up to normal operating temperature.
2. Select "SELF-LEARNING CONT" in "WORK SUPPORT" mode with CONSULT-II.
3. Clear the self-learning control coefficient by touching "CLEAR".
4. Run engine for at least 10 minutes at idle speed.  
**Is the 1st trip DTC P0172 or P0175 detected?**  
**Is it difficult to start engine?**

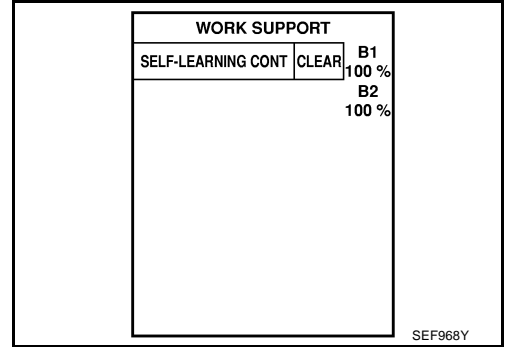

**⊗ Without CONSULT-II**

1. Start engine and warm it up to normal operating temperature.
2. Turn ignition switch OFF.
3. Disconnect mass air flow sensor harness connector, and restart and run engine for at least 5 seconds at idle speed.
4. Stop engine and reconnect mass air flow sensor harness connector.
5. Make sure DTC P0102 is displayed.
6. Erase the DTC memory. Refer to [EC-61, "HOW TO ERASE EMISSION-RELATED DIAGNOSTIC INFORMATION"](#).
7. Make sure DTC P0000 is displayed.
8. Run engine for at least 10 minutes at idle speed.  
**Is the 1st trip DTC P0172 or P0175 detected?**  
**Is it difficult to start engine?**

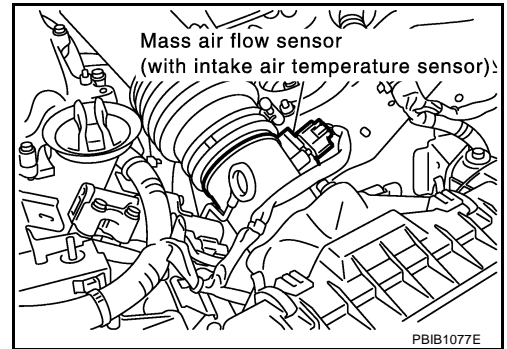

Yes or No

- Yes >> Perform trouble diagnosis for DTC P0172, P0175. Refer to [EC-230](#).
- No >> GO TO 3.

A  
 EC  
 C  
 D  
 E  
 F  
 G  
 H  
 I  
 J  
 K  
 L  
 M

## DTC P1146, P1166 HO2S2

### 3. CHECK HO2S2 GROUND CIRCUIT FOR OPEN AND SHORT

1. Turn ignition switch OFF.
2. Disconnect ECM harness connector.
3. Disconnect heated oxygen sensor 2 harness connector.

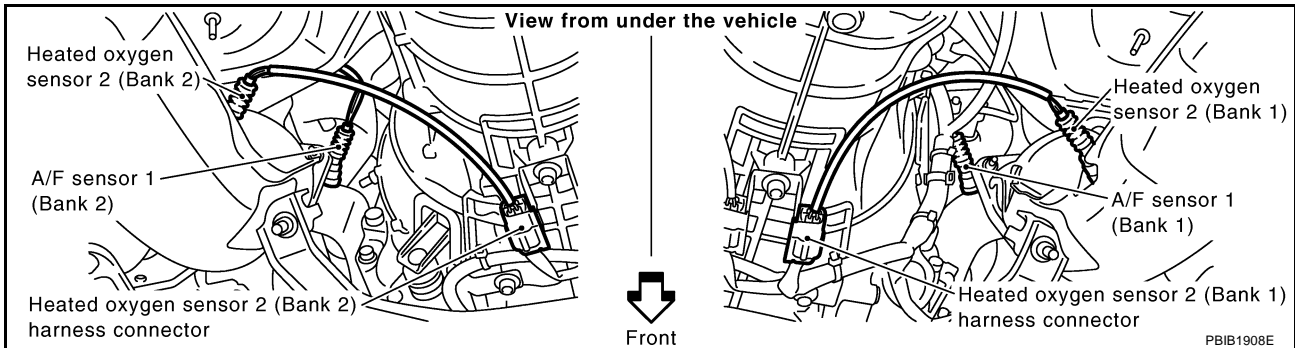

4. Check harness continuity between HO2S2 terminal 4 and ECM terminal 78.  
Refer to Wiring Diagram.

**Continuity should exist.**

5. Also check harness for short to ground and short to power.

**OK or NG**

OK >> GO TO 4.

NG >> Repair open circuit or short to ground or short to power in harness or connectors.

### 4. CHECK HO2S2 INPUT SIGNAL CIRCUIT FOR OPEN AND SHORT

1. Check harness continuity between ECM terminal and HO2S2 terminal as follows.  
Refer to Wiring Diagram.

DTC	Terminals		Bank
	ECM	Sensor	
P1146	74	1	1
P1166	55	1	2

**Continuity should exist.**

2. Check harness continuity between the following terminals and ground.  
Refer to Wiring Diagram.

DTC	Terminals		Bank
	ECM	Sensor	
P1146	74	1	1
P1166	55	1	2

**Continuity should not exist.**

3. Also check harness for short to power.

**OK or NG**

OK >> GO TO 5.

NG >> Repair open circuit or short to ground or short to power in harness or connectors.

**5. CHECK HEATED OXYGEN SENSOR 2**

Refer to [EC-423, "Component Inspection"](#) .

OK or NG

- OK >> GO TO 6.
- NG >> Replace malfunctioning heated oxygen sensor 2.

**6. CHECK INTERMITTENT INCIDENT**

Refer to [EC-129, "TROUBLE DIAGNOSIS FOR INTERMITTENT INCIDENT"](#) .

>> INSPECTION END

**Component Inspection  
HEATED OXYGEN SENSOR 2**

ABS009KX

Ⓟ With CONSULT-II

1. Turn ignition switch ON and select "DATA MONITOR" mode with CONSULT-II.
2. Start engine and warm it up to the normal operating temperature.
3. Turn ignition switch OFF and wait at least 10 seconds.
4. Start engine and keep the engine speed between 3,500 and 4,000 rpm for at least 1 minute under no load.
5. Let engine idle for 1 minute.
6. Select "FUEL INJECTION" in "ACTIVE TEST" mode, and select "HO2S2 (B1)/(B2)" as the monitor item with CONSULT-II.

DATA MONITOR	
MONITOR	NO DTC
ENG SPEED	XXX rpm
COOLAN TEMP/S	XXX °C

SEF174Y

ACTIVE TEST	
FUEL INJECTION	25 %
MONITOR	
ENG SPEED	XXX rpm
HO2S2 (B1)	XXX V
HO2S2 (B2)	XXX V

PBIB1672E

7. Check "HO2S2 (B1)/(B2)" at idle speed when adjusting "FUEL INJECTION" to ±25%.

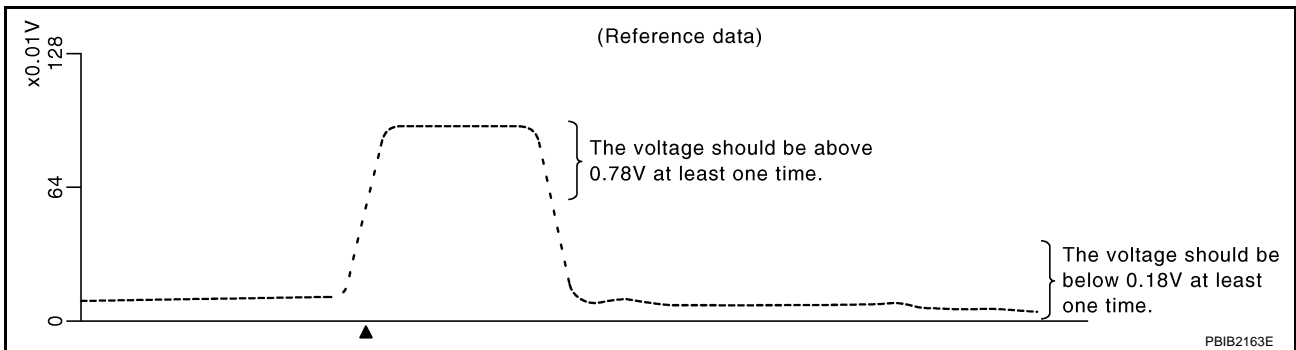

"HO2S2 (B1)/(B2)" should be above 0.78V at least once when the "FUEL INJECTION" is +25%.  
 "HO2S2 (B1)/(B2)" should be below 0.18V at least once when the "FUEL INJECTION" is -25%.

**CAUTION:**

- Discard any heated oxygen sensor which has been dropped from a height of more than 0.5 m (19.7 in) onto a hard surface such as a concrete floor; use a new one.

## DTC P1146, P1166 HO2S2

- Before installing new oxygen sensor, clean exhaust system threads using Oxygen Sensor Thread Cleaner tool J-43897-18 or J-43897-12 and approved anti-seize lubricant.

### ⊗ Without CONSULT-II

1. Start engine and warm it up to the normal operating temperature.
2. Turn ignition switch OFF and wait at least 10 seconds.
3. Start engine and keep the engine speed between 3,500 and 4,000 rpm for at least 1 minute under no load.
4. Let engine idle for 1 minute.
5. Set voltmeter probes between ECM terminal 74 [HO2S2 (B1) signal] or 55 [HO2S2 (B2) signal] and ground.
6. Check the voltage when revving up to 4,000 rpm under no load at least 10 times.  
(Depress and release accelerator pedal as soon as possible.)  
**The voltage should be above 0.78V at least once during this procedure.**  
**If the voltage is above 0.78V at step 6, step 7 is not necessary.**
7. Keep vehicle at idling for 10 minutes, then check voltage. Or check the voltage when coasting from 80 km/h (50 MPH) in D position (A/T), 4th gear position (M/T).  
**The voltage should be below 0.18V at least once during this procedure.**
8. If NG, replace heated oxygen sensor 2.

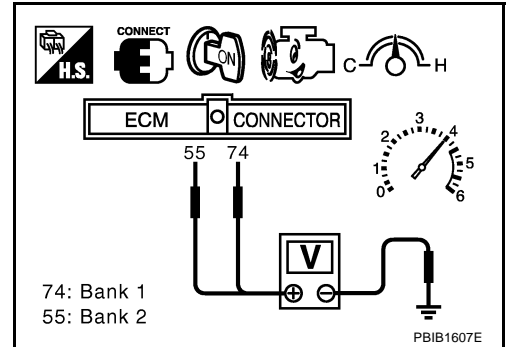

### CAUTION:

- Discard any heated oxygen sensor which has been dropped from a height of more than 0.5 m (19.7 in) onto a hard surface such as a concrete floor; use a new one.
- Before installing new oxygen sensor, clean exhaust system threads using Oxygen Sensor Thread Cleaner tool J-43897-18 or J-43897-12 and approved anti-seize lubricant.

## Removal and Installation HEATED OXYGEN SENSOR 2

ABS009KY

Refer to [EM-23, "EXHAUST MANIFOLD AND THREE WAY CATALYST"](#) .



**DTC P1147, P1167 HO2S2**

PF2:226A0

**Component Description**

ABS009KZ

The heated oxygen sensor 2, after three way catalyst 1, monitors the oxygen level in the exhaust gas on each bank.

Even if switching characteristics of the air fuel ratio (A/F) sensor 1 are shifted, the air-fuel ratio is controlled to stoichiometric, by the signal from the heated oxygen sensor 2.

This sensor is made of ceramic zirconia. The zirconia generates voltage from approximately 1V in richer conditions to 0V in leaner conditions.

Under normal conditions the heated oxygen sensor 2 is not used for engine control operation.

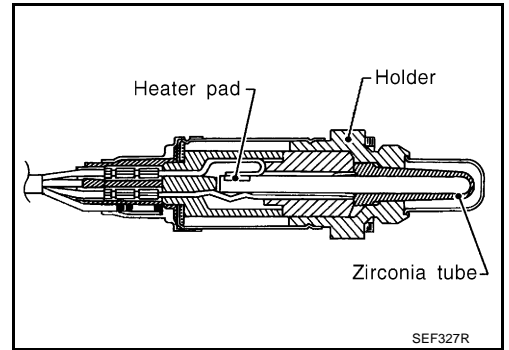

**CONSULT-II Reference Value in Data Monitor Mode**

ABS009L0

Specification data are reference values.

MONITOR ITEM	CONDITION		SPECIFICATION
HO2S2 (B1) HO2S2 (B2)	<ul style="list-style-type: none"> <li>Warm-up condition</li> <li>After keeping engine speed between 3,500 and 4,000 rpm for 1 minute and at idle for 1 minute under no load.</li> </ul>	Revving engine from idle to 3,000 rpm quickly.	0 - 0.3V ↔ Approx. 0.6 - 1.0V
HO2S2 MNTR (B1) HO2S2 MNTR (B2)			LEAN ↔ RICH

**On Board Diagnosis Logic**

ABS009L1

The heated oxygen sensor 2 has a much longer switching time between rich and lean than the air fuel ratio (A/F) sensor 1. The oxygen storage capacity before the three way catalyst causes the longer switching time. To judge the malfunctions of heated oxygen sensor 2, ECM monitors whether the maximum voltage of the sensor is sufficiently high during the various driving condition such as fuel-cut.

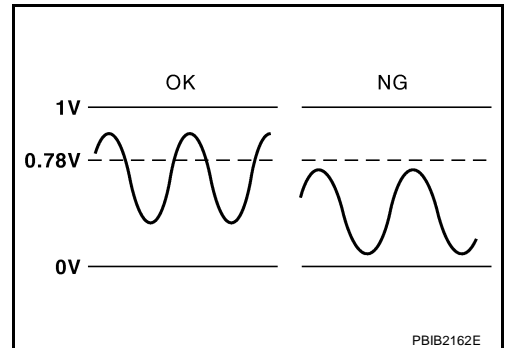

DTC No.	Trouble diagnosis name	DTC detecting condition	Possible cause
P1147 1147 (Bank 1)	Heated oxygen sensor 2 maximum voltage monitoring	The maximum voltage from the sensor is not reached to the specified voltage.	<ul style="list-style-type: none"> <li>Harness or connectors (The sensor circuit is open or shorted)</li> <li>Heated oxygen sensor 2</li> <li>Fuel pressure</li> <li>Fuel injector</li> <li>Intake air leaks</li> </ul>
P1167 1167 (Bank 2)			

## DTC Confirmation Procedure

### NOTE:

If DTC confirmation Procedure has been previously conducted, always turn ignition switch OFF and wait at least 10 seconds before conducting the next test.

### WITH CONSULT-II

#### TESTING CONDITION:

For better results, perform “DTC WORK SUPPORT” at a temperature of 0 to 30 °C (32 to 86 °F).

1. Turn ignition switch ON and select “DATA MONITOR” mode with CONSULT-II.
2. Start engine and warm it up to the normal operating temperature.
3. Turn ignition switch OFF and wait at least 10 seconds.
4. Start engine and keep the engine speed between 3,500 and 4,000 rpm for at least 1 minute under no load.
5. Let engine idle for 1 minute.
6. Make sure that “COOLAN TEMP/S” indicates more than 70°C (158°F).  
If not, warm up engine and go to next step when “COOLAN TEMP/S” indication reaches to 70°C (158°F).
7. Open engine hood.
8. Select “HO2S2 (B1) P1147” or “HO2S2 (B2) P1167” of “HO2S2” in “DTC WORK SUPPORT” mode with CONSULT-II.
9. Start engine and following the instruction of CONSULT-II.

DATA MONITOR	
MONITOR	NO DTC
ENG SPEED	XXX rpm
COOLAN TEMP/S	XXX °C

SEF174Y

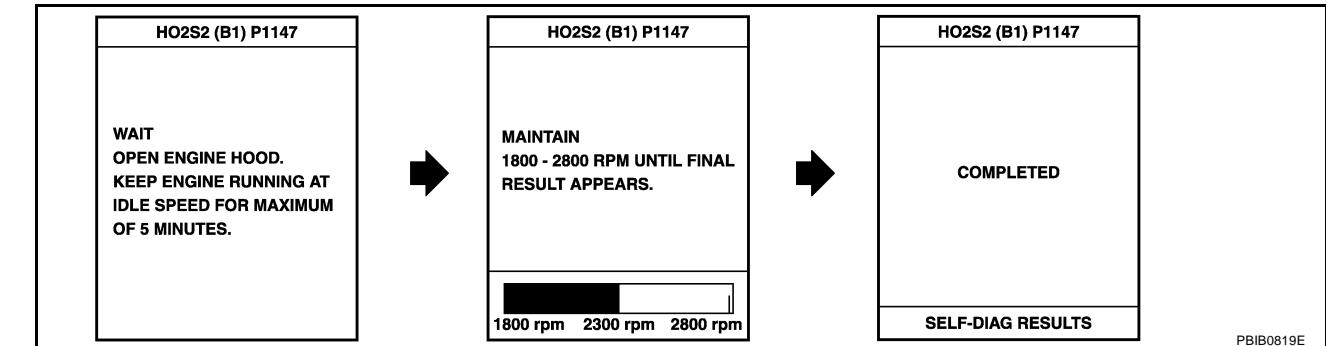

10. Make sure that “OK” is displayed after touching “SELF-DIAG RESULTS”.  
If “NG” is displayed, refer to [EC-431, "Diagnostic Procedure"](#).  
If “CAN NOT BE DIAGNOSED” is displayed, perform the following.
  - a. Turn ignition switch OFF and leave the vehicle in a cool place (soak the vehicle).
  - b. Return to step 1.

## Overall Function Check

Use this procedure to check the overall function of the heated oxygen sensor 2 circuit. During this check, a 1st trip DTC might not be confirmed.

### WITH GST

1. Start engine and warm it up to the normal operating temperature.
2. Turn ignition switch OFF and wait at least 10 seconds.
3. Start engine and keep the engine speed between 3,500 and 4,000 rpm for at least 1 minute under no load.
4. Let engine idle for 1 minute.
5. Set voltmeter probes between ECM terminal 74 [HO2S2 (B1) signal] or 55 [HO2S2 (B2) signal] and ground.

## DTC P1147, P1167 HO2S2

6. Check the voltage when revving up to 4,000 rpm under no load at least 10 times.  
(Depress and release accelerator pedal as soon as possible.)  
**The voltage should be above 0.78V at least once during this procedure.**  
**If the voltage can be confirmed in step 6, step 7 is not necessary.**
7. Keep vehicle at idling for 10 minutes, then check the voltage. Or check the voltage when coasting from 80 km/h (50 MPH) in D position (A/T), 4th gear position (M/T).  
**The voltage should be above 0.78V at least once during this procedure.**
8. If NG, go to [EC-431, "Diagnostic Procedure"](#).

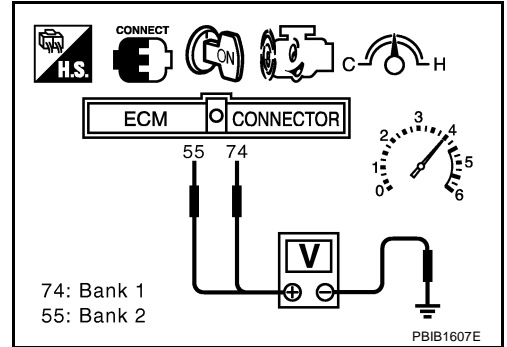

A  
EC  
C  
D  
E  
F  
G  
H  
I  
J  
K  
L  
M

# DTC P1147, P1167 HO2S2

ABS009L4

## Wiring Diagram BANK 1

### EC-O2S2B1-01

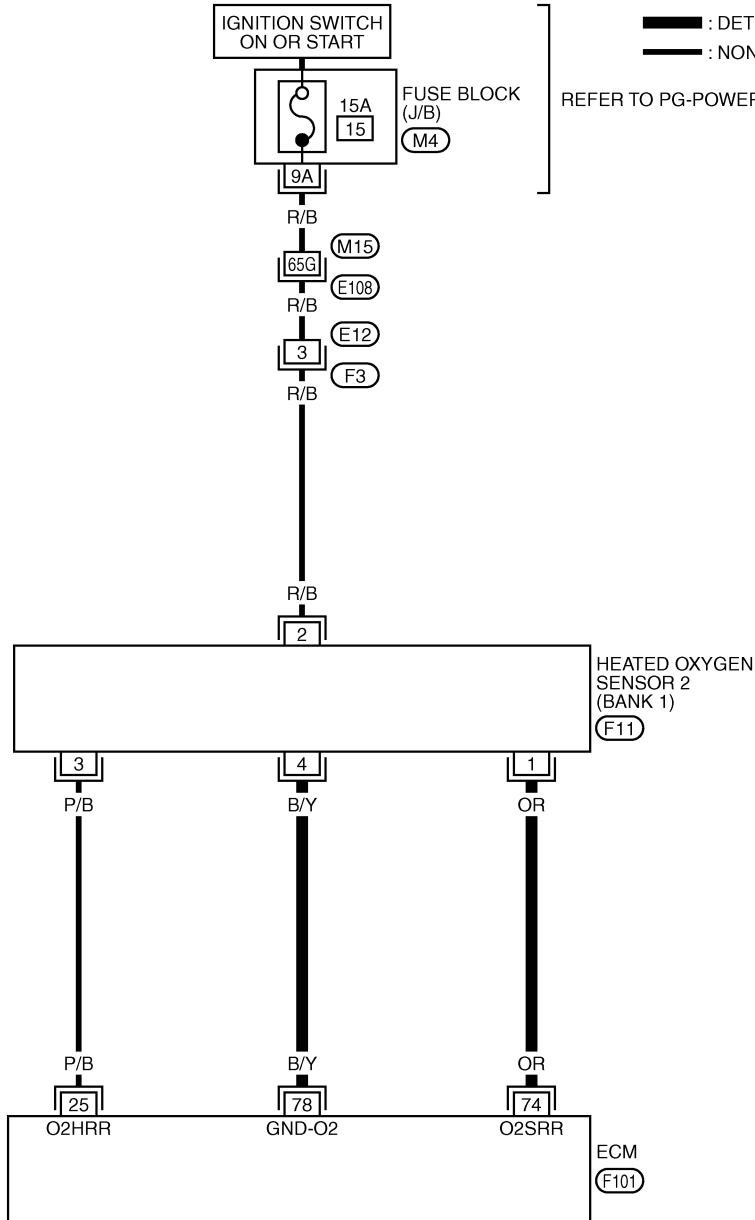

REFER TO THE FOLLOWING.

- E108 -SUPER MULTIPLE JUNCTION (SMJ)
- M4 -FUSE BLOCK-JUNCTION BOX (J/B)

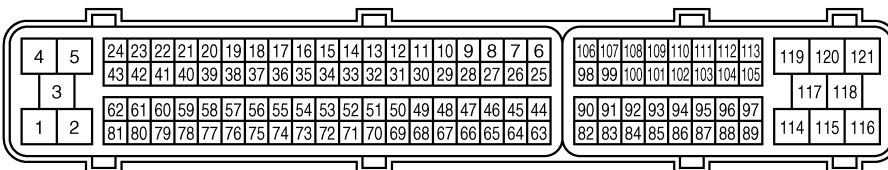

TBWT0482E

## DTC P1147, P1167 HO2S2

Specification data are reference values and are measured between each terminal and ground.

**CAUTION:**

**Do not use ECM ground terminals when measuring input/output voltage. Doing so may result in damage to the ECM's transistor. Use a ground other than ECM terminals, such as the ground.**

TER-MINAL NO.	WIRE COLOR	ITEM	CONDITION	DATA (DC Voltage)
74	OR	Heated oxygen sensor 2 (bank 1)	<p><b>[Engine is running]</b></p> <ul style="list-style-type: none"> <li>● <b>Warm-up condition</b></li> <li>● Revving engine from idle to 3,000 rpm quickly after the following conditions are met.</li> <li>– After keeping the engine speed between 3,500 and 4,000 rpm for 1 minute and at idle for 1 minute under no load.</li> </ul>	0 - Approximately 1.0V
78	B/Y	Sensor ground (Heated oxygen sensor)	<p><b>[Engine is running]</b></p> <ul style="list-style-type: none"> <li>● <b>Warm-up condition</b></li> <li>● Idle speed</li> </ul>	Approximately 0V

A  
EC  
C  
D  
E  
F  
G  
H  
I  
J  
K  
L  
M

# DTC P1147, P1167 HO2S2

**BANK 2**

**EC-O2S2B2-01**

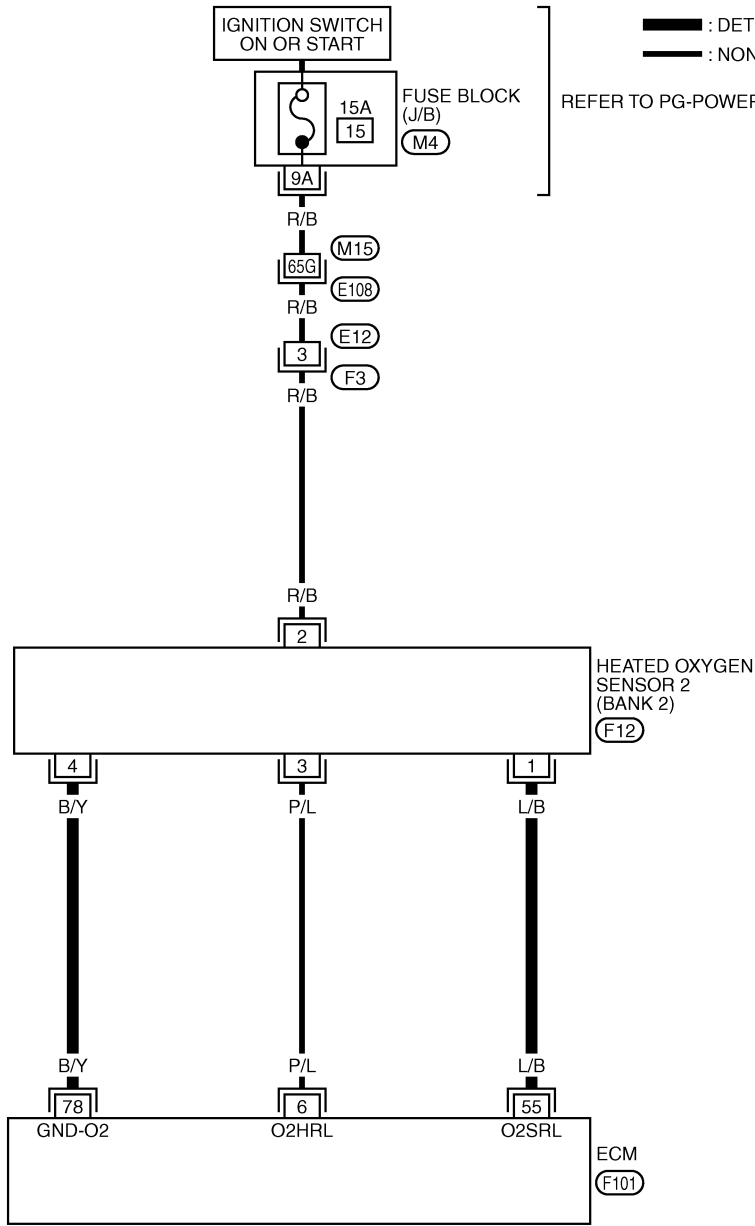

REFER TO THE FOLLOWING.

E108 -SUPER MULTIPLE JUNCTION (SMJ)

M4 -FUSE BLOCK-JUNCTION BOX (J/B)

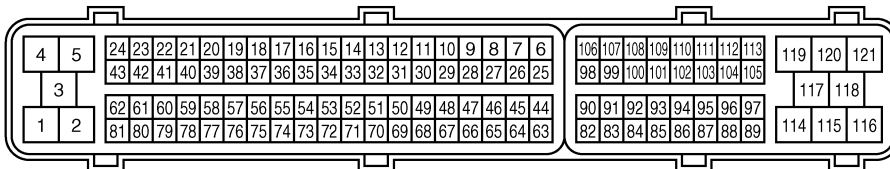

TBWT0483E

# DTC P1147, P1167 HO2S2

Specification data are reference values and are measured between each terminal and ground.

**CAUTION:**

**Do not use ECM ground terminals when measuring input/output voltage. Doing so may result in damage to the ECM's transistor. Use a ground other than ECM terminals, such as the ground.**

TER-MINAL NO.	WIRE COLOR	ITEM	CONDITION	DATA (DC Voltage)
55	L/B	Heated oxygen sensor 2 (bank 2)	<p><b>[Engine is running]</b></p> <ul style="list-style-type: none"> <li>● Warm-up condition</li> <li>● Revving engine from idle to 3,000 rpm quickly after the following conditions are met.</li> <li>- After keeping the engine speed between 3,500 and 4,000 rpm for 1 minute and at idle for 1 minute under no load.</li> </ul>	0 - Approximately 1.0V
78	B/Y	Sensor ground (Heated oxygen sensor)	<p><b>[Engine is running]</b></p> <ul style="list-style-type: none"> <li>● Warm-up condition</li> <li>● Idle speed</li> </ul>	Approximately 0V

## Diagnostic Procedure

ABS009L5

### 1. CHECK GROUND CONNECTIONS

1. Turn ignition switch OFF.
2. Loosen and retighten three ground screws on the body. Refer to [EC-138, "Ground Inspection"](#).

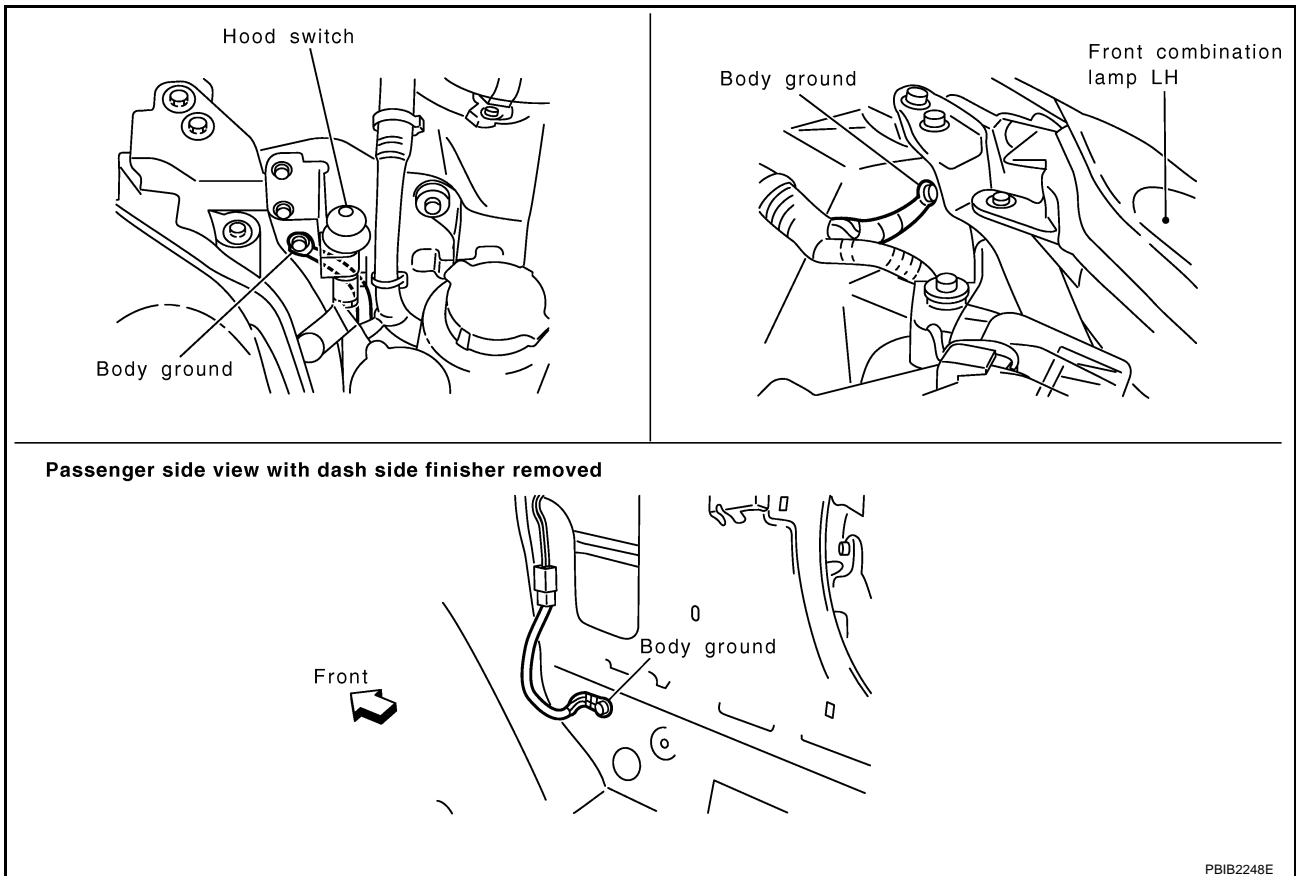

**OK or NG**

- OK >> GO TO 2.
- NG >> Repair or replace ground connections.

## 2. CLEAR THE SELF-LEARNING DATA

### With CONSULT-II

1. Start engine and warm it up to normal operating temperature.
2. Select "SELF-LEARNING CONT" in "WORK SUPPORT" mode with CONSULT-II.
3. Clear the self-learning control coefficient by touching "CLEAR".
4. Run engine for at least 10 minutes at idle speed.  
**Is the 1st trip DTC P0171 or P0174 detected?**  
**Is it difficult to start engine?**

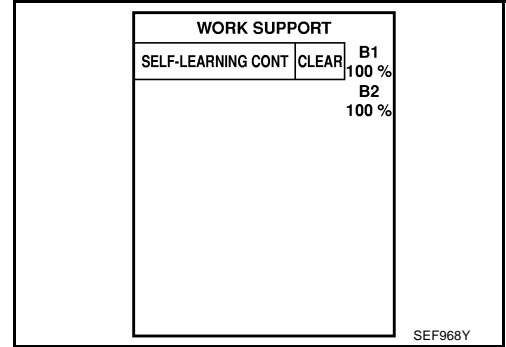

### Without CONSULT-II

1. Start engine and warm it up to normal operating temperature.
2. Turn ignition switch OFF.
3. Disconnect mass air flow sensor harness connector, and restart and run engine for at least 5 seconds at idle speed.
4. Stop engine and reconnect mass air flow sensor harness connector.
5. Make sure DTC P0102 is displayed.
6. Erase the DTC memory. Refer to [EC-61, "HOW TO ERASE EMISSION-RELATED DIAGNOSTIC INFORMATION"](#).
7. Make sure DTC P0000 is displayed.
8. Run engine for at least 10 minutes at idle speed.  
**Is the 1st trip DTC P0171 or P0174 detected?**  
**Is it difficult to start engine?**

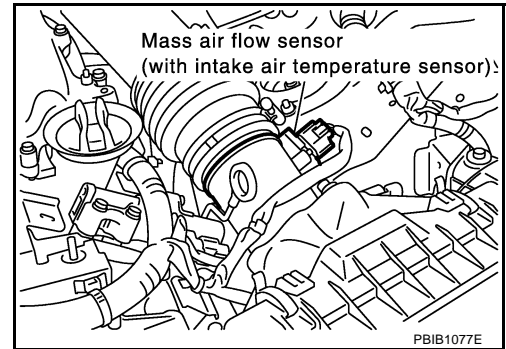

#### Yes or No

- Yes >> Perform trouble diagnosis for DTC P0171 or P0174. Refer to [EC-221](#).
- No >> GO TO 3.



## DTC P1147, P1167 HO2S2

### 3. CHECK HO2S2 GROUND CIRCUIT FOR OPEN AND SHORT

1. Turn ignition switch OFF.
2. Disconnect ECM harness connector.
3. Disconnect heated oxygen sensor 2 harness connector.

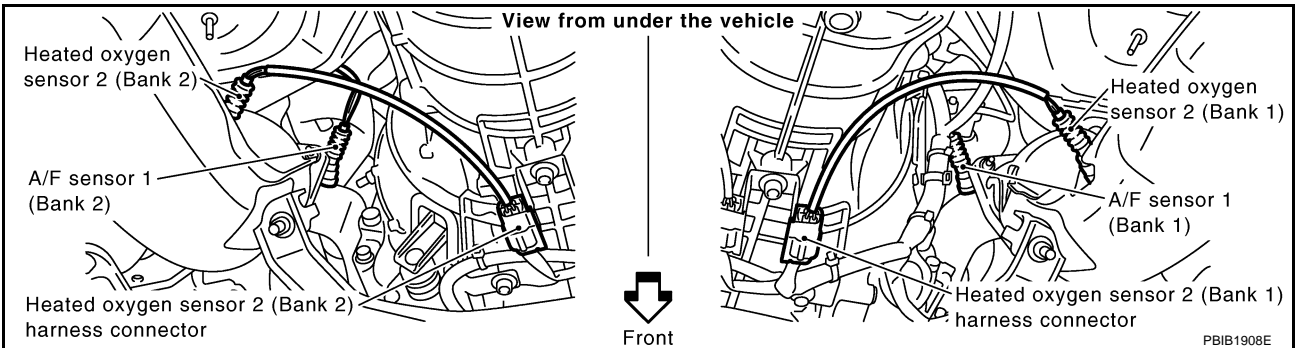

4. Check harness continuity between HO2S2 terminal 4 and ECM terminal 78. Refer to Wiring Diagram.

**Continuity should exist.**

5. Also check harness for short to ground and short to power.

**OK or NG**

OK >> GO TO 4.

NG >> Repair open circuit or short to ground or short to power in harness or connectors.

### 4. CHECK HO2S2 INPUT SIGNAL CIRCUIT FOR OPEN AND SHORT

1. Check harness continuity between ECM terminal and HO2S2 terminal as follows. Refer to Wiring Diagram.

DTC	Terminals		Bank
	ECM	Sensor	
P1147	74	1	1
P1167	55	1	2

**Continuity should exist.**

2. Check harness continuity between the following terminals and ground. Refer to Wiring Diagram.

DTC	Terminals		Bank
	ECM	Sensor	
P1147	74	1	1
P1167	55	1	2

**Continuity should not exist.**

3. Also check harness for short to power.

**OK or NG**

OK >> GO TO 5.

NG >> Repair open circuit or short to ground or short to power in harness or connectors.

## 5. CHECK HEATED OXYGEN SENSOR 2

Refer to [EC-434, "Component Inspection"](#) .

OK or NG

- OK >> GO TO 6.
- NG >> Replace malfunctioning heated oxygen sensor 2.

## 6. CHECK INTERMITTENT INCIDENT

Refer to [EC-129, "TROUBLE DIAGNOSIS FOR INTERMITTENT INCIDENT"](#) .

>> INSPECTION END

### Component Inspection HEATED OXYGEN SENSOR 2

ABS009L6

 With CONSULT-II

1. Turn ignition switch ON and select "DATA MONITOR" mode with CONSULT-II.
2. Start engine and warm it up to the normal operating temperature.
3. Turn ignition switch OFF and wait at least 10 seconds.
4. Start engine and keep the engine speed between 3,500 and 4,000 rpm for at least 1 minute under no load.
5. Let engine idle for 1 minute.

DATA MONITOR	
MONITOR	NO DTC
ENG SPEED	XXX rpm
COOLANT TEMP/S	XXX °C

SEF174Y

6. Select "FUEL INJECTION" in "ACTIVE TEST" mode, and select "HO2S2 (B1)/(B2)" as the monitor item with CONSULT-II.

ACTIVE TEST	
FUEL INJECTION	25 %
MONITOR	
ENG SPEED	XXX rpm
HO2S2 (B1)	XXX V
HO2S2 (B2)	XXX V

PBIB1672E

7. Check "HO2S2 (B1)/(B2)" at idle speed when adjusting "FUEL INJECTION" to  $\pm 25\%$ .

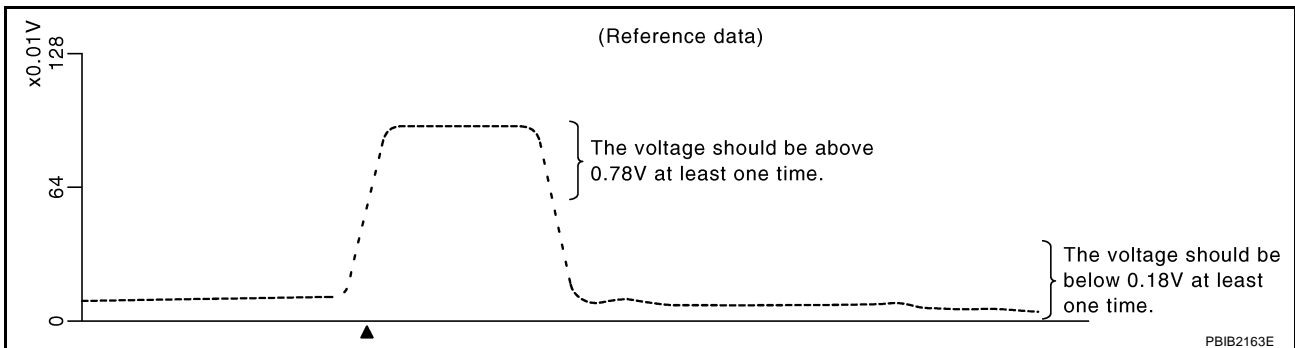

"HO2S2 (B1)/(B2)" should be above 0.78V at least once when the "FUEL INJECTION" is +25%.

"HO2S2 (B1)/(B2)" should be below 0.18V at least once when the "FUEL INJECTION" is -25%.

### CAUTION:

- Discard any heated oxygen sensor which has been dropped from a height of more than 0.5 m (19.7 in) onto a hard surface such as a concrete floor; use a new one.

## DTC P1147, P1167 HO2S2

- Before installing new oxygen sensor, clean exhaust system threads using Oxygen Sensor Thread Cleaner tool J-43897-18 or J-43897-12 and approved anti-seize lubricant.

### ⊗ Without CONSULT-II

1. Start engine and warm it up to the normal operating temperature.
2. Turn ignition switch OFF and wait at least 10 seconds.
3. Start engine and keep the engine speed between 3,500 and 4,000 rpm for at least 1 minute under no load.
4. Let engine idle for 1 minute.
5. Set voltmeter probes between ECM terminal 74 [HO2S2 (B1) signal] or 55 [HO2S2 (B2) signal] and ground.
6. Check the voltage when revving up to 4,000 rpm under no load at least 10 times.  
(Depress and release accelerator pedal as soon as possible.)  
**The voltage should be above 0.78V at least once during this procedure.**  
**If the voltage is above 0.78V at step 6, step 7 is not necessary.**
7. Keep vehicle at idling for 10 minutes, then check voltage. Or check the voltage when coasting from 80 km/h (50 MPH) in D position (A/T), 4th gear position (M/T).  
**The voltage should be below 0.18V at least once during this procedure.**
8. If NG, replace heated oxygen sensor 2.

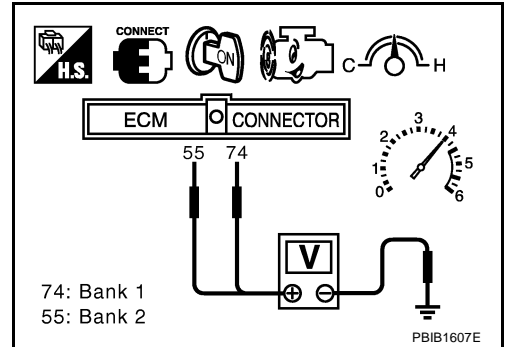

### CAUTION:

- Discard any heated oxygen sensor which has been dropped from a height of more than 0.5 m (19.7 in) onto a hard surface such as a concrete floor; use a new one.
- Before installing new oxygen sensor, clean exhaust system threads using Oxygen Sensor Thread Cleaner tool J-43897-18 or J-43897-12 and approved anti-seize lubricant.

## Removal and Installation HEATED OXYGEN SENSOR 2

ABS009L7

Refer to [EM-23, "EXHAUST MANIFOLD AND THREE WAY CATALYST"](#) .

# DTC P1148, P1168 CLOSED LOOP CONTROL

## DTC P1148, P1168 CLOSED LOOP CONTROL

PFP:22690

### On Board Diagnosis Logic

ABS00AMM

These self-diagnoses have the one trip detection logic.

DTC No.	Trouble diagnosis name	DTC detecting condition	Possible cause
P1148 1148 (Bank 1)	Closed loop control function	The closed loop control function for bank 1 does not operate even when vehicle is driving in the specified condition.	<ul style="list-style-type: none"><li>● Harness or connectors [The air fuel ratio (A/F) sensor 1 circuit is open or shorted.]</li><li>● Air fuel ratio (A/F) sensor 1</li><li>● Air fuel ratio (A/F) sensor 1 heater</li></ul>
P1168 1168 (Bank 2)		The closed loop control function for bank 2 does not operate even when vehicle is driving in the specified condition.	

DTC P1148 or P1168 is displayed with another DTC for air fuel ratio (A/F) sensor 1.  
Perform the trouble diagnosis for the corresponding DTC.

# DTC P1211 TCS CONTROL UNIT

## DTC P1211 TCS CONTROL UNIT

PFP:47850

### Description

ABS009LC

The malfunction information related to TCS is transferred through the CAN communication line from VDC/TCS/ABS control unit (models with VDC) or "ABS actuator and electric unit (control unit)" (models without VDC) to ECM.

**Be sure to erase the malfunction information such as DTC not only for VDC/TCS/ABS control unit (models with VDC) or "ABS actuator and electric unit (control unit)" (models without VDC) but also for ECM after TCS related repair.**

### On Board Diagnosis Logic

ABS009LD

**Freeze frame data is not stored in the ECM for this self-diagnosis. The MIL will not light up for this self-diagnosis.**

DTC No.	Trouble diagnosis name	DTC detecting condition	Possible cause
P1211 1211	TCS control unit	ECM receives a malfunction information from VDC/TCS/ABS control unit (models with VDC) or "ABS actuator and electric unit (control unit)" (models without VDC).	<ul style="list-style-type: none"><li>● VDC/TCS/ABS control unit (models with VDC)</li><li>● ABS actuator and electric unit (control unit) (models without VDC)</li><li>● TCS related parts</li></ul>

### DTC Confirmation Procedure

ABS009LE

#### TESTING CONDITION:

**Before performing the following procedure, confirm that battery voltage is more than 10.5V at idle.**

#### ④ WITH CONSULT-II

1. Turn ignition switch ON.
2. Select "DATA MONITOR" mode with CONSULT-II.
3. Start engine and let it idle for at least 60 seconds.
4. If 1st trip DTC is detected, go to [EC-437, "Diagnostic Procedure"](#)

DATA MONITOR	
MONITOR	NO DTC
ENG SPEED	XXX rpm

SEF058Y

#### ④ WITH GST

Follow the procedure "WITH CONSULT-II" above.

### Diagnostic Procedure

ABS009LF

Go to [BRC-94, "TROUBLE DIAGNOSIS"](#) (With VDC models) or [BRC-46, "TROUBLE DIAGNOSIS"](#) (Without VDC models).

# DTC P1212 TCS COMMUNICATION LINE

## DTC P1212 TCS COMMUNICATION LINE

PFP:47850

### Description

ABS009LG

#### NOTE:

If DTC P1212 is displayed with DTC U1000 or U1001, first perform the trouble diagnosis for DTC U1000, U1001. Refer to [EC-139, "DTC U1000, U1001 CAN COMMUNICATION LINE"](#).

This CAN communication line is used to control the smooth engine operation during the TCS operation. Pulse signals are exchanged between ECM and VDC/TCS/ABS control unit (models with VDC) or "ABS actuator and electric unit (control unit)" (models without VDC).

Be sure to erase the malfunction information such as DTC not only for VDC/TCS/ABS control unit (models with VDC) or "ABS actuator and electric unit (control unit)" (models without VDC) but also for ECM after TCS related repair.

### On Board Diagnosis Logic

ABS009LH

Freeze frame data is not stored in the ECM for this self-diagnosis. The MIL will not light up for this self-diagnosis.

DTC No.	Trouble diagnosis name	DTC detecting condition	Possible cause
P1212 1212	TCS communication line	ECM can not receive the information from VDC/TCS/ABS control unit (models with VDC) or "ABS actuator and electric unit (control unit)" (models without VDC) continuously.	<ul style="list-style-type: none"><li>● Harness or connectors (The CAN communication line is open or shorted.)</li><li>● VDC/TCS/ABS control unit (models with VDC)</li><li>● ABS actuator and electric unit (control unit) (models without VDC)</li><li>● Dead (Weak) battery</li></ul>

### DTC Confirmation Procedure

ABS009LI

#### TESTING CONDITION:

Before performing the following procedure, confirm that battery voltage is more than 10.5V at idle.

#### WITH CONSULT-II

1. Turn ignition switch ON.
2. Select "DATA MONITOR" mode with CONSULT-II.
3. Start engine and let it idle for at least 10 seconds.
4. If a 1st trip DTC is detected, go to [EC-438, "Diagnostic Procedure"](#).

DATA MONITOR	
MONITOR	NO DTC
ENG SPEED	XXX rpm

SEF058Y

#### WITH GST

Follow the procedure "WITH CONSULT-II" above.

### Diagnostic Procedure

ABS009LJ

Go to [BRC-94, "TROUBLE DIAGNOSIS"](#) (models with VDC) or refer to [BRC-46, "TROUBLE DIAGNOSIS"](#) (models without VDC).

# DTC P1217 ENGINE OVER TEMPERATURE

## DTC P1217 ENGINE OVER TEMPERATURE

PPF:00000

### Description SYSTEM DESCRIPTION

ABS009LK

#### NOTE:

If DTC P1217 is displayed with DTC U1000 or U1001, first perform the trouble diagnosis for DTC U1000, U1001. Refer to [EC-139, "DTC U1000, U1001 CAN COMMUNICATION LINE"](#).

### Cooling Fan Control

Sensor	Input Signal to ECM	ECM function	Actuator
Crankshaft position sensor (POS) Camshaft position sensor (PHASE)	Engine speed*1	Cooling fan control	IPDM E/R (Cooling fan relays)
Battery	Battery voltage*1		
Wheel sensor	Vehicle speed*2		
Engine coolant temperature sensor	Engine coolant temperature		
Air conditioner switch	Air conditioner ON signal*2		
Refrigerant pressure sensor	Refrigerant pressure		

\*1: The ECM determines the start signal status by the signals of engine speed and battery voltage.

\*2: This signal is sent to ECM through CAN communication line.

The ECM controls the cooling fan corresponding to the vehicle speed, engine coolant temperature, refrigerant pressure, and air conditioner ON signal. The control system has 3-step control [HIGH/LOW/OFF].

### Cooling Fan Operation

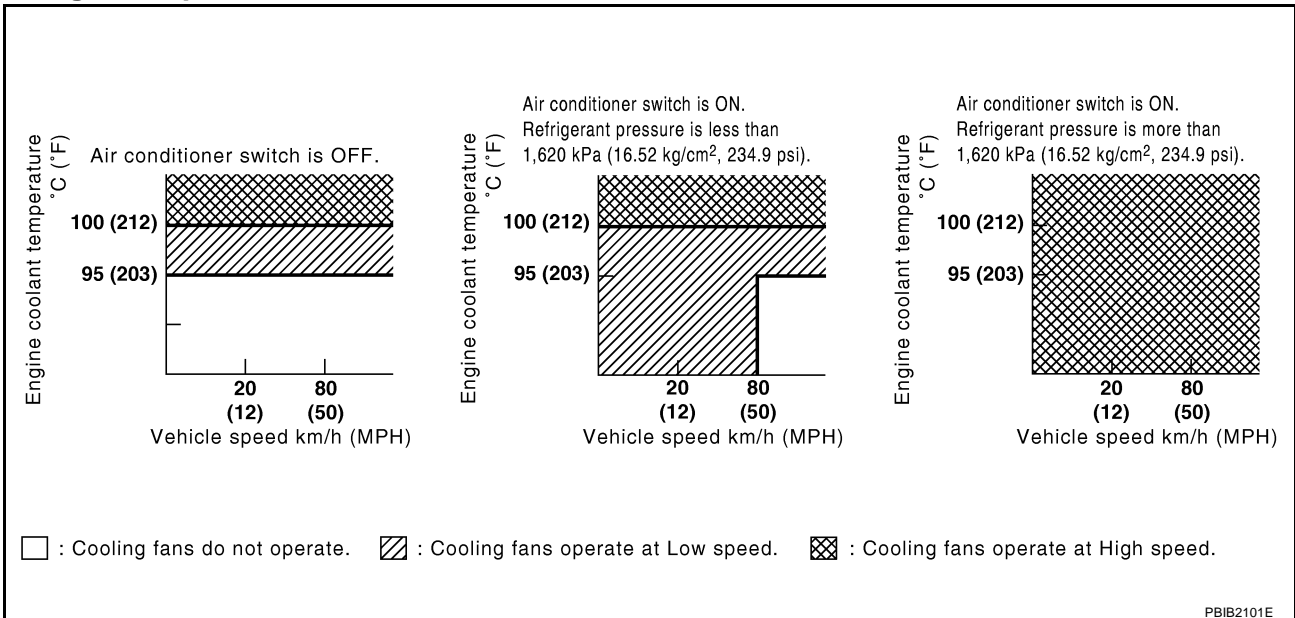

# DTC P1217 ENGINE OVER TEMPERATURE

## Cooling Fan Relay Operation

The ECM controls cooling fan relays in the IPDM E/R through CAN communication line.

Cooling fan speed	Cooling fan relay		
	1	2	3
Stop	OFF	OFF	OFF
Low	ON	OFF	OFF
High	ON	ON	ON

## COMPONENT DESCRIPTION

### Cooling Fan Motor

The cooling fan operates at each speed when the current flows in the cooling fan motor as follows.

Cooling fan speed	Cooling fan motor terminals	
	(+)	(-)
Low	1	4
	2	3
High	1 and 2	3 and 4

## CONSULT-II Reference Value in Data Monitor Mode

ABS009LL

Specification data are reference values.

MONITOR ITEM	CONDITION	SPECIFICATION
AIR COND SIG	● Engine: After warming up, idle the engine	Air conditioner switch: OFF OFF
		Air conditioner switch: ON (Compressor operates.) ON
COOLING FAN	● Engine: After warming up, idle the engine ● Air conditioner switch: OFF	Engine coolant temperature is 94°C (201°F) or less OFF
		Engine coolant temperature is between 95°C (203°F) and 99°C (210°F) LOW
		Engine coolant temperature is 100°C (212°F) or more HI

## On Board Diagnosis Logic

ABS009LM

If the cooling fan or another component in the cooling system malfunctions, engine coolant temperature will rise.

When the engine coolant temperature reaches an abnormally high temperature condition, a malfunction is indicated.

**This self-diagnosis has the one trip detection logic.**

DTC No.	Trouble diagnosis name	DTC detecting condition	Possible cause
P1217 1217	Engine over temperature (Overheat)	<ul style="list-style-type: none"> <li>● Cooling fan does not operate properly (Overheat).</li> <li>● Cooling fan system does not operate properly (Overheat).</li> <li>● Engine coolant was not added to the system using the proper filling method.</li> <li>● Engine coolant is not within the specified range.</li> </ul>	<ul style="list-style-type: none"> <li>● Harness or connectors (The cooling fan circuit is open or shorted.)</li> <li>● Cooling fan</li> <li>● IPDM E/R (Cooling fan relays)</li> <li>● Radiator hose</li> <li>● Radiator</li> <li>● Radiator cap</li> <li>● Water pump</li> <li>● Thermostat</li> </ul> <p>For more information, refer to <a href="#">EC-451</a>, "Main 12 Causes of Overheating".</p>



# DTC P1217 ENGINE OVER TEMPERATURE

## CAUTION:

When a malfunction is indicated, be sure to replace the coolant. Refer to [CO-9, "Changing Engine Coolant"](#) . Also, replace the engine oil. Refer to [LU-8, "Changing Engine Oil"](#) .

1. Fill radiator with coolant up to specified level with a filling speed of 2 liters per minute. Be sure to use coolant with the proper mixture ratio. Refer to [MA-13, "ANTI-FREEZE COOLANT MIXTURE RATIO"](#) .
2. After refilling coolant, run engine to ensure that no water-flow noise is emitted.

## Overall Function Check

ABS009LN

Use this procedure to check the overall function of the cooling fan. During this check, a DTC might not be confirmed.

## WARNING:

Never remove the radiator cap when the engine is hot. Serious burns could be caused by high pressure fluid escaping from the radiator.

Wrap a thick cloth around cap. Carefully remove the cap by turning it a quarter turn to allow built-up pressure to escape. Then turn the cap all the way off.

### WITH CONSULT-II

1. Check the coolant level in the reservoir tank and radiator.  
**Allow engine to cool before checking coolant level.**  
If the coolant level in the reservoir tank and/or radiator is below the proper range, skip the following steps and go to [EC-445, "Diagnostic Procedure"](#) .
2. Confirm whether customer filled the coolant or not. If customer filled the coolant, skip the following steps and go to [EC-445, "Diagnostic Procedure"](#) .
3. Turn ignition switch ON.
4. Perform "COOLING FAN" in "ACTIVE TEST" mode with CONSULT-II.
5. If the results are NG, go to [EC-445, "Diagnostic Procedure"](#) .

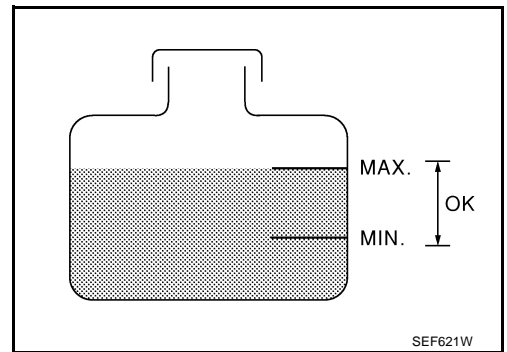

ACTIVE TEST	
COOLING FAN	OFF
MONITOR	
COOLANT TEMP/S	XXX °C

SEF646X

### WITH GST

1. Check the coolant level in the reservoir tank and radiator.  
**Allow engine to cool before checking coolant level.**  
If the coolant level in the reservoir tank and/or radiator is below the proper range, skip the following steps and go to [EC-445, "Diagnostic Procedure"](#) .
2. Confirm whether customer filled the coolant or not. If customer filled the coolant, skip the following steps and go to [EC-445, "Diagnostic Procedure"](#) .
3. Start engine.  
**CAUTION:**  
**Be careful not to overheat engine.**
4. Turn air conditioner switch ON.
5. Turn blower fan switch ON.

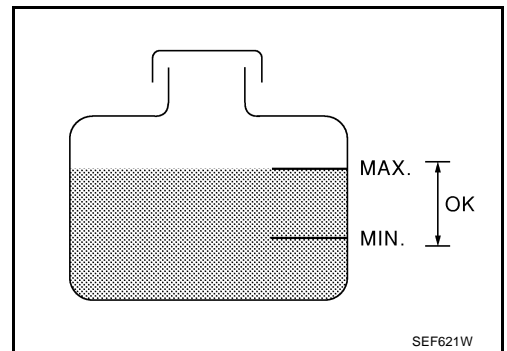

## DTC P1217 ENGINE OVER TEMPERATURE

6. Make sure that cooling fan operates at low speed.  
If NG, go to [EC-445. "Diagnostic Procedure"](#) .  
If OK, go to the following step.
7. Turn ignition switch OFF.
8. Turn air conditioner switch and blower fan switch OFF.
9. Disconnect engine coolant temperature sensor harness connector.
10. Connect 150Ω resistor to engine coolant temperature sensor harness connector.

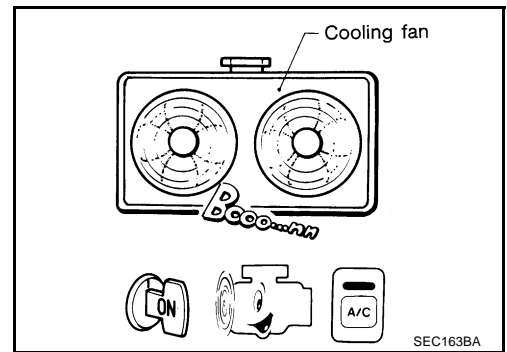

11. Restart engine and make sure that cooling fan operates at higher speed than low speed.

**CAUTION:**

**Be careful not to overheat engine.**

12. If NG, go to [EC-445. "Diagnostic Procedure"](#) .

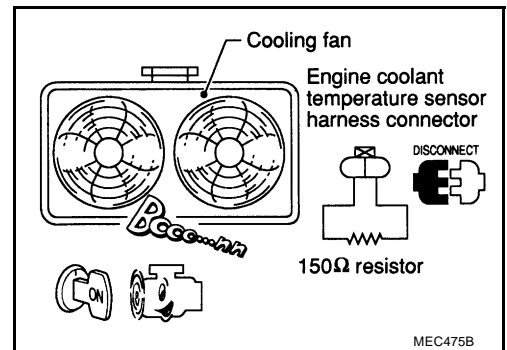



# DTC P1217 ENGINE OVER TEMPERATURE

## Wiring Diagram

ABS009LO

### EC-COOL/F-01

-  : DETECTABLE LINE FOR DTC
-  : NON-DETECTABLE LINE FOR DTC
-  : DATA LINE

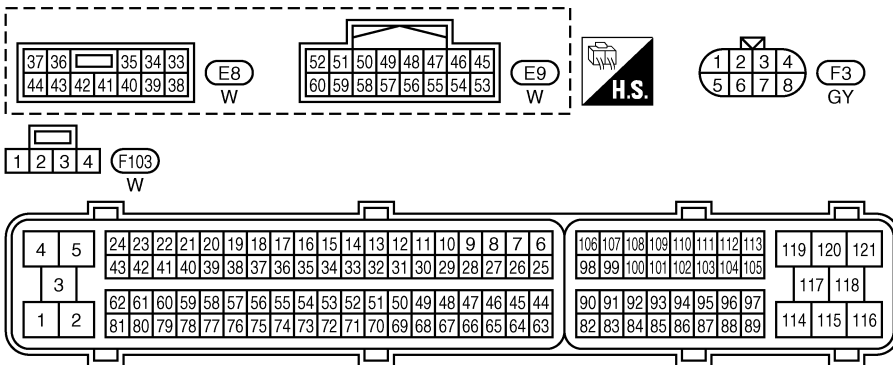
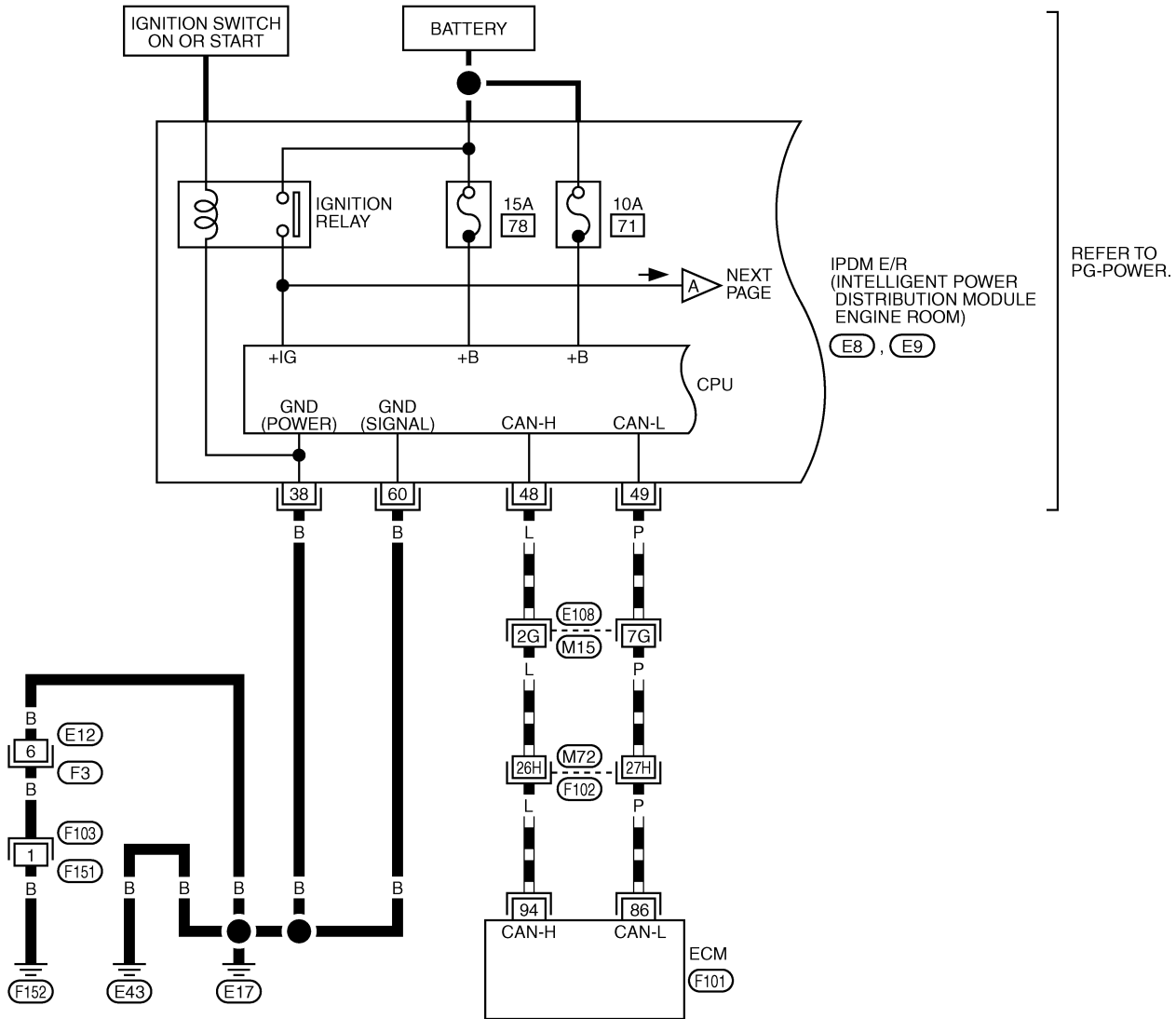

TBWT0629E

# DTC P1217 ENGINE OVER TEMPERATURE

EC-COOL/F-02

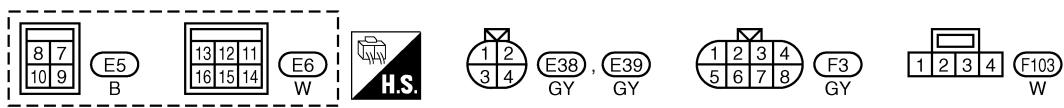
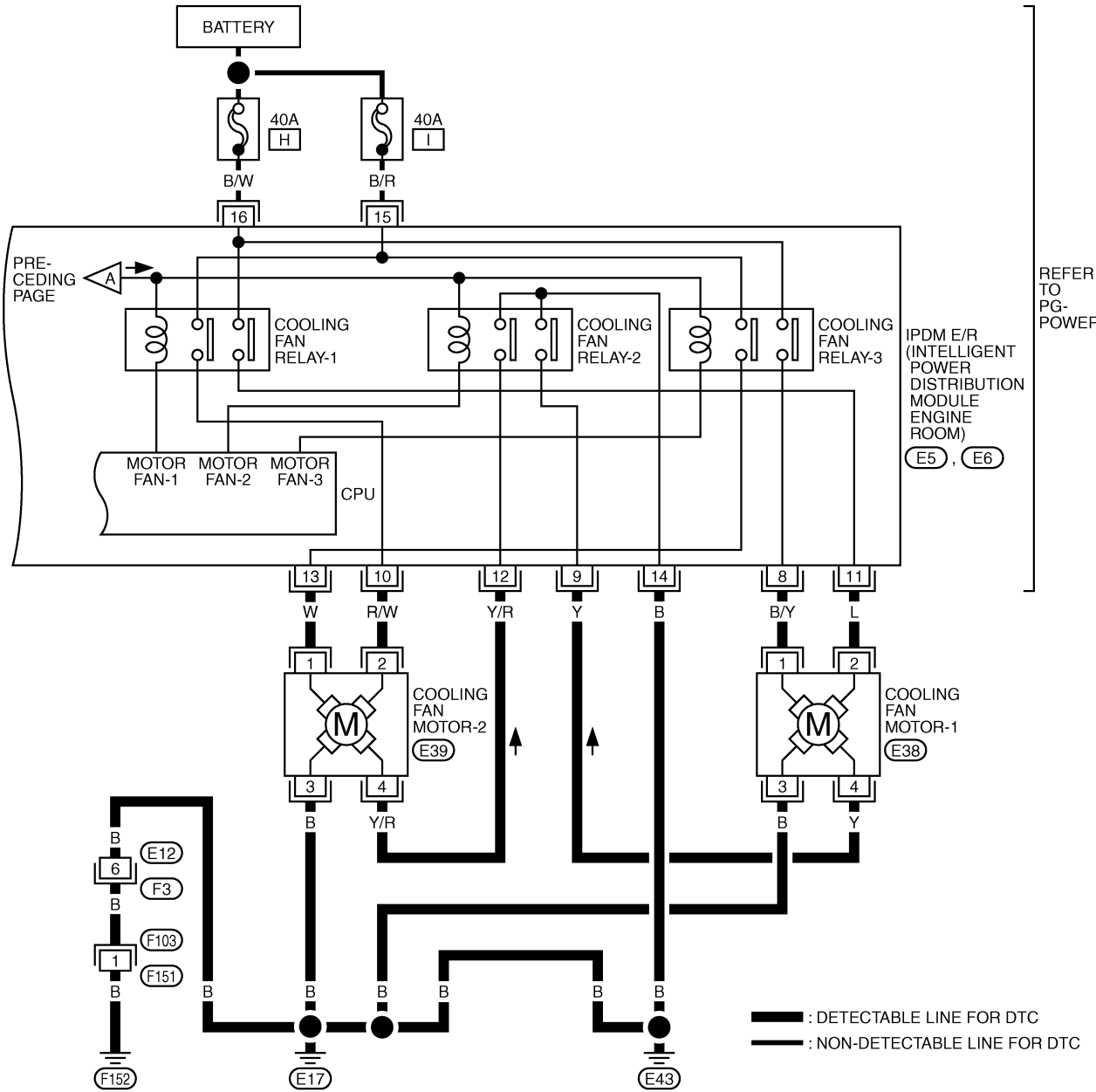

TBWT0630E

# DTC P1217 ENGINE OVER TEMPERATURE

ABS009LP

## Diagnostic Procedure

### 1. INSPECTION START

Do you have CONSULT-II?

Yes or No

- Yes >> GO TO 2.
- No >> GO TO 4.

### 2. CHECK COOLING FAN LOW SPEED OPERATION

#### ① With CONSULT-II

1. Start engine and let it idle.
2. Select "COOLING FAN" in "ACTIVE TEST" mode with CONSULT-II and touch "LOW" on the CONSULT-II screen.
3. Make sure that cooling fans-1 and -2 operate at low speed.

OK or NG

- OK >> GO TO 3.
- NG >> Check cooling fan low speed control circuit. (Go to [EC-448](#), "PROCEDURE A" .)

ACTIVE TEST	
COOLING FAN	LOW
MONITOR	
COOLANT TEMP/S	XXX °C

SEF784Z

### 3. CHECK COOLING FAN HIGH SPEED OPERATION

#### ① With CONSULT-II

1. Touch "HIGH" on the CONSULT-II screen.
2. Make sure that cooling fans-1 and -2 operate at higher speed than low speed.

OK or NG

- OK >> GO TO 6.
- NG >> Check cooling fan high speed control circuit. (Go to [EC-450](#), "PROCEDURE B" .)

ACTIVE TEST	
COOLING FAN	HIGH
MONITOR	
COOLANT TEMP/S	XXX °C

SEF785Z

### 4. CHECK COOLING FAN LOW SPEED OPERATION

#### ⊗ Without CONSULT-II

1. Start engine and let it idle.
2. Turn air conditioner switch ON.
3. Turn blower fan switch ON.
4. Make sure that cooling fans-1 and -2 operate at low speed.

OK or NG

- OK >> GO TO 5.
- NG >> Check cooling fan low speed control circuit. (Go to [EC-448](#), "PROCEDURE A" .)

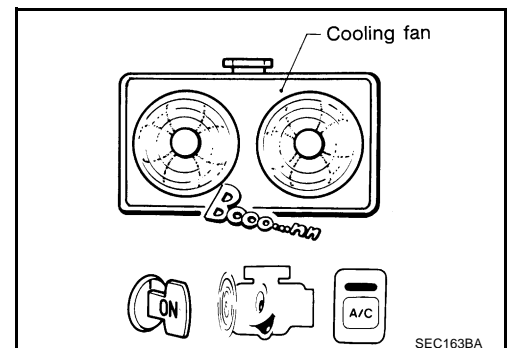

# DTC P1217 ENGINE OVER TEMPERATURE

## 5. CHECK COOLING FAN HIGH SPEED OPERATION

### ⊗ Without CONSULT-II

1. Turn ignition switch OFF.
2. Turn air conditioner switch and blower fan switch OFF.
3. Disconnect engine coolant temperature sensor harness connector.
4. Connect 150Ω resistor to engine coolant temperature sensor harness connector.
5. Restart engine and make sure that cooling fans-1 and -2 operate at higher speed than low speed.

#### OK or NG

OK >> GO TO 6.

NG >> Check cooling fan high speed control circuit. (Go to [EC-450, "PROCEDURE B"](#).)

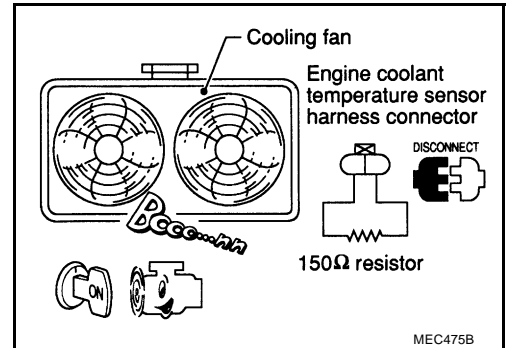

## 6. CHECK COOLING SYSTEM FOR LEAK

Apply pressure to the cooling system with a tester, and check if the pressure drops.

**Testing pressure: 157 kPa (1.6 kg/cm<sup>2</sup> , 23 psi)**

### CAUTION:

Higher than the specified pressure may cause radiator damage. Pressure should not drop.

#### OK or NG

OK >> GO TO 7.

NG >> Check the following for leak. Refer to [CO-9, "LEAK CHECK"](#).

- Hose
- Radiator
- Water pump

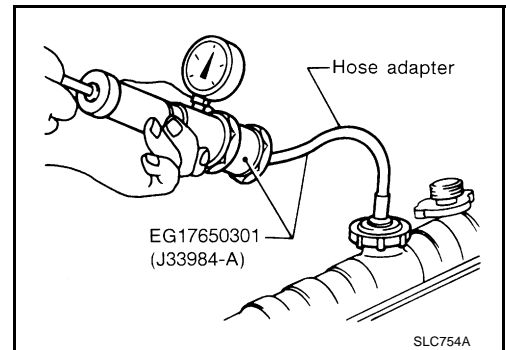

## 7. CHECK RADIATOR CAP

Apply pressure to cap with a tester.

**Radiator cap relief pressure: 59 - 98 kPa (0.6 - 1.0 kg/cm<sup>2</sup> , 9 - 14 psi)**

#### OK or NG

OK >> GO TO 8.

NG >> Replace radiator cap.

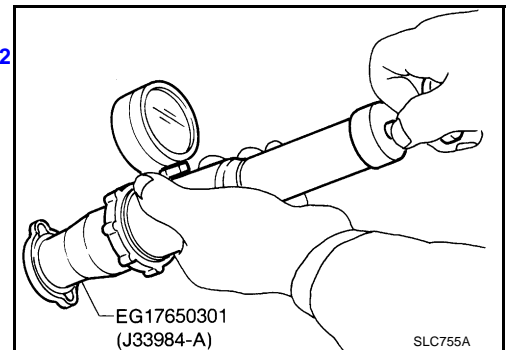

# DTC P1217 ENGINE OVER TEMPERATURE

## 8. CHECK THERMOSTAT

1. Check valve seating condition at normal room temperatures.  
**It should seat tightly.**
2. Check valve opening temperature and valve lift.

**Valve opening temperature: 76.5°C (170°F) [standard]**

**Valve lift: More than 8.6 mm/90°C (0.339 in/194°F)**

3. Check if valve is closed at 5°C (9°F) below valve opening temperature.  
For details, refer to [CO-26, "WATER INLET AND THERMOSTAT ASSEMBLY"](#) .

### OK or NG

- OK >> GO TO 9.  
NG >> Replace thermostat

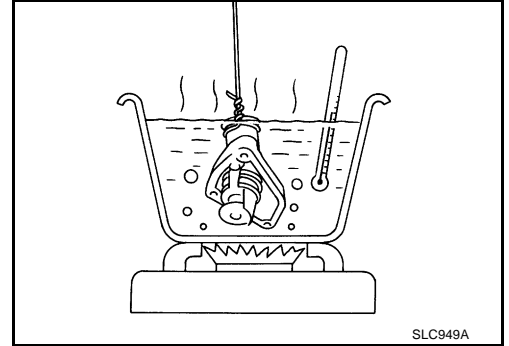

## 9. CHECK ENGINE COOLANT TEMPERATURE SENSOR

Refer to [EC-183, "Component Inspection"](#) .

### OK or NG

- OK >> GO TO 10.  
NG >> Replace engine coolant temperature sensor.

## 10. CHECK MAIN 12 CAUSES

If the cause cannot be isolated, go to [EC-451, "Main 12 Causes of Overheating"](#) .

**>> INSPECTION END**

A  
EC  
C  
D  
E  
F  
G  
H  
I  
J  
K  
L  
M

# DTC P1217 ENGINE OVER TEMPERATURE

## PROCEDURE A

### 1. CHECK POWER SUPPLY CIRCUIT

1. Turn ignition switch OFF.
2. Disconnect IPDM E/R harness connector E6.
3. Check voltage between IPDM E/R terminals 15, 16 and ground with CONSULT-II or tester.

**Voltage: Battery voltage**

OK or NG

- OK >> GO TO 3.  
NG >> GO TO 2.

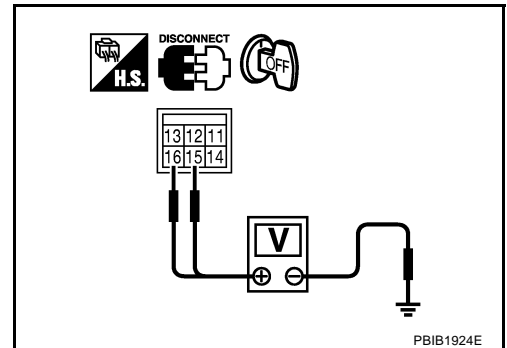

### 2. DETECT MALFUNCTIONING PART

Check the following.

- 40A fusible links
- Harness for open or short between IPDM E/R and battery

>> Repair open circuit or short to ground or short to power in harness or connectors.

### 3. CHECK COOLING FAN MOTORS CIRCUIT

1. Disconnect cooling fan motor-1 harness connector and cooling fan motor-2 harness connector.
2. Disconnect IPDM E/R harness connector E5.
3. Check harness continuity between the following;  
cooling fan motor-1 terminal 2 and IPDM E/R terminal 11,  
cooling fan motor-1 terminal 3 and ground.  
IPDM E/R terminal 38, 60 and ground.  
Refer to wiring diagram.

**Continuity should exist.**

4. Check harness continuity between the following;  
cooling fan motor-2 terminal 2 and IPDM E/R terminal 10,  
cooling fan motor-2 terminal 3 and ground.  
Refer to wiring diagram.

**Continuity should exist.**

5. Also check harness for short to ground and short to power.

OK or NG

- OK >> GO TO 5.  
NG >> GO TO 4.

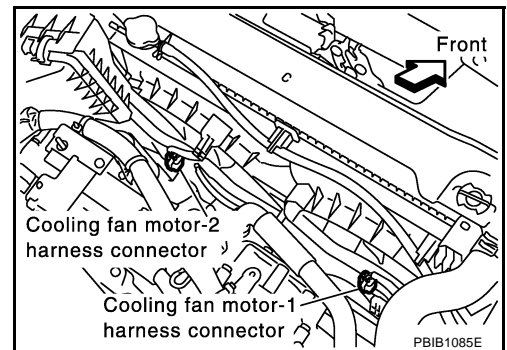



# DTC P1217 ENGINE OVER TEMPERATURE

---

## 4. DETECT MALFUNCTIONING PART

---

Check the following.

- Harness connector E12, F3
- Harness connector F103, F151
- Harness for open or short between cooling fan motor-1 and IPDM E/R
- Harness for open or short between cooling fan motor-1 and ground
- Harness for open or short between cooling fan motor-2 and IPDM E/R
- Harness for open or short between cooling fan motor-2 and ground
- Harness for open or short between IPDM E/R and ground

>> Repair open circuit or short to ground or short to power in harness or connectors.

---

## 5. CHECK COOLING FAN MOTORS

---

Refer to [EC-451, "Component Inspection"](#) .

OK or NG

OK >> GO TO 6.

NG >> Replace cooling fan motors.

---

## 6. CHECK INTERMITTENT INCIDENT

---

Perform [EC-129, "TROUBLE DIAGNOSIS FOR INTERMITTENT INCIDENT"](#) .

OK or NG

OK >> Replace IPDM E/R. Refer to [PG-17, "IPDM E/R \(INTELLIGENT POWER DISTRIBUTION MODULE ENGINE ROOM\)"](#) .

NG >> Repair or replace harness or connector.

A  
EC  
C  
D  
E  
F  
G  
H  
I  
J  
K  
L  
M

# DTC P1217 ENGINE OVER TEMPERATURE

## PROCEDURE B

### 1. CHECK COOLING FAN MOTORS CIRCUIT

1. Turn ignition switch OFF.
2. Disconnect cooling fan motor-1 harness connector and cooling fan motor-2 harness connector.
3. Disconnect IPDM E/R harness connectors E5, E6.
4. Check harness continuity between the following;  
cooling fan motor-1 terminal 1 and IPDM E/R terminal 8,  
cooling fan motor-1 terminal 4 and IPDM E/R terminal 9,  
IPDM E/R terminal 14, 38, 60 and ground,  
Refer to wiring diagram.

**Continuity should exist.**

5. Also check harness connector for short to ground or short to power.
6. Check harness continuity between the following;  
cooling fan motor-2 terminal 1 and IPDM E/R terminal 13,  
cooling fan motor-2 terminal 4 and IPDM E/R terminal 12,  
Refer to wiring diagram.

**Continuity should exist.**

7. Also check harness for short to ground and short to power.

OK or NG

- OK >> GO TO 3.  
NG >> GO TO 2.

### 2. DETECT MALFUNCTIONING PART

Check the following.

- Harness connector E12, F3
- Harness connector F103, F151
- Harness for open or short between cooling fan motor-1 and IPDM E/R
- Harness for open or short between cooling fan motor-2 and IPDM E/R
- Harness for open or short between IPDM E/R and ground

>> Repair open circuit or short to ground or short to power in harness or connectors.

### 3. CHECK COOLING FAN MOTORS

Refer to [EC-451, "Component Inspection"](#) .

OK or NG

- OK >> GO TO 4.  
NG >> Replace cooling fan motors.

### 4. CHECK INTERMITTENT INCIDENT

Perform [EC-129, "TROUBLE DIAGNOSIS FOR INTERMITTENT INCIDENT"](#) .

OK or NG

- OK >> Replace IPDM E/R. Refer to [PG-17, "IPDM E/R \(INTELLIGENT POWER DISTRIBUTION MODULE ENGINE ROOM\)"](#) .  
NG >> Repair or replace harness connectors.

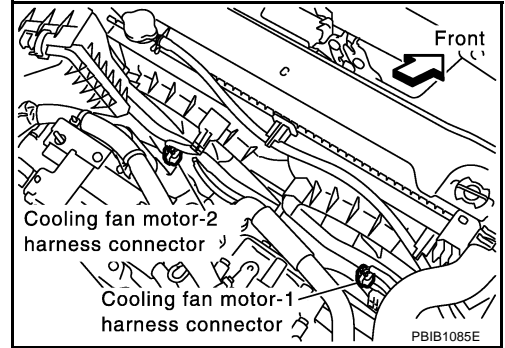

# DTC P1217 ENGINE OVER TEMPERATURE

## Main 12 Causes of Overheating

ABS009LQ

Engine	Step	Inspection item	Equipment	Standard	Reference page
OFF	1	<ul style="list-style-type: none"> <li>Blocked radiator</li> <li>Blocked condenser</li> <li>Blocked radiator grille</li> <li>Blocked bumper</li> </ul>	<ul style="list-style-type: none"> <li>Visual</li> </ul>	No blocking	—
	2	<ul style="list-style-type: none"> <li>Coolant mixture</li> </ul>	<ul style="list-style-type: none"> <li>Coolant tester</li> </ul>	50 - 50% coolant mixture	<a href="#">MA-13</a>
	3	<ul style="list-style-type: none"> <li>Coolant level</li> </ul>	<ul style="list-style-type: none"> <li>Visual</li> </ul>	Coolant up to MAX level in reservoir tank and radiator filler neck	<a href="#">CO-9</a>
	4	<ul style="list-style-type: none"> <li>Radiator cap</li> </ul>	<ul style="list-style-type: none"> <li>Pressure tester</li> </ul>	59 - 98 kPa (0.6 - 1.0 kg/cm <sup>2</sup> , 9 - 14 psi) (Limit)	<a href="#">CO-14</a>
ON*2	5	<ul style="list-style-type: none"> <li>Coolant leaks</li> </ul>	<ul style="list-style-type: none"> <li>Visual</li> </ul>	No leaks	<a href="#">CO-9</a>
ON*2	6	<ul style="list-style-type: none"> <li>Thermostat</li> </ul>	<ul style="list-style-type: none"> <li>Touch the upper and lower radiator hoses</li> </ul>	Both hoses should be hot	<a href="#">CO-26</a>
ON*1	7	<ul style="list-style-type: none"> <li>Cooling fan</li> </ul>	<ul style="list-style-type: none"> <li>CONSULT-II</li> </ul>	Operating	See trouble diagnosis for DTC P1217 ( <a href="#">EC-439</a> ).
OFF	8	<ul style="list-style-type: none"> <li>Combustion gas leak</li> </ul>	<ul style="list-style-type: none"> <li>Color checker chemical tester 4 Gas analyzer</li> </ul>	Negative	—
ON*3	9	<ul style="list-style-type: none"> <li>Coolant temperature gauge</li> </ul>	<ul style="list-style-type: none"> <li>Visual</li> </ul>	Gauge less than 3/4 when driving	—
		<ul style="list-style-type: none"> <li>Coolant overflow to reservoir tank</li> </ul>	<ul style="list-style-type: none"> <li>Visual</li> </ul>	No overflow during driving and idling	<a href="#">CO-9</a>
OFF*4	10	<ul style="list-style-type: none"> <li>Coolant return from reservoir tank to radiator</li> </ul>	<ul style="list-style-type: none"> <li>Visual</li> </ul>	Should be initial level in reservoir tank	<a href="#">CO-9</a>
OFF	11	<ul style="list-style-type: none"> <li>Cylinder head</li> </ul>	<ul style="list-style-type: none"> <li>Straight gauge feeler gauge</li> </ul>	0.1 mm (0.004 in) Maximum distortion (warping)	<a href="#">EM-90</a>
	12	<ul style="list-style-type: none"> <li>Cylinder block and pistons</li> </ul>	<ul style="list-style-type: none"> <li>Visual</li> </ul>	No scuffing on cylinder walls or piston	<a href="#">EM-109</a>

\*1: Turn the ignition switch ON.

\*2: Engine running at 3,000 rpm for 10 minutes.

\*3: Drive at 90 km/h (55 MPH) for 30 minutes and then let idle for 10 minutes.

\*4: After 60 minutes of cool down time.

For more information, refer to [CO-5, "OVERHEATING CAUSE ANALYSIS"](#).

## Component Inspection COOLING FAN MOTORS-1 AND -2

ABS009LR

- Disconnect cooling fan motor harness connectors.
- Supply cooling fan motor terminals with battery voltage and check operation.

	Speed	terminals	
		(+)	(-)
Cooling fan motor	Low	1	4
	High	2	3
		1 and 2	3 and 4

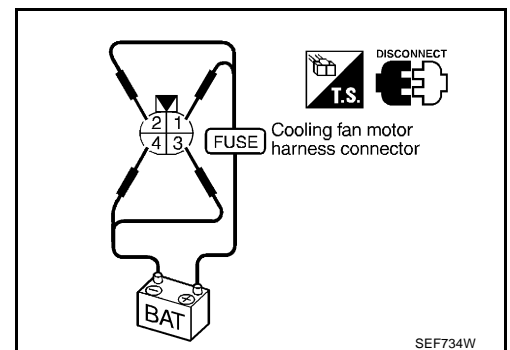

**Cooling fan motor should operate.**

If NG, replace cooling fan motor.

# DTC P1225 TP SENSOR

PFP:16119

## DTC P1225 TP SENSOR

### Component Description

ABS009LS

Electric throttle control actuator consists of throttle control motor, throttle position sensor, etc. The throttle position sensor responds to the throttle valve movement.

The throttle position sensor has the two sensors. These sensors are a kind of potentiometers which transform the throttle valve position into output voltage, and emit the voltage signal to the ECM. In addition, these sensors detect the opening and closing speed of the throttle valve and feed the voltage signals to the ECM. The ECM judges the current opening angle of the throttle valve from these signals and the ECM controls the throttle control motor to make the throttle valve opening angle properly in response to driving condition.

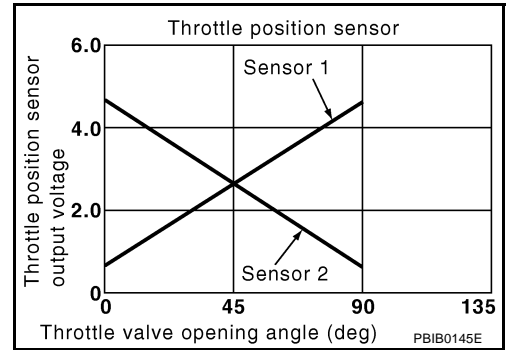

### On Board Diagnosis Logic

ABS009LT

The MIL will not light up for this diagnosis.

DTC No.	Trouble diagnosis name	DTC detecting condition	Possible cause
P1225 1225	Closed throttle position learning performance problem	Closed throttle position learning value is excessively low.	<ul style="list-style-type: none"> <li>Electric throttle control actuator (TP sensor 1 and 2)</li> </ul>

### DTC Confirmation Procedure

ABS009LU

#### NOTE:

If DTC Confirmation Procedure has been previously conducted, always turn ignition switch OFF and wait at least 10 seconds before conducting the next test.

#### TESTING CONDITION:

Before performing the following procedure, confirm that battery voltage is more than 10V at idle.

#### WITH CONSULT-II

- Turn ignition switch ON.
- Select "DATA MONITOR" mode with CONSULT-II.
- Turn ignition switch OFF and wait at least 10 seconds.
- Turn ignition switch ON.
- If 1st trip DTC is detected, go to [EC-453, "Diagnostic Procedure"](#)

DATA MONITOR	
MONITOR	NO DTC
ENG SPEED	XXX rpm

SEF058Y

#### WITH GST

Follow the procedure "WITH CONSULT-II" above.

# DTC P1225 TP SENSOR

## Diagnostic Procedure

ABS009LV

### 1. CHECK ELECTRIC THROTTLE CONTROL ACTUATOR VISUALLY

1. Turn ignition switch OFF.
2. Remove the intake air duct.
3. Check if foreign matter is caught between the throttle valve and the housing.

#### OK or NG

- OK >> GO TO 2.  
NG >> Remove the foreign matter and clean the electric throttle control actuator inside.

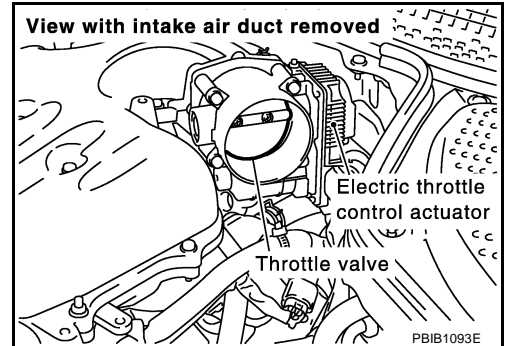

### 2. REPLACE ELECTRIC THROTTLE CONTROL ACTUATOR

1. Replace the electric throttle control actuator.
2. Perform [EC-42, "Throttle Valve Closed Position Learning"](#) .
3. Perform [EC-43, "Idle Air Volume Learning"](#) .

>> INSPECTION END

## Removal and Installation ELECTRIC THROTTLE CONTROL ACTUATOR

ABS009LW

Refer to [EM-16, "INTAKE MANIFOLD COLLECTOR"](#) .

# DTC P1226 TP SENSOR

PFP:16119

## DTC P1226 TP SENSOR

### Component Description

ABS009LX

Electric throttle control actuator consists of throttle control motor, throttle position sensor, etc. The throttle position sensor responds to the throttle valve movement.

The throttle position sensor has the two sensors. These sensors are a kind of potentiometers which transform the throttle valve position into output voltage, and emit the voltage signal to the ECM. In addition, these sensors detect the opening and closing speed of the throttle valve and feed the voltage signals to the ECM. The ECM judges the current opening angle of the throttle valve from these signals and the ECM controls the throttle control motor to make the throttle valve opening angle properly in response to driving condition.

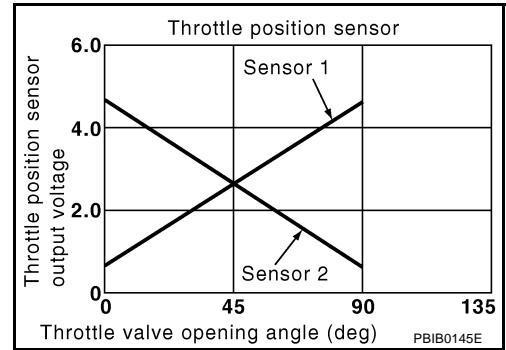

### On Board Diagnosis Logic

ABS009LY

The MIL will not light up for this diagnosis.

DTC No.	Trouble diagnosis name	DTC detecting condition	Possible cause
P1226 1226	Closed throttle position learning performance problem	Closed throttle position learning is not performed successfully, repeatedly.	<ul style="list-style-type: none"> <li>Electric throttle control actuator (TP sensor 1 and 2)</li> </ul>

### DTC Confirmation Procedure

ABS009LZ

#### NOTE:

If DTC Confirmation Procedure has been previously conducted, always turn ignition switch OFF and wait at least 10 seconds before conducting the next test.

#### TESTING CONDITION:

Before performing the following procedure, confirm that battery voltage is more than 10V at idle.

#### Ⓜ WITH CONSULT-II

- Turn ignition switch ON.
- Select "DATA MONITOR" mode with CONSULT-II.
- Turn ignition switch OFF and wait at least 10 seconds.
- Turn ignition switch ON.
- Repeat steps 3 and 4 for 32 times.
- If 1st trip DTC is detected, go to [EC-455, "Diagnostic Procedure"](#)

The screenshot shows a rectangular window titled 'DATA MONITOR'. Inside the window, there are two columns: 'MONITOR' and 'NO DTC'. Below these columns, the text 'ENG SPEED' is displayed on the left and 'XXX rpm' is displayed on the right. The label 'SEF058Y' is located at the bottom right corner of the window.

#### Ⓜ WITH GST

Follow the procedure "With CONSULT-II" above.

# DTC P1226 TP SENSOR

## Diagnostic Procedure

ABS009M0

### 1. CHECK ELECTRIC THROTTLE CONTROL ACTUATOR VISUALLY

1. Turn ignition switch OFF.
2. Remove the intake air duct.
3. Check if foreign matter is caught between the throttle valve and the housing.

#### OK or NG

- OK >> GO TO 2.  
NG >> Remove the foreign matter and clean the electric throttle control actuator inside.

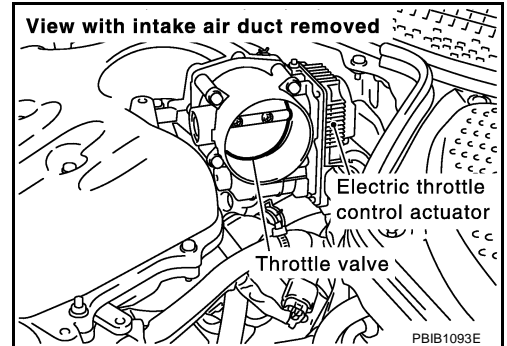

### 2. REPLACE ELECTRIC THROTTLE CONTROL ACTUATOR

1. Replace the electric throttle control actuator.
2. Perform [EC-42, "Throttle Valve Closed Position Learning"](#) .
3. Perform [EC-43, "Idle Air Volume Learning"](#) .

>> INSPECTION END

## Removal and Installation ELECTRIC THROTTLE CONTROL ACTUATOR

ABS009M1

Refer to [EM-16, "INTAKE MANIFOLD COLLECTOR"](#) .

# DTC P1229 SENSOR POWER SUPPLY

## DTC P1229 SENSOR POWER SUPPLY

PFP:16119

### On Board Diagnosis Logic

ABS009M2

This self-diagnosis has the one trip detection logic.

DTC No.	Trouble diagnosis name	DTC detecting condition	Possible cause
P1229 1229	Sensor power supply circuit short	ECM detects a voltage of power source for sensor is excessively low or high.	<ul style="list-style-type: none"> <li>● Harness or connectors (APP sensor 1 circuit is shorted.) (EVAP control system pressure sensor circuit is shorted.) (PSP sensor circuit is shorted.) (Refrigerant pressure sensor circuit is shorted.)</li> <li>● Accelerator pedal position sensor (APP sensor 1)</li> <li>● EVAP control system pressure sensor</li> <li>● Power steering pressure sensor</li> <li>● Refrigerant pressure sensor</li> </ul>

### FAIL-SAFE MODE

When the malfunction is detected, ECM enters fail-safe mode and the MIL lights up.

Engine operation condition in fail-safe mode

ECM stops the electric throttle control actuator control, throttle valve is maintained at a fixed opening (approx. 5 degrees) by the return spring.

### DTC Confirmation Procedure

ABS009M3

#### NOTE:

If DTC Confirmation Procedure has been previously conducted, always turn ignition switch OFF and wait at least 10 seconds before conducting the next test.

#### TESTING CONDITION:

Before performing the following procedure, confirm that battery voltage is more than 10V at idle.

#### WITH CONSULT-II

1. Turn ignition switch ON.
2. Select "DATA MONITOR" mode with CONSULT-II.
3. Start engine and let it idle for 1 second.
4. If DTC is detected, go to [EC-458, "Diagnostic Procedure"](#).

DATA MONITOR	
MONITOR	NO DTC
ENG SPEED	XXX rpm

SEF058Y

#### WITH GST

Follow the procedure "WITH CONSULT-II" above.



# DTC P1229 SENSOR POWER SUPPLY

## Wiring Diagram

ABS009M4

### EC-SEN/PW-01

: DETECTABLE LINE FOR DTC  
 : NON-DETECTABLE LINE FOR DTC

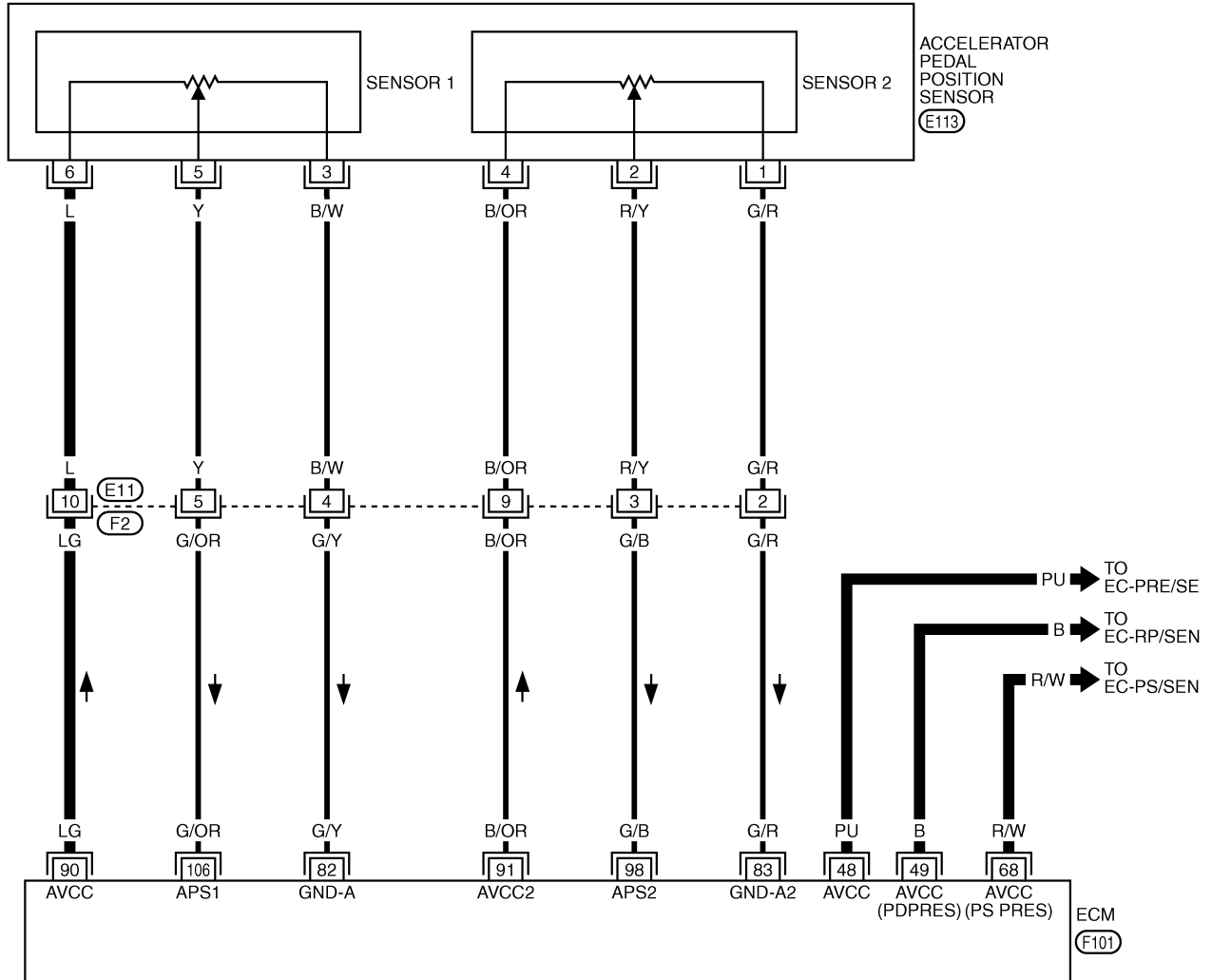

# DTC P1229 SENSOR POWER SUPPLY

Specification data are reference values and are measured between each terminal and ground.

**CAUTION:**

Do not use ECM ground terminals when measuring input/output voltage. Doing so may result in damage to the ECM's transistor. Use a ground other than ECM terminals, such as the ground.

TER-MINAL NO.	WIRE COLOR	ITEM	CONDITION	DATA (DC Voltage)
48	PU	Sensor power supply (EVAP control system pressure sensor)	[Ignition switch: ON]	Approximately 5V
49	B	Sensor power supply (Refrigerant pressure sensor)	[Ignition switch: ON]	Approximately 5V
68	R/W	Sensor power supply (Power steering pressure sensor)	[Ignition switch: ON]	Approximately 5V
90	LG	Sensor power supply (APP sensor 1)	[Ignition switch: ON]	Approximately 5V

## Diagnostic Procedure

ABS009M5

### 1. CHECK GROUND CONNECTIONS

1. Turn ignition switch OFF.
2. Loosen and retighten three ground screws on the body. Refer to [EC-138, "Ground Inspection"](#) .

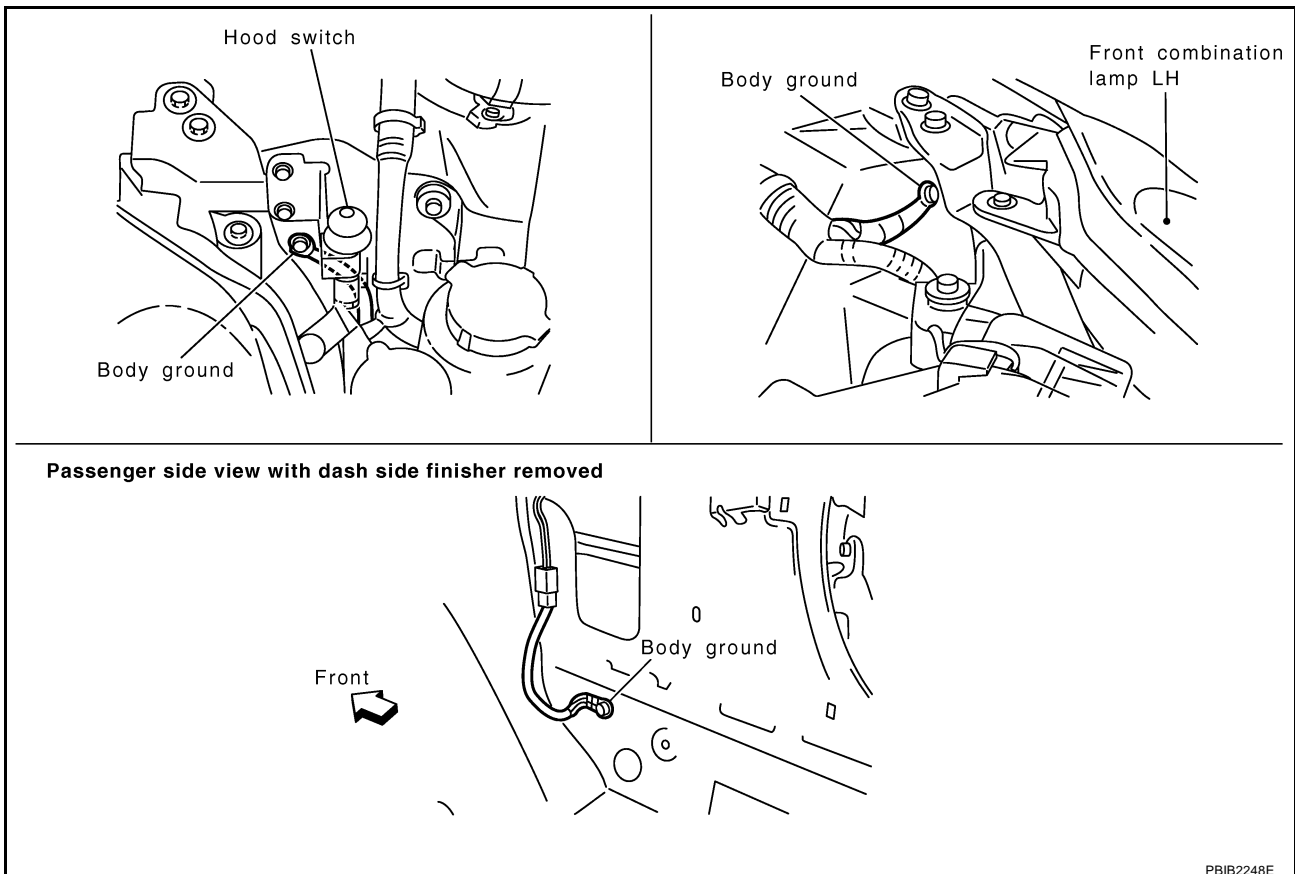

PBIB2248E

**OK or NG**

- OK >> GO TO 2.
- NG >> Repair or replace ground connections.

# DTC P1229 SENSOR POWER SUPPLY

## 2. CHECK ACCELERATOR PEDAL POSITION SENSOR 1 POWER SUPPLY CIRCUIT

1. Disconnect accelerator pedal position (APP) sensor harness connector.
2. Turn ignition switch ON.

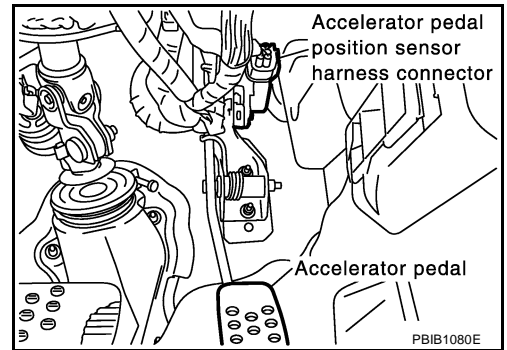

3. Check voltage between APP sensor terminal 6 and ground with CONSULT-II or tester.

**Voltage: Approximately 5V**

OK or NG

- OK >> GO TO 4.  
 NG >> GO TO 3.

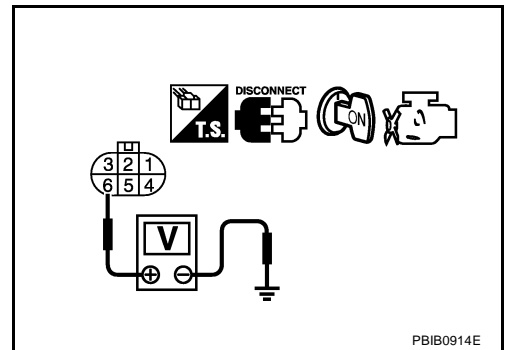

## 3. CHECK SENSOR POWER SUPPLY CIRCUITS

Check harness for short to power and short to ground, between the following terminals.

ECM terminal	Sensor terminal	Reference Wiring Diagram
90	APP sensor terminal 6	<a href="#">EC-591</a>
48	EVAP control system pressure sensor terminal 3	<a href="#">EC-322</a>
49	Refrigerant pressure sensor terminal 1	<a href="#">EC-648</a>
68	PSP sensor terminal 1	<a href="#">EC-370</a>

OK or NG

- OK >> GO TO 4.  
 NG >> Repair short to ground or short to power in harness or connectors.

## 4. CHECK COMPONENTS

Check the following.

- EVAP control system pressure sensor (Refer to [EC-319, "Component Inspection"](#) .)
- Refrigerant pressure sensor (Refer to [ATC-86, "COMPONENT INSPECTION"](#) .)
- Power steering pressure sensor (Refer to [EC-373, "Component Inspection"](#) .)

OK or NG

- OK >> GO TO 7.  
 NG >> Replace malfunctioning component.

## 5. CHECK APP SENSOR

Refer to [EC-595, "Component Inspection"](#) .

OK or NG

- OK >> GO TO 7.  
 NG >> GO TO 6.

## DTC P1229 SENSOR POWER SUPPLY

---

### 6. REPLACE ACCELERATOR PEDAL ASSEMBLY

---

1. Replace accelerator pedal assembly.
2. Perform [EC-42, "Accelerator Pedal Released Position Learning"](#) .
3. Perform [EC-42, "Throttle Valve Closed Position Learning"](#) .
4. Perform [EC-43, "Idle Air Volume Learning"](#) .

>> INSPECTION END

### 7. CHECK INTERMITTENT INCIDENT

---

Refer to [EC-129, "TROUBLE DIAGNOSIS FOR INTERMITTENT INCIDENT"](#) .

>> INSPECTION END

# DTC P1271, P1281 A/F SENSOR 1

## DTC P1271, P1281 A/F SENSOR 1

PF2:22693

### Component Description

ABS00A87

The air fuel ratio (A/F) sensor 1 is a planar dual-cell limit current sensor. The sensor element of the A/F sensor 1 is the combination of a Nernst concentration cell (sensor cell) with an oxygen-pump cell, which transports ions. It has a heater in the element.

The sensor is capable of precise measurement  $\lambda = 1$ , but also in the lean and rich range. Together with its control electronics, the sensor outputs a clear, continuous signal throughout a wide  $\lambda$  range ( $0.7 < \lambda < \text{air}$ ).

The exhaust gas components diffuse through the diffusion gap at the electrode of the oxygen pump and Nernst concentration cell, where they are brought to thermodynamic balance.

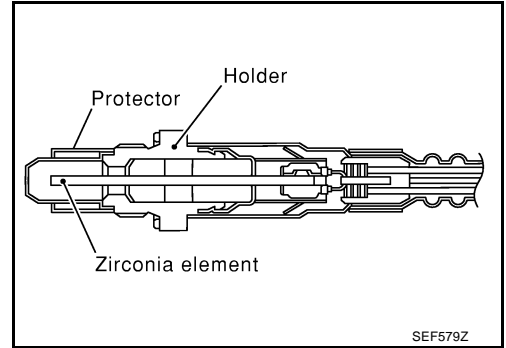

An electronic circuit controls the pump current through the oxygen-pump cell so that the composition of the exhaust gas in the diffusion gap remains constant at  $\lambda = 1$ . Therefore, the A/F sensor 1 is able to indicate air/fuel ratio by this pumping of current. In addition, a heater is integrated in the sensor to ensure the required operating temperature of 700 - 800°C (1,292 - 1,472°F).

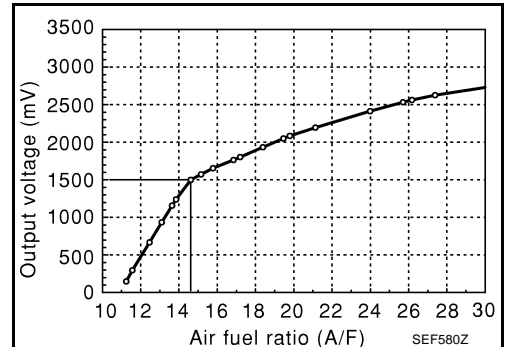

### CONSULT-II Reference Value in Data Monitor Mode

ABS00A88

Specification data are reference values.

MONITOR ITEM	CONDITION	SPECIFICATION
A/F SEN1 (B1) A/F SEN1 (B2)	● Engine: After warming up Maintaining engine speed at 2,000 rpm	Fluctuates around 1.5V

### On Board Diagnosis Logic

ABS00A89

To judge the malfunction, the diagnosis checks that the A/F signal computed by ECM from the A/F sensor 1 signal is not inordinately low.

DTC No.	Trouble diagnosis name	DTC detecting condition	Possible Cause
P1271 1271 (Bank 1)	Air fuel ratio (A/F) sensor 1 circuit no activity detected	● The A/F signal computed by ECM from the A/F sensor 1 signal is constantly approx. 0V.	<ul style="list-style-type: none"> <li>● Harness or connectors (The A/F sensor 1 circuit is open or shorted.)</li> <li>● Air fuel ratio (A/F) sensor 1</li> </ul>
P1281 1281 (Bank 2)			

### DTC Confirmation Procedure

ABS00A8A

#### CAUTION:

Always drive vehicle at a safe speed.

#### NOTE:

If DTC Confirmation Procedure has been previously conducted, always turn ignition switch OFF and wait at least 10 seconds before conducting the next test.

#### TESTING CONDITION:

Before performing the following procedure, confirm that battery voltage is more than 11V at idle.

#### WITH CONSULT-II

1. Start engine and warm it up to normal operating temperature.
2. Select "A/F SEN1 (B1)" or "A/F SEN1 (B2)" in "DATA MONITOR" mode with CONSULT-II.

## DTC P1271, P1281 A/F SENSOR 1

3. Check "A/F SEN1 (B1)" or "A/F SEN1 (B2)" indication.  
If the indication is constantly approx. 0V, go to [EC-466. "Diagnostic Procedure"](#).  
If the indication is not constantly approx. 0V, go to next step.
4. Turn ignition switch OFF, wait at least 10 seconds and then restart engine.
5. Drive and accelerate vehicle to more than 40 km/h (25 MPH) within 20 seconds after restarting engine.
6. Maintain the following conditions for about 20 consecutive seconds.

DATA MONITOR	
MONITOR	NO DTC
ENG SPEED	XXX rpm
COOLAN TEMP/S	XXX °C
A/F SEN1 (B1)	XXX V

SEF581Z

ENG SPEED	1,000 - 3,200 rpm
VHCL SPEED SE	More than 40 km/h (25 MPH)
B/FUEL SCHDL	1.5 - 9.0 msec
Shift lever	Suitable position

**NOTE:**

- Keep the accelerator pedal as steady as possible during the cruising.
  - If this procedure is not completed within 1 minute after restarting engine at step 4, return to step 4.
7. If 1st trip DTC is displayed, go to [EC-466. "Diagnostic Procedure"](#).

**WITH GST**

Follow the procedure "WITH CONSULT-II" above.

# DTC P1271, P1281 A/F SENSOR 1

## Wiring Diagram BANK 1

ABS00A8B

EC-AF1B1-01

A  
EC  
C  
D  
E  
F  
G  
H  
I  
J  
K  
L  
M

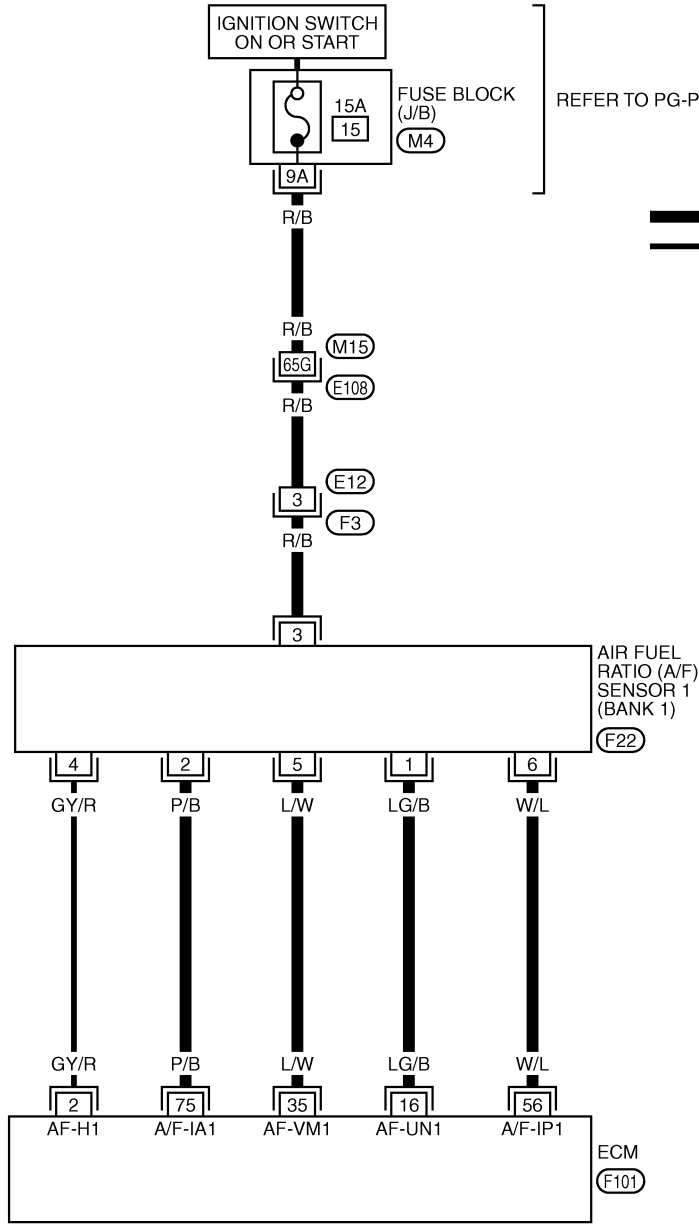

REFER TO PG-POWER.

— : DETECTABLE LINE FOR DTC  
— : NON-DETECTABLE LINE FOR DTC

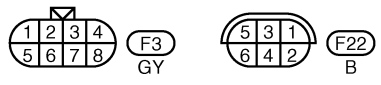

REFER TO THE FOLLOWING.

- E108 -SUPER MULTIPLE JUNCTION (SMJ)
- M4 -FUSE BLOCK-JUNCTION BOX (J/B)

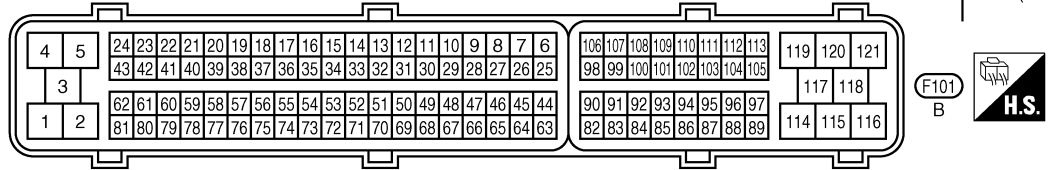

## DTC P1271, P1281 A/F SENSOR 1

Specification data are reference values and are measured between each terminal and ground.

**CAUTION:**

**Do not use ECM ground terminals when measuring input/output voltage. Doing so may result in damage to the ECM's transistor. Use a ground other than ECM terminals, such as the ground.**

TER-MINAL NO.	WIRE COLOR	ITEM	CONDITION	DATA (DC Voltage)
16	LG/B	A/F sensor 1 (Bank 1)	<b>[Engine is running]</b> <ul style="list-style-type: none"><li>● <b>Warm-up condition</b></li><li>● Idle speed</li></ul>	Approximately 3.1V
35	L/W			Approximately 2.6V
56	W/L			Approximately 2.3V
75	P/B			Approximately 2.3V



# DTC P1271, P1281 A/F SENSOR 1

BANK 2

EC-AF1B2-01

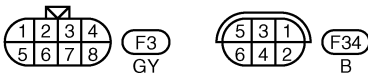
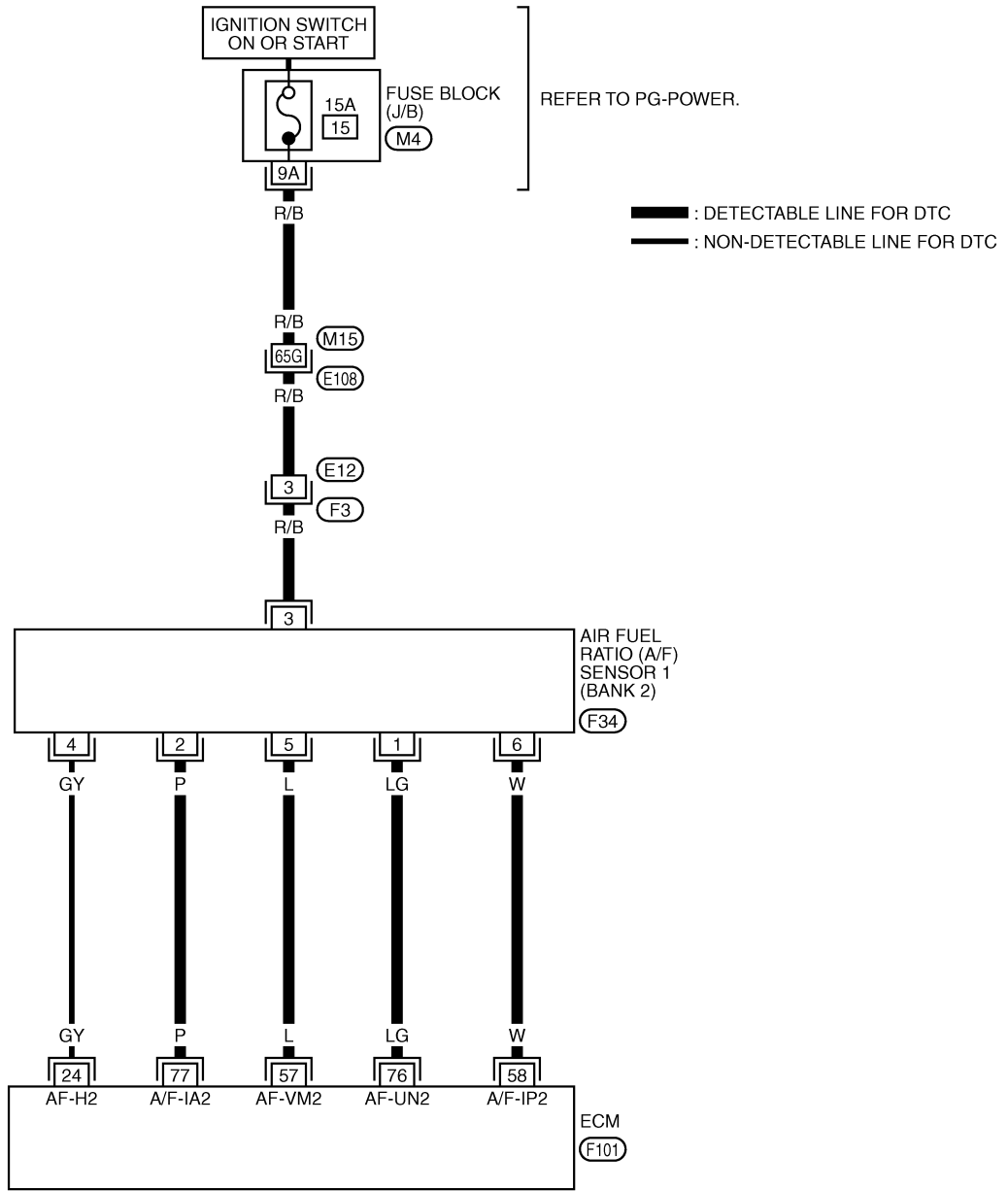

REFER TO THE FOLLOWING.

E108 -SUPER MULTIPLE JUNCTION (SMJ)

M4 -FUSE BLOCK-JUNCTION BOX (J/B)

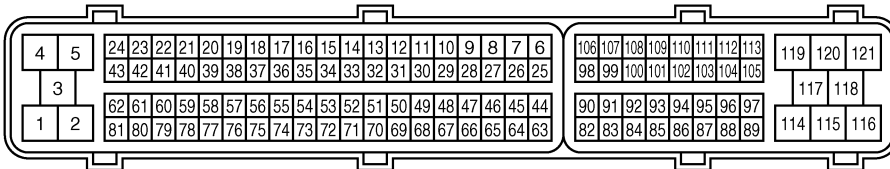

TBWT0707E

# DTC P1271, P1281 A/F SENSOR 1

Specification data are reference values and are measured between each terminal and ground.

**CAUTION:**

Do not use ECM ground terminals when measuring input/output voltage. Doing so may result in damage to the ECM's transistor. Use a ground other than ECM terminals, such as the ground.

TER-MINAL NO.	WIRE COLOR	ITEM	CONDITION	DATA (DC Voltage)
57	L	A/F sensor 1 (Bank 2)	<b>[Engine is running]</b> ● Warm-up condition ● Idle speed	Approximately 2.6V
58	W			Approximately 2.3V
76	LG			Approximately 3.1V
77	P			Approximately 2.3V

## Diagnostic Procedure

ABS00A8C

### 1. CHECK GROUND CONNECTIONS

1. Turn ignition switch OFF.
2. Loosen and retighten three ground screws on the body. Refer to [EC-138, "Ground Inspection"](#).

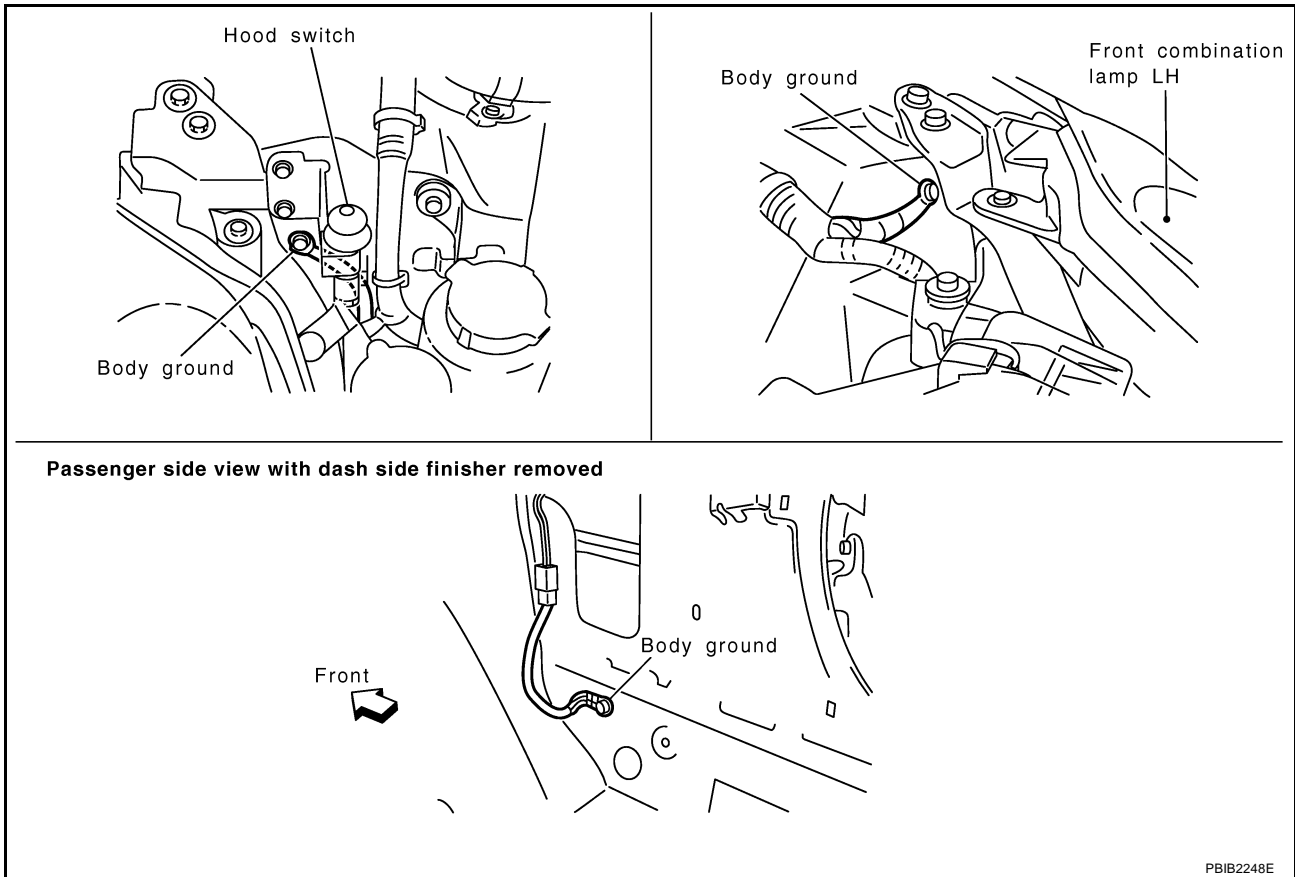

**OK or NG**

- OK >> GO TO 2.
- NG >> Repair or replace ground connections.

# DTC P1271, P1281 A/F SENSOR 1

## 2. CHECK AIR FUEL RATIO (A/F) SENSOR 1 POWER SUPPLY CIRCUIT

1. Disconnect A/F sensor 1 harness connector.

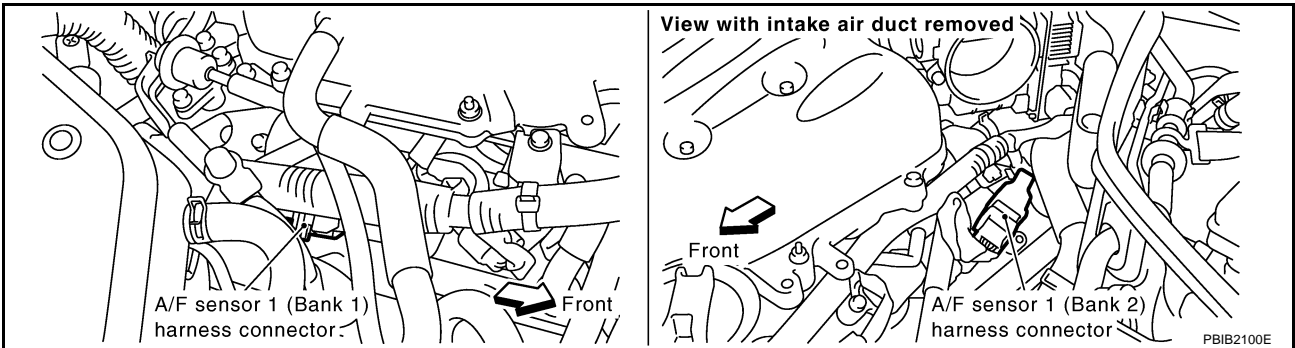

2. Turn ignition switch ON.
3. Check voltage between A/F sensor 1 terminal 3 and ground with CONSULT-II or tester.

**Voltage: Battery voltage**

OK or NG

- OK >> GO TO 4.
- NG >> GO TO 3.

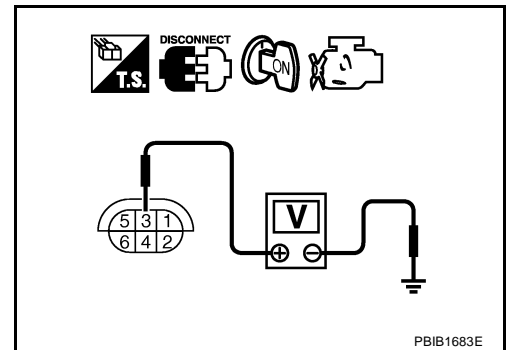

## 3. DETECT MALFUNCTIONING PART

Check the following.

- Harness connectors M15, E108
- Harness connectors E12, F3
- Fuse block (J/B) connector M4
- 15A fuse
- Harness for open or short between A/F sensor 1 and fuse

>> Repair or replace harness or connectors.

## DTC P1271, P1281 A/F SENSOR 1

### 4. CHECK A/F SENSOR 1 INPUT SIGNAL CIRCUIT FOR OPEN AND SHORT

1. Turn ignition switch OFF.
2. Disconnect ECM harness connector.
3. Check harness continuity between the following terminals.  
Refer to Wiring Diagram.

	A/F sensor 1 terminal	ECM terminal
Bank1	1	16
	2	75
	5	35
	6	56
Bank 2	1	76
	2	77
	5	57
	6	58

**Continuity should exist.**

4. Check harness continuity between the following terminals and ground.  
Refer to Wiring Diagram.

Bank 1		Bank 2	
A/F sensor 1 terminal	ECM terminal	A/F sensor 1 terminal	ECM terminal
1	16	1	76
2	75	2	77
5	35	5	57
6	56	6	58

**Continuity should not exist.**

5. Also check harness for short to power.

OK or NG

OK >> GO TO 5.

NG >> Repair open circuit or short to ground or short to power in harness or connectors.

### 5. CHECK INTERMITTENT INCIDENT

Perform [EC-129, "TROUBLE DIAGNOSIS FOR INTERMITTENT INCIDENT"](#) .

OK or NG

OK >> GO TO 6.

NG >> Repair or replace.

### 6. REPLACE AIR FUEL RATIO (A/F) SENSOR 1

Replace A/F sensor 1.

**CAUTION:**

- Discard any A/F sensor which has been dropped from a height of more than 0.5 m (19.7 in) onto a hard surface such as a concrete floor; use a new one.
- Before installing new A/F sensor, clean exhaust system threads (using Oxygen Sensor Thread Cleaner tool J-43897-18 or J-43897-12) and approved anti-seize lubricant.

>> INSPECTION END

# DTC P1271, P1281 A/F SENSOR 1

## Removal and Installation AIR FUEL RATIO (A/F) SENSOR 1

ABS00A8D

Refer to [EM-23, "EXHAUST MANIFOLD AND THREE WAY CATALYST"](#) .

A

EC

C

D

E

F

G

H

I

J

K

L

M

# DTC P1272, P1282 A/F SENSOR 1

PFP:22693

## DTC P1272, P1282 A/F SENSOR 1

### Component Description

ABS00A8E

The air fuel ratio (A/F) sensor 1 is a planar dual-cell limit current sensor. The sensor element of the A/F sensor 1 is the combination of a Nernst concentration cell (sensor cell) with an oxygen-pump cell, which transports ions. It has a heater in the element.

The sensor is capable of precise measurement  $\lambda = 1$ , but also in the lean and rich range. Together with its control electronics, the sensor outputs a clear, continuous signal throughout a wide  $\lambda$  range ( $0.7 < \lambda < \text{air}$ ).

The exhaust gas components diffuse through the diffusion gap at the electrode of the oxygen pump and Nernst concentration cell, where they are brought to thermodynamic balance.

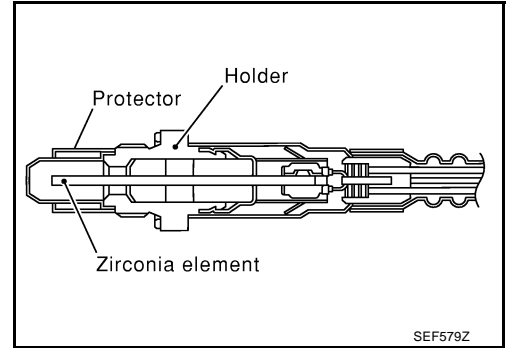

An electronic circuit controls the pump current through the oxygen-pump cell so that the composition of the exhaust gas in the diffusion gap remains constant at  $\lambda = 1$ . Therefore, the A/F sensor 1 is able to indicate air/fuel ratio by this pumping of current. In addition, a heater is integrated in the sensor to ensure the required operating temperature of 700 - 800°C (1,292 - 1,472°F).

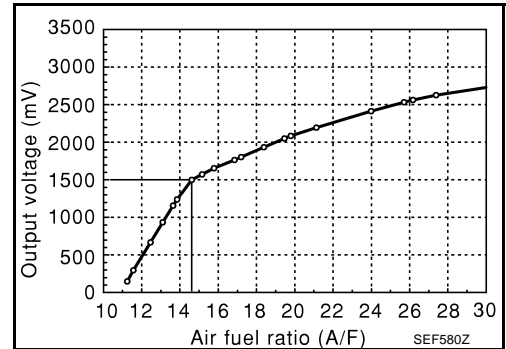

### CONSULT-II Reference Value in Data Monitor Mode

ABS00A8F

Specification data are reference values.

MONITOR ITEM	CONDITION	SPECIFICATION
A/F SEN1 (B1) A/F SEN1 (B2)	● Engine: After warming up Maintaining engine speed at 2,000 rpm	Fluctuates around 1.5V

### On Board Diagnosis Logic

ABS00A8G

To judge the malfunction, the diagnosis checks that the A/F signal computed by ECM from the A/F sensor 1 signal is not inordinately high.

DTC No.	Trouble diagnosis name	DTC detecting condition	Possible Cause
P1272 1272 (Bank 1)	Air fuel ratio (A/F) sensor 1 circuit no activity detected	● The A/F signal computed by ECM from the A/F sensor 1 signal is constantly approx. 5V.	<ul style="list-style-type: none"> <li>● Harness or connectors (The A/F sensor 1 circuit is open or shorted.)</li> <li>● Air fuel ratio (A/F) sensor 1</li> </ul>
P1282 1282 (Bank 2)			

### DTC Confirmation Procedure

ABS00A8H

#### CAUTION:

Always drive vehicle at a safe speed.

#### NOTE:

If DTC Confirmation Procedure has been previously conducted, always turn ignition switch OFF and wait at least 10 seconds before conducting the next test.

#### TESTING CONDITION:

Before performing the following procedure, confirm that battery voltage is more than 11V at idle.

#### WITH CONSULT-II

1. Start engine and warm it up to normal operating temperature.
2. Select "A/F SEN1 (B1)" or "A/F SEN1 (B2)" in "DATA MONITOR" mode with CONSULT-II.

## DTC P1272, P1282 A/F SENSOR 1

3. Check "A/F SEN1 (B1)" or "A/F SEN1 (B2)" indication.  
If the indication is constantly approx. 5V, go to [EC-475, "Diagnostic Procedure"](#).  
If the indication is not constantly approx. 5V, go to next step.
4. Turn ignition switch OFF, wait at least 10 seconds and then restart engine.
5. Drive and accelerate vehicle to more than 40 km/h (25 MPH) within 20 seconds after restarting engine.
6. Maintain the following conditions for about 20 consecutive seconds.

DATA MONITOR	
MONITOR	NO DTC
ENG SPEED	XXX rpm
COOLAN TEMP/S	XXX °C
A/F SEN1 (B1)	XXX V

SEF581Z

ENG SPEED	1,000 - 3,200 rpm
VHCL SPEED SE	More than 40 km/h (25 MPH)
B/FUEL SCHDL	1.5 - 9.0 msec
shift lever	Suitable position

**NOTE:**

- Keep the accelerator pedal as steady as possible during the cruising.
  - If this procedure is not completed within 1 minute after restarting engine at step 4, return to step 4.
7. If 1st trip DTC is displayed, go to [EC-475, "Diagnostic Procedure"](#).

**WITH GST**

Follow the procedure "WITH CONSULT-II" above.

A  
EC  
C  
D  
E  
F  
G  
H  
I  
J  
K  
L  
M

# DTC P1272, P1282 A/F SENSOR 1

ABS00A8I

## Wiring Diagram BANK 1

EC-AF1B1-01

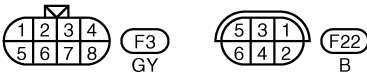
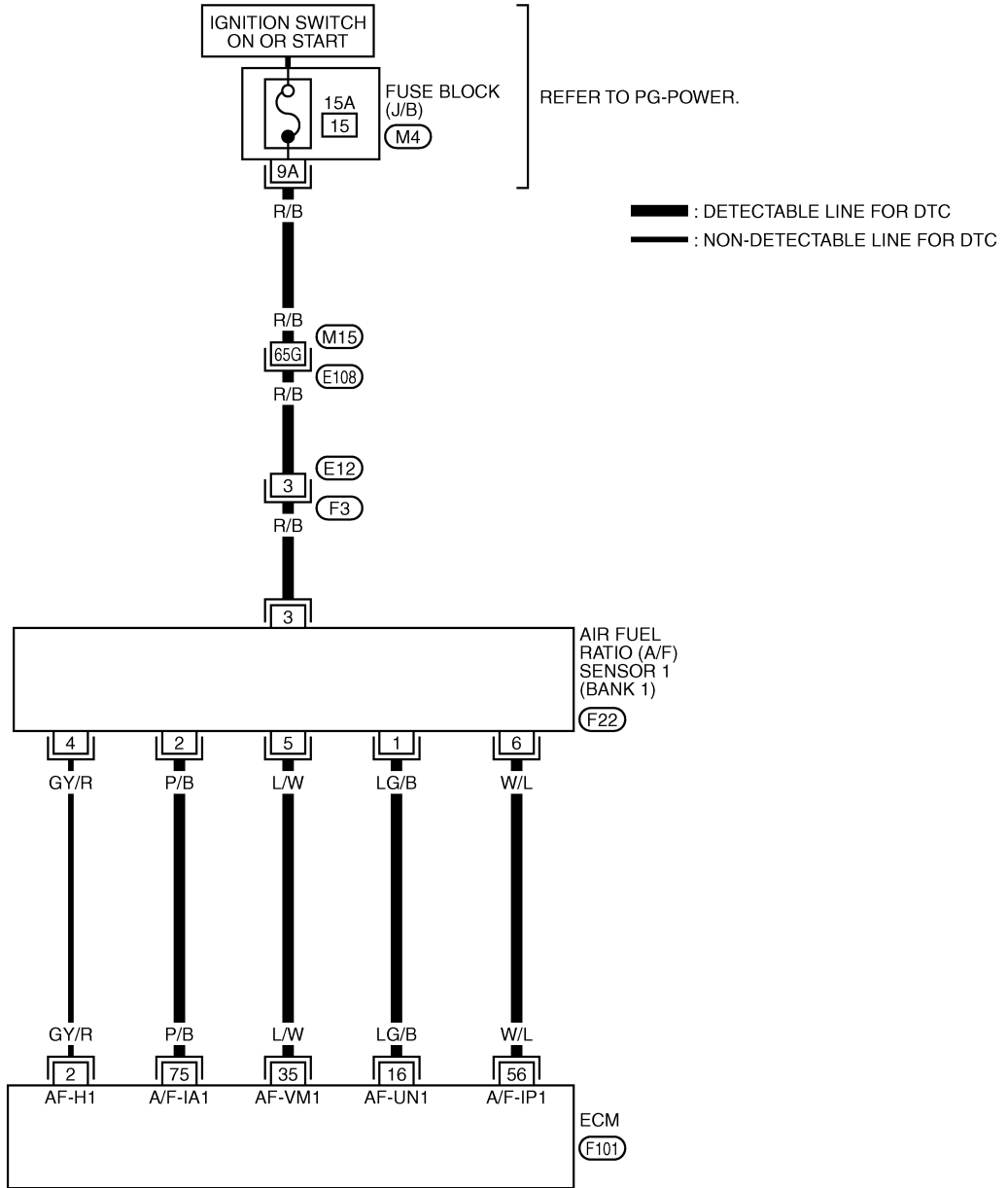

REFER TO THE FOLLOWING.

E108 -SUPER MULTIPLE JUNCTION (SMJ)

M4 -FUSE BLOCK-JUNCTION BOX (J/B)

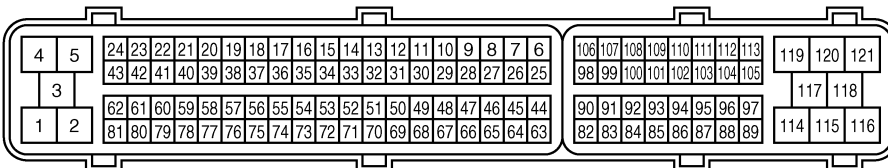

TBWT0706E



## DTC P1272, P1282 A/F SENSOR 1

Specification data are reference values and are measured between each terminal and ground.

**CAUTION:**

**Do not use ECM ground terminals when measuring input/output voltage. Doing so may result in damage to the ECM's transistor. Use a ground other than ECM terminals, such as the ground.**

TER-MINAL NO.	WIRE COLOR	ITEM	CONDITION	DATA (DC Voltage)
16	LG/B	A/F sensor 1 (Bank 1)	<b>[Engine is running]</b> ● Warm-up condition ● Idle speed	Approximately 3.1V
35	L/W			Approximately 2.6V
56	W/L			Approximately 2.3V
75	P/B			Approximately 2.3V

A  
EC  
C  
D  
E  
F  
G  
H  
I  
J  
K  
L  
M

# DTC P1272, P1282 A/F SENSOR 1

BANK 2

EC-AF1B2-01

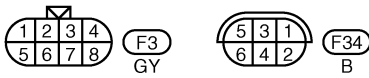
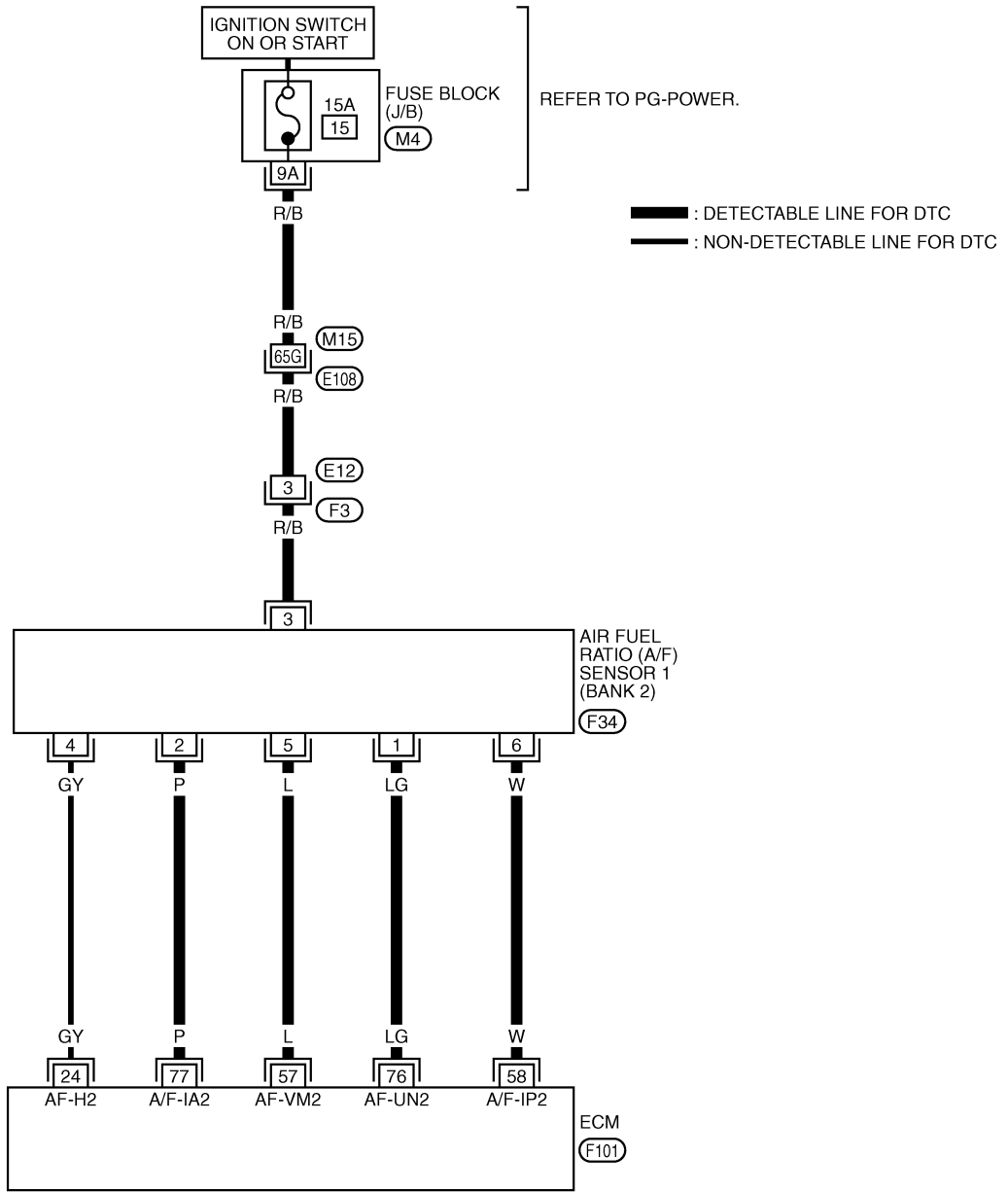

REFER TO THE FOLLOWING.

(E108) -SUPER MULTIPLE JUNCTION (SMJ)

(M4) -FUSE BLOCK-JUNCTION BOX (J/B)

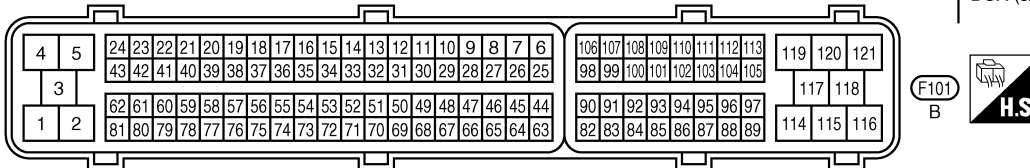

TBWT0707E

# DTC P1272, P1282 A/F SENSOR 1

Specification data are reference values and are measured between each terminal and ground.

**CAUTION:**

Do not use ECM ground terminals when measuring input/output voltage. Doing so may result in damage to the ECM's transistor. Use a ground other than ECM terminals, such as the ground.

TER-MINAL NO.	WIRE COLOR	ITEM	CONDITION	DATA (DC Voltage)
57	L	A/F sensor 1 (Bank 2)	<b>[Engine is running]</b> ● Warm-up condition ● Idle speed	Approximately 2.6V
58	W			Approximately 2.3V
76	LG			Approximately 3.1V
77	P			Approximately 2.3V

## Diagnostic Procedure

ABS00A8J

### 1. CHECK GROUND CONNECTIONS

1. Turn ignition switch OFF.
2. Loosen and retighten three ground screws on the body. Refer to [EC-138, "Ground Inspection"](#).

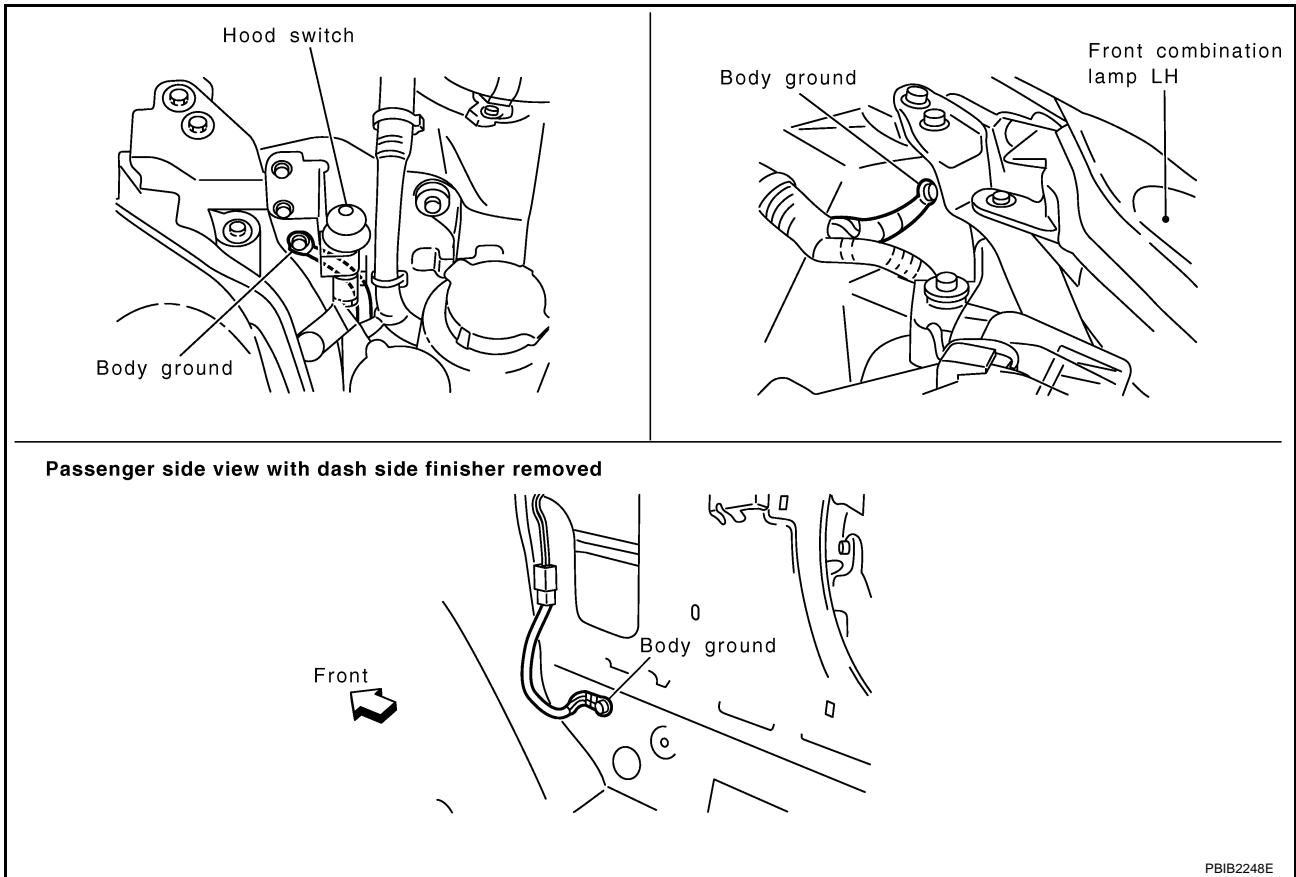

**OK or NG**

- OK >> GO TO 2.
- NG >> Repair or replace ground connections.

## DTC P1272, P1282 A/F SENSOR 1

### 2. CHECK AIR FUEL RATIO (A/F) SENSOR 1 POWER SUPPLY CIRCUIT

1. Disconnect A/F sensor 1 harness connector.

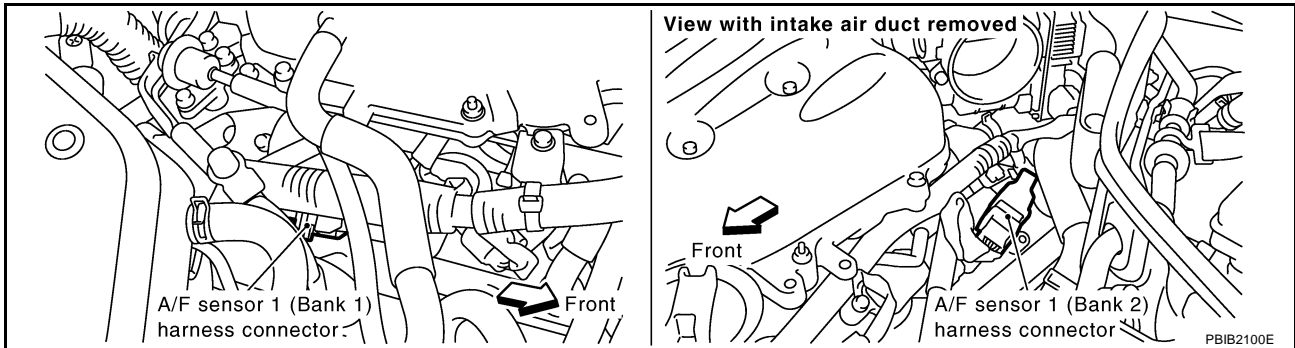

2. Turn ignition switch ON.
3. Check voltage between A/F sensor 1 terminal 3 and ground with CONSULT-II or tester.

**Voltage: Battery voltage**

OK or NG

- OK >> GO TO 4.
- NG >> GO TO 3.

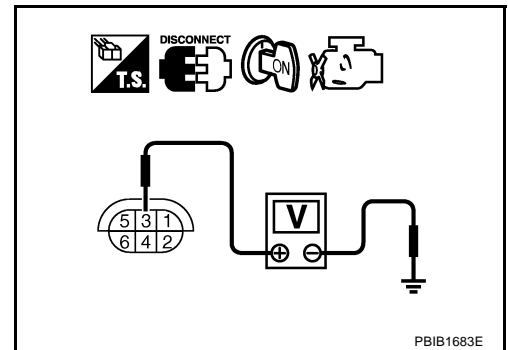

### 3. DETECT MALFUNCTIONING PART

Check the following.

- Harness connectors M15, E108
- Harness connectors E12, F3
- Fuse block (J/B) connector M4
- 15A fuse
- Harness for open or short between A/F sensor 1 and fuse

>> Repair or replace harness or connectors.

# DTC P1272, P1282 A/F SENSOR 1

## 4. CHECK A/F SENSOR 1 INPUT SIGNAL CIRCUIT FOR OPEN AND SHORT

1. Turn ignition switch OFF.
2. Disconnect ECM harness connector.
3. Check harness continuity between the following terminals.  
Refer to Wiring Diagram.

	A/F sensor 1 terminal	ECM terminal
Bank1	1	16
	2	75
	5	35
	6	56
Bank 2	1	76
	2	77
	5	57
	6	58

**Continuity should exist.**

4. Check harness continuity between the following terminals and ground.  
Refer to Wiring Diagram.

Bank 1		Bank 2	
A/F sensor 1 terminal	ECM terminal	A/F sensor 1 terminal	ECM terminal
1	16	1	76
2	75	2	77
5	35	5	57
6	56	6	58

**Continuity should not exist.**

5. Also check harness for short to power.

OK or NG

OK >> GO TO 5.

NG >> Repair open circuit or short to ground or short to power in harness or connectors.

## 5. CHECK INTERMITTENT INCIDENT

Perform [EC-129, "TROUBLE DIAGNOSIS FOR INTERMITTENT INCIDENT"](#) .

OK or NG

OK >> GO TO 6.

NG >> Repair or replace.

## 6. REPLACE AIR FUEL RATIO (A/F) SENSOR 1

Replace A/F sensor 1.

**CAUTION:**

- Discard any A/F sensor which has been dropped from a height of more than 0.5 m (19.7 in) onto a hard surface such as a concrete floor; use a new one.
- Before installing new A/F sensor, clean exhaust system threads (using Oxygen Sensor Thread Cleaner tool J-43897-18 or J-43897-12) and approved anti-seize lubricant.

>> INSPECTION END

## DTC P1272, P1282 A/F SENSOR 1

---

### Removal and Installation AIR FUEL RATIO (A/F) SENSOR 1

ABS00A8K

Refer to [EM-23, "EXHAUST MANIFOLD AND THREE WAY CATALYST"](#) .

## DTC P1273, P1283 A/F SENSOR 1

PFP:22693

### Component Description

ABS00A8L

The air fuel ratio (A/F) sensor 1 is a planar dual-cell limit current sensor. The sensor element of the A/F sensor 1 is the combination of a Nernst concentration cell (sensor cell) with an oxygen-pump cell, which transports ions. It has a heater in the element.

The sensor is capable of precise measurement  $\lambda = 1$ , but also in the lean and rich range. Together with its control electronics, the sensor outputs a clear, continuous signal throughout a wide  $\lambda$  range ( $0.7 < \lambda < \text{air}$ ).

The exhaust gas components diffuse through the diffusion gap at the electrode of the oxygen pump and Nernst concentration cell, where they are brought to thermodynamic balance.

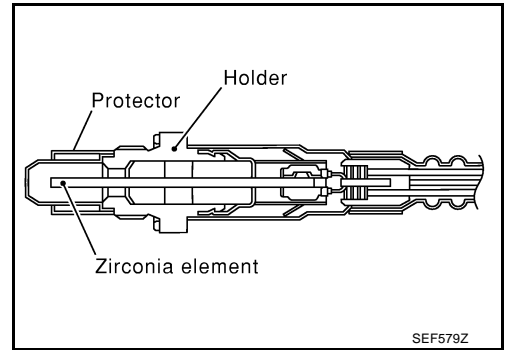

An electronic circuit controls the pump current through the oxygen-pump cell so that the composition of the exhaust gas in the diffusion gap remains constant at  $\lambda = 1$ . Therefore, the A/F sensor 1 is able to indicate air/fuel ratio by this pumping of current. In addition, a heater is integrated in the sensor to ensure the required operating temperature of 700 - 800°C (1,292 - 1,472°F).

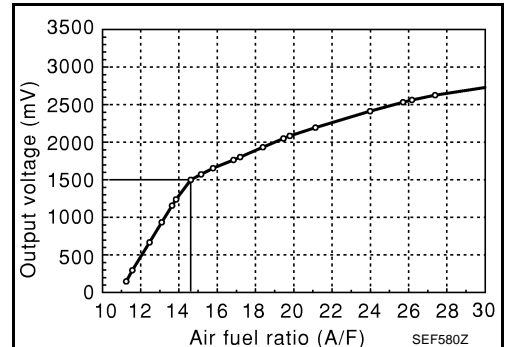

### CONSULT-II Reference Value in Data Monitor Mode

ABS00A8M

Specification data are reference values.

MONITOR ITEM	CONDITION	SPECIFICATION
A/F SEN1 (B1) A/F SEN1 (B2)	● Engine: After warming up Maintaining engine speed at 2,000 rpm	Fluctuates around 1.5V

### On Board Diagnosis Logic

ABS00A8N

To judge the malfunction, the A/F signal computed by ECM from the A/F sensor 1 signal is monitored not to be shifted to LEAN side or RICH side.

DTC No.	Trouble diagnosis name	DTC detecting condition	Possible Cause
P1273 1273 (Bank 1)	Air fuel ratio (A/F) sensor 1 lean shift monitoring	● The output voltage computed by ECM from the A/F sensor 1 signal is shifted to the lean side for a specified period.	<ul style="list-style-type: none"> <li>● Air fuel ratio (A/F) sensor 1</li> <li>● Air fuel ratio (A/F) sensor 1 heater</li> <li>● Fuel pressure</li> <li>● Fuel injector</li> <li>● Intake air leaks</li> </ul>
P1283 1283 (Bank 2)			

### DTC Confirmation Procedure

ABS00A8O

#### NOTE:

If DTC Confirmation Procedure has been previously conducted, always turn ignition switch OFF and wait at least 10 seconds before conducting the next test.

#### TESTING CONDITION:

**Before performing the following procedure, confirm that battery voltage is more than 11V at idle.**

#### Ⓟ WITH CONSULT-II

1. Start engine and warm it up to normal operating temperature.
2. Turn ignition switch OFF and wait at least 10 seconds.
3. Turn ignition switch ON and select "SELF-LEARNING CONT" in "WORK SUPPORT" mode with CONSULT-II.

## DTC P1273, P1283 A/F SENSOR 1

4. Clear the self-learning coefficient by touching "CLEAR".
5. Turn ignition switch OFF and wait at least 10 seconds.
6. Start engine and keep the engine speed between 3,500 and 4,000 rpm for 1 minute under no load.
7. Let engine idle for 1 minute.
8. Keep engine speed between 2,500 and 3,000 rpm for 20 minutes.
9. If 1st trip DTC is detected, go to [EC-484, "Diagnostic Procedure"](#).

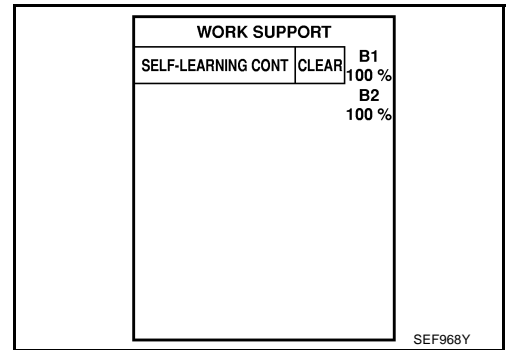

### WITH GST

1. Start engine and warm it up to normal operating temperature.
2. Turn ignition switch OFF and wait at least 10 seconds.
3. Disconnect mass air flow sensor harness connector.
4. Start engine and let it idle for at least 5 seconds.
5. Stop engine and reconnect mass air flow sensor harness connector.
6. Select "MODE 3" with GST and make sure that DTC P0102 is detected.
7. Select "MODE 4" with GST and erase the DTC P0102.
8. Start engine and keep the engine speed between 3,500 and 4,000 rpm for 1 minute under no load.
9. Let engine idle for 1 minute.
10. Keep engine speed between 2,500 and 3,000 rpm for 20 minutes.
11. Select "MODE 7" with GST.  
If 1st trip DTC is detected, go to [EC-484, "Diagnostic Procedure"](#).

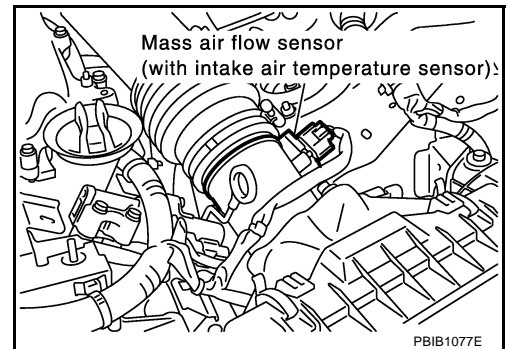



# DTC P1273, P1283 A/F SENSOR 1

## Wiring Diagram BANK 1

ABS00A8P

EC-AF1B1-01

A  
EC  
C  
D  
E  
F  
G  
H  
I  
J  
K  
L  
M

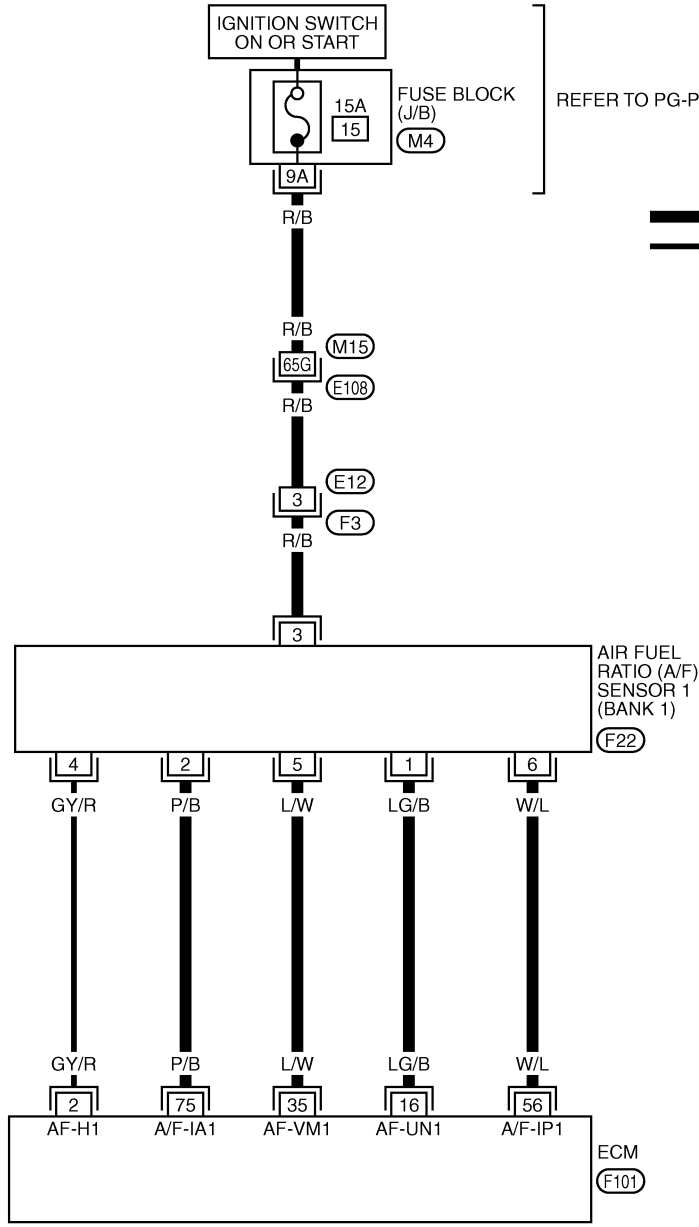

REFER TO PG-POWER.

— : DETECTABLE LINE FOR DTC  
— : NON-DETECTABLE LINE FOR DTC

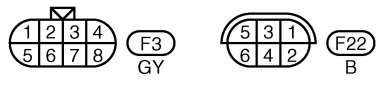

REFER TO THE FOLLOWING.  
 (E108) -SUPER MULTIPLE JUNCTION (SMJ)  
 (M4) -FUSE BLOCK-JUNCTION BOX (J/B)

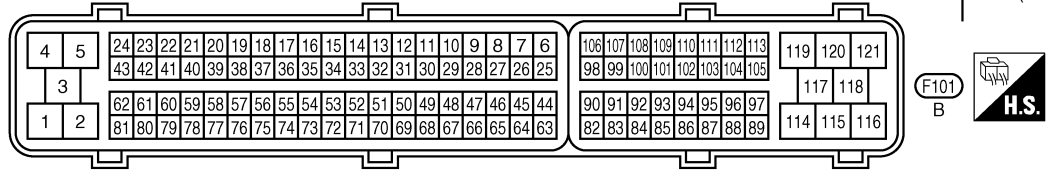

TBWT0706E

## DTC P1273, P1283 A/F SENSOR 1

Specification data are reference values and are measured between each terminal and ground.

**CAUTION:**

**Do not use ECM ground terminals when measuring input/output voltage. Doing so may result in damage to the ECM's transistor. Use a ground other than ECM terminals, such as the ground.**

TER-MINAL NO.	WIRE COLOR	ITEM	CONDITION	DATA (DC Voltage)
16	LG/B	A/F sensor 1 (Bank 1)	<b>[Engine is running]</b> <ul style="list-style-type: none"><li>● <b>Warm-up condition</b></li><li>● Idle speed</li></ul>	Approximately 3.1V
35	L/W			Approximately 2.6V
56	W/L			Approximately 2.3V
75	P/B			Approximately 2.3V

# DTC P1273, P1283 A/F SENSOR 1

BANK 2

EC-AF1B2-01

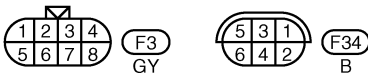
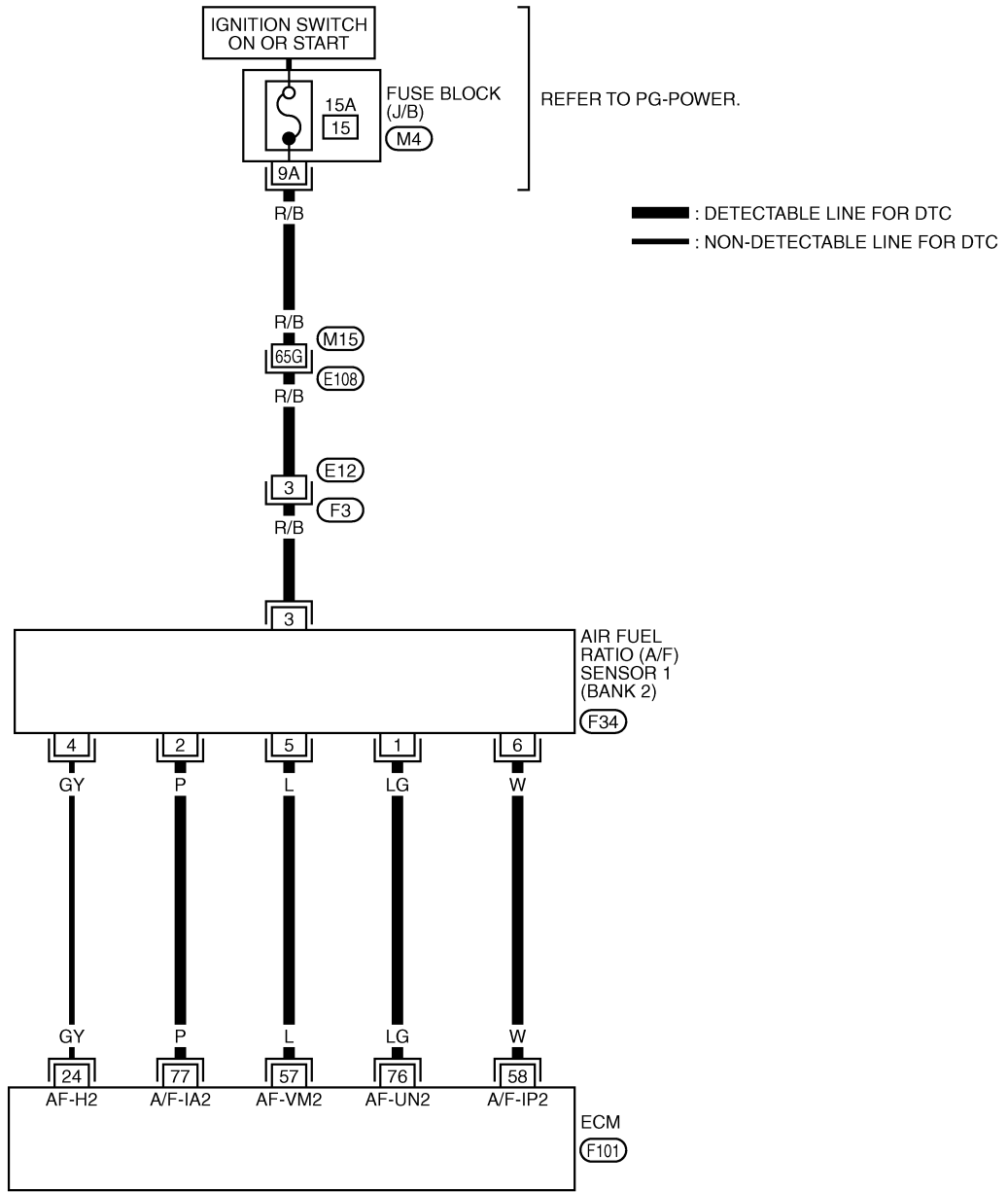

REFER TO THE FOLLOWING.

E108 -SUPER MULTIPLE JUNCTION (SMJ)

M4 -FUSE BLOCK-JUNCTION BOX (J/B)

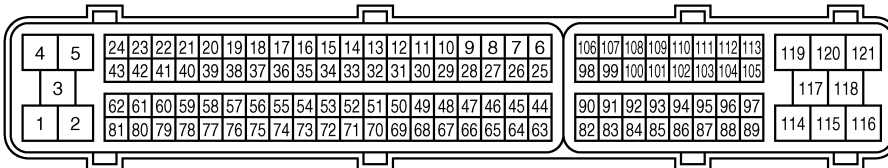

TBWT0707E

# DTC P1273, P1283 A/F SENSOR 1

Specification data are reference values and are measured between each terminal and ground.

**CAUTION:**

Do not use ECM ground terminals when measuring input/output voltage. Doing so may result in damage to the ECM's transistor. Use a ground other than ECM terminals, such as the ground.

TER-MINAL NO.	WIRE COLOR	ITEM	CONDITION	DATA (DC Voltage)
57	L	A/F sensor 1 (Bank 2)	<b>[Engine is running]</b> ● Warm-up condition ● Idle speed	Approximately 2.6V
58	W			Approximately 2.3V
76	LG			Approximately 3.1V
77	P			Approximately 2.3V

## Diagnostic Procedure

ABS00A8Q

### 1. CHECK GROUND CONNECTIONS

1. Turn ignition switch OFF.
2. Loosen and retighten three ground screws on the body. Refer to [EC-138, "Ground Inspection"](#).

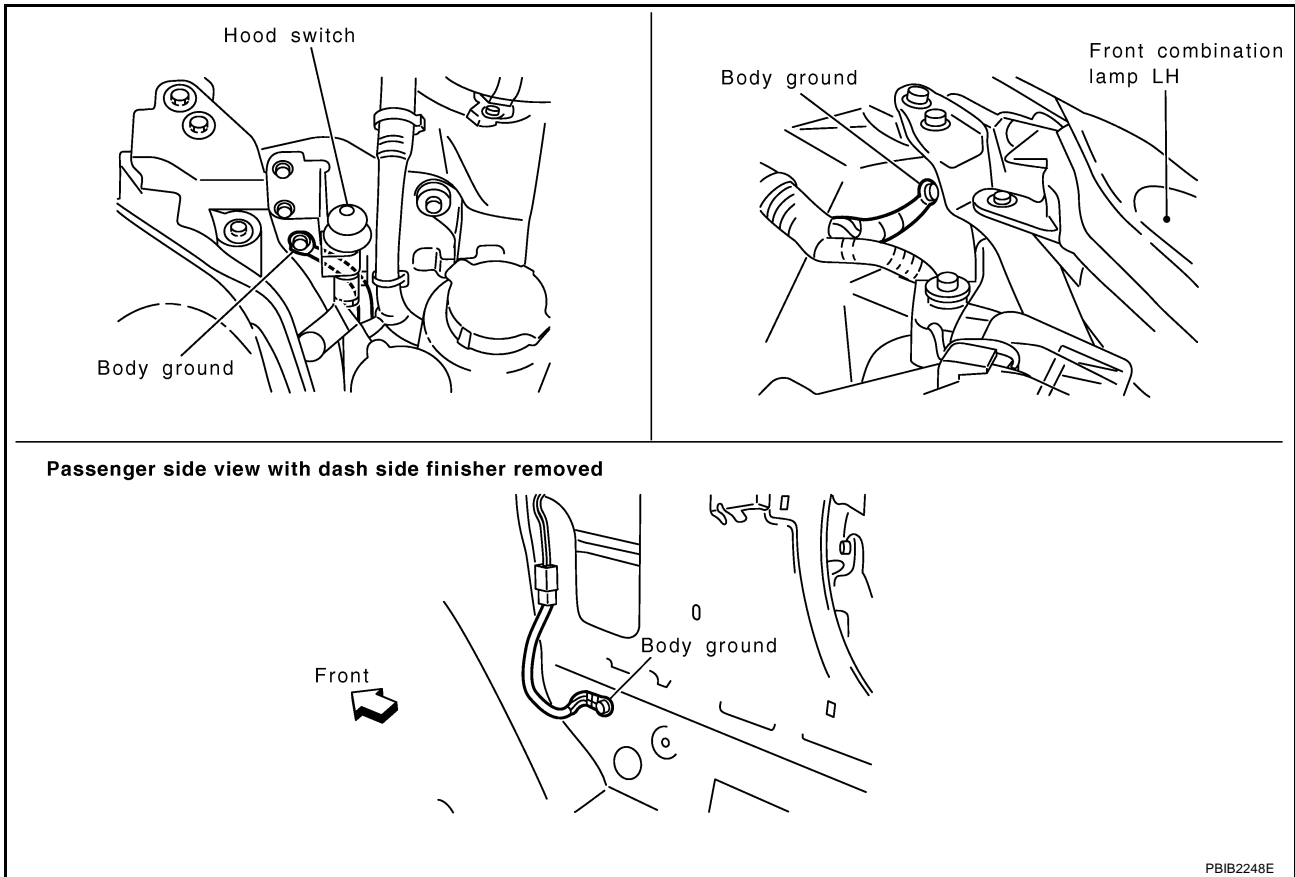

PBIB2248E

**OK or NG**

- OK >> GO TO 2.
- NG >> Repair or replace ground connections.

# DTC P1273, P1283 A/F SENSOR 1

## 2. RETIGHTEN A/F SENSOR 1

Loosen and retighten the A/F sensor 1.

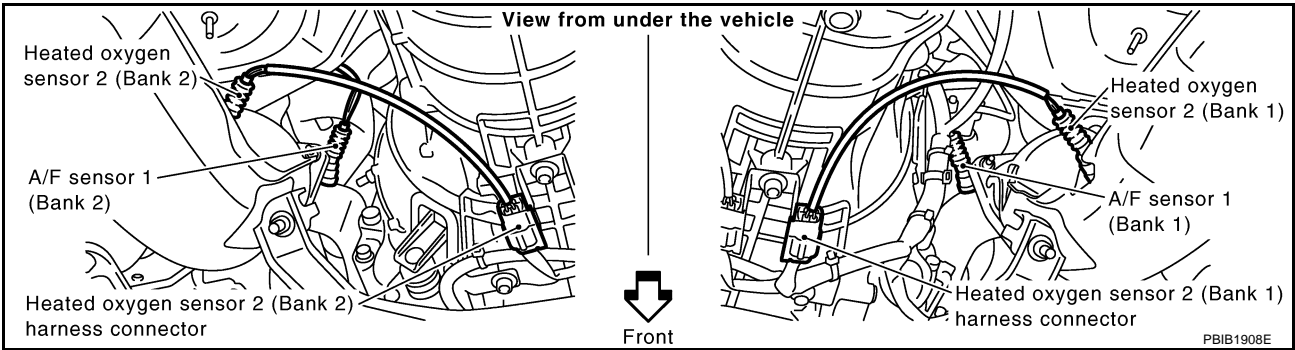

**Tightening torque: 40 - 60 N-m (4.1 - 6.1 kg-m, 30 - 44 ft-lb)**

>> GO TO 3.

## 3. CLEAR THE SELF-LEARNING DATA

### With CONSULT-II

1. Start engine and warm it up to normal operating temperature.
2. Select "SELF-LEARNING CONT" in "WORK SUPPORT" mode with CONSULT-II.
3. Clear the self-learning control coefficient by touching "CLEAR".
4. Run engine for at least 10 minutes at idle speed.

**Is the 1st trip DTC P0171 or P0174 detected?  
Is it difficult to start engine?**

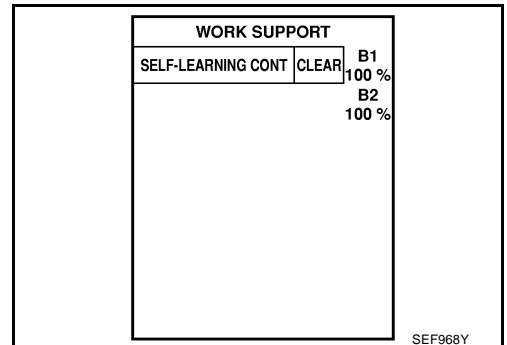

### Without CONSULT-II

1. Start engine and warm it up to normal operating temperature.
  2. Turn ignition switch OFF.
  3. Disconnect mass air flow sensor harness connector.
  4. Restart engine and let it idle for at least 5 seconds.
  5. Stop engine and reconnect mass air flow sensor harness connector.
  6. Make sure DTC P0102 is displayed.
  7. Erase the DTC memory. Refer to [EC-61, "HOW TO ERASE EMISSION-RELATED DIAGNOSTIC INFORMATION"](#).
  8. Make sure DTC P0000 is displayed.
  9. Run engine for at least 10 minutes at idle speed.
- Is the 1st trip DTC P0171 or P0174 detected?  
Is it difficult to start engine?**

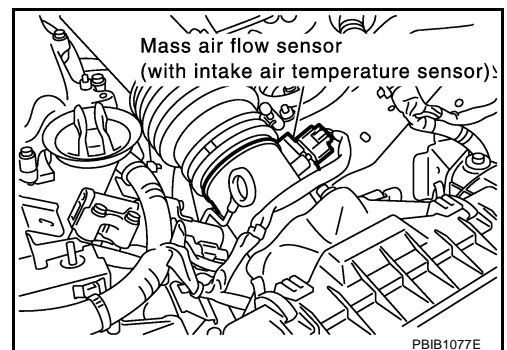

Yes or No

- Yes >> Perform trouble diagnosis for DTC P0171 or P0174. Refer to [EC-221](#).  
No >> GO TO 4.

## DTC P1273, P1283 A/F SENSOR 1

### 4. CHECK A/F SENSOR 1 POWER SUPPLY CIRCUIT

1. Turn ignition switch OFF.
2. Disconnect A/F sensor 1 harness connector.

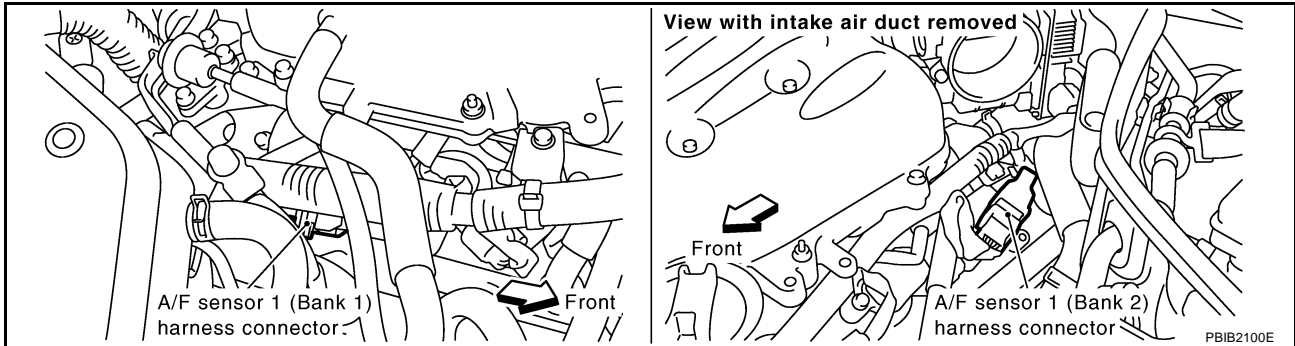

3. Turn ignition switch ON.
4. Check voltage between A/F sensor 1 terminal 3 and ground with CONSULT-II or tester.

**Voltage: Battery voltage**

OK or NG

- OK >> GO TO 6.
- NG >> GO TO 5.

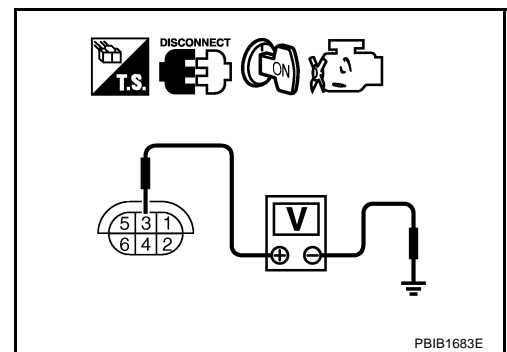

### 5. DETECT MALFUNCTIONING PART

Check the following.

- Harness connectors M15, E108
- Harness connectors E12, F3
- Fuse block (J/B) connector M4
- 15A fuse
- Harness for open or short between A/F sensor 1 and fuse

>> Repair or replace harness or connectors.

# DTC P1273, P1283 A/F SENSOR 1

## 6. CHECK A/F SENSOR 1 INPUT SIGNAL CIRCUIT FOR OPEN AND SHORT

1. Turn ignition switch OFF.
2. Disconnect ECM harness connector.
3. Check harness continuity between the following terminals.  
Refer to Wiring Diagram.

	A/F sensor 1 terminal	ECM terminal
Bank1	1	16
	2	75
	5	35
	6	56
Bank 2	1	76
	2	77
	5	57
	6	58

**Continuity should exist.**

4. Check harness continuity between the following terminals and ground.  
Refer to Wiring Diagram.

Bank 1		Bank 2	
A/F sensor 1 terminal	ECM terminal	A/F sensor 1 terminal	ECM terminal
1	16	1	76
2	75	2	77
5	35	5	57
6	56	6	58

**Continuity should not exist.**

5. Also check harness for short to power.

OK or NG

OK >> GO TO 7.

NG >> Repair open circuit or short to ground or short to power in harness or connectors.

## 7. CHECK A/F SENSOR 1 HEATER

Refer to [EC-383, "Component Inspection"](#) .

OK or NG

OK >> GO TO 8.

NG >> Replace A/F sensor 1.

## 8. CHECK INTERMITTENT INCIDENT

Perform [EC-129, "TROUBLE DIAGNOSIS FOR INTERMITTENT INCIDENT"](#) .

OK or NG

OK >> GO TO 9.

NG >> Repair or replace.

## DTC P1273, P1283 A/F SENSOR 1

---

### 9. REPLACE AIR FUEL RATIO (A/F) SENSOR 1

---

Replace A/F sensor 1.

**CAUTION:**

- Discard any A/F sensor which has been dropped from a height of more than 0.5 m (19.7 in) onto a hard surface such as a concrete floor; use a new one.
- Before installing new A/F sensor, clean exhaust system threads (using Oxygen Sensor Thread Cleaner tool J-43897-18 or J-43897-12) and approved anti-seize lubricant.

>> INSPECTION END

### Removal and Installation AIR FUEL RATIO (A/F) SENSOR 1

ABS00A8R

Refer to [EM-23, "EXHAUST MANIFOLD AND THREE WAY CATALYST"](#) .



## DTC P1274, P1284 A/F SENSOR 1

PFP:22693

### Component Description

ABS00A8S

The air fuel ratio (A/F) sensor 1 is a planar dual-cell limit current sensor. The sensor element of the A/F sensor 1 is the combination of a Nernst concentration cell (sensor cell) with an oxygen-pump cell, which transports ions. It has a heater in the element.

The sensor is capable of precise measurement  $\lambda = 1$ , but also in the lean and rich range. Together with its control electronics, the sensor outputs a clear, continuous signal throughout a wide  $\lambda$  range ( $0.7 < \lambda < \text{air}$ ).

The exhaust gas components diffuse through the diffusion gap at the electrode of the oxygen pump and Nernst concentration cell, where they are brought to thermodynamic balance.

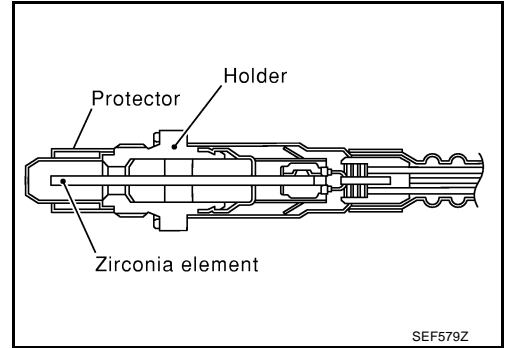

An electronic circuit controls the pump current through the oxygen-pump cell so that the composition of the exhaust gas in the diffusion gap remains constant at  $\lambda = 1$ . Therefore, the A/F sensor 1 is able to indicate air/fuel ratio by this pumping of current. In addition, a heater is integrated in the sensor to ensure the required operating temperature of 700 - 800°C (1,292 - 1,472°F).

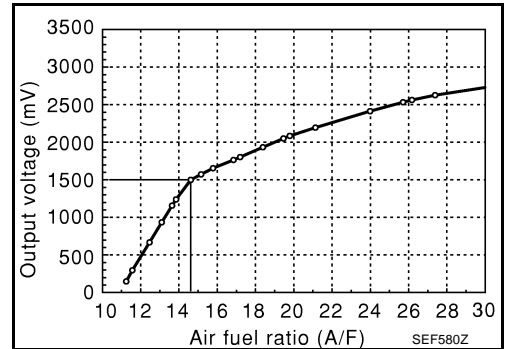

### CONSULT-II Reference Value in Data Monitor Mode

ABS00A8T

Specification data are reference values.

MONITOR ITEM	CONDITION	SPECIFICATION
A/F SEN1 (B1) A/F SEN1 (B2)	● Engine: After warming up Maintaining engine speed at 2,000 rpm	Fluctuates around 1.5V

### On Board Diagnosis Logic

ABS00A8U

To judge the malfunction, the A/F signal computed by ECM from the A/F sensor 1 signal is monitored not to be shifted to LEAN side or RICH side.

DTC No.	Trouble diagnosis name	DTC detecting condition	Possible Cause
P1274 1274 (Bank 1)	Air fuel ratio (A/F) sensor 1 rich shift monitoring	● The A/F signal computed by ECM from the A/F sensor 1 signal is shifted to the rich side for a specified period.	<ul style="list-style-type: none"> <li>● Air fuel ratio (A/F) sensor 1</li> <li>● Air fuel ratio (A/F) sensor 1 heater</li> <li>● Fuel pressure</li> <li>● Fuel injector</li> </ul>
P1284 1284 (Bank 2)			

### DTC Confirmation Procedure

ABS00A8V

#### NOTE:

If DTC Confirmation Procedure has been previously conducted, always turn ignition switch OFF and wait at least 10 seconds before conducting the next test.

#### TESTING CONDITION:

Before performing the following procedure, confirm that battery voltage is more than 11V at idle.

#### Ⓟ WITH CONSULT-II

1. Start engine and warm it up to normal operating temperature.
2. Turn ignition switch OFF and wait at least 10 seconds.
3. Turn ignition switch ON and select "SELF-LEARNING CONT" in "WORK SUPPORT" mode with CONSULT-II.

## DTC P1274, P1284 A/F SENSOR 1

4. Clear the self-learning coefficient by touching "CLEAR".
5. Turn ignition switch OFF and wait at least 10 seconds.
6. Start engine and keep the engine speed between 3,500 and 4,000 rpm for 1 minute under no load.
7. Let engine idle for 1 minute.
8. Keep engine speed between 2,500 and 3,000 rpm for 20 minutes.
9. If 1st trip DTC is detected, go to [EC-494, "Diagnostic Procedure"](#).

WORK SUPPORT		
SELF-LEARNING CONT	CLEAR	B1 100 %
		B2 100 %

SEF968Y

### WITH GST

1. Start engine and warm it up to normal operating temperature.
2. Turn ignition switch OFF and wait at least 10 seconds.
3. Disconnect mass air flow sensor harness connector.
4. Start engine and let it idle for at least 5 seconds.
5. Stop engine and reconnect mass air flow sensor harness connector.
6. Select "MODE 3" with GST and make sure that DTC P0102 is detected.
7. Select "MODE 4" with GST and erase the DTC P0102.
8. Start engine and keep the engine speed between 3,500 and 4,000 rpm for 1 minute under no load.
9. Let engine idle for 1 minute.
10. Keep engine speed between 2,500 and 3,000 rpm for 20 minutes.
11. Select "MODE 7" with GST.  
If 1st trip DTC is detected, go to [EC-494, "Diagnostic Procedure"](#).

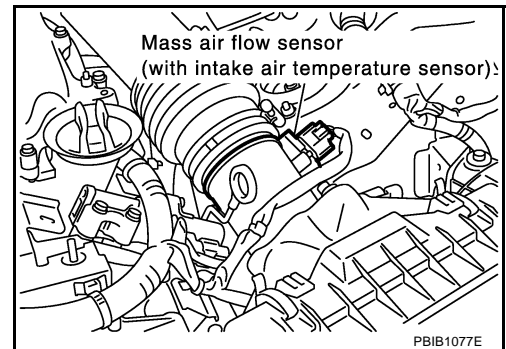

# DTC P1274, P1284 A/F SENSOR 1

## Wiring Diagram BANK 1

ABS00A8W

EC-AF1B1-01

A  
EC  
C  
D  
E  
F  
G  
H  
I  
J  
K  
L  
M

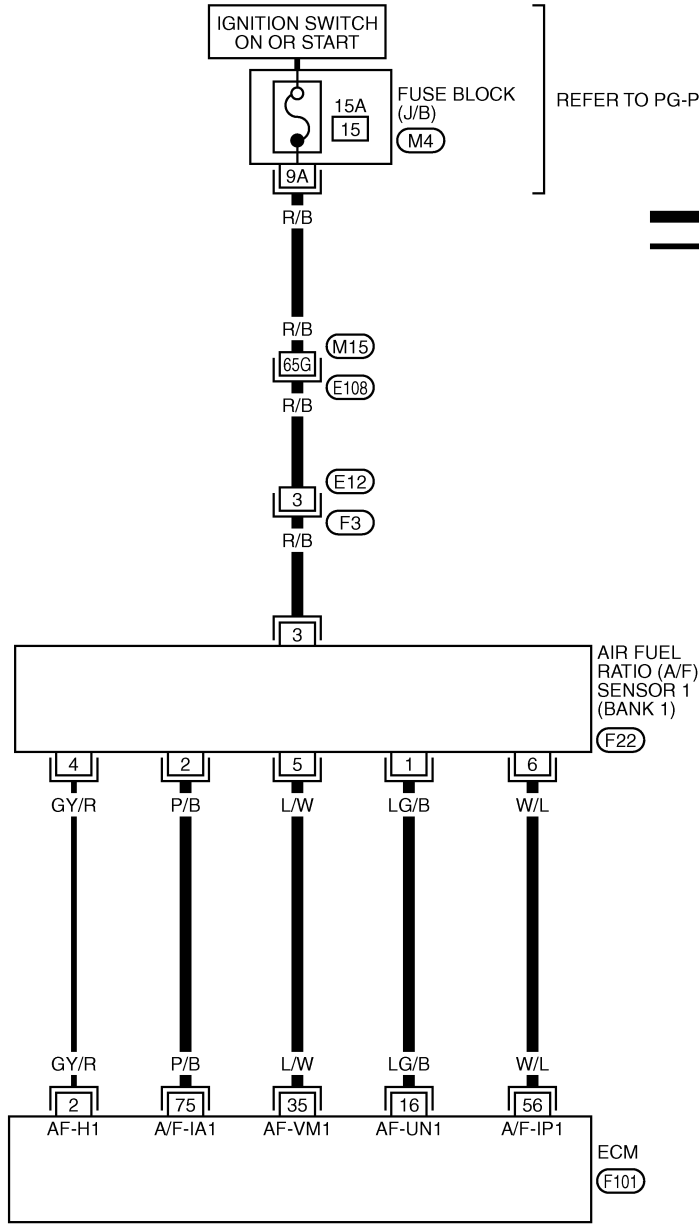

— : DETECTABLE LINE FOR DTC  
— : NON-DETECTABLE LINE FOR DTC

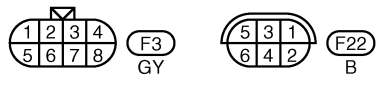

REFER TO THE FOLLOWING.

E108 -SUPER MULTIPLE JUNCTION (SMJ)

M4 -FUSE BLOCK-JUNCTION BOX (J/B)

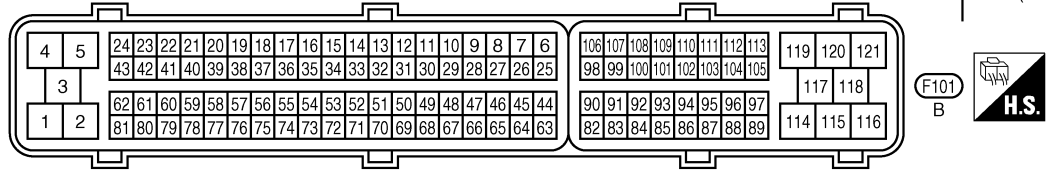

TBWT0706E

## DTC P1274, P1284 A/F SENSOR 1

Specification data are reference values and are measured between each terminal and ground.

**CAUTION:**

**Do not use ECM ground terminals when measuring input/output voltage. Doing so may result in damage to the ECM's transistor. Use a ground other than ECM terminals, such as the ground.**

TER-MINAL NO.	WIRE COLOR	ITEM	CONDITION	DATA (DC Voltage)
16	LG/B	A/F sensor 1 (Bank 1)	<b>[Engine is running]</b> <ul style="list-style-type: none"><li>● <b>Warm-up condition</b></li><li>● Idle speed</li></ul>	Approximately 3.1V
35	L/W			Approximately 2.6V
56	W/L			Approximately 2.3V
75	P/B			Approximately 2.3V

# DTC P1274, P1284 A/F SENSOR 1

**BANK 2**

**EC-AF1B2-01**

A  
EC  
C  
D  
E  
F  
G  
H  
I  
J  
K  
L  
M

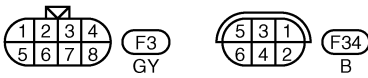
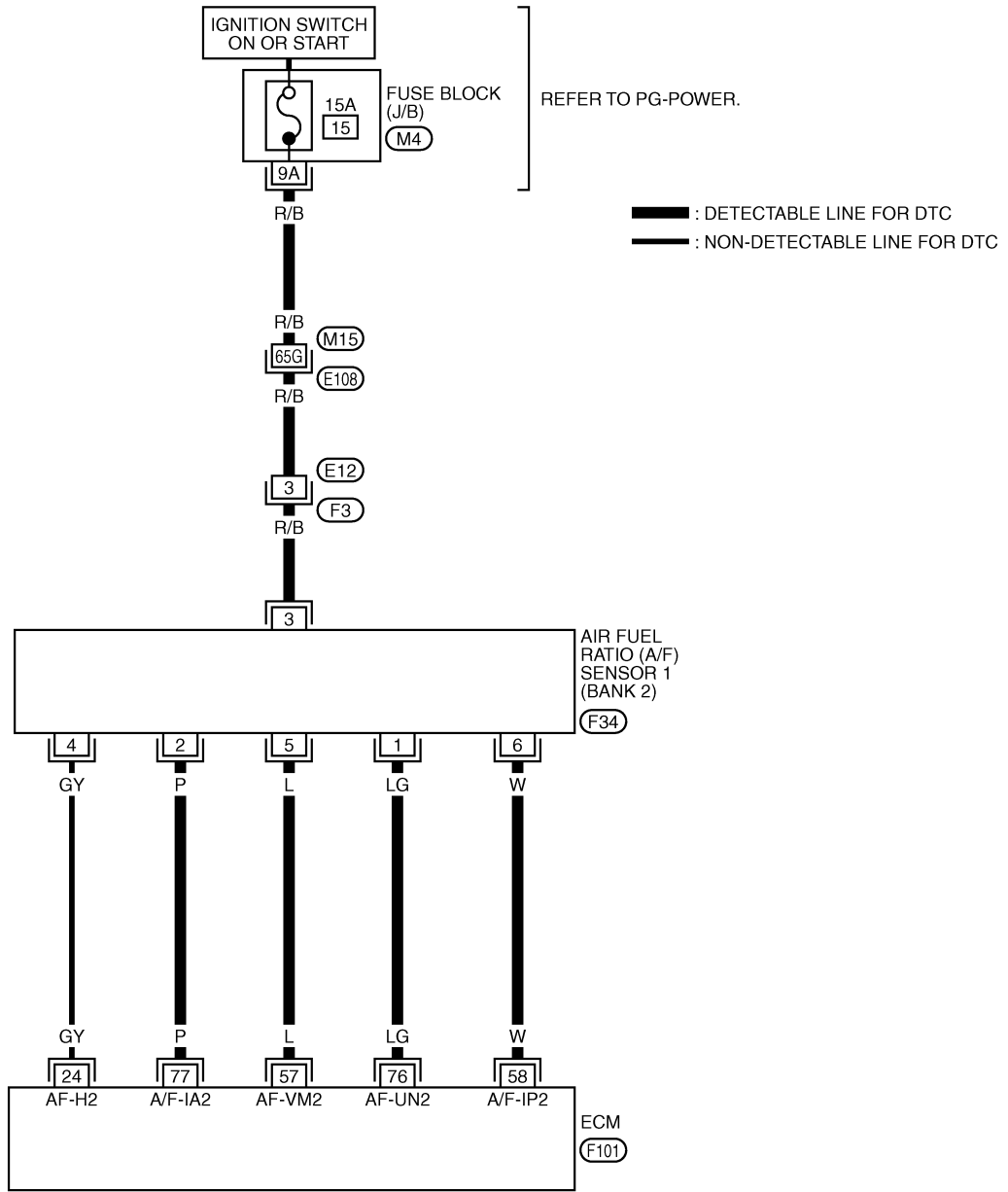

REFER TO THE FOLLOWING.

E108 -SUPER MULTIPLE JUNCTION (SMJ)

M4 -FUSE BLOCK-JUNCTION BOX (J/B)

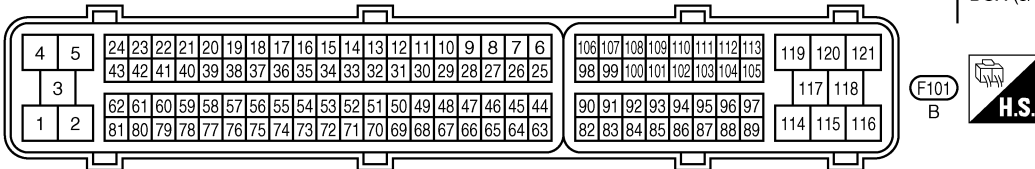

TBWT0707E

# DTC P1274, P1284 A/F SENSOR 1

Specification data are reference values and are measured between each terminal and ground.

**CAUTION:**

Do not use ECM ground terminals when measuring input/output voltage. Doing so may result in damage to the ECM's transistor. Use a ground other than ECM terminals, such as the ground.

TER-MINAL NO.	WIRE COLOR	ITEM	CONDITION	DATA (DC Voltage)
57	L	A/F sensor 1 (Bank 2)	<b>[Engine is running]</b> ● Warm-up condition ● Idle speed	Approximately 2.6V
58	W			Approximately 2.3V
76	LG			Approximately 3.1V
77	P			Approximately 2.3V

## Diagnostic Procedure

ABS00A8X

### 1. CHECK GROUND CONNECTIONS

1. Turn ignition switch OFF.
2. Loosen and retighten three ground screws on the body. Refer to [EC-138, "Ground Inspection"](#).

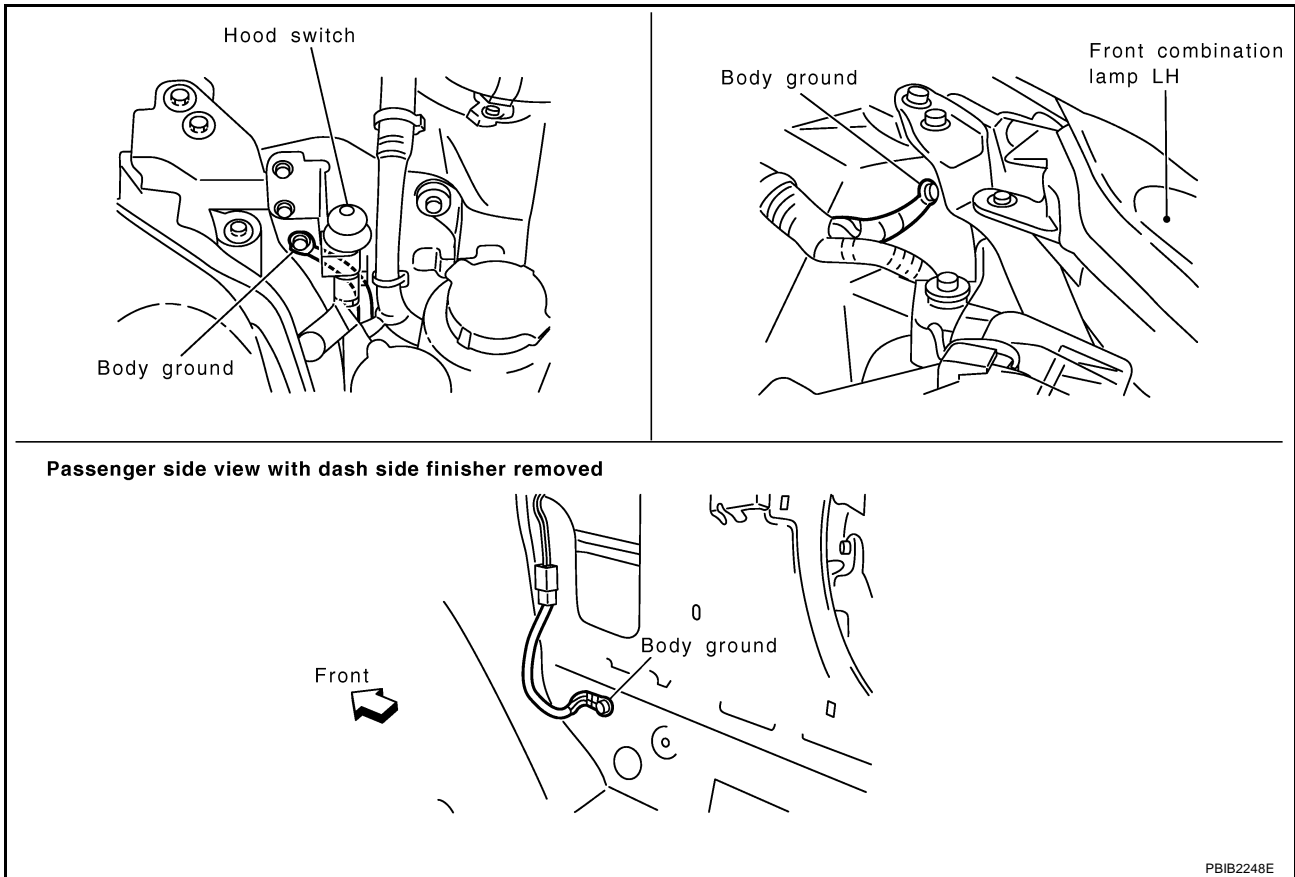

**OK or NG**

- OK >> GO TO 2.
- NG >> Repair or replace ground connections.

# DTC P1274, P1284 A/F SENSOR 1

## 2. RETIGHTEN A/F SENSOR 1

Loosen and retighten the A/F sensor 1.

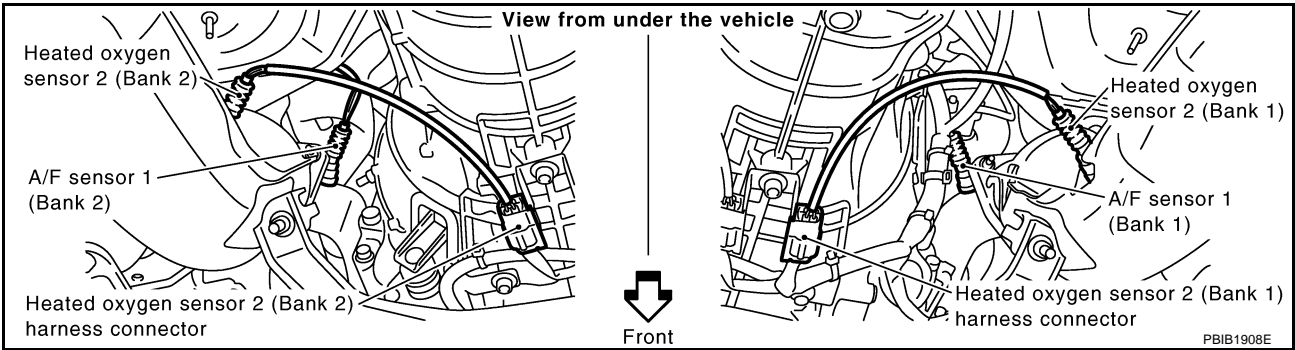

**Tightening torque: 40 - 60 N-m (4.1 - 6.1 kg-m, 30 - 44 ft-lb)**

>> GO TO 3.

## 3. CLEAR THE SELF-LEARNING DATA.

### With CONSULT-II

1. Start engine and warm it up to normal operating temperature.
2. Select "SELF-LEARNING CONT" in "WORK SUPPORT" mode with CONSULT-II.
3. Clear the self-learning control coefficient by touching "CLEAR".
4. Run engine for at least 10 minutes at idle speed.

**Is the 1st trip DTC P0172 or P0175 detected?  
Is it difficult to start engine?**

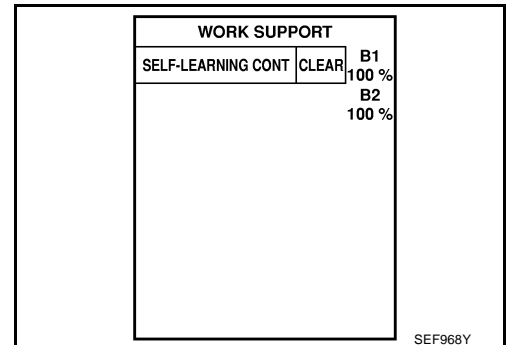

### Without CONSULT-II

1. Start engine and warm it up to normal operating temperature.
  2. Turn ignition switch OFF.
  3. Disconnect mass air flow sensor harness connector.
  4. Restart engine and let it idle for at least 5 seconds.
  5. Stop engine and reconnect mass air flow sensor harness connector.
  6. Make sure DTC P0102 is displayed.
  7. Erase the DTC memory. Refer to [EC-61, "HOW TO ERASE EMISSION-RELATED DIAGNOSTIC INFORMATION"](#).
  8. Make sure DTC P0000 is displayed.
  9. Run engine for at least 10 minutes at idle speed.
- Is the 1st trip DTC P0172 or P0175 detected?  
Is it difficult to start engine?**

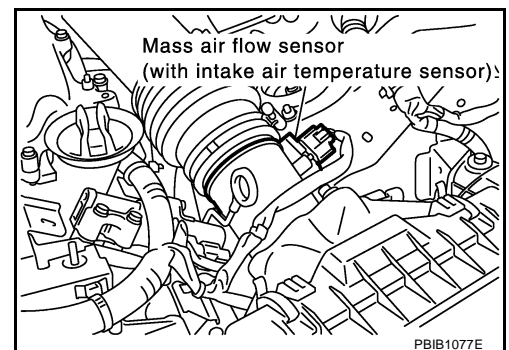

Yes or No

- Yes >> Perform trouble diagnosis for DTC P0172 or P0175. Refer to [EC-230](#).  
No >> GO TO 4.

## DTC P1274, P1284 A/F SENSOR 1

### 4. CHECK HARNESS CONNECTOR

1. Turn ignition switch OFF.
2. Disconnect A/F sensor 1 harness connector.

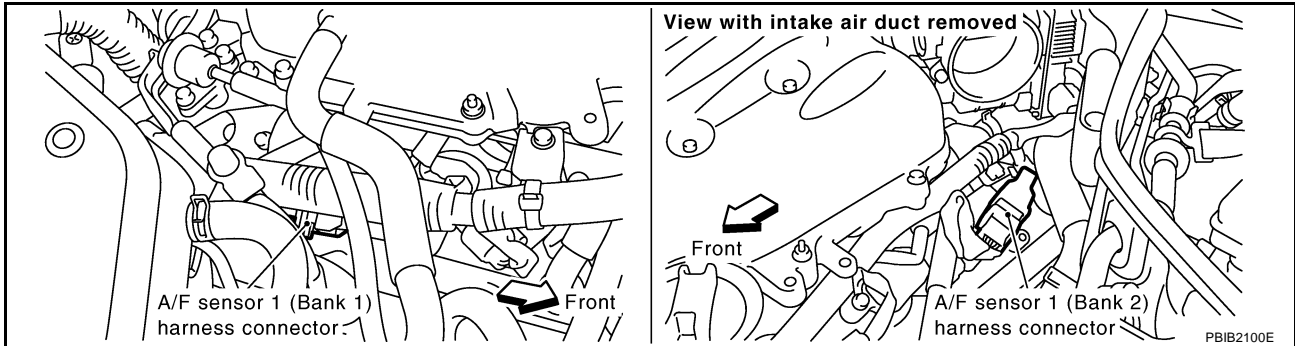

3. Check harness connector for water.  
**Water should not exit.**

OK or NG

- OK >> GO TO 5.  
NG >> Repair or replace harness connector.

### 5. CHECK A/F SENSOR 1 POWER SUPPLY CIRCUIT

1. Turn ignition switch ON.
2. Check voltage between A/F sensor 1 terminal 3 and ground with CONSULT-II or tester.

**Voltage: Battery voltage**

OK or NG

- OK >> GO TO 7.  
NG >> GO TO 6.

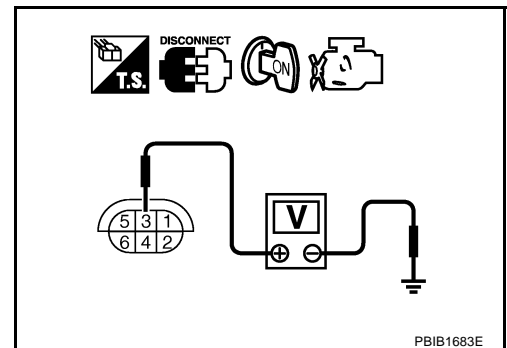

### 6. DETECT MALFUNCTIONING PART

Check the following.

- Harness connectors M15, E108
- Harness connectors E12, F3
- Fuse block (J/B) connector M4
- 15A fuse
- Harness for open or short between A/F sensor 1 and fuse

>> Repair or replace harness or connectors.



# DTC P1274, P1284 A/F SENSOR 1

## 7. CHECK A/F SENSOR 1 INPUT SIGNAL CIRCUIT FOR OPEN AND SHORT

1. Turn ignition switch OFF.
2. Disconnect ECM harness connector.
3. Check harness continuity between the following terminals.  
Refer to Wiring Diagram.

	A/F sensor 1 terminal	ECM terminal
Bank1	1	16
	2	75
	5	35
	6	56
Bank 2	1	76
	2	77
	5	57
	6	58

**Continuity should exist.**

4. Check harness continuity between the following terminals and ground.  
Refer to Wiring Diagram.

Bank 1		Bank 2	
A/F sensor 1 terminal	ECM terminal	A/F sensor 1 terminal	ECM terminal
1	16	1	76
2	75	2	77
5	35	5	57
6	56	6	58

**Continuity should not exist.**

5. Also check harness for short to power.

OK or NG

OK >> GO TO 8.

NG >> Repair open circuit or short to ground or short to power in harness or connectors.

## 8. CHECK A/F SENSOR 1 HEATER

Refer to [EC-383, "Component Inspection"](#) .

OK or NG

OK >> GO TO 9.

NG >> Replace A/F sensor 1.

## 9. CHECK INTERMITTENT INCIDENT

Perform [EC-129, "TROUBLE DIAGNOSIS FOR INTERMITTENT INCIDENT"](#) .

OK or NG

OK >> GO TO 10.

NG >> Repair or replace.

## DTC P1274, P1284 A/F SENSOR 1

---

### 10. REPLACE AIR FUEL RATIO (A/F) SENSOR 1

---

Replace A/F sensor 1.

**CAUTION:**

- Discard any A/F sensor which has been dropped from a height of more than 0.5 m (19.7 in) onto a hard surface such as a concrete floor; use a new one.
- Before installing new A/F sensor, clean exhaust system threads (using Oxygen Sensor Thread Cleaner tool J-43897-18 or J-43897-12) and approved anti-seize lubricant.

>> INSPECTION END

### Removal and Installation AIR FUEL RATIO (A/F) SENSOR 1

ABS00A8Y

Refer to [EM-23, "EXHAUST MANIFOLD AND THREE WAY CATALYST"](#) .

# DTC P1276, P1286 A/F SENSOR 1

## DTC P1276, P1286 A/F SENSOR 1

PFP:22693

### Component Description

ABS00A8Z

The air fuel ratio (A/F) sensor 1 is a planar dual-cell limit current sensor. The sensor element of the A/F sensor 1 is the combination of a Nernst concentration cell (sensor cell) with an oxygen-pump cell, which transports ions. It has a heater in the element.

The sensor is capable of precise measurement  $\lambda = 1$ , but also in the lean and rich range. Together with its control electronics, the sensor outputs a clear, continuous signal throughout a wide  $\lambda$  range ( $0.7 < \lambda < \text{air}$ ).

The exhaust gas components diffuse through the diffusion gap at the electrode of the oxygen pump and Nernst concentration cell, where they are brought to thermodynamic balance.

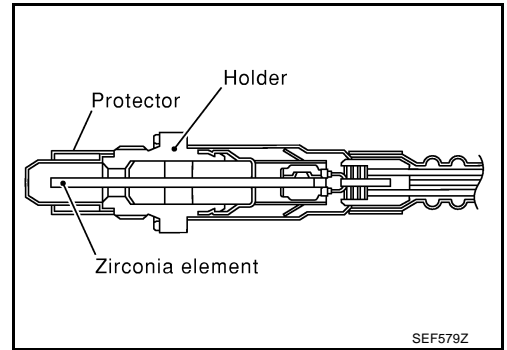

An electronic circuit controls the pump current through the oxygen-pump cell so that the composition of the exhaust gas in the diffusion gap remains constant at  $\lambda = 1$ . Therefore, the A/F sensor 1 is able to indicate air/fuel ratio by this pumping of current. In addition, a heater is integrated in the sensor to ensure the required operating temperature of 700 - 800°C (1,292 - 1,472°F).

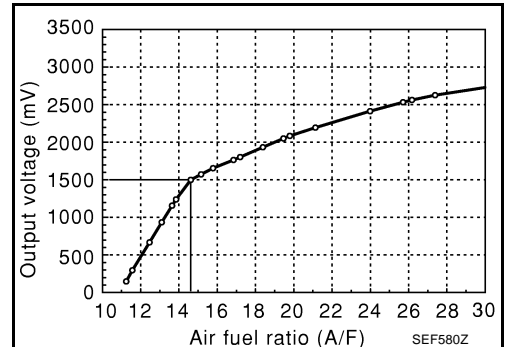

### CONSULT-II Reference Value in Data Monitor Mode

ABS00A90

Specification data are reference values.

MONITOR ITEM	CONDITION	SPECIFICATION
A/F SEN1 (B1) A/F SEN1 (B2)	● Engine: After warming up Maintaining engine speed at 2,000 rpm	Fluctuates around 1.5V

### On Board Diagnosis Logic

ABS00A91

To judge the malfunction, the diagnosis checks that the A/F signal computed by ECM from the A/F sensor 1 signal fluctuates according to fuel feedback control.

DTC No.	Trouble diagnosis name	DTC detecting condition	Possible Cause
P1276 1276 (Bank 1)	Air fuel ratio (A/F) sensor 1 circuit high voltage	● The A/F signal computed by ECM from the A/F sensor 1 signal is constantly approx. 1.5V.	<ul style="list-style-type: none"> <li>● Harness or connectors (The A/F sensor 1 circuit is open or shorted.)</li> <li>● Air fuel ratio (A/F) sensor 1</li> </ul>
P1286 1286 (Bank 2)			

### DTC Confirmation Procedure

ABS00A92

#### CAUTION:

Always drive vehicle at a safe speed.

#### NOTE:

If DTC Confirmation Procedure has been previously conducted, always turn ignition switch OFF and wait at least 10 seconds before conducting the next test.

#### TESTING CONDITION:

Before performing the following procedure, confirm that battery voltage is more than 11V at idle.

#### WITH CONSULT-II

1. Start engine and warm it up to normal operating temperature.
2. Select "A/F SEN1 (B1)" or "A/F SEN1 (B2)" in "DATA MONITOR" mode with CONSULT-II.
3. Check "A/F SEN1 (B1)" or "A/F SEN1 (B2)" indication.

## DTC P1276, P1286 A/F SENSOR 1

If the indication is constantly approx. 1.5V and does not fluctuates, go to [EC-505, "Diagnostic Procedure"](#) .  
 If the indication fluctuates around 1.5V, go to next step.

4. Select "A/F SEN1 (B1) P1276" or "A/F SEN1 (B2) P1286" of "A/F SEN1" in "DTC WORK SUPPORT" mode with CONSULT-II.
5. Touch "START".
6. When the following conditions are met, "TESTING" will be displayed on the CONSULT-II screen.

ENG SPEED	1,100 - 3,200 rpm
VHCL SPEED SE	More than 64 km/h (46 MPH)
B/FUEL SCHDL	1.0 - 8.0 msec
Shift lever	<ul style="list-style-type: none"> <li>● D position (A/T)</li> <li>● 5th position (M/T)</li> </ul>

**If "TESTING" is not displayed after 20 seconds, retry from step 2.**

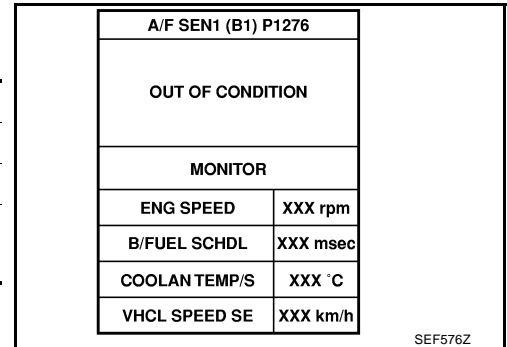

7. Release accelerator pedal fully.  
**NOTE:**  
 Never apply brake during releasing the accelerator pedal.

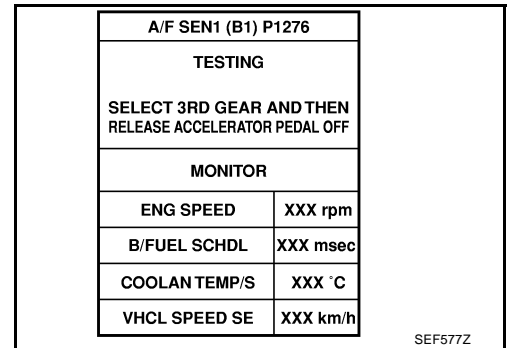

8. Make sure that "TESTING" changes to "COMPLETED".  
**If "TESTING" changed to "OUT OF CONDITION", retry from step 6.**
9. Make sure that "OK" is displayed after touching "SELF-DIAG RESULT".  
 If "NG" is displayed, go to [EC-505, "Diagnostic Procedure"](#) .

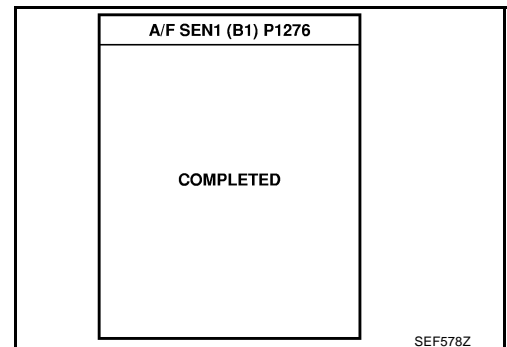

### Overall Function Check

ABS00A93

Use this procedure to check the overall function of the A/F sensor 1 circuit. During this check, a 1st trip DTC might not be confirmed.

#### WITH GST

1. Start engine and warm it up to normal operating temperature.
2. Drive the vehicle at a speed of 80 km/h (50 MPH) for a few minutes in the suitable gear position.
3. Set D position (A/T) or 5th position (M/T), then release the accelerator pedal fully until the vehicle speed decreases to 50 km/h (30 MPH).

**NOTE:**  
 Never apply brake during releasing the accelerator pedal.

4. Repeat steps 2 to 3 for five times.
5. Stop the vehicle and turn ignition switch OFF.
6. Wait at least 10 seconds and restart engine.
7. Repeat steps 2 to 3 for five times.

## DTC P1276, P1286 A/F SENSOR 1

---

8. Stop the vehicle and connect GST to the vehicle.
9. Make sure that no DTC is displayed.  
If the DTC is displayed, go to [EC-505, "Diagnostic Procedure"](#).

A

EC

C

D

E

F

G

H

I

J

K

L

M

# DTC P1276, P1286 A/F SENSOR 1

ABS00A94

## Wiring Diagram BANK 1

EC-AF1B1-01

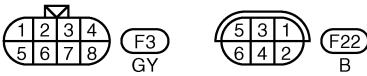
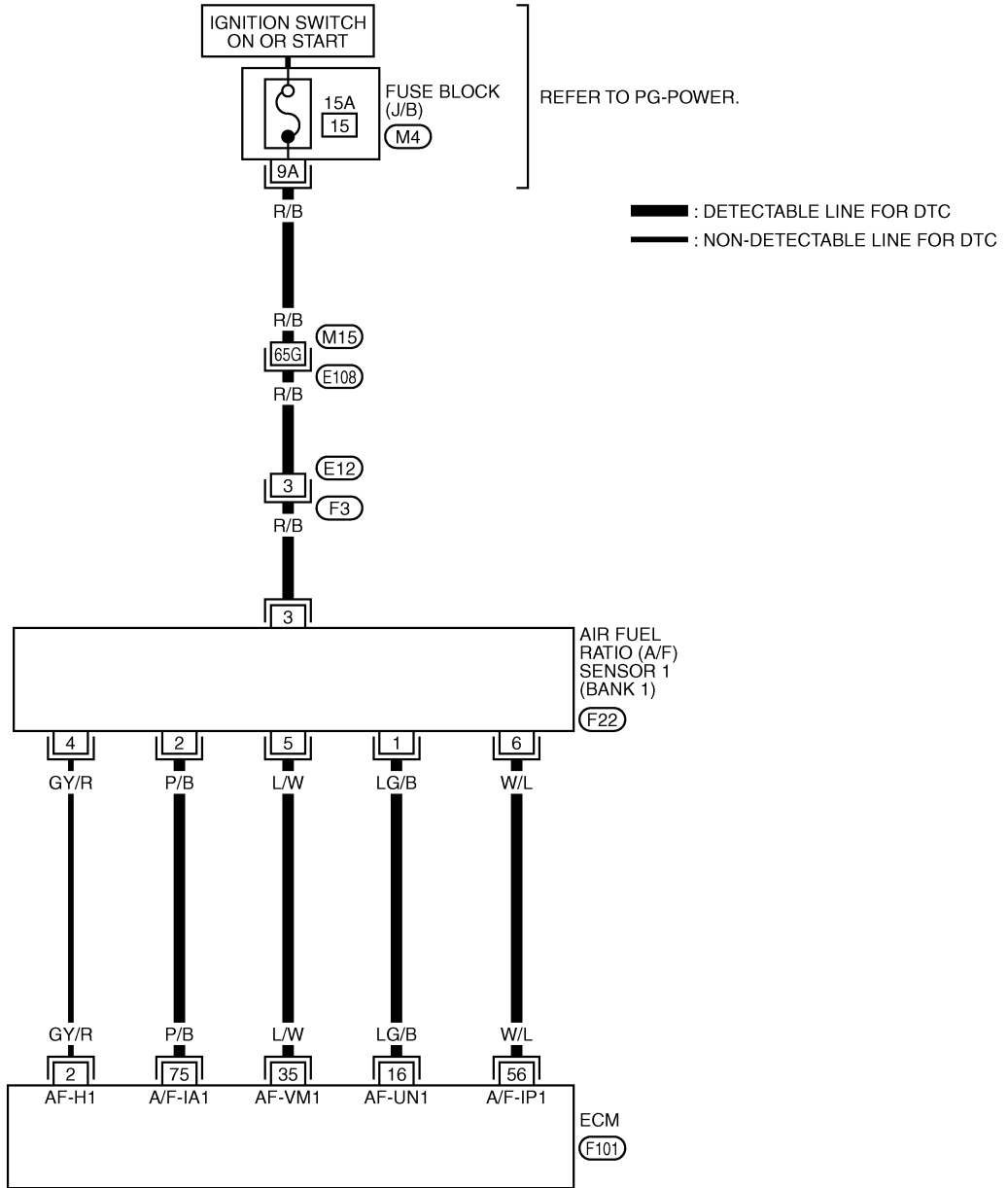

REFER TO THE FOLLOWING.

(E108) -SUPER MULTIPLE JUNCTION (SMJ)

(M4) -FUSE BLOCK-JUNCTION BOX (J/B)

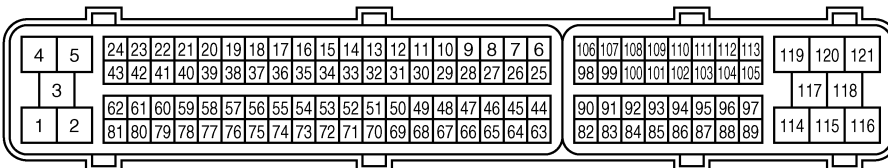

TBWT0706E

## DTC P1276, P1286 A/F SENSOR 1

Specification data are reference values and are measured between each terminal and ground.

**CAUTION:**

**Do not use ECM ground terminals when measuring input/output voltage. Doing so may result in damage to the ECM's transistor. Use a ground other than ECM terminals, such as the ground.**

TER-MINAL NO.	WIRE COLOR	ITEM	CONDITION	DATA (DC Voltage)
16	LG/B	A/F sensor 1 (Bank 1)	<b>[Engine is running]</b> ● Warm-up condition ● Idle speed	Approximately 3.1V
35	L/W			Approximately 2.6V
56	W/L			Approximately 2.3V
75	P/B			Approximately 2.3V

A  
EC  
C  
D  
E  
F  
G  
H  
I  
J  
K  
L  
M

# DTC P1276, P1286 A/F SENSOR 1

**BANK 2**

**EC-AF1B2-01**

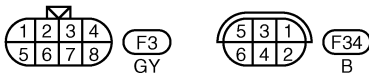
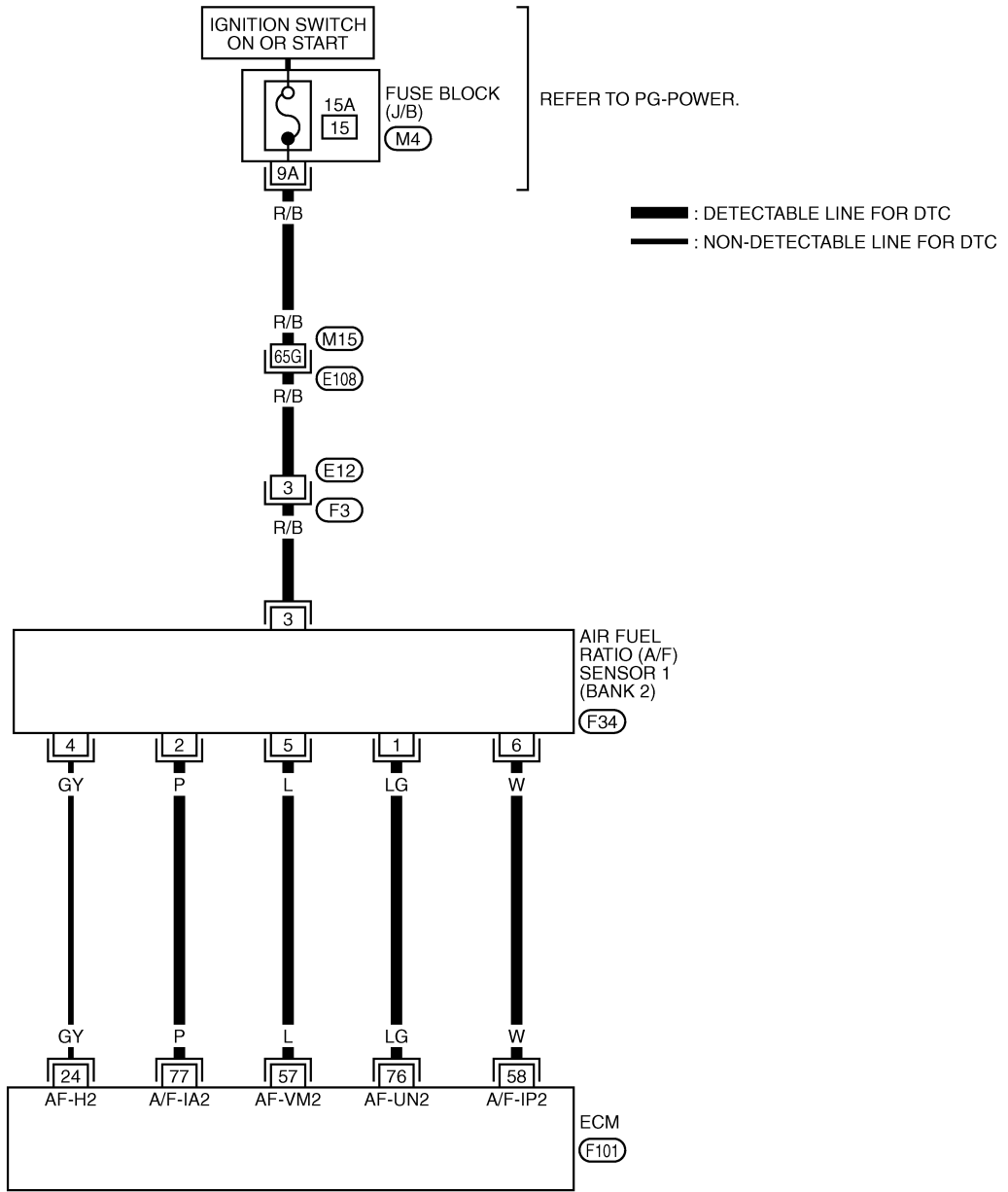

REFER TO THE FOLLOWING.

(E108) -SUPER MULTIPLE JUNCTION (SMJ)

(M4) -FUSE BLOCK-JUNCTION BOX (J/B)

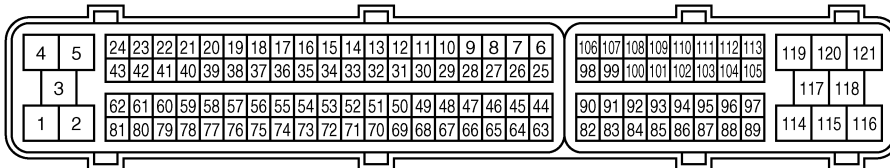

TBWT0707E



# DTC P1276, P1286 A/F SENSOR 1

Specification data are reference values and are measured between each terminal and ground.

**CAUTION:**

Do not use ECM ground terminals when measuring input/output voltage. Doing so may result in damage to the ECM's transistor. Use a ground other than ECM terminals, such as the ground.

TER-MINAL NO.	WIRE COLOR	ITEM	CONDITION	DATA (DC Voltage)
57	L	A/F sensor 1 (Bank 2)	<b>[Engine is running]</b> ● Warm-up condition ● Idle speed	Approximately 2.6V
58	W			Approximately 2.3V
76	LG			Approximately 3.1V
77	P			Approximately 2.3V

## Diagnostic Procedure

ABS00A95

### 1. CHECK GROUND CONNECTIONS

1. Turn ignition switch OFF.
2. Loosen and retighten three ground screws on the body. Refer to [EC-138, "Ground Inspection"](#).

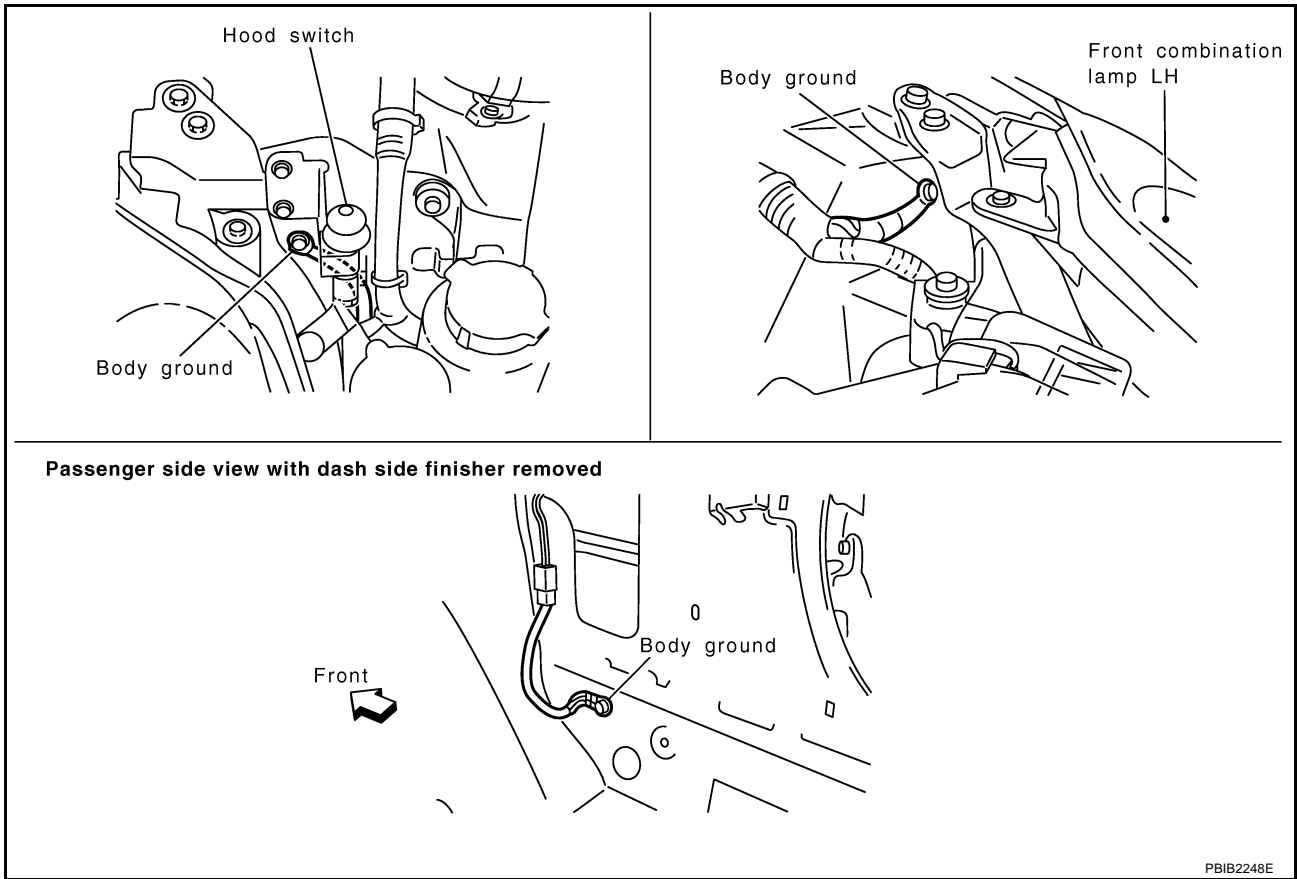

**OK or NG**

- OK >> GO TO 2.
- NG >> Repair or replace ground connections.

## DTC P1276, P1286 A/F SENSOR 1

### 2. CHECK AIR FUEL RATIO (A/F) SENSOR 1 POWER SUPPLY CIRCUIT

1. Disconnect A/F sensor 1 harness connector.

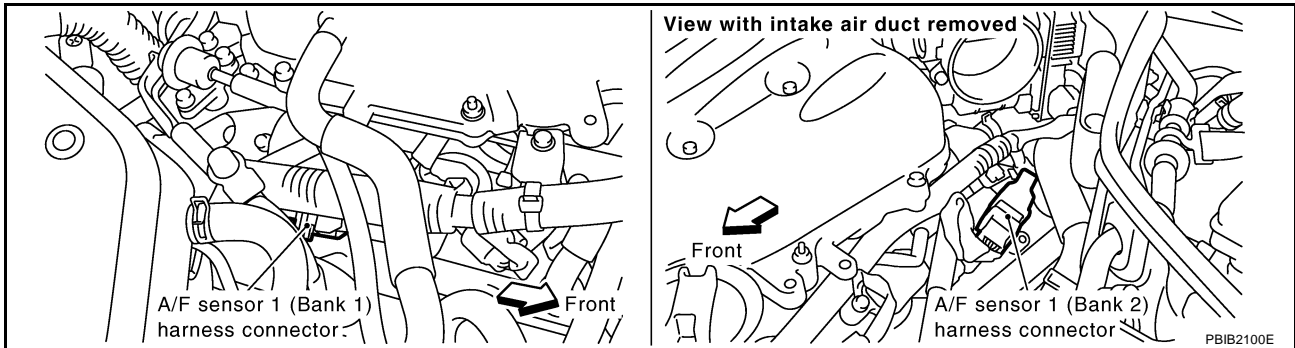

2. Turn ignition switch ON.
3. Check voltage between A/F sensor 1 terminal 3 and ground with CONSULT-II or tester.

**Voltage: Battery voltage**

OK or NG

- OK >> GO TO 4.
- NG >> GO TO 3.

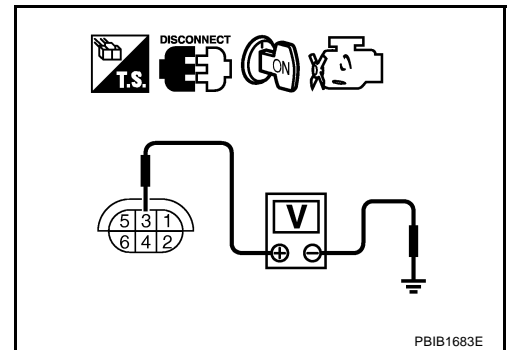

### 3. DETECT MALFUNCTIONING PART

Check the following.

- Harness connectors M15, E108
- Harness connectors E12, F3
- Fuse block (J/B) connector M4
- 15A fuse
- Harness for open or short between A/F sensor 1 and fuse

>> Repair or replace harness or connectors.

# DTC P1276, P1286 A/F SENSOR 1

## 4. CHECK A/F SENSOR 1 INPUT SIGNAL CIRCUIT FOR OPEN AND SHORT

1. Turn ignition switch OFF.
2. Disconnect ECM harness connector.
3. Check harness continuity between the following terminals.  
Refer to Wiring Diagram.

	A/F sensor 1 terminal	ECM terminal
Bank1	1	16
	2	75
	5	35
	6	56
Bank 2	1	76
	2	77
	5	57
	6	58

**Continuity should exist.**

4. Check harness continuity between the following terminals and ground.  
Refer to Wiring Diagram.

Bank 1		Bank 2	
A/F sensor 1 terminal	ECM terminal	A/F sensor 1 terminal	ECM terminal
1	16	1	76
2	75	2	77
5	35	5	57
6	56	6	58

**Continuity should not exist.**

5. Also check harness for short to power.

OK or NG

OK >> GO TO 5.

NG >> Repair open circuit or short to ground or short to power in harness or connectors.

## 5. CHECK INTERMITTENT INCIDENT

Perform [EC-129, "TROUBLE DIAGNOSIS FOR INTERMITTENT INCIDENT"](#) .

OK or NG

OK >> GO TO 6.

NG >> Repair or replace.

## 6. REPLACE AIR FUEL RATIO (A/F) SENSOR 1

Replace A/F sensor 1.

**CAUTION:**

- Discard any A/F sensor which has been dropped from a height of more than 0.5 m (19.7 in) onto a hard surface such as a concrete floor; use a new one.
- Before installing new A/F sensor, clean exhaust system threads (using Oxygen Sensor Thread Cleaner tool J-43897-18 or J-43897-12) and approved anti-seize lubricant.

>> INSPECTION END

## DTC P1276, P1286 A/F SENSOR 1

---

### Removal and Installation AIR FUEL RATIO (A/F) SENSOR 1

ABS00A96

Refer to [EM-23, "EXHAUST MANIFOLD AND THREE WAY CATALYST"](#) .

## DTC P1278, P1288 A/F SENSOR 1

PFP:22693

### Component Description

ABS00A97

The air fuel ratio (A/F) sensor 1 is a planar dual-cell limit current sensor. The sensor element of the A/F sensor 1 is the combination of a Nernst concentration cell (sensor cell) with an oxygen-pump cell, which transports ions. It has a heater in the element.

The sensor is capable of precise measurement  $\lambda = 1$ , but also in the lean and rich range. Together with its control electronics, the sensor outputs a clear, continuous signal throughout a wide  $\lambda$  range ( $0.7 < \lambda < \text{air}$ ).

The exhaust gas components diffuse through the diffusion gap at the electrode of the oxygen pump and Nernst concentration cell, where they are brought to thermodynamic balance.

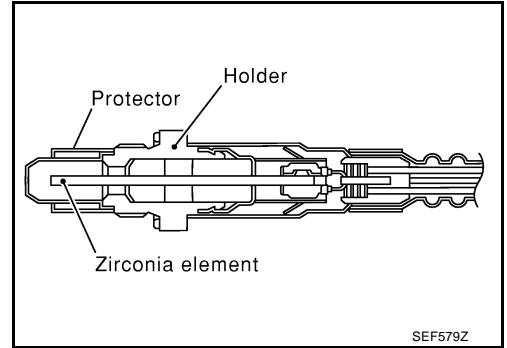

An electronic circuit controls the pump current through the oxygen-pump cell so that the composition of the exhaust gas in the diffusion gap remains constant at  $\lambda = 1$ . Therefore, the A/F sensor 1 is able to indicate air/fuel ratio by this pumping of current. In addition, a heater is integrated in the sensor to ensure the required operating temperature of 700 - 800°C (1,292 - 1,472°F).

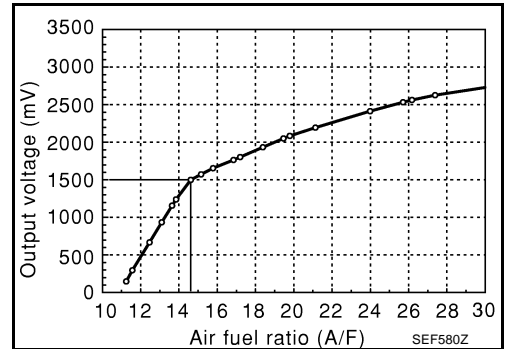

### CONSULT-II Reference Value in Data Monitor Mode

ABS00A98

Specification data are reference values.

MONITOR ITEM	CONDITION	SPECIFICATION
A/F SEN1 (B1) A/F SEN1 (B2)	<ul style="list-style-type: none"> <li>Engine: After warming up</li> </ul>	Maintaining engine speed at 2,000 rpm  Fluctuates around 1.5V

### On Board Diagnosis Logic

ABS00A99

To judge the malfunction of A/F sensor 1, this diagnosis measures response time of the A/F signal computed by ECM from the A/F sensor 1 signal. The time is compensated by engine operating (speed and load), fuel feedback control constant, and the A/F sensor 1 temperature index. Judgment is based on whether the compensated time (the A/F signal cycling time index) is inordinately long or not.

DTC No.	Trouble diagnosis name	DTC detecting condition	Possible Cause
P1278 1278 (Bank 1)	Air fuel ratio (A/F) sensor 1 circuit slow response	<ul style="list-style-type: none"> <li>The response (from RICH to LEAN) of the A/F signal computed by ECM from A/F sensor 1 signal takes more than the specified time.</li> </ul>	<ul style="list-style-type: none"> <li>Harness or connectors (The A/F sensor 1 circuit is open or shorted.)</li> <li>Air fuel ratio (A/F) sensor 1</li> <li>Air fuel ratio (A/F) sensor 1 heater</li> <li>Fuel pressure</li> <li>Fuel injector</li> <li>Intake air leaks</li> <li>Exhaust gas leaks</li> <li>PCV</li> <li>Mass air flow sensor</li> </ul>
P1288 1288 (Bank 2)			

# DTC P1278, P1288 A/F SENSOR 1

ABS00A9A

## DTC Confirmation Procedure

### NOTE:

If DTC Confirmation Procedure has been previously conducted, always turn ignition switch OFF and wait at least 10 seconds before conducting the next test.

### TESTING CONDITION:

Before performing the following procedure, confirm that battery voltage is more than 11V at idle.

### WITH CONSULT-II

1. Start engine and warm it up to normal operating temperature.
2. Turn ignition switch OFF and wait at least 10 seconds.
3. Start engine and keep the engine speed between 3,500 and 4,000 rpm for at least 1 minute under no load.
4. Let engine idle for 1 minute.
5. Select "A/F SEN1(B1) P1278/P1279" or "A/F SEN1(B1) P1288/P1289" of "A/F SEN1" in "DTC WORK SUPPORT" mode with CONSULT-II.
6. Touch "START".  
If "COMPLETED" appears on CONSULT-II screen, go to step 10.  
If "COMPLETED" does not appear on CONSULT-II screen, go to the following step.

A/F SEN1 (B1) P1278/P1279	
OUT OF CONDITION	
MONITOR	
ENG SPEED	XXX rpm
B/FUEL SCHDL	XXX msec
COOLAN TEMP/S	XXX °C
VHCL SPEED SE	XXX km/h

PBIB0756E

7. After perform the following procedure, "TESTING" will be displayed on the CONSULT-II screen.
  - a. Increase the engine speed up to 4,000 to 5,000 rpm and keep it for 10 seconds.
  - b. Fully release accelerator pedal and then let engine idle for about 10 seconds.  
**If "TESTING" is not displayed after 10 seconds, refer to [EC-125. "TROUBLE DIAGNOSIS - SPECIFICATION VALUE"](#).**
8. Wait for about 20 seconds at idle at under the condition that "TESTING" is displayed on the CONSULT-II screen.

A/F SEN1 (B1) P1278/P1279	
TESTING	
MONITOR	
ENG SPEED	XXX rpm
B/FUEL SCHDL	XXX msec
COOLAN TEMP/S	XXX °C
VHCL SPEED SE	XXX km/h

PBIB1925E

9. Make sure that "TESTING" changes to "COMPLETED".  
**If "TESTING" changed to "OUT OF CONDITION", refer to [EC-125. "TROUBLE DIAGNOSIS - SPECIFICATION VALUE"](#).**
10. Make sure that "OK" is displayed after touching "SELF-DIAG RESULT".  
If "NG" is displayed, go to [EC-515. "Diagnostic Procedure"](#).

A/F SEN1 (B1) P1278/P1279	
COMPLETED	

PBIB0758E

### WITH GST

1. Start engine and warm it up to normal operating temperature.
2. Select "MODE 1" with GST.
3. Calculate the total value of "Short term fuel trim" and "Long term fuel trim" indications.  
Make sure that the total percentage should be within  $\pm 15\%$ .  
If OK, go to the following step.  
If NG, check the following.

## DTC P1278, P1288 A/F SENSOR 1

---

- Intake air leaks
  - Exhaust gas leaks
  - Incorrect fuel pressure
  - Lack of fuel
  - Fuel injector
  - Incorrect PCV hose connection
  - PCV valve
  - Mass air flow sensor
4. Turn ignition switch OFF and wait at least 10 seconds.
5. Start engine and keep the engine speed between 3,500 and 4,000 rpm for at least 1 minute under no load.
6. Let engine idle for 1 minute.
7. Increase the engine speed up to 4,000 to 5,000 rpm and keep it for 10 seconds.
8. Fully release accelerator pedal and then let engine idle for about 1 minute.
9. Select "MODE 7" with GST.  
If 1st trip DTC is detected, go to [EC-515, "Diagnostic Procedure"](#) .

A

EC

C

D

E

F

G

H

I

J

K

L

M

# DTC P1278, P1288 A/F SENSOR 1

ABS00A9B

## Wiring Diagram BANK 1

EC-AF1B1-01

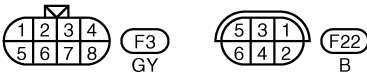
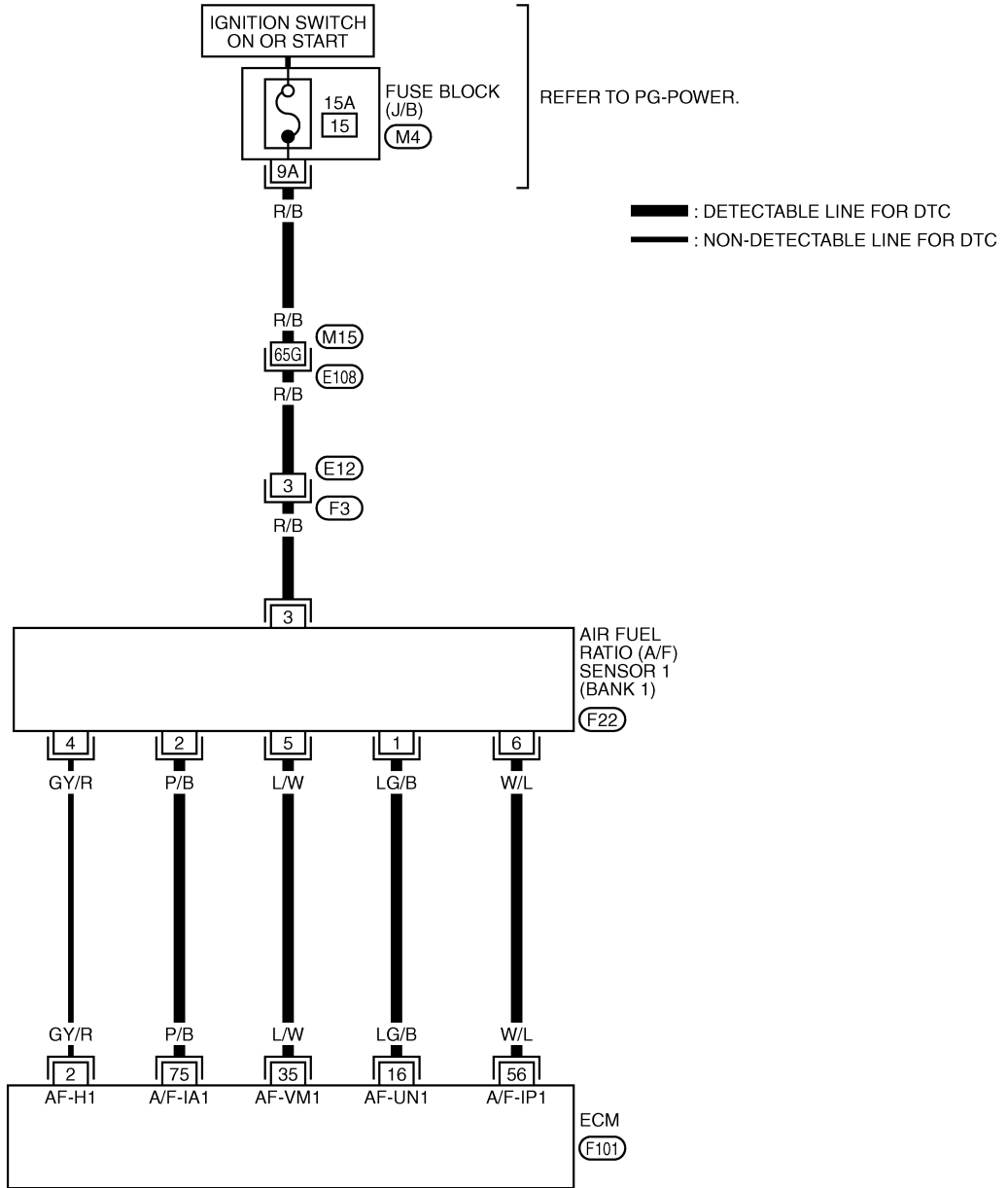

REFER TO THE FOLLOWING.

(E108) -SUPER MULTIPLE JUNCTION (SMJ)

(M4) -FUSE BLOCK-JUNCTION BOX (J/B)

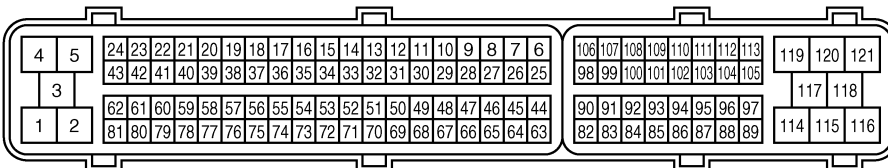

TBWT0706E



## DTC P1278, P1288 A/F SENSOR 1

Specification data are reference values and are measured between each terminal and ground.

**CAUTION:**

**Do not use ECM ground terminals when measuring input/output voltage. Doing so may result in damage to the ECM's transistor. Use a ground other than ECM terminals, such as the ground.**

TER-MINAL NO.	WIRE COLOR	ITEM	CONDITION	DATA (DC Voltage)
16	LG/B	A/F sensor 1 (Bank 1)	<b>[Engine is running]</b> ● Warm-up condition ● Idle speed	Approximately 3.1V
35	L/W			Approximately 2.6V
56	W/L			Approximately 2.3V
75	P/B			Approximately 2.3V

A  
EC  
C  
D  
E  
F  
G  
H  
I  
J  
K  
L  
M

# DTC P1278, P1288 A/F SENSOR 1

**BANK 2**

**EC-AF1B2-01**

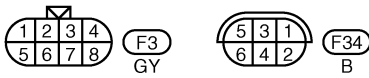
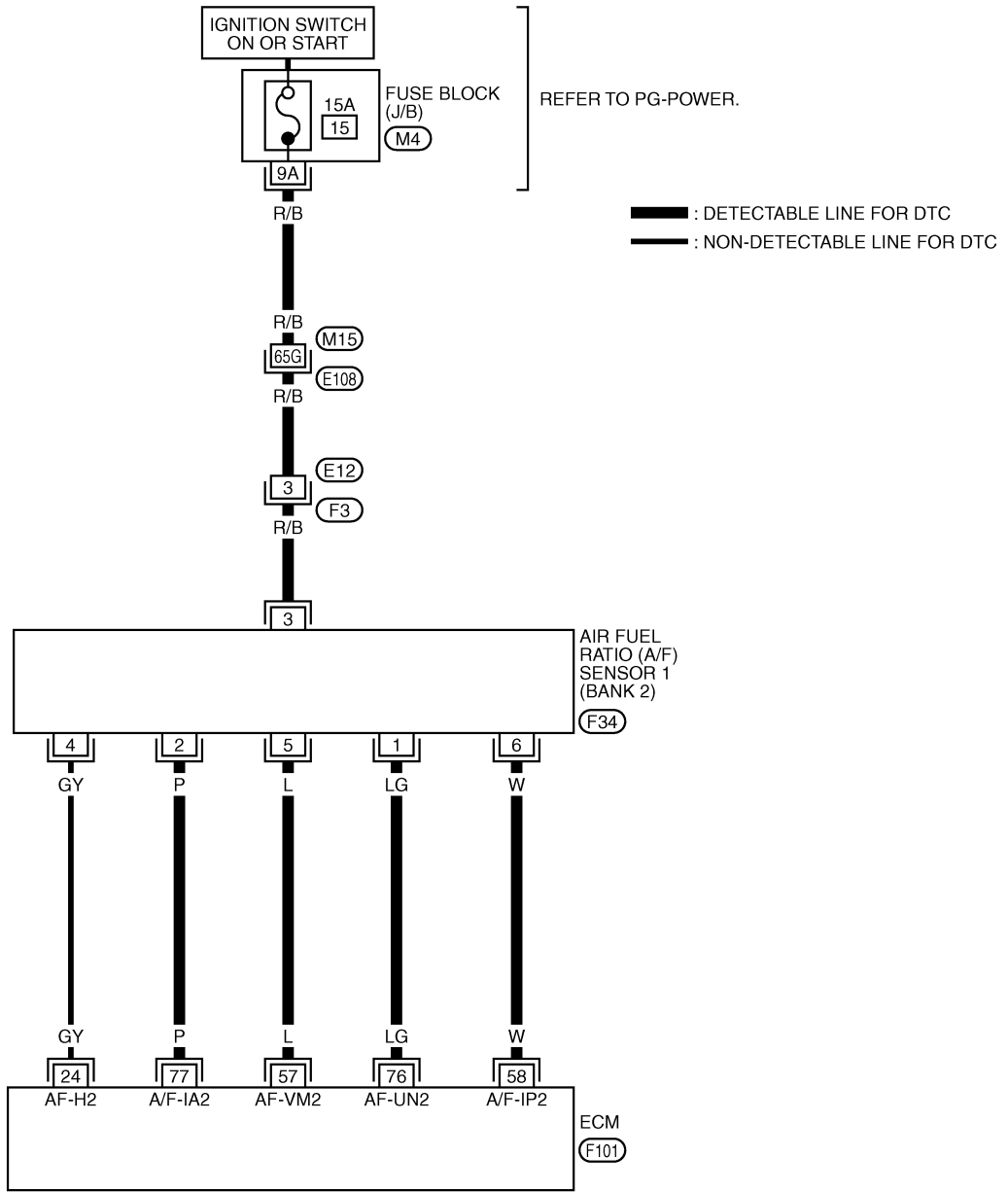

REFER TO THE FOLLOWING.

(E108) -SUPER MULTIPLE JUNCTION (SMJ)

(M4) -FUSE BLOCK-JUNCTION BOX (J/B)

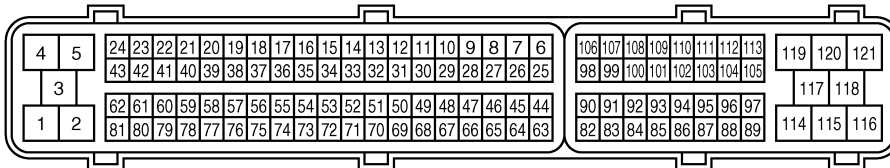

TBWT0707E

# DTC P1278, P1288 A/F SENSOR 1

Specification data are reference values and are measured between each terminal and ground.

**CAUTION:**

Do not use ECM ground terminals when measuring input/output voltage. Doing so may result in damage to the ECM's transistor. Use a ground other than ECM terminals, such as the ground.

TER-MINAL NO.	WIRE COLOR	ITEM	CONDITION	DATA (DC Voltage)
57	L	A/F sensor 1 (Bank 2)	<b>[Engine is running]</b> ● Warm-up condition ● Idle speed	Approximately 2.6V
58	W			Approximately 2.3V
76	LG			Approximately 3.1V
77	P			Approximately 2.3V

## Diagnostic Procedure

ABS00A9C

### 1. CHECK GROUND CONNECTIONS

1. Turn ignition switch OFF.
2. Loosen and retighten three ground screws on the body. Refer to [EC-138, "Ground Inspection"](#).

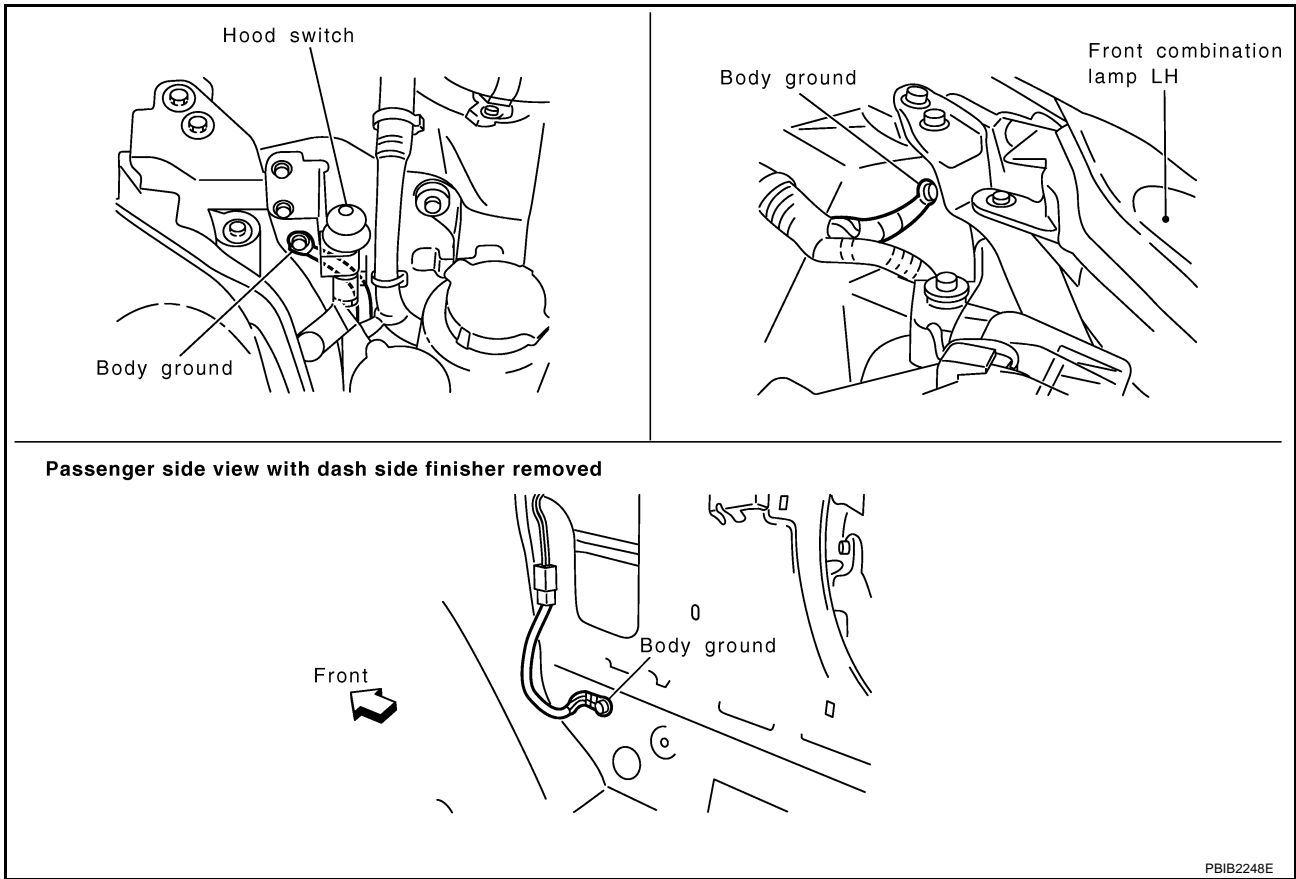

**OK or NG**

- OK >> GO TO 2.
- NG >> Repair or replace ground connections.

## DTC P1278, P1288 A/F SENSOR 1

### 2. RETIGHTEN A/F SENSOR 1

Loosen and retighten the A/F sensor 1.

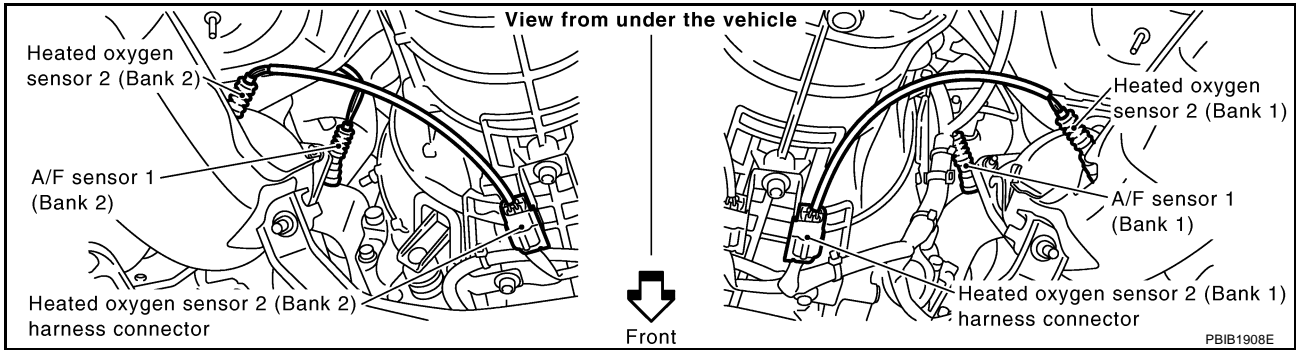

**Tightening torque: 40 - 60 N-m (4.1 - 6.1 kg-m, 30 - 44 ft-lb)**

>> GO TO 3.

### 3. CHECK EXHAUST GAS LEAK

1. Start engine and run it at idle.
2. Listen for an exhaust gas leak before three way catalyst 1.

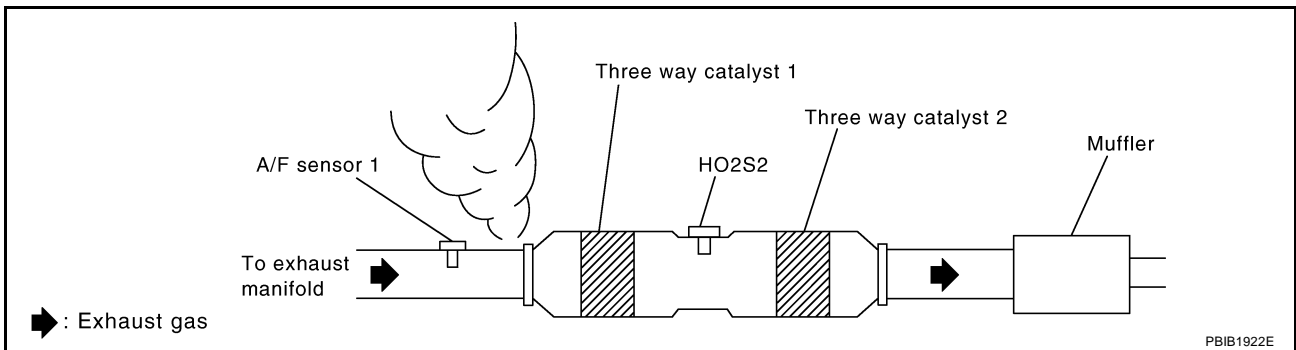

OK or NG

- OK >> GO TO 4.  
NG >> Repair or replace.

### 4. CHECK FOR INTAKE AIR LEAK

Listen for an intake air leak after the mass air flow sensor.

OK or NG

- OK >> GO TO 5.  
NG >> Repair or replace.

# DTC P1278, P1288 A/F SENSOR 1

## 5. CLEAR THE SELF-LEARNING DATA

### With CONSULT-II

1. Start engine and warm it up to normal operating temperature.
2. Select "SELF-LEARNING CONT" in "WORK SUPPORT" mode with CONSULT-II.
3. Clear the self-learning control coefficient by touching "CLEAR" or "START".
4. Run engine for at least 10 minutes at idle speed.  
**Is the 1st trip DTC P0171, P172, P0174 or P0175 detected?  
Is it difficult to start engine?**

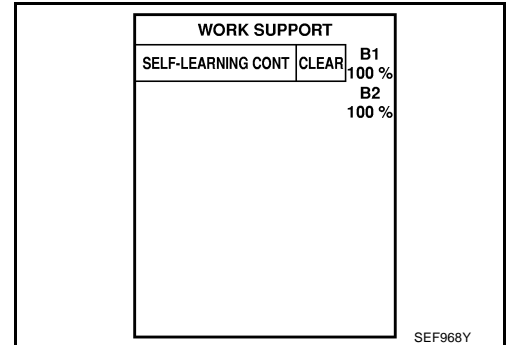

### Without CONSULT-II

1. Start engine and warm it up to normal operating temperature.
2. Turn ignition switch OFF.
3. Disconnect mass air flow sensor harness connector.
4. Restart engine and let it idle for at least 5 seconds.
5. Stop engine and reconnect mass air flow sensor harness connector.
6. Make sure DTC P0102 is displayed.
7. Erase the DTC memory. Refer to [EC-61, "HOW TO ERASE EMISSION-RELATED DIAGNOSTIC INFORMATION"](#).
8. Make sure DTC P0000 is displayed.
9. Run engine for at least 10 minutes at idle speed.  
**Is the 1st trip DTC P0171, P0172, P0174 or P0175 detected?  
Is it difficult to start engine?**

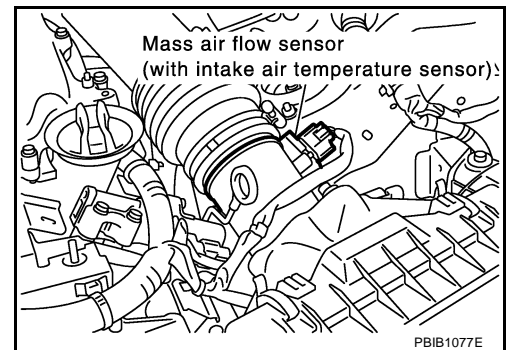

### Yes or No

- Yes >> Perform trouble diagnosis for DTC P0171, P0174 or P0172, P0175. Refer to [EC-221](#) or [EC-230](#).
- No >> GO TO 6.

## DTC P1278, P1288 A/F SENSOR 1

### 6. CHECK A/F SENSOR 1 POWER SUPPLY CIRCUIT

1. Turn ignition switch OFF.
2. Disconnect A/F sensor 1 harness connector.

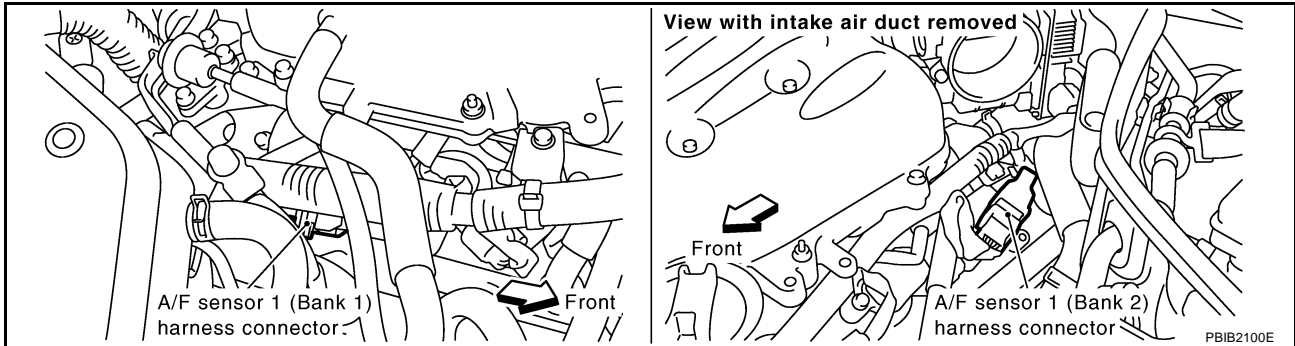

3. Turn ignition switch ON.
4. Check voltage between A/F sensor 1 terminal 3 and ground with CONSULT-II or tester.

**Voltage: Battery voltage**

OK or NG

- OK >> GO TO 8.
- NG >> GO TO 7.

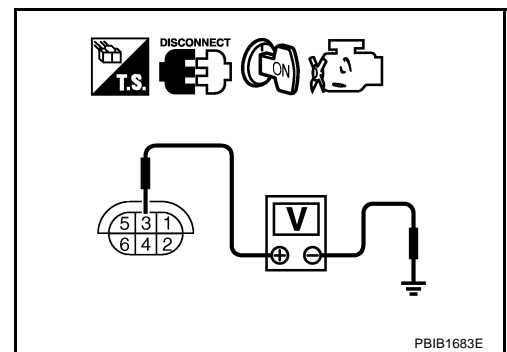

### 7. DETECT MALFUNCTIONING PART

Check the following.

- Harness connectors M15, E108
- Harness connectors E12, F3
- Fuse block (J/B) connector M4
- 15A fuse
- Harness for open or short between A/F sensor 1 and fuse

>> Repair or replace harness or connectors.

## DTC P1278, P1288 A/F SENSOR 1

### 8. CHECK A/F SENSOR 1 INPUT SIGNAL CIRCUIT FOR OPEN AND SHORT

1. Turn ignition switch OFF.
2. Disconnect ECM harness connector.
3. Check harness continuity between the following terminals.  
Refer to Wiring Diagram.

	A/F sensor 1 terminal	ECM terminal
Bank1	1	16
	2	75
	5	35
	6	56
Bank 2	1	76
	2	77
	5	57
	6	58

**Continuity should exist.**

4. Check harness continuity between the following terminals and ground.  
Refer to Wiring Diagram.

Bank 1		Bank 2	
A/F sensor 1 terminal	ECM terminal	A/F sensor 1 terminal	ECM terminal
1	16	1	76
2	75	2	77
5	35	5	57
6	56	6	58

**Continuity should not exist.**

5. Also check harness for short to power.

OK or NG

OK >> GO TO 9.

NG >> Repair open circuit or short to ground or short to power in harness or connectors.

### 9. CHECK AIR FUEL RATIO (A/F) SENSOR 1 HEATER

Refer to [EC-383, "Component Inspection"](#) .

OK or NG

OK >> GO TO 10.

NG >> Replace A/F sensor 1.

### 10. CHECK MASS AIR FLOW SENSOR

Refer to [EC-161, "Component Inspection"](#) .

OK or NG

OK >> GO TO 11.

NG >> Replace mass air flow sensor.

## 11. CHECK PCV VALVE

---

Refer to [EC-686, "POSITIVE CRANKCASE VENTILATION"](#) .

OK or NG

- OK >> GO TO 12.
- NG >> Repair or replace PCV valve.

## 12. CHECK INTERMITTENT INCIDENT

---

Perform [EC-129, "TROUBLE DIAGNOSIS FOR INTERMITTENT INCIDENT"](#) .

OK or NG

- OK >> GO TO 13.
- NG >> Repair or replace.

## 13. REPLACE AIR FUEL RATIO (A/F) SENSOR 1

---

Replace A/F sensor 1.

**CAUTION:**

- Discard any A/F sensor which has been dropped from a height of more than 0.5 m (19.7 in) onto a hard surface such as a concrete floor; use a new one.
- Before installing new A/F sensor, clean exhaust system threads (using Oxygen Sensor Thread Cleaner tool J-43897-18 or J-43897-12) and approved anti-seize lubricant.

>> INSPECTION END

### Removal and Installation AIR FUEL RATIO (A/F) SENSOR 1

ABS00A9D

Refer to [EM-23, "EXHAUST MANIFOLD AND THREE WAY CATALYST"](#) .



## DTC P1279, P1289 A/F SENSOR 1

PFP:22693

### Component Description

ABS00A9E

The air fuel ratio (A/F) sensor 1 is a planar dual-cell limit current sensor. The sensor element of the A/F sensor 1 is the combination of a Nernst concentration cell (sensor cell) with an oxygen-pump cell, which transports ions. It has a heater in the element.

The sensor is capable of precise measurement  $\lambda = 1$ , but also in the lean and rich range. Together with its control electronics, the sensor outputs a clear, continuous signal throughout a wide  $\lambda$  range ( $0.7 < \lambda < \text{air}$ ).

The exhaust gas components diffuse through the diffusion gap at the electrode of the oxygen pump and Nernst concentration cell, where they are brought to thermodynamic balance.

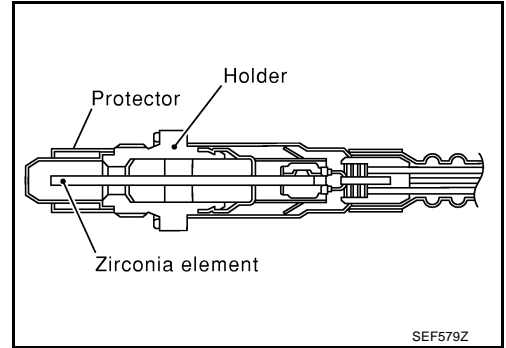

An electronic circuit controls the pump current through the oxygen-pump cell so that the composition of the exhaust gas in the diffusion gap remains constant at  $\lambda = 1$ . Therefore, the A/F sensor 1 is able to indicate air/fuel ratio by this pumping of current. In addition, a heater is integrated in the sensor to ensure the required operating temperature of 700 - 800°C (1,292 - 1,472°F).

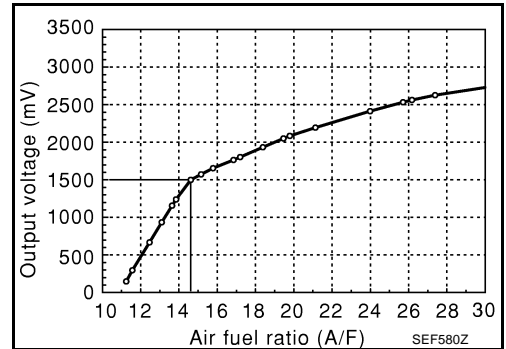

### CONSULT-II Reference Value in Data Monitor Mode

ABS00A9F

Specification data are reference values.

MONITOR ITEM	CONDITION	SPECIFICATION
A/F SEN1 (B1) A/F SEN1 (B2)	<ul style="list-style-type: none"> <li>Engine: After warming up</li> </ul> Maintaining engine speed at 2,000 rpm	Fluctuates around 1.5V

### On Board Diagnosis Logic

ABS00A9G

To judge the malfunction of A/F sensor 1, this diagnosis measures response time of the A/F signal computed by ECM from the air fuel ratio A/F sensor 1 signal. The time is compensated by engine operating (speed and load), fuel feedback control constant, and the A/F sensor 1 temperature index. Judgment is based on whether the compensated time (the A/F signal cycling time index) is inordinately long or not.

DTC No.	Trouble diagnosis name	DTC detecting condition	Possible Cause
P1279 1279 (Bank 1)	Air fuel ratio (A/F) sensor 1 circuit slow response	<ul style="list-style-type: none"> <li>The response (from LEAN to RICH) of the A/F signal computed by ECM from A/F sensor 1 signal takes more than the specified time.</li> </ul>	<ul style="list-style-type: none"> <li>Harness or connectors (The A/F sensor 1 circuit is open or shorted.)</li> <li>Air fuel ratio (A/F) sensor 1</li> <li>Air fuel ratio (A/F) sensor 1 heater</li> <li>Fuel pressure</li> <li>Fuel injector</li> <li>Intake air leaks</li> <li>Exhaust gas leaks</li> <li>PCV</li> <li>Mass air flow sensor</li> </ul>
P1289 1289 (Bank 2)			

# DTC P1279, P1289 A/F SENSOR 1

ABS00A9H

## DTC Confirmation Procedure

### NOTE:

If DTC Confirmation Procedure has been previously conducted, always turn ignition switch OFF and wait at least 10 seconds before conducting the next test.

### TESTING CONDITION:

Before performing the following procedure, confirm that battery voltage is more than 11V at idle.

### WITH CONSULT-II

1. Start engine and warm it up to normal operating temperature.
2. Turn ignition switch OFF and wait at least 10 seconds.
3. Start engine and keep the engine speed between 3,500 and 4,000 rpm for at least 1 minute under no load.
4. Let engine idle for 1 minute.
5. Select "A/F SEN1(B1) P1278/P1279" or "A/F SEN1(B1) P1288/P1289" of "A/F SEN1" in "DTC WORK SUPPORT" mode with CONSULT-II.
6. Touch "START".  
If "COMPLETED" appears on CONSULT-II screen, go to step 10.  
If "COMPLETED" does not appear on CONSULT-II screen, go to the following step.

A/F SEN1 (B1) P1278/P1279	
OUT OF CONDITION	
MONITOR	
ENG SPEED	XXX rpm
B/FUEL SCHDL	XXX msec
COOLAN TEMP/S	XXX °C
VHCL SPEED SE	XXX km/h

PBIB0756E

7. After perform the following procedure, "TESTING" will be displayed on the CONSULT-II screen.
  - a. Increase the engine speed up to 4,000 to 5,000 rpm and keep it for 10 seconds.
  - b. Fully release accelerator pedal and then let engine idle for about 10 seconds.  
**If "TESTING" is not displayed after 10 seconds, refer to [EC-125, "TROUBLE DIAGNOSIS - SPECIFICATION VALUE"](#).**
8. Wait for about 20 seconds at idle at under the condition that "TESTING" is displayed on the CONSULT-II screen.

A/F SEN1 (B1) P1278/P1279	
TESTING	
MONITOR	
ENG SPEED	XXX rpm
B/FUEL SCHDL	XXX msec
COOLAN TEMP/S	XXX °C
VHCL SPEED SE	XXX km/h

PBIB1925E

9. Make sure that "TESTING" changes to "COMPLETED".  
**If "TESTING" changed to "OUT OF CONDITION", refer to [EC-125, "TROUBLE DIAGNOSIS - SPECIFICATION VALUE"](#).**
10. Make sure that "OK" is displayed after touching "SELF-DIAG RESULT".  
If "NG" is displayed, go to [EC-527, "Diagnostic Procedure"](#).

A/F SEN1 (B1) P1278/P1279	
COMPLETED	

PBIB0758E

### WITH GST

1. Start engine and warm it up to normal operating temperature.
2. Select "MODE 1" with GST.
3. Calculate the total value of "Short term fuel trim" and "Long term fuel trim" indications.  
Make sure that the total percentage should be within  $\pm 15\%$ .  
If OK, go to the following step.  
If NG, check the following.

## DTC P1279, P1289 A/F SENSOR 1

---

- Intake air leaks
  - Exhaust gas leaks
  - Incorrect fuel pressure
  - Lack of fuel
  - Fuel injector
  - Incorrect PCV hose connection
  - PCV valve
  - Mass air flow sensor
4. Turn ignition switch OFF and wait at least 10 seconds.
  5. Start engine and keep the engine speed between 3,500 and 4,000 rpm for at least 1 minute under no load.
  6. Let engine idle for 1 minute.
  7. Increase the engine speed up to 4,000 to 5,000 rpm and keep it for 10 seconds.
  8. Fully release accelerator pedal and then let engine idle for about 1 minute.
  9. Select "MODE 7" with GST.  
If 1st trip DTC is detected, go to [EC-527, "Diagnostic Procedure"](#) .

A

EC

C

D

E

F

G

H

I

J

K

L

M

# DTC P1279, P1289 A/F SENSOR 1

ABS00A9I

## Wiring Diagram BANK 1

EC-AF1B1-01

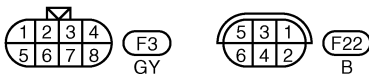
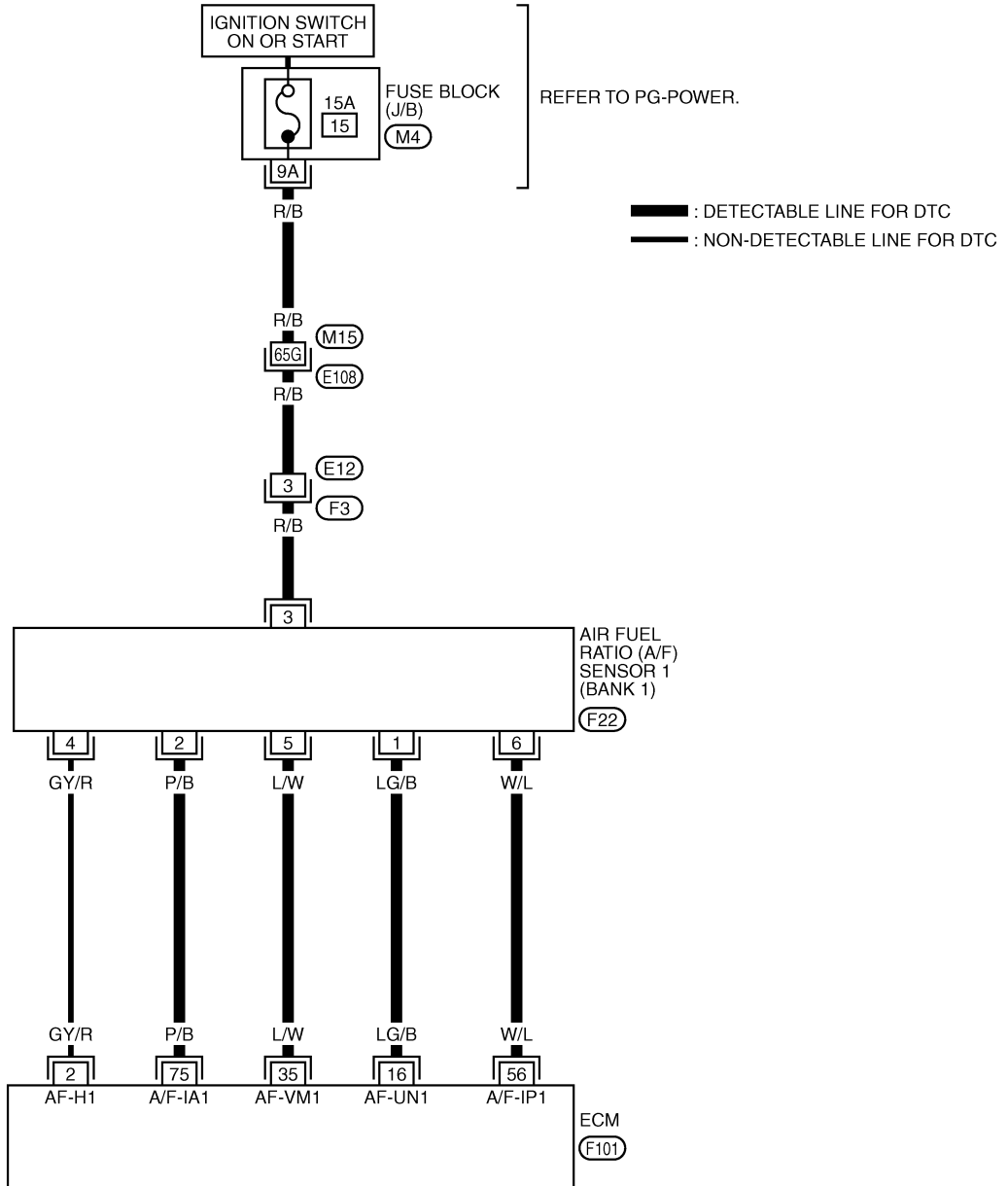

REFER TO THE FOLLOWING.

- (E108) -SUPER MULTIPLE JUNCTION (SMJ)
- (M4) -FUSE BLOCK-JUNCTION BOX (J/B)

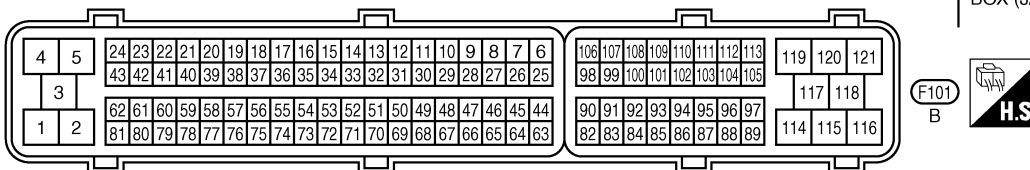

TBWT0706E

## DTC P1279, P1289 A/F SENSOR 1

Specification data are reference values and are measured between each terminal and ground.

**CAUTION:**

**Do not use ECM ground terminals when measuring input/output voltage. Doing so may result in damage to the ECM's transistor. Use a ground other than ECM terminals, such as the ground.**

TER-MINAL NO.	WIRE COLOR	ITEM	CONDITION	DATA (DC Voltage)
16	LG/B	A/F sensor 1 (Bank 1)	<b>[Engine is running]</b> ● Warm-up condition ● Idle speed	Approximately 3.1V
35	L/W			Approximately 2.6V
56	W/L			Approximately 2.3V
75	P/B			Approximately 2.3V

A  
EC  
C  
D  
E  
F  
G  
H  
I  
J  
K  
L  
M

# DTC P1279, P1289 A/F SENSOR 1

**BANK 2**

**EC-AF1B2-01**

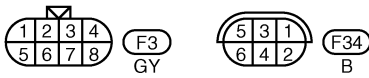
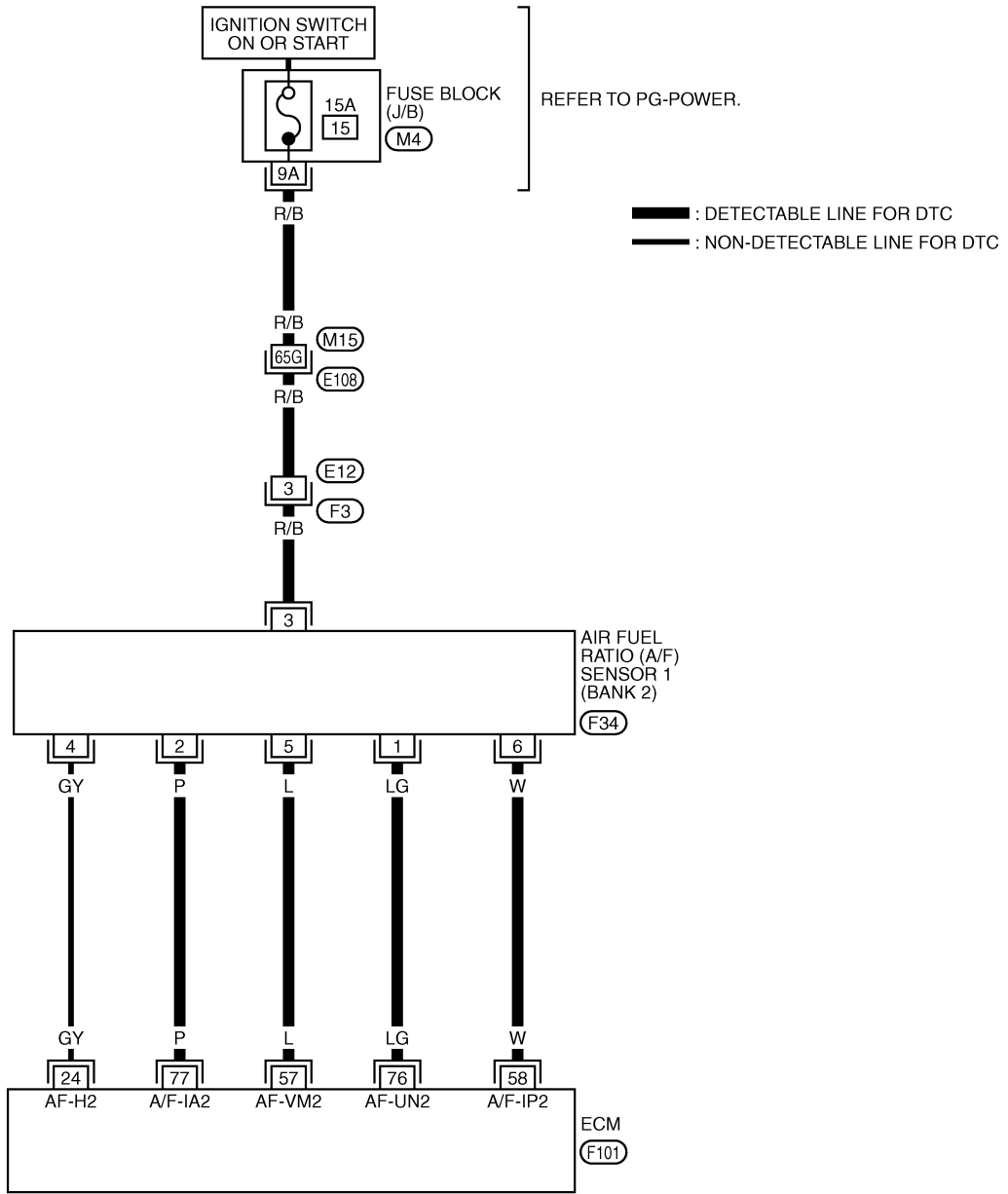

REFER TO THE FOLLOWING.

(E108) -SUPER MULTIPLE JUNCTION (SMJ)

(M4) -FUSE BLOCK-JUNCTION BOX (J/B)

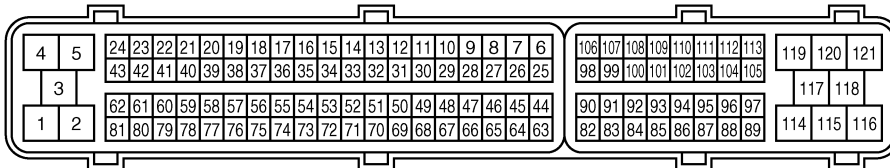

TBWT0707E

# DTC P1279, P1289 A/F SENSOR 1

Specification data are reference values and are measured between each terminal and ground.

**CAUTION:**

Do not use ECM ground terminals when measuring input/output voltage. Doing so may result in damage to the ECM's transistor. Use a ground other than ECM terminals, such as the ground.

TER-MINAL NO.	WIRE COLOR	ITEM	CONDITION	DATA (DC Voltage)
57	L	A/F sensor 1 (Bank 2)	<b>[Engine is running]</b> ● Warm-up condition ● Idle speed	Approximately 2.6V
58	W			Approximately 2.3V
76	LG			Approximately 3.1V
77	P			Approximately 2.3V

## Diagnostic Procedure

ABS00A9J

### 1. CHECK GROUND CONNECTIONS

1. Turn ignition switch OFF.
2. Loosen and retighten three ground screws on the body. Refer to [EC-138, "Ground Inspection"](#).

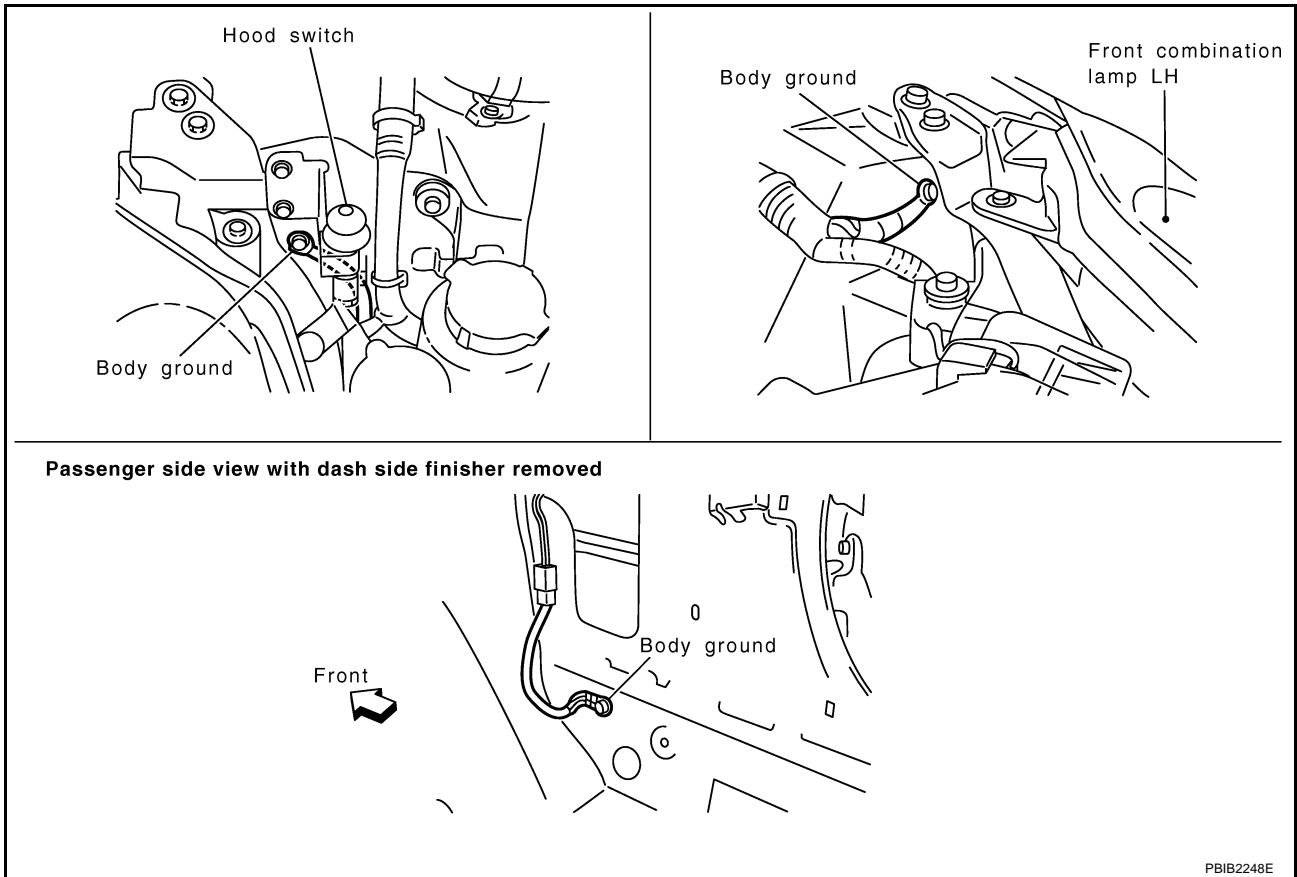

**OK or NG**

- OK >> GO TO 2.
- NG >> Repair or replace ground connections.

## DTC P1279, P1289 A/F SENSOR 1

### 2. RETIGHTEN A/F SENSOR 1

Loosen and retighten the A/F sensor 1.

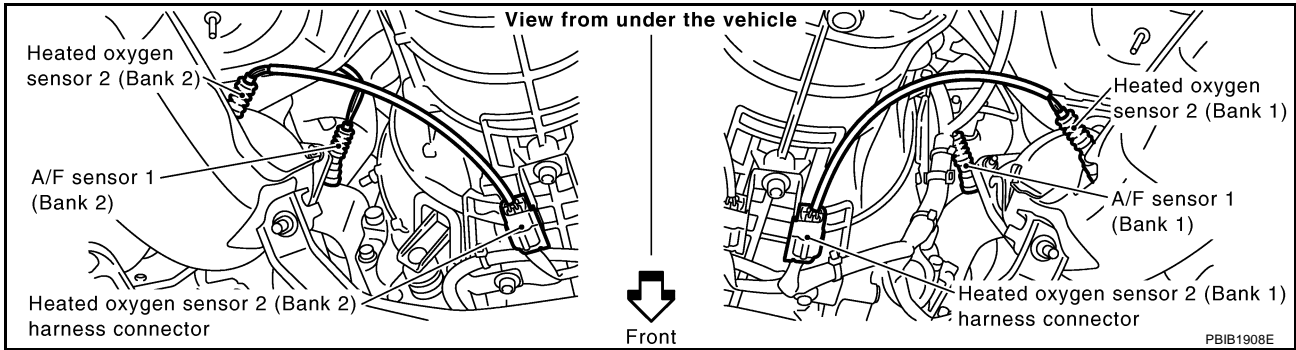

**Tightening torque: 40 - 60 N-m (4.1 - 6.1 kg-m, 30 - 44 ft-lb)**

>> GO TO 3.

### 3. CHECK EXHAUST GAS LEAK

1. Start engine and run it at idle.
2. Listen for an exhaust gas leak before three way catalyst 1.

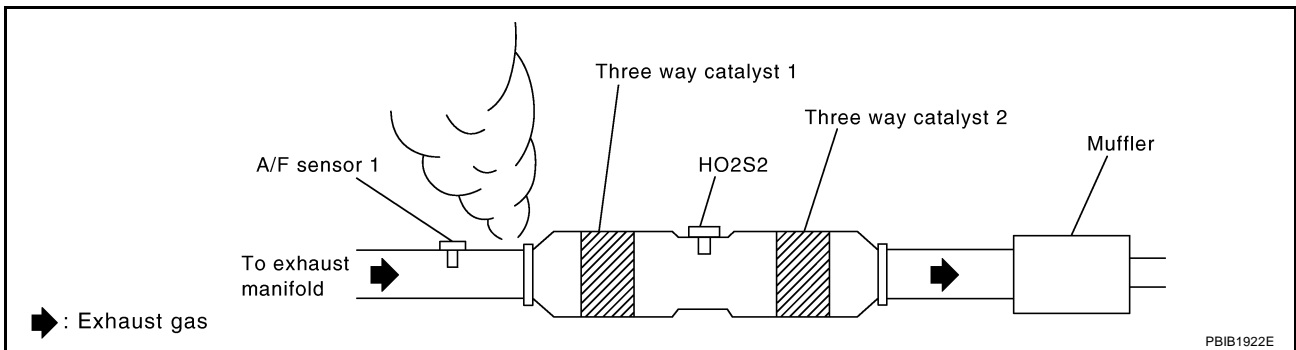

OK or NG

- OK >> GO TO 4.  
NG >> Repair or replace.

### 4. CHECK FOR INTAKE AIR LEAK

Listen for an intake air leak after the mass air flow sensor.

OK or NG

- OK >> GO TO 5.  
NG >> Repair or replace.



# DTC P1279, P1289 A/F SENSOR 1

## 5. CLEAR THE SELF-LEARNING DATA

### With CONSULT-II

1. Start engine and warm it up to normal operating temperature.
2. Select "SELF-LEARNING CONT" in "WORK SUPPORT" mode with CONSULT-II.
3. Clear the self-learning control coefficient by touching "CLEAR" or "START".
4. Run engine for at least 10 minutes at idle speed.  
**Is the 1st trip DTC P0171, P172, P0174 or P0175 detected?  
Is it difficult to start engine?**

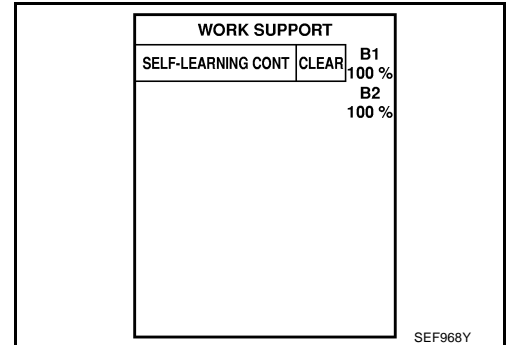

### Without CONSULT-II

1. Start engine and warm it up to normal operating temperature.
2. Turn ignition switch OFF.
3. Disconnect mass air flow sensor harness connector.
4. Restart engine and let it idle for at least 5 seconds.
5. Stop engine and reconnect mass air flow sensor harness connector.
6. Make sure DTC P0102 is displayed.
7. Erase the DTC memory. Refer to [EC-61, "HOW TO ERASE EMISSION-RELATED DIAGNOSTIC INFORMATION"](#).
8. Make sure DTC P0000 is displayed.
9. Run engine for at least 10 minutes at idle speed.  
**Is the 1st trip DTC P0171, P0172, P0174 or P0175 detected?  
Is it difficult to start engine?**

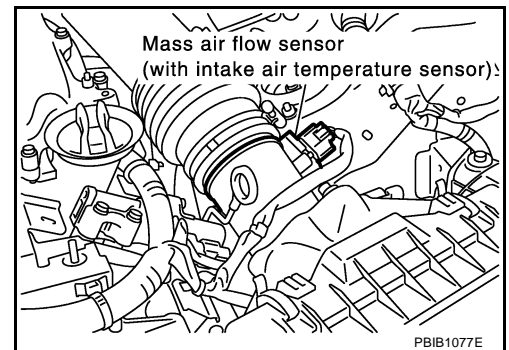

Yes or No

- Yes >> Perform trouble diagnosis for DTC P0171, P0174 or P0172, P0175. Refer to [EC-221](#) or [EC-230](#).
- No >> GO TO 6.

## DTC P1279, P1289 A/F SENSOR 1

### 6. CHECK A/F SENSOR 1 POWER SUPPLY CIRCUIT

1. Turn ignition switch OFF.
2. Disconnect A/F sensor 1 harness connector.

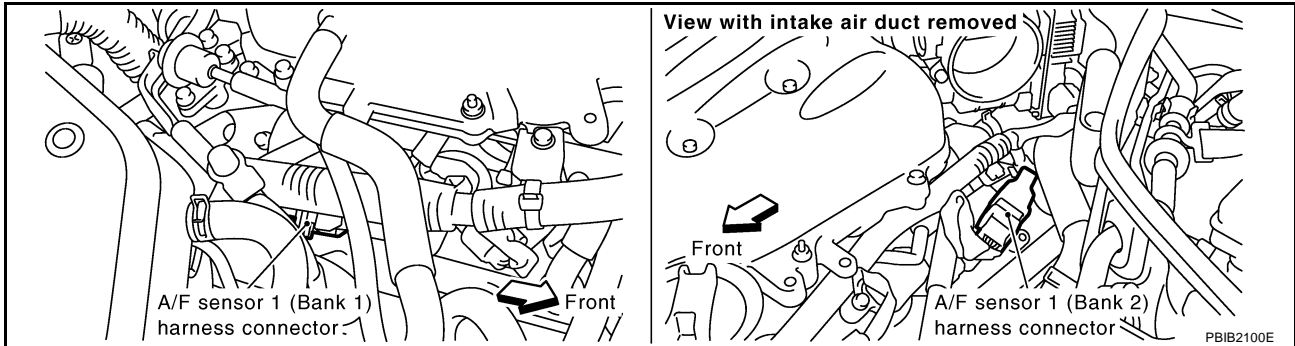

3. Turn ignition switch ON.
4. Check voltage between A/F sensor 1 terminal 3 and ground with CONSULT-II or tester.

**Voltage: Battery voltage**

OK or NG

- OK >> GO TO 8.
- NG >> GO TO 7.

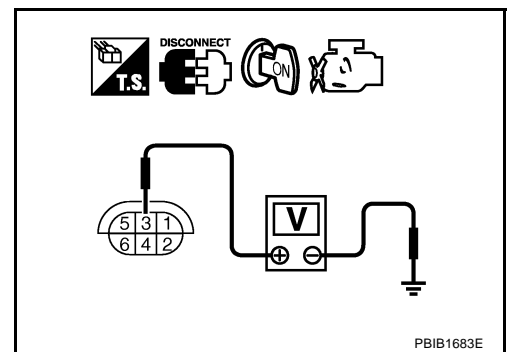

### 7. DETECT MALFUNCTIONING PART

Check the following.

- Harness connectors M15, E108
- Harness connectors E12, F3
- Fuse block (J/B) connector M4
- 15A fuse
- Harness for open or short between A/F sensor 1 and fuse

>> Repair or replace harness or connectors.

## DTC P1279, P1289 A/F SENSOR 1

### 8. CHECK A/F SENSOR 1 INPUT SIGNAL CIRCUIT FOR OPEN AND SHORT

1. Turn ignition switch OFF.
2. Disconnect ECM harness connector.
3. Check harness continuity between the following terminals.  
Refer to Wiring Diagram.

	A/F sensor 1 terminal	ECM terminal
Bank1	1	16
	2	75
	5	35
	6	56
Bank 2	1	76
	2	77
	5	57
	6	58

**Continuity should exist.**

4. Check harness continuity between the following terminals and ground.  
Refer to Wiring Diagram.

Bank 1		Bank 2	
A/F sensor 1 terminal	ECM terminal	A/F sensor 1 terminal	ECM terminal
1	16	1	76
2	75	2	77
5	35	5	57
6	56	6	58

**Continuity should not exist.**

5. Also check harness for short to power.

OK or NG

OK >> GO TO 9.

NG >> Repair open circuit or short to ground or short to power in harness or connectors.

### 9. CHECK AIR FUEL RATIO (A/F) SENSOR 1 HEATER

Refer to [EC-383, "Component Inspection"](#) .

OK or NG

OK >> GO TO 10.

NG >> Replace A/F sensor 1.

### 10. CHECK MASS AIR FLOW SENSOR

Refer to [EC-161, "Component Inspection"](#) .

OK or NG

OK >> GO TO 11.

NG >> Replace mass air flow sensor.

---

## 11. CHECK PCV VALVE

---

Refer to [EC-686, "POSITIVE CRANKCASE VENTILATION"](#) .

OK or NG

- OK >> GO TO 12.
- NG >> Repair or replace PCV valve.

---

## 12. CHECK INTERMITTENT INCIDENT

---

Perform [EC-129, "TROUBLE DIAGNOSIS FOR INTERMITTENT INCIDENT"](#) .

OK or NG

- OK >> GO TO 13.
- NG >> Repair or replace.

---

## 13. REPLACE AIR FUEL RATIO (A/F) SENSOR 1

---

Replace A/F sensor 1.

**CAUTION:**

- Discard any A/F sensor which has been dropped from a height of more than 0.5 m (19.7 in) onto a hard surface such as a concrete floor; use a new one.
- Before installing new A/F sensor, clean exhaust system threads (using Oxygen Sensor Thread Cleaner tool J-43897-18 or J-43897-12) and approved anti-seize lubricant.

>> INSPECTION END

### Removal and Installation AIR FUEL RATIO (A/F) SENSOR 1

ABS00A9K

Refer to [EM-23, "EXHAUST MANIFOLD AND THREE WAY CATALYST"](#)

# DTC P1444 EVAP CANISTER PURGE VOLUME CONTROL SOLENOID VALVE

## DTC P1444 EVAP CANISTER PURGE VOLUME CONTROL SOLENOID VALVE

PFP:14920

### Description SYSTEM DESCRIPTION

ABS009M6

Sensor	Input Signal to ECM	ECM function	Actuator
Crankshaft position sensor (POS) Camshaft position sensor (PHASE)	Engine speed*1	EVAP canister purge flow control	EVAP canister purge vol- ume control solenoid valve
Mass air flow sensor	Amount of intake air		
Engine coolant temperature sensor	Engine coolant temperature		
Battery	Battery voltage*1		
Throttle position sensor	Throttle position		
Accelerator pedal position sensor	Accelerator pedal position		
Air fuel ratio (A/F) sensor 1	Density of oxygen in exhaust gas (Mixture ratio feedback signal)		
Fuel tank temperature sensor	Fuel temperature in fuel tank		
Wheel sensor*2	Vehicle speed		

\*1: ECM determines the start signal status by the signals of engine speed and battery voltage.

\*2: This signal is sent to the ECM through CAN communication line.

This system controls flow rate of fuel vapor from the EVAP canister. The opening of the vapor by-pass passage in the EVAP canister purge volume control solenoid valve changes to control the flow rate. The EVAP canister purge volume control solenoid valve repeats ON/OFF operation according to the signal sent from the ECM. The opening of the valve varies for optimum engine control. The optimum value stored in the ECM is determined by considering various engine conditions. When the engine is operating, the flow rate of fuel vapor from the EVAP canister is regulated as the air flow changes.

### COMPONENT DESCRIPTION

The EVAP canister purge volume control solenoid valve uses a ON/OFF duty to control the flow rate of fuel vapor from the EVAP canister. The EVAP canister purge volume control solenoid valve is moved by ON/OFF pulses from the ECM. The longer the ON pulse, the greater the amount of fuel vapor that will flow through the valve.

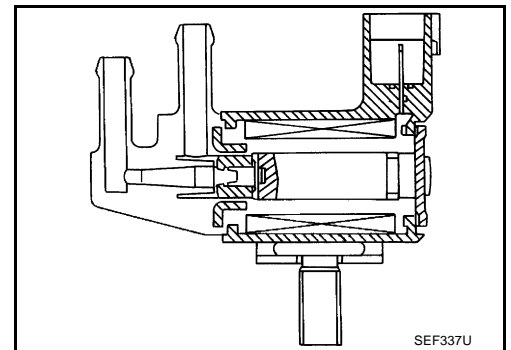

### CONSULT-II Reference Value in Data Monitor Mode

ABS009M7

Specification data are reference values.

MONITOR ITEM	CONDITION		SPECIFICATION
PURG VOL C/V	<ul style="list-style-type: none"> <li>● Engine: After warming up</li> <li>● Shift lever: P or N (A/T), Neutral (M/T)</li> <li>● Air conditioner switch: OFF</li> <li>● No-load</li> </ul>	Idle	0%
		2,000 rpm	—

# DTC P1444 EVAP CANISTER PURGE VOLUME CONTROL SOLENOID VALVE

## On Board Diagnosis Logic

ABS009M8

DTC No.	Trouble diagnosis name	DTC detecting condition	Possible cause
P1444 1444	EVAP canister purge volume control solenoid valve	The canister purge flow is detected during the specified driving conditions, even when EVAP canister purge volume control solenoid valve is completely closed.	<ul style="list-style-type: none"> <li>● EVAP control system pressure sensor</li> <li>● EVAP canister purge volume control solenoid valve (The valve is stuck open.)</li> <li>● EVAP canister vent control valve</li> <li>● EVAP canister</li> <li>● Hoses (Hoses are connected incorrectly or clogged.)</li> </ul>

## DTC Confirmation Procedure

ABS009M9

### NOTE:

If DTC Confirmation Procedure has been previously conducted, always turn ignition switch OFF and wait at least 10 seconds before conducting the next test.

### TESTING CONDITION:

**Always perform test at a temperature of 5°C (41°F) or more.**

### WITH CONSULT-II

1. Start engine and warm it up to normal operating temperature.
2. Turn ignition switch OFF and wait at least 10 seconds.
3. Turn ignition switch ON.
4. Select "PURG VOL CN/V P1444" of "EVAPORATIVE SYSTEM" in "DTC WORK SUPPORT" mode with CONSULT-II.
5. Touch "START".

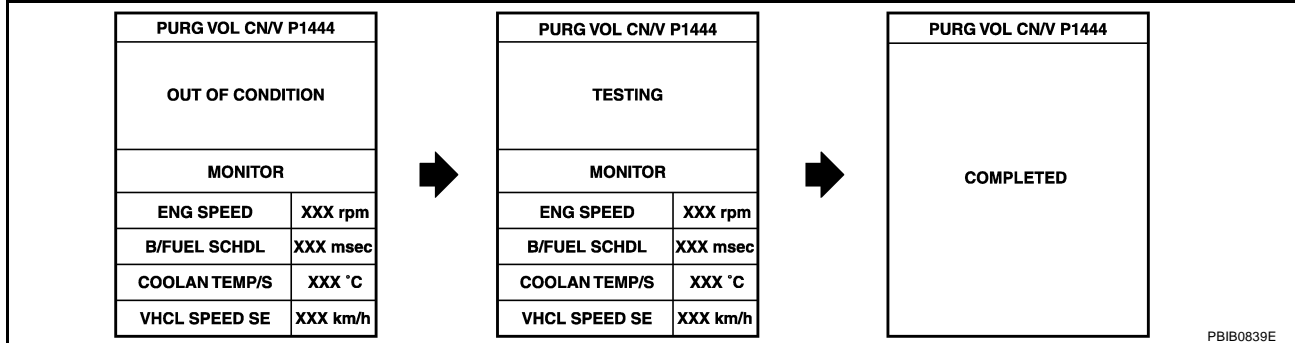

6. Start engine and let it idle until "TESTING" on CONSULT-II changes to "COMPLETED". (It will take approximately 10 seconds.)  
**If "TESTING" is not displayed after 5 minutes, retry from step 2.**
7. Make sure that "OK" is displayed after touching "SELF-DIAG RESULTS". If "NG" is displayed, refer to [EC-537, "Diagnostic Procedure"](#).

### WITH GST

1. Start engine and warm it up to normal operating temperature.
2. Turn ignition switch OFF and wait at least 10 seconds.
3. Start engine and let it idle for at least 20 seconds.
4. Select "MODE 7" with GST.
5. If 1st trip DTC is detected, go to [EC-537, "Diagnostic Procedure"](#).

# DTC P1444 EVAP CANISTER PURGE VOLUME CONTROL SOLENOID VALVE

## Wiring Diagram

ABS009MA

EC-PGC/V-01

A  
EC  
C  
D  
E  
F  
G  
H  
I  
J  
K  
L  
M

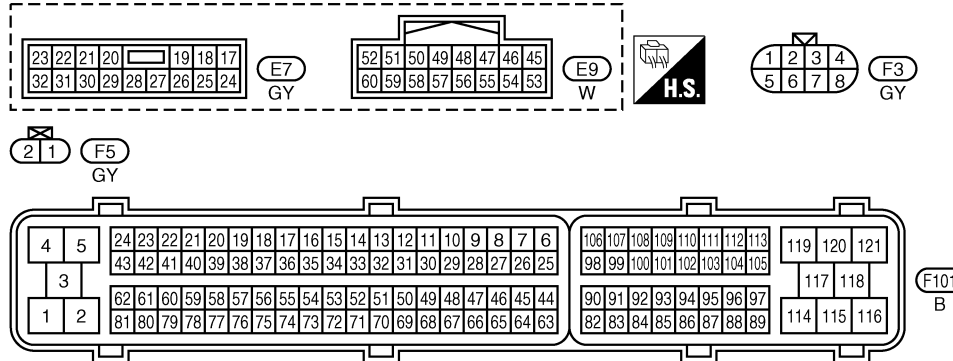
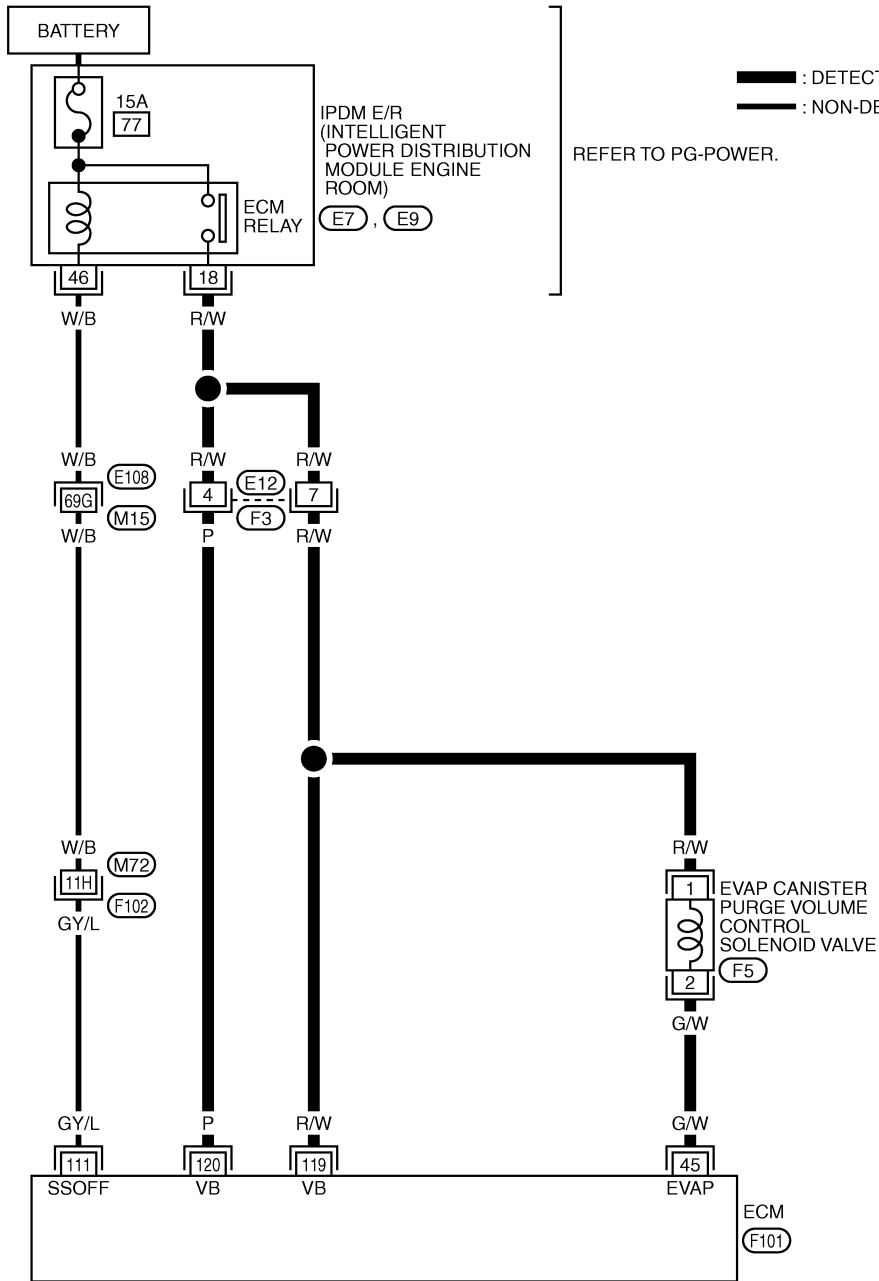

REFER TO THE FOLLOWING.  
 E108, F102 -SUPER MULTIPLE JUNCTION (SMJ)

# DTC P1444 EVAP CANISTER PURGE VOLUME CONTROL SOLENOID VALVE

Specification data are reference values and are measured between each terminal and ground.  
Pulse signal is measured by CONSULT-II.

**CAUTION:**

**Do not use ECM ground terminals when measuring input/output voltage. Doing so may result in damage to the ECM's transistor. Use a ground other than ECM terminals, such as the ground.**

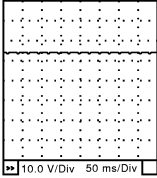
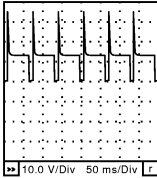
TER-MINAL NO.	WIRE COLOR	ITEM	CONDITION	DATA (DC Voltage)
45	G/W	EVAP canister purge volume control solenoid valve	<p><b>[Engine is running]</b></p> <ul style="list-style-type: none"> <li>● Idle speed</li> <li>● Accelerator pedal is not depressed even slightly, after engine starting.</li> </ul>	<p>BATTERY VOLTAGE (11 - 14V)★</p> 
			<p><b>[Engine is running]</b></p> <ul style="list-style-type: none"> <li>● Engine speed is about 2,000 rpm (More than 100 seconds after starting engine).</li> </ul>	<p>BATTERY VOLTAGE (11 - 14V)★</p> 
111	GY/L	ECM relay (Self shut-off)	<p><b>[Engine is running]</b> <b>[Ignition switch: OFF]</b></p> <ul style="list-style-type: none"> <li>● A few seconds after turning ignition switch OFF</li> </ul>	0 - 1.5V
			<p><b>[Ignition switch: OFF]</b></p> <ul style="list-style-type: none"> <li>● More than a few seconds after turning ignition switch OFF</li> </ul>	BATTERY VOLTAGE (11 - 14V)
119 120	R/W P	Power supply for ECM	<b>[Ignition switch: ON]</b>	BATTERY VOLTAGE (11 - 14V)

★: Average voltage for pulse signal (Actual pulse signal can be confirmed by oscilloscope.)



# DTC P1444 EVAP CANISTER PURGE VOLUME CONTROL SOLENOID VALVE

## Diagnostic Procedure

ABS009MB

### 1. CHECK EVAP CANISTER PURGE VOLUME CONTROL SOLENOID VALVE POWER SUPPLY CIRCUIT

1. Turn ignition switch OFF.
2. Disconnect EVAP canister purge volume control solenoid valve harness connector.
3. Turn ignition switch ON.

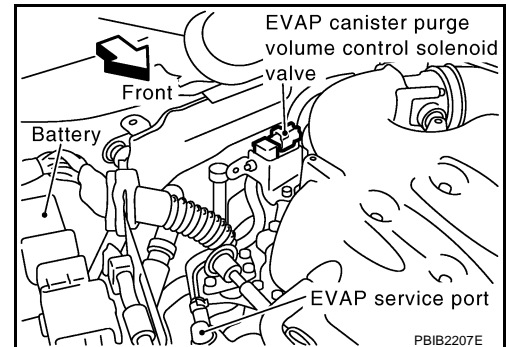

4. Check voltage between EVAP canister purge volume control solenoid valve terminal 1 and ground with CONSULT-II or tester.

**Voltage: Battery voltage**

OK or NG

- OK >> GO TO 3.
- NG >> GO TO 2.

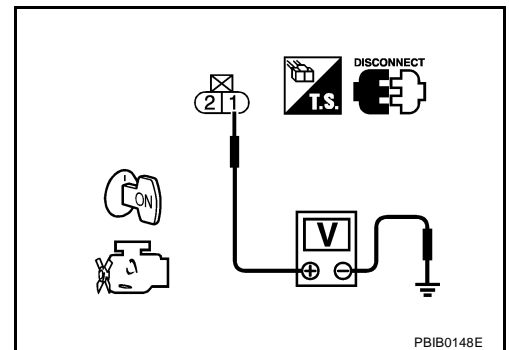

### 2. DETECT MALFUNCTIONING PART

Check the following.

- Harness connectors E12, F3
- Harness for open or short between EVAP canister purge volume control solenoid valve and IPDM E/R
- Harness for open or short between EVAP canister purge volume control solenoid valve and ECM

>> Repair open circuit or short to ground or short to power in harness or connectors.

### 3. CHECK EVAP CANISTER PURGE VOLUME CONTROL SOLENOID VALVE OUTPUT SIGNAL CIRCUIT FOR OPEN AND SHORT

1. Turn ignition switch OFF.
2. Disconnect ECM harness connector.
3. Check harness continuity between ECM terminal 45 and EVAP canister purge volume control solenoid valve terminal 2. Refer to Wiring Diagram.

**Continuity should exist.**

4. Also check harness for short to ground and short to power.

OK or NG

- OK >> GO TO 4.
- NG >> Repair open circuit or short to ground or short to power in harness or connectors.

# DTC P1444 EVAP CANISTER PURGE VOLUME CONTROL SOLENOID VALVE

## 4. CHECK EVAP CONTROL SYSTEM PRESSURE SENSOR CONNECTOR

1. Disconnect EVAP control system pressure sensor harness connector.
2. Check connectors for water.

**Water should not exist.**

OK or NG

- OK >> GO TO 5.  
NG >> Replace EVAP control system pressure sensor.

## 5. CHECK EVAP CONTROL SYSTEM PRESSURE SENSOR

Refer to [EC-328, "Component Inspection"](#) .

OK or NG

- OK (With CONSULT-II)>>GO TO 6.  
OK (Without CONSULT-II)>>GO TO 7.  
NG >> Replace EVAP control system pressure sensor.

## 6. CHECK EVAP CANISTER PURGE VOLUME CONTROL SOLENOID VALVE

 **With CONSULT-II**

1. Turn ignition switch OFF.
2. Reconnect harness connectors disconnected.
3. Start engine.
4. Perform "PURG VOL CONT/V" in "ACTIVE TEST" mode with CONSULT-II. Check that engine speed varies according to the valve opening.

OK or NG

- OK >> GO TO 8.  
NG >> GO TO 7.

ACTIVE TEST	
PURG VOL CONT/V	XXX %
MONITOR	
ENG SPEED	XXX rpm
A/F ALPHA-B1	XX %
A/F ALPHA-B2	XX %

PBIB1678E

## 7. CHECK EVAP CANISTER PURGE VOLUME CONTROL SOLENOID VALVE

Refer to [EC-540, "Component Inspection"](#) .

OK or NG

- OK >> GO TO 8.  
NG >> Replace EVAP canister purge volume control solenoid valve.

## 8. CHECK RUBBER TUBE FOR CLOGGING

1. Disconnect rubber tube connected to EVAP canister vent control valve.
2. Check the rubber tube for clogging.

OK or NG

- OK >> GO TO 9.  
NG >> Clean the rubber tube using an air blower.

## 9. CHECK EVAP CANISTER VENT CONTROL VALVE

Refer to [EC-315, "Component Inspection"](#) .

OK or NG

- OK >> GO TO 10.  
NG >> Replace EVAP canister vent control valve.

# DTC P1444 EVAP CANISTER PURGE VOLUME CONTROL SOLENOID VALVE

## 10. CHECK IF EVAP CANISTER SATURATED WITH WATER

1. Remove EVAP canister with EVAP canister vent control valve and EVAP control system pressure sensor attached.
2. Check if water will drain from the EVAP canister.

OK or NG

- OK >> GO TO 11.  
NG >> GO TO 13.

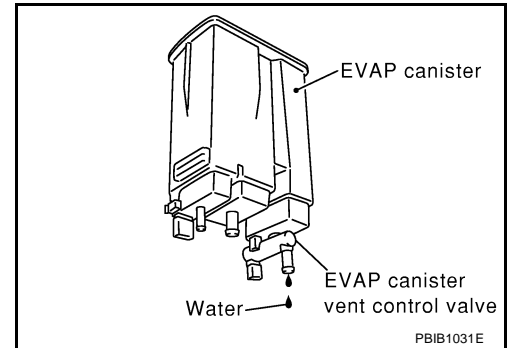

## 11. CHECK EVAP CANISTER

Weigh the EVAP canister with the EVAP canister vent control valve and EVAP control system pressure sensor attached.

**The weight should be less than 2.2 kg (4.9 lb).**

OK or NG

- OK >> GO TO 13.  
NG >> GO TO 12.

## 12. DETECT MALFUNCTIONING PART

Check the following.

- EVAP canister for damage
- EVAP hose between EVAP canister and vehicle frame for clogging or poor connection

>> Repair hose or replace EVAP canister.

## 13. CHECK INTERMITTENT INCIDENT

Refer to [EC-129, "TROUBLE DIAGNOSIS FOR INTERMITTENT INCIDENT"](#) .

>> INSPECTION END

# DTC P1444 EVAP CANISTER PURGE VOLUME CONTROL SOLENOID VALVE

## Component Inspection

### EVAP CANISTER PURGE VOLUME CONTROL SOLENOID VALVE

ABS009MC

#### ④ With CONSULT-II

Check air passage continuity of EVAP canister purge volume control solenoid valve under the following conditions.

Condition (PURG VOL CONT/V value)	Air passage continuity between A and B
100%	Yes
0%	No

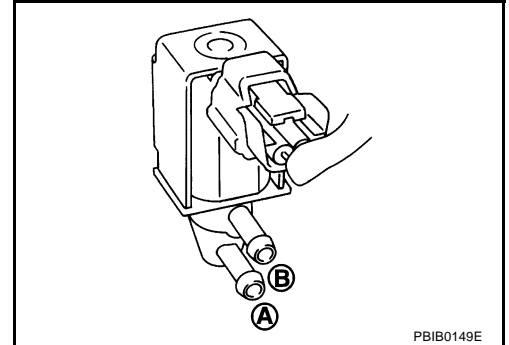

#### ⊗ Without CONSULT-II

Check air passage continuity of EVAP canister purge volume control solenoid valve under the following conditions.

Condition	Air passage continuity between A and B
12V direct current supply between terminals 1 and 2	Yes
No supply	No

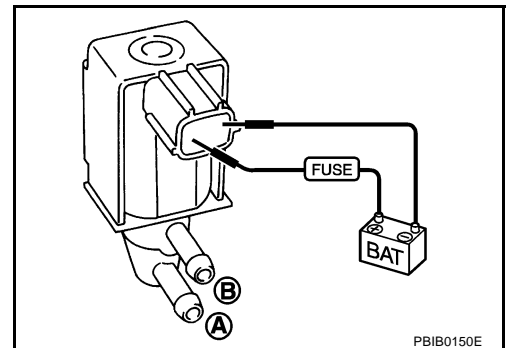

## Removal and Installation

### EVAP CANISTER PURGE VOLUME CONTROL SOLENOID VALVE

ABS009MD

Refer to [EM-16, "INTAKE MANIFOLD COLLECTOR"](#) .

# DTC P1446 EVAP CANISTER VENT CONTROL VALVE

## DTC P1446 EVAP CANISTER VENT CONTROL VALVE

PF14935

### Component Description

ABS009ME

The EVAP canister vent control valve is located on the EVAP canister and is used to seal the canister vent.

This solenoid valve responds to signals from the ECM. When the ECM sends an ON signal, the coil in the solenoid valve is energized. A plunger will then move to seal the canister vent. The ability to seal the vent is necessary for the on board diagnosis of other evaporative emission control system components.

This solenoid valve is used only for diagnosis, and usually remains opened.

When the vent is closed, under normal purge conditions, the evaporative emission control system is depressurized and allows "EVAP Control System" diagnosis.

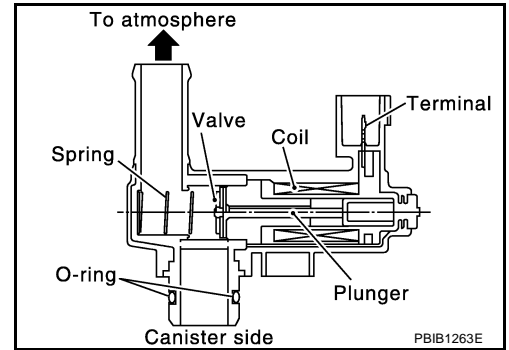

A

EC

C

D

E

F

G

H

View from under the vehicle

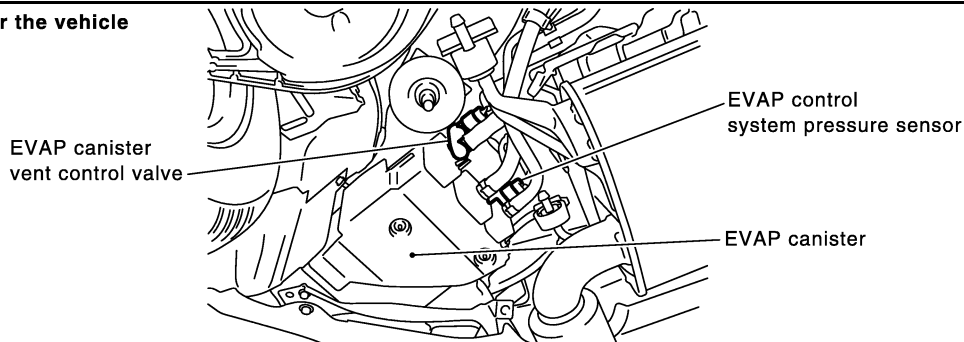

I

J

### CONSULT-II Reference Value in Data Monitor Mode

ABS009MF

Specification data are reference values.

MONITOR ITEM	CONDITION	SPECIFICATION
VENT CONT/V	● Ignition switch: ON	OFF

### On Board Diagnosis Logic

ABS009MG

DTC No.	Trouble diagnosis name	DTC detecting condition	Possible cause
P1446 1446	EVAP canister vent control valve close	EVAP canister vent control valve remains closed under specified driving conditions.	<ul style="list-style-type: none"> <li>● EVAP canister vent control valve</li> <li>● EVAP control system pressure sensor and the circuit</li> <li>● Blocked rubber tube to EVAP canister vent control valve</li> <li>● EVAP canister is saturated with water</li> </ul>

K

L

M

# DTC P1446 EVAP CANISTER VENT CONTROL VALVE

ABS009MH

## DTC Confirmation Procedure

### NOTE:

If DTC Confirmation Procedure has been previously conducted, always turn ignition switch OFF and wait at least 10 seconds before conducting the next test.

### WITH CONSULT-II

1. Turn ignition switch ON and wait at least 5 seconds.
2. Turn ignition switch OFF and wait at least 10 seconds.
3. Turn ignition switch ON and select "DATA MONITOR" mode with CONSULT-II.
4. Start engine and let it idle for at least 1 minute.
5. Repeat next procedures three times.
  - a. Increase the engine speed up to 3,000 to 3,500 rpm and keep it for 2 minutes and 50 seconds to 3 minutes.  
**Never exceed 3 minutes.**
  - b. Fully released accelerator pedal and keep engine idle for about 5 seconds.
6. If 1st trip DTC is detected, go to [EC-546, "Diagnostic Procedure"](#)

DATA MONITOR	
MONITOR	NO DTC
ENG SPEED	XXX rpm

SEF058Y

If 1st trip DTC is not detected, go to the next step.

7. Repeat next procedure 20 times.
  - a. Quickly increase the engine speed up to 4,000 to 4,500 rpm or more and keep it for 25 to 30 seconds.
  - b. Fully released accelerator pedal and keep engine idle for at least 35 seconds.

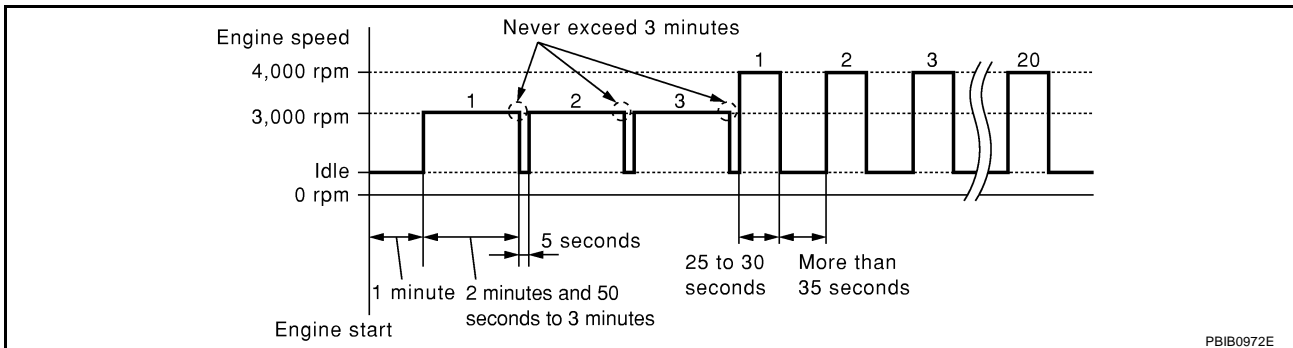

8. If 1st trip DTC is detected, go to [EC-546, "Diagnostic Procedure"](#) .

### WITH GST

Follow the procedure "WITH CONSULT-II" above.

# DTC P1446 EVAP CANISTER VENT CONTROL VALVE

## Wiring Diagram COUPE MODELS

ABS009MI

### EC-VENT/V-01

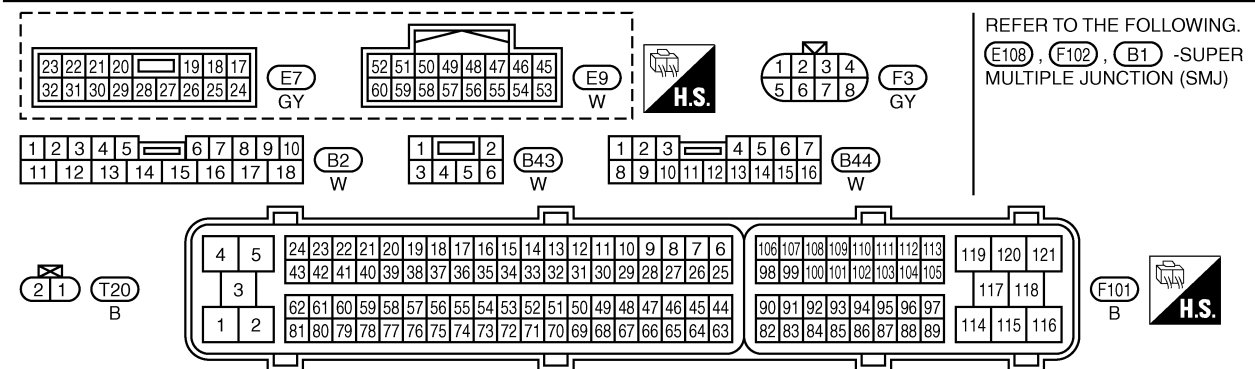
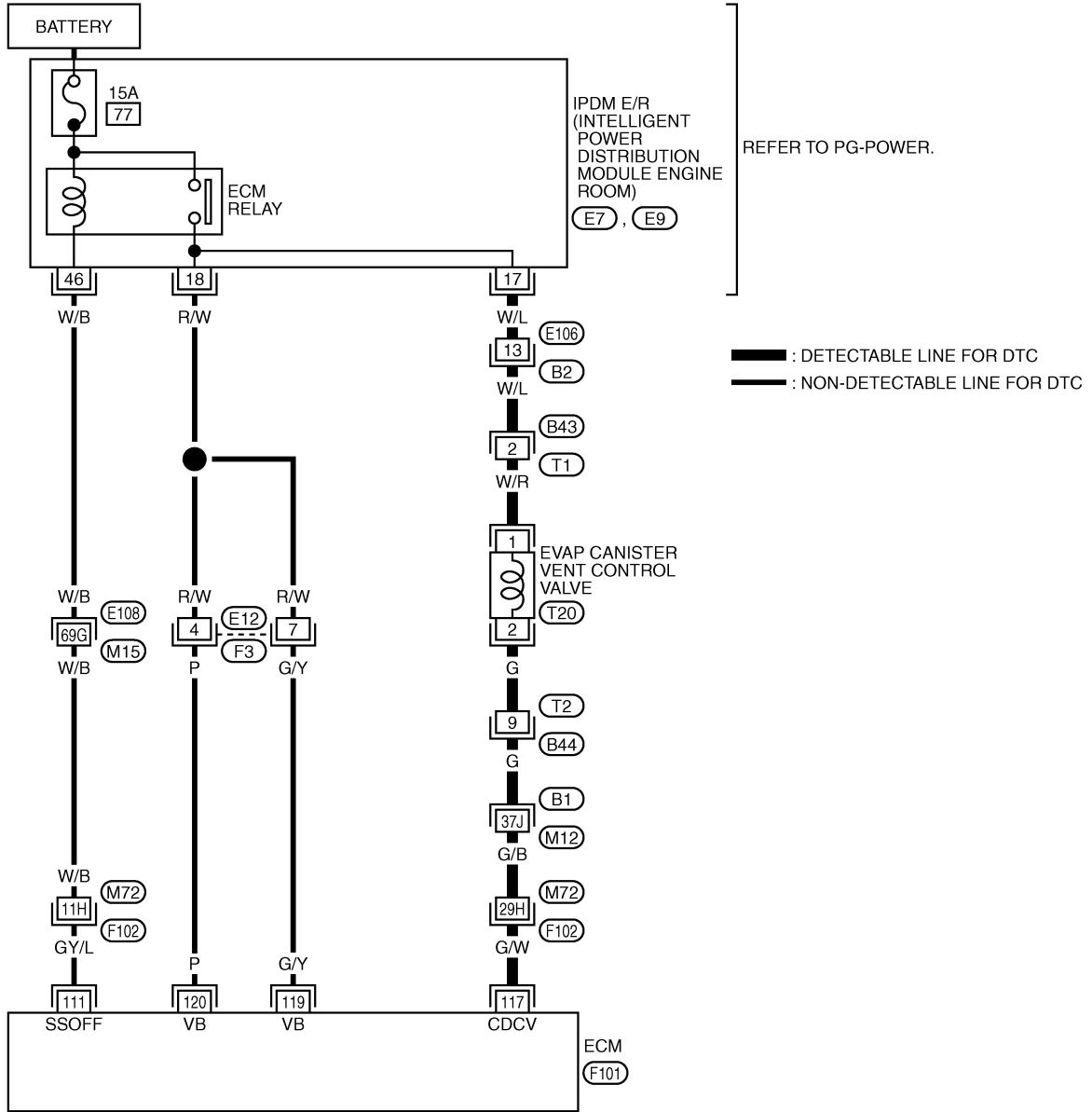

TBWT0620E

## DTC P1446 EVAP CANISTER VENT CONTROL VALVE

Specification data are reference values and are measured between each terminal and ground.

**CAUTION:**

**Do not use ECM ground terminals when measuring input/output voltage. Doing so may result in damage to the ECM's transistor. Use a ground other than ECM terminals, such as the ground.**

TER-MINAL NO.	WIRE COLOR	ITEM	CONDITION	DATA (DC Voltage)
111	GY/L	ECM relay (Self shut-off)	<b>[Engine is running]</b> <b>[Ignition switch: OFF]</b> ● A few seconds after turning ignition switch OFF	0 - 1.5V
			<b>[Ignition switch: OFF]</b> ● More than a few seconds after turning ignition switch OFF	BATTERY VOLTAGE (11 - 14V)
117	G/W	EVAP canister vent control valve	<b>[Ignition switch: ON]</b>	BATTERY VOLTAGE (11 - 14V)
119 120	R/W P	Power supply for ECM	<b>[Ignition switch: ON]</b>	BATTERY VOLTAGE (11 - 14V)



# DTC P1446 EVAP CANISTER VENT CONTROL VALVE

## ROADSTER MODELS

## EC-VENT/V-02

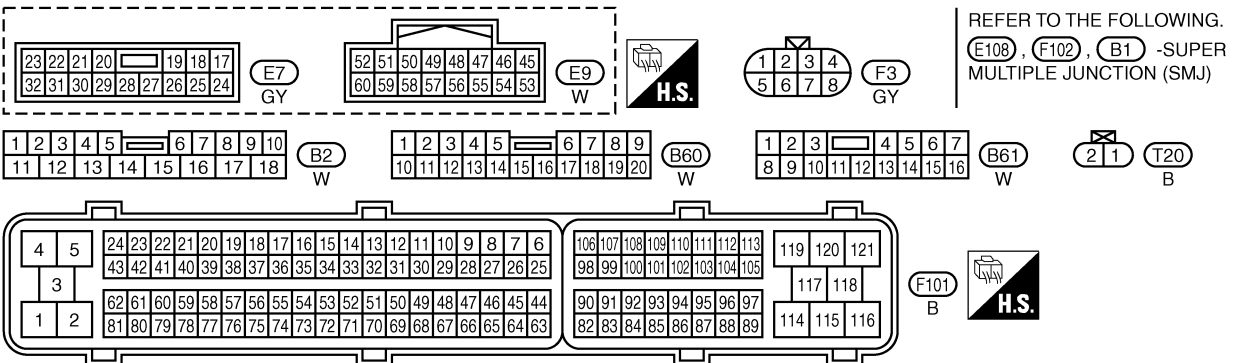
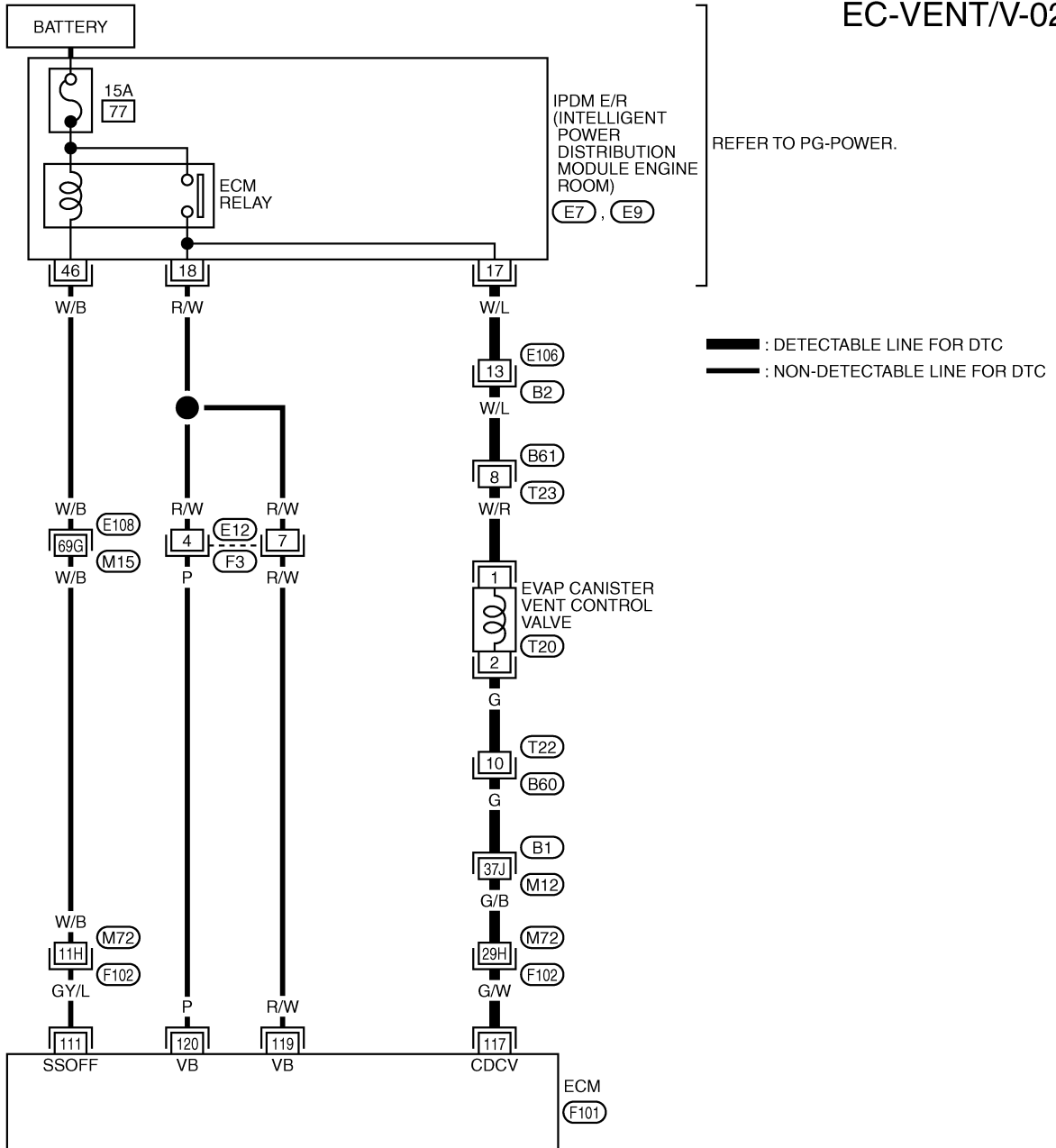

TBWT0621E

# DTC P1446 EVAP CANISTER VENT CONTROL VALVE

Specification data are reference values and are measured between each terminal and ground.

## CAUTION:

Do not use ECM ground terminals when measuring input/output voltage. Doing so may result in damage to the ECM's transistor. Use a ground other than ECM terminals, such as the ground.

TER-MINAL NO.	WIRE COLOR	ITEM	CONDITION	DATA (DC Voltage)
111	GY/L	ECM relay (Self shut-off)	[Engine is running] [Ignition switch: OFF] ● A few seconds after turning ignition switch OFF	0 - 1.5V
			[Ignition switch: OFF] ● More than a few seconds after turning ignition switch OFF	BATTERY VOLTAGE (11 - 14V)
117	G/W	EVAP canister vent control valve	[Ignition switch: ON]	BATTERY VOLTAGE (11 - 14V)
119 120	R/W P	Power supply for ECM	[Ignition switch: ON]	BATTERY VOLTAGE (11 - 14V)

## Diagnostic Procedure

ABS009MJ

### 1. CHECK RUBBER TUBE

1. Turn ignition switch OFF.
2. Disconnect rubber tube connected to EVAP canister vent control valve.

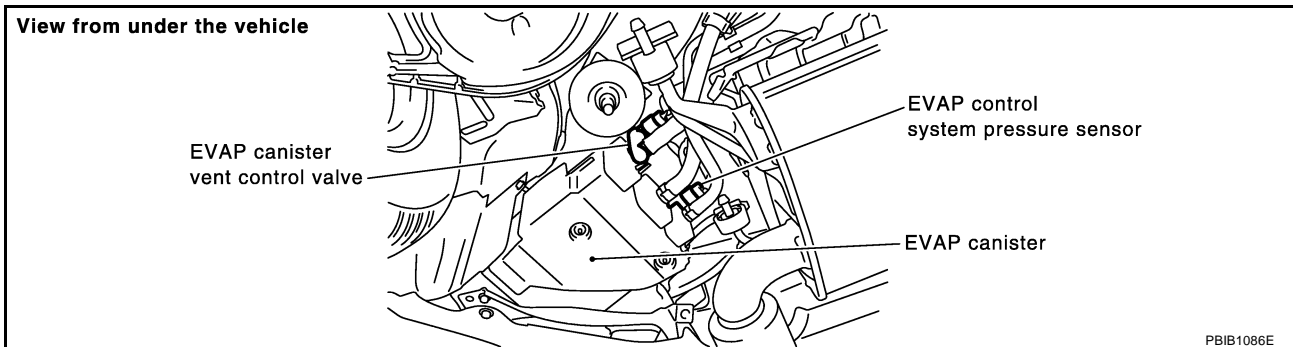

3. Check the rubber tube for clogging.

OK or NG

- OK >> GO TO 2.  
NG >> Clean rubber tube using an air blower.

### 2. CHECK EVAP CANISTER VENT CONTROL VALVE

Refer to [EC-548, "EVAP CANISTER VENT CONTROL VALVE"](#) .

OK or NG

- OK >> GO TO 3.  
NG >> Replace EVAP canister vent control valve.

# DTC P1446 EVAP CANISTER VENT CONTROL VALVE

## 3. CHECK IF EVAP CANISTER SATURATED WITH WATER

1. Remove EVAP canister with EVAP canister vent control valve and EVAP control system pressure sensor attached.
2. Check if water will drain from the EVAP canister.

OK or NG

OK >> GO TO 4.

NG >> GO TO 6.

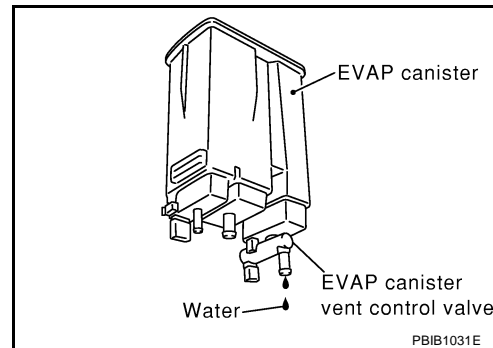

## 4. CHECK EVAP CANISTER

Weigh the EVAP canister with the EVAP canister vent control valve and EVAP control system pressure sensor attached.

**The weight should be less than 2.2 kg (4.9 lb).**

OK or NG

OK >> GO TO 6.

NG >> GO TO 5.

## 5. DETECT MALFUNCTIONING PART

Check the following.

- EVAP canister for damage
- EVAP hose between EVAP canister and vehicle frame for clogging or poor connection

>> Repair hose or replace EVAP canister.

## 6. CHECK EVAP CONTROL SYSTEM PRESSURE SENSOR CONNECTOR

1. Disconnect EVAP control system pressure sensor harness connector.
2. Check connectors for water.

**Water should not exist.**

OK or NG

OK >> GO TO 7.

NG >> Replace EVAP control system pressure sensor.

## 7. CHECK EVAP CONTROL SYSTEM PRESSURE SENSOR

Refer to [EC-328, "Component Inspection"](#) .

OK or NG

OK >> GO TO 8.

NG >> Replace EVAP control system pressure sensor.

## 8. CHECK INTERMITTENT INCIDENT

Refer to [EC-129, "TROUBLE DIAGNOSIS FOR INTERMITTENT INCIDENT"](#) .

>> INSPECTION END

# DTC P1446 EVAP CANISTER VENT CONTROL VALVE

ABS009MK

## Component Inspection EVAP CANISTER VENT CONTROL VALVE

### With CONSULT-II

1. Remove EVAP canister vent control valve from EVAP canister.
2. Check portion **B** of EVAP canister vent control valve for being rusted.  
If NG, replace EVAP canister vent control valve.  
If OK, go to next step.
3. Reconnect harness connectors disconnected.
4. Turn ignition switch ON.

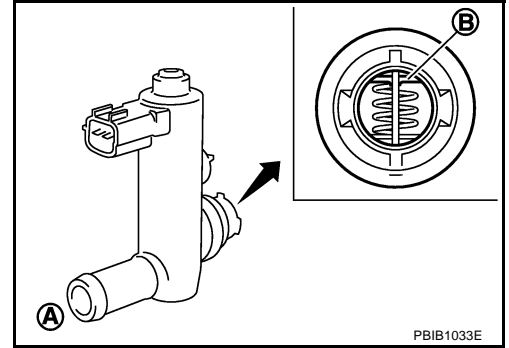

5. Perform "VENT CONTROL/V" in "ACTIVE TEST" mode.
6. Check air passage continuity and operation delay time.  
**Make sure new O-ring is installed properly.**

Condition VENT CONTROL/V	Air passage continuity between A and B
ON	No
OFF	Yes

Operation takes less than 1 second.

If NG, replace EVAP canister vent control valve.  
If OK, go to next step.

7. Clean the air passage (Portion **A** to **B**) of EVAP canister vent control valve using an air blower.
8. Perform step 6 again.

### Without CONSULT-II

1. Remove EVAP canister vent control valve from EVAP canister.
2. Check portion **B** of EVAP canister vent control valve for being rusted.

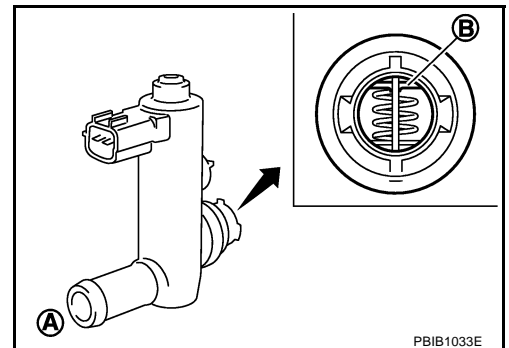

3. Check air passage continuity and operation delay time under the following conditions.  
**Make sure new O-ring is installed properly.**

Condition	Air passage continuity between A and B
12V direct current supply between terminals 1 and 2	No
OFF	Yes

Operation takes less than 1 second.

If NG, replace EVAP canister vent control valve.  
If OK, go to next step.

4. Clean the air passage (Portion **A** to **B**) of EVAP canister vent control valve using an air blower.

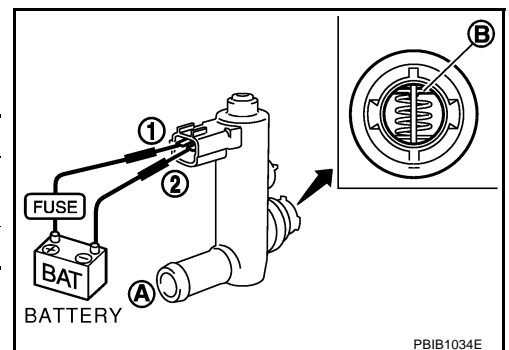

# DTC P1446 EVAP CANISTER VENT CONTROL VALVE

---

5. Perform step 3 again.

A

**EC**

C

D

E

F

G

H

I

J

K

L

M

# DTC P1564 ASCD STEERING SWITCH

## DTC P1564 ASCD STEERING SWITCH

PFP:25551

### Component Description

ABS009ML

ASCD steering switch has variant values of electrical resistance for each button. ECM reads voltage variation of switch, and determines which button is operated.

Refer to [EC-688, "AUTOMATIC SPEED CONTROL DEVICE \(ASCD\)"](#) for the ASCD function.

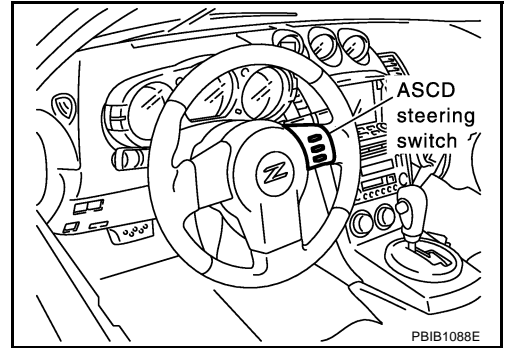

### CONSULT-II Reference Value in Data Monitor Mode

ABS009MM

Specification data are reference values.

MONITOR ITEM	CONDITION		SPECIFICATION
MAIN SW	● Ignition switch: ON	ON/OFF (MAIN) switch: Pressed	ON
		ON/OFF (MAIN) switch: Released	OFF
CANCEL SW	● Ignition switch: ON	CANCEL switch: Pressed	ON
		CANCEL switch: Released	OFF
RESUME/ACC SW	● Ignition switch: ON	ACCEL/RESUME switch: Pressed	ON
		ACCEL/RESUME switch: Released	OFF
SET SW	● Ignition switch: ON	COAST/SET switch: Pressed	ON
		COAST/SET switch: Released	OFF

### On Board Diagnosis Logic

ABS009MN

This self-diagnosis has the one trip detection logic.

The MIL will not light up for this diagnosis.

#### NOTE:

If DTC P1564 is displayed with DTC P0605, first perform the trouble diagnosis for DTC P0605. Refer to [EC-374](#).

DTC No.	Trouble Diagnosis Name	DTC Detecting Condition	Possible Cause
P1564 1564	ASCD steering switch	<ul style="list-style-type: none"> <li>● An excessively high voltage signal from the ASCD steering switch is sent to ECM.</li> <li>● ECM detects that input signal from the ASCD steering switch is out of the specified range.</li> <li>● ECM detects that the ASCD steering switch is stuck ON.</li> </ul>	<ul style="list-style-type: none"> <li>● Harness or connectors (The switch circuit is open or shorted.)</li> <li>● ASCD steering switch</li> <li>● ECM</li> </ul>

# DTC P1564 ASCD STEERING SWITCH

ABS009MO

## DTC Confirmation Procedure

### NOTE:

If DTC Confirmation Procedure has been previously conducted, always turn ignition switch OFF and wait at least 10 seconds before conducting the next test.

### WITH CONSULT-II

1. Turn ignition switch ON.
2. Select "DATA MONITOR" mode with CONSULT-II.
3. Wait at least 10 seconds.
4. Press ON/OFF (MAIN) switch for at least 10 seconds, then release it and wait at least 10 seconds.
5. Press CANCEL switch for at least 10 seconds, then release it and wait at least 10 seconds.
6. Press ACCEL/RESUME switch for at least 10 seconds, then release it and wait at least 10 seconds.
7. Press COAST/SET switch for at least 10 seconds, then release it and wait at least 10 seconds.
8. If DTC is detected, go to [EC-554, "Diagnostic Procedure"](#) .

### WITH GST

Follow the procedure "WITH CONSULT-II" above.

A

EC

C

D

E

F

G

H

I

J

K

L

M

# DTC P1564 ASCD STEERING SWITCH

## Wiring Diagram

ABS009MP

EC-ASC/SW-01

: DETECTABLE LINE FOR DTC  
 : NON-DETECTABLE LINE FOR DTC

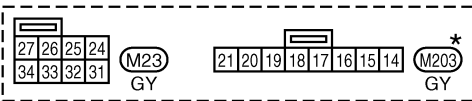
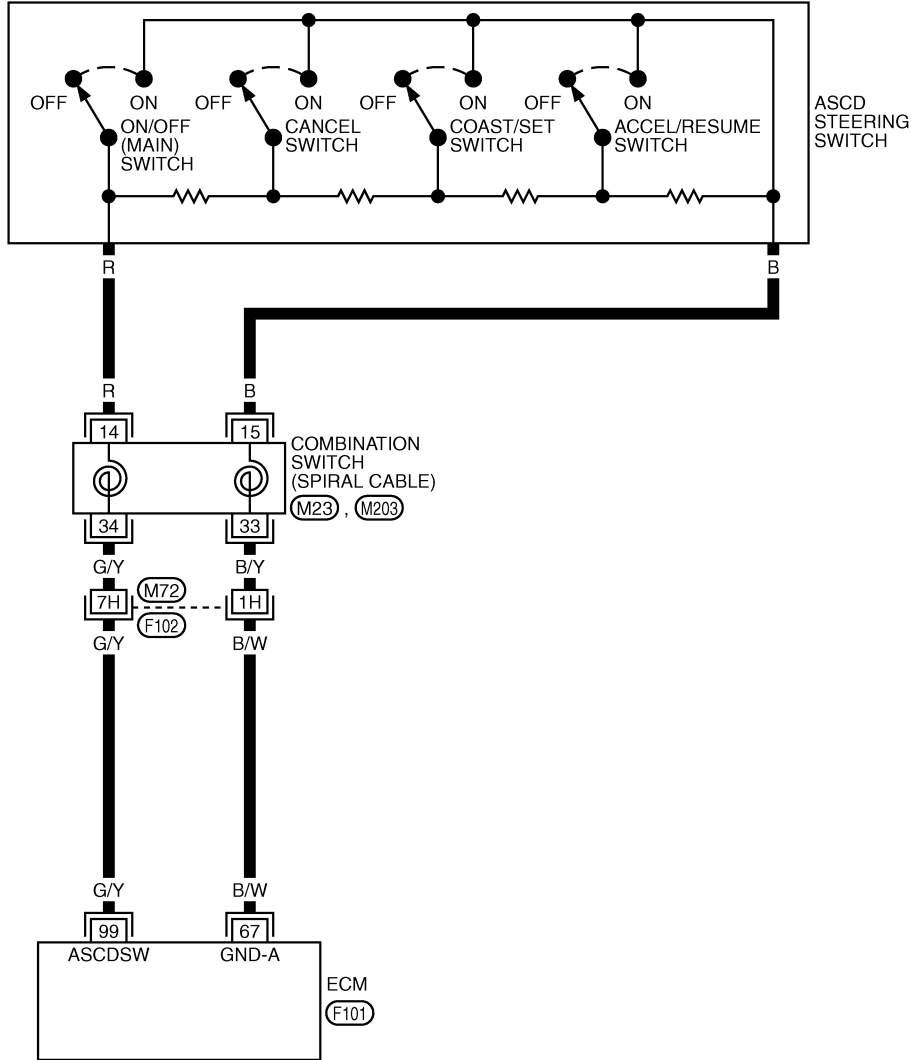

REFER TO THE FOLLOWING.

F102 -SUPER MULTIPLE JUNCTION (SMJ)

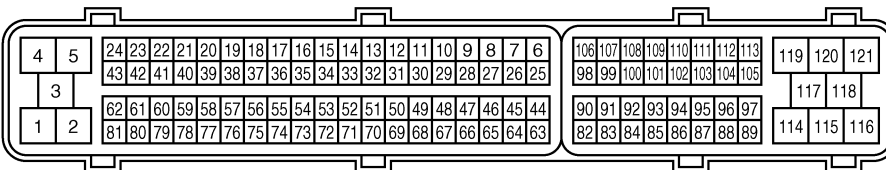

\*: THIS CONNECTOR IS NOT SHOWN IN "HARNESS LAYOUT", PG SECTION.

TBWT0501E



## DTC P1564 ASCD STEERING SWITCH

Specification data are reference values and are measured between each terminal and ground.

**CAUTION:**

**Do not use ECM ground terminals when measuring input/output voltage. Doing so may result in damage to the ECM's transistor. Use a ground other than ECM terminals, such as the ground.**

TER-MINAL NO.	WIRE COLOR	ITEM	CONDITION	DATA (DC Voltage)
67	B/W	Sensor ground	<b>[Engine is running]</b> <ul style="list-style-type: none"> <li>● Warm-up condition</li> <li>● Idle speed</li> </ul>	Approximately 0V
99	G/Y	ASCD steering switch	<b>[Ignition switch: ON]</b> <ul style="list-style-type: none"> <li>● ASCD steering switch: OFF</li> </ul>	Approximately 4V
			<b>[Ignition switch: ON]</b> <ul style="list-style-type: none"> <li>● ON/OFF (MAIN) switch: Pressed</li> </ul>	Approximately 0V
			<b>[Ignition switch: ON]</b> <ul style="list-style-type: none"> <li>● CANCEL switch: Pressed</li> </ul>	Approximately 1V
			<b>[Ignition switch: ON]</b> <ul style="list-style-type: none"> <li>● ACCEL/RESUME switch: Pressed</li> </ul>	Approximately 3V
			<b>[Ignition switch: ON]</b> <ul style="list-style-type: none"> <li>● COAST/SET switch: Pressed</li> </ul>	Approximately 2V

A  
EC  
C  
D  
E  
F  
G  
H  
I  
J  
K  
L  
M

# DTC P1564 ASCD STEERING SWITCH

ABS009MQ

## Diagnostic Procedure

### 1. CHECK GROUND CONNECTIONS

1. Turn ignition switch OFF.
2. Loosen and retighten three ground screws on the body. Refer to [EC-138, "Ground Inspection"](#).

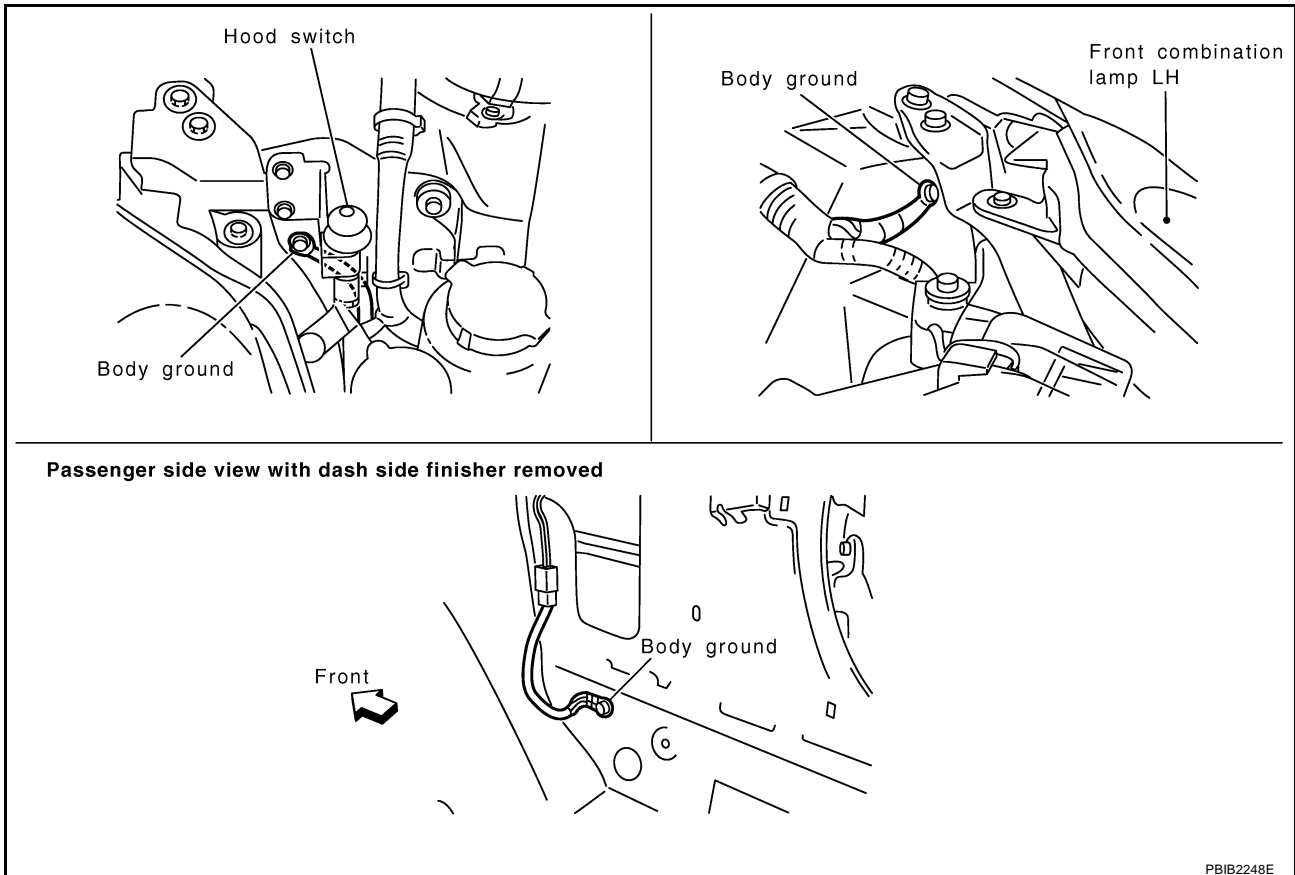

#### OK or NG

- OK >> GO TO 2.
- NG >> Repair or replace ground connections.

# DTC P1564 ASCD STEERING SWITCH

## 2. CHECK ASCD STEERING SWITCH CIRCUIT

### With CONSULT-II

- Turn ignition switch ON.
- Select "MAIN SW", "RESUME/ACC SW", "SET SW" and "CANCEL SW" in "DATA MONITOR" mode with CONSULT-II.
- Check each item indication under the following conditions.

Switch	Monitor item	Condition	Indication
ON/OFF (MAIN) switch	MAIN SW	Pressed	ON
		Released	OFF
CANCEL switch	CANCEL SW	Pressed	ON
		Released	OFF
ACCEL/RESUME switch	RESUME/ACC SW	Pressed	ON
		Released	OFF
COAST/SET switch	SET SW	Pressed	ON
		Released	OFF

DATA MONITOR	
MONITOR	NO DTC
MAIN SW	OFF
CANCEL SW	OFF
RESUME/ACC SW	OFF
SET SW	OFF

SEC006D

### Without CONSULT-II

- Turn ignition switch ON.
- Check voltage between ECM terminal 99 and ground with pressing each button.

Switch	Condition	Voltage [V]
ON/OFF (MAIN) switch	Pressed	Approx. 0
	Released	Approx. 4
CANCEL switch	Pressed	Approx. 1
	Released	Approx. 4
ACCEL/RESUME switch	Pressed	Approx. 3
	Released	Approx. 4
COAST/SET switch	Pressed	Approx. 2
	Released	Approx. 4

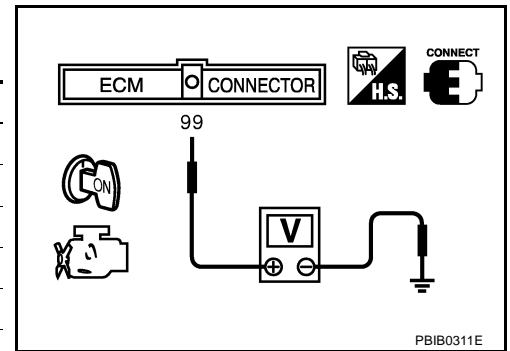

#### OK or NG

- OK >> GO TO 8.  
 NG >> GO TO 3.

## 3. CHECK ASCD STEERING SWITCH GROUND CIRCUIT FOR OPEN AND SHORT

- Turn ignition switch OFF.
- Disconnect ECM harness connector.
- Disconnect combination switch harness connector M203.
- Check harness continuity between combination switch terminal 15 and ECM terminal 67. Refer to Wiring Diagram.

**Continuity should exist.**

- Also check harness for short to ground and short to power.

#### OK or NG

- OK >> GO TO 5.  
 NG >> GO TO 4.

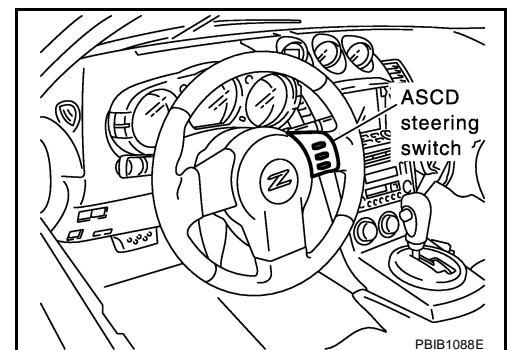

# DTC P1564 ASCD STEERING SWITCH

---

## 4. DETECT MALFUNCTIONING PART

---

Check the following.

- Harness connectors M72, F102
- Combination switch (spiral cable)
- Harness for open and short between ECM and combination switch

>> Repair open circuit or short to ground or short to power in harness or connectors.

## 5. CHECK ASCD STEERING SWITCH INPUT SIGNAL CIRCUIT FOR OPEN AND SHORT

---

1. Check harness continuity between ECM terminal 99 and combination switch terminal 14.  
Refer to Wiring Diagram.

**Continuity should exist.**

2. Also check harness for short to ground and short to power.

OK or NG

OK >> GO TO 7.  
NG >> GO TO 6.

## 6. DETECT MALFUNCTIONING PART

---

Check the following.

- Harness connectors M72, F102
- Combination switch (spiral cable)
- Harness for open and short between ECM and combination switch

>> Repair open circuit or short to ground or short to power in harness or connectors.

## 7. CHECK ASCD STEERING SWITCH

---

Refer to [EC-557, "Component Inspection"](#) .

OK or NG

OK >> GO TO 8.  
NG >> Replace steering wheel.

## 8. CHECK INTERMITTENT INCIDENT

---

Refer to [EC-129, "TROUBLE DIAGNOSIS FOR INTERMITTENT INCIDENT"](#) .

>> INSPECTION END

# DTC P1564 ASCD STEERING SWITCH

ABS009MR

## Component Inspection ASCD STEERING SWITCH

1. Disconnect combination switch (spiral cable).
2. Check continuity between combination switch (spiral cable) terminals 14 and 15 with pushing each switch.

Switch	Condition	Resistance [ $\Omega$ ]
ON/OFF (MAIN) switch	Pressed	Approx. 0
	Released	Approx. 4,000
CANCEL switch	Pressed	Approx. 250
	Released	Approx. 4,000
ACCEL/RESUME switch	Pressed	Approx. 1,480
	Released	Approx. 4,000
COAST/SET switch	Pressed	Approx. 660
	Released	Approx. 4,000

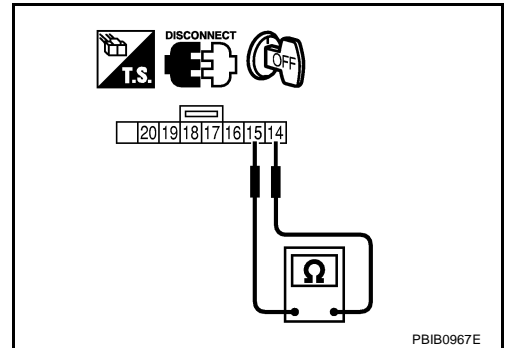

PBIB0967E

A  
EC  
C  
D  
E  
F  
G  
H  
I  
J  
K  
L  
M

# DTC P1572 ASCD BRAKE SWITCH

## DTC P1572 ASCD BRAKE SWITCH

PFP:25320

### Component Description

ABS009MS

When the brake pedal is depressed, ASCD brake switch is turned OFF and stop lamp switch is turned ON. ECM detects the state of the brake pedal by this input of two kinds (ON/OFF signal).

Refer to [EC-688, "AUTOMATIC SPEED CONTROL DEVICE \(ASCD\)"](#) for the ASCD function.

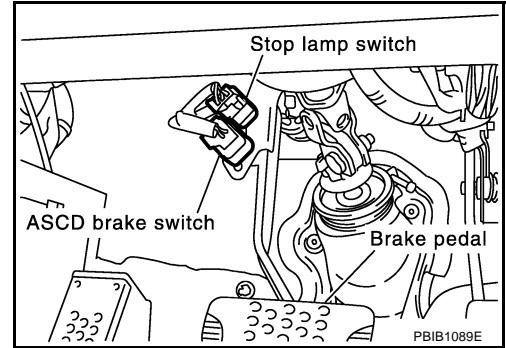

### CONSULT-II Reference Value in Data Monitor Mode

ABS009MT

Specification data are reference values.

MONITOR ITEM	CONDITION		SPECIFICATION
BRAKE SW 1 (ASCD brake switch)	● Ignition switch: ON	● Clutch pedal (M/T) and brake pedal: Fully released	ON
		● Clutch pedal (M/T) and/or brake pedal: Slightly depressed	OFF
BRAKE SW 2 (stop lamp switch)	● Ignition switch: ON	● Brake pedal: Fully released	OFF
		● Brake pedal: Slightly depressed	ON

### On Board Diagnosis Logic

ABS009MU

This self-diagnosis has the one trip detection logic.  
The MIL will not light up for this diagnosis.

#### NOTE:

This self-diagnosis has the one trip detection logic. When malfunction A is detected, DTC is not stored in ECM memory. And in that case, 1st trip DTC and 1st trip freeze frame data are displayed. 1st trip DTC is erased when ignition switch OFF. And even when malfunction A is detected in two consecutive trips, DTC is not stored in ECM memory.

DTC No.	Trouble Diagnosis Name	DTC Detecting Condition		Possible Cause
P1572 1572	ASCD brake switch	A)	When the vehicle speed is above 30km/h (19 MPH), ON signals from the stop lamp switch and the ASCD brake switch are sent to ECM at the same time.	<ul style="list-style-type: none"> <li>● Harness or connectors (The stop lamp switch circuit is shorted.)</li> <li>● Harness or connectors (The ASCD brake switch circuit is shorted.)</li> <li>● Harness or connectors (The ASCD clutch switch circuit is shorted.) (M/T models)</li> <li>● Stop lamp switch</li> <li>● ASCD brake switch</li> <li>● ASCD clutch switch (M/T models)</li> <li>● Incorrect stop lamp switch installation</li> <li>● Incorrect ASCD brake switch installation</li> <li>● Incorrect ASCD clutch switch installation (M/T models)</li> <li>● ECM</li> </ul>
		B)	ASCD brake switch signal is not sent to ECM for extremely long time while the vehicle is driving	

# DTC P1572 ASCD BRAKE SWITCH

ABS009MV

## DTC Confirmation Procedure

### CAUTION:

Always drive vehicle at a safe speed.

### NOTE:

- If DTC Confirmation Procedure has been previously conducted, always turn ignition switch OFF and wait at least 10 seconds before conducting the next test.
- Procedure for malfunction B is not described here. It takes extremely long time to complete procedure for malfunction B. By performing procedure for malfunction A, the incident that causes malfunction B can be detected.

### TESTING CONDITION:

Steps 4 and 5 may be conducted with the drive wheels lifted in the shop or by driving the vehicle. If a road test is expected to be easier, it is unnecessary to lift the vehicle.

### WITH CONSULT-II

1. Start engine (VDC switch or TCS switch OFF).
2. Select "DATA MONITOR" mode with CONSULT-II.
3. Press MAIN switch and make sure that CRUISE indicator lights up.
4. Drive the vehicle for at least 5 consecutive seconds under the following condition.

VHCL SPEED SE	More than 30 km/h (19 MPH)
Shift lever	Suitable position

If 1st trip DTC is detected, go to [EC-563, "Diagnostic Procedure"](#)

If 1st trip DTC is not detected, go to the following step.

5. Drive the vehicle for at least 5 consecutive seconds under the following condition.

VHCL SPEED SE	More than 30 km/h (19 MPH)
Shift lever	Suitable position
Driving location	Depress the brake pedal for more than five seconds so as not to come off from the above-mentioned vehicle speed.

6. If 1st trip DTC is detected, go to [EC-563, "Diagnostic Procedure"](#).

### WITH GST

Follow the procedure "WITH CONSULT-II" above.

DATA MONITOR	
MONITOR	NO DTC
ENG SPEED	XXX rpm
VHCL SPEED SE	XXX km/h
CRUISE LAMP	ON
BRAKE SW 1	ON
BRAKE SW 2	OFF

PBIB2386E

A  
EC  
C  
D  
E  
F  
G  
H  
I  
J  
K  
L  
M

# DTC P1572 ASCD BRAKE SWITCH

ABS009MW

## Wiring Diagram A/T MODELS

EC-ASC/BS-01

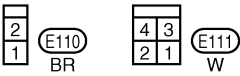
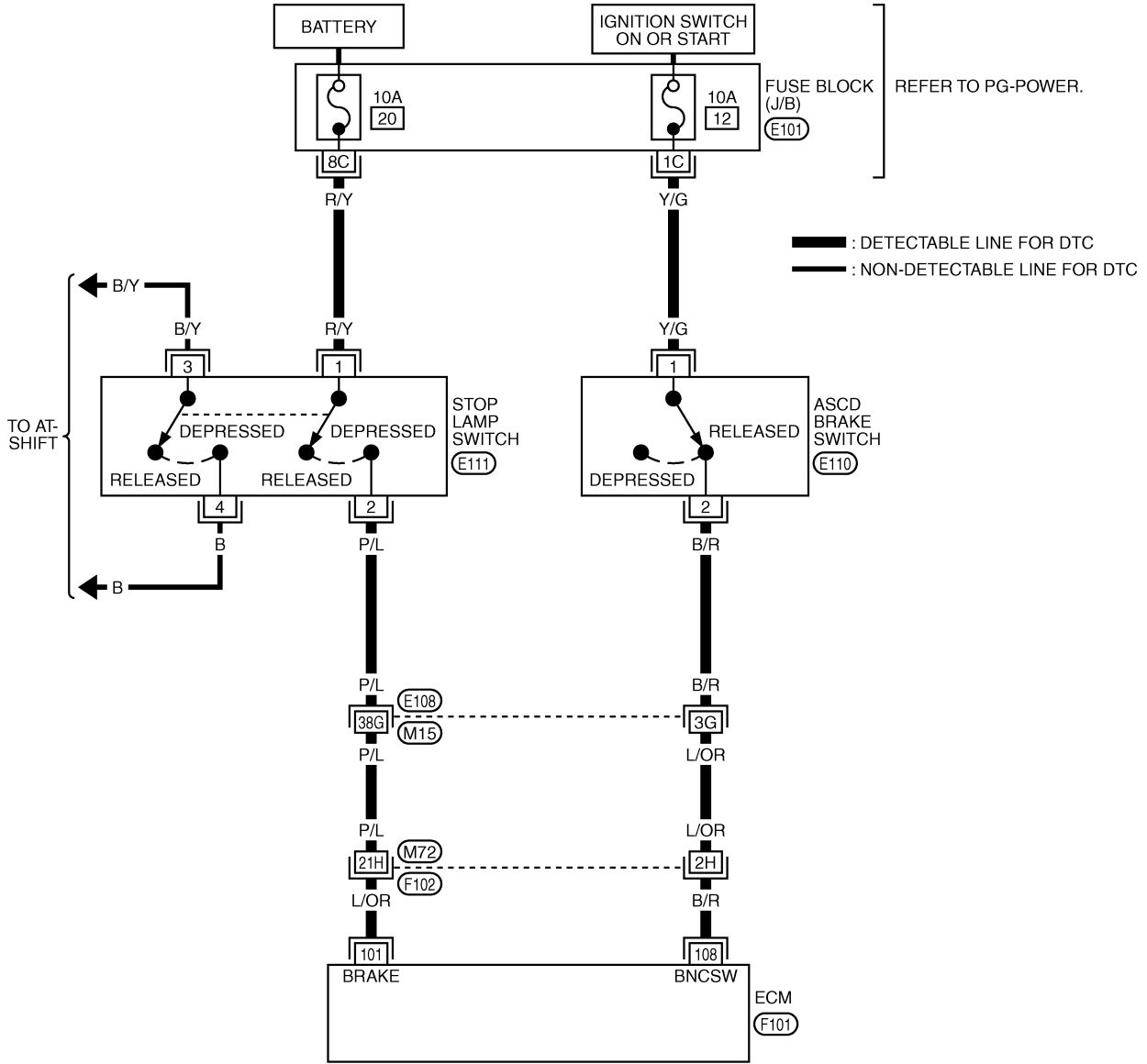

REFER TO THE FOLLOWING.  
 (E108), (F102) -SUPER MULTIPLE JUNCTION (SMJ)  
 (E101) -FUSE BLOCK-JUNCTION BOX (J/B)

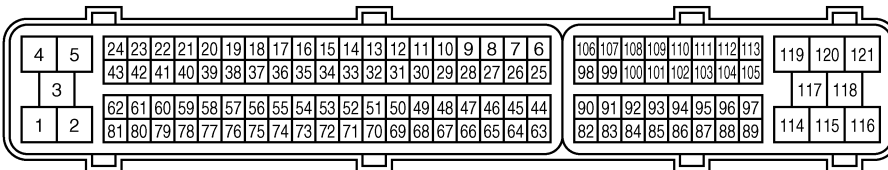

TBWT0502E



## DTC P1572 ASCD BRAKE SWITCH

Specification data are reference values and are measured between each terminal and ground.

**CAUTION:**

**Do not use ECM ground terminals when measuring input/output voltage. Doing so may result in damage to the ECM's transistor. Use a ground other than ECM terminals, such as the ground.**

TER-MINAL NO.	WIRE COLOR	ITEM	CONDITION	DATA (DC Voltage)
101	L/OR	Stop lamp switch	<b>[Ignition switch: OFF]</b> ● Brake pedal is fully released	Approximately 0V
			<b>[Ignition switch: OFF]</b> ● Brake pedal is slightly depressed	BATTERY VOLTAGE (11 - 14V)
108	B/R	ASCD brake switch	<b>[Ignition switch: ON]</b> ● Brake pedal is slightly depressed	Approximately 0V
			<b>[Ignition switch: ON]</b> ● Brake pedal is fully released	BATTERY VOLTAGE (11 - 14V)

A  
EC  
C  
D  
E  
F  
G  
H  
I  
J  
K  
L  
M

# DTC P1572 ASCD BRAKE SWITCH

M/T MODELS

EC-ASC/BS-02

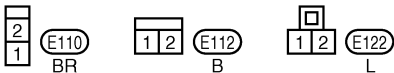
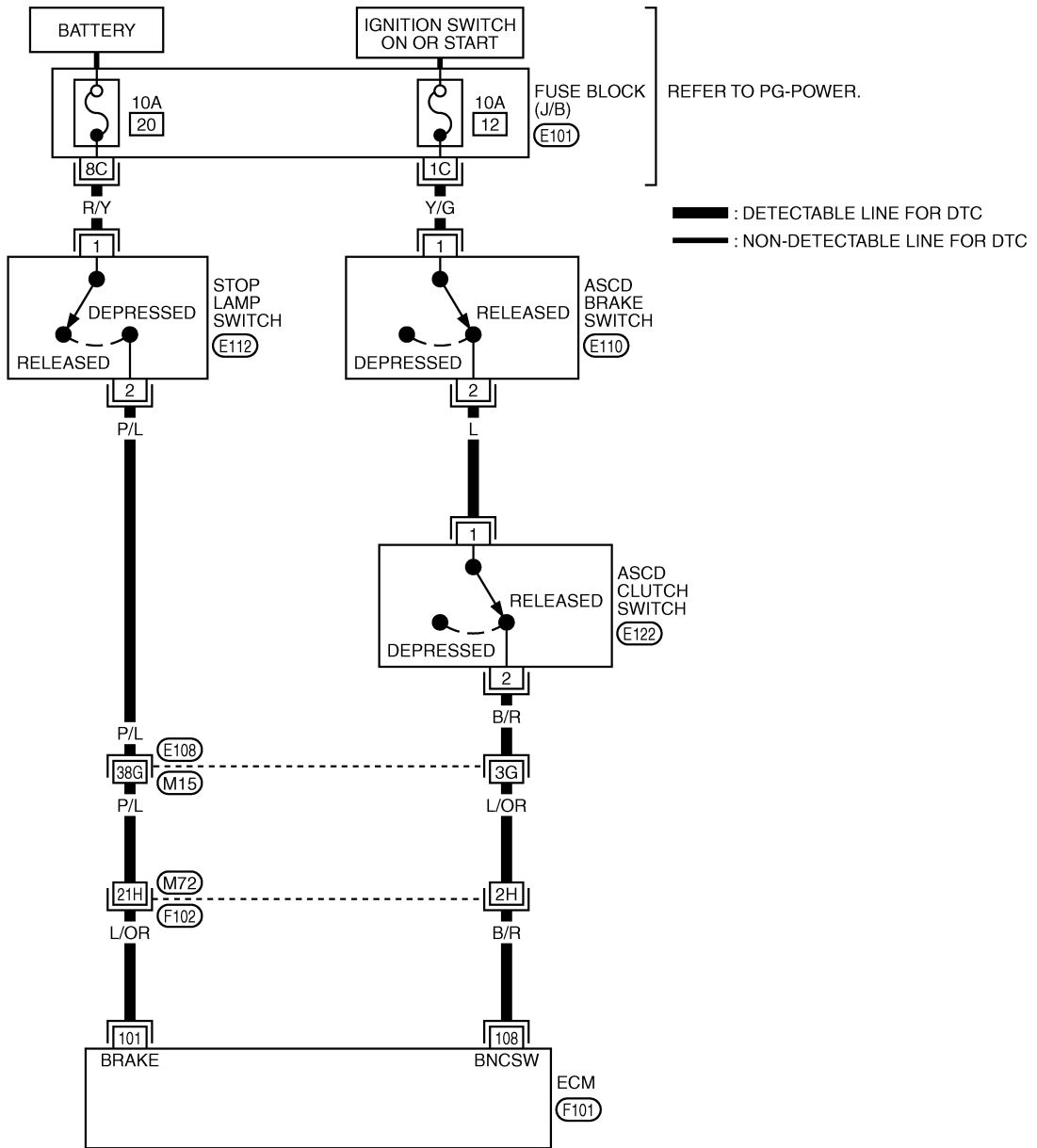

REFER TO THE FOLLOWING.  
 (E108), (F102) -SUPER MULTIPLE JUNCTION (SMJ)  
 (E101) -FUSE BLOCK-JUNCTION BOX (J/B)

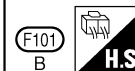
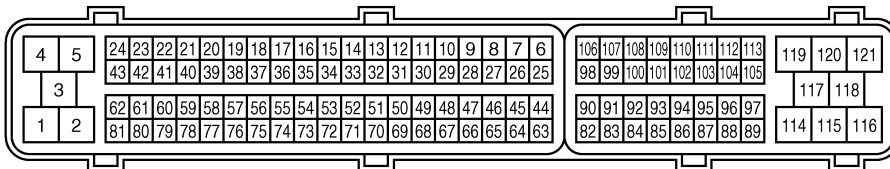

TBWT0503E

# DTC P1572 ASCD BRAKE SWITCH

Specification data are reference values and are measured between each terminal and ground.

**CAUTION:**

**Do not use ECM ground terminals when measuring input/output voltage. Doing so may result in damage to the ECM's transistor. Use a ground other than ECM terminals, such as the ground.**

TER-MINAL NO.	WIRE COLOR	ITEM	CONDITION	DATA (DC Voltage)
101	L/OR	Stop lamp switch	[Ignition switch: OFF] ● Brake pedal is fully released	Approximately 0V
			[Ignition switch: OFF] ● Brake pedal is slightly depressed	BATTERY VOLTAGE (11 - 14V)
108	B/R	ASCD brake switch	[Ignition switch: ON] ● Brake pedal and/or clutch pedal are slightly depressed	Approximately 0V
			[Ignition switch: ON] ● Brake pedal and clutch pedal are fully released	BATTERY VOLTAGE (11 - 14V)

## Diagnostic Procedure

ABS009MX

### A/T MODELS

#### 1. CHECK OVERALL FUNCTION-I

 **With CONSULT-II**

- Turn ignition switch ON.
- Select "BRAKE SW1" in "DATA MONITOR" mode with CONSULT-II.
- Check "BRAKE SW1" indication under the following conditions.

CONDITION	INDICATION
When brake pedal is slightly depressed	OFF
When brake pedal is fully released	ON

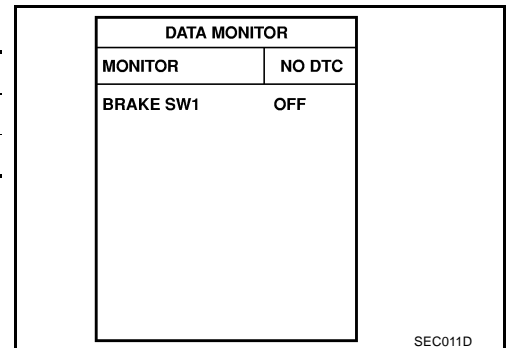

 **Without CONSULT-II**

- Turn ignition switch ON.
- Check voltage between ECM terminal 108 and ground under the following conditions.

CONDITION	VOLTAGE
When brake pedal is slightly depressed	Approximately 0V
When brake pedal is fully released	Battery voltage

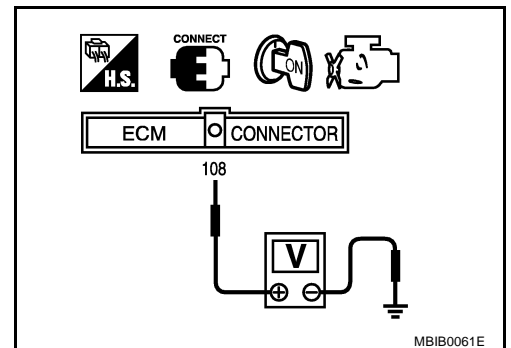

**OK or NG**

- OK >> GO TO 2.
- NG >> GO TO 3.

# DTC P1572 ASCD BRAKE SWITCH

## 2. CHECK OVERALL FUNCTION-II

### ④ With CONSULT-II

1. Select "BRAKE SW2" in "DATA MONITOR" mode with CONSULT-II.
2. Check "BRAKE SW2" indication under the following conditions.

CONDITION	INDICATION
When brake pedal is fully released	OFF
When brake pedal is slightly depressed	ON

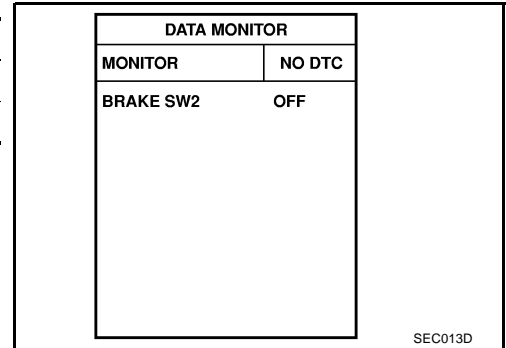

### ⊗ Without CONSULT-II

Check voltage between ECM terminal 101 and ground under the following conditions.

CONDITION	VOLTAGE
When brake pedal is fully released	Approximately 0V
When brake pedal is slightly depressed	Battery voltage

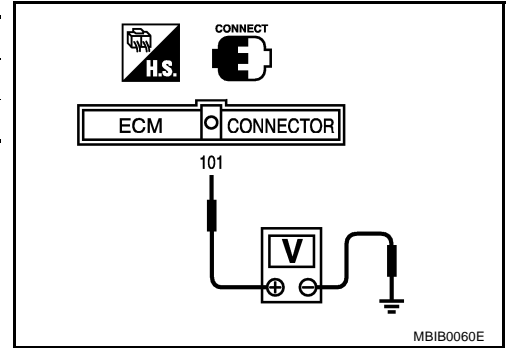

### OK or NG

- OK >> GO TO 13.
- NG >> GO TO 8.

## DTC P1572 ASCD BRAKE SWITCH

### 3. CHECK ASCD BRAKE SWITCH POWER SUPPLY CIRCUIT

1. Turn ignition switch OFF.
2. Disconnect ASCD brake switch harness connector.
3. Turn ignition switch ON.

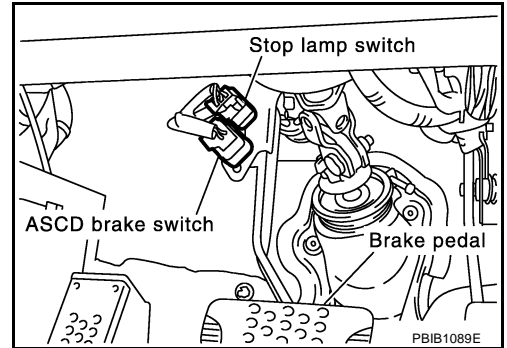

4. Check voltage between ASCD brake switch terminal 1 and ground with CONSULT-II or tester.

**Voltage: Battery voltage**

OK or NG

- OK >> GO TO 5.
- NG >> GO TO 4.

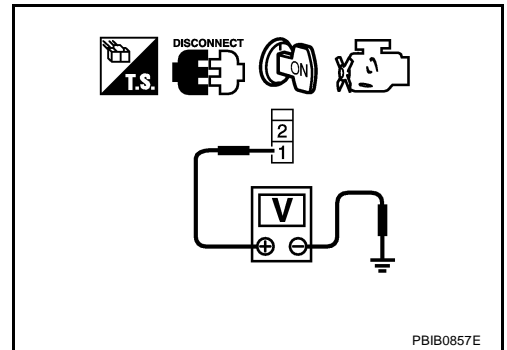

### 4. DETECT MALFUNCTIONING PART

Check the following.

- Fuse block (J/B) connector E101
- 10A fuse
- Harness for open or short between ASCD brake switch and fuse

>> Repair open circuit or short to ground or short to power in harness or connectors.

### 5. CHECK ASCD BRAKE SWITCH INPUT SIGNAL CIRCUIT FOR OPEN AND SHORT

1. Turn ignition switch OFF.
2. Disconnect ECM harness connector.
3. Check harness continuity between ECM terminal 108 and ASCD brake switch terminal 2. Refer to Wiring Diagram.

**Continuity should exist.**

4. Also check harness for short to ground and short to power.

OK or NG

- OK >> GO TO 7.
- NG >> GO TO 6.

# DTC P1572 ASCD BRAKE SWITCH

## 6. DETECT MALFUNCTIONING PART

Check the following.

- Harness connectors E108, M15
- Harness connectors M72, F102
- Harness for open or short between ECM and ASCD brake switch

>> Repair open circuit or short to ground or short to power in harness or connectors.

## 7. CHECK ASCD BRAKE SWITCH

Refer to [EC-573, "Component Inspection"](#)

OK or NG

OK >> GO TO 13.

NG >> Replace ASCD brake switch.

## 8. CHECK STOP LAMP SWITCH POWER SUPPLY CIRCUIT

1. Turn ignition switch OFF.
2. Disconnect stop lamp switch harness connector.

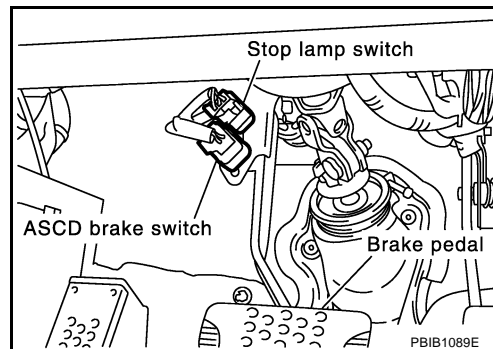

3. Check voltage between stop lamp switch terminal 1 and ground with CONSULT -II or tester.

**Voltage: Battery voltage**

OK or NG

OK >> GO TO 10.

NG >> GO TO 9.

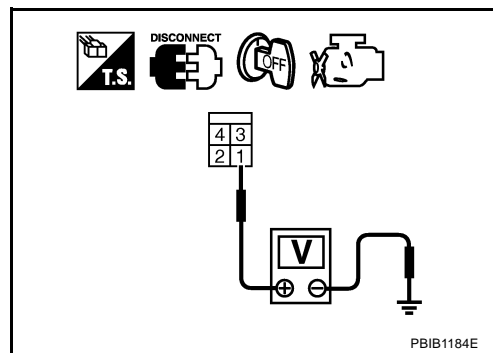

## 9. DETECT MALFUNCTIONING PART

Check the following.

- Fuse block (J/B) connector E101
- 10A fuse
- Harness for open or short between stop lamp switch and battery

>> Repair open circuit or short to ground or short to power in harness or connectors.

# DTC P1572 ASCD BRAKE SWITCH

---

## 10. CHECK STOP LAMP SWITCH INPUT SIGNAL CIRCUIT FOR OPEN AND SHORT

---

1. Disconnect ECM harness connector.
2. Check harness continuity between ECM terminal 101 and stop lamp switch terminal 2.  
Refer to Wiring Diagram.

**Continuity should exist.**

3. Also check harness for short to ground and short to power.

OK or NG

- OK >> GO TO 12.
- NG >> GO TO 11.

---

## 11. DETECT MALFUNCTIONING PART

---

Check the following.

- Harness connectors E108, M15
- Harness connectors M72, F102
- Harness for open or short between ECM and stop lamp switch

>> Repair open circuit or short to ground or short to power in harness or connectors.

---

## 12. CHECK STOP LAMP SWITCH

---

Refer to [EC-573, "Component Inspection"](#)

OK or NG

- OK >> GO TO 13.
- NG >> Replace stop lamp switch.

---

## 13. CHECK INTERMITTENT INCIDENT

---

Refer to [EC-129, "TROUBLE DIAGNOSIS FOR INTERMITTENT INCIDENT"](#) .

>> **INSPECTION END**

A

EC

C

D

E

F

G

H

I

J

K

L

M

# DTC P1572 ASCD BRAKE SWITCH

## M/T MODELS

### 1. CHECK OVERALL FUNCTION-I

#### ④ With CONSULT-II

1. Turn ignition switch ON.
2. Select "BRAKE SW1" in "DATA MONITOR" mode with CONSULT-II.
3. Check "BRAKE SW1" indication under the following conditions.

CONDITION	INDICATION
When brake pedal and/or clutch pedal are slightly depressed	OFF
When brake pedal and clutch pedal are fully released	ON

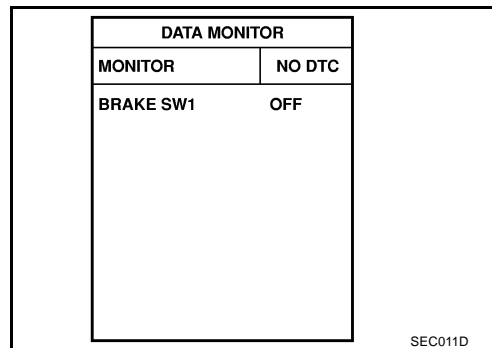

#### ⊗ Without CONSULT-II

1. Turn ignition switch ON.
2. Check voltage between ECM terminal 108 and ground under the following conditions.

CONDITION	VOLTAGE
When brake pedal and/or clutch pedal are slightly depressed	Approximately 0V
When brake pedal and clutch pedal are fully released	Battery voltage

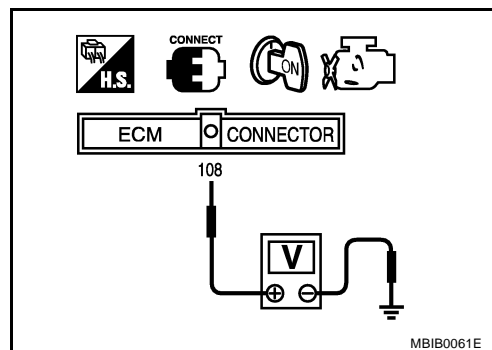

#### OK or NG

- OK >> GO TO 2.  
 NG >> GO TO 3.



# DTC P1572 ASCD BRAKE SWITCH

## 2. CHECK OVERALL FUNCTION-II

### With CONSULT-II

1. Select "BRAKE SW2" in "DATA MONITOR" mode with CONSULT-II.
2. Check "BRAKE SW2" indication the following conditions.

CONDITION	INDICATION
When brake pedal is fully released	OFF
When brake pedal is slightly depressed	ON

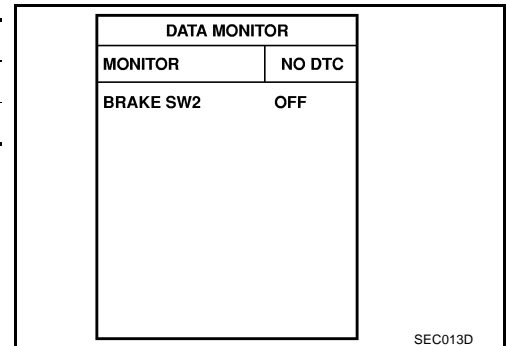

### Without CONSULT-II

Check voltage between ECM terminal 101 and ground under the following conditions.

CONDITION	VOLTAGE
When brake pedal is fully released	Approximately 0V
When brake pedal is slightly depressed	Battery voltage

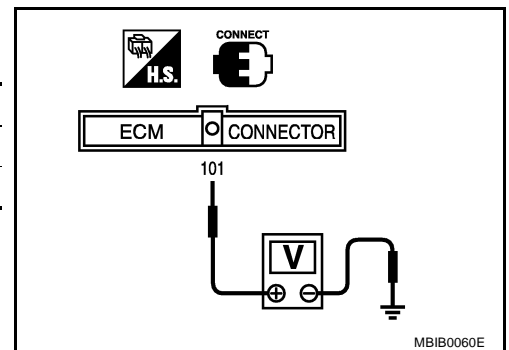

#### OK or NG

- OK >> GO TO 16.  
 NG >> GO TO 11.

## 3. CHECK ASCD BRAKE SWITCH CIRCUIT

1. Turn ignition switch OFF.
2. Disconnect ASCD clutch switch harness connector.
3. Turn ignition switch ON.

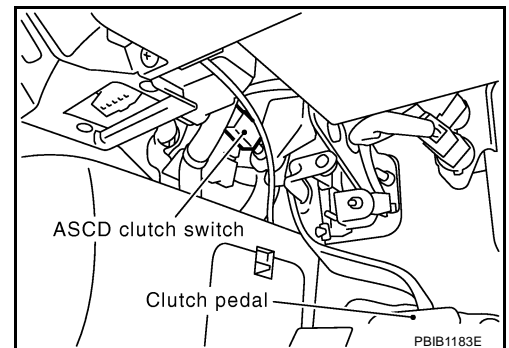

4. Check voltage between ASCD clutch switch terminal 1 and ground with CONSULT-II or tester.

**Voltage: Battery voltage**

#### OK or NG

- OK >> GO TO 8.  
 NG >> GO TO 4.

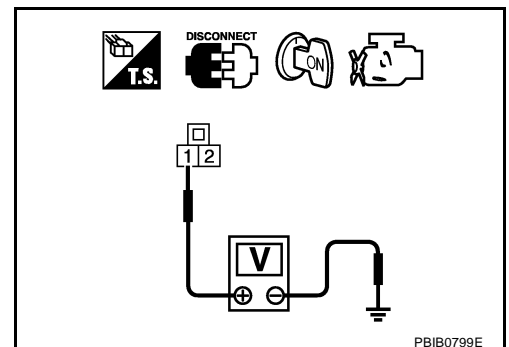

# DTC P1572 ASCD BRAKE SWITCH

## 4. CHECK ASCD BRAKE SWITCH POWER SUPPLY CIRCUIT

1. Turn ignition switch OFF.
2. Disconnect ASCD brake switch harness connector.
3. Turn ignition switch ON.

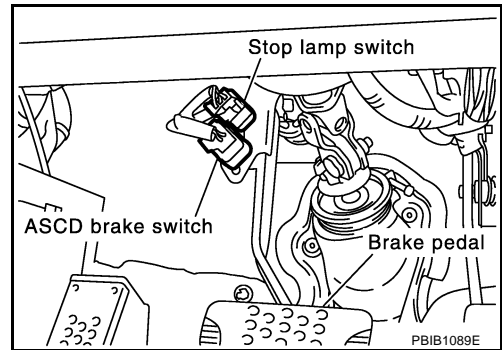

4. Check voltage between ASCD brake switch terminal 1 and ground with CONSULT-II or tester.

**Voltage: Battery voltage**

OK or NG

- OK >> GO TO 6.
- NG >> GO TO 5.

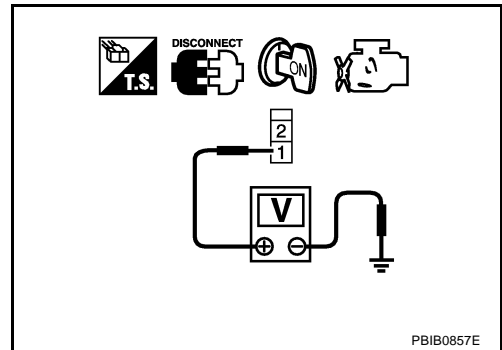

## 5. DETECT MALFUNCTIONING PART

Check the following.

- Fuse block (J/B) connector E101
- 10A fuse
- Harness for open or short between ASCD brake switch and fuse

>> Repair open circuit or short to ground or short to power in harness or connectors.

## 6. CHECK ASCD BRAKE SWITCH INPUT SIGNAL CIRCUIT FOR OPEN AND SHORT

1. Turn ignition switch OFF.
2. Check harness continuity between ASCD brake switch terminal 2 and ASCD clutch switch terminal 1. Refer to Wiring Diagram.

**Continuity should exist.**

3. Also check harness for short to ground and short to power.

OK or NG

- OK >> GO TO 7.
- NG >> Repair open circuit or short to ground or short to power in harness or connectors.

## 7. CHECK ASCD BRAKE SWITCH

Refer to [EC-573, "Component Inspection"](#)

OK or NG

- OK >> GO TO 16.
- NG >> Replace ASCD brake switch.

# DTC P1572 ASCD BRAKE SWITCH

## 8. CHECK ASCD CLUTCH SWITCH INPUT SIGNAL CIRCUIT FOR OPEN AND SHORT

1. Turn ignition switch OFF.
2. Disconnect ECM harness connector.
3. Check harness continuity between ASCD clutch switch terminal 2 and ECM terminal 108.  
Refer to Wiring Diagram.

**Continuity should exist.**

4. Also check harness for short to ground and short to power.

OK or NG

- OK >> GO TO 10.
- NG >> GO TO 9.

## 9. DETECT MALFUNCTIONING PART

Check the following.

- Harness connectors E108, M15
- Harness connectors M72, F102
- Harness for open or short between ECM and ASCD clutch switch

>> Repair open circuit or short to ground or short to power in harness or connectors.

## 10. CHECK ASCD CLUTCH SWITCH

Refer to [EC-573, "Component Inspection"](#).

OK or NG

- OK >> GO TO 16.
- NG >> Replace ASCD clutch switch.

## 11. CHECK STOP LAMP SWITCH POWER SUPPLY CIRCUIT

1. Turn ignition switch OFF.
2. Disconnect stop lamp switch harness connector.

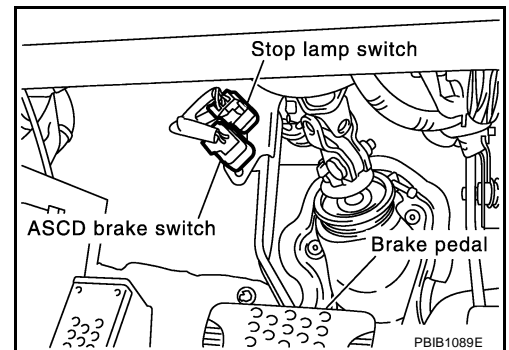

3. Check voltage between stop lamp switch terminal 1 and ground with CONSULT -II or tester.

**Voltage: Battery voltage**

OK or NG

- OK >> GO TO 13.
- NG >> GO TO 12.

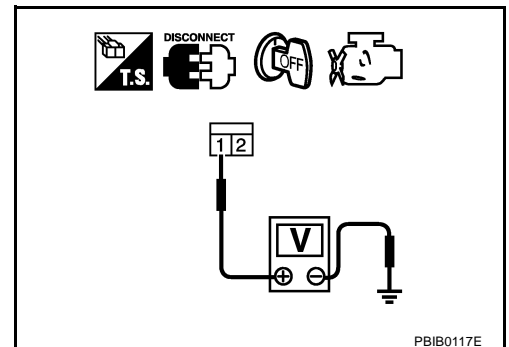

# DTC P1572 ASCD BRAKE SWITCH

---

## 12. DETECT MALFUNCTIONING PART

---

Check the following.

- Fuse block (J/B) connector E101
- 10A fuse
- Harness for open or short between stop lamp switch and battery

>> Repair open circuit or short to ground or short to power in harness or connectors.

---

## 13. CHECK STOP LAMP SWITCH INPUT SIGNAL CIRCUIT FOR OPEN AND SHORT

---

1. Disconnect ECM harness connector.
2. Check harness continuity between ECM terminal 101 and stop lamp switch terminal 2.  
Refer to Wiring Diagram.

**Continuity should exist.**

3. Also check harness for short to ground and short to power.

OK or NG

- OK >> GO TO 15.  
NG >> GO TO 14.

---

## 14. DETECT MALFUNCTIONING PART

---

Check the following.

- Harness connectors E108, M15
- Harness connectors M72, F102
- Harness for open or short between ECM and stop lamp switch

>> Repair open circuit or short to ground or short to power in harness or connectors.

---

## 15. CHECK STOP LAMP SWITCH

---

Refer to [EC-573. "Component Inspection"](#)

OK or NG

- OK >> GO TO 16.  
NG >> Replace stop lamp switch.

---

## 16. CHECK INTERMITTENT INCIDENT

---

Refer to [EC-129. "TROUBLE DIAGNOSIS FOR INTERMITTENT INCIDENT"](#) .

>> **INSPECTION END**

# DTC P1572 ASCD BRAKE SWITCH

ABS009MY

## Component Inspection ASCD BRAKE SWITCH

1. Turn ignition switch OFF.
2. Disconnect ASCD brake switch harness connector.
3. Check harness continuity between ASCD brake switch terminals 1 and 2 under the following conditions.

Condition	Continuity
When brake pedal is fully released.	Should exist.
When brake pedal is slightly depressed.	Should not exist.

If NG, adjust ASCD brake switch installation, refer to [BR-6](#), "[BRAKE PEDAL](#)", and perform step 3 again.

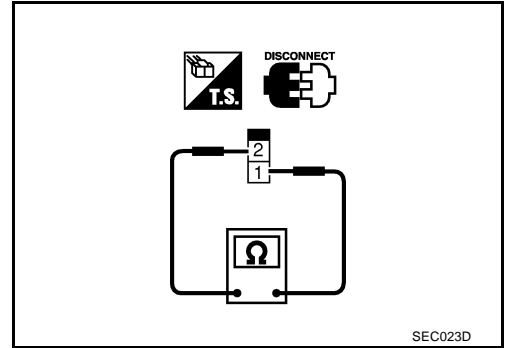

## ASCD CLUTCH SWITCH

1. Turn ignition switch OFF.
2. Disconnect ASCD clutch switch harness connector.
3. Check harness continuity between ASCD clutch switch terminals 1 and 2 under the following conditions.

Condition	Continuity
When clutch pedal is fully released.	Should exist.
When clutch pedal is slightly depressed.	Should not exist.

If NG, adjust ASCD clutch switch installation, refer to [CL-5](#), "[CLUTCH PEDAL](#)", and perform step 3 again.

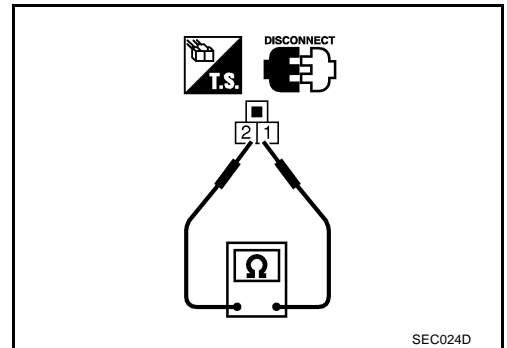

## STOP LAMP SWITCH

1. Turn ignition switch OFF.
2. Disconnect stop lamp switch harness connector.
3. Check harness continuity between stop lamp switch terminals 1 and 2 under the following conditions.

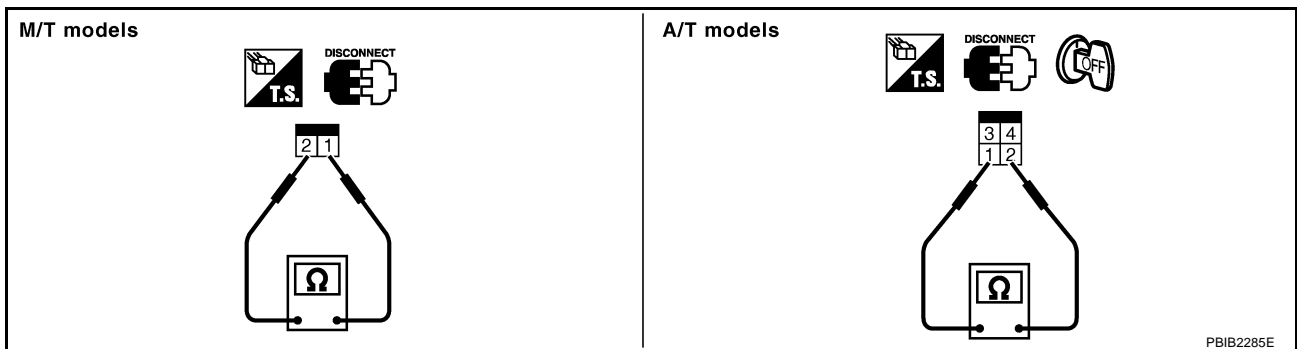

Condition	Continuity
When brake pedal is fully released.	Should not exist.
When brake pedal is slightly depressed.	Should exist.

If NG, adjust stop lamp switch installation, refer to [BR-6](#), "[BRAKE PEDAL](#)", and perform step 3 again.

A  
EC  
C  
D  
E  
F  
G  
H  
I  
J  
K  
L  
M

# DTC P1574 ASCD VEHICLE SPEED SENSOR

## DTC P1574 ASCD VEHICLE SPEED SENSOR

PFP:31036

### Component Description

ABS009MZ

The ECM receives two vehicle speed sensor signals via CAN communication line. One is sent from “unified meter and A/C amp.”, and the other is from TCM (Transmission control module). The ECM uses these signals for ASCD control. Refer to [EC-688, "AUTOMATIC SPEED CONTROL DEVICE \(ASCD\)"](#) for ASCD functions.

### On Board Diagnosis Logic

ABS009N0

This self-diagnosis has the one trip detection logic.  
The MIL will not light up for this diagnosis.

#### NOTE:

- If DTC P1574 is displayed with DTC U1000, U1001, first perform the trouble diagnosis for DTC U1000, U1001. Refer to [EC-139, "DTC U1000, U1001 CAN COMMUNICATION LINE"](#) .
- If DTC P1574 is displayed with DTC P0500, first perform the trouble diagnosis for DTC P0500. Refer to [EC-363, "DTC P0500 VSS"](#)
- If DTC P1574 is displayed with DTC P0605, first perform the trouble diagnosis for DTC P0605. Refer to [EC-374, "DTC P0605 ECM"](#)

DTC No.	Trouble Diagnosis Name	DTC Detecting Condition	Possible Cause
P1574 1574	ASCD vehicle speed sensor	ECM detects a difference between two vehicle speed signals is out of the specified range.	<ul style="list-style-type: none"> <li>● Harness or connectors (The CAN communication line is open or shorted.)</li> <li>● Unified meter and A/C amp.</li> <li>● VDC/TCS/ABS control unit (models with VDC)</li> <li>● ABS actuator and electric unit (control unit) (models without VDC)</li> <li>● Wheel sensor</li> <li>● TCM(A/T models)</li> <li>● ECM</li> </ul>

### DTC Confirmation Procedure

ABS009N1

#### CAUTION:

Always drive vehicle at a safe speed.

#### NOTE:

If DTC Confirmation Procedure has been previously conducted, always turn ignition switch OFF and wait at least 10 seconds before conducting the next test.

#### TESTING CONDITION:

Step 3 may be conducted with the drive wheels lifted in the shop or by driving the vehicle. If a road test is expected to be easier, it is unnecessary to lift the vehicle.

#### WITH CONSULT-II

1. Start engine (VDC switch or TCS switch OFF).
2. Select “DATA MONITOR” mode with CONSULT-II.
3. Drive the vehicle at more than 40 km/h (25 MPH).
4. If DTC is detected, go to [EC-575, "Diagnostic Procedure"](#) .

DATA MONITOR	
MONITOR	NO DTC
ENG SPEED	XXX rpm

SEF058Y

#### WITH GST

Follow the procedure “WITH CONSULT-II” above.

# DTC P1574 ASCD VEHICLE SPEED SENSOR

## Diagnostic Procedure

ABS009N2

### 1. CHECK DTC WITH TCM

Check DTC with TCM. Refer to [AT-37](#) .

OK or NG

OK >> GO TO 2.

NG >> Perform trouble shooting relevant to DTC indicated.

### 2. CHECK DTC WITH “VDC/TSC/ABS CONTROL UNIT (MODELS WITH VDC)” OR “ABS ACTUATOR AND ELECTRIC UNIT (CONTROL UNIT) (MODELS WITHOUT VDC)”

Refer to [BRC-94, "TROUBLE DIAGNOSIS"](#) or refer to [BRC-46, "TROUBLE DIAGNOSIS"](#) .

OK or NG

OK >> GO TO 3.

NG >> Repair or replace.

### 3. CHECK DTC WITH “UNIFIED METER AND A/C AMP.”

Refer to [DI-4, "COMBINATION METERS"](#) .

>> INSPECTION END

A

EC

C

D

E

F

G

H

I

J

K

L

M

# DTC P1706 PNP SWITCH

## DTC P1706 PNP SWITCH

PF3:32006

### Component Description

ABS009N3

When the gear position is P or N (A/T), Neutral (M/T), park/neutral position (PNP) switch is ON. ECM detects the position because the continuity of the line (the ON signal) exists.

### CONSULT-II Reference Value in Data Monitor Mode

ABS009N4

Specification data are reference values.

MONITOR ITEM	CONDITION		SPECIFICATION
P/N POSI SW	● Ignition switch: ON	Shift lever: P or N (A/T), Neutral (M/T)	ON
		Shift lever: Except above	OFF

### On Board Diagnosis Logic

ABS009N5

DTC No.	Trouble diagnosis name	DTC detecting condition	Possible cause
P1706 1706	Park/neutral position switch	The signal of the park/neutral position (PNP) switch is not changed in the process of engine starting and driving.	<ul style="list-style-type: none"> <li>● Harness or connectors [The park/neutral position (PNP) switch circuit is open or shorted.]</li> <li>● Park/neutral position (PNP) switch</li> <li>● Unified meter and A/C amp. (A/T models)</li> <li>● TCM (A/T models)</li> </ul>

### DTC Confirmation Procedure

ABS009N6

#### CAUTION:

Always drive vehicle at a safe speed.

#### NOTE:

If DTC Confirmation Procedure has been previously conducted, always turn ignition switch OFF and wait at least 10 seconds before conducting the next test.

#### WITH CONSULT-II

1. Turn ignition switch ON.
2. Select "P/N POSI SW" in "DATA MONITOR" mode with CONSULT-II. Then check the "P/N POSI SW" signal under the following conditions.

Position (Shift lever)	Known-good signal
N or P position (A/T) Neutral position (M/T)	ON
Except above position	OFF

If NG, go to [EC-581, "Diagnostic Procedure"](#).

If OK, go to following step.

3. Select "DATA MONITOR" mode with CONSULT-II.
4. Start engine and warm it up to normal operating temperature.
5. Maintain the following conditions for at least 60 consecutive seconds.

ENG SPEED	1,400 - 6375 rpm
COOLAN TEMP/S	More than 70°C (158°F)
B/FUEL SCHDL	2.0 - 31.8 msec
VHCL SPEED SE	More than 64 km/h (40 MPH)
Shift lever	Suitable position

6. If 1st trip DTC is detected, go to [EC-581, "Diagnostic Procedure"](#).

DATA MONITOR	
MONITOR	NO DTC
P/N POSI SW	ON

SEF212Y

DATA MONITOR	
MONITOR	NO DTC
ENG SPEED	XXX rpm
COOLAN TEMP/S	XXX °C
VHCL SPEED SE	XXX km/h
P/N POSI SW	OFF
B/FUEL SCHDL	XXX msec

SEF213Y



# DTC P1706 PNP SWITCH

ABS009N7

## Overall Function Check

Use this procedure to check the overall function of the park/neutral position (PNP) switch circuit. During this check, a 1st trip DTC might not be confirmed.

### WITH GST

1. Turn ignition switch ON.
2. Check voltage between ECM terminal 102 (PNP switch signal) and ground under the following conditions.

Condition (Gear position)	Voltage V (Known good data)
P or N position (A/T) Neutral position (M/T)	Approx. 0
Except above position	BATTERY VOLTAGE (11 - 14V)

3. If NG, go to [EC-581, "Diagnostic Procedure"](#) .

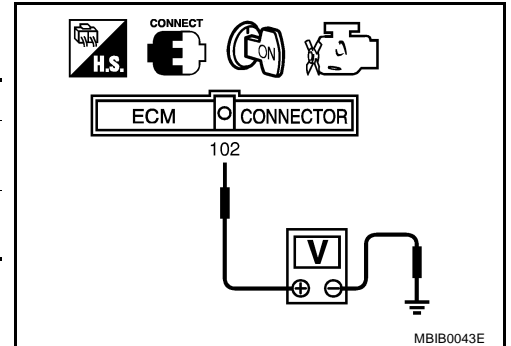

A  
EC  
C  
D  
E  
F  
G  
H  
I  
J  
K  
L  
M

# DTC P1706 PNP SWITCH

ABS009NB

## Wiring Diagram A/T MODELS

### EC-PNP/SW-01

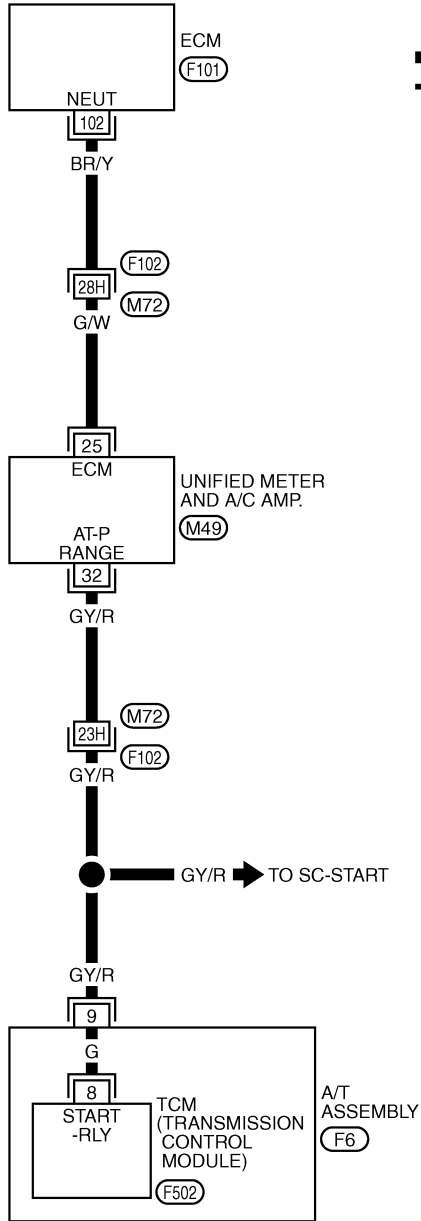

**—** : DETECTABLE LINE FOR DTC  
**—** : NON-DETECTABLE LINE FOR DTC

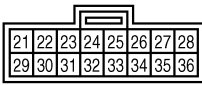

M49  
GY

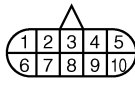

F6  
GY

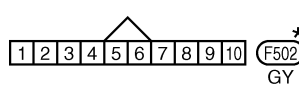

\*  
F502  
GY

REFER TO THE FOLLOWING.

F102 -SUPER MULTIPLE JUNCTION (SMJ)

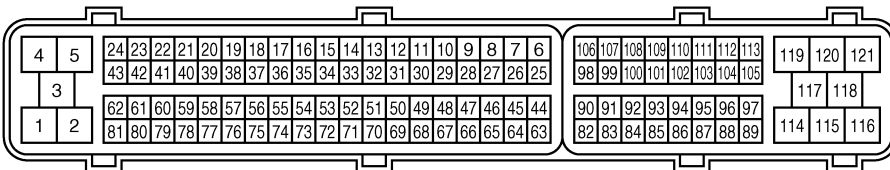

F101  
B



\*: THIS CONNECTOR IS NOT SHOWN IN "HARNES LAYOUT", PG SECTION.

TBWM0525E

## DTC P1706 PNP SWITCH

Specification data are reference values and are measured between each terminal and ground.

**CAUTION:**

**Do not use ECM ground terminals when measuring input/output voltage. Doing so may result in damage to the ECM's transistor. Use a ground other than ECM terminals, such as the ground.**

TER-MINAL NO.	WIRE COLOR	ITEM	CONDITION	DATA (DC Voltage)
102	BR/Y	PNP switch	<b>[Ignition switch: ON]</b> ● Selector lever: P or N	Approximately 0V
			<b>[Ignition switch: ON]</b> ● Except above position	BATTERY VOLTAGE (11 - 14V)

A  
EC  
C  
D  
E  
F  
G  
H  
I  
J  
K  
L  
M

# DTC P1706 PNP SWITCH

M/T MODELS

EC-PNP/SW-02

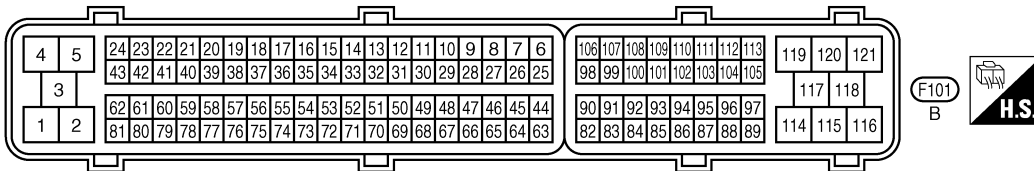
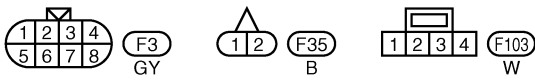
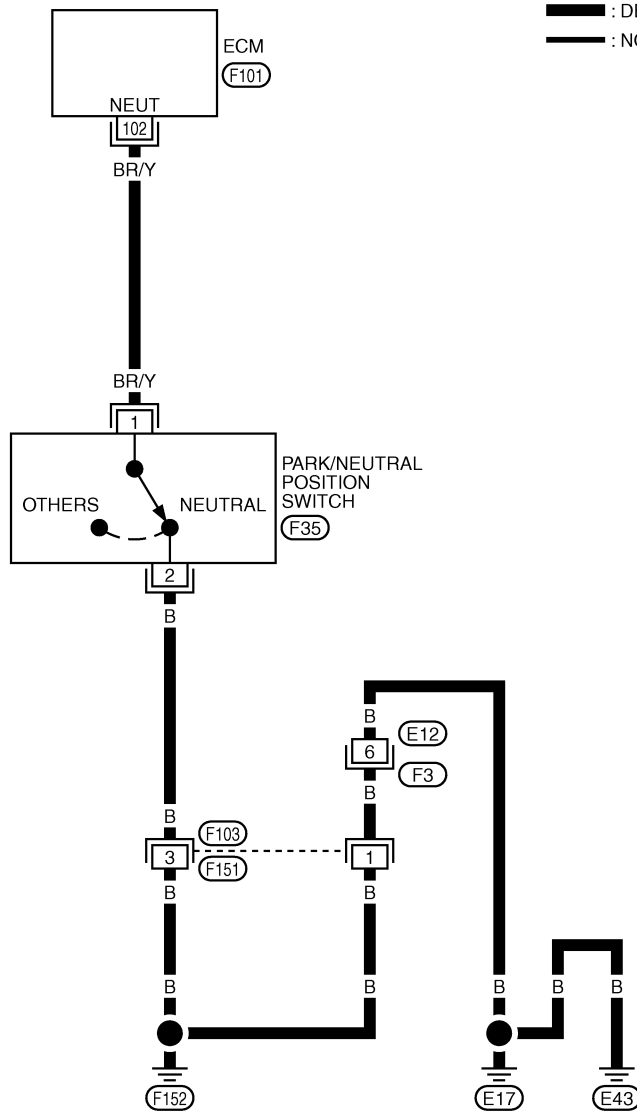

TBWT0505E

# DTC P1706 PNP SWITCH

Specification data are reference values and are measured between each terminal and ground.

## CAUTION:

Do not use ECM ground terminals when measuring input/output voltage. Doing so may result in damage to the ECM's transistor. Use a ground other than ECM terminals, such as the ground.

TER-MINAL NO.	WIRE COLOR	ITEM	CONDITION	DATA (DC Voltage)
102	BR/Y	PNP switch	<b>[Ignition switch: ON]</b> ● Shift lever: Neutral	Approximately 0V
			<b>[Ignition switch: ON]</b> ● Except above position	BATTERY VOLTAGE (11 - 14V)

## Diagnostic Procedure

ABS009N9

### A/T MODELS

#### 1. CHECK DTC WITH TCM

Refer to [AT-37, "OBD-II Diagnostic Trouble Code \(DTC\)"](#) .

OK or NG

OK >> GO TO 2.

NG >> Repair or replace.

#### 2. CHECK STARTING SYSTEM

Turn ignition switch OFF, then turn it to START.

**Does starter motor operate?**

Yes or No

Yes >> GO TO 3.

No >> Refer to [SC-10, "STARTING SYSTEM"](#) .

#### 3. CHECK PNP SWITCH INPUT SIGNAL CIRCUIT FOR OPEN AND SHORT-I

1. Turn ignition switch OFF.
2. Disconnect A/T assembly harness connector.
3. Disconnect "unified meter and A/C amp." harness connector.
4. Check harness continuity between A/T assembly terminal 9 and "unified meter and A/C amp." terminal 32. Refer to Wiring Diagram.

**Continuity should exist.**

5. Also check harness for short to ground and short to power.

OK or NG

OK >> GO TO 5.

NG >> GO TO 4.

#### 4. DETECT MALFUNCTIONING PART

Check the following.

- Harness connectors F102, M72
- Harness for open or short between A/T assembly and "unified meter and A/C amp."

>> Repair open circuit or short to ground or short to power in harness or connectors.

# DTC P1706 PNP SWITCH

---

## 5. CHECK PNP SWITCH INPUT SIGNAL CIRCUIT FOR OPEN AND SHORT-II

---

1. Disconnect ECM harness connector.
2. Check harness continuity between ECM terminal 102 and “unified meter and A/C amp.” terminal 25. Refer to Wiring Diagram.

**Continuity should exist.**

3. Also check harness for short to ground and short to power.

OK or NG

- OK >> GO TO 7.  
NG >> GO TO 6.

---

## 6. DETECT MALFUNCTIONING PART

---

Check the following.

- Harness connectors F102, M72
- Harness for open or short between ECM and “unified meter and A/C amp.”

>> Repair open circuit or short to ground or short to power in harness or connectors.

---

## 7. CHECK PNP SWITCH INPUT SIGNAL CIRCUIT FOR OPEN AND SHORT-III

---

1. Check harness continuity between A/T assembly terminal 9 and TCM terminal 8. Refer to [AT-104, "DTC P0615 START SIGNAL CIRCUIT"](#) .

**Continuity should exist.**

2. Also check harness for short to ground and short to power.

OK or NG

- OK >> GO TO 8.  
NG >> Repair open circuit or short to ground or short to power in harness connectors.

---

## 8. CHECK INTERMITTENT INCIDENT

---

Refer to [EC-129, "TROUBLE DIAGNOSIS FOR INTERMITTENT INCIDENT"](#) .

OK or NG

- OK >> GO TO 9.  
NG >> Repair or replace.

---

## 9. REPLACE “UNIFIED METER AND A/C AMP.”

---

Refer to [DI-54, "UNIFIED METER AND A/C AMP"](#) .

>> **INSPECTION END**

# DTC P1706 PNP SWITCH

## M/T MODELS

### 1. CHECK PNP SWITCH GROUND CIRCUIT

1. Turn ignition switch OFF.
2. Disconnect park/neutral position (PNP) switch harness connector.
3. Check harness continuity between PNP switch terminal 2 and ground.  
Refer to Wiring Diagram.

**Continuity should exist.**

4. Also check harness for short to power.

#### OK or NG

- OK >> GO TO 3  
NG >> GO TO 2.

### 2. DETECT MALFUNCTIONING PART

Check the following.

- Harness connectors F103, F151
- Harness connector E12, F3
- Harness for open or short between PNP switch and ground

>> Repair open circuit or short to power in harness or connectors.

### 3. CHECK PNP SWITCH INPUT SIGNAL CIRCUIT

1. Disconnect ECM harness connector.
2. Check harness continuity between ECM terminal 102 and PNP switch terminal 1.  
Refer to Wiring Diagram.

**Continuity should exist.**

3. Also check harness for short to ground and short to power.

#### OK or NG

- OK >> GO TO 4.  
NG >> Repair open circuit or short to ground or short to power in harness or connectors.

### 4. CHECK PNP SWITCH

Refer to [MT-12, "NEUTRAL POSITION SWITCH"](#) .

#### OK or NG

- OK >> GO TO 5.  
NG >> Replace PNP switch.

### 5. CHECK INTERMITTENT INCIDENT

Refer to [EC-129, "TROUBLE DIAGNOSIS FOR INTERMITTENT INCIDENT"](#) .

>> **INSPECTION END**

# DTC P1805 BRAKE SWITCH

## DTC P1805 BRAKE SWITCH

PFP:25320

### Description

ABS009NA

Brake switch signal is applied to the ECM through the stop lamp switch when the brake pedal is depressed. This signal is used mainly to decrease the engine speed when the vehicle is driving.

### CONSULT-II Reference Value in Data Monitor Mode

ABS009NB

Specification data are reference values.

MONITOR ITEM	CONDITION		SPECIFICATION
BRAKE SW	● Ignition switch: ON	Brake pedal: Fully released	OFF
		Brake pedal: Slightly depressed	ON

### On Board Diagnosis Logic

ABS009NC

The MIL will not light up for this diagnosis.

DTC No.	Trouble diagnosis name	DTC detecting condition	Possible cause
P1805 1805	Brake switch	A brake switch signal is not sent to ECM for extremely long time while the vehicle is driving.	<ul style="list-style-type: none"> <li>● Harness or connectors (Stop lamp switch circuit is open or shorted.)</li> <li>● Stop lamp switch</li> </ul>

### FAIL-SAFE MODE

When the malfunction is detected, the ECM enters fail-safe mode.

Engine operating condition in fail-safe mode

ECM controls the electric throttle control actuator by regulating the throttle opening to a small range. Therefore, acceleration will be poor.

Vehicle condition	Driving condition
When engine is idling	Normal
When accelerating	Poor acceleration

### DTC Confirmation Procedure

ABS009ND

#### WITH CONSULT-II

1. Turn ignition switch ON.
2. Fully depress the brake pedal for at least 5 seconds.
3. Erase the DTC with CONSULT-II.
4. Select "DATA MONITOR" mode with CONSULT-II.
5. If 1st trip DTC is detected, go to [EC-586, "Diagnostic Procedure"](#)

DATA MONITOR	
MONITOR	NO DTC
ENG SPEED	XXX rpm
BRAKE SW	ON

PBIB1952E

#### WITH GST

Follow the procedure "WITH CONSULT-II" above.



# DTC P1805 BRAKE SWITCH

## Wiring Diagram

ABS009NE

EC-BRK/SW-01

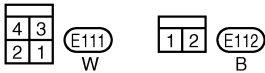
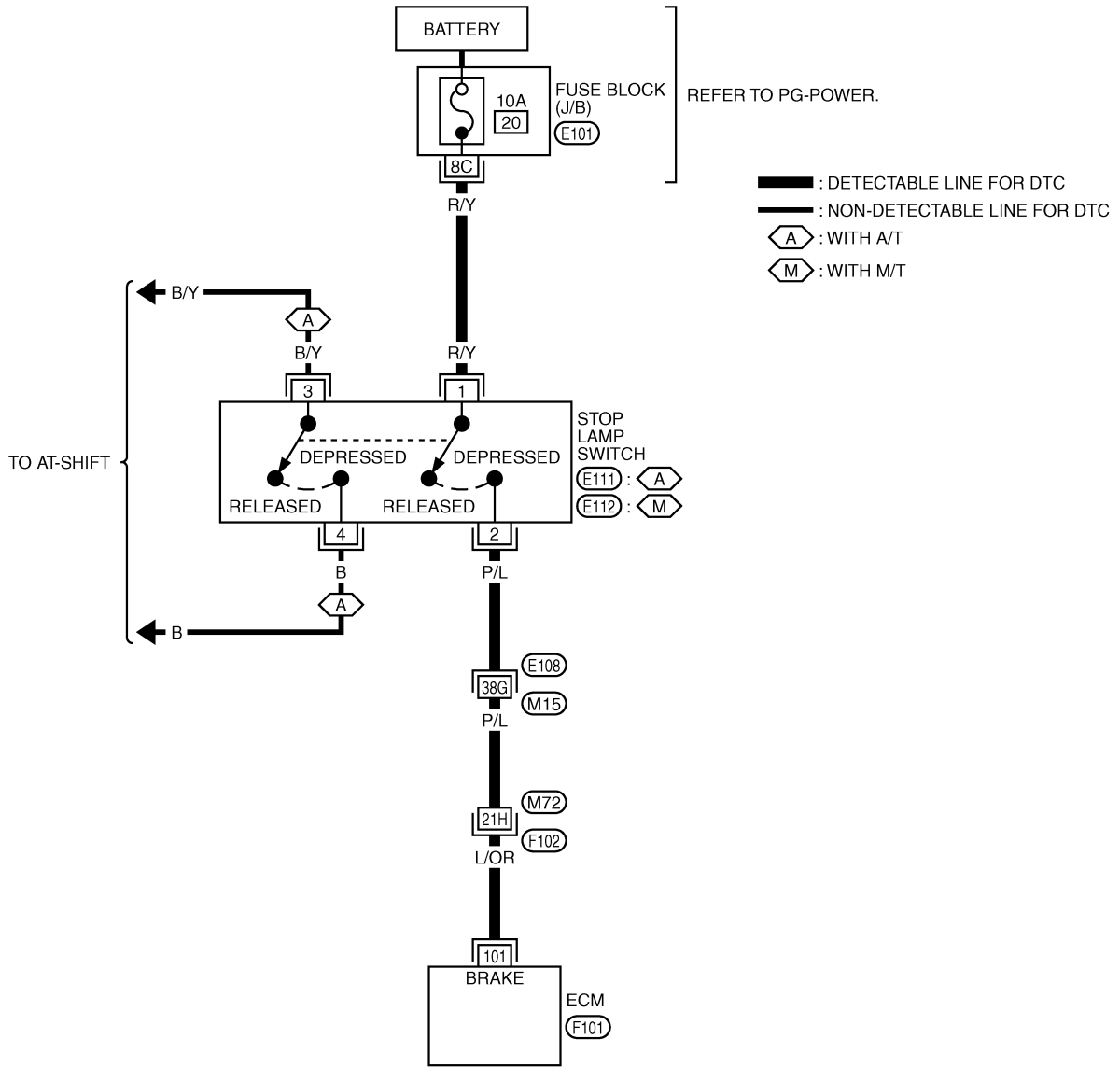

REFER TO THE FOLLOWING.

(E108), (F102) -SUPER MULTIPLE JUNCTION (SMJ)

(E101) -FUSE BLOCK-JUNCTION BOX (J/B)

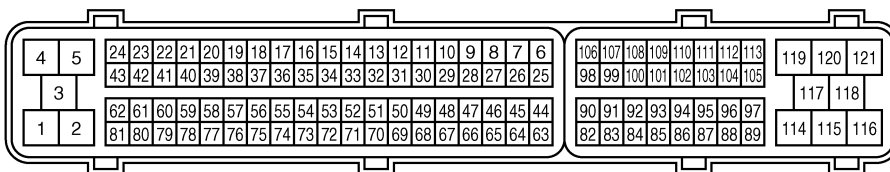

TBWT0506E

# DTC P1805 BRAKE SWITCH

Specification data are reference values and are measured between each terminal and ground.

## CAUTION:

Do not use ECM ground terminals when measuring input/output voltage. Doing so may result in damage to the ECM's transistor. Use a ground other than ECM terminals, such as the ground.

TER-MINAL NO.	WIRE COLOR	ITEM	CONDITION	DATA (DC Voltage)
101	L/OR	Stop lamp switch	[Ignition switch: OFF] ● Brake pedal is fully released	Approximately 0V
			[Ignition switch: OFF] ● Brake pedal is slightly depressed	BATTERY VOLTAGE (11 - 14V)

## Diagnostic Procedure

ABS009NF

### 1. CHECK STOP LAMP SWITCH CIRCUIT

- Turn ignition switch OFF.
- Check the stop lamp when depressing and releasing the brake pedal.

Brake pedal	Stop lamp
Fully released	Not illuminated
slightly depressed	Illuminated

#### OK or NG

- OK >> GO TO 4.  
NG >> GO TO 2.

### 2. CHECK STOP LAMP SWITCH POWER SUPPLY CIRCUIT

- Disconnect stop lamp switch harness connector.

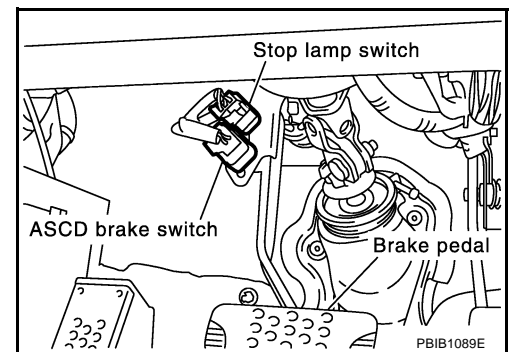

- Check voltage between stop lamp switch terminal 1 and ground with CONSULT-II or tester.

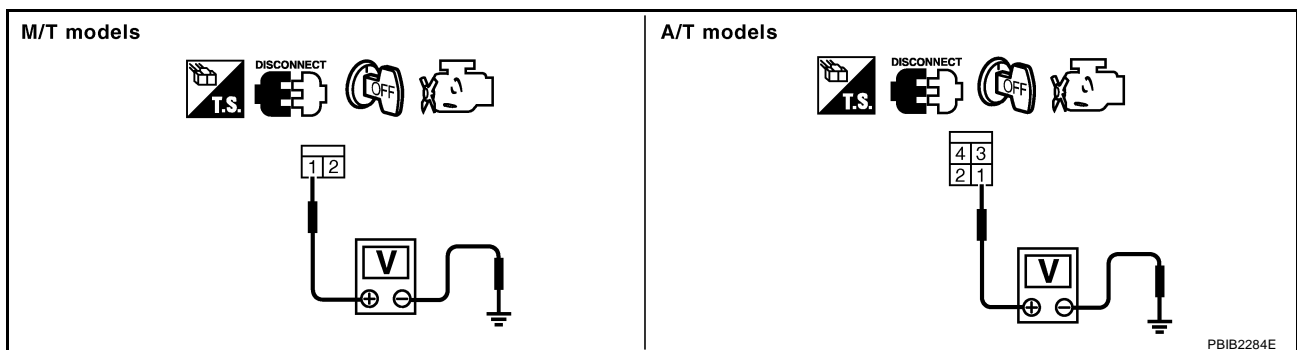

**Voltage: Battery voltage**

#### OK or NG

- OK >> GO TO 4.  
NG >> GO TO 3.

# DTC P1805 BRAKE SWITCH

## 3. DETECT MALFUNCTIONING PART

Check the following.

- 10A fuse
- Fuse block (J/B) connector E101
- Harness for open and short between stop lamp switch and fuse

>> Repair open circuit or short to ground or short to power in harness or connectors.

## 4. CHECK STOP LAMP SWITCH INPUT SIGNAL CIRCUIT FOR OPEN AND SHORT

1. Turn ignition switch OFF.
2. Disconnect ECM harness connector.
3. Disconnect stop lamp switch harness connector.
4. Check harness continuity between ECM terminal 101 and stop lamp switch terminal 2.  
Refer to Wiring Diagram.

**Continuity should exist.**

5. Also check harness for short to ground and short to power.

OK or NG

- OK >> GO TO 6.
- NG >> GO TO 5.

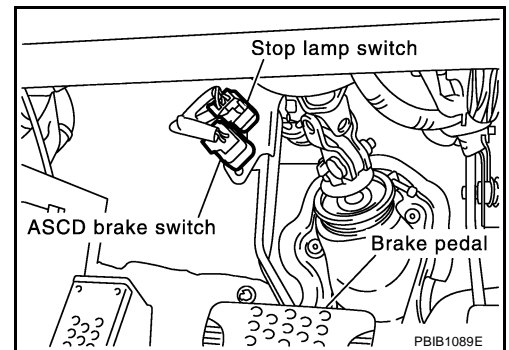

## 5. DETECT MALFUNCTIONING PART

Check the following.

- Harness connectors E108, M15
- Harness connectors M72, F102
- Harness for open or short between ECM and stop lamp switch

>> Repair open circuit or short to ground or short to power in harness or connectors.

## 6. CHECK STOP LAMP SWITCH

Refer to [EC-588, "Component Inspection"](#) .

OK or NG

- OK >> GO TO 7.
- NG >> Replace stop lamp switch.

## 7. CHECK INTERMITTENT INCIDENT

Refer to [EC-129, "TROUBLE DIAGNOSIS FOR INTERMITTENT INCIDENT"](#) .

>> **INSPECTION END**

# DTC P1805 BRAKE SWITCH

ABS009NG

## Component Inspection STOP LAMP SWITCH

1. Disconnect stop lamp switch harness connector.

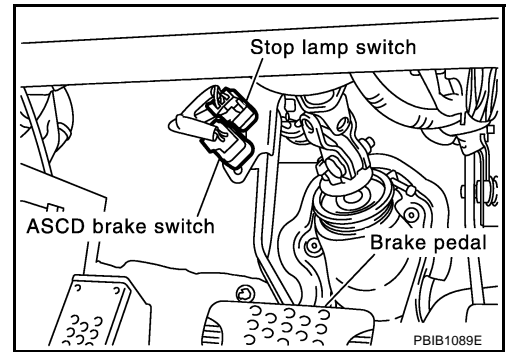

2. Check continuity between stop lamp switch terminals 1 and 2 under the following conditions.

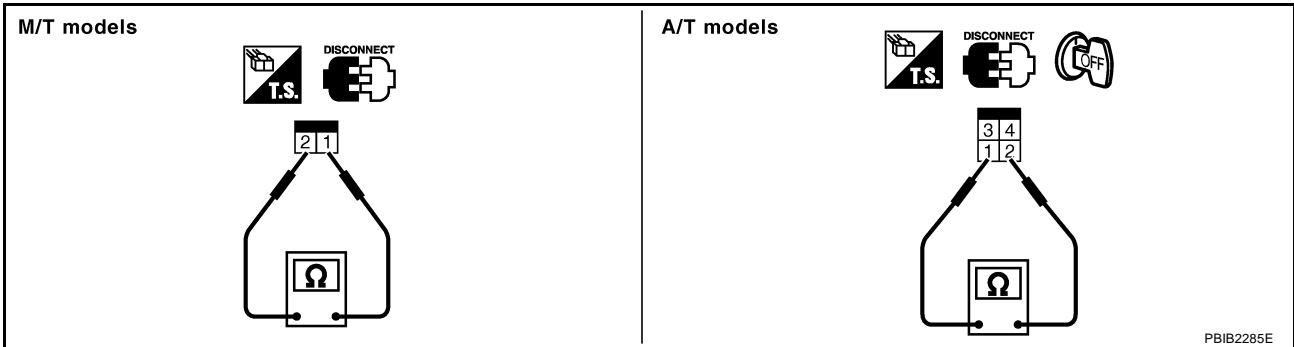

Conditions	Continuity
Brake pedal fully released	Should not exist.
Brake pedal slightly depressed	Should exist.

3. If NG, adjust stop lamp switch installation, refer to [BR-6, "BRAKE PEDAL"](#), and perform step 2 again.

# DTC P2122, P2123 APP SENSOR

## DTC P2122, P2123 APP SENSOR

PPF:18002

### Component Description

ABS009NH

The accelerator pedal position sensor is installed on the upper end of the accelerator pedal assembly. The sensor detects the accelerator position and sends a signal to the ECM.

Accelerator pedal position sensor has two sensors. These sensors are a kind of potentiometers which transform the accelerator pedal position into output voltage, and emit the voltage signal to the ECM. In addition, these sensors detect the opening and closing speed of the accelerator pedal and feed the voltage signals to the ECM. The ECM judges the current opening angle of the accelerator pedal from these signals and controls the throttle control motor based on these signals.

Idle position of the accelerator pedal is determined by the ECM receiving the signal from the accelerator pedal position sensor. The ECM uses this signal for the engine operation such as fuel cut.

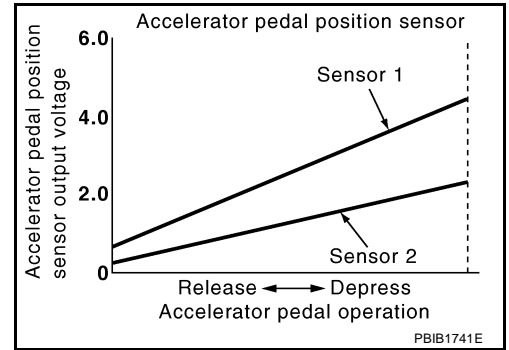

### CONSULT-II Reference Value in Data Monitor Mode

ABS009NI

Specification data are reference values.

MONITOR ITEM	CONDITION		SPECIFICATION
ACCEL SEN 1	● Ignition switch: ON (Engine stopped)	Accelerator pedal: Fully released	0.5 - 1.0V
		Accelerator pedal: Fully depressed	4.0 - 4.8V
ACCEL SEN 2*	● Ignition switch: ON (Engine stopped)	Accelerator pedal: Fully released	0.3 - 1.2V
		Accelerator pedal: Fully depressed	3.9 - 4.8V
CLSD THL POS	● Ignition switch: ON (Engine stopped)	Accelerator pedal: Fully released	ON
		Accelerator pedal: Slightly depressed	OFF

\*: Accelerator pedal position sensor 2 signal is converted by ECM internally. Thus, it differ from ECM terminal voltage.

### On Board Diagnosis Logic

ABS009NJ

These self-diagnoses have the one trip detection logic.

#### NOTE:

If DTC P2122 or P2123 is displayed with DTC P1229, first perform the trouble diagnosis for DTC P1229. Refer to [EC-456](#).

DTC No.	Trouble diagnosis name	DTC detecting condition	Possible cause
P2122 2122	Accelerator pedal position sensor 1 circuit low input	An excessively low voltage from the APP sensor 1 is sent to ECM.	● Harness or connectors (The APP sensor 1 circuit is open or shorted.) ● Accelerator pedal position sensor (Accelerator pedal position sensor 1)
P2123 2123	Accelerator pedal position sensor 1 circuit high input	An excessively high voltage from the APP sensor 1 is sent to ECM.	

### FAIL-SAFE MODE

When the malfunction is detected, ECM enters fail-safe mode and the MIL lights up.

#### Engine operating condition in fail-safe mode

The ECM controls the electric throttle control actuator in regulating the throttle opening in order for the idle position to be within +10 degrees.

The ECM regulates the opening speed of the throttle valve to be slower than the normal condition.

So, the acceleration will be poor.

# DTC P2122, P2123 APP SENSOR

ABS009NK

## DTC Confirmation Procedure

### NOTE:

If DTC Confirmation Procedure has been previously conducted, always turn ignition switch OFF and wait at least 10 seconds before conducting the next test.

### TESTING CONDITION:

Before performing the following procedure, confirm that battery voltage is more than 10V at idle.

#### WITH CONSULT-II

1. Turn ignition switch ON.
2. Select "DATA MONITOR" mode with CONSULT-II.
3. Start engine and let it idle for 1 second.
4. If DTC is detected, go to [EC-593, "Diagnostic Procedure"](#) .

DATA MONITOR	
MONITOR	NO DTC
ENG SPEED	XXX rpm

SEF058Y

#### WITH GST

Follow the procedure "WITH CONSULT-II" above.

# DTC P2122, P2123 APP SENSOR

## Wiring Diagram

ABS009NL

### EC-APPS1-01

: DETECTABLE LINE FOR DTC  
 : NON-DETECTABLE LINE FOR DTC

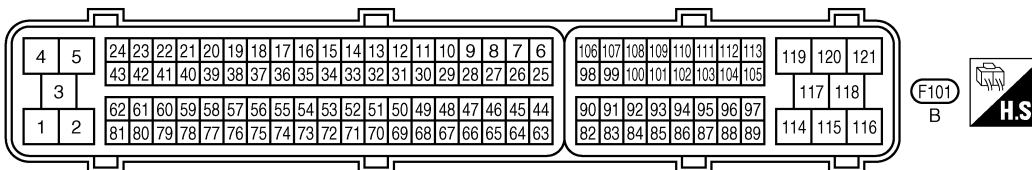
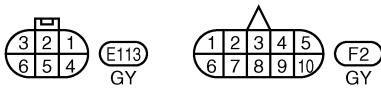
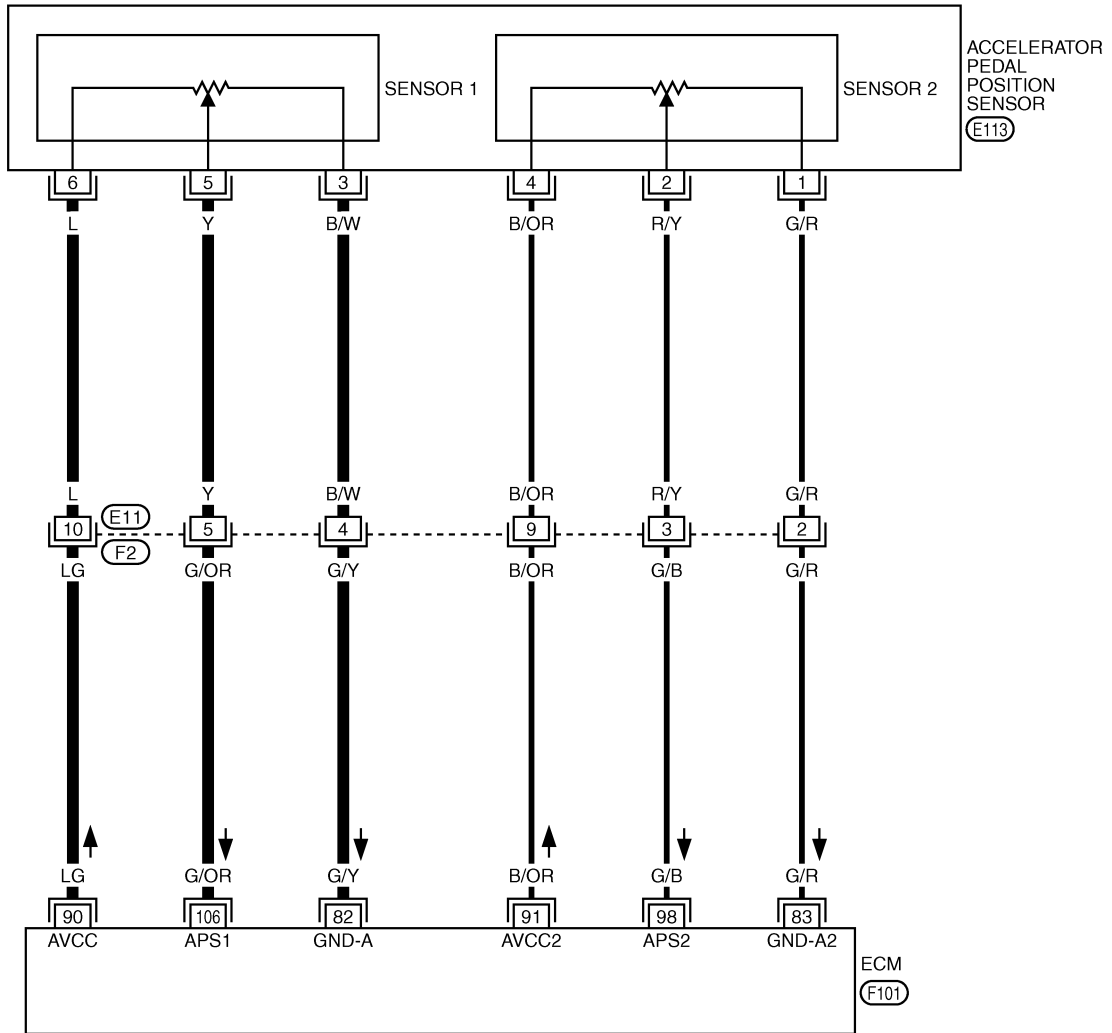

TBWT0507E

## DTC P2122, P2123 APP SENSOR

Specification data are reference values and are measured between each terminal and ground.

**CAUTION:**

**Do not use ECM ground terminals when measuring input/output voltage. Doing so may result in damage to the ECM's transistor. Use a ground other than ECM terminals, such as the ground.**

TER-MINAL NO.	WIRE COLOR	ITEM	CONDITION	DATA (DC Voltage)
82	G/Y	Sensor ground (APP sensor 1)	<b>[Engine is running]</b> <ul style="list-style-type: none"> <li>● Warm-up condition</li> <li>● Idle speed</li> </ul>	Approximately 0V
83	G/R	Sensor ground (APP sensor 2)	<b>[Engine is running]</b> <ul style="list-style-type: none"> <li>● Warm-up condition</li> <li>● Idle speed</li> </ul>	Approximately 0V
90	LG	Sensor power supply (APP sensor 1)	<b>[Ignition switch: ON]</b>	Approximately 5V
91	B/OR	Sensor power supply (APP sensor 2)	<b>[Ignition switch: ON]</b>	Approximately 5V
98	G/B	Accelerator pedal position sensor 2	<b>[Ignition switch: ON]</b> <ul style="list-style-type: none"> <li>● Engine stopped</li> <li>● Accelerator pedal is fully released</li> </ul>	0.15 - 0.60V
			<b>[Ignition switch: ON]</b> <ul style="list-style-type: none"> <li>● Engine stopped</li> <li>● Accelerator pedal is fully depressed</li> </ul>	1.95 - 2.40V
106	G/OR	Accelerator pedal position sensor 1	<b>[Ignition switch: ON]</b> <ul style="list-style-type: none"> <li>● Engine stopped</li> <li>● Accelerator pedal is fully released</li> </ul>	0.5 - 1.0V
			<b>[Ignition switch: ON]</b> <ul style="list-style-type: none"> <li>● Engine stopped</li> <li>● Accelerator pedal is fully depressed</li> </ul>	3.9 - 4.7V



# DTC P2122, P2123 APP SENSOR

ABS009NM

## Diagnostic Procedure

### 1. CHECK GROUND CONNECTIONS

1. Turn ignition switch OFF.
2. Loosen and retighten three ground screws on the body. Refer to [EC-138, "Ground Inspection"](#).

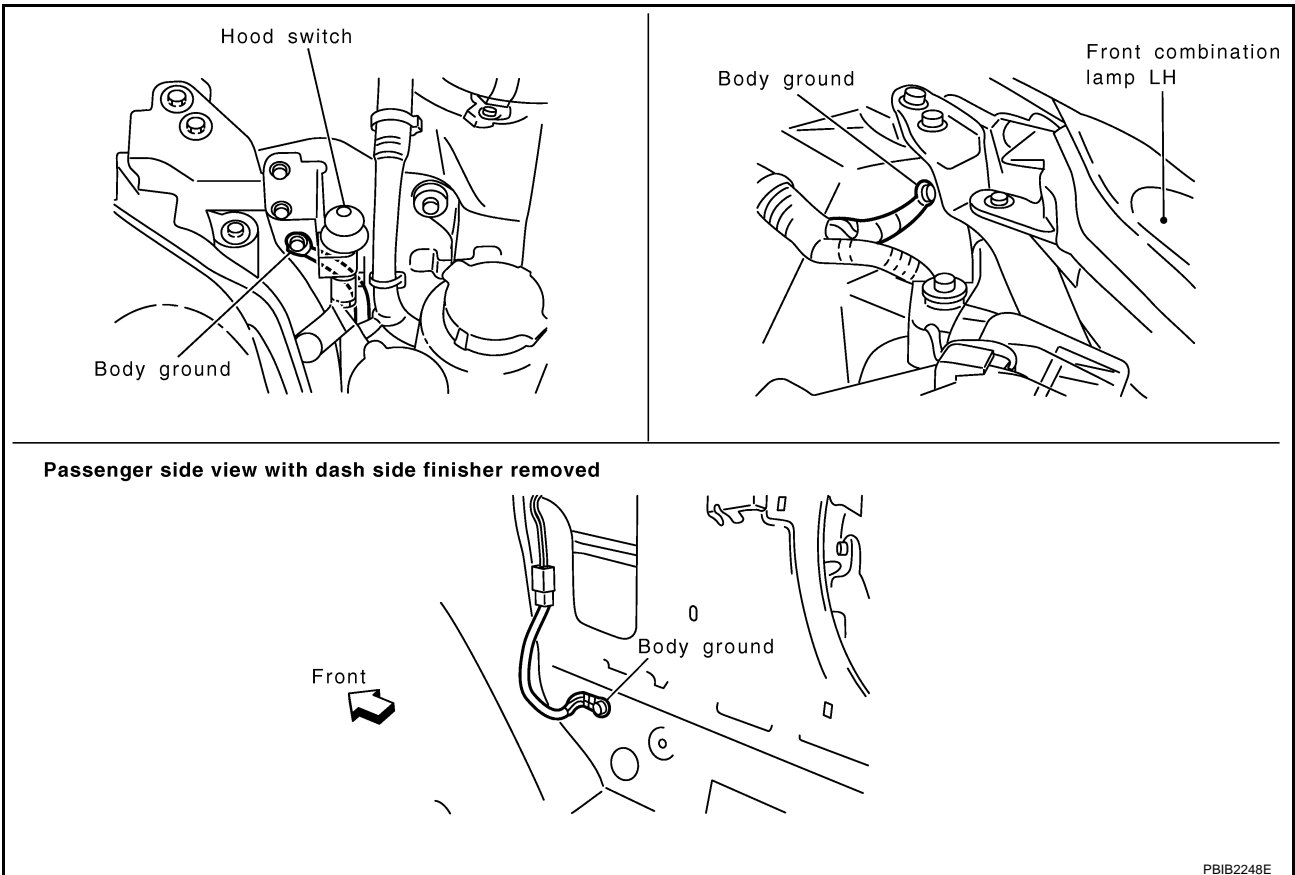

#### OK or NG

- OK >> GO TO 2.
- NG >> Repair or replace ground connections.

A  
EC  
C  
D  
E  
F  
G  
H  
I  
J  
K  
L  
M

# DTC P2122, P2123 APP SENSOR

## 2. CHECK APP SENSOR 1 POWER SUPPLY CIRCUIT

1. Disconnect accelerator pedal position (APP) sensor harness connector.
2. Turn ignition switch ON.

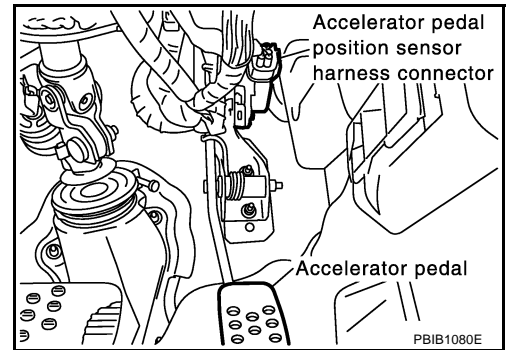

3. Check voltage between APP sensor terminal 6 and ground with CONSULT-II or tester.

**Voltage: Approximately 5V**

OK or NG

- OK >> GO TO 4.  
NG >> GO TO 3.

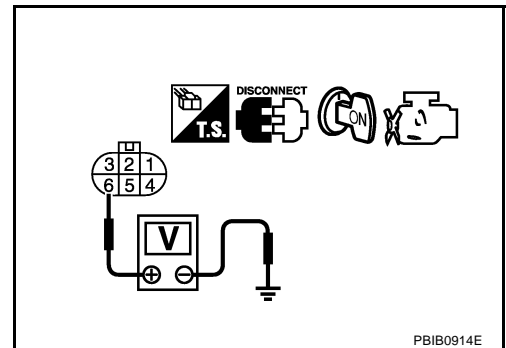

## 3. DETECT MALFUNCTIONING PART

Check the following.

- Harness connectors E11, F2
- Harness for open or short between ECM and accelerator pedal position sensor

>> Repair open circuit or short to ground or short to power in harness or connectors.

## 4. CHECK APP SENSOR 1 GROUND CIRCUIT FOR OPEN AND SHORT

1. Turn ignition switch OFF.
2. Disconnect ECM harness connector.
3. Check harness continuity between APP sensor terminal 3 and ECM terminal 82. Refer to Wiring Diagram.

**Continuity should exist.**

4. Also check harness for short to ground and short to power.

OK or NG

- OK >> GO TO 6.  
NG >> GO TO 5.

## 5. DETECT MALFUNCTIONING PART

Check the following.

- Harness connectors E11, F2
- Harness for open or short between ECM and accelerator pedal position sensor

>> Repair open circuit or short to ground or short to power in harness or connectors.

# DTC P2122, P2123 APP SENSOR

## 6. CHECK APP SENSOR INPUT SIGNAL CIRCUIT FOR OPEN AND SHORT

1. Check harness continuity between ECM terminal 106 and APP sensor terminal 5.  
Refer to Wiring Diagram.

**Continuity should exist.**

2. Also check harness for short to ground and short to power.

OK or NG

- OK >> GO TO 8.
- NG >> GO TO 7.

## 7. DETECT MALFUNCTIONING PART

Check the following.

- Harness connectors E11, F2
- Harness for open or short between ECM and accelerator pedal position sensor

>> Repair open circuit or short to ground or short to power in harness or connectors.

## 8. CHECK APP SENSOR

Refer to [EC-621, "Component Inspection"](#).

OK or NG

- OK >> GO TO 10.
- NG >> GO TO 9.

## 9. REPLACE ACCELERATOR PEDAL ASSEMBLY

1. Replace accelerator pedal assembly.
2. Perform [EC-42, "Accelerator Pedal Released Position Learning"](#).
3. Perform [EC-42, "Throttle Valve Closed Position Learning"](#).
4. Perform [EC-43, "Idle Air Volume Learning"](#).

>> INSPECTION END

## 10. CHECK INTERMITTENT INCIDENT

Refer to [EC-129, "TROUBLE DIAGNOSIS FOR INTERMITTENT INCIDENT"](#).

>> INSPECTION END

### Component Inspection ACCELERATOR PEDAL POSITION SENSOR

ABS009NN

1. Reconnect all harness connectors disconnected.
2. Turn ignition switch ON.
3. Check voltage between ECM terminals 106 (APP sensor 1 signal), 98 (APP sensor 2 signal) and ground under the following conditions.

Terminal	Accelerator pedal	Voltage
106 (Accelerator pedal position sensor 1)	Fully released	0.5 - 1.0V
	Fully depressed	3.9 - 4.7V
98 (Accelerator pedal position sensor 2)	Fully released	0.15 - 0.60V
	Fully depressed	1.95 - 2.40V

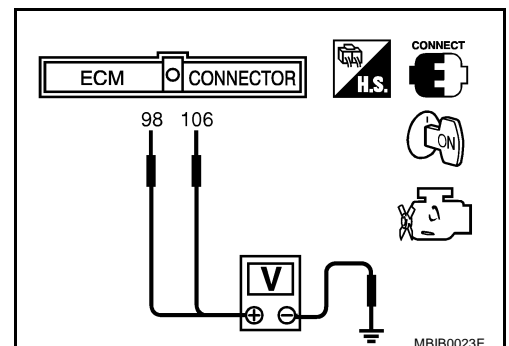

## DTC P2122, P2123 APP SENSOR

---

4. If NG, replace accelerator pedal assembly and go to next step.
5. Perform [EC-42, "Accelerator Pedal Released Position Learning"](#) .
6. Perform [EC-42, "Throttle Valve Closed Position Learning"](#) .
7. Perform [EC-43, "Idle Air Volume Learning"](#) .

### **Removal and Installation** **ACCELERATOR PEDAL**

ABS009NO

Refer to [ACC-3, "ACCELERATOR CONTROL SYSTEM"](#) .

# DTC P2127, P2128 APP SENSOR

## DTC P2127, P2128 APP SENSOR

PFP:18002

### Component Description

ABS009NP

The accelerator pedal position sensor is installed on the upper end of the accelerator pedal assembly. The sensor detects the accelerator position and sends a signal to the ECM.

Accelerator pedal position sensor has two sensors. These sensors are a kind of potentiometers which transform the accelerator pedal position into output voltage, and emit the voltage signal to the ECM. In addition, these sensors detect the opening and closing speed of the accelerator pedal and feed the voltage signals to the ECM. The ECM judges the current opening angle of the accelerator pedal from these signals and controls the throttle control motor based on these signals.

Idle position of the accelerator pedal is determined by the ECM receiving the signal from the accelerator pedal position sensor. The ECM uses this signal for the engine operation such as fuel cut.

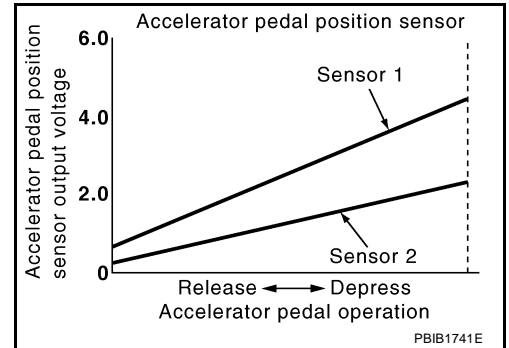

### CONSULT-II Reference Value in Data Monitor Mode

ABS009NQ

Specification data are reference values.

MONITOR ITEM	CONDITION	SPECIFICATION
ACCEL SEN 1	● Ignition switch: ON (Engine stopped) Accelerator pedal: Fully released	0.5 - 1.0V
	Accelerator pedal: Fully depressed	4.0 - 4.8V
ACCEL SEN 2*	● Ignition switch: ON (Engine stopped) Accelerator pedal: Fully released	0.3 - 1.2V
	Accelerator pedal: Fully depressed	3.9 - 4.8V
CLSD THL POS	● Ignition switch: ON (Engine stopped) Accelerator pedal: Fully released	ON
	Accelerator pedal: Slightly depressed	OFF

\*: Accelerator pedal position sensor 2 signal is converted by ECM internally. Thus, it differ from ECM terminal voltage.

### On Board Diagnosis Logic

ABS009NR

These self-diagnoses have the one trip detection logic.

DTC No.	Trouble diagnosis name	DTC detecting condition	Possible cause
P2127 2127	Accelerator pedal position sensor 2 circuit low input	An excessively low voltage from the APP sensor 2 is sent to ECM.	<ul style="list-style-type: none"> <li>● Harness or connectors (The APP sensor 2 circuit is open or shorted.) (TP sensor circuit is shorted.)</li> <li>● Accelerator pedal position sensor (Accelerator pedal position sensor 2)</li> <li>● Electric throttle control actuator (TP sensor 1 and 2)</li> </ul>
P2128 2128	Accelerator pedal position sensor 2 circuit high input	An excessively high voltage from the APP sensor 2 is sent to ECM.	

### FAIL-SAFE MODE

When the malfunction is detected, ECM enters fail-safe mode and the MIL lights up.

#### Engine operating condition in fail-safe mode

The ECM controls the electric throttle control actuator in regulating the throttle opening in order for the idle position to be within +10 degrees.

The ECM regulates the opening speed of the throttle valve to be slower than the normal condition.

So, the acceleration will be poor.

# DTC P2127, P2128 APP SENSOR

ABS009NS

## DTC Confirmation Procedure

### NOTE:

If DTC Confirmation Procedure has been previously conducted, always turn ignition switch OFF and wait at least 10 seconds before conducting the next test.

### TESTING CONDITION:

Before performing the following procedure, confirm that battery voltage is more than 10V at idle.

#### WITH CONSULT-II

1. Turn ignition switch ON.
2. Select "DATA MONITOR" mode with CONSULT-II.
3. Start engine and let it idle for 1 second.
4. If DTC is detected, go to [EC-601, "Diagnostic Procedure"](#) .

DATA MONITOR	
MONITOR	NO DTC
ENG SPEED	XXX rpm

SEF058Y

#### WITH GST

Follow the procedure "WITH CONSULT-II" above.

# DTC P2127, P2128 APP SENSOR

ABS009NT

## Wiring Diagram

EC-APPS2-01

: DETECTABLE LINE FOR DTC  
 : NON-DETECTABLE LINE FOR DTC

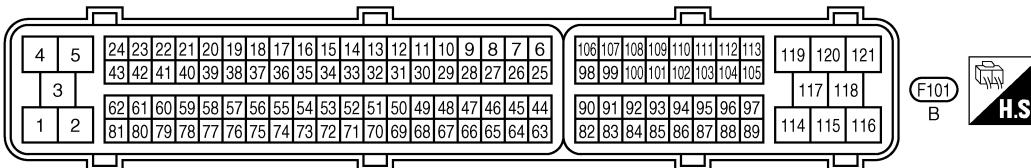
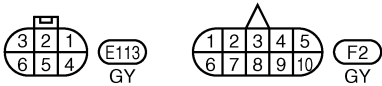
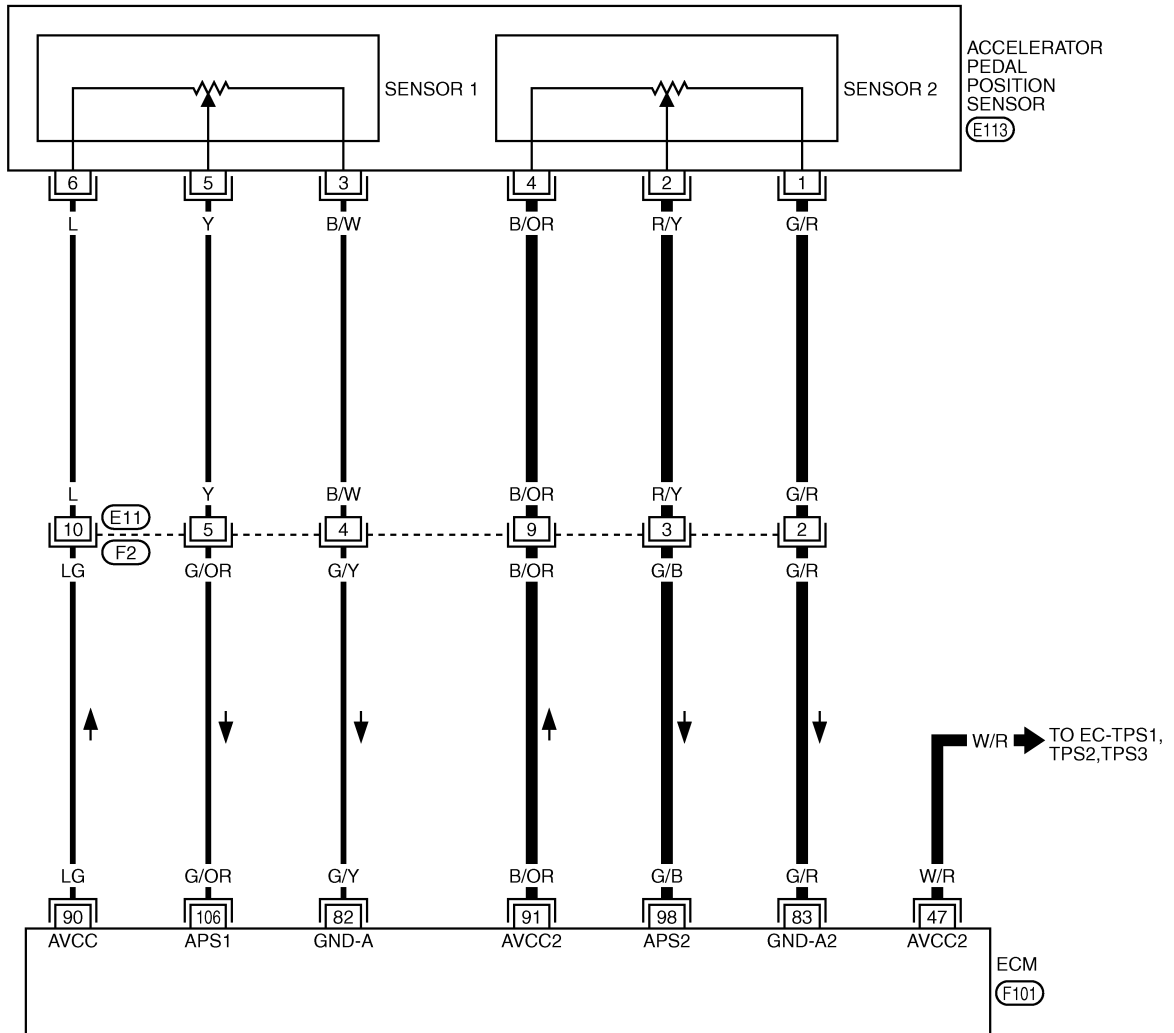

TBWT0784E

## DTC P2127, P2128 APP SENSOR

Specification data are reference values and are measured between each terminal and ground.

**CAUTION:**

**Do not use ECM ground terminals when measuring input/output voltage. Doing so may result in damage to the ECM's transistor. Use a ground other than ECM terminals, such as the ground.**

TER-MINAL NO.	WIRE COLOR	ITEM	CONDITION	DATA (DC Voltage)
47	W/R	Sensor power supply (Throttle position sensor)	<b>[Ignition switch: ON]</b>	Approximately 0V
82	G/Y	Sensor ground (APP sensor 1)	<b>[Engine is running]</b> ● Warm-up condition ● Idle speed	Approximately 0V
83	G/R	Sensor ground (APP sensor 2)	<b>[Engine is running]</b> ● Warm-up condition ● Idle speed	Approximately 0V
90	LG	Sensor power supply (APP sensor 1)	<b>[Ignition switch: ON]</b>	Approximately 5V
91	B/OR	Sensor power supply (APP sensor 2)	<b>[Ignition switch: ON]</b>	Approximately 5V
98	G/B	Accelerator pedal position sensor 2	<b>[Ignition switch: ON]</b> ● Engine stopped ● Accelerator pedal is fully released	0.15 - 0.60V
			<b>[Ignition switch: ON]</b> ● Engine stopped ● Accelerator pedal is fully depressed	1.95 - 2.40V
106	G/OR	Accelerator pedal position sensor 1	<b>[Ignition switch: ON]</b> ● Engine stopped ● Accelerator pedal is fully released	0.5 - 1.0V
			<b>[Ignition switch: ON]</b> ● Engine stopped ● Accelerator pedal is fully depressed	3.9 - 4.7V



# DTC P2127, P2128 APP SENSOR

ABS009NU

## Diagnostic Procedure

### 1. CHECK GROUND CONNECTIONS

1. Turn ignition switch OFF.
2. Loosen and retighten three ground screws on the body. Refer to [EC-138, "Ground Inspection"](#).

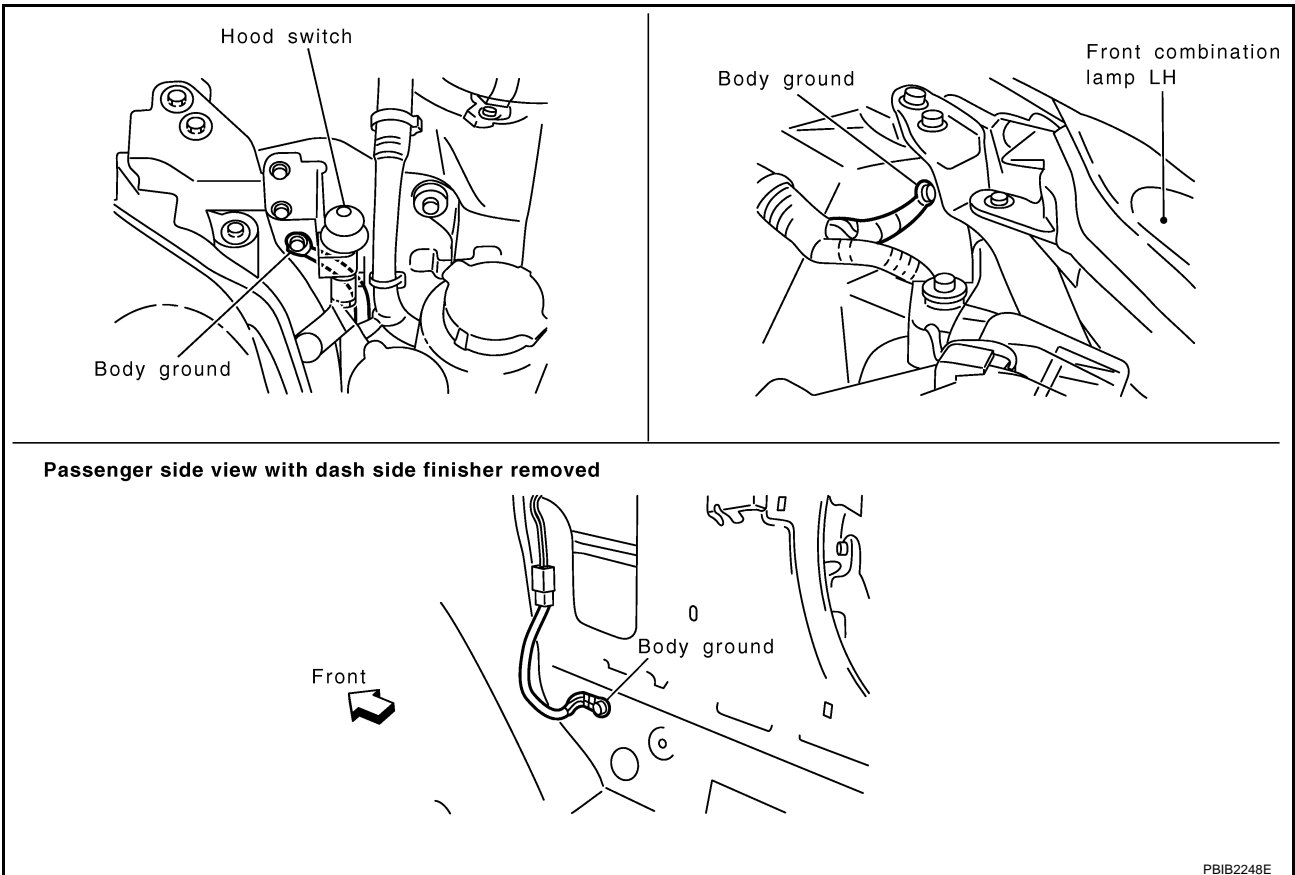

#### OK or NG

- OK >> GO TO 2.
- NG >> Repair or replace ground connections.

A  
EC  
C  
D  
E  
F  
G  
H  
I  
J  
K  
L  
M

# DTC P2127, P2128 APP SENSOR

## 2. CHECK APP SENSOR 2 POWER SUPPLY CIRCUIT-I

1. Disconnect accelerator pedal position (APP) sensor harness connector.
2. Turn ignition switch ON.

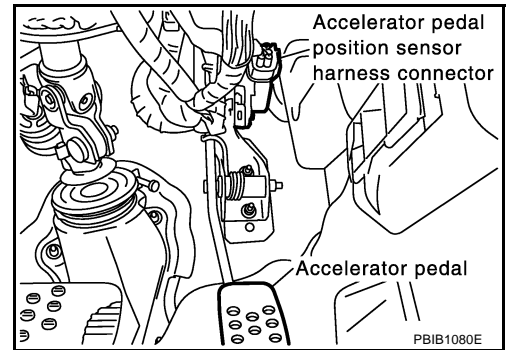

3. Check voltage between APP sensor terminal 4 and ground with CONSULT-II or tester.

**Voltage: Approximately 5V**

OK or NG

- OK >> GO TO 8.  
NG >> GO TO 3.

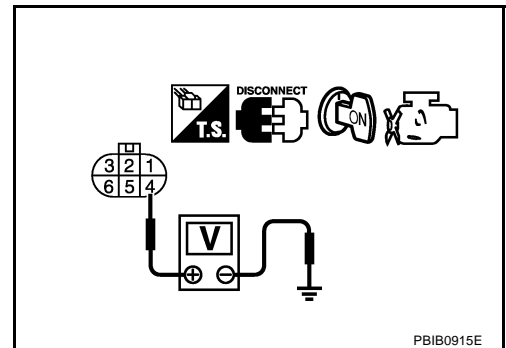

## 3. CHECK APP SENSOR 2 POWER SUPPLY CIRCUIT-II

1. Turn ignition switch OFF.
2. Disconnect ECM harness connector.
3. Check harness continuity between APP sensor terminal 4 and ECM terminal 91. Refer to Wiring Diagram.

**Continuity should exist.**

OK or NG

- OK >> GO TO 5.  
NG >> GO TO 4.

## 4. DETECT MALFUNCTIONING PART

Check the following.

- Harness connectors E11, F2
- Harness for open between ECM and accelerator pedal position sensor

>> Repair or replace open circuit.

## 5. CHECK APP SENSOR 2 POWER SUPPLY CIRCUIT-III

Check harness for short to power and short to ground, between the following terminals.

ECM terminal	Sensor terminal	Reference Wiring Diagram
91	APP sensor terminal 4	<a href="#">EC-599</a>
47	Electric throttle control actuator terminal 1	<a href="#">EC-607</a>

OK or NG

- OK >> GO TO 6.  
NG >> Repair short to ground or short to power in harness or connectors.

# DTC P2127, P2128 APP SENSOR

---

## 6. CHECK THROTTLE POSITION SENSOR

---

Refer to [EC-612, "Component Inspection"](#) .

OK or NG

- OK >> GO TO 14.
- NG >> GO TO 7.

---

## 7. REPLACE ELECTRIC THROTTLE CONTROL ACTUATOR

---

1. Replace the electric throttle control actuator.
2. Perform [EC-42, "Throttle Valve Closed Position Learning"](#) .
3. Perform [EC-43, "Idle Air Volume Learning"](#) .

>> **INSPECTION END**

---

## 8. CHECK APP SENSOR 2 GROUND CIRCUIT FOR OPEN AND SHORT

---

1. Turn ignition switch OFF.
2. Disconnect ECM harness connector.
3. Check harness continuity between APP sensor terminal 1 and ECM terminal 83.  
Refer to Wiring Diagram.

**Continuity should exist.**

4. Also check harness for short to ground and short to power.

OK or NG

- OK >> GO TO 10.
- NG >> GO TO 9.

---

## 9. DETECT MALFUNCTIONING PART

---

Check the following.

- Harness connectors E11, F2
- Harness for open or short between ECM and accelerator pedal position sensor

>> Repair open circuit or short to ground or short to power in harness or connectors.

---

## 10. CHECK APP SENSOR 2 INPUT SIGNAL CIRCUIT FOR OPEN AND SHORT

---

1. Check harness continuity between ECM terminal 98 and APP sensor terminal 2.  
Refer to Wiring Diagram.

**Continuity should exist.**

2. Also check harness for short to ground and short to power.

OK or NG

- OK >> GO TO 12.
- NG >> GO TO 11.

---

## 11. DETECT MALFUNCTIONING PART

---

Check the following.

- Harness connectors E11, F2
- Harness for open or short between ECM and accelerator pedal position sensor

>> Repair open circuit or short to ground or short to power in harness or connectors.

A

EC

C

D

E

F

G

H

I

J

K

L

M

# DTC P2127, P2128 APP SENSOR

## 12. CHECK APP SENSOR

Refer to [EC-621, "Component Inspection"](#) .

OK or NG

- OK >> GO TO 13.
- NG >> GO TO 14.

## 13. REPLACE ACCELERATOR PEDAL ASSEMBLY

1. Replace accelerator pedal assembly.
2. Perform [EC-42, "Accelerator Pedal Released Position Learning"](#) .
3. Perform [EC-42, "Throttle Valve Closed Position Learning"](#) .
4. Perform [EC-43, "Idle Air Volume Learning"](#) .

>> INSPECTION END

## 14. CHECK INTERMITTENT INCIDENT

Refer to [EC-129, "TROUBLE DIAGNOSIS FOR INTERMITTENT INCIDENT"](#) .

>> INSPECTION END

### Component Inspection ACCELERATOR PEDAL POSITION SENSOR

ABS009NV

1. Reconnect all harness connectors disconnected.
2. Turn ignition switch ON.
3. Check voltage between ECM terminals 106 (APP sensor 1 signal), 98 (APP sensor 2 signal) and ground under the following conditions.

Terminal	Accelerator pedal	Voltage
106 (Accelerator pedal position sensor 1)	Fully released	0.5 - 1.0V
	Fully depressed	3.9 - 4.7V
98 (Accelerator pedal position sensor 2)	Fully released	0.15 - 0.60V
	Fully depressed	1.95 - 2.40V

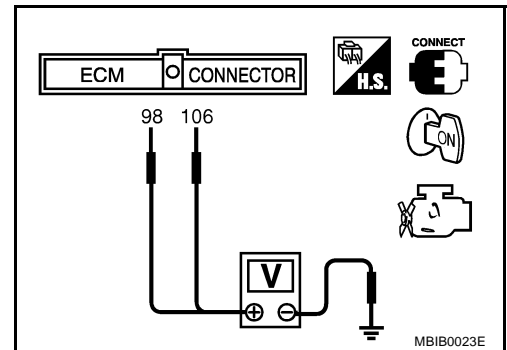

4. If NG, replace accelerator pedal assembly and go to next step.
5. Perform [EC-42, "Accelerator Pedal Released Position Learning"](#) .
6. Perform [EC-42, "Throttle Valve Closed Position Learning"](#) .
7. Perform [EC-43, "Idle Air Volume Learning"](#) .

### Removal and Installation ACCELERATOR PEDAL

ABS009NW

Refer to [ACC-3, "ACCELERATOR CONTROL SYSTEM"](#) .

# DTC P2135 TP SENSOR

PF16:16119

## DTC P2135 TP SENSOR

### Component Description

ABS009NX

Electric throttle control actuator consists of throttle control motor, throttle position sensor, etc. The throttle position sensor responds to the throttle valve movement.

The throttle position sensor has the two sensors. These sensors are a kind of potentiometers which transform the throttle valve position into output voltage, and emit the voltage signal to the ECM. In addition, these sensors detect the opening and closing speed of the throttle valve and feed the voltage signals to the ECM. The ECM judges the current opening angle of the throttle valve from these signals and the ECM controls the throttle control motor to make the throttle valve opening angle properly in response to driving condition.

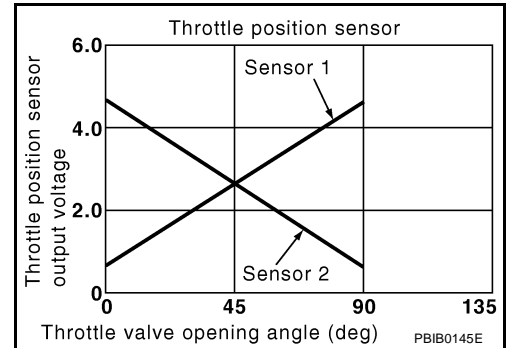

### CONSULT-II Reference Value in Data Monitor Mode

ABS009NY

Specification data are reference values.

MONITOR ITEM	CONDITION		SPECIFICATION
THRTL SEN 1 THRTL SEN 2*	<ul style="list-style-type: none"> <li>Ignition switch: ON (Engine stopped)</li> <li>Shift lever: D (A/T), 1st (M/T)</li> </ul>	Accelerator pedal: Fully released	More than 0.36V
		Accelerator pedal: Fully depressed	Less than 4.75V

\*: Throttle position sensor 2 signal is converted by ECM internally. Thus, it differs from ECM terminal voltage signal.

### On Board Diagnosis Logic

ABS009NZ

This self-diagnosis has the one trip detection logic.

DTC No.	Trouble diagnosis name	DTC detecting condition	Possible cause
P2135 2135	Throttle position sensor circuit range/performance problem	Rationally incorrect voltage is sent to ECM compared with the signals from TP sensor 1 and TP sensor 2.	<ul style="list-style-type: none"> <li>Harness or connector (The TP sensor 1 and 2 circuit is open or shorted.) (APP sensor 2 circuit is shorted.)</li> <li>Electric throttle control actuator (TP sensor 1 and 2)</li> <li>Accelerator pedal position sensor (APP sensor 2)</li> </ul>

### FAIL-SAFE MODE

When the malfunction is detected, the ECM enters fail-safe mode and the MIL lights up.

#### Engine operation condition in fail-safe mode

The ECM controls the electric throttle control actuator in regulating the throttle opening in order for the idle position to be within +10 degrees.

The ECM regulates the opening speed of the throttle valve to be slower than the normal condition.

So, the acceleration will be poor.

# DTC P2135 TP SENSOR

ABS00900

## DTC Confirmation Procedure

### NOTE:

If DTC Confirmation Procedure has been previously conducted, always turn ignition switch OFF and wait at least 10 seconds before conducting the next test.

### TESTING CONDITION:

Before performing the following procedure, confirm that battery voltage is more than 10V at idle.

#### WITH CONSULT-II

1. Turn ignition switch ON.
2. Select "DATA MONITOR" mode with CONSULT-II.
3. Start engine and let it idle for 1 second.
4. If DTC is detected, go to [EC-609, "Diagnostic Procedure"](#) .

DATA MONITOR	
MONITOR	NO DTC
ENG SPEED	XXX rpm

SEF058Y

#### WITH GST

Follow the procedure "WITH CONSULT-II" above.

# DTC P2135 TP SENSOR

## Wiring Diagram

ABS00901

### EC-TPS3-01

: DETECTABLE LINE FOR DTC  
 : NON-DETECTABLE LINE FOR DTC

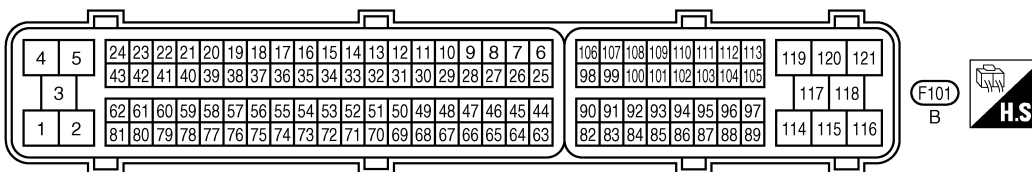
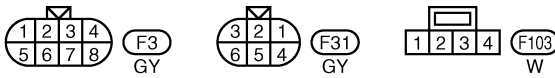
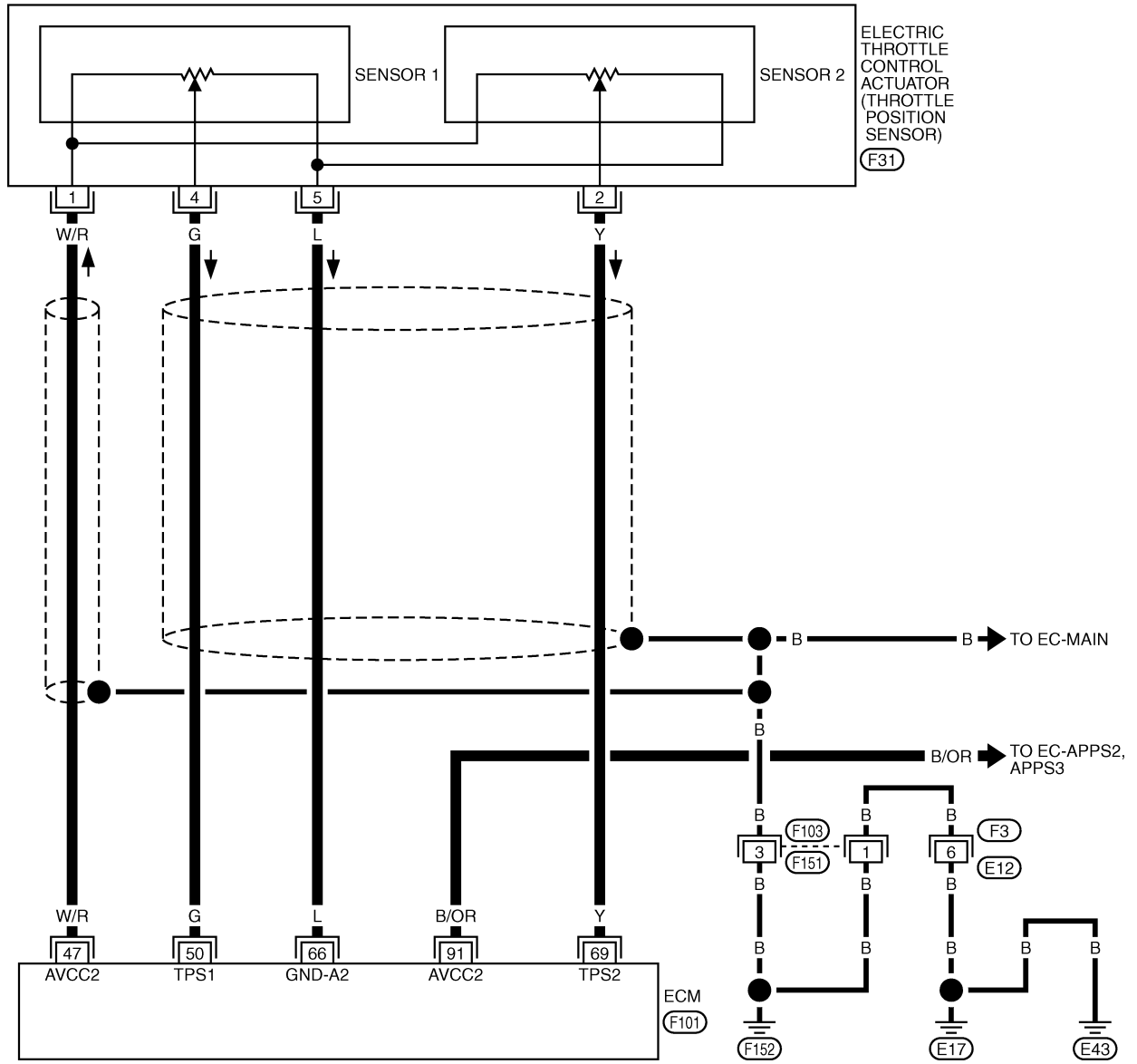

TBW07085E

## DTC P2135 TP SENSOR

Specification data are reference values and are measured between each terminal and ground.

**CAUTION:**

**Do not use ECM ground terminals when measuring input/output voltage. Doing so may result in damage to the ECM's transistor. Use a ground other than ECM terminals, such as the ground.**

TER-MINAL NO.	WIRE COLOR	ITEM	CONDITION	DATA (DC Voltage)
47	W/R	Sensor power supply (Throttle position sensor)	<b>[Ignition switch: ON]</b>	Approximately 5V
50	G	Throttle position sensor 1	<b>[Ignition switch: ON]</b> <ul style="list-style-type: none"> <li>● Engine stopped</li> <li>● Shift lever: D (A/T) or 1st (M/T)</li> <li>● Accelerator pedal is fully released</li> </ul>	More than 0.36V
			<b>[Ignition switch: ON]</b> <ul style="list-style-type: none"> <li>● Engine stopped</li> <li>● Shift lever: D (A/T) or 1st (M/T)</li> <li>● Accelerator pedal is fully depressed</li> </ul>	Less than 4.75V
66	L	Sensor ground (Throttle position sensor)	<b>[Engine is running]</b> <ul style="list-style-type: none"> <li>● <b>Warm-up condition</b></li> <li>● Idle speed</li> </ul>	Approximately 0V
69	Y	Throttle position sensor 2	<b>[Ignition switch: ON]</b> <ul style="list-style-type: none"> <li>● Engine stopped</li> <li>● Shift lever: D (A/T) or 1st (M/T)</li> <li>● Accelerator pedal is fully released</li> </ul>	Less than 4.75V
			<b>[Ignition switch: ON]</b> <ul style="list-style-type: none"> <li>● Engine stopped</li> <li>● Shift lever: D (A/T) or 1st (M/T)</li> <li>● Accelerator pedal is fully depressed</li> </ul>	More than 0.36V
91	B/OR	Sensor power supply (APP sensor 2)	<b>[Ignition switch: ON]</b>	Approximately 5V



# DTC P2135 TP SENSOR

ABS00902

## Diagnostic Procedure

### 1. CHECK GROUND CONNECTIONS

1. Turn ignition switch OFF.
2. Loosen and retighten three ground screws on the body. Refer to [EC-138, "Ground Inspection"](#).

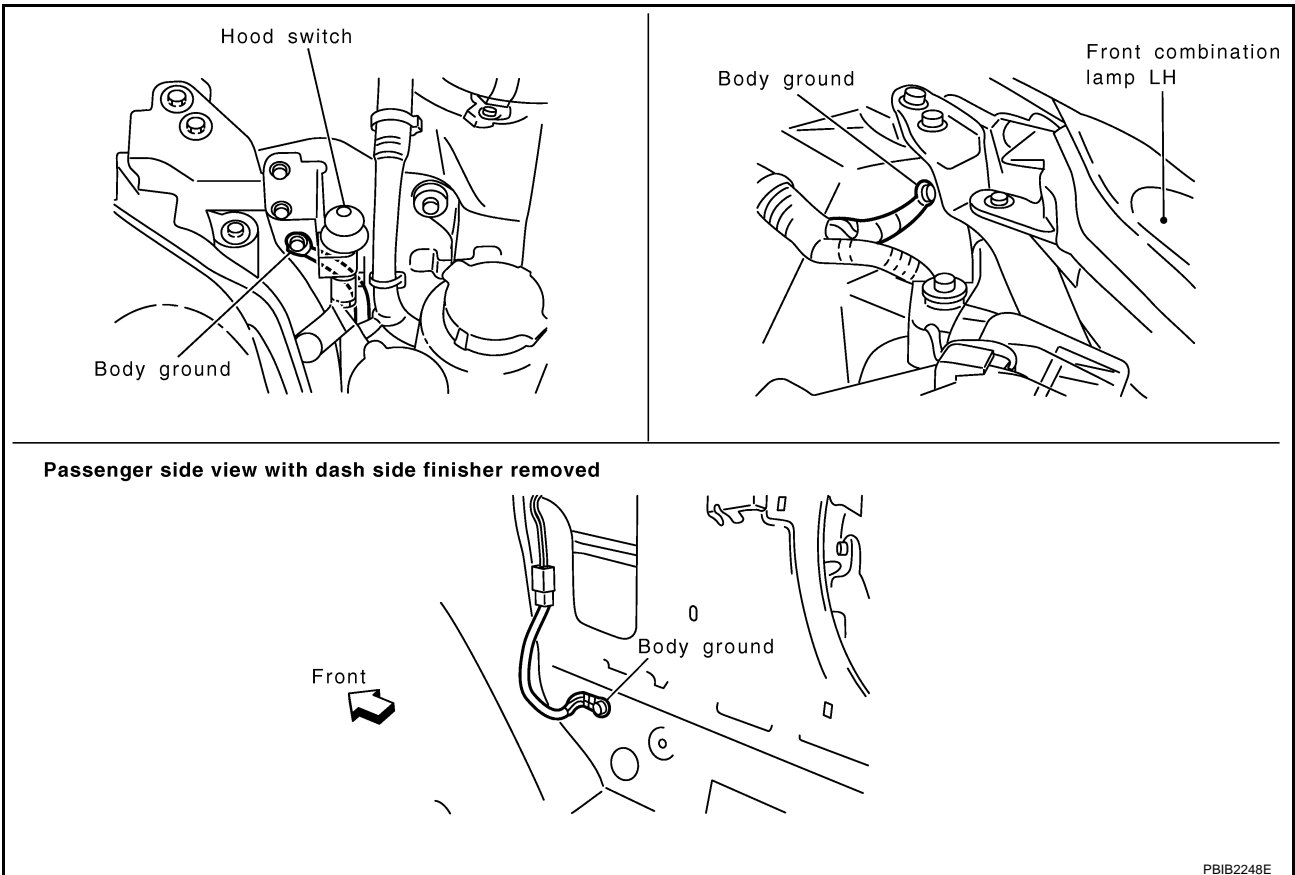

#### OK or NG

- OK >> GO TO 2.
- NG >> Repair or replace ground connections.

A  
EC  
C  
D  
E  
F  
G  
H  
I  
J  
K  
L  
M

# DTC P2135 TP SENSOR

## 2. CHECK THROTTLE POSITION SENSOR POWER SUPPLY CIRCUIT-I

1. Disconnect electric throttle control actuator harness connector.
2. Turn ignition switch ON.

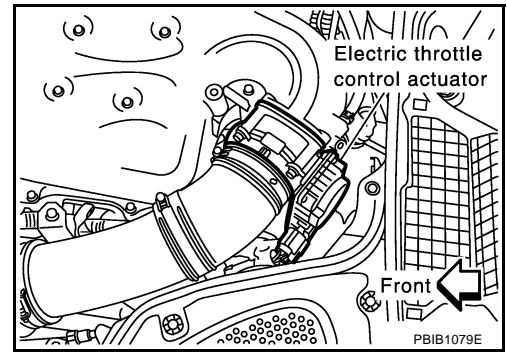

3. Check voltage between electric throttle control actuator terminal 1 and ground with CONSULT-II or tester.

**Voltage: Approximately 5V**

OK or NG

OK >> GO TO 3.

NG >> Repair open circuit or short to ground or short to power in harness or connectors.

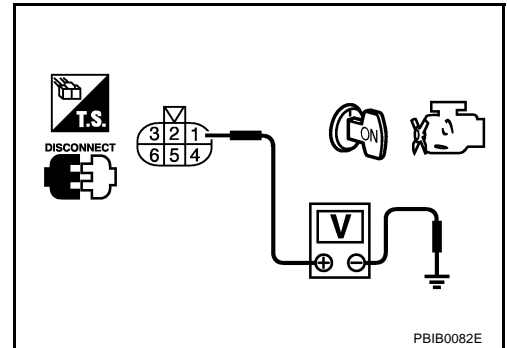

## 3. CHECK THROTTLE POSITION SENSOR POWER SUPPLY CIRCUIT-II

1. Turn ignition switch OFF.
2. Disconnect ECM harness connector.
3. Check harness continuity between electric throttle control actuator terminal 1 and ECM terminal 47. Refer to Wiring Diagram.

**Continuity should exist.**

OK or NG

OK >> GO TO 4.

NG >> Repair or replace open circuit.

## 4. CHECK THROTTLE POSITION SENSOR POWER SUPPLY CIRCUIT-III

Check harness for short to power and short to ground, between the following terminals.

ECM terminal	Sensor terminal	Reference Wiring Diagram
47	Electric throttle control actuator terminal 1	<a href="#">EC-607</a>
91	APP sensor terminal 4	<a href="#">EC-599</a>

OK or NG

OK >> GO TO 5.

NG >> Repair short to ground or short to power in harness or connectors.

## 5. CHECK APP SENSOR

Refer to [EC-604, "Component Inspection"](#).

OK or NG

OK >> GO TO 11.

NG >> GO TO 6.

# DTC P2135 TP SENSOR

---

## 6. REPLACE ACCELERATOR PEDAL ASSEMBLY

---

1. Replace accelerator pedal assembly.
2. Perform [EC-42, "Accelerator Pedal Released Position Learning"](#) .
3. Perform [EC-42, "Throttle Valve Closed Position Learning"](#) .
4. Perform [EC-43, "Idle Air Volume Learning"](#) .

>> INSPECTION END

---

## 7. CHECK THROTTLE POSITION SENSOR GROUND CIRCUIT FOR OPEN AND SHORT

---

1. Turn ignition switch OFF.
2. Disconnect ECM harness connector.
3. Check harness continuity between electric throttle control actuator terminal 5 and ECM terminal 66.  
Refer to Wiring Diagram.

**Continuity should exist.**

4. Also check harness for short to ground and short to power.

OK or NG

OK >> GO TO 8.

NG >> Repair open circuit or short to ground or short to power in harness or connectors.

---

## 8. CHECK THROTTLE POSITION SENSOR INPUT SIGNAL CIRCUIT FOR OPEN AND SHORT

---

1. Check harness continuity between the following;  
ECM terminal 50 and electric throttle control actuator terminal 4,  
ECM terminal 69 and electric throttle control actuator terminal 2.  
Refer to Wiring Diagram.

**Continuity should exist.**

2. Also check harness for short to ground and short to power.

OK or NG

OK >> GO TO 9.

NG >> Repair open circuit or short to ground or short to power in harness or connectors.

---

## 9. CHECK THROTTLE POSITION SENSOR

---

Refer to [EC-612, "Component Inspection"](#) .

OK or NG

OK >> GO TO 11.

NG >> GO TO 10.

---

## 10. REPLACE ELECTRIC THROTTLE CONTROL ACTUATOR

---

1. Replace the electric throttle control actuator.
2. Perform [EC-42, "Throttle Valve Closed Position Learning"](#) .
3. Perform [EC-43, "Idle Air Volume Learning"](#) .

>> INSPECTION END

---

## 11. CHECK INTERMITTENT INCIDENT

---

Refer to [EC-129, "TROUBLE DIAGNOSIS FOR INTERMITTENT INCIDENT"](#) .

>> INSPECTION END

# DTC P2135 TP SENSOR

ABS00903

## Component Inspection THROTTLE POSITION SENSOR

1. Reconnect all harness connectors disconnected.
2. Perform [EC-42, "Throttle Valve Closed Position Learning"](#) .
3. Turn ignition switch ON.
4. Set shift lever to D (A/T) or 1st (M/T) position.
5. Check voltage between ECM terminals 50 (TP sensor 1 signal), 69 (TP sensor 2 signal) and ground under the following conditions.

Terminal	Accelerator pedal	Voltage
50 (Throttle position sensor 1)	Fully released	More than 0.36V
	Fully depressed	Less than 4.75V
69 (Throttle position sensor 2)	Fully released	Less than 4.75V
	Fully depressed	More than 0.36V

6. If NG, replace electric throttle control actuator and go to the next step.
7. Perform [EC-42, "Throttle Valve Closed Position Learning"](#) .
8. Perform [EC-43, "Idle Air Volume Learning"](#) .

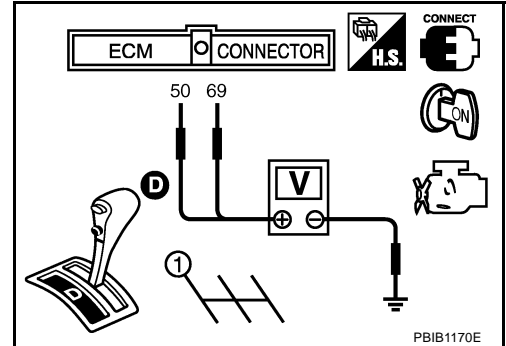

## Removal and Installation ELECTRIC THROTTLE CONTROL ACTUATOR

ABS00904

Refer to [EM-16, "INTAKE MANIFOLD COLLECTOR"](#) .

# DTC P2138 APP SENSOR

## DTC P2138 APP SENSOR

PPF:18002

### Component Description

ABS00905

The accelerator pedal position sensor is installed on the upper end of the accelerator pedal assembly. The sensor detects the accelerator position and sends a signal to the ECM.

Accelerator pedal position sensor has two sensors. These sensors are a kind of potentiometers which transform the accelerator pedal position into output voltage, and emit the voltage signal to the ECM. In addition, these sensors detect the opening and closing speed of the accelerator pedal and feed the voltage signals to the ECM. The ECM judges the current opening angle of the accelerator pedal from these signals and controls the throttle control motor based on these signals.

Idle position of the accelerator pedal is determined by the ECM receiving the signal from the accelerator pedal position sensor. The ECM uses this signal for the engine operation such as fuel cut.

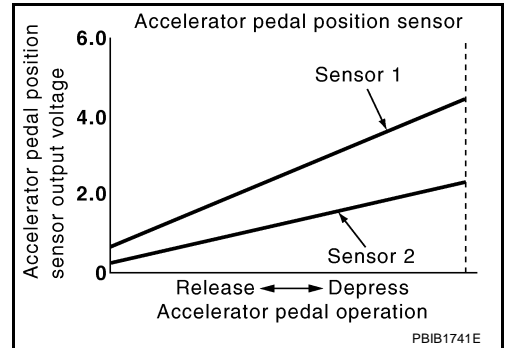

### CONSULT-II Reference Value in Data Monitor Mode

ABS00906

Specification data are reference values.

MONITOR ITEM	CONDITION		SPECIFICATION
ACCEL SEN 1	● Ignition switch: ON (Engine stopped)	Accelerator pedal: Fully released	0.5 - 1.0V
		Accelerator pedal: Fully depressed	4.0 - 4.8V
ACCEL SEN 2*	● Ignition switch: ON (Engine stopped)	Accelerator pedal: Fully released	0.3 - 1.2V
		Accelerator pedal: Fully depressed	3.9 - 4.8V
CLSD THL POS	● Ignition switch: ON (Engine stopped)	Accelerator pedal: Fully released	ON
		Accelerator pedal: Slightly depressed	OFF

\*: Accelerator pedal position sensor 2 signal is converted by ECM internally. Thus, it differ from ECM terminal voltage.

### On Board Diagnosis Logic

ABS00907

This self-diagnosis has the one trip detection logic.

#### NOTE:

If DTC P2138 is displayed with DTC P1229, first perform the trouble diagnosis for DTC P1229.

Refer to [EC-456](#).

DTC No.	Trouble diagnosis name	DTC detecting condition	Possible cause
P2138 2138	Accelerator pedal position sensor circuit range/performance problem	Rationally incorrect voltage is sent to ECM compared with the signals from APP sensor 1 and APP sensor 2.	<ul style="list-style-type: none"> <li>● Harness or connector (The APP sensor 1 and 2 circuit is open or shorted.) (TP sensor circuit is shorted.)</li> <li>● Accelerator pedal position sensor 1 and 2</li> <li>● Electric throttle control actuator (TP sensor 1 and 2)</li> </ul>

### FAIL-SAFE MODE

When the malfunction is detected, ECM enters fail-safe mode and the MIL lights up.

#### Engine operating condition in fail-safe mode

The ECM controls the electric throttle control actuator in regulating the throttle opening in order for the idle position to be within +10 degrees.

The ECM regulates the opening speed of the throttle valve to be slower than the normal condition.

So, the acceleration will be poor.

# DTC P2138 APP SENSOR

ABS00908

## DTC Confirmation Procedure

### NOTE:

If DTC Confirmation Procedure has been previously conducted, always turn ignition switch OFF and wait at least 10 seconds before conducting the next test.

### TESTING CONDITION:

Before performing the following procedure, confirm that battery voltage is more than 10V at idle.

#### WITH CONSULT-II

1. Turn ignition switch ON.
2. Select "DATA MONITOR" mode with CONSULT-II.
3. Start engine and let it idle for 1 second.
4. If DTC is detected, go to [EC-617, "Diagnostic Procedure"](#) .

DATA MONITOR	
MONITOR	NO DTC
ENG SPEED	XXX rpm

SEF058Y

#### WITH GST

Follow the procedure "WITH CONSULT-II" above.

# DTC P2138 APP SENSOR

## Wiring Diagram

ABS00909

EC-APPS3-01

: DETECTABLE LINE FOR DTC  
 : NON-DETECTABLE LINE FOR DTC

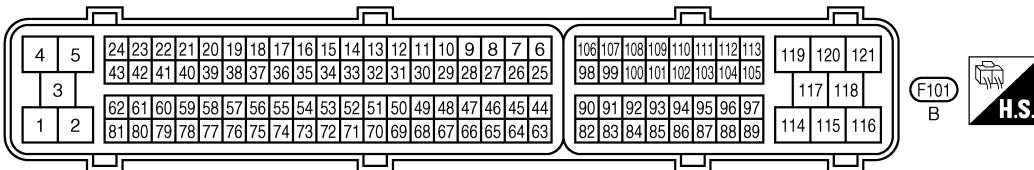
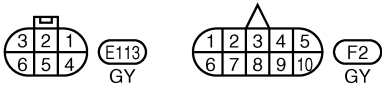
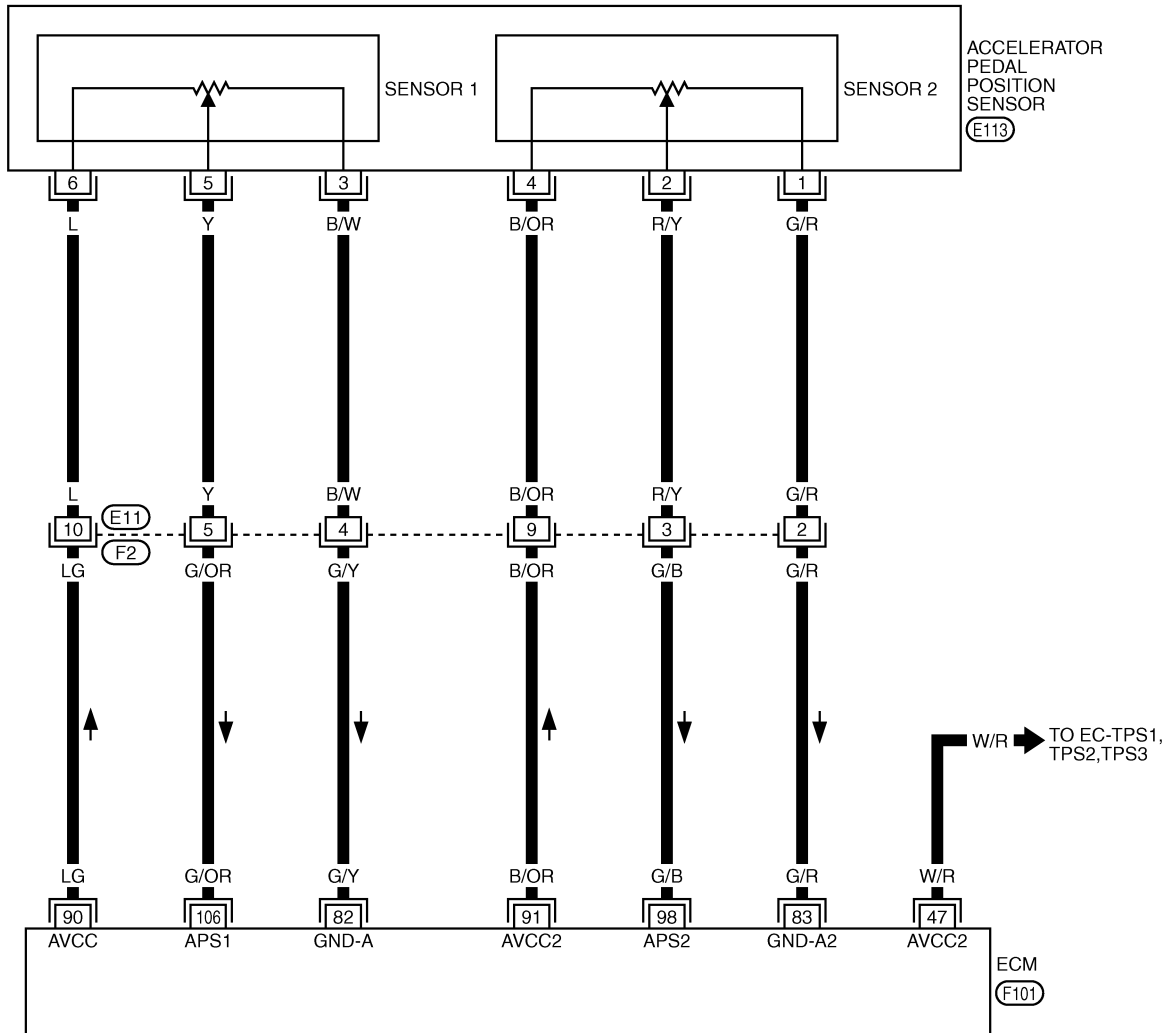

TBWT0786E

## DTC P2138 APP SENSOR

Specification data are reference values and are measured between each terminal and ground.

**CAUTION:**

**Do not use ECM ground terminals when measuring input/output voltage. Doing so may result in damage to the ECM's transistor. Use a ground other than ECM terminals, such as the ground.**

TER-MINAL NO.	WIRE COLOR	ITEM	CONDITION	DATA (DC Voltage)
47	W/R	Sensor power supply (Throttle position sensor)	<b>[Ignition switch: ON]</b>	Approximately 5V
82	G/Y	Sensor ground (APP sensor 1)	<b>[Engine is running]</b> ● Warm-up condition ● Idle speed	Approximately 0V
83	G/R	Sensor ground (APP sensor 2)	<b>[Engine is running]</b> ● Warm-up condition ● Idle speed	Approximately 0V
90	LG	Sensor power supply (APP sensor 1)	<b>[Ignition switch: ON]</b>	Approximately 5V
91	B/OR	Sensor power supply (APP sensor 2)	<b>[Ignition switch: ON]</b>	Approximately 5V
98	G/B	Accelerator pedal position sensor 2	<b>[Ignition switch: ON]</b> ● Engine stopped ● Accelerator pedal is fully released	0.15 - 0.60V
			<b>[Ignition switch: ON]</b> ● Engine stopped ● Accelerator pedal is fully depressed	1.95 - 2.40V
106	G/OR	Accelerator pedal position sensor 1	<b>[Ignition switch: ON]</b> ● Engine stopped ● Accelerator pedal is fully released	0.5 - 1.0V
			<b>[Ignition switch: ON]</b> ● Engine stopped ● Accelerator pedal is fully depressed	3.9 - 4.7V



# DTC P2138 APP SENSOR

ABS0090A

## Diagnostic Procedure

### 1. CHECK GROUND CONNECTIONS

1. Turn ignition switch OFF.
2. Loosen and retighten three ground screws on the body. Refer to [EC-138, "Ground Inspection"](#).

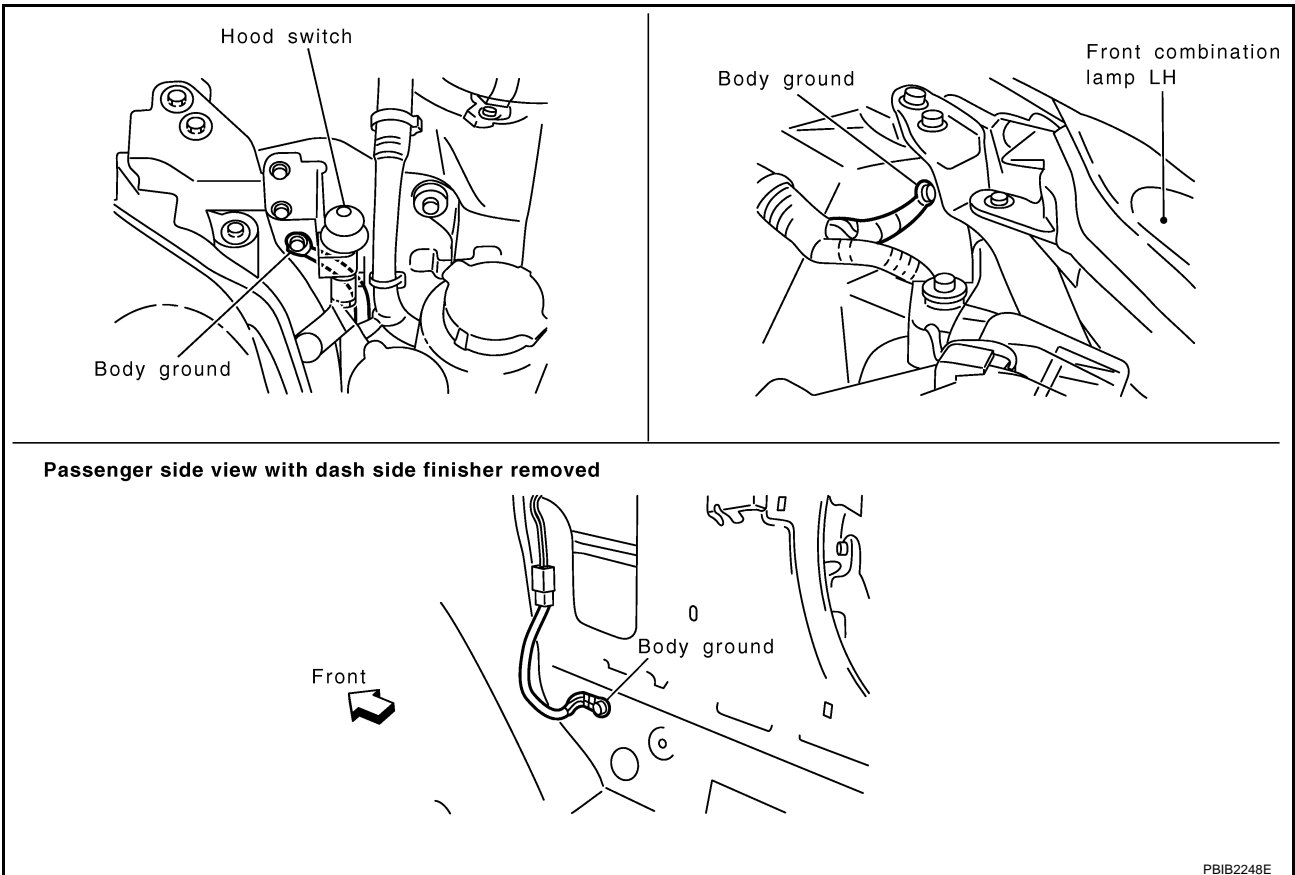

#### OK or NG

- OK >> GO TO 2.
- NG >> Repair or replace ground connections.

A  
EC  
C  
D  
E  
F  
G  
H  
I  
J  
K  
L  
M

# DTC P2138 APP SENSOR

## 2. CHECK APP SENSOR POWER 1 SUPPLY CIRCUIT

1. Disconnect accelerator pedal position (APP) sensor harness connector.
2. Turn ignition switch ON.

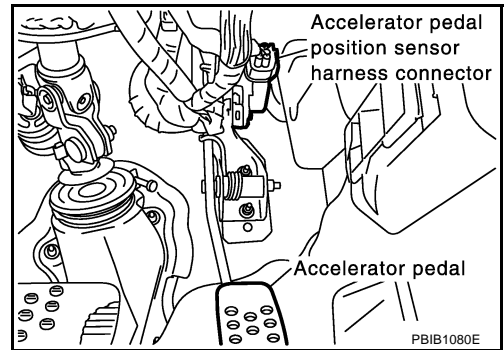

3. Check voltage between APP sensor terminal 6 and ground with CONSULT-II or tester.

**Voltage: Approximately 5V**

OK or NG

OK >> GO TO 4.

NG >> GO TO 3.

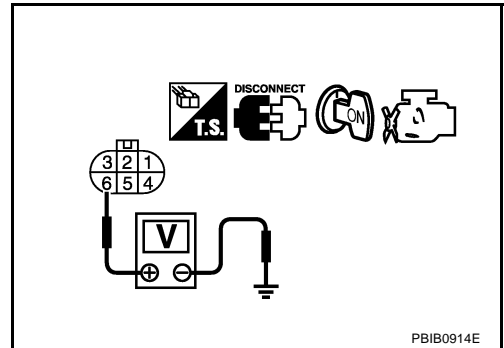

## 3. DETECT MALFUNCTIONING PART

Check the following.

- Harness connectors E11, F2
- Harness for open or short between ECM and accelerator pedal position sensor

>> Repair open circuit or short to ground or short to power in harness or connectors.

## 4. CHECK APP SENSOR 2 POWER SUPPLY CIRCUIT-I

Check voltage between APP sensor terminal 4 and ground with CONSULT-II or tester.

**Voltage: Approximately 5V**

OK or NG

OK >> GO TO 10.

NG >> GO TO 5.

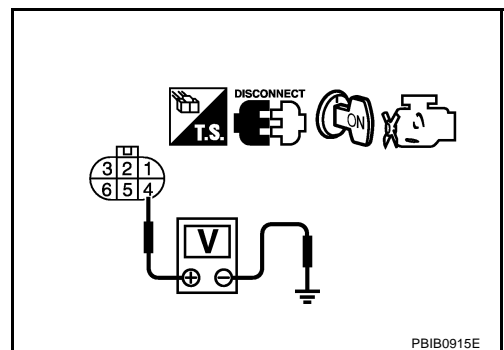

# DTC P2138 APP SENSOR

## 5. CHECK APP SENSOR 2 POWER SUPPLY CIRCUIT-II

1. Turn ignition switch OFF.
2. Disconnect ECM harness connector.
3. Check harness continuity between APP sensor terminal 4 and ECM terminal 91.  
Refer to Wiring Diagram.

**Continuity should exist.**

OK or NG

- OK >> GO TO 7.  
NG >> GO TO 6.

## 6. DETECT MALFUNCTIONING PART

Check the following.

- Harness connectors E11, F2
- Harness for open between ECM and accelerator pedal position sensor

>> Repair or replace open circuit.

## 7. CHECK APP SENSOR 2 POWER SUPPLY CIRCUIT-III

Check harness for short to power and short to ground, between the following terminals.

ECM terminal	Sensor terminal	Reference Wiring Diagram
91	APP sensor terminal 4	<a href="#">EC-615</a>
47	Electric throttle control actuator terminal 1	<a href="#">EC-607</a>

OK or NG

- OK >> GO TO 8.  
NG >> Repair short to ground or short to power in harness or connectors.

## 8. CHECK THROTTLE POSITION SENSOR

Refer to [EC-612, "Component Inspection"](#) .

OK or NG

- OK >> GO TO 16.  
NG >> GO TO 9.

## 9. REPLACE ELECTRIC THROTTLE CONTROL ACTUATOR

1. Replace the electric throttle control actuator.
2. Perform [EC-42, "Throttle Valve Closed Position Learning"](#) .
3. Perform [EC-43, "Idle Air Volume Learning"](#) .

>> INSPECTION END

# DTC P2138 APP SENSOR

---

## 10. CHECK APP SENSOR GROUND CIRCUIT FOR OPEN AND SHORT

---

1. Turn ignition switch OFF.
2. Disconnect ECM harness connector.
3. Check harness continuity between the following;  
APP sensor terminal 1 and ECM terminal 83,  
APP sensor terminal 3 and ECM terminal 82.  
Refer to Wiring Diagram.

**Continuity should exist.**

4. Also check harness for short to ground and short to power.

OK or NG

- OK >> GO TO 12.  
NG >> GO TO 11.

---

## 11. DETECT MALFUNCTIONING PART

---

Check the following.

- Harness connectors E11, F2
- Harness for open or short between ECM and accelerator pedal position sensor

>> Repair open circuit or short to ground or short to power in harness or connectors.

---

## 12. CHECK APP SENSOR INPUT SIGNAL CIRCUIT FOR OPEN AND SHORT

---

1. Check harness continuity between ECM terminal 106 and APP sensor terminal 5, ECM terminal 98 and APP sensor terminal 2.  
Refer to Wiring Diagram.

**Continuity should exist.**

2. Also check harness for short to ground and short to power.

OK or NG

- OK >> GO TO 14.  
NG >> GO TO 13.

---

## 13. DETECT MALFUNCTIONING PART

---

Check the following.

- Harness connectors E11, F2
- Harness for open or short between ECM and accelerator pedal position sensor

>> Repair open circuit or short to ground or short to power in harness or connectors.

---

## 14. CHECK APP SENSOR

---

Refer to [EC-621, "Component Inspection"](#) .

OK or NG

- OK >> GO TO 16.  
NG >> GO TO 15.

# DTC P2138 APP SENSOR

## 15. REPLACE ACCELERATOR PEDAL ASSEMBLY

1. Replace accelerator pedal assembly.
2. Perform [EC-42, "Accelerator Pedal Released Position Learning"](#) .
3. Perform [EC-42, "Throttle Valve Closed Position Learning"](#) .
4. Perform [EC-43, "Idle Air Volume Learning"](#) .

>> INSPECTION END

## 16. CHECK INTERMITTENT INCIDENT

Refer to [EC-129, "TROUBLE DIAGNOSIS FOR INTERMITTENT INCIDENT"](#) .

>> INSPECTION END

### Component Inspection ACCELERATOR PEDAL POSITION SENSOR

ABS0090B

1. Reconnect all harness connectors disconnected.
2. Turn ignition switch ON.
3. Check voltage between ECM terminals 106 (APP sensor 1 signal), 98 (APP sensor 2 signal) and ground under the following conditions.

Terminal	Accelerator pedal	Voltage
106 (Accelerator pedal position sensor 1)	Fully released	0.5 - 1.0V
	Fully depressed	3.9 - 4.7V
98 (Accelerator pedal position sensor 2)	Fully released	0.15 - 0.60V
	Fully depressed	1.95 - 2.40V

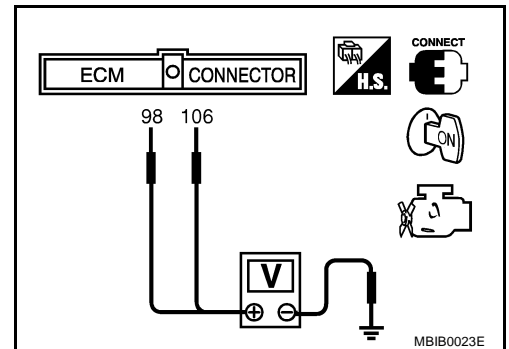

4. If NG, replace accelerator pedal assembly and go to next step.
5. Perform [EC-42, "Accelerator Pedal Released Position Learning"](#) .
6. Perform [EC-42, "Throttle Valve Closed Position Learning"](#) .
7. Perform [EC-43, "Idle Air Volume Learning"](#) .

### Removal and Installation ACCELERATOR PEDAL

ABS0090C

Refer to [ACC-3, "ACCELERATOR CONTROL SYSTEM"](#) .

# IGNITION SIGNAL

## IGNITION SIGNAL

PFP:22448

### Component Description

ABS0090D

### IGNITION COIL & POWER TRANSISTOR

The ignition signal from the ECM is sent to and amplified by the power transistor. The power transistor turns ON and OFF the ignition coil primary circuit. This ON/OFF operation induces the proper high voltage in the coil secondary circuit.

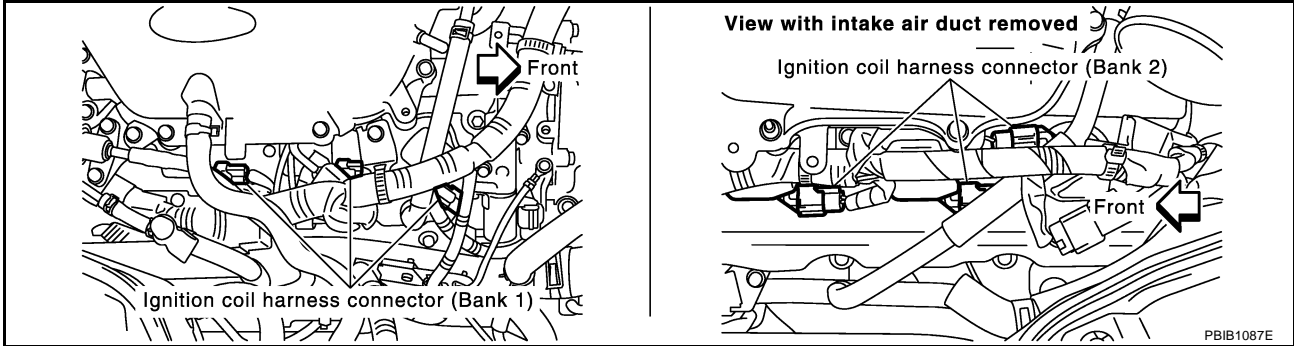

# IGNITION SIGNAL

## Wiring Diagram

ABS0090E

### EC-IGNSYS-01

A  
EC  
C  
D  
E  
F  
G  
H  
I  
J  
K  
L  
M

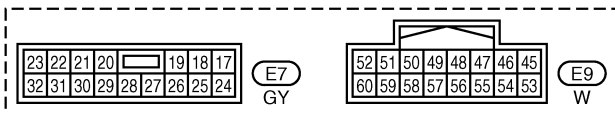
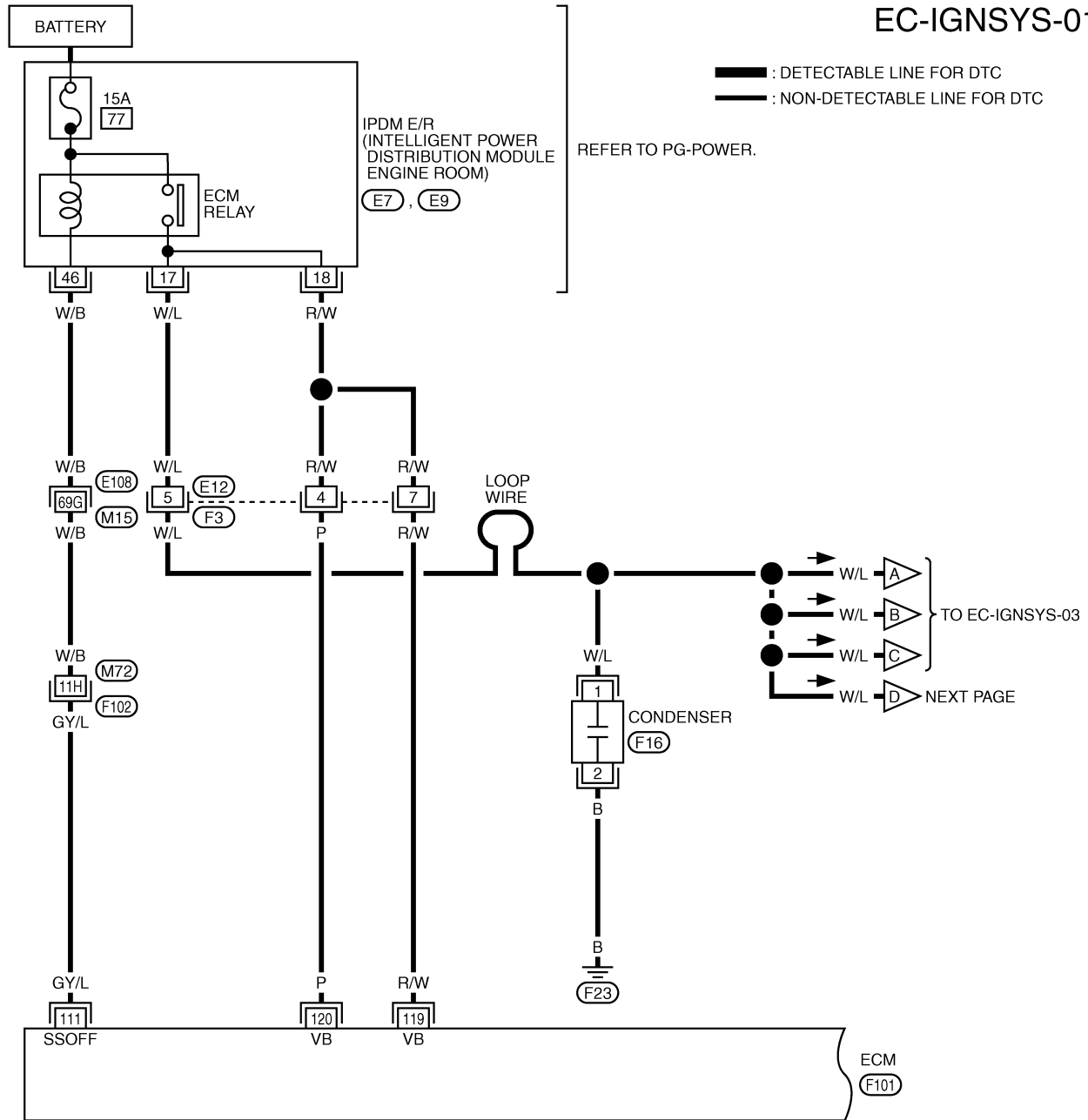

REFER TO THE FOLLOWING.  
 E108, F102 -SUPER MULTIPLE JUNCTION (SMJ)

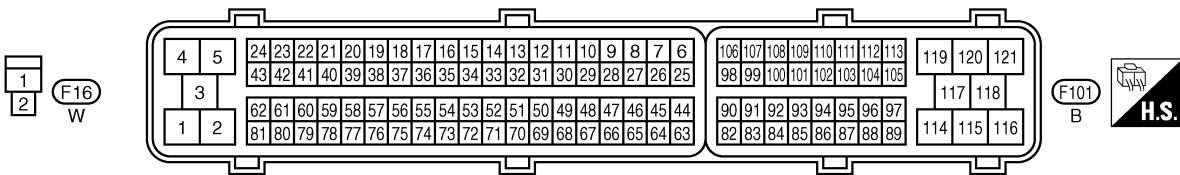

TBWT0631E

## IGNITION SIGNAL

Specification data are reference values and are measured between each terminal and ground.

**CAUTION:**

**Do not use ECM ground terminals when measuring input/output voltage. Doing so may result in damage to the ECM's transistor. Use a ground other than ECM terminals, such as the ground.**

TER-MINAL NO.	WIRE COLOR	ITEM	CONDITION	DATA (DC Voltage)
111	GY/L	ECM relay (Self shut-off)	<b>[Engine is running]</b> <b>[Ignition switch: OFF]</b> <ul style="list-style-type: none"> <li>● A few seconds after turning ignition switch OFF</li> </ul>	0 - 1.5V
			<b>[Ignition switch: OFF]</b> <ul style="list-style-type: none"> <li>● More than a few seconds after turning ignition switch OFF</li> </ul>	BATTERY VOLTAGE (11 - 14V)
119 120	R/W P	Power supply for ECM	<b>[Ignition switch: ON]</b>	BATTERY VOLTAGE (11 - 14V)



# IGNITION SIGNAL

## EC-IGNSYS-02

: DETECTABLE LINE FOR DTC  
 : NON-DETECTABLE LINE FOR DTC

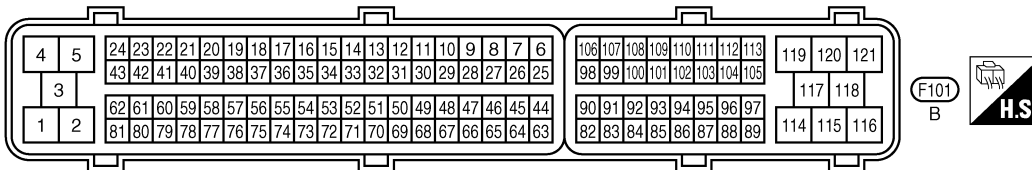
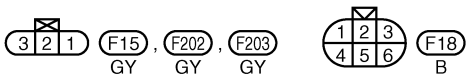
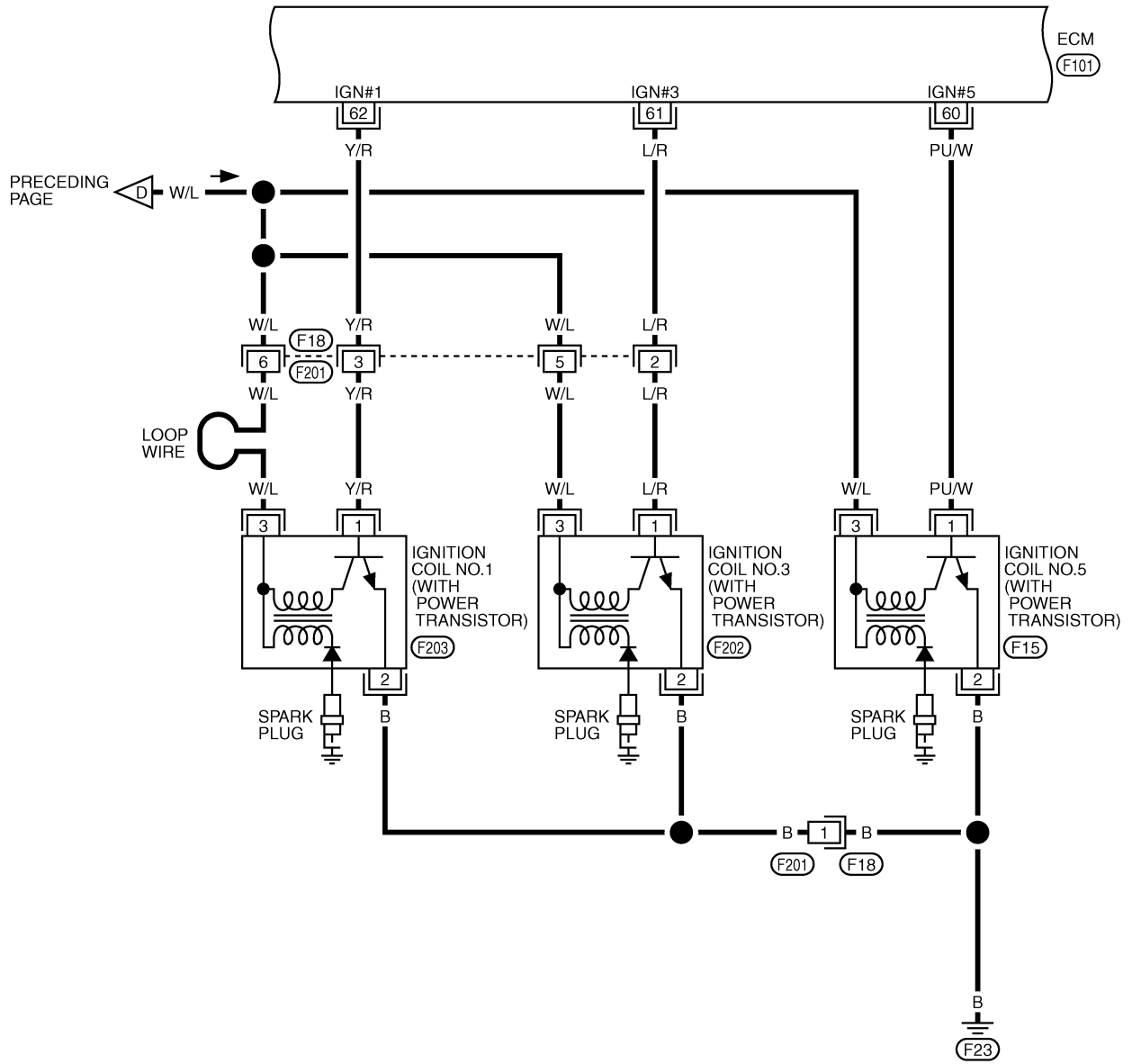

TBWT0518E

# IGNITION SIGNAL

Specification data are reference values and are measured between each terminal and ground.  
Pulse signal is measured by CONSULT-II.

**CAUTION:**

**Do not use ECM ground terminals when measuring input/output voltage. Doing so may result in damage to the ECM's transistor. Use a ground other than ECM terminals, such as the ground.**

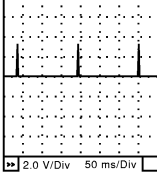
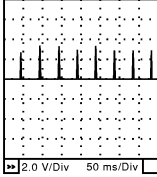
TER-MINAL NO.	WIRE COLOR	ITEM	CONDITION	DATA (DC Voltage)
60 61 62	PU/W L/R Y/R	Ignition signal No. 5 Ignition signal No. 3 Ignition signal No. 1	<p><b>[Engine is running]</b></p> <ul style="list-style-type: none"> <li>● Warm-up condition</li> <li>● Idle speed</li> </ul> <p><b>NOTE:</b> The pulse cycle changes depending on rpm at idle.</p>	<p>0 - 0.2V★</p>  <p style="text-align: right; font-size: small;">SEC986C</p>
			<p><b>[Engine is running]</b></p> <ul style="list-style-type: none"> <li>● Warm-up condition</li> <li>● Engine speed is 2,500 rpm.</li> </ul>	<p>0.1 - 0.4V★</p>  <p style="text-align: right; font-size: small;">SEC987C</p>

★: Average voltage for pulse signal (Actual pulse signal can be confirmed by oscilloscope.)

# IGNITION SIGNAL

## EC-IGNSYS-03

: DETECTABLE LINE FOR DTC  
 : NON-DETECTABLE LINE FOR DTC

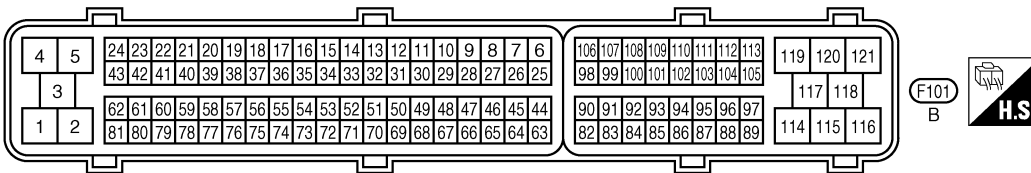
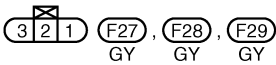
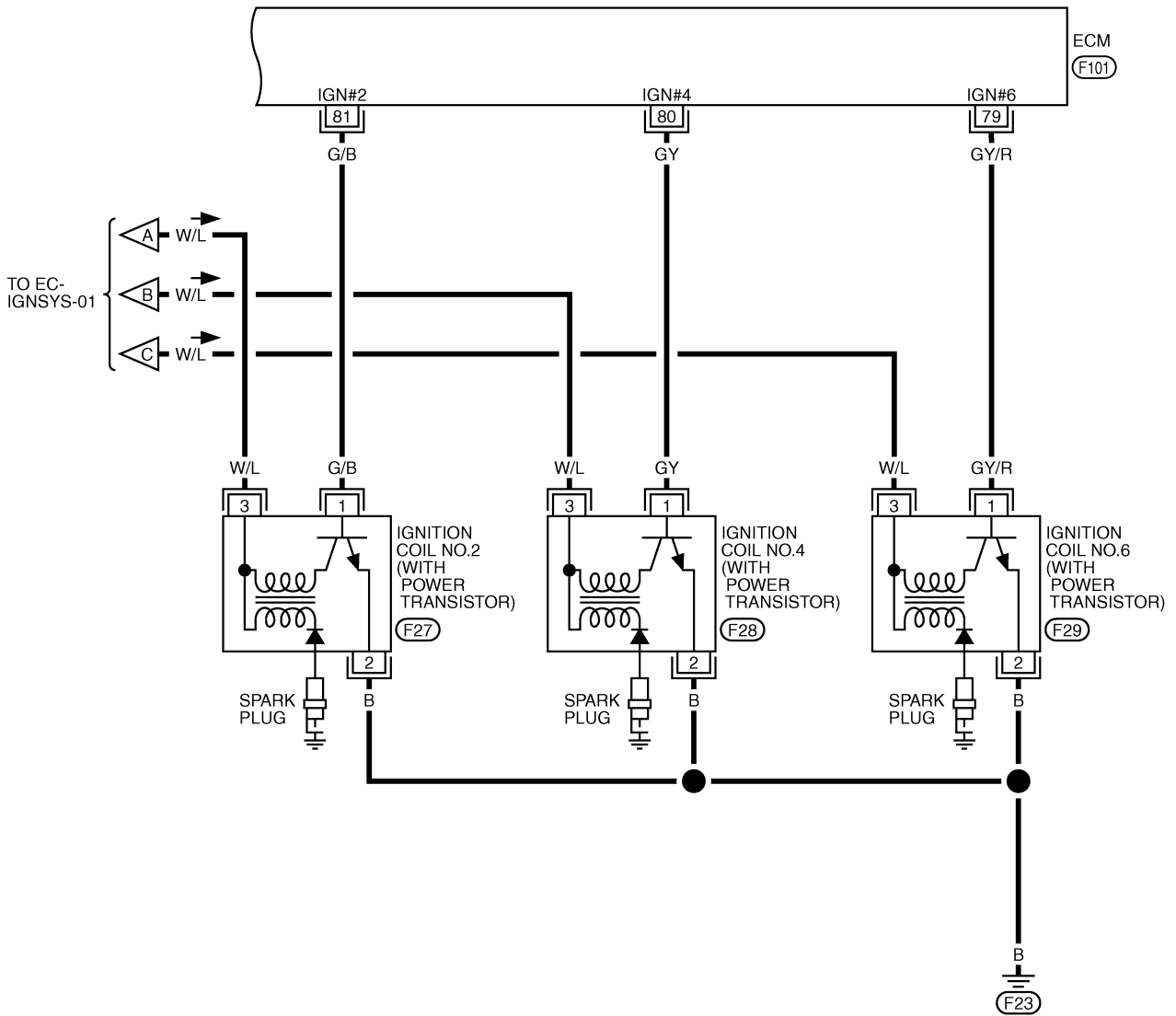

TBWT0240E

# IGNITION SIGNAL

Specification data are reference values and are measured between each terminal and ground.  
Pulse signal is measured by CONSULT-II.

**CAUTION:**

**Do not use ECM ground terminals when measuring input/output voltage. Doing so may result in damage to the ECM's transistor. Use a ground other than ECM terminals, such as the ground.**

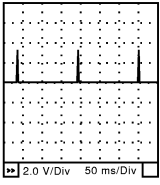
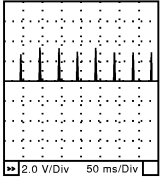
TER-MINAL NO.	WIRE COLOR	ITEM	CONDITION	DATA (DC Voltage)
79 80 81	GY/R GY G/B	Ignition signal No. 6 Ignition signal No. 4 Ignition signal No. 2	<p>[Engine is running]</p> <ul style="list-style-type: none"> <li>● Warm-up condition</li> <li>● Idle speed</li> </ul> <p><b>NOTE:</b> The pulse cycle changes depending on rpm at idle.</p>	<p>0 - 0.2V★</p>  <p>SEC986C</p>
			<p>[Engine is running]</p> <ul style="list-style-type: none"> <li>● Warm-up condition</li> <li>● Engine speed is 2,500 rpm.</li> </ul>	<p>0.1 - 0.4V★</p>  <p>SEC987C</p>

★: Average voltage for pulse signal (Actual pulse signal can be confirmed by oscilloscope.)

## Diagnostic Procedure

ABS0090F

### 1. CHECK ENGINE START

Turn ignition switch OFF, and restart engine.

**Is engine running?**

Yes or No

- Yes (With CONSULT-II)>>GO TO 2.
- Yes (Without CONSULT-II)>>GO TO 3.
- No >> GO TO 4.

### 2. CHECK OVERALL FUNCTION

④ **With CONSULT-II**

- Perform "POWER BALANCE" in "ACTIVE TEST" mode with CONSULT-II.
- Make sure that each circuit produces a momentary engine speed drop.

OK or NG

- OK >> **INSPECTION END**
- NG >> GO TO 10.

ACTIVE TEST	
POWER BALANCE	
MONITOR	
ENG SPEED	XXX rpm
MAS A/F SE-B1	XXX V

PBIB0133E

# IGNITION SIGNAL

## 3. CHECK OVERALL FUNCTION

### ⊗ Without CONSULT-II

1. Let engine idle.
2. Read the voltage signal between ECM terminals 60, 61, 62, 79, 80, 81 and ground with an oscilloscope.
3. Verify that the oscilloscope screen shows the signal wave as shown below.

#### NOTE:

The pulse cycle changes depending on rpm at idle.

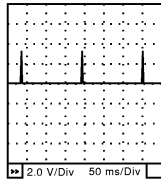

SEC986C

#### OK or NG

- OK >> **INSPECTION END**  
NG >> GO TO 10.

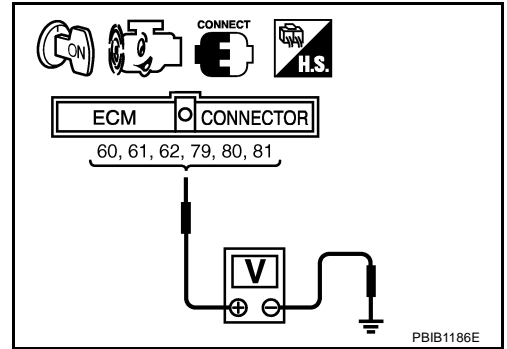

## 4. CHECK IGNITION COIL POWER SUPPLY CIRCUIT-I

1. Turn ignition switch OFF, wait at least 10 seconds and then turn ON.
2. Check voltage between ECM terminals 119, 120 and ground with CONSULT-II or tester.

**Voltage: Battery voltage**

#### OK or NG

- OK >> GO TO 5.  
NG >> Go to [EC-130. "POWER SUPPLY AND GROUND CIRCUIT"](#).

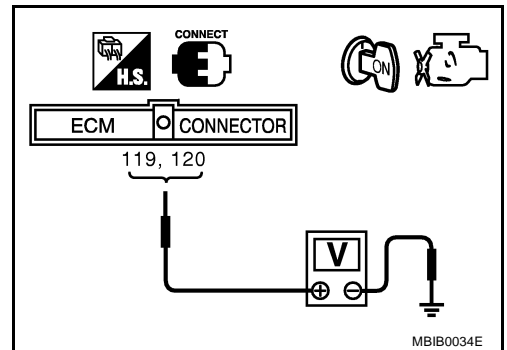

# IGNITION SIGNAL

## 5. CHECK IGNITION COIL POWER SUPPLY CIRCUIT-II

1. Turn ignition switch OFF.
2. Disconnect condenser harness connector.
3. Turn ignition switch ON.

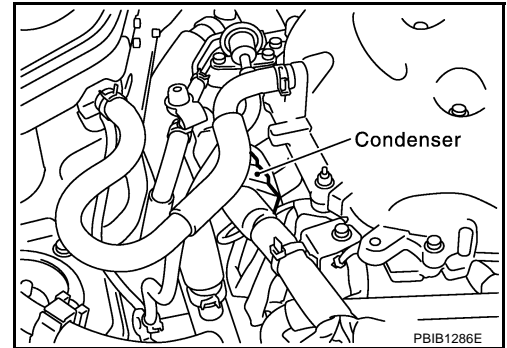

4. Check voltage between condenser terminal 1 and ground with CONSULT-II or tester.

**Voltage: Battery voltage**

OK or NG

- OK >> GO TO 8.
- NG >> GO TO 6.

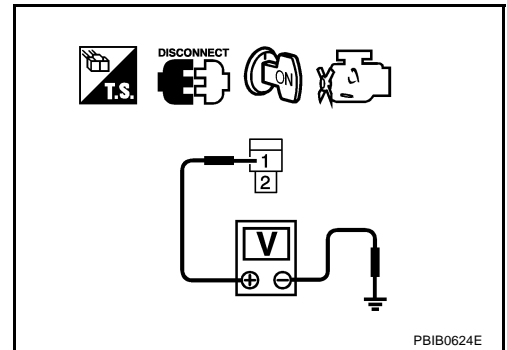

## 6. CHECK IGNITION COIL POWER SUPPLY CIRCUIT-III

1. Turn ignition switch OFF.
2. Disconnect IPDM E/R harness connector E7.
3. Check harness continuity between IPDM E/R terminal 17 and condenser terminal 1. Refer to Wiring Diagram.

**Continuity should exist.**

4. Also check harness for short to ground and short to power.

OK or NG

- OK >> GO TO 17.
- NG >> GO TO 7.

## 7. DETECT MALFUNCTIONING PART

Check the following.

- Harness connectors E12, F3
- Harness for open and short between IPDM E/R and condenser

>> Repair open circuit or short to ground or short to power in harness or connectors.

# IGNITION SIGNAL

## 8. CHECK CONDENSER GROUND CIRCUIT FOR OPEN AND SHORT

1. Turn ignition switch OFF.
2. Check harness continuity between condenser terminal 2 and ground.  
Refer to Wiring Diagram.

**Continuity should exist.**

3. Also check harness for short to power.

OK or NG

OK >> GO TO 9.

NG >> Repair open circuit or short to power in harness or connectors.

## 9. CHECK CONDENSER

Refer to [EC-633, "Component Inspection"](#) .

OK or NG

OK >> GO TO 10.

NG >> Replace condenser.

## 10. CHECK IGNITION COIL POWER SUPPLY CIRCUIT-IV

1. Turn ignition switch OFF.
2. Reconnect all harness connectors disconnected.
3. Disconnect ignition coil harness connector.

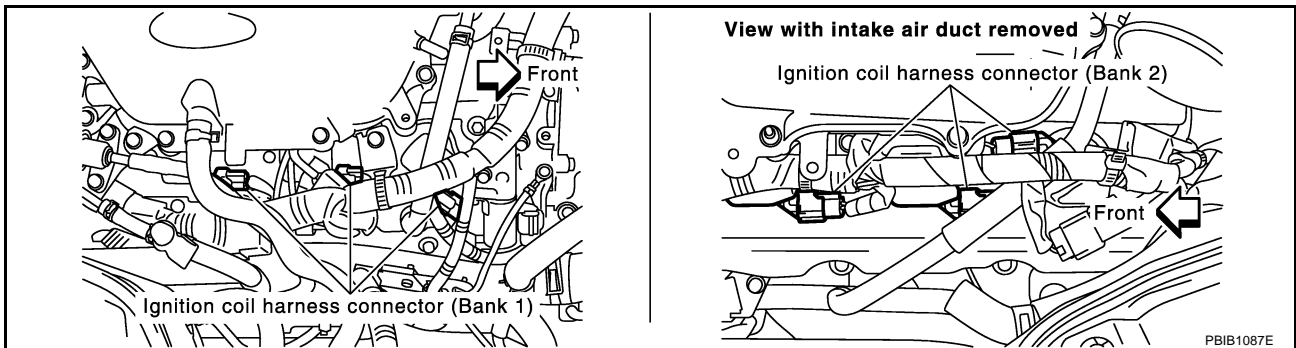

4. Turn ignition switch ON.
5. Check voltage between ignition coil terminal 3 and ground with CONSULT-II or tester.

**Voltage: Battery voltage**

OK or NG

OK >> GO TO 12.

NG >> GO TO 11.

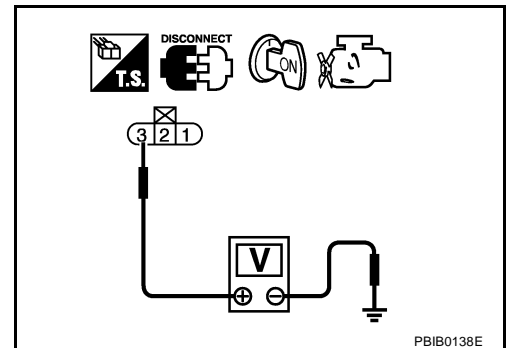

## 11. DETECT MALFUNCTIONING PART

Check the following.

- Harness connectors F18, F201
- Harness for open or short between ignition coil and harness connector F3

>> Repair or replace harness or connectors.

# IGNITION SIGNAL

---

## 12. CHECK IGNITION COIL GROUND CIRCUIT FOR OPEN AND SHORT

---

1. Turn ignition switch OFF.
2. Check harness continuity between ignition coil terminal 2 and ground.  
Refer to Wiring Diagram.

**Continuity should exist.**

3. Also check harness for short to power.

OK or NG

- OK >> GO TO 14.  
NG >> GO TO 13.

---

## 13. DETECT MALFUNCTIONING PART

---

Check the following.

- Harness connectors F18, F201
- Harness for open or short between ignition coil and ground

>> Repair open circuit or short to power in harness or connectors.

---

## 14. CHECK IGNITION COIL OUTPUT SIGNAL CIRCUIT FOR OPEN AND SHORT

---

1. Disconnect ECM harness connector.
2. Check harness continuity between ECM terminals 60, 61, 62, 79, 80, 81 and ignition coil terminal 1.  
Refer to Wiring Diagram.

**Continuity should exist.**

3. Also check harness for short to ground and short to power.

OK or NG

- OK >> GO TO 16.  
NG >> GO TO 15.

---

## 15. DETECT MALFUNCTIONING PART

---

Check the following.

- Harness connectors F18, F201
- Harness for open or short between ignition coil and ECM

>> Repair open circuit or short to ground or short to power in harness or connectors.

---

## 16. CHECK IGNITION COIL WITH POWER TRANSISTOR

---

Refer to [EC-633, "Component Inspection"](#) .

OK or NG

- OK >> GO TO 17.  
NG >> Replace ignition coil with power transistor.

---

## 17. CHECK INTERMITTENT INCIDENT

---

Refer to [EC-129, "TROUBLE DIAGNOSIS FOR INTERMITTENT INCIDENT"](#) .

OK or NG

- OK >> Replace IPDM E/R. Refer to [PG-17, "IPDM E/R \(INTELLIGENT POWER DISTRIBUTION MODULE ENGINE ROOM\)"](#) .  
NG >> Repair open circuit or short to ground or short to power in harness or connectors.



# IGNITION SIGNAL

ABS0090G

## Component Inspection IGNITION COIL WITH POWER TRANSISTOR

1. Turn ignition switch OFF.
2. Disconnect ignition coil harness connector.
3. Check resistance between ignition coil terminals as follows.

Terminal No. (Polarity)	Resistance $\Omega$ [at 25°C (77°F)]
1 and 2	Except 0 or $\infty$
1 and 3	Except 0
2 and 3	

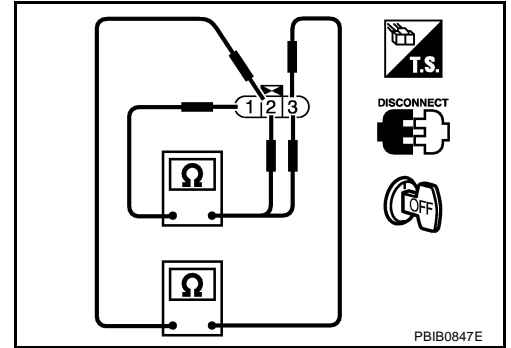

## CONDENSER

1. Turn ignition switch OFF.
2. Disconnect condenser harness connector.
3. Check resistance between condenser terminals 1 and 2.

**Resistance: Above 1 M $\Omega$  [at 25°C (77°F)]**

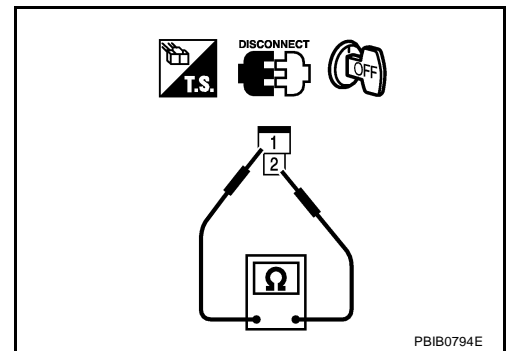

## Removal and Installation IGNITION COIL WITH POWER TRANSISTOR

Refer to [EM-33, "IGNITION COIL"](#) .

A  
EC  
C  
D  
E  
F  
G  
H  
I  
J  
K  
L  
M

# INJECTOR CIRCUIT

## INJECTOR CIRCUIT

PFP:16600

### Component Description

ABS0090I

The fuel injector is a small, precise solenoid valve. When the ECM supplies a ground to the injector circuit, the coil in the injector is energized. The energized coil pulls the needle valve back and allows fuel to flow through the injector into the intake manifold. The amount of fuel injected depends upon the injection pulse duration. Pulse duration is the length of time the injector remains open. The ECM controls the injection pulse duration based on engine fuel needs.

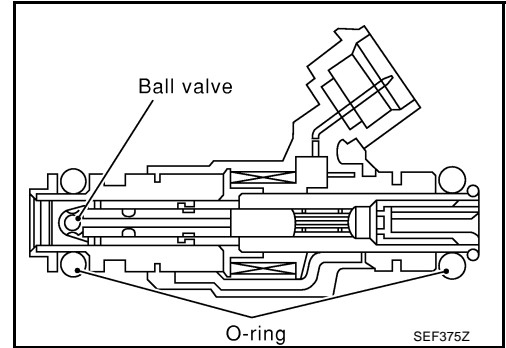

### CONSULT-II Reference Value in Data Monitor Mode

ABS0090J

Specification data are reference values.

MONITOR ITEM	CONDITION	SPECIFICATION
B/FUEL SCHDL	See <a href="#">EC-125. "TROUBLE DIAGNOSIS - SPECIFICATION VALUE"</a> .	
INJ PULSE-B1 INJ PULSE-B2	<ul style="list-style-type: none"> <li>● Engine: After warming up</li> <li>● Shift lever: P or N (A/T), Neutral (M/T)</li> </ul>	Idle 2.0 - 3.0 msec
	<ul style="list-style-type: none"> <li>● Air conditioner switch: OFF</li> <li>● No-load</li> </ul>	2,000 rpm 1.9 - 2.9 msec

# INJECTOR CIRCUIT

ABS0090K

## Wiring Diagram

### EC-INJECT-01

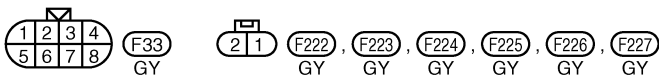
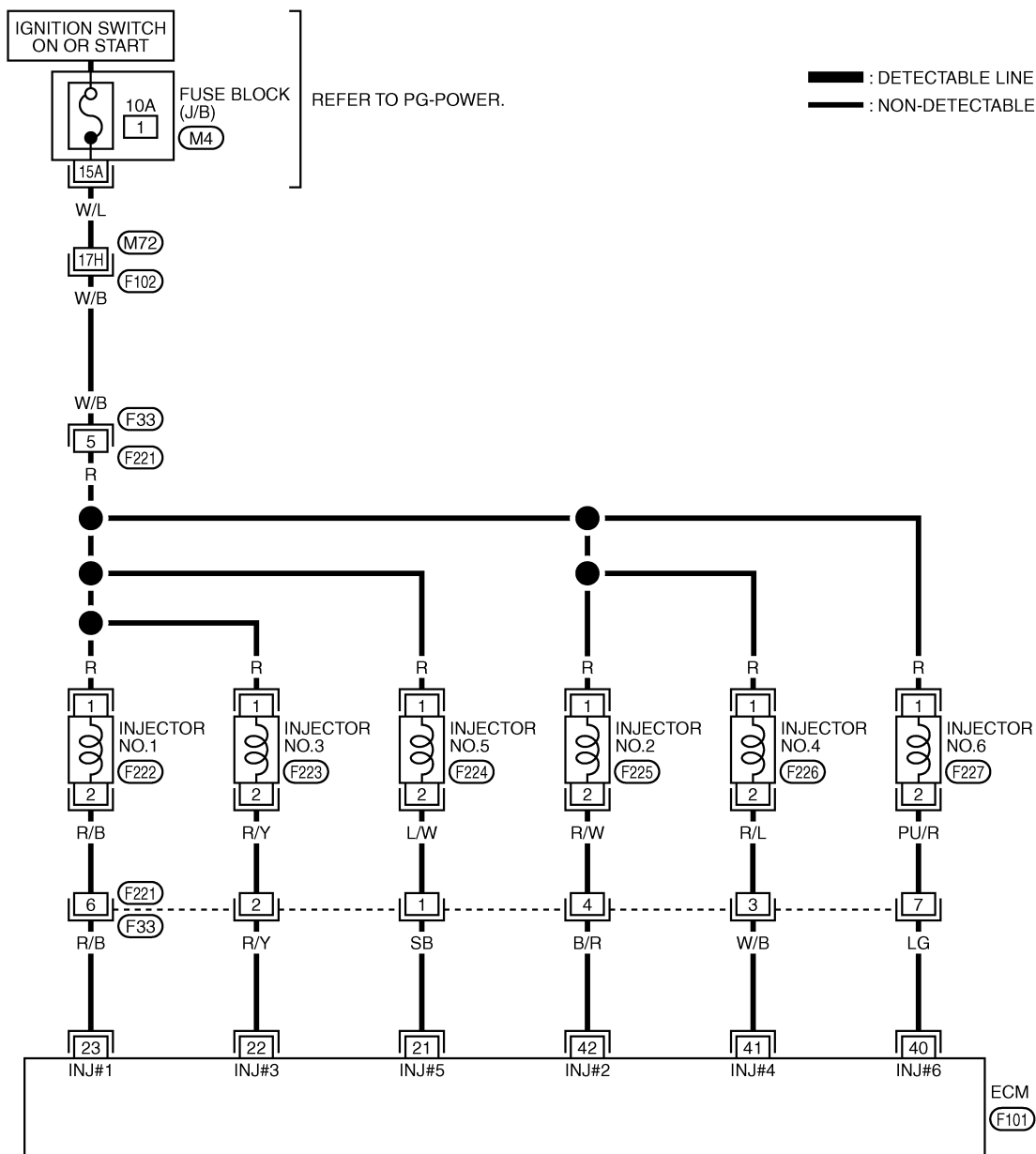

REFER TO THE FOLLOWING.

(F102) -SUPER MULTIPLE JUNCTION (SMJ)

(M4) -FUSE BLOCK-JUNCTION BOX (J/B)

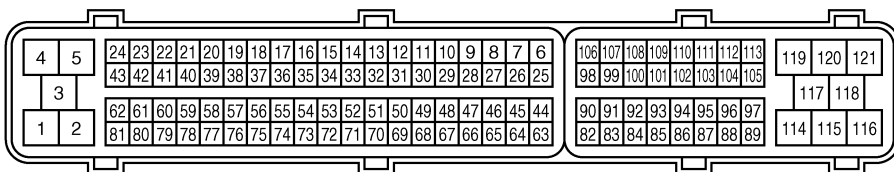

TBWT0632E

# INJECTOR CIRCUIT

Specification data are reference values and are measured between each terminal and ground.  
Pulse signal is measured by CONSULT-II.

## CAUTION:

Do not use ECM ground terminals when measuring input/output voltage. Doing so may result in damage to the ECM's transistor. Use a ground other than ECM terminals, such as the ground.

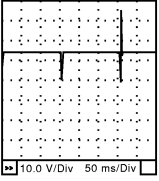
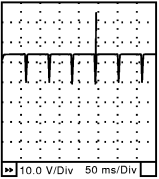
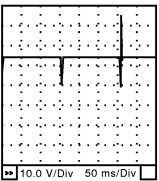
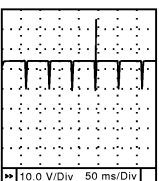
TER-MINAL NO.	WIRE COLOR	ITEM	CONDITION	DATA (DC Voltage)
21 22 23	SB R/Y R/B	Injector No. 5 Injector No. 3 Injector No. 1	<p>[Engine is running]</p> <ul style="list-style-type: none"> <li>● Warm-up condition</li> <li>● Idle speed</li> </ul> <p><b>NOTE:</b> The pulse cycle changes depending on rpm at idle.</p>	<p>BATTERY VOLTAGE (11 - 14V)★</p>  <p>SEC984C</p>
			<p>[Engine is running]</p> <ul style="list-style-type: none"> <li>● Warm-up condition</li> <li>● Engine speed is 2,000 rpm</li> </ul>	<p>BATTERY VOLTAGE (11 - 14V)★</p>  <p>SEC985C</p>
40 41 42	LG W/B B/R	Injector No. 6 Injector No. 4 Injector No. 2	<p>[Engine is running]</p> <ul style="list-style-type: none"> <li>● Warm-up condition</li> <li>● Idle speed</li> </ul> <p><b>NOTE:</b> The pulse cycle changes depending on rpm at idle.</p>	<p>BATTERY VOLTAGE (11 - 14V)★</p>  <p>SEC984C</p>
			<p>[Engine is running]</p> <ul style="list-style-type: none"> <li>● Warm-up condition</li> <li>● Engine speed is 2,000 rpm</li> </ul>	<p>BATTERY VOLTAGE (11 - 14V)★</p>  <p>SEC985C</p>

★: Average voltage for pulse signal (Actual pulse signal can be confirmed by oscilloscope.)

## Diagnostic Procedure

ABS0090L

### 1. INSPECTION START

Turn ignition switch to START.

**Is any cylinder ignited?**

Yes or No

Yes >> GO TO 2.

No >> GO TO 3.

# INJECTOR CIRCUIT

## 2. CHECK OVERALL FUNCTION

### ④ With CONSULT-II

1. Start engine.
2. Perform "POWER BALANCE" in "ACTIVE TEST" mode with CONSULT-II.
3. Make sure that each circuit produces a momentary engine speed drop.

ACTIVE TEST	
POWER BALANCE	
MONITOR	
ENG SPEED	XXX rpm
MAS A/F SE-B1	XXX V

PBIB0133E

### ⊗ Without CONSULT-II

1. Start engine.
2. Listen to each injector operating sound.  
**Clicking noise should be heard.**

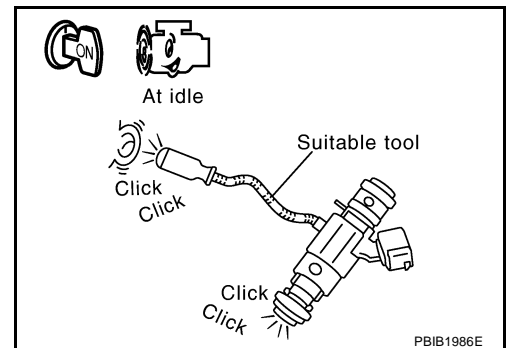

### OK or NG

- OK >> **INSPECTION END**  
NG >> GO TO 3.

# INJECTOR CIRCUIT

## 3. CHECK INJECTOR POWER SUPPLY CIRCUIT

1. Turn ignition switch OFF.
2. Disconnect injector harness connector.
3. Turn ignition switch ON.

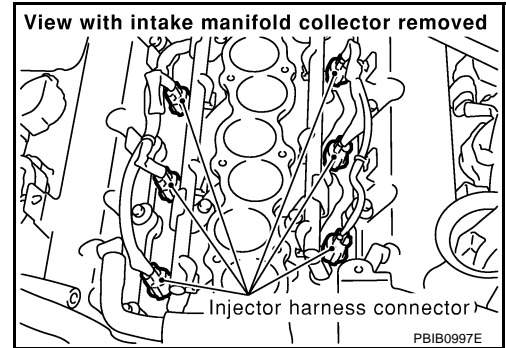

4. Check voltage between injector terminal 1 and ground with CONSULT-II or tester.

**Voltage: Battery voltage**

OK or NG

- OK >> GO TO 5.
- NG >> GO TO 4.

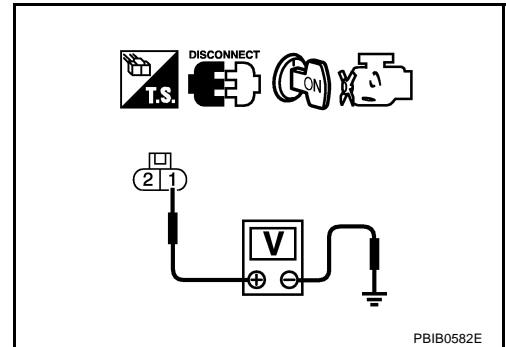

## 4. DETECT MALFUNCTIONING PART

Check the following.

- Harness connectors M72, F102
- Harness connectors F33, F221
- Fuse block (J/B) connector M4
- 10A fuse
- Harness for open or short between injector and fuse

>> Repair open circuit or short to ground or short to power in harness or connectors.

## 5. CHECK INJECTOR OUTPUT SIGNAL CIRCUIT FOR OPEN AND SHORT

1. Turn ignition switch OFF.
2. Disconnect ECM harness connector.
3. Check harness continuity between injector terminal 2 and ECM terminals 21, 22, 23, 40, 41, 42. Refer to Wiring Diagram.

**Continuity should exist.**

4. Also check harness for short to ground and short to power.

OK or NG

- OK >> GO TO 7.
- NG >> GO TO 6.

# INJECTOR CIRCUIT

## 6. DETECT MALFUNCTIONING PART

Check the following.

- Harness connectors F33, F221
- Harness for open or short between injector and ECM

>> Repair open circuit or short to ground or short to power in harness or connectors.

## 7. CHECK INJECTOR

Refer to [EC-639, "Component Inspection"](#) .

OK or NG

- OK >> GO TO 8.
- NG >> Replace injector.

## 8. CHECK INTERMITTENT INCIDENT

Refer to [EC-129, "TROUBLE DIAGNOSIS FOR INTERMITTENT INCIDENT"](#) .

>> INSPECTION END

### Component Inspection INJECTOR

1. Disconnect injector harness connector.
2. Check resistance between terminals as shown in the figure.

**Resistance: 11.1 - 14.5Ω [at 10 - 60°C (50 - 140°F)]**

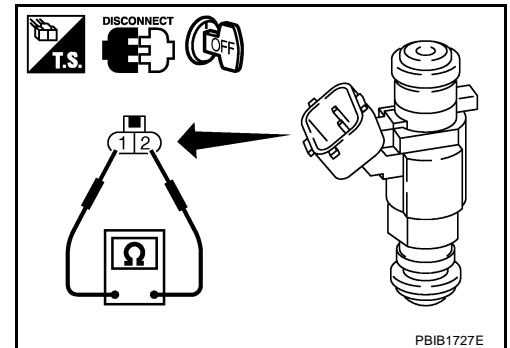

### Removal and Installation INJECTOR

Refer to [EM-36, "FUEL INJECTOR AND FUEL TUBE"](#) .

# FUEL PUMP CIRCUIT

## FUEL PUMP CIRCUIT

PFP:17042

### Description SYSTEM DESCRIPTION

ABS00900

Sensor	Input Signal to ECM	ECM Function	Actuator
Crankshaft position sensor (POS) Camshaft position sensor (PHASE)	Engine speed*	Fuel pump control	Fuel pump relay
Battery	Battery voltage*		

\*: ECM determines the start signal status by the signals of engine speed and battery voltage.

The ECM activates the fuel pump for several seconds after the ignition switch is turned ON to improve engine startability. If the ECM receives a engine speed signal from the camshaft position sensor (PHASE), it knows that the engine is rotating, and causes the pump to operate. If the engine speed signal is not received when the ignition switch is ON, the engine stalls. The ECM stops pump operation and prevents battery discharging, thereby improving safety. The ECM does not directly drive the fuel pump. It controls the ON/OFF fuel pump relay, which in turn controls the fuel pump.

Condition	Fuel pump operation
Ignition switch is turned to ON.	Operates for 1 second.
Engine running and cranking	Operates.
When engine is stopped	Stops in 1.5 seconds.
Except as shown above	Stops.

### COMPONENT DESCRIPTION

A turbine type design fuel pump is used in the fuel tank.

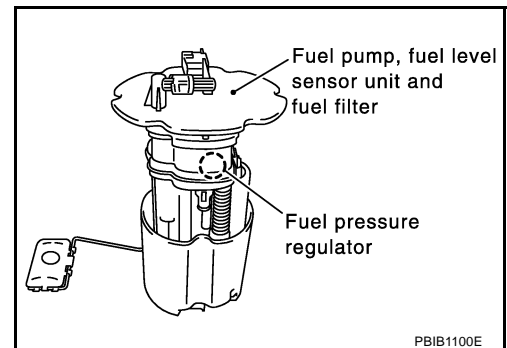

### CONSULT-II Reference Value in Data Monitor Mode

ABS0090P

Specification data are reference values.

MONITOR ITEM	CONDITION	SPECIFICATION
FUEL PUMP RLY	<ul style="list-style-type: none"> <li>For 1 second after turning ignition switch ON</li> <li>Engine running or cranking</li> </ul>	ON
	<ul style="list-style-type: none"> <li>Except above conditions</li> </ul>	OFF



# FUEL PUMP CIRCUIT

## Wiring Diagram

ABS0090Q

EC-F/PUMP-01

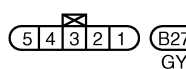
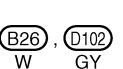
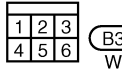
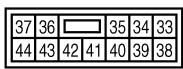
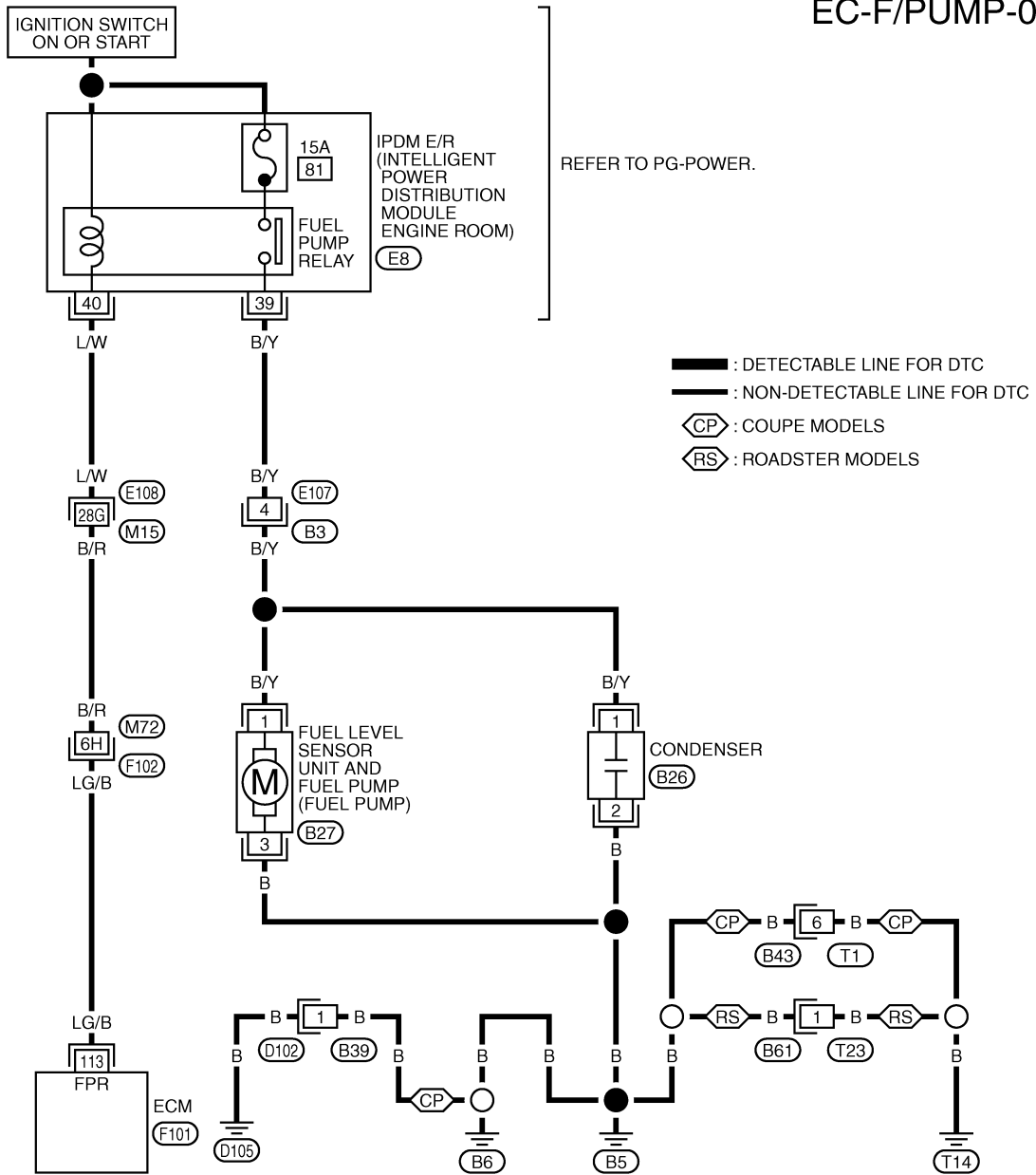

REFER TO THE FOLLOWING.  
 E108, F102 -SUPER MULTIPLE JUNCTION (SMJ)

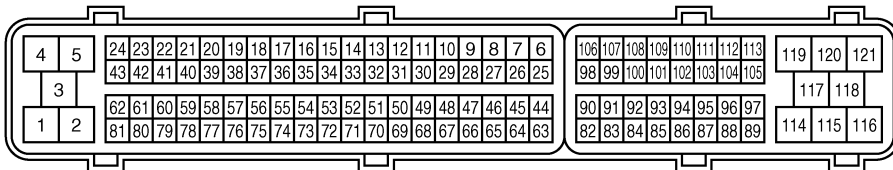
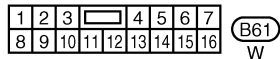
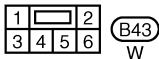

TBWT0633E

# FUEL PUMP CIRCUIT

Specification data are reference values and are measured between each terminal and ground.

**CAUTION:**

Do not use ECM ground terminals when measuring input/output voltage. Doing so may result in damage to the ECM's transistor. Use a ground other than ECM terminals, such as the ground.

TER-MINAL NO.	WIRE COLOR	ITEM	CONDITION	DATA (DC Voltage)
113	LG/B	Fuel pump relay	[Ignition switch: ON] ● For 1 second after turning ignition switch ON	0 - 1.5V
			[Engine is running] [Ignition switch: ON] ● More than 1 second after turning ignition switch ON.	BATTERY VOLTAGE (11 - 14V)

## Diagnostic Procedure

ABS0090R

### 1. CHECK OVERALL FUNCTION

1. Turn ignition switch ON.
2. Pinch fuel feed hose with two fingers.

**Fuel pressure pulsation should be felt on the fuel feed hose for 1 second after ignition switch is turned ON.**

OK or NG

- OK >> **INSPECTION END**  
 NG >> GO TO 2.

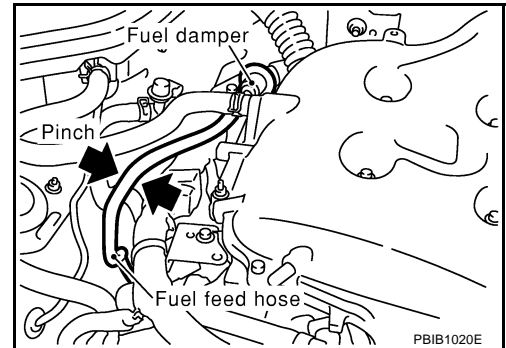

### 2. CHECK FUEL PUMP POWER SUPPLY CIRCUIT-I

1. Turn ignition switch OFF.
2. Disconnect ECM harness connector.
3. Turn ignition switch ON.
4. Check voltage between ECM terminal 113 and ground with CONSULT-II or tester.

**Voltage: Battery voltage**

OK or NG

- OK >> GO TO 5.  
 NG >> GO TO 3.

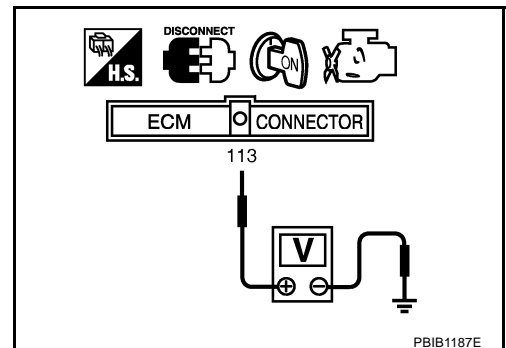

# FUEL PUMP CIRCUIT

## 3. CHECK FUEL PUMP POWER SUPPLY CIRCUIT-I

Check voltage between IPDM E/R terminal 40 and ground with CONSULT-II or tester.

**Voltage: Battery voltage**

OK or NG

- OK >> GO TO 4.
- NG >> GO TO 15.

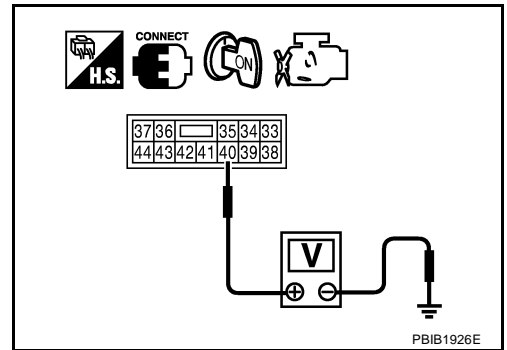

## 4. DETECT MALFUNCTIONING PART

Check the following.

- Harness connectors E108, M15
- Harness connectors M72, F102
- Harness for open or short between IPDM E/R and ECM

>> Repair open circuit or short to ground or short to power in harness or connectors.

## 5. CHECK CONDENSER POWER SUPPLY CIRCUIT-I

1. Turn ignition switch OFF.
2. Reconnect all harness connectors disconnected.
3. Disconnect condenser harness connector.
4. Turn ignition switch ON.
5. Check voltage between condenser terminal 1 and ground with CONSULT-II or tester.

**Voltage: Battery voltage should exist for 1 second after ignition switch is turned ON.**

OK or NG

- OK >> GO TO 9.
- NG >> GO TO 6.

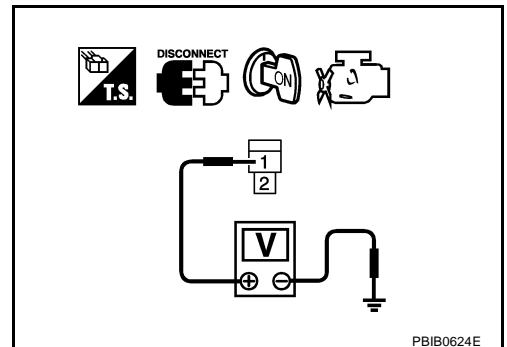

## 6. CHECK 15A FUSE

1. Turn ignition switch OFF.
2. Disconnect 15A fuse.
3. Check 15A fuse.

OK or NG

- OK >> GO TO 7.
- NG >> Replace fuse.

# FUEL PUMP CIRCUIT

---

## 7. CHECK CONDENSER POWER SUPPLY CIRCUIT-II

---

1. Disconnect IPDM E/R harness connector E8.
2. Check harness continuity between IPDM E/R terminal 39 and condenser terminal 1.  
Refer to Wiring Diagram.

**Continuity should exist.**

3. Also check harness for short to ground and short to power.

OK or NG

OK >> GO TO 15.  
NG >> GO TO 8.

---

## 8. DETECT MALFUNCTIONING PART

---

Check the following.

- Harness connectors E107, B3
- Harness for open or short between IPDM E/R and condenser

>> Repair open circuit or short to ground or short to power in harness or connectors.

---

## 9. CHECK CONDENSER GROUND CIRCUIT

---

1. Check harness continuity between condenser terminal 2 and ground.  
Refer to Wiring Diagram.

**Continuity should exist.**

2. Also check harness for short to power.

OK or NG

OK >> GO TO 11.  
NG >> GO TO 10

---

## 10. DETECT MALFUNCTIONING PART

---

Check the following.

- Harness connectors B43, T1 (Coupe models)
- Harness connectors B39, D102 (Coupe models)
- Harness connectors B61, T23 (Roadster models)
- Harness for open or short between condenser and ground

>> Repair open circuit or short to power in harness or connectors.

---

## 11. CHECK CONDENSER

---

Refer to [EC-646, "Component Inspection"](#).

OK or NG

OK >> GO TO 12.  
NG >> Replace condenser.

# FUEL PUMP CIRCUIT

## 12. CHECK FUEL PUMP POWER SUPPLY AND GROUND CIRCUIT FOR OPEN AND SHORT

1. Disconnect "fuel level sensor unit and fuel pump" harness connector.
2. Check harness continuity between the following;  
"fuel level sensor unit and fuel pump" terminal 1 and harness connector B3 terminal 4,  
"fuel level sensor unit and fuel pump" terminal 3 and ground.  
Refer to Wiring Diagram.

**Continuity should exist.**

3. Also check harness for short to ground and short to power.

OK or NG

OK >> GO TO 14.

NG >> GO TO 13.

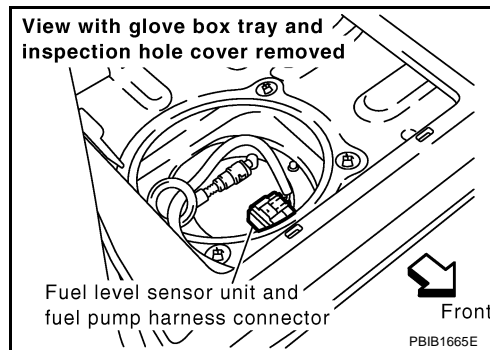

## 13. DETECT MALFUNCTIONING PART

Check the following.

- Harness connector B3
- Harness connectors B43, T1 (Coupe models)
- Harness connectors B39, D102 (Coupe models)
- Harness connectors B61, T23 (Roadster models)
- Harness for open or short between fuel pump and harness connector B3
- Harness for open or short between fuel pump and ground

>> Repair open circuit or short to ground or short to power in harness or connectors.

## 14. CHECK FUEL PUMP

Refer to [EC-646, "Component Inspection"](#) .

OK or NG

OK >> GO TO 15.

NG >> Replace fuel pump.

## 15. CHECK INTERMITTENT INCIDENT

Refer to [EC-129, "TROUBLE DIAGNOSIS FOR INTERMITTENT INCIDENT"](#) .

OK or NG

OK >> Replace IPDM E/R.

NG >> Repair or replace harness or connectors.

# FUEL PUMP CIRCUIT

ABS0090S

## Component Inspection FUEL PUMP

1. Disconnect "fuel level sensor unit and fuel pump" harness connector.
2. Check resistance between "fuel level sensor unit and fuel pump" terminals 1 and 3.

**Resistance: 0.2 - 5.0Ω [at 25°C (77°F)]**

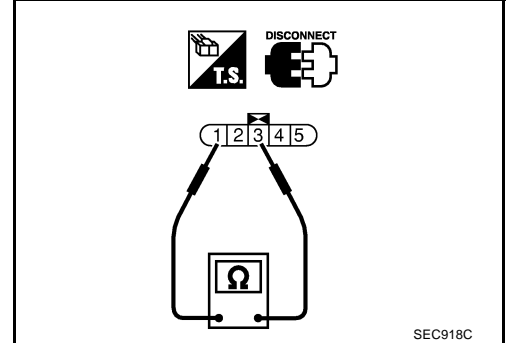

## CONDENSER

1. Turn ignition switch OFF.
2. Disconnect condenser harness connector.
3. Check resistance between condenser terminals 1 and 2.

**Resistance: Above 1 MΩ [at 25°C (77°C)]**

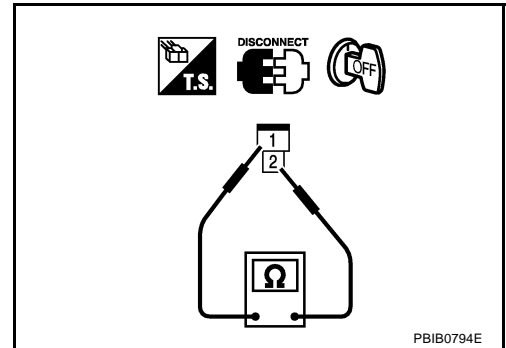

## Removal and Installation FUEL PUMP

ABS0090T

Refer to [FL-4, "FUEL LEVEL SENSOR UNIT, FUEL FILTER AND FUEL PUMP ASSEMBLY"](#) .

# REFRIGERANT PRESSURE SENSOR

## REFRIGERANT PRESSURE SENSOR

PFP:92136

### Component Description

ABS0090U

The refrigerant pressure sensor is installed at the condenser of the air conditioner system. The sensor uses an electrostatic volume pressure transducer to convert refrigerant pressure to voltage. The voltage signal is sent to ECM, and ECM controls cooling fan system.

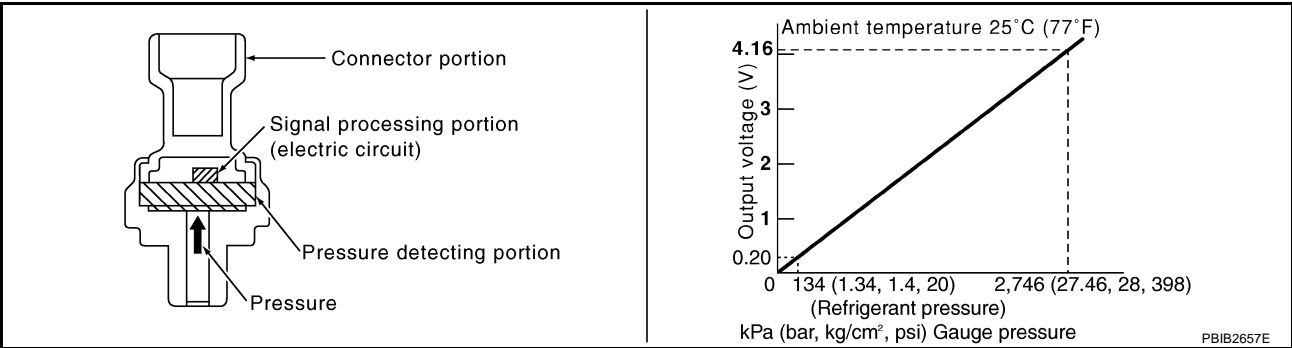
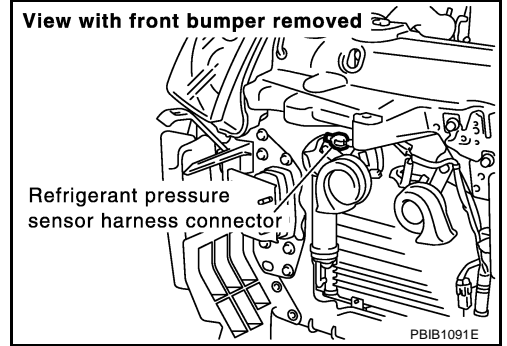





# REFRIGERANT PRESSURE SENSOR

Specification data are reference values and are measured between each terminal and ground.

**CAUTION:**

Do not use ECM ground terminals when measuring input/output voltage. Doing so may result in damage to the ECM's transistor. Use a ground other than ECM terminals, such as the ground.

TER-MINAL NO.	WIRE COLOR	ITEM	CONDITION	DATA (DC Voltage)
49	B	Sensor power supply (Refrigerant pressure sensor)	[Ignition switch: ON]	Approximately 5V
67	B/W	Sensor ground	[Engine is running] ● Warm-up condition ● Idle speed	Approximately 0V
70	G/R	Refrigerant pressure sensor	[Engine is running] ● Warm-up condition ● Both A/C switch and blower switch are ON. (Compressor operates.)	1.0 - 4.0V

## Diagnostic Procedure

ABS0090W

### 1. CHECK REFRIGERANT PRESSURE SENSOR OVERALL FUNCTION

1. Start engine and warm it up to normal operating temperature.
2. Turn A/C switch and blower switch ON.
3. Check voltage between ECM terminal 70 and ground with CONSULT-II or tester.

**Voltage: 1.0 - 4.0V**

OK or NG

- OK >> **INSPECTION END**
- NG >> **GO TO 2.**

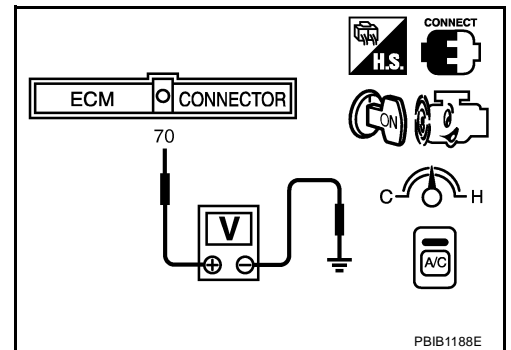

# REFRIGERANT PRESSURE SENSOR

## 2. CHECK GROUND CONNECTIONS

1. Turn A/C switch and blower switch OFF.
2. Stop engine.
3. Turn ignition switch OFF.
4. Loosen and retighten three ground screws on the body. Refer to [EC-138, "Ground Inspection"](#) .

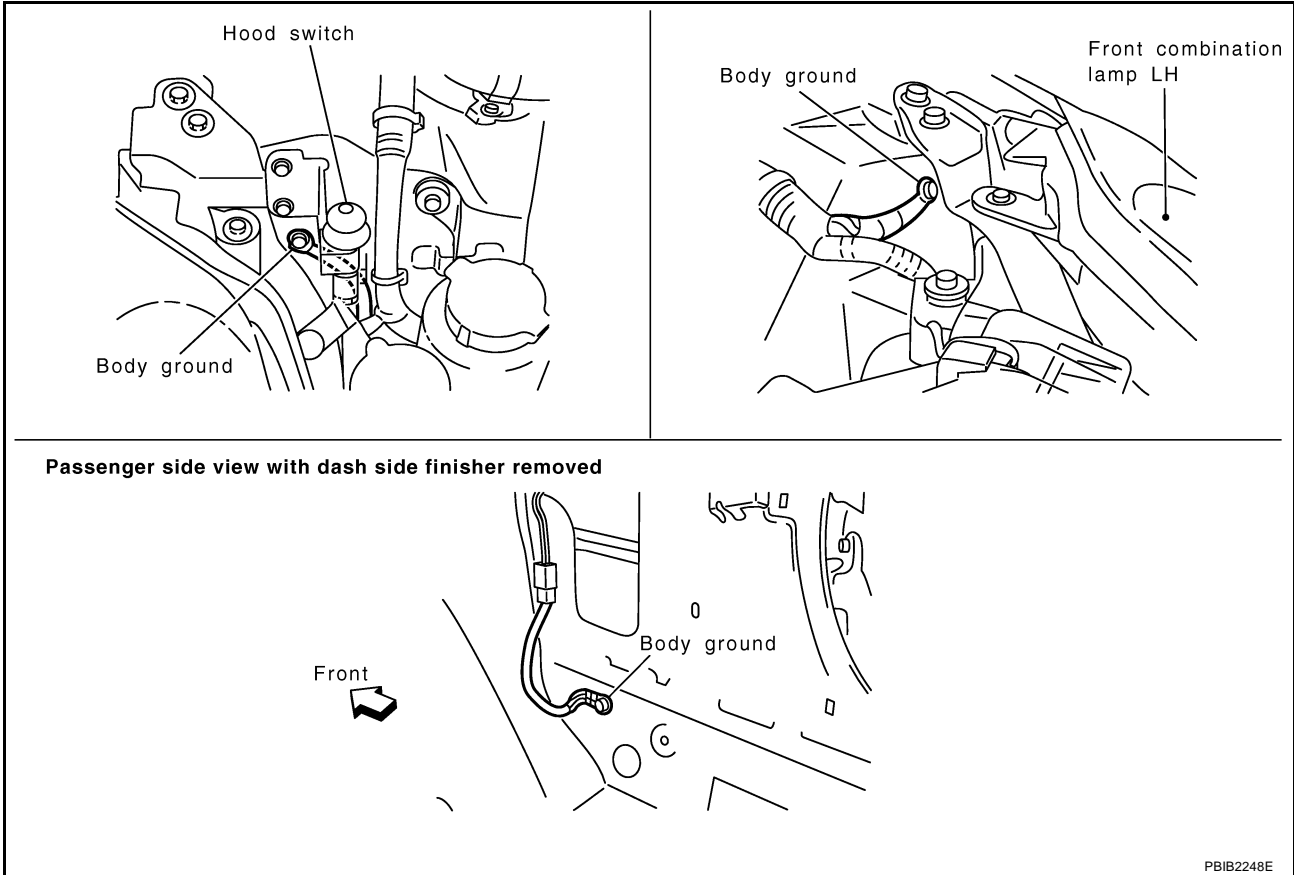

OK or NG

OK >> GO TO 3.

NG >> Repair or replace ground connections.

# REFRIGERANT PRESSURE SENSOR

## 3. CHECK REFRIGERANT PRESSURE SENSOR POWER SUPPLY CIRCUIT

1. Disconnect refrigerant pressure sensor harness connector.
2. Turn ignition switch ON.

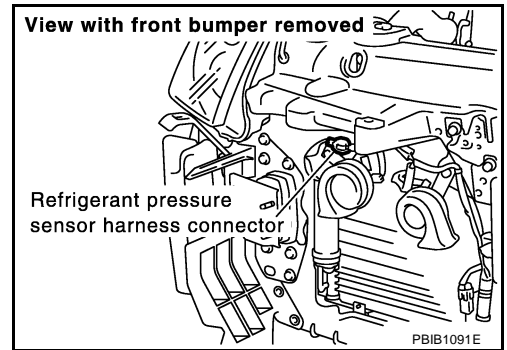

3. Check voltage between refrigerant pressure sensor terminal 1 and ground with CONSULT-II or tester.

**Voltage: Approximately 5V**

OK or NG

- OK >> GO TO 5.
- NG >> GO TO 4.

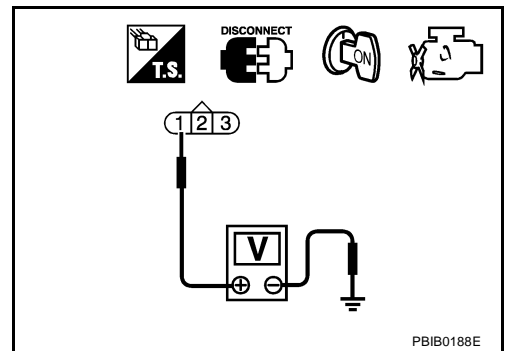

## 4. DETECT MALFUNCTIONING PART

Check the following.

- Harness connectors E251, E31
- Harness connectors E10, F1
- Harness for open or short between ECM and refrigerant pressure sensor

>> Repair open circuit or short to ground or short to power in harness or connectors.

## 5. CHECK REFRIGERANT PRESSURE SENSOR GROUND CIRCUIT FOR OPEN AND SHORT

1. Turn ignition switch OFF.
2. Disconnect ECM harness connector.
3. Check harness continuity between refrigerant pressure sensor terminal 3 and ECM terminal 67. Refer to Wiring Diagram.

**Continuity should exist.**

4. Also check harness for short to ground and short to power.

OK or NG

- OK >> GO TO 7.
- NG >> GO TO 6.

## 6. DETECT MALFUNCTIONING PART

Check the following.

- Harness connectors E251, E31
- Harness connectors E10, F1
- Harness for open or short between ECM and refrigerant pressure sensor

>> Repair open circuit or short to ground or short to power in harness or connectors.

# REFRIGERANT PRESSURE SENSOR

---

## 7. CHECK REFRIGERANT PRESSURE SENSOR INPUT SIGNAL CIRCUIT FOR OPEN AND SHORT

---

1. Check harness continuity between ECM terminal 70 and refrigerant pressure sensor terminal 2.  
Refer to Wiring Diagram.

**Continuity should exist.**

2. Also check harness for short to ground and short to power.

OK or NG

- OK >> GO TO 9.
- NG >> GO TO 8.

## 8. DETECT MALFUNCTIONING PART

---

Check the following.

- Harness connectors E251, E31
- Harness connectors E10, F1
- Harness for open or short between ECM and refrigerant pressure sensor

>> Repair open circuit or short to ground or short to power in harness or connectors.

## 9. CHECK INTERMITTENT INCIDENT

---

Refer to [EC-129, "TROUBLE DIAGNOSIS FOR INTERMITTENT INCIDENT"](#) .

OK or NG

- OK >> Replace refrigerant pressure sensor.
- NG >> Repair or replace.

### **Removal and Installation** **REFRIGERANT PRESSURE SENSOR**

ABS0090X

Refer to [ATC-143, "Removal and Installation of Refrigerant Pressure Sensor"](#) .

# ELECTRICAL LOAD SIGNAL

## ELECTRICAL LOAD SIGNAL

PFP:25350

### Description

ABS0090Y

The electrical load signal (Headlamp switch signal, rear window defogger switch signal, etc.) is transferred through the CAN communication line from BCM to ECM via IPDM E/R.

### CONSULT-II Reference Value in Data Monitor Mode

ABS0090Z

Specification data are reference values.

MONITOR ITEM	CONDITION		SPECIFICATION
LOAD SIGNAL	● Ignition switch: ON	Rear window defogger switch is ON and/or lighting switch is in 2nd.	ON
		Rear window defogger switch is OFF and lighting switch is OFF.	OFF

### Diagnostic Procedure

ABS009P0

#### 1. CHECK LOAD SIGNAL CIRCUIT OVERALL FUNCTION-I

1. Turn ignition switch ON.
2. Connect CONSULT-II and select "DATA MONITOR" mode.
3. Select "LOAD SIGNAL" and check indication under the following conditions.

Condition	Indication
Rear window defogger switch: ON	ON
Rear window defogger switch: OFF	OFF

#### OK or NG

- OK >> GO TO 2.  
NG >> GO TO 3.

DATA MONITOR	
MONITORING	NO DTC
LOAD SIGNAL	ON

PBIB0103E

#### 2. CHECK LOAD SIGNAL CIRCUIT OVERALL FUNCTION-II

Check "LOAD SIGNAL" indication under the following conditions.

Condition	Indication
Lighting switch: ON at 2nd position	ON
Lighting switch: OFF	OFF

#### OK or NG

- OK >> **INSPECTION END**  
NG >> GO TO 4.

DATA MONITOR	
MONITORING	NO DTC
LOAD SIGNAL	ON

PBIB0103E

#### 3. CHECK REAR WINDOW DEFOGGER SYSTEM

Refer to [GW-56, "REAR WINDOW DEFOGGER"](#) .

>> **INSPECTION END**

#### 4. CHECK HEADLAMP SYSTEM

Refer to [LT-7, "HEADLAMP \(FOR USA\) - XENON TYPE -"](#) , [LT-38, "HEADLAMP \(FOR USA\) - CONVENTIONAL TYPE -"](#) , [LT-68, "HEADLAMP \(FOR CANADA\) - XENON TYPE -"](#) or [LT-105, "HEADLAMP \(FOR CANADA\) - CONVENTIONAL TYPE -"](#) .

>> **INSPECTION END**

# ASCD BRAKE SWITCH

## ASCD BRAKE SWITCH

PFP:25320

### Component Description

ABS009P1

When the brake pedal is depressed, ASCD brake switch is turned OFF and stop lamp switch is turned ON. ECM detects the state of the brake pedal by this input of two kinds (ON/OFF signal).

Refer to [EC-688, "AUTOMATIC SPEED CONTROL DEVICE \(ASCD\)"](#) for the ASCD function.

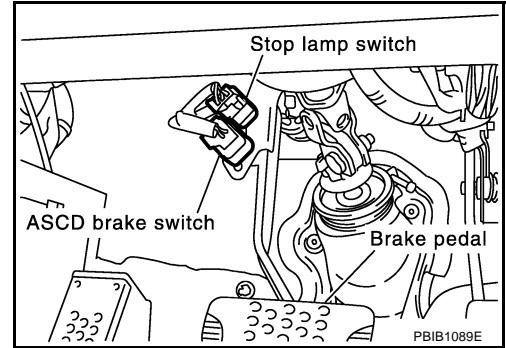

### CONSULT-II Reference Value in Data Monitor Mode

ABS009P2

Specification data are reference values.

MONITOR ITEM	CONDITION		SPECIFICATION
BRAKE SW 1 (ASCD brake switch)	● Ignition switch: ON	● Clutch pedal (M/T) and brake pedal: Fully released	ON
		● Clutch pedal (M/T) and/or brake pedal: Slightly depressed	OFF
BRAKE SW 2 (stop lamp switch)	● Ignition switch: ON	● Brake pedal: Fully released	OFF
		● Brake pedal: Slightly depressed	ON

# ASC D BRAKE SWITCH

## Wiring Diagram A/T MODELS

ABS009P3

### EC-ASCBOF-01

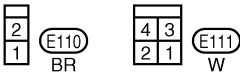
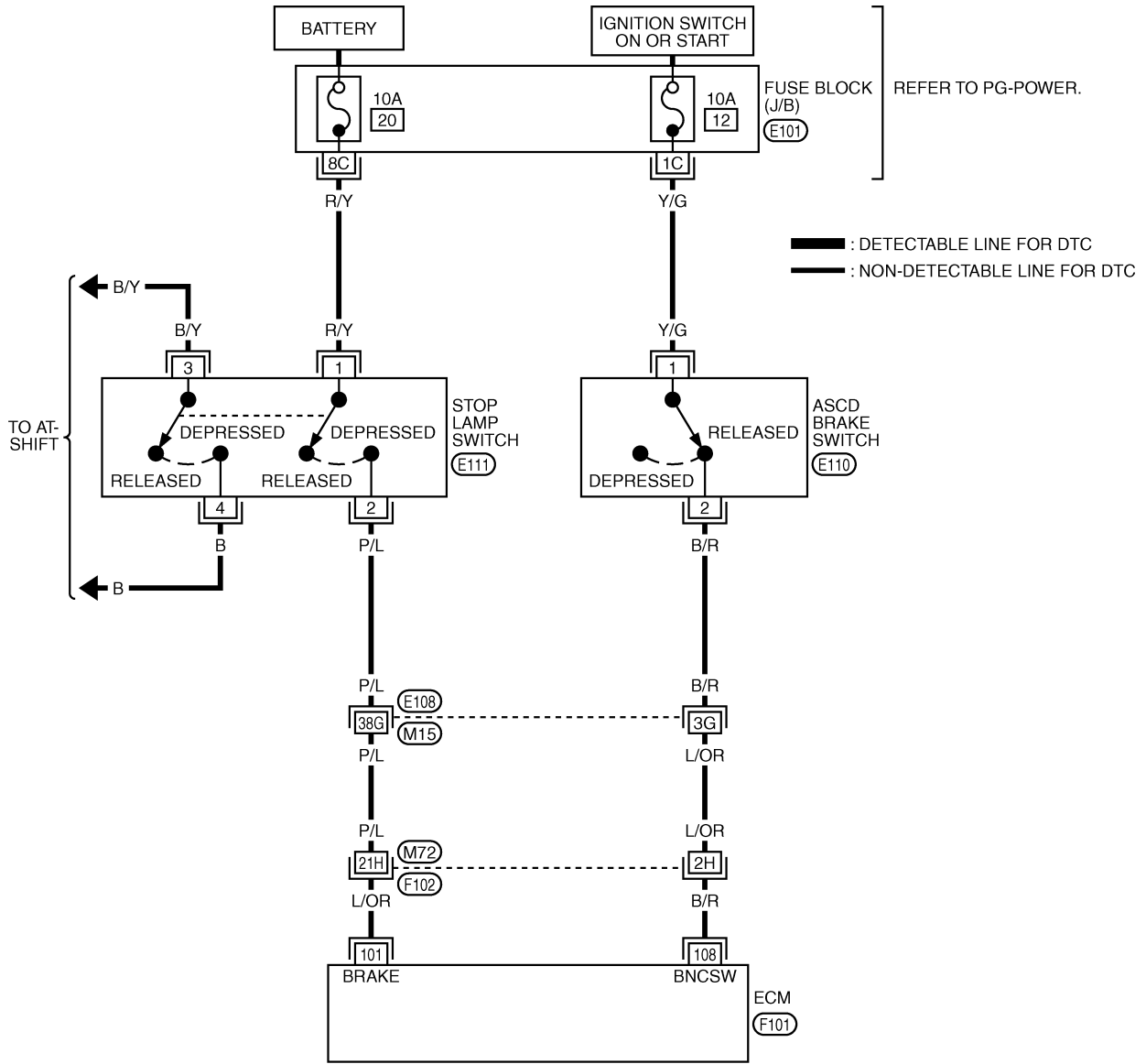

REFER TO THE FOLLOWING.  
 (E108), (F102) -SUPER MULTIPLE JUNCTION (SMJ)  
 (E101) -FUSE BLOCK-JUNCTION BOX (J/B)

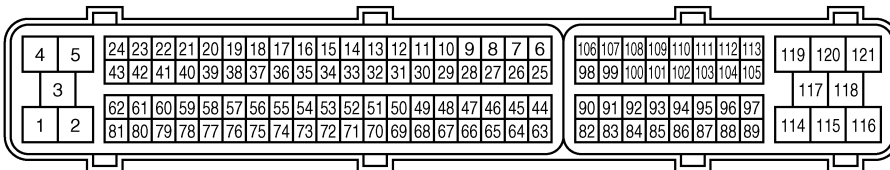

TBWT0515E

## ASCD BRAKE SWITCH

Specification data are reference values and are measured between each terminal and ground.

**CAUTION:**

**Do not use ECM ground terminals when measuring input/output voltage. Doing so may result in damage to the ECM's transistor. Use a ground other than ECM terminals, such as the ground.**

TER-MINAL NO.	WIRE COLOR	ITEM	CONDITION	DATA (DC Voltage)
101	L/OR	Stop lamp switch	<b>[Ignition switch: OFF]</b> ● Brake pedal is fully released	Approximately 0V
			<b>[Ignition switch: OFF]</b> ● Brake pedal is slightly depressed	BATTERY VOLTAGE (11 - 14V)
108	B/R	ASCD brake switch	<b>[Ignition switch: ON]</b> ● Brake pedal is slightly depressed	Approximately 0V
			<b>[Ignition switch: ON]</b> ● Brake pedal is fully released	BATTERY VOLTAGE (11 - 14V)



# ASCD BRAKE SWITCH

M/T MODELS

EC-ASCBOF-02

A  
EC  
C  
D  
E  
F  
G  
H  
I  
J  
K  
L  
M

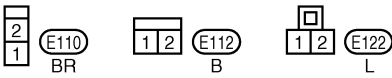
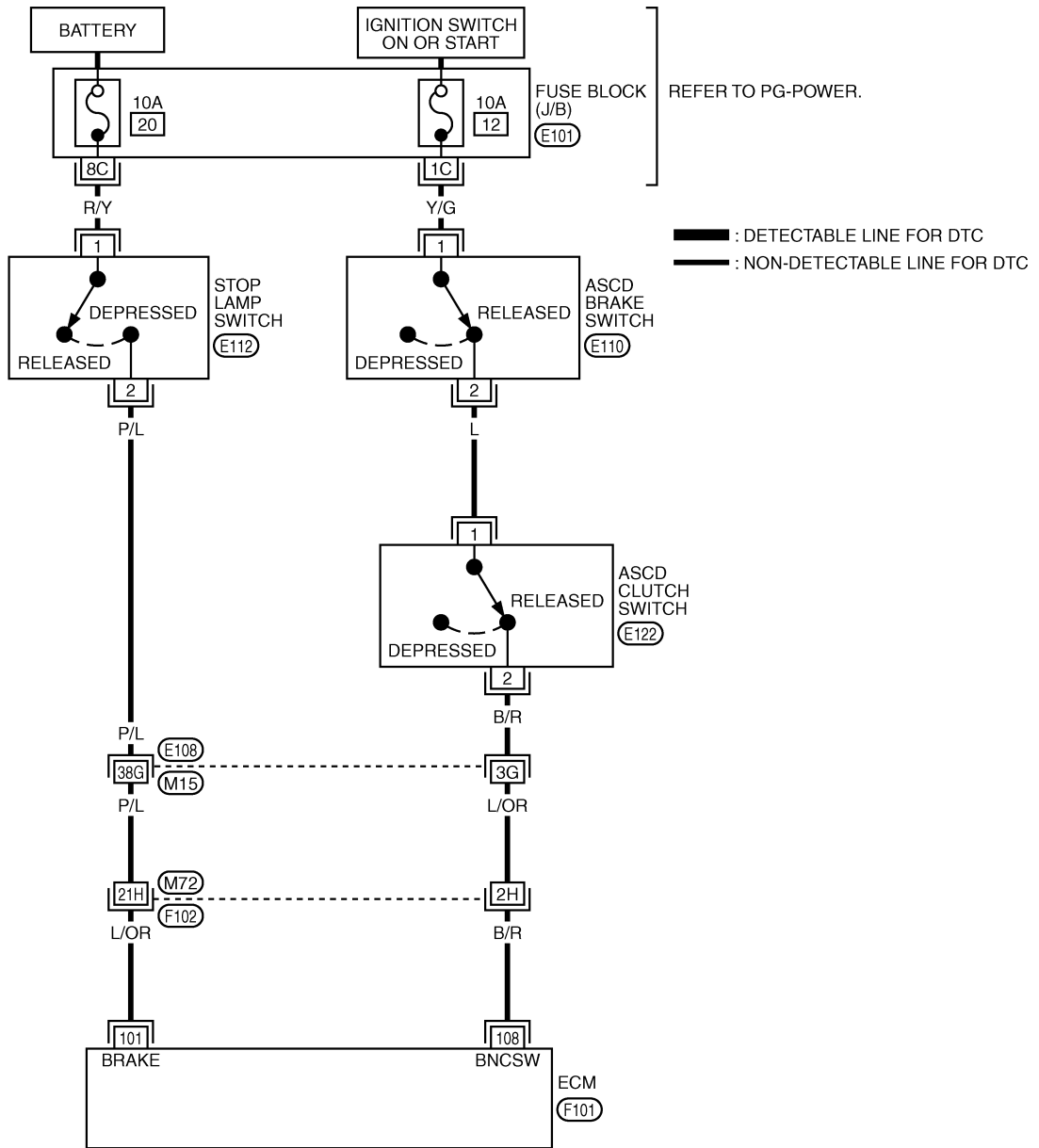

REFER TO THE FOLLOWING.  
 (E108), (F102) -SUPER MULTIPLE JUNCTION (SMJ)  
 (E101) -FUSE BLOCK-JUNCTION BOX (J/B)

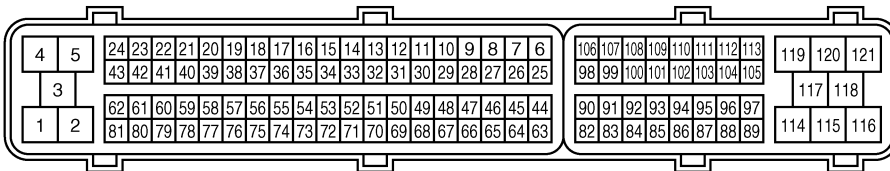

TBWT0516E

# ASCD BRAKE SWITCH

Specification data are reference values and are measured between each terminal and ground.

**CAUTION:**

Do not use ECM ground terminals when measuring input/output voltage. Doing so may result in damage to the ECM's transistor. Use a ground other than ECM terminals, such as the ground.

TER-MINAL NO.	WIRE COLOR	ITEM	CONDITION	DATA (DC Voltage)
101	L/OR	Stop lamp switch	[Ignition switch: OFF] ● Brake pedal is fully released	Approximately 0V
			[Ignition switch: OFF] ● Brake pedal is slightly depressed	BATTERY VOLTAGE (11 - 14V)
108	B/R	ASCD brake switch	[Ignition switch: ON] ● Brake pedal and/or clutch pedal are slightly depressed	Approximately 0V
			[Ignition switch: ON] ● Brake pedal and clutch pedal are fully released	BATTERY VOLTAGE (11 - 14V)

## Diagnostic Procedure

ABS009P4

### A/T MODELS

#### 1. CHECK OVERALL FUNCTION-I

 **With CONSULT-II**

1. Turn ignition switch ON.
2. Select "BRAKE SW1" in "DATA MONITOR" mode with CONSULT-II.
3. Check "BRAKE SW1" indication under the following conditions.

CONDITION	INDICATION
When brake pedal is slightly depressed	OFF
When brake pedal is fully released	ON

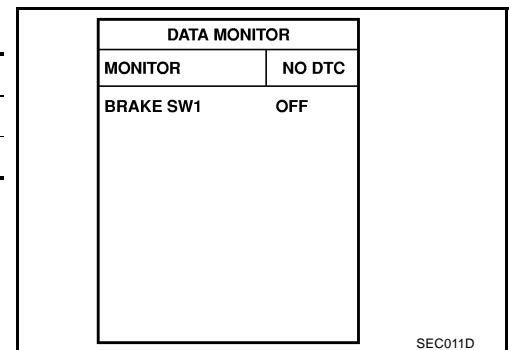

 **Without CONSULT-II**

1. Turn ignition switch ON.
2. Check voltage between ECM terminal 108 and ground under the following conditions.

CONDITION	VOLTAGE
When brake pedal is slightly depressed	Approximately 0V
When brake pedal is fully released	Battery voltage

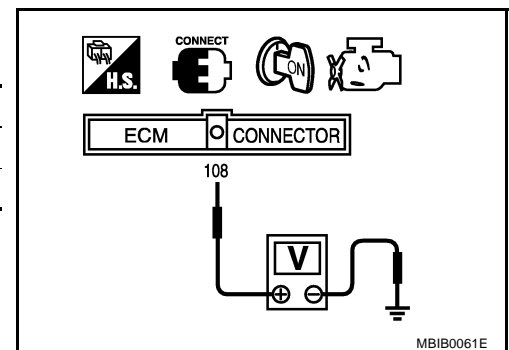

OK or NG

- OK >> GO TO 2.
- NG >> GO TO 3.

# ASCD BRAKE SWITCH

## 2. CHECK OVERALL FUNCTION-II

### ④ With CONSULT-II

1. Select "BRAKE SW2" in "DATA MONITOR" mode with CONSULT-II.
2. Check "BRAKE SW2" indication under the following conditions.

CONDITION	INDICATION
When brake pedal is fully released	OFF
When brake pedal is slightly depressed	ON

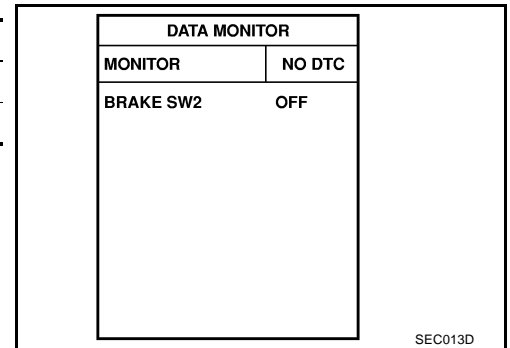

### ⊗ Without CONSULT-II

Check voltage between ECM terminal 101 and ground under the following conditions.

CONDITION	VOLTAGE
When brake pedal is fully released	Approximately 0V
When brake pedal is slightly depressed	Battery voltage

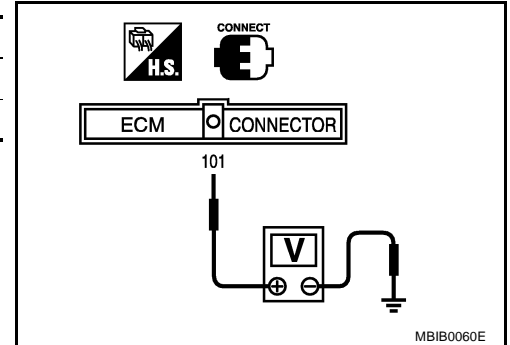

OK or NG

- OK >> **INSPECTION END**  
 NG >> GO TO 8.

A  
 EC  
 C  
 D  
 E  
 F  
 G  
 H  
 I  
 J  
 K  
 L  
 M

# ASCD BRAKE SWITCH

## 3. CHECK ASCD BRAKE SWITCH POWER SUPPLY CIRCUIT

1. Turn ignition switch OFF.
2. Disconnect ASCD brake switch harness connector.
3. Turn ignition switch ON.

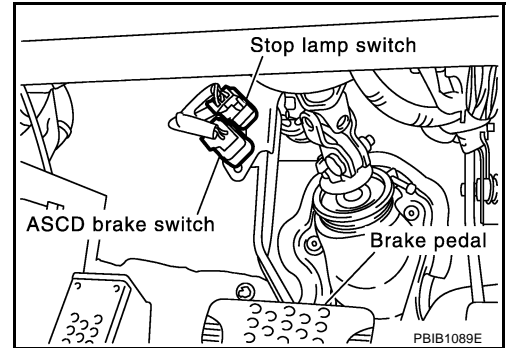

4. Check voltage between ASCD brake switch terminal 1 and ground with CONSULT-II or tester.

**Voltage: Battery voltage**

OK or NG

- OK >> GO TO 5.
- NG >> GO TO 4.

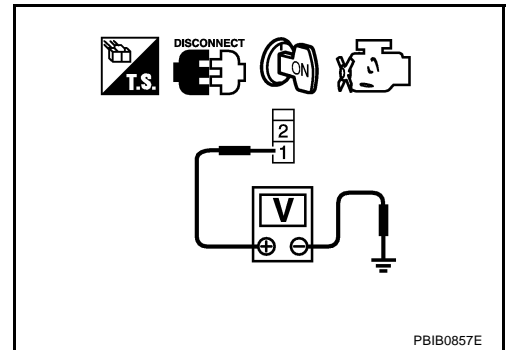

## 4. DETECT MALFUNCTIONING PART

Check the following.

- Fuse block (J/B) connector E101
- 10A fuse
- Harness for open or short between ASCD brake switch and fuse

>> Repair open circuit or short to ground or short to power in harness or connectors.

## 5. CHECK ASCD BRAKE SWITCH INPUT SIGNAL CIRCUIT FOR OPEN AND SHORT

1. Turn ignition switch OFF.
2. Disconnect ECM harness connector.
3. Check harness continuity between ECM terminal 108 and ASCD brake switch terminal 2. Refer to Wiring Diagram.

**Continuity should exist.**

4. Also check harness for short to ground and short to power.

OK or NG

- OK >> GO TO 7.
- NG >> GO TO 6.

# ASCD BRAKE SWITCH

## 6. DETECT MALFUNCTIONING PART

Check the following.

- Harness connectors E108, M15
- Harness connectors M72, F102
- Harness for open or short between ECM and ASCD brake switch

>> Repair open circuit or short to ground or short to power in harness or connectors.

## 7. CHECK ASCD BRAKE SWITCH

Refer to [EC-573, "Component Inspection"](#)

OK or NG

OK >> GO TO 13.

NG >> Replace ASCD brake switch.

## 8. CHECK STOP LAMP SWITCH POWER SUPPLY CIRCUIT

1. Turn ignition switch OFF.
2. Disconnect stop lamp switch harness connector.

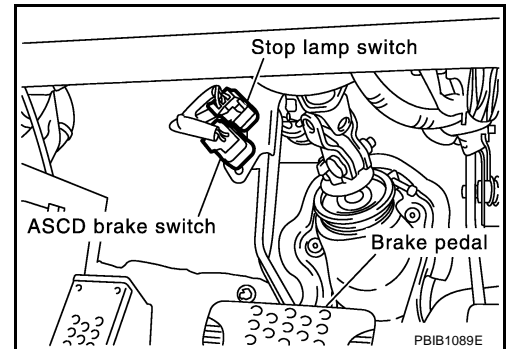

3. Check voltage between stop lamp switch terminal 1 and ground with CONSULT -II or tester.

**Voltage: Battery voltage**

OK or NG

OK >> GO TO 10.

NG >> GO TO 9.

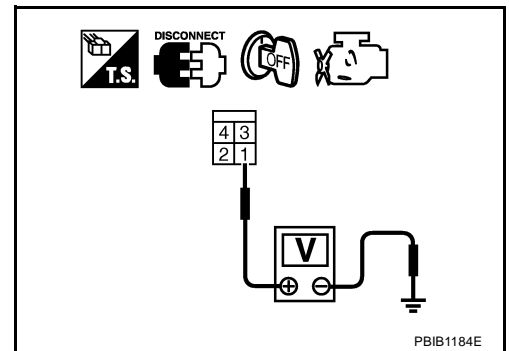

## 9. DETECT MALFUNCTIONING PART

Check the following.

- Fuse block (J/B) connector E101
- 10A fuse
- Harness for open or short between stop lamp switch and battery

>> Repair open circuit or short to ground or short to power in harness or connectors.

# ASCD BRAKE SWITCH

---

## 10. CHECK STOP LAMP SWITCH INPUT SIGNAL CIRCUIT FOR OPEN AND SHORT

---

1. Disconnect ECM harness connector.
2. Check harness continuity between ECM terminal 101 and stop lamp switch terminal 2.  
Refer to Wiring Diagram.

**Continuity should exist.**

3. Also check harness for short to ground and short to power.

OK or NG

- OK >> GO TO 12.  
NG >> GO TO 11.

---

## 11. DETECT MALFUNCTIONING PART

---

Check the following.

- Harness connectors E108, M15
- Harness connectors M72, F102
- Harness for open or short between ECM and stop lamp switch

>> Repair open circuit or short to ground or short to power in harness or connectors.

---

## 12. CHECK STOP LAMP SWITCH

---

Refer to [EC-573, "Component Inspection"](#)

OK or NG

- OK >> GO TO 13.  
NG >> Replace stop lamp switch.

---

## 13. CHECK INTERMITTENT INCIDENT

---

Refer to [EC-129, "TROUBLE DIAGNOSIS FOR INTERMITTENT INCIDENT"](#) .

>> **INSPECTION END**

# ASCD BRAKE SWITCH

## M/T MODELS

### 1. CHECK OVERALL FUNCTION-I

#### With CONSULT-II

1. Turn ignition switch ON.
2. Select "BRAKE SW1" in "DATA MONITOR" mode with CONSULT-II.
3. Check "BRAKE SW1" indication under the following conditions.

CONDITION	INDICATION
When brake pedal and/or clutch pedal are slightly depressed	OFF
When brake pedal and clutch pedal are fully released	ON

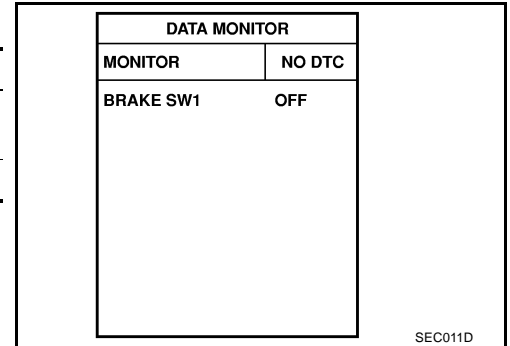

#### Without CONSULT-II

1. Turn ignition switch ON.
2. Check voltage between ECM terminal 108 and ground under the following conditions.

CONDITION	VOLTAGE
When brake pedal and/or clutch pedal are slightly depressed	Approximately 0V
When brake pedal and clutch pedal are fully released	Battery voltage

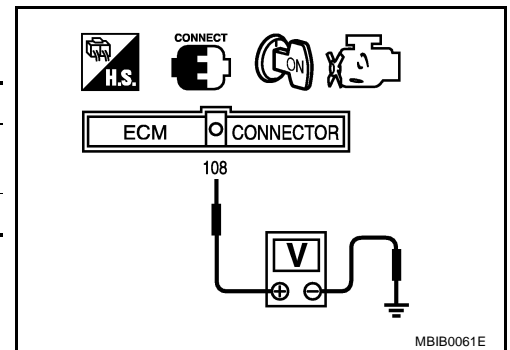

#### OK or NG

- OK >> GO TO 2.  
 NG >> GO TO 3.

A  
 EC  
 C  
 D  
 E  
 F  
 G  
 H  
 I  
 J  
 K  
 L  
 M

# ASCD BRAKE SWITCH

## 2. CHECK OVERALL FUNCTION-II

### With CONSULT-II

1. Select "BRAKE SW2" indication in "DATA MONITOR" mode.
2. Check "BRAKE SW2" indication under the following conditions.

CONDITION	INDICATION
When brake pedal is fully released	OFF
When brake pedal is slightly depressed	ON

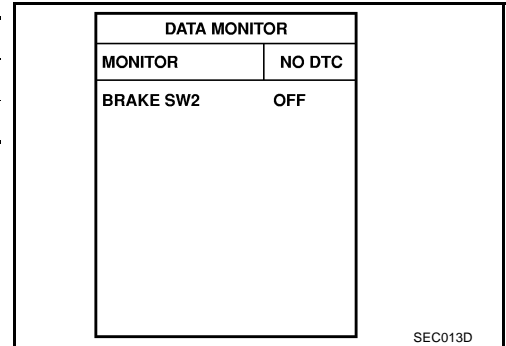

### Without CONSULT-II

Check voltage between ECM terminal 101 and ground under the following conditions.

CONDITION	VOLTAGE
When brake pedal is fully released	Approximately 0V
When brake pedal is slightly depressed	Battery voltage

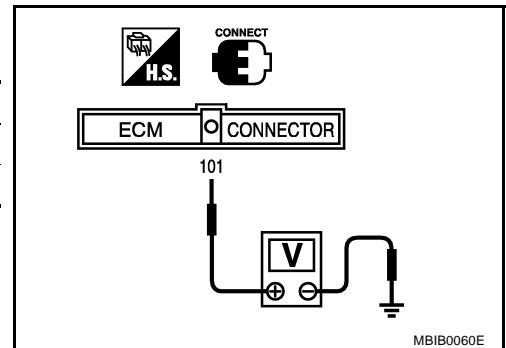

### OK or NG

- OK >> **INSPECTION END**  
 NG >> GO TO 11.

## 3. CHECK ASCD BRAKE SWITCH CIRCUIT

1. Turn ignition switch OFF.
2. Disconnect ASCD clutch switch harness connector.
3. Turn ignition switch ON.

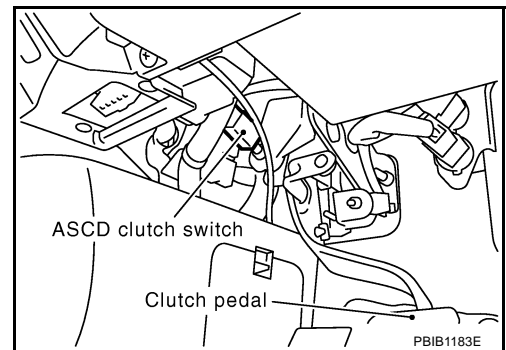

4. Check voltage between ASCD clutch switch terminal 1 and ground with CONSULT-II or tester.

**Voltage: Battery voltage**

### OK or NG

- OK >> GO TO 8.  
 NG >> GO TO 4.

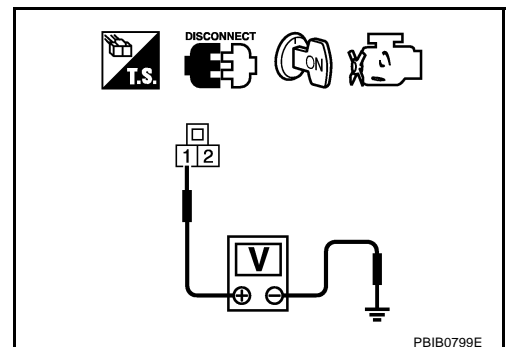



# ASCD BRAKE SWITCH

## 4. CHECK ASCD BRAKE SWITCH POWER SUPPLY CIRCUIT

1. Turn ignition switch OFF.
2. Disconnect ASCD brake switch harness connector.
3. Turn ignition switch ON.

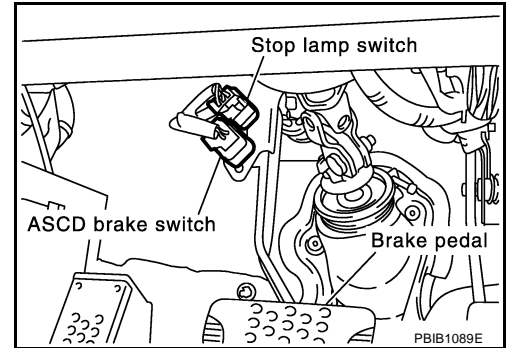

4. Check voltage between ASCD brake switch terminal 1 and ground with CONSULT-II or tester.

**Voltage: Battery voltage**

OK or NG

- OK >> GO TO 6.
- NG >> GO TO 5.

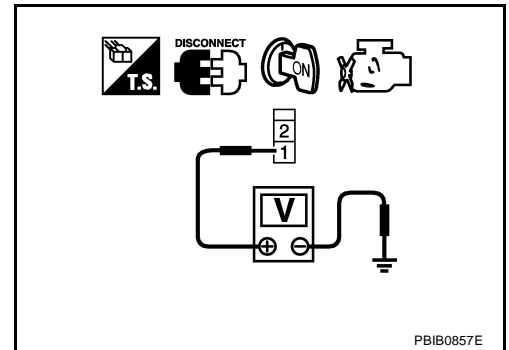

## 5. DETECT MALFUNCTIONING PART

Check the following.

- Fuse block (J/B) connector E101
- 10A fuse
- Harness for open or short between ASCD brake switch and fuse

>> Repair open circuit or short to ground or short to power in harness or connectors.

## 6. CHECK ASCD BRAKE SWITCH INPUT SIGNAL CIRCUIT FOR OPEN AND SHORT

1. Turn ignition switch OFF.
2. Check harness continuity between ASCD brake switch terminal 2 and ASCD clutch switch terminal 1. Refer to Wiring Diagram.

**Continuity should exist.**

3. Also check harness for short to ground and short to power.

OK or NG

- OK >> GO TO 7.
- NG >> Repair open circuit or short to ground or short to power in harness or connectors.

## 7. CHECK ASCD BRAKE SWITCH

Refer to [EC-573, "Component Inspection"](#)

OK or NG

- OK >> GO TO 16.
- NG >> Replace ASCD brake switch.

# ASCD BRAKE SWITCH

## 8. CHECK ASCD CLUTCH SWITCH INPUT SIGNAL CIRCUIT FOR OPEN AND SHORT

1. Turn ignition switch OFF.
2. Disconnect ECM harness connector.
3. Check harness continuity between ASCD clutch switch terminal 2 and ECM terminal 108.  
Refer to Wiring Diagram.

**Continuity should exist.**

4. Also check harness for short to ground and short to power.

OK or NG

- OK >> GO TO 10.
- NG >> GO TO 9.

## 9. DETECT MALFUNCTIONING PART

Check the following.

- Harness connectors E108, M15
- Harness connectors M72, F102
- Harness for open or short between ECM and ASCD clutch switch

>> Repair open circuit or short to ground or short to power in harness or connectors.

## 10. CHECK ASCD CLUTCH SWITCH

Refer to [EC-573, "Component Inspection"](#).

OK or NG

- OK >> GO TO 16.
- NG >> Replace ASCD clutch switch.

## 11. CHECK STOP LAMP SWITCH POWER SUPPLY CIRCUIT

1. Turn ignition switch OFF.
2. Disconnect stop lamp switch harness connector.

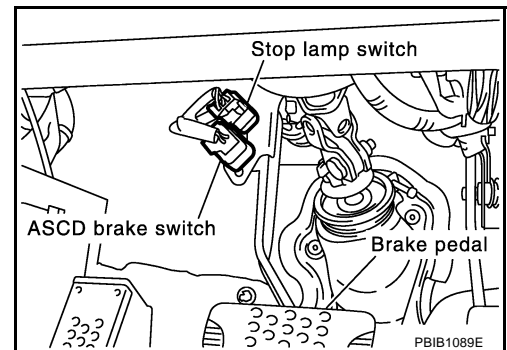

3. Check voltage between stop lamp switch terminal 1 and ground with CONSULT-II or tester.

**Voltage: Battery voltage**

OK or NG

- OK >> GO TO 13.
- NG >> GO TO 12.

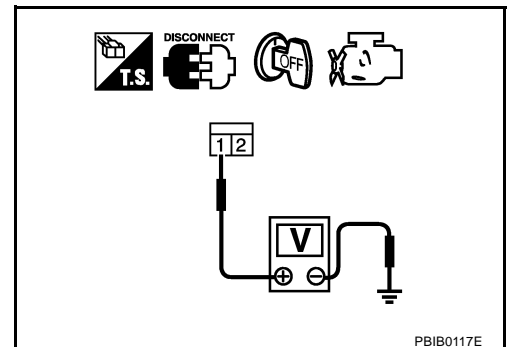

# ASCD BRAKE SWITCH

---

## 12. DETECT MALFUNCTIONING PART

---

Check the following.

- Fuse block (J/B) connector E101
- 10A fuse
- Harness for open or short between stop lamp switch and fuse

>> Repair open circuit or short to ground or short to power in harness or connectors.

---

## 13. CHECK STOP LAMP SWITCH INPUT SIGNAL CIRCUIT FOR OPEN AND SHORT

---

1. Disconnect ECM harness connector.
2. Check harness continuity between ECM terminal 101 and stop lamp switch terminal 2.  
Refer to Wiring Diagram.

**Continuity should exist.**

3. Also check harness for short to ground and short to power.

OK or NG

- OK >> GO TO 15.
- NG >> GO TO 14.

---

## 14. DETECT MALFUNCTIONING PART

---

Check the following.

- Harness connectors E108, M15
- Harness connectors M72, F102
- Harness for open or short between ECM and stop lamp switch

>> Repair open circuit or short to ground or short to power in harness or connectors.

---

## 15. CHECK STOP LAMP SWITCH

---

Refer to [EC-573, "Component Inspection"](#)

OK or NG

- OK >> GO TO 16.
- NG >> Replace stop lamp switch.

---

## 16. CHECK INTERMITTENT INCIDENT

---

Refer to [EC-129, "TROUBLE DIAGNOSIS FOR INTERMITTENT INCIDENT"](#) .

>> **INSPECTION END**

A  
EC  
C  
D  
E  
F  
G  
H  
I  
J  
K  
L  
M

# ASCD BRAKE SWITCH

ABS009P5

## Component Inspection ASCD BRAKE SWITCH

1. Turn ignition switch OFF.
2. Disconnect ASCD brake switch harness connector.
3. Check harness continuity between ASCD brake switch terminals 1 and 2 under the following conditions.

Condition	Continuity
When brake pedal is fully released.	Should exist.
When brake pedal is slightly depressed.	Should not exist.

If NG, adjust ASCD brake switch installation, refer to [BR-6](#), "[BRAKE PEDAL](#)", and perform step 3 again.

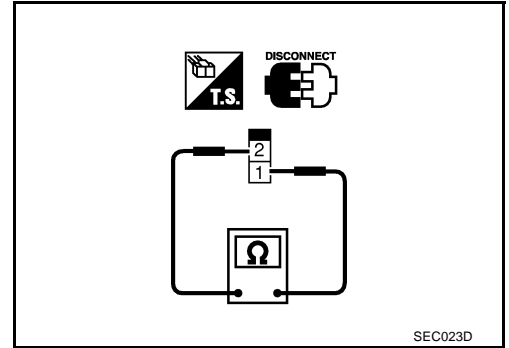

## ASCD CLUTCH SWITCH

1. Turn ignition switch OFF.
2. Disconnect ASCD clutch switch harness connector.
3. Check harness continuity between ASCD clutch switch terminals 1 and 2 under the following conditions.

Condition	Continuity
When clutch pedal is fully released.	Should exist.
When clutch pedal is slightly depressed.	Should not exist.

If NG, adjust ASCD clutch switch installation, refer to [CL-5](#), "[CLUTCH PEDAL](#)", and perform step 3 again.

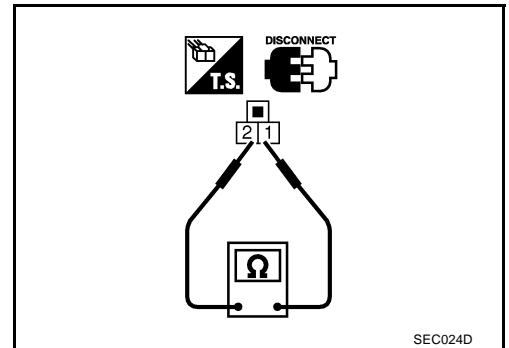

## STOP LAMP SWITCH

1. Turn ignition switch OFF.
2. Disconnect stop lamp switch harness connector.
3. Check harness continuity between stop lamp switch terminals 1 and 2 under the following conditions.

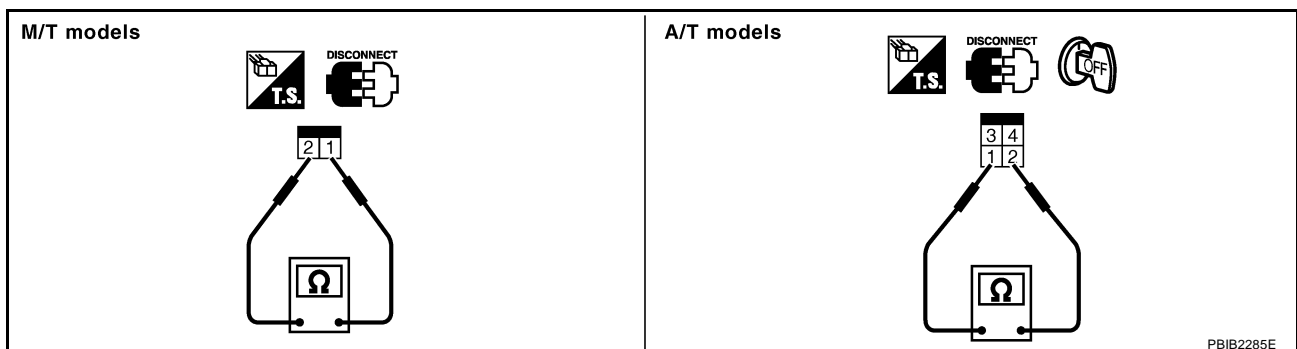

Condition	Continuity
When brake pedal is fully released.	Should not exist.
When brake pedal is slightly depressed.	Should exist.

If NG, adjust stop lamp switch installation, refer to [BR-6](#), "[BRAKE PEDAL](#)", and perform step 3 again.

# ASCD INDICATOR

## ASCD INDICATOR

PFP:24814

### Component Description

ABS009P6

ASCD indicator lamp illuminates to indicate ASCD operation status. Lamp has two indicators, CRUISE and SET, and is integrated in combination meter.

CRUISE indicator illuminates when ON/OFF (MAIN) switch on ASCD steering switch is turned ON to indicated that ASCD system is ready for operation.

SET indicator illuminates when following conditions are met.

- CRUISE indicator is illuminated.
- COAST/SET switch on ASCD steering switch is turned ON while vehicle speed is within the range of ASCD setting.

SET indicator remains lit during ASCD control.

Refer to [EC-688, "AUTOMATIC SPEED CONTROL DEVICE \(ASCD\)"](#) for the ASCD function.

### CONSULT-II Reference Value in Data Monitor Mode

ABS009P7

Specification data are reference value.

MONITOR ITEM	CONDITION		SPECIFICATION
CRUISE LAMP	● Ignition switch: ON	● ON/OFF (MAIN) switch: Pressed at the 1st time → at the 2nd time	ON → OFF
SET LAMP	● ON/OFF (MAIN) switch: ON ● When vehicle speed is between 40 km/h (25 MPH) and 144 km/h (89 MPH)	● ASCD: Operating	ON
		● ASCD: Not operating	OFF

# ASC D INDICATOR

ABS009P8

## Wiring Diagram

EC-ASCIND-01

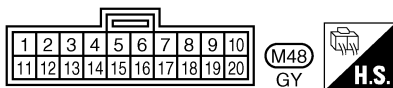
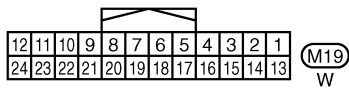
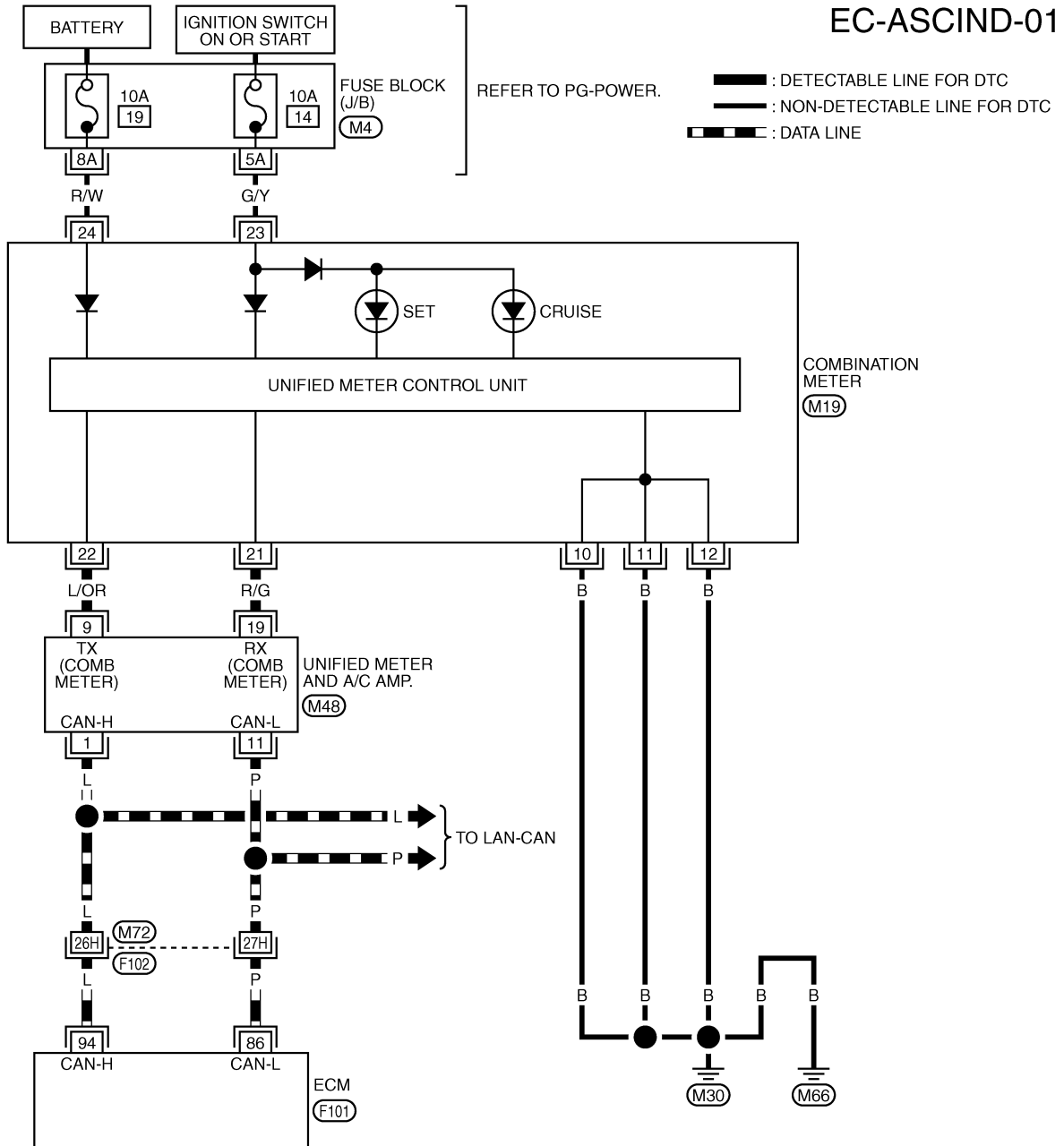

REFER TO THE FOLLOWING.

(F102) -SUPER MULTIPLE JUNCTION (SMJ)

(M4) -FUSE BLOCK-JUNCTION BOX (J/B)

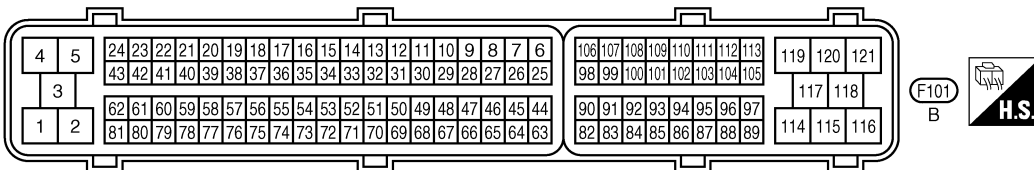

TBWT0699E

# ASCD INDICATOR

## Diagnostic Procedure

ABS009P9

### 1. CHECK OVERALL FUNCTION

Check ASCD indicator under the following conditions.

ASCD INDICATOR	CONDITION		SPECIFICATION
CRUISE LAMP	● Ignition switch: ON	● ON/OFF (MAIN) switch: Pressed at the 1st time → at the 2nd time	ON → OFF
SET LAMP	● ON/OFF (MAIN) switch: ON ● When vehicle speed is between 40 km/h (25 MPH) and 144 km/h (89 MPH)	● ASCD: Operating	ON
		● ASCD: Not operating	OFF

OK or NG

OK >> **INSPECTION END**

NG >> GO TO 2.

### 2. CHECK DTC

Check that DTC U1000 or U1001 is not displayed.

OK or NG

OK >> GO TO 3.

NG >> Perform trouble diagnoses for DTC U1000, U1001. Refer to [EC-139, "DTC U1000, U1001 CAN COMMUNICATION LINE"](#).

### 3. CHECK DTC WITH "UNIFIED METER AND A/C AMP."

Refer to [DI-59, "SELF-DIAGNOSIS RESULTS"](#).

OK or NG

OK >> GO TO 4.

NG >> Go to [DI-23, "Communication Line Inspection"](#).

### 4. CHECK INTERMITTENT INCIDENT

Refer to [EC-129, "TROUBLE DIAGNOSIS FOR INTERMITTENT INCIDENT"](#).

>> **INSPECTION END**

# MIL AND DATA LINK CONNECTOR

PF2:24814

## MIL AND DATA LINK CONNECTOR

### Wiring Diagram

ABS009PA

## EC-MIL/DL-01

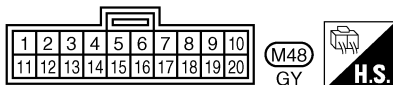
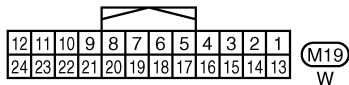
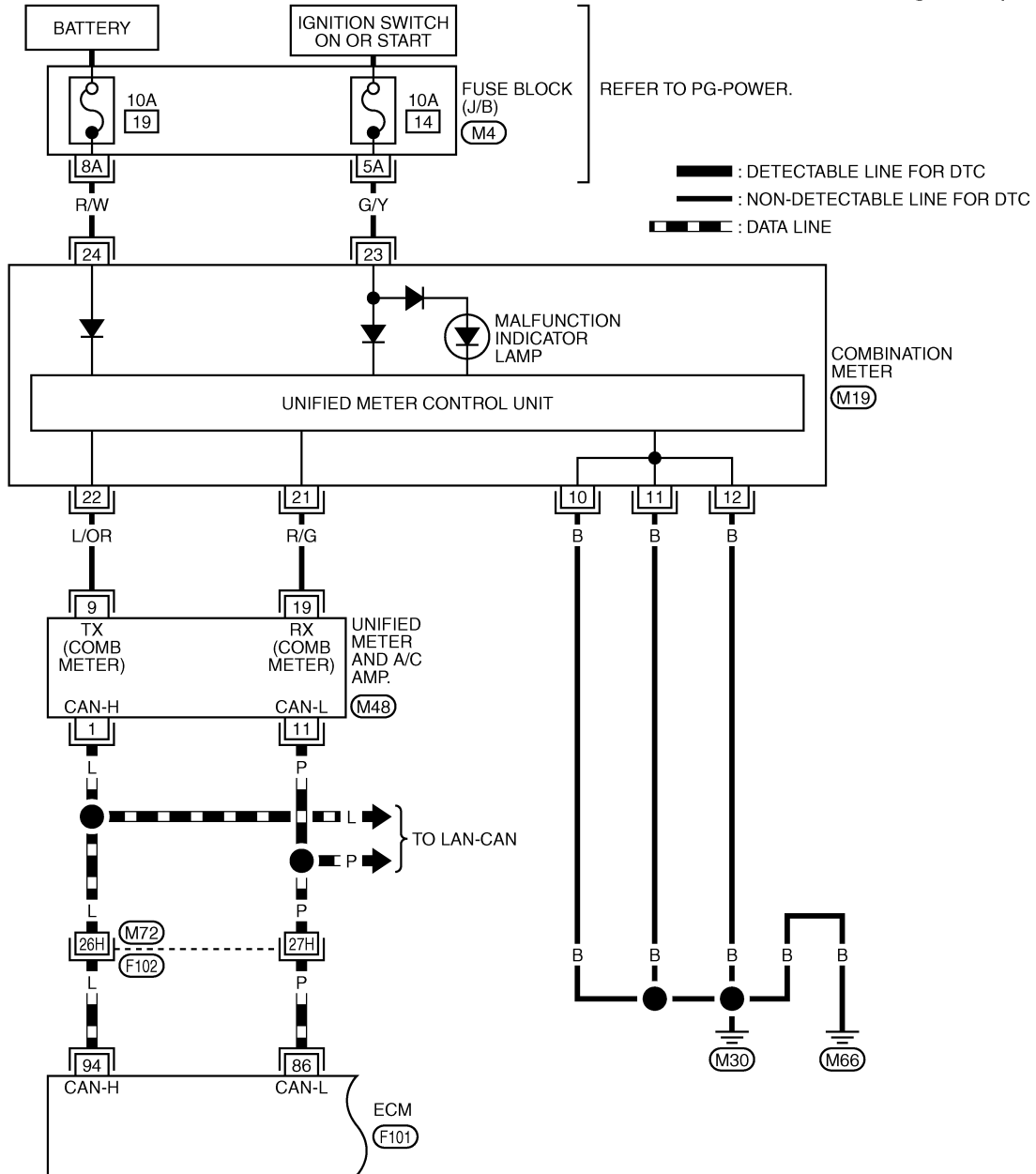

REFER TO THE FOLLOWING.

(F102) -SUPER MULTIPLE JUNCTION (SMJ)

(M4) -FUSE BLOCK-JUNCTION BOX (J/B)

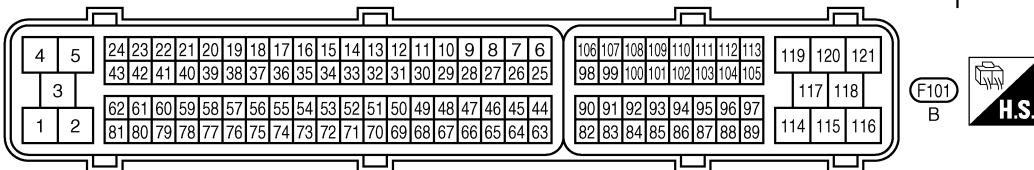

TBWT0700E





# EVAPORATIVE EMISSION SYSTEM

## EVAPORATIVE EMISSION SYSTEM

PFP:14950

### Description SYSTEM DESCRIPTION

ABS009PB

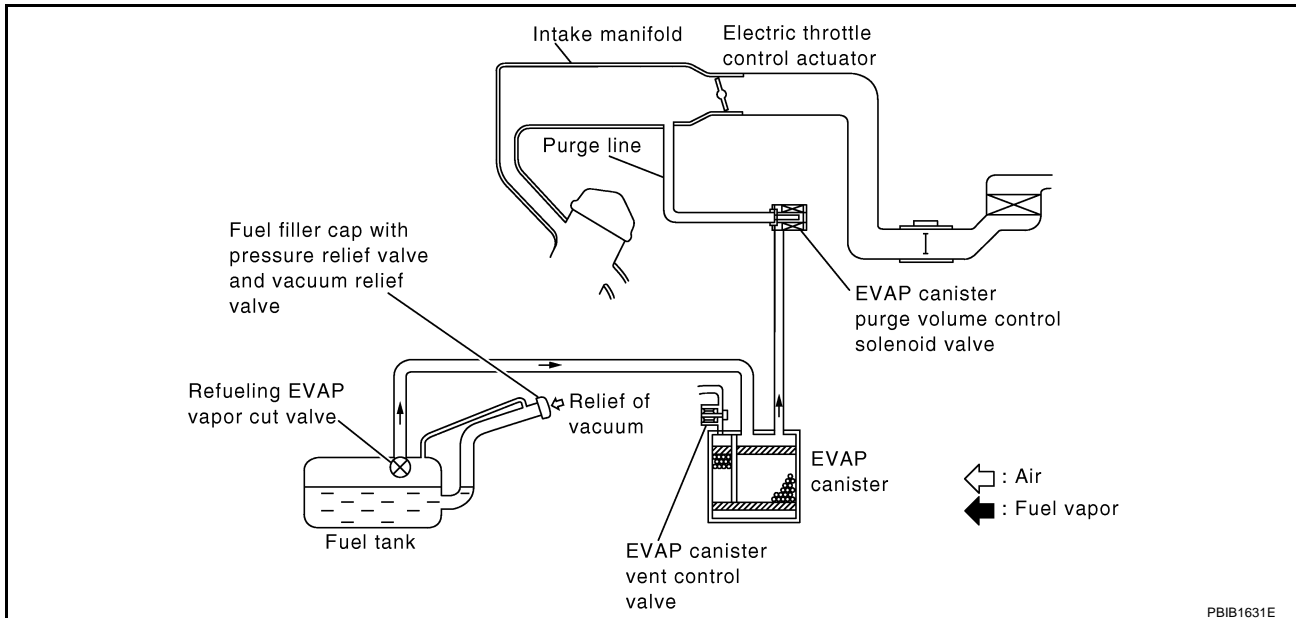

The evaporative emission system is used to reduce hydrocarbons emitted into the atmosphere from the fuel system. This reduction of hydrocarbons is accomplished by activated charcoals in the EVAP canister. The fuel vapor in the sealed fuel tank is led into the EVAP canister which contains activated carbon and the vapor is stored there when the engine is not operating or when refueling to the fuel tank. The vapor in the EVAP canister is purged by the air through the purge line to the intake manifold when the engine is operating. EVAP canister purge volume control solenoid valve is controlled by ECM. When the engine operates, the flow rate of vapor controlled by EVAP canister purge volume control solenoid valve is proportionally regulated as the air flow increases. EVAP canister purge volume control solenoid valve also shuts off the vapor purge line during decelerating and idling.



# EVAPORATIVE EMISSION SYSTEM

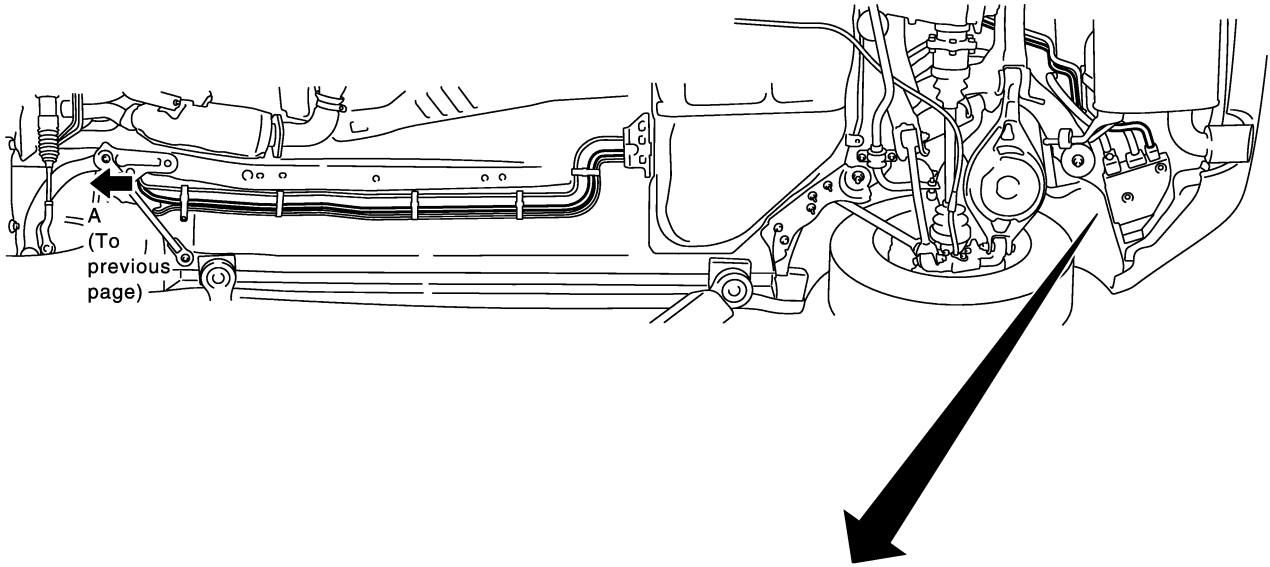

**View from under the vehicle**

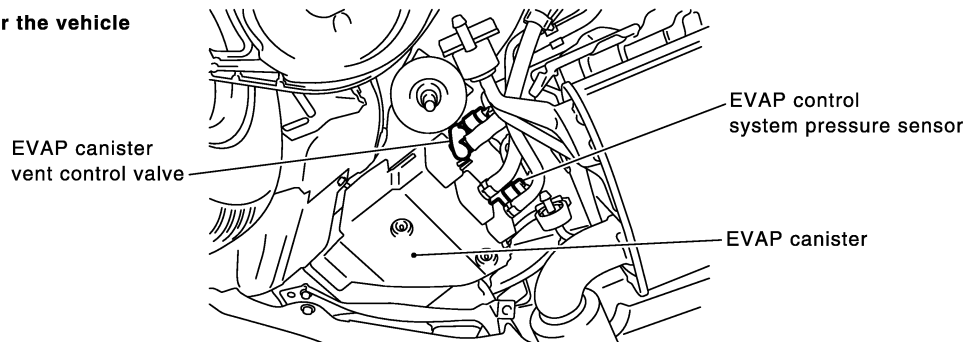

PBIB1066E

# EVAPORATIVE EMISSION SYSTEM

## Component Inspection EVAP CANISTER

ABS009PC

Check EVAP canister as follows:

1. Block port **B** .
2. Blow air into port **A** and check that it flows freely out of port **C** .
3. Release blocked port **B** .
4. Apply vacuum pressure to port **B** and check that vacuum pressure exists at the ports **A** and **C** .
5. Block port **A** and **B** .
6. Apply pressure to port **C** and check that there is no leakage.

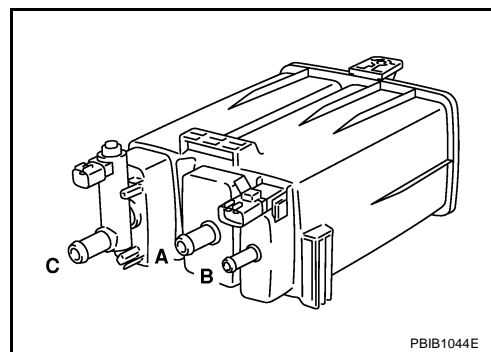

## FUEL TANK VACUUM RELIEF VALVE (BUILT INTO FUEL FULLER CAP)

1. Wipe clean valve housing.

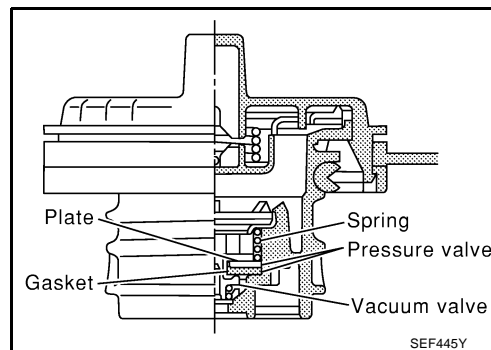

2. Check valve opening pressure and vacuum.

**Pressure:** 15.3 - 20.0 kPa (0.156 - 0.204 kg/cm<sup>2</sup> , 2.22 - 2.90 psi)

**Vacuum:** -6.0 to -3.3 kPa (-0.061 to -0.034 kg/cm<sup>2</sup> , -0.87 to -0.48 psi)

3. If out of specification, replace fuel filler cap as an assembly.

### CAUTION:

Use only a genuine fuel filler cap as a replacement. If an incorrect fuel filler cap is used, the MIL may come on.

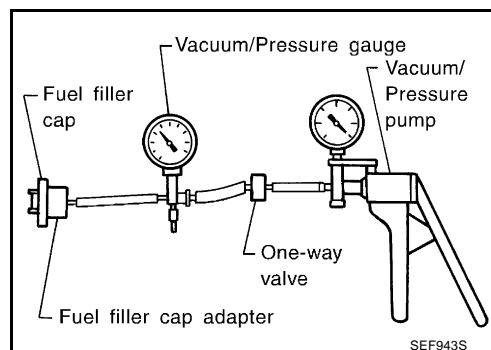

## EVAP CANISTER PURGE VOLUME CONTROL SOLENOID VALVE

Refer to [EC-306](#) .

## FUEL TANK TEMPERATURE SENSOR

Refer to [EC-246](#) .

## EVAP CANISTER VENT CONTROL VALVE

Refer to [EC-315](#) .

## EVAP CONTROL SYSTEM PRESSURE SENSOR

Refer to [EC-328](#) .

# EVAPORATIVE EMISSION SYSTEM

## EVAP SERVICE PORT

Positive pressure is delivered to the EVAP system through the EVAP service port. If fuel vapor leakage in the EVAP system occurs, use a leak detector to locate the leak.

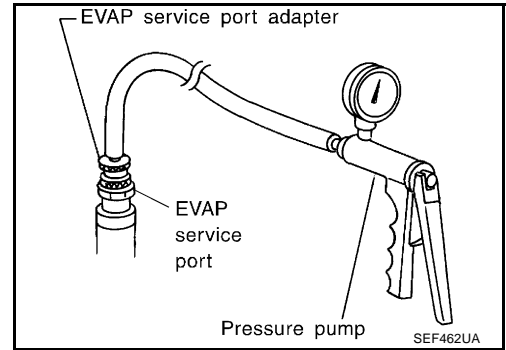

## Removal and Installation EVAP CANISTER

Tighten EVAP canister as shown in the figure.

ABS009PD

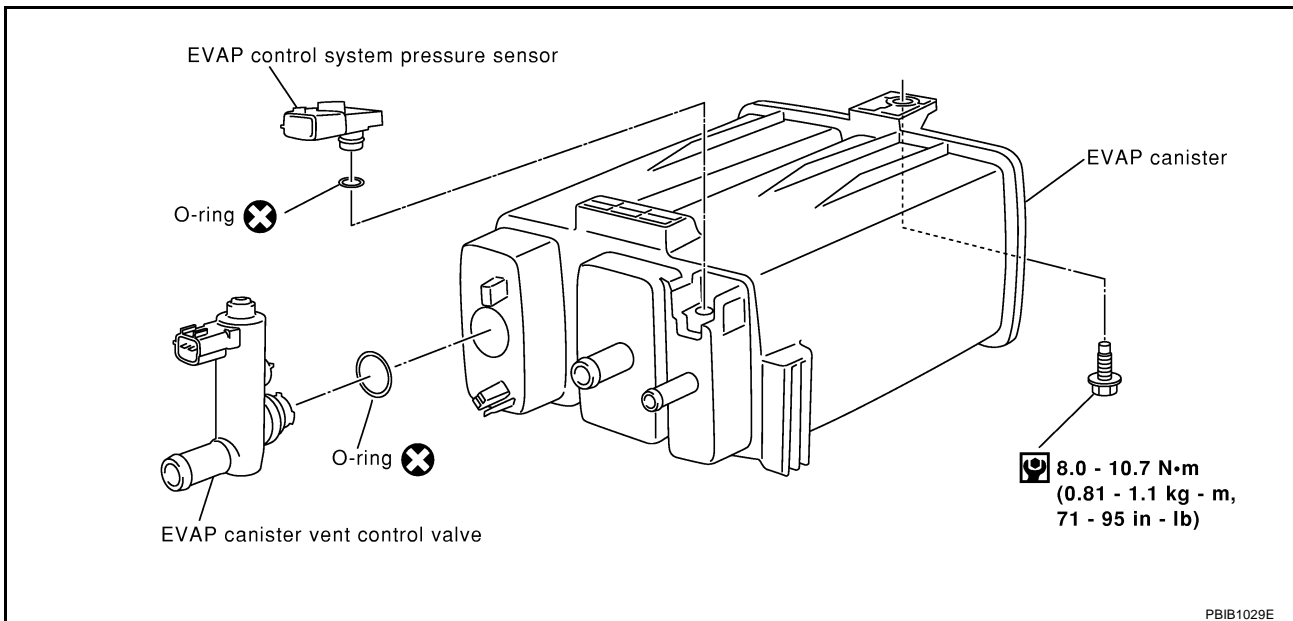

## EVAP CANISTER VENT CONTROL VALVE

1. Turn EVAP canister vent control valve counterclockwise.
2. Remove the EVAP canister vent control valve.

**Always replace O-ring with new one.**

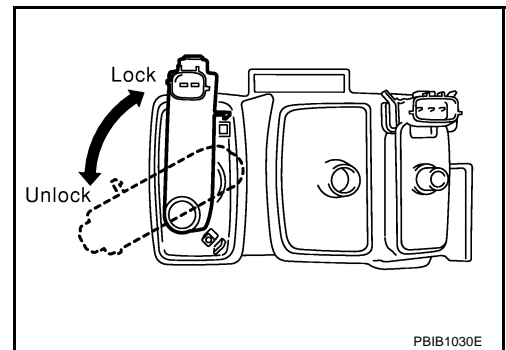

## How to Detect Fuel Vapor Leakage

### CAUTION:

- Never use compressed air or a high pressure pump.
- Do not exceed 4.12 kPa (0.042 kg/cm<sup>2</sup>, 0.6 psi) of pressure in EVAP system.

### NOTE:

- Do not start engine.
- Improper installation of EVAP service port adapter to the EVAP service port may cause a leak.

ABS009PE

# EVAPORATIVE EMISSION SYSTEM

## Ⓟ WITH CONSULT-II

1. Attach the EVAP service port adapter securely to the EVAP service port.
2. Also attach the pressure pump and hose to the EVAP service port adapter.
3. Turn ignition switch ON.
4. Select the "EVAP SYSTEM CLOSE" of "WORK SUPPORT MODE" with CONSULT-II.
5. Touch "START". A bar graph (Pressure indicating display) will appear on the screen.

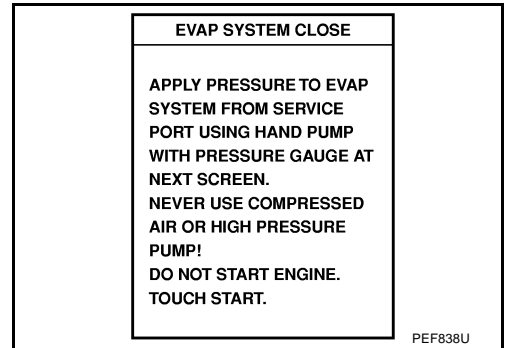

6. Apply positive pressure to the EVAP system until the pressure indicator reaches the middle of the bar graph.
7. Remove EVAP service port adapter and hose with pressure pump.

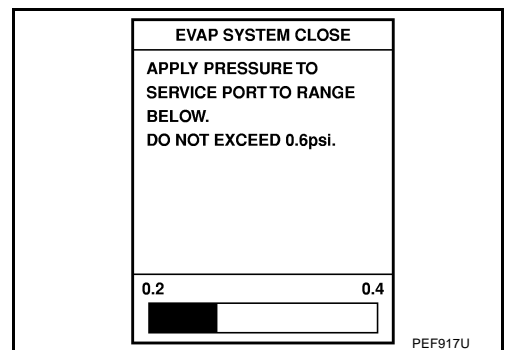

8. Locate the leak using a leak detector. Refer to [EC-675, "EVAPORATIVE EMISSION LINE DRAWING"](#).

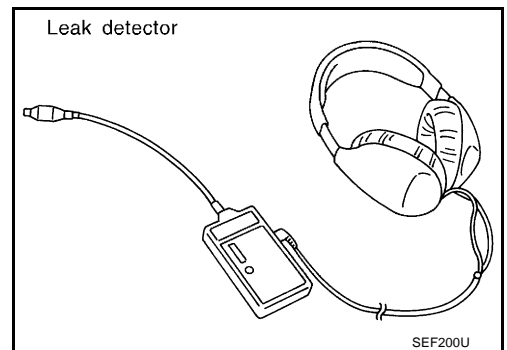

## ⓧ WITHOUT CONSULT-II

1. Attach the EVAP service port adapter securely to the EVAP service port.
2. Also attach the pressure pump with pressure gauge to the EVAP service port adapter.

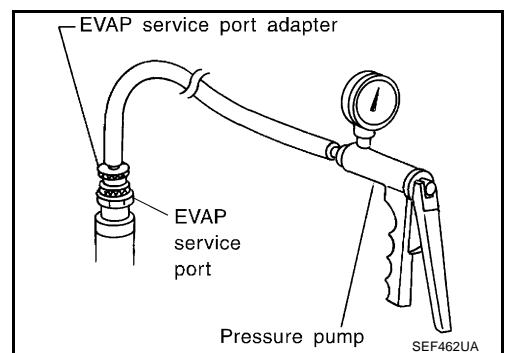

A  
EC  
C  
D  
E  
F  
G  
H  
I  
J  
K  
L  
M

## EVAPORATIVE EMISSION SYSTEM

3. Apply battery voltage to between the terminals of EVAP canister vent control valve to make a closed EVAP system.

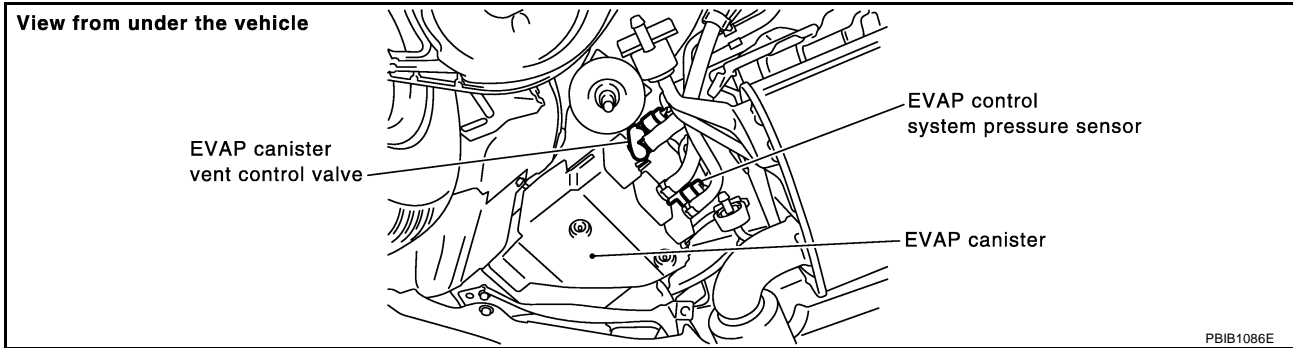

4. To locate the leak, deliver positive pressure to the EVAP system until pressure gauge points reach 1.38 to 2.76 kPa (0.014 to 0.028 kg/cm<sup>2</sup> , 0.2 to 0.4 psi).
5. Remove EVAP service port adapter and hose with pressure pump.
6. Locate the leak using a leak detector. Refer to [EC-675, "EVAPORATIVE EMISSION LINE DRAWING"](#) .



# ON BOARD REFUELING VAPOR RECOVERY (ORVR)

## ON BOARD REFUELING VAPOR RECOVERY (ORVR)

PFP:00032

### System Description

ABS009PF

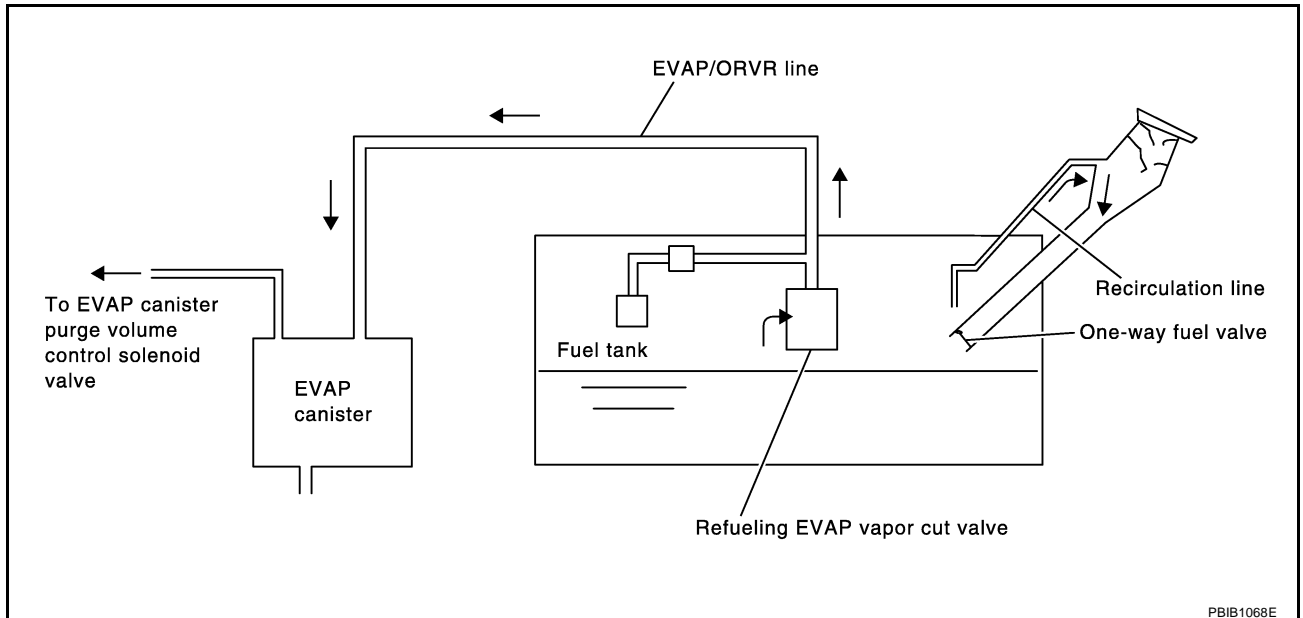

From the beginning of refueling, the air and vapor inside the fuel tank go through refueling EVAP vapor cut valve and EVAP/ORVR line to the EVAP canister. The vapor is absorbed by the EVAP canister and the air is released to the atmosphere.

When the refueling has reached the full level of the fuel tank, the refueling EVAP vapor cut valve is closed and refueling is stopped because of auto shut-off. The vapor which was absorbed by the EVAP canister is purged during driving.

#### **WARNING:**

When conducting inspections below, be sure to observe the following:

- Put a "CAUTION: INFLAMMABLE" sign in workshop.
- Do not smoke while servicing fuel system. Keep open flames and sparks away from work area.
- Be sure to furnish the workshop with a CO<sub>2</sub> fire extinguisher.

#### **CAUTION:**

- Before removing fuel line parts, carry out the following procedures:
  - Put drained fuel in an explosion-proof container and put lid on securely.
  - Release fuel pressure from fuel line. Refer to [EC-45. "FUEL PRESSURE RELEASE"](#).
  - Disconnect battery ground cable.
- Always replace O-ring when the fuel gauge retainer is removed.
- Do not kink or twist hose and tube when they are installed.
- Do not tighten hose and clamps excessively to avoid damaging hoses.
- After installation, run engine and check for fuel leaks at connection.
- Do not attempt to top off the fuel tank after the fuel pump nozzle shuts off automatically. Continued refueling may cause fuel overflow, resulting in fuel spray and possibly a fire.

# ON BOARD REFUELING VAPOR RECOVERY (ORVR)

ABS009PG

## Diagnostic Procedure

**SYMPTOM: FUEL ODOR FROM EVAP CANISTER IS STRONG.**

### 1. CHECK EVAP CANISTER

1. Remove EVAP canister with EVAP canister vent control valve and EVAP control system pressure sensor attached.
2. Weigh the EVAP canister with EVAP canister vent control valve and EVAP control system pressure sensor attached.  
**The weight should be less than 2.2 kg (4.9 lb).**

OK or NG

- OK >> GO TO 2.  
NG >> GO TO 3.

### 2. CHECK IF EVAP CANISTER SATURATED WITH WATER

Does water drain from the EVAP canister?

Yes or No

- Yes >> GO TO 3.  
No >> GO TO 5.

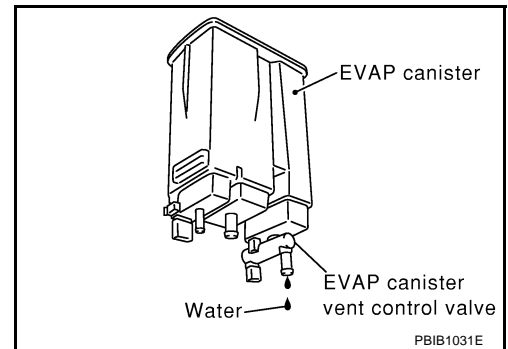

### 3. REPLACE EVAP CANISTER

Replace EVAP canister with a new one.

>> GO TO 4.

### 4. DETECT MALFUNCTIONING PART

Check the EVAP hose between EVAP canister and vehicle frame for clogging or poor connection.

>> Repair or replace EVAP hose.

### 5. CHECK REFUELING EVAP VAPOR CUT VALVE

Refer to [EC-684, "Component Inspection"](#).

OK or NG

- OK >> **INSPECTION END**  
NG >> Replace refueling EVAP vapor cut valve with fuel tank.

# ON BOARD REFUELING VAPOR RECOVERY (ORVR)

**SYMPTOM: CANNOT REFUEL/FUEL ODOR FROM THE FUEL FILLER OPENING IS STRONG WHILE REFUELING.**

## 1. CHECK EVAP CANISTER

1. Remove EVAP canister with EVAP canister vent control valve and EVAP control system pressure sensor attached.
2. Weigh the EVAP canister with EVAP canister vent control valve and EVAP control system pressure sensor attached.  
**The weight should be less than 2.2 kg (4.9 lb).**

OK or NG

- OK >> GO TO 2.  
NG >> GO TO 3.

## 2. CHECK IF EVAP CANISTER SATURATED WITH WATER

Does water drain from the EVAP canister?

Yes or No

- Yes >> GO TO 3.  
No >> GO TO 5.

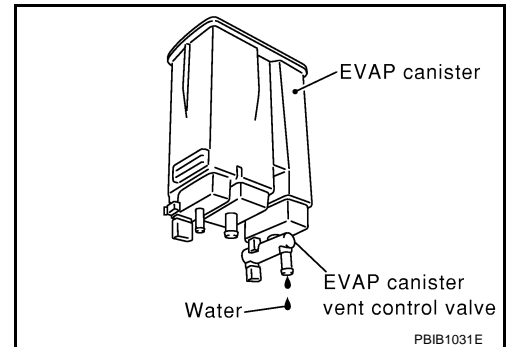

## 3. REPLACE EVAP CANISTER

Replace EVAP canister with a new one.

>> GO TO 4.

## 4. DETECT MALFUNCTIONING PART

Check the EVAP hose between EVAP canister and vehicle frame for clogging or poor connection.

>> Repair or replace EVAP hose.

## 5. CHECK VENT HOSES AND VENT TUBES

Check hoses and tubes between EVAP canister and refueling control valve for clogging, kink, looseness and improper connection.

OK or NG

- OK >> GO TO 6.  
NG >> Repair or replace hoses and tubes.

## 6. CHECK FILLER NECK TUBE

Check recirculation line for clogging, dents and cracks.

OK or NG

- OK >> GO TO 7.  
NG >> Replace filler neck tube.

# ON BOARD REFUELING VAPOR RECOVERY (ORVR)

## 7. CHECK REFUELING EVAP VAPOR CUT VALVE

Refer to [EC-684, "Component Inspection"](#) .

OK or NG

- OK >> GO TO 8.
- NG >> Replace refueling EVAP vapor cut valve with fuel tank.

## 8. CHECK FUEL FILLER TUBE

Check filler neck tube and hose connected to the fuel tank for clogging, dents and cracks.

OK or NG

- OK >> GO TO 9.
- NG >> Replace fuel filler tube.

## 9. CHECK ONE-WAY FUEL VALVE-I

Check one-way valve for clogging.

OK or NG

- OK >> GO TO 10.
- NG >> Repair or replace one-way fuel valve with fuel tank.

## 10. CHECK ONE-WAY FUEL VALVE-II

1. Make sure that fuel is drained from the tank.
2. Remove fuel filler tube and hose.
3. Check one-way fuel valve for operation as follows.  
When a stick is inserted, the valve should open, when removing stick it should close.

**Do not drop any material into the tank.**

OK or NG

- OK >> **INSPECTION END**
- NG >> Replace fuel filler tube or replace one-way fuel valve with fuel tank.

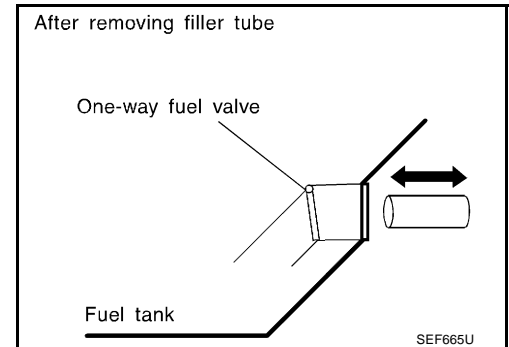

## Component Inspection REFUELING EVAP VAPOR CUT VALVE

Ⓟ **With CONSULT-II**

1. Remove fuel tank. Refer to [FL-10, "FUEL TANK"](#) .
2. Drain fuel from the tank as follows:
  - a. Remove fuel feed hose located on the fuel gauge retainer.
  - b. Connect a spare fuel hose, one side to fuel gauge retainer where the hose was removed and the other side to a fuel container.
  - c. Drain fuel using "FUEL PUMP RELAY" in "ACTIVE TEST" mode with CONSULT-II.
3. Check refueling EVAP vapor cut valve for being stuck to close as follows.  
Blow air into the refueling EVAP vapor cut valve (from the end of EVAP/ORVR line hose), and check that the air flows freely into the tank.
4. Check refueling EVAP vapor cut valve for being stuck to open as follows.
  - a. Connect vacuum pump to hose end.
  - b. Remove fuel gauge retainer with fuel gauge unit.  
**Always replace O-ring with new one.**
  - c. Put fuel tank upside down.

## ON BOARD REFUELING VAPOR RECOVERY (ORVR)

- d. Apply vacuum pressure to hose end [-13.3 kPa (-100 mmHg, -3.94 inHg)] with fuel gauge retainer remaining open and check that the pressure is applicable.

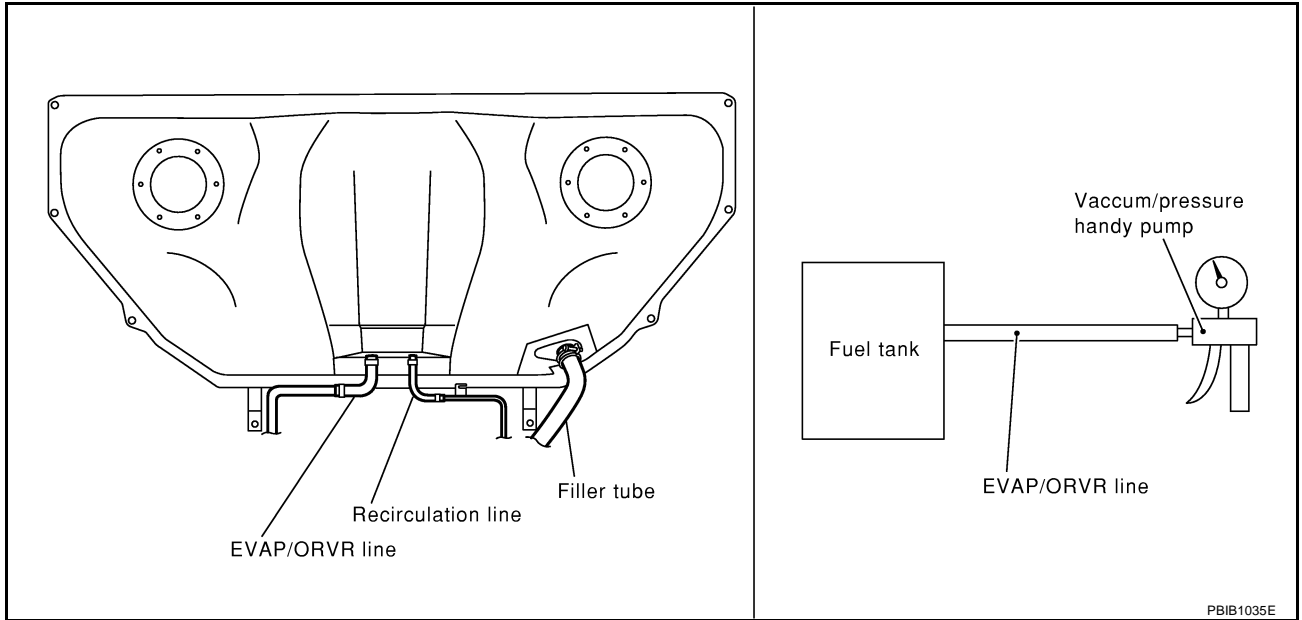

### ⊗ Without CONSULT-II

1. Remove fuel tank. Refer to [FL-10, "FUEL TANK"](#).
2. Drain fuel from the tank as follows:
  - a. Remove fuel gauge retainer.
  - b. Drain fuel from the tank using a handy pump into a fuel container.
3. Check refueling EVAP vapor cut valve for being stuck to close as follows. Blow air into the refueling EVAP vapor cut valve (from the end of EVAP/ORVR line hose), and check that the air flows freely into the tank.
4. Check refueling EVAP vapor cut valve for being stuck to open as follows.
  - a. Connect vacuum pump to hose end.
  - b. Remove fuel gauge retainer with fuel gauge unit.  
**Always replace O-ring with new one.**
  - c. Put fuel tank upside down.
- d. Apply vacuum pressure to hose end [-13.3 kPa (-100 mmHg, -3.94 inHg)] with fuel gauge retainer remaining open and check that the pressure is applicable.

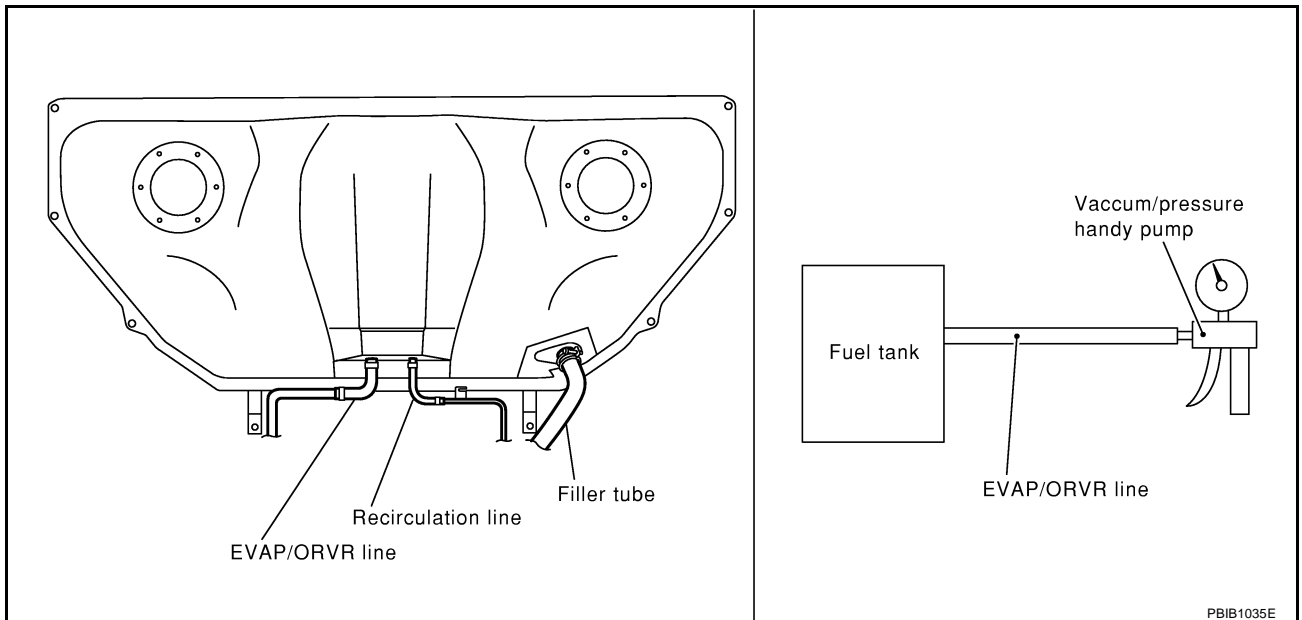

# POSITIVE CRANKCASE VENTILATION

## POSITIVE CRANKCASE VENTILATION

PCV:11810

### Description SYSTEM DESCRIPTION

ABS009PI

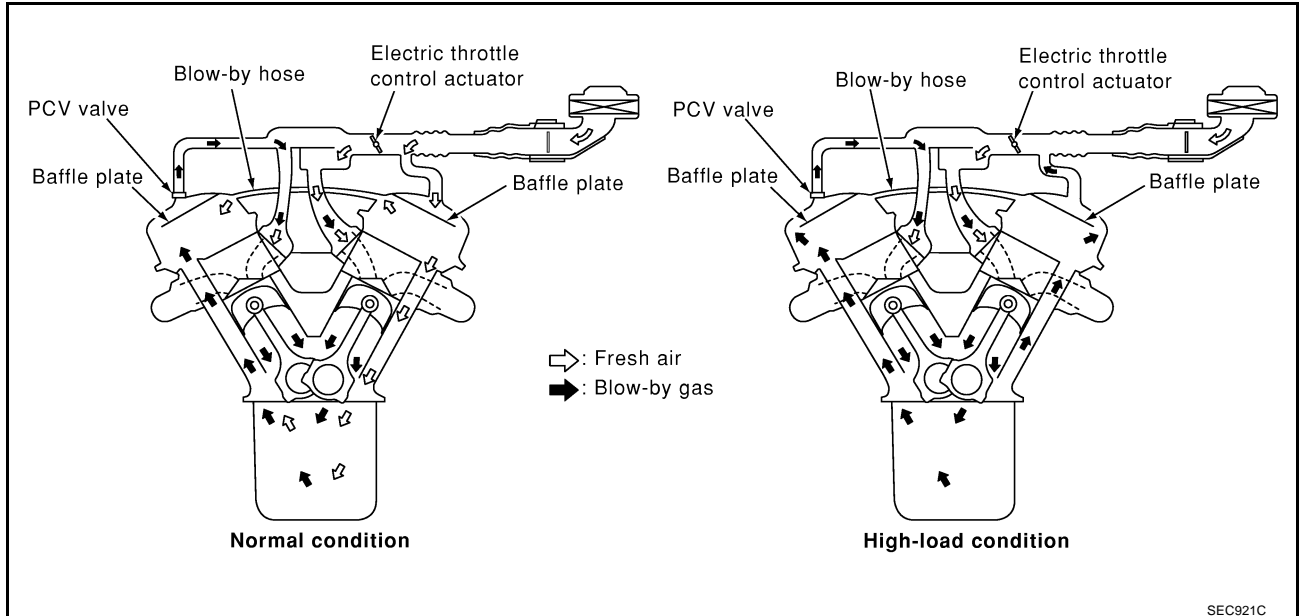

SEC921C

This system returns blow-by gas to the intake manifold.

The positive crankcase ventilation (PCV) valve is provided to conduct crankcase blow-by gas to the intake manifold. During partial throttle operation of the engine, the intake manifold sucks the blow-by gas through the PCV valve. Normally, the capacity of the valve is sufficient to handle any blow-by and a small amount of ventilating air. The ventilating air is then drawn from the air inlet tubes into the crankcase. In this process the air passes through the hose connecting air inlet tubes to rocker cover. Under full-throttle condition, the manifold vacuum is insufficient to draw the blow-by flow through the valve. The flow goes through the hose connection in the reverse direction.

On vehicles with an excessively high blow-by, the valve does not meet the requirement. This is because some of the flow will go through the hose connection to the air inlet tubes under all conditions.

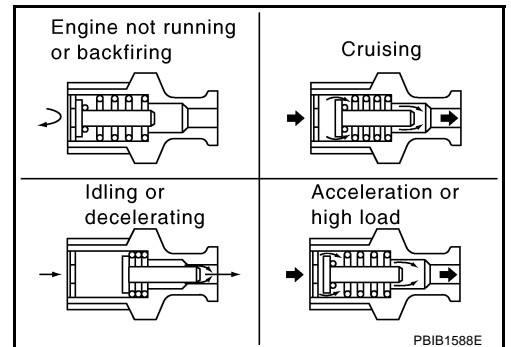

PBIB1588E

### Component Inspection PCV (POSITIVE CRANKCASE VENTILATION) VALVE

ABS009PJ

With engine running at idle, remove PCV valve from rocker cover. A properly working valve makes a hissing noise as air passes through it. A strong vacuum should be felt immediately when a finger is placed over valve inlet.

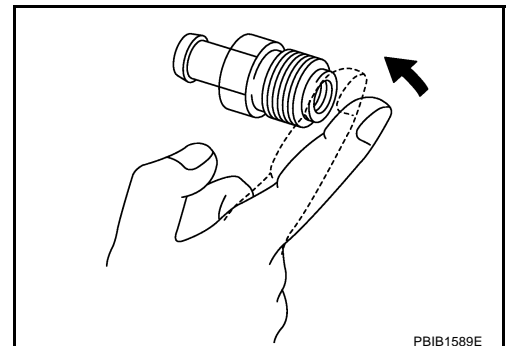

PBIB1589E

# POSITIVE CRANKCASE VENTILATION

## PCV VALVE VENTILATION HOSE

1. Check hoses and hose connections for leaks.
2. Disconnect all hoses and clean with compressed air. If any hose cannot be freed of obstructions, replace.

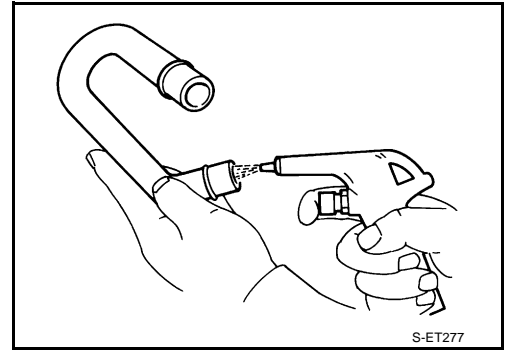

A

EC

C

D

E

F

G

H

I

J

K

L

M

# AUTOMATIC SPEED CONTROL DEVICE (ASCD)

## AUTOMATIC SPEED CONTROL DEVICE (ASCD)

PFP:18930

### System Description INPUT/OUTPUT SIGNAL CHART

ABS009PK

Sensor	Input signal to ECM	ECM function	Actuator
ASCD brake switch	Brake pedal operation	ASCD vehicle speed control	Electric throttle control actuator
Stop lamp switch	Brake pedal operation		
ASCD clutch switch	Clutch pedal operation		
ASCD steering switch	ASCD steering switch operation		
Park/Neutral position (PNP) switch	Gear position		
Unified meter and A/C amp.*	Vehicle speed		
TCM* (A/T models)	Powertrain revolution		

\*: This signal is sent to the ECM through CAN communication line.

### BASIC ASCD SYSTEM

Refer to Owner's Manual for ASCD operating instructions.

Automatic Speed Control Device (ASCD) allows a driver to keep vehicle at predetermined constant speed without depressing accelerator pedal. Driver can set vehicle speed in advance between approximately 40 km/h (25 MPH) and 144 km/h (89 MPH).

ECM controls throttle angle of electric throttle control actuator to regulate engine speed.

Operation status of ASCD is indicated by CRUISE indicator and SET indicator in combination meter. If any malfunction occurs in ASCD system, it automatically deactivates control.

#### NOTE:

**Always drive vehicle in safe manner according to traffic conditions and obey all traffic laws.**

### SET OPERATION

Press ON/OFF (MAIN) switch. (The CRUISE indicator in combination meter illuminates.)

When vehicle speed reaches a desired speed between approximately 40 km/h (25 MPH) and 144 km/h (89 MPH), press COAST/SET switch. (Then SET indicator in combination meter illuminates.)

### ACCEL OPERATION

If the ACCEL/RESUME switch is pressed during cruise control driving, increase the vehicle speed until the switch is released or vehicle speed reaches maximum speed controlled by the system.

And then ASCD will keep the new set speed.

### CANCEL OPERATION

When any of following conditions exist, cruise operation will be canceled.

- CANCEL switch is pressed
- More than 2 switches at ASCD steering switch are pressed at the same time (Set speed will be cleared)
- Brake pedal is depressed
- Clutch pedal is depressed or gear position is changed to the neutral position (M/T models)
- Selector lever is changed to N, P, R position (A/T models)
- Vehicle speed decreased to 13 km/h (8 MPH) lower than the set speed
- VDC/TCS system is operated

When the ECM detects any of the following conditions, the ECM will cancel the cruise operation and inform the driver by blinking indicator lamp.

- Engine coolant temperature is slightly higher than the normal operating temperature, CRUISE lamp may blink slowly.  
When the engine coolant temperature decreases to the normal operating temperature, CRUISE lamp will stop blinking and the cruise operation will be able to work by pressing COAST/SET switch or ACCEL/RESUME switch.
- Malfunction for some self-diagnoses regarding ASCD control: SET lamp will blink quickly.

If ON/OFF (MAIN) switch is turned to OFF during ASCD is activated, all of ASCD operations will be canceled and vehicle speed memory will be erased.



# AUTOMATIC SPEED CONTROL DEVICE (ASCD)

## COAST OPERATION

When the COAST/SET switch is pressed during cruise control driving, decrease vehicle set speed until the switch is released. And then ASCD will keep the new set speed.

A

## RESUME OPERATION

When the ACCEL/RESUME switch is pressed after cancel operation other than pressing ON/OFF (MAIN) switch is performed, vehicle speed will return to last set speed. To resume vehicle set speed, vehicle condition must meet following conditions.

EC

- Brake pedal is released
- Clutch pedal is released (M/T models)
- A/T selector lever is in other than P and N positions (A/T models)
- Vehicle speed is greater than 40 km/h (25 MPH) and less than 144 km/h (89 MPH)

C

D

## Component Description

ABS009PL

### ASCD STEERING SWITCH

Refer to [EC-550](#) .

E

### ASCD BRAKE SWITCH

Refer to [EC-558](#) , and [EC-654](#) .

F

### ASCD CLUTCH SWITCH

Refer to [EC-558](#) .

G

### STOP LAMP SWITCH

Refer to [EC-558](#) , [EC-584](#) and [EC-654](#) .

H

### ELECTRIC THROTTLE CONTROL ACTUATOR

Refer to [EC-395](#) , [EC-397](#) , [EC-404](#) and [EC-409](#) .

I

### ASCD INDICATOR

Refer to [EC-669](#) .

J

K

L

M

# SERVICE DATA AND SPECIFICATIONS (SDS)

## SERVICE DATA AND SPECIFICATIONS (SDS)

PFP:00030

### Fuel Pressure

ABS009PM

Fuel pressure at idling kPa (kg/cm<sup>2</sup>, psi)

Approximately 350 (3.57, 51)

### Idle Speed and Ignition Timing

ABS009PN

Target idle speed		A/T	No-load* (in P or N position)	650±50 rpm
		M/T	No-load* (in Neutral position)	
Air conditioner: ON	Coupe	A/T	In P or N position	775 or more
		M/T	In Neutral position	
	Roadster	A/T	In P or N position	700 rpm or more
		M/T	In Neutral position	
Ignition timing		A/T	In P or N position	15° ± 5° BTDC
		M/T	In Neutral position	

\*: Under the following conditions:

- Air conditioner switch: OFF
- Electric load: OFF (Lights, heater fan & rear window defogger)
- Steering wheel: Kept in straight-ahead position

### Calculated Load Value

ABS009PO

Conditions	Calculated load value % (Using CONSULT-II or GST)
At idle	5 - 35
At 2,500 rpm	5 - 35

### Mass Air Flow Sensor

ABS009PP

Supply voltage	Battery voltage (11 - 14V)
Output voltage at idle	0.9 - 1.2V*
Mass air flow (Using CONSULT-II or GST)	2.0 - 6.0 g-m/sec at idle* 7.0 - 20.0 g-m/sec at 2,500 rpm*

\*: Engine is warmed up to normal operating temperature and running under no-load.

### Intake Air Temperature Sensor

ABS009PQ

Temperature °C (°F)	Resistance kΩ
25 (77)	1.94 - 2.06
80 (176)	0.295 - 0.349

### Engine Coolant Temperature Sensor

ABS009PR

Temperature °C (°F)	Resistance kΩ
20 (68)	2.1 - 2.9
50 (122)	0.68 - 1.00
90 (194)	0.236 - 0.260

### Air Fuel Ratio (A/F) Sensor 1 Heater

ABS009PS

Resistance [at 25°C (77°F)]	2.3 - 4.3Ω
-----------------------------	------------

### Heated Oxygen sensor 2 Heater

ABS009PT

Resistance [at 25°C (77°F)]	5.0 - 7.0Ω
-----------------------------	------------

### Crankshaft Position Sensor (POS)

ABS009PU

Refer to [EC-273, "Component Inspection"](#).

# SERVICE DATA AND SPECIFICATIONS (SDS)

## Camshaft Position Sensor (PHASE)

ABS009PV

A

Refer to [EC-282, "Component Inspection"](#) .

## Throttle Control Motor

ABS009PW

EC

Resistance [at 25°C (77°F)]	Approximately 1 - 15Ω
-----------------------------	-----------------------

## Injector

ABS009PX

C

Resistance [at 10 - 60°C (50 - 140°F)]	11.1 - 14.5Ω
--	--------------

## Fuel Pump

ABS009PY

D

Resistance [at 25°C (77°F)]	0.2 - 5.0Ω
-----------------------------	------------

E

F

G

H

I

J

K

L

M

# SERVICE DATA AND SPECIFICATIONS (SDS)

---