

SECTION **FSU**  
FRONT SUSPENSION

A  
B  
C  
D

FSU

CONTENTS

<b>PRECAUTIONS</b> .....	<b>2</b>	<b>TRANSVERSE LINK</b> .....	<b>13</b>	F
Caution .....	2	Removal and Installation .....	13	
<b>PREPARATION</b> .....	<b>3</b>	REMOVAL .....	13	G
Special Service Tools (SST) .....	3	INSPECTION AFTER REMOVAL .....	13	
Commercial Service Tools .....	3	INSTALLATION .....	13	H
<b>NOISE, VIBRATION AND HARSHNESS (NVH)</b>		<b>UPPER LINK</b> .....	<b>14</b>	
<b>TROUBLESHOOTING</b> .....	<b>4</b>	Removal and Installation .....	14	I
NVH Troubleshooting Chart .....	4	REMOVAL .....	14	J
<b>FRONT SUSPENSION ASSEMBLY</b> .....	<b>5</b>	INSPECTION AFTER REMOVAL .....	14	
On-Vehicle Inspection and Service .....	5	INSTALLATION .....	15	K
INSPECTION OF BALL JOINT END PLAY OF		<b>COMPRESSION ROD</b> .....	<b>16</b>	
EACH LINK .....	5	Removal and Installation .....	16	L
SHOCK ABSORBER INSPECTION .....	5	REMOVAL .....	16	M
Wheel Alignment Inspection .....	6	INSPECTION AFTER REMOVAL .....	16	
DESCRIPTION .....	6	AXIAL END PLAY INSPECTION .....	17	
PRELIMINARY CHECK .....	6	INSTALLATION .....	17	
INSPECTION OF CAMBER, CASTER AND		<b>STABILIZER BAR</b> .....	<b>18</b>	
KINGPIN INCLINATION ANGLES .....	6	Removal and Installation .....	18	
Components .....	8	REMOVAL .....	18	
Removal and Installation .....	9	INSPECTION AFTER REMOVAL .....	18	
REMOVAL .....	9	INSTALLATION .....	18	
INSTALLATION .....	9	<b>FRONT SUSPENSION MEMBER</b> .....	<b>19</b>	
<b>COIL SPRING AND SHOCK ABSORBER</b> .....	<b>10</b>	Removal and Installation .....	19	
Removal and Installation .....	10	REMOVAL .....	19	
REMOVAL .....	10	INSPECTION AFTER REMOVAL .....	19	
INSTALLATION .....	10	INSTALLATION .....	19	
Disassembly and Assembly .....	10	<b>TOWER BAR</b> .....	<b>20</b>	
DISASSEMBLY .....	10	Removal and Installation .....	20	
INSPECTION AFTER DISASSEMBLY .....	11	REMOVAL .....	20	
ASSEMBLY .....	11	INSTALLATION .....	20	
		<b>SERVICE DATA</b> .....	<b>21</b>	
		Wheel Alignment (Unladen) .....	21	
		Ball Joint .....	21	
		Wheelarch Height (Unladen*) .....	21	

# PRECAUTIONS

---

## PRECAUTIONS

PFP:00001

### Caution

AES0002P

- When installing rubber bushings, final tightening must be carried out under unladen conditions with tires on ground. Oil will shorten the life of rubber bushings. Be sure to wipe off any spilled oil.
- Unladen conditions mean that fuel, engine coolant and lubricant are full. Spare tire, jack, hand tools and mats are in designated positions.
- After servicing suspension parts, be sure to check wheel alignment.
- Caulking nuts are not reusable. Always use new ones when installing. Since new caulking nuts are pre-oiled, tighten as they are.
- Avoid burden to front cross bar.

# PREPARATION

## PREPARATION

FFP:00002

### Special Service Tools (SST)

AES0002Q

The actual shapes of Kent-Moore tools may differ from those of special service tools illustrated here.

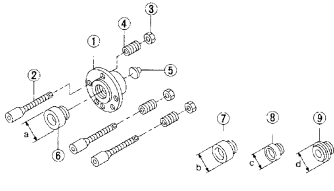
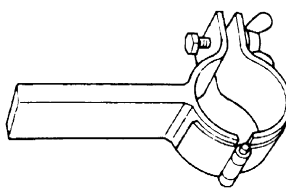
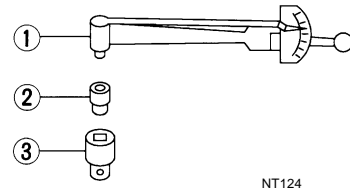
Tool number (Kent-Moore No.) Tool name	Description
KV991040S0 ( — ) CCK gauge attachment 1. Plate 2. Guide bolts 3. Nuts 4. Springs 5. Center plate 6. KV9910 4020 Adapter A a: 72 mm (2.83 in) dia. 7. KV9910 4030 Adapter B b: 65 mm (2.56 in) dia. 8. KV9910 4040 Adapter C c: 57 mm (2.24 in) dia. 9. KV9910 4050 Adapter D d: 53.4 mm (2.102 in) dia.	 <p style="text-align: center;">S-NT498</p> <p>Measuring wheel alignment</p>
ST3565 2000 ( — ) Strut attachment	 <p style="text-align: center;">ZZA0807D</p> <p>Disassembling and assembling shock absorber</p>
ST3127 S000 (See J25742-1) Preload gauge 1. GG91030000 Torque wrench (J25765) 2. HT62940000 ( — ) Socket adapter (1/2") 3. HT62900000 ( — ) Socket adapter (3/8")	 <p style="text-align: center;">NT124</p> <p>Measuring rotating torque of ball joint</p>

## Commercial Service Tools

AES0002R

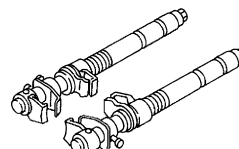
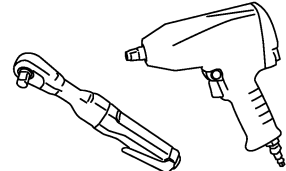
Tool name	Description
Spring compressor	 <p style="text-align: center;">S-NT717</p> <p>Removing coil spring</p>
Power tool	 <p style="text-align: center;">PBIC0190E</p> <ul style="list-style-type: none"> <li>● Removing wheel nuts</li> <li>● Removing brake caliper assembly</li> <li>● Removing undercover</li> <li>● Removing front suspension components parts</li> </ul>

# NOISE, VIBRATION AND HARSHNESS (NVH) TROUBLESHOOTING

## NOISE, VIBRATION AND HARSHNESS (NVH) TROUBLESHOOTING

PF0:00003

### NVH Troubleshooting Chart

AES0002S

Use chart below to help you find the cause of the symptom. If necessary, repair or replace these parts.

Symptom		Possible cause and SUSPECTED PARTS											Reference page						
		Improper installation, looseness	Shock absorber deformation, damage or deflection	Bushing or mounting deterioration	Parts interference	Spring fatigue	Suspension looseness	Incorrect wheel alignment	Stabilizer bar fatigue	PROPELLER SHAFT	DIFFERENTIAL	REAR AXLE AND REAR SUSPENSION	TIRES	ROAD WHEEL	DRIVE SHAFT	BRAKES	STEERING		
Noise	FRONT SUSPENSION	Noise	x	x	x	x	x	x			x	x	x	x	x	x	x	FSU-8	
		Shake	x	x	x	x		x			x		x	x	x	x		FSU-11	
		Vibration	x	x	x	x	x				x		x	x		x		—	
		Shimmy	x	x	x	x			x				x	x	x		x		—
		Judder	x	x	x							x		x	x		x		FSU-8
		Poor quality ride or handling	x	x	x	x	x		x	x			x	x	x				FSU-6
																	FSU-18		
																	NVH in PR section		
																	NVH in RFD section.		
																	NVH in RAX and RSU section.		
																	NVH in WT section.		
																	NVH in WT section.		
																	NVH in RAX section.		
																	NVH in BR section.		
																	NVH in PS section.		

x: Applicable

# FRONT SUSPENSION ASSEMBLY

## FRONT SUSPENSION ASSEMBLY

PFP:54010

### On-Vehicle Inspection and Service

AES0002U

Make sure the mounting conditions (looseness, back lash) of each component and component statuses (wear, damage) are normal.

#### INSPECTION OF BALL JOINT END PLAY OF EACH LINK

1. Set front wheels in a straight-ahead position. Do not depress brake pedal.
2. Check ball joint axial end play of each link.

#### **CAUTION:**

**Be careful not to damage ball joint boot.**

#### Upper Link Ball Joint

- Measure axial end play by installing and moving up/down with an iron pry bar or something similar between upper link and steering knuckle.

**Standard value**

**Axial end play : 0 mm (0 in)**

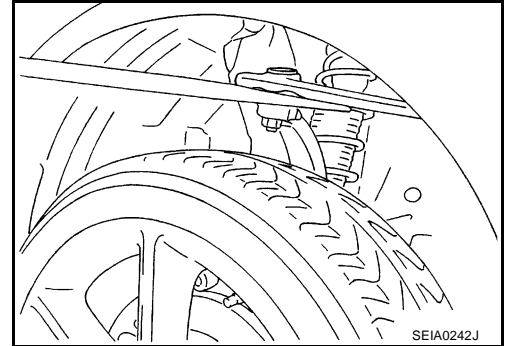

#### Steering Knuckle Lower Ball Joint

- Measure axial end play by installing and moving up/down with an iron pry bar or something similar between steering knuckle and wheel.

**Standard value**

**Axial end play : 0 mm (0 in)**

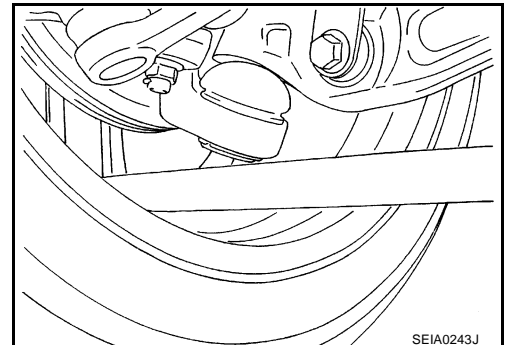

#### Compression Rod Ball Joint

- Measure axial end play by installing and moving up/down with an iron pry bar or something similar between compression rod and transverse link.

**Standard value**

**Axial end play : 0 mm (0 in)**

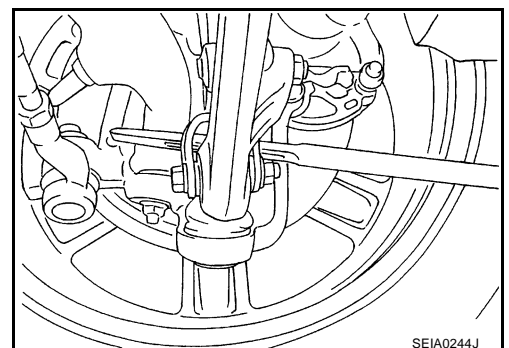

#### SHOCK ABSORBER INSPECTION

Check shock absorber for oil leakage, damage and replace if necessary. Refer to [FSU-10, "COIL SPRING AND SHOCK ABSORBER"](#).

A

B

C

D

**FSU**

F

G

H

I

J

K

L

M

# FRONT SUSPENSION ASSEMBLY

AES0002V

## Wheel Alignment Inspection

### DESCRIPTION

- Measure wheel alignment under unladen conditions.

#### NOTE:

Unladen conditions mean that fuel, engine coolant, and lubricant are full. Spare tire, jack, hand tools and mats are designated positions.

### PRELIMINARY CHECK

1. Check tires for improper air pressure and wear.
2. Check road wheels for runout.
3. Check wheel bearing axial end play.
4. Check ball joint axial end play of compression rod, upper link, and steering knuckle
5. Check shock absorber operation.
6. Check each mounting part of axle and suspension for looseness and deformation.
7. Check each link, rod and member for cracks, deformation and other damage.
8. Check vehicle posture.

### INSPECTION OF CAMBER, CASTER AND KINGPIN INCLINATION ANGLES

- Camber, caster, kingpin inclination angles cannot be adjusted.
- Before inspection, mount front wheels onto turning radius gauge. Mount rear wheels onto a stand that has same height so vehicle will remain horizontal.

### Using a CCK Gauge

Install CCK gauge attachment (SST: KV991040S0) as following procedure in wheel, then measure wheel alignment.

1. Remove wheel nuts (2), and install a guide bolt to hub bolt.
2. Screw adapter into plate body until it contacts body tightly.
3. Screw center plate into plate.
4. Insert plate on guide bolt. Put spring in, and then evenly screw both guide bolt nut. When fastening guide bolt nut, do not completely compress spring.

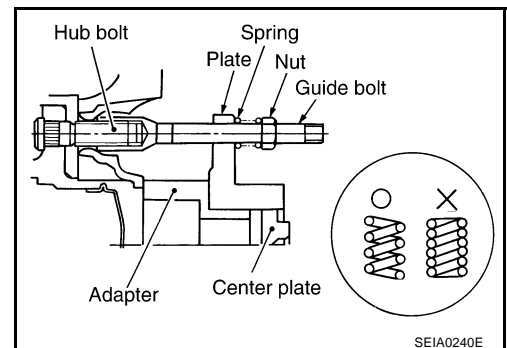

5. Place the dent of alignment gauge onto the projection of center plate and tightly contact them to measure.

#### Standard value

#### Camber, caster, kingpin inclination angles:

Refer to [FSU-21, "SERVICE DATA"](#) .

#### CAUTION:

- If camber, caster, or kingpin inclination angle is outside the standard, check front suspension parts for wear and damage, and replace suspect parts if necessary.
- King pin inclination angle is reference value, no inspection is required. (Due to the type of suspension, the kingpin inclination angle cannot be measured correctly using a normal alignment tester.)

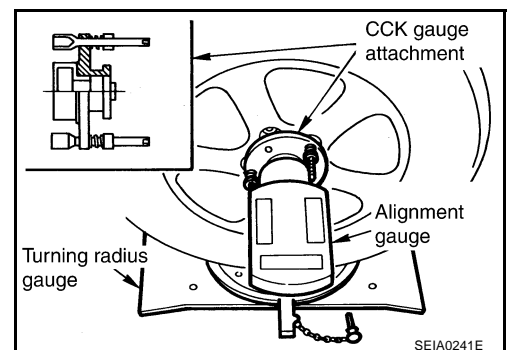

# FRONT SUSPENSION ASSEMBLY

## Toe-In Inspection

Measure toe-in using the following procedure.

### WARNING:

- Always perform the following procedure on a flat surface.
  - Make sure that no person is in front of vehicle before pushing it.
1. Bounce front of vehicle up and down to stabilize the posture.
  2. Push vehicle straight ahead about 5 m (16 ft).
  3. Put a mark on base line of the tread (rear side) of both tires at the same height of hub center. These are measuring points.
  4. Measure distance "A" (rear side).
  5. Push vehicle slowly ahead to rotate wheels 180 degrees (1/2 turn).  
If wheels have rotated more than 180 degrees (1/2 turn), try the above procedure again from the beginning. Never push vehicle backward.
  6. Measure distance "B" (front side).

### Standard value

Total toe-in : Refer to [FSU-21, "SERVICE DATA"](#) .

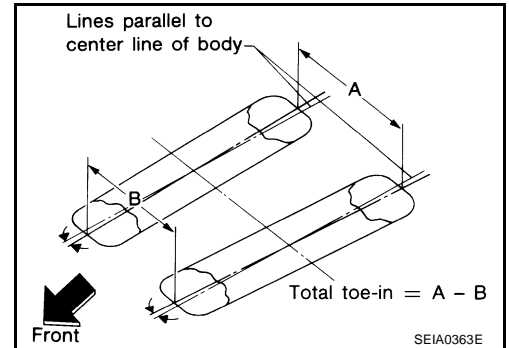
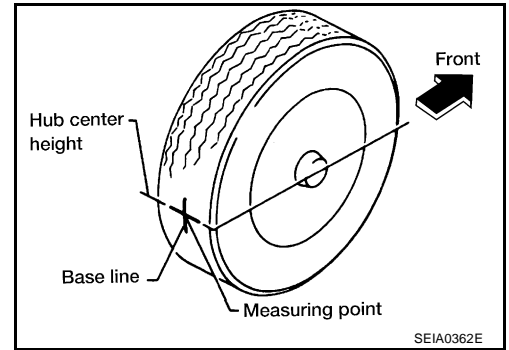

A  
B  
C  
D

FSU

F  
G  
H

I  
J  
K  
L  
M

# FRONT SUSPENSION ASSEMBLY

## Components

AES0002T

SEC.400·401·406

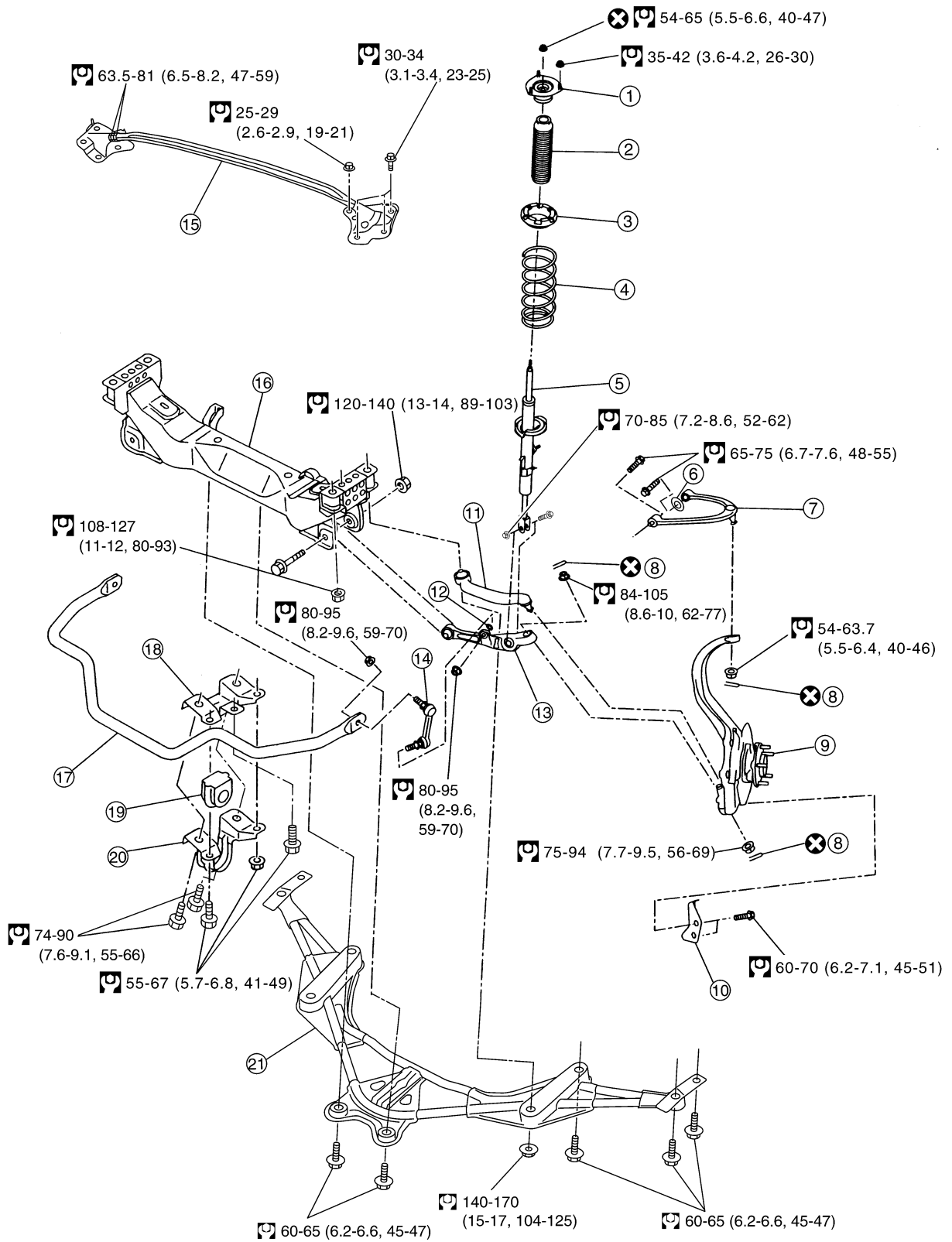

: N·m (kg-m, ft-lb)

: Always replace after every disassembly

SEIA0602E



# FRONT SUSPENSION ASSEMBLY

- |                              |                               |                              |
|------------------------------|-------------------------------|------------------------------|
| 1. Mounting insulator        | 2. Bound bumper               | 3. Spring upper seat         |
| 4. Coil spring               | 5. Shock absorber             | 6. Stopper rubber            |
| 7. Upper link                | 8. Cotter pin                 | 9. Front axle                |
| 10. Steering stopper bracket | 11. Compression rod           | 12. Washer                   |
| 13. Transverse link          | 14. Stabilizer connecting rod | 15. Tower bar                |
| 16. Front suspension member  | 17. Stabilizer bar            | 18. Stabilizer clamp bracket |
| 19. Stabilizer bushing       | 20. Stabilizer clamp          | 21. Front cross bar          |

A  
B  
C

## Removal and Installation

AES000DM

### REMOVAL

1. Remove tire with power tool.
2. Remove brake caliper with power tool. Hang it in a place where it will not interfere with work. Refer to [BR-25, "FRONT DISC BRAKE \(CLZ25VD TYPE\)"](#), [BR-31, "FRONT DISC BRAKE \(OPB27VA TYPE\)"](#).
3. Remove undercover with power tool.
4. Remove fixing bolts and nuts, then remove front cross bar from vehicle with power tool.
5. Remove steering hydraulic piping bracket from front suspension member. Refer to [PS-34, "HYDRAULIC LINE"](#).
6. Remove steering gear and front suspension member attachment bolts and hang steering gear on vehicle. Refer to [PS-17, "POWER STEERING GEAR AND LINKAGE"](#).
7. Set jack under engine.  
**CAUTION:**  
**When setting jack to engine, use a wooden block or an equivalent for the setting.**
8. Remove fixing bolt and nut between shock absorber and transverse link with power tool.
9. Remove cotter pin of upper link ball joint, then loosen mounting nut.
10. Use a ball joint remover (suitable tool) to remove upper link from steering knuckle. Be careful not to damage ball joint boot.  
**CAUTION:**  
**Tighten temporarily mounting nut to prevent damage to threads and to prevent ball joint remover (suitable tool) from coming off.**
11. Remove fixing nut and washer located at the bottom of stabilizer connecting rod, and then remove stabilizer connecting rod from transverse link with power tool.
12. Remove fixing nuts between engine mounting insulator and front suspension member. Refer to [EM-103, "ENGINE ASSEMBLY"](#).
13. Remove fixing nuts between front suspension member and body with power tool.
14. Remove front suspension assembly from vehicle.

D

FSU

F

G

H

I

J

K

L

### INSTALLATION

- Refer to [FSU-8, "Components"](#) for tightening torque. Install in the reverse order of removal.  
**NOTE:**  
Refer to component parts location and do not reuse non-reusable parts.
- Perform final tightening of shock absorber lower side (rubber bushing) under unladen condition with tires on ground. Check wheel alignment. Refer to [FSU-21, "SERVICE DATA"](#).

M

# COIL SPRING AND SHOCK ABSORBER

## COIL SPRING AND SHOCK ABSORBER

PFP:54302

### Removal and Installation

AES0002W

#### REMOVAL

1. Remove tire with power tool.
2. Remove undercover with power tool.
3. Remove harness of wheel sensor from shock absorber. Refer to [BRC-83, "WHEEL SENSORS"](#) (With TCS), [BRC-143, "WHEEL SENSORS"](#) (With VDC).

#### CAUTION:

**Do not pull on wheel sensor harness.**

4. Remove mounting nuts of brake hose from shock absorber.
5. Remove mounting bolt and nut between shock absorber and transverse link with power tool.
6. Remove tower bar. Refer to [FSU-20, "TOWER BAR"](#).
7. Remove mounting nuts on mounting insulator with power tool, then remove shock absorber from vehicle.

#### INSTALLATION

- Refer to [FSU-8, "Components"](#) for tightening torque. Install in the reverse order of removal.

#### NOTE:

Refer to component parts location and do not reuse non-reusable parts.

- Perform final tightening of shock absorber lower side (rubber bushing) under unladen condition with tires on ground. Check wheel alignment. Refer to [FSU-21, "SERVICE DATA"](#).

### Disassembly and Assembly

AES0002X

#### DISASSEMBLY

#### NOTE:

Make sure piston rod on shock absorber is not damaged when removing components from shock absorber.

1. Install strut attachment (SST) to shock absorber and fix it in a vise.

#### CAUTION:

**When installing strut attachment (SST) to shock absorber, wrap a shop cloth around shock absorber to protect it from damage.**

2. Using a spring compressor (commercial service tool), compress coil spring between spring upper seat and spring lower seat (on shock absorber) until coil spring is free.

#### CAUTION:

**Be sure spring compressor (commercial service tool) is securely attached to coil spring. Compress coil spring.**

3. Check that coil spring between spring upper seat and spring lower seat is free and then secure piston rod tip so that piston rod does not turn, and remove piston rod lock nut.
4. Remove mounting insulator, bound bumper, spring upper seat. Then remove coil spring from shock absorber.
5. Gradually release spring compressor (commercial service tool), and remove coil spring.

#### CAUTION:

**Loosen while making sure coil spring attachment position does not move.**

6. Remove strut attachment (SST) from shock absorber.

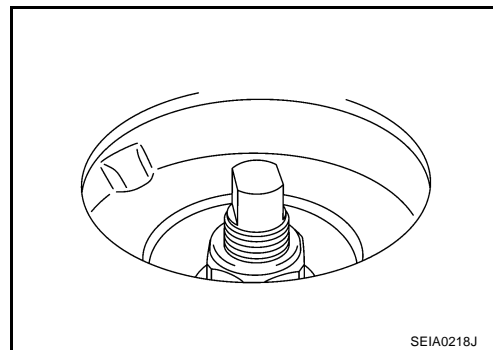
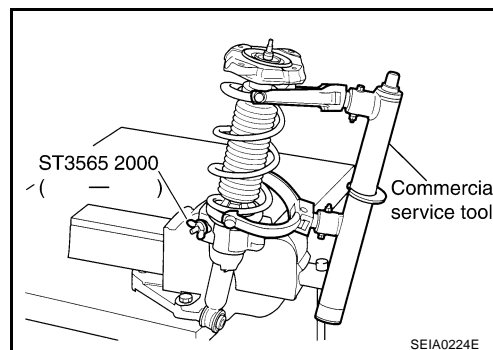

# COIL SPRING AND SHOCK ABSORBER

## INSPECTION AFTER DISASSEMBLY

### Shock Absorber Inspection

- Check shock absorber for deformation, cracks, damage, and replace if necessary.
- Check piston rod for damage, uneven wear, distortion, and replace if necessary.
- Check welded and sealed areas for oil leakage, and replace if necessary.

### Mounting Insulator and Rubber Parts Inspection

Check mounting insulator for cracks and rubber parts for wear. Replace them if necessary.

### Coil Spring Inspection

Check coil spring for cracks, wear or damage, and replace if necessary.

## ASSEMBLY

### NOTE:

Make sure piston rod on shock absorber is not damaged when attaching components to shock absorber.

1. Install strut attachment (SST) to shock absorber and fix it in a vise.

### CAUTION:

**When installing strut attachment (SST) to shock absorber, wrap a shop cloth around shock absorber to protect it from damage.**

2. Compress coil spring using a spring compressor (commercial service tool), and install it onto shock absorber.

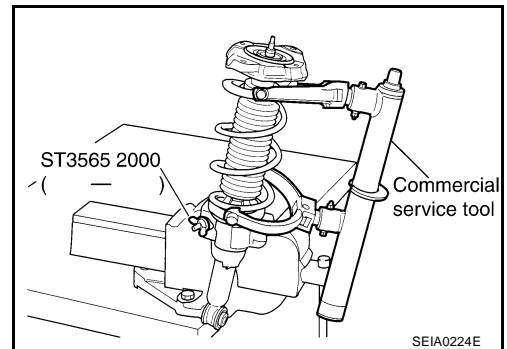

### CAUTION:

● Install coil spring as shown in the figure with large diameter side [100 mm (3.94 in)] up and small diameter side [90 mm (3.54 in)] down. (Identification paint is the 4th winding point from lower side.)

● Be sure spring compressor (commercial service tool) is securely attached to coil spring. Compress coil spring.

3. Apply soapy water to bound bumper and insert into mounting insulator.

### CAUTION:

**Do not use machine oil.**

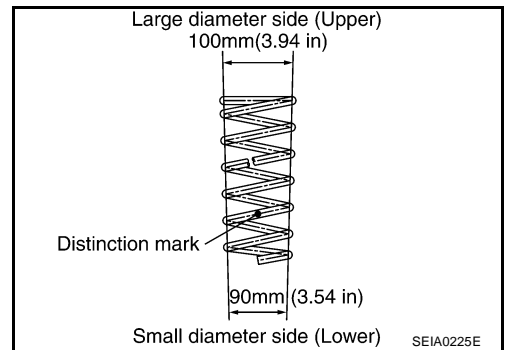

A

B

C

D

FSU

F

G

H

I

J

K

L

M

## COIL SPRING AND SHOCK ABSORBER

- Attach spring upper seat and mounting insulator as shown in the figure.

**CAUTION:**

- Make sure coil spring is securely seated in spring mounting groove of spring upper seat.
- The bottom part of spring should be at the position of A point of spring seat.

- Secure piston rod tip so that piston rod does not turn, and tighten the specified torque on piston rod lock nut.
- Gradually release spring compressor (commercial service tool), and remove coil spring.

**CAUTION:**

Loosen spring compressor (commercial service tool) while making sure coil spring attachment position does not move.

- Remove strut attachment (SST) from shock absorber.

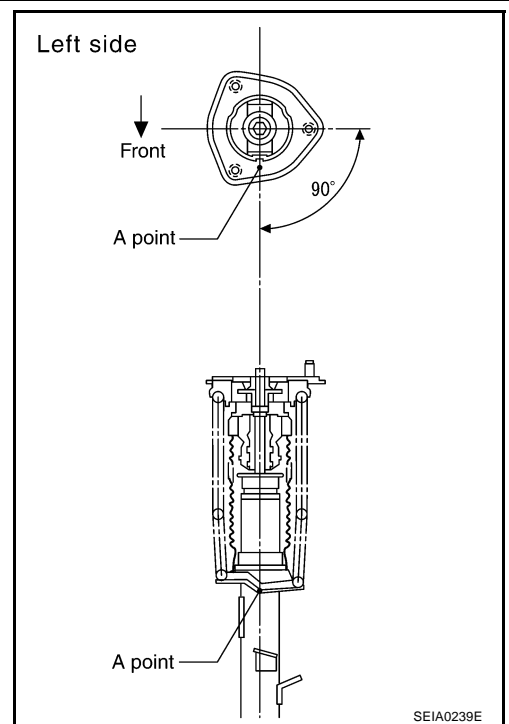

# TRANSVERSE LINK

## TRANSVERSE LINK

PPF:54500

### Removal and Installation

AES0002Y

#### REMOVAL

1. Remove tire with power tool. A
2. Remove undercover with power tool. B
3. Remove mounting nut and washer on lower portion of stabilizer connecting rod with power tool.
4. Remove mounting nut between transverse link and shock absorber on lower position. C
5. Remove mounting nut between transverse link and front suspension member with power tool.
6. Remove transverse link from steering knuckle. Refer to [FAX-4, "FRONT WHEEL HUB AND KNUCKLE"](#). D
7. Remove transverse link from vehicle.

#### INSPECTION AFTER REMOVAL

##### Visual Inspection

Check transverse link and bushing for deformation, cracks, or damage. If any non-standard condition is found, replace it. FSU

#### INSTALLATION

- Refer to [FSU-8, "Components"](#) for tightening torque. Install in the reverse order of removal. F
- NOTE:**  
Refer to component parts location and do not reuse non-reusable parts. G
- Perform final tightening of front suspension member installation position and shock absorber lower side (rubber bushing) under unladen condition with tires on ground. Check wheel alignment. Refer to [FSU-21, "SERVICE DATA"](#). H
- I
- J
- K
- L
- M

# UPPER LINK

PFP:54524

AES00031

## UPPER LINK

### Removal and Installation

#### REMOVAL

1. Remove tire with power tool.
2. Remove undercover with power tool.
3. Remove shock absorber. Refer to [FSU-10, "COIL SPRING AND SHOCK ABSORBER"](#).
4. Remove cotter pin of upper link ball joint, then loosen mounting nut.
5. Use a ball joint remover (suitable tool) to remove upper link from steering knuckle. Be careful not to damage ball joint boot.

#### CAUTION:

**Tighten temporarily mounting nut to prevent damage to threads and to prevent ball joint remover (suitable tool) from coming off.**

6. Remove bolts holding upper link to body with power tool.
7. Remove upper link from vehicle.

#### INSPECTION AFTER REMOVAL

##### Visual Inspection

- Check upper link and bushing for deformation, cracks, or damage. If any non-standard condition is found, replace it.
- Check boot of ball joint for cracks, or other damage, and also for grease leakage. If any non-standard condition is found, replace it.

##### Ball Joint Inspection

- Manually move ball stud to confirm it moves smoothly with no binding.

##### Swing Torque Inspection

#### NOTE:

Before measurement, move ball joint at least ten times by hand to check for smooth movement.

- Hook spring scale at ball stud. Confirm spring scale measurement value is within the specifications when ball stud begins moving.

**Standard value**

**Swing torque:**

**Less than 2.0 N-m (0.20 kg-m, 18 in-lb)**

**Measured value of spring scale:**

**Less than 34.8 N (3.5 kg, 7.8 lb)**

- If it is outside the specified range, replace upper link assembly.

##### Rotating Torque Inspection

- Attach mounting nut to ball stud. Check that rotating torque is within specifications with a preload gauge (SST).

**Standard value**

**Rotating torque:**

**Less than 2.0 N-m (0.20 kg-m, 18 in-lb)**

- If it is outside the specified range, replace upper link assembly.

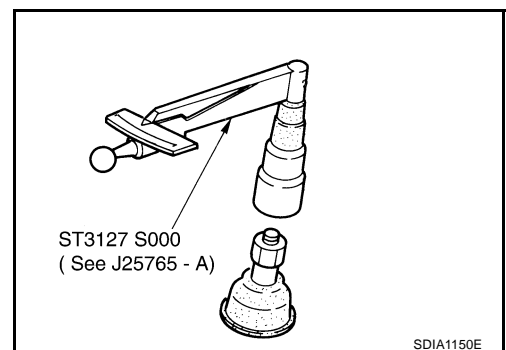
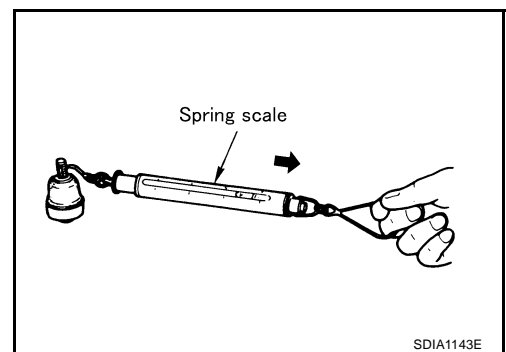

# UPPER LINK

---

## Axial End Play Inspection

- Move tip of ball joint in axial direction to check for looseness.

### Standard value

**Axial end play : 0 mm (0 in)**

- If it is outside the specified range, replace upper link assembly.

## INSTALLATION

- Refer to [FSU-8, "Components"](#) for tightening torque. Install in the reverse order of removal.

### NOTE:

Refer to component parts location and do not reuse non-reusable parts.

- Perform final tightening of front suspension member installation position (rubber bushing) under unladen condition with tires on ground. Check wheel alignment. Refer to [FSU-21, "SERVICE DATA"](#) .

A

B

C

D

FSU

F

G

H

I

J

K

L

M

# COMPRESSION ROD

## COMPRESSION ROD

PFP:54468

### Removal and Installation

#### REMOVAL

AES00032

1. Remove tire with power tool.
2. Remove undercover with power tool.
3. Remove front cross bar from vehicle with power tool.
4. Remove cotter pin of compression rod ball joint, and loosen nut.
5. Use a ball joint remover (suitable tool) to remove compression rod from steering knuckle. Be careful not to damage ball joint boot.

#### CAUTION:

**Tighten temporarily mounting nut to prevent damage to threads and to prevent ball joint remover (suitable tool) from coming off.**

6. Remove compression rod from vehicle.

#### INSPECTION AFTER REMOVAL

##### Visual Inspection

- Check compression rod and bushing for deformation, cracks, or damage. If any non-standard condition is found, replace it.
- Check boot of ball joint for cracks, or other damage, and also for grease leakage. If any non-standard condition is found, replace it.

##### Ball Joint Inspection

- Manually move ball stud to confirm it moves smoothly with no binding.

##### Swing Torque Inspection

#### NOTE:

Before measurement, move ball joint at least ten times by hand to check for smooth movement.

- Hook spring scale at ball stud. Confirm spring scale measurement value is within the specifications when ball stud begins moving.

#### Standard value

#### Swing torque:

**0.147 - 2.45 N·m (0.02 - 0.24 kg·m, 2 - 21 in-lb)**

#### Measured value of spring scale:

**2.37 - 39.5 N (0.24 - 4.03 kg, 0.53 - 8.88 lb)**

- If it is outside the specified range, replace compression rod assembly.

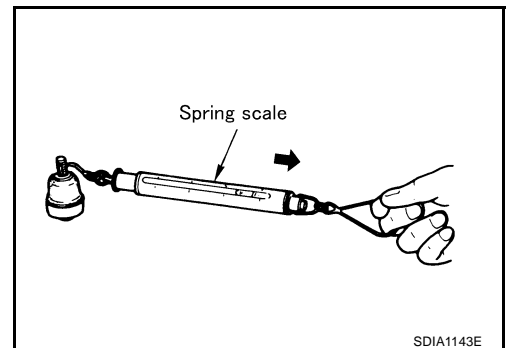

##### Rotating Torque Inspection

- Attach mounting nut to ball stud. Check that rotating torque is within the specifications with a preload gauge (SST).

#### Standard value

#### Rotating torque:

**0.147 - 2.45 N·m (0.02 - 0.24 kg·m, 2 - 21 in-lb)**

- If it is outside the specified range, replace compression rod assembly.

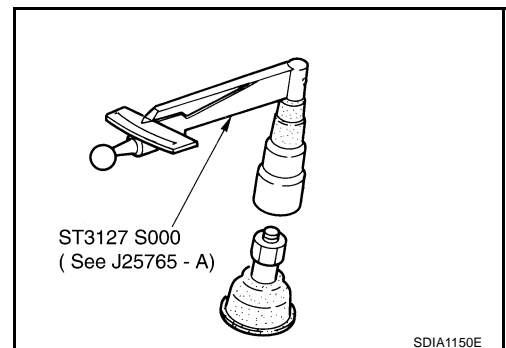



# COMPRESSION ROD

---

## AXIAL END PLAY INSPECTION

- Move tip of ball joint in axial direction to check for looseness.

### Standard value

**Axial end play : 0 mm (0 in)**

- If it is outside the specified range, replace compression rod assembly.

## INSTALLATION

- Refer to [FSU-8, "Components"](#) for tightening torque. Install in the reverse order of removal.

### NOTE:

Refer to component parts location and do not reuse non-reusable parts.

- Perform final tightening of installation position between front suspension member and front cross bar (rubber bushing) under unladen condition with tires on ground. Check wheel alignment. Refer to [FSU-21, "SERVICE DATA"](#).

A

B

C

D

FSU

F

G

H

I

J

K

L

M

# STABILIZER BAR

## STABILIZER BAR

PFP:54611

### Removal and Installation

AES000C0

#### REMOVAL

1. Remove tire with power tool.
2. Remove undercover with power tool.
3. Remove mounting nut on upper portion of stabilizer connecting rod with power tool.
4. Remove fixing bolts and nuts, then remove stabilizer clamp, stabilizer bushing, and stabilizer clamp bracket.
5. Remove stabilizer bar from vehicle.

#### INSPECTION AFTER REMOVAL

Check stabilizer bar, stabilizer connecting rod, stabilizer bushing, stabilizer clamp and stabilizer clamp bracket for deformation, cracks and damage, and replace if necessary.

#### INSTALLATION

- Refer to [FSU-8, "Components"](#) for tightening torque. Install in the reverse order of removal.
- Tighten each bolt and nut as shown in the figure for tightening stabilizer bracket and stabilizer clamp. Tightening order is as follows. 1 (fully tighten) → 2 (temporarily tighten) → 3 (temporarily tighten) → 2 (fully tighten) → 3 (fully tighten) → 4, 5 (temporarily tighten) → 4, 5 (fully tighten).

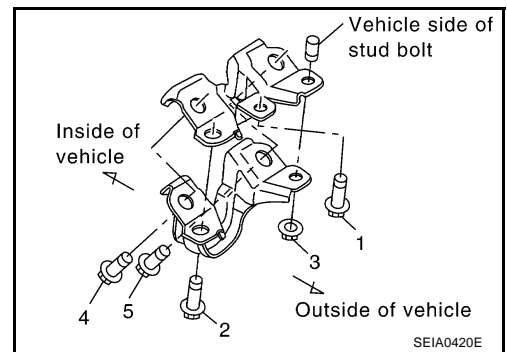

- Stabilizer bar uses pillow ball type connecting rod. Position ball joint with case on pillow ball head parallel to stabilizer bar.

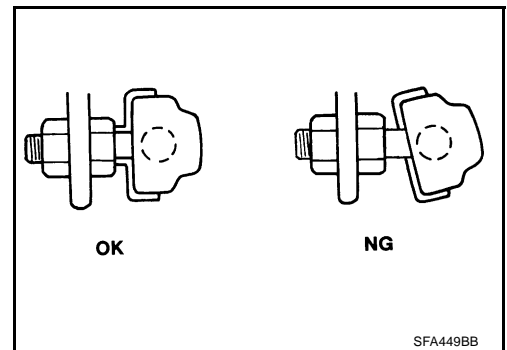

# FRONT SUSPENSION MEMBER

## FRONT SUSPENSION MEMBER

PPF:54401

### Removal and Installation

AES000C1

#### REMOVAL

1. Remove tire with power tool.
2. Remove undercover with power tool.
3. Remove fixing bolts and nuts, then remove front cross bar from vehicle with power tool.
4. Remove steering hydraulic piping bracket from front suspension member. Refer to [PS-34, "HYDRAULIC LINE"](#).
5. Remove steering gear and front suspension member attachment bolts and hang steering gear on vehicle. Refer to [PS-17, "POWER STEERING GEAR AND LINKAGE"](#).
6. Remove transverse link from front suspension member with power tool. Refer to [FSU-13, "TRANSVERSE LINK"](#).
7. Set jack under engine.  
**CAUTION:**  
**When setting jack to engine, use a wooden block or an equivalent for the setting.**
8. Remove fixing nuts between engine mounting insulator and front suspension member. Refer to [EM-103, "ENGINE ASSEMBLY"](#).
9. Remove fixing nuts between front suspension member and body with power tool.
10. Remove front suspension member from vehicle.

#### INSPECTION AFTER REMOVAL

Check front suspension member for deformation, cracks, or any other damage. Replace if necessary.

#### INSTALLATION

- Refer to [FSU-8, "Components"](#) for tightening torque. Install in the reverse order of removal.
- Perform final tightening of installation position between front suspension member and transverse link (rubber bushing) under unladen condition with tires on level ground. Check wheel alignment. Refer to [FSU-21, "SERVICE DATA"](#).

A

B

C

D

FSU

F

G

H

I

J

K

L

M

# TOWER BAR

## TOWER BAR

PF5:544A2

### Removal and Installation

AES000DE

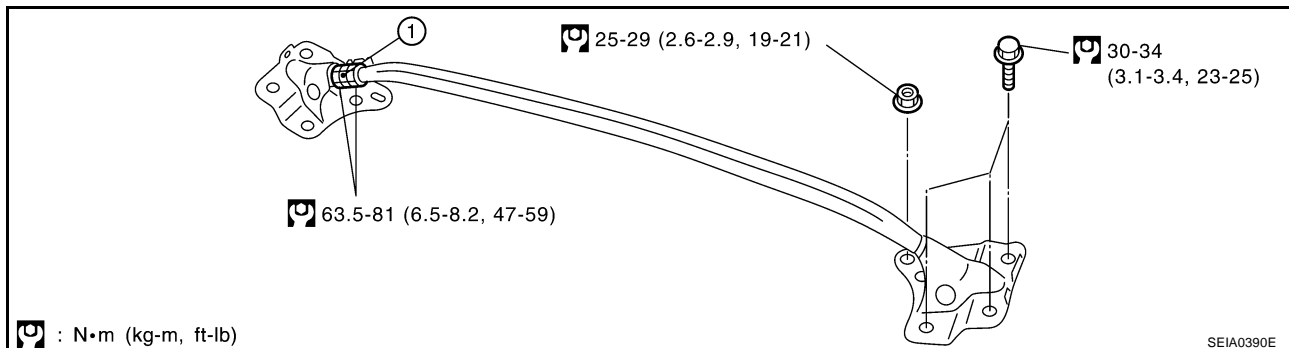

1. Center bolt

### REMOVAL

1. Fix center bolt, and then loosen nut in the right and left side.
2. Loosen center bolt to the direction in the figure on 660° (Or turn bolt 1.7 times) to place the black mark of center bolt above.
3. Remove tower bar fixing bolts and nuts, and remove tower bar from vehicle with power tool.

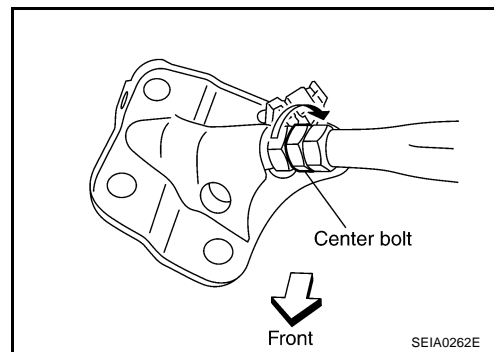

### INSTALLATION

1. Install tower bar and tighten at the specified torque.

#### NOTE:

If it is hard to install tower bar, install it turning center bolt.

2. Tighten center bolt to the direction in the figure on 660° (Or turn bolt 1.7 times) to place the black mark of center bolt above.

#### NOTE:

The space between tower bar and engine collector should be between 10.0 mm (0.394 in) and 17.0 mm (0.669 in).

3. Tighten both nut of the right and left side of center bolt.

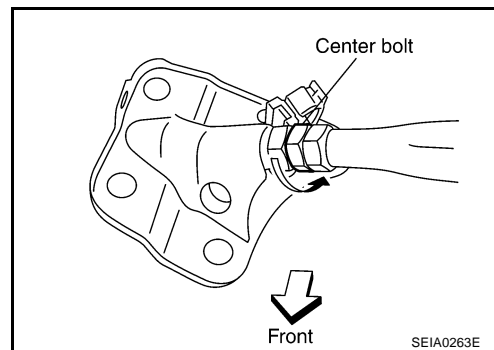

# SERVICE DATA

## SERVICE DATA

PPF:00030

### Wheel Alignment (Unladen)

AES00033

Camber Degree minute (Decimal degree)	Minimum	- 1° 20' (- 1.33°)	
	Nominal	- 0° 35' (- 0.58°)	
	Maximum	0° 10' (0.17°)	
	Left and right difference	45' (0.75°)	
Caster Degree minute (Decimal degree)	Minimum	7° 25' (7.42°)	
	Nominal	8° 10' (8.17°)	
	Maximum	8° 55' (8.92°)	
	Left and right difference	45' (0.75°)	
Kingpin inclination Degree minute (Decimal degree)	Minimum	4° 20' (4.33°)	
	Nominal	5° 05' (5.08°)	
	Maximum	5° 50' (5.83°)	
Total toe-in	Distance (A - B)	Minimum	0 mm (0 in)
		Nominal	1 mm (0.04 in)
		Maximum	2 mm (0.08 in)

### Ball Joint

AES00034

Swing torque	Less than 2.0 N-m (0.20 kg-m, 18 in-lb) (Upper link) 0.147 - 2.45 N-m (0.02 - 0.24 kg-m, 2 - 21 in-lb) (Compression rod)
Measurement on spring balance (cotter pinhole position)	Less than 34.8 N (3.5 kg, 7.8 lb) (Upper link) 2.37 - 39.5 N (0.24 - 4.03 kg, 0.53 - 8.88 lb) (Compression rod)
Rotating torque	Less than 2.0 N-m (0.20 kg-m, 18 in-lb) (Upper link) 0.147 - 2.45 N-m (0.02 - 0.24 kg-m, 2 - 21 in-lb) (Compression rod)
Axial end play	0 mm (0 in)

### Wheelarch Height (Unladen\*)

AES00035

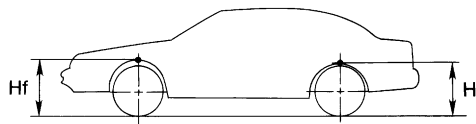

SFA818A

Applied model	225/50R17 (Front) 235/50R17 (Rear)		225/45R18 (Front) 245/45R18 (Rear)	
	Coupe	Road star	Coupe	Road star
Front (Hf)	681 mm (26.81 in)	679 mm (26.73 in)	683 mm (26.89 in)	
Rear (Hr)	700 mm (27.56 in)	699 mm (27.52 in)	706 mm (27.80 in)	705 mm (27.76 in)

\*: Fuel, radiator coolant and engine oil full. Spare tire, jack, hand tools and mats in designated positions.

**SERVICE DATA**

---