

SECTION **SRS**

SUPPLEMENTAL RESTRAINT SYSTEM (SRS)

A
B
C
D
E
F
G
H
I
J
K
L
M

CONTENTS

PRECAUTIONS	3	DIAGNOSTIC PROCEDURE 3	27
Precautions for Supplemental Restraint System (SRS) "AIR BAG" and "SEAT BELT PRE-TENSIONER"	3	DIAGNOSTIC PROCEDURE 4 (CONTINUED FROM DIAGNOSTIC PROCEDURE 2)	29
Precautions for SRS "AIR BAG" and "SEAT BELT PRE-TENSIONER" Service	3	DIAGNOSTIC PROCEDURE 5	29
Precautions for Battery Service	3	Trouble Diagnosis without CONSULT-II	33
Wiring Diagrams and Trouble Diagnosis	3	DIAGNOSTIC PROCEDURE 6	33
PREPARATION	4	WARNING LAMP FLASH CODE CHART	34
Commercial Service Tools	4	Trouble Diagnosis: "AIR BAG" Warning Lamp Does Not Turn OFF	38
SUPPLEMENTAL RESTRAINT SYSTEM (SRS)	5	DIAGNOSTIC PROCEDURE 7	38
SRS Configuration	5	Trouble Diagnosis: "AIR BAG" Warning Lamp Does Not Turn ON	39
Front Seat Belt Pre-tensioner with Load Limiter	6	DIAGNOSTIC PROCEDURE 8	39
Front Side Air Bag	6	DRIVER AIR BAG MODULE	40
Side Curtain Air Bag/For Coupe	6	Removal and Installation	40
TROUBLE DIAGNOSIS	7	REMOVAL	40
Trouble Diagnosis Introduction	7	INSTALLATION	41
DIAGNOSIS FUNCTION	7	SPIRAL CABLE	42
HOW TO PERFORM TROUBLE DIAGNOSES FOR QUICK AND ACCURATE REPAIR	7	Removal and Installation	42
WORK FLOW	8	REMOVAL	42
Component Parts Location	9	INSTALLATION	43
Schematic	10	FRONT PASSENGER AIR BAG MODULE	44
Wiring Diagram — SRS —/For Coupe	11	Removal and Installation	44
Wiring Diagram — SRS —/For Roadster	15	REMOVAL	44
CONSULT-II Function	19	INSTALLATION	44
DIAGNOSIS MODE FOR CONSULT-II	19	SIDE CURTAIN AIR BAG MODULE (FOR COUPE)..	45
HOW TO CHANGE SELF-DIAGNOSIS MODE WITH CONSULT-II	19	Removal and Installation	45
HOW TO ERASE SELF-DIAGNOSTIC RESULTS	20	REMOVAL	45
Self-Diagnosis Function (Without CONSULT-II)	20	INSTALLATION	46
HOW TO CHANGE SELF-DIAGNOSTIC MODE WITHOUT CONSULT-II	20	CRASH ZONE SENSOR	47
HOW TO ERASE SELF-DIAGNOSTIC RESULTS	20	Removal and Installation	47
SRS Operation Check	21	REMOVAL	47
DIAGNOSTIC PROCEDURE 1	21	INSTALLATION	47
Trouble Diagnosis with CONSULT-II	23	SIDE AIR BAG (SATELLITE) SENSOR	48
DIAGNOSTIC PROCEDURE 2	23	Removal and Installation	48
		REMOVAL	48
		INSTALLATION	48
		FRONT SEAT BELT PRE-TENSIONER	49
		Removal and Installation	49

SRS

DIAGNOSIS SENSOR UNIT	50	SION)	51
Removal and Installation	50	For Side Collision	52
REMOVAL	50	WHEN THE SIDE AIR BAG IS ACTIVATED IN	
INSTALLATION	50	THE SIDE COLLISION:	52
ECU DISCRIMINATED NO.	50	WHEN SRS IS NOT ACTIVATED IN THE SIDE	
COLLISION DIAGNOSIS	51	COLLISION:	53
For Frontal Collision	51	SRS INSPECTION (FOR SIDE COLLISION)	53
SRS INSPECTION (FOR FRONTAL COLLI-			

PRECAUTIONS

PRECAUTIONS

PPF:00001

Precautions for Supplemental Restraint System (SRS) “AIR BAG” and “SEAT BELT PRE-TENSIONER”

AHS0001K

The Supplemental Restraint System such as “AIR BAG” and “SEAT BELT PRE-TENSIONER”, used along with a front seat belt, helps to reduce the risk or severity of injury to the driver and front passenger for certain types of collision. This system includes seat belt switch inputs and dual stage front air bag modules. The SRS system uses the seat belt switches to determine the front air bag deployment, and may only deploy one front air bag, depending on the severity of a collision and whether the front occupants are belted or unbelted. Information necessary to service the system safely is included in the SRS and SB section of this Service Manual.

WARNING:

- To avoid rendering the SRS inoperative, which could increase the risk of personal injury or death in the event of a collision which would result in air bag inflation, all maintenance must be performed by an authorized NISSAN/INFINITI dealer.
- Improper maintenance, including incorrect removal and installation of the SRS, can lead to personal injury caused by unintentional activation of the system. For removal of Spiral Cable and Air Bag Module, see the SRS section.
- Do not use electrical test equipment on any circuit related to the SRS unless instructed to in this Service Manual. SRS wiring harnesses can be identified by yellow and/or orange harnesses or harness connectors.

Precautions for SRS “AIR BAG” and “SEAT BELT PRE-TENSIONER” Service

AHS000JX

- Do not use electrical test equipment to check SRS circuits unless instructed in this Service Manual.
- Before servicing the SRS, turn ignition switch OFF, and disconnect both battery cables. Then wait at least 3 minutes.
For approximately 3 minutes after the cables are removed, it is still possible for the air bag and seat belt pre-tensioner to deploy. Therefore, do not work on any SRS connectors or wires until at least 3 minutes have passed.
- Diagnosis sensor unit must always be installed with their arrow marks “⇐” pointing towards the front of the vehicle for proper operation. Also check diagnosis sensor unit for cracks, deformations or rust before installation and replace if required.
- The spiral cable must be set to the neutral position since its rotations are limited. Do not attempt to turn steering wheel or column, if steering gear was disconnected from the column shaft.
- Handle air bag module carefully. Always put a driver air bag module with the pad side facing upward.
- Conduct self-diagnosis to check entire SRS for proper function after replacing any components.
- After an air bag deployment, the front instrument panel assembly should be replaced if damaged.
- Always replace instrument panel pad following front passenger air bag deployment.

Precautions for Battery Service

AHS000NY

Before disconnecting the battery, lower both the driver and passenger windows. This will prevent any interference between the window edge and the vehicle when the door is opened/closed. During normal operation, the window slightly raises and lowers automatically to prevent any window to vehicle interference. The automatic window function will not work with the battery disconnected.

Wiring Diagrams and Trouble Diagnosis

AHS0001M

When you read wiring diagrams, refer to the following:

- [GI-15, "How to Read Wiring Diagrams"](#) in GI section
- [PG-4, "POWER SUPPLY ROUTING CIRCUIT"](#) in PG section

When you perform trouble diagnosis, refer to the following:

- [GI-11, "HOW TO FOLLOW TEST GROUPS IN TROUBLE DIAGNOSES"](#) in GI section
- [GI-27, "How to Perform Efficient Diagnosis for an Electrical Incident"](#) in GI section

Check for any service bulletins before servicing the vehicle.

PREPARATION

PREPARATION

PFP:00002

Commercial Service Tools

AHS00010

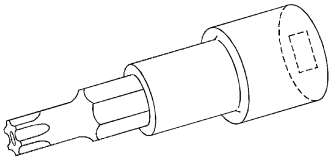
Tool name	Description
<p data-bbox="164 400 432 427">Tamper resistant TORX bit</p>  <p data-bbox="826 506 884 523">S-NT757</p>	<p data-bbox="978 400 1075 427">Size: T30</p>

SUPPLEMENTAL RESTRAINT SYSTEM (SRS)

SUPPLEMENTAL RESTRAINT SYSTEM (SRS)

PPF:28556

SRS Configuration

AHS0001P

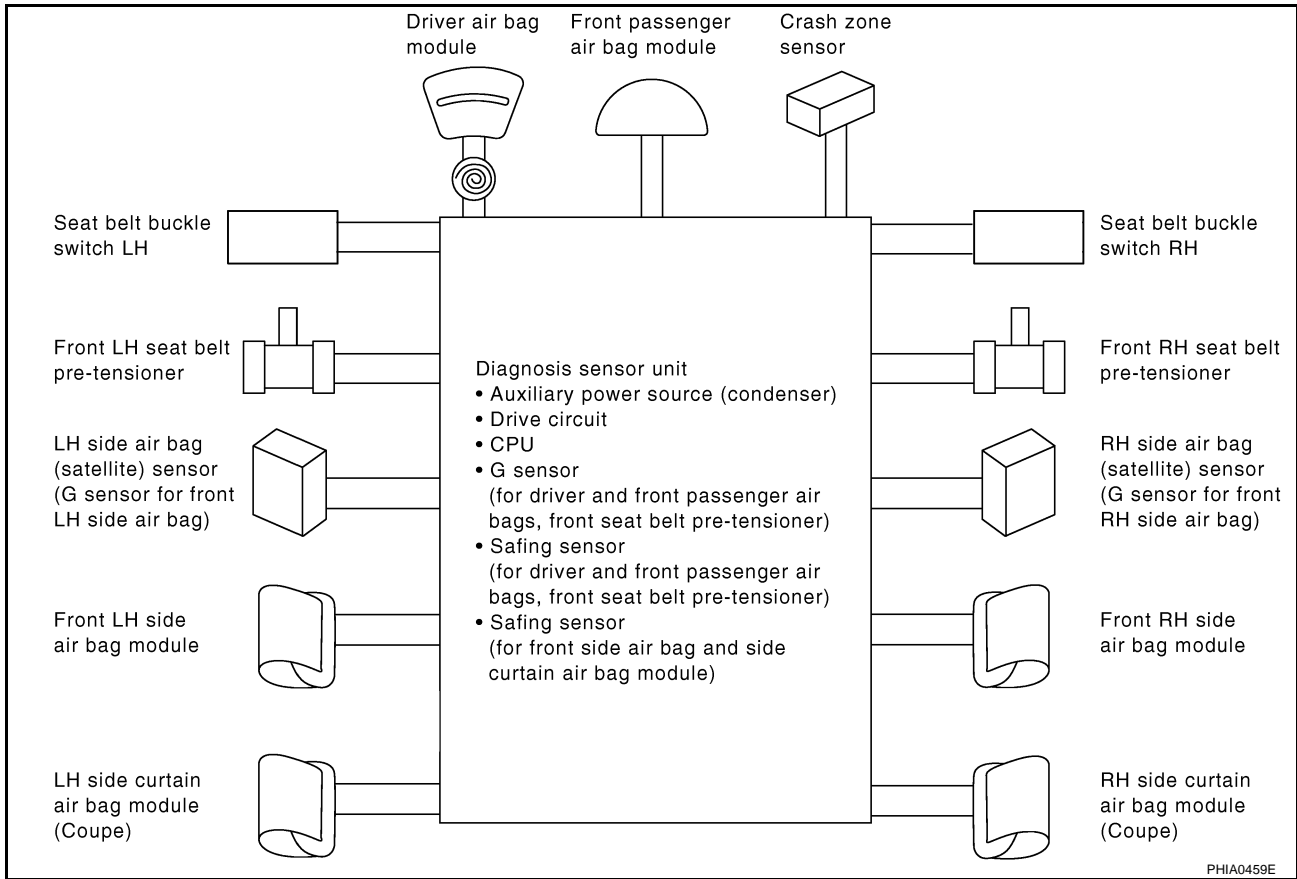

A
B
C
D
E
F
G

SRS

I
J
K
L
M

The air bag deploys if the diagnosis sensor unit activates while the ignition switch is in the ON or START position.

The collision modes for which supplemental restraint systems are activated are different among the SRS systems. For example, the driver air bag module and front passenger air bag module are activated in a frontal collision but not in a side collision.

SRS configurations which are activated for some collision modes are as follows;

SRS configuration	Frontal collision	Left side collision	Right side collision
Driver air bag module	×	—	—
Front passenger air bag module	×	—	—
Front LH seat belt pre-tensioner	×	—	—
Front RH seat belt pre-tensioner	×	—	—
Front LH side air bag module	—	×	—
Front RH side air bag module	—	—	×
LH side curtain air bag module*	—	×	—
RH side curtain air bag module*	—	—	×

*: For Coupe

SUPPLEMENTAL RESTRAINT SYSTEM (SRS)

Front Seat Belt Pre-tensioner with Load Limiter

AHS0001Q

The seat belt pre-tensioner system with load limiter is installed for both the driver's seat and the front passenger seat. It operates simultaneously with the SRS air bag system in the event of a frontal collision with an impact exceeding a specified level.

When the frontal collision with an impact exceeding a specified level occurs, seat belt slack resulting from clothing or other factors is immediately taken up by the pre-tensioner. Vehicle passengers are securely restrained.

When passengers in a vehicle are thrown forward in a collision and the restraining force of the seat belt exceeds a specified level, the load limiter permits the specified extension of the seat belt by the twisting of the ELR shaft, and a relaxation of the chest-area seat belt web tension while maintaining force.

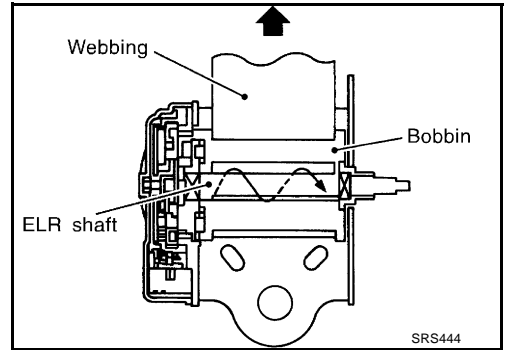

Front Side Air Bag

AHS0001R

Front side air bag is built-in type.

The front seatbacks with built-in type side air bag have the labels as shown.

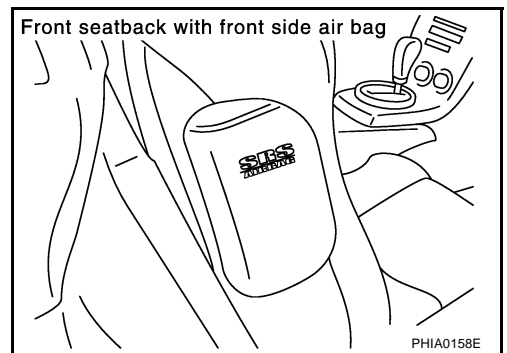

Side Curtain Air Bag/For Coupe

AHS0001S

The side curtain air bags have the labels as shown.



TROUBLE DIAGNOSIS

TROUBLE DIAGNOSIS

PF0:00004

Trouble Diagnosis Introduction

AHS0001T

CAUTION:

- Do not use electrical test equipment on any circuit related to the SRS unless instructed in this Service Manual. SRS wiring harnesses can be identified by yellow and/or orange harnesses or harness connectors.
- Do not repair, splice or modify the SRS wiring harness. If the harness is damaged, replace it with a new one.
- Keep ground portion clean.

DIAGNOSIS FUNCTION

The SRS self-diagnostic results can be read by using "AIR BAG" warning lamp and/or CONSULT-II.

The User mode is exclusively prepared for the customer (driver). This mode warns the driver of a system malfunction through the operation of the "AIR BAG" warning lamp.

The Diagnosis mode allows the technician to locate and inspect the malfunctioning part.

The mode applications for the "AIR BAG" warning lamp and CONSULT-II are as follows:

	User mode	Diagnosis mode	Display type
"AIR BAG" warning lamp	X	X	ON-OFF operation
CONSULT-II	—	X	Monitoring

HOW TO PERFORM TROUBLE DIAGNOSES FOR QUICK AND ACCURATE REPAIR

A good understanding of the malfunction conditions can make troubleshooting faster and more accurate.

In general, each customer feels differently about a malfunction. It is important to fully understand the symptoms or conditions for a customer complaint.

Information from Customer

WHAT..... Vehicle model

WHEN..... Date, Frequencies

WHERE..... Road conditions

HOW..... Operating conditions, Symptoms

Preliminary Check

Make sure that the following parts are in good order.

- Battery (Refer to [SC-4, "How to Handle Battery"](#) .)
- Fuse (Refer to [SRS-11, "Wiring Diagram — SRS —/For Coupe"](#) or [SRS-15, "Wiring Diagram — SRS —/For Roadster"](#) .)
- System component-to-harness connections

A
B
C
D
E
F
G
I
J
K
L
M

SRS

TROUBLE DIAGNOSIS

WORK FLOW

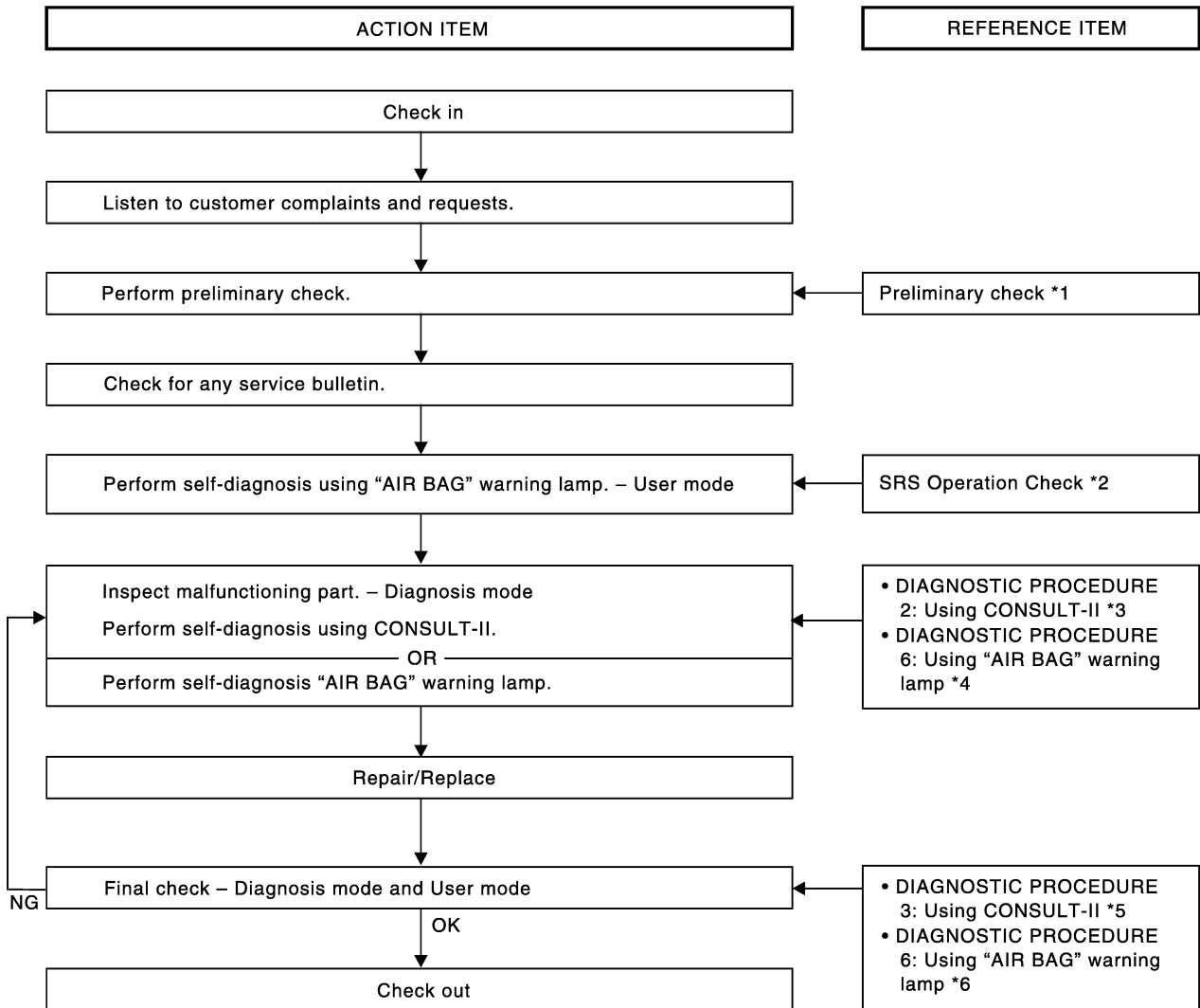

PHIA0217E

*1: [SRS-7. "Preliminary Check"](#).

*2: [SRS-21. "SRS Operation Check"](#).

*3: [SRS-23. "DIAGNOSTIC PROCEDURE 2"](#).

*4: [SRS-33. "DIAGNOSTIC PROCEDURE 6"](#).

*5: [SRS-27. "DIAGNOSTIC PROCEDURE 3"](#).

*6: [SRS-33. "DIAGNOSTIC PROCEDURE 6"](#).

TROUBLE DIAGNOSIS

Component Parts Location

AHS0001U

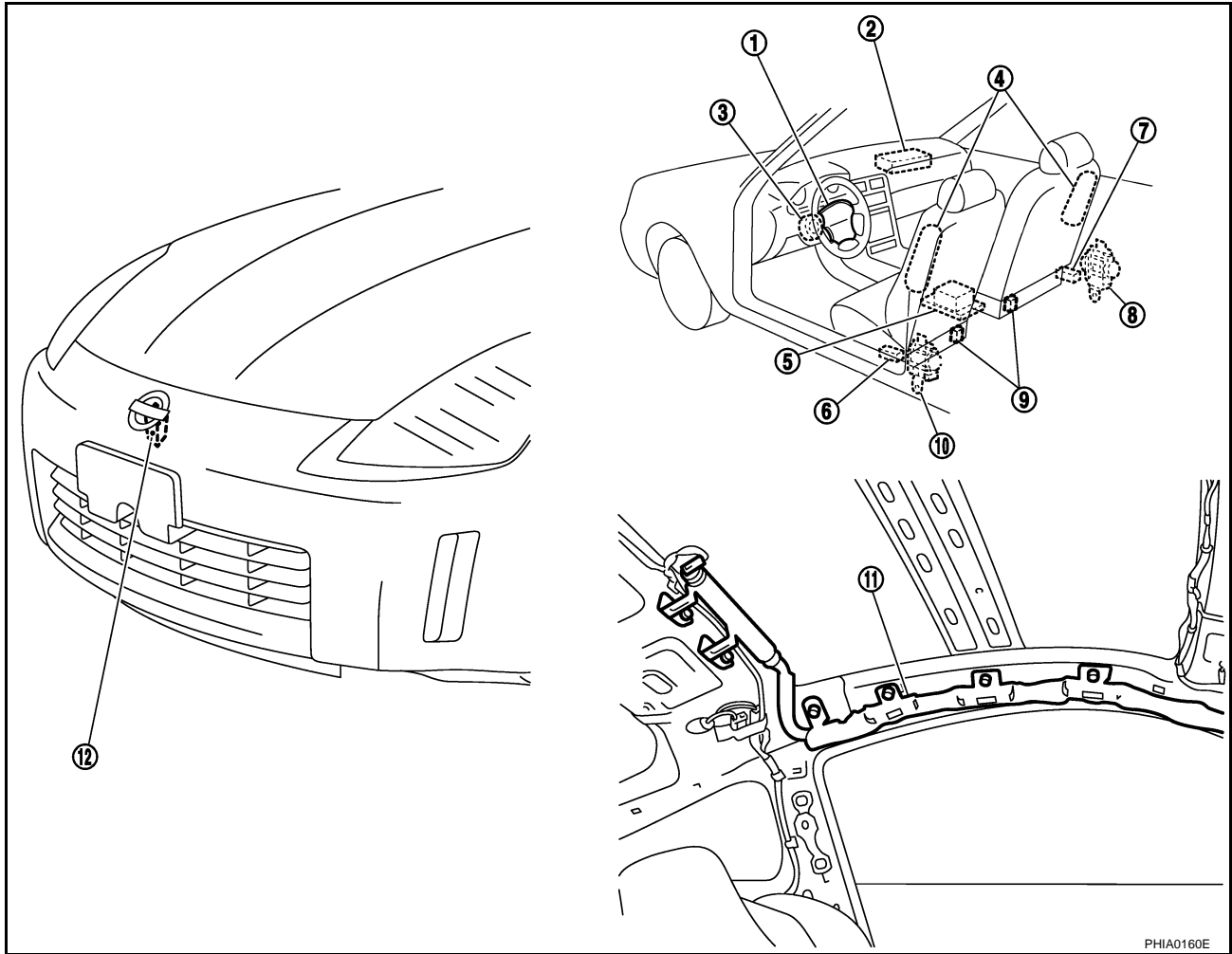

- | | | |
|---------------------------------------|-----------------------------------|---------------------------------------|
| 1. Driver air bag module | 2. Front passenger air bag module | 3. Spiral cable |
| 4. Front side air bag module | 5. Diagnosis sensor unit | 6. Side air bag (Satellite) sensor LH |
| 7. Side air bag (Satellite) sensor RH | 8. Seat belt pre-tensioner RH | 9. Seat belt buckle switches |
| 10. Seat belt pre-tensioner LH | 11. Side curtain air bag module* | 12. Crash zone sensor |

*: For Coupe

A
B
C
D
E
F
G
SRS
I
J
K
L
M

TROUBLE DIAGNOSIS

Schematic

AHS0001V

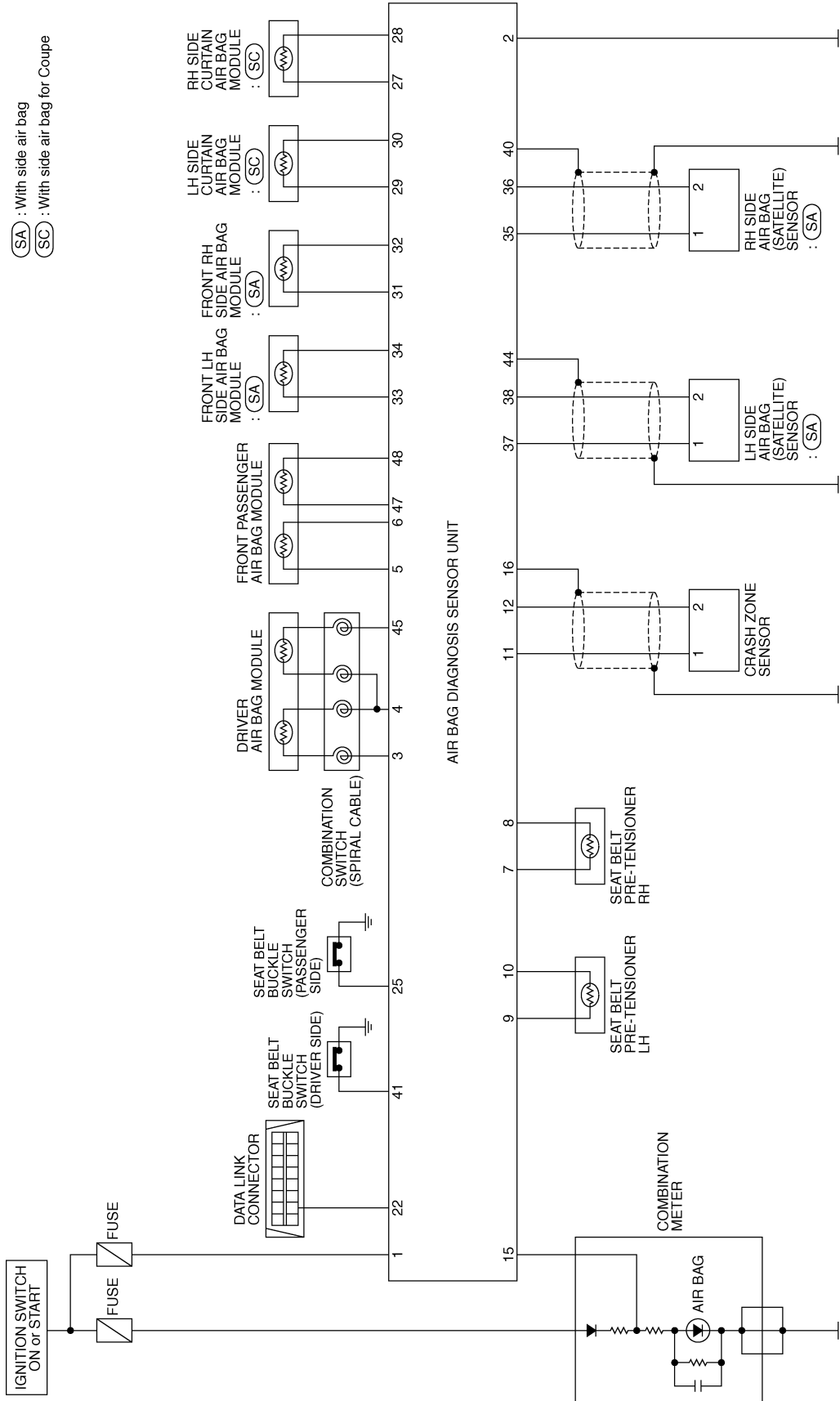

THWT0079E

TROUBLE DIAGNOSIS

Wiring Diagram — SRS —/For Coupe

AHS0001W

SRS-SRS-01

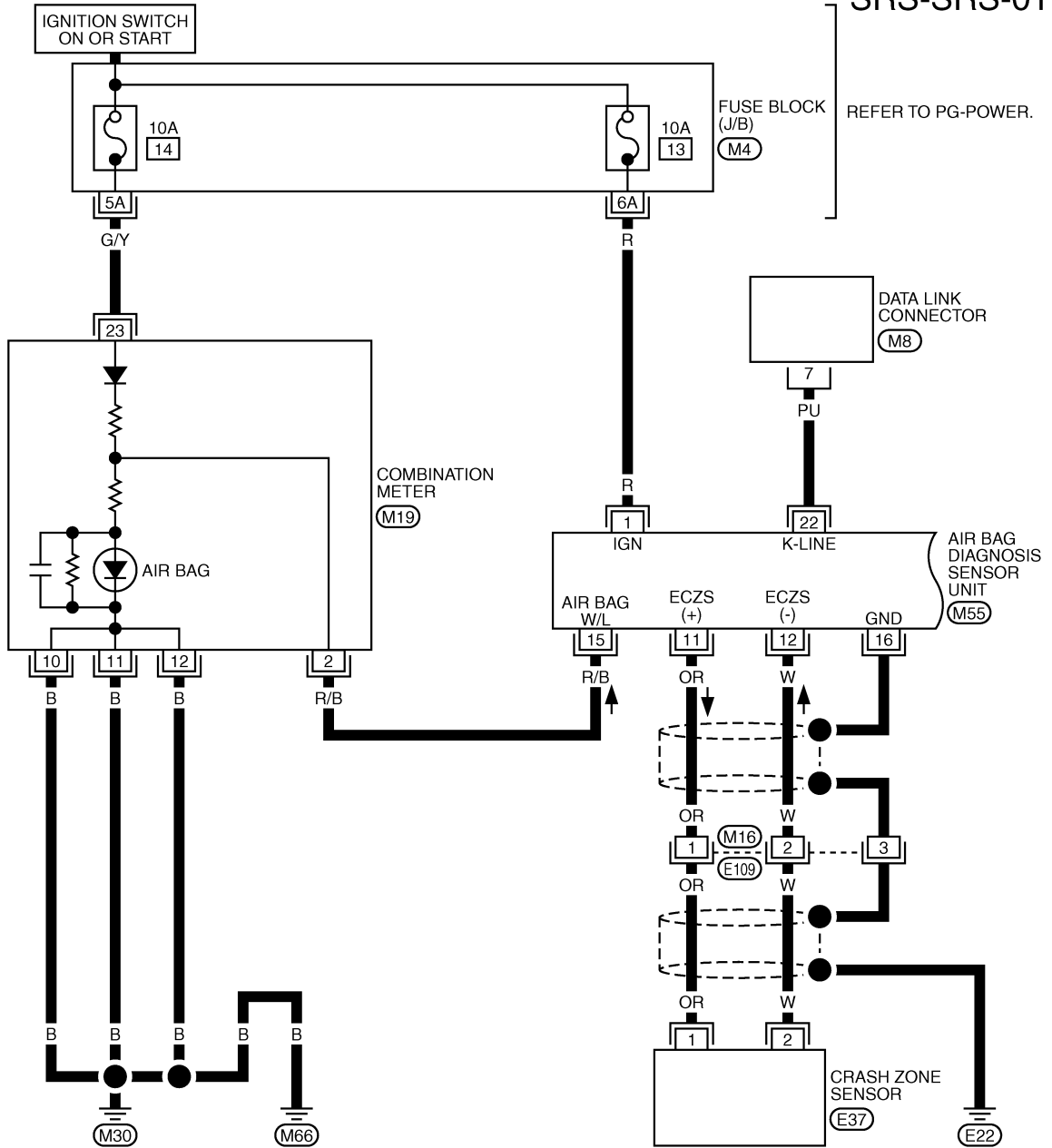

A
B
C
D
E
F
G
SRS
I
J
K
L
M

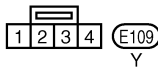
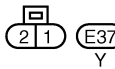
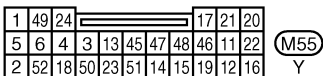
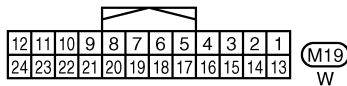
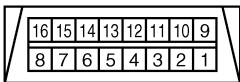

REFER TO THE FOLLOWING.
(M4) -FUSE BLOCK-JUNCTION BOX (J/B)

THWT0080E

TROUBLE DIAGNOSIS

SRS-SRS-02

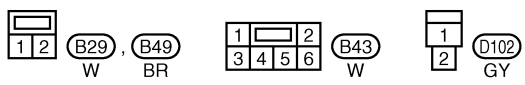
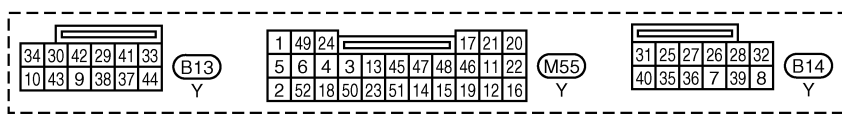
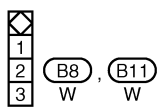
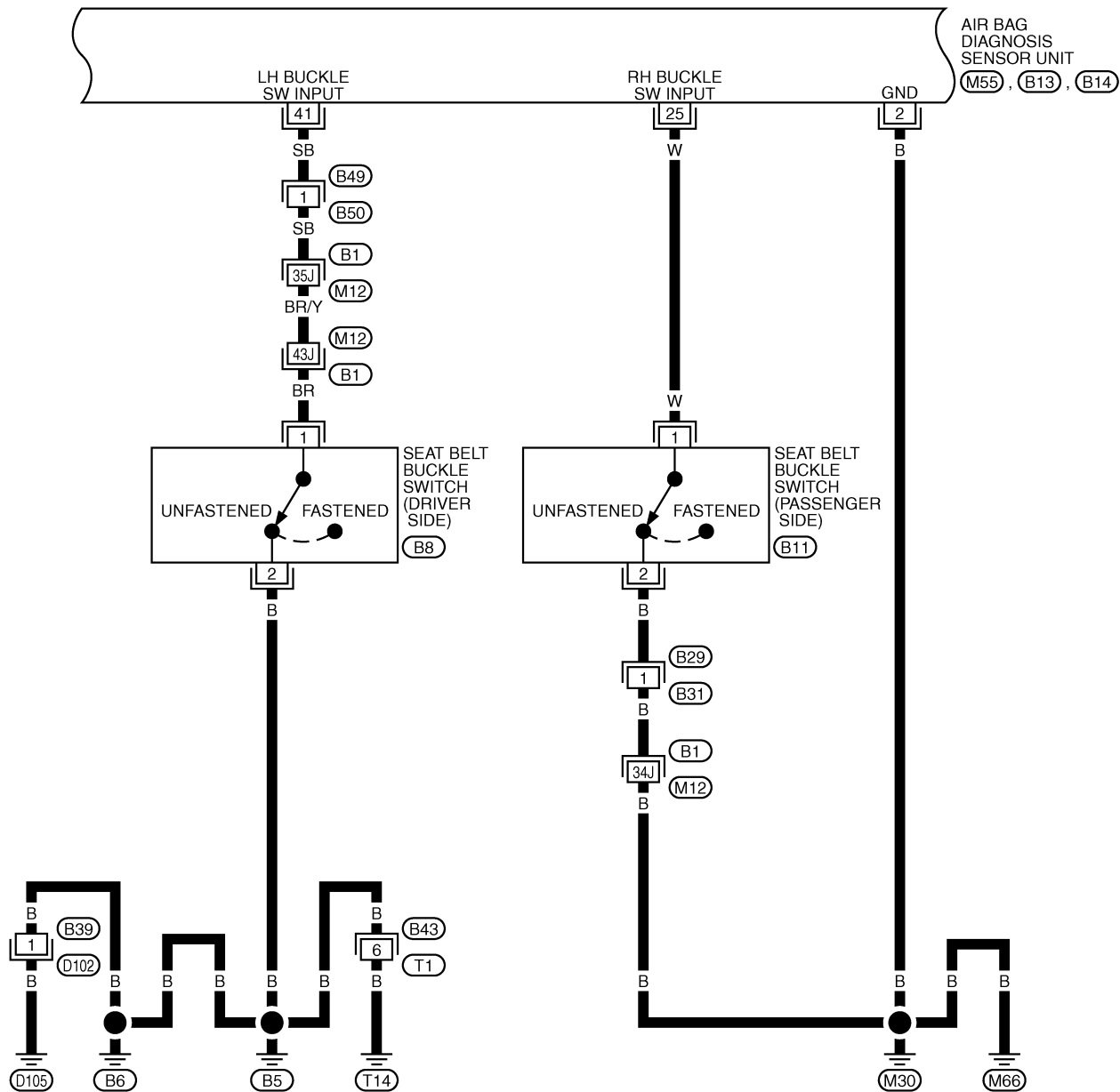

REFER TO THE FOLLOWING.
 (B1) -SUPER MULTIPLE JUNCTION (SMJ)

THWT0081E

TROUBLE DIAGNOSIS

SRS-SRS-03

A
B
C
D
E
F
G
H
I
J
K
L
M

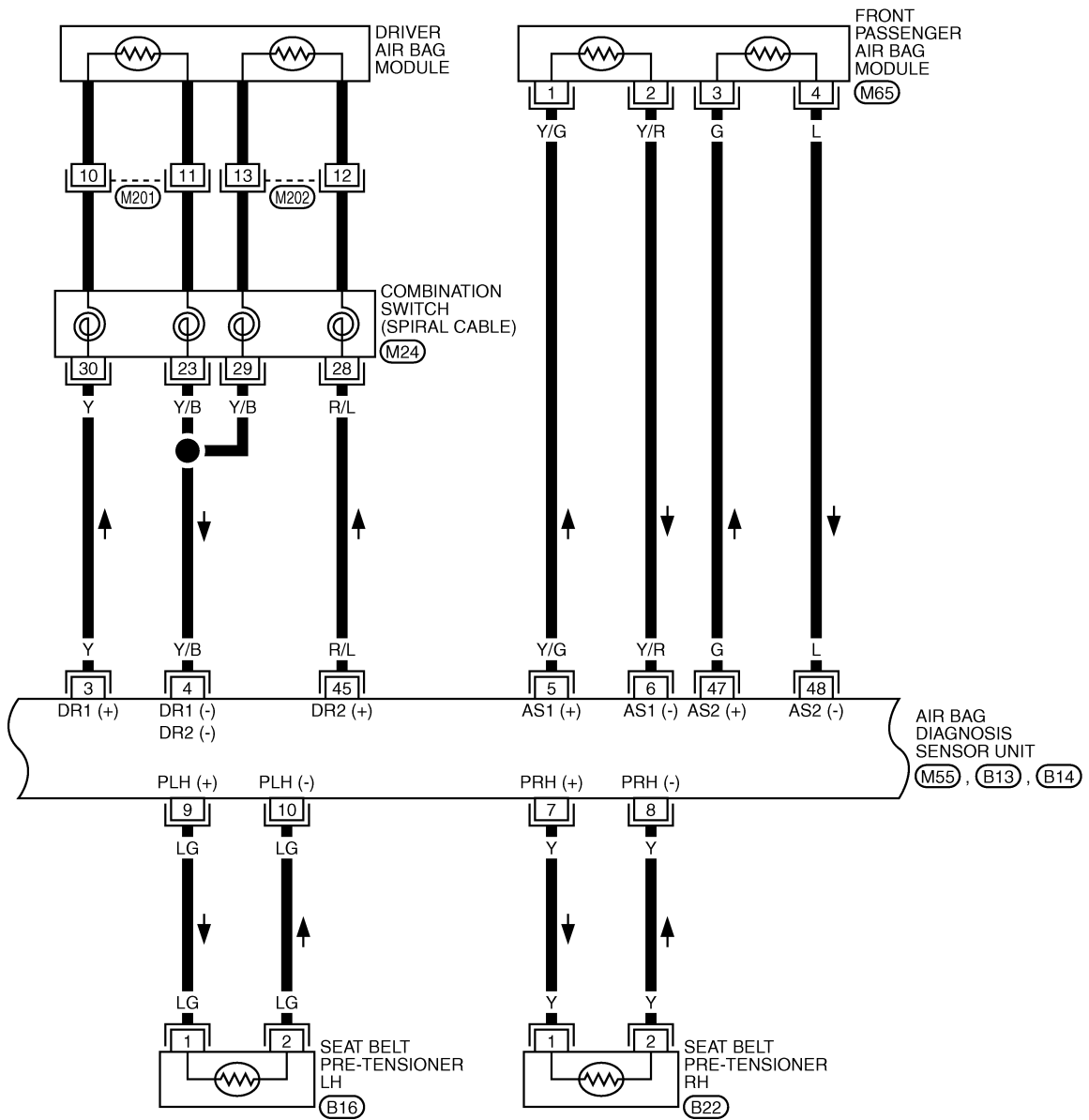

SRS

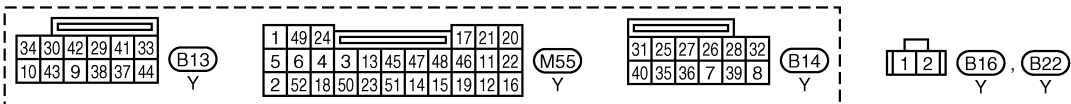
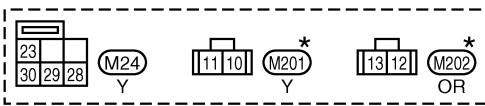

*: THIS CONNECTOR IS NOT SHOWN IN "HARNESS LAYOUT", PG SECTION.

THWT0082E

TROUBLE DIAGNOSIS

SRS-SRS-04

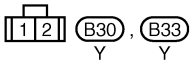
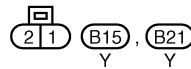
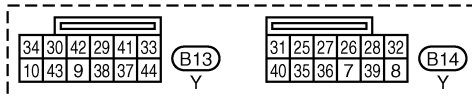
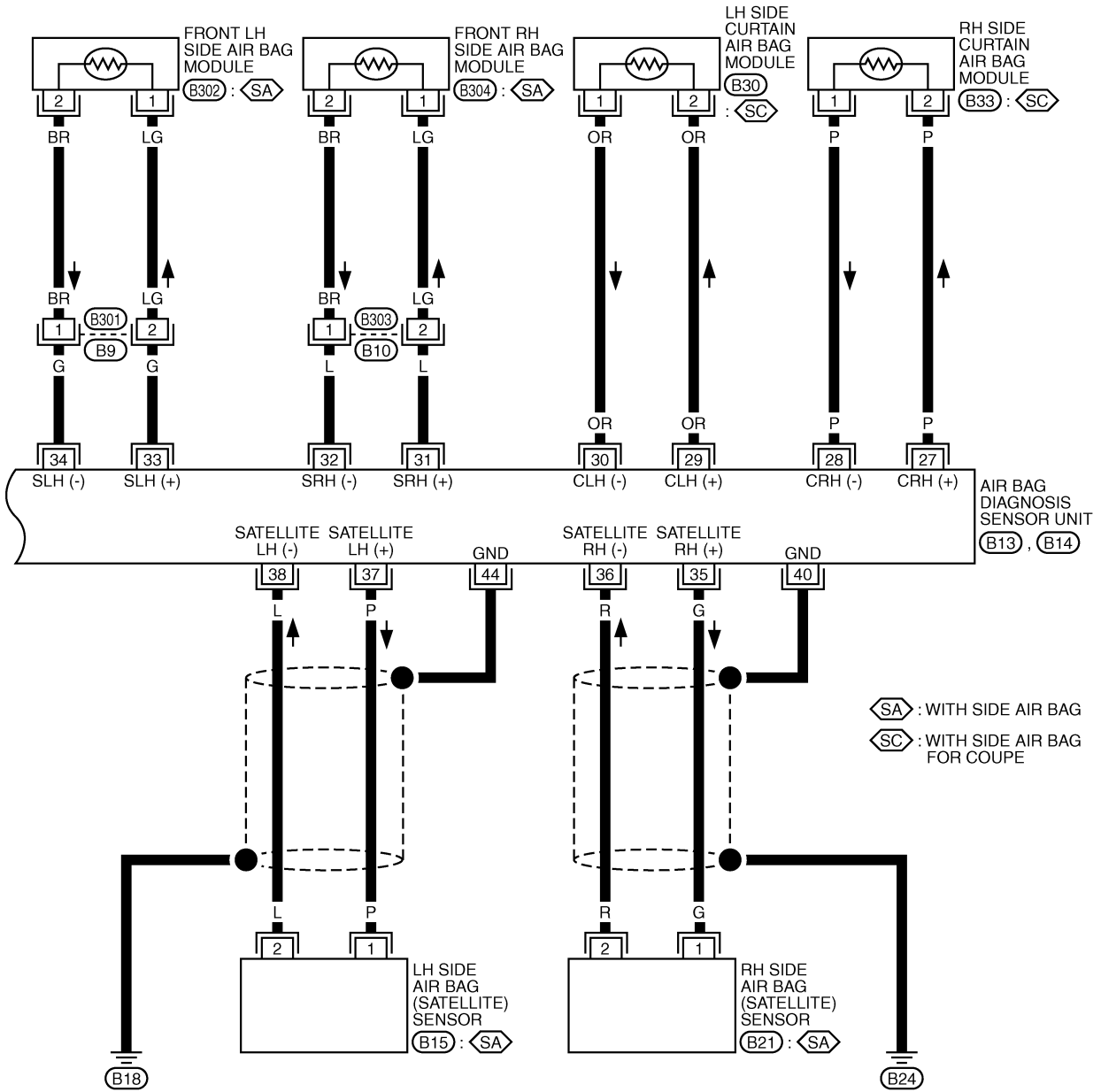

*: THIS CONNECTOR IS NOT SHOWN IN "HARNES LAYOUT", PG SECTION.

THWT0083E

TROUBLE DIAGNOSIS

Wiring Diagram — SRS —/For Roadster

AHS000JO

SRS-SRS-05

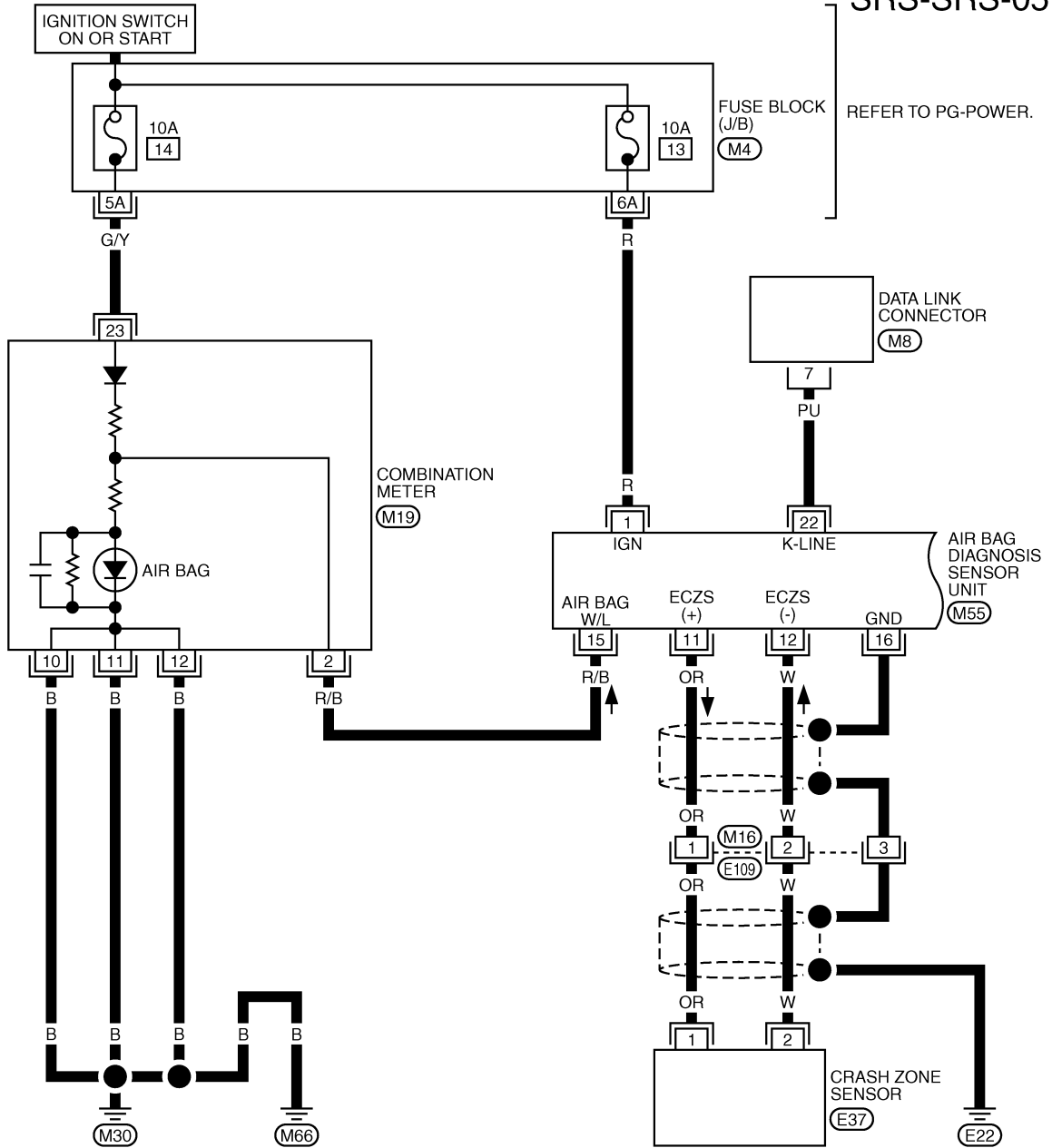

A
B
C
D
E
F
G
SRS
I
J
K
L
M

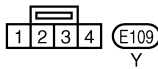
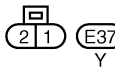
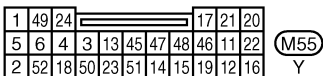
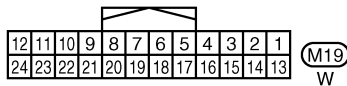
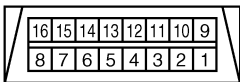

REFER TO THE FOLLOWING.
 (M4) -FUSE BLOCK-JUNCTION BOX (J/B)

THWT0084E

TROUBLE DIAGNOSIS

SRS-SRS-06

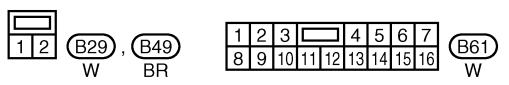
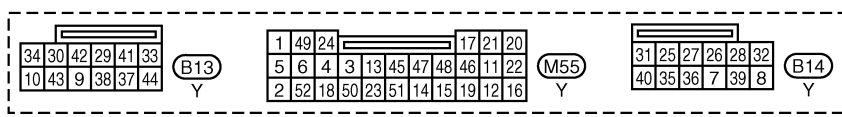
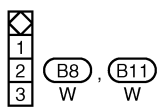
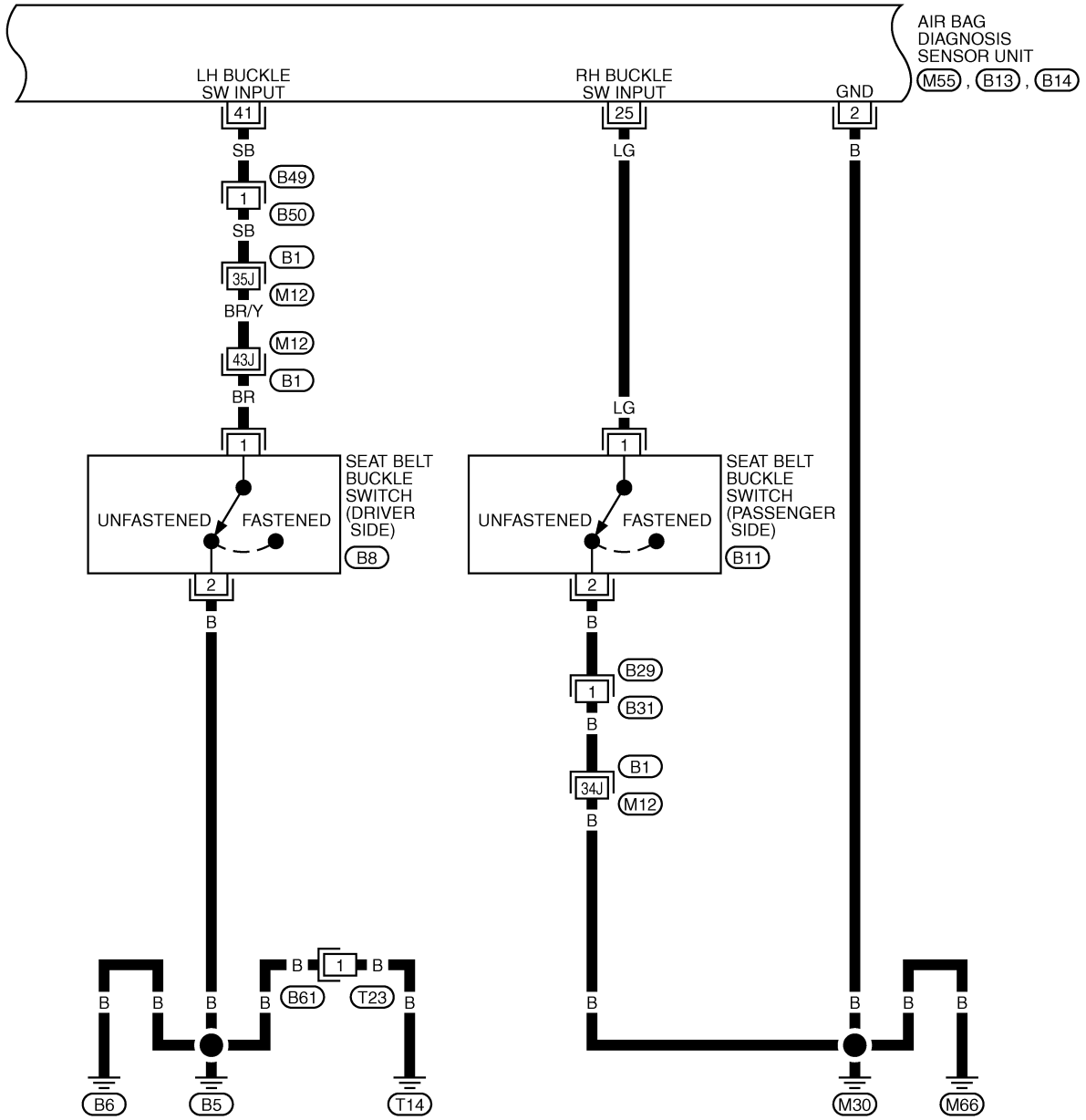

REFER TO THE FOLLOWING.
 (B1) -SUPER MULTIPLE JUNCTION (SMJ)

THWT0085E

TROUBLE DIAGNOSIS

SRS-SRS-07

A
B
C
D
E
F
G
H
I
J
K
L
M

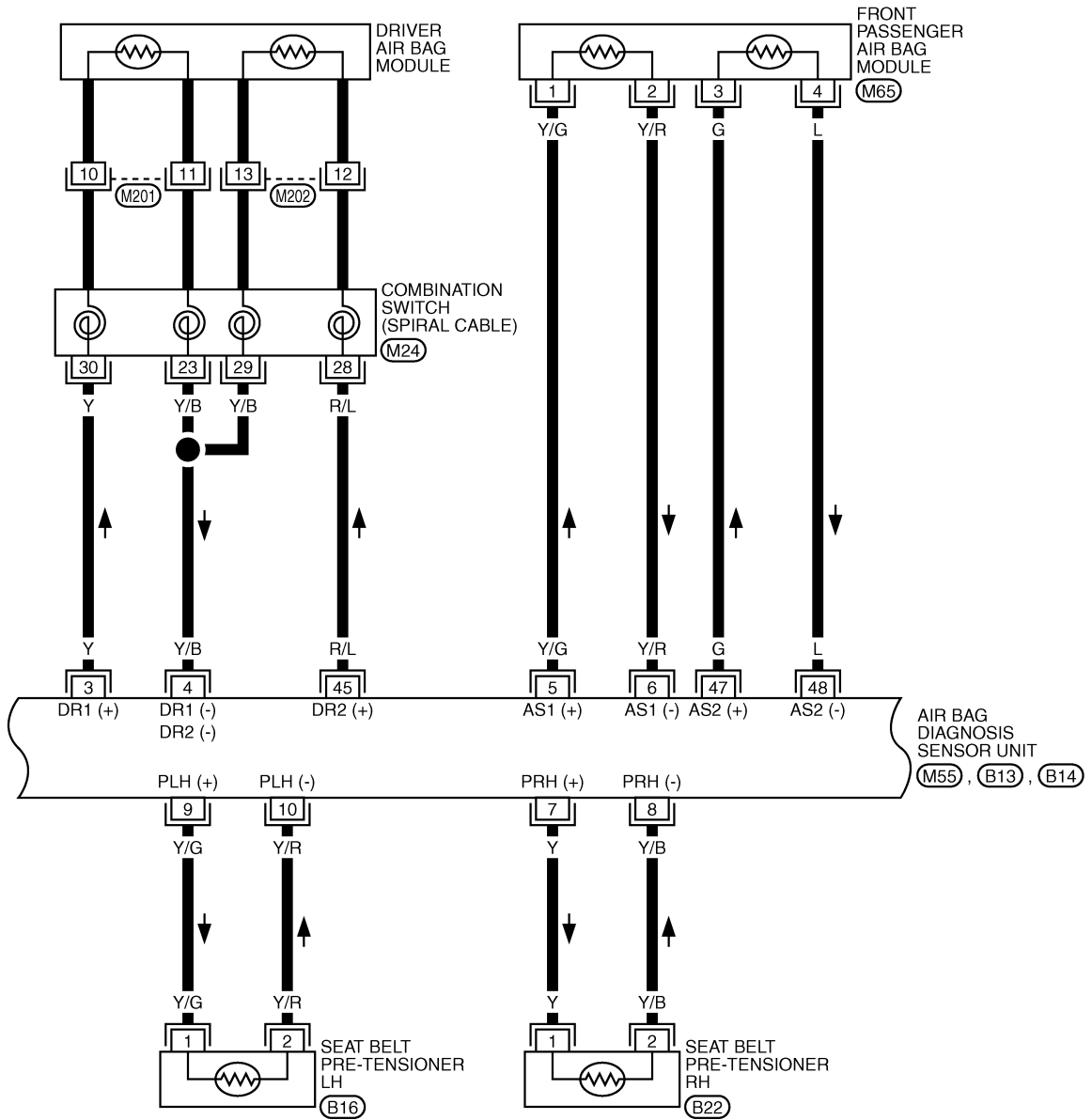

SRS

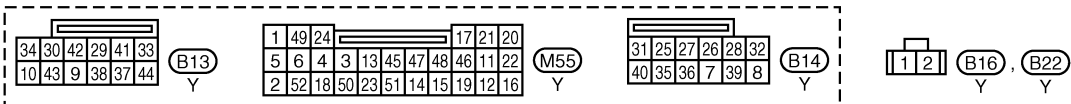
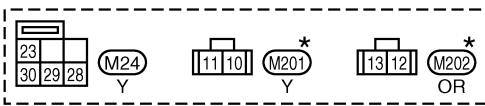

*: THIS CONNECTOR IS NOT SHOWN IN "HARNESS LAYOUT", PG SECTION.

THWT0086E

TROUBLE DIAGNOSIS

SRS-SRS-08

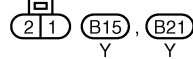
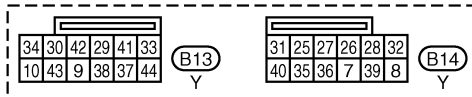
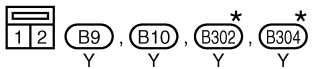
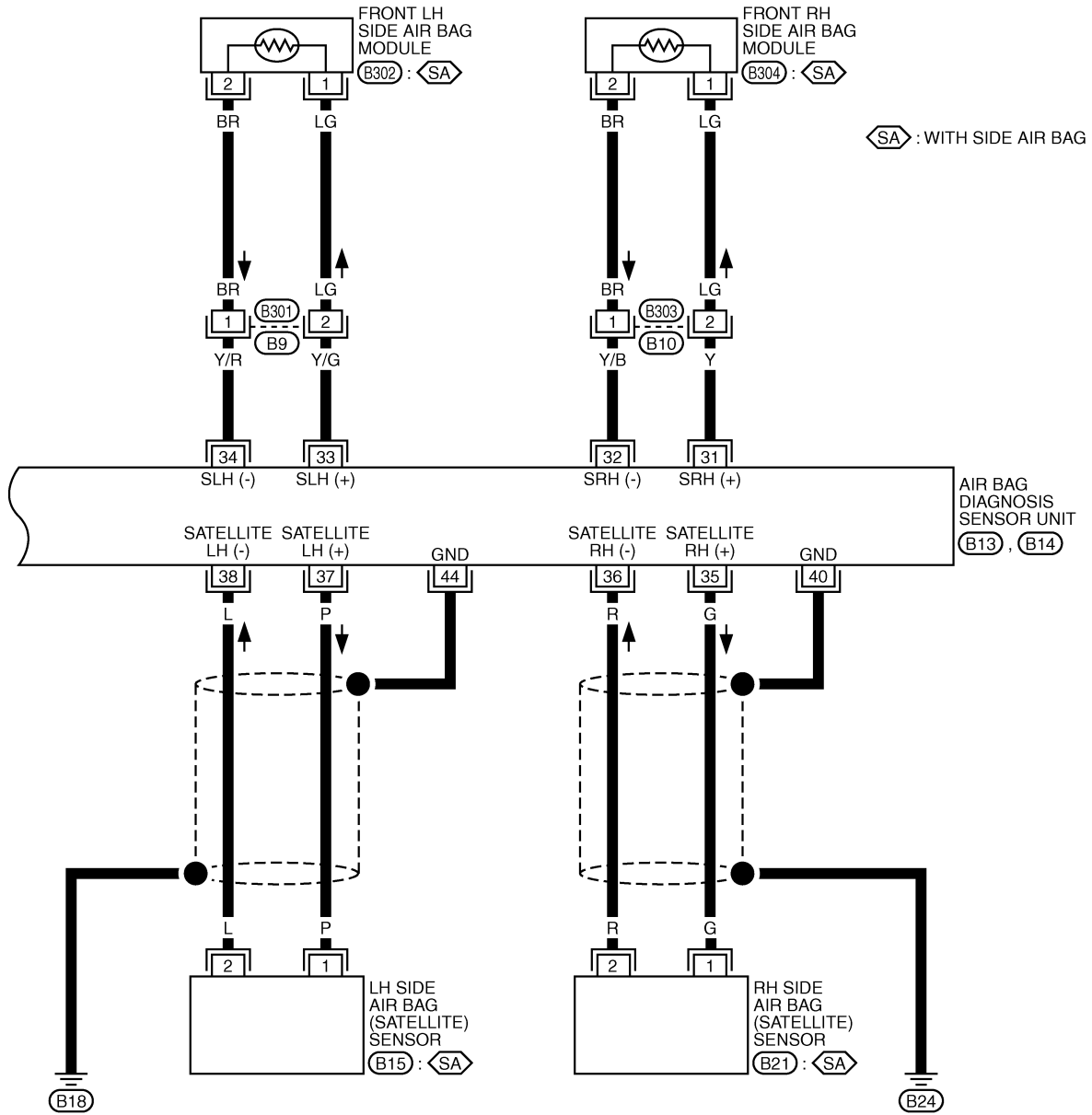

*: THIS CONNECTOR IS NOT SHOWN IN "HARNES LAYOUT", PG SECTION.

THWT0087E

TROUBLE DIAGNOSIS

AHS0001X

CONSULT-II Function DIAGNOSIS MODE FOR CONSULT-II

- “SELF-DIAG [CURRENT]”
A current self-diagnostic results (also indicated by the number of warning lamp flashes in the Diagnosis mode) is displayed on the CONSULT-II screen in real time. This refers to a malfunctioning part requiring repairs.
- “SELF-DIAG [PAST]”
Self-diagnostic results previously stored in the memory are displayed on the CONSULT-II screen. The stored results are not erased until memory erasing is performed.
- “TROUBLE DIAG RECORD”
With TROUBLE DIAG RECORD, diagnostic results previously erased by a reset operation can be displayed on the CONSULT-II screen.
- “ECU DISCRIMINATED NO.”
The diagnosis sensor unit for each vehicle model is assigned with its own, individual classification number. This number will be displayed on the CONSULT-II screen, as shown. When replacing the diagnosis sensor unit, refer to the part number for the compatibility. After installation, replacement with a correct unit can be checked by confirming this classification number on the CONSULT-II screen.
After repair, make sure the discriminated number of diagnosis sensor unit installed to vehicle are same. Refer to [SRS-50, "ECU DISCRIMINATED NO."](#) .

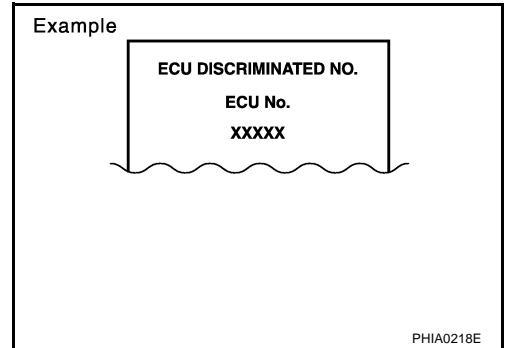

Ⓜ HOW TO CHANGE SELF-DIAGNOSIS MODE WITH CONSULT-II

From User Mode to Diagnosis Mode

After selecting “AIR BAG” on the “SELECT SYSTEM” screen, User mode automatically changes to Diagnosis mode.

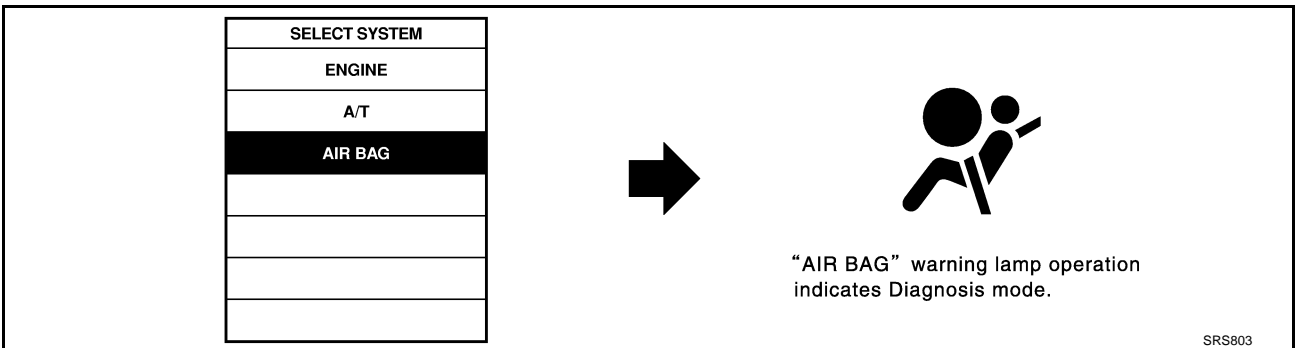

From Diagnosis Mode to User Mode

To return to User mode from Diagnosis mode, touch “BACK” key of CONSULT-II until “SELECT SYSTEM” appears, then diagnosis mode automatically changes to User mode.

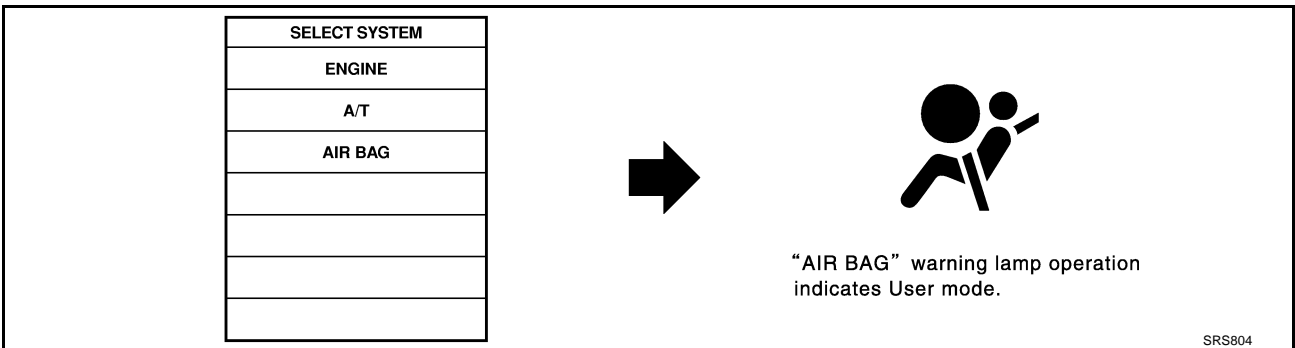

A
B
C
D
E
F
G
I
J
K
L
M

SRS

TROUBLE DIAGNOSIS

HOW TO ERASE SELF-DIAGNOSTIC RESULTS

- “SELF-DIAG [CURRENT]”
A current self-diagnostic result is displayed on the CONSULT-II screen in real time.
After the malfunction is repaired completely, no malfunction is detected on “SELF-DIAG [CURRENT]”.
- “SELF-DIAG [PAST]”
Return to the “SELF-DIAG [CURRENT]” CONSULT-II screen by touching “BACK” key of CONSULT-II and select “SELF-DIAG [CURRENT]” in SELECT DIAG MODE. Touch “ERASE” in “SELF-DIAG [CURRENT]” mode.
NOTE:
If the memory of the malfunction in “SELF-DIAG [PAST]” is not erased, the User mode shows the system malfunction by the operation of the warning lamp even if the malfunction is repaired completely.
- “TROUBLE DIAG RECORD”
The memory of “TROUBLE DIAG RECORD” cannot be erased.

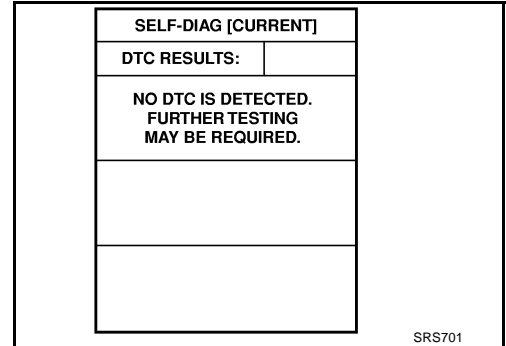

Self-Diagnosis Function (Without CONSULT-II)

AHS0001Y

- The reading of these results is accomplished “User mode” and “Diagnosis mode”.
- After a malfunction is repaired, turn ignition switch ON. Diagnosis mode returns to the User mode. At that time, the self-diagnostic result is cleared.

HOW TO CHANGE SELF-DIAGNOSTIC MODE WITHOUT CONSULT-II

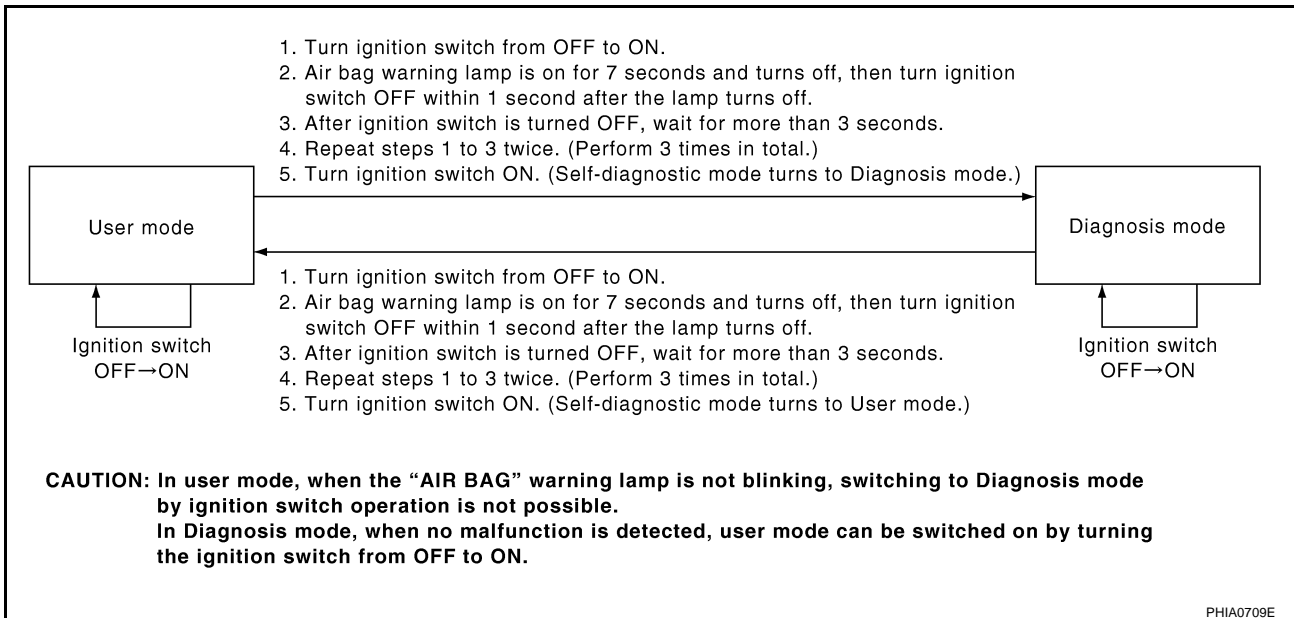

HOW TO ERASE SELF-DIAGNOSTIC RESULTS

After a malfunction is repaired, turn the ignition switch OFF for at least one second, then back ON. Diagnosis mode returns to the User mode. At that time, the self-diagnostic results are cleared.

TROUBLE DIAGNOSIS

SRS Operation Check DIAGNOSTIC PROCEDURE 1

AHS0001Z

Checking Air Bag Operation by Using “AIR BAG” Warning Lamp — User Mode

1. Turn ignition switch from OFF to ON, and make sure that the air bag warning lamp blinks.
2. Compare the SRS air bag warning lamp blinking pattern with the examples.

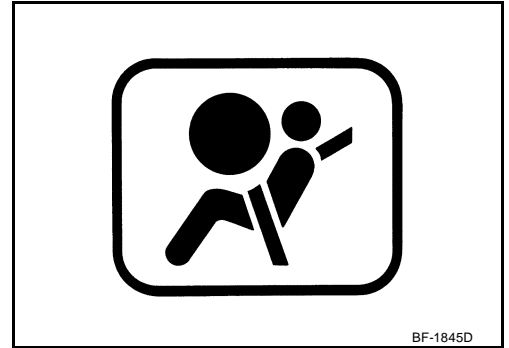

A

B

C

D

E

F

G

SRS

I

J



K

L

M

TROUBLE DIAGNOSIS

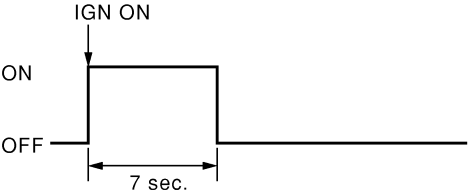
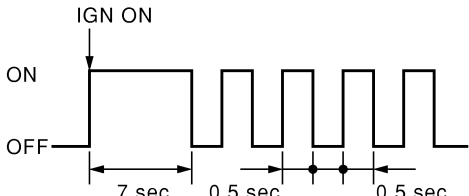
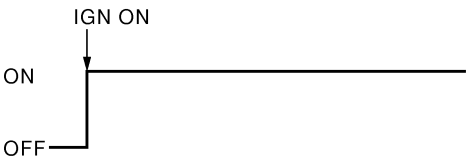
Warning lamp examples

"AIR BAG" warning lamp operation-User mode-	SRS condition	Reference item
 <p style="text-align: right; margin-right: 50px;">SHIA0011E</p>	<ul style="list-style-type: none"> ● No malfunction is detected. ● No further action is necessary. 	—
 <p style="text-align: right; margin-right: 50px;">SHIA0012E</p>	<ul style="list-style-type: none"> ● The system is malfunctioning and needs to be repaired as indicated. 	<p>Go to SRS-23. "DIAGNOSTIC PROCEDURE 2" or SRS-33. "DIAGNOSTIC PROCEDURE 6" .</p>
 <p style="text-align: right; margin-right: 50px;">SHIA0013E</p>	<ul style="list-style-type: none"> ● Air bag is deployed. ● Seat belt pre-tensioner is deployed. ● Diagnosis sensor unit is malfunctioning. ● Air bag power supply circuit is malfunctioning. ● SRS air bag warning lamp circuit is malfunctioning. 	<p>Go to SRS-51. "COLLISION DIAGNOSIS" .</p> <p>Go to SRS-38. "Trouble Diagnosis: "AIR BAG" Warning Lamp Does Not Turn OFF" .</p>
 <p style="text-align: right; margin-right: 50px;">SHIA0014E</p>	<ul style="list-style-type: none"> ● Diagnosis sensor unit is malfunctioning. ● Air bag warning lamp circuit is malfunctioning. 	<p>Go to SRS-39. "Trouble Diagnosis: "AIR BAG" Warning Lamp Does Not Turn ON" .</p>

TROUBLE DIAGNOSIS

Trouble Diagnosis with CONSULT-II DIAGNOSTIC PROCEDURE 2

AHS0009A

CAUTION:

If CONSULT-II is used with no connection of CONSULT-II CONVERTER, malfunctions might be detected in self-diagnosis depending on control unit which carry out CAN communication.

1. Turn ignition switch OFF.
2. Connect CONSULT-II and CONSULT-II CONVERTER to the data link connector.

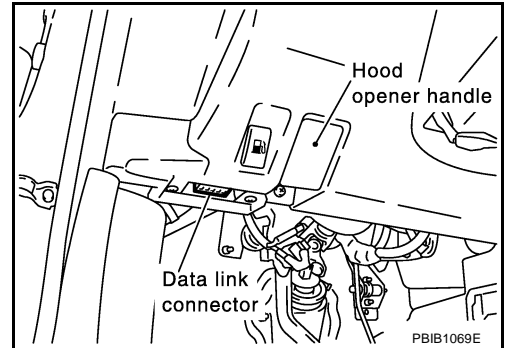

3. Turn ignition switch ON.
4. Touch "START (NISSAN BASED VHCL)".

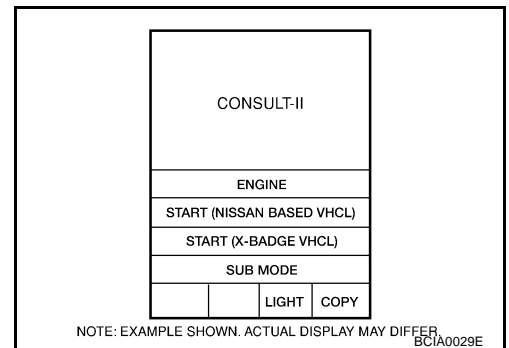

5. Touch "AIR BAG".
If "AIR BAG" is not indicated, go to [GI-39, "CONSULT-II Data Link Connector \(DLC\) Circuit"](#).

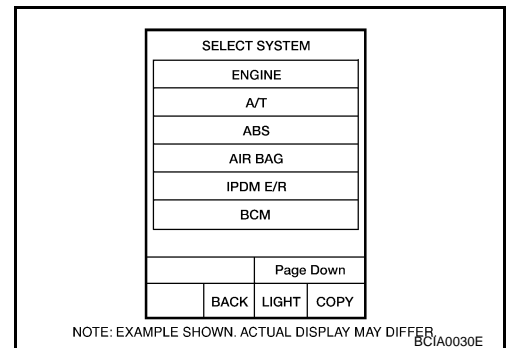

6. Touch "SELF-DIAG [CURRENT]".

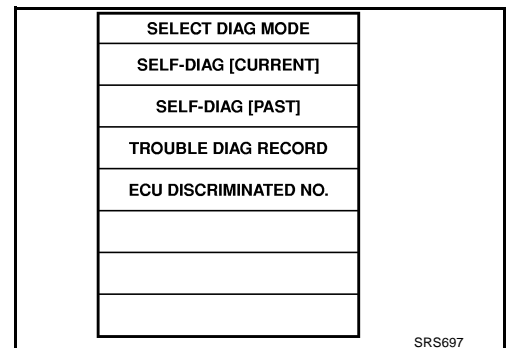

A
B
C
D
E
F
G
I
J
K
L
M

SRS

TROUBLE DIAGNOSIS

7. Diagnostic code is displayed on “SELF-DIAG [CURRENT]”.

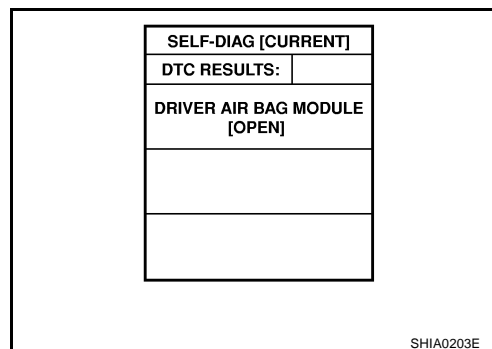

If no malfunction is detected on “SELF-DIAG [CURRENT]” even though malfunction is detected in “SRS Operation Check”, check the battery voltage. If the battery voltage is less than 9 V, charge or replace the battery. [SRS-27. "DIAGNOSTIC PROCEDURE 3"](#) . If the battery voltage is OK, go to [SRS-29. "DIAGNOSTIC PROCEDURE 4 \(CONTINUED FROM DIAGNOSTIC PROCEDURE 2\)"](#) diagnose the following cases:

- Self-diagnostic result “SELF-DIAG [PAST]” (previously stored in the memory) might not be erased after repair.
- The SRS system malfunctions intermittently.

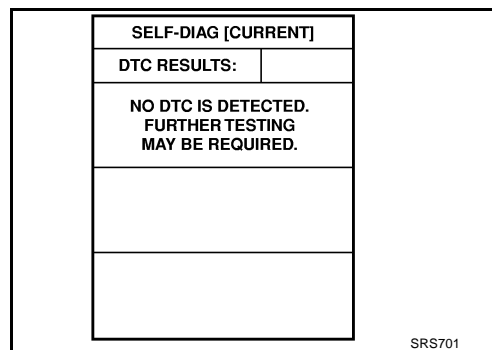

CONSULT-II Diagnostic Code Chart (“SELF-DIAG [CURRENT]”)

Diagnostic item	Explanation	Repair order “Recheck SRS at each replacement”
NO DTC IS DETECTED.	When malfunction is indicated by the “AIR BAG” warning lamp in User mode.	<ul style="list-style-type: none"> ● Low battery voltage (Less than 9V) ● Self-diagnostic results “SELF-DIAG [PAST]” (previously stored in the memory) might not be erased after repair. ● Intermittent malfunction has been detected in the past.
	<ul style="list-style-type: none"> ● No malfunction is detected. 	—
DRIVER AIRBAG MODULE [OPEN]	<ul style="list-style-type: none"> ● Driver air bag module circuit is open (including the spiral cable). 	<ol style="list-style-type: none"> 1. Visually check the wiring harness connection. 2. Replace the harness if it has visible damage.
DRIVER AIRBAG MODULE [VB-SHORT]	<ul style="list-style-type: none"> ● Driver air bag module circuit is shorted to a power supply circuit (including the spiral cable). 	<ol style="list-style-type: none"> 3. Replace driver air bag module. 4. Replace the spiral cable.
DRIVER AIRBAG MODULE [GND-SHORT]	<ul style="list-style-type: none"> ● Driver air bag module circuit is shorted to ground (including the spiral cable). 	<ol style="list-style-type: none"> 5. Replace the diagnosis sensor unit. 6. Replace the related harness.
DRIVER AIRBAG MODULE [SHORT]	<ul style="list-style-type: none"> ● Driver air bag module circuit is shorted between lines. 	
ASSIST A/B MODULE [VB-SHORT]	<ul style="list-style-type: none"> ● Front passenger air bag module circuit is shorted to a power supply circuit. 	<ol style="list-style-type: none"> 1. Visually check the wiring harness connection.
ASSIST A/B MODULE [OPEN]	<ul style="list-style-type: none"> ● Front passenger air bag module circuit is open. 	<ol style="list-style-type: none"> 2. Replace the harness if it has visible damage.
ASSIST A/B MODULE [GND-SHORT]	<ul style="list-style-type: none"> ● Front passenger air bag module circuit is shorted to ground. 	<ol style="list-style-type: none"> 3. Replace front passenger air bag module.
ASSIST A/B MODULE [SHORT]	<ul style="list-style-type: none"> ● Front passenger air bag module circuit is shorted between lines. 	<ol style="list-style-type: none"> 4. Replace the diagnosis sensor unit. 5. Replace the related harness.

TROUBLE DIAGNOSIS

Diagnostic item	Explanation	Repair order "Recheck SRS at each replacement"
CRASH ZONE SEN [UNIT FAIL] CRASH ZONE SEN [COMM FAIL] CRASH ZONE SEN [UNMATCH]	● Crash zone sensor	1. Visually check the wiring harness connection. 2. Replace the harness if it has visible damage. 3. Replace the crash zone sensor. 4. Replace the diagnosis sensor unit. 5. Replace the related harness.
SIDE MODULE LH [OPEN]	● Front LH side air bag module circuit is open.	1. Visually check the wiring harness connection.
SIDE MODULE LH [VB-SHORT]	● Front LH side air bag module circuit is shorted to a power supply circuit.	2. Replace the harness if it has visible damage.
SIDE MODULE LH [GND-SHORT]	● Front LH side air bag module circuit is shorted to ground.	3. Replace front LH setback assembly (front LH side air bag module).
SIDE MODULE LH [SHORT]	● Front LH side air bag module circuit is shorted between lines.	4. Replace the diagnosis sensor unit. 5. Replace the related harness.
SIDE MODULE RH [OPEN]	● Front RH side air bag module circuit is open.	1. Visually check the wiring harness connection.
SIDE MODULE RH [VB-SHORT]	● Front RH side air bag module circuit is shorted to some power supply circuit.	2. Replace the harness if it has visible damage.
SIDE MODULE RH [GND-SHORT]	● Front RH side air bag module circuit is shorted to ground.	3. Replace front RH setback assembly (front RH side air bag module).
SIDE MODULE RH [SHORT]	● Front RH side air bag module circuit is shorted between lines.	4. Replace the diagnosis sensor unit. 5. Replace the related harness.
SATELLITE SENS LH [UNIT FAIL] SATELLITE SENS LH [COMM FAIL] SATELLITE SENS LH [UNMATCH]	● LH side air bag (Satellite) sensor	1. Visually check the wiring harness connection. 2. Replace the harness if it has visible damage. 3. Replace the LH side air bag (Satellite) sensor. 4. Replace the diagnosis sensor unit. 5. Replace the related harness.
SATELLITE SENS RH [UNIT FAIL] SATELLITE SENS RH [COMM FAIL] SATELLITE SENS RH [UNMATCH]	● RH side air bag (Satellite) sensor	1. Visually check the wiring harness connection. 2. Replace the harness if it has visible damage. 3. Replace the RH side air bag (Satellite) sensor. 4. Replace the diagnosis sensor unit. 5. Replace the related harness.
PRE-TEN FRONT LH [OPEN]	● Front LH pre-tensioner circuit is open.	1. Visually check the wiring harness connections.
PRE-TEN FRONT LH [VB-SHORT]	● Front LH pre-tensioner circuit is shorted to a power supply circuit.	2. Replace the harness if it has visible damage.
PRE-TEN FRONT LH [GND-SHORT]	● Front LH pre-tensioner circuit is shorted to ground.	3. Replace front LH seat belt.
PRE-TEN FRONT LH [SHORT]	● Front LH pre-tensioner circuit is shorted between lines.	4. Replace the diagnosis sensor unit. 5. Replace the related harness.

A
B
C
D
E
F
G
SRS
I
J
K
L
M

TROUBLE DIAGNOSIS

Diagnostic item	Explanation	Repair order "Recheck SRS at each replacement"
PRE-TEN FRONT RH [OPEN]	● Front RH pre-tensioner circuit is shorted to a power supply circuit.	1. Visually check the wiring harness connections. 2. Replace the harness if it has visible damage. 3. Replace front RH seat belt. 4. Replace the diagnosis sensor unit. 5. Replace the related harness.
PRE-TEN FRONT RH [VB-SHORT]	● Front RH pre-tensioner is shorted to a power supply circuit.	
PRE-TEN FRONT RH [GND-SHORT]	● Front RH pre-tensioner circuit is shorted to ground.	
PRE-TEN FRONT RH [SHORT]	● Front RH pre-tensioner circuit is shorted between lines.	
CURTAIN MODULE LH* [OPEN]	● LH side curtain air bag module circuit is open.	1. Visually check the wiring harness connection. 2. Replace the harness if it has visible damage. 3. Replace LH side curtain air bag module. 4. Replace the diagnosis sensor unit. 5. Replace the related harness.
CURTAIN MODULE LH* [VB-SHORT]	● LH side curtain air bag module circuit is shorted to some power supply circuits.	
CURTAIN MODULE LH* [GND-SHORT]	● LH side curtain air bag module circuit is shorted to ground.	
CURTAIN MODULE LH* [SHORT]	● LH side curtain air bag module circuit is shorted between lines.	
CURTAIN MODULE RH* [OPEN]	● RH side curtain air bag module circuit is open.	1. Visually check the wiring harness connection. 2. Replace the harness if it has visible damage. 3. Replace RH side curtain air bag module. 4. Replace the diagnosis sensor unit. 5. Replace the related harness.
CURTAIN MODULE RH* [VB-SHORT]	● RH side curtain air bag module circuit is shorted to a power supply circuit.	
CURTAIN MODULE RH* [GND-SHORT]	● RH side curtain air bag module circuit is shorted to ground.	
CURTAIN MODULE RH* [SHORT]	● RH side curtain air bag module circuit is shorted between lines.	
CONTROL UNIT	● Diagnosis sensor unit is malfunctioning.	1. Visually check the wiring harness connection. 2. Replace the diagnosis sensor unit.

*: For coupe

NOTE:

- Follow the procedures in numerical order when repairing malfunctioning parts. Confirm whether malfunction is eliminated using air bag warning lamp or CONSULT-II each time repair is finished. If malfunction is still observed, proceed to the next step. When malfunction is eliminated, further repair work is not required.

TROUBLE DIAGNOSIS

DIAGNOSTIC PROCEDURE 3

Final checking after repairing SRS by using CONSULT-II — Diagnosis mode

CAUTION:

If CONSULT-II is used with no connection of CONSULT-II CONVERTER, malfunctions might be detected in self-diagnosis depending on control unit which carry out CAN communication.

1. After repairing SRS, connect both battery cables.
2. Connect CONSULT-II and CONSULT-II CONVERTER to data link connector.

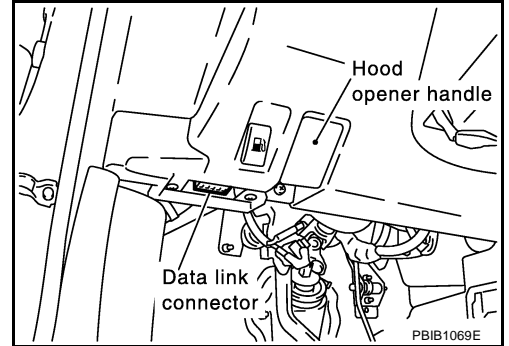

3. Turn ignition switch ON.
4. Touch "START (NISSAN BASED VHCL)".

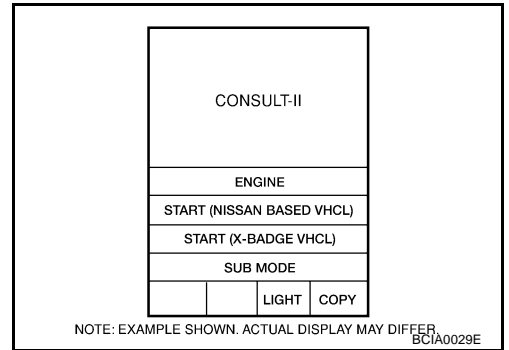

5. Touch "AIR BAG".
If "AIR BAG" is not indicated, go to [GI-39, "CONSULT-II Data Link Connector \(DLC\) Circuit"](#).

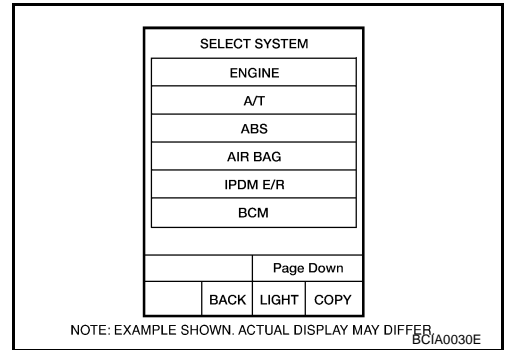

6. Touch "SELF-DIAG [CURRENT]".

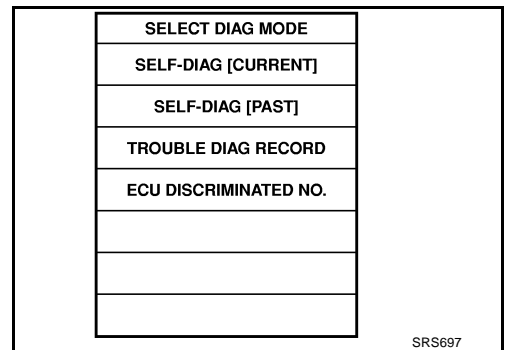

A
B
C
D
E
F
G
I
J
K
L
M

SRS

TROUBLE DIAGNOSIS

7. If no malfunction is detected on "SELF-DIAG [CURRENT]", repair of SRS is completed. Go to step 8.
 If any malfunction is detected on "SELF-DIAG [CURRENT]", the malfunctioning part is not repaired completely or another malfunctioning part is detected. Go to [SRS-23, "DIAGNOSTIC PROCEDURE 2"](#) , and repair malfunctioning part completely.

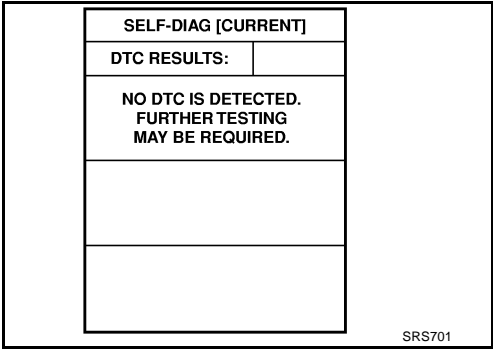

8. Touch "ERASE".

NOTE:

- Touch "ERASE" to clear the memory of the malfunction ("SELF-DIAG [PAST]").
- If the memory of the malfunction in "SELF-DIAG [PAST]" is not erased, the User mode shows the system malfunction by the operation of the warning lamp even if the malfunction is repaired completely.

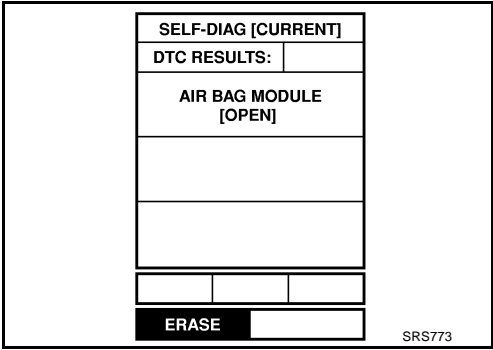

9. Touch "BACK" key of CONSULT-II to "SELECT DIAG MODE" screen. Touch "SELF-DIAG [PAST]".

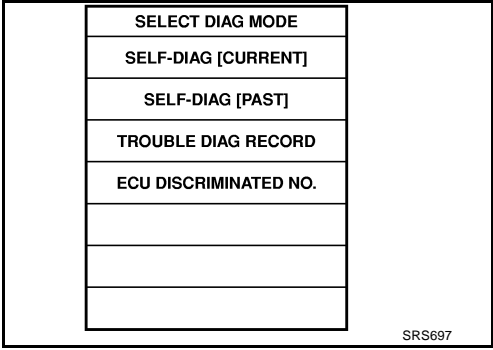

10. Make sure that no malfunction is detected on "SELF-DIAG [PAST]".
 11. Touch "BACK" key of CONSULT-II until "SELECT SYSTEM" appears in order to return to User mode from Diagnosis mode.
 12. Turn ignition switch OFF then turn off and disconnect CONSULT-II. Go to [SRS-21, "Checking Air Bag Operation by Using "AIR BAG" Warning Lamp — User Mode"](#) .

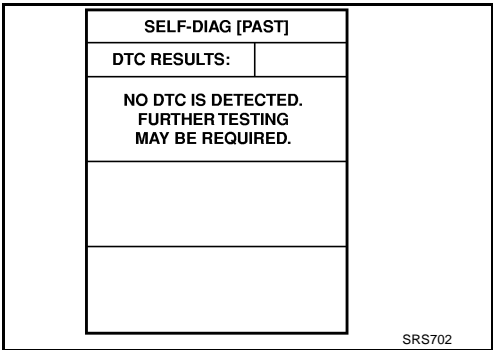

TROUBLE DIAGNOSIS

DIAGNOSTIC PROCEDURE 4 (CONTINUED FROM DIAGNOSTIC PROCEDURE 2)

Inspecting SRS malfunctioning record

1. CONSIDER POSSIBILITY OF NOT ERASING SELF-DIAGNOSTIC RESULT AFTER REPAIRING

Is it the first time for maintenance of SRS?

YES or NO

YES >> Go to [SRS-23, "DIAGNOSTIC PROCEDURE 2"](#) .

NO >> Self-diagnostic result "SELF-DIAG [PAST]" (previously stored in the memory) might not be erased after repair. Go to [SRS-27, "DIAGNOSTIC PROCEDURE 3"](#) .

DIAGNOSTIC PROCEDURE 5

Inspecting SRS intermittent malfunction by using CONSULT-II — Diagnosis mode

CAUTION:

If CONSULT-II is used with no connection of CONSULT-II CONVERTER, malfunction might be detected in self-diagnosis depending on control unit which carry out CAN communication.

1. Turn ignition switch OFF.
2. Connect CONSULT-II and CONSULT-II CONVERTER to data link connector.

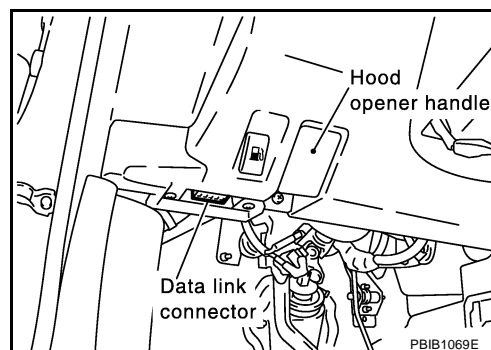

3. Turn ignition switch ON.
4. Touch "START (NISSAN BASED VHCL)".

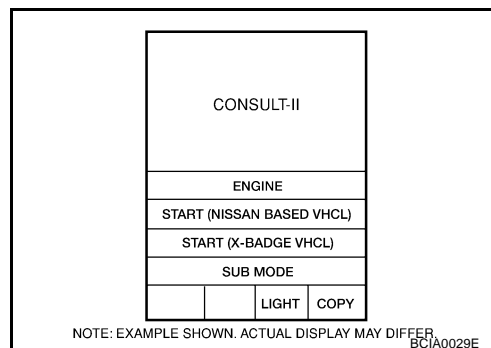

5. Touch "AIR BAG".
If "AIR BAG" is not indicated, go to [GI-39, "CONSULT-II Data Link Connector \(DLC\) Circuit"](#) .

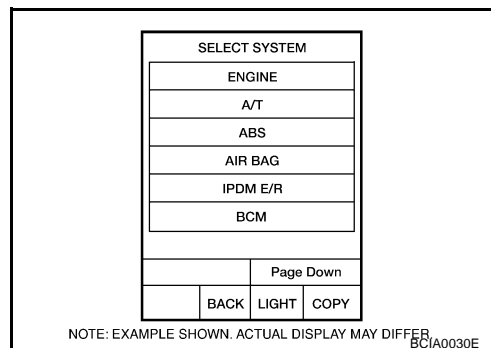

A
B
C
D
E
F
G
SRS
I
J
K
L
M

TROUBLE DIAGNOSIS

6. Touch "SELF-DIAG [PAST]".

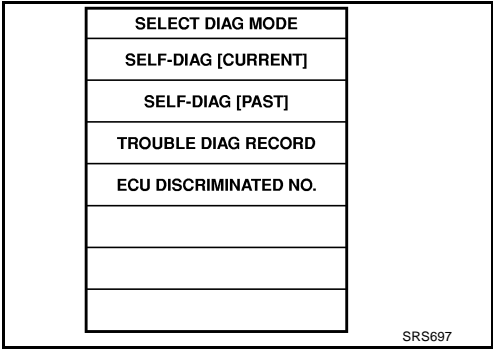

7. If diagnostic codes are displayed on "SELF-DIAG [PAST]", go to step 10.

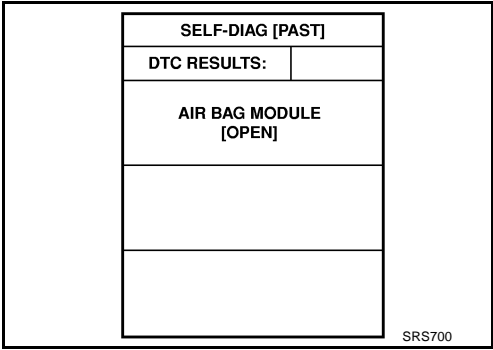

If no malfunction is detected on "SELF-DIAG [PAST]", touch "BACK" and go back to "SELECT DIAG MODE".

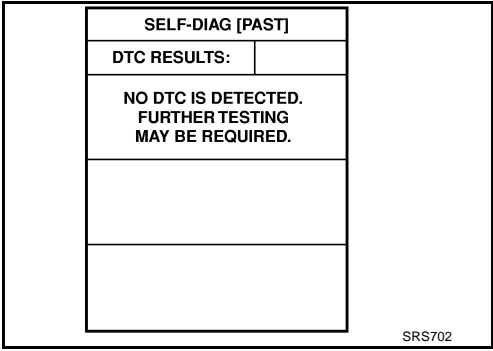

8. Touch "TROUBLE DIAG RECORD".

NOTE:
With "TROUBLE DIAG RECORD", diagnosis results previously erased by a reset operation can be displayed.

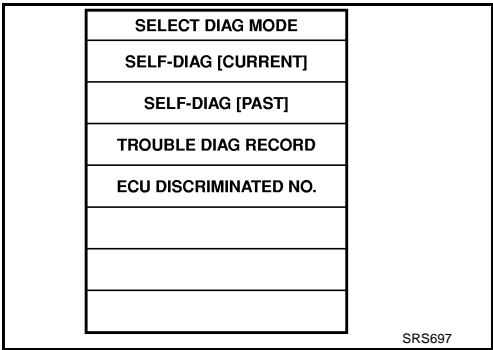

- 9. Diagnostic code is displayed on "TROUBLE DIAG RECORD".
- 10. Touch "PRINT".
- 11. Compare diagnostic codes to [SRS-31, "CONSULT-II Diagnostic Code Chart \("SELF-DIAG \[PAST\]" or "TROUBLE DIAG RECORD"\)"](#).
- 12. Touch "BACK" key of CONSULT-II until "SELECT SYSTEM" appears.
- 13. Turn ignition switch OFF, then turn off and disconnect CONSULT-II, and both battery cables.

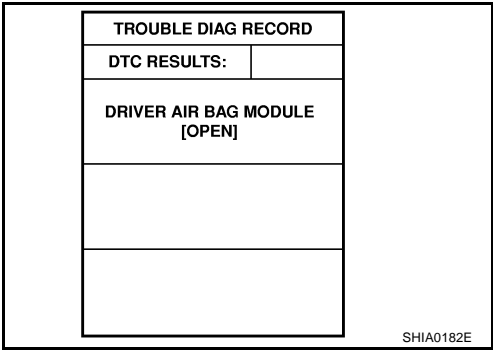

TROUBLE DIAGNOSIS

14. Repair the system as outlined by the “Repair order” in “Intermittent Malfunction Diagnostic Code Chart”, that corresponds to the self-diagnostic result. For replacement procedure of component parts, refer to the Removal and Installation procedure for the appropriate component.

15. Go to [SRS-27, "DIAGNOSTIC PROCEDURE 3"](#) , for final checking.

CONSULT-II Diagnostic Code Chart (“SELF-DIAG [PAST]” or “TROUBLE DIAG RECORD”)

Diagnostic item	Explanation	Repair order “Recheck SRS at each replacement”
NO DTC IS DETECTED.	When malfunction is indicated by the “AIR BAG” warning lamp in User mode.	<ul style="list-style-type: none"> ● Low battery voltage (Less than 9V)
	<ul style="list-style-type: none"> ● No malfunction is detected. 	<ul style="list-style-type: none"> ● Go to SRS-27, "DIAGNOSTIC PROCEDURE 3" .
DRIVER AIRBAG MODULE [OPEN]	<ul style="list-style-type: none"> ● Driver air bag module circuit is open (including the spiral cable). 	<ol style="list-style-type: none"> 1. Visually check the wiring harness connection. 2. Replace the harness if it has visible damage. 3. If the harness check result is OK, replace driver air bag module, diagnosis sensor unit and spiral cable.
DRIVER AIRBAG MODULE [VB-SHORT]	<ul style="list-style-type: none"> ● Driver air bag module circuit is shorted to a power supply circuit (including the spiral cable). 	
DRIVER AIRBAG MODULE [GND-SHORT]	<ul style="list-style-type: none"> ● Driver air bag module circuit is shorted to ground (including the spiral cable). 	
DRIVER AIRBAG MODULE [SHORT]	<ul style="list-style-type: none"> ● Driver air bag module circuit is shorted between lines. 	
ASSIST A/B MODULE [OPEN]	<ul style="list-style-type: none"> ● Front passenger air bag module circuit is open. 	<ol style="list-style-type: none"> 1. Visually check the wiring harness connection. 2. Replace the harness if it has visible damage. 3. If the harness check result is OK, replace the diagnosis sensor unit and front passenger air bag module.
ASSIST A/B MODULE [VB-SHORT]	<ul style="list-style-type: none"> ● Front passenger air bag module circuit is shorted to a power supply circuit. 	
ASSIST A/B MODULE [GND-SHORT]	<ul style="list-style-type: none"> ● Front passenger air bag module circuit is shorted to ground. 	
ASSIST A/B MODULE [SHORT]	<ul style="list-style-type: none"> ● Front passenger air bag module circuit is shorted between lines. 	
CRASH ZONE SEN [UNIT FAIL] CRASH ZONE SEN [COMM FAIL] CRASH ZONE SEN [UNMATCH]	<ul style="list-style-type: none"> ● Crash zone sensor 	<ol style="list-style-type: none"> 1. Visually check the wiring harness connection. 2. Replace the harness if it has visible damage. 3. If the harness check result is OK, replace crash zone sensor and diagnosis sensor unit.
SIDE MODULE LH [OPEN]	<ul style="list-style-type: none"> ● Front LH side air bag module circuit is open. 	<ol style="list-style-type: none"> 1. Visually check the wiring harness connection. 2. Replace the harness if it has visible damage. 3. If the harness check result is OK, replace the diagnosis sensor unit and LH side air bag module.
SIDE MODULE LH [VB-SHORT]	<ul style="list-style-type: none"> ● Front LH side air bag module circuit is shorted to a power supply circuit. 	
SIDE MODULE LH [GND-SHORT]	<ul style="list-style-type: none"> ● Front LH side air bag module circuit is shorted to ground. 	
SIDE MODULE LH [SHORT]	<ul style="list-style-type: none"> ● Front LH side air bag module circuit is shorted between lines. 	

TROUBLE DIAGNOSIS

Diagnostic item	Explanation	Repair order "Recheck SRS at each replacement"
SIDE MODULE RH [OPEN]	● Front RH side air bag module circuit is open.	1. Visually check the wiring harness connection. 2. Replace the harness if it has visible damage. 3. If the harness check result is OK, replace the diagnosis sensor unit and RH side air bag module.
SIDE MODULE RH [VB-SHORT]	● Front RH side air bag module circuit is shorted to a power supply circuit.	
SIDE MODULE RH [GND-SHORT]	● Front RH side air bag module circuit is shorted to ground.	
SIDE MODULE RH [SHORT]	● Front RH side air bag module circuit is shorted between lines.	
SATELLITE SENS LH [UNIT FAIL] SATELLITE SENS LH [COMM FAIL] SATELLITE SENS LH [UNMATCH]	● LH side air bag (Satellite) sensor	1. Visually check the wiring harness connection. 2. Replace the harness if it has visible damage. 3. If the harness check result is OK, replace the diagnosis sensor unit and LH side air bag (Satellite) sensor.
SATELLITE SENS RH [UNIT FAIL] SATELLITE SENS RH [COMM FAIL] SATELLITE SENS RH [UNMATCH]	● RH side air bag (Satellite) sensor	
PRE-TEN FRONT LH [OPEN]	● Front LH pre-tensioner circuit is open.	1. Visually check the wiring harness connections. 2. Replace the harness if it has visible damage. 3. If the harness check result is OK, replace the diagnosis sensor unit and front LH seat belt.
PRE-TEN FRONT LH [VB-SHORT]	● Front LH pre-tensioner circuit is shorted to a power supply circuit.	
PRE-TEN FRONT LH [GND-SHORT]	● Front LH pre-tensioner circuit is shorted to ground.	
PRE-TEN FRONT LH [SHORT]	● Front LH pre-tensioner circuit is shorted between lines.	
PRE-TEN FRONT RH [OPEN]	● Front RH pre-tensioner circuit is open.	1. Visually check the wiring harness connections. 2. Replace the harness if it has visible damage. 3. If the harness check result is OK, replace the diagnosis sensor unit and front RH seat belt.
PRE-TEN FRONT RH [VB-SHORT]	● Front RH pre-tensioner is shorted to a power supply circuit.	
PRE-TEN FRONT RH [GND-SHORT]	● Front RH pre-tensioner is shorted to ground.	
PRE-TEN FRONT RH [SHORT]	● Front RH pre-tensioner circuit is shorted between lines.	
CURTAIN MODULE LH* [OPEN]	● LH side curtain air bag module circuit is open.	1. Visually check the wiring harness connection. 2. Replace the harness if it has visible damage. 3. If the harness check result is OK, replace the diagnosis sensor unit and LH side curtain air bag module.
CURTAIN MODULE LH* [VB-SHORT]	● LH side curtain air bag module circuit is shorted to a power supply circuits.	
CURTAIN MODULE LH* [GND-SHORT]	● LH side curtain air bag module circuit is shorted to ground.	

TROUBLE DIAGNOSIS

Diagnostic item	Explanation	Repair order "Recheck SRS at each replacement"
CURTAIN MODULE RH* [OPEN]	● RH side curtain air bag module circuit is open.	1. Visually check the wiring harness connection. 2. Replace the harness if it has visible damage. 3. If the harness check result is OK, replace the diagnosis sensor unit and RH side curtain air bag module.
CURTAIN MODULE RH* [VB-SHORT]	● RH side curtain air bag module circuit is shorted to a power supply circuit.	
CURTAIN MODULE RH* [GND-SHORT]	● The RH side curtain air bag module circuit is shorted to ground.	
CURTAIN MODULE RH* [SHORT]	● RH side curtain air bag module circuit is shorted between lines.	
CONTROL UNIT	● Diagnosis sensor unit is malfunctioning.	1. Visually check the wiring harness connection. 2. Replace the diagnosis sensor unit.

*: For coupe

Trouble Diagnosis without CONSULT-II DIAGNOSTIC PROCEDURE 6

AHS0009B

Inspecting SRS Malfunctioning Parts by Using "AIR BAG" Warning Lamp — Diagnosis Mode

NOTE:

SRS will not enter Diagnosis mode if no malfunction is detected in User mode.

1. Turn ignition switch ON.
2. After "AIR BAG" warning lamp lights for 7 seconds, turn ignition switch OFF within 1 second.
3. Wait more than 3 seconds.
4. Repeat the steps 1 to 3 two times.
5. Turn ignition switch ON.

SRS is now in Diagnosis mode.

"AIR BAG" warning lamp operates in Diagnosis mode as follows:

A
B
C
D
E
F
G
I
J
K
L
M

SRS

TROUBLE DIAGNOSIS

WARNING LAMP FLASH CODE CHART

<Diagnosis results (previously stored in the memory) might not be erased after repair or intermittent malfunctions have been detected in the past.>

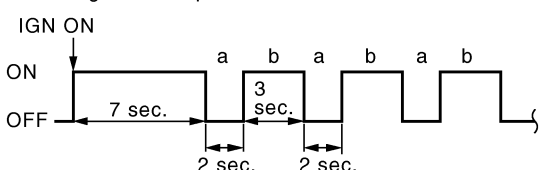
Flash pattern	Repair order
<p>a through b are repeated.</p> <p>IGN ON</p> 	<ol style="list-style-type: none"> 1. Erase memory. (Once key switch is turned from OFF to ON, TROUBLE DIAG RECORD will be erased.)

PHIA0532E

<Driver air bag module>

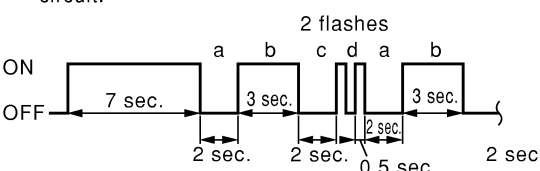
Flash pattern	Repair order
<p>a through d are repeated.</p> <p>d: Two flashes indicates malfunctioning driver air bag module circuit.</p> 	<ol style="list-style-type: none"> 1. Visually check the wiring harness connection. 2. Replace the harness if it has visible damage. 3. Replace the spiral cable. 4. Replace driver air bag module. (Before disposal, it must be deployed.) 5. Replace the diagnosis sensor unit. 6. Replace the related harness.

PHIA0185E

<Diagnosis sensor unit>

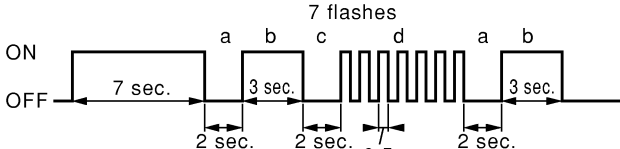
Flash pattern	Repair order
<p>a through d are repeated.</p> <p>d: Seven flashes indicate malfunctioning diagnosis sensor unit circuit.</p> 	<ol style="list-style-type: none"> 1. Visually check the wiring harness connections. 2. Replace the harness if it has visible damage. 3. Replace the diagnosis sensor unit. 4. Replace the related harness.

SHIA0028E

<Front passenger air bag module>

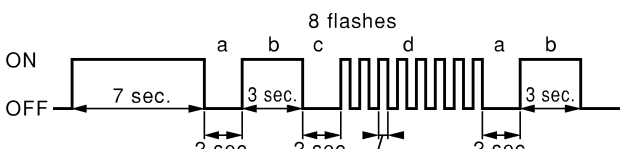
Flash pattern	Repair order
<p>a through d are repeated.</p> <p>d: Eight flashes indicate malfunctioning front passenger air bag module circuit.</p> 	<ol style="list-style-type: none"> 1. Visually check the wiring harness connection. 2. Replace the harness if it has visible damage. 3. Replace front passenger air bag module. (Before disposal, it must be deployed.) 4. Replace the diagnosis sensor unit. 5. Replace the related harness.

SHIA0029E

TROUBLE DIAGNOSIS

<Crash zone sensor>	
Flash pattern	Repair order
<p>a through d are repeated. d: Six flashes indicate malfunctioning crash zone sensor circuit.</p>	<ol style="list-style-type: none"> 1. Visually check the wiring harness connection. 2. Replace the harness if it has visible damage. 3. Replace the crash zone sensor. 4. Replace the diagnosis sensor unit. 5. Replace the related harness.

SHIA0083E

<Front RH seat belt pre-tensioner>	
Flash pattern	Repair order
<p>a through d are repeated. d: One flash indicates malfunctioning front RH seat belt pre-tensioner circuit.</p>	<ol style="list-style-type: none"> 1. Visually check the wiring harness connections. 2. Replace the harness if it has visible damage. 3. Replace front RH seat belt pre-tensioner. (Before disposal, it must be activated.) 4. Replace the diagnosis sensor unit. 5. Replace the related harness.

SHIA0030E

<Front LH seat belt pre-tensioner>	
Flash pattern	Repair order
<p>a through d are repeated. d: Three flashes indicate malfunctioning front LH seat belt pre-tensioner circuit.</p>	<ol style="list-style-type: none"> 1. Visually check the wiring harness connections. 2. Replace the harness if it has visible damage. 3. Replace front LH seat belt pre-tensioner. (Before disposal, it must be activated.) 4. Replace the diagnosis sensor unit. 5. Replace the related harness.

SHIA0031E

<RH side air bag (Satellite) sensor>	
Flash pattern	Repair order
<p>a through f are repeated. f: Three flashes indicate malfunctioning RH side air bag (Satellite) sensor circuit.</p>	<ol style="list-style-type: none"> 1. Visually check the wiring harness connection. 2. Replace the harness if it has visible damage. 3. Replace the RH side air bag (Satellite) sensor. 4. Replace the diagnosis sensor unit. 5. Replace the related harness.

SHIA0032E

A
B
C
D
E
F
G
I
J
K
L
M

SRS

TROUBLE DIAGNOSIS

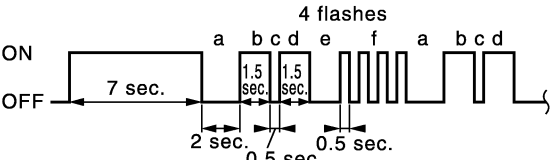
<LH side air bag (Satellite) sensor>	
Flash pattern	Repair order
<p>a through f are repeated. f: Four flashes indicate malfunctioning LH side air bag (Satellite) sensor.</p> 	<ol style="list-style-type: none"> 1. Visually check the wiring harness connection. 2. Replace the harness if it has visible damage. 3. Replace the LH side air bag (Satellite) sensor. 4. Replace the diagnosis sensor unit. 5. Replace the related harness.

SHIA0033E

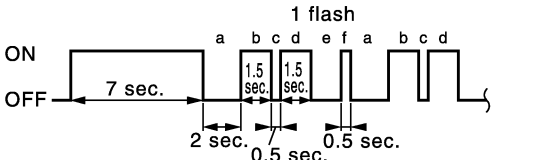
<Front RH side air bag module>	
Flash pattern	Repair order
<p>a through f are repeated. f: One flash indicate malfunctioning front RH side air bag module circuit.</p> 	<ol style="list-style-type: none"> 1. Visually check the wiring harness connection. 2. Replace the harness if it has visible damage. 3. Replace front RH side air bag module. (Before disposal, it must be deployed.) 4. Replace the diagnosis sensor unit. 5. Replace the related harness.

SHIA0034E

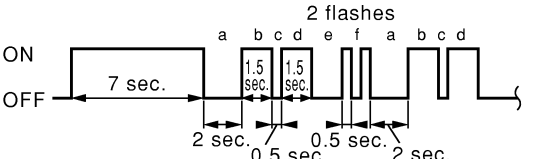
<Front LH side air bag module>	
Flash pattern	Repair order
<p>a through f are repeated. f: Two flashes indicate malfunctioning front LH side air bag module circuit.</p> 	<ol style="list-style-type: none"> 1. Visually check the wiring harness connection. 2. Replace the harness if it has visible damage. 3. Replace front LH side air bag module. (Before disposal, it must be deployed.) 4. Replace the diagnosis sensor unit. 5. Replace the related harness.

SHIA0035E

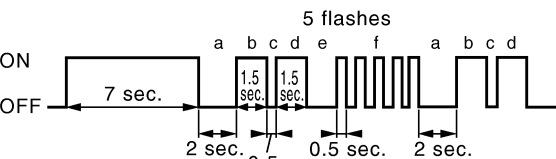
<RH side curtain air bag module (Coupe)>	
Flash pattern	Repair order
<p>a through f are repeated. f: Five flashes indicate malfunctioning RH side curtain air bag module circuit.</p> 	<ol style="list-style-type: none"> 1. Visually check the wiring harness connection. 2. Replace the harness if it has visible damage. 3. Replace RH side curtain air bag module. (Before disposal, it must be deployed.) 4. Replace the diagnosis sensor unit. 5. Replace the related harness.

PHIA0461E

TROUBLE DIAGNOSIS

<LH side curtain air bag module (Coupe)>

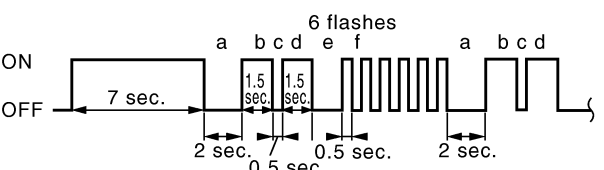
Flash pattern	Repair order
<p>a through f are repeated. f: Six flashes indicate malfunctioning LH side curtain air bag module circuit.</p> 	<ol style="list-style-type: none"> 1. Visually check the wiring harness connection. 2. Replace the harness if it has visible damage. 3. Replace LH side curtain air bag module. (Before disposal, it must be deployed.) 4. Replace the diagnosis sensor unit. 5. Replace the related harness.

PHIA0462E

A
B
C
D
E
F
G
I
J
K
L
M

SRS

TROUBLE DIAGNOSIS

Trouble Diagnosis: "AIR BAG" Warning Lamp Does Not Turn OFF DIAGNOSTIC PROCEDURE 7

AHS0009C

1. CHECK THE DEPLOYMENT OF AIR BAG MODULE

Is air bag module deployed?

YES or NO

YES >> Refer to [SRS-51, "COLLISION DIAGNOSIS"](#).

NO >> GO TO 2.

2. CHECK THE AIR BAG FUSE

Check 10A fuse [No.13, located in fuse block (J/B)].

Refer to [PG-4, "POWER SUPPLY ROUTING CIRCUIT"](#).

OK or NG

OK >> GO TO 4.

NG >> GO TO 3.

3. CHECK AIR BAG FUSE AGAIN

Replace "AIR BAG" fuse and turn ignition switch ON.

Does the "AIR BAG" fuse blow again?

YES >> Repair main harness.

NO >> **INSPECTION END**

4. CHECK DIAGNOSIS SENSOR UNIT

 **With CONSULT-II**

Connect CONSULT-II and touch "START".

- Is "AIR BAG" displayed on CONSULT-II?

YES or NO

YES >> GO TO 5.

NO >> Visually check the wiring harness connection of diagnosis sensor unit. If the harness connection check result is OK, replace diagnosis sensor unit.

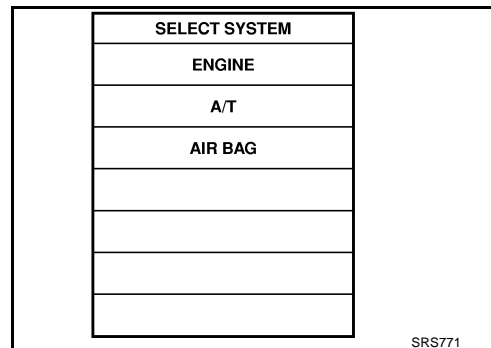

5. CHECK HARNESS CONNECTION

Is harness connection between warning lamp and diagnosis sensor unit OK?

OK or NG

OK >> Replace diagnosis sensor unit.

NG >> Connect "AIR BAG" warning lamp and diagnosis sensor unit connector properly. If "AIR BAG" warning lamp still does not go off, replace harness.

TROUBLE DIAGNOSIS

Trouble Diagnosis: "AIR BAG" Warning Lamp Does Not Turn ON DIAGNOSTIC PROCEDURE 8

AHS0009D

A

1. CHECK "METER" FUSE

Check 10A fuse [No.14, located in fuse block (J/B)].
Refer to [PG-4, "POWER SUPPLY ROUTING CIRCUIT"](#).

B

OK or NG

- OK >> GO TO 3.
- NG >> GO TO 2.

C

2. CHECK "METER" FUSE AGAIN

Replace 10A fuse [No.14, located in fuse block (J/B)] and turn ignition switch ON.

D

Does the meter fuse blow again?

- YES >> Repair the related harness.
- NO >> **INSPECTION END**

E

3. CHECK HARNESS CONNECTION BETWEEN DIAGNOSIS SENSOR UNIT AND COMBINATION METER

Disconnect diagnosis sensor unit connector and turn ignition switch ON.

F

- Does "AIR BAG" warning lamp turn ON?

YES or NO

- YES >> Replace diagnosis sensor unit.
- NO >> Replace combination meter assembly.

G

SRS

I

J

K

L

M

DRIVER AIR BAG MODULE

PFP:K8510

DRIVER AIR BAG MODULE

Removal and Installation

AHS00024

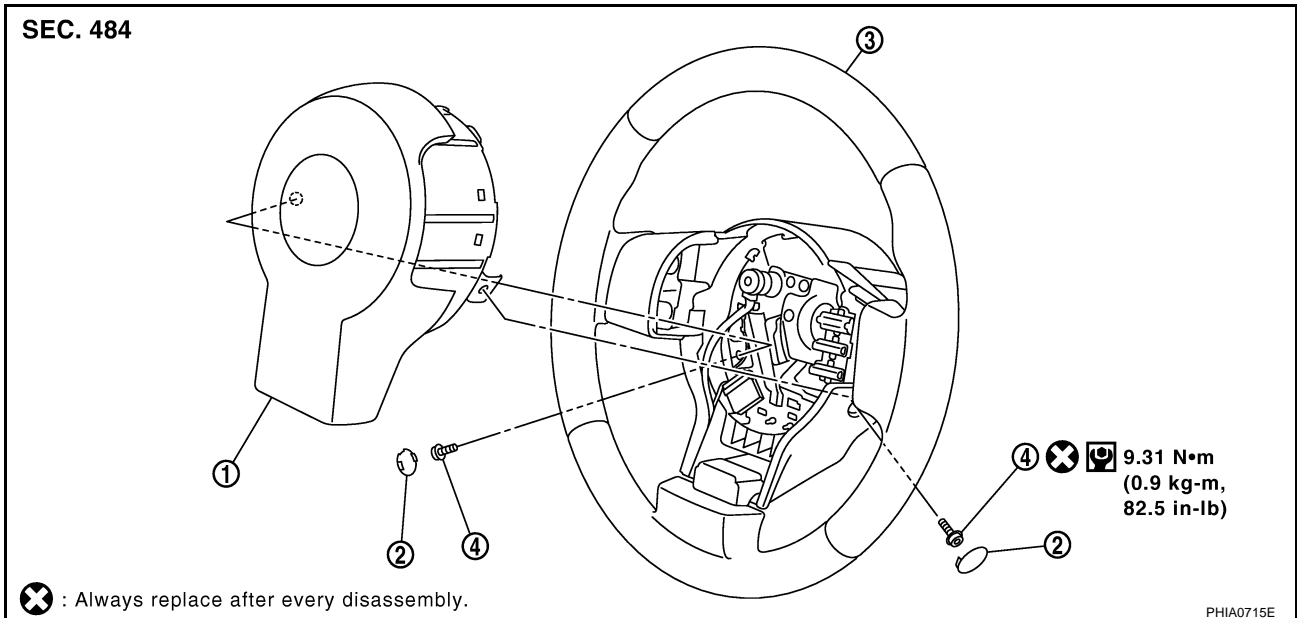

1. Driver air bag module
2. Side lid (RH/LH)
3. Steering wheel
4. TORX bolt (T30)

REMOVAL

CAUTION:

- Before servicing SRS, turn the ignition switch off, disconnect both battery cables and wait at least 3 minutes.
 - Always work from the side of driver air bag module.
1. Remove the side lids (RH/LH).
 2. Using Tamper resistant TORX bit (T30), remove the TORX bolts (T30) at right and left.

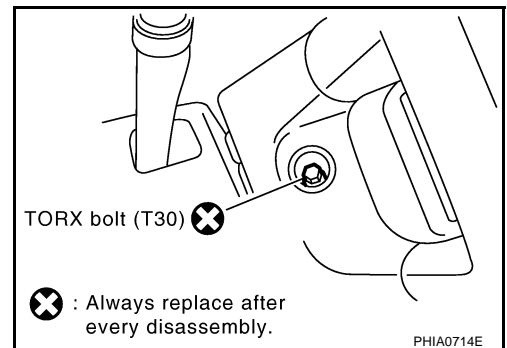

3. Disconnect the steering wheel switch sub-harness connector.
4. Disconnect the air bag harness connector, and remove the driver air bag module.

CAUTION:

- For installing / removing driver air bag module connector, insert thin screwdriver wrapped in tape into notch, lift lock and remove connector.
- Install connector with lock raised, and push lock into connector.

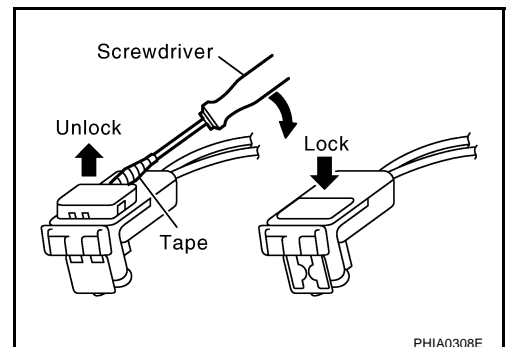

DRIVER AIR BAG MODULE

CAUTION:

- Always work from the side of driver air bag module.
 - Always place driver air bag module with pad side facing upward.
 - Do not insert any foreign objects (screwdriver, etc.) into driver air bag module.
 - Do not disassemble driver air bag module.
 - Do not use old bolts after removal; replace with new bolts.
 - Do not expose the driver air bag module to temperatures exceeding 90°C (194°F).
-
- Replace driver air bag module if it has been dropped or sustained an impact.
 - Do not allow oil, grease or water to come in contact with the front passenger air bag module.

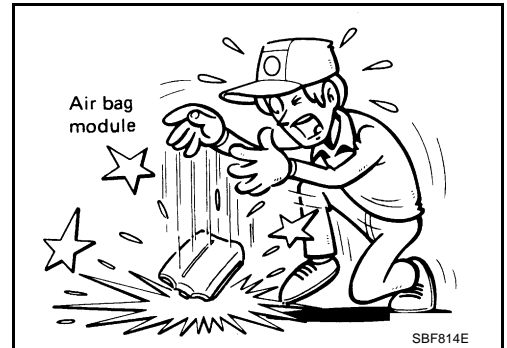
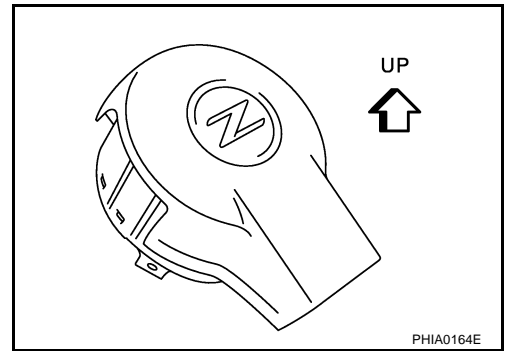

INSTALLATION

Install in the reverse order of removal.

CAUTION:

- For installing the air bag module, tighten the TORX bolts (T30).
- After the work is completed, perform self-diagnosis to make sure that no malfunction is detected. Refer to [SRS-21, "SRS Operation Check"](#).

A
B
C
D
E
F
G
SRS
I
J
K
L
M

SPIRAL CABLE

SPIRAL CABLE

PFP:25554

Removal and Installation

AHS00025

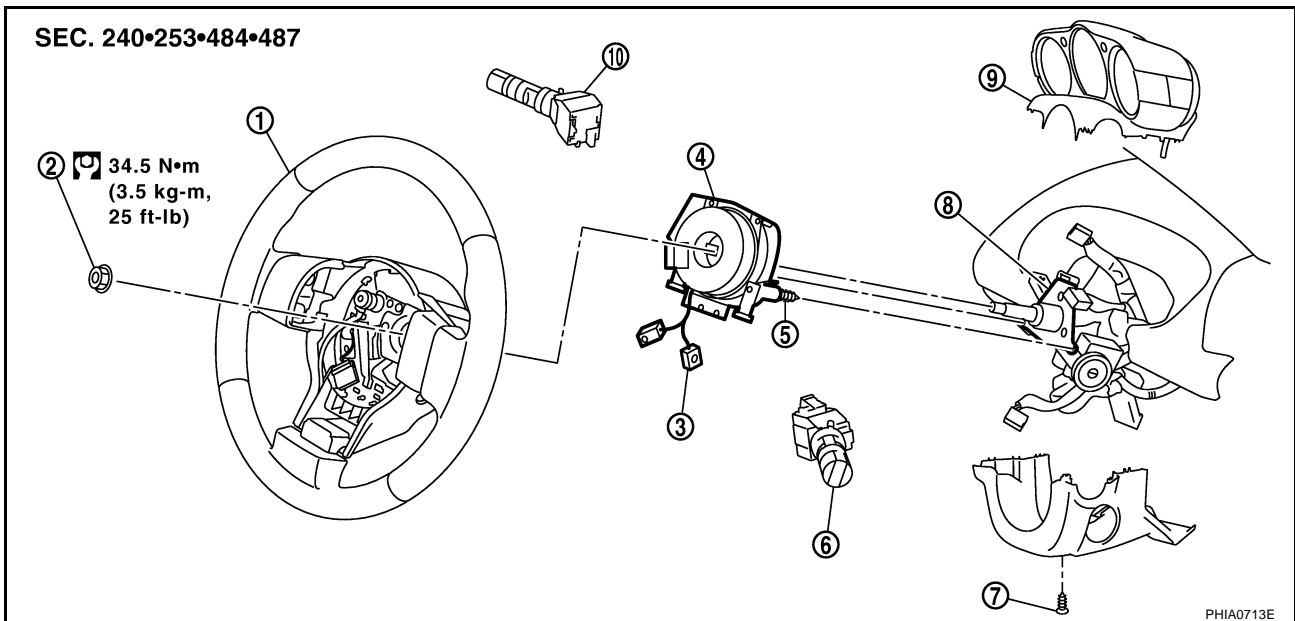

- | | | |
|-------------------------------------|-----------------------------|------------------------------------|
| 1. Steering wheel | 2. Nut | 3. Driver air bag module connector |
| 4. Spiral cable | 5. Scerw (Do not remove) | 6. Wiper and washer switch |
| 7. Screw | 8. Steering column assembly | 9. Combination meter |
| 10. Lighting and turn signal switch | | |

REMOVAL

CAUTION:

Before servicing SRS, turn the ignition switch off, disconnect both battery cables and wait at least 3 minutes.

1. Remove driver air bag module. Refer to [SRS-40, "Removal and Installation"](#).
2. Set the steering wheel in the neutral position.
3. Remove steering wheel nut.
4. Remove combination meter assembly. Refer to [DI-28, "Removal and Installation for Combination Meter"](#).
5. Disconnect the spiral cable connector.

CAUTION:

Do not tap or bump the steering wheel.

6. Remove steering wheel with steering wheel puller.

CAUTION:

Be careful not to over-tighten puller on steering wheel.

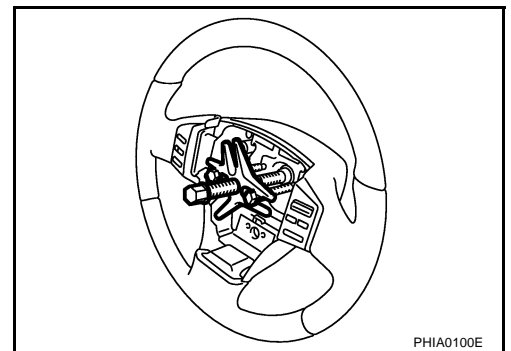

7. Loosen the spiral cable fixing screws, remove the spiral cable.

CAUTION:

- Do not disassemble spiral cable.
- Do not apply lubricant to the spiral cable.

SPIRAL CABLE

8. Remove the horn switch connector and then spiral cable connector.

CAUTION:

Also, with the steering linkage disconnected the cable may snap by turning the steering wheel beyond the limited number of turns.

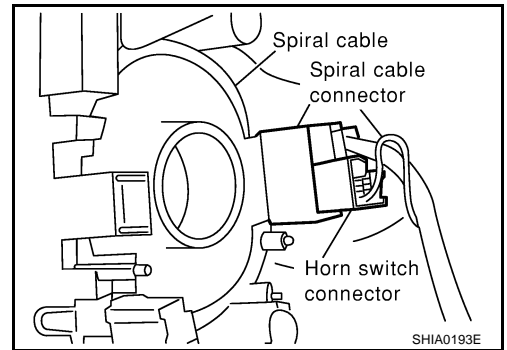

A
B
C
D
E
F
G
I
J
K
L
M

INSTALLATION

Install in the reverse order of removal.

CAUTION:

- The spiral cable may snap due to steering operation if the cable is installed in an improper position.
- Also, with the steering linkage disconnected the cable may snap by turning the steering wheel beyond the limited number of turns. The spiral cable can be turned counterclockwise about 2.5 turns from the right end position.
- After the work is completed, perform self-diagnosis to make sure that no malfunction is detected. Refer to [SRS-21, "SRS Operation Check"](#) .

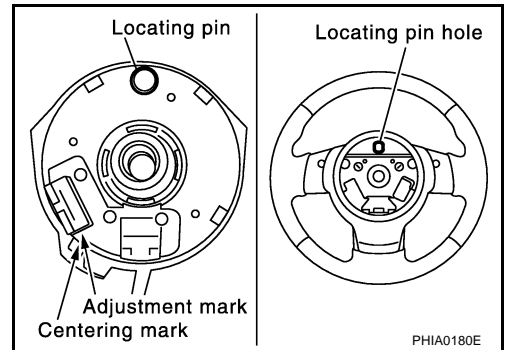

SRS

FRONT PASSENGER AIR BAG MODULE

PFP:K8515

FRONT PASSENGER AIR BAG MODULE

Removal and Installation REMOVAL

AHS00026

CAUTION:

- Before servicing SRS, turn the ignition switch off, disconnect both battery cables and wait at least 3 minutes.
 - Always work from the side of or under front passenger air bag module.
1. Remove instrument passenger panel lower. Refer to [IP-13, "\(M\) Instrument Passenger Panel Lower"](#) .
 2. Remove cluster lid C. Refer to [IP-14, "\(R\) Cluster Lid C"](#) .
 3. Disconnect passenger air bag connector.
 4. Remove special bolt, then remove front passenger air bag module.

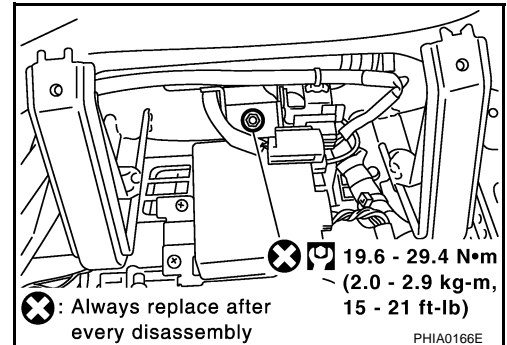

CAUTION:

- Always place front passenger air bag module with caution label side facing upward.
- Do not insert any foreign objects (screwdriver, etc.) into front passenger air bag module.
- Do not disassemble front passenger air bag module.
- Do not use old bolts after removal; replace with new bolts.

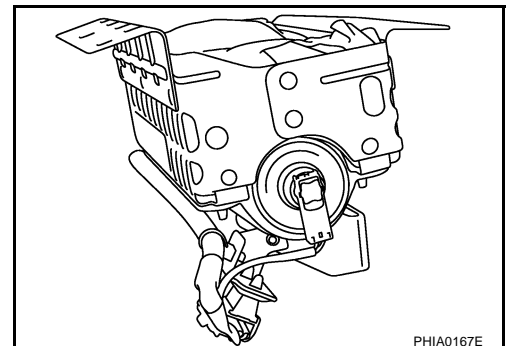

- Replace front passenger air bag module if it has been dropped or sustained an impact.
- Do not expose the front passenger air bag module to temperatures exceeding 90°C (194°F).
- Do not allow oil, grease or water to come in contact with the front passenger air bag module.
- After front passenger air bag module inflates, the instrument panel assembly should be replaced.



INSTALLATION

Install in the reverse order of removal.

CAUTION:

- Always work from the side of or under front passenger air bag module.
- After the work is completed, perform self-diagnosis to make sure that no malfunction is detected. Refer to [SRS-21, "SRS Operation Check"](#) .

SIDE CURTAIN AIR BAG MODULE (FOR COUPE)

SIDE CURTAIN AIR BAG MODULE (FOR COUPE)

PFP:985P0

Removal and Installation

AHS00028

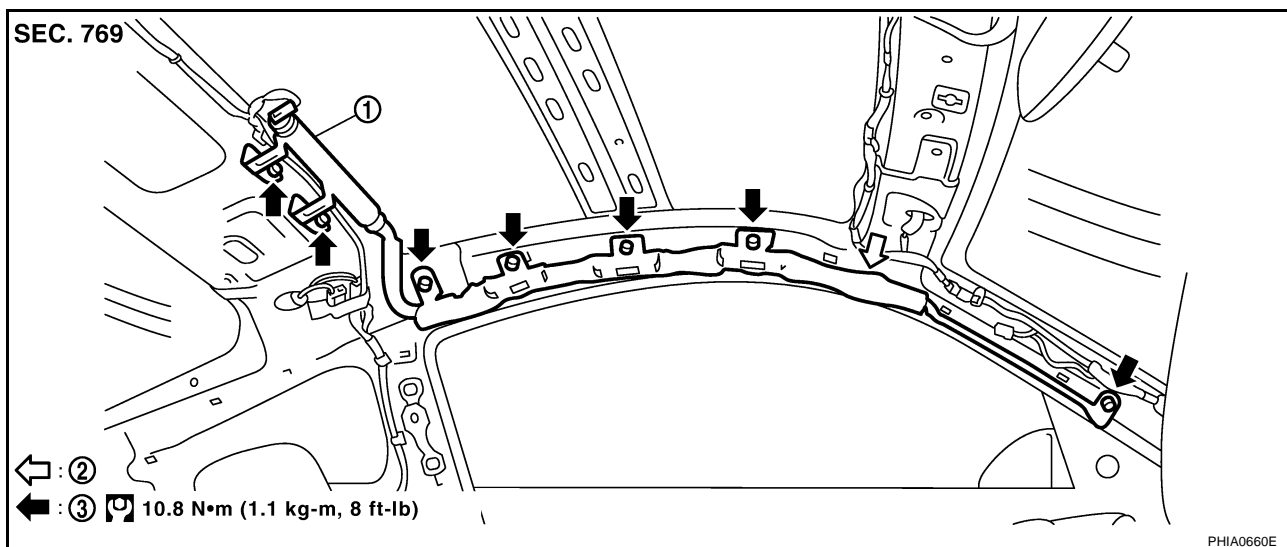

1. Side curtain air bag module

2. Clip

3. Bolt

REMOVAL

CAUTION:

- Before servicing SRS, turn the ignition switch off, disconnect both battery cables and wait at least 3 minutes.
 - Always work from the side of the side curtain air bag module.
1. Remove headlining. Refer to [EI-44, "Removal and Installation \(for Coupe Models\)"](#).
 2. Disconnect side curtain air bag connector.
 3. Remove side curtain air bag module fixing bolts and clip.
 4. Remove the side curtain air bag module.

CAUTION:

- Always place the side curtain air bag module with the warning label facing upward.
- Do not disassemble side curtain air bag module.
- Do not insert any foreign objects (screwdriver, etc.) into air bag module connector.

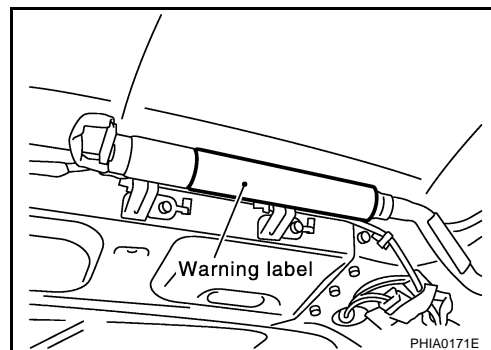

- Replace side curtain air bag module if it has been dropped or sustained an impact.
- Do not expose the air bag module to temperatures exceeding 90°C (194°F).
- Do not allow oil, grease or water to come in contact with the side curtain air bag module.



SIDE CURTAIN AIR BAG MODULE (FOR COUPE)

INSTALLATION

Install in the reverse order of removal.

CAUTION:

- Always work from the side of the side curtain air bag module.
- After replacement of side curtain air bag module, perform self-diagnosis to make sure that no malfunction is detected. Refer to [SRS-21, "SRS Operation Check"](#) .

CRASH ZONE SENSOR

CRASH ZONE SENSOR

PPF:98531

Removal and Installation REMOVAL

AHS00029

CAUTION:

Before servicing SRS, turn the ignition switch off, disconnect both battery cables and wait at least 3 minutes.

1. Remove crash zone sensor connector.
2. Remove crash zone sensor fixing nuts.

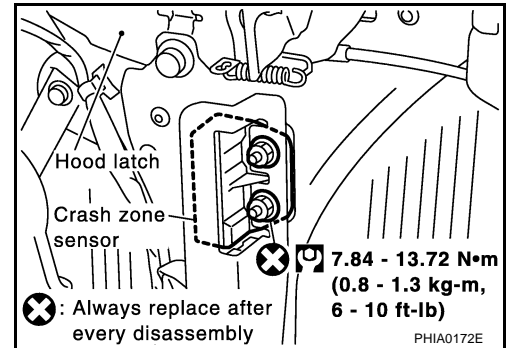

CAUTION:

- Replace crash zone sensor if it has been dropped or sustained an impact.
- Do not disassemble crash zone sensor.

INSTALLATION

Install in the reverse order of removal.

CAUTION:

- Check crash zone sensor for proper installation.
- After the work is complete, perform self-diagnosis to make sure that no malfunction is detected. Refer to [SRS-21, "SRS Operation Check"](#).

A
B
C
D
E
F
G
I
J
K
L
M

SRS

SIDE AIR BAG (SATELLITE) SENSOR

PFP:98830

AHS0002A

SIDE AIR BAG (SATELLITE) SENSOR

Removal and Installation REMOVAL

CAUTION:

Before servicing SRS, turn the ignition switch off, disconnect both battery cables and wait at least 3 minutes.

1. Remove seat belt pre-tensioner. Refer to [SB-4, "Removal and Installation of Seat Belt \(Coupe\)"](#) or [SB-6, "Removal and Installation of Seat Belt \(Roadster\)"](#).
2. Remove side air bag (Satellite) sensor fixing nuts.
3. Remove the side air bag (Satellite) sensor connector.

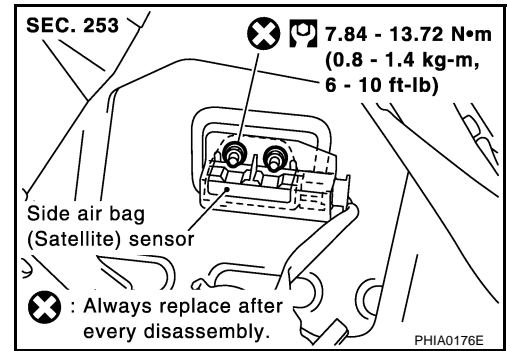

CAUTION:

- Do not use old nuts; replace with new ones.
- Check side air bag (Satellite) sensor to ensure it is free of deformities, dents, cracks or rust. If it shows any visible signs of damage, replace it with new one.
- Do not attempt to disassemble side air bag (Satellite) sensor.
- Replace side air bag (Satellite) sensor if it has been dropped or sustained an impact.

INSTALLATION

Install in the reverse order of removal.

CAUTION:

- Check side air bag (Satellite) sensor for proper installation.
- After replacement of side air bag (Satellite) sensor, perform self-diagnosis to make sure that no malfunction is detected. Refer to [SRS-21, "SRS Operation Check"](#).

FRONT SEAT BELT PRE-TENSIONER

FRONT SEAT BELT PRE-TENSIONER

PFP:86884

Removal and Installation

AHS002B

For removal and installation procedures, refer to [SB-4, "Removal and Installation of Seat Belt \(Coupe\)"](#) or [SB-6, "Removal and Installation of Seat Belt \(Roadster\)"](#) .

A

B

C

D

E

F

G

SRS

I

J

K

L

M

DIAGNOSIS SENSOR UNIT

PFP:28556

DIAGNOSIS SENSOR UNIT

Removal and Installation

REMOVAL

AHS0002C

CAUTION:

Before servicing SRS, turn the ignition switch off, disconnect both battery cables and wait at least 3 minutes.

1. Disconnect each harness connector for the air bag module and seat belt pre-tensioner.
2. Remove center console. Refer to [IP-11, "Removal and Installation"](#).
3. Disconnect diagnosis sensor unit connector.
4. Remove fixing bolts from the diagnosis sensor unit.

 Hexagon head bolt : 24.5 N-m (2.5 kg-m, 18 ft-lb)

 Special bolt : 19.6 N-m (2.0 kg-m, 14 ft-lb)

 Ground bolt : 6.9 N-m (0.7 kg-m, 61 in-lb)

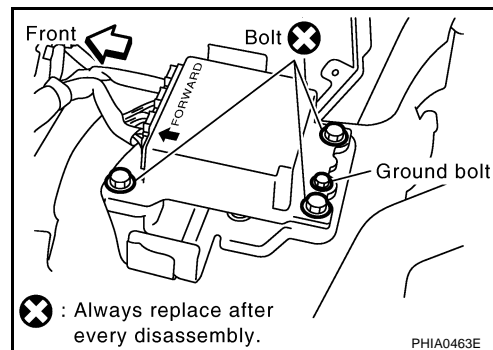

CAUTION:

- Do not use old bolts. Replace with new ones.
- Check diagnosis sensor unit bracket to ensure it is free of deformities, dents, cracks or rust. If it shows any visible signs of damage, replace with new one.
- Replace diagnosis sensor unit if it has been dropped or sustained an impact.

INSTALLATION

Install in the reverse order of removal.

CAUTION:

- Check the diagnosis sensor unit for proper installation.
- After replacement of diagnosis sensor unit, perform self-diagnosis to make sure that no malfunction is detected. Refer to [SRS-21, "SRS Operation Check"](#).

ECU DISCRIMINATED NO.

After replacing the diagnosis sensor unit, make sure that the diagnosis sensor unit identification is correct for the vehicle as equipped.

Model	Specification	ECU DISCRIMINATED No.
Coupe	Models with driver and passenger air bags and seat belt pre-tensioner	FA51
	Models with driver and passenger air bags, seat belt pre-tensioner, side air bags and curtain air bags	FA53
Roadster	Models with driver and passenger air bags and seat belt pre-tensioner	FA86
	Models with driver and passenger air bags, seat belt pre-tensioner and side air bags	FA52

COLLISION DIAGNOSIS

For Frontal Collision

AHS0002E

To repair the SRS, perform the following steps.

When SRS (except the front side air bag and side curtain air bag modules) is activated in a collision:

1. Replace the diagnosis sensor unit.
2. Remove the air bag modules (except the front side air bag modules and side curtain air bag modules), crash zone sensor assembly, bracket and seat belt pre-tensioner assemblies.
3. Check the SRS components using the table below:
 - Replace any SRS components showing visible signs of damage (dents, cracks and deformation).
4. Install new air bag modules (except the front side air bag modules and side curtain air bag modules) crash zone sensor assembly, bracket and seat belt pre-tensioner assemblies.
5. Perform self-diagnosis using CONSULT-II or "AIR BAG" warning lamp. Refer to [SRS-21, "SRS Operation Check"](#) for details. Ensure entire SRS operates properly.

When SRS is not activated in a collision:

1. Check the SRS components using the table below:
 - Replace any SRS components showing visible signs of damage (dents, cracks and deformation).
2. Perform self-diagnosis using CONSULT-II or "AIR BAG" warning lamp. Refer to [SRS-21, "SRS Operation Check"](#) for details. Ensure entire SRS operates properly.

When only one front air bag module is activated in a collision:

1. Replace the following components:
 - Diagnosis sensor unit
 - Crash zone sensor
 - Activated front air bag and seat belt pre-tensioner.
2. Check the other SRS components using the table below. (Refer to "SRS is NOT activated".)
 - Replace any SRS components showing visible signs of damage (dents, cracks and deformation).
3. Perform self-diagnosis using CONSULT-II or "AIR BAG" warning lamp. Refer to [SRS-21, "SRS Operation Check"](#) for details. Ensure entire SRS operates properly.

Only one front air bag may inflate a crash, depending on the crash severity and whether the front occupants are belted or unbelted. This does not indicate improper performance of the system. Perform self-diagnosis to make sure the entire SRS operates properly.

SRS INSPECTION (FOR FRONTAL COLLISION)

Part	SRS is activated	SRS is NOT activated
Air bag module (driver and front passenger air bag module)	REPLACE Install with new bolts.	<ol style="list-style-type: none"> 1. Remove air bag module. Check harness cover and connectors for damage, terminals for deformities, and harness for binding. 2. <ul style="list-style-type: none"> - Install driver air bag module into the steering wheel to check fit and alignment with the wheel. - Install passenger air bag module into the instrument panel to check fit with the instrument panel. 3. No damage found, reinstall with new bolts. 4. If damaged—REPLACE air bag modules with new special bolts.
Crash zone sensor	REPLACE the crash zone sensor and bracket with new nuts.	<ol style="list-style-type: none"> 1. Remove the crash zone sensor. Check harness connectors for damage, terminals for deformities, and harness for binding. 2. Check for visible signs of damage (dents, cracks, deformation) of the crash zone sensor and bracket. 3. Install the crash zone sensor to check fit. 4. No damage found, reinstall with new bolts. 5. If damaged—REPLACE the crash zone sensor and bracket with new nuts.

A
B
C
D
E
F
G
I
J
K
L
M

SRS

COLLISION DIAGNOSIS

Part	SRS is activated	SRS is NOT activated
Seat belt pre-tensioner assemblies	REPLACE Install seat belt pre-tensioner with new bolts.	<ol style="list-style-type: none"> 1. Remove seat belt pre-tensioners. Check harness cover and connectors for damage, terminals for deformities, and harness for binding. 2. Check belts for damage and anchors for loose mounting. 3. Check retractor for smooth operation. 4. Check seat belt adjuster for damage. 5. If no damage is found, reinstall seat belt pre-tensioner assembly with new bolts. 6. If damaged—REPLACE seat belt pre-tensioners with new bolts.
Diagnosis sensor unit	REPLACE Install with new bolts.	<ol style="list-style-type: none"> 1. Check case for dents, cracks or deformities. 2. Check connectors for damage, and terminals for deformities. 3. If no damage is found, reinstall with new bolts and ground bolt. 4. If damaged—REPLACE diagnosis sensor unit with new bolts and ground bolt.
Steering wheel	<ol style="list-style-type: none"> 1. Visually check steering wheel for deformities. 2. Check harness (built into steering wheel) and connectors for damage, and terminals for deformities. 3. Install air bag module to check fit or alignment with steering wheel. 4. Check steering wheel for excessive free play. 5. If no damage is found, reinstall with nut. 6. If damaged—REPLACE. 	
Spiral cable	<ol style="list-style-type: none"> 1. Visually check spiral cable and combination switch for damage. 2. Check connectors and protective tape for damage. 3. Check steering wheel for noise, binding or heavy operation. 4. If no damage is found, reinstall with screws. 5. If damaged—REPLACE. 	
Harness and connectors	<ol style="list-style-type: none"> 1. Check connectors for poor connection, damage, and terminals for deformities. 2. Check harness for binding, chafing, cuts, or deformities. 3. If no damage is found, reinstall the harness and connectors. 4. If damaged—REPLACE damaged section of harness. Do not repair, splice or modify any SRS harness. 	
Instrument panel	<ol style="list-style-type: none"> 1. Visually check instrument panel for damage. 2. If no damage is found, reinstall the instrument panel. 3. If damaged—REPLACE the instrument panel with bolts. 	

For Side Collision

AHS0002F

WHEN THE SIDE AIR BAG IS ACTIVATED IN THE SIDE COLLISION:

1. Replace the following components:
 - All parts of front seatback (including front seatback frame) with front side air bag module (on the side on which front side air bag is activated)
 - Curtain air bag module (on the side on which side curtain air bag is activated)
 - Diagnosis sensor unit
 - Satellite sensor (on the side on which side air bag and side curtain air bag is activated)
2. Check the SRS components and the related parts using the following table.
 - Replace any SRS components and the related parts showing visible signs of damage (dents, cracks, deformation).
3. Perform self-diagnosis using CONSULT-II or "AIR BAG" warning lamp. Refer to [SRS-21, "SRS Operation Check"](#) . Ensure entire SRS operates properly.

COLLISION DIAGNOSIS

WHEN SRS IS NOT ACTIVATED IN THE SIDE COLLISION:

1. Check the SRS components and the related parts using the following table.
 - Replace any SRS components and the related parts showing visible signs of damage (dents, cracks, deformation).
2. Perform self-diagnosis using CONSULT-II or “AIR BAG” warning lamp. Refer to [SRS-21, "SRS Operation Check"](#) . Ensure entire SRS operates properly.

SRS INSPECTION (FOR SIDE COLLISION)

Part	Front side air bag and side curtain air bag is activated	Front side air bag and side curtain air bag is NOT activated
(LH or RH) side curtain air bag module*	Replace the side curtain air bag module. (Repair the center pillar inner, etc. before installing new one if damaged.)	<ol style="list-style-type: none"> 1. Check for visible signs of damage (dents, tears, deformation) of the center pillar on the collision side. 2. If damaged— Remove the side curtain air bag module. 3. Check for visible signs of damaged (tears etc.) of the side curtain air bag module. 4. Check harness and connectors for damage, and terminals for deformities. 5. If no damage is found, reinstall the side curtain air bag module with new bolts. 6. If damaged—REPLACE the side curtain air bag module with new bolts.
Front (LH or RH) side air bag module	REPLACE all parts of seatback with deployed front side air bag module.	<ol style="list-style-type: none"> 1. Check for visible signs of damage (dents, tears, deformation) of the seat back on the collision side. 2. Check harness and connectors for damage, and terminals for deformities. 3. If damaged—REPLACE the front seatback assembly.
(LH or RH) side air bag (Satellite) sensor	REPLACE the side air bag (Satellite) sensor on the collision side with new nuts. (Repair the center pillar inner, etc. before installing new one if damaged.)	<ol style="list-style-type: none"> 1. Remove the side air bag (Satellite) sensor on the collision side. Check harness connectors for damage, terminals for deformities, and harness for binding. 2. Check for visible signs of damage (dents, cracks, deformation) of the side air bag (Satellite) sensor. 3. Install the side air bag (Satellite) sensor to check fit. 4. If no damage is found, reinstall the side sir bag (Satellite) sensor with new nuts. 5. If damaged—REPLACE the side air bag (Satellite) sensor with new nuts.
Diagnosis sensor unit	REPLACE the diagnosis sensor unit with the new bolts.	<ol style="list-style-type: none"> 1. Check case and bracket for dents, cracks or deformities. 2. Check connectors for damage, and terminals for deformities. 3. If no damage is found, reinstall the diagnosis sensor unit with new bolts and ground bolt. 4. If damaged—REPLACE the diagnosis sensor unit with new bolts and ground bolt.
Seat belt pre-tensioner assembly	<ol style="list-style-type: none"> 1. Check if the seat belt can be extended smoothly. If the seat belt cannot be extended smoothly, <ul style="list-style-type: none"> – Check for deformities of the center pillar inner. – If the center pillar inner has no damage, REPLACE the seat belt pre-tensioner assembly. 2. Remove the seat belt pre-tensioner assembly on the collision side. Check harness cover and connectors for damage, terminals for deformities, and harness for binding. 3. Check for visible signs of damage (dents, cracks, deformation) of the seat belt pre-tensioner assembly. 4. Check seat belt adjuster for damage. 5. If no damage is found, reinstall the seat belt pre-tensioner assembly. 6. If damaged—REPLACE the seat belt pre-tensioner assembly with new bolts. 	
Seat with front side air bag	REPLACE all parts of front seatback (including front seatback frame)	<ol style="list-style-type: none"> 1. Visually check the seat on the collision side. 2. Remove the seat on the collision side and check the following for damage and deformities. <ul style="list-style-type: none"> – Harness, connectors and terminals – Frame and recliner (for front and rear seat), and also adjuster and slides (for front seat) 3. If no damage is found, reinstall the seat. 4. If damaged—REPLACE the damaged seat parts using new bolts.

COLLISION DIAGNOSIS

Part	Front side air bag and side curtain air bag is activated	Front side air bag and side curtain air bag is NOT activated
Center inner pillar	1. Check the center inner pillar on the collision side for damage (dents, cracks, deformation). 2. If damaged—REPAIR the center inner pillar.	
Trim/headlining*	1. Check for visible signs of damage (dents, cracks, deformation) of the interior trim on the collision side. 2. If damaged—REPLACE the damaged trim parts.	

*: For coupe