

SECTION **AV**

AUDIO VISUAL, NAVIGATION & TELEPHONE SYSTEM

CONTENTS

PRECAUTIONS	4	Power Supply Circuit Inspection	36
Precautions for Supplemental Restraint System (SRS) "AIR BAG" and "SEAT BELT PRE-TENSIONER"	4	AudioPilot® Does Not Work	37
Precautions for Battery Service	4	Removal and Installation of Audio Unit (Base System)	40
Wiring Diagrams and Trouble Diagnosis	4	REMOVAL	40
PREPARATION	5	INSTALLATION	40
Commercial Service Tools	5	Locking CD Auto-Changer Mechanism (Audio Unit of BOSE System)	40
AUDIO	6	DAMPER LOCK PROCEDURE	40
System Description	6	Removal and Installation of Audio Unit (BOSE System)	41
BASE SYSTEM FOR COUPE MODELS	6	REMOVAL	41
BASE SYSTEM FOR ROADSTER MODELS	6	INSTALLATION	41
BOSE SYSTEM FOR COUPE MODELS	6	Removal and Installation of Door Speaker	41
BOSE SYSTEM FOR ROADSTER MODELS	7	REMOVAL	41
Component Parts and Harness Connector Location	9	INSTALLATION	41
Schematic	10	Removal and Installation of Rear Speaker	42
BOSE SYSTEM	10	REMOVAL	42
Wiring Diagram — AUDIO —	11	INSTALLATION	42
BASE SYSTEM FOR COUPE MODELS	11	Removal and Installation of Tweeter	42
BASE SYSTEM FOR ROADSTER MODELS	13	REMOVAL	42
BOSE SYSTEM FOR COUPE MODELS	15	INSTALLATION	42
BOSE SYSTEM FOR ROADSTER MODELS	22	Removal and Installation of Woofer and Woofer Amp. (BOSE System)	43
Terminals and Reference Value for Audio Unit for Base System	28	REMOVAL	43
Terminals and Reference Value for Audio Unit for BOSE System	29	INSTALLATION	43
Terminals and Reference Value for BOSE Speaker Amp.	30	Removal and Installation of BOSE Speaker Amp... ..	44
Terminals and Reference Value for Woofer Amp... ..	32	REMOVAL	44
Trouble Diagnosis	33	INSTALLATION	44
PROBLEM WITH RADIO, TAPE AND CD (BASE SYSTEM)	33	Removal and Installation of Microphone	44
PROBLEM WITH RADIO, TAPE AND CD (BOSE SYSTEM)	33	REMOVAL	44
FOR RADIO ONLY	34	INSTALLATION	44
FOR CASSETTE PLAYER ONLY	34	AUDIO ANTENNA	45
FOR CD ONLY	35	System Description	45
Noise Inspection	35	Wiring Diagram — M/ANT —	46
TYPE OF NOISE AND POSSIBLE CAUSE	35	Location of Antenna	47
		Removal and Installation of Antenna Amp.	47
		REMOVAL	47

INSTALLATION	47	Cluster Lid Amp.	90
Removal and Installation of Antenna	48	Vehicle Speed Signal Check	91
REMOVAL	48	Illumination Signal Check	92
INSTALLATION	48	Ignition Signal Check	92
NAVIGATION SYSTEM	49	Reverse Signal Check	93
System Description	49	When Display Cover is Closed, Display is Stay On...93	
LOCATION DETECTION PRINCIPLE	49	Screen is Not Shown	94
MAP-MATCHING	50	Lid Does Not Move	98
GPS (GLOBAL POSITIONING SYSTEM)	51	Color of RGB Image is Not Proper	100
COMPONENT DESCRIPTION	52	Screen is Rolling	102
BIRDVIEW™	53	Voice Guidance Is Not Heard	103
MAP DISPLAY	54	The Position of The Current-Location Mark is Not Correct	105
FUNCTION OF NAVI SWITCH	54	Radio Wave From The GPS Satellite is Not Received	105
“VIEW” MODE	58	Driving Test	106
“HEADING” MODE	58	Example of Symptoms Judged Not Malfunction ..107	
“NEARBY DISPLAY ICONS” MODE	58	BASIC OPERATION	107
“SAVE CURRENT LOCATION” MODE	58	VEHICLE MARK	107
“ADJUST CURRENT LOCATION” MODE	59	DESTINATION, PASSING POINTS, AND MENU ITEMS CANNOT BE SELECTED/SET	107
“AUTO RE-ROUTE” MODE	59	VOICE GUIDANCE	108
“AVOID AREA SETTING” MODE	59	ROUTE SEARCHING	108
“BUTTON TONE/BEEP RESPONSE” MODE	60	EXAMPLES OF CURRENT-LOCATION MARK DISPLACEMENT	109
“CLEAR MEMORY” MODE	60	CURRENT-LOCATION MARK SHOWS A POSITION WHICH IS COMPLETELY WRONG	112
“EDIT ADDRESS BOOK” MODE	60	CURRENT-LOCATION MARK JUMPS	112
“GPS INFORMATION” MODE	60	CURRENT-LOCATION MARK IS IN A RIVER OR THE SEA	113
“QUICK STOP CUSTOMER SETTING” MODE...61		CURRENT-LOCATION MARK AUTOMATICALLY ROTATES	113
“SET AVERAGE SPEED” MODE	61	WHEN DRIVING ON THE SAME ROAD, SOMETIMES THE CURRENT-LOCATION MARK IS IN THE RIGHT PLACE AND SOMETIMES IT IS THE WRONG PLACE	113
“TRACKING” MODE	61	LOCATION CORRECTION BY MAP MATCHING IS SLOW	113
GUIDE VOLUME SETTING	61	ALTHOUGH THE GPS RECEIVING DISPLAY IS GREEN, THE VEHICLE MARK DOES NOT RETURN TO THE CORRECT LOCATION	113
Precautions for NAVI Control Unit Replacement ...	62	THE NAME OF THE CURRENT PLACE IS NOT DISPLAYED	113
Component Parts and Harness Connector Location..	63	CONTENTS OF THE DISPLAY DIFFER FOR THE BIRDVIEW™ AND THE (FLAT) MAP SCREEN.	113
Schematic	64	Program Loading	114
Wiring Diagram — NAVI —	65	Removal and Installation of NAVI Control Unit	115
FOR COUPE MODELS	65	REMOVAL	115
FOR ROADSTER MODELS	69	INSTALLATION	115
Terminals and Reference Value for NAVI Control Unit	73	Removal and Installation of GPS Antenna	115
Terminals and Reference Value for Display Unit ...	75	REMOVAL	115
Terminals and Reference Value for NAVI Switch ...	77	INSTALLATION	115
Self-Diagnosis Function	78	Removal and Installation of NAVI Switch	116
DESCRIPTION	78	REMOVAL	116
DIAGNOSIS ITEM	78	INSTALLATION	116
Self-Diagnosis Mode	79	Removal and Installation of Display Unit	116
OPERATION PROCEDURE	79	REMOVAL	116
SELF-DIAGNOSIS RESULT	80		
CONFIRMATION/ADJUSTMENT Mode	81		
OPERATION PROCEDURE	81		
DISPLAY DIAGNOSIS	82		
VEHICLE SIGNALS	83		
NAVIGATION	83		
HISTORY OF ERRORS	84		
DIAGNOSIS BY HISTORY OF ERRORS	84		
Power Supply and Ground Circuit Check for NAVI Control Unit	87		
Power Supply and Ground Circuit Check for Display Unit	88		
Power Supply and Ground Circuit Check for NAVI Switch	89		
Power Supply and Ground Circuit Check for Power			

INSTALLATION	116
Removal and Installation of Power Cluster Lid Amp..	117
REMOVAL	117
INSTALLATION	117

A
B
C
D
E
F
G
H
I
J
AV
L
M

PRECAUTIONS

PRECAUTIONS

PFP:00001

Precautions for Supplemental Restraint System (SRS) “AIR BAG” and “SEAT BELT PRE-TENSIONER”

AKS008YS

The Supplemental Restraint System such as “AIR BAG” and “SEAT BELT PRE-TENSIONER”, used along with a front seat belt, helps to reduce the risk or severity of injury to the driver and front passenger for certain types of collision. This system includes seat belt switch inputs and dual stage front air bag modules. The SRS system uses the seat belt switches to determine the front air bag deployment, and may only deploy one front air bag, depending on the severity of a collision and whether the front occupants are belted or unbelted. Information necessary to service the system safely is included in the SRS and SB section of this Service Manual.

WARNING:

- To avoid rendering the SRS inoperative, which could increase the risk of personal injury or death in the event of a collision which would result in air bag inflation, all maintenance must be performed by an authorized NISSAN/INFINITI dealer.
- Improper maintenance, including incorrect removal and installation of the SRS, can lead to personal injury caused by unintentional activation of the system. For removal of Spiral Cable and Air Bag Module, see the SRS section.
- Do not use electrical test equipment on any circuit related to the SRS unless instructed to in this Service Manual. SRS wiring harnesses can be identified by yellow and/or orange harnesses or harness connectors.

Precautions for Battery Service

AKS003RI

Before disconnecting the battery, lower both the driver and passenger windows. This will prevent any interference between the window edge and the vehicle when the door is opened/closed. During normal operation, the window slightly raises and lowers automatically to prevent any window to vehicle interference. The automatic window function will not work with the battery disconnected.

Wiring Diagrams and Trouble Diagnosis

AKS0010F

When reading wiring diagrams, refer to the following:

- [GI-15, "How to Read Wiring Diagrams"](#)
- [PG-4, "POWER SUPPLY ROUTING CIRCUIT"](#)

When performing trouble diagnosis, refer to the following:

- [GI-11, "HOW TO FOLLOW TEST GROUPS IN TROUBLE DIAGNOSES"](#)
- [GI-27, "How to Perform Efficient Diagnosis for an Electrical Incident"](#)

PREPARATION

PREPARATION

PFP:00002

Commercial Service Tools

AKS0010G

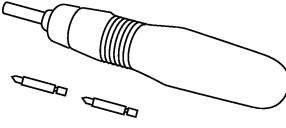
Tool name	Description
<p>Power tool</p>  <p>PBIC0191E</p>	<p>Loosening bolts and nuts</p>

A
B
C
D
E
F
G
H
I
J
L
M

AV

AUDIO

System Description

BASE SYSTEM FOR COUPE MODELS

AKS0010H

Refer to Owner's Manual for audio system operating instructions.

Power is supplied at all times

- through 15A fuse [No. 37, located in the fuse and fusible link box]
- to audio unit terminal 6.

With the ignition switch in the ACC or ON position, power is supplied

- through 10A fuse [No. 6, located in the fuse block (J/B)]
- to audio unit terminal 10.

Ground is supplied through the case of the audio unit.

When of audio switch is pushed, audio signals are supplied

- through audio unit terminals 1, 2, 3, 4, 13, 14, 15, and 16
- to terminals 1 and 2 of driver door speaker and passenger door speaker
- to terminals 1 and 2 of rear speaker LH and RH
- to terminals 1 and 2 of tweeter (driver side) and tweeter (passenger side).

BASE SYSTEM FOR ROADSTER MODELS

Refer to Owner's Manual for audio system operating instructions.

Power is supplied at all times

- through 15A fuse [No. 37, located in the fuse and fusible link box]
- to audio unit terminal 6.

With the ignition switch in the ACC or ON position, power is supplied

- through 10A fuse [No. 6, located in the fuse block (J/B)]
- to audio unit terminal 10.

Ground is supplied through the case of the audio unit.

When of audio switch is pushed, audio signals are supplied

- through audio unit terminals 1, 2, 3, 4, 13, 14, 15, and 16
- to terminals 1 and 2 of driver door speaker and passenger door speaker
- to terminals 1 and 2 of rear speaker LH and RH
- to terminals 1 and 2 of tweeter (driver side) and tweeter (passenger side).

BOSE SYSTEM FOR COUPE MODELS

CD auto-changer (built into audio unit) operation is controlled by audio unit.

Refer to Owner's Manual for audio system operating instructions.

Power is supplied at all times

- through 15A fuse [No. 37, located in the fuse and fusible link box]
- to audio unit terminal 6
- to BOSE speaker amp. terminal 11
- to option connector for satellite radio receiver terminal 1,
- through 15A fuse [No. 17, located in the fuse block (J/B)]
- to woofer amp. terminal 8.

With the ignition switch in the ACC or ON position, power is supplied

- through 10A fuse [No. 6, located in the fuse block (J/B)]
- to audio unit terminal 10
- to option connector for satellite radio receiver terminal 6,
- through audio unit terminal 12
- to BOSE speaker amp. terminal 41,
- through BOSE speaker amp. terminal 32
- to woofer amp. terminal 6.

Ground is supplied through the case of the audio unit.

AUDIO

Ground is also supplied

- to BOSE speaker amp. terminal 27
- to woofer amp. terminal 7
- through body ground B5, B6, D105 and T14.

When audio switch is pushed, audio signals are supplied

- through audio unit terminals 1, 2, 3, 4, 13, 14, 15, and 16
- to BOSE speaker amp. terminals 33, 34, 35, 36, 37, 38, 39 and 40.

Audio signals are amplified by the BOSE speaker amp.

The amplified audio signals are supplied

- through BOSE speaker amp. terminals 12, 19, 20, 21, 22, 23, 24, 25, 26 and 28
- to terminals 1 and 2 of driver door speaker and passenger door speaker
- to terminals 1 and 2 of rear speaker LH and RH
- to terminals 1 and 2 of tweeter (driver side) and tweeter (passenger side)
- to terminals 1 and 2 of woofer amp.

Audio signals are amplified by the woofer amp.

The amplified audio signals are supplied

- through woofer amp. terminals 3 and 4
- to terminals 1 and 2 of woofer.

BOSE SYSTEM FOR ROADSTER MODELS

CD auto-changer (built into audio unit) operation is controlled by audio unit.

Refer to Owner's Manual for audio system operating instructions.

Power is supplied at all times

- through 15A fuse [No. 37, located in the fuse and fusible link box]
- to audio unit terminal 6
- to BOSE speaker amp. terminal 11,
- through 15A fuse [No. 17, located in the fuse block (J/B)]
- to woofer amp. terminal 8.

With the ignition switch in the ACC or ON position, power is supplied

- through 10A fuse [No. 6, located in the fuse block (J/B)]
- to audio unit terminal 10,
- through audio unit terminal 12
- to BOSE speaker amp. terminal 41,
- through BOSE speaker amp. terminal 32
- to woofer amp. terminal 6.

Ground is supplied through the case of the audio unit.

Ground is also supplied

- to BOSE speaker amp. terminal 27
- to woofer amp. terminal 7
- through body ground B5, B6 and T14.

When audio switch is pushed, audio signals are supplied

- through audio unit terminals 1, 2, 3, 4, 13, 14, 15, and 16
- to BOSE speaker amp. terminals 33, 34, 35, 36, 37, 38, 39 and 40.

Audio signals are amplified by the BOSE speaker amp.

The amplified audio signals are supplied

- through BOSE speaker amp. terminals 12, 19, 20, 21, 22, 23, 24, 25, 26 and 28
- to terminals 1 and 2 of driver door speaker and passenger door speaker
- to terminals 1 and 2 of rear speaker LH and RH
- to terminals 1 and 2 of tweeter (driver side) and tweeter (passenger side)
- to terminals 1 and 2 of woofer amp.

Audio signals are amplified by the woofer amp.

A
B
C
D
E
F
G
H
I
J
L
M

AV

AUDIO

The amplified audio signals are supplied

- through woofer amp. terminals 3 and 4
- to terminals 1 and 2 of woofer.

AudioPilot® System

AudioPilot® is the sound improving system that picks up any noises or the sound of music coming into the vehicle by a microphone under the steering, and that the BOSE speaker amp. revises the frequency feature of music at real time in response to the frequency feature of the noise while driving and listening to music.

- If low frequency area noise from vehicle is loud, it adjusts low frequency element of music to be bigger than vehicle noise.
- If high frequency area noise from vehicle is loud, it adjusts high frequency element of music to be bigger than vehicle noise.
- If vehicle noise is smaller than the setting volume, correction is not performed.

This eliminates vehicle noise when listening to music.

AUDIO

Component Parts and Harness Connector Location

AKS00995

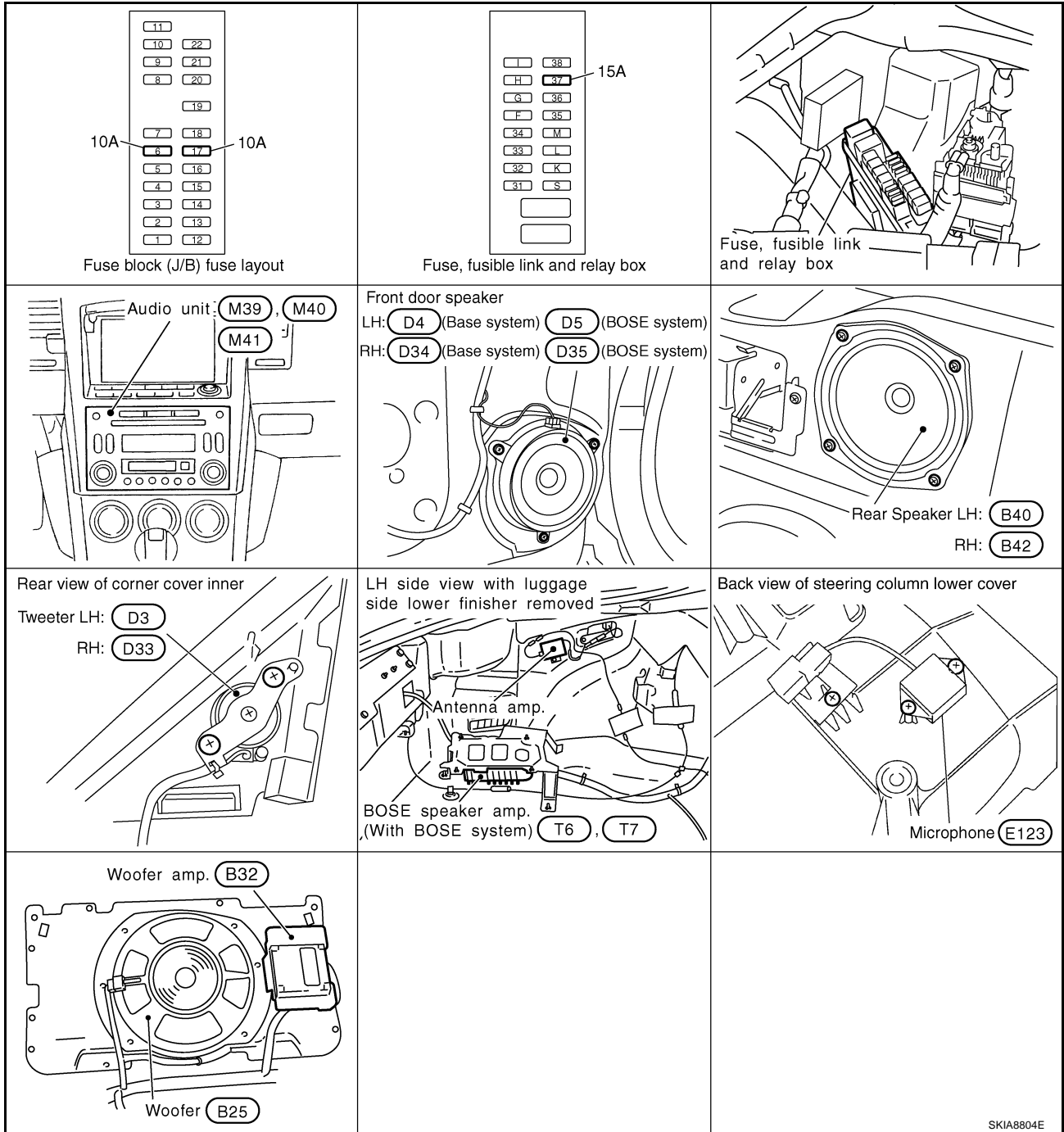

SKIA8804E

A
B
C
D
E
F
G
H
I
J
AV
L
M

AUDIO

AKS0010I

Schematic BOSE SYSTEM

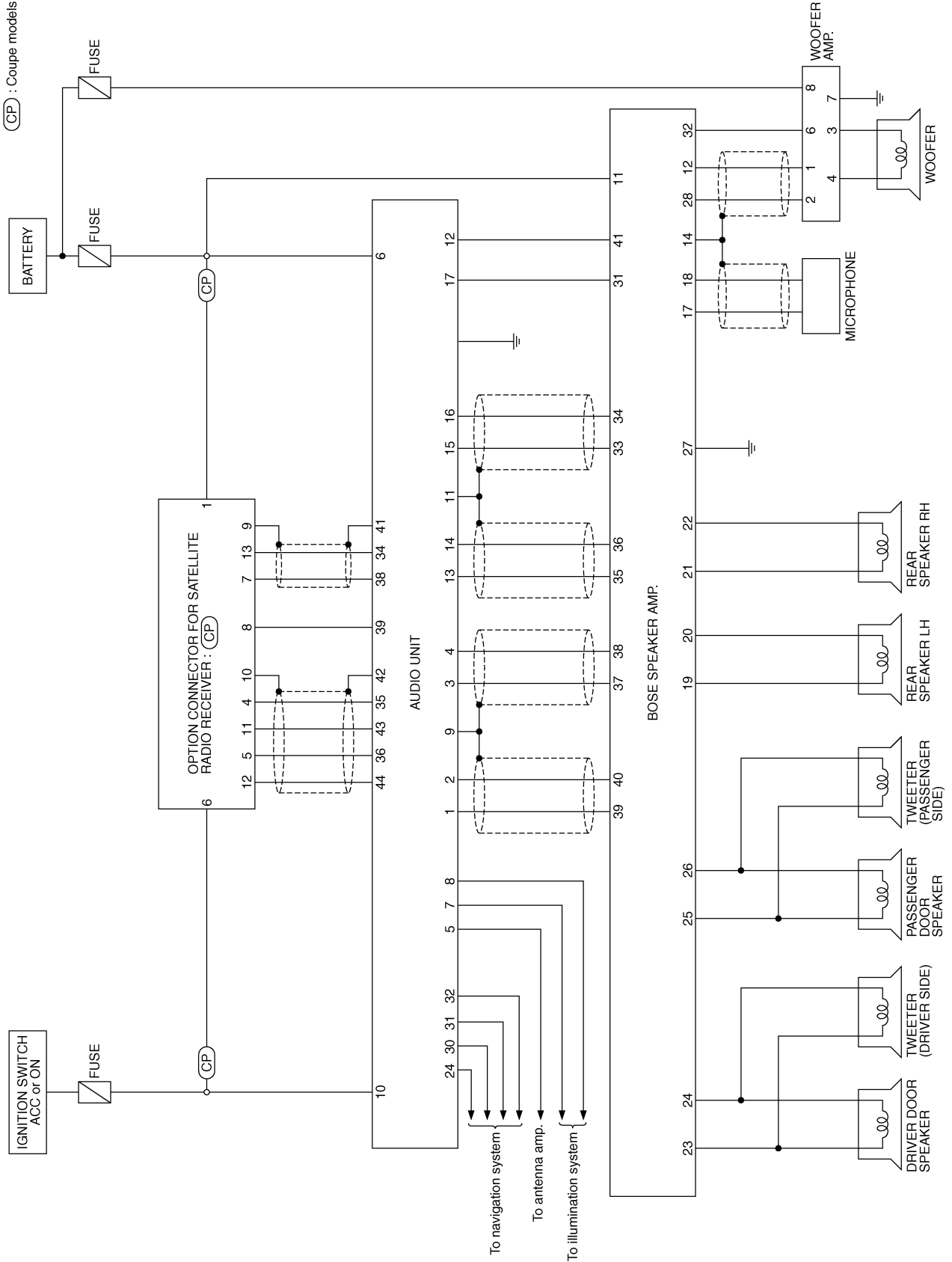

TKWT1528E

AUDIO

AKS0010J

Wiring Diagram — AUDIO — BASE SYSTEM FOR COUPE MODELS

AV-AUDIO-01

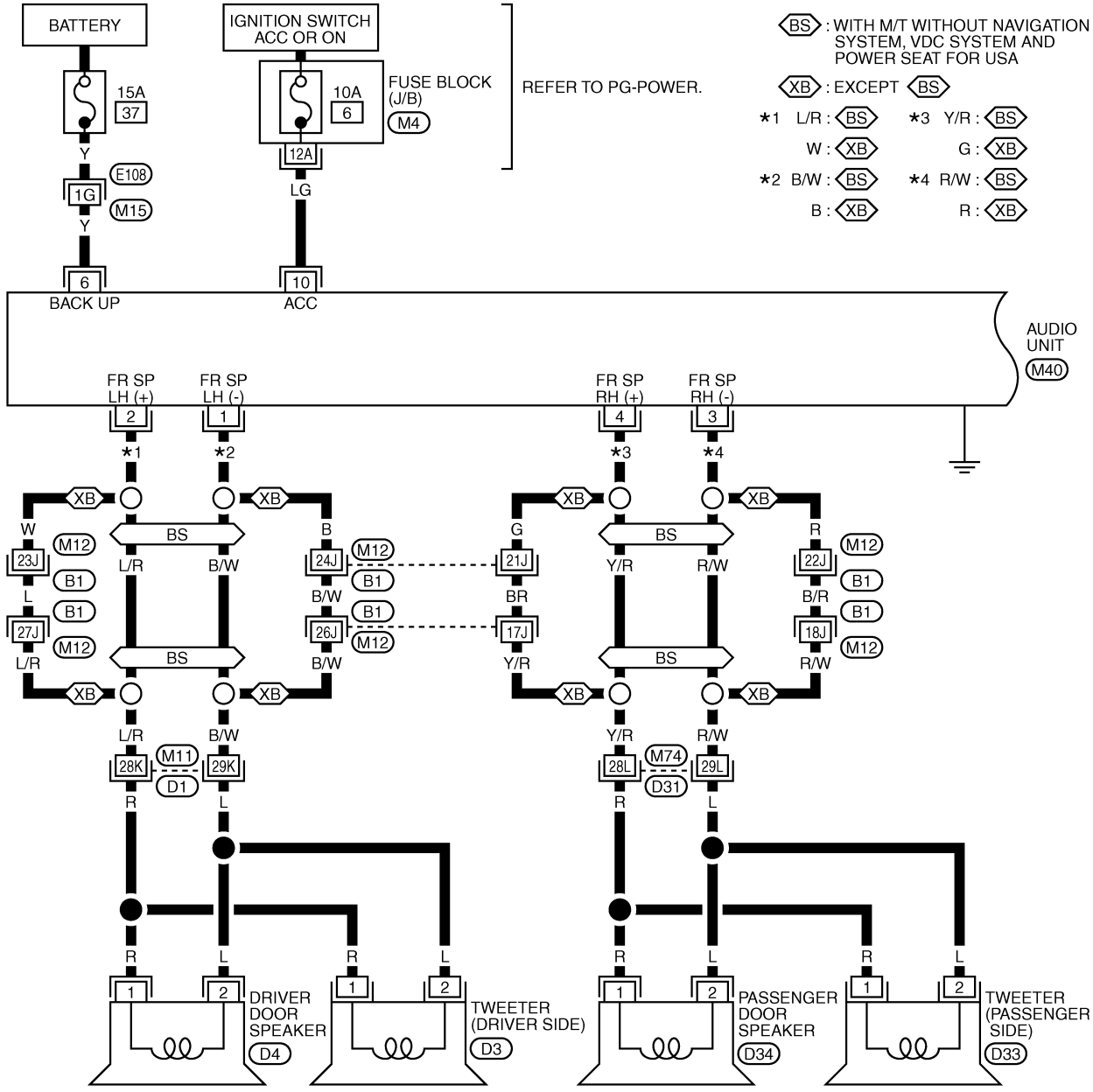

BS : WITH M/T WITHOUT NAVIGATION SYSTEM, VDC SYSTEM AND POWER SEAT FOR USA

XB : EXCEPT **BS**

*1 L/R : **BS** *3 Y/R : **BS**
 W : **XB** G : **XB**
 *2 B/W : **BS** *4 R/W : **BS**
 B : **XB** R : **XB**

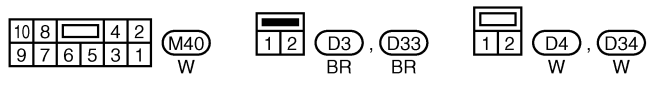

REFER TO THE FOLLOWING.

(E108), (B1), (D1), (D31)
 -SUPER MULTIPLE JUNCTION (SMJ)
 (M4) -FUSE BLOCK-JUNCTION BOX (J/B)

AV
L
M

AUDIO

AV-AUDIO-02

- WN : WITH NAVIGATION SYSTEM
BS : WITH M/T WITHOUT NAVIGATION SYSTEM, VDC SYSTEM AND POWER SEAT FOR USA
XB : EXCEPT BS
 *1 LG/R: BS *3 L/OR: BS
 BR: XB L: XB
 *2 B/Y: BS *4 B/P: BS
 B/R: XB P: XB

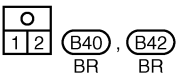
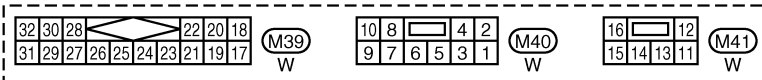
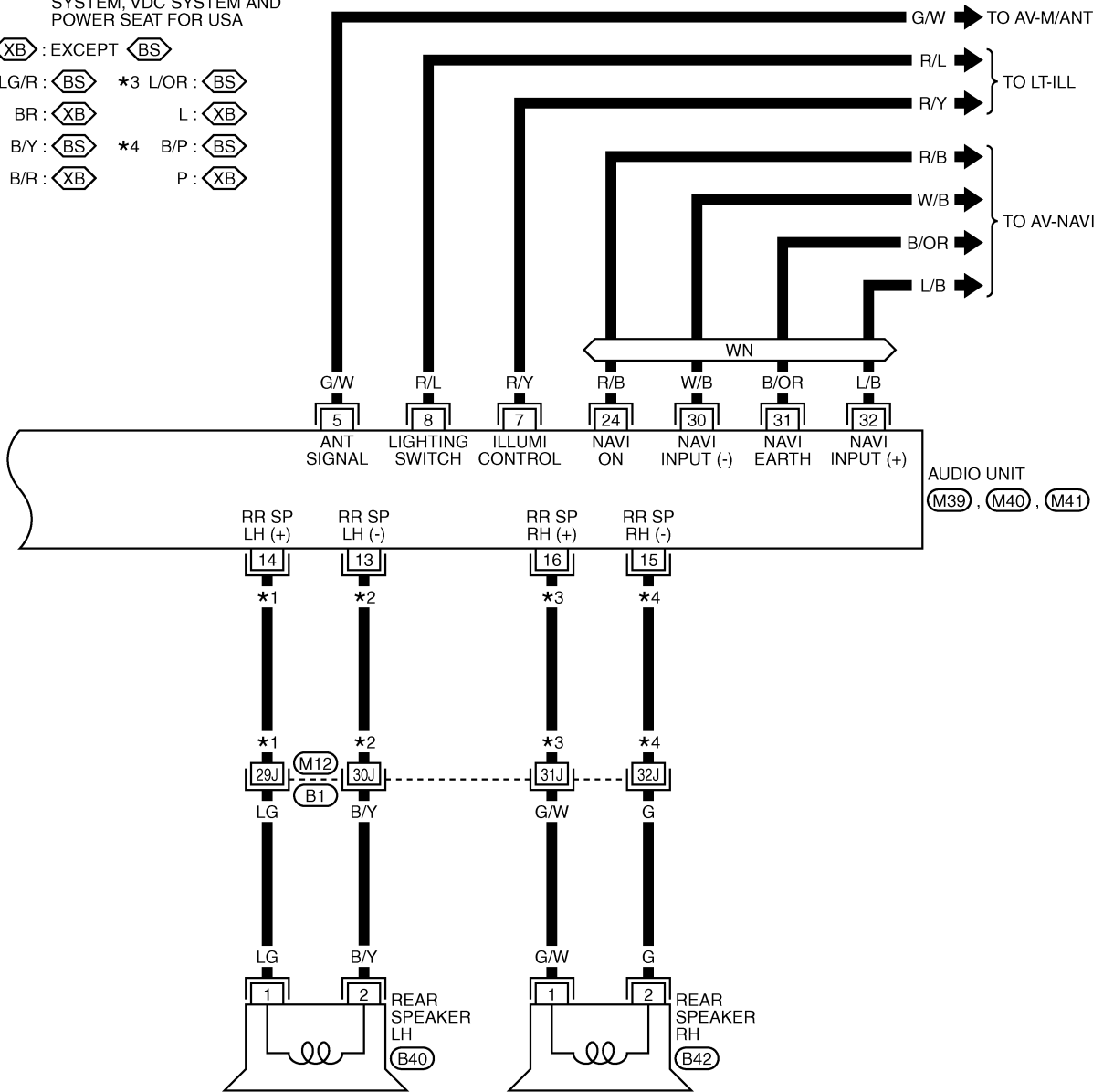

REFER TO THE FOLLOWING.
B1 -SUPER MULTIPLE JUNCTION (SMJ)

TKWT1525E

AUDIO

BASE SYSTEM FOR ROADSTER MODELS

AV-AUDIO-03

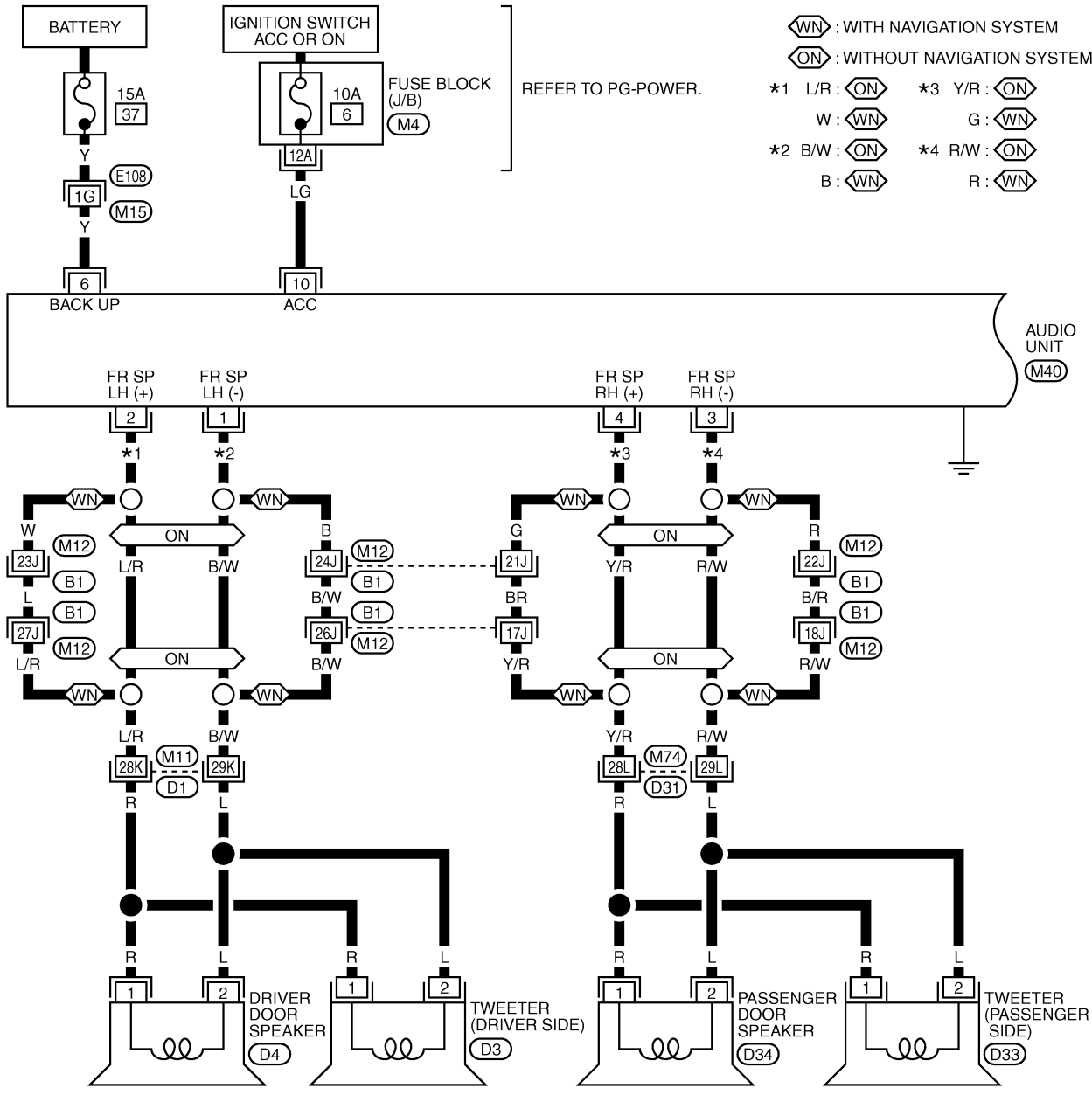

- WN : WITH NAVIGATION SYSTEM
ON : WITHOUT NAVIGATION SYSTEM
- *1 L/R : ON *3 Y/R : ON
 W : WN G : WN
 *2 B/W : ON *4 R/W : ON
 B : WN R : WN

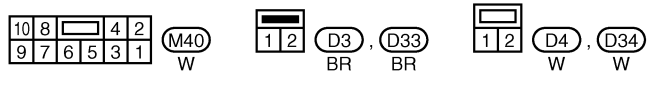

REFER TO THE FOLLOWING.

E108, B1, D1, D31
 -SUPER MULTIPLE JUNCTION (SMJ)
M4 -FUSE BLOCK-JUNCTION BOX (J/B)

A
B
C
D
E
F
G
H
I
J
AV
L
M

AUDIO

AV-AUDIO-04

- WN : WITH NAVIGATION SYSTEM
ON : WITHOUT NAVIGATION SYSTEM
 *1 LG/R : ON *3 L/OR : ON
 BR : WN L : WN
 *2 B/Y : ON *4 B/P : ON
 B/R : WN P : WN

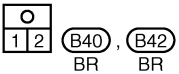
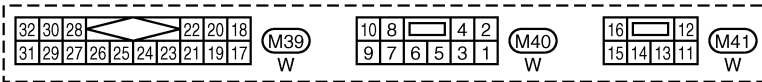
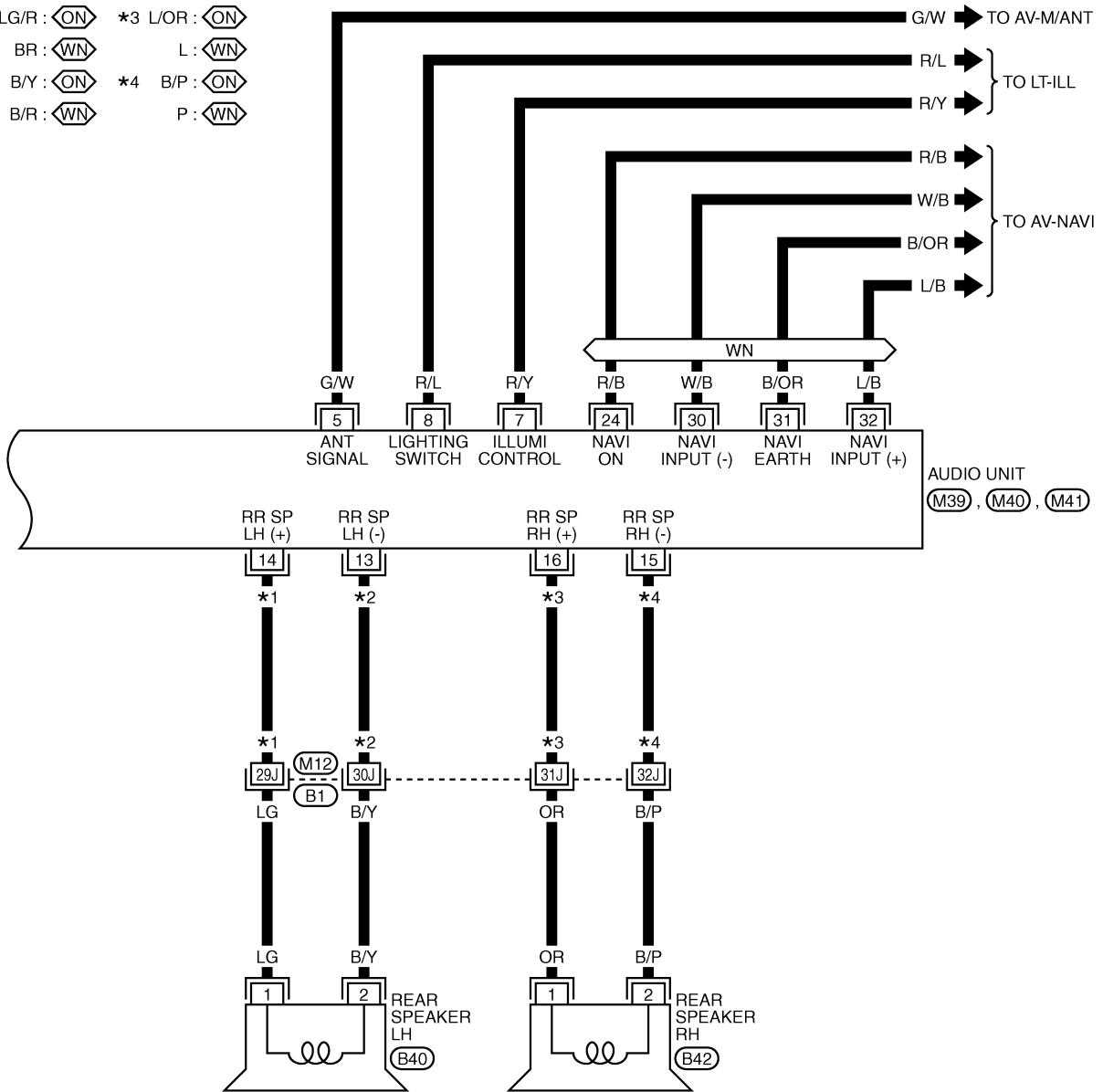

REFER TO THE FOLLOWING.
B1 -SUPER MULTIPLE JUNCTION (SMJ)

TKWT1527E

AUDIO

BOSE SYSTEM FOR COUPE MODELS

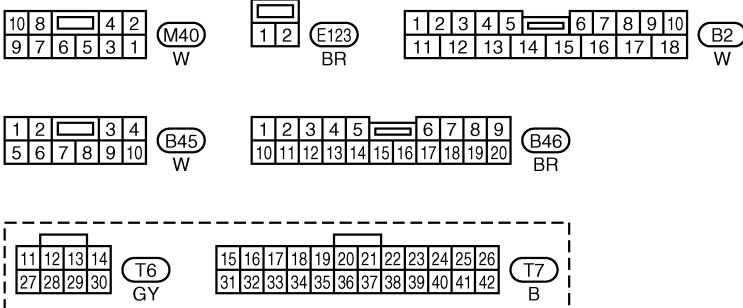
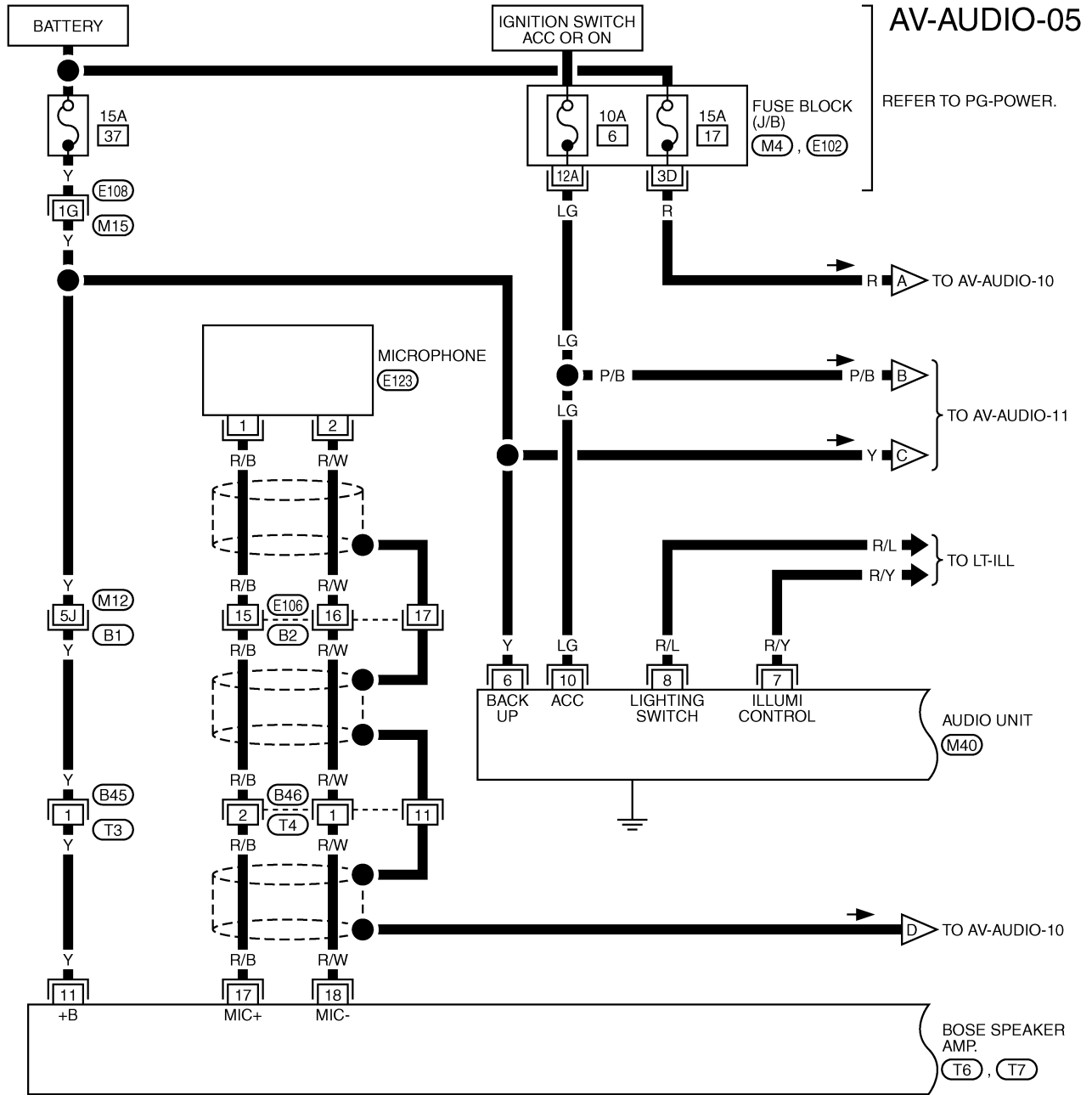

REFER TO THE FOLLOWING.
 (E108), (B1) -SUPER MULTIPLE JUNCTION (SMJ)
 (M4), (E102) -FUSE BLOCK-JUNCTION BOX (J/B)

A
B
C
D
E
F
G
H
I
J
AV
L
M

AUDIO

AV-AUDIO-06

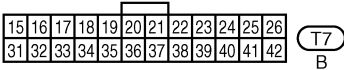
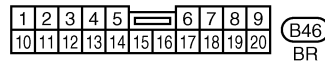
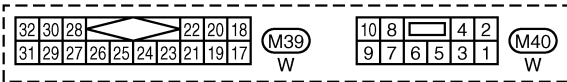
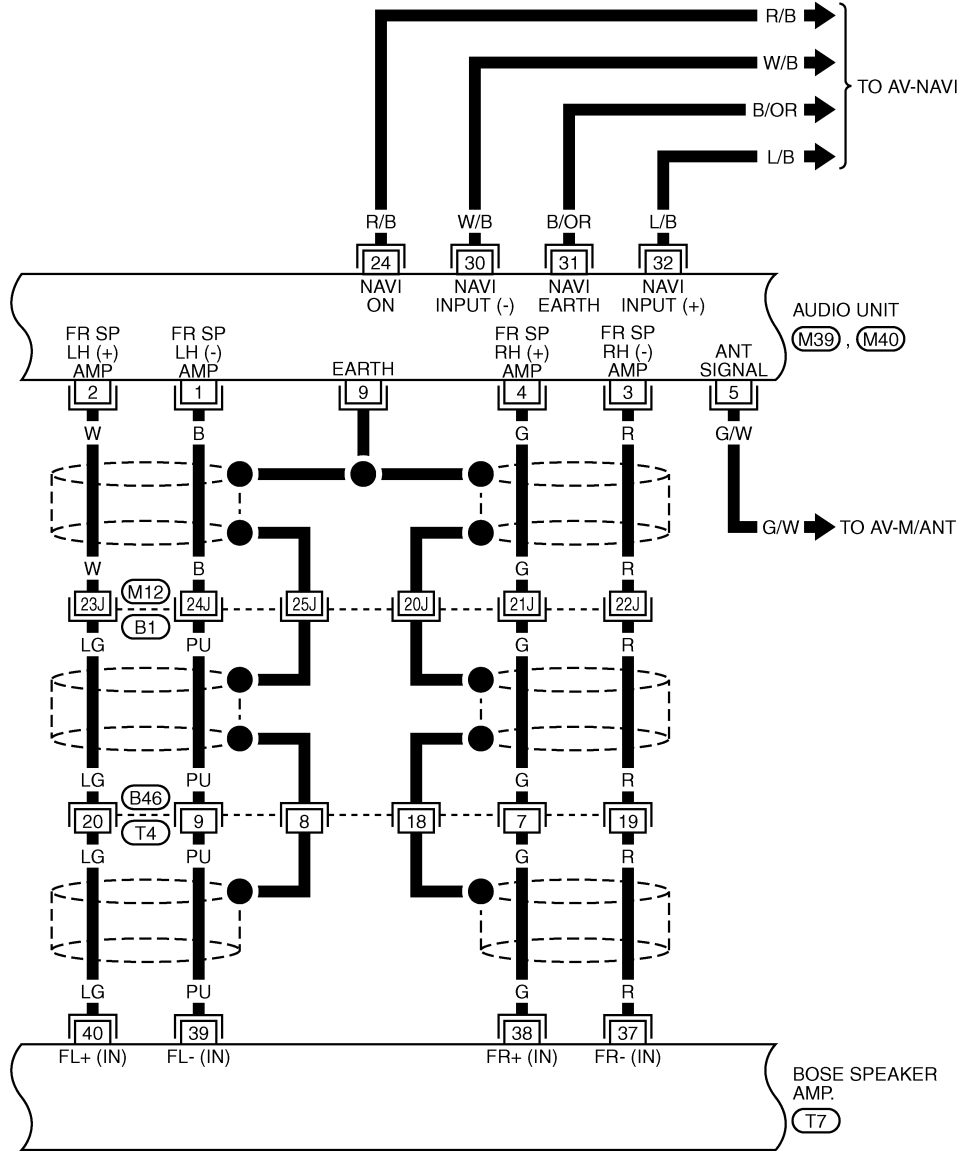

REFER TO THE FOLLOWING.

(B1) -SUPER MULTIPLE JUNCTION (SMJ)

TKWT1530E

AUDIO

AV-AUDIO-07

A
B
C
D
E
F
G
H
I
J
K
L
M

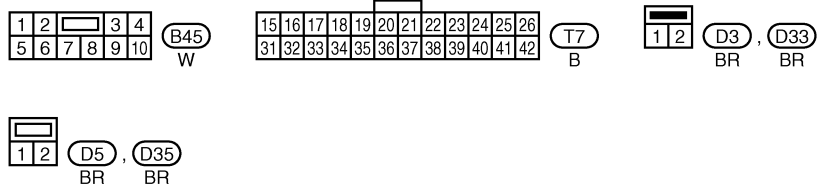
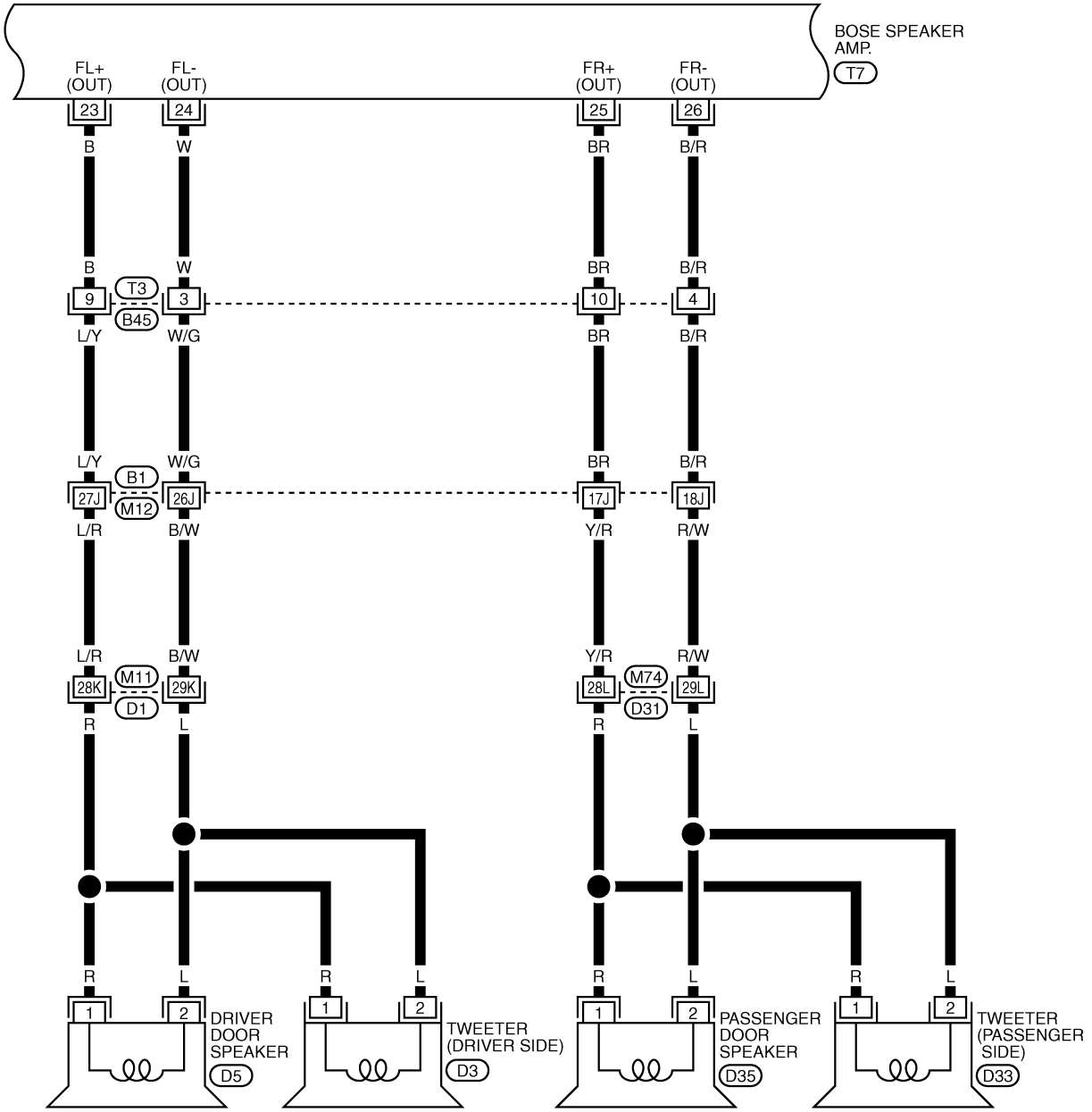

REFER TO THE FOLLOWING.
(B1), (D1), (D31) -SUPER
MULTIPLE JUNCTION (SMJ)

TKWT1531E

AUDIO

AV-AUDIO-08

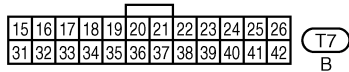
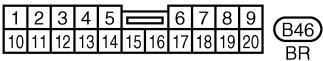
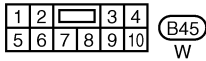
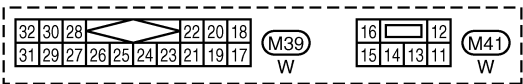
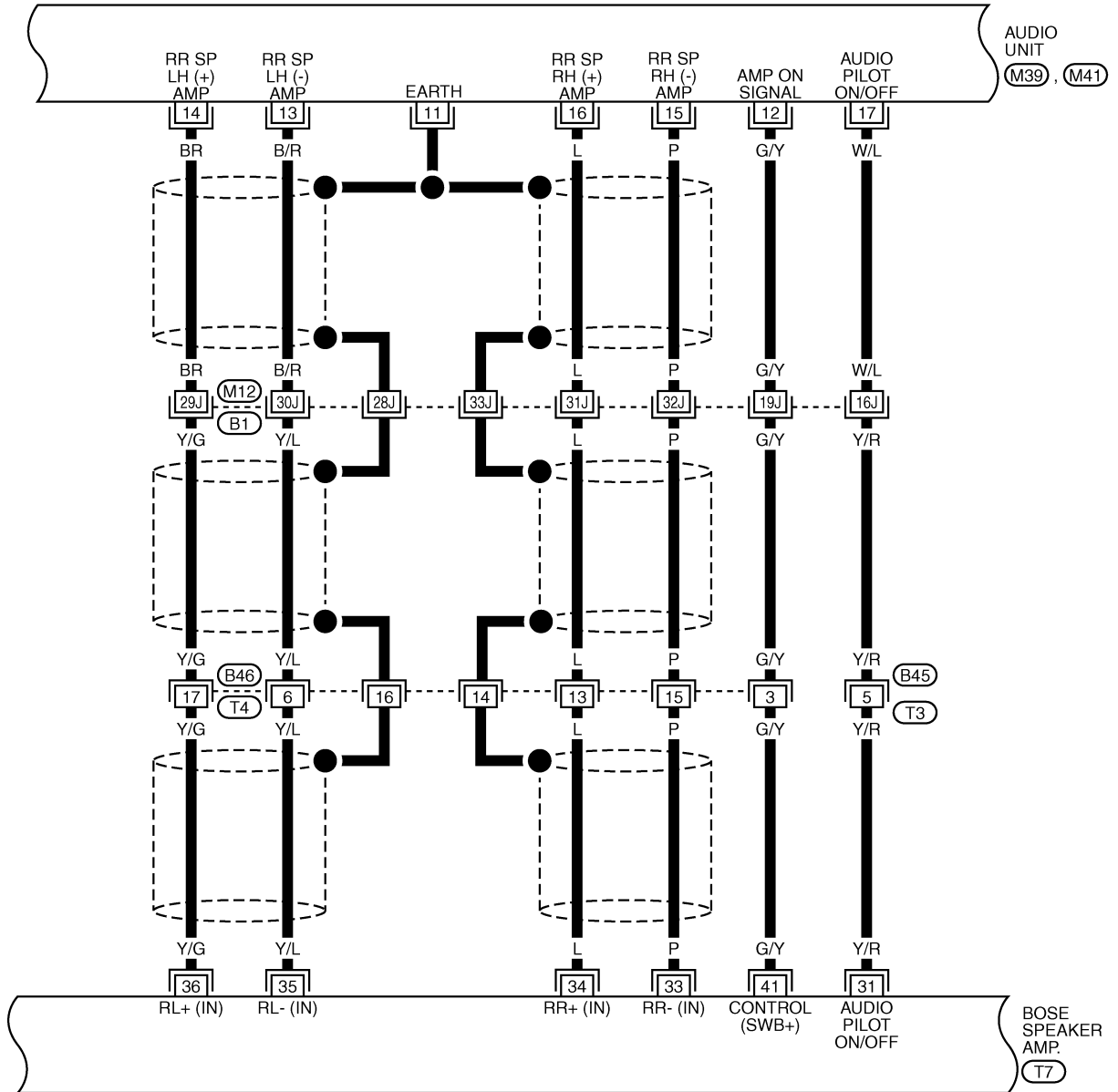

REFER TO THE FOLLOWING.

(B1) -SUPER MULTIPLE JUNCTION (SMJ)

TKWT1532E

AUDIO

AV-AUDIO-09

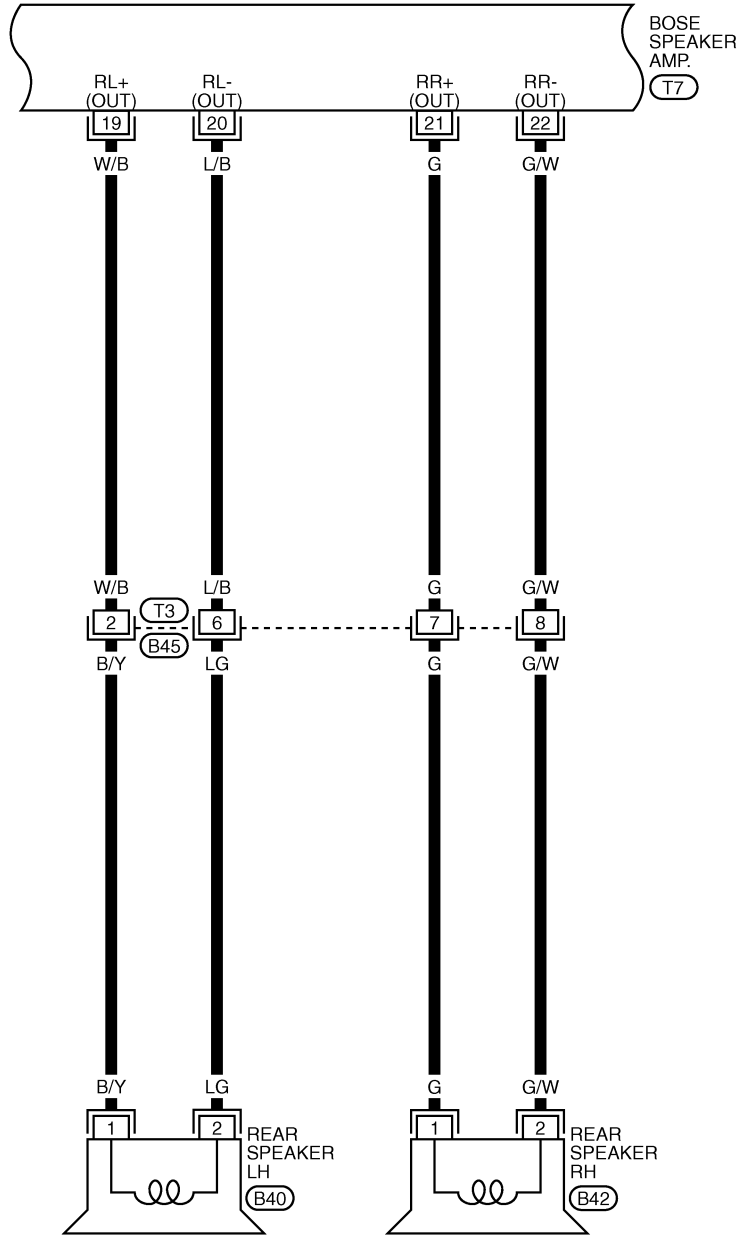

A
B
C
D
E
F
G
H
I
J
AV
L
M

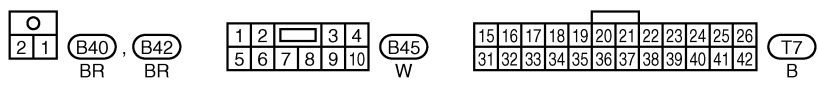

TKWT1533E

AUDIO

AV-AUDIO-10

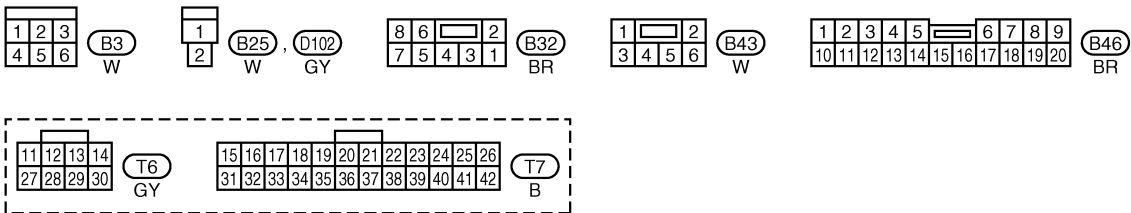
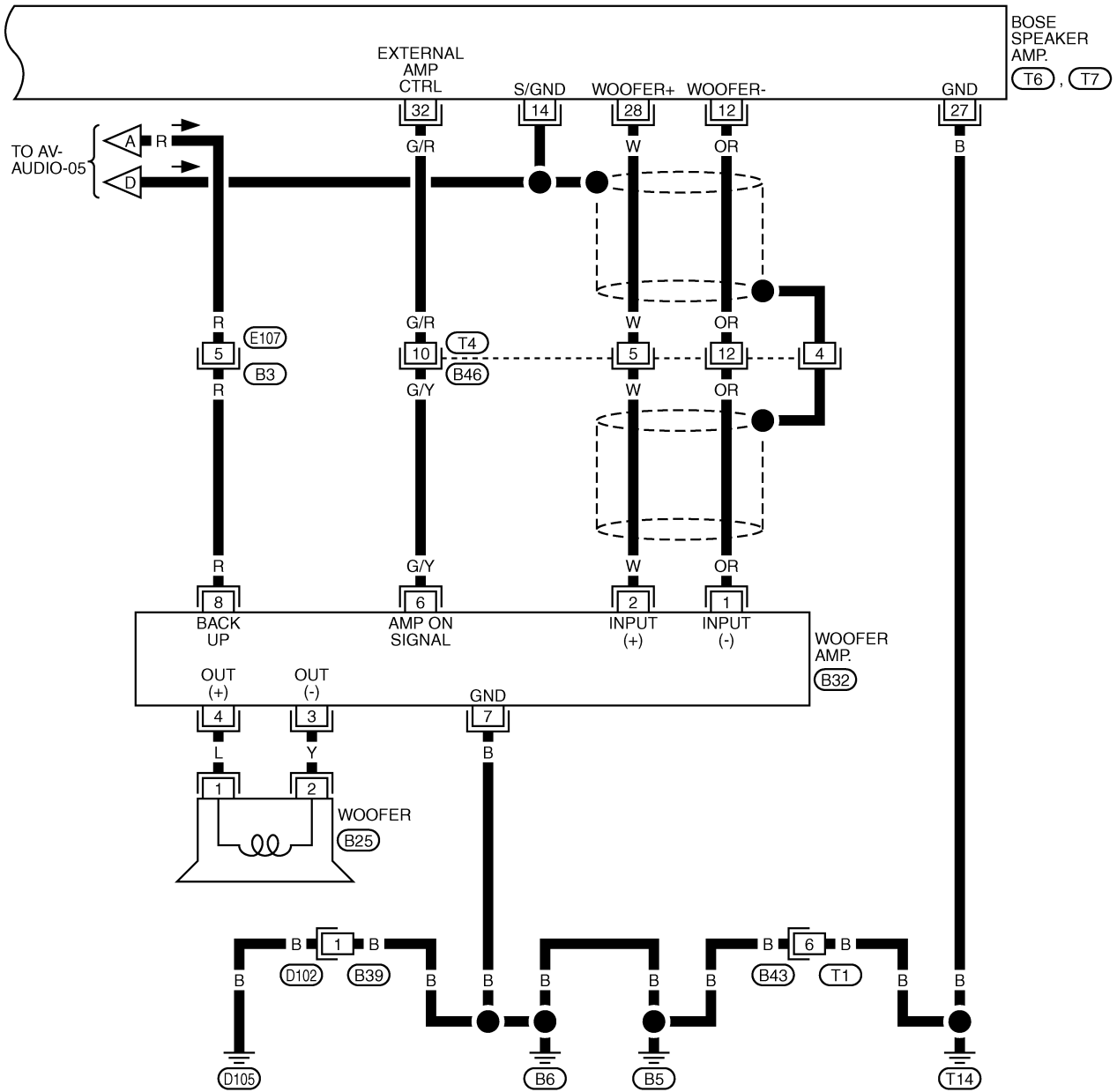

TKWT1534E

AUDIO

AV-AUDIO-11

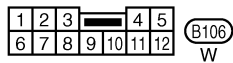
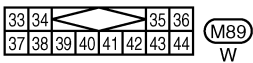
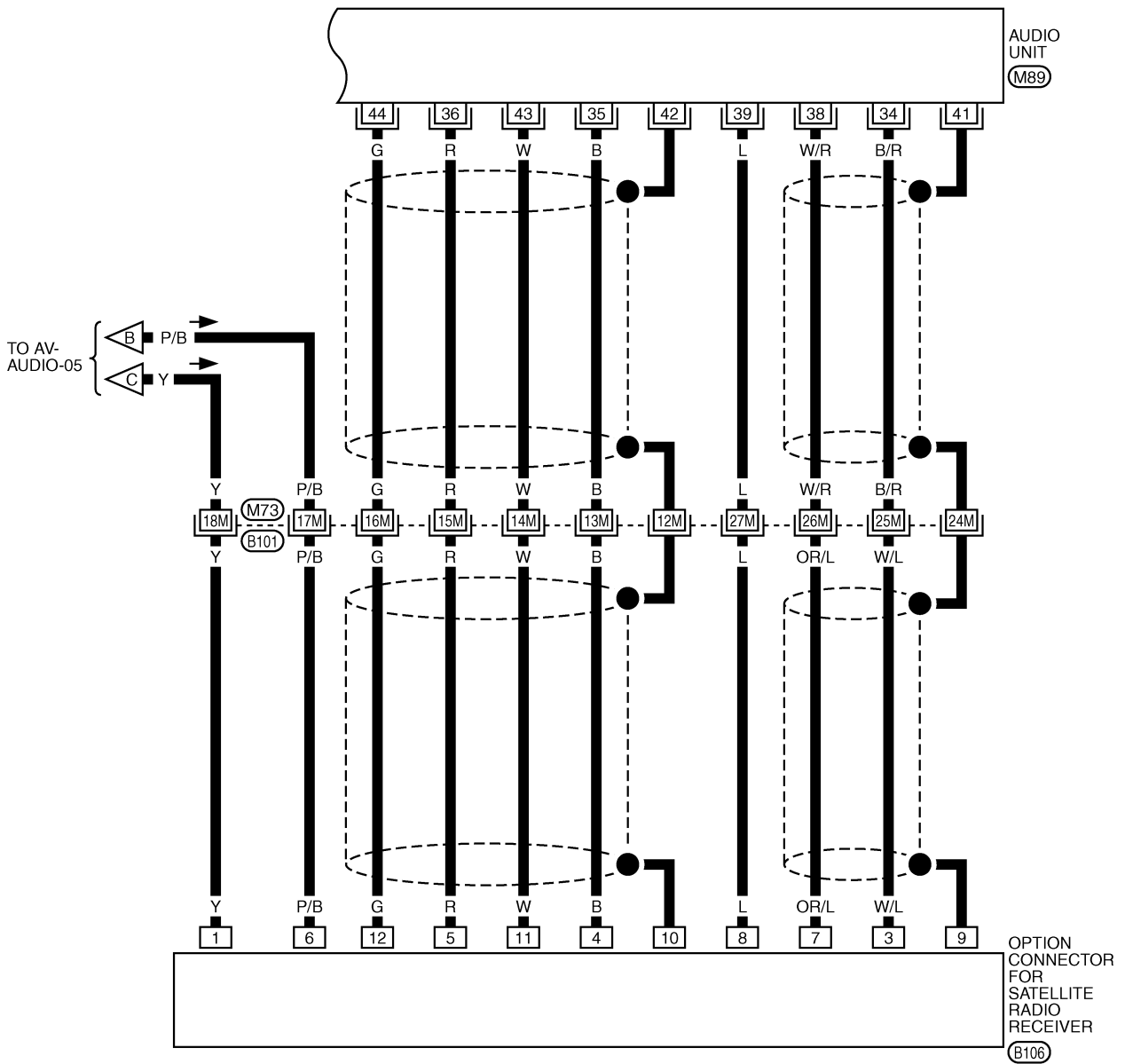

REFER TO THE FOLLOWING.
(B101) -SUPER MULTIPLE JUNCTION (SMJ)

TKWT1535E

AUDIO

BOSE SYSTEM FOR ROADSTER MODELS

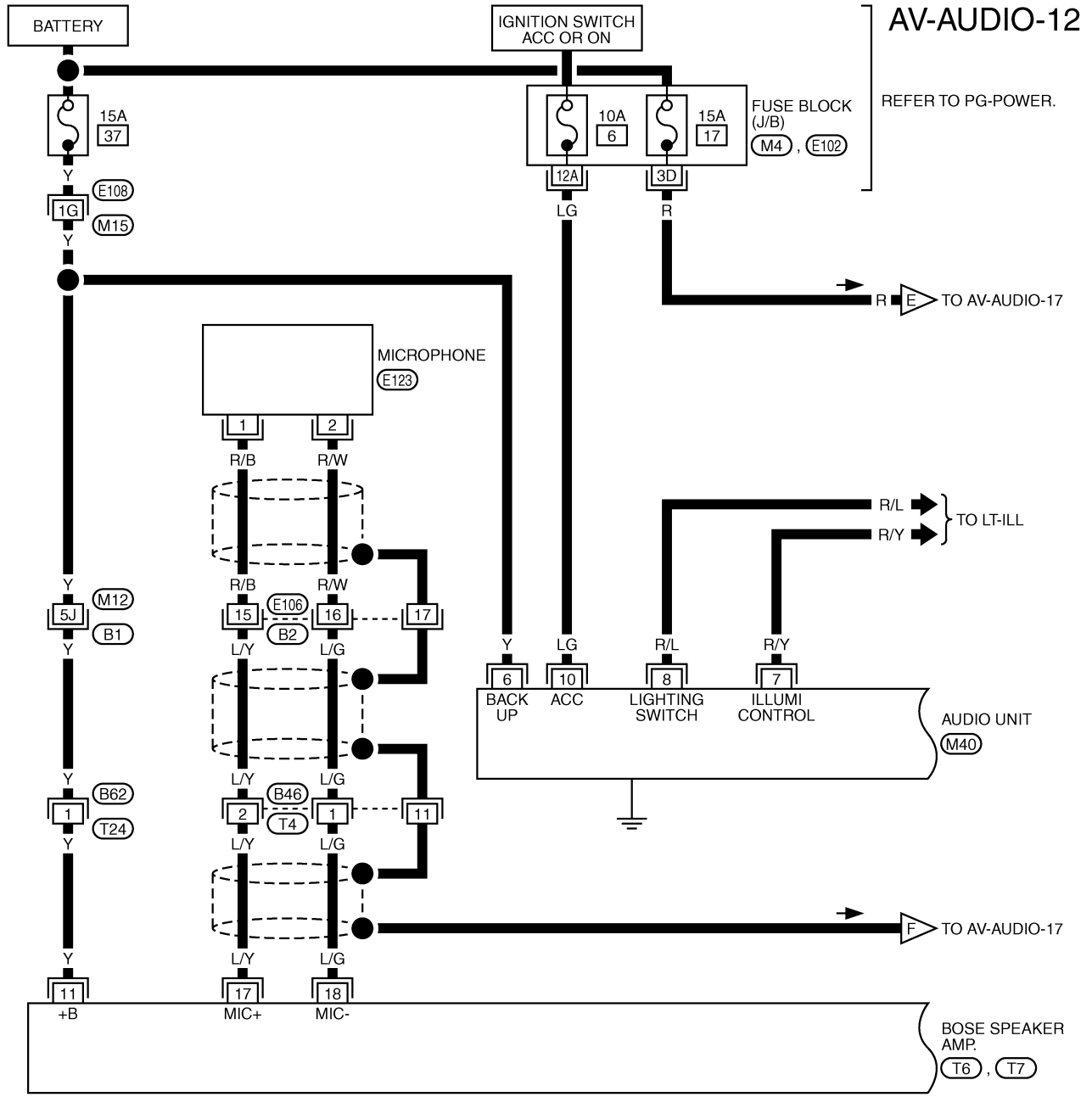

AV-AUDIO-12

REFER TO PG-POWER.

R/L
R/Y } TO LT-ILL

AUDIO UNIT
(M40)

BOSE SPEAKER
AMP.
(T6, T7)

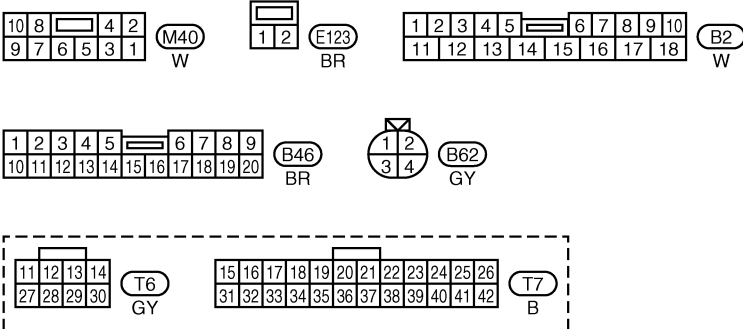

REFER TO THE FOLLOWING.

(E108), (B1) -SUPER MULTIPLE
JUNCTION (SMJ)

(M4), (E102) -FUSE BLOCK-
JUNCTION BOX (J/B)

AUDIO

AV-AUDIO-13

A
B
C
D
E
F
G
H
I
J
AV
L
M

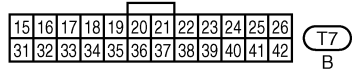
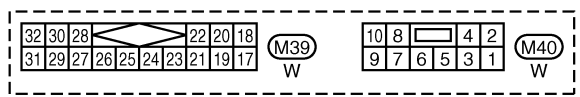
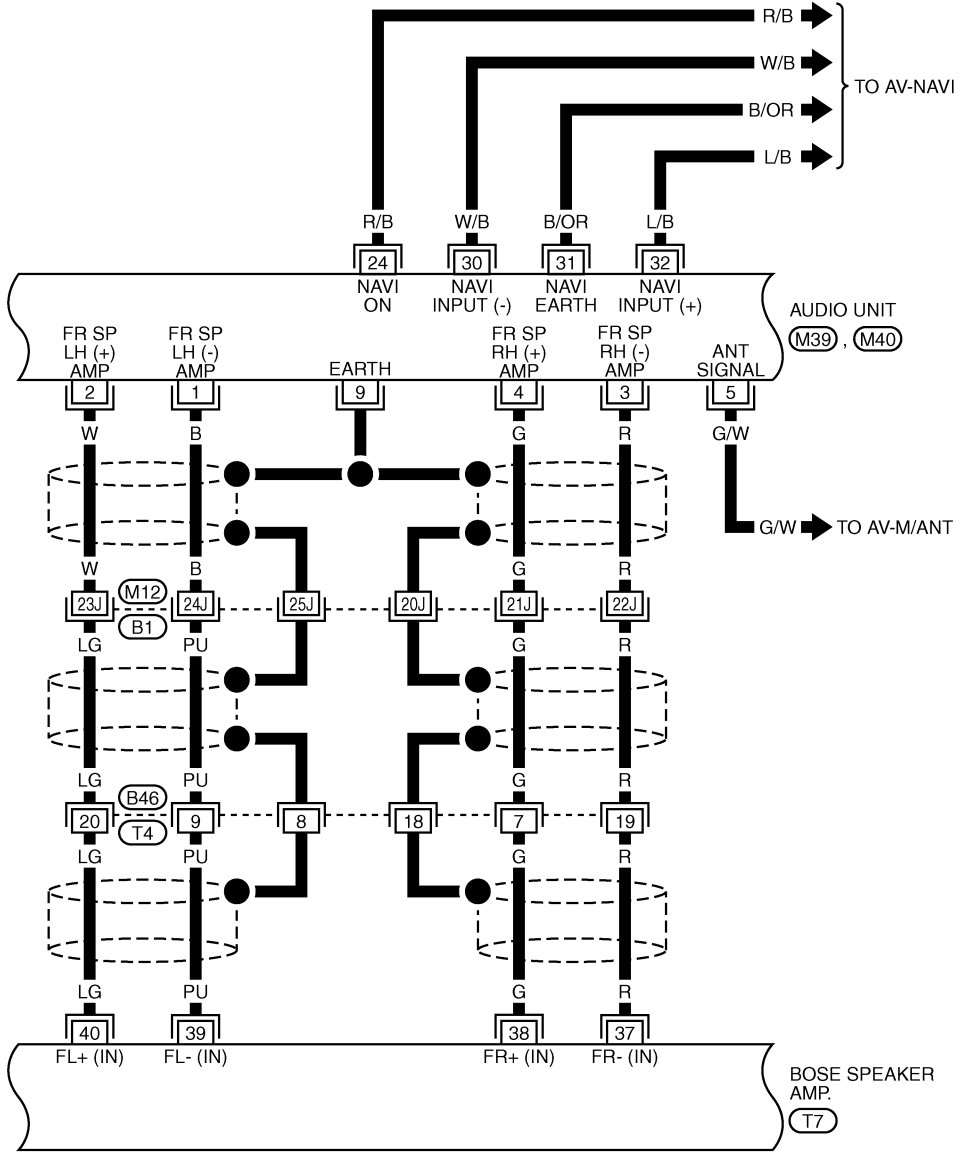

REFER TO THE FOLLOWING.
 (B1) -SUPER MULTIPLE JUNCTION (SMJ)

TKWT1537E

AUDIO

AV-AUDIO-14

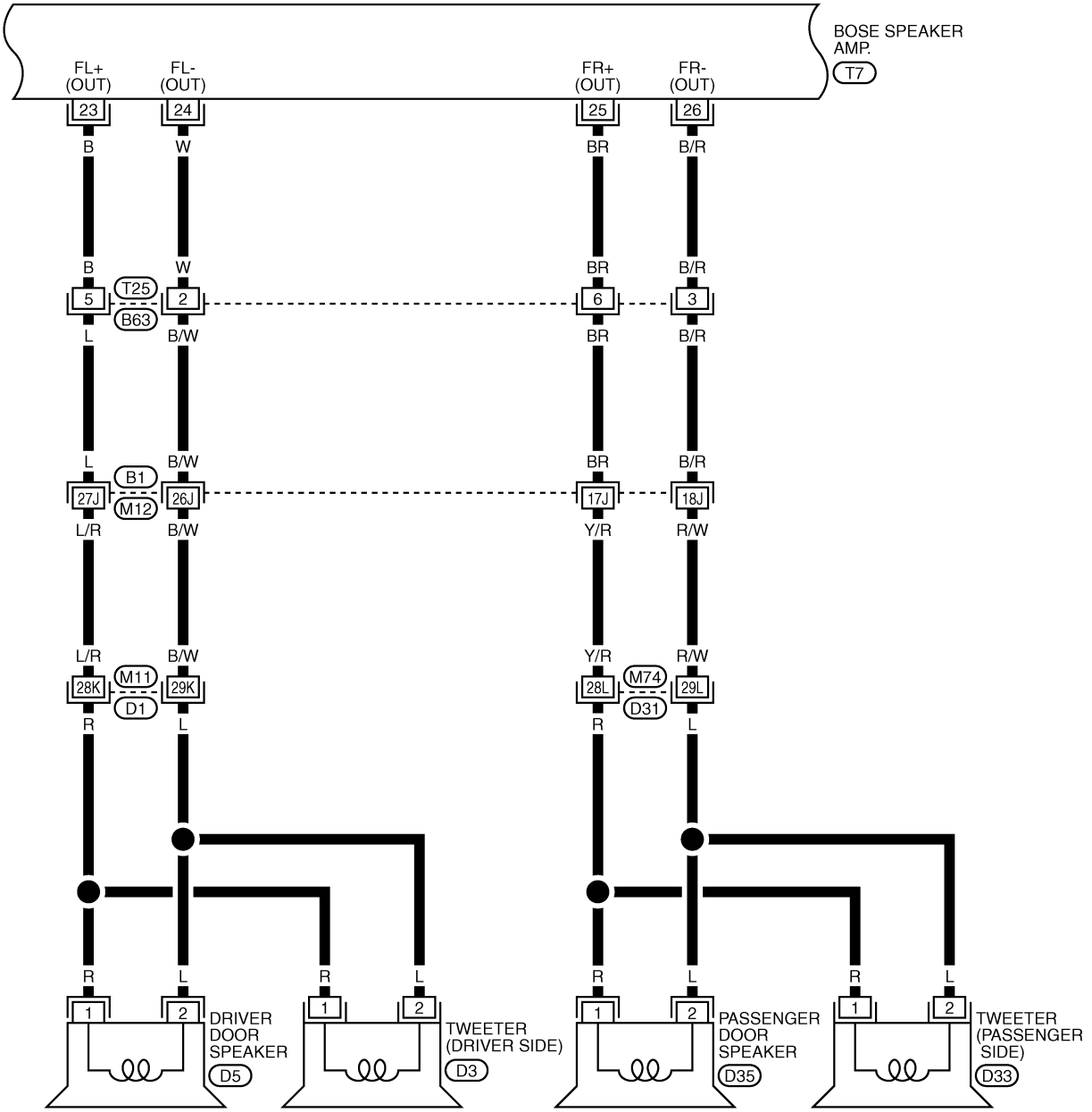

REFER TO THE FOLLOWING.
 (B1), (D1), (D31) -SUPER
 MULTIPLE JUNCTION (SMJ)

TKWT1538E

AUDIO

AV-AUDIO-15

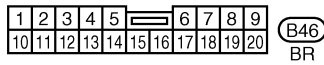
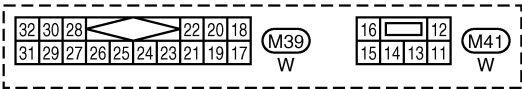
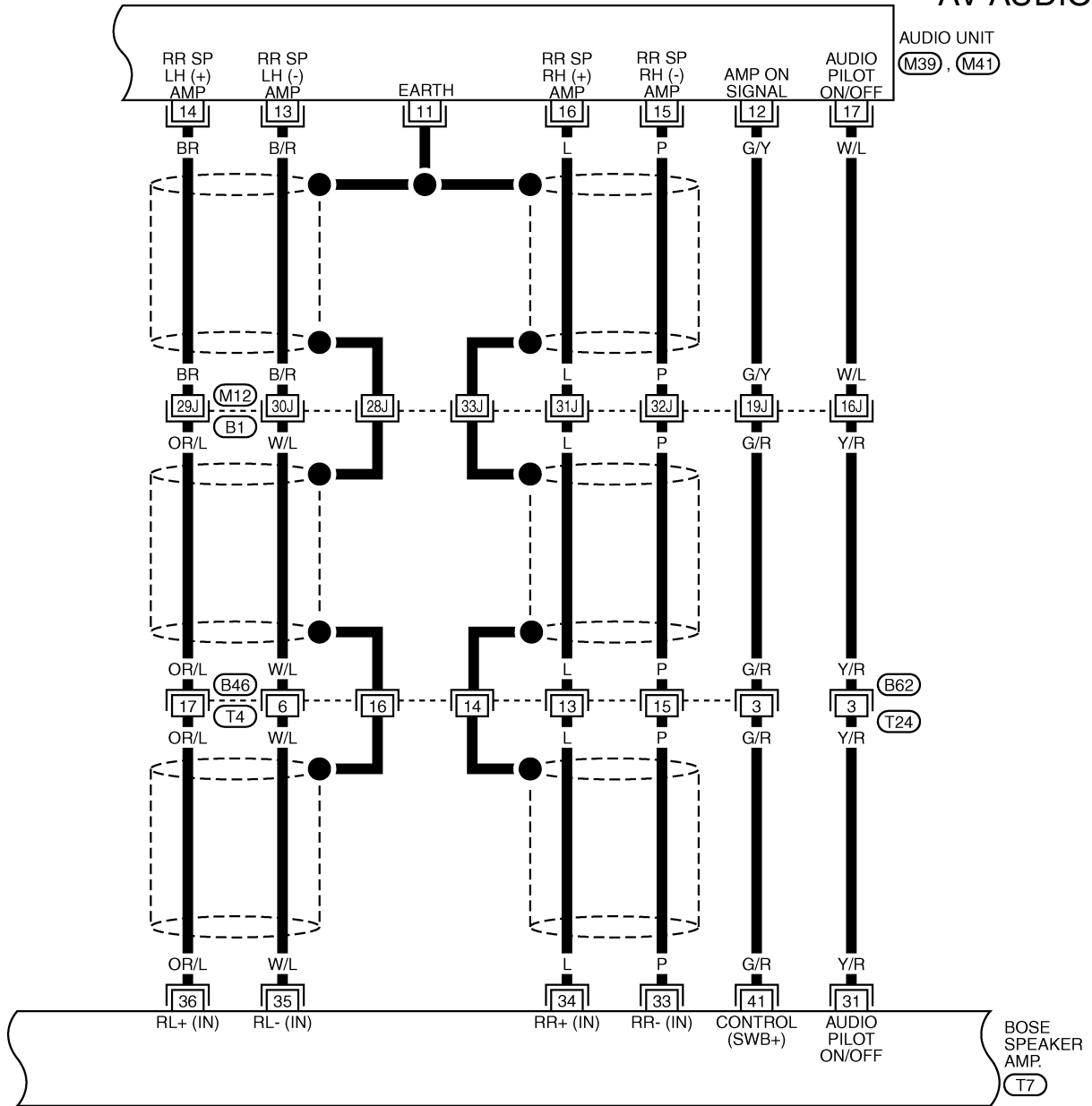

REFER TO THE FOLLOWING.

(B1) -SUPER MULTIPLE JUNCTION (SMJ)

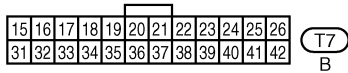
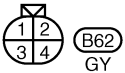

TKWT1539E

AUDIO

AV-AUDIO-16

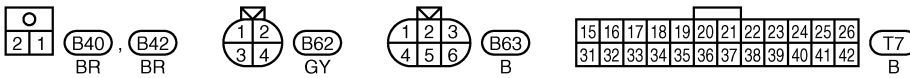
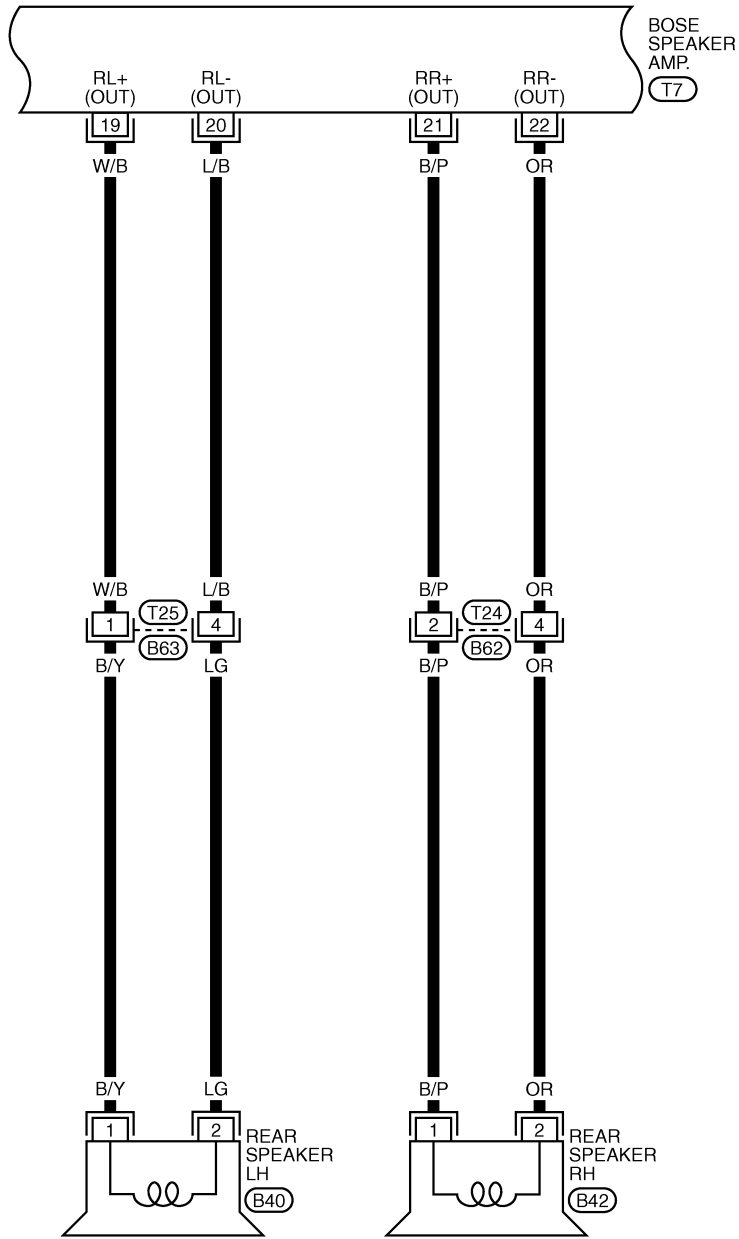

TKWT1540E

AUDIO

AV-AUDIO-17

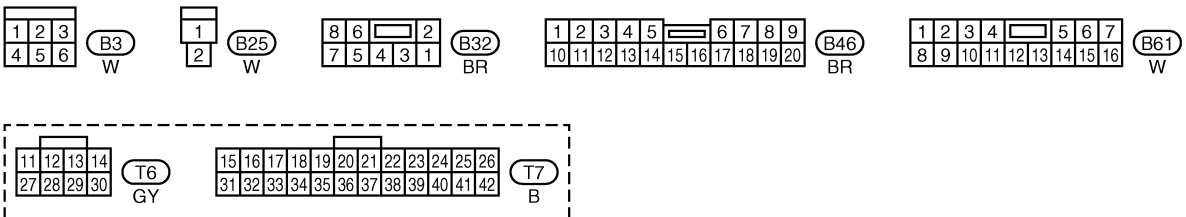
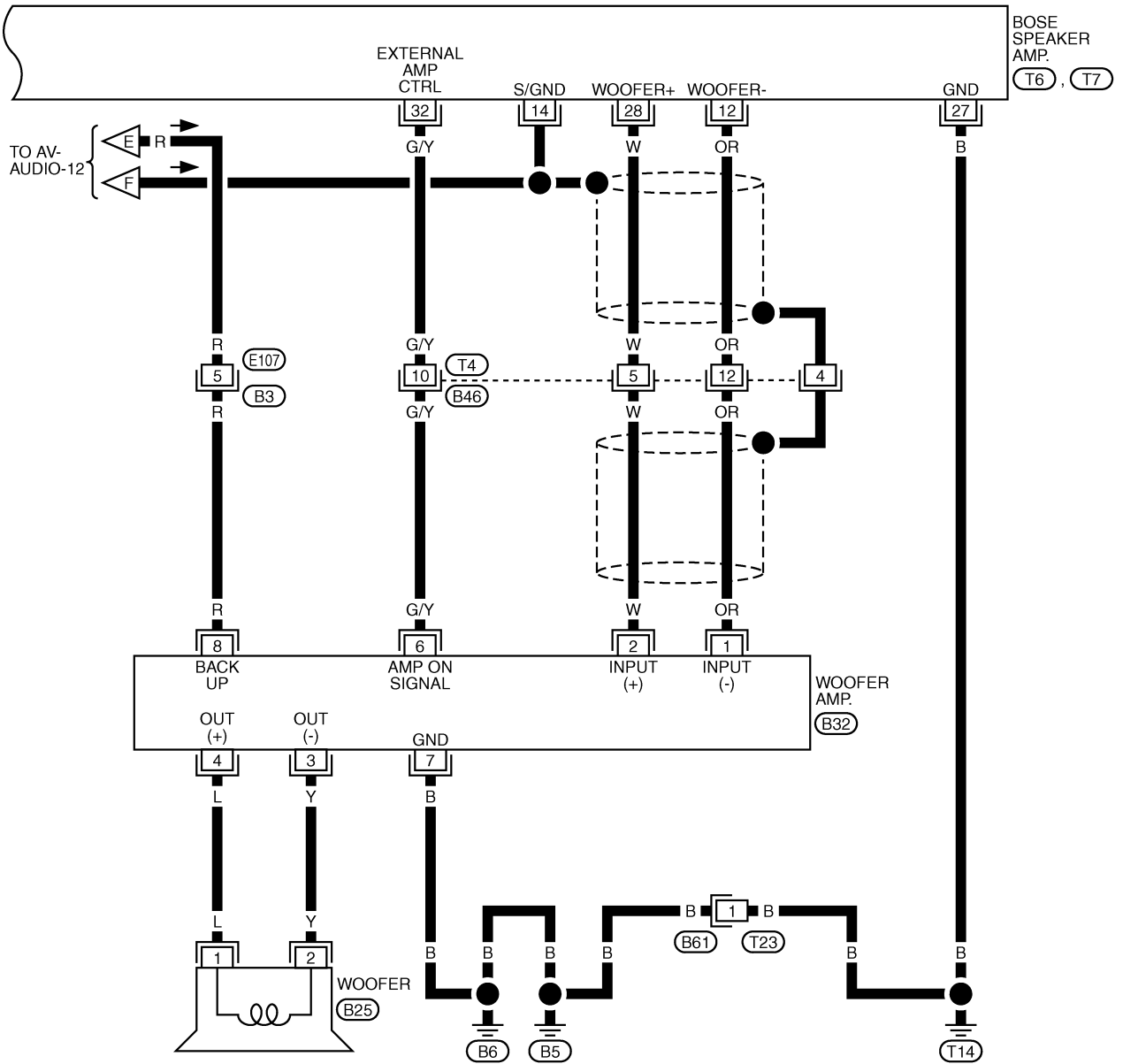

TKWT1541E

AUDIO

Terminals and Reference Value for Audio Unit for Base System

AKS0010K

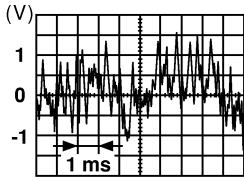
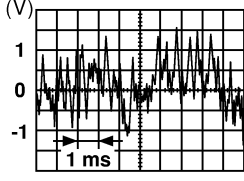
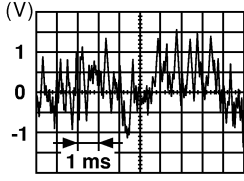
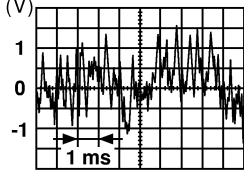
Terminal (Wire color)		Item	Signal input/ output	Condition		Reference value	Example of symptom
+	-			Ignition switch	Operation		
2 (L/R) ^{*1} (W) ^{*2}	1 (B/W) ^{*1} (B) ^{*2}	Audio sound signal front LH	Output	ON	Receive audio signal	 <p style="text-align: right; font-size: small;">SKIA0177E</p>	No sound from driver door speaker and tweeter (driver side).
4 (Y/R) ^{*1} (G) ^{*2}	3 (R/W) ^{*1} (R) ^{*2}	Audio sound signal front RH	Output	ON	Receive audio signal	 <p style="text-align: right; font-size: small;">SKIA0177E</p>	No sound from passenger door speaker and tweeter (passen- ger side).
5 (G/W)	Ground	Antenna signal	Output	ON	-	Approx. 12V	Antenna amp. does not work properly.
6 (Y)	Ground	Battery power supply	Input	OFF	-	Battery voltage	System does not work properly.
7 (R/Y)	Ground	Illumination control signal	Input	ON	Illumination control switch is operated by lighting switch in ON position	Changes between approx. 0 and approx. 12V	Audio unit illumina- tion cannot be controlled.
8 (R/L)	Ground	Lighting switch signal	Input	ON	Lighting switch ON	Approx. 12V	Audio unit illumina- tion does not function when lighting switch is ON.
					Lighting switch OFF	Approx. 0V	
10 (LG)	Ground	ACC power supply	Input	ACC	-	Battery voltage	System does not work properly.
14 (LG/R) ^{*1} (BR) ^{*2}	13 (B/Y) ^{*1} (B/R) ^{*2}	Audio sound signal rear LH	Output	ON	Receive audio signal	 <p style="text-align: right; font-size: small;">SKIA0177E</p>	No sound from rear speaker LH.
16 (L/OR) ^{*1} (L) ^{*2}	15 (B/P) ^{*1} (P) ^{*2}	Audio sound signal rear RH	Output	ON	Receive audio signal	 <p style="text-align: right; font-size: small;">SKIA0177E</p>	No sound from rear speaker RH.

- *1: Coupe models with M/T without navigation system, VDC system and power seat for USA, or Roadster models without navigation system.
- *2: Except *1

AUDIO

Terminals and Reference Value for Audio Unit for BOSE System

AKS0010L

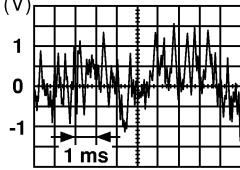
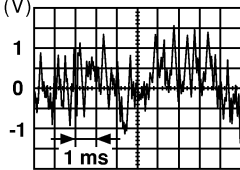
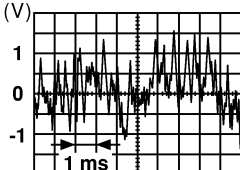
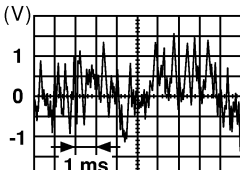
Terminal (Wire color)		Item	Signal input/ output	Condition		Reference value	Example of symptom
+	-			Ignition switch	Operation		
2 (W)	1 (B)	Audio sound signal front LH	Output	ON	Receive audio signal	 <small>SKIA0177E</small>	No sound from driver door speaker and tweeter (driver side).
4 (G)	3 (R)	Audio sound signal front RH	Output	ON	Receive audio signal	 <small>SKIA0177E</small>	No sound from passenger door speaker and tweeter (passen- ger side).
5 (G/W)	Ground	Antenna signal	Output	ON	-	Approx. 12V	Antenna amp. does not work properly.
6 (Y)	Ground	Battery power supply	Input	OFF	-	Battery voltage	System does not work properly.
7 (R/Y)	Ground	Illumination control signal	Input	ON	Illumination control switch is operated by lighting switch in ON position	Changes between approx. 0 and approx. 12V	Audio unit illumina- tion cannot be controlled.
8 (R/L)	Ground	Lighting switch signal	Input	ON	Lighting switch ON	Approx. 12V	Audio unit illumina- tion does not function when lighting switch is ON.
					Lighting switch OFF	Approx. 0V	
9	Ground	Shield	-	ON	-	Approx. 0V	-
10 (LG)	Ground	ACC power supply	Input	ACC	-	Battery voltage	System does not work properly.
11	Ground	Shield	-	ON	-	Approx. 0V	-
12 (G/Y)	Ground	Amp. ON signal	Output	ON	-	Approx. 12V	BOSE speaker amp. does not work properly.
14 (BR)	13 (B/R)	Audio sound signal rear LH	Output	ON	Receive audio signal	 <small>SKIA0177E</small>	No sound from rear speaker LH.
16 (L)	15 (P)	Audio sound signal rear RH	Output	ON	Receive audio signal	 <small>SKIA0177E</small>	No sound from rear speaker RH.

A
B
C
D
E
F
G
H
I
J
K
L
M

AV

AUDIO

Terminal (Wire color)		Item	Signal input/ output	Condition		Reference value	Example of symptom
+	-			Ignition switch	Operation		
17 (W/L)	Ground	AudioPilot® ON/OFF signal	Output	ON	AudioPilot® OFF	Approx. 7.5V	AudioPilot® sys- tem does not operate properly.
					AudioPilot® ON	Approx. 0V	

Terminals and Reference Value for BOSE Speaker Amp. AKS0010M

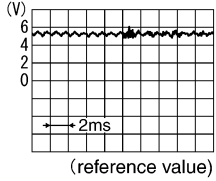
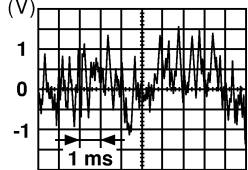
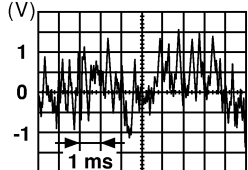
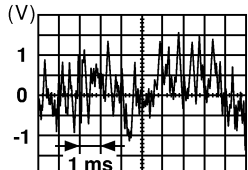
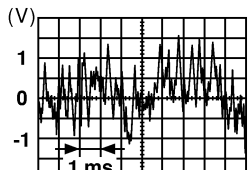
Terminal (Wire color)		Item	Signal input/ output	Condition		Reference value	Example of symptom
+	-			Ignition switch	Operation		
11 (Y)	Ground	Battery power supply	Input	ON	-	Battery voltage	BOSE speaker amp. does not work properly.
14	Ground	Shield	-	ON	-	Approx. 0V	-
17 (R/B) ^{*1} (L/Y) ^{*2}	18 (R/W) ^{*1} (L/G) ^{*2}	Microphone signal	Input	ON	Microphone test operate		AudioPilot® sys- tem does not operate properly.
19 (W/B)	20 (L/B)	Audio sound signal rear LH	Output	ON	Receive audio signal		No sound from rear speaker LH.
21 (G) ^{*1} (B/P) ^{*2}	22 (G/W) ^{*1} (OR) ^{*2}	Audio sound signal rear RH	Output	ON	Receive audio signal		No sound from rear speaker RH.
23 (B)	24 (W)	Audio sound signal front LH	Output	ON	Receive audio signal		No sound from driver door speaker and tweeter (driver side).
25 (BR)	26 (B/R)	Audio sound signal front RH	Output	ON	Receive audio signal		No sound from passenger door speaker and tweeter (passen- ger side).
27 (B)	Ground	Ground	-	ON	-	Approx. 0V	-

AUDIO

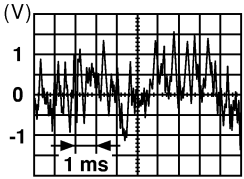
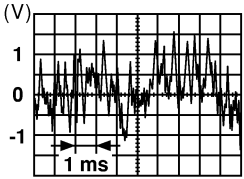
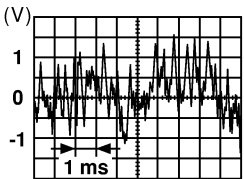
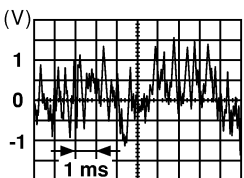
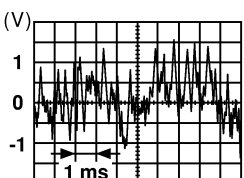
Terminal (Wire color)		Item	Signal input/ output	Condition		Reference value	Example of symptom
+	-			Ignition switch	Operation		
28 (W)	12 (OR)	Audio sound signal woofer	Output	ON	Receive audio signal	 SKIA0177E	No sound from woofer.
31 (Y/R)	Ground	AudioPilot® ON/OFF signal	Input	ON	AudioPilot® OFF	Approx. 7.5V	AudioPilot® sys- tem does not operate properly.
					AudioPilot® ON	Approx. 0V	
32 (G/R) ^{*1} (G/Y) ^{*2}	Ground	External amp. control signal	Output	ON	-	Approx. 12V	Woofer amp. does not work properly.
34 (L)	33 (P)	Audio sound signal rear RH	Input	ON	Receive audio signal	 SKIA0177E	No sound from rear speaker RH.
36 (Y/G) ^{*1} (OR/L) ^{*2}	35 (Y/L) ^{*1} (W/L) ^{*2}	Audio sound signal rear LH	Input	ON	Receive audio signal	 SKIA0177E	No sound from rear speaker LH.
38 (G)	37 (R)	Audio sound signal front RH	Input	ON	Receive audio signal	 SKIA0177E	No sound from passenger door speaker and tweeter (passen- ger side).
40 (LG)	39 (PU)	Audio sound signal front LH	Input	ON	Receive audio signal	 SKIA0177E	No sound from driver door speaker and tweeter (driver side).
41 (G/Y) ^{*1} (G/R) ^{*2}	Ground	Control (SWB+)	Input	ON	-	Approx. 12V	BOSE speaker amp. does not work properly.

*1: Coupe models

*2: Roadster models

A
B
C
D
E
F
G
H
I
J
AV
L
M

AUDIO

Terminals and Reference Value for Woofer Amp.

AKS009RD

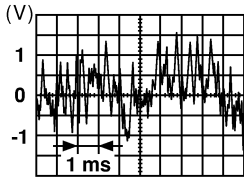
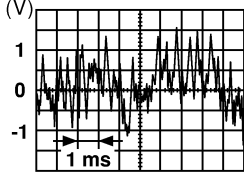
Terminal (Wire color)		Item	Signal input/ output	Condition		Reference value	Example of symptom
+	-			Ignition switch	Operation		
2 (W)	1 (OR)	Audio sound signal woofer	Input	ON	Receive audio signal		No sound from woofer.
4 (L)	3 (Y)	Audio sound signal woofer	Output	ON	Receive audio signal		No sound from woofer.
6 (G/Y)	Ground	Amp. ON sig- nal	Input	ON	-	Approx. 12V	Woofer amp. does not work properly.
7 (B)	Ground	Ground	-	ON	-	Approx. 0V	-
8 (R)	Ground	Battery power supply	Input	OFF	-	Battery voltage	Woofer amp. does not work properly.

AUDIO

AKS0010P

Trouble Diagnosis

The majority of the audio malfunctions are the result of outside causes (bad CD/cassette, electromagnetic interference, etc.). Check the symptoms below to diagnose the malfunction.

PROBLEM WITH RADIO, TAPE AND CD (BASE SYSTEM)

Symptom	Check item	Possible cause
Inoperative	<ul style="list-style-type: none"> ● Make sure that the ignition switch is in the ACC position. 	<ul style="list-style-type: none"> ● Audio unit ● Audio unit power supply circuit. Refer to AV-36, "Power Supply Circuit Inspection".
No sound	<ul style="list-style-type: none"> ● Make sure that the volume is not turned down. ● Make sure that the balance and fader control knobs are centered. 	<ul style="list-style-type: none"> ● Audio unit ● Open or short in harness between audio unit and speaker ● Speaker
Poor sound	<ul style="list-style-type: none"> ● Make sure that the bass and treble adjustment is centered. 	<ul style="list-style-type: none"> ● Audio unit ● Speaker
Noisy	–	<ul style="list-style-type: none"> ● Audio unit ● Each electrical equipment

PROBLEM WITH RADIO, TAPE AND CD (BOSE SYSTEM)

Symptom	Check item	Possible cause
Inoperative	<ul style="list-style-type: none"> ● Make sure that the ignition switch is in the ACC position. 	<ul style="list-style-type: none"> ● Audio unit ● Audio unit power supply circuit. Refer to AV-36, "Power Supply Circuit Inspection".
No sound	<ul style="list-style-type: none"> ● Make sure that the volume is not turned down. ● Make sure that the balance and fader control knobs are centered. 	<ul style="list-style-type: none"> ● BOSE speaker amp. power supply and ground circuit. Refer to AV-36, "Power Supply Circuit Inspection". ● Open or short in harness between audio unit and BOSE speaker amp. ● Open or short in harness between BOSE speaker amp. and speaker ● Audio unit ● BOSE speaker amp. ● Speaker
Woofer does not sound	–	<ul style="list-style-type: none"> ● Woofer amp. power supply and ground circuit. Refer to AV-36, "Power Supply Circuit Inspection". ● Open or short in harness between woofer amp. and woofer ● Open or short in harness between BOSE speaker amp. and woofer amp. ● BOSE speaker amp. ● Woofer amp. ● Woofer
Poor sound	<ul style="list-style-type: none"> ● Make sure that the bass and treble adjustment is centered. 	<ul style="list-style-type: none"> ● Audio unit ● BOSE speaker amp. ● Speaker
Noisy	–	<ul style="list-style-type: none"> ● Audio unit ● BOSE speaker amp. ● Each electrical equipment

AUDIO

FOR RADIO ONLY

Symptom	Check item	Possible cause
No sound	<ul style="list-style-type: none"> ● Make sure that the audio unit is tuned to a station's frequency. 	<ul style="list-style-type: none"> ● Audio unit ● Antenna feeder ● Antenna amp. ON signal ● Antenna amp. ● Antenna
Noisy	<ul style="list-style-type: none"> ● Make sure that the audio unit is tuned to a station's frequency. ● Make sure that the signal of the received station is not weak. ● Check whether or not the malfunction occurs only in a particular area. (Note) 	<ul style="list-style-type: none"> ● Audio unit ● Antenna feeder ● Antenna amp. ON signal ● Antenna amp. ● Antenna ● Noise prevention parts ● Each electrical equipment ● Wire harness of each piece of electrical equipment
Selected radio stations stored in memory are deleted	-	<ul style="list-style-type: none"> ● Audio unit

NOTE:

This is noise resulting from variations in field strength, such as fading noise and multi-path noise, or external noise from trains and other sources. It is not a malfunction.

- Fading noise: This noise occurs because of variations in the field strength in a narrow range due to mountains or buildings blocking the signal.
- Multi-path noise: This noise results from the waves sent directly from the broadcast station arriving at the antenna at a different time from the waves which reflect off of mountains or buildings.

FOR CASSETTE PLAYER ONLY

Symptom	Check item	Possible cause
Cassette tape cannot be inserted	<ul style="list-style-type: none"> ● Make sure that a cassette tape is not already inserted. ● Make sure that the cassette has no deformation or other malfunction. 	<ul style="list-style-type: none"> ● Cassette tape ● Audio unit
Cassette tape cannot be ejected	<ul style="list-style-type: none"> ● Make sure that the cassette has no deformation or other malfunction. ● Make sure that the cassette tape does not sag. 	
Auto reverse does not work, or the tape direction changes in the middle of play	<ul style="list-style-type: none"> ● There is a problem with tape winding. Check that there is no slack or other malfunction. ● Make sure that an old cassette tape is not being used. 	
There is much noise	<ul style="list-style-type: none"> ● Check that the cassette tape itself does not have a lot of noise, or that the tape does not have a low recording level. 	
The sound is not clear	<ul style="list-style-type: none"> ● Make sure that the tune is recorded on tape with Dolby B NR OFF and played with Dolby B NR ON. ● Make sure that the sound quality of the cassette tape itself is not poor. 	
Sound fluctuates/tape speed not correct	<ul style="list-style-type: none"> ● Make sure that there is no tape winding problem, sagging, stretching, or other malfunction. ● Make sure that there is no problem with the recording speed of the cassette tape. 	
No sound	<ul style="list-style-type: none"> ● Make sure that the cassette tape has been recorded on. 	

AUDIO

FOR CD ONLY

Symptom	Check item	Possible cause
CD cannot be inserted	<ul style="list-style-type: none"> ● Make sure that a CD is not already inserted. 	<ul style="list-style-type: none"> ● CD ● Audio unit
CD cannot be ejected	-	
The CD cannot be played	<ul style="list-style-type: none"> ● Make sure that the CD is not upside down. ● Make sure that there is no dirt, damage, or water on the disc. 	
The sound skips, stops suddenly, or is distorted	<ul style="list-style-type: none"> ● Make sure that there is no dirt, damage, or water on the disc. ● Make sure that the trouble is not due to strong vibration. 	

Noise Inspection

AKS0010Q

The vehicle itself can be a source of noise if noise prevention parts or electrical equipment is malfunction. Check if noise is caused and/or changed by engine speed, ignition switch turned to each position, and operation of each piece of electrical equipment, and determine the cause.

NOTE:

The source of the noise can be found easily by listening to the noise while removing the fuses of electrical components, one by one.

TYPE OF NOISE AND POSSIBLE CAUSE

Symptom	Check item	
Occurs only when engine is ON	A continuous growling noise occurs. The speed of the noise varies with changes in the engine speed.	<ul style="list-style-type: none"> ● Ignition condenser
	A whistling noise occurs while the engine speed is high. A booming noise occurs while the engine is running and the lighting switch is ON.	<ul style="list-style-type: none"> ● Alternator
The occurrence of the noise is linked with the operation of the fuel pump	<ul style="list-style-type: none"> ● Fuel pump condenser 	
Noise only occurs when various electrical components are operating	A cracking or snapping sound occurs with the operation of various switches.	<ul style="list-style-type: none"> ● Relay malfunction, audio unit malfunction
	The noise occurs when various motors are operating.	<ul style="list-style-type: none"> ● Motor case ground ● Motor
The noise occurs constantly, not just under certain conditions	<ul style="list-style-type: none"> ● Poor ground of antenna amplifier or antenna feeder line 	
A cracking or snapping sound occurs while the vehicle is being driven, especially when it is vibrating excessively	<ul style="list-style-type: none"> ● Ground wire of body parts ● Ground due to incorrect installation of parts ● Wiring connections or a short circuit 	

AUDIO

AKS0010R

Power Supply Circuit Inspection

1. CHECK FUSE

Make sure that the following fuses of the audio unit, BOSE speaker amp. and woofer amp. are not blown.

Unit	Signal	Fuse No.
Audio unit	Battery power supply	37
	Ignition switch ACC or ON	6
BOSE speaker amp.	Battery power supply	37
Woofer amp.	Battery power supply	17

OK or NG

OK >> GO TO 2.

NG >> If fuse is blown, be sure to eliminate cause of malfunction before installing new fuse. Refer to [PG-4, "POWER SUPPLY ROUTING CIRCUIT"](#).

2. CHECK POWER SUPPLY CIRCUIT

1. Check voltage between audio unit harness connector terminals and ground.

Unit	Terminals			OFF	ACC	ON	
	Connector	(+)					(-)
		Terminal (Wire color)					
Audio unit	M40	6 (Y)	Ground	Battery voltage	Battery voltage	Battery voltage	
		10 (LG)	Ground	0 V	Battery voltage	Battery voltage	

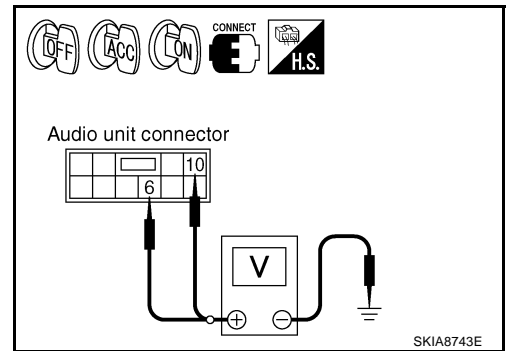

2. Check voltage between BOSE speaker amp., woofer amp. harness connector terminals and ground (BOSE system).

Unit	Terminals			OFF	ACC	ON	
	Connector	(+)					(-)
		Terminal (Wire color)					
BOSE speaker amp.	T6	11 (Y)	Ground	Battery voltage	Battery voltage	Battery voltage	
Woofer amp.	B32	8 (R)					

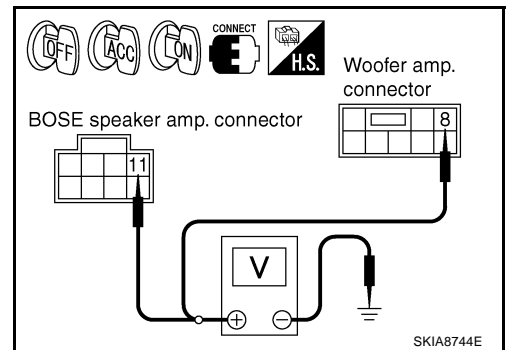

OK or NG

OK >> ● INSPECTION END (Base system)

● GO TO 3 (BOSE system).

NG >> Repair harness or connector.

AUDIO

3. CHECK GROUND CIRCUIT

1. Turn ignition switch OFF.
2. Disconnect BOSE speaker amp. and woofer amp. connectors.
3. Check continuity between BOSE speaker amp. harness connector T6 terminal 27 (B) and ground.

27 – Ground : Continuity should exist.

4. Check continuity between woofer amp. harness connector B32 terminal 7 (B) and ground.

7 – Ground : Continuity should exist.

OK or NG

- OK >> INSPECTION END
NG >> Repair harness or connector.

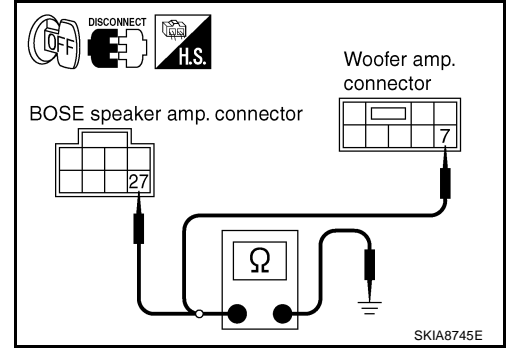

AudioPilot® Does Not Work

1. CHECK AUDIO UNIT

Check AudioPilot® turns ON.

OK or NG

- OK >> GO TO 2.
NG >> Turn AudioPilot® ON.

2. CHECK HARNESS

1. Turn ignition switch OFF.
2. Disconnect audio unit and BOSE speaker amp. connectors.
3. Check continuity between audio unit harness connector M39 terminal 17 (W/L) and BOSE speaker amp. harness connector T7 terminal 31 (Y/R).

17 – 31 : Continuity should exist.

4. Check continuity between audio unit harness connector M39 terminal 17 (W/L) and ground.

17 – Ground : Continuity should not exist.

OK or NG

- OK >> GO TO 3.
NG >> Repair harness or connector.

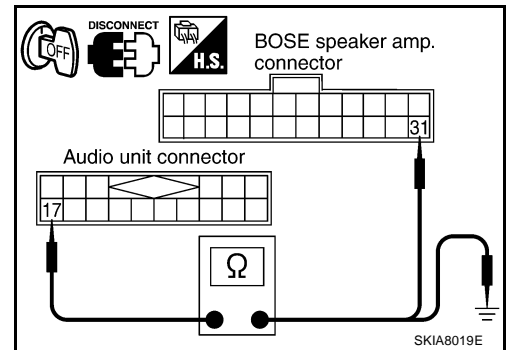

A
B
C
D
E
F
G
H
I
J
AV
L
M

AUDIO

3. CHECK AUDIOPILOT® SIGNAL

1. Connect audio unit and BOSE speaker amp. connectors.
2. Turn ignition switch ON.
3. Check voltage between audio unit harness connector terminals and ground.

Terminals			Condition	Voltage
(+)		(-)		
Connector	Terminal (Wire color)			
M39	17 (W/L)	Ground	AudioPilot® OFF	Approx. 7.5V
			AudioPilot® ON	Approx. 0V

OK or NG

- OK >> GO TO 4.
 NG >> Replace audio unit.

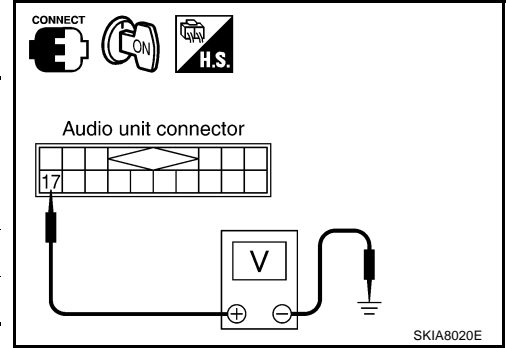

4. CHECK 1: MICROPHONE CIRCUIT

1. Turn ignition switch OFF
2. Disconnect BOSE speaker amp. and microphone connectors.
3. Check continuity between BOSE speaker amp. harness connector T7 terminal 17 (R/B for Coupe models, L/Y for Roadster models) and microphone harness connector E123 terminal 1 (R/B).

17 – 1 : Continuity should exist.

4. Check continuity between BOSE speaker amp. harness connector T7 terminal 17 (R/B for Coupe models, L/Y for Roadster models) and ground.

17 – Ground : Continuity should not exist.

OK or NG

- OK >> GO TO 5.
 NG >> Repair harness or connector.

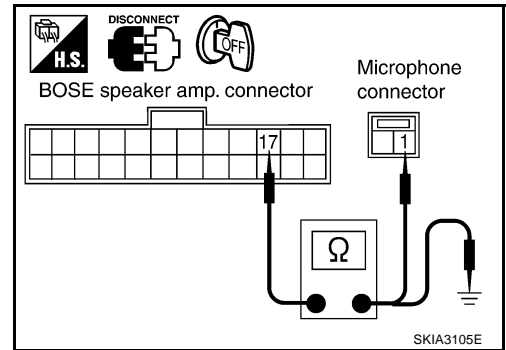

5. CHECK 2: MICROPHONE CIRCUIT

1. Check continuity between BOSE speaker amp. harness connector T7 terminal 18 (R/W for Coupe models, L/G for Roadster models) and microphone harness connector E123 terminal 2 (R/W).

18 – 2 : Continuity should exist.

2. Check continuity between BOSE speaker amp. harness connector T7 terminal 18 (R/W for Coupe models, L/G for Roadster models) and ground.

18 – Ground : Continuity should not exist.

OK or NG

- OK >> GO TO 6.
 NG >> Repair harness or connector.

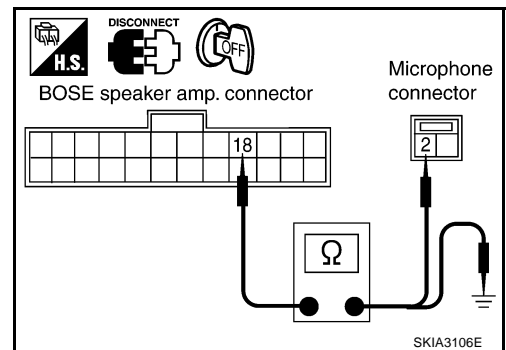

AUDIO

6. CHECK MICROPHONE SIGNAL

1. Connect BOSE speaker amp. and microphone connectors.
2. Turn ignition switch ON.
3. Check voltage waveform between BOSE speaker amp. harness connector T7 terminal 17 (R/B for Coupe models, L/Y for Roadster models) and 18 (R/W for Coupe models, L/G for Roadster models) using CONSULT-II or oscilloscope, when inputting some sounds (voice, etc.) toward the microphone.

17 – 18:

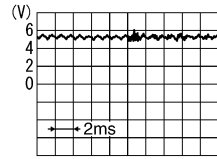

(reference value)

PKIA2104E

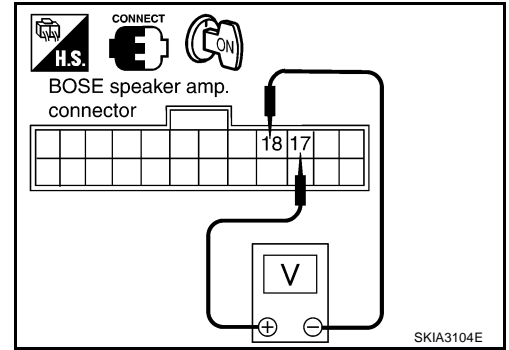

Does the voltage signal change with sounds?

- YES >> Replace BOSE speaker amp.
NO >> Replace microphone.

A
B
C
D
E
F
G
H
I
J
L
M

AV

AUDIO

Removal and Installation of Audio Unit (Base System)

AKS002ZS

REMOVAL

1. Remove cluster lid C. Refer to [IP-10, "INSTRUMENT PANEL ASSEMBLY"](#).
2. Remove screws (4), and remove audio unit.

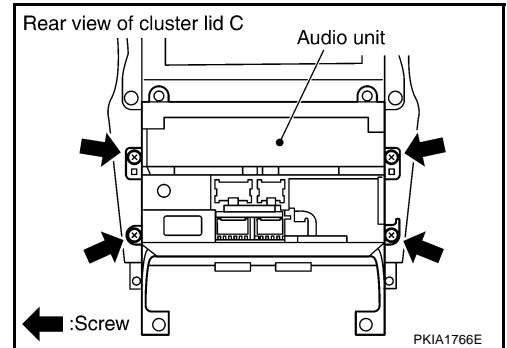

3. Remove screws (8), and remove bracket.

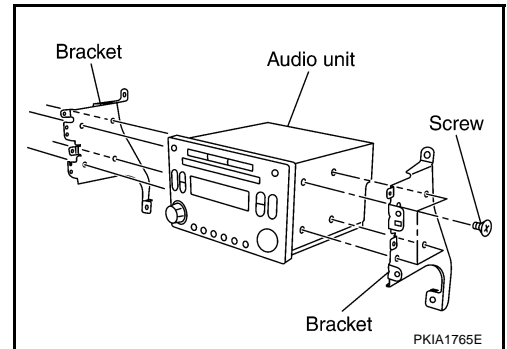

INSTALLATION

Installation is the reverse order of removal.

Locking CD Auto-Changer Mechanism (Audio Unit of BOSE System)

AKS0010U

CAUTION:

- Prior to removing a malfunctioning CD auto-changer unit (Audio unit of BOSE system) that will be shipped for repair, the changer mechanism **MUST BE LOCKED** to prevent the mechanism from being damaged during shipping.
- If a CD is jammed or unable to be removed from the unit, do **NOT** lock the changer mechanism. If the unit is to be shipped for repair, carefully package the unit to prevent vibration and shock.

DAMPER LOCK PROCEDURE

1. Eject and remove any CDs from the audio unit (BOSE system).
2. Turn ignition switch OFF. Wait until audio unit (BOSE system) display is off and mechanism stops moving (mechanism sound stops).
3. Press any one of the disc selection buttons once. When a display shows on the audio unit (BOSE system), press the same disc selection button again within 5 seconds.
 - The changer mechanism will lock itself within 10 seconds.
4. After mechanism stops moving (mechanism sound stops), open the driver and passenger window, and then disconnect negative battery cable.

CAUTION:

After the battery cables are disconnected, do not open/close the driver and/or front passenger door with the window in the full up position. The automatic window adjusting function will not work and the side roof panel may be damaged.

NOTE:

After installing a new or remanufactured audio unit (BOSE system), switching the audio unit (BOSE system) ON will automatically unlock the mechanism. A special unlocking procedure is not required.

AUDIO

Removal and Installation of Audio Unit (BOSE System)

AKS0010V

REMOVAL

1. Perform damper lock operation. Refer to [AV-40, "Locking CD Auto-Changer Mechanism \(Audio Unit of BOSE System\)"](#) .
2. Remove cluster lid C. Refer to [IP-10, "INSTRUMENT PANEL ASSEMBLY"](#) .
3. Remove screws (4), and remove audio unit.

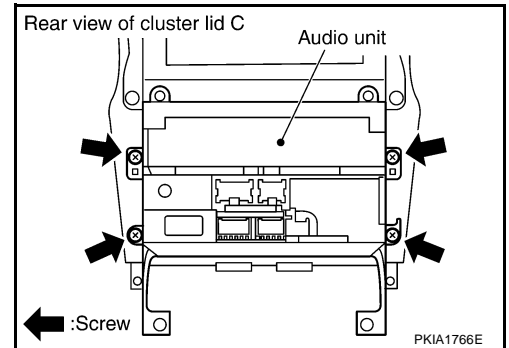

4. Remove screws (8), and remove bracket.

CAUTION:

- When carrying audio unit body, do not touch internal mechanism access from cassette tape slot.
- Be careful not to allow foreign matter from cassette tape slot.

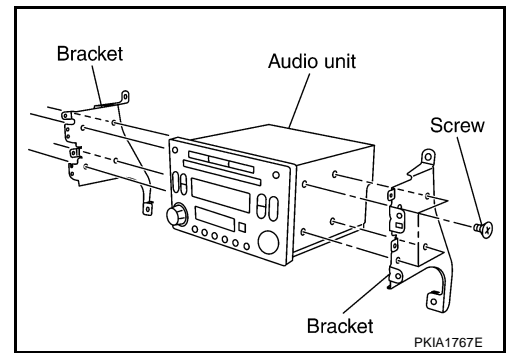

INSTALLATION

Installation is the reverse order of removal.

Removal and Installation of Door Speaker

AKS0010Y

REMOVAL

1. Remove door finisher. Refer to [EI-32, "Removal and Installation"](#) .
2. Remove screws (3) and remove door speaker.

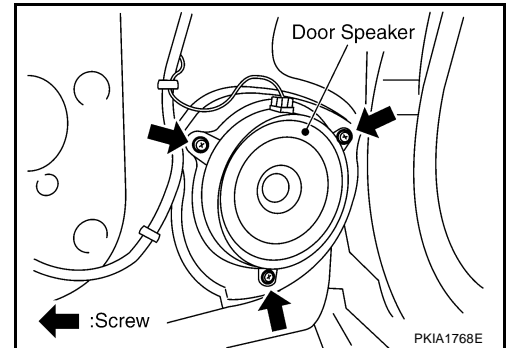

INSTALLATION

Installation is the reverse order of removal.

A
B
C
D
E
F
G
H
I
J
L
M

AV

AUDIO

Removal and Installation of Rear Speaker

AKS002ZT

REMOVAL

1. Remove luggage floor finisher upper (front) (Coupe models) or luggage floor finisher upper (Roadster models). Refer to [EI-38, "Removal and Installation \(for Coupe Models\)"](#) or [EI-40, "Removal and Installation \(for Roadster Models\)"](#) .
2. Remove screws (4) and remove rear speaker.

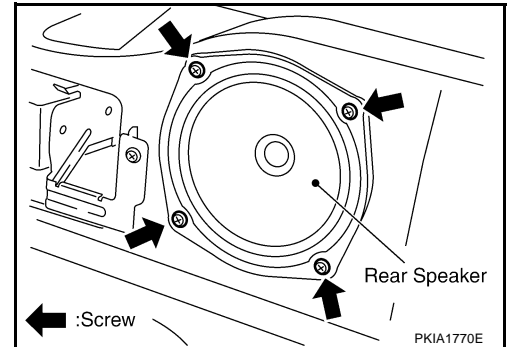

INSTALLATION

Installation is the reverse order of removal.

Removal and Installation of Tweeter

AKS00110

REMOVAL

1. Remove corner cover inner. Refer to [GW-87, "Removal and Installation"](#) .
2. Remove screws (2), and remove tweeter from corner cover inner.

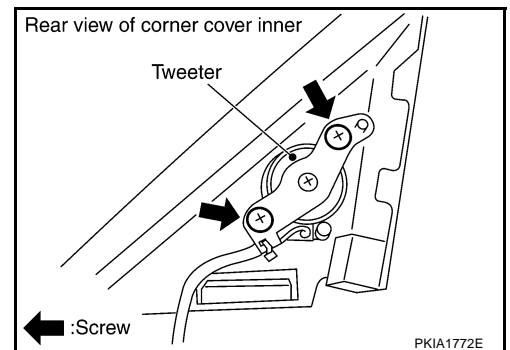

INSTALLATION

Installation is the reverse order of removal.

AUDIO

Removal and Installation of Woofer and Woofer Amp. (BOSE System)

AKS00111

REMOVAL

Woofer Assembly

1. Remove luggage floor finisher lower. Refer to [EI-38, "Removal and Installation \(for Coupe Models\)"](#) or [EI-40, "Removal and Installation \(for Roadster Models\)"](#).
2. Remove woofer mounting screws (4), and remove woofer.
3. Remove bracket mounting bolts (12), and remove bracket.
4. Remove woofer amp. mounting bolts (2), and remove woofer amp. from bracket.

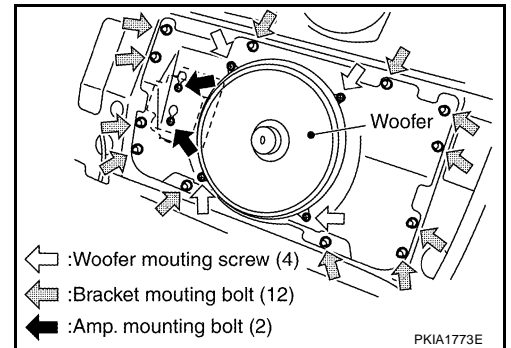

Woofer or Woofer Amp. Only

1. Remove luggage floor finisher mask. Refer to [EI-38, "Removal and Installation \(for Coupe Models\)"](#) or [EI-40, "Removal and Installation \(for Roadster Models\)"](#).
2. Remove woofer mounting screws (4), and remove woofer.
3. Remove woofer amp. mounting bolts (2), and remove woofer amp. from bracket.

INSTALLATION

Installation is the reverse order of removal, taking care of the following point.

Bracket mounting bolt:

: 9 N-m (0.92 kg-m, 80 in-lb)

AUDIO

Removal and Installation of BOSE Speaker Amp.

AKS00112

REMOVAL

1. Remove trunk side box. Refer to [EI-38, "Removal and Installation \(for Coupe Models\)"](#) or [EI-47, "Removal and Installation"](#) .
2. Remove luggage floor carpet and spare tire cover (Coupe models) or trunk floor carpet and spare tire cover.(Roadster models). Refer to [EI-38, "Removal and Installation \(for Coupe Models\)"](#) or [EI-47, "Removal and Installation"](#) .
3. Remove nuts (3), and remove BOSE speaker amp. from trunk room floor.

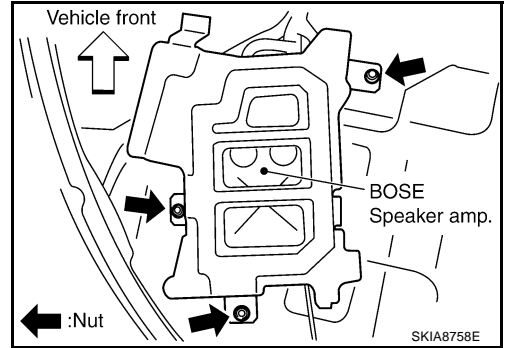

4. Remove bolts (4), and remove bracket.

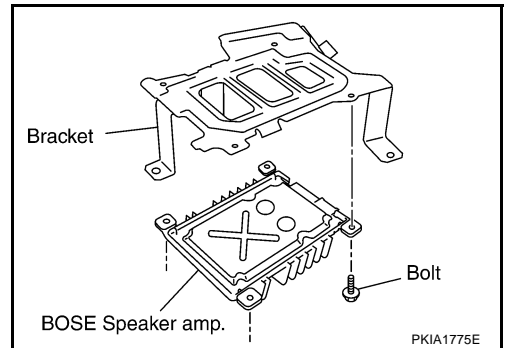

INSTALLATION

Installation is the reverse order of removal.

Removal and Installation of Microphone

AKS00376

REMOVAL

1. Remove steering column lower cover. Refer to [IP-10, "INSTRUMENT PANEL ASSEMBLY"](#) .
2. Remove screws (3), and remove microphone.

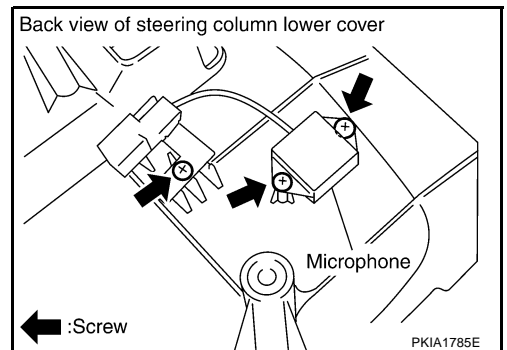

INSTALLATION

Installation is the reverse order of removal.

AUDIO ANTENNA

AUDIO ANTENNA

PFP:28200

System Description

AKS00113

With the ignition switch in ACC or ON, power is supplied

- through 10A fuse [No. 6, located in the fuse block (J/B)]
- to audio unit terminal 10.

Ground is supplied through the case of the antenna amp.

When the radio switch is turned ON, antenna signal is supplied

- through audio unit terminal 5
- to the antenna amp. terminal 1.

Then the antenna amp. is activated.

The amplified radio signals are supplied to the audio unit through the antenna amp.

A

B

C

D

E

F

G

H

I

J

AV

L

M

AUDIO ANTENNA

AKS00114

Wiring Diagram — M/ANT —

AV-M/ANT-01

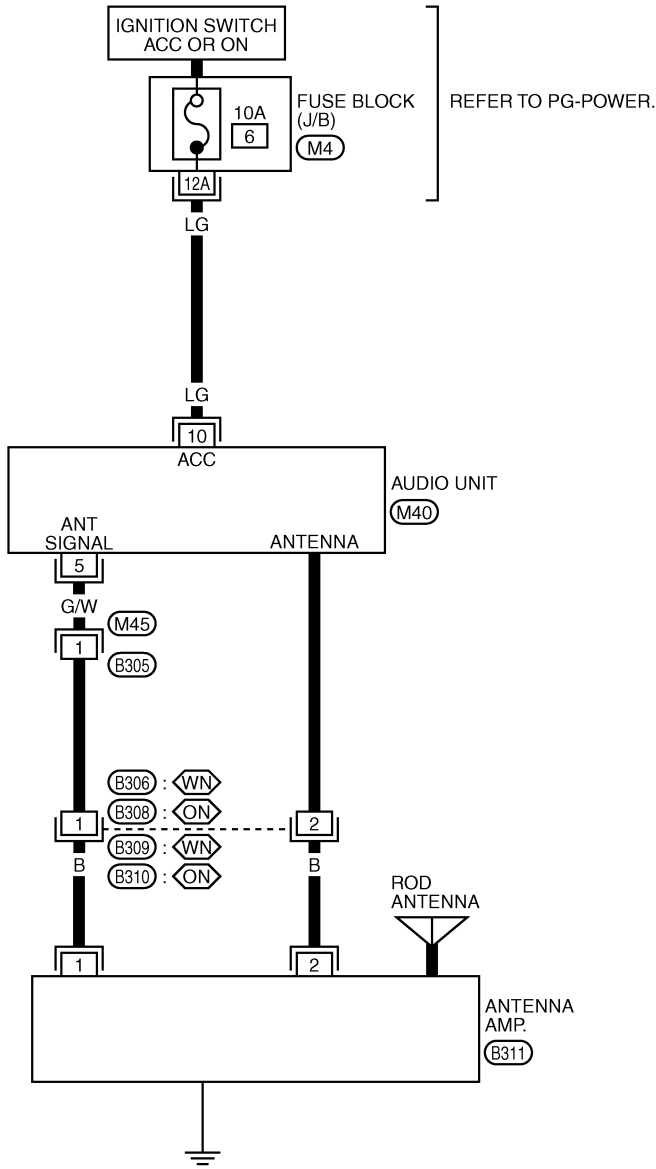

: WITH NAVIGATION SYSTEM
 : WITHOUT NAVIGATION SYSTEM

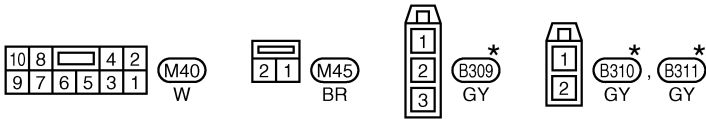

REFER TO THE FOLLOWING.
 -FUSE BLOCK-JUNCTION BOX (J/B)

*: THIS CONNECTOR IS NOT SHOWN IN "HARNESS LAYOUT", PG SECTION.

TKWT0509E

AUDIO ANTENNA

Location of Antenna

AKS00115

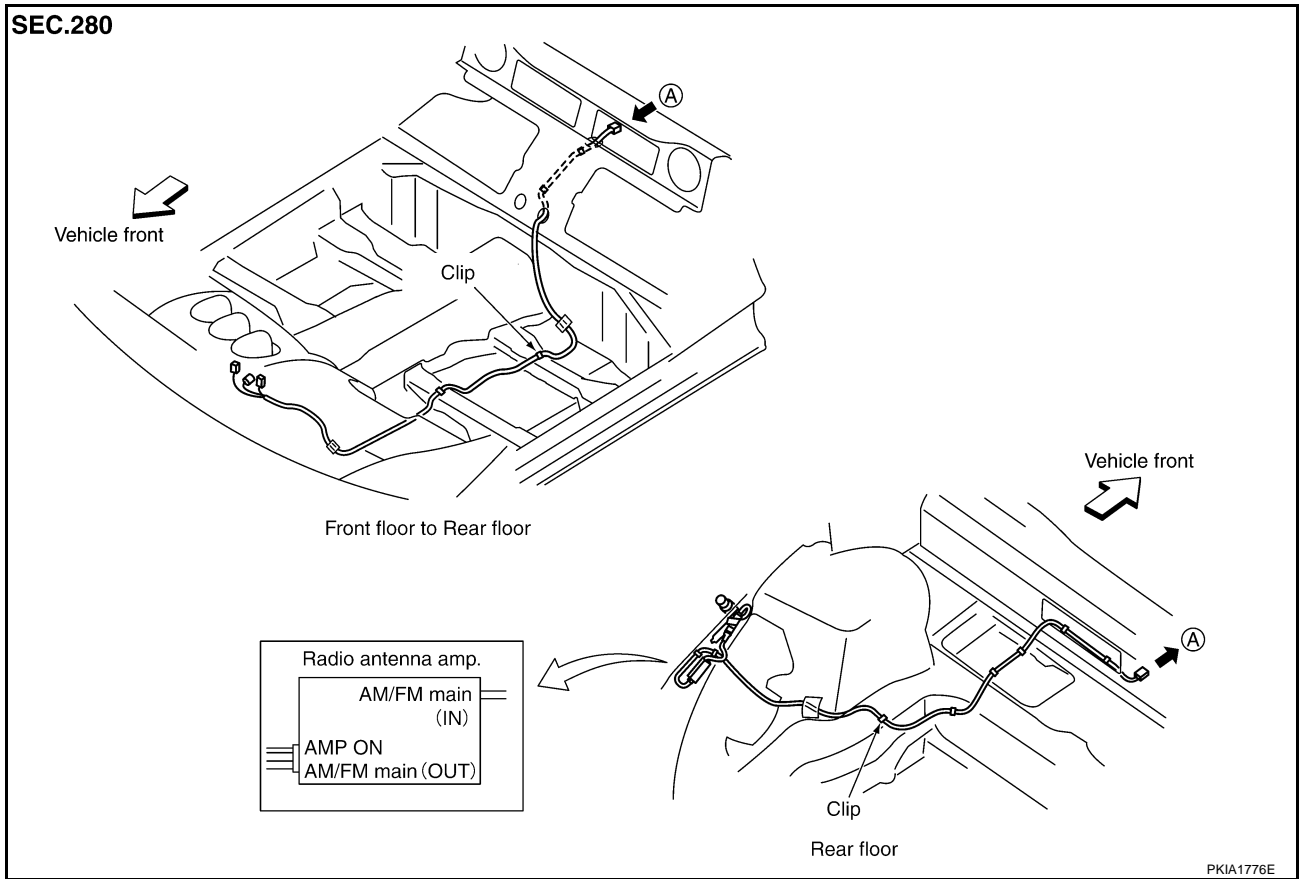

Removal and Installation of Antenna Amp.

AKS002ZY

REMOVAL

1. Remove luggage side finisher lower (LH) (Coupe models) or trunk front finisher (Roadster models). Refer to [EI-38, "Removal and Installation \(for Coupe Models\)"](#) or [EI-47, "Removal and Installation"](#).
2. Remove luggage floor carpet and spare tire cover (Coupe models) or trunk floor carpet and spare tire cover (Roadster models). Refer to [EI-38, "Removal and Installation \(for Coupe Models\)"](#) or [EI-47, "Removal and Installation"](#).
3. Remove screw (1) and remove antenna amp.

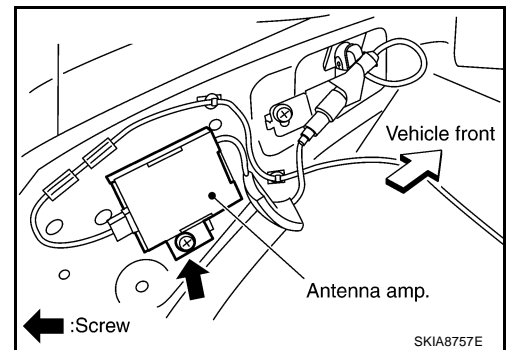

INSTALLATION

Installation is the reverse order of removal.

AUDIO ANTENNA

Removal and Installation of Antenna

AKS002ZZ

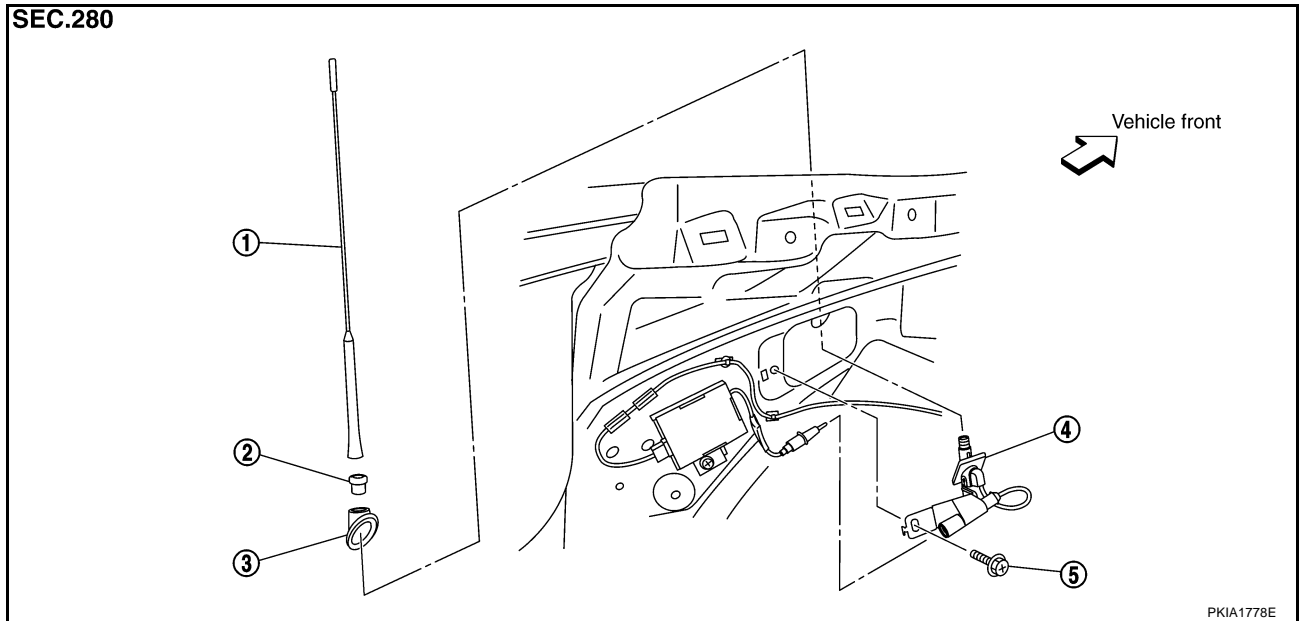

1. Antenna rod
2. Antenna nut
3. Antenna base
4. Antenna assembly
5. Screw

REMOVAL

1. Remove luggage side finisher lower (LH) (Coupe models) or trunk front finisher (Roadster models). Refer to [EI-38, "Removal and Installation \(for Coupe Models\)"](#) or [EI-47, "Removal and Installation"](#).
2. Remove antenna rod and remove antenna nut.
3. Disconnect antenna amp. plug.
4. Remove screw and remove antenna assembly.
5. Remove antenna base.

INSTALLATION

Installation is the reverse order of removal.

NAVIGATION SYSTEM

PFP:25915

System Description

AKS00117

LOCATION DETECTION PRINCIPLE

The navigation system periodically calculates the vehicle's current position according to the following three signals:

- Travel distance of the vehicle as determined by the vehicle speed sensor
- Turning angle of the vehicle as determined by the gyroscope (angular velocity sensor)
- Direction of vehicle travel as determined by the GPS antenna (GPS information)

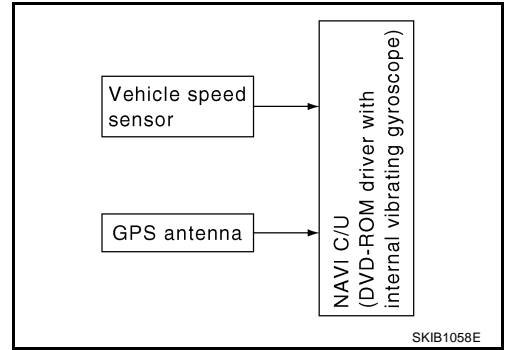

The current position of the vehicle is then identified by comparing the calculated vehicle position with map data read from the map DVD-ROM, which is stored in the DVD-ROM drive (map-matching), and indicated on the screen as a current-location mark. More accurate data is judged and used by comparing vehicle position detection results found by the GPS with the result by map-matching.

The current vehicle position will be calculated by detecting the distance the vehicle moved from the previous calculation point and its direction.

- **Travel distance**
Travel distance calculations are based on the vehicle speed sensor input signal. Therefore, the calculation may become incorrect as the tires wear down. To prevent this, an automatic distance correction function has been adopted.
- **Travel direction**
Change in the travel direction of the vehicle is calculated by a gyroscope (angular velocity sensor) and a GPS antenna (GPS information). They have both advantages and disadvantages.

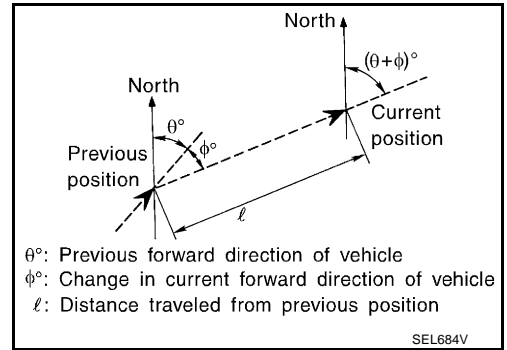

Type	Advantage	Disadvantage
Gyroscope (angular velocity sensor)	Can detect the vehicle's turning angle quite accurately.	Direction errors may accumulate when vehicle is driven for long distances without stopping.
GPS antenna (GPS information)	Can detect the vehicle's travel direction (North/South/East/West).	Correct direction cannot be detected when vehicle speed is low.

More accurate traveling direction is detected because priorities are set for the signals from these two devices according to the situation.

NAVIGATION SYSTEM

MAP-MATCHING

Map-matching compares a current location detected by the method in the "Location Detection Principle" (refer to [AV-49](#)) with a road map data from Map DVD-ROM stored in DVD-ROM drive.

NOTE:

The road map data is based on data stored in the map DVD-ROM.

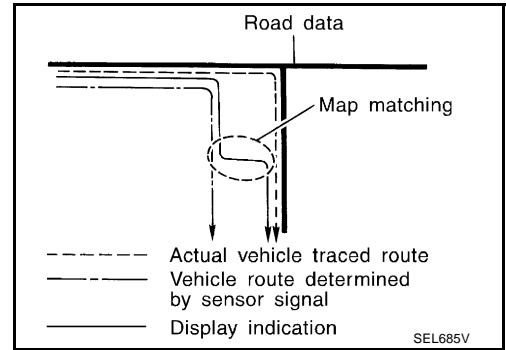

The vehicle position may not be corrected under the following circumstances and after driving for a certain time when GPS information is difficult to receive. In this case, the current-location mark on the display must be corrected manually.

- In map-matching, alternative routes to reach the destination will be shown and prioritized, after the road on which the vehicle is currently driven has been judged and the current-location mark has been repositioned.
If there is an error in distance and/or direction, alternative routes will be shown in different order of priority, and the incorrect road can be avoided.
If two roads are running in parallel, they are of the same priority. Therefore, the current-location mark may appear on either of them alternately, depending on maneuvering of the steering wheel and configuration of the road.

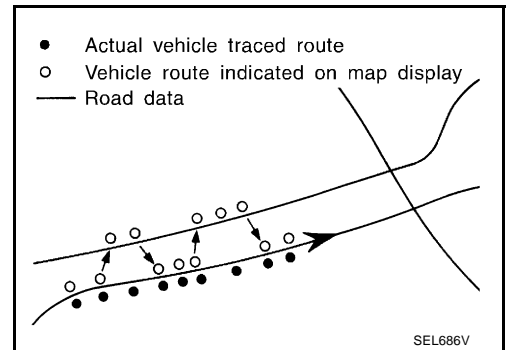

- Map-matching does not function correctly when a road on which the vehicle is driving is new and not recorded in the map DVD-ROM, or when road pattern stored in the map data and the actual road pattern are different due to repair.
When driving on a road not present in the map, the map-matching function may find another road and position the current-location mark on it. Then, when the correct road is detected, the current-location mark may change to it.
- Effective range for comparing the vehicle position and travel direction calculated by the distance and direction with the road data read from the map DVD-ROM is limited. Therefore, when there is an excessive gap between current vehicle position and the position on the map, correction by map-matching is not possible.

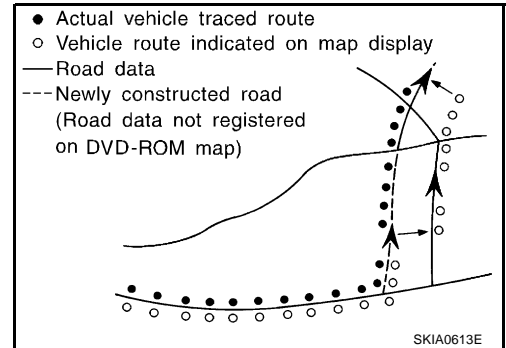

NAVIGATION SYSTEM

GPS (GLOBAL POSITIONING SYSTEM)

GPS (Global Positioning System) was developed for and is controlled by the US Department of Defense. The system utilizes GPS satellites (NAVSTAR), sending out radio waves while flying on an orbit around the earth at an altitude of approximately 21,000 km (13,100 miles).

The GPS receiver calculates the vehicle's position in three dimensions (latitude/longitude/altitude) according to the time lag of the radio waves received from four or more GPS satellites (three-dimensional positioning). If radio waves were received only from three GPS satellites, the GPS receiver calculates the vehicle's position in two dimensions (latitude/longitude), utilizing the altitude data calculated previously with radio waves from four or more GPS satellites (two-dimensional positioning).

Position correction by GPS is not available while the vehicle is stopped.

Accuracy of GPS will deteriorate under the following conditions:

- In two-dimensional positioning, GPS accuracy will deteriorate when altitude of the vehicle position changes.
- The accuracy can be even lower depending on the arrangement of the GPS satellites utilized for the positioning.
- Position detection is not possible when vehicle is in an area where radio waves from the GPS satellite do not reach, such as in a tunnel, parking lot in a building, and under an elevated highway. Radio waves from the GPS satellites may not be received when some object is located over the GPS antenna.

NOTE:

- Even a high-precision three dimensional positioning, the detection result has an error about 10 m (30 ft).
- Because the signals of GPS satellite is controlled by the Tracking and Control Center in the United States, the accuracy may be degraded lower intentionally or the radio waves may stop.

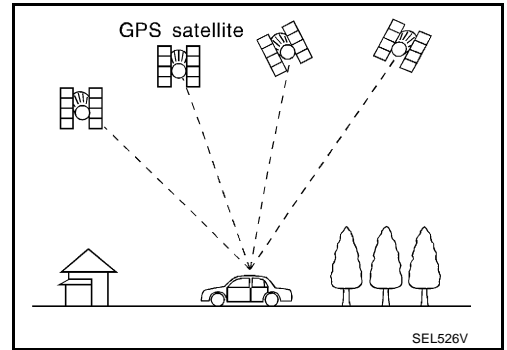

A

B

C

D

E

F

G

H

I

J

AV

L

M

NAVIGATION SYSTEM

COMPONENT DESCRIPTION

NAVI Control Unit

- The gyro (angular speed sensor) and the DVD-ROM drive are built-in units that control the navigation functions.
- Signals are received from the gyro, the vehicle speed sensor, and the GPS antenna. Vehicle location is determined by combining this data with the data contained in the DVD-ROM map. Locational information is shown on LCD(liquid crystal display) screen.

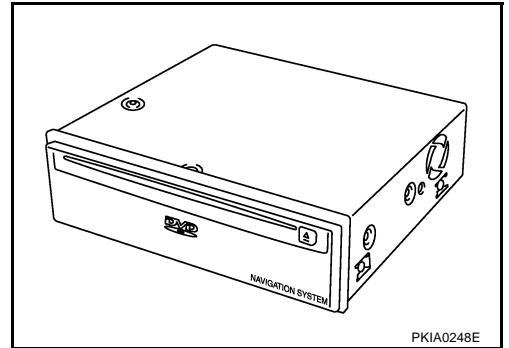

DVD-ROM Drive

Maps, traffic control regulations, and other pertinent information can be easily read from the DVD-ROM disc.

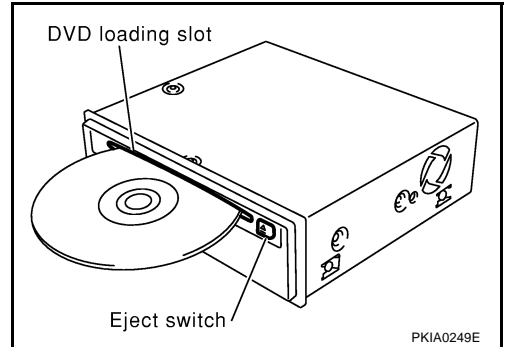

Map DVD-ROM

- The map DVD-ROM has maps, traffic control regulations, and other pertinent information.
- To improve DVD-ROM map matching and route determination functions, the DVD-ROM uses an exclusive Nissan format. Therefore, the use of a DVD-ROM provided by other manufacturers cannot be used.

Gyro (Angular Speed Sensor)

- The oscillator gyro sensor is used to detect changes in vehicle steering angle.
- The gyro is built into the NAVI control unit.

NAVIGATION SYSTEM

BIRDVIEW™

The BIRDVIEW™ provides a detailed and easily seen display of road conditions covering the vehicle's immediate to distant area.

- MAP DISPLAY



- BIRDVIEW™

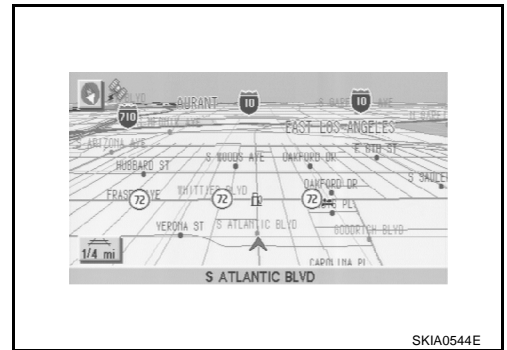

Description

- Display area: Trapezoidal representation showing approximate distances (W_n , D , and W_d).
- Ten horizontal grid lines indicate display width while six vertical grid lines indicate display depth and direction.
- Drawing line area shows open space, depth, and immediate front area. Each area is to a scale of approximately 5:6:25.
- Pushing the "ZOOM IN" button during operation displays the scale change and the view point height on the left side of the screen. The height of the view point increases or decreases when "ZOOM" or "WIDE" is selected with the joystick.

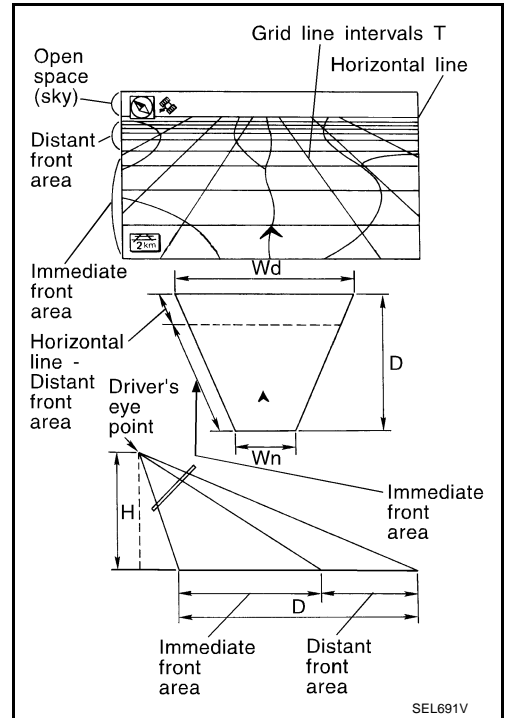

NAVIGATION SYSTEM

Display with Pushed "ROUTE" Switch

- Easy Mode

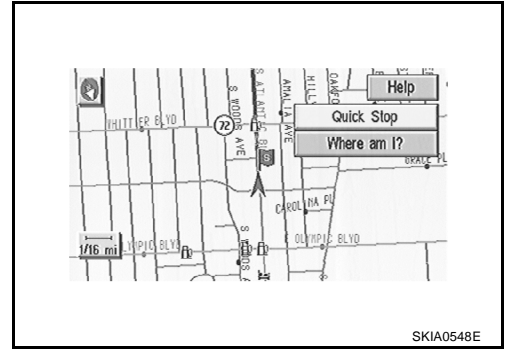

- Expert Mode

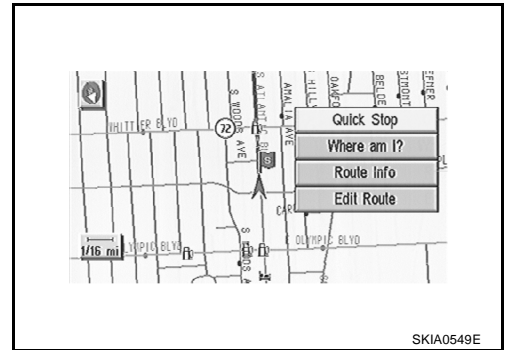

The function of each icon is as follows:

Icon	MODE		Description
	Easy	Expert	
Quick Stop	×	×	The selected facility is set as the destination or waypoint. (Route guidance has been turned OFF or the destination has been reached)
Where am I?	×	×	Next, current and previous street names can be displayed.
Route Info.*		×	The following items can be set. <ul style="list-style-type: none"> ● Complete Route ● Turn List ● Route Simulation (Displayed only when the destination area has been set.)
Edit Route*		×	Change the destination or add the transit points of the route set in the route guidance. (Displayed only when the automatic reroute function has been turned OFF and the recommended route is not followed.)
Help	×		Explanation of Navigational functions appear on the Display.

*: When destinations have been entered, route guidance has been turned OFF or destination has been reached, "Route Info." and "Edit Route" are not displayed.

NAVIGATION SYSTEM

Display with Pushed "SETTING" Switch

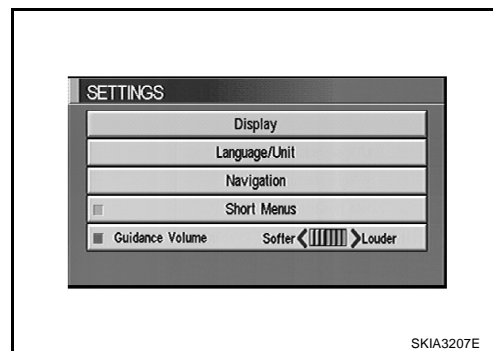

The function of each icon is as follows:

Icon	Description
Display	Settings of display can be performed.
Language/Unit	Settings of Language or unit can be performed.
Navigation	Settings and adjusting of navigation can be performed.
Short Menus	Easy Mode and Expert Easy Mode can be switched.
Guidance Volume	The volume and/or on/off of voice prompt can be controlled by the joystick.
Help (only easy mode)	Explanation of Navigational Functions Appear on the Display.

Display with Pushed "INFO" Switch

Push "INFO" switch to display maintenance information.

- Engine Oil and Oil Filter are displayed as Maintenance information.

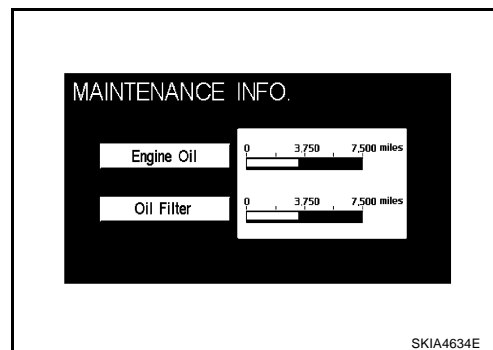

Display Setting

How To Perform Navigation Setting

1. Start the engine.
 2. Push "SETTING" switch.
 3. Select "Display".
- Brightness, contrast, or map background setting can be changed.
 - Display sleep mode ON/OFF can be switched.
 - Display sleep mode timer can be set.

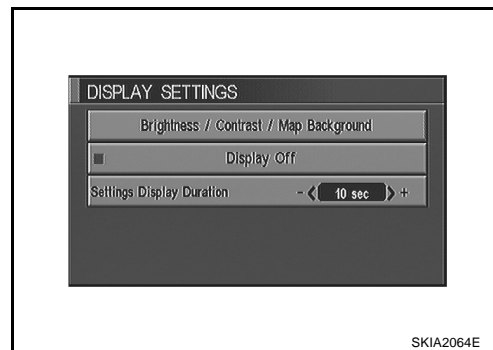

NAVIGATION SYSTEM

Language Setting

How To Perform Navigation Setting

1. Start the engine.
 2. Push "SETTING" switch.
 3. Select "Language".
- Language setting can be switched.
 - Unit setting can be changed.

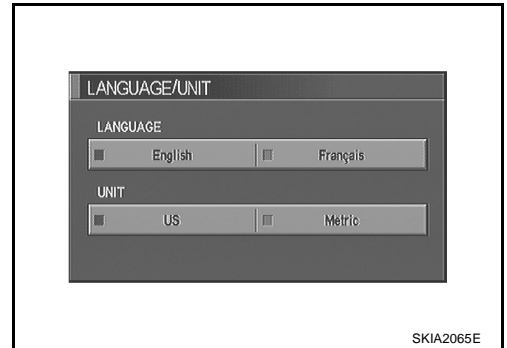

Navigation Setting

How To Perform Navigation Setting

1. Start the engine.
2. Push "SETTING" switch.
3. Select "Navigation".

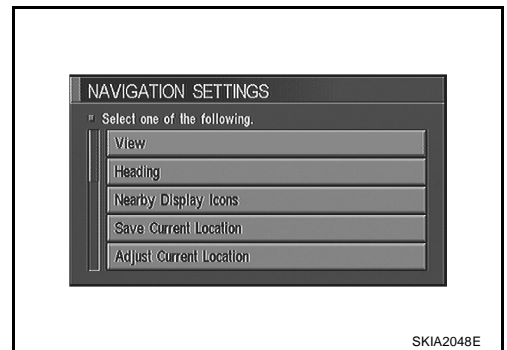

Application Items

Icon	Description	Reference page
View	Map display mode can be switched.	AV-58
Heading	Heading of the map display can be customized for either north heading or the actual driving direction of the vehicle.	AV-58
Nearby Display Icons	Icons of facilities can be displayed. Facilities to be displayed can be selected from the variety selections.	AV-58
Save Current Location	Current vehicle location can be registered in Address Book.	AV-58
Adjust Current Location	Current location of position marker can be adjusted. Direction of position marker also can be calibrated when heading direction of the vehicle on the display is not matched with the actual direction.	AV-59
Auto Re-route ON/OFF	ON/OFF of Auto Re-route can be switched.	AV-59
Avoid Area Setting	A particular area can be avoided when routing.	AV-59
Button Tone/Beep Response	Button tone can be selected ON/OFF.	AV-60
Clear Memory	Address Book, Previous destination or Avoid area can be deleted.	AV-60
Edit Address Book	Address Book can be edited.	AV-60
GPS Information	The GPS data includes longitude, latitude and altitude (distance above sea level) of the present vehicle position, and current date and time for the area in which the vehicle is being driven. Also indicated are the GPS reception conditions and the GPS satellite position.	AV-60
Quick Stop Customer Setting	One facility of your selection can be added to your Quick Stop.	AV-61
Set Average speed	Average vehicle speed can be set to calibrate estimated journey time for the destination.	AV-61
Tracking	Tracking to the present vehicle position can be displayed.	AV-61

A
B
C
D
E
F
G
H
I
J
AV
L
M

NAVIGATION SYSTEM

“VIEW” MODE

1. Select “Birdview” or “Plan view” icon.
 - To open the map screen display with BIRDVIEW™, select “Birdview”.
 - To open the map screen display with Plan View, select “Plan View”.

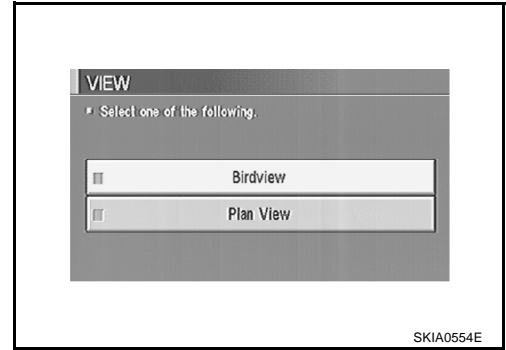

“HEADING” MODE

- To display North up, select “North up”.
- To display the car heading up, select “Heading up”.

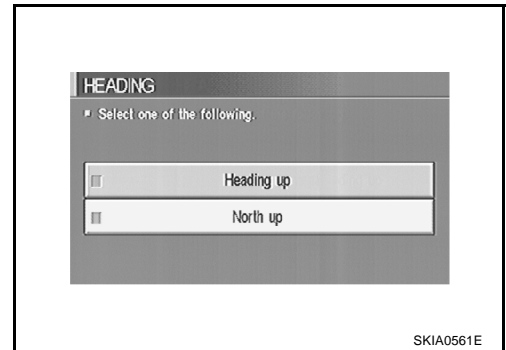

“NEARBY DISPLAY ICONS” MODE

- Select an icon to display on the map screen.

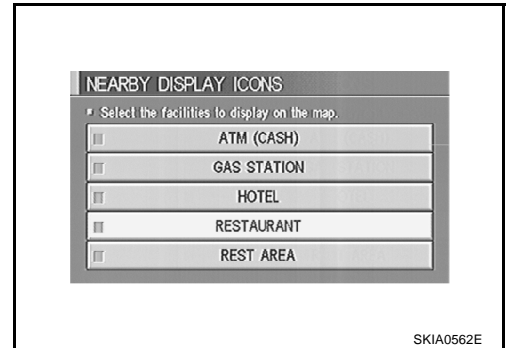

“SAVE CURRENT LOCATION” MODE

- The current vehicle location can be registered in “Address Book”.

NOTE:

“Address Book” can store 50 items max.

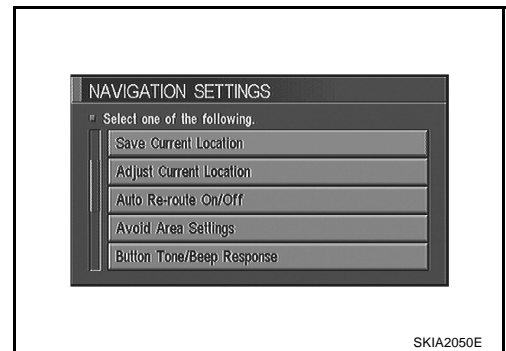

NAVIGATION SYSTEM

“ADJUST CURRENT LOCATION” MODE

1. Select an icon “right” or “left” to calibrate the heading direction.
(Arrow marks will rotate corresponding to the calibration key.)

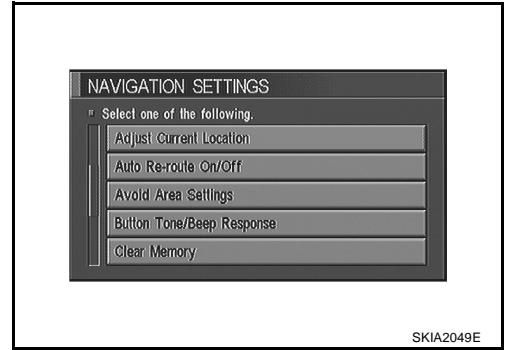

2. Select “Set”. Then the vehicle mark will be matched to the arrow mark.

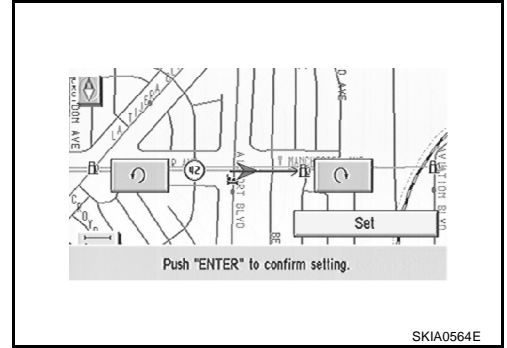

“AUTO RE-ROUTE” MODE

- To Perform the auto re-route of route, select “On”.
- Not to Perform the auto re-route of route, select “Off”.

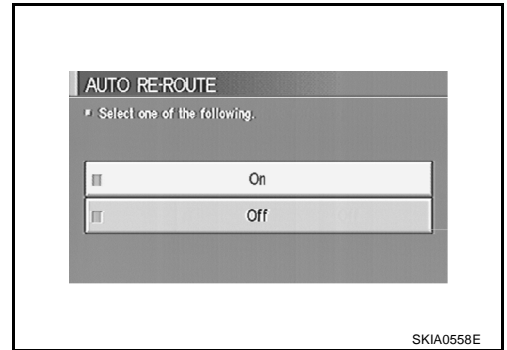

“AVOID AREA SETTING” MODE

- Areas to avoid can be registered.

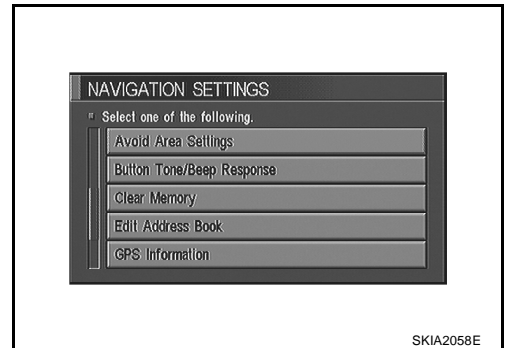

A
B
C
D
E
F
G
H
I
J
AV
L
M

NAVIGATION SYSTEM

“BUTTON TONE/BEEP RESPONSE” MODE

- If beep is required, select “On”.
- If no beep is required, select “Off”.

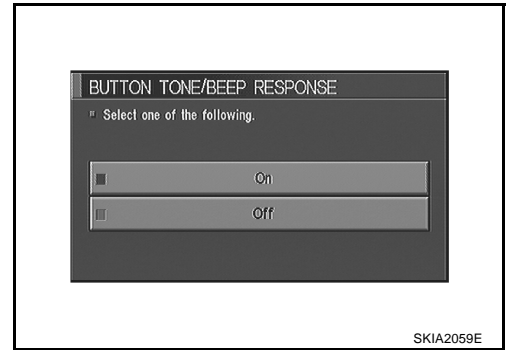

“CLEAR MEMORY” MODE

- To delete all the stored places in “Address Book”, “Avoid Area” and “Previous Dest”, select “Yes”.

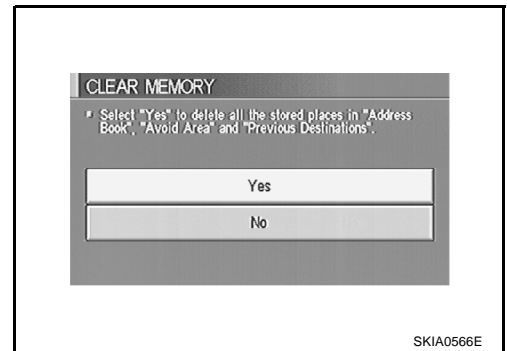

“EDIT ADDRESS BOOK” MODE

- Edit the items registered in Address Book.

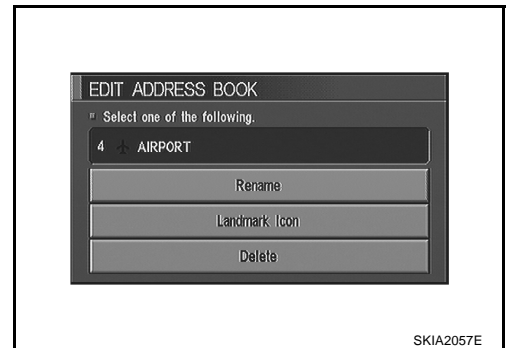

“GPS INFORMATION” MODE

- Latitude, longitude, altitude, astrometric state, and satellite location are displayed as GPS information.

NOTE:

Altitude is displayed only in three-dimensional status.

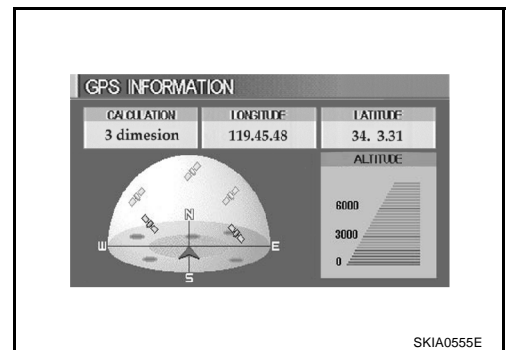

NAVIGATION SYSTEM

“QUICK STOP CUSTOMER SETTING” MODE

- Select a category for the “Quick Stop” menu.

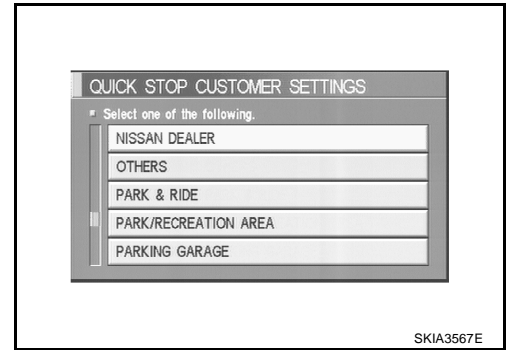

A
B
C
D

“SET AVERAGE SPEED” MODE

- Set the average vehicle speed to calibrate the estimated journey time for the destination.
- Set three items; “Freeway”, “Main Roads”, and “Ordinary Roads”.

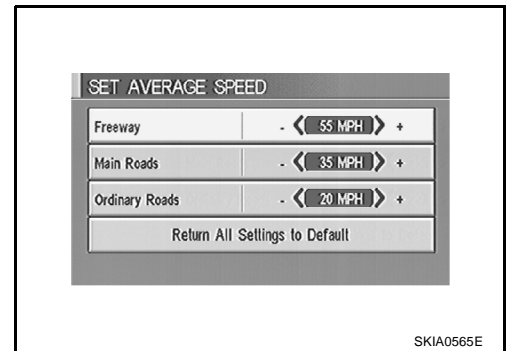

E
F
G
H

“TRACKING” MODE

- To leave no trail on the map, select “Off”.
- To leave a trail in the map, select “On”.

NOTE:

When a trail display is turned OFF, trail data is erased from the memory.

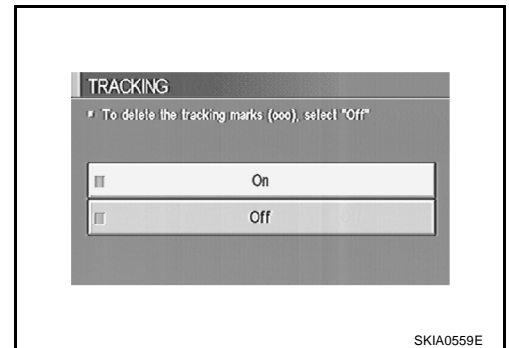

I
J
AV
L

GUIDE VOLUME SETTING

Description

Following voice guidance setting can be changed.

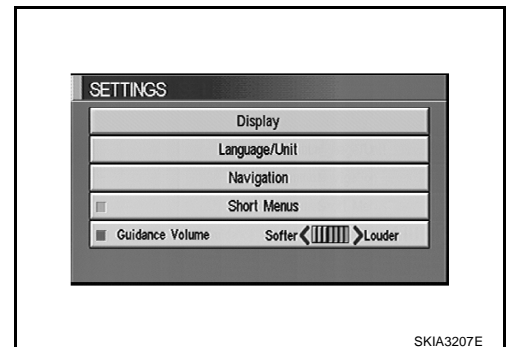

M

Activation/Deactivation Setting

- The voice prompt can be turned on/off by Pushing the “Guidance Volume” button.

Voice Volume Setting

- Volume of the voice can be controlled by bending the joystick to left/right.

Precautions for NAVI Control Unit Replacement

AKS00118

- When replacing the NAVI control unit, eject the map DVD-ROM before disconnecting the battery.
- The NAVI control unit has the following information stored in its memory. Record the memory contents before replacing the control unit, and input them in the new unit as necessary.

<Image quality>

- **Brightness of light when ON/OFF**
- **Dimming switching**
- **Display color switching**

<Navigation mode>

- **Latest status (map screen/BIRDVIEW™, reduced scale, rotation angle of map screen, route guidance ON/OFF, track ON/OFF, etc.)**
- **Current position**
- **Destination, passing point 1 - 5**
- **Registered places, their names, etc.**

NOTE:

Only removing the battery does not erase the memory.

NAVIGATION SYSTEM

Component Parts and Harness Connector Location

AKS00119

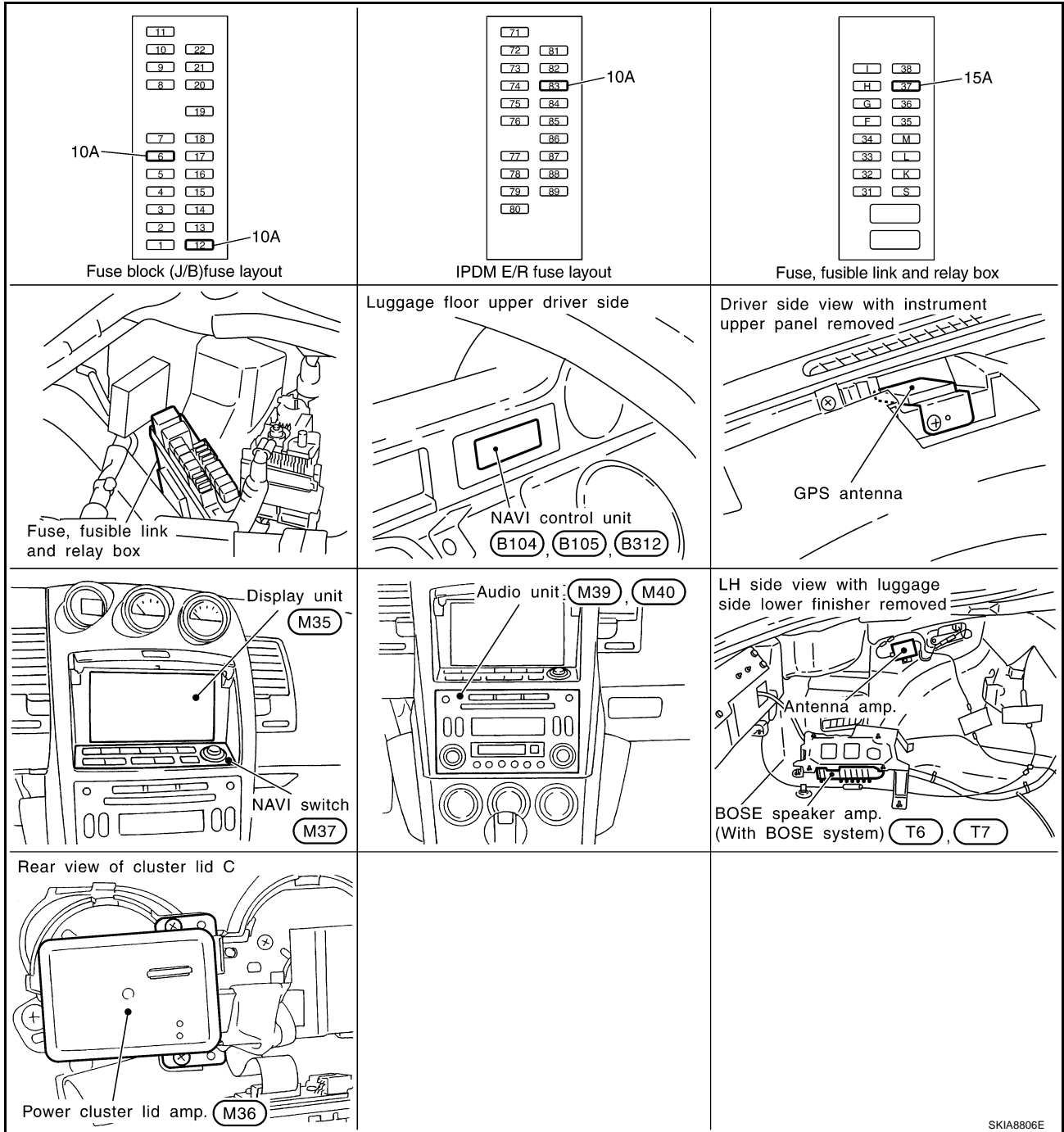

SKIA8806E

A
B
C
D
E
F
G
H
I
J
AV
L
M

NAVIGATION SYSTEM

Schematic

AKS0011A

- (A) : With A/T
- (M) : With M/T
- (WB) : With BOSE system

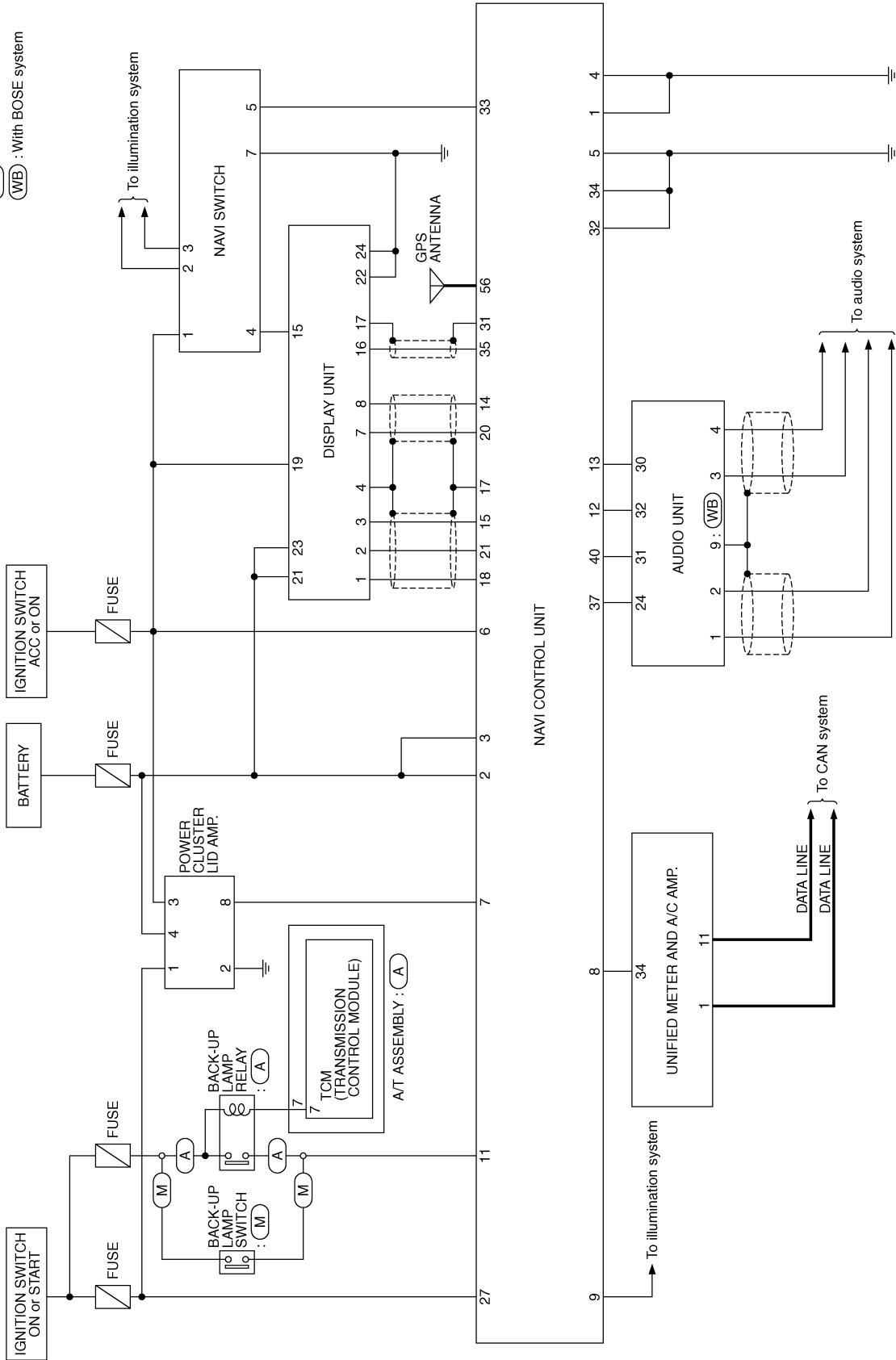

NAVIGATION SYSTEM

Wiring Diagram — NAVI — FOR COUPE MODELS

AKS0011B

A
B
C
D
E
F
G
H
I
J
K
L
M

AV-NAVI-01

REFER TO PG-POWER.

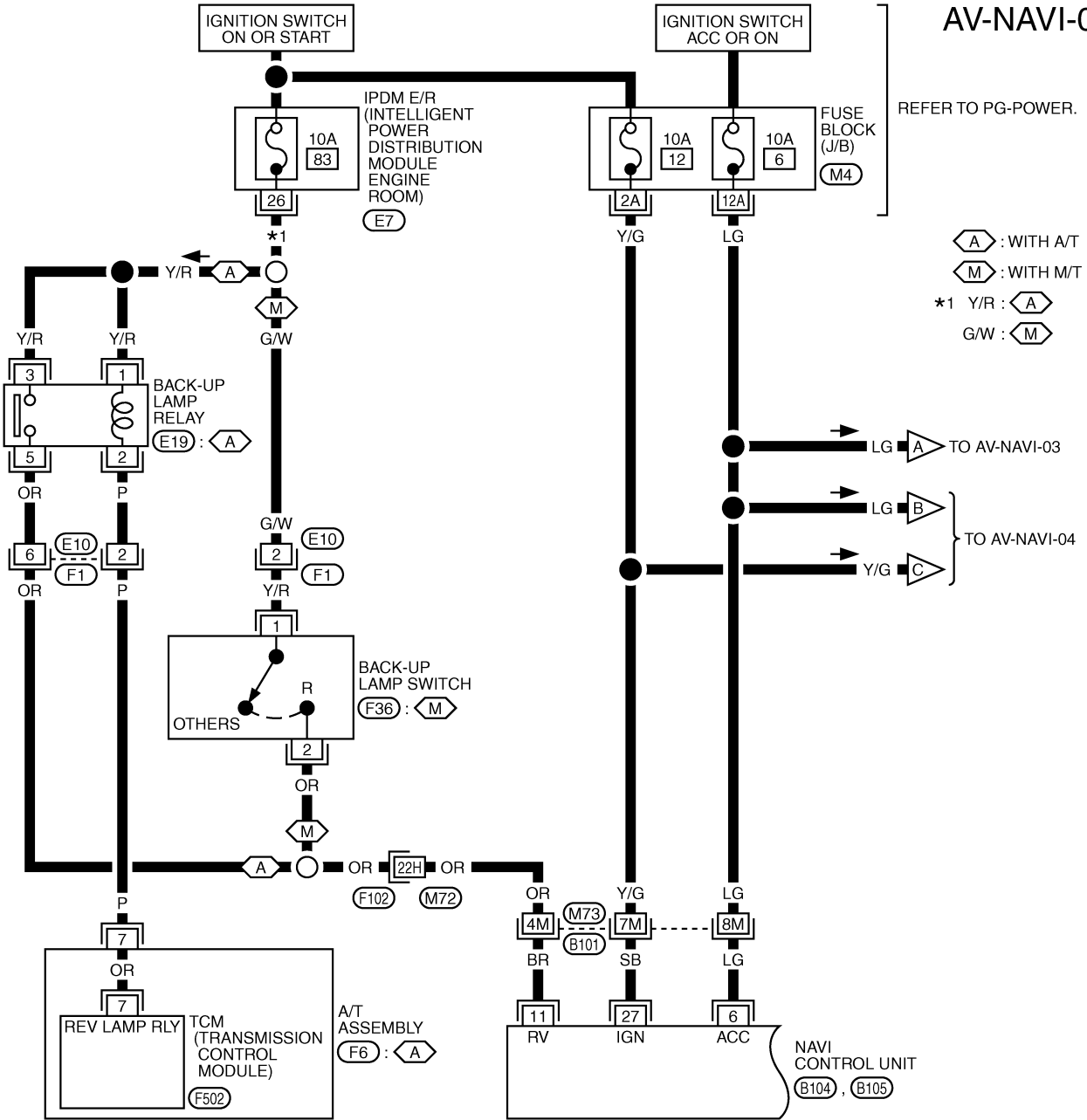

A : WITH A/T
M : WITH M/T
 *1 Y/R : A
 G/W : M

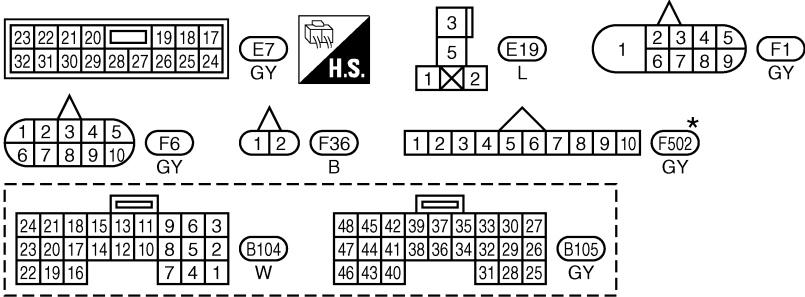

REFER TO THE FOLLOWING.
F102, B101 -SUPER MULTIPLE JUNCTION (SMJ)
M4 -FUSE BLOCK-JUNCTION BOX (J/B)

*: THIS CONNECTOR IS NOT SHOWN IN "HARNESS LAYOUT", PG SECTION.

NAVIGATION SYSTEM

AV-NAVI-02

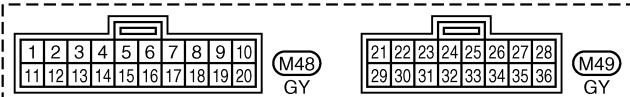
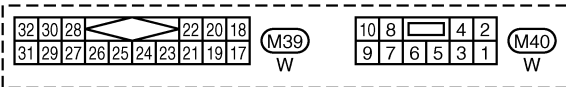
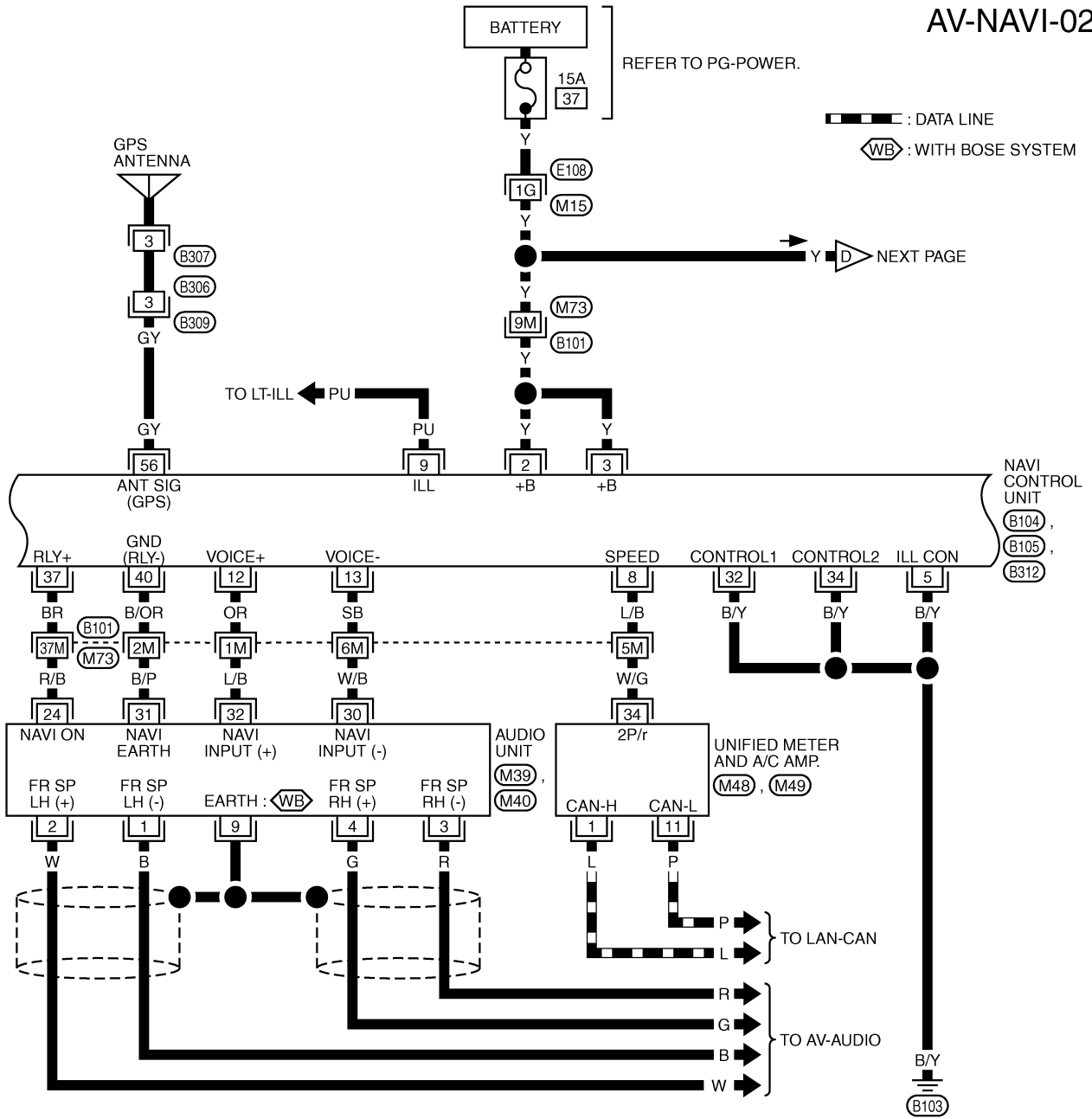

*: THIS CONNECTOR IS NOT SHOWN IN "HARNESS LAYOUT", PG SECTION.

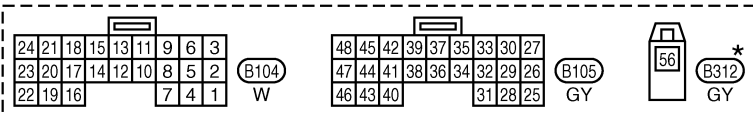

REFER TO THE FOLLOWING.
 (E108), (B101) -SUPER MULTIPLE JUNCTION (SMJ)

TKWT1545E

NAVIGATION SYSTEM

AV-NAVI-03

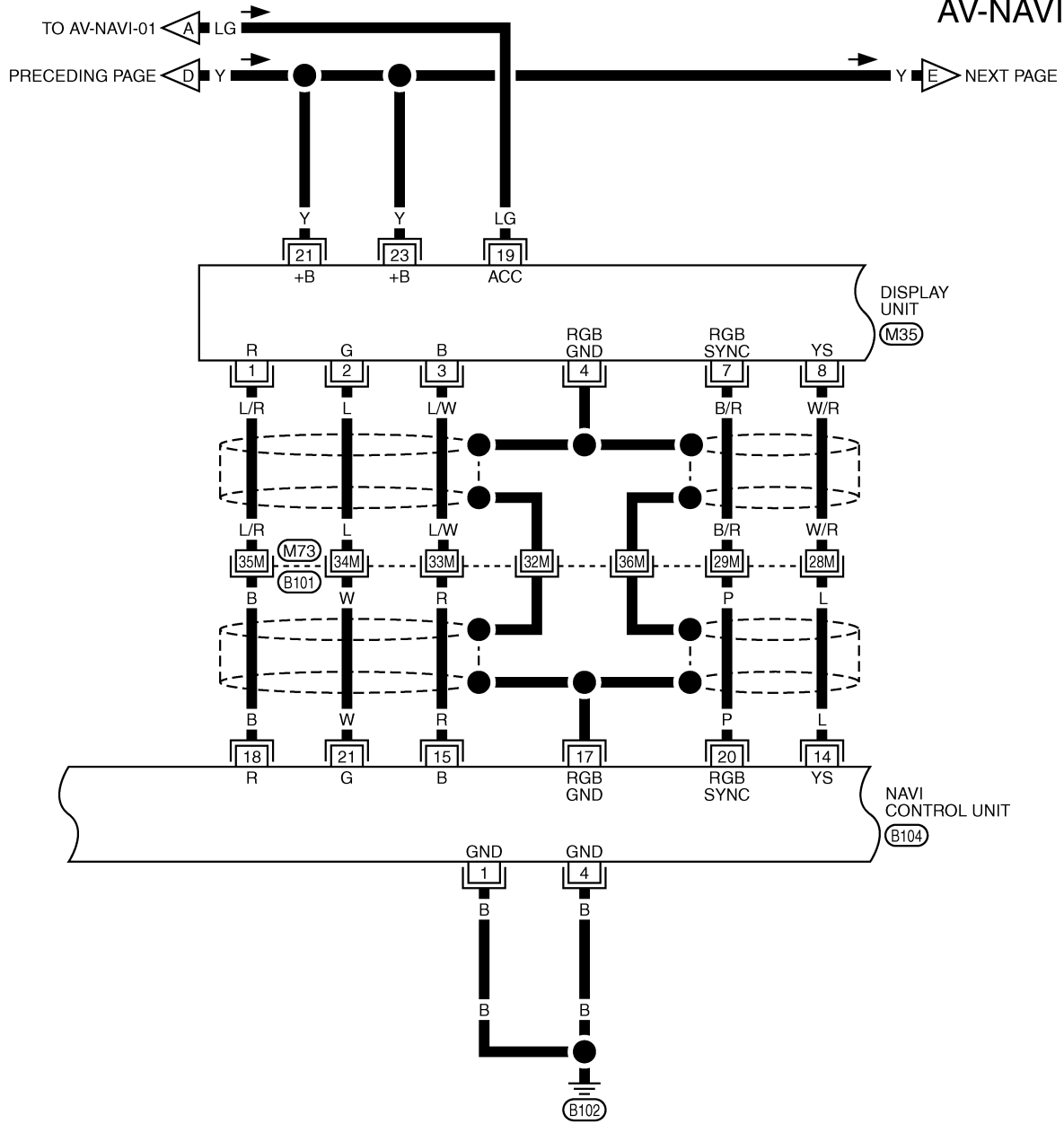

24	22	20	18	16	14	10	8	6	4	2		
23	21	19	17	15	13	12	11	9	7	5	3	1

(M35)
GY

24	21	18	15	13	11	9	6	3
23	20	17	14	12	10	8	5	2
22	19	16			7	4	1	

(B104)
W

REFER TO THE FOLLOWING.
(B101) -SUPER MULTIPLE JUNCTION (SMJ)

TKWT1546E

NAVIGATION SYSTEM

AV-NAVI-04

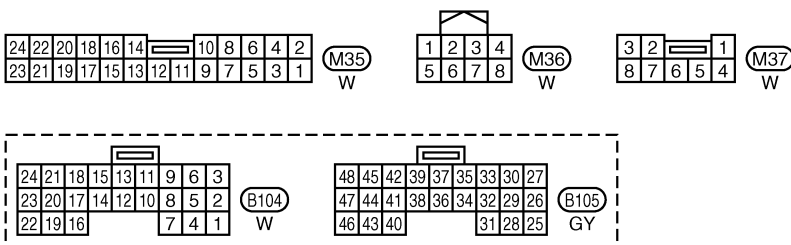
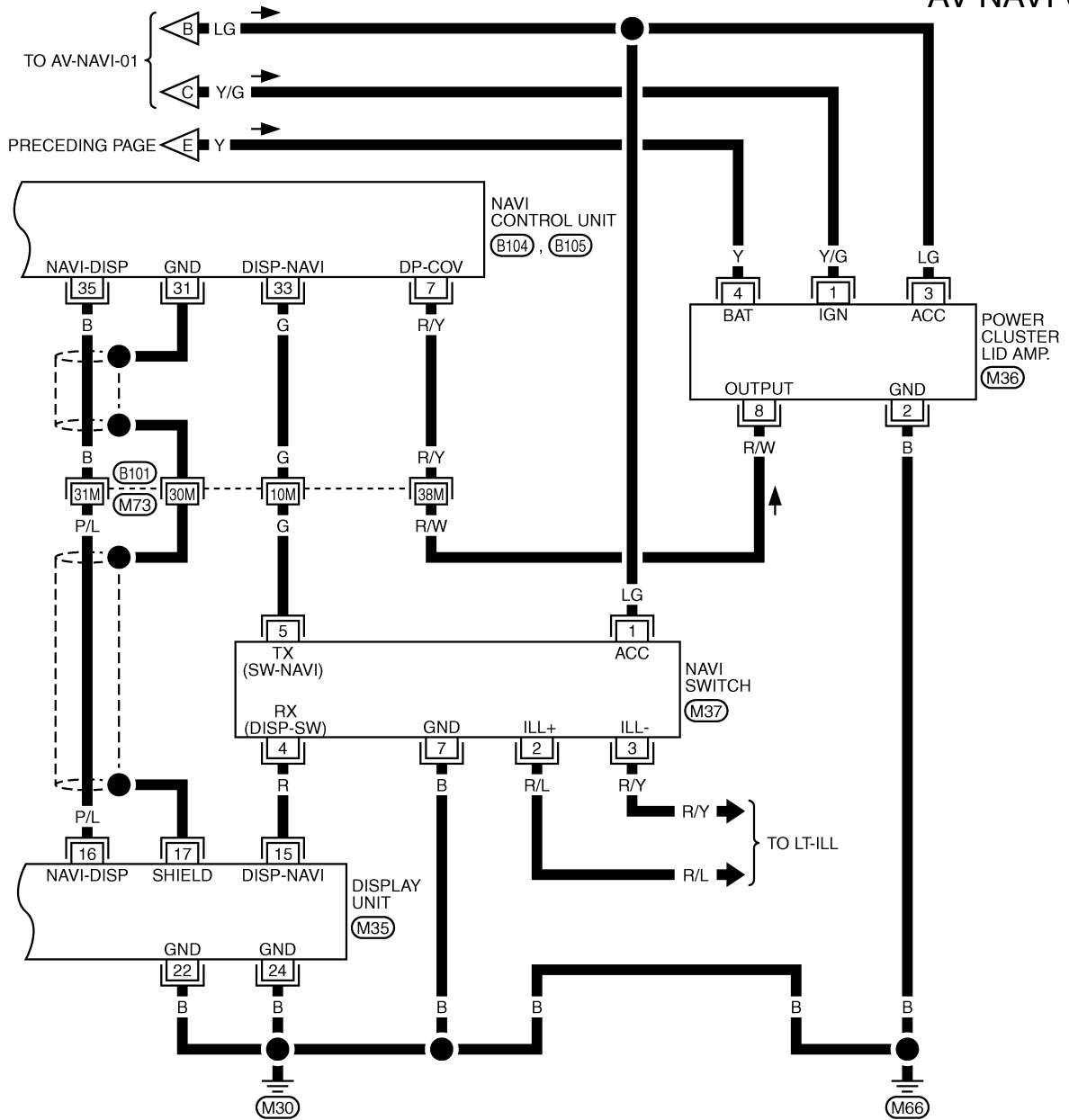

REFER TO THE FOLLOWING.
 (B101) -SUPER MULTIPLE JUNCTION (SMJ)

TKWT1547E

NAVIGATION SYSTEM

FOR ROADSTER MODELS

AV-NAVI-05

A
B
C
D
E
F
G
H
I
J
AV
L
M

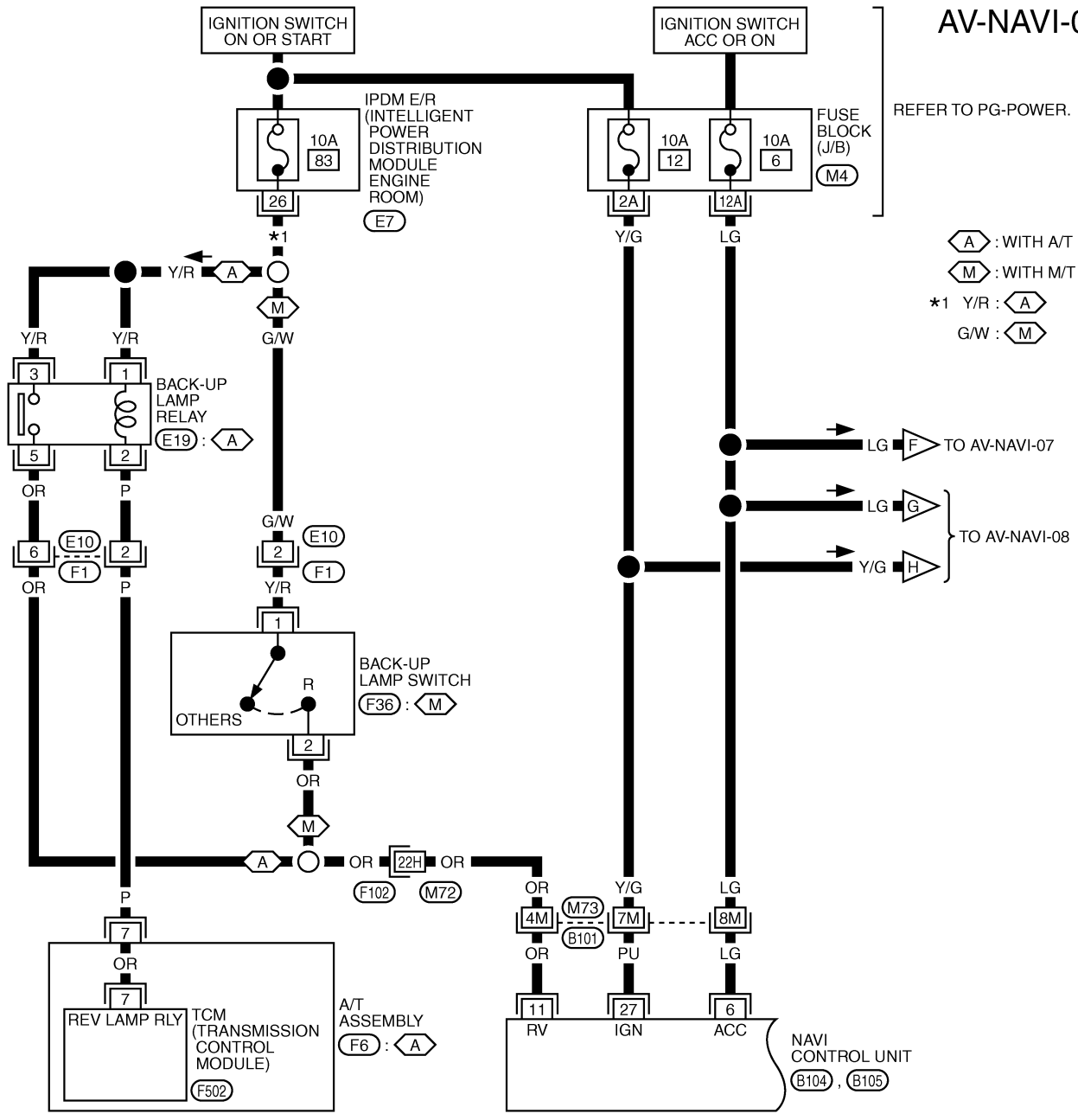

REFER TO PG-POWER.

A : WITH A/T
M : WITH M/T
 *1 Y/R : A
 G/W : M

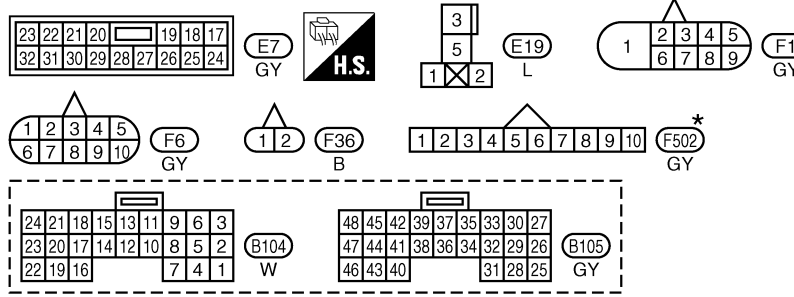

REFER TO THE FOLLOWING.
F102, B101 -SUPER MULTIPLE JUNCTION (SMJ)
M4 -FUSE BLOCK-JUNCTION BOX (J/B)

*: THIS CONNECTOR IS NOT SHOWN IN "HARNESS LAYOUT", PG SECTION.

TKWM1324E

NAVIGATION SYSTEM

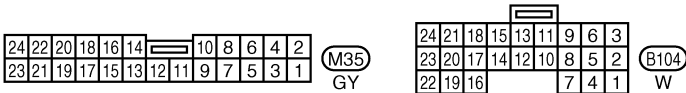
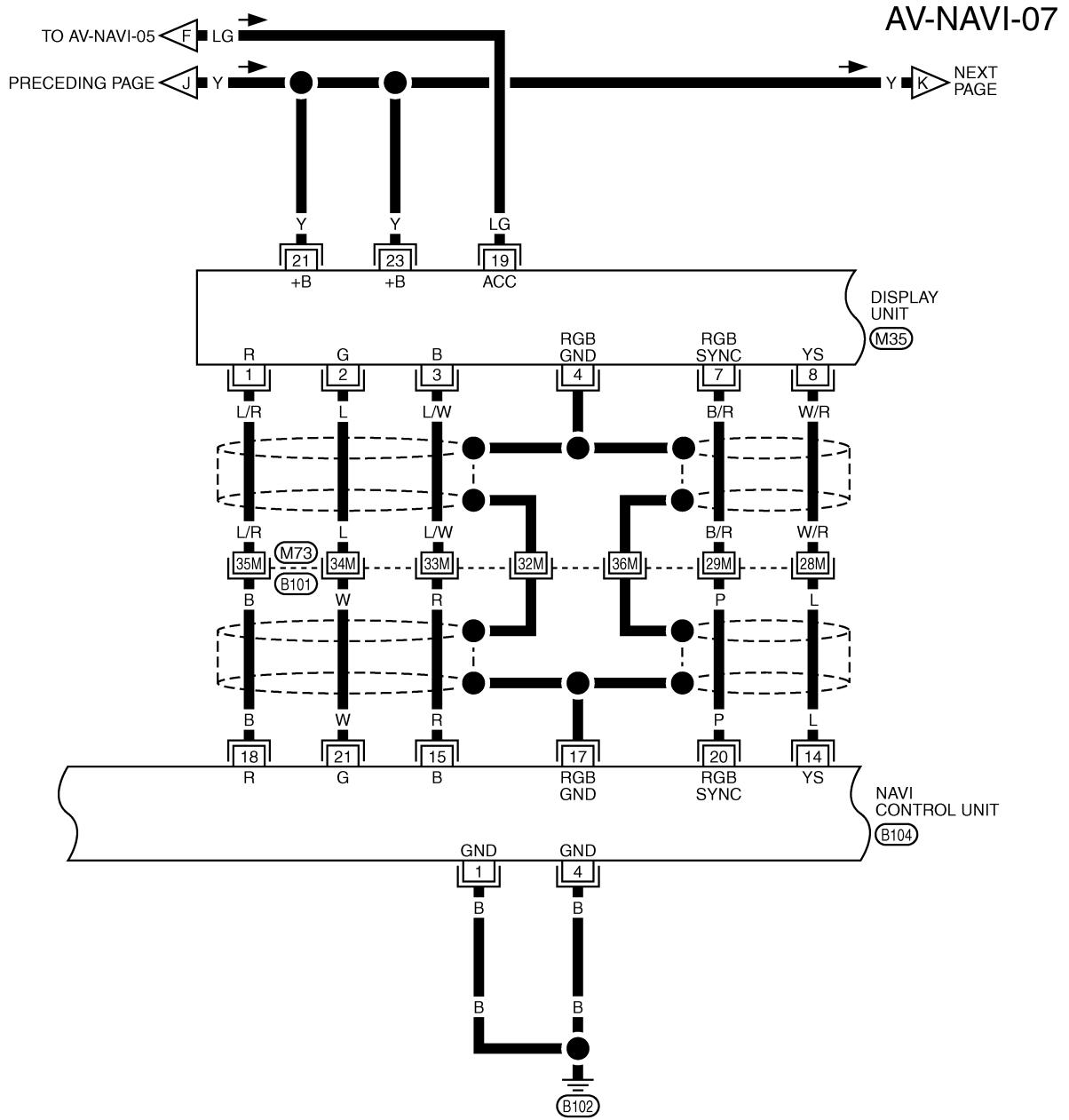

REFER TO THE FOLLOWING.
(B101) -SUPER MULTIPLE JUNCTION (SMJ)

TKWT1550E

NAVIGATION SYSTEM

AV-NAVI-08

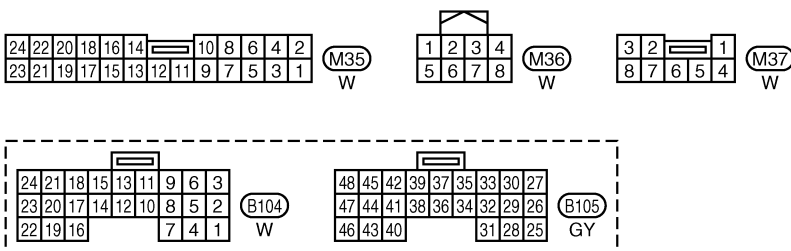
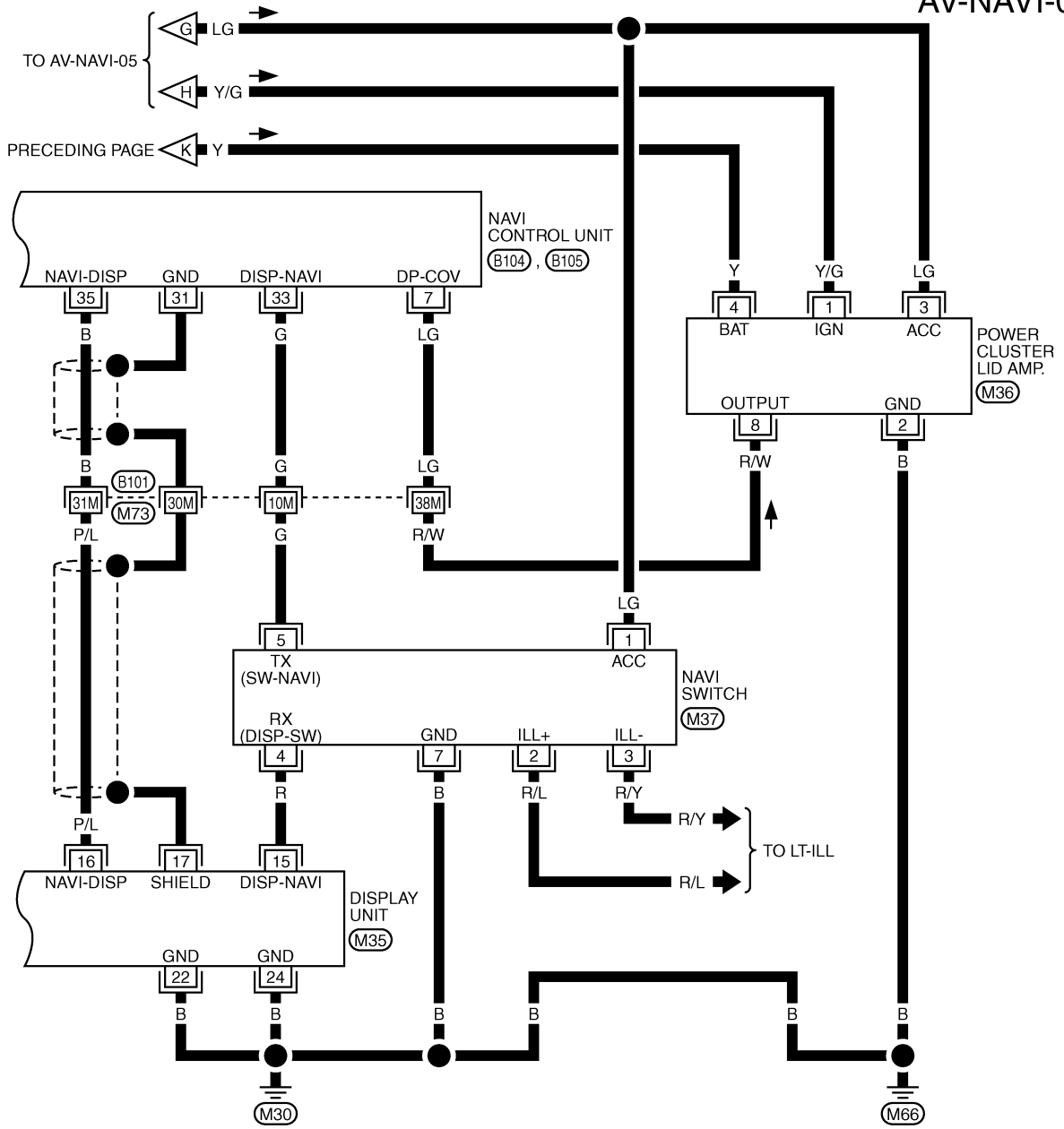

REFER TO THE FOLLOWING.
 (B101) -SUPER MULTIPLE JUNCTION (SMJ)

TKWT1551E

NAVIGATION SYSTEM

AKS0011D

Terminals and Reference Value for NAVI Control Unit

- Measure using circuit tester and oscilloscope.
- Measure with connector connected unless otherwise specified.
- CAUTION:**
Confirm voltage between negative terminal on each unit and ground is approximately 0V.
- If ignition switch ON is required in measurement condition, measure with engine running to prevent battery discharge.

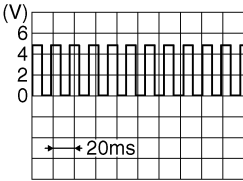
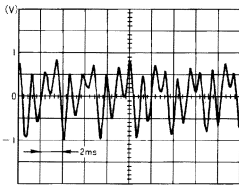
Terminal (Wire color)		Item	Signal input/ output	Condition		Reference value	Example of symptom
+	-			Ignition switch	Operation		
1 (B)	Ground	Ground	-	ON	-	Approx. 0V	-
2 (Y)	Ground	Battery power supply	Input	OFF	-	Battery voltage	System does not work properly.
3 (Y)							
4 (B)	Ground	Ground	-	ON	-	Approx. 0V	-
5 (B/Y)	Ground	Ground	-	ON	-	Approx. 0V	-
6 (LG)	Ground	ACC power supply	Input	ACC	-	Battery voltage	System does not work properly.
7 (R/Y) ^{*1} (LG) ^{*2}	Ground	Display cover ON signal	Input	ON	Display cover is opened	Approx. 5V	Display does not work properly.
					Except for above	Approx. 0V	
8 (L/B) ^{*1} (GY) ^{*2}	Ground	Vehicle speed signal (2-pulse)	Input	ON	When vehicle speed is approx. 40 km/ h (25 MPH)	 <small>SKIA6649J</small>	Navigation cur- rent-location mark does not indicate the cor- rect position.
9 (PU) ^{*1} (R/L) ^{*2}	Ground	Illumination signal	Input	ON	Lighting switch ON	Approx. 12V	Screen does not switch to night- time mode after the lighting switch is turned ON.
					Lighting switch OFF	Approx. 0V	
11 (BR) ^{*1} (OR) ^{*2}	Ground	Reverse signal	Input	ON	Select R-posi- tion	Approx. 12V	The navigation current-location mark moves strangely when the vehicle is moving back- wards.
					Other position	Approx. 0V	
12 (OR)	13 (SB)	Voice guidance signal	Output	ON	Push the "VOICE" switch	 <small>SKIA0171J</small>	Only route guid- ance and opera- tion guide are not heard.

A
B
C
D
E
F
G
H
I
J
AV
L
M

NAVIGATION SYSTEM

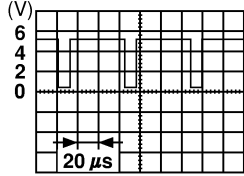
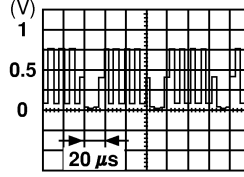
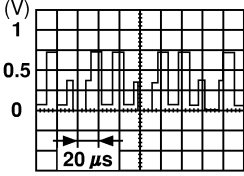
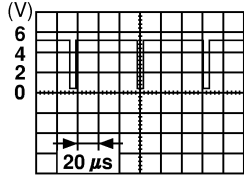
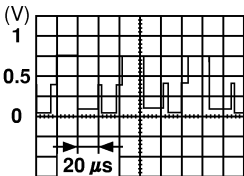
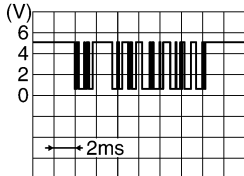
Terminal (Wire color)		Item	Signal input/ output	Condition		Reference value	Example of symptom
+	-			Ignition switch	Operation		
14 (L)	17	RGB area signal	Output	ON	-	 <small>SKIA0162E</small>	Screen is not shown.
15 (R)	17	RGB signal (B: blue)	Output	ON	Select "Color bar" of CONFIRMA- TION/ ADJUST- MENT function	 <small>SKIA0167E</small>	Screen looks yellowish.
17	Ground	Ground (RGB)	-	ON	-	Approx. 0V	-
18 (B)	17	RGB signal (R: red)	Output	ON	Select "Color bar" of CONFIRMA- TION/ ADJUST- MENT function	 <small>SKIA0165E</small>	Screen looks bluish.
20 (P)	17	RGB synchronizing signal	Output	ON	-	 <small>SKIA0164E</small>	Screen is rolling.
21 (W)	17	RGB signal (G: green)	Output	ON	Select "Color bar" of CONFIRMA- TION/ ADJUST- MENT function	 <small>SKIA0166E</small>	Screen looks reddish.
27 (SB) ^{*1} (PU) ^{*2}	Ground	Ignition signal	Input	ON	-	Battery voltage	Navigation cur- rent-location mark does not indicate the cor- rect position.
31	Ground	Ground	-	ON	-	Approx. 0V	-
32 (B/Y)	Ground	Ground	-	ON	-	Approx. 0V	-
33 (G)	Ground	Communica- tion signal (DISP-NAVI)	Input	ON	-	 <small>SKIB0231E</small>	Screen is not shown.
34 (B/Y)	Ground	Ground	-	ON	-	Approx. 0V	-

NAVIGATION SYSTEM

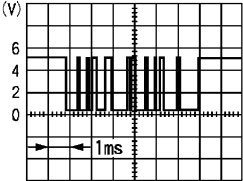
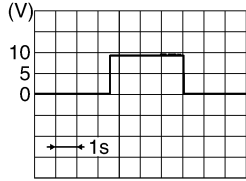
Terminal (Wire color)		Item	Signal input/ output	Condition		Reference value	Example of symptom
+	-			Ignition switch	Operation		
35 (B)	31	Communica- tion signal (NAVI-DISP)	Output	ON	-	 SKIA0832E	Screen is not shown.
37 (BR)	Ground	Voice guidance ON signal	Output	ON	Push the "VOICE" switch	 SKIB0232E	Only route guid- ance and opera- tion guide are not heard.
40 (B/OR)	Ground	Ground	-	ON	-	Approx. 0V	-
56 (GY)	Ground	GPS antenna signal	Input	ON	Connector is not connected	Approx. 5V	Navigation sys- tem GPS correc- tion is not possible.

*1 : Coupe models

*2 : Roadster models

Terminals and Reference Value for Display Unit

AKS0011E

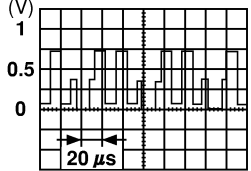
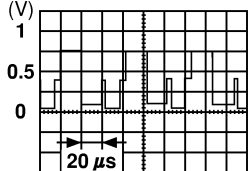
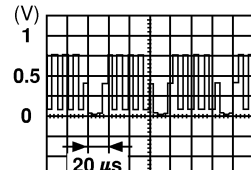
Terminal (Wire color)		Item	Signal input/ output	Condition		Reference value	Example of symptom
+	-			Ignition switch	Operation		
1 (L/R)	4	RGB signal (R: red)	Input	ON	Select "Color bar" of CONFIRMA- TION/ ADJUST- MENT function	 SKIA0165E	Screen looks bluish.
2 (L)	4	RGB signal (G: green)	Input	ON	Select "Color bar" of CONFIRMA- TION/ ADJUST- MENT function	 SKIA0166E	Screen looks reddish.
3 (L/W)	4	RGB signal (B: blue)	Input	ON	Select "Color bar" of CONFIRMA- TION/ ADJUST- MENT function	 SKIA0167E	Screen looks yellowish.
4	Ground	RGB Ground	-	ON	-	Approx. 0V	-

NAVIGATION SYSTEM

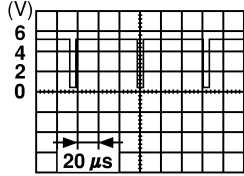
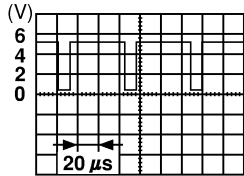
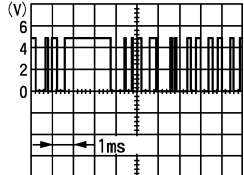
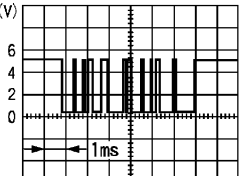
Terminal (Wire color)		Item	Signal input/ output	Condition		Reference value	Example of symptom
+	-			Ignition switch	Operation		
7 (B/R)	4	RGB synchronizing signal	Input	ON	-	 SKIA0164E	Screen is rolling.
8 (W/R)	4	RGB area signal	Input	ON	-	 SKIA0162E	Screen is not shown.
15 (R)	Ground	Communica- tion signal (DISP-NAVI)	Output	ON	-	 SKIA0835E	Screen is not shown.
16 (P/L)	17	Communica- tion signal (NAVI-DISP)	Input	ON	-	 SKIA0832E	Screen is not shown.
17	Ground	Shield	-	ON	-	Approx. 0V	-
19 (LG)	Ground	ACC power supply	Input	ACC	-	Battery voltage	System does not work properly.
21 (Y)	Ground	Battery power supply	Input	OFF	-	Battery voltage	System does not work properly.
22 (B)	Ground	Ground	-	ON	-	Approx. 0V	-
23 (Y)	Ground	Battery power supply	Input	OFF	-	Battery voltage	System does not work properly.
24 (B)	Ground	Ground	-	ON	-	Approx. 0V	-

NAVIGATION SYSTEM

Terminals and Reference Value for NAVI Switch

AKS0011F

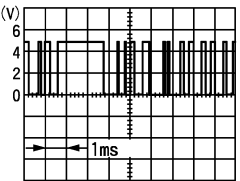
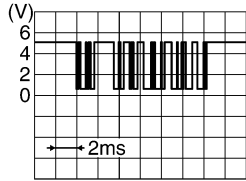
Terminal (Wire color)		Item	Signal input/ output	Condition		Reference value	Example of symptom
+	-			Ignition switch	Operation		
1 (LG)	Ground	ACC power supply	Input	ACC	-	Battery voltage	Screen is not shown.
2 (R/L)	Ground	Illumination signal (+)	Input	ON	Lighting switch ON	Approx. 12V	NAVI switch illu- mination does not function when lighting switch is ON.
					Lighting switch OFF	Approx. 0V	
3 (R/Y)	Ground	Illumination signal (-)	Input	ON	Illumination control switch is operated by lighting switch in ON position	Changes between approx. 0 and approx. 12V	NAVI switch illu- mination cannot be controlled.
4 (R)	Ground	Communica- tion signal (DISP-SW)	Input	ON	-	 SKIA0835E	Screen is not shown.
5 (G)	Ground	Communica- tion signal (SW-NAVI)	Output	ON	-	 SKIB0231E	Screen is not shown.
7 (B)	Ground	Ground	-	ON	-	Approx. 0V	-

A
B
C
D
E
F
G
H
I
J
AV
L
M

AV

NAVIGATION SYSTEM

AKS0011G

Self-Diagnosis Function

DESCRIPTION

- Diagnosis function consists of the self-diagnosis mode performed automatically and the CONFIRMATION/ADJUSTMENT mode operated manually.
- Self-diagnosis mode checks for connections between the units constituting this system, analyzes each individual unit at the same time, and displays the results on the LCD screen.
- CONFIRMATION/ADJUSTMENT mode is used to perform trouble diagnosis that require operation and judgment by an operator (trouble that cannot be automatically judged by the system), to check/change the set value, and to display the History of Errors of the navigation system.

DIAGNOSIS ITEM

Mode		Description	
Self-diagnosis		<ul style="list-style-type: none"> ● NAVI Control unit diagnosis (DVD-ROM drive will not be diagnosed when no map DVD-ROM is in it.). ● Performs diagnosis of each unit and connections between control unit and GPS antenna, as well as between control unit and each unit. 	
CONFIRMATION/ ADJUSTMENT	Display diagnosis	Color tone and shading of the screen can be checked by the display of a color bar and a gray scale.	
	Vehicle signals	Analyzes the following vehicle signals: Vehicle speed signal, light signal, ignition switch signal, and reverse signal.	
	Navigation	Display Longitude & Latitude	Display the map. Use the joystick to adjust position. Longitude and latitude will be displayed.
		Speed Calibration	Under ordinary conditions, the navigation system distance measuring function will automatically compensate for minute decreases in wheel and tire diameter caused by tire wear or low pressure. Speed calibration immediately restores system accuracy in cases such as when distance calibration is needed because of the use of tire chains in inclement weather.
		Angle adjustment	Corrects difference between actual turning angle of a vehicle and turning angle of the car mark on the display.
		Initialize Location	This mode is for initializing the current location. Use when the vehicle is transported a long distance on a trailer, etc.
History of Errors		Diagnosis results previously stored in the memory (before turning ignition switch ON) are displayed in this mode. Time and location when/where the errors occurred are also displayed.	

NAVIGATION SYSTEM

Self-Diagnosis Mode OPERATION PROCEDURE

AKS0011H

1. Start the engine.
2. Push and hold "MAP" and "D/N" switches simultaneously for 5 seconds or more.
 - Push the "PREVIOUS" switch and the initial system screen will be shown.

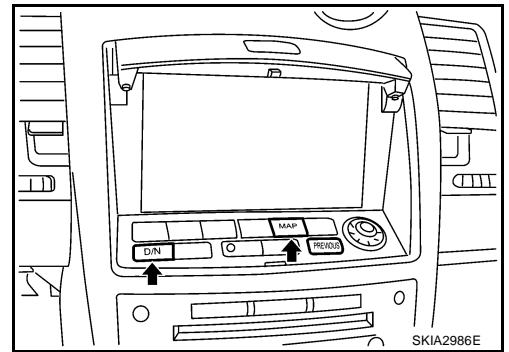

3. The initial trouble diagnosis screen will be shown, and items "SELF-DIAGNOSIS" and "CONFIRMATION/ADJUSTMENT" will become selective.

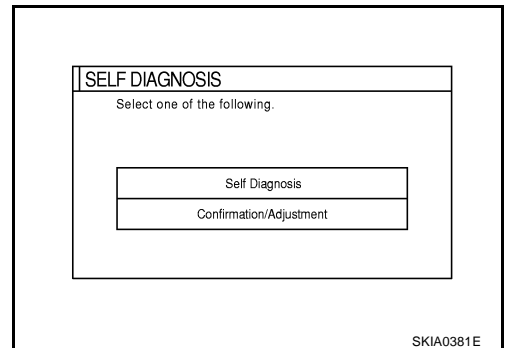

4. Perform self-diagnosis by selecting the "SELF-DIAGNOSIS".
 - Self-diagnosis subdivision screen will be shown and the operation enters the self-diagnosis mode.
 - A bar graph shown below the self-diagnosis subdivision screen indicates progress of the diagnosis.

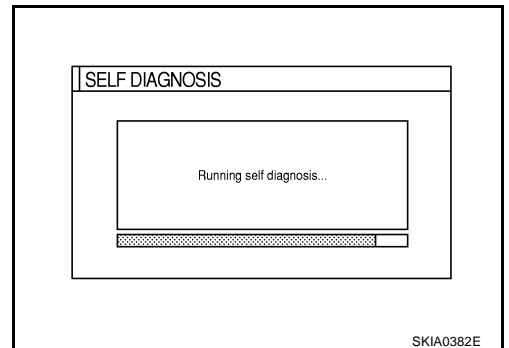

5. On the "Self diagnosis" screen, each unit name will be colored according to the diagnosis result, as follows.

Green : No malfunctioning.

Yellow : Cannot be judged by self-diagnosis results.

Red : Unit is malfunctioning.

Gray : Diagnosis has not been done.

- If several malfunctions are present in a unit, color of its switch on the screen will be either red, yellow, or gray, determined by the malfunction of the highest priority.
- Lines between control unit and display or GPS antenna are green or yellow based on diagnosis results.
- Lines between control unit and units other than those above are gray regardless of diagnosis results.

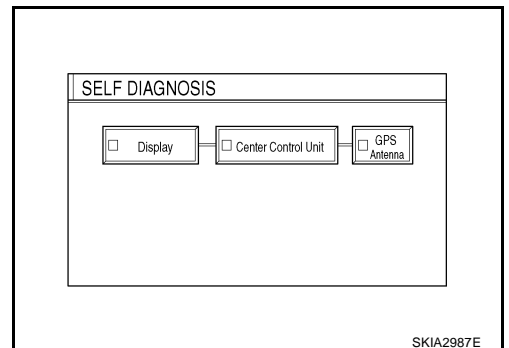

A
B
C
D
E
F
G
H
I
J
L
M

AV

NAVIGATION SYSTEM

6. Select a switch on the “Self diagnosis” screen and comments for the diagnosis results will be shown.

- When the switch is green, the following comment will be shown. “Self-diagnosis was successful. Further diagnosis and adjustments are recommended. Follow the “confirmation and adjustments” menu or refer to the service manual.”.
- When the switch is yellow, the following comment will be shown. “Connection to the following unit is abnormal. See the service manual for further details”.
- When the switch is red, the following comment will be shown. “Center Control Unit is abnormal”.
- When the switch is gray, the following comment will be shown. “Self-diagnosis for DVD-ROM DRIVER of NAVI was not conducted because no DVD-ROM was available.”.

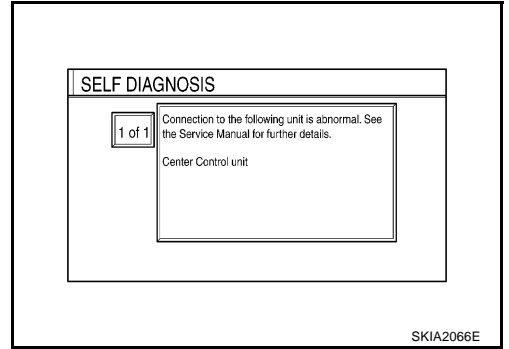

SELF-DIAGNOSIS RESULT

Quick Reference Table

1. Select an applicable diagnosis No. in the diagnosis result quick reference table.
2. Find estimated malfunctioning system in the diagnosis No. table and perform check by referring to the AV communication line wiring diagram. Refer to [AV-65. "Wiring Diagram — NAVI —"](#) .
3. Turn ignition switch to OFF and perform self-diagnosis again.

Screen switch				Diagnosis No.
Switch color	Center Control unit*1	Display	GPS antenna	
Red	×			1
Gray	×			2
Yellow	×			3
	×			4
	×		×	5
	×	×	×	6

*1: Center Control unit =NAVI control unit

CAUTION:

- If display has any error, self-diagnosis cannot start.
- If AV communication between display and NAVI control unit has any error, self-diagnosis cannot start.

NAVIGATION SYSTEM

Self-diagnosis Codes

Diagnosis No.	Possible cause
1	NAVI control unit malfunction
2	NAVI control unit judged no map DVD-ROM is inserted.
3	When "DVD-ROM error. Please check disc." is shown. 1. Eject map DVD-ROM and check if it is compatible with the system. 2. Check ejected DVD-ROM for dirt, damage, and warpage. 3. If no error is found, insert a known good map DVD-ROM of the same type and perform self-diagnosis again. If same result is shown, the NAVI control unit is malfunctioning. If result is normal, the map DVD-ROM is malfunctioning.
4	If "Error found in DVD-ROM or DVD-ROM driver in control unit. Please perform diagnosis in accordance with service manual" is shown, carry out same inspection as diagnosis No. 3.
5	GPS antenna system 1. Visually check for a broken wire in the GPS antenna coaxial cable. 2. Disconnect the GPS antenna connector and check that approximately 5V is supplied from NAVI control unit. If not, the NAVI control unit is inoperative. If the voltage is supplied, replace the GPS antenna and perform self-diagnosis again. If the same result is shown, the NAVI control unit is inoperative.
6	AV communication line circuit malfunction. <ul style="list-style-type: none"> ● Check for short circuit in AV communication line. Refer to AV-94. "Screen is Not Shown". ● If no error is found during the above checks, communication circuit in NAVI control unit has a malfunction.

CONFIRMATION/ADJUSTMENT Mode OPERATION PROCEDURE

AKS00111

1. Start the engine.
2. Push and hold "MAP" and "D/N" switches simultaneously for 5 seconds or more.
 - Push the "PREVIOUS" switch and the initial system screen will be shown.

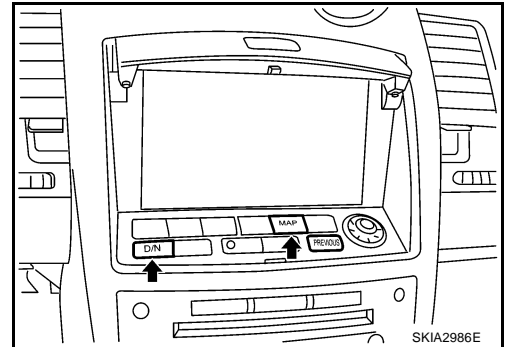

3. The initial trouble diagnosis screen will be shown, and items "SELF-DIAGNOSIS" and "CONFIRMATION/ADJUSTMENT" will become selective.

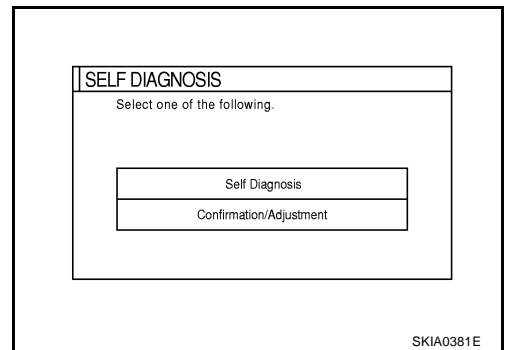

A
B
C
D
E
F
G
H
I
J
L
M

AV

NAVIGATION SYSTEM

4. When "CONFIRMATION/ADJUSTMENT" is selected on the initial trouble diagnosis screen, the operation will enter the CONFIRMATION/ADJUSTMENT mode. In this mode, check and adjustment of each item will become possible.
5. Select each switch on "CONFIRMATION/ADJUSTMENT" screen to display the relevant diagnosis screen.

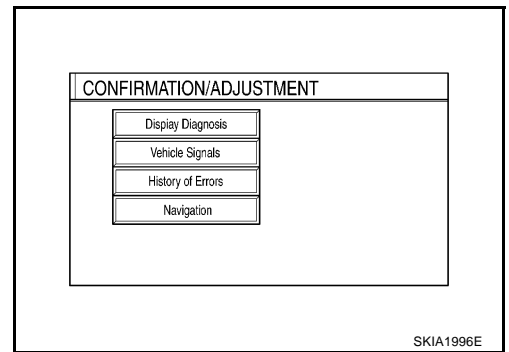

DISPLAY DIAGNOSIS

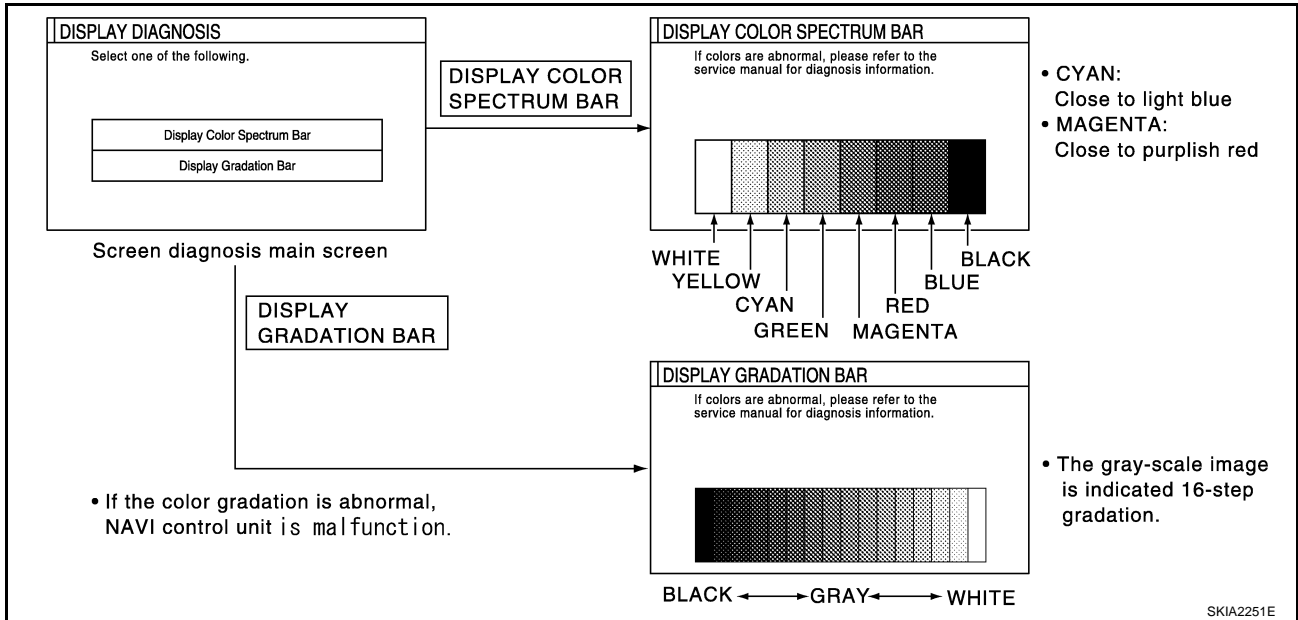

CAUTION:

When Display Color Spectrum Bar screen is completed after "PREV" switch is Pushed, the screen color changes once. This is normal.

- When RGB signal error occurred in the RGB system, tone of the color bar will change as follows.

R (red) signal error : Screen looks bluish.
G (green) signal error : Screen looks reddish.
B (blue) signal error : Screen looks yellowish.

- When the color of the screen looks unusual, refer to [AV-100, "Color of RGB Image is Not Proper"](#) .

NAVIGATION SYSTEM

VEHICLE SIGNALS

- A comparison check can be made of each actual vehicle signal and the signals recognized by the system.

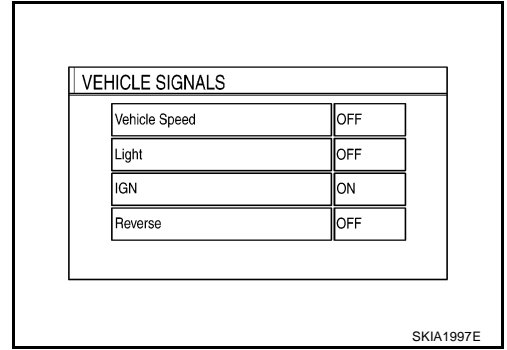

Diagnosis item	Display	Condition	Remarks
Vehicle speed	ON	Vehicle speed > 0 km/h (0 MPH)	Changes in indication may be delayed by approx. 1.5 seconds. This is normal.
	OFF	Vehicle speed = 0 km/h (0 MPH)	
	-	Ignition switch in ACC position	
Lights	ON	Lighting switch ON	-
	OFF	Lighting switch OFF	
IGN	ON	Ignition switch ON	-
	OFF	Ignition switch ACC	
Reverse	ON	Selector lever in R-position	Changes in indication may be delayed by approx. 1.5 seconds. This is normal.
	OFF	Selector lever in other than R-position	
	-	Ignition switch in ACC position	

- If vehicle speed is NG, refer to [AV-91, "Vehicle Speed Signal Check"](#) .
- If light is NG, refer to [AV-92, "Illumination Signal Check"](#) .
- If IGN is NG, refer to [AV-92, "Ignition Signal Check"](#) .
- If reverse is NG, refer to [AV-93, "Reverse Signal Check"](#) .

NAVIGATION

Angle Adjustment

- Adjusts turning angle output detected by the gyroscope.

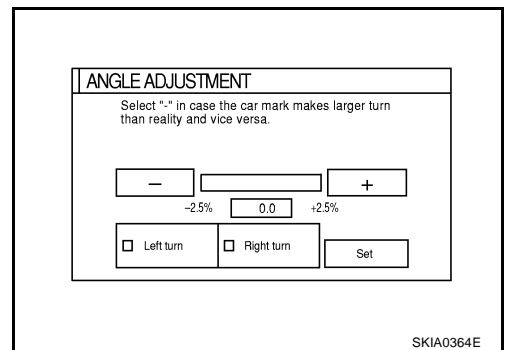

NAVIGATION SYSTEM

Speed Calibration

- During normal driving, distance error caused by tire wear and tire pressure change is automatically adjusted for by the automatic distance correction function. This function, on the other hand, is for immediate adjustment, in cases such as driving with tire chain fitted on tires.

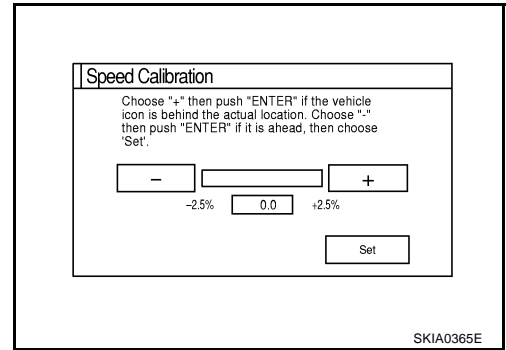

HISTORY OF ERRORS

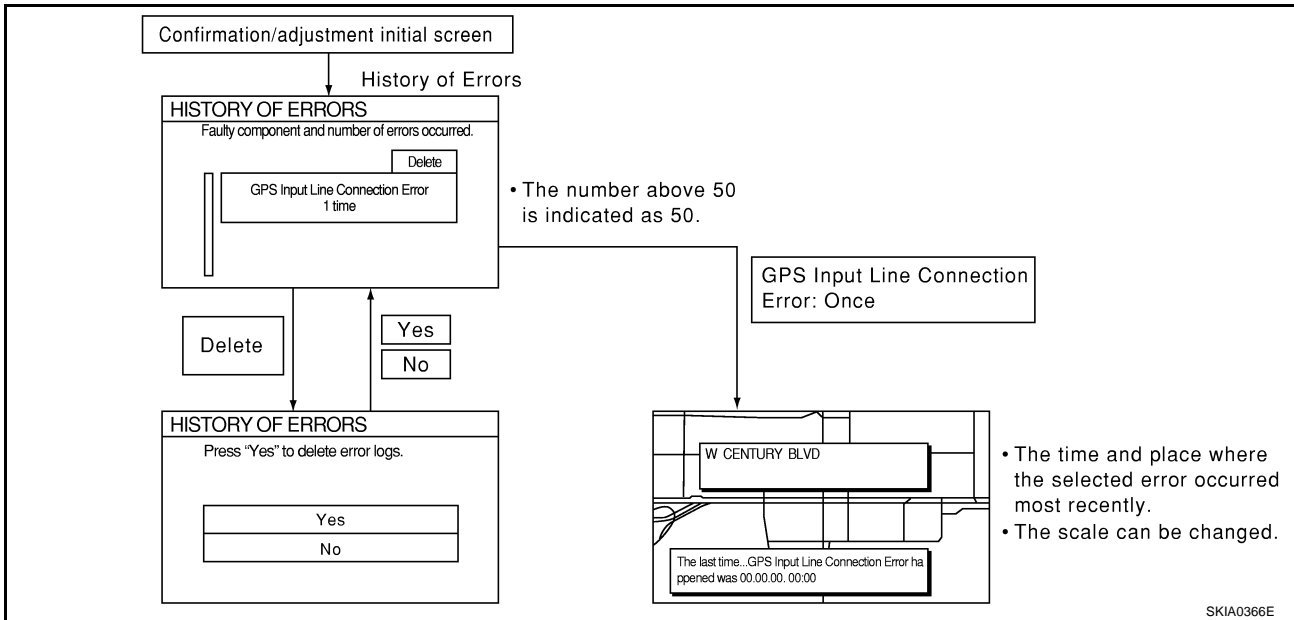

DIAGNOSIS BY HISTORY OF ERRORS

The "Self-diagnosis" results indicate whether an error occurred during the period from when the ignition switch is turned to ON until "Self-diagnosis" is completed.

If an error occurred before the ignition switch was turned to ON and does not occur again until the "Self-diagnosis" is completed, the diagnosis result will be judged normal. Therefore, those errors in the past, which cannot be found by the "Self-diagnosis", must be found by diagnosing the "History of Errors".

The History of Errors displays the time and place of the most recent occurrence of that error. However, take note of the following points.

- Correct time of the error occurrence may not be displayed when the GPS antenna substrate within the NAVI control unit has malfunctioned.
- Place of the error occurrence is represented by the position of the current-location mark at the time when the error occurred. If the current-location mark has deviated from the correct position, then the place of the error occurrence may be located correctly.
- The maximum number of occurrences which can be stored is 50. For the 51st and later occurrences, the displayed number remains 50.

When a reproducible malfunction occurred but its cause cannot be identified because several errors are present, record the item, number and place (longitude/latitude) of error occurrence (or delete the History of Errors), then turn the ignition switch from OFF to ON to reproduce the malfunction. Check the History of Errors to find the items which show an increased number of occurrences, and diagnose the item.

NAVIGATION SYSTEM

Error item	Possible causes	Example of symptom
	Action/symptom	
Gyro sensor disconnected	Communications malfunction between NAVI control unit and internal gyro	<ul style="list-style-type: none"> ● Navigation location detection performance has deteriorated. (Angular velocity cannot be detected.)
	<ul style="list-style-type: none"> ● Perform self-diagnosis. ● When the NAVI control unit is judged normal by self-diagnosis, the symptom may be intermittent, caused by strong radio interference. 	
GPS disconnected	Communication error between NAVI control unit and internal GPS substrate	<ul style="list-style-type: none"> ● Navigation location detection performance has deteriorated. (Location correction using GPS is not performed.) ● GPS receiving status remains gray.
	<ul style="list-style-type: none"> ● Perform self-diagnosis. ● When the NAVI control unit is judged normal by self-diagnosis, the symptom may be intermittent, caused by strong radio interference. 	
GPS transmission cable malfunction	Malfunctioning transmission wires to NAVI control unit and internal GPS substrate	<ul style="list-style-type: none"> ● During self-diagnosis, GPS diagnosis is not performed.
	<ul style="list-style-type: none"> ● Perform self-diagnosis. ● When the NAVI control unit is judged normal by self-diagnosis, the symptom may be intermittent, caused by strong radio interference. 	
GPS input line connection error	Malfunctioning receiving wires to NAVI control unit and internal GPS substrate	<ul style="list-style-type: none"> ● Navigation location detection performance has deteriorated. (Location correction using GPS is not performed.) ● GPS receiving status remains gray.
	<ul style="list-style-type: none"> ● Perform self-diagnosis. ● When the NAVI control unit is judged normal by self-diagnosis, the symptom may be intermittent, caused by strong radio interference. 	
GPS TCX0 over GPS TCX0 under	Oscillating frequency of the GPS substrate frequency synchronization oscillation circuit exceeded (or below) the specification	<ul style="list-style-type: none"> ● Navigation location detection performance has deteriorated. (Location correction using GPS is not performed.) ● GPS receiving status remains gray.
	<ul style="list-style-type: none"> ● Perform self-diagnosis. ● When the NAVI control unit is judged normal by self-diagnosis, the symptom may be intermittent, caused by strong radio interference, or the control unit may have been subjected to excessively high or low temperatures. 	
GPS ROM malfunction GPS RAM malfunction	Contents of ROM (or RAM) in GPS substrate are malfunctioning.	<ul style="list-style-type: none"> ● Location detection accuracy of the navigation system will deteriorate, depending on the malfunctioning area in the memory, because GPS cannot make correct positioning. (Location correction using GPS is not performed.)
	<ul style="list-style-type: none"> ● Perform self-diagnosis. ● When the NAVI control unit is judged normal by self-diagnosis, the symptom may be intermittent, caused by strong radio interference. 	
GPS RTC malfunction	Clock IC in GPS substrate is malfunctioning.	<ul style="list-style-type: none"> ● Correct time may not be displayed. ● After the power is turned on, the system always takes some time until GPS positioning becomes possible. (The GPS receiver starts positioning without re-collecting the whole satellite information when it judged the data stored in the receiver is correct.) ● Correct time of error occurrence may not be stored in the "History of Errors".
	<ul style="list-style-type: none"> ● Perform self-diagnosis. ● When the NAVI control unit is judged normal by self-diagnosis, the symptom may be intermittent, caused by strong radio interference. 	
GPS antenna disconnected	Malfunctioning connection between GPS substrate in NAVI control unit and GPS antenna.	<ul style="list-style-type: none"> ● Navigation location detection performance has deteriorated. (Location correction using GPS is not performed.) ● GPS receiving status remains gray.
	<ul style="list-style-type: none"> ● Perform self-diagnosis. ● When connection between NAVI control unit and GPS antenna is judged normal by self-diagnosis, the symptom may be intermittent, caused by impact or vibration. 	

A
B
C
D
E
F
G
H
I
J
AV
L
M

NAVIGATION SYSTEM

Error item	Possible causes	Example of symptom
	Action/symptom	
Low voltage of GPS	The power voltage supplied to the GPS circuit board has decreased.	<ul style="list-style-type: none"> ● Navigation location detection performance has deteriorated. (Location correction using GPS is not performed.) ● GPS receiving status remains gray.
	<ul style="list-style-type: none"> ● Perform self-diagnosis. ● When connection between NAVI control unit and GPS antenna is judged normal by self-diagnosis, the symptom may be intermittent, caused by impact or vibration. 	
DVD-ROM Malfunction DVD-ROM Read error DVD-ROM Response Error	Malfunctioning NAVI control unit	-
	Dedicated map DVD-ROM is in the system, but the data cannot be read.	<ul style="list-style-type: none"> ● The map of a particular location cannot be displayed. ● Specific guidance information cannot be displayed. ● Map display is slow. ● Guidance information display is slow. ● System has been affected by vibration.
	<ul style="list-style-type: none"> ● Is map DVD-ROM damaged, warped, or dirty? <ul style="list-style-type: none"> - If damaged or warped, the map DVD-ROM is malfunctioning. - If dirty, wipe the DVD-ROM clean with a soft cloth. ● Perform self-diagnosis. ● When NAVI control unit is judged normal by self-diagnosis, the symptom is judged intermittent, caused by vibration. 	

NAVIGATION SYSTEM

Power Supply and Ground Circuit Check for NAVI Control Unit

AKS0011J

1. CHECK FUSE

Make sure that the following fuses of the NAVI control unit are not blown.

Unit	Signal	Fuse No.
NAVI control unit	Battery power supply	37
	Ignition switch ACC or ON	6

OK or NG

OK >> GO TO 2.

NG >> If fuse is blown, be sure to eliminate cause of malfunction before installing new fuse. Refer to [PG-4, "POWER SUPPLY ROUTING CIRCUIT"](#).

2. CHECK POWER SUPPLY CIRCUIT

Check voltage between NAVI control unit harness connector terminals and ground.

Terminals		(-)	OFF	ACC	ON
(+)	Terminal (Wire color)				
B104	2 (Y)	Ground	Battery voltage	Battery voltage	Battery voltage
	3 (Y)		Battery voltage	Battery voltage	Battery voltage
	6 (LG)		0V	Battery voltage	Battery voltage

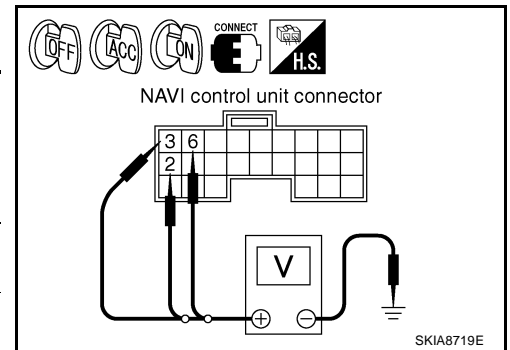

OK or NG

OK >> GO TO 3.

NG >> Repair harness or connector.

3. CHECK GROUND CIRCUIT

- Turn ignition switch OFF.
- Disconnect NAVI control unit connector.
- Check continuity between NAVI control unit harness connector B104 terminals 1 (B), 4 (B) and ground.

1, 4 – Ground : Continuity should exist.

OK or NG

OK >> INSPECTION END

NG >> Repair harness or connector.

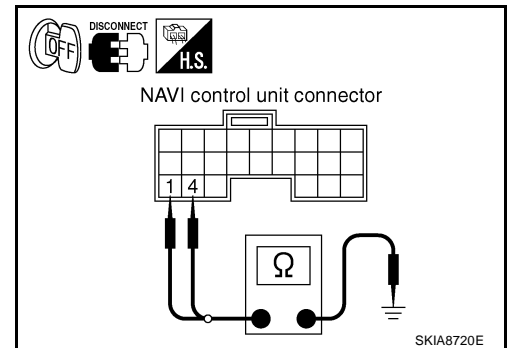

NAVIGATION SYSTEM

AKS0011K

Power Supply and Ground Circuit Check for Display Unit

1. CHECK FUSE

Make sure that the following fuses of the display unit are not blown.

Unit	Signal	Fuse No.
Display unit	Battery power supply	37
	Ignition switch ACC or ON	6

OK or NG

OK >> GO TO 2.

NG >> If fuse is blown, be sure to eliminate cause of malfunction before installing new fuse. Refer to [PG-4, "POWER SUPPLY ROUTING CIRCUIT"](#).

2. CHECK POWER SUPPLY CIRCUIT

Check voltage between display unit harness connector terminals and ground.

Terminals		(-)	OFF	ACC	ON
(+)	Terminal (Wire color)				
M35	21 (Y)	Ground	Battery voltage	Battery voltage	Battery voltage
	23 (Y)		Battery voltage	Battery voltage	Battery voltage
	19 (LG)		0V	Battery voltage	Battery voltage

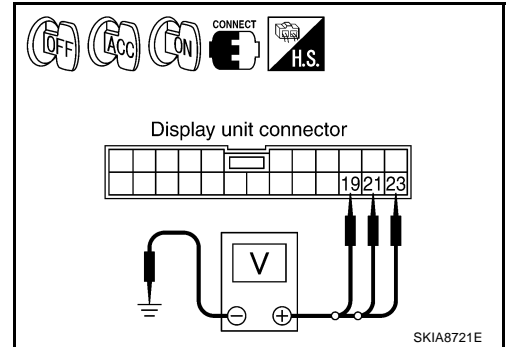

OK or NG

OK >> GO TO 3.

NG >> Repair harness or connector.

3. CHECK GROUND CIRCUIT

1. Turn ignition switch OFF.
2. Disconnect display unit connector.
3. Check continuity between display unit harness connector M35 terminals 22 (B), 24 (B) and ground.

22, 24 – Ground : Continuity should exist.

OK or NG

OK >> INSPECTION END

NG >> Repair harness or connector.

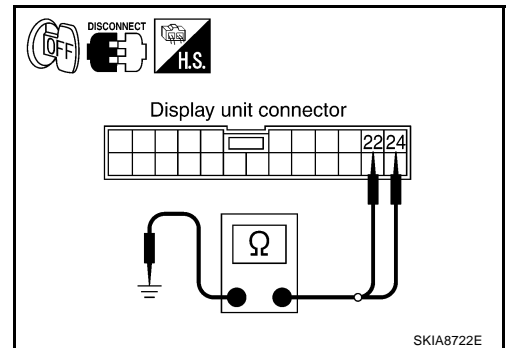

NAVIGATION SYSTEM

Power Supply and Ground Circuit Check for NAVI Switch

AKS003LT

1. CHECK FUSE

Make sure that the following fuses of the NAVI switch are not blown.

Unit	Signal	Fuse No.
NAVI switch	Ignition switch ACC or ON	6

OK or NG

OK >> GO TO 2.

NG >> If fuse is blown, be sure to eliminate cause of malfunction before installing new fuse. Refer to [PG-4. "POWER SUPPLY ROUTING CIRCUIT"](#).

2. CHECK POWER SUPPLY CIRCUIT

Check voltage between NAVI switch harness connector terminal and ground.

Terminals			OFF	ACC	ON
(+)		(-)			
Connector	Terminal (Wire color)	(-)			
M37	1 (LG)	Ground	0V	Battery voltage	Battery voltage

OK or NG

OK >> GO TO 3.

NG >> Repair harness or connector.

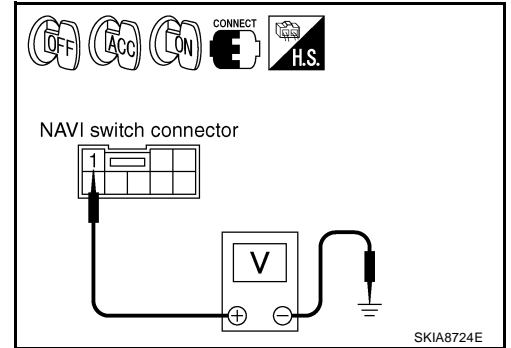

3. CHECK GROUND CIRCUIT

1. Turn ignition switch OFF.
2. Disconnect NAVI switch connector.
3. Check continuity between NAVI switch harness connector M37 terminal 7 (B) and ground.

7 – Ground : Continuity should exist.

OK or NG

OK >> INSPECTION END

NG >> Repair harness or connector.

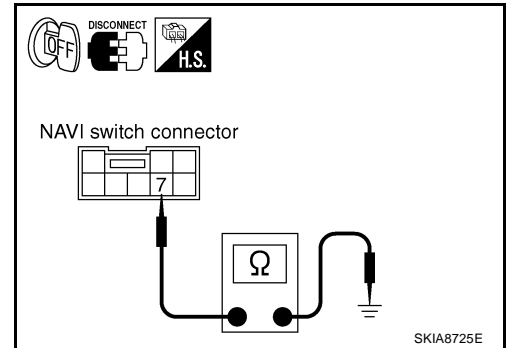

NAVIGATION SYSTEM

Power Supply and Ground Circuit Check for Power Cluster Lid Amp.

AKS009K4

1. CHECK FUSE

Make sure that the following fuses of the power cluster lid amp. are not blown.

Unit	Signal	Fuse No.
Power cluster lid amp.	Battery power supply	37
	Ignition switch ACC or ON	6
	Ignition switch ON or START	12

OK or NG

OK >> GO TO 2.

NG >> If fuse is blown, be sure to eliminate cause of malfunction before installing new fuse. Refer to [PG-4, "POWER SUPPLY ROUTING CIRCUIT"](#).

2. CHECK POWER SUPPLY CIRCUIT

Check voltage between power cluster lid amp. harness connector terminals and ground.

Terminals		(-)	OFF	ACC	ON
(+)	Terminal (Wire color)				
M36	4 (Y)	Ground	Battery voltage	Battery voltage	Battery voltage
	3 (LG)		0V	Battery voltage	Battery voltage
	1 (Y/G)		0V	0V	Battery voltage

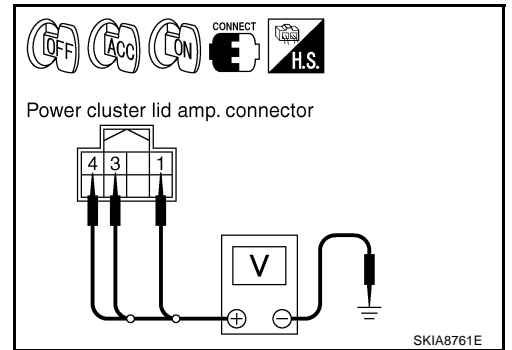

OK or NG

OK >> GO TO 3.

NG >> Repair harness or connector.

3. CHECK GROUND CIRCUIT

1. Turn ignition switch OFF.
2. Disconnect power cluster lid amp. connector.
3. Check continuity between power cluster lid amp. harness connector M36 terminal 2 (B) and ground.

2 – Ground : Continuity should exist.

OK or NG

OK >> INSPECTION END

NG >> Repair harness or connector.

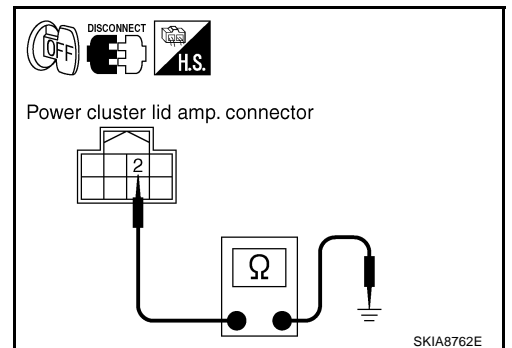

Vehicle Speed Signal Check

1. CHECK SPEEDOMETER FUNCTION

Does speedometer is operated normally?

YES or NO

YES >> GO TO 2.

NO >> Check combination meter trouble diagnosis. Refer to [DI-19, "Vehicle Speed Signal Inspection"](#) in "COMBINATION METERS".

2. CHECK HARNESS

1. Turn ignition switch OFF.
2. Disconnect NAVI control unit and unified meter and A/C amp. connectors.
3. Check continuity between NAVI control unit harness connector B104 terminal 8 (L/B for Coupe models, GY for Roadster models) and unified meter and A/C amp. harness connector M49 terminal 34 (W/G).

8 – 34 : Continuity should exist.

4. Check continuity between NAVI control unit harness connector B104 terminal 8 (L/B for Coupe models, GY for Roadster models) and ground.

8 – Ground : Continuity should not exist.

OK or NG

OK >> GO TO 3.

NG >> Repair harness or connector.

3. CHECK NAVI CONTROL UNIT

1. Connect NAVI control unit connector.
2. Turn ignition switch ON.
3. Check voltage between NAVI control unit harness connector B104 terminal 8 (L/B for Coupe models, GY for Roadster models) and ground.

8 – Ground : Approx. 5V

OK or NG

OK >> GO TO 4.

NG >> Replace NAVI control unit.

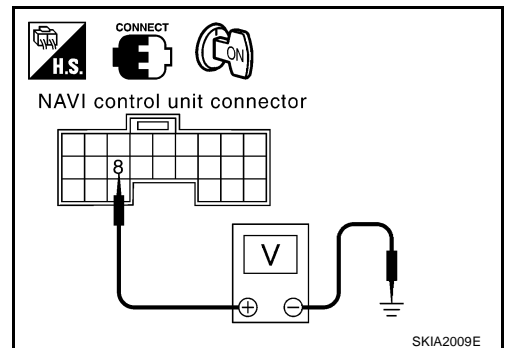
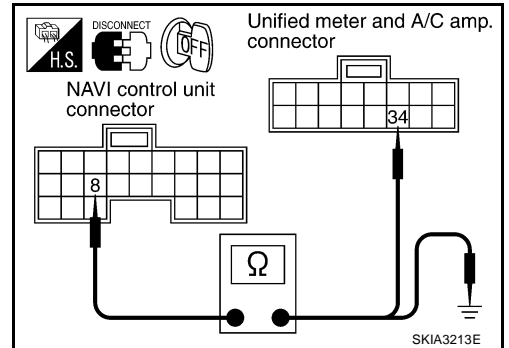

A
B
C
D
E
F
G
H
I
J
L
M

AV

NAVIGATION SYSTEM

4. CHECK VEHICLE SPEED SIGNAL

1. Connect unified meter and A/C amp. connector.
2. Start engine and drive vehicle at more than 40 km/h (25MPH).
3. Check voltage waveform between NAVI control unit harness connector B104 terminal 8 (L/B for Coupe models, GY for Roadster models) and ground using CONSULT-II or oscilloscope.

8 – Ground

: Refer to [AV-73, "Terminals and Reference Value for NAVI Control Unit"](#) .

OK or NG

OK >> INSPECTION END

NG >> Replace unified meter and A/C amp. Refer to [DI-63, "Removal and Installation of Unified Meter and A/C Amp."](#) .

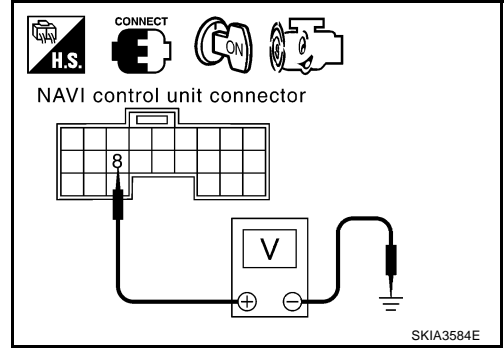

Illumination Signal Check

AKS0011M

1. CHECK TAIL LAMP OPERATION

When lighting switch turned 1st or 2nd position, does tail lamp illuminate?

YES or NO

YES >> GO TO 2.

NO >> Go to tail lamp trouble diagnosis. Refer to [LT-179, "PARKING, LICENSE PLATE AND TAIL LAMPS"](#) .

2. CHECK ILLUMINATION SIGNAL

Check voltage between NAVI control unit harness connector terminal and ground.

Terminals		Lighting switch position	Voltage (V)
(+)	(-)		
Connector	Terminal (Wire color)		
B104	9 (*1)	ON	Approx. 12
		OFF	Approx. 0

*1: Coupe models (PU) , Roadster models(R/L)

OK or NG

OK >> INSPECTION END

NG >> Repair harness or connector.

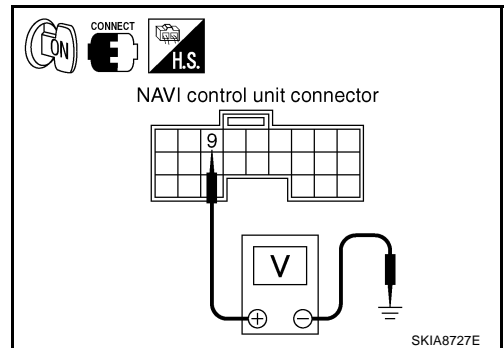

Ignition Signal Check

AKS0011N

1. CHECK IGNITION SIGNAL

1. Turn ignition switch ON.
2. Check voltage between NAVI control unit harness connector B105 terminal 27 (SB for Coupe models, PU for Roadster models) and ground.

27 – Ground

: Battery voltage

OK or NG

OK >> INSPECTION END

NG >> Repair harness or connector.

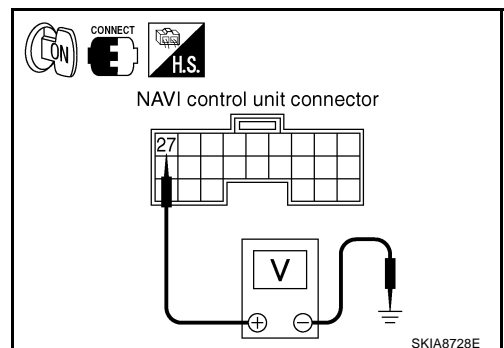

NAVIGATION SYSTEM

AKS00110

Reverse Signal Check

1. CHECK REVERSE LAMP

1. Turn ignition switch ON.
2. With the A/T selector lever in R-position, does "R" in the shift position indicator come on?

YES or NO

YES >> GO TO 2.

NO >> Check "BACK-UP LAMP" system. Refer to [LT-174, "BACK-UP LAMP"](#) .

2. CHECK REVERSE SIGNAL

1. Shift the A/T selector lever in R-position.
2. Check voltage between NAVI control unit harness connector terminal and ground.

Terminals		A/T selector lever position	Voltage (V)
(+)			
Connector	Terminal (Wire color)		
B104	11 (*1)	R-position	Approx. 12
		Other than R-position	Approx. 0

*1: Coupe models (BR) , Roadster models (OR)

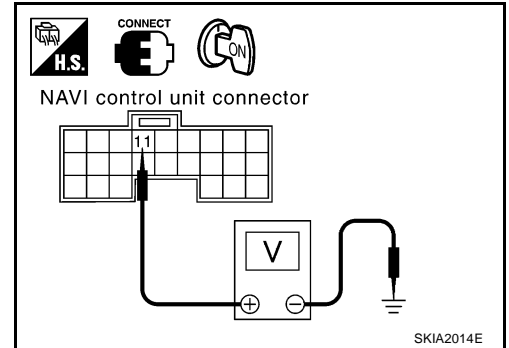

OK or NG

OK >> INSPECTION END

NG >> Repair harness or connector.

When Display Cover is Closed, Display is Stay On

AKS00322

1. CHECK HARNESS

1. Turn ignition switch OFF.
2. Disconnect NAVI control unit and power cluster lid amp. connectors.
3. Check continuity between NAVI control unit harness connector B104 terminal 7 (R/Y for Coupe models, LG for Roadster models) and power cluster lid amp. harness connector M36 terminal 8 (R/W).

7 – 8

: Continuity should exist.

OK or NG

OK >> GO TO 2.

NG >> Repair harness or connector.

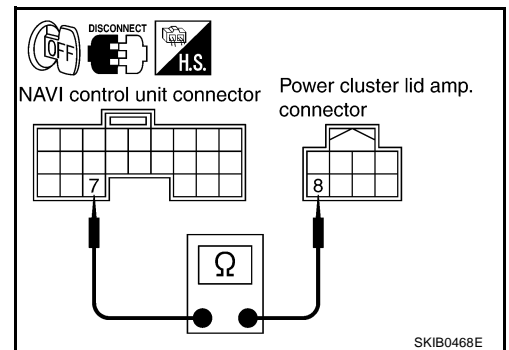

2. CHECK POWER CLUSTER LID AMP.

1. Turn ignition switch OFF.
2. Replace power cluster lid amp.

Does the system operate normally?

OK >> INSPECTION END

NG >> Replace cluster lid D.

Screen is Not Shown

1. CHECK BEEP SOUND

Check if beep sound is heard twice under the following conditions.

- ten seconds after ignition switch is turned on.
- when MAP switch and D/N switch are pressed simultaneously for five seconds.

Is the beep sound heard?

- YES >> ● Go to 2 if beep sound is heard twice only ten seconds after ignition switch is turned on.
- Go to 6 if beep sound is heard only when MAP switch and D/N switch are pushed simultaneously for five seconds.
 - Go to 9 if beep sound is heard twice under both conditions.
- NO >> GO TO 13.

2. CHECK NAVI SWITCH POWER SUPPLY AND GROUND CIRCUIT

Check NAVI switch power supply and ground circuit. Refer to [AV-89, "Power Supply and Ground Circuit Check for NAVI Switch"](#).

OK or NG

- OK >> GO TO 3.
 NG >> Repair malfunctioning parts.

3. CHECK COMMUNICATION LINE

1. Turn ignition switch OFF.
2. Disconnect NAVI control unit, display unit and NAVI switch connectors.
3. Check continuity between NAVI control unit harness connector B105 terminal 33 (G) and NAVI switch harness connector M37 terminal 5 (G).

33 – 5 : Continuity should exist.

4. Check continuity between NAVI control unit harness connector B105 terminal 33 (G) and ground.

33 – Ground : Continuity should not exist.

OK or NG

- OK >> GO TO 4.
 NG >> Repair harness or connector.

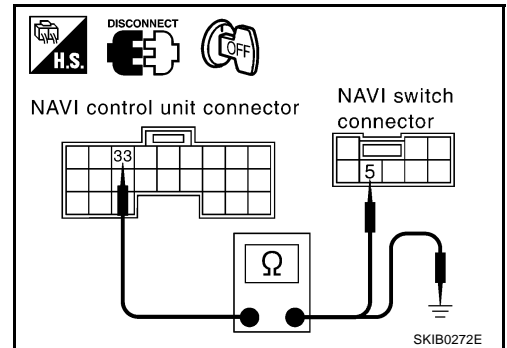

4. CHECK NAVI CONTROL UNIT

1. Connect NAVI control unit connector.
2. Turn ignition switch ON.
3. Check voltage between NAVI control unit harness connector B105 terminal 33 (G) and ground.

33 – Ground : Approx. 4V

OK or NG

- OK >> GO TO 5.
 NG >> Replace NAVI control unit.

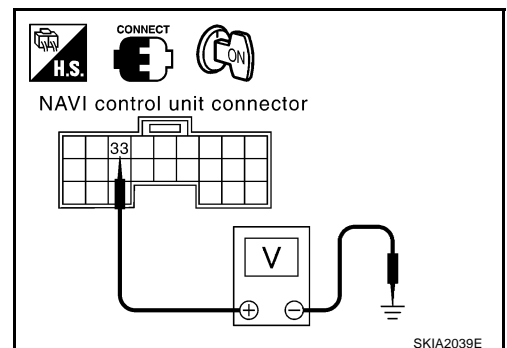

NAVIGATION SYSTEM

5. CHECK COMMUNICATION SIGNAL (SW-NAVI)

1. Turn ignition switch OFF.
2. Connect display unit and NAVI switch connectors.
3. Turn ignition switch ON.
4. Check voltage waveform between NAVI control unit harness connector B105 terminal 33 (G) and ground using CONSULT-II or oscilloscope.

33 – Ground

: Refer to [AV-73](#), "[Terminals and Reference Value for NAVI Control Unit](#)".

OK or NG

- OK >> Replace NAVI control unit.
NG >> Replace NAVI switch.

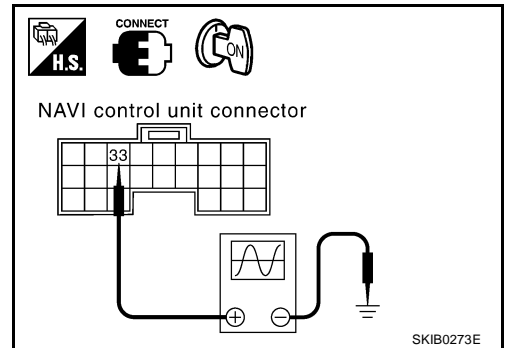

6. CHECK COMMUNICATION LINE

1. Turn ignition switch OFF.
2. Disconnect NAVI control unit, display unit and NAVI switch connectors.
3. Check continuity between NAVI control unit harness connector B105 terminals 35 (B), 31 and display unit harness connector M35 terminals 16 (P/L), 17.

35 – 16

: Continuity should exist.

31 – 17

: Continuity should exist.

4. Check continuity between NAVI control unit harness connector B105 terminal 35 (B) and ground.

35 – Ground

: Continuity should not exist.

OK or NG

- OK >> GO TO 7.
NG >> Repair harness or connector.

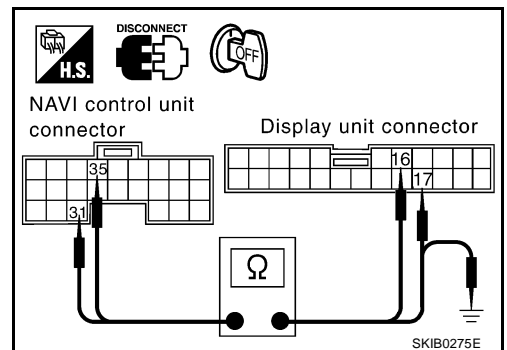

7. CHECK DISPLAY UNIT

1. Connect display unit connector.
2. Turn ignition switch ON.
3. Check voltage between display unit harness connector M35 terminals 16 (P/L) and 17.

16 – 17

: Approx. 4.2V

OK or NG

- OK >> GO TO 8.
NG >> Replace display unit.

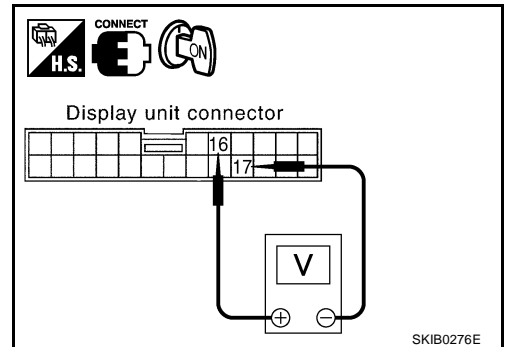

NAVIGATION SYSTEM

8. CHECK COMMUNICATION SIGNAL (NAVI-DISP)

1. Turn ignition switch OFF.
2. Connect NAVI switch and NAVI control unit connectors.
3. Turn ignition switch ON.
4. Check voltage waveform between display unit harness connector M35 terminals 16 (P/L) and 17 using CONSULT-II or oscilloscope.

16 – 17

: Refer to [AV-75, "Terminals and Reference Value for Display Unit"](#) .

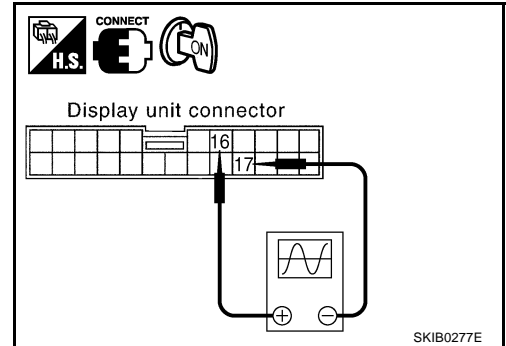

OK or NG

- OK >> Replace display unit.
NG >> Replace NAVI control unit.

9. CHECK DISPLAY UNIT POWER SUPPLY AND GROUND CIRCUIT

Check display unit power supply and ground circuit. Refer to [AV-88, "Power Supply and Ground Circuit Check for Display Unit"](#) .

OK or NG

- OK >> GO TO 10.
NG >> Repair malfunctioning parts.

10. CHECK COMMUNICATION LINE

1. Turn ignition switch OFF.
2. Disconnect display unit, NAVI switch and NAVI control unit connectors.
3. Check continuity between display unit harness connector M35 terminal 15 (R) and NAVI switch harness connector M37 terminal 4 (R).

15 – 4

: Continuity should exist.

4. Check continuity between display unit harness connector M35 terminal 15 (R) and ground.

15 – Ground

: Continuity should not exist.

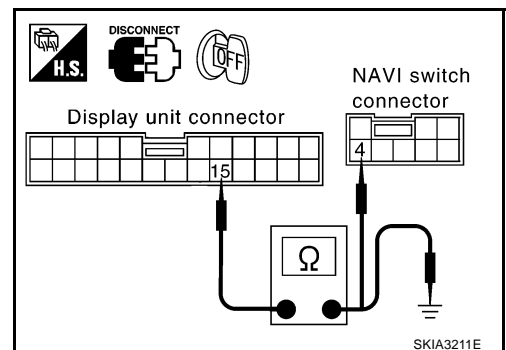

OK or NG

- OK >> GO TO 11.
NG >> Repair harness or connector.

11. CHECK NAVI SWITCH

1. Connect NAVI switch connector.
2. Turn ignition switch ON.
3. Check voltage between NAVI switch harness connector M37 terminal 4 (R) and ground.

4 – Ground

: Approx. 4.7V

OK or NG

- OK >> GO TO 12.
NG >> Replace NAVI switch.

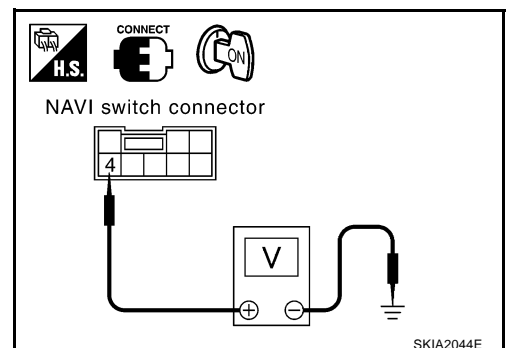

NAVIGATION SYSTEM

12. CHECK COMMUNICATION SIGNAL (DISP-SW)

1. Turn ignition switch OFF.
2. Connect display unit and NAVI control unit connectors.
3. Turn ignition switch ON.
4. Check voltage waveform between NAVI switch harness connector M37 terminal 4 (R) and ground using CONSULT-II or oscilloscope.

4 – Ground

: Refer to [AV-77, "Terminals and Reference Value for NAVI Switch"](#) .

OK or NG

- OK >> Replace NAVI switch.
NG >> Replace display unit.

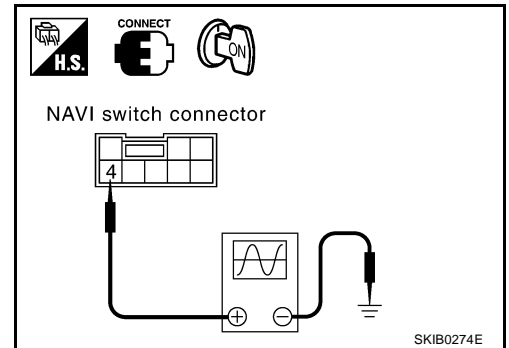

13. CHECK NAVI CONTROL UNIT POWER SUPPLY AND GROUND CIRCUIT

Check NAVI control unit power supply and ground circuit. Refer to [AV-87, "Power Supply and Ground Circuit Check for NAVI Control Unit"](#) .

OK or NG

- OK >> GO TO 14.
NG >> Repair malfunctioning parts.

14. CHECK HARNESS

1. Turn ignition switch OFF.
2. Disconnect NAVI control unit and display unit connectors.
3. Check continuity between NAVI control unit harness connector B104 terminal 14 (L) and display unit harness connector M35 terminal 8 (W/R).

14 – 8

: Continuity should exist.

4. Check continuity between NAVI control unit harness connector B104 terminal 14 (L) and ground.

14 – Ground

: Continuity should not exist.

OK or NG

- OK >> GO TO 15.
NG >> Repair harness or connector.

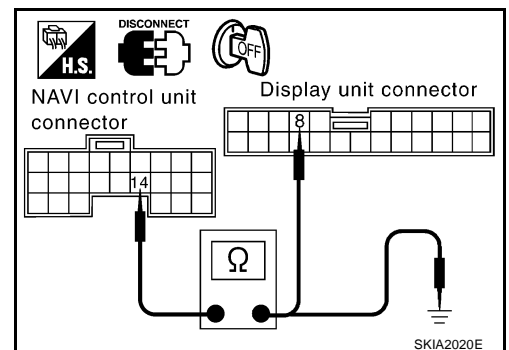

15. CHECK RGB AREA SIGNAL

1. Connect NAVI control unit and display unit connectors.
2. Turn ignition switch ON.
3. Check voltage waveform between NAVI control unit harness connector B104 terminals 14 (L) and 17 using CONSULT-II or oscilloscope.

14 – 17

: Refer to [AV-73, "Terminals and Reference Value for NAVI Control Unit"](#) .

OK or NG

- OK >> GO TO 16.
NG >> Replace NAVI control unit.

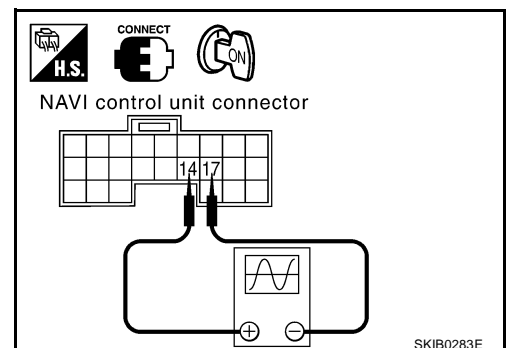

NAVIGATION SYSTEM

16. CHECK DISPLAY UNIT

Check if brightness of screen changes when D/N switch on AV switch is turned on after turning on ignition switch.

Does brightness of screen change?

OK >> GO TO 17.

NG >> Replace display unit.

17. CHECK HARNESS

1. Turn ignition switch OFF.
2. Disconnect NAVI control unit and power cluster lid amp. connectors.
3. Check continuity between NAVI control unit harness connector B104 terminal 7 (R/Y for Coupe models, LG for Roadster models) and ground.

7 – Ground : Continuity should not exist.

OK or NG

OK >> GO TO 18.

NG >> Repair harness or connector.

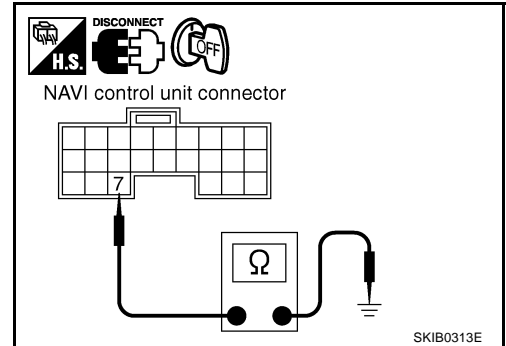

18. CHECK NAVI CONTROL UNIT INPUT SIGNAL

1. Connect NAVI control unit connector.
2. Turn ignition switch ON.
3. Check voltage between NAVI control unit harness connector terminal and ground.

Connector	Terminal (Wire color)	Condition	Voltage (V)
B104	7 (*1)	Display cover is opened	Approx. 5

*1 : Coupe models (R/Y), Roadster models (LG)

OK or NG

OK >> GO TO 19.

NG >> Replace NAVI control unit.

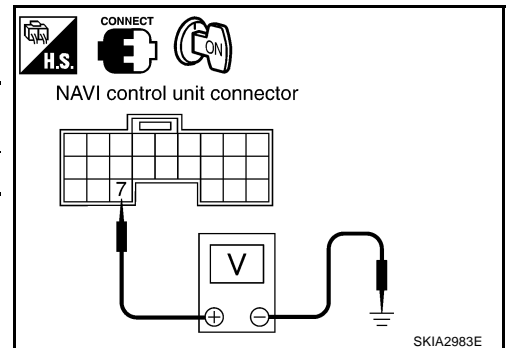

19. CHECK POWER CLUSTER LID AMP.

1. Turn ignition switch OFF.
2. Replace power cluster lid amp.

Does the system operate normally?

OK >> INSPECTION END

NG >> Replace cluster lid D.

Lid Does Not Move

1. CHECK POWER CLUSTER LID AMP. POWER SUPPLY AND GROUND

Check power cluster lid amp. power supply and ground circuit. Refer to [AV-90, "Power Supply and Ground Circuit Check for Power Cluster Lid Amp."](#)

OK or NG

OK >> GO TO 2.

NG >> Repair malfunctioning parts.

AKS009K5

NAVIGATION SYSTEM

2. CHECK POWER CLUSTER LID AMP.

1. Turn ignition switch OFF.
2. Replace power cluster lid amp.

Does the system operate normally?

OK >> INSPECTION END
NG >> Replace cluster lid D.

A

B

C

D

E

F

G

H

I

J

AV

L

M

NAVIGATION SYSTEM

AKS0011Q

Color of RGB Image is Not Proper

1. CHECK RGB HARNESS

1. Turn ignition switch OFF.
2. Disconnect NAVI control unit and display unit connectors.
3. Check continuity as following.

● When the screen looks bluish

Terminals				Continuity
NAVI control unit		Display unit		
Connector	Terminal (Wire color)	Connector	Terminal (Wire color)	
B104	18 (B)	M35	1 (L/R)	Yes
	17		4	

Terminals				Continuity
NAVI control unit		Ground	Continuity	
Connector	Terminal (Wire color)			
B104	18 (B)			No
	17			

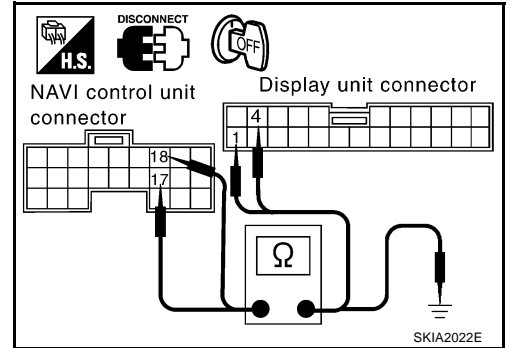

● When the screen looks reddish

Terminals				Continuity
NAVI control unit		Display unit		
Connector	Terminal (Wire color)	Connector	Terminal (Wire color)	
B104	21 (W)	M35	2 (L)	Yes
	17		4	

Terminals				Continuity
NAVI control unit		Ground	Continuity	
Connector	Terminal (Wire color)			
B104	21 (W)			No
	17			

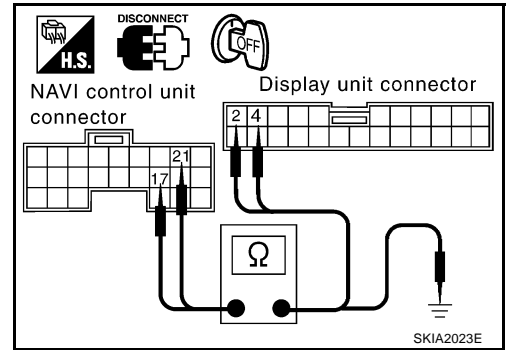

● When the screen looks yellowish

Terminals				Continuity
NAVI control unit		Display unit		
Connector	Terminal (Wire color)	Connector	Terminal (Wire color)	
B104	15 (R)	M35	3 (L/W)	Yes
	17		4	

Terminals				Continuity
NAVI control unit		Ground	Continuity	
Connector	Terminal (Wire color)			
B104	15 (R)			No
	17			

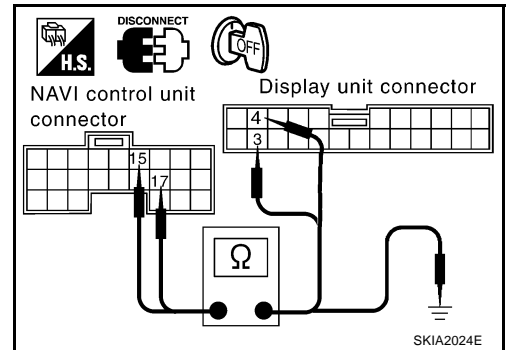

OK or NG

- OK >> GO TO 2.
- NG >> Repair harness or connector.

NAVIGATION SYSTEM

2. CHECK RGB SIGNAL

1. Connect NAVI control unit and display unit connectors.
2. Turn ignition switch ON.
3. Display "Color bar" by "CONFIRMATION/ADJUSTMENT" mode.
4. Check the following using CONSULT-II or oscilloscope.

- **When the screen looks bluish.**

Check voltage waveform between NAVI control unit harness connector B104 terminals 18 (B) and 17.

18 – 17

: Refer to [AV-73, "Terminals and Reference Value for NAVI Control Unit"](#) .

- **When the screen looks reddish.**

Check voltage waveform between NAVI control unit harness connector B104 terminals 21 (W) and 17.

21 – 17

: Refer to [AV-73, "Terminals and Reference Value for NAVI Control Unit"](#) .

- **When the screen looks yellowish.**

Check voltage waveform between NAVI control unit harness connector B104 terminals 15 (R) and 17.

15 – 17

: Refer to [AV-73, "Terminals and Reference Value for NAVI Control Unit"](#) .

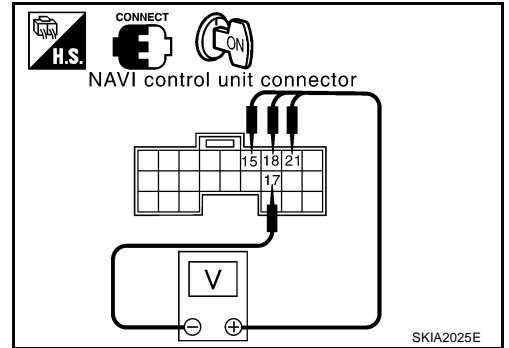

OK or NG

- OK >> Replace display unit.
- NG >> Replace NAVI control unit.

A
B
C
D
E
F
G
H
I
J
L
M

AV

NAVIGATION SYSTEM

AKS0011R

Screen is Rolling

1. CHECK RGB SYNCHRONIZING CIRCUIT

1. Turn ignition switch OFF.
2. Disconnect NAVI control unit and display unit connectors.
3. Check continuity between NAVI control unit harness connector B104 terminals 20 (P), 17 and display unit harness connector M35 terminals 7 (B/R), 4.

20 – 7 : **Continuity should exist.**

17 – 4 : **Continuity should exist.**

4. Check continuity between NAVI control unit harness connector B104 terminal 20 (P) and ground.

20 – Ground : **Continuity should not exist.**

OK or NG

OK >> GO TO 2.

NG >> Repair harness or connector.

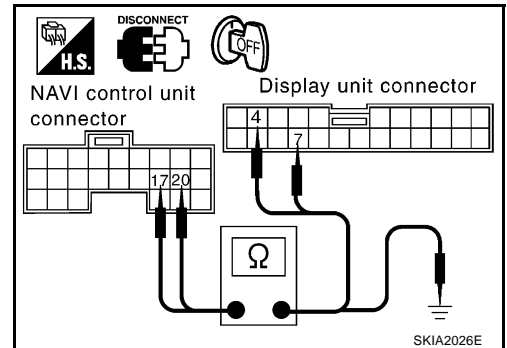

2. CHECK RGB SYNCHRONIZING SIGNAL

1. Connect NAVI control unit and display unit connectors.
2. Turn ignition switch ON.
3. Check voltage waveform between NAVI control unit harness connector B104 terminals 20 (P) and 17 using CONSULT-II or oscilloscope.

20 – 17 : **Refer to [AV-73, "Terminals and Reference Value for NAVI Control Unit"](#) .**

OK or NG

OK >> Replace display unit.

NG >> Replace NAVI control unit.

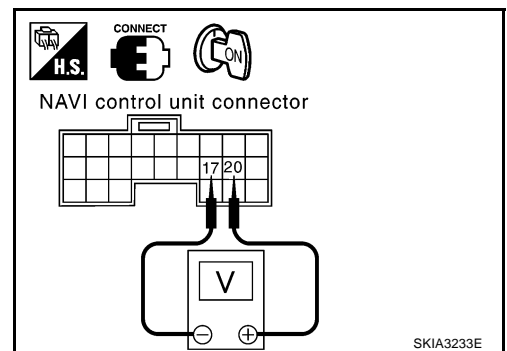

NAVIGATION SYSTEM

AKS0011S

Voice Guidance Is Not Heard

1. CHECK VOICE GUIDANCE SETTING

- While driving in the dark pink route, voice guidance does not operate.

NOTE:

Voice guidance is only available at intersections that satisfy certain conditions (indicated by ● on the map). Therefore, guidance may not be given even when the route on the map changes direction.

- Is volume setting not switched ON?

YES or NO

YES >> GO TO 2.

NO >> Switch the setting ON and turn the volume up.

2. CHECK HARNESS

- Turn ignition switch OFF.
- Disconnect NAVI control unit and audio unit connectors.
- Check continuity between NAVI control unit harness connector terminals and audio unit harness connector terminals.

Terminals				Continuity
NAVI control unit		Audio unit		
Connector	Terminal (Wire color)	Connector	Terminal (Wire color)	
B104	12 (OR)	M39	32 (L/B)	Yes
	13 (SB)		30 (W/B)	
B105	37 (BR)		24 (R/B)	
	40 (B/OR)		31 (B/P)	

- Check continuity between NAVI control unit harness connector terminals and ground.

Terminals			Continuity
NAVI control unit		Ground	
Connector	Terminal (Wire color)		
B104	12 (OR)	Ground	No
	13 (SB)		
B105	37 (BR)		
	40 (B/OR)		

OK or NG

OK >> GO TO 3.

NG >> Repair harness or connector.

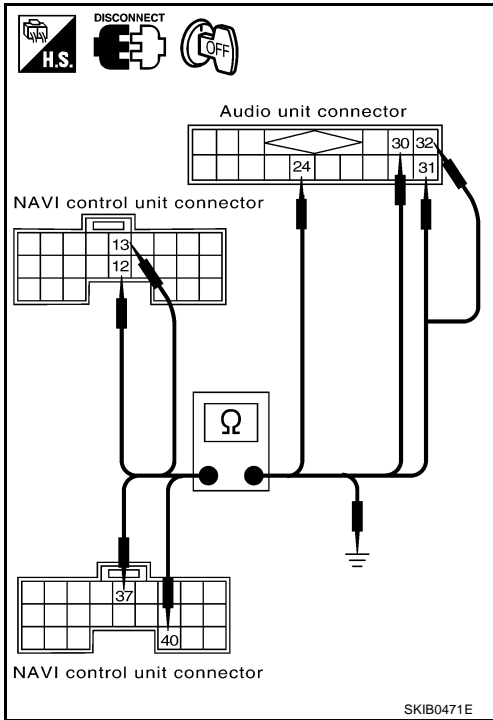

NAVIGATION SYSTEM

3. CHECK VOICE GUIDANCE ON SIGNAL

1. Connect NAVI control unit and audio unit connectors.
2. Turn ignition switch ON.
3. Push "VOICE" switch.
4. Check voltage waveform between NAVI control unit harness connector B105 terminal 37 (BR) and ground using CONSULT-II or oscilloscope.

37 – Ground

: Refer to [AV-73, "Terminals and Reference Value for NAVI Control Unit"](#) .

OK or NG

- OK >> GO TO 4.
- NG >> Replace NAVI control unit.

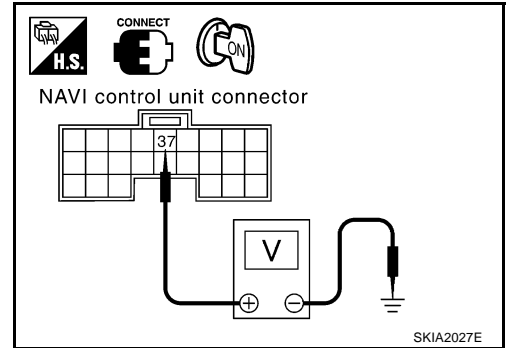

4. CHECK VOICE GUIDANCE SIGNAL

1. Push the "VOICE" switch.
2. Check voltage waveform between NAVI control unit harness connector B104 terminals 12 (OR) and 13 (SB) using CONSULT-II or oscilloscope.

12 – 13

: Refer to [AV-73, "Terminals and Reference Value for NAVI Control Unit"](#) .

OK or NG

- OK >> Replace audio unit.
- NG >> Replace NAVI control unit.

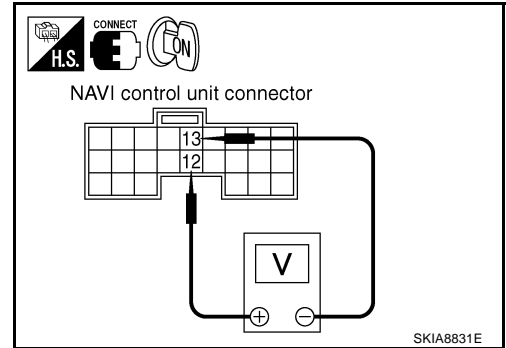

The Position of The Current-Location Mark is Not Correct

AKS00120

1. SELF-DIAGNOSIS

Perform self-diagnosis function. Refer to [AV-79, "Self-Diagnosis Mode"](#) .

OK or NG

OK >> GO TO 2.

NG >> Check the applicable parts.

2. HISTORY OF ERRORS DIAGNOSIS

Was any error stored in [AV-84, "HISTORY OF ERRORS"](#) of the "CONFIRMATION/ADJUSTMENT" mode?

YES or NO

YES >> [AV-84, "HISTORY OF ERRORS"](#).

NO >> [AV-106, "Driving Test"](#).

Radio Wave From The GPS Satellite is Not Received

AKS00121

1. ENVIRONMENT CHECK

Check if any metal object that intercepts radio waves or an object that emits radio waves (such as a portable phone) is located near the GPS antenna. Check if the vehicle is shielded by a building.

OK or NG

OK >> ● System is normal.

The GPS antenna may not be able to receive radio waves from the GPS satellite if it is shielded by metal object or an object emitting radio waves is placed near it.

NG >> GO TO 2.

2. SELF-DIAGNOSIS

Perform self-diagnosis function. Refer to [AV-79, "Self-Diagnosis Mode"](#) .

OK or NG

OK >> Replace GPS antenna.

NG >> Check the applicable parts.

A

B

C

D

E

F

G

H

I

J

AV

L

M

Driving Test

1. DRIVING TEST 1

1. Scroll the map screen to display the area to make correction. Push "ENTER" and select "CURRENT LOCATION CORRECTION".
2. Correct direction of the vehicle mark.
3. Perform the distance correction of the "CONFIRMATION/ADJUSTMENT" mode.

NOTE:

Normally, adjustment is not necessary because this system has automatic distance correction function. However, when a tire chain is fitted, adjustment in accordance with the tire diameter ratio must be made.

4. Are symptoms applicable to the [AV-107, "Example of Symptoms Judged Not Malfunction"](#) present after driving the vehicle?

YES or NO

YES >> Limit of the location detection capacity of the navigation system

NO >> GO TO 2.

2. DRIVING TEST 2

- Did any problem occur when the proper test in the following test patterns is performed?
- Test pattern
Driving test finds the difference between the symptoms monitored with and without each sensor.
 - Test pattern 1: Test method with no GPS location correction
Disconnect the GPS antenna connector connected to the NAVI control unit. Accurately adjust the current position and the direction, then drive the vehicle.
 - Test pattern 2: Test method with no map-matching
Accurately adjust the current position and the direction. Eject the map DVD-ROM from the NAVI control unit with the ignition switch turned to OFF, then drive the vehicle. After driving, insert the map DVD-ROM back in the unit, display the track of the vehicle on the map screen and compare it with the actual road configuration.
- Sample tests
 - <To determine if the current-location mark skips at the same position, if so, whether it is caused by map-matching or by GPS>
Perform test pattern 1.
 - <To determine if the pattern of streets displayed is correct or not>
Perform test pattern 1 and 2.
Compare the track of the vehicle on the map screen and the actual road configuration. For fairly accurate tracking, plotting shall be made every several hundred meters.
 - <When the distance is adjusted accurately>
Perform test pattern 1 and 2.
Drive on a road of which distance is accurately known (by utilizing distance posts on a highway). Calculate the rate of change (increased/decreased) of the distance by comparing with the actual distance.
Correction = A/B
A: Distance shown on the screen
B: Actual distance

YES or NO

YES >> ● If adjustment is insufficient, perform adjustment again.

- If any error is found in the map, please let us know.

- Replace NAVI control unit.

NO >> Limit of the location detection capacity of the navigation system

NAVIGATION SYSTEM

Example of Symptoms Judged Not Malfunction BASIC OPERATION

AKS00123

Symptom	Cause	Remedy
No image is shown.	Display brightness adjustment is set fully to DARK side.	Adjust the display brightness.
No guide sound is heard. Audio guide volume is too low or too high.	Volume control is set to OFF, MIN or MAX.	Adjust the audio guide volume.
	Audio guidance is not available while the vehicle is driving on a dark pink route.	System is not malfunction.
Screen is too dark. Motion of the image is too slow.	Temperature inside the vehicle is low.	Wait until the temperature inside the vehicle reaches the proper temperature.
Small black or bright spots appear on the screen.	Symptom peculiar to a liquid crystal display.	System is not malfunction.

VEHICLE MARK

Symptom	Cause	Remedy
Map screen and BIRDVIEW™Name of the place vary with the screen.	Some thinning of the character data is done to prevent the display becoming to complex. In some cases and in some locations, the display contents may differ. The same place name, street name, etc. may not be displayed every time on account of the data processing.	System is not malfunction.
Vehicle mark is not positioned correctly.	Vehicle is transferred by ferry or by towing after its ignition switch is turned to OFF.	Drive the vehicle for a while in the GPS satellite signal receiving condition.
Screen will not switch to nighttime mode after the lighting switch is turned ON.	The daytime screen is selected by the "SWITCH SCREENS" when the last time the screen dimming setting is done. Switching between daytime/nighttime screen may be inhibited by the automatic illumination adjustment function.	Perform screen dimming and select the nighttime screen by "SWITCH SCREENS".
Map screen will not scroll in accordance with the vehicle travel.	Current location is not displayed.	Push "MAP" switch to display the current location.
Vehicle mark will not be shown.	Current location is not displayed.	Push "MAP" switch to display the current location.
Accuracy indicator (GPS satellite mark) on the map screen stays gray.	GPS satellite signal is intercepted because the vehicle is in or behind a building.	Move the vehicle out to an open space.
	GPS satellite signal cannot be received because an obstacle is placed on top of the display.	Do not place anything in the center on top of the display.
	GPS satellites are located badly.	Wait until the location becomes better.
Vehicle location accuracy is low.	Accuracy indicator (GPS satellite mark) on the map screen stays gray.	Current location is not determined.
	Vehicle speed setting by the vehicle speed pulse has been deviated (advanced or retarded) from the actual vehicle speed because tire chain is fitted or the system has been used on another vehicle.	Drive the vehicle for a while [for approx. 30 minutes at approx. 30 km/h (19 MPH)] and the deviation will be automatically adjusted. If advancement or retard still occur, perform the distance adjustment by "CONFIRMATION/ADJUSTMENT" mode of diagnosis function.
	Map data has error or omission. (Vehicle mark is always deviated to the same position.)	As a rule, an updated map DVD-ROM will be released once a year.

DESTINATION, PASSING POINTS, AND MENU ITEMS CANNOT BE SELECTED/SET

Symptom	Cause	Remedy
Destination cannot be set.	Destination to be set is on an highway.	Set the destination on an ordinary road.
Passing point is not searched when re-searching the route.	The vehicle has already passed the passing point, or the system judged so.	To include the passing points that have been passed into the route again, set the route again.

A
B
C
D
E
F
G
H
I
J
AV
L
M

NAVIGATION SYSTEM

Symptom	Cause	Remedy
Route information will not be displayed.	Route searching has not been done.	Set the destination and perform route searching.
	Vehicle mark is not on the recommended route.	Drive on the recommended route.
	Route guidance is turned OFF.	Turn the route guidance ON.
	Route information is not available on the dark pink route.	System is not malfunction.
After the route searching, no guide sign will appear as the vehicle goes near the entrance/exit to the toll road.	Vehicle mark is not on the recommended route. (On the display, only guide signs related to the recommended route will be shown.)	Drive on the recommended route.
Automatic route searching is not possible.	Vehicle is driving on a highway (gray route), or no recommended route is available.	Drive on a road to be searched. Or re-search the route manually. In this case, however, the whole route will be searched.
Performed automatic detour search (or detour search). However, the result is the same as that of the previous search.	Performed search with every conditions considered. However, the result is the same as that of the previous search.	System is not malfunction.
Passing points cannot be set.	More than five passing points were set.	Passing points can be set up to five. To stop at more than five points, perform sharing in several steps.
When setting the route, the starting point cannot be selected.	The current vehicle location is always set as the starting point of a route.	System is not malfunction.
Some menu items cannot be selected.	The vehicle is being driven.	Stop the vehicle at a safe place and then operate the system.

VOICE GUIDANCE

Symptom	Cause	Remedy
Voice guidance will not operate.	Note: Voice guidance is only available at intersections that satisfy certain conditions (indicated by ● on the map). Therefore, guidance may not be given even when the route on the map changes direction.	System is not malfunction.
	The vehicle is not on the recommended route.	Return to the recommended route or re-search the route.
	Voice guidance is turned OFF.	Turn the voice guidance ON.
	Route guidance is turned OFF.	Turn the route guidance ON.
Voice guidance does not match the actual road pattern.	Voice guidance may vary with the direction to which the vehicle is turn and the connection of the road to other roads.	Drive in conformity to the actual traffic rules.

ROUTE SEARCHING

Symptom	Cause	Remedy
No route is shown.	No road to be searched is found around the destination.	Find wider road (orange road or wider) nearby and reset the destination and passing points onto it. Take care of the traveling direction when there are separate up and down roads.
	Starting point and the destination are too close.	Set the destination at more distant point.
	Conditional traffic regulation (day of the week/ time of the day) is set at the area around the current position or the destination.	Turn the time-regulating search conditions OFF. Turn "Avoid regulation time" in the search conditions OFF.
Indicated route is intermittent.	In some areas, highways (gray routes) are not used for the search ^(Note) Therefore, the route to the current position or the passing points may be intermittent.	System is not malfunction.

NAVIGATION SYSTEM

Symptom	Cause	Remedy
When the vehicle has passed the recommended route, it is deleted from the screen.	A recommended route is controlled by each section. When the vehicle has passed the passing point 1, then the map data from the starting point up to the passing point 1 will be deleted. (The data may remain undeleted in some area.)	System is not malfunction.
Detouring route is recommended.	In some areas, highways (gray routes) are not used for the search. (Note). Therefore, detour route may be recommended.	Set the route closer to the basic route (gray route).
	A detour route may be shown when some traffic regulation (one-way traffic, etc.) is set at the area around the starting point or the destination.	Slightly move the starting point or the destination, or set the passing point on the route of your choice.
	In the area where highways (gray routes) are used for the search, left turn has priority around the current position and the destination (passing points). For this reason, the recommended route may be detouring.	System is not malfunction.
Landmarks on the map do not match the actual ones.	This can be happen due to omission or error in the map data.	As a rule, an updated map DVD-ROM will be released once a year. Wait until the latest map has become available.
Recommended route is far from the starting point, passing points, and destination.	Starting point, passing points, and destination of the route guidance were set far from the desired points because route searching data around these area were not stored.	Reset the destination onto the road nearby. If this road is one of the highways (gray routes), an ordinary road nearby may be displayed as the recommended route.

NOTE:

Except for the ordinance-designated cities and the prefectural capitals (Applicable areas may be changed in the updated map disc.)

EXAMPLES OF CURRENT-LOCATION MARK DISPLACEMENT

Vehicle's travel amount is calculated by reading its travel distance and turning angle. Therefore, if the vehicle is driven in the following manner, an error will occur in the vehicle's current location display. If correct location has not been restored after driving the vehicle for a while, perform location correction.

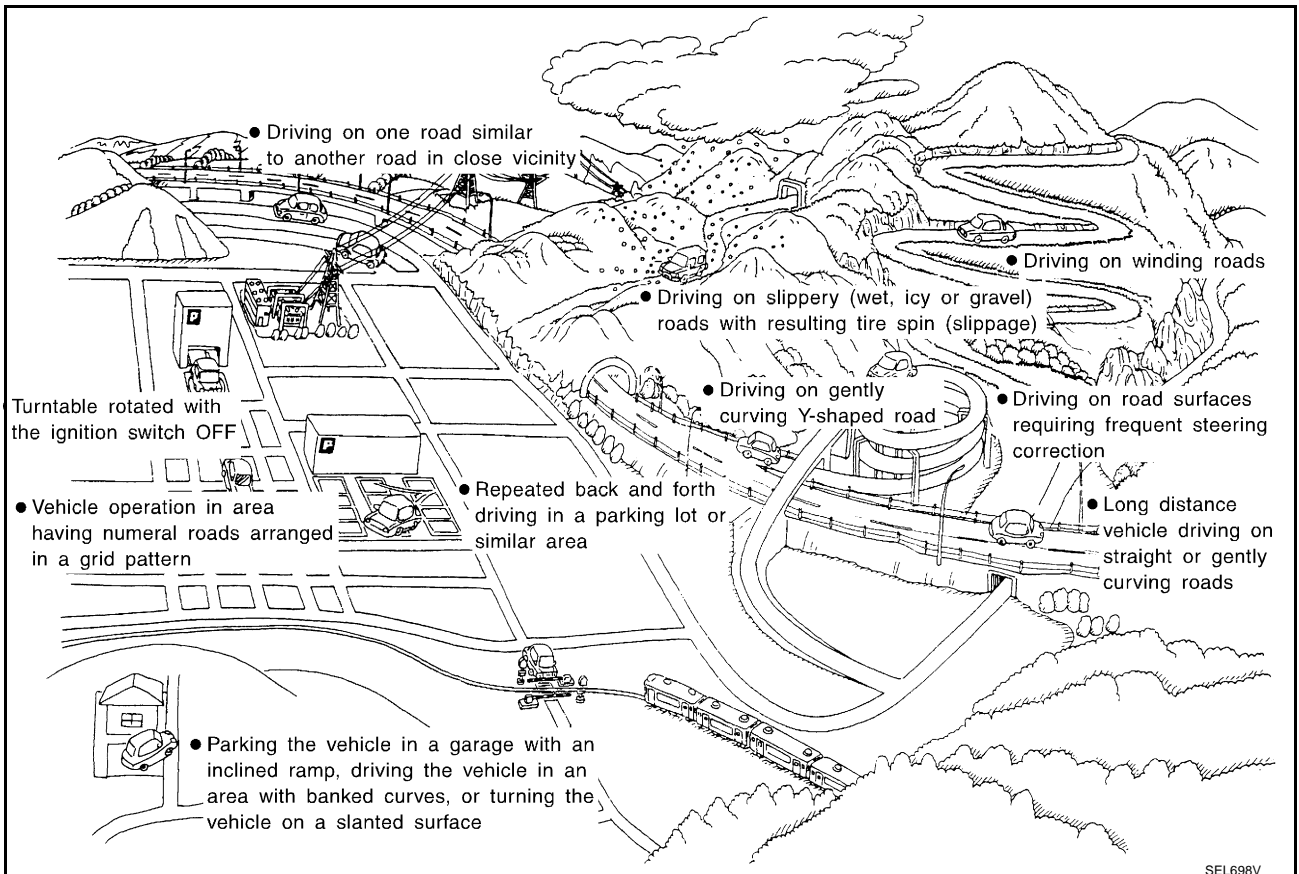

SEL698V

NAVIGATION SYSTEM

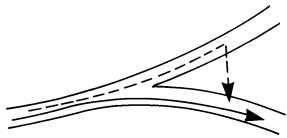
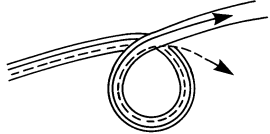
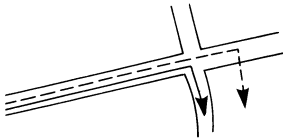
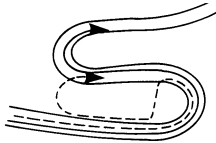
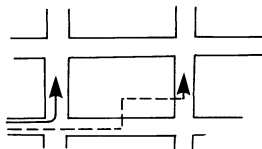
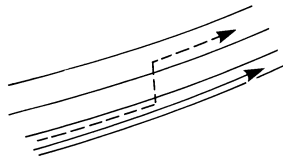
	Cause (condition)	Driving condition	Remarks (correction, etc.)
Road configuration	<p>Y-intersections</p>  <p style="text-align: center; font-size: small;">ELK0192D</p>	<p>At a Y intersection or similar gradual division of roads, error the direction of travel deduced by the sensor may result in the current-location mark appearing on the wrong road.</p>	
	<p>Spiral roads</p>  <p style="text-align: center; font-size: small;">ELK0193D</p>	<p>When driving on a large, continuous spiral road (such as loop bridge), turning angle error is accumulated and the vehicle mark may deviate from the correct location.</p>	
	<p>Straight roads</p>  <p style="text-align: center; font-size: small;">ELK0194D</p>	<p>When driving on a long, straight road and slow curve without stopping, map-matching does not work effectively enough and distance errors may accumulate. As a result, the vehicle mark may deviate from the correct location when the vehicle turned at a corner.</p>	If after travelling about 10 km (6 miles) the correct location has not been restored, perform location correction and, if necessary, direction correction.
	<p>Zigzag roads</p>  <p style="text-align: center; font-size: small;">ELK0195D</p>	<p>When driving on a zigzag road, the map may be matched to other roads in the similar direction nearby at every turn, and the vehicle mark may deviate from the correct location.</p>	
	<p>Roads laid out in a grid pattern</p>  <p style="text-align: center; font-size: small;">ELK0196D</p>	<p>When driving at where roads are laid out in a grid pattern, where many roads are running in the similar direction nearby, the map may be matched to them by mistake and the vehicle mark may deviate from the correct location.</p>	
	<p>Parallel roads</p>  <p style="text-align: center; font-size: small;">ELK0197D</p>	<p>When two roads are running in parallel (such as highway and sideway), the map may be matched to the other road by mistake and the vehicle mark may deviate from the correct location.</p>	

NAVIGATION SYSTEM

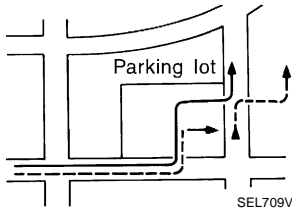
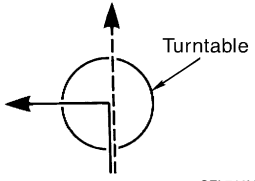
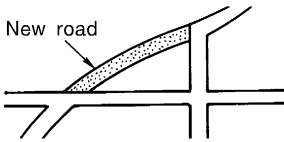
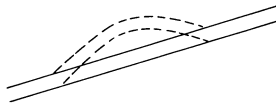
	Cause (condition)	Driving condition	Remarks (correction, etc.)
Place	In a parking lot  SEL709V	When driving in a parking lot, or other location where there are no roads on the map, matching may place the vehicle mark on a nearby road. When the vehicle returns to the road, the vehicle mark may have deviated from the correct location. When driving in circle or turning the steering wheel repeatedly, direction errors accumulate, and the vehicle mark may deviate from the correct location.	If after travelling about 10 km (6 miles) the correct location has not been restored, perform location correction and, if necessary, direction correction.
	Turntable  SEL710V	When the ignition switch is OFF, the navigation system cannot get the signal from the gyroscope (angular speed sensor). Therefore, the displayed direction may be wrong and the correct road may not be easily returned to after rotating the vehicle on a turntable with the ignition OFF.	
	Slippery roads	On snow, wet roads, gravel, or other roads where tires may slip easily, accumulated mileage errors may cause the vehicle mark to deviate from the correct road.	
	Slopes	When parking in sloped garages, when travelling on banked roads, or in other cases where the vehicle turns when tilted, an error in the turning angle will occur, and the vehicle mark may deviate from the road.	
Map data	Road not displayed on the map screen  SEL699V	When driving on new roads or other roads not displayed on the map screen, map matching does not function correctly and matches the location to a nearby road. When the vehicle returns to a road which is on the map, the vehicle mark may deviate from the correct road.	
	Different road pattern (Changed due to repair)  ELK0201D	If the road pattern stored in the map data and the actual road pattern are different, map matching does not function correctly and matches the location to a nearby road. The vehicle mark may deviate from the correct road.	
Vehicle	Use of tire chains	When tire chains are used, the mileage is not correctly detected, and the vehicle mark may deviate from the correct road.	Drive the vehicle for a while. If the distance is still deviated, adjust it by using the distance adjustment function. (If the tire chain is removed, recover the original value.)

A
B
C
D
E
F
G
H
I
J
L
M

AV

NAVIGATION SYSTEM

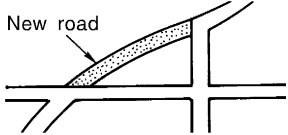
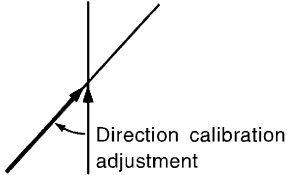
	Cause (condition)	Driving condition	Remarks (correction, etc.)
Precautions for driving	Just after the engine is started	If the vehicle is driven off just after the engine is started when the gyroscope (angular speed sensor) correction is not completed, the vehicle can lose its direction and may have deviated from the correct location.	Wait for a short while before driving after starting the engine.
	Continuous driving without stopping	When driving long distances without stopping, direction errors may accumulate, and the current-location mark may deviate from the correct road.	Stop and adjust the orientation.
	Abusive driving	Spinning the wheels or engaging in other kinds of abusive driving may result in the system being unable to perform correct detection, and may cause the vehicle mark to deviate from the correct road.	If after travelling about 10 km (6 miles) the correct location has not been restored, perform location correction and, if necessary, direction correction.
How to correct location	Position correction accuracy  <small style="float: right;">SEL699V</small>	If the accuracy of location settings is poor, accuracy may be reduced when the correct road cannot be found, particularly in places where there are many roads.	Enter in the road displayed on the screen with an accuracy of approx. 1 mm. NOTE: Whenever possible, use detailed map for the correction.
	Direction when location is corrected  <small style="float: right;">SEL702V</small>	If the accuracy of location settings during correction is poor, accuracy may be reduced afterwards.	Perform direction correction.

CURRENT-LOCATION MARK SHOWS A POSITION WHICH IS COMPLETELY WRONG

In the following cases, the current-location mark may appear on completely different position in the map depending on the GPS satellite signal receiving conditions. In this case, perform location correction and direction correction.

- When location correction has not been done
 - If the receiving conditions of the GPS satellite signal is poor, if the current-location mark becomes out of place, it may move to a completely different location and not come back if location correction is not done. The position will be corrected if the GPS signal can be received.
- When the vehicle has traveled by ferry, or when the vehicle has been being towed
 - Because calculation of the current location cannot be done when travelling with the ignition OFF, for example when traveling by ferry or when being towed, the location before travel is displayed. If the precise location can be detected with GPS, the location will be corrected.

CURRENT-LOCATION MARK JUMPS

In the following cases, the current-location mark may appear to jump as a result of automatic correction of the current location.

- When map matching has been done
 - If the current location and the current-location mark are different when map matching is done, the current-location mark may seem to jump. At this time, the location may be "corrected" to the wrong road or to a location which is not on a road.
- When GPS location correction has been done
 - If the current location and the current-location mark are different when the location is corrected using GPS measurements, the current-location mark may seem to jump. At this time, the location may be "corrected" to a location which is not on a road.

NAVIGATION SYSTEM

CURRENT-LOCATION MARK IS IN A RIVER OR THE SEA

The navigation system moves the current location mark with no distinction between land and rivers or sea. If the location mark is somehow out of place, it may appear that the vehicle is driving in a river or the sea.

A

CURRENT-LOCATION MARK AUTOMATICALLY ROTATES

The system wrongly memorizes the rotating status as stopping when the ignition switch is turned ON with the turntable rotating. That causes the current-location mark to rotate when the vehicle is stopped.

B

WHEN DRIVING ON THE SAME ROAD, SOMETIMES THE CURRENT-LOCATION MARK IS IN THE RIGHT PLACE AND SOMETIMES IT IS THE WRONG PLACE

C

The conditions of the GPS antenna (GPS data) and gyroscope (angular speed sensor) change gradually. Depending on the road traveled and the operation of the steering wheel, the location detection results will be different. Therefore, even on a road on which the location has never been wrong, conditions may cause the vehicle mark to deviate.

D

LOCATION CORRECTION BY MAP MATCHING IS SLOW

E

- The map matching function needs to refer to the data of the surrounding area. It is necessary to drive some distance for the function to work.
- Because map matching operates on this principle, when there are many roads running in similar directions in the surrounding area, no matching determination may be made. The location may not be corrected until some special feature is found.

F

ALTHOUGH THE GPS RECEIVING DISPLAY IS GREEN, THE VEHICLE MARK DOES NOT RETURN TO THE CORRECT LOCATION

G

- The GPS accuracy has an error of about 100 m (300 ft). In some cases the current-location mark may not be on the correct street, even when GPS location-correction is done.
- The navigation system compares the results of GPS location detection with the results from map-matching location detection. The one which is determined to have higher accuracy is used.
- GPS location correction may not be performed when the vehicle is stopped.

H

I

THE NAME OF THE CURRENT PLACE IS NOT DISPLAYED

The current place name may not be displayed if there are no place names displayed on the map screen.

J

CONTENTS OF THE DISPLAY DIFFER FOR THE BIRDVIEW™ AND THE (FLAT) MAP SCREEN.

Difference of the BIRDVIEW™ Screen From The Flat Map Screen Are As Follows

- The current place name displays names which are primarily in the direction of vehicle travel.
- The amount of time before the vehicle travel or turn angle is updated on the screen is longer than for the (flat) map display.
- The conditions for display of place names, roads, and other data are different for nearby areas and for more distant areas.
- Some thinning of the character data is done to prevent the display becoming to complex. In some cases and in some locations, the display contents may differ.
- The same place name, street name, etc. may be displayed multiple times.

AV

L

M

Program Loading

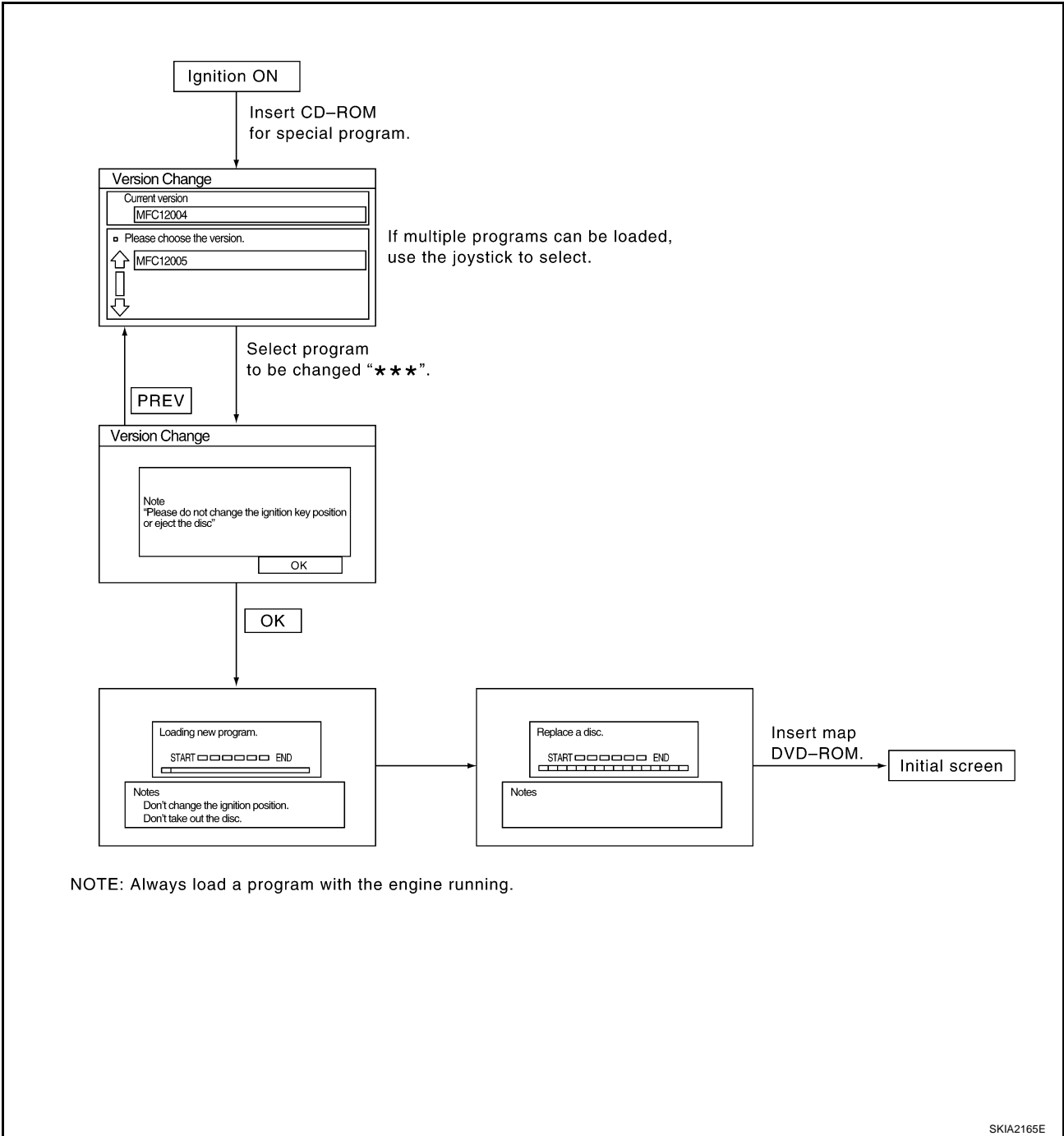

NAVIGATION SYSTEM

Removal and Installation of NAVI Control Unit

AKS00125

REMOVAL

1. Remove luggage floor finisher upper (front) (Coupe models) or luggage floor finisher upper (Roadster models). Refer to [EI-38, "Removal and Installation \(for Coupe Models\)"](#) or [EI-40, "Removal and Installation \(for Roadster Models\)"](#) .
2. Remove screws (4) and remove NAVI control unit.

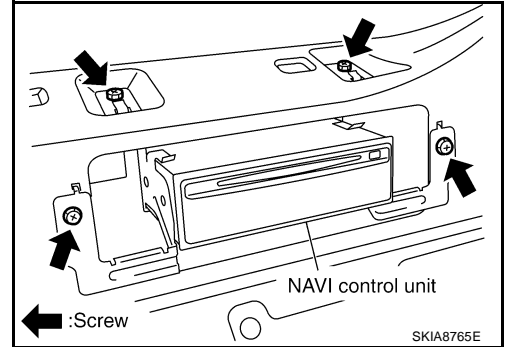

3. Remove screws (4) and remove bracket.

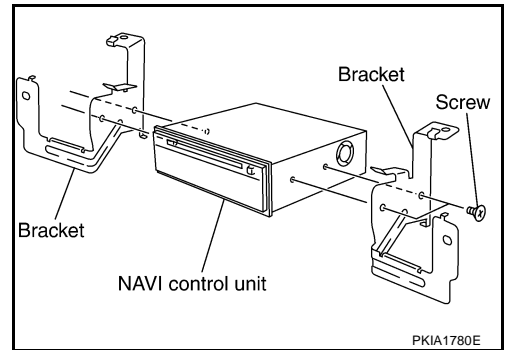

INSTALLATION

Installation is the reverse order of removal.

Removal and Installation of GPS Antenna

AKS00126

REMOVAL

1. Remove instrument driver panel upper. Refer to [IP-10, "INSTRUMENT PANEL ASSEMBLY"](#) .
2. Remove screw (1) and remove GPS antenna.

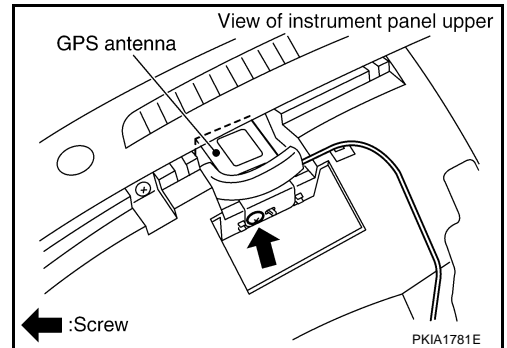

INSTALLATION

Installation is the reverse order of removal.

A
B
C
D
E
F
G
H
I
J
AV
L
M

NAVIGATION SYSTEM

Removal and Installation of NAVI Switch

AKS00127

REMOVAL

1. Insert cloth-covered driver into gaps between NAVI switch and cluster lid C, and remove NAVI switch.
2. Disconnect connector, and remove.

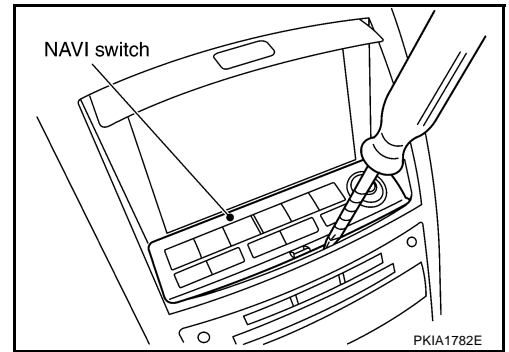

INSTALLATION

Installation is the reverse order of removal.

Removal and Installation of Display Unit

AKS00128

REMOVAL

1. Remove cluster lid C. Refer to [IP-10, "INSTRUMENT PANEL ASSEMBLY"](#).
2. Remove screws (2) and remove display unit.

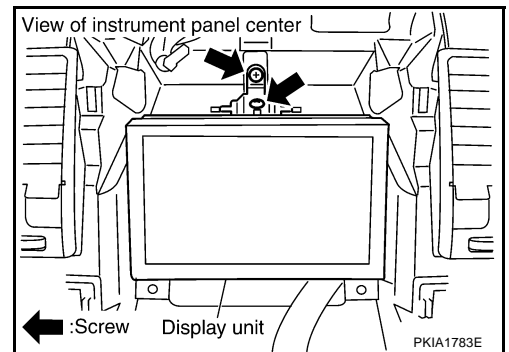

3. Remove screws (4), and remove bracket.

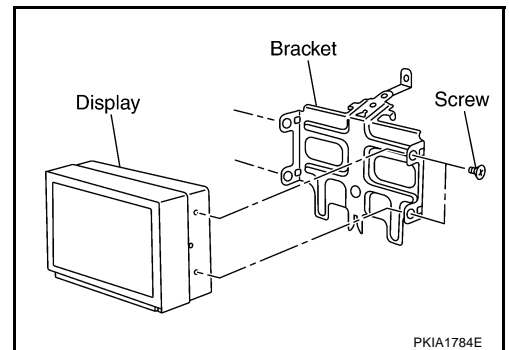

INSTALLATION

Installation is the reverse order of removal.

NAVIGATION SYSTEM

Removal and Installation of Power Cluster Lid Amp.

AKS009M2

REMOVAL

1. Remove cluster lid C. Refer to [IP-10, "INSTRUMENT PANEL ASSEMBLY"](#) .
2. Shift a connector in a direction of an arrow of a right illustration and pull out a flexible print circuit.

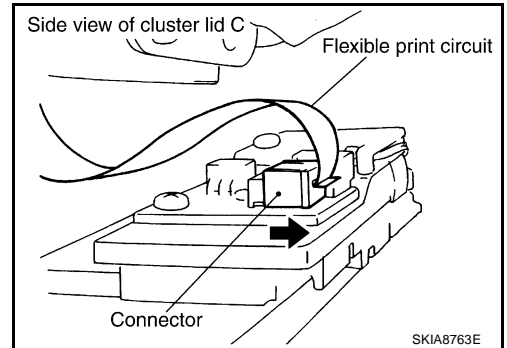

3. Remove screws (2), and remove power cluster lid amp..

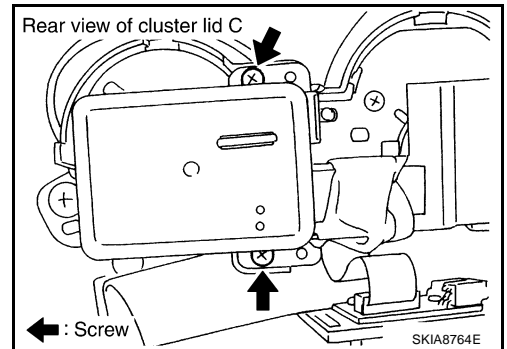

INSTALLATION

Installation is the reverse order of removal.

A
B
C
D
E
F
G
H
I
J
L
M

AV

NAVIGATION SYSTEM
