

SECTION **BL**

BODY, LOCK & SECURITY SYSTEM

A
B
C
D
E
F
G
H
BL
J
K
L
M

CONTENTS

PRECAUTIONS	5	INSTALLATION	17
Precautions for Supplemental Restraint System (SRS) "AIR BAG" and "SEAT BELT PRE-TENSIONER"	5	Hood Lock Control Inspection	17
Precautions for Battery Service	5	RADIATOR CORE SUPPORT	19
Precautions for Work	5	Removal and Installation	19
Wiring Diagnosis and Trouble Diagnosis	5	REMOVAL	19
PREPARATION	6	INSTALLATION	20
Special Service Tools	6	POWER DOOR LOCK SYSTEM	21
Commercial Service Tools	6	Component Parts and Harness Connector Location..	21
SQUEAK AND RATTLE TROUBLE DIAGNOSIS	7	FOR ROADSTER	21
Work Flow	7	FOR COUPE	22
CUSTOMER INTERVIEW	7	System Description	23
DUPLICATE THE NOISE AND TEST DRIVE	8	POWER WINDOW SERIAL LINK	24
CHECK RELATED SERVICE BULLETINS	8	OUTLINE	24
LOCATE THE NOISE AND IDENTIFY THE ROOT CAUSE	8	Schematic	25
REPAIR THE CAUSE	8	Wiring Diagram —D/LOCK— /For Coupe	26
CONFIRM THE REPAIR	9	FIG. 1	26
Generic Squeak and Rattle Troubleshooting	9	FIG. 2	27
INSTRUMENT PANEL	9	FIG. 3	28
CENTER CONSOLE	9	FIG. 4	29
DOORS	9	FIG. 5	30
TRUNK	10	Wiring Diagram —D/LOCK— /For Roadster	31
SUNROOF/HEADLINING	10	FIG. 1	31
SEATS	10	FIG. 2	32
UNDERHOOD	10	FIG. 3	33
Diagnostic Worksheet	11	Terminals and Reference Value for BCM	34
HOOD	13	Terminal and Reference Value for Power Window	
Fitting Adjustment	13	Main Switch	34
LONGITUDINAL AND LATERAL CLEARANCE ADJUSTMENT	13	Work Flow	35
FRONT END HEIGHT ADJUSTMENT	13	Preliminary Check	35
SURFACE HEIGHT ADJUSTMENT	14	FUSE CHECK	35
Removal and Installation of Hood Assembly	15	CONSULT-II Function	36
REMOVAL	15	CONSULT-II BASIC OPERATION PROCEDURE	36
INSTALLATION	15	WORK SUPPORT	37
Removal and Installation of Hood Lock Control	16	DATA MONITOR	37
REMOVAL	16	ACTIVE TEST	37
		Trouble Diagnoses Symptom Chart	39
		Door Switch Check	40
		Key Switch (insert) Check	41
		Door Lock and Unlock Switch Check	43

Driver Side Door Lock Actuator Check	46	Horn Function Check	91
Passenger Side Door Lock Actuator Check	48	Headlamp Alarm Check	91
Door Key Cylinder Switch Check	50	Interior Lamp and Step Lamp Operation Check	91
Back Door Opener Switch Check	52	ID Code Entry Procedure	92
Back Door Opener Actuator Check	53	KEY FOB ID SETUP WITH CONSULT-II	92
FUEL FILLER LID OPENER	55	KEY FOB ID SETUP WITHOUT CONSULT-II	94
System Description/For Roadster	55	Key Fob Battery Replacement	95
FUEL LID OPEN OPERATION	55	DOOR	96
FUEL LID OPENER CANCEL OPERATION	55	Fitting Adjustment	96
Wiring Diagram —F/LID— /For Coupe	56	COUPE	96
Wiring Diagram —F/LID— / For Roadster	57	ROADSTER	97
CONSULT-II Function/For Roadster	58	DOOR	97
CONSULT-IIBASICOPERATIONPROCEDURE	58	STRIKER ADJUSTMENT	97
DATA MONITOR	59	DOVE TAIL FEMALE ADJUSTMENT (ROAD-	
ACTIVE TEST	59	STER)	98
Terminals and Reference Value for BCM/For Road-		Removal and Installation	98
ster	60	REMOVAL	98
Trouble Diagnosis/For Roadster	60	INSTALLATION	99
FUEL LID DOSE NOT OPEN WITH FUEL LID		Removal and Installation of Dove Tail Male &	
OPENER SWITCH	60	Female (Roadster)	100
REMOTE KEYLESS ENTRY SYSTEM	63	REMOVAL	100
Component Parts and Harness Connector Location..	63	INSTALLATION	100
FOR COUPE	63	Door Weatherstrip	101
FOR ROADSTER	64	REMOVAL	101
System Description	65	INSTALLATION	101
INPUTS	65	DOOR LOCK	102
OPERATION PROCEDURE	66	Component Structure	102
CAN Communication System Description	67	Inspection and Adjustment	102
CAN Communication Unit	67	EXTERIOR HANDLE ROD ADJUSTMENT	102
Schematic	68	Removal and Installation	102
Wiring Diagram — KEYLES— /For Coupe	69	REMOVAL	102
FIG. 1	69	INSTALLATION	103
FIG. 2	70	Disassembly and Assembly	103
FIG. 3	71	DISASSEMBLY	103
Wiring Diagram — KEYLES— /For Roadster	72	ASSEMBLY	103
Terminals and Reference Value for BCM	75	BACK DOOR	104
Terminals and Reference Value for IPDM E/R	76	Fitting Adjustment	104
CONSULT-II Function	76	VERTICAL/LATERAL CLEARANCE ADJUST-	
CONSULT-II Inspection Procedure for BCM	76	MENT	104
“MULTI REMOTE ENT”	76	Back Door Assembly	105
CONSULT-II Application Items for BCM	78	REMOVAL	105
“MULTI REMOTE CONTENT”	78	INSTALLATION	105
CONSULT-II Inspection Procedure for IPDM E/R... 80		INSPECTION	106
“IPDM E/R”	80	Removal and Installation of Back Door Striker	106
CONSULT-II Application Items for IPDM E/R	81	REMOVAL	106
DATA MONITOR	81	INSTALLATION	106
ACTIVE TEST	81	Removal and Installation of Back Door Stay	106
Work Flow	81	REMOVAL	106
Trouble Diagnosis Chart by Symptom	81	INSTALLATION	108
Key Fob Battery and Function Check	83	Removal and Installation of Back Door Weatherstrip	108
ACC Switch Check	84	REMOVAL	108
Door Switch Check	85	INSTALLATION	108
DRIVER SIDE DOOR SWITCH AND PASSEN-		BACK DOOR LOCK	109
GER SIDE DOOR SWITCH CHECK	85	Removal and Installation of Back Door Lock & Back	
BACK DOOR SWITCH CHECK/FOR COUPE ... 86		Door Opener Actuator	109
Trunk Room Lamp Switch Check/For Roadster ... 88		REMOVAL	109
Key Switch Check	89	INSTALLATION	109
IPDM E/R Operation Check	90	INSPECTION	109
		Removal and Installation of Back Door Opener	

Switch (External)	110	System Description	131	
REMOVAL	110	DESCRIPTION	131	A
INSTALLATION	110	POWER SUPPLY AND GROUND	132	
Removal and Installation of Back Door Emergency		INITIAL CONDITION TO ACTIVATE THE SYS-		
Opener Cable	111	TEM	132	B
REMOVAL	111	VEHICLE SECURITY SYSTEM ALARM OPER-		
INSTALLATION	111	ATION	132	
TRUNK LID	112	VEHICLE SECURITY SYSTEM DEACTIVATION	133	C
Fitting Adjustment	112	PANIC ALARM OPERATION	133	
LONGITUDINAL AND LATERAL CLEARANCE		CAN Communication System Description	133	
ADJUSTMENT	112	CAN Communication Unit	133	
SURFACE HEIGHT ADJUSTMENT	112	Schematic	134	D
Removal and Installation of Trunk Lid Assembly ..	114	Wiring Diagram —VEHSEC—	135	
REMOVAL	114	FIG. 1	135	
INSTALLATION	114	FIG. 2	136	E
Removal and Installation of Trunk Lid Stay	115	FIG. 3	137	
REMOVAL	115	FIG. 4	138	
INSTALLATION	115	FIG. 5	139	F
Removal and Installation of Trunk Lid Lock Assem-		Terminals and Reference Value for BCM	140	
bly	115	Terminals and Reference Value for IPDM E/R	140	
REMOVAL	115	CONSULT-II Function of BCM	141	G
INSTALLATION	115	CONSULT-IIBASIC OPERATION PROCEDURE		
Removal and Installation of Trunk Lid Striker	115	CONSULT-II APPLICATION ITEM	141	
REMOVAL	115	CONSULT-II APPLICATION ITEM	142	H
INSTALLATION	115	CONSULT-II Function of IPDM E/R	143	
Removal and Installation of Trunk Lid Emergency		BASIC OPERATION PROCEDURE	143	
Opener Cable	117	CONSULT-II APPLICATION ITEM	144	
REMOVAL	117	Trouble Diagnosis	144	BL
INSTALLATION	117	WORK FLOW	144	
Removal and Installation of Trunk Lid Emergency		Preliminary Check	145	
Opener Cable (Secondary)	118	Symptom Chart	146	J
REMOVAL	118	Diagnostic Procedure 1	147	
INSTALLATION	118	1 – 1 DOOR SWITCH CHECK	147	
Removal and Installation of Trunk Lid Hinge	118	1 – 2 BACK DOOR SWITCH CHECK/FOR		
REMOVAL	118	COUPE	148	K
INSTALLATION	118	1 – 3 TRUNK ROOM LAMP SWITCH CHECK/		
Removal and Installation of Lift Spring	118	FOR ROADSTER	150	
REMOVAL	118	1 – 4 HOOD SWITCH CHECK	151	L
INSTALLATION	118	Diagnostic Procedure 2	153	
Removal and Installation of Trunk Lid Weatherstrip.	119	SECURITY INDICATOR LAMP CHECK	153	
REMOVAL	119	Diagnostic Procedure 3	153	M
INSTALLATION	119	DOOR KEY CYLINDER SWITCH CHECK	153	
TRUNK LID OPENER	120	Diagnostic Procedure 4	154	
Component Parts and Harness Connector Location	120	VEHICLE SECURITY HORN ALARM CHECK .	154	
System Description	120	Diagnostic Procedure 5	154	
TRUNK LID OPENER CANCEL OPERATION .	120	VEHICLE SECURITY HEADLAMP ALARM		
TRUNK OPENER OPERATION WITH KEY FOB	121	CHECK	154	
Wiring Diagram—T/LID—	122	Diagnostic Procedure 6	155	
Terminals and Reference Value for BCM	123	DOOR LOCK AND UNLOCK SWITCH CHECK	155	
CONSULT-II Function	123	NVIS (NISSAN VEHICLE IMMOBILIZER SYSTEM-		
CONSULT-IIBASIC OPERATION PROCEDURE		NATS)	156	
ACTIVE TEST	123	Component Parts and Harness Connector Location	156	
Trouble Diagnosis	124	System Description	157	
TRUNK DOSE NOT OPEN WITH TRUNK LID		System Composition	158	
OPENER SWITCH	125	ECM Re-Communicating Function	158	
TRUNK DOSE NOT CLOSE	128	Wiring Diagram — NATS —	159	
VEHICLE SECURITY (THEFT WARNING) SYSTEM 130		Terminals and Reference Value for BCM	160	
Component Parts and Harness Connector Location	130	CONSULT-II	160	
		CONSULT-II INSPECTION PROCEDURE	160	

CONSULT-II DIAGNOSTIC TEST MODE FUNCTION	161	PASSENGER COMPARTMENT (COUPE)	207
HOW TO READ SELF-DIAGNOSTIC RESULTS	162	REAR BODY (COUPE)	209
NVIS (NATS) SELF-DIAGNOSTIC RESULTS ITEM CHART	162	Body Alignment (Roadster)	211
Work Flow	163	BODY CENTER MARKS (ROADSTER)	211
Trouble Diagnoses	164	PANEL PARTS MATCHING MARKS (ROADSTER)	212
SYMPTOM MATRIX CHART 1	164	DESCRIPTION	213
SYMPTOM MATRIX CHART 2	165	ENGINE COMPARTMENT	214
DIAGNOSTIC SYSTEM DIAGRAM	165	UNDERBODY	216
Diagnostic Procedure 1	166	PASSENGER COMPARTMENT (ROADSTER)	218
Diagnostic Procedure 2	167	SOFT TOP MOUNTING BRACKET (ROADSTER)	220
Diagnostic Procedure 3	168	REAR BODY (ROADSTER)	222
Diagnostic Procedure 4	170	Handling Precautions For Plastics (Coupe)	224
Diagnostic Procedure 5	171	HANDLING PRECAUTIONS FOR PLASTICS	224
Diagnostic Procedure 6	172	LOCATION OF PLASTIC PARTS (COUPE)	225
How to Replace NATS Antenna Amp.	173	Handling Precautions For Plastics (Roadster)	227
INTEGRATED HOMELINK TRANSMITTER	174	HANDLING PRECAUTIONS FOR PLASTICS	227
Wiring Diagram —TRNSCV—	174	LOCATION OF PLASTIC PARTS (ROADSTER)	228
Trouble Diagnoses	175	Precautions In Repairing High Strength Steel	230
DIAGNOSTIC PROCEDURE	175	HIGH STRENGTH STEEL (HSS) USED IN NISSAN VEHICLES	230
BODY REPAIR	177	Replacement Operations (Coupe)	233
Body Exterior Paint Color (Coupe)	177	DESCRIPTION	233
Body Exterior Paint Color (Roadster)	178	HOODLEDGE (COUPE)	236
Body Component Parts (Coupe)	179	FRONT SIDE MEMBER (COUPE)	237
UNDERBODY COMPONENT PARTS	179	FRONT SIDE MEMBER (PARTIAL REPLACEMENT) (COUPE)	239
BODY COMPONENT PARTS	181	FRONT PILLAR (COUPE)	240
Body Component Parts (Roadster)	183	OUTER SILL (COUPE)	242
UNDERBODY COMPONENT PARTS	183	REAR FENDER (COUPE)	243
BODY COMPONENT PARTS	185	REAR PANEL (COUPE)	244
Corrosion Protection	187	REAR FLOOR REAR (COUPE)	245
DESCRIPTION	187	REAR SIDE MEMBER EXTENSION (COUPE)	247
ANTI-CORROSIVE WAX	188	Replacement Operations (Roadster)	249
UNDERCOATING	189	DESCRIPTION	249
STONE GUARD COAT	190	HOODLEDGE (ROADSTER)	252
Body Sealing (Coupe)	191	FRONT SIDE MEMBER (ROADSTER)	253
DESCRIPTION	191	FRONT SIDE MEMBER (PARTIAL REPLACEMENT) (ROADSTER)	255
Body Sealing (Roadster)	195	FRONT PILLAR (ROADSTER)	256
DESCRIPTION	195	OUTER SILL (ROADSTER)	258
Body Construction (Coupe)	198	REAR FENDER (ROADSTER)	260
BODY CONSTRUCTION	198	LOCK PILLAR REINFORCEMENT (ROADSTER)	261
Body Construction (Roadster)	199	REAR PANEL (ROADSTER)	263
BODY CONSTRUCTION	199	REAR FLOOR REAR (ROADSTER)	264
Body Alignment (Coupe)	200	REAR SIDE MEMBER EXTENSION (ROADSTER)	266
BODY CENTER MARKS (COUPE)	200		
PANEL PARTS MATCHING MARKS (COUPE)	201		
DESCRIPTION	202		
ENGINE COMPARTMENT	203		
UNDERBODY	205		

PRECAUTIONS

PRECAUTIONS

PF0:00001

Precautions for Supplemental Restraint System (SRS) “AIR BAG” and “SEAT BELT PRE-TENSIONER”

AIS000BP

The Supplemental Restraint System such as “AIR BAG” and “SEAT BELT PRE-TENSIONER”, used along with a front seat belt, helps to reduce the risk or severity of injury to the driver and front passenger for certain types of collision. This system includes seat belt switch inputs and dual stage front air bag modules. The SRS system uses the seat belt switches to determine the front air bag deployment, and may only deploy one front air bag, depending on the severity of a collision and whether the front occupants are belted or unbelted. Information necessary to service the system safely is included in the SRS and SB section of this Service Manual.

WARNING:

- To avoid rendering the SRS inoperative, which could increase the risk of personal injury or death in the event of a collision which would result in air bag inflation, all maintenance must be performed by an authorized NISSAN/INFINITI dealer.
- Improper maintenance, including incorrect removal and installation of the SRS, can lead to personal injury caused by unintentional activation of the system. For removal of Spiral Cable and Air Bag Module, see the SRS section.
- Do not use electrical test equipment on any circuit related to the SRS unless instructed to in this Service Manual. SRS wiring harnesses can be identified by yellow and/or orange harnesses or harness connectors.

Precautions for Battery Service

AIS003N6

Before disconnecting the battery, lower both the driver and passenger windows. This will prevent any interference between the window edge and the vehicle when the door is opened/closed. During normal operation, the window slightly raises and lowers automatically to prevent any window to vehicle interference. The automatic window function will not work with the battery disconnected.

Precautions for Work

AIS000BQ

- After removing and installing the opening/closing parts, be sure to carry out fitting adjustments to check their operation.
- Check the lubrication level, damage, and wear of each part. If necessary, grease or replace it.

Wiring Diagnosis and Trouble Diagnosis

AIS000BR

When you read wiring diagrams, refer to the following:

- [GI-15, "How to Read Wiring Diagrams"](#).
- [PG-4, "POWER SUPPLY ROUTING CIRCUIT"](#).

When you perform trouble diagnosis, refer to the following:

- [GI-11, "HOW TO FOLLOW TEST GROUPS IN TROUBLE DIAGNOSES"](#).
- [GI-27, "How to Perform Efficient Diagnosis for an Electrical Incident"](#).
Check for any Service bulletins before servicing the vehicle.

PREPARATION

PREPARATION

PFP:00002

Special Service Tools

AIS000BS

The actual shapes of Kent-Moore tools may differ from those of special service tools illustrated here.

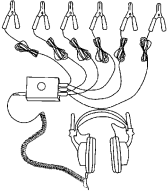
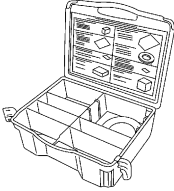
Tool number (Kent-Moore No.) Tool name	Description
(J-39570) Chassis ear	 <p style="text-align: right; margin-right: 20px;">SIIA0993E</p> Locating the noise
(J-43980) NISSAN Squeak and Rattle Kit	 <p style="text-align: right; margin-right: 20px;">SIIA0994E</p> Repairing the cause of noise

Commercial Service Tools

AIS000BT

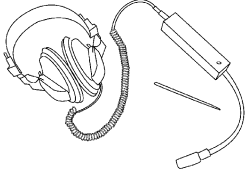
Tool name	Description
Engine ear	 <p style="text-align: right; margin-right: 20px;">SIIA0995E</p> Locating the noise

SQUEAK AND RATTLE TROUBLE DIAGNOSIS

SQUEAK AND RATTLE TROUBLE DIAGNOSIS

PFP:00000

Work Flow

AIS000BU

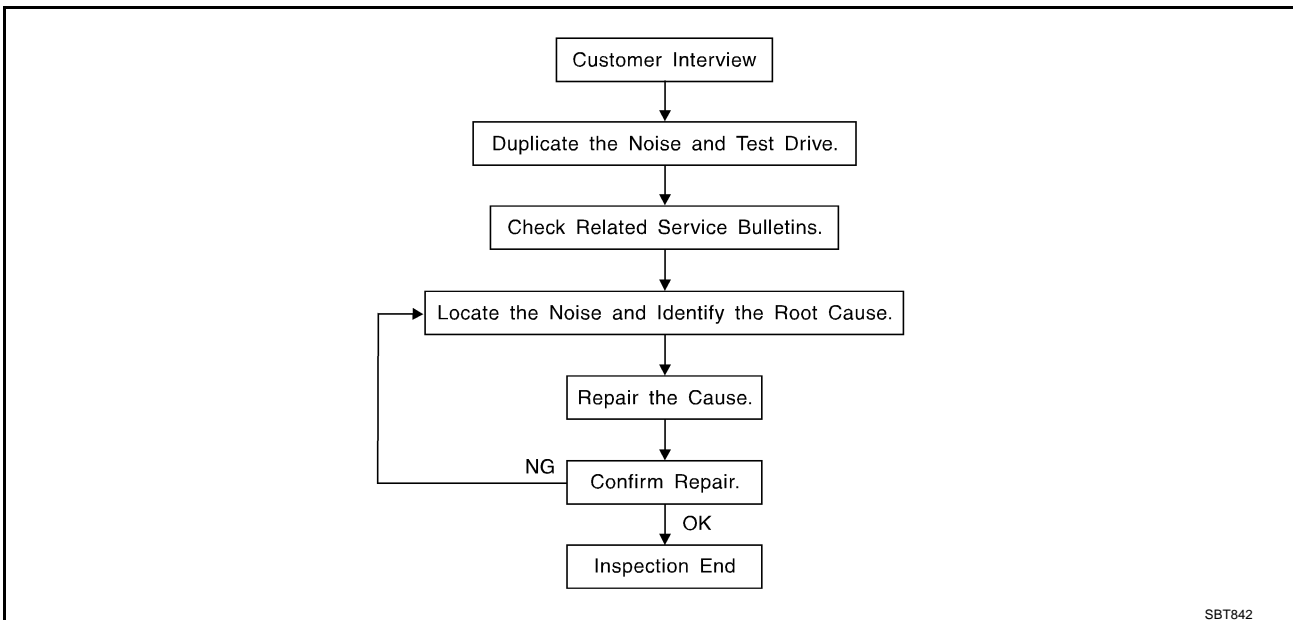

CUSTOMER INTERVIEW

Interview the customer if possible, to determine the conditions that exist when the noise occurs. Use the Diagnostic Worksheet during the interview to document the facts and conditions when the noise occurs and any customer's comments; refer to [BL-11, "Diagnostic Worksheet"](#). This information is necessary to duplicate the conditions that exist when the noise occurs.

- The customer may not be able to provide a detailed description or the location of the noise. Attempt to obtain all the facts and conditions that exist when the noise occurs (or does not occur).
- If there is more than one noise in the vehicle, be sure to diagnose and repair the noise that the customer is concerned about. This can be accomplished by test driving the vehicle with the customer.
- After identifying the type of noise, isolate the noise in terms of its characteristics. The noise characteristics are provided so the customer, service adviser and technician are all speaking the same language when defining the noise.
- Squeak—(Like tennis shoes on a clean floor)
Squeak characteristics include the light contact/fast movement/brought on by road conditions/hard surfaces=higher pitch noise/softer surfaces=lower pitch noises/edge to surface=chirping
- Creak—(Like walking on an old wooden floor)
Creak characteristics include firm contact/slow movement/twisting with a rotational movement/pitch dependent on materials/often brought on by activity.
- Rattle—(Like shaking a baby rattle)
Rattle characteristics include the fast repeated contact/vibration or similar movement/loose parts/missing clip or fastener/incorrect clearance.
- Knock—(Like a knock on a door)
Knock characteristics include hollow sounding/sometimes repeating/often brought on by driver action.
- Tick—(Like a clock second hand)
Tick characteristics include gentle contacting of light materials/loose components/can be caused by driver action or road conditions.
- Thump—(Heavy, muffled knock noise)
Thump characteristics include softer knock/dead sound often brought on by activity.
- Buzz—(Like a bumble bee)
Buzz characteristics include high frequency rattle/firm contact.
- Often the degree of acceptable noise level will vary depending upon the person. A noise that you may judge as acceptable may be very irritating to the customer.
- Weather conditions, especially humidity and temperature, may have a great effect on noise level.

SQUEAK AND RATTLE TROUBLE DIAGNOSIS

DUPLICATE THE NOISE AND TEST DRIVE

If possible, drive the vehicle with the customer until the noise is duplicated. Note any additional information on the Diagnostic Worksheet regarding the conditions or location of the noise. This information can be used to duplicate the same conditions when you confirm the repair.

If the noise can be duplicated easily during the test drive, to help identify the source of the noise, try to duplicate the noise with the vehicle stopped by doing one or all of the following:

- 1) Close a door.
 - 2) Tap or push/pull around the area where the noise appears to be coming from.
 - 3) Rev the engine.
 - 4) Use a floor jack to recreate vehicle "twist".
 - 5) At idle, apply engine load (electrical load, half-clutch on M/T model, drive position on A/T model).
 - 6) Raise the vehicle on a hoist and hit a tire with a rubber hammer.
- Drive the vehicle and attempt to duplicate the conditions the customer states exist when the noise occurs.
 - If it is difficult to duplicate the noise, drive the vehicle slowly on an undulating or rough road to stress the vehicle body.

CHECK RELATED SERVICE BULLETINS

After verifying the customer concern or symptom, check ASIST for Technical Service Bulletins (TSBs) related to that concern or symptom.

If a TSB relates to the symptom, follow the procedure to repair the noise.

LOCATE THE NOISE AND IDENTIFY THE ROOT CAUSE

1. Narrow down the noise to a general area. To help pinpoint the source of the noise, use a listening tool (Chassis Ear: J-39570, Engine Ear and mechanics stethoscope).
2. Narrow down the noise to a more specific area and identify the cause of the noise by:
 - removing the components in the area that you suspect the noise is coming from.
Do not use too much force when removing clips and fasteners, otherwise clips and fastener can be broken or lost during the repair, resulting in the creation of new noise.
 - tapping or pushing/pulling the component that you suspect is causing the noise.
Do not tap or push/pull the component with excessive force, otherwise the noise will be eliminated only temporarily.
 - feeling for a vibration with your hand by touching the component(s) that you suspect is (are) causing the noise.
 - placing a piece of paper between components that you suspect are causing the noise.
 - looking for loose components and contact marks.
Refer to [BL-9, "Generic Squeak and Rattle Troubleshooting"](#) .

REPAIR THE CAUSE

- If the cause is a loose component, tighten the component securely.
- If the cause is insufficient clearance between components:
 - separate components by repositioning or loosening and retightening the component, if possible.
 - insulate components with a suitable insulator such as urethane pads, foam blocks, felt cloth tape or urethane tape. A Nissan Squeak and Rattle Kit (J-43980) is available through your authorized Nissan Parts Department.

CAUTION:

Do not use excessive force as many components are constructed of plastic and may be damaged.

Always check with the Parts Department for the latest parts information.

The following materials are contained in the Nissan Squeak and Rattle Kit (J-43980). Each item can be ordered separately as needed.

URETHANE PADS [1.5 mm (0.059 in) thick]

Insulates connectors, harness, etc.

76268-9E005: 100 × 135 mm (3.94 × 5.31 in)/76884-71L01: 60 × 85 mm (2.36 × 3.35 in)/76884-71L02: 15 × 25 mm (0.59 × 0.98 in)

INSULATOR (Foam blocks)

Insulates components from contact.Can be used to fill space behind a panel.

73982-9E000: 45 mm (1.77 in) thick, 50 × 50 mm (1.97 × 1.97 in)/73982-50Y00: 10 mm (0.39 in) thick, 50 × 50 mm (1.97 × 1.97 in)

SQUEAK AND RATTLE TROUBLE DIAGNOSIS

INSULATOR (Light foam block)

80845-71L00: 30 mm (1.18 in) thick, 30 × 50 mm (1.18×1.97 in)

FELT CLOTHTAPE

Used to insulate where movement does not occur. Ideal for instrument panel applications.

68370-4B000: 15 × 25 mm (0.59 × 0.98 in) pad/68239-13E00: 5 mm (0.20 in) wide tape roll The following materials, not found in the kit, can also be used to repair squeaks and rattles.

UHMW(TEFLON) TAPE

Insulates where slight movement is present. Ideal for instrument panel applications.

SILICONE GREASE

Used in of UHMW tape that will be visible or not fit.

Note: Will only last a few months.

SILICONE SPRAY

Use when grease cannot be applied.

DUCT TAPE

Use to eliminate movement.

CONFIRM THE REPAIR

Confirm that the cause of a noise is repaired by test driving the vehicle. Operate the vehicle under the same conditions as when the noise originally occurred. Refer to the notes on the Diagnostic Worksheet.

Generic Squeak and Rattle Troubleshooting

AIS000BV

Refer to Table of Contents for specific component removal and installation information.

INSTRUMENT PANEL

Most incidents are caused by contact and movement between:

1. The cluster lid A and instrument panel
2. Acrylic lens and combination meter housing
3. Instrument panel to front pillar garnish
4. Instrument panel to windshield
5. Instrument panel mounting pins
6. Wiring harnesses behind the combination meter
7. A/C defroster duct and duct joint

These incidents can usually be located by tapping or moving the components to duplicate the noise or by pressing on the components while driving to stop the noise. Most of these incidents can be repaired by applying felt cloth tape or silicon spray (in hard to reach areas). Urethane pads can be used to insulate wiring harness.

CAUTION:

Do not use silicone spray to isolate a squeak or rattle. If you saturate the area with silicone, you will not be able to recheck the repair.

CENTER CONSOLE

Components to pay attention to include:

1. Shifter assembly cover to finisher
2. A/C control unit and cluster lid C
3. Wiring harnesses behind audio and A/C control unit

The instrument panel repair and isolation procedures also apply to the center console.

DOORS

Pay attention to the:

1. Finisher and inner panel making a slapping noise
2. Inside handle escutcheon to door finisher
3. Wiring harnesses tapping
4. Door striker out of alignment causing a popping noise on starts and stops

Tapping or moving the components or pressing on them while driving to duplicate the conditions can isolate many of these incidents. You can usually insulate the areas with felt cloth tape or insulator foam blocks from the Nissan Squeak and Rattle Kit (J-43980) to repair the noise.

A
B
C
D
E
F
G
H
BL
J
K
L
M

SQUEAK AND RATTLE TROUBLE DIAGNOSIS

TRUNK

Trunk noises are often caused by a loose jack or loose items put into the trunk by the owner. In addition look for:

1. Trunk lid dumpers out of adjustment
2. Trunk lid striker out of adjustment
3. The trunk lid torsion bars knocking together
4. A loose license plate or bracket

Most of these incidents can be repaired by adjusting, securing or insulating the item(s) or component(s) causing the noise.

SUNROOF/HEADLINING

Noises in the sunroof/headlining area can often be traced to one of the following:

1. Sunroof lid, rail, linkage or seals making a rattle or light knocking noise
2. Sunvisor shaft shaking in the holder
3. Front or rear windshield touching headlining and squeaking

Again, pressing on the components to stop the noise while duplicating the conditions can isolate most of these incidents. Repairs usually consist of insulating with felt cloth tape.

SEATS

When isolating seat noise it's important to note the position the seat is in and the load placed on the seat when the noise is present. These conditions should be duplicated when verifying and isolating the cause of the noise.

Cause of seat noise include:

1. Headrest rods and holder
2. A squeak between the seat pad cushion and frame
3. The rear seatback lock and bracket

These noises can be isolated by moving or pressing on the suspected components while duplicating the conditions under which the noise occurs. Most of these incidents can be repaired by repositioning the component or applying urethane tape to the contact area.

UNDERHOOD

Some interior noise may be caused by components under the hood or on the engine wall. The noise is then transmitted into the passenger compartment.

Causes of transmitted underhood noise include:

1. Any component mounted to the engine wall
2. Components that pass through the engine wall
3. Engine wall mounts and connectors
4. Loose radiator mounting pins
5. Hood bumpers out of adjustment
6. Hood striker out of adjustment

These noises can be difficult to isolate since they cannot be reached from the interior of the vehicle. The best method is to secure, move or insulate one component at a time and test drive the vehicle. Also, engine RPM or load can be changed to isolate the noise. Repairs can usually be made by moving, adjusting securing, or insulating the component causing the noise.

SQUEAK AND RATTLE TROUBLE DIAGNOSIS

Diagnostic Worksheet

AIS000BW

A
B
C
D
E
F
G
H
BL
J
K
L
M

SQUEAK & RATTLE DIAGNOSTIC WORKSHEET

Dear Nissan Customer:

We are concerned about your satisfaction with your Nissan vehicle. Repairing a squeak or rattle sometimes can be very difficult. To help us fix your Nissan right the first time, please take a moment to note the area of the vehicle where the squeak or rattle occurs and under what conditions. You may be asked to take a test drive with a service advisor or technician to ensure we confirm the noise you are hearing.

I. WHERE DOES THE NOISE COME FROM? (circle the area of the vehicle)

The illustrations are for reference only, and may not reflect the actual configuration of your vehicle.

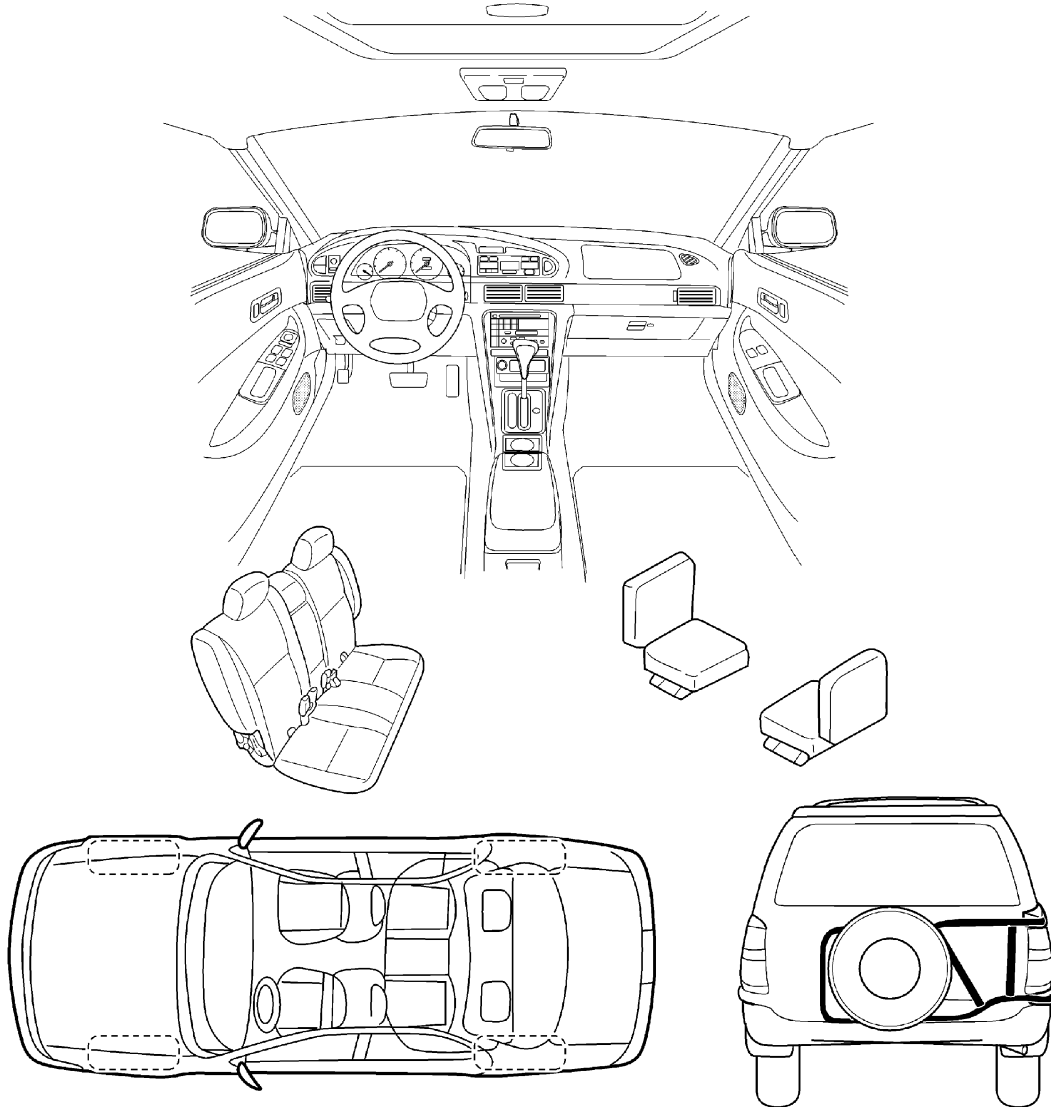

Continue to the back of the worksheet and briefly describe the location of the noise or rattle. In addition, please indicate the conditions which are present when the noise occurs.

PIIB0723E

SQUEAK AND RATTLE TROUBLE DIAGNOSIS

SQUEAK & RATTLE DIAGNOSTIC WORKSHEET- page 2

Briefly describe the location where the noise occurs:

II. WHEN DOES IT OCCUR? (check the boxes that apply)

- | | |
|--|---|
| <input type="checkbox"/> anytime | <input type="checkbox"/> after sitting out in the sun |
| <input type="checkbox"/> 1 st time in the morning | <input type="checkbox"/> when it is raining or wet |
| <input type="checkbox"/> only when it is cold outside | <input type="checkbox"/> dry or dusty conditions |
| <input type="checkbox"/> only when it is hot outside | <input type="checkbox"/> other: _____ |

III. WHEN DRIVING:

- through driveways
- over rough roads
- over speed bumps
- only at about ____ mph
- on acceleration
- coming to a stop
- on turns : left, right or either (circle)
- with passengers or cargo
- other: _____
- after driving ____ miles or ____ minutes

IV. WHAT TYPE OF NOISE?

- squeak (like tennis shoes on a clean floor)
- creak (like walking on an old wooden floor)
- rattle (like shaking a baby rattle)
- knock (like a knock on a door)
- tick (like a clock second hand)
- thump (heavy, muffled knock noise)
- buzz (like a bumble bee)

TO BE COMPLETED BY DEALERSHIP PERSONNEL

Test Drive Notes:

	YES	NO	Initials of person performing
Vehicle test driven with customer	<input type="checkbox"/>	<input type="checkbox"/>	_____
- Noise verified on test drive	<input type="checkbox"/>	<input type="checkbox"/>	_____
- Noise source located and repaired	<input type="checkbox"/>	<input type="checkbox"/>	_____
- Follow up test drive performed to confirm repair	<input type="checkbox"/>	<input type="checkbox"/>	_____

VIN: _____ Customer Name: _____

W.O. #: _____ Date: _____

This form must be attached to Work Order

SBT844

HOOD

HOOD

PFP:F5100

Fitting Adjustment

AIS0059R

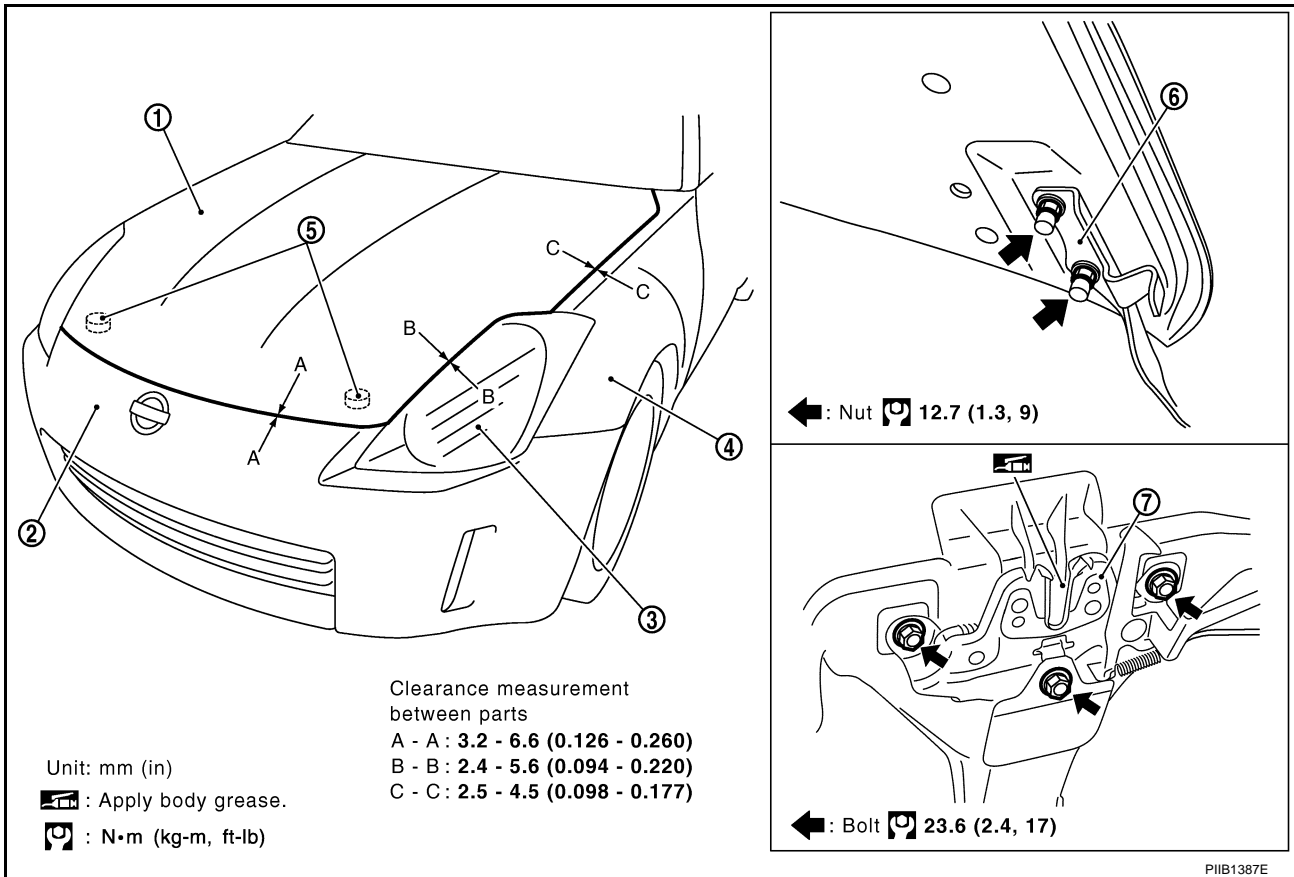

- | | | |
|-----------------------|------------------|---------------|
| 1. Hood assembly | 2. Front bumper | 3. Head lamp |
| 4. Front fender | 5. Bumper rubber | 6. Hood hinge |
| 7. Hood lock assembly | | |

LONGITUDINAL AND LATERAL CLEARANCE ADJUSTMENT

1. Remove hood lock assembly, loosen the hood hinge nuts and close the hood.
2. Adjust the lateral and longitudinal clearance, and open the hood to tighten the hood hinge mounting bolts to the specified torque.
3. Install the hood lock temporarily, and align the hood striker and hood lock so that the centers of hood striker and hood lock become vertical viewed from the front, by moving the hood lock laterally.
4. Tighten hood lock assembly mounting bolts to the specified torque.

CAUTION:

Adjust right/left clearance between hood and each part to the following specification.

Hood and head lamp (B-B) : Less than 2.0 mm (0.08 in)

Hood and fender (C-C) : Less than 1.0 mm (0.04 in)

FRONT END HEIGHT ADJUSTMENT

1. Remove the hood lock and adjust the height by rotating the bumper rubber until the hood becomes 1 to 1.5 mm (0.04 to 0.059 in) lower than the fender.
2. Temporarily tighten the hood lock assembly, and position it by engaging it with the hood striker. Check the hood lock and hood striker for looseness, and tighten the hood lock assembly mounting bolts to the specified torque.

HOOD

SURFACE HEIGHT ADJUSTMENT

1. Remove hood lock assembly, and adjust the surface height difference of hood and fender according to the fitting standard dimension, by rotating RH and LH bumper rubbers.
2. Install hood lock temporarily, and move hood lock laterally until the centers of striker and lock become vertical when viewed from the front.
3. Make sure that the hood lock secondary latch is properly engaged with the secondary striker with hood's own weight.
4. Make sure that the hood lock primary latch is securely engaged with the hood striker with hood's own weight by dropping hood from approx. 200 mm(7.87 in) height.

CAUTION:

Do not drop hood from a height of 300 mm (11.81 in) or more.

5. Move hood lockup and down until striker smoothly engages the lock when the hood is closed.
6. When pulling the hood opener lever gently, make sure that front end of the hood rises by approximately 20 mm (0.79 in) and that hood striker and hood lock primary latch is disengaged. Also make sure that hood opener returns to the original position.
7. After adjustment, tighten lock bolts to the specified torque.

CAUTION:

Adjust evenness between hood and fender to the following specification.

Hood and fender (C-C) : 0 ± 1.0 mm (0 ± 0.04 in)

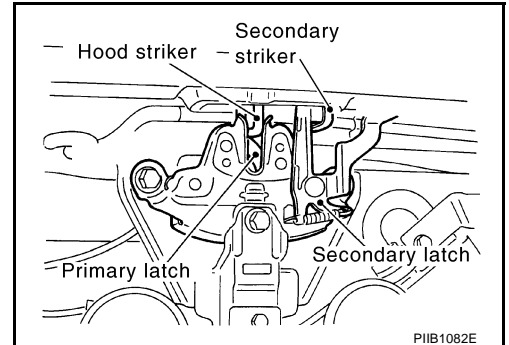

HOOD

Removal and Installation of Hood Assembly

AIS0059S

A
B
C
D
E
F
G
H
BL
J
K
L
M

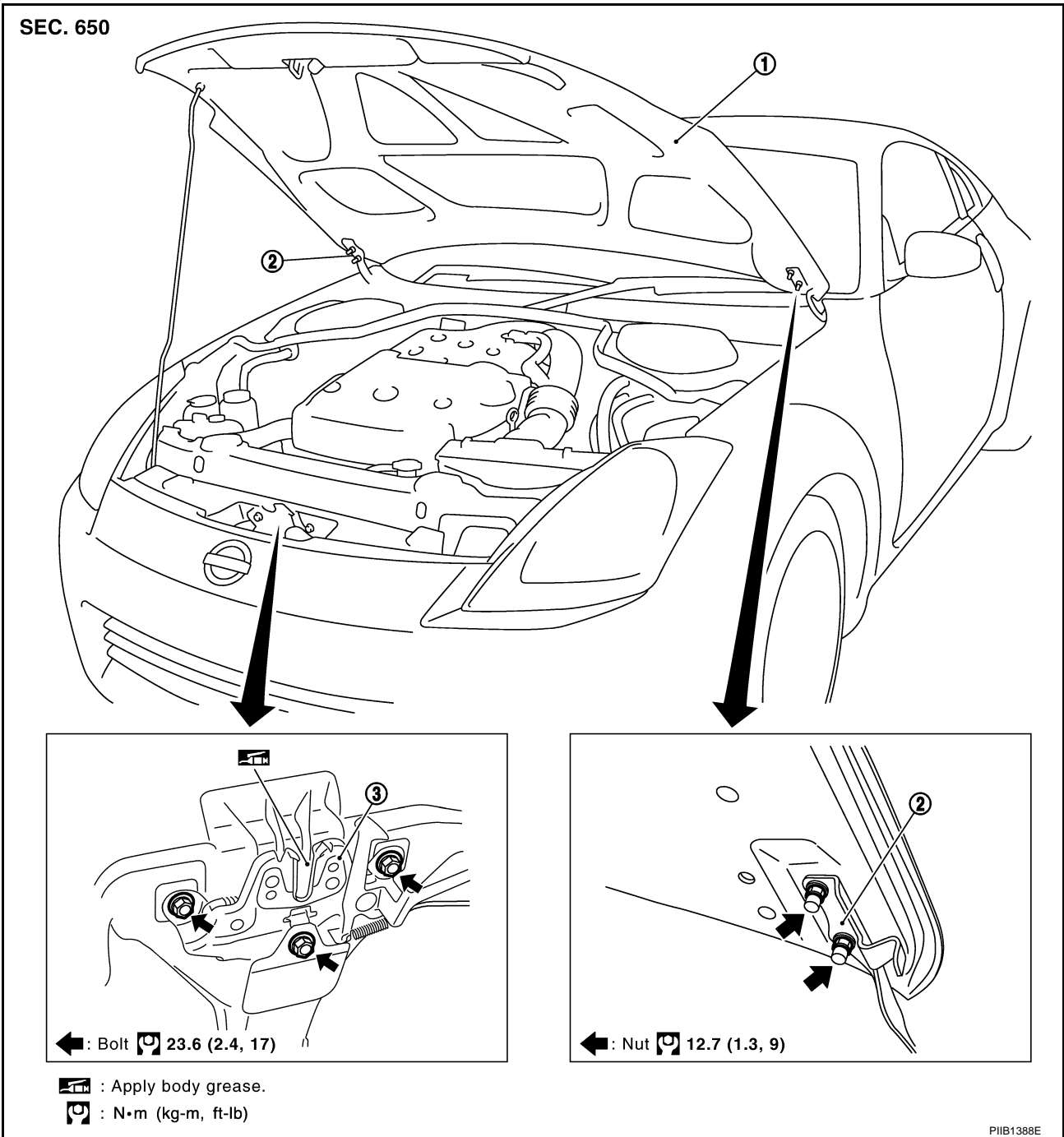

REMOVAL

Remove the hinge mounting nuts on the hood to remove the hood assembly.

CAUTION:

Operate with two workers, because of its heavy weight.

INSTALLATION

- Install in the reverse order of removal.
- Apply Anti-Corrosion Wax or equivalent to the attaching portion of hood hinge, hood ledge, and hood assembly.
- After installing, perform hood fitting adjustment. Refer to [BL-13, "Fitting Adjustment"](#).

HOOD

Removal and Installation of Hood Lock Control

AIS0059T

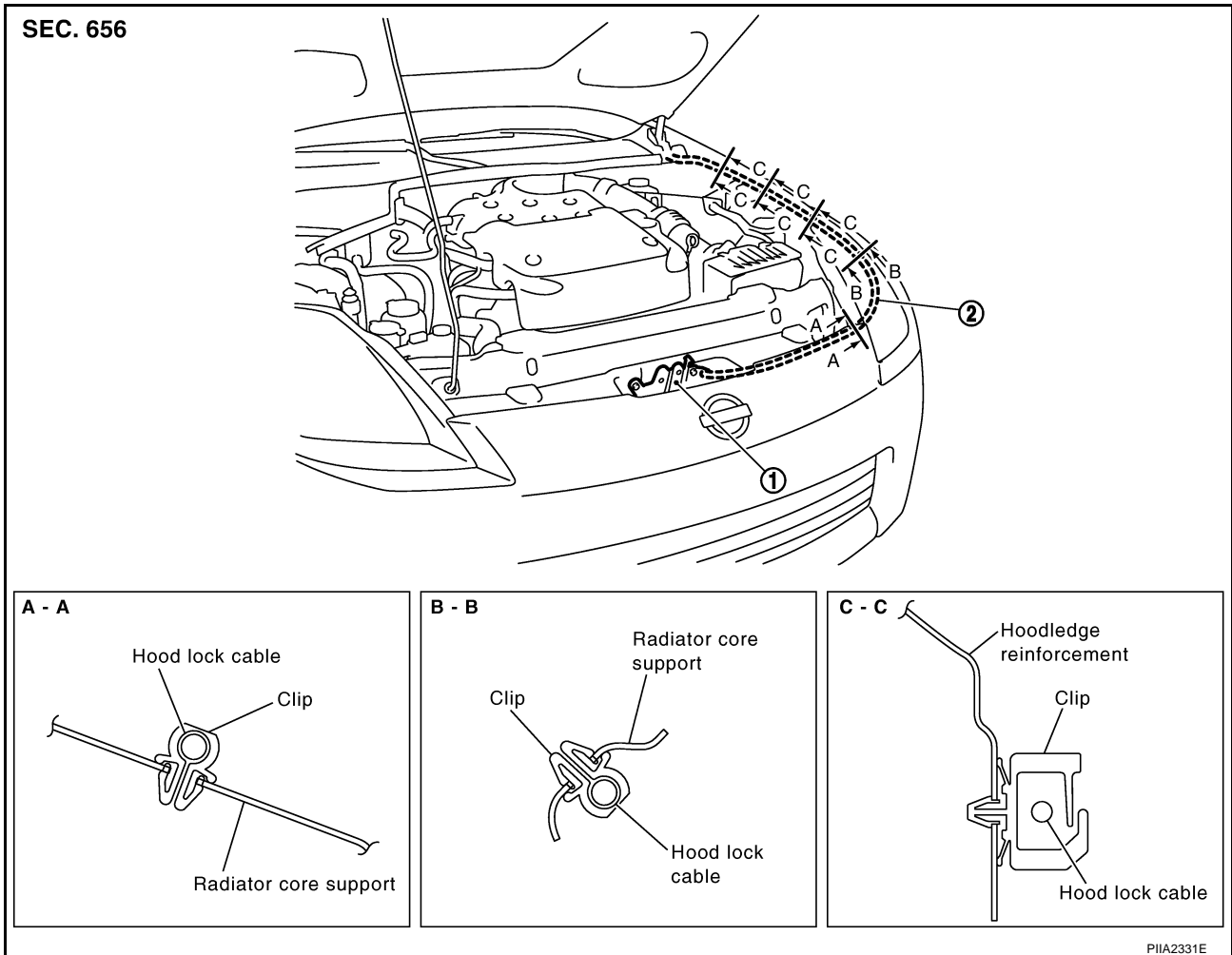

REMOVAL

1. Remove the fender protector (LH). Refer to [EI-21, "FENDER PROTECTOR"](#).
2. Remove the hood lock assembly.

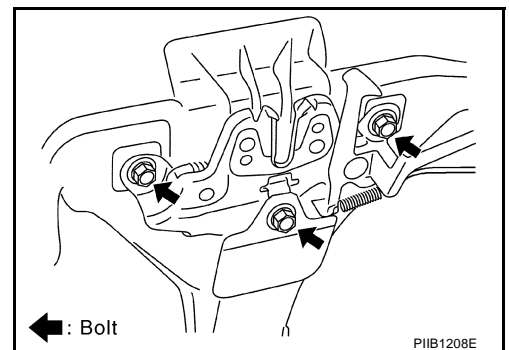

3. Remove the dash side finisher. Refer to [IP-10, "Component Parts Drawing"](#).
4. Remove hood lock cable and unclip it from portion of radiator core support.

HOOD

5. While pulling the hood lock cable, remove hood lock cable connected to hood opener handle.
6. Remove grommet on dash board, and pull hood lock cable toward passenger compartment.

CAUTION:

While pulling, be careful not to damage (peeling) the outside of the hood lock cable.

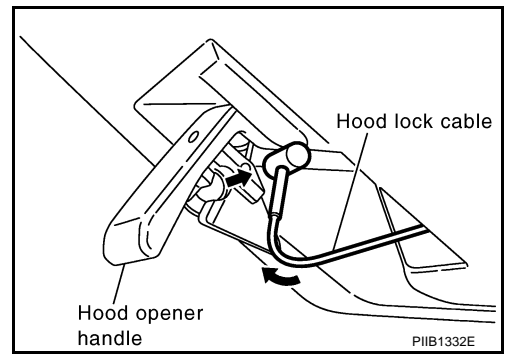

INSTALLATION

1. Pull the hood lock cable through the panel hole to the engine compartment. Be careful not to bend the cable too much, keeping the radius 100 mm (3.94 in) or more.
2. Check that the cable is not offset from the positioning grommet, and push the grommet into the panel hole securely.
3. Apply the sealant to the grommet (at * mark) properly.
4. Install while pulling hood lock cable.

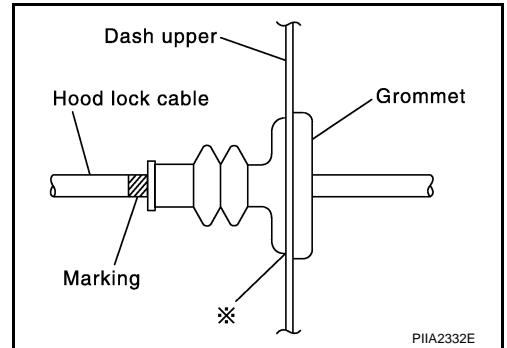

5. Install the hood lock cable securely to the hood lock.
6. Install hood lock assembly.
7. After installing, check the hood lock adjustment and hood opener operation.

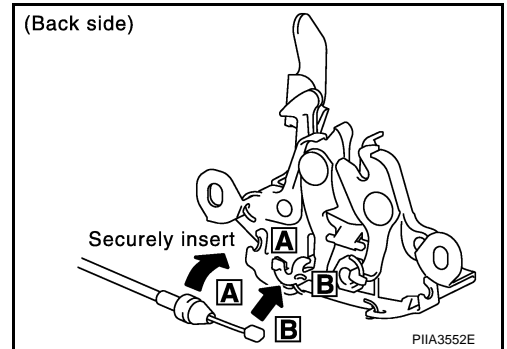

Hood Lock Control Inspection

CAUTION:

If the hood lock cable is bent or deformed, replace it.

1. Check that the secondary latch is properly engaged with the secondary striker with hood's own weight by dropping it from approx. 200 mm (7.87 in) height.
2. While operating the hood opener, carefully check that the front end of the hood is raised by approx. 20 mm (0.79 in). Also check that the hood opener returns to the original position.

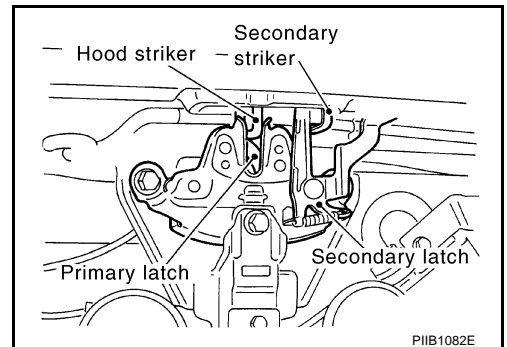

HOOD

3. Check the hood lock lubrication condition. If necessary, apply "body grease" to the points shown in the figure.

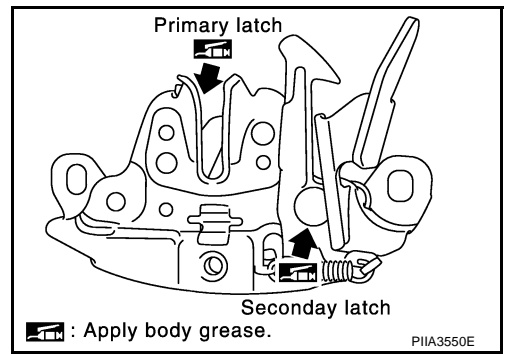

RADIATOR CORE SUPPORT

PFP:62500

AIS000C1

RADIATOR CORE SUPPORT

Removal and Installation

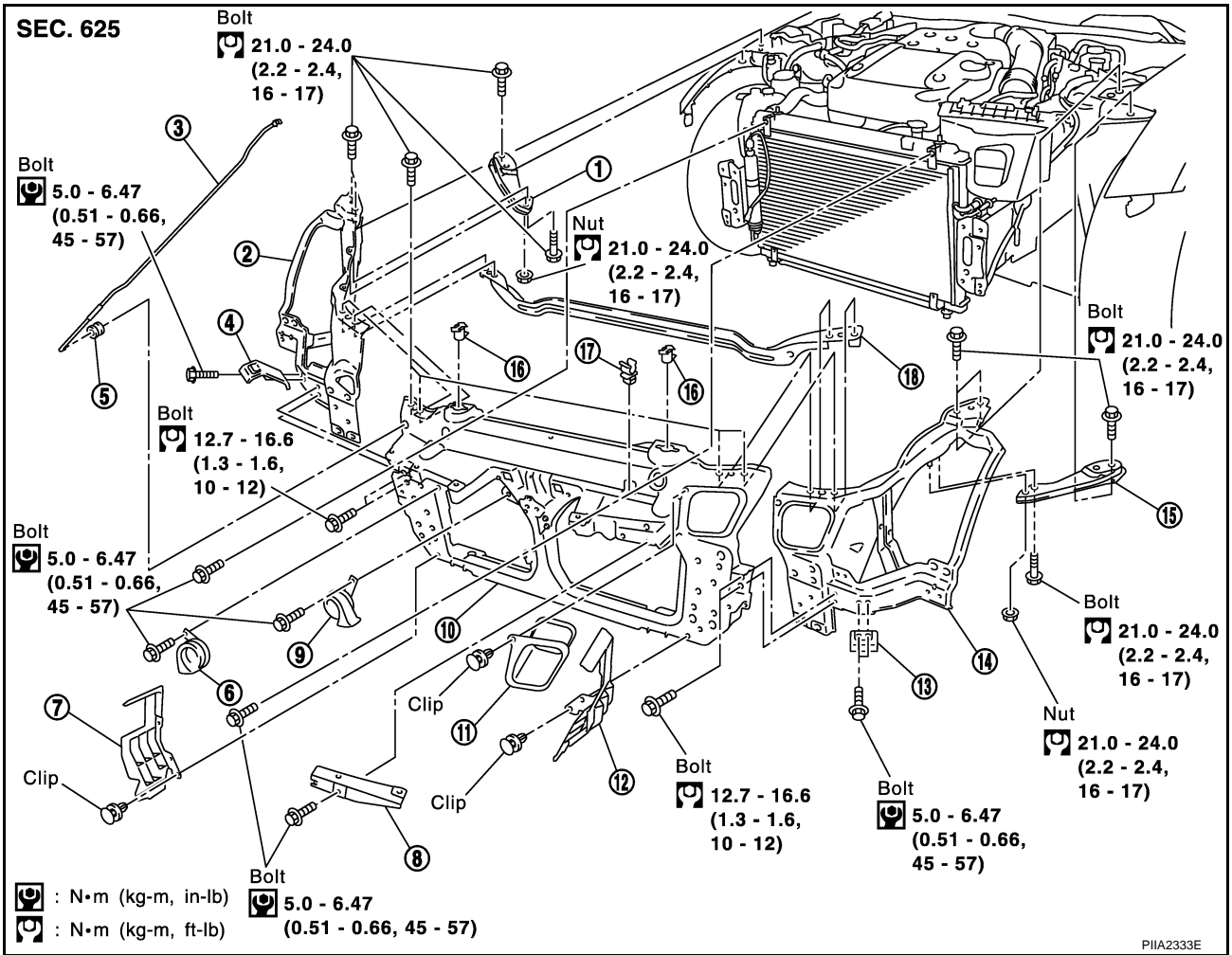

- | | | |
|---|--|--|
| 1. Radiator core support side stay (RH) | 2. Radiator core support side (RH) | 3. Hood stay |
| 4. Bumper retainer (RH) | 5. Grommet | 6. Horn (High) |
| 7. Air guide (RH) | 8. Bumper fascia stay radiator core support center | 9. Horn (Low) |
| 10. Radiator core support center | 11. Air duct | 12. Air guide (LH) |
| 13. Bumper retainer (LH) | 14. Radiator core support side (LH) | 15. Radiator core support side stay (LH) |
| 16. Radiator upper bracket | 17. Hood rod clamp | 18. Radiator core support bar |

REMOVAL

1. Remove hood assembly. Refer to [BL-15, "Removal and Installation of Hood Assembly"](#) .
2. Remove front bumper. Refer to [EI-14, "Removal and Installation"](#) .
3. Remove head lamp (LH/RH). Refer to [LT-35, "Removal and Installation"](#) .
4. Remove hood lock assembly, and then hood lock cable. Refer to [BL-16, "Removal and Installation of Hood Lock Control"](#) .
5. Remove washer tank. Refer to [WW-33, "Removal and Installation of Washer Tank"](#) .
6. Remove crash zone sensor. Refer to [SRS-47, "Removal and Installation"](#) .
7. Remove washer tank inlet clip. Refer to [WW-33, "Removal and Installation of Washer Tank"](#) .
8. Remove the oil cooler. Refer to [PS-34, "HYDRAULIC LINE"](#) .
9. Remove horn connectors.
10. Remove mounting harness clip on radiator core support center and side to separate the harness.
11. Remove resonator mounting screws.

RADIATOR CORE SUPPORT

12. Remove radiator upper bracket, and radiator core support side and radiator core support hood ledge stay bolts. Remove radiator core support center and side together.

CAUTION:

Put a wooden block under the radiator assembly to prevent the radiator assembly from falling.

13. Remove radiator core support center and side together.
14. After removing radiator core support center and side together, the following parts are separated.
 - Remove the hood stay, grommet and hood rod clamp
 - Horn (High/Low)
 - Air duct
 - Air guide (LH/RH)
 - Bumper fascia stay radiator core support center
 - Bumper retainer (LH/RH)
 - Radiator core support side and radiator core support side bar
 - Radiator core support side hood ledge stay (LH/RH)
 - Ambient sensor

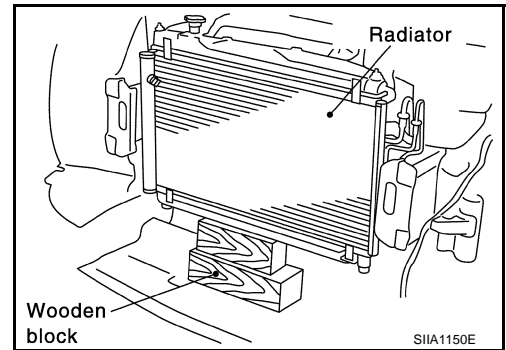

INSTALLATION

Install in the reverse order of removal.

CAUTION:

After installing, check the hood lock adjustment and hood opener operation. Refer to [BL-13. "Fitting Adjustment"](#) .

POWER DOOR LOCK SYSTEM

PPF:24814

AIS004CZ

POWER DOOR LOCK SYSTEM

Component Parts and Harness Connector Location FOR ROADSTER

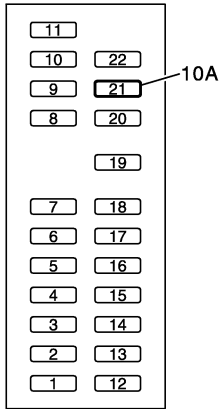

Fuse block (J/B) fuse layout

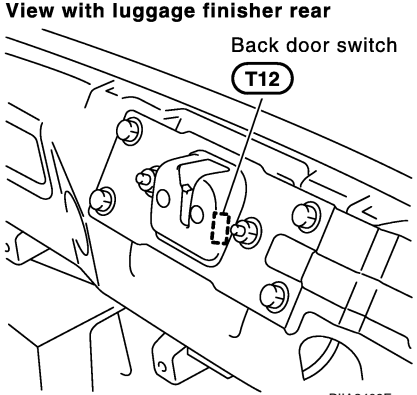
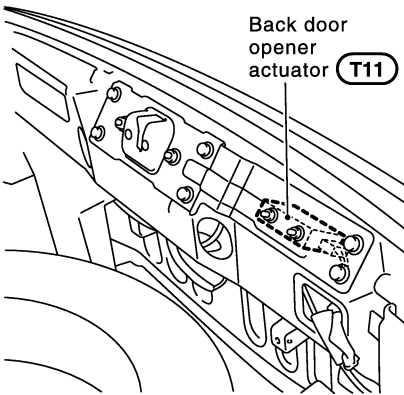
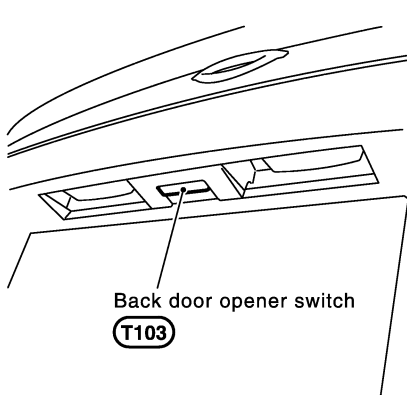
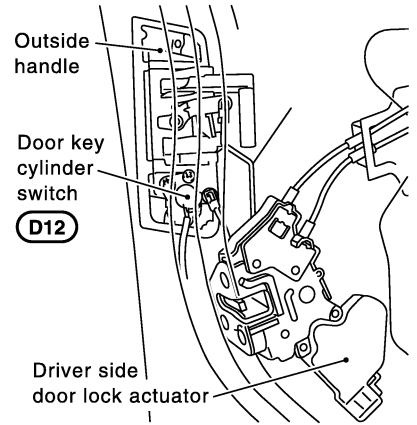
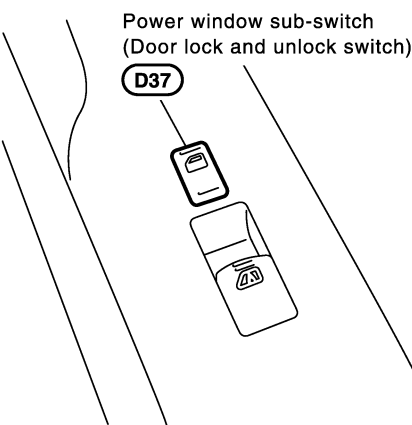
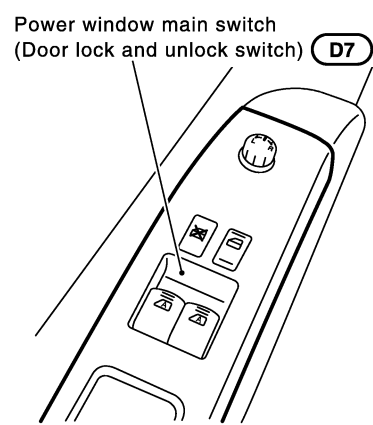
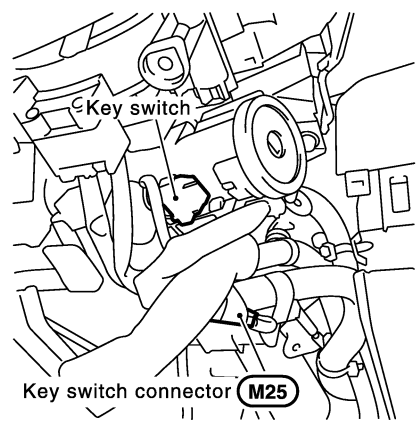
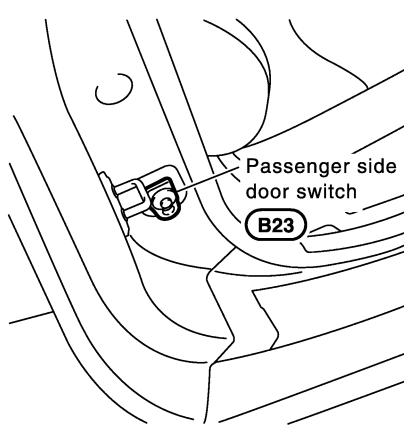
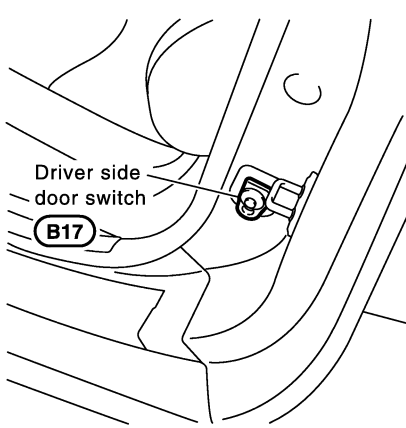
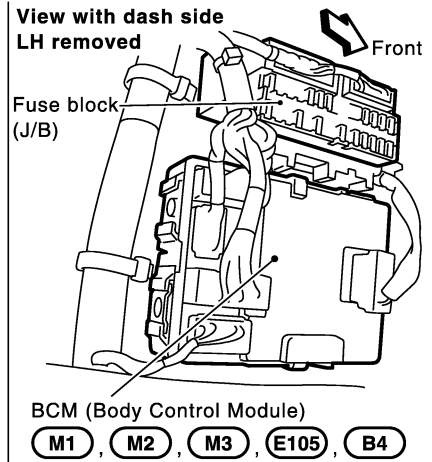
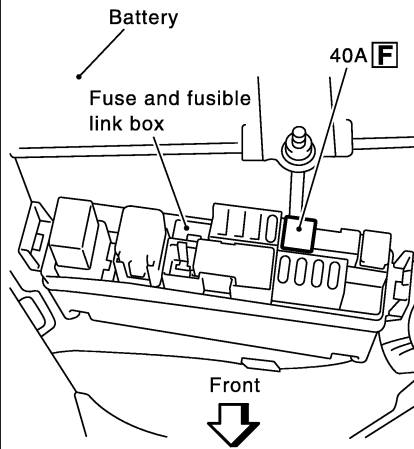

PIIA2409E

A
B
C
D
E
F
G
H
I
J
K
L
M

BL

POWER DOOR LOCK SYSTEM

FOR COUPE

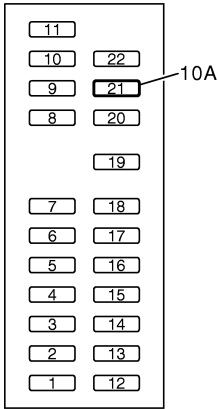

Fuse block (J/B) fuse layout

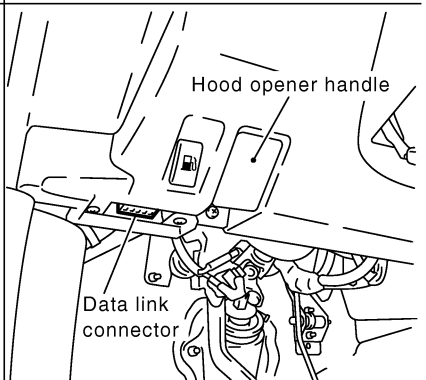
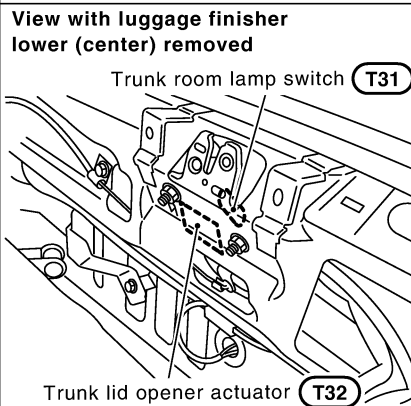
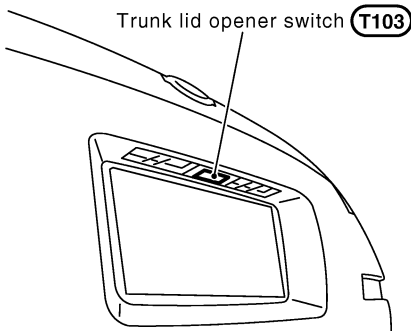
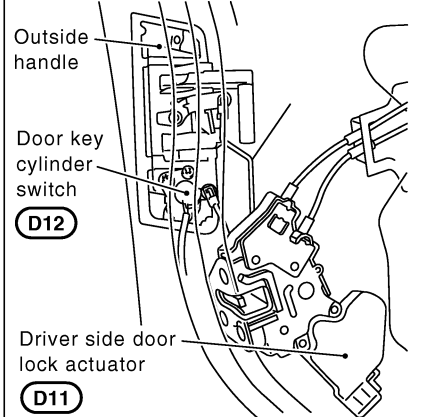
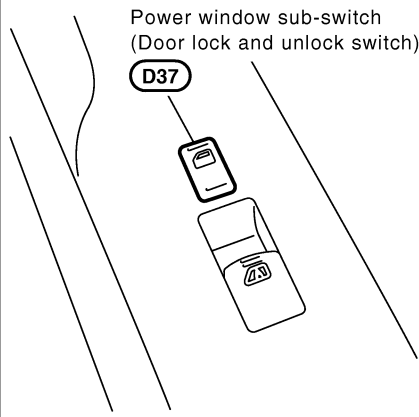
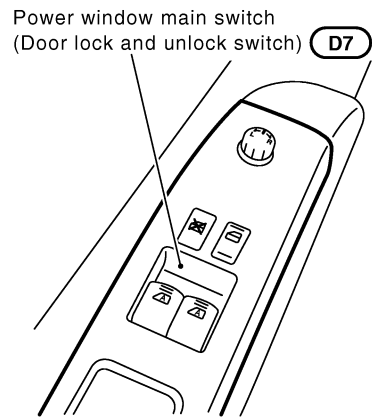
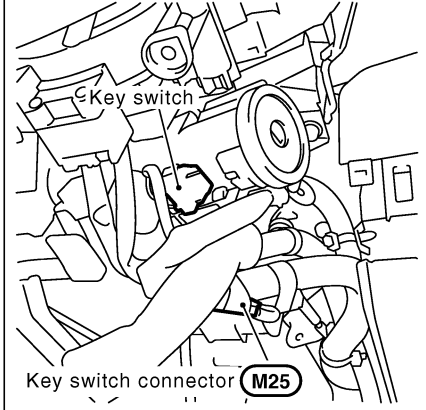
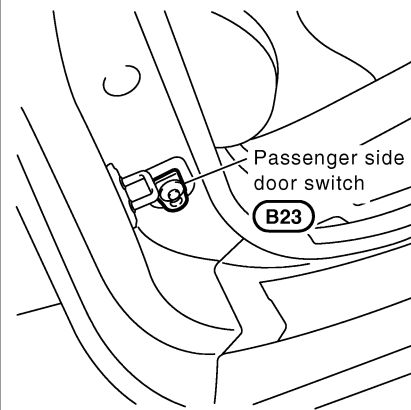
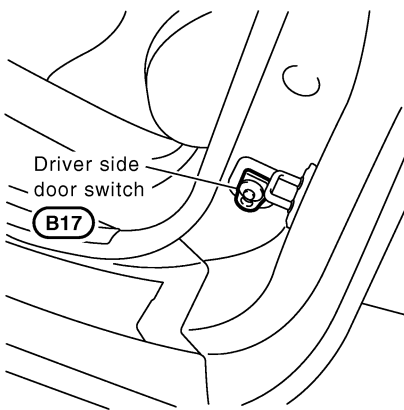
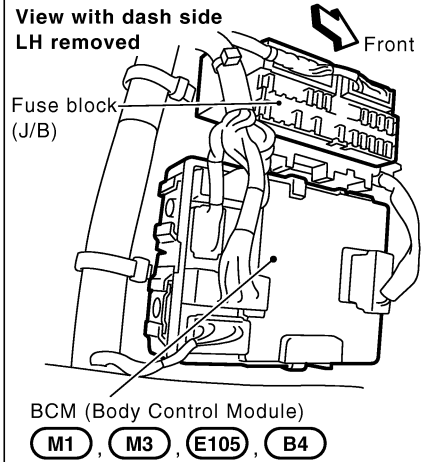
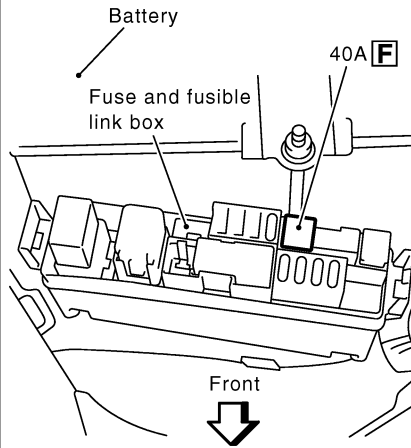

PIIA8064E

POWER DOOR LOCK SYSTEM

AIS004D0

System Description

Power is supplied at all times

- through 40A fusible link (letter **F** , located in the fuse and fusible link box)
- to BCM terminal 7, and
- through 10A fuse [No. 21, located in the fuse block (J/B)]
- to key switch terminal 2.

With ignition key inserted, power is supplied

- through key switch terminal 1
- to BCM terminal 62.

Ground is supplied to terminal 8 of BCM through grounds E17, E43 and F152.

When the door is locked and unlocked with power window main switch (door lock and unlock switch), ground is supplied

- to power window main switch (door lock and unlock switch) terminal 15
- through grounds M30 and M66.

Power window main switch (door lock and unlock switch) operation signal is supplied

- through power window main switch (door lock and unlock switch) terminal 12
- to BCM terminal 74.

When the door is locked and unlocked with power window sub-switch (door lock and unlock switch), ground is supplied

- to power window sub-switch (door lock and unlock switch) terminal 11
- through grounds M30 and M66.

Power window sub-switch (door lock and unlock switch) operation signal is supplied

- through power window sub-switch (door lock and unlock switch) terminal 16
- to BCM terminal 74.

When the door is locked with door key cylinder switch, ground is supplied

- to power window main switch (door lock and unlock switch) terminal 6
- through door key cylinder switch terminal 3
- through door key cylinder switch terminal 2
- through grounds M30 and M66.

Door key cylinder switch operation signal is supplied

- through power window main switch (door lock and unlock switch) terminal 12
- to BCM terminal 74.

When the door is unlocked with door key cylinder switch, ground is supplied

- to power window main switch (door lock and unlock switch) terminal 7
- through door key cylinder switch terminal 1
- through door key cylinder switch terminal 2
- through grounds M30 and M66.

Door key cylinder switch operation signal is supplied

- through power window main switch (door lock and unlock switch) terminal 12
- to BCM terminal 74.

BCM is connected to power window main switch (door lock and unlock switch) and power window sub-switch (door lock and unlock switch) as serial link.

A

B

C

D

E

F

G

H

BL

J

K

L

M

POWER DOOR LOCK SYSTEM

POWER WINDOW SERIAL LINK

Power window main switch, power window sub-switch and BCM transmit and receive the signal by power window serial link.

The under mentioned signal is transmitted from power window main switch to BCM.

- Door lock and unlock switch signal.

The under mentioned signal is transmitted from power window sub-switch to BCM.

- Door lock and unlock switch signal.

OUTLINE

Functions Available by Operating the Door Lock and Unlock Switches on Driver's Door and Passenger's Door

- With the locking operation of door lock and unlock switch, door lock actuators of driver's and passenger's doors are locked.
- With the unlocking operation of door lock and unlock switch, door lock actuators of driver's and passenger's doors are unlocked.

Functions Available by Operating the Key Cylinder Switch

- With the locking operation of door key cylinder, door lock actuators of all doors are locked.
- When door key cylinder is unlocked, door lock actuator (driver side) is unlocked.
- When door key cylinder is unlocked for the second time within 5 seconds after the first unlock operation, door lock actuators on driver's and passenger's doors are unlocked.

Unlock mode can be changed by using CONSULT-II "WORK SUPPORT" mode in "DOOR LOCK-UNLOCK SET".

Refer to [BL-37, "WORK SUPPORT"](#) .

Key Reminder Door System

When door lock and unlock switch is operated to lock doors with ignition key put in key cylinder and driver's and passenger's door open, driver and passenger door lock actuators are locked and then unlocked.

Back Door Opener Operation/For Coupe

When back door opener switch is ON with driver's door unlocked, power is supplied

- through BCM terminal 19.

Then back door opener actuator opens back door.

POWER DOOR LOCK SYSTEM

Schematic

AIS004D1

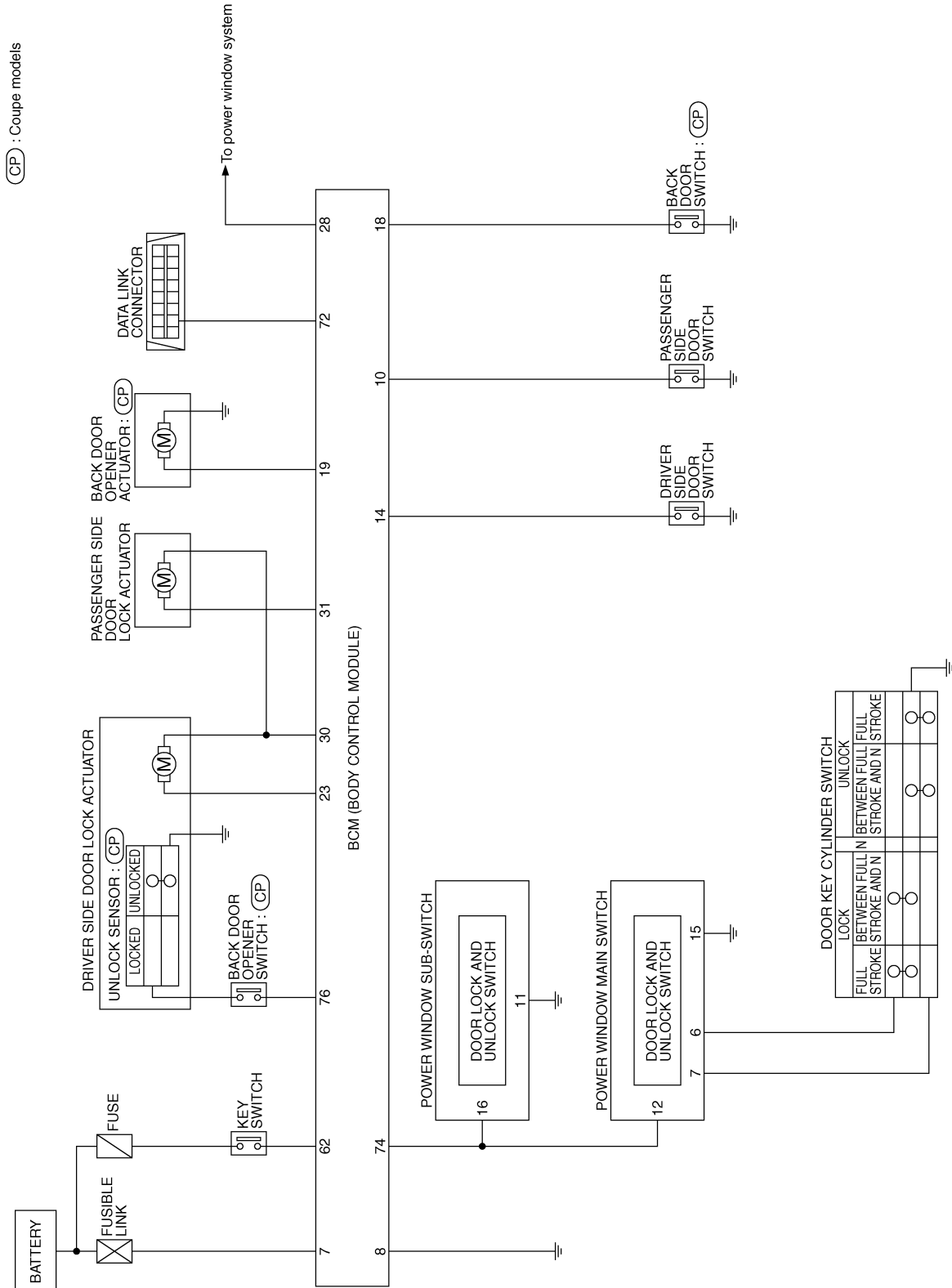

A
B
C
D
E
F
G
H
J
K
L
M

BL

POWER DOOR LOCK SYSTEM

Wiring Diagram —D/LOCK— /For Coupe
FIG. 1

AIS004D2

BL-D/LOCK-01

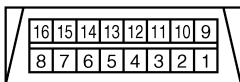
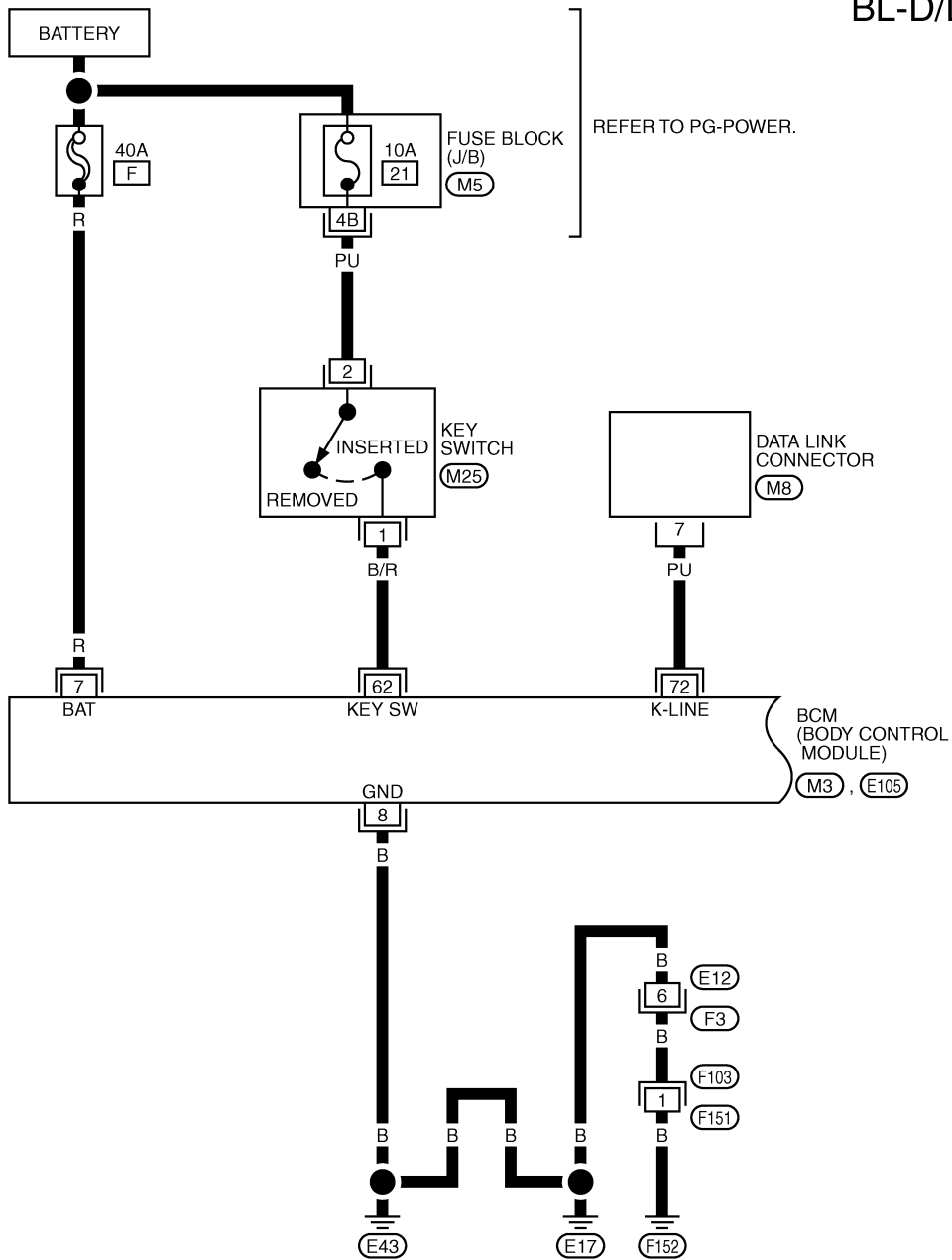

M8
W

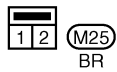

M25
BR

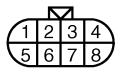

F3
GY

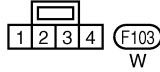

F103
W

REFER TO THE FOLLOWING.

M5 - FUSE BLOCK-JUNCTION BOX (J/B)

M3, E105 - ELECTRICAL UNITS

TIWT0759E

POWER DOOR LOCK SYSTEM

FIG. 2

BL-D/LOCK-02

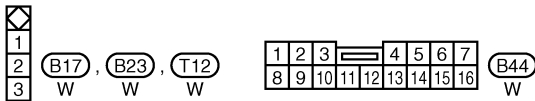
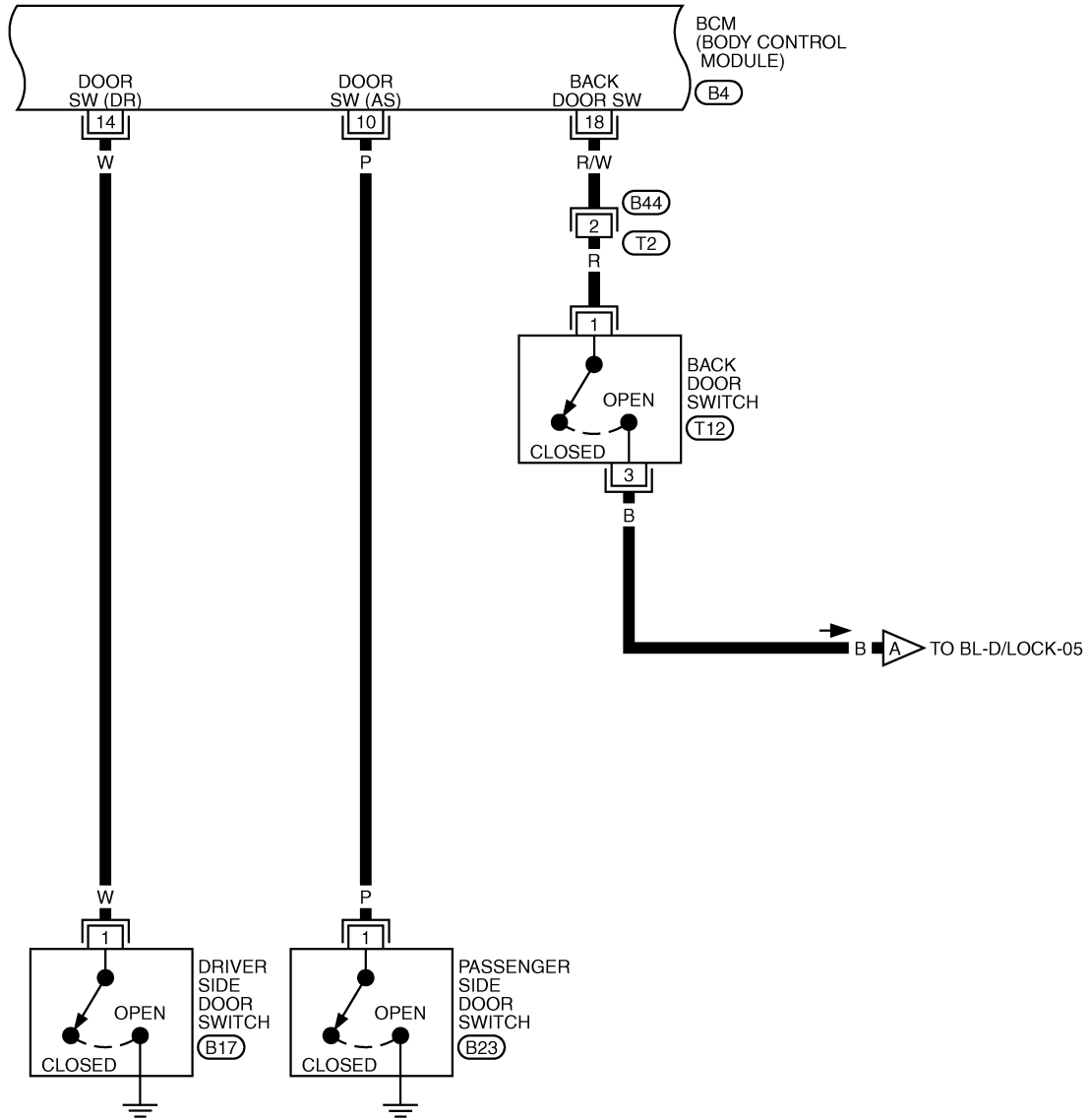

REFER TO THE FOLLOWING.
 (B4) -ELECTRICAL UNITS

A
B
C
D
E
F
G
H
I
J
K
L
M

BL

POWER DOOR LOCK SYSTEM

FIG. 3

BL-D/LOCK-03

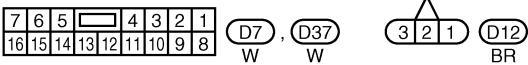
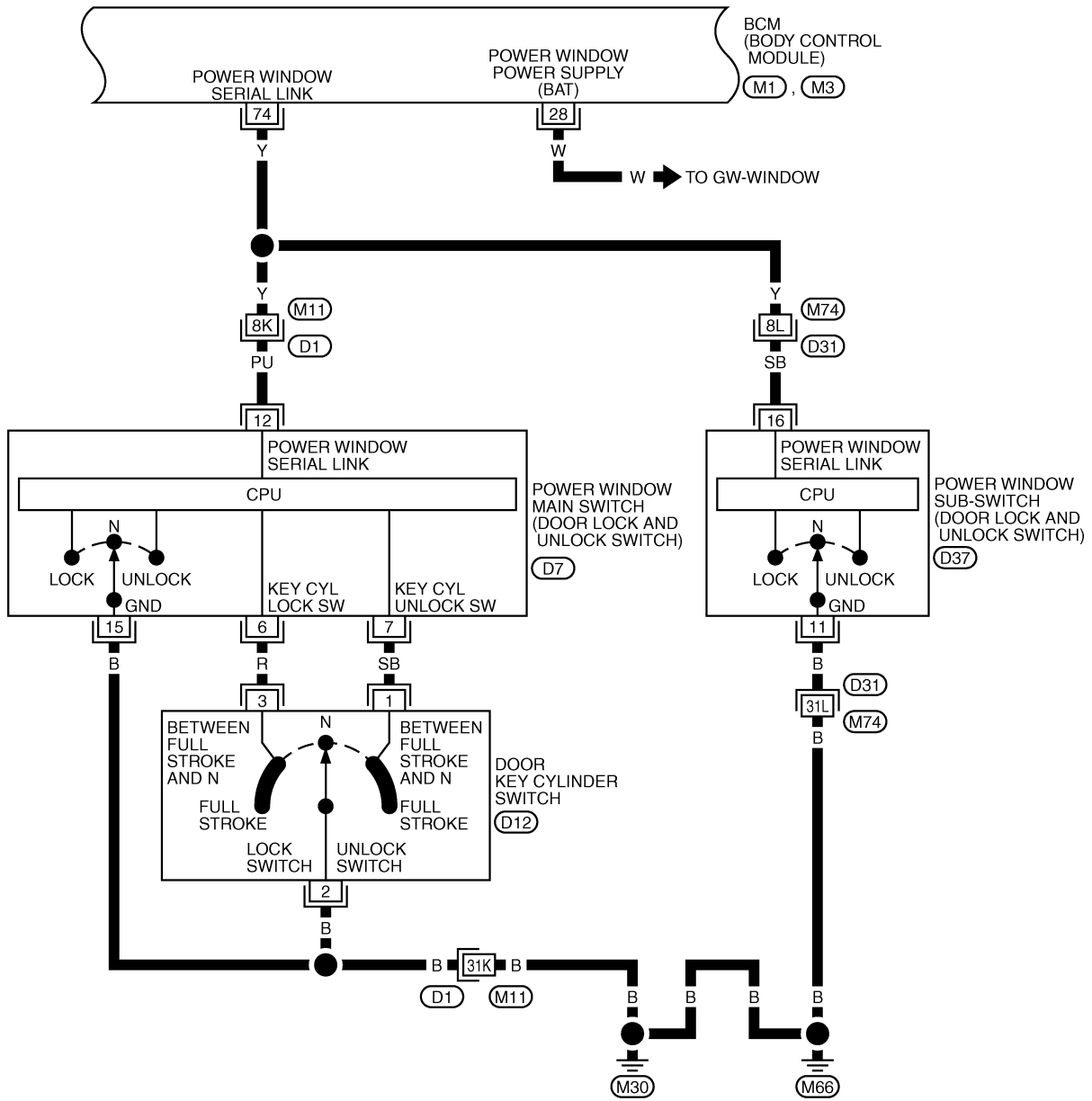

REFER TO THE FOLLOWING.

- (D1), (D31) -SUPER MULTIPLE JUNCTION (SMJ)
- (M1), (M3) -ELECTRICAL UNITS

TIWT0269E

POWER DOOR LOCK SYSTEM

FIG. 4

BL-D/LOCK-04

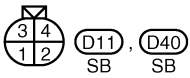
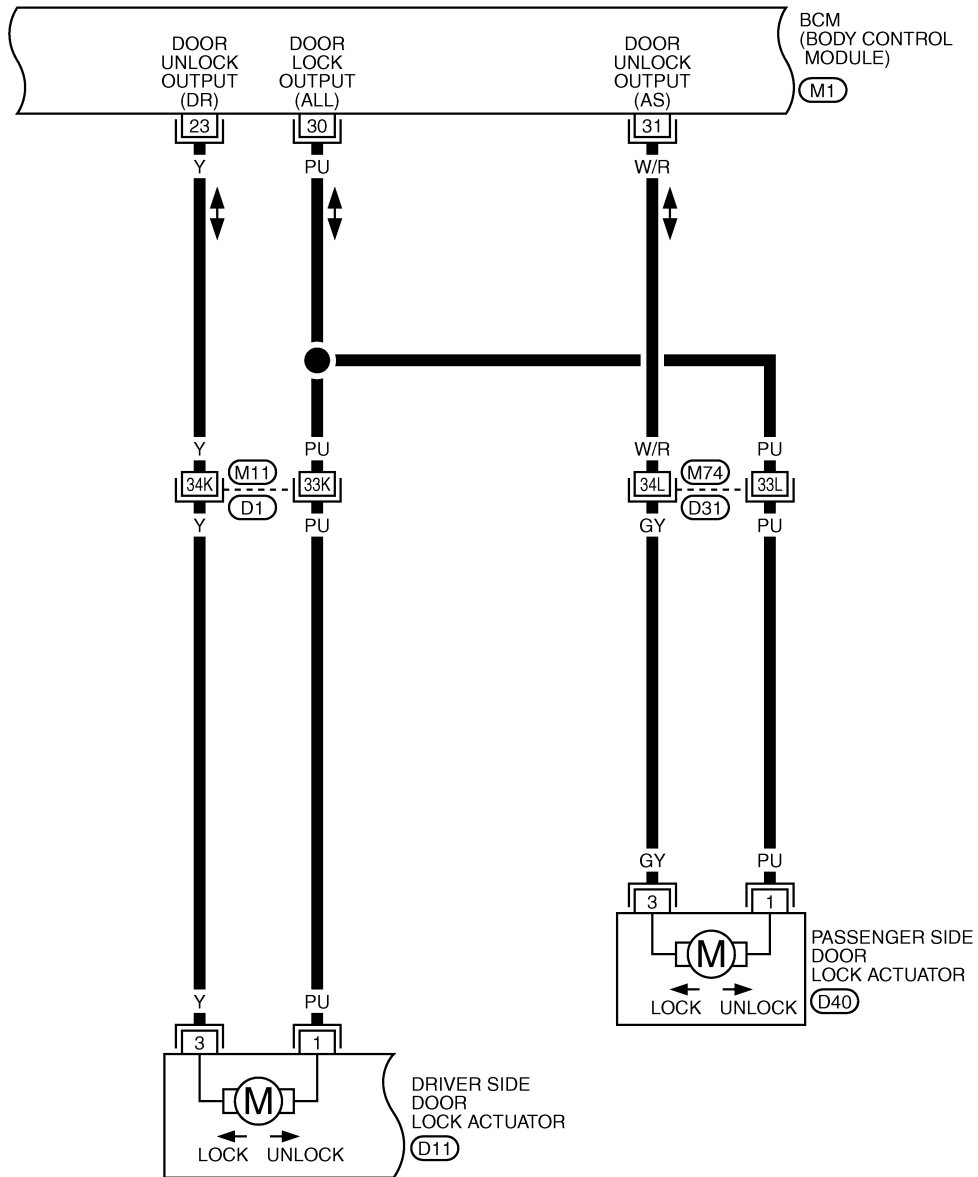

REFER TO THE FOLLOWING.
 (D1) , (D31) -SUPER MULTIPLE JUNCTION (SMJ)
 (M1) -ELECTRICAL UNITS

TIWT0627E

POWER DOOR LOCK SYSTEM

FIG. 5

BL-D/LOCK-05

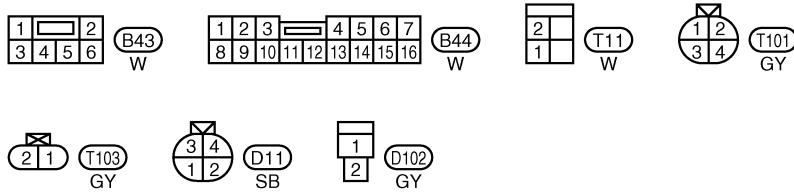
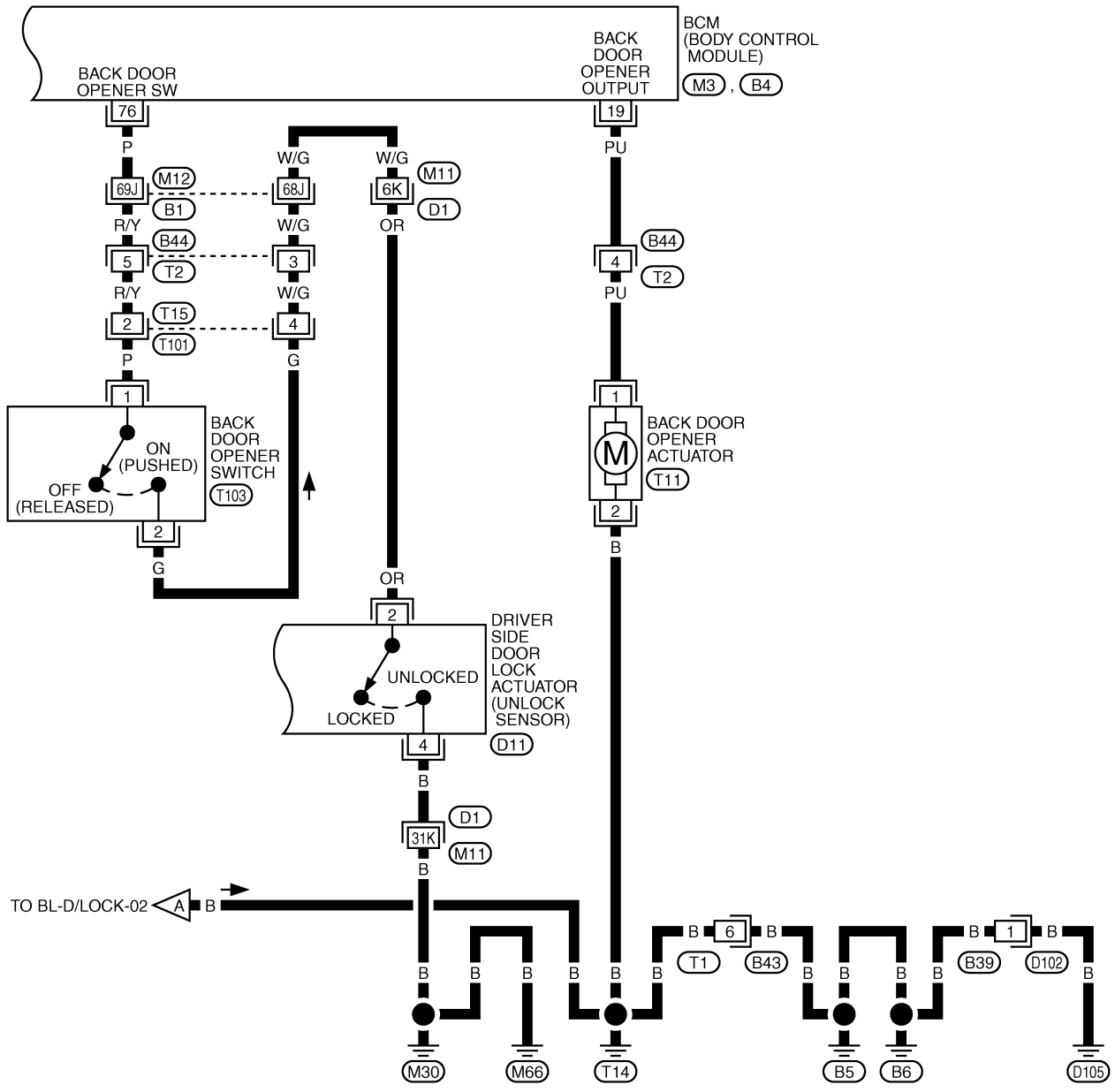

REFER TO THE FOLLOWING.
 (B1), (D1) -SUPER MULTIPLE JUNCTION (SMJ)
 (M3), (B4) -ELECTRICAL UNITS

TIWT0628E

POWER DOOR LOCK SYSTEM

Wiring Diagram —D/LOCK— /For Roadster
FIG. 1

AIS004DI

BL-D/LOCK-06

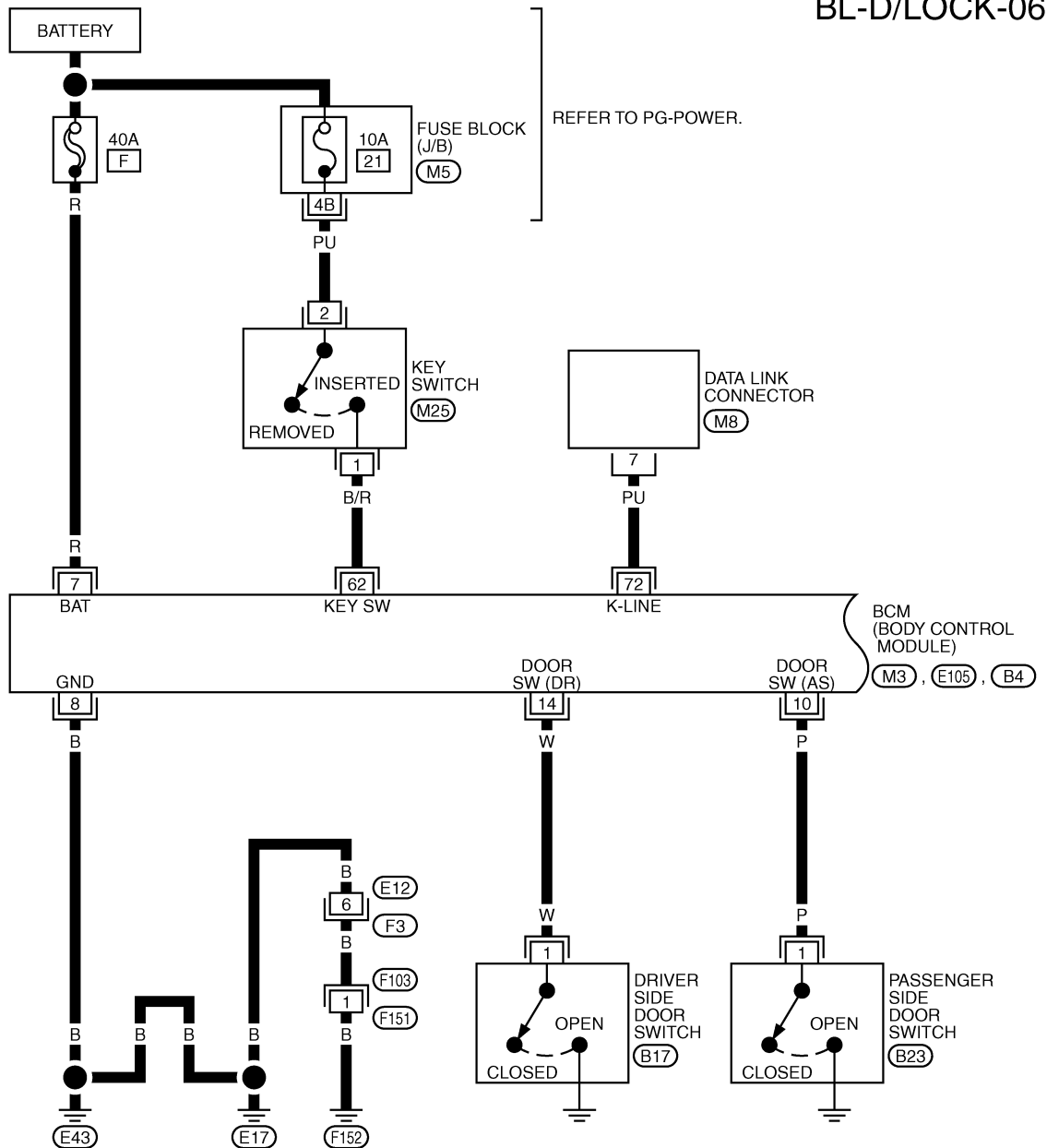

A
B
C
D
E
F
G
H
BL
J
K
L
M

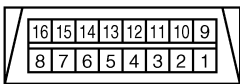

(M8)
W

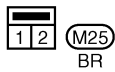

(M25)
BR

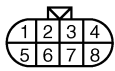

(F3)
B

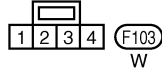

(F103)
W



(B17)
W

(B23)
W

REFER TO THE FOLLOWING.

(M5) - FUSE BLOCK-JUNCTION BOX (J/B)

(M3), (E105), (B4)

- ELECTRICAL UNITS

TIWT0737E

POWER DOOR LOCK SYSTEM

FIG. 2

BL-D/LOCK-07

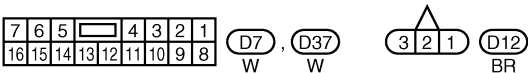
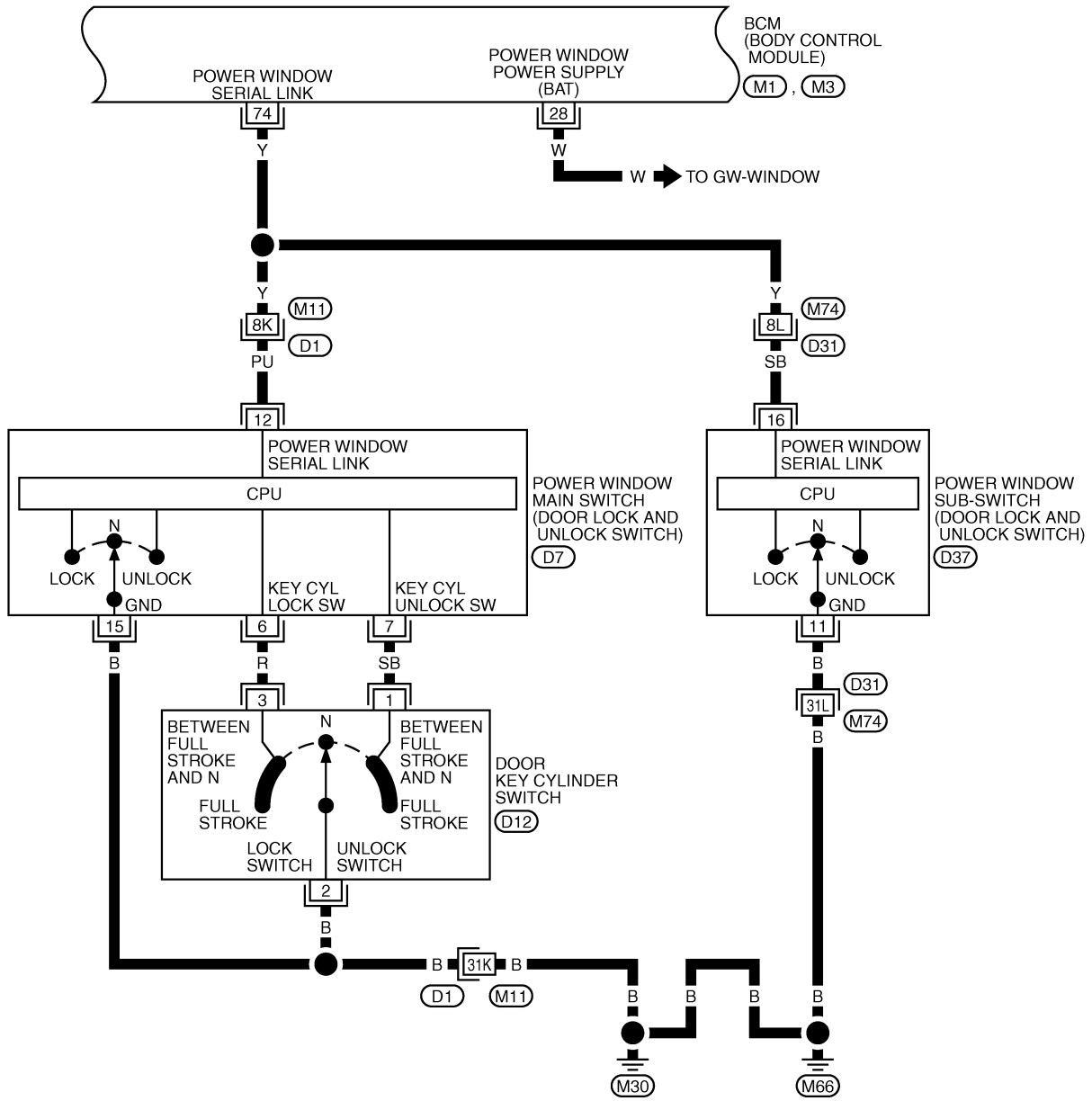

REFER TO THE FOLLOWING.
 (D1), (D31) -SUPER MULTIPLE JUNCTION (SMJ)
 (M1), (M3) -ELECTRICAL UNITS

POWER DOOR LOCK SYSTEM

FIG. 3

BL-D/LOCK-08

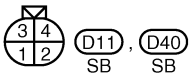
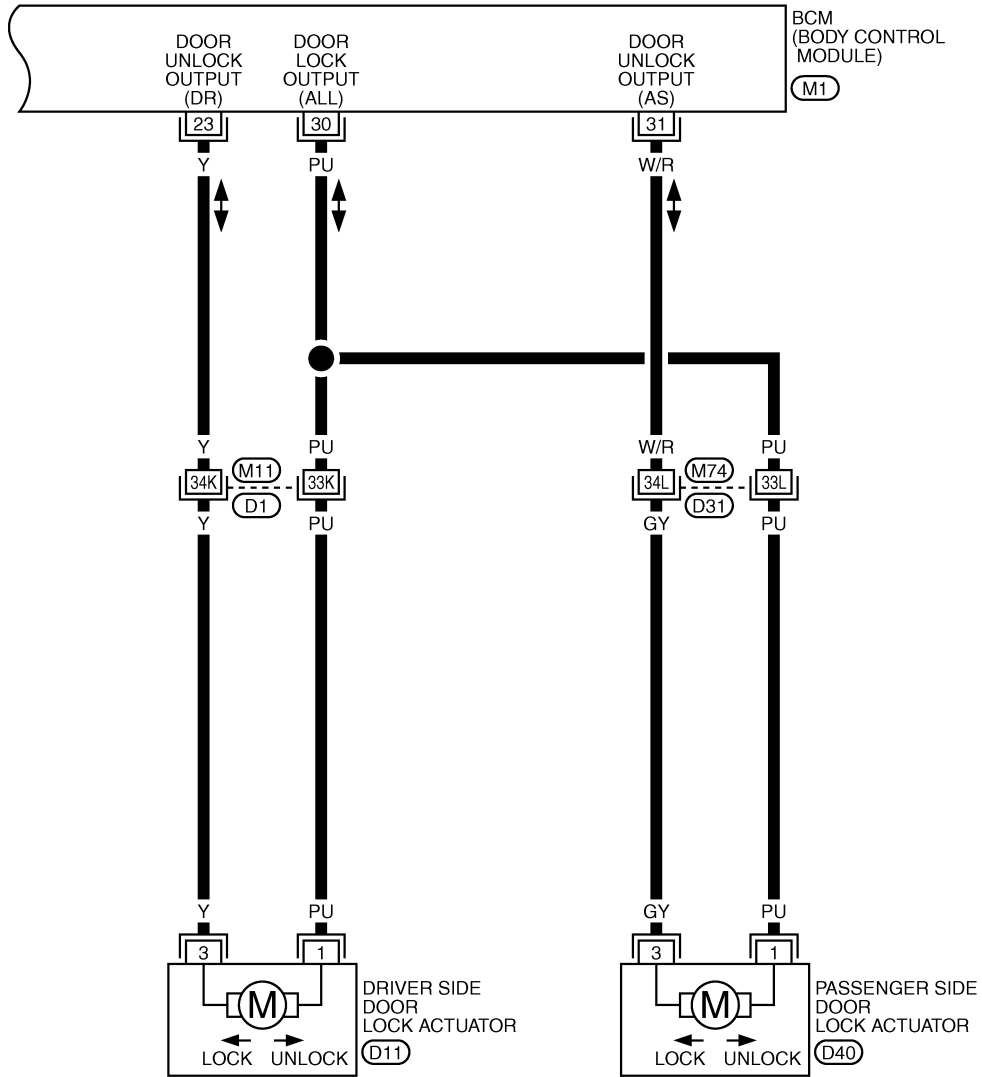

REFER TO THE FOLLOWING.
 (D1), (D31) -SUPER MULTIPLE JUNCTION (SMJ)
 (M1) -ELECTRICAL UNITS

TIWT0739E

POWER DOOR LOCK SYSTEM

Terminals and Reference Value for BCM

AIS004D3

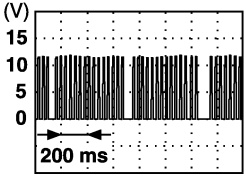
Terminal	Wire color	Item	Condition	Voltage (V) (Approx.)
7	R	Power source (Fusible link)	—	Battery voltage
8	B	Ground	—	0
10	P	Passenger side door switch	ON (Open) → OFF (Closed)	0 → 5
14	W	Driver side door switch	ON (Open) → OFF (Closed)	0 → 5
18	R/W	Back door switch	ON (Open) → OFF (Closed)	0 → Battery voltage *
19	PU	Back door opener output	Press the back door opener switch when driver side door is unlocked	0 → Battery voltage
23	Y	Driver side door lock actuator (unlock)	Door lock / unlock switch (Free → Unlock)	0 → Battery voltage
28	W	Battery power supply	—	Battery voltage
30	PU	All door lock actuator (lock)	Door lock / unlock switch (Free → Lock)	0 → Battery voltage
31	W/R	Passenger side door lock actuator (unlock)	Door lock / unlock switch (Free → Unlock)	0 → Battery voltage
62	B/R	Ignition key switch (insert)	ON (Key inserted) → OFF (Key removed from IGN key cylinder)	Battery voltage → 0
72	PU	Data link connector	—	—
74	Y	Power window switch serial link	—	 PIIA2344J
76	P	Back door opener switch	Press the back door opener switch when driver side door is unlocked	5 → 0

*When interior lamp battery saver control is in OFF: Approx. 5V

Terminal and Reference Value for Power Window Main Switch

AIS004D4

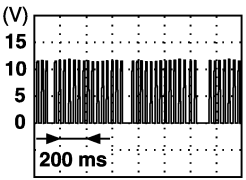
Terminal	Wire color	Item	Condition	Voltage (V) (Approx.)
6	R	Key cylinder switch lock signal	Key position (Neutral → Locked)	5 → 0
7	SB	Key cylinder switch unlock signal	Key position (Neutral → Unlocked)	5 → 0
12	PU	Power window switch serial link	—	 PIIA2344J
15	B	Ground	—	0

POWER DOOR LOCK SYSTEM

Work Flow

AIS004D5

1. Check the symptom and customer's requests.
2. Understand the outline of system. Refer to [BL-23, "System Description"](#) .
3. Perform the preliminary check. Refer to [BL-35, "Preliminary Check"](#) .
4. Does power window system operate normally? If Yes GO TO 5, If No Refer to [GW-18, "POWER WINDOW SYSTEM"](#)
5. According to the trouble diagnosis chart, repair or replace the cause of the malfunction. Refer to [BL-39, "Trouble Diagnoses Symptom Chart"](#) .
6. Does power door lock system operate normally? If Yes, GO TO 7, If No, GO TO 5.
7. INSPECTION END.

Preliminary Check FUSE CHECK

AIS004D6

1. FUSE INSPECTION

1. Turn ignition switch OFF.
2. Check 40A fusible link (letter **F** , located in the fuse and fusible link box).

NOTE:

Refer to [BL-21, "Component Parts and Harness Connector Location"](#) .

OK or NG

OK >> GO TO 2

NG >> If fuse is blown, be sure to eliminate cause of malfunction before installing new fuse. Refer to [PG-4, "POWER SUPPLY ROUTING CIRCUIT"](#) .

2. CHECK POWER SUPPLY CIRCUIT

1. Disconnect BCM connector.
2. Check voltage between BCM connector E105 terminal 7 and ground.

7 (R) – Ground

Battery voltage should exist.

OK or NG

OK >> GO TO 3

NG >> Check BCM power supply circuit for open or short.

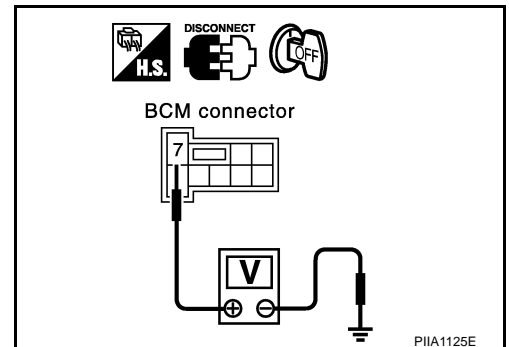

3. CHECK GROUND CIRCUIT

Check continuity between BCM connector E105 terminal 8 and ground.

8 (B) – Ground

Continuity should exist.

OK or NG

OK >> Power supply and ground circuit is OK.

NG >> Check BCM ground circuit for open or short.

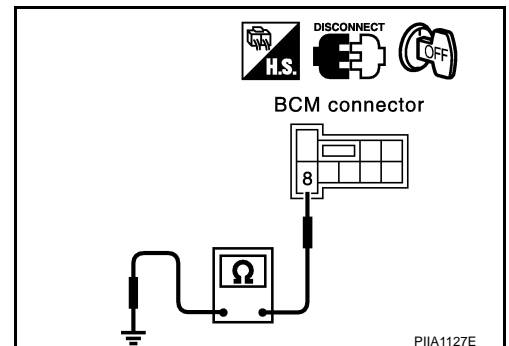

POWER DOOR LOCK SYSTEM

AIS004D7

CONSULT-II Function

Power door lock system check with data monitor and active test can be executed by combining data reception and command transmission via communication line from BCM.

BCM diagnosis part	Inspection item, self-diagnosis mode	Content
Door lock	Work support	Changes the setting for each function.
	Data monitor	Displays BCM input data on real-time basis.
	Active test	Sends drive signals to door lock actuator to perform operation check.

CONSULT-II BASIC OPERATION PROCEDURE

CAUTION:

If CONSULT-II is used with no connection of CONSULT-II CONVERTER, malfunctions might be detected in self-diagnosis, depending on control unit which carry out CAN communication.

1. Turn ignition switch "OFF".
2. Connect "CONSULT-II" and CONSULT-II CONVERTER to data link connector.

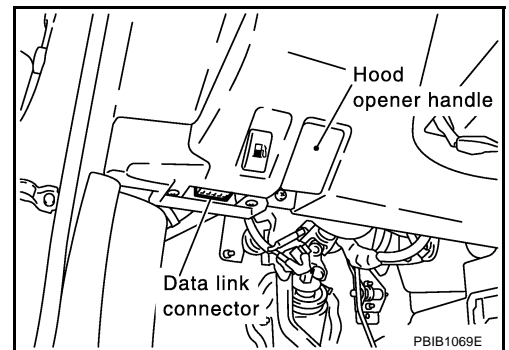

3. Turn ignition switch "ON".
4. Touch "START(NISSAN BASED VHCL)".

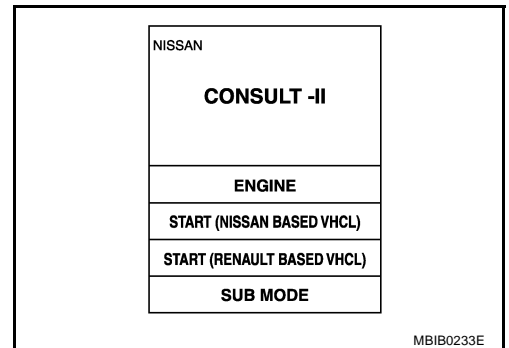

5. Touch "BCM".
If "BCM" is not indicated, go to [GI-39](#) , "CONSULT-II Date Link Connector (DLC) Circuit"

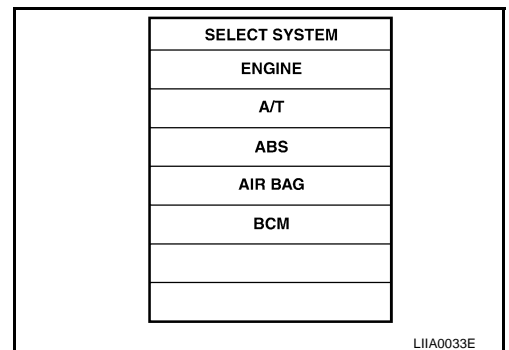

POWER DOOR LOCK SYSTEM

6. Touch "DOOR LOCK".

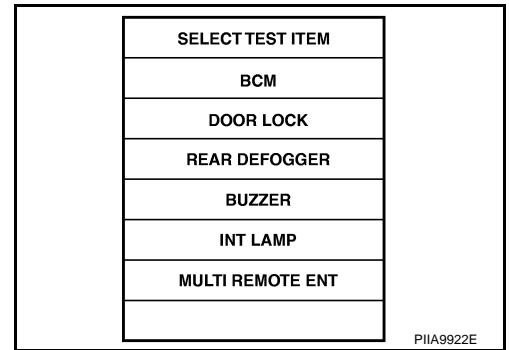

7. Select diagnosis mode. "WORK SUPPORT", "DATA MONITOR" and "ACTIVE TEST" are available.

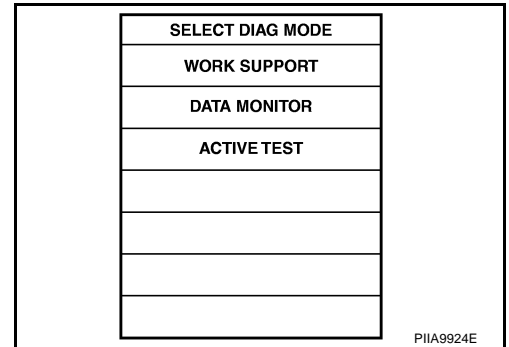

WORK SUPPORT

Work item	Description
DOOR LOCK-UNLOCK SET	Select unlock mode can be changed in this mode. Selects ON-OFF of select unlock mode.
ANTI-LOCK OUT SET	Key reminder door mode can be changed in this mode. Selects ON-OFF of key reminder door mode.

DATA MONITOR

Monitor item "operation"	Content
KEY ON SW	"ON/OFF" Indicates [ON/OFF] condition of key switch.
LOCK SW DR/AS	"ON/OFF" Indicates [ON/OFF] condition of lock signal from lock/unlock switch of driver and passenger side.
UNLK SW DR/AS	"ON/OFF" Indicates [ON/OFF] condition of unlock signal from lock/unlock switch of driver and passenger side.
KEY CYL LK-SW	"ON/OFF" Indicates [ON/OFF] condition of lock signal from key cylinder.
KEY CYL UN-SW	"ON/OFF" Indicates [ON/OFF] condition of unlock signal from key cylinder.
LK BUTTON/SIG	"ON/OFF" Indicates [ON/OFF] condition of lock signal from key fob.
UN BUTTON/SIG	"ON/OFF" Indicates [ON/OFF] condition of unlock signal from key fob.
IGN ON SW	"ON/OFF" Indicates [ON/OFF] condition of ignition switch.
DOOR SW-DR	"ON/OFF" Indicates [ON/OFF] condition of driver side door switch.
DOOR SW-AS	"ON/OFF" Indicates [ON/OFF] condition of passenger side door switch.
BACK DOOR SW*1	"ON/OFF" Indicates [ON/OFF] condition of back door switch.
TRNK OPN MNTR*2	"ON/OFF" Indicates [ON/OFF] condition of trunk lid opener switch.

*1: For Coupe

*2: For Roadster

ACTIVE TEST

Test item	Content
ALL D/LK MTR	This test is able to check all door lock actuators lock operation. These actuators lock when "ON" on CONSULT-II screen is touched.

POWER DOOR LOCK SYSTEM

Test item	Content
DR D/UN MTR	This test is able to check driver side door lock actuator unlock operation. This actuator unlock when "ON" on CONSULT-II screen is touched.
NON DR D/UN	This test is able to check door lock actuators (except driver side door lock actuator) unlock operation. These actuator unlock when "ON" on CONSULT-II screen is touched.

POWER DOOR LOCK SYSTEM

Trouble Diagnoses Symptom Chart

AI5004DB

Symptom	Diagnoses service procedure	Refer to page
Key reminder door system does not operate properly.	1. Preliminary check.	BL-35
	2. Key switch (Insert) check.	BL-41
	3. Door switch check.	BL-40
	4. Replace BCM.	BCS-17
Power door lock does not operate by door lock and unlock switch on power window main switch or power window sub-switch.	1. Preliminary check.	BL-35
	2. Door lock and unlock switch check.	BL-43
	3. Driver side door lock actuator check.	BL-46
	4. Passenger side door lock actuator check.	BL-48
	5. Replace BCM	BCS-17
Driver side door lock actuator does not operate.	1. Preliminary check.	BL-35
	2. Driver side door lock actuator check.	BL-46
Passenger side door lock actuator does not operate.	1. Preliminary check.	BL-35
	2. Passenger side door lock actuator check.	BL-48
Power door lock does not operate by door key cylinder operation, but operates by door lock and unlock switch.	1. Preliminary check.	BL-35
	2. Door key cylinder switch check.	BL-50
	3. Replace power window main switch.	EI-32
Back door opener does not operate.	1. Preliminary check.	BL-35
	2. Back door opener switch check.	BL-52
	3. Back door opener actuator check.	BL-53

A
B
C
D
E
F
G
H

BL

J
K
L
M

POWER DOOR LOCK SYSTEM

AIS004D9

Door Switch Check

1. CHECK DOOR SWITCH INPUT SIGNAL

With CONSULT-II

Check door switches ("DOOR SW-AS" and "DOOR SW-DR") in "DATA MONITOR" mode with CONSULT-II.

Monitor item	Condition
DOOR SW-DR	OPEN : ON
	CLOSE : OFF
DOOR SW-AS	OPEN : ON
	CLOSE : OFF

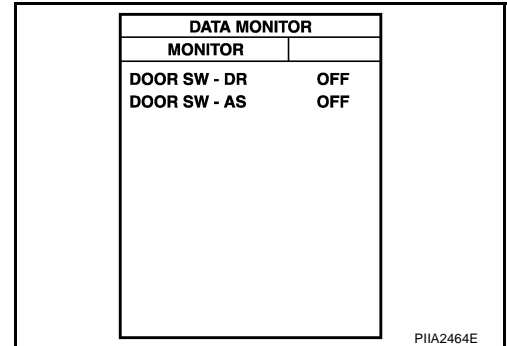

Without CONSULT-II

Check voltage between BCM connector and ground.

Item	Con- nector	Terminals		Condition	Voltage (V) (Approx.)
		(+) Terminal (Wire color)	(-)		
Passenger side door switch	B4	10 (P)	Ground	OPEN	0
				CLOSE	5
Driver side door switch		14 (W)	Ground	OPEN	0
				CLOSE	5

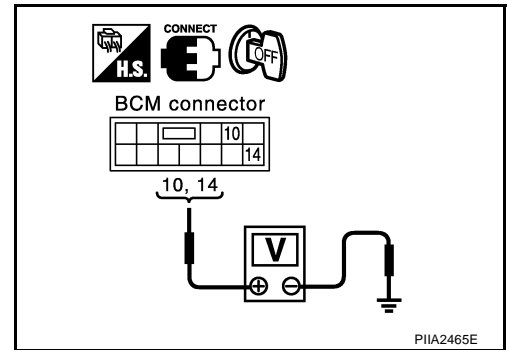

OK or NG

OK >> Door switch is OK.

NG >> GO TO 2.

2. CHECK DOOR SWITCH

- Turn ignition switch OFF.
- Disconnect door switch and BCM connector.
- Check continuity between door switch connector B17, B23, terminals 1 and BCM connector B4 terminals 10, 14.

Driver side door switch – BCM

1 (W) – 14 (W) :Continuity should exist.

Passenger door switch – BCM

1 (P) – 10 (P) :Continuity should exist.

- Check continuity between door switch harness connector B17, B23, terminals 1 and ground.

1 (W or R) – Ground :Continuity should not exist.

OK or NG

OK >> GO TO 3.

NG >> Repair or replace harness.

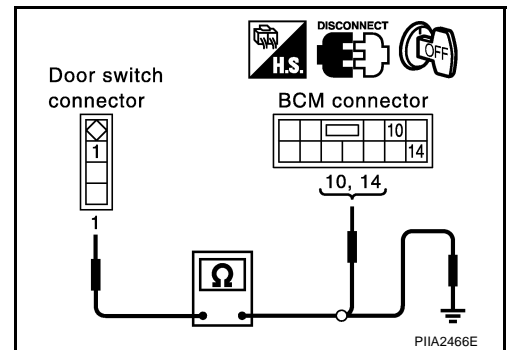

POWER DOOR LOCK SYSTEM

3. CHECK DOOR SWITCH

Check continuity between door switch connector B17 (driver side) or B23 (passenger side) terminal 1 (R/W) and ground.

Terminal		Door switch	Continuity
1	Ground	Pushed	No
		Released	Yes

OK or NG

- OK >> Further inspection is necessary. Refer to symptom chart.
- NG >> Replace malfunction door switch.

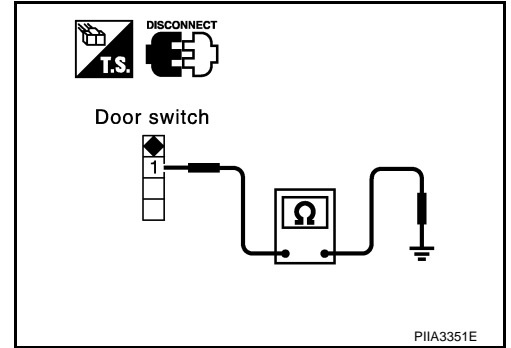

Key Switch (insert) Check

1. CHECK KEY SWITCH INPUT SIGNAL

With CONSULT-II

Check ignition key cylinder switch "KEY ON SW" in "DATE MONITOR" mode with CONSULT-II

- When key is inserted in ignition key cylinder
KEY ON SW :ON
- When key is removed in ignition key cylinder
KEY ON SW :OFF

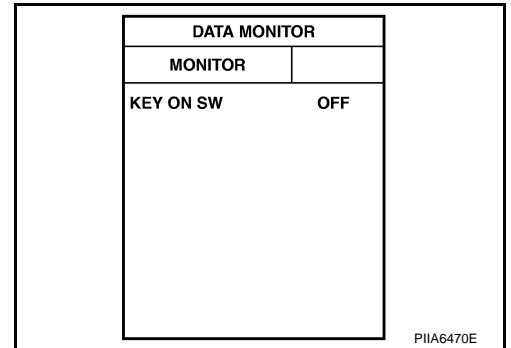

Without CONSULT-II

Check voltage between BCM connector and ground.

Terminals		Condition	Voltage (V) (Approx.)
(+)	(-)		
Connector	Terminal (Wire color)	Ground	Key is inserted Battery voltage
M3	62 (B/R)		

OK or NG

- OK >> Key switch is OK.
- NG >> GO TO 2.

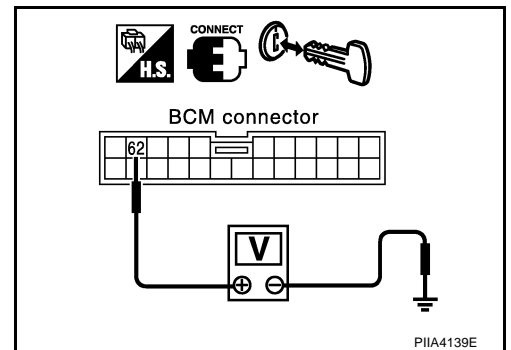

POWER DOOR LOCK SYSTEM

2. CHECK KEY SWITCH (INSERT)

1. Turn ignition switch OFF.
2. Disconnect key switch connector.
3. Check continuity between key switch terminals 1 and 2.

Terminals		Condition	Continuity
1	2	Key is inserted in ignition key cylinder	Yes
		Key is removed from ignition key cylinder	No

OK or NG

OK >> Check the following.

- 10A fuse [No. 21, located in fuse block (J/B)]
- Harness for open or short between key switch and fuse
- Harness for open or short between BCM and key switch

NG >> Replace key switch.

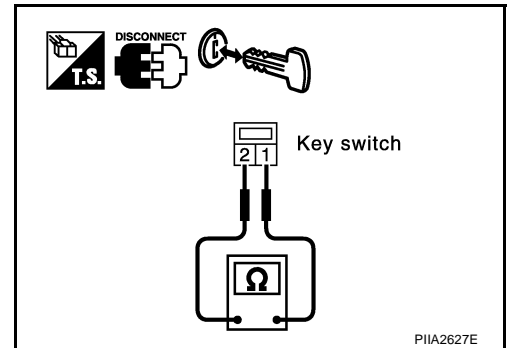

POWER DOOR LOCK SYSTEM

AIS004DB

Door Lock and Unlock Switch Check

1. CHECK POWER WINDOW OPERATION

Does power window system operate normally?

YES or NO?

YES >> GO TO 2

NO >> Refer to [GW-33, "Trouble Diagnoses Symptom Chart"](#) .

2. CHECK DOOR LOCK AND UNLOCK SWITCH OUTPUT SIGNAL

With CONSULT-II

Check door lock and unlock switch ("LOCK SW DR/AS", "UNLK SW DR/AS") in DATA MONITOR mode with CONSULT-II. Refer to [BL-37, "DATA MONITOR"](#) .

- When door lock and unlock switch is turned to LOCK

LOCK SW DR/AS :ON

- When door lock and unlock switch is turned to UNLOCK

UNLK SW DR/AS :ON

DATA MONITOR	
MONITOR	
LOCK SW DR/AS	OFF
UNLK SW DR/AS	OFF

LIIA0172E

Without CONSULT-II

- Remove key from ignition switch, and close the doors of driver side and passenger side.
- Check the signal between BCM connector and ground with oscilloscope when door lock and unlock switch (driver side and passenger side) is turned "LOCK" or "UNLOCK".
- Make sure signals which are shown in the figure below can be detected during 10 second just after door lock and unlock switch (driver side or passenger side) is turned "LOCK" or "UNLOCK".

Terminals		Signal
(+)	(-)	
Connector	Terminal (Wire color)	<p>PIIA1297E</p>
M3	74 (Y)	
		Ground

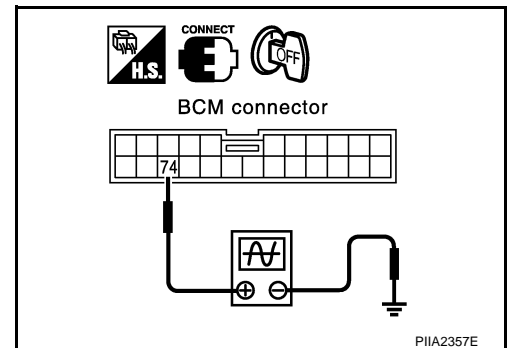

OK or NG

OK >> GO TO 3.

NG >> GO TO 4.

POWER DOOR LOCK SYSTEM

3. CHECK BCM OUTPUT SIGNAL

Check power window serial link ("POWER WINDOW DOWN") in "ACTIVE TEST" mode with CONSULT-II. Refer to [BL-79, "Active Test"](#).

When "ACTIVE TEST" is executed, the window of driver side and passenger side are go down.

OK or NG

- OK >> Further inspection is necessary. Refer to symptom chart.
- NG >> Replace BCM.

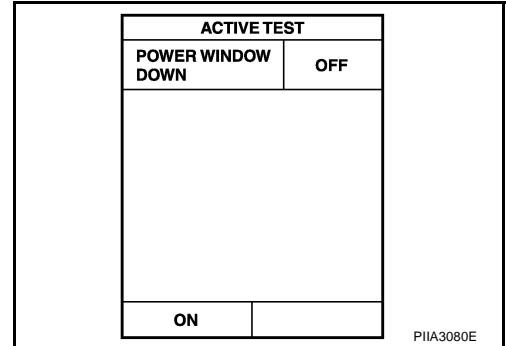

4. CHECK DOOR LOCK AND UNLOCK SWITCH GROUND HARNESS

1. Turn ignition switch OFF.
2. Disconnect power window main switch (door lock and unlock switch) and power window sub-switch (door lock and unlock switch) connector.
3. Check continuity between power window main switch (door lock and unlock switch) connector D7 terminal 15 and ground.

15 (B) – Ground

:Continuity should exist.

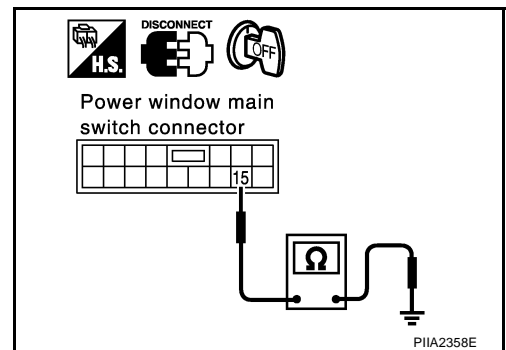

4. Check continuity between power window sub-switch (door lock and unlock switch) connector D37 terminal 11 and ground.

11 (B) – Ground

:Continuity should exist.

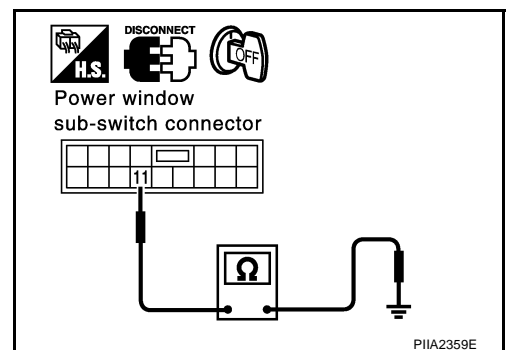

OK or NG

- OK >> GO TO 5.
- NG >> Repair or replace harness.

POWER DOOR LOCK SYSTEM

5. CHECK POWER WINDOW SERIAL LINK CIRCUIT

1. Disconnect BCM connector.
2. Check continuity between BCM connector M3 terminal 74 and power window main switch (door lock and unlock switch) connector D7 terminal 12.

74 (Y) – 12 (PU)

:Continuity should exist.

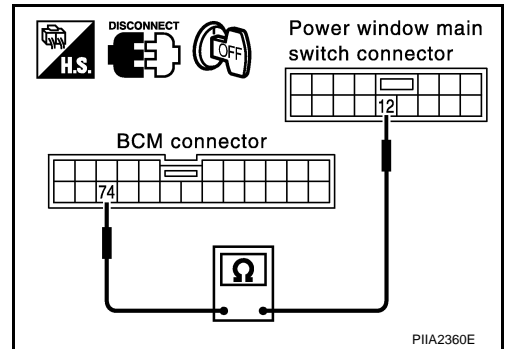

3. Check continuity between BCM connector M3 terminal 74 and power window sub-switch (door lock and unlock switch) connector D37 terminal 16.

74 (Y) – 16 (SB)

:Continuity should exist.

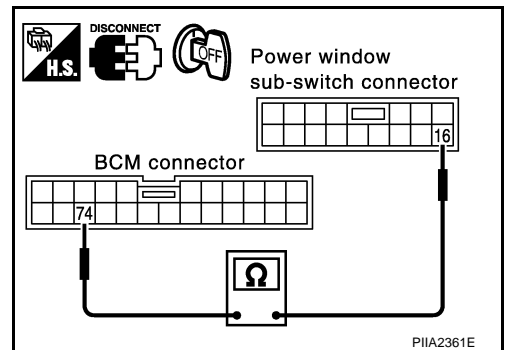

OK or NG

- OK >> Replace power window main switch.
- NG >> Repair or replace harness.

POWER DOOR LOCK SYSTEM

AIS004DC

Driver Side Door Lock Actuator Check

1. CHECK DOOR LOCK ACTUATOR SIGNAL

1. Turn ignition switch OFF.
2. Disconnect driver side door lock actuator connector.
3. Check voltage between driver side door lock actuator connector and ground.

Terminals		Condition	Voltage (V) (Approx.)
(+)	(-)		
Connector	Terminal (Wire color)	Ground	
D11	1 (PU)		
	3 (Y)	Driver door lock/unlock switch is turned to UNLOCK.	0 → Battery voltage

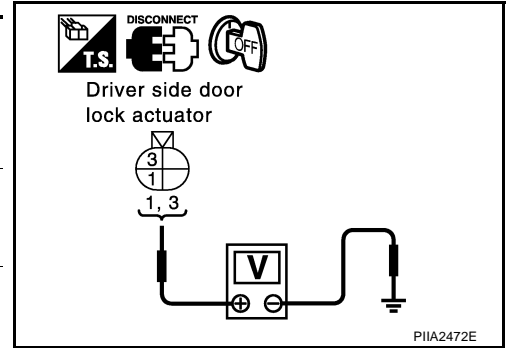

OK or NG

- OK >> Replace driver side door lock actuator.
 NG >> GO TO 2.

2. CHECK DOOR LOCK ACTUATOR HARNESS

1. Disconnect BCM connector.
2. Check continuity between BCM connector M1 terminals 23, 30 and driver side door lock actuator connector D11 terminals 1, 3 and ground.

BCM – Driver side door lock actuator

23 (Y) – 3 (Y) :Continuity should exist.

30 (PU) – 1 (PU) :Continuity should exist.

BCM – Ground

23 (Y) – Ground :Continuity should not exist.

30 (PU) – Ground :Continuity should not exist.

OK or NG

- OK >> GO TO 3.
 NG >> Repair or replace harness between BCM and driver side door lock actuator.

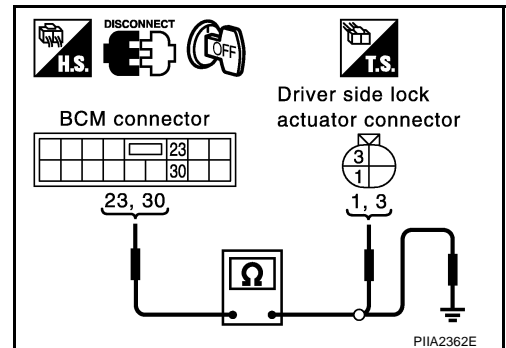

POWER DOOR LOCK SYSTEM

3. CHECK OUTPUT SIGNAL

1. Connect BCM connector.
2. Check voltage between BCM connector and ground.

Terminals		Condition	Voltage (V) (Approx.)
(+)	(-)		
Connector	Terminal (Wire color)	Ground	
M1	23 (Y)		
	30 (PU)	Driver door lock/unlock switch is turned to LOCK.	0 → Battery voltage

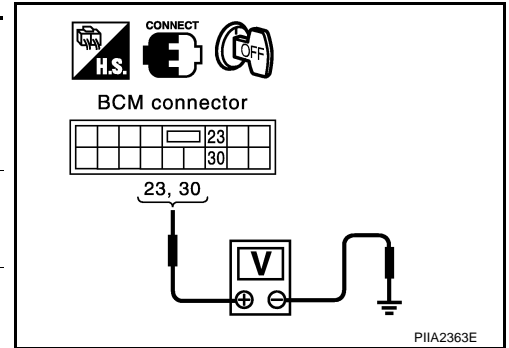

OK or NG

- OK >> Check the condition of the harness and the connector.
 NG >> GO TO 4.

4. CHECK BCM

Check continuity between BCM connector E105 terminal 8 and connector M1 terminals 23, 30.

- 8 (B) – 23 (Y) :Continuity should exist.**
8 (B) – 30 (PU) :Continuity should exist.

OK or NG

- OK >> Check the condition of the harness and the connector.
 NG >> Replace BCM.

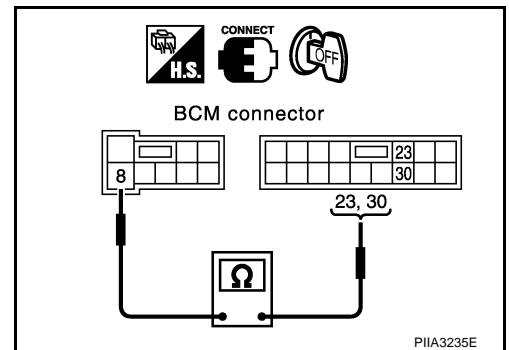

POWER DOOR LOCK SYSTEM

AI5004DD

Passenger Side Door Lock Actuator Check

1. CHECK DOOR LOCK ACTUATOR SIGNAL

1. Turn ignition switch OFF.
2. Disconnect passenger side door lock actuator connector.
3. Check voltage between passenger side door lock actuator connector and ground.

Terminals		Condition	Voltage (V) (Approx.)
(+)	(-)		
D40	1 (PU)	Ground	Driver door lock/unlock switch is turned to LOCK. 0 → Battery voltage
	3 (GY)		Driver door lock/unlock switch is turned to UNLOCK. 0 → Battery voltage

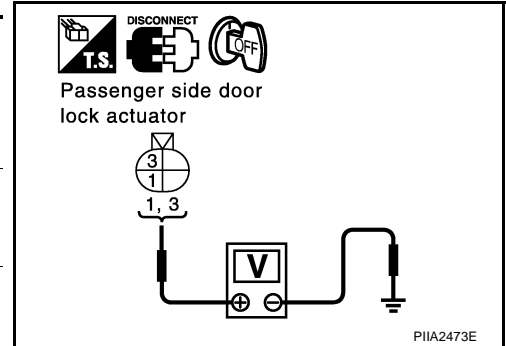

OK or NG

- OK >> Replace passenger side door lock actuator.
 NG >> GO TO 2.

2. CHECK DOOR LOCK ACTUATOR HARNESS

1. Disconnect BCM connector.
2. Check continuity between BCM connector M1 terminals 30, 31 and passenger side door lock actuator connector D40 terminals 1, 3 and ground.

BCM – Passenger side door lock actuator

30 (PU) – 1 (PU) :Continuity should exist.

31 (W/R) – 3 (GY) :Continuity should exist.

BCM – Ground

30 (PU) – Ground :Continuity should not exist.

31 (W/R) – Ground :Continuity should not exist.

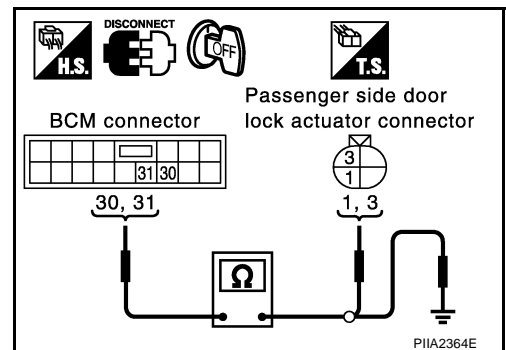

OK or NG

- OK >> GO TO 3.
 NG >> Repair or replace harness between BCM and passenger side door lock actuator.

POWER DOOR LOCK SYSTEM

3. CHECK OUTPUT SIGNAL

1. Connect BCM harness connector.
2. Check voltage between BCM connector and ground.

Terminals		Condition	Voltage (V) (Approx.)
(+)	(-)		
Connector	Terminal (Wire color)	Ground	
M1	30 (PU)		
	31 (W/R)	Driver door lock/unlock switch is turned to UNLOCK.	0 → Battery voltage

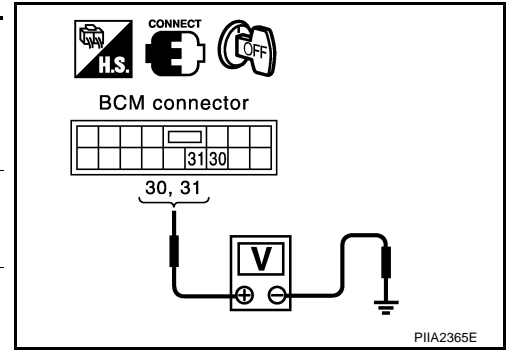

OK or NG

- OK >> Check the condition of the harness and the connector.
 NG >> GO TO 4.

4. CHECK BCM

Check continuity between BCM connector E105 terminal 8 and connector M1 terminals 30, 31.

- 8 (B) – 30 (PU) :Continuity should exist.**
8 (B) – 31 (W/R) :Continuity should exist.

OK or NG

- OK >> Check the condition of the harness and the connector.
 NG >> Replace BCM.

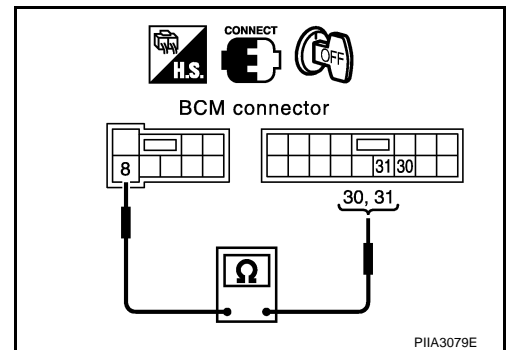

POWER DOOR LOCK SYSTEM

AIS004DE

Door Key Cylinder Switch Check

1. CHECK DOOR KEY CYLINDER SWITCH INPUT SIGNAL

With CONSULT-II

- Check door key cylinder switch ("KEY CYL LK SW") in "DATA MONITOR" mode with CONSULT-II.

"KEY CYL LK-SW" should be "ON" when key inserted in door key cylinder is turned to lock.

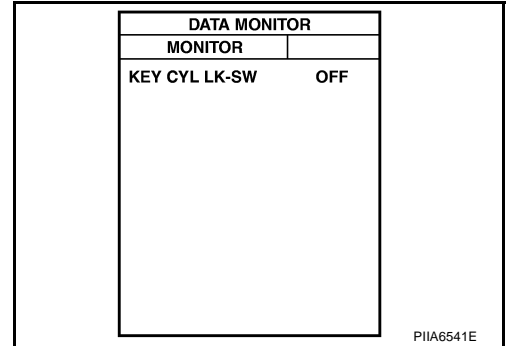

PIIA6541E

- Check door key cylinder switch ("KEY CYL UN-SW") in "DATA MONITOR" mode with CONSULT-II.

"KEY CYL UN-SW" should be "ON" when key inserted in door key cylinder is turned to unlock.

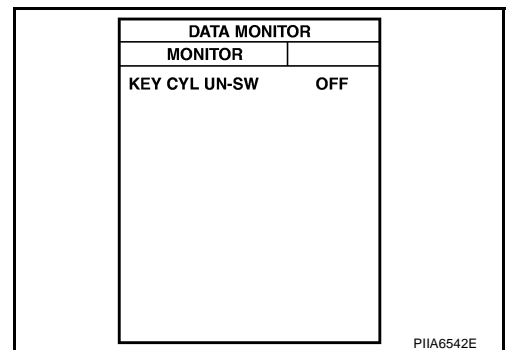

PIIA6542E

Without CONSULT-II

Check voltage between power window main switch (door lock and unlock switch) connector and ground.

Terminals		Key position	Voltage (V) (Approx.)
(+)	(-)		
D7	6 (R)	Neutral/Unlock	5
		Lock	0
	7 (SB)	Neutral/Lock	5
		Unlock	0

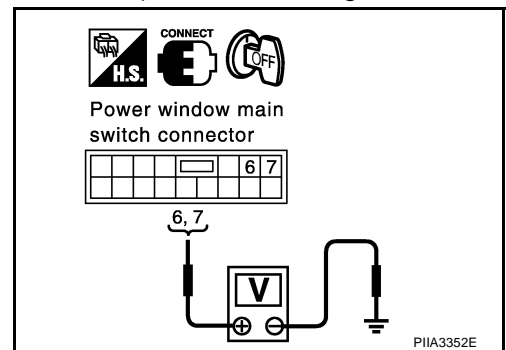

PIIA3352E

OK or NG

- OK >> Further inspection is necessary. Refer to symptom chart.
- NG >> GO TO 2.

POWER DOOR LOCK SYSTEM

2. CHECK DOOR KEY CYLINDER SWITCH CIRCUIT

1. Turn ignition switch OFF.
2. Disconnect power window main switch (door lock and unlock switch) and door key cylinder switch connector.
3. Check continuity between power window main switch (door lock and unlock switch) connector D7 terminals 6, 7 and door key cylinder switch connector D12 terminals 1, 3.

6 (R) – 3 (R) :Continuity should exist.
7 (SB) – 1 (SB) :Continuity should exist.

OK or NG

- OK >> GO TO 3.
 NG >> Repair or replace harness between power window main switch and door key cylinder switch.

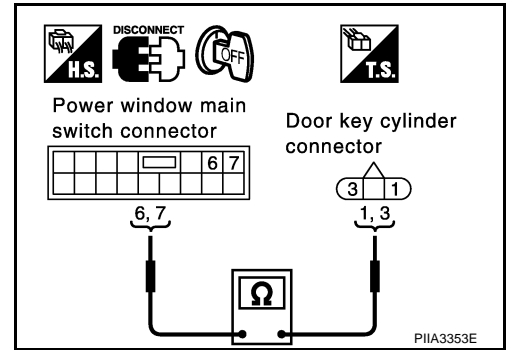

3. CHECK DOOR KEY CYLINDER SWITCH GROUND CHECK

Check continuity between door key cylinder switch connector D12 terminal 2 and ground.

2 (B) – Ground :Continuity should exist.

OK or NG

- OK >> GO TO 4.
 NG >> Repair or replace harness.

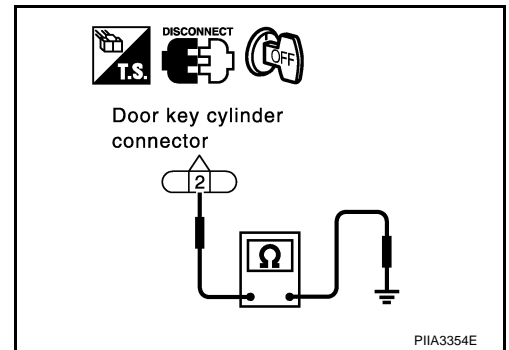

4. CHECK DOOR KEY CYLINDER SWITCH

Check continuity between door key cylinder switch terminals 1, 3 and 2.

Terminals	Key position	Continuity
1	Neutral/Lock	No
	Unlock	Yes
3	Neutral/Unlock	No
	Lock	Yes

OK or NG

- OK >> Further inspection is necessary. Refer to symptom chart.
 NG >> Replace door key cylinder switch.

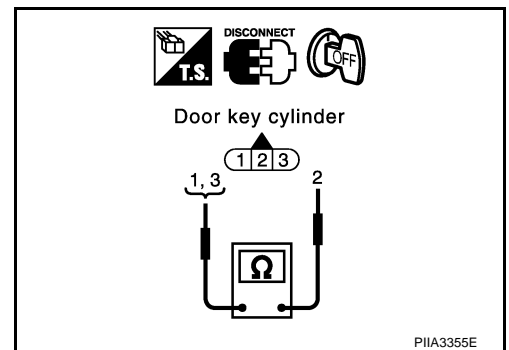

POWER DOOR LOCK SYSTEM

AIS004DF

Back Door Opener Switch Check

1. CHECK BACK DOOR OPENER SIGNAL

Check voltage between BCM connector and ground.
Press back door opener switch when driver side door is unlocked.

Terminals		Condition	Voltage (V) (Approx.)
(+)	(-)		
Connector	Terminal (Wire color)		
M3	76 (P)	Ground	
		Back door opener switch ON	0
		Back door opener switch OFF	Battery voltage*

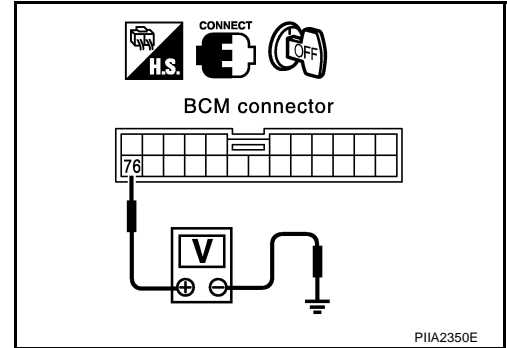

*: When interior lamp battery saver control is in OFF position. →Approx.5V

OK or NG

- OK >> GO TO 2.
- NG >> Replace BCM.

2. CHECK BACK DOOR OPENER SWITCH HARNESS

1. Turn ignition switch OFF.
2. Disconnect BCM and back door opener switch connector.
3. Check continuity between BCM connector M3 terminal 76 and back door opener switch connector T103 terminal 1.

76 (P) – 1 (P) :Continuity should exist.

OK or NG

- OK >> GO TO 3.
- NG >> Repair or replace harness between BCM and back door opener switch.

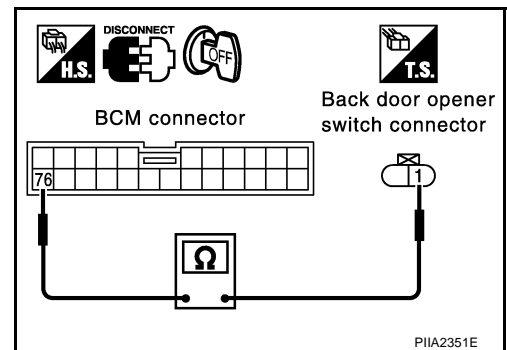

3. CHECK BACK DOOR OPENER SWITCH

Check continuity between back door opener switch terminals 1 and 2.

Terminals		Condition	Continuity
1	2	Back door opener switch: ON	Yes
		Back door opener switch: OFF	No

OK or NG

- OK >> GO TO 4.
- NG >> Replace back door opener switch.

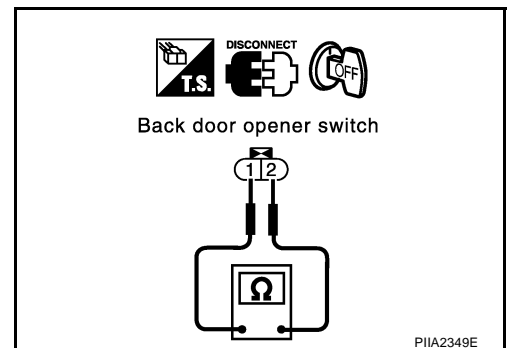

POWER DOOR LOCK SYSTEM

4. CHECK DOOR LOCK ACTUATOR HARNESS

1. Disconnect driver side door lock actuator connector.
2. Check continuity between back door opener switch connector T103 terminal 2 and driver side door lock actuator connector D11 terminal 2.

2 (G) – 2 (OR) :Continuity should exist.

OK or NG

OK >> GO TO 5.

NG >> Repair or replace harness between back door opener switch and driver side door lock actuator.

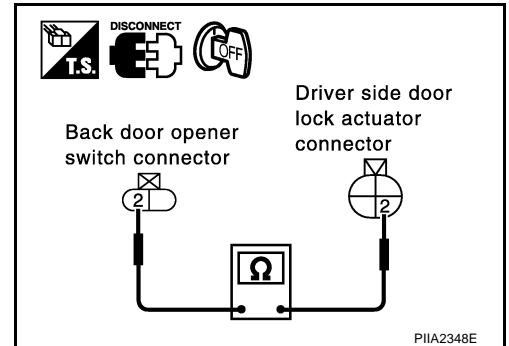

5. CHECK DOOR LOCK ACTUATOR GROUND HARNESS

Check continuity between driver side door lock actuator connector D11 terminal 4 and ground.

4 (B) – Ground :Continuity should exist.

OK or NG

OK >> Replace driver side door lock actuator.

NG >> Repair or replace harness.

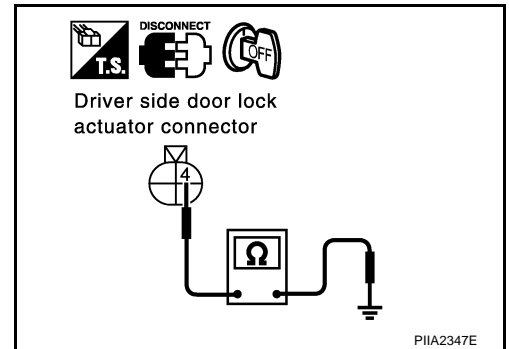

Back Door Opener Actuator Check

1. CHECK BACK DOOR OPENER ACTUATOR SIGNAL

Check voltage between BCM connector and ground.
Press the back door opener switch when driver side door is unlocked.

Terminals		Condition	Voltage (V) (Approx.)
(+)	(-)		
Connector	Terminal (Wire color)	Ground	Back door opener switch ON
B4	19 (PU)		Back door opener switch OFF
			Battery voltage
			0

OK or NG

OK >> GO TO 2.

NG >> Replace BCM.

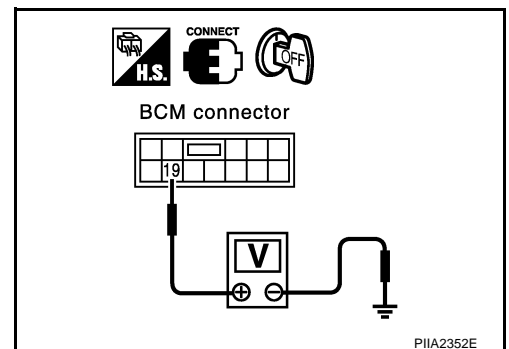

POWER DOOR LOCK SYSTEM

2. CHECK BACK DOOR OPENER ACTUATOR HARNESS

1. Turn ignition switch OFF.
2. Disconnect BCM and back door opener actuator connector.
3. Check continuity between BCM connector B4 terminal 19 and back door opener actuator connector T11 terminal 1.

19 (PU) – 1 (PU)

:Continuity should exist.

OK or NG

OK >> GO TO 3.

NG >> Repair or replace harness between BCM and back door opener actuator.

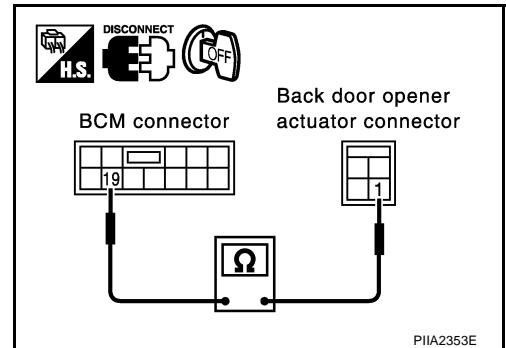

3. CHECK BACK DOOR OPENER ACTUATOR GROUND HARNESS

Check continuity between back door opener actuator connector T11 terminal 2 and ground.

2 (B) – Ground

:Continuity should exist.

OK or NG

OK >> Replace back door opener actuator.

NG >> Repair or replace.

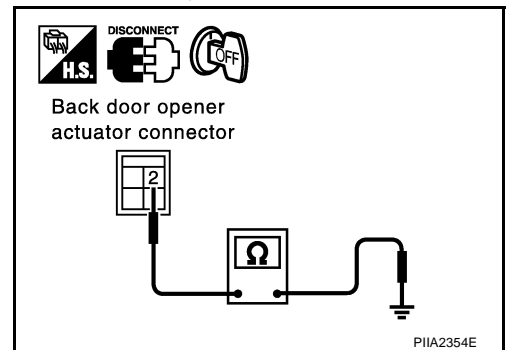

FUEL FILLER LID OPENER

FUEL FILLER LID OPENER

PFPP:78820

System Description/For Roadster

AIS00405

Power is supplied at all times

- through 40A fusible link (letter **F** , located in the fuse and fusible link box)
- to BCM terminal 7.

Ground is supplied

- to BCM terminal 8
- through body grounds E17, E43, and F152.

FUEL LID OPEN OPERATION

When fuel lid opener switch is ON (pushed), ground is supplied

- to BCM terminal 11
- through fuel lid opener switch terminals 1 and 2
- through body grounds M30 and M66.

And power is supplied

- to BCM terminal 20
- through fuel lid opener actuator terminals 1 and 2, and
- through body grounds B5, B6, and T14.

Then fuel lid opener actuator opens fuel lid.

FUEL LID OPENER CANCEL OPERATION

Fuel lid cannot open when vehicle condition is in arm or alarm phase.

A

B

C

D

E

F

G

H

BL

J

K

L

M

FUEL FILLER LID OPENER

Wiring Diagram —F/LID— /For Coupe

AIS00109

BL-F/LID-01

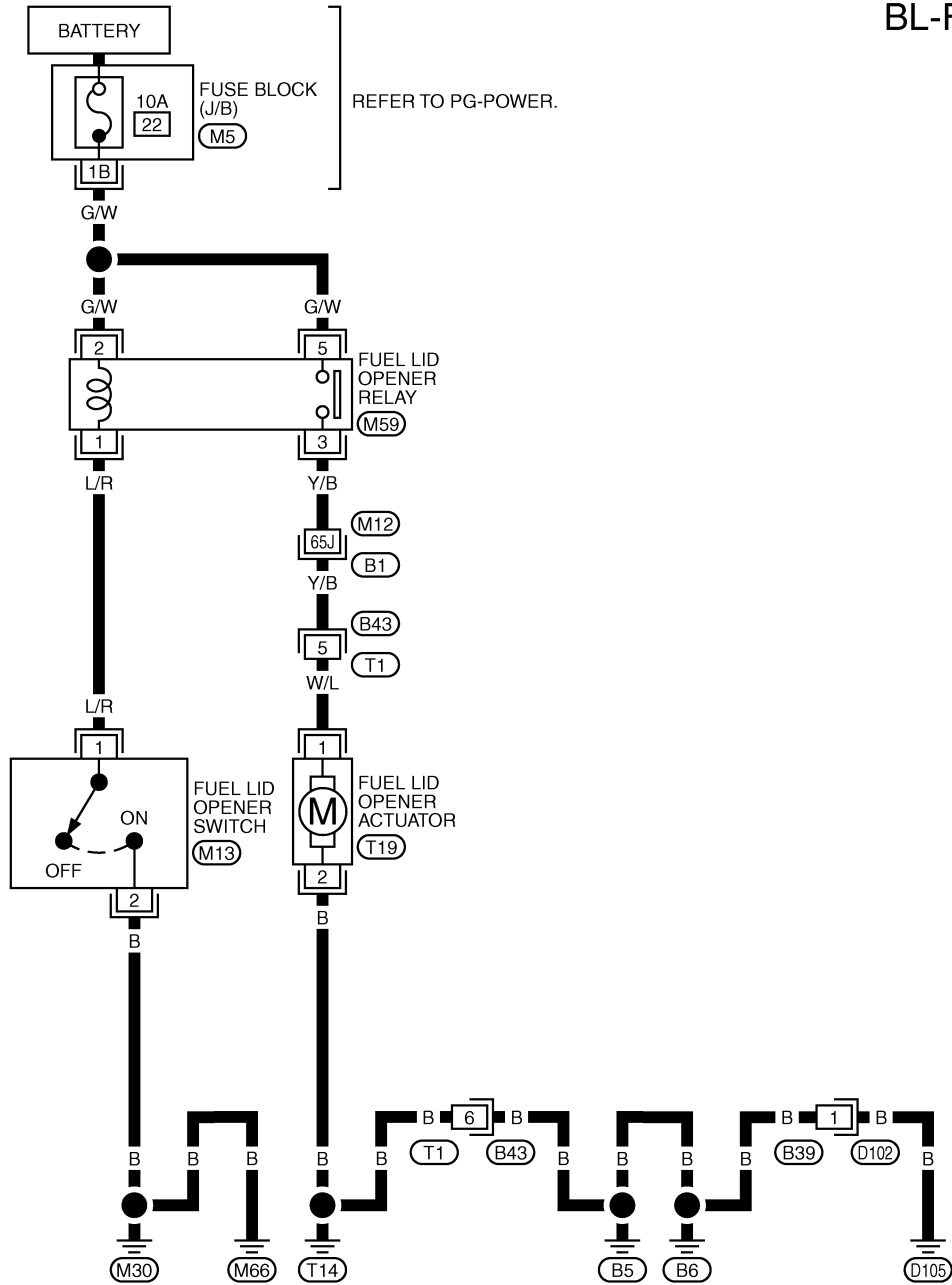

REFER TO PG-POWER.

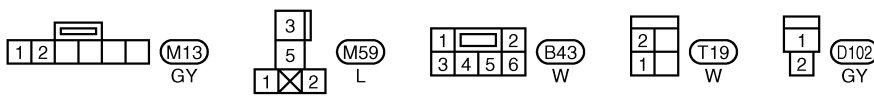

REFER TO THE FOLLOWING.

- (B1) -SUPER MULTIPLE JUNCTION (SMJ)
- (M5) -FUSE BLOCK-JUNCTION BOX (J/B)

TIWT0633E

FUEL FILLER LID OPENER

Wiring Diagram —F/LID— / For Roadster

AIS004DH

BL-F/LID-02

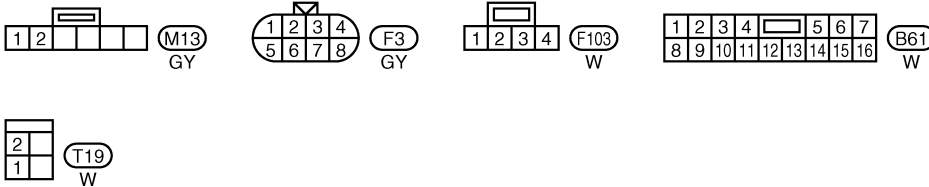
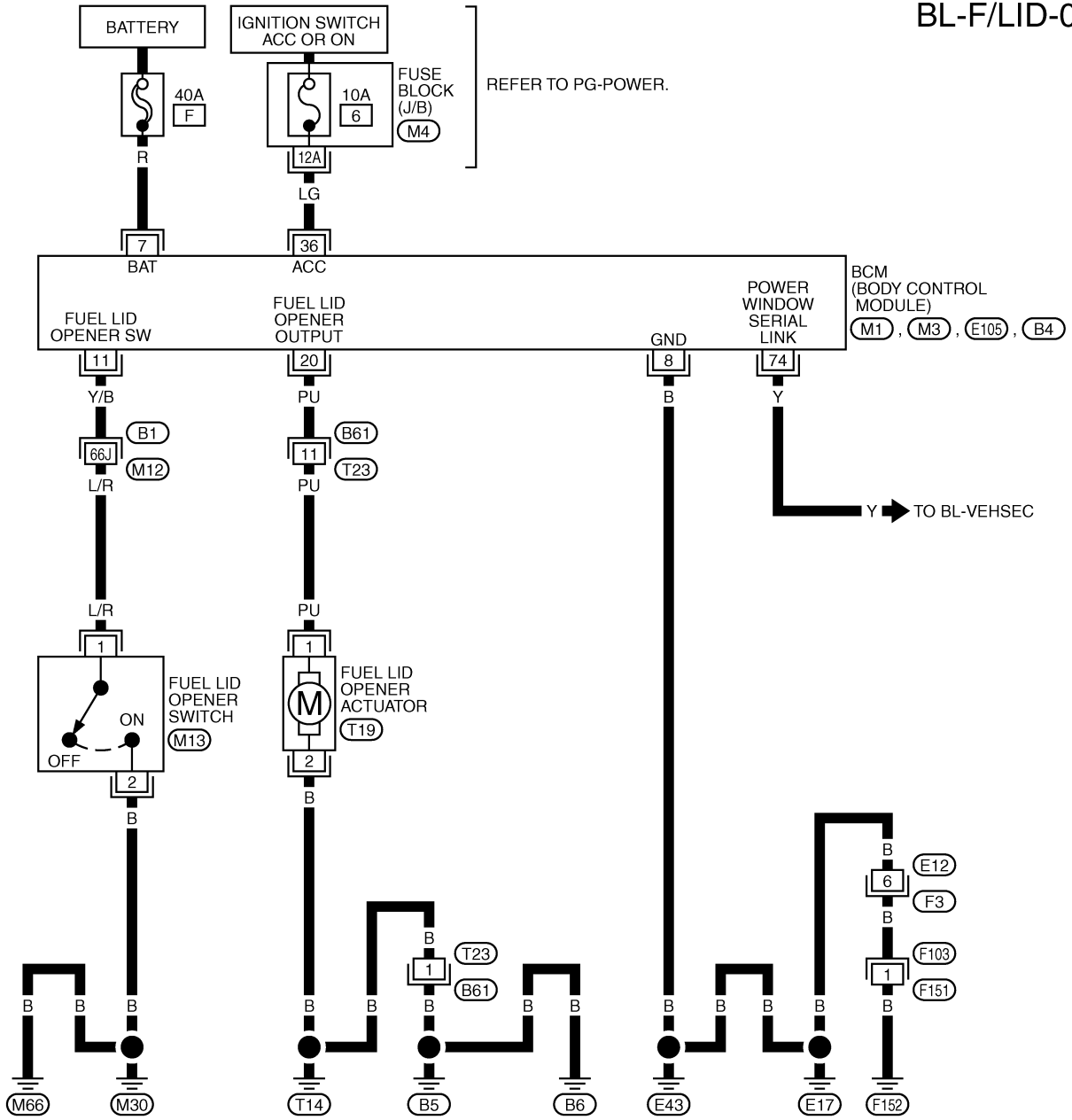

REFER TO THE FOLLOWING.

- (B1) -SUPER MULTIPLE JUNCTION (SMJ)
- (M4) -FUSE BLOCK-JUNCTION BOX (J/B)
- (M1), (M3), (E105), (B4) -ELECTRICAL UNIT

TWT0740E

FUEL FILLER LID OPENER

CONSULT-II Function/For Roadster

AIS00406

Fuel filler lid opener check with data monitor and active test can be executed by combining data reception and command transmission via communication line from BCM.

BCM diagnosis part	Inspection item, self-diagnosis mode	Content
Fuel lid	Data monitor	Displays BCM input data on real-time basis.
	Active test	Sends drive signals to fuel lid opener actuator to perform operation check.

CONSULT-II BASIC OPERATION PROCEDURE

CAUTION:

If CONSULT-II is used with no connection of CONSULT-II CONVERTER, malfunctions might be detected in self-diagnosis depending on control unit which carry out CAN communication.

1. Turn ignition switch "OFF".
2. Connect "CONSULT-II" and CONSULT-II CONVERTER to data link connector.

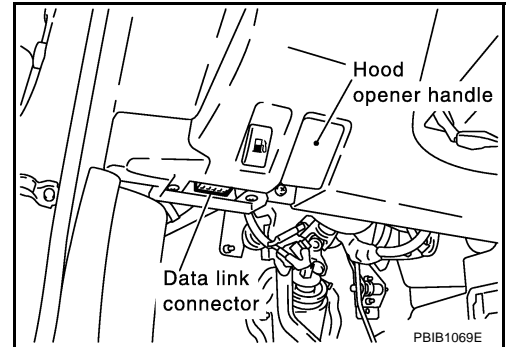

3. Turn ignition switch "ON".
4. Touch "START(NISSAN BASED VHCL)".

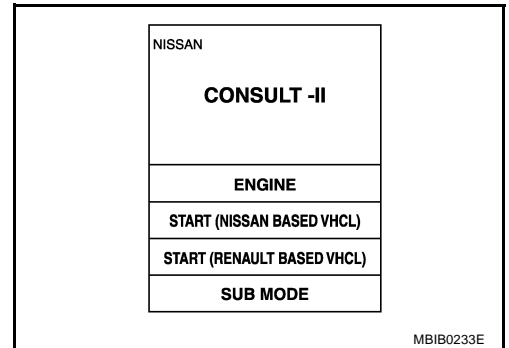

5. Touch "BCM".
If "BCM" is not indicated, go to [GI-39](#) , "CONSULT-II Date Link Connector (DLC) Circuit"

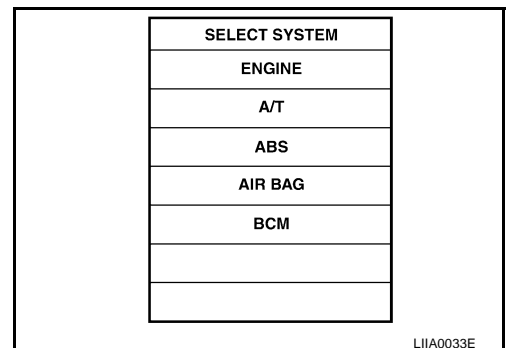

FUEL FILLER LID OPENER

6. Touch "FUEL LID".

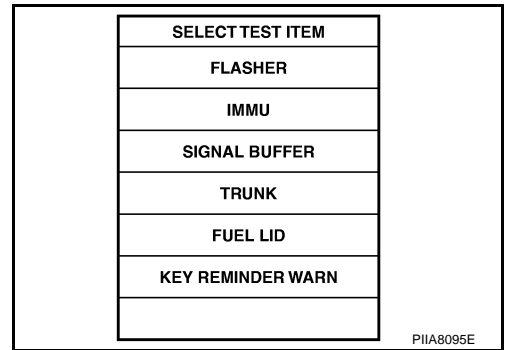

A
B
C
D

7. Select diagnosis mode.
"DATA MONITOR" and "ACTIVE TEST"

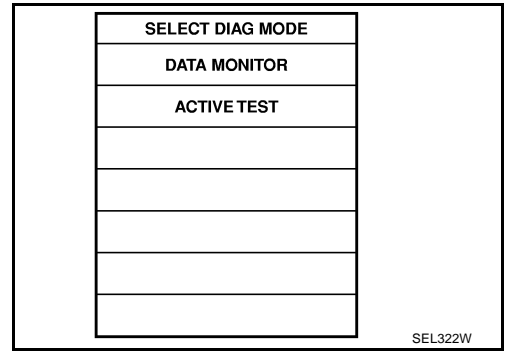

E
F
G
H

DATA MONITOR

Monitor item "operation"	Content
F/LID OPN SW	Indicates [ON/OFF] condition of fuel lid opener switch.

BL

ACTIVE TEST

Test item	Content
FUEL LID OPEN	This test is able to check fuel lid opener actuator unlock operation. This actuator unlocks when "ON" on CONSULT-II screen is touched.

J
K
L
M

FUEL FILLER LID OPENER

Terminals and Reference Value for BCM/For Roadster

AIS00407

Terminal	Wire color	Item	Condition	Voltage [V] (Approx.)
7	R	Power source (Fusible link)	—	Battery voltage
8	B	Ground	—	0
11	Y/B	Fuel lid opener switch	Fuel lid opener switch is ON	0
			Fuel lid opener switch is OFF	Battery voltage
20	PU	Fuel lid opener release output signal	Fuel lid opener switch is ON	0
			Fuel lid opener switch is OFF	Battery voltage (For 0.5s)

Trouble Diagnosis/For Roadster FUEL LID DOES NOT OPEN WITH FUEL LID OPENER SWITCH

AIS00408

1. VEHICLE CONDITION

Check vehicle security system.

Arm phase or alarm phase?

Yes or No

- Yes >> Cancel arm phase or alarm phase condition.
No >> GO TO 2.

2. CHECK FUEL LID OPEN INPUT SIGNAL

Ⓟ With CONSULT-II

Check door switches ("F/LID OPN SW") in "DATA MONITOR" mode with CONSULT-II.

Monitor item	Condition
F/LID OPN SW	OPEN : ON
	CLOSE : OFF

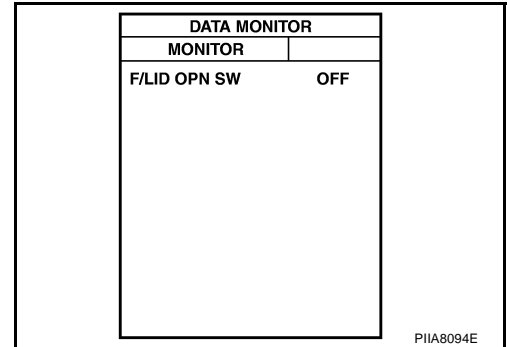

⊗ Without CONSULT-II

1. Turn ignition switch OFF.
2. Check voltage between BCM and ground.

Connector	Terminal (Wire color)		Condition	Voltage [V] (Approx.)
	(+)	(-)		
M3	11 (Y/B)	Ground	Fuel lid opener switch ON	0
			Fuel lid opener switch OFF	Battery voltage

OK or NG

- OK >> GO TO 3.
NG >> GO TO 6.

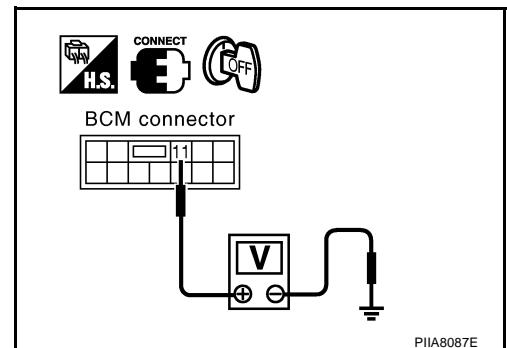

FUEL FILLER LID OPENER

3. CHECK FUEL LID OPEN OUTPUT SIGNAL

Check voltage between BCM and ground.

Connector	Terminal (Wire color)		Condition	Voltage [V] (Approx.)
	(+)	(-)		
B4	20 (PU)	Ground	Fuel lid opener switch ON	Battery voltage (for 0.5s)
			Fuel lid opener switch OFF	0

OK or NG

OK >> GO TO 4.

NG >> Replace BCM. Refer to [BCS-17, "Removal and Installation of BCM"](#).

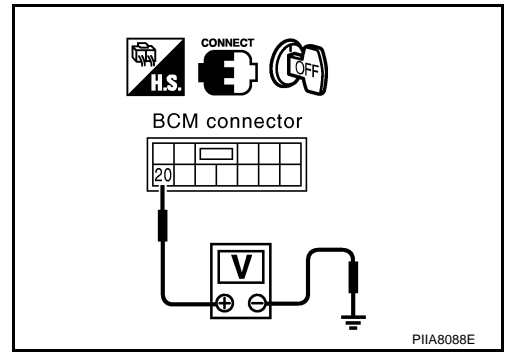

4. CHECK FUEL LID OPENER ACTUATOR CIRCUIT

1. Disconnect BCM connector and fuel lid opener actuator connector.
2. Check continuity between BCM harness connector B4 terminal 20 (PU) and fuel lid opener actuator harness connector T19 terminal 1 (PU).

20 (PU) - 1 (PU) : Continuity should exist.

3. Check continuity between fuel lid opener actuator harness connector T19 terminal 1 (PU) and ground.

1 (PU) - ground : Continuity should not exist.

OK or NG

OK >> GO TO 5.

NG >> Repair harness or connector.

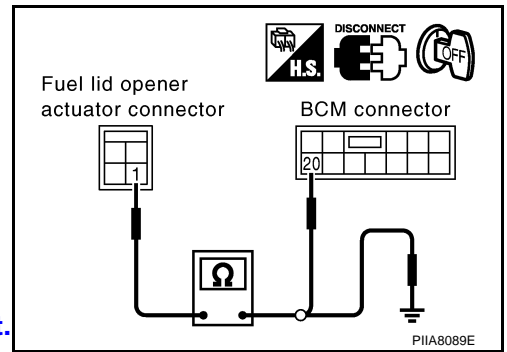

5. CHECK FUEL LID OPENER ACTUATOR GROUND CIRCUIT

Check continuity between fuel lid opener actuator harness connector T19 terminal 2 (B) and ground.

2 (B) - ground : Continuity should exist.

OK or NG

OK >> Replace fuel lid opener actuator.

NG >> Repair harness or connector.

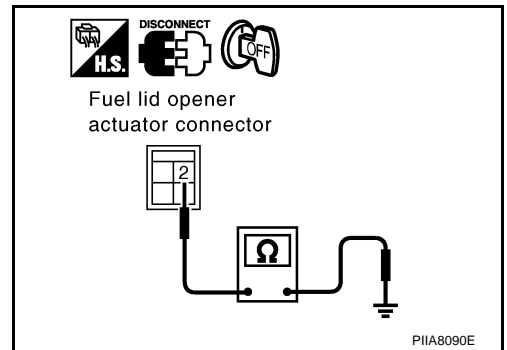

FUEL FILLER LID OPENER

6. CHECK FUEL LID OPENER SWITCH

1. Disconnect fuel lid opener switch
2. Check continuity between fuel lid opener switch harness connector M13 terminals 1 and 2.

Terminals		Fuel lid opener switch condition	Continuity
1	2	ON (Pushed)	Yes
		OFF (Released)	No

OK or NG

- OK >> GO TO 7.
 NG >> Replace fuel lid opener switch.

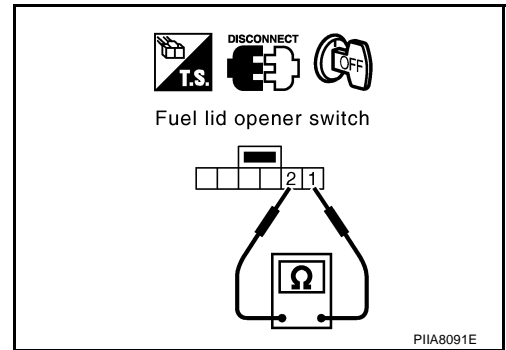

7. CHECK FUEL LID OPENER SWITCH CIRCUIT

1. Disconnect BCM connector.
2. Check continuity between BCM harness connector B4 terminal 11 (Y/B) and fuel lid opener switch harness connector B71 terminal 1 (R).

11 (Y/B) - 1 (R) : Continuity should exist.

3. Check continuity between BCM harness connector B4 terminal 11 (Y/B) and ground.

11 (Y/B) - ground : Continuity should not exist.

OK or NG

- OK >> GO TO 8.
 NG >> Repair harness or connector.

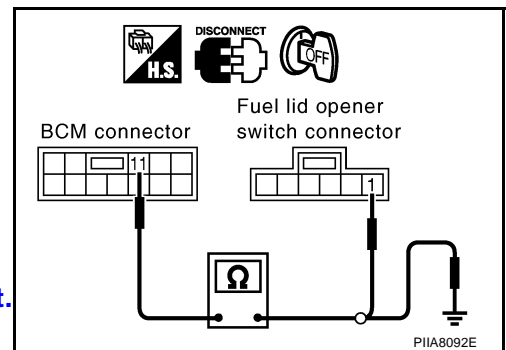

8. CHECK FUEL LID OPENER SWITCH GROUND CIRCUIT

Check continuity between fuel lid opener switch harness connector M13 terminal 2 (B) and ground.

2 (B) - ground : Continuity should exist.

OK or NG

- OK >> Replace fuel lid opener switch.
 NG >> Repair harness or connector.

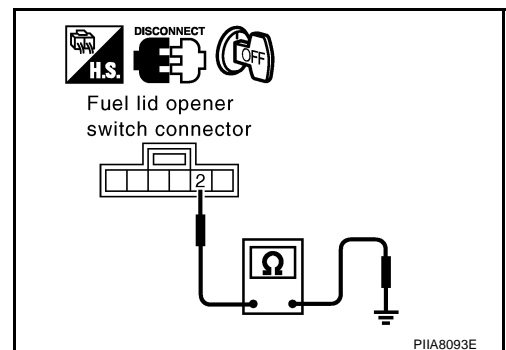

REMOTE KEYLESS ENTRY SYSTEM

PPF:28596

A
B
C
D
E
F
G
H
BL
J
K
L
M

REMOTE KEYLESS ENTRY SYSTEM

Component Parts and Harness Connector Location FOR COUPE

AIS000CK

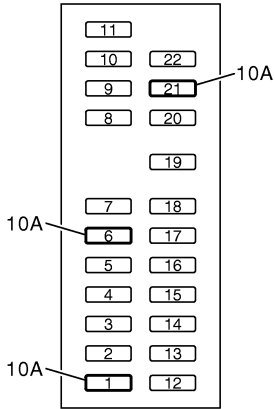

Fuse block (J/B) fuse layout

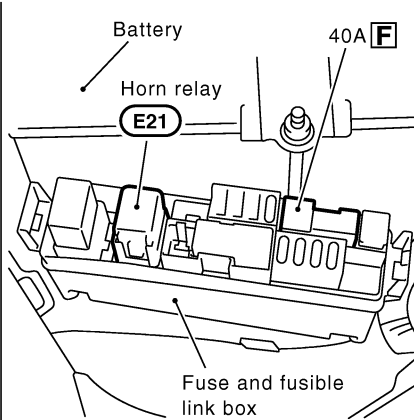

Fuse and fusible link box

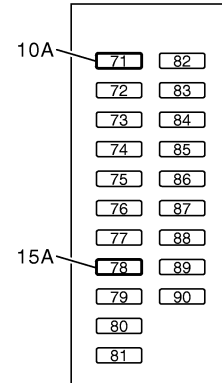

IPDM E/R fuse layout

View with steering lower column cover removed

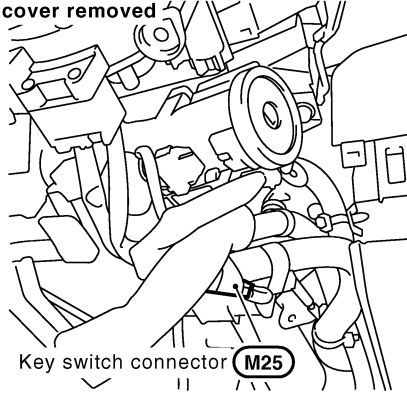

Key switch connector (M25)

View with dash side LH removed

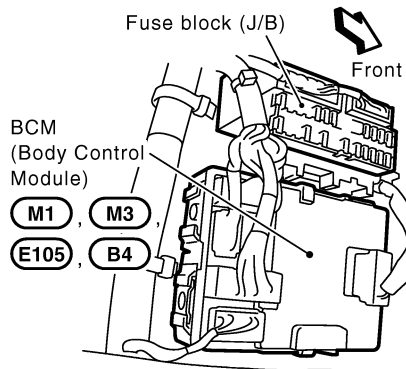

BCM (Body Control Module)
M1, M3, E105, B4

View with cowl top removed

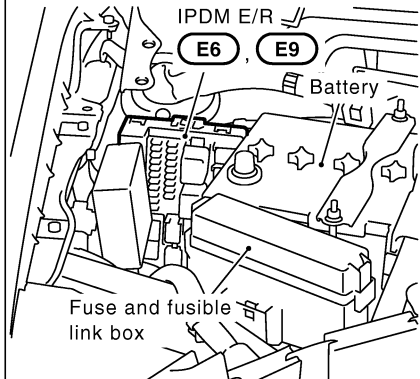

Fuse and fusible link box

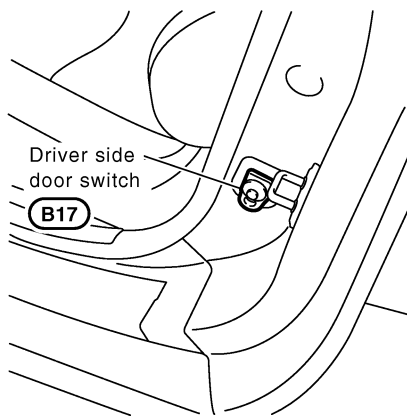

Driver side door switch (B17)

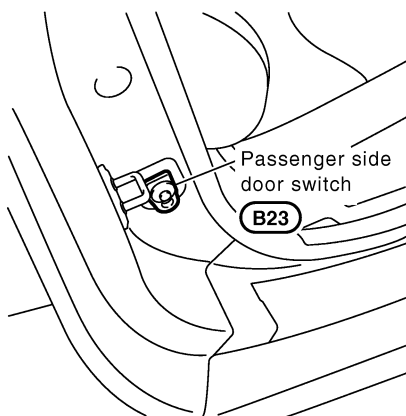

Passenger side door switch (B23)

View with luggage finisher rear

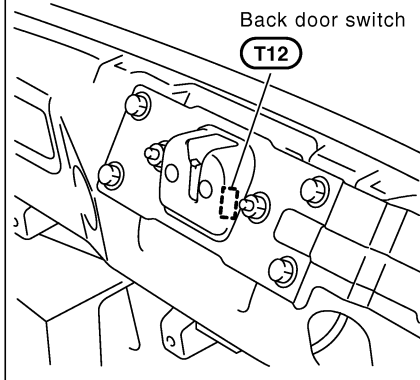

Back door switch (T12)

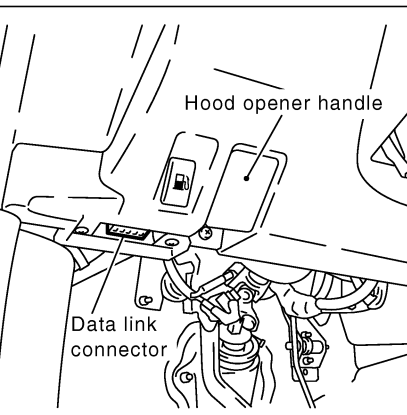

Hood opener handle
Data link connector

View with front bumper removed

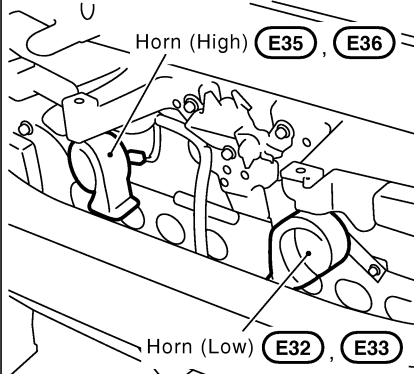

Horn (High) (E35, E36)
Horn (Low) (E32, E33)

View with luggage finisher lower (center) removed (Roadster models)

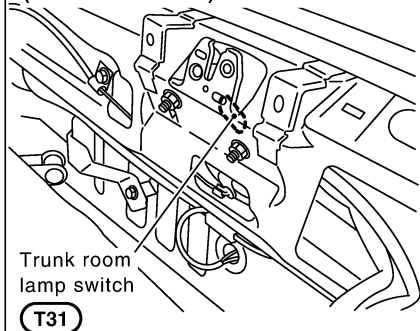

Trunk room lamp switch (T31)

PIIA9441E

REMOTE KEYLESS ENTRY SYSTEM

FOR ROADSTER

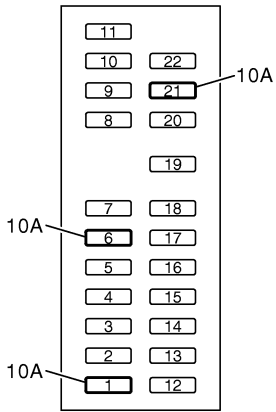

Fuse block (J/B) fuse layout

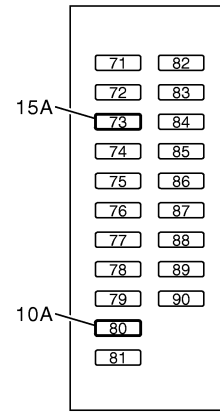
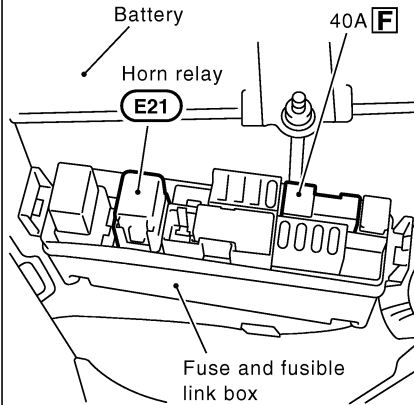

IPDM E/R fuse layout

View with steering lower column cover removed

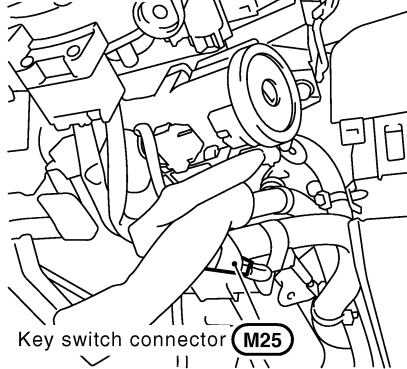

View with dash side LH removed

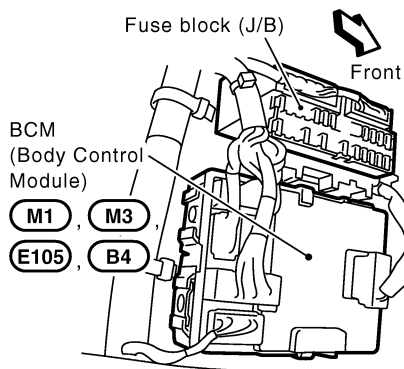

View with cowl top removed

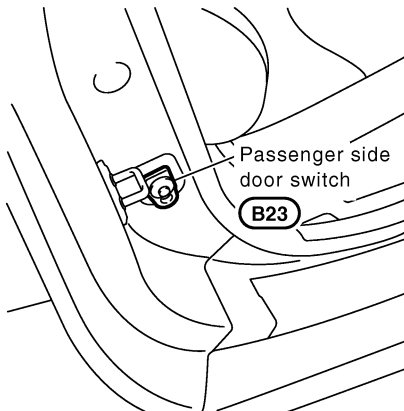
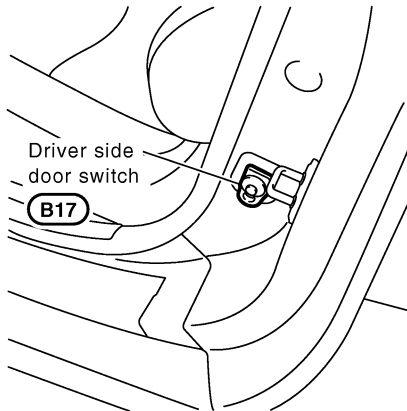
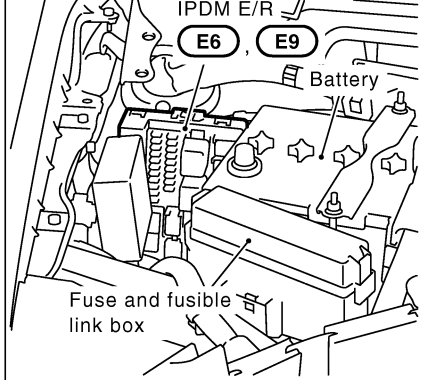

View with luggage finisher lower (center) removed

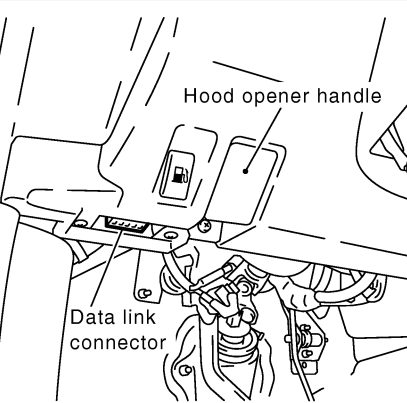
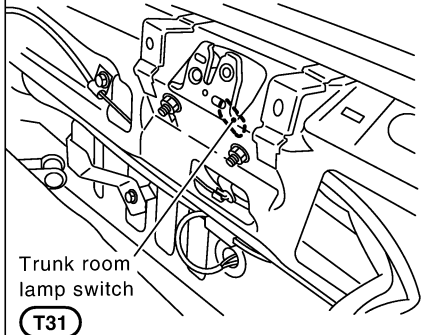

View with front bumper removed

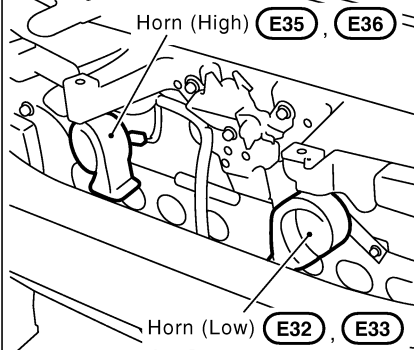

PIIA8065E

REMOTE KEYLESS ENTRY SYSTEM

AIS000CL

System Description

INPUTS

Power is supplied at all times

- to BCM terminal 7
- through 40A fusible link (letter **F** , located in the fuse and fusible link box).
- to key switch terminal 2
- through 10A fuse (No.21,located in the fuse and fusible link box).

When the ignition switch is ON, power is supplied

- to BCM terminal 35
- through 10A fuse [No.1,located in the fuse block (J/B)].

When the ignition switch is ACC, power is supplied

- to BCM terminal 36
- through 10A fuse [No.6,located in the fuse block (J/B)].

When the driver side door switch is ON (door is OPEN), ground is supplied

- to BCM terminal 14
- through driver side door switch terminal 1
- to driver door switch case ground.

When the passenger side door switch is ON (door is OPEN), ground is supplied

- to BCM terminal 10
- through passenger side door switch terminal 1
- to passenger side door switch case ground.

When the back door switch is ON (door is OPEN), ground is supplied

- to BCM terminal 18
- through the back door switch terminal land 3
- to body grounds B5, B6, D105 and T14.

When the trunk room lamp switch is ON (trunk is OPEN), ground is supplied (Roadster models)

- to BCM terminal 18
- through the trunk room lamp switch terminal 1 and 2
- to body grounds B5,B6 and T14.

When the key switch is ON (key is inserted in ignition key cylinder), power is supplied

- through key switch terminal 1
- to BCM terminal 1.

Key fob signal is sent to BCM (the antenna of the system is combined with BCM).

The remote keyless entry system controls operation of the

- power door lock
- hazard and horn reminder
- auto door lock
- interior lamp and step lamp
- panic alarm
- back door opener (For coupe)
- trunk lid opener (For roadster)
- keyless power window down (open)

A

B

C

D

E

F

G

H

BL

J

K

L

M

REMOTE KEYLESS ENTRY SYSTEM

OPERATION PROCEDURE

Power Door Lock Operation

BCM receives a LOCK signal from key fob. BCM locks all doors receiving of LOCK signal from key fob. When an UNLOCK signal is sent from key fob once, driver's door will be unlocked. Then, if an UNLOCK signal is sent from key fob again within 5 seconds, all other doors will be unlocked.

Hazard Reminder

When the doors are locked or unlocked by key fob, power is supplied to hazard warning lamp and it flashes as follows

- LOCK operation: C mode (flash twice) or S mode (flash twice)
- UNLOCK operation: C mode (flash once) or S mode (does not flash)

Horn Reminder

BCM output to IPDM E/R for horn reminder signal as DATA LINE (CAN H line and CAN L line). The horn reminder has C mode (horn chirp mode) and S mode (non-horn chirp mode).

Operating function of hazard and horn reminder

Remote controller operation	C mode		S mode	
	Lock	Unlock	Lock	Unlock
Hazard warning lamp flash	Twice	Once	Twice	—
Horn sound	Once	—	—	—

Hazard and horn reminder does not operate if any door switch is ON (any door is OPEN).

How to change hazard and horn reminder mode

🔑 With CONSULT-II

Hazard and horn reminder can be changed using "WORK SUPPORT" mode in "MULTI ANSWER BACK SET". Refer to [BL-78, "Work Support"](#).

⊗ Without CONSULT-II

When LOCK and UNLOCK signals are sent from the key fob for more than 2 seconds at the same time, the hazard and horn reminder mode is changed and hazard warning lamp flashes and horn sounds as follows:

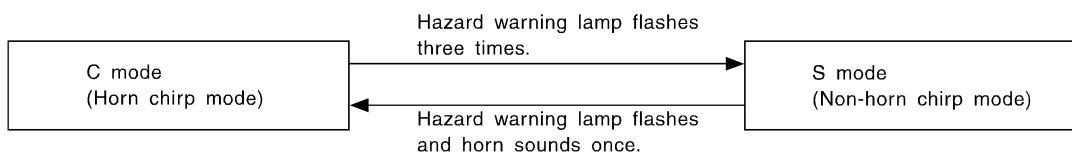

SEL153WA

Auto Door Lock Operation

Auto lock function signal is sent for operation when any of the following signals are not sent within 1 minute after the unlock signal is sent from the key fob:

- when door switch is turned ON for open.
- when the key switch is turned ON.
- when the lock signal is sent from the key fob.

Auto door lock mode can be changed using "WORK SUPPORT" mode in "AUTO LOCK SET". Refer to [BL-78, "Work Support"](#).

Interior Lamp and Step Lamp Operation

When the following conditions come:

- condition of interior lamp switch is DOOR position;
- door switch OFF (when all the doors are closed);

REMOTE KEYLESS ENTRY SYSTEM

Remote keyless entry system turns on interior lamp (for 30 seconds) with input of UNLOCK signal from key fob.

For detailed description, refer to [LT-207, "MAP LAMP TIMER OPERATION"](#) .

Panic Alarm Operation

When key switch is OFF (when ignition key is not inserted in key cylinder), BCM turns on and off horn and headlamp intermittently with input of PANIC ALARM signal from key fob.

The alarm automatically turns off after 25 seconds or when BCM receives any signal from key fob.

For detailed description, refer to [BL-133, "PANIC ALARM OPERATION"](#) .

Back Door Operation/For Coupe

When a BACK DOOR OPEN signal is sent with key OFF (ignition key removed from key cylinder) from key fob, power is supplied through BCM terminal 19.

When power and ground are supplied, back door opener actuator opens back door.

Trunk Opener Operation/For Roadster

When a TRUNK OPEN signal is sent with key OFF (ignition key removed from key cylinder) from key fob, power is supplied through BCM terminal 19.

When power and ground are supplied, trunk lid opener actuator opens trunk.

Keyless Power Window Down (open) Operation

When key fob unlock switch is turned ON with ignition switch OFF, and key fob unlock switch is detected to be on continuously for 3 seconds, the driver's door and passenger's door power windows are simultaneously opened.

Power window is operated to open and the operation continues as long as the key fob unlock switch is pressed.

CAN Communication System Description

AIS00104

CAN (Controller Area Network) is a serial communication line for real time application. It is an on-vehicle multiplex communication line with high data communication speed and excellent error detection ability. Many electronic control units are equipped onto a vehicle, and each control unit shares information and links with other control units during operation (not independent). In CAN communication, control units are connected with 2 communication lines (CAN H line, CAN L line) allowing a high rate of information transmission with less wiring. Each control unit transmits/receives data but selectively reads required data only.

CAN Communication Unit

AIS00411

Refer to [LAN-5, "CAN COMMUNICATION"](#) .

REMOTE KEYLESS ENTRY SYSTEM

Schematic

AIS000CN

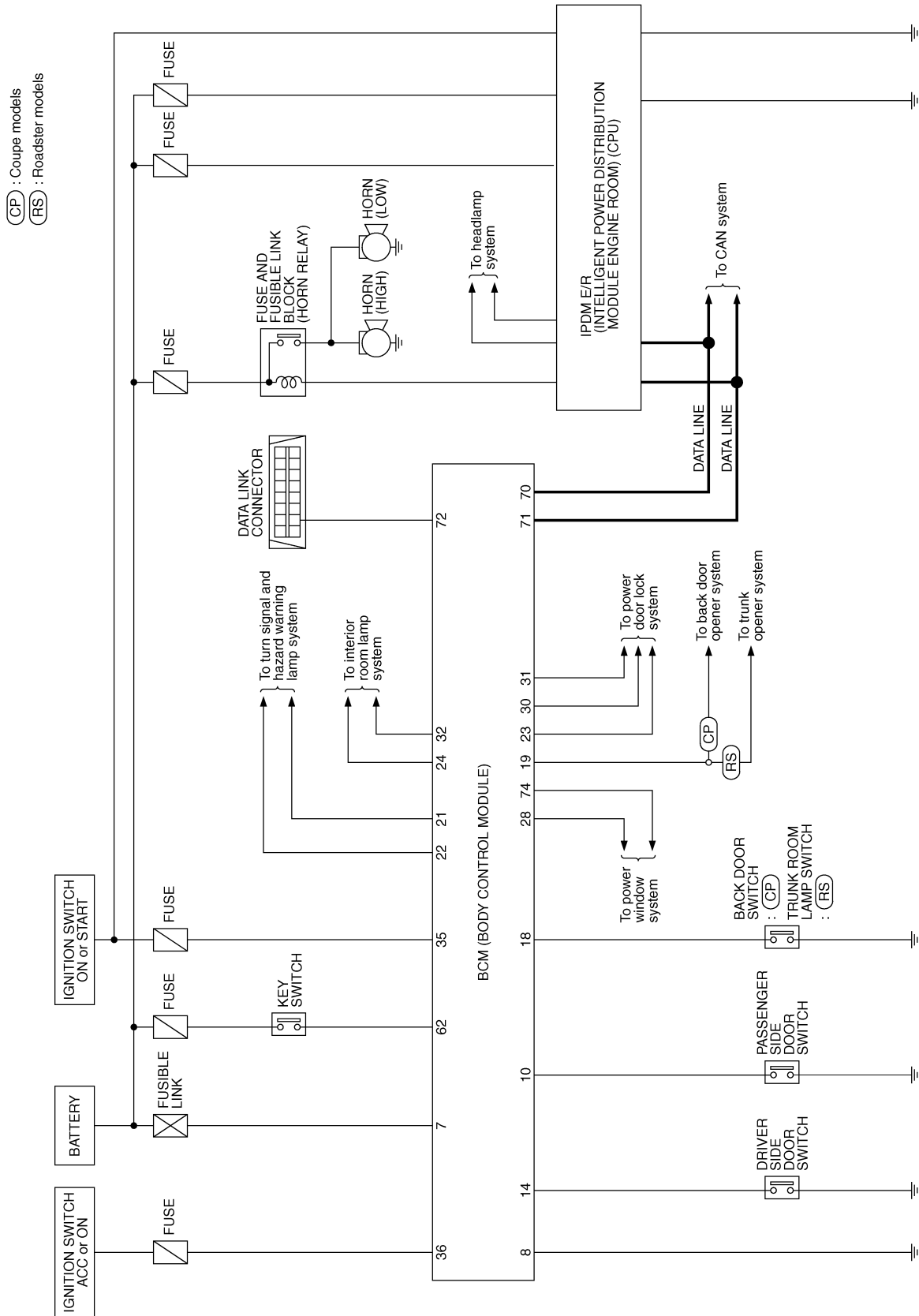

TIWT0741E

REMOTE KEYLESS ENTRY SYSTEM

Wiring Diagram — KEYLES— /For Coupe
FIG. 1

AIS000CO

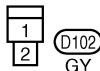
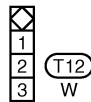
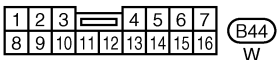
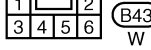
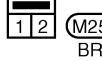
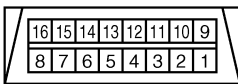
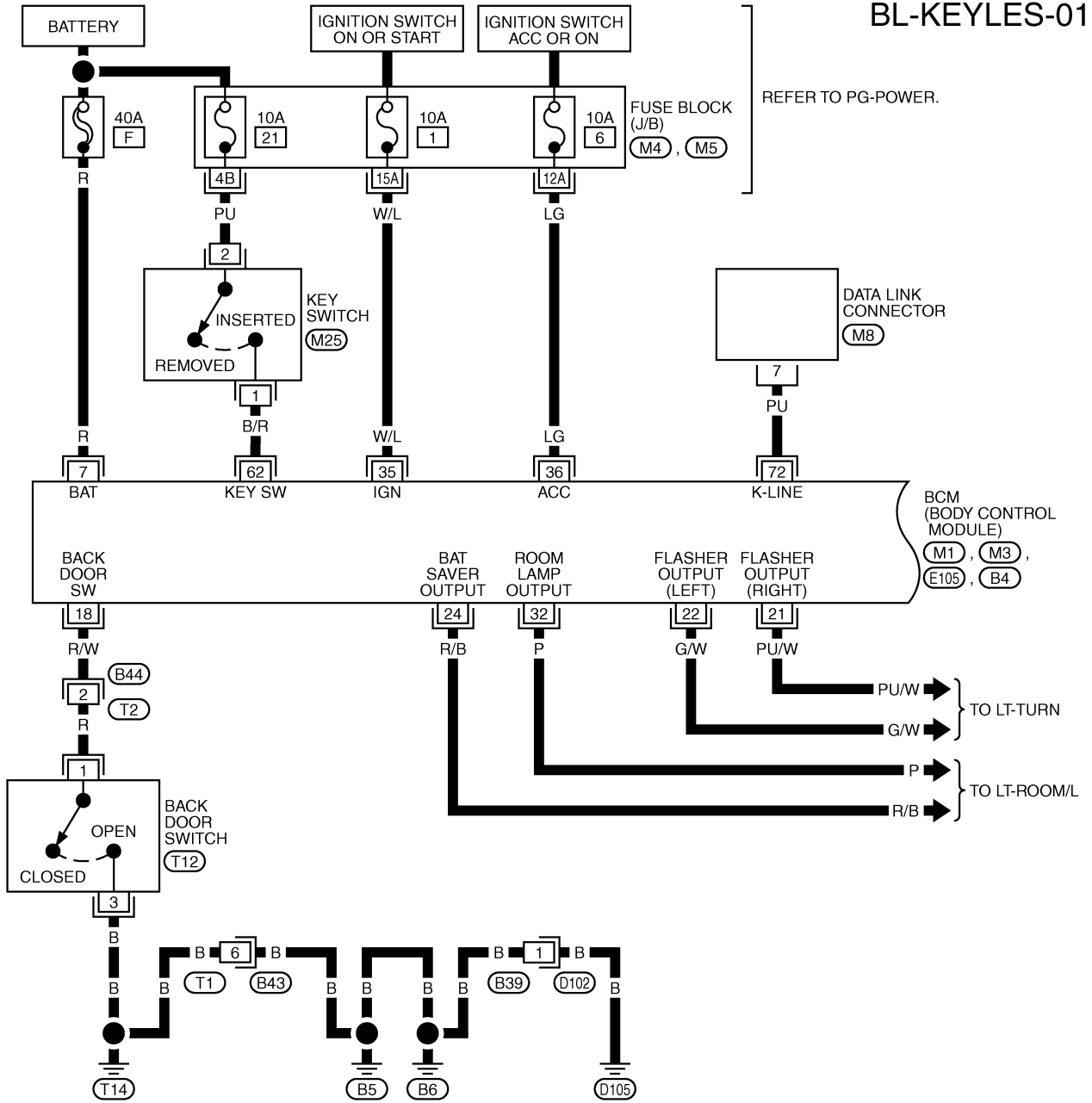

REFER TO THE FOLLOWING.

(M4), (M5) - FUSE BLOCK-JUNCTION BOX (J/B)

(M1), (M3), (E105), (B4) - ELECTRICAL UNITS

TIWT0761E

REMOTE KEYLESS ENTRY SYSTEM

FIG. 2

BL-KEYLES-02

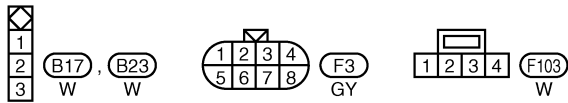
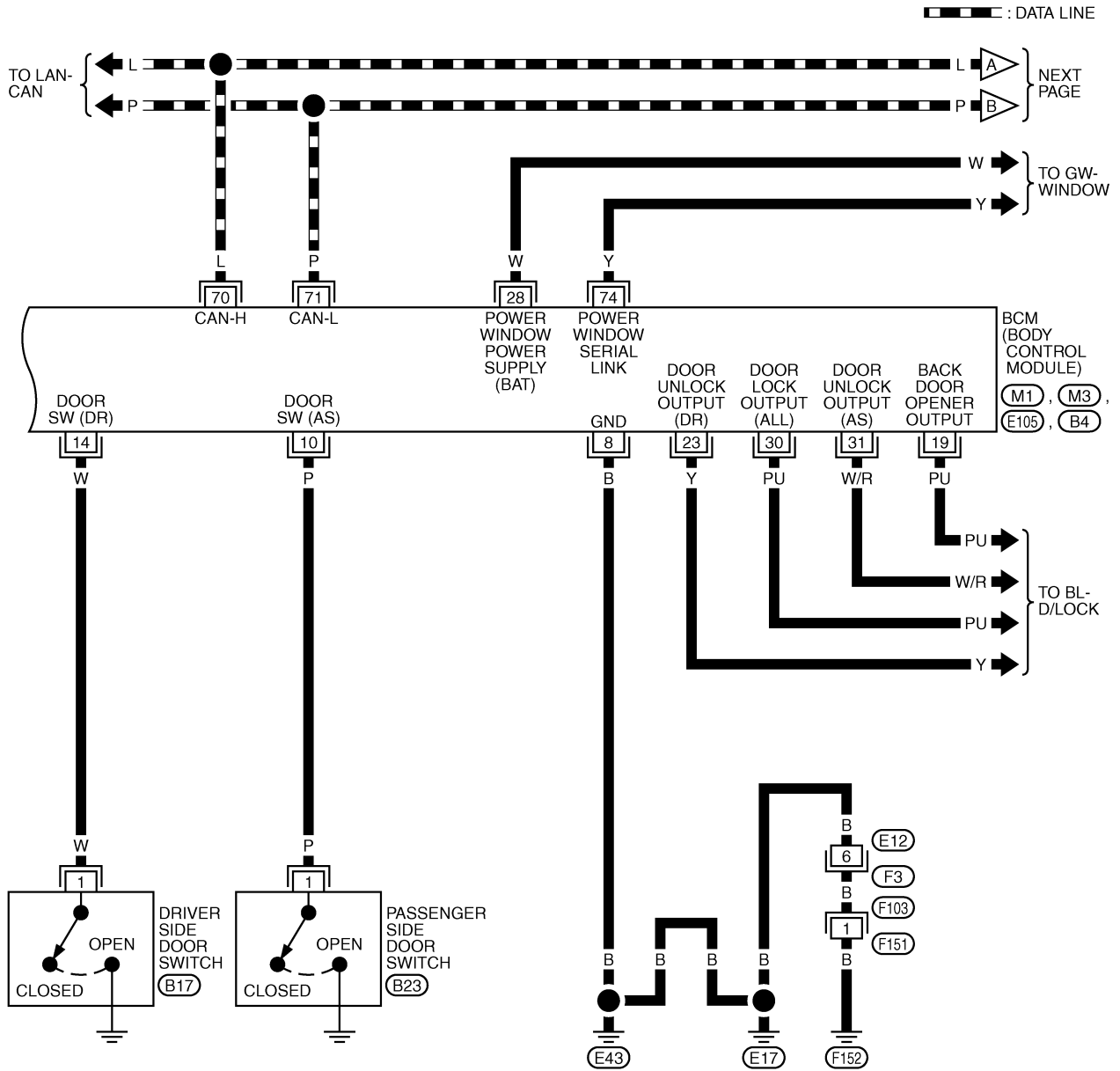

REFER TO THE FOLLOWING.
 (M1), (M3), (E105), (B4)
 -ELECTRICAL UNITS

TIWT0775E

REMOTE KEYLESS ENTRY SYSTEM

FIG. 3

BL-KEYLES-03

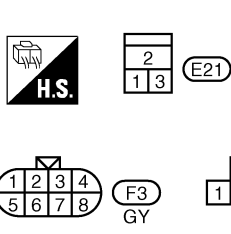
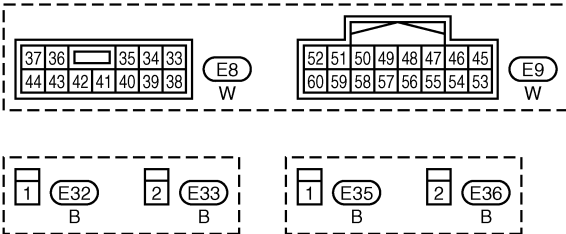
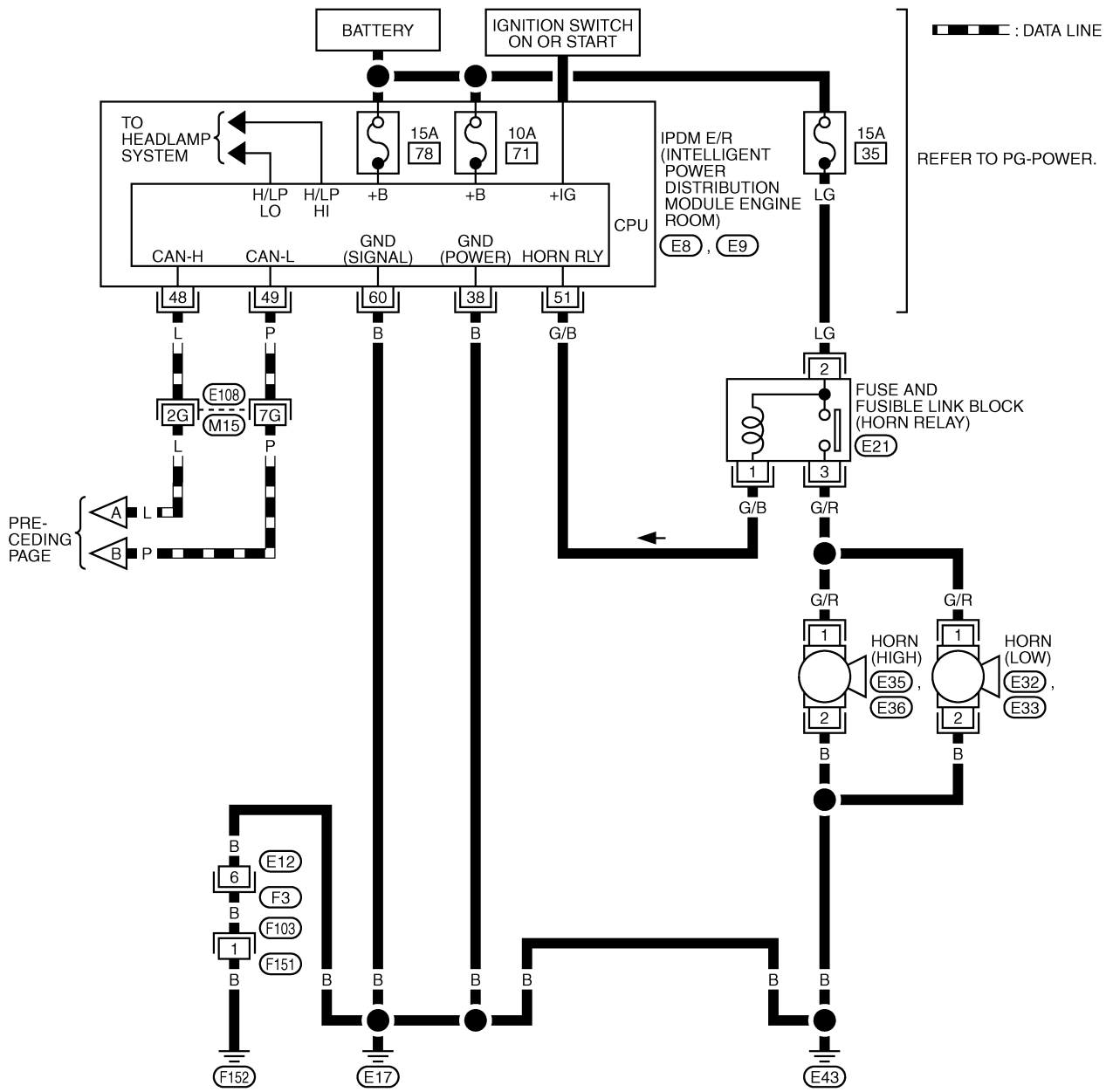

REFER TO THE FOLLOWING.
 (E108) -SUPER MULTIPLE JUNCTION (SMJ)

A
B
C
D
E
F
G
H
J
K
L
M

BL

REMOTE KEYLESS ENTRY SYSTEM

Wiring Diagram — KEYLES— /For Roadster

AIS004DJ

BL-KEYLES-04

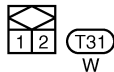
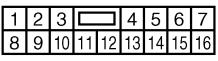
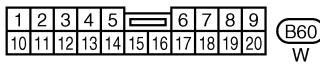
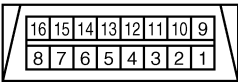
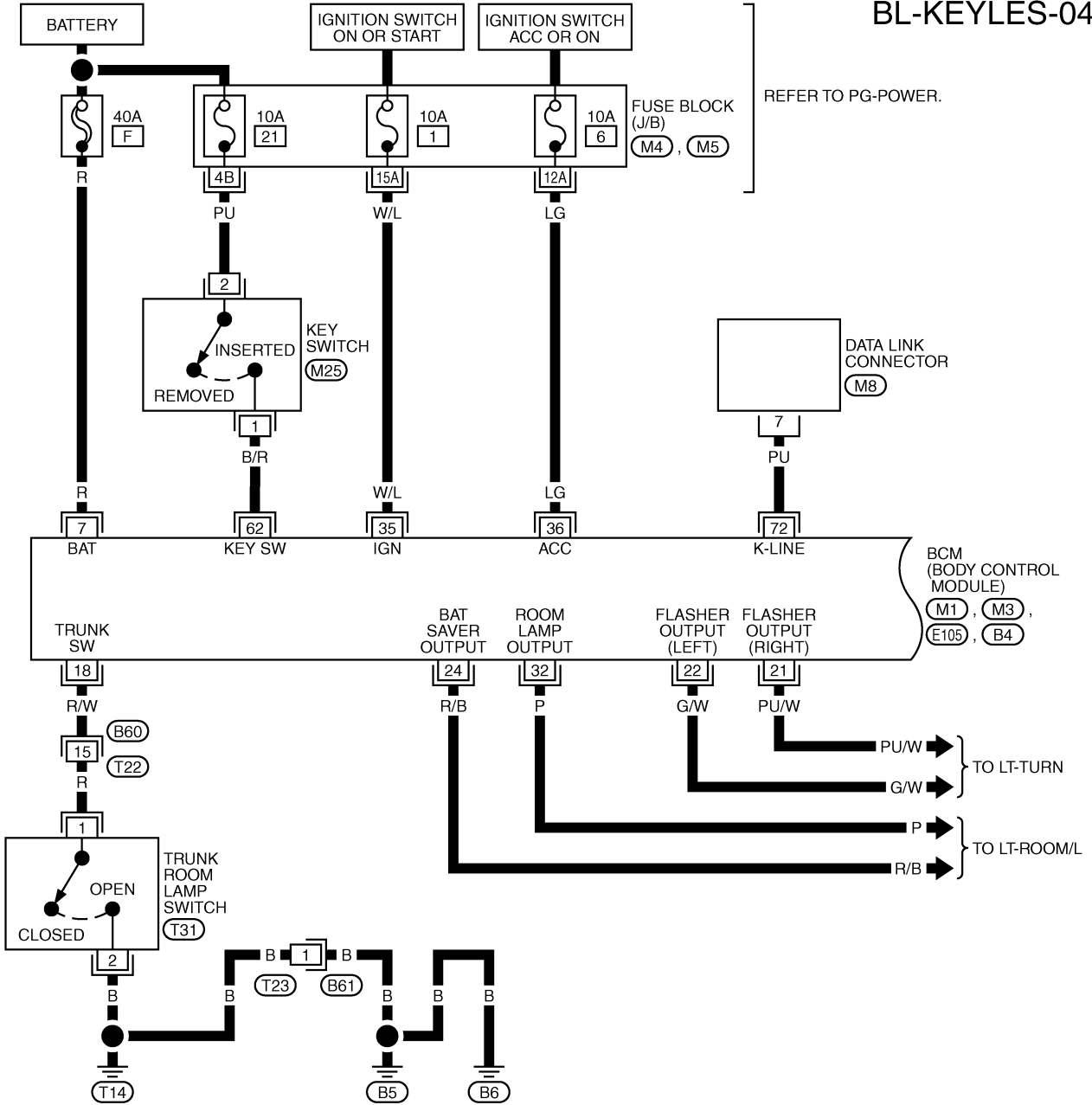

REFER TO THE FOLLOWING.

(M4), (M5) - FUSE BLOCK-JUNCTION BOX (J/B)

(M1), (M3), (E105), (B4) - ELECTRICAL UNITS

TIWT0742E

REMOTE KEYLESS ENTRY SYSTEM

BL-KEYLES-05

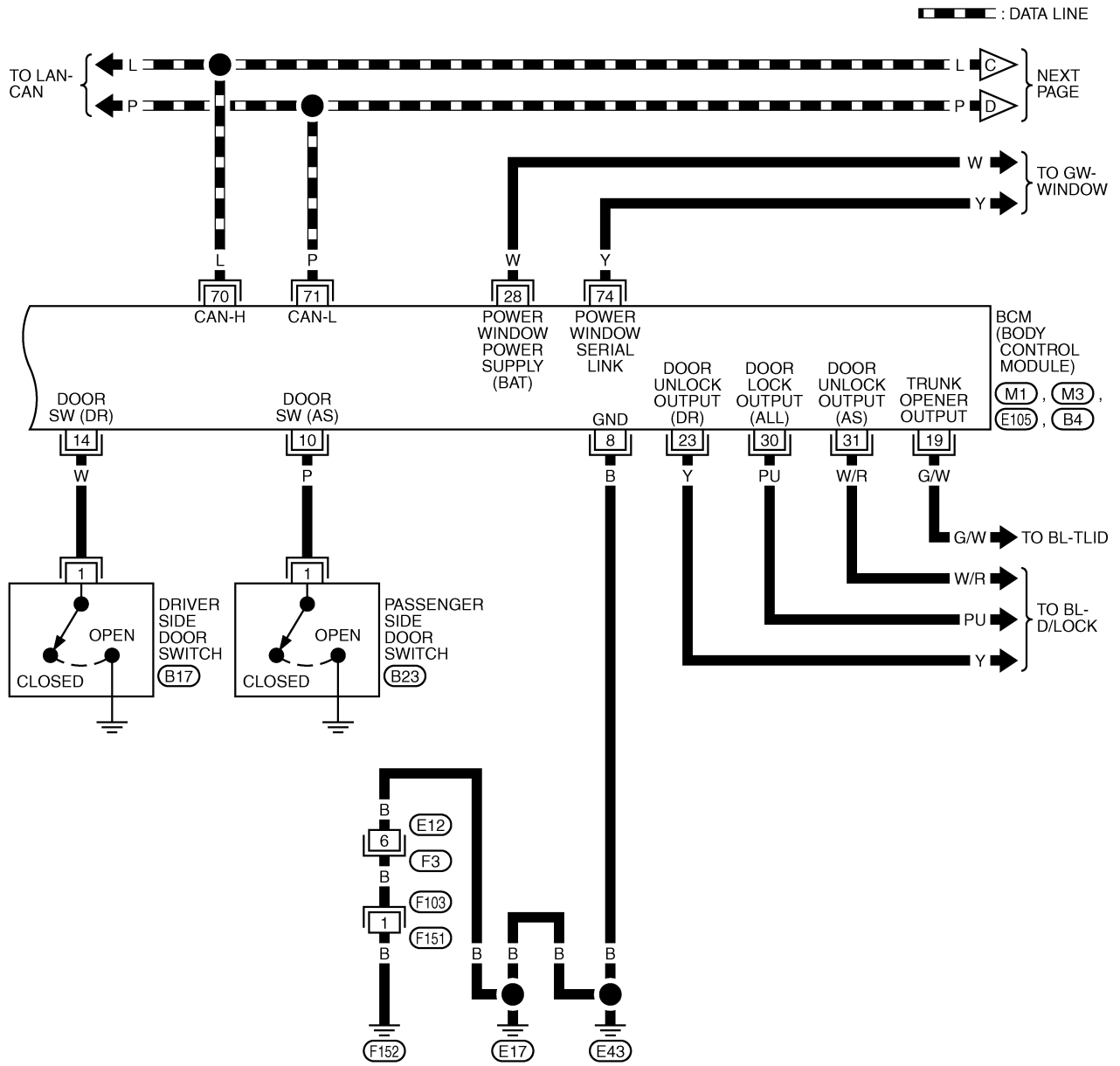

REFER TO THE FOLLOWING.
 (M1), (M3), (E105), (B4)
 -ELECTRICAL UNITS

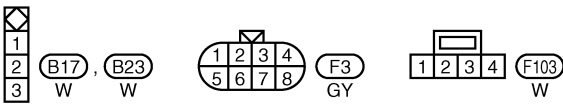

TIWT0743E

REMOTE KEYLESS ENTRY SYSTEM

BL-KEYLES-06

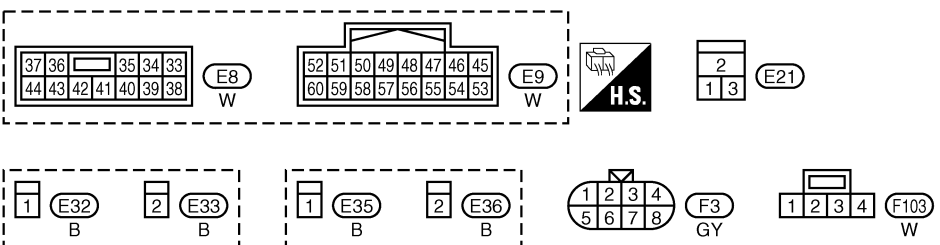
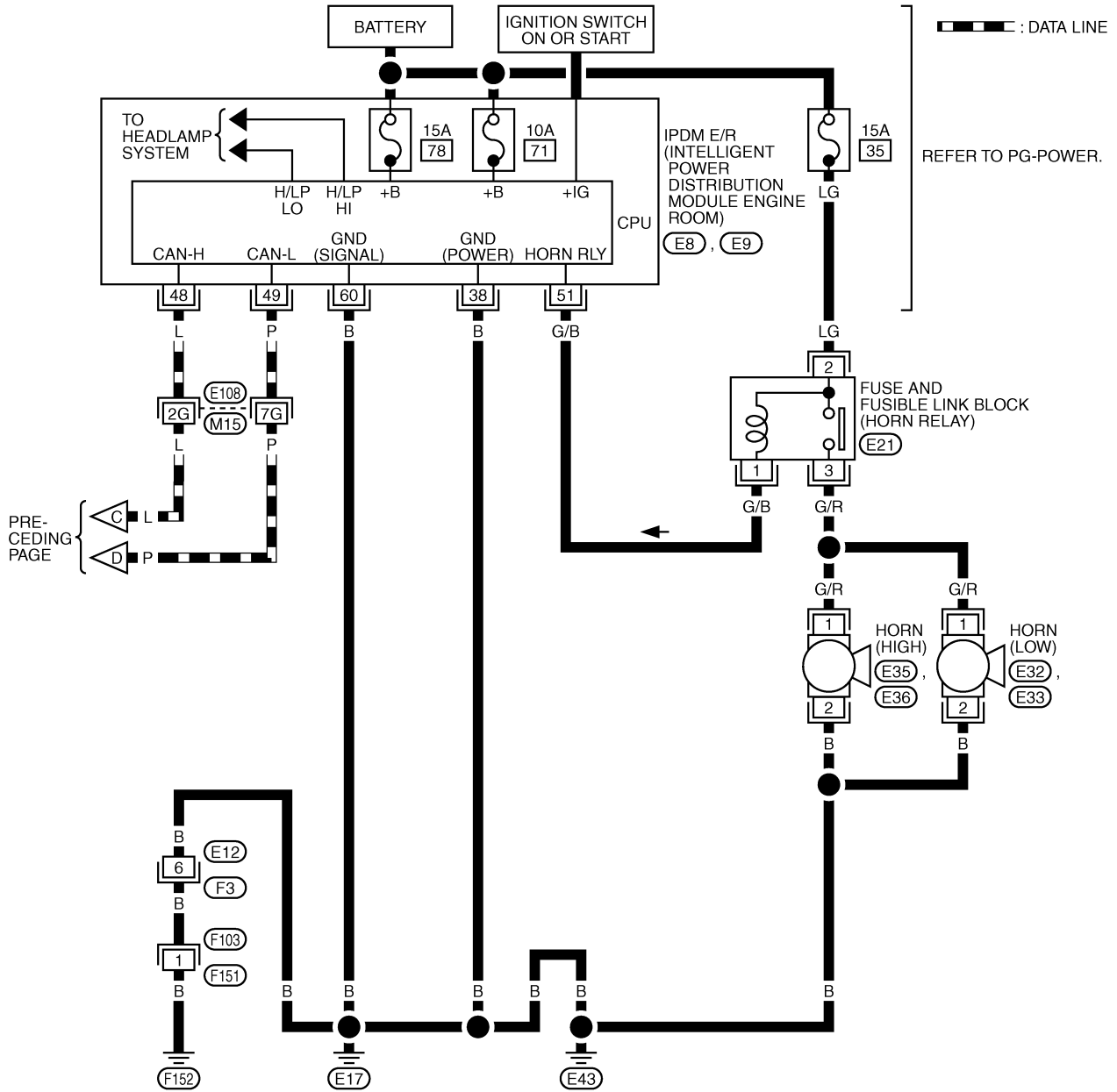

TIWT0744E

REMOTE KEYLESS ENTRY SYSTEM

Terminals and Reference Value for BCM

AIS000CP

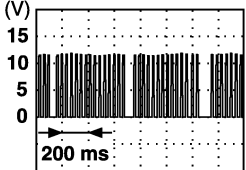
Terminal	Wire color	Item	Condition	Voltage (V) (Approx.)
7	R	Power source (Fusible link)	—	Battery voltage
8	B	Ground	—	0
10	P	Passenger side door switch	ON (Open) → OFF (Closed)	0 → Approx. 5
14	W	Driver side door switch	ON (Open) → OFF (Closed)	0 → Approx. 5
18	R/W	Back door switch	ON (Open) → OFF (Closed)	0 → Battery voltage*1
		Trunk room lamp switch*3		
19	PU	Back door lock actuator	Locked (OFF) → Unlocked (ON)	0 → Battery voltage
		Trunk lid opener actuator*3		
21	PU/W	Right turn signal lamp	When door lock or unlock is operated using key fob*2 (ON → OFF)	Battery voltage → 0
22	G/W	Left turn signal lamp	When door lock or unlock is operated using key fob*2 (ON → OFF)	Battery voltage → 0
23	Y	Driver side door lock actuator (Unlock)	Door lock / unlock switch (Free → Unlock)	0 → Battery voltage
28	W	Battery power supply	—	Battery voltage
30	PU	Door lock actuators	Door lock / unlock switch (Free → Lock)	0 → Battery voltage
31	W/R	Passenger side door lock actuator	Door lock / unlock switch (Free → Unlock)	0 → Battery voltage
35	W/L	Ignition switch (ON or START)	Ignition switch (ON or START position)	Battery voltage
36	LG	ACC power supply (ACC or ON)	Ignition switch (ACC position)	Battery voltage
62	B/R	Ignition key switch (Insert)	ON (Key inserted) → OFF (Key removed from IGN key cylinder)	Battery voltage → 0
70	L	CAN – H	—	—
71	P	CAN – L	—	—
72	PU	Data link connector	—	—
74	Y	Power window switch (Serial link)	Driver side door and passenger side door are closed. (Each door switches are OFF.)	 <p>PIIA2344J</p>

*1: When interior lamp battery saver control is in OFF: Approx 5V.

*2: In the state that hazard reminder operates.

*3: For roadster.

REMOTE KEYLESS ENTRY SYSTEM

Terminals and Reference Value for IPDM E/R

AIS001MF

Terminal	Wire color	Item	Condition	Voltage (V) (Approx.)
38	B	Ground	—	0
48	L	CAN – H	—	0
49	P	CAN – L	—	0
51	G/B	Horn relay	When door lock is operated using key fob* (ON → OFF)	Battery voltage → 0
60	B	Ground	—	0

*: In the state that horn reminder operates.

CONSULT-II Function

AIS000CQ

- The following functions are executed by combining data received and command transmitted via the communication line from the BCM.

BCM diagnosis position	Inspection items and diagnosis mode		Description
BCM C/U*	Self-diagnosis results		Carries out the self-diagnosis.
	Data monitor	CAN diagnosis support monitor	Displays CAN communication system diagnosis, displays transmission status, and communication status of each unit communicated with BCM.
		Selection from menu	Displays the input data to BCM on real-time basis.
MULTI REMOTE ENT	Data monitor		Displays the input remote keyless entry system data to BCM on real-time basis.
	Active test		Sends a drive signal to check the operation.
	Work support		Changes the setting for each function.

*:Refer to [BCS-15. "CAN Communication Inspection Using CONSULT-II \(Self-Diagnosis\)"](#) .

CONSULT-II Inspection Procedure for BCM

AIS000CR

CAUTION:

If CONSULT-II is used with no connection of CONSULT-II CONVERTER, malfunctions might be detected in self-diagnosis depending on control unit which carry out CAN communication.

“MULTI REMOTE ENT”

- Turn ignition switch “OFF”.
- Connect “CONSULT-II” and “CONSULT-II CONVERTER” to the data link connector.

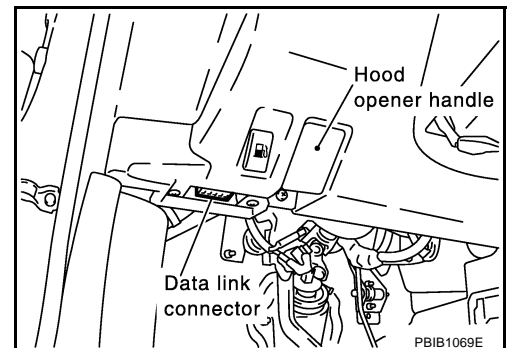

- Turn ignition switch “ON”.

REMOTE KEYLESS ENTRY SYSTEM

4. Touch "START(NISSAN BASED VHCL)".

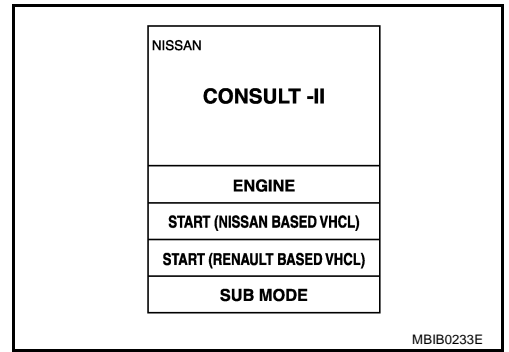

A
B
C
D

5. Touch "BCM".
If "BCM" is not indicated, go to [GI-39, "CONSULT-II Data Link Connector \(DLC\) Circuit"](#) .

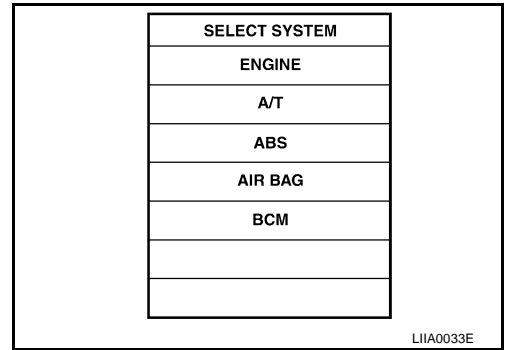

E
F
G

6. Touch "MULTI REMOTE ENT".

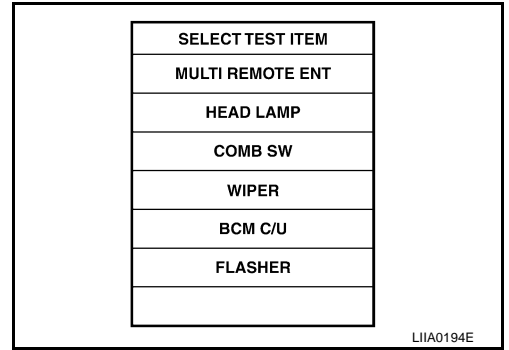

H
I
J
K

7. Select diagnosis mode.
"WORK SUPPORT", "DATA MONITOR", "ACTIVE TEST" are available.

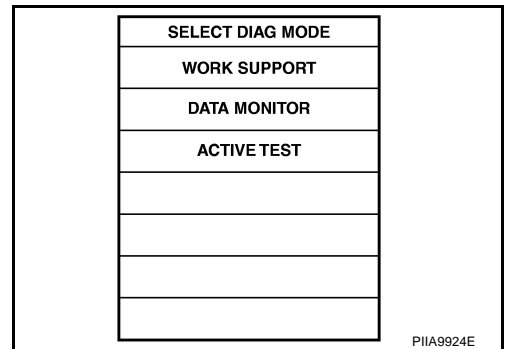

L
M

BL

REMOTE KEYLESS ENTRY SYSTEM

CONSULT-II Application Items for BCM “MULTI REMOTE CONTENT”

AIS000CS

Work Support

Test Item	Description
REMO CONT ID CONFIR	It can be checked whether key fob ID code is registered or not in this mode.
REMO CONT ID REGIST	Key fob ID code can be registered.
REMO CONT ID ERASUR	Key fob ID code can be erased.
MULTI ANSWER BACK SET	Hazard and horn reminder mode can be changed in this mode. The reminder mode will be changed when “MODE SET” on CONSULT-II screen is touched.
AUTO LOCK SET	Auto locking function mode can be changed in this mode. The function mode will be changed when “MODE SET” on CONSULT-II screen is touched.
PANIC ALRM SET	Panic alarm operation mode can be changed in this mode. The operation mode will be changed when “MODE SET” on CONSULT-II screen is touched.
TRUNK OPEN SET	Back door opener operation mode can be changed in this mode. The operation mode will be changed when “MODE SET” on CONSULT-II screen is touched.
	Trunk lid opener operation mode can be changed in this mode. The operation mode will be changed when “MODE SET” on CONSULT-II screen is touched.
PW DOWN SET	Keyless power window down (open) operation mode can be changed in this mode. The operation mode will be changed when “MODE SET” on CONSULT-II screen is touched.

Hazard and horn reminder mode

	ON (C mode)		OFF (S mode)		MODE 3		MODE 4		MODE 5		MODE 6	
	Lock	Unlock	Lock	Unlock	Lock	Unlock	Lock	Unlock	Lock	Unlock	Lock	Unlock
Key fob operation												
Hazard warning lamp flash	Twice	Once	Twice	—	—	—	Twice	Once	Twice	—	—	Once
Horn sound	Once	—	—	—	—	—	—	—	Once	—	Once	—

Auto door lock operation mode

	MODE 1	MODE 2	MODE 3
Auto locking function	1 minutes	Nothing	5 minutes

Panic alarm operation mode

	MODE 1	MODE 2	MODE 3
Key fob operation	0.5 seconds	Nothing	1.5 seconds

Back door open operation mode

	MODE 1	MODE 2	MODE 3
Key fob operation	0.5 seconds	Nothing	1.5 seconds

Trunk lid open operation mode (Roadster models)

	MODE 1	MODE 2	MODE 3
Key fob operation	0.5 seconds	Nothing	1.5 seconds

Power window down (open) operation mode

	MODE 1	MODE 2	MODE 3
Key fob operation	3 seconds	Nothing	5 seconds

Data Monitor

Monitored Item	Description
IGN ON SW	Indicates [ON/OFF] condition of ignition switch in ON position.
ACC ON SW	Indicates [ON/OFF] condition of ignition switch in ACC position.

REMOTE KEYLESS ENTRY SYSTEM

Monitored Item	Description
KEY ON SW	Indicates [ON/OFF] condition of key switch.
DOOR SW-DR	Indicates [ON/OFF] condition of driver side door switch.
DOOR SW-AS	Indicates [ON/OFF] condition of passenger side door switch.
BACK DOOR SW	Indicates [ON/OFF] condition of back door switch (For Coupe).
LOCK SW DR/AS	Indicates [ON/OFF] condition of lock signal from lock/unlock switch.
UNLK SW DR/AS	Indicates [ON/OFF] condition of unlock signal from lock/unlock switch.
KEY CYL LK SW	Indicates [ON/OFF] condition of lock signal from door key cylinder switch.
LK BUTTON/SIG	Indicates [ON/OFF] condition of lock signal from key fob.
UN BUTTON/SIG	Indicates [ON/OFF] condition of unlock signal from key fob.
PANIC BTN	Indicates [ON/OFF] condition of panic signal from key fob.
TRUNK OPNR SW	Indicates [ON/OFF] condition of trunk room lamp switch (For Roadster).
TRUNK BTN/SIG	Indicates [ON/OFF] condition of back door open signal from key fob.
	Indicates [ON/OFF] condition of trunk open signal from key fob. (For Roadster)
TRUNK OPN MNTR	Indicates [ON/OFF] condition of trunk lid opener switch. (For Roadster)
UN BUTTON ON	Indicates [ON/OFF] condition of unlock signal from key fob.
LK/UN BTN ON	Indicates [ON/OFF] condition of lock/unlock signal at the same time from key fob.
DOOR SW-RR	This is displayed even when it is not equipped.

Active Test

Test Item	Description
INT LAMP	This test is able to check interior lamp operation. The interior lamp is turned on when "ON" on CONSULT-II screen is touched.
IGN ILLUM	This is displayed even when it is not equipped.
TRUNK/BACK DOOR	This test is able to check back door (For Coupe) or trunk lid (For Roadster) opener actuator operation. The back door (For Coupe) or trunk (For Roadster) is unlocked when "ON" on CONSULT-II screen is touched.
HORN	This test is able to check panic alarm and horn reminder operations. The horn activate for 0.02 seconds after "ON" on CONSULT-II screen is touched.
HEAD LAMP(HI)	This test is able to check headlamps panic alarm operation. The headlamp illuminates for 0.5 seconds after "ON" on CONSULT-II screen is touched.
POWER WINDOW DOWN	This test is able to check power window open operation. The front power windows activate for 10 seconds after "ON" or CONSULT-II screen is touched.
FLASHER RIGHT	This test is able to check hazard reminder operation. The right hazard lamp turns on when "ON" on CONSULT-II screen is touched.
FLASHER LEFT	This test is able to check hazard reminder operation. The left hazard lamp turns on when "ON" on CONSULT-II screen is touched.
FLASHER RIGHT (CAN)	This test is able to check hazard reminder operation. The right hazard indicator lamp turns on when "ON" on CONSULT-II screen is touched.
FLASHER LEFT (CAN)	This test is able to check hazard reminder operation. The left hazard indicator lamp turns on when "ON" on CONSULT-II screen is touched.

REMOTE KEYLESS ENTRY SYSTEM

AIS004U6

CONSULT-II Inspection Procedure for IPDM E/R

CAUTION:

If CONSULT-II is used with no connection of CONSULT-II CONVERTER, malfunctions might be detected in self-diagnosis depending on control unit which carry out CAN communication.

“IPDM E/R”

1. Turn ignition switch “OFF”.
2. Connect “CONSULT-II” and “CONSULT-II CONVERTER” to the data link connector.

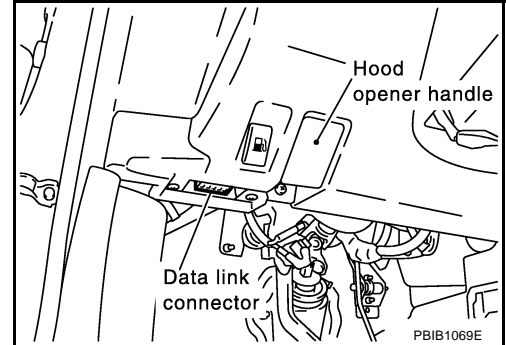

3. Turn ignition switch “ON”.
4. Touch “START(NISSAN BASED VHCL)”.

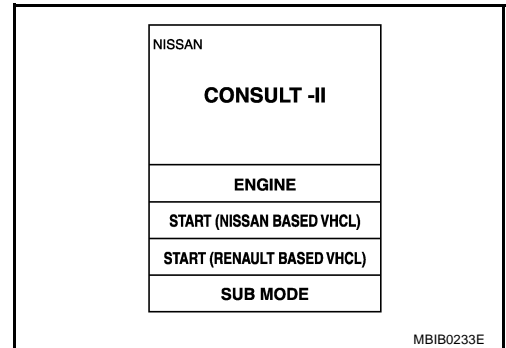

5. Touch “IPDM E/R”.
- If “IPDM E/R” is not indicated, go to [GI-39, "CONSULT-II Data Link Connector \(DLC\) Circuit"](#).

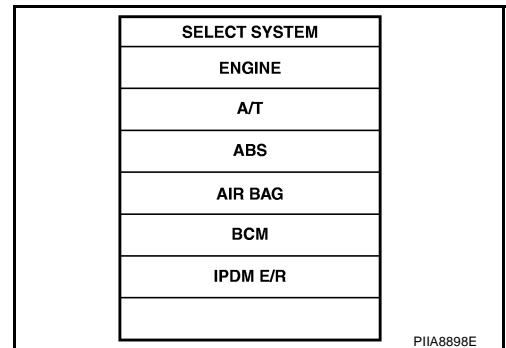

6. Select diagnosis mode. “SELF-DIAG RESULTS”, “DATA MONITOR” and “ACTIVE TEST” are available.

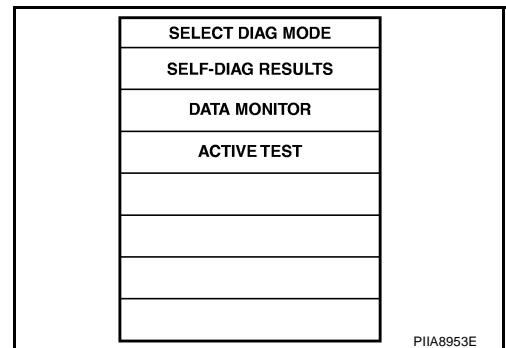

REMOTE KEYLESS ENTRY SYSTEM

CONSULT-II Application Items for IPDM E/R DATA MONITOR

AIS004U7

Monitored Item	Description
HORN CHIRP	Indicates [ON/OFF] condition of horn function by IPDM E/R.

ACTIVE TEST

Test Item	Description
HORN	This test is able to check horn operation. Horn activates when "ON" on CONSULT-II screen is touched.

Work Flow

AIS000CT

1. Check the trouble symptom and customer's requests.
2. Understand outline of system. Refer to [BL-65, "System Description"](#) .
3. Confirm that power door lock system operates normally. Refer to [BL-21, "POWER DOOR LOCK SYSTEM"](#) .
4. Refer to trouble diagnosis chart by symptom, repair or replace any malfunctioning parts. Refer to [BL-81, "Trouble Diagnosis Chart by Symptom"](#) .
5. Inspection end.

Trouble Diagnosis Chart by Symptom

AIS000CV

NOTE:

- Always check the "Work Flow" before troubleshooting. Refer to [BL-81, "Work Flow"](#) .
- Always check key fob battery before replacing key fob.
- The panic alarm operation, back door or trunk lid (Roadster models) opener operation and keyless power window down operation of remote keyless entry system do not activate with the ignition key inserted in the ignition key cylinder.

Symptom	Diagnoses/service procedure	Reference page
All functions of remote keyless entry system do not operate.	1. Key fob battery and function check	BL-83
	2. Replace key fob. Refer to ID Code Entry Procedure. NOTE: If the result of key fob function check with CONSULT-II is OK, key fob is not malfunctioning.	BL-92
	3. Replace BCM	BCS-17
The new ID of key fob cannot be entered without CONSULT-II.	1. Key fob battery and function check	BL-83
	2. Key switch check	BL-89
	3. Door switch check	BL-85
	4. ACC switch check	BL-84
	5. Door lock and unlock switch check	BL-43
	6. Replace key fob. Refer to ID Code Entry Procedure. NOTE: If the result of key fob function check with CONSULT-II is OK, key fob is not malfunctioning.	BL-92
	7. Replace BCM	BCS-17
Door lock or unlock does not work.	1. Door lock operation check.	BL-23
	2. Key fob battery and function check.	BL-83
	3. Replace key fob. Refer to ID Code Entry Procedure. NOTE: If the result of key fob function check with CONSULT-II is OK, key fob is not malfunctioning.	BL-92
	4. Replace BCM	BCS-17

REMOTE KEYLESS ENTRY SYSTEM

Symptom	Diagnoses/service procedure	Reference page
Back door does not open when back door opener button is continuously pressed.	1. Back door opener operation check.	BL-23
	2. Back door open operation mode check.	BL-78
	3. Key fob battery and function check	BL-83
	4. Key switch check	BL-89
	5. Replace BCM	BCS-17
Trunk does not open when trunk opener button is continuously pressed. (Roadster models)	1. Trunk opener operation check.	BL-120
	2. Trunk open operation mode check.	BL-78
	3. Key fob battery and function check	BL-83
	4. Key switch check	BL-89
	5. Replace BCM	BCS-17
Hazard reminder does not activate properly when pressing lock or unlock button of key fob.	1. Hazard reminder mode check* *: Hazard reminder can be activated or deactivated. First check the hazard reminder setting.	BL-78
	2. Check hazard warning lamp function with hazard switch.	LT-136
	3. Door switch check	BL-85
	4. Replace BCM	BCS-17
Horn reminder does not activate properly when pressing lock button of key fob.	1. Horn reminder mode check* *: Horn reminder can be activated or deactivated. First check the horn chirp setting.	BL-78
	2. Check horn chirp function with horn switch.	BL-91
	3. Door switch check	BL-85
	4. IPDM E/R operation check	BL-90
	5. Replace BCM	BCS-17
Interior lamp and step lamp operation do not activate properly.	1. Interior lamp and step lamp operation check	BL-91
	2. Door switch check	BL-85
	3. Replace BCM	BCS-17
Panic alarm (horn and headlamp) does not activate when panic alarm button is continuously pressed.	1. Panic alarm mode check* *: Panic alarm can be activated or deactivated. First check the Panic alarm setting.	BL-78
	2. Key fob battery and function check	BL-83
	3. Headlamp alarm check	BL-91
	4. Check horn chirp function with horn switch.	BL-91
	5. IPDM E/R operation check	BL-90
	6. Key switch check	BL-89
	7. Replace key fob. Refer to ID Code Entry Procedure. NOTE: If the result of key fob function check with CONSULT-II is OK, key fob is not malfunctioning.	BL-92
	8. Replace BCM	BCS-17
Auto door lock operation does not activate properly. (All other remote keyless entry system function is OK.)	1. Auto door lock operation mode check* *: Auto door lock operation can be activated or deactivated. First check the auto door lock operation setting.	BL-78
	2. Replace BCM	BCS-17
Keyless power window down (open) operation does not activate properly. (All other remote keyless entry system function is OK.)	1. Power window down operation mode check* *: Power window down operation can be activated or deactivated. First check the power window down setting.	BL-78
	2. Check power window function	GW-19
	3. Replace BCM	BCS-17

REMOTE KEYLESS ENTRY SYSTEM

AIS000CW

Key Fob Battery and Function Check

1. CHECK KEY FOB BATTERY

1. Remove key fob battery. Refer to [BL-95, "Key Fob Battery Replacement"](#).
2. Measure voltage between battery positive and negative terminals.

Voltage : 2.5V - 3.0V

NOTE:

Key fob does not function if battery is not set correctly.

OK or NG

- OK >> GO TO 2
 NG >> Replace battery.

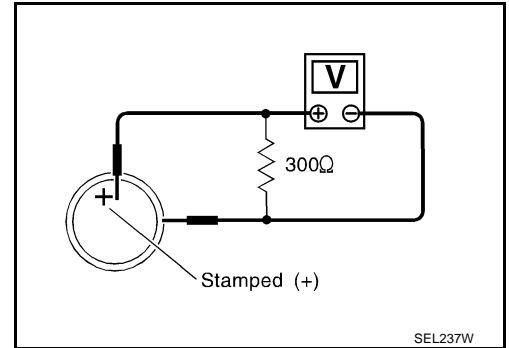

2. CHECK KEY FOB FUNCTION

With CONSULT-II

Check key fob function in "DATA MONITOR" mode with CONSULT-II.

When pushing each button of key fob, the corresponding monitor item should be turned as follows.

Condition	Monitor item
Pushing LOCK	LK BUTTON/SIG : ON
Pushing UNLOCK	UN BUTTON/SIG : ON
Keep pushing UNLOCK	UN BUTTON ON : ON*
	*: "UN BUTTON ON" turns to ON 3 seconds after UNLOCK button keeps pushing.
Pushing TRUNK	TRUNK BTN/SIG : ON
Pushing PANIC	PANIC BTN : ON
Pushing LOCK and UNLOCK at the same time	LK/UN BTN ON : ON

DATA MONITOR	
MONITOR	
LK BUTTON/SIG	OFF
UN BUTTON/SIG	OFF
UN BUTTON ON	OFF
TRUNK BTN/SIG	OFF
PANIC BTN	OFF
LK/UN BTN ON	OFF

OK or NG

- OK >> Key fob is OK.
 NG >> Replace key fob.

REMOTE KEYLESS ENTRY SYSTEM

AIS0010V

ACC Switch Check

1. CHECK ACC SWITCH

With CONSULT-II

Check ACC switch ("ACC SW") in "DATA MONITOR" mode with CONSULT-II.

Monitor item	Condition
ACC SW	Ignition switch position is ACC or ON : ON
	Ignition switch position is OFF : OFF

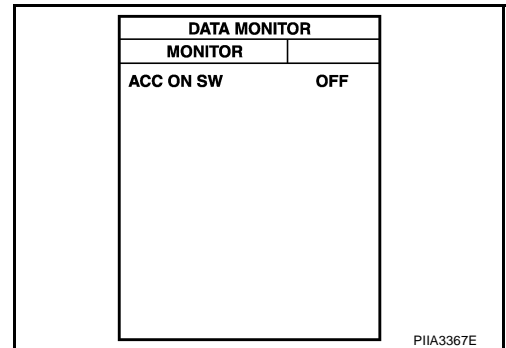

Without CONSULT-II

Check voltage between BCM connector and ground.

Item	Terminals (Wire color)			Condition	Voltage [V] (Approx.)
	(+)		(-)		
	Con- nector	Terminal (Wire color)			
Ignition switch	M1	36 (LG)	Ground	ACC or ON	Battery voltage
				OFF	0

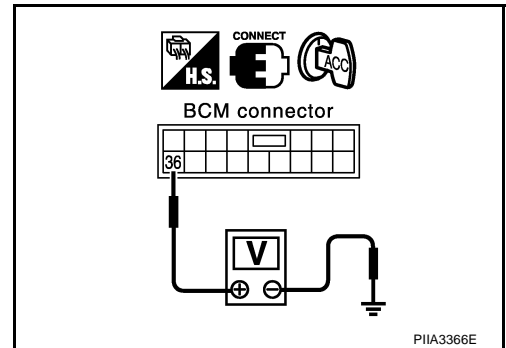

OK or NG

OK >> ACC switch is OK.

NG >> Check the following.

- 10A fuse [No. 6, located in fuse block (J/B)]
- Harness for open or short between BCM and fuse.

REMOTE KEYLESS ENTRY SYSTEM

AIS000CX

Door Switch Check

DRIVER SIDE DOOR SWITCH AND PASSENGER SIDE DOOR SWITCH CHECK

1. CHECK DOOR SWITCH INPUT SIGNAL

① With CONSULT-II

Check door switches ("DOOR SW-DR" and "DOOR SW-AS") in "DATA MONITOR" mode with CONSULT-II.

Monitor item	Condition	
DOOR SW-DR	OPEN	: ON
	CLOSE	: OFF
DOOR SW-AS	OPEN	: ON
	CLOSE	: OFF

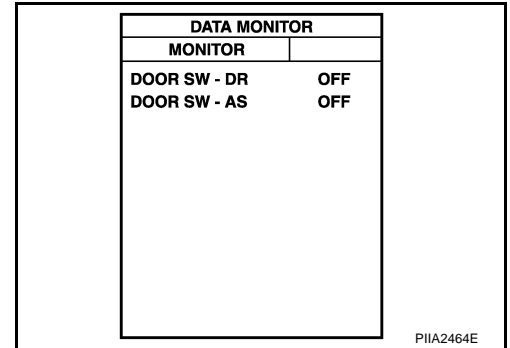

⊗ Without CONSULT-II

Check voltage between BCM connector and ground.

Item	Terminals (Wire color)		Condition	Voltage [V] (Approx.)
	(+)	(-)		
Passenger side door switch	B4	10 (P)	OPEN	0
			CLOSE	5
Driver side door switch		14 (W)	OPEN	0
			CLOSE	5

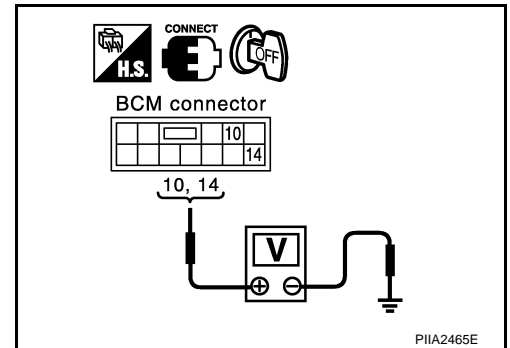

OK or NG

- OK >> Door switch is OK.
- NG >> GO TO 2

2. CHECK DOOR SWITCH

1. Turn ignition switch OFF.
2. Disconnect door switch and BCM connector.
3. Check continuity between door switch connector B17, B23 terminal 1 (P, W) and BCM connector B4 terminal 10 (P), 14 (W).

Passenger side door

1 (P) - 10 (P) :Continuity should exist.

Driver side door

1 (W) - 14 (W) :Continuity should exist.

4. Check continuity between door switch connector B17, B23 terminal 1(P, W) and ground.

Each door switch

1 (P, W) - Ground :Continuity should not exist.

OK or NG

- OK >> Check door switch.
- NG >> Repair or replace door switch harness.

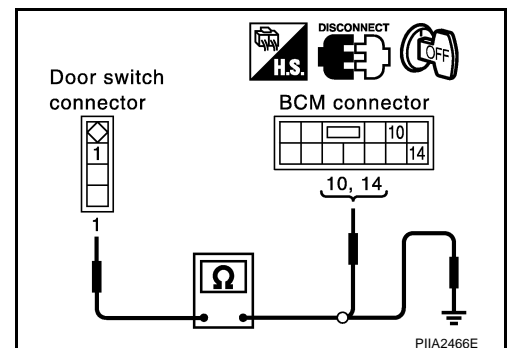

REMOTE KEYLESS ENTRY SYSTEM

BACK DOOR SWITCH CHECK/FOR COUPE

1. CHECK BACK DOOR SWITCH INPUT SIGNAL

④ With CONSULT-II

Check back door switch ("BACK DOOR SW") in "DATA MONITOR" mode with CONSULT-II.

Monitor item	Condition
BACK DOOR SW	OPEN : ON
	CLOSE : OFF

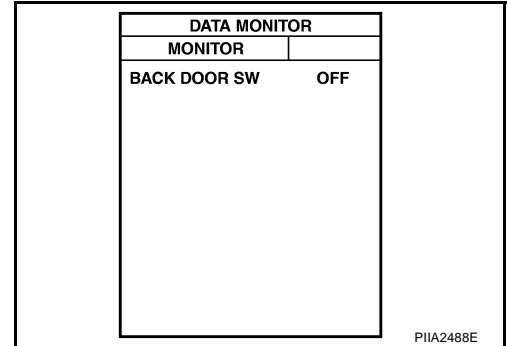

⊗ Without CONSULT-II

1. Turn ignition switch OFF.
2. Check voltage between BCM connector and ground.

Item	Terminals (Wire color)			Condition	Voltage (V) (Approx.)
	Con- nector	(+)			
		Terminal (Wire color)			
Back door switch	B4	18 (R/W)	Ground	OPEN	0
				CLOSE	Battery voltage*

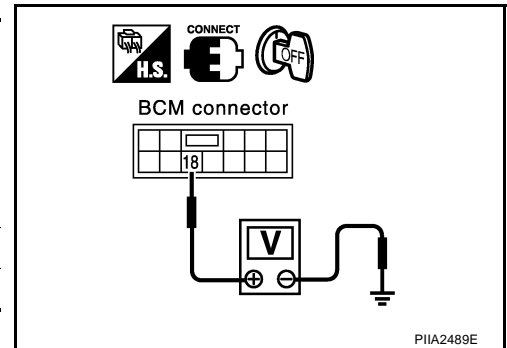

* : When interior lamp battery saver control is in OFF. → Approx. 5V

OK or NG

- OK >> Back door switch circuit is OK.
 NG >> GO TO 2.

2. CHECK DOOR SWITCH HARNESS

1. Turn ignition switch OFF.
2. Disconnect back door switch and BCM connector.
3. Check continuity between BCM connector B4 terminal 18 (R/W) and back door switch connector T12 terminal 1 (R).

18 (R/W) - 1 (R) :Continuity should exist.

4. Check continuity between BCM connector B4 terminal 18(R/W) and ground.

18 (R/W) - Ground :Continuity should not exist.

OK or NG

- OK >> GO TO 3.
 NG >> Repair or replace back door switch harness.

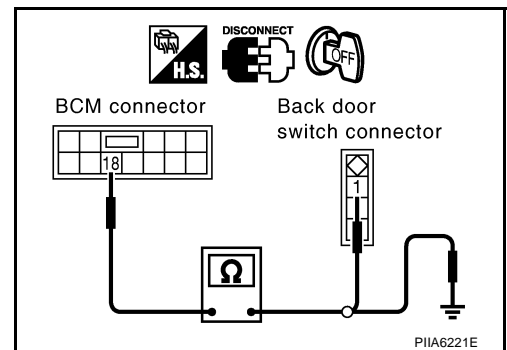

REMOTE KEYLESS ENTRY SYSTEM

3. CHECK BACK DOOR SWITCH

Check continuity between back door switch terminals 1 and 3.

Terminal	Back door switch condition	Continuity
1 - 3	Open position	Yes
	Closed position	No

OK or NG

OK >> GO TO 4.

NG >> Replace back door switch.

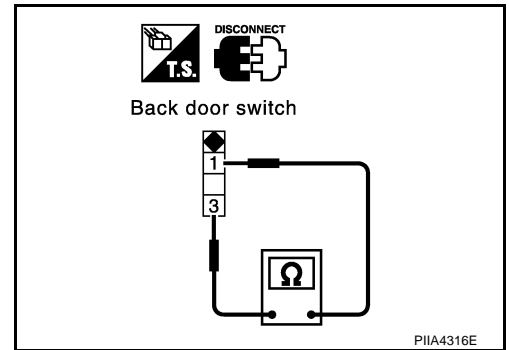

4. CHECK BACK DOOR SWITCH

Check continuity between door switch connector T12 terminal 3 (B) and ground.

3 (B) - Ground : Continuity should exist.

OK or NG

OK >> Check harness connection.

NG >> Repair or replace back door switch harness.

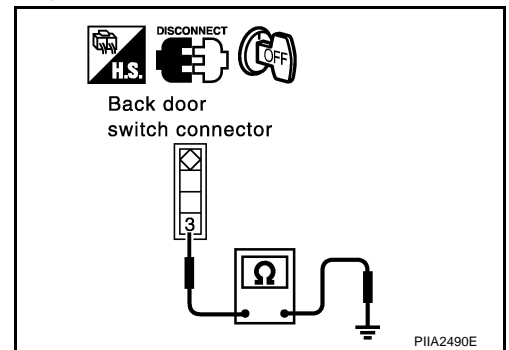

A
B
C
D
E
F
G
H
BL
J
K
L
M

REMOTE KEYLESS ENTRY SYSTEM

AIS003XV

Trunk Room Lamp Switch Check/For Roadster

1. CHECK TRUNK ROOM LAMP SWITCH INPUT SIGNAL

With CONSULT-II

Check trunk lid opener switch ("TRUNK OPN MNTR") in "DATA MONITOR" mode with CONSULT-II.

Monitor item	Condition
TRNK OPN MNTR	OPEN : ON
	CLOSE : OFF

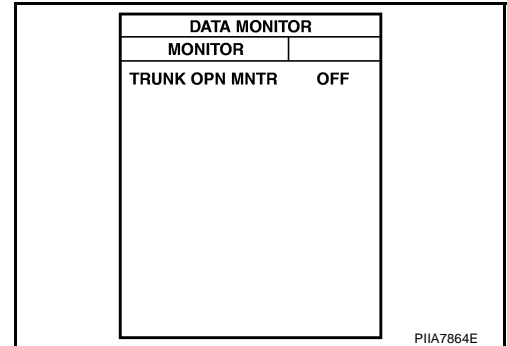

Without CONSULT-II

Check voltage between BCM connector and ground.

Item	Terminals (Wire color)		Condition	Voltage [V] (Approx.)
	(+)	(-)		
Trunk room lamp	B4	18 (R/W)	OPEN	0
			CLOSE	Battery voltage*

*: When interior lamp battery saver control is in OFF. → Approx. 5V.

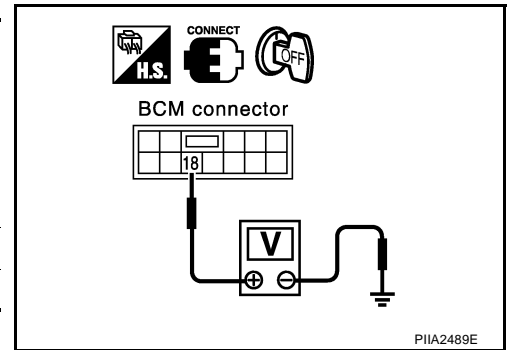

OK or NG

- OK >> Trunk room lamp switch is OK.
- NG >> GO TO 2.

2. CHECK TRUNK ROOM LAMP SWITCH HARNESS

1. Turn ignition switch OFF.
2. Disconnect back door switch and BCM connector.
3. Check continuity between trunk room lamp switch connector T30 terminal 1 (R) and BCM connector B4 terminal 18 (R/W).

1 (R) - 18 (R/W) :Continuity should exist.

4. Check continuity between back door switch connector T12 terminal 1(R/W) and ground.

1 (R) - Ground :Continuity should not exist.

OK or NG

- OK >> GO TO 3.
- NG >> Repair or replace trunk room lamp switch harness.

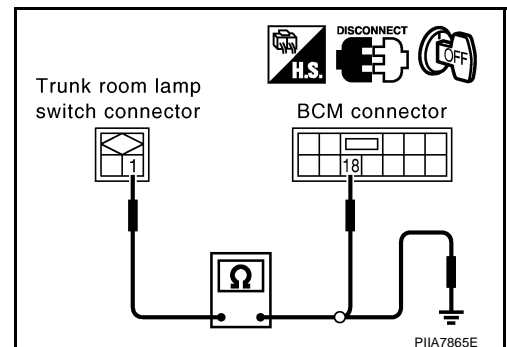

REMOTE KEYLESS ENTRY SYSTEM

3. CHECK TRUNK ROOM LAMP SWITCH

1. Turn ignition switch OFF.
2. Disconnect trunk room lamp switch and BCM connector.
3. Check continuity between trunk room lamp connector T31 terminal 2 (B) and ground.

2 (B) - Ground :Continuity should exist.

OK or NG

- OK >> Check trunk room lamp switch.
- NG >> Repair or replace trunk room lamp switch harness.

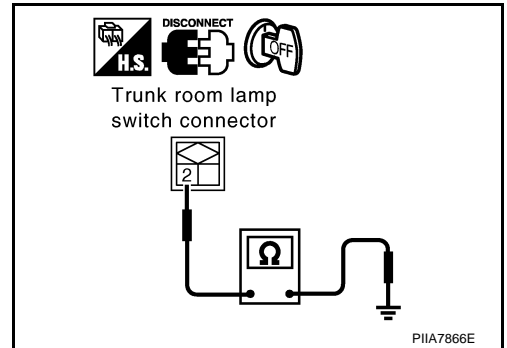

AIS000CZ

Key Switch Check

1. CHECK KEY SWITCH INPUT SIGNAL

With CONSULT-II

Check ignition key cylinder switch "KEY ON SW" in "DATE MONITOR" mode with CONSULT-II

- When key is inserted in ignition key cylinder
KEY ON SW :ON
- When key is removed in ignition key cylinder
KEY ON SW :OFF

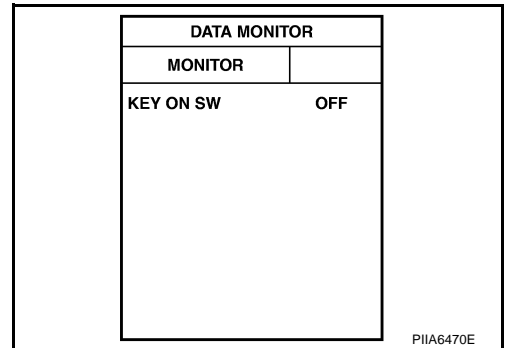

Without CONSULT-II

Check voltage between BCM connector and ground.

Connector	Terminal (Wire color)		Condition of key switch	Voltage (V) (Approx.)
	(+)	(-)		
M3	62 (B/R)	Ground	Key is inserted.	Battery voltage
			Key is removed.	0

OK or NG

- OK >> Key switch is OK.
- NG >> GO TO 2.

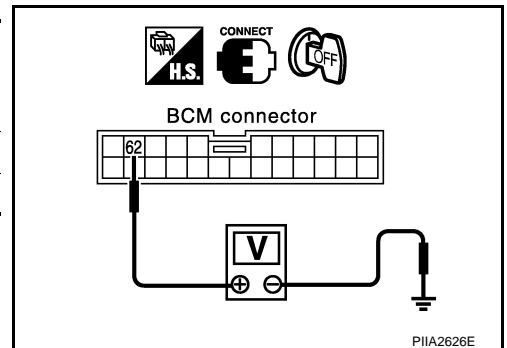

REMOTE KEYLESS ENTRY SYSTEM

2. CHECK KEY SWITCH

Check continuity key switch terminal.

Connector	Terminal	Condition of key switch	Continuity
M25	1 – 2	Key is inserted.	Yes
		Key is removed.	No

OK or NG?

OK >> Check the following.

- 10A fuse [No. 21, located in fuse block (J/B)]
- Harness for open or short between key switch and fuse
- Harness for open or short between BCM and key switch

NG >> Replace key switch.

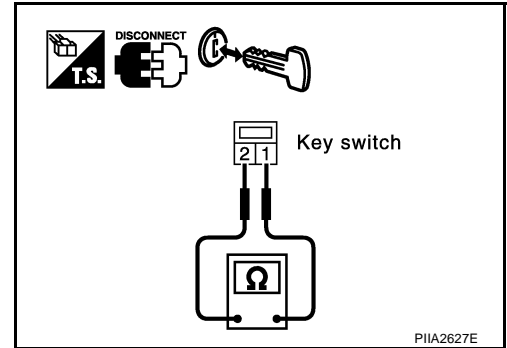

IPDM E/R Operation Check

AIS001NY

1. CHECK IPDM E/R INPUT VOLTAGE

Check voltage between IPDM E/R connector E9 terminal 51 (G/B) and ground.

51 (G/B) – Ground : Battery voltage.

OK or NG

OK >> Replace IPDM E/R.

NG >> GO TO 2.

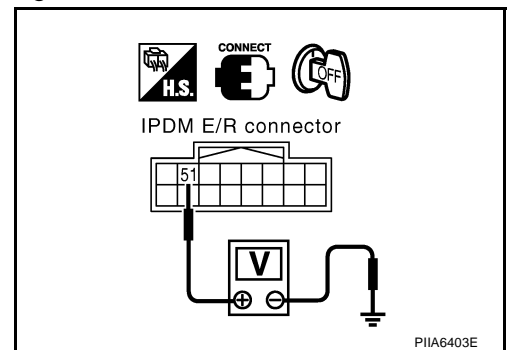

2. CHECK IPDM E/R HARNESS

1. Turn ignition switch OFF.
2. Disconnect IPDM E/R and horn relay connector.
3. Check continuity between IPDM E/R connector E9 terminal 51 (G/B) and horn relay connector E21 terminal 1 (G/B).

1 (G/B) - 51(G/B) :Continuity should exist.

OK or NG

OK >> Check harness connection.

NG >> Repair or replace harness.

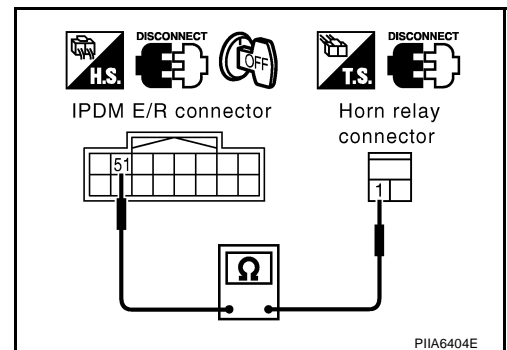

REMOTE KEYLESS ENTRY SYSTEM

Horn Function Check

AIS000D2

First perform the "SELF-DIAG RESULTS" in "BCM" with CONSULT-II, then perform the trouble diagnosis of malfunction system indicated "SELF-DIAG RESULTS" of "BCM". Refer to [BCS-15, "CAN Communication Inspection Using CONSULT-II \(Self-Diagnosis\)"](#) .

1. CHECK HORN OPERATION

Check if horn sounds with horn switch.

Does horn operate?

Yes >> Horn circuit is OK.

No >> Check horn circuit. Refer to [WW-52, "Wiring Diagram — HORN —"](#) .

Headlamp Alarm Check

AIS0010W

First perform the "SELF-DIAG RESULTS" in "BCM" with CONSULT-II, then perform the trouble diagnosis of malfunction system indicated "SELF-DIAG RESULTS" of "BCM". Refer to [BCS-15, "CAN Communication Inspection Using CONSULT-II \(Self-Diagnosis\)"](#) .

1. CHECK HEADLAMP OPERATION

Does headlamp come on when turning lighting switch "ON".

YES or NO

Yes >> Headlamp alarm circuit is OK.

No >> Check headlamp system. Refer to [LT-7, "HEADLAMP \(FOR USA\) - XENON TYPE -"](#) , [LT-37, "HEADLAMP \(FOR USA\) - CONVENTIONAL TYPE -"](#) , [LT-66, "HEADLAMP \(FOR CANADA\) - XENON TYPE -"](#) , [LT-101, "HEADLAMP \(FOR CANADA\) - CONVENTIONAL TYPE -"](#) .

Interior Lamp and Step Lamp Operation Check

AIS000D3

1. CHECK ILLUMINATION OPERATION

When interior lamp switch is in "DOOR" position, open the door (driver side or passenger side).

Interior lamp and step lamp should illuminate.

OK or NG

OK >> Interior lamp and step lamp circuit is OK.

NG >> Check illumination circuit. Refer to [LT-210, "Wiring Diagram — ROOM/L —"](#) .

A
B
C
D
E
F
G
H
J
K
L
M

BL

REMOTE KEYLESS ENTRY SYSTEM

AIS000D4

ID Code Entry Procedure KEY FOB ID SETUP WITH CONSULT-II

CAUTION:

If CONSULT-II is used with no connection of CONSULT-II CONVERTER, malfunctions might be detected in self-diagnosis depending on control unit which carry out CAN communication.

NOTE:

If a key fob is lost, the ID code of the lost key fob must be erased to prevent unauthorized use. When the ID code of a lost key fob is not known, all controller ID codes should be erased. After all ID codes are erased, the ID codes of all remaining and/or new key fobs must be re-registered.

1. Turn ignition switch "OFF".
2. Connect "CONSULT-II" and "CONSULT-II CONVERTER" to the data link connector.

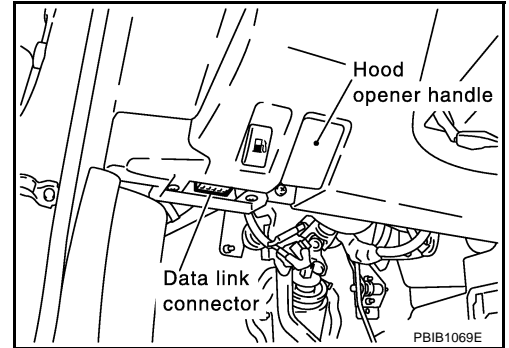

3. Turn ignition switch ON.
4. Touch "START (NISSAN BASED VHCL)".

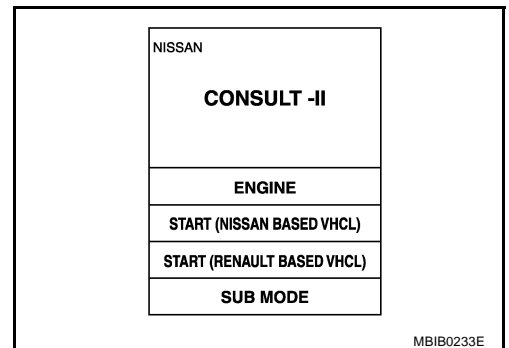

5. Touch "BCM".
If "BCM" is not indicated, go to [GI-39, "CONSULT-II Data Link Connector \(DLC\) Circuit"](#).

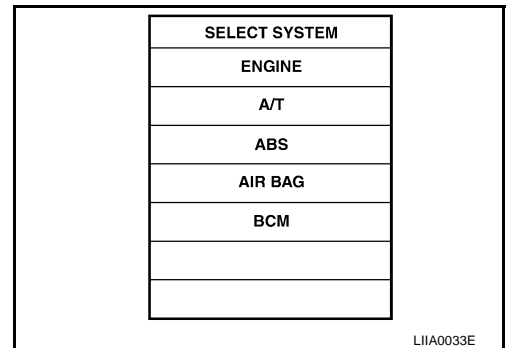

6. Touch "MULTI REMOTE ENT".

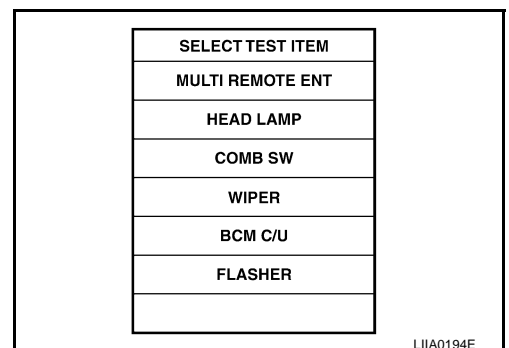

REMOTE KEYLESS ENTRY SYSTEM

7. Touch "WORK SUPPORT".

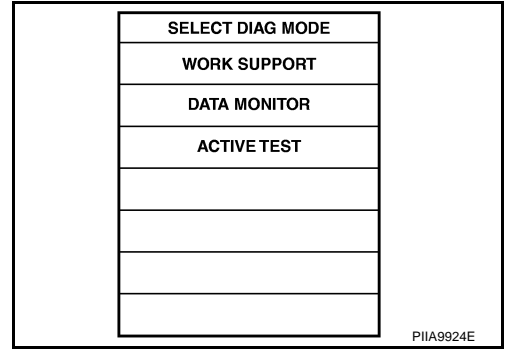

A
B
C
D

8. The items shown on the figure can be set up.

- "REMO CONT ID REGIST"
Use this mode to register a key fob ID code.

NOTE:

Register the ID code when key fob or BCM is replaced, or when additional key fob is required.

- "REMO CONT ID ERASUR"
Use this mode to erase a key fob ID code.
- "REMO CONT ID CONFIR"
Use this mode to confirm if a key fob ID code is registered or not.

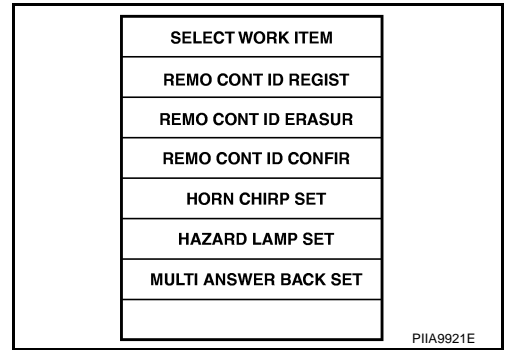

E
F
G
H

BL

J
K
L
M

REMOTE KEYLESS ENTRY SYSTEM

KEY FOB ID SETUP WITHOUT CONSULT-II

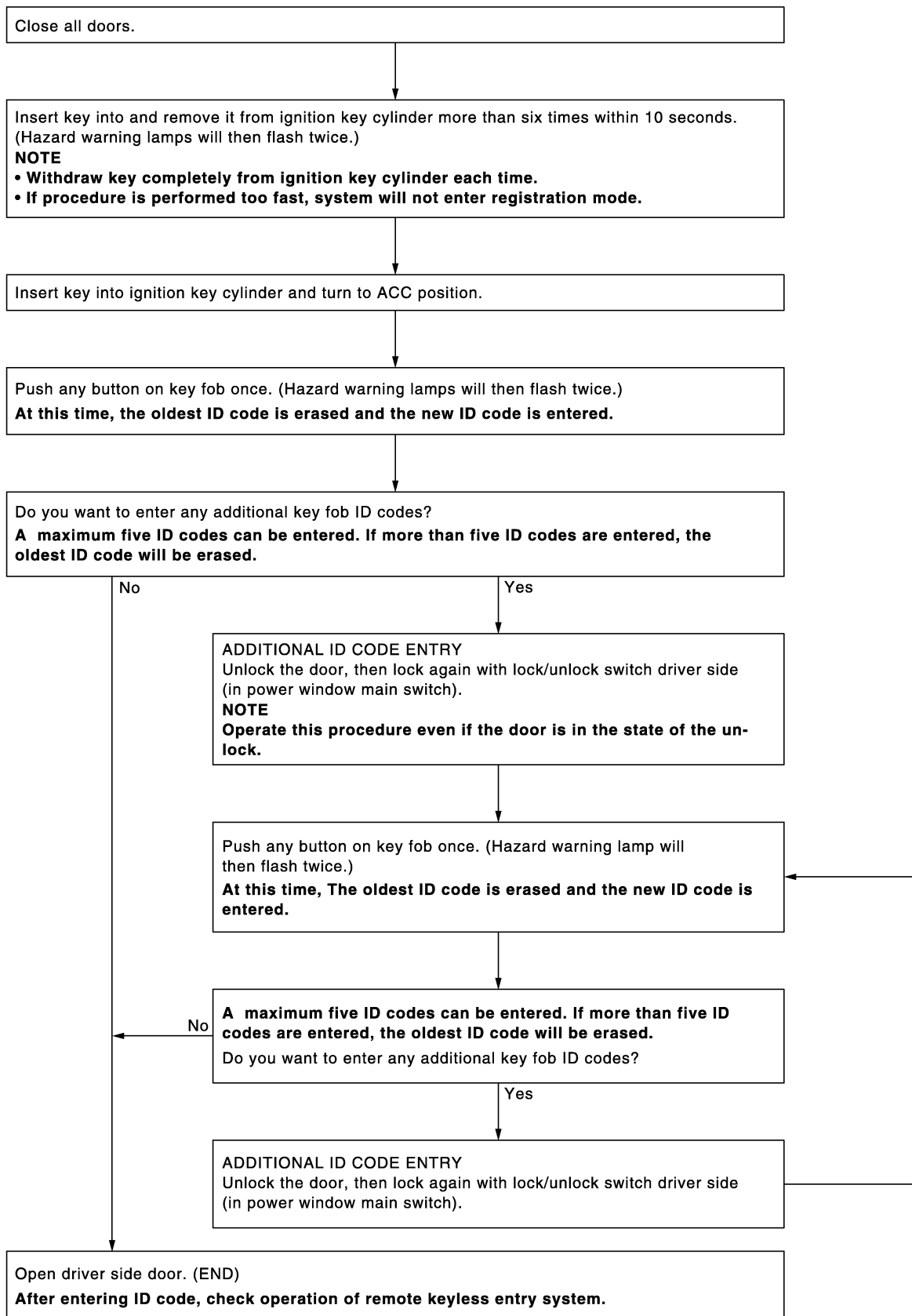

PIIA2839E

REMOTE KEYLESS ENTRY SYSTEM

NOTE:

- If a key fob is lost, the ID code of the lost key fob must be erased to prevent unauthorized use. A specific ID code can be erased with CONSULT-II. However, when the ID code of a lost key fob is not known, all controller ID codes should be erased. After all ID codes are erased, the ID codes of all remaining and/or new key fobs must be re-registered.
To erase all ID codes in memory, register one ID code (key fob) five times. After all ID codes are erased, the ID codes of all remaining and/or new key fobs must be re-registered.
- When registering an additional key fob, the existing ID codes in memory may or may not be erased. If five ID codes are stored in memory, when an additional code is registered, only the oldest code is erased. If less than five ID codes are stored in memory, when an additional ID code is registered, the new ID code is added and no ID codes are erased.
- If you need to activate more than two additional new key fobs, repeat the procedure "Additional ID code entry" for each new key fob.
- Entry of maximum five ID codes is allowed. When more than five ID codes are entered, the oldest ID code will be erased.
- Even if same ID code that is already in the memory is input, the same ID code can be entered. The code is counted as an additional code.

Key Fob Battery Replacement

AIS000D5

NOTE:

- Be careful not to touch the circuit board or battery terminal.
- The keyfob is water-resistant. However, if it does get wet, immediately wipe it dry.

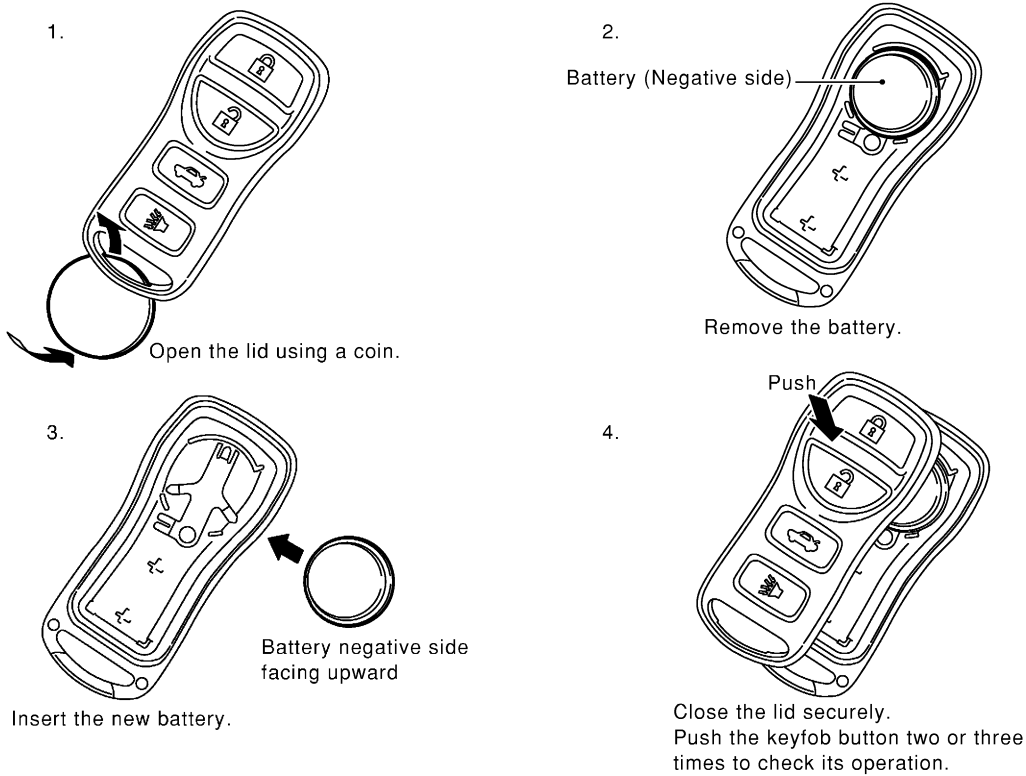

DOOR

PFP:80100

AIS000D6

DOOR

Fitting Adjustment COUPE

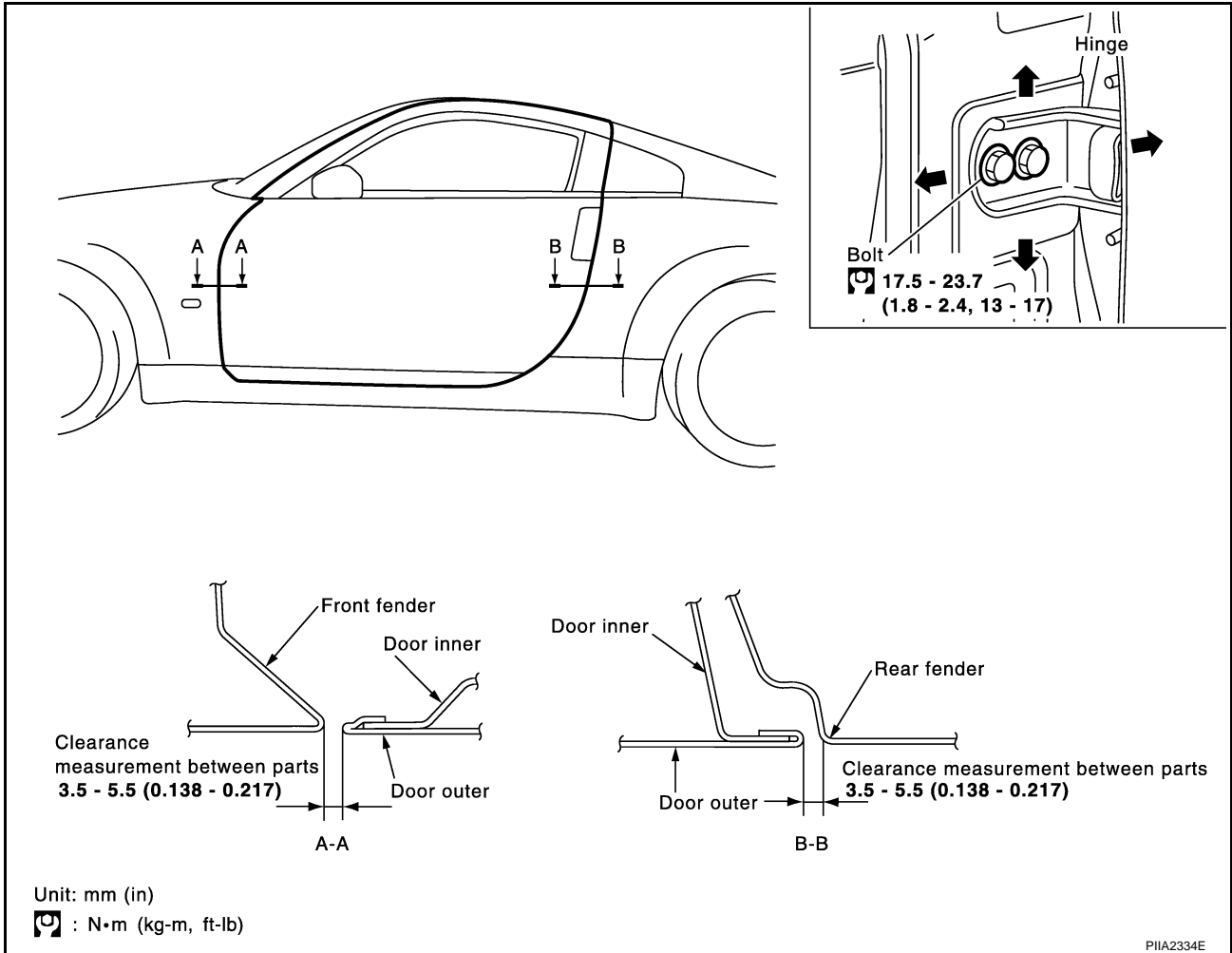

DOOR

ROADSTER

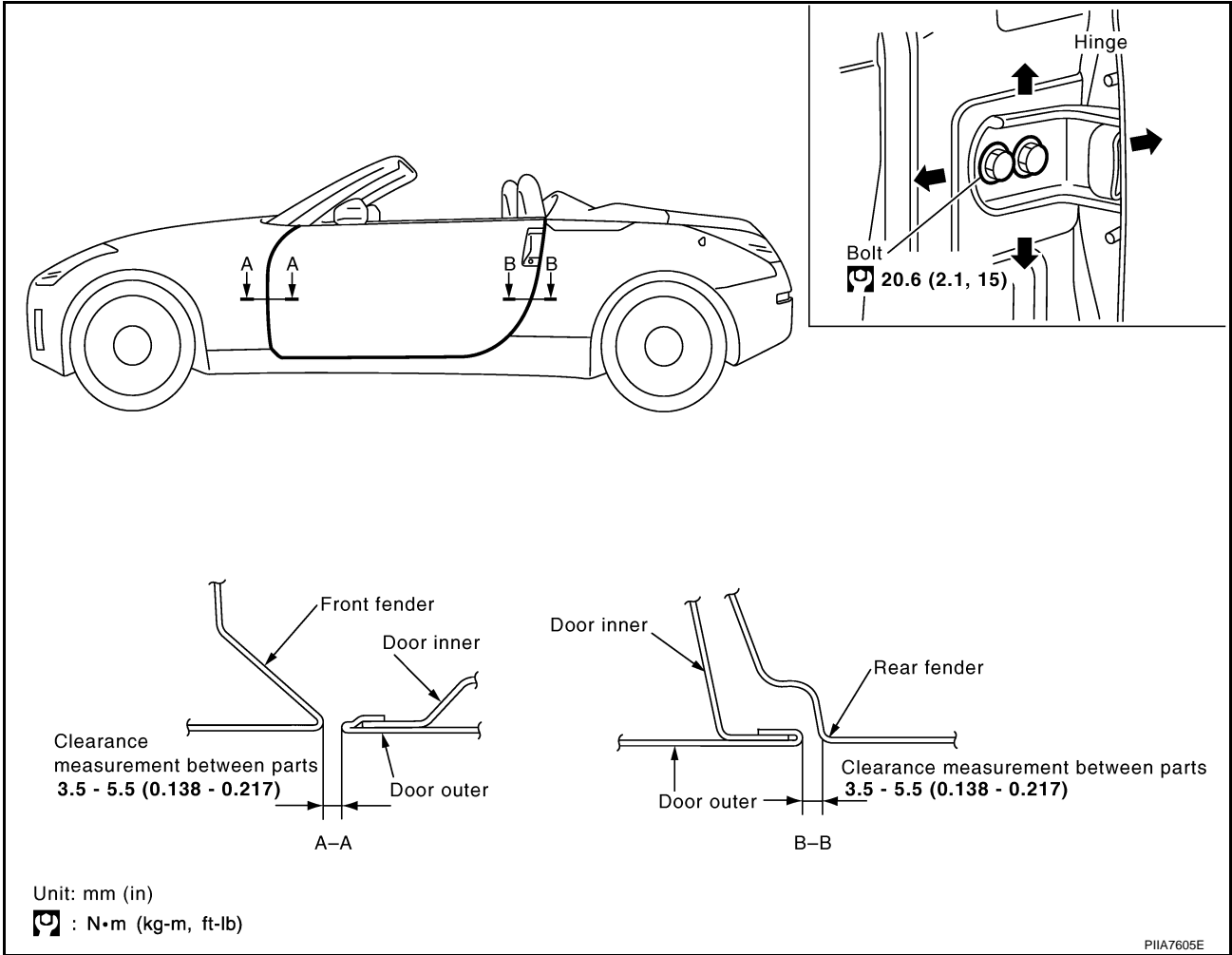

A
B
C
D
E
F
G
H
BL
J
K
L
M

DOOR

Longitudinal Clearance and Surface Height Adjustment at Front End

1. Remove the fender protector. Refer to [EI-21, "FENDER PROTECTOR"](#).
2. Loosen the hinge mounting bolts. Raise the door at rear end to adjust.

STRIKER ADJUSTMENT

1. Adjust the striker so that it becomes parallel with the lock insertion direction.

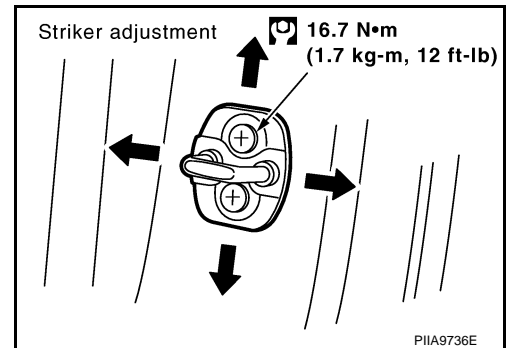

DOOR

DOVE TAIL FEMALE ADJUSTMENT (ROADSTER)

1. Adjust the dove tail female so that it becomes parallel with the lock insertion direction.

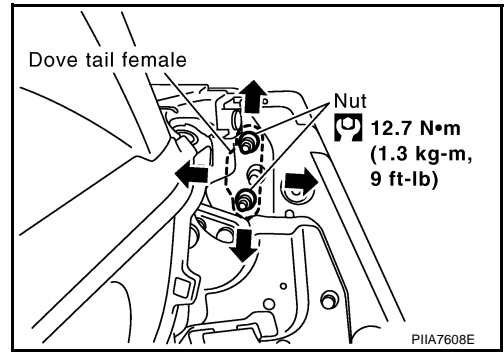

Removal and Installation

CAUTION:

- When removing and installing the door assembly, support the door with a jack and shop cloth to protect the door and body.
- When removing and installing door assembly, be sure to carry out the fitting adjustment.
- Check the hinge rotating part for poor lubrication. If necessary, apply “body grease”.
- After installing, check operation.

REMOVAL

1. Pull the lever and remove the door harness connector while removing tabs of door harness connector.

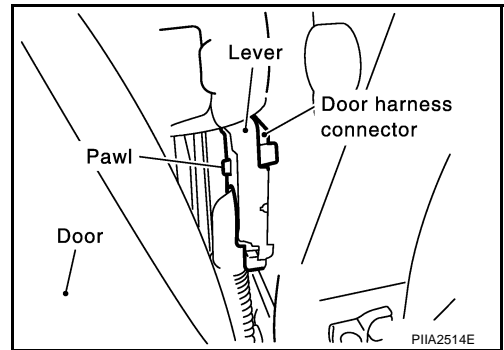

2. Remove the mounting bolts of the check link on the vehicle.

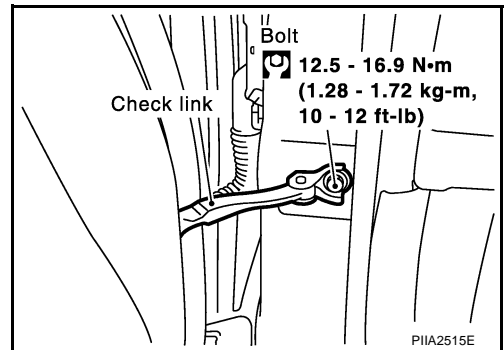

3. Remove the door-side hinge mounting nuts, and remove the door assembly.

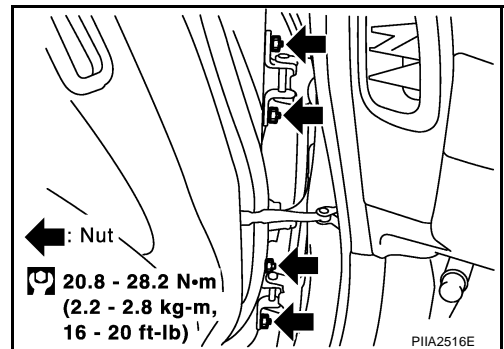

DOOR

INSTALLATION

Install in the reverse order of removal.

A

B

C

D

E

F

G

H

BL

J

K

L

M

DOOR

Removal and Installation of Dove Tail Male & Female (Roadster)

AIS003X8

REMOVAL

1. Remove the TORX bolts (T30) of dove tail male.

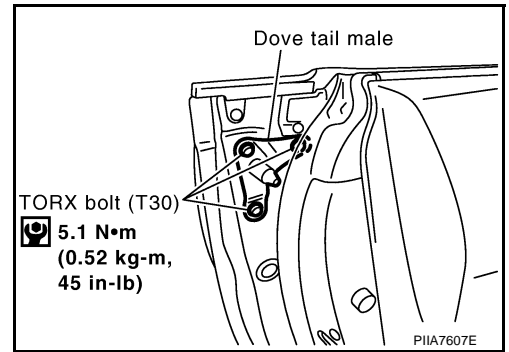

2. Holding roof locate like a figure.

3. Remove the body side welt. Refer to [EI-36, "Removal and Installation \(for Roadster Models\)"](#).

4. Remove the rear side finisher and kicking plate inner. Refer to [EI-36, "Removal and Installation \(for Roadster Models\)"](#).

5. Remove the shoulder anchor. Refer to [SB-6, "Removal and Installation of Seat Belt \(Roadster\)"](#).

6. Remove the rear side trim. Refer to [EI-36, "Removal and Installation \(for Roadster Models\)"](#).

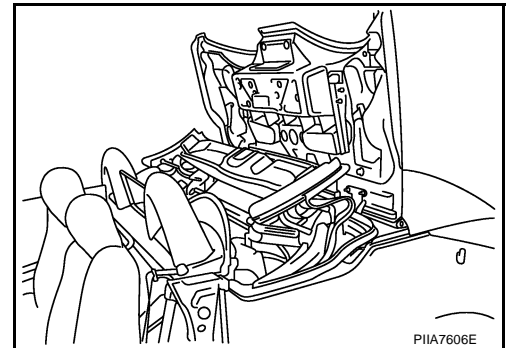

7. Remove the dove tail female mounting nuts. Remove the dove tail female.

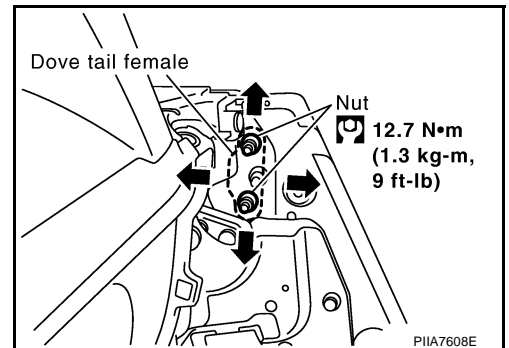

INSTALLATION

Install in the reverse order of removal.

DOOR

Door Weatherstrip

AI5000DB

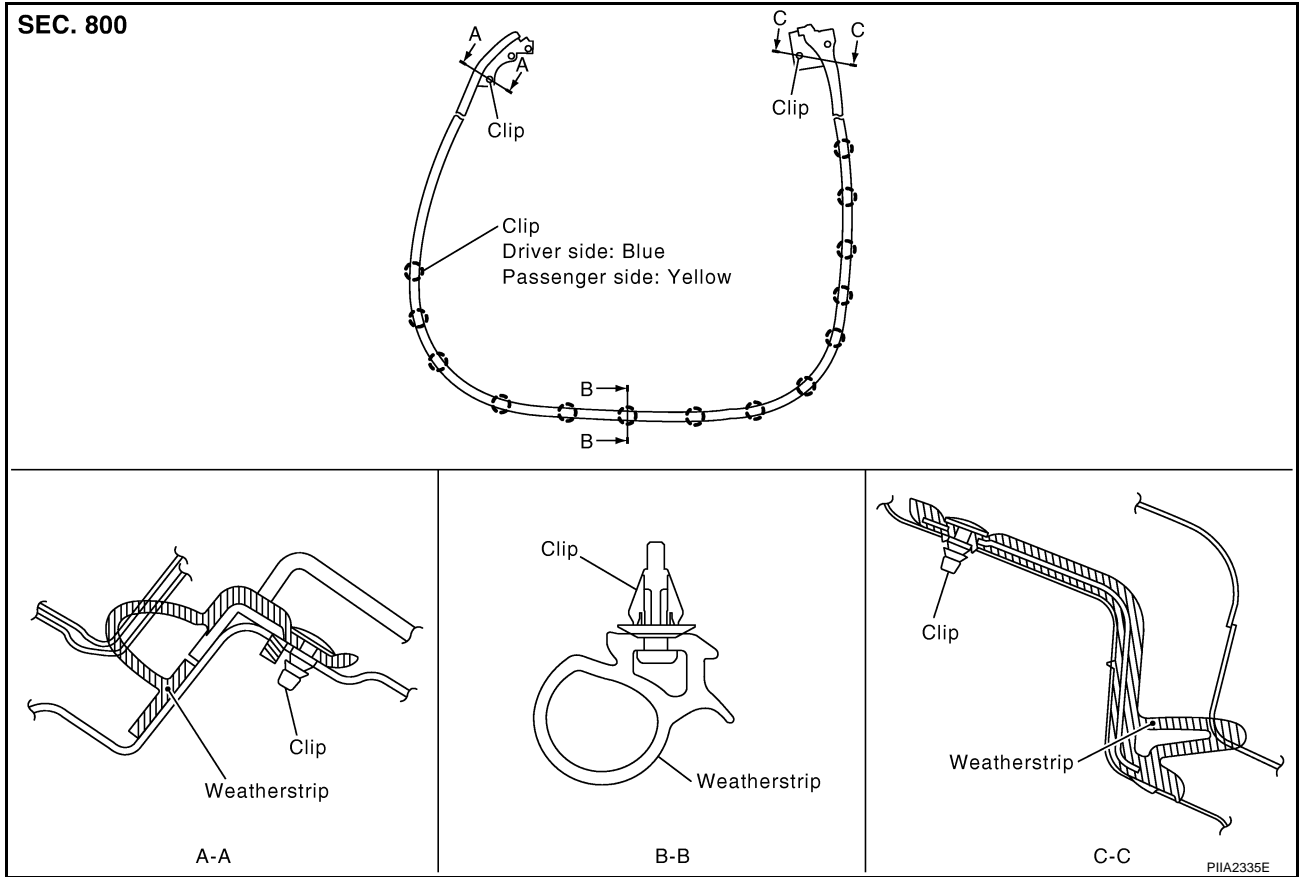

REMOVAL

Remove the weatherstrip clips and remove weatherstrip.

INSTALLATION

Install in the reverse order of removal.

A

B

C

D

E

F

G

H

BL

J

K

L

M

DOOR LOCK

DOOR LOCK

PFP:80502

Component Structure

AIS000D9

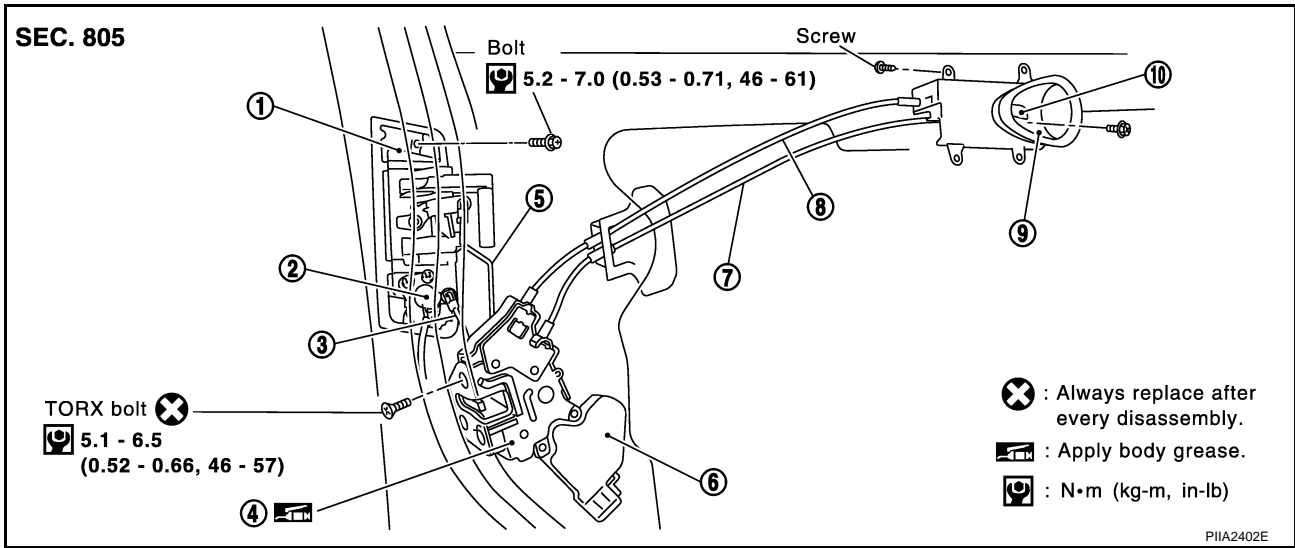

PIIA2402E

- | | | |
|-----------------------|------------------------------------|------------------------------------|
| 1. Outside handle | 2. Key cylinder (driver side only) | 3. Key lock rod (driver side only) |
| 4. Door lock assembly | 5. Outside handle rod | 6. Door lock actuator |
| 7. Lock knob cable | 8. Inside handle cable | 9. Inside handle |
| 10. Lock knob | | |

Inspection and Adjustment

AIS000DA

1. Remove the door finisher. Refer to [EI-32, "Removal and Installation"](#).
2. Remove the door window and door module assembly. Refer to [GW-54, "Removal and Installation"](#).

EXTERIOR HANDLE ROD ADJUSTMENT

Rotate the bushing to adjust so that the clearance between the bushing and rod becomes as shown in the figure.

CAUTION:

Be careful not to make the clearance 0 mm (0 in) or the rod will be pressed continuously.

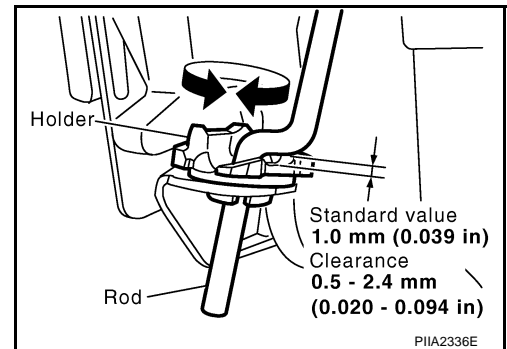

PIIA2336E

Removal and Installation

AIS000DB

REMOVAL

1. Remove the door finisher. Refer to [EI-32, "Removal and Installation"](#).
2. Remove the door window and door module assembly. Refer to [GW-54, "Removal and Installation"](#).
3. Disconnect the inside handle cable and locking knob cable from the back side of the door finisher.

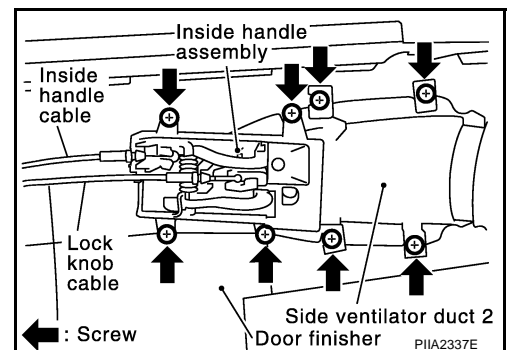

PIIA2337E

DOOR LOCK

4. Reach to separate the key cylinder (driver side only) rod and outside handle rod connection (on the handle).
5. Disconnect the door lock actuator connector.
6. Remove the mounting screws (TORX T30), remove the door lock assembly.

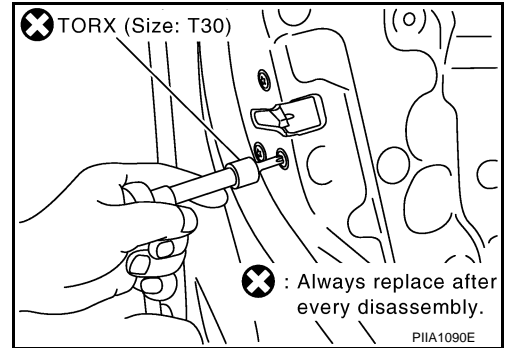

7. Remove the outside handle mounting bolts, remove the outside handle.

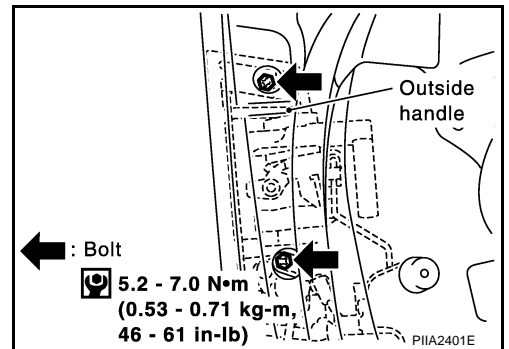

INSTALLATION

Install in the reverse order of removal.

CAUTION:

- To install each rod, be sure to rotate the rod holder until a click is felt.
- After installing, check operation.
- After installing, perform fitting adjustment. Refer to [BL-96. "Fitting Adjustment"](#).

Disassembly and Assembly

DISASSEMBLY

CAUTION:

Be sure to remove or install the actuator with the door lock assembly removed.

1. Remove the mounting screws, and remove the actuator from the door lock assembly.
2. Pull the actuator straight downward to separate it from the door lock assembly.

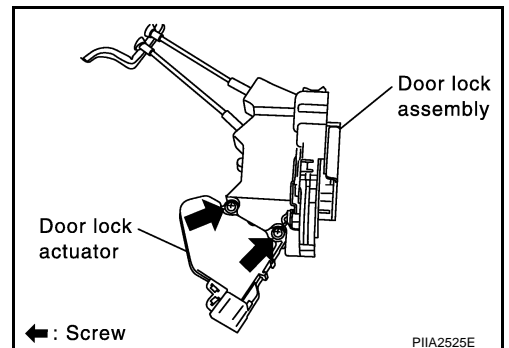

ASSEMBLY

1. Align the actuator pivot with the cutout on the knob lever of the door lock assembly, then assemble the actuator.
2. Move the knob lever and the actuator pivot toward the lock-on direction, and check that it engages securely.

BACK DOOR

PFP:90100

BACK DOOR

Fitting Adjustment

AIS0013P

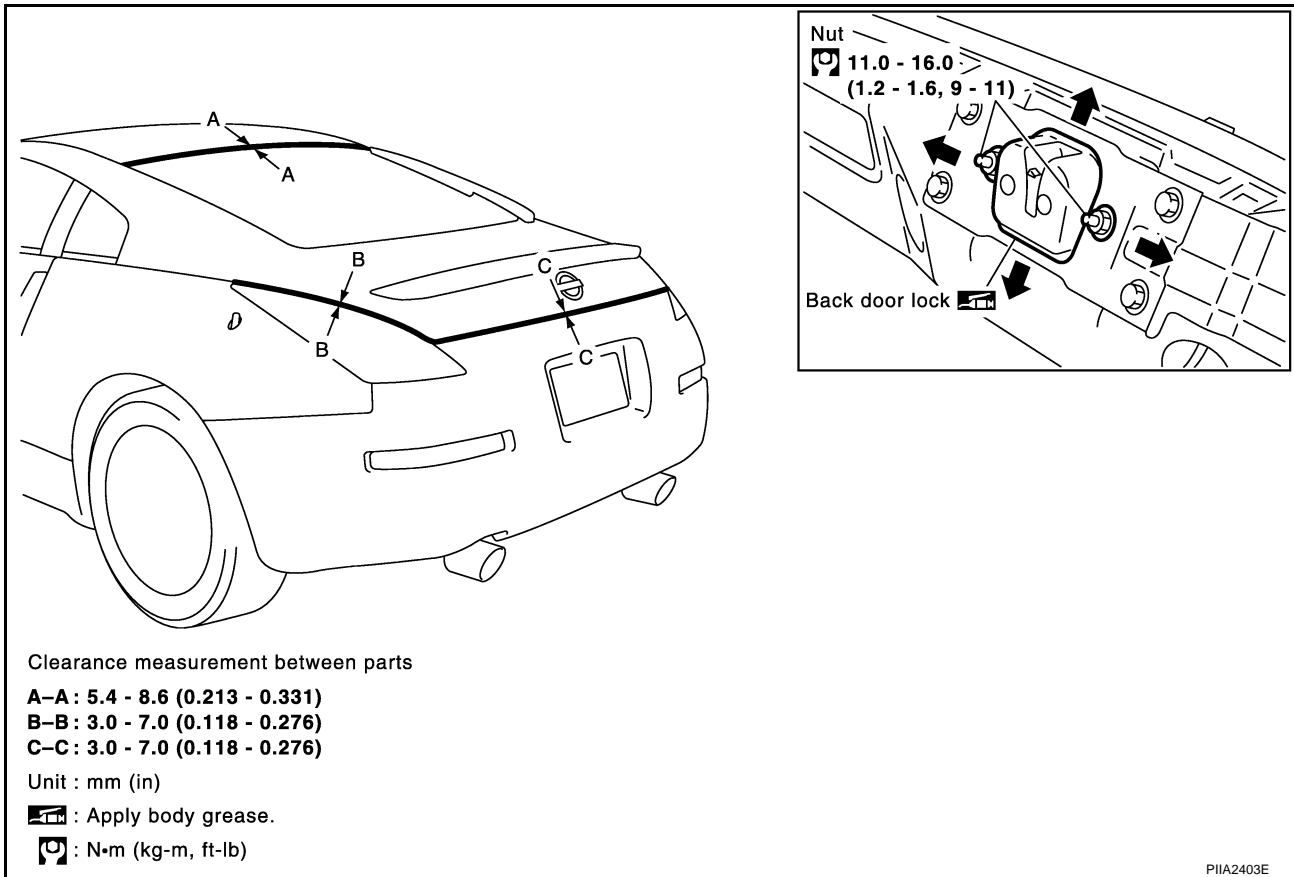

VERTICAL/LATERAL CLEARANCE ADJUSTMENT

1. Remove back door weatherstrip. Refer to [BL-108, "Removal and Installation of Back Door Weatherstrip"](#).
2. Remove the luggage finisher lower (center). Refer to [EI-39, "LUGGAGE FLOOR TRIM"](#).
3. Loosen the back door lock mounting bolts. Raise the back door lock to the top position, and temporarily tighten the back door lock mounting bolt at the position.
4. Close the back door lightly and adjust the surface height, then open the back door to finally tighten the back door lock mounting bolts to the specified torque.

BACK DOOR

AIS0013Q

Back Door Assembly REMOVAL

1. Remove the headlining. Refer to [EI-43, "Removal and Installation \(for Coupe Models\)"](#).
2. Disconnect each harness connector, which is out to body from back door.
3. Support the back door striker with a proper material to prevent it from falling.

WARNING:

Body injury may occur if no supporting rod is holding the back door open when removing the damper stay.

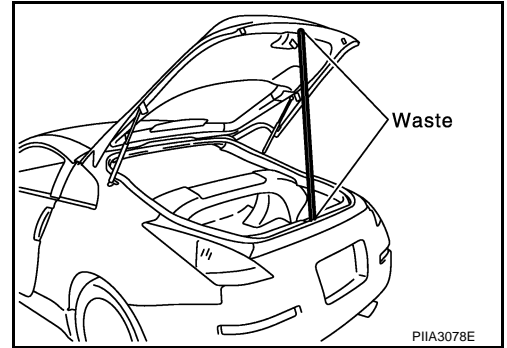

4. Remove stud balls on back door.

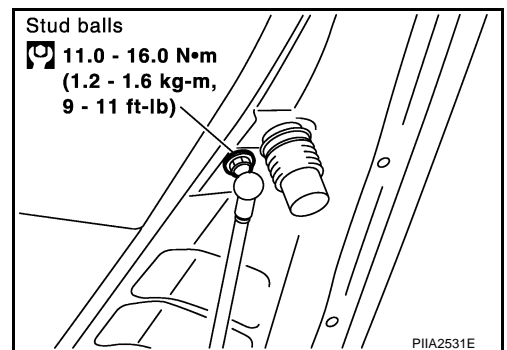

5. Remove hinge mount nuts of the body and remove back door assembly.

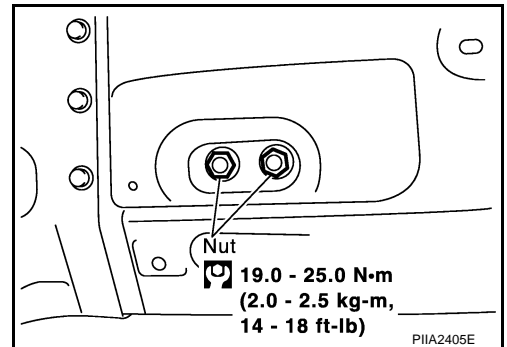

INSTALLATION

Install in the reverse order of removal.

CAUTION:

- Operate with two workers, because of its heavy weight.
- After installing, check operation.
- After installing, perform fitting adjustment. Refer to [BL-104, "Fitting Adjustment"](#).
- After installing, apply touch-up paint (the body color) onto the head of the hinge mounting bolts.

A
B
C
D
E
F
G
H
BL
J
K
L
M

BACK DOOR

INSPECTION

1. Check hinges for the following items
 - Malfunction noise or door closing and opening effort
 - Component wear or damage
2. Apply body grease to the rotating part of the hinge.

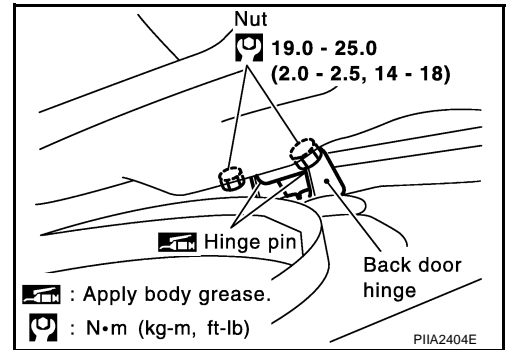

AIS0013R

Removal and Installation of Back Door Striker

REMOVAL

1. Remove back door finisher lower. Refer to [EI-46, "BACK DOOR FINISHER"](#).
2. Remove mounting screws, and remove striker from the vehicle.

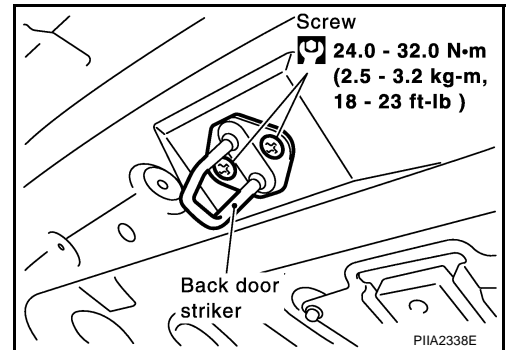

INSTALLATION

Install in the reverse order of removal.

CAUTION:

After installing, perform fitting adjustment.

Removal and Installation of Back Door Stay

REMOVAL

1. Support the back door striker with a proper material to prevent it from falling.

WARNING:

Body injury may occur if no supporting rod is holding the back door open when removing the damper stay.

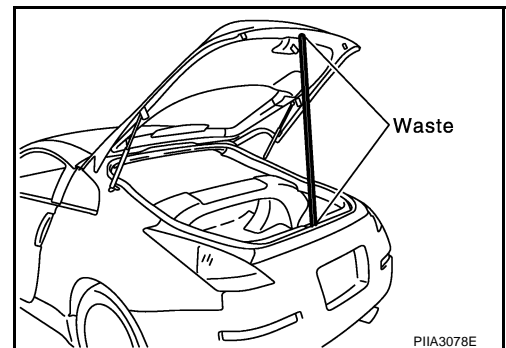

2. Remove stud balls on back door.

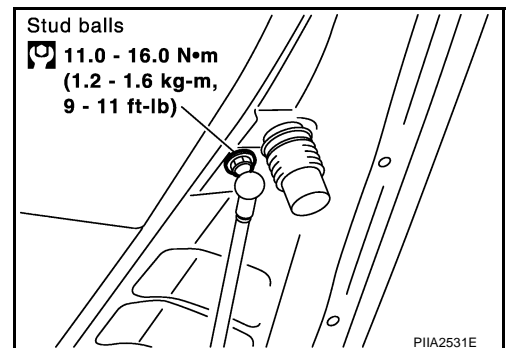

BACK DOOR

3. Remove back door stay assembly (gas stay) bracket adjusting nuts and remove back door stay assembly.

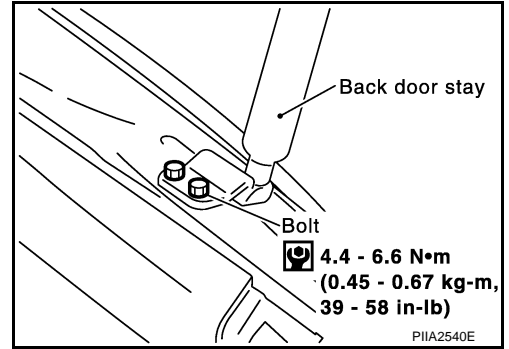

A
B
C
D
E
F
G
H
BL
J
K
L
M

BACK DOOR

INSTALLATION

Install in the reverse order of removal.

CAUTION:

After installing, check operation.

Removal and Installation of Back Door Weatherstrip

AIS0013T

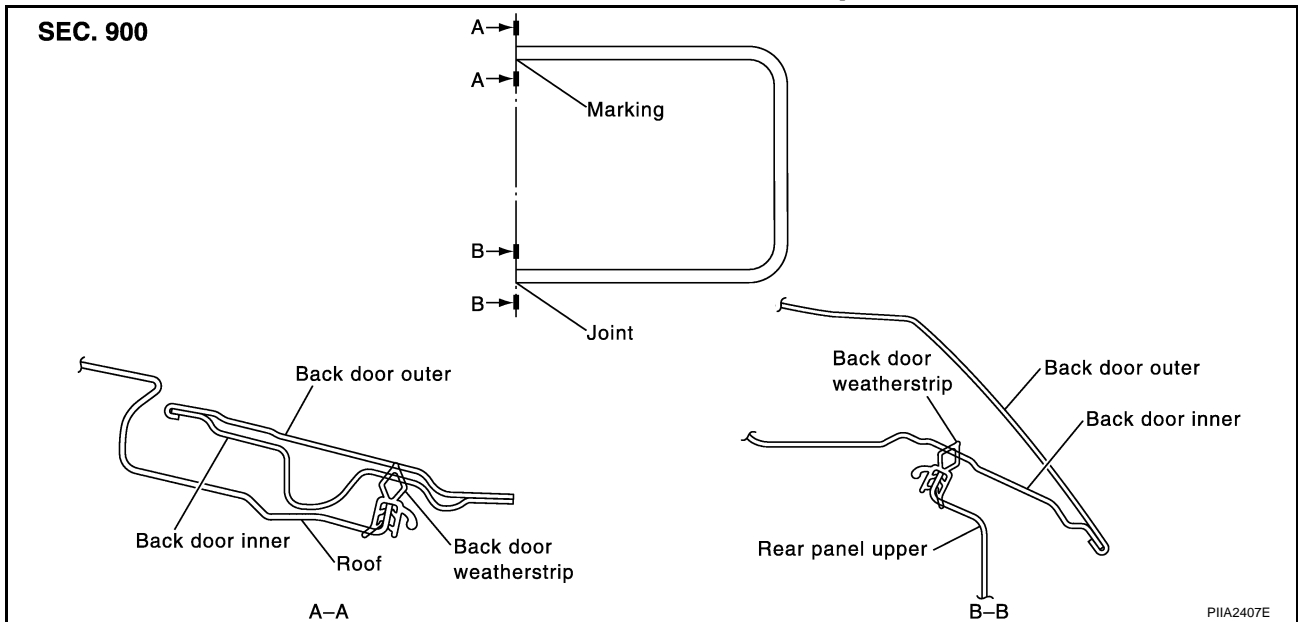

REMOVAL

Pull up and remove engagement with body from weatherstrip joint.

CAUTION:

After removal, do not pull strongly on the weatherstrip.

INSTALLATION

Install in the reverse order of removal.

1. Working from the upper section, align weatherstrip mark with vehicle center position mark and install weatherstrip onto the vehicle.
2. For the lower section, align the weatherstrip seam with center of the striker.
3. After installation, pull the weatherstrip gently to ensure that there is no loose section.

NOTE:

Make sure the weatherstrip is fit tightly at each corner and back door rear plate.

BACK DOOR LOCK

BACK DOOR LOCK

PF9:90504

Removal and Installation of Back Door Lock & Back Door Opener Actuator

AI50013U

REMOVAL

1. Remove back door weatherstrip. Refer to [BL-108, "Removal and Installation of Back Door Weatherstrip"](#).
2. Remove luggage finisher lower (center). Refer to [EI-39, "LUGGAGE FLOOR TRIM"](#).
3. Disconnect the connector and the clip of the back door opener.
4. Remove the mounting bolts.

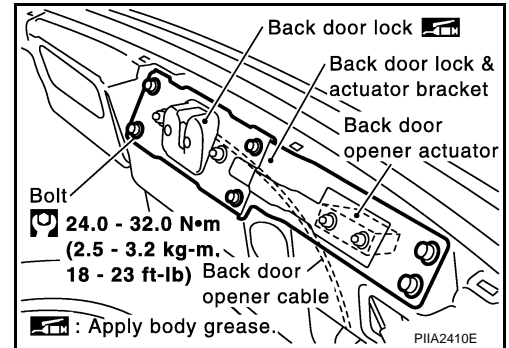

5. Disconnect the connector of the back door opener actuator and back door opener cable, remove the bracket.
6. Remove the mounting nuts, remove back door lock and back door opener actuator.

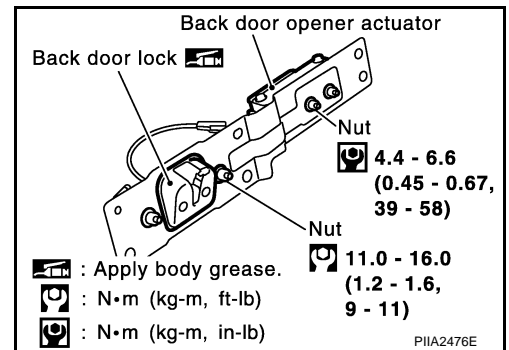

INSTALLATION

1. Install in the reverse order of removal.
2. After installing, check the operation.

CAUTION:

- After installing, check operation.
- After installing, perform fitting adjustment. Refer to [BL-104, "Fitting Adjustment"](#).

INSPECTION

1. Check back door lock for the following items.
 - Malfunction noise or door closing and opening effort
 - Component wear or damage
2. Apply body grease to the rotating part of the back door lock.

BACK DOOR LOCK

Removal and Installation of Back Door Opener Switch (External)

AIS0013V

REMOVAL

1. Remove rear bumper fascia assembly. Refer to [EI-17, "Removal and Installation"](#) .
2. Remove the mounting screws of the license plate bracket.

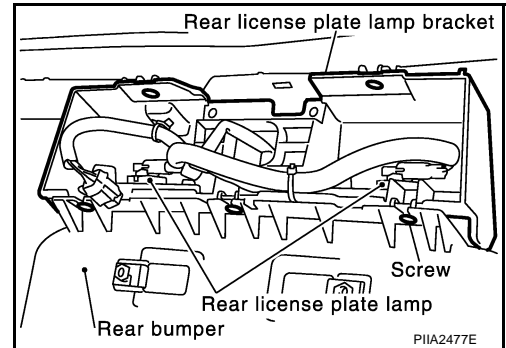

3. Remove the mounting screws and connector of the back door opener switch.

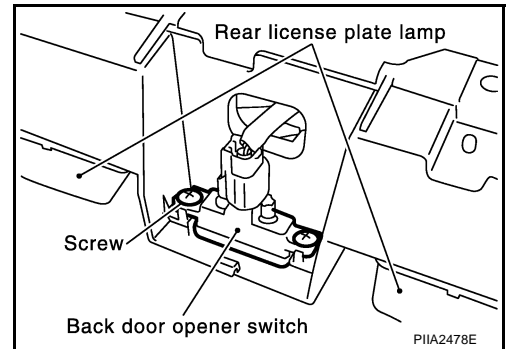

INSTALLATION

1. Install in the reverse order of removal.
2. After installing, check the operation.

BACK DOOR LOCK

Removal and Installation of Back Door Emergency Opener Cable

AIS005VW

A
B
C
D
E
F
G
H
BL
J
K
L
M

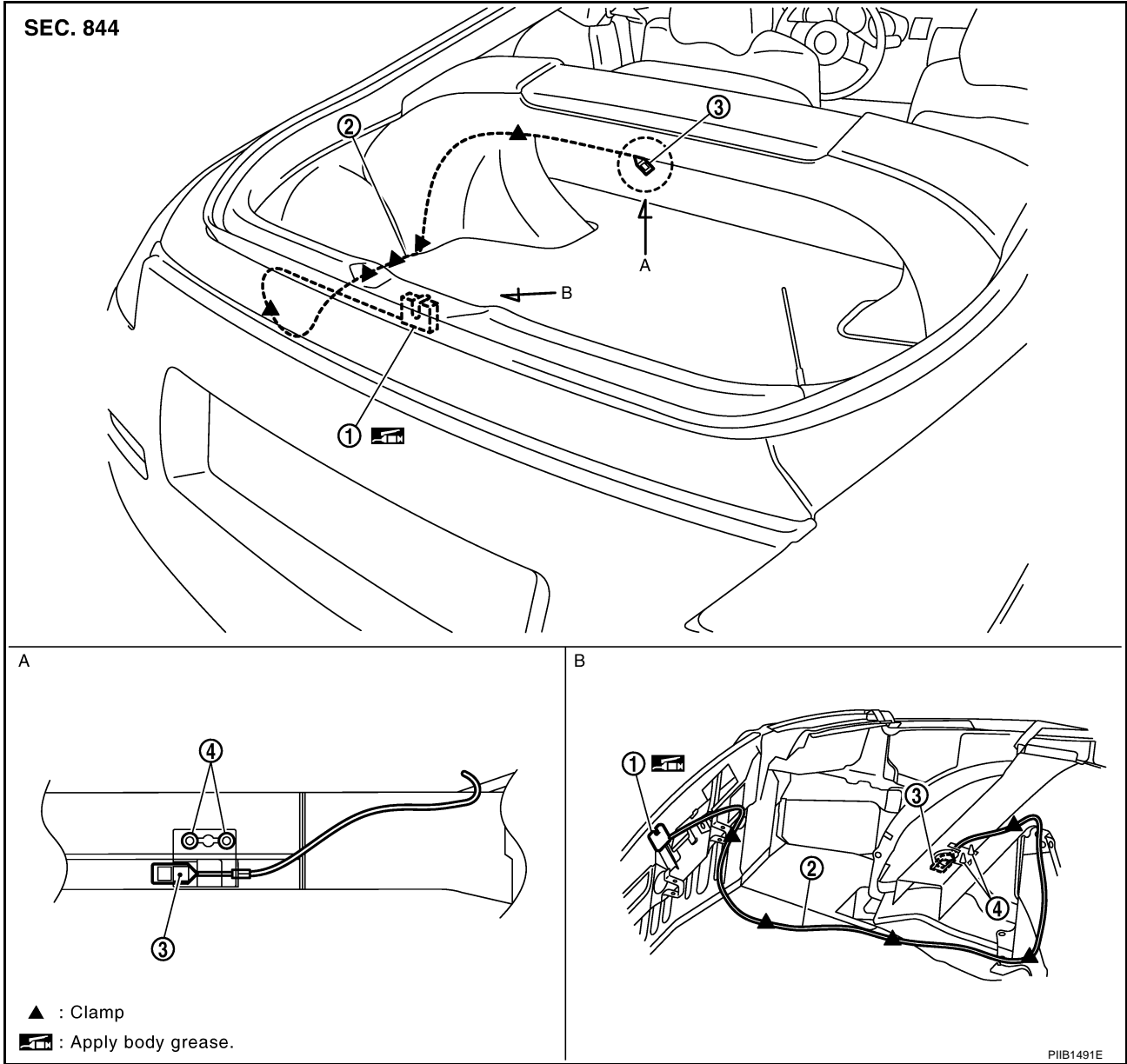

- 1. Back door lock assembly
- 2. Back door emergency opener cable
- 3. hook
- 4. Clip

REMOVAL

1. Remove back door weather strip. Refer to [BL-108, "Removal and Installation of Back Door Weatherstrip"](#).
2. Remove luggage finisher lower (center), luggage side finisher lower (LH), luggage side finisher upper (LH), trunk side box, luggage floor carpet, strut cover rear, strut cover lower (center), and strut cover lower (LH). Refer to [EI-38, "Removal and Installation \(for Coupe Models\)"](#).
3. Disconnect back door emergency opener cable from back door lock.
4. Disconnect back door emergency opener cable from back door emergency opener cable clamp, and then remove back door emergency opener cable.

INSTALLATION

1. Install in the reverse order of removal.
2. After installing, check the operation.

TRUNK LID

PFP:H4300

AIS005F8

TRUNK LID

Fitting Adjustment

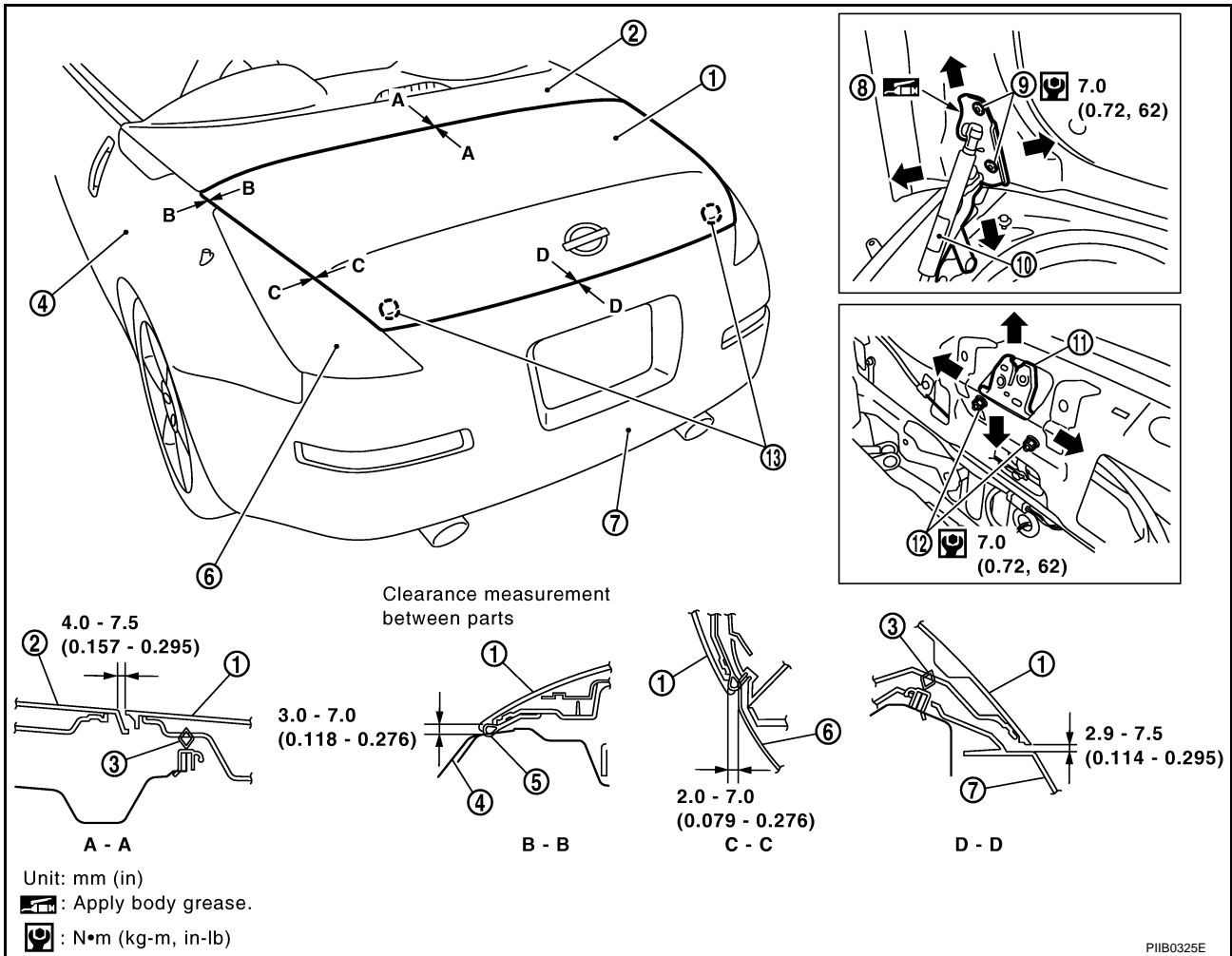

- | | | |
|-----------------------|-----------------------------|---------------------------|
| 1. Trunk lid assembly | 2. Storage lid | 3. Trunk lid weatherstrip |
| 4. Rear fender | 5. Trunk lid moulding | 6. Rear combination lamp |
| 7. Rear bumper fascia | 8. Trunk lid hinge | 9. TORX bolt (T30) |
| 10. Trunk lid stay | 11. Trunk lid lock assembly | 12. Nut |
| 13. Bumper rubber | | |

LONGITUDINAL AND LATERAL CLEARANCE ADJUSTMENT

1. Remove trunk rear finisher. Refer to [EI-47, "TRUNK ROOM TRIM & TRUNK LID FINISHER"](#).
2. Loosen trunk lid hinge mounting bolts, and remove trunk lid lock. And then, close trunk lid.
3. Tighten trunk lid hinge mounting bolts to the specified torque after adjusting lateral clearance and clearance to storage lid and rear bumper fascia.
4. Position trunk lid lock and engage trunk lid striker. Check trunk lid striker and trunk lid lock for looseness.
5. Tighten trunk lid mounting bolts to the specified torque.

SURFACE HEIGHT ADJUSTMENT

1. Remove trunk rear finisher. Refer to [EI-47, "TRUNK ROOM TRIM & TRUNK LID FINISHER"](#).
2. Remove trunk lid lock. Rotate bumper rubber to adjust height between trunk lid and bumper fascia.
3. Position trunk lid lock and engage trunk lid striker. Check trunk lid striker and trunk lid lock for looseness. Tighten trunk lid mounting bolts to the specified torque.
4. Adjust lateral clearance and surface height between trunk lid and other parts so that they are within the following dimensional difference.

CAUTION:

Adjust evenness between trunk lid and each part to the following specification.

TRUNK LID

Trunk lid and storage lid (A–A) : 0 ± 1.0 mm (0 ± 0.04 in)

Trunk lid and rear bumper fascia (D–D) : 0.85 ± 2.1 mm (0.0335 ± 0.083 in)

A

B

C

D

E

F

G

H

BL

J

K

L

M

TRUNK LID

Removal and Installation of Trunk Lid Assembly

AIS005F9

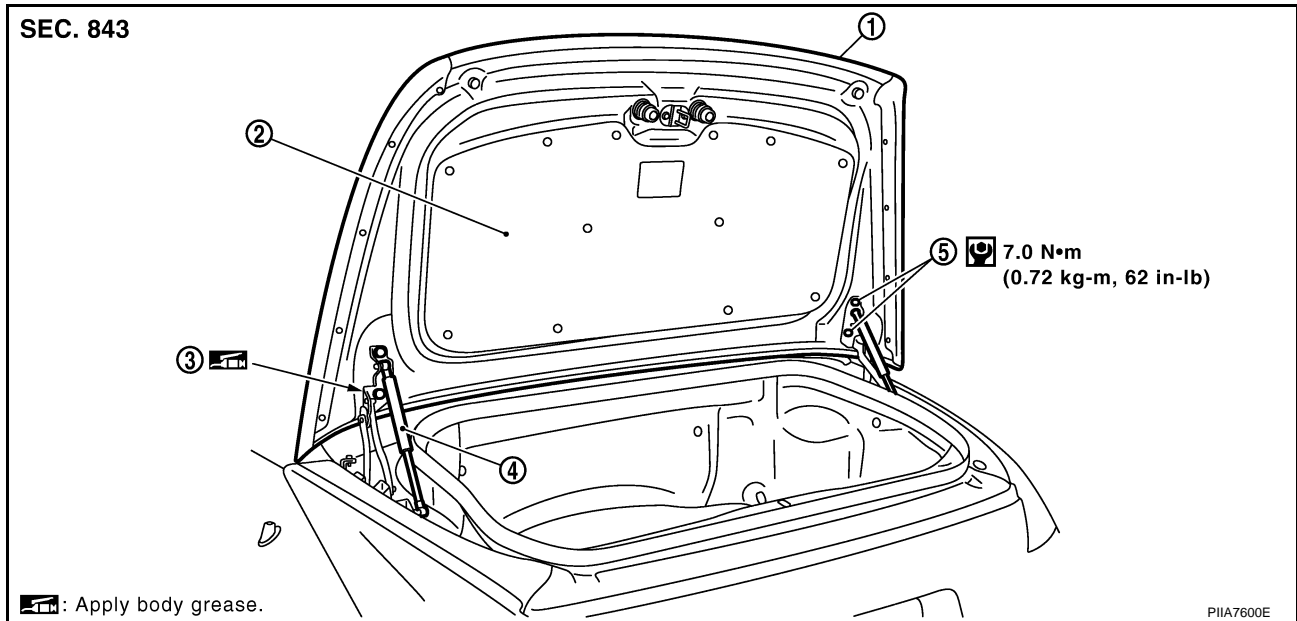

1. Trunk lid assembly
2. Trunk lid insulator
3. Trunk lid hinge
4. Trunk lid stay
5. TORX bolt (T30)

CAUTION:
Operate with two workers, because of its heavy weight.

REMOVAL

1. Screwdriver into the gap and remove holder.
2. Remove trunk lid stay (gas stay).
3. Remove the trunk lid hinge bolts, trunk lid assembly side and remove the trunk lid assembly.

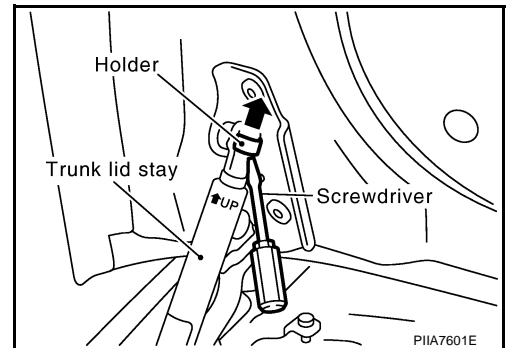

INSTALLATION

Note the following, and install in the reverse order of removal.
Install holder to trunk lid stay, and then push it into trunk lid hinge (stud ball) when installing trunk lid stay.

CAUTION:

- Check trunk lid open/close operation after installation
- Apply sealant and coat with the same body color paint to trunk lid hinge installation part and mounting bolts.

TRUNK LID

Removal and Installation of Trunk Lid Stay

AIS005FA

REMOVAL

1. Screwdriver into the gap and remove holder.
2. Remove trunk lid stay.

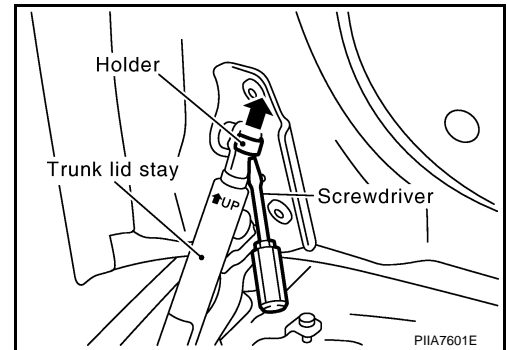

INSTALLATION

1. Note the following, and install in the reverse order of removal.
Install holder to trunk lid stay, and then push it into trunk lid hinge (stud ball) when installing trunk lid stay.
2. After installation, check the operation.

Removal and Installation of Trunk Lid Lock Assembly

AIS005FB

REMOVAL

1. Remove the trunk lid weatherstrip. Refer to [BL-119, "Removal and Installation of Trunk Lid Weatherstrip"](#).
2. Remove trunk lid release lever. Refer to [EI-47, "Removal and Installation"](#).
3. Remove the trunk lid finisher. Refer to [EI-47, "TRUNK ROOM TRIM & TRUNK LID FINISHER"](#).
4. Disconnect the release lever cable and trunk lid opener cable from the clip.
5. After removing the harness connector, remove the mounting bolts, and remove the trunk lid lock.

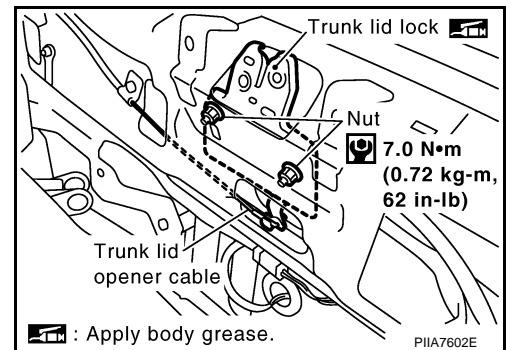

INSTALLATION

1. Install in the reverse order of removal.

CAUTION:

- After installing, close the trunk lid height. Perform the lock and surface height adjustment. Refer to [BL-112, "Fitting Adjustment"](#).
- After installing, check the operation.

Removal and Installation of Trunk Lid Striker

AIS005FC

REMOVAL

Remove the mounting bolts, then remove the striker from the trunk lock support.

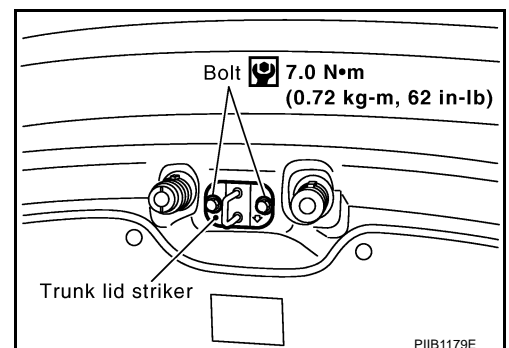

INSTALLATION

1. Install in the reverse order of removal.

TRUNK LID

2. After installing, close the trunk lid height. Perform the lock and surface height adjustment. Refer to [BL-112, "Fitting Adjustment"](#).
3. After installation, check the operation.

TRUNK LID

Removal and Installation of Trunk Lid Emergency Opener Cable

AIS005VX

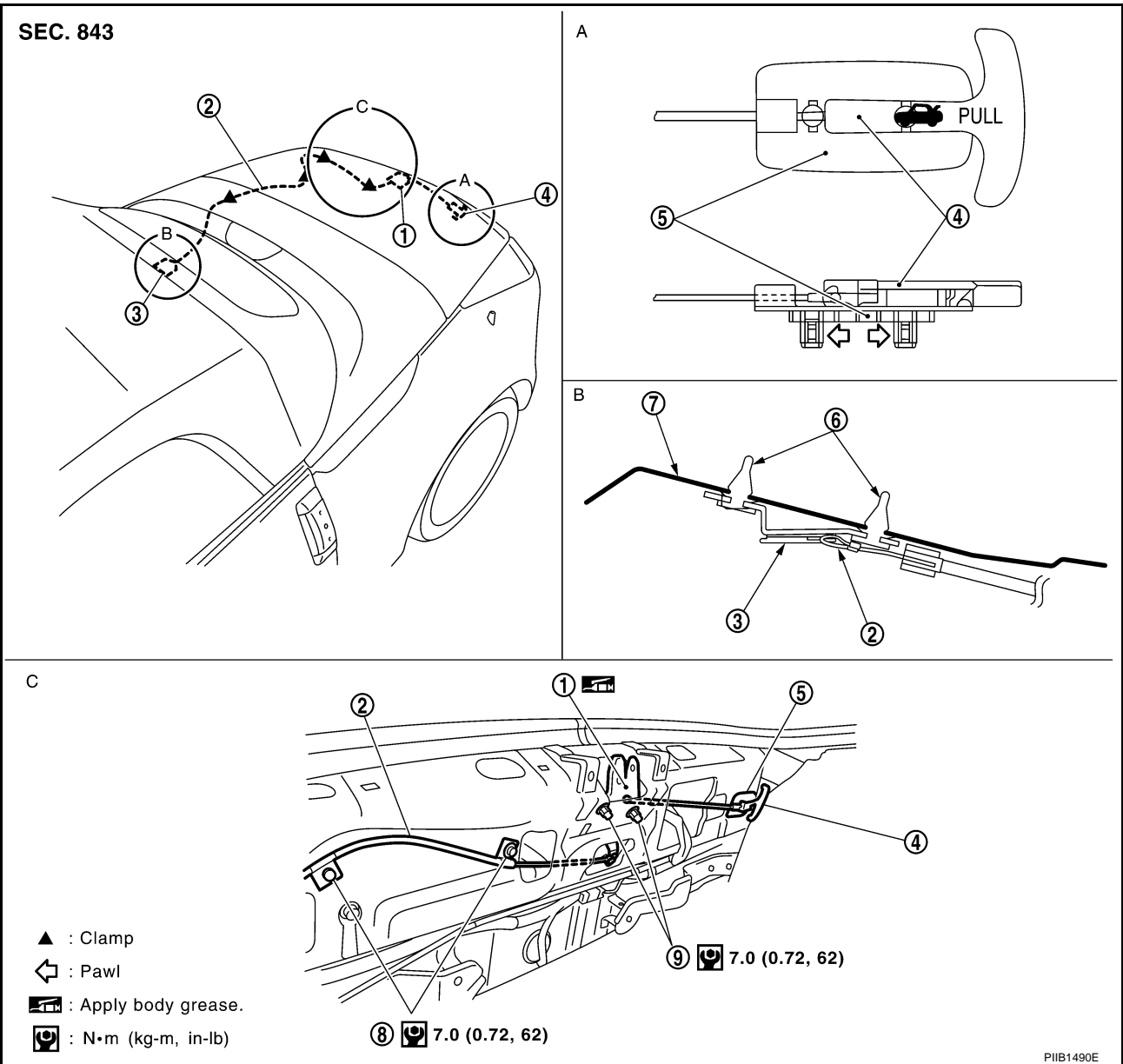

- | | | |
|---|--|--|
| 1. Trunk lid lock assembly | 2. Trunk lid emergency opener cable | 3. Trunk lid emergency opener cable hook |
| 4. Trunk lid emergency opener lever (secondary) | 5. Trunk lid emergency opener lever holder | 6. Clip |
| 7. Panel | 8. Bolt | 9. Nut |

REMOVAL

1. Remove trunk lid weatherstrip. Refer to [BL-119, "Removal and Installation of Trunk Lid Weatherstrip"](#).
2. Remove trunk floor carpet, spare tire cover, trunk rear finisher, trunk front finisher, and trunk side box. Refer to [EI-47, "TRUNK ROOM TRIM & TRUNK LID FINISHER"](#).
3. Remove floor box lid. Refer to [EI-40, "Removal and Installation \(for Roadster Models\)"](#).
4. Disconnect trunk lid emergency opener cable from trunk lid lock.
5. Disconnect each clamp of trunk lid emergency opener cable.

INSTALLATION

1. Install in the reverse order of removal.
2. After installing, check the operation.

A
B
C
D
E
F
G
H
BL
J
K
L
M

TRUNK LID

Removal and Installation of Trunk Lid Emergency Opener Cable (Secondary)

AIS005W3

REMOVAL

1. Remove trunk lid weatherstrip. Refer to [BL-119, "Removal and Installation of Trunk Lid Weatherstrip"](#).
2. Remove rear finisher. Refer to [EI-47, "TRUNK ROOM TRIM & TRUNK LID FINISHER"](#).
3. Disconnect each harness connector of trunk lid lock.
4. Remove trunk lid lock mounting bolts, and then remove trunk lid emergency opener cable (secondary).

INSTALLATION

1. Install in the reverse order of removal.
2. After installing, check the operation.

Removal and Installation of Trunk Lid Hinge

AIS005FD

REMOVAL

1. Remove trunk lid stay. Refer to [BL-115, "Removal and Installation of Trunk Lid Stay"](#).
2. Remove trunk lid assembly. Refer to [BL-114, "Removal and Installation of Trunk Lid Assembly"](#).
3. Remove trunk lid hinge mounting bolts, and then remove trunk lid hinge.

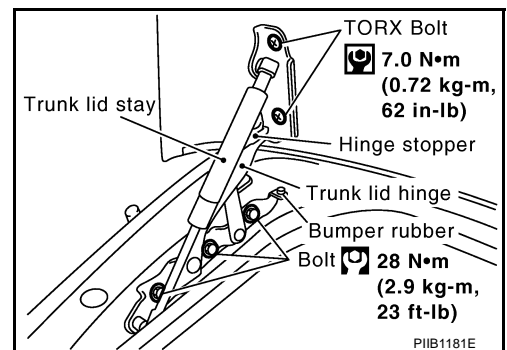

INSTALLATION

1. Position trunk lid hinge to body side. Temporarily tighten front side bolt and rear side bolt in this order, and then tighten them to the specified torque.
2. Install trunk lid to trunk lid hinge.
3. Install trunk lid stay.

CAUTION:

- Before installing trunk lid hinge, apply anticorrosive agent onto the mounting surface of the vehicle body.
- After installation, perform trunk lid fitting adjustment. Refer to [BL-112, "Fitting Adjustment"](#).
- Check trunk lid open/close operation after installation
- Apply sealant and the same body color paint to trunk lid hinge and mounting bolts to cover broken seal area.

Removal and Installation of Lift Spring

AIS005FE

REMOVAL

Rotate lift spring bottom clockwise/counterclockwise by approximately 90 deg, and then remove lift spring.

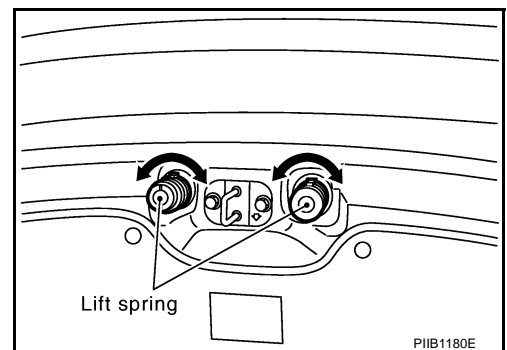

INSTALLATION

Install in the reverse order of removal.

TRUNK LID

Removal and Installation of Trunk Lid Weatherstrip

AIS005FF

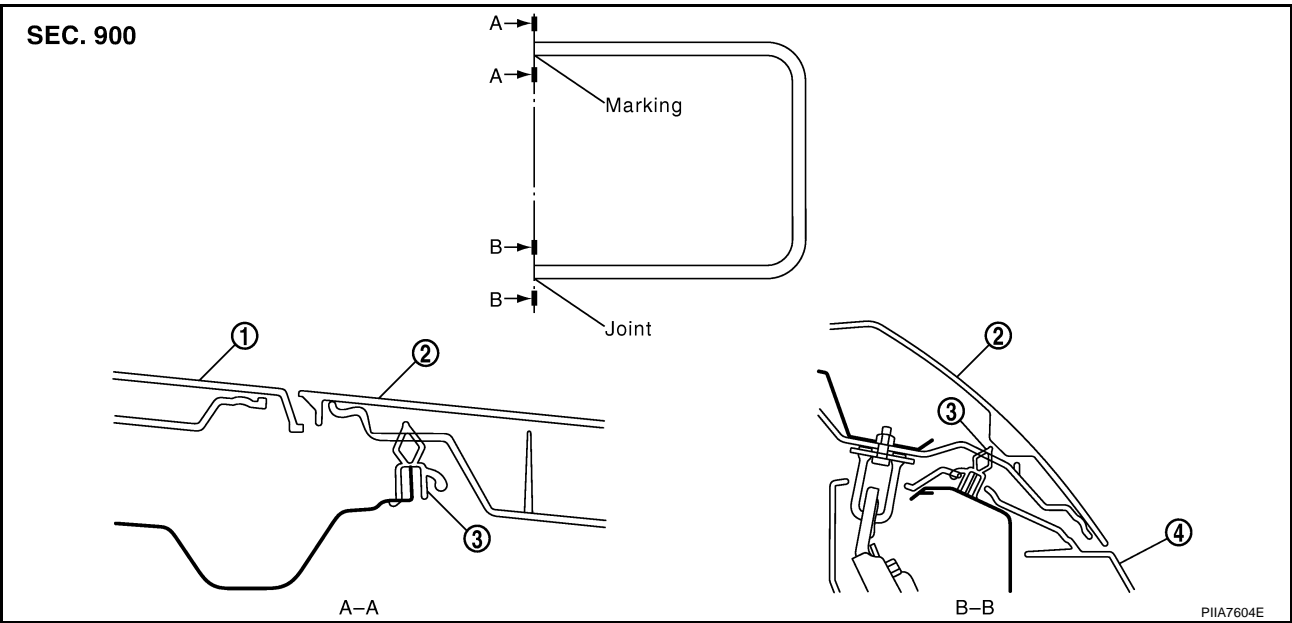

1. Storage lid
2. Trunk lid assembly
3. Trunk lid weatherstrip
4. Rear bumper fascia

REMOVAL

Pull up and remove engagement with body from weatherstrip joint.

CAUTION:

After removal, do not pull strongly on the weatherstrip.

INSTALLATION

Install in the reverse order of removal.

1. Install the weatherstrip from the front with the vehicle center mark aligned to the weatherstrip mark.
2. At rear side, align the weatherstrip seam to the center of the striker.
3. After installing, pull the weatherstrip lightly to check for looseness.

CAUTION:

The weatherstrip should fit tightly onto the corners and trunk lid rear plate.

A
B
C
D
E
F
G
H
J
K
L
M

BL

TRUNK LID OPENER

PFP:84640

TRUNK LID OPENER

Component Parts and Harness Connector Location

AIS00409

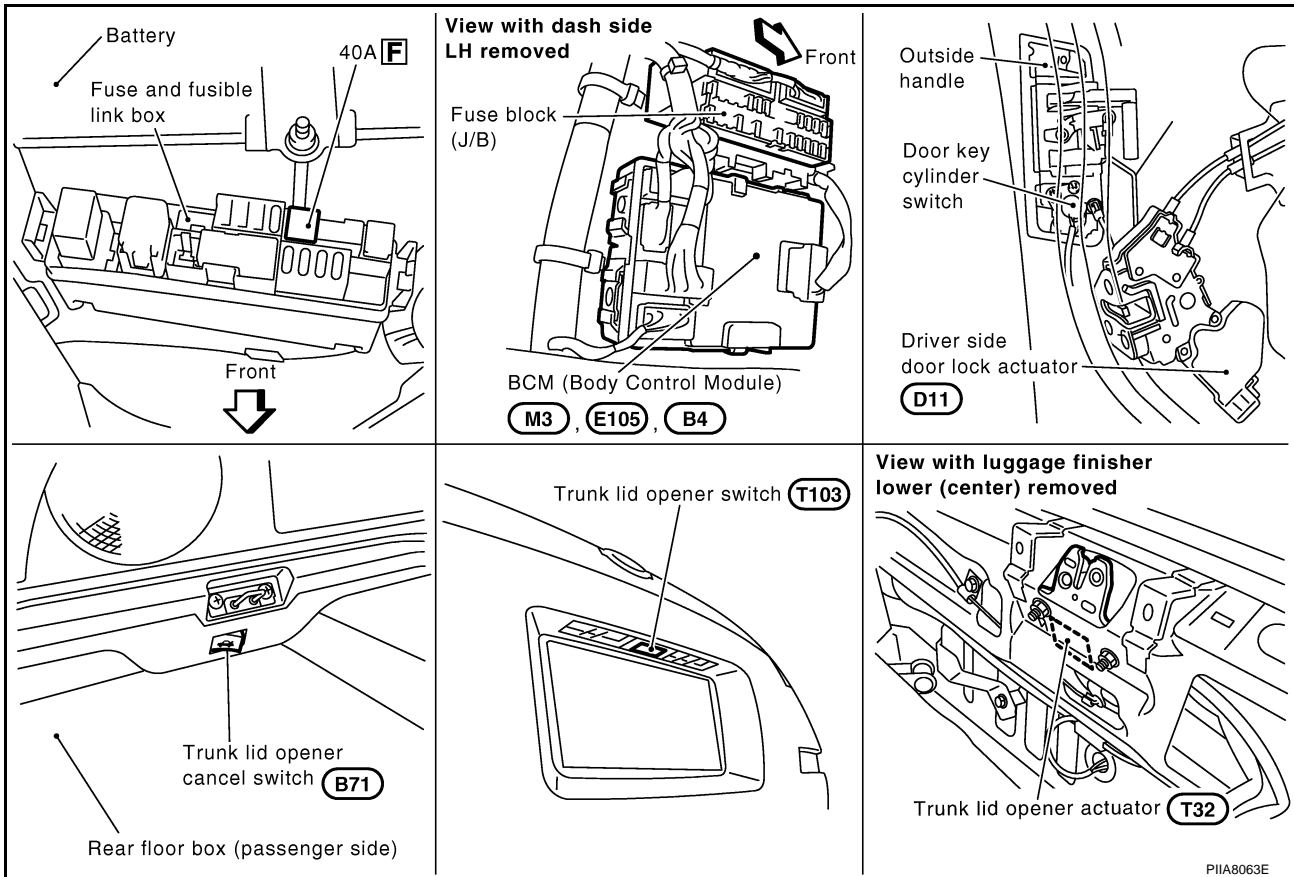

System Description

AIS003X1

Power is supplied at all times

- through 40A fusible link (letter **F** , located in the fuse and fusible link box)
- to BCM terminal 7.

Ground is supplied

- to BCM terminal 8
- through body grounds E17, E43, and F152.

When trunk lid opener switch is ON (pushed) with trunk lid opener cancel switch is ON and driver's door unlocked ground is supplied

- to BCM terminal 76
- through trunk lid opener cancel switch terminals 1 and 2,
- through trunk lid opener switch terminals 1 and 2,
- through driver side door lock actuator (unlock sensor) terminals 2 and 4, and
- through body grounds M30 and M66.

And power is supplied

- to BCM terminal 19
- through trunk lid opener actuator terminals 1 and 2
- through body grounds B5, B6 and T14.

Then trunk lid opener actuator opens trunk.

TRUNK LID OPENER CANCEL OPERATION

When trunk lid opener cancel switch is OFF (CANCEL), it cannot open trunk with trunk lid opener switch.

TRUNK LID OPENER

TRUNK OPENER OPERATION WITH KEY FOB

Open the trunk with key fob. Refer to [BL-67, "Trunk Opener Operation/For Roadster"](#) .

A

B

C

D

E

F

G

H

BL

J

K

L

M

TRUNK LID OPENER

AIS003XJ

Wiring Diagram—T/LID—

BL-TLID-01

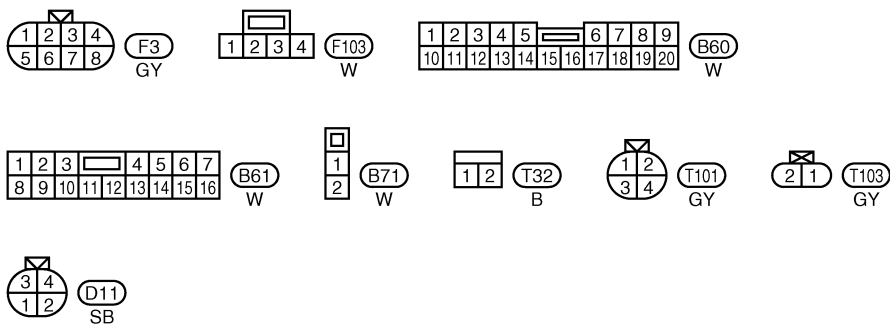
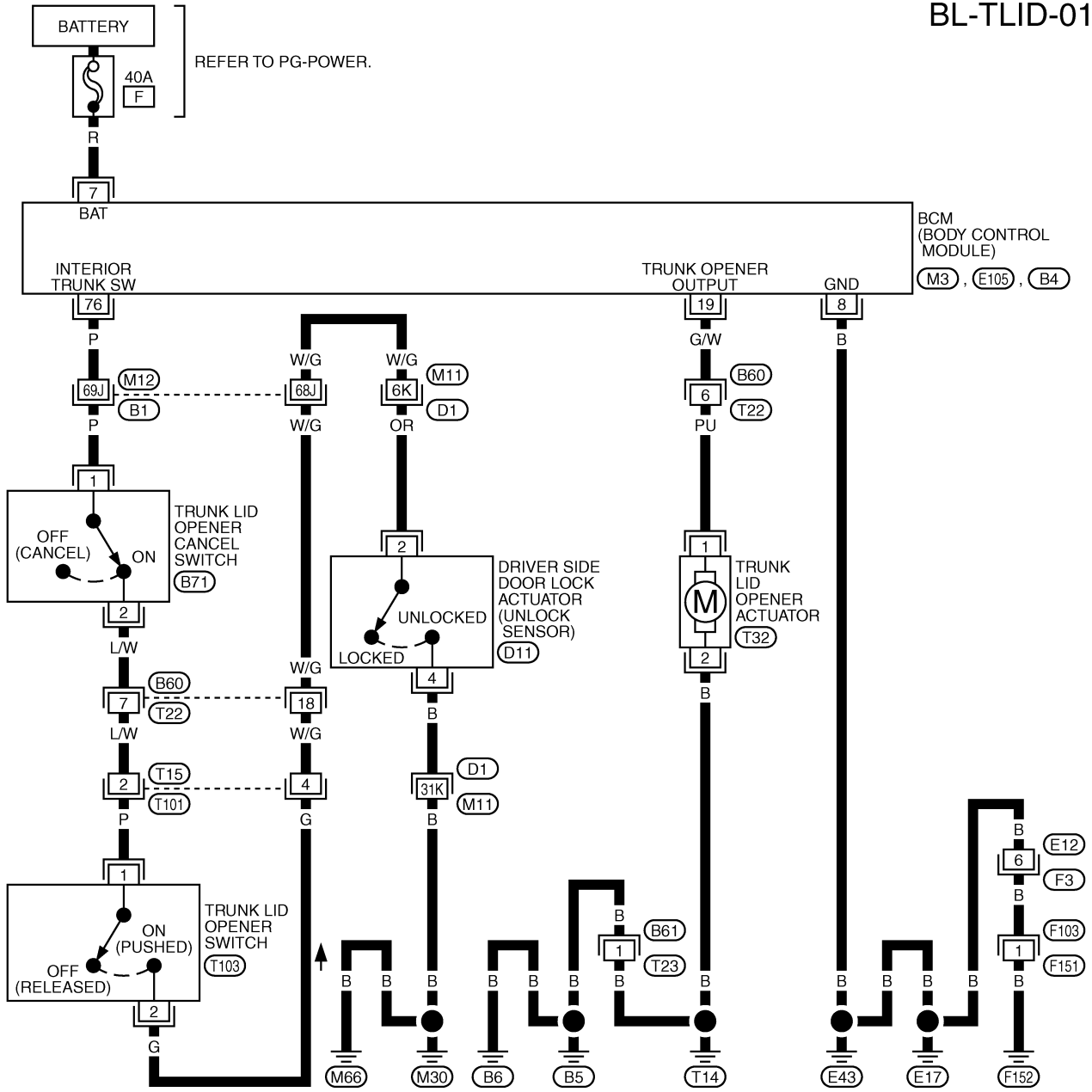

REFER TO THE FOLLOWING.
 (B1), (D1) -SUPER MULTIPLE JUNCTION (SMJ)
 (M3), (E105), (B4) -ELECTRICAL UNITS

TWT0760E

TRUNK LID OPENER

Terminals and Reference Value for BCM

AIS003Y4

Terminal	Wire color	Item	Condition	Voltage (V) (Approx.)	
7	R	Power source (Fusible link)	—	Battery voltage	
8	B	Ground	—	0	
19	G/W	Trunk lid opener release output signal	Closed (OFF) → Opened (ON)	0 → Battery voltage	
76	P	Trunk lid opener switch	Trunk lid opener cancel switch is ON	Trunk lid opener switch is ON	0
				Trunk lid opener switch is OFF	5
			Driver side door is locked	Trunk lid opener cancel switch is OFF	5

CONSULT-II Function CONSULT-II BASIC OPERATION PROCEDURE

AIS0040A

CAUTION:

If CONSULT-II is used with no connection of CONSULT-II CONVERTER, malfunctions might be detected in self-diagnosis depending on control unit which carry out CAN communication.

1. Turn ignition switch "OFF".
2. Connect "CONSULT-II" and CONSULT-II CONVERTER to data link connector.

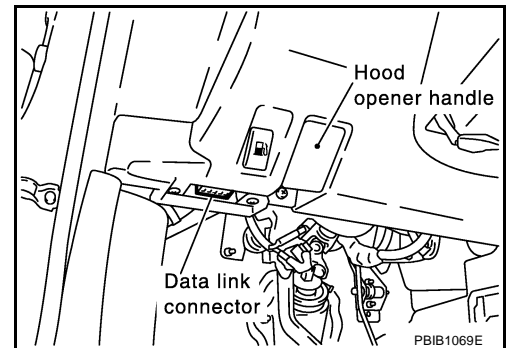

3. Turn ignition switch "ON".
4. Touch "START(NISSAN BASED VHCL)".

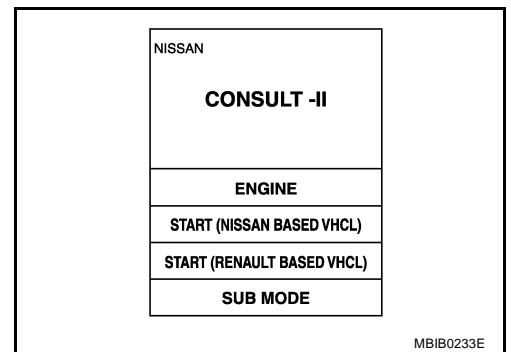

5. Touch "BCM".
If "BCM" is not indicated, go to [GI-39](#), "CONSULT-II Data Link Connector (DLC) Circuit"

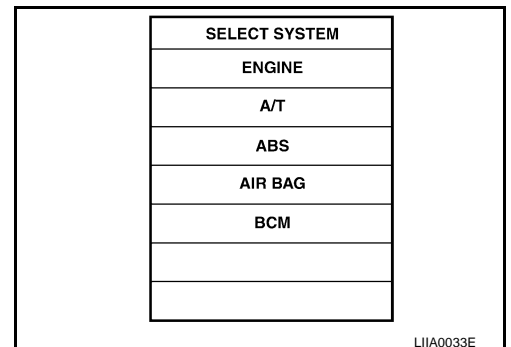

TRUNK LID OPENER

6. Touch "TRUNK".

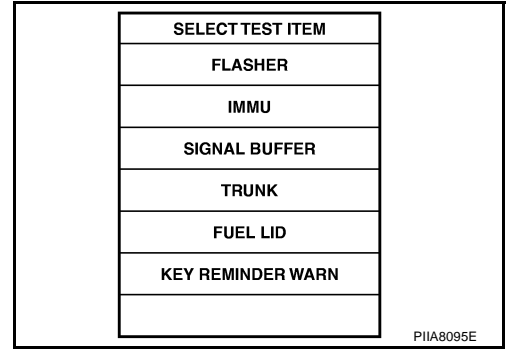

7. Select diagnosis mode.
"ACTIVE TEST"

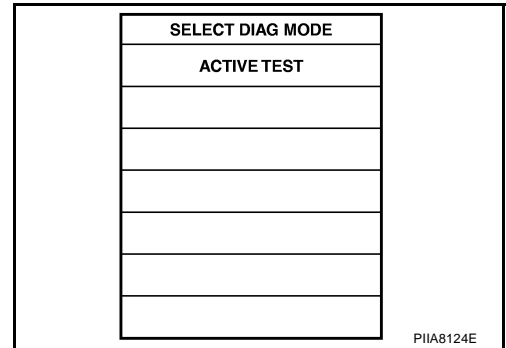

ACTIVE TEST

Test item	Content
TRUNK/BACK DOOR	This test is able to check trunk lid opener actuator unlock operation. This actuator unlocks when "ON" on CONSULT-II screen is touched.

TRUNK LID OPENER

AIS003Y5

Trouble Diagnosis

TRUNK DOSE NOT OPEN WITH TRUNK LID OPENER SWITCH

1. CHECK TRUNK LID OPENER CANCEL SWITCH

Check trunk lid opener cancel switch position.

Does trunk lid opener cancel switch turn OFF?

Yes or No

- Yes >> Turn on trunk lid opener cancel switch.
- No >> GO TO 2.

2. CHECK TRUNK LID OPEN INPUT SIGNAL

1. Remove Key from ignition key cylinder.
2. Turn on trunk lid opener cancel switch.
3. Unlock driver side door.
4. Check voltage between BCM and ground.

Connector	Terminal (Wire color)		Condition	Voltage (V) [Approx.]
	(+)	(-)		
M3	76 (P)	Ground	Trunk lid opener switch ON	0
			Trunk lid opener switch OFF	5

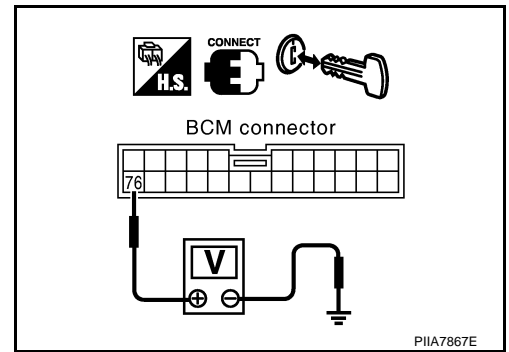

OK or NG

- OK >> GO TO 3.
- NG >> GO TO 6.

3. CHECK TRUNK LID OPEN OUTPUT SIGNAL

Check voltage between BCM and ground.

Connector	Terminal (Wire color)		Condition	Voltage (V) [Approx.]
	(+)	(-)		
B4	19 (G/W)	Ground	Trunk lid opener switch ON	Battery voltage
			Trunk lid opener switch OFF	0

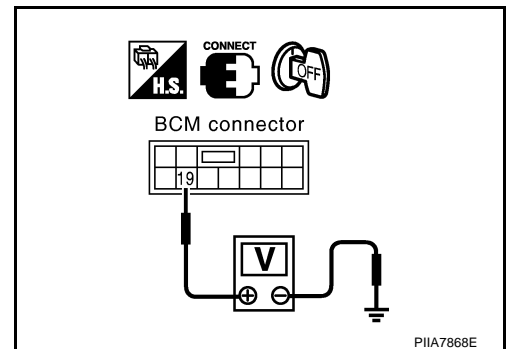

OK or NG

- OK >> GO TO 4.
- NG >> Replace BCM. Refer to [BCS-17, "Removal and Installation of BCM"](#).

TRUNK LID OPENER

4. CHECK TRUNK LID OPENER ACTUATOR CIRCUIT

1. Disconnect BCM connector and trunk lid opener actuator connector.
2. Check continuity between BCM harness connector B4 terminal 19 (G/W) and trunk lid opener actuator harness connector T32 terminal 1 (PU).

19 (G/W) - 1 (PU) : Continuity should exist.

3. Check continuity between BCM harness connector B4 terminal 19 (G/W) and ground.

19 (G/W) - ground : Continuity should not exist.

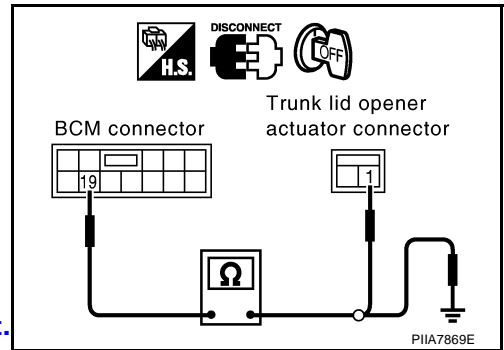

OK or NG

OK >> GO TO 5.

NG >> Repair harness or connector.

5. CHECK TRUNK LID OPENER ACTUATOR GROUND CIRCUIT

Check continuity between trunk lid opener actuator harness connector T32 terminal 2 (B) and ground.

2 (B) - ground : Continuity should exist.

OK or NG

OK >> Replace trunk lid opener actuator.

NG >> Repair harness or connector.

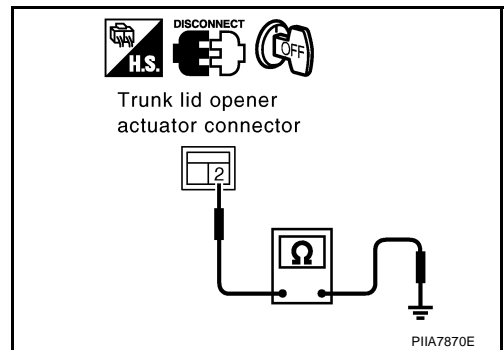

6. CHECK TRUNK LID OPENER CANCEL SWITCH

1. Disconnect trunk lid opener cancel switch.
2. Check continuity between trunk lid opener cancel switch harness connector B71 terminals 1 and 2.

Terminals		Trunk lid opener cancel switch condition	Continuity
1	2	ON	Yes
		OFF	No

OK or NG

OK >> GO TO 7.

NG >> Replace trunk lid opener cancel switch.

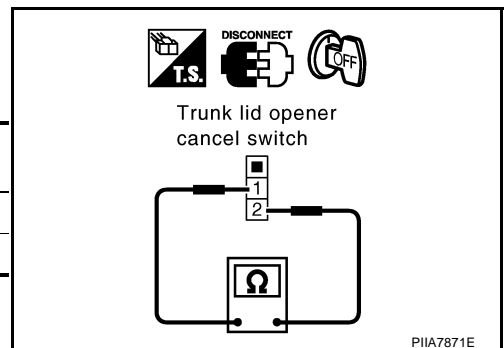

TRUNK LID OPENER

7. CHECK TRUNK LID OPENER SWITCH

1. Disconnect trunk lid opener switch
2. Check continuity between trunk lid opener switch harness connector T103 terminals 1 and 2.

Terminals		Trunk lid opener switch condition	Continuity
1	2	ON (Pushed)	Yes
		OFF (Released)	No

OK or NG

- OK >> GO TO 8.
 NG >> Replace trunk lid opener switch.

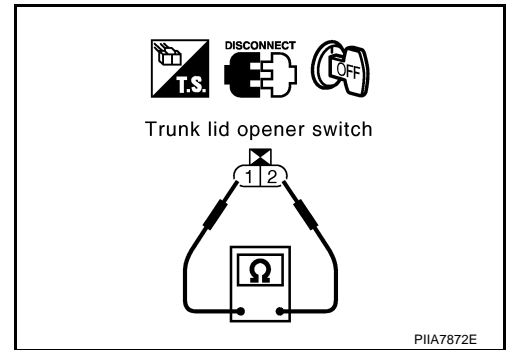

8. CHECK TRUNK LID OPENER CANCEL SWITCH CIRCUIT

1. Disconnect BCM connector.
2. Check continuity between BCM harness connector M3 terminal 76 (P) and trunk lid opener cancel switch harness connector B71 terminal 1 (P).

76 (P) - 1 (GY) : Continuity should exist.

OK or NG

- OK >> GO TO 9.
 NG >> Repair harness or connector.

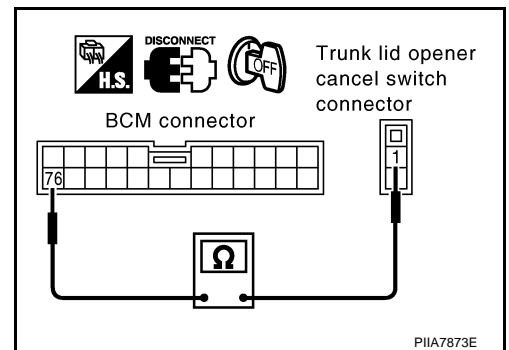

9. CHECK TRUNK LID OPENER SWITCH CIRCUIT

Check continuity between trunk lid opener cancel switch harness connector B71 terminal 2 (L/W) and trunk lid opener switch harness connector T103 terminal 1 (P).

2 (L/W) - 1 (P) : Continuity should exist.

OK or NG

- OK >> GO TO 10.
 NG >> Repair harness or connector.

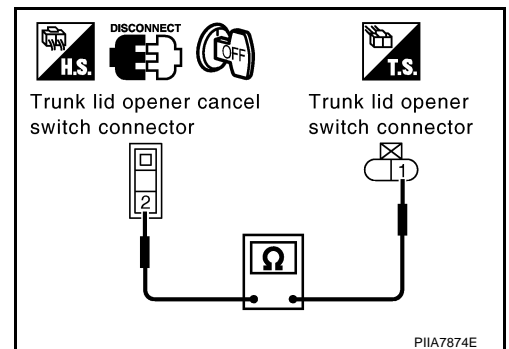

10. CHECK DRIVER SIDE DOOR LOCK ACTUATOR CIRCUIT

1. Disconnect driver side door lock actuator connector.
2. Check continuity between trunk lid opener switch harness connector T103 terminal 2 (G) and driver side door lock actuator switch harness connector D11 terminal 2 (OR).

2 (G) - 2 (OR) : Continuity should exist.

OK or NG

- OK >> GO TO 11.
 NG >> Repair harness or connector.

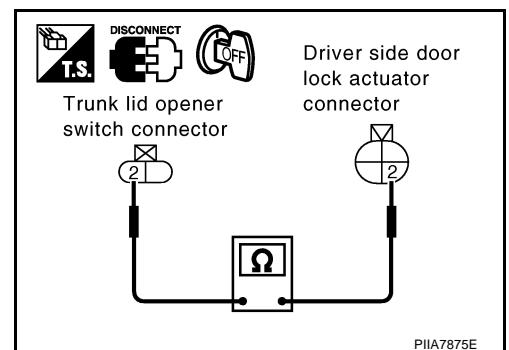

TRUNK LID OPENER

11. CHECK DRIVER SIDE DOOR LOCK ACTUATOR GROUND CIRCUIT

Check continuity between driver side door lock actuator switch harness connector D11 terminal 4 (B) and ground.

4 (B) - ground : Continuity should exist.

OK or NG

- OK >> Replace driver side door lock actuator.
- NG >> Repair harness or connector.

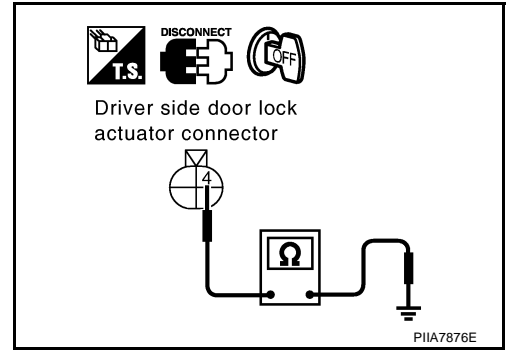

TRUNK DOSE NOT CLOSE

1. CHECK TRUNK LID OPEN INPUT SIGNAL

1. Remove Key from ignition key cylinder.
2. Turn on trunk lid opener cancel switch.
3. Unlock driver side door.
4. Check voltage between BCM and ground.

Connector	Terminal (Wire color)		Condition	Voltage (V) [Approx.]
	(+)	(-)		
M3	76 (P)	Ground	Trunk lid opener switch ON	0
			Trunk lid opener switch OFF	5

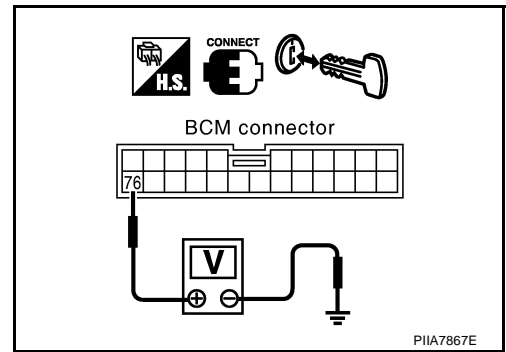

OK or NG

- OK >> GO TO 2.
- NG >> Replace BCM.

2. CHECK TRUNK LID OPENER CANCEL SWITCH

1. Disconnect trunk lid opener cancel switch.
2. Check continuity between trunk lid opener cancel switch harness connector B71 terminals 1 and 2.

Terminals		Trunk lid opener cancel switch condition	Continuity
1	2	ON	Yes
		OFF	No

OK or NG

- OK >> GO TO 3.
- NG >> Replace trunk lid opener cancel switch.

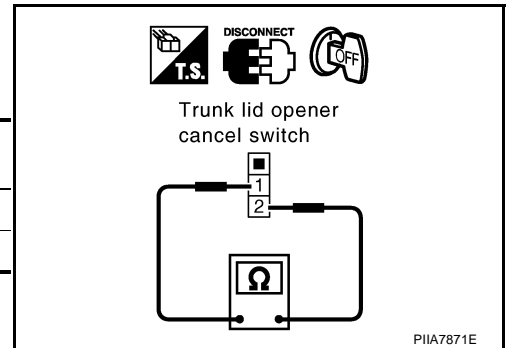

TRUNK LID OPENER

3. CHECK TRUNK LID OPENER SWITCH

1. Disconnect trunk lid opener switch
2. Check continuity between trunk lid opener switch harness connector T103 terminals 1 and 2.

Terminals		Trunk lid opener switch condition	Continuity
1	2	ON (Pushed)	Yes
		OFF (Released)	No

OK or NG

- OK >> GO TO 4.
 NG >> Replace trunk lid opener switch.

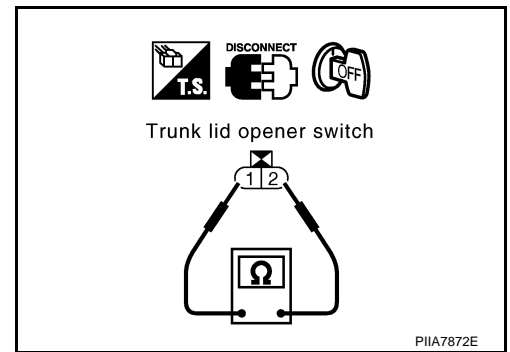

4. CHECK TRUNK LID OPENER CANCEL SWITCH CIRCUIT

1. Disconnect BCM connector.
2. Check continuity between BCM harness connector M3 terminal 76 (P) and ground.

76 (P) - ground : Continuity should not exist.

OK or NG

- OK >> GO TO 5.
 NG >> Repair harness or connector.

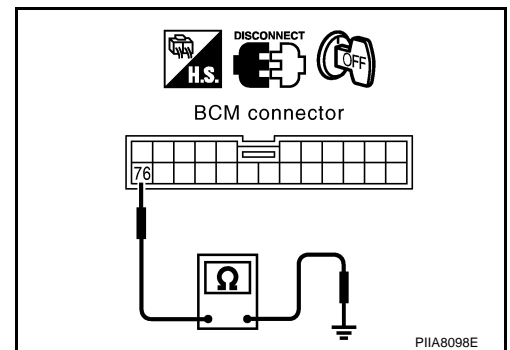

5. CHECK TRUNK LID OPENER SWITCH CIRCUIT

Check continuity between trunk lid opener cancel switch harness connector B71 terminal 2 (L) and ground.

2 (L) - ground : Continuity should not exist.

OK or NG

- OK >> GO TO 6.
 NG >> Repair harness or connector.

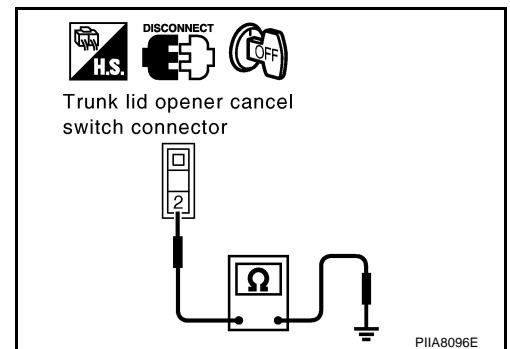

6. CHECK DRIVER SIDE DOOR LOCK ACTUATOR CIRCUIT

1. Disconnect driver side door lock actuator connector.
2. Check continuity between trunk lid opener switch harness connector T103 terminal 2 (G) and ground.

2 (G) - ground : Continuity should not exist.

OK or NG

- OK >> Replace BCM.
 NG >> Repair harness or connector.

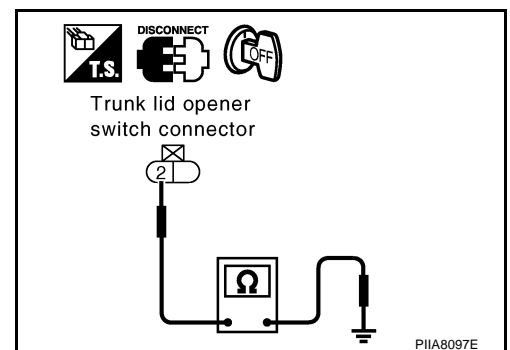

VEHICLE SECURITY (THEFT WARNING) SYSTEM

PFP:28491

AIS0014P

VEHICLE SECURITY (THEFT WARNING) SYSTEM

Component Parts and Harness Connector Location

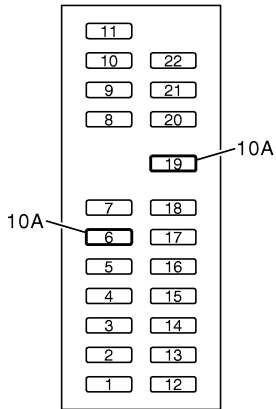

Fuse block (J/B) fuse layout

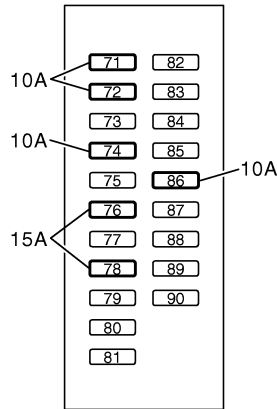

IPDM E/R fuse layout

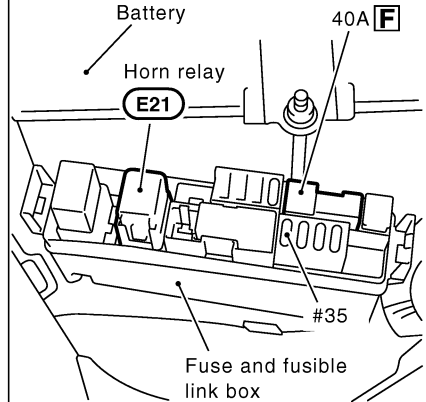

Fuse and fusible link box

View with dash side LH removed

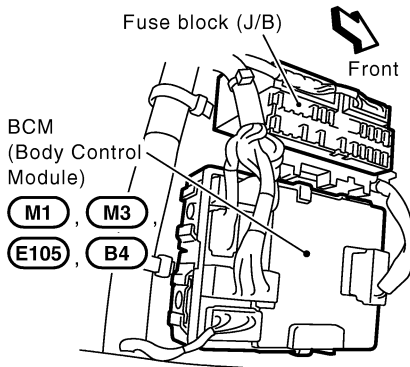

View with cowl top removed

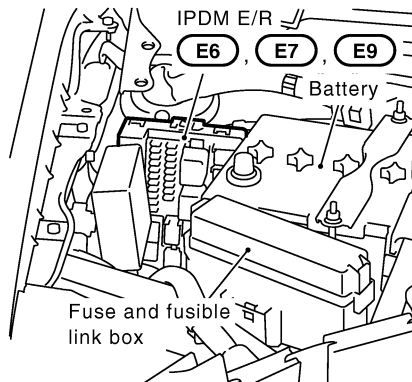

Power window main switch (Door lock and unlock switch)

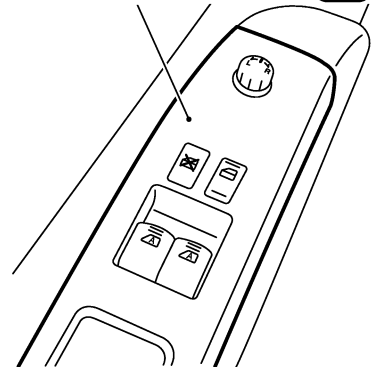

Power window sub-switch (Door lock and unlock switch)

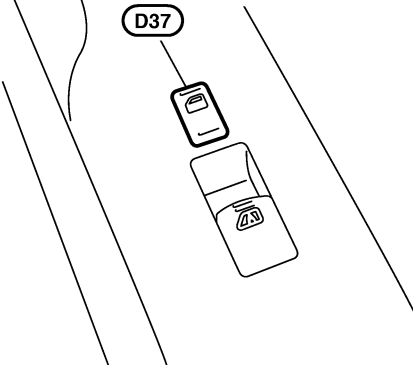

View with luggage finisher rear

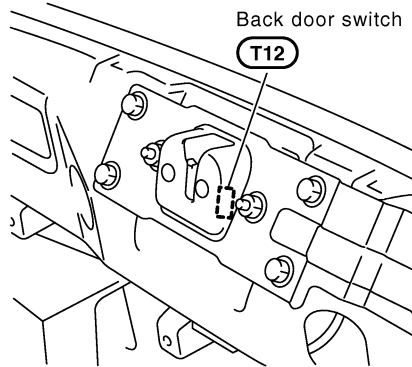

Driver side door switch



View with luggage finisher lower (center) removed (Roadster models)

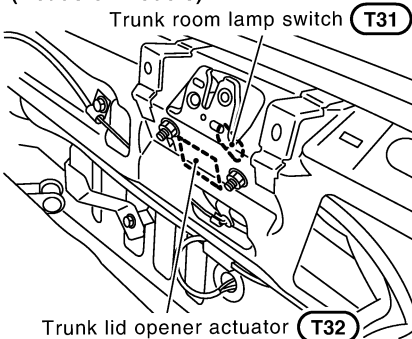

Passenger side door switch

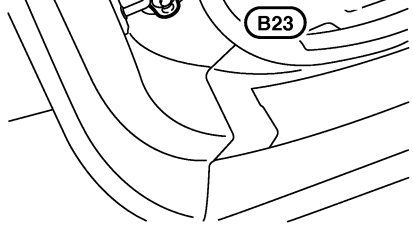

PIIA9442E

VEHICLE SECURITY (THEFT WARNING) SYSTEM

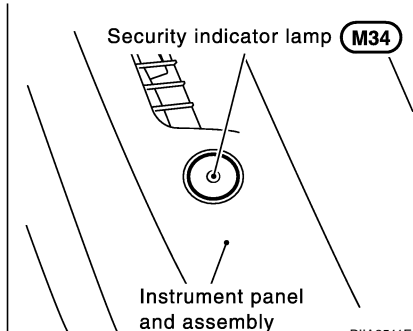
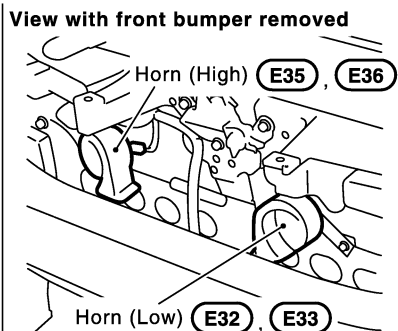
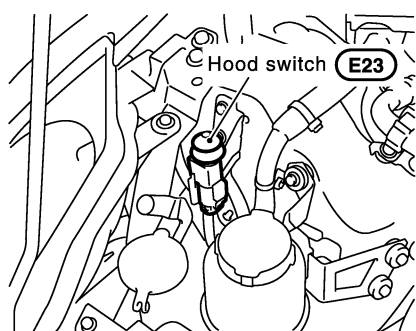

PIIA2511E
AIS0014Q

System Description

DESCRIPTION

Operation Flow

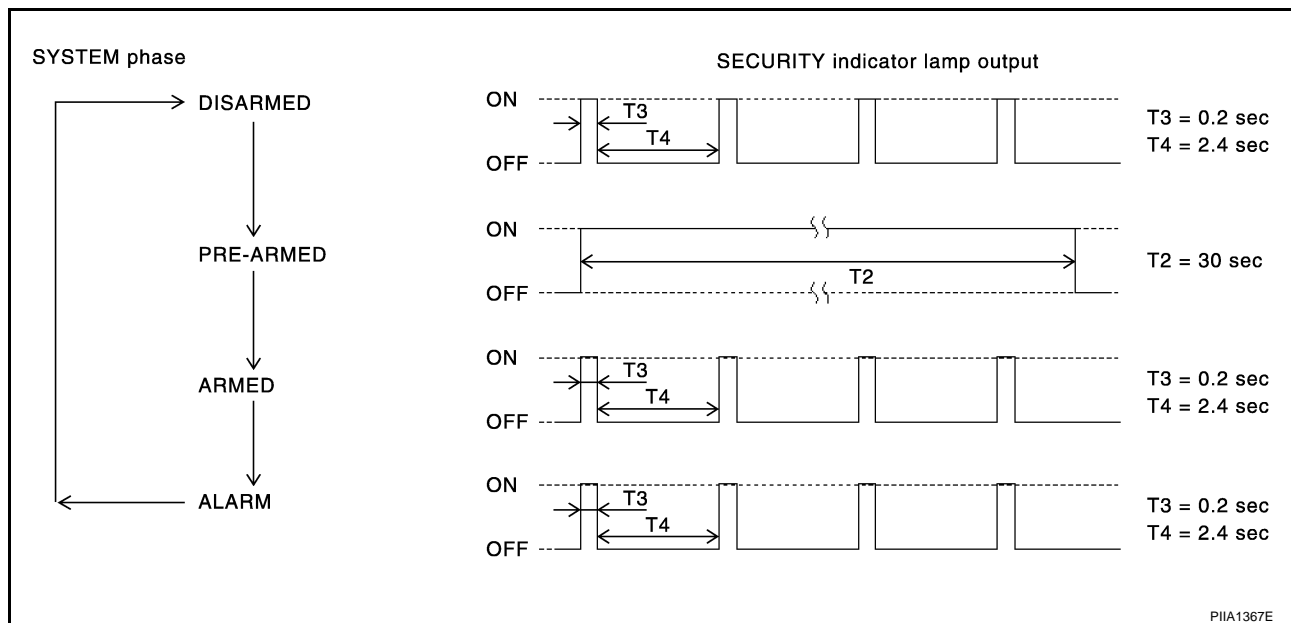

Setting the Vehicle Security System

Initial condition

- Ignition switch is in OFF position.

Disarmed phase

- When hood, doors, back door (for Coupe) or trunk (for Roadster) is open, the vehicle security system is set in the disarmed phase on the assumption that the owner is inside or near the vehicle.
- When the vehicle security system is in the disarmed phase, the security indicator lamp blinks every 2.4 seconds.

Pre-armed phase and armed phase

When the following operation 1 or 2 is performed, the vehicle security system turns into the “pre-armed” phase. (The security indicator lamp illuminates.)

1. BCM receives LOCK signal from door key cylinder switch or key fob after hood, all doors and back door (for Coupe) or trunk (for Roadster) are closed.
2. Hood, all doors and back door (for Coupe) or trunk (for Roadster) are closed after doors are locked by key or door lock and unlock switch.
The security indicator lamp illuminates for 30 seconds. Then, the system automatically shifts into the “armed” phase.

Canceling the Set Vehicle Security System

When one of the following operations is performed, the armed phase is canceled.

1. Unlock the doors with the key or the key fob.
2. Open the back door (for Coupe) or trunk (for Roadster) with the key fob.

VEHICLE SECURITY (THEFT WARNING) SYSTEM

3. Turn ignition switch to "ON" or "ACC" position.

Canceling the Alarm Operation of the Vehicle Security System

When one of the following operations is performed, the alarm operation is canceled.

- Unlock the door with the key or key fob.
- Open the trunk (for Roadster) with the key fob.

Activating the Alarm Operation of the Vehicle Security System

Make sure the system is in the armed phase. (The security indicator lamp blinks every 2.4 seconds.)

When the following operation 1 or 2 is performed, the system sounds the horns and flashes the headlamps for about 50 seconds.

1. Hood, any door or trunk (for Roadster) is opened during armed phase.
2. Disconnecting and connecting the battery connector before canceling armed phase.

POWER SUPPLY AND GROUND

Power is supplied at all times

- through 10A fuse [No.19, located in the fuse block (J/B)]
- to security indicator lamp terminal 1.

Power is supplied at all times

- through 40A fusible link (letter **F** , located in the fuse and fusible link box)
- to BCM terminal 7.

With the ignition switch in the ACC or ON position, power is supplied

- through 10A fuse [No. 6, located in the fuse block (J/B)]
- to BCM terminal 36.

Ground is supplied.

- to BCM terminal 8
- through body grounds E17, E43 and F152.

INITIAL CONDITION TO ACTIVATE THE SYSTEM

The operation of the vehicle security system is controlled by the doors, hood and trunk (for Roadster).

To activate the vehicle security system, BCM must receive signals indicating the doors, hood and trunk (for Roadster) are closed and the doors are locked by key or key fob.

When a door is open, BCM terminals 10, 14 or 18 receives a ground signal from each door switch.

When driver side door is unlocked by power window main switch (door lock and unlock switch), BCM terminal 74 receives a signal from terminal 12 of power window main switch.

When passenger side door is unlocked by power window sub-switch (door lock and unlock switch), BCM terminal 74 receives a signal from terminal 16 of power window sub-switch.

When the hood is open, IPDM E/R receives a ground signal

- from hood switch terminal 1
- to IPDM E/R terminal 56
- through body grounds E17, E43 and F152.

The IPDM E/R then sends a signal to the BCM via CAN communication line.

When the back door (for Coupe) or trunk (for Roadster) is open, BCM terminal 18 receives a ground signal

- from terminal 1 of the back door switch (for Coupe) or trunk room lamp switch (for Roadster)
- through body grounds B5, B6, T14 or D105 (for Coupe).

VEHICLE SECURITY SYSTEM ALARM OPERATION

The vehicle security system is triggered by

- opening a driver or passenger side door
- opening the back door (for Coupe)
- opening the trunk (for Roadster)
- opening the hood
- detection of battery disconnect and connect.

The vehicle security system will be triggered once the system is in armed phase,

VEHICLE SECURITY (THEFT WARNING) SYSTEM

when BCM receives a ground signal at terminals 10, 14 (door switch), 18 (back door switch or trunk room lamp switch), or IPDM E/R receives a ground signal at terminal 56 (hood switch).

Power is supplied at all times

- to horn relay terminal 2
- through 15A fuse (No. 35, located in the fuse and fusible link box).

When the vehicle security system is triggered, ground is supplied intermittently to both headlamp relay and horn relay.

When both headlamp relay (with built-in IPDM E/R) and horn relay are energized and then power is supplied to headlamps (high beam and low beam) and horns (HIGH and LOW).

The headlamps flash and the horn sounds intermittently.

The alarm automatically turns off after 50 seconds, but will reactivate if the vehicle is tampered with again.

VEHICLE SECURITY SYSTEM DEACTIVATION

To deactivate the vehicle security system, a door must be unlocked or back door (for Coupe) or trunk (for Roadster) must be opened with the key or key fob.

When the key is used to unlock a door, BCM terminal 74 receives signal

- from terminal 12 of the power window main switch (door lock and unlock switch).

When the BCM receives either above signal or unlock signal from key fob, the vehicle security system is deactivated. (Disarmed phase)

PANIC ALARM OPERATION

Remote keyless entry system may or may not operate vehicle security system (horn and headlamps) as required.

When the remote keyless entry system is triggered, ground is supplied intermittently to both headlamp relay and horn relay.

When both headlamp relay (with built-in IPDM E/R) and horn relay are energized and then power is supplied to headlamps (high beam and low beam) and horns (HIGH and LOW).

The headlamp flashes and the horn sounds intermittently.

The alarm automatically turns off after 25 seconds or when BCM receives any signal from key fob.

CAN Communication System Description

AIS0014R

CAN (Controller Area Network) is a serial communication line for real time application. It is an on-vehicle multiplex communication line with high data communication speed and excellent error detection ability. Many electronic control units are equipped onto a vehicle, and each control unit shares information and links with other control units during operation (not independent). In CAN communication, control units are connected with 2 communication lines (CAN H line, CAN L line) allowing a high rate of information transmission with less wiring. Each control unit transmits/receives data but selectively reads required data only.

CAN Communication Unit

AIS00410

Refer to [LAN-5, "CAN COMMUNICATION"](#) .

VEHICLE SECURITY (THEFT WARNING) SYSTEM

Schematic

AIS0014S

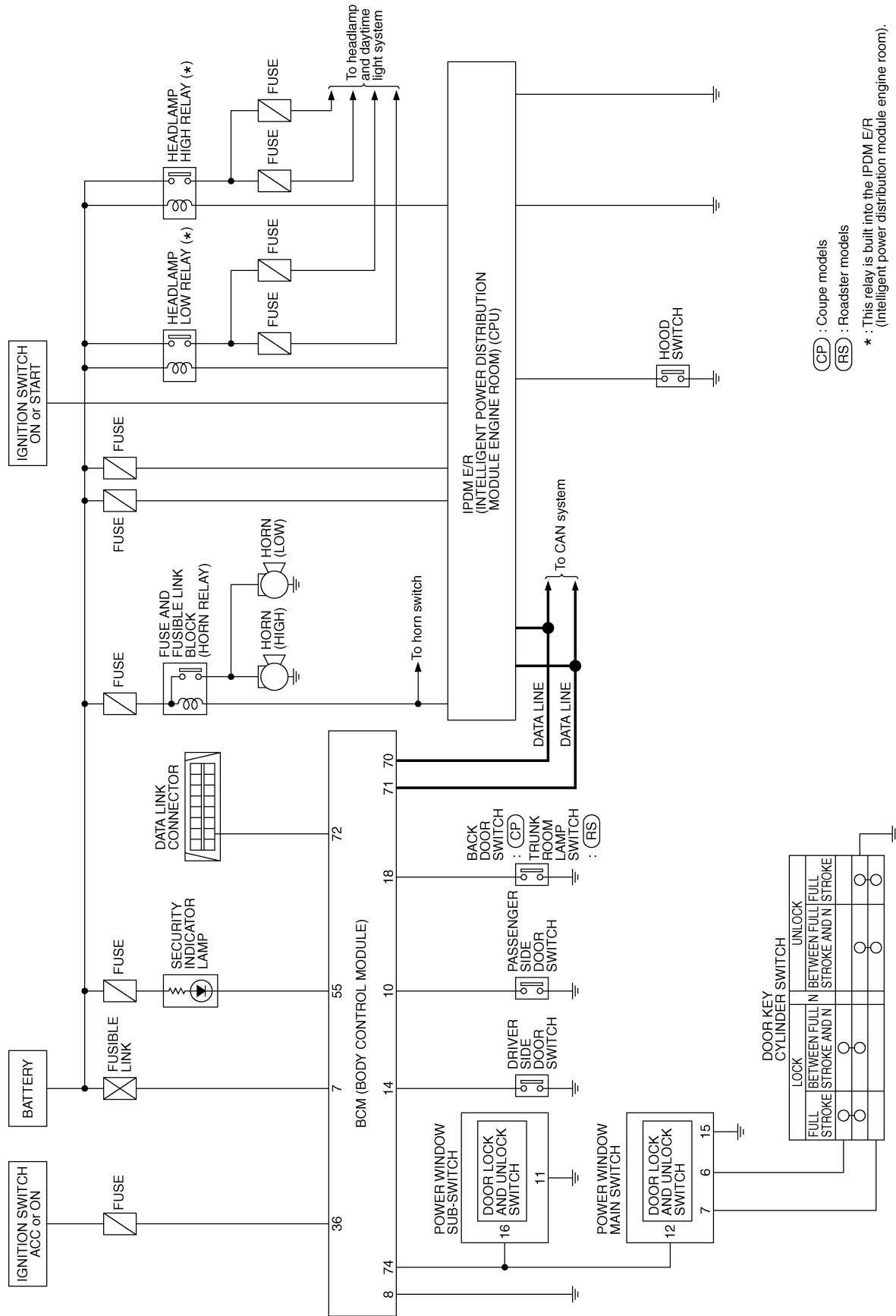

TIWT0745E

VEHICLE SECURITY (THEFT WARNING) SYSTEM

Wiring Diagram —VEHSEC—
FIG. 1

AIS0014T

BL-VEHSEC-01

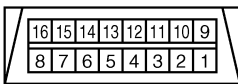
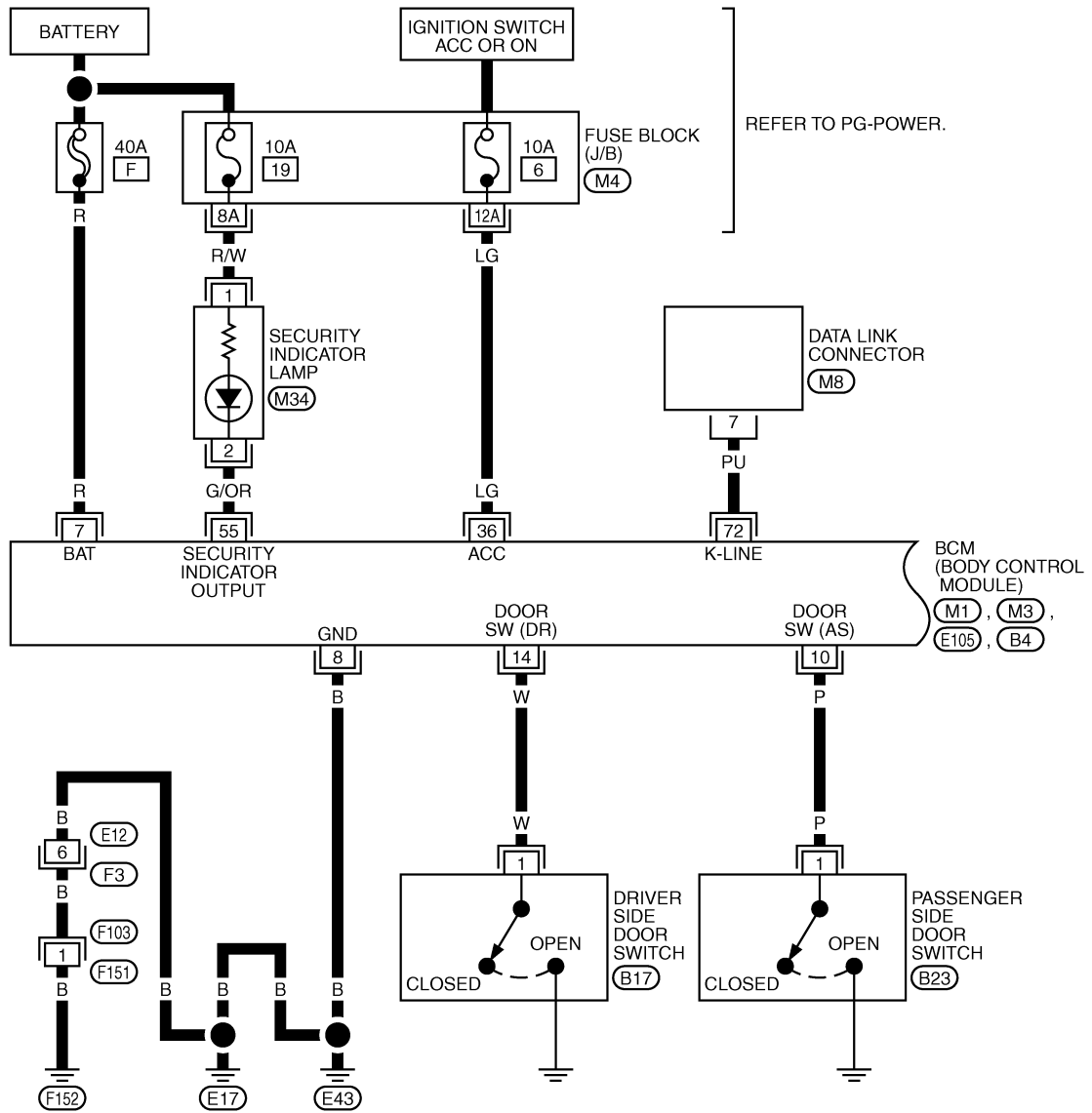

(M8)
W

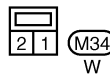

(M34)
W

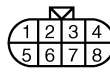

(F3)
GY

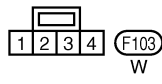

(F103)
W



(B17), (B23)
W

REFER TO THE FOLLOWING.

(M4) - FUSE BLOCK-JUNCTION BOX (J/B)

(M1), (M3), (E105), (B4)
- ELECTRICAL UNITS

TIWT0746E

VEHICLE SECURITY (THEFT WARNING) SYSTEM

FIG. 2

BL-VEHSEC-02

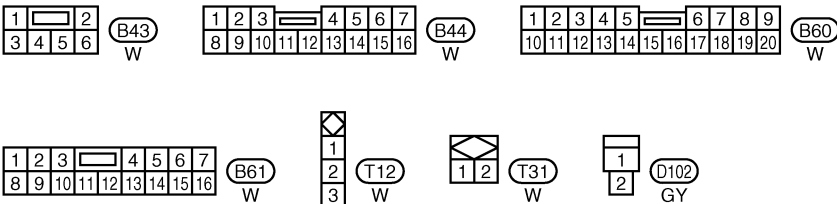
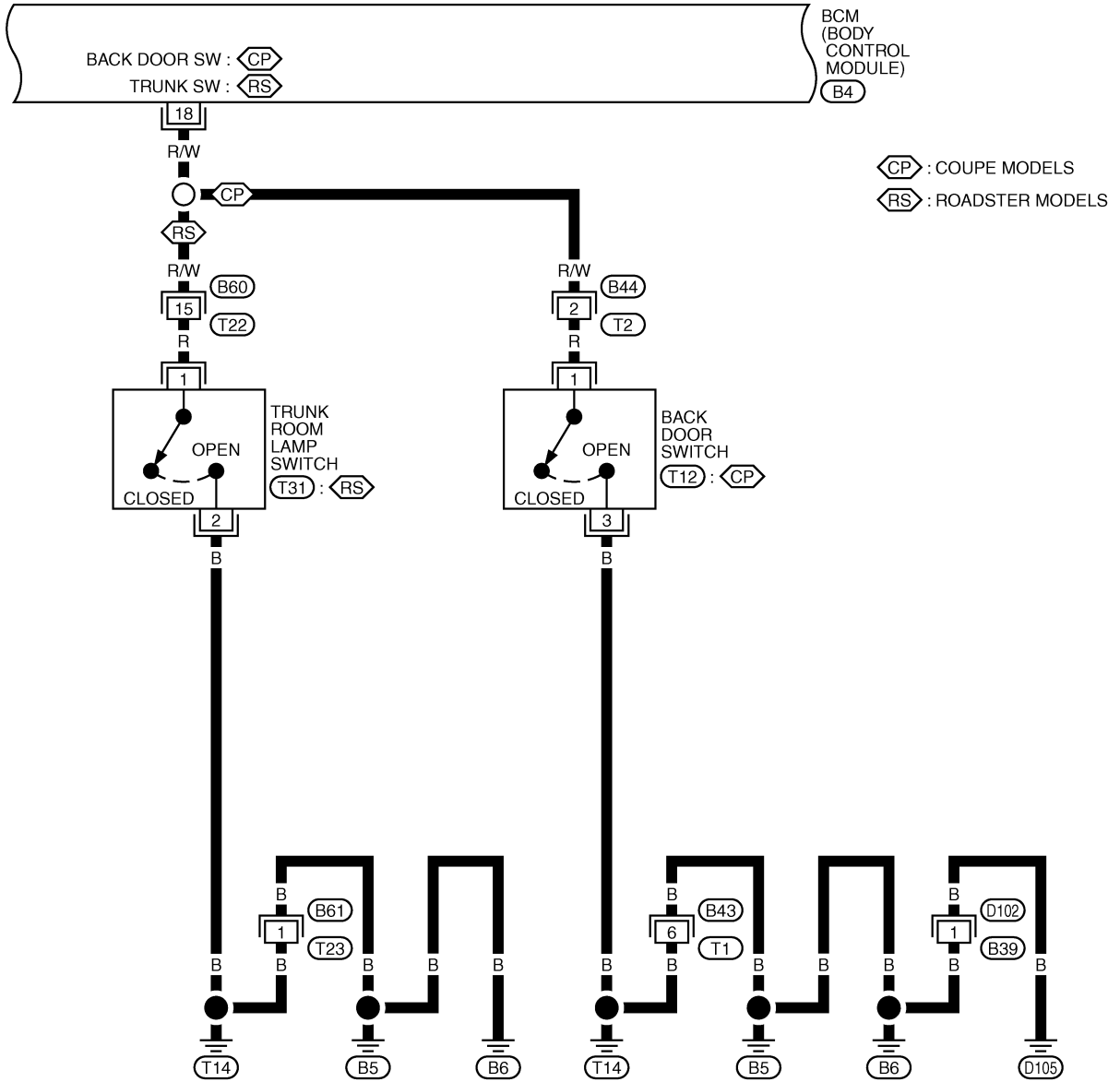

REFER TO THE FOLLOWING.
(B4) -ELECTRICAL UNITS

TIWT0747E

VEHICLE SECURITY (THEFT WARNING) SYSTEM

FIG. 3

BL-VEHSEC-03

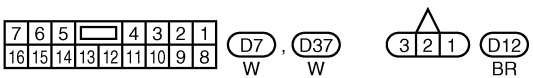
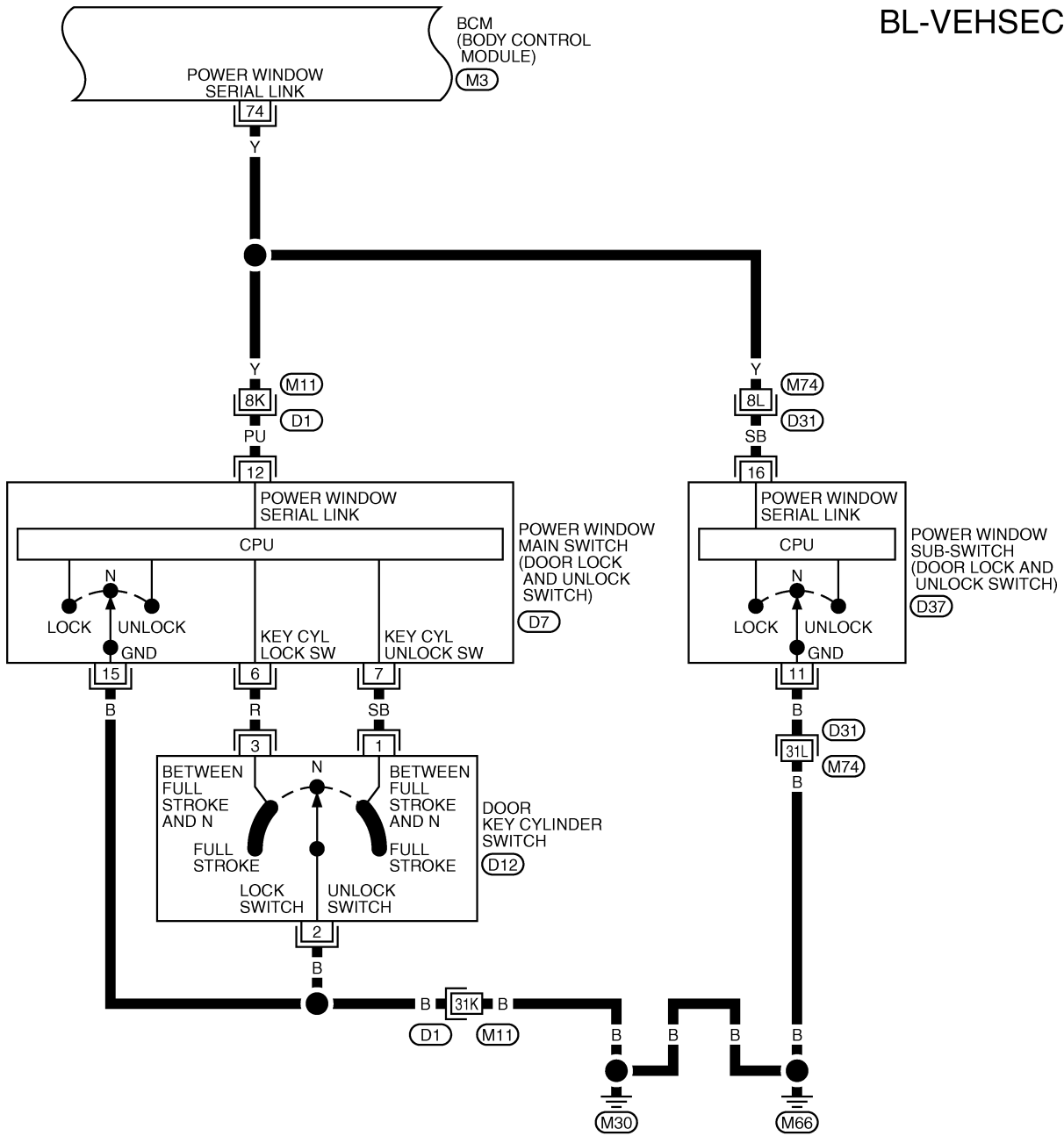

REFER TO THE FOLLOWING.
 (D1), (D31) -SUPER MULTIPLE JUNCTION (SMJ)
 (M3) -ELECTRICAL UNITS

A
B
C
D
E
F
G
H
BL
J
K
L
M

VEHICLE SECURITY (THEFT WARNING) SYSTEM

FIG. 4

BL-VEHSEC-04

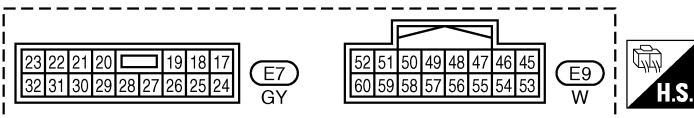
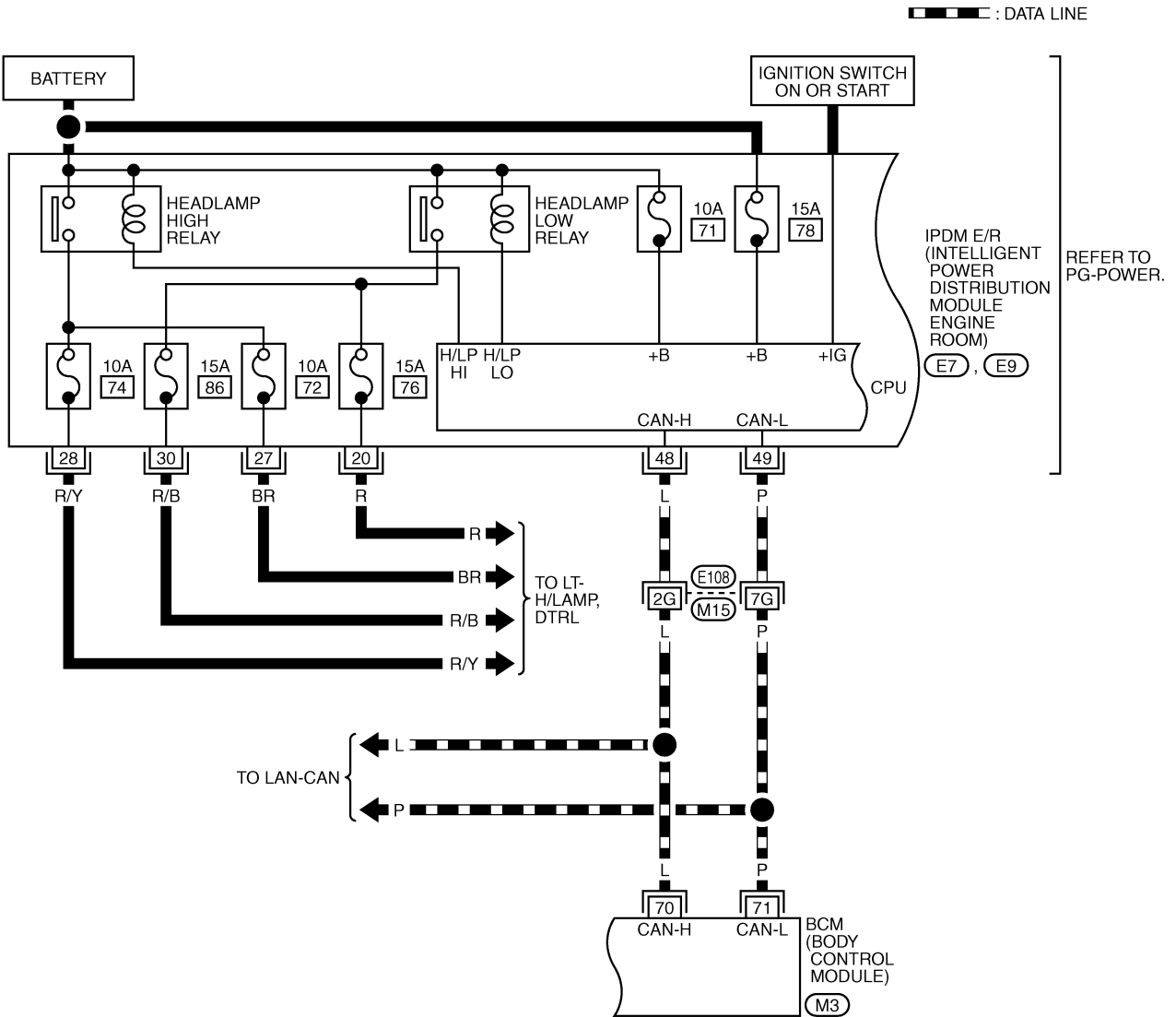

REFER TO THE FOLLOWING.

(E108) -SUPER MULTIPLE JUNCTION (SMJ)

(M3) -ELECTRICAL UNITS

VEHICLE SECURITY (THEFT WARNING) SYSTEM

FIG. 5

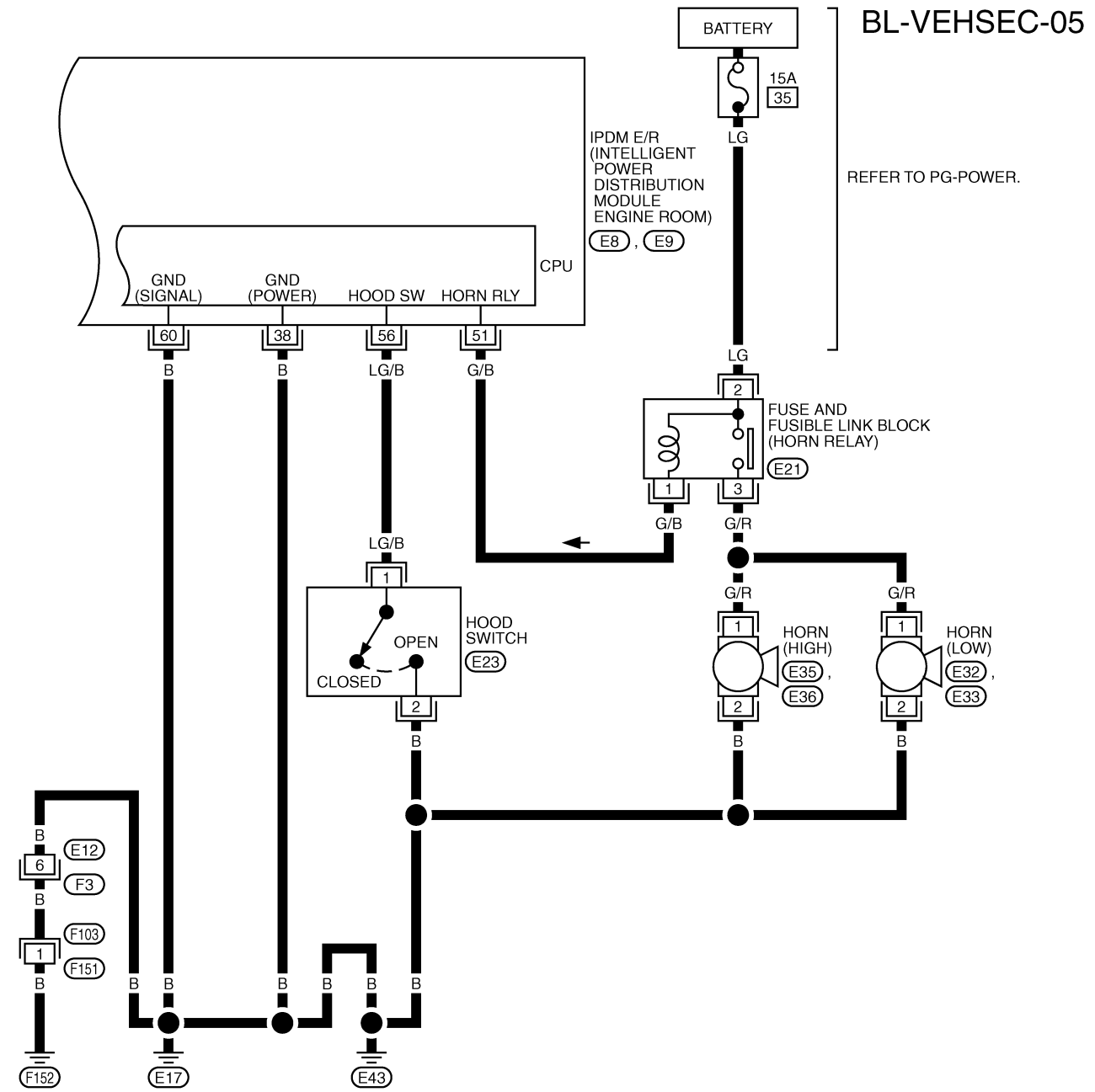

BL-VEHSEC-05

REFER TO PG-POWER.

A
B
C
D
E
F
G
H
J
K
L
M

BL

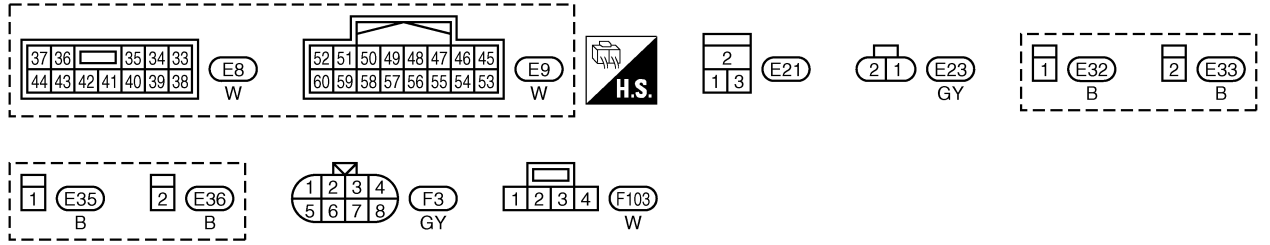

TIWT0749E

VEHICLE SECURITY (THEFT WARNING) SYSTEM

Terminals and Reference Value for BCM

AIS0014U

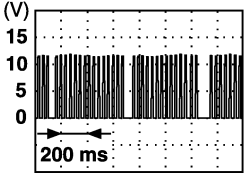
Terminal	Wire color	Item	Condition	Voltage [V] (Approx.)
7	R	Power source (Fusible link)	—	Battery voltage
8	B	Ground	—	0
10	P	Passenger side door switch	ON (Open) → OFF (Closed)	0 → 5
14	W	Driver side door switch	ON (Open) → OFF (Closed)	0 → 5
18	R/W	Back door switch	ON (Open) → OFF (Closed)	0 → Battery voltage* ¹
		Trunk room lamp switch* ²		
36	LG	ACC power supply (ACC or ON)	Ignition switch (ACC position)	Battery voltage
55	G/OR	Security indicator lamp	Goes off → Illuminates (Every 2.4 seconds)	Battery voltage → 0
70	L	CAN-H	—	—
71	P	CAN-L	—	—
72	PU	Data link connector	—	—
74	Y	Power window switch (Serial link)	Driver side door and passenger side door are closed. (Each door switch is OFF)	 <p style="text-align: right; font-size: small;">PIIA2344J</p>

*1: When interior lamp battery saver control is in OFF: Approx.5V.

*2: For roadster

Terminals and Reference Value for IPDM E/R

AIS0014V

Terminal	Wire color	Item	Condition	Voltage (V) (Approx.)
38	B	Ground	—	0
48	L	CAN-H	—	—
49	P	CAN-L	—	—
51	G/B	Horn relay	ON → OFF	0 → Battery voltage
56	LG/B	Hood switch	ON (Open) → OFF (closed)	0 → Battery voltage
60	B	Ground	—	0

VEHICLE SECURITY (THEFT WARNING) SYSTEM

AIS0014W

CONSULT-II Function of BCM CONSULT-II BASIC OPERATION PROCEDURE

CAUTION:

If CONSULT-II is used with no connection of CONSULT-II CONVERTER, malfunctions might be detected in self-diagnosis depending on control unit which carry out CAN communication.

1. Turn ignition switch "OFF".
2. Connect CONSULT-II and CONSULT-II CONVERTER to data link connector.

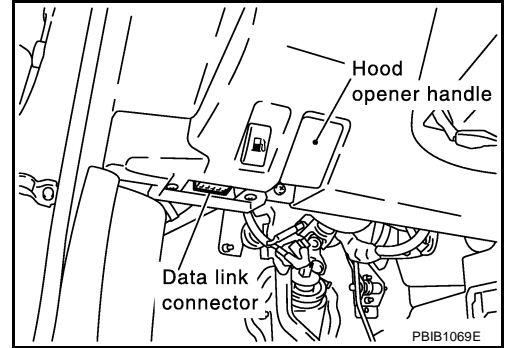

3. Turn ignition switch "ON".
4. Touch "START(NISSAN BASED VHCL)".

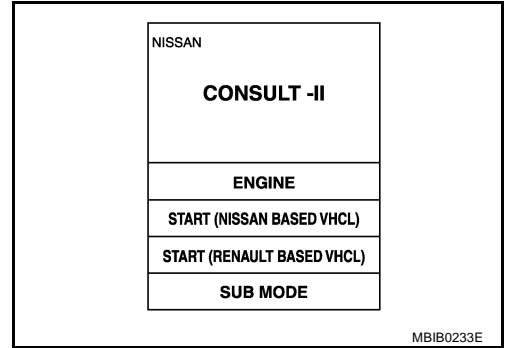

5. Touch "BCM".
If "BCM" is not indicated, go to [GI-39, "CONSULT-II Data Link Connector \(DLC\) Circuit"](#).

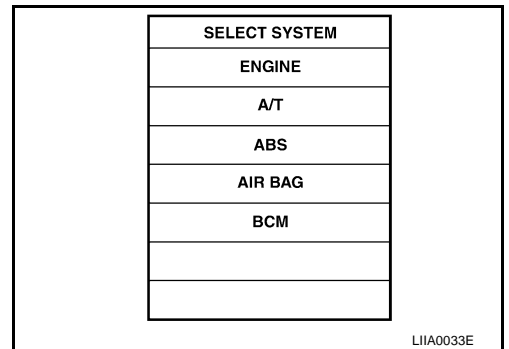

6. Touch "THEFT ALM".

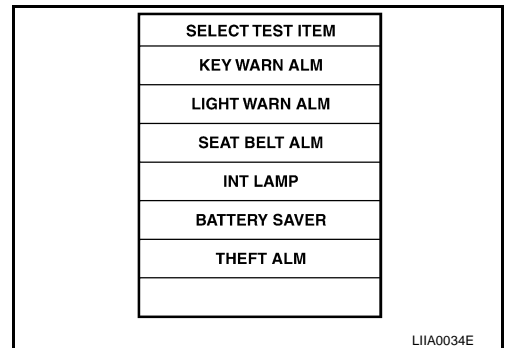

A
B
C
D
E
F
G
H
BL
J
K
L
M

VEHICLE SECURITY (THEFT WARNING) SYSTEM

7. Select diagnosis mode.
 "WORK SUPPORT", "DATE MONITOR", "ACTIVE TEST" are available.

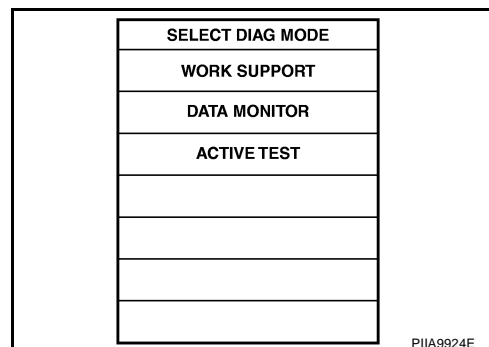

CONSULT-II APPLICATION ITEM

Work Support

Test Item	Description
SECURITY ALARM SET	This mode is able to confirm and change security alarm ON-OFF setting.
THEFT ALM TRG	The switch which triggered vehicle security alarm is recorded. This mode is able to confirm and erase the record of vehicle security alarm. The trigger data can be erased by touching "CLEAR" on CONSULT-II screen.

Data Monitor

Monitored Item	Description
IGN ON SW	Indicates [ON/OFF] condition of ignition switch.
ACC ON SW	Indicates [ON/OFF] condition of ignition switch in ACC position.
KEY CYL LK SW	Indicates [ON/OFF] condition of lock signal from key cylinder switch.
KEY CYL UN SW	Indicates [ON/OFF] condition of unlock signal from key cylinder switch.
DOOR SW-DR	Indicates [ON/OFF] condition of driver side door switch.
DOOR SW-AS	Indicates [ON/OFF] condition of passenger side door switch.
BACK DOOR SW	Indicates [ON/OFF] condition of back door switch.
TRUNK OPNR SW	Indicates [ON/OFF] condition of trunk room lamp switch. (Roadster models)
TRUNK OPN MNTR	This is displayed even when it is not equipped. Indicates [ON/OFF] condition of trunk lid opener switch. (Roadster models)
TRUNK KEY SW	This is displayed even when it is not equipped.
DOOR SW-RR	This is displayed even when it is not equipped.
HOOD SW	Indicates [ON/OFF] condition of hood switch.
LOCK SW DR/AS	Indicates [ON/OFF] condition of lock signal from driver and passenger side door lock/unlock switch.
UNLK SW DR/AS	Indicates [ON/OFF] condition of unlock signal from driver and passenger side door lock/unlock switch.
LK BUTTON/SIG	Indicates [ON/OFF] condition of lock signal from key fob.
UN BUTTON/SIG	Indicates [ON/OFF] condition of unlock signal from key fob.
TRUNK BTN/SIG	Indicate [ON/OFF] condition of back door open signal from key fob (for Coupe). Indicates [ON/OFF] condition of trunk open signal from key fob (for Roadster).

Active Test

Test Item	Description
THEFT IND	This test is able to check security indicator lamp operation. The lamp will be turned on when "ON" on CONSULT-II screen is touched.
HORN	This test is able to check vehicle security horn (horn alarm) operation. The horns will be activated for 0.5 seconds after "ON" on CONSULT-II screen is touched.
HEAD LAMP	This test is able to check vehicle security lamp (headlamp alarm) operation. The headlamps will be activated for 0.5 seconds after "ON" on CONSULT-II screen is touched.

VEHICLE SECURITY (THEFT WARNING) SYSTEM

AIS004U5

CONSULT-II Function of IPDM E/R BASIC OPERATION PROCEDURE

CAUTION:

If CONSULT-II is used with no connection of CONSULT-II CONVERTER, malfunctions might be detected in self-diagnosis depending on control unit which carry out CAN communication.

1. Turn ignition switch "OFF".
2. Connect CONSULT-II and CONSULT-II CONVERTER to data link connector.

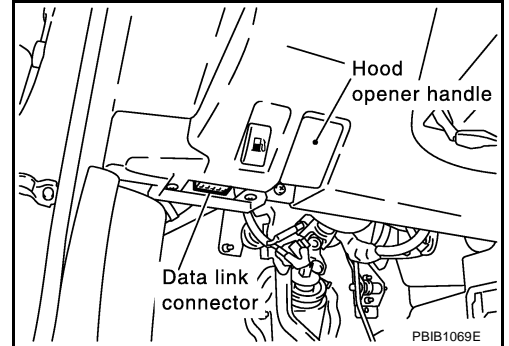

3. Turn ignition switch "ON".
4. Touch "START(NISSAN BASED VHCL)".

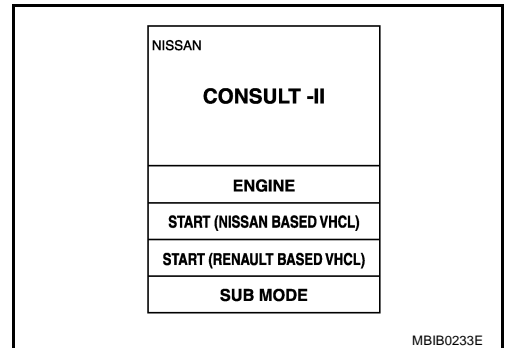

5. Touch "IPDM".
If "IPDM" is not indicated, go to [GI-39, "CONSULT-II Data Link Connector \(DLC\) Circuit"](#).

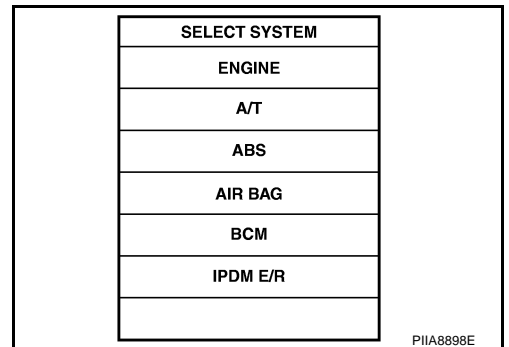

6. Select diagnosis mode.
"DATE MONITOR" and "ACTIVE TEST" are available.

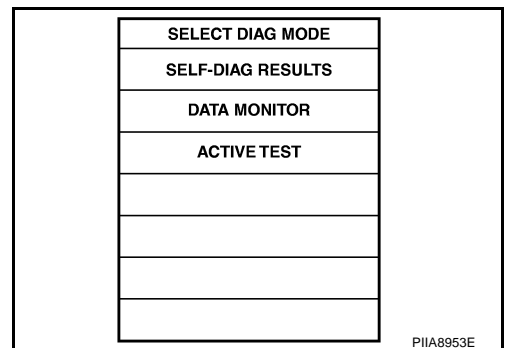

A
B
C
D
E
F
G
H
BL
J
K
L
M

VEHICLE SECURITY (THEFT WARNING) SYSTEM

CONSULT-II APPLICATION ITEM

Data Monitor

Monitored Item	Description
HL LO REQ	Indicates [ON/OFF] condition of headlamp low beam.
HL HI REQ	Indicates [ON/OFF] condition of headlamp high beam.
HOOD SW	Indicates [ON/OFF] condition of hood switch.
THFT HRN REQ	Indicates [ON/OFF] condition of horn relay.

Active Test

Test Item	Description
LAMPS	This test is able to check theft warning lamp (headlamp alarm) operation. The headlamps will be activated for 0.5 seconds after "ON" on CONSULT-II screen is touched.
HORN	This test is able to check theft warning horn (horn alarm) operation. The horns will be activated for 0.5 seconds after "ON" on CONSULT-II screen is touched.

Trouble Diagnosis WORK FLOW

AIS0014X

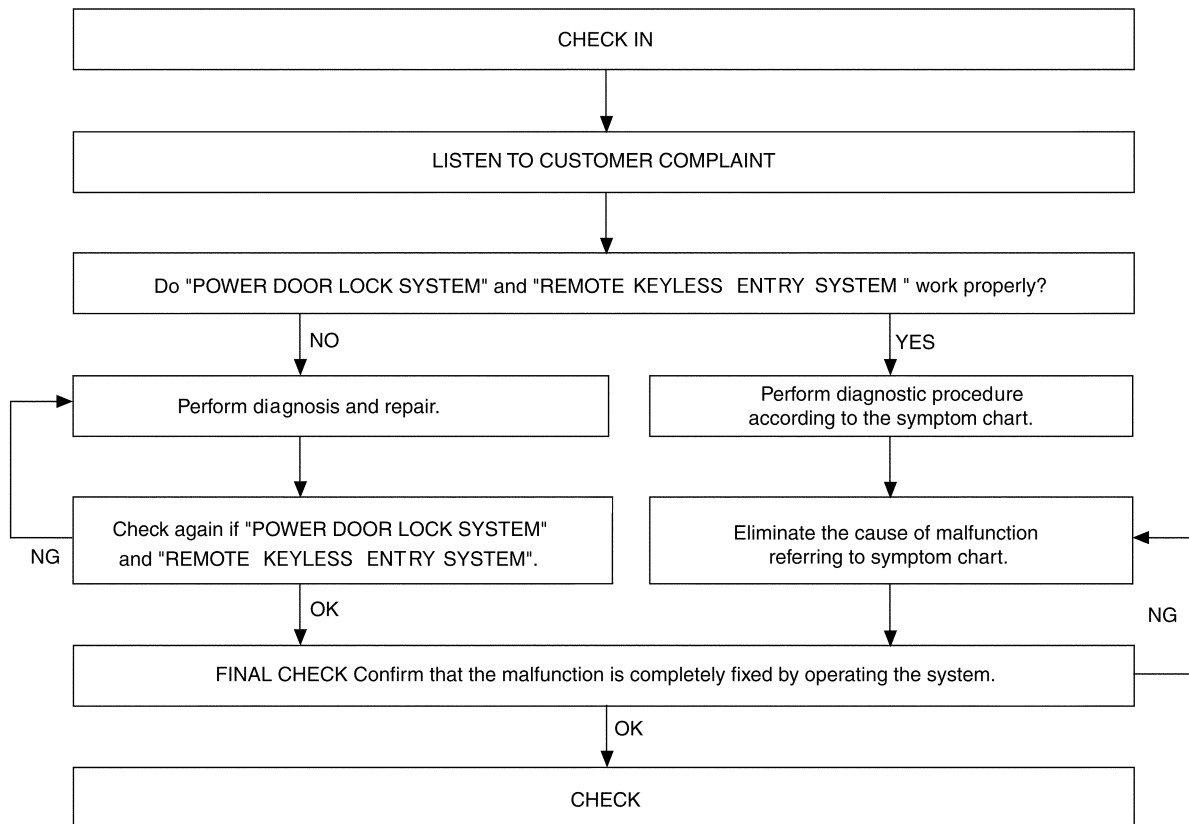

LIIA0123E

- "POWER DOOR LOCK SYSTEM" Diagnosis; refer to [BL-35, "Work Flow"](#) .
- "REMOTE KEYLESS ENTRY" Diagnosis; refer to [BL-81, "Work Flow"](#) .

VEHICLE SECURITY (THEFT WARNING) SYSTEM

AIS0014Y

Preliminary Check

The system operation is canceled by turning ignition switch to "ACC" at any step between START and ARMED in the following flow chart.

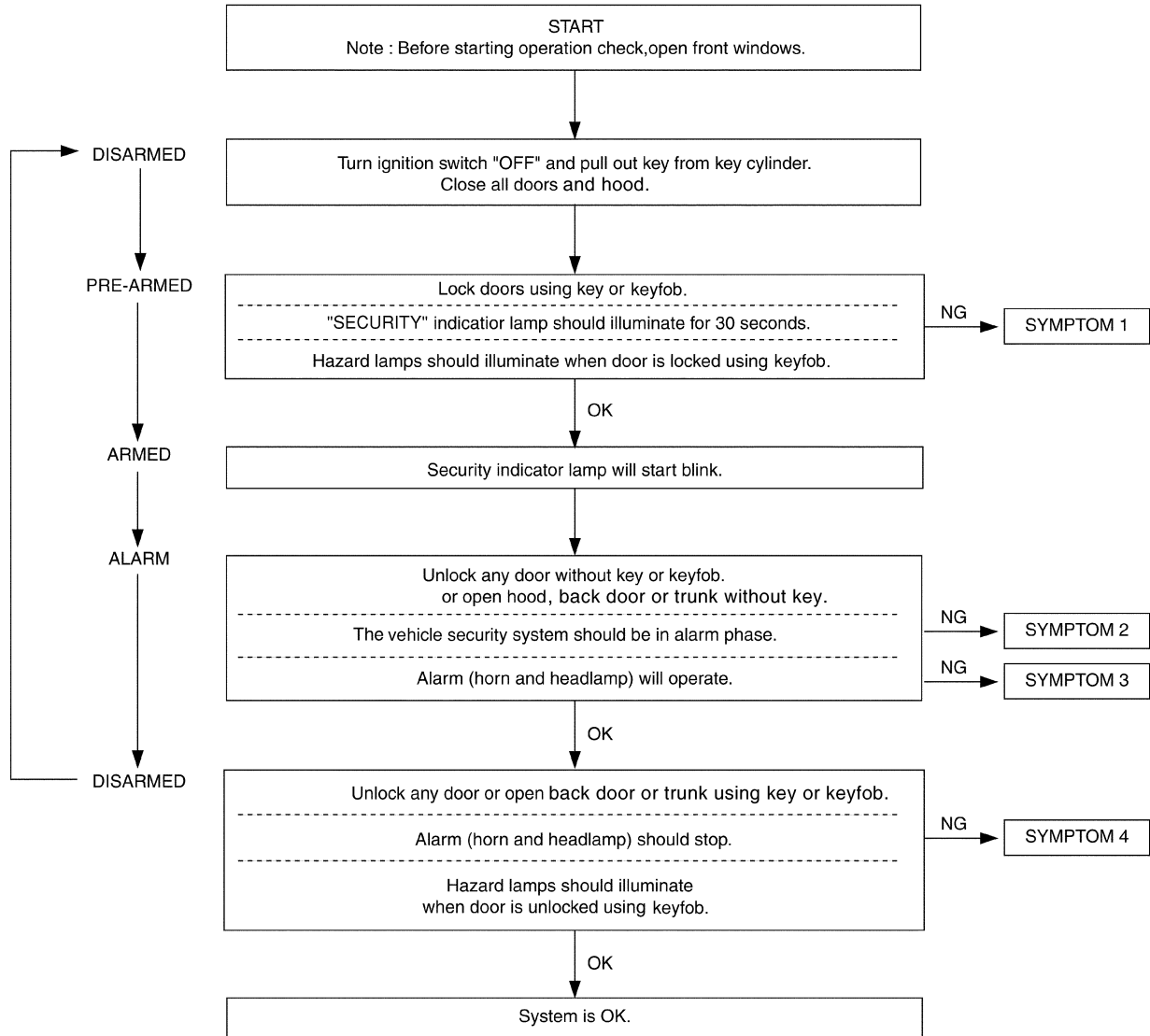

PIIA8954E

After performing preliminary check, go to symptom chart. Refer to [BL-146. "Symptom Chart"](#) .

VEHICLE SECURITY (THEFT WARNING) SYSTEM

Symptom Chart

AIS0014Z

PROCEDURE		Diagnostic procedure	Reference page	
SYMPTOM				
1	Vehicle security system cannot be set by	Door switch	Diagnostic Procedure 1 (Door, hood, back door switch or trunk room lamp switch check)	BL-147
		Lock/unlock switch	Diagnostic Procedure 6 (Door lock/unlock switch check)	BL-155
		Door outside key	Diagnostic Procedure 3 (Door key cylinder switch check)	BL-153
		Key fob	Check remote keyless entry system function.	BL-65
		BCM	If the above systems are "OK", replace BCM.	BCS-17
	Security indicator does not turn "ON".		Diagnostic Procedure 2 (Security indicator lamp check)	BL-153
		If the above systems are "OK", replace BCM.	BCS-17	
2	*1 Vehicle security system does not alarm when	Any door is opened.	Diagnostic Procedure 1 (Door, hood and trunk room lamp switch check)	BL-147
			If the above systems are "OK", replace BCM.	BCS-17
3	Vehicle security alarm does not activate.	Horn alarm	Diagnostic Procedure 4 (Vehicle security horn alarm check)	BL-154
			If the above systems are "OK", replace BCM.	BCS-17
	Headlamp alarm	Diagnostic Procedure 5 (Vehicle security headlamp alarm check)	BL-154	
		If the above systems are "OK", replace BCM.	BCS-17	
4	Vehicle security system cannot be canceled by	Door outside key	Diagnostic Procedure 3 (Door key cylinder switch check)	BL-153
		Key fob	Check remote keyless entry system function.	BL-65
			If the above systems are "OK", replace BCM.	BCS-17

*1: Make sure the system is in the armed phase.

VEHICLE SECURITY (THEFT WARNING) SYSTEM

AIS00150

Diagnostic Procedure 1 1 – 1 DOOR SWITCH CHECK

Driver Side Door Switch and Passenger Side Door Switch Check

1. CHECK DOOR SWITCH INPUT SIGNAL

With CONSULT-II

Check door switches (“DOOR SW-DR” and “DOOR SW-AS”) in “DATA MONITOR” mode with CONSULT-II.

Monitor item	Condition	
DOOR SW-DR	OPEN	: ON
	CLOSE	: OFF
DOOR SW-AS	OPEN	: ON
	CLOSE	: OFF

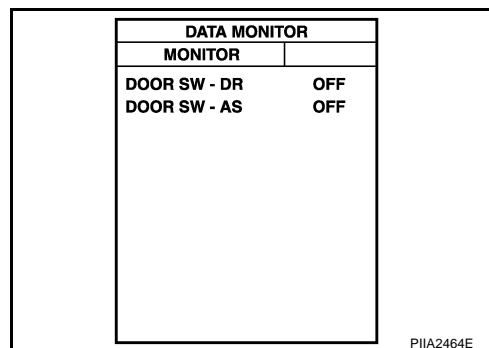

Without CONSULT-II

Check voltage between BCM connector and ground.

Item	(+)		(-)	Condition	Voltage [V] (Approx.)
	Con- nector	Terminal (Wire color)			
Passenger side door switch	B4	10 (P)	Ground	OPEN	0
				CLOSE	5
Driver side door switch		14 (W)		OPEN	0
				CLOSE	5

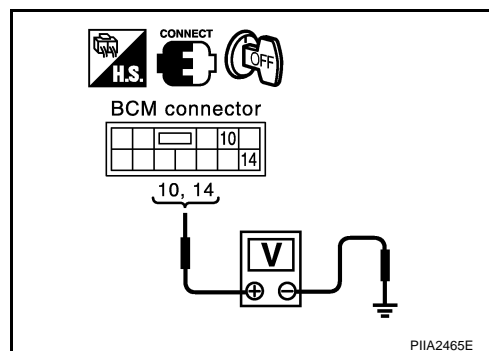

OK or NG

OK >> Door switch is OK, and go to the following

- [BL-148, "1 – 2 BACK DOOR SWITCH CHECK/FOR COUPE"](#)
- [BL-150, "1 – 3 TRUNK ROOM LAMP SWITCH CHECK/FOR ROADSTER"](#)

NG >> GO TO 2.

VEHICLE SECURITY (THEFT WARNING) SYSTEM

2. CHECK DOOR SWITCH

1. Turn ignition switch OFF.
2. Disconnect door switch and BCM connector.
3. Check continuity between door switch connector B17, B23 terminal 1 and BCM connector B4 terminal 10, 14.

Passenger side door

1 (P) - 10 (P) :Continuity should exist.

Driver side door

1 (W) - 14 (W) :Continuity should exist.

4. Check continuity between door switch connector B17, B23 terminal 1(P, W) and ground.

Each door switch

1 (P, W) - Ground :Continuity should not exist.

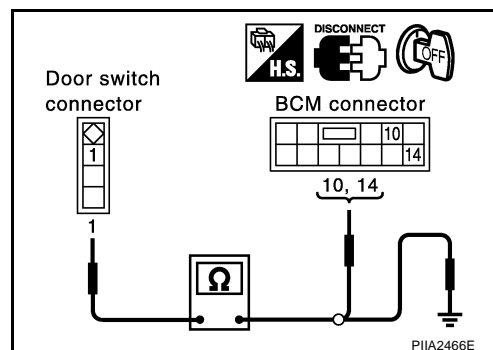

OK or NG

OK >> Check door switch.

NG >> Repair or replace door switch harness.

1 – 2 BACK DOOR SWITCH CHECK/FOR COUPE

1. CHECK BACK DOOR SWITCH INPUT SIGNAL

With CONSULT-II

Check back door switch (“BACK DOOR SW”) in “DATA MONITOR” mode with CONSULT-II.

Monitor item	Condition
BACK DOOR SW	OPEN : ON
	CLOSE : OFF

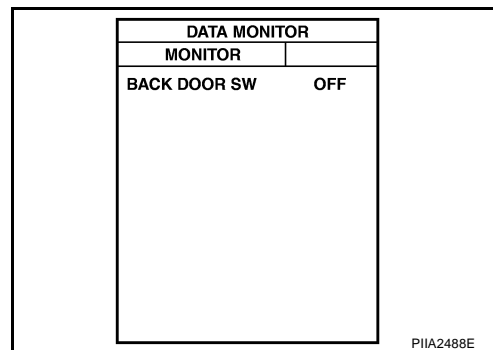

Without CONSULT-II

Check voltage between BCM connector and ground.

Item	(+)		(-)	Condition	Voltage (V) (Approx.)
	Con- nector	Terminal (Wire color)			
Back door switch	B4	18 (R/W)	Ground	OPEN	0
				CLOSE	Buttery voltage

OK or NG

OK >> Back door switch is OK, and go to [BL-151, "1 – 4 HOOD SWITCH CHECK"](#) .

NG >> GO TO 2.

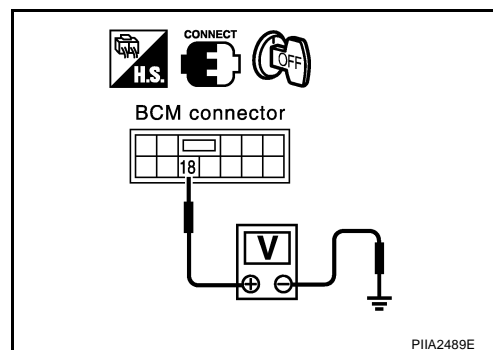

VEHICLE SECURITY (THEFT WARNING) SYSTEM

2. CHECK BACK DOOR SWITCH HARNESS

NOTE:

There is diode in the back door circuit.

1. Turn ignition switch OFF.
2. Disconnect BCM and back door switch connectors.
3. Check continuity between BCM connector B4 terminal 18 and back door switch connector T12 terminal 1.

18 (R/W) - 1 (R/W) : Continuity should exist.

4. Check continuity between BCM connector B4 terminal 18 and ground.

18 (R/W) - Ground : Continuity should not exist.

OK or NG

OK >> GO TO 3

NG >> Check the diode. If the diode is OK, repair or replace harness.

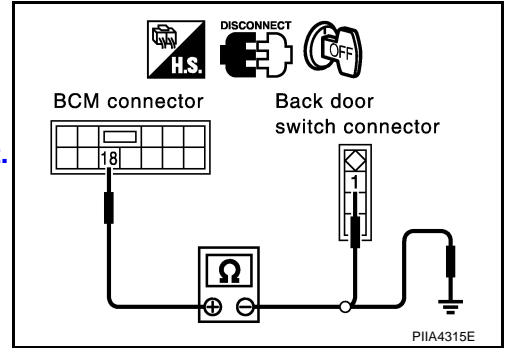

3. CHECK BACK DOOR SWITCH

Check continuity between door switch terminals 1 and 3.

Terminal	Back door switch condition	Continuity
1 - 3	Open position	Yes
	Closed position	No

OK or NG

OK >> GO TO 4.

NG >> Replace back door switch.

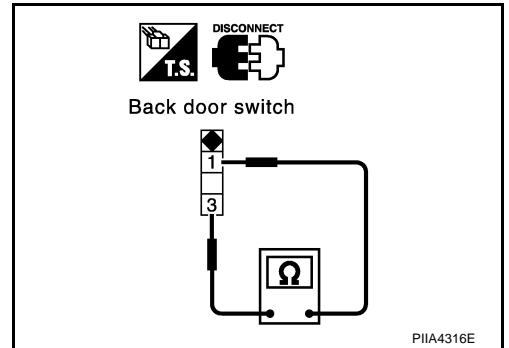

4. CHECK BACK DOOR SWITCH GROUND HARNESS

Check continuity between back door switch connector T12 terminal 3 and ground.

3 (B) - Ground : Continuity should exist.

OK or NG

OK >> Back door switch circuit is OK.

NG >> Repair or replace harness.

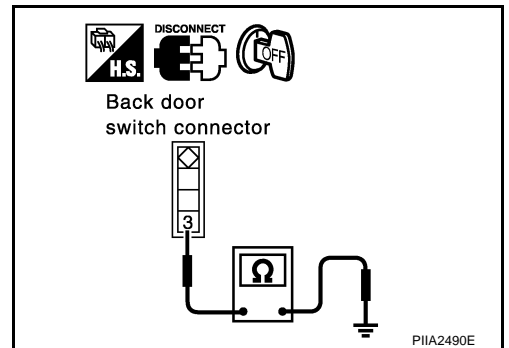

VEHICLE SECURITY (THEFT WARNING) SYSTEM

1 – 3 TRUNK ROOM LAMP SWITCH CHECK/FOR ROADSTER

1. CHECK TRUNK ROOM LAMP SWITCH INPUT SIGNAL

Ⓟ With CONSULT-II

Check trunk lid opener switch ("TRUNK OPN MNTR") in "DATA MONITOR" mode with CONSULT-II.

Monitor item	Condition
TRNK OPN MNTR	OPEN : ON
	CLOSE : OFF

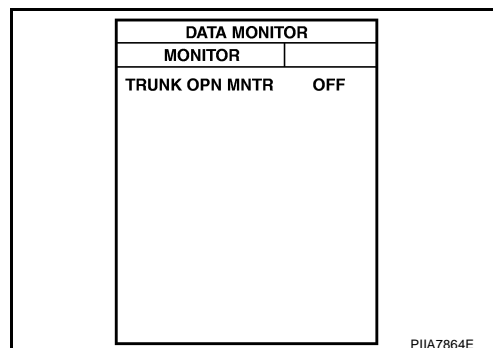

⊗ Without CONSULT-II

Check voltage between BCM connector and ground.

Item	(+)		(-)	Condition	Voltage [V] (Approx.)
	Con- nector	Terminal (Wire color)			
Trunk room lamp	B4	18 (R/W)	Ground	OPEN	0
				CLOSE	5* ¹ Battery voltage* ²

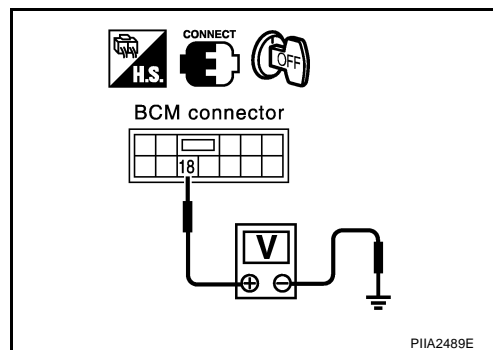

*1: When the retained power operation is not activated.

*2: When the retained power operation is activated.

OK or NG

OK >> Trunk room lamp switch is OK, and go to [BL-151, "1 – 4 HOOD SWITCH CHECK"](#) .

NG >> GO TO 2

2. CHECK TRUNK ROOM LAMP SWITCH HARNESS

- Turn ignition switch OFF.
- Disconnect trunk room lamp switch and BCM connector.
- Check continuity between trunk room lamp switch connector T31 terminal 1 and BCM connector B4 terminal 18.

1 (R) - 18 (R/W) :Continuity should exist.

- Check continuity between trunk room lamp switch connector T31 terminal 1(R) and ground.

1 (R) - Ground :Continuity should not exist.

OK or NG

OK >> GO TO 3

NG >> Replace trunk room lamp switch harness.

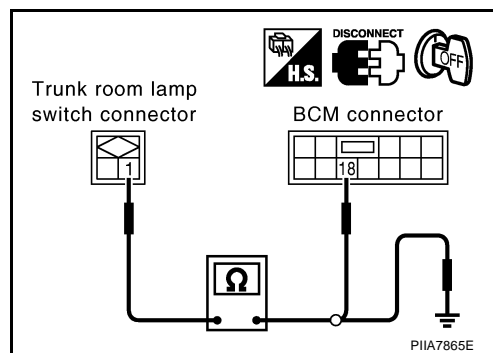

VEHICLE SECURITY (THEFT WARNING) SYSTEM

3. CHECK TRUNK ROOM LAMP SWITCH

1. Turn ignition switch OFF.
2. Check continuity between trunk room lamp switch connector T31 terminal 2 and ground.

2 (B) - Ground :Continuity should exist.

OK or NG

- OK >> Check trunk room lamp switch.
 NG >> Repair or replace trunk room lamp switch harness.

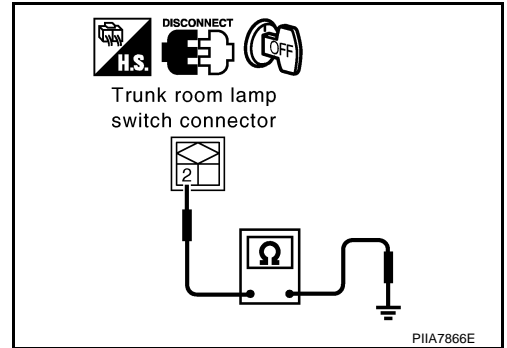

1 – 4 HOOD SWITCH CHECK

First perform the “SELF-DIAG RESULTS” in “BCM” with CONSULT-II, then perform the trouble diagnosis of malfunction system indicated “SELF-DIAG RESULTS” of “BCM”. Refer to [BCS-15. "CAN Communication Inspection Using CONSULT-II \(Self-Diagnosis\)"](#) .

1. CHECK HOOD SWITCH

Check hood switch and hood fitting condition.

OK or NG

- OK >> GO TO 2.
 NG >> Adjust installation of hood switch.

2. CHECK HOOD SWITCH INPUT SIGNAL

With CONSULT-II

- Check “HOOD SW” in “DATA MONITOR” mode in “IPDM E/R”.

Monitor item	Condition
HOOD SW	Hood open : ON
	Hood closed : OFF

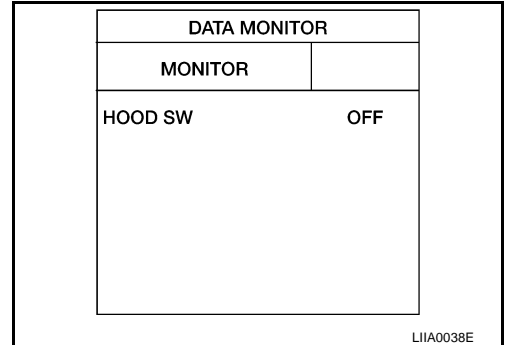

Without CONSULT-II

- Check voltage between IPDM E/R connector and ground.

Terminals (Wire color)		Condition	Voltage (V) (Approx.)
(+)	(-)		
Con- nector	Terminal (Wire color)		
E9	56 (LG/B)	Closed	Battery voltage
		Open	0

OK or NG

- OK >> Hood switch is OK.
 NG >> GO TO 3.

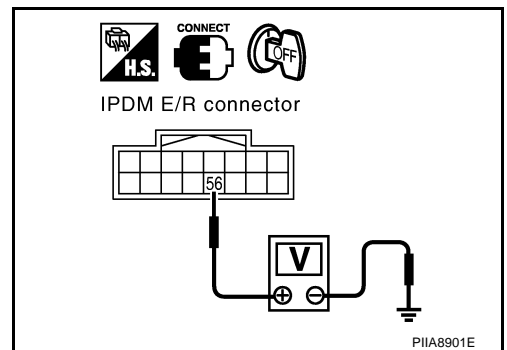

VEHICLE SECURITY (THEFT WARNING) SYSTEM

3. CHECK HOOD SWITCH HARNESS

1. Turn ignition switch OFF.
2. Disconnect IPDM E/R and hood switch connector.
3. Check continuity between hood switch connector E23 terminal 1 and IPDM E/R connector E9 terminal 56.

1 (LG/B) - 56 (LG/B) : Continuity should exist.

4. Check continuity between hood switch connector E23 terminal 1 and ground.

1 (LG/B) - Ground : Continuity should not exist.

OK or NG

OK >> GO TO 4.

NG >> Repair or replace hood switch harness.

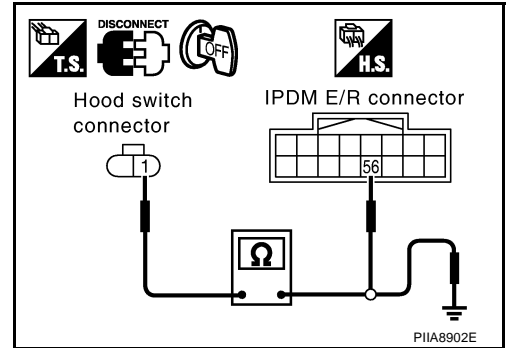

4. CHECK HOOD SWITCH GROUND CIRCUIT

Check continuity between hood switch connector E23 terminal 2 and ground.

2 (B) - Ground : Continuity should exist.

OK or NG

OK >> GO TO 5.

NG >> Repair or replace hood switch harness.

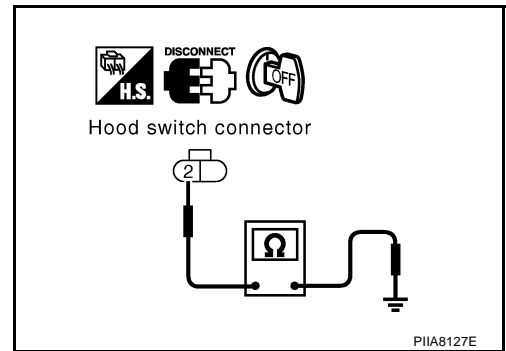

5. CHECK HOOD SWITCH

Check continuity between hood switch connector E23 terminals 1 and 2.

Terminals	Condition	Continuity
1 - 2	Pressed	No
	Released	Yes

OK or NG

OK >> Replace IPDM E/R.

NG >> Replace hood switch.

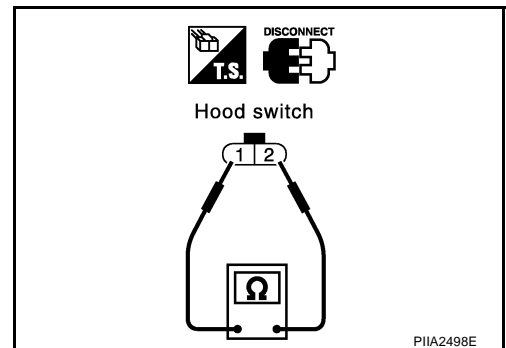

VEHICLE SECURITY (THEFT WARNING) SYSTEM

Diagnostic Procedure 2 SECURITY INDICATOR LAMP CHECK

AIS00151

1. SECURITY INDICATOR LAMP ACTIVE TEST

Ⓟ With CONSULT-II

Check "THEFT IND" in "ACTIVE TEST" mode with CONSULT-II.

Perform operation shown on display.
Indicator lamp should illuminate.

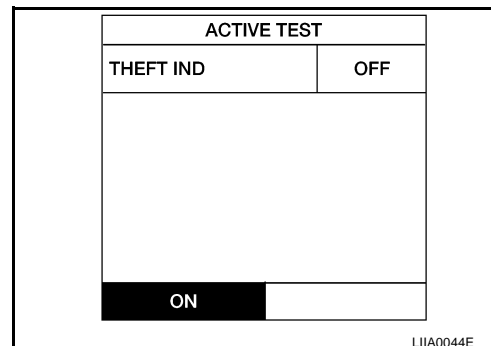

⊗ Without CONSULT-II

1. Disconnect BCM connector M3.
2. Check voltage between BCM connector M3 terminal 55 (G/OR) and ground.

55 (G/OR) - Ground : Battery voltage

OK or NG

- OK >> Security indicator lamp is OK.
NG >> GO TO 2.

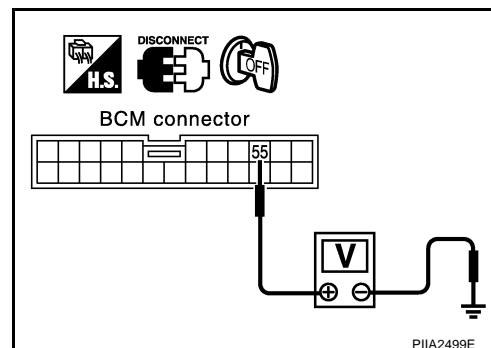

2. CHECK POWER SUPPLY CIRCUIT FOR SECURITY INDICATOR LAMP

1. Disconnect security indicator lamp connector.
2. Check voltage between security indicator lamp connector M34 terminal 1 and ground.

1 (R/W) - Ground : Battery voltage

OK or NG

- OK >> Check the following.
- Harness for open or short between security indicator lamp and BCM.
 - Indicator lamp condition
- NG >> Check the following.
- 10A fuse [No. 19, located in fuse block (J/B)]
 - Harness for open or short between security indicator lamp and fuse

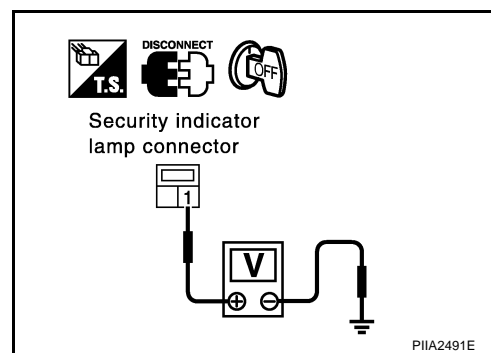

Diagnostic Procedure 3 DOOR KEY CYLINDER SWITCH CHECK

AIS00152

1. CHECK DOOR KEY CYLINDER SWITCH DRIVER SIDE OPERATION

Do doors lock/unlock when using the key?

YES or NO

- YES >> Door key cylinder switch operation is OK.
NO >> Check door key cylinder switch circuit. Refer to [BL-50, "Door Key Cylinder Switch Check"](#) .

VEHICLE SECURITY (THEFT WARNING) SYSTEM

Diagnostic Procedure 4 VEHICLE SECURITY HORN ALARM CHECK

AIS00153

First perform the "SELF-DIAG RESULTS" of "BCM" with CONSULT-II, then perform the trouble diagnosis of malfunction system indicated in "SELF-DIAG RESULTS" of "BCM". Refer to [BCS-15, "CAN Communication Inspection Using CONSULT-II \(Self-Diagnosis\)"](#) .

1. CHECK HORN OPERATION

Check if horn sounds with horn switch.

Does horn operate?

YES >> GO TO 2.

NO >> Check horn circuit. Refer to [WW-52, "HORN"](#) .

2. CHECK IPDM E/R INPUT VOLTAGE

Check voltage between IPDM E/R connector E9 terminal 51 (G/B) and ground.

51 (G/B) – Ground : Battery voltage.

OK or NG

OK >> Replace IPDM E/R.

NG >> GO TO 3.

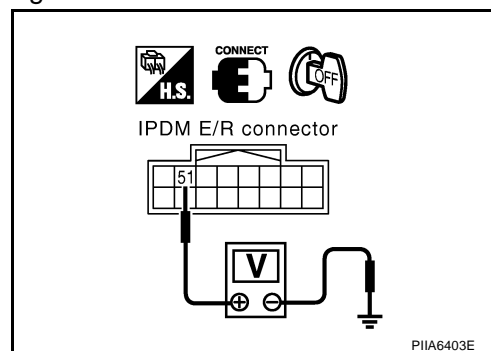

3. CHECK IPDM E/R HARNESS

1. Turn ignition switch OFF.
2. Disconnect IPDM E/R and horn relay connector.
3. Check continuity between IPDM E/R connector E9 terminal 51 (G/B) and horn relay connector E21 terminal 1 (G/B).

1 (G/B) - 51(G/B) : Continuity should exist.

OK or NG

OK >> Horn circuit is OK.

NG >> Repair or replace harness.

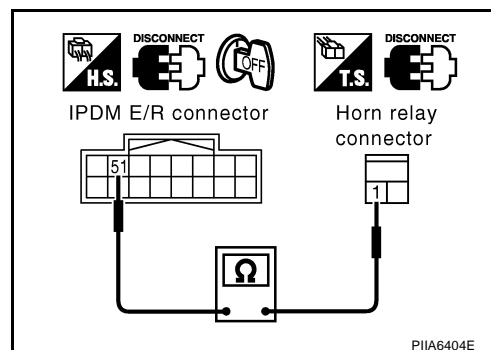

Diagnostic Procedure 5 VEHICLE SECURITY HEADLAMP ALARM CHECK

AIS00154

1. CHECK HEAD LAMP OPERATION

Does headlamp come on when turning lighting switch "ON"?

YES or NO

YES >> Headlamp alarm circuit is OK.

NO >> Check headlamp system. Refer to [LT-7, "HEADLAMP \(FOR USA\) - XENON TYPE -"](#) , [LT-37, "HEADLAMP \(FOR USA\) - CONVENTIONAL TYPE -"](#) , [LT-66, "HEADLAMP \(FOR CANADA\) - XENON TYPE -"](#) , [LT-101, "HEADLAMP \(FOR CANADA\) - CONVENTIONAL TYPE -"](#) .

VEHICLE SECURITY (THEFT WARNING) SYSTEM

Diagnostic Procedure 6

AIS00155

DOOR LOCK AND UNLOCK SWITCH CHECK

1. CHECK DOOR LOCK AND UNLOCK SWITCH INPUT SIGNAL

Do doors lock/unlock when using power window main switch (door lock and unlock switch) or power window sub-switch (door lock and unlock switch)?

YES or NO?

YES >> Door lock and unlock switch is OK.

NO >> Refer to [BL-43, "Door Lock and Unlock Switch Check"](#) .

A

B

C

D

E

F

G

H

BL

J

K

L

M

NVIS (NISSAN VEHICLE IMMOBILIZER SYSTEM-NATS)

NVIS (NISSAN VEHICLE IMMOBILIZER SYSTEM-NATS)

PFP:25386

Component Parts and Harness Connector Location

AISS00143

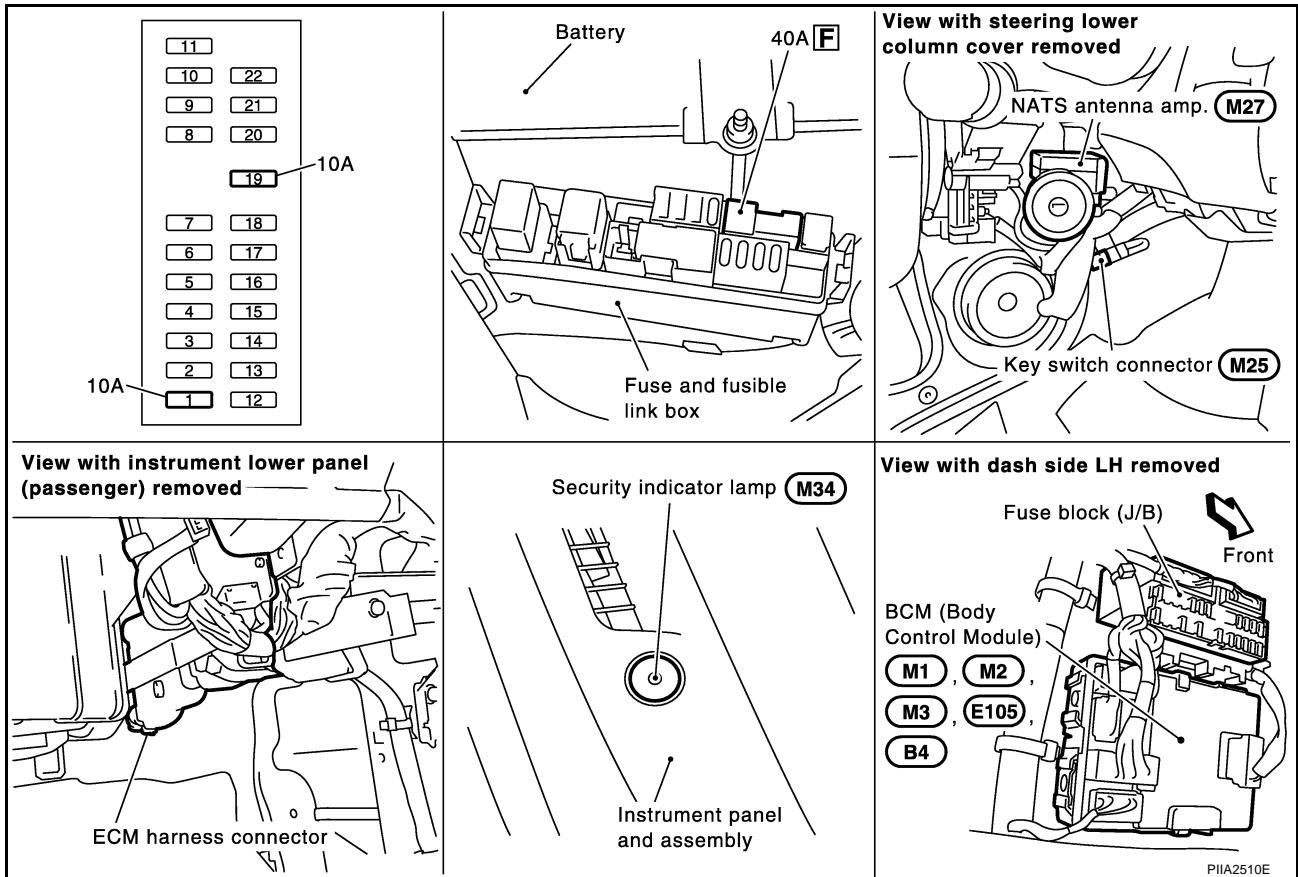

NOTE:

If customer reports a "No start" condition, request ALL KEYS to be brought to an NISSAN dealer in case of a NVIS (NATS) malfunction.

NVIS (NISSAN VEHICLE IMMOBILIZER SYSTEM-NATS)

System Description

AIIS00144

NVIS (Nissan Vehicle Immobilizer System-NATS) has the following immobilizer functions:

- Since only NVIS (NATS) ignition keys, whose ID Nos. have been registered into the ECM and BCM (NATS control unit), allow the engine to run, a vehicle operation without a key registered in NVIS (NATS) is prevented by NVIS (NATS).
That is to say, NVIS (NATS) will immobilize the engine if someone tries to start it without the registered key of NVIS (NATS).
- All of the originally supplied ignition key IDs (except for card plate key) have been registered in NVIS (NATS).
If requested by the vehicle owner, a maximum of five key IDs can be registered into the NVIS (NATS) components.
- The security indicator blinks when the ignition switch is in “OFF” or “ACC” position. Therefore, NVIS (NATS) warns outsiders that the vehicle is equipped with the anti-theft system.
- When NVIS (NATS) detects trouble, the security indicator lamp lights up while ignition key is in the “ON” position.
- NVIS (NATS) trouble diagnoses, system initialization and additional registration of other NVIS (NATS) ignition key IDs must be carried out using CONSULT-II hardware and CONSULT-II NVIS (NATS) software. When NVIS (NATS) initialization has been completed, the ID of the inserted ignition key is automatically registered in NVIS (NATS). Then, if necessary, additional registration of other NVIS (NATS) ignition key IDs can be carried out.
Regarding the procedures of NVIS (NATS) initialization and NVIS (NATS) ignition key ID registration, refer to CONSULT-II Operation Manual NATS-IVIS/NVIS.
- **When servicing a malfunction of the NVIS (NATS) (indicated by lighting up of Security Indicator Lamp) or registering another NVIS (NATS) ignition key ID No., it may be necessary to re-register original key identification. Therefore, be sure to receive ALL KEYS from vehicle owner.**

A

B

C

D

E

F

G

H

BL

J

K

L

M

NVIS (NISSAN VEHICLE IMMOBILIZER SYSTEM-NATS)

AIS00145

System Composition

The immobilizer function of the NVIS (NATS) consists of the following:

- NATS ignition key
- NATS antenna amp. located in the ignition key cylinder
- BCM (NATS control unit)
- Engine control module (ECM)
- Security indicator

NOTE:

The communication between ECM and BCM uses the CAN communication system.

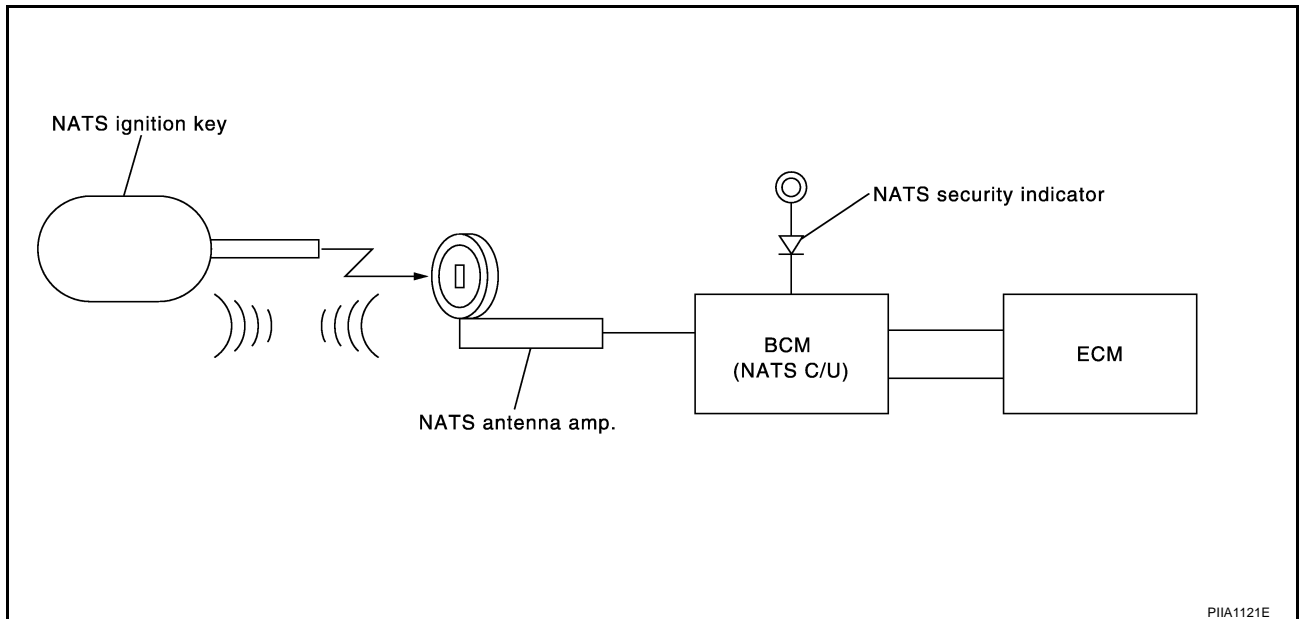

ECM Re-Communicating Function

AIS00146

Performing following procedure can automatically perform re-communication of ECM and BCM, but only when the ECM has been replaced with a new one (*1).

*1: New one means a virgin ECM which has never been energized on-board.

(In this step, initialization procedure by CONSULT-II is not necessary)

NOTE:

- **When registering new Key IDs or replacing the ECM other than brand new, refer to CONSULT-II Operation Manual NATS-IVIS/NVIS.**
 - **If multiple keys are attached to the key holder, separate them before work.**
 - **Distinguish keys with unregistered key ID from those with registered ID.**
1. Install ECM.
 2. Using a registered key (*2), turn ignition switch to "ON".
*2: To perform this step, use the key (except for card plate key) that has been used before performing ECM replacement.
 3. Maintain ignition switch in "ON" position for at least 5 seconds.
 4. Turn ignition switch to "OFF".
 5. Start engine.
If engine can be started, procedure is completed.
If engine cannot be started, refer to CONSULT-II Operation Manual NATS-IVIS/NVIS and initialize control unit.

NVIS (NISSAN VEHICLE IMMOBILIZER SYSTEM-NATS)

Wiring Diagram — NATS —

AIS00147

BL-NATS-01

▬ : DATA LINE

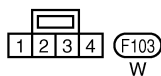
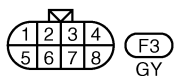
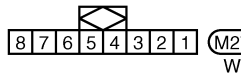
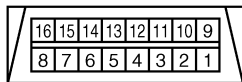
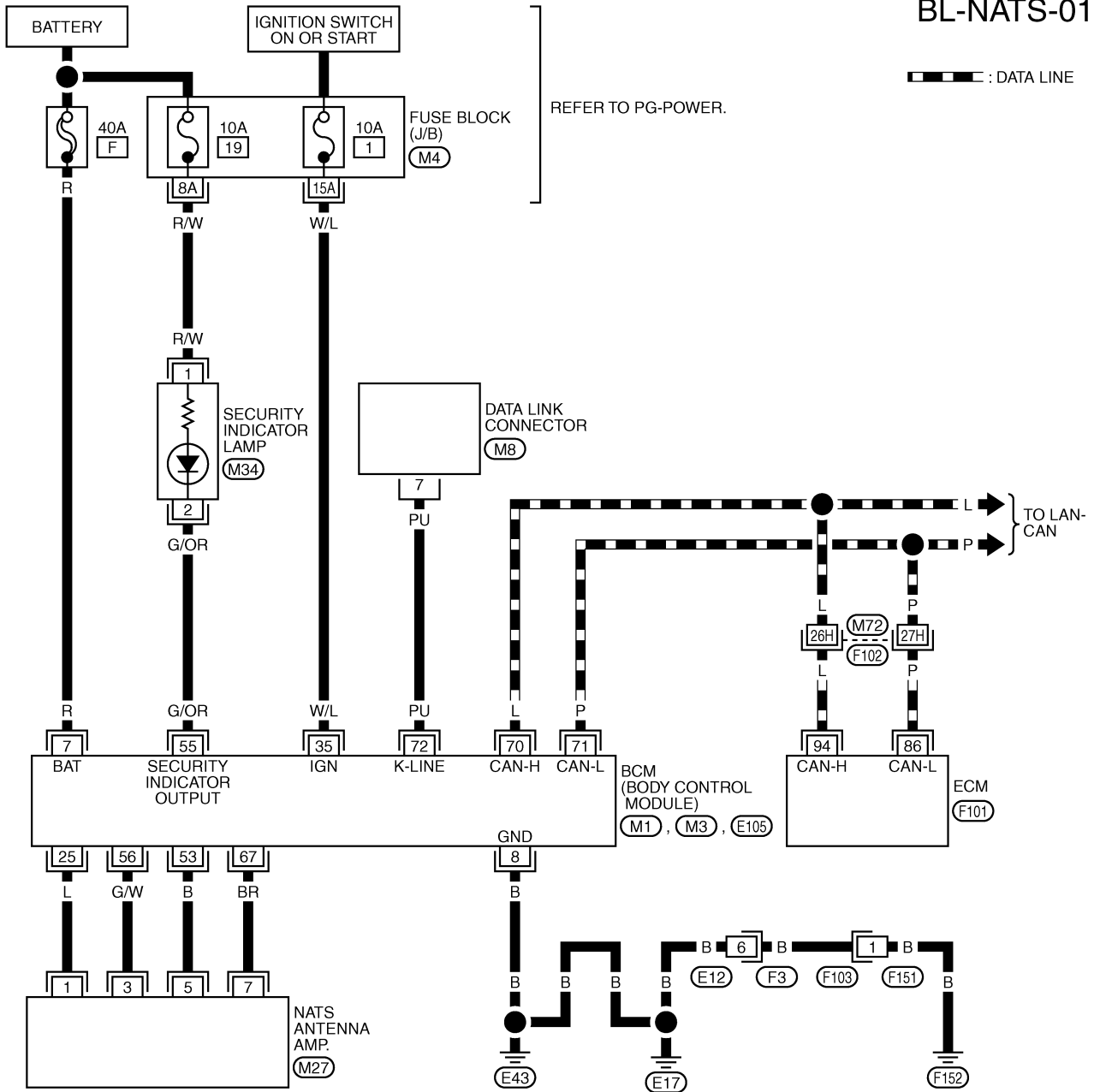

REFER TO THE FOLLOWING.

(F102) -SUPER MULTIPLE JUNCTION (SMJ)

(M4) -FUSE BLOCK-JUNCTION BOX (J/B)

(M1), (M3), (E105), (F101) -ELECTRICAL UNITS

TIWT0762E

NVIS (NISSAN VEHICLE IMMOBILIZER SYSTEM-NATS)

Terminals and Reference Value for BCM

AIS00148

Terminal	Wire color	Item	Condition	Voltage (V) (Approx.)
7	R	Power source (Fusible link)	—	Battery voltage
8	B	Ground	—	0
25	L	NATS antenna amp.	Ignition switch: OFF → ON	0 → 5 (for 3 seconds)
35	W/L	Ignition switch (ON or START)	Ignition switch (ON or START position)	Battery voltage
53	B	NATS antenna amp.	—	0
55	G/OR	Security indicator lamp	Goes OFF → illuminates (Every 2.4 seconds)	Battery voltage → 0
56	G/W	NATS antenna amp.	Ignition switch (OFF → ON)	Just after turning ignition switch "ON": Pointer of tester should move.
67	BR	NATS antenna amp.	Ignition switch (OFF → ON)	Just after turning ignition switch "ON": Pointer of tester should move.
70	L	CAN-H	—	—
71	P	CAN-L	—	—
72	PU	Data link connector	—	—

CONSULT-II

CONSULT-II INSPECTION PROCEDURE

AIS00149

CAUTION:

If CONSULT-II is used with no connection of CONSULT-II CONVERTER, malfunctions might be detected in self-diagnosis depending on control unit which carry out CAN communication.

1. Turn ignition switch OFF.
2. Insert NVIS (NATS) program card into CONSULT-II.

Program card : NATS (AEN02C)

3. Connect CONSULT-II and CONSULT-II CONVERTER to data link connector.

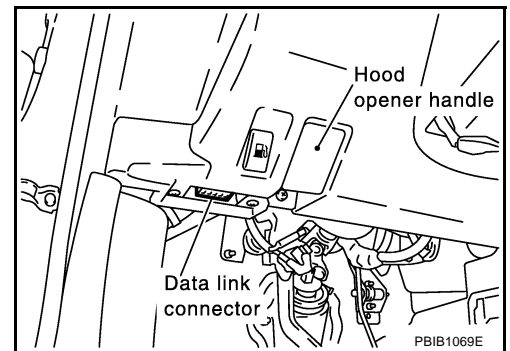

4. Turn ignition switch ON.
5. Touch "START".

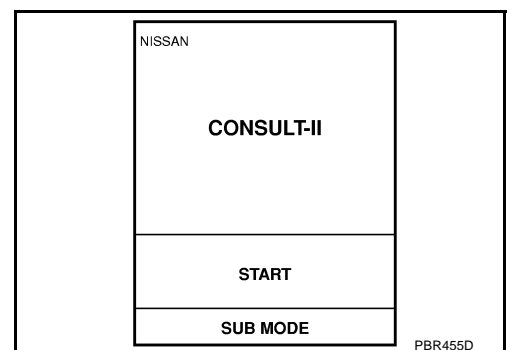

NVIS (NISSAN VEHICLE IMMOBILIZER SYSTEM-NATS)

6. Touch "OTHER".

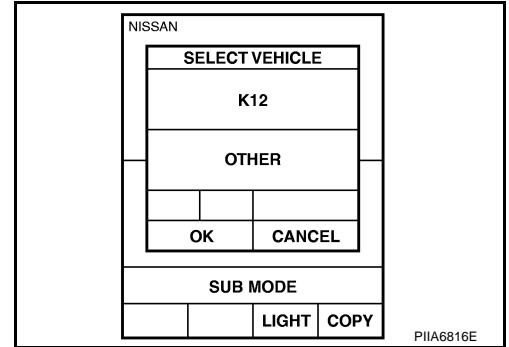

7. Select "NATS V.5.0".
If "NATS V.5.0" is not indicated, go to [GI-39, "CONSULT-II Data Link Connector \(DLC\) Circuit"](#).

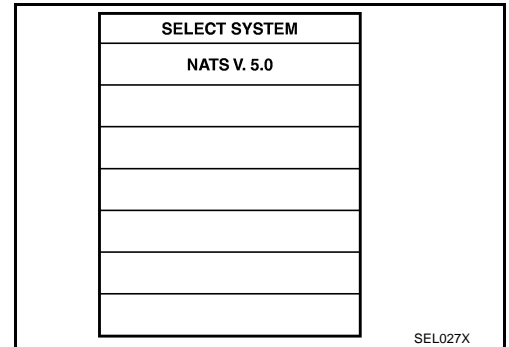

8. Perform each diagnostic test mode according to each service procedure.
For further information, see the CONSULT-II Operation Manual NATS-IVIS/NVIS.

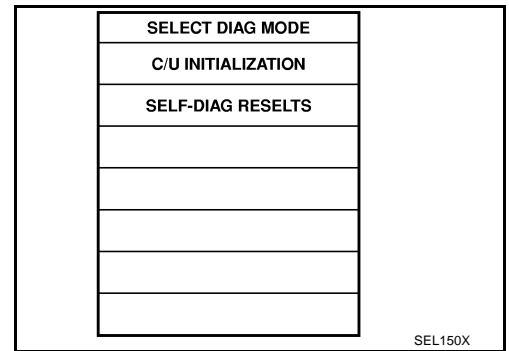

CONSULT-II DIAGNOSTIC TEST MODE FUNCTION

CONSULT-II DIAGNOSTIC TEST MODE	Description
C/U INITIALIZATION	When replacing any of the following components, C/U initialization and re-registration of all NATS ignition keys are necessary. [(NATS ignition key/ BCM (NATS control unit)/ ECM)]
SELF-DIAG RESULTS	Detected items (screen terms) are as shown in the chart. Refer to BL-162, "NVIS (NATS) SELF-DIAGNOSTIC RESULTS ITEM CHART" .

NOTE:

- When any initialization is performed, all ID previously registered will be erased and all NATS ignition keys must be registered again.
- The engine cannot be started with an unregistered key. In this case, the system will show "DIFFERENCE OF KEY" or "LOCK MODE" as a self-diagnostic result on the CONSULT-II screen.
- In rare case, "CHAIN OF ECM-IMMU" might be stored as a self-diagnostic result during key registration procedure, even if the system is not malfunctioning.

NVIS (NISSAN VEHICLE IMMOBILIZER SYSTEM-NATS)

HOW TO READ SELF-DIAGNOSTIC RESULTS

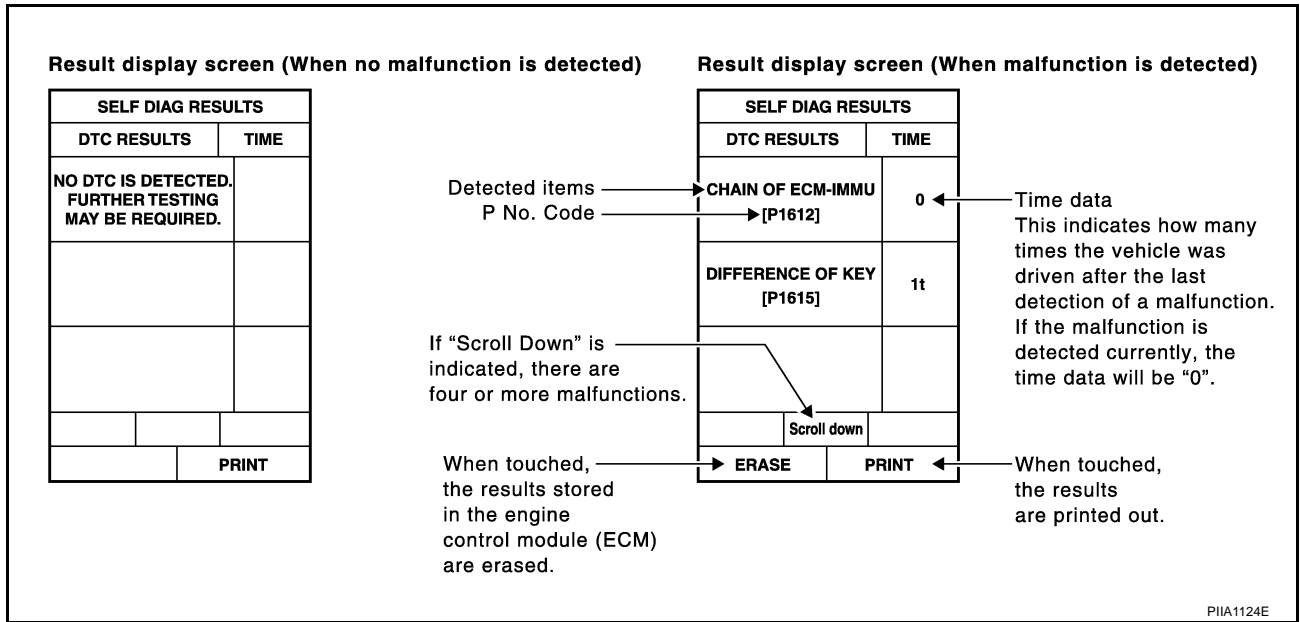

NVIS (NATS) SELF-DIAGNOSTIC RESULTS ITEM CHART

Detected items [NVIS (NATS) program card screen terms]	P No. Code (Self-diagnostic result of "ENGINE")	Malfunction is detected when.....	Reference page
CHAIN OF ECM-IMMU [P1612]	NATS MAL-FUNCTION P1612	Communication impossible between ECM and BCM (NATS control unit) In rare case, "CHAIN OF ECM-IMMU" might be stored during key registration procedure, even if the system is not malfunctioning.	Refer to BL-166 , "Diagnostic Procedure 1".
DIFFERENCE OF KEY [P1615]	NATS MAL-FUNCTION P1615	BCM (NATS control unit) can receive the key ID signal but the result of ID verification between key ID and BCM (NATS control unit) is NG.	Refer to BL-167 , "Diagnostic Procedure 2".
CHAIN OF IMMUN-KEY [P1614]	NATS MAL-FUNCTION P1614	BCM (NATS control unit) cannot receive the key ID signal.	Refer to BL-168 , "Diagnostic Procedure 3".
ID DISCORD, IMM-ECM [P1611]	NATS MAL-FUNCTION P1611	The result of ID verification between BCM (NATS control unit) and ECM is NG. System initialization is required.	Refer to BL-170 , "Diagnostic Procedure 4".
LOCK MODE [P1610]	NATS MAL-FUNCTION P1610	When the starting operation is carried out five or more times consecutively under the following conditions, NVIS (NATS) will shift the mode to one which prevents the engine from being started. <ul style="list-style-type: none"> ● Unregistered ignition key is used. ● BCM (NATS control unit) or ECM's malfunctioning. 	Refer to BL-172 , "Diagnostic Procedure 6".
DON'T ERASE BEFORE CHECKING ENG DIAG	—	All engine trouble codes except NVIS (NATS) trouble code has been detected in ECM.	Refer to BL-163 , "Work Flow".

NVIS (NISSAN VEHICLE IMMOBILIZER SYSTEM-NATS)

AI50014A

Work Flow

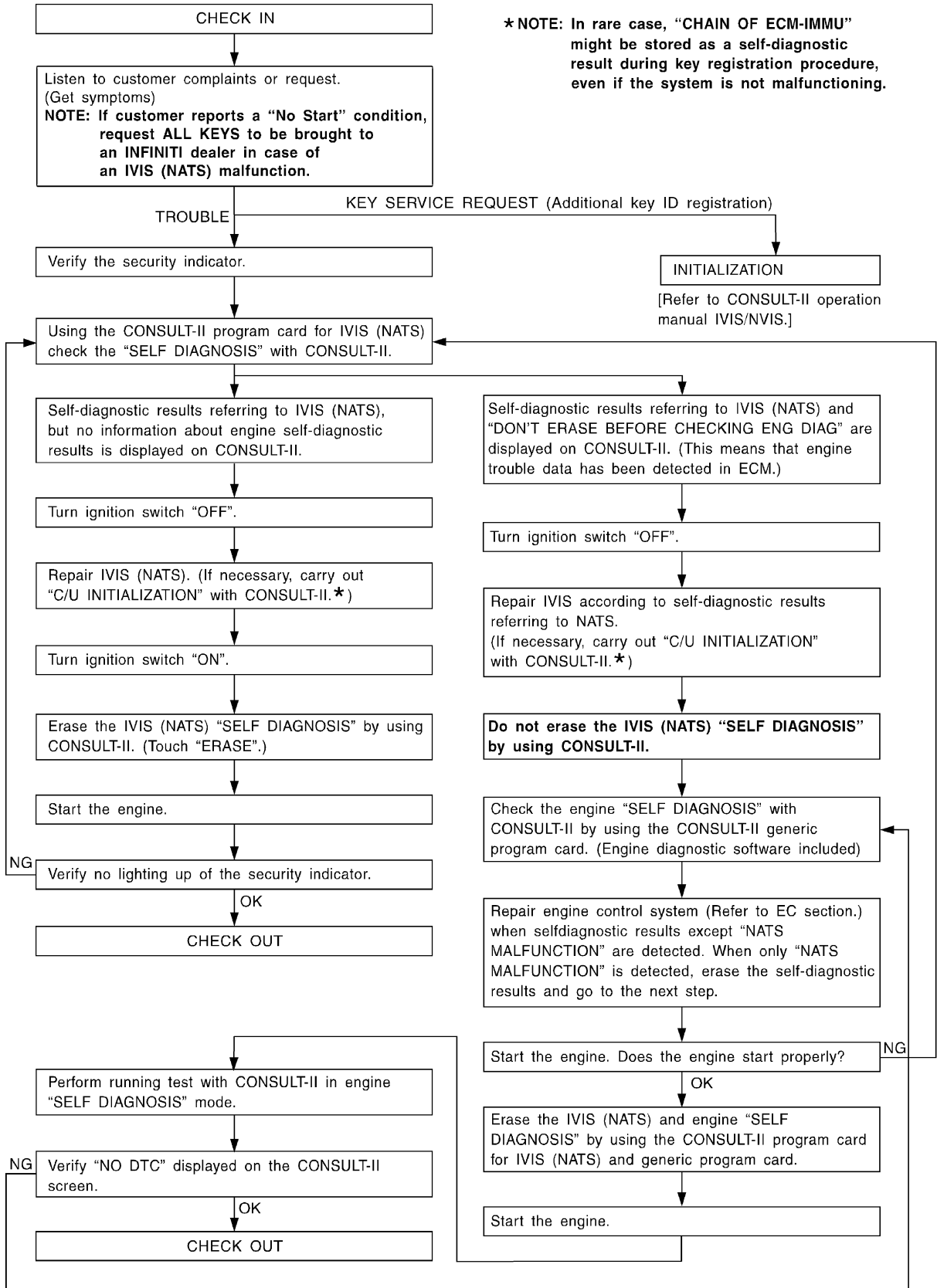

SEL024X

NVIS (NISSAN VEHICLE IMMOBILIZER SYSTEM-NATS)

AIS0014B

Trouble Diagnoses SYMPTOM MATRIX CHART 1

Self-diagnosis related item

SYMPTOM	Displayed "SELF-DIAG RESULTS" on CONSULT-II screen.	DIAGNOSTIC PROCEDURE (Reference page)	SYSTEM (Malfunctioning part or mode)	REFERENCE PART NO. OF ILLUSTRATION ON SYSTEM DIAGRAM
<ul style="list-style-type: none"> ● Security indicator lighting up* ● Engine cannot be started 	CHAIN OF ECM-IMMU [P1612]	PROCEDURE 1 (BL-166)	In rare case, "CHAIN OF ECM-IMMU" might be stored during key registration procedure, even if the system is not malfunctioning.	—
			Open circuit in battery voltage line of BCM (NATS control unit) circuit	C1
			Open circuit in ignition line of BCM (NATS control unit) circuit	C2
			Open circuit in ground line of BCM (NATS control unit) circuit	C3
			Open or short circuit between BCM (NATS control unit) and ECM communication line	C4
			ECM	B
			BCM (NATS control unit)	A
	DIFFERENCE OF KEY [P1615]	PROCEDURE 2 (BL-167)	Unregistered key	D
			BCM (NATS control unit)	A
	CHAIN OF IMMU-KEY [P1614]	PROCEDURE 3 (BL-168)	Malfunction of key ID chip	E5
			Communication line between ANT/ AMP and BCM (NATS control unit): Open circuit or short circuit of battery voltage line or ground line	E1
				E2
			Open circuit in power source line of ANT/ AMP circuit	E3
			Open circuit in ground line of ANT/ AMP circuit	E4
			NATS antenna amp.	E6
BCM (NATS control unit)			A	
ID DISCORD, IMM-ECM [P1611]	PROCEDURE 4 (BL-170)	System initialization has not yet been completed.	F	
		ECM	B	
LOCK MODE [P1610]	PROCEDURE 6 (BL-172)	LOCK MODE	D	
Security indicator lighting up*	DON'T ERASE BEFORE CHECKING ENG DIAG	WORK FLOW (BL-163)	Engine trouble data and NVIS (NATS) trouble data have been detected in ECM	—

*: When NVIS (NATS) detects trouble, the security indicator lights up while ignition key is in the "ON" position.

NVIS (NISSAN VEHICLE IMMOBILIZER SYSTEM-NATS)

SYMPTOM MATRIX CHART 2

Non self-diagnosis related item

SYMPTOM	DIAGNOSTIC PROCEDURE (Reference page)	SYSTEM (Malfunctioning part or mode)	REFERENCE PART NO. OF ILLUSTRATION ON SYSTEM DIAGRAM
Security indicator does not light up*.	PROCEDURE 5 (BL-171)	Security indicator.	—
		Open circuit between Fuse and BCM (NATS control unit)	—
		BCM (NATS control unit)	A

*: CONSULT-II self-diagnostic results display screen "no malfunction is detected".

DIAGNOSTIC SYSTEM DIAGRAM

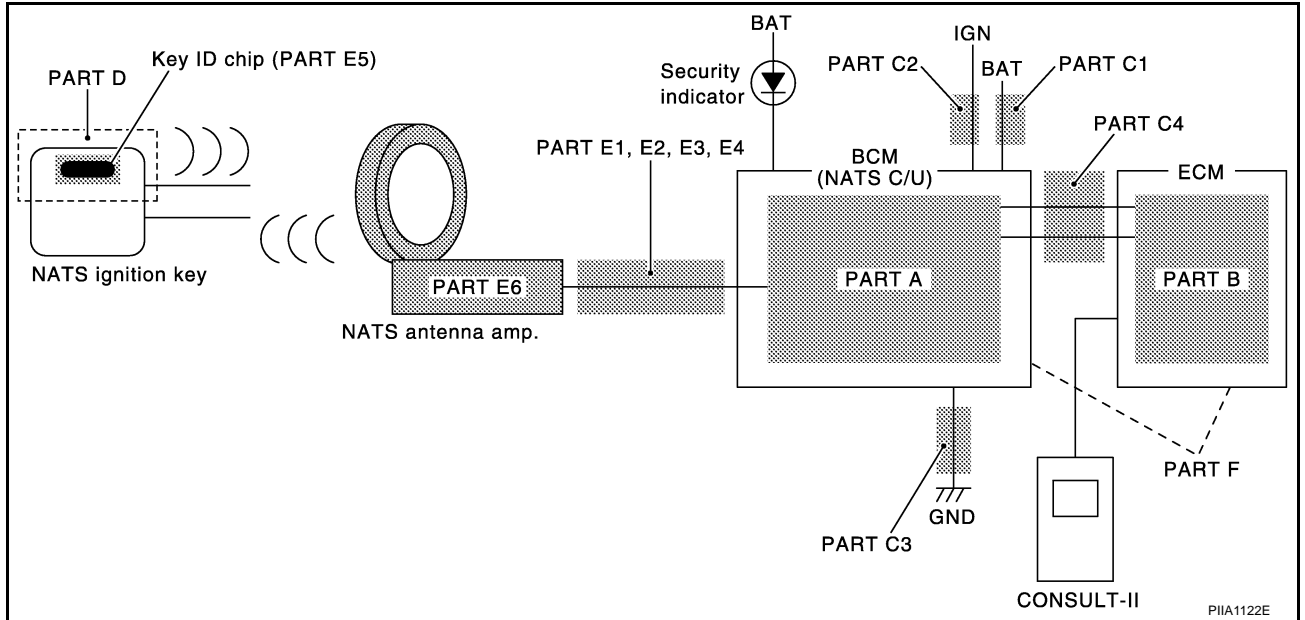

NVIS (NISSAN VEHICLE IMMOBILIZER SYSTEM-NATS)

AIS0014C

Diagnostic Procedure 1

Self-diagnostic results:

“CHAIN OF ECM-IMMU” displayed on CONSULT-II screen

First perform the “SELF-DIAG RESULTS” in “BCM” with CONSULT-II, then perform the trouble diagnosis of malfunction system indicated “SELF-DIAG RESULTS” of “BCM”. Refer to [BCS-15, "CAN Communication Inspection Using CONSULT-II \(Self-Diagnosis\)"](#) .

1. CONFIRM SELF-DIAGNOSTIC RESULTS

Confirm SELF-DIAGNOSTIC RESULTS “CHAIN OF ECM-IMMU” displayed on CONSULT-II screen.

NOTE:

In rare case, “CHAIN OF ECM-IMMU” might be stored during key registration procedure, even if the system is not malfunctioning.

Is CONSULT-II screen displayed as above?

Yes >> GO TO 2.

No >> GO TO [BL-164, "SYMPTOM MATRIX CHART 1"](#) .

SELF DIAGNOSIS	
DTC RESULTS	TIME
CHAIN OF ECM-IMMU [P1612]	0

PIIA1260E

2. CHECK POWER SUPPLY CIRCUIT FOR BCM (NATS CONTROL UNIT)

1. Disconnect BCM (NATS control unit) connector.
2. Check voltage between BCM (NATS control unit) connector E105 terminal 7 (R) and ground with CONSULT-II or tester.

7 (R) – Ground : Battery voltage should exist.

OK or NG

OK >> GO TO 3.

NG >> Check the following.

- 40A fusible link (letter **F** , located in fuse and fusible link box)
- Harness for open or short between fuse and BCM (NATS control unit) connector
Ref. Part No. C1

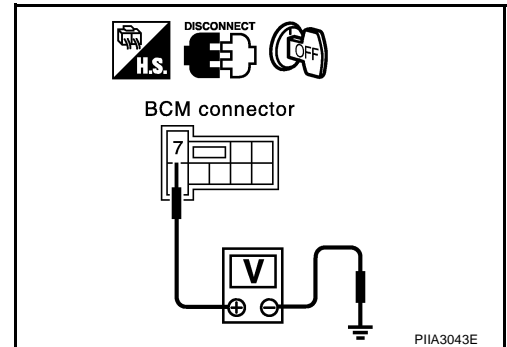

3. CHECK IGN SW. ON SIGNAL

1. Turn ignition switch ON.
2. Check voltage between BCM (NATS control unit) connector M1 terminal 35 (W/L) and ground with CONSULT-II or tester.

35 (W/L) – Ground : Battery voltage should exist.

OK or NG

OK >> GO TO 4.

NG >> Check the following.

- 10A fuse [No. 1, located in the fuse block (J/B)]
- Harness for open or short between fuse and BCM (NATS control unit) connector
Ref. part No. C2

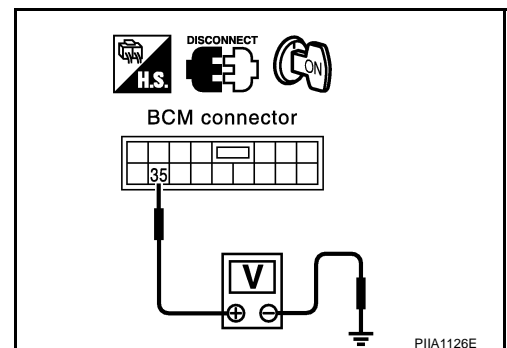

NVIS (NISSAN VEHICLE IMMOBILIZER SYSTEM-NATS)

4. CHECK GROUND CIRCUIT FOR BCM (NATS CONTROL UNIT)

1. Turn ignition OFF.
2. Check continuity between BCM (NATS control unit) connector E105 terminal 8 (B) and ground.

8 (B) – Ground : Continuity should exist.

OK or NG

- OK >> GO TO 5.
NG >> Repair harness. **Ref. part No. C3**

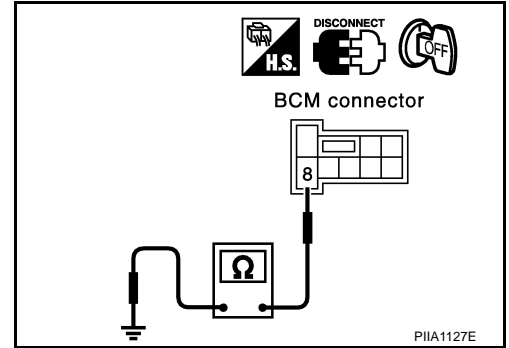

5. REPLACE BCM (NATS CONTROL UNIT)

1. Replace BCM (NATS control unit) **Ref. part No. A**
2. Perform initialization with CONSULT-II.
For initialization, refer to “CONSULT-II Operation Manual NATS-IVIS/NVIS”.

Does the engine start?

- Yes >> BCM (NATS control unit) is malfunctioning.
- Replace BCM (NATS control unit). **Ref. part No. A**
 - Perform initialization with CONSULT-II.
 - For initialization, refer to “CONSULT-II Operation Manual NATS-IVIS/NVIS”.
- No >> ECM is malfunctioning.
- Replace ECM. **Ref. part No. B**
 - Perform initialization or re-communicating function.
 - For initialization, refer to “CONSULT-II Operation Manual NATS-IVIS/NVIS”.
 - For re-communicating function, refer to [BL-158, "ECM Re-Communicating Function"](#) .

Diagnostic Procedure 2

AIS0014D

Self-diagnostic results:

“DIFFERENCE OF KEY” displayed on CONSULT-II screen

1. CONFIRM SELF-DIAGNOSTIC RESULTS

Confirm SELF-DIAGNOSTIC RESULTS “DIFFERENCE OF KEY” displayed on CONSULT-II screen.

Is CONSULT-II screen displayed as above?

- Yes >> GO TO 2.
No >> GO TO [BL-164, "SYMPTOM MATRIX CHART 1"](#) .

SELF DIAG RESULTS	
DTC RESULTS	TIME
DIFFERENCE OF KEY [P1615]	0

PIIA1261E

NVIS (NISSAN VEHICLE IMMOBILIZER SYSTEM-NATS)

2. PERFORM INITIALIZATION WITH CONSULT-II

Perform initialization with CONSULT-II. Re-register all NATS ignition key IDs.
For initialization and registration of NATS ignition key IDs, refer to "CONSULT-II Operation Manual NATS-IVIS/NVIS".

NOTE:

If the initialization is not completed or malfunctions, CONSULT-II shows message on the screen.

Can the system be initialized and can the engine be started with re-registered NATS ignition key?

- Yes >> Ignition key ID was unregistered. **Ref. part No. D**
No >> BCM (NATS control unit) is malfunctioning.
- Replace BCM (NATS control unit). **Ref. part No. A**
 - Perform initialization with CONSULT-II.
 - For initialization, refer to "CONSULT-II Operation Manual NATS-IVIS/NVIS".

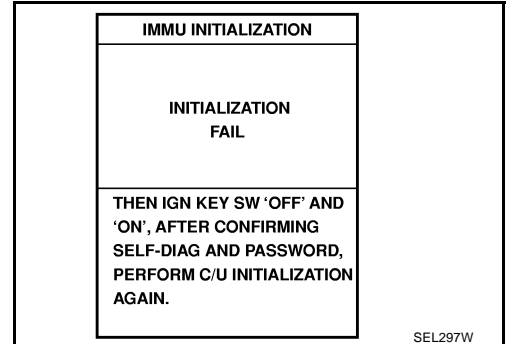

Diagnostic Procedure 3

AIS0014E

Self-diagnostic results:

"CHAIN OF IMMU-KEY" displayed on CONSULT-II screen

1. CONFIRM SELF-DIAGNOSTIC RESULTS

Confirm SELF-DIAGNOSTIC RESULTS "CHAIN OF IMMU-KEY" displayed on CONSULT-II screen.

Is CONSULT-II screen displayed as shown in figure?

- Yes >> GO TO 2.
No >> GO TO [BL-164, "SYMPTOM MATRIX CHART 1"](#) .

The screenshot shows a rectangular window with a black border. At the top, it says 'SELF DIAGNOSIS'. Below that, there is a table with two columns: 'DTC RESULTS' and 'TIME'. The first row shows 'CHAIN OF IMMU-KEY [P1614]' under 'DTC RESULTS' and '0' under 'TIME'. There are two empty rows below it. In the bottom right corner of the window, it says 'PIIA1263E'.

SELF DIAGNOSIS	
DTC RESULTS	TIME
CHAIN OF IMMU-KEY [P1614]	0

2. CHECK NATS ANTENNA AMP. INSTALLATION

Check NATS antenna amp. installation. Refer to [BL-173, "How to Replace NATS Antenna Amp."](#) .

OK or NG

- OK >> GO TO 3.
NG >> Reinstall NATS antenna amp. correctly.

3. CHECK NVIS (NATS) IGNITION KEY ID CHIP

Start engine with another registered NATS ignition key.

Does the engine start?

- Yes >> Ignition key ID chip is malfunctioning.
- Replace the ignition key.
Ref. part No, E5
 - Perform initialization with CONSULT-II.
For initialization, refer to "CONSULT-II Operation Manual NATS-IVIS/NVIS".
- No >> GO TO 4.

NVIS (NISSAN VEHICLE IMMOBILIZER SYSTEM-NATS)

4. CHECK POWER SUPPLY FOR NATS ANTENNA AMP.

1. Turn ignition switch "ON".
2. Check voltage between NATS antenna amp. connector M27 terminal 1 (L) and ground with CONSULT-II or tester.

Just after turning ignition switch "ON"

Voltage: Approx. 5V (For 3 seconds)

OK or NG

OK >> GO TO 5.

NG >> ● Check harness for open or short between NATS antenna amp. and BCM (NATS control unit).

NOTE:

If harness is OK, replace BCM (NATS control unit), perform initialization with CONSULT-II. For initialization, refer to "CONSULT-II Operation Manual NATS-IVIS/NVIS".

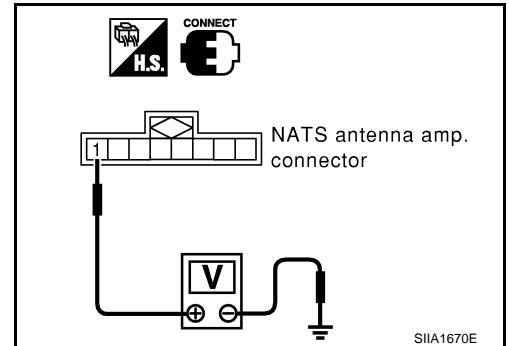

5. CHECK NATS ANTENNA AMP. SIGNAL LINE- 1

Check voltage between NATS antenna amp. connector M27 terminal 3 (G/W) and ground with analogue tester.

Before turning ignition switch "ON"

Voltage: 0V

Just after turning ignition switch "ON"

: Pointer of tester should move.

OK or NG

OK >> GO TO 6.

NG >> ● Check harness for open or short between NATS antenna amp. and BCM (NATS control unit).

NOTE:

If harness is OK, replace BCM (NATS control unit), perform initialization with CONSULT-II. For initialization, refer to "CONSULT-II Operation Manual NATS-IVIS/NVIS".

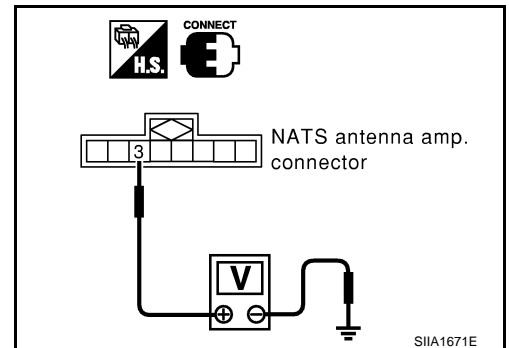

6. CHECK NATS ANTENNA AMP. SIGNAL LINE- 2

Check voltage between NATS antenna amp. connector M27 terminal 7 (BR) and ground with analogue tester.

Before turning ignition switch "ON"

Voltage: 0V

Just after turning ignition switch "ON"

: Pointer of tester should move.

OK or NG

OK >> GO TO 7.

NG >> ● Check harness for open or short between NATS antenna amp. and BCM (NATS control unit).

NOTE:

If harness is OK, replace BCM (NATS control unit), perform initialization with CONSULT-II. For initialization, refer to "CONSULT-II Operation Manual NATS-IVIS/NVIS".

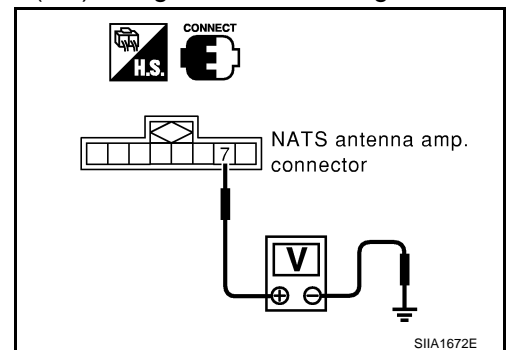

NVIS (NISSAN VEHICLE IMMOBILIZER SYSTEM-NATS)

7. CHECK NATS ANTENNA AMP. GROUND LINE CIRCUIT

1. Turn ignition switch "OFF".
2. Check continuity between NATS antenna amp. connector M27 terminal 5 (B) and ground.

5 (B) – Ground : Continuity should exist.

OK or NG

- OK >> NATS antenna amp. is malfunctioning. **Ref. part No. E6**
NG >> Replace NATS antenna amp.

- Check harness for open or short between NATS antenna amp. and BCM (NATS control unit).

NOTE:

If harness is OK, replace BCM (NATS control unit), perform initialization with CONSULT-II. For initialization, refer to "CONSULT-II Operation Manual NATS-IVIS/NVIS".

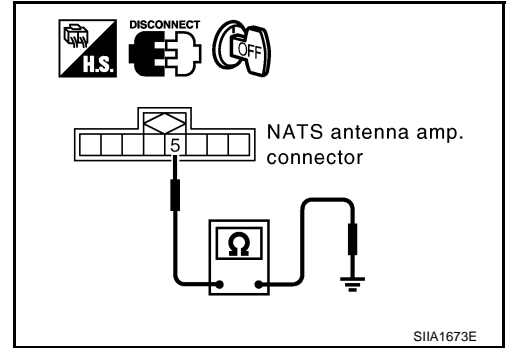

Diagnostic Procedure 4

AIS0014F

Self-diagnostic results:

"ID DISCORD, IMM-ECM" displayed on CONSULT-II screen

1. CONFIRM SELF-DIAGNOSTIC RESULTS

Confirm SELF-DIAGNOSTIC RESULTS "ID DISCORD, IMM-ECM" displayed on CONSULT-II screen.

NOTE:

"ID DISCORD IMM-ECM":

Registered ID of BCM (NATS control unit) is in discord with that of ECM.

Is CONSULT-II screen displayed as above?

- Yes >> GO TO 2.
No >> GO TO [BL-164, "SYMPTOM MATRIX CHART 1"](#).

SELF DIAG RESULTS	
DTC RESULTS	TIME
ID DISCORD, IMM-ECM [P1611]	0

PIIA1262E

2. PERFORM INITIALIZATION WITH CONSULT-II

Perform initialization with CONSULT-II. Re-register all NATS ignition key IDs.

For initialization, refer to "CONSULT-II Operation Manual NATS-IVIS/NVIS".

NOTE:

If the initialization is not completed or malfunctions, CONSULT-II shows message on the screen.

Can the system be initialized?

- Yes >> ● Start engine. (END)
● (System initialization had not been completed. **Ref. part No. F**)

- No >> ECM is malfunctioning.
● Replace ECM. **Ref. part No. B**
● Perform initialization with CONSULT-II.
For initialization, refer to "CONSULT-II Operation Manual NATS-IVIS/NVIS".

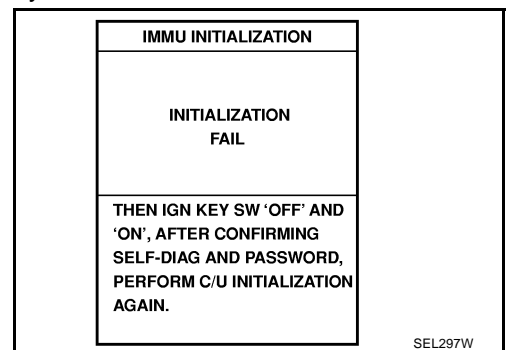

NVIS (NISSAN VEHICLE IMMOBILIZER SYSTEM-NATS)

AIS0014G

Diagnostic Procedure 5

“SECURITY INDICATOR LAMP DOES NOT LIGHT UP”

1. CHECK FUSE

Check 10A fuse [No.19, located in the fuse block (J/B)]

OK or NG

- OK >> GO TO 2.
- NG >> Replace fuse.

2. CHECK SECURITY INDICATOR LAMP

1. Install 10A fuse.
2. Start engine and turn ignition switch OFF.
3. Check the security indicator lamp lights up.

Security indicator lamp should light up.

OK or NG

- OK >> Inspection END.
- NG >> GO TO 3.

3. CHECK SECURITY INDICATOR LAMP POWER SUPPLY CIRCUIT

1. Disconnect security indicator lamp connector.
2. Check voltage between security indicator lamp connector M34 terminal 1 (R/W) and ground.

1 (R/W) – Ground : Battery voltage should exist.

OK or NG

- OK >> GO TO 4.
- NG >> Check harness for open or short between fuse and security indicator lamp.

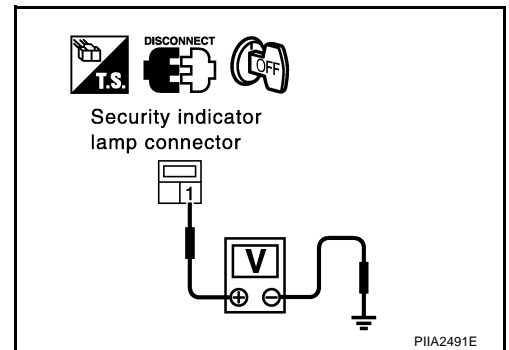

4. CHECK BCM (NATS CONTROL UNIT) FUNCTION

1. Connect security indicator lamp connector.
2. Disconnect BCM (NATS control unit) connector M3.
3. Check voltage between BCM (NATS control unit) connector M3 terminal 55 (G/OR) and ground.

55 (G/OR) – Ground : Battery voltage should exist.

OK or NG

- OK >> BCM (NATS control unit) is malfunctioning.
 - Replace BCM (NATS control unit).
Ref. part No. A
 - Perform initialization with CONSULT-II.
 - For initialization, refer to “CONSULT-II Operation Manual NATS-IVIS/NVIS”.
- NG >> Check the following.
 - Harness for open or short between security indicator lamp and BCM (NATS control unit).
 - Indicator lamp condition

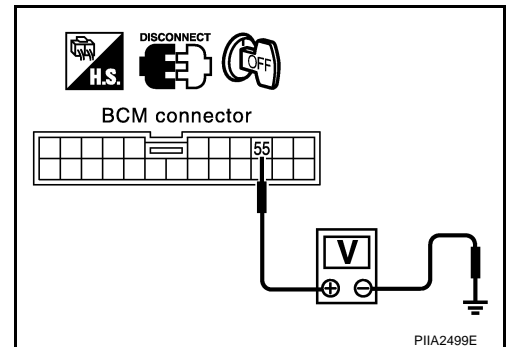

NVIS (NISSAN VEHICLE IMMOBILIZER SYSTEM-NATS)

AI50014H

Diagnostic Procedure 6

Self-diagnostic results:

“LOCK MODE” displayed on CONSULT-II screen

1. CONFIRM SELF-DIAGNOSTIC RESULTS

Confirm SELF-DIAGNOSTIC RESULTS “LOCK MODE” is displayed on CONSULT-II screen.

Is CONSULT-II screen displayed as above?

Yes >> GO TO 2.

No >> GO TO [BL-164, "SYMPTOM MATRIX CHART 1"](#).

SELF DIAG RESULTS	
DTC RESULTS	TIME
LOCK MODE [P1610]	0

PIIA1264E

2. ESCAPE FROM LOCK MODE

1. Turn ignition switch OFF.
2. Turn ignition switch ON with registered key. (Do not start engine.) Wait 5 seconds.
3. Return the key to OFF position. Wait 5 seconds.
4. Repeat steps 2 and 3 twice (total of three cycles).
5. Start the engine.

Does engine start?

Yes >> System is OK (Now system is escaped from “LOCK MODE”).

No >> GO TO 3.

3. PERFORM INITIALIZATION WITH CONSULT-II

Perform initialization with CONSULT-II.

For initialization, refer to “CONSULT-II Operation Manual NATS-IVIS/NVIS”.

NOTE:

If the initialization is not completed or malfunctions, CONSULT-II shows the message on the screen.

Can the system be initialized?

Yes >> System is OK.

No >> GO TO 4

IMMU INITIALIZATION
INITIALIZATION FAIL
THEN IGN KEY SW 'OFF' AND 'ON', AFTER CONFIRMING SELF-DIAG AND PASSWORD, PERFORM C/U INITIALIZATION AGAIN.

SEL297W

NVIS (NISSAN VEHICLE IMMOBILIZER SYSTEM-NATS)

4. PERFORM INITIALIZATION WITH CONSULT-II AGAIN

1. Replace BCM (NATS control unit).
2. Perform initialization with CONSULT-II.
For initialization, refer to "CONSULT-II Operation Manual NATS-IVIS/NVIS".

NOTE:

If the initialization is not completed or malfunctions, CONSULT-II shows the message on the screen.

Can the system be initialized?

- Yes >> System is OK. (BCM (NATS control unit) is malfunctioning. **Ref. part No. A**)
- No >> ECM is malfunctioning.
- Replace ECM. **Ref. part No. B**
 - Perform initialization with CONSULT-II.
For initialization, refer to "CONSULT-II Operation Manual NATS-IVIS/NVIS".

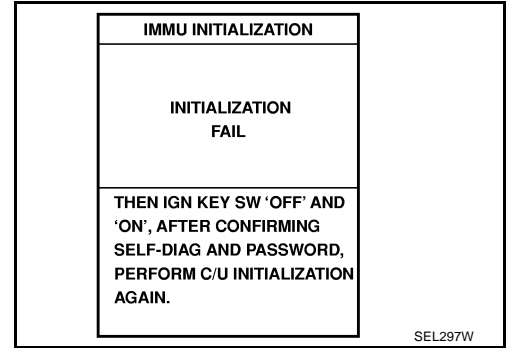

How to Replace NATS Antenna Amp.

AI50014I

NOTE:

- If NATS antenna amp. is not installed correctly, NVIS (NATS) system will not operate properly and SELF-DIAG RESULTS on CONSULT-II screen will show "LOCK MODE" or "CHAIN OF IMMU-KEY".
- Initialization is not necessary only when NATS antenna amp. is replaced with a new one.

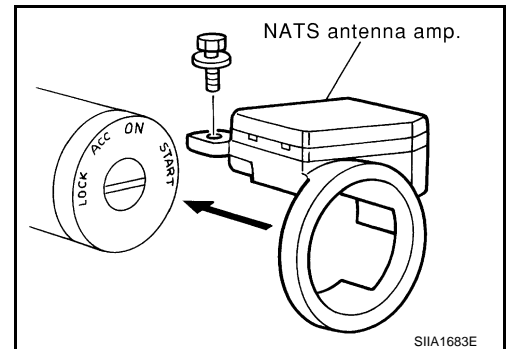

INTEGRATED HOMELINK TRANSMITTER

PF9:96401

INTEGRATED HOMELINK TRANSMITTER

Wiring Diagram —TRNSCV—

AIS000EK

BL-TRNSCV-01

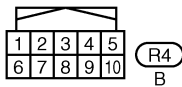
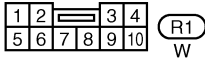
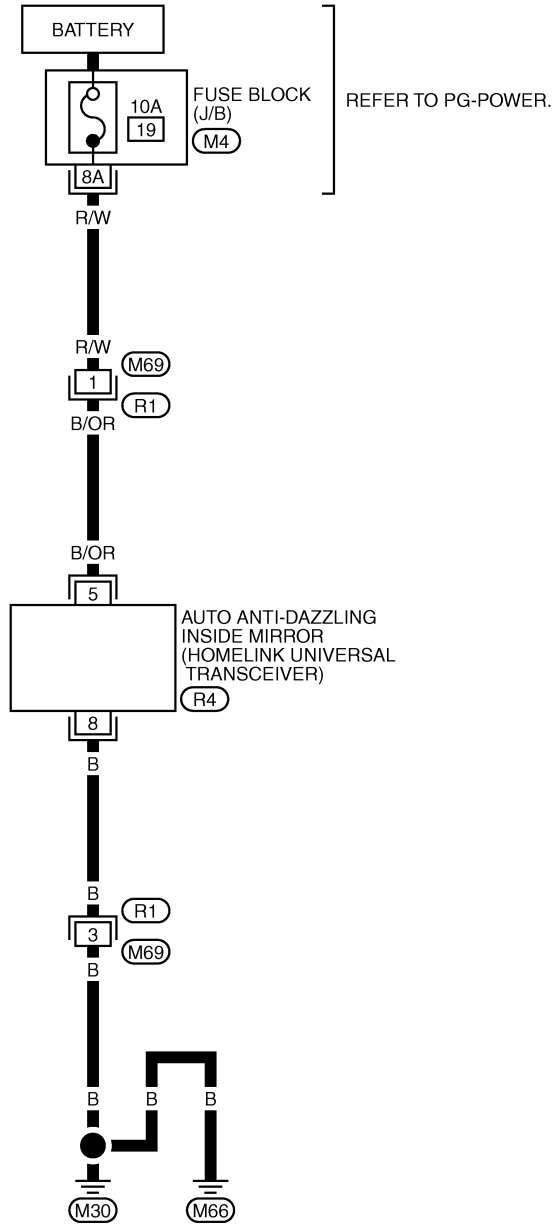

REFER TO THE FOLLOWING.

(M4) - FUSE BLOCK-JUNCTION BOX (J/B)

TIWT0497E

INTEGRATED HOMELINK TRANSMITTER

AIS000EL

Trouble Diagnoses DIAGNOSTIC PROCEDURE

SYMPTOM: Transmitter Does Not Activate Receiver.

Before conducting the procedure given below, make sure that system receiver (garage door opener, etc.) operates with original, hand-held transmitter. If NG, receiver or hand-held transmitter is malfunctioning, not vehicle related.

1. ILLUMINATION CHECK

1. Turn ignition switch "OFF".
2. Does red light (LED) of transmitter illuminate when any transmitter button is pressed?

YES or NO

- YES >> GO TO 2.
NO >> GO TO 3.

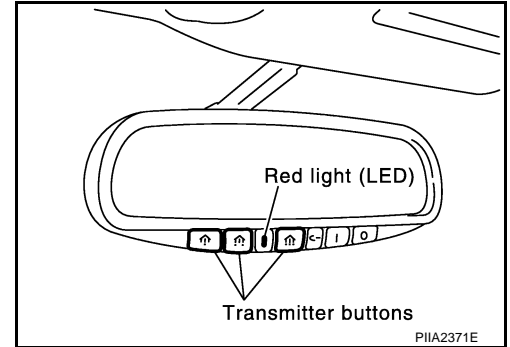

2. TRANSMITTER CHECK

Check transmitter with Tool*.

*:For details, refer to Technical Service Bulletin.

OK or NG

- OK >> Receiver or hand-held transmitter malfunction, not vehicle related.
NG >> Replace inside mirror assembly.

3. CHECK POWER SUPPLY

1. Disconnect transmitter connector.
2. Turn ignition switch "OFF".
3. Check voltage between auto anti-dazzling inside mirror (integrated homelink transmitter) connector R4 terminal 5 (B/OR) and ground.

5 (B/OR) – Ground : Battery voltage

OK or NG

- OK >> GO TO 4.
NG >> ● Check 10A fuse. [No. 19 located in the fuse block (J/B)]
● Harness for open or short between fuse and anti-dazzling inside mirror (integrated homelink transmitter).

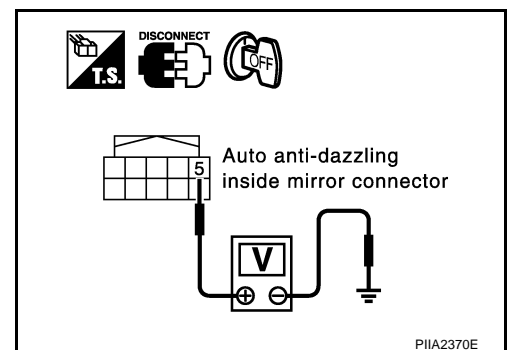

INTEGRATED HOMELINK TRANSMITTER

4. GROUND CIRCUIT CHECK

Check continuity between anti-dazzling inside mirror (integrated homelink transmitter) connector R4 terminal 8 (B) and ground.

8 (B) – Ground :Continuity should exist.

OK or NG

- OK >> Replace inside mirror assembly.
- NG >> Harness for open or short between anti-dazzling inside mirror (integrated homelink transmitter) body ground.

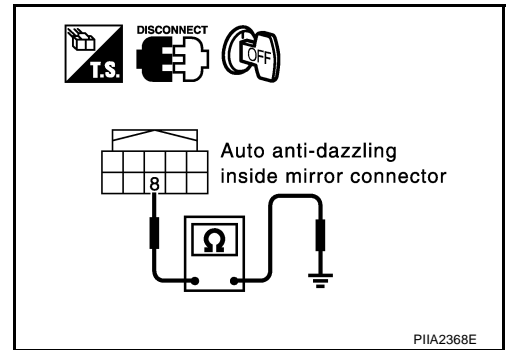

BODY REPAIR

BODY REPAIR

PPF:60100

Body Exterior Paint Color (Coupe)

AIS0043R

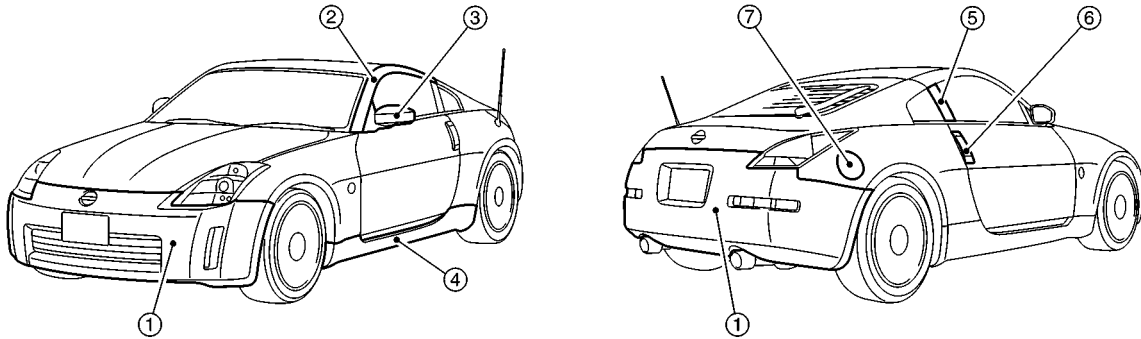

SIIA1975E

Component	Color code	BA17	BAX6	BB17	BKH3	BKY0	BQX1	BWV2	BK25		
	Description	Orange	Red	Blue	Black	Silver	White	Silver	Silver		
	Paint type	2P	2S	CPM	2S	M	3P	M	M		
	Hard clear coat	-	X	X	X	-	-	-	-		
1	Bumper fascia		Body color	BA17	BAX6	BB17	BKH3	BKY0	BQX1	BWV2	BK25
2	Front pillar finisher		Body color	BA17	BAX6	BB17	BKH3	BKY0	BQX1	BWV2	BK25
3	Door outside mirror	Case	Body color	BA17	BAX6	BB17	BKH3	BKY0	BQX1	BWV2	BK25
		Base	Body color	BA17	BAX6	BB17	BKH3	BKY0	BQX1	BWV2	BK25
4	Center mud-guard		Body color	BA17	BAX6	BB17	BKH3	BKY0	BQX1	BWV2	BK25
5	Door sash		Black	GROSS 88	GROSS 88	GROSS 88	GROSS 88	GROSS 88	GROSS 88	GROSS 88	GROSS 88
6	Door outside handle and escutcheon		Velour chromium-plate	Cr2p	Cr2p	Cr2p	Cr2p	Cr2p	Cr2p	Cr2p	Cr2p
7	Fuel filler lid		Body color	BA17	BAX6	BB17	BKH3	BKY0	BQX1	BWV2	BK25

2S:Solid + Clear, M:Metallic, 2P:2-Coat pearl, 3P:3-Coat pearl, CPM:Clear pearl metallic

A
B
C
D
E
F
G
H
I
J
K
L
M

BL

BODY REPAIR

Body Exterior Paint Color (Roadster)

AIS0044F

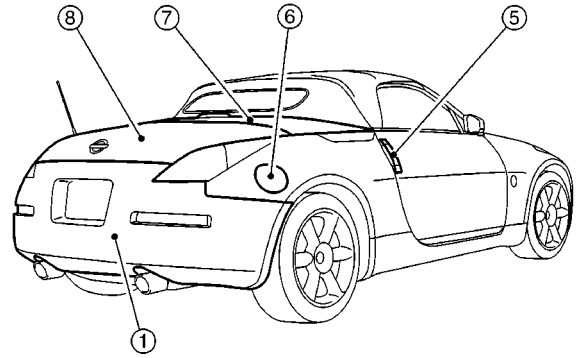
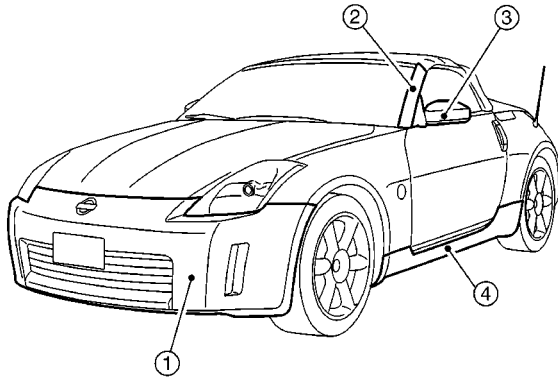

SIAA2295E

Component		Color code	BA17	BAX6	BB17	BKH3	BKY0	BQX1	BWV2
		Description	Orange	Red	Blue	Black	Silver	White	Silver
		Paint type	2P	2S	CPM	2S	M	3P	M
		Hard clear coat	-	X	X	X	-	-	-
1	Bumper fascia	Body color	BA17	BAX6	BB17	BKH3	BKY0	BQX1	BWV2
2	Front pillar finisher	Body color	BA17	BAX6	BB17	BKH3	BKY0	BQX1	BWV2
3	Door outside mirror	Case	BA17	BAX6	BB17	BKH3	BKY0	BQX1	BWV2
		Base	BA17	BAX6	BB17	BKH3	BKY0	BQX1	BWV2
4	Center mudguard	Body color	BA17	BAX6	BB17	BKH3	BKY0	BQX1	BWV2
5	Door outside handle and escutcheon	Velour chromium-plate	Cr2p	Cr2p	Cr2p	Cr2p	Cr2p	Cr2p	Cr2p
6	Fuel filler lid	Body color	BA17	BAX6	BB17	BKH3	BKY0	BQX1	BWV2
7	Storage lid	Body color	BA17	BAX6	BB17	BKH3	BKY0	BQX1	BWV2
8	Trunk lid	Body color	BA17	BAX6	BB17	BKH3	BKY0	BQX1	BWV2

2S:Solid + Clear, M:Metallic, 2P:2-Coat pearl, 3P:3-Coat pearl, CPM:Clear pearl metallic

BODY REPAIR

Body Component Parts (Coupe) UNDERBODY COMPONENT PARTS

AIS0044G

A
B
C
D
E
F
G
H
BL
J
K
L
M

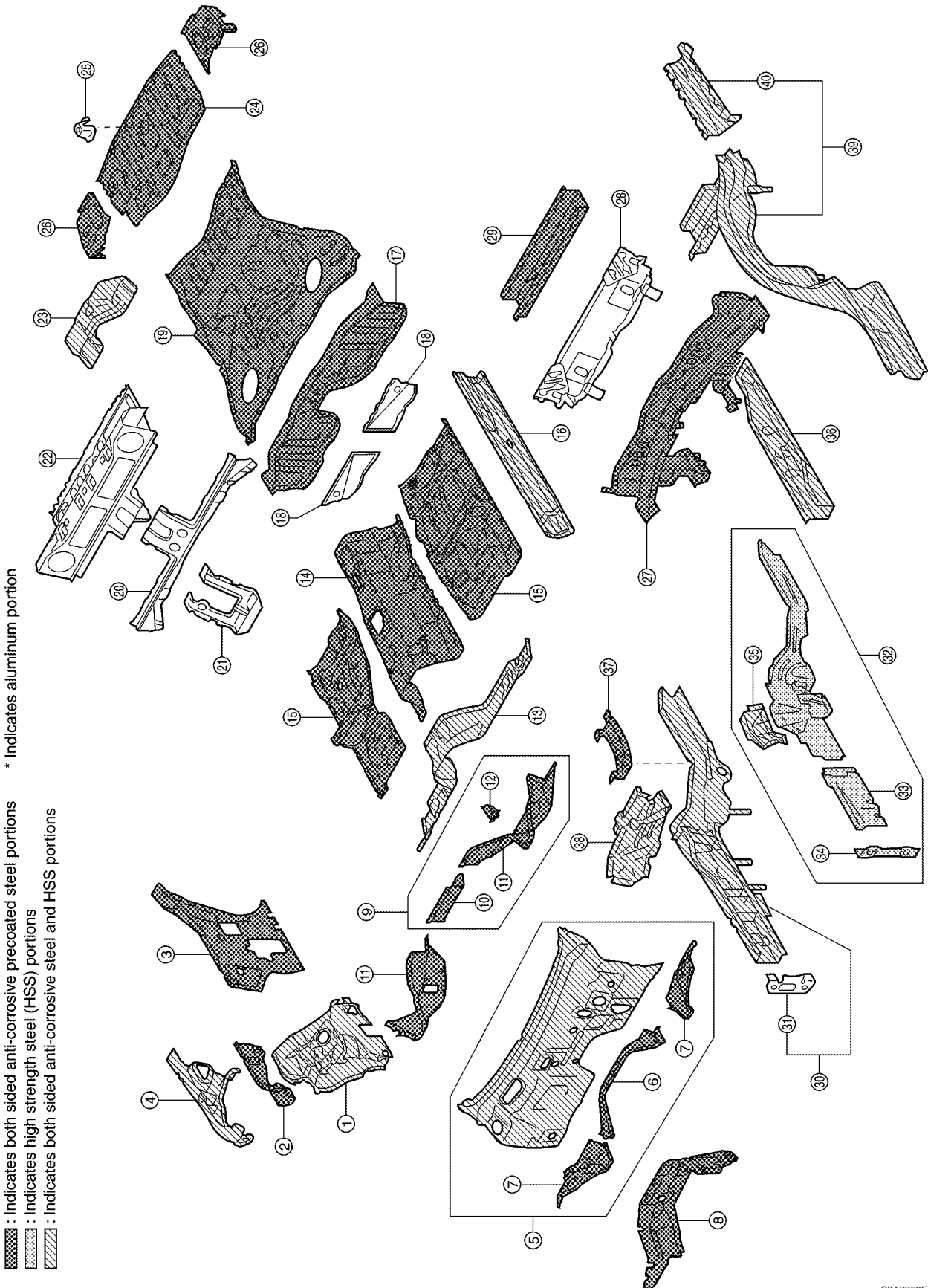

* Indicates aluminum portion

▨ : Indicates both sided anti-corrosive pre-coated steel portions

▨ : Indicates high strength steel (HSS) portions

▨ : Indicates both sided anti-corrosive steel and HSS portions

BODY REPAIR

1. Front strut housing (RH&LH)
2. Upper front hoodledge (RH&LH)
3. Upper rear hoodledge (RH&LH)
4. Hoodledge reinforcement (RH&LH)
5. Upper dash assembly
6. Lower dash crossmember center reinforcement
7. Lower dash crossmember reinforcement
8. Cowl top
9. Lower dash crossmember assembly
10. Front crossmember center
11. Lower dash crossmember
12. Steering column mounting reinforcement
13. Lower dash
14. Front floor center
15. Front floor
16. Inner sill (RH&LH)
17. Rear seat crossmember reinforcement assembly
18. Rear floor gusset
19. Rear floor front
20. Rear step upper panel assembly
21. Rear step lower panel assembly
22. Inside step panel
23. Rear floor seat belt anchor reinforcement
24. Rear floor rear
25. Spare tire clamp bracket
26. Rear floor side
27. Rear seat crossmember
28. 2ND rear crossmember
29. Rear center crossmember assembly
30. Front side member assembly (RH&LH)
31. Inner front towing hook bracket (RH&LH)
32. Front side member closing plate assembly (RH&LH)
33. Front side member front closing plate (RH&LH)
34. Outer front towing hook bracket (RH&LH)
35. Front side member center closing plate (RH&LH)
36. Front side member rear extension (RH&LH)
37. Front side member rear reinforcement (RH&LH)
38. Front side member outrigger assembly (RH&LH)
39. Rear side member assembly (RH&LH)
40. Rear side member extension (RH&LH)

BODY REPAIR

BODY COMPONENT PARTS

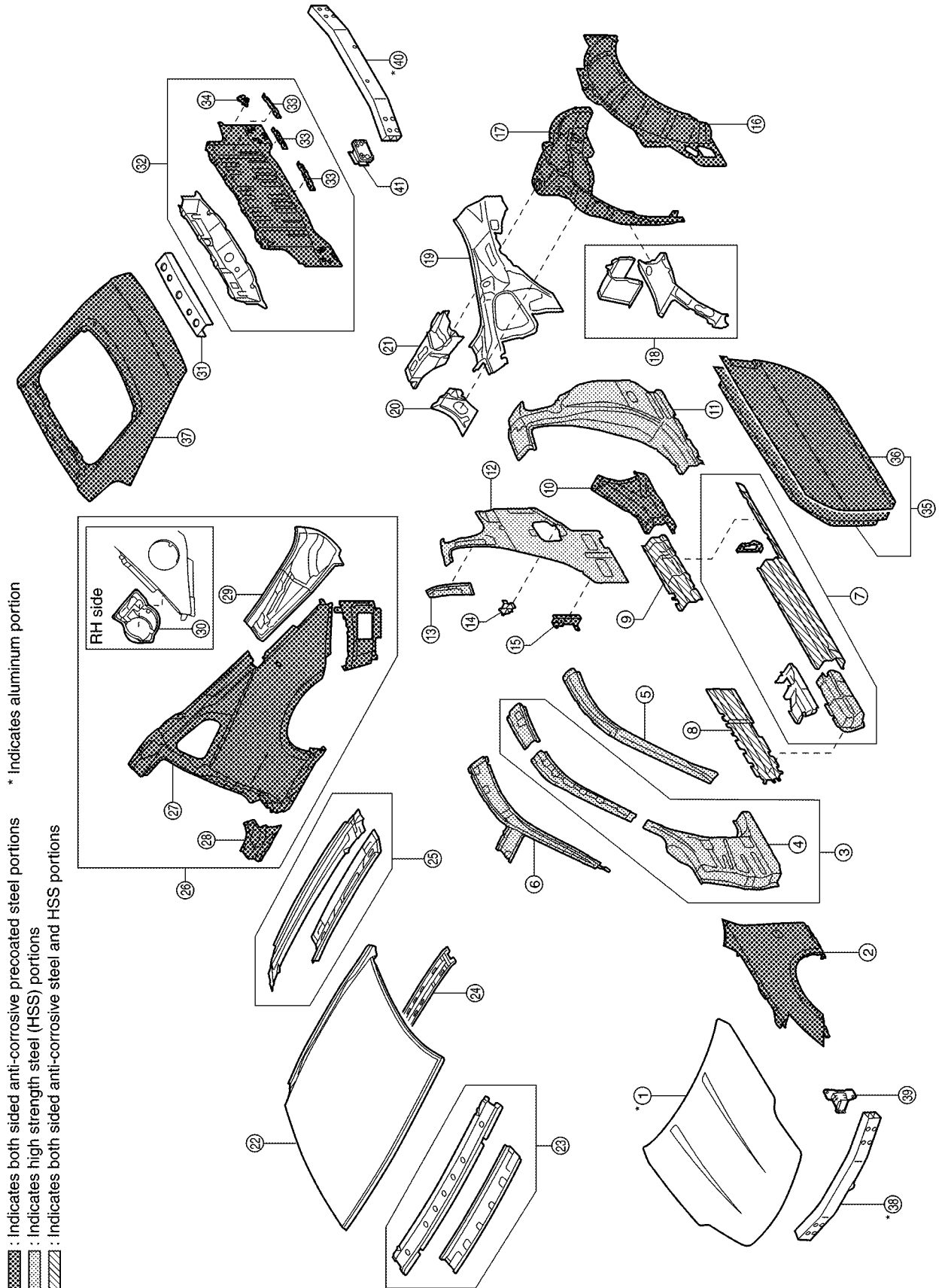

A
B
C
D
E
F
G
H
BL
J
K
L
M

1. Hood
2. Front fender (RH&LH)

SIIA2357E

BODY REPAIR

3. Front pillar reinforcement assembly (RH&LH)
4. Front pillar hinge brace (RH&LH)
5. Outer front pillar (RH&LH)
6. Inner side roof rail (RH&LH)
7. Outer sill reinforcement assembly (RH&LH)
8. Lower front pillar reinforcement (RH&LH)
9. Lower center pillar bulkhead assembly (RH&LH)
10. Outer rear wheel house extension (RH&LH)
11. Outer lock pillar reinforcement (RH&LH)
12. Inner lock pillar assembly (RH&LH)
13. Inner lock pillar reinforcement (RH&LH)
14. Seat belt anchor assembly (RH&LH)
15. Outer sill brace (RH&LH)
16. Outer rear wheel house (RH&LH)
17. Inner rear wheel house (RH&LH)
18. Inner rear pillar joint (RH&LH)
19. Inner rear pillar (RH&LH)
20. Seat back support (RH&LH)
21. Side parcel shelf (RH&LH)
22. Roof
23. Front roof rail assembly
24. Roof bow No.1
25. Rear roof rail assembly
26. Rear fender assembly (RH&LH)
27. Rear fender (RH&LH)
28. Outer sill extension (RH&LH)
29. Rear fender corner (RH&LH)
30. Fuel filler lid base
31. Parcel shelf
32. Rear panel assembly
33. Rear bumper fascia bracket
34. Rear bumper fascia center bracket (RH&LH)
35. Front door assembly (RH&LH)
36. Outer front door panel (RH&LH)
37. Back door
38. Front bumper reinforcement
39. Front bumper stay (RH&LH)
40. Rear bumper reinforcement
41. Rear bumper stay (RH&LH)

BODY REPAIR

Body Component Parts (Roadster) UNDERBODY COMPONENT PARTS

AI5006VM

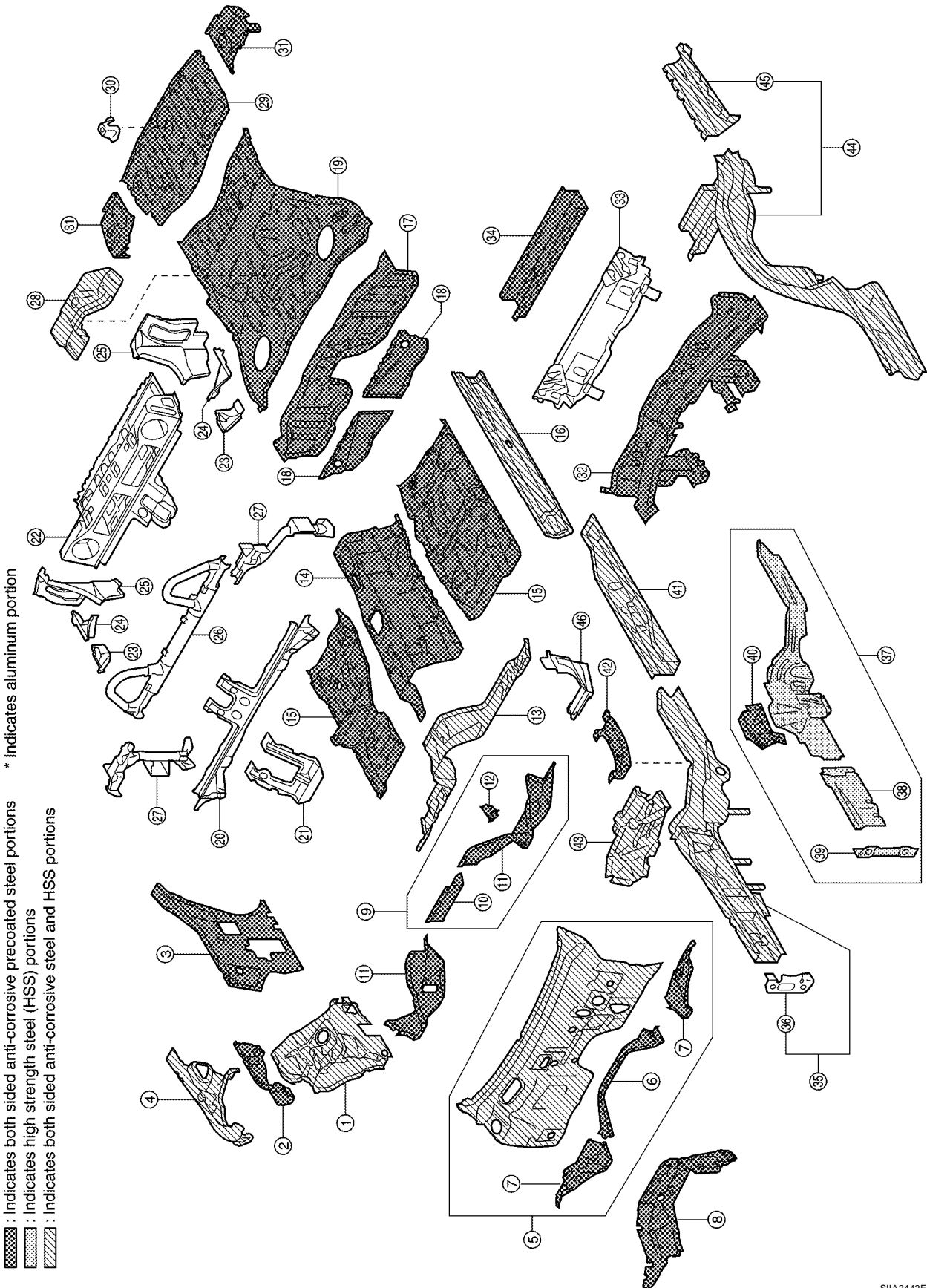



A
B
C
D
E
F
G
H
BL
J
K
L
M

BODY REPAIR

1. Front strut housing (RH&LH)
2. Upper front hoodledge (RH&LH)
3. Upper rear hoodledge (RH&LH)
4. Hoodledge reinforcement (RH&LH)
5. Upper dash assembly
6. Lower dash crossmember center reinforcement
7. Lower dash crossmember reinforcement
8. Cowl top
9. Lower dash crossmember assembly
10. Front crossmember center
11. Lower dash crossmember A
12. Steering column mounting reinforcement
13. Lower dash
14. Front floor center
15. Front floor
16. Inner sill (RH&LH)
17. Rear seat crossmember reinforcement assembly
18. Rear floor gusset
19. Rear floor front
20. Rear step upper panel assembly
21. Rear step lower panel assembly
22. Inside step panel
23. Guard frame gusset
24. Rear side member connector
25. Inner rear wheelhouse connector
26. Guard frame assembly
27. Inside guard frame post
28. Rear floor seat belt anchor reinforcement
29. Rear floor rear
30. Spare tire clamp bracket
31. Rear floor side
32. Rear seat crossmember
33. 2ND rear crossmember
34. Rear center crossmember assembly
35. Front side member assembly (RH&LH)
36. Inner front towing hook bracket (RH&LH)
37. Front side member closing plate assembly (RH&LH)
38. Front side member front closing plate (RH&LH)
39. Outer front towing hook bracket (RH&LH)
40. Front side member center closing plate (RH&LH)
41. Front side member rear extension (RH&LH)
42. Front side member rear reinforcement (RH&LH)
43. Front side member outrigger assembly (RH&LH)
44. Rear side member assembly (RH&LH)
45. Rear side member extension (RH&LH)
46. Lower dash crossmember B

BODY REPAIR

BODY COMPONENT PARTS

-  : Indicates both sided anti-corrosive pre-coated steel portions
-  : Indicates high strength steel (HSS) portions
-  : Indicates both sided anti-corrosive steel and HSS portions
- * : Indicates aluminum portion

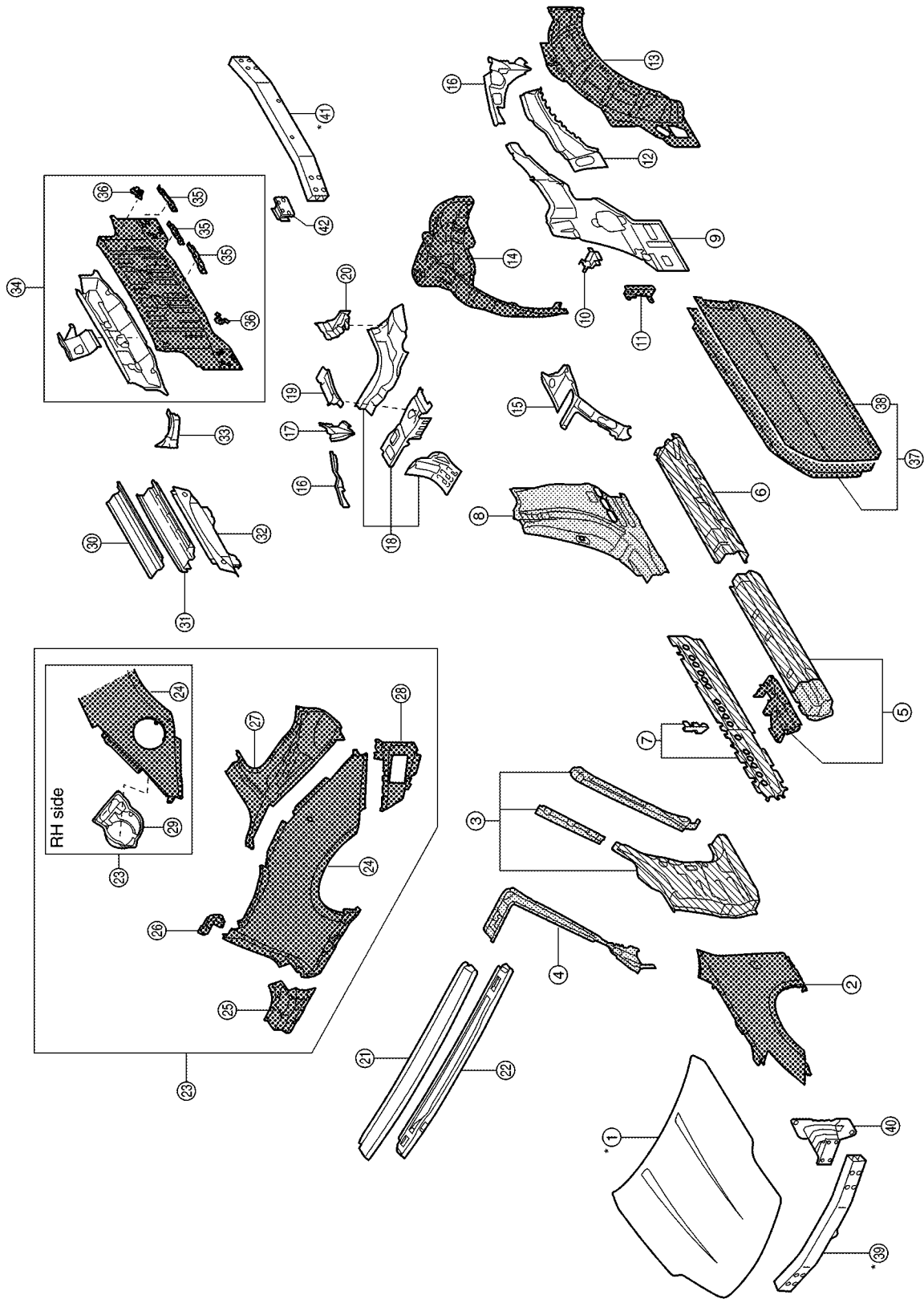

A
B
C
D
E
F
G
H
BL
J
K
L
M

BODY REPAIR

1. Hood
2. Front fender (RH&LH)
3. Outer front pillar assembly (RH&LH)
4. Inner side roof rail (RH&LH)
5. Outer front sill reinforcement assembly (RH&LH)
6. Outer rear sill reinforcement assembly (RH&LH)
7. Lower front pillar reinforcement assembly (RH&LH)
8. Outer lock pillar reinforcement (RH&LH)
9. Inner rear pillar (RH&LH)
10. Seat belt anchor assembly (RH&LH)
11. Outer sill brace (RH&LH)
12. Rear side waist reinforcement (RH&LH)
13. Outer rear wheel house (RH&LH)
14. Inner rear wheel house (RH&LH)
15. Rear pillar joint (RH&LH)
16. Lower inner rear pillar
17. Lower rear pillar rear (RH)
18. Side parcel shelf assembly (RH&LH)
19. Side parcel shelf (RH&LH)
20. Rear pillar gusset (RH&LH)
21. Outer front roof rail
22. Inner front roof rail
23. Rear fender assembly
24. Rear fender
25. Outer sill extension (RH&LH)
26. Rear fender extension A (RH&LH)
27. Rear fender extension B (RH&LH)
28. Rear fender extension C (RH&LH)
29. Fuel filler lid base
30. Rear waist
31. Parcel shelf
32. Seat back support
33. Rear panel bracket reinforcement (RH&LH)
34. Rear panel assembly
35. Center rear bumper fascia bracket
36. Rear bumper fascia bracket
37. Front door assembly (RH&LH)
38. Outer front door panel (RH&LH)
39. Front bumper reinforcement
40. Front bumper stay (RH&LH)
41. Rear bumper reinforcement
42. Rear bumper stay (RH&LH)

BODY REPAIR

Corrosion Protection

AI500441

DESCRIPTION

To provide improved corrosion prevention, the following anti-corrosive measures have been implemented in NISSAN production plants. When repairing or replacing body panels, it is necessary to use the same anti-corrosive measures.

Anti-corrosive Precoated Steel (Galvannealed Steel)

To improve repairability and corrosion resistance, a new type of anti-corrosive precoated steel sheet has been adopted replacing conventional zinc-coated steel sheet.

Galvannealed steel is electroplated and heated to form Zinc-iron alloy, which provides excellent and long term corrosion resistance with cationic electrodeposition primer.

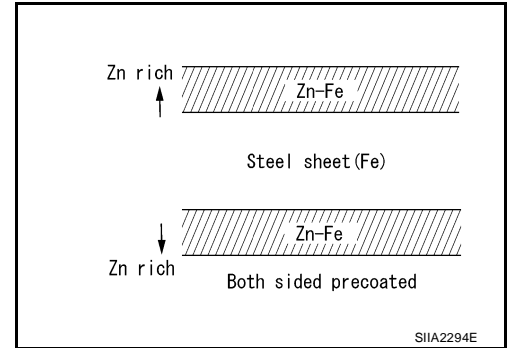

Nissan Genuine Service Parts are fabricated from galvannealed steel. Therefore, it is recommended that GENUINE NISSAN PARTS or equivalent be used for panel replacement to maintain the anti-corrosive performance built into the vehicle at the factory.

Phosphate Coating Treatment and Cationic Electrodeposition Primer

A phosphate coating treatment and a cationic electrodeposition primer, which provide excellent corrosion protection, are employed on all body components.

CAUTION:

Confine paint removal during welding operations to an absolute minimum.

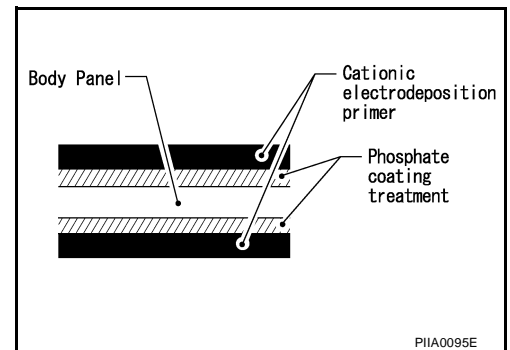



Nissan Genuine Service Parts are also treated in the same manner. Therefore, it is recommended that GENUINE NISSAN PARTS or equivalent be used for panel replacement to maintain anti-corrosive performance built into the vehicle at the factory.

BODY REPAIR

ANTI-CORROSIVE WAX

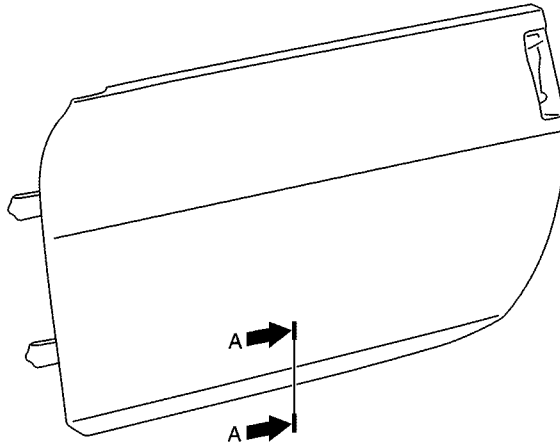
To improve corrosion resistance, anti-corrosive wax is applied inside the body sill and inside other closed sections. Accordingly, when replacing these parts, be sure to apply anti-corrosive wax to the appropriate areas of the new parts. Select an excellent anti-corrosive wax which will penetrate after application and has a long shelf life.



 : Indicates anti-corrosive wax coated portions.

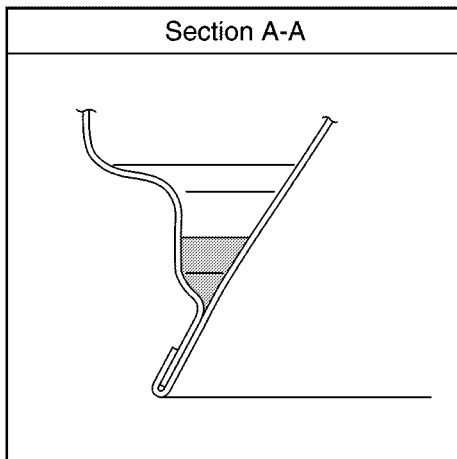

BODY REPAIR

UNDERCOATING

The underside of the floor and wheelhouse are undercoated to prevent rust, vibration, noise and stone chipping. Therefore, when such a panel is replaced or repaired, apply undercoating to that part. Use an undercoating which is rust preventive, soundproof, vibration-proof, shock-resistant, adhesive, and durable.

Precautions in Undercoating

1. Do not apply undercoating to any place unless specified (such as the areas above the muffler and three way catalyst which are subjected to heat).
2. Do not undercoat the exhaust pipe or other parts which become hot.
3. Do not undercoat rotating parts.
4. Apply bitumen wax after applying undercoating.
5. After putting seal on the vehicle, put undercoating on it.

 : Indicates undercoated portions.

 : Indicates sealed portions.

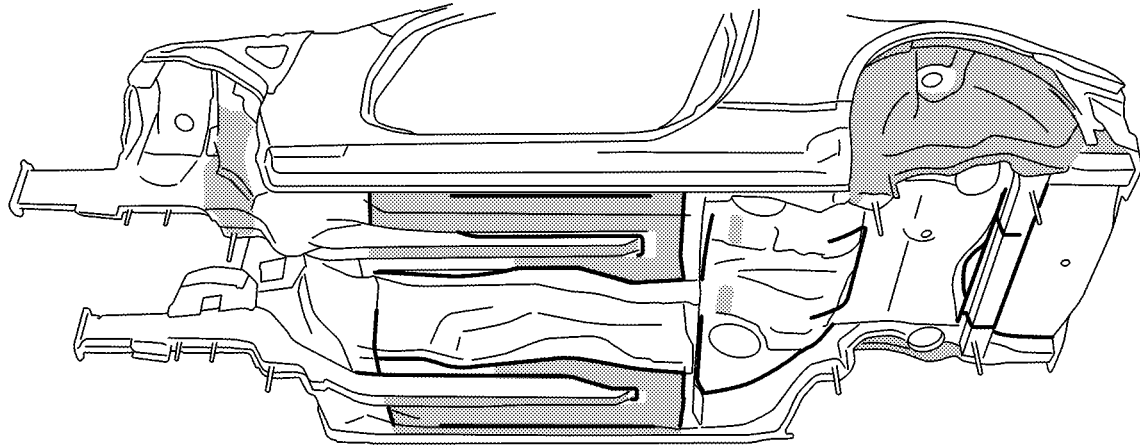



SIA2298E

BODY REPAIR

STONE GUARD COAT

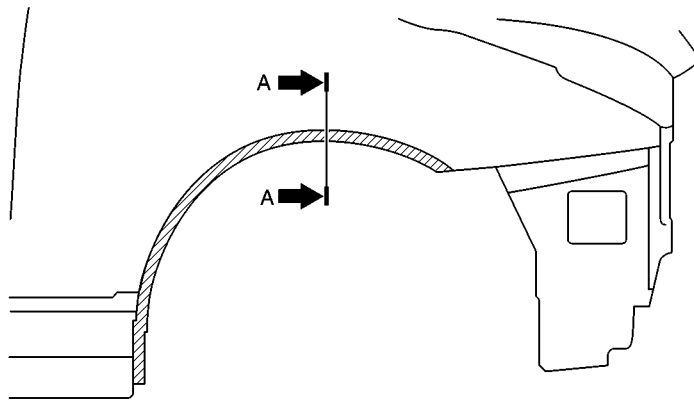
To prevent damage caused by stones, the lower outer body panel (fender, door, etc.) have an additional layer of Stone Guard Coating over the ED primer coating. When replacing or repairing these panels, apply Stone Guard coating to the same portions as before. Use a coating which is rust preventive, durable, shock-resistant and has a long shelf life.



 : Indicates stone guard coated portions.

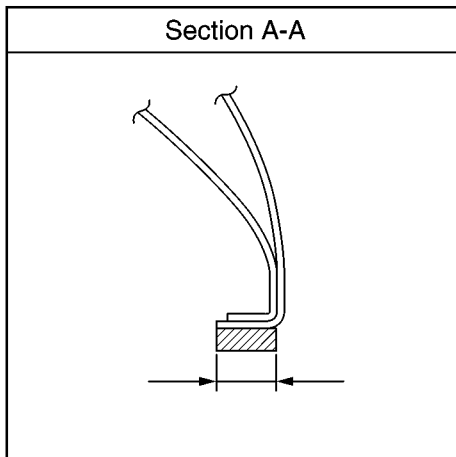

SIA2299E

BODY REPAIR

Body Sealing (Coupe) DESCRIPTION

AIS0044J

The following figure shows the areas which are sealed at the factory. Sealant which has been applied to these areas should be smooth and free from cuts or gaps. Care should be taken not to apply an excess amount of sealant and not to allow other unaffected parts to come into contact with the sealant.

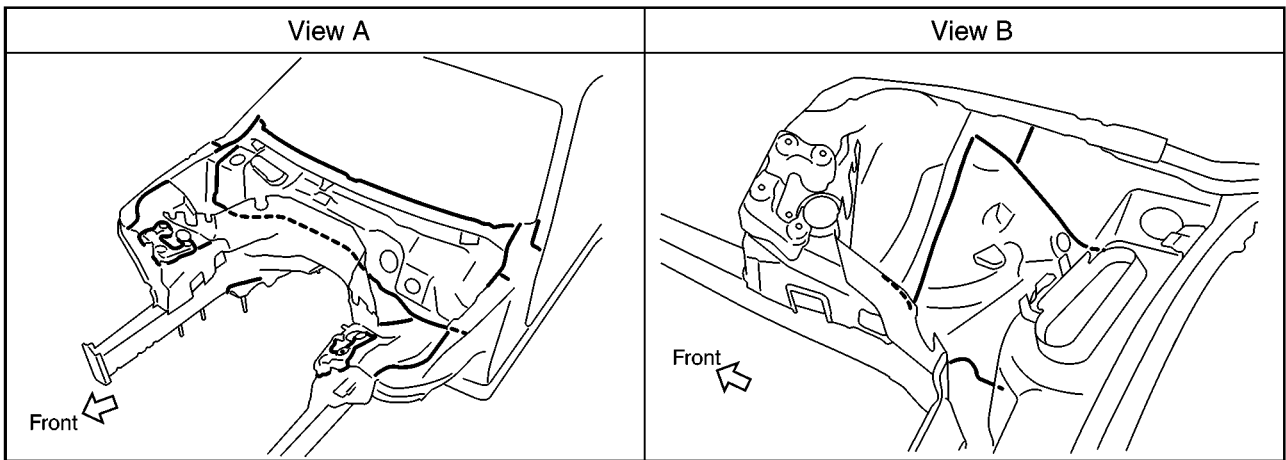
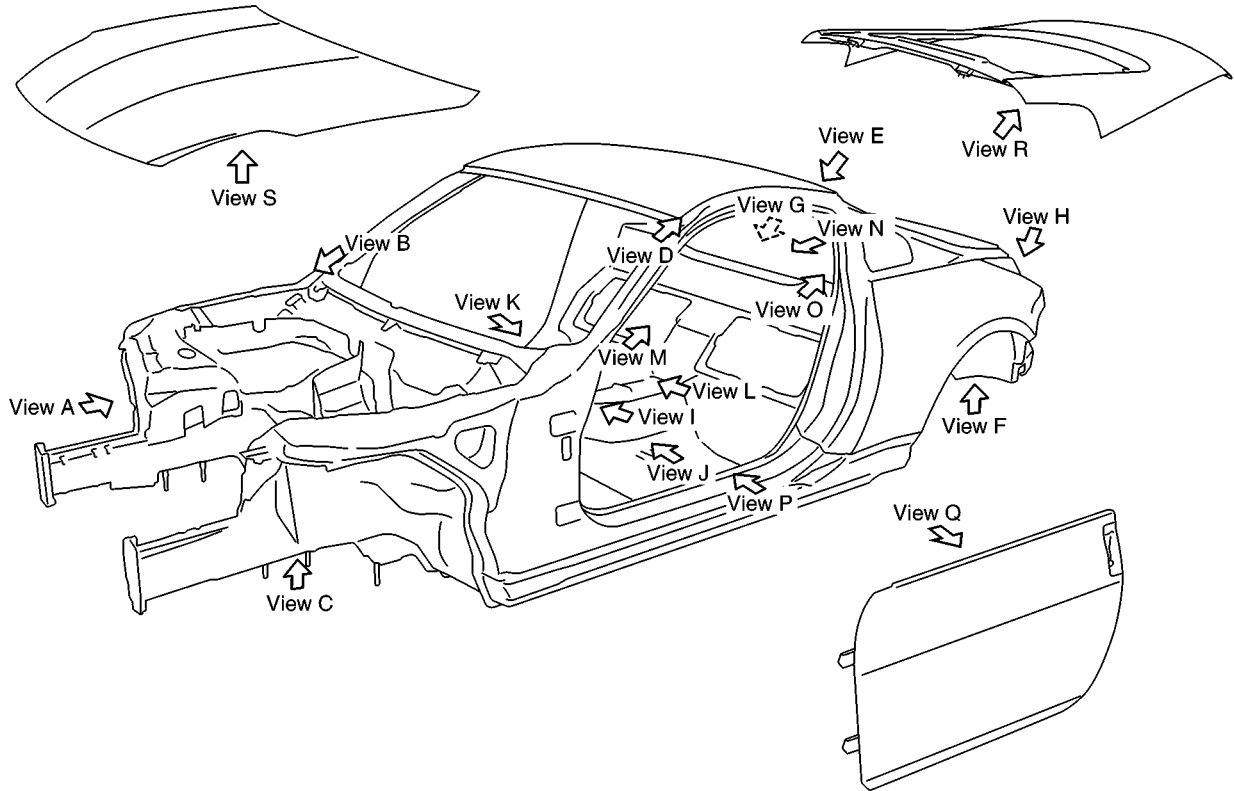

A
B
C
D
E
F
G
H
BL
J
K
L
M

SIIA1976E

BODY REPAIR

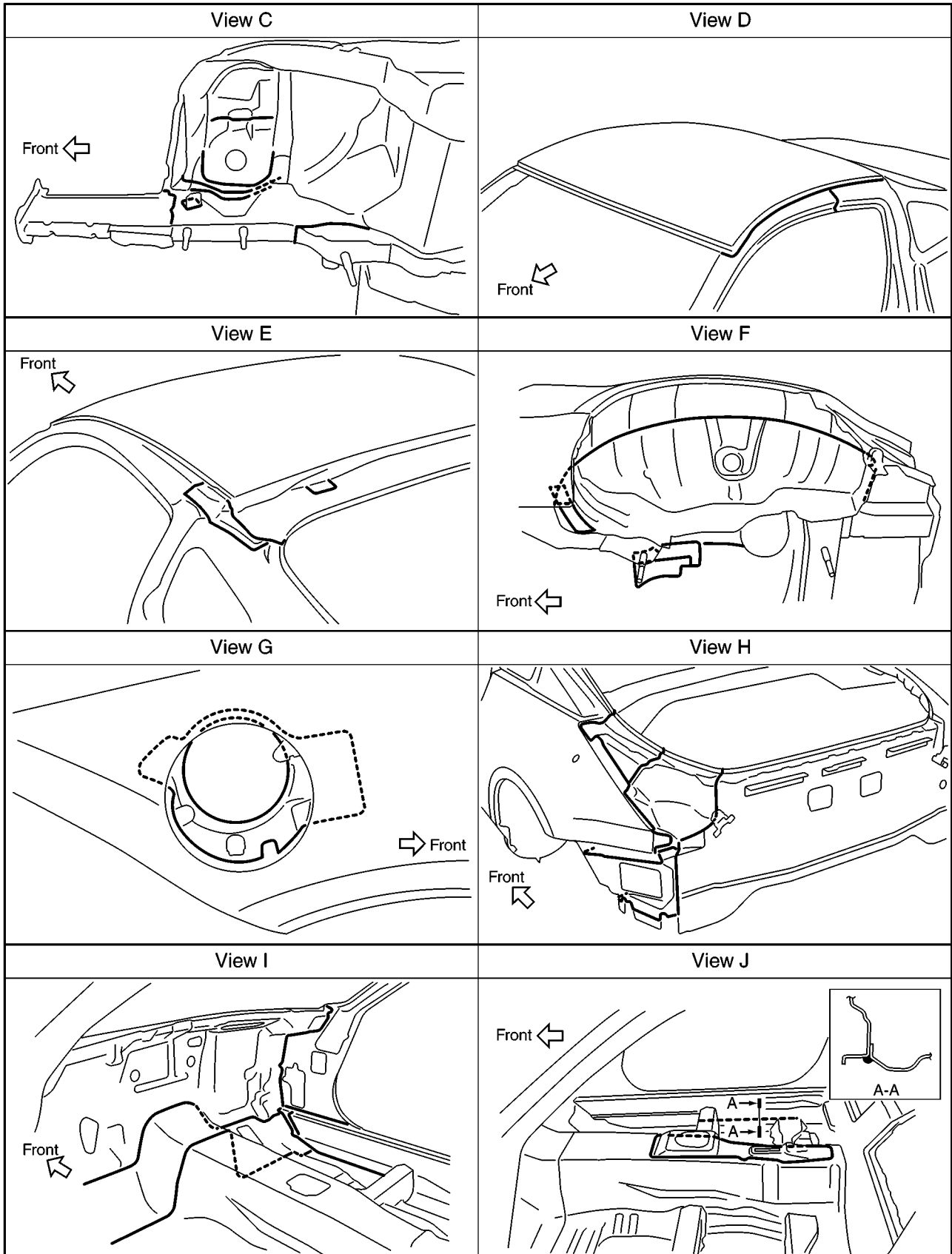

SIA1977E

BODY REPAIR

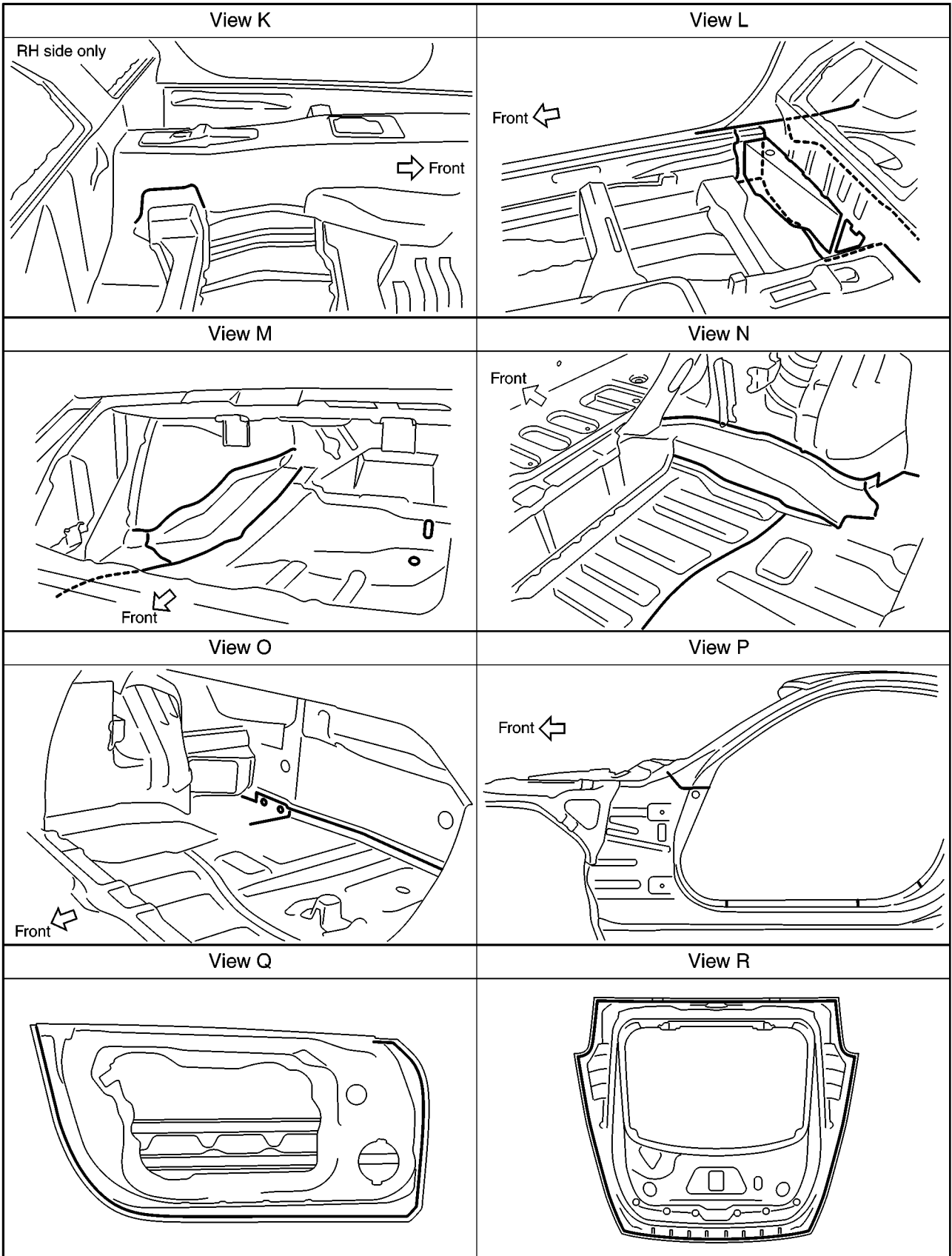

A
B
C
D
E
F
G
H
BL
J
K
L
M

SIIA1978E

BODY REPAIR

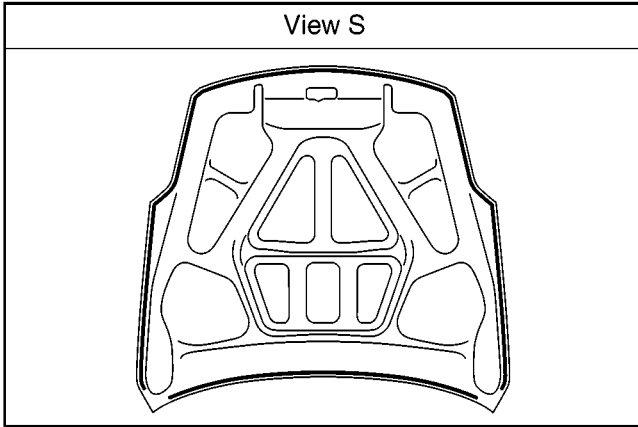

SIA2335E

BODY REPAIR

Body Sealing (Roadster) DESCRIPTION

AIS0044K

The following figure shows the areas which are sealed at the factory. Sealant which has been applied to these areas should be smooth and free from cuts or gaps. Care should be taken not to apply an excess amount of sealant and not to allow other unaffected parts to come into contact with the sealant.

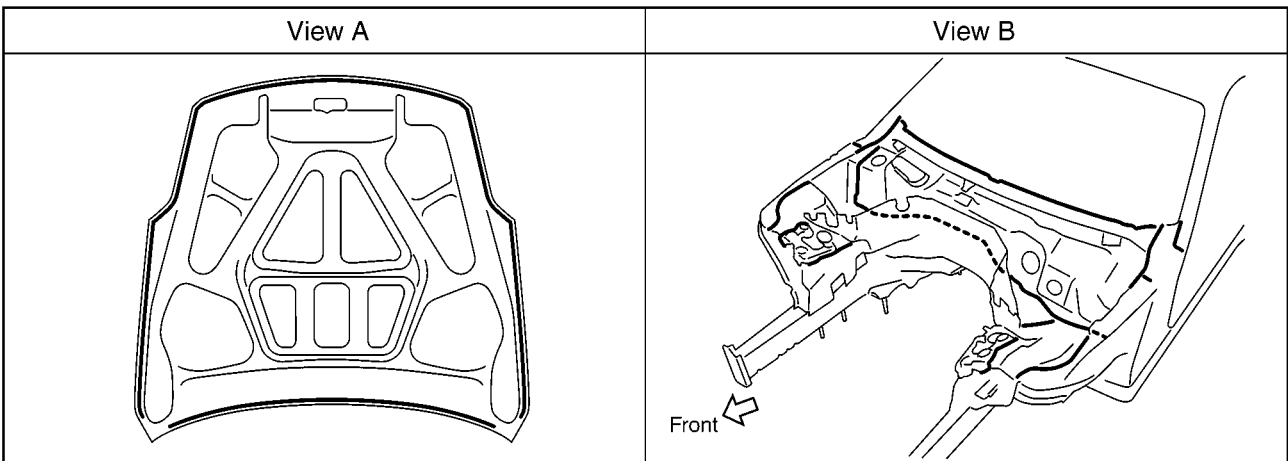
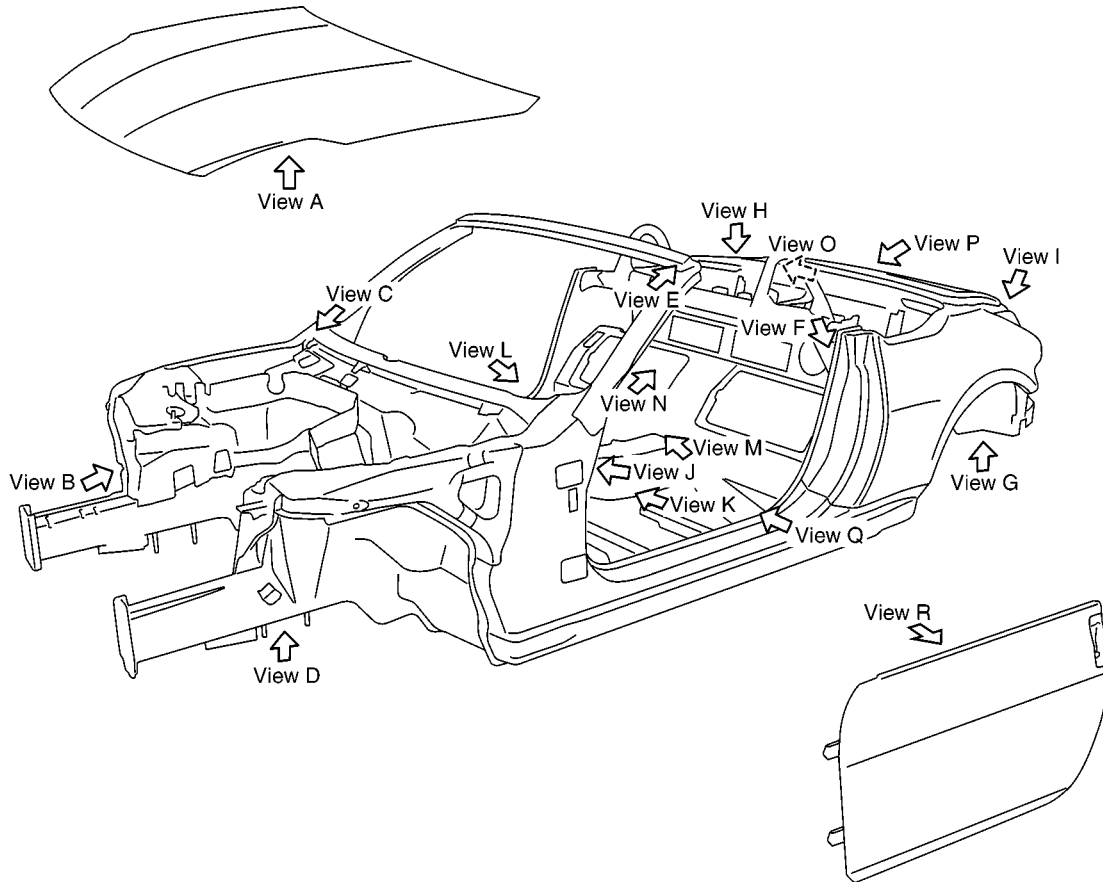

SIA2300E

BODY REPAIR

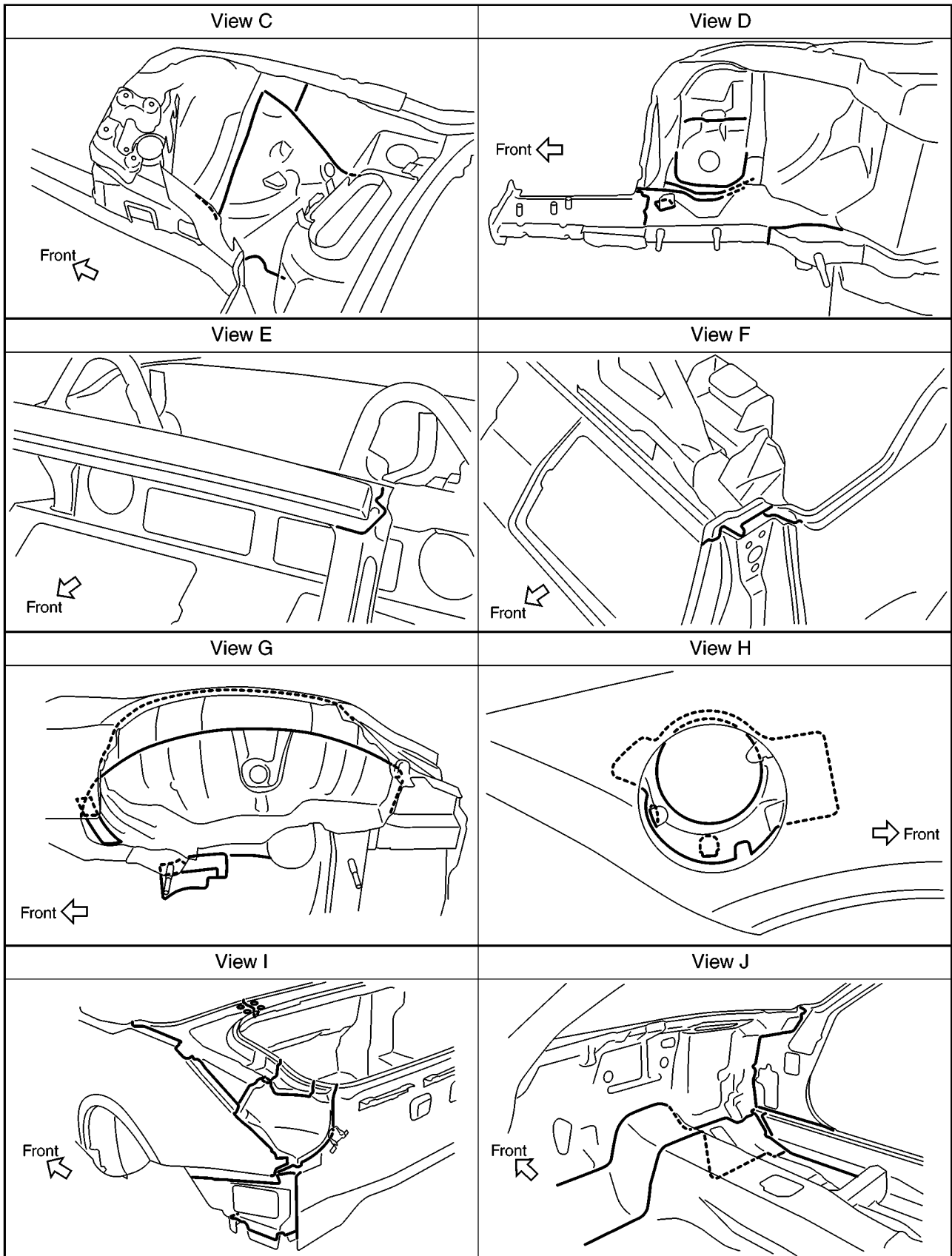

SIA2301E

BODY REPAIR

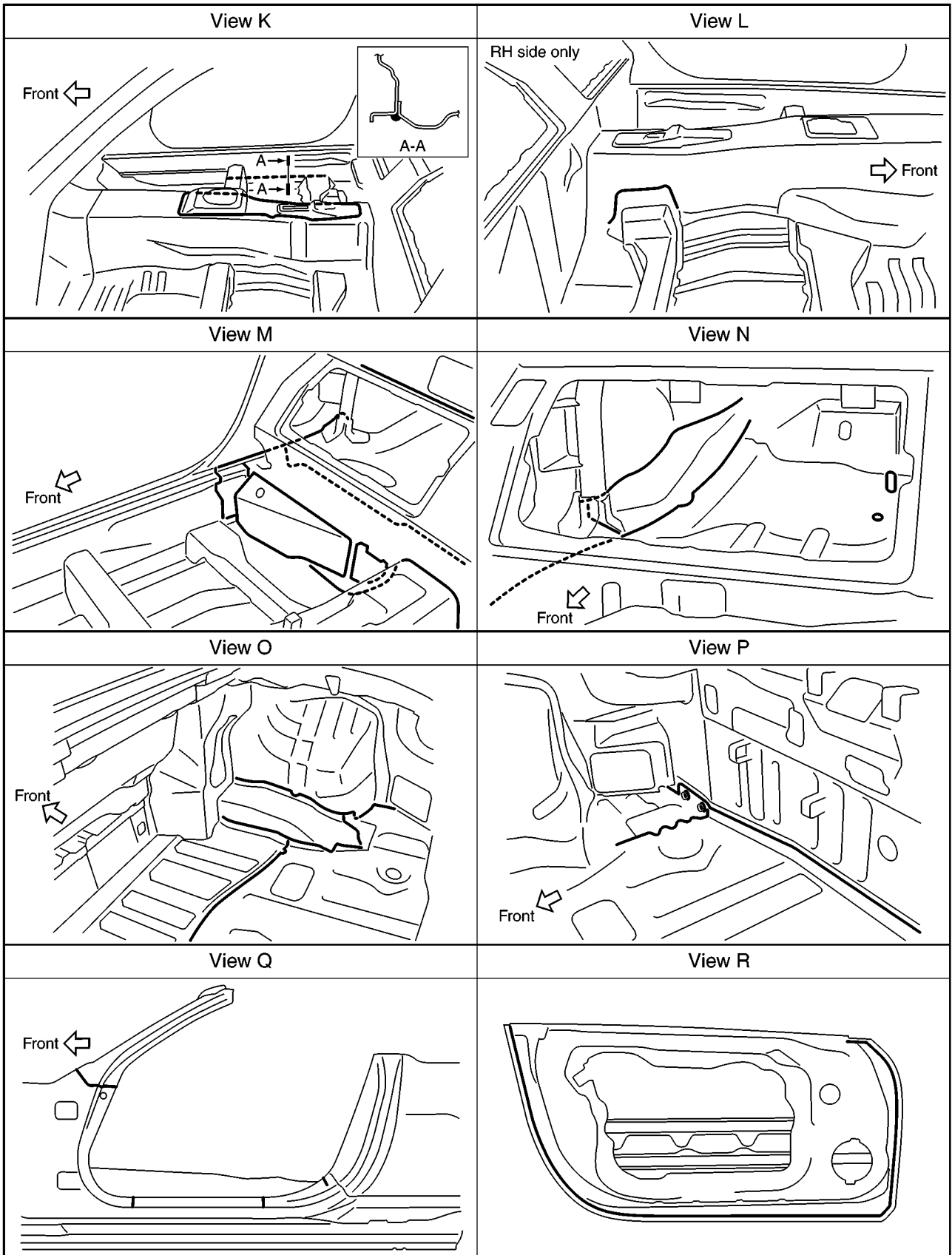

A
B
C
D
E
F
G
H
BL
J
K
L
M

SIIA2302E

BODY REPAIR

Body Construction (Coupe) BODY CONSTRUCTION

AIS0044L

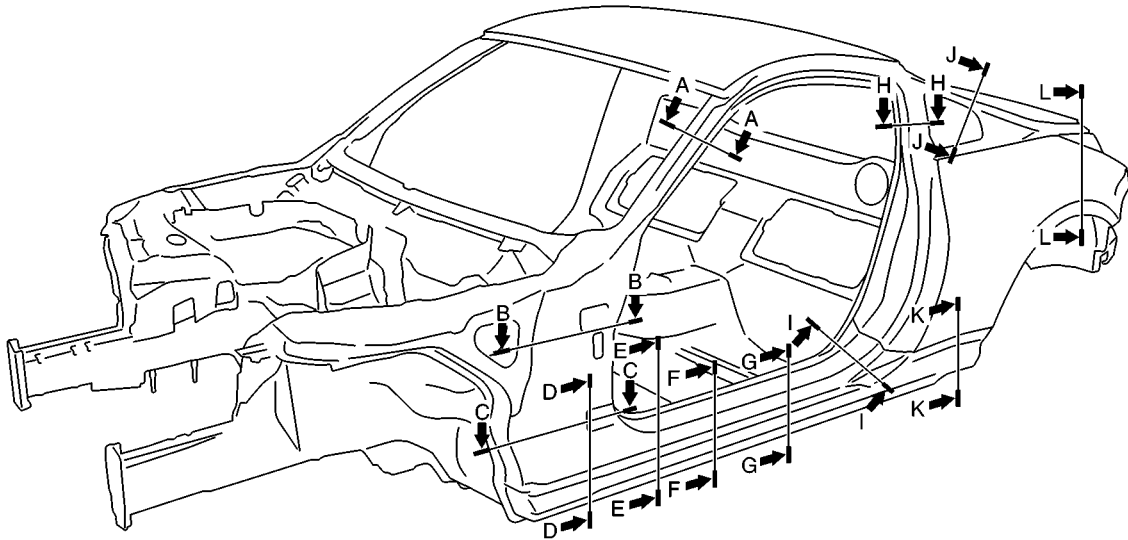

Section A-A	Section B-B	Section C-C	Section D-D
Section E-E	Section F-F	Section G-G	Section H-H
Section I-I	Section J-J	Section K-K	Section L-L

SIIA2362E

BODY REPAIR

Body Construction (Roadster) BODY CONSTRUCTION

AIS0044M

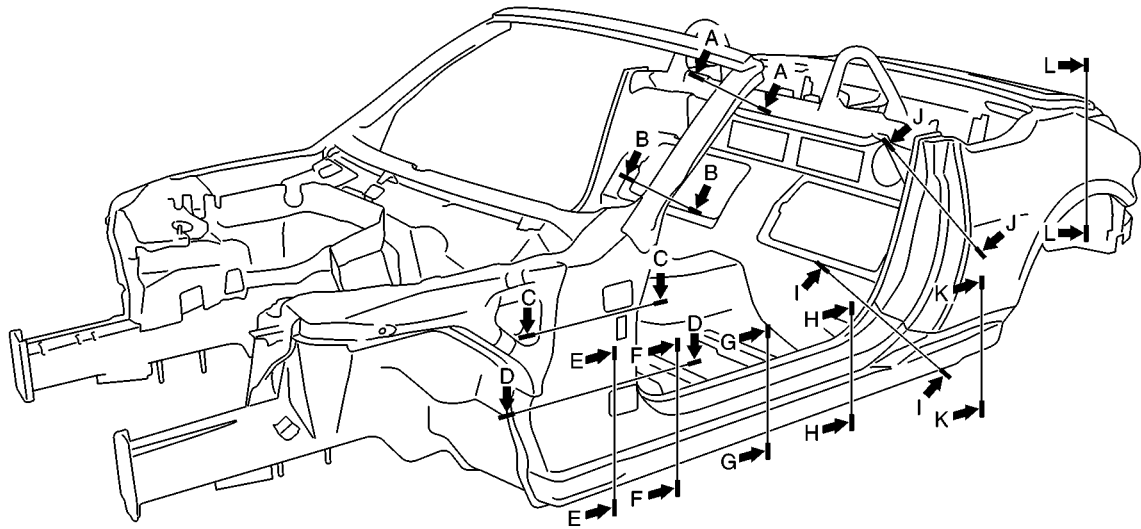

Section A-A	Section B-B	Section C-C	Section D-D
Section E-E	Section F-F	Section G-G	Section H-H
Section I-I	Section J-J	Section K-K	Section L-L

A
B
C
D
E
F
G
H
J
K
L
M

BL

SIIA2303E

BODY REPAIR

AIS0044N

Body Alignment (Coupe) BODY CENTER MARKS (COUPE)

A mark has been placed on each part of the body to indicate the vehicle center. When repairing parts damaged by an accident which might affect the vehicle frame (members, pillars, etc.), more accurate and effective repair will be possible by using these marks together with body alignment specifications.

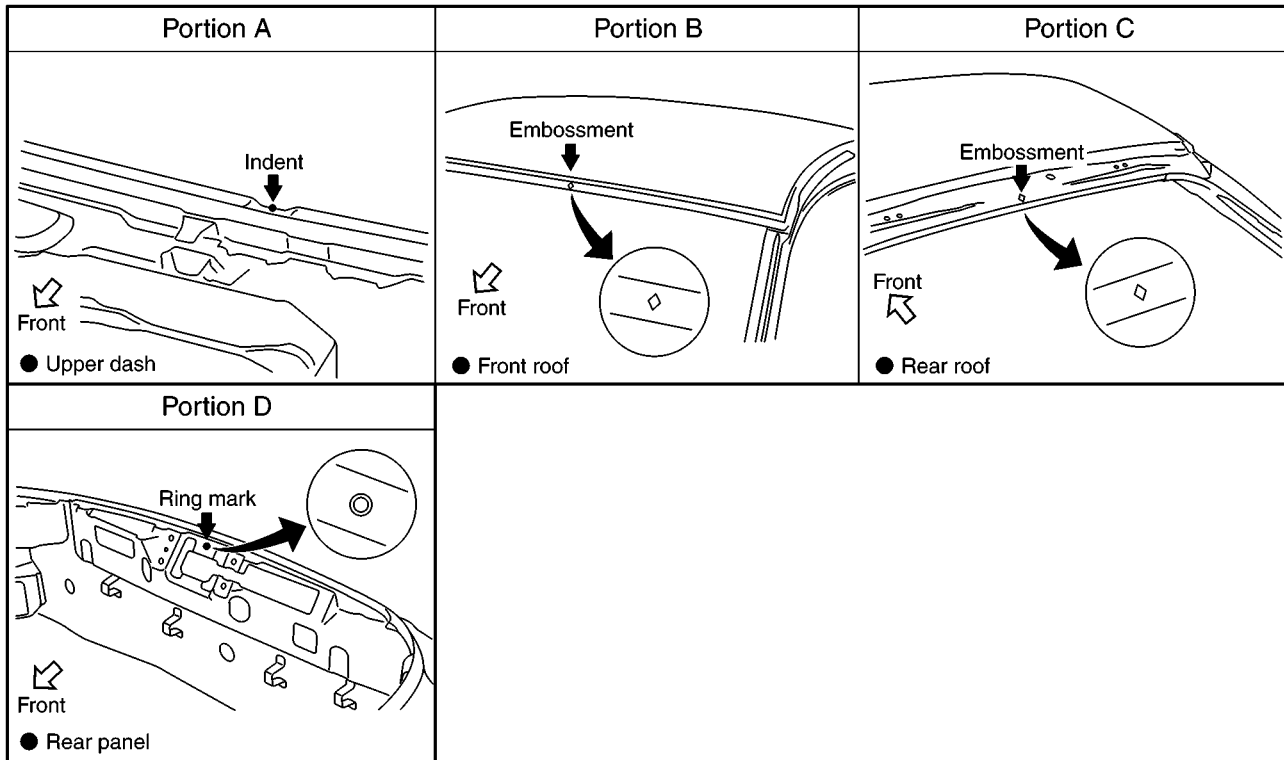
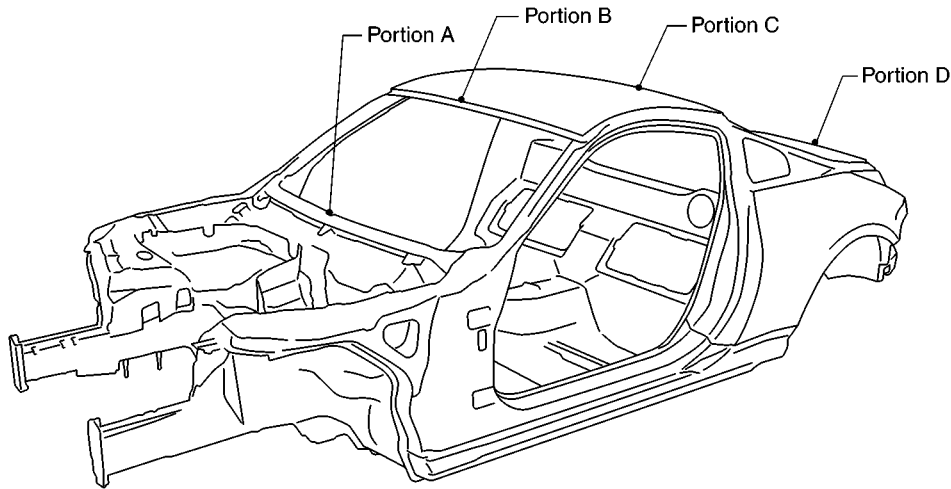

SIA1974E

BODY REPAIR

PANEL PARTS MATCHING MARKS (COUPE)

A mark has been placed on each body panel to indicate the parts matching positions. When repairing parts damaged by an accident which might affect the vehicle structure (members, pillars, etc.), more accurate and effective repair will be possible by using these marks together with body alignment specifications.

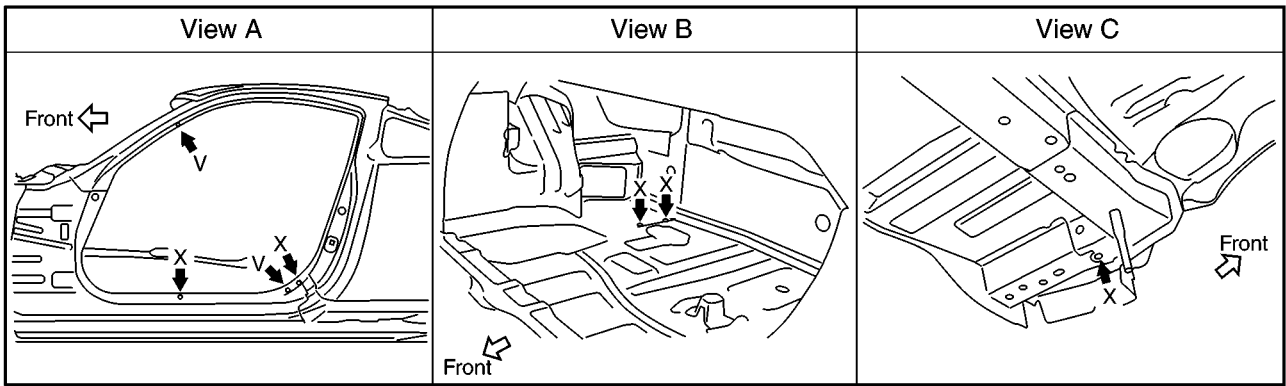
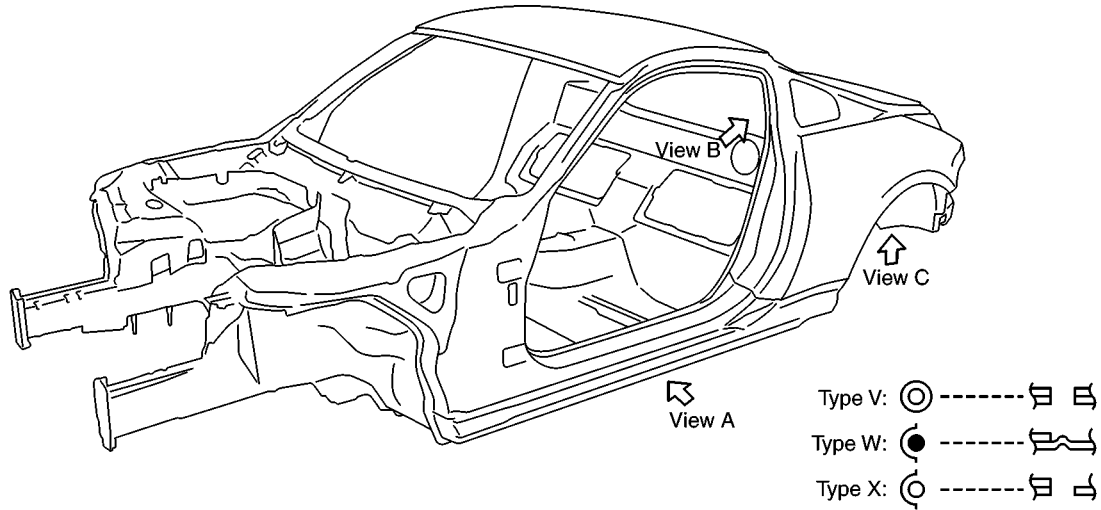

A
B
C
D
E
F
G
H
BL
J
K
L
M

SIA1981E

BODY REPAIR

DESCRIPTION

- All dimensions indicated in the figures are actual.
- When using a tracking gauge, adjust both pointers to equal length. Then check the pointers and gauge itself to make sure there is no free play.
- When a measuring tape is used, check to be sure there is no elongation, twisting or bending.
- Measurements should be taken at the center of the mounting holes.
- An asterisk (*) following the value at the measuring point indicates that the measuring point on the other side is symmetrically the same value.
- The coordinates of the measurement points are the distances measured from the standard line of "X", "Y" and "Z".

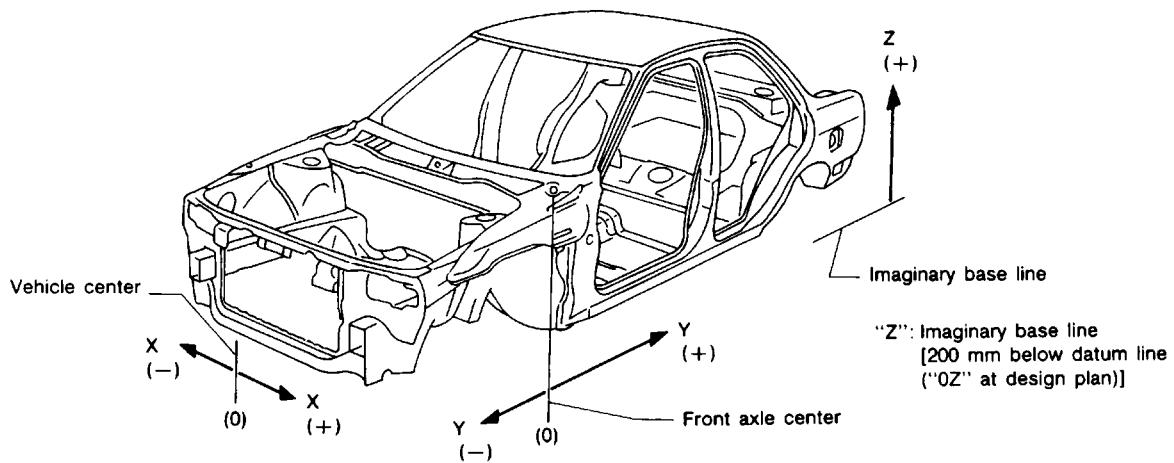

PIIA0104E

BODY REPAIR

ENGINE COMPARTMENT

Measurement

Figures marked with a (*) indicate symmetrically identical dimensions on both right and left hand sides of the vehicle.

Unit : mm

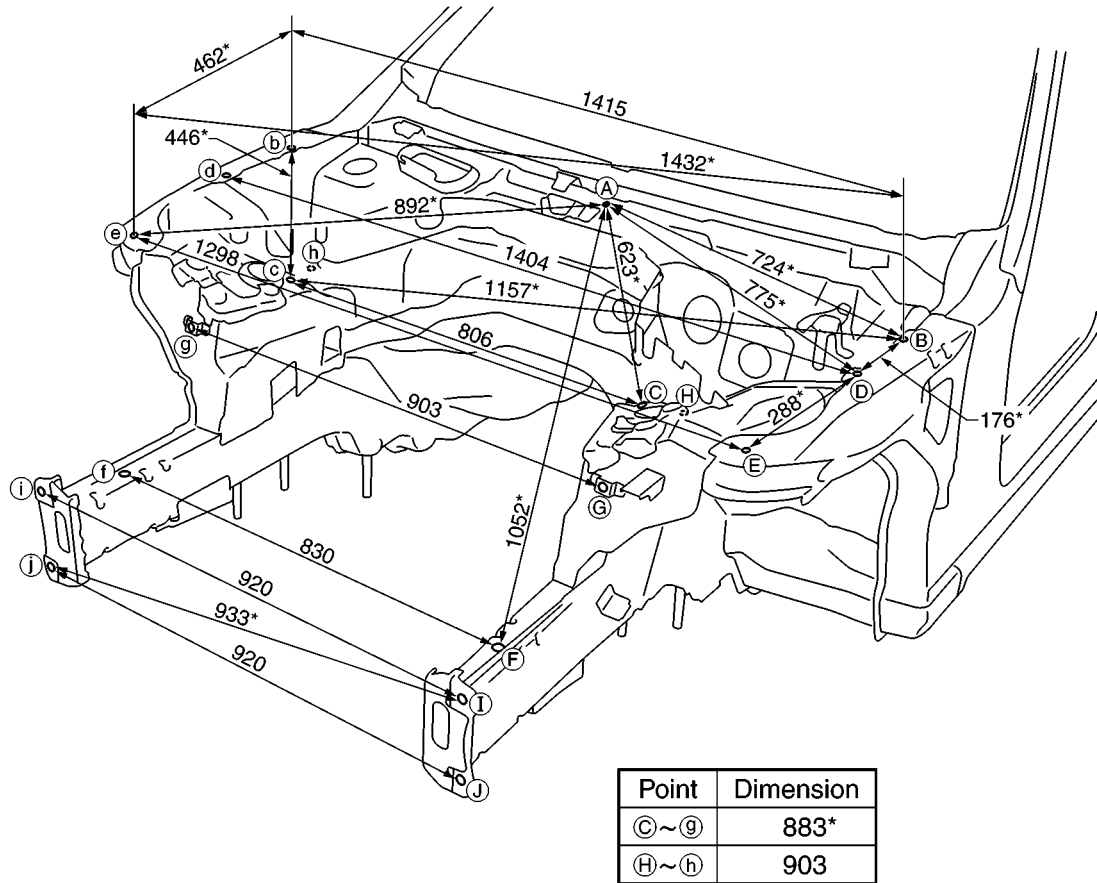

SIIA2306E

A
B
C
D
E
F
G
H
BL
J
K
L
M

BODY REPAIR

Measurement Points

(A) : Upper dash positioning mark center of center positioning mark

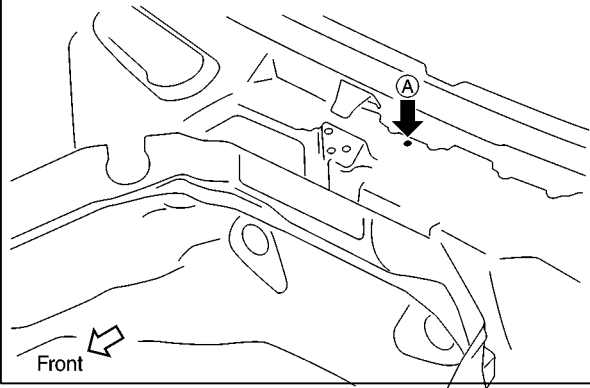

(B, b, D, d) : Front fender installing hole center (7dia.)

(C, c) : Front strut installing hole center (10dia.)

(E, e) : Radiator core support installing hole center (12dia.)

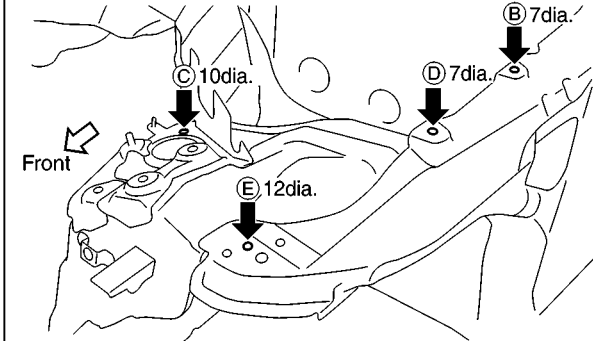

(F) : Front side member hole center (20dia.)

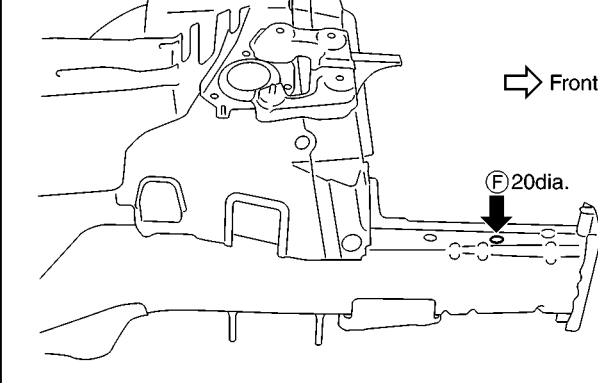

(f) : Front side member hole center (20dia.)

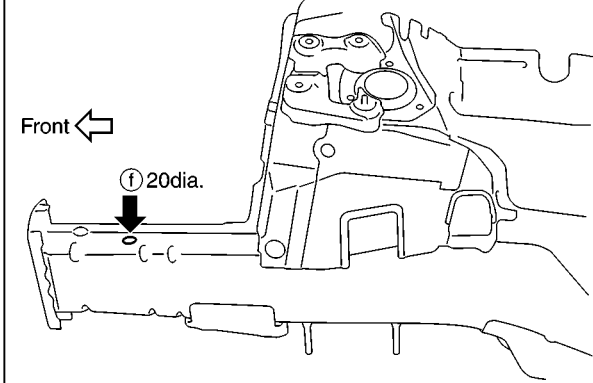

(G, g) : Nut holder hole center (16dia.)

(I, i, J, j) : Front bumper stay installing hole center (9dia.)

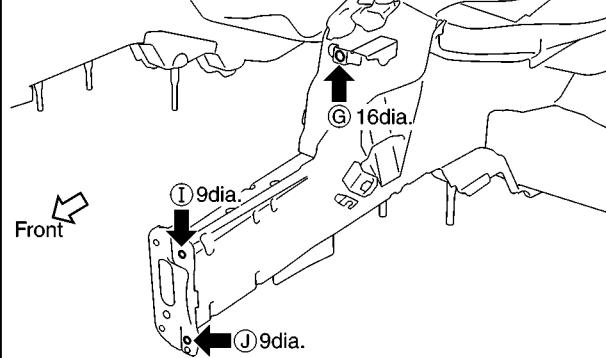

(H, h) : Nut holder hole center (16dia.)

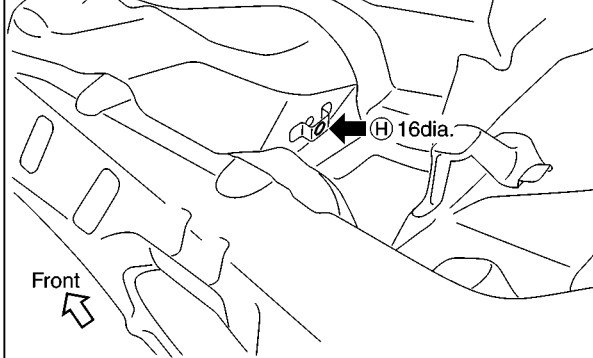

SIIA2307E

BODY REPAIR

UNDERBODY Measurement

Unit : mm

Figures marked with a (*) indicate symmetrically identical dimensions on both right and left hand sides of the vehicle.

★ : Bolt head

All dimensions indicated in this figure are actual.

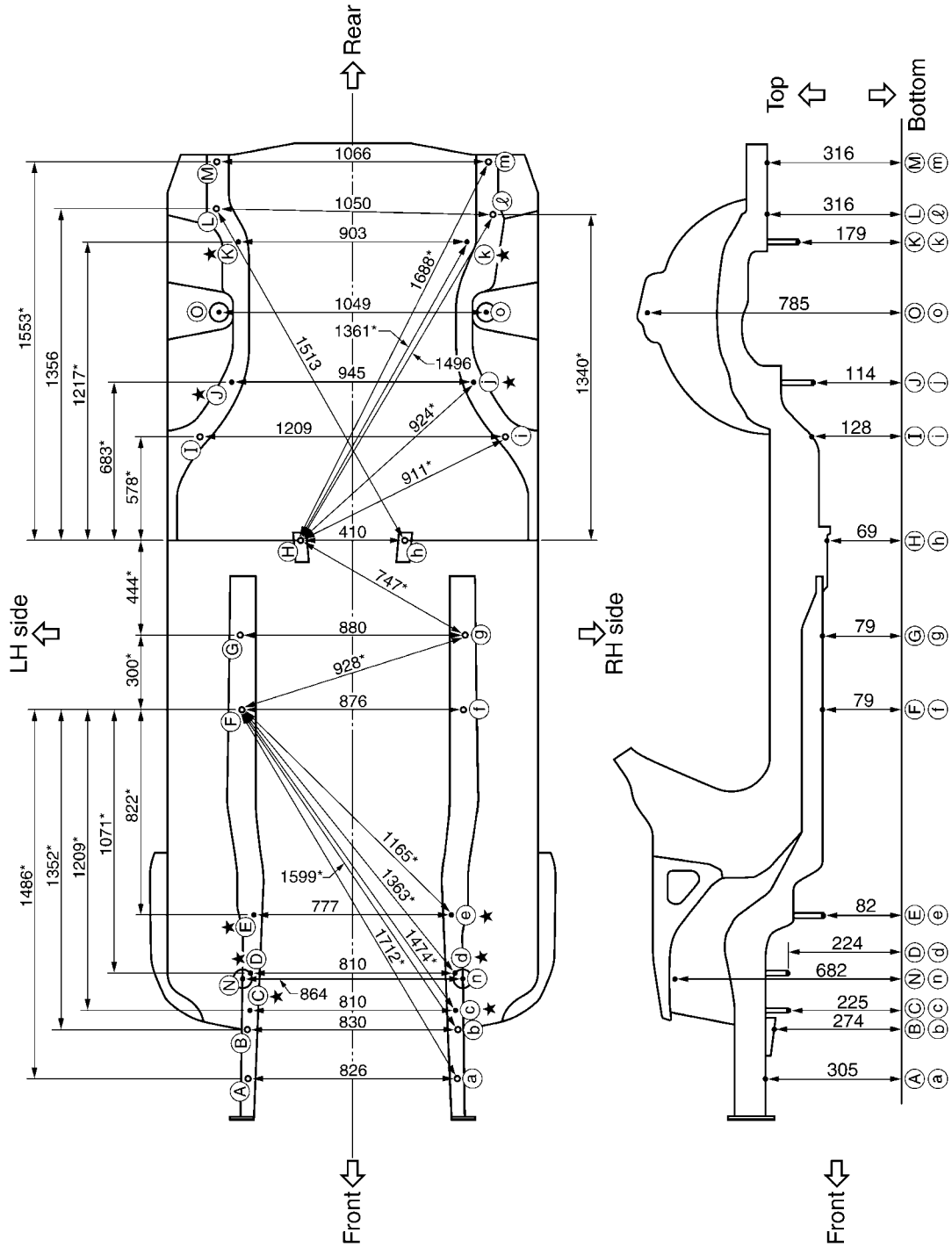

A
B
C
D
E
F
G
H
BL
J
K
L
M

BODY REPAIR

Measurement Points

Unit : mm

As viewed from underside.

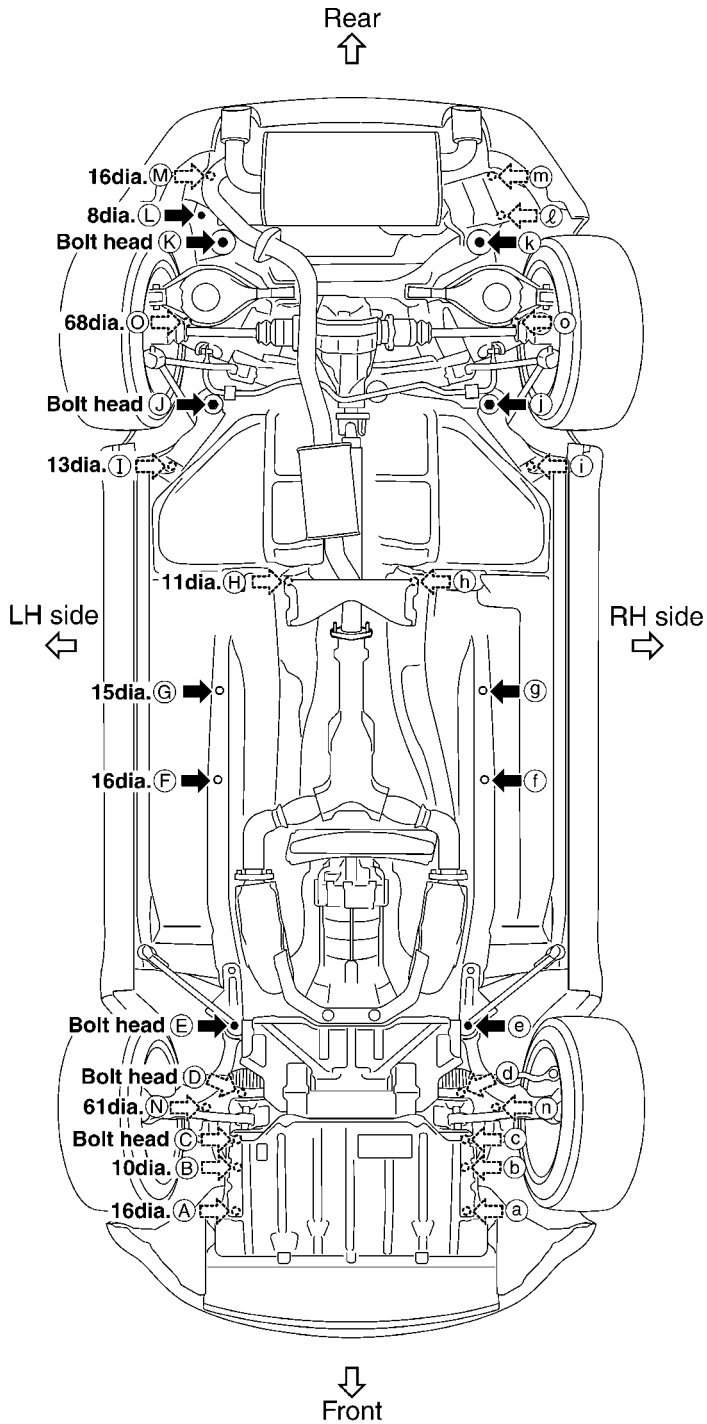

Coordinates:

(A), a	(I), i
X:413	X:605
Y:-368	Y:2191
Z:305	Z:128
(B), b	(J), j
X:415	X:473
Y:-238	Y:2404
Z:274	Z:114
(C), c	(K), k
X:405	X:452
Y:-100	Y:2964
Z:225	Z:179
(D), d	(L)
X:405	X:550
Y:39	Y:3065
Z:224	Z:316
(E), e	(l)
X:388	X:-500
Y:279	Y:3073
Z:82	Z:316
(F), f	(M), m
X:438	X:533
Y:1100	Y:3275
Z:79	Z:316
(G), g	
X:440	
Y:1400	
Z:79	
(H), h	
X:205	
Y:1777	
Z:69	

Front and rear strut tower centers

Coordinates:

(N), n
X:432
Y:28
Z:682

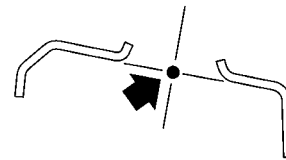

(O), o
X:524
Y:2682
Z:785

Front: (N), (n) 61dia.
Rear: (O), (o) 68dia.

SIIA2348E

BODY REPAIR

PASSENGER COMPARTMENT (COUPE)

Measurement

Unit : mm

Figures marked with a (*) indicate symmetrically identical dimensions on both right and left hand sides of the vehicle.

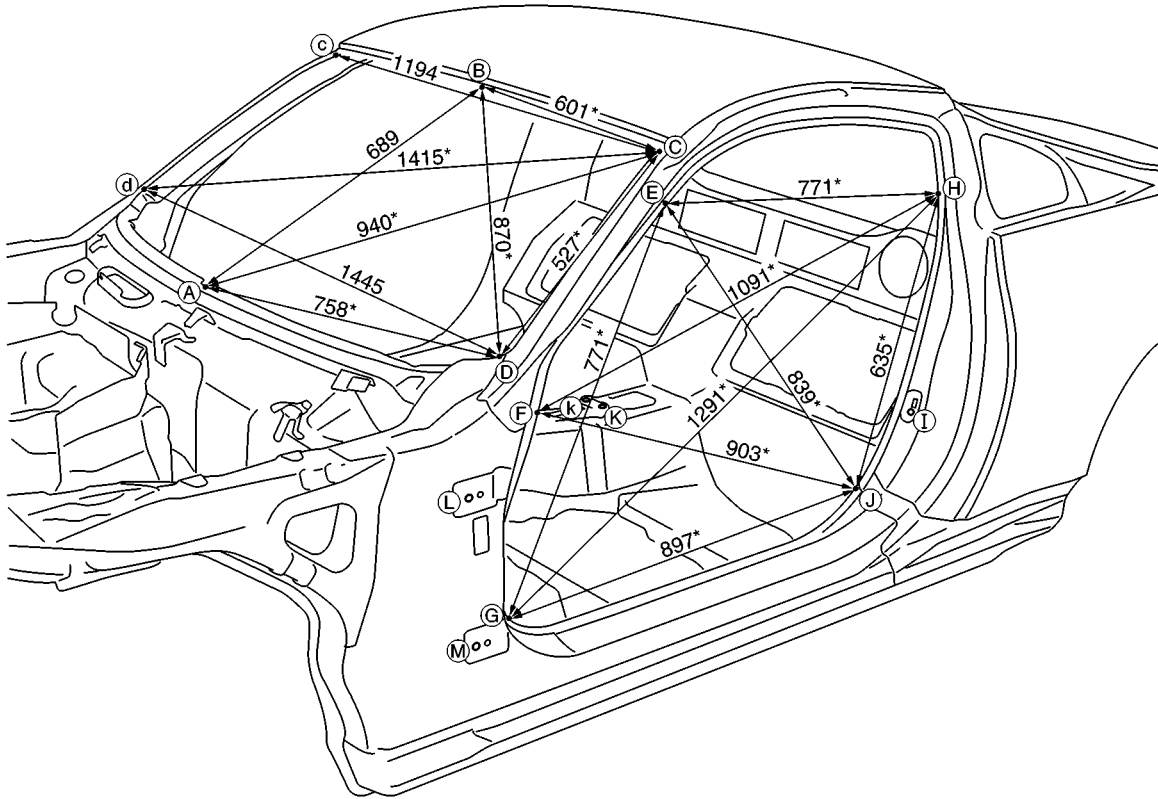

Point	Dimension	Point	Dimension	Point	Dimension
⑤~⑤	1,317	⑧~⑧	1,909*	①~②	1,052*
⑤~⑥	1,583*	⑧~⑩	1,707*	①~③	1,043*
⑤~⑧	1,546*	⑨~⑧	1,363	①~④	956*
⑤~⑩	1,618*	⑨~⑩	1,543*	①~⑤	715*
②~②	1,440	⑩~⑩	1,452	③~④	1,178*
②~③	1,452	①~⑤	993*	④~④	1,181*

SIIA1988E

BODY REPAIR

Measurement Points

(A) : Upper dash crossmember indent of center positioning mark

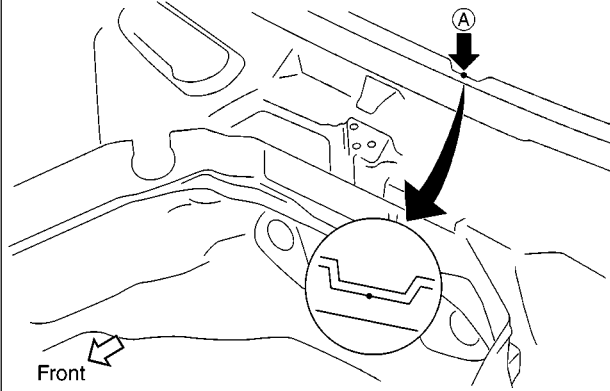

(B) : Front roof flange end of center positioning mark

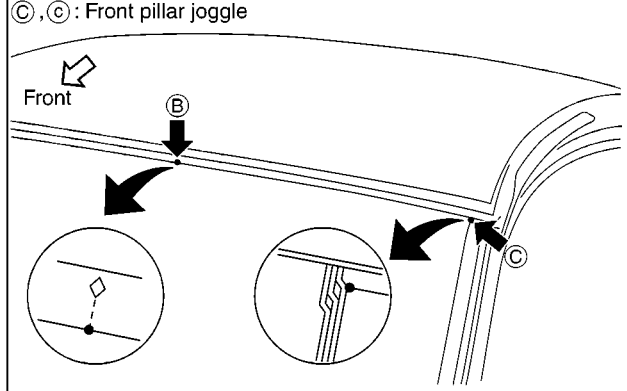

(D) , (d) : Front pillar hinge brace joggle

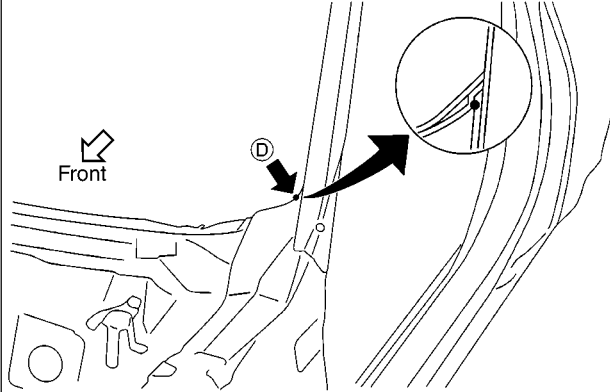

(E) , (e) : Front pillar hole center (6dia.)

(F) , (f) : Front pillar hinge brace joggle

(G) , (g) : Front pillar hinge brace ring mark flange end

(L) , (l) , (M) , (m) : Door hinge installing hole center (12dia.)

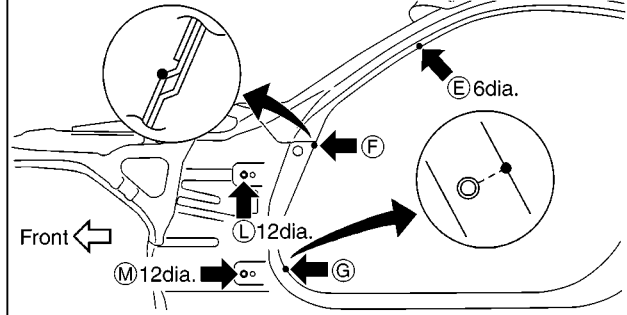

(H) , (h) : Rear fender hole flange end

(I) , (i) : Door switch installing hole center (9dia.)

(J) , (j) : Outer sill extension joggle

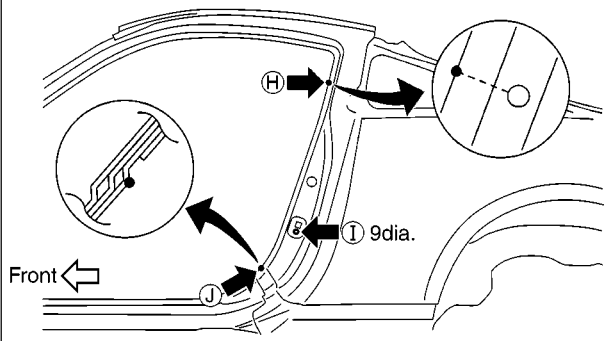

(K) , (k) : Air bag sensor bracket installing hole center (7dia.)

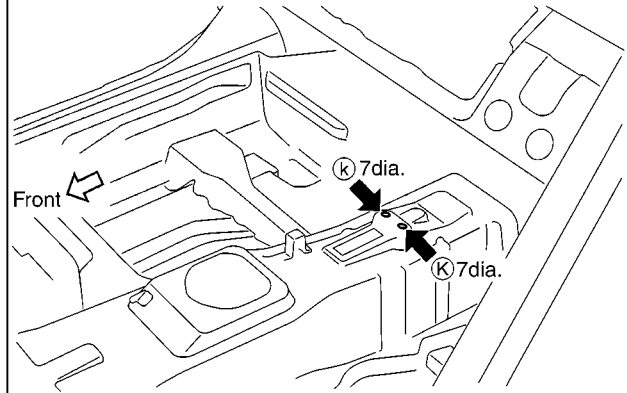

SIIA2351E

BODY REPAIR

REAR BODY (COUPE)

Measurement

Figures marked with a (*) indicate symmetrically identical dimensions on both right and left hand sides of the vehicle.

Unit : mm

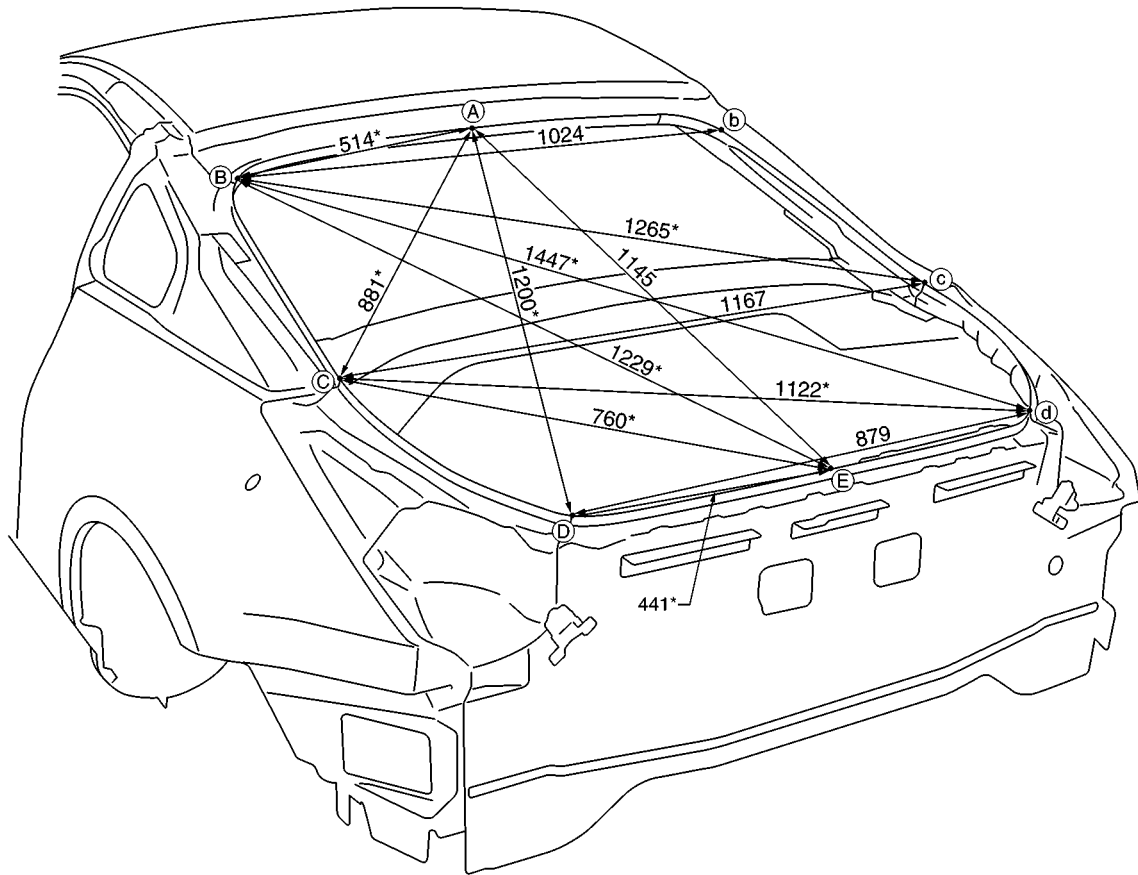

A
B
C
D
E
F
G
H
BL
J
K
L
M

SIA1990E

BODY REPAIR

Measurement Points

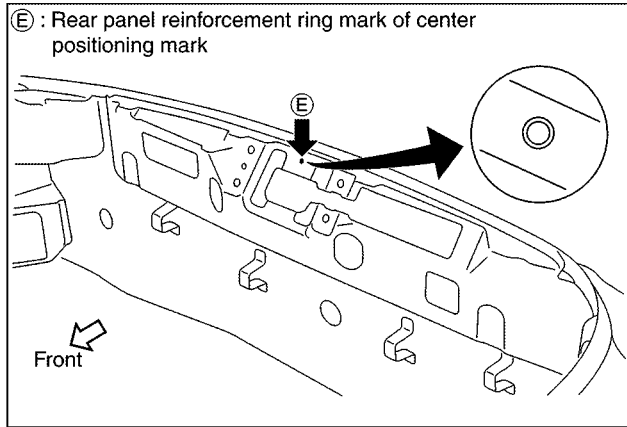
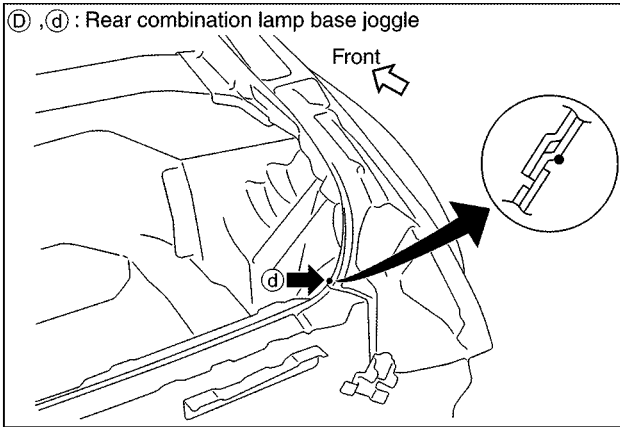
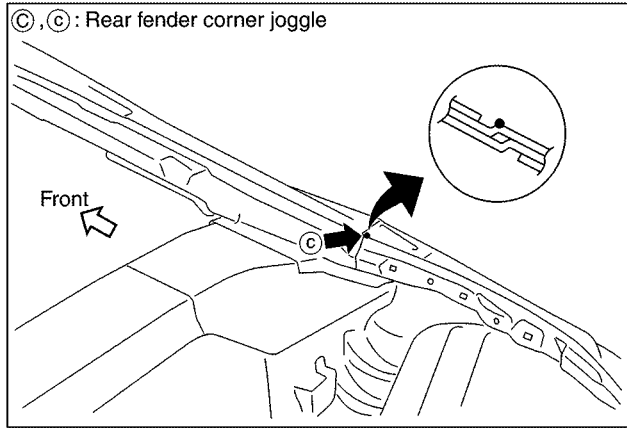
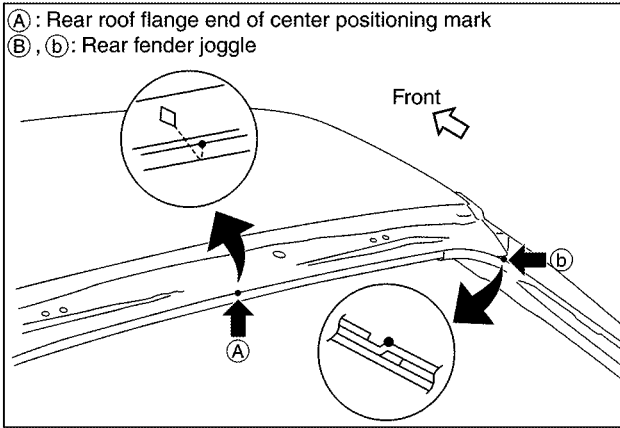

SIA1991E

BODY REPAIR

Body Alignment (Roadster) BODY CENTER MARKS (ROADSTER)

AIS006VN

A mark has been placed on each part of the body to indicate the vehicle center. When repairing parts damaged by an accident which might affect the vehicle frame (members, pillars, etc.), more accurate and effective repair will be possible by using these marks together with body alignment specifications.

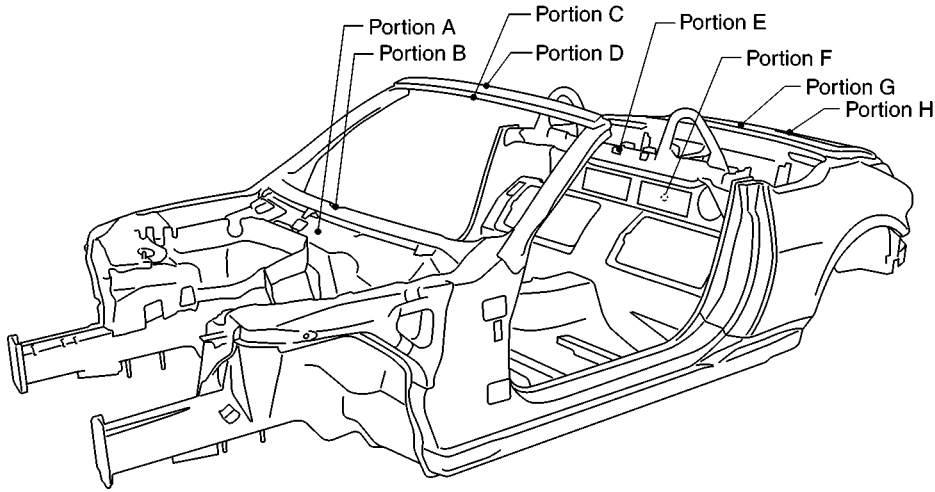

Portion A,B	Portion C,D	Portion E,F,G	
<p>Indent</p> <p>Embossment</p> <p>Front</p> <ul style="list-style-type: none"> ● Upper dash 	<p>Front</p> <p>Embossment</p> <p>Embossment</p> <ul style="list-style-type: none"> ● Roof 	<p>Hole 4dia.</p> <p>Hole 8dia.</p> <p>Embossment</p> <p>Front</p> <ul style="list-style-type: none"> ● Guard frame ● Inside step panel ● Rear waist 	
<th data-bbox="151 1207 582 1255">Portion H</th> <td data-bbox="582 1207 1444 1583"></td>		Portion H	
<p>Ring mark</p> <p>Front</p> <ul style="list-style-type: none"> ● Rear panel 			

SIA2304E

BODY REPAIR

PANEL PARTS MATCHING MARKS (ROADSTER)

A mark has been placed on each body panel to indicate the parts matching positions. When repairing parts damaged by an accident which might affect the vehicle structure (members, pillars, etc.), more accurate and effective repair will be possible by using these marks together with body alignment specifications.

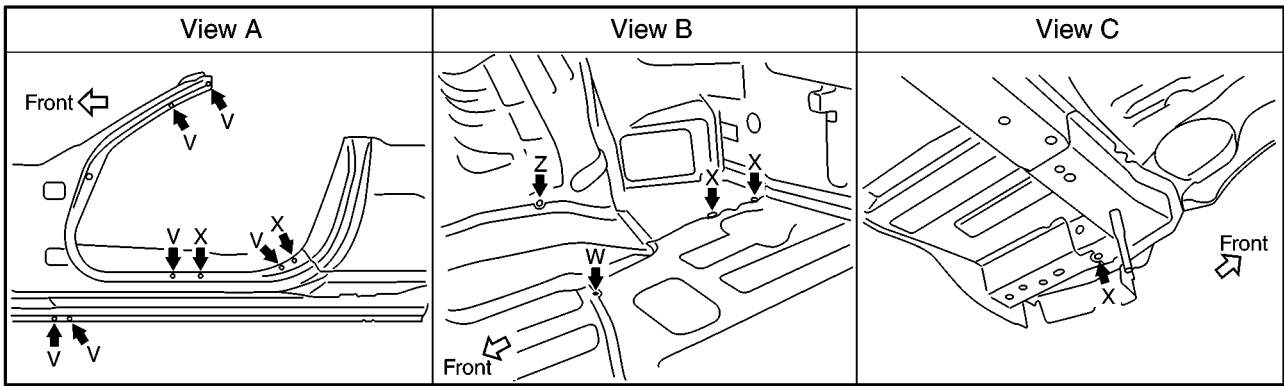
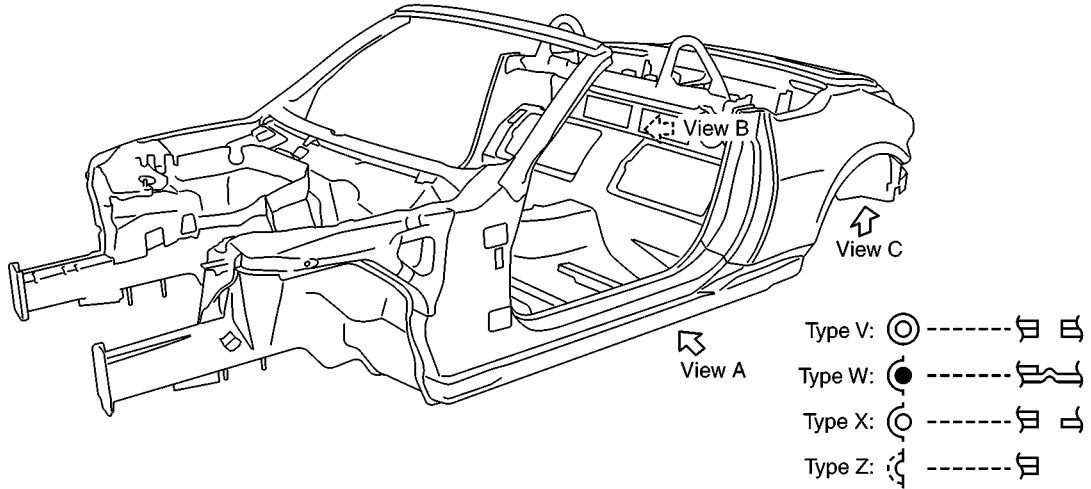

SIA2305E

BODY REPAIR

DESCRIPTION

- All dimensions indicated in the figures are actual.
- When using a tracking gauge, adjust both pointers to equal length. Then check the pointers and gauge itself to make sure there is no free play.
- When a measuring tape is used, check to be sure there is no elongation, twisting or bending.
- Measurements should be taken at the center of the mounting holes.
- An asterisk (*) following the value at the measuring point indicates that the measuring point on the other side is symmetrically the same value.
- The coordinates of the measurement points are the distances measured from the standard line of "X", "Y" and "Z".

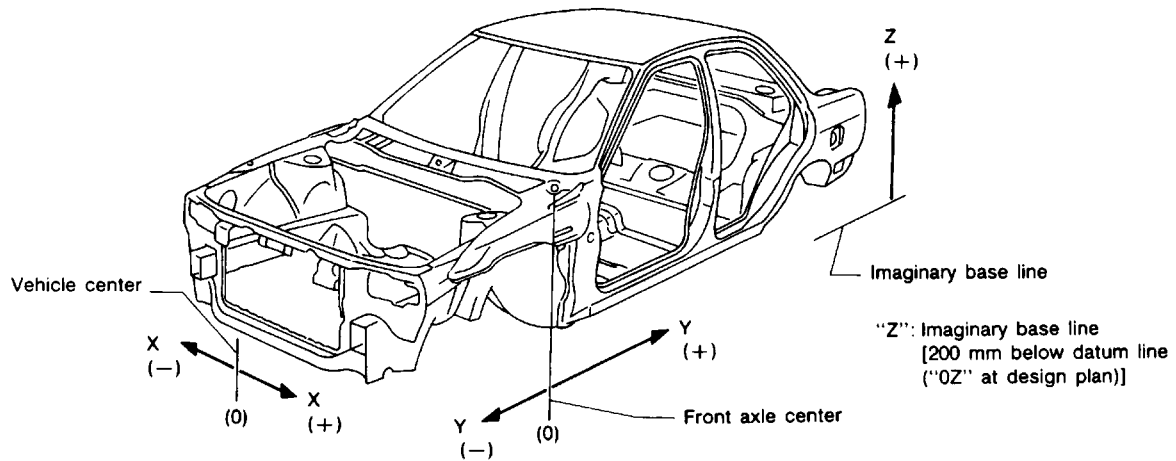

PIIA0104E

A
B
C
D
E
F
G
H
J
K
L
M

BL

BODY REPAIR

ENGINE COMPARTMENT

Measurement

Figures marked with a (*) indicate symmetrically identical dimensions on both right and left hand sides of the vehicle.

Unit : mm

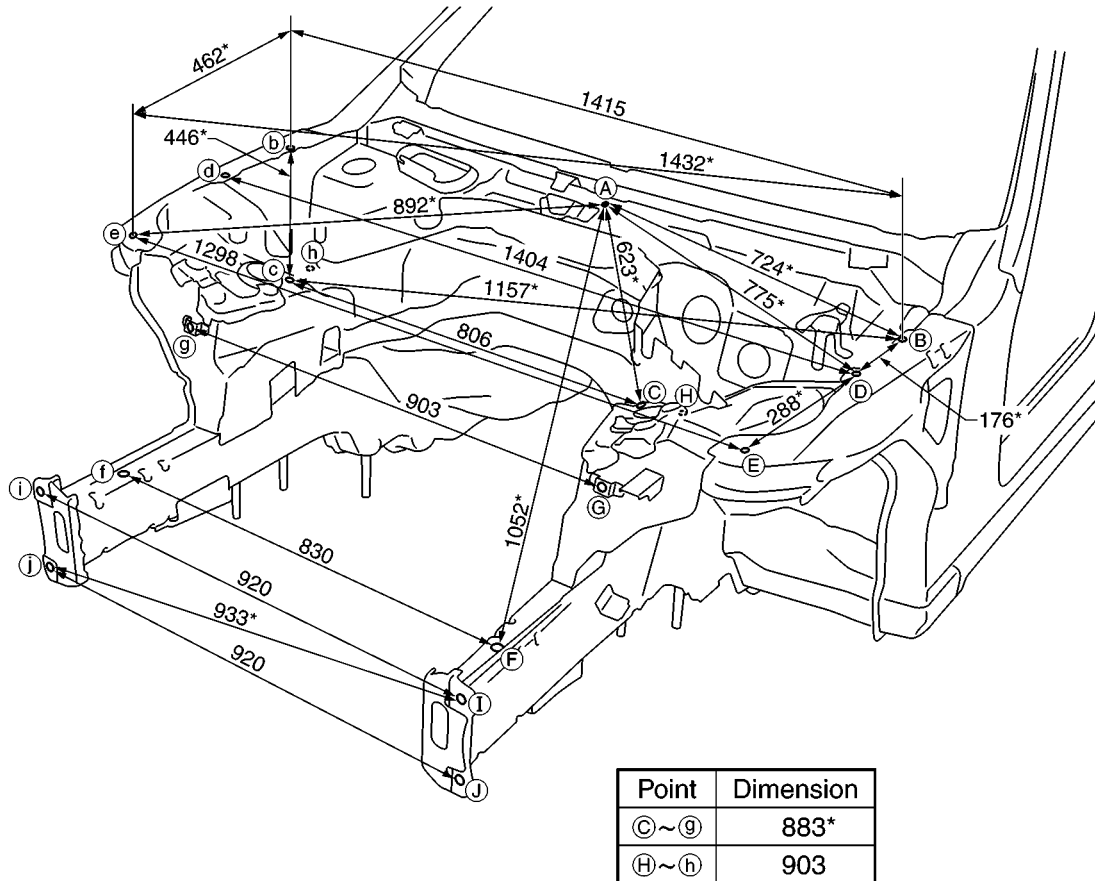

SIIA2306E

BODY REPAIR

Measurement Points

(A) : Upper dash positioning mark center of center positioning mark

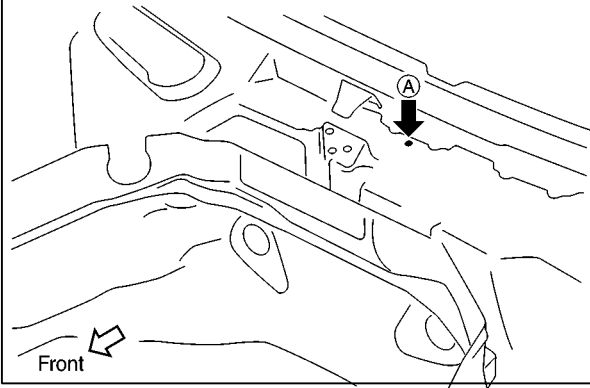

(B, b, D, d) : Front fender installing hole center (7dia.)
 (C, c) : Front strut installing hole center (10dia.)
 (E, e) : Radiator core support installing hole center (12dia.)

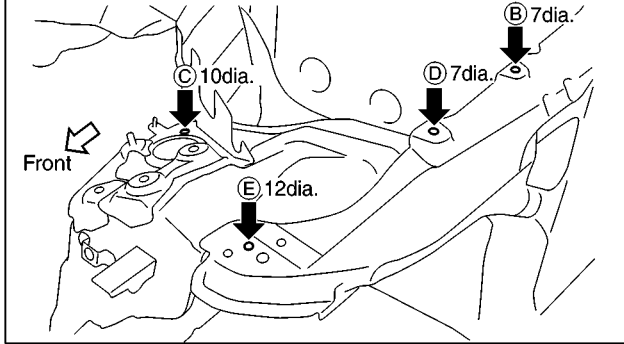

(F) : Front side member hole center (20dia.)

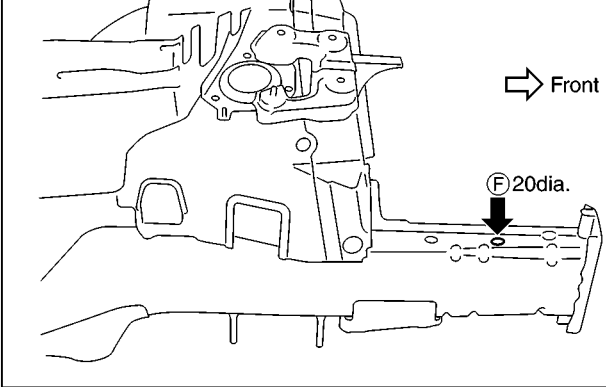

(f) : Front side member hole center (20dia.)

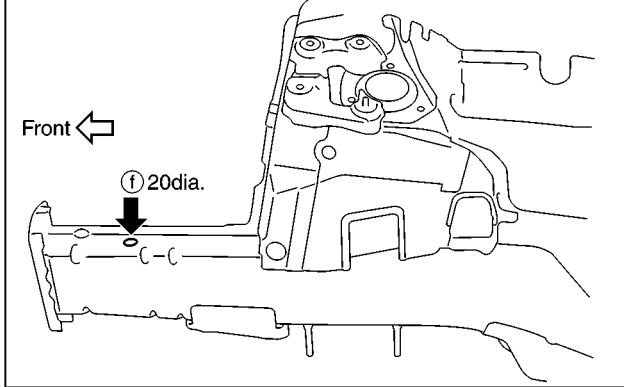

(G, g) : Nut holder hole center (16dia.)
 (I, i, J, j) : Front bumper stay installing hole center (9dia.)

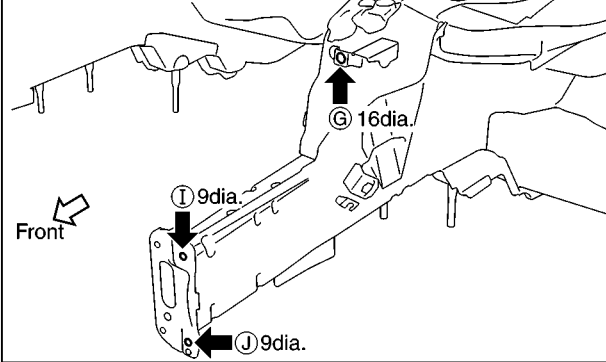

(H, h) : Nut holder hole center (16dia.)

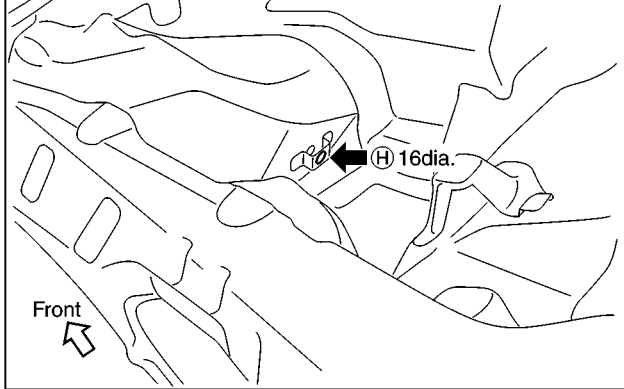

A
B
C
D
E
F
G
H
BL
J
K
L
M

SIIA2307E

BODY REPAIR

UNDERBODY Measurement

Unit : mm

Figures marked with a (*) indicate symmetrically identical dimensions on both right and left hand sides of the vehicle.

As viewed from underside.

★ : Bolt head

All dimensions indicated in this figure are actual.

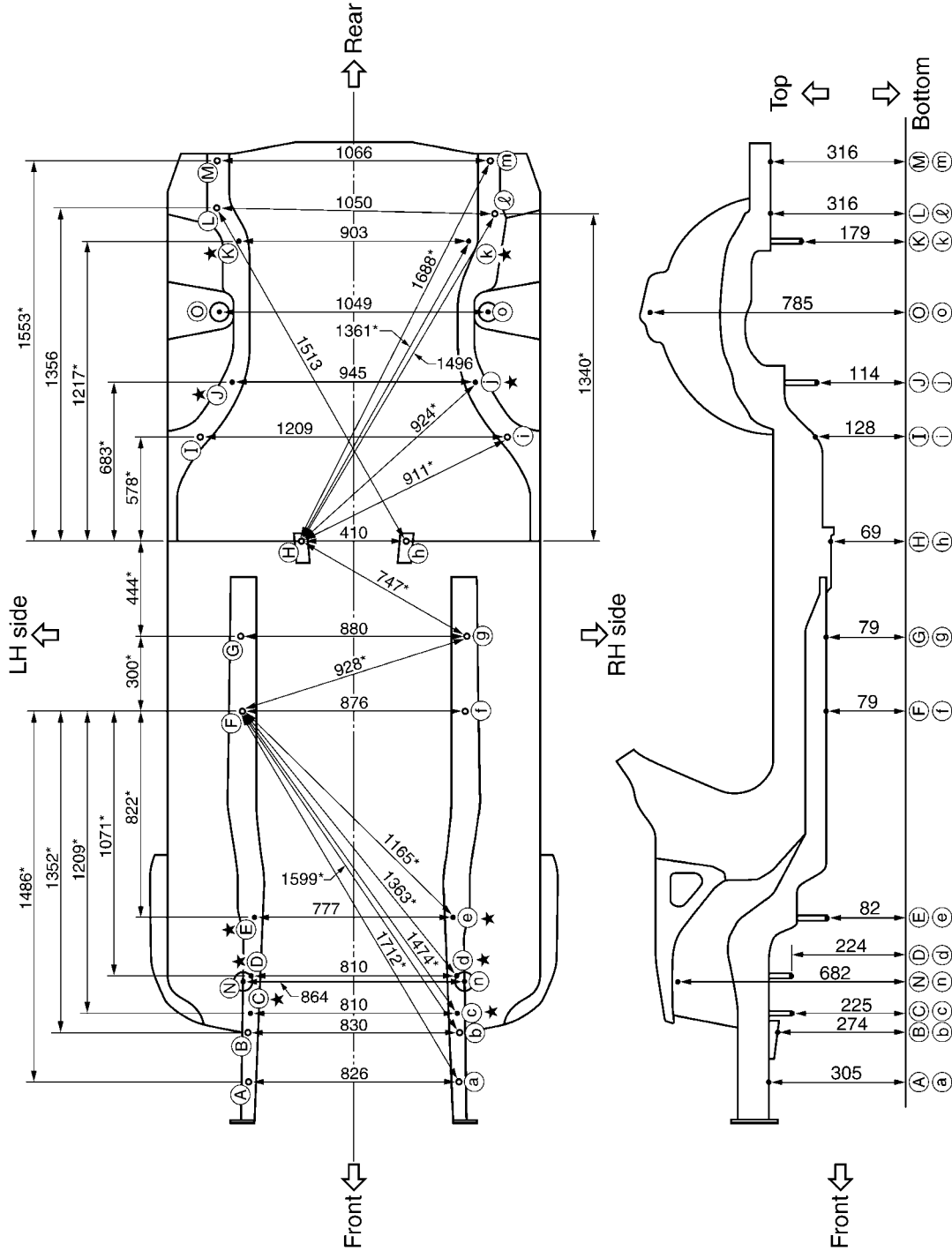

SIIA2347E

BODY REPAIR

Measurement Points

Unit : mm

As viewed from underside.

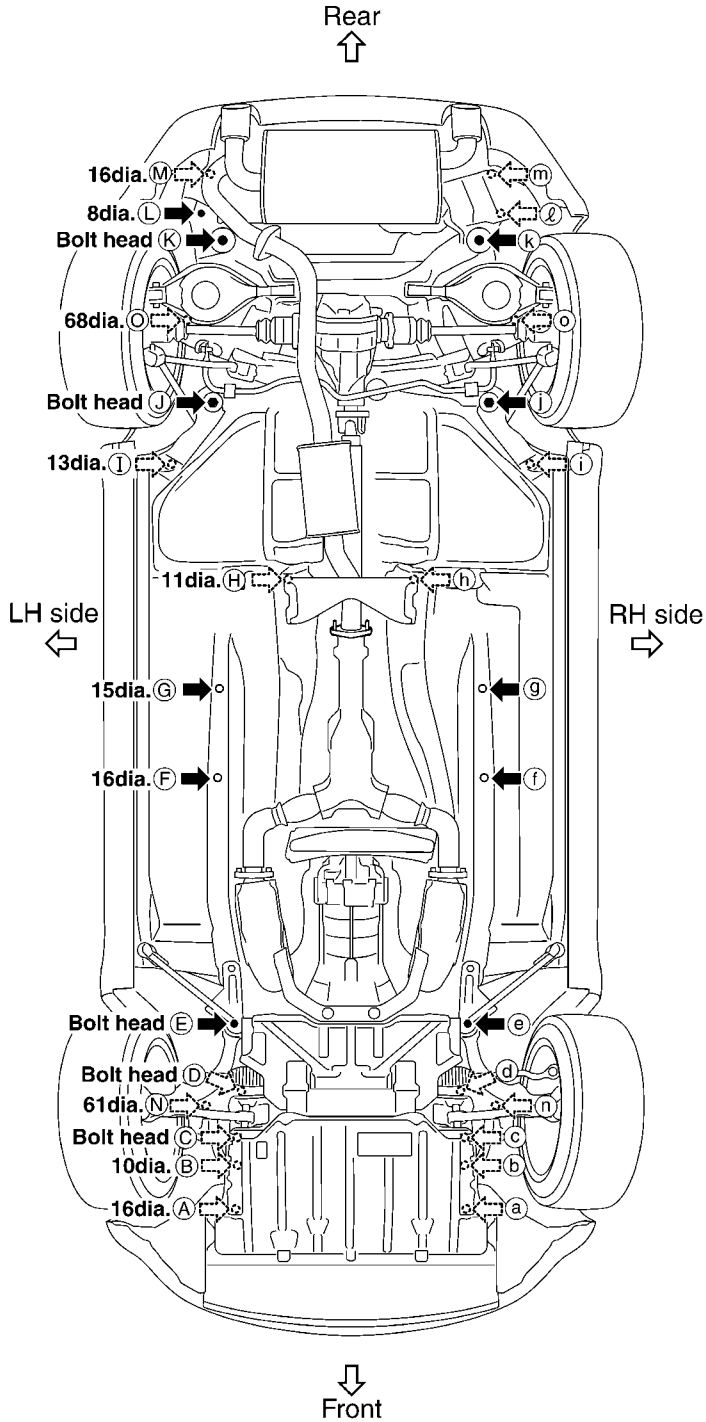

Coordinates:

(A), (a)	(I), (i)
X:413	X:605
Y:-368	Y:2191
Z:305	Z:128
(B), (b)	(J), (j)
X:415	X:473
Y:-238	Y:2404
Z:274	Z:114
(C), (c)	(K), (k)
X:405	X:452
Y:-100	Y:2964
Z:225	Z:179
(D), (d)	(L)
X:405	X:550
Y:39	Y:3065
Z:224	Z:316
(E), (e)	(l)
X:388	X:-500
Y:279	Y:3073
Z:82	Z:316
(F), (f)	(M), (m)
X:438	X:533
Y:1100	Y:3275
Z:79	Z:316
(G), (g)	
X:440	
Y:1400	
Z:79	
(H), (h)	
X:205	
Y:1777	
Z:69	

Front and rear strut tower centers

Coordinates:

(N), (n)
X:432
Y:28
Z:682

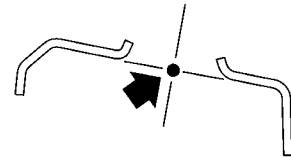

(O), (o)
X:524
Y:2682
Z:785

Front: (N), (n) 61dia.
Rear: (O), (o) 68dia.

SIIA2348E

BODY REPAIR

PASSENGER COMPARTMENT (ROADSTER)

Measurement

Unit : mm

Figures marked with a (*) indicate symmetrically identical dimensions on both right and left hand sides of the vehicle.

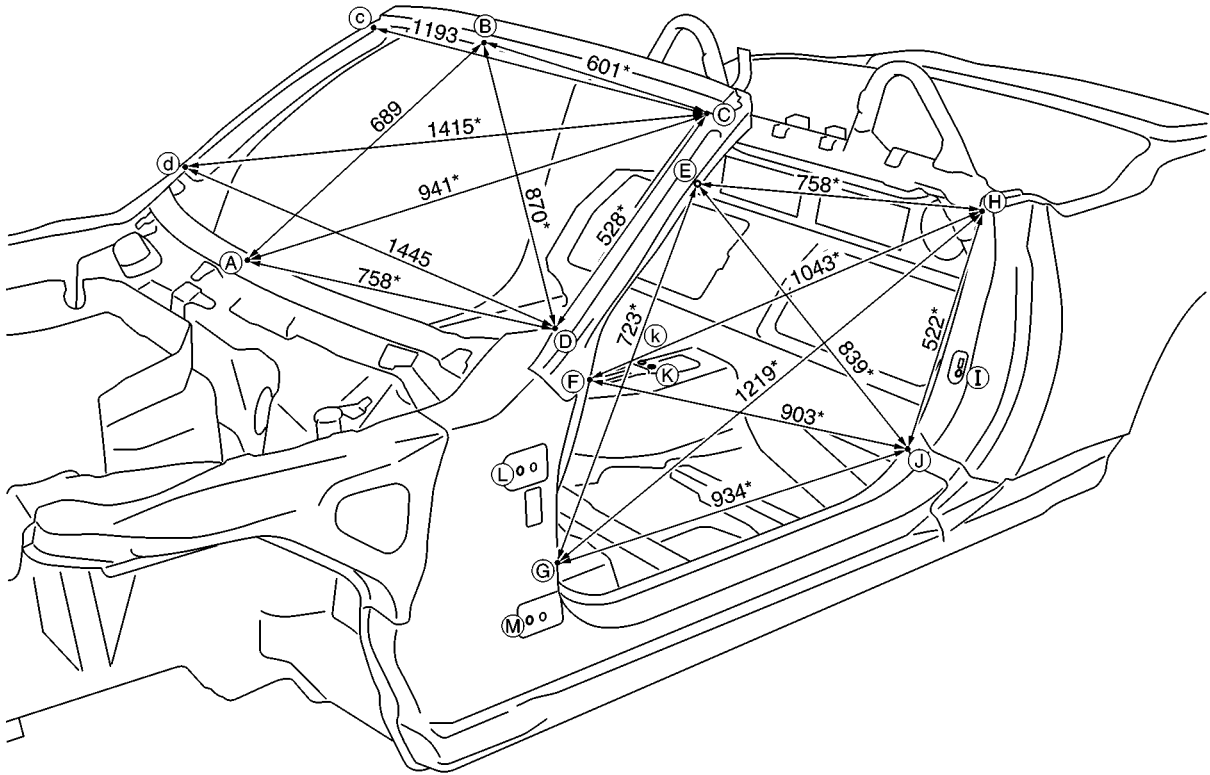

Point	Dimension	Point	Dimension	Point	Dimension
E~e	1,317	G~h	1,882*	K~F	1,052*
E~g	1,561*	G~J	1,727*	K~G	1,071*
E~h	1,563*	H~h	1,417	K~H	902*
E~j	1,618*	H~J	1,527*	K~J	715*
F~f	1,440	J~J	1,452	L~I	1,178*
G~g	1,452	K~E	993*	M~I	1,181*

SIA2308E

BODY REPAIR

Measurement Points

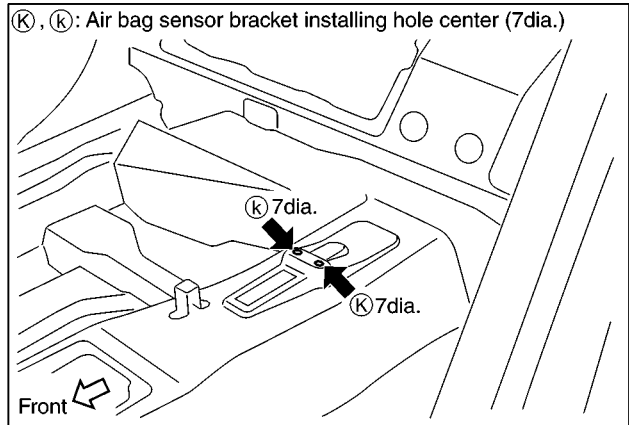
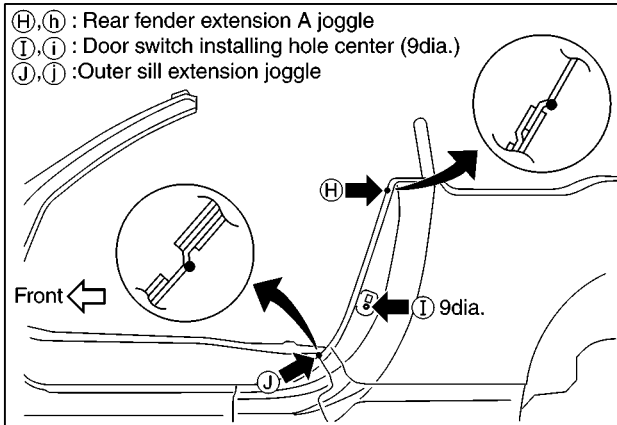
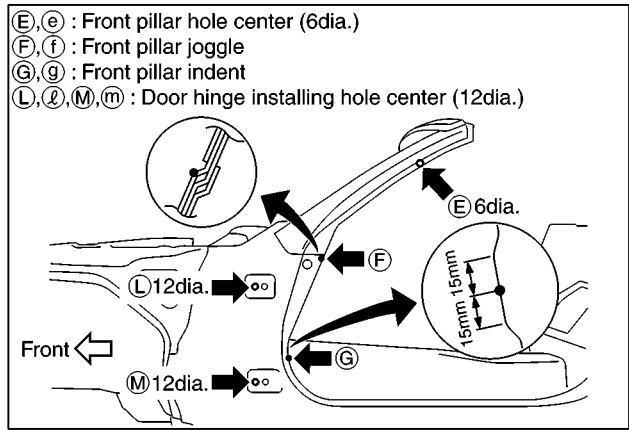
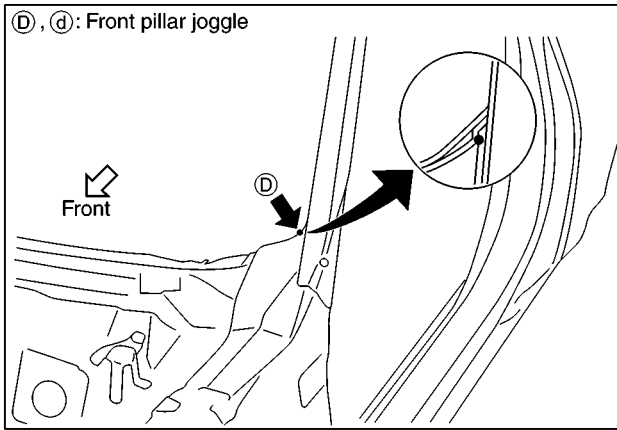
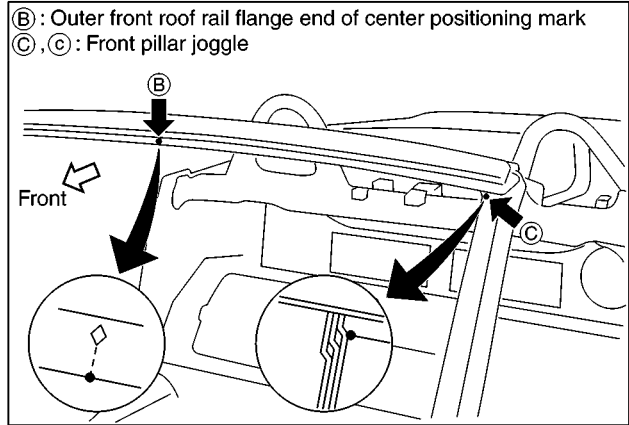
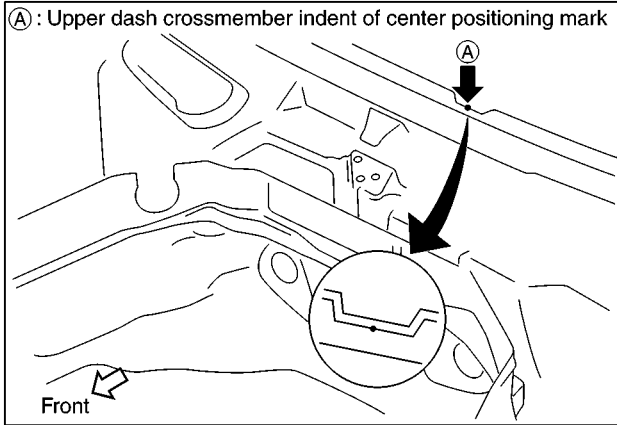

A
B
C
D
E
F
G
H
I
J
K
L
M

BL

SIIA2444E

BODY REPAIR

SOFT TOP MOUNTING BRACKET (ROADSTER)

Measurement

Figures marked with a (*) indicate symmetrically identical dimensions on both right and left hand sides of the vehicle.

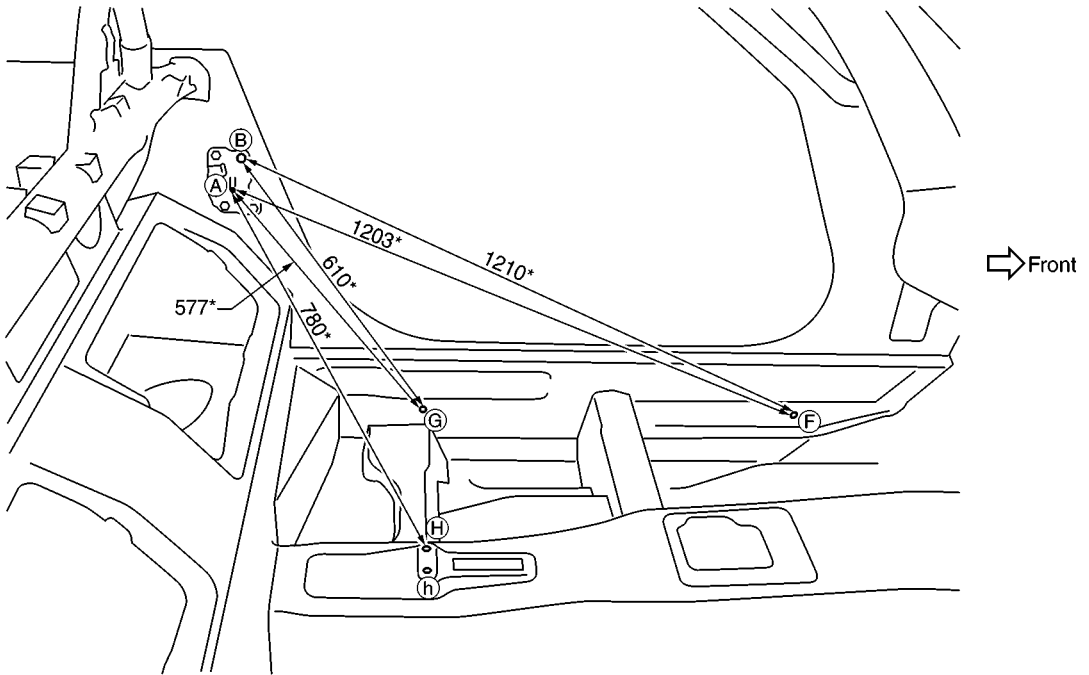
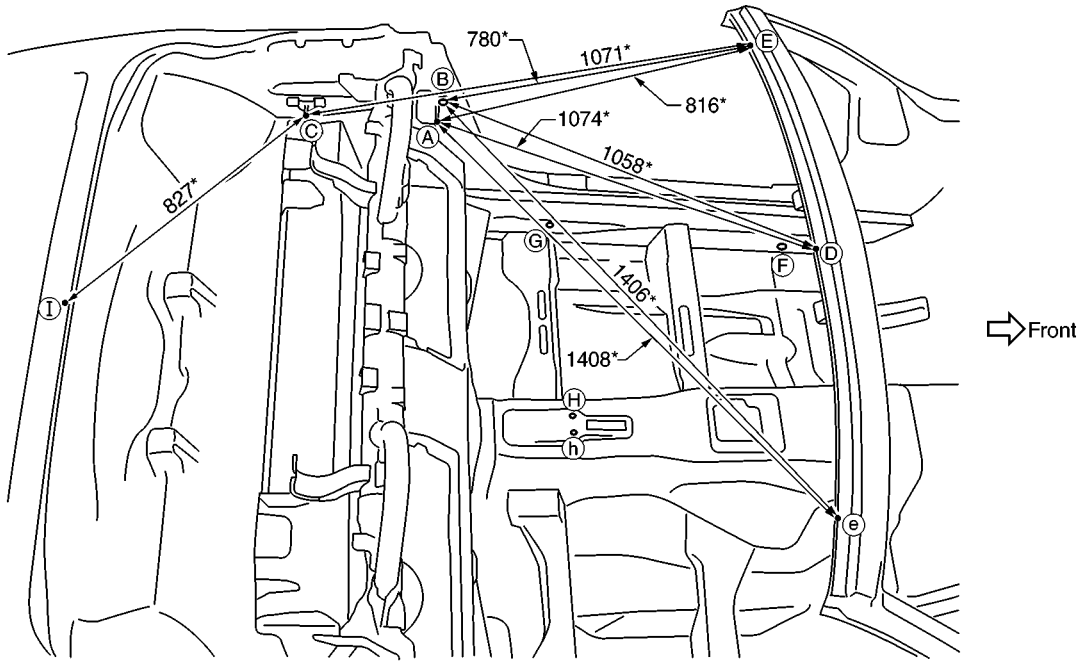

Point	Dimension
A~a	1,344

SIIA2325E

BODY REPAIR

Measurement Points

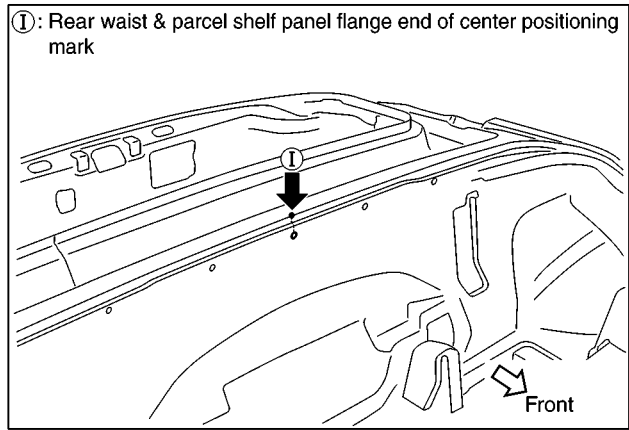
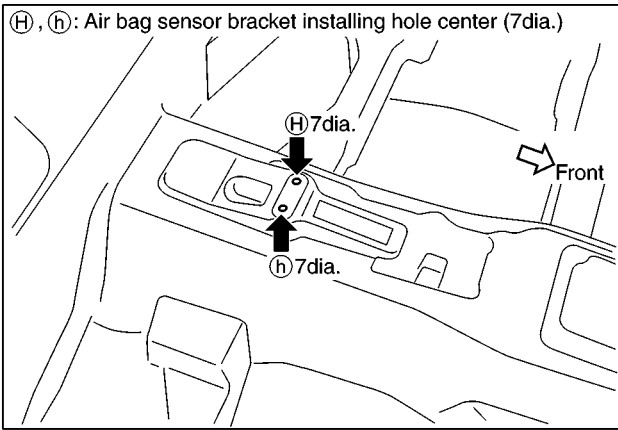
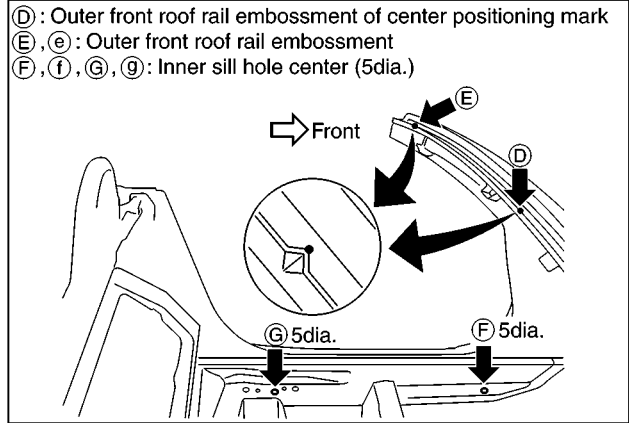
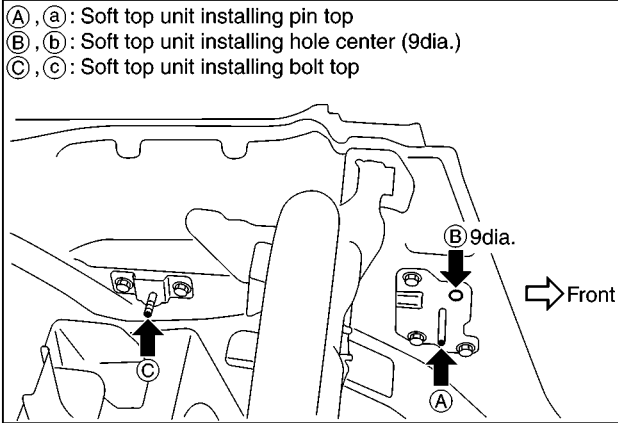

A
 B
 C
 D
 E
 F
 G
 H
 BL
 J
 K
 L
 M

BL

SIIA2445E

BODY REPAIR

REAR BODY (ROADSTER)

Measurement

Figures marked with a (*) indicate symmetrically identical dimensions on both right and left hand sides of the vehicle.

Unit : mm

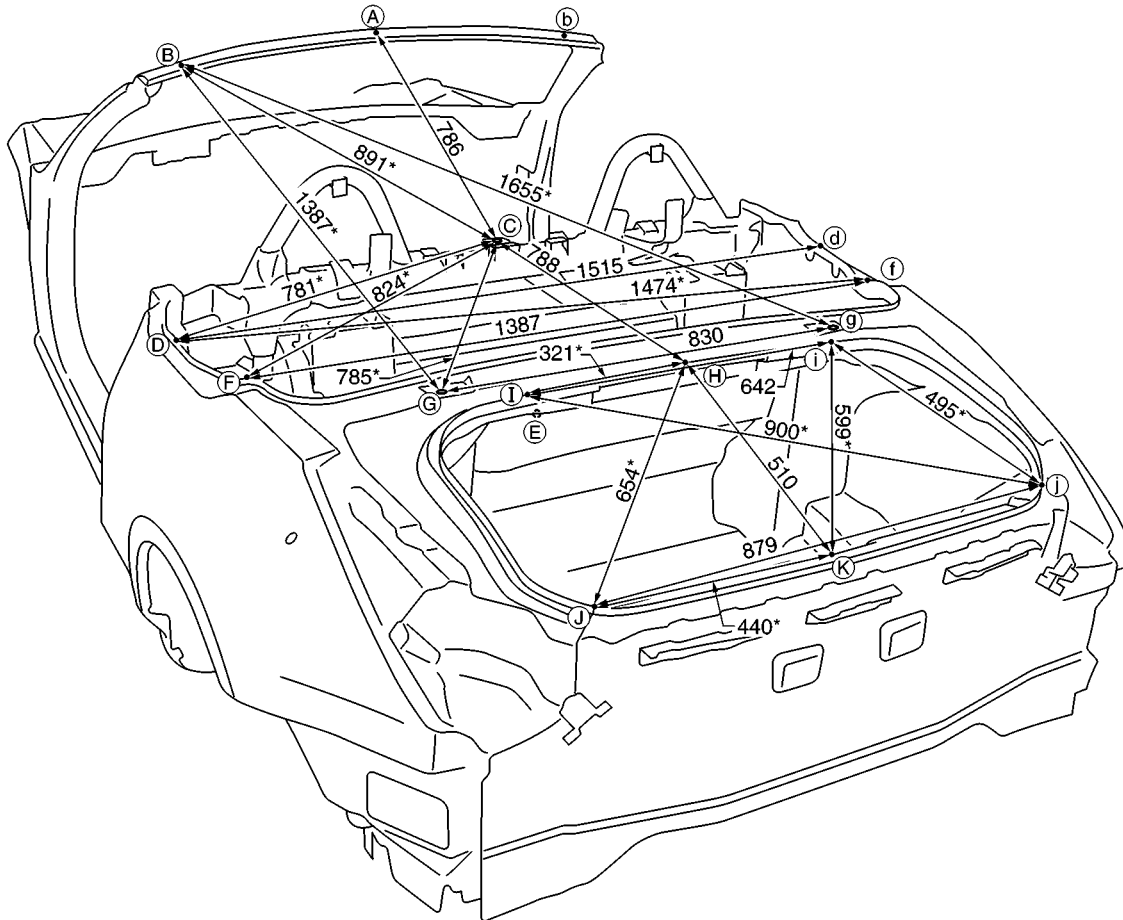

Point	Dimension
E~D	821*
E~F	767*
E~G	622*
E~H	580

BODY REPAIR

Measurement Points

- (A) : Outer front roof rail embossment of center positioning mark
- (B) , (b) : Outer front roof rail embossment
- (C) : Guard frame hole center of center positioning mark (4dia.)

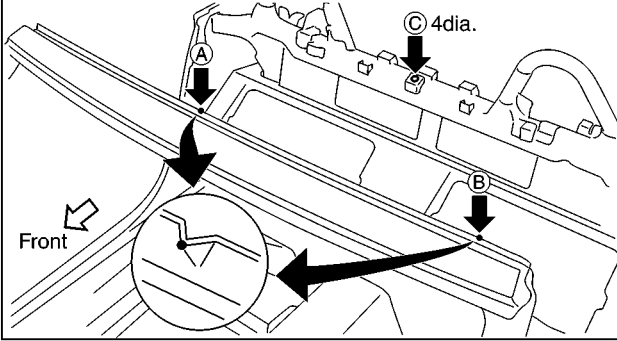

- (D) , (d) : Inner rear pillar joggle
- (E) : Inside step panel hole center of center positioning mark (8dia.)
- (F) , (f) : Rear fender extension B joggle

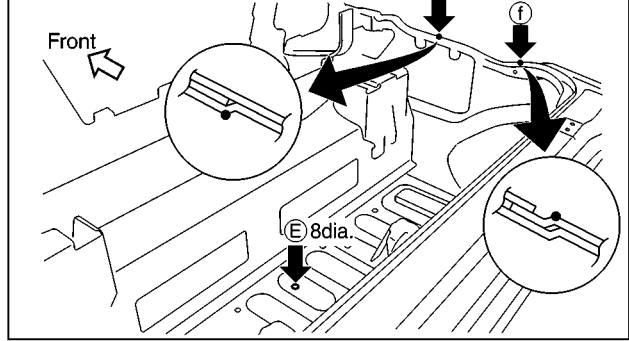

- (I) , (i) : Parcel shelf joggle

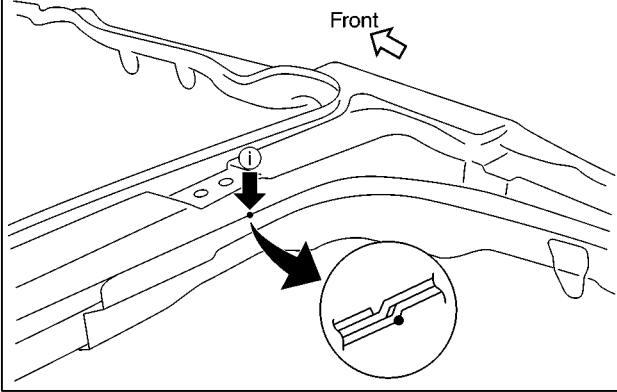

- (G) , (g) : Storage lid hinge installing hole center (8dia.)
- (H) : Rear waist flange end of center positioning mark
- (J) , (j) : Rear combination lamp base joggle
- (K) : Rear panel reinforcement ring mark center of center positioning mark

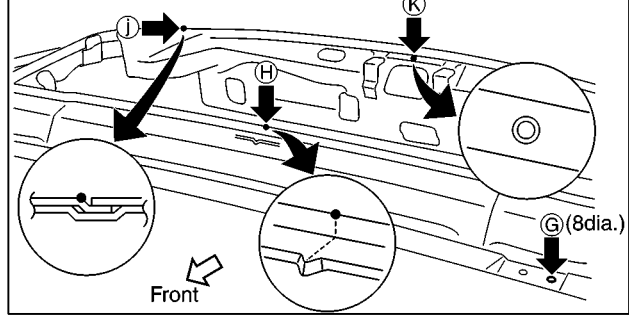

A
B
C
D
E
F
G
H
I
J
K
L
M

BL

SIIA2446E

BODY REPAIR

Handling Precautions For Plastics (Coupe) HANDLING PRECAUTIONS FOR PLASTICS

AIS0044P

Abbreviation	Material name	Heat resisting temperature °C(°F)	Resistance to gasoline and solvents	Other cautions
PE	Polyethylene	60(140)	Gasoline and most solvents are harmless if applied for a very short time (wipe up quickly).	Flammable
PVC	Poly Vinyl Chloride	80(176)	Same as above.	Poison gas is emitted when burned.
EPM/EPDM	Ethylene Propylene (Diene) copolymer	80(176)	Same as above.	Flammable
PP	Polypropylene	90(194)	Same as above.	Flammable, avoid battery acid.
UP	Unsaturated Polyester	90(194)	Same as above.	Flammable
PS	Polystyrene	80(176)	Avoid solvents.	Flammable
ABS	Acrylonitrile Butadiene Styrene	80(176)	Avoid gasoline and solvents.	
AES	Acrylonitrile Ethylene Styrene	80(176)	Same as above.	
PMMA	Poly Methyl Methacrylate	85(185)	Same as above.	
EVAC	Ethylene Vinyl Acetate	90(194)	Same as above.	
ASA	Acrylonitrile Styrene Acrylate	100(222)	Same as above.	Flammable
PPE	Poly Phenylene Ether	110(230)	Same as above.	
PC	Polycarbonate	120(248)	Same as above.	
PAR	Polyarylate	180(356)	Same as above.	
PUR	Polyurethane	90(194)	Same as above.	
POM	Poly Oxymethylene	120(248)	Same as above.	Avoid battery acid.
PBT+PC	Poly Butylene Terephthalate + Polycarbonate	120(248)	Same as above.	Flammable
PA	Polyamide	140(284)	Same as above.	Avoid immersing in water.
PBT	Poly Butylene Terephthalate	140(284)	Same as above.	
PET	Polyester	180(356)	Same as above.	
PEI	Polyetherimide	200(392)	Same as above.	

1. When repairing and painting a portion of the body adjacent to plastic parts, consider their characteristics (influence of heat and solvent) and remove them if necessary or take suitable measures to protect them.
2. Plastic parts should be repaired and painted using methods suiting the materials' characteristics.

BODY REPAIR

LOCATION OF PLASTIC PARTS (COUPE)

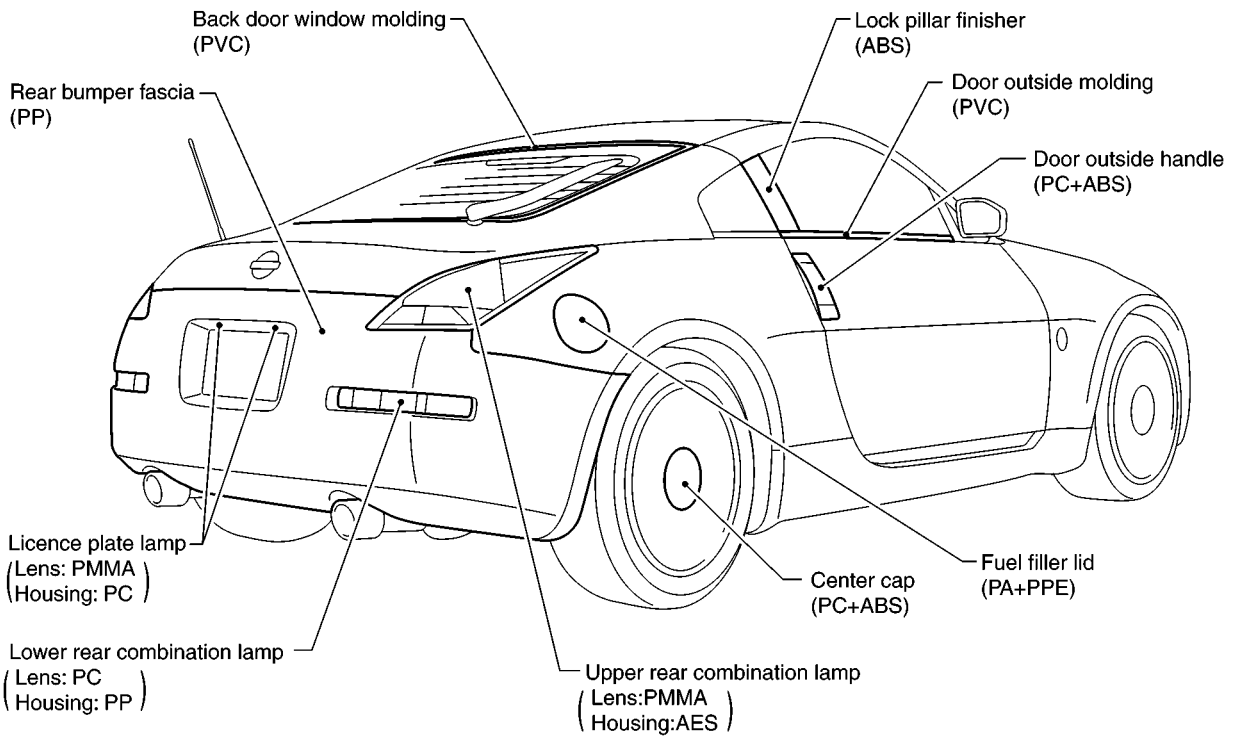
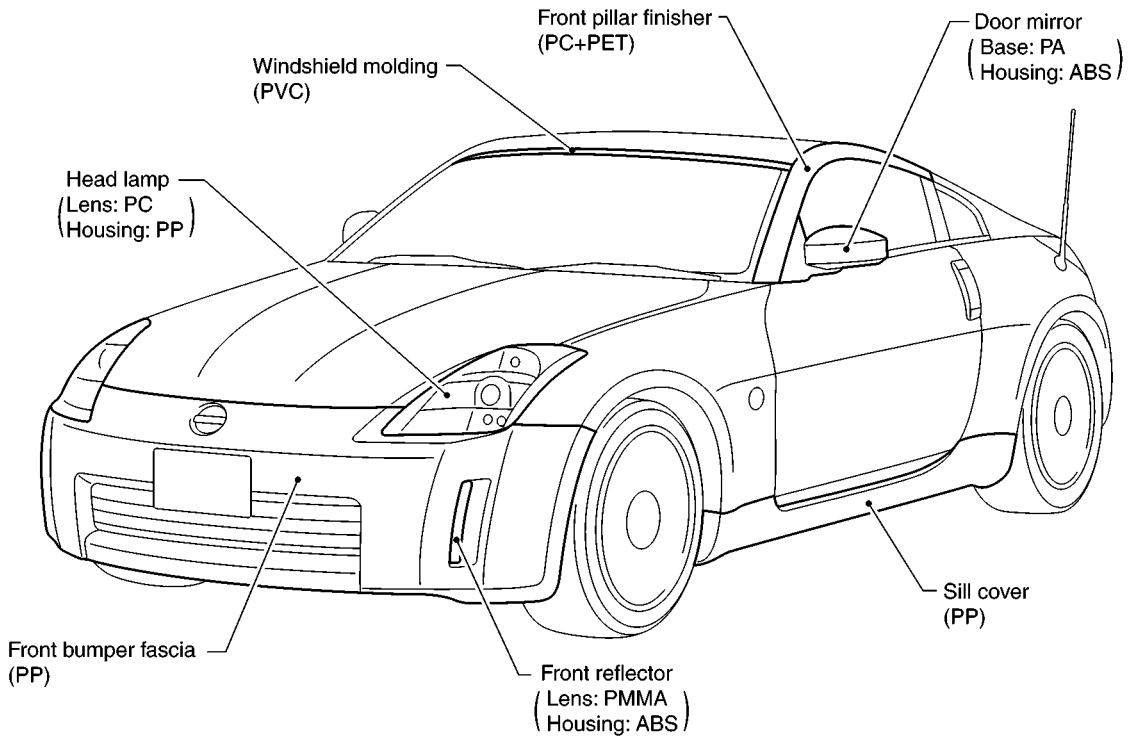

A
B
C
D
E
F
G
H
BL
J
K
L
M

SIIA2360E

BODY REPAIR

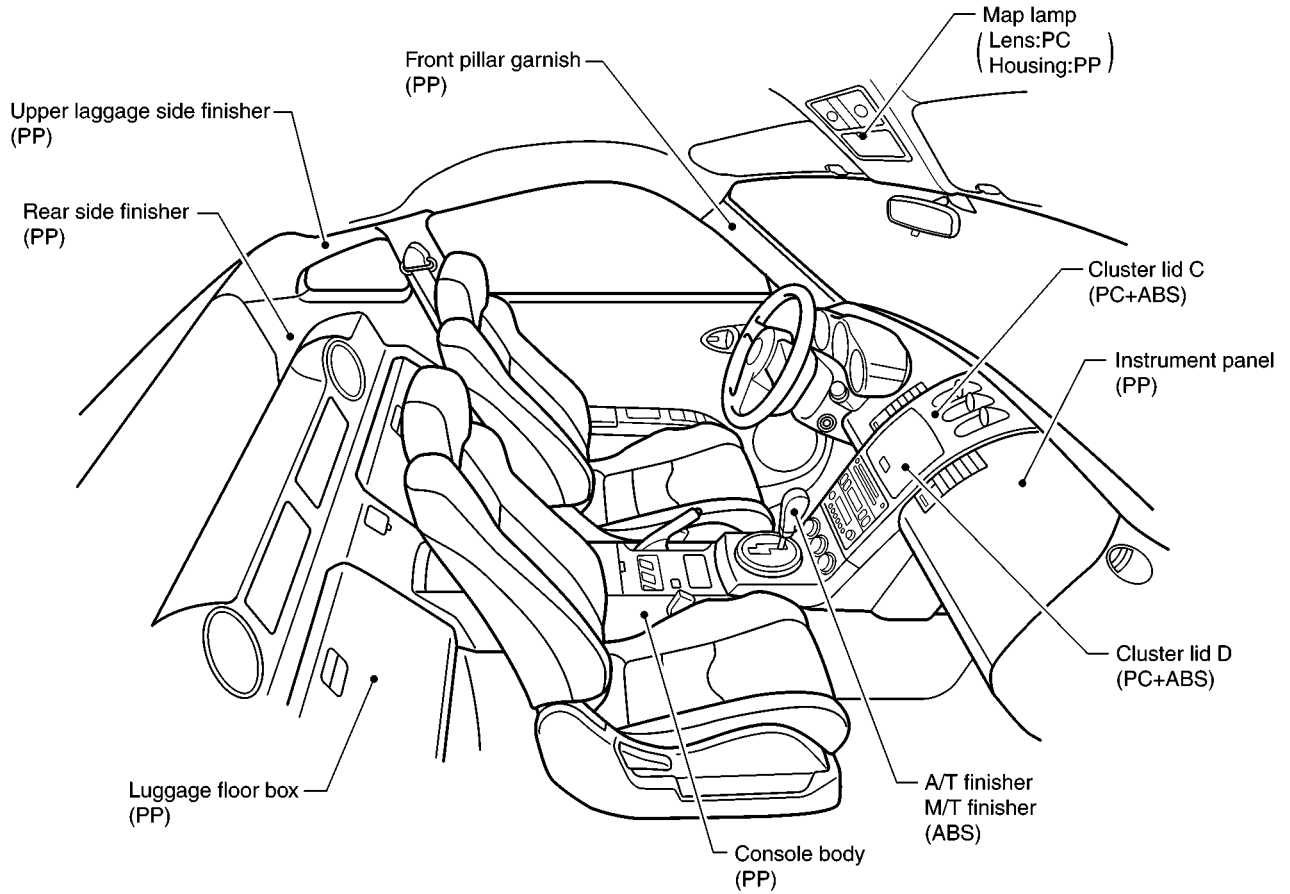

SIA1983E

BODY REPAIR

Handling Precautions For Plastics (Roadster)

AIS006VO

HANDLING PRECAUTIONS FOR PLASTICS

Abbreviation	Material name	Heat resisting temperature °C(°F)	Resistance to gasoline and solvents	Other cautions
PE	Polyethylene	60(140)	Gasoline and most solvents are harmless if applied for a very short time (wipe up quickly).	Flammable
PVC	Poly Vinyl Chloride	80(176)	Same as above.	Poison gas is emitted when burned.
EPM/EPDM	Ethylene Propylene (Diene) copolymer	80(176)	Same as above.	Flammable
PP	Polypropylene	90(194)	Same as above.	Flammable, avoid battery acid.
UP	Unsaturated Polyester	90(194)	Same as above.	Flammable
PS	Polystyrene	80(176)	Avoid solvents.	Flammable
ABS	Acrylonitrile Butadiene Styrene	80(176)	Avoid gasoline and solvents.	
AES	Acrylonitrile Ethylene Styrene	80(176)	Same as above.	
PMMA	Poly Methyl Methacrylate	85(185)	Same as above.	
EVAC	Ethylene Vinyl Acetate	90(194)	Same as above.	
ASA	Acrylonitrile Styrene Acrylate	100(222)	Same as above.	Flammable
PPE	Poly Phenylene Ether	110(230)	Same as above.	
PC	Polycarbonate	120(248)	Same as above.	
PAR	Polyarylate	180(356)	Same as above.	
PUR	Polyurethane	90(194)	Same as above.	
POM	Poly Oxymethylene	120(248)	Same as above.	Avoid battery acid.
PBT+PC	Poly Butylene Terephthalate + Polycarbonate	120(248)	Same as above.	Flammable
PA	Polyamide	140(284)	Same as above.	Avoid immersing in water.
PBT	Poly Butylene Terephthalate	140(284)	Same as above.	
PET	Polyester	180(356)	Same as above.	
PEI	Polyetherimide	200(392)	Same as above.	

1. When repairing and painting a portion of the body adjacent to plastic parts, consider their characteristics (influence of heat and solvent) and remove them if necessary or take suitable measures to protect them.
2. Plastic parts should be repaired and painted using methods suiting the materials' characteristics.

BODY REPAIR

LOCATION OF PLASTIC PARTS (ROADSTER)

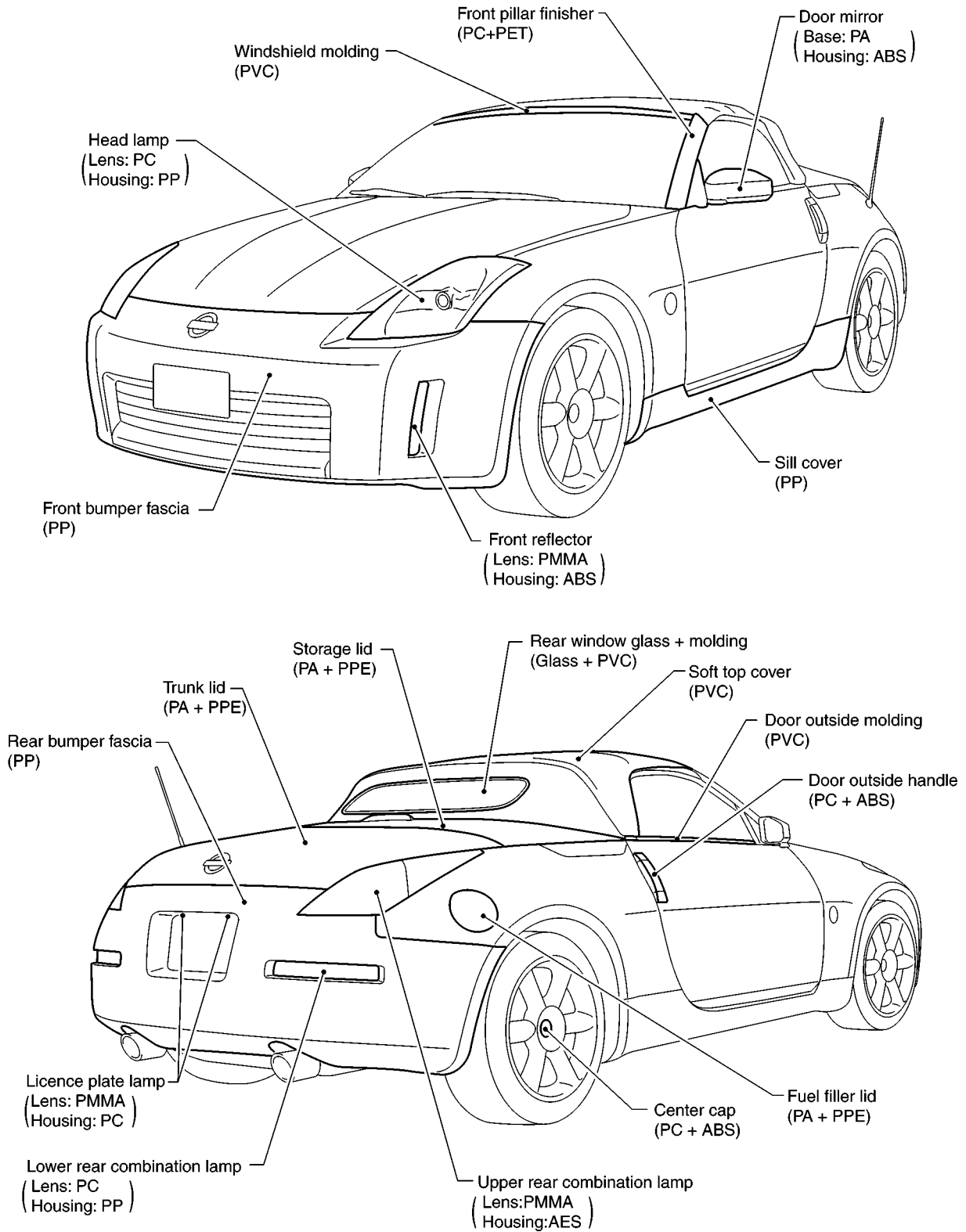

SIIA2361E

BODY REPAIR

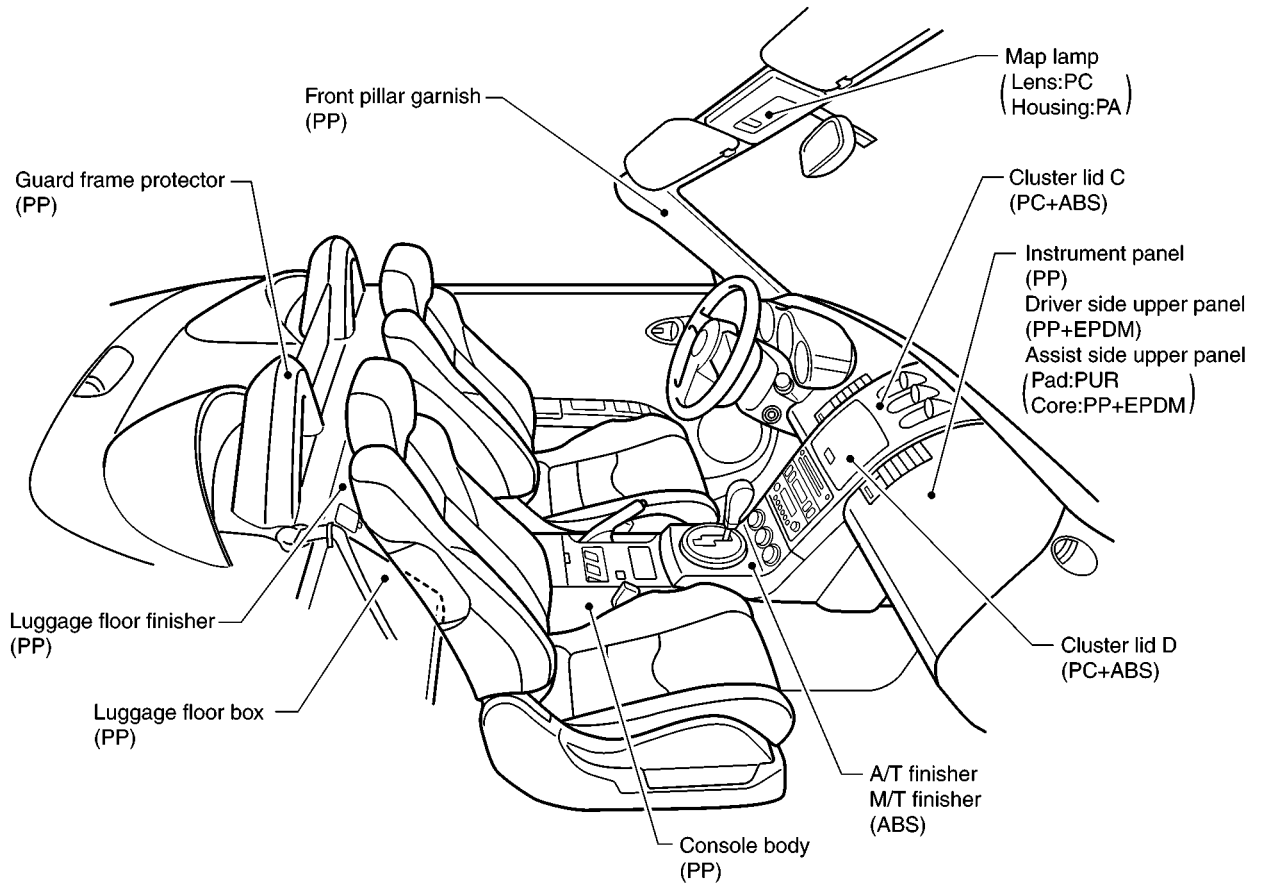

A
B
C
D
E
F
G
H
BL
J
K
L
M

SIA2447E

BODY REPAIR

Precautions In Repairing High Strength Steel

AIS0044R

High strength steel is used for body panels in order to reduce vehicle weight. Accordingly, precautions in repairing automotive bodies made of high strength steel are described below:

HIGH STRENGTH STEEL (HSS) USED IN NISSAN VEHICLES

Tensile strength	Nissan/Infiniti designation	Major applicable parts
373 N/mm ² (38kg/mm ² ,54klb/sq in)	SP130	<ul style="list-style-type: none">● Front & rear side member assembly● Hoodledge assembly● Upper dash● Body side● Other reinforcements
785-981 N/mm ² (80-100kg/mm ² ,114-142klb/sq in)	SP150	<ul style="list-style-type: none">● Front door guard beam

SP130 is the most commonly used HSS.

BODY REPAIR

Read the Following Precautions When Repairing HSS:

1. Additional points to consider

- The repair of reinforcements (such as side members) by heating is not recommended since it may weaken the component. When heating is unavoidable, do not heat HSS parts above 550°C (1,022°F). Verify heating temperature with a thermometer. (Crayon-type and other similar type thermometer are appropriate.)

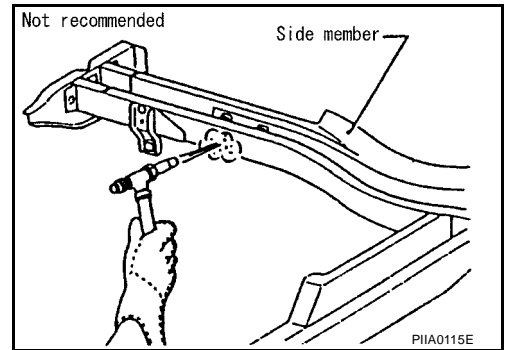

- When straightening body panels, use caution in pulling any HSS panel. Because HSS is very strong, pulling may cause deformation in adjacent portions of the body. In this case, increase the number of measuring points, and carefully pull the HSS panel.

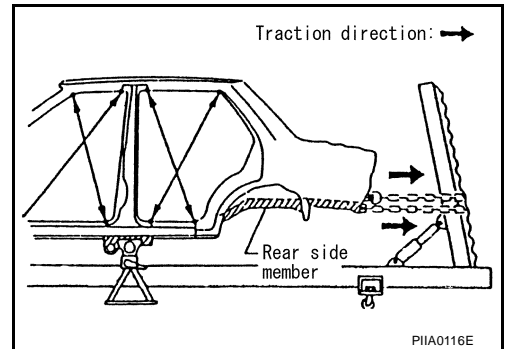

- When cutting HSS panels, avoid gas (torch) cutting if possible. Instead, use a saw to avoid weakening surrounding areas due to heat. If gas (torch) cutting is unavoidable, allow a minimum margin of 50 mm (1.97in).

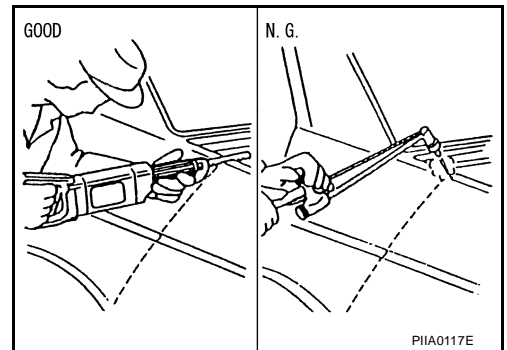

- When welding HSS panels, use spot welding whenever possible in order to minimize weakening surrounding areas due to heat. If spot welding is impossible, use M.I.G. welding. Do not use gas (torch) welding because it is inferior in welding strength.

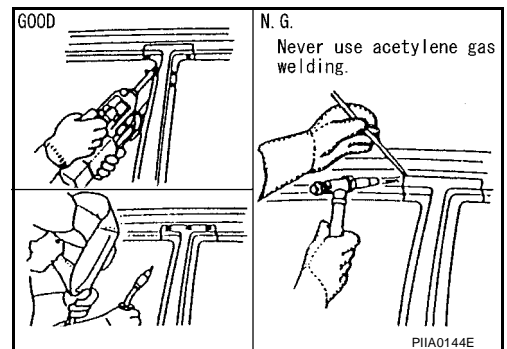

A
B
C
D
E
F
G
H
BL
J
K
L
M

BODY REPAIR

- The spot weld on HSS panels is harder than that of an ordinary steel panel.
Therefore, when cutting spot welds on a HSS panel, use a low speed high torque drill (1,000 to 1,200 rpm) to increase drill bit durability and facilitate the operation.

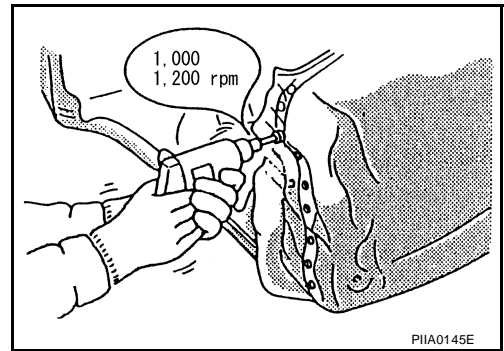

2. Precautions in spot welding HSS

This work should be performed under standard working conditions. Always note the following when spot welding HSS:

- The electrode tip diameter must be sized properly according to the metal thickness.

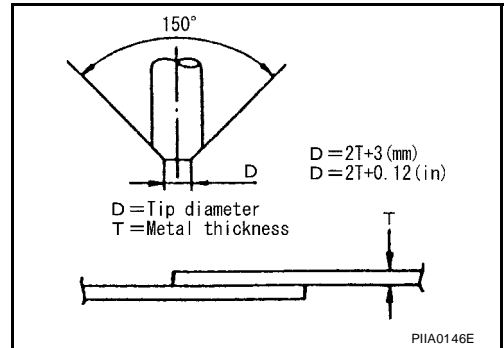

- The panel surfaces must fit flush to each other, leaving no gaps.

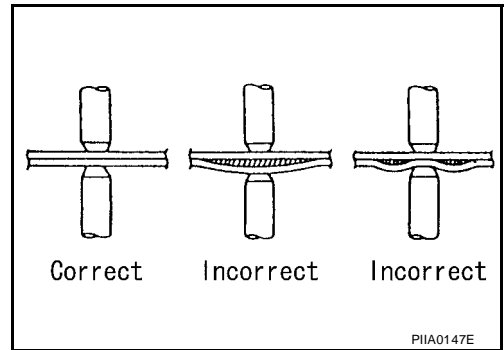

- Follow the specifications for the proper welding pitch.

Thickness (t)	Minimum pitch (l)
0.6 (0.024)	10 (0.39) or over
0.8 (0.031)	12 (0.47) or over
1.0 (0.039)	18 (0.71) or over
1.2 (0.047)	20 (0.79) or over
1.6 (0.063)	27 (1.06) or over
1.8 (0.071)	31 (1.22) or over

Unit:mm

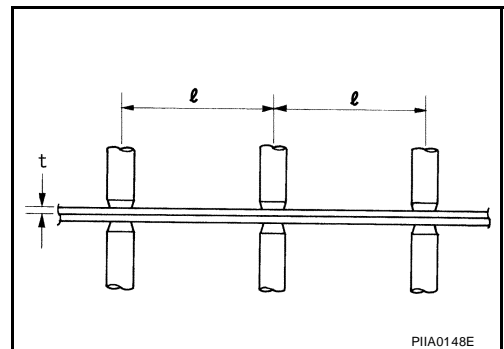

BODY REPAIR

Replacement Operations (Coupe)

AIS0044S

DESCRIPTION

This section is prepared for technicians who have attained a high level of skill and experience in repairing collision-damaged vehicles and also use modern service tools and equipment. Persons unfamiliar with body repair techniques should not attempt to repair collision-damaged vehicles by using this section.

Technicians are also encouraged to read Body Repair Manual (Fundamentals) in order to ensure that the original functions and quality of the vehicle can be maintained. The Body Repair Manual (Fundamentals) contains additional information, including cautions and warning, that are not including in this manual. Technicians should refer to both manuals to ensure proper repairs.

Please note that these information are prepared for worldwide usage, and as such, certain procedures might not apply in some regions or countries.

A

B

C

D

E

F

G

H

BL

J







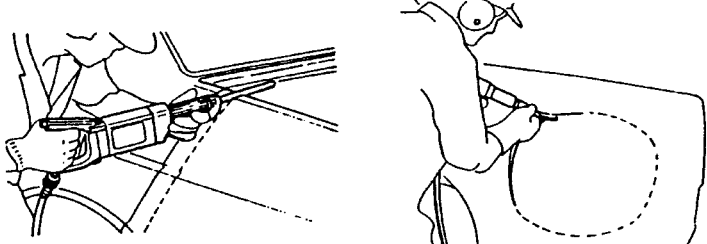
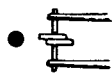
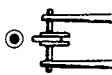

K

L

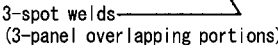
M

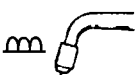
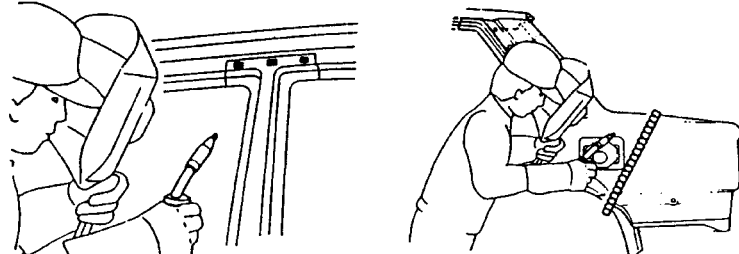
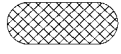
BODY REPAIR

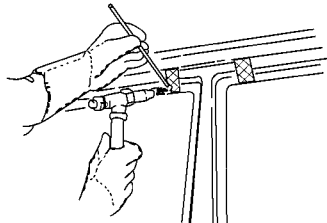
The symbols used in this section for cutting and welding / brazing operations are shown below.

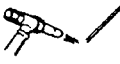
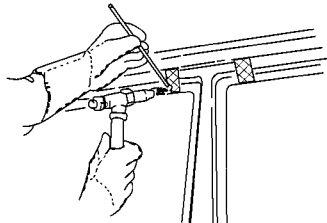
 <p>Saw cut or air chisel cut</p>		
<p>Spot weld</p> <p>●●●● 2-spot welds</p>  <p>●●●● 3-spot welds</p> 	<p>2-spot welds (2-panel overlapping portions)</p>  <p>3-spot welds (3-panel overlapping portions)</p> 	
<p>■ ■ ■ ■ MIG plug weld</p>  <p>~~~~~ MIG seam weld/ Point weld</p> 		
<p>▨ ▨ ▨ ▨ Brazing</p>  		
<p>▩ ▩ ▩ ▩ Soldering</p>  		
<p>————— Sealing</p>		

BODY REPAIR

- Front pillar butt joint can be determined anywhere within shaded area as shown in the figure. The best location for the butt joint is at position A due to the construction of the vehicle. Refer to the front pillar section.

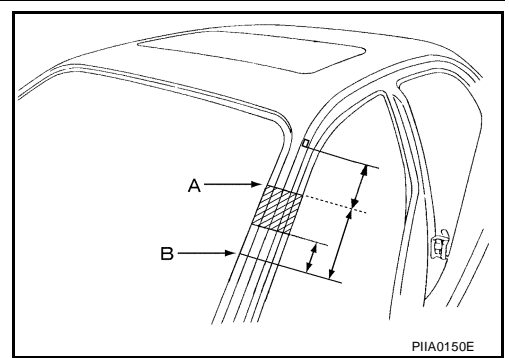

- Determine cutting position and record distance from the locating indent. Use this distance when cutting the service part. Cut outer front pillar over 60 mm above inner front pillar cut position.

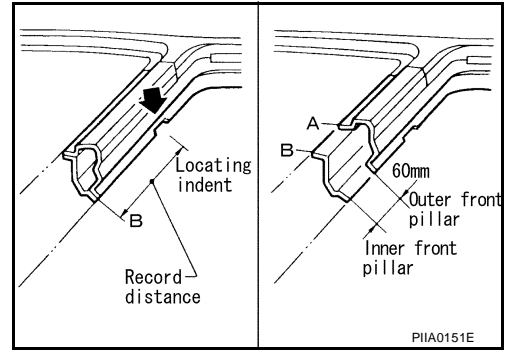

- Prepare a cutting jig to make outer pillar easier to cut. Also, this will permit service part to be accurately cut at joint position.

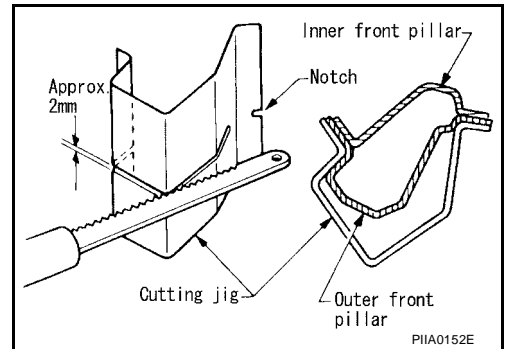

- An example of cutting operation using a cutting jig is as follows.

1. Mark cutting lines.
A: Cut position of outer pillar
B: Cut position of inner pillar
2. Align cutting line with notch on jig. Clamp jig to pillar.
3. Cut outer pillar along groove of jig. (At position A)
4. Remove jig and cut remaining portions.
5. Cut inner pillar at position B in same manner.

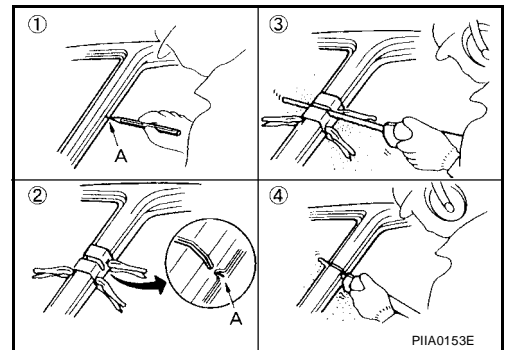

A
B
C
D
E
F
G
H
BL
J
K
L
M

BODY REPAIR

HOODLEDGE (COUPE)

Service Joint

Remove front side member center closing plate for easier installation.

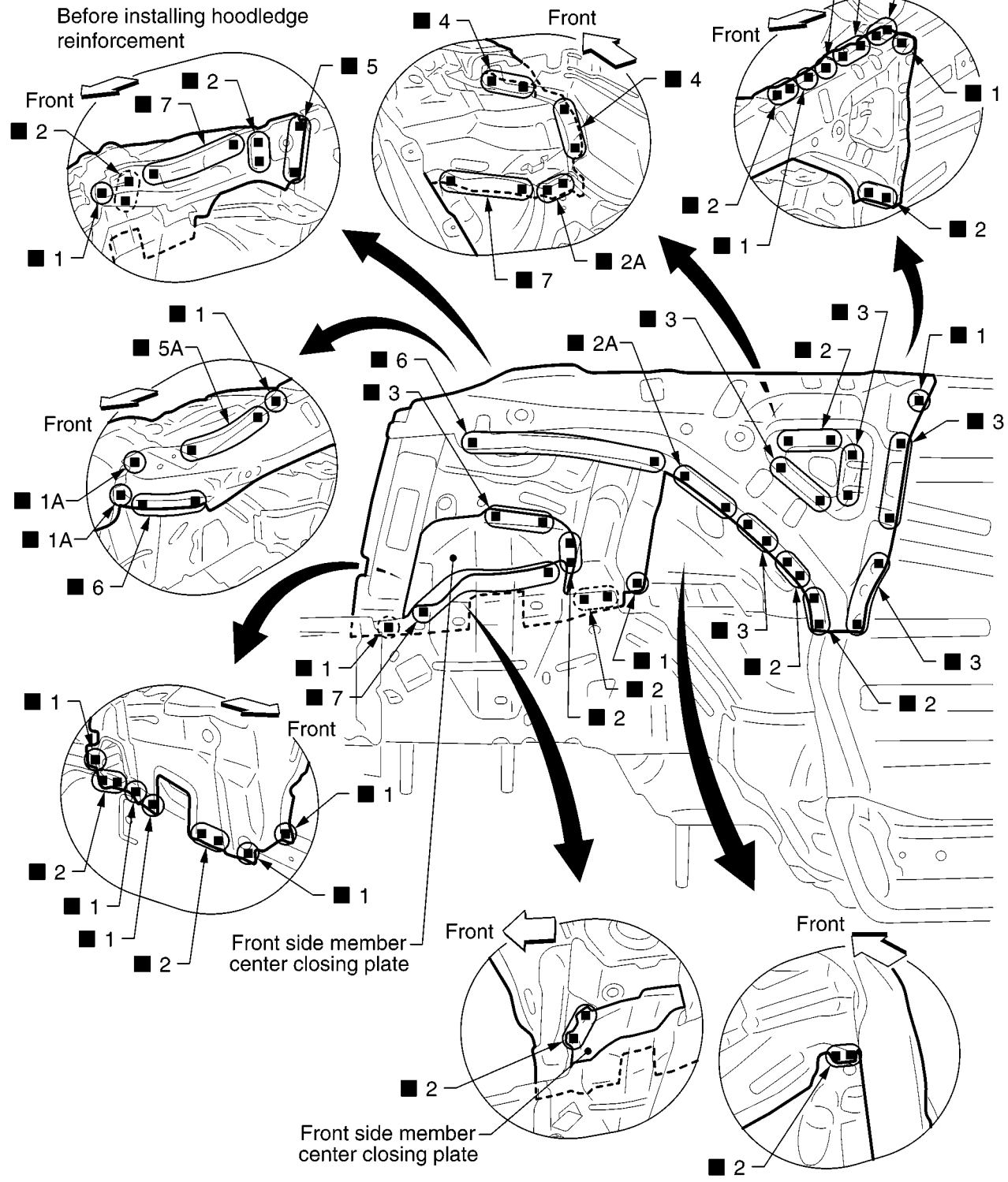

2-spot welds

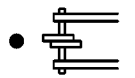

3-spot welds

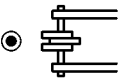

M I G plug weld



For 3 panels plug weld method



M I G seam weld/
Point weld



SIA1992E

Change parts

● Front strut housing (LH)

● Upper front hoodledge (LH)

● Hoodledge reinforcement (LH)

BODY REPAIR

Change parts

- Front side member assembly (LH)
- Front side member closing plate assembly (LH)
- Front side member outrigger assembly (LH)
- Front side member rear reinforcement (LH)

BODY REPAIR

FRONT SIDE MEMBER (PARTIAL REPLACEMENT) (COUPE)

A
B
C
D
E
F
G
H
BL
J
K
L
M

Service Joint

(This figure shows right front side member)
Remove stabilizer bracket reinforcement for easier installation.

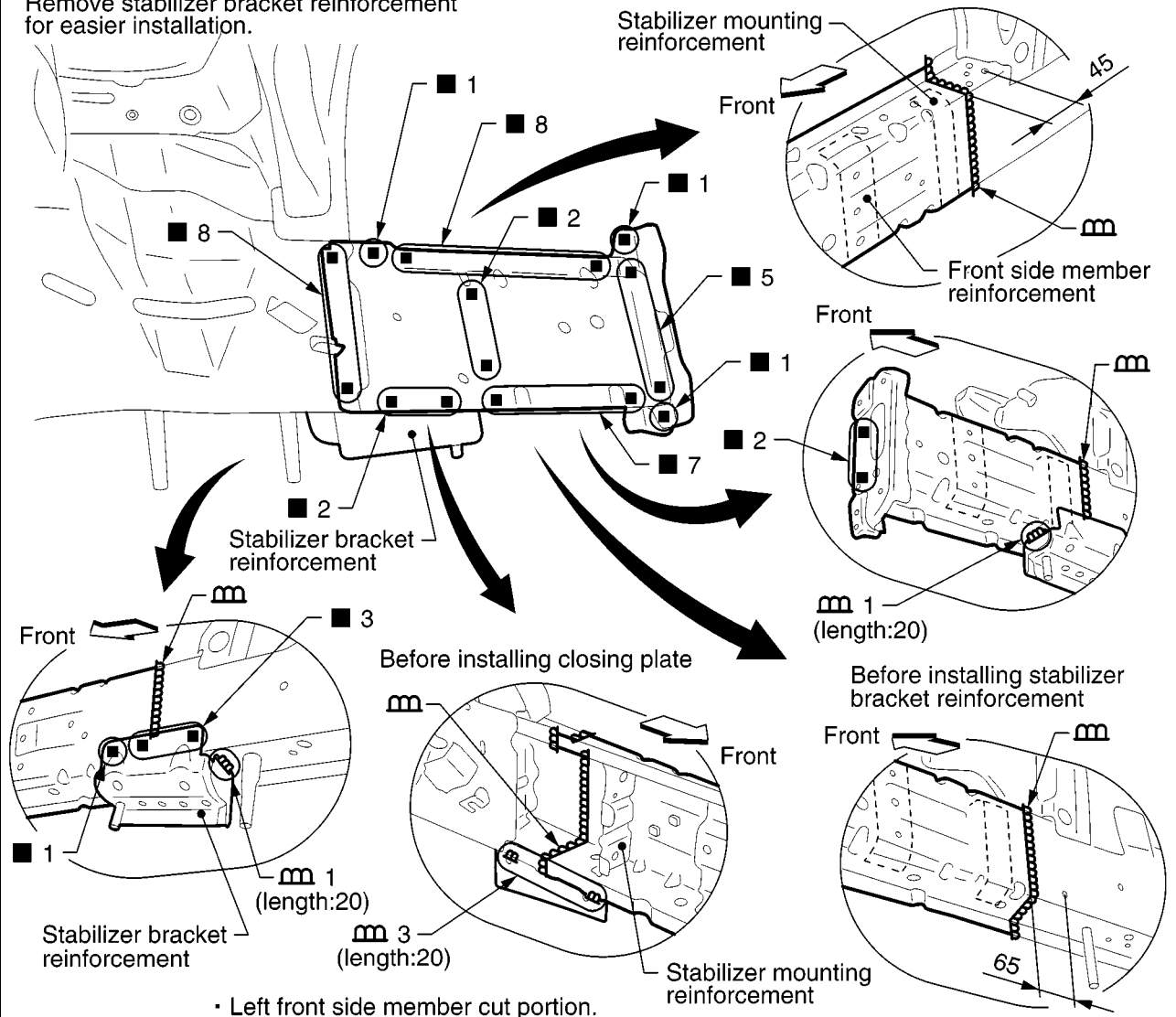

• Left front side member cut portion.

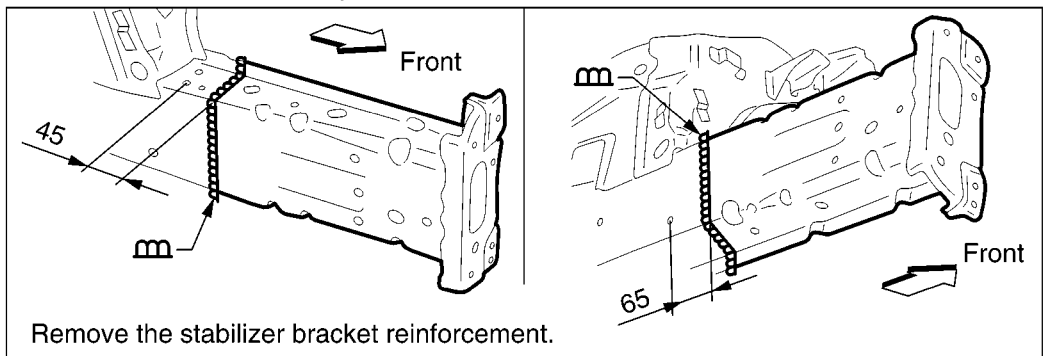

Unit:mm

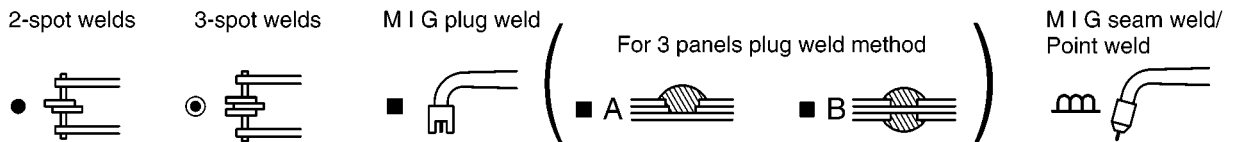

SIIA1994E

Change parts

- Front side member assembly (RH)
- Front side member front closing plate (RH)
- Outer front towing hook bracket (RH)

BODY REPAIR

FRONT PILLAR (COUPE)

- Work after hoodledge reinforcement has been removed.

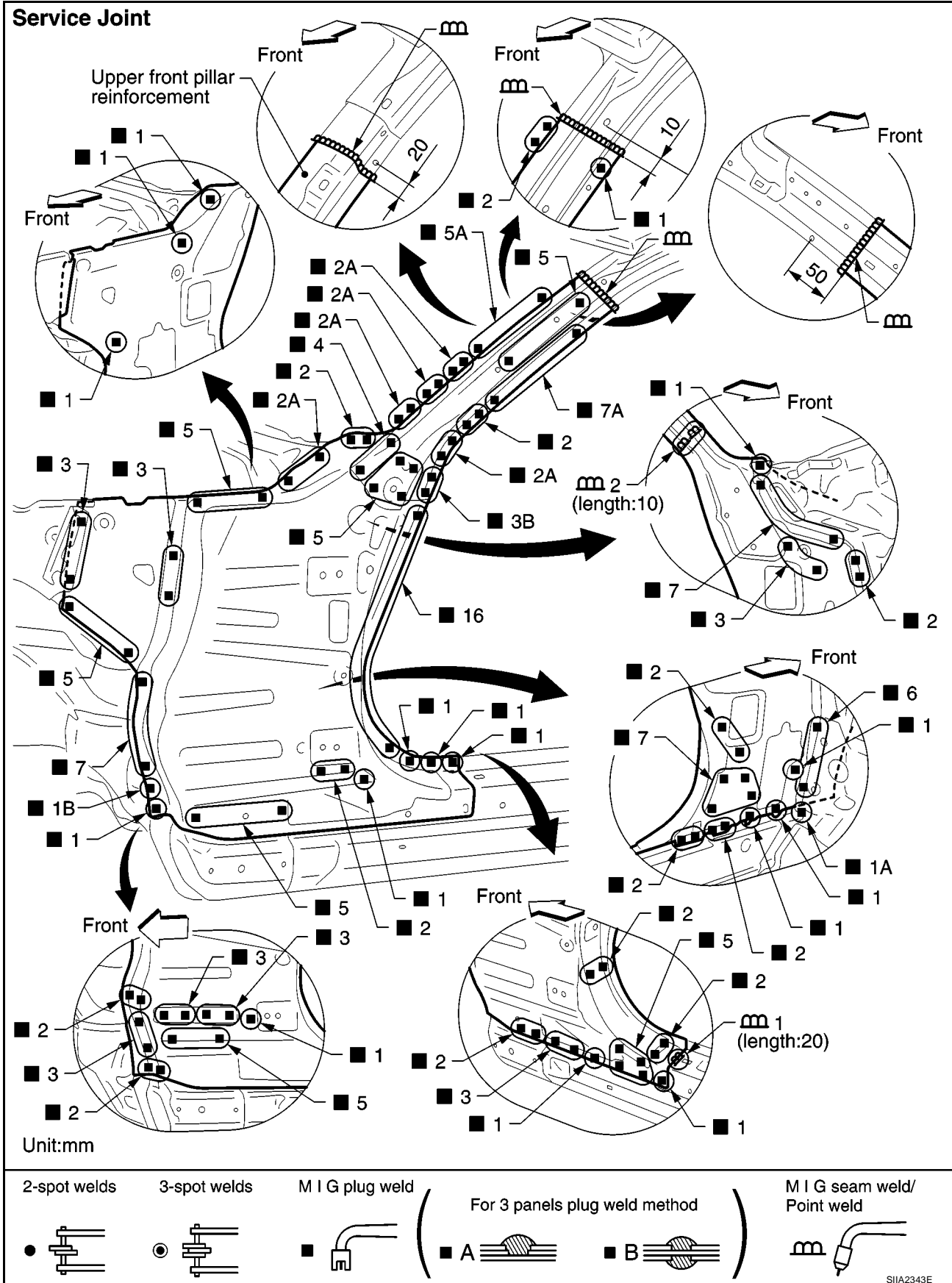

BODY REPAIR

Change parts

- Front pillar reinforcement assembly (LH)
- Outer front pillar (LH)
- Inner side roof rail (LH)
- Upper rear hoodledge (LH)

A

B

C

D

E

F

G

H

BL

J

K

L

M

BODY REPAIR

OUTER SILL (COUPE)

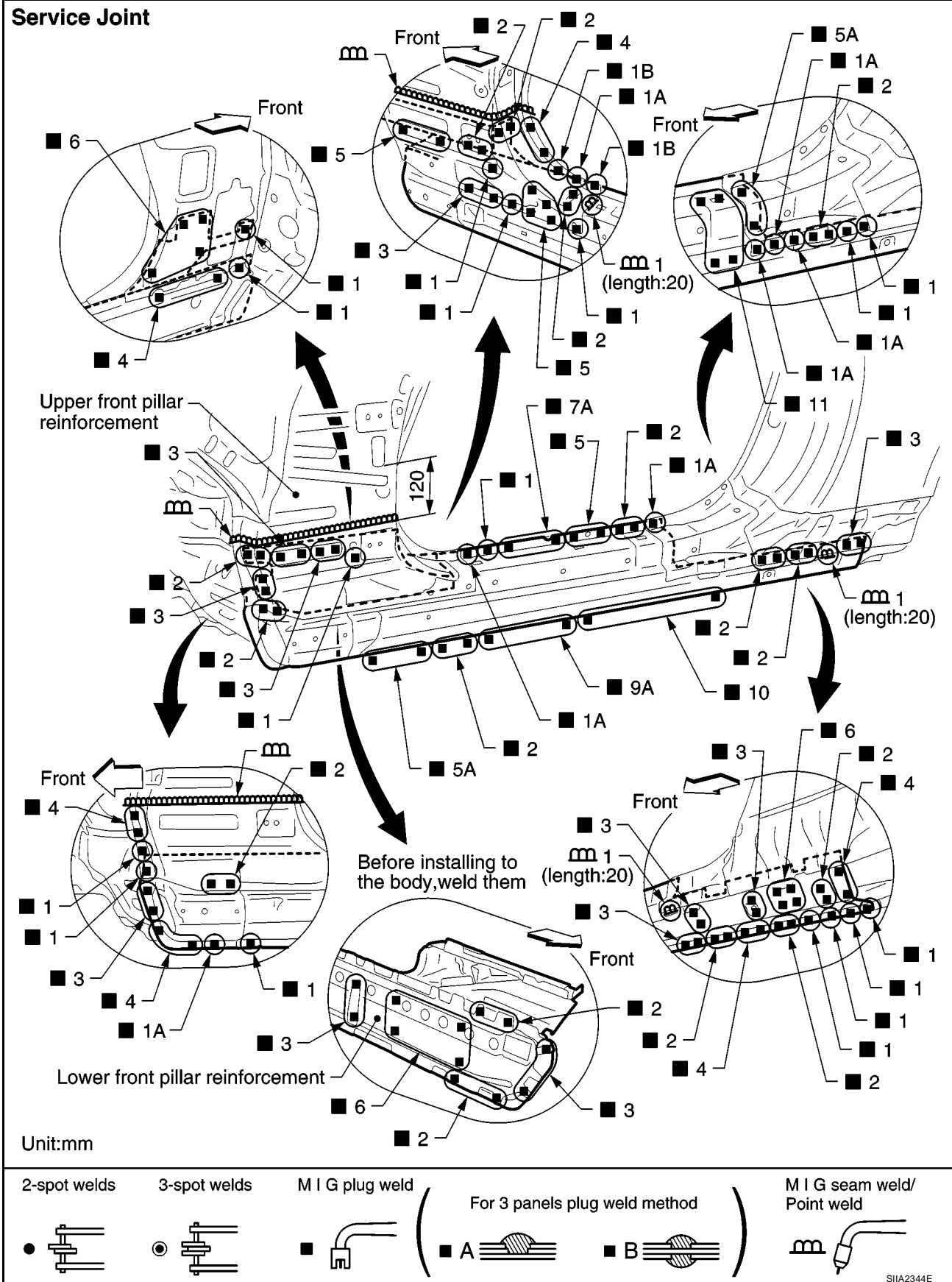

SIIA2344E

BODY REPAIR

REAR FENDER (COUPE)

Service Joint

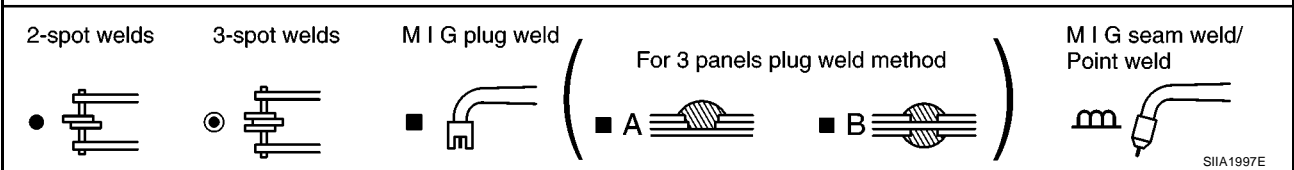
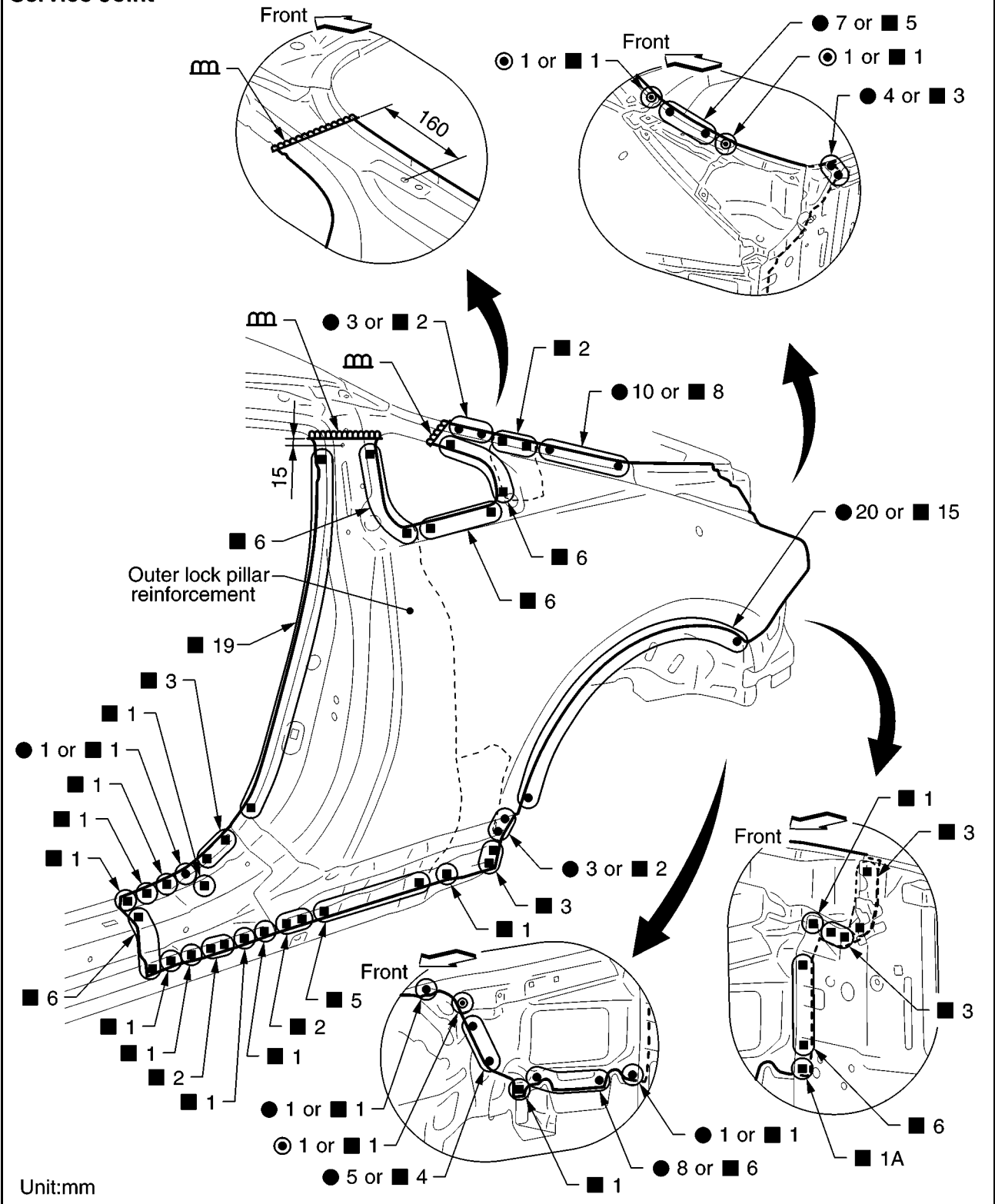

- Change parts
- Rear fender assembly (LH)

A
B
C
D
E
F
G
H
BL
J
K
L
M

BODY REPAIR

REAR PANEL (COUPE)

Service Joint

★ indicates that there is an equivalent welding portion with the same dimensions on the opposite side.

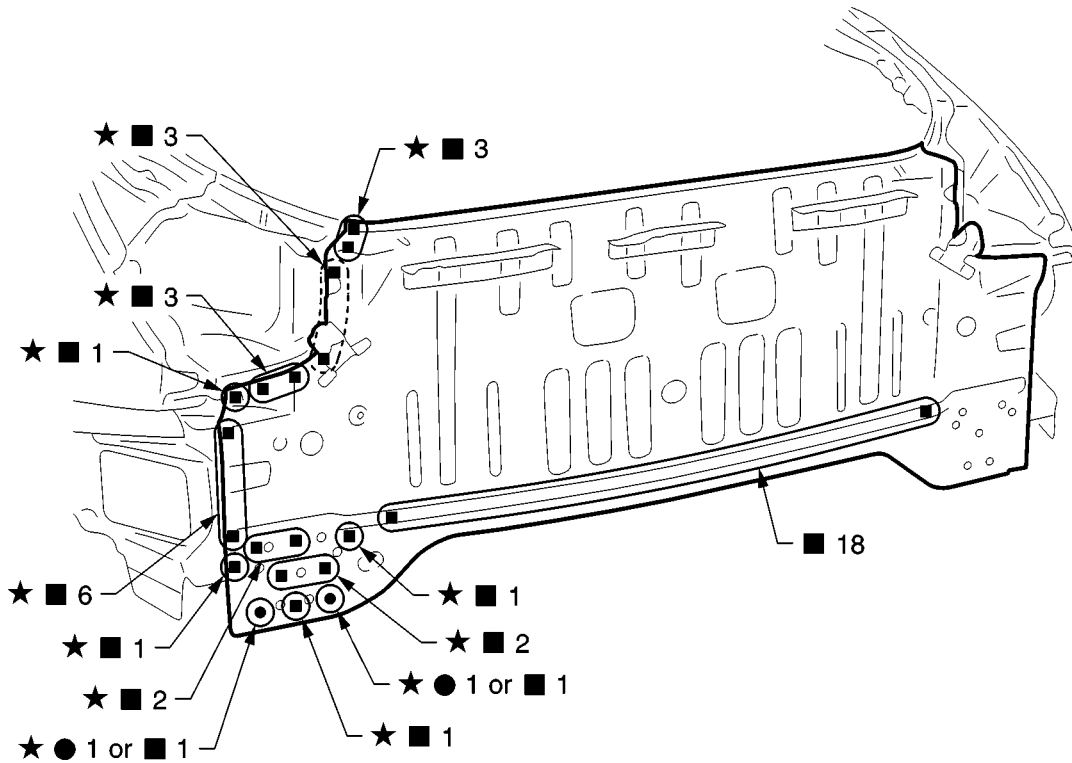

2-spot welds



3-spot welds



M I G plug weld



For 3 panels plug weld method



M I G seam weld/
Point weld



SIIA2346E

Change parts

- Rear panel assembly

BODY REPAIR

REAR FLOOR REAR (COUPE)

- Work after rear panel assembly has been removed.

A
B
C
D
E
F
G
H
BL
J
K
L
M

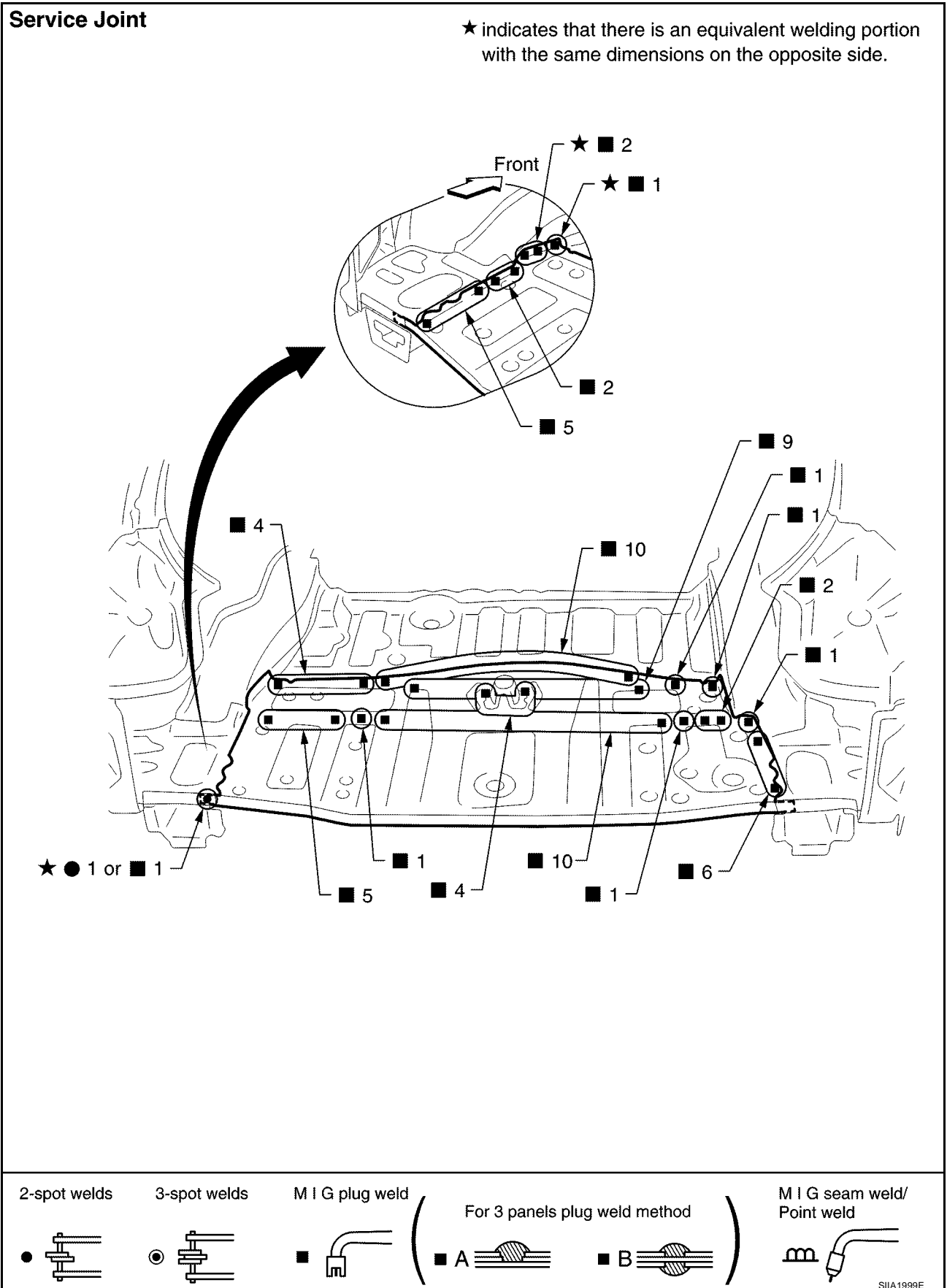

BODY REPAIR

Change parts

- Rear floor rear
- Spare tire clamp bracket

BODY REPAIR

REAR SIDE MEMBER EXTENSION (COUPE)

- Work after rear panel assembly has been removed.

A
B
C
D
E
F
G
H
BL
J
K
L
M

Service Joint

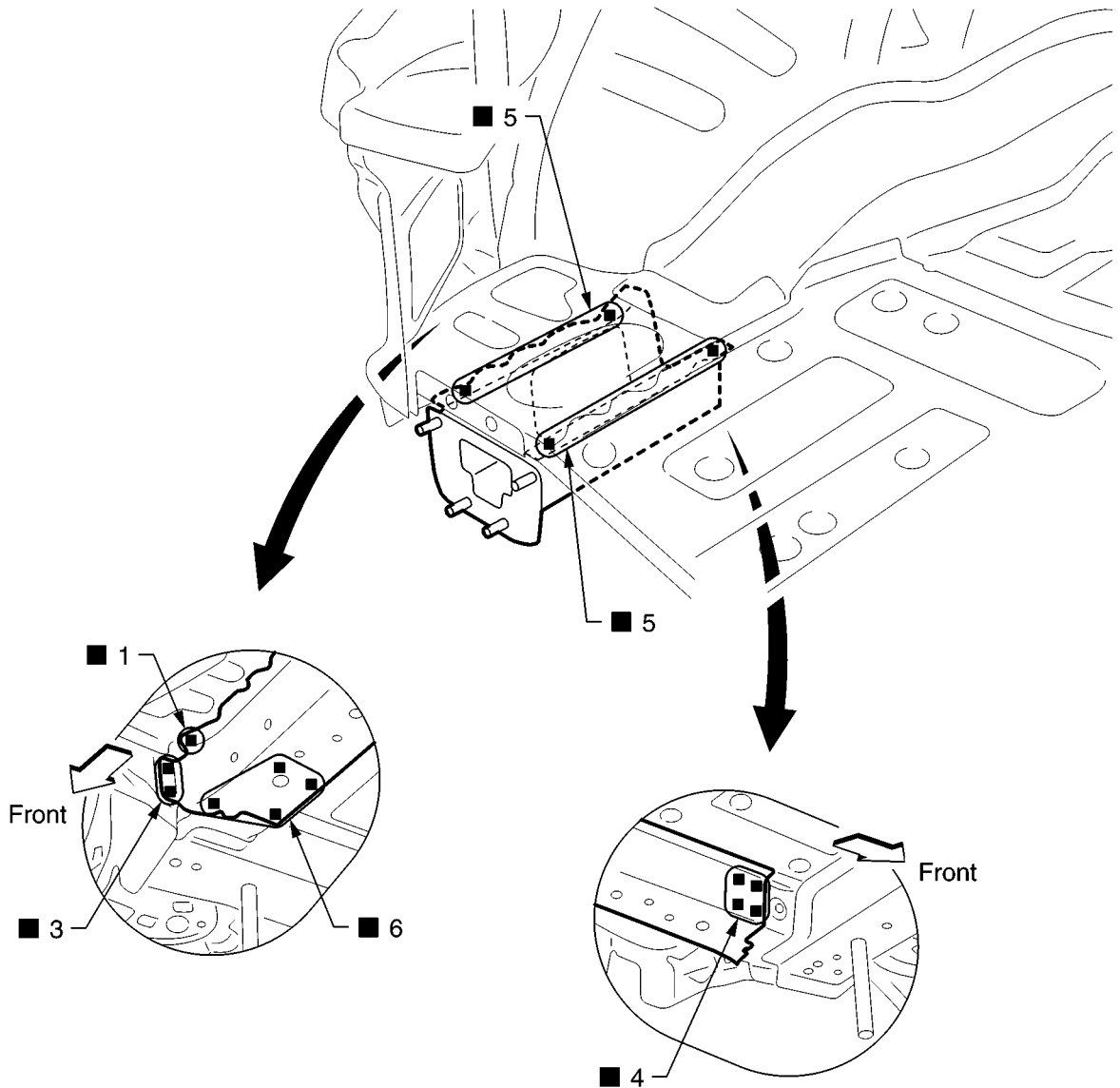

2-spot welds

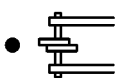

3-spot welds



M I G plug weld



For 3 panels plug weld method



M I G seam weld/
Point weld



SIIA2000E

BODY REPAIR

Change parts

- Rear side member extension (LH)

BODY REPAIR

Replacement Operations (Roadster)

AIS006VP

DESCRIPTION

This section is prepared for technicians who have attained a high level of skill and experience in repairing collision-damaged vehicles and also use modern service tools and equipment. Persons unfamiliar with body repair techniques should not attempt to repair collision-damaged vehicles by using this section.

Technicians are also encouraged to read Body Repair Manual (Fundamentals) in order to ensure that the original functions and quality of the vehicle can be maintained. The Body Repair Manual (Fundamentals) contains additional information, including cautions and warning, that are not including in this manual. Technicians should refer to both manuals to ensure proper repairs.

Please note that these information are prepared for worldwide usage, and as such, certain procedures might not apply in some regions or countries.

A

B

C

D

E

F

G

H

BL

J









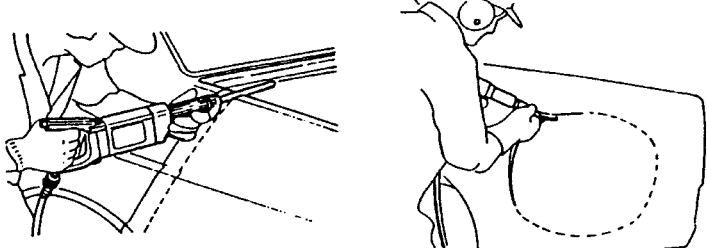
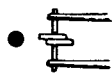
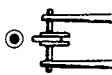

K

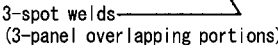
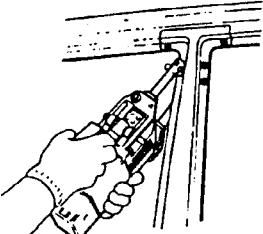
L

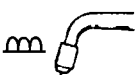
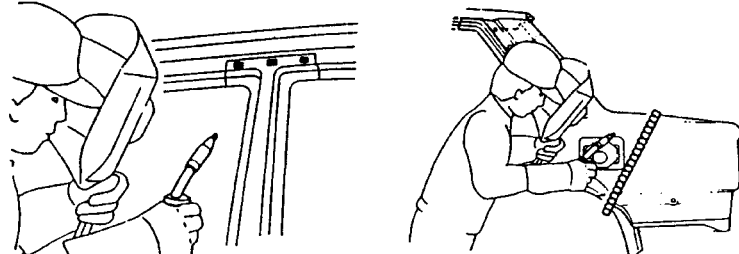
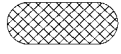
M

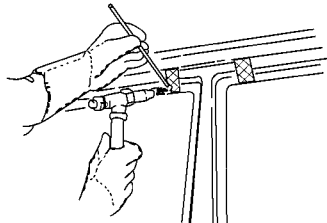
BODY REPAIR

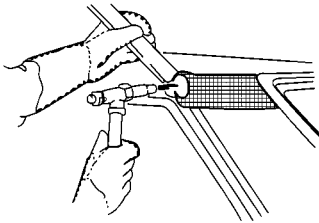
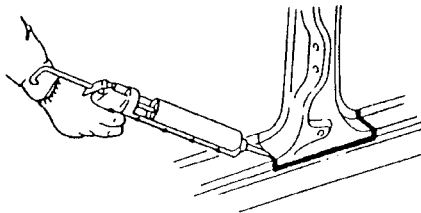
The symbols used in this section for cutting and welding / brazing operations are shown below.

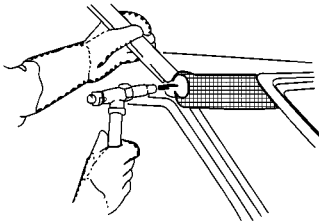
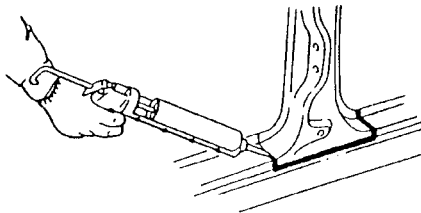
 <p>Saw cut or air chisel cut</p>		
<p>Spot weld</p> <p>●●●● 2-spot welds</p>   <p>●●●●● 3-spot welds</p>  	<p>2-spot welds (2-panel overlapping portions)</p>  <p>3-spot welds (3-panel overlapping portions)</p> 	
<p>■ ■ ■ ■ MIG plug weld</p>   <p>~~~~~ MIG seam weld/ Point weld</p>  		
<p>▨ ▨ ▨ ▨ Brazing</p>  		
<p>▩ ▩ ▩ ▩ Soldering</p>  		
<p>————— Sealing</p>		

BODY REPAIR

- Front pillar butt joint can be determined anywhere within shaded area as shown in the figure. The best location for the butt joint is at position A due to the construction of the vehicle. Refer to the front pillar section.

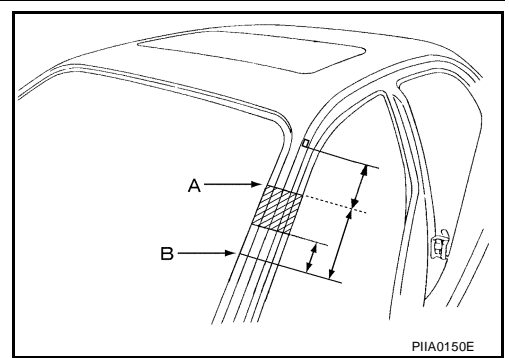

- Determine cutting position and record distance from the locating indent. Use this distance when cutting the service part. Cut outer front pillar over 60 mm above inner front pillar cut position.

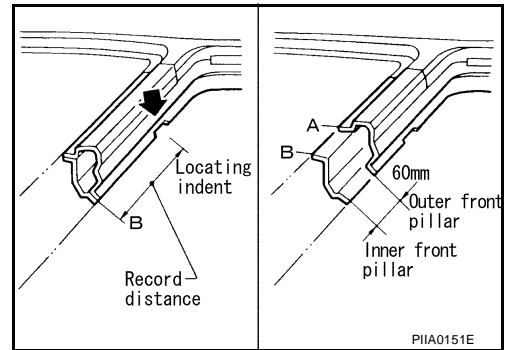

- Prepare a cutting jig to make outer pillar easier to cut. Also, this will permit service part to be accurately cut at joint position.

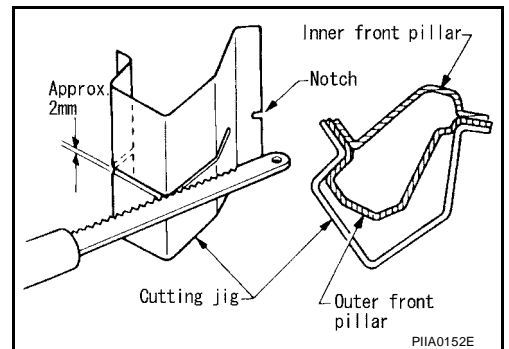

- An example of cutting operation using a cutting jig is as follows.

1. Mark cutting lines.
A: Cut position of outer pillar
B: Cut position of inner pillar
2. Align cutting line with notch on jig. Clamp jig to pillar.
3. Cut outer pillar along groove of jig. (At position A)
4. Remove jig and cut remaining portions.
5. Cut inner pillar at position B in same manner.

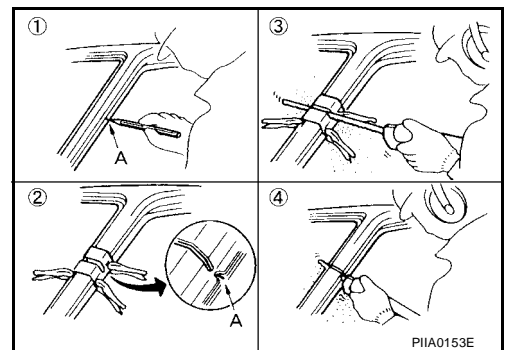

A
B
C
D
E
F
G
H
BL
J
K
L
M

BODY REPAIR

HOODLEDGE (ROADSTER)

Service Joint

Remove front side member center closing plate for easier installation.

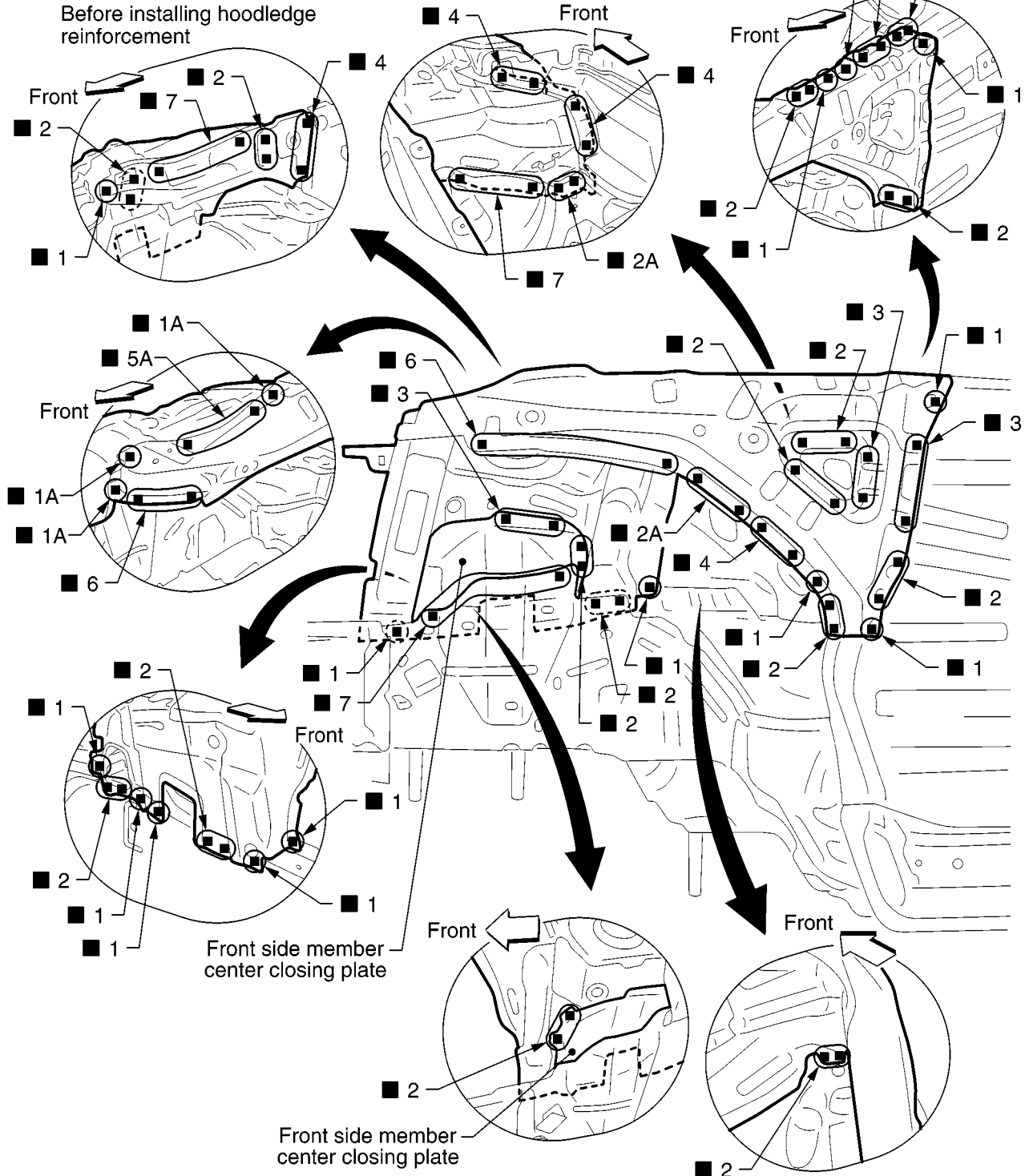

2-spot welds



3-spot welds



M I G plug weld



For 3 panels plug weld method



M I G seam weld/
Point weld



SIIA2314E

Change parts

● Front strut housing (LH)

● Upper front hoodledge (LH)

● Hoodledge reinforcement (LH)

BODY REPAIR

FRONT SIDE MEMBER (ROADSTER)

- Work after hoodledge has been removed.

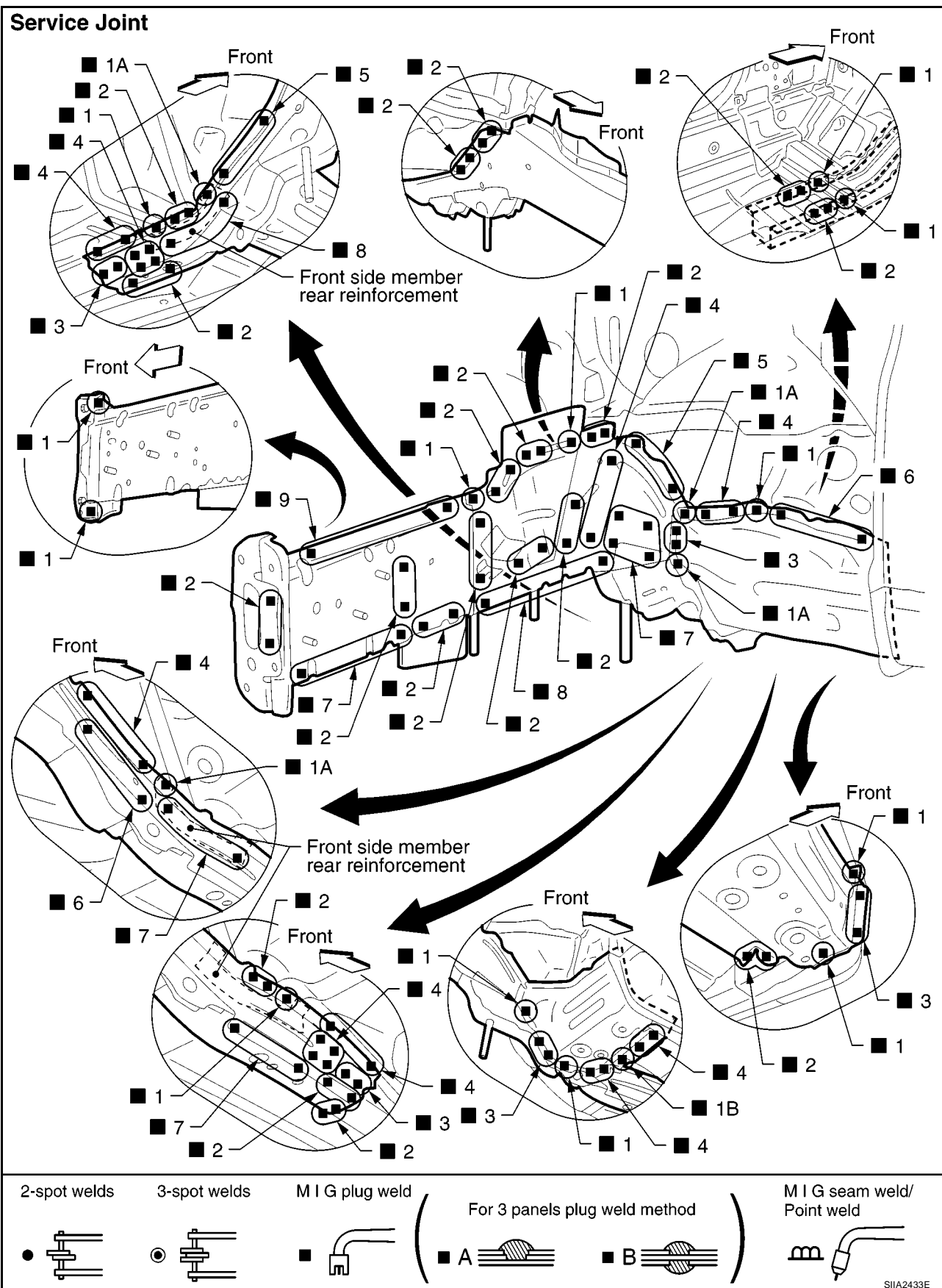

A
B
C
D
E
F
G
H
BL
J
K
L
M

BODY REPAIR

Change parts

- Front side member assembly (LH)
- Front side member closing plate assembly (LH)
- Front side member outrigger assembly (LH)
- Front side member rear reinforcement (LH)

BODY REPAIR

FRONT SIDE MEMBER (PARTIAL REPLACEMENT) (ROADSTER)

A
B
C
D
E
F
G
H
BL
J
K
L
M

Service Joint

(This figure shows right front side member)

Remove stabilizer bracket reinforcement for easier installation.

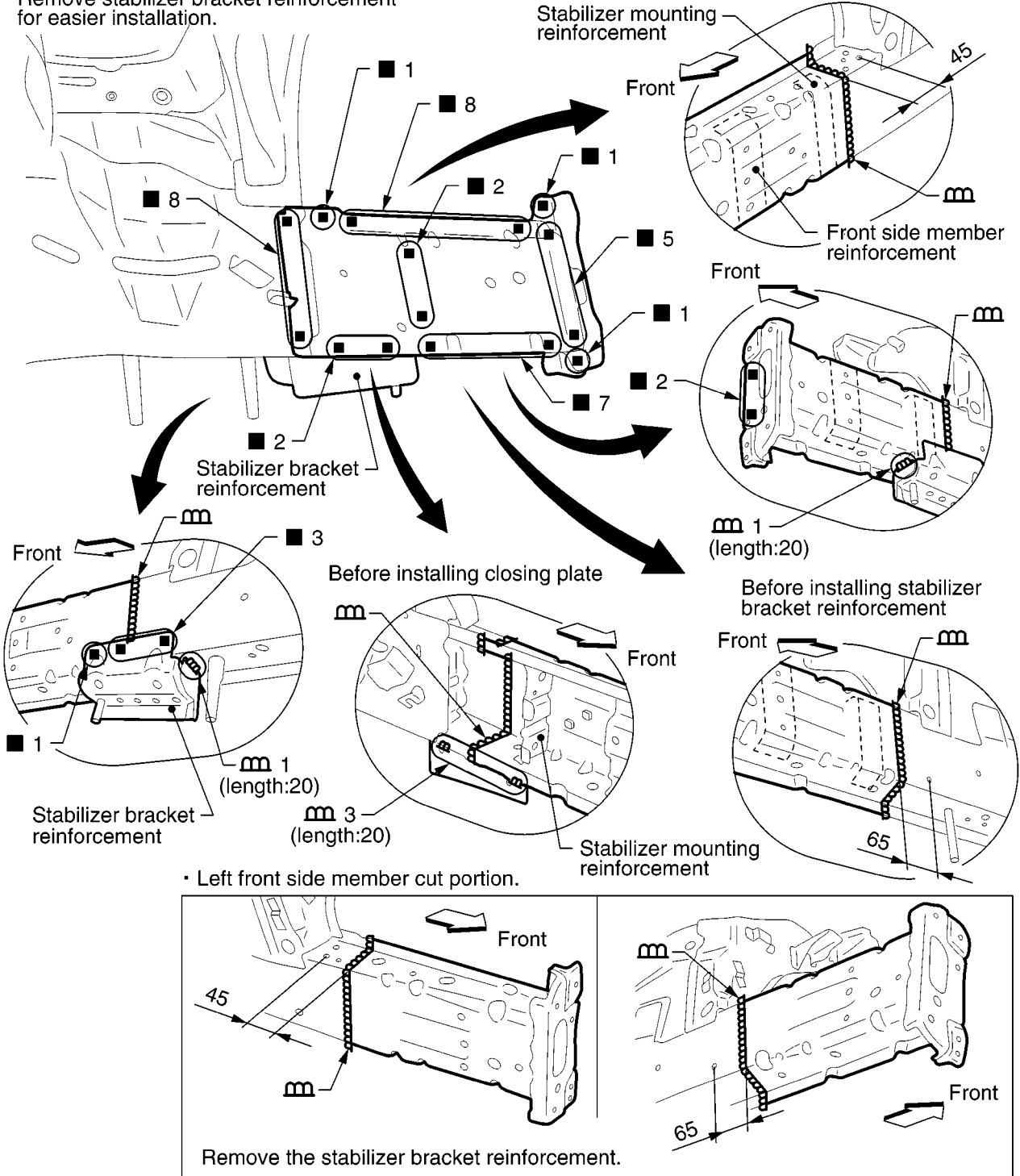

Unit:mm

2-spot welds

3-spot welds

MIG plug weld

(For 3 panels plug weld method)

MIG seam weld/
Point weld



SIIA2316E

Change parts

- Front side member assembly (RH)
- Front side member front closing plate (RH)
- Outer front towing hook bracket (RH)

BODY REPAIR

FRONT PILLAR (ROADSTER)

- Work after hoodledge reinforcement has been removed.

Service Joint

Remove outer sill reinforcement for easier installation.

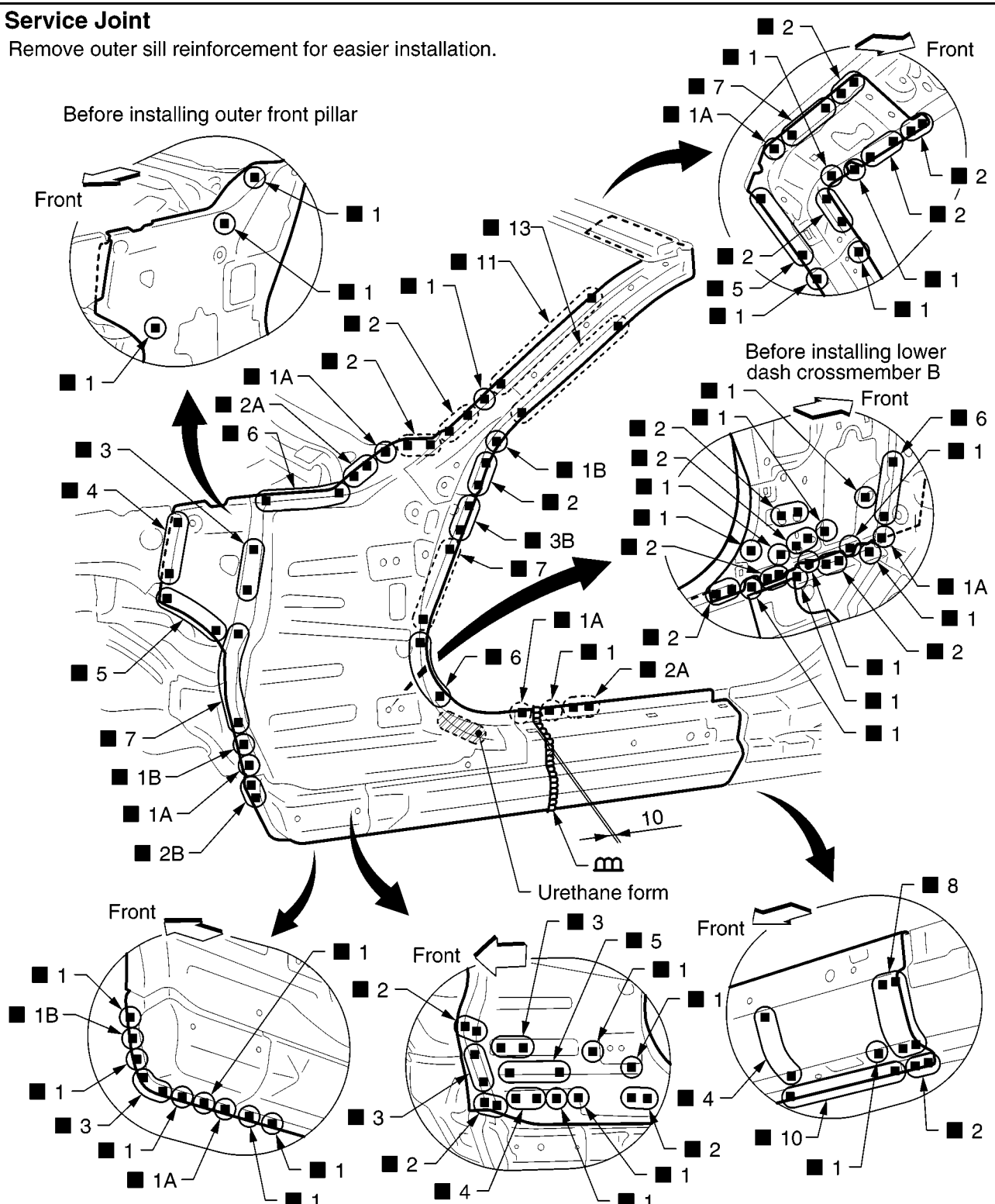

Unit:mm

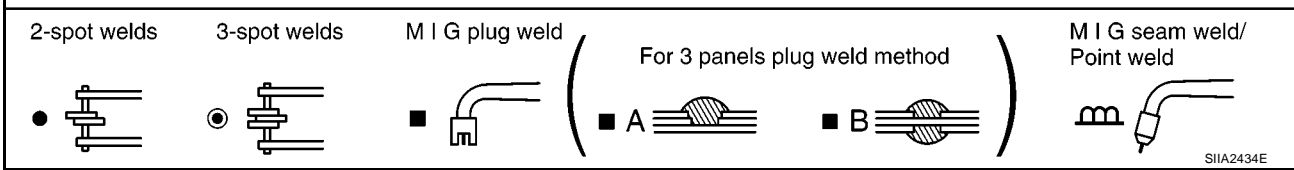

SIIA2434E

BODY REPAIR

Change parts

- Outer front pillar assembly (LH)
- Outer front sill reinforcement assembly (LH)
- Inner side roof rail (LH)
- Upper rear hoodledge (LH)
- Lower front pillar reinforcement assembly (LH)

A
B
C
D
E
F
G
H
BL
J
K
L
M

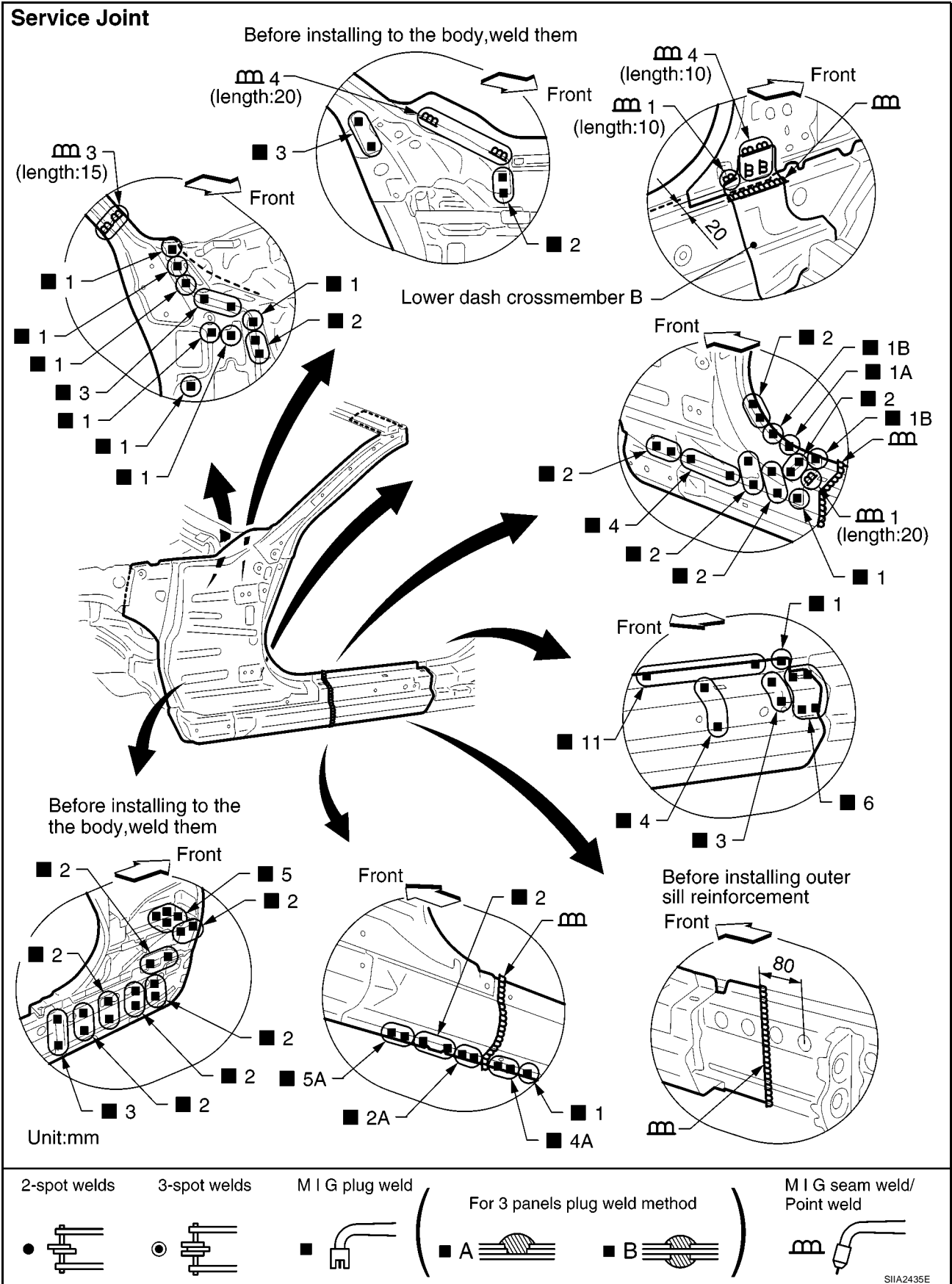

BODY REPAIR

Change parts

- Outer front sill reinforcement assembly (LH)
- Outer rear sill reinforcement assembly (LH)

A

B

C

D

E

F

G

H

BL

J

K

L

M

BODY REPAIR

REAR FENDER (ROADSTER)

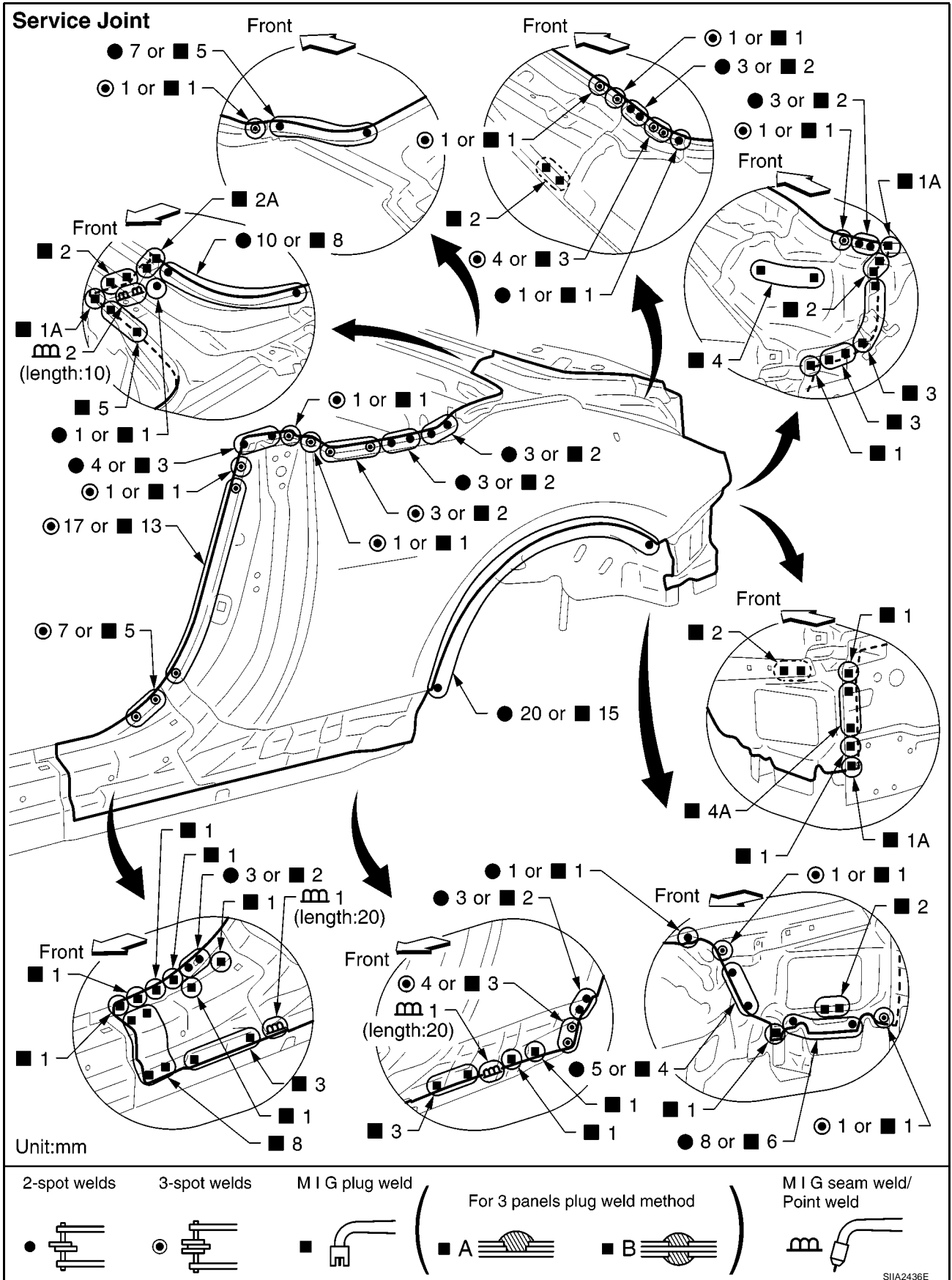

Change parts

- Rear fender assembly (LH)

BODY REPAIR

LOCK PILLAR REINFORCEMENT (ROADSTER)

- Work after rear fender has been removed.

A
B
C
D
E
F
G
H
BL
J
K
L
M

Service Joint

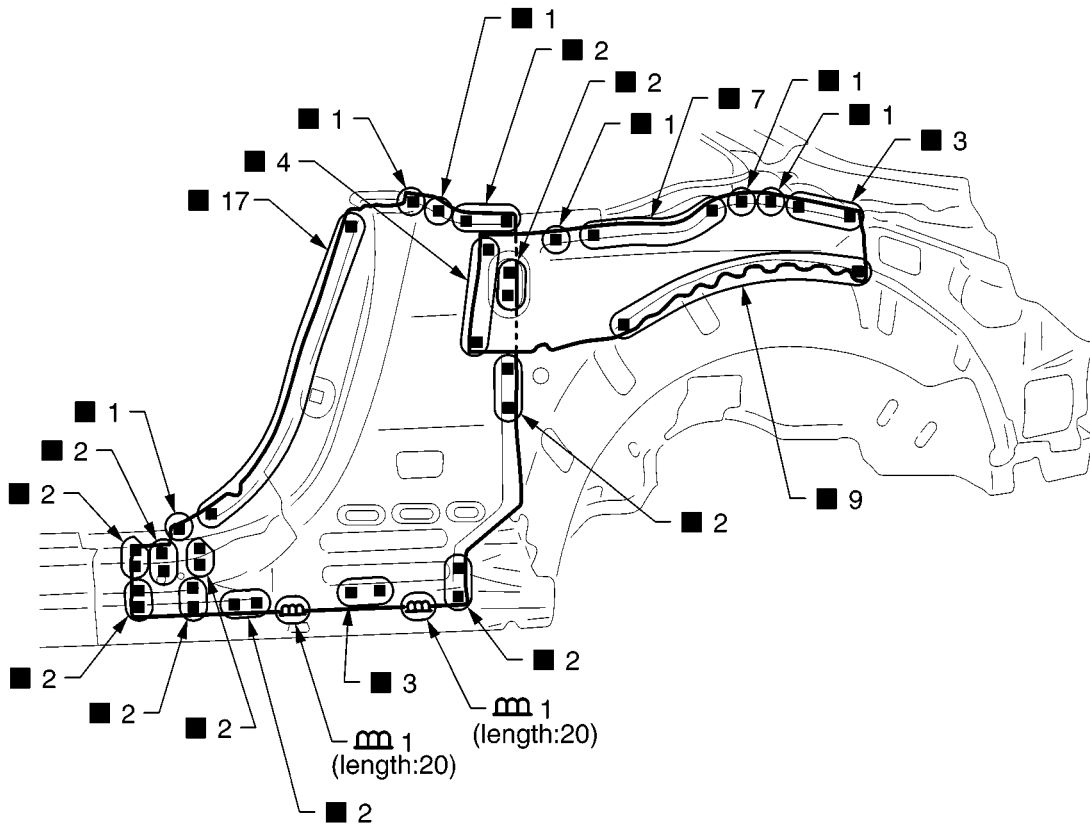

Unit:mm

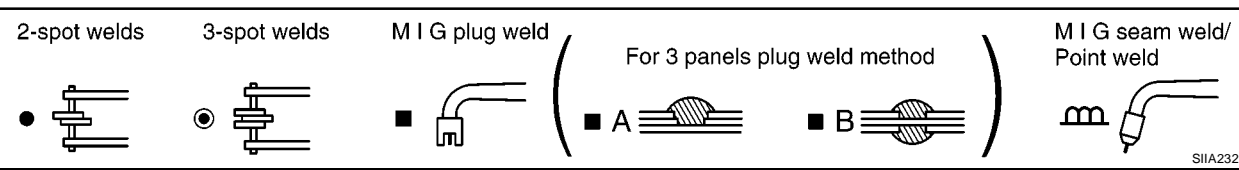

SIIA2321E

BODY REPAIR

Change parts

- Outer lock pillar reinforcement (LH)
- Rear side waist reinforcement (LH)

BODY REPAIR

REAR PANEL (ROADSTER)

Service Joint

Remove rear panel bracket reinforcement for easier installation.

★ indicates that there is an equivalent welding portion with the same dimensions on the opposite side.

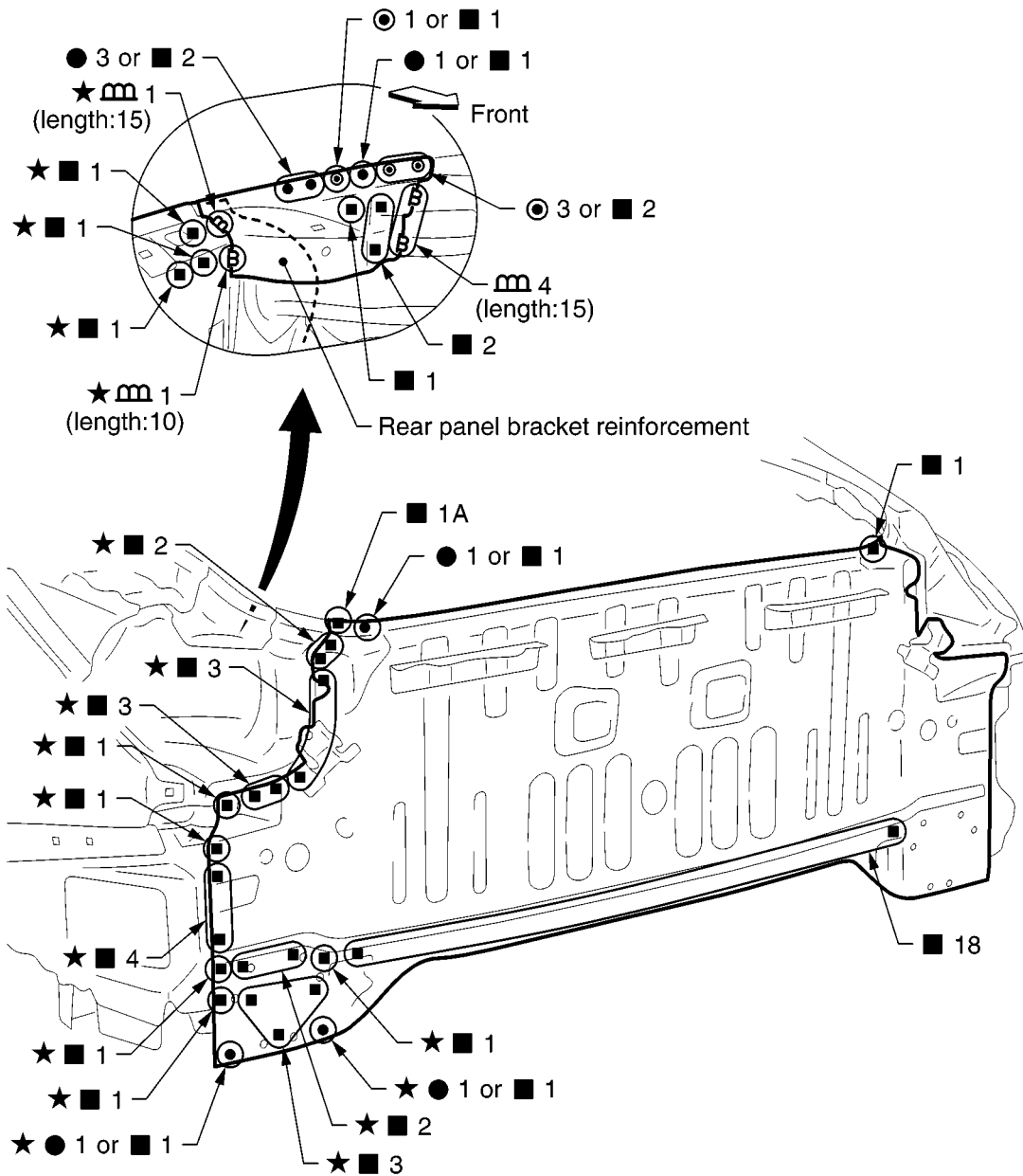

Unit:mm

2-spot welds



3-spot welds



M I G plug weld



For 3 panels plug weld method



M I G seam weld/
Point weld



SIIA2322E

Change parts

- Rear panel assembly

A
B
C
D
E
F
G
H
BL
J
K
L
M

BODY REPAIR

REAR FLOOR REAR (ROADSTER)

- Work after rear panel assembly has been removed.

Service Joint

★ indicates that there is an equivalent welding portion with the same dimensions on the opposite side.

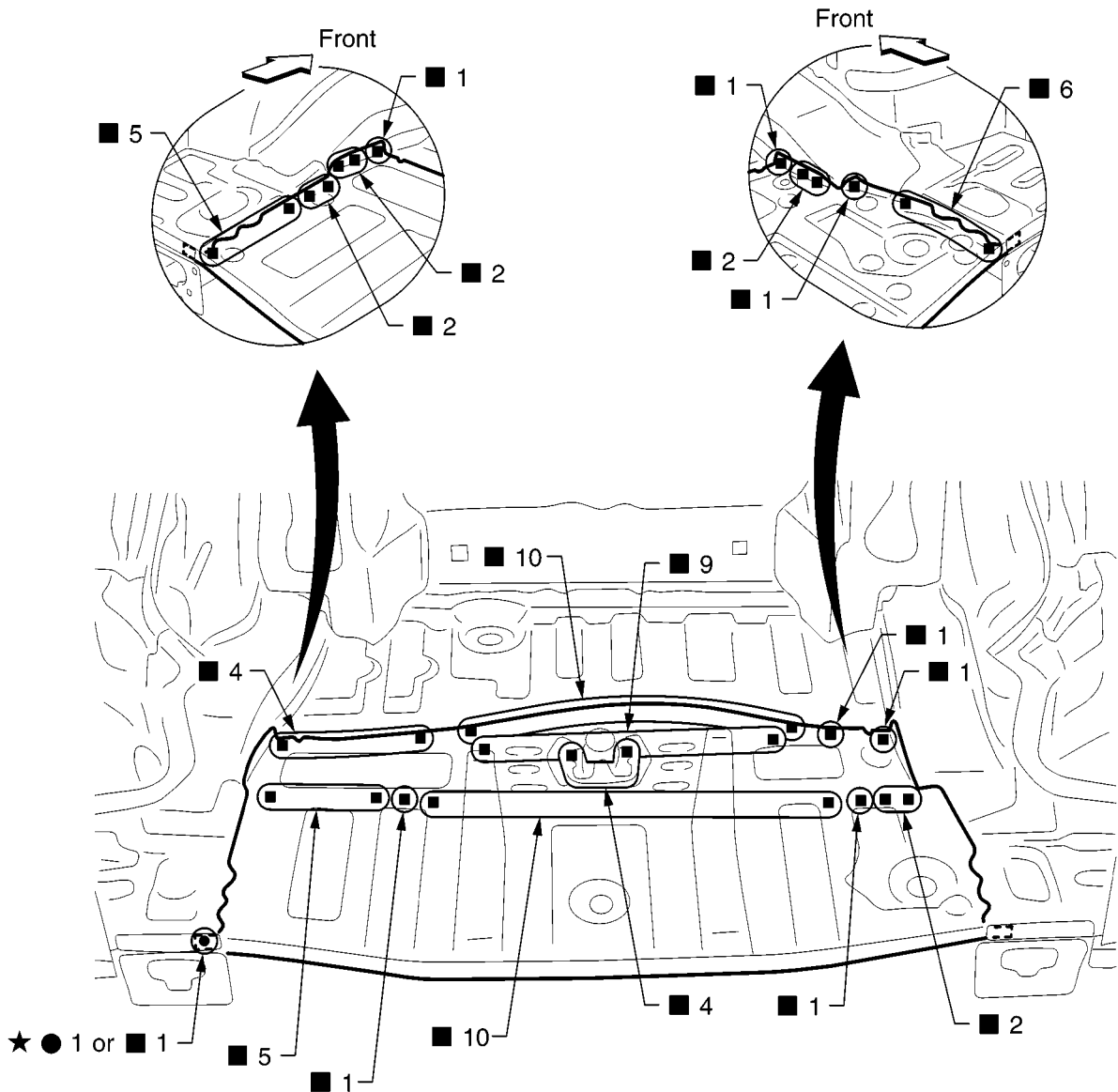

★ ● 1 or ■ 1

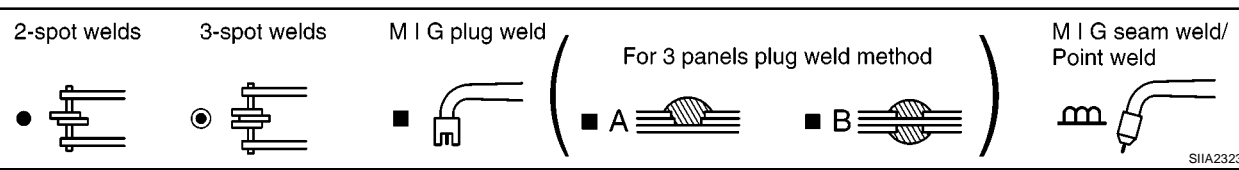

SIIA2323E

BODY REPAIR

Change parts

- Rear floor rear
- Spare tire clamp bracket

A

B

C

D

E

F

G

H

BL

J

K

L

M

BODY REPAIR

REAR SIDE MEMBER EXTENSION (ROADSTER)

- Work after rear panel assembly has been removed.

Service Joint

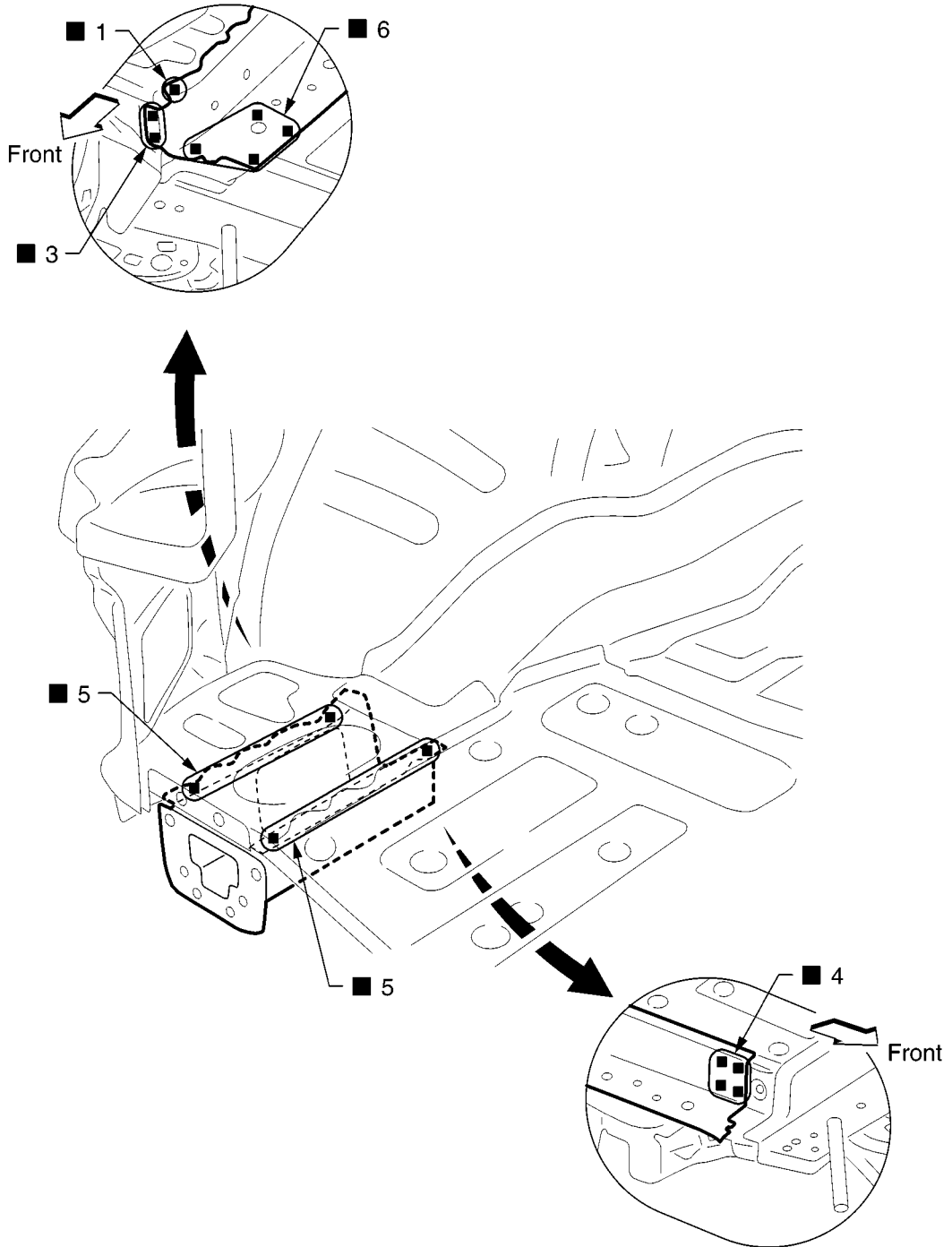

2-spot welds

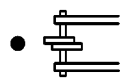

3-spot welds



M I G plug weld



For 3 panels plug weld method



M I G seam weld/
Point weld



SIIA2324E

BODY REPAIR

Change parts

- Rear side member extension (LH)

A

B

C

D

E

F

G

H

BL

J

K

L

M

BODY REPAIR
