

A
B
C
D
E

SECTION **BR** BRAKE SYSTEM

CONTENTS

<p>PRECAUTIONS 3</p> <p> Precautions for Supplemental Restraint System (SRS) "AIR BAG" and "SEAT BELT PRE-TENSIONER" 3</p> <p> Precautions for Battery Service 3</p> <p> Precautions for Brake System 3</p> <p>PREPARATION 4</p> <p> Commercial Service Tools 4</p> <p>NOISE, VIBRATION AND HARSHNESS (NVH)</p> <p>TROUBLESHOOTING 5</p> <p> NVH Troubleshooting Chart 5</p> <p>BRAKE PEDAL 6</p> <p> Inspection and Adjustment 6</p> <p> PLAY AND CLEARANCE BETWEEN THE BRAKE PEDAL AND FLOOR PANEL WITH PEDAL DEPRESSED 6</p> <p> ADJUSTMENT 7</p> <p> Removal and Installation 7</p> <p> COMPONENT PARTS DRAWING 7</p> <p> REMOVAL 8</p> <p> INSPECTION AFTER REMOVAL 8</p> <p> INSTALLATION 8</p> <p>BRAKE FLUID 9</p> <p> On-Board Inspection 9</p> <p> LEVEL CHECK 9</p> <p> Drain and Refill 9</p> <p> Bleeding Brake System 10</p> <p>BRAKE PIPING AND HOSE 11</p> <p> Hydraulic Circuit 11</p> <p> Removal and Installation of the Front Brake Piping Brake Hose (Vehicles With CLZ25VD Caliper) 11</p> <p> REMOVAL 11</p> <p> INSTALLATION 11</p> <p> Removal and Installation of the Front Brake Piping Brake Hose (Vehicles With Brembo OPB27VA Calipers) 12</p> <p> REMOVAL 12</p> <p> INSTALLATION 12</p> <p> Removal and Installation of the Rear Brake Piping Brake Hose (With AD14VE Calipers) 12</p>	<p> REMOVAL 12</p> <p> INSTALLATION 13</p> <p> Removal and Installation of the Rear Brake Piping Brake Hose (With Brembo OPB13VB Calipers) 13</p> <p> REMOVAL 13</p> <p> INSTALLATION 13</p> <p> Inspection After Installation 13</p> <p>BRAKE MASTER CYLINDER 14</p> <p> On-Board Inspection 14</p> <p> LEAK INSPECTION 14</p> <p> Removal and Installation 14</p> <p> REMOVAL 14</p> <p> INSTALLATION 14</p> <p> Components 15</p> <p> Disassembly and Assembly 15</p> <p> MODELS WITHOUT VDC 15</p> <p> MODELS WITH VDC 18</p> <p>BRAKE BOOSTER 22</p> <p> On-Vehicle Service 22</p> <p> OPERATING CHECK 22</p> <p> AIRTIGHT CHECK 22</p> <p> Removal and Installation 22</p> <p> REMOVAL 23</p> <p> INSPECTION AFTER REMOVAL 23</p> <p> INSTALLATION 23</p> <p>VACUUM LINES 24</p> <p> Removal and Installation 24</p> <p> Inspection 24</p> <p> VISUAL INSPECTION 24</p> <p> CHECK VALVE INSPECTION 24</p> <p>FRONT DISC BRAKE (CLZ25VD TYPE) 25</p> <p> On-Board Inspection 25</p> <p> PAD WEAR INSPECTION 25</p> <p> Components 25</p> <p> Removal and Installation of Brake Pad 26</p> <p> REMOVAL 26</p> <p> INSTALLATION 26</p> <p> Removal and Installation of Caliper Assembly 27</p> <p> REMOVAL 27</p>
--	---

BR

G

H

I

J

K

L

M

INSTALLATION	27	Removal and Installation of Caliper Assembly	39
Disassembly and Assembly of Caliper Assembly...	28	REMOVAL	39
DISASSEMBLY	28	INSTALLATION	39
CALIPER INSPECTION	28	Disassembly and Assembly of Caliper Assembly ...	40
ASSEMBLY	29	DISASSEMBLY	40
DISC ROTOR INSPECTION	30	CALIPER INSPECTION	40
BRAKE BURNISHING PROCEDURE	30	ASSEMBLY	41
FRONT DISC BRAKE (OPB27VA TYPE)	31	DISC ROTOR INSPECTION	42
On-Board Inspection	31	REAR DISC BRAKE (OPB13VB TYPE)	44
PAD WEAR INSPECTION	31	On-Board Inspection	44
Component	31	PAD WEAR INSPECTION	44
Removal and Installation of Brake Pad	32	Components	44
REMOVAL	32	Removal and Installation of Brake Pad	45
HOW TO APPLY GREASE TO THE BRAKE PAD..	33	REMOVAL	45
INSTALLATION	33	HOW TO APPLY GREASE TO THE BRAKE PAD..	46
Removal and Installation of Caliper Assembly	34	INSTALLATION	46
REMOVAL	34	Removal and Installation of Caliper Assembly	47
INSTALLATION	34	REMOVAL	47
Disassembly and Assembly of Caliper Assembly...	35	INSTALLATION	47
DISASSEMBLY	35	Disassembly and Assembly of Caliper Assembly ...	47
CALIPER INSPECTION	35	DISASSEMBLY	47
ASSEMBLY	35	CALIPER INSPECTION	48
DISC ROTOR INSPECTION	36	ASSEMBLY	48
BRAKE BURNISHING PROCEDURE	37	DISC ROTOR INSPECTION	49
REAR DISC BRAKE (AD14VE TYPE)	38	SERVICE DATA AND SPECIFICATIONS (SDS)	50
On-Board Inspection	38	General Specifications	50
PAD WEAR INSPECTION	38	Brake Pedal	50
Components	38	Brake Booster	50
Removal and Installation of Brake Pad	39	Check Valve	50
REMOVAL	39	Front Disc Brake	50
INSTALLATION	39	Rear Disc Brake	51

PRECAUTIONS

PRECAUTIONS

PF0:00001

Precautions for Supplemental Restraint System (SRS) “AIR BAG” and “SEAT BELT PRE-TENSIONER”

AFS0027G

The Supplemental Restraint System such as “AIR BAG” and “SEAT BELT PRE-TENSIONER”, used along with a front seat belt, helps to reduce the risk or severity of injury to the driver and front passenger for certain types of collision. This system includes seat belt switch inputs and dual stage front air bag modules. The SRS system uses the seat belt switches to determine the front air bag deployment, and may only deploy one front air bag, depending on the severity of a collision and whether the front occupants are belted or unbelted. Information necessary to service the system safely is included in the SRS and SB section of this Service Manual.

WARNING:

- To avoid rendering the SRS inoperative, which could increase the risk of personal injury or death in the event of a collision which would result in air bag inflation, all maintenance must be performed by an authorized NISSAN/INFINITI dealer.
- Improper maintenance, including incorrect removal and installation of the SRS, can lead to personal injury caused by unintentional activation of the system. For removal of Spiral Cable and Air Bag Module, see the SRS section.
- Do not use electrical test equipment on any circuit related to the SRS unless instructed to in this Service Manual. SRS wiring harnesses can be identified by yellow and/or orange harnesses or harness connectors.

Precautions for Battery Service

AFS0026R

Before disconnecting the battery, lower both the driver and passenger windows. This will prevent any interference between the window edge and the vehicle when the door is opened/closed. During normal operation, the window slightly raises and lowers automatically to prevent any window to vehicle interference. The automatic window function will not work with the battery disconnected.

Precautions for Brake System

AFS0007W

- Recommended fluid is brake fluid “DOT 3”.
- Never reuse drained brake fluid.
- Be careful not to splash brake fluid on painted areas.
- To clean or wash all parts of master cylinder and disc brake caliper, use clean brake fluid.
- Never use mineral oils such as gasoline or kerosene. They will ruin rubber parts of the hydraulic system.
- Use flare nut wrench when removing and installing brake tube.
- When installing brake piping, be sure to check torque.
- Before working, turn the ignition switch OFF and disconnect the connectors for the control unit or the battery negative terminal.
- Burnish the brake contact surfaces after refinishing or replacing drums or rotors, after replacing pads or linings, or if a soft pedal occurs at very low mileage.
Refer to [BR-30, "BRAKE BURNISHING PROCEDURE"](#).

WARNING:

- Clean brake pads and shoes with a waste cloth, then wipe with a dust collector.

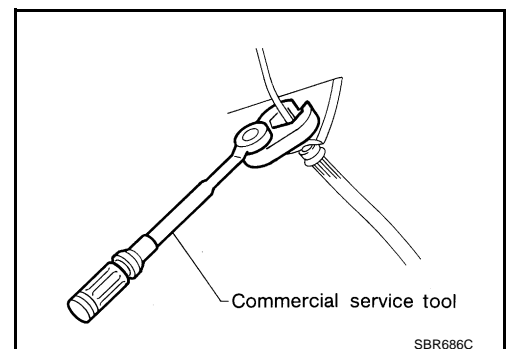

PREPARATION

PREPARATION

PFP:00002

Commercial Service Tools

AFS0007X

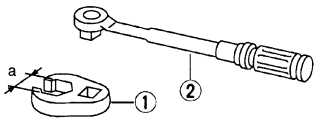
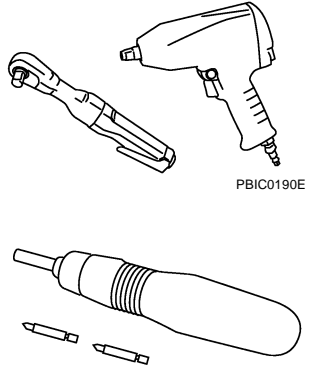
Tool name	Description
<p>1. Flare nut crowfoot a:10 mm (0.39 in)/12mm(0.47 in)</p> <p>2. Torque wrench</p>  <p>S-NT360</p>	<p>Removing and installing each brake piping</p>
<p>Power tool</p>  <p>PBIC0190E</p> <p>PBIC0191E</p>	<p>Removing front and rear caliper assembly, tires</p>

NOISE, VIBRATION AND HARSHNESS (NVH) TROUBLESHOOTING

NOISE, VIBRATION AND HARSHNESS (NVH) TROUBLESHOOTING

PFP:00003

NVH Troubleshooting Chart

AFS0007Y

Use the chart below to help you find the cause of the symptom. If necessary, repair or replace these parts.

Symptom		BRAKE	Possible cause and SUSPECTED PARTS														Reference page						
			Pads - damaged	Pads - uneven wear	Shims damaged	Rotor imbalance	Rotor damage	Rotor runout	Rotor deformation	Rotor deflection	Rotor rust	Rotor thickness variation	Drum out of round	PROPELLER SHAFT	DIFFERENTIAL	AXLE AND SUSPENSION		TIRES	ROAD WHEEL	DRIVE SHAFT	STEERING		
Noise	BRAKE	Noise	x	x	x																BR-26, BR-32, BR-39, BR-45		
		Shake				x																BR-25, BR-31, BR-38, BR-44	
		Shimmy, Judder				x	x	x	x	x	x											BR-25, BR-31, BR-38, BR-44	
Shake	BRAKE	Noise																					
		Shake																					
		Shimmy, Judder																					
Shimmy, Judder	BRAKE	Noise																					
		Shake																					
		Shimmy, Judder																					

x: Applicable

A
B
C
D
E
BR
G
H
I
J
K
L
M

BRAKE PEDAL

BRAKE PEDAL

PFPA:46501

Inspection and Adjustment

AFS0007Z

PLAY AND CLEARANCE BETWEEN THE BRAKE PEDAL AND FLOOR PANEL WITH PEDAL DEPRESSED

1. Check the brake pedal free height from the dash lower panel.
2. Adjust the height referring to the following specifications.

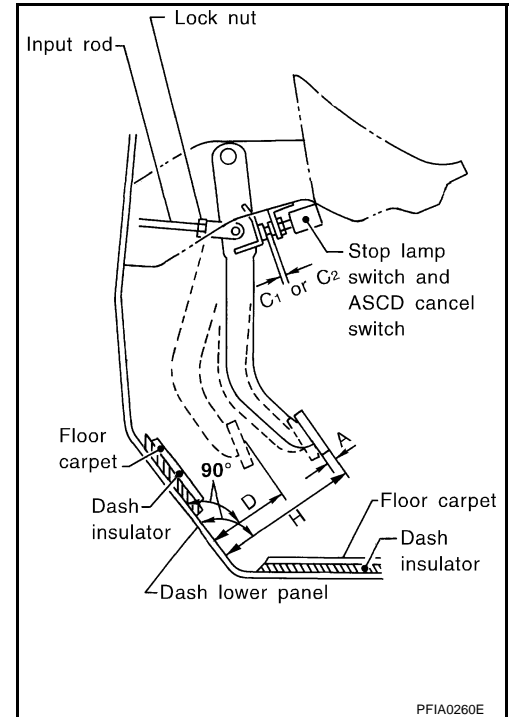

H	Brake pedal height (from dash lower panel top surface)	M/T Model	154 - 164 mm (6.06- 6.46 in)
		A/T model	162 - 172 mm (6.38 - 6.77 in)
D	Depressed pedal height (under a force of 490 N (50 kg, 110 lb) with the engine running)	M/T Model	More than 90 mm (3.54 in)
		A/T Model	More than 95 mm (3.74 in)
C1 or C2	Clearance between the stopper rubber and the threaded end of the stop lamp switch and ASCD cancel switch.		0.74 - 1.96 mm (0.0291 - 0.0772 in)
A	Pedal play		3 - 11 mm (0.12 - 0.43 in)

BRAKE PEDAL

ADJUSTMENT

1. Loosen the stop lamp switch and ASCD cancel switch by rotating it counterclockwise by 45°.
2. Loosen the lock nut (A) on the input rod, then rotate the input rod to set the pedal to the specified height, and tighten the lock nut (A) to the specified torque. Refer to [BR-22, "BRAKE BOOSTER"](#).

CAUTION:

Check that the threaded end of the input rod stays inside the clevis.

3. With the pedal pulled and held by hand, press the stop lamp switch and ASCD cancel switch until its threaded end contacts the stopper rubber.
4. With the threaded end of the stop lamp switch contacting the stopper rubber and ASCD cancel switch, rotate the switch clockwise by 45° to secure.

CAUTION:

Make sure that the clearance (C) between the stopper rubber and threaded end of the stop lamp switch and ASCD cancel switch is within the standard.

5. Check the pedal play.

CAUTION:

Make sure that the stop lamps go off when the pedal is released.

6. Start the engine to check the brake pedal's depressed height.

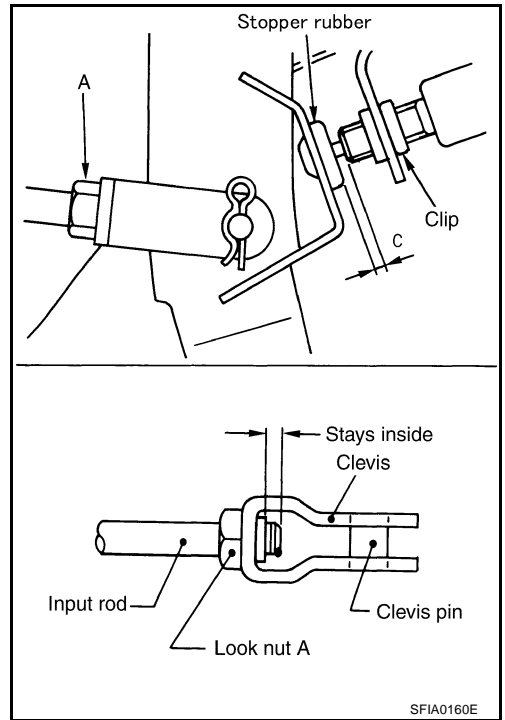

Removal and Installation COMPONENT PARTS DRAWING

AFS00080

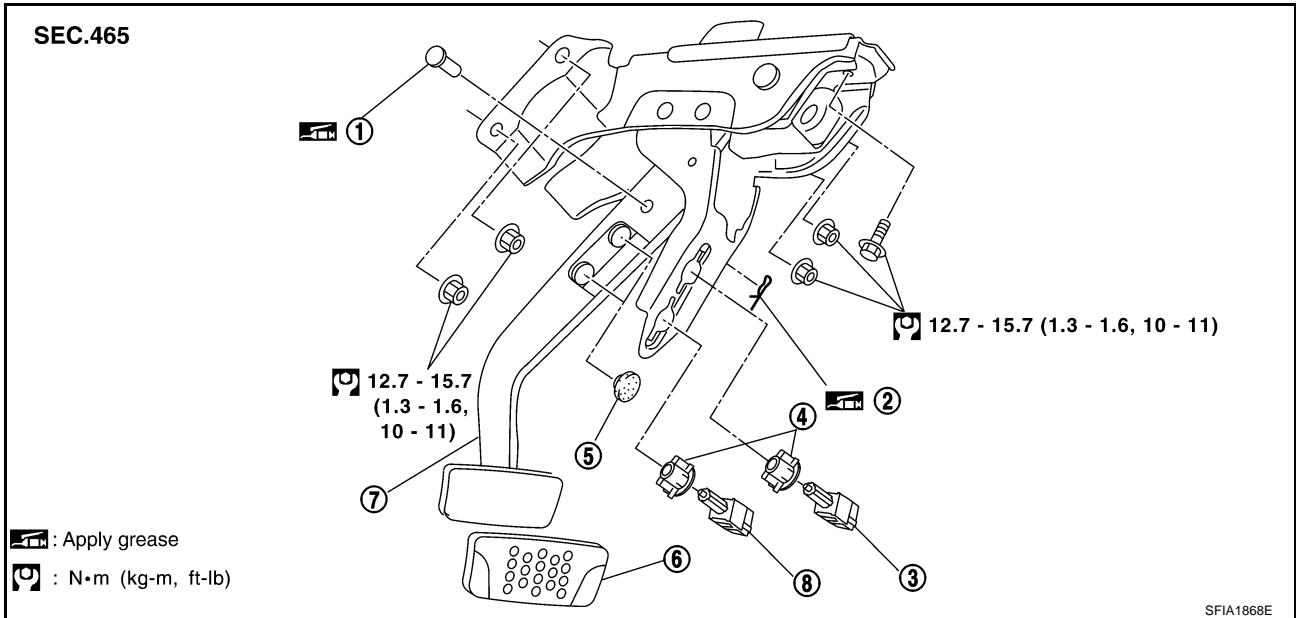

- | | | |
|-------------------------|---------------------|-----------------------|
| 1. Clevis pin | 2. Snap pin | 3. ASCD cancel switch |
| 4. Clip | 5. Stopper rubber | 6. Pedal pad |
| 7. Brake pedal assembly | 8. Stop lamp switch | |

BRAKE PEDAL

REMOVAL

1. Remove the lower driver-side instrument panel. Refer to [IP-10, "INSTRUMENT PANEL ASSEMBLY"](#) .
2. Remove the steering column. Refer to [PS-10, "STEERING COLUMN"](#) .
3. Remove the stop lamp switch and ASCD cancel switch from the pedal assembly.
4. Remove the snap pin and clevis pin from the brake booster clevis.
5. Remove the mounting nuts and bolt from the bracket, and remove the pedal assembly from the vehicle.

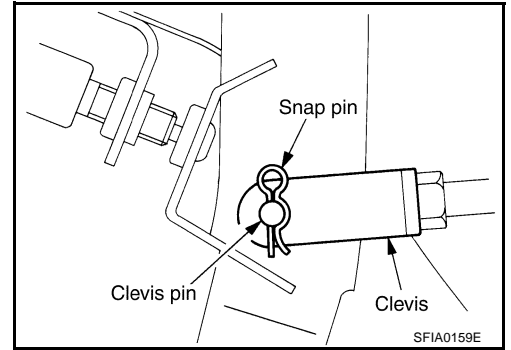

INSPECTION AFTER REMOVAL

- Check that the rivets in the upper part of the brake pedal are not deformed.
 - Make sure the sub bracket and the slide plate are at least 4 mm (0.16 in) apart.
-
- Check the brake pedal for bend, damage, and cracks on the welded parts. Replace the applicable part if a failure is detected.
 - Check the clevis pin and resin stopper for damage and deformation. If a failure is detected, replace the clevis pin.

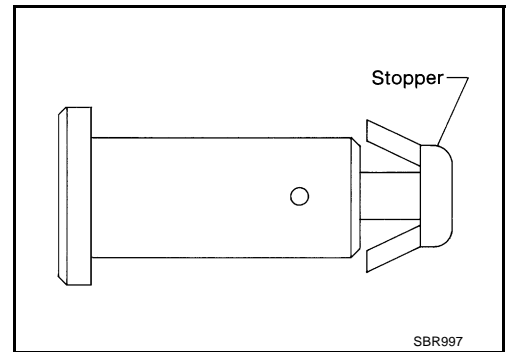
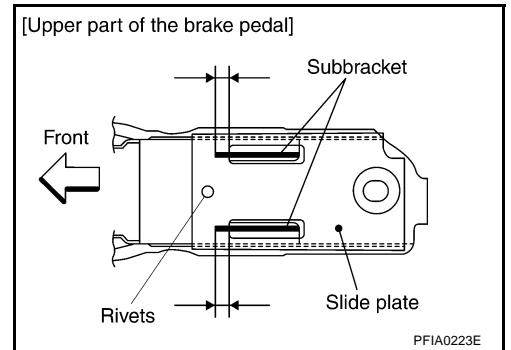

INSTALLATION

Paying attention to the following items, install in the reverse order of removal.

- After installing the brake pedal assembly to the vehicle, adjust the brake pedal.

BRAKE FLUID

BRAKE FLUID

PFP:KN100

On-Board Inspection LEVEL CHECK

AFS000TY

- Check that the fluid level in the reservoir tank is within the standard (between MAX and MIN lines).
- Visually check around the reservoir tank for fluid leaks.
- If fluid level is excessively low, check brake system for leaks.
- If warning lamp remains illuminated after parking lever is released, check brake system for fluid leakage.

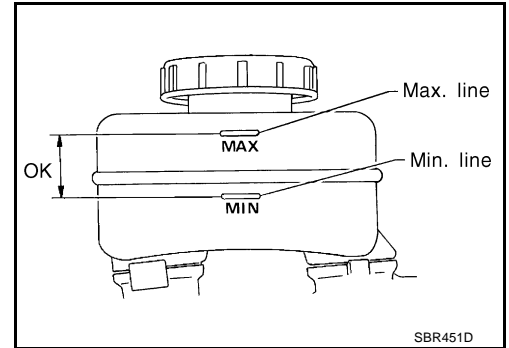

Drain and Refill

AFS000TZ

CAUTION:

- Refill with new brake fluid "DOT3".
- Never reuse drained brake fluid.
- Do not let brake fluid come in contact with painted surfaces on the body. This might damage the paint, so if it does come in contact, immediately wipe area and wash off with water.

1. Connect a vinyl tube to bleed valve.
2. Depress the brake pedal, loosen the bleed valve, and gradually remove the brake fluid.
3. Turn the key switch to the off position and remove the battery negative terminal.

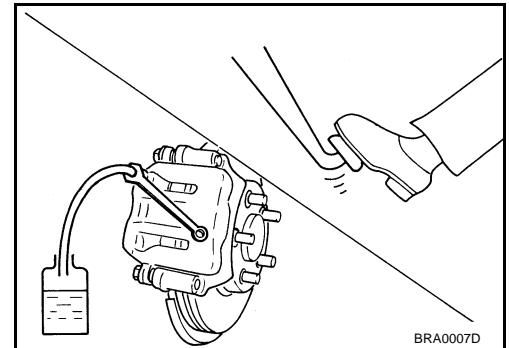

4. Make sure there is no foreign material in the reservoir tank, and refill with new brake fluid.
5. Rest foot on brake pedal. Loosen bleed valve. Slowly depress pedal until it stops. Tighten bleed valve. Release brake pedal. Repeat this process a few times, then pause to add new brake fluid to master cylinder. Continue until new brake fluid flows out. Bleed Air. Refer to [BR-10, "Bleeding Brake System"](#) .

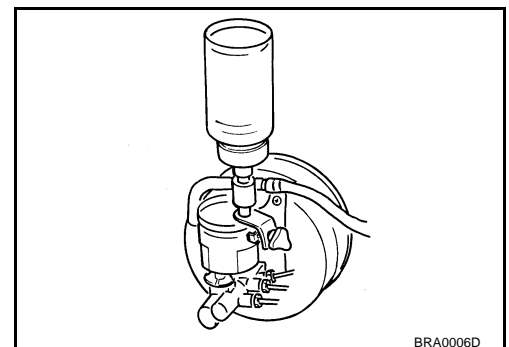

Bleeding Brake System

AFS000U0

CAUTION:

While bleeding, pay attention to master cylinder fluid level.

1. Turn the ignition switch to the OFF position.
2. Connect a vinyl tube to the rear right bleed valve.
3. Fully depress brake pedal 4 to 5 times.
4. With the brake pedal depressed, loosen the bleed valve to let the air out, and then tighten it immediately.
5. Repeat steps 3, 4 until no more air comes out.
6. Tighten the bleed valve to the specified torque. Refer to [BR-25, "Components"](#) ,[BR-31, "Component"](#) ,[BR-38, "Components"](#) ,[BR-44, "Components"](#) .
7. In steps 2 to 6 below, with the master cylinder reservoir tank filled at least half way, bleed air from the front left, rear left, and front right tires, in that order.

BRAKE PIPING AND HOSE

PFP:46210

Hydraulic Circuit

AFS000U1

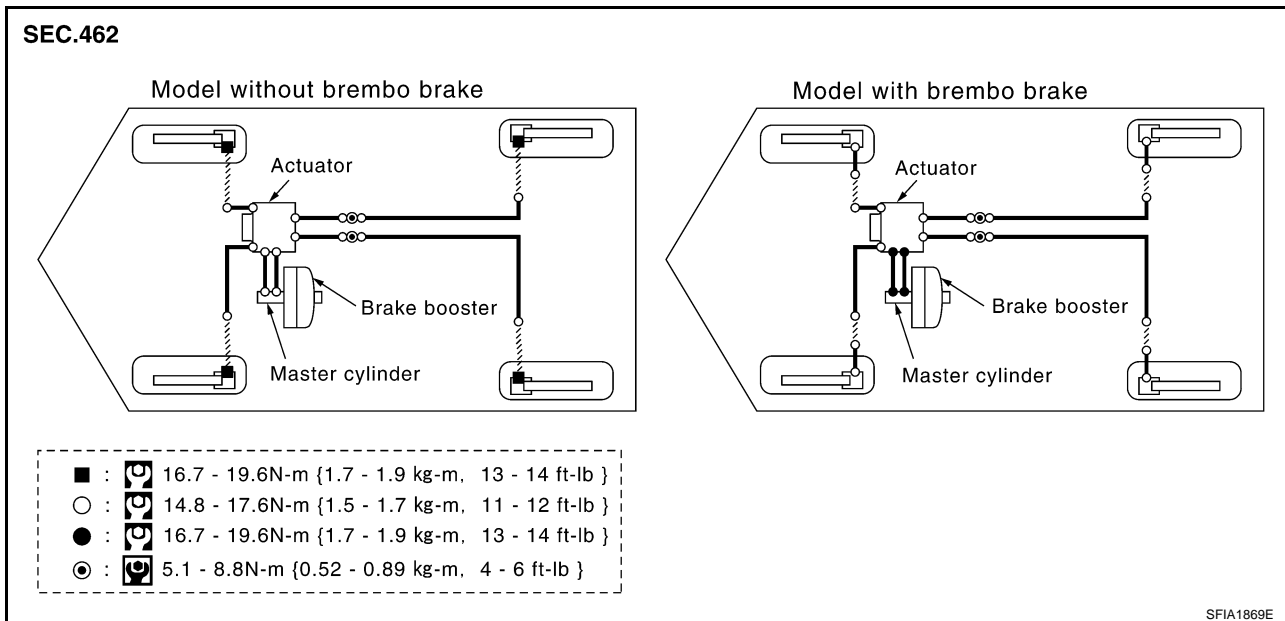

CAUTION:

- Make sure it does not twist or break when being attached.
- Make sure there is no interference with other parts when turning steering both clockwise and counterclockwise.
- The brake piping is an important safety part. If a brake fluid leak is detected, always disassemble the parts. Replace applicable part with a new one, if necessary.
- Do not let brake fluid come in contact with painted surfaces on the body. This might damage the paint, so if it does come in contact, immediately wipe area and wash off with water.
- Do not bend or twist brake hose sharply, or strongly pull it.
- When removing components, cover connections so that no dirt, dust, or other foreign matter gets in.
- Refill with new brake fluid " DOT 3 "
- Never reuse drained brake fluid.

Removal and Installation of the Front Brake Piping Brake Hose (Vehicles With CLZ25VD Caliper)

AFS000U3

REMOVAL

1. Drain brake fluid. Refer to [BR-9, "Drain and Refill"](#) .
2. Using a flare nut wrench, remove brake tube from brake hose.
3. Remove union bolt and remove the brake hose from the caliper assembly.
4. Remove the lock plate and nut, and remove the brake hose from the vehicle.

INSTALLATION

1. Attach the brake hose to the vehicle and tighten the nut to the specified torque.

: 19.6 - 23.5 N-m (2.0 - 2.3 kg-m, 15 - 17 ft-lb)

NOTE:

When removed bracket attaching the bolt is tightened with provisions torque.

: 10.8 - 15.6 N-m (1.1 - 1.5 kg-m, 8 - 11 ft-lb)

2. Install brake hose by aligning with the protrusion on caliper assembly, and tighten union bolts to the specified torque.

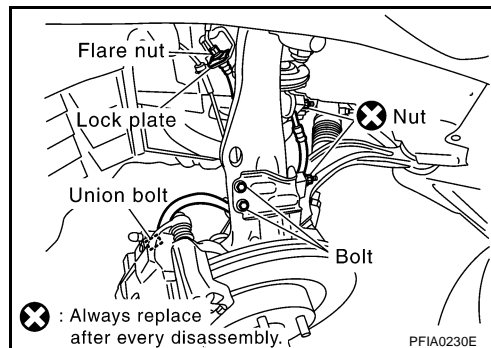

BRAKE PIPING AND HOSE

 : 16.7 - 19.6 N-m (1.7 - 1.9 kg-m, 13 - 14 ft-lb)

CAUTION:

Do not reuse the copper washer.

3. Attach the brake hose to the brake tube, partially tighten the flare nut as far as possible by hand, then secure it to the bracket with the lock plate.
4. Using a flare nut wrench, tighten the flare nut to the specified torque.

 : 14.8 - 17.6 (1.5 - 1.7 kg-m, 11 - 12 ft-lb)

5. Refill brake fluid and bleed air. Refer to [BR-9, "Drain and Refill"](#) .

Removal and Installation of the Front Brake Piping Brake Hose (Vehicles With Brembo OPB27VA Calipers)

AFS000XZ

REMOVAL

1. Drain brake fluid. Refer to [BR-9, "Drain and Refill"](#) .
2. Using a flare nut wrench, remove the brake tube from the brake hose.
3. Using a flare nut wrench, remove the caliper-side brake tube from the brake hose.
4. Remove the lock plate and nut, and remove the brake hose from the vehicle.

INSTALLATION

1. Attach the brake hose to the vehicle and tighten the nut to the specified torque.

 **Nut** : 19.6 - 23.5 N-m (2.0 - 2.3 kg-m, 15 - 17 ft-lb)

 **Bolt** : 10.8 - 15.6 N-m (1.1 - 1.5 kg-m, 8 - 11 ft-lb)

2. Attach the caliper-side brake tube to the brake hose, partially tighten the flare nut as far as possible by hand, then tighten it to the specified torque with flare nut torque wrench.

 : 14.8 - 17.6 N-m (1.5 - 1.7 kg-m, 11 - 12 ft-lb)

3. Attach the brake hose to the brake tube, partially tighten the flare nut as far as possible by hand, then secure to the bracket with the lock plate.
4. Using a flare nut torque wrench, tighten the flare nut to the specified torque with flare nut torque.

 : 14.8 - 17.6 N-m (1.5 - 1.7 kg-m, 11 - 12 ft-lb)

5. Refill brake fluid and bleed air. Refer to [BR-10, "Bleeding Brake System"](#)

Removal and Installation of the Rear Brake Piping Brake Hose (With AD14VE Calipers)

AFS000U4

REMOVAL

1. Drain brake fluid. Refer to [BR-9, "Drain and Refill"](#) .
2. Using a flare nut wrench, remove brake tube from brake hose.
3. Remove union bolts, and then remove brake hose from the caliper assembly.
4. Remove the lock plate and then remove the brake hose from the vehicle.

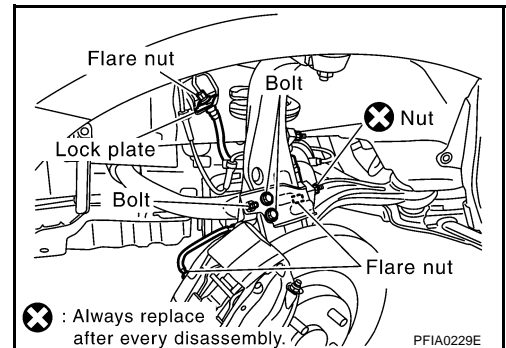

BRAKE PIPING AND HOSE

INSTALLATION

1. Attach the brake hose L-pin to the caliper assembly positioning hole and tighten the union bolt to the specified torque.

 : 1 6.7 - 19.6 N·m (1.7 - 1.9 kg-m, 13 - 14 ft-lb)

CAUTION:

Do not reuse the copper washer.

2. After securing the brake hose to the vehicle with the lock plate, partially tighten the brake tube flare nut as far as possible by hand and then tighten to the specified torque with flare nut torque wrench.

 : 14.8 - 17.6 N·m (1.5 - 1.7 kg-m, 11 - 12 ft-lb)

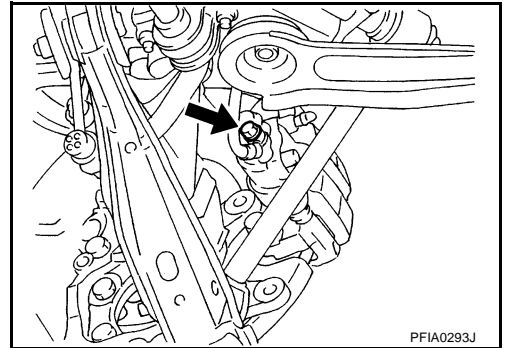

3. Refill brake fluid and bleed air. Refer to [BR-10, "Bleeding Brake System"](#).

Removal and Installation of the Rear Brake Piping Brake Hose (With Brembo OPB13VB Calipers)

AFS000U5

REMOVAL

1. Drain brake fluid. Refer to [BR-9, "Drain and Refill"](#).
2. Using a flare nut wrench, remove the brake tube from the brake hose.
3. Using a flare nut wrench, remove the caliper-side brake tube from the brake hose.
4. Remove the lock plate and bolt, and remove the brake hose from the vehicle.

INSTALLATION

1. Attach the brake hose to the vehicle and tighten the bolt to the specified torque.

 : 19.6 - 23.5 N·m (2.0 - 2.3 kg-m, 15 - 17 ft-lb)

2. Attach the caliper-side brake tube to brake hose, partially tighten the flare nut as far as possible by hand, then tighten it to the specified torque with flare nut torque wrench.

 : 14.8 - 17.6 N·m (1.5 - 1.7kg-m, 11 - 12 ft-lb)

3. Attach the brake hose to the brake tube, partially tighten the flare nut as far as possible by hand, then secure to the bracket with the lock plate.
4. Using a flare nut torque wrench, tighten the flare nut to the specified torque.

 : 14.8 - 17.6 N·m (1.5 - 1.7 kg-m, 11 - 12 ft-lb)

5. Refill brake fluid and bleed air. Refer to [BR-10, "Bleeding Brake System"](#).

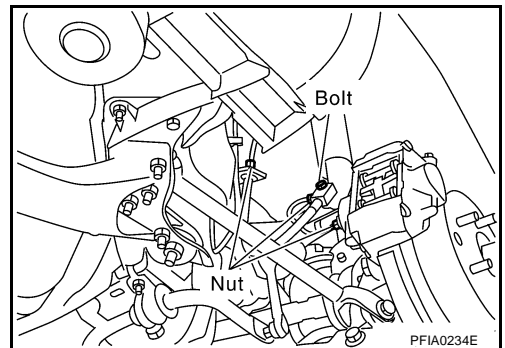

Inspection After Installation

AFS000U6

CAUTION:

If a leak is detected at the connections, retighten it or, if necessary, replace the damaged part.

1. Check hose, tube, and connections for fluid leaks, damage, twist, deformation, contact with other parts, and loose connections.
2. While depressing pedal under a force of 785 N (80 kg, 177 lb) with engine running for approximately 5 seconds, check for fluid leakage from each part.

BRAKE MASTER CYLINDER

BRAKE MASTER CYLINDER

PFP:46010

On-Board Inspection LEAK INSPECTION

AFS000U7

- Check for leaking in the master cylinder installation surface, the reservoir tank installation surface, and the brake tube connections.

Removal and Installation

AFS000U8

CAUTION:

Do not let brake fluid come in contact with painted surfaces on the body. This might damage the paint, so if it does come in contact, immediately wipe area and wash off with water.

REMOVAL

1. Drain brake fluid. Refer to [BR-9, "Drain and Refill"](#) .
2. Remove the fluid surface sensor harness connector.
3. Using a flare nut wrench, disconnect master cylinder assembly and brake tube.
4. Remove the master cylinder assembly nut and remove the master cylinder assembly from the vehicle. Refer to [BR-22, "Removal and Installation"](#) .

INSTALLATION

CAUTION:

- Refill with new brake fluid "DOT3".
 - Never reuse drained brake fluid.
1. Attach the master cylinder assembly to the brake booster assembly and tighten the nut to the specified torque. [BR-22, "Removal and Installation"](#)

CAUTION:

Vehicles equipped with VDC require particular attention when conducting the following installation.

- Make sure the sliding surface of the primary piston rod is not damaged, and that no foreign matter become attached.
 - Do not reuse the O-ring on the rear end of the master cylinder as it is a non-reusable part.
 - Apply the silicon grease in the inner kit to and around the O-ring at the rear end of the master cylinder and to the inside of the booster.
2. Install brake tube to master cylinder assembly and temporarily tighten flare nuts by hand.
 3. Tighten the brake tube flare nut to the specified torque with flare nut torque wrench. Refer to [BR-11, "Hydraulic Circuit"](#) .
 4. Refill brake fluid and bleed air. Refer to [BR-10, "Bleeding Brake System"](#) .

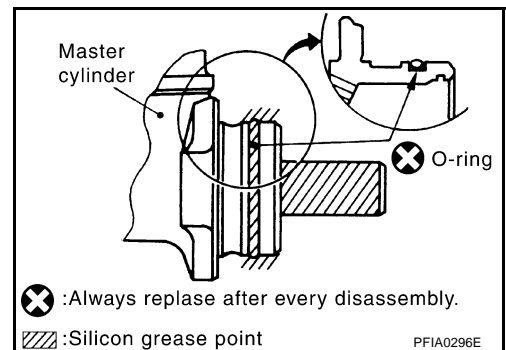

BRAKE MASTER CYLINDER

Components

AFS0010N

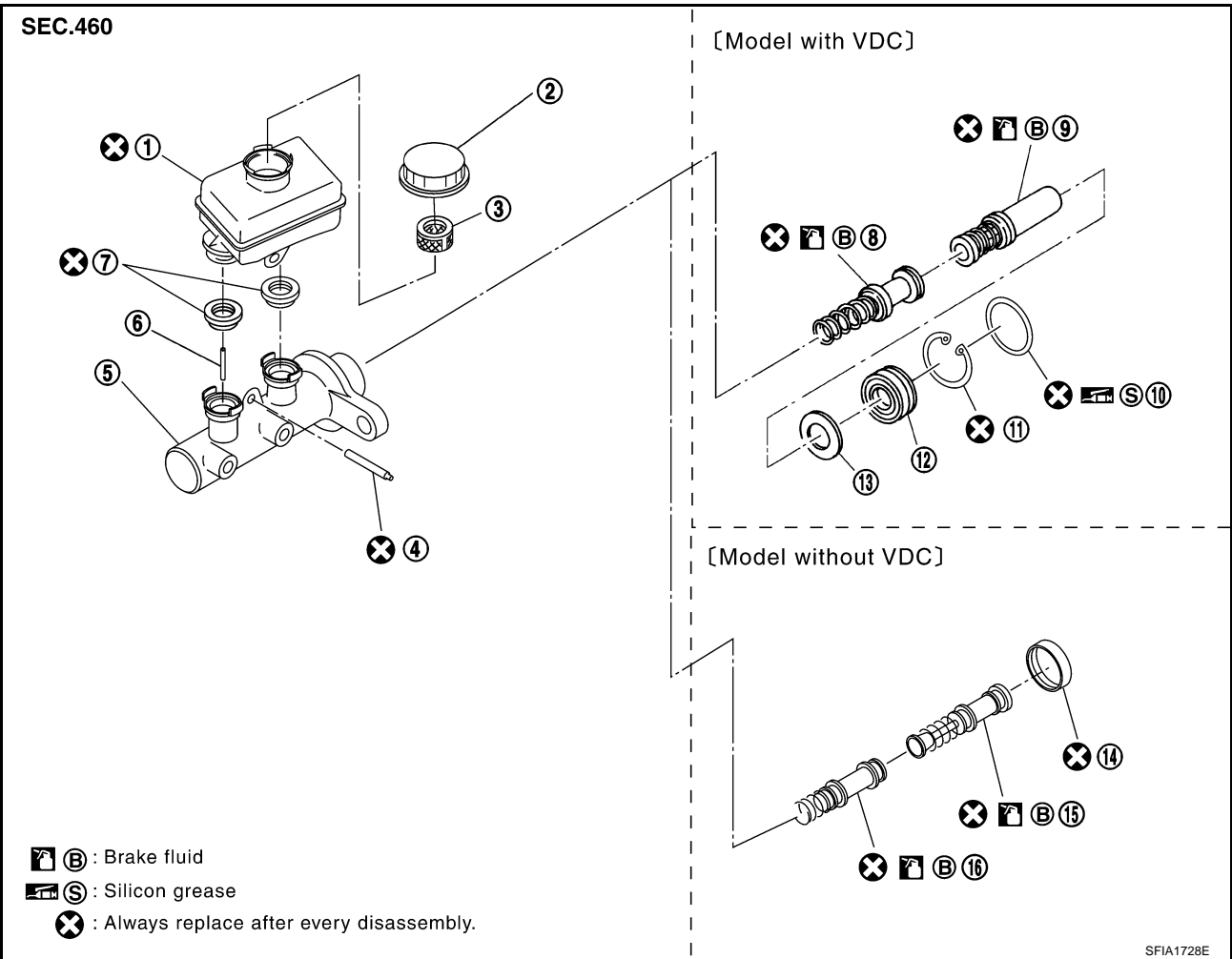

A
B
C
D
E
BR
G
H
I
J
K
L
M

- | | | |
|-------------------------------|------------------------------|-----------------------------|
| 1. Reservoir tank | 2. Reservoir cap | 3. Oil strainer |
| 4. Pin | 5. Cylinder body | 6. Piston stopper |
| 7. Grommet | 8. Secondary piston assembly | 9. Primary piston assembly |
| 10. O-ring | 11. Snap ring | 12. Guide assembly |
| 13. Plate | 14. Stopper cap | 15. Primary piston assembly |
| 16. Secondary piston assembly | | |

Disassembly and Assembly MODELS WITHOUT VDC

AFS000U9

Disassembly

CAUTION:

Only remove the reservoir tank when absolutely necessary.

- Using a flat-bladed screwdriver as shown in the figure, lift up the tabs on the stopper cap and remove it from the master cylinder. The piston inside the master cylinder might pop out when this is done, so hold the stopper cap down at the same time.

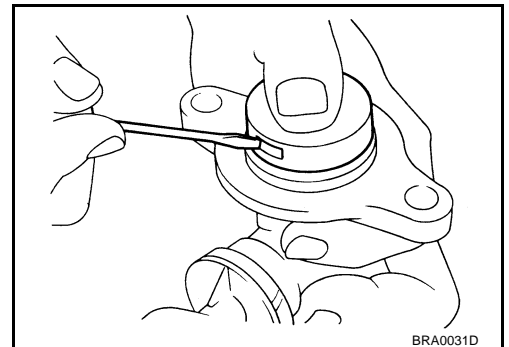

BRAKE MASTER CYLINDER

2. Attach the attachment in the inner kit to the reservoir cap as shown in the figure.

CAUTION:

When attaching the attachment to the reservoir cap, make sure it is pointing in the right direction.

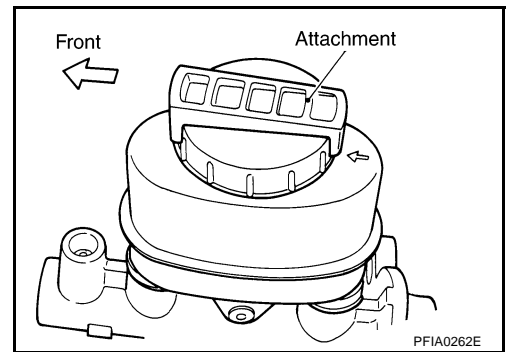

3. Place the side of the cylinder body with chamfering around the pin insertion hole facing up, and secure the master cylinder assembly with a vise.

CAUTION:

- Tighten without letting the pin securing the reservoir tank and cylinder body come in contact with the pin insertion hole of the reservoir tank.
- When securing the master cylinder assembly with the vise, be sure not to over-tighten.
- When securing in a vise, use copper plates or cloth to protect the flange.

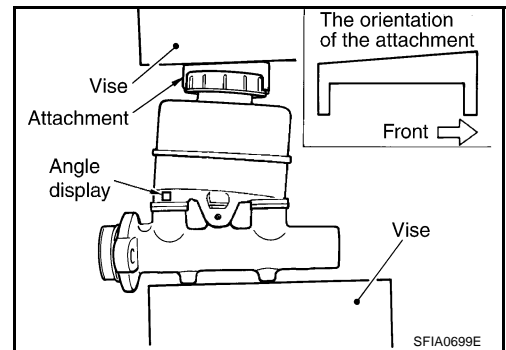

4. Using a pin punch [commercial service tool: diameter Approx. 4 mm (0.16 in)], remove mounting pins on the reservoir tank.
5. Remove master cylinder assembly from the vise.
6. Remove reservoir tank and grommet from cylinder body.

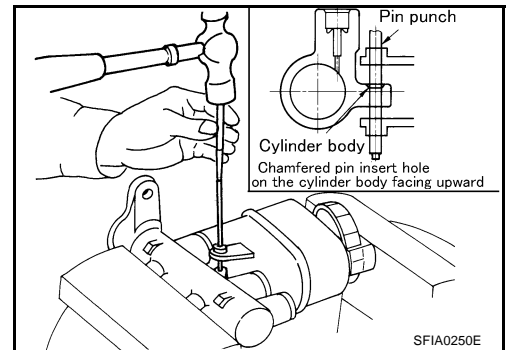

7. Using a Phillips flat-bladed screwdriver, push in the piston and remove the piston stopper from the cylinder body.
8. Carefully pull the primary piston assembly straight out to prevent cylinder inner wall from being damaged.

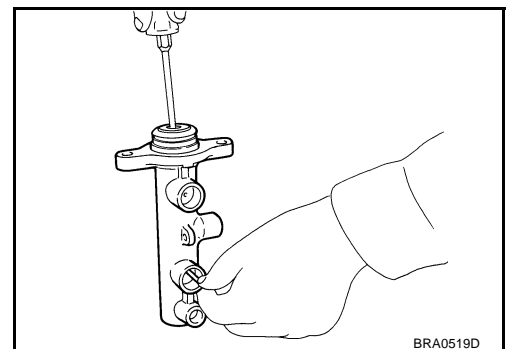

9. Tap flange using a soft block such as wood, and carefully pull the secondary piston assembly straight out to prevent cylinder inner wall from being damaged.

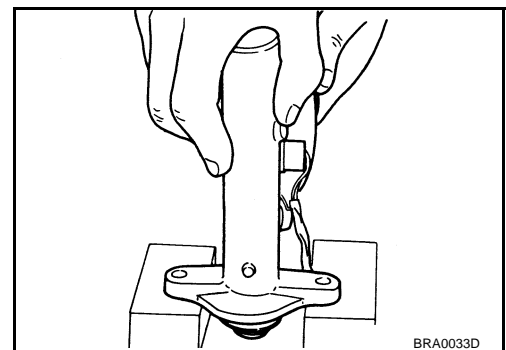

BRAKE MASTER CYLINDER

Inspection After Disassembly

Master cylinder

- Check that there is no damage, friction, rusting, or pinholes on the cylinder inner wall, and replace if there are any non-standard conditions.

Assembly

CAUTION:

- Never use mineral oils such as kerosene, gasoline during the cleaning and assembly process.
- Make sure there is no foreign matter such as dirt or dust attached to the inner cylinder walls, the piston, or the cap seal, and use care to avoid damaging parts with the assembly tools.
- Do not drop parts. If a part is dropped, do not use it.

1. Apply fluid to cylinder inner wall body and contact surface of the piston assembly. Then insert secondary piston assembly and primary piston assembly into cylinder body in this order.

CAUTION:

- Do not reuse the primary and secondary piston assemblies.
- Be sure to replace the assembly without disassembling the new inner kit.
- Pay attention to the orientation of the piston cup, and insert straight to prevent the cup from being caught by cylinder inner wall.

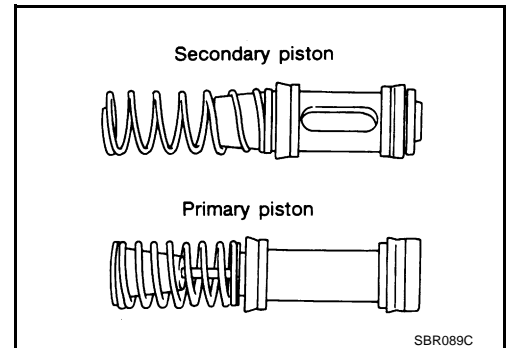

2. Perform a visual inspection of the secondary piston slit through the tank boss hole on the secondary side of the cylinder body, and attach the piston stopper.

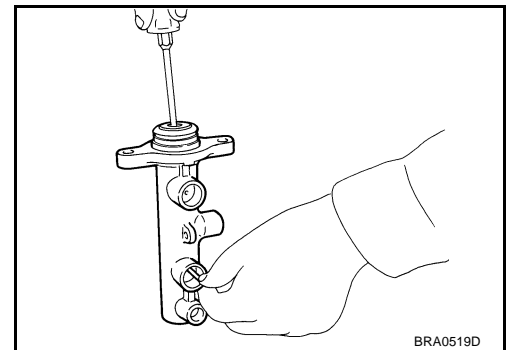

3. Holding down the piston with the stopper cap, push the stopper cap tabs so they are firmly into the cylinder grooves, then attach the stopper cap.

CAUTION:

Do not reuse the stopper cap.

4. Apply brake fluid the grommet and attach to the cylinder body.

CAUTION:

Do not reuse the grommet.

5. Attach the attachment in the inner kit to the reservoir cap as described in disassembly step 2.

CAUTION:

Make sure the attachment is pointing in the right direction.

6. Master cylinder assembly is fixed in the vise as described in disassembly step 3.

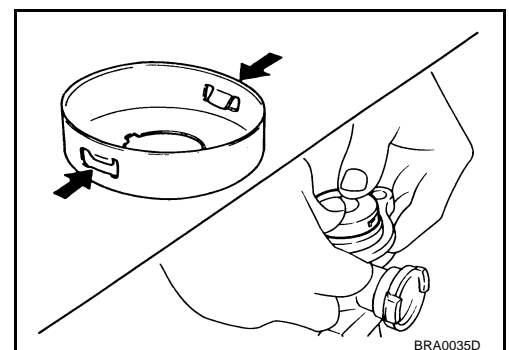

A

B

C

D

E

BR

G

H

I

J

K

L

M

BRAKE MASTER CYLINDER

- Using a pin punch [commercial service tool: diameter Approx. 4 mm (0.16 in)], attach the reservoir tank mounting pin so that the attachment side and the opposite side are identical.

CAUTION:

Do not reuse reservoir tank and mounting pin.

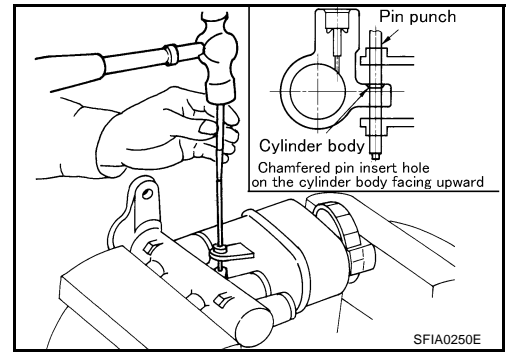

MODELS WITH VDC

Disassembly

CAUTION:

- While working, cover the primary piston rod with cloth to prevent it from being damaged.
 - Only remove the reservoir tank when absolutely necessary.
- Place the side of the cylinder body with chamfering around the pin insertion hole up, and secure the cylinder body flange section with a vise as shown in the figure.

CAUTION:

When securing in a vise, use copper plates or cloth to protect the flange.

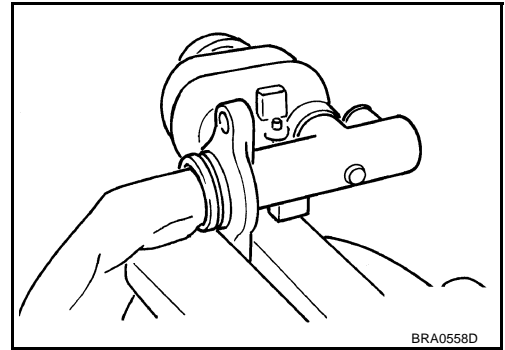

- Using a pin punch [commercial service tool: diameter Approx 4 mm (0.16 in)], remove the reservoir tank mounting pin.
- Remove master cylinder assembly from the vise.
- Remove reservoir tank and grommet from cylinder body.

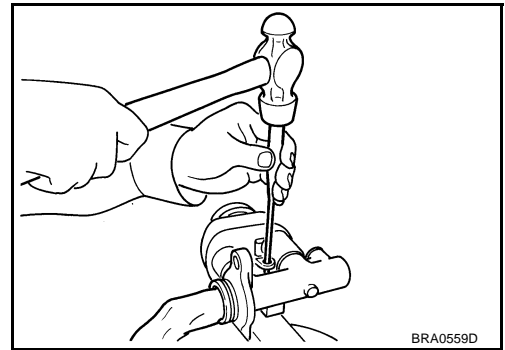

- Push in the primary piston and remove the stopper pin from the cylinder body secondary-side tank boss hole.

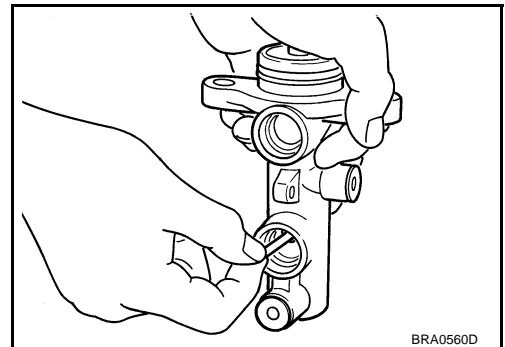

BRAKE MASTER CYLINDER

6. Remove the snap ring while pushing the primary piston in to prevent the piston from popping out.
7. Holding the primary piston rod, pull the primary piston assembly, the plate, and the guide straight out.
8. Remove the plate and guide from the primary piston.

CAUTION:

When removing the plate from the primary piston rod, make sure the inside of the plate does not damage the rod.

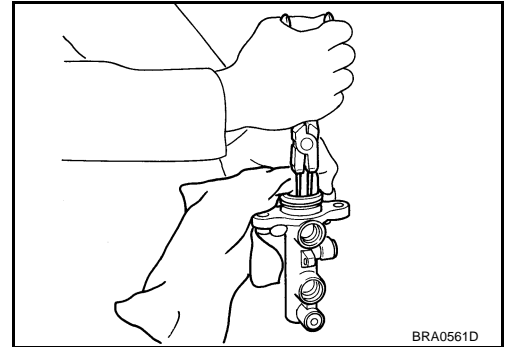

9. Tap flange using a soft block such as wood, and carefully pull the secondary piston assembly straight out to prevent cylinder inner wall from being damaged.

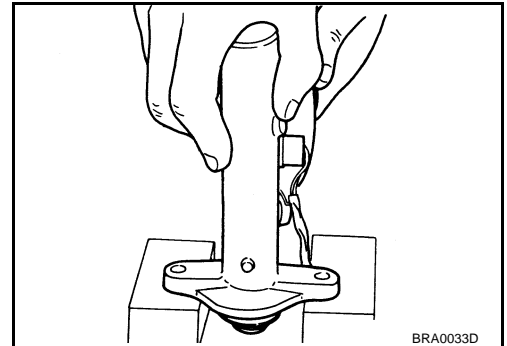

Inspection After Disassembly

Master cylinder

- Check that there is no damage, friction, rusting, or pinholes on the cylinder inner wall, and replace if there are any non-standard conditions.

Assembly

CAUTION:

- Never use mineral oils such as kerosene, gasoline during the cleaning and assembly process.
- Make sure there is no foreign matter such as dirt or dust attached to the inner cylinder walls, the piston, or the cap seal, and use care to avoid damaging parts with the assembly tools.
- Do not drop parts. If a part is dropped, do not use it.

1. Apply brake fluid to the inside surface of the cylinder body and the contact surface of the piston assembly, and apply the silicon grease in the inner kit to the primary piston rod.
2. Insert the secondary piston and the primary piston into the cylinder body.

CAUTION:

- Do not reuse the primary and secondary piston assemblies.
 - Be sure to replace the assembly without disassembling the new inner kit.
 - Pay attention to the orientation of the piston cup, and insert straight to prevent the cup from being caught by cylinder inner wall.
3. Visually inspect the secondary piston slit through the piston stopper mounting hole and then install the piston stopper while pushing in the primary piston.

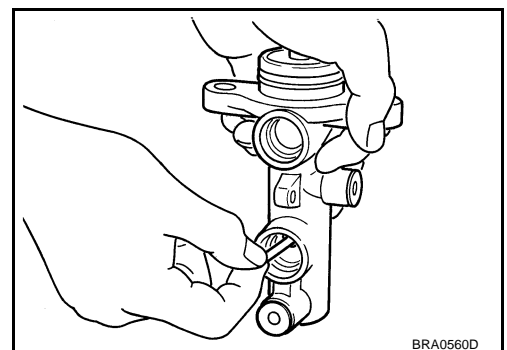
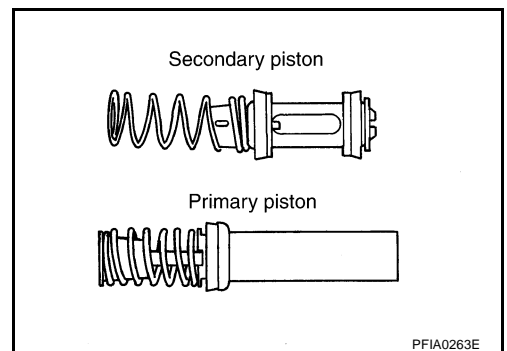

BRAKE MASTER CYLINDER

4. Insert the plate and guide into the cylinder body.

CAUTION:

- Make sure not to damage the primary piston rod.
- Pay attention to the direction of the guide.
- Do not drop the O-ring.
- Make sure the guide and/or plate are not inserted at an angle.

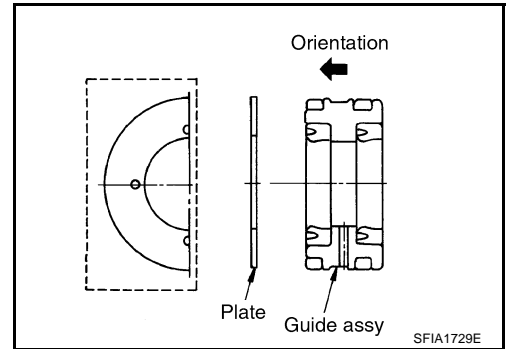

5. Cover the primary piston rod with cloth to prevent it getting damaged, and attach the snap ring with the primary piston pushed in.

CAUTION:

- Make sure the area around the snap ring is snug in the cylinder body bore groove.
- Do not reuse the snap ring.

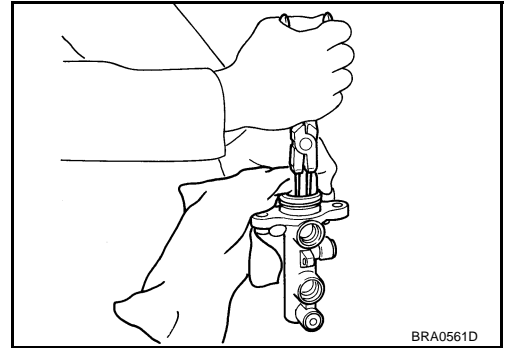

6. Place the side of the cylinder body with chamfering around the pin insertion hole up, and secure the cylinder body flange section with a vise.

CAUTION:

When securing in a vise, use copper plates or cloth to protect the flange.

7. Apply brake fluid to the grommet and attach the reservoir tank to the master cylinder.

CAUTION:

Do not reuse the grommet.

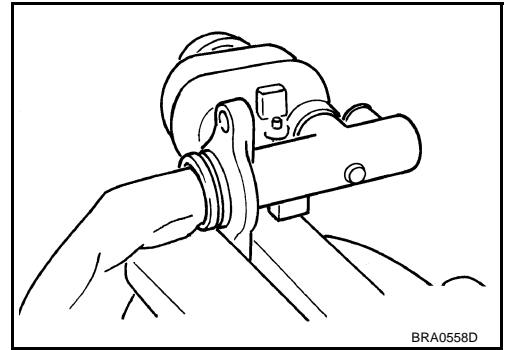

NOTE:

Attach the reservoir tank in the orientation shown in the figure.

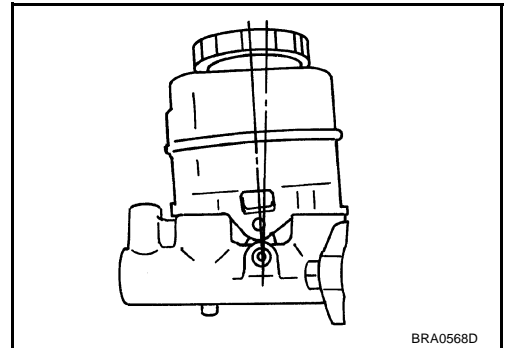

BRAKE MASTER CYLINDER

8. Tilt the reservoir tank so that the mounting pin can be inserted as shown in the figure, and insert the mounting pin. When the mounting pin has passed the master cylinder pinhole, return the reservoir tank to a level position. Attach the mounting pin to the opposite mounting pin hole of the reservoir tank so that it is the same as the insertion side.

CAUTION:

- Be sure to insert pin from the chamfered pinhole of cylinder body.
- Do not reuse reservoir tank and mounting pin.

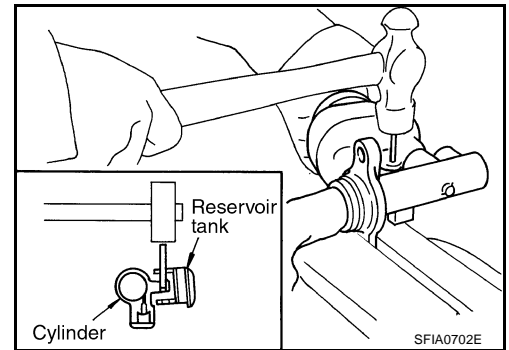

A
B
C
D
E

BR

G
H
I
J
K
L
M

BRAKE BOOSTER

BRAKE BOOSTER

PFP:47200

On-Vehicle Service OPERATING CHECK

AFS0008B

With the engine stopped, change the vacuum to the atmospheric pressure by depressing the brake pedal several times. Then with brake pedal fully depressed, start the engine and when the vacuum pressure reaches the standard, check that the clearance between the brake pedal and floor panel decreases.

CAUTION:

Depressing pedal interval is approximately 5 seconds.

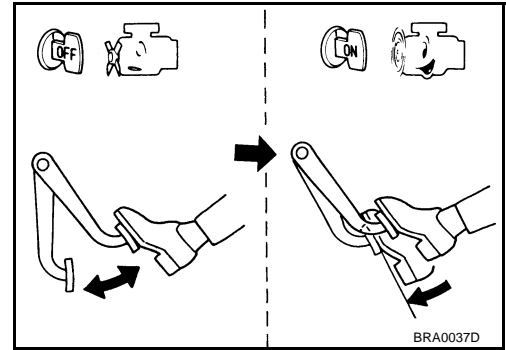

AIRTIGHT CHECK

- Run the engine at idle for approximately 1 minute, and stop it after applying vacuum to the booster. Depress the brake pedal normally to change the vacuum to the atmospheric pressure. Check that distance between the brake pedal and floor panel gradually increases.
- Depress brake pedal while engine is running, and stop engine with pedal depressed. The pedal stroke should not change after holding pedal down for 30 seconds.

CAUTION:

Depressing pedal interval is approximately 5 seconds.

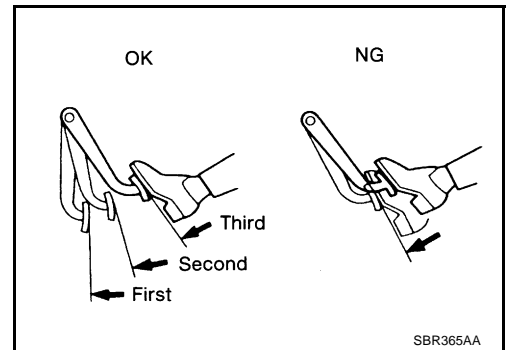

Removal and Installation

AFS000UA

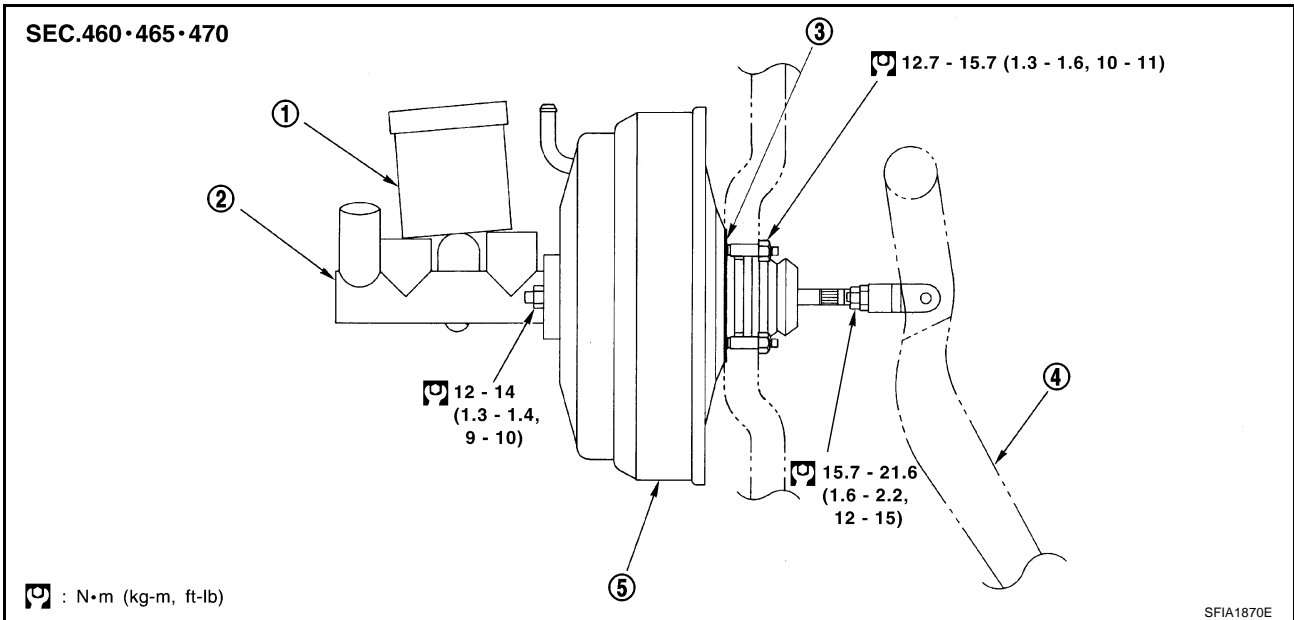

- | | | |
|-------------------|--------------------|-----------|
| 1. Reservoir tank | 2. Master cylinder | 3. Gasket |
| 4. Brake pedal | 5. Brake booster | |

BRAKE BOOSTER

REMOVAL

CAUTION:

- Be careful not to deform or bend brake piping while removing and installing the brake booster.
 - Replace clevis pin if it is damaged.
 - Be careful not to damage brake booster stud bolt threads. If brake booster is tilted or inclined during installation, the dash panel may damage the threads.
 - Attach the check valve in the correct orientation.
1. Remove vacuum hose from the brake booster. Refer to [BR-24, "VACUUM LINES"](#).
 2. Remove the brake master cylinder. [BR-22, "Removal and Installation"](#)
 3. Remove the brake piping between brake master cylinder and ABS actuator and electric unit (control unit)/VDC actuator. Refer to [BR-11, "Hydraulic Circuit"](#)

CAUTION:

For M/T vehicles with remove the brake piping after removing the clutch reservoir tank bolt.

4. Remove the brake pedal attachment snap pin and clevis pin from inside the vehicle.
5. Remove the nuts on the brake booster and brake pedal assembly.
6. Remove brake booster assembly from the engine compartment side.

INSPECTION AFTER REMOVAL

Output Rod Length Inspection

1. Using a handy vacuum pump, apply a vacuum of -66.7 kPa (-500 mmHg , 19.69 inHg) to the brake booster.
2. Check output rod length.

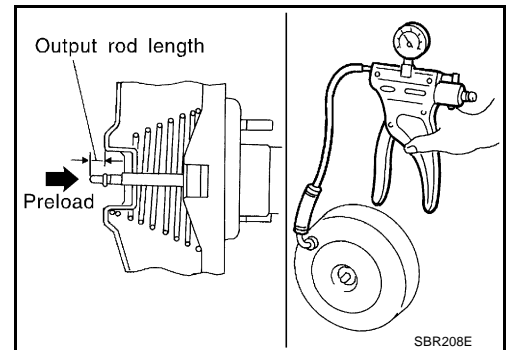

Standard dimension when vacuum -66.7 kPa (-500 mmHg , -19.69 inHg):

With TCS models : 10.4 mm (0.409 in)

With VDC models : -6.2 mm (-0.244 in)

INSTALLATION

1. Loosen the lock nut to adjust the input rod length so that the length B (in the figure on the right) satisfies the specified value.

Length "B" : 125 mm (4.92 in)

2. After adjusting "B", temporarily tighten the lock nut to install the booster assembly to the vehicle. At this time, make sure to install a gasket between the booster assembly and the vehicle.
3. Connect the brake pedal with the clevis of the input rod.
4. Install the pedal bracket mounting nuts and tighten them to the specified torque.
5. Install the brake piping between brake master cylinder and ABS actuator and electric unit (control unit) /VDC actuator. Refer to [BR-11, "Hydraulic Circuit"](#)
6. Install the master cylinder to the booster assembly. [BR-22, "Removal and Installation"](#)
7. Adjust the height and play of the brake pedal.
8. Tighten the lock nut of the input rod to the specified torque.
9. Refill new brake fluid and bleed air. Refer to [BR-10, "Bleeding Brake System"](#)

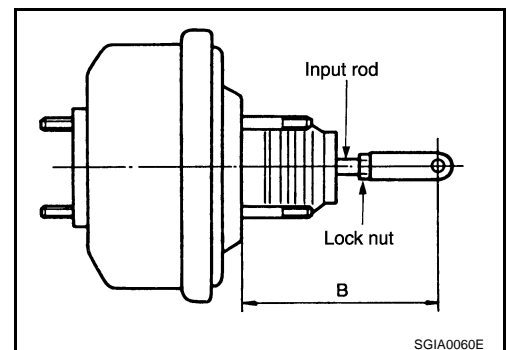

VACUUM LINES

VACUUM LINES

PFP:41920

Removal and Installation

AFS0008D

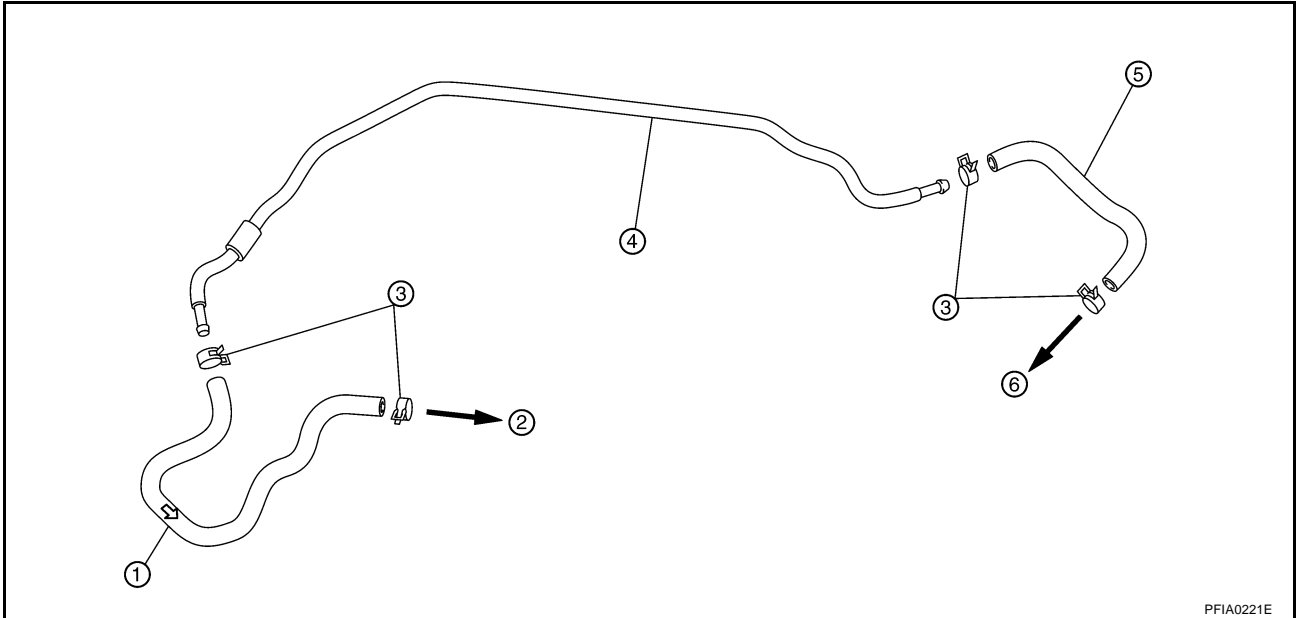

PFIA0221E

- | | | |
|---|--------------------|------------------|
| 1. Check valve inclusion position stamp | 2. Intake manifold | 3. Clamp |
| 4. Vacuum piping | 5. Vacuum hose | 6. Brake booster |

CAUTION:

- Because vacuum hose contains a check valve, it must be installed in the correct orientation. Refer to the stamp or label to confirm correct installation. The brake booster will not operate normally if the hose is installed in the wrong direction.
- Insert the vacuum hose for at least 24 mm (0.94 in).
- Never use lubricating oil during assembly.

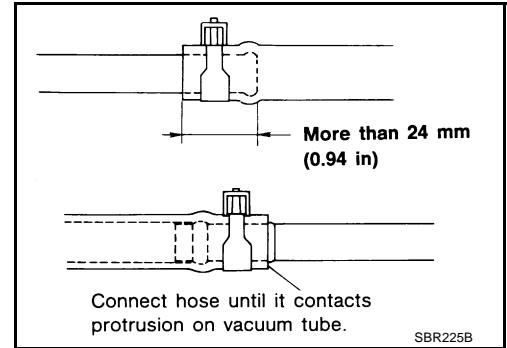

SBR225B

Inspection

VISUAL INSPECTION

Check for improper assembly, damage and deteriorate.

CHECK VALVE INSPECTION

Airtightness Inspection

Use a hand-held vacuum pump to check.

When connected to booster side (1):

Vacuum decrease should be within 1.3 kPa (10 mmHg, 0.39 inHg) for 15 seconds under a vacuum of - 66.7 kPa (- 500 mmHg, - 19.69 inHg)

When connected to engine side (2):

No vacuum will be applied

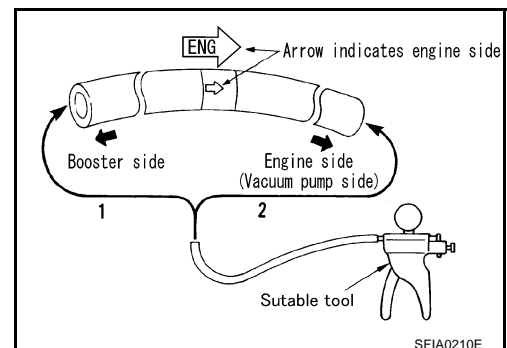

SFIA0210E

FRONT DISC BRAKE (CLZ25VD TYPE)

FRONT DISC BRAKE (CLZ25VD TYPE)

PFP:41000

On-Board Inspection PAD WEAR INSPECTION

AFS00168

- Inspect the thickness of the pad through the cylinder body inspection hole. Use a scale for inspection if necessary.

Standard

Standard thickness : 11.0 mm (0.433 in)

Repair limit thickness : 2.0 mm (0.079 in)

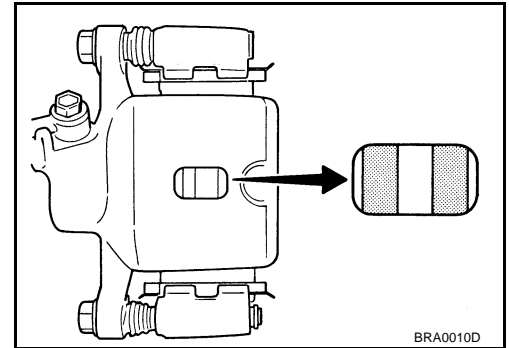

BRA0010D

Components

AFS00169

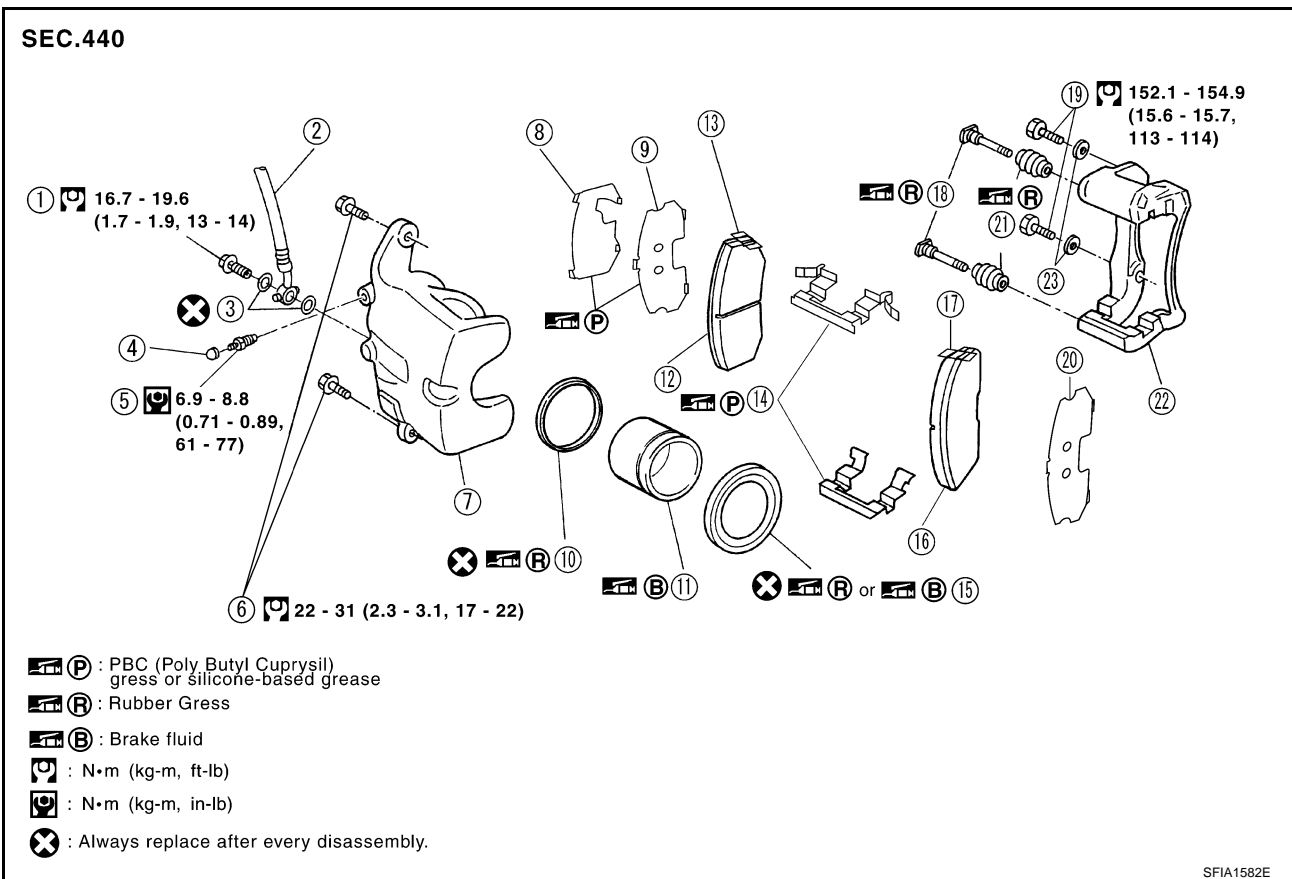

- | | | |
|-------------------------|---------------------|----------------------|
| 1. Union bolt | 2. Brake hose | 3. Copper washer |
| 4. Cap | 5. Bleed valve | 6. Sliding pin bolt |
| 7. Cylinder body | 8. Inner shim cover | 9. Inner shim |
| 10. Piston seal | 11. Piston | 12. Inner pad |
| 13. Pad wear sensor | 14. Pad retainer | 15. Piston boot |
| 16. Outer pad | 17. Pad wear sensor | 18. Sliding pin bolt |
| 19. Torque member bolts | 20. Outer shim | 21. Slide pin boot |
| 22. Torque member | 23. Washer | |

CAUTION:

- Clean dust on caliper and brake pad with a vacuum dust collector. Do not blow with compressed air.
- While the brake pad and cylinder body are separated, the piston may suddenly jump out, so do not depress the brake pedal.

FRONT DISC BRAKE (CLZ25VD TYPE)

- It is not necessary to remove bolts on torque member and brake hose except for disassembly or replacement of the caliper assembly. In this case, hang cylinder body with a wire so that brake hose is not under tension.
- Do not damage piston boot.
- If any shim is subject to serious corrosion, replace it with a new one.
- Always replace shims and shim covers as a set when replacing brake pads.
- Keep the rotor clean of brake fluid.

Removal and Installation of Brake Pad

AFS0016A

REMOVAL

1. Remove tires from vehicle with power tool.
2. Remove lower sliding pin bolt (1).
3. Hang the cylinder body with a wire and remove the pad and shim from the torque member.

CAUTION:

When removing the pad retainer from the torque member, lift the pad retainer in the direction shown by the arrow (shown in the figure) so as not to deform it.

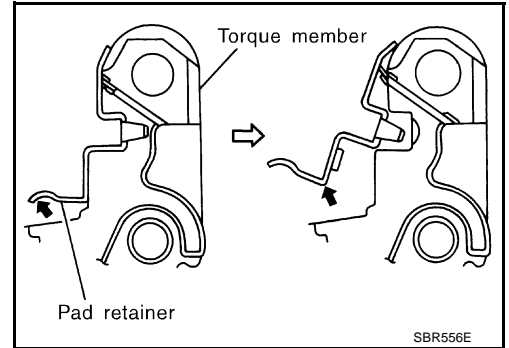

INSTALLATION

1. Apply PBC (Poly Butyl Cuprysil) grease or silicone -based grease between inner shim cover and inner shim.
2. Attach the inner shim and shim cover to the inner pad and the outer shim to the outer pad.

CAUTION:

Attach the inner shim cover in the direction shown in the figure.

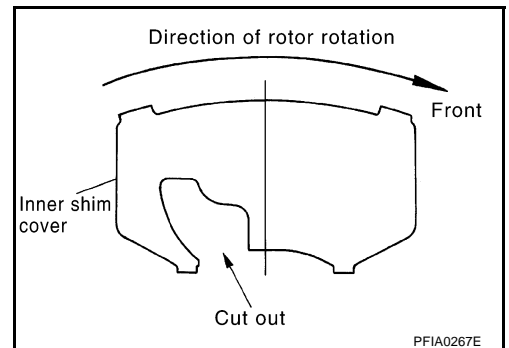

3. Apply PBC (Poly Butyl Cuprysil) grease or silicone -based grease to the contact surface of the pad retainer and attach the pad retainer and pad to the torque member.

CAUTION:

Since both the inner and outer pads have pad return mechanisms on the upper pad retainer, when attaching a pad, make sure the pad return lever is firmly attached to the pad wear sensor.

4. Push the piston in so that the pad is firmly attached and attach the cylinder body to the torque member.

NOTE:

Using a disc brake piston tool (commercial service tool), etc., makes it easier to push in the piston.

CAUTION:

- By pushing in the piston, the brake fluid returns to the master cylinder reservoir tank. Watch the level of the surface of the reservoir tank.

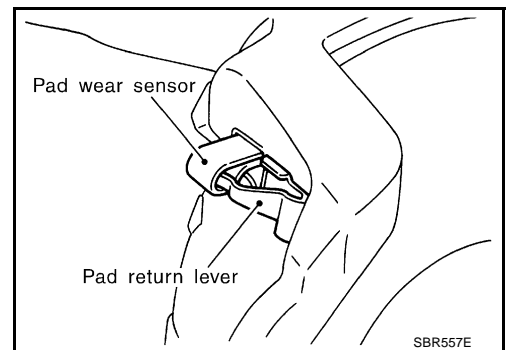

FRONT DISC BRAKE (CLZ25VD TYPE)

- When attaching the pad retainer, attach it firmly so that it does not float up higher than the torque member, as shown in the figure.
5. Install lower sliding pin bolt (1), and tighten it to the specified torque.
 6. Check brake for drag.
 7. Attach the tires to the vehicle.

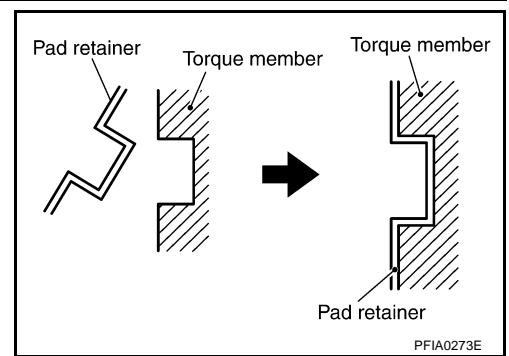

Removal and Installation of Caliper Assembly REMOVAL

1. Remove tires from vehicle with power tool.(Commercial service tool)
2. Drain brake fluid. Refer to [BR-9, "Drain and Refill"](#) .
3. Remove union bolts and torque member bolts, and remove caliper assembly.
4. Remove disc rotor.

INSTALLATION

CAUTION:

- Refill with new brake fluid "DOT3"
- Never reuse drained brake fluid.

1. Install disc rotor.
2. Install caliper assembly to the vehicle, and tighten bolts to the specified torque.

 : 152.1 - 154.9 N-m (15.6 - 15.7 kg-m, 113 - 114 ft - lb)

CAUTION:

- Do not allow the knuckle attachment surface, caliper attachment surface, the screws, the bolts, or the washers to come in contact with oil or water.

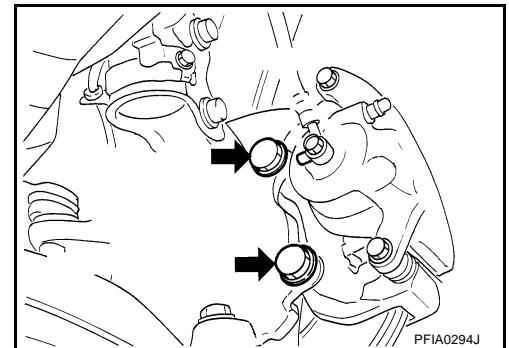

3. Install brake hose to the caliper assembly, and tighten union bolts to the specified torque.

 : 16.7 - 19.6 N-m (1.7 - 1.9 kg-m, 13 - 14 ft-lb)

CAUTION:

- Do not reuse the copper washer for union bolts.
- Attach the brake hose to the protrusion on the caliper assembly attachment part.

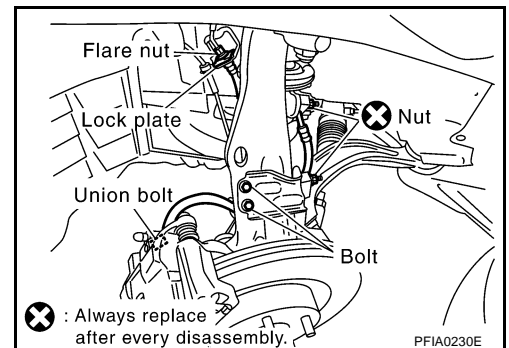

4. Refill new brake fluid and bleed air. Refer to [BR-10, "Bleeding Brake System"](#) .
5. Attach the tires to the vehicle.

A
B
C
D
E

BR

G
H
I
J
K
L
M

FRONT DISC BRAKE (CLZ25VD TYPE)

AFS0016C

Disassembly and Assembly of Caliper Assembly DISASSEMBLY

1. Remove the slide pin bolt, and then remove the pad, shim, shim cover, and pad retainer from the torque member.

CAUTION:

When removing the pad retainer from the torque member, lift it in the direction indicated by the arrow in the figure so that it does not deform.

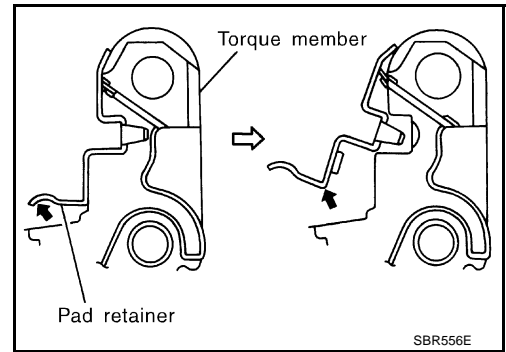

2. Remove sliding pins and sliding pin boots from torque member.
3. Place a wooden block as shown in the figure, and blow air from union bolt mounting hole to remove pistons and piston boots.

CAUTION:

Do not get your fingers caught in the piston.

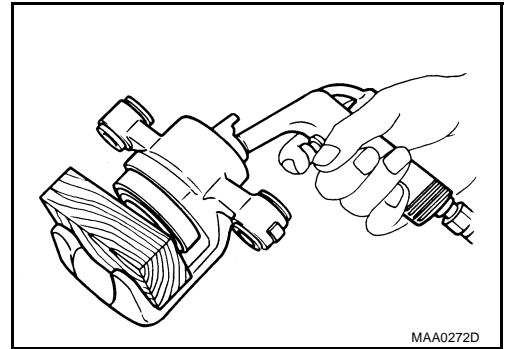

4. Using a flat-bladed screwdriver, remove the piston seal from the cylinder body.

CAUTION:

Be careful not to damage cylinder inner wall.

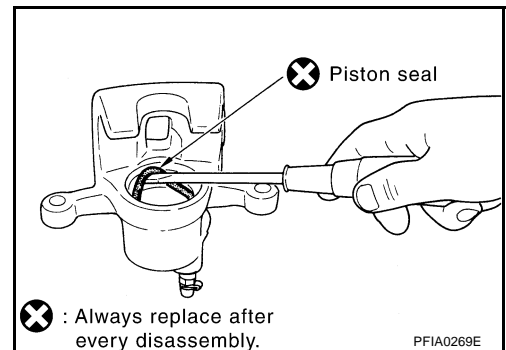

CALIPER INSPECTION

Cylinder Body

CAUTION:

- Use new brake fluid to clean. Never use mineral oils such as gasoline or kerosene.
- Check for corrosion, wear, or damage to the cylinder inner wall, and replace the caliper if there are any non-standard conditions.
- Minor flaws caused by corrosion or a foreign material can be removed by polishing the surface with a fine sandpaper. Replace the cylinder body, if necessary.

Torque Member

Check for wear, cracks, and damage. If damage or deformation is present, replace the affected part.

Piston

CAUTION:

- Since the piston surface is plated, do not repair using sandpaper.
- Check piston surface for corrosion, wear, and damage. If any non-standard condition is detected, replace applicable part.

FRONT DISC BRAKE (CLZ25VD TYPE)

Sliding Pins, Sliding Pin Bolts, and Sliding Pin Boots

Check sliding pin and sliding pin boot for wear, damage, and cracks. If damage or deformation is present, replace the affected part.

ASSEMBLY

CAUTION:

Do not use Nissan Rubber Grease (KRE00 00010, KRE00 00010 01) when assembling.

1. Apply rubber grease to the piston seal and attach to cylinder body.

CAUTION:

Do not reuse the piston seals.

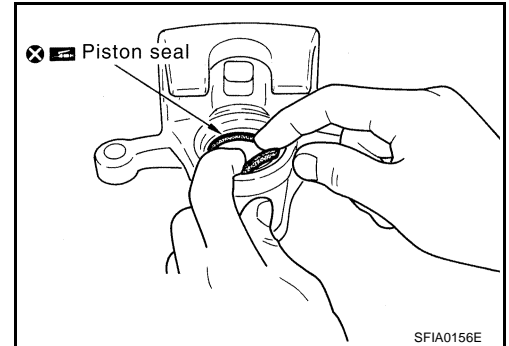

2. Apply brake fluid or rubber grease to the piston boot, place it on the piston, and firmly insert the piston boot cylinder-side lip into the cylinder body groove.

CAUTION:

Do not reuse the piston boot.

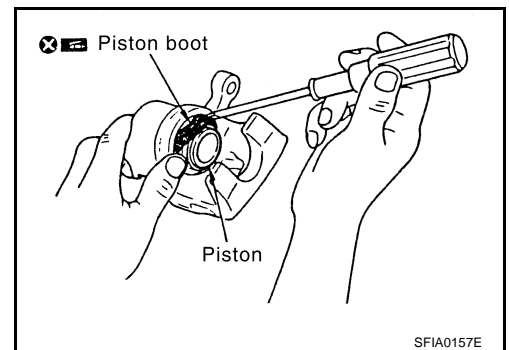

3. Apply brake fluid or rubber grease to the piston, insert into the cylinder body by hand and firmly attach the piston boot piston-side lip into the piston groove.

CAUTION:

Press the piston evenly and vary the pressing point to prevent cylinder inner wall from being rubbed.

4. Install sliding pins and sliding pin boots to torque member.

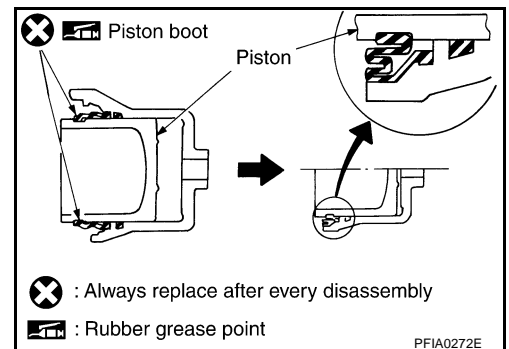

5. Apply PBC (Poly Butyl Cuprysil) grease or silicone -based grease between inner shim cover and inner shim.

6. Attach the inner shim and shim cover to the inner pad and the outer shim to the outer pad.

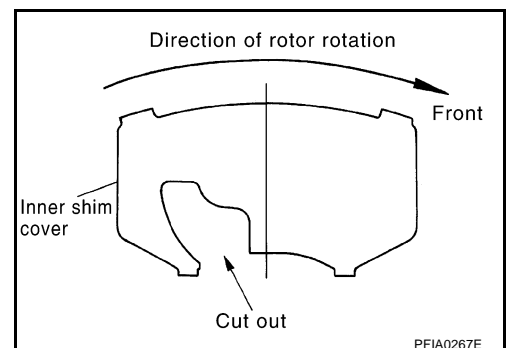

FRONT DISC BRAKE (CLZ25VD TYPE)

- Apply PBC (Poly Butyl Cuprysil) grease or silicone -based grease to the contact surface of the pad retainer and attach the pad retainer and pad to the torque member.
- Install cylinder body. Tighten sliding pin bolt to the specified torque.

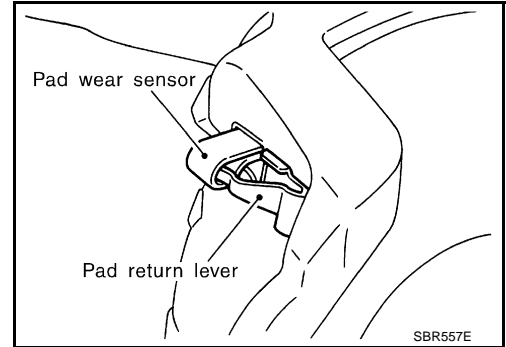

DISC ROTOR INSPECTION

Visual Inspection

Check surface of the disc rotor for uneven wear, cracks, and serious damage. If any non-standard condition is detected, replace applicable part.

Runout Inspection

- Using wheel nuts, fix disc rotor to the wheel hub. (2 or more positions)
- Inspect runout using a dial gauge.

Standard value

(measured at 10 mm (0.39 in) inside the disc edge)

Runout limit
(with it attached to the vehicle) : 0.035 mm (0.0014 in) or less

Runout limit (just the disc rotor) : 0.020 mm (0.0008 in) or less

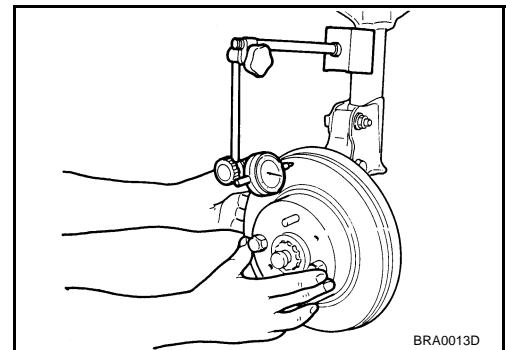

NOTE:

Make sure that wheel bearing axial endplay is within the specifications before measuring runout. Refer to [FAX-4, "On-Vehicle Inspection and Service"](#).

- If runout is outside the limit, find the minimum runout point by shifting mounting positions of the disc rotor and wheel hub by one hole.

Thickness Inspection

Using a micrometer, check thickness of the disc rotor. If thickness is outside the standard, replace disc rotor.

Standard

Standard thickness : 24.0 mm (0.945 in)

Wear limit : 22.0 mm (0.866 in)

Maximum uneven wear : 0.015 mm (0.0006 in) or less
(measured at 8 positions)

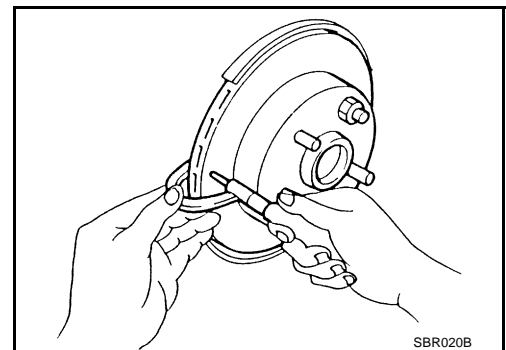

BRAKE BURNISHING PROCEDURE

Burnish the brake contact surface according to the following procedure after refinishing or replacing rotors, after replacing pads, or if a soft pedal occurs at very low mileage.

CAUTION:

Only perform this procedure under safe road and traffic conditions. Use extreme caution.

- Drive the vehicle on a straight smooth road at 50 km/h (31 MPH).
- Use medium brake pedal /foot effort to bring the vehicle to a complete stop from 50 km/h (31 MPH). Adjust brake pedal /foot pressure such that vehicle stopping time equals 3 to 5 seconds.
- To cool the brake system, drive the vehicle at 50 km/h (31 MPH) for 1 minute without stopping.
- Repeat steps 1 to 3, 10 times or more to complete the burnishing procedure.

FRONT DISC BRAKE (OPB27VA TYPE)

FRONT DISC BRAKE (OPB27VA TYPE)

PFP:41000

On-Board Inspection PAD WEAR INSPECTION

AFS000Y6

- Inspect the thickness of the pad through the caliper inspection hole. Use a scale for inspection if necessary.

Standard

Standard thickness : 9.3 mm (0.366 in)

Repair limit thickness : 2.0 mm (0.079 in)

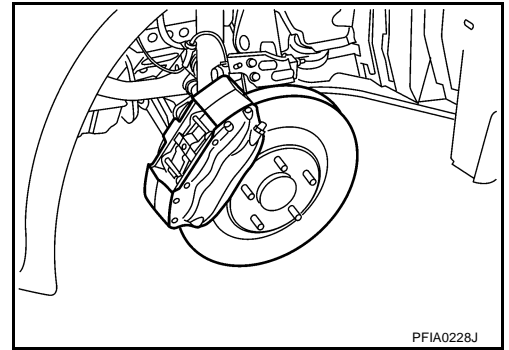

PFIA0228J

Component

AFS000Y7

NOTE:

Refer to [BR-33, "HOW TO APPLY GREASE TO THE BRAKE PAD"](#) for how to apply grease to brake pads.

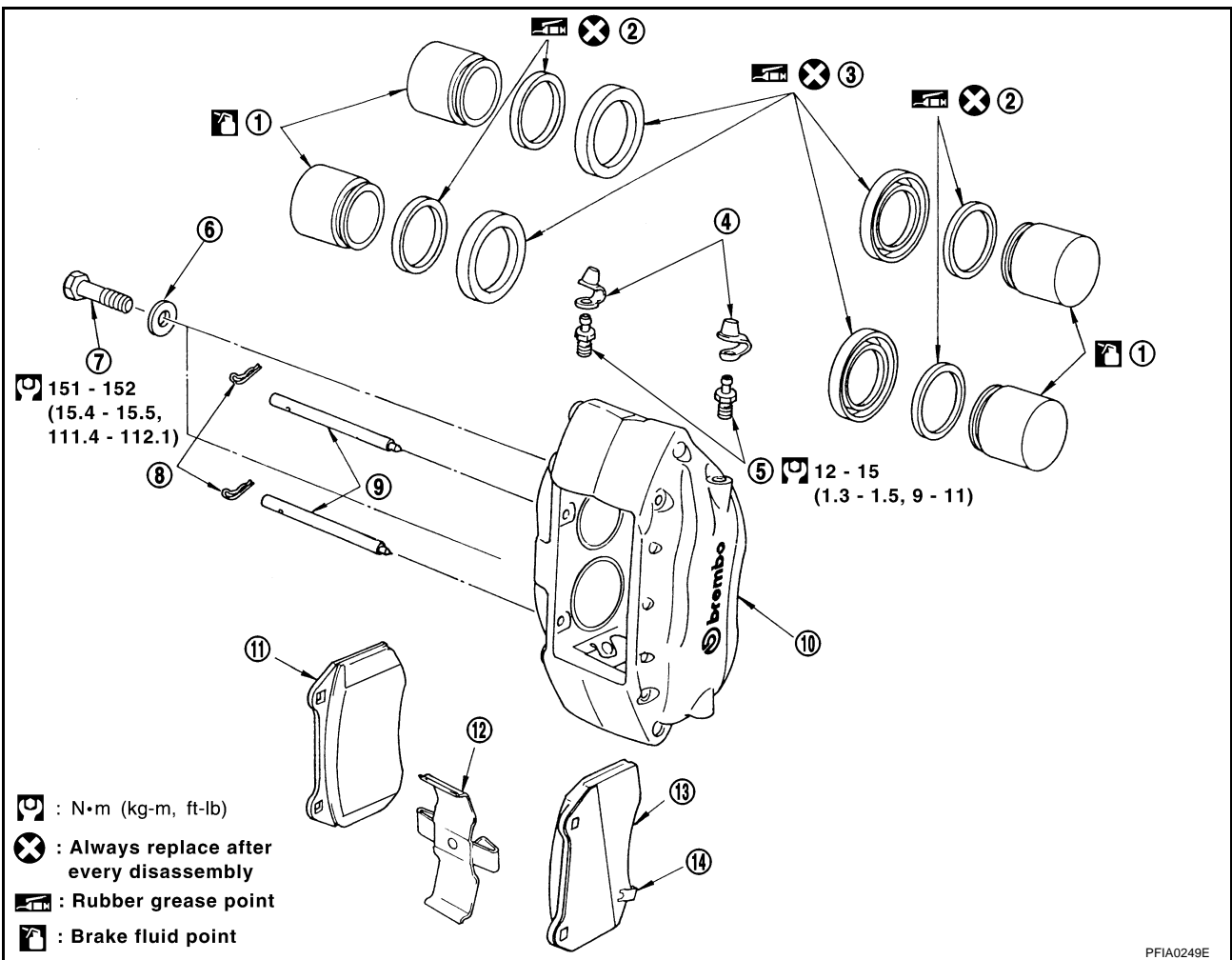

PFIA0249E

- | | | |
|---------------|---------------------|------------------|
| 1. Piston | 2. Piston seal | 3. Piston boot |
| 4. Cap | 5. Bleed valve | 6. Washer |
| 7. Bolt | 8. Clips | 9. Pad pins |
| 10. Caliper | 11. Inner pad | 12. Cross spring |
| 13. Outer pad | 14. Pad wear sensor | |

FRONT DISC BRAKE (OPB27VA TYPE)

CAUTION:

- Clean dust on caliper and brake pad with a vacuum dust collector. Do not blow with compressed air.
- While the brake pad and cylinder body are separated, the piston may suddenly jump out, so do not depress the brake pedal.
- Apart from caliper assembly, disassembly or replacement, there is no need to remove caliper bolts or brake hose or tube.
- Do not damage piston boot.
- Keep the rotor clean of brake fluid.

Removal and Installation of Brake Pad REMOVAL

AFS000Y8

1. Remove tires from vehicle with power tool.(Commercial service tool)
2. Remove the clip from the pad pin.

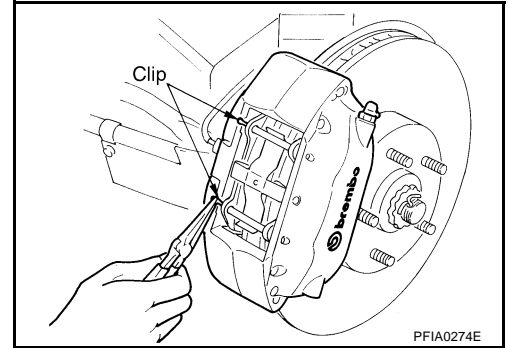

3. Remove the pad pin while holding down the cross spring, then remove the cross spring from the caliper.

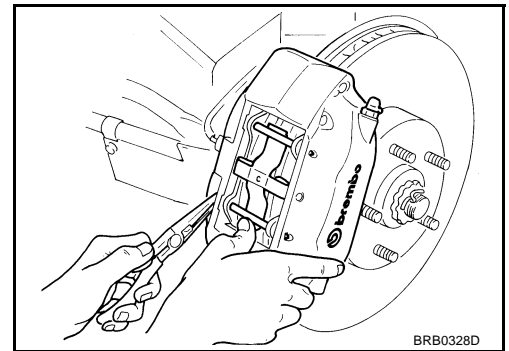

4. Using pliers, remove the pad from the caliper.

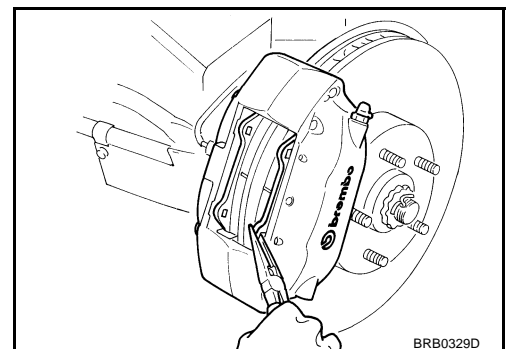

FRONT DISC BRAKE (OPB27VA TYPE)

HOW TO APPLY GREASE TO THE BRAKE PAD

Pad Side

Apply PBC (Poly Butyl Cuprysil) grease or silicone-based grease about 0.5 g (0.018 oz) per surface equally to back plate side of Inner Pad and Outer Pad. (Refer to the figure)

CAUTION:

Make sure no foreign matter attaches itself to the grease.

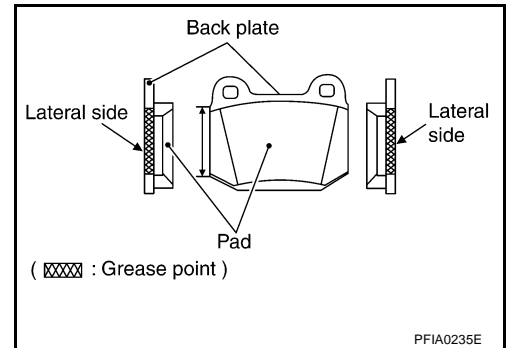

INSTALLATION

1. Insert the piston to the position where the pad is attached.

NOTE:

Using a disc brake piston tool (commercial service tool), etc., makes it easier to push in the piston.

CAUTION:

By pushing in the piston, the brake fluid returns to the master cylinder reservoir tank. Watch the level of the surface of the reservoir tank.

2. Attach pad.

CAUTION:

- Attach the pad with wear sensor to the outer side.
- The side of the shim with the larger cutouts should be on the entry side of the disc rotor spin.

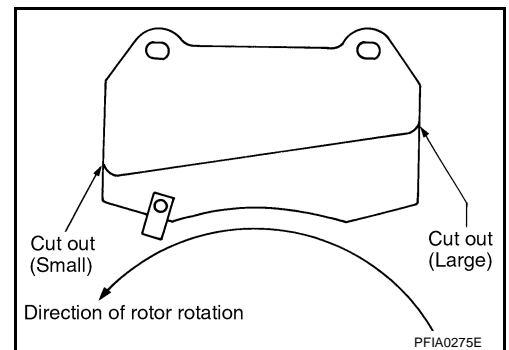

3. Insert the upper pad pin from the inner cylinder side, then insert firmly to the outer cylinder side through the hole in the top of the pad.
4. As shown in the figure, place the top of the cross spring over the top pad pin, press in the cross spring, push the lower pad pin from the inner cylinder side to the outer cylinder side, and secure the cross spring.
5. Insert the clip in the small hole at the end of the pad pin.

CAUTION:

If the clip is not fully attached, the pad pin or the pad could fall out while the vehicle is in motion.

6. Attach the tires to the vehicle.

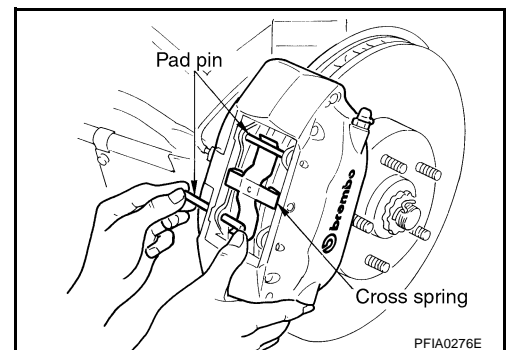

FRONT DISC BRAKE (OPB27VA TYPE)

AFS000Y9

Removal and Installation of Caliper Assembly REMOVAL

1. Remove tires from vehicle with power tool.
2. Drain brake fluid. Refer to [BR-9, "Drain and Refill"](#) .
3. Remove the brake pad. Refer to [BR-32, "Removal and Installation of Brake Pad"](#) .
4. Remove the brake tube flare nut using a flare wrench.
5. Remove the brake tube bracket from the knuckle spindle.

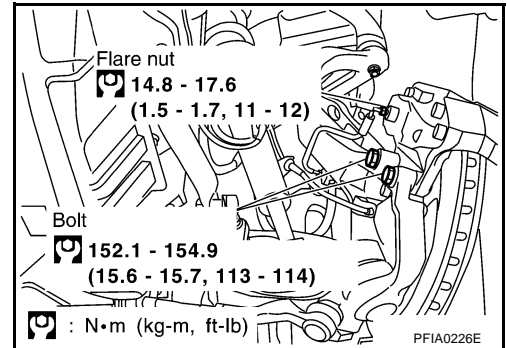

6. Remove the caliper bolt and remove the caliper assembly from the vehicle.
7. Remove disc rotor.

INSTALLATION

CAUTION:

- Refill with new brake fluid "DOT3"
- Never reuse drained brake fluid.

1. Install disc rotor.
2. Install caliper assembly to the vehicle, and tighten bolts to the specified torque.

CAUTION:

When attaching the caliper assembly to the vehicle, wipe any oil off the knuckle spindle washers and caliper assembly attachment surfaces.

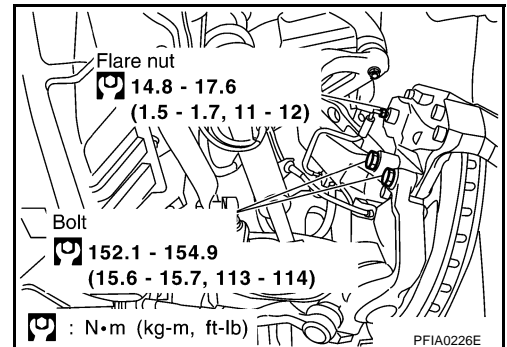

3. Attach the brake tube to the caliper assembly and partially tighten the flare nut.
4. Attach the brake tube bracket to the knuckle spindle and tighten to the specified torque.

: 10.8 - 15.6 N·m (1.1 -1.5 kg-m, 8 - 11 ft-lb)

5. Using a flare nut torque wrench, tighten the caliper assembly and brake tube connection flare nut to the specified torque.

: 14.8 - 17.6 N·m (1.5 - 1.7 kg-m, 11 - 12 ft-lb)

6. Attach brake pad. Refer to [BR-32, "Removal and Installation of Brake Pad"](#) .
7. Refill new brake fluid and bleed air. Refer to [BR-10, "Bleeding Brake System"](#) .
8. Attach the tires to the vehicle.

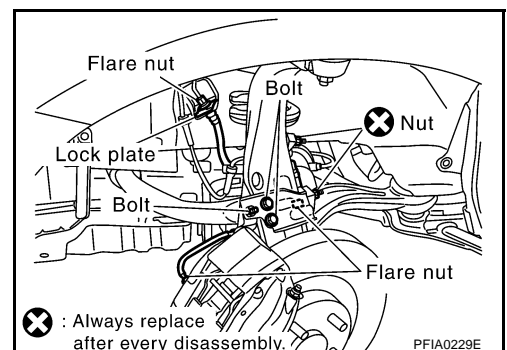

FRONT DISC BRAKE (OPB27VA TYPE)

Disassembly and Assembly of Caliper Assembly DISASSEMBLY

AFS000YA

1. Insert a piece of wood as shown in the figure, blow air in through the flare nut mounting hole, and remove the piston and piston boot. If the four pistons do not all come out at the same time, press the piston(s) that have come out a ways into the cylinder body and blow air in again.

CAUTION:

Do not get your fingers caught in the piston.

2. Remove the piston boot from the piston.

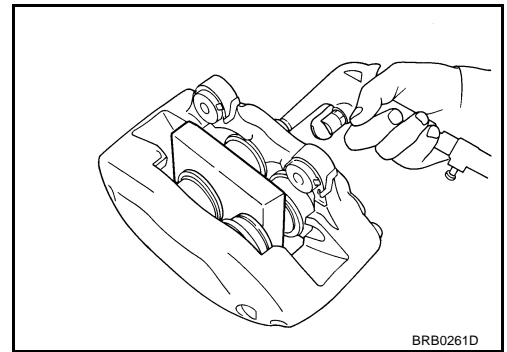

3. Using a flat-bladed screwdriver, remove the piston seal.

CAUTION:

- Be careful not to damage cylinder inner wall.
- Never remove the four bolts from the inner and outer sides of the caliper. Do not tighten them further, either.

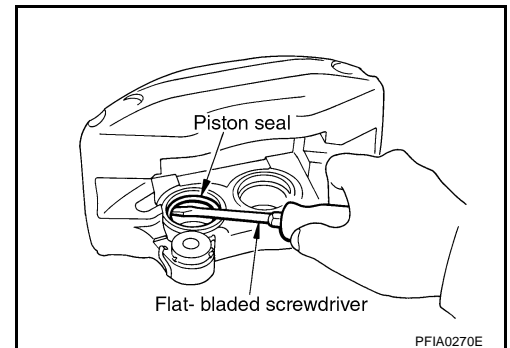

CALIPER INSPECTION

Caliper

CAUTION:

- Use new brake fluid to clean. Never use mineral oils such as gasoline or kerosene.
- Check for corrosion, wear, or damage to the cylinder inner wall, and replace the caliper if there are any non-standard conditions.

Piston

CAUTION:

- Since the piston surface is plated, do not repair using sandpaper.
- Check piston surface for corrosion, wear, and damage. If any non-standard condition is detected, replace applicable part.

ASSEMBLY

CAUTION:

Do not use Nissan Rubber Grease (KRE00 00010, KRE00 00010 01) when assembling.

1. Apply a rubber grease to the piston seal and attach to cylinder body.

CAUTION:

Do not reuse the piston seals.

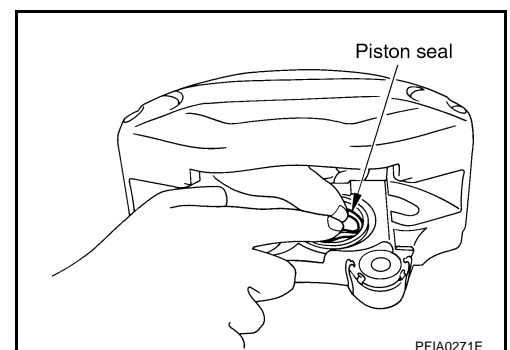

FRONT DISC BRAKE (OPB27VA TYPE)

2. Apply brake fluid or rubber grease to the piston boot, place it on the piston, and firmly insert the piston boot cylinder-side lip into the cylinder body groove.
3. Insert the piston into the cylinder body by hand and firmly attach the piston boot piston-side lip into the piston groove.

CAUTION:

Press the piston evenly and vary the pressing point to prevent cylinder inner wall from being rubbed.

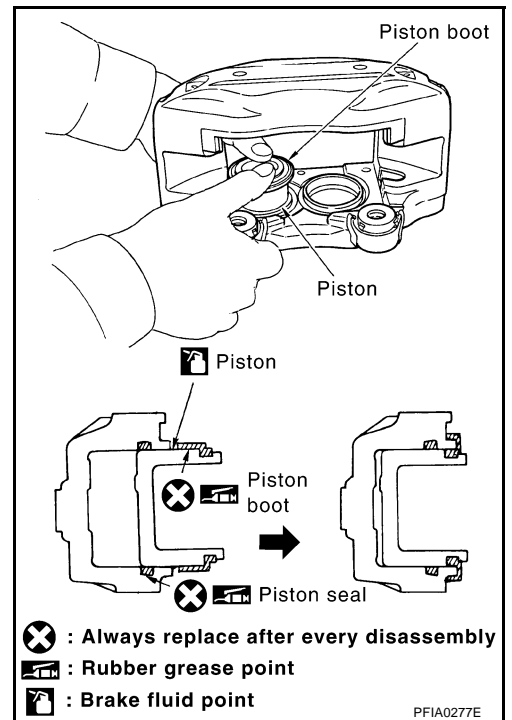

4. Attach the shim and shim cover to the pad and attach to the caliper.

DISC ROTOR INSPECTION

Visual Inspection

Check surface of the disc rotor for uneven wear, cracks, and serious damage. If any non-standard condition is detected, replace applicable part.

Runout Inspection

1. Using wheel nuts, fix disc rotor to the wheel hub. (2 or more positions)
2. Inspect runout using a dial gauge.

Standard value
(measured at 10 mm (0.39 in) inside the disc edge)

Runout limit : 0.050 mm (0.0020 in) or less
(with it attached to the vehicle)

Runout limit (just the disc rotor) : 0.040 mm (0.0016 in) or less

NOTE:

Make sure that wheel bearing axial endplay is within the specifications before measuring runout. Refer to [FAX-4, "On-Vehicle Inspection and Service"](#).

3. If runout is outside the limit, find the minimum runout point by shifting mounting positions of the disc rotor and wheel hub by one hole.

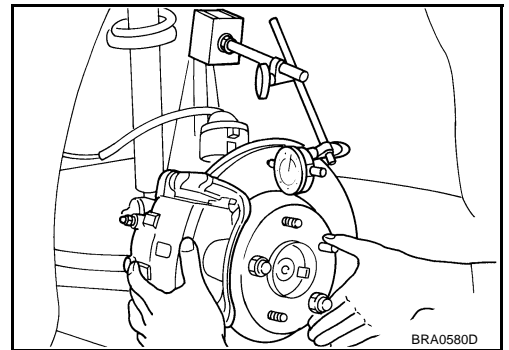

FRONT DISC BRAKE (OPB27VA TYPE)

Thickness Inspection

Using a micrometer, check thickness of the disc rotor. If thickness is outside the standard, replace disc rotor.

Standard

Standard thickness : 30.0 mm (1.181 in)

Wear limit : 28.4 mm (1.118 in)

**Maximum uneven wear
(measured at 8 positions)** : 0.015 mm (0.0006 in) or
less

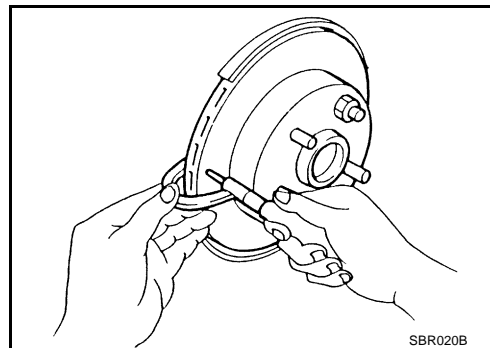

BRAKE BURNISHING PROCEDURE

Refer to [BR-30, "BRAKE BURNISHING PROCEDURE"](#).

A
B
C
D
E
BR
G
H
I
J
K
L
M

REAR DISC BRAKE (AD14VE TYPE)

REAR DISC BRAKE (AD14VE TYPE)

PF4:44000

On-Board Inspection PAD WEAR INSPECTION

AFS000YC

- Inspect the thickness of the pad through the cylinder body inspection hole. Use a scale for inspection if necessary.

Standard

Standard thickness : 8.5 mm (0.335 in)

Repair limit thickness : 2.0 mm (0.079 in)

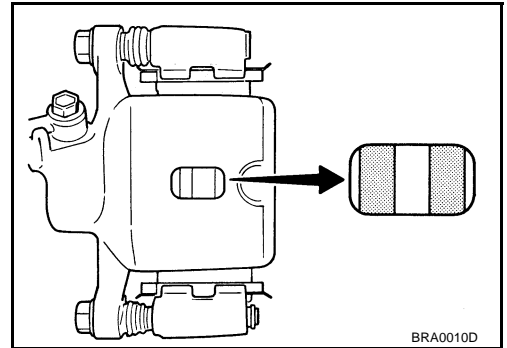

BRA0010D

Components

AFS000YD

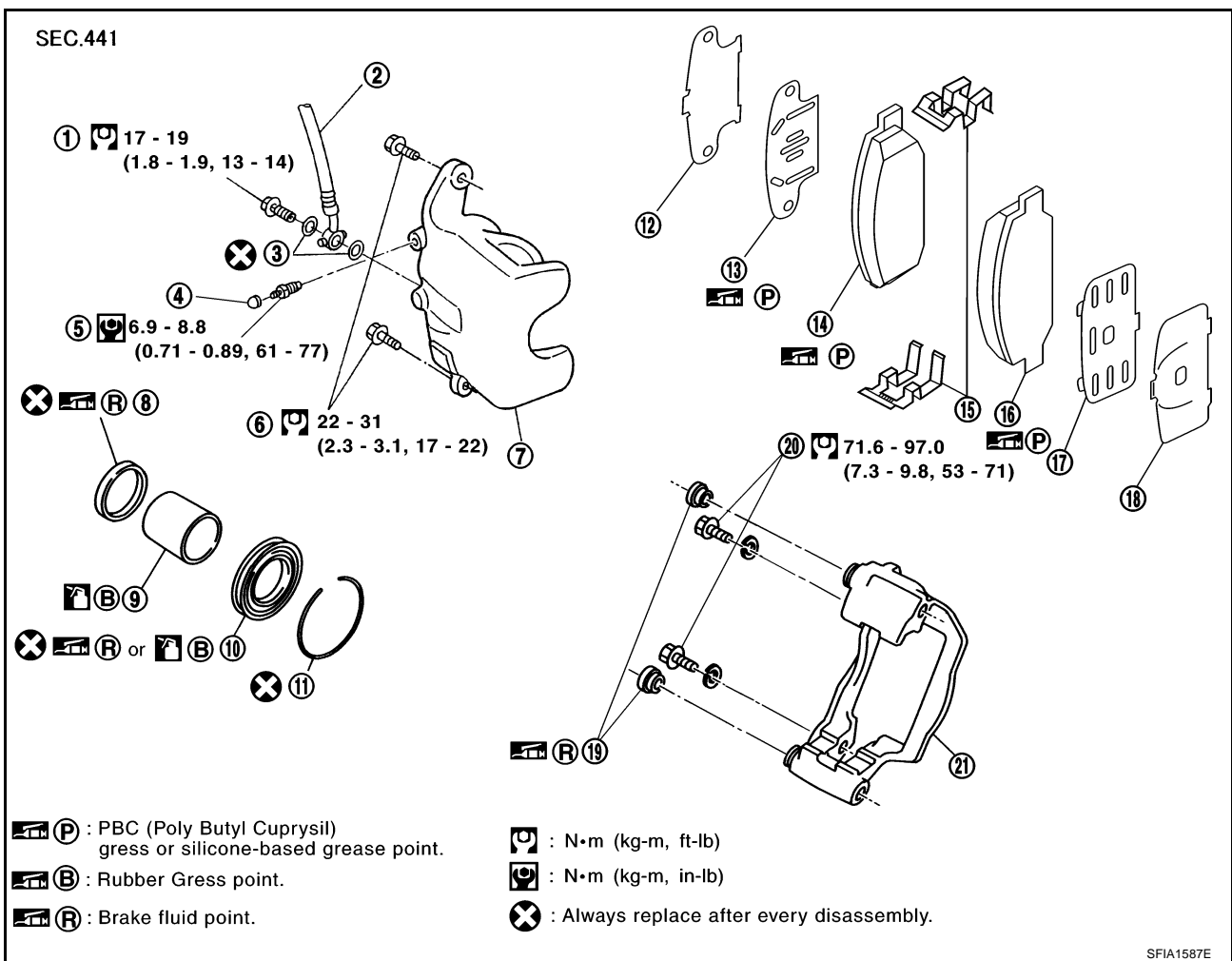

SFIA1587E

- | | | |
|--------------------|-------------------------|----------------------|
| 1. Union bolt | 2. Brake hose | 3. Copper washer |
| 4. Cap | 5. Bleed valve | 6. Sliding pin bolt |
| 7. Cylinder body | 8. Piston seal | 9. Piston |
| 10. Piston boot | 11. Retaining ring | 12. Inner shim cover |
| 13. Inner shim | 14. Inner pad | 15. Pad retainer |
| 16. Outer pad | 17. Outer shim | 18. Outer shim cover |
| 19. Slide pin boot | 20. Torque member bolts | 21. Torque member |

REAR DISC BRAKE (AD14VE TYPE)

CAUTION:

- Clean dust on caliper and brake pad with a vacuum dust collector. Do not blow with compressed air.
- While removing cylinder body, never depress the brake pedal because the piston will pop out.
- It is not necessary to remove bolts on torque member and brake hose except for disassembly or replacement of the caliper assembly. In this case, hang cylinder body with a wire so that brake hose is not under tension.
- Do not damage piston boot.
- Always replace shims and shim covers as a set when replacing brake pads.
- Keep the rotor clean of brake fluid.

Removal and Installation of Brake Pad

AFS000YE

REMOVAL

1. Remove tires from vehicle with power tool.(Commercial service tool)
2. Remove sliding pin bold (one on top).
3. Hang cylinder body with a wire, and remove pads, pad retainers, shims from torque member.

INSTALLATION

1. Apply PBC (Poly Butyl Cuprysil) grease or silicon- based grease to the rear of the pad and to both sides of the shim, and attach the inner shim and shim cover to the inner pad, and the outer shim and outer shim cover to the outer pad.
2. Attach the pad retainer and pad to the torque member.
3. Push the piston in so that the pad is firmly attached and attach the cylinder body to the torque member.

NOTE:

Using a disc brake piston tool (commercial service tool), etc., makes it easier to push in the piston.

CAUTION:

By pushing in the piston, the brake fluid returns to the master cylinder reservoir tank. Watch the level of the surface of the reservoir tank.

4. Attach the sliding pin bolt (one on top) and tighten to the specified torque.
5. Check brake for drag.
6. Attach the tires to the vehicle.

Removal and Installation of Caliper Assembly

AFS000YF

REMOVAL

1. Remove tires from vehicle with power tool.
2. Drain brake fluid. Refer to [BR-9, "Drain and Refill"](#) .
3. Remove union bolts and torque member bolts, and remove caliper assembly.
4. Remove disc rotor.

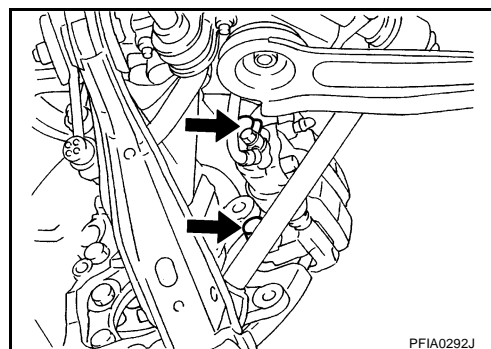

INSTALLATION

CAUTION:

- Refill with new brake fluid "DOT 3".
 - Never reuse drained brake fluid.
1. Install disc rotor.
 2. Install caliper assembly to the vehicle, and tighten bolts to the specified torque.

CAUTION:

Before installing caliper assembly to the vehicle, wipe off oil and grease on washer seats on axle assembly and mounting surface of caliper assembly.

3. Install brake hose to caliper assembly and tighten union bolts to the specified torque.

REAR DISC BRAKE (AD14VE TYPE)

CAUTION:

- Do not reuse the copper washer for union bolts.
 - Securely attach brake hose to protrusion on caliper assembly.
4. Insert new brake fluid and bleed air. Refer to [BR-10, "Bleeding Brake System"](#).
 5. Attach the tires to the vehicle.

Disassembly and Assembly of Caliper Assembly DISASSEMBLY

AFS000YG

1. Remove the slide pin bolt, and then remove the pad, shim, shim cover, and pad retainer from the torque member and cylinder.
2. Remove sliding pin boot from torque member.
3. As shown in the figure, using a flat-bladed screwdriver, remove the retaining ring from the cylinder body.

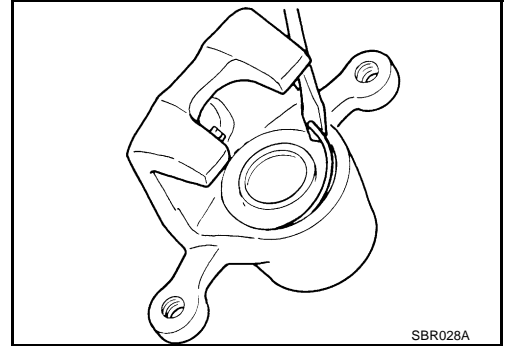

4. Place a wooden block as shown in the figure, and blow air from union bolt mounting hole to remove pistons and piston boots.

CAUTION:

Do not get your fingers caught in the piston.

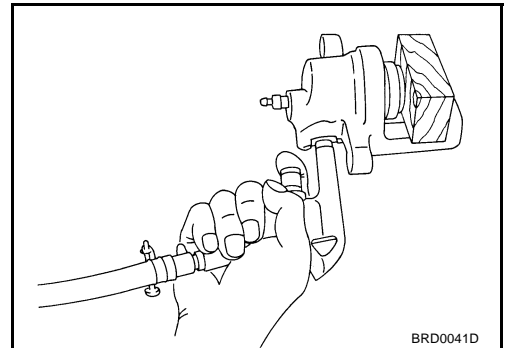

5. Using a flat-bladed screwdriver, remove piston seals from cylinder body.

CAUTION:

Be careful not to damage cylinder inner wall.

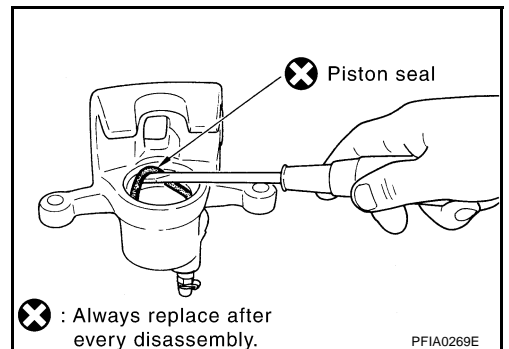

CALIPER INSPECTION

Cylinder Body

CAUTION:

- Use new brake fluid to clean. Never use mineral oils such as gasoline or kerosene.
- Check inner wall of cylinder for corrosion, wear, and damage. If any non-standard condition is detected, replace cylinder body.
- Minor flaws caused by corrosion or a foreign material can be removed by polishing the surface with a fine sandpaper. Replace the cylinder body, if necessary.

Torque Member

Check for wear, cracks, and damage. If damage or deformation is present, replace the affected part.

REAR DISC BRAKE (AD14VE TYPE)

Piston

CAUTION:

Since the piston surface is plated, do not repair using sandpaper.

Check piston surface for corrosion, wear, and damage. If any non-standard condition is detected, replace applicable part.

Sliding Pin Bolts and Sliding Pin Boots

Check that there is no wear, damage, or cracks in the sliding pin bolts and sliding pin boots, and if there are, replace them.

ASSEMBLY

CAUTION:

Do not use Nissan Rubber Grease (KRE00 00010, KRE00 00010 01) when assembling.

1. Apply a rubber grease to the piston seal and attach to cylinder body.

CAUTION:

Do not reuse the piston seals.

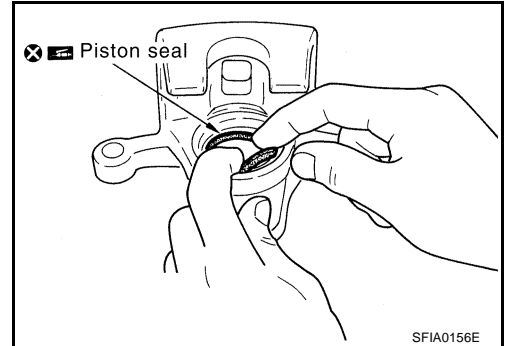

2. Apply brake fluid or rubber grease to the piston boot, place it on the piston, and firmly insert the piston boot cylinder-side lip into the cylinder body groove.

CAUTION:

Do not reuse the piston boot.

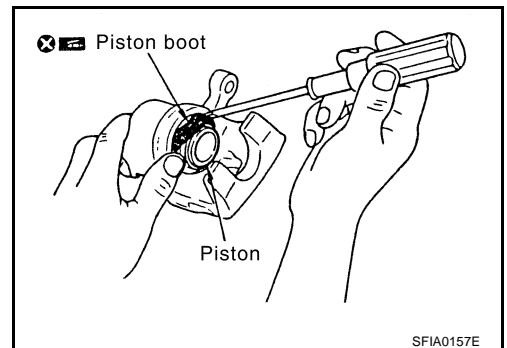

3. Apply a brake fluid to the piston, insert into the cylinder body by hand and firmly attach the piston boot piston-side lip into the piston groove.

CAUTION:

Press the piston evenly and vary the pressing point to prevent cylinder inner wall from being rubbed.

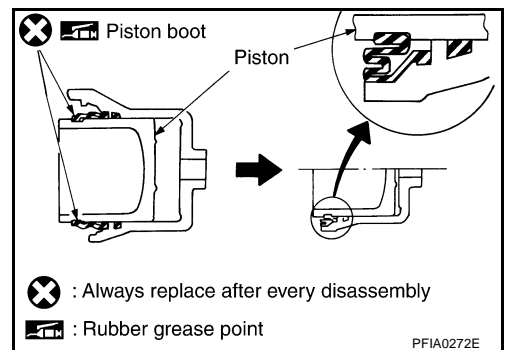

A
B
C
D
E
BR
G
H
I
J
K
L
M

REAR DISC BRAKE (AD14VE TYPE)

- Fix piston boot with retaining ring.

CAUTION:

- Make sure the boot is firmly in the cylinder body groove.
- Do not reuse the retaining ring.

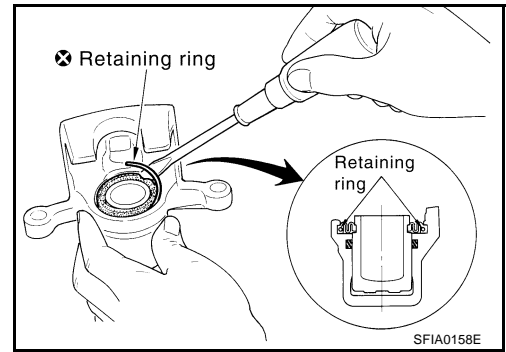

- Attach the sliding pin bolt and sliding pin boot to the torque member.
- Apply PBC (Poly Butyl Cuprysil) grease or silicon-based grease to the rear of the pad and to both sides of the shim, and attach the inner shim and shim cover to the inner pad, and the outer shim and outer shim cover to the outer pad.
- Attach the pad retainer and pad to the torque member.

CAUTION:

When attaching the pad retainer, attach it firmly so that it does not float up higher than the torque member, as shown in the figure.

- After assembling shims and shim covers to pad, install it to the torque member.
- Install cylinder body. Tighten sliding pin bolts to the specified torque.

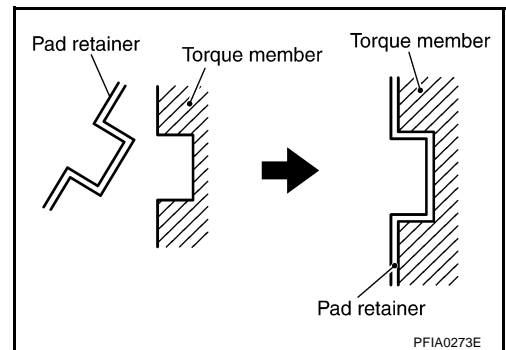

DISC ROTOR INSPECTION

Visual Inspection

Check surface of the disc rotor for uneven wear, cracks, and serious damage. If any non-standard condition is detected, replace applicable part.

Runout Inspection

- Using wheel nuts, fix disc rotor to the wheel hub. (2 or more positions)
- Inspect runout using a dial gauge.

Standard value

(measured at 10 mm (0.39 in) inside the disc edge)

Measurement position : At a point 10 mm (0.39 in) from outer edge of the disc.

Runout limit (with it attached to the vehicle) : 0.10 mm (0.0039 in) or less

Runout limit (just the disc rotor) : 0.07 mm (0.0028 in) or less

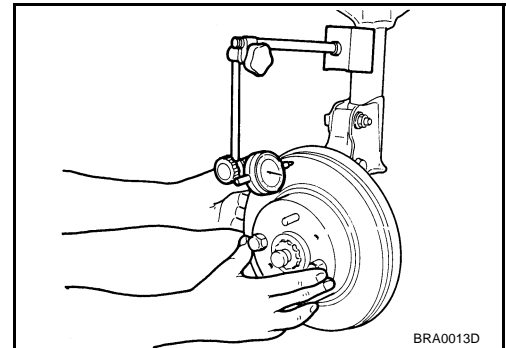

NOTE:

Make sure that wheel bearing axial endplay is within the specification before measuring runout. Refer to [RAX-6, "On-Vehicle Inspection and Service"](#).

- If runout is outside the limit, find the minimum runout point by shifting mounting positions of the disc rotor and wheel hub by one hole.

REAR DISC BRAKE (AD14VE TYPE)

Thickness Inspection

Using a micrometer, check thickness of the disc rotor. If thickness is outside the standard, replace disc rotor.

Standard

Standard thickness : 16.0 mm (0.630 in)

Wear limit : 14.0 mm (0.551 in)

Maximum uneven wear (measured at 8 positions) : 0.015 mm (0.0006 in) or less

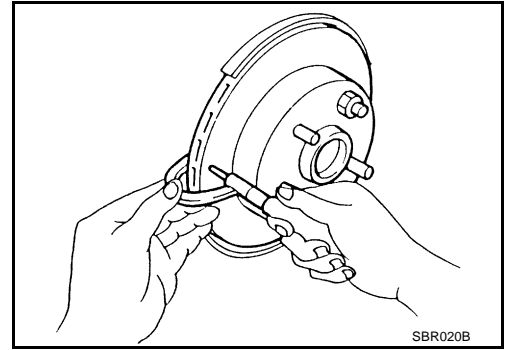

A
B
C
D

E

BR

G

H

I

J

K

L

M

REAR DISC BRAKE (OPB13VB TYPE)

REAR DISC BRAKE (OPB13VB TYPE)

PFP:44000

On-Board Inspection PAD WEAR INSPECTION

AFS000YI

- Inspect the thickness of the pad through the caliper inspection hole. Use a scale for inspection if necessary.

Standard

Standard thickness : 9.1 mm (0.358 in)

Repair limit thickness : 2.0 mm (0.079 in)

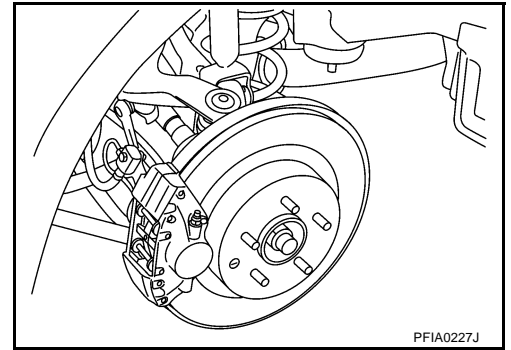

Components

AFS000YJ

NOTE:

Refer to [BR-46, "HOW TO APPLY GREASE TO THE BRAKE PAD"](#) for how to apply grease to brake pads.

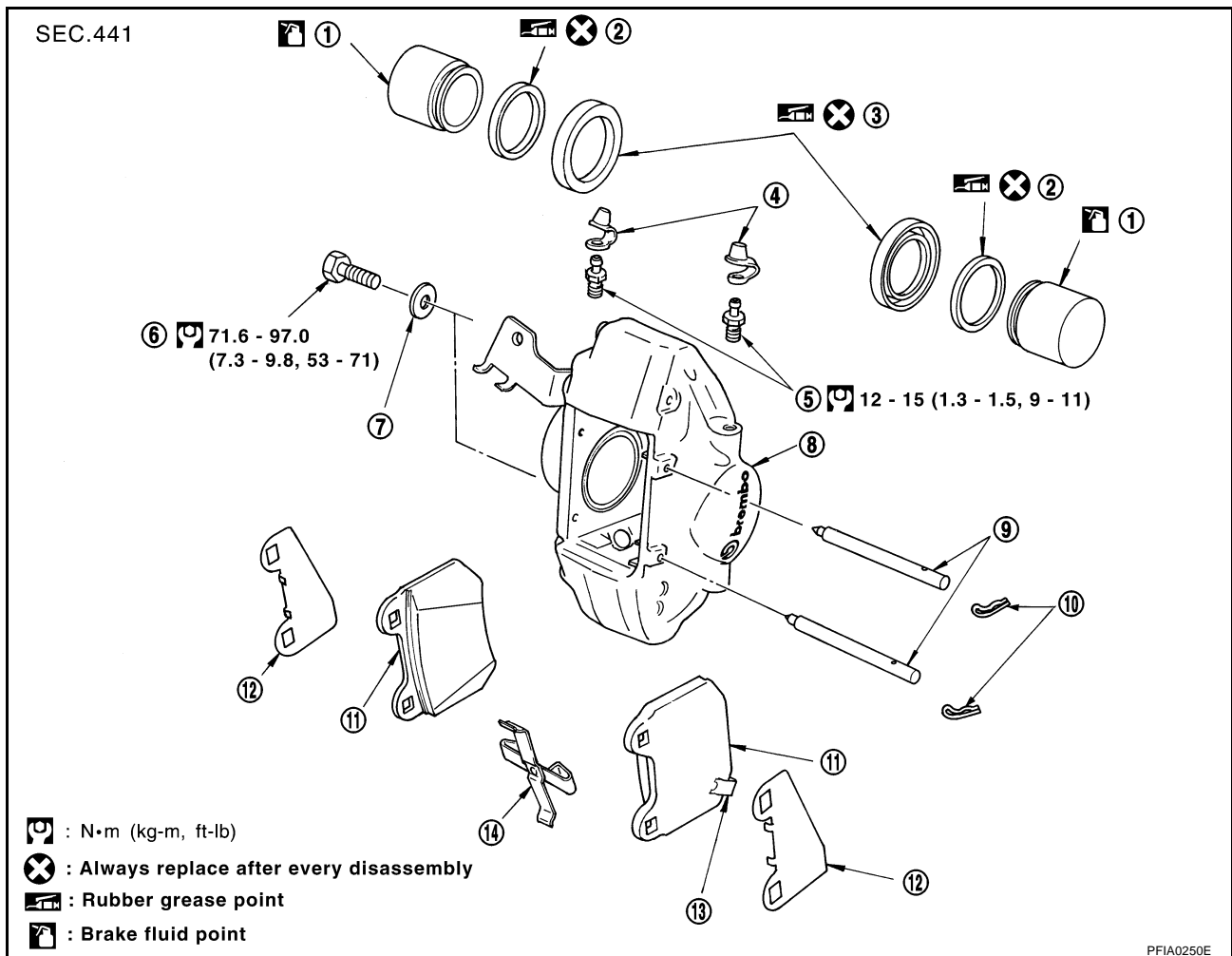

- | | | |
|---------------------|------------------|----------------|
| 1. Piston | 2. Piston seal | 3. Piston boot |
| 4. Cap | 5. Bleed valve | 6. Bolt |
| 7. Washer | 8. Caliper | 9. Pad pins |
| 10. Clips | 11. Brake pad | 12. Shim cover |
| 13. Pad wear sensor | 14. Cross spring | |

REAR DISC BRAKE (OPB13VB TYPE)

CAUTION:

- Clean dust on caliper and brake pad with a vacuum dust collector. Do not blow with compressed air.
- While removing cylinder body, never depress the brake pedal because the piston will pop out.
- Apart from caliper assembly, disassembly or replacement, there is no need to remove caliper bolts or brake hose or tube.
- Do not damage piston boot.
- Always replace shim cover as a set when replacing brake pads.
- Keep the rotor clean of brake fluid.

Removal and Installation of Brake Pad

REMOVAL

1. Remove tires from vehicle with power tool.
2. Remove the clip from the pad pin.

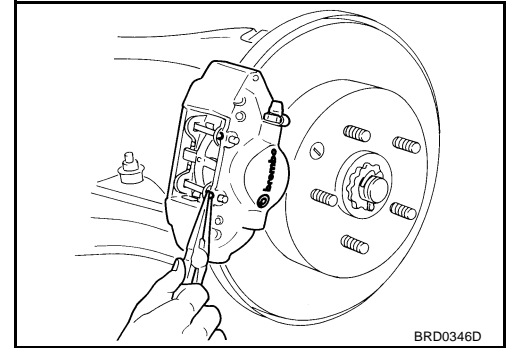

3. Remove the pad pin while holding down the cross spring, then remove the cross spring from the caliper.

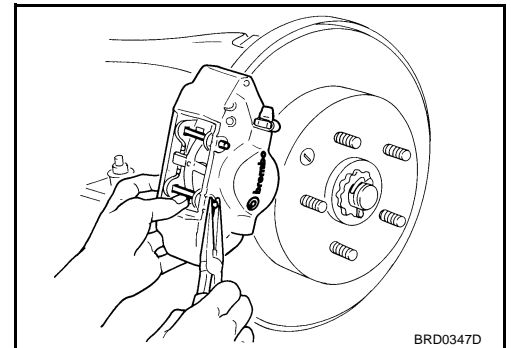

4. Using pliers, remove the pad from the caliper.

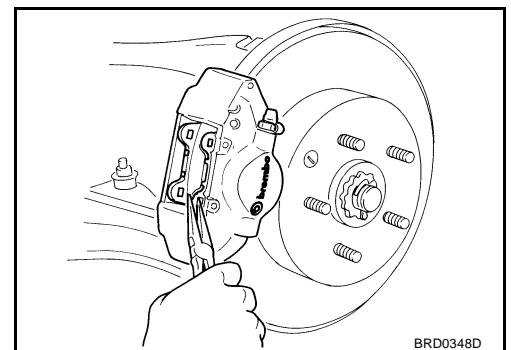

A
B
C
D
E
BR
G
H
I
J
K
L
M

REAR DISC BRAKE (OPB13VB TYPE)

HOW TO APPLY GREASE TO THE BRAKE PAD

Pad Side

Apply PBC (Poly Butyl Cuprysil) grease or silicone-based grease about 0.5 g (0.018 oz) per surface equally to back plate side of Inner Pad and Outer Pad. (Refer to the figure)

CAUTION:

Make sure no foreign matter attaches itself to the grease.

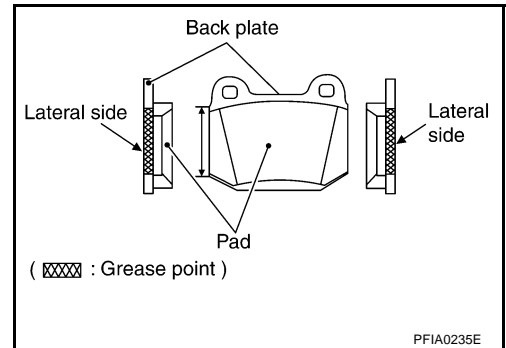

Pad Rear

Apply approximately 1.5 g (0.053 oz) of PBC (Poly Butyl Cuprysil) grease or silicone-based grease between shim cover and pad.

CAUTION:

Make sure no foreign matter attaches itself to the grease.

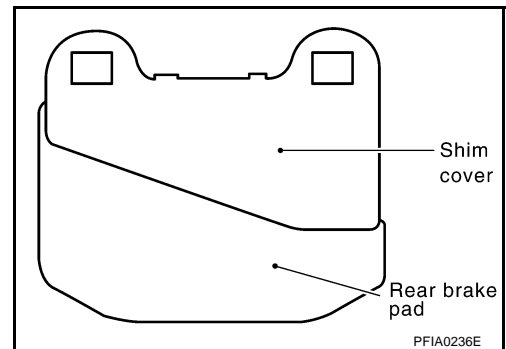

INSTALLATION

1. Insert the piston to the position where the pad is attached.

NOTE:

Using a disc brake piston tool (commercial service tool), etc., makes it easier to push in the piston.

CAUTION:

- Pushing the piston in will make the brake fluid return to the master cylinder reservoir tank, so watch the level of the surface of the reservoir tank.
- The side of the shim with the larger cutouts should be on the entry side of the disc rotor spin.

2. Attach pad and shim cover.

CAUTION:

Attach the pad with wear sensor to the outer side.

3. Insert the upper pad pin from the outer cylinder side, then insert firmly to the inner cylinder side through the hole in the top of the pad.
4. As shown in the figure, place the top of the cross spring over the top pad pin, press in the cross spring, push the lower pad pin from the outer cylinder side to the inner cylinder side, and secure the cross spring.
5. Insert the clip in the small hole at the end of the pad pin.

CAUTION:

If the clip is not fully attached, the pad pin or the pad could fall out while the vehicle is in motion.

6. Attach the tires to the vehicle.

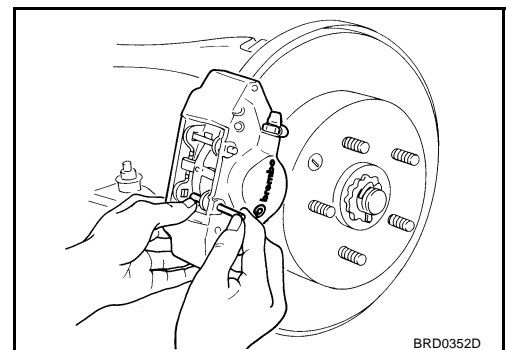

REAR DISC BRAKE (OPB13VB TYPE)

Removal and Installation of Caliper Assembly

REMOVAL

1. Remove tires from vehicle with power tool.
2. Drain brake fluid. Refer to [BR-9, "Drain and Refill"](#).
3. Remove the brake pad. Refer to [BR-45, "Removal and Installation of Brake Pad"](#).
4. Remove the brake tube flare nut using a flare wrench.
5. Remove the brake hose bolt, move the brake hose, and remove the caliper assembly from the vehicle.
6. Remove disc rotor.

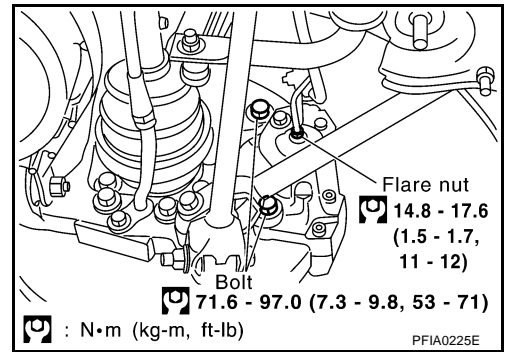

INSTALLATION

CAUTION:

- Refill with new brake fluid "DOT3".
- Never reuse drained brake fluid.

1. Install disc rotor.
2. Attach the brake tube to the caliper assembly and partially tighten the flare nut.
3. Attach the caliper assembly to the vehicle and tighten the bolt to the specified torque.
4. Tighten the flare nut to the specified torque.
5. Attach brake pad. Refer to [BR-46, "INSTALLATION"](#).
6. Refill new brake fluid and bleed air. Refer to [BR-10, "Bleeding Brake System"](#).
7. Attach the tires to the vehicle.

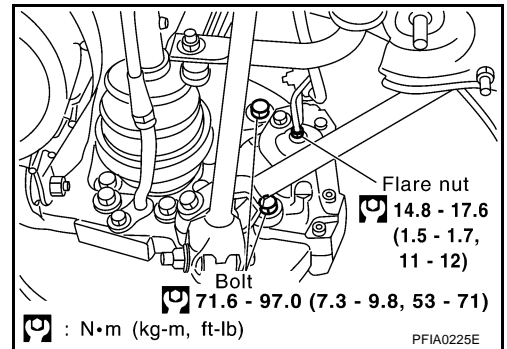

Disassembly and Assembly of Caliper Assembly

DISASSEMBLY

1. Insert a piece of wood as shown in the figure, blow air in through the flare nut mounting hole, and remove the piston and piston boot.

CAUTION:

Do not get your fingers caught in the piston.

2. Remove the piston boot from the piston.

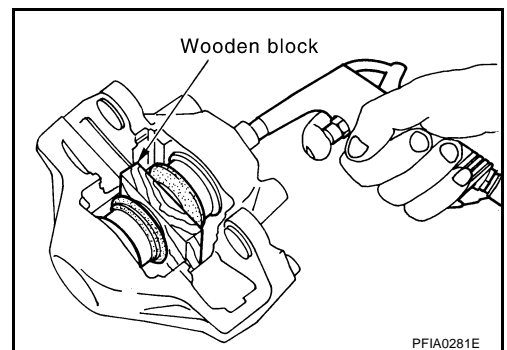

3. Using a flat-bladed screwdriver, remove the piston seal.

CAUTION:

- Be careful not to damage cylinder inner wall.
- Never remove the four bolts from the inner and outer sides of the caliper. Do not tighten them further, either.

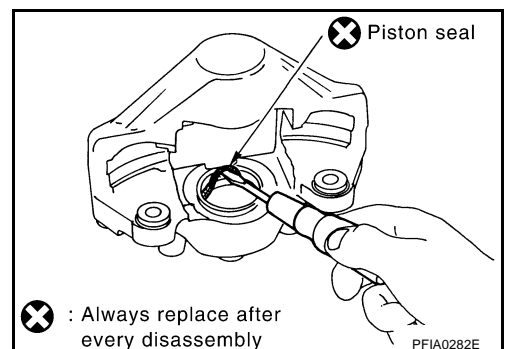

REAR DISC BRAKE (OPB13VB TYPE)

CALIPER INSPECTION

Caliper

CAUTION:

- Use new brake fluid to clean. Never use mineral oils such as gasoline or kerosene.
- Check for corrosion, wear, or damage to the cylinder inner wall, and replace the caliper if there are any non-standard conditions.

Piston

CAUTION:

- Since the piston surface is plated, do not repair using sandpaper.
- Check piston surface for corrosion, wear, and damage. If any non-standard condition is detected, replace applicable part.

ASSEMBLY

CAUTION:

Do not use Nissan rubber grease (KRE00 00010, KRE00 00010 01) during assembly.

1. Apply a rubber grease to the piston seals, and install them to cylinder body.

CAUTION:

Do not reuse the piston seals.

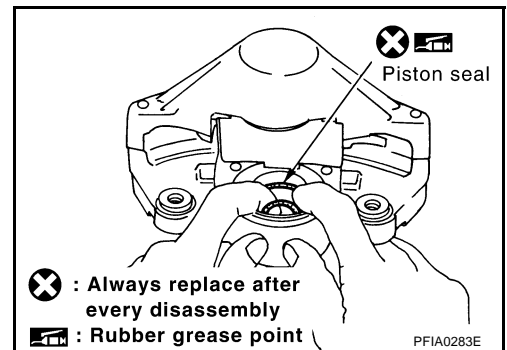

2. Apply brake fluid or rubber grease to the piston boot, place it on the piston, and firmly insert the piston boot cylinder-side lip into the cylinder body groove.
3. Insert the piston into the cylinder body by hand and firmly attach the piston boot piston-side lip into the piston groove.

CAUTION:

Press the piston evenly and vary the pressing point to prevent cylinder inner wall from being rubbed.

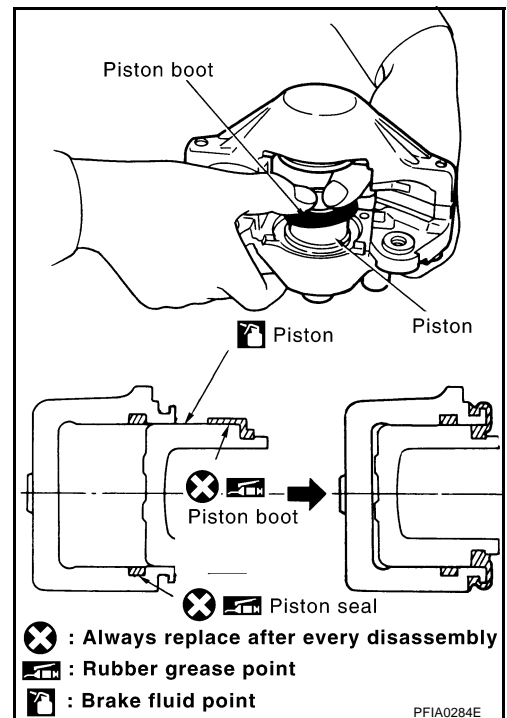

REAR DISC BRAKE (OPB13VB TYPE)

DISC ROTOR INSPECTION

Visual Inspection

Check surface of the disc rotor for uneven wear, cracks, and serious damage. If any non-standard condition is detected, replace applicable part.

Runout Inspection

1. Using wheel nuts, fix disc rotor to the wheel hub. (2 or more positions)
2. Inspect runout using a dial gauge.

Standard value (measured at 10 mm (0.39 in) inside the disc edge)

Runout limit (with it attached to the vehicle) : 0.07 mm (0.0028 in) or less

Runout limit (just for disc rotor) : 0.050 mm (0.0020 in) or less

NOTE:

Make sure that wheel bearing axial endplay is within the specification before measuring runout. Refer to [RAX-6, "On-Vehicle Inspection and Service"](#).

3. If runout is outside the limit, find the minimum runout point by shifting mounting positions of the disc rotor and wheel hub by one hole.

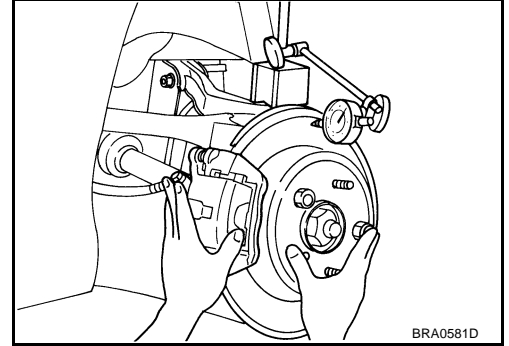

Thickness Inspection

Using a micrometer, check thickness of the disc rotor. If thickness is outside the standard, replace disc rotor.

Standard

Standard thickness : 22.0 mm (0.866 in)

Wear limit : 20.2 mm (0.795 in)

Maximum uneven wear (measured at 8 positions) : 0.015 mm (0.0020 in) or less

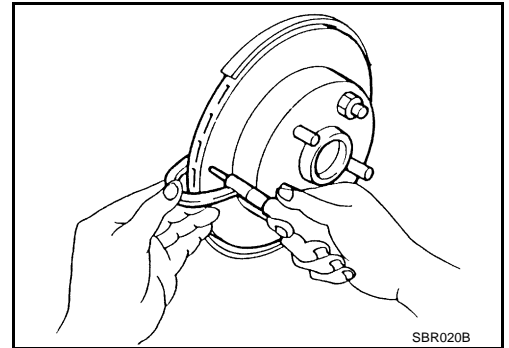

A
B
C
D
E
BR
G
H
I
J
K
L
M

SERVICE DATA AND SPECIFICATIONS (SDS)

SERVICE DATA AND SPECIFICATIONS (SDS)

PF0:00030

General Specifications

AFS0008Q

Unit: mm (in)

Front brake	Brake model	CLZ25VD	OPB27VA	
	Rotor outer diameter × thickness	296 × 24.0 (11.65 × 0.945)	324 × 30.0 (12.76 × 1.181)	
	Pad Length × width × thickness	125.6 × 46.0 × 11.0 (4.94 × 1.811 × 0.433)	117.1 × 53.3 × 9.3 (4.61 × 2.098 × 0.366)	
	Cylinder bore diameter	57.2 (2.252)	38 (1.50) × 2 + 44 (1.73) × 2	
Rear brake	Brake model	AD14VE	OPB13VB	
	Rotor outer diameter × thickness	292 × 16 (11.50 × 0.63)	332 × 22 (13.07 × 0.87)	
	Pad Length × width × thickness	83.0 × 33.0 × 8.5 (3.268 × 1.299 × 0.335)	76.6 × 45 × 9.1 (3.016 × 1.77 × 0.358)	
	Cylinder bore diameter	42.86 (1.6874)	40.0 × 2 (1.575)	
Master cylinder	Cylinder bore diameter	26.99 (1.0626)		
Control valve	Valve model	Electric brake force distribution		
Brake booster	Booster model	Coupe	V255	M215T
		Roadster	M215T	–
	Diaphragm diameter	Coupe	255 (10.04)	Pri:230(9.06) Sec:205(8.07)
		Roadster	Pri: 230 (9.06) Sec: 205 (8.07)	
Recommended brake fluid		DOT 3		

Brake Pedal

AFS0008R

Brake pedal height (from dash lower panel top surface)	M/T model	154 - 164 mm (6.06 - 6.46 in)
	A/T model	162 - 172 mm (6.38 - 6.77 in)
Depressed pedal height (under a force of 490 N (50 kg, 110 lb) with the engine running)	M/T model	More than 90 mm (3.54 in)
	A/T model	More than 95 mm (3.74 in)
Clearance between the stopper rubber and the threaded end of the stop lamp switch and ASCD cancel switch.		0.74 - 1.96 mm (0.0291 - 0.0772 in)
Pedal play		3 - 11 mm (0.12 - 0.43 in)

Brake Booster Vacuum type

AFS0008T

Vacuum leakage [at vacuum of – 66.7 kPa (– 500 mmHg, – 19.69 inHg)]	Within 3.3 kPa (25 mmHg, 0.98 inHg) of vacuum for 15 seconds
Input rod installation standard dimension	125 mm (4.92 in)

Check Valve

AFS0008S

Vacuum leakage [at vacuum of – 66.7 kPa(– 500 mmHg, – 19.69 inHg)]	within 1.3 kPa (10 mmHg, 0.39 inHg) of vacuum for 15 seconds
---	--

Front Disc Brake

AFS0008U

Brake model	CLZ25VD	OPB27VA	
Brake pad	Standard thickness (new)	11.0 mm (0.433 in)	9.3 mm (0.366 in)
	Repair limit thickness	2.0 mm (0.079 in)	2.0 mm (0.079 in)

SERVICE DATA AND SPECIFICATIONS (SDS)

Brake model		CLZ25VD	OPB27VA
Disc rotor	Standard thickness (new)	24.0 mm (0.945 in)	30.0mm (1.181 in)
	Repair limit thickness	22.0 mm (0.866 in)	28.4mm (1.118 in)
	Maximum uneven wear (measured at 8 positions)	0.015mm (0.0006 in) or less	0.015 mm (0.0006 in) or less
	Runout limit (with it attached to the vehicle)	0.035 mm (0.0014 in) or less	0.050 mm (0.0020 in) or less
	Runout limit (just the disc rotor)	0.020 mm (0.0008 in) or less	0.040 mm (0.0016 in) or less

Rear Disc Brake

AFS0008V

Brake model		AD14VE	OPB13VB
Brake pad	Standard thickness (new)	8.5 mm (0.335 in)	9.1 mm (0.358 in)
	Repair limit thickness	2.0 mm (0.079 in)	2.0 mm (0.079 in)
Disc rotor	Standard thickness (new)	16.0 mm (0.630 in)	22.0 mm (0.866 in)
	Repair limit thickness	14.0 mm (0.551 in)	20.2 mm (0.795 in)
	Maximum uneven wear (measured at 8 positions)	0.015 mm (0.0006 in) or less	0.015 mm (0.0006 in) or less
	Runout limit (with it attached to the vehicle)	0.10 mm (0.0039 in) or less	0.07 mm (0.0028 in) or less
	Runout limit (just the disc rotor)	0.07 mm (0.0028 in) or less	0.050 mm (0.0020 in) or less

SERVICE DATA AND SPECIFICATIONS (SDS)
