

FRONT AXLE AND FRONT SUSPENSION

SECTION FA

CONTENTS

PRECAUTIONS AND PREPARATION	2	Joint Assembly (Transaxle side).....	19
Precautions.....	2	Joint Assembly (Wheel side).....	19
Special Service Tools.....	2	Support Bearing.....	19
Commercial Service Tools.....	3	Support Bearing Bracket.....	19
FRONT AXLE AND FRONT SUSPENSION	4	Assembly.....	19
ON-VEHICLE SERVICE	5	Wheel Side.....	20
Front Axle and Front Suspension Parts.....	5	Transaxle Side.....	21
Front Wheel Bearing.....	6	Support Bearing.....	22
Front Wheel Alignment.....	6	FRONT SUSPENSION	23
Preliminary Inspection.....	7	FRONT SUSPENSION — Coil Spring and Strut	
Camber, Caster And Kingpin Inclination.....	7	Assembly	24
Toe-In.....	7	Removal and Installation.....	24
Front Wheel Turning Angle.....	8	Disassembly.....	24
Drive Shaft.....	8	Inspection.....	24
FRONT AXLE	9	Strut Assembly.....	24
FRONT AXLE — Wheel Hub and Knuckle	10	Strut Mounting Insulator.....	25
Removal.....	10	Thrust Bearing.....	25
Installation.....	11	Coil Spring And Insulator.....	25
Disassembly.....	11	Assembly.....	25
Wheel Hub.....	11	FRONT SUSPENSION — Stabilizer Bar	26
Wheel Bearing.....	12	Removal and Installation.....	26
Inspection.....	12	Inspection.....	26
Wheel Hub And Knuckle.....	12	FRONT SUSPENSION — Transverse Link and	
Snap Ring.....	12	Lower Ball Joint	27
Assembly.....	13	Removal and Installation.....	27
FRONT AXLE — Drive Shaft	15	Inspection.....	27
Removal.....	15	SERVICE DATA AND SPECIFICATIONS (SDS)	28
Installation.....	16	General Specifications.....	28
Transaxle Side.....	16	Coil Spring.....	28
Wheel Side.....	16	Strut.....	28
Components.....	17	Front Stabilizer Bar.....	28
Disassembly.....	17	Wheelarch Height.....	28
Transaxle Side.....	17	Drive Shaft.....	28
Wheel Side.....	18	Inspection and Adjustment.....	29
Support Bearing.....	18	Wheel Alignment.....	29
Inspection.....	19	Wheel Bearing.....	29
Drive Shaft.....	19	Lower Ball Joint.....	29
Boot.....	19	Wheel Runout.....	29

GI

MA

EM

LC

EF &
EC

FE

CL

MT

AT

FA

RA

BR

ST

BF

HA

EL

IDX

PRECAUTIONS AND PREPARATION

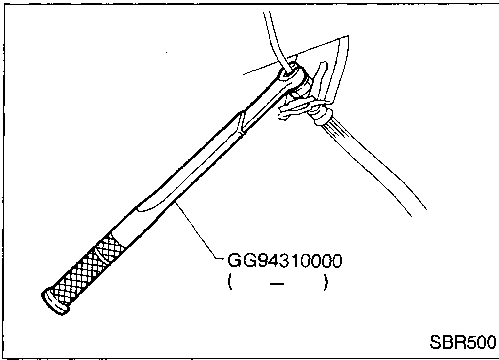

Precautions

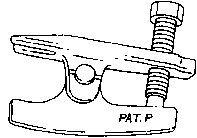
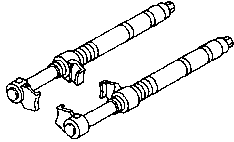
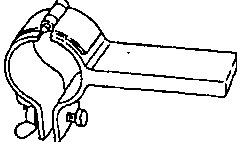
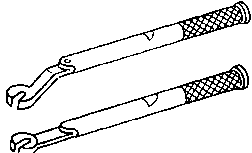
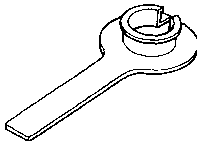

- When installing rubber parts, final tightening must be carried out under unladen condition* with tires on ground.
*: Fuel, radiator coolant and engine oil full. Spare tire, jack, hand tools and mats in designated positions.
- When removing each suspension part, check wheel alignment and adjust if necessary.
- Use flare nut wrench when removing or installing brake tubes.
- Always torque brake lines when installing.

Special Service Tools

Tool number (Kent-Moore No.) Tool name	Description
HT72520000 (J25730-A) Ball joint remover	 <p style="text-align: right;">Removing tie-rod outer end and lower ball joint</p>
HT71780000 (-) Spring compressor	 <p style="text-align: right;">Removing and installing coil spring</p>
ST35652000 (-) Strut attachment	 <p style="text-align: right;">Fixing strut assembly</p>
GG94310000 (-) Flare nut wrench	 <p style="text-align: right;">Removing and installing brake piping</p>
KV38106700 (J34296) KV38106800 (J34297) Differential side oil seal protector	 <p style="text-align: right;">Installing drive shaft</p> <p style="text-align: right;">LH: KV38106700 RH: KV38106800</p>

PRECAUTIONS AND PREPARATION

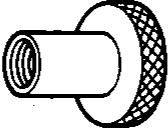
Commercial Service Tools

Tool name	Description
Attachment Wheel alignment	
Flare nut crows foot	
Torque wrench	

GI

MA

EM

LC

EF &
EC

FE

CL

MT

AT

FA

SA

BR

ST

BF

HA

EL

IDX

FRONT AXLE AND FRONT SUSPENSION

When installing rubber parts, final tightening must be carried out under unladen condition* with tires on ground.

* Fuel, radiator coolant and engine oil full.
Spare tire, jack, hand tools and mats in designated positions.

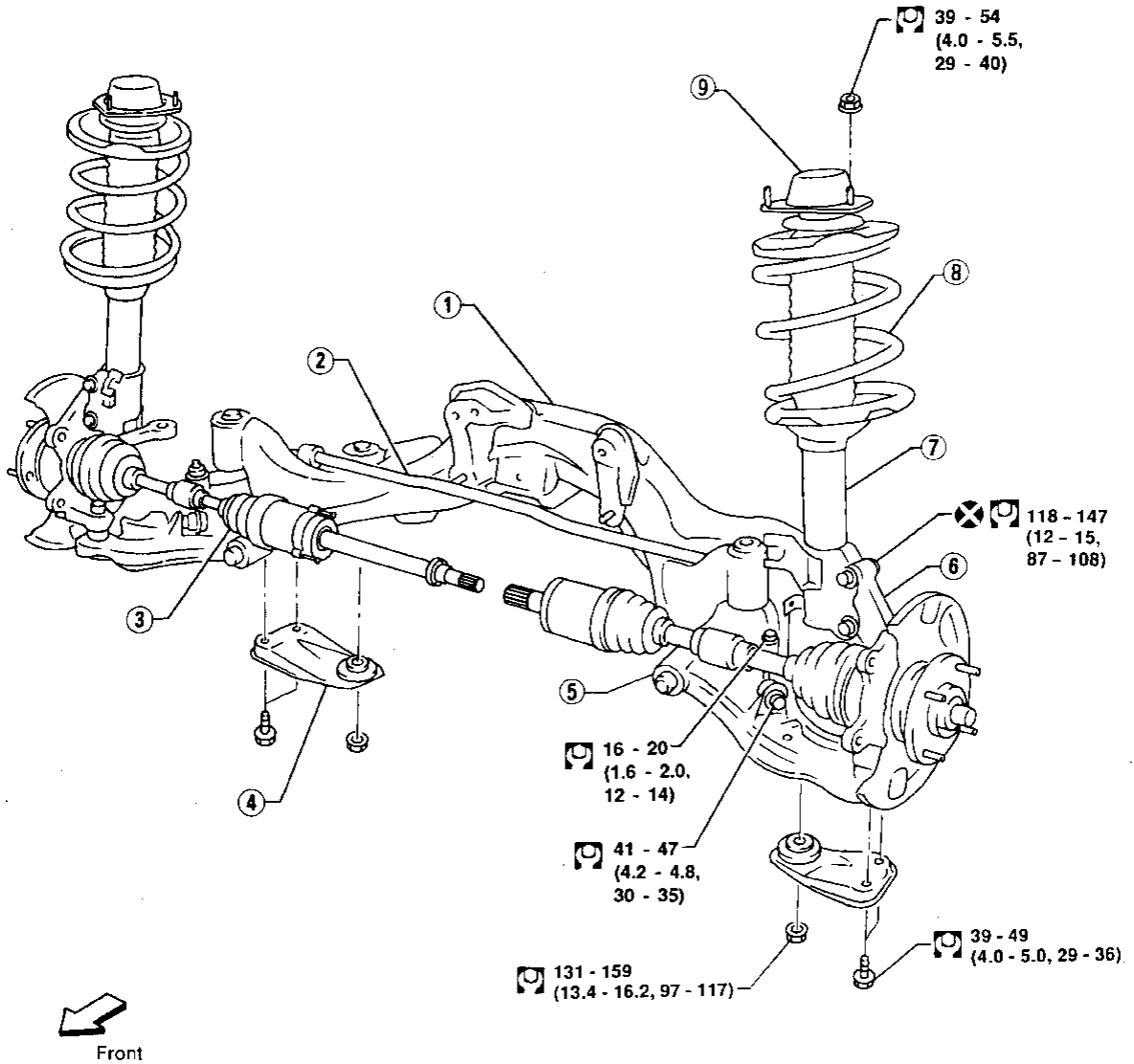

: N·m (kg-m, ft-lb)

AFA038

- ① Suspension member
- ② Stabilizer bar
- ③ Drive shaft

- ④ Rebound stopper
- ⑤ Transverse link
- ⑥ Knuckle

- ⑦ Strut assembly
- ⑧ Coil spring
- ⑨ Strut mounting insulator assembly

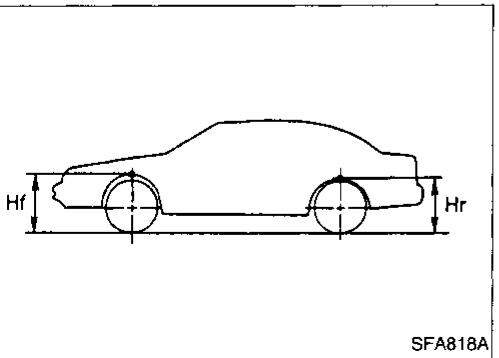
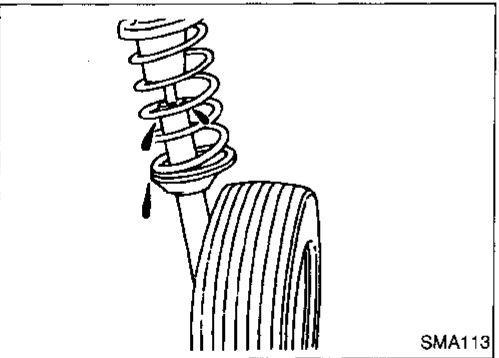
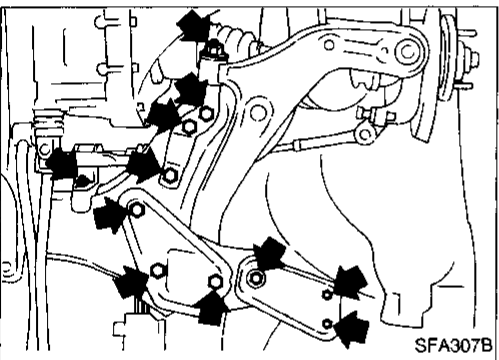
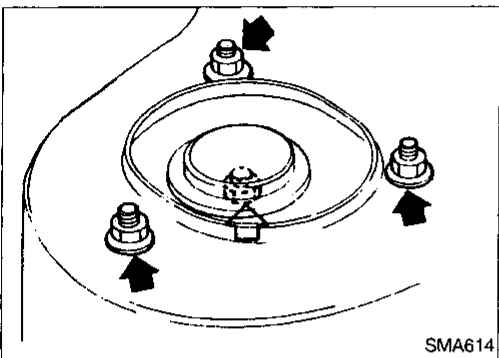
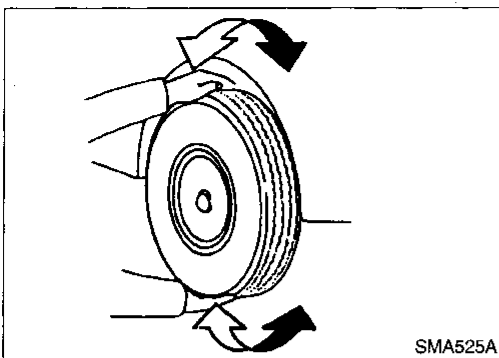

Front Axle and Front Suspension Parts

Check front axle and front suspension parts for looseness, cracks, wear or other damage.

- Shake each front wheel to check for excessive play.

- Make sure that cotter pin is inserted.
- Retighten all nuts and bolts to the specified torque.

Tightening torque:
Refer to FA-23.

- Check strut (shock absorber) for oil leakage or other damage.

- Check spring height from top of wheelarch to ground.
 - (1) Vehicle must be unladen*, parked on a level surface, and tires checked for proper inflation and wear (tread wear indicator must not be showing).

*: Fuel, radiator coolant and engine oil full. Spare tire, jack, hand tools and mats in designated positions.

- (2) Bounce vehicle up and down several times before measuring.
Standard height: Refer to FA-28.
- (3) Spring height is not adjustable. If out of specification, check for worn springs or suspension parts.

GI

MA

EM

LC

EF &

EC

FE

CL

MT

AT

FA

RA

BR

ST

BF

HA

EL

IDX

ON-VEHICLE SERVICE

Front Axle and Front Suspension Parts (Cont'd)

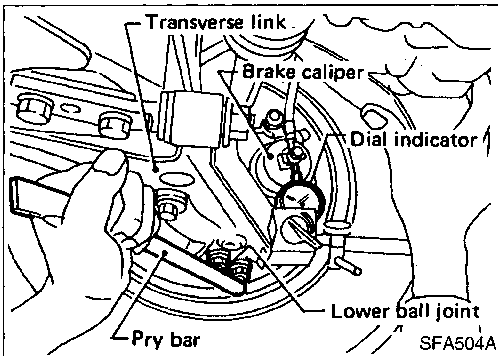
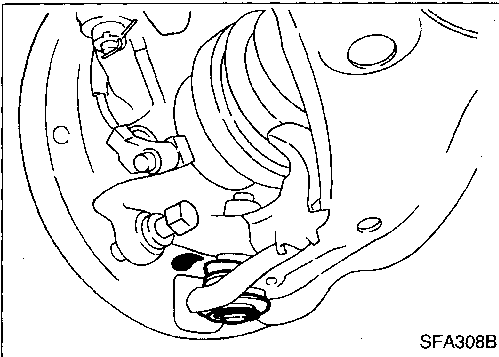

- Check suspension ball joint for grease leakage and ball joint dust cover for cracks or other damage. If ball joint dust cover is cracked or damaged, replace transverse link.

- Check suspension ball joint end play.
 - (1) Jack up front of vehicle and set the stands.
 - (2) Clamp dial indicator onto transverse link and place indicator tip on lower edge of brake caliper.
 - (3) Make sure front wheels are straight and brake pedal is depressed.
 - (4) Place a pry bar between transverse link and inner rim of road wheel.
 - (5) While raising and releasing pry bar, observe maximum dial indicator value.

Vertical end play:

0 mm (0 in)

- (6) If ball joint vertical end play exists, remove the transverse link and recheck the ball joint. Refer to FA-27.

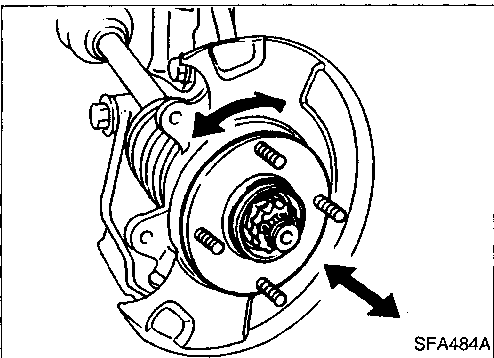

Front Wheel Bearing

- Check that wheel bearings operate smoothly.
- Check axial end play.

Axial end play:

0.05 mm (0.0020 in) or less

- If axial end play is not within specification or wheel bearing does not turn smoothly, replace wheel bearing assembly. Refer to FA-10.

Front Wheel Alignment

Before checking front wheel alignment, be sure to make a preliminary inspection (Unladen*).

*: Fuel, radiator coolant and engine oil full. Spare tire, jack, hand tools and mats in designated positions.

ON-VEHICLE SERVICE

Front Wheel Alignment (Cont'd)

PRELIMINARY INSPECTION

1. Check tires for wear and improper inflation.
2. Check wheel runout.

Wheel runout:

Refer to SDS, FA-29.

3. Check front wheel bearings for looseness.
4. Check front suspension for looseness.
5. Check steering linkage for looseness.
6. Check that front shock absorbers work properly by using the standard bounce test.
7. Check vehicle posture (Unladen).

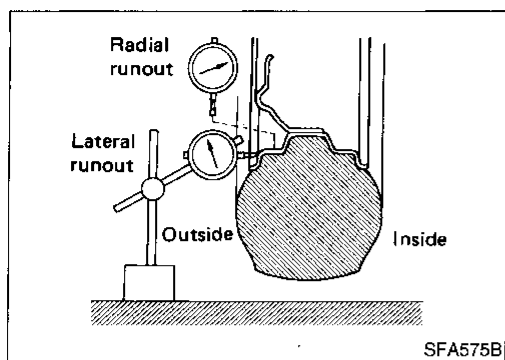

CAMBER, CASTER AND KINGPIN INCLINATION

Camber, caster and kingpin inclination are preset at factory and cannot be adjusted.

1. Measure camber, caster and kingpin inclination of both right and left wheels with a suitable alignment gauge.

Camber, Caster and Kingpin inclination:

Refer to SDS, FA-29.

2. If camber, caster and kingpin inclination are not within specification, inspect and replace any damaged or worn front suspension parts.

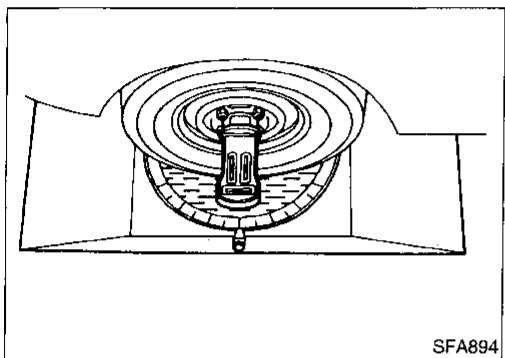

TOE-IN

1. Draw a base line around the tread.
 - After lowering front of vehicle, move it up and down to eliminate friction, and set steering wheel in straight-ahead position.

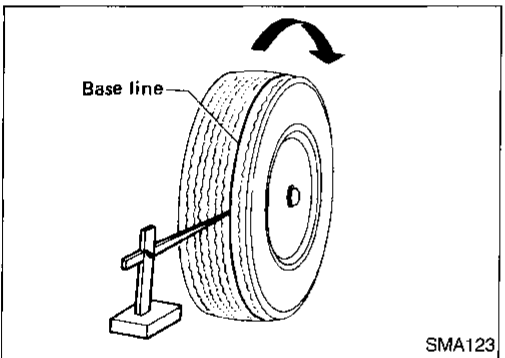

2. Measure toe-in.
 - Measure distance "A" and "B" at the same height as hub center.

Toe-in:

Refer to SDS, FA-29.

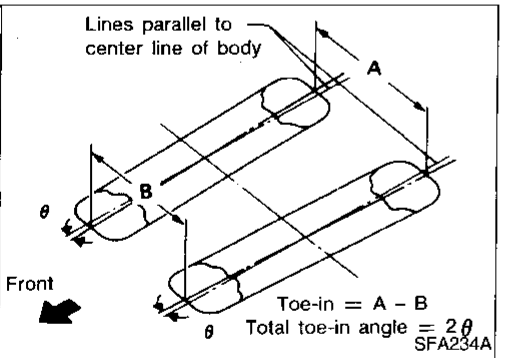

3. Adjust toe-in by varying the length of steering tie-rods.
 - (1) Loosen lock nuts.
 - (2) Adjust toe-in by screwing tie-rods in or out.

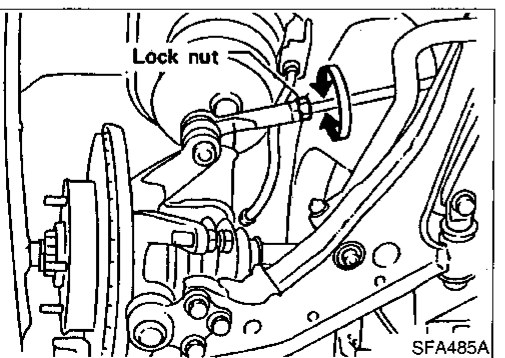

ON-VEHICLE SERVICE

Front Wheel Alignment (Cont'd)

Standard length "L":

Refer to ST section ("Inspection and Adjustment", "SERVICE DATA AND SPECIFICATIONS").

- (3) Tighten lock nuts to specified torque.

Lock nut tightening torque:

78 - 98 N·m (8.0 - 10.0 kg-m, 58 - 72 ft-lb)

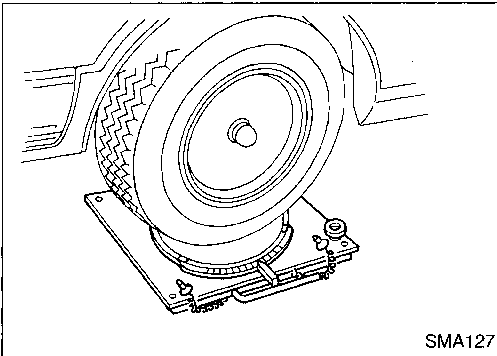
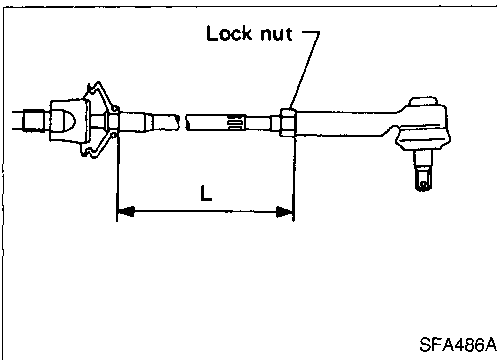

FRONT WHEEL TURNING ANGLE

1. Set wheels in straight-ahead position and then move vehicle forward until front wheels rest on turning radius gauge properly.

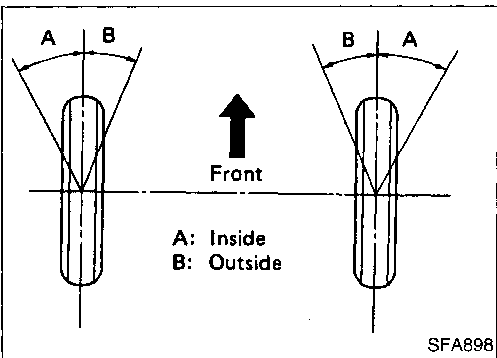

2. Rotate steering wheel all the way right and left; measure turning angle.

Wheel turning angle (Full turn):

Inside wheel: 31°30' - 35°30'

Outside wheel: 25°36' - 29°36'

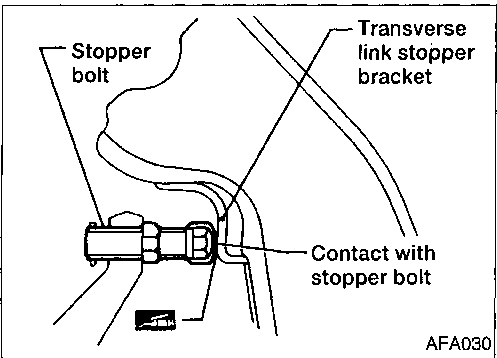

3. If stopper bolt head does not contact stopper bracket at specified outside wheel angle, adjust stopper bolt to contact stopper bracket at correct angle.

Adjust protrusion of stopper bolt before placing stopper bolt cap.

Apply grease to face of stopper bracket that bolt touches.

Stopper bolt lock nut tightening torque:

54 - 72 N·m (5.5 - 7.3 kg-m, 40 - 53 ft-lb)

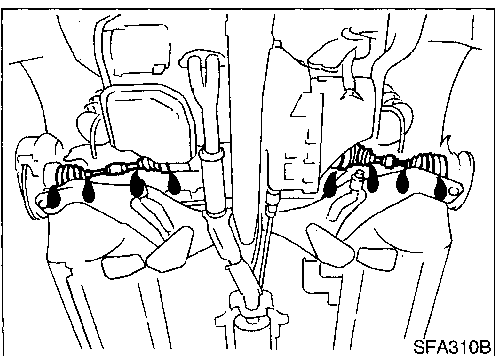

Drive Shaft

Check for grease leakage or other damage.

FRONT AXLE

GI
MA
EM
LC
EF & EC
FE
CL
MT
AT
FA
RA
BR
ST
BF
HA
EL
IDX

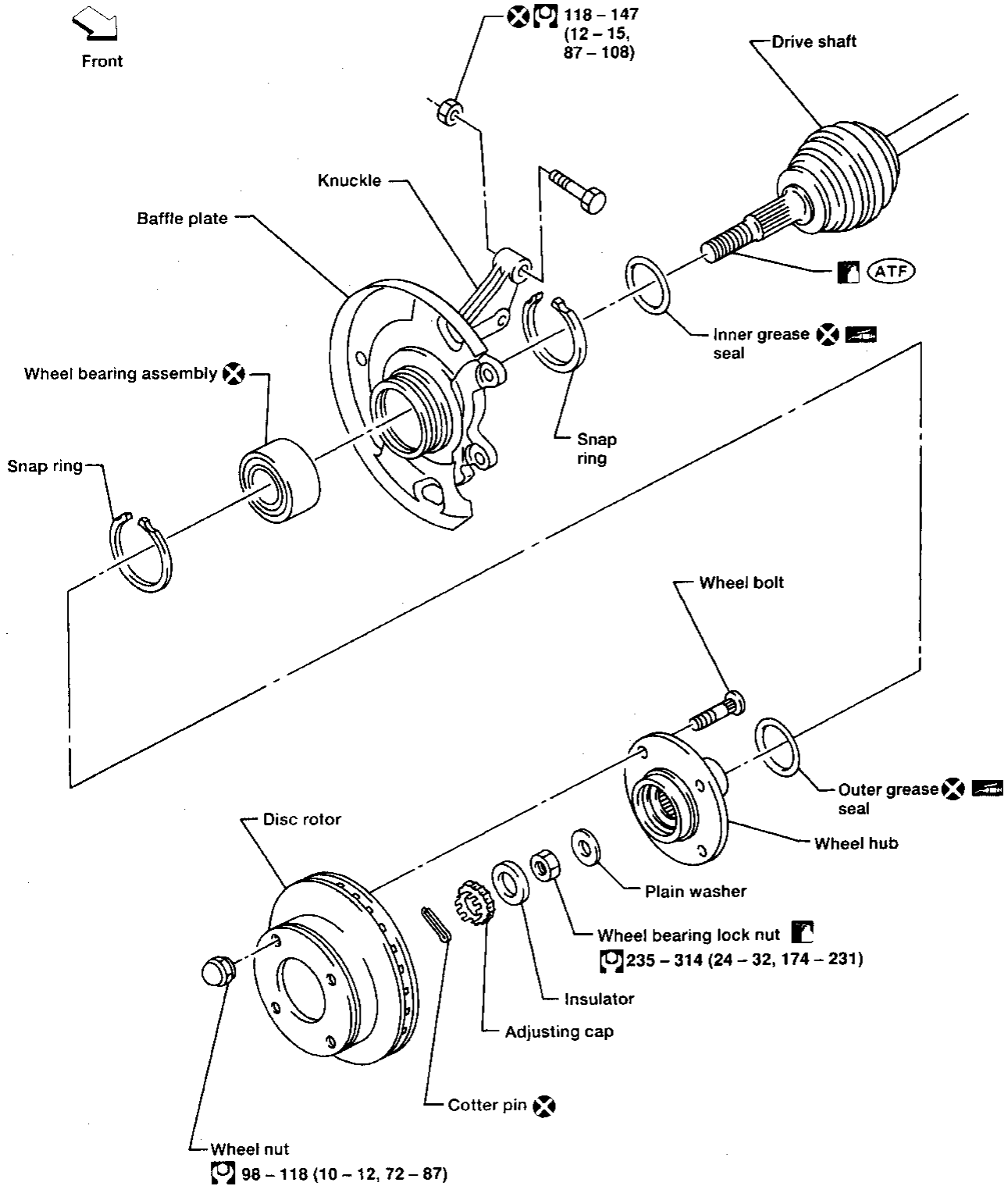

: N·m (kg-m, ft-lb)

AFA037

FRONT AXLE — Wheel Hub and Knuckle

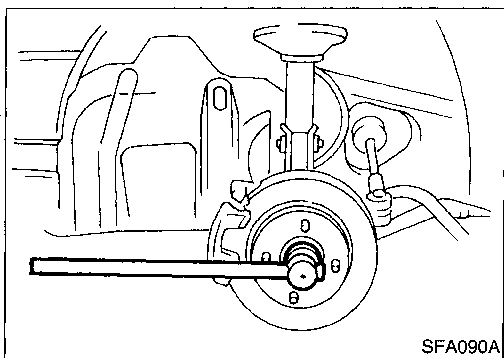

Removal

- Remove wheel bearing lock nut.

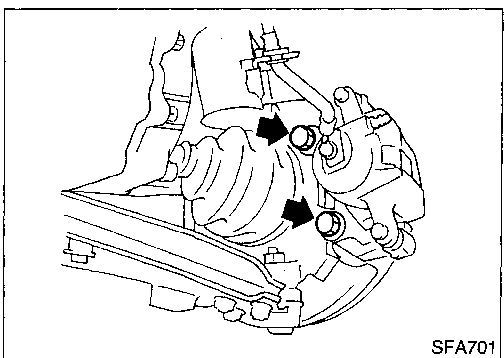

- Remove brake caliper assembly.
Brake hose need not be disconnected from brake caliper. Be careful not to depress brake pedal, or piston will pop out. Make sure brake hose is not twisted.

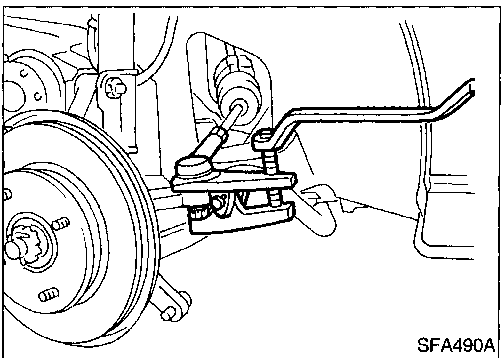

- Separate tie-rod from knuckle with Tool.
Install stud nut conversely on stud bolt to prevent damage to stud bolt.

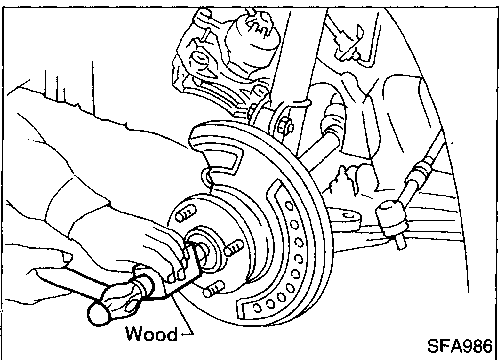

- Separate drive shaft from knuckle by lightly tapping it. If it is hard to remove, use a puller.
When removing drive shaft, cover boots with shop towel to prevent damage to them.

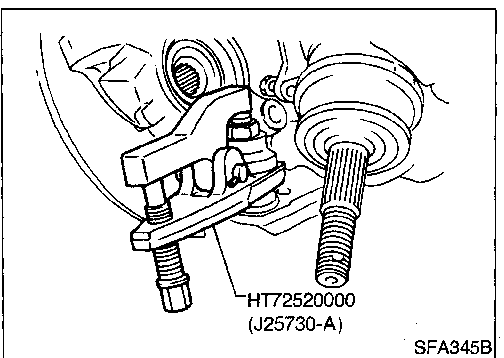

- Loosen lower ball joint tightening nut.
- Separate knuckle from lower ball joint stud with Tool.
- Remove knuckle from transverse link.

FRONT AXLE — Wheel Hub and Knuckle

Removal (Cont'd)

- Remove strut lower mounting bolts.

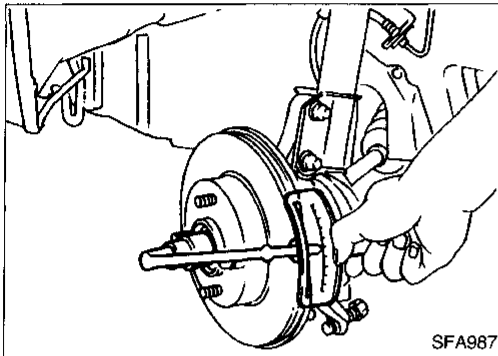
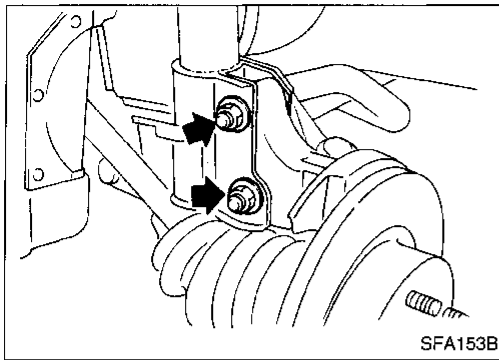

Installation

- Install knuckle with wheel hub.
 - Replace strut lower mounting nuts.
- When installing knuckle to strut, be sure to hold bolts and tighten nuts.

: 118 - 147 N·m
(12 - 15 kg-m, 87 - 108 ft-lb)

Before tightening wheel bearing lock nut, apply oil to threaded portion of drive shaft and to both sides of plain washer.

- Tighten wheel bearing lock nut.
- : 235 - 314 N·m
(24 - 32 kg-m, 174 - 231 ft-lb)

GI

MA

EM

LC

EF &
EC

FE

CL

MT

AT

FA

RA

BR

ST

BF

HA

EL

IDX

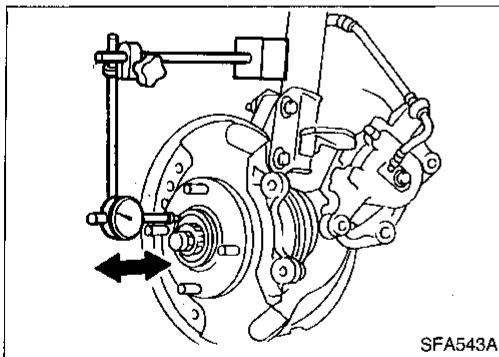

- Check wheel bearing axial end play.
Axial end play:
0.05 mm (0.0020 in) or less.

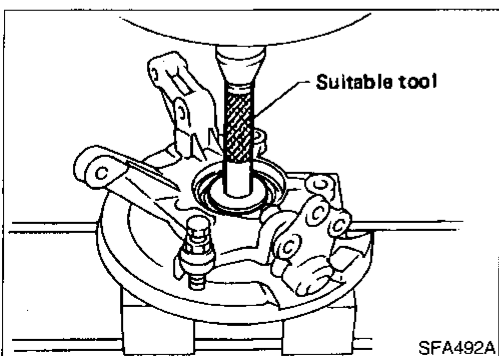

Disassembly

CAUTION:

When removing wheel hub or wheel bearing from knuckle, replace wheel bearing assembly (outer race, inner races and grease seals) with a new one.

WHEEL HUB

Press out hub with inner race (outside) from knuckle with a suitable tool.

FRONT AXLE — Wheel Hub and Knuckle

Disassembly (Cont'd)

WHEEL BEARING

When replacing wheel bearing, replace wheel bearing assembly (inner races and outer race).

- Remove bearing inner race (outside), then remove outer grease seal.

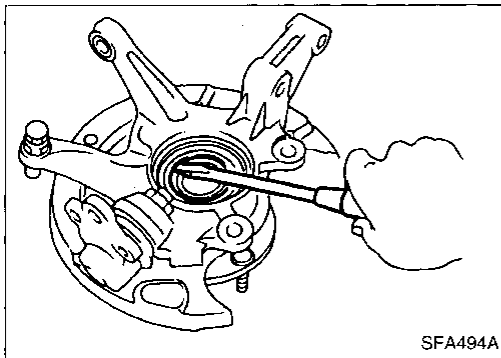
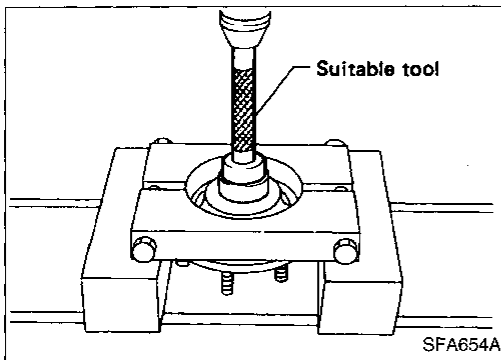

- Remove inner grease seal from knuckle.

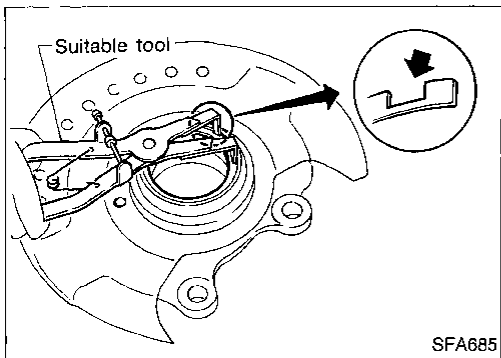

- Remove inner and outer snap rings.

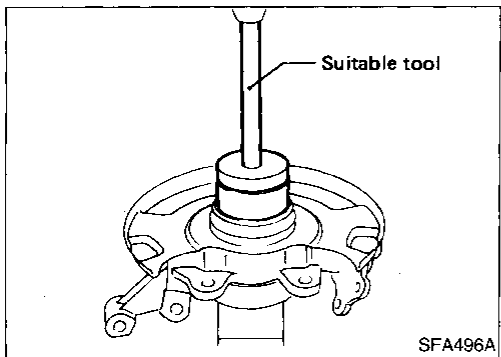

- Press out bearing outer race.

Inspection

WHEEL HUB AND KNUCKLE

Check wheel hub and knuckle for cracks by using a magnetic exploration or dyeing test.

SNAP RING

Check snap ring for wear or cracks. Replace if necessary.

FRONT AXLE — Wheel Hub and Knuckle

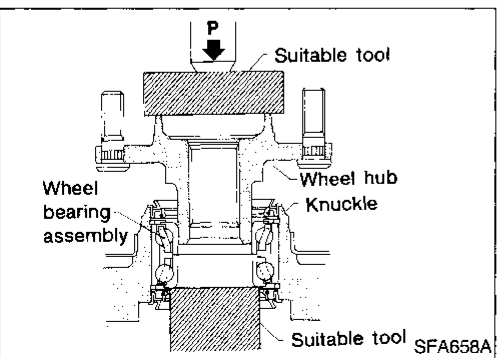
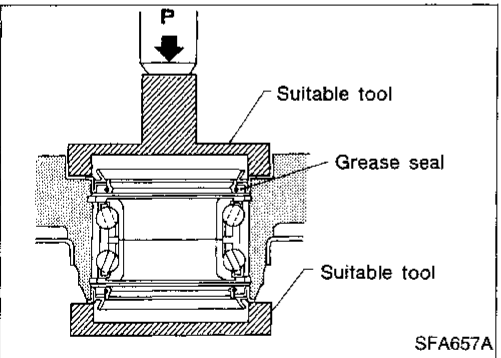
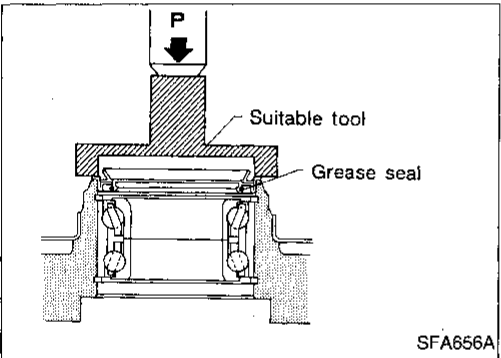
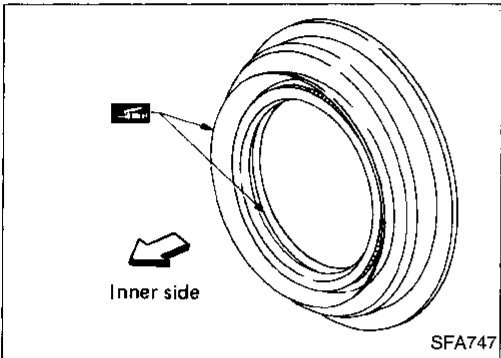
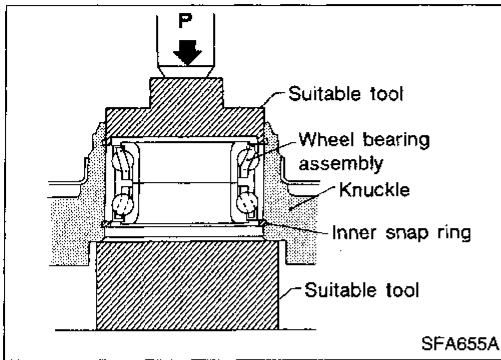

Assembly

1. Install inner snap ring into groove of knuckle.
2. Press new wheel bearing assembly into knuckle.

Maximum load P:

29 kN (3 ton, 3.3 US ton, 3.0 Imp ton)

CAUTION:

- Do not press inner race of wheel bearing assembly.
 - Do not apply oil or grease to mating surfaces of wheel bearing outer race and knuckle.
3. Install outer snap ring into groove of knuckle.
 4. Pack grease seal lip with multi-purpose grease.

5. Install outer grease seal.

6. Install inner grease seal.

7. Press wheel hub into knuckle.

Maximum load P:

29 kN (3 ton, 3.3 US ton, 3.0 Imp ton)

Be careful not to damage grease seal.

GI
MA
EM
LC
EF & EC
FE
CL
MT
AT
FA
RA
BR
ST
BF
HA
EL
IDX

FRONT AXLE — Wheel Hub and Knuckle

Assembly (Cont'd)

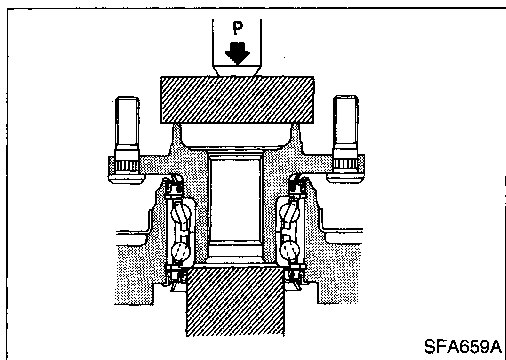

8. Check bearing operation.

(1) Add load P with press.

Load P:

34.3 - 49.0 kN

(3.5 - 5.0 ton, 3.9 - 5.5 US ton, 3.44 - 4.92 Imp ton)

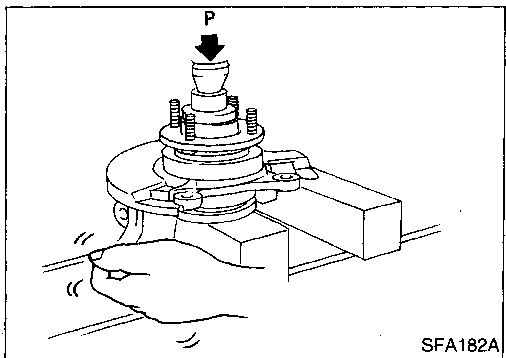

(2) Spin knuckle several turns in both directions.

(3) Make sure that wheel bearings operate smoothly.

FRONT AXLE — Drive Shaft

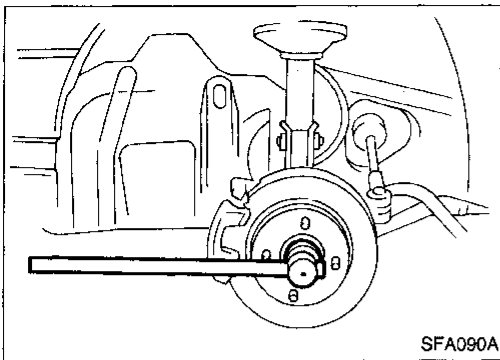

Removal

- Remove wheel bearing lock nut.

Brake caliper need not be disconnected.

Do not twist or stretch brake hose when moving components.

- Remove cotter pin and nut securing lower ball joint to knuckle.
- Strike knuckle with a hammer and pull down transverse link to separate lower ball joint from knuckle.

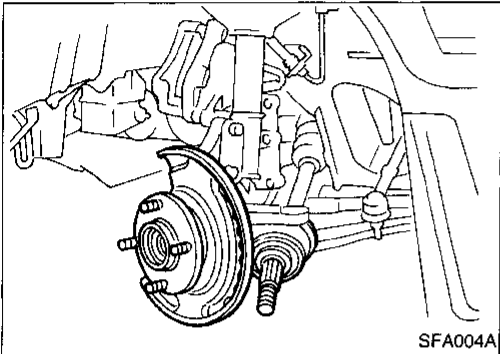

- Remove tie-rod ball joint.
- Separate drive shaft from knuckle by slightly tapping it. If it is hard to remove, use a puller.

When removing drive shaft, cover boots with shop towel to prevent damage to them.

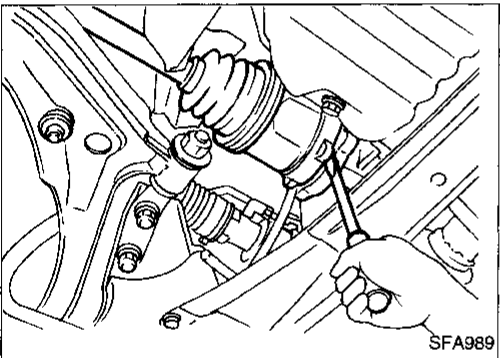

1. Remove right drive shaft from transaxle.

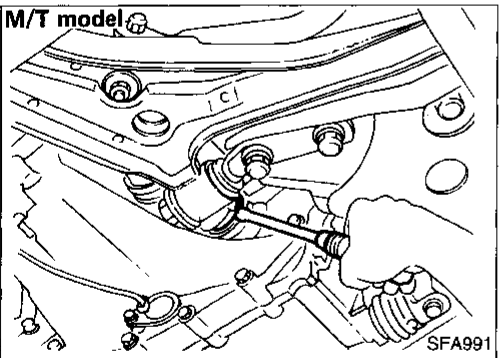

2. Remove left drive shaft with a suitable tool.

— **FOR M/T MODELS** —

- Pry drive shaft from transaxle as shown at left.

GI

MA

EM

LC

EF &

EC

FE

CL

MT

AT

FA

RA

BR

ST

BF

HA

EL

IDX

FRONT AXLE — Drive Shaft

A/T model

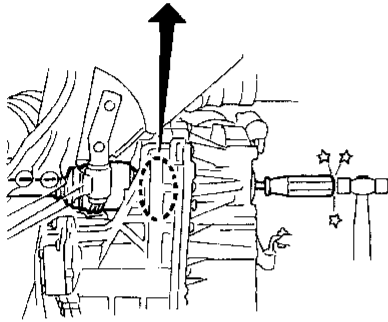
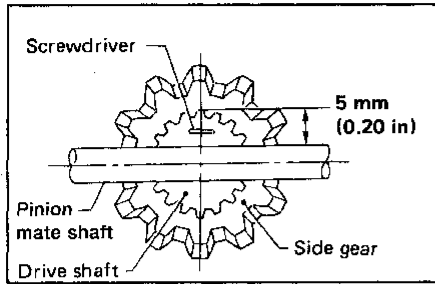

AFA035

RH

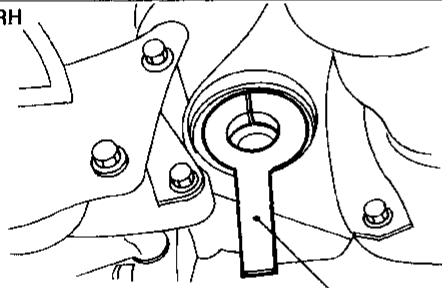

KV38106800
(J34297)

AFA033

LH

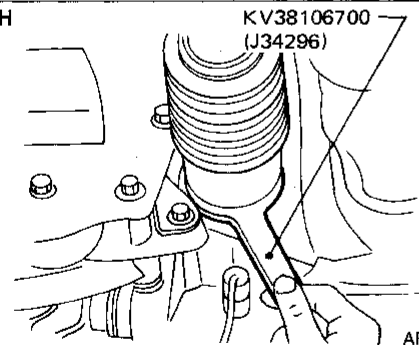

KV38106700
(J34296)

AFA034

Removal (Cont'd)

— FOR A/T MODELS —

- Insert screwdriver into transaxle opening for right drive shaft and strike with a hammer.

Be careful not to damage pinion mate shaft and side gear.

Installation

TRANSAXLE SIDE

1. Drive a new oil seal to transaxle. Refer to MT or AT section ("Differential Side Oil Seal Replacement", "ON-VEHICLE SERVICE").
2. Set Tool along the inner circumference of oil seal (transaxle side).

3. Insert drive shaft into transaxle. Be sure to properly align the serrations and then withdraw Tool.
4. Push drive shaft, then press-fit circular clip on the drive shaft into circular clip groove of side gear.
5. After its insertion, try to pull the flange out of the slide joint by hand. If it pulls out, the circular clip is not properly meshed with the side gear.

WHEEL SIDE

- Install drive shaft into knuckle.
- Tighten wheel bearing lock nut. Refer to FA-11.

Components

Circular clip:

Make sure circular clip is properly meshed with side gear (transaxle side) and joint assembly (wheel side), and will not come out.

Be careful not to damage boots. Use suitable protector or cloth during removal and installation.

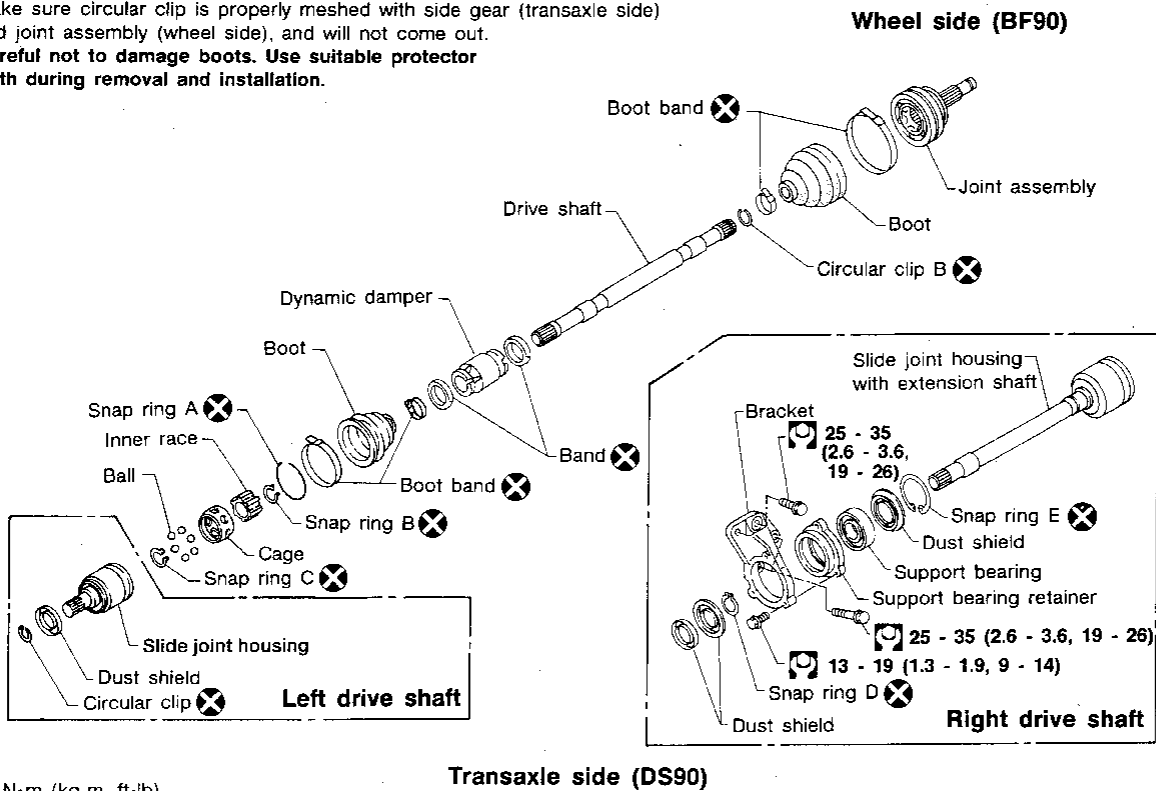

: N·m (kg-m, ft-lb)

Transaxle side (DS90)

AFA039

GI
MA
EM
LC
EF &
EC
FE
CL
WT
AT
FA

RA
BR
ST
BF
HA
EL
DX

Disassembly

TRANSAXLE SIDE

1. Remove boot bands.
2. Put matching marks on slide joint housing and inner race, before separating joint assembly.
3. Pry off snap ring "A" with a screwdriver, and pull out slide joint housing.

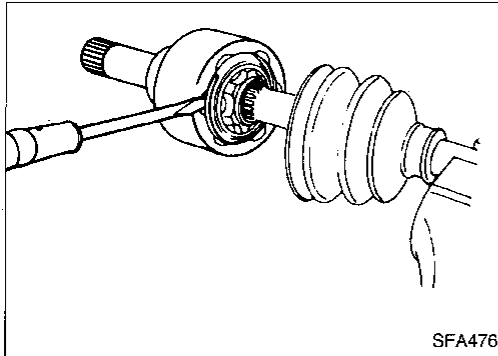

SFA476

4. Put matching marks on inner race and drive shaft.
5. Remove snap ring "C", then remove ball cage, inner race and balls as a unit.
6. Remove snap ring "B".
7. Draw out boot.

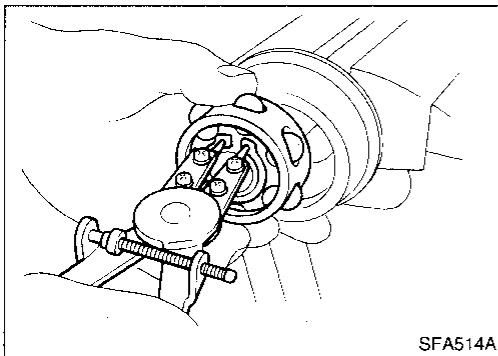

SFA514A

Cover drive shaft serrations with tape so as not to damage the boot.

FRONT AXLE – Drive Shaft

Disassembly (Cont'd)

WHEEL SIDE

CAUTION:

The joint on the wheel side cannot be disassembled.

- Before separating joint assembly, put matching marks on drive shaft and joint assembly.
- Separate joint assembly with a suitable tool.

Be careful not to damage threads on drive shaft.

- Remove boot bands.

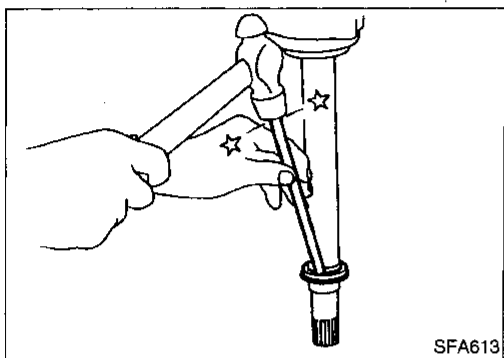
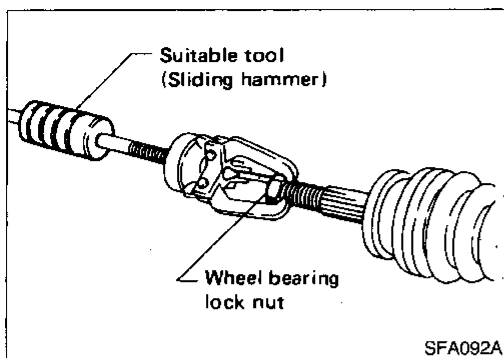

SUPPORT BEARING

- Remove dust shield.

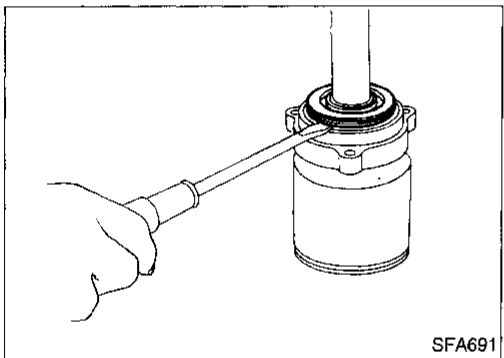

- Remove snap ring.

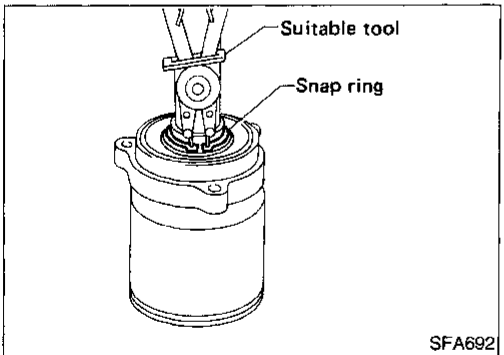

- Press support bearing assembly off of drive shaft.

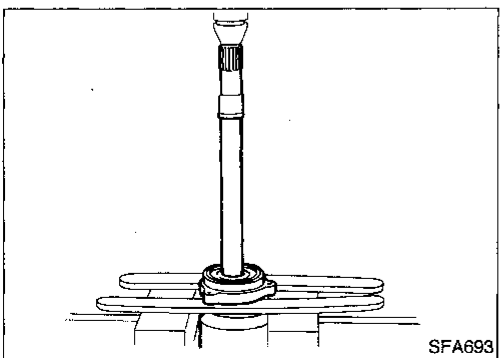

FRONT AXLE — Drive Shaft

Disassembly (Cont'd)

- Separate support bearing from retainer.

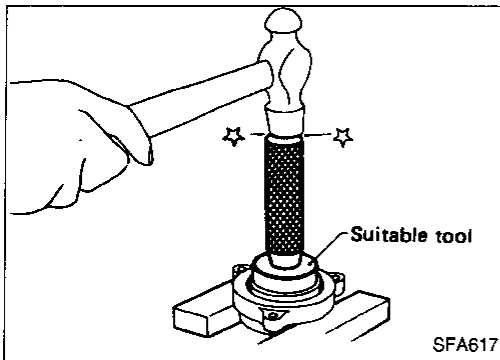

Inspection

Thoroughly clean all parts in cleaning solvent, and dry with compressed air. Check parts for evidence of deformation or other damage.

DRIVE SHAFT

Replace drive shaft if it is twisted or cracked.

BOOT

Check boot for fatigue, cracks, or wear. Replace boot with new boot bands.

JOINT ASSEMBLY (Transaxle side)

Replace joint assembly if it is deformed or damaged.

JOINT ASSEMBLY (Wheel side)

Replace joint assembly if it is deformed or damaged.

SUPPORT BEARING

Make sure wheel bearing rolls freely and is free from noise, cracks, pitting or wear.

SUPPORT BEARING BRACKET

Check support bearing bracket for cracks with a magnetic exploration or dyeing test.

Assembly

- After drive shaft has been assembled, ensure that it moves smoothly over its entire range without binding.
- Use NISSAN GENUINE GREASE or equivalent after every overhaul.

GI

MA

EM

LC

EF &
EC

FE

CL

MT

AT

FA

RA

BR

ST

BF

HA

EL

IDX

FRONT AXLE — Drive Shaft

Assembly (Cont'd)

WHEEL SIDE

1. Install boot and new small boot band on drive shaft.

Cover drive shaft serration with tape so as not to damage boot during installation.

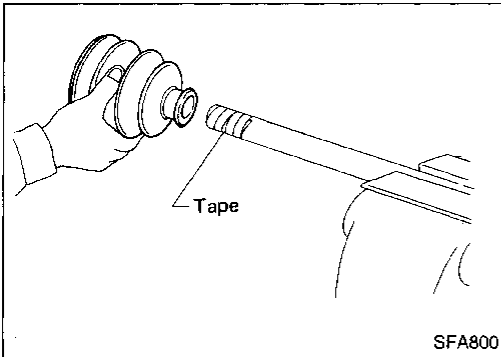

2. Set joint assembly onto drive shaft by lightly tapping it. Secure joint assembly, ensuring marks which were made during disassembly are properly aligned.

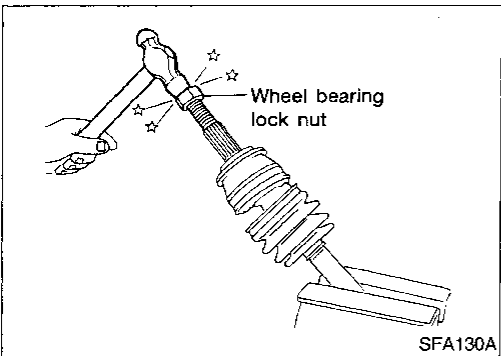

3. Pack drive shaft with specified amount of grease.

Specified amount of grease:

100 - 120 g (3.53 - 4.23 oz)

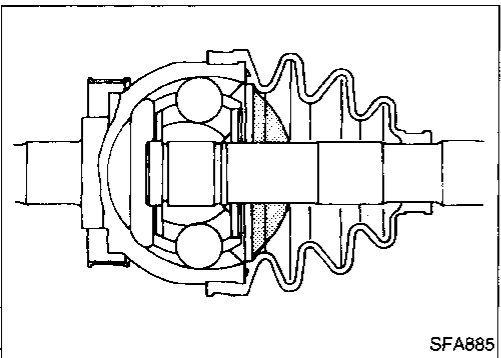

4. Make sure that boot is properly installed on the drive shaft groove.

Set boot so that it does not swell and deform when its length is "L₁".

Length "L₁":

84.5 - 86.5 mm (3.327 - 3.406 in)

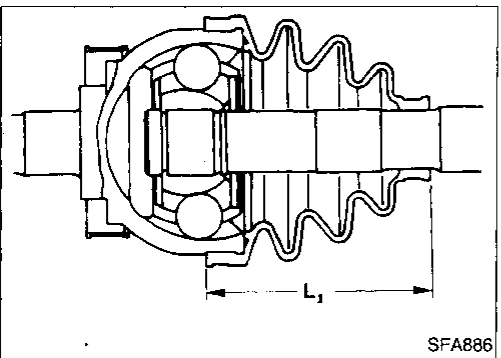

5. Lock new larger and smaller boot bands securely with a suitable tool.

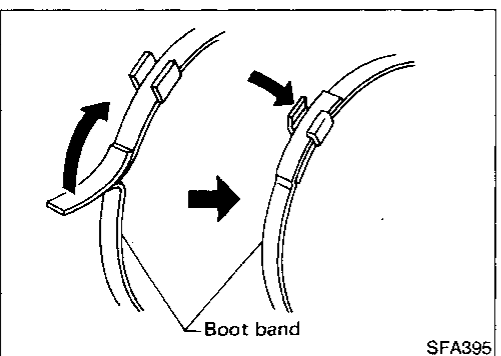

FRONT AXLE — Drive Shaft

Assembly (Cont'd)

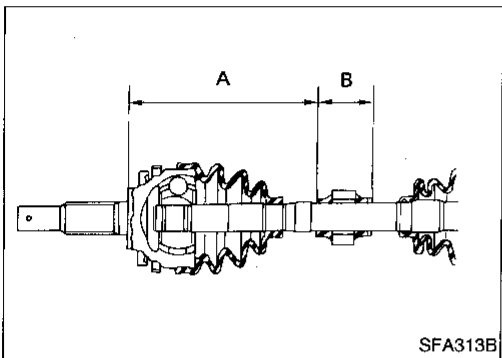
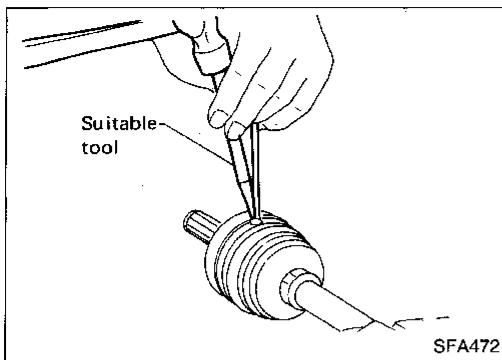

Dynamic damper

1. Use new damper bands when installing.
2. Install dynamic damper from stationary-joint side while holding it securely.

Length:

Unit: mm (in)

	LH	RH
"A"	203.1 (8.00)	185.6 (7.31)
"B"	70 (2.76)	50 (1.97)

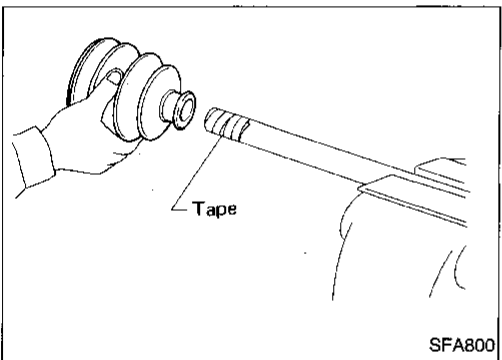

TRANSAXLE SIDE

1. Install boot and new small boot band on drive shaft.
Cover drive shaft serration with tape so as not to damage boot during installation.

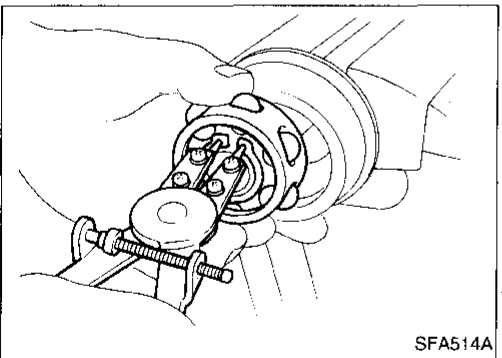

2. Install new snap ring "B", then securely install ball cage, inner race and balls as a unit, making sure the marks which were made during disassembly are properly aligned.
3. Install new snap ring "C".

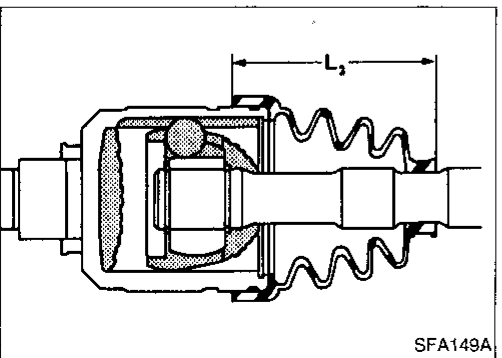

4. Pack drive shaft with specified amount of grease.
Specified amount of grease:
145 - 165 g (5.11 - 5.82 oz)
5. Install slide joint housing, then install new snap ring "A".
6. Make sure that boot is properly installed on the drive shaft groove.
Set boot so that it does not swell and deform when its length is "L₂".
Length "L₂":
97 - 99 mm (3.82 - 3.90 in)

FRONT AXLE — Drive Shaft

Assembly (Cont'd)

7. Lock new larger and smaller boot bands securely with a suitable tool.

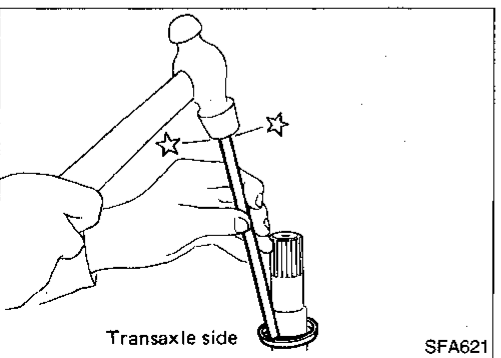
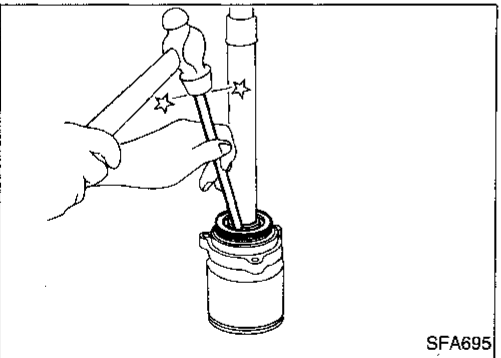
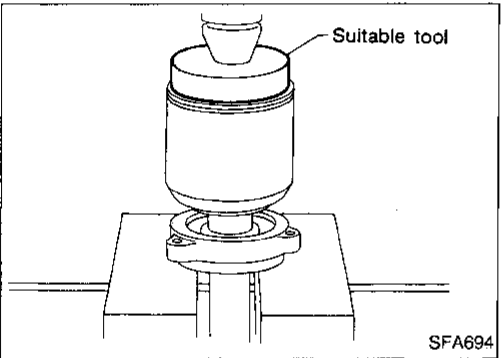
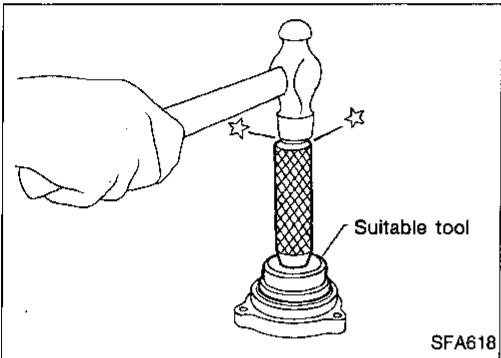
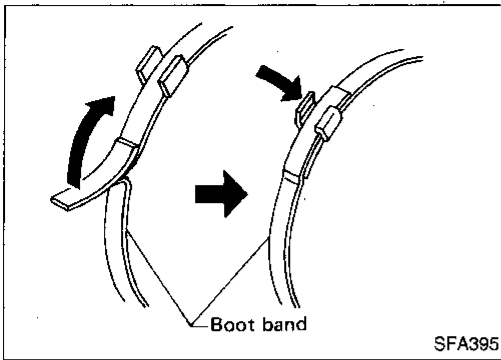

SUPPORT BEARING

- Install bearing into retainer.
- Press drive shaft into bearing.
- Install snap ring.
- Install new dust shield.

FRONT SUSPENSION

When installing rubber parts, final tightening must be carried out under unladen condition* with tires on ground.

* Fuel, radiator coolant and engine oil full.
Spare tire, jack, hand tools and mats in designated positions.

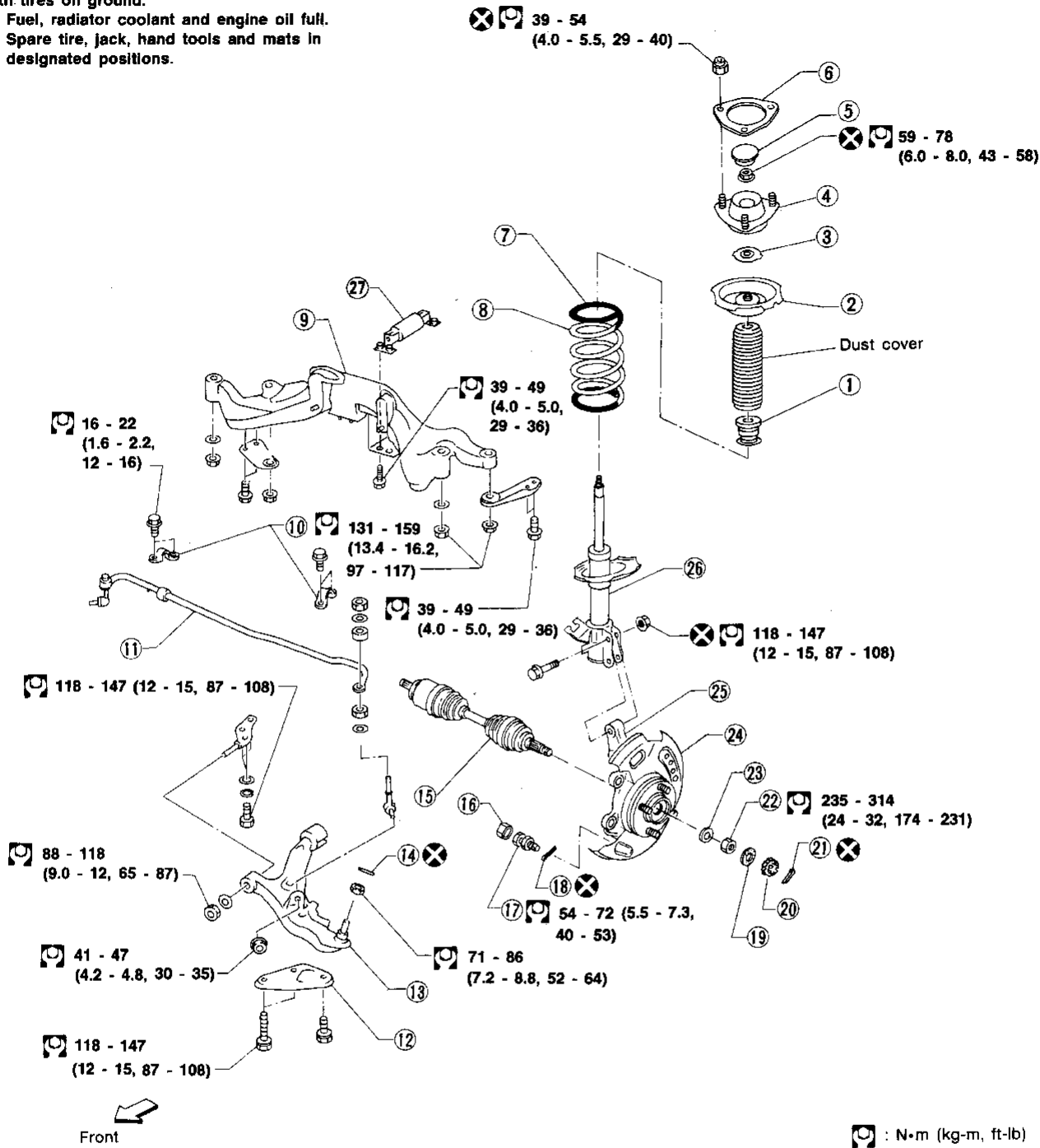

GI
MA
EM
LC
EF & EC
FE
CL
WT
AT
FA
RA
BR
ST
BF
HA
EL

- | | | |
|---------------------------|-------------------------|---------------------------|
| ① Bound bumper assembly | ⑩ Stabilizer clamp | ⑲ Insulator (Rubber) |
| ② Upper spring seat | ⑪ Stabilizer | ⑳ Adjusting cap |
| ③ Dust seal | ⑫ Compression rod clamp | ㉑ Cotter pin |
| ④ Strut insulator | ⑬ Transverse link | ㉒ Wheel bearing lock nut |
| ⑤ Cap | ⑭ Cotter pin | ㉓ Plain washer |
| ⑥ Spacer | ⑮ Drive shaft | ㉔ Baffle plate |
| ⑦ (Polyurethane tube) | ⑯ Cap | ㉕ Knuckle |
| ⑧ Coil spring | ⑰ Stopper bolt | ㉖ Strut assembly |
| ⑨ Front suspension member | ⑱ Cotter pin | ㉗ Dynamic damper assembly |

FRONT SUSPENSION — Coil Spring and Strut Assembly

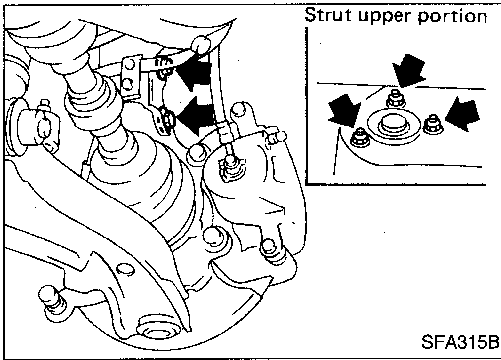

Removal and Installation

- Remove strut assembly fixing bolts and nuts (to hoodledge).
Do not remove piston rod lock nut on vehicle.

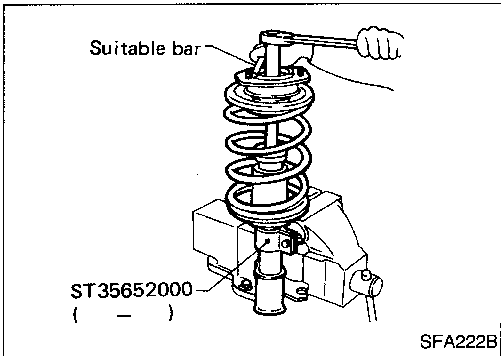

Disassembly

1. Set strut assembly in vise with Tool, then **loosen** piston rod lock nut.
Do not remove piston rod lock nut at this time.

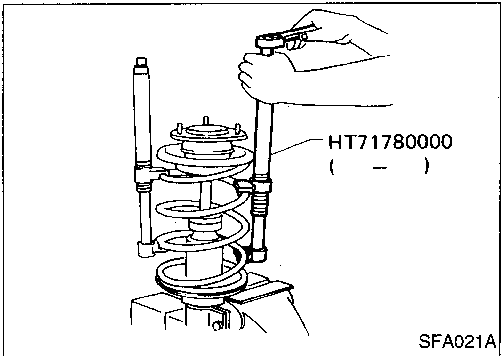

2. Compress spring with Tool so that the strut mounting insulator can be turned by hand.

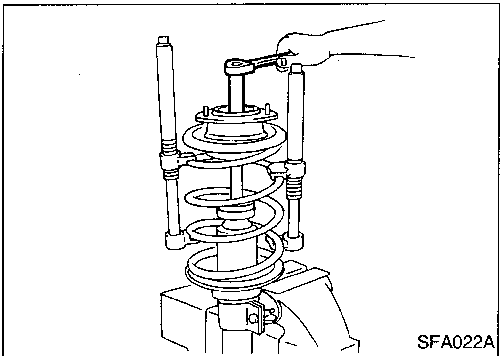

3. Remove piston rod lock nut.

Inspection

STRUT ASSEMBLY

- Check for smooth operation through a full stroke, both compression and extension.
- Check for oil leakage occurring on welded or gland packing portion.
- Check piston rod for cracks, deformation or other damage.
- Replace if necessary.

FRONT SUSPENSION – Coil Spring and Strut Assembly

Inspection (Cont'd)

STRUT MOUNTING INSULATOR

- Check cemented rubber-to-metal portion for separation or cracks.
- Check rubber parts for deterioration.

THRUST BEARING

- Check thrust bearing parts for abnormal noise or excessive rattle in axial direction.
- Replace if necessary.

COIL SPRING AND INSULATOR

Check for cracks, deformation or other damage. Replace if necessary.

GI

MA

EM

LC

EF &
EC

FE

CL

MT

AT

FA

RA

BR

ST

BF

HA

EL

IDX

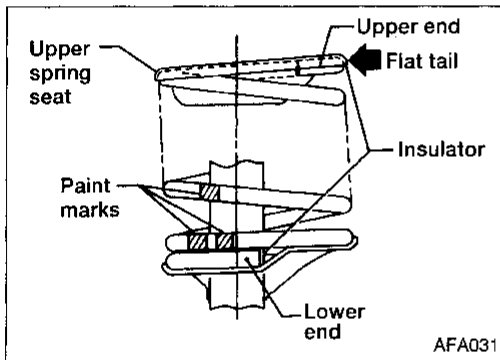

Assembly

- When installing coil spring on strut, it must be positioned as shown in the figure at left.

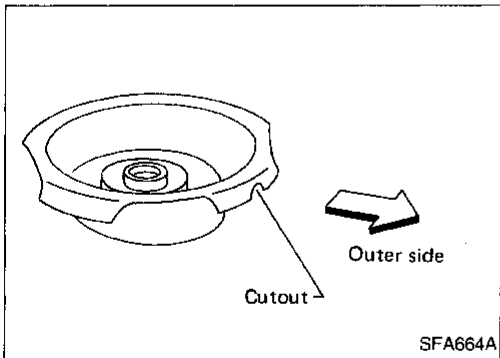

- Install upper spring seat with its cutout facing the outer side of vehicle, in line with the strut-to-knuckle attachment points.
- Replace strut lower mounting nuts.

When installing strut to knuckle, be sure to hold bolts and tighten nuts.

**⚙️: 118 - 147 N·m
(12 - 15 kg-m, 87 - 108 ft-lb)**

FRONT SUSPENSION — Stabilizer Bar

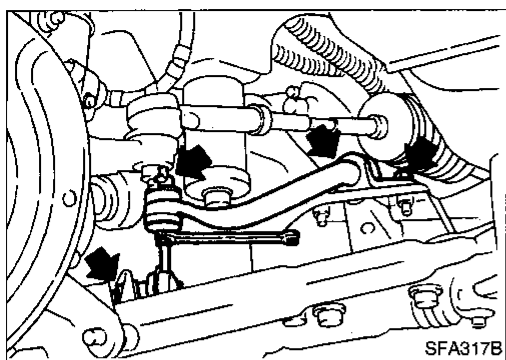

Removal and Installation

- Remove stabilizer bar.

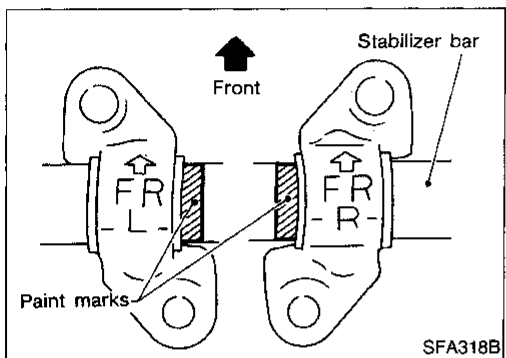

- When installing stabilizer, make sure that paint mark and clamp face in their correct directions.

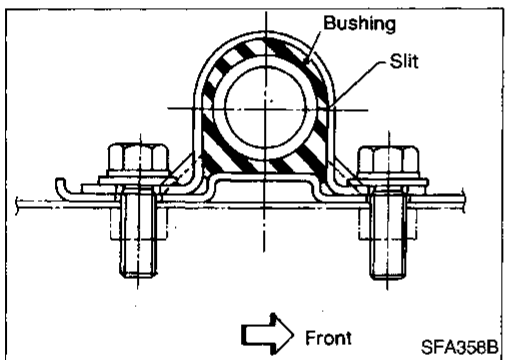

- Make sure that slit in bushing is in the position shown in the figure.

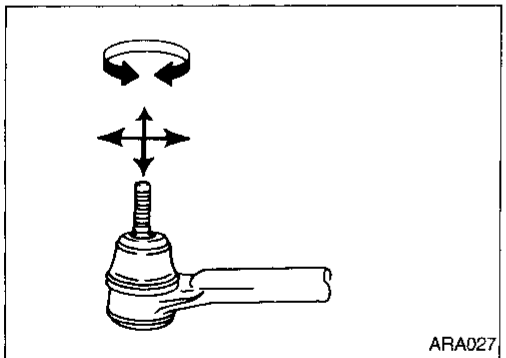

Inspection

- Check stabilizer for deformation or cracks. Replace if necessary.
- Check rubber bushings for deterioration or cracks. Replace if necessary.
- Check ball joint can rotate in all directions. If movement is not smooth and free, replace stabilizer bar link.

Removal and Installation

1. Remove stabilizer connecting rod from transverse link.
2. Remove cotter pin and lock nut securing lower ball joint to knuckle.
3. Strike knuckle with a hammer to separate lower ball joint from knuckle.

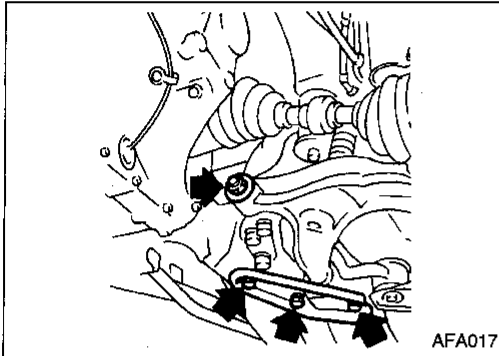

4. Remove bolts and nuts shown at left.
5. Remove transverse link and lower ball joint.
6. Install fixing bolts and nuts.
Tightening torque:
Refer to FA-23.
7. During installation, final tightening must be carried out at curb weight with tires on the ground.
8. After installation, check wheel alignment. Refer to FA-6.

Inspection

- Check transverse link for damage, cracks or deformation. Replace if necessary.
- Check rubber bushing for damage, cracks and deformation. Replace transverse link if necessary.

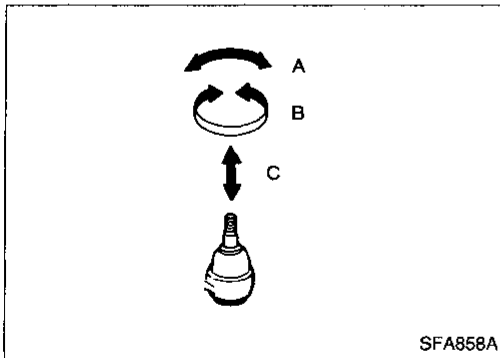

- Check ball joint for play. If ball stud is worn, play in axial direction is excessive or joint is hard to swing, replace if necessary. Before checking, turn ball joint at least 10 revolutions so that ball joint is properly broken in.

Swinging force "A":

(measuring point: cotter pin hole of ball stud):

7.8 - 54.9 N (0.8 - 5.6 kg, 1.8 - 12.3 lb)

Turning torque "B":

0.5 - 3.4 N·m (5 - 35 kg-cm, 4.3 - 30.4 in-lb)

Vertical end play "C":

0 mm (0 in)

- Check dust cover for damage. Replace it and cover clamp if necessary.

SERVICE DATA AND SPECIFICATIONS (SDS)

General Specifications

COIL SPRING

Applied model	XE/GLE/GXE		SE	
	M/T	A/T	M/T	A/T
Wire diameter mm (in)	13.4 (0.528)	13.6 (0.535)	13.6 (0.535)	13.8 (0.543)
Coil diameter mm (in)	173.8 (6.84)	174.2 (6.86)		174.6 (6.87)
Free length mm (in)	365 (14.37)	375 (14.76)	354 (13.94)	364 (14.33)
Spring constant N/mm (kg/mm, lb/in)	21.6 (2.2, 123)		23.5 (2.4, 134)	
Identification color	White x 2	White x 1, Pink x 1	White x 1, Pink x 1	White x 1, Light green x 1

STRUT

Applied model	XE/GLE/GXE	SE
Piston rod diameter mm (in)	22 (0.87)	
Damping force [at 0.3 m (1.0 ft)/sec.] N (kg, lb)		
Expansion	1,196 (122, 269)	1,314 (134, 295)
Compression	333 (34, 75)	471 (48, 106)

FRONT STABILIZER BAR

Applied model	M/T	A/T
Stabilizer diameter mm (in)	21.0 (0.827)	
Identification color	Green	Pink

WHEELARCH HEIGHT (Unladen*)



SFA818A

Applied model	XE/GLE/GXE	SE
Front (Hf) mm (in)	691 (27.20)	690 (27.17)
Rear (Hr) mm (in)	680 (26.77)	678 (26.69)

*: Fuel, radiator coolant and engine oil full. Spare tire, jack, hand tools and mate in designated positions.

DRIVE SHAFT

Applied model	All
Joint type	
Transaxle side	DS90
Wheel side	BF90
Boot length mm (in)	
Transaxle side (L ₂)	97 - 99 (3.82 - 3.90)
Wheel side (L ₁)	84.5 - 86.5 (3.327 - 3.406)
Grease	Nissan genuine grease or equivalent
Capacity g (oz)	
Transaxle side	145 - 165 (5.11 - 5.82)
Wheel side	100 - 120 (3.53 - 4.23)

Transaxle side

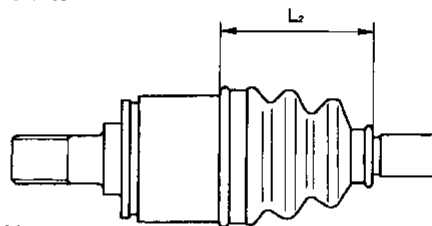

Wheel side

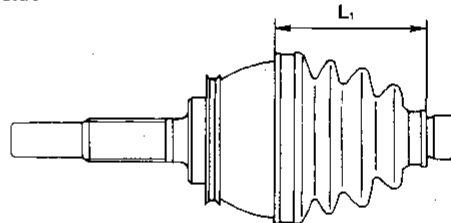

SERVICE DATA AND SPECIFICATIONS (SDS)

Inspection and Adjustment

WHEEL ALIGNMENT (Unladen*1)

Applied model	All	
Camber	degree	-0°50' to 0°40'
Caster	degree	1°55' - 3°25'
Kingpin inclination	degree	13°20' - 14°50'
Toe-in		
A - B	mm (in)	0 - 2 (0 - 0.08)
Total angle 2θ	degree	0' - 12'
Front wheel turning angle		
Full turn*2	Inside	31°30' - 35°30'
	Outside	25°36' - 29°36'

*1: Fuel, radiator coolant and engine oil full. Spare tire, jack, hand tools and mats in designated positions.

*2: On power steering models, wheel turning force (at circumference of steering wheel) of 98 to 147 N (10 to 15 kg, 22 to 33 lb) with engine idle.

WHEEL BEARING

Wheel bearing axial end play limit	mm (in)	0.05 (0.0020) or less
Wheel bearing lock nut tightening torque	N•m (kg-m, ft-lb)	235 - 314 (24 - 32, 174 - 231)

LOWER BALL JOINT

Swinging force (Measured at cotter pin hole)	N (kg, lb)	7.8 - 54.9 (0.8 - 5.6, 1.8 - 12.3)
Turning torque	N•m (kg-cm, in-lb)	0.5 - 3.4 (5 - 35, 4.3 - 30.4)
Vertical end play limit	mm (in)	0 (0)

WHEEL RUNOUT

Unit: mm (in)

Wheel type	Aluminum wheel	Steel wheel
Maximum radial runout limit	0.3 (0.012) or less	0.5 (0.020) or less
Maximum lateral runout limit	0.3 (0.012) or less	0.8 (0.031) or less

GI

WA

EM

LC

EF &

EC

FE

CL

MT

AT

FA

RA

BR

ST

BF

HA

EL

IDX