

SECTION **BR**

CONTENTS

PRECAUTIONS AND PREPARATION	2	Installation	15
Precautions	2	VACUUM HOSE	16
Supplemental Restraint System "Air Bag".....	2	Removal and Installation	16
Brake System	2	Inspection.....	16
Commercial Service Tools	3	Hoses And Connectors.....	16
CHECK AND ADJUSTMENT	4	Check Valve.....	16
Checking Brake Fluid Level.....	4	FRONT DISC BRAKE	17
Checking Brake Line.....	4	Pad Replacement	17
Changing Brake Fluid.....	4	Removal	18
AIR BLEEDING	5	Disassembly.....	19
Bleeding Procedure	5	Inspection — Caliper	19
BRAKE HYDRAULIC LINE	6	Cylinder Body	19
Removal.....	6	Piston.....	19
Inspection	6	Slide Pin, Pin Bolt And Pin Boot	19
Installation.....	6	Inspection — Rotor.....	19
CONTROL VALVE	7	Runout	19
Proportioning Valve.....	7	Thickness.....	20
Inspection	7	Assembly.....	20
Removal (Separated type)	7	Installation.....	20
Installation (Separated type)	8	REAR DRUM BRAKE	21
Removal And Installation (Built-in type)	8	Removal.....	21
BRAKE PEDAL AND BRACKET	9	Inspection — Wheel Cylinder	23
Removal and Installation	9	Wheel Cylinder Overhaul.....	23
Inspection.....	9	Inspection — Drum.....	23
Adjustment	9	Inspection — Lining	24
MASTER CYLINDER	11	Installation	24
Removal.....	11	REAR DISC BRAKE	26
Disassembly.....	11	Pad Replacement	26
Inspection.....	12	Removal	28
Assembly.....	12	Disassembly.....	28
Installation	13	Inspection — Caliper	29
BRAKE BOOSTER	14	Cylinder Body	29
On-vehicle Service.....	14	Torque Member	29
Operating Check.....	14	Piston.....	29
Airtight Check	14	Slide Pin, Pin Bolt And Pin Boot	29
Removal.....	14	Inspection — Rotor.....	30
Inspection.....	15	Runout	30
Output Rod Length Check.....	15	Thickness.....	30

CONTENTS (Cont'd.)

Assembly.....	30	Actuator Motor Ground.....	50	GI
Installation.....	32	Control Module Ground.....	50	
PARKING BRAKE CONTROL	33	Relay Box Ground.....	50	
Removal and Installation.....	33	Circuit Diagram for Quick Pinpoint Check.....	51	MA
Inspection.....	33	Diagnostic Procedure 1 (Not self-diagnostic item).....	52	
Adjustment.....	34	Diagnostic Procedure 2 (Not Self-diagnostic Item).....	53	EM
ANTI-LOCK BRAKE SYSTEM	35	Diagnostic Procedure 3.....	56	LC
Purpose.....	35	Actuator Solenoid Valve (Malfunction code No. 45, 41 or 55).....	56	
Operation.....	35	Diagnostic Procedure 4.....	57	EC
System Description.....	36	Wheel Sensor Or Rotor.....	57	
Sensor.....	36	Diagnostic Procedure 5.....	59	FE
Control Module.....	36	Motor Relay Or Motor.....	59	
Removal and Installation.....	37	Diagnostic Procedure 6.....	62	CL
Front Wheel Sensor.....	37	Solenoid Valve Relay.....	62	
Rear Wheel Sensor.....	37	Diagnostic Procedure 7.....	64	CL
Control Module.....	38	Power Supply (Low voltage).....	64	
Actuator.....	38	Diagnostic Procedure 8.....	64	MT
Actuator Relays.....	38	Stop Lamp Switch Circuit.....	64	
Wiring Diagram – ABS –.....	40	Diagnostic Procedure 9.....	64	AT
TROUBLE DIAGNOSES	44	Control Module.....	64	
How to Perform Trouble Diagnoses for Quick and Accurate Repair.....	44	Electrical Components Inspection.....	65	FA
Introduction.....	44	Wheel Sensor.....	65	
Self-diagnosis.....	45	Motor Relay.....	65	FA
Function.....	45	Solenoid Valve Relay.....	65	
Self-Diagnosis Procedure.....	45	SERVICE DATA AND SPECIFICATIONS (SDS)	66	RA
How To Read Self-Diagnostic Results (Malfunction codes).....	46	General Specifications.....	66	
How To Erase Self-Diagnostic Results (Malfunction codes).....	46	Inspection and Adjustment.....	66	
Malfunction Code/Symptom Chart.....	47	Disc Brake.....	66	BR
Component Parts and Harness Connector Location.....	48	Drum Brake.....	66	
Preliminary Check.....	49	Brake Pedal.....	66	ST
Ground Circuit Check.....	50	Parking Brake.....	66	

When you read wiring diagrams:

- Read GI section, "HOW TO READ WIRING DIAGRAMS".
- See EL section, "POWER SUPPLY ROUTING" for power distribution circuit.

When you perform trouble diagnosis, read GI section, "HOW TO FOLLOW FLOW CHART IN TROUBLE DIAGNOSIS" and "HOW TO PERFORM EFFICIENT DIAGNOSIS FOR AN ELECTRICAL INCIDENT".

RS

BT

HA

EL

IDX

PRECAUTIONS AND PREPARATION

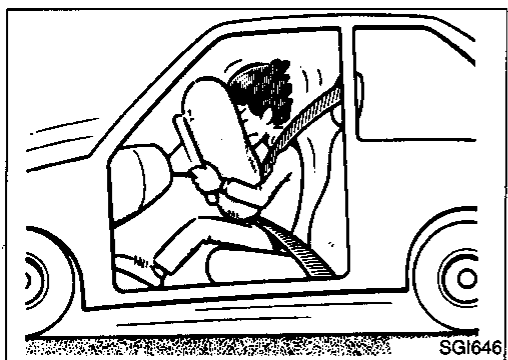

Precautions

SUPPLEMENTAL RESTRAINT SYSTEM "AIR BAG"

The Supplemental Restraint System "Air Bag", used along with a seat belt, helps to reduce the risk or severity of injury to the driver and front passenger in a frontal collision. The Supplemental Restraint System consists of air bag modules (located in the center of the steering wheel and on the instrument panel on the passenger side), a diagnosis sensor unit, warning lamp, wiring harness and spiral cable. Information necessary to service the system safely is included in the **RS** section of this Service Manual.

WARNING:

- To avoid rendering the SRS inoperative, which could increase the risk of personal injury or death in the event of a collision which would result in air bag inflation, all maintenance must be performed by an authorized NISSAN dealer.
- Improper maintenance, including incorrect removal and installation of the SRS, can lead to personal injury caused by unintentional activation of the system.
- All SRS electrical wiring harnesses and connectors are covered with yellow outer insulation. Do not use electrical test equipment on any circuit related to the SRS "Air Bag".

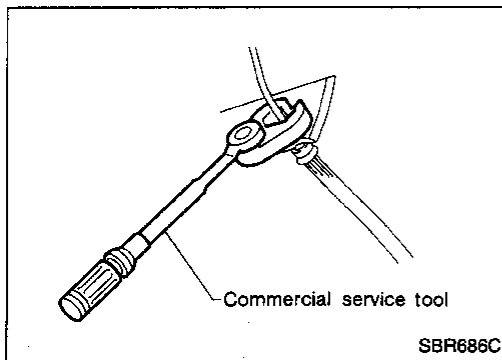

BRAKE SYSTEM

- Use brake fluid "DOT 3".
- Never reuse drained brake fluid.
- Be careful not to splash brake fluid on painted areas; it may cause paint damage. If brake fluid is splashed on painted areas, wash it away with water immediately.
- To clean master cylinder parts, disc brake caliper parts or wheel cylinder parts, use clean brake fluid.
- Never use mineral oils such as gasoline or kerosene. They will ruin rubber parts of hydraulic system.
- Use flare nut wrench when removing or installing brake tubes.
- Always torque brake lines when installing.

WARNING:

Clean brake pads and shoes with a waste cloth, then wipe with a dust collector.

PRECAUTIONS AND PREPARATION

Commercial Service Tools

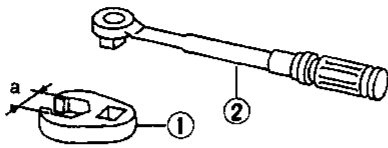
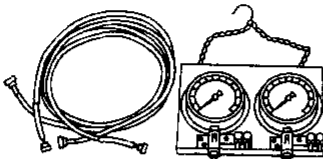
Tool name	Description	
① Flare nut crows foot ② Torque wrench	<div style="text-align: center;">  </div> <p style="text-align: right;">Removing and installing each brake piping</p> <p style="text-align: right;">a: 10 mm (0.39 in)</p> <p>NT360</p>	GI MA EM
Brake fluid pressure gauge	<div style="text-align: center;">  </div> <p style="text-align: right;">Measuring brake fluid pressure</p> <p>NT151</p>	LC EC FE

CL

MT

AT

FA

RA

BR

ST

RS

BT

HA

EL

IDX

CHECK AND ADJUSTMENT

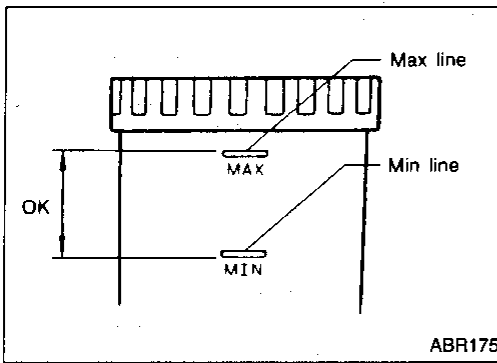

Checking Brake Fluid Level

- Check fluid level in reservoir tank. It should be between Max. and Min. lines on reservoir tank.
- If fluid level is extremely low, check brake system for leaks.
- If the brake warning lamp comes on, check brake fluid level switch and parking brake switch.

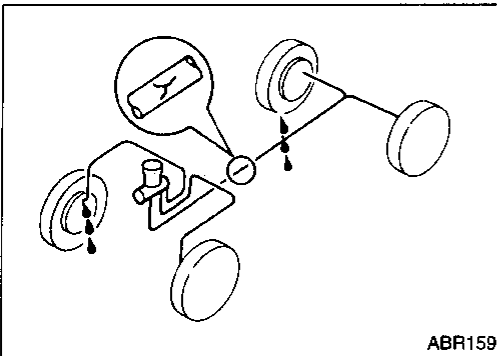

Checking Brake Line

CAUTION:

If leakage occurs around joints, retighten or, if necessary, replace damaged parts.

1. Check brake lines (tubes and hoses) for cracks, deterioration or other damage. Replace any damaged parts.
2. Check for oil leakage by fully depressing brake pedal while engine is running.

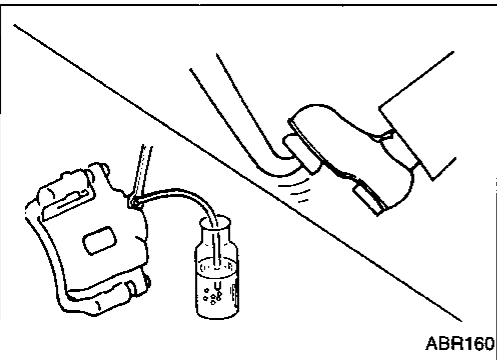

Changing Brake Fluid

CAUTION:

- Refill with new brake fluid "DOT 3".
- Always keep fluid level higher than minimum line on reservoir tank.
- Never reuse drained brake fluid.
- Be careful not to splash brake fluid on painted areas; it may cause paint damage. If brake fluid is splashed on painted areas, wash it away with water immediately.

1. Clean inside of reservoir tank, and refill with new brake fluid.
2. Connect a vinyl tube to each air bleeder valve.
3. Drain brake fluid from each air bleeder valve by depressing brake pedal.
4. Refill until new brake fluid comes out of each air bleeder valve.

Use same procedure as in bleeding hydraulic system to refill brake fluid. Refer to BR-5.

AIR BLEEDING

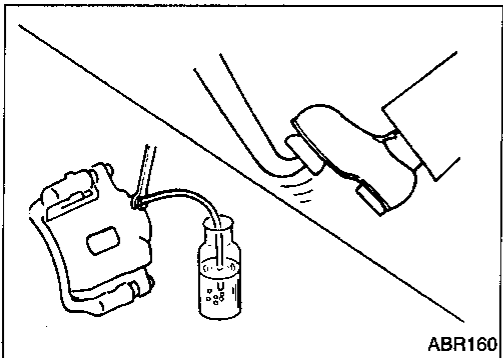
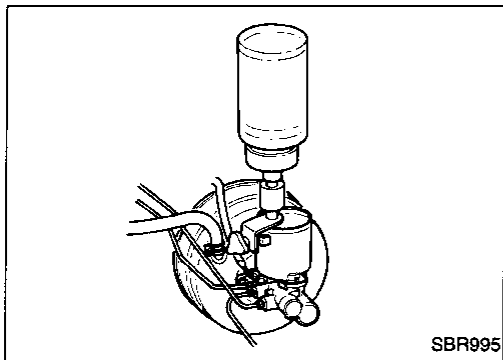

Bleeding Procedure

CAUTION:

- Carefully monitor brake fluid level at master cylinder during bleeding operation.
 - Fill reservoir with new brake fluid "DOT 3". Make sure it is full at all times while bleeding air out of system.
 - Place a container under master cylinder to avoid spillage of brake fluid.
 - For models with ABS, turn ignition switch OFF and disconnect ABS actuator connectors or battery ground cable.
 - Bleed air in the following order.
Right rear brake → Left front brake → Left rear brake → Right front brake
1. Connect a transparent vinyl tube to air bleeder valve.
 2. Fully depress brake pedal several times.
 3. With brake pedal depressed, open air bleeder valve to release air.
 4. Close air bleeder valve.
 5. Release brake pedal slowly.
 6. Repeat steps 2. through 5. until clear brake fluid comes out of air bleeder valve.

GI
MA
EM
LC
EC
FE
CL
MT
AT
FA
RA
BR
ST
RS
BT
HA
EL
IDX

BRAKE HYDRAULIC LINE

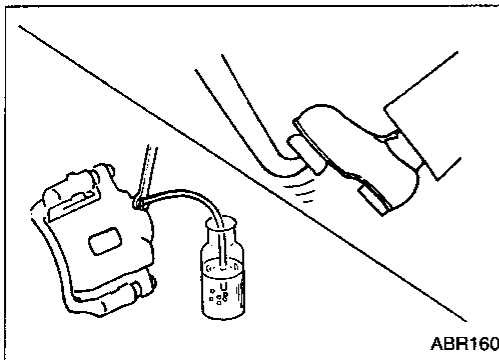
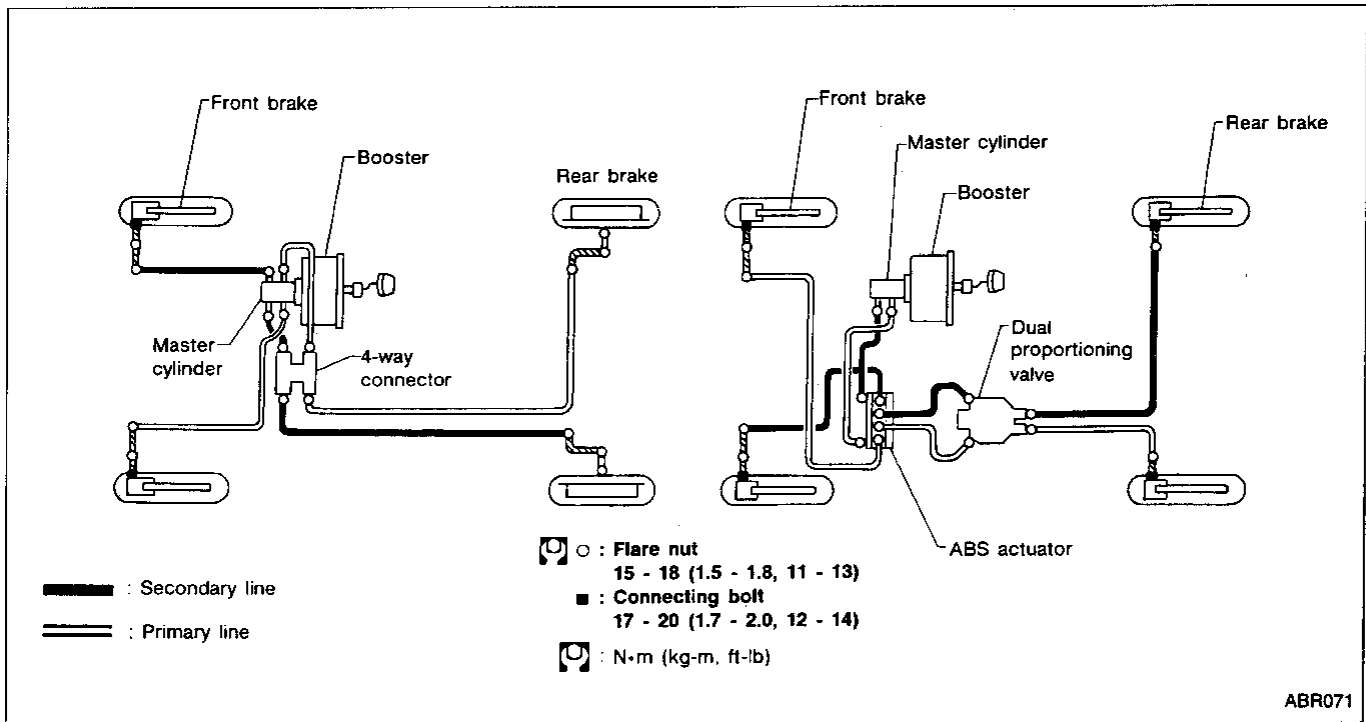

REMOVAL

CAUTION:

- Be careful not to splash brake fluid on painted areas; it may cause paint damage. If brake fluid is splashed on painted areas, wash it away with water immediately.
 - All hoses must be free from excessive bending, twisting and pulling.
1. Connect a vinyl tube to air bleeder valve.
 2. Drain brake fluid from each air bleeder valve by depressing brake pedal.
 3. Remove flare nut securing brake tube to hose, then withdraw lock spring.
 4. Cover openings to prevent entrance of dirt whenever disconnecting hydraulic line.

INSPECTION

Check brake lines (tubes and hoses) for cracks, deterioration or other damage. Replace any damaged parts.

INSTALLATION

CAUTION:

- Refill with new brake fluid "DOT 3".
 - Never reuse drained brake fluid.
1. Tighten all flare nuts and connecting bolts.
 - Flare nut:
 - : 15 - 18 N·m (1.5 - 1.8 kg·m, 11 - 13 ft·lb)
 - Connecting bolt:
 - : 17 - 20 N·m (1.7 - 2.0 kg·m, 12 - 14 ft·lb)
 2. Refill until new brake fluid comes out of each air bleeder valve.
 3. Bleed air. Refer to "Bleeding Procedure" (BR-5).

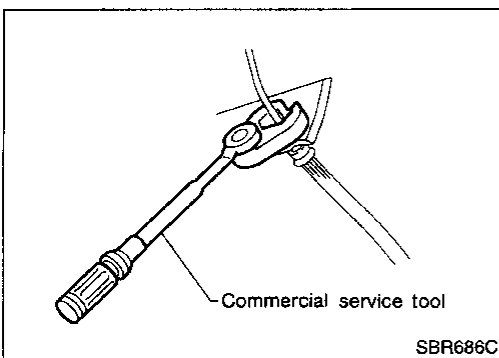

CONTROL VALVE

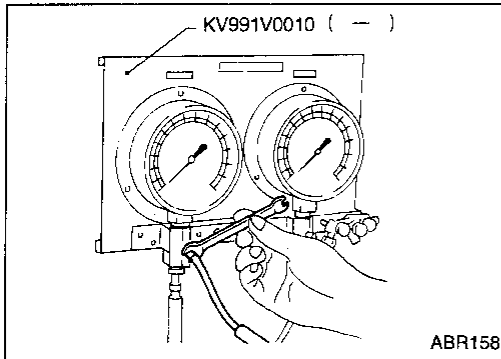
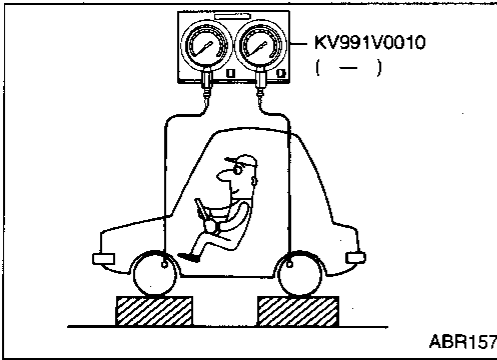

Proportioning Valve INSPECTION

CAUTION:

- Carefully monitor brake fluid level at master cylinder.
 - Use new brake fluid "DOT 3".
 - Be careful not to splash brake fluid on painted areas; it may cause paint damage. If brake fluid is splashed on paint areas, wash it away with water immediately.
 - Depress pedal slowly when raising front brake pressure.
 - Check rear brake pressure 2 seconds after front brake pressure reaches specified value.
 - For models with ABS, disconnect harness connectors from ABS actuator relay box before checking.
1. Connect Tool to air bleeders of front and rear brakes on either LH or RH side.
 2. Bleed air from the Tool.
 3. Check rear brake pressure by depressing brake pedal (increasing front brake pressure).

Unit: kPa (kg/cm², psi)

	Without ABS	With ABS
Applied pressure (Front brake) D ₁	5,394 (55, 782)	5,884 (60, 853)
Output pressure (Rear brake) D ₂	2,452 - 2,844 (25 - 29, 356 - 412)	3,334 - 3,727 (34 - 38, 483 - 540)

If output pressure is out of specifications, replace dual proportioning valve (separated type) or master cylinder assembly (built-in type).

4. Bleed air after disconnecting the Tool. Refer to BR-5.

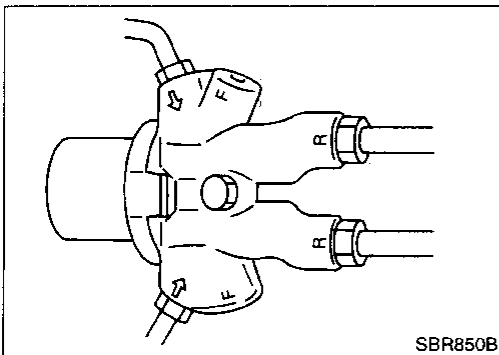
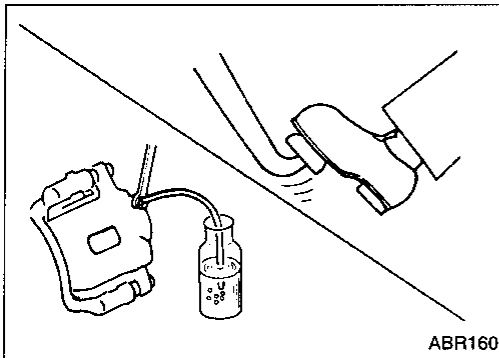

REMOVAL (Separated type)

CAUTION:

- Be careful not to splash brake fluid on painted areas; it may cause paint damage. If brake fluid is splashed on painted areas, wash it away with water immediately.
1. Connect a vinyl tube to air bleeder valve.
 2. Drain brake fluid from each air bleeder valve by depressing brake pedal.
 3. Loosen flare nut.
 4. Remove proportioning valve mounting bolt, then remove flare nut.

GI
MA
EM
LC
EC
FE
CL
MT
AT
FA
RA
BR
ST
RS
BT
HA
EL
IDX

CONTROL VALVE

Proportioning Valve (Cont'd)

INSTALLATION (Separated type)

CAUTION:

- **Refill with new brake fluid "DOT 3".**
- **Never reuse drained brake fluid.**
- 1. Temporarily fit flare nut to proportioning valve.
- 2. Tighten proportioning valve mounting bolt, then tighten flare nut.

Flare nut:

: **15 - 18 N·m (1.5 - 1.8 kg-m, 11 - 13 ft-lb)**

3. Refill until new brake fluid comes out of each air bleeder valve.
4. Bleed air. Refer to BR-5.

REMOVAL AND INSTALLATION (Built-in type)

Always replace together with master cylinder as an assembly.

- Refer to BR-11.

BRAKE PEDAL AND BRACKET

Removal and Installation

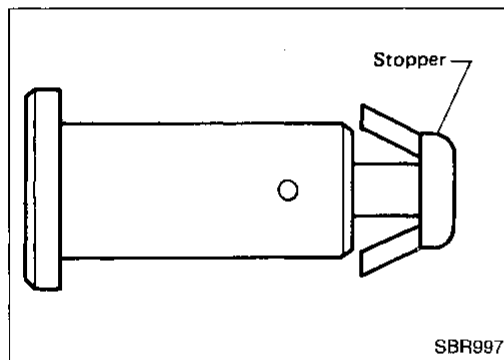
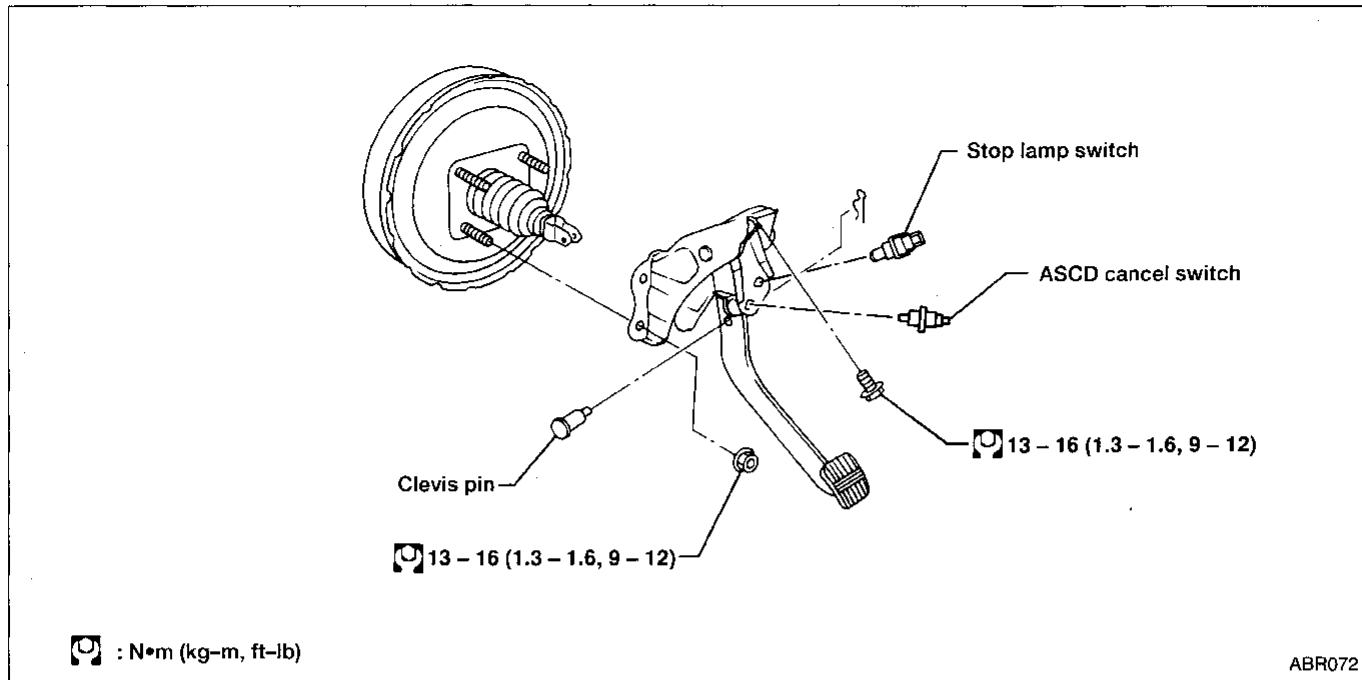

Inspection

Check brake pedal for following items:

- Brake pedal bend
- Clevis pin deformation
- Crack of any welded portion
- Crack or deformation of clevis pin stopper

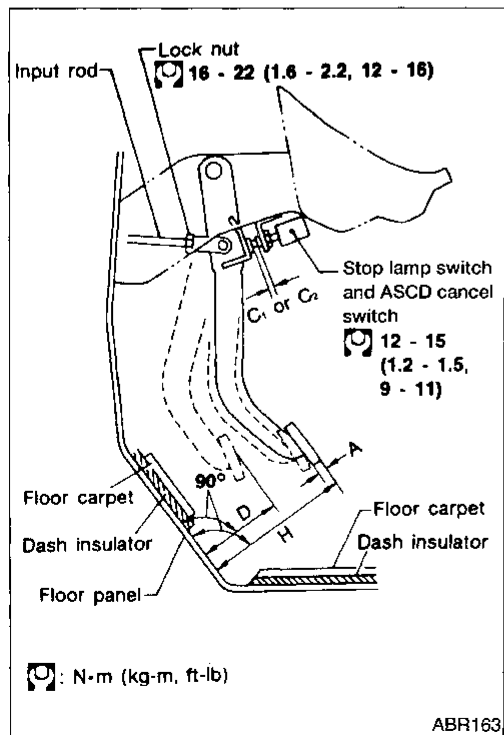

Adjustment

Check brake pedal free height from dash reinforcement panel.

- H: Free height**
Refer to SDS, BR-66.
- D: Depressed height**
Refer to SDS, BR-66.
Under force of 490 N (50 kg, 110 lb) with engine running
- C₁, C₂: Clearance between pedal stopper and threaded end of stop lamp switch and ASCD cancel switch**
0.3 - 1.0 mm (0.012 - 0.039 in)
- A: Pedal free play**
1.0 - 3.0 mm (0.039 - 0.118 in)

BRAKE PEDAL AND BRACKET

Adjustment (Cont'd)

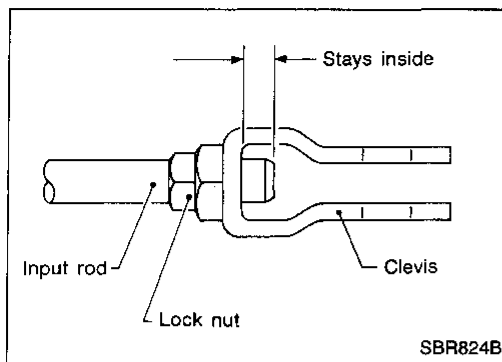

If necessary, adjust brake pedal free height.

1. Loosen lock nut and adjust pedal free height by turning brake booster input rod. Tighten lock nut.

Make sure that tip of input rod stays inside of clevis.

2. Loosen lock nut and adjust clearance "C₁" and "C₂" with stop lamp switch and ASCD switch respectively. Then tighten lock nuts.
3. Check pedal free play.

Make sure that stop lamps go off when pedal is released.

4. Check brake pedal depressed height while engine is running. If lower than specification, check for leaks, air in system, or damage to components (master cylinder, wheel cylinder, etc.). Then make necessary repairs.

MASTER CYLINDER

Removal

CAUTION:

Be careful not to splash brake fluid on painted areas; it may cause paint damage. If brake fluid is splashed on painted areas, wash it away with water immediately.

1. Connect a vinyl tube to air bleeder valve.
2. Drain brake fluid from each air bleeder valve, depressing brake pedal to empty fluid from master cylinder.
3. Remove brake pipe flare nuts.
4. Remove master cylinder mounting nuts.

Disassembly

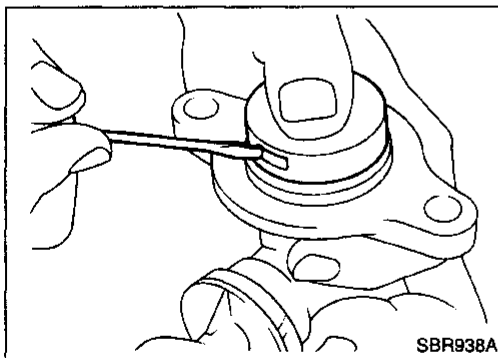
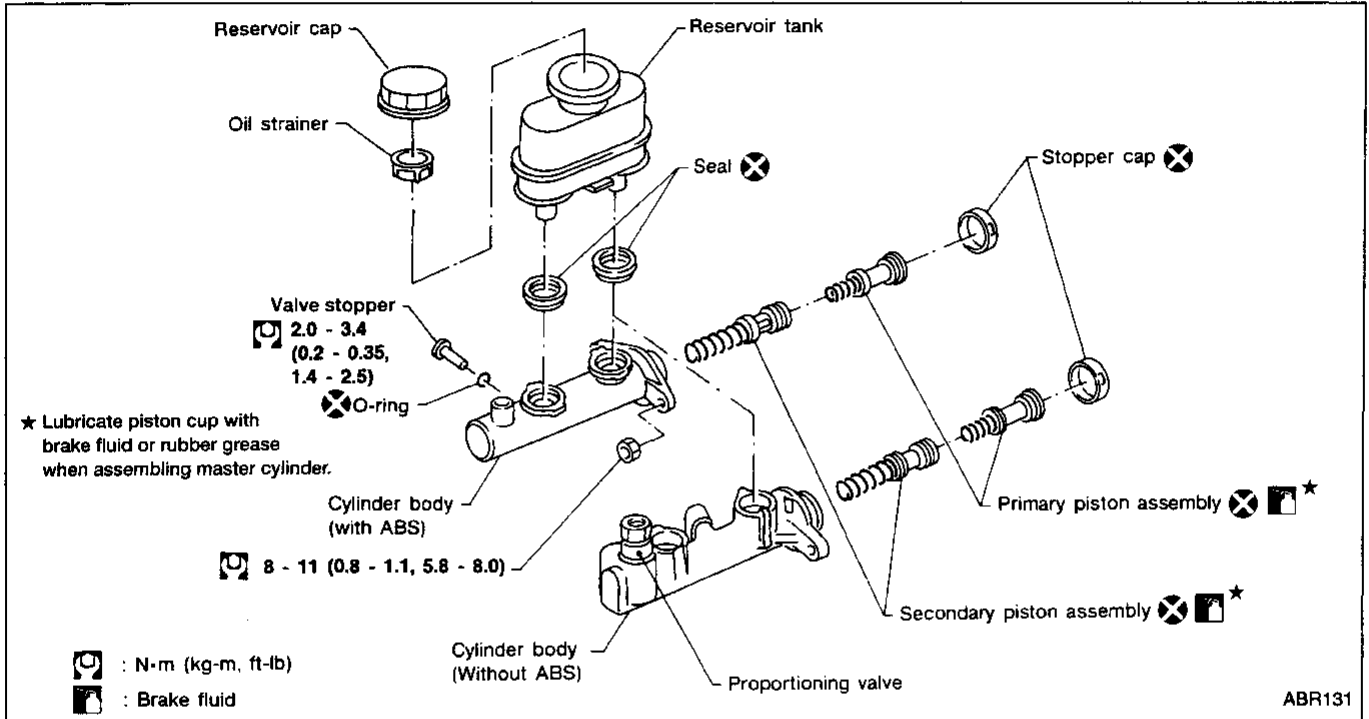

1. Bend claws of stopper cap outward.

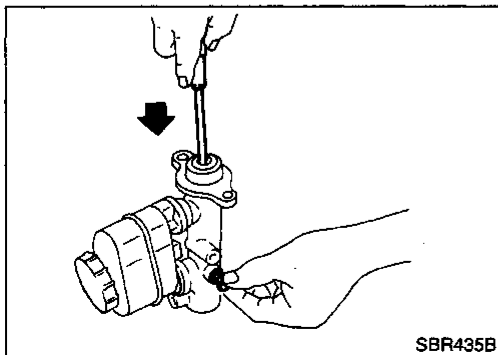

2. Remove valve stopper while piston is pushed into cylinder (Models with ABS only).

MASTER CYLINDER

Disassembly (Cont'd)

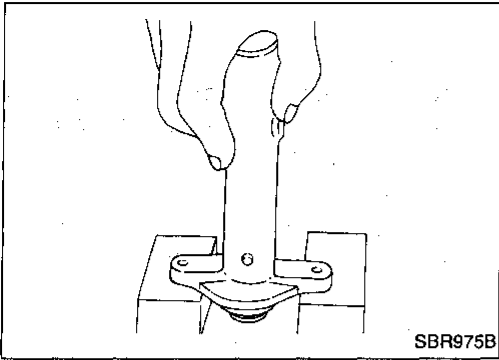

3. Remove piston assemblies.

If it is difficult to remove secondary piston assembly, tap flange with mallet or equivalent and pull out secondary piston.

4. Draw out reservoir tank.

Inspection

Check master cylinder inner wall for pin holes or scratches. Replace if damaged.

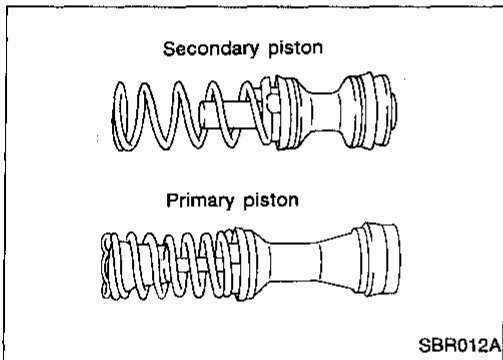

Assembly

1. Insert secondary piston assembly. Then insert primary piston assembly.

- Pay attention to direction of piston cups in figure. Also, insert pistons squarely to avoid scratches on cylinder bore.
- Pay attention to alignment of secondary piston slit with valve stopper mounting hole of cylinder body (For models with ABS only).

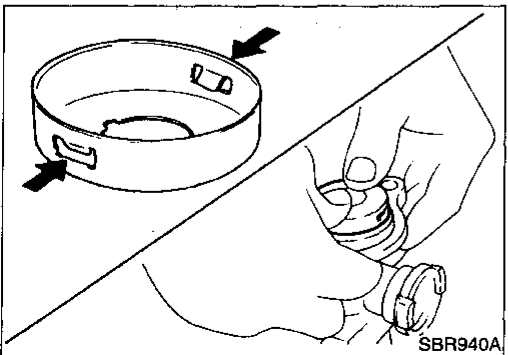
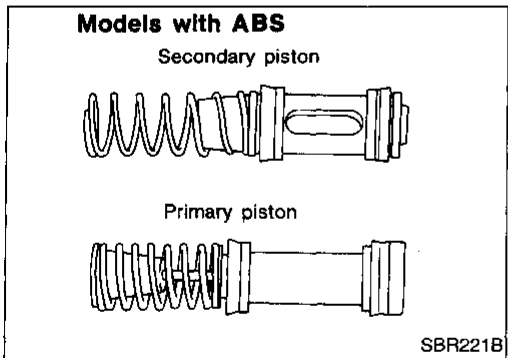

2. Install stopper cap.

Before installing stopper cap, ensure that claws are bent inward.

3. Push reservoir tank seals into cylinder body.

4. Push reservoir tank into cylinder body.

MASTER CYLINDER

Assembly (Cont'd)

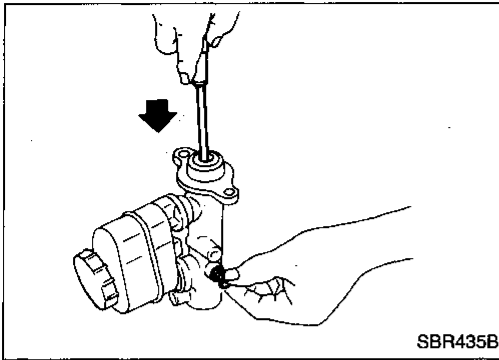

5. Install valve stopper while piston is pushed into cylinder.
(Models with ABS only)

Installation

CAUTION:

- Refill with new brake fluid "DOT 3".
 - Never reuse drained brake fluid.
1. Place master cylinder onto brake booster and secure mounting nuts lightly.
 2. Fit flare nuts to master cylinder.
 3. Tighten mounting nuts.
⚙️: **8 - 11 N·m (0.8 - 1.1 kg-m, 5.8 - 8.0 ft-lb)**
 4. Tighten flare nuts.
⚙️: **15 - 18 N·m (1.5 - 1.8 kg-m, 11 - 13 ft-lb)**
 5. Bleed air. Refer to "Bleeding Procedure" (BR-5).

GI

MA

EM

LC

EC

FE

CL

MT

AT

FA

RA

BR

ST

RS

BT

HA

EL

IDX

BRAKE BOOSTER

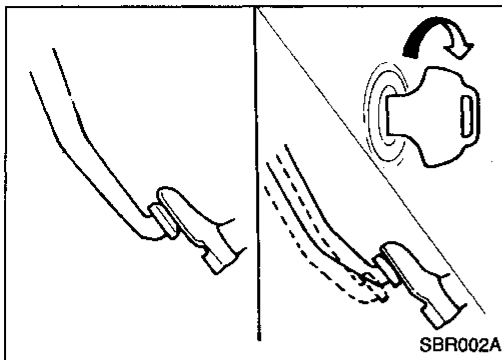

On-vehicle Service

OPERATING CHECK

- Depress brake pedal several times with engine off. After exhausting vacuum, make sure there is no change in pedal stroke.
- Depress brake pedal, then start engine. If pedal goes down slightly, operation is normal.

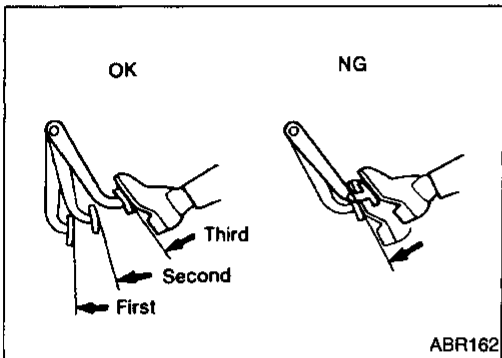

AIRTIGHT CHECK

- Start engine, and stop it after one or two minutes. Depress brake pedal several times slowly. Booster is airtight if pedal stroke is less each time.
- Depress brake pedal while engine is running, and stop engine with pedal depressed. The pedal stroke should not change after holding pedal down **30 seconds**.

Removal

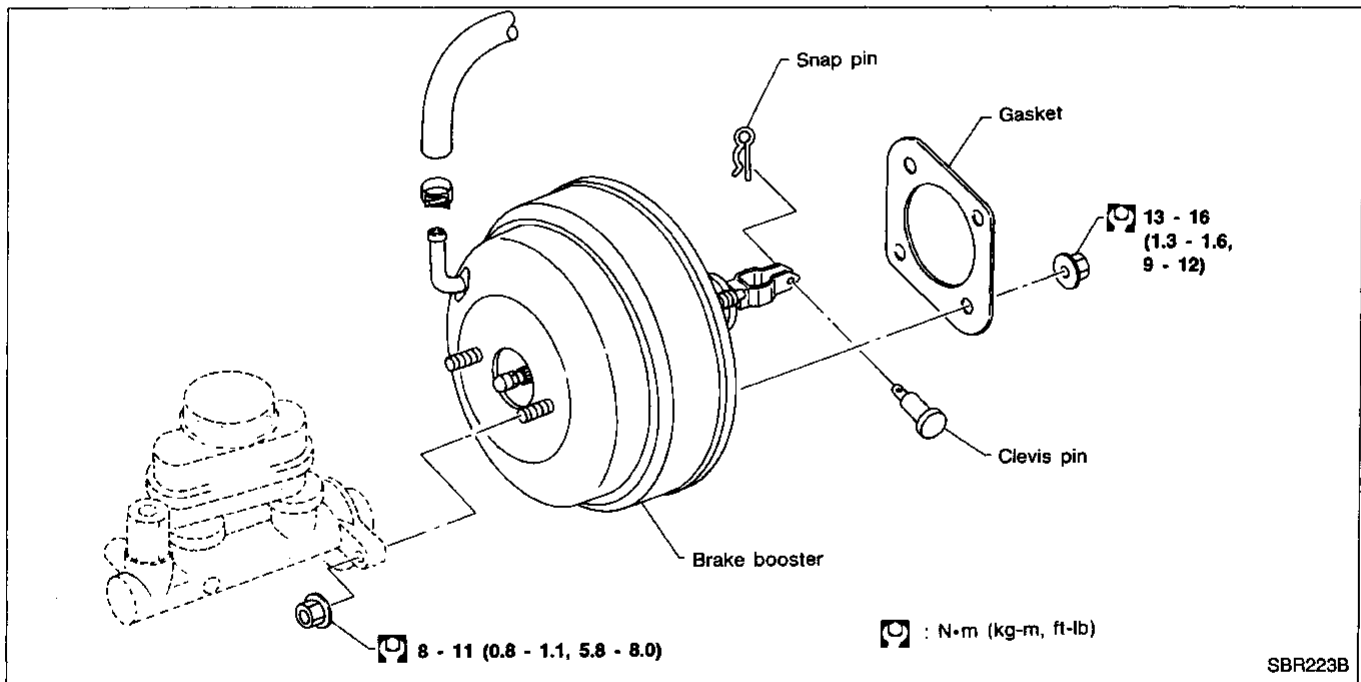

CAUTION:

- Be careful not to splash brake fluid on painted areas; it may cause paint damage. If brake fluid is splashed on painted areas, wash it away with water immediately.
- Be careful not to deform or bend brake pipes, during removal of booster.
- It is necessary to remove ABS actuator and actuator bracket first because space around booster is limited.

BRAKE BOOSTER

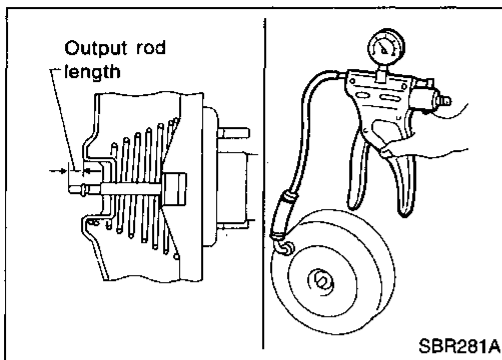

Inspection

OUTPUT ROD LENGTH CHECK

1. Apply vacuum of -66.7 kPa (-500 mmHg, -19.69 inHg) to brake booster with a handy vacuum pump.
2. Check output rod length.

Specified length:

10.275 - 10.525 mm (0.4045 - 0.4144 in)

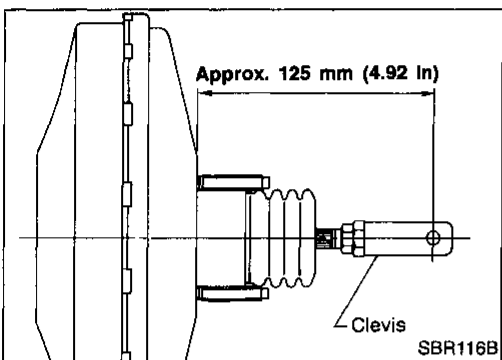

Installation

CAUTION:

- Be careful not to deform or bend brake pipes, during installation of booster.
- Replace clevis pin if damaged.
- Refill with new brake fluid "DOT 3".
- Never reuse drained brake fluid.
- Take care not to damage brake booster mounting bolt thread when installing. Due to the narrow angle of installation, the threads can be damaged by the dash panel.

1. Before fitting booster, temporarily adjust clevis to dimension shown.
2. Fit booster, then secure mounting nuts (brake pedal bracket to brake booster) lightly.
3. Connect brake pedal and booster input rod with clevis pin.
4. Secure mounting nuts.
Torque: 13 - 16 N·m (1.3 - 1.6 kg-m, 9 - 12 ft-lb)
5. Install master cylinder. Refer to BR-13.
6. Bleed air. Refer to BR-5.

GI

MA

EM

LC

EC

FE

CL

MT

AT

FA

RA

BR

ST

RS

BT

HA

EL

IDX

VACUUM HOSE

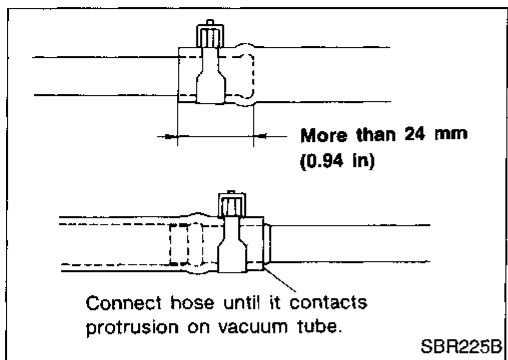

SBR225B

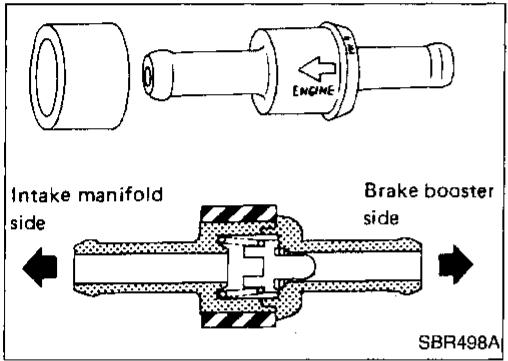

SBR498A

Removal and Installation

CAUTION:

When installing vacuum hoses, pay attention to the following points.

- Do not apply any oil or lubricants to vacuum hose and check valve.
- Insert vacuum tube into vacuum hose as shown.

- Install check valve, paying attention to its direction.

Inspection

HOSES AND CONNECTORS

Check vacuum lines, connections and check valve for airtightness, improper attachment, chafing or deterioration.

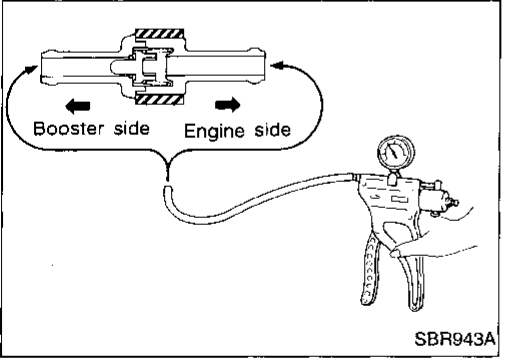

SBR943A

CHECK VALVE

Check vacuum with a vacuum pump.

Connect to booster side	Vacuum should exist.
Connect to engine side	Vacuum should not exist.

Pad Replacement

WARNING:

Clean brakes with a vacuum dust collector to minimize risk of health hazard from powder caused by friction.

CAUTION:

- When cylinder body is open, do not depress brake pedal or piston will pop out.
- Be careful not to damage piston boot or get oil on rotor. Always replace shims when replacing pads.
- If shims are rusted or show peeling of the rubber coat, replace them with new shims.
- It is not necessary to remove connecting bolt except for disassembly or replacement of caliper assembly. In this case, suspend cylinder body with wire so as not to stretch brake hose.

GI

MA

EM

LC

EC

FE

CL

MT

AT

FA

RA

BR

ST

RS

BT

HA

EL

IDX

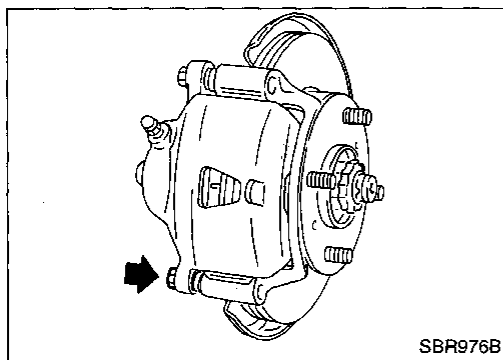

1. Remove master cylinder reservoir cap.
2. Remove lower pin bolt.

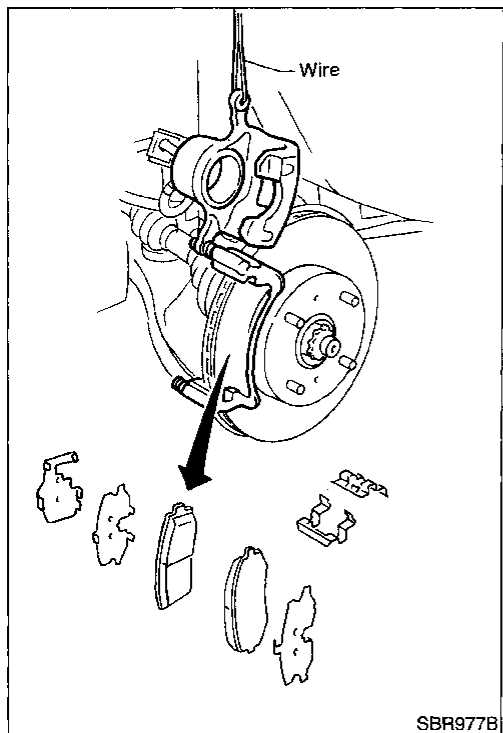

3. Open cylinder body upward. Then remove pad retainers and inner and outer shims.

Standard pad thickness:

M/T model 11.0 mm (0.433 in)

A/T model 10.0 mm (0.394 in)

Pad wear limit:

2.0 mm (0.079 in)

- Carefully monitor brake fluid level because brake fluid will return to reservoir when pushing back piston.

FRONT DISC BRAKE

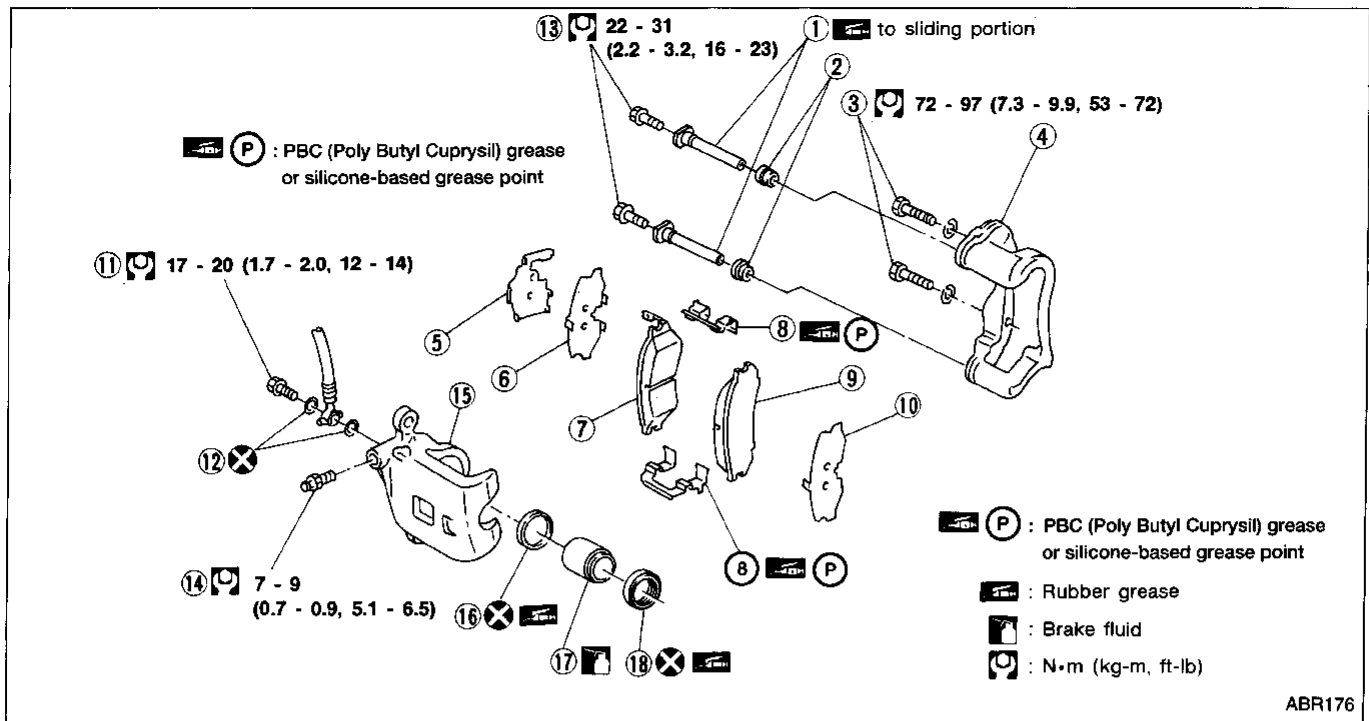

ABR176

- | | | |
|-----------------------------|-------------------|-----------------|
| ① Main pin | ⑦ Inner pad | ⑬ Main pin bolt |
| ② Pin boot | ⑧ Pad retainer | ⑭ Bleed valve |
| ③ Torque member fixing bolt | ⑨ Outer pad | ⑮ Cylinder body |
| ④ Torque member | ⑩ Outer shim | ⑯ Piston seal |
| ⑤ Shim cover | ⑪ Connecting bolt | ⑰ Piston |
| ⑥ Inner shim | ⑫ Copper washer | ⑱ Piston boot |

Removal

WARNING:

Clean brakes with a vacuum dust collector to minimize risk of health hazard from powder caused by friction.

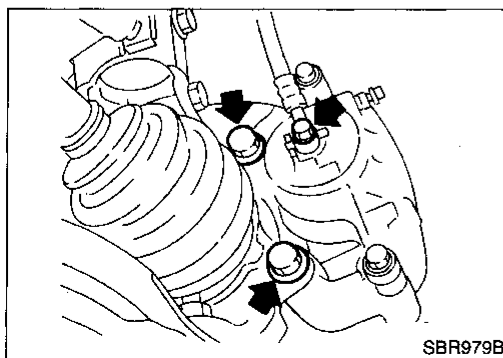

SBR979B

Remove torque member fixing bolts and connecting bolt. It is not necessary to remove connecting bolt except for disassembly or replacement of caliper assembly. In this case, suspend caliper assembly with wire so as not to stretch brake hose.

FRONT DISC BRAKE

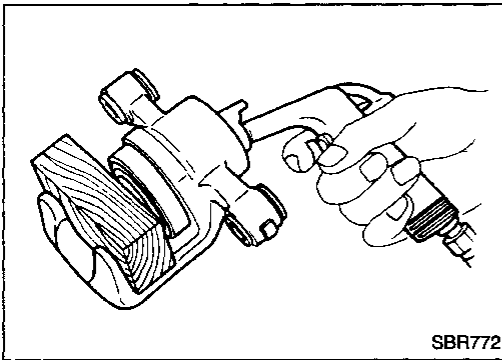

Disassembly

WARNING:

Do not place your fingers in front of piston.

CAUTION:

Do not scratch or score cylinder wall.

1. Push out piston with dust seal with compressed air.
2. Remove piston seal with a suitable tool.

GI

MA

EM

LC

Inspection — Caliper

CYLINDER BODY

- Check inside surface of cylinder for score, rust, wear, damage or presence of foreign objects. If any of the above conditions are observed, replace cylinder body.
- Minor damage from rust or foreign objects may be eliminated by polishing surface with a fine emery paper. Replace cylinder body if necessary.

EC

FE

CL

CAUTION:

Use brake fluid to clean. Never use mineral oil.

MT

PISTON

CAUTION:

Piston sliding surface is plated. Do not polish with emery paper even if rust or foreign objects are stuck to sliding surface.

AT

Check piston for score, rust, wear, damage or presence of foreign objects. Replace if any of the above conditions are observed.

FA

RA

SLIDE PIN, PIN BOLT AND PIN BOOT

Check for wear, cracks, rust or other damage. Replace if any of the above conditions are observed.

BR

ST

RS

BT

HA

EL

IDX

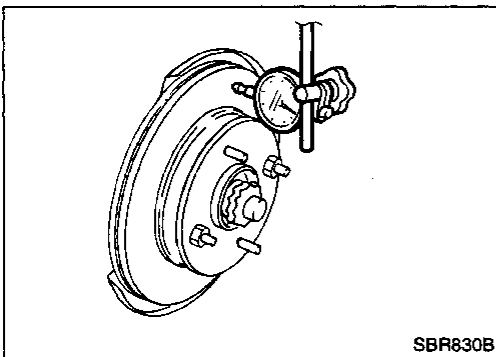

Inspection — Rotor

RUNOUT

1. Secure rotor to wheel hub with at least two nuts (M12 x 1.25).
2. Check runout using a dial indicator.

Make sure that wheel bearing axial end play is within the specifications before measuring. Refer to FA section ("Front Wheel Bearing", "ON-VEHICLE SERVICE").

Maximum runout:

0.07 mm (0.0028 in)

FRONT DISC BRAKE

Inspection — Rotor (Cont'd)

3. If the runout is out of specification, find minimum runout position as follows:
 - a. Remove nuts and rotor from wheel hub.
 - b. Shift the rotor one hole and secure rotor to wheel hub with nuts.
 - c. Measure runout.
 - d. Repeat steps a. to c. so that minimum runout position can be found.
4. If the runout is still out of specification, turn rotor with on-car brake lathe ("MAD, DL-8700", "AMMCO 700 and 705" or equivalent).

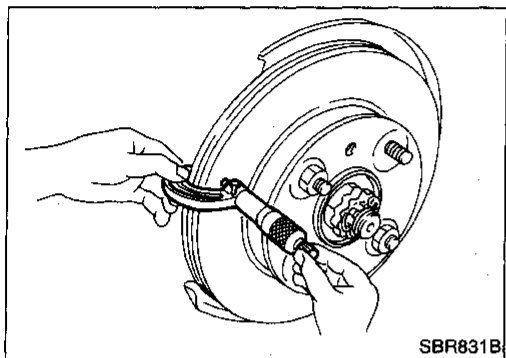

THICKNESS

Thickness variation (At least 8 positions):
Maximum 0.01 mm (0.0004 in)

If thickness variation exceeds the specification, turn rotor with on-car brake lathe.

Rotor repair limit:
20.0 mm (0.787 in)

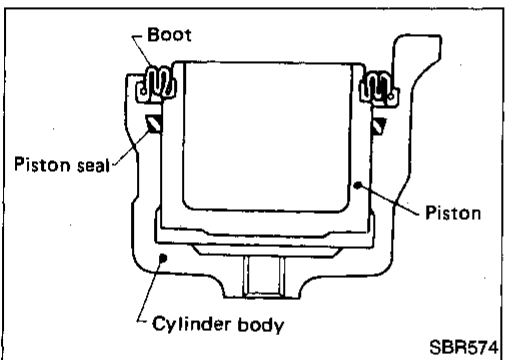

Assembly

1. Insert piston seal into groove on cylinder body.
2. With piston boot fitted to piston, insert piston boot into groove on cylinder body and install piston.
3. Properly secure piston boot.

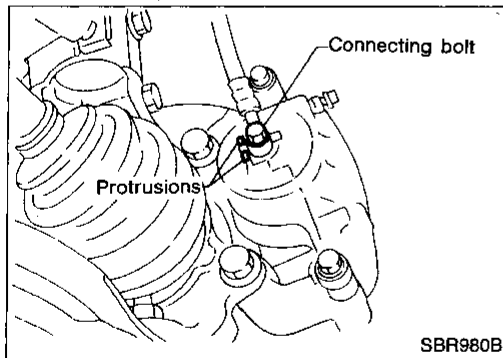

Installation

CAUTION:

- Refill with new brake fluid "DOT 3".
 - Never reuse drained brake fluid.
1. Install caliper assembly.
 2. Install brake hose to caliper securely.
 3. Install all parts and secure all bolts.
 4. Bleed air. Refer to "Bleeding Procedure" (BR-5).

REAR DRUM BRAKE

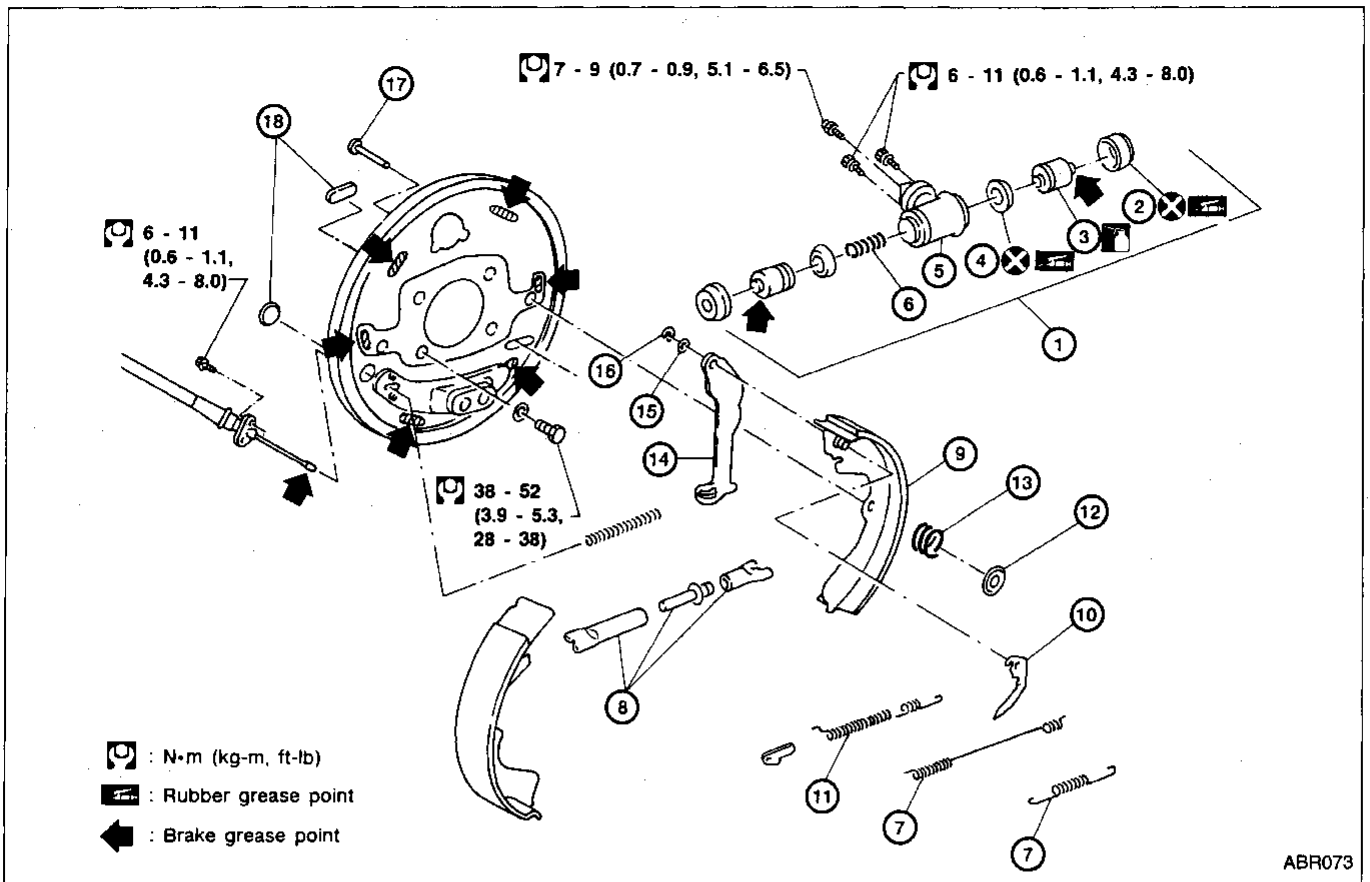

ABR073

- | | | |
|---------------------------|-------------------|-------------------------|
| ① Wheel cylinder assembly | ⑦ Return spring | ⑬ Shoe hold-down spring |
| ② Boot | ⑧ Adjuster | ⑭ Toggle lever |
| ③ Piston | ⑨ Shoe | ⑮ Washer |
| ④ Piston cup | ⑩ Adjuster lever | ⑯ Retainer ring |
| ⑤ Cylinder body | ⑪ Adjuster spring | ⑰ Shoe hold-down pin |
| ⑥ Spring | ⑫ Retainer | ⑱ Plug |

Removal

WARNING:

Clean brakes with a vacuum dust collector to minimize the hazard of airborne particles or other materials.

CAUTION:

Make sure parking brake lever is released completely.

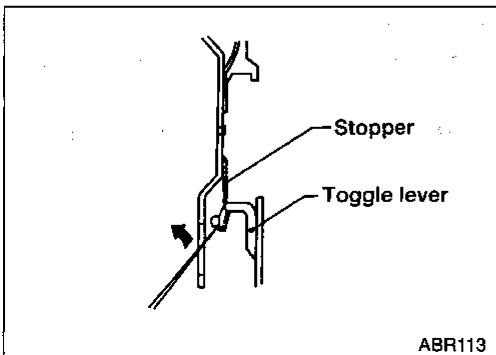

ABR113

1. Release parking brake lever fully, then remove drum. If drum is hard to remove, the following procedures should be carried out.
 - a. Remove plug. Then push down stopper to back plate to make clearance between brake shoe and drum as shown.

GI
MA
EM
LC
EC
FE
CL
MT
AT
FA
RA
BR
ST
RS
BT
HA
EL
IDX

REAR DRUM BRAKE

Removal (Cont'd)

- b. Tighten the two bolts gradually.

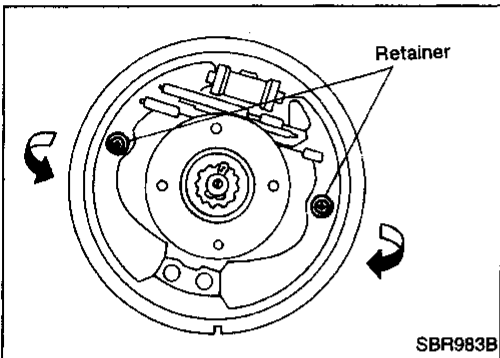
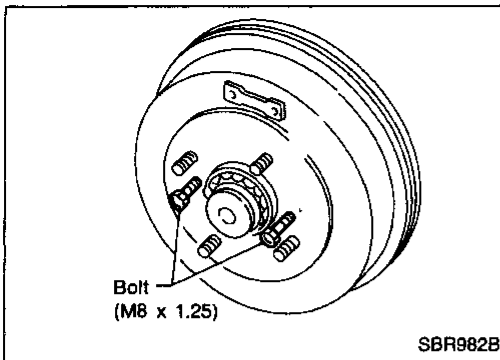

2. Push in shoe hold-down pins from behind the back plate. While pushing in the retainer, turn it and remove the shoe hold-down pins.
3. Pull out brake shoes in the direction of the arrows as illustrated.

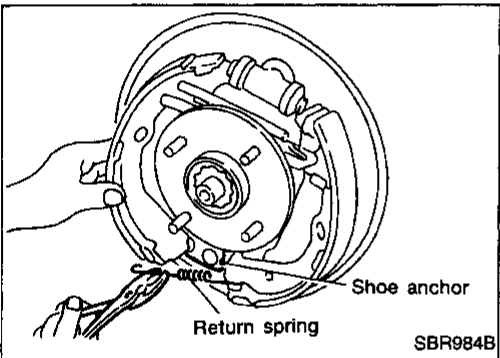

4. Using pliers, remove the lower return spring from shoe.

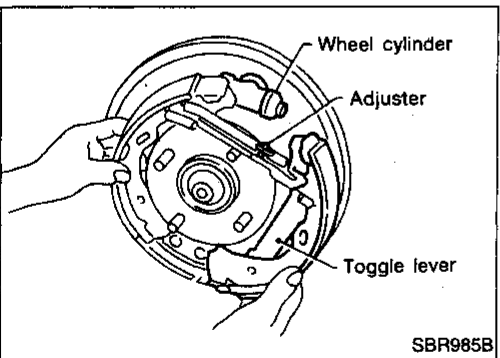

5. Separate shoes, one at a time, from wheel cylinder, and remove them from back plate with the adjuster assembly still on as shown.

Be careful not to scratch or damage wheel cylinder boot.

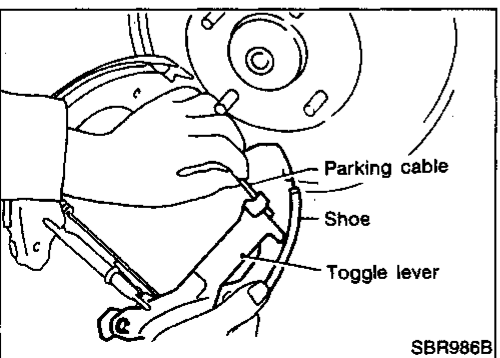

6. Disconnect parking brake cable from toggle lever. **Be careful not to damage parking brake cable when separating it.**
7. Remove adjuster return spring and shoe return spring.

REAR DRUM BRAKE

Removal (Cont'd)

8. Remove retainer ring with a suitable tool. Then separate toggle lever and brake shoe.

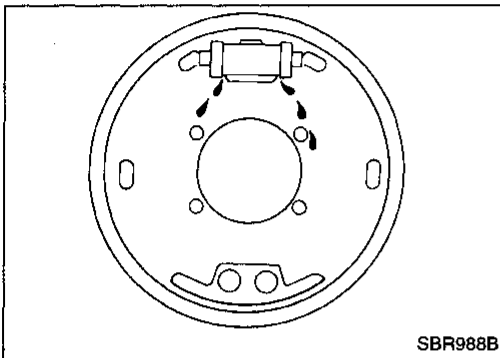
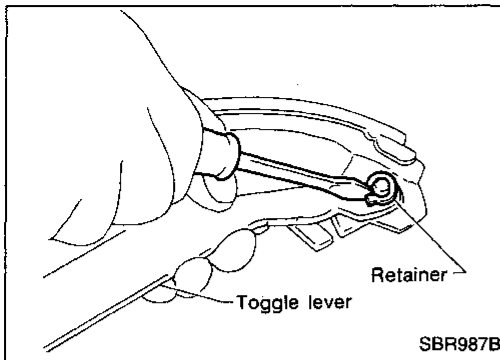

Inspection — Wheel Cylinder

- Check wheel cylinder for leakage.
- Check for wear, damage and loose conditions. Replace if any such condition exists.

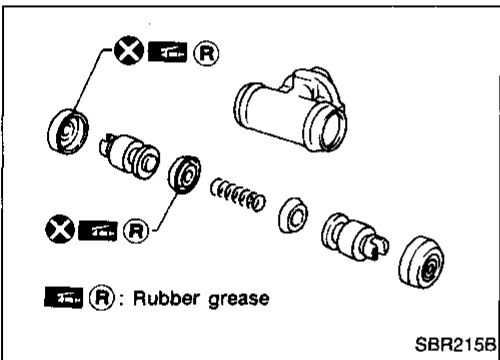

Wheel Cylinder Overhaul

- Check all internal parts for wear, rust and damage. Replace if necessary.
- Pay attention so as not to scratch cylinder when installing pistons.

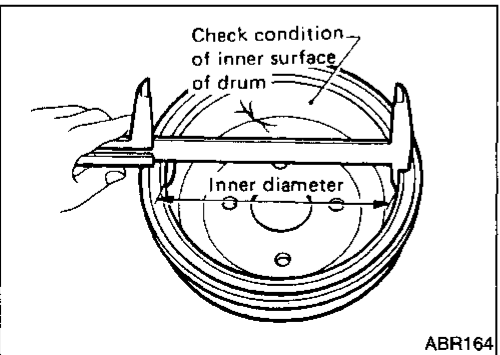
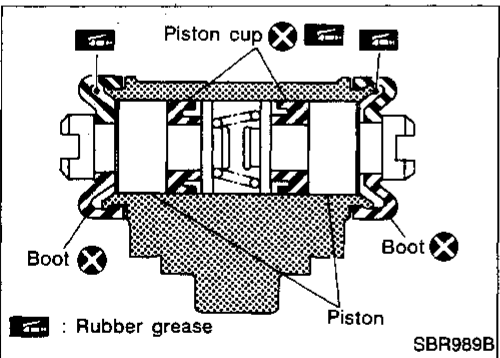

Inspection — Drum

Maximum inner diameter:

230 mm (9.06 in)

Out-of-roundness:

0.03 mm (0.0012 in) or less

- Contact surface should be fine finished with No. 120 to 150 emery paper.
- Using a drum lathe, lathe brake drum if it shows scoring, partial wear or stepped wear.
- After brake drum has been completely reconditioned or replaced, check drum and shoes for proper contact pattern.

GI

MA

EM

LC

EC

FE

CL

MT

AT

FA

RA

BR

ST

RS

BT

HA

EL

IDX

REAR DRUM BRAKE

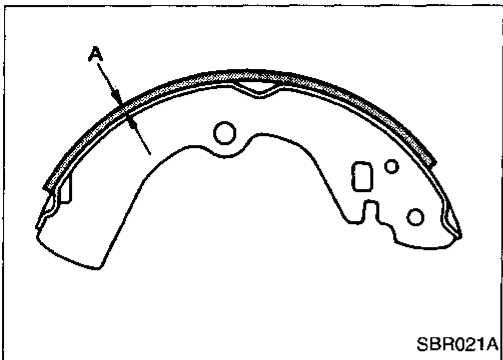

Inspection — Lining

Check lining thickness.

Standard lining thickness:

4.1 mm (0.161 in)

Lining wear limit (A):

1.5 mm (0.059 in)

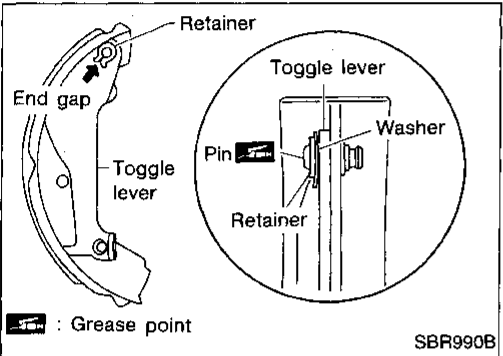

Installation

Always perform shoe clearance adjustment. Refer to BR-34.

1. Fit toggle lever to brake shoe with retainer ring.

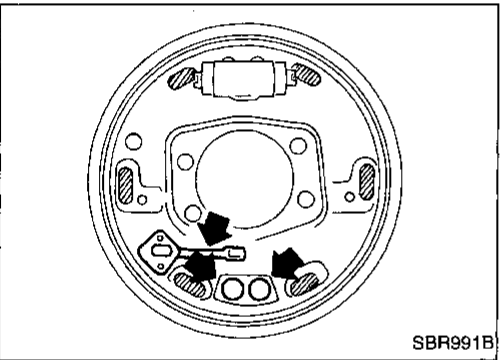

2. Apply brake grease to the contact areas shown at left.

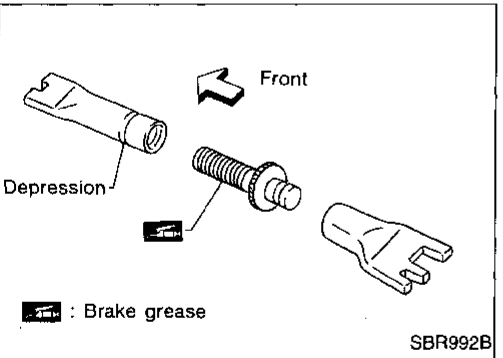

3. Shorten adjuster by rotating it.

• Pay attention to direction of adjuster.

Wheel	Screw	Depression
Left	Left-hand thread	Yes
Right	Right-hand thread	No

4. Apply brake grease to adjuster as shown.

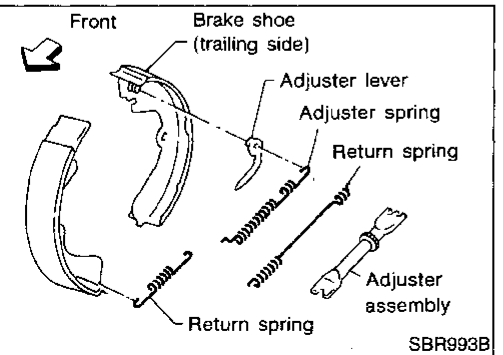

5. Install adjuster and adjuster lever; then install upper return spring and adjuster spring as shown.

REAR DRUM BRAKE

Installation (Cont'd)

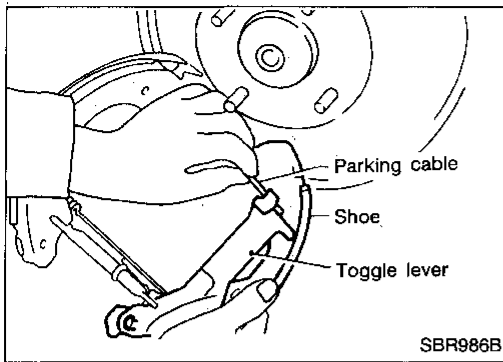

6. Connect parking brake cable to toggle lever.
Be careful not to damage brake cable.

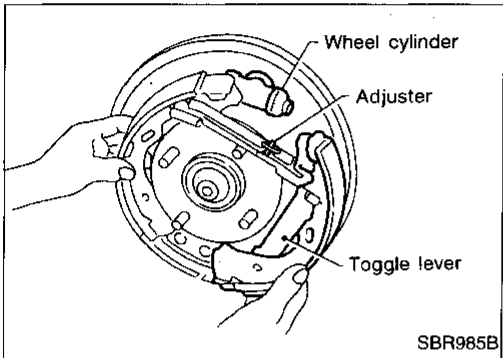

7. Install shoes on wheel cylinder one at a time.
Do not allow the piston to spring away when assembling.
8. Install lower return spring.

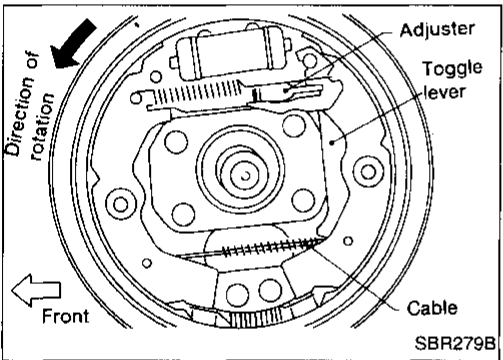

9. Secure shoe installation with shoe hold-down pins and retainer.
10. Check to make sure all parts are installed properly.
Pay attention to direction of adjuster assembly.
11. Install brake drum.
12. When installing new wheel cylinder, bleed air. Refer to "Bleeding Procedure" (BR-5).
13. Adjust parking brake. Refer to BR-34.

GI

MA

EM

LC

EC

FE

CL

MT

AT

FA

RA

BR

ST

RS

BT

HA

EL

IDX

REAR DISC BRAKE

Pad Replacement

WARNING:

Clean brake pads with a vacuum dust collector to minimize the hazard of airborne particles or other materials.

CAUTION:

- When cylinder body is open, do not depress brake pedal, or piston will pop out.
- Be careful not to damage piston boot or get oil on rotor. Always replace shims when replacing pads.
- If shims are rusted or show peeling of rubber coat, replace them with new shims.
- It is not necessary to remove connecting bolt except for disassembly or replacement of caliper assembly. In this case, suspend cylinder body with wire so as not to stretch brake hose.
- Carefully monitor brake fluid level because brake fluid will return to reservoir when pushing back piston.

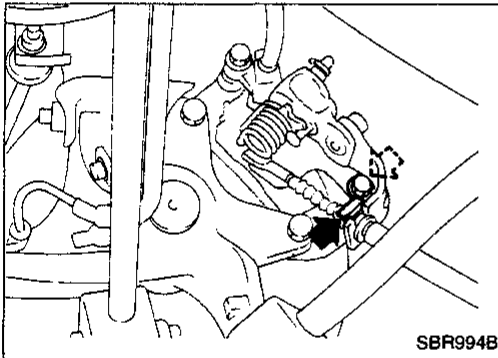

1. Remove master cylinder reservoir cap.
2. Remove brake cable lock spring.
3. Disconnect cable.
4. Remove lower pin bolt.

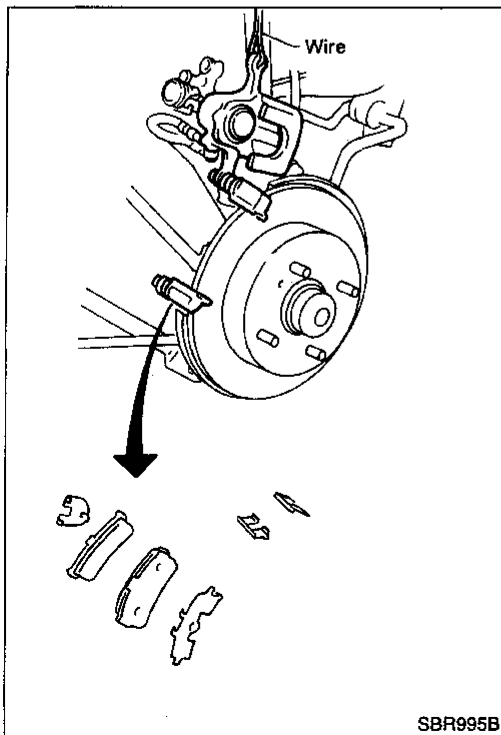

5. Open cylinder body upward. Then remove pad retainers, and inner and outer shims.

Standard pad thickness:

10 mm (0.39 in)

Pad wear limit:

1.5 mm (0.059 in)

REAR DISC BRAKE

Pad Replacement (Cont'd)

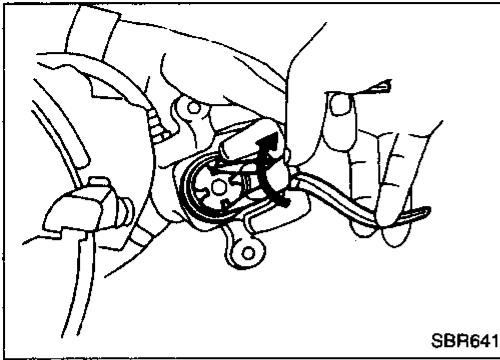

6. When installing new pads, push piston into cylinder body by turning piston clockwise.

Carefully monitor brake fluid level because brake fluid will return to reservoir when pushing back piston.

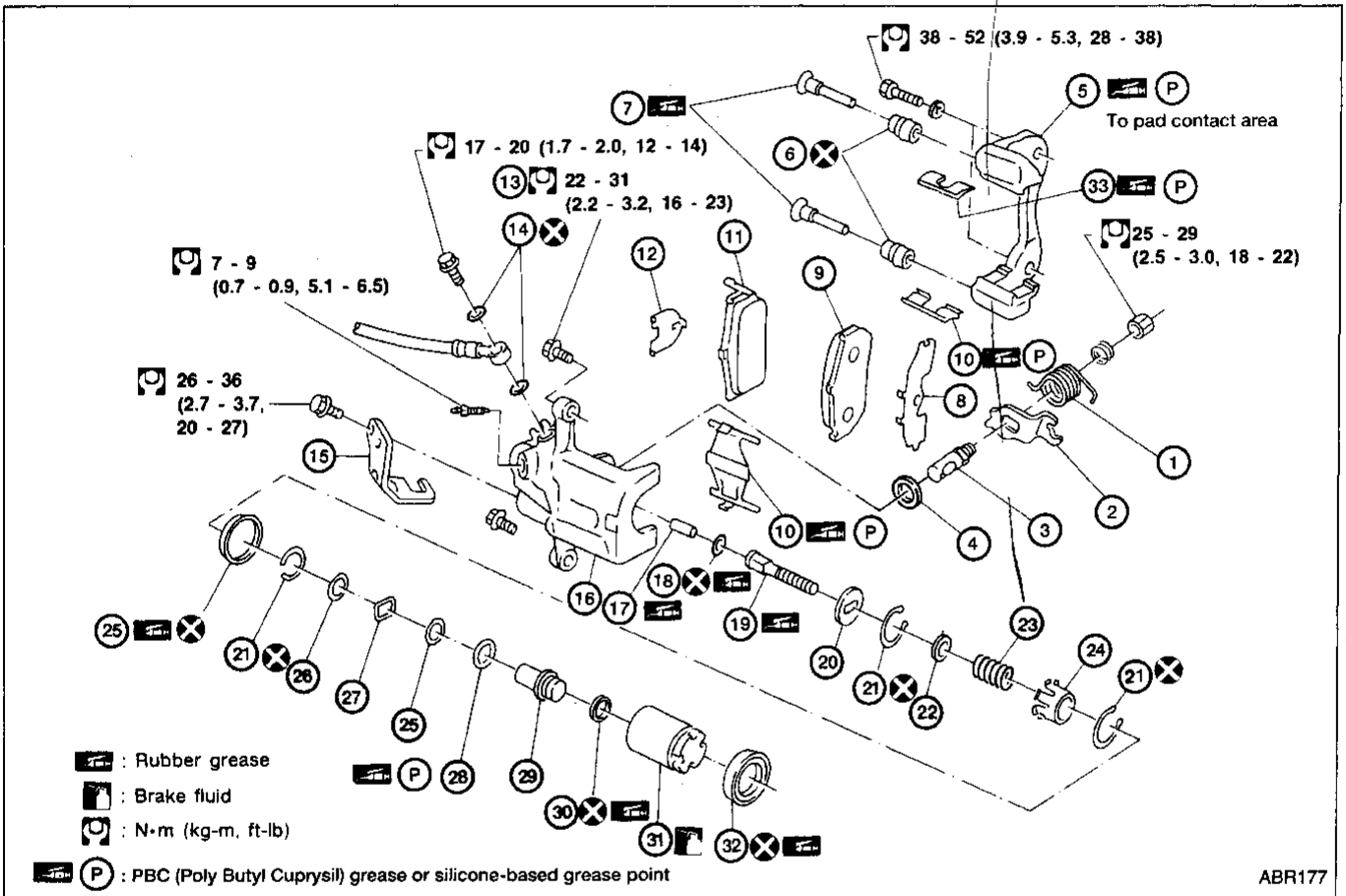

- ① Spring
- ② Toggle lever
- ③ Cam
- ④ Cam boot
- ⑤ Torque member
- ⑥ Pin boot
- ⑦ Side pin
- ⑧ Outer shim
- ⑨ Outer pad
- ⑩ Pad retainer
- ⑪ Inner pad

- ⑫ Inner shim
- ⑬ Pin bolt
- ⑭ Copper washer
- ⑮ Cable guide
- ⑯ Cylinder
- ⑰ Strut
- ⑱ O-ring
- ⑲ Push rod
- ⑳ Key plate
- ㉑ Snap ring
- ㉒ Spring seat

- ㉓ Spring
- ㉔ Spring cover
- ㉕ Piston seal
- ㉖ Spacer
- ㉗ Wave washer
- ㉘ Bearing
- ㉙ Adjuster nut
- ㉚ Piston cup
- ㉛ Piston
- ㉜ Piston boot

GI
MA
EM
LC
EC
FE
CL
MT
AT
FA
RA
BR
ST
RS
BT
HA
EL
IDX

REAR DISC BRAKE

Removal

WARNING:

Clean brake pads with a vacuum dust collector to minimize the hazard of airborne particles or other materials.

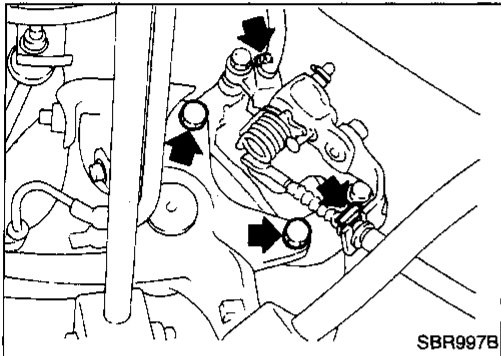

1. Remove brake cable mounting bracket bolt and lock spring.
2. Remove torque member fixing bolts and connecting bolt.

It is not necessary to remove connecting bolt except for disassembly or replacement of caliper assembly. In this case, suspend caliper assembly with wire so as not to stretch brake hose.

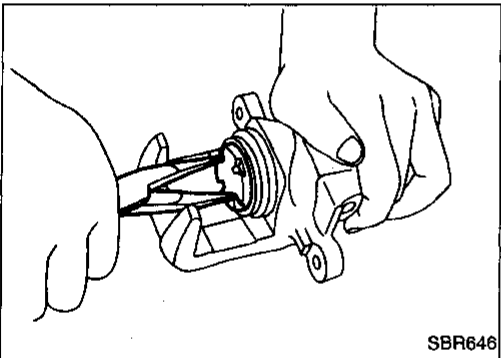

Disassembly

1. Remove piston by turning it counterclockwise with suitable long nose pliers.

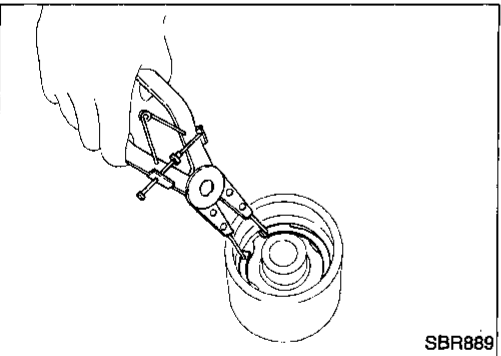

2. Pry off snap ring from piston with suitable pliers and remove adjusting nut.

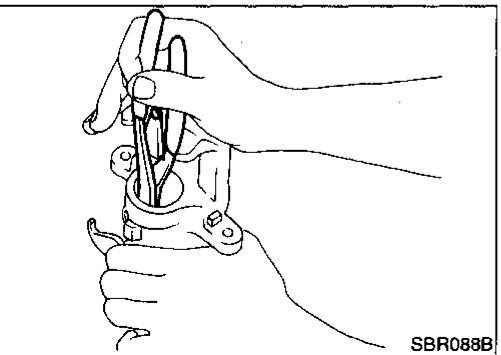

3. Disassemble cylinder body.
 - a. Pry off snap ring with suitable pliers, then remove spring cover, spring and seat.
 - b. Pry off snap ring, then remove key plate, push rod and strut.

REAR DISC BRAKE

Disassembly (Cont'd)

c. Remove piston seal.

Be careful not to damage cylinder body.

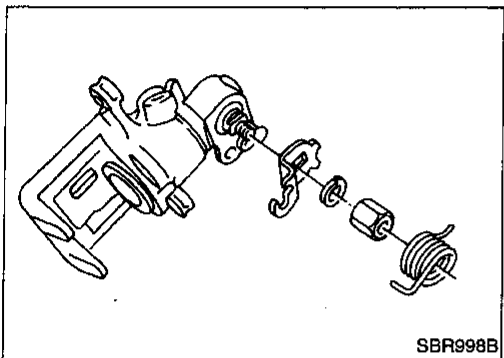
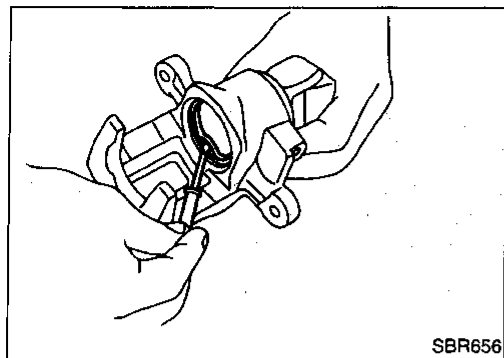

4. Remove return spring and toggle lever.

Inspection — Caliper

CYLINDER BODY

CAUTION:

Use brake fluid to clean cylinder. Never use mineral oil.

- Check inside surface of cylinder for score, rust, wear, damage or presence of foreign objects. If any of the above conditions are observed, replace cylinder body.
- Minor damage from rust or foreign objects may be eliminated by polishing surface with a fine emery paper. Replace cylinder body if necessary.

TORQUE MEMBER

Check for wear, cracks or other damage. Replace if necessary.

PISTON

CAUTION:

Piston sliding surface is plated. Do not polish with emery paper even if rust or foreign objects are stuck to sliding surface.

Check piston for score, rust, wear, damage or presence of foreign objects. Replace if any of the above conditions are observed.

SLIDE PIN, PIN BOLT AND PIN BOOT

Check for wear, cracks, rust or other damage. Replace if any of the above conditions are observed.

GI

MA

EM

LC

EC

FE

CL

MT

AT

FA

RA

BR

ST

RS

BT

HA

EL

IDX

REAR DISC BRAKE

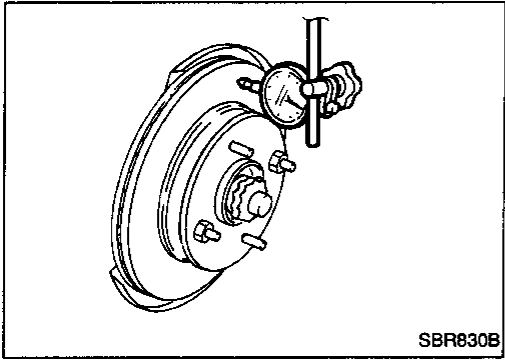

Inspection — Rotor

RUNOUT

1. Secure rotor to wheel hub with two nuts (M12 x 1.25).
2. Check runout using a dial indicator.

Make sure that wheel bearing axial end play is within the specifications before measuring. Refer to RA section ("Rear Wheel Bearing", "ON-VEHICLE SERVICE").

3. Change relative positions of rotor and wheel hub so that runout is minimized.

**Maximum runout :
0.07 mm (0.0028 in)**

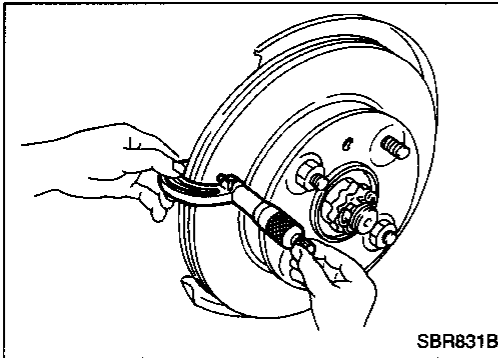

THICKNESS

Rotor repair limit:

**Minimum thickness
8.0 mm (0.315 in)**

**Thickness variation (At least 8 portions)
Maximum 0.02 mm (0.0008 in)**

Replace rotor if any of the above do not meet the specifications.

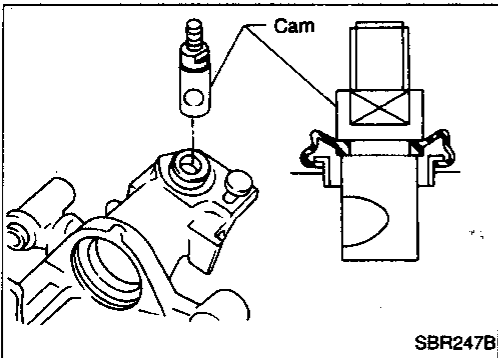

Assembly

1. Insert cam with depression facing toward open end of cylinder.

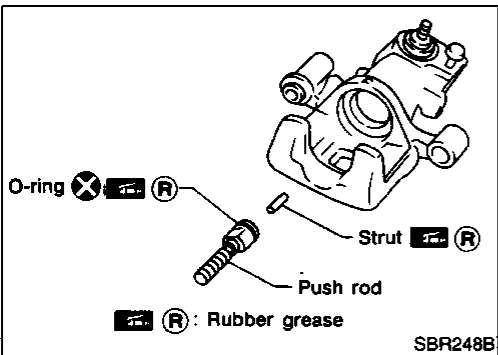

2. Generously apply rubber grease to strut and push rod to make insertion easy.

REAR DISC BRAKE

Assembly (Cont'd)

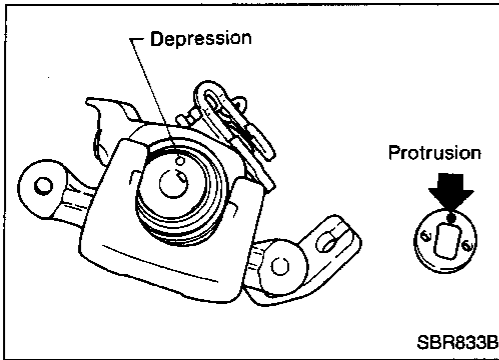

3. Mate protrusion on key plate with depression in cylinder bottom.

GI

MA

EM

LC

EC

FE

CL

MT

AT

FA

RA

BR

ST

RS

BT

HA

EL

IDX

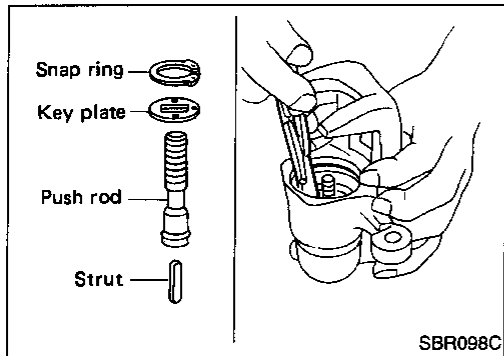

4. Install snap ring with a suitable tool.

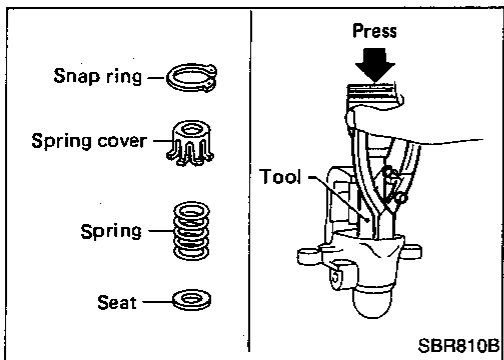

5. Install seat, spring, spring cover and snap ring with a suitable tool.

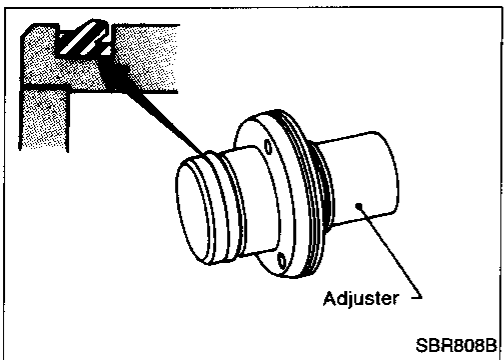

6. Install cup in the specified direction.

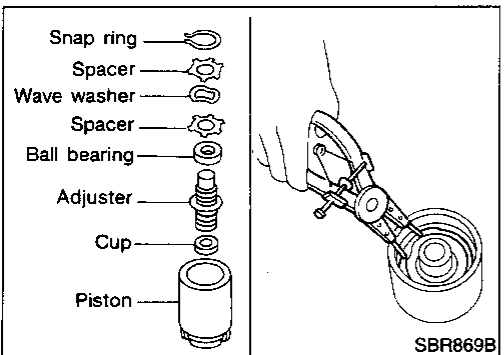

7. Install cup, adjuster, bearing, spacers, washers and snap ring with a suitable tool.

REAR DISC BRAKE

Assembly (Cont'd)

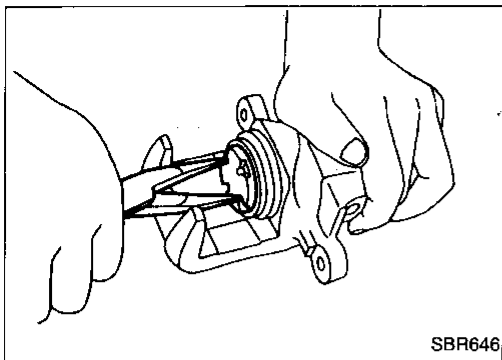

8. Insert piston seal into groove on cylinder body.
9. With piston boot fitted to piston, insert piston boot into groove on cylinder body and fit piston by turning it clockwise with suitable long nose pliers.

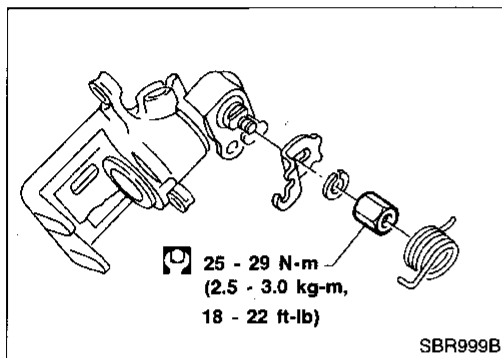

10. Fit toggle lever and return spring.

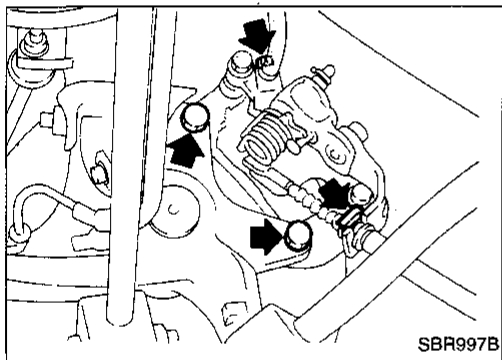

Installation

CAUTION:

- Refill with new brake fluid "DOT 3".
 - Never reuse drained brake fluid.
1. Install caliper assembly.
 2. Install brake hose to caliper securely.
 3. Install all parts and secure all bolts.
 4. Bleed air. Refer to "Bleeding Procedure" (BR-5).

PARKING BRAKE CONTROL

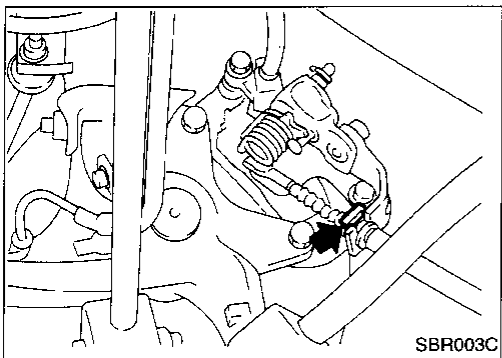
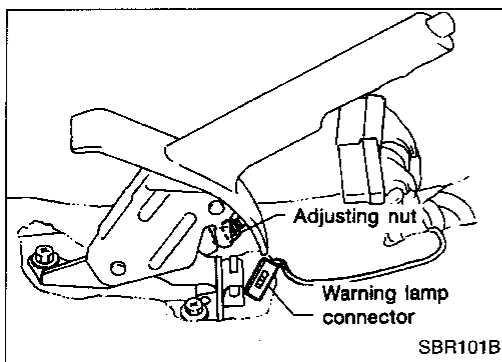
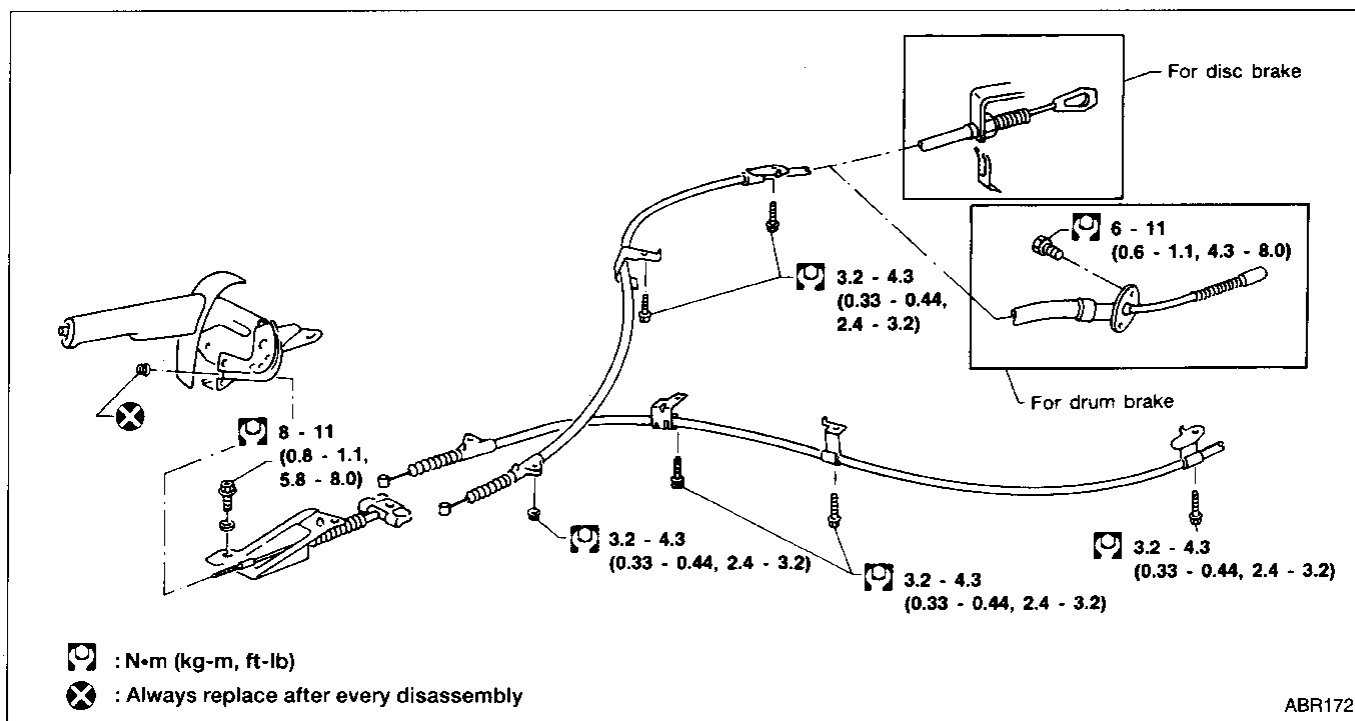

Removal and Installation

1. To remove parking brake cable, first remove center console.
2. Disconnect warning lamp connector.
3. Remove bolts, slacken off and remove adjusting nut.
4. Remove lock plate and disconnect cable (disc brake only). For drum brake models, refer to BR-21.

Inspection

1. Check control lever for wear or other damage. Replace if necessary.
2. Check wires for discontinuity or deterioration. Replace if necessary.
3. Check warning lamp and switch. Replace if necessary.
4. Check parts at each connecting portion and, if deformed or damaged, replace.

GI
MA
EM
LC
EC
FE
CL
MT
AT
FA
RA
BR
ST
RS
BT
HA
EL
IDX

PARKING BRAKE CONTROL

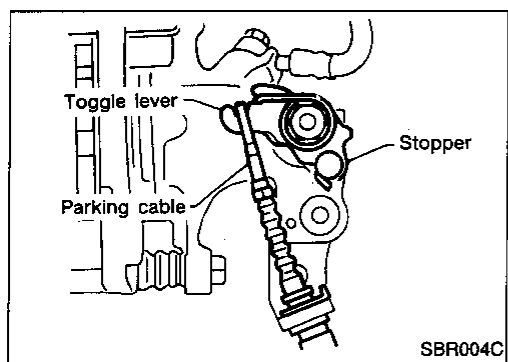

Adjustment

Before or after adjustment, pay attention to the following points.

- a. For rear disc brake be sure that toggle lever returns to stopper when parking brake lever is released.
- b. There is no drag when parking brake lever is released.

1. Adjust clearance between shoe and drum/pad and rotor as follows:

- a. Release parking brake lever and loosen adjusting nut.
- b. Depress brake pedal fully at least 10 times with engine running.

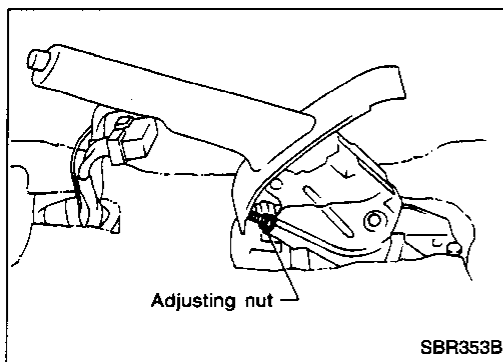

2. Pull control lever 4 - 5 notches. Then adjust control lever by turning adjusting nut.

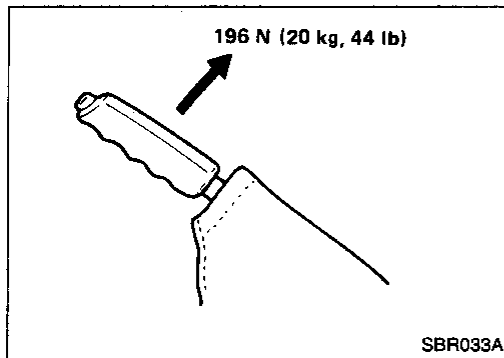

3. Pull control lever with specified amount of force. Check lever stroke and ensure smooth operation.

Number of notches: 7 - 8

4. Bend warning lamp switch plate to ensure:

- Warning lamp comes on when lever is lifted "A" notches.
- Warning lamp goes out when lever is fully released.

Number of "A" notches: 1 or less

ANTI-LOCK BRAKE SYSTEM

Purpose

The Anti-Lock Brake System (ABS) consists of electronic and hydraulic components. It allows for control of braking force so that locking of the wheels can be avoided.

The ABS:

- 1) Improves proper tracking performance through steering wheel operation.
- 2) Eases obstacle avoidance through steering wheel operation.
- 3) Improves vehicle stability.

Operation

- When the vehicle speed is less than 10 km/h (6 MPH) this system does not work.
- The Anti-Lock Brake System (ABS) has self-test capabilities. The system turns on the anti-lock warning light for one second each time the ignition switch is turned "ON". After the engine is started, the anti-lock warning light turns off. The system performs a test the first time the vehicle reaches 6 km/h (4 MPH). A mechanical noise may be heard as the ABS performs this self-test. This is a normal part of the self-test feature. If a malfunction is found during this check, the anti-lock warning light will stay on.
- While driving, a mechanical noise may be heard during ABS operation. This is a normal condition.

GI

MA

EM

LC

EC

FE

CL

MT

AT

FA

RA

BR

ST

RS

BT

HA

EL

IDX

ANTI-LOCK BRAKE SYSTEM

System Components

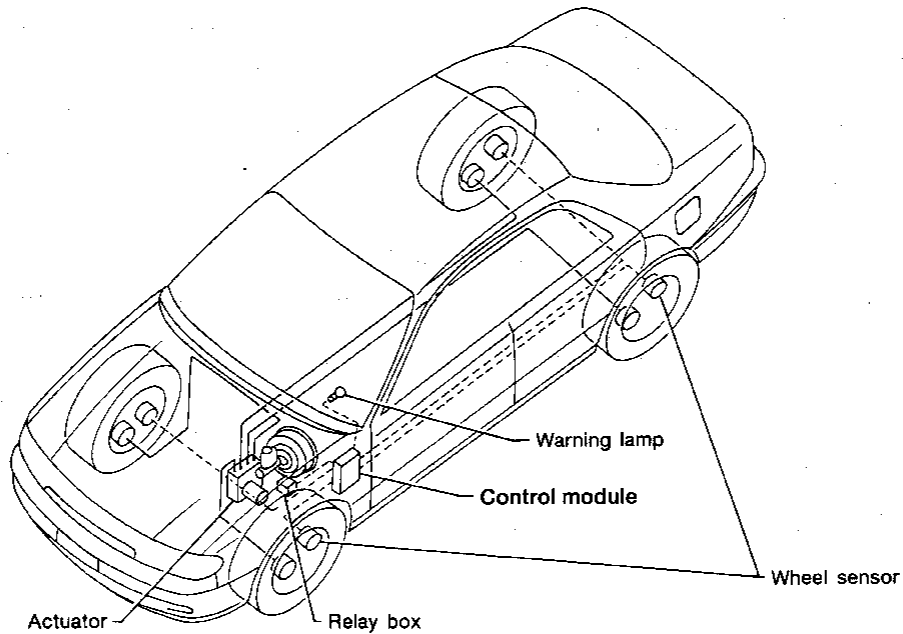

ABR077

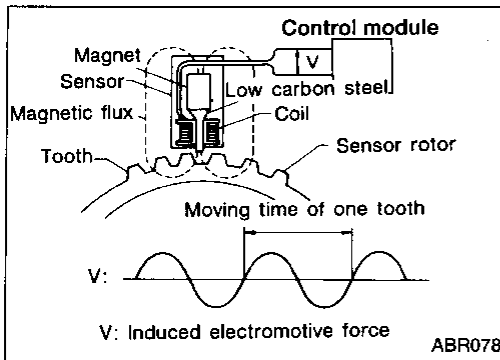

ABR078

System Description

SENSOR

The sensor unit consists of a gear-shaped sensor rotor and a sensor element. The element contains a bar magnet around which a coil is wound. The sensor is installed on the back side of the brake rotor. Sine-wave current is generated by the sensor as the wheel rotates. The frequency and voltage increase(s) as the rotating speed increases.

CONTROL MODULE

The control module computes the wheel rotating speed by the signal current sent from the sensor. Then it supplies a DC current of 0, 2, or 5 amperes to the actuator solenoid valve. It also controls ON-OFF operation of the valve relay and pump relay. If any electrically detectable malfunction should occur in the system, the control module causes the warning lamp to light up. In this condition, the ABS will be deactivated by the control module, and the vehicle's braking system reverts to normal operation.

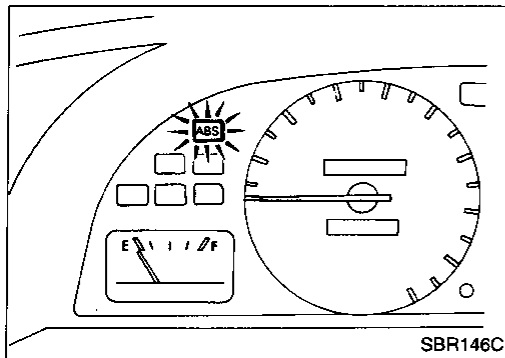

SBR146C

ANTI-LOCK BRAKE SYSTEM

Removal and Installation

CAUTION:

Be careful not to damage sensor edge and sensor rotor teeth. When removing the front or rear wheel hub assembly, disconnect the ABS wheel sensor from the assembly and move it away.

FRONT WHEEL SENSOR

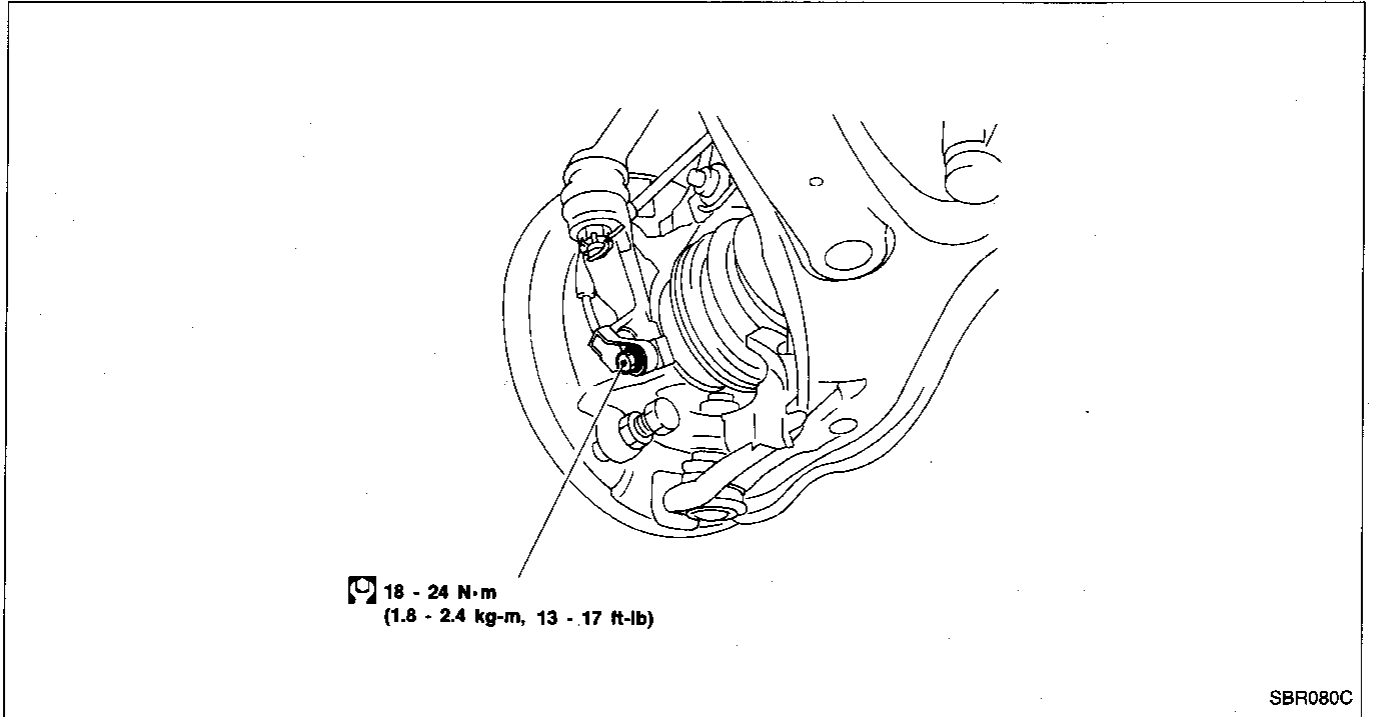

REAR WHEEL SENSOR

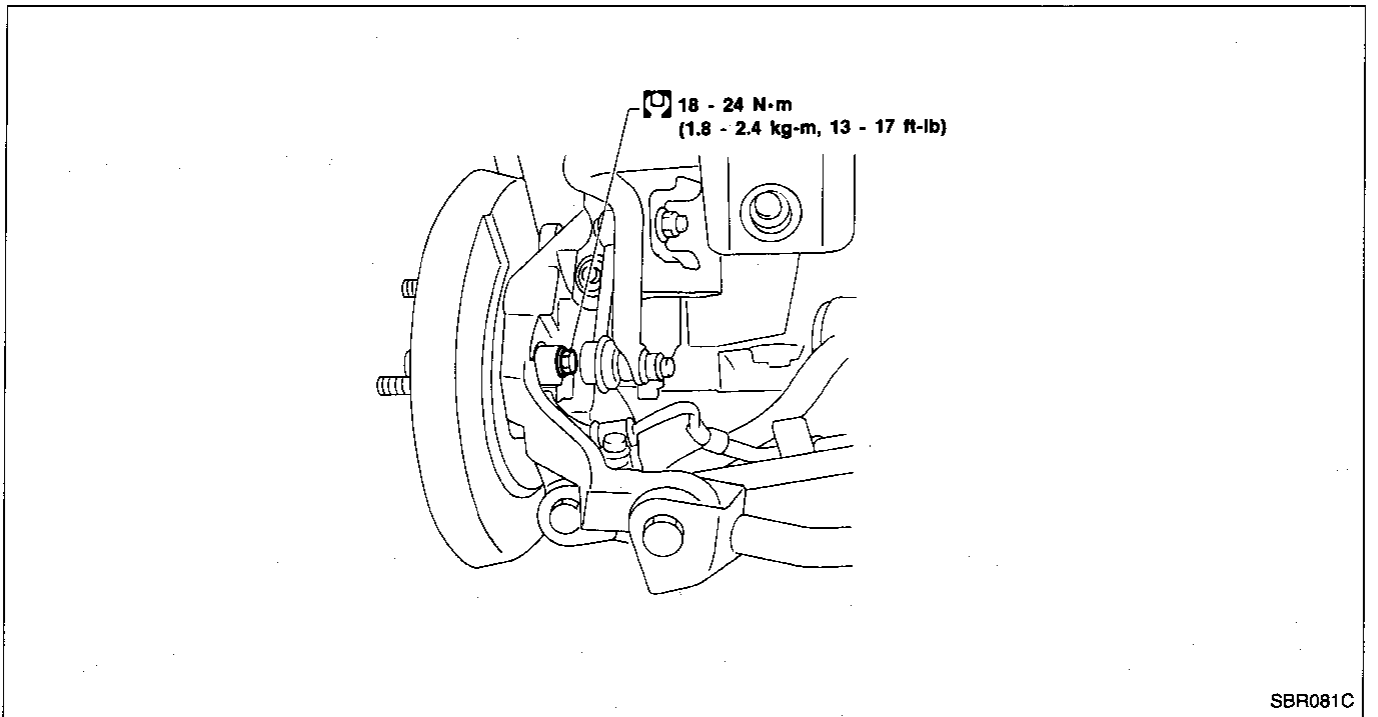

GI
MA
EM
LC
EC
FE
CL
MT
AT
FA
RA
BR
ST
RS
BT
HA
EL
IDX

ANTI-LOCK BRAKE SYSTEM

Removal and Installation (Cont'd)

CONTROL MODULE

Location: Driver side dash side lower.

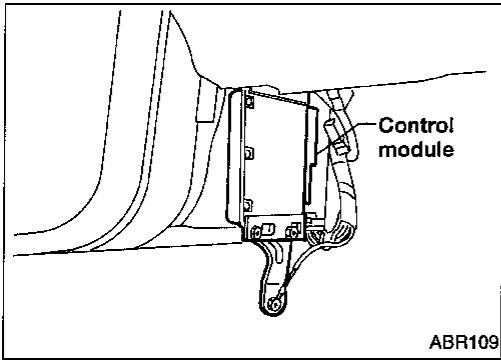

ACTUATOR

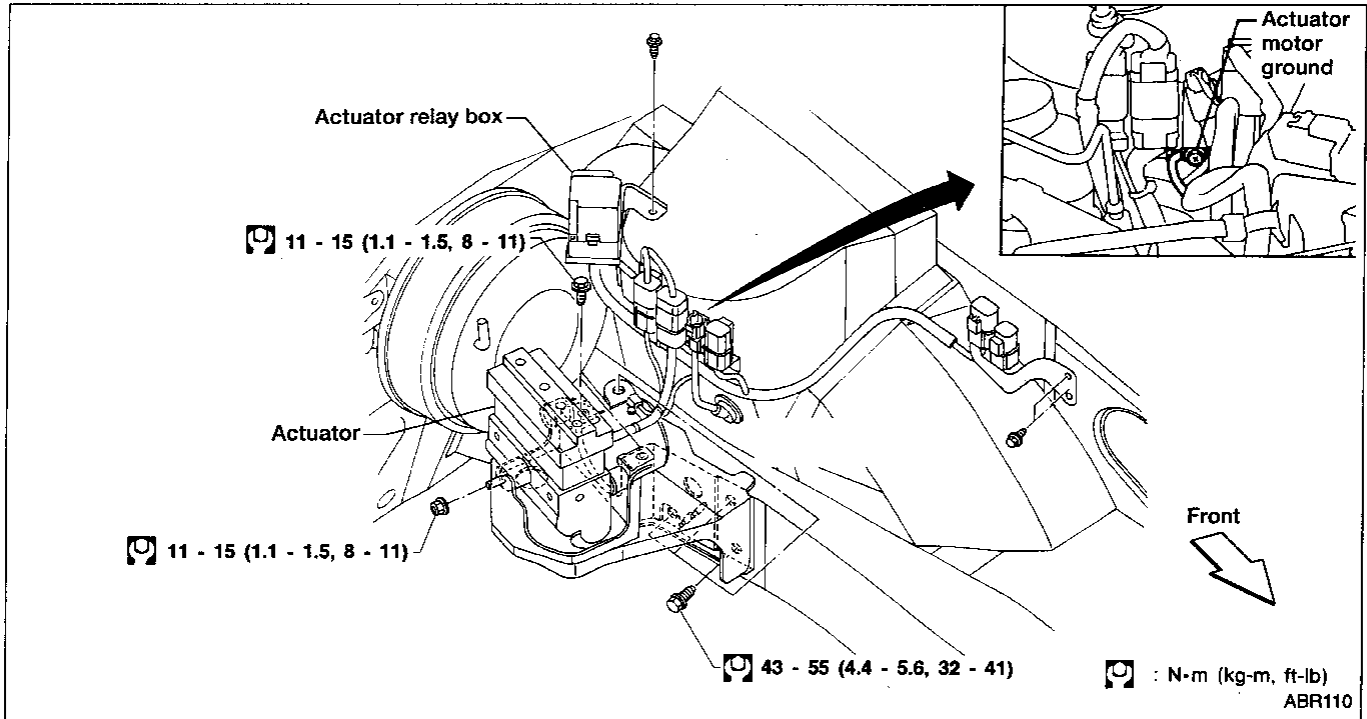

CAUTION:

After installation, pay attention to the following points.

- Refill brake fluid and bleed air. Refer to BR-4 and BR-5, respectively.

1. Remove actuator relay assembly.
2. Drain brake fluid. Remove master cylinder.
3. Remove actuator.

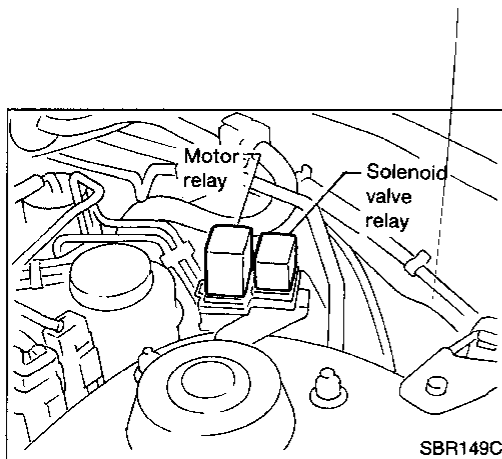

ACTUATOR RELAYS

Large: MOTOR RELAY

Small: SOLENOID VALVE RELAY

1. Disconnect battery cable.
2. Remove actuator relay cover.

It is not necessary to remove the two screws for relay box.

ANTI-LOCK BRAKE SYSTEM

NOTE

GI

MA

EM

LC

EC

FE

CL

MT

AT

FA

RA

BR

ST

RS

BT

HA

EL

IDX

ANTI-LOCK BRAKE SYSTEM

Wiring Diagram -ABS-

BR-ABS-01

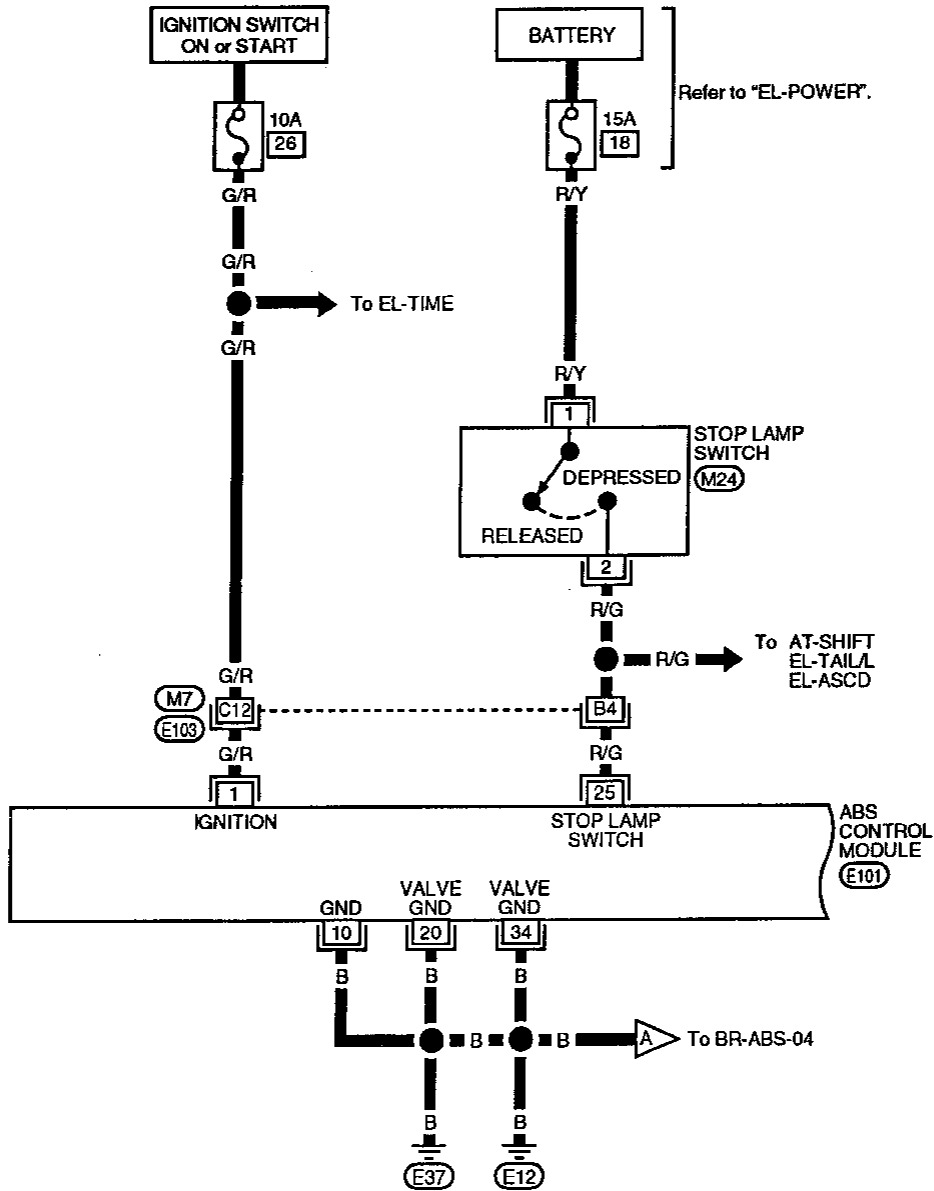

Refer to last page (Foldout page).

(M7) (E103)

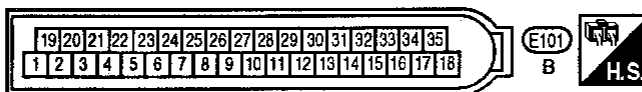

ANTI-LOCK BRAKE SYSTEM

Wiring Diagram -ABS- (Cont'd)

BR-ABS-02

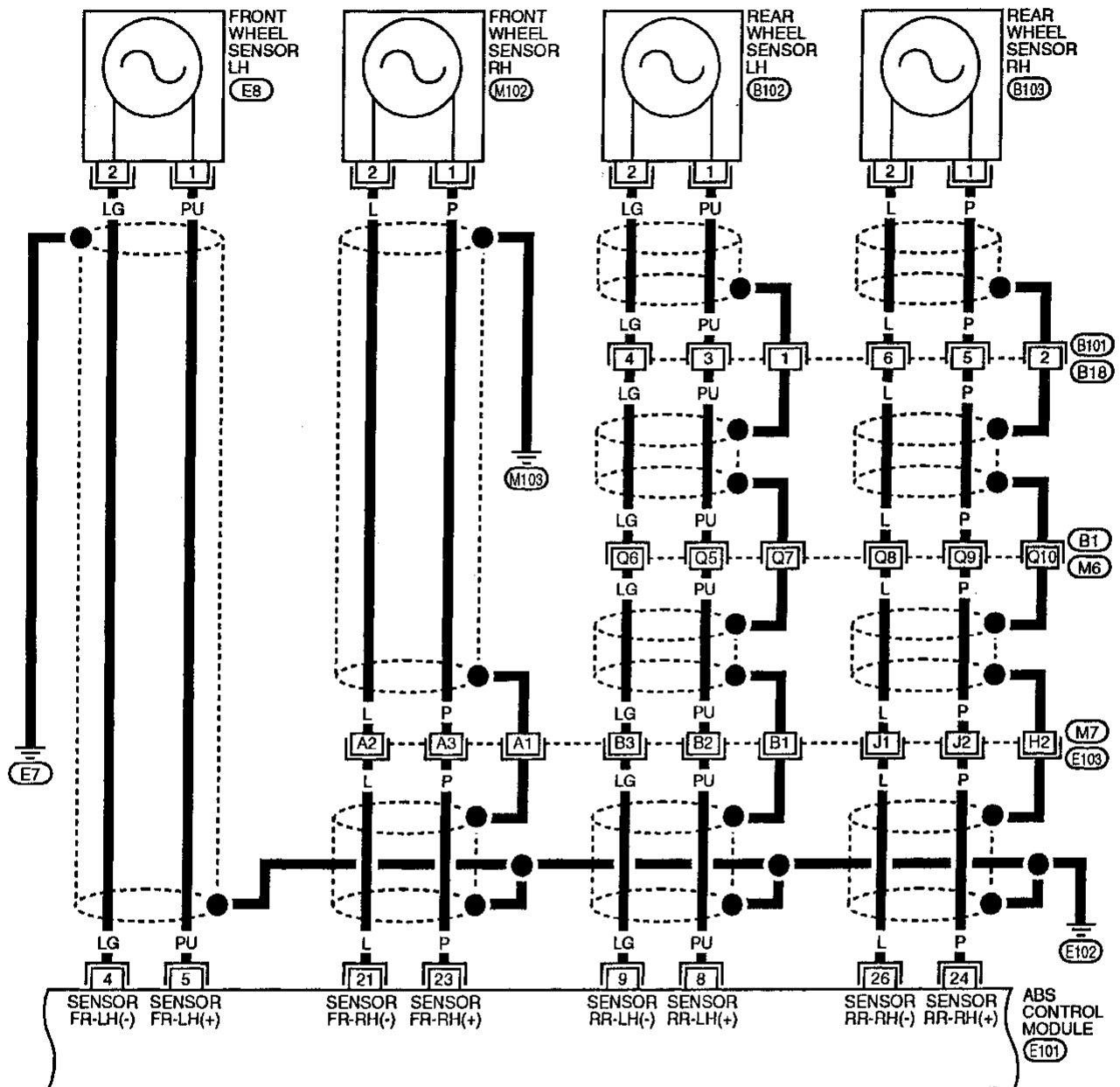

1 12 M102 E8 B102 B103
GY, BR, BR, GY

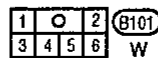

Refer to last page (Foldout page).

M6, B1
M7, E103

GI
MA
EM
LC
EC
FE
CL
MT
AT
FA
RA
BR
ST
RS
BT
HA
EL
IDX

ANTI-LOCK BRAKE SYSTEM

Wiring Diagram -ABS- (Cont'd)

BR-ABS-03

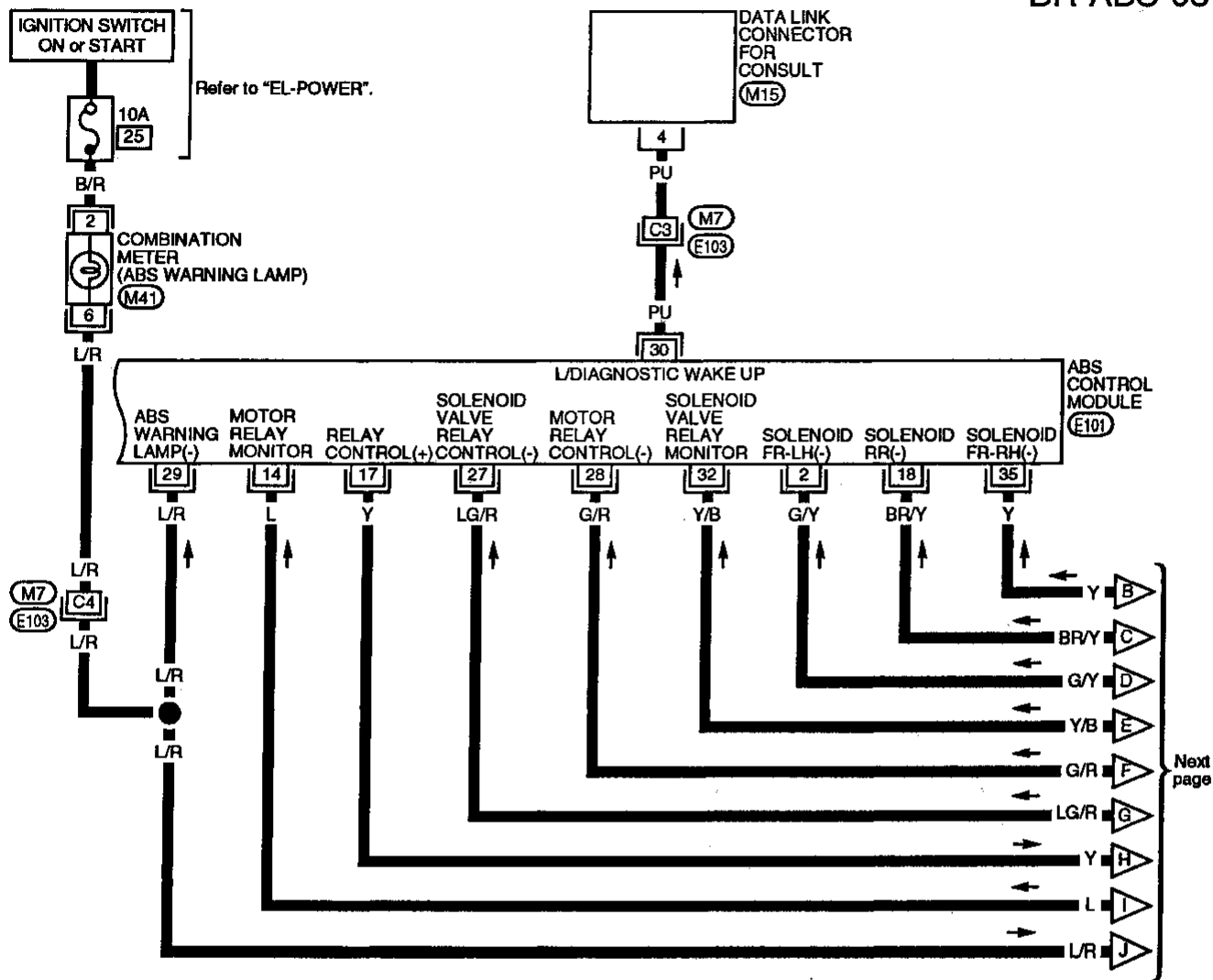

Refer to last page (Foldout page).

(M7), (E103)

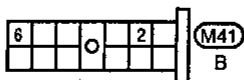
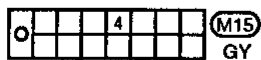

ANTI-LOCK BRAKE SYSTEM

Wiring Diagram -ABS- (Cont'd)

BR-ABS-04

GI
MA
EM
LC
EC
FE
CL
MT
AT
FA
RA
BR
ST
RS
BT
HA
EL
IDX

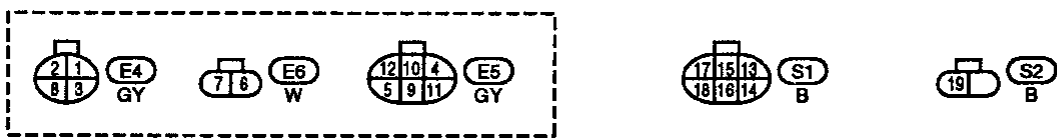
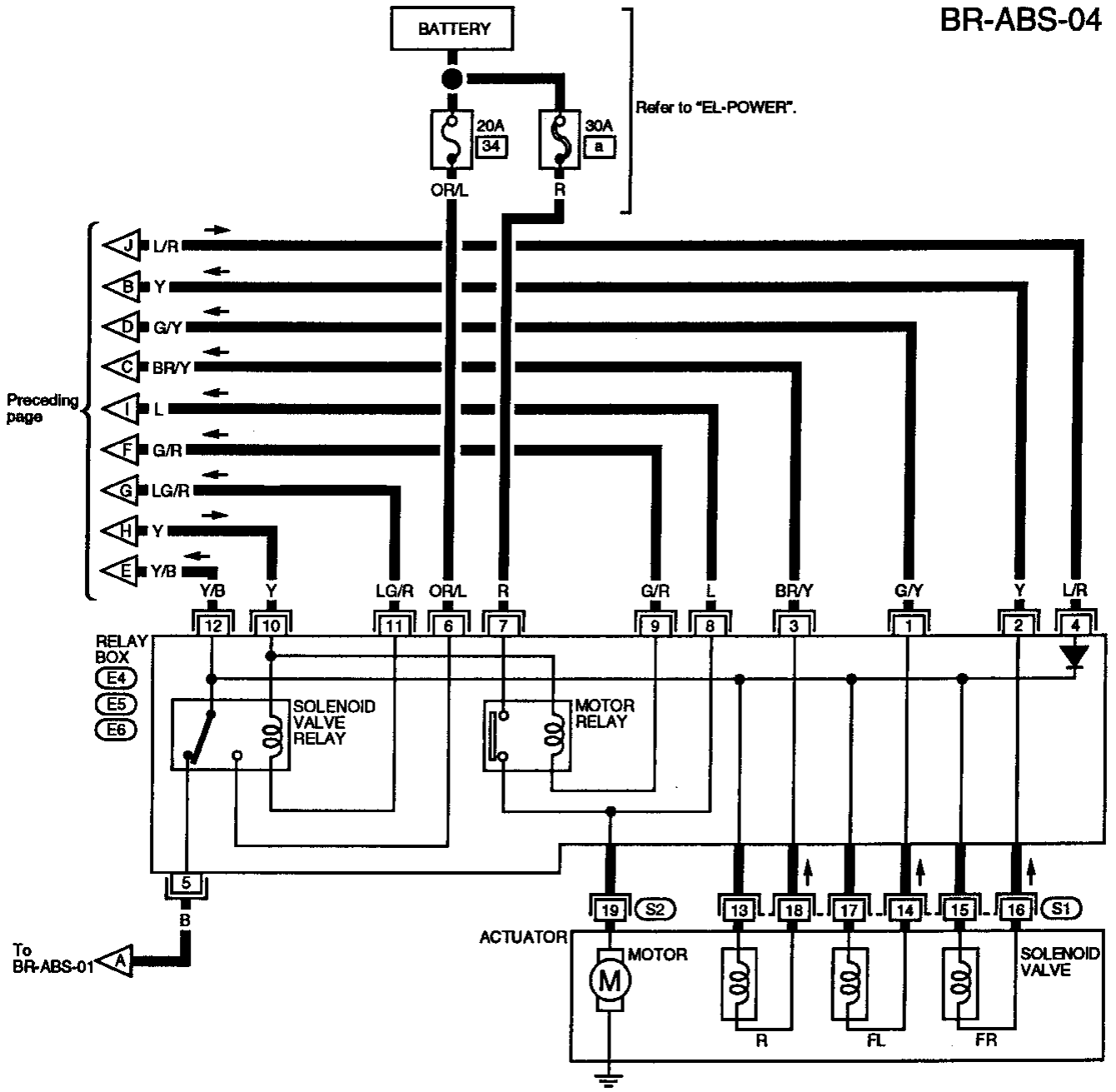

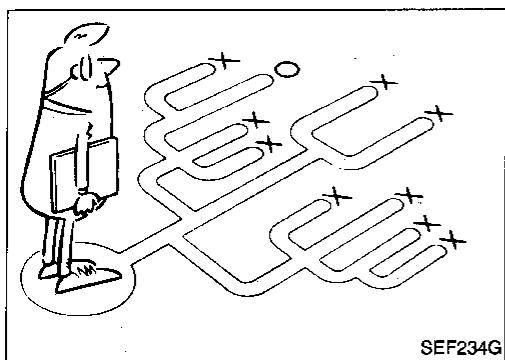
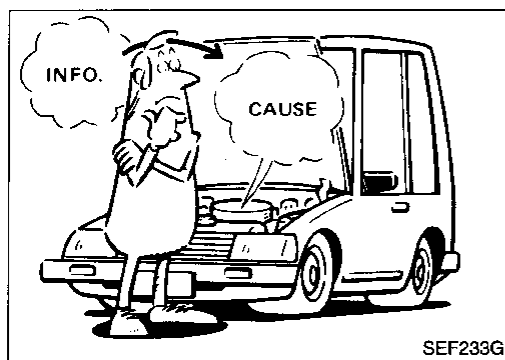

How to Perform Trouble Diagnoses for Quick and Accurate Repair

INTRODUCTION

The ABS system has an electronic control module to control major functions. The control module accepts input signals from sensors and instantly drives actuators. It is essential that both kinds of signals are proper and stable. It is also important to check for conventional problems: such as air leaks in the booster lines, lack of brake fluid, or other problems with the brake system.

It is much more difficult to diagnose a problem that occurs intermittently rather than continuously. Most intermittent problems are caused by poor electric connections or faulty wiring. In this case, careful checking of suspicious circuits may help prevent the replacement of good parts.

A visual check only may not find the cause of the problems, so a road test should be performed.

Before undertaking actual checks, take just a few minutes to talk with a customer who approaches with a ABS complaint. The customer is a very good source of information on such problems; especially intermittent ones. Through the talks with the customer, find out what symptoms are present and under what conditions they occur.

Start your diagnosis by looking for "conventional" problems first. This is one of the best ways to troubleshoot brake problems on an ABS controlled vehicle.

GI
MA
EM
LC
EC
FE
CL
MT
AT
FA
RA
BR
ST
RS
BT
HA
EL
IDX

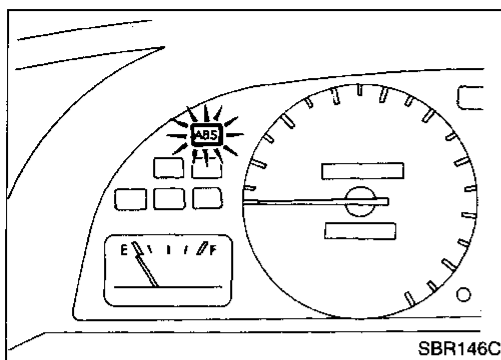

Self-diagnosis

FUNCTION

- When a problem occurs in the ABS, the warning lamp on the instrument panel comes on. To start the self-diagnostic results mode, ground the self-diagnostic (check) terminal located on the "Data Link Connector for Consult". The location of the malfunction is indicated by the warning lamp flashing on the instrument panel.

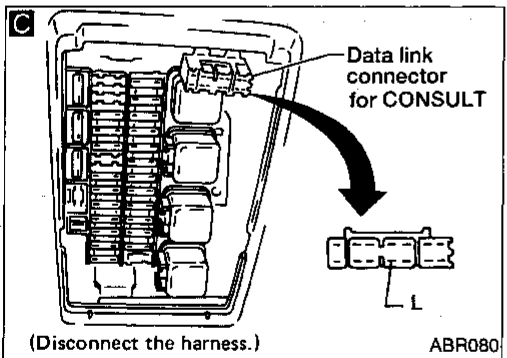
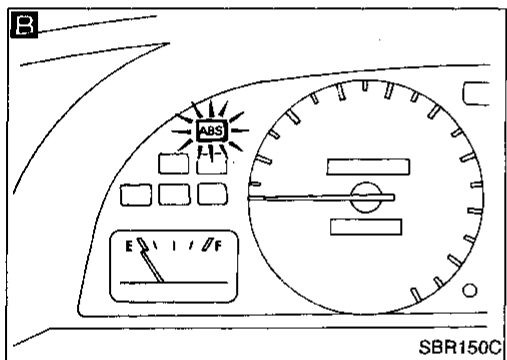
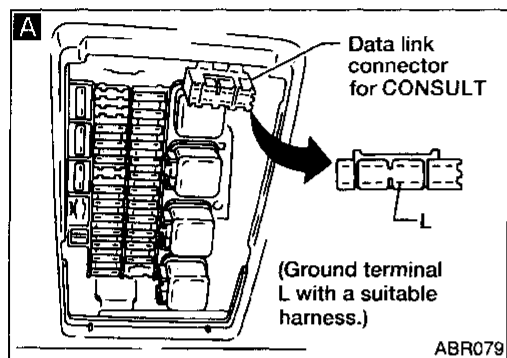

SELF-DIAGNOSIS PROCEDURE

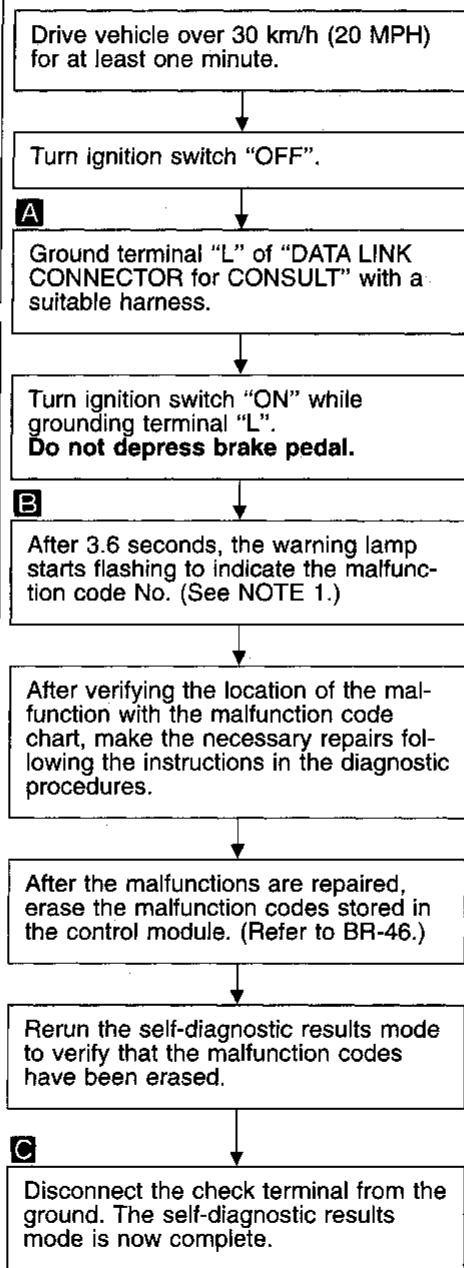

NOTE 1: The indication terminates after five minutes. However, when the ignition switch is turned from "OFF" to "ON", the indication starts flashing again.

TROUBLE DIAGNOSES

Self-diagnosis (Cont'd)

Ⓐ

Check warning lamp for deactivation after driving vehicle over 30 km/h (20 MPH) for at least one minute.

After making certain that warning lamp does not come on, test the ABS in a safe area to verify that it functions properly.

HOW TO READ SELF-DIAGNOSTIC RESULTS (Malfunction codes)

- Determine the code No. by counting the number of times the warning lamp flashes on and off.
- When several malfunctions occur at one time, up to three code numbers can be stored; the latest malfunction will be indicated first.
- The indication begins with the start code 12. After that a maximum of three code numbers appear in the order of the latest one first. The indication then returns to the start code to repeat (the indication will stay on for five minutes at the most).
- The malfunction code chart is given on the next page.

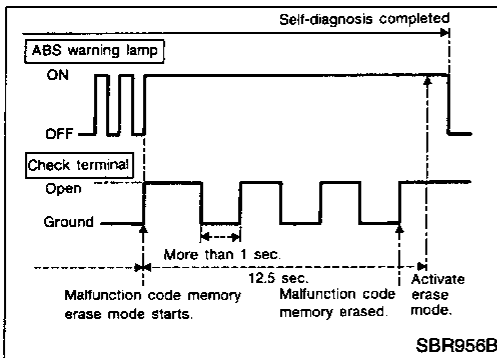
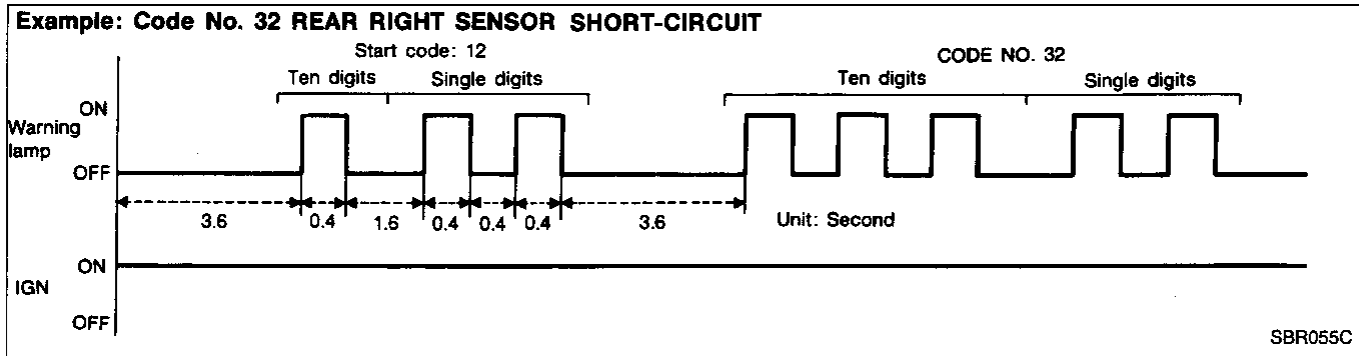

HOW TO ERASE SELF-DIAGNOSTIC RESULTS (Malfunction codes)

1. Disconnect the check terminal from ground (ABS warning lamp will stay lit.)
2. Within 12.5 seconds, ground the check terminal 3 times. Each terminal ground must last more than 1 second. The ABS warning lamp goes out after the erase operation has been completed.
3. Again, perform self-diagnosis, refer to BR-45. Only the start code should appear, no malfunction codes.

TROUBLE DIAGNOSES

Self-diagnosis (Cont'd)

MALFUNCTION CODE/SYMPTOM CHART

Code No. or symptom	Malfunctioning part	Diagnostic procedure	
45	Front left actuator solenoid valve	3	GI
41	Front right actuator solenoid valve	3	
55	Rear actuator solenoid valve	3	MA
25	Front left sensor (open-circuit)	4	
26	Front left sensor (short-circuit)	4	EM
21	Front right sensor (open-circuit)	4	
22	Front right sensor (short-circuit)	4	LC
35	Rear left sensor (open-circuit)	4	
36	Rear left sensor (short-circuit)	4	
31	Rear right sensor (open-circuit)	4	EC
32	Rear right sensor (short-circuit)	4	
18	Sensor rotor	4	FE
61	Actuator motor or motor relay	5	
63	Solenoid valve relay circuit (except power supply for relay coil)	6	CL
57	Power supply (Low voltage)	7	MT
16	Stop lamp switch circuit	8	
71	Control module	9	AT
Warning lamp stays on when ignition switch is turned on.	Control module power supply circuit Warning lamp bulb circuit Control module or control module connector Solenoid valve relay stuck Power supply for solenoid valve relay coil	2	FA
Warning lamp stays on, during self-diagnosis.	Control module	-	RA
Warning lamp does not come on when ignition switch is turned on.	Fuse, warning lamp bulb or warning lamp circuit Control module	1	BR
Warning lamp does not come on during self-diagnosis.	Control module	-	ST

GI

MA

EM

LC

EC

FE

CL

MT

AT

FA

RA

BR

ST

RS

BT

HA

EL

IDX

Component Parts and Harness Connector Location

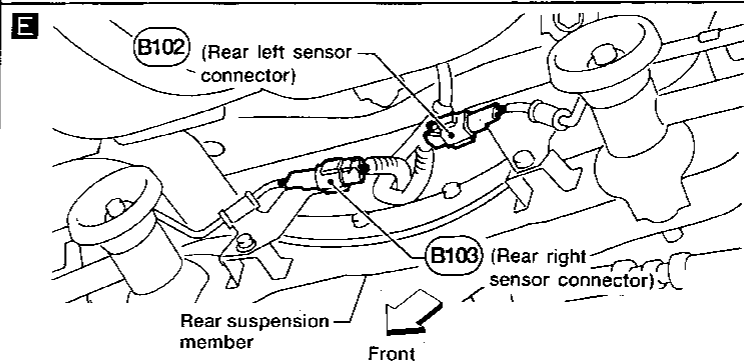
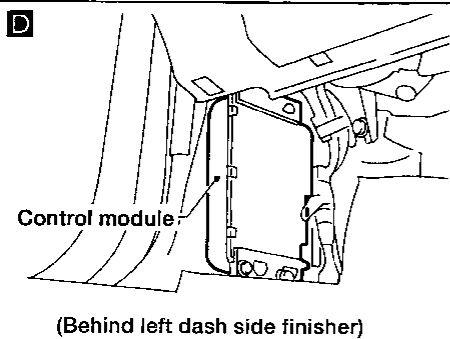
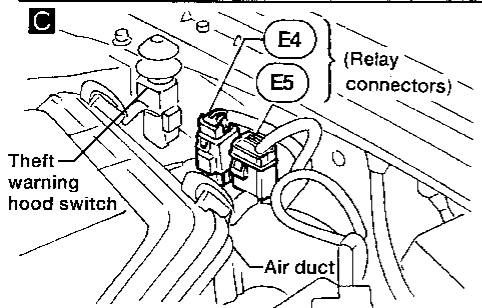
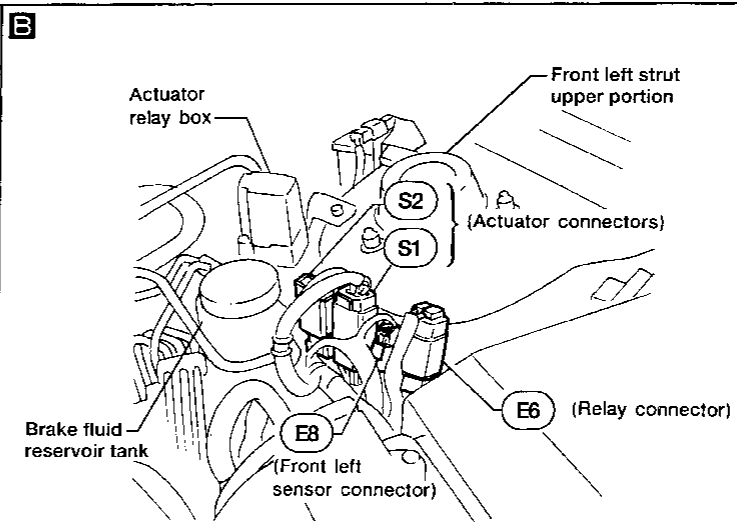
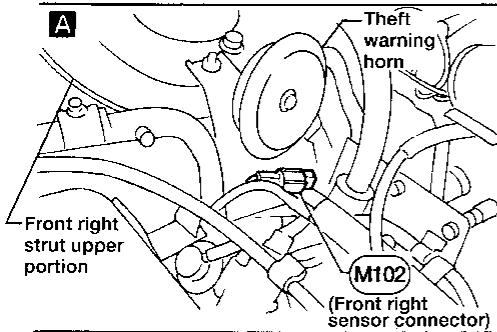
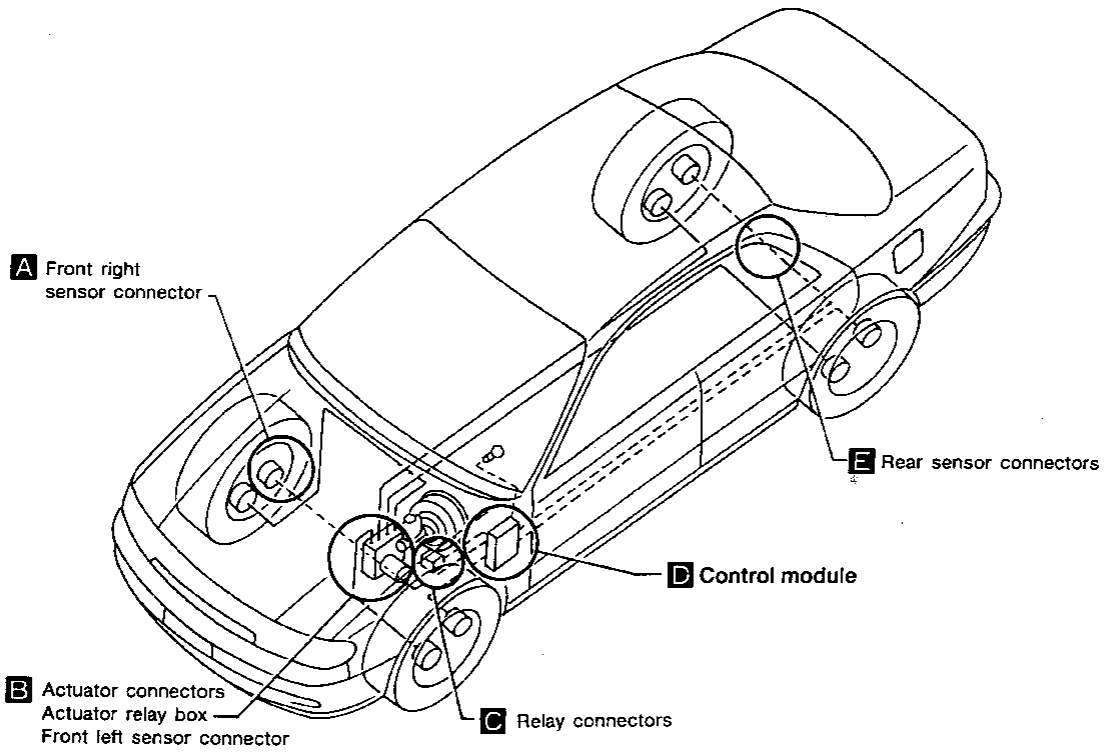

ABR111

TROUBLE DIAGNOSES

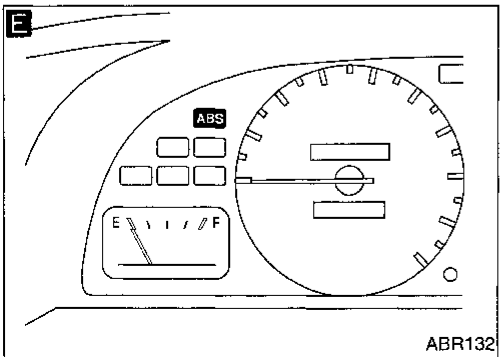
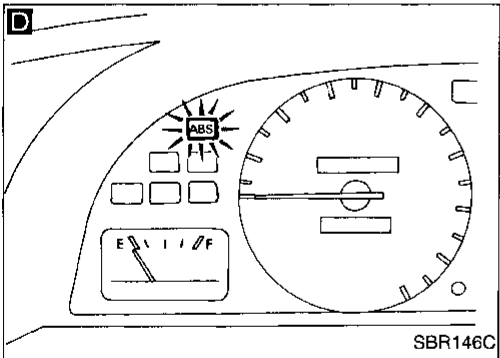
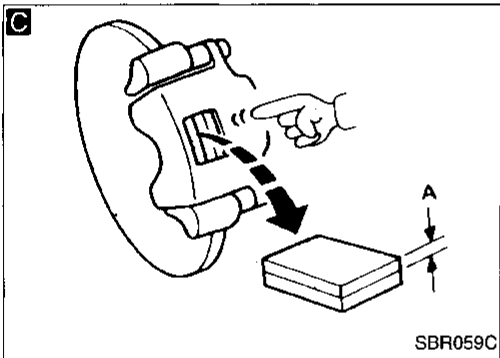
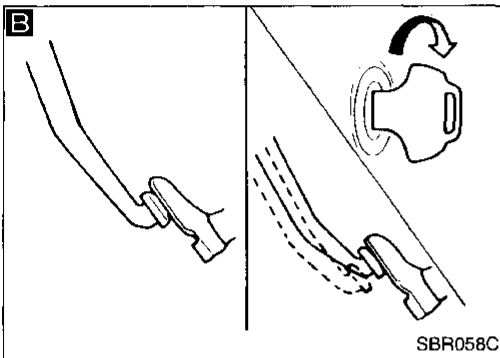
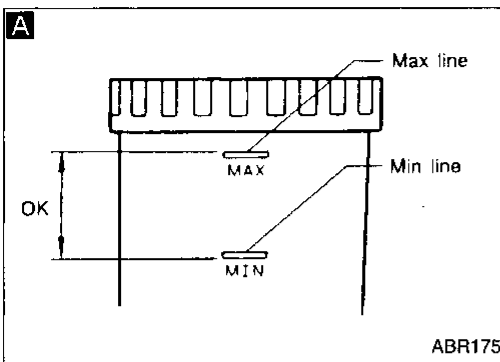

Preliminary Check

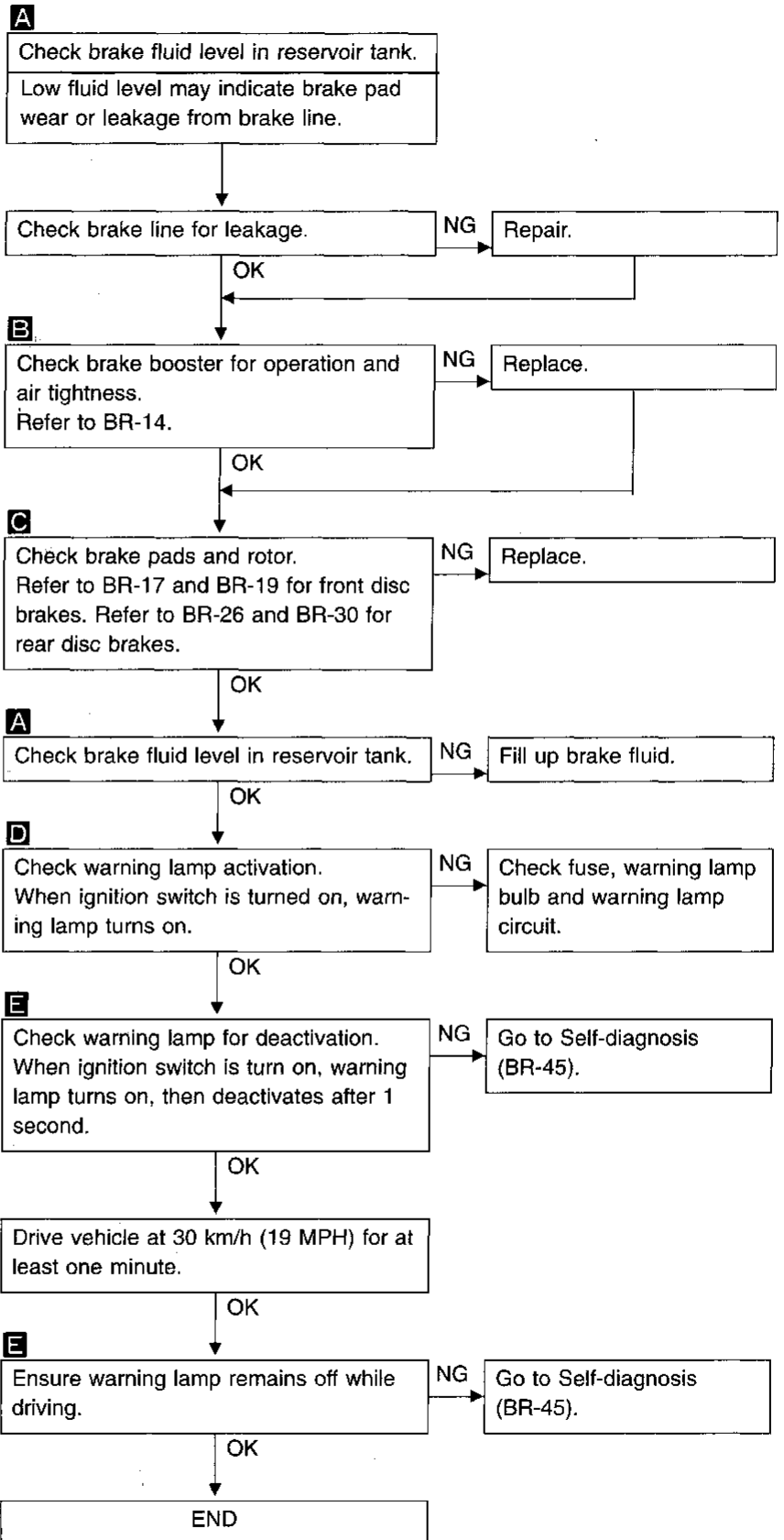

GI
MA
EM
LC
EC
FE
CL
MT
AT
FA
RA
BR
ST
RS
BT
HA
EL
IDX

TROUBLE DIAGNOSES

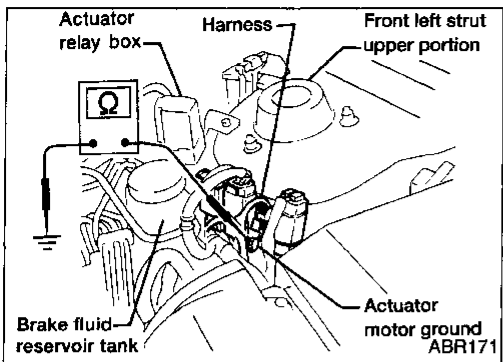

Ground Circuit Check

ACTUATOR MOTOR GROUND

- Check resistance between actuator motor ground terminal and body ground.
Resistance: 0Ω

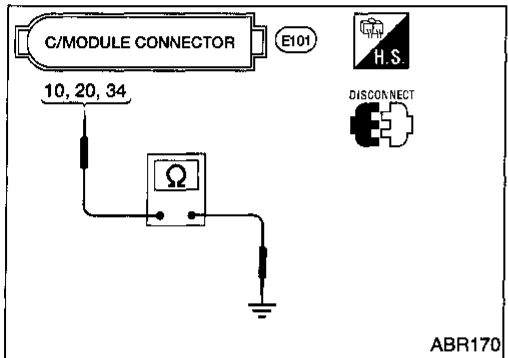

CONTROL MODULE GROUND

- Check resistance between the terminals and ground.
Resistance: 0Ω

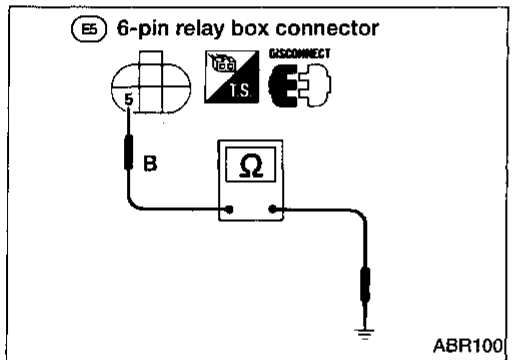

RELAY BOX GROUND

- Check resistance between relay box harness connector terminal ⑤ and ground.
Resistance: 0Ω

Circuit Diagram for Quick Pinpoint Check

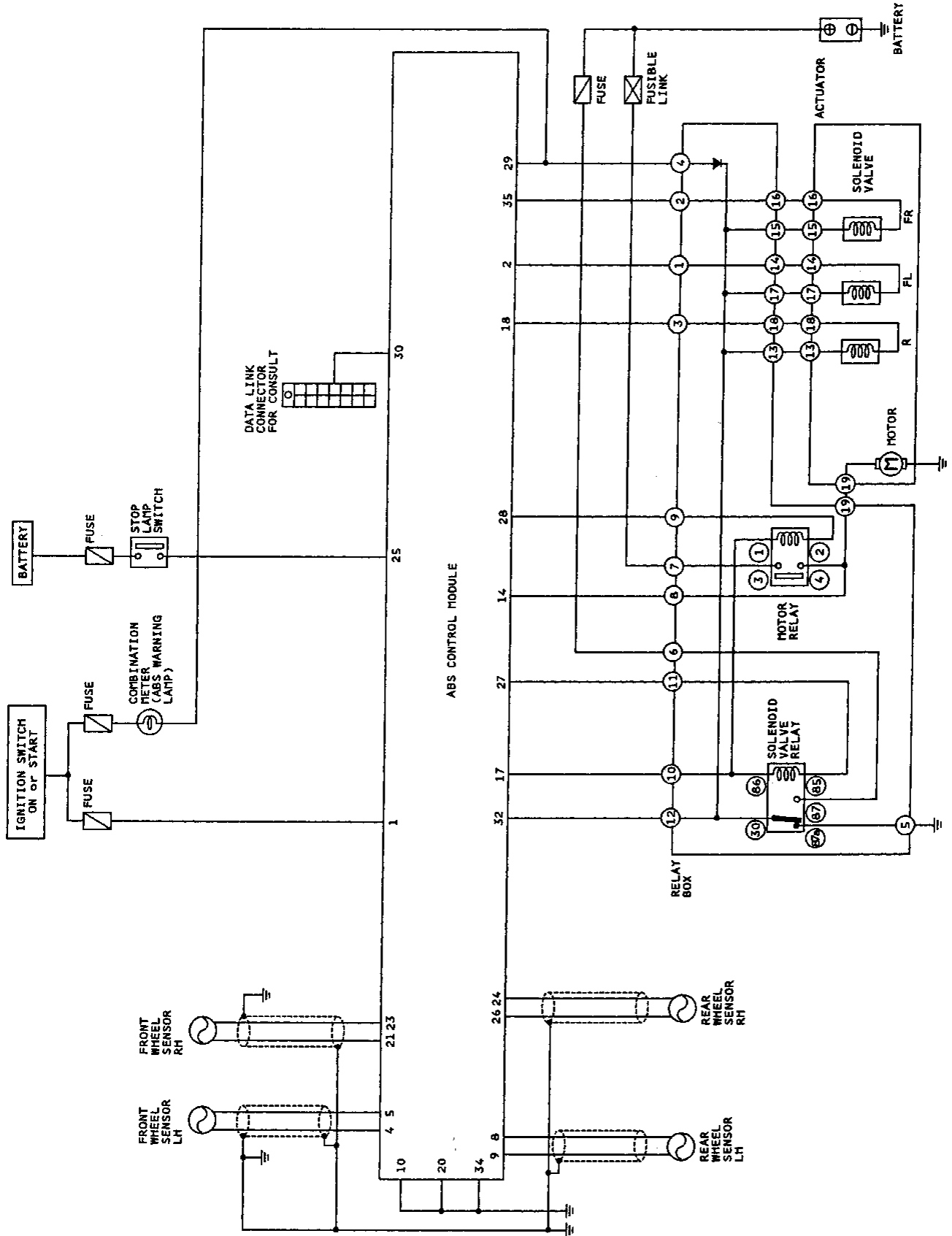

GI
 MA
 EM
 LC
 EC
 FE
 CL
 MT
 AT
 FA
 RA
BR
 ST
 RS
 BT
 HA
 EL
 IDX

TROUBLE DIAGNOSES

Diagnostic Procedure 1 (Not self-diagnostic item)

Warning lamp does not come on when ignition switch is turned on.

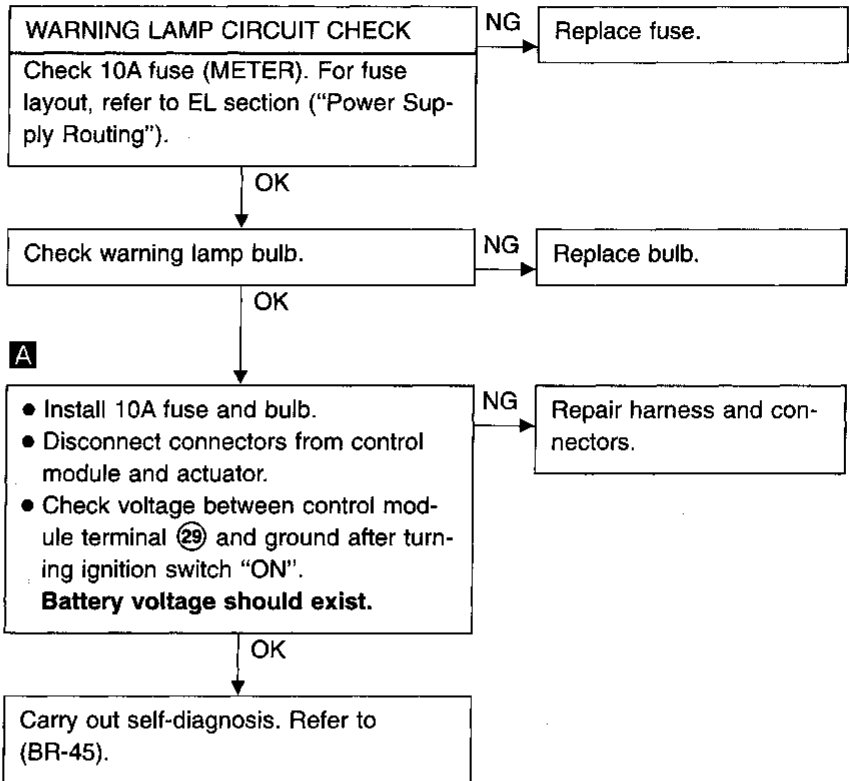
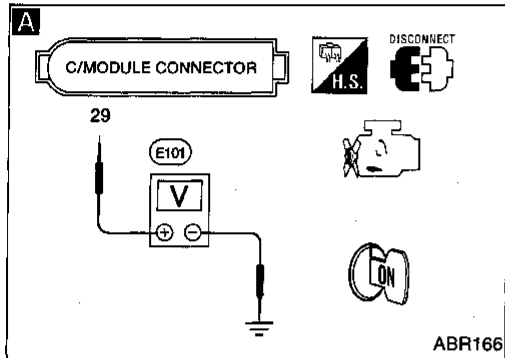

TROUBLE DIAGNOSES

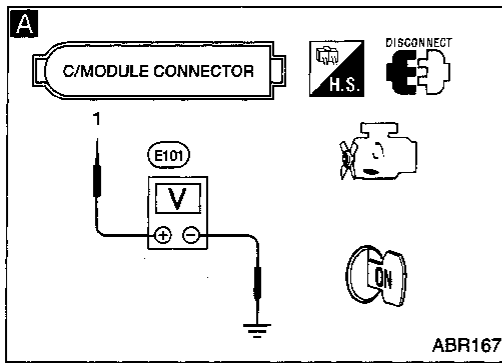

Diagnostic Procedure 2 (Not Self-diagnostic Item)

Warning lamp stays on when ignition switch is turned on.

CONTROL MODULE POWER SUPPLY CIRCUIT

Check 10A fuse for control module. For fuse layout, refer to Wiring Diagram (BR-36).

NG → (B) (BR-55)

OK

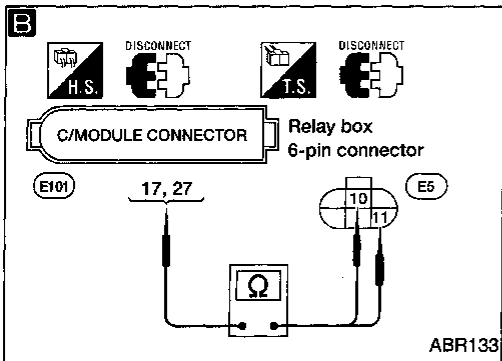

A

- Disconnect connector from control module.
- Check voltage between control module connector terminal ① and ground after turning ignition switch "ON". **Battery voltage should exist.**

NG → Repair harness and connector.

OK

B

SOLENOID VALVE RELAY COIL POWER SUPPLY CIRCUIT

- Turn ignition switch "OFF". Disconnect relay box 6-pin connector.
- Check continuity between control module connector terminals and relay box 6-pin connector (body side) terminals.

NG → Repair harness and connector.

Control module	Relay box
①⑦	⑩
②⑦	⑪

Continuity should exist.

OK

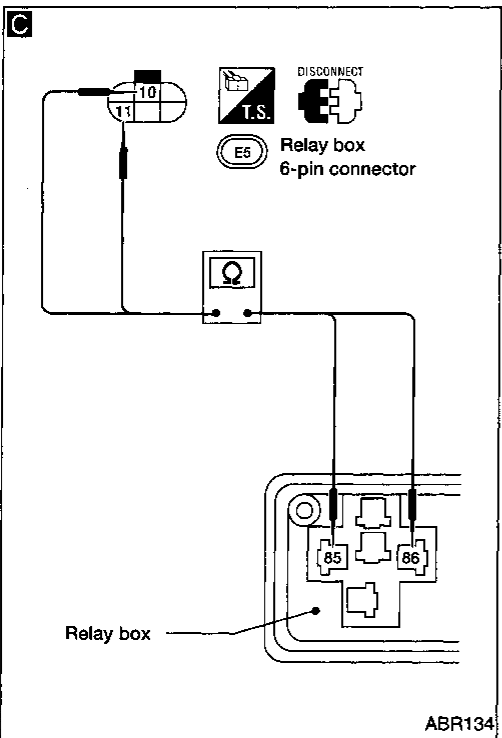

C

CIRCUIT CHECK

- Disconnect solenoid valve relay.
- Check continuity between relay box 6-pin connector (relay box side) terminals and solenoid valve relay box terminals.

NG → Replace relay box assembly.

Relay box connector	Relay box
⑩	⑧⑥
⑪	⑧⑤

Continuity should exist.

OK

SOLENOID VALVE RELAY CHECK

Refer to SOLENOID VALVE RELAY in Electrical Components Inspection (BR-62).

NG → Replace solenoid valve relay.

OK

(A)

GI
MA
EM
LC
EC
FE
CL
MT
AT
FA
RA
BR
ST
RS
BT
HA
EL
IDX

TROUBLE DIAGNOSES

Diagnostic Procedure 2 (Not Self-diagnostic Item) (Cont'd)

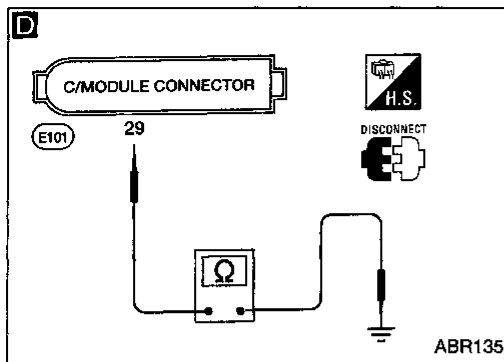

D

GROUND-SHORT CHECK FOR WARNING LAMP CIRCUIT.

- Turn ignition switch "OFF"
- Disconnect connectors from control module and relay box.
- Check continuity between control module connector terminal ②⑨ and body ground.

Continuity should not exist.

NG → Repair harness and connector.

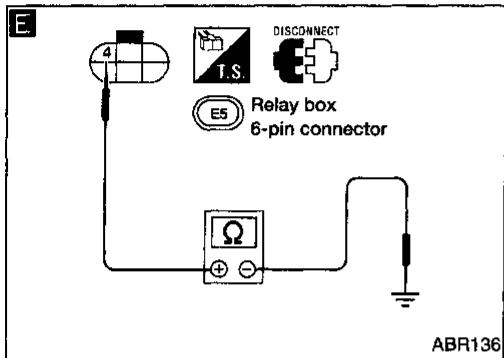

E

- Disconnect relay box 6-pin connector.
- Check continuity between relay box 6-pin connector (relay box side) terminal ④ and body ground.

Continuity should not exist.

Note: Pay attention to tester polarity*.

NG → Replace relay box assembly.

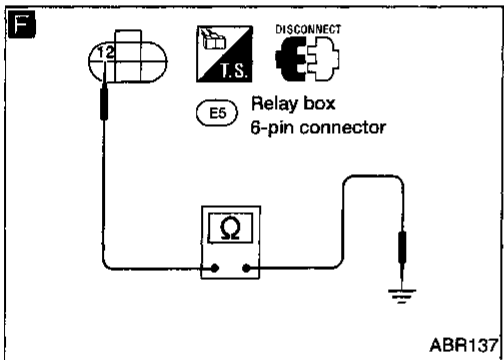

F

SOLENOID VALVE CHECK CIRCUIT

- Check continuity between relay box 6-pin connector (body side) terminal ⑫ and body ground.

Continuity should not exist

NG → Repair harness and connector.

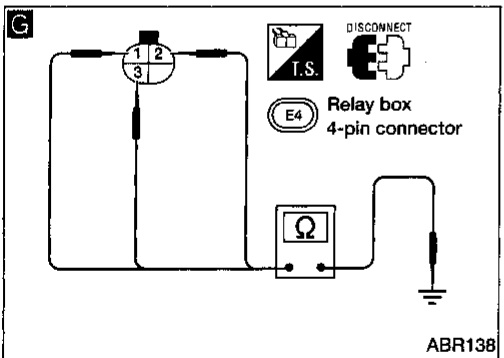

G

SOLENOID VALVE CIRCUIT

- Disconnect relay box 6-pin connector.
- Disconnect relay box 4-pin connector.
- Check continuity between relay box 4-pin connector (relay box side) terminals ①, ②, ③ and body ground.

Continuity should not exist.

NG → Replace relay box assembly.

OK

Replace control module.

*: Specifications may vary depending on the type of tester.
Before performing this inspection, refer to the instruction manual of the tester.

TROUBLE DIAGNOSES

Diagnostic Procedure 2 (Not Self-diagnostic Item) (Cont'd)

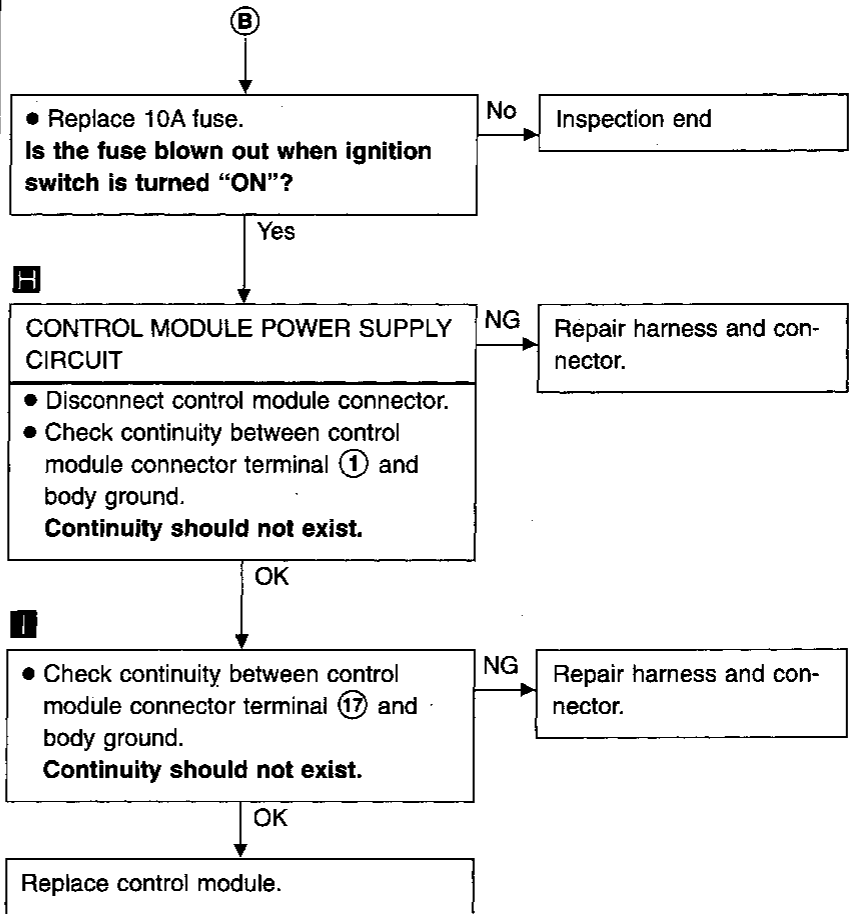
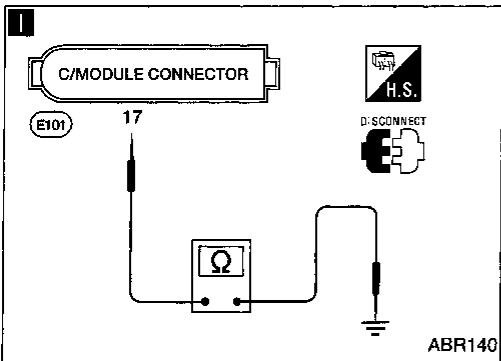
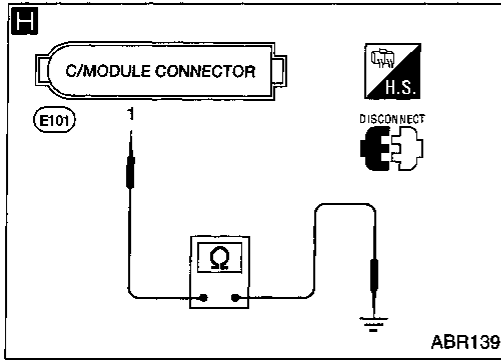

GI
 MA
 EM
 LC
 EC
 FE
 CL
 MT
 AT
 FA
 RA
BR
 ST
 RS
 BT
 HA
 EL
 IDX

TROUBLE DIAGNOSES

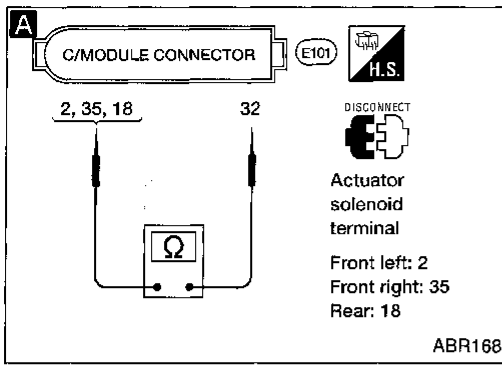

Diagnostic Procedure 3 ACTUATOR SOLENOID VALVE (Malfunction code No. 45, 41 or 55)

- Disconnect connectors from control unit and actuator. Check terminals for damage or loose connection. Then reconnect connectors.
- Carry out self-diagnosis again.
Does warning lamp activate again?

No → Inspection end

Yes

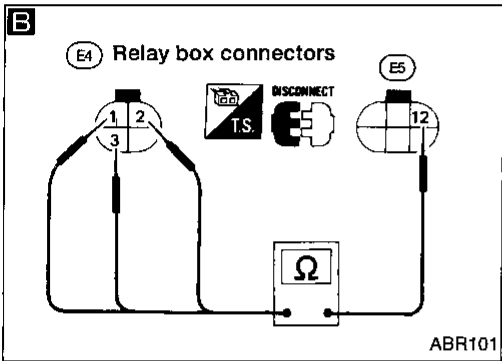

A

ACTUATOR SOLENOID VALVE CHECK.

- Disconnect control module connector.
- Check resistance between control module connector terminals.

Code No.	Terminals
45	③② - ②
41	③② - ③⑤
55	③② - ①⑧

Resistance: 1.07 - 1.17Ω

OK → Replace control module.

NG

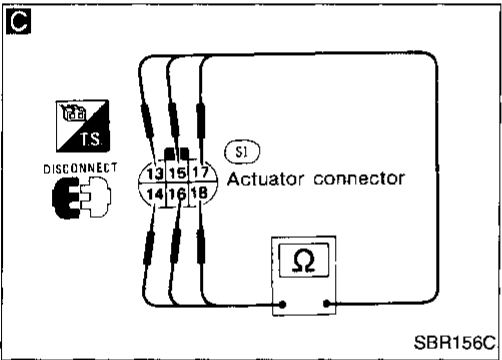

B

- Disconnect relay box connectors.
- Check resistance between relay box connector (relay box side) terminals.

Code No.	4-pin connector	6-pin connector
45	①	⑫
41	②	⑫
55	③	⑫

Resistance: 1.07 - 1.17Ω

OK → Repair harness between relay box 6-pin connector terminal ⑫ and control module connector terminal ③②, or between relay box 4-pin connector terminals ①, ②, ③ and control module connector terminals ②, ③⑤, ①⑧.

NG

C

- Disconnect actuator connector.
- Check resistance between actuator connector (actuator side) terminals.

Code No.	Terminals
45	⑰ - ⑭
41	⑱ - ⑰
55	⑬ - ⑱

Resistance: 1.07 - 1.17Ω

OK → Replace relay box assembly.

NG

Replace actuator.

TROUBLE DIAGNOSES

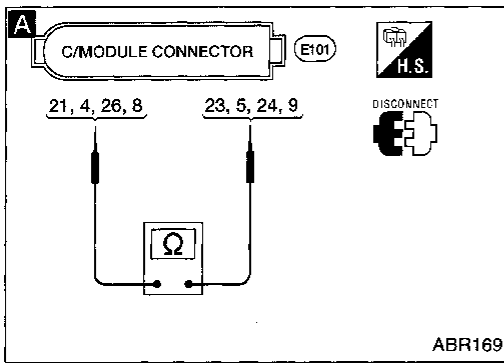

Diagnostic Procedure 4 WHEEL SENSOR OR ROTOR (Malfunction code No. 21, 22, 25, 26, 31, 32, 35, 36 or 18)

- Disconnect connectors from control module and wheel sensor indicated by malfunction code No. Check terminals for damage or loose connection. Then reconnect connectors.
- Carry out self-diagnosis again.

Does warning lamp activate again?

No → Inspection end

Yes

A

WHEEL SENSOR ELECTRICAL CHECK

- Disconnect control module connector.
- Check resistance between control module connector terminals.

Code No. 21 or 22 (Front RH wheel)
Terminals ②① and ②③

Code No. 25 or 26 (Front LH wheel)
Terminals ④ and ⑤

Code No. 31 or 32 (Rear RH wheel)
Terminals ②⑥ and ②④

Code No. 35 or 36 (Rear LH wheel)
Terminals ⑧ and ⑨

Resistance: 1.0 - 1.25kΩ

OK → A

NG

Note

CHECK WHEEL SENSOR

Refer to "Electrical Components Inspection" (BR-65).

Note

NG → Replace wheel sensor.

OK

Note

Repair harness and connectors between control module connector and wheel sensor connector.

Note: Wheel position should be distinguished by code No. except code No. 18 (sensor rotor).

GI
MA
EM
LC
EC
FE
CL
MT
AT
FA
RA
BR
ST
RS
BT
HA
EL
IDX

TROUBLE DIAGNOSES

Diagnostic Procedure 4 (Cont'd)

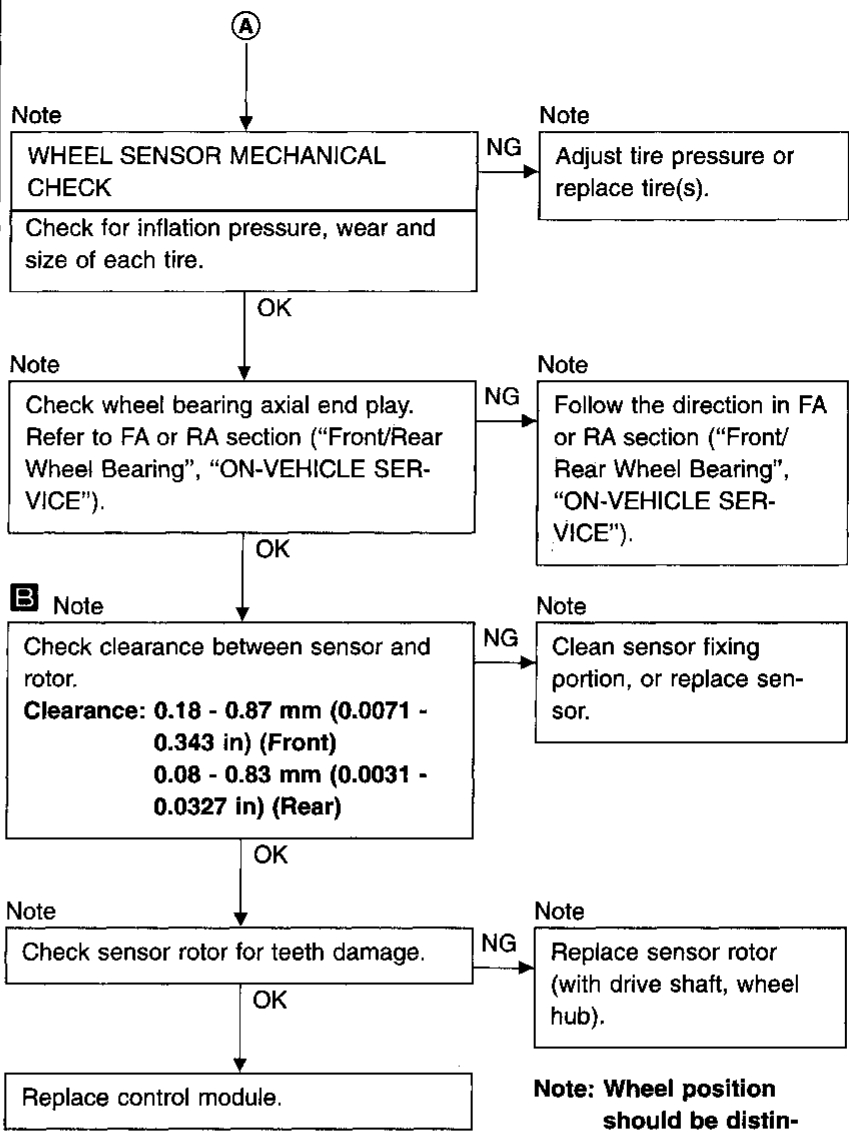
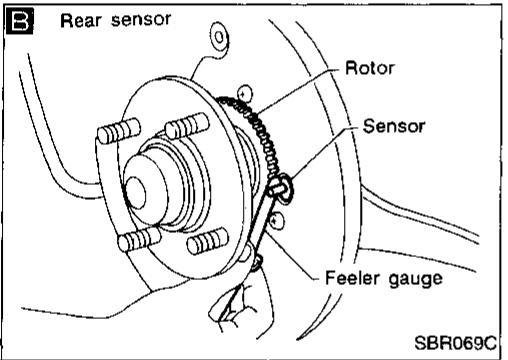
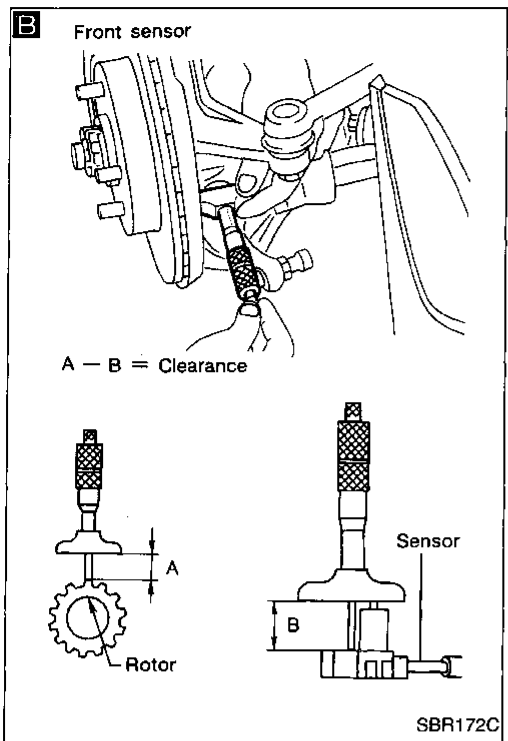

Note: Wheel position should be distinguished by code No. except code No. 18 (sensor rotor).

TROUBLE DIAGNOSES

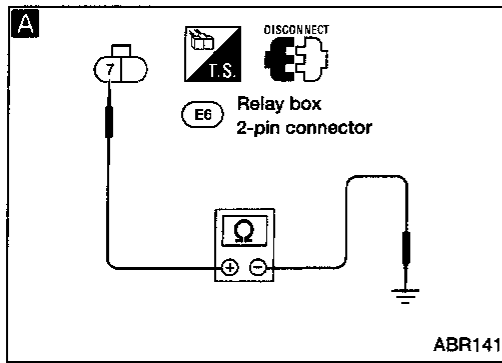

Diagnostic Procedure 5 MOTOR RELAY OR MOTOR (Malfunction code No. 61)

MOTOR POWER SUPPLY CIRCUIT

- Check fusible link for relay box. For fusible link layout, refer to Wiring Diagram (BR-36).

NG → (B)

OK

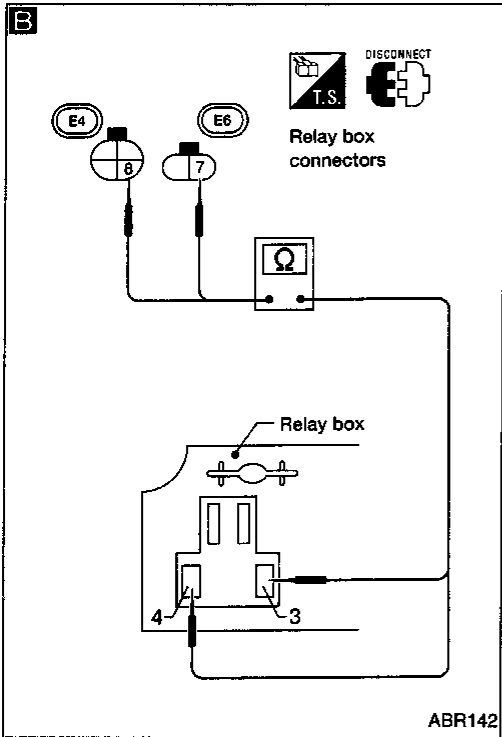

- Disconnect connectors from control module and actuator. Check terminals for damage or loose connection. Then reconnect connectors.
- Carry out self-diagnosis again.
Does warning light activate again?

No → Inspection end.

Yes

(A)

- Disconnect relay box 2-pin connector.
- Check voltage between connector (body side) terminal (7) and ground.
Battery voltage should exist.

NG → Repair harness and connectors.

OK

(B)

MOTOR RELAY CIRCUIT

- Remove motor relay.
- Disconnect relay box connectors.
- Check continuity between relay box connector (relay box side) terminals and relay box terminals.

NG → Replace actuator assembly.

Relay box connector	Relay box
(7)	(3)
(8)	(4)

Continuity should exist.

OK

(C)

MOTOR CHECK

Check motor by connecting terminal (7) for relay box connector and terminal (19) for actuator connector with a suitable harness.
Motor should operate.

Do not connect harness for more than 5 seconds.

NG → Check continuity between actuator and ground. If OK, replace actuator.

OK
→ (A)

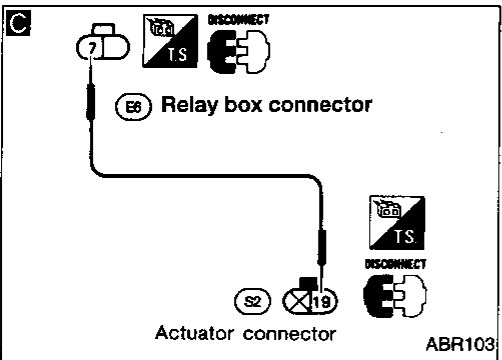

GI
MA
EM
LC
EC
FE
CL
MT
AT
FA
RA
BR
ST
RS
BT
HA
EL
IDX

TROUBLE DIAGNOSES

Diagnostic Procedure 5 (Cont'd)

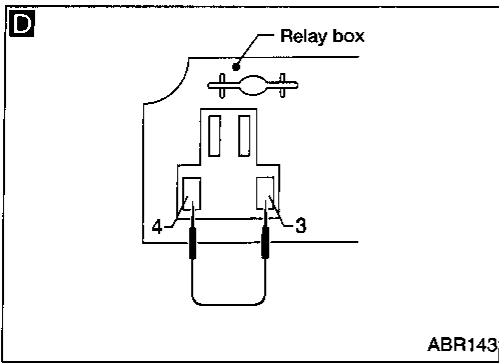

D

MOTOR CHECK

- Connect relay box connectors.
- Connect suitable wire between relay box terminals ③ and ④.

Motor should operate.
Do not connect wire for more than 5 seconds.

NG → Replace relay box assembly.

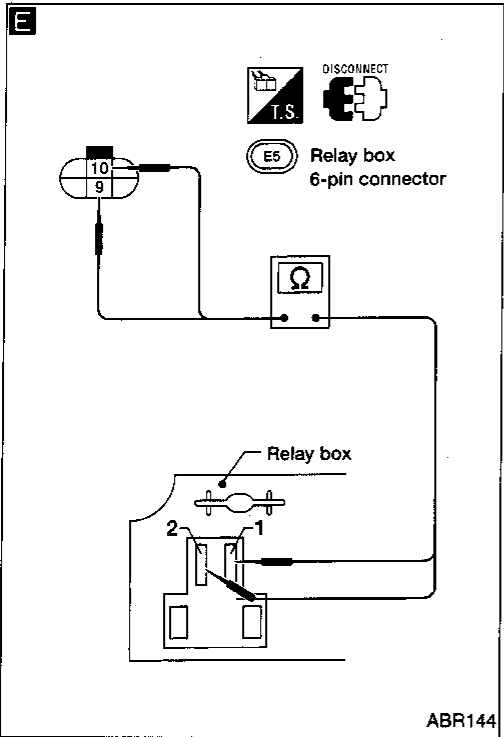

OK

MOTOR RELAY CHECK

NG → Replace motor relay.

Refer to MOTOR RELAY in Electrical Components Inspection (BR-62).

OK

E

MOTOR RELAY CIRCUIT

- Disconnect relay box 6-pin connector.
- Check continuity between relay box connector (relay box side) terminals and relay box terminals.

Relay box connector	Relay box
⑩	①
⑨	②

Continuity should exist.

NG → Replace relay box assembly.

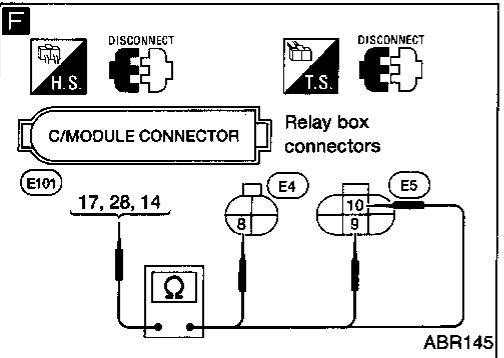

F

CIRCUIT CHECK

- Disconnect control module connector.
- Check continuity between control module connector terminals and relay box connector (body side) terminals.

Control module connector	Relay box connector
⑰	⑩
⑳	⑨
⑭	⑧

Continuity should exist.

NG → Repair harness and connectors.

OK

Replace control module.

NG → Repair harness and connectors.

TROUBLE DIAGNOSES

Diagnostic Procedure 5 (Cont'd)

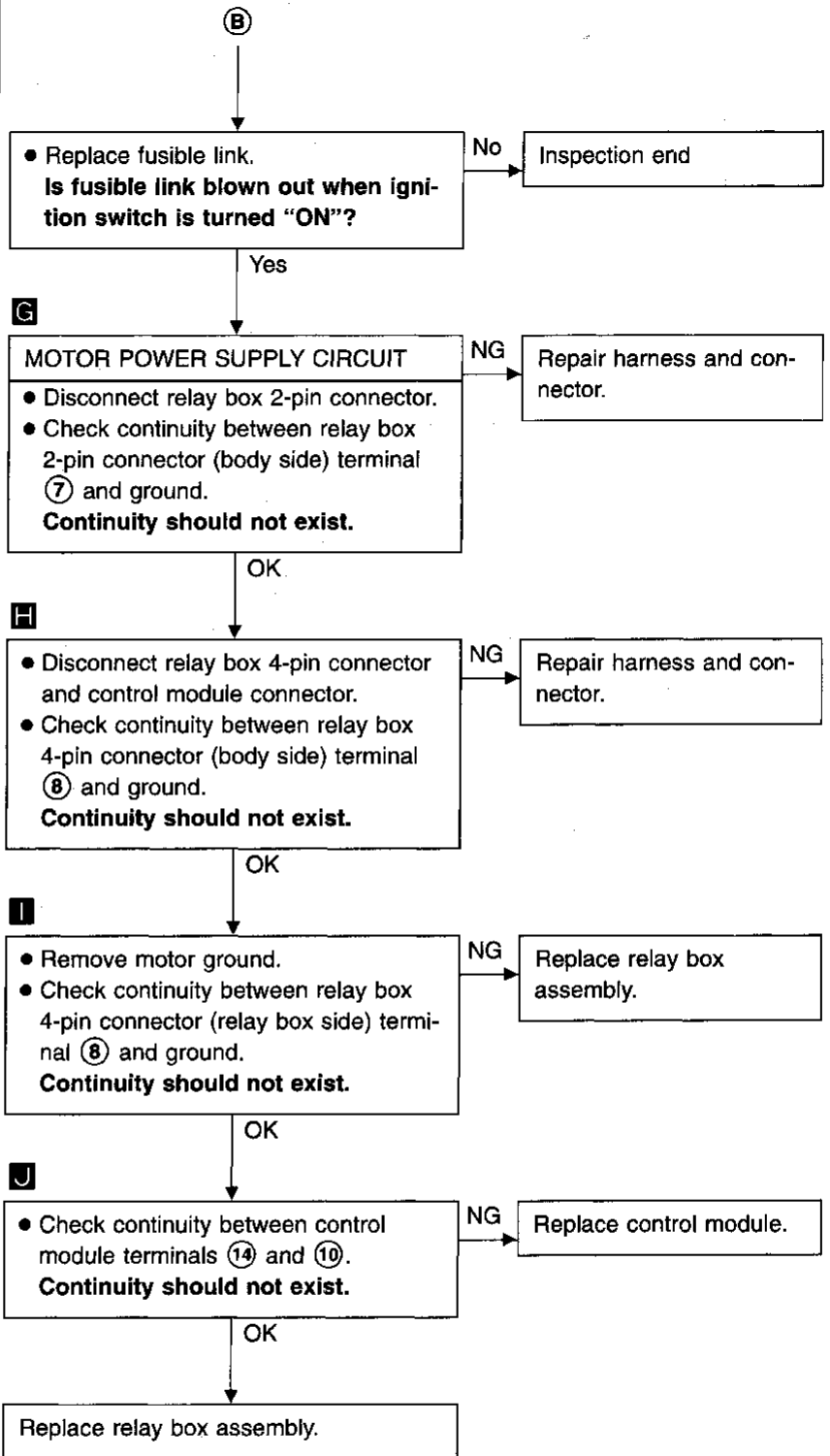
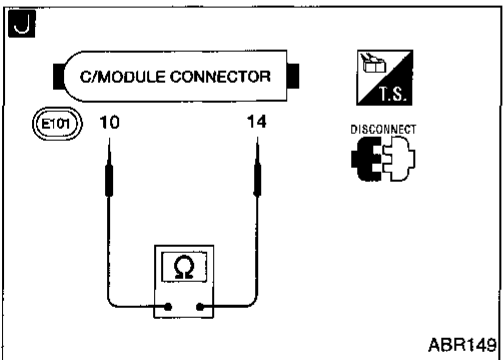
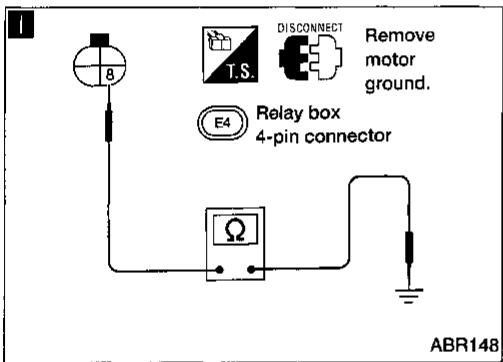
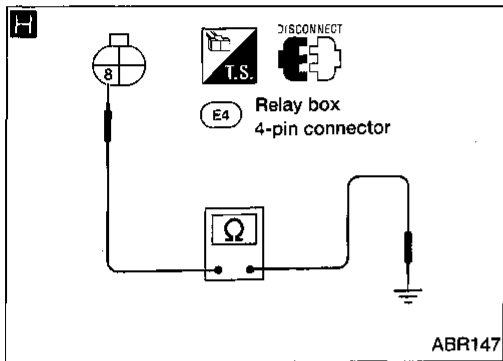
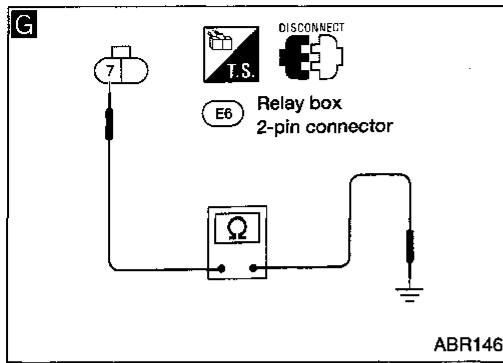

GI
MA
EM
LC
EC
FE
CL
MT
AT
FA
RA
BR
ST
RS
BT
HA
EL
IDX

Diagnostic Procedure 6 SOLENOID VALVE RELAY (Malfunction code No. 63)

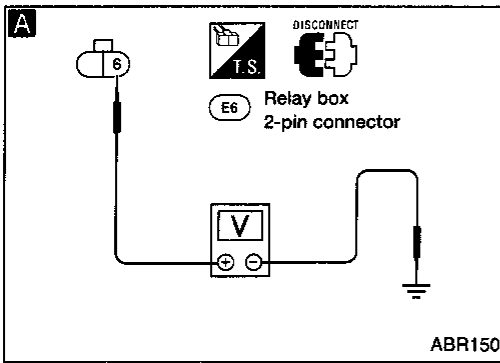

SOLENOID VALVE POWER SUPPLY CHECK

- Check 20A fuse. For fuse layout, refer to Wiring Diagram (BR-36).

NG → (A) (See next page.)

OK

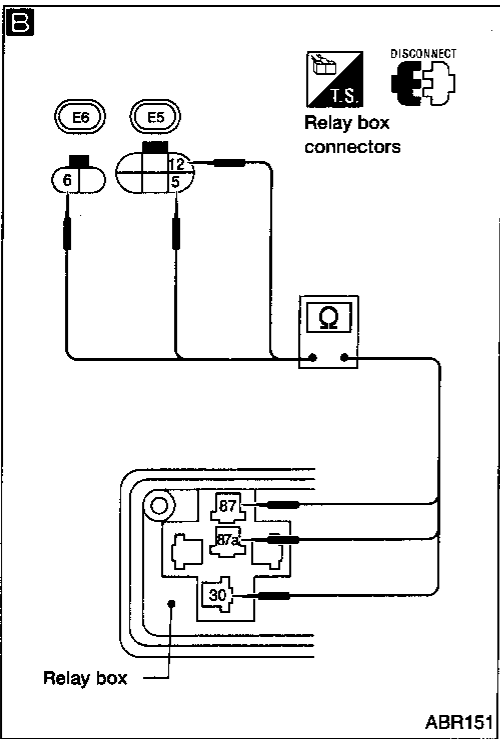

- Disconnect connectors from control module and actuator. Check terminals for damage or loose connection. Then reconnect connectors.
- Carry out self-diagnosis again.

Does warning lamp activate again?

No → Inspection end.

Yes

A

SOLENOID VALVE POWER SUPPLY CHECK

- Disconnect connectors from relay box.
- Check voltage between relay box 2-pin connector (body side) terminal ⑥ and ground.

Battery voltage should exist.

NG → Repair harness and connector.

OK

SOLENOID VALVE RELAY CHECK

Refer to SOLENOID VALVE RELAY in Electrical Components Inspection (BR-65).

NG → Replace solenoid valve relay.

OK

B

SOLENOID VALVE RELAY CIRCUIT CHECK

Check continuity between relay box terminals and relay box connector (relay box side) terminals.

Relay box terminals	Connector terminals
③⑩	⑫
⑧⑦	⑥
⑧⑦a	⑤

Continuity should exist.

NG → Replace actuator.

OK

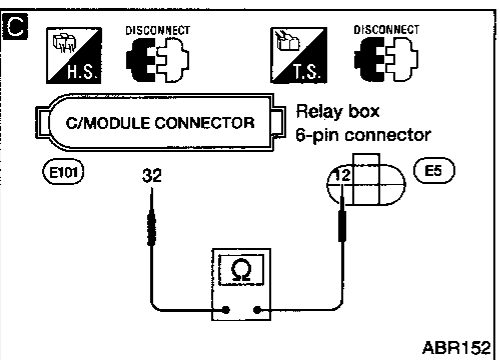

C

CIRCUIT CHECK

- Disconnect control module connector.
- Check continuity between control module connector terminal ③② and relay box connector (body side) terminal ⑫.

Continuity should exist.

NG → Repair harness and connectors.

OK

Replace control module.

TROUBLE DIAGNOSES

Diagnostic Procedure 6 (Cont'd)

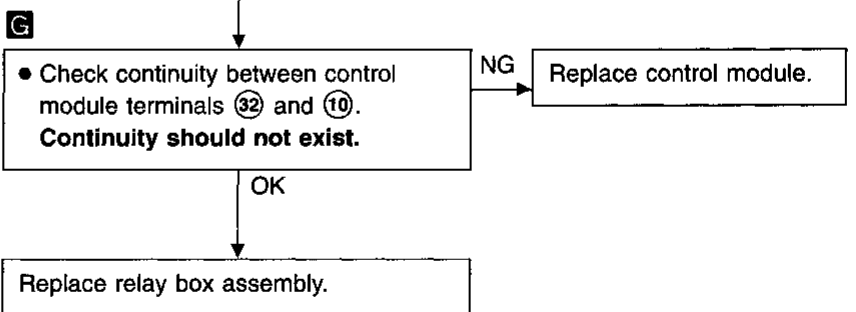
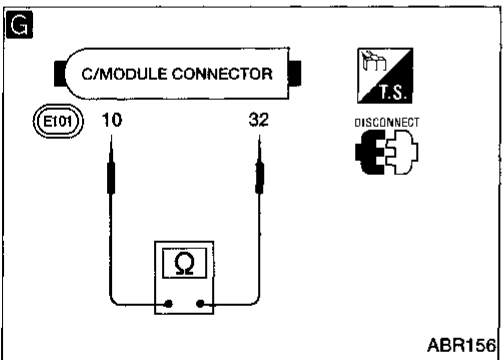
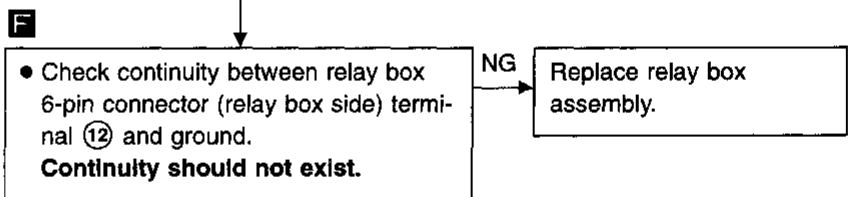
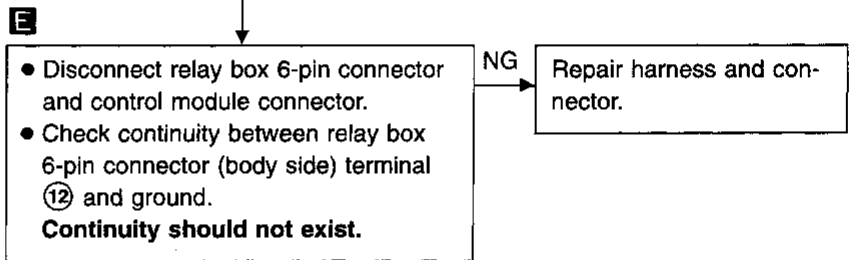
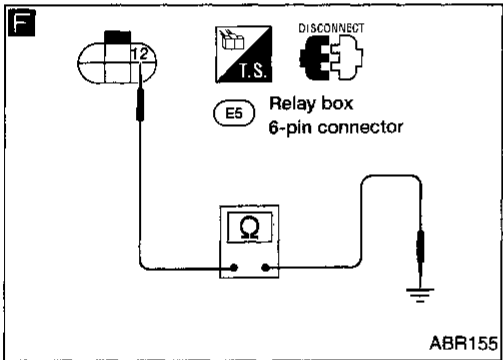
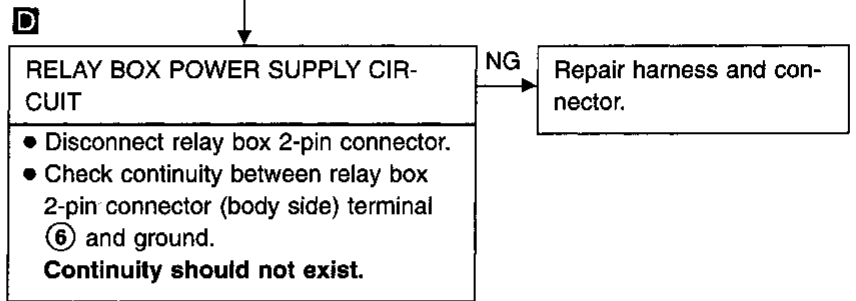
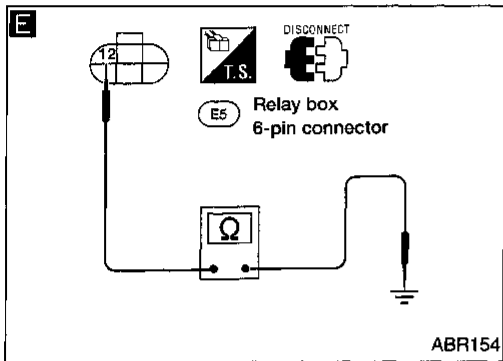
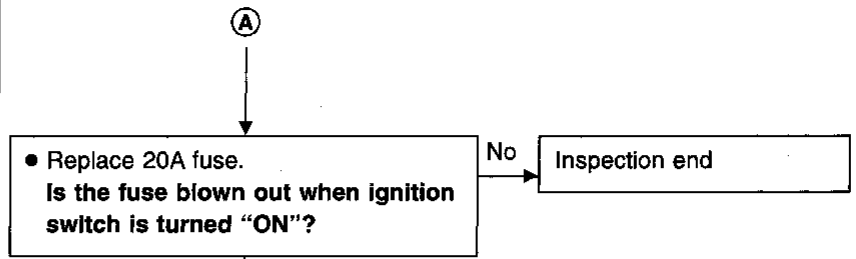
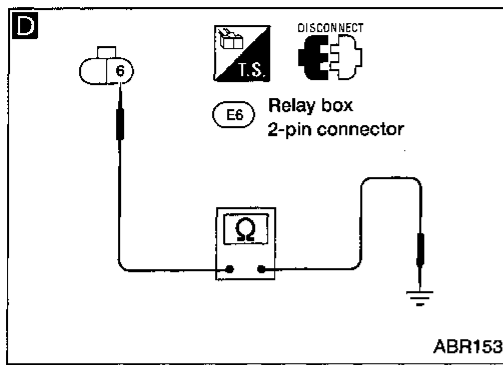

GI
MA
EM
LC
EC
FE
CL
MT
AT
FA
RA
BR
ST
RS
BT
HA
EL
IDX

TROUBLE DIAGNOSES

Diagnostic Procedure 7

POWER SUPPLY (Low voltage) (Malfunction code No. 57)

BATTERY CHECK
• Check battery. Refer to EL section ("BATTERY").

Diagnostic Procedure 8

STOP LAMP SWITCH CIRCUIT (Malfunction code No. 16)

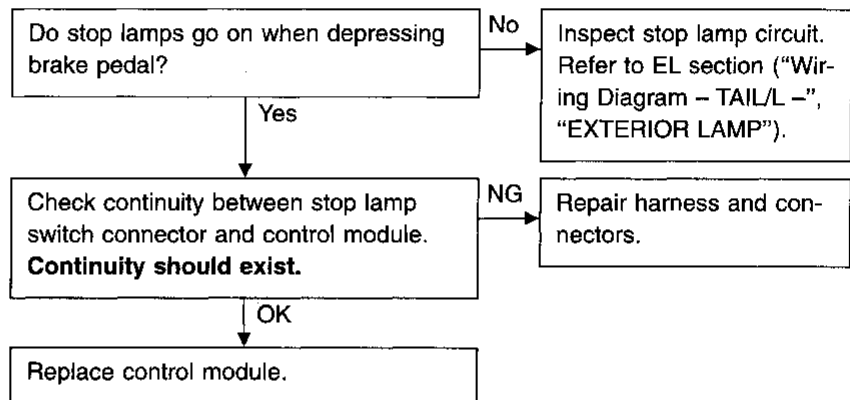

Diagnostic Procedure 9

CONTROL MODULE (Malfunction code No. 71)

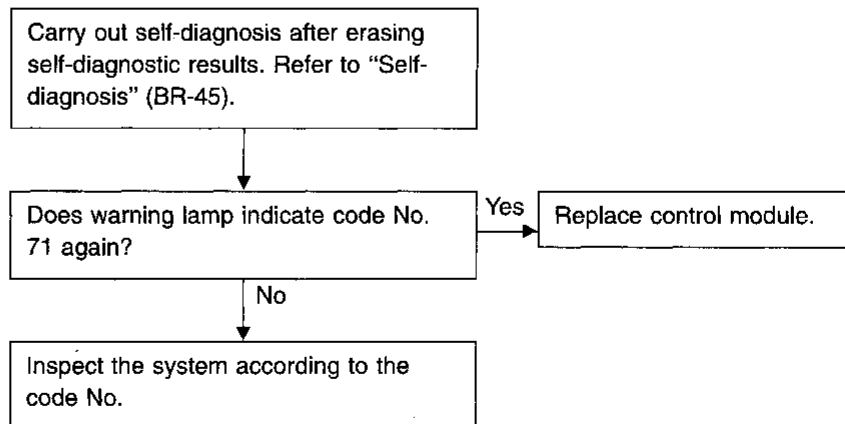

TROUBLE DIAGNOSES

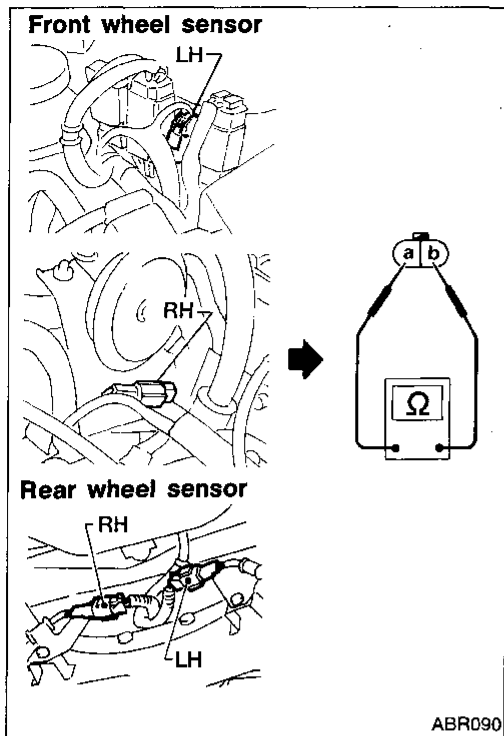

Electrical Components Inspection

WHEEL SENSOR

Check resistance between terminals (a) and (b).
Resistance: 1.0 - 1.25kΩ

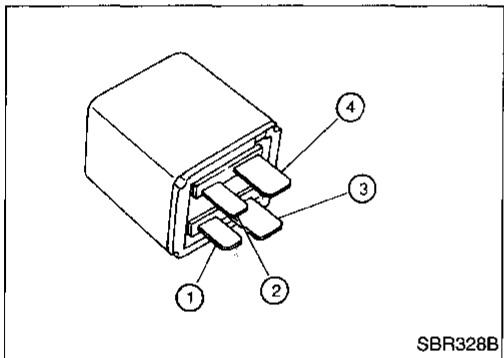

MOTOR RELAY

Condition	Continuity existence between terminals (3) and (4)
Battery positive voltage not applied between terminals (1) and (2).	No
Battery positive voltage applied between terminals (1) and (2).	Yes

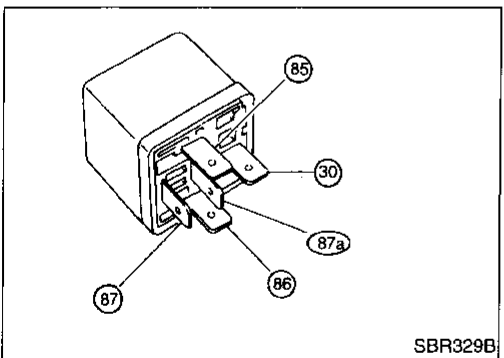

SOLENOID VALVE RELAY

Condition	Continuity existence between terminals (30) and (87a)	Continuity existence between terminals (30) and (87)
Battery positive voltage not applied between terminals (85) and (86).	Yes	No
Battery positive voltage applied between terminals (85) and (86).	No	Yes

GI

MA

EM

LC

EC

FE

CL

MT

AT

FA

RA

BR

ST

RS

BT

HA

EL

IDX

SERVICE DATA AND SPECIFICATIONS (SDS)

General Specifications

Model	Without ABS	With ABS
Front brake		
Brake model	CL25VB	
Cylinder bore diameter mm (in)	57.2 (2.252)	
Pad mm (in)	M/T model: 125.6 x 45.3 x 11.0 (4.94 x 1.783 x 0.433) A/T model: 125.6 x 45.3 x 10.0 (4.94 x 1.783 x 0.394)	
Length x width x thickness		
Rotor outer diameter x thickness mm (in)	280 x 22 (11.02 x 0.87)	
Rear brake		
Brake model	LT23E	CL9HA
Cylinder bore diameter mm (in)	19.05 (3/4)	33.96 (1.3370)
Lining or pad mm (in)	M/T model: 219.4 x 35 x 4.1 (8.64 x 1.38 x 0.161) A/T model: 89.1 x 39.5 x 10 (3.508 x 1.555 x 0.39)	
Length x width x thickness		
Drum inner diameter or rotor outer diameter x thickness mm (in)	228.6 (9)	258 x 9 (10.16 x 0.35)

Model	Without ABS	With ABS
Master cylinder		
Cylinder bore diameter mm (in)	23.81 (15/16)	25.40 (1)
Control valve		
Valve model	Dual proportioning valve (built-in type)	Dual proportioning valve (separated type)
Split point kPa (kg/cm ² , psi) x reducing ratio	1,961 (20, 284) x 0.2	2,942 (30, 427) x 0.2
Brake booster		
Booster model	M195T	M215T
Diaphragm diameter mm (in)	Primary: 205 (8.07) Secondary: 180 (7.09)	Primary: 230 (9.06) Secondary: 205 (8.07)
Recommended brake fluid	DOT 3	

Inspection and Adjustment BRAKE PEDAL

DISC BRAKE

Brake model	CL25VB	CL9HA
Pad wear limit mm (in)		
Minimum thickness	2.0 (0.079)	1.5 (0.059)
Rotor repair limit mm (in)		
Minimum thickness	20.0 (0.787)	8.0 (0.315)

DRUM BRAKE

Brake model	LT23E
Lining wear limit mm (in)	
Minimum thickness	1.5 (0.059)
Drum repair limit mm (in)	
Maximum inner diameter	230 (9.06)
Out-of-roundness	0.03 (0.0012)

Free height "H" mm (in)	
M/T	169 - 179 (6.65 - 7.05)
A/T	177 - 187 (6.97 - 7.36)
Depressed height "D" mm (in)	
[under force of 490 N (50 kg, 110 lb) with engine running]	90 (3.54)
Clearance between switches and pedal stopper bracket "C" mm (in)	0.3 - 1.0 (0.012 - 0.039)
Pedal free play "A" mm (in)	1.0 - 3.0 (0.039 - 0.118)

PARKING BRAKE

Number of notches	
[under force of 196 N (20 kg, 44 lb)]	7 - 8
Number of notches when warning lamp switch comes on	1