

A  
B  
C  
D  
E  
F  
G  
H  
I  
MTC  
K  
L  
M

# SECTION MTC

## MANUAL AIR CONDITIONER

### CONTENTS

<b>PRECAUTIONS</b> .....	<b>3</b>	FAN CONTROL DIAL .....	21
Precautions for Supplemental Restraint System (SRS) "AIR BAG" and "SEAT BELT PRE-TENSIONER" .....	3	AIR CONTROL DIAL .....	21
Precautions for Working with HFC-134a (R-134a).....	3	TEMPERATURE CONTROL DIAL .....	21
Contaminated Refrigerant .....	3	RECIRCULATION (REC) SWITCH .....	21
General Refrigerant Precautions .....	4	AIR CONDITIONER (A/C) SWITCH .....	21
Precautions for Leak Detection Dye .....	4	Discharge Air Flow .....	22
A/C Identification Label .....	4	System Description .....	23
Precautions for Refrigerant Connection .....	5	SWITCHES AND THEIR CONTROL FUNCTION..	23
FEATURES OF NEW TYPE REFRIGERANT CONNECTION .....	5	CAN Communication System Description .....	23
O-RING AND REFRIGERANT CONNECTION.....	6	FOR TCS MODELS .....	23
Precautions for Servicing Compressor .....	9	FOR A/T MODELS .....	25
Precautions for Service Equipment .....	9	FOR M/T MODELS .....	26
RECOVERY/RECYCLING EQUIPMENT .....	9	<b>TROUBLE DIAGNOSIS</b> .....	<b>28</b>
ELECTRONIC LEAK DETECTOR .....	9	How to Perform Trouble Diagnoses for Quick and Accurate Repair .....	28
VACUUM PUMP .....	10	WORK FLOW .....	28
MANIFOLD GAUGE SET .....	10	SYMPTOM TABLE .....	28
SERVICE HOSES .....	10	Component Parts and Harness Connector Location..	29
SERVICE COUPLERS .....	11	ENGINE COMPARTMENT .....	29
REFRIGERANT WEIGHT SCALE .....	11	PASSENGER COMPARTMENT .....	31
CALIBRATING ACR4 WEIGHT SCALE .....	11	Circuit Diagram .....	32
CHARGING CYLINDER .....	11	Wiring Diagram — HEATER — .....	33
Wiring Diagrams and Trouble Diagnosis .....	11	Wiring Diagram — A/C,M — .....	35
<b>PREPARATION</b> .....	<b>12</b>	Operational Check .....	38
Special Service Tools .....	12	CONDITIONS: .....	38
HFC-134a (R-134a) Service Tools and Equipment..	12	PROCEDURE: .....	38
Commercial Service Tools .....	15	A/C System .....	40
<b>REFRIGERATION SYSTEM</b> .....	<b>16</b>	DIAGNOSTIC PROCEDURE .....	40
Refrigeration Cycle .....	16	Mode Door Motor Circuit .....	42
REFRIGERANT FLOW .....	16	INSPECTION FLOW .....	42
REFRIGERANT SYSTEM PROTECTION .....	16	SYSTEM DESCRIPTION .....	43
Component Layout .....	17	DIAGNOSTIC PROCEDURE .....	43
<b>LUBRICANT</b> .....	<b>18</b>	MODE DOOR .....	44
Maintenance of Lubricant Quantity in Compressor..	18	Air Mix Door .....	45
LUBRICANT .....	18	INSPECTION FLOW .....	45
CHECKING AND ADJUSTING .....	18	CONTROL LINKAGE ADJUSTMENT .....	45
<b>AIR CONDITIONER CONTROL</b> .....	<b>21</b>	Intake Door Motor Circuit .....	46
Control Operation .....	21	INSPECTION FLOW .....	46
		SYSTEM DESCRIPTION .....	47
		DIAGNOSTIC PROCEDURE .....	47

CONTROL LINKAGE ADJUSTMENT .....	48	<b>REFRIGERANT LINES .....</b>	<b>79</b>
Blower Motor Circuit .....	49	HFC-134a (R-134a) Service Procedure .....	79
INSPECTION FLOW .....	49	SETTING OF SERVICE TOOLS AND EQUIP-	
DIAGNOSTIC PROCEDURE .....	49	MENT .....	79
ELECTRICAL COMPONENTS INSPECTION ...	53	Components .....	80
Magnet Clutch Circuit .....	54	Removal and Installation for Compressor —	
INSPECTION FLOW .....	54	QR25DE Models .....	83
DIAGNOSTIC PROCEDURE .....	55	REMOVAL .....	83
REFRIGERANT PRESSURE SENSOR .....	57	INSTALLATION .....	83
Insufficient Cooling .....	58	Removal and Installation for Compressor —	
INSPECTION FLOW .....	58	VQ35DE Models .....	84
PERFORMANCE CHART .....	59	REMOVAL .....	84
TROUBLE DIAGNOSES FOR ABNORMAL		INSTALLATION .....	84
PRESSURE .....	59	Removal and Installation for Compressor Clutch ...	85
Insufficient Heating .....	63	REMOVAL .....	85
INSPECTION FLOW .....	63	INSPECTION .....	86
Noise .....	64	INSTALLATION .....	86
INSPECTION FLOW .....	64	BREAK-IN OPERATION .....	87
Intake Sensor Circuit .....	65	Removal and Installation for Low-pressure Flexible	
COMPONENT DESCRIPTION .....	65	Hose .....	87
DIAGNOSTIC PROCEDURE .....	65	REMOVAL .....	87
<b>CONTROL UNIT .....</b>	<b>67</b>	INSTALLATION .....	87
Removal and Installation .....	67	Removal and Installation for High-pressure flexible	
REMOVAL .....	67	hose .....	88
INSTALLATION .....	67	REMOVAL .....	88
<b>INTAKE SENSOR .....</b>	<b>68</b>	INSTALLATION .....	88
Removal and Installation .....	68	Removal and Installation for High-pressure Pipe ...	88
<b>BLOWER UNIT .....</b>	<b>69</b>	REMOVAL .....	88
Removal and Installation .....	69	INSTALLATION .....	88
REMOVAL .....	69	Removal and Installation for Refrigerant Pressure	
<b>BLOWER MOTOR .....</b>	<b>70</b>	Sensor .....	88
Removal and Installation .....	70	Removal and Installation for Condenser .....	88
<b>INTAKE DOOR MOTOR .....</b>	<b>71</b>	REMOVAL .....	88
Removal and Installation .....	71	INSTALLATION .....	89
<b>IN-CABIN MICROFILTER .....</b>	<b>72</b>	Removal and Installation for Liquid Tank .....	89
Removal and Installation .....	72	Removal and Installation for Evaporator .....	90
FUNCTION .....	72	REMOVAL .....	90
REPLACEMENT TIMING .....	72	INSTALLATION .....	91
REPLACEMENT PROCEDURES .....	72	Removal and Installation for Expansion Valve .....	91
<b>HEATER &amp; COOLING UNIT ASSEMBLY .....</b>	<b>73</b>	REMOVAL .....	91
Removal and Installation .....	73	INSTALLATION .....	91
REMOVAL .....	73	Checking for Refrigerant Leaks .....	91
INSTALLATION .....	73	Checking System for Leaks Using the Fluorescent	
<b>HEATER CORE .....</b>	<b>74</b>	Leak Detector .....	92
Removal and Installation .....	74	Dye Injection .....	92
<b>MODE DOOR MOTOR .....</b>	<b>75</b>	Electronic Refrigerant Leak Detector .....	92
Removal and Installation .....	75	PRECAUTIONS FOR HANDLING LEAK	
DRIVER SIDE MODE DOOR MOTOR .....	75	DETECTOR .....	92
<b>BLOWER FAN RESISTER .....</b>	<b>76</b>	CHECKING PROCEDURE .....	93
Removal and Installation .....	76	<b>SERVICE DATA AND SPECIFICATIONS (SDS) .....</b>	<b>95</b>
<b>DUCTS AND GRILLES .....</b>	<b>77</b>	Service Data and Specifications (SDS) .....	95
Removal and Installation .....	77	COMPRESSOR .....	95
Ventilator Duct, Defroster Nozzle and Defroster		LUBRICANT .....	95
Ducts .....	77	REFRIGERANT .....	95
Center Ventilator Grille .....	77	ENGINE IDLING SPEED .....	95
Side Ventilator Grille LH .....	77	BELT TENSION .....	95
Side Ventilator Grille RH .....	78		
Floor duct .....	78		

# PRECAUTIONS

## PRECAUTIONS

PFP:00001

### Precautions for Supplemental Restraint System (SRS) “AIR BAG” and “SEAT BELT PRE-TENSIONER”

EJS00022

The Supplemental Restraint System such as “AIR BAG” and “SEAT BELT PRE-TENSIONER”, used along with a front seat belt, helps to reduce the risk or severity of injury to the driver and front passenger for certain types of collision. Information necessary to service the system safely is included in the SRS and SB section of this Service Manual.

#### **WARNING:**

- To avoid rendering the SRS inoperative, which could increase the risk of personal injury or death in the event of a collision which would result in air bag inflation, all maintenance must be performed by an authorized NISSAN/INFINITI dealer.
- Improper maintenance, including incorrect removal and installation of the SRS, can lead to personal injury caused by unintentional activation of the system. For removal of Spiral Cable and Air Bag Module, see the SRS section.
- Do not use electrical test equipment on any circuit related to the SRS unless instructed to in this Service Manual. SRS wiring harnesses can be identified by yellow and/or orange harnesses or harness connectors.

### Precautions for Working with HFC-134a (R-134a)

EJS00023

#### **WARNING:**

- CFC-12 (R-12) refrigerant and HFC-134a (R-134a) refrigerant are not compatible. If the refrigerants are mixed, compressor failure is likely to occur. Refer to [MTC-3, "Contaminated Refrigerant"](#). To determine the purity of HFC-134a (R-134a) in the vehicle and recovery tank, use Refrigerant Recovery/Recycling Recharging equipment (ACR4) (J-39500-NI) and Refrigerant Identifier.
- Use only specified lubricant for the HFC-134a (R-134a) A/C system and HFC-134a (R-134a) components. If lubricant other than that specified is used, compressor failure is likely to occur.
- The specified HFC-134a (R-134a) lubricant rapidly absorbs moisture from the atmosphere. The following handling precautions must be observed:
  - When removing refrigerant components from a vehicle, immediately cap (seal) the component to minimize the entry of moisture from the atmosphere.
  - When installing refrigerant components to a vehicle, do not remove the caps (unseal) until just before connecting the components. Connect all refrigerant loop components as quickly as possible to minimize the entry of moisture into system.
  - Only use the specified lubricant from a sealed container. Immediately reseal containers of lubricant. Without proper sealing, lubricant will become moisture saturated and should not be used.
  - Avoid breathing A/C refrigerant and lubricant vapor or mist. Exposure may irritate eyes, nose and throat. Remove R-134a from the A/C system using certified service equipment meeting requirements of SAE J2210 (R-134a recycling equipment), or J2209 (R-134a recovery equipment). If accidental system discharge occurs, ventilate work area before resuming service. Additional health and safety information may be obtained from refrigerant and lubricant manufacturers.
  - Do not allow lubricant (Nissan A/C System Oil Type DH-PS) to come in contact with styrofoam parts. Damage may result.

### Contaminated Refrigerant

EJS00024

If a refrigerant other than pure R-134a is identified in a vehicle, your options are:

- Explain to the customer that environmental regulations prohibit the release of contaminated refrigerant into the atmosphere.
- Explain that recovery of the contaminated refrigerant could damage your service equipment and refrigerant supply.
- Suggest the customer return the vehicle to the location of previous service where the contamination may have occurred.
- If you choose to perform the repair, recover the refrigerant using only **dedicated equipment and containers. Do not recover contaminated refrigerant into your existing service equipment.** If your facility does not have dedicated recovery equipment, you may contact a local refrigerant product retailer for available service. This refrigerant must be disposed of in accordance with all federal and local regulations. In addition, replacement of all refrigerant system components on the vehicle is recommended.

A  
B  
C  
D  
E  
F  
G  
H  
I  
K  
L  
M

MTC

# PRECAUTIONS

- If the vehicle is within the warranty period, the air conditioner warranty is void. Please contact Nissan Customer Affairs for further assistance.

## General Refrigerant Precautions

EJS000Z5

### WARNING:

- Do not release refrigerant into the air. Use approved recovery/recycling equipment to capture the refrigerant every time an air conditioning system is discharged.
- Always wear eye and hand protection (goggles and gloves) when working with any refrigerant or air conditioning system.
- Do not store or heat refrigerant containers above 52°C (125°F).
- Do not heat a refrigerant container with an open flame; if container warming is required, place the bottom of the container in a warm pail of water.
- Do not intentionally drop, puncture, or incinerate refrigerant containers.
- Keep refrigerant away from open flames: poisonous gas will be produced if refrigerant burns.
- Refrigerant will displace oxygen, therefore be certain to work in well ventilated areas to prevent suffocation.
- Do not pressure test or leak test HFC-134a (R-134a) service equipment and/or vehicle air conditioning systems with compressed air during repair. Some mixtures of air and R-134a have been shown to be combustible at elevated pressures. These mixtures, if ignited, may cause injury or property damage. Additional health and safety information may be obtained from refrigerant manufacturers.

## Precautions for Leak Detection Dye

EJS000Z6

- The A/C system contains a fluorescent leak detection dye used for locating refrigerant leaks. An ultraviolet (UV) lamp is required to illuminate the dye when inspecting for leaks.
- Always wear fluorescence enhancing UV safety glasses to protect your eyes and enhance the visibility of the fluorescent dye.
- A compressor shaft seal should not be repaired because of dye seepage. The compressor shaft seal should only be repaired after confirming the leak with an electronic refrigerant leak detector (J-41995).
- Always remove any dye from the leak area after repairs are complete to avoid a misdiagnosis during a future service.
- Do not allow dye to come into contact with painted body panels or interior components. If dye is spilled, clean immediately with the approved dye cleaner. Fluorescent dye left on a surface for an extended period of time **cannot be removed**.
- Do not spray the fluorescent dye cleaning agent on hot surfaces (engine exhaust manifold, etc.).
- Do not use more than one refrigerant dye bottle (1/4 ounce / 7.4 cc) per A/C system.
- Leak detection dyes for R-134a and R-12 A/C systems are different. Do not use R-134a leak detection dye in R-12 A/C systems or R-12 leak detection dye in R-134a A/C systems or A/C system damage may result.
- The fluorescent properties of the dye will remain for over three (3) years unless a compressor failure occurs.

## A/C Identification Label

EJS000Z7

Vehicles with factory installed fluorescent dye have this identification label on the underside of hood.

### NOTE:

Vehicles with factory installed fluorescent dye have a green label.

AIR CONDITIONER NISSAN		
	REFRIGERANT	COMPRESSOR LUBRICANT
TYPE (PART NO.)	HFC134a (R134a)	Nissan Luminous Oil Type DH-PS [KLH00-PAGS0]
AMOUNT	0.50 ± .025 kg (1.10 ± 0.055lbs)	150ml (5.03 oz)

**CAUTION PRECAUTION**

- REFRIGERANT UNDER HIGH PRESSURE.
- SYSTEM TO BE SERVICED BY QUALIFIED PERSONNEL.
- IMPROPER SERVICE METHODS MAY CAUSE PERSONAL INJURY.
- CONSULT SERVICE MANUAL.
- THIS AIR CONDITIONER SYSTEM COMPLIES WITH SAE J-639.

Nissan Motor Corporation in USA, Carson, CA

WJIA0012E

# PRECAUTIONS

EJS00028

## Precautions for Refrigerant Connection

A new type refrigerant connection has been introduced to all refrigerant lines except the following locations.

- Expansion valve to cooling unit
- Evaporator pipes to evaporator (inside cooling unit)
- Refrigerant pressure sensor

## FEATURES OF NEW TYPE REFRIGERANT CONNECTION

- The O-ring has been relocated. It has also been provided with a groove for proper installation. This eliminates the chance of the O-ring being caught in, or damaged by, the mating part. The sealing direction of the O-ring is now set vertically in relation to the contacting surface of the mating part to improve sealing characteristics.
- The reaction force of the O-ring will not occur in the direction that causes the joint to pull out, thereby facilitating piping connections.

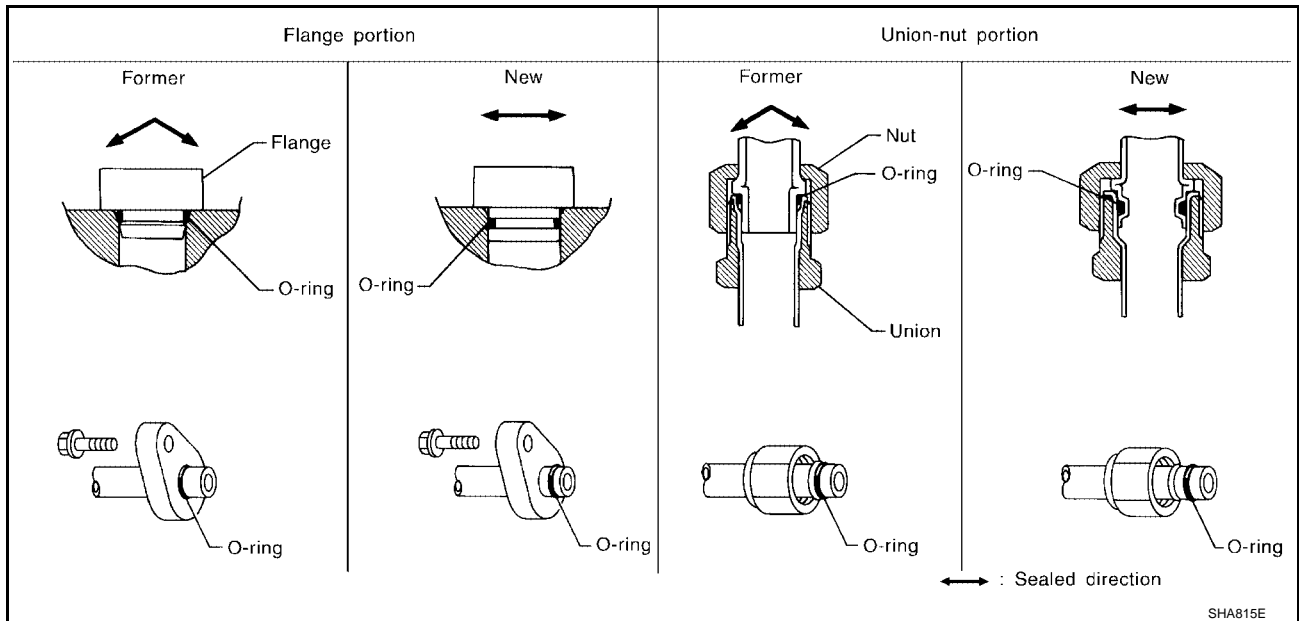

A  
B  
C  
D  
E  
F  
G  
H  
I  
MTC  
K  
L  
M

# PRECAUTIONS

## O-RING AND REFRIGERANT CONNECTION

### QR25DE Models

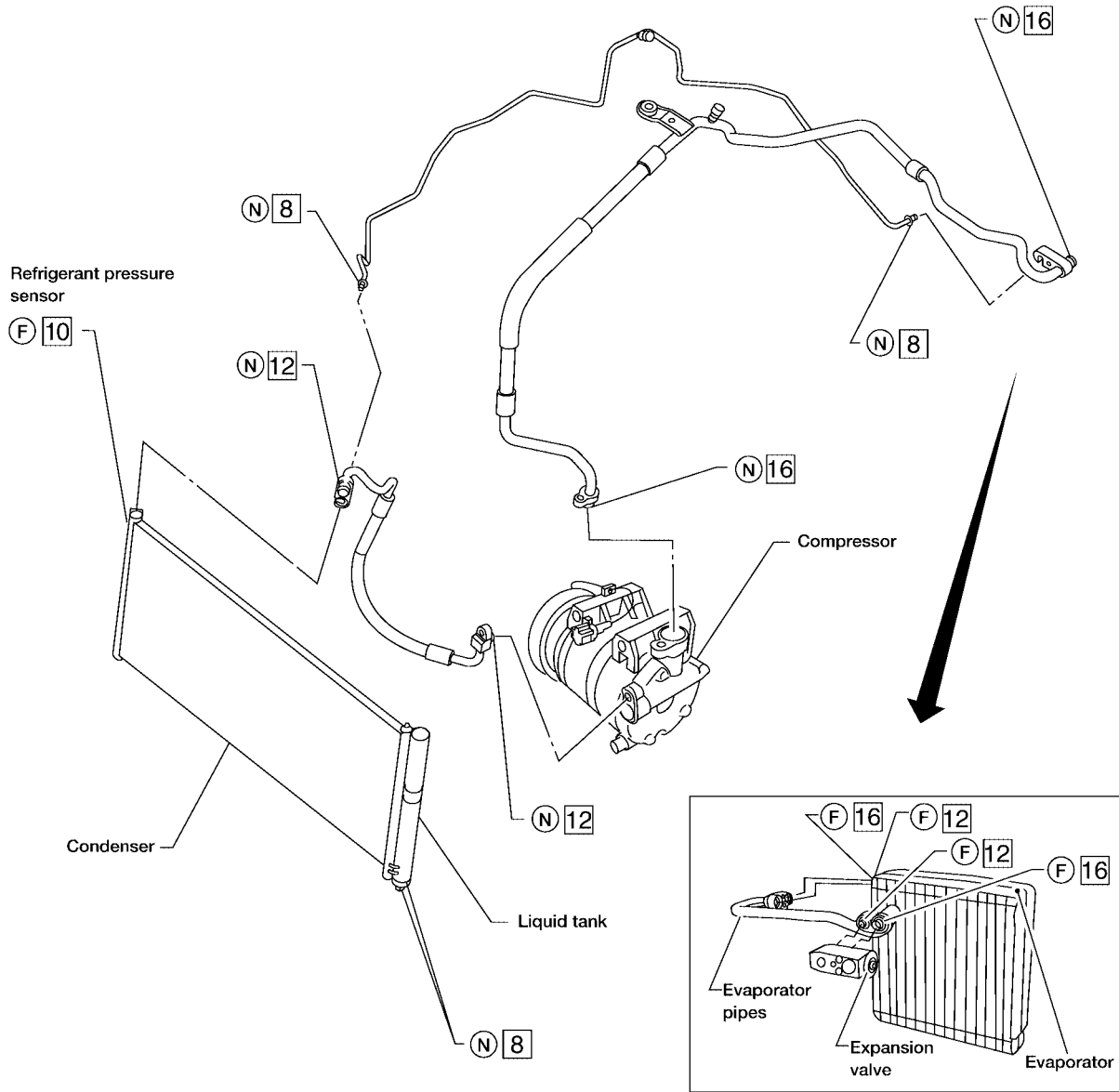

(F) : Former type refrigerant connection

(N) : New type refrigerant connection

□ : O-ring size

WJIA0131E

# PRECAUTIONS

## VQ35DE Models

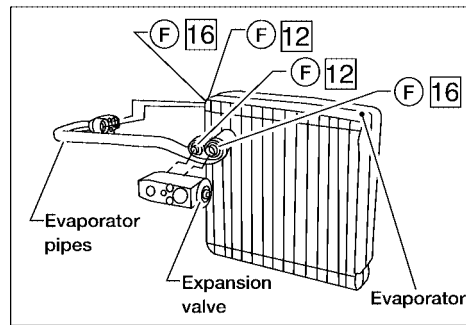
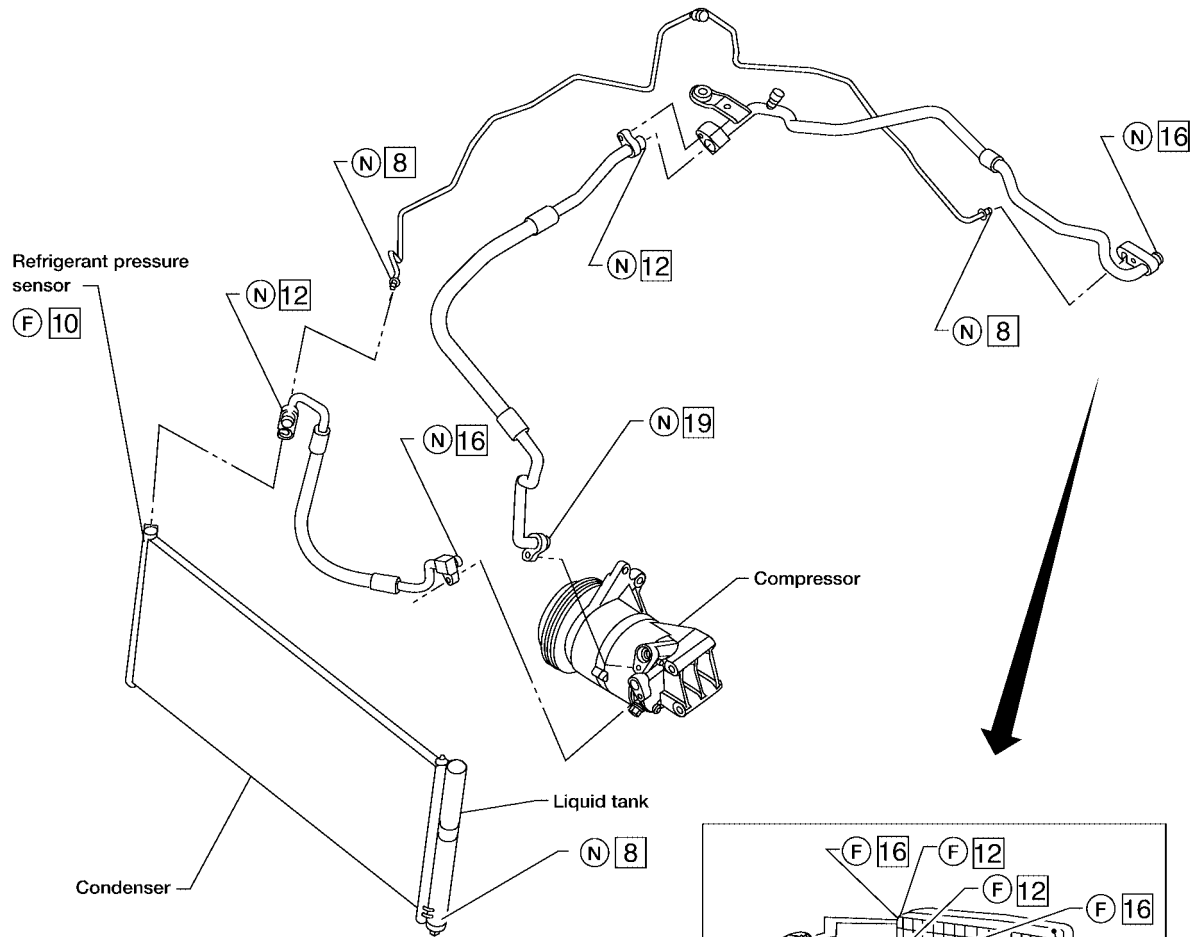

(F) : Former type refrigerant connection

(N) : New type refrigerant connection

□ : O-ring size

WJIA0135E

### CAUTION:

The new and former refrigerant connections use different O-ring configurations. Do not confuse O-rings since they are not interchangeable. If a wrong O-ring is installed, refrigerant will leak at, or around, the connection.

A  
B  
C  
D  
E  
F  
G  
H  
I  
MTC  
K  
L  
M

# PRECAUTIONS

## O-Ring Part Numbers and Specifications

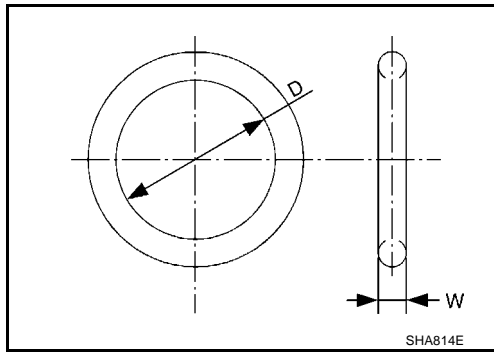

Connection type	O-ring size	Part number*	D mm (in)	W mm (in)
New	8	92471 N8210	6.8 (0.268)	1.85 (0.0728)
Former	10	J2476 89956	9.25 (0.3642)	1.78 (0.0701)
New	12	92472 N8210	10.9 (0.429)	2.43 (0.0957)
Former		92475 71L00	11.0 (0.433)	2.4 (0.094)
New	16	92473 N8210	13.6 (0.535)	2.43 (0.0957)
Former		92475 72L00	14.3 (0.563)	2.3 (0.091)
New	19	92474 N8210	16.5 (0.650)	2.43 (0.0957)

\*: Always check with the Parts Department for the latest parts information.

### WARNING:

Make sure all refrigerant is discharged into the recycling equipment and the pressure in the system is less than atmospheric pressure. Then gradually loosen the discharge side hose fitting and remove it.

### CAUTION:

When replacing or cleaning refrigerant cycle components, observe the following.

- When the compressor is removed, store it in the same position as it is when mounted on the car. Failure to do so will cause lubricant to enter the low pressure chamber.
- When connecting tubes, always use a torque wrench and a back-up wrench.
- After disconnecting tubes, immediately plug all openings to prevent entry of dirt and moisture.
- When installing an air conditioner in the vehicle, connect the pipes as the final stage of the operation. Do not remove the seal caps of pipes and other components until just before required for connection.
- Allow components stored in cool areas to warm to working area temperature before removing seal caps. This prevents condensation from forming inside A/C components.
- Thoroughly remove moisture from the refrigeration system before charging the refrigerant.
- Always replace used O-rings.
- When connecting tube, apply lubricant to circle of the O-rings shown in illustration. Be careful not to apply lubricant to threaded portion.  
Lubricant name: Nissan A/C System Oil Type DH-PS  
Part number: KLH00-PAGS0
- O-ring must be closely attached to dented portion of tube.
- When replacing the O-ring, be careful not to damage O-ring and tube.
- Connect tube until you hear it click, then tighten the nut or bolt by hand until snug. Make sure that the O-ring is installed to tube correctly.



# PRECAUTIONS

- After connecting line, conduct leak test and make sure that there is no leakage from connections. When the gas leaking point is found, disconnect that line and replace the O-ring. Then tighten connections of seal seat to the specified torque.

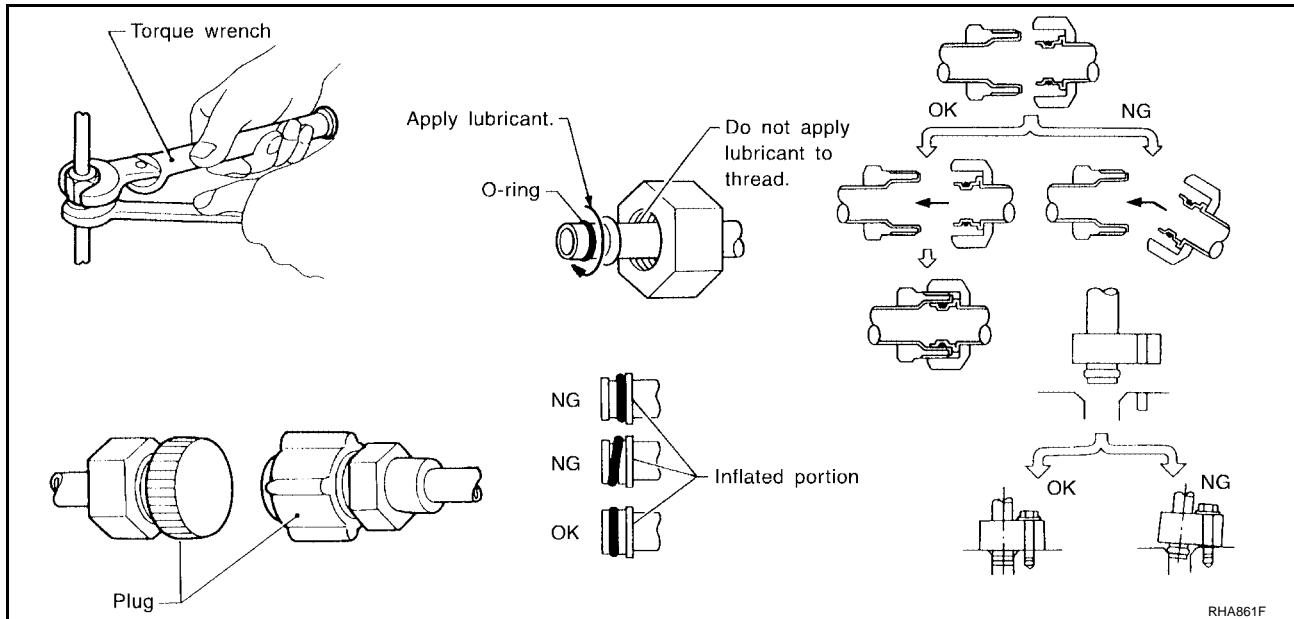

## Precautions for Servicing Compressor

EJS00029

- Plug all openings to prevent moisture and foreign matter from entering.
- When the compressor is removed, store it in the same position as it is when mounted on the car.
- When replacing or repairing compressor, follow "Maintenance of Lubricant Quantity in Compressor" exactly. Refer to [MTC-18, "Maintenance of Lubricant Quantity in Compressor"](#).
- Keep friction surfaces between clutch and pulley clean. If the surface is contaminated, with lubricant, wipe it off by using a clean waste cloth moistened with thinner.
- After compressor service operation, turn the compressor shaft by hand more than 5 turns in both directions. This will equally distribute lubricant inside the compressor. After the compressor is installed, let the engine idle and operate the compressor for 1 hour.
- After replacing the compressor magnet clutch, apply voltage to the new one and check for normal operation. [Gap between clutch disc and pulley is 0.3 - 0.6 mm (0.012 - 0.024 in)]

## Precautions for Service Equipment RECOVERY/RECYCLING EQUIPMENT

EJS0002A

Follow the manufacturer's instructions for machine operation and machine maintenance. Never introduce any refrigerant other than that specified into the machine.

## ELECTRONIC LEAK DETECTOR

Follow the manufacturer's instructions for tester operation and tester maintenance.

# PRECAUTIONS

## VACUUM PUMP

The lubricant contained inside the vacuum pump is not compatible with the specified lubricant for HFC-134a (R-134a) A/C systems. The vent side of the vacuum pump is exposed to atmospheric pressure so the vacuum pump lubricant may migrate out of the pump into the service hose. This is possible when the pump is switched off after evacuation (vacuuming) and hose is connected to it. To prevent this migration, use a manual valve situated near the hose-to-pump connection, as follows.

- Usually vacuum pumps have a manual isolator valve as part of the pump. Close this valve to isolate the service hose from the pump.
- For pumps without an isolator, use a hose equipped with a manual shut-off valve near the pump end. Close the valve to isolate the hose from the pump.
- If the hose has an automatic shut off valve, disconnect the hose from the pump: as long as the hose is connected, the valve is open and lubricating oil may migrate.

Some one-way valves open when vacuum is applied and close under a no vacuum condition. Such valves may restrict the pump's ability to pull a deep vacuum and are not recommended.

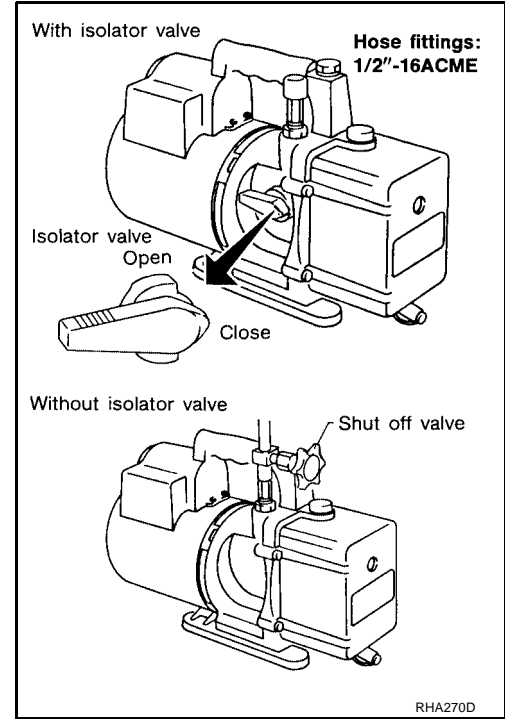

## MANIFOLD GAUGE SET

Be certain that the gauge face indicates R-134a or 134a. Make sure the gauge set has 1/2"-16 ACME threaded connections for service hoses. Confirm the set has been used only with refrigerant HFC-134a (R-134a) along with specified lubricant.

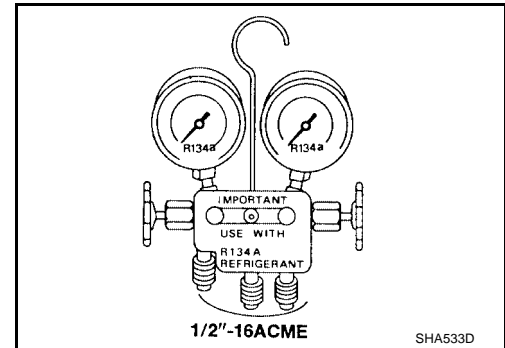

## SERVICE HOSES

Be certain that the service hoses display the markings described (colored hose with black stripe). All hoses must include positive shut-off devices (either manual or automatic) near the end of the hoses opposite the manifold gauge.

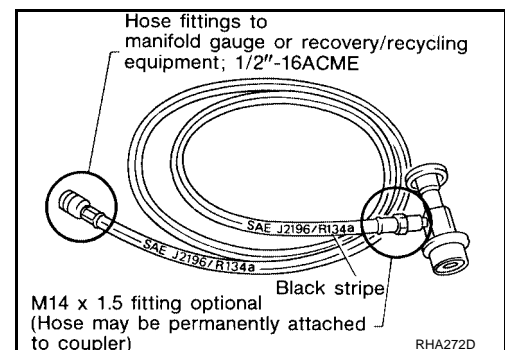

# PRECAUTIONS

## SERVICE COUPLERS

Never attempt to connect HFC-134a (R-134a) service couplers to a CFC-12 (R-12) A/C system. The HFC-134a (R-134a) couplers will not properly connect to the CFC-12 (R-12) system. However, if an improper connection is attempted, discharging and contamination may occur.

Shut-off valve rotation	A/C service valve
Clockwise	Open
Counterclockwise	Close

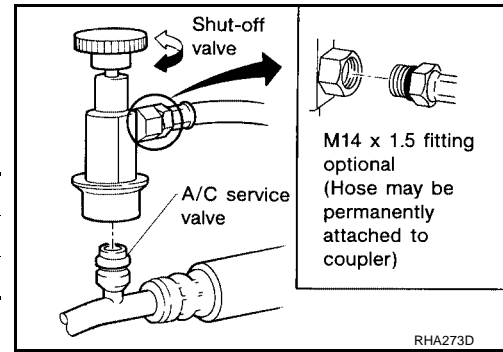

## REFRIGERANT WEIGHT SCALE

Verify that no refrigerant other than HFC-134a (R-134a) and specified lubricants have been used with the scale. If the scale controls refrigerant flow electronically, the hose fitting must be 1/2"-16 ACME.

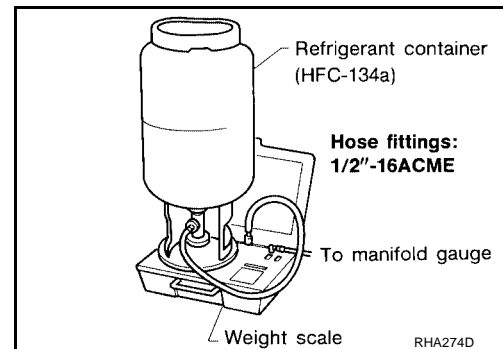

## CALIBRATING ACR4 WEIGHT SCALE

Calibrate the scale every three months.

To calibrate the weight scale on the ACR4 (J-39500-NI):

1. Press **Shift/Reset** and **Enter** at the same time.
2. Press **8787** . "A1" will be displayed.
3. Remove all weight from the scale.
4. Press **0** , then press **Enter** . "0.00" will be displayed and change to "A2" .
5. Place a known weight (dumbbell or similar weight), between 4.5 and 36.3 kg (10 and 80 lb) on the center of the weight scale.
6. Enter the known weight using four digits. (Example 10 lbs = 10.00, 10.5 lbs = 10.50)
7. Press **Enter** — the display returns to the vacuum mode.
8. Press **Shift/Reset** and **Enter** at the same time.
9. Press **6** — the known weight on the scale is displayed.
10. Remove the known weight from the scale. "0.00" will be displayed.
11. Press **Shift/Reset** to return the ACR4 to the program mode.

## CHARGING CYLINDER

Using a charging cylinder is not recommended. Refrigerant may be vented into air from cylinder's top valve when filling the cylinder with refrigerant. Also, the accuracy of the cylinder is generally less than that of an electronic scale or of quality recycle/recharge equipment.

## Wiring Diagrams and Trouble Diagnosis

EJS000ZB

When you read wiring diagrams, refer to the following:

- [GI-12, "How to Read Wiring Diagrams"](#)
- [PG-5, "Wiring Diagram — POWER —"](#)

When you perform trouble diagnosis, refer to the following:

- [GI-9, "How to Follow Trouble Diagnoses"](#)
- [GI-25, "How to Perform Efficient Diagnosis for an Electrical Incident"](#)

A  
B  
C  
D  
E  
F  
G  
H  
I  
K  
L  
M

MTC

# PREPARATION

## PREPARATION

PFP:00002

### Special Service Tools

EJS000ZC

The actual shapes of Kent-Moore tools may differ from those of special service tools illustrated here.

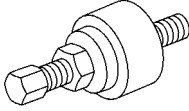
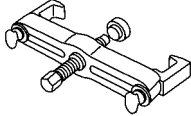
Tool number (Kent-Moore No.) Tool name		Description
KV99234330 (J-38873) Pulley installer	  LHA171	Installing pulley
KV99233130 (J-29884) Pulley puller	  LHA172	Removing pulley

## HFC-134a (R-134a) Service Tools and Equipment



EJS000ZD

Never mix HFC-134a refrigerant and/or its specified lubricant with CFC-12 (R-12) refrigerant and/or its lubricant.

Separate and non-interchangeable service equipment must be used for handling each type of refrigerant/lubricant.

Refrigerant container fittings, service hose fittings and service equipment fittings (equipment which handles refrigerant and/or lubricant) are different between CFC-12 (R-12) and HFC-134a (R-134a). This is to avoid mixed use of the refrigerants/lubricant.

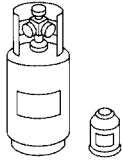
Adapters that convert one size fitting to another must never be used: refrigerant/lubricant contamination will occur and compressor failure will result.

Tool number (Kent-Moore No.) Tool name		Description
HFC-134a (R-134a) refrigerant	  S-NT196	Container color: Light blue Container marking: HFC-134a (R-134a) Fitting size: Thread size ● large container 1/2" -16 ACME
KLH00-PAGS0 (-) Nissan A/C System Oil Type DH-PS	  S-NT197	Type: Poly alkylene glycol oil (PAG), type DH-PS Application: HFC-134a (R-134a) vane rotary compressors (Nissan only) Lubricity: 40 mℓ (1.4 US fl oz, 1.4 Imp fl oz)

# PREPARATION

Tool number (Kent-Moore No.) Tool name	Description	
(J-39500-NI) Recovery/Recycling Recharging equipment (ACR4)	Function:Refrigerant Recovery and Recycling and Recharging	A B C D
(J-41995) Electronic refrigerant leak detector	Power supply: ● DC 12V (Cigarette lighter)	E F G H
(J-43926) Refrigerant dye leak detection kit Kit includes: (J-42220) UV lamp and UV safety glasses (J-41459) Refrigerant dye injector (J-41447) qty. 24 HFC-134a (R-134a) refrigerant dye (J-43872) Refrigerant dye cleaner	Power supply: DC 12V (Battery terminal)	I MTC K
(J-42220) Fluorescent dye leak detector	Power supply: DC 12V (Battery terminal) For checking refrigerant leak when flu- orescent dye is installed in A/C system. Includes: UV lamp and UV safety glasses	L M
(J-41447) HFC-134a (R-134a) Fluorescent leak detection dye (Box of 24, 1/4 ounce bottles)	Application: For HFC-134a (R-134a) PAG oil Container: 1/4 ounce (7.4cc) bottle (Includes self-adhesive dye identifica- tion labels for affixing to vehicle after charging system with dye.)	

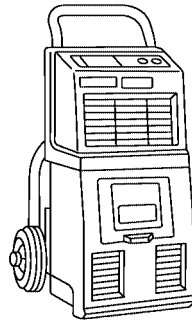

RJIA0195E

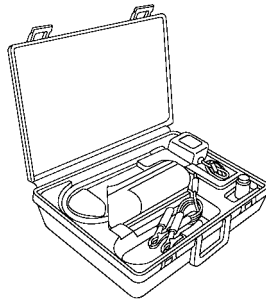

AHA281A

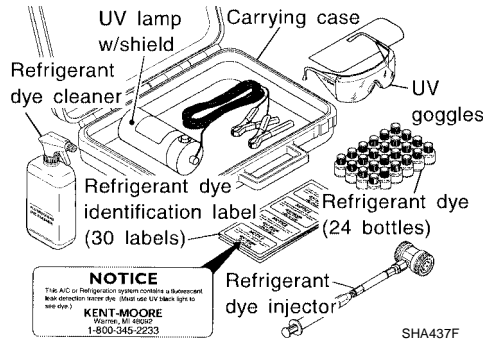

SHA437F

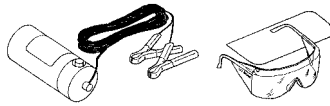



SHA438F



Refrigerant dye  
(24 bottles)

SHA439F

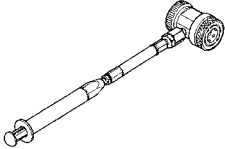
# PREPARATION

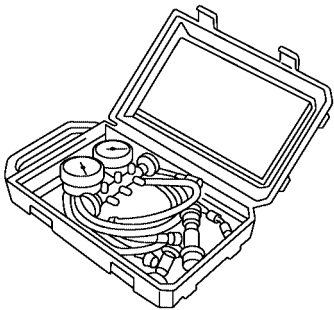
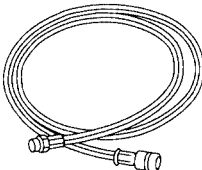
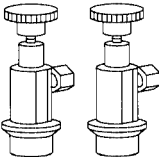
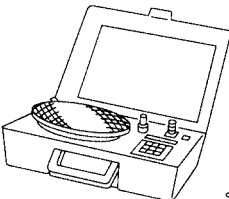
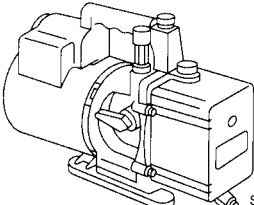
Tool number (Kent-Moore No.) Tool name	Description
(J-41459) HFC-134a (R-134a) Dye injector Use with J-41447, 1/4 ounce bottle  <small>SHA440F</small>	For injecting 1/4 ounce of fluorescent leak detection dye into A/C system.
(J-43872) Dye cleaner  <small>SHA441F</small>	For cleaning dye spills.
(J-39183-C) Manifold gauge set (with hoses and couplers)  <small>RJIA0196E</small>	<b>Identification:</b> <ul style="list-style-type: none"> <li>● The gauge face indicates R-134a. Fitting size: Thread size</li> <li>● 1/2<sup>2</sup> -16 ACME</li> </ul>
<b>Service hoses</b> <ul style="list-style-type: none"> <li>● High side hose (J-39500-72B)</li> <li>● Low side hose (J-39500-72R)</li> <li>● Utility hose (J-39500-72Y)</li> </ul>  <small>S-NT201</small>	<b>Hose color:</b> <ul style="list-style-type: none"> <li>● Low side hose: Blue with black stripe</li> <li>● High side hose: Red with black stripe</li> <li>● Utility hose: Yellow with black stripe or green with black stripe</li> </ul> Hose fitting to gauge: <ul style="list-style-type: none"> <li>● 1/2<sup>2</sup> -16 ACME</li> </ul>
<b>Service couplers</b> <ul style="list-style-type: none"> <li>● High side coupler (J-39500-20A)</li> <li>● Low side coupler (J-39500-24A)</li> </ul>  <small>S-NT202</small>	<b>Hose fitting to service hose:</b> <ul style="list-style-type: none"> <li>● M14 x 1.5 fitting is optional or permanently attached.</li> </ul>
(J-39699) Refrigerant weight scale  <small>S-NT200</small>	For measuring of refrigerant Fitting size: Thread size <ul style="list-style-type: none"> <li>● 1/2<sup>2</sup> -16 ACME</li> </ul>
(J-39649) Vacuum pump (Including the isolator valve)  <small>S-NT203</small>	<b>Capacity:</b> <ul style="list-style-type: none"> <li>● Air displacement: 4 CFM</li> <li>● Micron rating: 20 microns</li> <li>● Oil capacity: 482 g (17 oz) Fitting size: Thread size</li> <li>● 1/2<sup>2</sup> -16 ACME</li> </ul>

# PREPARATION

## Commercial Service Tools

EJS000ZE

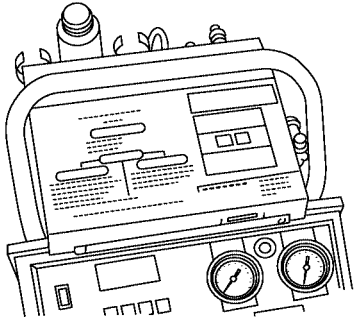
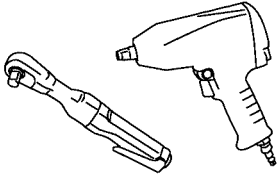
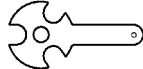
Tool name	Description
<p>(J-41810-NI) Refrigerant identifier equipment- (R-134a)</p>  <p style="text-align: right;">RJIA0197E</p>	<p>Checks refrigerant purity and for system contamination</p>
<p>Power tool</p>  <p style="text-align: right;">PBIC0190E</p>	<p>Loosening bolts and nuts</p>
<p>(J-44614) Clutch disc holding tool</p>  <p style="text-align: right;">WHA230</p>	<p>Clutch disc holding tool</p>

A  
B  
C  
D  
E  
F  
G  
H  
I

**MTC**

K  
L  
M

# REFRIGERATION SYSTEM

PF:KA990

EJS000ZF

## REFRIGERATION SYSTEM

### Refrigeration Cycle REFRIGERANT FLOW

The refrigerant flows in the standard pattern, that is, through the compressor, the condenser, the liquid tank, through the evaporator, and back to the compressor. The refrigerant evaporation through the evaporator coil is controlled by an externally equalized expansion valve, located inside the evaporator case.

### REFRIGERANT SYSTEM PROTECTION

#### Refrigerant Pressure Sensor

The refrigerant system is protected against excessively high or low pressures by the refrigerant pressure sensor, located on the condenser. If the system pressure rises above or falls below the specifications, the refrigerant pressure sensor detects the pressure inside the refrigerant line and sends the voltage signal to the ECM. ECM makes the A/C relay go OFF and stops the compressor when pressure on the high pressure side detected by refrigerant pressure sensor is over about 2,746 kPa (28 kg/cm<sup>2</sup>, 398 psi) or below about 120 kPa (1.22 kg/cm<sup>2</sup>, 17.4 psi).

#### Pressure Relief Valve

The refrigerant system is also protected by a pressure relief valve, located in the rear head of the compressor. When the pressure of refrigerant in the system increases to an abnormal level [more than 3,727 kPa (38 kg/cm<sup>2</sup>, 540 psi)], the release port on the pressure relief valve automatically opens and releases refrigerant into the atmosphere.

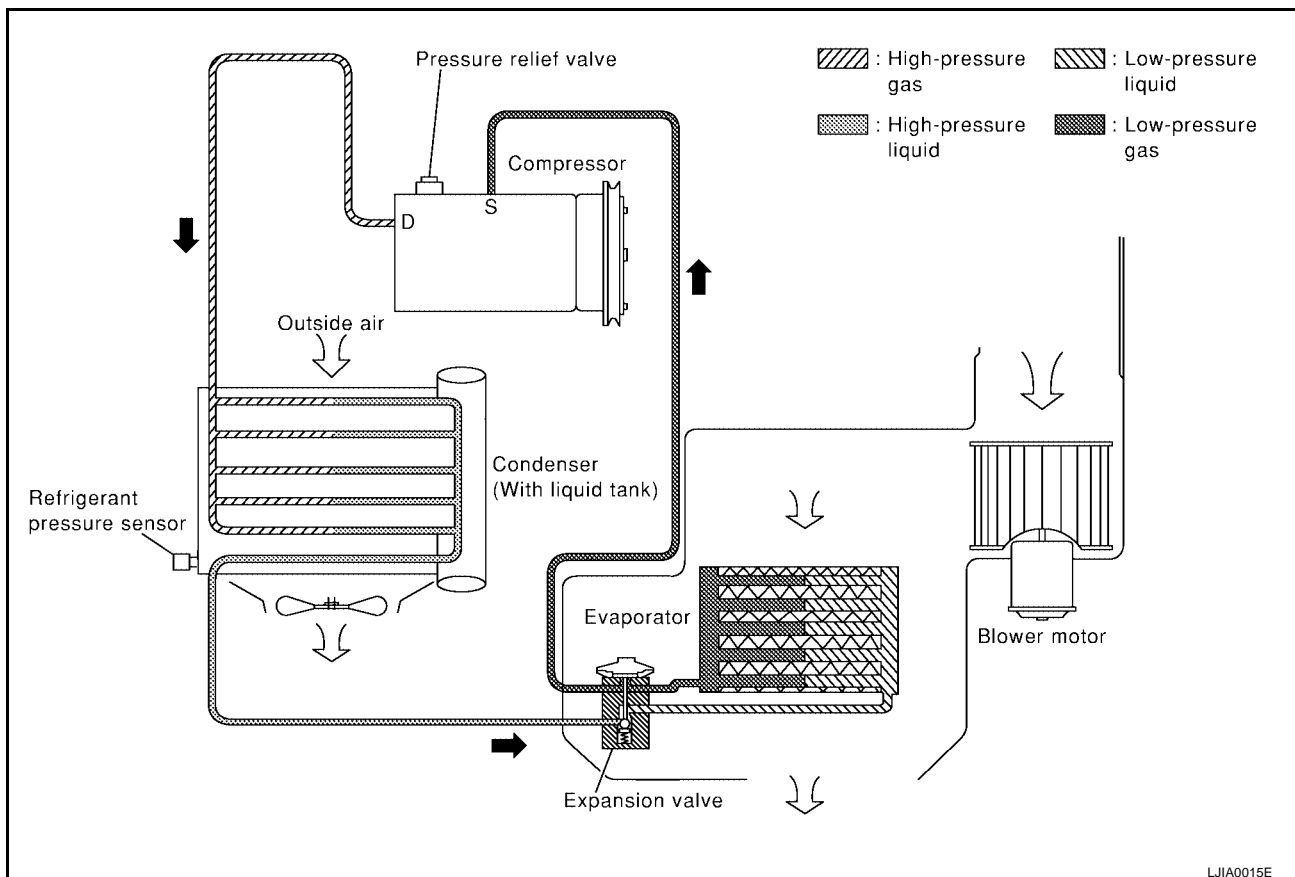



# REFRIGERATION SYSTEM

EJS000ZG

## Component Layout

SEC. 270 • 271 • 272 • 273

A  
B  
C  
D  
E  
F  
G  
H  
I  
MTC  
K  
L  
M

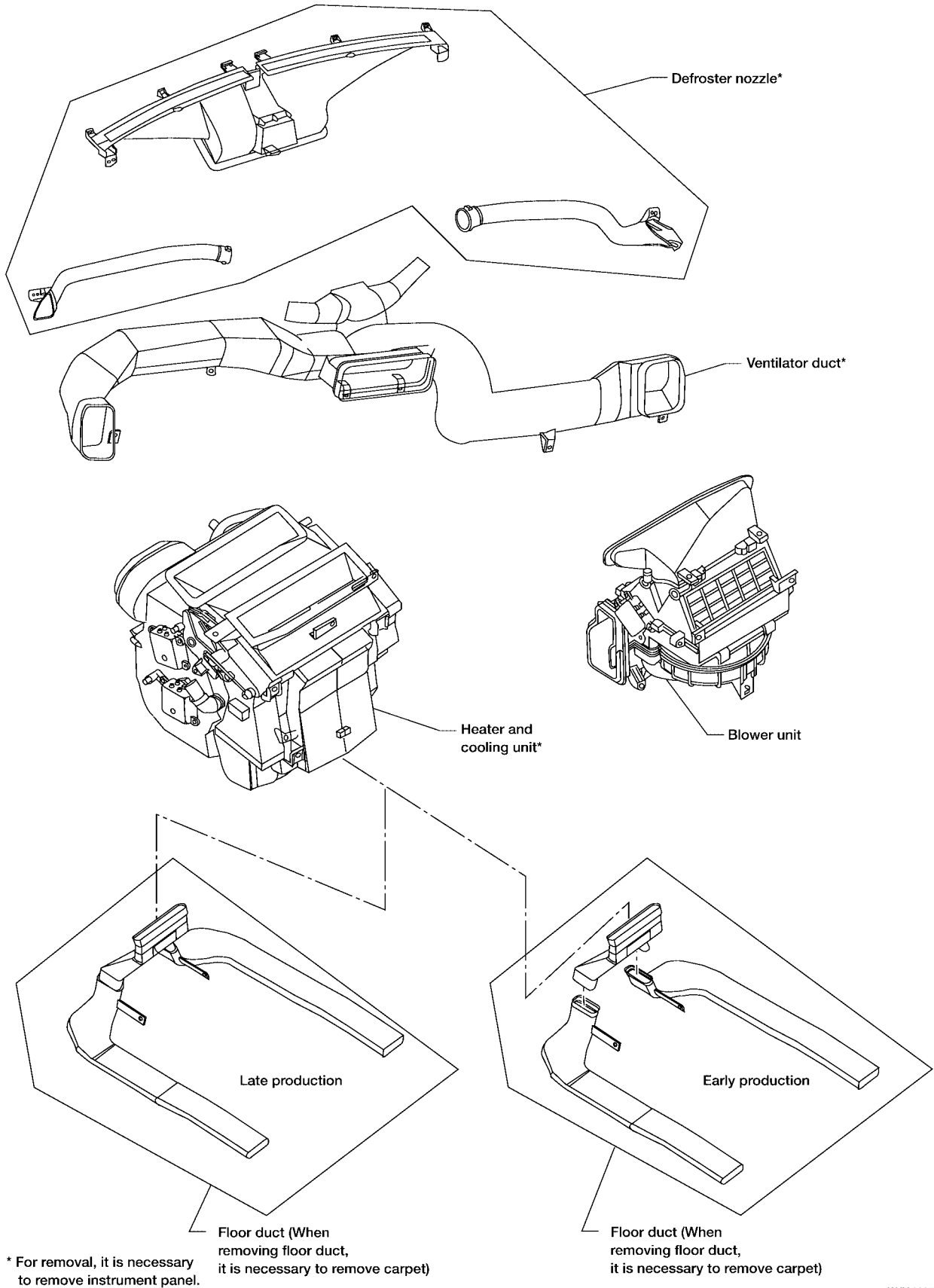

WJIA0287E

# LUBRICANT

PPF:KLG00

## LUBRICANT

### Maintenance of Lubricant Quantity in Compressor

EJS000ZH

The lubricant in the compressor circulates through the system with the refrigerant. Add lubricant to compressor when replacing any component or after a large refrigerant leakage has occurred. It is important to maintain the specified amount.

If lubricant quantity is not maintained properly, the following malfunctions may result:

- Lack of lubricant: May lead to a seized compressor
- Excessive lubricant: Inadequate cooling (thermal exchange interference)

## LUBRICANT

**Name: Nissan A/C System Oil Type DH-PS**

**Part number: KLH00-PAGS0**

### CHECKING AND ADJUSTING

Adjust the lubricant quantity according to the test group shown below.

## 1. LUBRICANT RETURN OPERATION

---

Can lubricant return operation be performed?

- A/C system works properly.
- There is no evidence of a large amount of lubricant leakage.

Yes or No

- Yes >> GO TO 2.  
No >> GO TO 3.

## 2. PERFORM LUBRICANT RETURN OPERATION, PROCEEDING AS FOLLOWS

---

1. Start engine, and set the following conditions:
  - **Test condition**
  - Engine speed: Idling to 1,200 rpm**
  - A/C switch: ON**
  - Blower speed: Max. position**
  - Temp. control: Optional [Set so that intake air temperature is 25 to 30°C (77 to 86°F).]**
  - Intake position: Recirculation (REC)**
2. Perform lubricant return operation for about 10 minutes.
3. Stop engine.

### **CAUTION:**

**If excessive lubricant leakage is noted, do not perform the lubricant return operation.**

>> GO TO 3.

## 3. CHECK COMPRESSOR

---

Should the compressor be replaced?

Yes or No

- Yes >> GO TO [MTC-19, "Lubricant Adjustment Procedure for Compressor Replacement"](#) .  
No >> GO TO 4.

## 4. CHECK ANY PART

---

Is there any part to be replaced? (Evaporator, condenser, liquid tank or in case there is evidence of a large amount of lubricant leakage.)

Yes or No

- Yes >> GO TO [MTC-19, "Lubricant Adjusting Procedure for Component Replacement Except Compressor"](#) .  
No >> Carry out the A/C performance test.

# LUBRICANT

## Lubricant Adjusting Procedure for Component Replacement Except Compressor

After replacing any of the following major components, add the correct amount of lubricant to the system.

### Amount of lubricant to be added

Part replaced	Lubricant to be added to system	Remarks
	Amount of lubricant m ℓ (US fl oz, Imp fl oz)	
Evaporator	75 (2.5, 2.6)	—
Condenser	75 (2.5, 2.6)	—
Liquid tank	5 (0.2, 0.2)	Add if compressor is not replaced.
In case of refrigerant leak	30 (1.0, 1.1)	Large leak
	—	Small leak *1

- \*1: If refrigerant leak is small, no addition of lubricant is needed.

## Lubricant Adjustment Procedure for Compressor Replacement

1. Before connecting ACR4 to vehicle, check ACR4 gauges. No refrigerant pressure should be displayed. If OK, recover refrigerant from equipment lines.
2. Confirm refrigerant purity in supply tank using ACR4 and refrigerant identifier. If NG, refer to [MTC-3, "Contaminated Refrigerant"](#).
3. Connect ACR4 to vehicle. Confirm refrigerant purity in vehicle A/C system using ACR4 and refrigerant identifier. If NG, refer to [MTC-3, "Contaminated Refrigerant"](#).
4. Discharge refrigerant into the refrigerant recovery/recycling equipment. Measure lubricant discharged into the recovery/recycling equipment.
5. Drain the lubricant from the "old" (removed) compressor into a graduated container and recover the amount of lubricant drained.
6. Drain the lubricant from the "new" compressor into a separate, clean container.
7. Measure an amount of new lubricant installed equal to amount drained from "old" compressor. Add this lubricant to "new" compressor through the suction port opening.
8. Measure an amount of new lubricant equal to the amount recovered during discharging. Add this lubricant to "new" compressor through the suction port opening.
9. If the liquid tank also needs to be replaced, add an additional 5 m ℓ (0.2 US fl oz, 0.2 Imp fl oz) of lubricant at this time.

**Do not add this 5 m ℓ (0.2 US fl oz, 0.2 Imp fl oz) of lubricant if only replacing the compressor.**

# LUBRICANT

## Lubricant adjusting procedure for compressor replacement

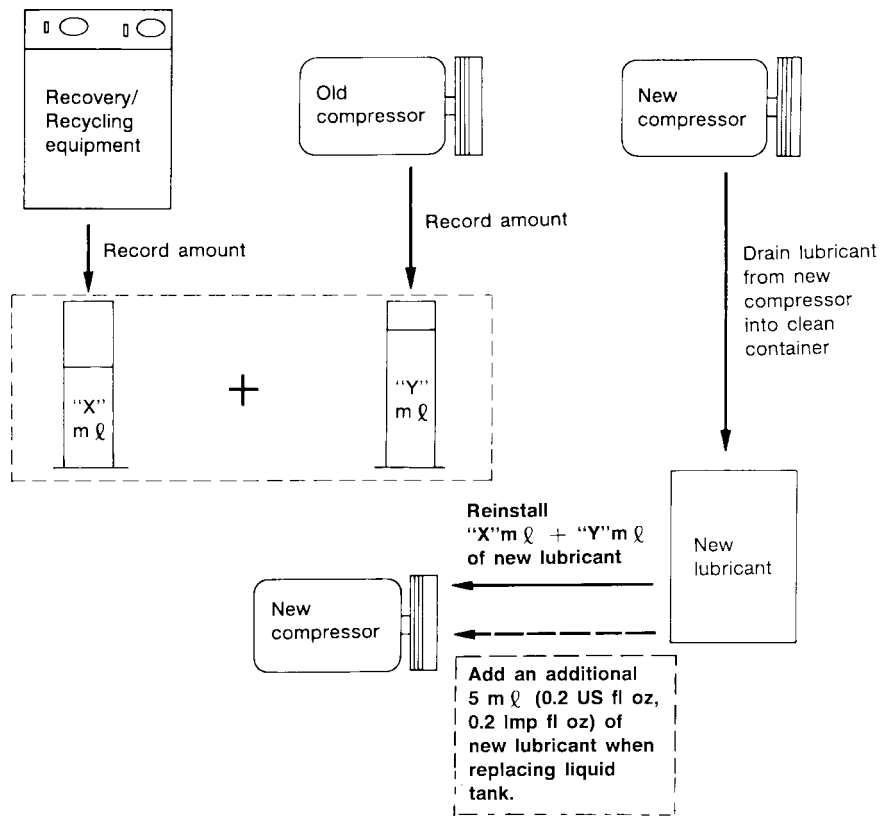

RHA065DD

# AIR CONDITIONER CONTROL

## AIR CONDITIONER CONTROL

PF27500

### Control Operation

EJS00021

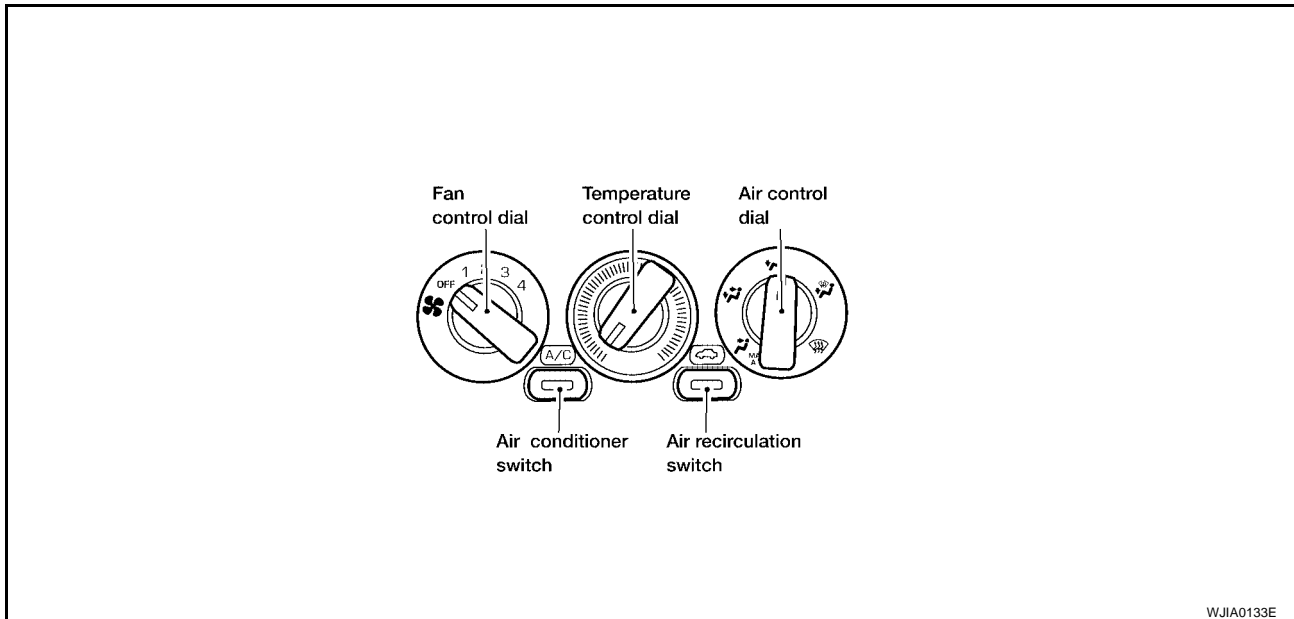

WJIA0133E

#### FAN CONTROL DIAL

This dial turns the fan ON and OFF, and controls fan speed.

#### AIR CONTROL DIAL

This dial allows control of the outlet air flow.

In , or mode, the intake door is set to "FRESH".

The compressor turns on when the dial is moved to "MAX A/C" or .

#### TEMPERATURE CONTROL DIAL

This dial allows adjustment of the temperature of the outlet air.

#### RECIRCULATION (REC) SWITCH

OFF position: Outside air is drawn into the passenger compartment.

ON position: Interior air is recirculated inside the vehicle. The indicator lamp will also light.

Recirculation is canceled when , or is selected, and resumes when another mode is chosen.

If the refrigerant pressure sensor input signal is high, recirculation is canceled, when , and mode is selected.

#### AIR CONDITIONER (A/C) SWITCH

The air conditioner switch controls the A/C system. When the switch is depressed with the fan ON, the compressor will turn ON. The indicator lamp will also light.

**The air conditioner cooling function operates only when the engine is running.**

A  
B  
C  
D  
E  
F  
G

H

I

MTC

K

L

M

# AIR CONDITIONER CONTROL

EJS000ZJ

## Discharge Air Flow

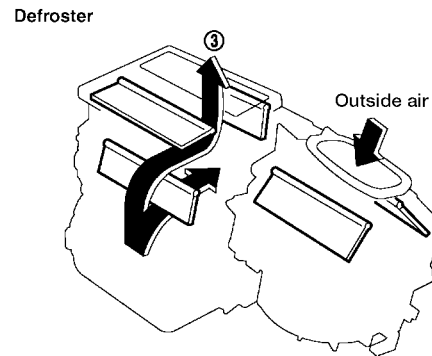
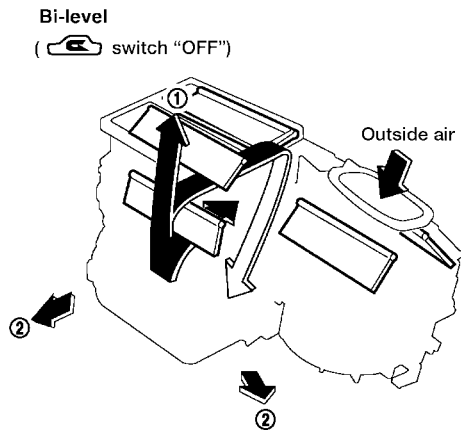
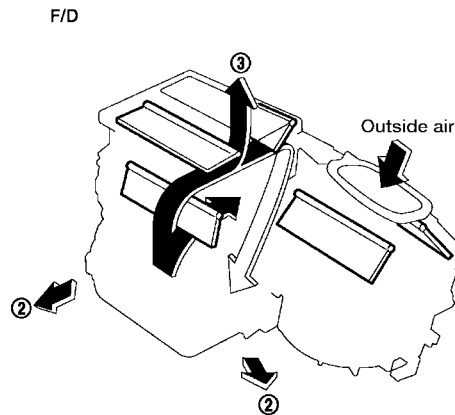
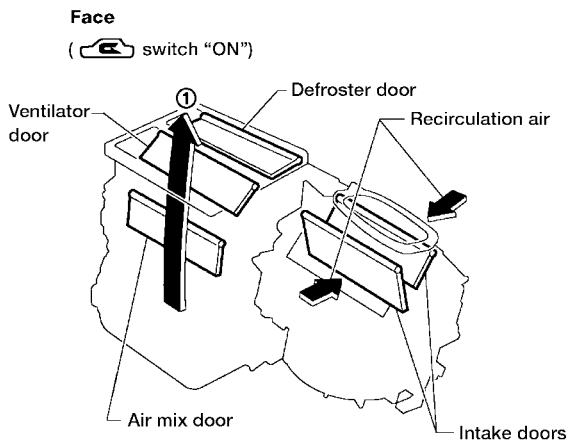
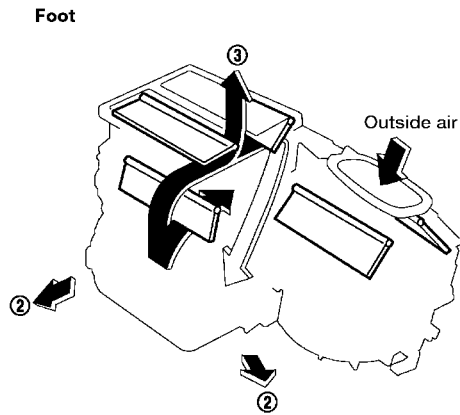
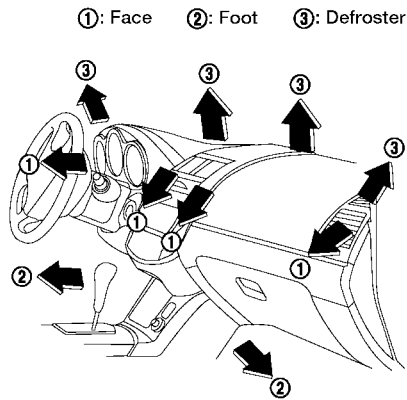

- ①: To face
- ②: To foot
- ③: To defroster

For air flow %, refer to "Operational Check", "TROUBLE DIAGNOSES".

WJIA0016E

# AIR CONDITIONER CONTROL

EJS000ZK

## System Description SWITCHES AND THEIR CONTROL FUNCTION

Knob/Switch	Knob/Switch position							Air outlet	Intake air	Compressor
	A/C									
A/C	○							—	—	ON*1
Mode		○						VENT	*4	*3
			○					B/L	*4	*3
				○				FOOT	FRE	*3
					○			D/F	FRE	*3
						○		DEF	FRE	*1
						○	—	REC*2	—	

\*1: Compressor is operated by ECM.  
 \*2: In and modes, REC switch is canceled  
 \*3: Compressor operates if A/C switch is ON.  
 \*4: Recirculation operates if REC switch is ON.

WJIA0134E

## CAN Communication System Description

EJS000ZL

CAN (Controller Area Network) is a serial communication line for real time application. It is an on-vehicle multiplex communication line with high data communication speed and excellent error detection ability. Many electronic control units are equipped onto a vehicle, and each control unit shares information and links with other control units during operation (not independent). In CAN communication, control units are connected with 2 communication lines (CAN H line, CAN L line) allowing a high rate of information transmission with less wiring. Each control unit transmits/receives data but selectively reads required data only.

### FOR TCS MODELS

#### System diagram

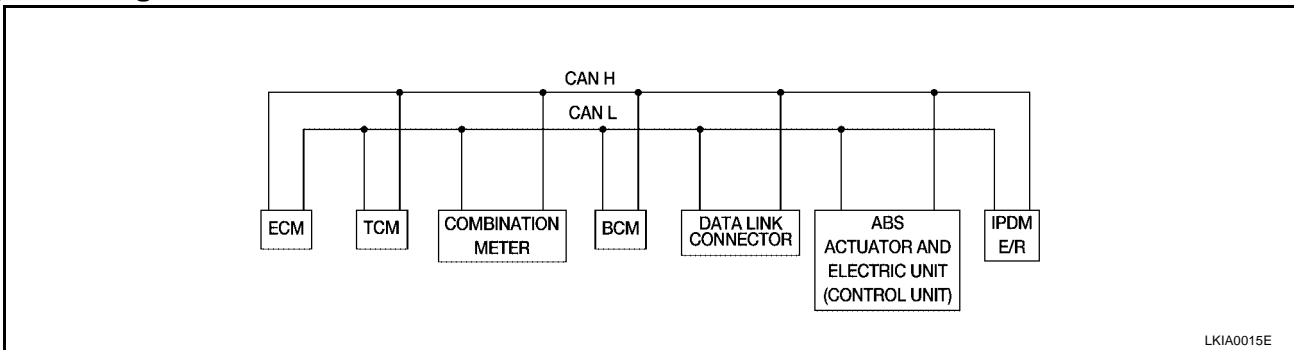

#### Input/output signal chart

T: Transmit R: Receive

Signals	ECM	TCM	COMBINATION METER	BCM	ABS/TCS control unit	IPDM E/R
Engine speed signal	T		R		R	
Engine coolant temperature signal	T		R			

A  
B  
C  
D  
E  
F  
G  
H  
I  
MTC  
K  
L  
M

## AIR CONDITIONER CONTROL

Signals	ECM	TCM	COMBINATION METER	BCM	ABS/TCS control unit	IPDM E/R
Accelerator pedal position signal	T					
Fuel consumption monitor signal	T		R			
A/T warning lamp signal		T	R			
A/T position indicator signal	R	T	R	R <sup>(R range only)</sup>	R	
ABS operation signal	R				T	
TCS operation signal	R	R			T	
Air conditioner switch signal	R			T		
Air conditioner compressor signal	R					T
A/C compressor request signal	T					R
Cooling fan motor operation signal	R					T
Cooling fan speed request signal	T					R
Position lights request			R	T		R
Position lights status				R		T
Low beam request				T		R
Low beam status	R			R		T
High beam request			R	T		R
High beam status	R			R		T
Front fog lights request				T		R
Front fog light status				R		T
OD cancel switch signal		R	T			R
Brake switch signal		R	T			
Vehicle speed signal	R		T			
	R		T	R		
Oil pressure switch			R			T
Sleep request1			R	T		
Sleep request2				T		R
N range switch signal		R	T			
P range switch signal		R	T			
Seat belt buckle switch signal			T	R		
Door switch signal			R	T		R
Tail lamp request			R	T		R
Turn indicator signal			R	T		
Buzzer output signal			R	T		
Trunk switch signal			R	T		
ASCD main switch signal	T		R			
ASCD cruise signal	T		R			
Wiper operation				R		T
Wiper stop position signal				R		T
Rear window defogger switch signal				T		R
Rear window defogger control signal	R			R		T



# AIR CONDITIONER CONTROL

## FOR A/T MODELS

### System diagram

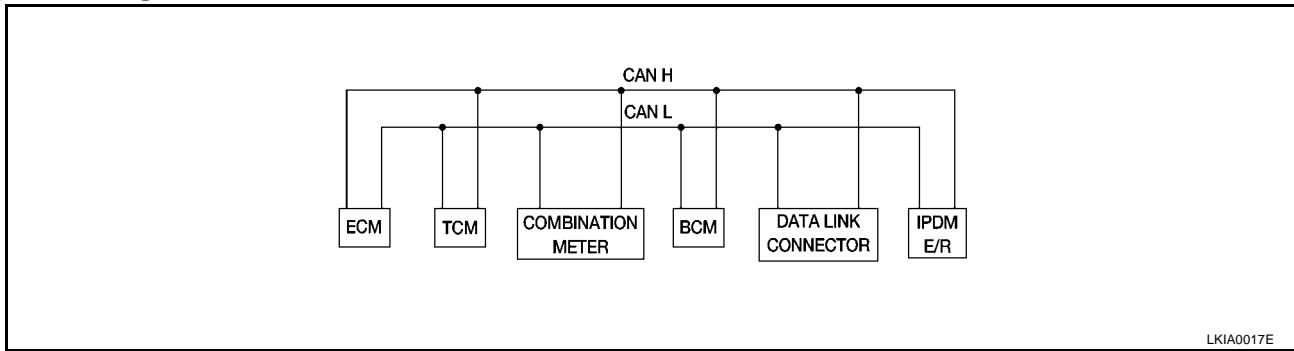

LKIA0017E

### Input/output signal chart

T: Transmit R: Receive

Signals	ECM	TCM	COMBINATION METER	BCM	IPDM E/R
Engine speed signal	T		R		
Engine coolant temperature signal	T		R		
Accelerator pedal position signal	T				R
Fuel consumption monitor signal	T		R		
A/T warning lamp signal		T	R		
A/T position indicator signal	R	T	R	R(R range only)	
Air conditioner switch signal	R			T	
Air conditioner compressor signal	R				T
A/C compressor request signal	T				R
Blower fan switch signal	R(QR25DE)			T	
Cooling fan motor operation signal	R			T	
Cooling fan speed request signal	T				R
Position lights request			R	T	R
Position lights status				R	T
Low beam request				T	R
Low beam status	R			R	T
High beam request			R	T	R
High beam status	R			R	T
Front fog lights request				T	R
Front fog light status				R	T
OD cancel switch signal		R	T		R
Brake switch signal		R	T		
Vehicle speed signal	R		T		
	R		T	R	
Oil pressure switch			R		T
Sleep request1			R	T	
Sleep request2				T	R
N range switch signal		R	T		
P range switch signal		R	T		
Seat belt buckle switch signal			T	R	
Door switch signal			R	T	R

# AIR CONDITIONER CONTROL

Signals	ECM	TCM	COMBINATION METER	BCM	IPDM E/R
Tail lamp request			R	T	R
Turn indicator signal			R	T	
Buzzer output signal			R	T	
Trunk switch signal			R	T	
ASCD main switch signal	T		R		
ASCD cruise signal	T		R		
Wiper operation				R	T
Wiper stop position signal				R	T
Rear window defogger switch signal				T	R
Rear window defogger control signal	R			R	T

## FOR M/T MODELS

### System diagram

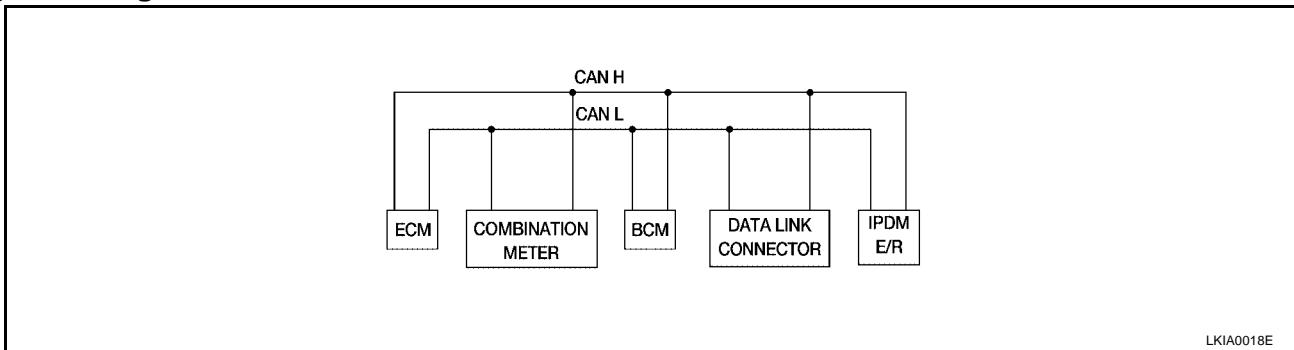

### Input/output signal chart

T: Transmit R: Receive

Signals	ECM	COMBINATION METER	BCM	IPDM E/R
Engine speed signal	T			
Engine coolant temperature signal	T			
Fuel consumption monitor signal	T			
Air conditioner switch signal	R		T	
Air conditioner compressor signal	R			T
A/C compressor request signal	T			R
Blower fan switch signal	R <sup>(QR25DE)</sup>		T	
Cooling fan motor operation signal	R			T
Cooling fan speed request signal	T			R
Position lights request		R	T	R
Position lights status			R	T
Low beam request			T	R
Low beam status	R		R	T
High beam request		R	T	R
High beam status	R		R	T
Front fog lights request			T	R
Front fog light status			R	T
Vehicle speed signal	R	T		
Oil pressure switch		R		T

## AIR CONDITIONER CONTROL

Signals	ECM	COMBINATION METER	BCM	IPDM E/R	
Sleep request1		R	T		A
Sleep request2			T	R	B
Seat belt buckle switch signal		T	R		C
Door switch signal		R	T	R	D
Tail lamp request		R	T	R	E
Turn indicator signal		R	T		F
Buzzer output signal		R	T		G
Trunk switch signal		R	T		H
ASCD main switch signal	T	R			I
ASCD cruise signal	T	R			MTC
Wiper operation			R	T	K
Wiper stop position signal			R	T	L
Rear window defogger switch signal			T	R	M
Rear window defogger control signal	R		R	T	

# TROUBLE DIAGNOSIS

## TROUBLE DIAGNOSIS

PFP:00004

### How to Perform Trouble Diagnoses for Quick and Accurate Repair WORK FLOW

EJS000ZM

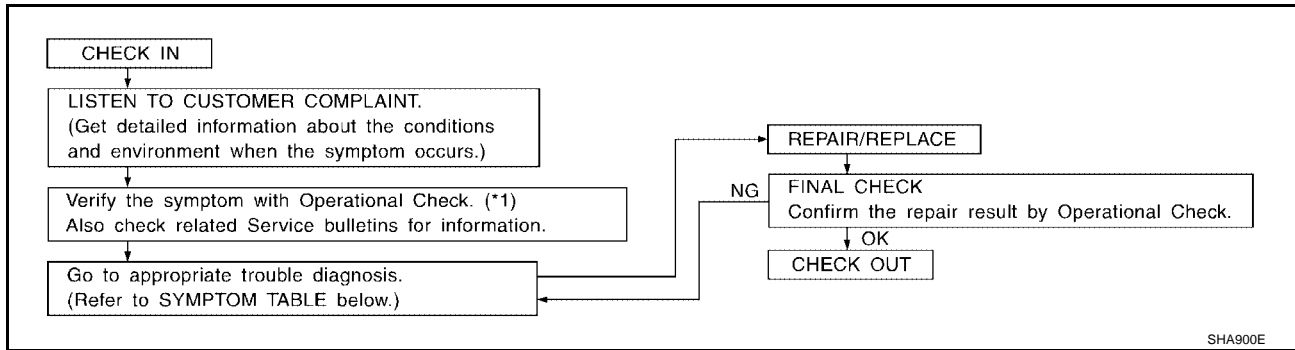

SHA900E

\*1: [MTC-38. "Operational Check"](#)

### SYMPTOM TABLE

Symptom	Reference Page
● A/C system does not come on.	● Go to Trouble Diagnosis Procedure for A/C system. <a href="#">MTC-40</a>
● Air outlet does not change.	● Go to Trouble Diagnosis Procedure for Mode Door Motor. <a href="#">MTC-42</a>
● Mode door motor does not operate normally.	
● Air Mix door does not change.	● Go to Trouble Diagnosis Procedure for Air Mix Door. <a href="#">MTC-45</a>
● Intake door does not change.	● Go to Trouble Diagnosis Procedure for Intake Door Motor. <a href="#">MTC-46</a>
● Intake door motor does not operate normally.	
● Blower motor operation is malfunctioning.	● Go to Trouble Diagnosis Procedure for Blower Motor. <a href="#">MTC-49</a>
● Magnet clutch does not engage.	● Go to Trouble Diagnosis Procedure for Magnet Clutch. <a href="#">MTC-54</a>
● Insufficient cooling.	● Go to Trouble Diagnosis Procedure for Insufficient Cooling. <a href="#">MTC-58</a>
● Insufficient heating.	● Go to Trouble Diagnosis Procedure for Insufficient Heating. <a href="#">MTC-63</a>
● Noise.	● Go to Trouble Diagnosis Procedure for Noise. <a href="#">MTC-64</a>

# TROUBLE DIAGNOSIS

## Component Parts and Harness Connector Location ENGINE COMPARTMENT

EJS000ZN

### QR25DE Models

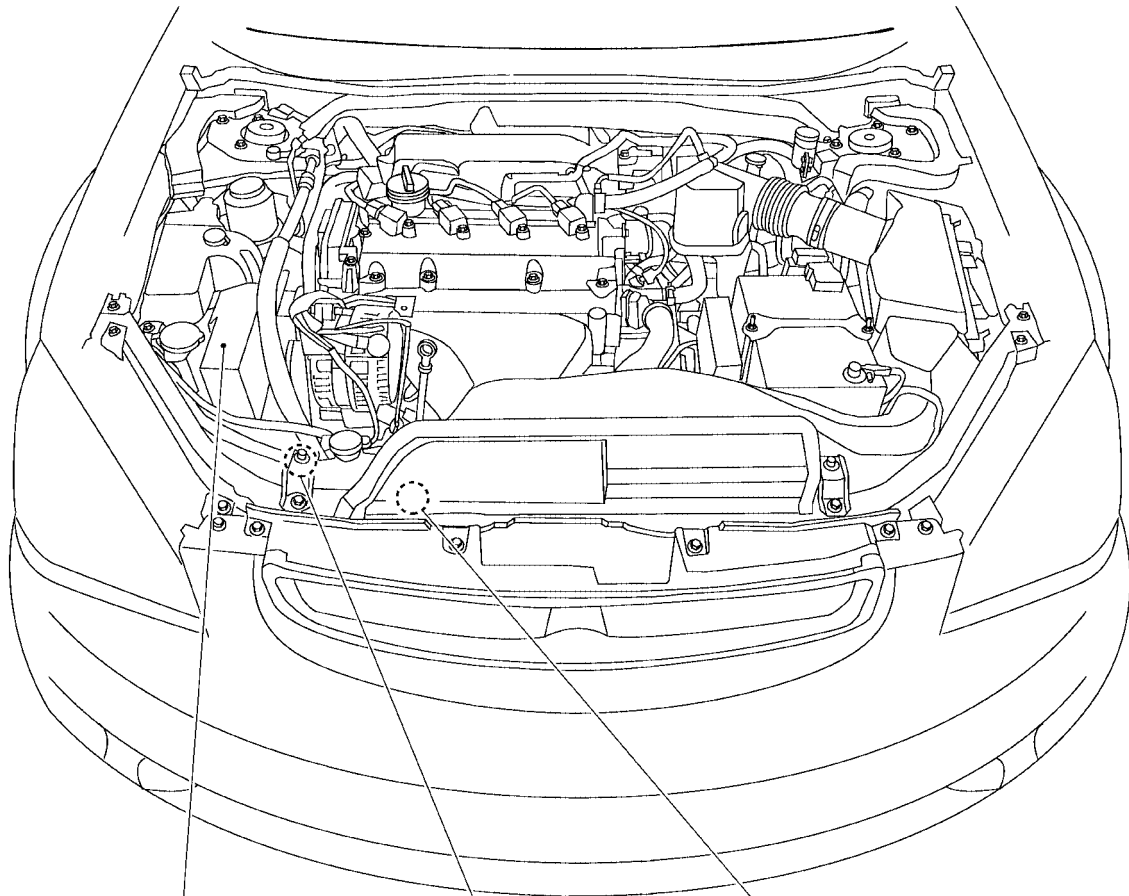
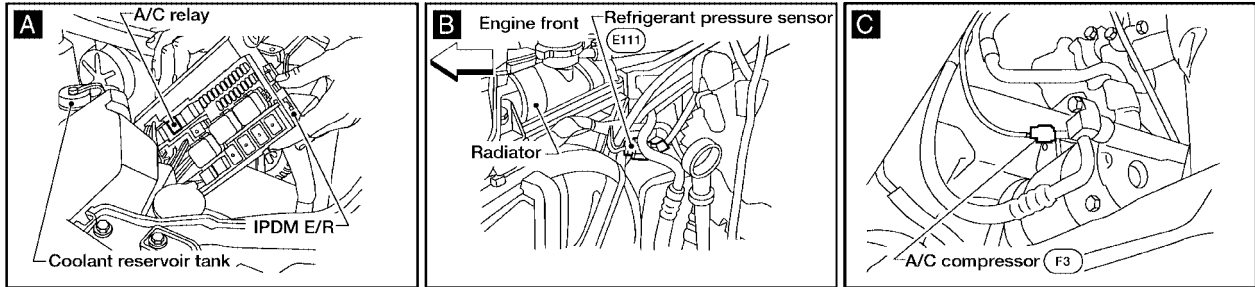

**A** IPDM E/R  
(A/C relay)

**B** Refrigerant pressure sensor

**C** A/C compressor

WJIA0136E

A  
B  
C  
D  
E  
F  
G  
H  
I  
MTC  
K  
L  
M

# TROUBLE DIAGNOSIS

## VQ35DE Models

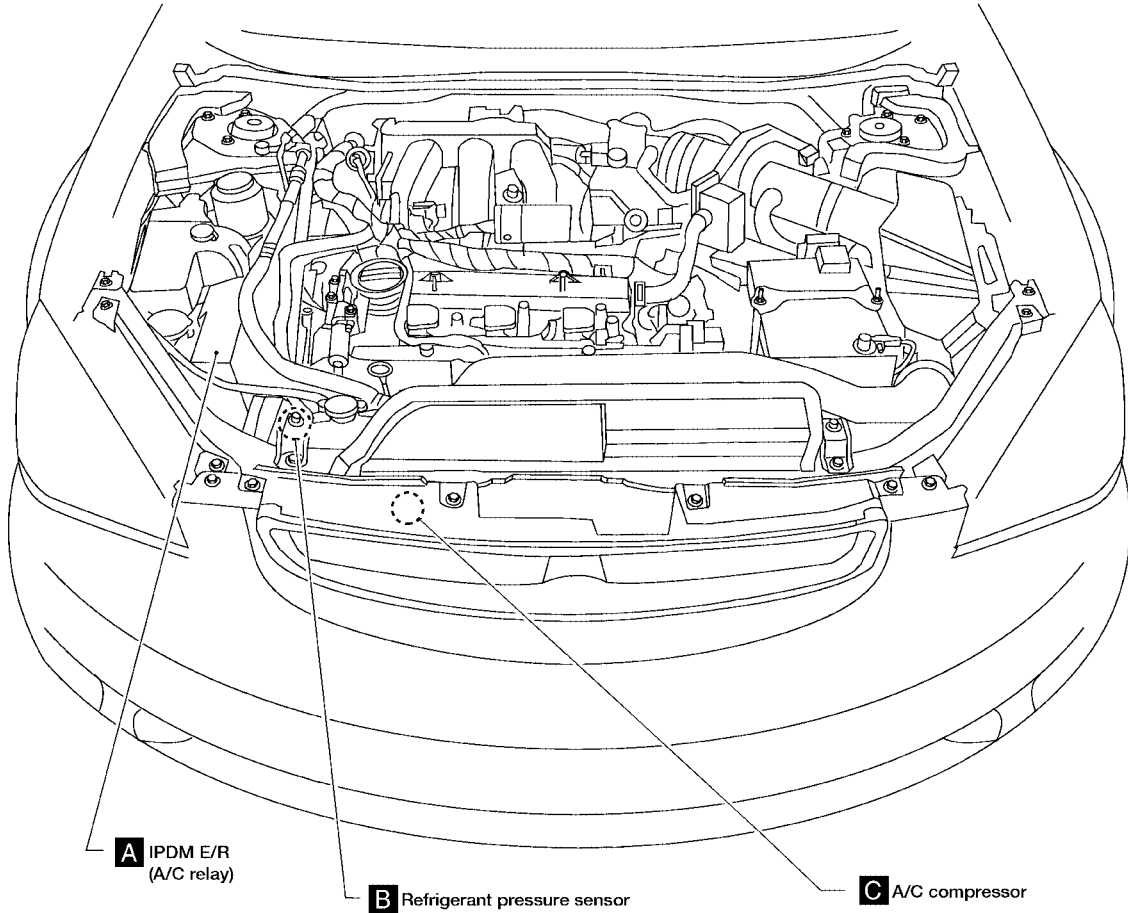
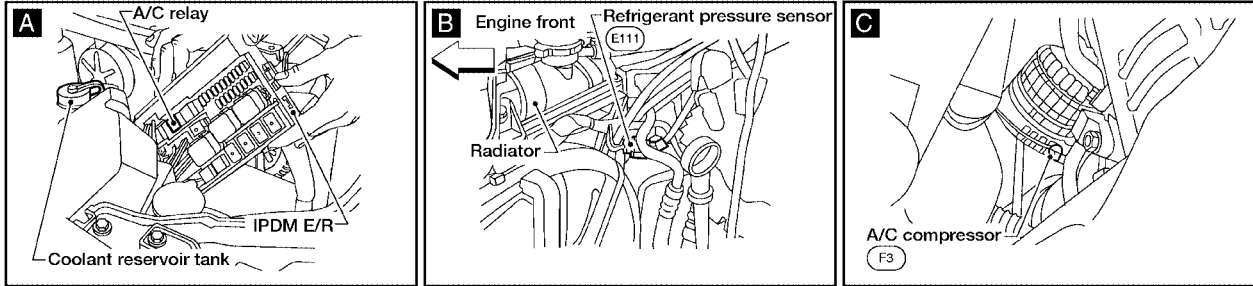

WJIA0137E

# TROUBLE DIAGNOSIS

## PASSENGER COMPARTMENT

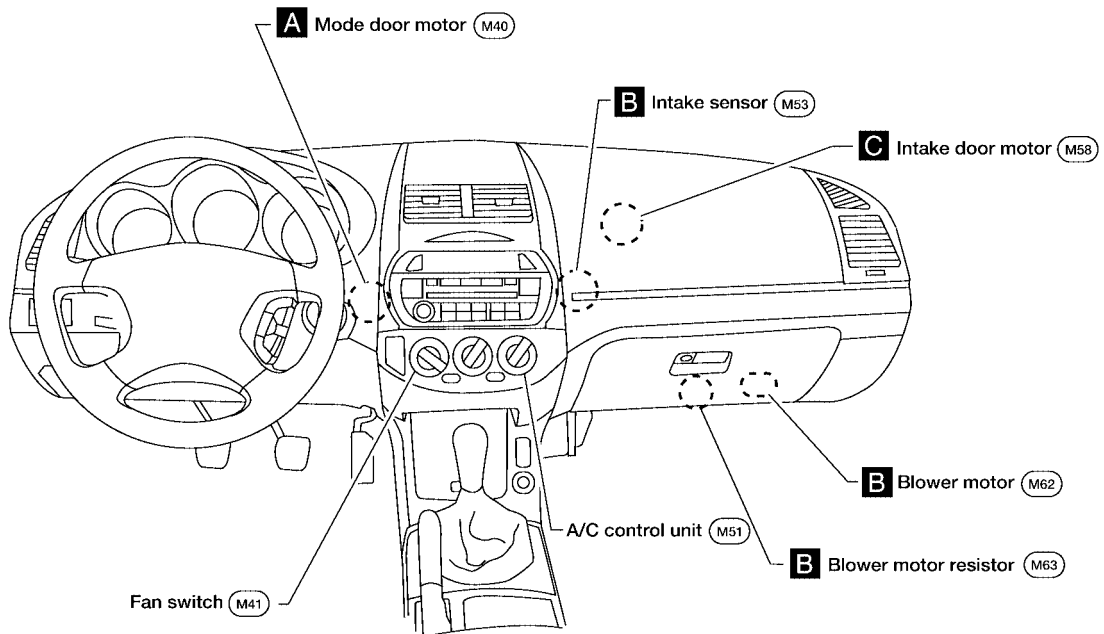
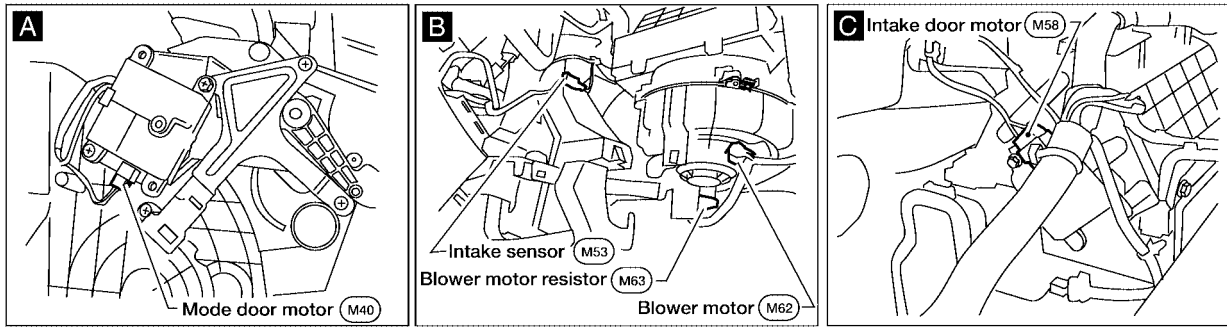

A  
B  
C  
D  
E  
F  
G  
H  
I  
MTC  
K  
L  
M

# TROUBLE DIAGNOSIS

## Circuit Diagram

EJS00020

\*1 (QR) : 33    \*2 (QR) : 34    (QR) : WITH QR25DE  
 (VQ) : 109    (VQ) : 113    (VQ) : WITH VQ35DE

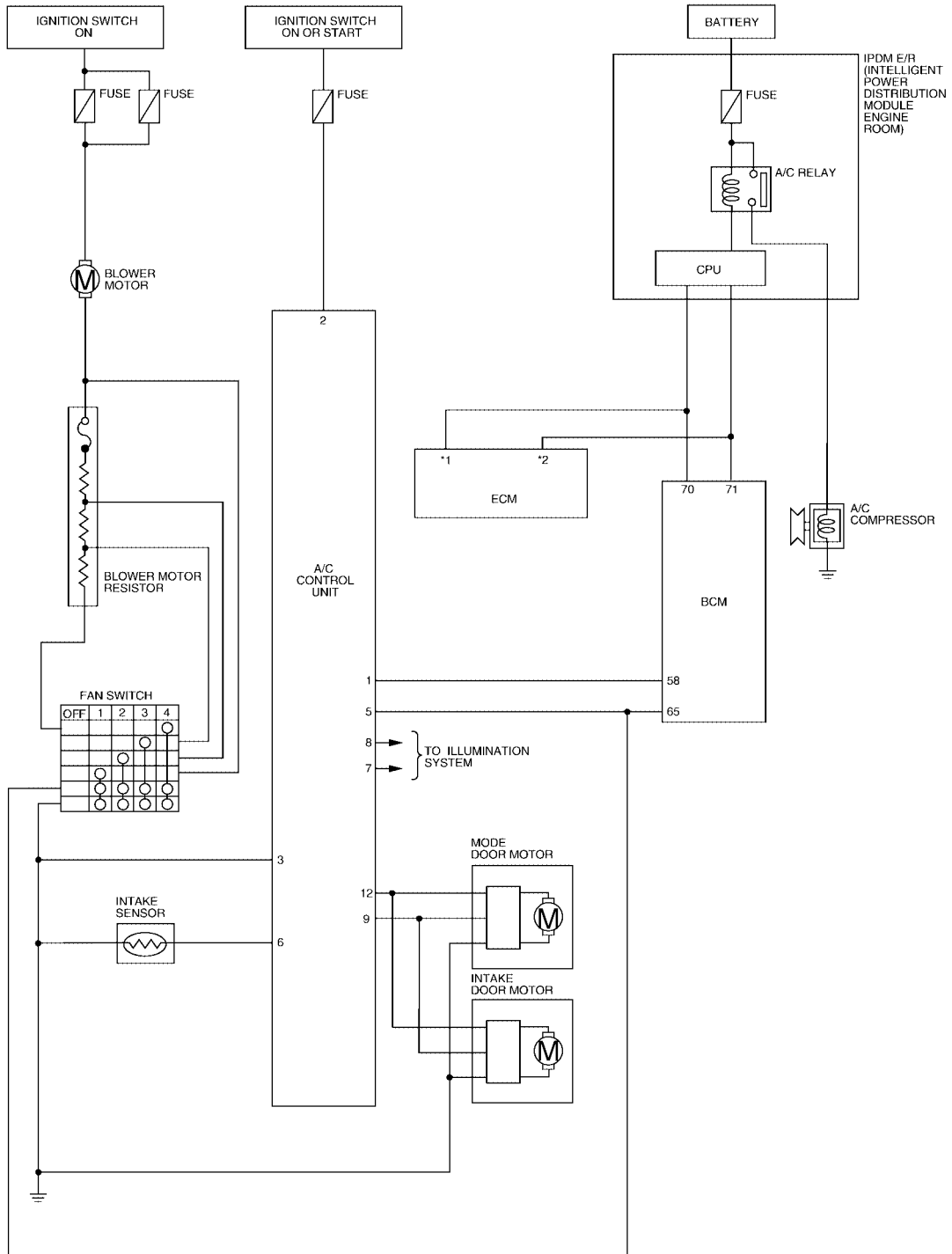

WJWA0011E



# TROUBLE DIAGNOSIS

## Wiring Diagram — HEATER —

EJS0002P

### MTC-HEATER-01

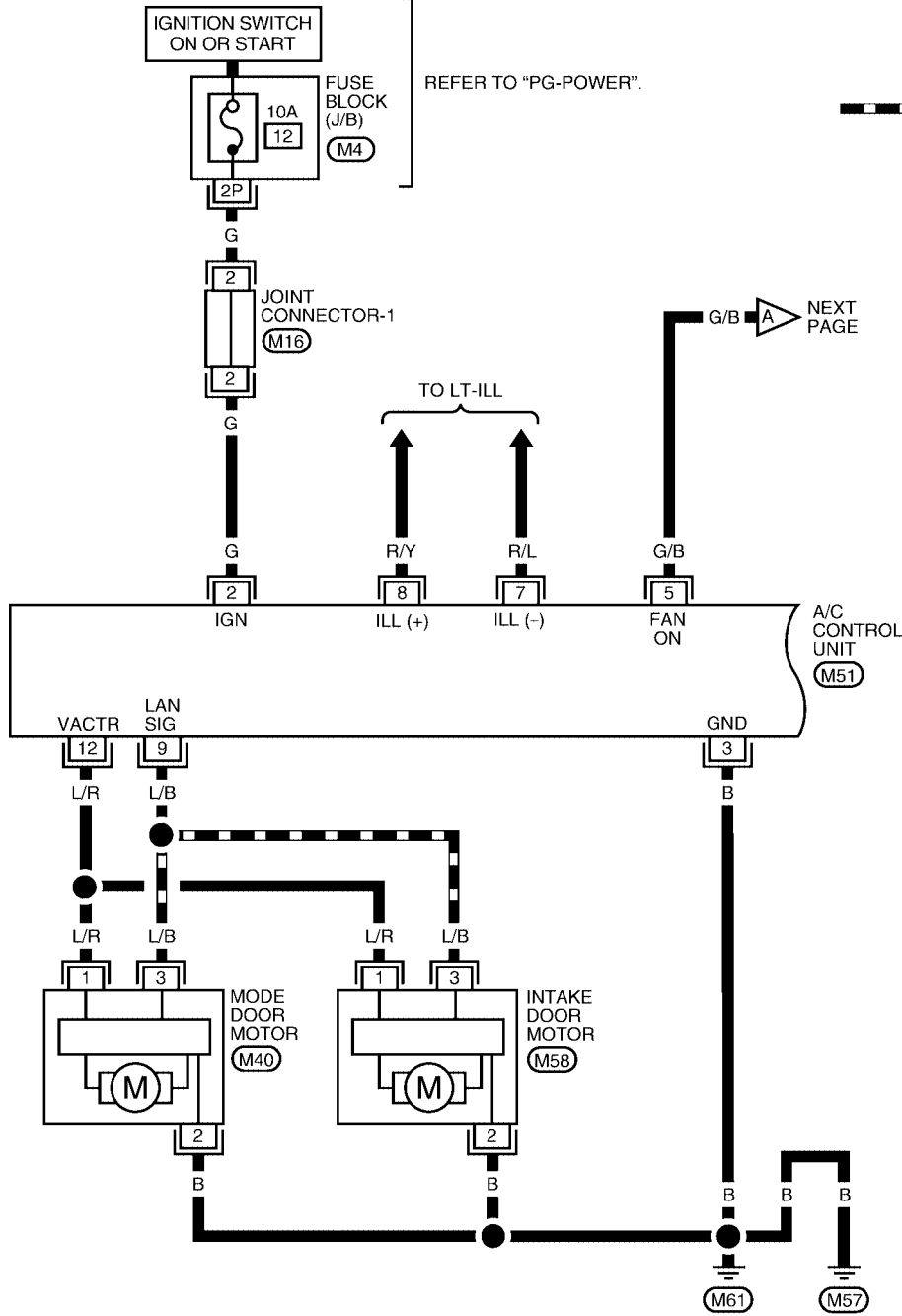

A  
B  
C  
D  
E  
F  
G  
H  
I  
MTC  
K  
L  
M

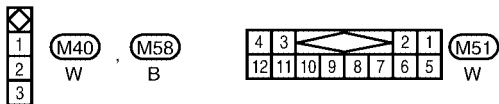

REFER TO THE FOLLOWING.  
 (M4) - FUSE BLOCK  
 JUNCTION BOX (J/B)  
 (M16) - JOINT CONNECTOR (J/C)

WJWA0012E

# TROUBLE DIAGNOSIS

## MTC-HEATER-02

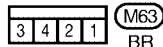
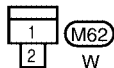
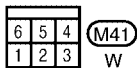
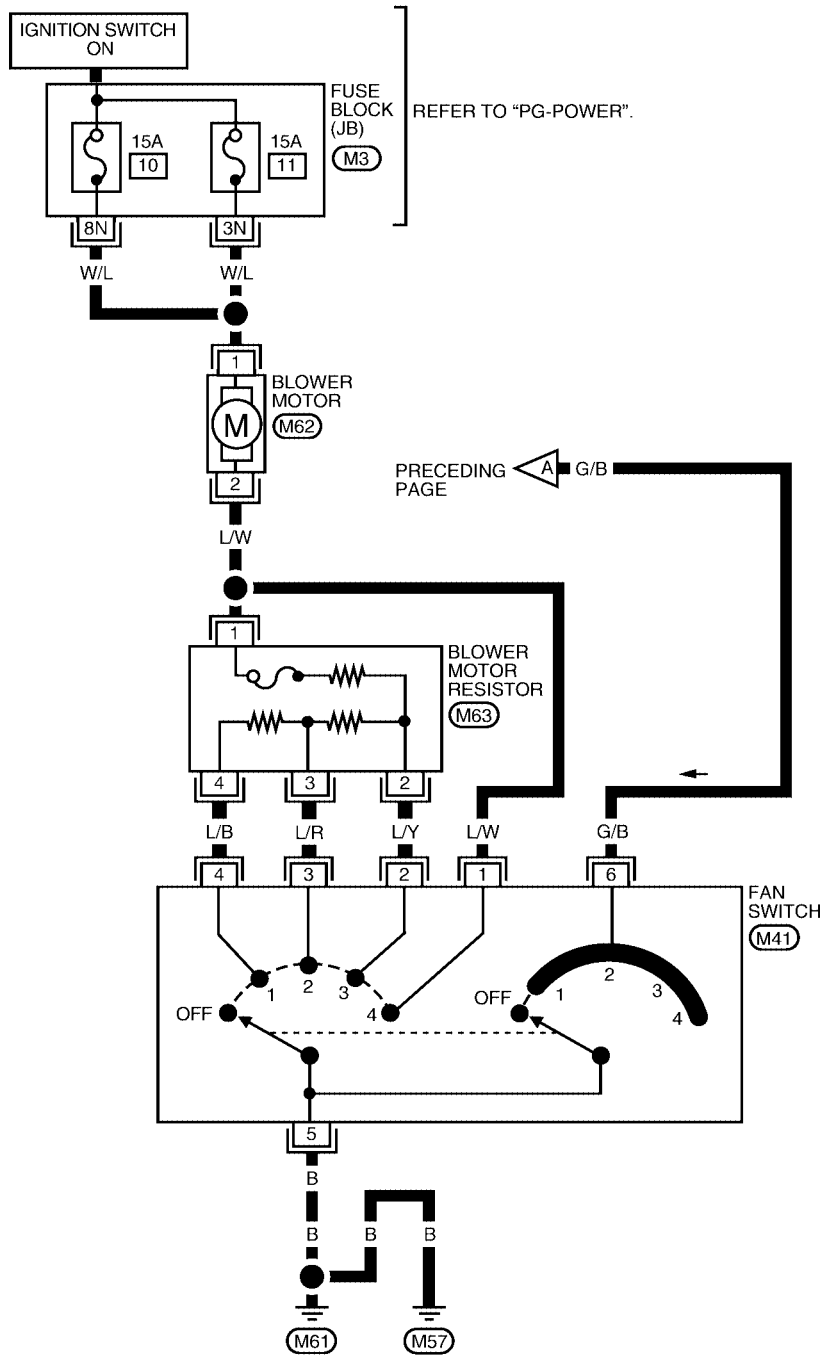

REFER TO THE FOLLOWING.

(M3) - FUSE BLOCK  
JUNCTION BOX (J/B)

WJWA0013E

# TROUBLE DIAGNOSIS

## Wiring Diagram — A/C,M —

EJS00020

### MTC-A/C,M-01

— — — — — : DATA LINE

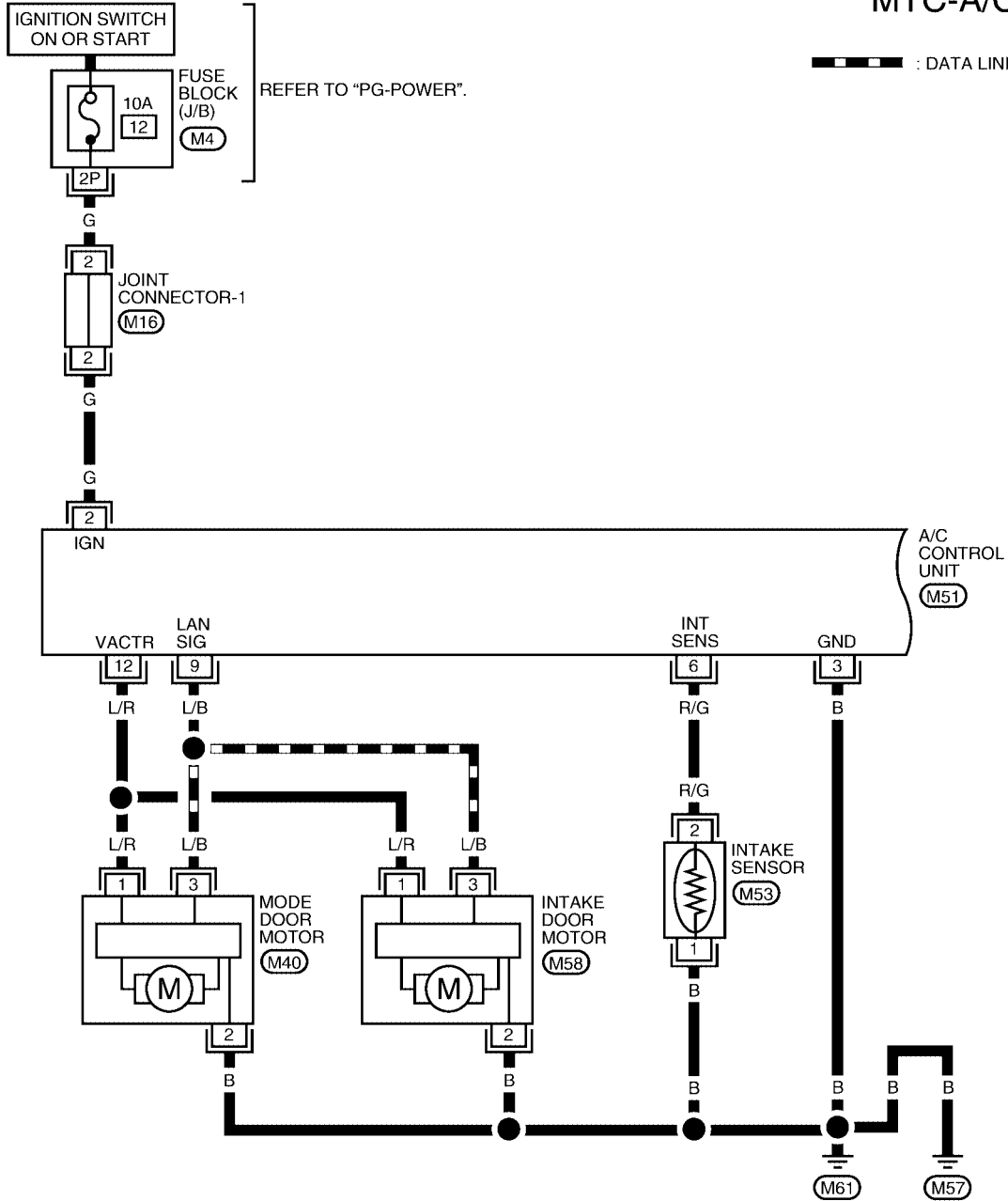

A  
B  
C  
D  
E  
F  
G  
H  
I  
MTC  
K  
L  
M

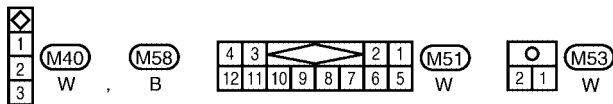

REFER TO THE FOLLOWING.

- (M4) - FUSE BLOCK
- (J/B) - JUNCTION BOX
- (M16) - JOINT CONNECTOR (J/C)

WJWA0014E

# TROUBLE DIAGNOSIS

MTC-A/C,M-02

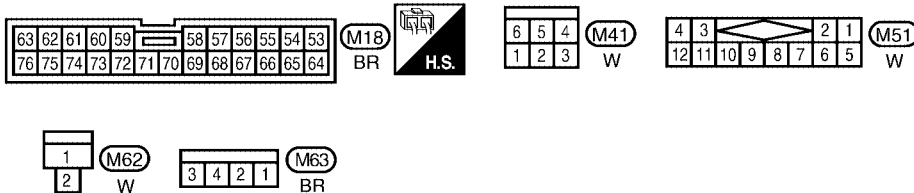
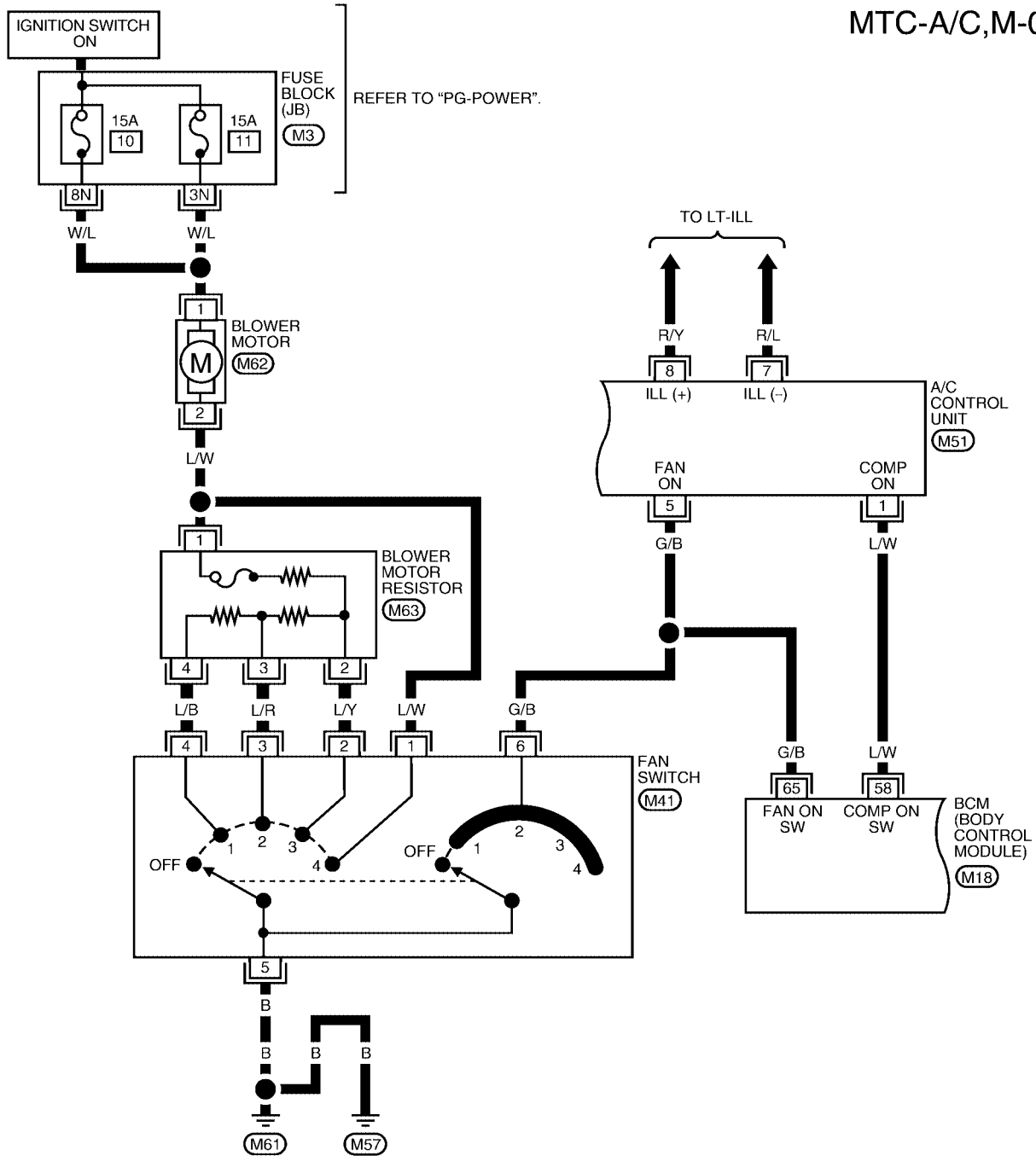

REFER TO THE FOLLOWING.

(M3) - FUSE BLOCK  
JUNCTION BOX (J/B)

WJWA0015E

# TROUBLE DIAGNOSIS

## MTC-A/C,M-03

A  
B  
C  
D  
E  
F  
G  
H  
I  
**MTC**  
K  
L  
M

— : DATA LINE

⬡QR : WITH QR25DE

⬡VQ : WITH VG35DE

\*1 ⬡QR : 34

\*2 ⬡VQ : 113

REFER TO "PG-POWER".

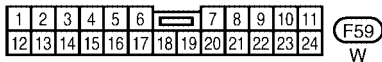
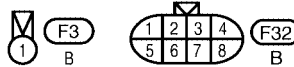
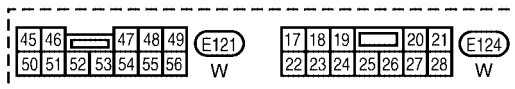
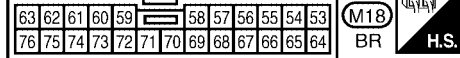
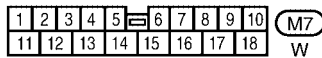
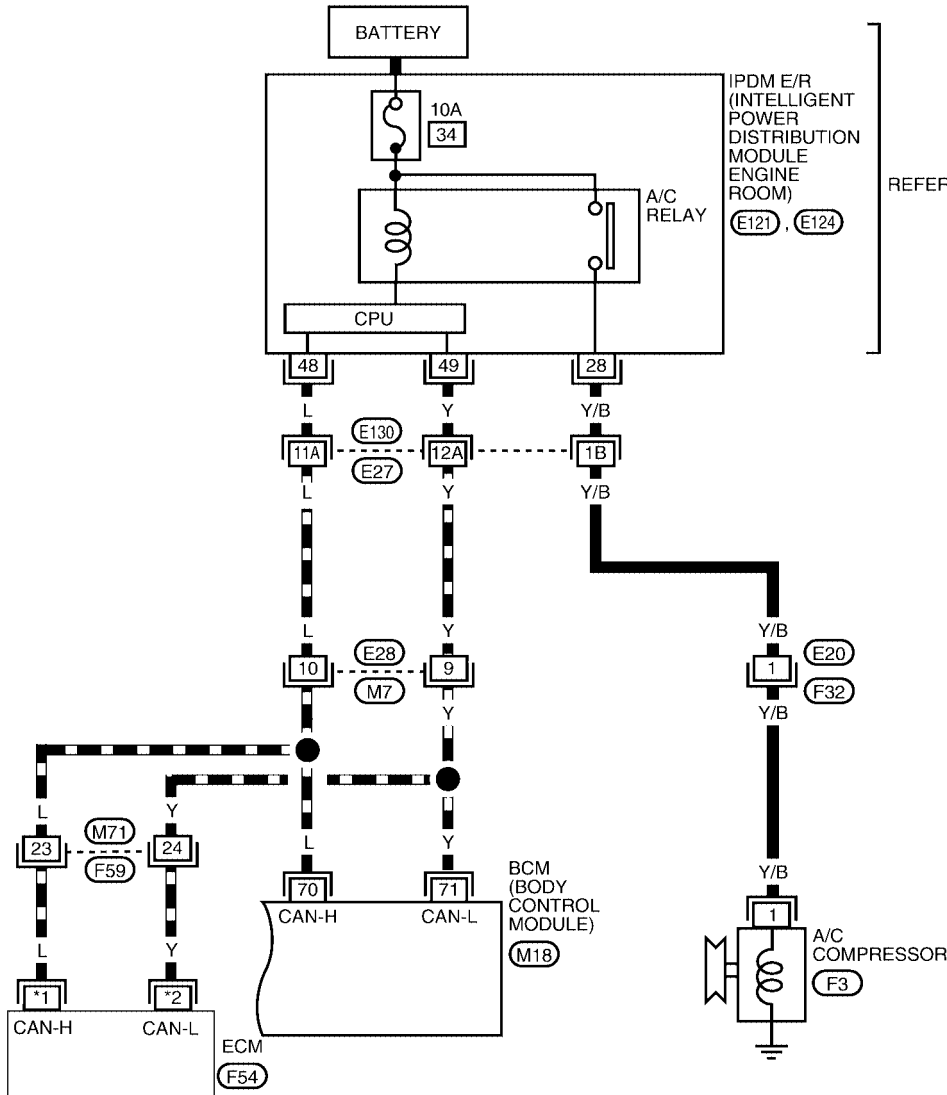

REFER TO THE FOLLOWING.

⬡E130 - SUPER MULTIPLE JUNCTION (SMJ)

⬡F54 - ELECTRICAL UNITS

⬡F32 - ELECTRICAL UNITS

WJWA0016E

# TROUBLE DIAGNOSIS

EJS000ZR

## Operational Check

The purpose of the operational check is to confirm that the system operates as it should. The systems which are checked are the blower, mode (discharge air), intake air, temperature decrease, temperature increase.

### CONDITIONS:

Engine running at normal operating temperature.

### PROCEDURE:

#### 1. Check Blower

1. Turn fan control dial to 1-speed.  
Blower should operate on 1-speed.
2. Then turn fan control dial to 2-speed.
3. Continue checking blower speed until all four speeds are checked.
4. Leave blower on 4-speed.

If NG, go to [MTC-49, "Blower Motor Circuit"](#).

If OK, continue with next check.

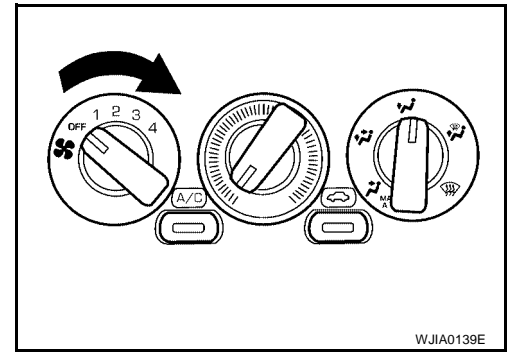

#### 2. Check Discharge Air

1. Turn air control dial to each position.
2. Confirm air discharge at all air outlets.

If NG, go to [MTC-42, "Mode Door Motor Circuit"](#).

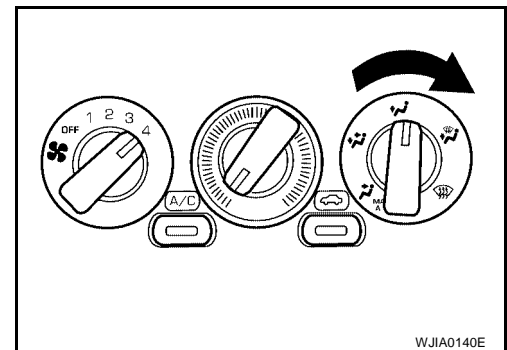

If OK, continue with next check.



#### 3. Check Recirculation

1. Press recirculation switch.  
Recirculation indicator should light.
2. Listen for intake door position change (you should hear blower sound change slightly).

#### NOTE:

Confirm that the RECIRCULATION (REC) switch is canceled in the FOOT (  ), D/F (  ) and DEF (  ) modes.

If NG, go to [MTC-46, "Intake Door Motor Circuit"](#).

If OK, continue with next check.

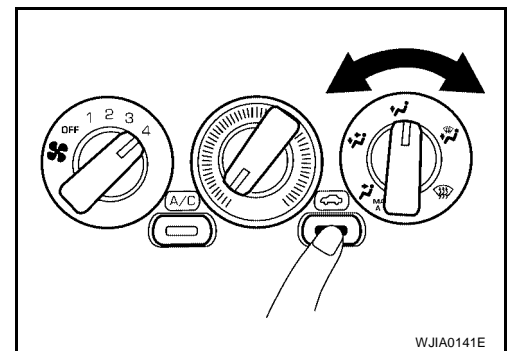

#### 4. Check Temperature Decrease

1. Turn fan control dial to 1-speed.
2. Turn temperature control dial to full cold.
3. Check for cold air at discharge air outlets.

If NG, go to [MTC-58, "Insufficient Cooling"](#).

If OK, continue with next check.

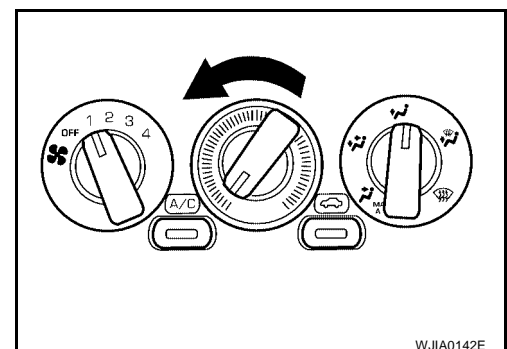

# TROUBLE DIAGNOSIS

## 5. Check Temperature Increase

1. Turn temperature control dial to full hot.
2. Check for hot air at discharge air outlets.

If NG, go to [MTC-63, "Insufficient Heating"](#) .  
If OK, continue with next check.

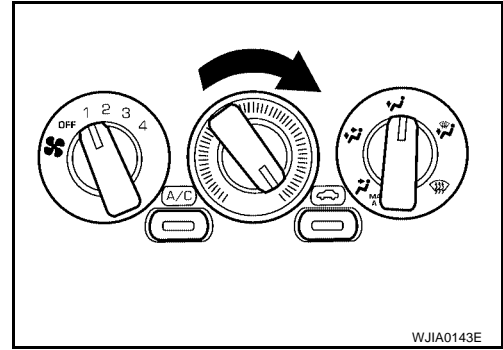

## 6. Check Air Conditioner Switch

Turn fan control dial to the desired (1- to 4-speed) position and push the air conditioner switch (if equipped) to turn ON the air conditioner. The indicator light should come on when air conditioner is ON.

If NG, go to [MTC-40, "A/C System"](#) .

If all operational checks are OK (symptom can not be duplicated), go to "Incident Simulation Tests" ([GI-25](#) ) and perform tests as outlined to simulate driving conditions environment. If symptom appears, refer to [MTC-28, "SYMPTOM TABLE"](#) and perform applicable trouble diagnosis procedures.

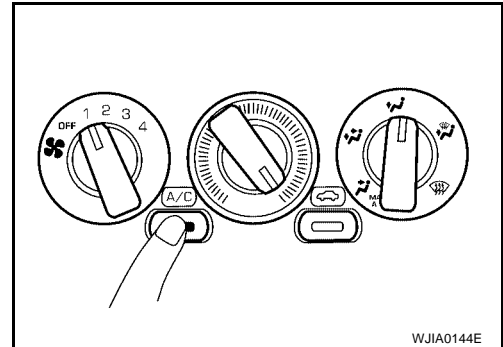

A  
B  
C  
D  
E  
F  
G  
H  
I

MTC

K  
L  
M

# TROUBLE DIAGNOSIS

EJS000ZS

## A/C System

SYMPTOM:

- A/C system does not come on.

### INSPECTION FLOW

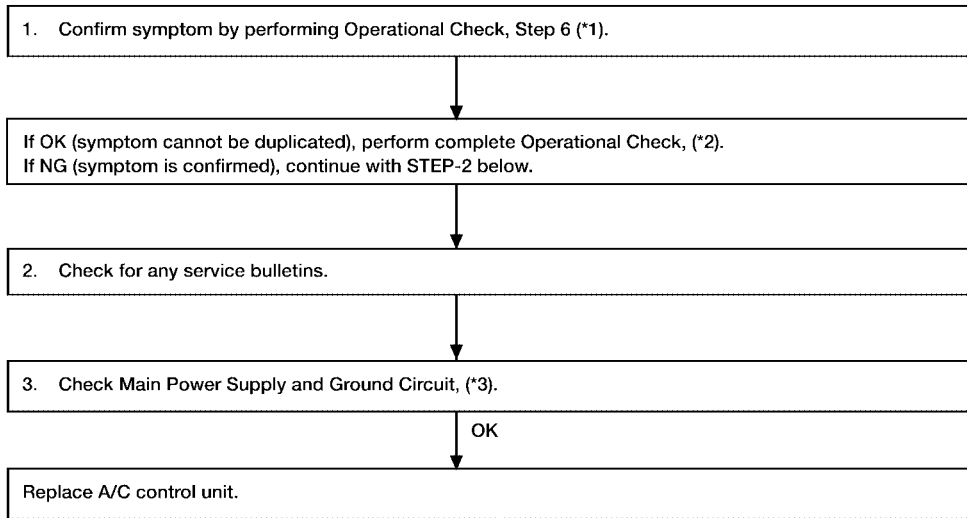

\*1: [MTC-39, "6. Check Air Conditioner Switch"](#)

\*2: [MTC-38, "Operational Check"](#)

\*3: [MTC-40, "DIAGNOSTIC PROCEDURE"](#)

WJIA0145E

## DIAGNOSTIC PROCEDURE

SYMPTOM:

- A/C system does not come on.

### 1. CHECK POWER SUPPLY CIRCUIT FOR A/C CONTROL UNIT

Terminal		Voltage (V) (Approx.)
(+)	(-)	
Connector	Wire color	Body ground 12V
M51-2	G	

OK or NG

OK >> GO TO 2.

NG >> Check 10A fuse (No. 12) at fuse block (J/B).

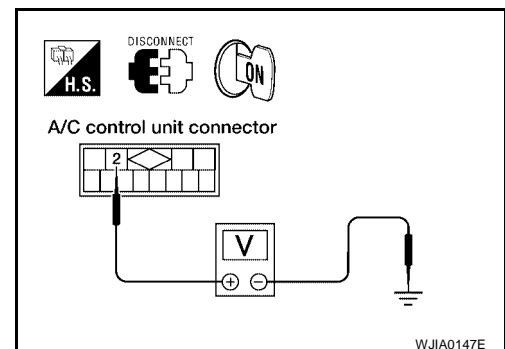



# TROUBLE DIAGNOSIS

## 2. CHECK BODY GROUND CIRCUIT FOR A/C CONTROL UNIT

Terminal		Body ground	Continuity
Connector	Wire color		Yes
M51-3	B		

If OK, check harness for short.

OK or NG

OK >> **INSPECTION END**

NG >> If NG, repair harness or connector.

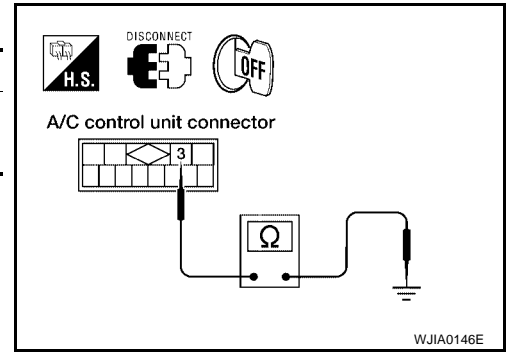

A  
B  
C  
D  
E  
F  
G  
H  
I  
MTC  
K  
L  
M

# TROUBLE DIAGNOSIS

EJS000ZT

## Mode Door Motor Circuit

### SYMPTOM:

- Air outlet does not change.
- Mode door motor does not operate normally.

### INSPECTION FLOW

1. Confirm symptom by performing the following operational check.

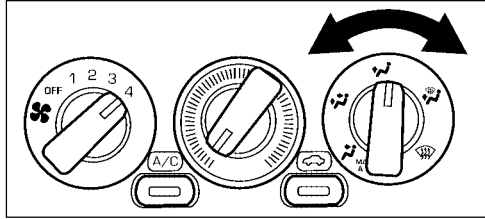

#### OPERATIONAL CHECK - Discharge air.

- 1) Turn air control dial to each position.
- 2) Confirm that discharge air comes out according to the air distribution table at left. Refer to "Discharge Air Flow" in "DESCRIPTION" (\*4).

Mode switch	Mode door/distribution		
	Face	Foot	Defroster
	100%	-	-
	60%	40%	-
	-	80%	20%
	-	60%	40%
	-	-	100%

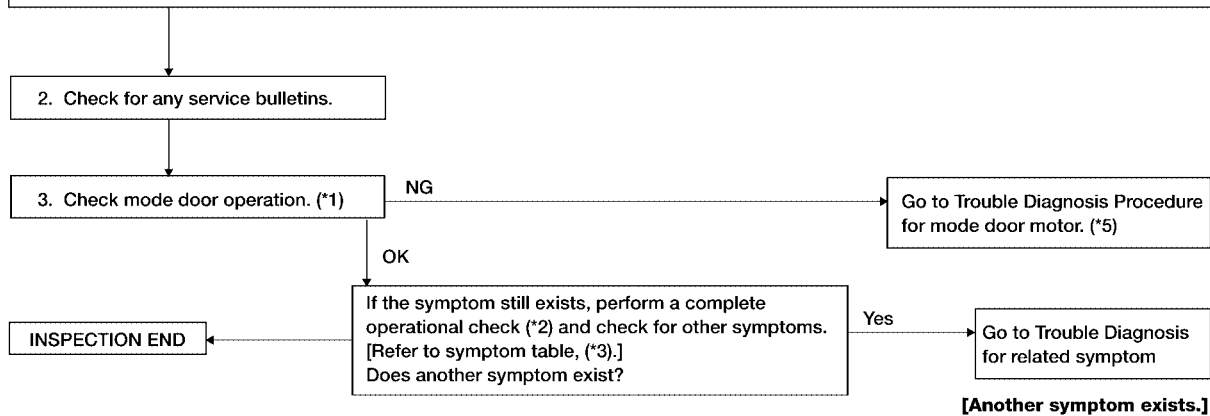

\*1 [MTC-44. "MODE DOOR"](#)

\*3 [MTC-28. "SYMPTOM TABLE"](#)

\*5 [MTC-43. "DIAGNOSTIC PROCEDURE"](#)

\*2 [MTC-38. "Operational Check"](#)

\*4 [MTC-22. "Discharge Air Flow"](#)

WJIA0205E

# TROUBLE DIAGNOSIS

## SYSTEM DESCRIPTION

### Mode Door Motor

The mode door motor is installed on the heater unit. Using a link it operates the mode door. When the air control dial is turned to each position, the mode door motor moves the mode door to control air flow direction.

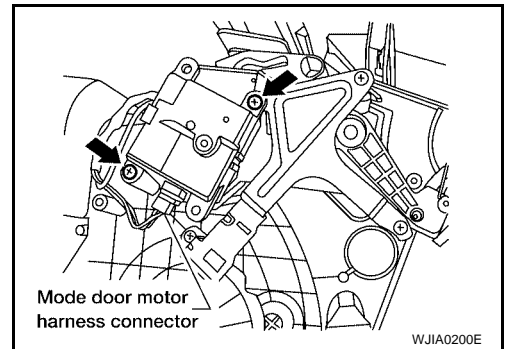
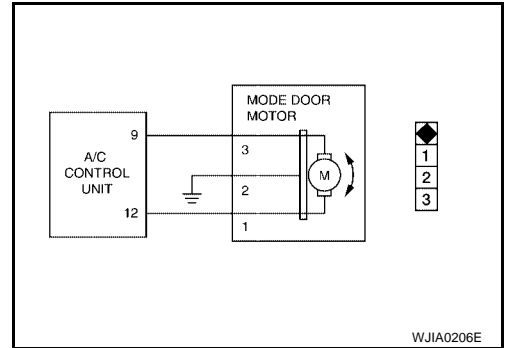

## DIAGNOSTIC PROCEDURE

**SYMPTOM:** Mode door motor does not operate normally.

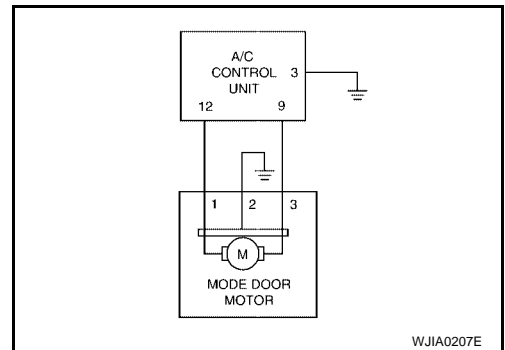

### 1. CHECK BODY GROUND CIRCUIT FOR MODE DOOR MOTOR

Terminals			Continuity
Connector	Wire color	Body ground	Yes
M40-2	B		

**Continuity should exist.**

If OK, check harness for short.

OK or NG

OK >> GO TO 2.

NG >> Repair harness or connector.

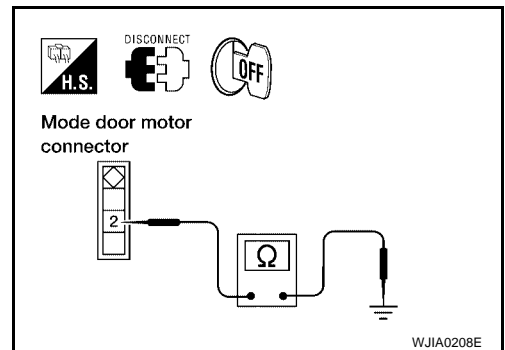

# TROUBLE DIAGNOSIS

## 2. CHECK CIRCUIT CONTINUITY BETWEEN EACH TERMINAL ON A/C CONTROL UNIT AND ON MODE DOOR MOTOR

Terminals				Continuity
Connectors	Wire colors	Connectors	Wire colors	
M51-9	L/B	M40-3	L/B	Yes
M51-12	L/R	M40-1	L/R	

**Continuity should exist.**

If OK, check harness for short.

OK or NG

OK >> GO TO 3.

NG >> Repair harness or connector.

## 3. CHECK FOR A/C CONTROL UNIT OUTPUT

1. Reconnect mode door motor connector.
2. Measure voltage across A/C control unit harness connector M51 terminals 9 (L/B) and 12 (L/R) while turning air control dial to each position.

**Voltage (V) : Approx. 12V**

OK or NG

OK >> Replace mode door motor.

NG >> Replace A/C control unit.

## MODE DOOR

1. Install mode door motor on heater unit.  
Ensure that the linkage is properly attached.
2. Connect mode door motor harness connector.
3. Turn ignition switch ON.
4. Check that the mode door operates properly when air control dial is turned to each position.

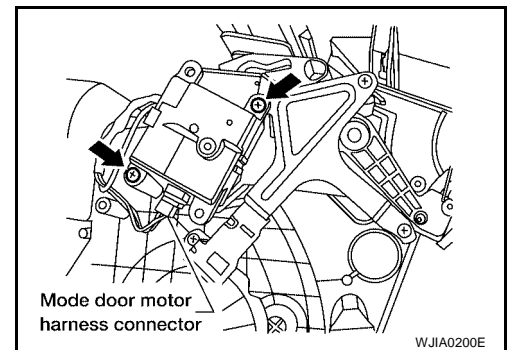
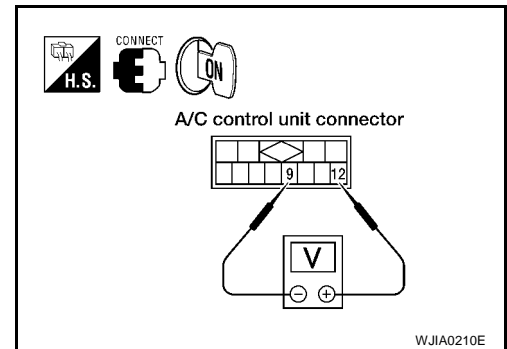
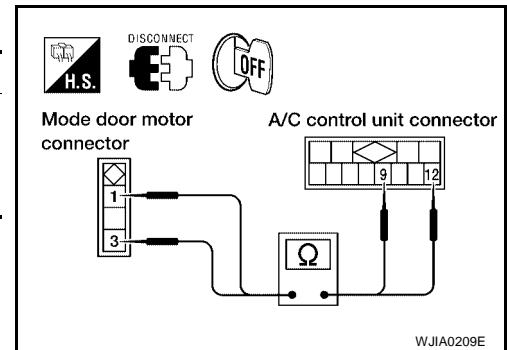

# TROUBLE DIAGNOSIS

EJS001LH

## Air Mix Door

**SYMPTOM:** Air mix door does not change.

### INSPECTION FLOW

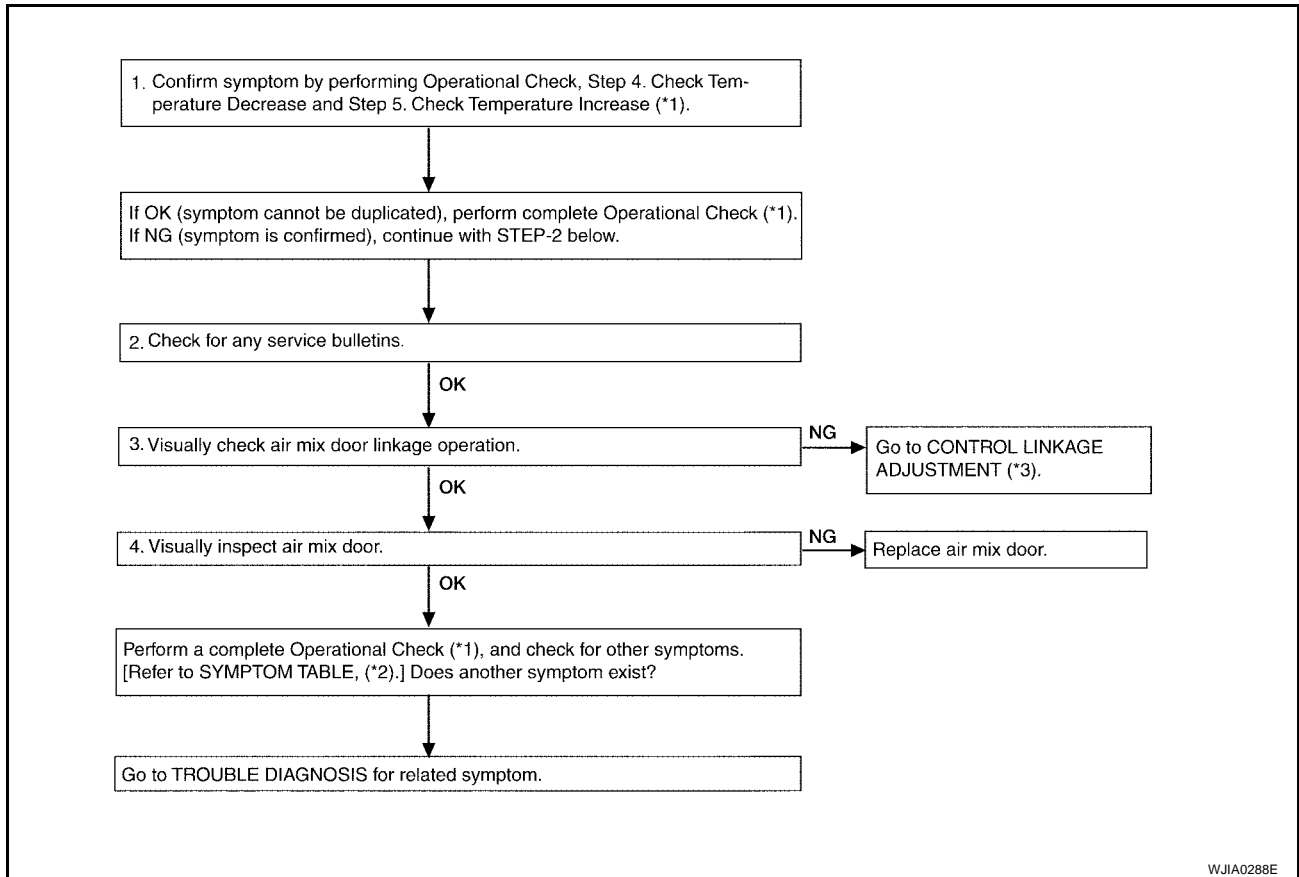

\*1 [MTC-38](#)

\*2 [MTC-28](#)

\*3 [MTC-45](#)

WJIA0288E

A  
B  
C  
D  
E  
F  
G  
H  
I

MTC

## CONTROL LINKAGE ADJUSTMENT

### Temperature control cable

1. Attach temperature control cable.
2. Rotate control knob to full cold position.
3. Remove slack from cable and install temperature control cable clamp.

**After positioning control cable, check for proper operation.**

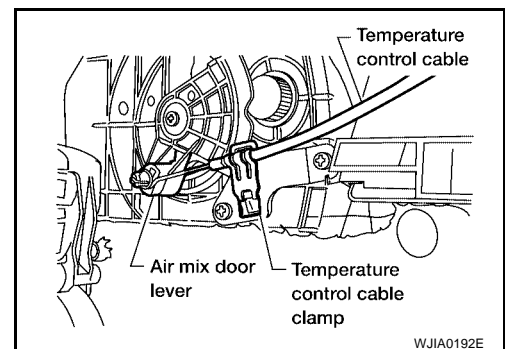

WJIA0192E

K  
L  
M

# TROUBLE DIAGNOSIS

EJS000ZU

## Intake Door Motor Circuit

Symptom:

- Intake door does not change.
- Intake door motor does not operate normally.

### INSPECTION FLOW

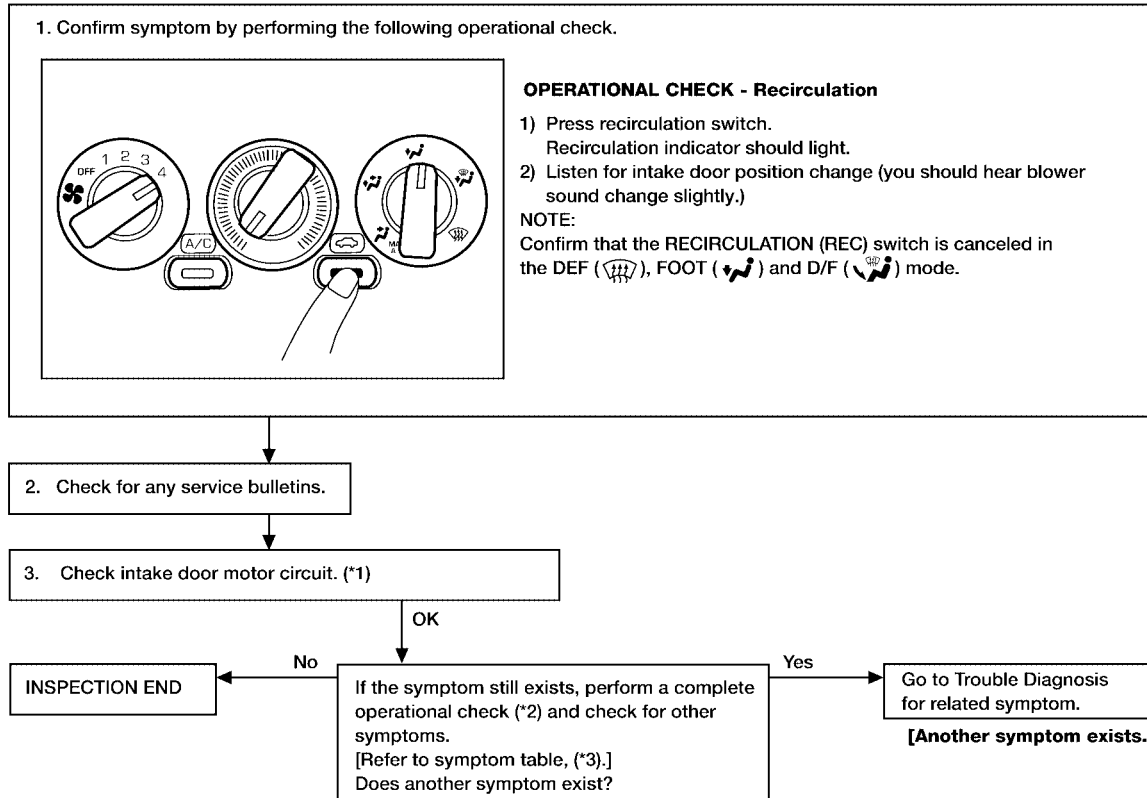

WJIA0148E

\*1: [MTC-46, "Intake Door Motor Circuit"](#) \*2: [MTC-38, "Operational Check"](#)

\*3: [MTC-28, "SYMPTOM TABLE"](#)

# TROUBLE DIAGNOSIS

## SYSTEM DESCRIPTION

### Intake Door Motor

The intake door motor is installed on the blower unit. Using a link it opens and closes the intake door.

When RECIRCULATION switch is at REC (except DEF and D/F modes), the A/C control unit sets the intake door at the "RECIRCULATION" position.

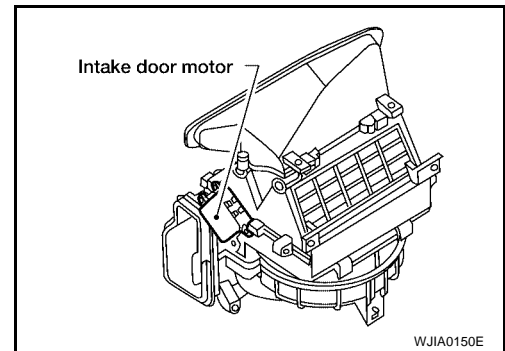
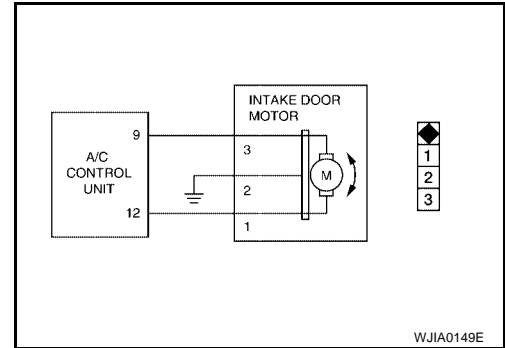

## DIAGNOSTIC PROCEDURE

**SYMPTOM:** Intake door does not change. Intake door motor does not operate normally.

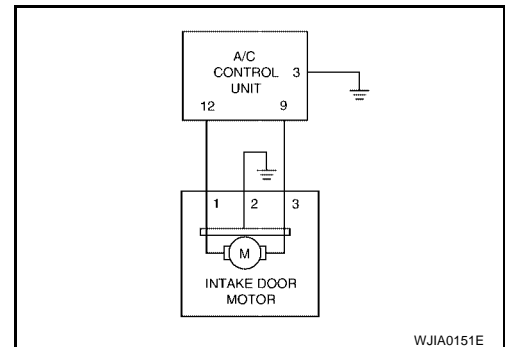

### 1. CHECK BODY GROUND CIRCUIT FOR INTAKE DOOR MOTOR

Terminals		Body ground	Continuity
Connector	Wire color		Yes
M58-2	B		Yes

**Continuity should exist.**

If OK, check harness for short.

OK or NG

OK >> GO TO 2.

NG >> Repair harness or connector.

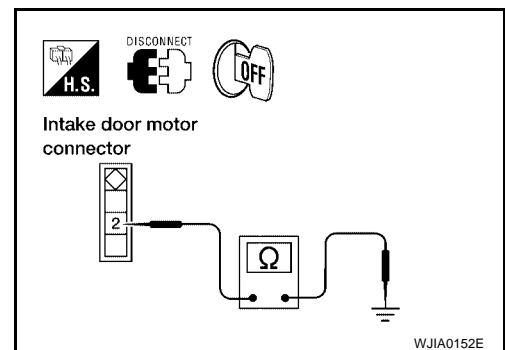

# TROUBLE DIAGNOSIS

## 2. CHECK CIRCUIT CONTINUITY BETWEEN EACH TERMINAL ON A/C CONTROL UNIT AND ON INTAKE DOOR MOTOR

Terminals				Continuity
Connectors	Wire colors	Connectors	Wire colors	
M51-9	L/B	M58-3	L/B	Yes
M51-12	L/R	M58-1	L/R	

**Continuity should exist.**

If OK, check harness for short.

OK or NG

OK >> GO TO 3.

NG >> Repair harness or connector.

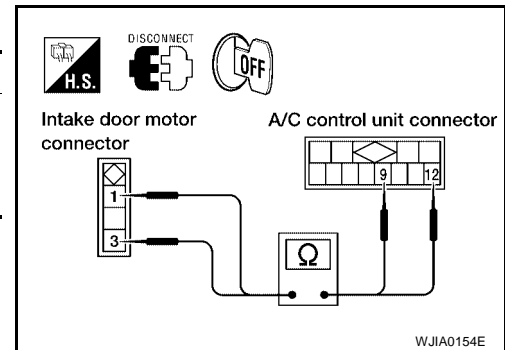

## 3. CHECK FOR A/C CONTROL UNIT OUTPUT

Measure voltage across A/C control unit harness terminals and body ground.

RECIRCULATION	Terminals			Condition	Voltage (V) (Approx.)
	(+)		(-)		
	Connectors	Wire colors			
REC(ON)	M51-9	L/B	Body ground	REC	12V
	M51-12	L/R		0V	
FRE(OFF)	M51-9	L/B		FRE	0V
	M51-12	L/R		12V	

OK or NG

OK >> Replace intake door motor.

NG >> Replace A/C control unit.

### CONTROL LINKAGE ADJUSTMENT

1. Install intake door motor on blower unit.  
Ensure that the intake door motor lever is fitted into the slit portion of intake door link.
2. Connect the intake door motor harness connector.
3. Turn ignition switch to ON.
4. Check that intake door operates properly when RECIRCULATION switch is turned ON and OFF.

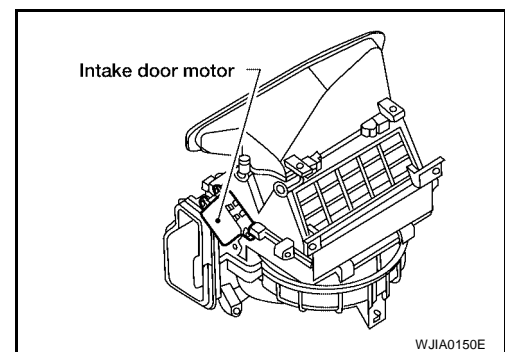



# TROUBLE DIAGNOSIS

EJS000ZV

## Blower Motor Circuit

Symptom:

- Blower motor operation is malfunctioning.

### INSPECTION FLOW

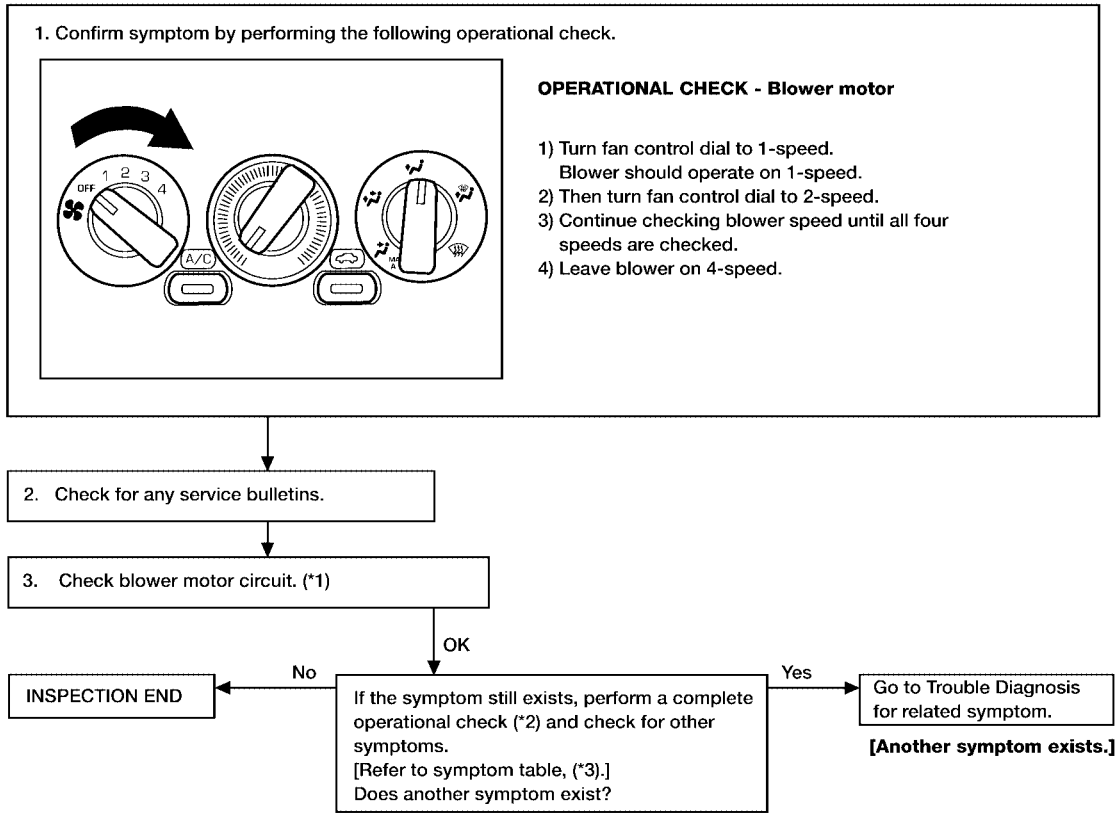

\*1: [MTC-49. "Blower Motor Circuit"](#)

\*2: [MTC-38. "Operational Check"](#)

\*3: [MTC-28. "SYMPTOM TABLE"](#)

WJIA0156E

### DIAGNOSTIC PROCEDURE

SYMPTOM:

- Blower motor operation is malfunctioning.

Test group No.	INCIDENT
1	Fan fails to rotate.
2	Fan does not rotate at 1-speed.
3	Fan does not rotate at 2-speed.
4	Fan does not rotate at 3-speed.
5	Fan does not rotate at 4-speed.

# TROUBLE DIAGNOSIS

## 1. DIAGNOSTIC PROCEDURE

Check if blower motor rotates properly at each fan speed.  
Conduct checks as per table above.

- 1 >> GO TO 2.
- 2, 3, 4 >> GO TO 8.
- 5 >> GO TO 10.

## 2. CHECK POWER SUPPLY FOR BLOWER MOTOR

Disconnect blower motor harness connector.

Terminals		Voltage (V) (Approx.)
(+)	(-)	
Connector	Wire color	12V
M62-1	W/L	

Yes or No

Yes >> GO TO 3.

No >> ● Check 15A fuses (No. 10 and No. 11) at fuse block (J/B).

- Check blower relay [located in fuse block (J/B)]. Refer to [PG-5, "Wiring Diagram — POWER —"](#).

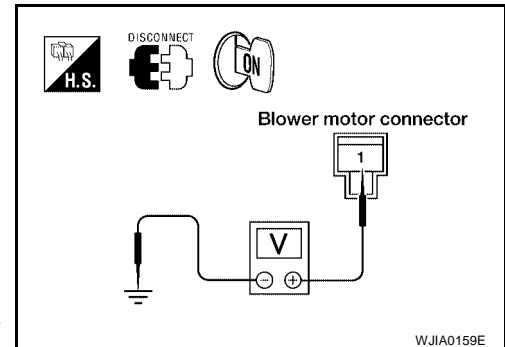

## 3. CHECK CIRCUIT CONTINUITY FOR BLOWER MOTOR

Turn fan control switch to any position except OFF.

Terminals		Voltage (V) (Approx.)
(+)	(-)	
Connector	Wire color	12V
M62-2	L/W	

**Continuity should exist.**

OK or NG

OK >> GO TO 4.

NG >> GO TO 5.

## 4. CHECK BLOWER MOTOR

(Refer to Electrical Components Inspection.)  
([MTC-53, "Blower motor"](#) )

OK or NG

OK >> INSPECTION END

NG >> Replace blower motor.

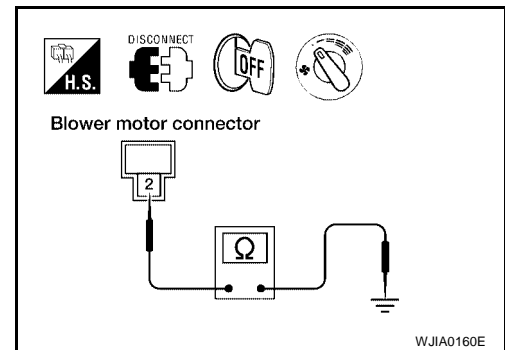

# TROUBLE DIAGNOSIS

## 5. CHECK BLOWER MOTOR CIRCUIT BETWEEN BLOWER MOTOR AND RESISTOR

Reconnect blower motor harness connector.

Terminals			Voltage (V) (Approx.)
(+)		(-)	
Connector	Wire color		12V
M63-1	L/W	Body ground	

Yes or No

- Yes >> GO TO 7.  
No >> GO TO 6.

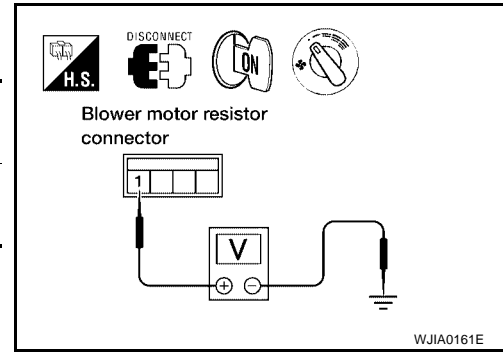

## 6. CHECK CIRCUIT CONTINUITY BETWEEN BLOWER MOTOR AND RESISTOR

Disconnect blower motor and resistor harness connectors.

Terminals				Continuity
Connector	Wire color	Connector	Wire color	
M63-1	L/W	M62-2	L/W	Yes

**Continuity should exist.**

If OK, check harness for short.

OK or NG

- OK >> INSPECTION END  
NG >> Repair harness or connector.

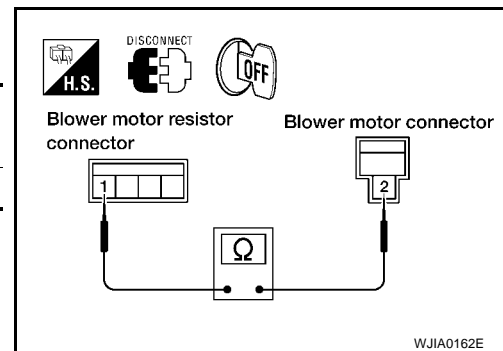

## 7. CHECK GROUND CIRCUIT FOR FAN SWITCH

- Disconnect fan switch harness connector.
- Check circuit continuity between fan switch harness terminal and body ground.

Terminals			Voltage (V) (Approx.)
(+)		(-)	
Connector	Wire color		12V
M41-5	B	Body ground	

OK or NG

- OK >> GO TO 8.  
NG >> Repair harness or connector.

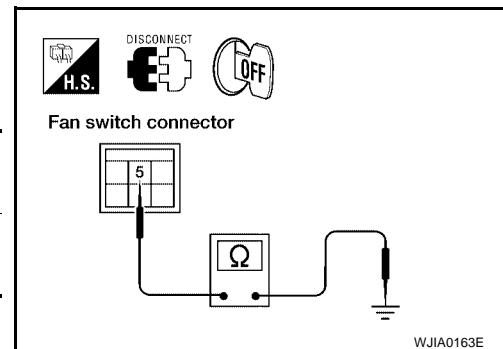

## 8. CHECK BLOWER MOTOR RESISTOR

Refer to [MTC-53, "Blower Motor Resistor"](#) .

OK or NG

- OK >> GO TO 9.  
NG >> Replace blower motor resistor.

A  
B  
C  
D  
E  
F  
G  
H  
I  
K  
L  
M

MTC

# TROUBLE DIAGNOSIS

## 9. CHECK RESISTOR HARNESS CONNECTOR

Reconnect resistor harness connector.

OK or NG

- 1 >> GO TO 12.
- 2, 3, 4 >> GO TO 10.

## 10. CHECK FAN SWITCH CIRCUIT

Do approx. 12 volts exist between each fan switch harness connector terminal and body ground?

Test group No.	Terminal		(-)	Voltage (V) (Approx.)
	(+)			
	Connector	Wire color		
2	M41-4	L/B	Body ground	12V
3	M41-3	L/R		
4	M41-2	L/Y		
5	M41-1	L/W		

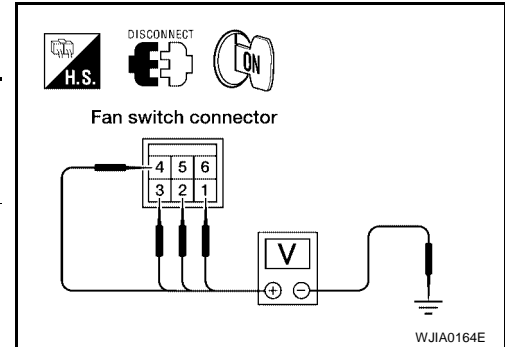

Yes or No

- Yes >> GO TO 12.
- No >> GO TO 11.

## 11. CHECK CIRCUIT CONTINUITY BETWEEN FAN SWITCH HARNESS TERMINAL AND RESISTOR HARNESS TERMINAL

Terminal No.				Continuity
Fan switch		Resistor		
Connectors	Wire colors	Connectors	Wire colors	
M41-4	L/B	M63-4	L/B	Yes
M41-3	L/R	M63-3	L/R	
M41-2	L/Y	M63-2	L/Y	
M41-1	L/W	M63-1	L/W	

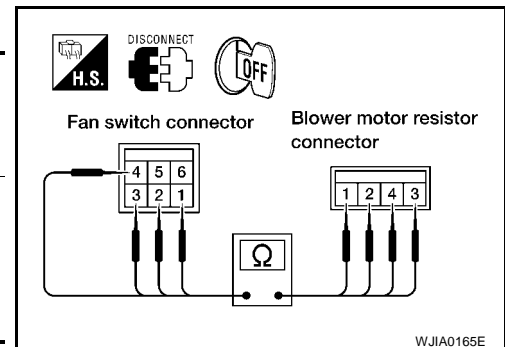

OK or NG

- OK >> Check harness for short.
- NG >> Repair harness or connector.

## 12. CHECK FAN SWITCH

Refer to [MTC-53, "Fan Switch"](#).

OK or NG

- OK >> INSPECTION END
- NG >> Replace fan switch.

# TROUBLE DIAGNOSIS

## ELECTRICAL COMPONENTS INSPECTION

### Fan Switch

Check continuity between terminals at each switch position.

SWITCH POSITION	Continuity between terminals
OFF	
1	4 — 5 — 6
2	3 — 5 — 6
3	2 — 5 — 6
4	1 — 5 — 6

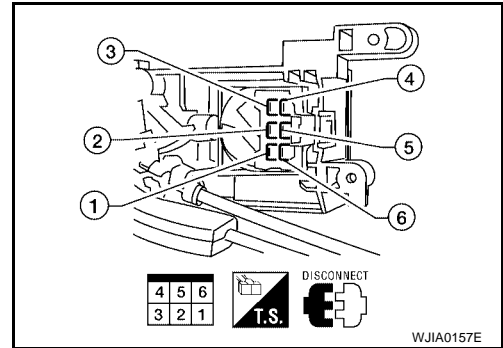

### Blower motor

Confirm smooth rotation of the blower motor.

- Ensure that there are no foreign particles inside the intake unit.

### Blower Motor Resistor

Check resistance between terminals.

Terminal No.		Resistance ( $\Omega$ ) (Approx.)
(+)	(-)	
3	1	0.9 - 1.1 $\Omega$
4		2.27 - 2.78 $\Omega$
2		0.3 - 0.38 $\Omega$

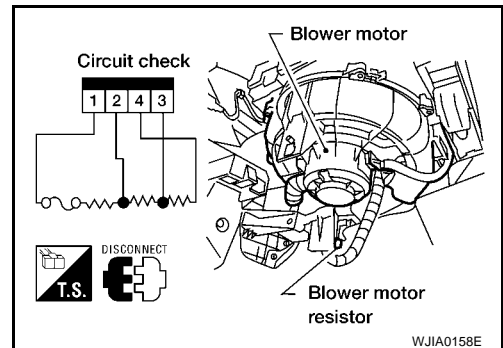

A  
B  
C  
D  
E  
F  
G  
H  
I  
M

MTC

# TROUBLE DIAGNOSIS

EJS000ZW

## Magnet Clutch Circuit

Symptom:

- Magnet clutch does not engage when A/C switch and fan switch are ON.

### INSPECTION FLOW

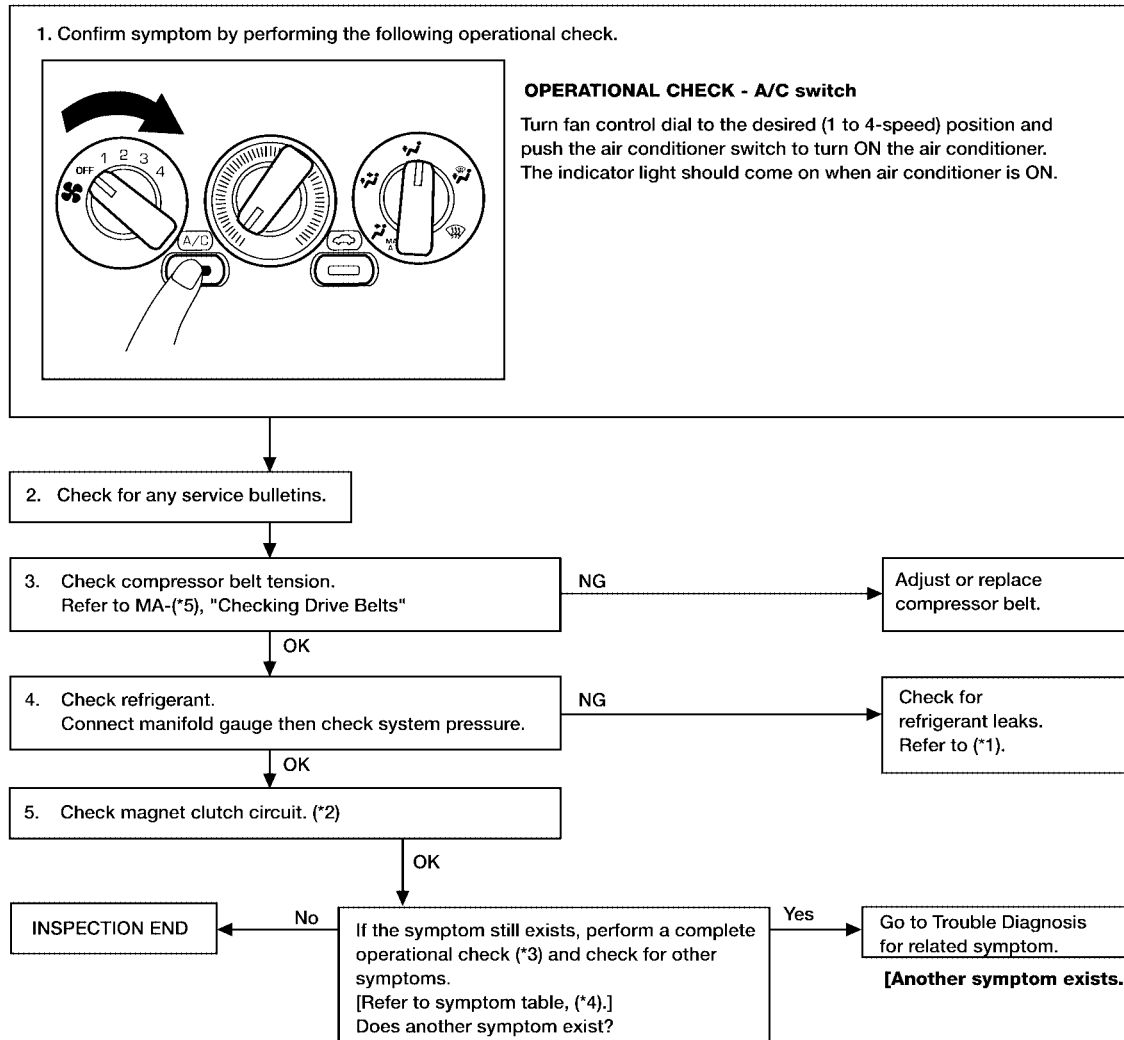

WJIA0166E

\*1: [MTC-91, "Checking for Refrigerant Leaks"](#)

\*2: [MTC-55, "DIAGNOSTIC PROCEDURE"](#)

\*3: [MTC-38, "Operational Check"](#)

\*4: [MTC-28, "SYMPTOM TABLE"](#)

\*5: [MA-14, "Checking Drive Belts"](#)

# TROUBLE DIAGNOSIS

## DIAGNOSTIC PROCEDURE

SYMPTOM:

- Magnet clutch does not engage when A/C switch and fan switch are ON.

### 1. CHECK POWER SUPPLY FOR COMPRESSOR

Disconnect compressor harness connector.

Terminals		Voltage (V) (Approx.)
(+)	(-)	
Connector	Wire color	12V
F3-1	Y/B	
		Body ground

OK or NG

- OK >> GO TO 2.
- NG >> GO TO 3.

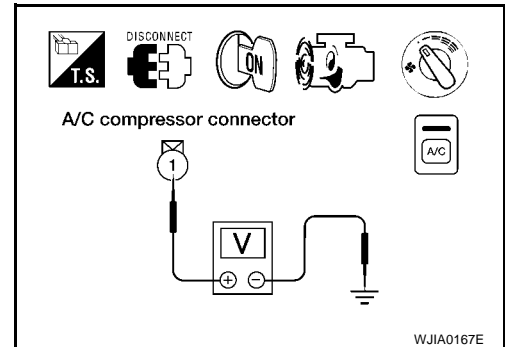

### 2. CHECK MAGNET CLUTCH COIL

Check magnet clutch coil.

OK or NG

- OK >> Check compressor mounting points for looseness or corrosion and repair as necessary.
- NG >> Replace magnet clutch. Refer to [MTC-85, "Removal and Installation for Compressor Clutch"](#).

### 3. CHECK MAGNET CLUTCH COIL POWER SUPPLY FROM IPDM E/R

Reconnect compressor harness connector.

Terminals		Voltage (V) (Approx.)
(+)	(-)	
Connector	Wire color	12V
E124-28	Y/B	
		Body ground

OK or NG

- OK >> Repair harness or connector between IPDM E/R and compressor.
- NG >> GO TO 4.

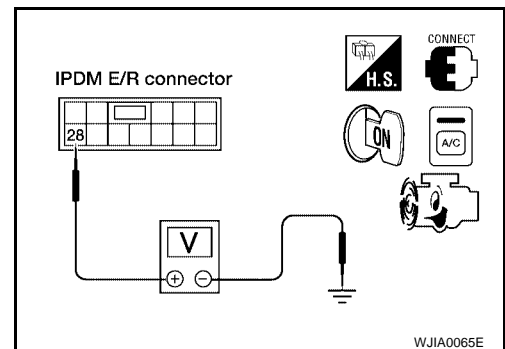

### 4. CHECK INTAKE SENSOR CIRCUIT

Refer to [MTC-65, "Intake Sensor Circuit"](#).

OK or NG

- OK >> GO TO 5.
- NG >> Repair as necessary.

### 5. CHECK REFRIGERANT PRESSURE SENSOR

Refer to [EC-595, "REFRIGERANT PRESSURE SENSOR"](#) (QR25DE models) or [EC-1266, "REFRIGERANT PRESSURE SENSOR"](#) (VQ35DE models).

OK or NG

- OK >> GO TO 6.
- NG >> Repair as necessary.

# TROUBLE DIAGNOSIS

## 6. CHECK FAN ON SIGNAL TO A/C CONTROL UNIT AND BCM

1. Disconnect A/C control unit harness connector M51.
2. Measure voltage between A/C control unit and body ground.
3. Reconnect A/C control unit harness connector M51 and disconnect BCM harness connector M18.
4. Measure voltage between BCM and body ground.

Terminals		Condition	Voltage (V) (Approx.)
(+)	(-)		
Connectors	Wire colors		
M51-5	G/B	FAN SW: OFF	5V
	G/B	FAN SW: ON	0V
M18-65	G/B	FAN SW: OFF	5V
	G/B	FAN SW: ON	0V

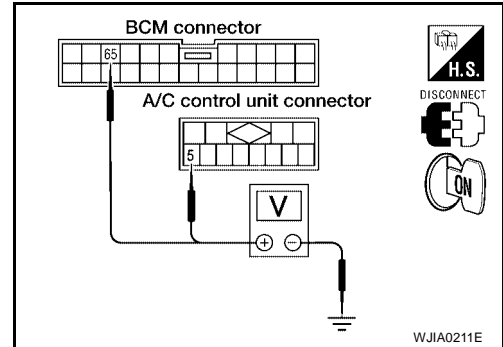

OK or NG

- OK >> GO TO 8.
- NG >> GO TO 7.

## 7. CHECK FAN SWITCH

Check fan switch. Refer to [MTC-53, "Fan Switch"](#).

OK or NG

- OK >> Repair harness or connectors between fan switch and A/C control unit and BCM.
- NG >> Replace fan switch.

## 8. CHECK COMPRESSOR ON SIGNAL

1. Reconnect A/C control unit harness connector.
2. With fan switch ON, measure voltage between A/C control unit and body ground with A/C switch OFF and ON.

Terminals		Condition	Voltage (V) (Approx.)
(+)	(-)		
Connector	Wire color		
M51-1	L/W	A/C SW: OFF	9V
	L/W	A/C SW: ON	0V

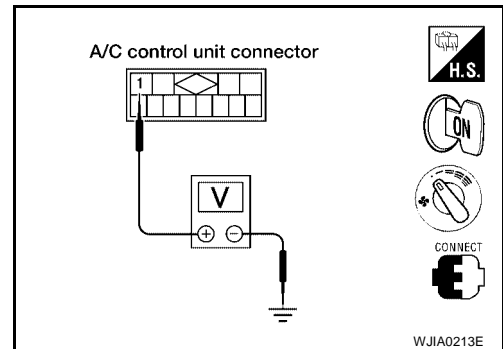

OK or NG

- OK >> GO TO 9.
- NG >> Replace A/C control unit.

## 9. CHECK COMPRESSOR ON SIGNAL CIRCUIT

1. Disconnect A/C control unit harness connector.
2. Check continuity between A/C control unit and BCM.

Terminals				Continuity
Connector	Wire color	Connector	Wire color	
M18-58	L/W	M51-1	L/W	Yes

If OK, check harness for short.

OK or NG

- OK >> GO TO 10.
- NG >> Repair harness or connectors.

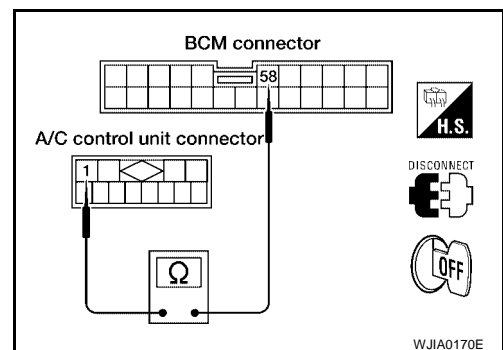



# TROUBLE DIAGNOSIS

## 10. CHECK CAN COMMUNICATION CIRCUITS

Check CAN communication circuits between BCM to ECM and between ECM to IPDM E/R. Refer to [LAN-3, "CAN COMMUNICATION"](#).

OK or NG

OK >> ECM is malfunctioning.

NG >> Repair or replace component based on diagnosis.

### REFRIGERANT PRESSURE SENSOR

Make sure that higher A/C refrigerant pressure results in higher refrigerant pressure sensor output voltage.

	OFF kPa (kg/cm <sup>2</sup> , psi)
Low-pressure side	Decreasing to 0.18 (0.00184, 0.03)
High-pressure side	Increasing to 2.74 (0.0279, 0.40)

Refer to [EC-595, "REFRIGERANT PRESSURE SENSOR"](#) (QR25DE models) or [EC-1266, "REFRIGERANT PRESSURE SENSOR"](#) (VQ35DE models).

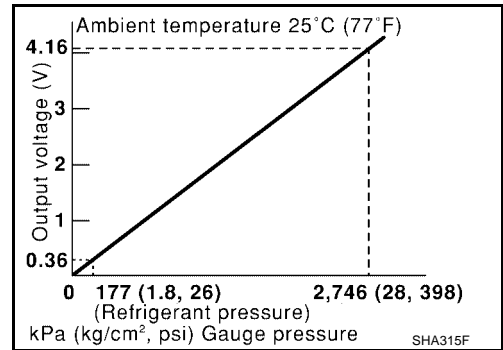
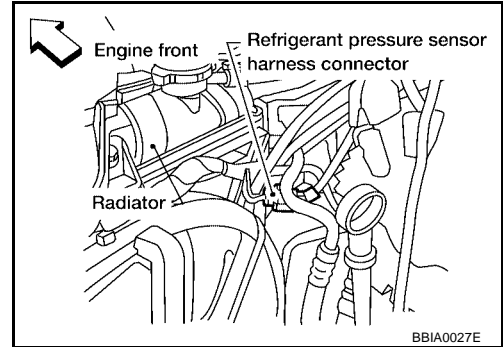

A  
B  
C  
D  
E  
F  
G  
H  
I  
MTC  
K  
L  
M

# TROUBLE DIAGNOSIS

EJS000ZX

## Insufficient Cooling

Symptom:

- Insufficient cooling.

### INSPECTION FLOW

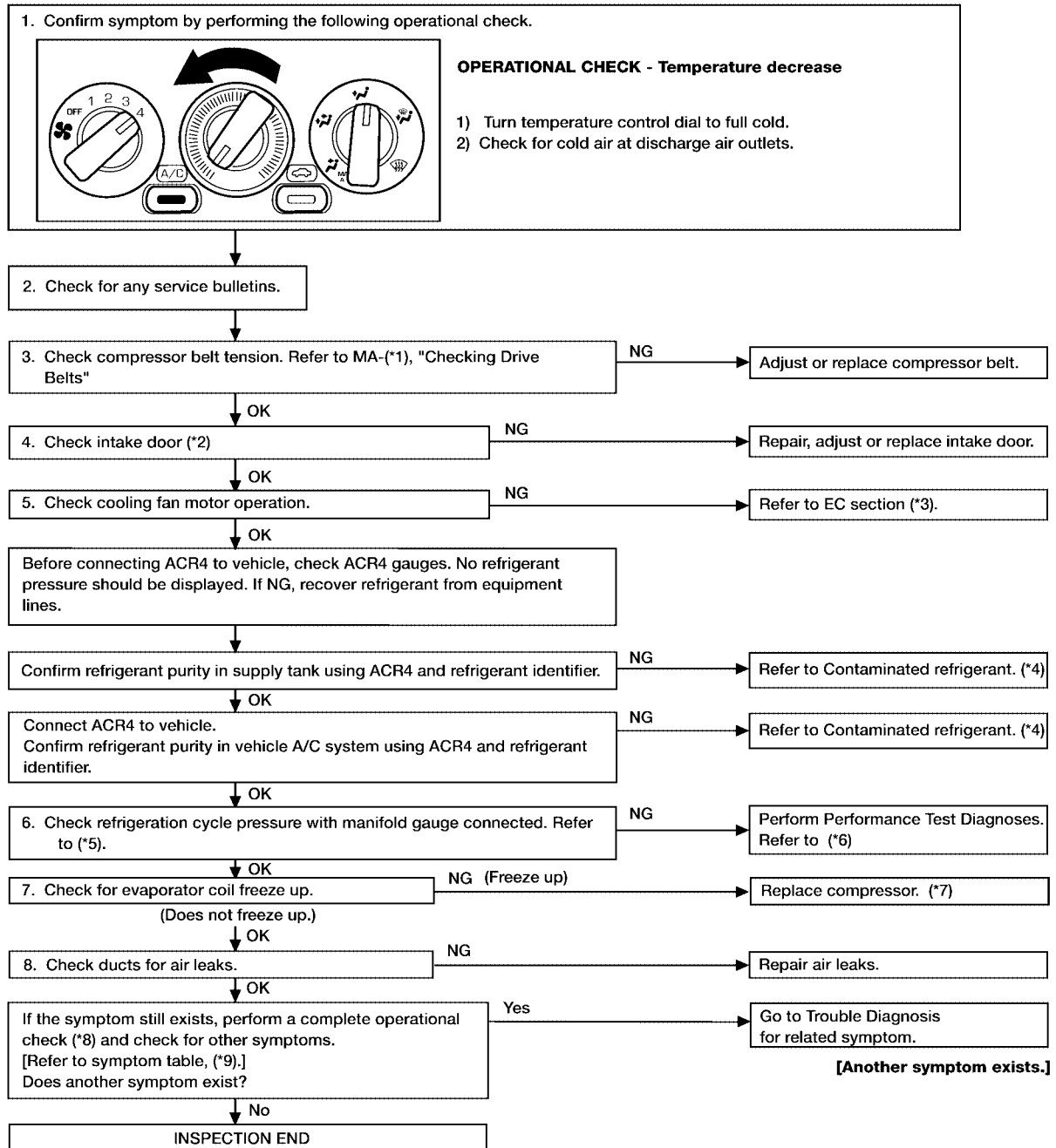

WJIA0175E

\*1: [MA-14. "Checking Drive Belts"](#) (QR25DE) or [MA-21. "Checking Drive Belts"](#) (VQ35DE)

\*2: [MTC-46. "Intake Door Motor Circuit"](#)

\*3: EC Section

\*4: [MTC-3. "Contaminated Refrigerant"](#)

\*5: [MTC-79. "HFC-134a \(R-134a\) Service Procedure"](#)

\*6: [MTC-59. "Performance Chart"](#)

\*7: [MTC-83. "Removal and Installation for Compressor — QR25DE Models"](#) or [MTC-84. "Removal and Installation for Compressor — VQ35DE Models"](#)

\*8: [MTC-38. "Operational Check"](#)



\*9: [MTC-28. "SYMPTOM TABLE"](#)

# TROUBLE DIAGNOSIS

## PERFORMANCE CHART

### Test Condition

Testing must be performed as follows:

Vehicle location	Indoors or in the shade (in a well-ventilated place)
Doors	Closed
Door window	Open
Hood	Open
TEMP.	Max. COLD
Mode switch	 (Ventilation) set
Intake switch	 (Recirculation) set
 (blower) speed	Max. speed set
Engine speed	Idle speed

Operate the air conditioning system for 10 minutes before taking measurements.

### Test Reading

#### Recirculating-to-discharge Air Temperature Table

Inside air (Recirculating air) at blower assembly inlet		Discharge air temperature at center ventilator °C (°F)
Relative humidity %	Air temperature °C (°F)	
50 - 60	25 (77)	10.0 - 12.3 (50 - 54)
	30 (86)	13.2 - 15.3 (56 - 60)
	35 (95)	17.2 - 21.0 (63 - 70)
60 - 70	25 (77)	12.3 - 14.9 (54 - 59)
	30 (86)	15.3 - 19.3 (60 - 67)
	35 (95)	21.0 - 24.4 (70 - 76)

#### Ambient Air Temperature-to-operating Pressure Table

Ambient air		High-pressure (Discharge side) kPa (kg/cm <sup>2</sup> , psi)	Low-pressure (Suction side) kPa (kg/cm <sup>2</sup> , psi)
Relative humidity %	Air temperature °C (°F)		
50 - 70	30 (86)	1,220 - 1,500 (12.44 - 15.30, 176.9 - 217.5)	240 - 295 (2.45 - 3.01, 34.8 - 42.8)
	35 (95)	1,360 - 1,690 (13.87 - 17.24, 197.2 - 245.1)	275 - 335 (2.81 - 3.42, 39.9 - 48.6)
	40 (104)	1,500 - 1,830 (12.44 - 18.67, 176.9 - 265.4)	310 - 375 (3.16 - 3.83, 45.0 - 54.4)

### TROUBLE DIAGNOSES FOR ABNORMAL PRESSURE

Whenever system's high and/or low side pressure is abnormal, diagnose using a manifold gauge. The marker above the gauge scale in the following tables indicates the standard (normal) pressure range. Since the standard (normal) pressure, differs from vehicle to vehicle, refer to Ambient Air Temperature-to-operating Pressure Table above.

# TROUBLE DIAGNOSIS

## Both High and Low-pressure Sides are Too High

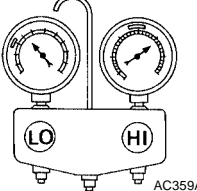
Gauge indication	Refrigerant cycle	Probable cause	Corrective action
<p>Both high and low-pressure sides are too high.</p> 	Pressure is reduced soon after water is splashed on condenser.	Excessive refrigerant charge in refrigeration cycle	Reduce refrigerant until specified pressure is obtained.
	Air suction by cooling fan is insufficient.	Insufficient condenser cooling performance ↓ 1. Condenser fins are clogged. 2. Improper fan rotation of cooling fan	<ul style="list-style-type: none"> <li>Clean condenser.</li> <li>Check and repair cooling fan as necessary.</li> </ul>
	<ul style="list-style-type: none"> <li>Low-pressure pipe is not cold.</li> <li>When compressor is stopped high-pressure value quickly drops by approximately 196 kPa (2 kg/cm<sup>2</sup>, 28 psi). It then decreases gradually thereafter.</li> </ul>	Poor heat exchange in condenser (After compressor operation stops, high pressure decreases too slowly.) ↓ Air in refrigeration cycle	Evacuate repeatedly and recharge system.
	Engine tends to overheat.	Engine cooling systems malfunction.	Check and repair each engine cooling system.
	<ul style="list-style-type: none"> <li>An area of the low-pressure pipe is colder than areas near the evaporator outlet.</li> <li>Plates are sometimes covered with frost.</li> </ul>	<ul style="list-style-type: none"> <li>Excessive liquid refrigerant on low-pressure side</li> <li>Excessive refrigerant discharge flow</li> <li>Expansion valve is open a little compared with the specification.</li> </ul> ↓ 1. Improper thermal valve installation 2. Improper expansion valve adjustment	Replace expansion valve.

## High-pressure Side is Too High and Low-pressure Side is Too Low

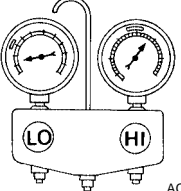
Gauge indication	Refrigerant cycle	Probable cause	Corrective action
<p>High-pressure side is too high and low-pressure side is too low.</p> 	Upper side of condenser and high-pressure side are hot, however, liquid tank is not so hot.	High-pressure tube or parts located between compressor and condenser are clogged or crushed.	<ul style="list-style-type: none"> <li>Check and repair or replace malfunctioning parts.</li> <li>Check lubricant for contamination.</li> </ul>

## High-pressure Side is Too Low and Low-pressure Side is Too High

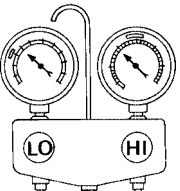
Gauge indication	Refrigerant cycle	Probable cause	Corrective action
<p>High-pressure side is too low and low-pressure side is too high.</p> 	High and low-pressure sides become equal soon after compressor operation stops.	Compressor pressure operation is improper. ↓ Damaged inside compressor packings	Replace compressor.
	No temperature difference between high and low-pressure sides	Compressor pressure operation is improper. ↓ Damaged inside compressor packings.	Replace compressor.

# TROUBLE DIAGNOSIS

## Both High- and Low-pressure Sides are Too Low

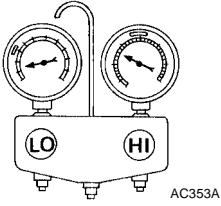
Gauge indication	Refrigerant cycle	Probable cause	Corrective action
<p>Both high- and low-pressure sides are too low.</p>  <p style="text-align: right; font-size: small;">AC353A</p>	<ul style="list-style-type: none"> <li>There is a big temperature difference between receiver drier outlet and inlet. Outlet temperature is extremely low.</li> <li>Liquid tank inlet and expansion valve are frosted.</li> </ul>	Liquid tank inside is slightly clogged.	<ul style="list-style-type: none"> <li>Replace desiccant assy.</li> <li>Check lubricant for contamination.</li> </ul>
	<ul style="list-style-type: none"> <li>Temperature of expansion valve inlet is extremely low as compared with areas near liquid tank.</li> <li>Expansion valve inlet may be frosted.</li> <li>Temperature difference occurs somewhere in high-pressure side</li> </ul>	High-pressure pipe located between receiver drier and expansion valve is clogged.	<ul style="list-style-type: none"> <li>Check and repair malfunctioning parts.</li> <li>Check lubricant for contamination.</li> </ul>
	Expansion valve and liquid tank are warm or only cool when touched.	Low refrigerant charge ↓ Leaking fittings or components	Check refrigerant for leaks. Refer to <a href="#">MTC-91, "Checking for Refrigerant Leaks"</a> .
	There is a big temperature difference between expansion valve inlet and outlet while the valve itself is frosted.	Expansion valve closes a little compared with the specification. ↓ 1. Improper expansion valve adjustment 2. Malfunctioning thermal valve 3. Outlet and inlet may be clogged.	<ul style="list-style-type: none"> <li>Remove foreign particles by using compressed air.</li> <li>Check lubricant for contamination.</li> </ul>
	An area of the low-pressure pipe is colder than areas near the evaporator outlet.	Low-pressure pipe is clogged or crushed.	<ul style="list-style-type: none"> <li>Check and repair malfunctioning parts.</li> <li>Check lubricant for contamination.</li> </ul>
	Air flow volume is not enough or is too low.	Evaporator is frozen.	<ul style="list-style-type: none"> <li>Check intake sensor operation. Refer to <a href="#">MTC-68, "INTAKE SENSOR"</a>.</li> <li>Replace compressor.</li> </ul>

## Low-pressure Side Sometimes Becomes Negative

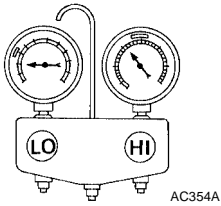
Gauge indication	Refrigerant cycle	Probable cause	Corrective action
<p>Low-pressure side sometimes becomes negative.</p>  <p style="text-align: right; font-size: small;">AC354A</p>	<ul style="list-style-type: none"> <li>Air conditioning system does not function and does not cyclically cool the compartment air.</li> <li>The system constantly functions for a certain period of time after compressor is stopped and restarted.</li> </ul>	Refrigerant does not discharge cyclically. ↓ Moisture is frozen at expansion valve outlet and inlet. ↓ Water is mixed with refrigerant.	<ul style="list-style-type: none"> <li>Drain water from refrigerant or replace refrigerant.</li> <li>Replace desiccant assy.</li> </ul>

# TROUBLE DIAGNOSIS

## Low-pressure Side Becomes Negative

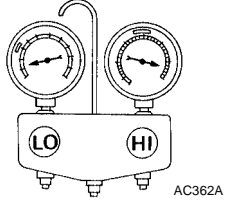
Gauge indication	Refrigerant cycle	Probable cause	Corrective action
<p>Low-pressure side becomes negative.</p> 	<p>Liquid tank or front/rear side of expansion valve's pipe is frosted or dewed.</p>	<p>High-pressure side is closed and refrigerant does not flow. ↓ Expansion valve or liquid tank is frosted.</p>	<p>Leave the system at rest until no frost is present. Start it again to check whether or not the problem is caused by water or foreign particles.</p> <ul style="list-style-type: none"> <li>● If water is the cause, initially cooling is okay. Then the water freezes causing a blockage. Drain water from refrigerant or replace refrigerant.</li> <li>● If due to foreign particles, remove expansion valve and remove the particles with dry and compressed air (not shop air).</li> <li>● If either of the above methods cannot correct the problem, replace expansion valve.</li> <li>● Replace desiccant assy.</li> <li>● Check lubricant for contamination.</li> </ul>

# TROUBLE DIAGNOSIS

EJS000ZY

## Insufficient Heating

SYMPTOM: Insufficient heating

### INSPECTION FLOW

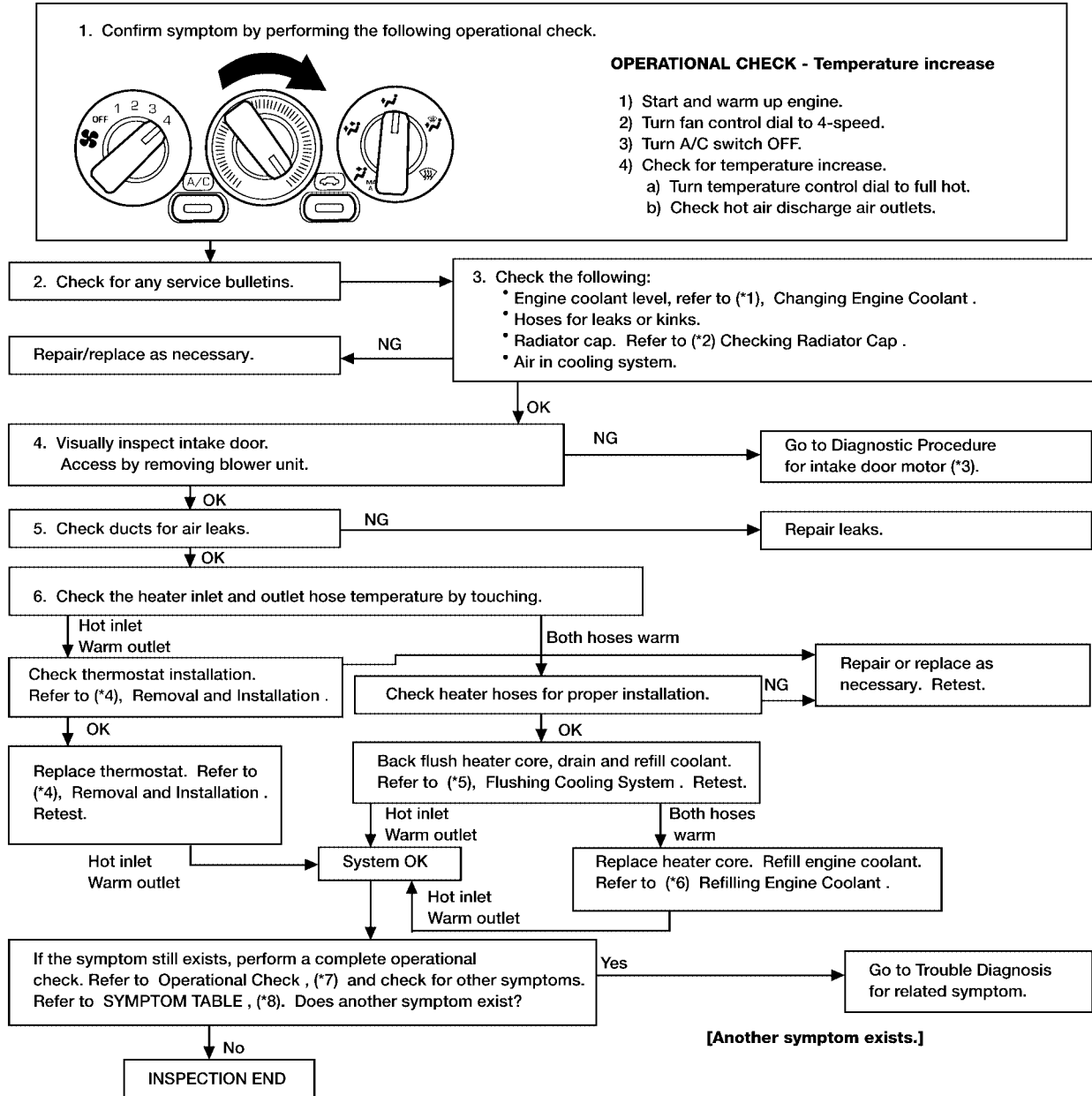

\*1: [MA-14, "Changing Engine Coolant"](#) (QR25DE) or [MA-22, "Changing Engine Coolant"](#) (VQ35DE)

\*2: [CO-11, "CHECKING RADIATOR CAP"](#) (QR25DE) or [CO-33, "CHECKING RADIATOR CAP"](#) (VQ35DE)

\*3: [MTC-46, "Intake Door Motor Circuit"](#)

\*4: [CO-20, "Removal and Installation"](#) (QR25DE) or [EC-1110, "Overall Function Check"](#) (VQ35DE)

\*5: [MA-16, "FLUSHING COOLING SYSTEM"](#) (QR25DE) or [MA-23, "FLUSHING COOLING SYSTEM"](#) (VQ35DE)

\*6: [CO-11, "Refilling Engine Coolant"](#) (QR25DE) or [CO-33, "Refilling Engine Coolant"](#) (VQ35DE)

\*7: [MTC-38, "Operational Check"](#)

\*8: [MTC-28, "SYMPTOM TABLE"](#)

WJIA0176E

# TROUBLE DIAGNOSIS

EJS000ZZ

## Noise

SYMPTOM: Noise

### INSPECTION FLOW

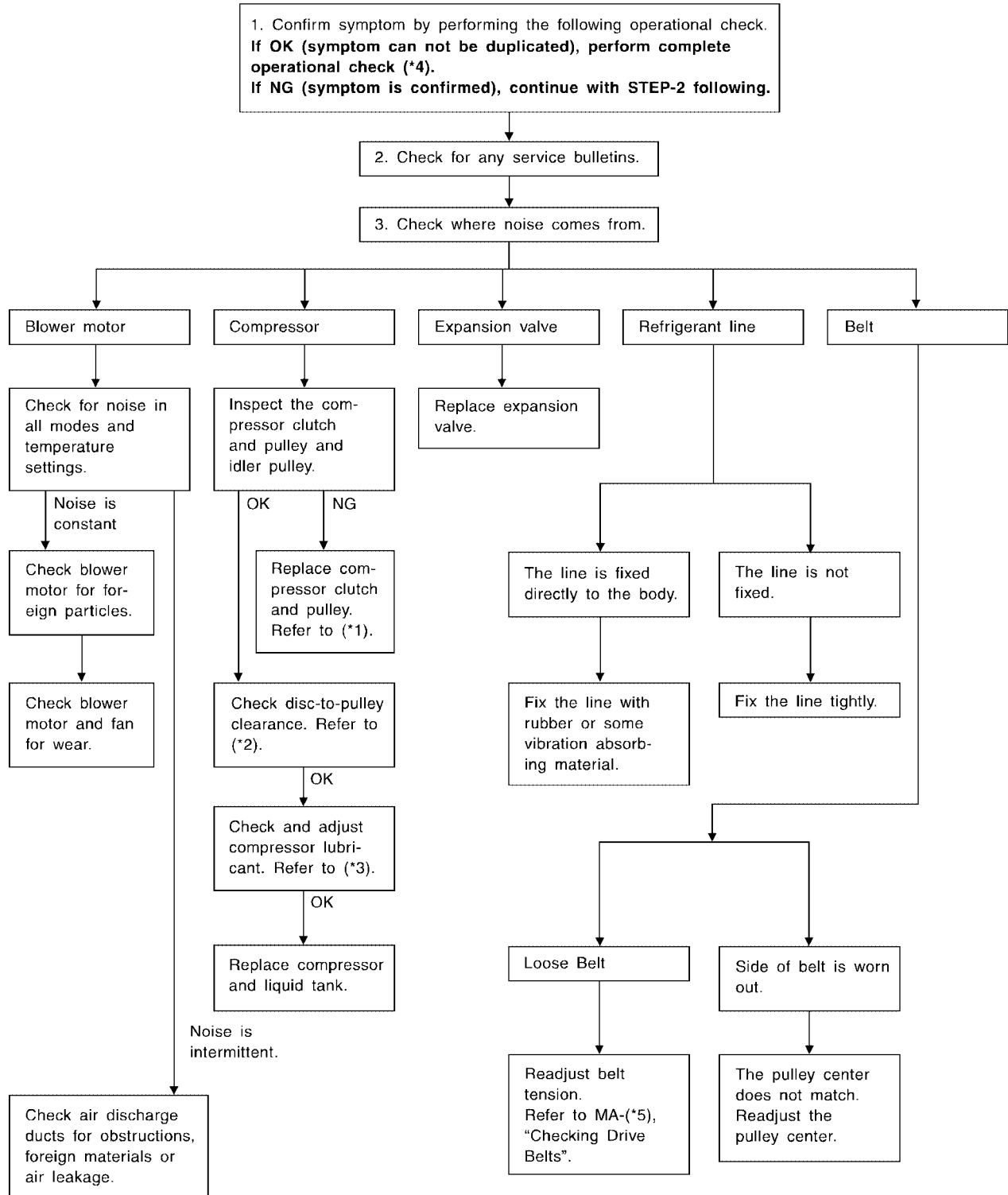

SHA331F



# TROUBLE DIAGNOSIS

\*1 [MTC-85, "Removal and Installation for Compressor Clutch"](#)

\*3 [MTC-18, "Maintenance of Lubricant Quantity in Compressor"](#)

\*5 [MA-14, "Checking Drive Belts" \(QR25DE\)](#) or [MA-21, "Checking Drive Belts" \(VQ35DE\)](#)

\*2 [MTC-86, "INSTALLATION"](#)

\*4 [MTC-38, "Operational Check"](#)

EJS00100

## Intake Sensor Circuit COMPONENT DESCRIPTION

### Intake Sensor

The intake sensor is located on the heater and cooling unit. It converts temperature of air after it passes through the evaporator into a resistance value which is then input to the A/C control unit. After disconnecting intake sensor harness connector, measure resistance between terminals 1 and 2 at sensor harness side, using the table below.

Temperature °C (°F)	Resistance kΩ
-15 (5)	12.34
-10 (14)	9.62
-5 (23)	7.56
0 (32)	6.00
5 (41)	4.80
10 (50)	3.87
15 (59)	3.15
20 (68)	2.57
25 (77)	2.12
30 (86)	1.76
35 (95)	1.47
40 (104)	1.23
45 (113)	1.04

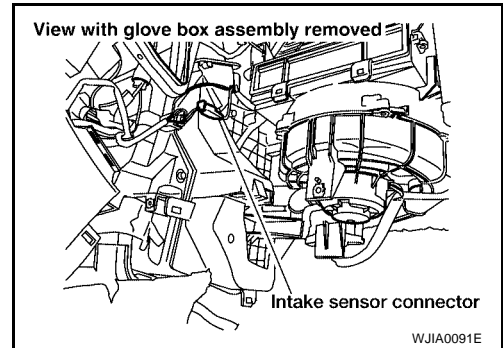

If NG, replace intake sensor.

### DIAGNOSTIC PROCEDURE

SYMPTOM: Intake sensor circuit is open or shorted.

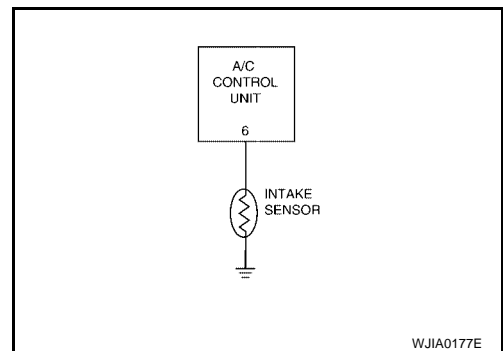

A  
B  
C  
D  
E  
F  
G  
H  
I

MTC

K  
L  
M

# TROUBLE DIAGNOSIS

## 1. CHECK INTAKE SENSOR CIRCUIT BETWEEN INTAKE SENSOR AND BODY GROUND

Disconnect intake sensor harness connector.

Terminal		Body ground	Continuity
Connector	Wire color		
M53-1	B		Yes

OK or NG

OK >> GO TO 2.

NG >> Repair harness or connector.

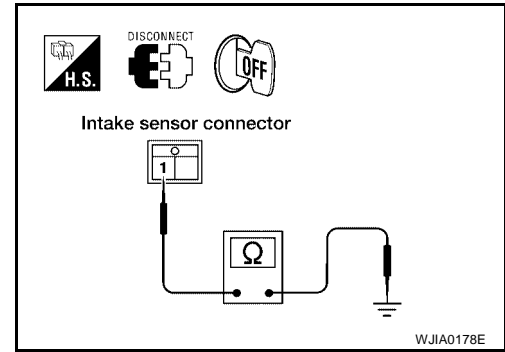

## 2. CHECK INTAKE SENSOR CIRCUIT BETWEEN INTAKE SENSOR AND A/C CONTROL UNIT

Disconnect A/C control unit harness connector.

Terminals				Continuity
Connector	Wire color	Connector	Wire color	
M53-2	R/G	M51-6	R/G	Yes

OK or NG

OK >> GO TO 3.

NG >> Repair harness or connector.

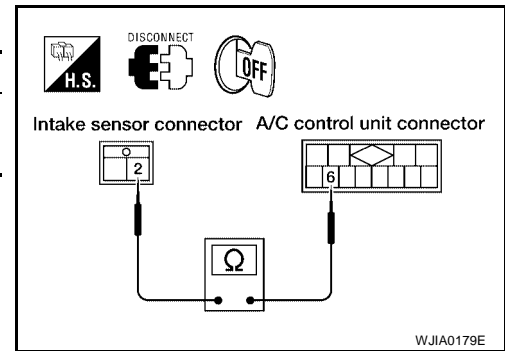

## 3. CHECK INTAKE SENSOR

Refer to [MTC-65, "Intake Sensor"](#) .

OK or NG

OK >> Replace A/C control unit.

NG >> Replace intake sensor.

# CONTROL UNIT

PFP:27500

EJS00101

## CONTROL UNIT

### Removal and Installation

#### REMOVAL

1. Remove cluster lid C. Refer to [IP-12, "Cluster Lid C"](#) .
2. Remove audio unit. Refer to [AV-22, "AUDIO UNIT"](#) .
3. Remove the temperature control cable clamp and then remove the cable from the air mix door lever.

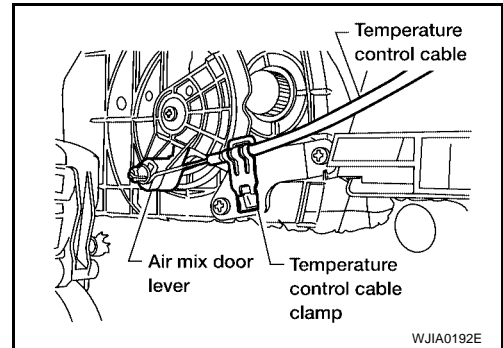

4. Remove the A/C control unit screws and then remove it from the instrument panel.
5. Disconnect the A/C control unit connectors and then remove it.

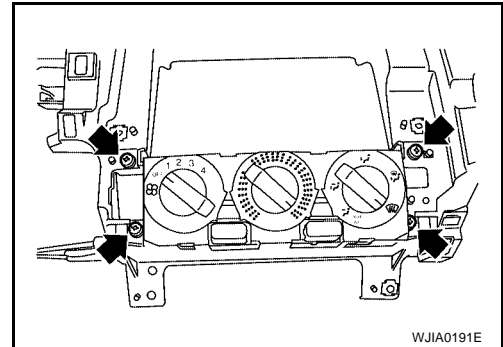

#### INSTALLATION

Installation is in the reverse order of removal.

#### Adjustment

1. Attach temperature control cable.
2. Rotate control knob to full cold position.
3. Remove slack from cable and install temperature control cable clamp.

**After positioning control cable, check for proper operation.**

A

B

C

D

E

F

G

H

I

MTC

K

L

M

# INTAKE SENSOR

## INTAKE SENSOR

PFP:27723

### Removal and Installation

EJS00102

1. Remove the evaporator. Refer to [MTC-90, "Removal and Installation for Evaporator"](#) .
2. Remove the intake sensor clip and then the sensor.

**CAUTION:**

**Be careful not to damage the core surface.**

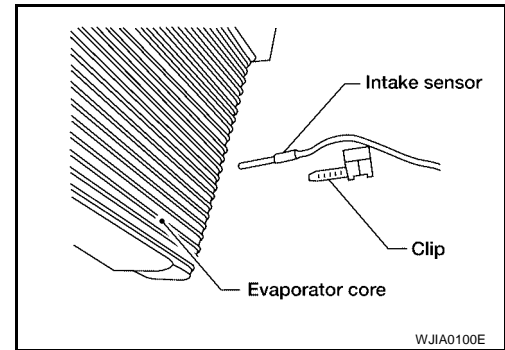

# BLOWER UNIT

## BLOWER UNIT

PFP:27200

### Removal and Installation

EJS00103

#### REMOVAL

1. Remove the glove box assembly. Refer to [IP-15, "Glove Box"](#) .
2. Remove the ECM.
3. Disconnect the blower motor, intake door motor and fan control amp. connector.
4. Remove the 2 bolts and 1 screw from the blower unit, then remove it.

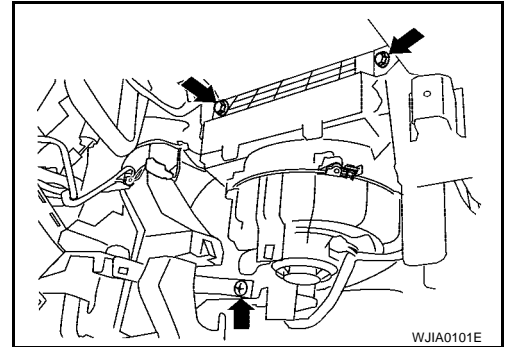

A  
B  
C  
D  
E  
F  
G  
H  
I

MTC

K  
L  
M

# BLOWER MOTOR

## BLOWER MOTOR

PFP:27226

### Removal and Installation

EJS00104

1. Remove the blower unit. Refer to [MTC-69, "Removal and Installation"](#).
2. Release the 8 tabs attaching blower motor to blower unit case and then remove it.

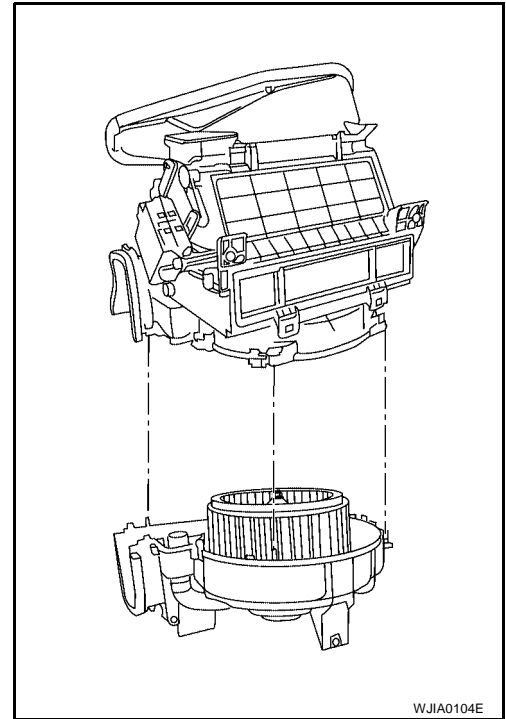

# INTAKE DOOR MOTOR

## INTAKE DOOR MOTOR

PFP:27730

### Removal and Installation

EJS00105

1. Remove the blower unit. Refer to [MTC-69, "Removal and Installation"](#).
2. Remove the screws and then the intake door motor from the blower unit.

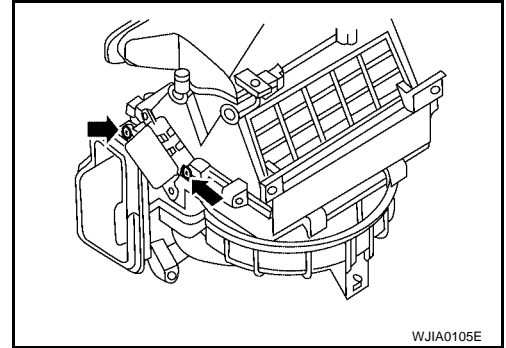

A  
B  
C  
D  
E  
F  
G  
H  
I

MTC

K  
L  
M

# IN-CABIN MICROFILTER

## IN-CABIN MICROFILTER

PFP:27277

### Removal and Installation FUNCTION

EJS001LK

Air inside passenger compartment is kept clean at either recirculation or fresh mode by installing in-cabin microfilter into blower unit.

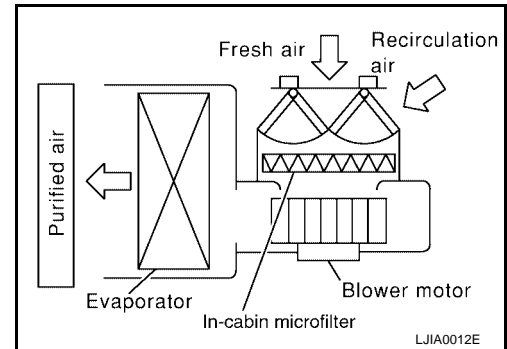

### REPLACEMENT TIMING

Replace in-cabin microfilter.

Refer to [MA-7, "SCHEDULE 1"](#) and [MA-10, "SCHEDULE 2"](#).

Caution label is fixed inside the glove box.

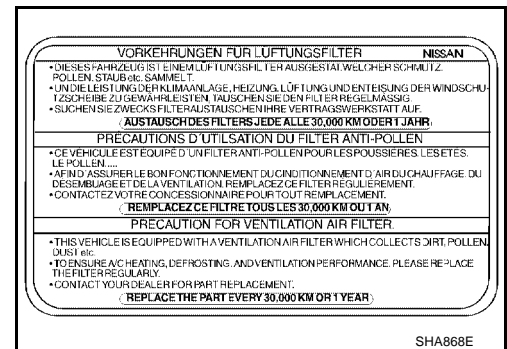

### REPLACEMENT PROCEDURES

1. Remove glove box assembly. Refer to [IP-15, "Glove Box"](#).
2. Remove in-cabin microfilter cover.
3. Take out the ventilation air filter from blower unit.
4. Replace with new in-cabin microfilter and reinstall on blower unit.
5. Reinstall glove box assembly.

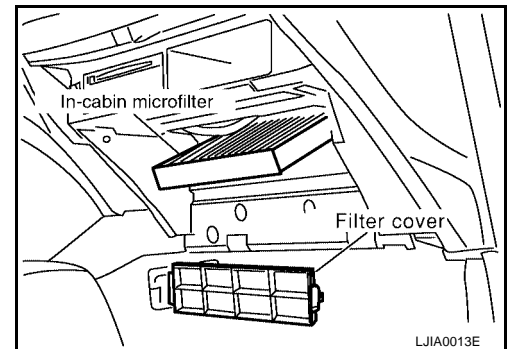



# HEATER & COOLING UNIT ASSEMBLY

## HEATER & COOLING UNIT ASSEMBLY

PF27110

### Removal and Installation

EJS00106

#### REMOVAL

1. Discharge refrigerant from A/C system. Refer to [MTC-79, "HFC-134a \(R-134a\) Service Procedure"](#) .
2. Drain coolant from cooling system. Refer to [MA-14, "Changing Engine Coolant"](#) (QR25DE models) or [MA-22, "Changing Engine Coolant"](#) (VQ35DE models).
3. Disconnect heater hoses from heater core pipes.
4. Disconnect refrigerant lines from evaporator.

#### **CAUTION:**

**Cap or wrap the joint of the pipe with suitable material such as vinyl tape to avoid entry of air.**

5. Remove the instrument panel. Refer to [IP-10, "INSTRUMENT PANEL ASSEMBLY"](#) .
6. Remove the blower unit. Refer to [MTC-69, "Removal and Installation"](#) .
7. Remove the temperature control cable clamp and then remove the cable from the air mix door lever.

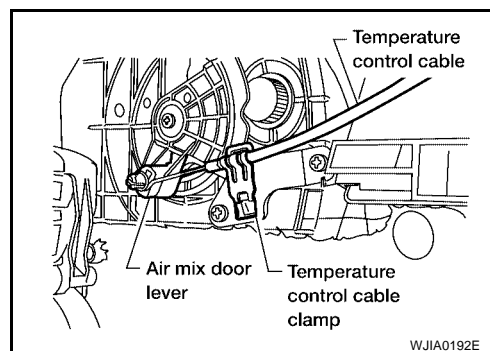

8. Disconnect mode door motor connector.
9. Remove the heater and cooling unit.

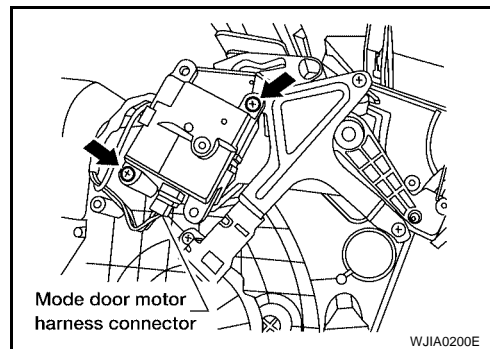

#### INSTALLATION

Install in the reverse order of removal.

#### **NOTE:**

When filling radiator with coolant, refer to [CO-11, "Refilling Engine Coolant"](#) (QR25DE models) or [CO-33, "Refilling Engine Coolant"](#) (VQ35DE models). Recharge the A/C system. Refer to [MTC-79, "HFC-134a \(R-134a\) Service Procedure"](#) .

# HEATER CORE

## HEATER CORE

PFP:27140

### Removal and Installation

EJS00107

1. Remove heater and cooling unit. Refer to [MTC-73, "Removal and Installation"](#).
2. Remove heater core pipe support screws and then remove it.

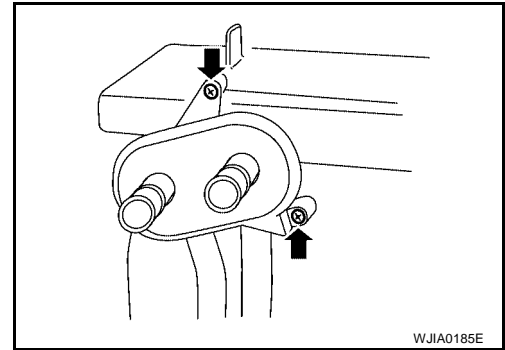

3. Remove heater core cover screws and then remove it.

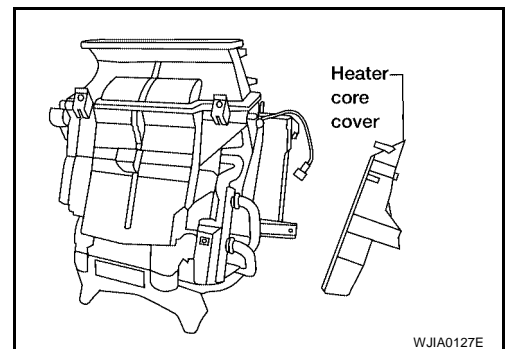

4. Remove heater core.

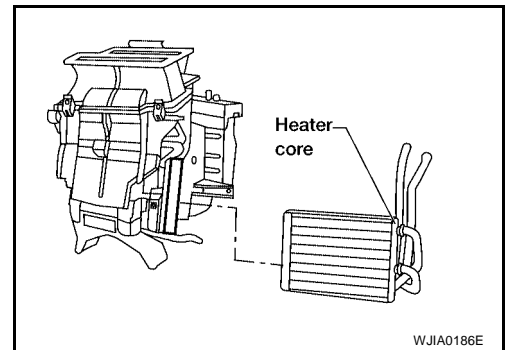

# MODE DOOR MOTOR

## MODE DOOR MOTOR

PF2:27731

### Removal and Installation

EJS00108

#### DRIVER SIDE MODE DOOR MOTOR

1. Remove the driver lower instrument panel assembly. Refer to [IP-13, "Driver Lower Instrument Panel"](#).
2. Disconnect the mode door motor connector.
3. Remove the mode door motor screws and then remove it.

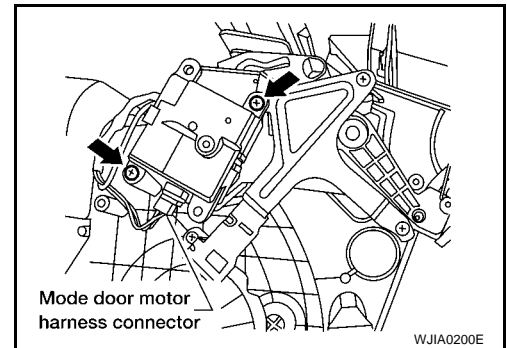

A  
B  
C  
D  
E  
F  
G  
H  
I  
M

MTC

# BLOWER FAN RESISTER

## BLOWER FAN RESISTER

PF2:27150

### Removal and Installation

EJS00109

1. Disconnect blower motor resistor connector.
2. Remove blower motor resistor screws and then remove it.

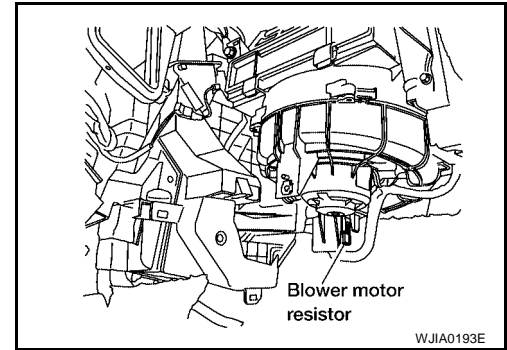

# DUCTS AND GRILLES

## DUCTS AND GRILLES

PFP:27860

### Removal and Installation

EJS0010A

### Ventilator Duct, Defroster Nozzle and Defroster Ducts

EJS0010B

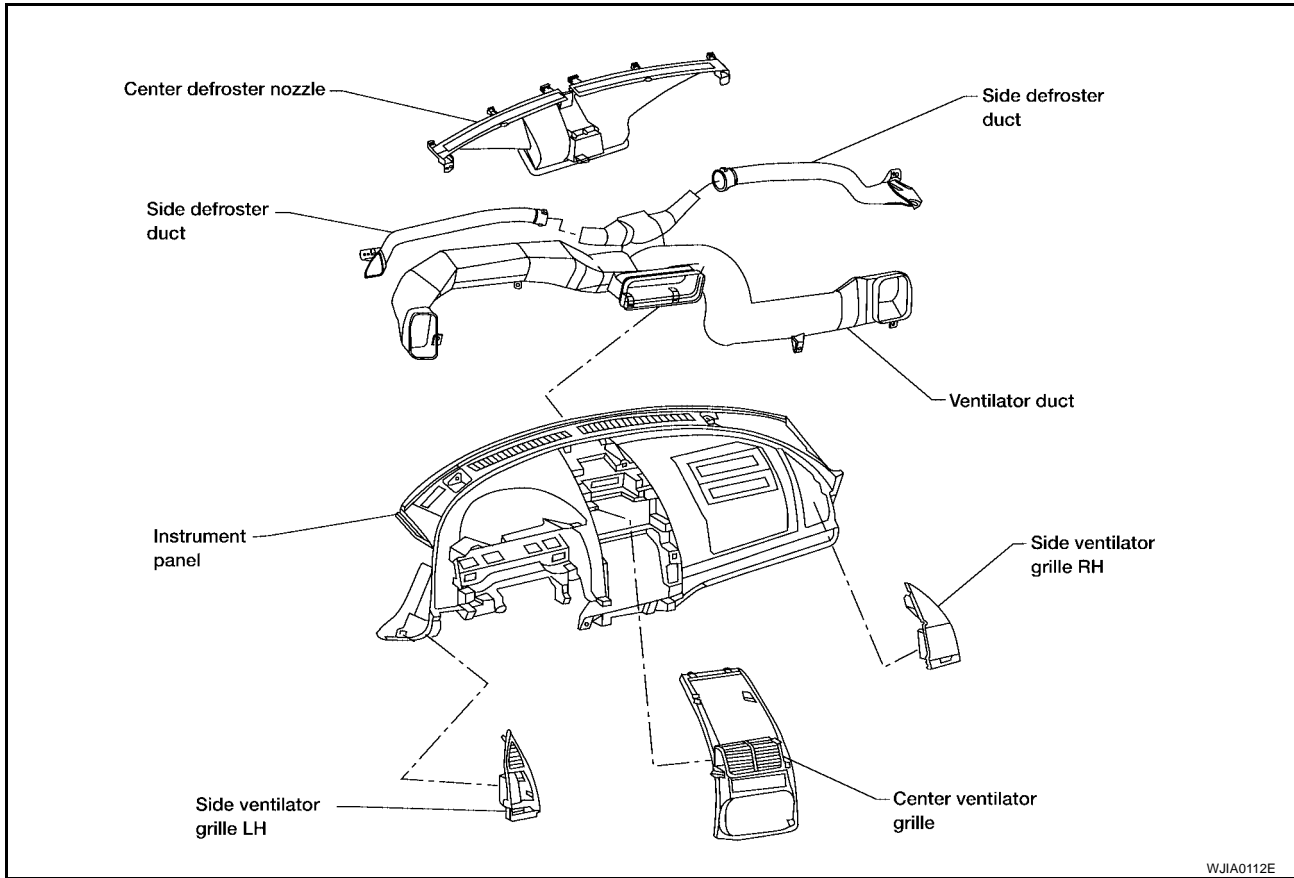

A  
B  
C  
D  
E  
F  
G  
H  
I

MTC

### Center Ventilator Grille

EJS0010C

1. Remove cluster lid D. Refer to [IP-13, "Cluster Lid D"](#).
2. Release the tabs to remove center ventilator grille.

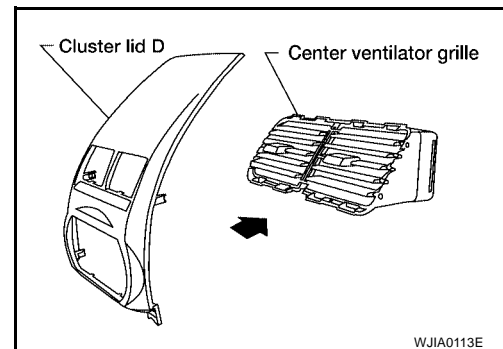

K  
L  
M

### Side Ventilator Grille LH

EJS0010D

1. Remove cluster lid A. Refer to [IP-13, "Cluster Lid A"](#).
2. Remove side ventilator grille LH.

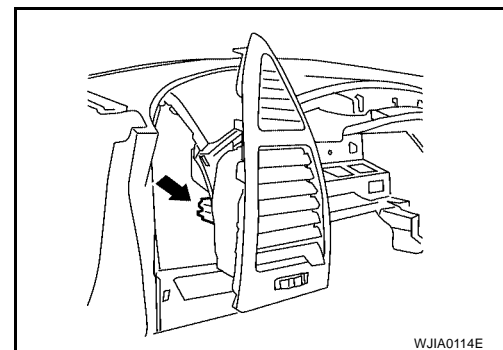

# DUCTS AND GRILLES

## Side Ventilator Grille RH

EJS0010E

1. Remove glove box assembly. Refer to [IP-15, "Glove Box"](#) .
2. Remove side ventilator grille RH screw and then remove it.

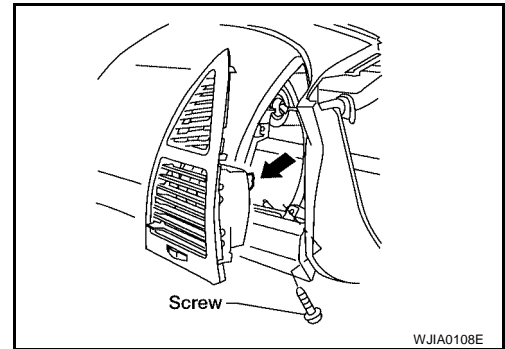

## Floor duct

EJS0010F

1. Remove the carpet. Refer to [EI-32, "FLOOR TRIM"](#) .
2. Release foam tape and slide floor duct rearward to release from clips.

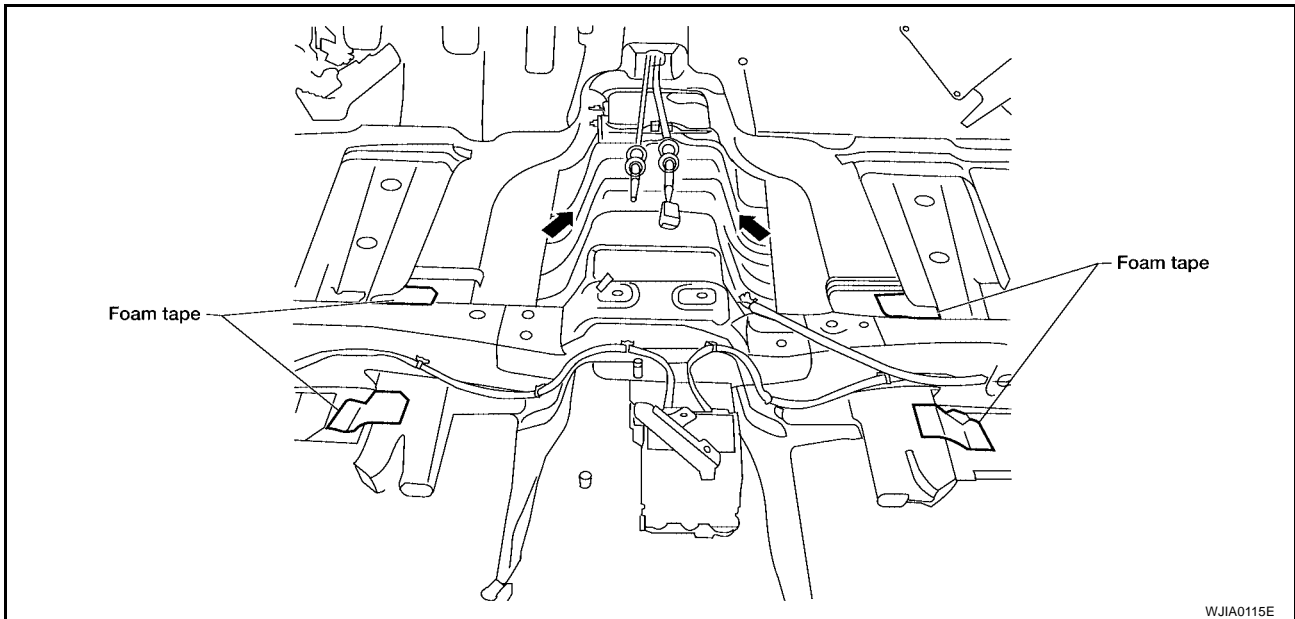

# REFRIGERANT LINES

## REFRIGERANT LINES

PFP:92600

### HFC-134a (R-134a) Service Procedure SETTING OF SERVICE TOOLS AND EQUIPMENT

EJS0010G

#### Discharging Refrigerant

**WARNING:**

Avoid breathing A/C refrigerant and lubricant vapor or mist. Exposure may irritate eyes, nose and throat. Remove HFC-134a (R-134a) from A/C system using certified service equipment meeting requirements of SAE J2210 (R-134a recycling equipment) or J2201 (R-134a recovery equipment). If accidental system discharge occurs, ventilate work area before resuming service. Additional health and safety information may be obtained from refrigerant and lubricant manufacturers.

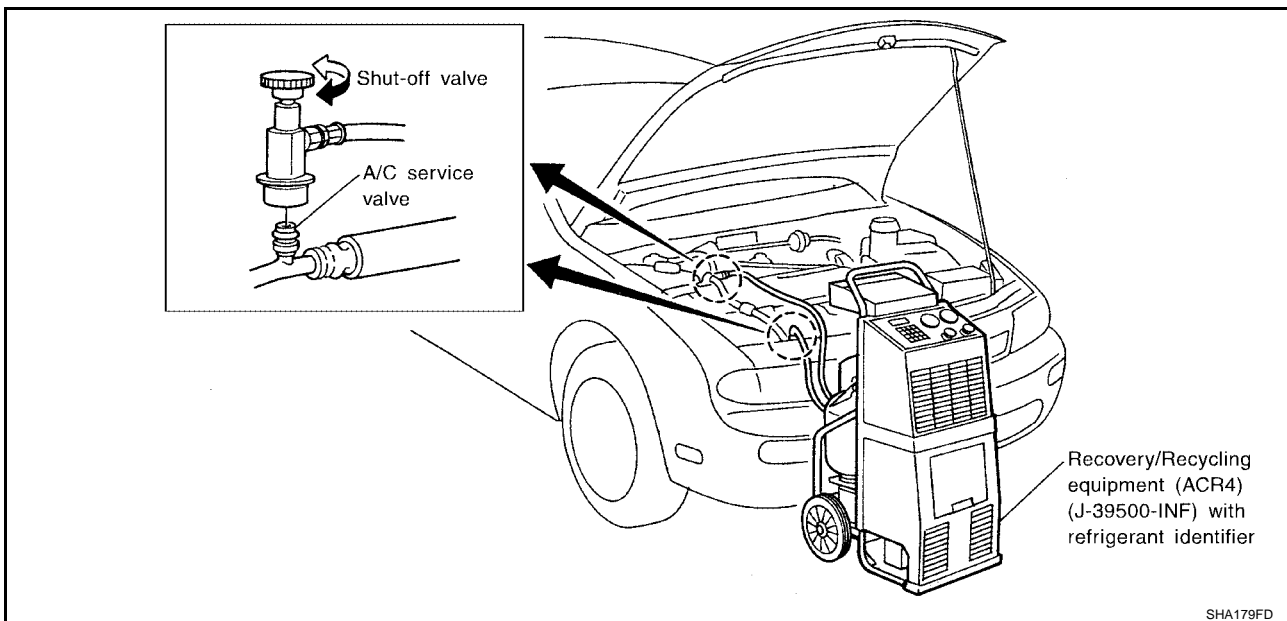

#### Evacuating System and Charging Refrigerant

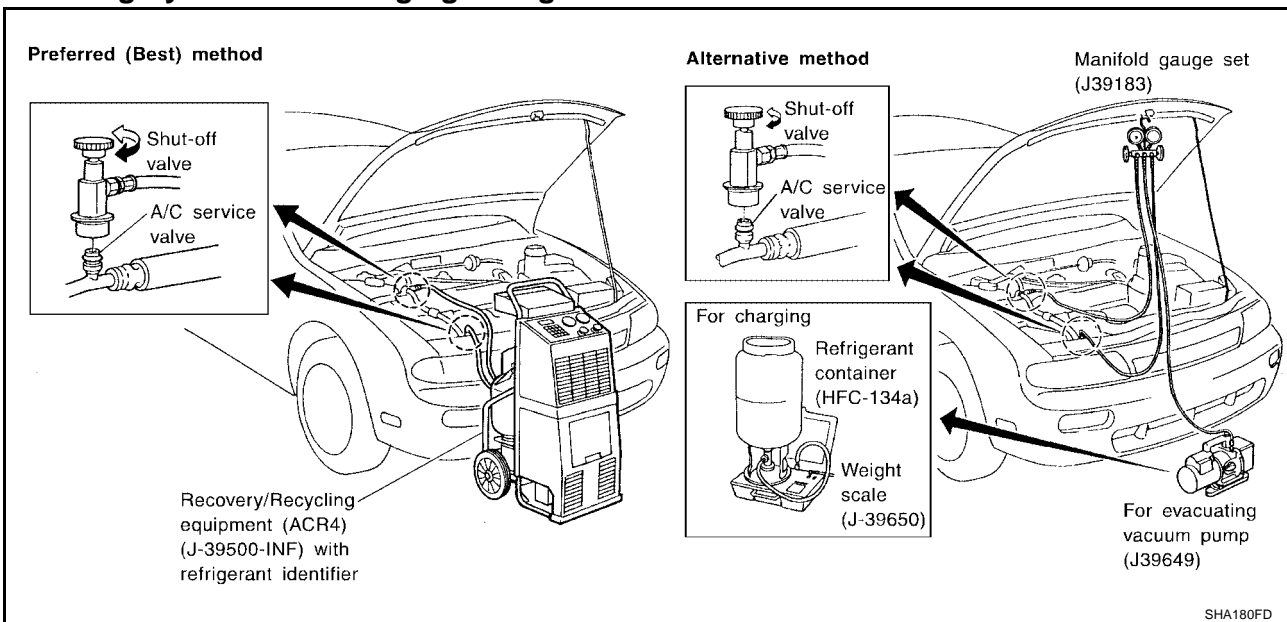

A  
B  
C  
D  
E  
F  
G  
H  
I

MTC

K  
L  
M

# REFRIGERANT LINES

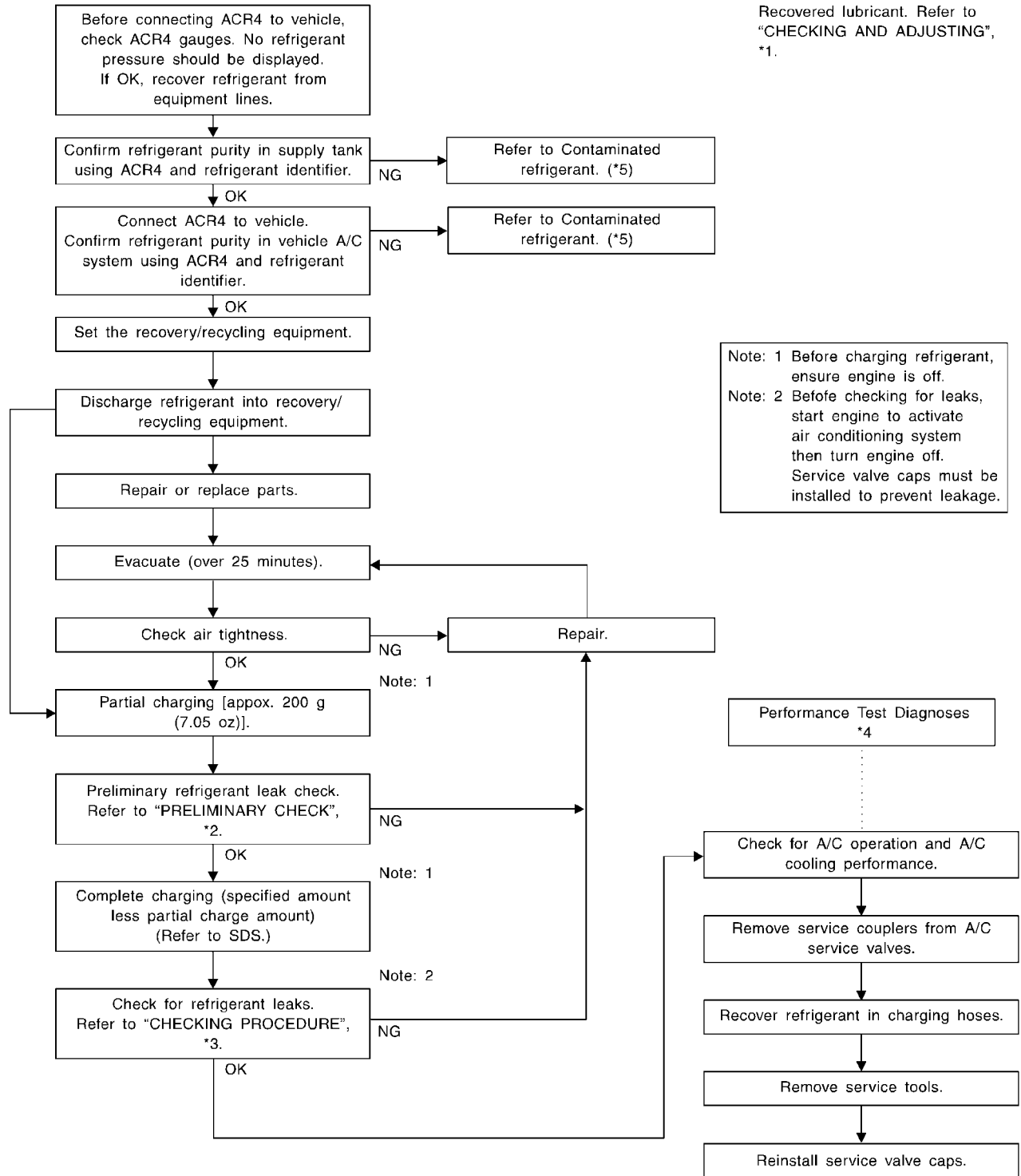

\*1 [MTC-18, "LUBRICANT"](#)

\*3 [MTC-91, "Checking for Refrigerant Leaks"](#)

\*5 [MTC-3, "Contaminated Refrigerant"](#)

\*2 [MTC-91, "Checking for Refrigerant Leaks"](#)

\*4 [MTC-59, "Performance Chart"](#)

SHA251F

## Components

Refer to [MTC-5, "Precautions for Refrigerant Connection"](#) .

EJS0010H



# REFRIGERANT LINES

## QR25DE Models

SEC. 214 • 271 • 274 • 276

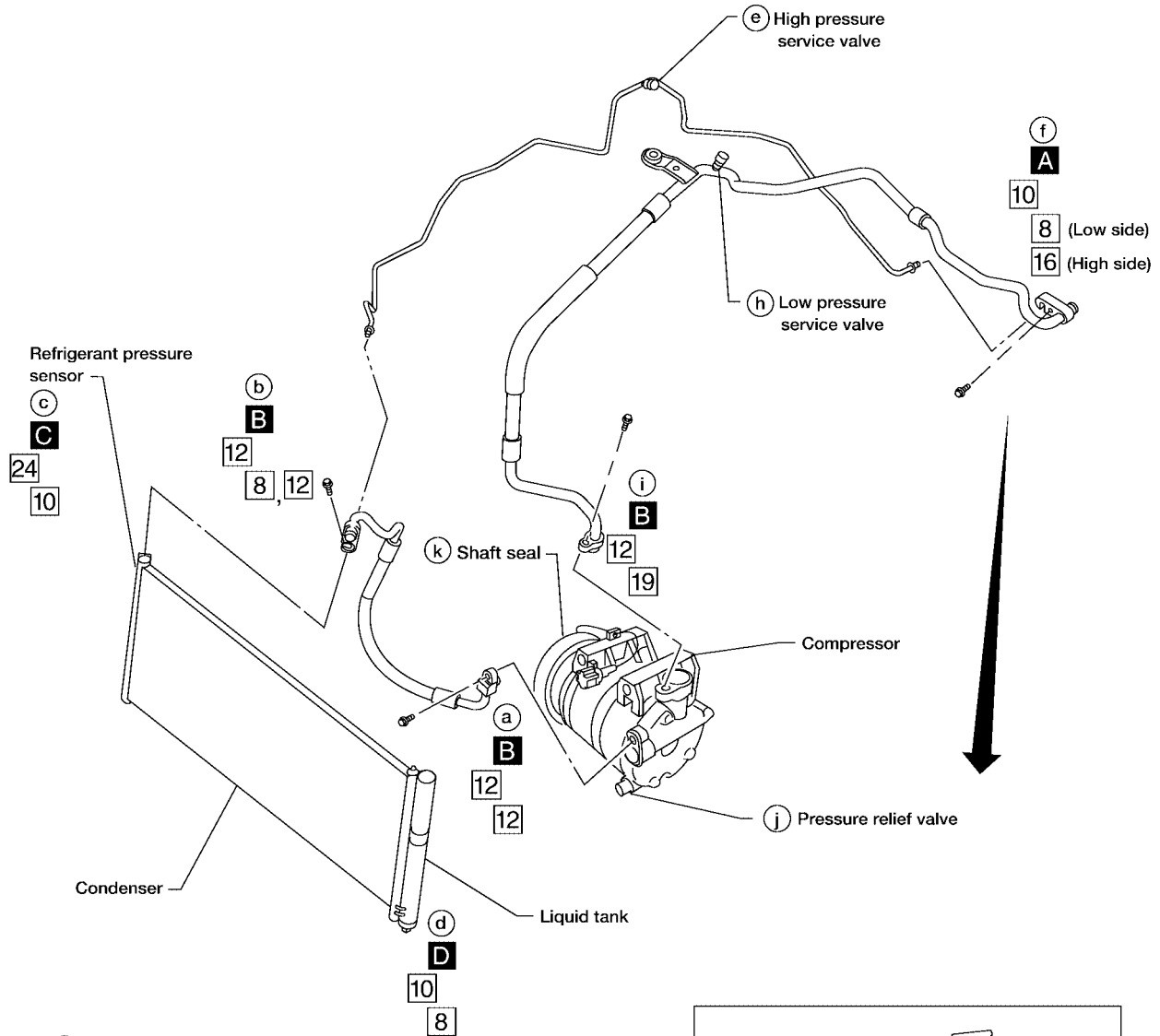

- : Refrigerant leak checking order
- : (Tightening torque)
- □ : (Wrench size)
- : (O-ring size)
- ⊗ : Nm (kg-m, in-lb)
- ⊕ : Nm (kg-m, ft-lb)
- A** : 2.9 – 5.9 (0.29 – 0.60, 26 – 52)
- B** : 7.8 – 19.6 (0.8 – 1.9, 69 – 173)
- C** : 9.8 – 11.7 (1.0 – 1.1, 7.3 – 8.6)
- D** : 5.0 – 6.47 (0.51 – 0.65, 45 – 57)

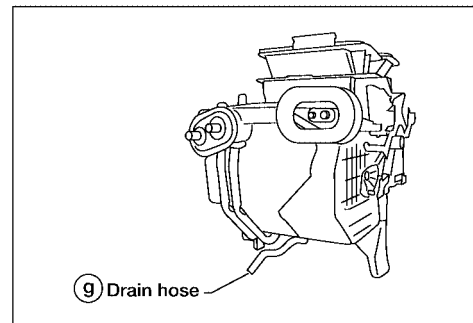

A  
B  
C  
D  
E  
F  
G  
H  
I  
K  
L  
M

MTC

WJIA0180E

# REFRIGERANT LINES

## VQ35DE Models

SEC. 214 • 271 • 274 • 276

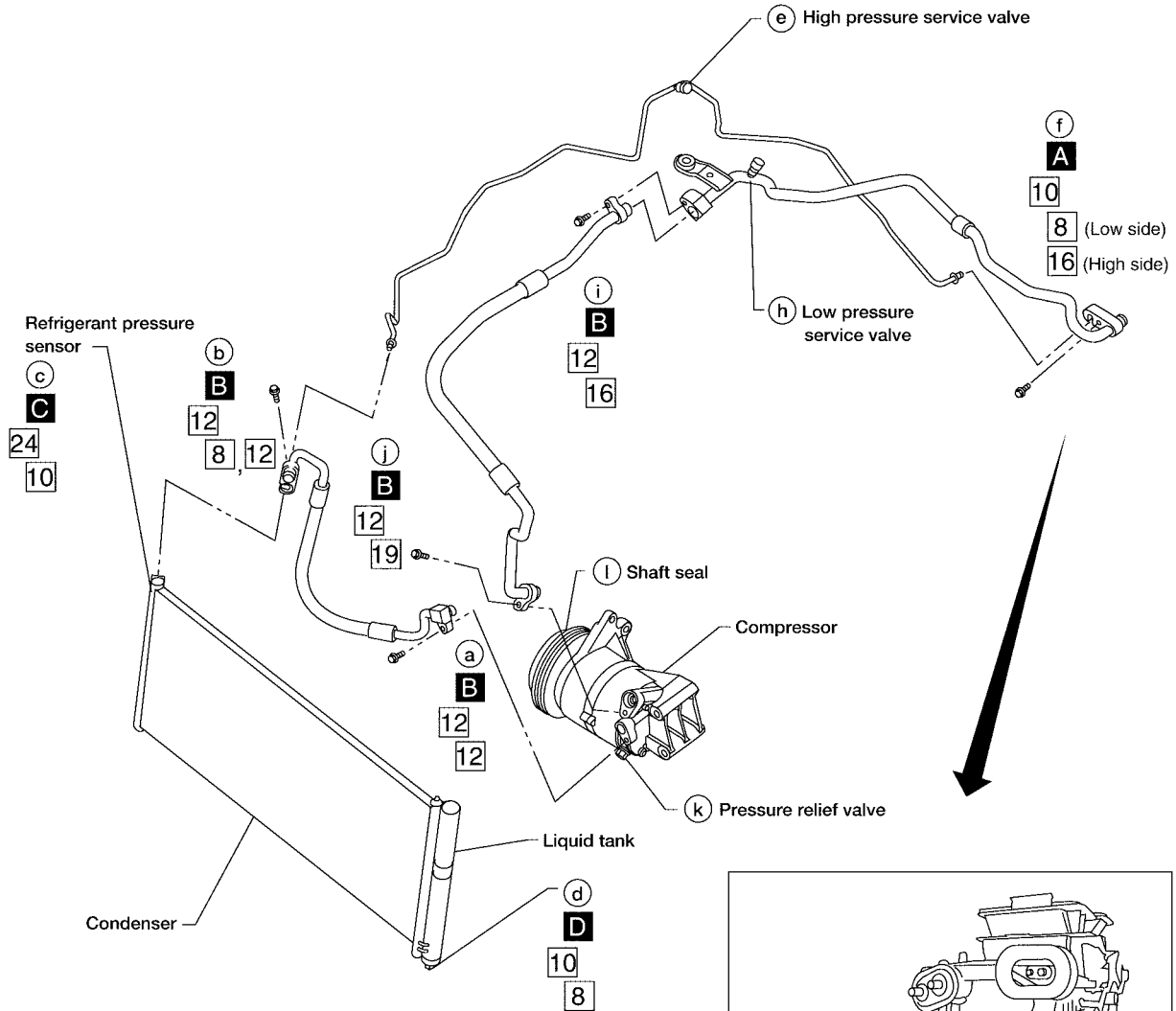

- : Refrigerant leak checking order
- : (Tightening torque)
- □ : (Wrench size)
- : (O-ring size)
- ⊗ : N·m (kg-m, in-lb)
- ⊙ : N·m (kg-m, ft-lb)
- A** : 2.9 – 5.9 (0.29 – 0.60, 26 – 52)
- B** : 7.8 – 19.6 (0.8 – 1.9, 69 – 173)
- C** : 9.8 – 11.7 (1.0 – 1.1, 7.3 – 8.6)
- D** : 5.0 – 6.47 (0.51 – 0.65, 45 – 57)

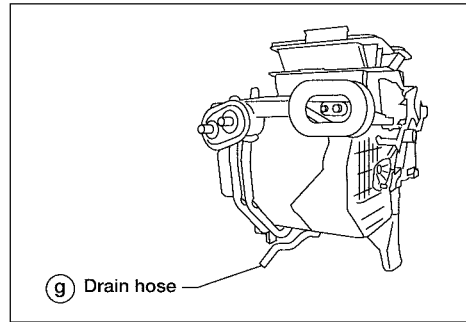

WJJA0116E

# REFRIGERANT LINES

## Removal and Installation for Compressor — QR25DE Models

EJS00101

SEC. 274 • 275

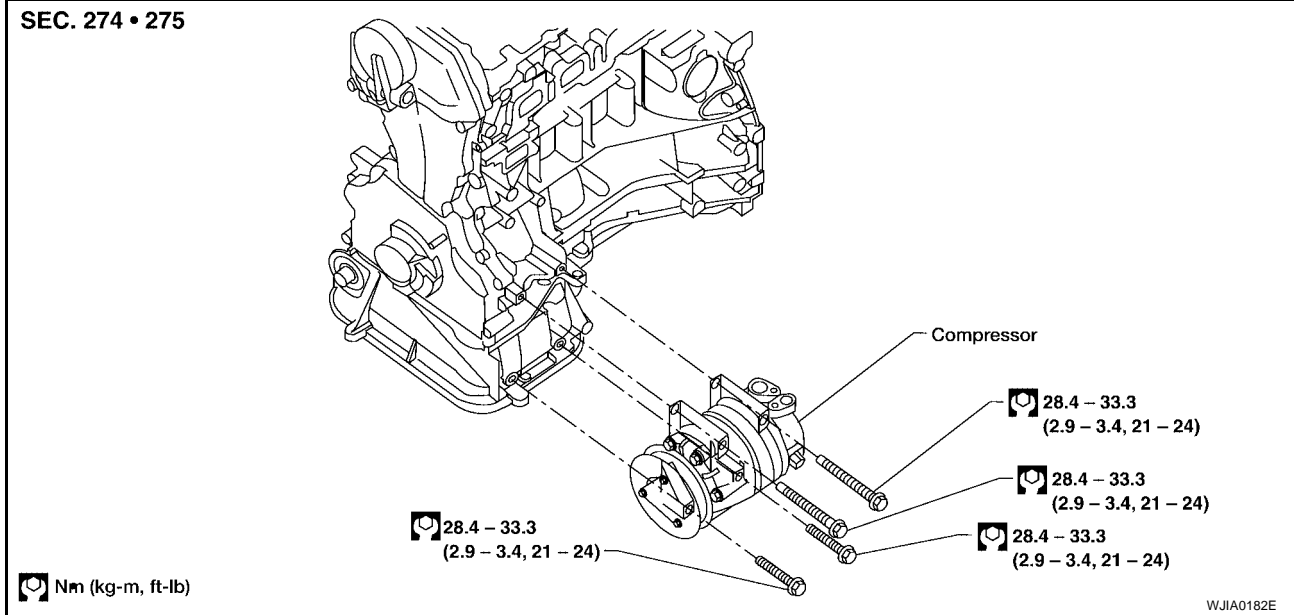

### REMOVAL

1. Discharge the refrigerant. Refer to [MTC-79, "HFC-134a \(R-134a\) Service Procedure"](#).
2. Remove the drive belt.  
Refer to [MA-14, "ENGINE MAINTENANCE \(QR25DE ENGINE\)"](#).
3. Disconnect the compressor connector.
4. Remove the high-pressure flexible hose and low-pressure flexible hose.

#### CAUTION:

Cap or wrap the joint of the pipe with suitable material such as vinyl tape to avoid the entry of air.

5. Remove the mounting bolts from compressor using power tools.

### INSTALLATION

#### CAUTION:

- Replace the O-ring of the low-pressure flexible hose and high-pressure flexible hose with a new one, then apply compressor oil to it when installing it.
- When charging refrigerant, check for leaks.

#### Bolts mounting the compressor

Tightening torque : 28.4 - 33.3 N·m (2.9 - 3.4 kg-m, 21 - 24 ft-lb)

Tightening torque : 59.8 - 69.6 N·m (6.1 - 7.0 kg-m, 45 - 51 ft-lb)

#### Bolt mounting the high- and low-pressure flexible hoses

Tightening torque : 7.8 - 19.6 N·m (0.8 - 1.9 kg-m, 69 - 173 in-lb)

# REFRIGERANT LINES

## Removal and Installation for Compressor — VQ35DE Models

EJS0010J

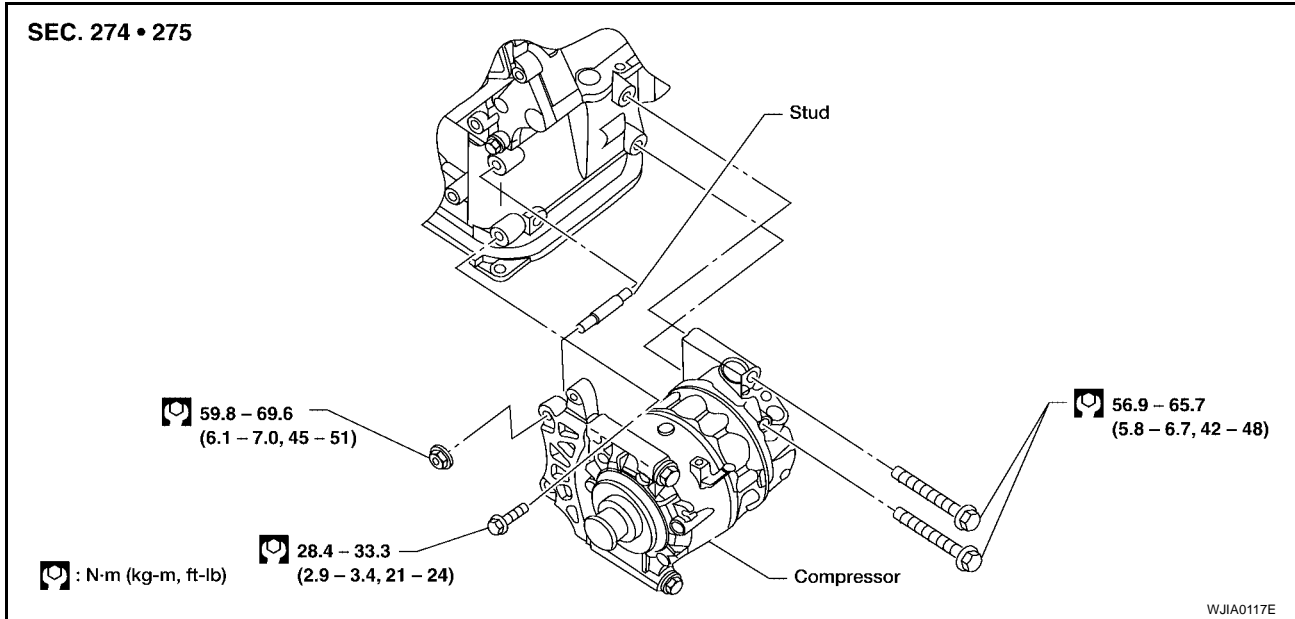

### REMOVAL

1. Discharge the refrigerant. Refer to [MTC-79, "HFC-134a \(R-134a\) Service Procedure"](#) .
2. Remove the drive belt.  
Refer to [MA-21, "ENGINE MAINTENANCE \(VQ35DE ENGINE\)"](#) .
3. Remove the coolant pipe bracket bolt.
4. Remove compressor mounting stud.
5. Disconnect the compressor connector.
6. Remove the high-pressure flexible hose and low-pressure flexible hose.

#### **CAUTION:**

**Cap or wrap the joint of the pipe with suitable material such as vinyl tape to avoid the entry of air.**

7. Remove the mounting bolts and nut from compressor using power tools.

### INSTALLATION

#### **CAUTION:**

- Replace the O-ring of the low-pressure flexible hose and high-pressure flexible hose with a new one, then apply compressor oil to it when installing it.
- When charging refrigerant, check for leaks.

#### **Bolts mounting the compressor (rear side)**

**Tightening torque** : 56.9 - 65.7 N-m (5.8 - 6.8 kg-m, 42 - 48 ft-lb)

#### **Bolt mounting the compressor (front side)**

**Tightening torque** : 28.4 - 33.3 N-m (2.9 - 3.4 kg-m, 21 - 24 ft-lb)

#### **Nut mounting the compressor (front side)**

**Tightening torque** : 59.8 - 69.6 N-m (6.1 - 7.0 kg-m, 45 - 51 ft-lb)

#### **Bolt mounting the high- and low-pressure flexible hoses**

**Tightening torque** : 7.8 - 19.6 N-m (0.8 - 1.9 kg-m, 69 - 173 in-lb)

# REFRIGERANT LINES

## Removal and Installation for Compressor Clutch

EJS0010K

### REMOVAL

- When removing center bolt, hold clutch disc with clutch disc tool.
- Remove the clutch disc.  
Clutch disc holding tool:  
(J-44614) Commercial service tool

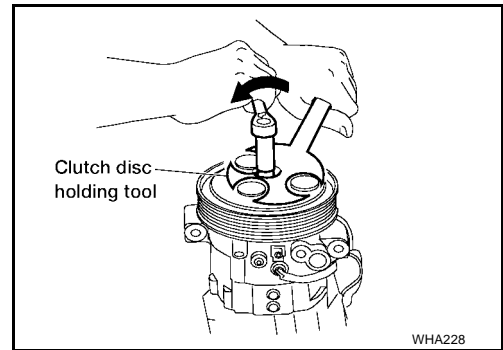

- Remove the snap ring using external snap ring pliers.

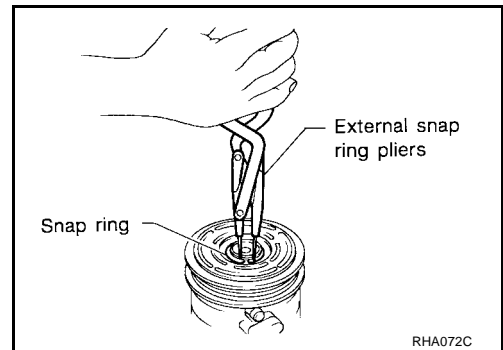

- Pulley removal:

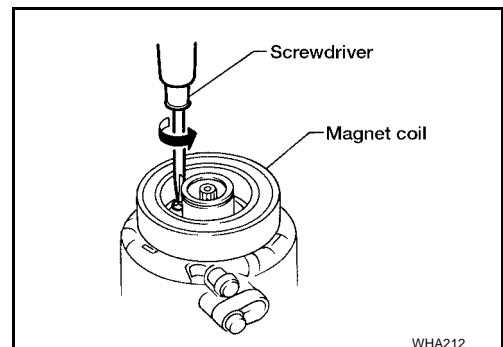
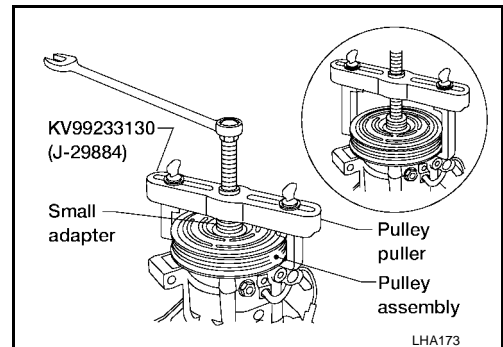

Use a pulley puller with small adapter. Position the small adapter on the end of the drive shaft and the center of the puller on the small adapter. Remove the pulley assembly with the puller.

**To prevent deformation of the pulley groove, the puller claws should be hooked under (not into) the pulley groove.**

- Remove the snap ring using external snap ring pliers.
- Remove the magnet coil harness clip using a screwdriver, remove the three magnet coil fixing screws and remove the magnet coil.

A  
B  
C  
D  
E  
F  
G  
H  
I  
MTC  
K  
L  
M

# REFRIGERANT LINES

## INSPECTION

### Clutch Disc

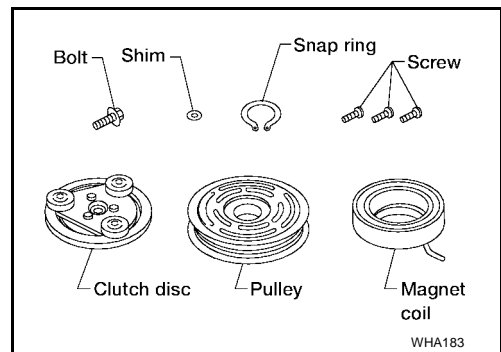

If the contact surface shows signs of damage due to excessive heat, replace clutch disc and pulley.

### Pulley

Check the appearance of the pulley assembly. If contact surface of pulley shows signs of excessive grooving, replace clutch disc and pulley. The contact surfaces of the pulley assembly should be cleaned with a suitable solvent before reinstallation.

### Coil

Check magnet coil for loose connection or cracked insulation.

## INSTALLATION

- Install the magnet coil.  
**Be sure to align the magnet coil pin with the hole in the compressor front head.**
- Install the magnet coil harness clip using a screwdriver.

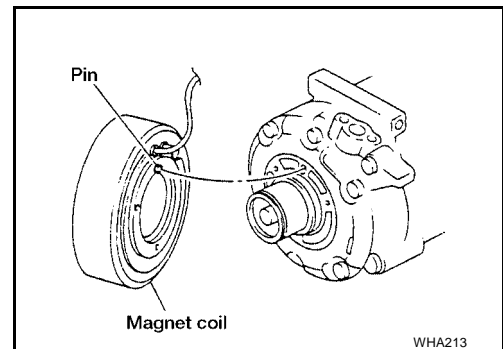

- Install the pulley assembly using the installer and a wrench, and then install the snap ring using snap ring pliers.

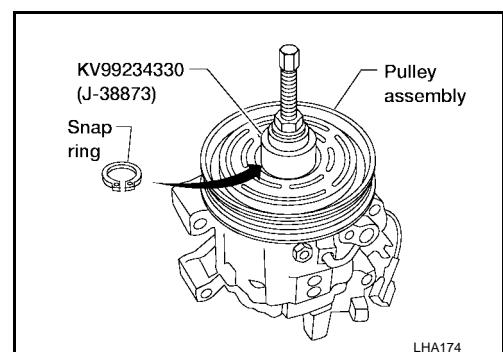

- Install the clutch disc on the drive shaft, together with the original shim(s). Press the clutch disc down by hand.

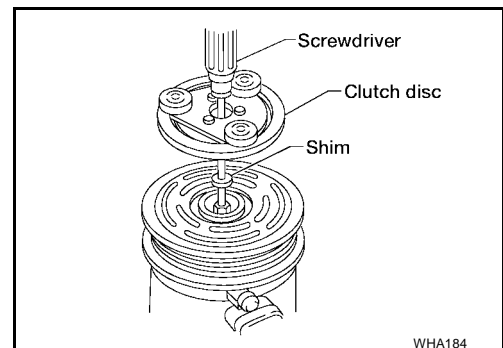

# REFRIGERANT LINES

- Using the clutch disc tool to prevent clutch disc rotation, tighten the bolt to 12 N·m (1.2 kg·m, 9 ft-lb).
- After tightening the bolt, check that the pulley rotates smoothly.

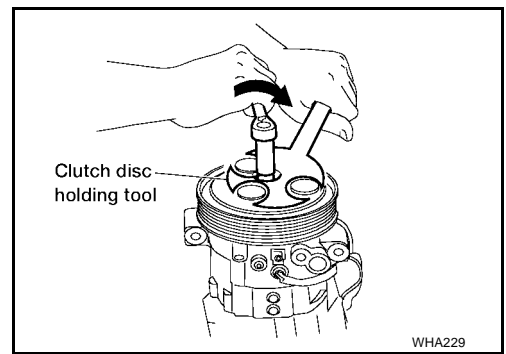

- Check clearance all the way around the clutch disc.  
**Clutch disc-to-pulley clearance : 0.3 - 0.6 mm (0.012 - 0.024 in)**

If the specified clearance is not obtained, replace adjusting spacer and readjust.

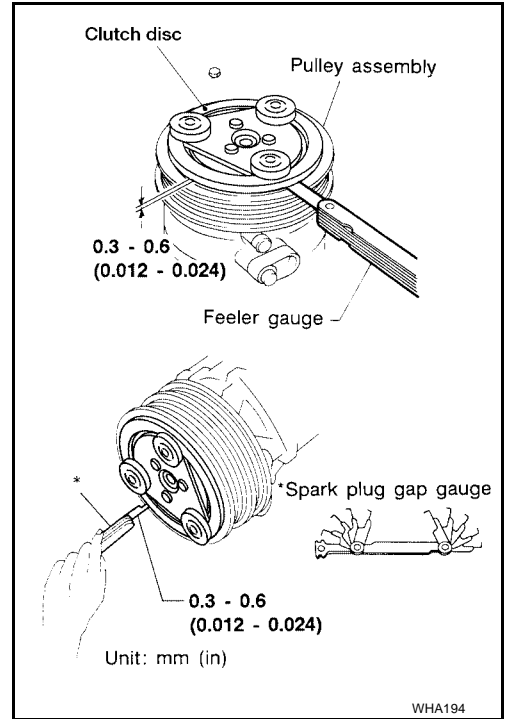

## BREAK-IN OPERATION

When replacing compressor clutch assembly, always conduct the break-in operation. This is done by engaging and disengaging the clutch about 30 times. Break-in operation raises the level of transmitted torque.

## Removal and Installation for Low-pressure Flexible Hose

EJS0010L

### REMOVAL

1. Discharge the refrigerant. Refer to [MTC-79, "HFC-134a \(R-134a\) Service Procedure"](#).

#### CAUTION:

Cap or wrap the joint of the pipe with suitable material such as vinyl tape to avoid the entry of air.

2. Remove the low-pressure flexible hose. Refer to [MTC-80, "Components"](#).

### INSTALLATION

#### CAUTION:

- Replace the O-ring of the low-pressure flexible hose with a new one, then apply compressor oil to it when installing it.
- When charging refrigerant, check for leaks.

**Bolt mounting the low-pressure flexible hose (evaporator side)**

**Tightening torque : 2.9 - 5.9 N·m (0.29 - 0.60 kg·m, 26 - 52 in-lb)**

**Bolt mounting the low-pressure flexible hose (compressor side)**

**Tightening torque : 7.8 - 19.6 N·m (0.8 - 1.9 kg·m, 69 - 173 in-lb)**

# REFRIGERANT LINES

**Bolt connecting the low-pressure flexible hose in-line connection (VQ35DE models)**

**Tightening torque : 7.8 - 19.6 N-m (0.8 - 1.9 kg-m, 69 - 173 in-lb)**

## Removal and Installation for High-pressure flexible hose

EJS0010M

### REMOVAL

1. Discharge the refrigerant. Refer to [MTC-79, "HFC-134a \(R-134a\) Service Procedure"](#).
2. Remove the high-pressure flexible hose. Refer to [MTC-80, "Components"](#).

### CAUTION:

Cap or wrap the joint of the pipe with suitable material such as vinyl tape to avoid the entry of air.

### INSTALLATION

### CAUTION:

- Replace the O-ring of the high-pressure flexible hose with a new one, then apply compressor oil to it when installing it.
- When charging refrigerant, check for leaks.

**Bolts mounting the high-pressure flexible hose**

**Tightening torque : 7.8 - 19.6 N-m (0.8 - 1.9 kg-m, 69 - 173 in-lb)**

## Removal and Installation for High-pressure Pipe

EJS0010N

### REMOVAL

1. Discharge the refrigerant. Refer to [MTC-79, "HFC-134a \(R-134a\) Service Procedure"](#).
2. Remove the high-pressure pipe. Refer to [MTC-80, "Components"](#).

### CAUTION:

Cap or wrap the joint of the pipe with suitable material such as vinyl tape to avoid the entry of air.

### INSTALLATION

### CAUTION:

- Replace the O-ring of the high-pressure pipe with a new one, then apply compressor oil to it when installing it.
- When charging refrigerant, check for leaks.

**Bolt mounting the high-pressure pipe (evaporator side)**

**Tightening torque : 2.9 - 5.9 N-m (0.29 - 0.60 kg-m, 26 - 52 in-lb)**

**Bolt mounting the high-pressure pipe (condenser side)**

**Tightening torque : 7.8 - 19.6 N-m (0.8 - 1.9 kg-m, 69 - 173 in-lb)**

## Removal and Installation for Refrigerant Pressure Sensor

EJS0010O

1. Discharge the refrigerant. Refer to [MTC-79, "HFC-134a \(R-134a\) Service Procedure"](#).
2. Disconnect the refrigerant pressure sensor connector and remove the refrigerant pressure sensor from condenser.

### CAUTION:

- Please be careful not to damage the condenser fins.
- Apply compressor oil to the O-ring of the refrigerant pressure sensor when installing it.

**Tightening : 9.8 - 11.7 N-m (1.0 - 1.2 kg-m, 7.3 - 8.6 ft-torque lb)**

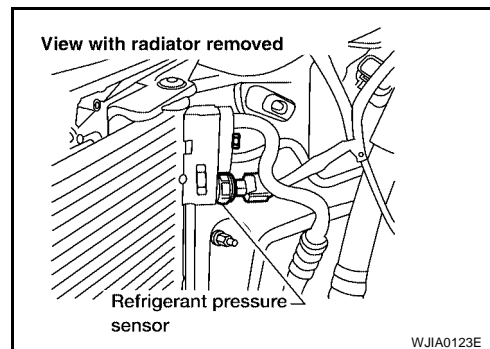

## Removal and Installation for Condenser

EJS0010P

### REMOVAL

1. Discharge the refrigerant. Refer to [MTC-79, "HFC-134a \(R-134a\) Service Procedure"](#).
2. Remove the radiator. Refer to [CO-34, "RADIATOR"](#).

### CAUTION:

Be careful not to damage the core surface of the condenser and the radiator.



# REFRIGERANT LINES

3. Disconnect the high-pressure flexible hose and the high-pressure pipe from the condenser.

**CAUTION:**

Cap or wrap the joint of the pipe with suitable material such as vinyl tape to avoid the entry of air.

4. Disconnect the refrigerant pressure sensor connector.
5. Remove the front fascia. Refer to [EI-13, "FRONT BUMPER"](#).

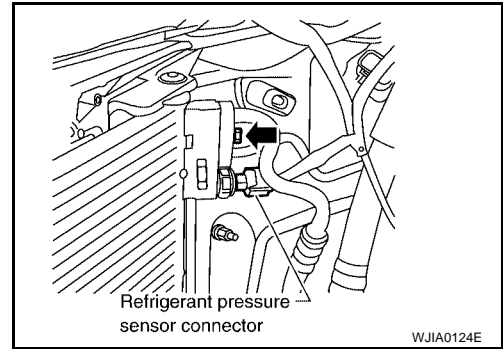

6. Remove the mounting nuts from condenser mounting brackets.

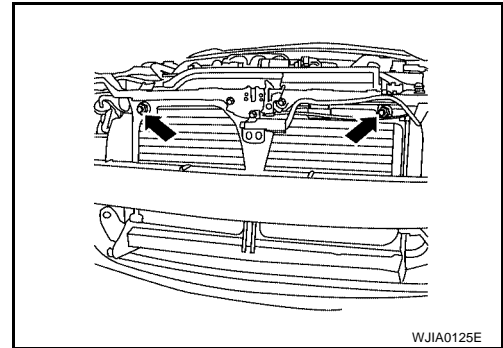

## INSTALLATION

**CAUTION:**

- Replace the O-rings of the high-pressure pipe and the high-pressure flexible hose with new ones, then apply compressor oil to them after installing them.
- When charging refrigerant, check for leaks.

High-pressure flexible hose and pipe mounting bolt

Tightening torque : 7.8 - 19.6 N·m (0.8 - 1.9 kg·m, 69 - 173 in·lb)

Condenser mounting nuts

Tightening torque : 5.0 - 6.79 N·m (0.51 - 0.69 kg·m, 45 - 60 in·lb)

## Removal and Installation for Liquid Tank

EJS0010Q

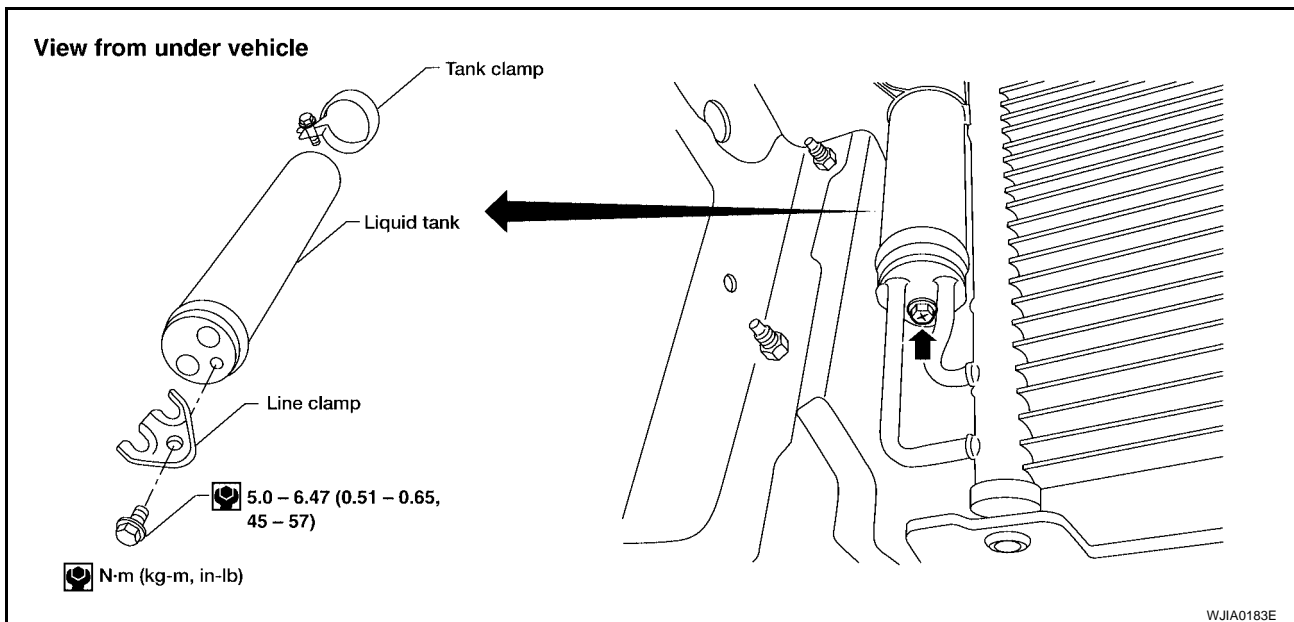

1. Discharge the refrigerant. Refer to [MTC-79, "HFC-134a \(R-134a\) Service Procedure"](#).
2. Remove the battery.

# REFRIGERANT LINES

3. Remove the hood switch (if equipped).
4. Remove the engine undercover using power tools.
5. Remove the bolt and line clamp.
6. Loosen the tank clamp and remove the liquid tank.

## Removal and Installation for Evaporator REMOVAL

EJS00317

1. Evacuate and recover the A/C system refrigerant. Refer to [MTC-79, "HFC-134a \(R-134a\) Service Procedure"](#).
2. Disconnect the battery negative terminal.
3. Disconnect the air cleaner to electronic throttle control actuator tube. Refer to [EM-16, "AIR CLEANER AND AIR DUCT"](#) (QR25DE), [EM-112, "AIR CLEANER AND AIR DUCT"](#) (VQ35DE).

### NOTE:

The tube is located between the air cleaner assembly and the intake manifold and is removed to access the expansion valve.

4. Disconnect the A/C pipe from the expansion valve.

### CAUTION:

**Cap or wrap the joint of the pipe with suitable material such as vinyl tape to avoid the entry of air.**

5. Remove the cooler grommet.
6. Remove the expansion valve.
7. Remove the center console side finisher RH. Refer to [IP-16, "Center Console"](#).
8. Remove the glove box assembly. Refer to [IP-15, "Glove Box"](#).
9. Remove the ECM.
  - Disconnect the ECM connector.
  - Remove the wire harness from the ECM mounting bracket.
  - Remove the two ECM mounting bracket nuts and disconnect the ground wire.
10. Remove the blower unit. Refer to [MTC-69, "BLOWER UNIT"](#).

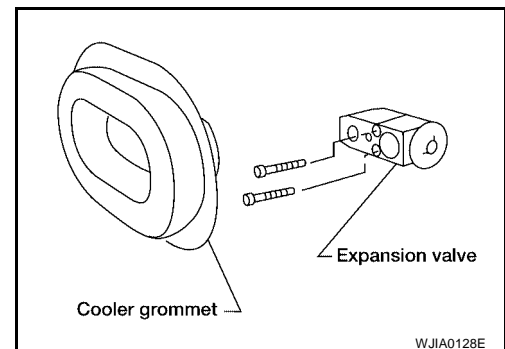

11. Remove the heater core cover.

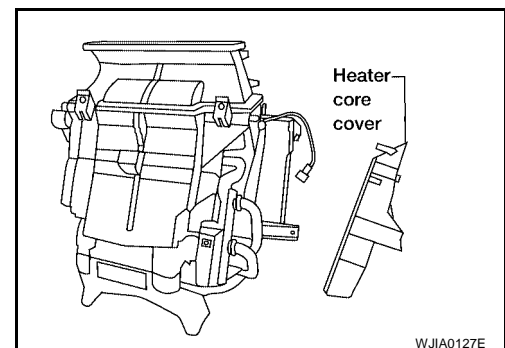

12. Remove the evaporator cover.

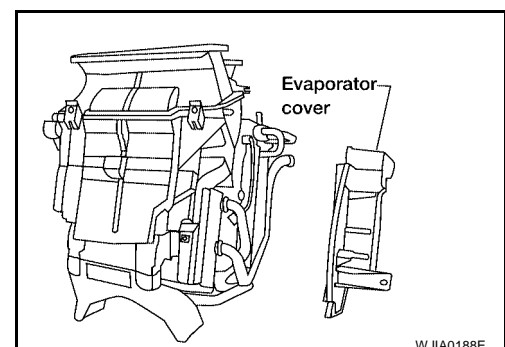

# REFRIGERANT LINES

13. Remove the evaporator.

- Remove the thermo control amplifier.
- Remove the intake sensor.

**CAUTION:**

- **Mark the mounting position of the intake sensor and thermo control amplifier.**

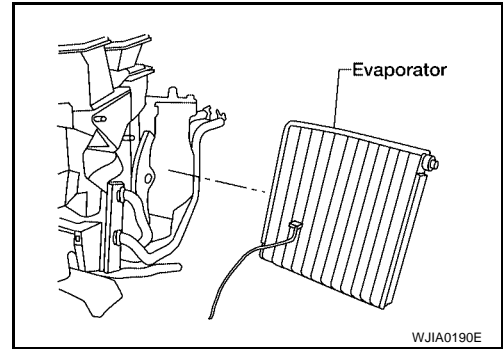

## INSTALLATION

Installation is in the reverse order of removal.

**Expansion valve mounting bolts : 2.9 - 5.0 N·m (0.29 - 0.51 kg·m, 26 - 44 in·lb)**

**CAUTION:**

- **Replace the O-rings with new ones, then apply compressor oil to them when installing them.**

## Removal and Installation for Expansion Valve REMOVAL

EJS00318

1. Evacuate and recover the A/C system refrigerant. Refer to [MTC-79, "HFC-134a \(R-134a\) Service Procedure"](#).
2. Disconnect the air cleaner to electronic throttle control actuator tube. Refer to [EM-16, "AIR CLEANER AND AIR DUCT"](#) (QR25DE), [EM-112, "AIR CLEANER AND AIR DUCT"](#) (VQ35DE).

**NOTE:**

The tube is located between the air cleaner assembly and the intake manifold and is removed to access the expansion valve.

3. Disconnect the A/C pipe from the expansion valve.

**CAUTION:**

**Cap or wrap the joint of the pipe with suitable material such as vinyl tape to avoid the entry of air.**

4. Remove the cooler grommet.
5. Remove the expansion valve.

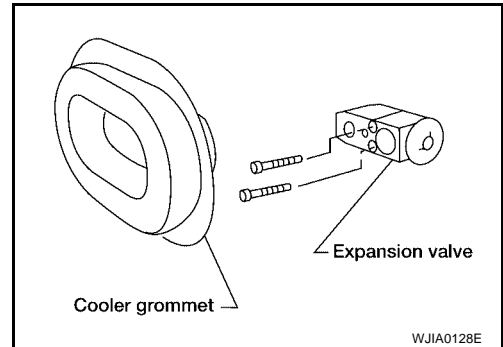

## INSTALLATION

Installation is in the reverse order of removal.

**Expansion valve mounting bolts : 2.9 - 5.0 N·m (0.29 - 0.51 kg·m, 26 - 44 in·lb)**

**CAUTION:**

- **Replace the O-rings with new ones, then apply compressor oil to them when installing them.**

## Checking for Refrigerant Leaks

EJS0010T

Perform a visual inspection of all refrigeration parts, fittings, hoses and components for signs of A/C lubricant leakage, damage and corrosion. A/C lubricant leakage may indicate an area of refrigerant leakage. Allow extra inspection time in these areas when using either an electronic refrigerant leak detector or fluorescent dye leak detector.

If dye is observed, confirm the leak with an electronic refrigerant leak detector. It is possible a prior leak was repaired and not properly cleaned.

When searching for leaks, do not stop when one leak is found but continue to check for additional leaks at all system components and connections.

A  
B  
C  
D  
E  
F  
G  
H  
I  
K  
L  
M

MTC

# REFRIGERANT LINES

When searching for refrigerant leaks using an electronic leak detector, move the probe along the suspected leak area at 25 - 50 mm (1 - 2 in) per second and no further than 6 mm (1/4 in) from the component.

## CAUTION:

**Moving the electronic leak detector probe slower and closer to the suspected leak area will improve the chances of finding a leak.**

## Checking System for Leaks Using the Fluorescent Leak Detector

EJS0010U

1. Check A/C system for leaks using the UV lamp and safety glasses (J-42220) in a low sunlight area (area without windows preferable). Illuminate all components, fittings and lines. The dye will appear as a bright green/yellow area at the point of leakage. Fluorescent dye observed at the evaporator drain opening indicates an evaporator core assembly (tubes, core or TXV) leak.
2. If the suspected area is difficult to see, use an adjustable mirror or wipe the area with a clean shop rag or cloth, with the UV lamp for dye residue.
3. After the leak is repaired, remove any residual dye using dye cleaner (J-43872) to prevent future misdiagnosis.
4. Perform a system performance check and verify the leak repair with an approved electronic refrigerant leak detector.

## NOTE:

Other gases in the work area or substances on the A/C components, for example, anti-freeze, windshield washer fluid, solvents and lubricants, may falsely trigger the leak detector. Make sure the surfaces to be checked are clean.

Clean with a dry cloth or blow off with shop air.

Do not allow the sensor tip of the detector to contact with any substance. This can also cause false readings and may damage the detector.

## Dye Injection

EJS0010V

(This procedure is only necessary when recharging the system or when the compressor has seized and was replaced.)

1. Check A/C system static (at rest) pressure. Pressure must be at least 345 kPa (50 psi).
2. Pour one bottle (1/4 ounce / 7.4 cc) of the A/C refrigerant dye into the injector tool (J-41459).
3. Connect the injector tool to the A/C LOW PRESSURE side service fitting.
4. Start engine and switch A/C ON.
5. When the A/C operating (compressor running), inject one bottle (1/4 ounce / 7.4 cc) of fluorescent dye through the low-pressure service valve using dye injector tool J-41459 (refer to the manufacturer's operating instructions).
6. With the engine still running, disconnect the injector tool from the service fitting.

## CAUTION:

**Be careful the A/C system or replacing a component, pour the dye directly into the open system connection and proceed with the service procedures.**

7. Operate the A/C system for a minimum of 20 minutes to mix the dye with the system oil. Depending on the leak size, operating conditions and location of the leak, it may take from minutes to days for the dye to penetrate a leak and become visible.

## Electronic Refrigerant Leak Detector PRECAUTIONS FOR HANDLING LEAK DETECTOR

EJS0010W

When performing a refrigerant leak check, use a J-41995 A/C leak detector or equivalent. Ensure that the instrument is calibrated and set properly per the operating instructions.

The leak detector is a delicate device. In order to use the leak detector properly, read the operating instructions and perform any specified maintenance.

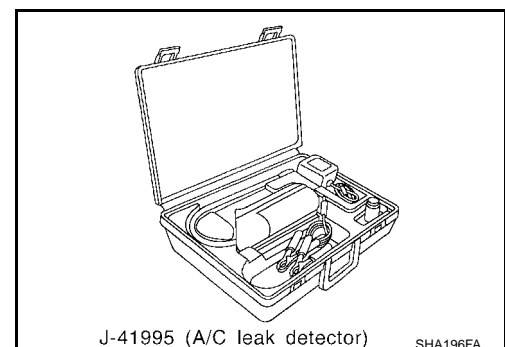

# REFRIGERANT LINES

1. Position probe approximately 5 mm (3/16 in) away from point to be checked.

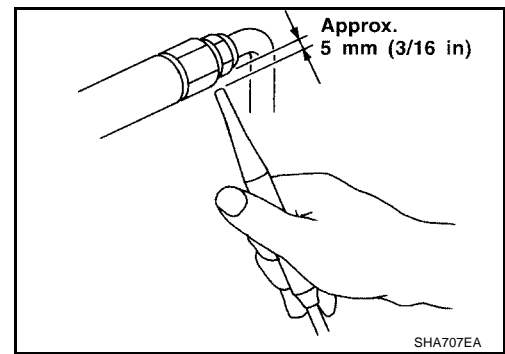

2. When testing, circle each fitting completely with probe.

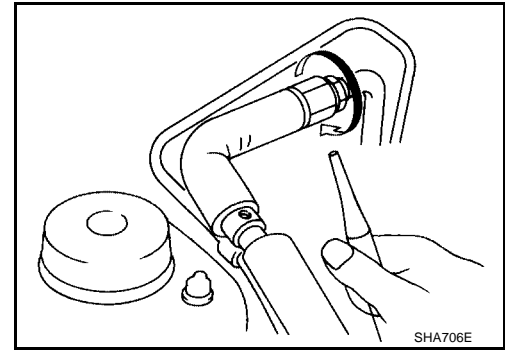

3. Move probe along component approximately 25 to 50 mm (1 to 2 in)/sec.

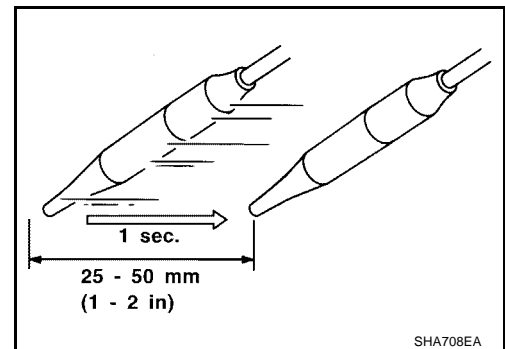

## CHECKING PROCEDURE

To prevent inaccurate or false readings, make sure there is no refrigerant vapor, shop chemicals, or cigarette smoke in the vicinity of the vehicle. Perform the leak test in calm area (low air/wind movement) so that the leaking refrigerant is not dispersed.

1. Turn engine OFF.
2. Connect a suitable A/C manifold gauge set to the A/C service ports.
3. Check if the A/C refrigerant pressure is at least 345 kPa (3.52 kg/cm<sup>2</sup>, 50 psi) above 16°C (61°F). If less than specification, recover/evacuate and recharge the system with the specified amount of refrigerant.

### NOTE:

At temperatures below 16°C (61°F), leaks may not be detected since the system may not reach 345 kPa (3.54 kg/cm<sup>2</sup>, 50 psi).

4. Conduct the leak test from the high side (compressor discharge a to evaporator inlet f) to the low side [evaporator drain hose g to shaft seal k (QR25DE models) or l (VQ35DE models)]. Refer to [MTC-80](#). Perform a leak check for the following areas carefully. Clean the component to be checked and move the leak detected probe completely around the connection/component.

Compressor

Check the fitting of high- and low-pressure hoses, relief valve and shaft seal.

Liquid tank

Check the refrigerant pressure sensor.

Service valves

Check all around the service valves. Ensure service valve caps are secured on the service valves (to prevent leaks).

## REFRIGERANT LINES

### NOTE:

After removing A/C manifold gauge set from service valves, wipe any residue from valves to prevent any false readings by leak detector.

### Cooling unit (Evaporator)

With engine OFF, turn blower fan on "High" for at least 15 seconds to dissipate any refrigerant trace in the cooling unit. Wait a minimum of 10 minutes accumulation time (refer to the manufacturer's recommended procedure for actual wait time) before inserting the leak detector probe into the drain hose.

Keep the probe inserted for at least 10 seconds. Use caution not to contaminate the probe tip with water or dirt that may be in the drain hose.

5. If a leak detector detects a leak, verify at least once by blowing compressed air into area of suspected leak, then repeat check as outlined above.
6. Do not stop when one leak is found. Continue to check for additional leaks at all system components. If no leaks are found, perform steps 7 - 10.
7. Start engine.
8. Set the heater A/C control as follows;
  - a. A/C switch: ON
  - b. Face mode
  - c. Intake position: Recirculation
  - d. Max cold temperature
  - e. Fan speed: High
9. Run engine at 1,500 rpm for at least 2 minutes.
10. Turn engine off and perform leak check again following steps 4 through 6 above.

Refrigerant leaks should be checked immediately after stopping the engine. Begin with the leak detector at the compressor. The pressure on the high pressure side will gradually drop after refrigerant circulation stops and pressure on the low pressure side will gradually rise, as shown in the graph. Some leaks are more easily detected when pressure is high.

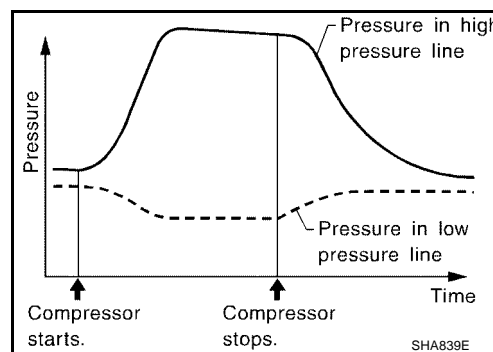

11. Before connecting ACR4 to vehicle, check ACR4 gauges. No refrigerant pressure should be displayed. If pressure is displayed, recover refrigerant from equipment lines and then check refrigerant purity.
12. Confirm refrigerant purity in supply tank using ACR4 and refrigerant identifier.
13. Confirm refrigerant purity in vehicle A/C system using ACR4 and refrigerant identifier.
14. Discharge A/C system using approved refrigerant recovery equipment. Repair the leaking fitting or component as necessary.
15. Evacuate and recharge A/C system and perform the leak test to confirm no refrigerant leaks.
16. Conduct A/C performance test to ensure system works properly.

# SERVICE DATA AND SPECIFICATIONS (SDS)

## SERVICE DATA AND SPECIFICATIONS (SDS)

PFP:00030

### Service Data and Specifications (SDS) COMPRESSOR

EJS0010X

Model	CALSONIC KANSEI make
Type	DKS-17D
Displacement cm <sup>3</sup> (cu in)/rev	175.5 (10.7)/rev
Cylinder bore × stroke mm (in)	30.5 (1.201) x 21.4 (0.84)
Direction of rotation	Clockwise (viewed from drive end)
Drive belt	Poly V

### LUBRICANT

Model	CALSONIC KANSEI make DKS-17D	
Name	Nissan A/C System Oil Type DH-PS	
Part number	KLH00-PAGS0	
Capacity m <sup>l</sup> (US fl oz, Imp fl oz)	Total in system	150 (5.03, 5.3)
	Compressor (Service part) charging amount	150 (5.03, 5.3)

### REFRIGERANT

Type	HFC-134a (R-134a)
Capacity kg (lb)	0.475 - 0.525 (1.045 - 1.155)

### ENGINE IDLING SPEED

Refer to [EC-38, "Idle Speed and Ignition Timing Check"](#) (QR25DE models) or [EC-656, "Idle Speed and Ignition Timing Check"](#) (VQ35DE models).

### BELT TENSION

Refer to [MA-14, "ENGINE MAINTENANCE \(QR25DE ENGINE\)"](#) or [MA-21, "ENGINE MAINTENANCE \(VQ35DE ENGINE\)"](#).

# SERVICE DATA AND SPECIFICATIONS (SDS)

---