

SECTION **ATC**

AUTOMATIC AIR CONDITIONER

A
B
C
D
E
F
G
H
I
J
K
L
M

CONTENTS

<p>PRECAUTIONS 4</p> <p> Precautions for Supplemental Restraint System (SRS) "AIR BAG" and "SEAT BELT PRE-TENSIONER" 4</p> <p> Precautions for Working with HFC-134a (R-134a).... 4</p> <p> Contaminated Refrigerant 4</p> <p> General Refrigerant Precautions 5</p> <p> Precautions for Leak Detection Dye 5</p> <p> A/C Identification Label 5</p> <p> Precautions for Refrigerant Connection 6</p> <p> FEATURES OF NEW TYPE REFRIGERANT CONNECTION 6</p> <p> O-RING AND REFRIGERANT CONNECTION..... 7</p> <p> Precautions for Servicing Compressor 9</p> <p> Precautions for Service Equipment 9</p> <p> RECOVERY/RECYCLING EQUIPMENT 9</p> <p> ELECTRONIC LEAK DETECTOR 9</p> <p> VACUUM PUMP 10</p> <p> MANIFOLD GAUGE SET 10</p> <p> SERVICE HOSES 10</p> <p> SERVICE COUPLERS 11</p> <p> CHARGING CYLINDER 11</p> <p> Wiring Diagrams and Trouble Diagnosis 11</p> <p>PREPARATION 12</p> <p> Special Service Tools 12</p> <p> HFC-134a (R-134a) Service Tools and Equipment.. 12</p> <p> Commercial Service Tools 15</p> <p>REFRIGERATION SYSTEM 16</p> <p> Refrigerant Cycle 16</p> <p> REFRIGERANT FLOW 16</p> <p> Refrigerant System Protection 16</p> <p> REFRIGERANT PRESSURE SENSOR 16</p> <p> PRESSURE RELIEF VALVE 16</p> <p> Component Layout 17</p> <p>LUBRICANT 18</p> <p> Maintenance of Lubricant Quantity in Compressor.. 18</p> <p> LUBRICANT 18</p> <p> CHECKING AND ADJUSTING 18</p> <p>AIR CONDITIONER CONTROL 21</p> <p> Overview Air Conditioner LAN Control System 21</p>	<p> System Construction 21</p> <p> OPERATION 21</p> <p> TRANSMISSION DATA AND TRANSMISSION ORDER 22</p> <p> AIR MIX DOOR CONTROL (AUTOMATIC TEMPERATURE CONTROL) 22</p> <p> FAN SPEED CONTROL 23</p> <p> INTAKE DOOR CONTROL 23</p> <p> OUTLET DOOR CONTROL 23</p> <p> MAGNET CLUTCH CONTROL 23</p> <p> SELF-DIAGNOSTIC SYSTEM 23</p> <p> Overview of Control system 23</p> <p> Control Operation 24</p> <p> DISPLAY SCREEN 24</p> <p> AUTO SWITCH 24</p> <p> ECON (ECONOMY) SWITCH 24</p> <p> TEMPERATURE DIAL (POTENTIO TEMPERATURE CONTROL) 24</p> <p> OFF SWITCH 24</p> <p> FAN SWITCH 24</p> <p> RECIRCULATION (REC) SWITCH 24</p> <p> DEFROSTER (DEF) SWITCH 24</p> <p> MODE SWITCH 24</p> <p> REAR WINDOW DEFOGGER SWITCH 24</p> <p> Discharge Air Flow 25</p> <p> System Description 26</p> <p> SWITCHES AND THEIR CONTROL FUNCTION.. 26</p> <p> CAN Communication System Description 26</p> <p> FOR TCS MODELS 27</p> <p> FOR A/T MODELS 28</p> <p> FOR M/T MODELS 29</p> <p>TROUBLE DIAGNOSIS 31</p> <p> How to Perform Trouble Diagnoses for Quick and Accurate Repair 31</p> <p> WORK FLOW 31</p> <p> SYMPTOM TABLE 31</p> <p> Component Parts and Harness Connector Location.. 32</p> <p> ENGINE COMPARTMENT 32</p> <p> PASSENGER COPARTMENT 33</p> <p> Circuit Diagram 34</p>
---	---

ATC

Wiring Diagram — A/C,A —	35	INSPECTION FLOW	88
Auto Amp. Terminals and Reference Value	39	Memory Function	89
INSPECTION OF AUTO AMP.	39	INSPECTION FLOW	89
A/C AUTO AMP. HARNESS CONNECTOR TER-		ECON (ECONOMY) Mode	90
MINAL LAYOUT	39	INSPECTION FLOW	90
AUTO AMP. INSPECTION TABLE	39	Ambient Sensor Circuit	90
Self-diagnosis	41	COMPONENT DESCRIPTION	90
DESCRIPTION	41	AMBIENT TEMPERATURE INPUT PROCESS...	90
FUNCTION CONFIRMATION PROCEDURE	42	DIAGNOSTIC PROCEDURE	91
AUXILIARY MECHANISM: TEMPERATURE		COMPONENT INSPECTION	92
SETTING TRIMMER	48	In-vehicle Sensor Circuit	92
Operational Check	49	COMPONENT DESCRIPTION	92
CONDITIONS:	49	DIAGNOSTIC PROCEDURE	93
PROCEDURE:	49	COMPONENT INSPECTION	95
Power Supply and Ground Circuit for Auto Amp. ...	52	Sunload Sensor Circuit	95
COMPONENT DESCRIPTION	52	COMPONENT DESCRIPTION	95
DIAGNOSTIC PROCEDURE	53	SUNLOAD INPUT PROCESS	95
LAN System Circuit	54	DIAGNOSTIC PROCEDURE	96
DIAGNOSTIC PROCEDURE	54	COMPONENT INSPECTION	97
Mode Door Motor Circuit	58	Intake Sensor Circuit	98
INSPECTION FLOW	58	COMPONENT DESCRIPTION	98
SYSTEM DESCRIPTION	59	DIAGNOSTIC PROCEDURE	99
COMPONENT DESCRIPTION	60	AUTO AMP	101
DIAGNOSTIC PROCEDURE	60	Removal and Installation	101
MODE DOOR	60	AMBIENT SENSOR	102
Air Mix Door Motor Circuit	61	Removal and Installation	102
INSPECTION FLOW	61	IN-VEHICLE SENSOR	103
SYSTEM DESCRIPTION	62	Removal and Installation	103
COMPONENT DESCRIPTION	63	SUNLOAD SENSOR	104
DIAGNOSTIC PROCEDURE	63	Removal and Installation	104
AIR MIX DOOR	63	INTAKE SENSOR	105
Intake Door Motor Circuit	64	Removal and Installation	105
INSPECTION FLOW	64	THERMO CONTROL AMPLIFIER	106
SYSTEM DESCRIPTION	65	Removal and Installation	106
COMPONENT DESCRIPTION	66	BLOWER UNIT	107
INTAKE DOOR	66	Removal and Installation	107
DIAGNOSTIC PROCEDURE	66	REMOVAL	107
Blower Motor Circuit	67	BLOWER MOTOR	108
INSPECTION FLOW	67	Removal and Installation	108
SYSTEM DESCRIPTION	68	INTAKE DOOR MOTOR	109
COMPONENT DESCRIPTION	69	Removal and Installation	109
DIAGNOSTIC PROCEDURE	69	IN-CABIN MICROFILTER	110
COMPONENT INSPECTION	72	Removal and Installation	110
Magnet Clutch Circuit	73	FUNCTION	110
INSPECTION FLOW	73	REPLACEMENT TIMING	110
SYSTEM DESCRIPTION	74	REPLACEMENT PROCEDURES	110
DIAGNOSTIC PROCEDURE	74	HEATER & COOLING UNIT ASSEMBLY	111
COMPONENT INSPECTION	78	Removal and Installation	111
Insufficient Cooling	79	REMOVAL	111
INSPECTION FLOW	79	INSTALLATION	111
PERFORMANCE TEST ANALYSIS	80	HEATER CORE	112
PERFORMANCE CHART	82	Removal and Installation	112
TROUBLE DIAGNOSIS FOR ABNORMAL		MODE DOOR MOTOR	113
PRESSURE	82	Removal and Installation	113
Insufficient Heating	86	AIR MIX DOOR MOTOR	114
INSPECTION FLOW	86	Removal and Installation	114
Noise	87	FAN CONTROL AMPLIFIER	115
INSPECTION FLOW	87	Removal and Installation	115
Self-diagnosis	88	DUCTS AND GRILLES	116

Removal and Installation	116	REMOVAL	125	
Ventilator Duct, Defroster Nozzle and Defroster Ducts	116	INSTALLATION	125	A
Center Ventilator Grille	116	Removal and Installation for Refrigerant Pressure Sensor	125	
Side Ventilator Grille LH	116	Removal and Installation for Condenser	125	B
Side Ventilator Grille RH	117	REMOVAL	125	
Floor duct	117	INSTALLATION	126	
REFRIGERANT LINES	118	Removal and Installation for Evaporator	126	C
HFC-134a (R-134a) Service Procedure	118	REMOVAL	126	
SETTING OF SERVICE TOOLS AND EQUIP- MENT	118	INSTALLATION	127	
Components	120	Removal and Installation for Expansion Valve	127	D
Removal and Installation for Compressor	121	REMOVAL	127	
REMOVAL	121	INSTALLATION	128	
INSTALLATION	121	Checking for Refrigerant Leaks	128	
Removal and Installation for Compressor Clutch	122	Checking System for Leaks Using the Fluorescent Leak Detector	128	E
REMOVAL	122	Dye Injection	129	
INSPECTION	123	Electronic Refrigerant Leak Detector	129	F
INSTALLATION	123	PRECAUTIONS FOR HANDLING LEAK DETECTOR	129	
BREAK-IN OPERATION	124	CHECKING PROCEDURE	130	
Removal and Installation for Low-pressure Flexible Hose	124	SERVICE DATA AND SPECIFICATIONS (SDS) ...	132	G
REMOVAL	124	Service Data and Specifications (SDS)	132	
INSTALLATION	124	COMPRESSOR	132	
Removal and Installation for High-pressure Flexible Hose	125	LUBRICANT	132	H
REMOVAL	125	REFRIGERANT	132	
INSTALLATION	125	ENGINE IDLING SPEED	132	
Removal and Installation for High-pressure Pipe	125	BELT TENSION	132	I

ATC

K
L
M

PRECAUTIONS

PRECAUTIONS

PFP:00001

Precautions for Supplemental Restraint System (SRS) “AIR BAG” and “SEAT BELT PRE-TENSIONER”

EJS001GD

The Supplemental Restraint System such as “AIR BAG” and “SEAT BELT PRE-TENSIONER”, used along with a front seat belt, helps to reduce the risk or severity of injury to the driver and front passenger for certain types of collision. This system includes seat belt switch inputs and dual stage front air bag modules. The SRS system uses the seat belt switches to determine the front air bag deployment, and may only deploy one front air bag, depending on the severity of a collision and whether the front occupants are belted or unbelted. Information necessary to service the system safely is included in the SRS and SB section of this Service Manual.

WARNING:

- To avoid rendering the SRS inoperative, which could increase the risk of personal injury or death in the event of a collision which would result in air bag inflation, all maintenance must be performed by an authorized NISSAN/INFINITI dealer.
- Improper maintenance, including incorrect removal and installation of the SRS, can lead to personal injury caused by unintentional activation of the system. For removal of Spiral Cable and Air Bag Module, see the SRS section.
- Do not use electrical test equipment on any circuit related to the SRS unless instructed to in this Service Manual. SRS wiring harnesses can be identified by yellow and/or orange harnesses or harness connectors.

Precautions for Working with HFC-134a (R-134a)

EJS001C0

WARNING:

- CFC-12 (R-12) refrigerant and HFC-134a (R-134a) refrigerant are not compatible. If the refrigerants are mixed compressor failure is likely to occur. Refer [ATC-4, "Contaminated Refrigerant"](#) . To determine the purity of HFC-134a (R-134a) in the vehicle and recovery tank, use Refrigerant Recovery/Recycling Recharging equipment and Refrigerant Identifier.
- Use only specified lubricant for the HFC-134a (R-134a) A/C system and HFC-134a (R-134a) components. If lubricant other than that specified is used, compressor failure is likely to occur.
- The specified HFC-134a (R-134a) lubricant rapidly absorbs moisture from the atmosphere. The following handling precautions must be observed:
 - When removing refrigerant components from a vehicle, immediately cap (seal) the component to minimize the entry of moisture from the atmosphere.
 - When installing refrigerant components to a vehicle, do not remove the caps (unseal) until just before connecting the components. Connect all refrigerant loop components as quickly as possible to minimize the entry of moisture into system.
 - Only use the specified lubricant from a sealed container. Immediately reseal containers of lubricant. Without proper sealing, lubricant will become moisture saturated and should not be used.
 - Avoid breathing A/C refrigerant and lubricant vapor or mist. Exposure may irritate eyes, nose and throat. Remove R-134a from the A/C system using certified service equipment meeting requirements of SAE J2210 (R-134a recycling equipment), or J2209 (R-134a recovery equipment). If accidental system discharge occurs, ventilate work area before resuming service. Additional health and safety information may be obtained from refrigerant and lubricant manufacturers.
 - Do not allow A/C lubricant to come in contact with styrofoam parts. Damage may result.

Contaminated Refrigerant

EJS001C1

If a refrigerant other than pure R-134a is identified in a vehicle, your options are:

- Explain to the customer that environmental regulations prohibit the release of contaminated refrigerant into the atmosphere.
- Explain that recovery of the contaminated refrigerant could damage your service equipment and refrigerant supply.
- Suggest the customer return the vehicle to the location of previous service where the contamination may have occurred.
- If you choose to perform the repair, recover the refrigerant using only **dedicated equipment and containers. Do not recover contaminated refrigerant into your existing service equipment.** If your facility does not have dedicated recovery equipment, you may contact a local refrigerant product retailer for avail-

PRECAUTIONS

able service. This refrigerant must be disposed of in accordance with all federal and local regulations. In addition, replacement of all refrigerant system components on the vehicle is recommended.

- If the vehicle is within the warranty period, the air conditioner warranty is void. Please contact Nissan Customer Affairs for further assistance.

General Refrigerant Precautions

EJS001C2

WARNING:

- Do not release refrigerant into the air. Use approved recovery/recycling equipment to capture the refrigerant every time an air conditioning system is discharged.
- Always wear eye and hand protection (goggles and gloves) when working with any refrigerant or air conditioning system.
- Do not store or heat refrigerant containers above 52°C (125°F).
- Do not heat a refrigerant container with an open flame; if container warming is required, place the bottom of the container in a warm pail of water.
- Do not intentionally drop, puncture, or incinerate refrigerant containers.
- Keep refrigerant away from open flames: poisonous gas will be produced if refrigerant burns.
- Refrigerant will displace oxygen, therefore be certain to work in well ventilated areas to prevent suffocation.
- Do not pressure test or leak test HFC-134a (R-134a) service equipment and/or vehicle air conditioning systems with compressed air during repair. Some mixtures of air and R-134a have been shown to be combustible at elevated pressures. These mixtures, if ignited, may cause injury or property damage. Additional health and safety information may be obtained from refrigerant manufacturers.

Precautions for Leak Detection Dye

EJS001C3

- The A/C system contains a fluorescent leak detection dye used for locating refrigerant leaks. An ultraviolet (UV) lamp is required to illuminate the dye when inspecting for leaks.
- Always wear fluorescence enhancing UV safety glasses to protect your eyes and enhance the visibility of the fluorescent dye.
- A compressor shaft seal should not be repaired because of dye seepage. The compressor shaft seal should only be repaired after confirming the leak with an electronic refrigerant leak detector (J-41995).
- Always remove any dye from the leak area after repairs are complete to avoid a misdiagnosis during a future service.
- Do not allow dye to come into contact with painted body panels or interior components. If dye is spilled, clean immediately with the approved dye cleaner. Fluorescent dye left on a surface for an extended period of time **cannot be removed**.
- Do not spray the fluorescent dye cleaning agent on hot surfaces (engine exhaust manifold, etc.).
- Do not use more than one refrigerant dye bottle (1/4 ounce / 7.4 cc) per A/C system.
- Leak detection dyes for R-134a and R-12 A/C systems are different. Do not use R-134a leak detection dye in R-12 A/C systems or R-12 leak detection dye in R-134a A/C systems or A/C system damage may result.
- The fluorescent properties of the dye will remain for over three (3) years unless a compressor failure occurs.

A/C Identification Label

EJS001C4

Vehicles with factory installed fluorescent dye have this identification label on the underside of hood.

NOTE:

Vehicles with factory installed fluorescent dye have a green label.

AIR CONDITIONER		NISSAN
	REFRIGERANT	COMPRESSOR LUBRICANT
TYPE (PART NO.)	HFC134a (R134a)	Nissan Luminous Oil Type DH-PS [KLH00-PAGS0]
AMOUNT	0.50 ± .025 kg (1.10 ± 0.055lbs)	150ml (5.03 oz)
CAUTION PRECAUTION		
<ul style="list-style-type: none"> • REFRIGERANT UNDER HIGH PRESSURE. • SYSTEM TO BE SERVICED BY QUALIFIED PERSONNEL. • IMPROPER SERVICE METHODS MAY CAUSE PERSONAL INJURY. • CONSULT SERVICE MANUAL. • THIS AIR CONDITIONER SYSTEM COMPLIES WITH SAE J-639. 		
Nissan Motor Corporation in USA, Carson, CA		

WJIA0012E

PRECAUTIONS

EJS001C5

Precautions for Refrigerant Connection

A new type refrigerant connection has been introduced to all refrigerant lines except the following locations.

- Expansion valve to cooling unit
- Evaporator pipes to evaporator (inside cooling unit)
- Refrigerant pressure sensor

FEATURES OF NEW TYPE REFRIGERANT CONNECTION

- The O-ring has been relocated. It has also been provided with a groove for proper installation. This eliminates the chance of the O-ring being caught in, or damaged by, the mating part. The sealing direction of the O-ring is now set vertically in relation to the contacting surface of the mating part to improve sealing characteristics.
- The reaction force of the O-ring will not occur in the direction that causes the joint to pull out, thereby facilitating piping connections.

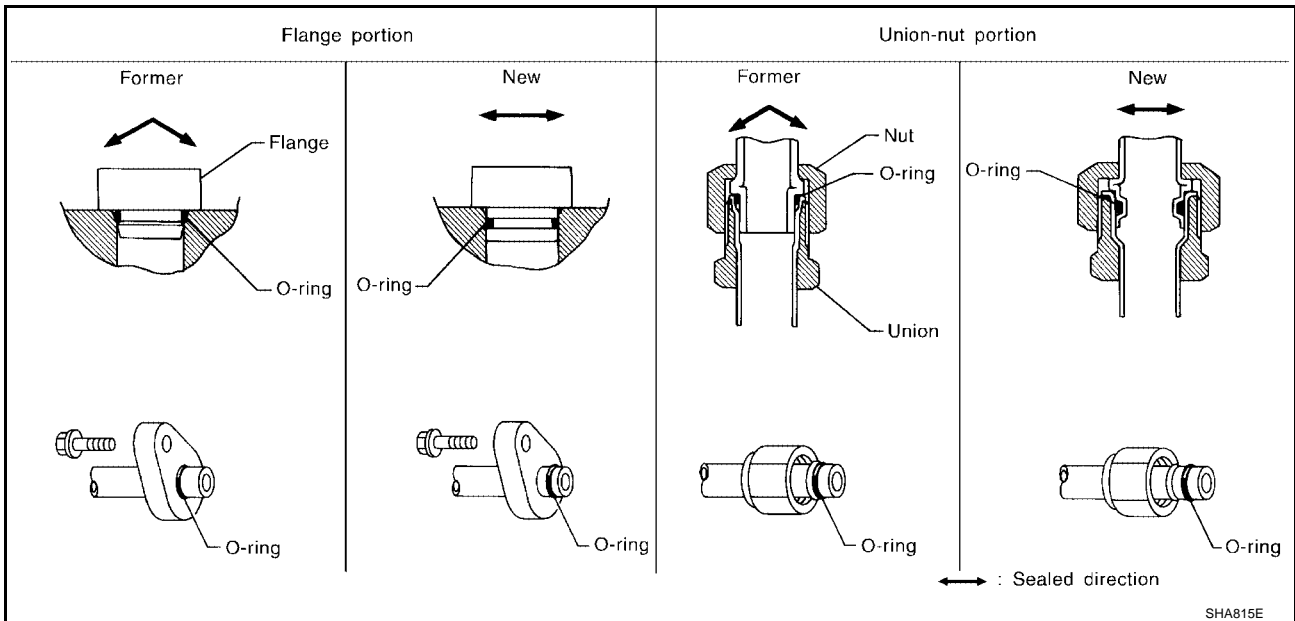

PRECAUTIONS

O-RING AND REFRIGERANT CONNECTION

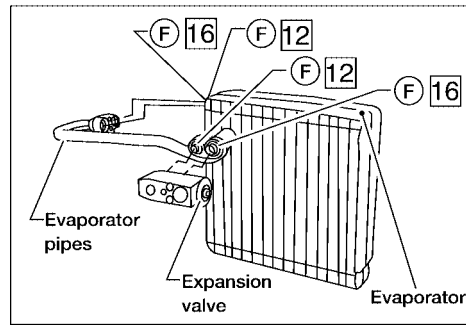
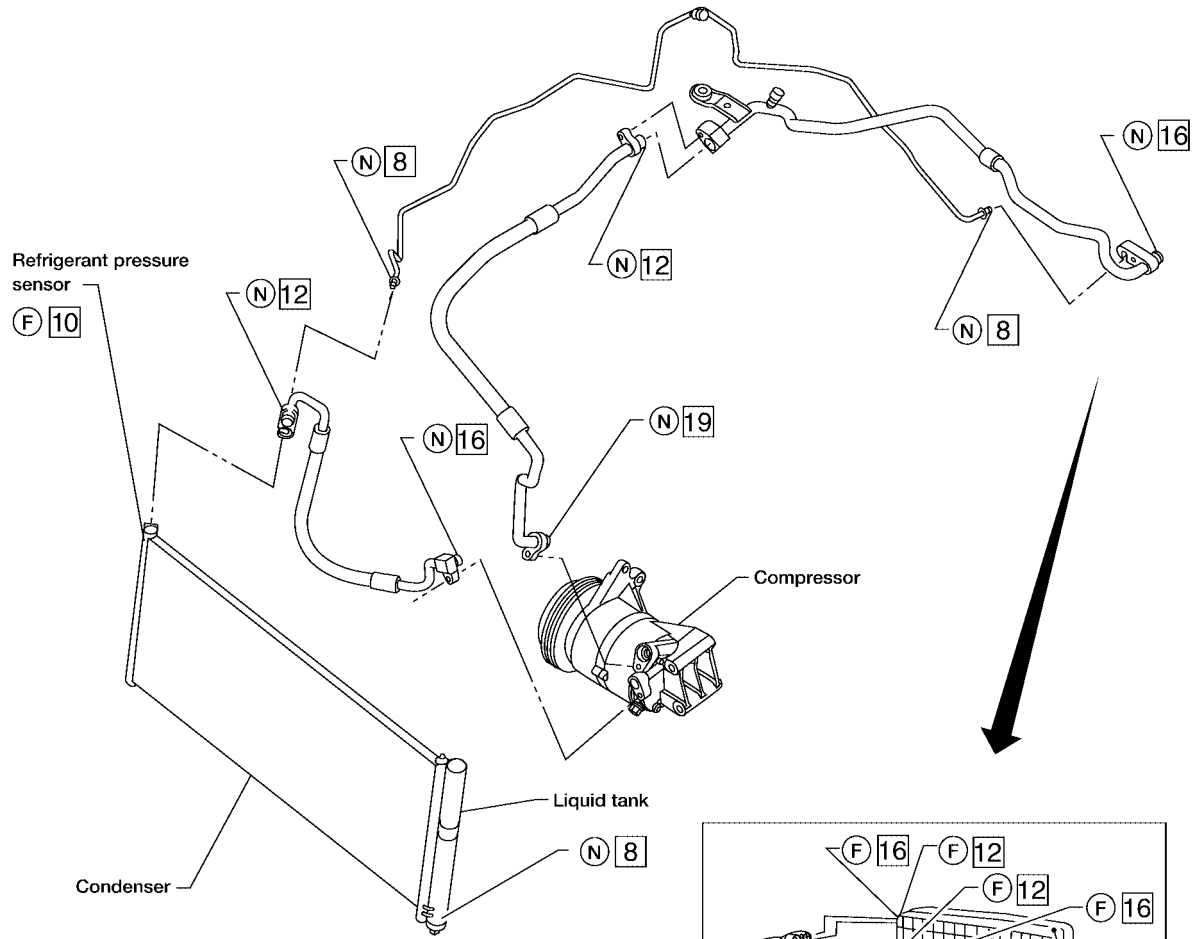

(F) : Former type refrigerant connection

(N) : New type refrigerant connection

□ : O-ring size

WJIA0135E

CAUTION:

The new and former refrigerant connections use different O-ring configurations. Do not confuse O-rings since they are not interchangeable. If a wrong O-ring is installed, refrigerant will leak at, or around, the connection.

A
B
C
D
E
F
G
H
I
ATC
K
L
M

PRECAUTIONS

O-Ring Part Numbers and Specifications

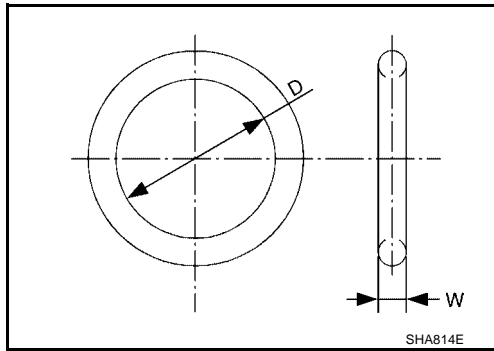

Conne- ction type	O-ring size	Part number*	D mm (in)	W mm (in)
New	8	92471 N8210	6.8 (0.268)	1.85 (0.0728)
Former	10	J2476 89956	9.25 (0.3642)	1.78 (0.0701)
New	12	92472 N8210	10.9 (0.429)	2.43 (0.0957)
Former		92475 71L00	11.0 (0.433)	2.4 (0.094)
New	16	92473 N8210	13.6 (0.535)	2.43 (0.0957)
Former		92475 72L00	14.3 (0.563)	2.3 (0.091)
New	19	92474 N8210	16.5 (0.650)	2.43 (0.0957)
Former		92477 N8200	17.12 (0.6740)	1.78 (0.0701)
New	24	92195 AH300	21.8 (0.858)	2.4 (0.094)

*: Always check with the Parts Department for the latest parts information.

WARNING:

Make sure all refrigerant is discharged into the recycling equipment and the pressure in the system is less than atmospheric pressure. Then gradually loosen the discharge side hose fitting and remove it.

CAUTION:

When replacing or cleaning refrigerant cycle components, observe the following.

- When the compressor is removed, store it in the same position as it is when mounted on the car. Failure to do so will cause lubricant to enter the low pressure chamber.
- When connecting tubes, always use a torque wrench and a back-up wrench.
- After disconnecting tubes, immediately plug all openings to prevent entry of dirt and moisture.
- When installing an air conditioner in the vehicle, connect the pipes as the final stage of the operation. Do not remove the seal caps of pipes and other components until just before required for connection.
- Allow components stored in cool areas to warm to working area temperature before removing seal caps. This prevents condensation from forming inside A/C components.
- Thoroughly remove moisture from the refrigeration system before charging the refrigerant.
- Always replace used O-rings.
- When connecting tube, apply lubricant to circle of the O-rings shown in illustration. Be careful not to apply lubricant to threaded portion.
Lubricant name: Nissan A/C System Lubricant Type DH-PS or equivalent
Part number: KLH00-PAGS0
- O-ring must be closely attached to dented portion of tube.
- When replacing the O-ring, be careful not to damage O-ring and tube.
- Connect tube until you hear it click, then tighten the nut or bolt by hand until snug. Make sure that the O-ring is installed to tube correctly.

PRECAUTIONS

- After connecting line, conduct leak test and make sure that there is no leakage from connections. When the gas leaking point is found, disconnect that line and replace the O-ring. Then tighten connections of seal seat to the specified torque.

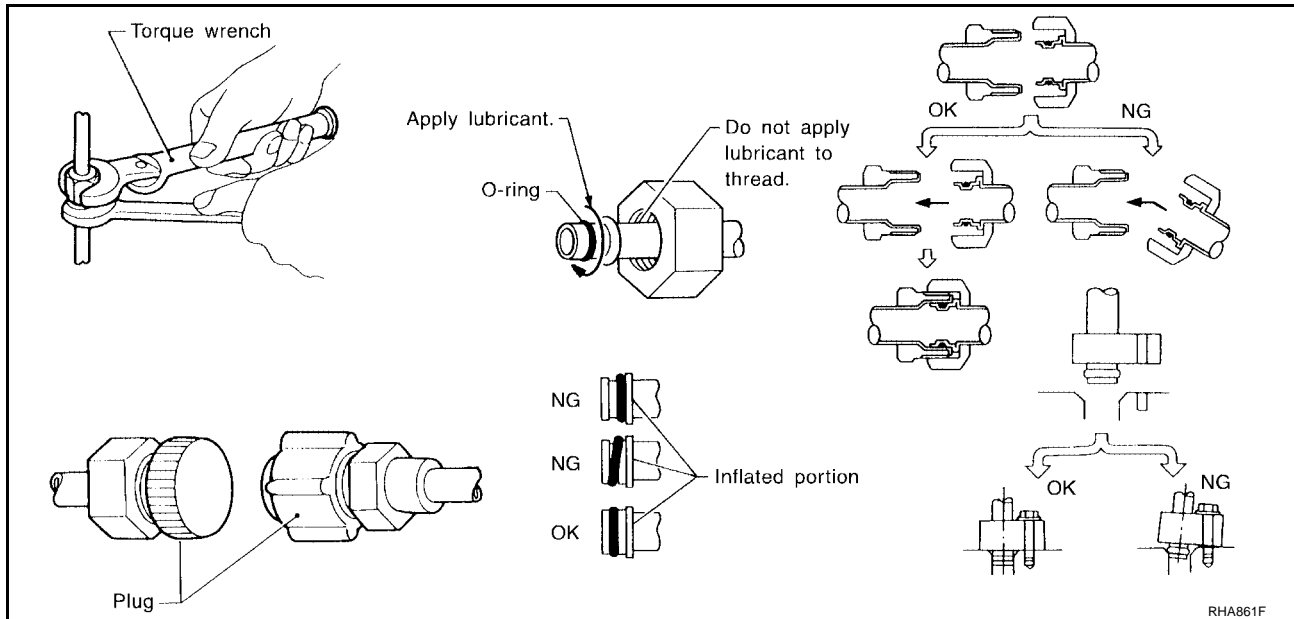

Precautions for Servicing Compressor

EJS001C6

- Plug all openings to prevent moisture and foreign matter from entering.
- When the compressor is removed, store it in the same position as it is when mounted on the car.
- When replacing or repairing compressor, follow "Maintenance of Lubricant Quantity in Compressor" exactly. Refer to [ATC-18, "Maintenance of Lubricant Quantity in Compressor"](#).
- Keep friction surfaces between clutch and pulley clean. If the surface is contaminated, with lubricant, wipe it off by using a clean waste cloth moistened with thinner.
- After compressor service operation, turn the compressor shaft by hand more than 5 turns in both directions. This will equally distribute lubricant inside the compressor. After the compressor is installed, let the engine idle and operate the compressor for 1 hour.
- After replacing the compressor magnet clutch, apply voltage to the new one and check for normal operation. [Gap between clutch disc and pulley is 0.3 - 0.6 mm (0.012 - 0.024 in)]

Precautions for Service Equipment RECOVERY/RECYCLING EQUIPMENT

EJS001C7

Follow the manufacturer's instructions for machine operation and machine maintenance. Never introduce any refrigerant other than that specified into the machine.

ELECTRONIC LEAK DETECTOR

Follow the manufacturer's instructions for tester operation and tester maintenance.

PRECAUTIONS

VACUUM PUMP

The lubricant contained inside the vacuum pump is not compatible with the specified lubricant for HFC-134a (R-134a) A/C systems. The vent side of the vacuum pump is exposed to atmospheric pressure so the vacuum pump lubricant may migrate out of the pump into the service hose. This is possible when the pump is switched off after evacuation (vacuuming) and hose is connected to it. To prevent this migration, use a manual valve situated near the hose-to-pump connection, as follows.

- Usually vacuum pumps have a manual isolator valve as part of the pump. Close this valve to isolate the service hose from the pump.
- For pumps without an isolator, use a hose equipped with a manual shut-off valve near the pump end. Close the valve to isolate the hose from the pump.
- If the hose has an automatic shut off valve, disconnect the hose from the pump: as long as the hose is connected, the valve is open and lubricating oil may migrate.

Some one-way valves open when vacuum is applied and close under a no vacuum condition. Such valves may restrict the pump's ability to pull a deep vacuum and are not recommended.

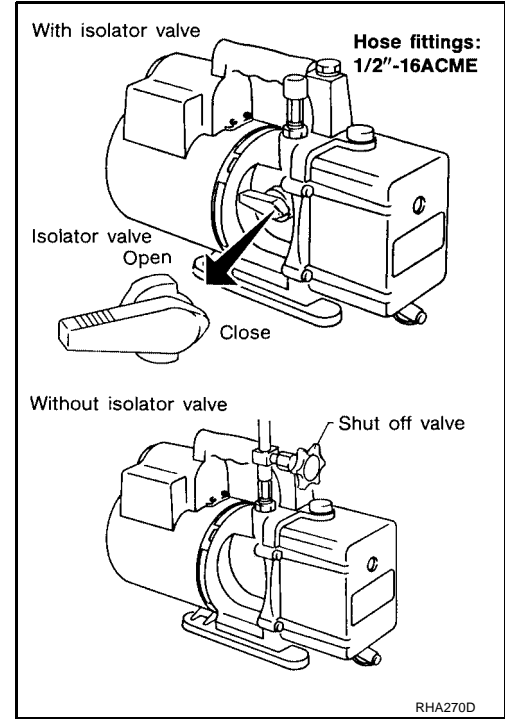

MANIFOLD GAUGE SET

Be certain that the gauge face indicates R-134a or 134a. Make sure the gauge set has 1/2"-16 ACME threaded connections for service hoses. Confirm the set has been used only with refrigerant HFC-134a (R-134a) along with specified lubricant.

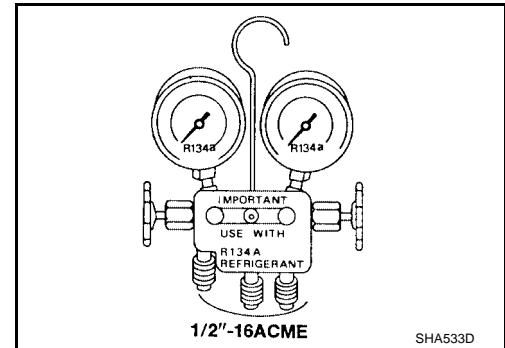

SERVICE HOSES

Be certain that the service hoses display the markings described (colored hose with black stripe). All hoses must include positive shut-off devices (either manual or automatic) near the end of the hoses opposite the manifold gauge.

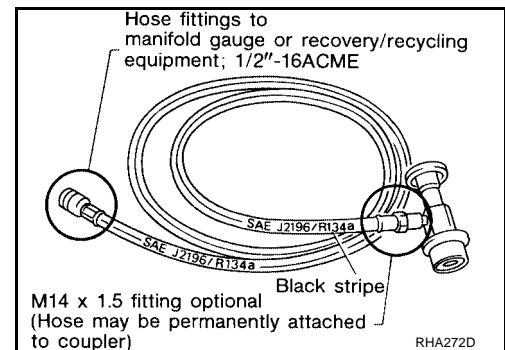

PRECAUTIONS

SERVICE COUPLERS

Never attempt to connect HFC-134a (R-134a) service couplers to a CFC-12 (R-12) A/C system. The HFC-134a (R-134a) couplers will not properly connect to the CFC-12 (R-12) system. However, if an improper connection is attempted, discharging and contamination may occur.

Shut-off valve rotation	A/C service valve
Clockwise	Open
Counterclockwise	Close

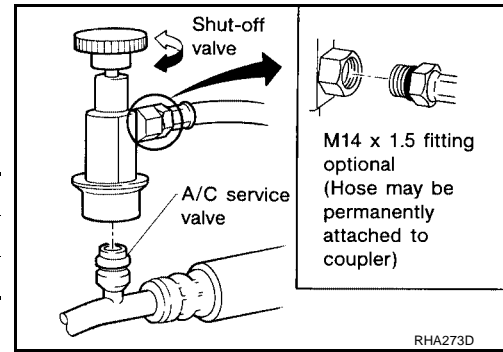

CHARGING CYLINDER

Using a charging cylinder is not recommended. Refrigerant may be vented into air from cylinder's top valve when filling the cylinder with refrigerant. Also, the accuracy of the cylinder is generally less than that of an electronic scale or of quality recycle/recharge equipment.

Wiring Diagrams and Trouble Diagnosis

EJS001GE

When you read wiring diagrams, refer to the following:

- [GI-12, "How to Read Wiring Diagrams"](#)
- [PG-3, "POWER SUPPLY ROUTING CIRCUIT"](#)

When you perform trouble diagnosis, refer to the following:

- [GI-9, "How to Follow Trouble Diagnoses"](#)
- [GI-25, "How to Perform Efficient Diagnosis for an Electrical Incident"](#)

A

B

C

D

E

F

G

H

I

ATC

K

L

M

PREPARATION

PREPARATION

PFP:00002

Special Service Tools

EJS001C9

The actual shapes of Kent-Moore tools may differ from those of special service tools illustrated here.

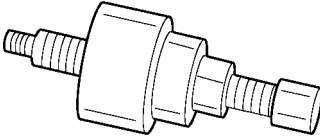
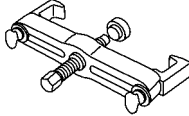
Tool number (Kent-Moore No.) Tool name	Description
(J-38873-A) Drive plate installer  WJIA0367E	Installing pulley and drive plate
KV99233130 (J-29884) Pulley puller  LHA172	Removing pulley

HFC-134a (R-134a) Service Tools and Equipment



EJS001CA

Never mix HFC-134a (R-134a) refrigerant and/or its specified lubricant with CFC-12 (R-12) refrigerant and/or its lubricant.



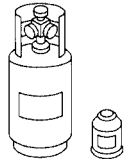

Separate and non-interchangeable service equipment must be used for handling each type of refrigerant/lubricant.

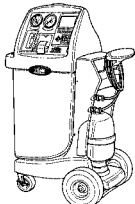
Refrigerant container fittings, service hose fittings and service equipment fittings (equipment which handles refrigerant and/or lubricant) are different between CFC-12 (R-12) and HFC-134a (R-134a). This is to avoid mixed use of the refrigerants/lubricant.

Adapters that convert one size fitting to another must never be used: refrigerant/lubricant contamination will occur and compressor failure will result.

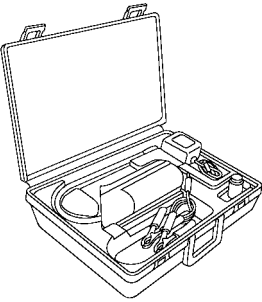
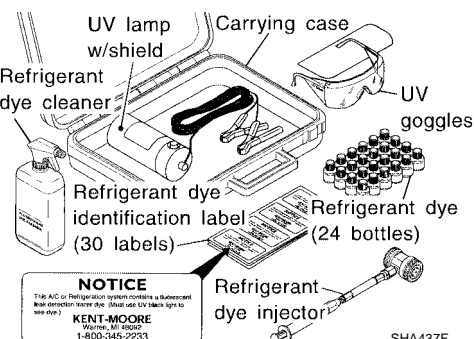
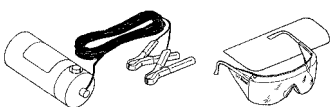
Tool number (Kent-Moore No.) Tool name	Description
HFC-134a (R-134a) refrigerant  S-NT196	Container color:Light blue Container marking:HFC-134a (R-134a) Fitting size: Thread size ● large container 1/2 ² -16 ACME
KLH00-PAGS0 (-) Nissan A/C System Lubricant Type DH-PS  S-NT197	Type:Poly alkylene glycol oil (PAG), type DH-PS Application:HFC-134a (R-134a) vane rotary compressors (Nissan only) Lubricity: 40 mℓ (1.4 US fl oz, 1.4 Imp fl oz)
(J-43600) Recovery/Recycling Recharging equipment (ACR2000)  WJIA0293E	Function:Refrigerant Recovery and Recycling and Recharging

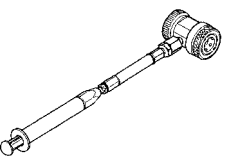
PREPARATION

Tool number (Kent-Moore No.) Tool name	Description	
<p>(J-41995) Electronic refrigerant leak detector</p>	 <p style="text-align: right; font-size: small;">AHA281A</p>	<p>B</p> <p>C</p> <p>D</p>
<p>(J-43926) Refrigerant dye leak detection kit Kit includes: (J-42220) UV lamp and UV safety glasses (J-41459) Refrigerant dye injector (J-41447) qty. 24 HFC-134a (R-134a) refrigerant dye (J-43872) Refrigerant dye cleaner</p>	 <p style="text-align: right; font-size: small;">SHA437F</p>	<p>E</p> <p>F</p> <p>G</p> <p>H</p>
<p>(J-42220) Fluorescent dye leak detector</p>	 <p style="text-align: right; font-size: small;">SHA438F</p>	<p>I</p> <p style="background-color: black; color: white; padding: 2px; text-align: center;">ATC</p>
<p>(J-41447) HFC-134a (R-134a) Fluorescent leak detection dye (Box of 24, 1/4 ounce bottles)</p>	 <p style="text-align: right; font-size: small;">SHA439F</p>	<p>K</p> <p>L</p>
<p>(J-41459) HFC-134a (R-134a) Dye injector Use with J-41447, 1/4 ounce bottle</p>	 <p style="text-align: right; font-size: small;">SHA440F</p>	<p>M</p>
<p>(J-43872) Dye cleaner</p>	 <p style="text-align: right; font-size: small;">SHA441F</p>	<p></p>

PREPARATION

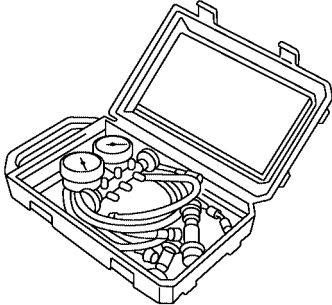
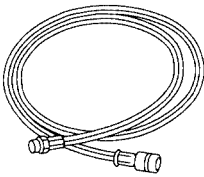
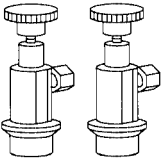
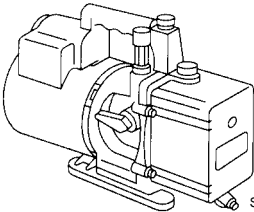
Tool number (Kent-Moore No.) Tool name	Description
<p>(J-39183-C) Manifold gauge set (with hoses and couplers)</p>	<div style="text-align: center;">  <p style="font-size: small; margin-top: 5px;">RJIA0196E</p> </div> <p>Identification:</p> <ul style="list-style-type: none"> ● The gauge face indicates R-134a. Fitting size: Thread size ● 1/2" -16 ACME
<p>Service hoses</p> <ul style="list-style-type: none"> ● High side hose (J-39500-72B) ● Low side hose (J-39500-72R) ● Utility hose (J-39500-72Y) 	<div style="text-align: center;">  <p style="font-size: small; margin-top: 5px;">S-NT201</p> </div> <p>Hose color:</p> <ul style="list-style-type: none"> ● Low side hose: Blue with black stripe ● High side hose: Red with black stripe ● Utility hose: Yellow with black stripe or green with black stripe <p>Hose fitting to gauge:</p> <ul style="list-style-type: none"> ● 1/2" -16 ACME
<p>Service couplers</p> <ul style="list-style-type: none"> ● High side coupler (J-39500-20A) ● Low side coupler (J-39500-24A) 	<div style="text-align: center;">  <p style="font-size: small; margin-top: 5px;">S-NT202</p> </div> <p>Hose fitting to service hose:</p> <ul style="list-style-type: none"> ● M14 x 1.5 fitting is optional or permanently attached.
<p>(J-39649) Vacuum pump (Including the isolator valve)</p>	<div style="text-align: center;">  <p style="font-size: small; margin-top: 5px;">S-NT203</p> </div> <p>Capacity:</p> <ul style="list-style-type: none"> ● Air displacement: 4 CFM ● Micron rating: 20 microns ● Oil capacity: 482 g (17 oz) Fitting size: Thread size ● 1/2" -16 ACME

PREPARATION

Commercial Service Tools

EJS001CB

Tool name	Description	A
<p>(J-41810-NI) Refrigerant identifier equipment- (R-134a)</p>	<p>For checking refrigerant purity and system contamination</p>	B C D
<p>Power tool</p>	<p>Loosening bolts and nuts</p>	E F G
<p>(J-44614) Clutch disc holding tool</p>	<p>Clutch disc holding tool</p>	H I

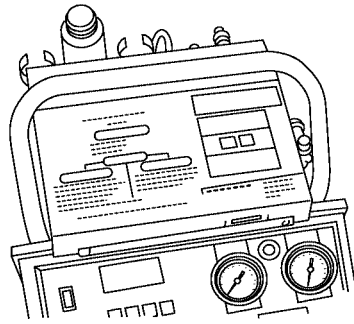

RJIA0197E

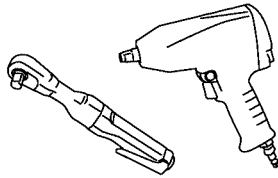

PBIC0190E

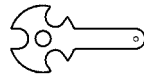

WHA230

ATC

K

L

M

REFRIGERATION SYSTEM

PF:KA990

REFRIGERATION SYSTEM

Refrigerant Cycle REFRIGERANT FLOW

EJS001CC

The refrigerant flows in the standard pattern, that is, through the compressor, the condenser with liquid tank, through the evaporator, and back to the compressor. The refrigerant evaporation through the evaporator coil is controlled by an externally equalized expansion valve, located inside the evaporator case.

Refrigerant System Protection REFRIGERANT PRESSURE SENSOR

EJS001CD

The refrigerant system is protected against excessively high or low pressures by the refrigerant pressure sensor, located on the condenser. If the system pressure rises above or falls below the specifications, the refrigerant pressure sensor detects the pressure inside the refrigerant line and sends the voltage signal to the ECM. ECM makes the A/C relay go OFF and stops the compressor when pressure on the high pressure side detected by refrigerant pressure sensor is over about 2,746 kPa (28 kg/cm², 398 psi), or below about 120 kPa (1.22 kg/cm², 17.4 psi).

PRESSURE RELIEF VALVE

The refrigerant system is also protected by a pressure relief valve, located in the rear head of the compressor. When the pressure of refrigerant in the system increases to an abnormal level [more than 3,727 kPa (38 kg/cm², 540 psi)], the release port on the pressure relief valve automatically opens and releases refrigerant into the atmosphere.

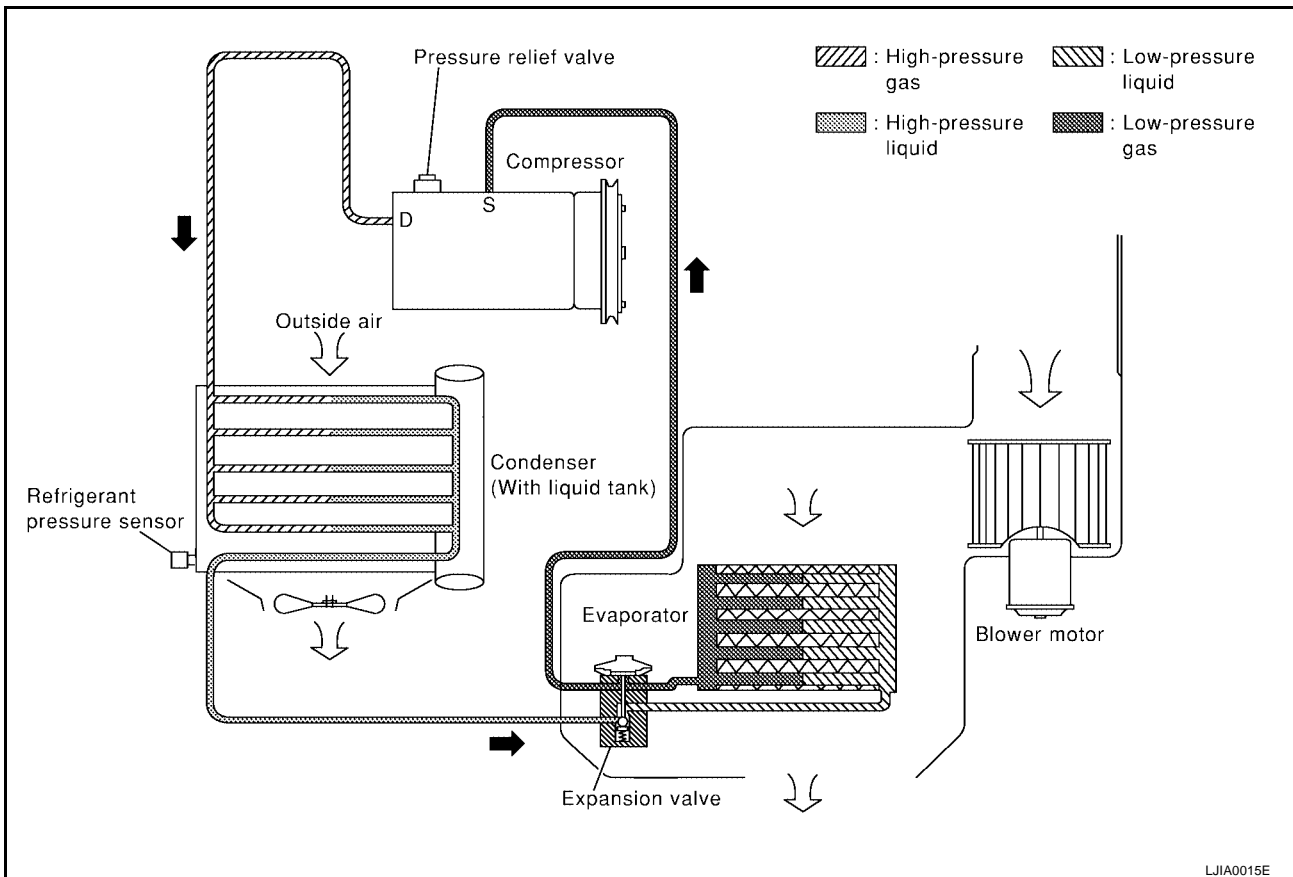

REFRIGERATION SYSTEM

Component Layout

EJS001CE

SEC. 270 • 271 • 272 • 273

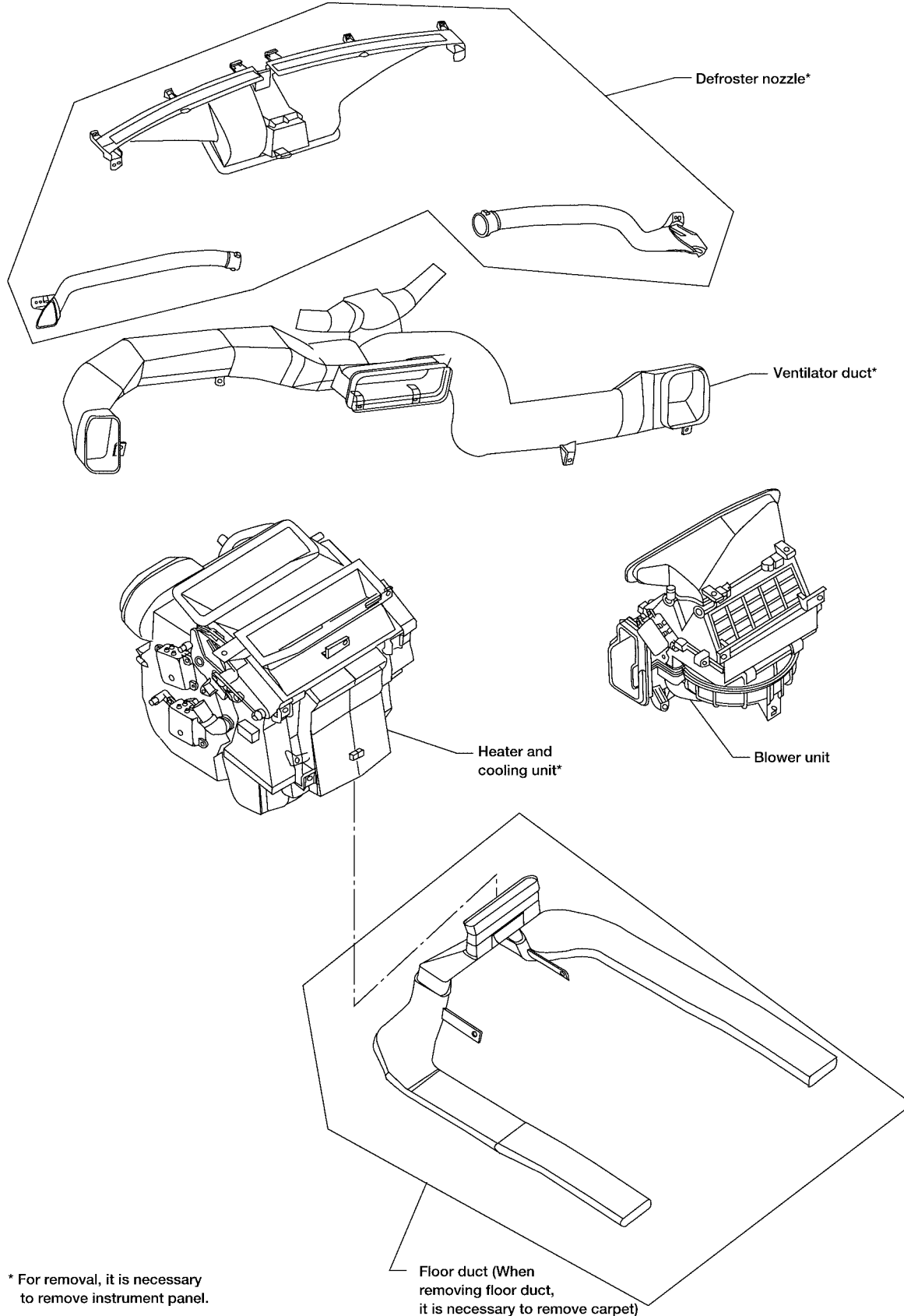

A
B
C
D
E
F
G
H
I
ATC
K
L
M

* For removal, it is necessary to remove instrument panel.

LJIA0011E

LUBRICANT

PPF:KLG00

LUBRICANT

Maintenance of Lubricant Quantity in Compressor

EJS001CF

The lubricant in the compressor circulates through the system with the refrigerant. Add lubricant to compressor when replacing any component or after a large refrigerant leakage has occurred. It is important to maintain the specified amount.

If lubricant quantity is not maintained properly, the following malfunctions may result:

- Lack of lubricant: May lead to a seized compressor
- Excessive lubricant: Inadequate cooling (thermal exchange interference)

LUBRICANT

Name: Nissan A/C System Lubricant Type DH-PS or equivalent

Part number: KLH00-PAGS0

CHECKING AND ADJUSTING

Adjust the lubricant quantity according to the test group shown below.

1. LUBRICANT RETURN OPERATION

Can lubricant return operation be performed?

- A/C system works properly.
- There is no evidence of a large amount of lubricant leakage.

Yes or No

- Yes >> GO TO 2.
No >> GO TO 3.

2. PERFORM LUBRICANT RETURN OPERATION, PROCEEDING AS FOLLOWS

1. Start engine, and set the following conditions:

- **Test condition**

Engine speed: Idling to 1,200 rpm

A/C switch: ON

Blower speed: Max. position

Temp. control: Optional [Set so that intake air temperature is 25 to 30°C (77 to 86°F).]

Intake position: Recirculation (REC)

2. Perform lubricant return operation for about 10 minutes.
3. Stop engine.

CAUTION:

If excessive lubricant leakage is noted, do not perform the lubricant return operation.

>> GO TO 3.

3. CHECK COMPRESSOR

Should the compressor be replaced?

Yes or No

- Yes >> GO TO [ATC-19, "Lubricant Adjustment Procedure for Compressor Replacement"](#) .
No >> GO TO 4.

4. CHECK ANY PART

Is there any part to be replaced? (Evaporator, condenser, liquid tank or in case there is evidence of a large amount of lubricant leakage.)

Yes or No

- Yes >> GO TO [ATC-19, "Lubricant Adjusting Procedure for Components Replacement Except Compressor"](#) .
No >> Carry out the A/C performance test.

LUBRICANT

Lubricant Adjusting Procedure for Components Replacement Except Compressor

After replacing any of the following major components, add the correct amount of lubricant to the system.

Amount of lubricant to be added

Part replaced	Lubricant to be added to system	Remarks
	Amount of lubricant m ℓ (US fl oz, Imp fl oz)	
Evaporator	75 (2.5, 2.6)	—
Condenser	75 (2.5, 2.6)	—
Liquid tank	5 (0.2, 0.2)	Add if compressor is not replaced.
In case of refrigerant leak	30 (1.0, 1.1)	Large leak
	—	Small leak *1

- *1: If refrigerant leak is small, no addition of lubricant is needed.

Lubricant Adjustment Procedure for Compressor Replacement

1. Before connecting recovery/recycling equipment to vehicle, check recovery/recycling equipment gauges. No refrigerant pressure should be displayed. If OK, recover refrigerant from equipment lines.
2. Confirm refrigerant purity in supply tank using recovery/recycling equipment and refrigerant identifier. If NG, refer to [ATC-4, "Contaminated Refrigerant"](#).
3. Connect recovery/recycling equipment to vehicle. Confirm refrigerant purity in vehicle A/C system using recovery/recycling equipment and refrigerant identifier. If NG, refer to [ATC-4, "Contaminated Refrigerant"](#).
4. Discharge refrigerant into the refrigerant recovery/recycling equipment. Measure lubricant discharged into the recovery/recycling equipment.
5. Drain the lubricant from the "old" (removed) compressor into a graduated container and recover the amount of lubricant drained.
6. Drain the lubricant from the "new" compressor into a separate, clean container.
7. Measure an amount of new lubricant installed equal to amount drained from "old" compressor. Add this lubricant to "new" compressor through the suction port opening.
8. Measure an amount of new lubricant equal to the amount recovered during discharging. Add this lubricant to "new" compressor through the suction port opening.
9. If the liquid tank also needs to be replaced, add an additional 5 m ℓ (0.2 US fl oz, 0.2 Imp fl oz) of lubricant at this time.

Do not add this 5 m ℓ (0.2 US fl oz, 0.2 Imp fl oz) of lubricant if only replacing the compressor.

LUBRICANT

Lubricant adjusting procedure for compressor replacement

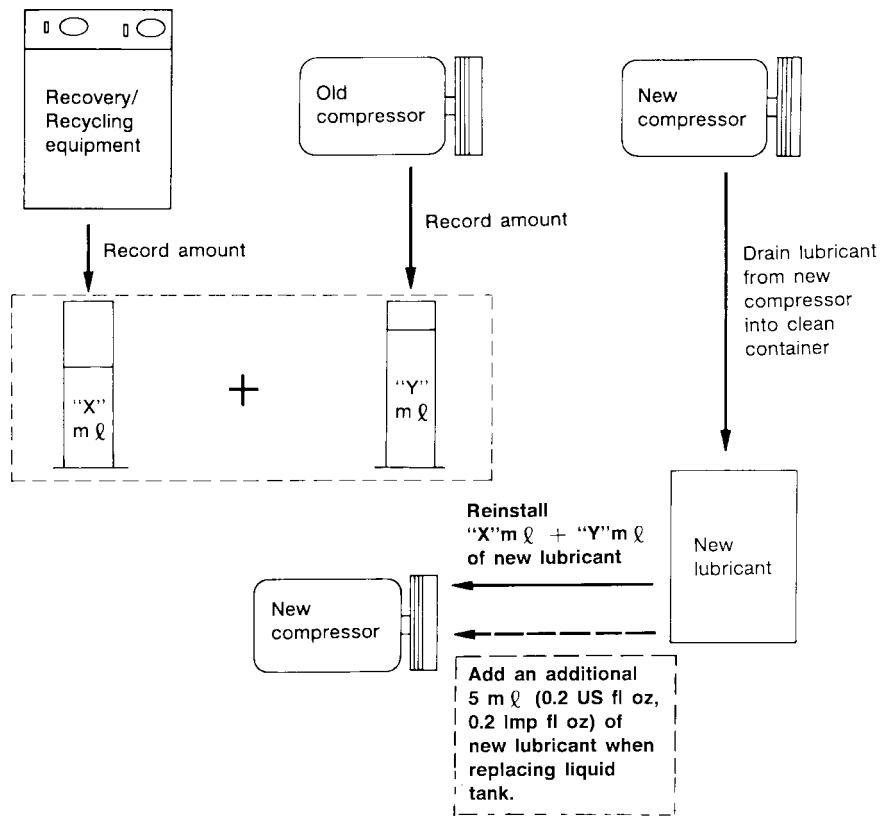

RHA065DD

AIR CONDITIONER CONTROL

AIR CONDITIONER CONTROL

PFP:27500

Overview Air Conditioner LAN Control System

EJS001CG

The LAN system consists of auto amp., air mix door motor and mode door motor. A configuration of these components is shown in the diagram below.

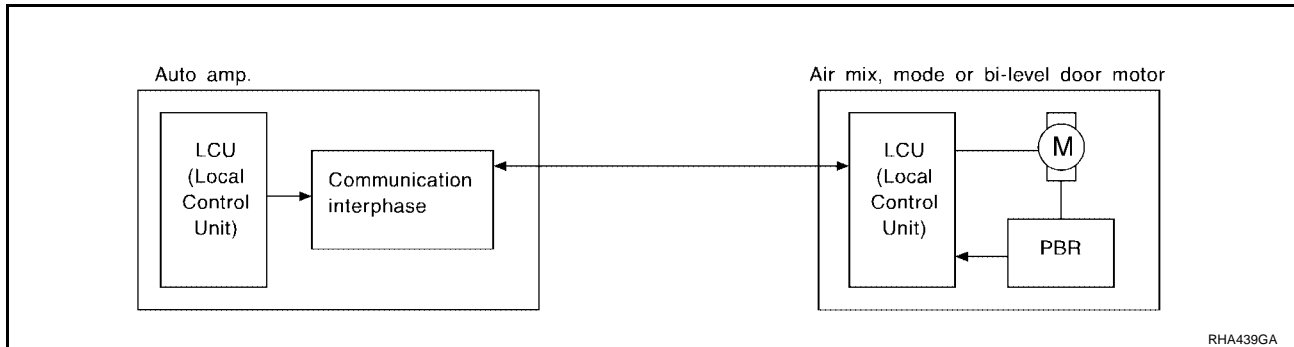

System Construction

EJS001CH

A small network is constructed between the auto amplifier, air mix door motor and mode door motor. The auto amplifier and motors are connected by data transmission lines and motor power supply lines. The LAN network is built through the ground circuits of the two motors.

Addresses, motor opening angle signals, motor stop signals and error checking messages are all transmitted through the data transmission lines connecting the auto amplifier and two motors.

The following functions are contained in LCUs built into the air mix door motor and the mode door motor.

- Address
- Motor opening angle signals
- Data transmission
- Motor stop and drive decision
- Opening angle sensor (PBR function)
- Comparison
- Decision (Auto amplifier indicated value and motor opening angle comparison)

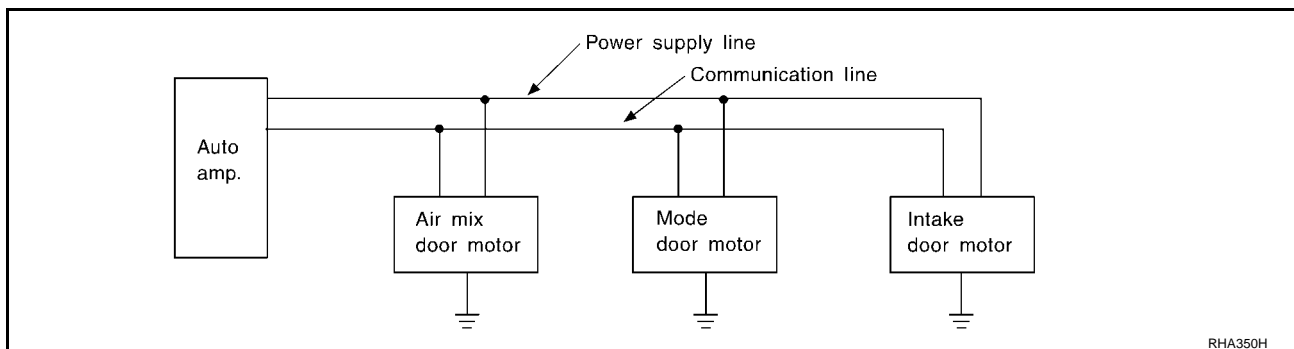

OPERATION

The auto amplifier receives data from each of the sensors. The amplifier sends air mix door, mode door and intake door opening angle data to the air mix door motor LCU, mode door motor LCU and intake door motor LCU.

The air mix door motor, mode door motor and intake door motor read their respective signals according to the address signal. Opening angle indication signals received from the auto amplifier and each of the motor position sensors are compared by the LCUs in each motor with the existing decision and opening angles. Subse-

AIR CONDITIONER CONTROL

quently, HOT/COLD, DEFROST/VENT or FRESH/RECIRCULATION operation is selected. The new selection data is returned to the auto amplifier.

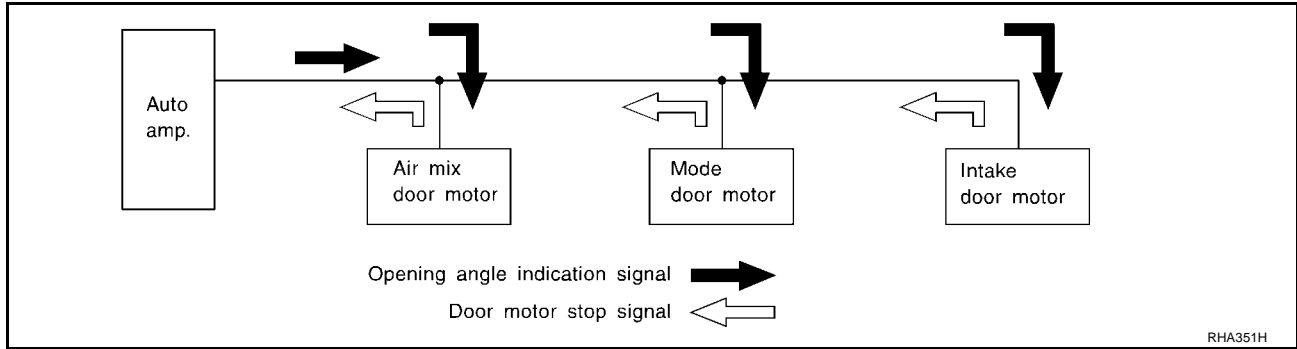

RHA351H

TRANSMISSION DATA AND TRANSMISSION ORDER

Amplifier data is transmitted consecutively to each of the door motors following the form shown in figure below. Start: Initial compulsory signal sent to each of the door motors.

Address: Data sent from the auto amplifier is selected according to data-based decisions made by the air mix door motor, mode door motor and intake door motor.

If the addresses are identical, the opening angle data and error check signals are received by the door motor LCUs. The LCUs then make the appropriate error decision. If the opening angle data is normal, door control begins.

If an error exists, the received data is rejected and corrected data received. Finally, door control is based upon the corrected opening angle data.

Opening angle: Data that shows the indicated door opening angle of each door motor.

Error check: Procedure by which sent and received data is checked for errors. Error data is then compiled. The error check prevents corrupted data from being used by the air mix door motor, mode door motor and intake door motor. Error data can be related to the following problems.

- Abnormal electrical frequency
- Poor electrical connections
- Signal leakage from transmission lines
- Signal level fluctuation

Stop signal: At the end of each transmission, a stop operation, in-operation, or internal problem message is delivered to the auto amplifier. This completes one data transmission and control cycle.

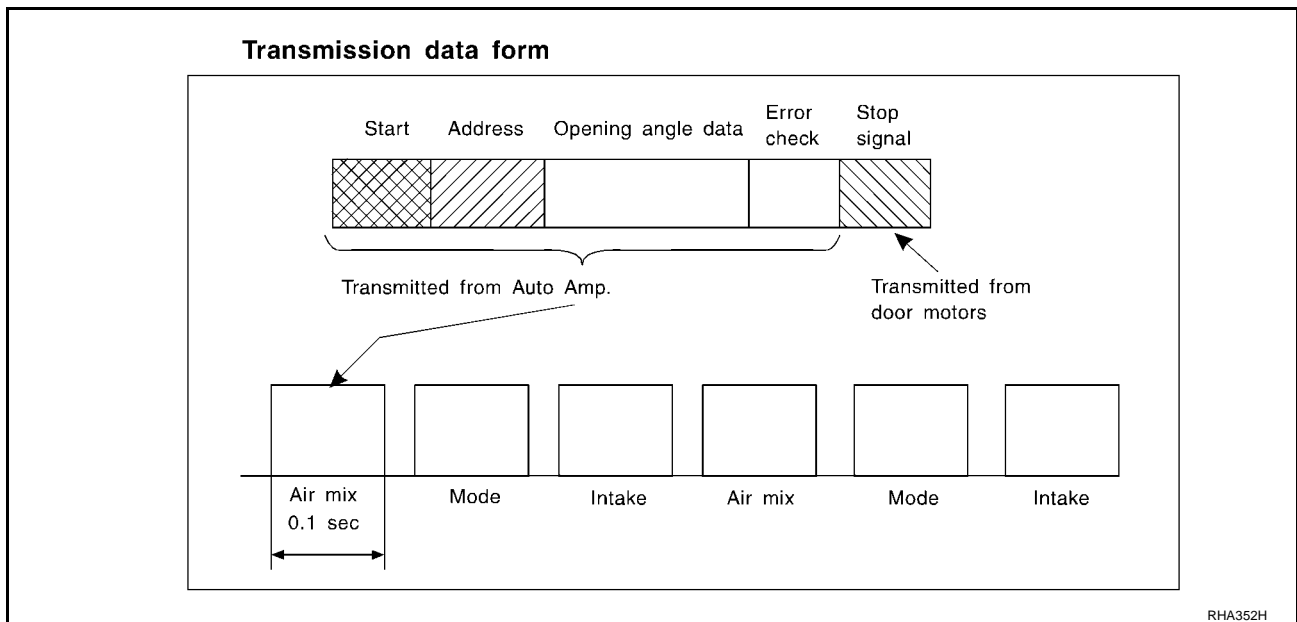

RHA352H

AIR MIX DOOR CONTROL (AUTOMATIC TEMPERATURE CONTROL)

The air mix door is automatically controlled so that in-vehicle temperature is maintained at a predetermined value by: The temperature setting, ambient temperature, in-vehicle temperature and amount of sunload.

AIR CONDITIONER CONTROL

FAN SPEED CONTROL

Blower speed is automatically controlled based on temperature setting, ambient temperature, in-vehicle temperature, intake temperature, amount of sunload and air mix door position.

With FAN switch set to AUTO, the blower motor starts to gradually increase air flow volume.

When engine coolant temperature is low, the blower motor operation is delayed to prevent cool air from flowing.

INTAKE DOOR CONTROL

The intake doors are automatically controlled by the: temperature setting, ambient temperature, in-vehicle temperature, intake temperature, amount of sunload and ON-OFF operation of the compressor.

OUTLET DOOR CONTROL

The outlet door is automatically controlled by the: temperature setting, ambient temperature, in-vehicle temperature, intake temperature and amount of sunload.

MAGNET CLUTCH CONTROL

The ECM controls compressor operation using input signals from the throttle position sensor and auto amplifier.

SELF-DIAGNOSTIC SYSTEM

The self-diagnostic system is built into the auto amplifier (LCU) to quickly locate the cause of problems.

Overview of Control system

EJS001C1

The control system consists of input sensors, switches, the automatic amplifier (microcomputer) and outputs. The relationship of these components is shown in the diagram below:

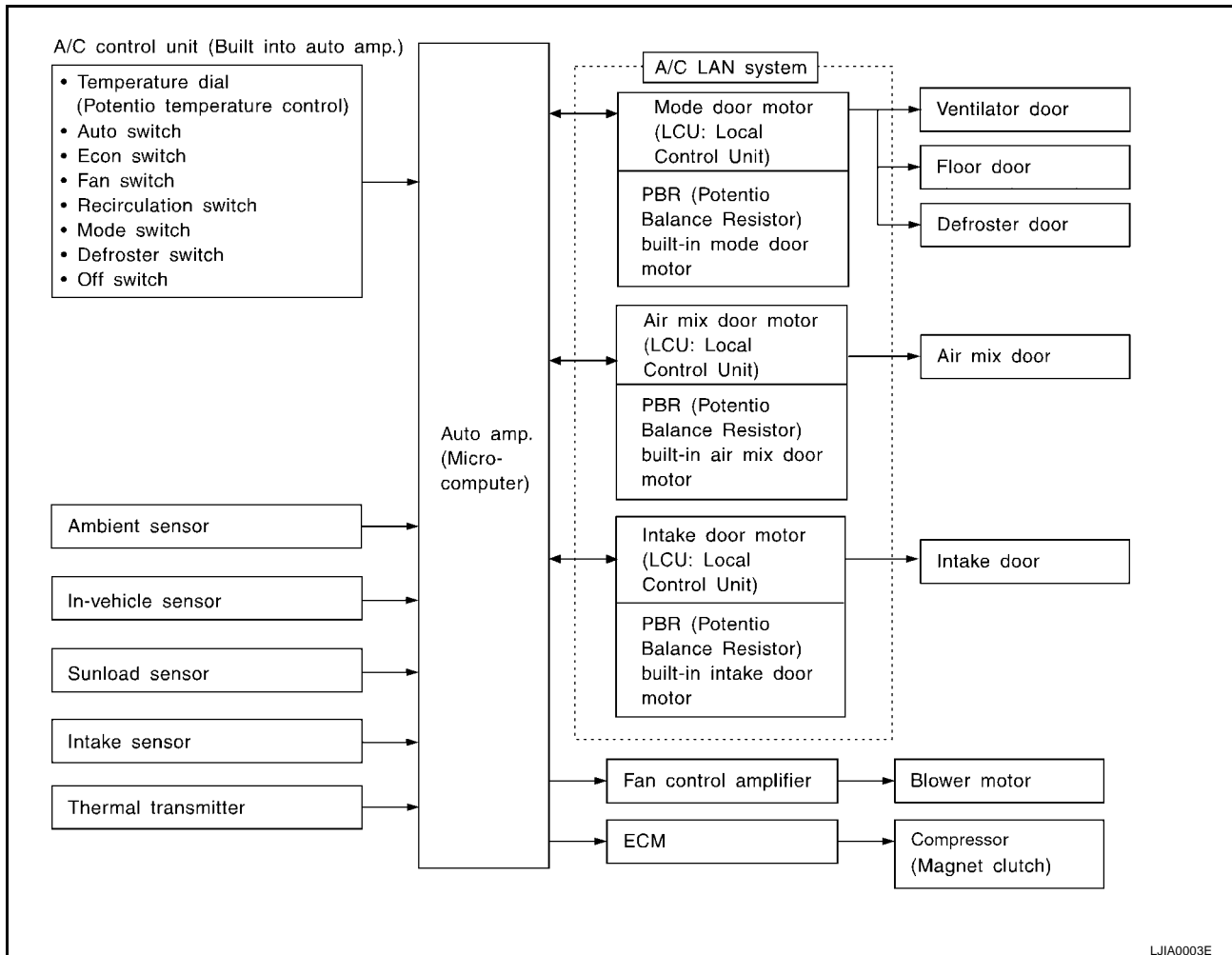

AIR CONDITIONER CONTROL

Control Operation

EJS001CJ

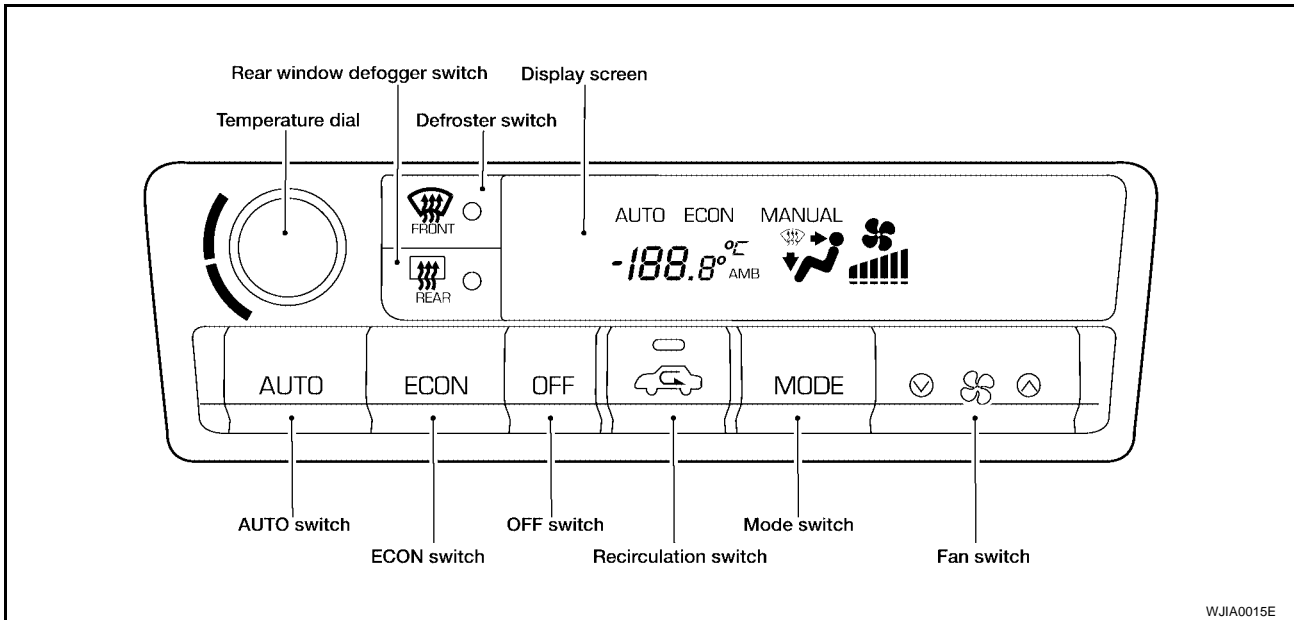

DISPLAY SCREEN

Displays the operational status of the system.

AUTO SWITCH

The compressor, intake doors, air mix door, outlet doors and blower speed are automatically controlled so that the in-vehicle temperature will reach, and be maintained at the set temperature selected by the operator.

ECON (ECONOMY) SWITCH

By pressing the ECON switch, the display screen should indicate ECON and the compressor always turns OFF. With the compressor OFF, the system will not remove heat (cool) or de-humidify. The system will maintain the in-vehicle temperature at the set temperature when the set temperature is above the ambient (outside) temperature. The system will set the intake doors to the outside air position.

TEMPERATURE DIAL (POTENTIO TEMPERATURE CONTROL)

Increases or decreases the set temperature.

OFF SWITCH

The compressor and blower are OFF, the intake doors are set to the outside air position, and the air outlet doors are set to the foot (80% foot and 20% defrost) position.

FAN SWITCH

Manually controls the blower speed. Five speeds are available for manual control (as shown on the display screen).

RECIRCULATION (REC) SWITCH

OFF position: Outside air is drawn into the passenger compartment.

ON position: Interior air is recirculated inside the vehicle.

DEFROSTER (DEF) SWITCH

Positions the air outlet doors to the defrost position. Also positions the intake doors to the outside air position. The compressor remains ON until the ignition is turned OFF.

MODE SWITCH

Controls the air discharge outlets.

REAR WINDOW DEFOGGER SWITCH

This switch turns the rear window defogger ON and OFF.

AIR CONDITIONER CONTROL

EJS001CK

Discharge Air Flow

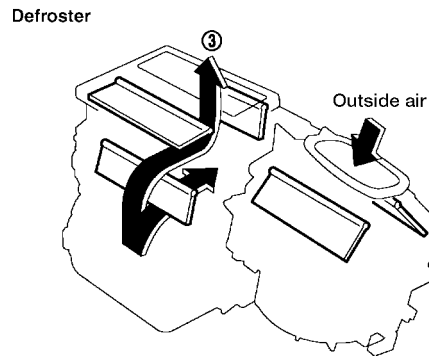
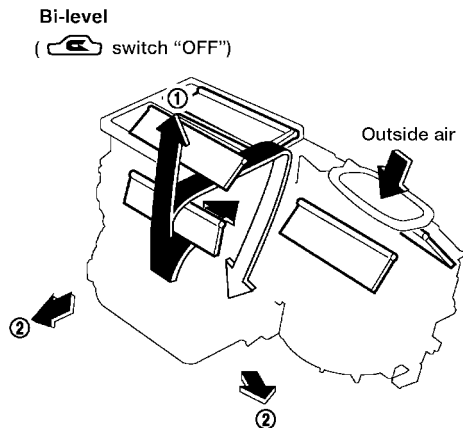
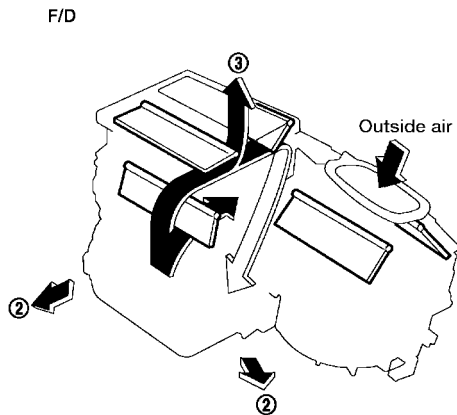
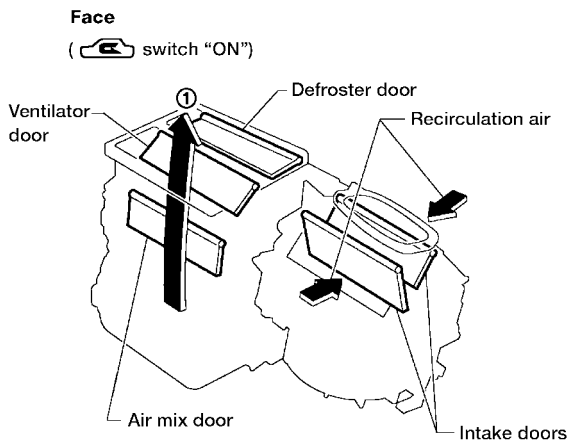
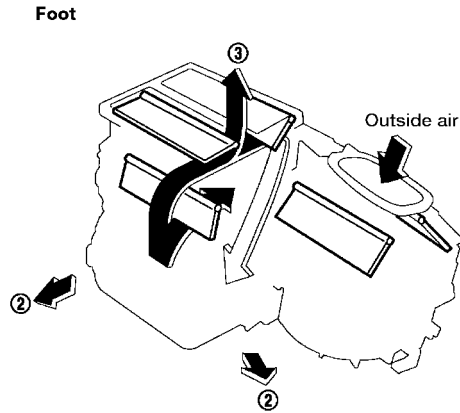
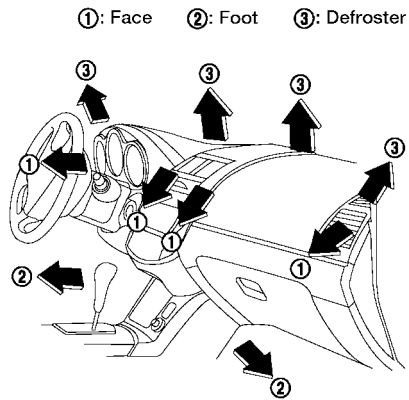

- ①: To face
- ②: To foot
- ③: To defroster

For air flow %, refer to "Operational Check", "TROUBLE DIAGNOSES".

WJIA0016E

A
B
C
D
E
F
G
H
I
ATC
K
L
M

AIR CONDITIONER CONTROL

EJS001CL

System Description SWITCHES AND THEIR CONTROL FUNCTION

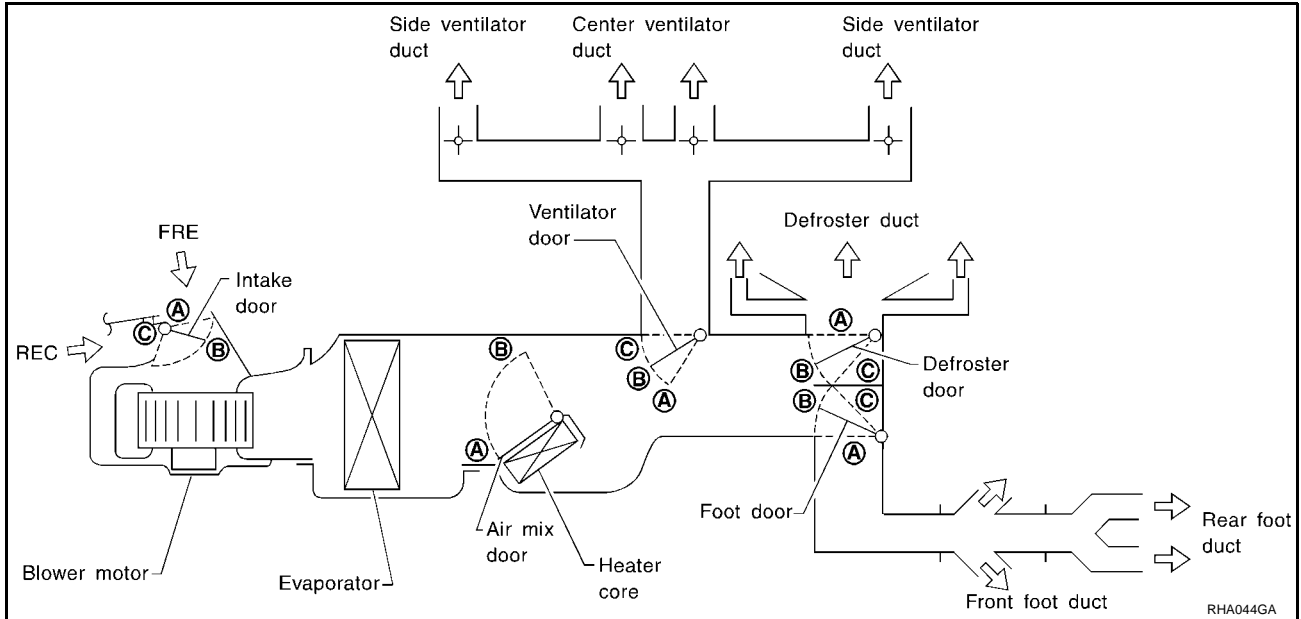

Position or switch	MODE SW				Front DEF SW		AUTO SW	ECON SW	REC SW		Temperature DIAL				
	VENT	B/L	FOOT	D/F	ON	OFF			ON	OFF					
Door							AUTO	ECON			18.0°C (60°F)	—	32.0°C (90°F)		
Ventilator door	A	B	C	C	C	—	AUTO	AUTO	—		—				
Foot door	A	B	C	C	A	—			—		—				
Defroster door	A	A	B	C	C	—			—		—				
Air mix door	—				—	—			—		A	AUTO	B	—	
Intake door	—				C	—			A	AUTO*1	—				

*1: Automatically controlled when REC switch is OFF.

WJIA0096E

CAN Communication System Description

EJS001CM

CAN (Controller Area Network) is a serial communication line for real time application. It is an on-vehicle multiplex communication line with high data communication speed and excellent error detection ability. Many electronic control units are equipped onto a vehicle, and each control unit shares information and links with other control units during operation (not independent). In CAN communication, control units are connected with 2 communication lines (CAN H line, CAN L line) allowing a high rate of information transmission with less wiring. Each control unit transmits/receives data but selectively reads required data only.

AIR CONDITIONER CONTROL

FOR TCS MODELS

System diagram

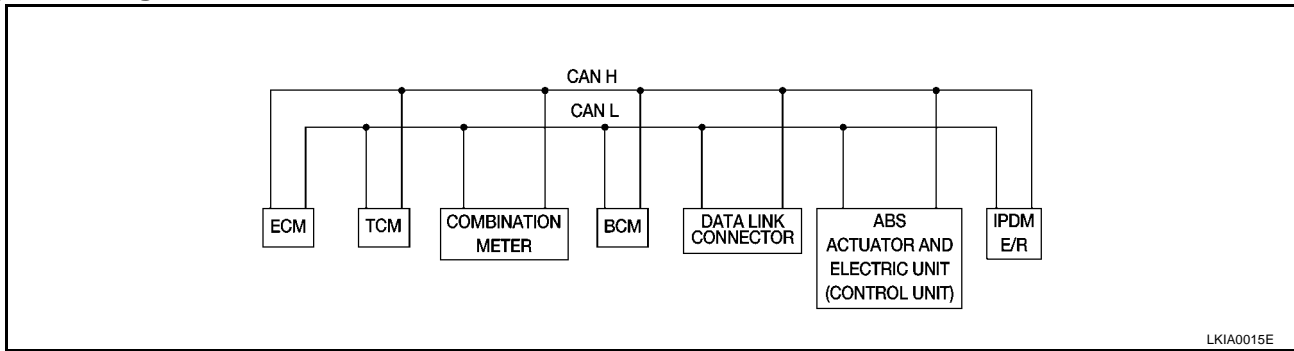

Input/output signal chart

T: Transmit R: Receive

Signals	ECM	TCM	COMBINATION METER	BCM	ABS/TCS control unit	IPDM E/R
Engine speed signal	T		R		R	
Engine coolant temperature signal	T		R			
Accelerator pedal position signal	T					
Fuel consumption monitor signal	T		R			
A/T warning lamp signal		T	R			
A/T position indicator signal	R	T	R	R ^(R range only)	R	
ABS operation signal	R				T	
TCS operation signal	R	R			T	
Air conditioner switch signal	R			T		
Air conditioner compressor signal	R					T
A/C compressor request signal	T					R
Cooling fan motor operation signal	R					T
Cooling fan speed request signal	T					R
Position lights request			R	T		R
Position lights status				R		T
Low beam request				T		R
Low beam status	R			R		T
High beam request			R	T		R
High beam status	R			R		T
Front fog lights request				T		R
Front fog light status				R		T
OD cancel switch signal		R	T			R
Brake switch signal		R	T			
Vehicle speed signal	R		T			
	R		T	R		
Oil pressure switch			R			T
Sleep request1			R	T		
Sleep request2				T		R
N range switch signal		R	T			
P range switch signal		R	T			
Seat belt buckle switch signal			T	R		

AIR CONDITIONER CONTROL

Signals	ECM	TCM	COMBINATION METER	BCM	ABS/TCS control unit	IPDM E/R
Door switch signal			R	T		R
Tail lamp request			R	T		R
Turn indicator signal			R	T		
Buzzer output signal			R	T		
Trunk switch signal			R	T		
ASCD main switch signal	T		R			
ASCD cruise signal	T		R			
Wiper operation				R		T
Wiper stop position signal				R		T
Rear window defogger switch signal				T		R
Rear window defogger control signal	R			R		T

FOR A/T MODELS

System diagram

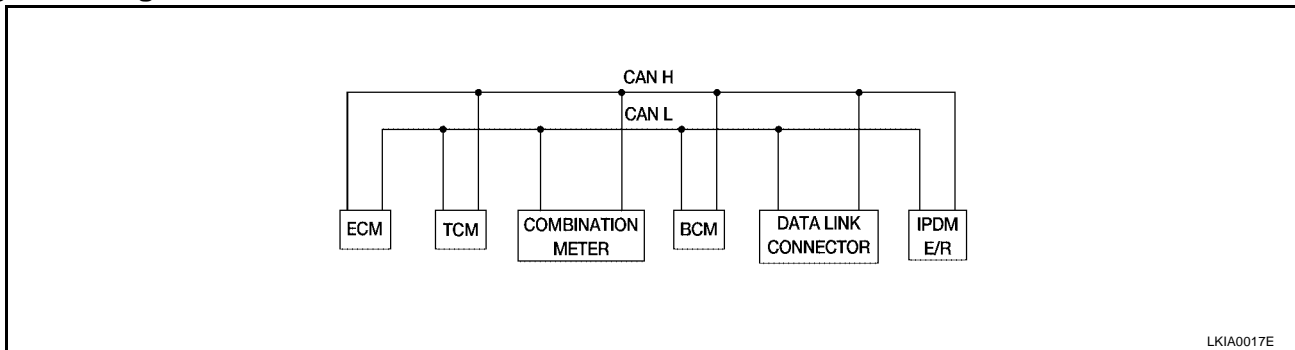

Input/output signal chart

T: Transmit R: Receive

Signals	ECM	TCM	COMBINATION METER	BCM	IPDM E/R
Engine speed signal	T		R		
Engine coolant temperature signal	T		R		
Accelerator pedal position signal	T				R
Fuel consumption monitor signal	T		R		
A/T warning lamp signal		T	R		
A/T position indicator signal	R	T	R	R ^(R range only)	
Air conditioner switch signal	R			T	
Air conditioner compressor signal	R				T
A/C compressor request signal	T				R
Blower fan switch signal	R ^(QR25DE)			T	
Cooling fan motor operation signal	R			T	
Cooling fan speed request signal	T				R
Position lights request			R	T	R
Position lights status				R	T
Low beam request				T	R
Low beam status	R			R	T
High beam request			R	T	R

AIR CONDITIONER CONTROL

Signals	ECM	TCM	COMBINATION METER	BCM	IPDM E/R
High beam status	R			R	T
Front fog lights request				T	R
Front fog light status				R	T
OD cancel switch signal		R	T		R
Brake switch signal		R	T		
Vehicle speed signal	R		T		
	R		T	R	
Oil pressure switch			R		T
Sleep request1			R	T	
Sleep request2				T	R
N range switch signal		R	T		
P range switch signal		R	T		
Seat belt buckle switch signal			T	R	
Door switch signal			R	T	R
Tail lamp request			R	T	R
Turn indicator signal			R	T	
Buzzer output signal			R	T	
Trunk switch signal			R	T	
ASCD main switch signal	T		R		
ASCD cruise signal	T		R		
Wiper operation				R	T
Wiper stop position signal				R	T
Rear window defogger switch signal				T	R
Rear window defogger control signal	R			R	T

FOR M/T MODELS

System diagram

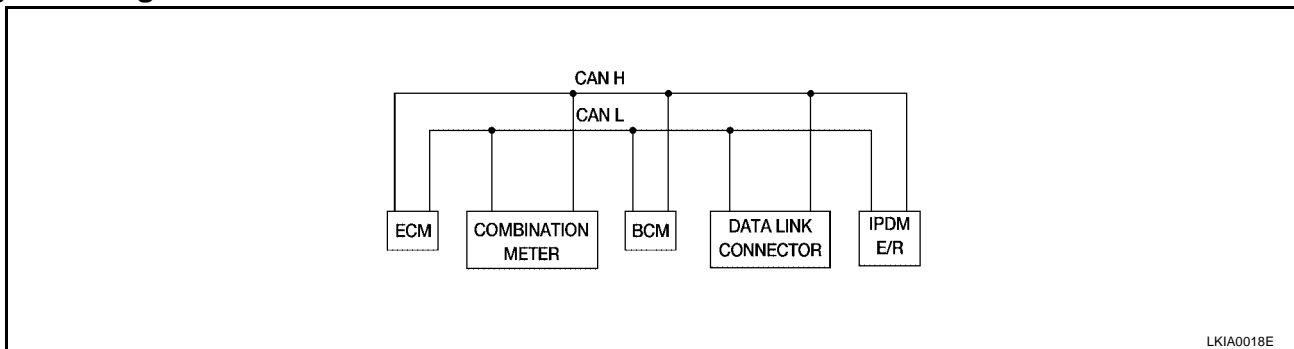

Input/output signal chart

Signals	ECM	COMBINATION METER	BCM	IPDM E/R
Engine speed signal	T			
Engine coolant temperature signal	T			
Fuel consumption monitor signal	T			
Air conditioner switch signal	R		T	
Air conditioner compressor signal	R			T
A/C compressor request signal	T			R

AIR CONDITIONER CONTROL

Signals	ECM	COMBINATION METER	BCM	IPDM E/R
Blower fan switch signal	R ^(QR25DE)		T	
Cooling fan motor operation signal	R			T
Cooling fan speed request signal	T			R
Position lights request		R	T	R
Position lights status			R	T
Low beam request			T	R
Low beam status	R		R	T
High beam request		R	T	R
High beam status	R		R	T
Front fog lights request			T	R
Front fog light status			R	T
Vehicle speed signal	R	T		
Oil pressure switch		R		T
Sleep request1		R	T	
Sleep request2			T	R
Seat belt buckle switch signal		T	R	
Door switch signal		R	T	R
Tail lamp request		R	T	R
Turn indicator signal		R	T	
Buzzer output signal		R	T	
Trunk switch signal		R	T	
ASCD main switch signal	T	R		
ASCD cruise signal	T	R		
Wiper operation			R	T
Wiper stop position signal			R	T
Rear window defogger switch signal			T	R
Rear window defogger control signal	R		R	T

TROUBLE DIAGNOSIS

PFP:00004

TROUBLE DIAGNOSIS

How to Perform Trouble Diagnoses for Quick and Accurate Repair WORK FLOW

EJS001CN

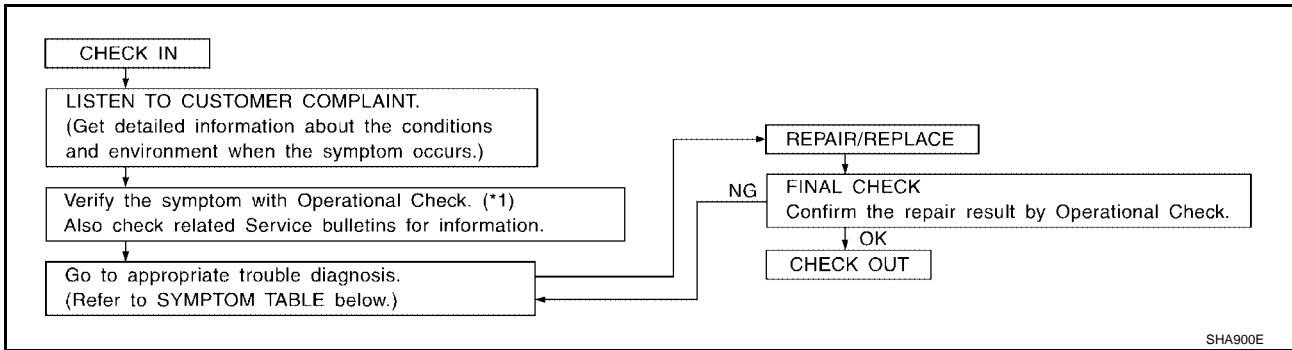

*1: [ATC-49](#)

SYMPTOM TABLE

Symptom		Reference Page
● A/C system does not come on.	● Go to Trouble Diagnosis Procedure for A/C system.	ATC-52
● Air outlet does not change.		
● Mode door motor does not operate normally.	● Go to Trouble Diagnosis Procedure for Mode Door Motor. (LAN)	ATC-58
● Discharge air temperature does not change.		
● Air mix door motor does not operate normally.	● Go to Trouble Diagnosis Procedure for Air Mix Door Motor. (LAN)	ATC-61
● Intake door does not change.		
● Intake door motor does not operate normally.	● Go to Trouble Diagnosis Procedure for Intake Door Motor. (LAN)	ATC-64
● Blower motor operation is malfunctioning.	● Go to Trouble Diagnosis Procedure for Blower Motor.	ATC-67
● Magnet clutch does not engage.	● Go to Trouble Diagnosis Procedure for Magnet Clutch.	ATC-73
● Insufficient cooling.	● Go to Trouble Diagnosis Procedure for Insufficient Cooling.	ATC-79
● Insufficient heating.	● Go to Trouble Diagnosis Procedure for Insufficient Heating.	ATC-86
● Noise.	● Go to Trouble Diagnosis Procedure for Noise.	ATC-87
● Self-diagnosis can not be performed.	● Go to Trouble Diagnosis Procedure for Self-diagnosis.	ATC-88
● Memory function does not operate.	● Go to Trouble Diagnosis Procedure for Memory Function.	ATC-89
● ECON mode does not operate.	● Go to Trouble Diagnosis Procedure for ECON (ECONOMY) — mode.	ATC-90

TROUBLE DIAGNOSIS

Component Parts and Harness Connector Location ENGINE COMPARTMENT

EJS001CO

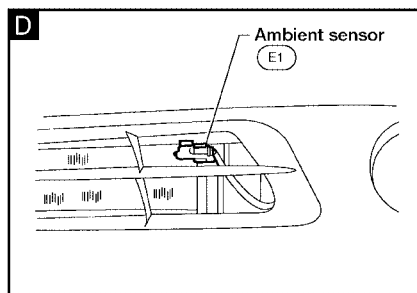
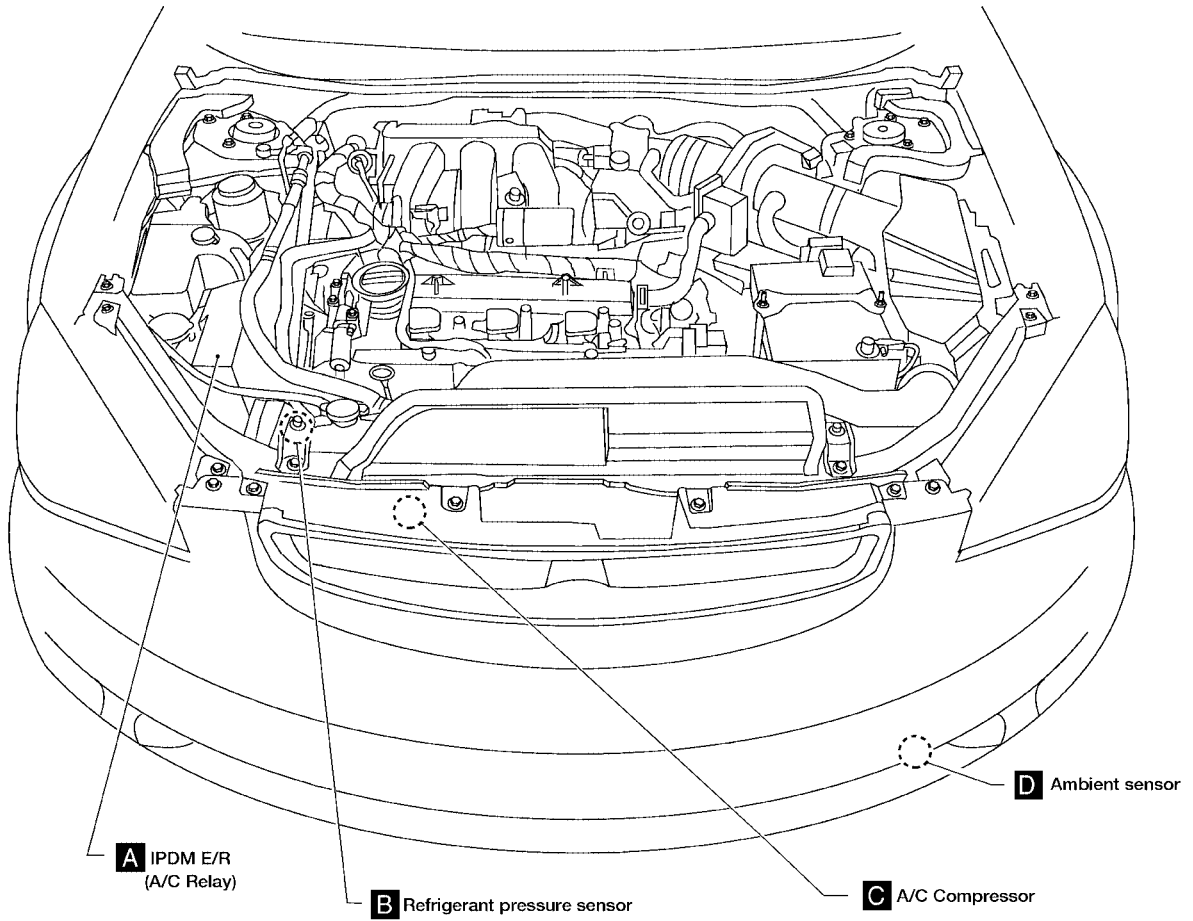
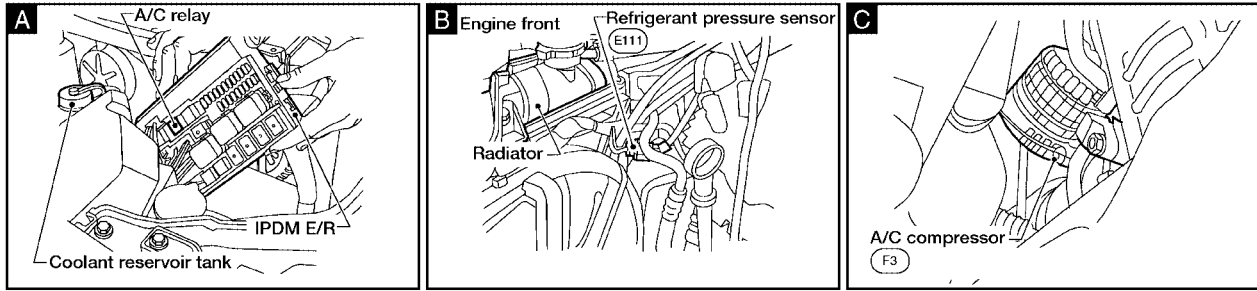

WJIA0017E

TROUBLE DIAGNOSIS

PASSENGER COPARTMENT

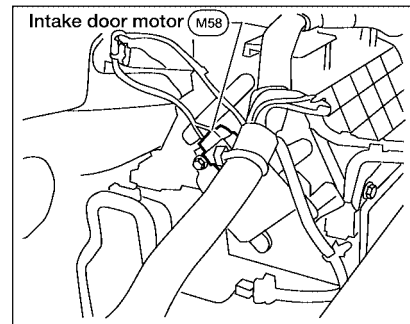
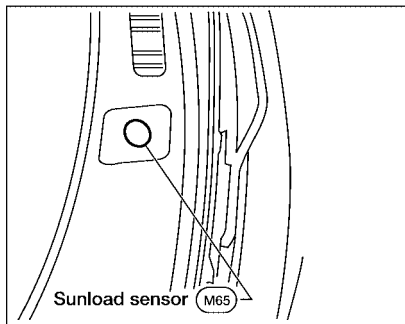
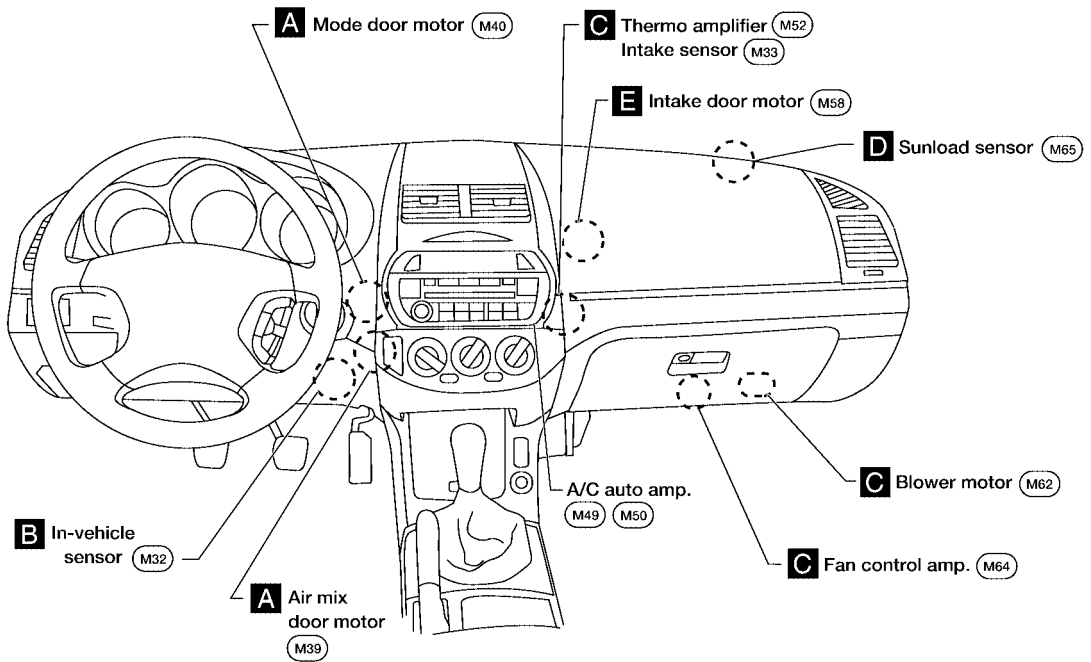
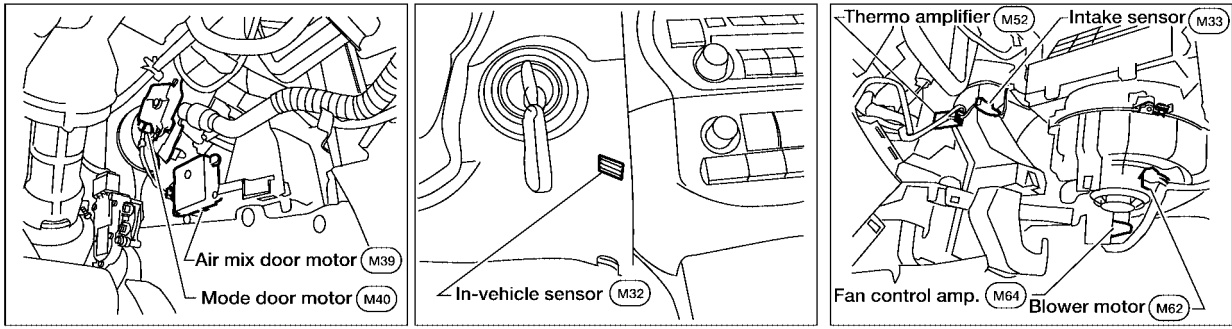

A
B
C
D
E
F
G
H
I
ATC
K
L
M

TROUBLE DIAGNOSIS

Circuit Diagram

EJS001CP

(N) : FOR CANADA

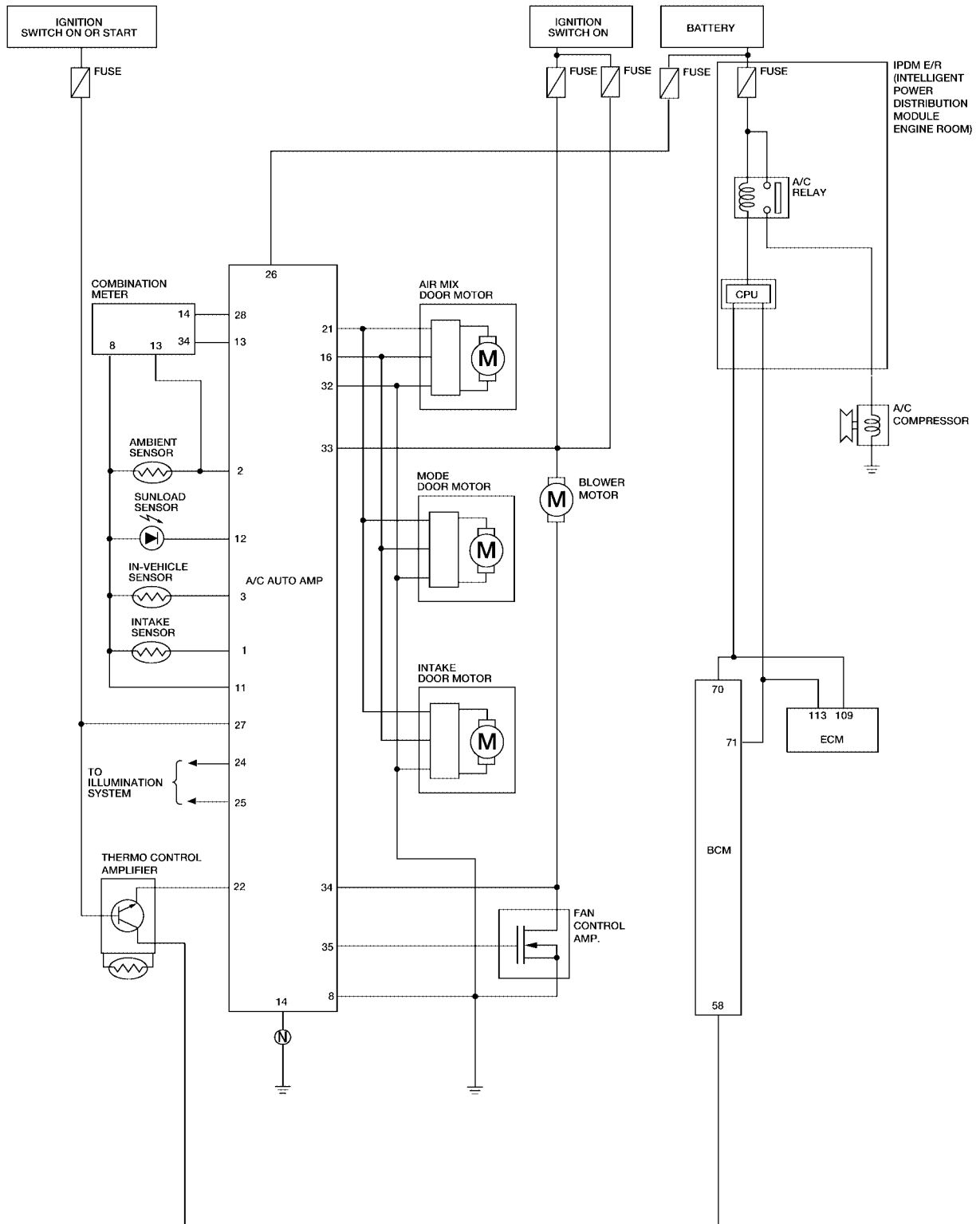

WJWA0006E

TROUBLE DIAGNOSIS

Wiring Diagram — A/C,A —

EJS001CQ

ATC-A/C,A-01

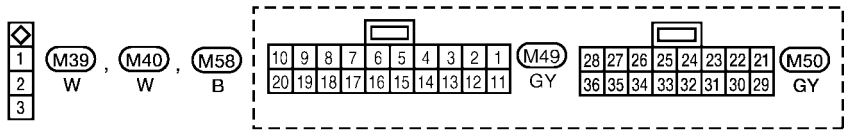
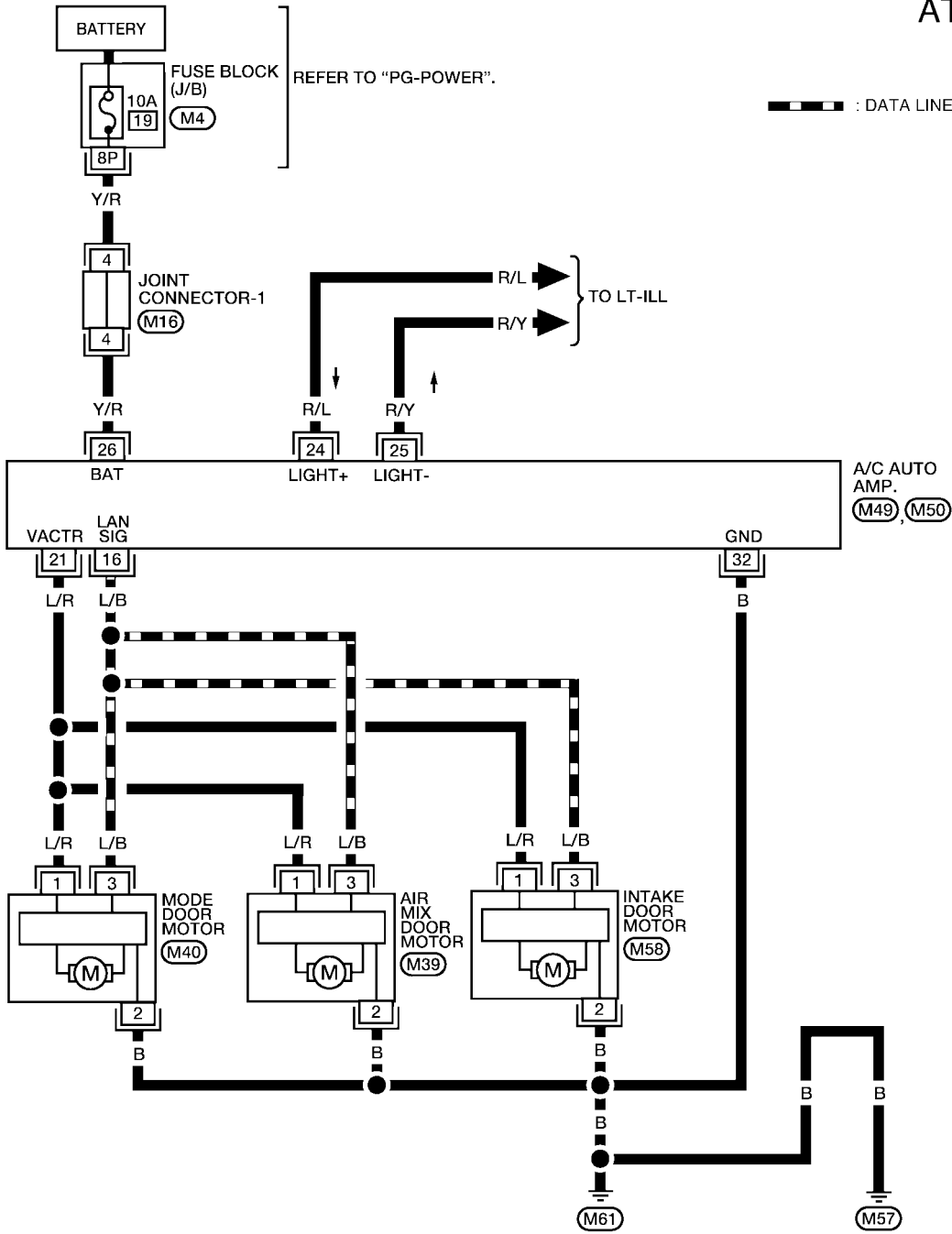

REFER TO THE FOLLOWING.
 (M4) - FUSE BLOCK
 - JUNCTION BOX (J/B)
 (M16) - JOINT CONNECTOR (J/C)

WJWA0027E

TROUBLE DIAGNOSIS

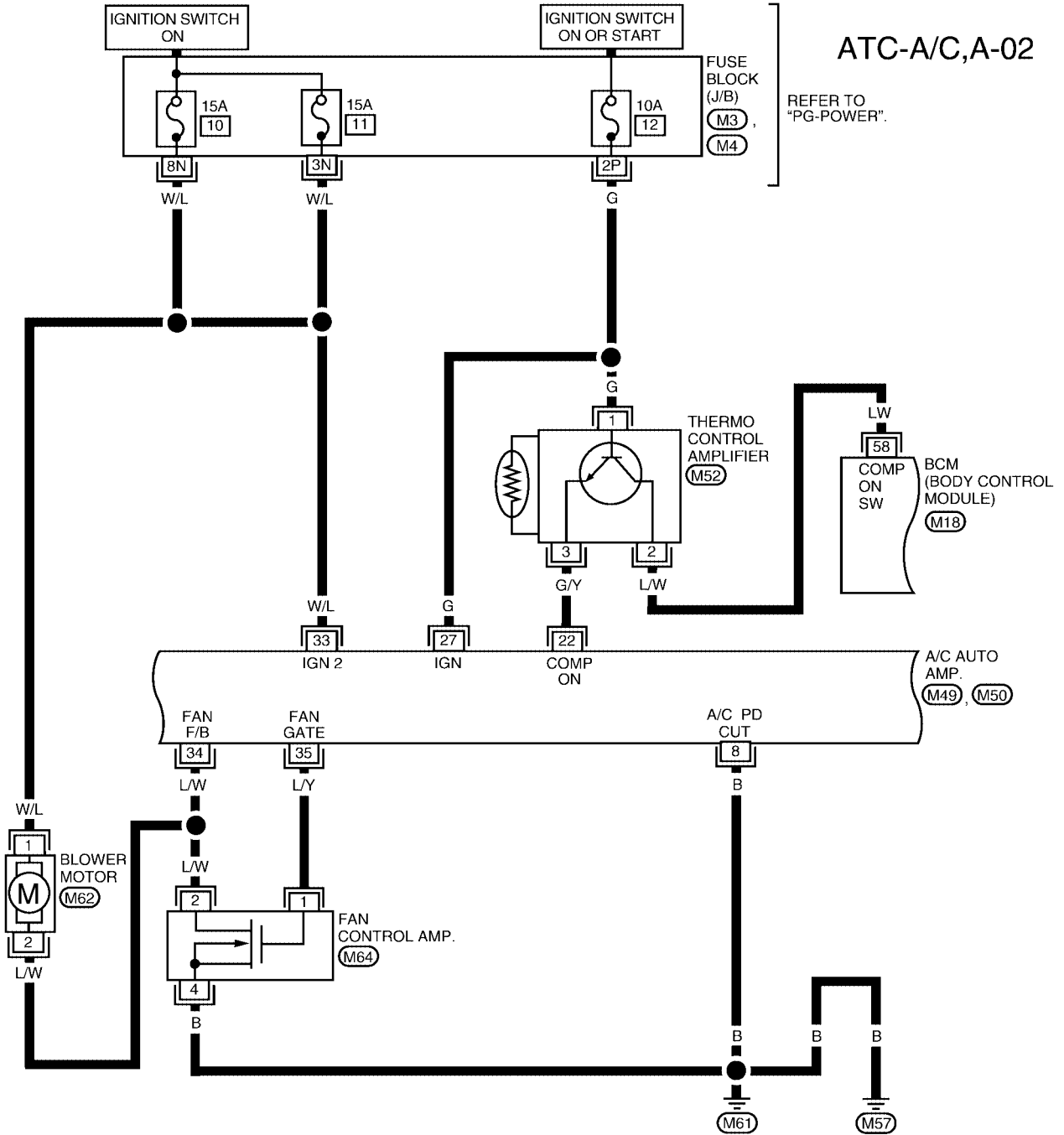

ATC-A/C, A-02

REFER TO "PG-POWER".

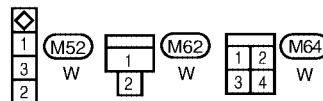
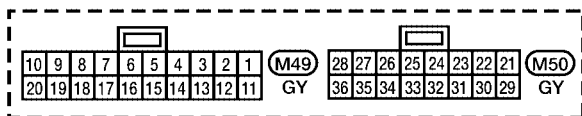
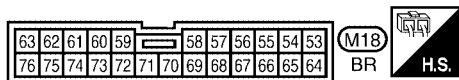

REFER TO THE FOLLOWING.

(M3), (M4) - FUSE BLOCK
- JUNCTION BOX (J/B)

WJWA0028E

TROUBLE DIAGNOSIS

ATC-A/C,A-03

(N) : FOR CANADA

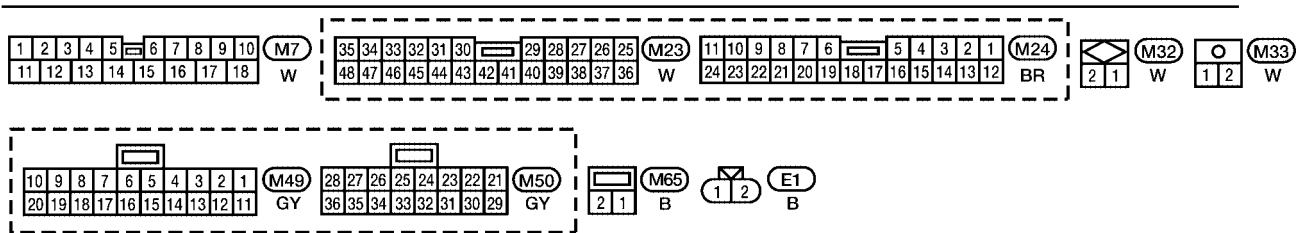
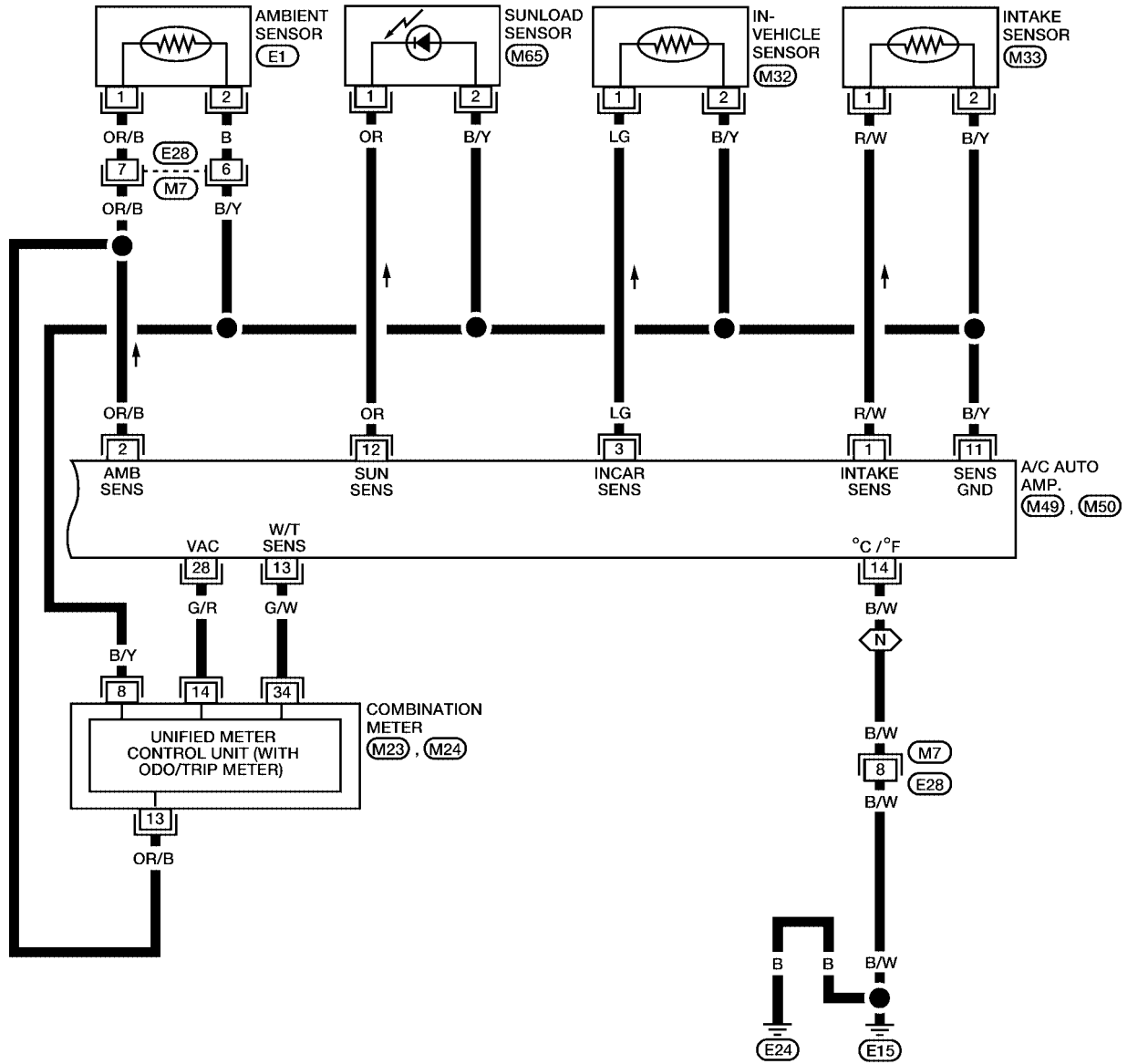

WJWA0009E

TROUBLE DIAGNOSIS

ATC-A/C,A-04

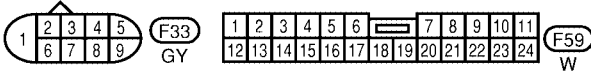
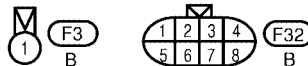
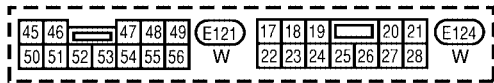
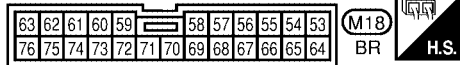
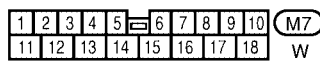
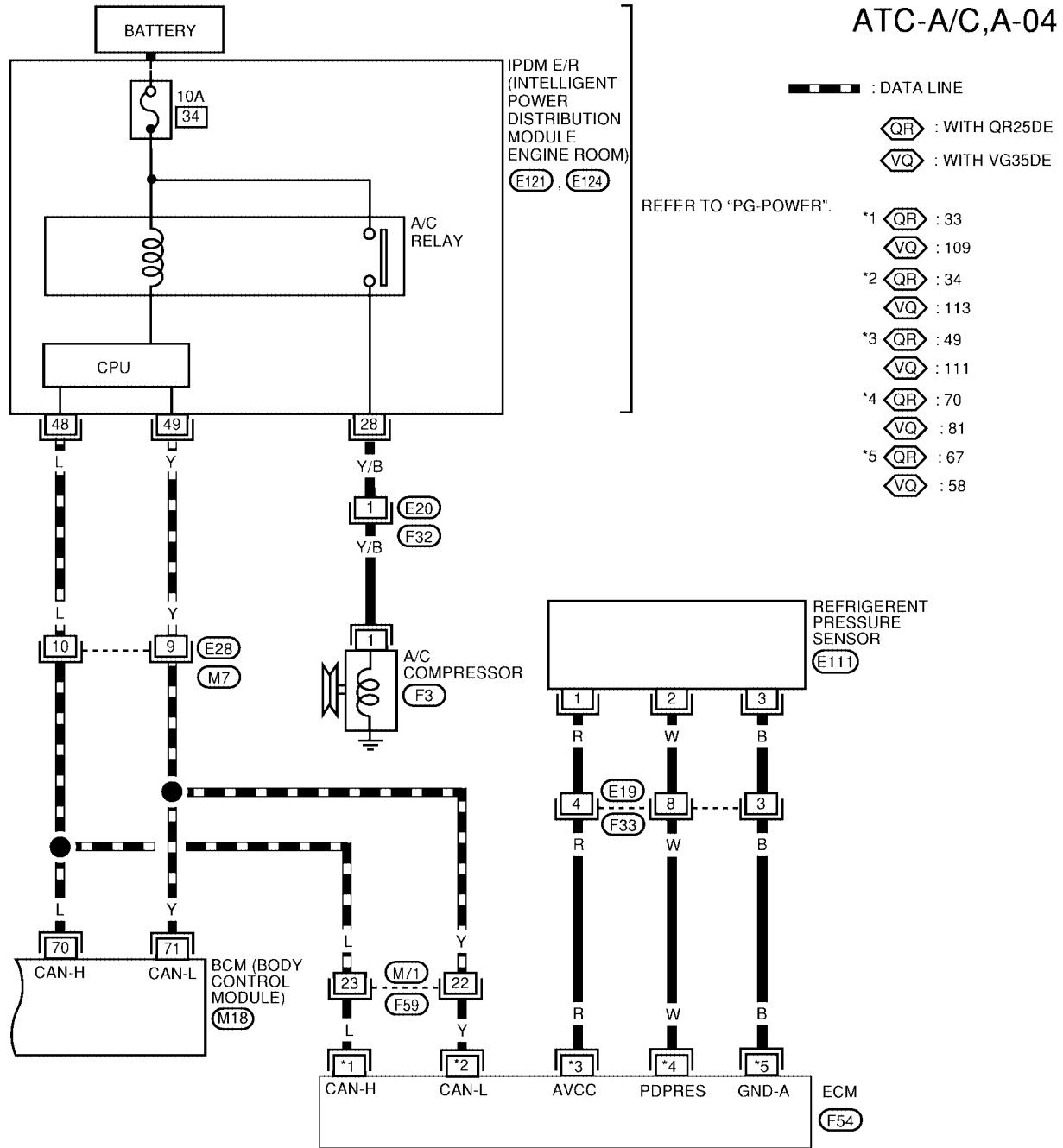

REFER TO THE FOLLOWING.

(F54) - ELECTRICAL UNITS

WJWA0112E

TROUBLE DIAGNOSIS

EJS001CR

Auto Amp. Terminals and Reference Value INSPECTION OF AUTO AMP.

- Measure voltage between each terminal and body ground by following "AUTO AMP. INSPECTION TABLE".

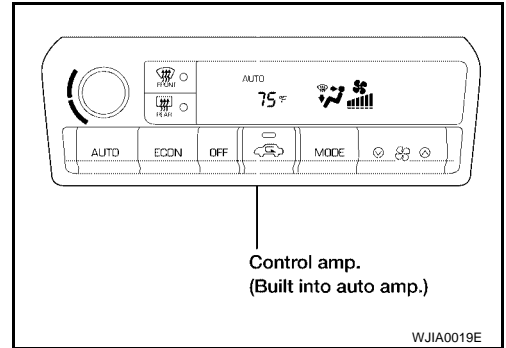

A/C AUTO AMP. HARNESS CONNECTOR TERMINAL LAYOUT

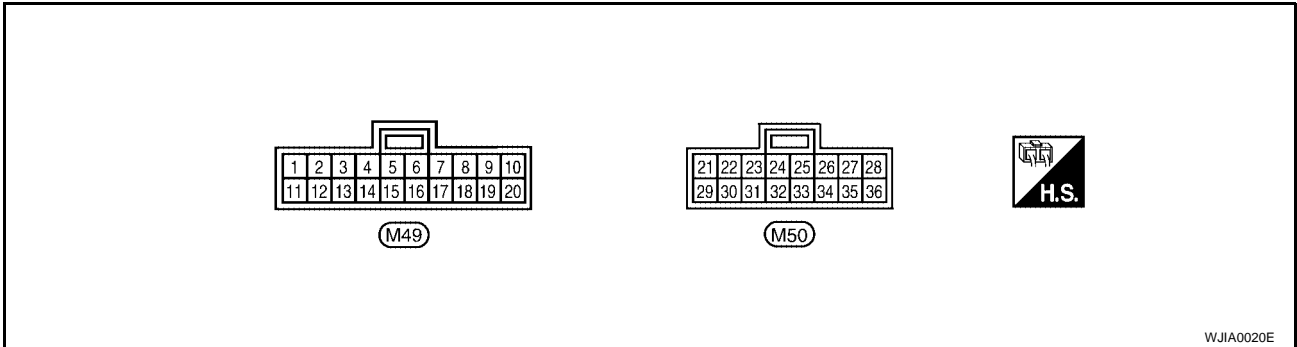

AUTO AMP. INSPECTION TABLE

TERMI- NAL NO.	ITEM	CONDITION		Voltage (V) (Approx.)	
1	Intake sensor	—		—	
2	Ambient sensor	—		—	
3	In-vehicle sensor	—		—	
8	A/C PD Cut	—		—	
11	Sensor ground		—	0	
12	Sunload sensor	—		—	
13	Water temperature sensor	—		—	
14	Ground (for Canada)	—		0	
16	A/C LAN signal		—	—	
21	Power supply for mode door motor, intake door motor and air mix door motor		—	12	
22	Compressor ON signal		Compressor	ON	0
				OFF	4.6
24	Illumination (+)	—		—	
25	Illumination (-)	—		—	
26	Power supply for BAT		—	Battery voltage	

A
B
C
D
E
F
G
H
I

ATC

K

L

M

TROUBLE DIAGNOSIS

TERMI- NAL NO.	ITEM	CONDITION		Voltage (V) (Approx.)
27	Power supply for IGN	—		12
28	Power supply for A/C ON signal	ON		4.6
		OFF		0
32	Ground	—		0
33	Power source for A/C	Ignition voltage feed back		12
34	Blower motor feed back	Fan speed: Low		7 - 10
35	Fan control AMP. control signal	Fan speed	Low, Middle low or Middle high	2.5 - 3.0
			High	9 - 10



TROUBLE DIAGNOSIS

EJS001CS

Self-diagnosis DESCRIPTION

The self-diagnostic system diagnoses sensors, door motors, blower motor, etc. by system line. Refer to applicable sections (items) for details. Shifting from normal control to the self-diagnostic system is accomplished by starting the engine (turning the ignition switch from "OFF" to "ON") and pressing "OFF" switch for at least 5 seconds. The "OFF" switch must be pressed within 10 seconds after starting the engine (ignition switch is turned "ON"). This system will be canceled by either pressing "AUTO" (AUTO) switch or turning the ignition switch "OFF". Shifting from one step to another is accomplished by means of turning TEMP dial right or left, as required.

Additionally shifting from STEP 5 to AUXILIARY MECHANISM is accomplished by means of pushing  (fan) UP switch.

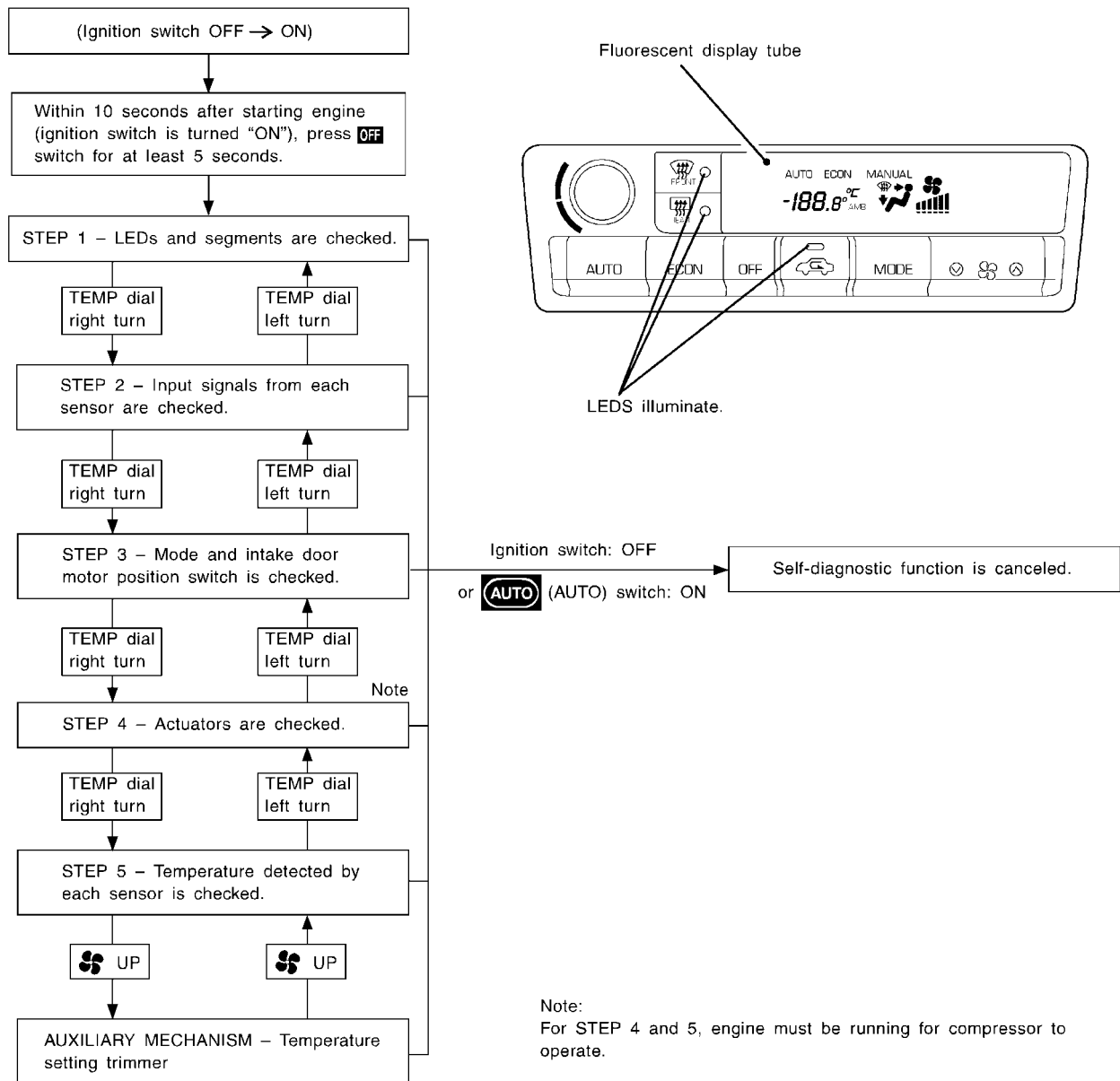

Perform all of the following tests to narrow the problem to a specific assembly, actuator, or function. Link to the Diagnostic Procedure which corresponds to malfunctions noted in these tests. If the A/C display screen has no display, check all power supply circuits to the A/C Auto Amp.

TROUBLE DIAGNOSIS

FUNCTION CONFIRMATION PROCEDURE

1. ENTER SELF-DIAGNOSTIC MODE

Perform steps 1 - 3.

1. Turn the ignition switch OFF.
2. Start the engine.
3. Immediately after starting the engine press and hold the OFF switch (for the auto A/C system) for at least 5 seconds.

The A/C Auto Amp. should now be in Self-Diagnosis mode. Self-Diagnosis steps 1 - 5 can now be performed. Self-Diagnosis step 1 will be displayed first. Shifting from one step to another is accomplished by turning the TEMP dial.

>> GO TO 2.

2. STEP 1 - DISPLAY CHECK

Verify all segments illuminate.

If all segments do not illuminate the fluorescent display tube is malfunctioning or the system has not entered self-diagnosis which would indicate a malfunctioning OFF switch.

Do all segments illuminate?

Display malfunction

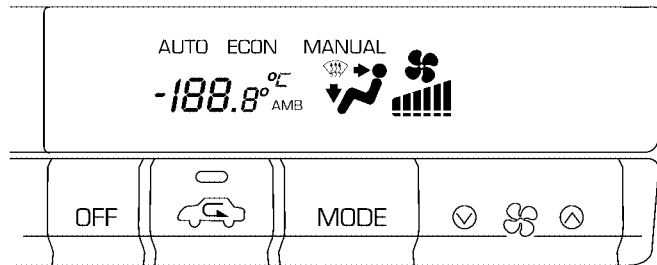

WJIA0022E

Yes or No

Yes >> GO TO 3.

- No >> ● Malfunctioning **OFF** switch, LED or fluorescent display tube.
● Replace A/C auto amp.

3. CHECK TO ADVANCE SELF-DIAGNOSIS STEP 2

1. Turn the TEMP dial clockwise.
2. Advance to self-diagnosis STEP 2.

If the system does not shift between step 1 and 2, a malfunctioning TEMP dial is indicated.

Yes or No

Yes >> GO TO 4.

- No >> ● Malfunctioning TEMP dial.
● Replace A/C auto amp.

TROUBLE DIAGNOSIS

4. CHECK TO RETURN SELF-DIAGNOSIS STEP 1

1. Turn the TEMP dial counterclockwise.
2. Return to self-diagnosis STEP 1.

If the system does not shift between step 1 and 2, a malfunctioning TEMP dial is indicated.

Yes or No

- Yes >> GO TO 5.
No >> ● Malfunctioning TEMP dial.
● Replace A/C auto amp.

5. STEP 2 - SENSOR CIRCUITS ARE CHECKED FOR OPEN OR SHORT CIRCUIT

Turn the TEMP dial clockwise, advance to STEP 2: Wait (about 25 seconds) for two digit Code to appear. This is the Electronic Sensor Input Check which includes circuits.

Does code No. 20 appear on the display?

Yes or No

- Yes >> GO TO 6.
No >> GO TO 13.

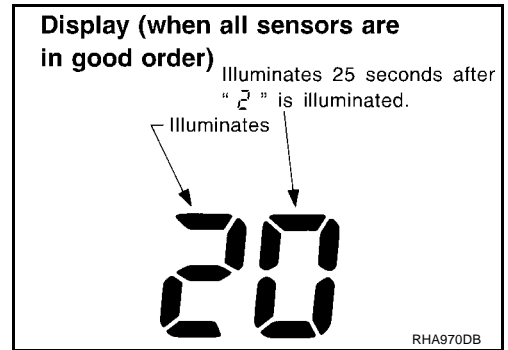

6. STEP 3 - MODE DOOR AND INTAKE DOOR POSITIONS ARE CHECKED

Turn the TEMP dial clockwise, advance to STEP 3. Wait (about 50 seconds) for two digit Code to appear. This is the Mode Door and Intake Door Position Switch input checks including circuits.

Does code No. 30 appear on the display?

Yes or No

- Yes >> GO TO 7.
No >> GO TO 14.

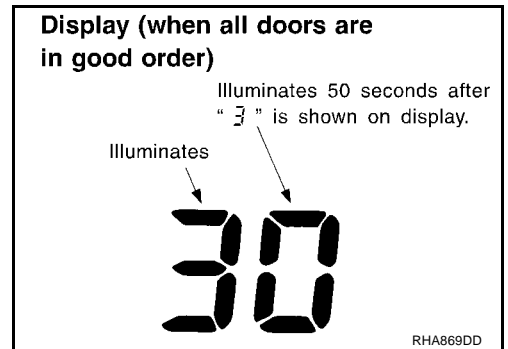

7. STEP 4 - OPERATION OF EACH ACTUATOR IS CHECKED

Turn the TEMP dial clockwise, advance to STEP 4.
Engine running.

This is Heater and A/C system check. Code 41 will be displayed. Use the DEF switch to advance the code number from 41 to 46. After 46, the display will return to code 41 and can be advanced to 46 again.

>> GO TO 8.

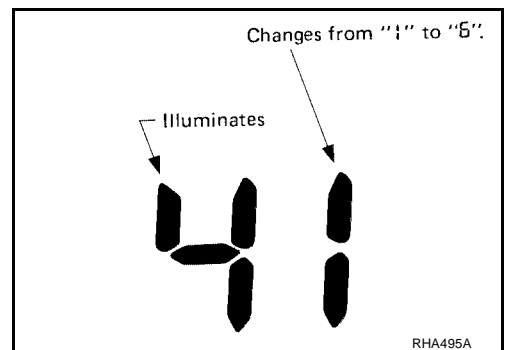

TROUBLE DIAGNOSIS

8. CHECK ACTUATORS

Confirm operation of system components according to the following charts.

Checks must be made visually, by listening to any noise, or by touching air outlets with your hand, etc. for improper operation.

Actuator	Code No.	41	42	43	44	45	46
Mode door		VENT	B/L	B/L	FOOT	D/F	DEF
Intake door		REC	REC	20% FRE	FRE	FRE	FRE
Air mix door		Full cold	Full cold	Full hot	Full hot	Full hot	Full hot
Blower motor		4-5 V	9-11 V	7-9 V	7-9 V	7-9 V	10-12 V
Compressor		ON	ON	OFF	OFF	ON	ON

Operating condition of each actuator cannot be checked by indicators.

Discharge air flow

Mode control knob	Air outlet/distribution		
	Face	Foot	Defroster
	100 %	—	—
	60 %	40 %	—
	—	80 %	20 %
	—	60 %	40 %
	—	—	100 %

OK or NG

OK >> GO TO 9.

- NG >> ● Air outlet does not change.
Go to [ATC-58, "Mode Door Motor Circuit"](#) .
- Intake door does not change.
Go to [ATC-64, "Intake Door Motor Circuit"](#) .
- Blower motor operation is malfunctioning.
Go to [ATC-67, "Blower Motor Circuit"](#) .
- Magnet clutch does not engage.
Go to [ATC-73, "Magnet Clutch Circuit"](#) .
- Discharge air temperature does not change.
Go to [ATC-61, "Air Mix Door Motor Circuit"](#) .

9. STEP 5 - TEMPERATURE OF EACH SENSOR IS CHECKED

Turn the TEMP dial clockwise, advance to STEP 5. This is Intake sensor, In Vehicle sensor and Ambient Sensor function check. Code 51 will be displayed.

NOTE:

Each sensor reading should be approximately the actual temperature.

>> GO TO 10.

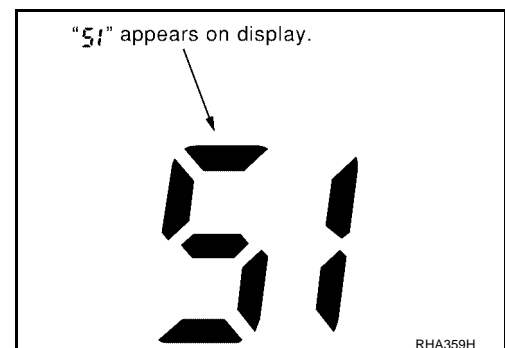

TROUBLE DIAGNOSIS

10. CHECK AMBIENT SENSOR

Press  (DEF) once, temperature detected by the Ambient Sensor is displayed.

OK or NG

OK >> GO TO 11.

NG >> Go to [ATC-90, "Ambient Sensor Circuit"](#) .

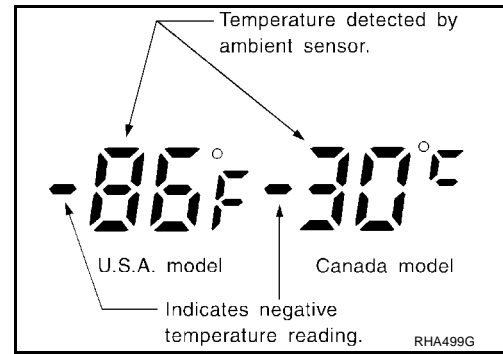

11. CHECK IN-VEHICLE SENSOR

Press  (DEF) second time, temperature detected by the In-Vehicle Sensor is displayed.

OK or NG

OK >> GO TO 12.

NG >> Go to [ATC-92, "In-vehicle Sensor Circuit"](#) .

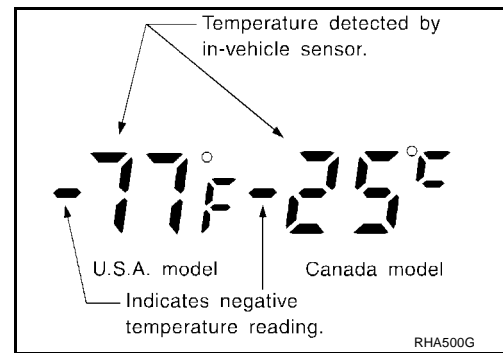

12. CHECK INTAKE SENSOR

Press  (DEF) third time, temperature detected by the Intake Sensor is displayed.

OK or NG

OK >> 1. Press  (DEF) switch the fourth time. Display returns to original presentation 51.

2. Turn ignition switch OFF or "  " (AUTO) switch ON.

3. END

NG >> Go to [ATC-98, "Intake Sensor Circuit"](#) .

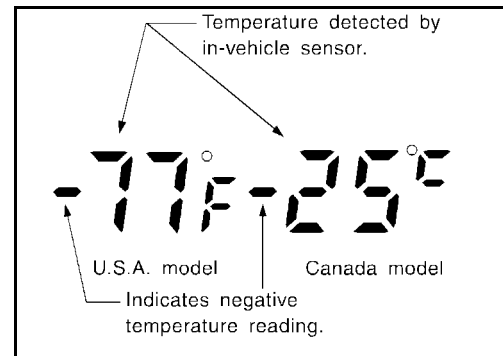

A
B
C
D
E
F
G
H
I
K
L
M

ATC

TROUBLE DIAGNOSIS

13. CHECK MALFUNCTIONING SENSOR

NOTE:

- A blinking mark (-) preceding the Code No. indicates a short circuit.
- No blinking mark (-) preceding the Code No. indicates an open circuit.
- If 2 or more items are malfunctioning the corresponding codes will alternately blink twice.
- A circuit will be detected as open or shorted and its code No. will be displayed when input signals correspond with conditions in the following chart.

Code No.	Sensor	Open circuit	Short circuit	Reference page
21	Ambient sensor	Less than - 41.9°C (-43°F)	Greater than 100°C (212°F)	ATC-90
-21				
22	In-vehicle sensor	Less than - 41.9°C (-43°F)	Greater than 100°C (212°F)	ATC-92
-22				
24	Intake sensor	Less than - 41.9°C (-43°F)	Greater than 100°C (212°F)	ATC-98
-24				
25	Sunload sensor*2	Less than 0.228mA	Greater than 0.98 mA	ATC-95
-25				
26	PBR*1	Greater than 95%	Less than 5%	ATC-61
-26				

*1: "95%" and "5%" refer to percentage with respect to stroke of air mix door. (Full cold: 0%, Full hot: 100%)

*2: **Conduct self-diagnosis STEP 2 under sunshine.**

When conducting indoors, direct light (more than 60W) at sunload sensor.

Display (when sensor malfunctions)

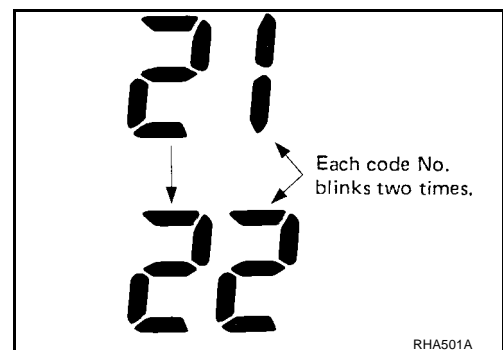
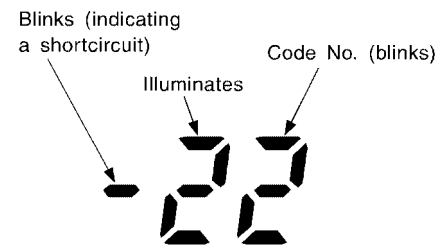

>> INSPECTION END

TROUBLE DIAGNOSIS

14. CHECK MALFUNCTIONING DOOR MOTOR POSITION SWITCH

- 30- Mode door and intake door position switches are in working order. Continue to next step.
- 31- Mode door circuit / switch in vent position switch is malfunctioning.
- 32- Mode door circuit / switch in B/L position switch is malfunctioning.
- 34- Mode door circuit / switch in Foot position switch is malfunctioning.
- 35- Mode door circuit / switch in Foot Def. position switch is malfunctioning.
- 36- Mode door circuit / switch in Def. position switch is malfunctioning.
- 37- Intake door mode circuit / switch in Fresh Air position is malfunctioning.
- 38- Intake door mode circuit / switch in 20% Fresh Air position is malfunctioning.
- 39- Intake door mode circuit / switch in Recirculation Air position is malfunctioning.

NOTE:

- If 2 or more items are malfunctioning the corresponding codes will alternately blink twice.
- If the Mode Door Motor harness is disconnected repeated display pattern of 31 → 32 → 34 → 35 → 36 will occur.
- If Intake Door Motor harness is disconnected repeated display pattern of 37 → 38 → 39 will occur.
- If any Mode Door Motor Position Switch is malfunctioning the Mode Door Motor will also malfunction.

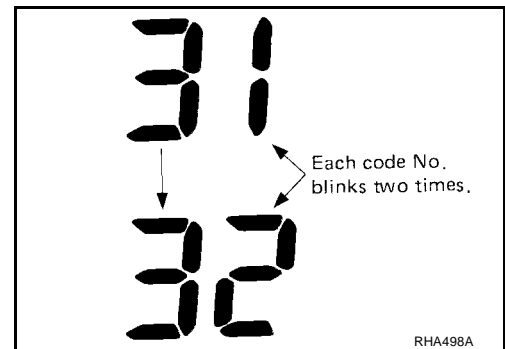
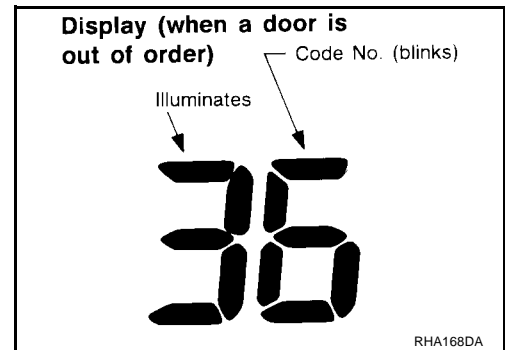

>> INSPECTION END

A
B
C
D
E
F
G
H
I
ATC
K
L
M

TROUBLE DIAGNOSIS

AUXILIARY MECHANISM: TEMPERATURE SETTING TRIMMER

Unconfirmed Incidents

The customer may feel that the cabin temperature is not being controlled or regulated to the temperature indicated by the auto A/C display screen. To satisfy individual driver preference the Temperature Setting Trimmer may be used to compensate in a range of $\pm 3^{\circ}\text{C}$ ($\pm 6^{\circ}\text{F}$).

1. Enter Self Diagnosis mode and select STEP 5.
2. Press the Fan Up  switch: This will set the A/C system in auxiliary mode and the display will show 61.
3. Turn the temperature dial clockwise or counterclockwise: The temperature will change at a rate of 0.5°C (1°F).

If power is lost to the A/C Auto Amp., trimmer setting is canceled and setting becomes that of initial condition, 0° .

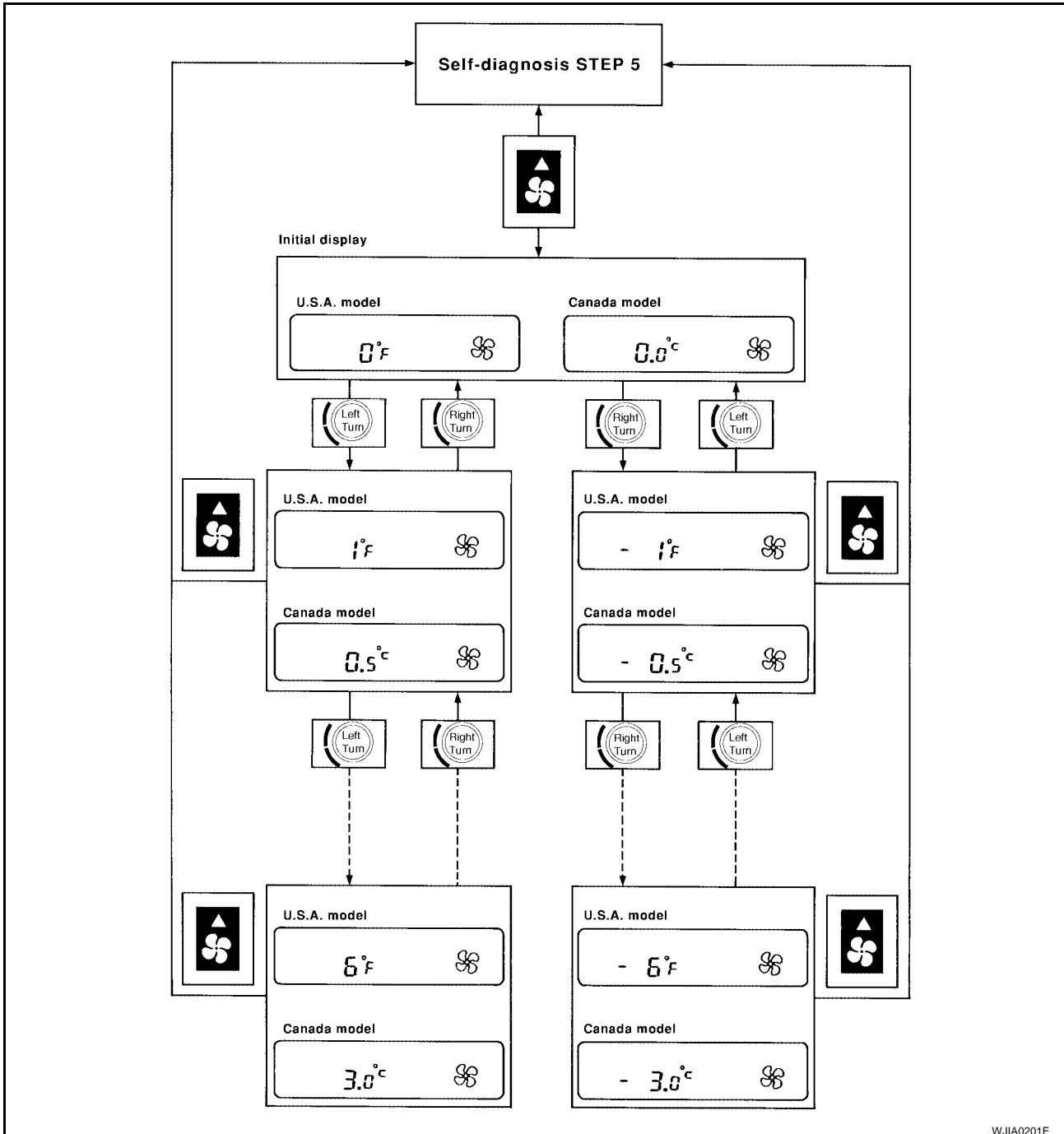

WJIA0201E

When battery cable is disconnected, trimmer operation is canceled. Temperature set becomes that of initial condition, i.e. 0°C (0°F).

TROUBLE DIAGNOSIS

EJS001CT

Operational Check

The purpose of the operational check is to confirm that the system operates properly.

CONDITIONS:

- Engine running and at normal operating temperature.

PROCEDURE:

1. Check Memory Function

1. Set the temperature 90°F or 32°C.
2. Press OFF switch.
3. Turn the ignition off.
4. Turn the ignition on.
5. Press the AUTO switch.
6. Confirm that the set temperature remains at previous temperature.
7. Press OFF switch.

If NG, go to [ATC-89, "Memory Function"](#).

If OK, continue with next check.

2. Check Blower

1. Press fan switch (up side) one time.
Blower should operate on low speed.
The fan symbol should have one bar lit.
2. Press fan switch (up side) one more time, and continue checking blower speed and fan symbol until all speeds are checked.
3. Leave blower on MAX speed.

If NG, go to [ATC-67, "Blower Motor Circuit"](#).

If OK, continue with next check.

3. Check Discharge Air

1. Press mode switch four times and DEF button.
2. Each position indicator should change shape.

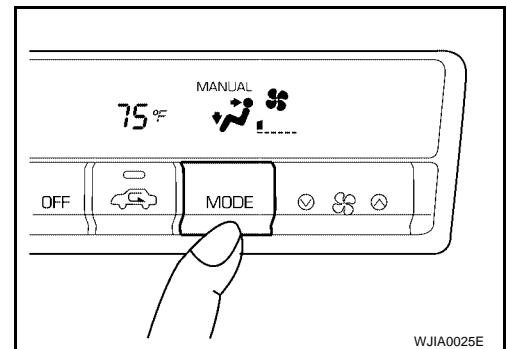
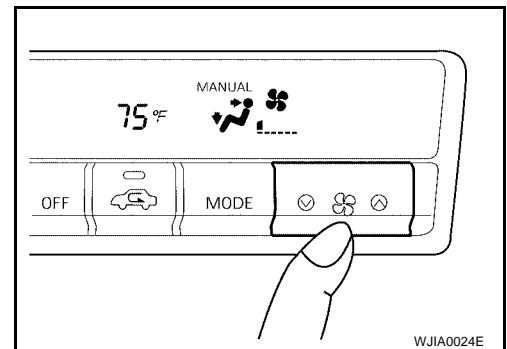
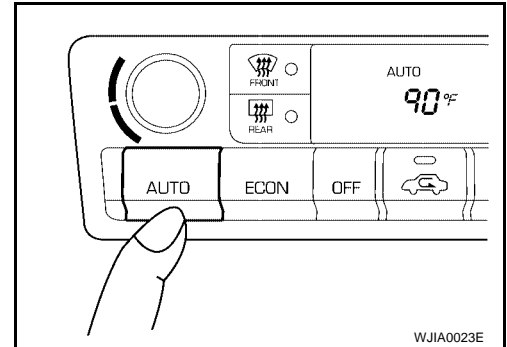

A
B
C
D
E
F
G
H
I
K
L
M

ATC

TROUBLE DIAGNOSIS





- Confirm that discharge air comes out according to the air distribution table.
Refer to [ATC-25, "Discharge Air Flow"](#).

NOTE:

Confirm that the compressor clutch is engaged (visual inspection) and intake door position is at FRESH when the DEF  is selected.

Intake door position is checked in the next step.
If NG, go to [ATC-58, "Mode Door Motor Circuit"](#).
If OK, continue with next check.

Discharge air flow

Mode control knob	Air outlet/distribution		
	Face	Foot	Defroster
	100%	–	–
	60%	40%	–
	–	80%	20%
	–	60%	40%
	–	–	100%

RHA654F

4. Check Recirculation

- Press REC  switch.
Recirculation indicator should illuminate.
- Listen for intake door position change (you should hear blower sound change slightly).

If NG, go to [ATC-64, "Intake Door Motor Circuit"](#).
If OK, continue with next check.

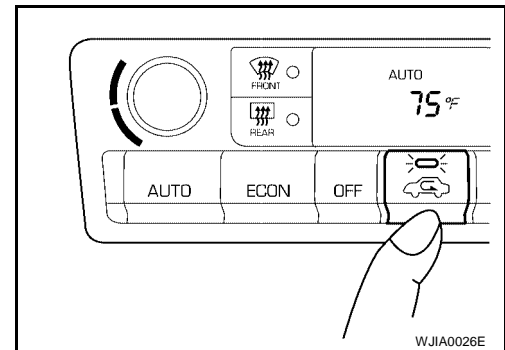

5. Check Temperature Decrease

- Turn the temperature dial counterclockwise until 18°C (60°F) is displayed.
- Check for cold air at discharge air outlets.

If NG, go to [ATC-79, "Insufficient Cooling"](#).
If OK, continue with next check.

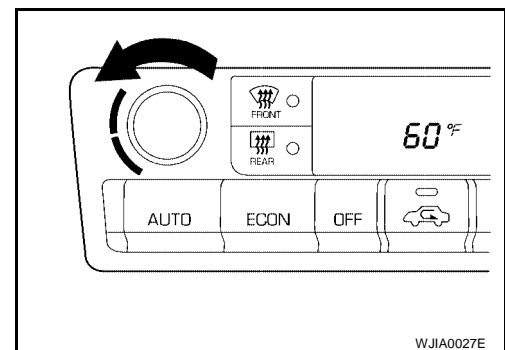

TROUBLE DIAGNOSIS

6. Check Temperature Increase

1. Turn the temperature dial clockwise until 32°C (90°F) is displayed.
2. Check for hot air at discharge air outlets.

If NG, go to [ATC-86, "Insufficient Heating"](#).

If OK, continue with next check.

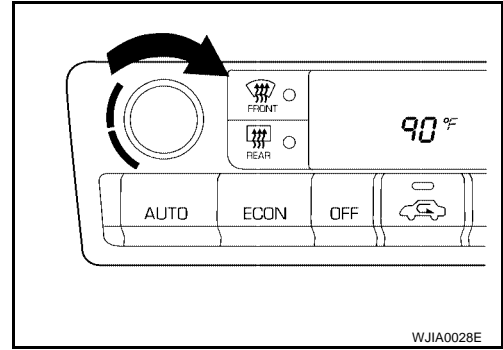

7. Check ECON (Economy) Mode

1. Set the temperature 25°C (75°F).
2. Press ECON switch.
3. Display should indicate ECON (no AUTO).
Confirm that the compressor clutch is not engaged (visual inspection).
(Discharge air and blower speed will depend on ambient, in-vehicle and set temperatures.)

If NG, go to [ATC-90, "ECON \(ECONOMY\) Mode"](#).

If OK, continue with next check.

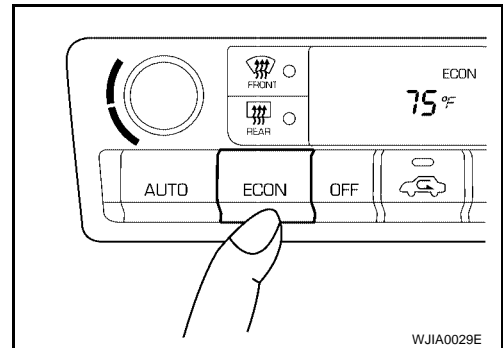

8. Check AUTO Mode

1. Press AUTO switch.
2. Display should indicate AUTO (no ECON).
Confirm that the compressor clutch engages (audio or visual inspection).
(Discharge air and blower speed will depend on ambient, in-vehicle and set temperatures.)

If NG, go to [ATC-53, "DIAGNOSTIC PROCEDURE"](#), then if necessary, [ATC-73, "Magnet Clutch Circuit"](#).

If all operational check are OK (symptom can not be duplicated), go to [GI-25, "How to Perform Efficient Diagnosis for an Electrical Incident"](#) and perform tests as outlined to simulate driving conditions environment. If symptom appears, refer to [ATC-31, "SYMPTOM TABLE"](#) and perform applicable trouble diagnosis procedures.

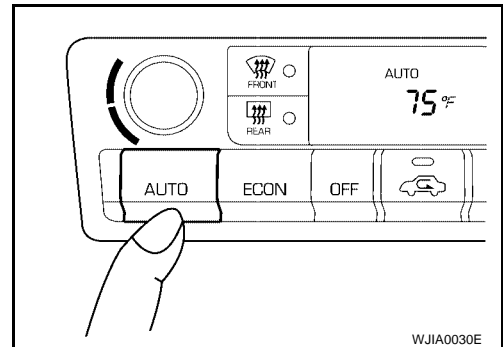

A
B
C
D
E
F
G
H
I
ATC
K
L
M

TROUBLE DIAGNOSIS

EJS001CU

Power Supply and Ground Circuit for Auto Amp.

SYMPTOM:

- A/C system does not come on.

INSPECTION FLOW

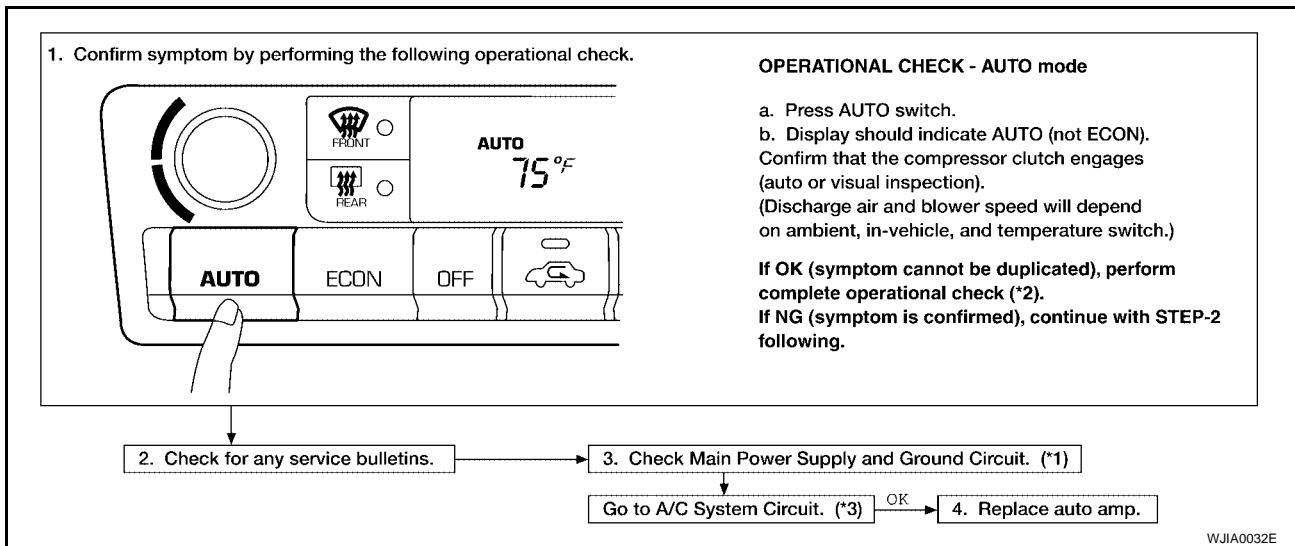

*1: [ATC-52](#)

*2: [ATC-49](#)

*3: [ATC-52](#)

COMPONENT DESCRIPTION

AUTOMATIC AMPLIFIER (AUTO AMP.)

The auto amplifier has a built-in microcomputer which processes information sent from various sensors needed for air conditioner operation. The air mix door motor, mode door motor, intake door motor, blower motor and compressor are then controlled.

The auto amplifier is unitized with control mechanisms. Signals from various switches and Potentio Temperature Control (PTC) are directly entered into auto amplifier.

Self-diagnostic functions are also built into auto amplifier to provide quick check of malfunctions in the auto air conditioner system.

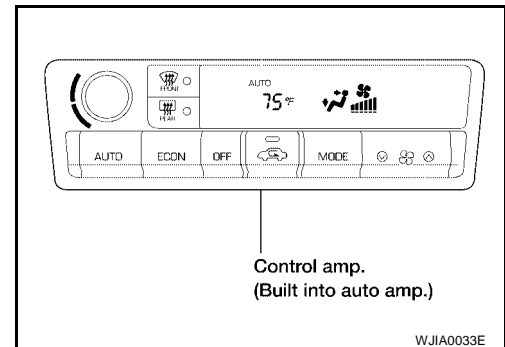

POTENTIO TEMPERATURE CONTROL (PTC)

The PTC is built into the A/C auto amp. It can be set at an interval of 0.5°C (1.0°F) in the 18°C (60°F) to 32°C (90°F) temperature range by pushing the temperature button. The set temperature is digitally displayed.

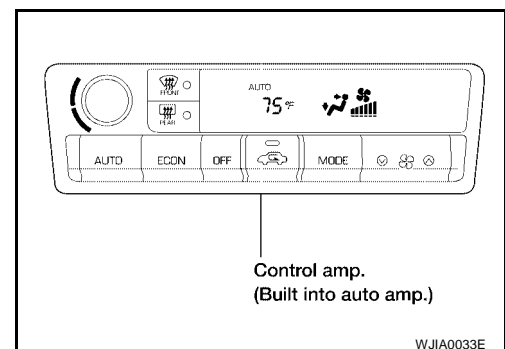

TROUBLE DIAGNOSIS

DIAGNOSTIC PROCEDURE

SYMPTOM:

- A/C system does not come on.

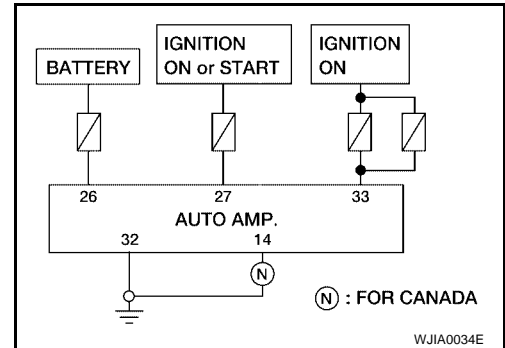

1. CHECK POWER SUPPLY CIRCUIT FOR AUTO AMP.

Terminals		Voltage (V) (Approx.)
(+)	(-)	
Connectors	Wire colors	Body ground 12V
M60-26	Y/R	
M60-27	G	
M60-33	W/L	

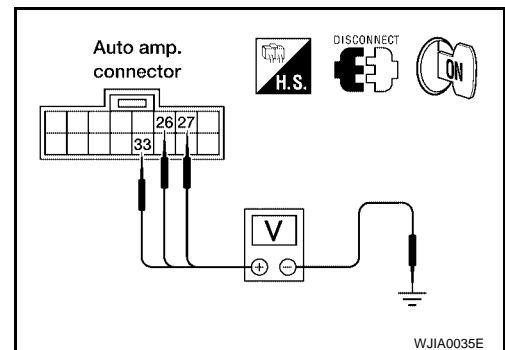

OK or NG

OK >> GO TO 2.

NG >> Check auto amp. ground circuit.

- Check 10A fuse [Nos. 12 and 19, located in the fuse block (J/B)] and 15A fuses [Nos. 10 and 11, located in the fuse block (J/B)].
- If fuses are OK, check for open circuit in wiring harness. Repair or replace as necessary.
- If fuses are NG, replace fuse and check wiring harness for short circuit. Repair or replace as necessary.

A
B
C
D
E
F
G
H
I
K
L
M

ATC

TROUBLE DIAGNOSIS

2. CHECK BODY GROUND CIRCUIT FOR AUTO AMP.

Terminals		Voltage (V) (Approx.)
(+)	(-)	
Connectors	Wire colors	Body ground 12V
M50-32	B	
M49-14 (Canada)	B/W	

Yes or No

- Yes >> ● Replace auto amp.
 ● INSPECTION END
- No >> Repair or replace harness.

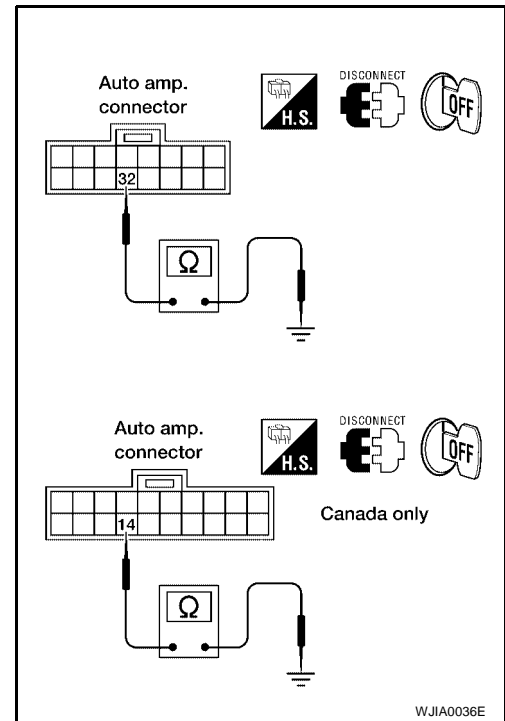

WJIA0036E

LAN System Circuit

EJS001CV

SYMPTOM: Mode door motor, intake door motor and/or air mix door motor does not operate normally.

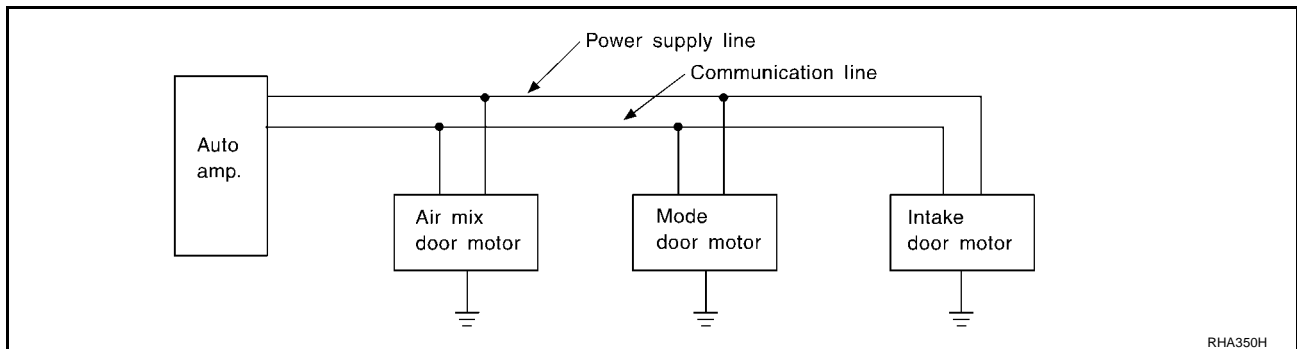

RHA350H

DIAGNOSTIC PROCEDURE

1. CHECK POWER SUPPLY FOR AUTO AMP. (LCU) SIDE

Terminals		Voltage (V) (Approx.)
(+)	(-)	
Connector	Terminal (wire color)	Body ground 12V
M50-21	L/R	

OK or NG

- OK >> GO TO 2.
- NG >> Replace auto amp.(LCU).

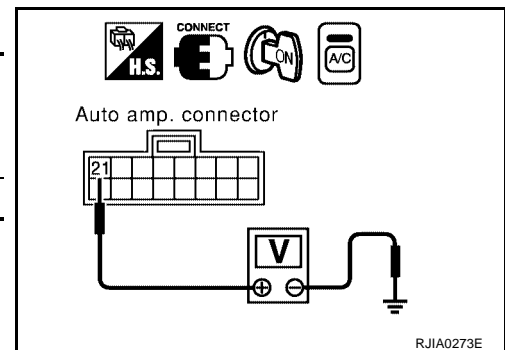

RJIA0273E

TROUBLE DIAGNOSIS

2. CHECK SIGNAL FOR AUTO AMP. (LCU) SIDE

Terminals			Voltage (V) (Approx.)
(+)		(-)	
Connector	Terminal (wire color)		
M49-16	L/B	Body ground	5.5V

OK or NG

OK >> GO TO 3.

NG >> Replace auto amp.(LCU).

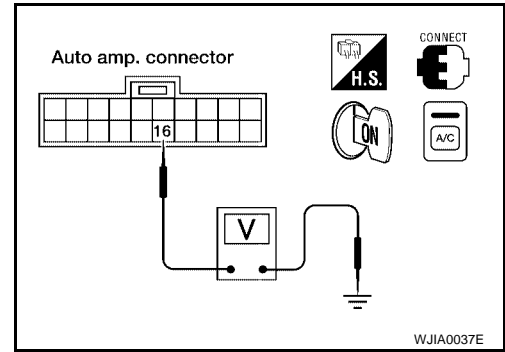

3. CHECK POWER SUPPLY FOR MOTOR SIDE

Door motors	Terminals		Voltage (V) (Approx.)	
	(+)			(-)
	Connector	wire colors		
Mode	M40-1	L/R	Body ground	
Air mix	M39-1	L/R		
Intake	M58-1	L/R		

OK or NG

OK >> GO TO 4.

NG >> Replace harness or connector.

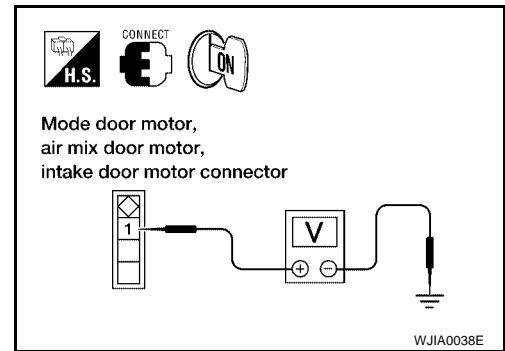

4. CHECK SIGNAL FOR MOTOR SIDE

Door motors	Terminals		Voltage (V) (Approx.)	
	(+)			(-)
	Connectors	wire colors		
Mode	M40-3	L/B	Body ground	
Air mix	M39-3	L/B		
Intake	M58-3	L/B		

OK or NG

OK >> GO TO 5.

NG >> Replace harness or connector.

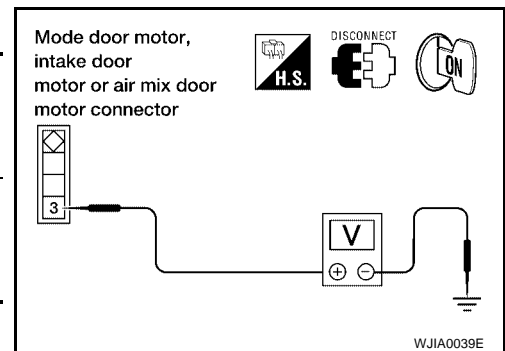

A
B
C
D
E
F
G
H
I
ATC
K
L
M

TROUBLE DIAGNOSIS

5. CHECK MOTOR GROUND CIRCUIT

Door motors	Terminals		(-)	Continuity
	(+) Connector			
	Connector	wire colors		
Mode	M40-2	B	Body ground	Yes
Air mix	M39-2	B		
Intake	M58-2	B		

OK or NG

- OK >> GO TO 6.
- NG >> Replace harness or connector.

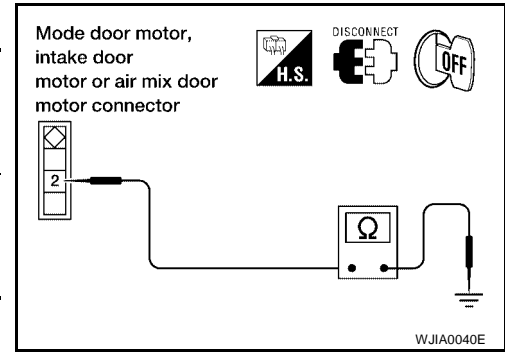

6. CHECK MOTOR OPERATION

Disconnect and reconnect the motor connectors and confirm the motor operation.

OK or NG

- OK >> (Return to operate normally.)
 - Poor contacting the motor connector
- NG >> (Does not operate normally.)
 - GO TO 7.

7. CHECK MODE DOOR MOTOR AND AIR MIX DOOR MOTOR OPERATION

1. Disconnect the intake door motor connector.
2. Reconnect the mode door motor connector and air mix door motor connector, confirm the mode door motor and air mix door motor operation.

OK or NG

- OK >> (Mode door motor and air mix door motor operate normally.)
 - Replace the intake door motor.
- NG >> (Mode door motor and air mix door motor do not operate normally.)
 - GO TO 8.

8. CHECK AIR MIX DOOR MOTOR AND INTAKE DOOR MOTOR OPERATION

1. Disconnect mode door motor connector.
2. Reconnect the intake door motor connector, confirm the air mix door motor and intake door motor operation.

OK or NG

- OK >> (Air mix door motor and intake door motor operate normally.)
 - Replace mode door motor.
- NG >> (Air mix door motor and intake door motor do not operate normally.)
 - GO TO 9.

TROUBLE DIAGNOSIS

9. CHECK INTAKE DOOR MOTOR AND MODE DOOR MOTOR OPERATION

1. Disconnect air mix door motor connector.
2. Reconnect mode door motor connector, confirm the intake door motor and mode door motor operation.

OK or NG

- OK >> (Intake door motor and mode door motor operate normally.)
- Replace air mix door motor.
- NG >> (Intake door motor and mode door motor do not operate normally.)
- Replace auto amp.

A

B

C

D

E

F

G

H

I

ATC

K

L

M

TROUBLE DIAGNOSIS

EJS001CW

Mode Door Motor Circuit

SYMPTOM:

- Air outlet does not change.
- Mode door motor does not operate normally.

INSPECTION FLOW

1. Confirm symptom by performing the following operational check.

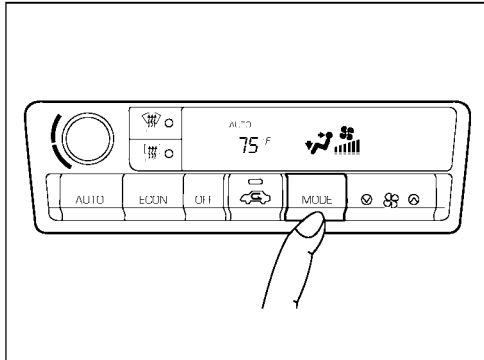

OPERATIONAL CHECK – Discharge air

- Press mode switch four times and DEF button.
- Each position indicator should change shape.
- Confirm that discharge air comes out according to the air distribution table.

Refer to "Discharge Air Flow" (*1).

NOTE:

- If OK (symptom cannot be duplicated), perform complete operational check (*2).
- If NG (symptom is confirmed), continue with STEP-2 following.
- Confirm that the compressor clutch is engaged (audio and visual inspection) and intake door position is at FRESH when DEF  is selected. Intake door position is checked in the next step.

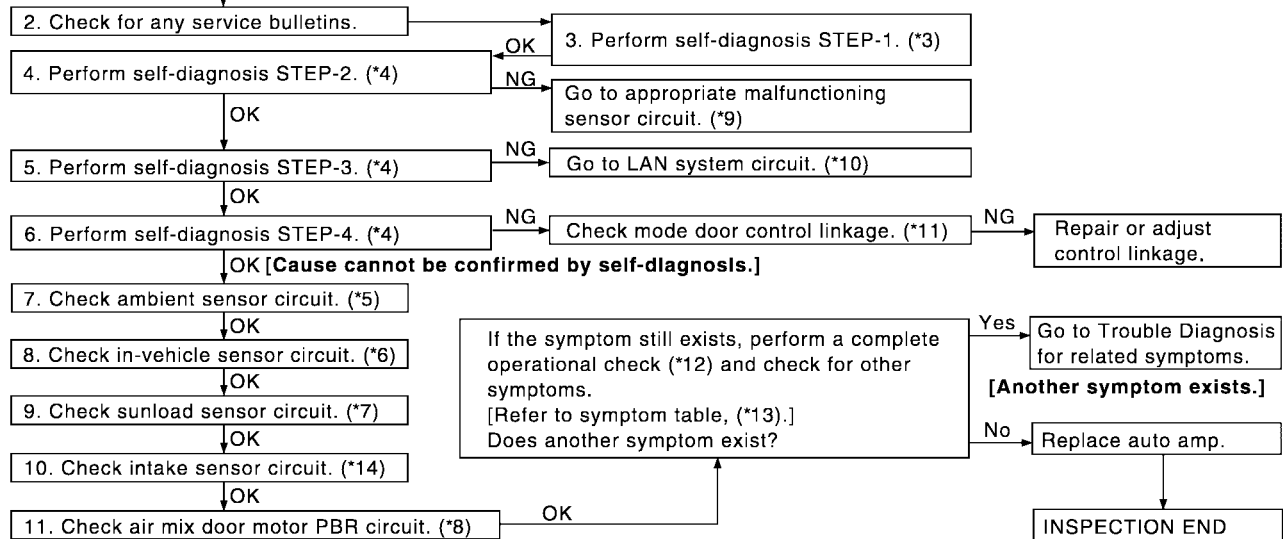

WJIA0041E

*1 [ATC-25. "Discharge Air Flow"](#)

*2 [ATC-49. "Operational Check"](#)

*3 [ATC-41. "Self-diagnosis"](#), see No.1

*4 [ATC-41. "Self-diagnosis"](#), see No. 5

*5 [ATC-90. "Ambient Sensor Circuit"](#)

*6 [ATC-92. "In-vehicle Sensor Circuit"](#)

*7 [ATC-95. "Sunload Sensor Circuit"](#)

*8 [ATC-61. "Air Mix Door Motor Circuit"](#)

*9 [ATC-88. "Self-diagnosis"](#), see No.14

*10 [ATC-54. "LAN System Circuit"](#)

*11 [ATC-58. "Mode Door Motor Circuit"](#)

*12 [ATC-49. "Operational Check"](#)

*13 [ATC-31. "SYMPTOM TABLE"](#)

*14 [ATC-98. "Intake Sensor Circuit"](#)

TROUBLE DIAGNOSIS

SYSTEM DESCRIPTION

Component Parts

Mode door control system components are:

- Auto amp.
- Mode door motor (LCU)
- In-vehicle sensor
- Ambient sensor
- Sunload sensor
- Intake sensor

System Operation

The auto amplifier receives data from each of the sensors. The amplifier sends air mix door, mode door and intake door opening angle data to the air mix door motor LCU, mode door motor LCU and intake door motor LCU.

The air mix door motor, mode door motor and intake door motor read their respective signals according to the address signal. Opening angle indication signals received from the auto amplifier and each of the motor position sensors are compared by the LCUs in each motor with the existing decision and opening angles. Subsequently, HOT/COLD or DEFROST/VENT or FRESH/RECIRCULATION operation is selected. The new selection data is returned to the auto amplifier.

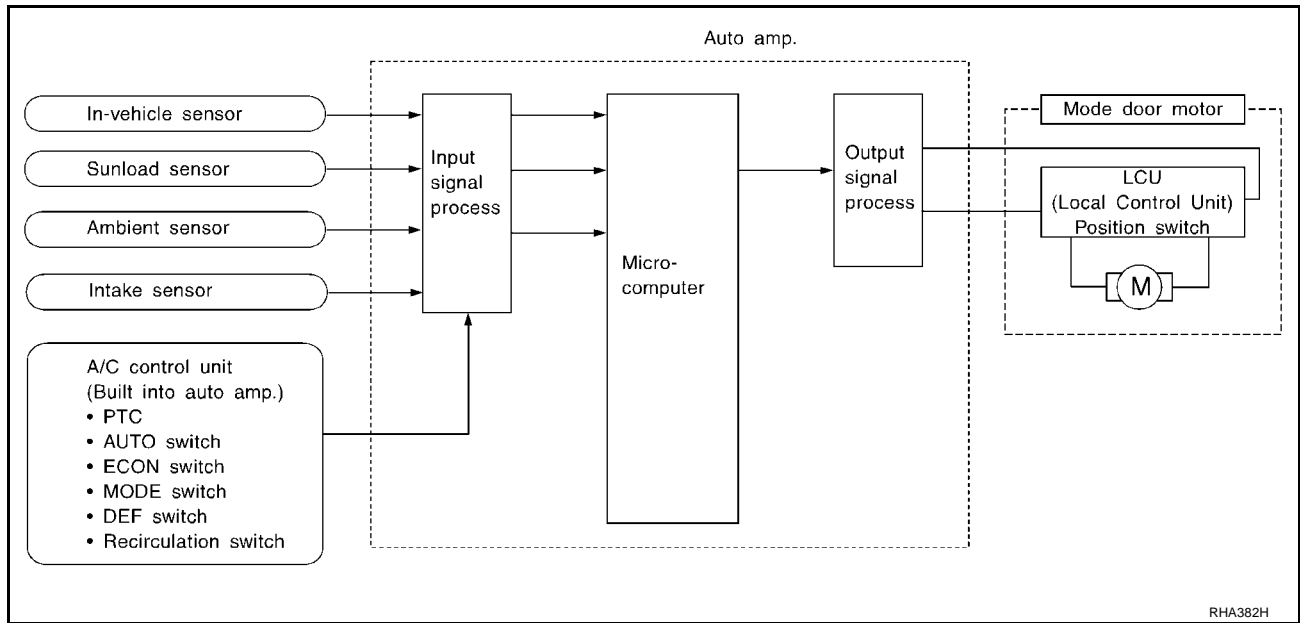

Mode Door Control Specification

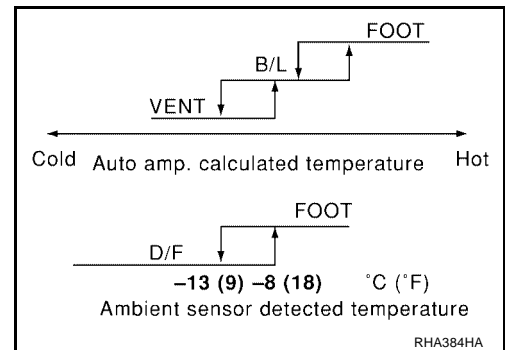

TROUBLE DIAGNOSIS

COMPONENT DESCRIPTION

Mode Door Motor

The mode door motor is attached to the heater and cooling unit. It rotates so that air is discharged from the outlet set by the auto amplifier. Motor rotation is conveyed to a link which activates the mode door.

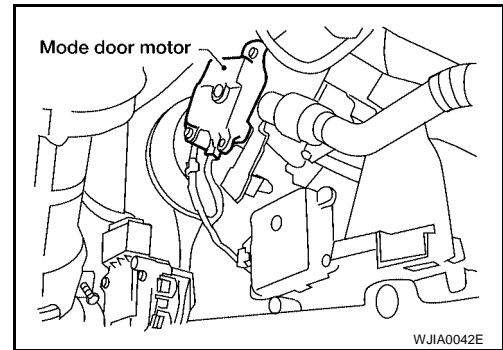

DIAGNOSTIC PROCEDURE

SYMPTOM: Mode door motor and/or air mix door motor does not operate normally.
Perform diagnostic procedure for LAN system circuit. Refer to [ATC-54, "LAN System Circuit"](#).

MODE DOOR

1. Install mode door motor on heater unit and connect it to main harness.
2. Set up code No. in Self-diagnosis STEP 4. Refer to [ATC-41, "Self-diagnosis"](#).
3. Move side link by hand and hold mode door in DEF mode.
4. Attach mode door motor rod to side link rod holder.
5. Make sure mode door operates properly when changing from code No. ~~41~~ to ~~46~~ by pushing DEF switch.

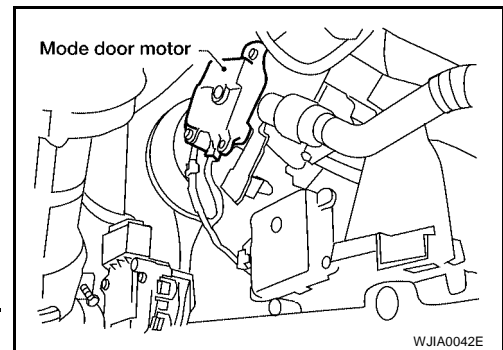

41	42	43	44	45	46
VENT	B/L	B/L	FOOT	D/F	DEF

TROUBLE DIAGNOSIS

EJS001CX

Air Mix Door Motor Circuit

SYMPTOM:

- Discharge air temperature does not change.
- Air mix door motor does not operate.

INSPECTION FLOW

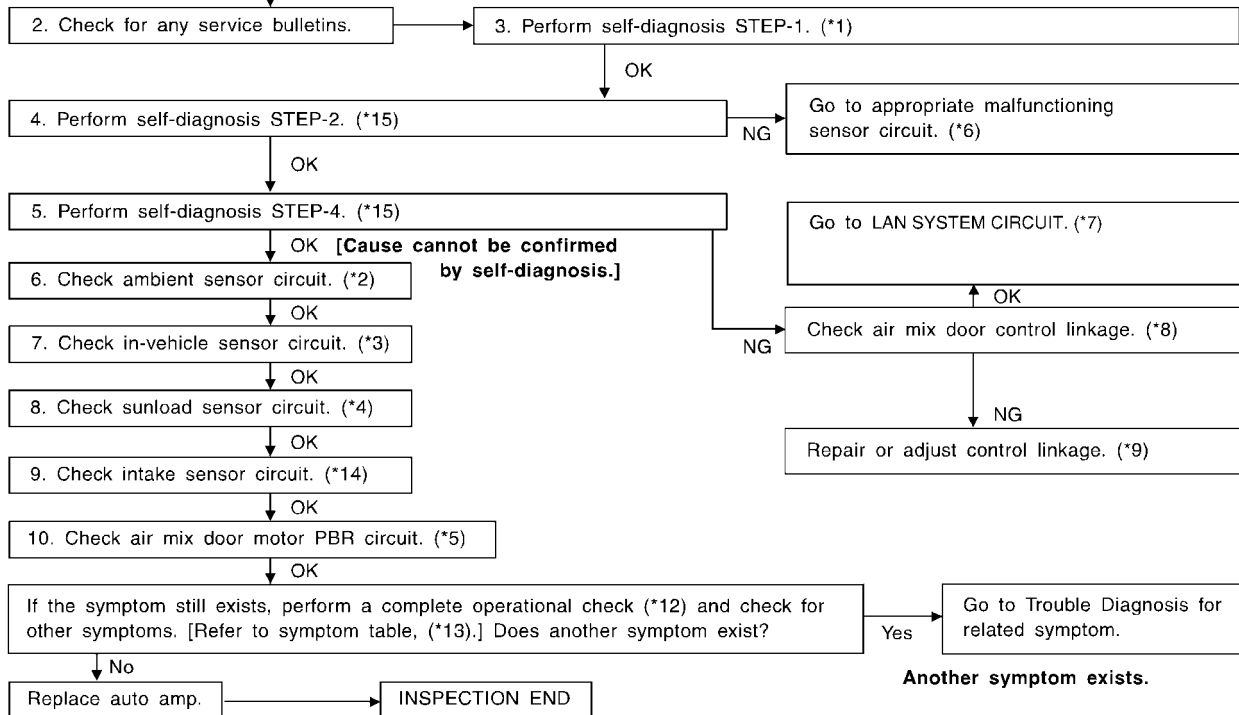
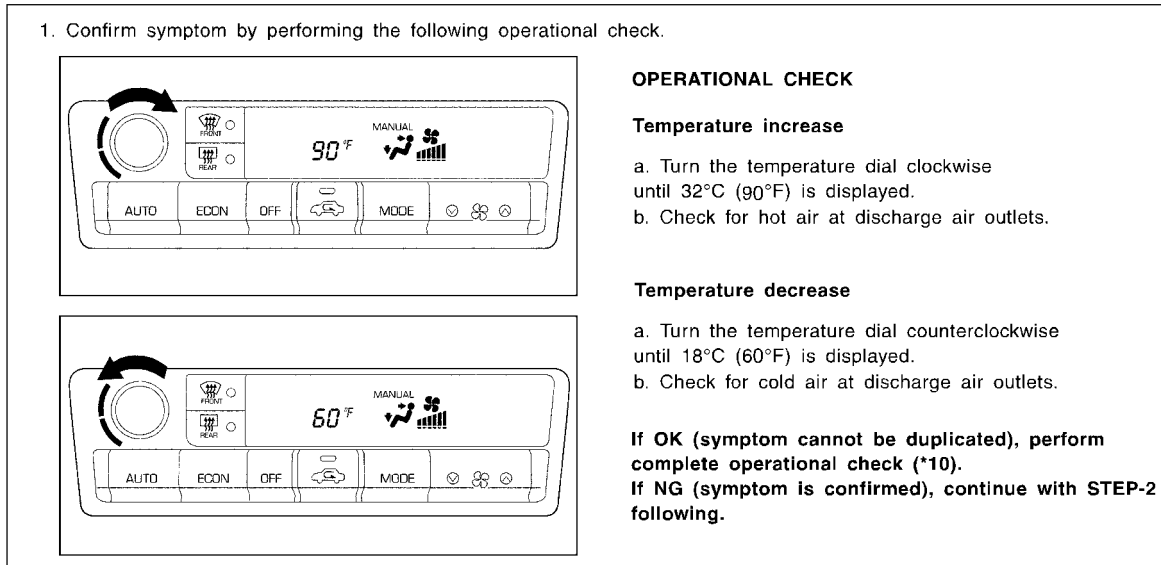

A
B
C
D
E
F
G
H
I
K
L
M

ATC

- | | | |
|---|--|---|
| *1 ATC-41. "Self-diagnosis" , see No.1 | *6 ATC-41. "Self-diagnosis" , see No. 14 | *12 ATC-49. "Operational Check" |
| *2 ATC-90. "Ambient Sensor Circuit" | *7 ATC-54. "LAN System Circuit" | *13 ATC-31. "SYMPTOM TABLE" |
| *3 ATC-92. "In-vehicle Sensor Circuit" | *8 ATC-61. "Air Mix Door Motor Circuit" | *14 ATC-98. "Intake Sensor Circuit" |
| *4 ATC-95. "Sunload Sensor Circuit" | *9 ATC-61. "Air Mix Door Motor Circuit" | *15 ATC-41. "Self-diagnosis" , see No.7 |
| *5 ATC-61. "Air Mix Door Motor Circuit" | *10 ATC-49. "Operational Check" | |

WJIA0043E

TROUBLE DIAGNOSIS

SYSTEM DESCRIPTION

Component Parts

Air mix door control system components are:

- Auto amp.
- Air mix door motor (LCU)
- In-vehicle sensor
- Ambient sensor
- Sunload sensor
- Sunload sensor
- Intake sensor

System Operation

The auto amplifier receives data from each of the sensors. The amplifier sends air mix door, mode door and intake door motor opening angle data to the air mix door motor LCU, mode door motor LCU and intake door motor LCU.

The air mix door motor, mode door motor and intake door motor read their respective signals according to the address signal. Opening angle indication signals received from the auto amplifier and each of the motor position sensors are compared by the LCUs in each motor with the existing decision and opening angles. Subsequently, HOT/COLD or DEFROST/VENT or FRESH/RECIRCULATION operation is selected. The new selection data is returned to the auto amplifier.

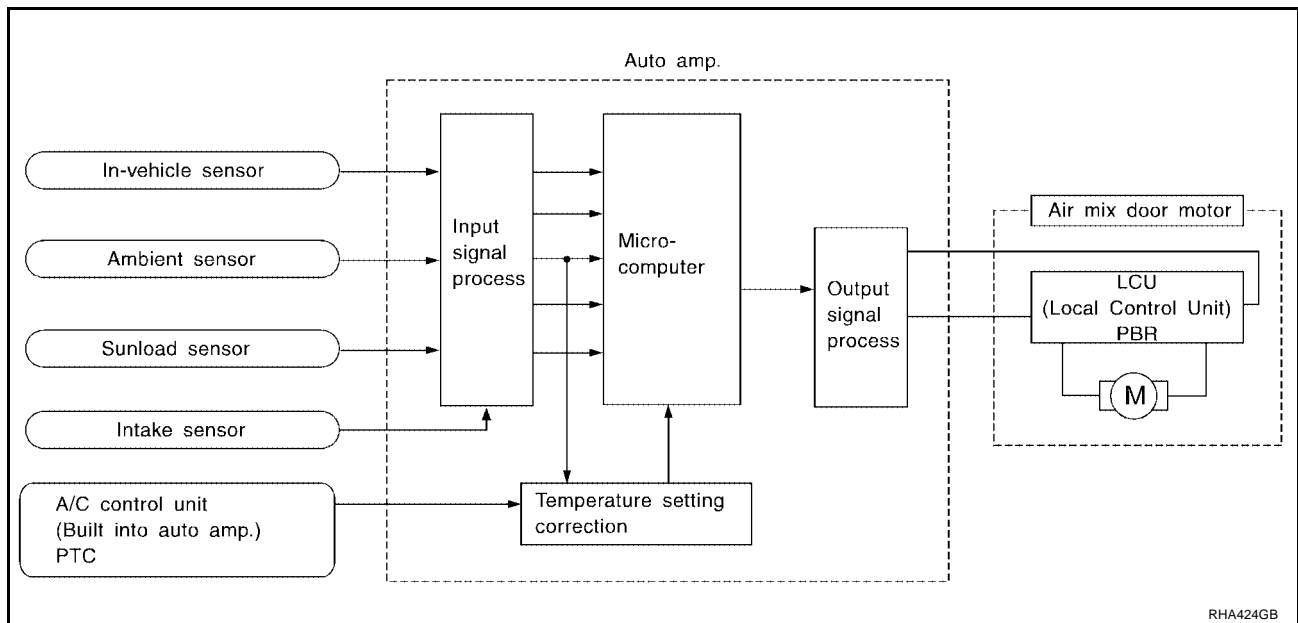

Air Mix Door Control Specification

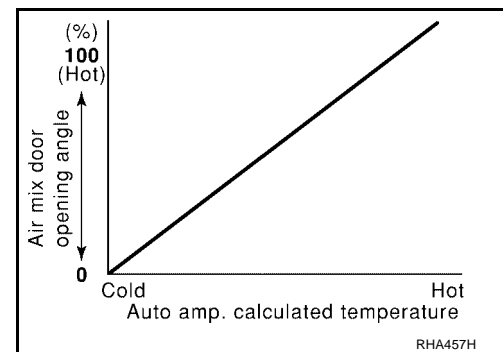

TROUBLE DIAGNOSIS

COMPONENT DESCRIPTION

Air Mix Door Motor

The air mix door motor is attached to the heater and cooling unit. It rotates so that the air mix door is opened or closed to a position set by the auto amplifier. Motor rotation is then conveyed through a shaft and the air mix door position is then fed back to the auto amplifier by PBR built-in air mix door motor.

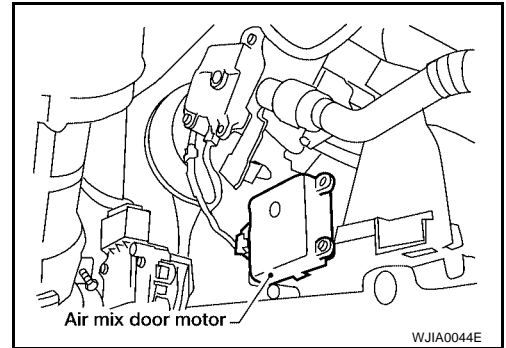

DIAGNOSTIC PROCEDURE

SYMPTOM: Discharge air temperature does not change.
 Perform diagnostic procedure for LAN system circuit. Refer to [ATC-54, "LAN System Circuit"](#).

AIR MIX DOOR

1. Install air mix door motor on heater unit and connect it to main harness.
2. Set up code No. 41 in Self-diagnosis STEP 4. Refer to [ATC-41, "Self-diagnosis"](#).
3. Move air mix door lever by hand and hold it in full cold position.
4. Attach air mix door lever to side link.
5. Make sure air mix door operates properly when changing from code No. 41 to 46 by pushing DEF switch.

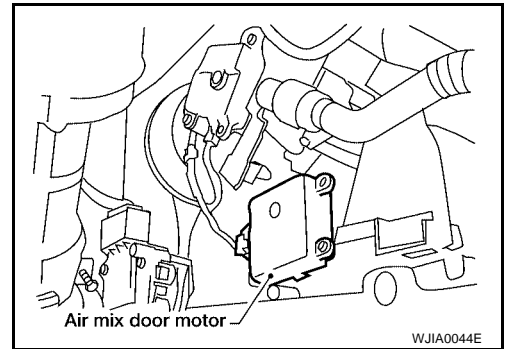

41	42	43	44	45	46
Full cold			Full hot		

A
B
C
D
E
F
G
H
I
K
L
M

ATC

TROUBLE DIAGNOSIS

EJS001CY

Intake Door Motor Circuit

SYMPTOM:

- Intake door does not change.
- Intake door motor does not operate normally.

INSPECTION FLOW

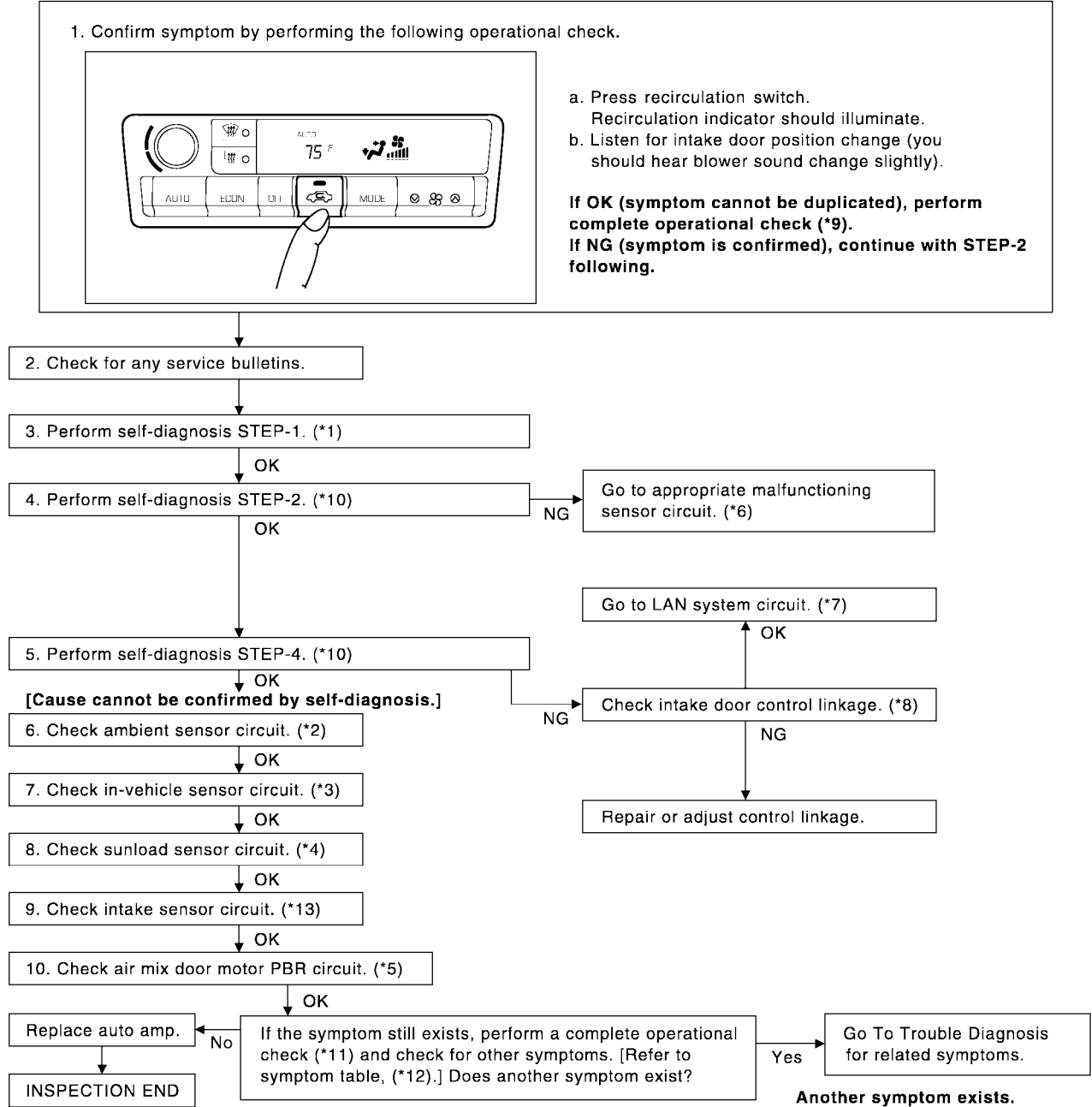

WJIA0046E

*1 [ATC-41, "Self-diagnosis"](#), see No.1

*6 [ATC-41, "Self-diagnosis"](#), see No. 14.

*11 [ATC-49, "Operational Check"](#)

*2 [ATC-90, "Ambient Sensor Circuit"](#)

*7 [ATC-54, "LAN System Circuit"](#)

*12 [ATC-31, "SYMPTOM TABLE"](#)

*3 [ATC-92, "In-vehicle Sensor Circuit"](#)

*8 [ATC-64, "Intake Door Motor Circuit"](#)

*13 [ATC-98, "Intake Sensor Circuit"](#)

*4 [ATC-95, "Sunload Sensor Circuit"](#)

*9 [ATC-49, "Operational Check"](#)

*5 [ATC-61, "Air Mix Door Motor Circuit"](#)

*10 [ATC-41, "Self-diagnosis"](#), see No.5 or 7

Another symptom exists.

TROUBLE DIAGNOSIS

SYSTEM DESCRIPTION

Component Parts

Intake door control system components are:

- Auto amp.
- Intake door motor
- A/C LAN system (PBR built-in mode motor and air mix door motor)
- In-vehicle sensor
- Ambient sensor
- Sunload sensor
- Intake sensor

System Operation

The intake door control determines intake door position based on the ambient temperature, the intake air temperature and the in-vehicle temperature. When the ECON, DEFROST, or OFF switches are pushed, the auto amplifier sets the intake door at the Fresh position.

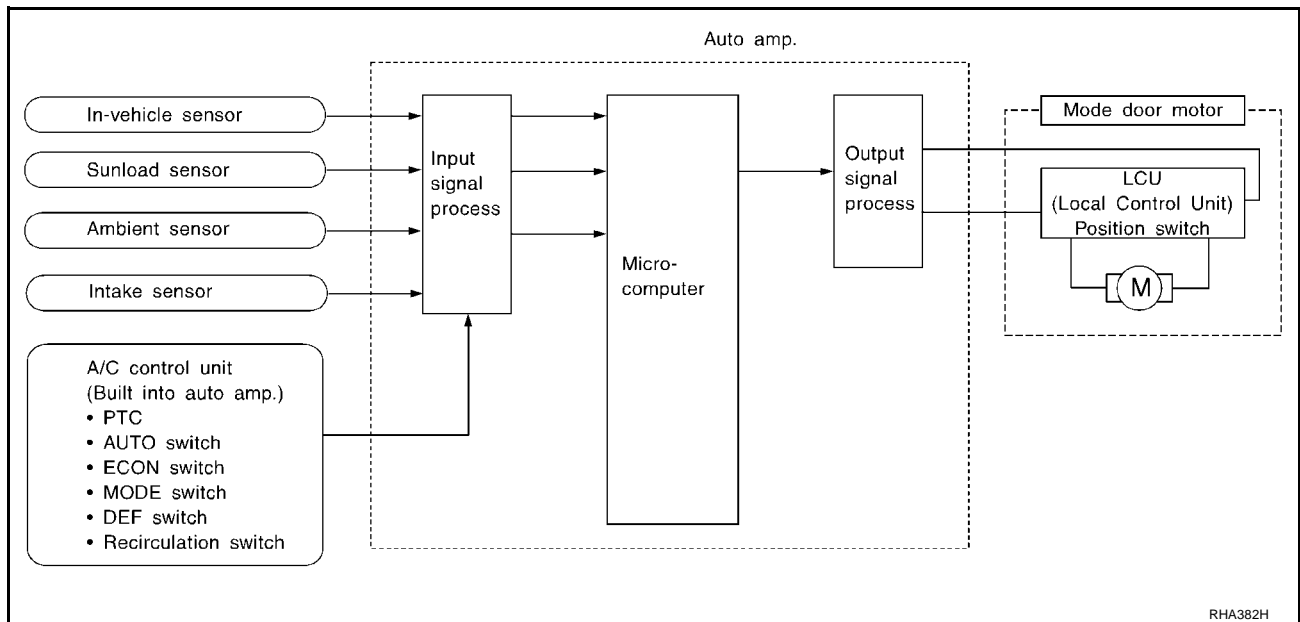

Intake Door Control Specification

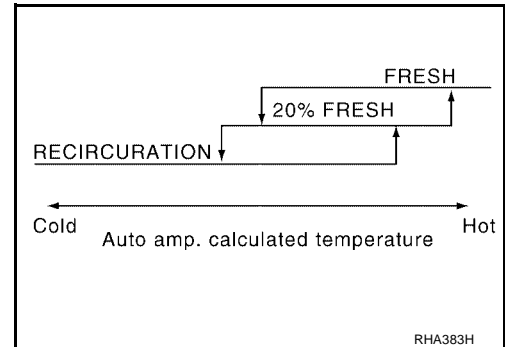

TROUBLE DIAGNOSIS

COMPONENT DESCRIPTION

Intake door motor

The intake door motor is attached to the intake unit. It rotates so that air is drawn from inlets set by the auto amplifier. Motor rotation is conveyed to a lever which activates the intake door.

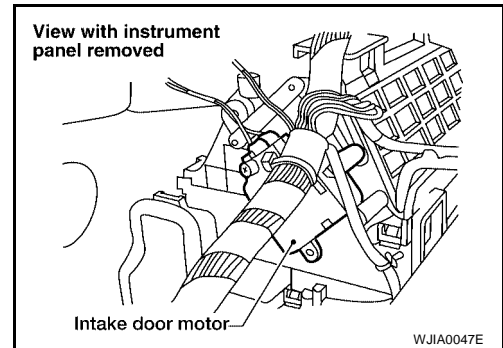

INTAKE DOOR

1. Install intake door motor on intake unit and connect it to main harness.
2. Set up code No. $4i$ in Self-diagnosis STEP 4. Refer to [ATC-41, "Self-diagnosis"](#).
3. Make sure intake door operates properly when changing from code No. $4i$ to 46 by pushing DEF switch.

41	42	43	44	45	46
REC		20% FRE	FRE		

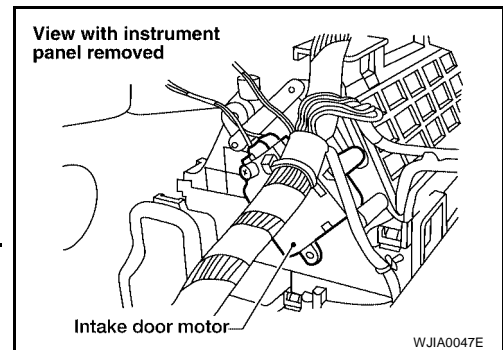

DIAGNOSTIC PROCEDURE

SYMPTOM: Intake door motor does not operate normally.

Perform diagnostic procedure for LAN system circuit. Refer to [ATC-54, "LAN System Circuit"](#).

TROUBLE DIAGNOSIS

EJS001CZ

Blower Motor Circuit

SYMPTOM:

- Blower motor operation is malfunctioning.

INSPECTION FLOW

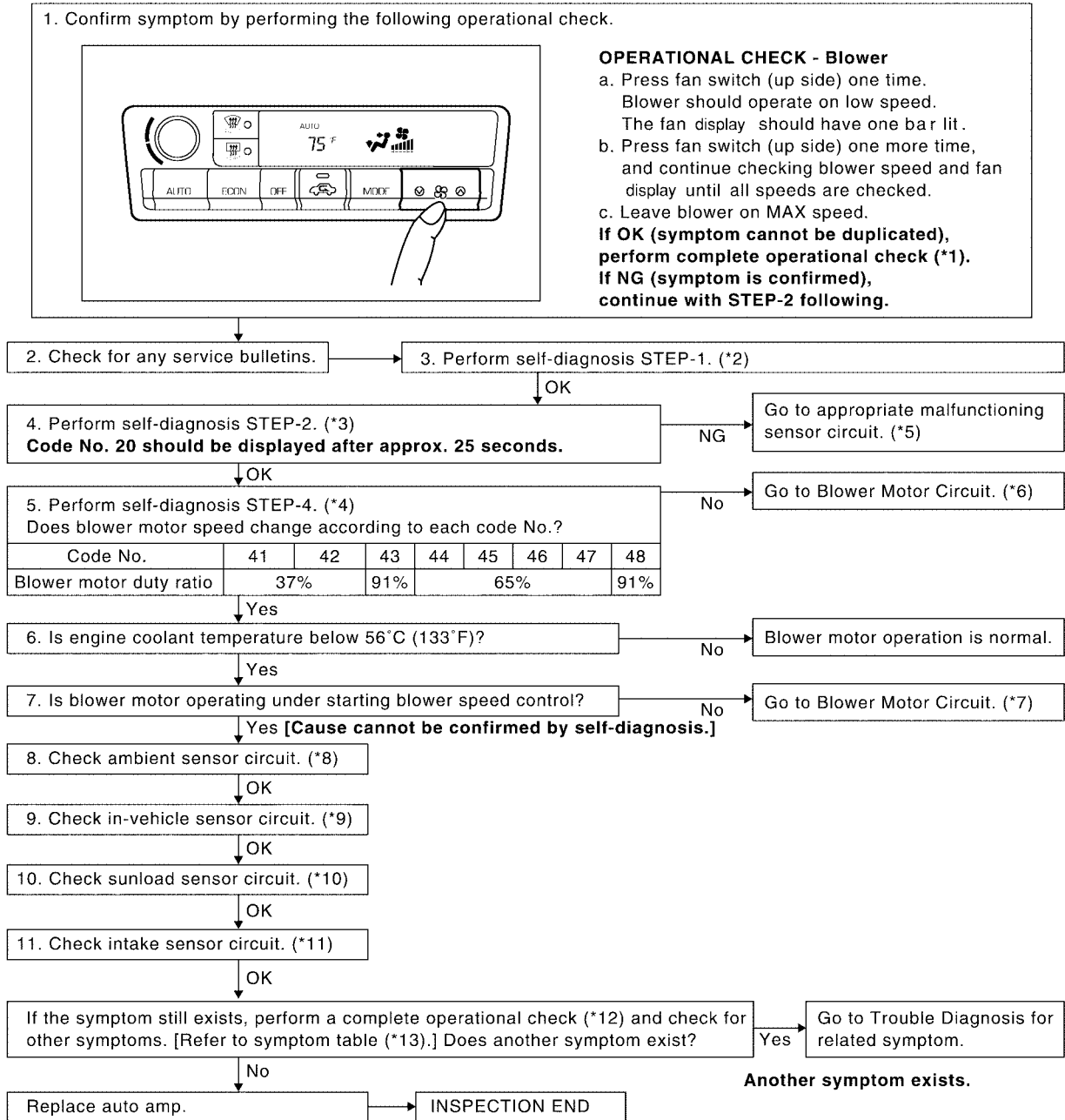

*1 [ATC-49. "Operational Check"](#)

*2 [ATC-88. "Self-diagnosis"](#), see No.1

*3 [ATC-41. "Self-diagnosis"](#), see No.5

*4 [ATC-41. "Self-diagnosis"](#), see No.7

*5 [ATC-41. "Self-diagnosis"](#), see No.14

*6 [ATC-67. "Blower Motor Circuit"](#)

*7 [ATC-67. "Blower Motor Circuit"](#)

*8 [ATC-90. "Ambient Sensor Circuit"](#)

*9 [ATC-92. "In-vehicle Sensor Circuit"](#)

*10 [ATC-95. "Sunload Sensor Circuit"](#)

*11 [ATC-98. "Intake Sensor Circuit"](#)

*12 Thermal transmitter (PG-3)

*13 [ATC-49. "Operational Check"](#)

*14 [ATC-31. "SYMPTOM TABLE"](#)

WJIA0048E

TROUBLE DIAGNOSIS

SYSTEM DESCRIPTION

Component Parts

Fan speed control system components are:

- Auto amp.
- A/C LAN system (PBR built-in mode door motor, air mix door motor and intake door motor)
- In-vehicle sensor
- Ambient sensor
- Sunload sensor
- Intake sensor

System Operation

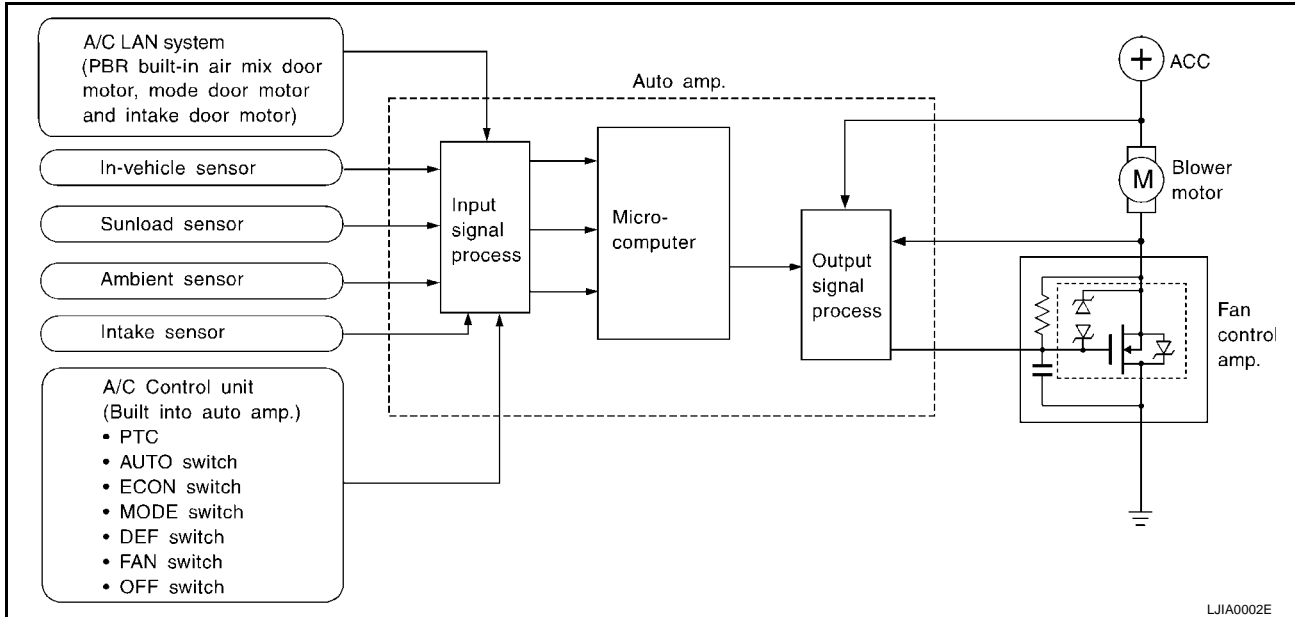

Automatic Mode

In the automatic mode, the blower motor speed is calculated by the automatic amplifier based on inputs from the PBR, in-vehicle sensor, sunload sensor, intake sensor and ambient sensor.

When the air flow is increased, the duty ratio of the blower fan motor's drive signal is changed at 8% sec. to prevent a sudden increase in air flow.

In addition to manual air flow control and the normal automatic air flow control, starting air flow control, low water temperature starting control and high passenger compartment temperature starting control are available.

Starting Fan Speed Control

Start Up From COLD SOAK Condition (Automatic mode)

In a cold start up condition where the engine coolant temperature is below 56°C (133°F), the blower will not operate for a short period of time (up to 150 seconds). The exact start delay time varies depending on the ambient and engine coolant temperature.

In the most extreme case (very low ambient) the blower starting delay will be 150 seconds as described above. After this delay, the blower will operate at low speed until the engine coolant temperature rises above 56°C (133°F), at which time the blower speed will increase to the objective speed.

Start Up From Normal or HOT SOAK Condition (Automatic mode)

The blower will begin operation momentarily after the A/C button is pushed. The blower speed will gradually rise to the objective speed over a time period of 3 seconds or less (actual time depends on the objective blower speed).

Blower Speed Compensation

Sunload

When the in-vehicle temperature and the set temperature are very close, the blower will be operating at low speed. The low speed will vary depending on the sunload. During conditions of high sunload, the blower low

TROUBLE DIAGNOSIS

speed is "normal" low speed (approx. 6V). During low or no sunload conditions, the low speed will drop to "low" low speed (approx. 5V).

Fan Speed Control Specification

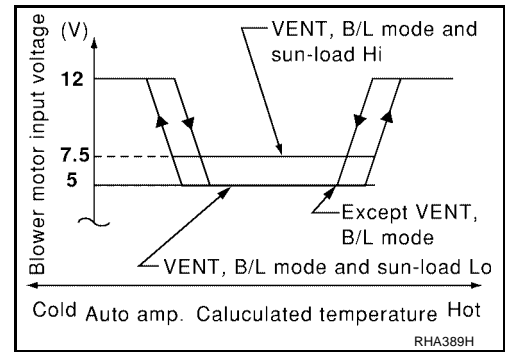

COMPONENT DESCRIPTION

Fan Control Amplifier

The fan control amplifier is located on the cooling unit. The fan control amp. receives a gate voltage from the auto amp. to smoothly maintain the blower fan motor voltage in the 5 to the 12V range (approx.).

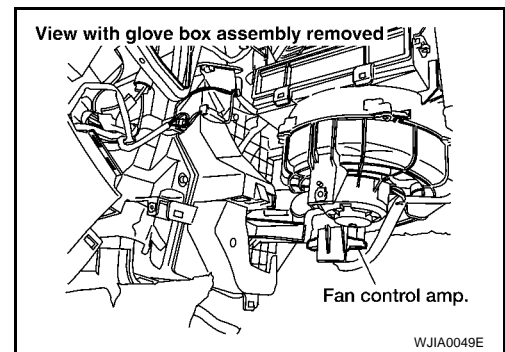

DIAGNOSTIC PROCEDURE

SYMPTOM: Blower motor operation is malfunctioning under Starting Fan Speed Control.

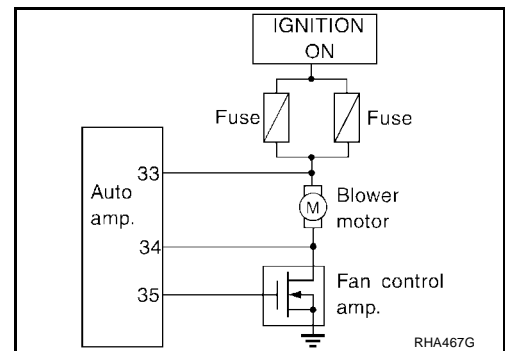

1. CHECK POWER SUPPLY FOR FAN CONTROL AMP.

Terminals		Voltage (V) (Approx.)
(+)		
Connector	Wire color	(-) Body ground
M64-2	L/W	

Yes or No

- Yes >> GO TO 2.
- No >> GO TO 8.

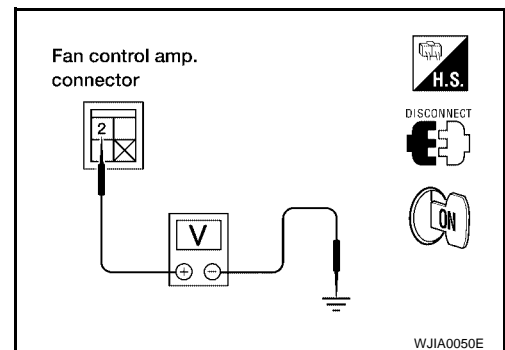

TROUBLE DIAGNOSIS

2. CHECK BODY GROUND CIRCUIT FOR FAN CONTROL AMP.

Terminals		Continuity	
Connector	Wire color	Body ground	Yes
M64-1	B		

Yes or No

- Yes >> Reconnect fan control amp. harness connector and GO TO 3.
 No >> Repair harness or connector.

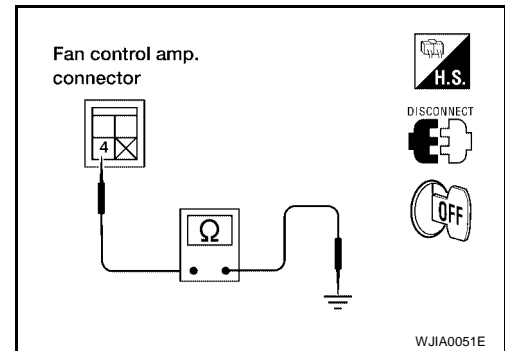

3. CHECK VOLTAGE FOR FAN CONTROL AMP.

Set up Self-diagnosis STEP 4.

Code No.	Terminal No.			Voltage (V) (Approx.)
	(+)		(-)	
	Connector	Wire color		
41-46	M64-2	L/Y	Body ground	12V

OK or NG

- OK >> GO TO 4.
 NG >> 1. If the voltage is less than 2.5V, replace fan control amp.
 2. If the voltage is more than 3.0V, GO TO 4.
 3. Go to "FUNCTION CONFIRMATION PROCEDURE", [ATC-88, "Self-diagnosis"](#) and perform self-diagnosis STEP 4.
 Confirm that blower motor operation is normal.

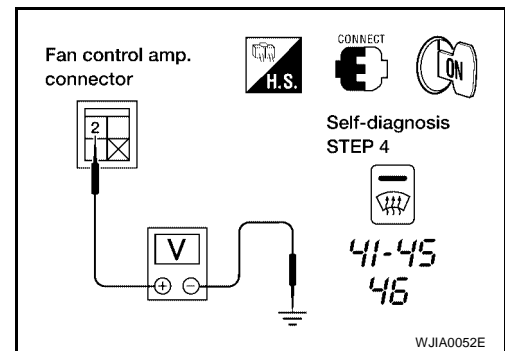

4. CHECK FAN CONTROL AMP.

Refer to [ATC-72, "Fan Control Amp."](#)

OK or NG

- OK >> GO TO 5.
 NG >> 1. Replace fan control amp.
 2. Go to "FUNCTION CONFIRMATION PROCEDURE", [ATC-41, "Self-diagnosis"](#) and perform self-diagnosis STEP 4.
 Confirm that blower motor operation is normal.

5. CHECK FAN CONTROL AMP. CIRCUIT BETWEEN FAN CONTROL AMP. AND AUTO AMP. (LCU)

1. Disconnect auto amp. (LCU) and fan control amp. harness connector.

Terminals				Continuity
Connector	Wire color	Connector	Wire color	Yes
M64-1	L/Y	M50-35	L/Y	

Continuity should exist.

If OK, check harness for short.

OK or NG

- OK >> GO TO 6.
 NG >> Repair harness or connector.

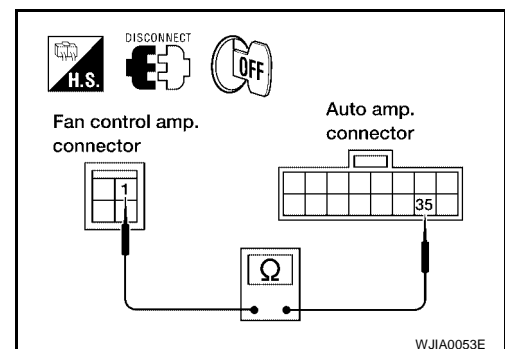

TROUBLE DIAGNOSIS

6. CHECK FAN FEEDBACK CIRCUIT

Reconnect auto amp. (LCU) harness connector.

Terminal		Voltage (V) (Approx.)
(+)	(-)	
Connector	Wire color	Body ground 12V
M50-34	L/W	

Yes or No

Yes >> GO TO 7.

No >> ● Check power supply circuit and 15A fuses [Nos. 10 and 11, located in the fuse block (J/B)].

● Refer to [PG-3, "POWER SUPPLY ROUTING CIRCUIT"](#).

- If OK, check for open circuit in wiring harness. Repair or replace as necessary.
- If NG, replace fuse and check wiring harness for short circuit. Repair or replace as necessary.

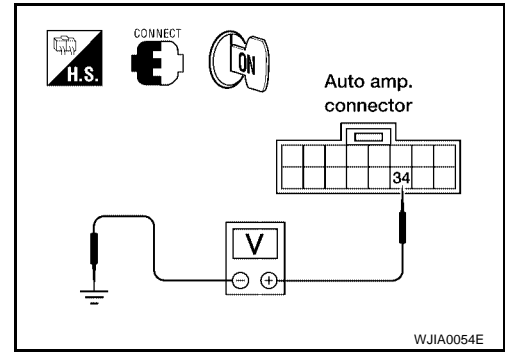

7. CHECK POWER SUPPLY FOR AUTO AMP.

Terminal		Voltage (V) (Approx.)
(+)	(-)	
Connector	Wire color	Body ground 12V
M50-26	Y/R	

Yes or No

Yes >> 1. Replace auto amp.

2. Go to "FUNCTION CONFIRMATION PROCEDURE", [ATC-41, "Self-diagnosis"](#) and perform self-diagnosis STEP 4.

Confirm that blower motor operation is normal.

No >> GO TO 10.

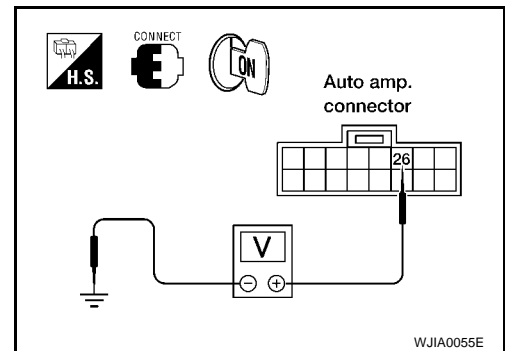

8. CHECK POWER SUPPLY FOR BLOWER MOTOR

Disconnect blower motor harness connector.

Terminal		Voltage (V) (Approx.)
(+)	(-)	
Connector	Wire color	Body ground 12V
M62-1	W/L	

Yes or No

Yes >> GO TO 9.

No >> Check power supply circuit and 15A fuses [Nos. 10 and 11, located in the fuse block (J/B)].

- Check blower motor relay.
- If OK, check for open circuit in wiring harness. Repair or replace as necessary.
- If NG, replace fuse and check wiring harness for short circuit. Repair or replace as necessary.

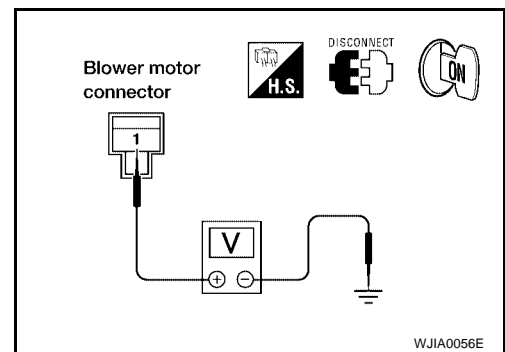

TROUBLE DIAGNOSIS

9. CHECK CIRCUIT CONTINUITY BETWEEN BLOWER MOTOR AND FAN CONTROL AMP.

Disconnect blower motor connector and auto amp. (LCU) connector.

Terminals				Continuity
Connector	Wire color	Connector	Wire color	
M62-2	L/W	M64-2	L/W	Yes

OK or NG

- OK >> Check blower motor. Refer to [ATC-72, "Blower Motor"](#).
1. If NG, replace blower motor.
 2. Go to "FUNCTION CONFIRMATION PROCEDURE", [ATC-41, "Self-diagnosis"](#) and perform self-diagnosis STEP 4.
Confirm that blower motor operation is normal.

NG >> Repair harness or connector.

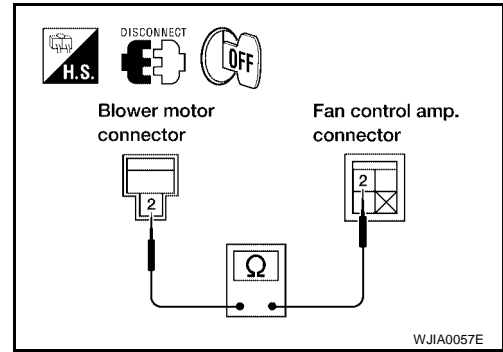

10. CHECK BLOWER MOTOR CIRCUIT BETWEEN BLOWER MOTOR AND AUTO AMP. (LCU)

Terminals				Continuity
Connector	Wire color	Connector	Wire color	
M62-2	L/W	M50-34	L/W	Yes

Continuity should exist.

If OK, check harness for short.

OK or NG

- OK >> INSPECTION END
 NG >> Repair harness or connector.

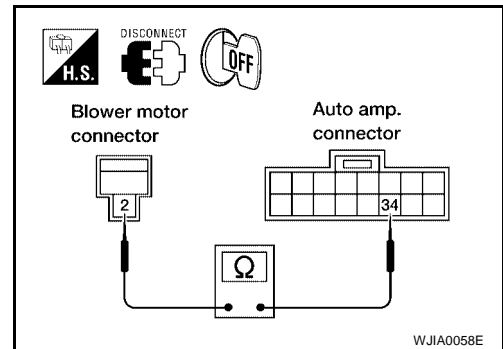

COMPONENT INSPECTION

Blower Motor

Confirm smooth rotation of the blower motor.

- Ensure that there are no foreign particles inside the intake unit.

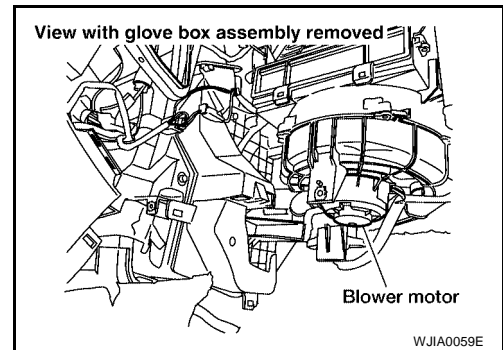

Fan Control Amp.

Check continuity between terminals.

Terminal Nos.

2 - 4

Continuity

Yes

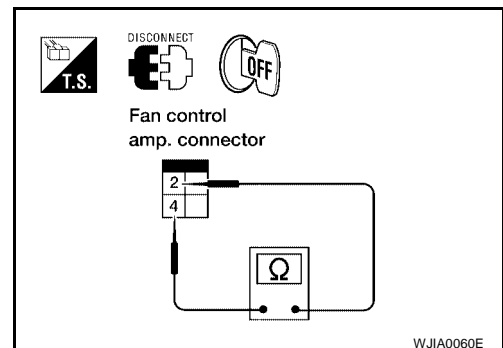

TROUBLE DIAGNOSIS

EJS001D0

Magnet Clutch Circuit

SYMPTOM: Magnet clutch does not engage.

INSPECTION FLOW

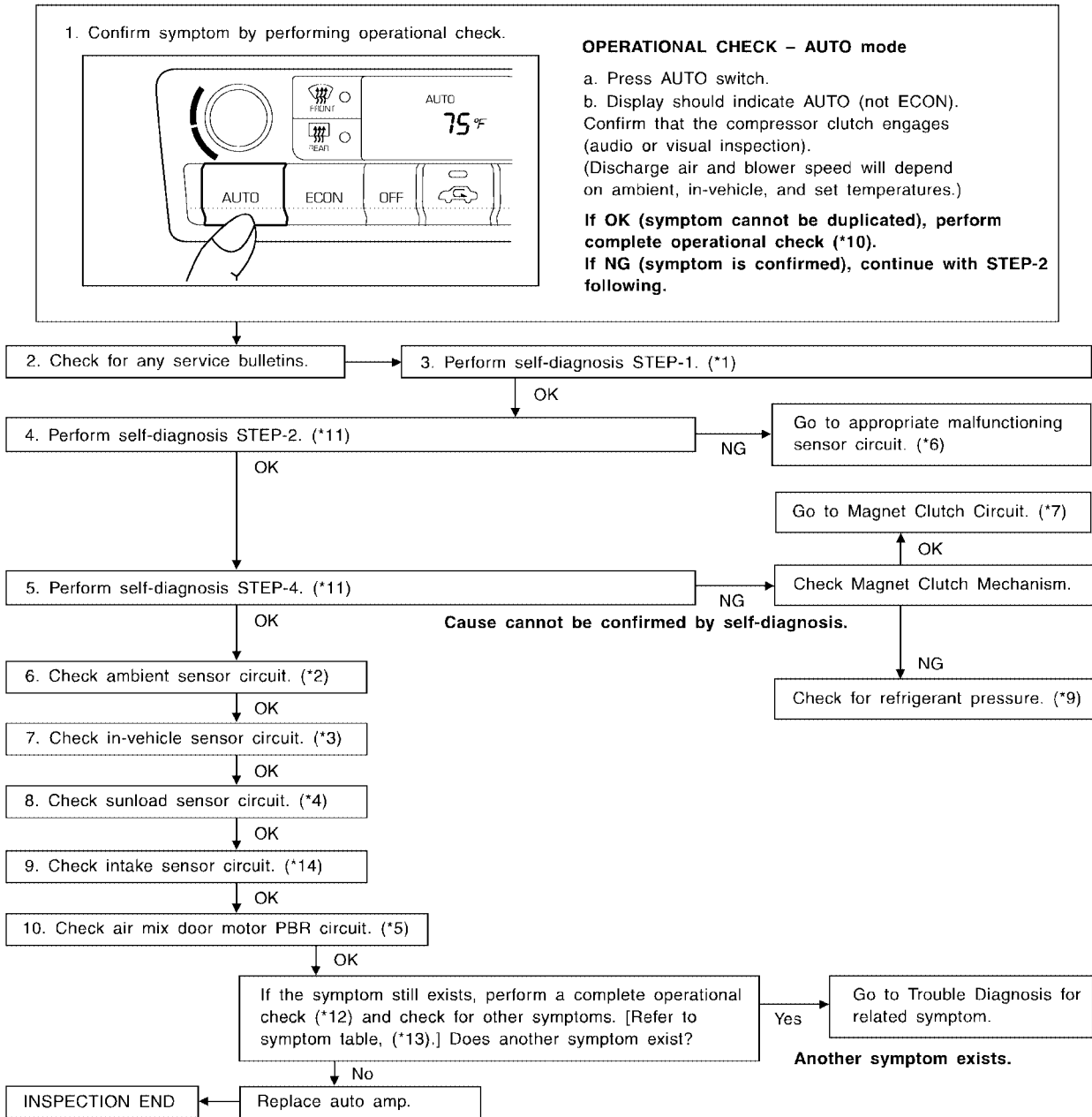

A
B
C
D
E
F
G
H
I
K
L
M

ATC

WJIA0061E

- *1 [ATC-41, "Self-diagnosis"](#), see No.1. *6 [ATC-41, "Self-diagnosis"](#), see No. 14.
- *2 [ATC-90, "Ambient Sensor Circuit"](#) *7 [ATC-73, "Magnet Clutch Circuit"](#) *11 [ATC-49, "Operational Check"](#)
- *3 [ATC-92, "In-vehicle Sensor Circuit"](#) *8 [ATC-82, "TROUBLE DIAGNOSIS FOR ABNORMAL PRESSURE"](#) *12 [ATC-31, "SYMPTOM TABLE"](#)
- *4 [ATC-95, "Sunload Sensor Circuit"](#) *9 [ATC-49, "Operational Check"](#) *13 [ATC-98, "Intake Sensor Circuit"](#)
- *5 [ATC-61, "Air Mix Door Motor Circuit"](#) *10 [ATC-41, "Self-diagnosis"](#), see No.7.

TROUBLE DIAGNOSIS

SYSTEM DESCRIPTION

Auto amplifier controls compressor operation by ambient temperature and signal from ECM.

Low Temperature Protection Control

Auto amp. will turn the compressor ON or OFF as determined by a signal detected by ambient sensor.

When ambient temperatures are greater than -2°C (28°F), the compressor turns ON. The compressor turns OFF when ambient temperatures are less than -5°C (23°F).

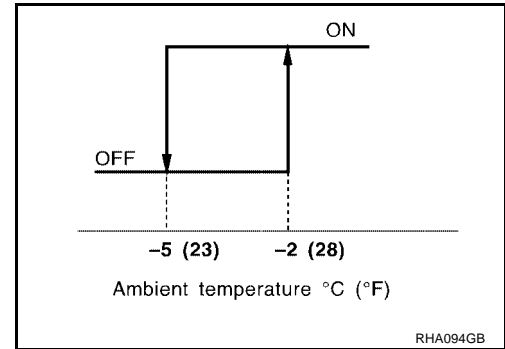

DIAGNOSTIC PROCEDURE

SYMPTOM: Magnet clutch does not engage when A/C switch is ON.

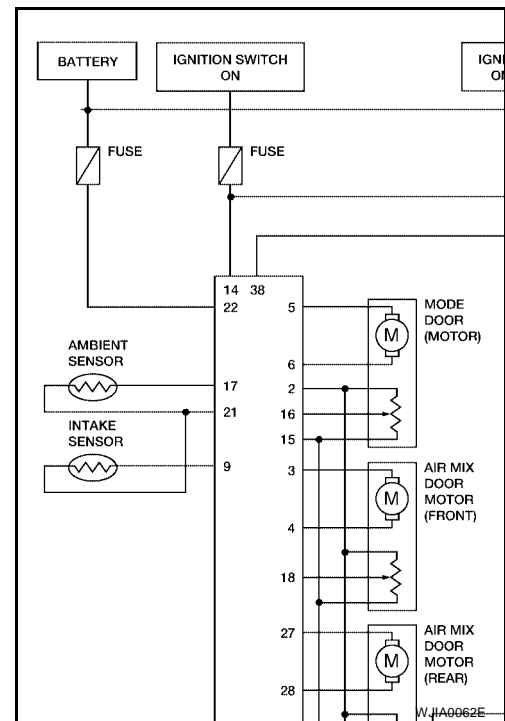

1. CHECK CIRCUIT CONTINUITY BETWEEN A/C RELAY IN IPDM E/R AND COMPRESSOR

Terminals				Continuity
Connector	Wire color	Connector	Wire color	
F3-1	Y/B	E124-28	Y/B	Yes

If OK, check harness for short.

OK or NG

OK >> GO TO 2.

NG >> Repair harness or connector.

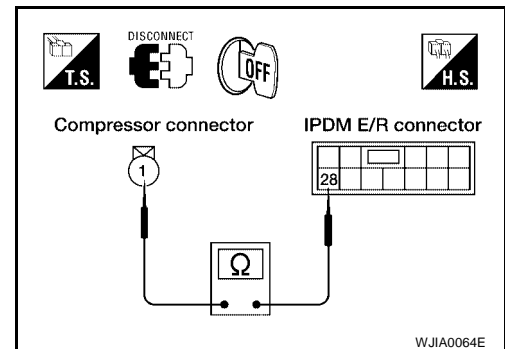

TROUBLE DIAGNOSIS

2. CHECK POWER SUPPLY FOR COMPRESSOR

Disconnect compressor harness connector.

Terminal		Voltage (V) (Approx.)
(+)	(-)	
Connector	Wire color	12V
F3-1	Y/B	
		Body ground

OK or NG

OK >> Check magnet clutch coil.

1. If NG, replace magnet clutch. Refer to [ATC-122](#).
"Removal and Installation for Compressor Clutch".

2. If OK, check compressor mounting points for looseness or corrosion and repair as necessary.

NG >> GO TO 3.

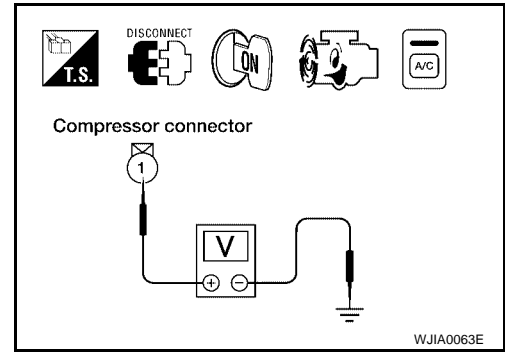

3. CHECK A/C RELAY IN IPDM E/R

Terminal		Voltage (V) (Approx.)
(+)	(-)	
Connector	Wire color	12V
E124-28	Y/B	
		Body ground

OK or NG

OK >> GO TO 4.

NG >> ● Disconnect BCM harness connector M18.

● GO TO 8.

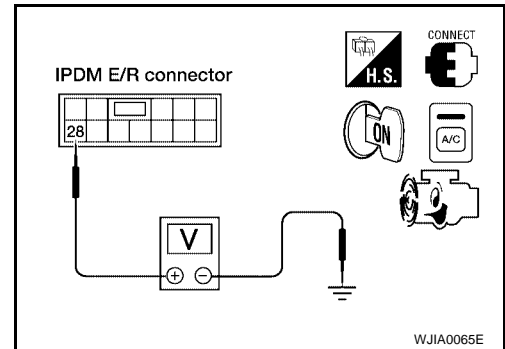

4. CHECK VOLTAGE FOR BCM

Terminal		Voltage (V) (Approx.)
(+)	(-)	
Connector	Wire color	12V
M18-58	L/W	
		Body ground

OK or NG

OK >> GO TO 5.

NG >> Check BCM.

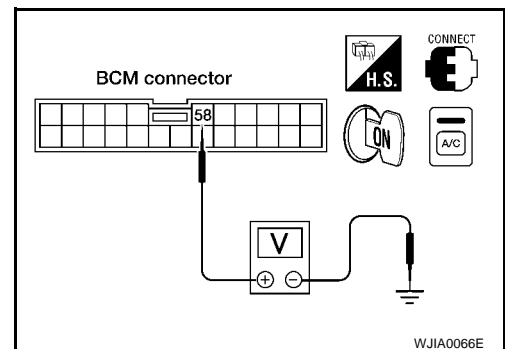

A
B
C
D
E
F
G
H
I
K
L
M

ATC

TROUBLE DIAGNOSIS

5. CHECK REFRIGERANT PRESSURE SENSOR INPUT SIGNAL

Terminal		Voltage (V) (Approx.)
(+)	(-)	
Connector	Wire color	Body ground 12V
F54-81	W	

OK or NG

- OK >> GO TO 6.
 NG >> 1. Repair harness or connector.
 2. Go to [ATC-42, "FUNCTION CONFIRMATION PROCEDURE"](#) and perform self-diagnosis STEP-4.
 Confirm that magnet clutch operation is normal.

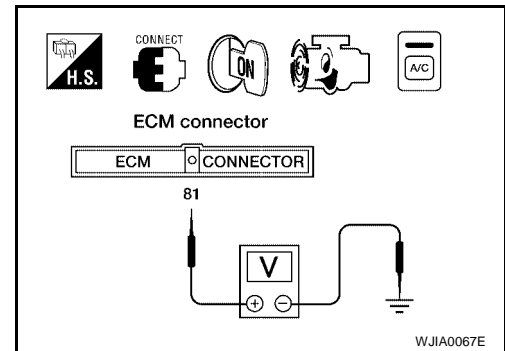

6. CHECK REFRIGERANT PRESSURE SENSOR

Refer to [ATC-78, "Refrigerant Pressure Sensor"](#).

OK or NG

- OK >> GO TO 7.
 NG >> Replace refrigerant pressure sensor.

7. CHECK VOLTAGE FOR THERMO CONTROL AMP.

Terminal		Voltage (V) (Approx.)
(+)	(-)	
Connector	Wire color	Body ground 12V
M52-1	G	

OK or NG

- OK >> GO TO 8.
 NG >> ● Check power supply circuit and 15A fuse [No.12 located at fuse block (J/B)]. Refer to [PG-3, "POWER SUPPLY ROUTING CIRCUIT"](#).
 ● If OK, check for open circuit in wiring harness.
 Repair or replace as necessary.
 ● If NG, replace fuse and check wiring harness for short circuit.
 Repair or replace as necessary.

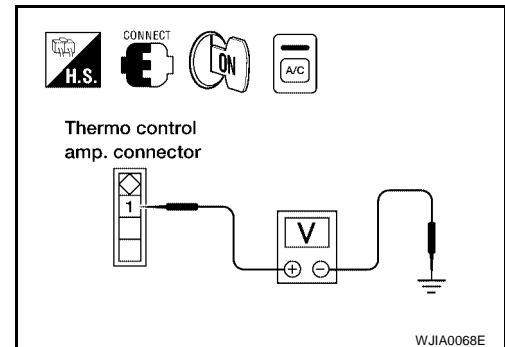

8. CHECK POWER SUPPLY FOR THERMO CONTROL AMP.

Terminal		Voltage (V) (Approx.)
(+)	(-)	
Connector	Wire color	Body ground 12V
M52-2	L/W	

OK or NG

- OK >> GO TO 9.
 NG >> Repair or replace thermo control amp.

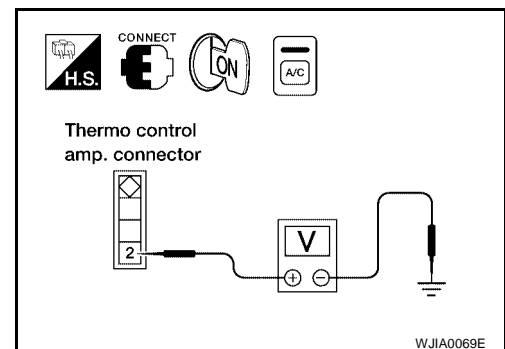

TROUBLE DIAGNOSIS

9. CHECK THERMO CONTROL AMP. OPERATION

Terminals		Continuity
(+)	(-)	
Connector	Wire color	Yes
M52-3	G/Y	
		Body ground

OK or NG

- OK >> GO TO 10.
- NG >> Replace thermo control amp.

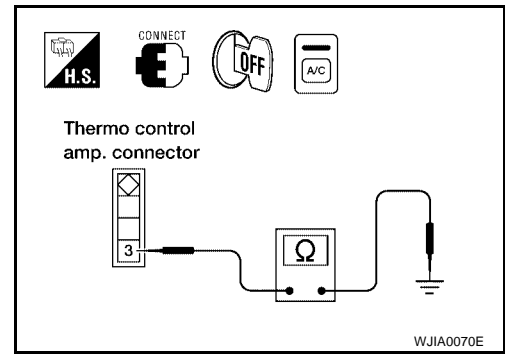

10. CHECK THERMO CONTROL AMP.

Refer to [ATC-78, "Thermo Control Amp."](#)

OK or NG

- OK >> GO TO 11.
- NG >> Repair harness or connector.

11. CHECK CIRCUIT CONTINUITY BETWEEN THERMO CONTROL AMP. AND AUTO AMP.

Disconnect auto amp. connector.

Terminals				Continuity
Connector	Wire color	Connector	Wire color	
M52-3	G/Y	M50-22	G/Y	Yes

OK or NG

- OK >> GO TO 12.
- NG >> Repair harness or connector.

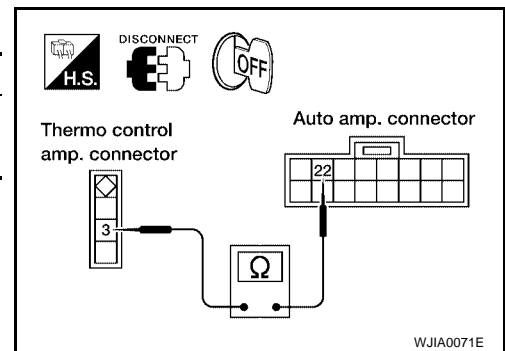

12. CHECK COMPRESSOR ON SIGNAL

When compressor is ON or OFF, check voltage between auto amp. and ground.

Terminal		Voltage (V) (Approx.)
(+)	(-)	
Connector	Wire color	Compressor ON: 0V Compressor OFF: 5V
M50-22	G/Y	
		Body ground

OK or NG

- OK >> GO TO 13.
- NG >>
 - When compressor is ON and voltage is not approx. 0V, replace auto amp.
 - When compressor is OFF and voltage is not approx. 5V, BCM is malfunctioning.

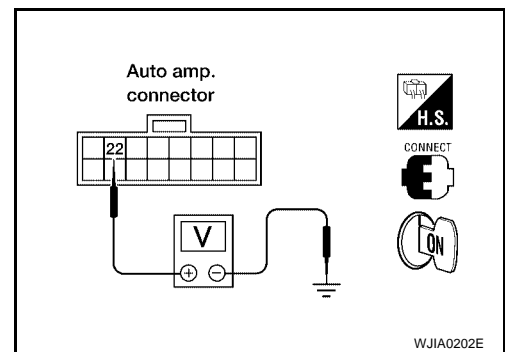

13. CHECK CAN COMMUNICATION CIRCUITS

Check CAN communication circuits between BCM to ECM and between ECM to IPDM E/R. Refer to [LAN-3, "CAN COMMUNICATION"](#)

OK or NG

- OK >> ECM malfunctioning.
- NG >> Repair or replace component based on the result of diagnosis.

A
B
C
D
E
F
G
H
I
K
L
M

ATC

TROUBLE DIAGNOSIS

COMPONENT INSPECTION

Refrigerant Pressure Sensor

The refrigerant pressure sensor is attached to the condenser.

- Refer to .

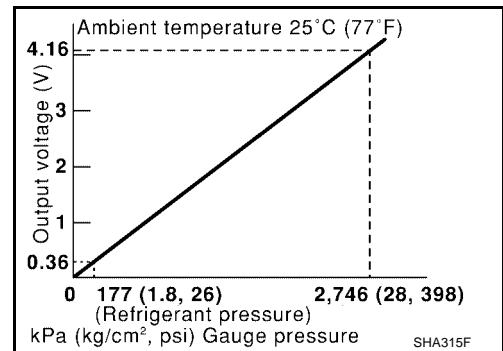
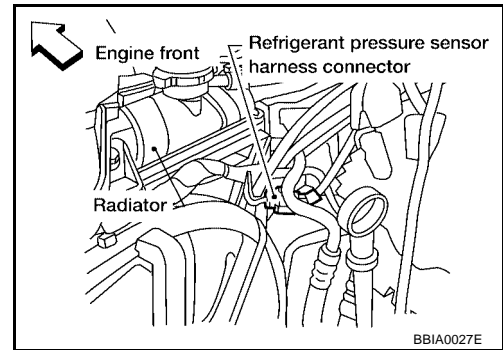

Thermo Control Amp.

1. Run engine and operate A/C system.
2. Connect the voltmeter from harness side.
3. Check the thermo control amp. operation as shown in the table.

Evaporator outlet air temperature °C (°F)	Thermo amp. operation	Voltage (V) (Approx.)
Decreasing to 2.5 - 3.5 (37 - 38)	Turn OFF	12V
Increasing to 4.0 - 5.0 (39 - 41)	Turn ON	0V

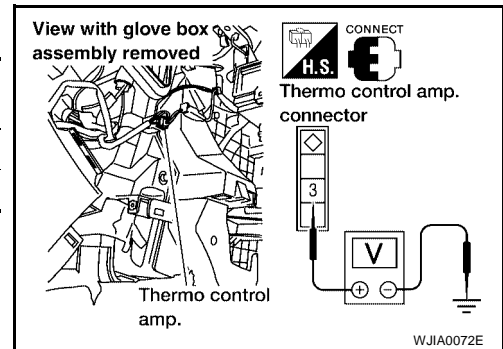

TROUBLE DIAGNOSIS

EJS001D1

Insufficient Cooling

SYMPTOM: Insufficient cooling

INSPECTION FLOW

1. Confirm symptom by performing the following operational check.

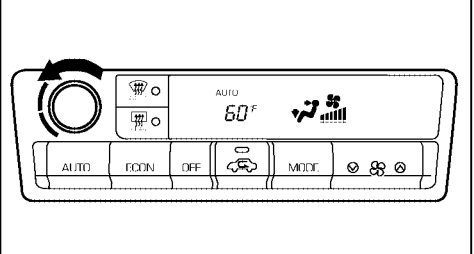

OPERATIONAL CHECK – Temperature decrease

- Turn the temperature dial counterclockwise until 18°C (60°F) is displayed.
- Check for cold air at discharge air outlets.

If OK (symptom cannot be duplicated), perform complete operational check (*10).
If NG (symptom is confirmed), continue with STEP-2 following.

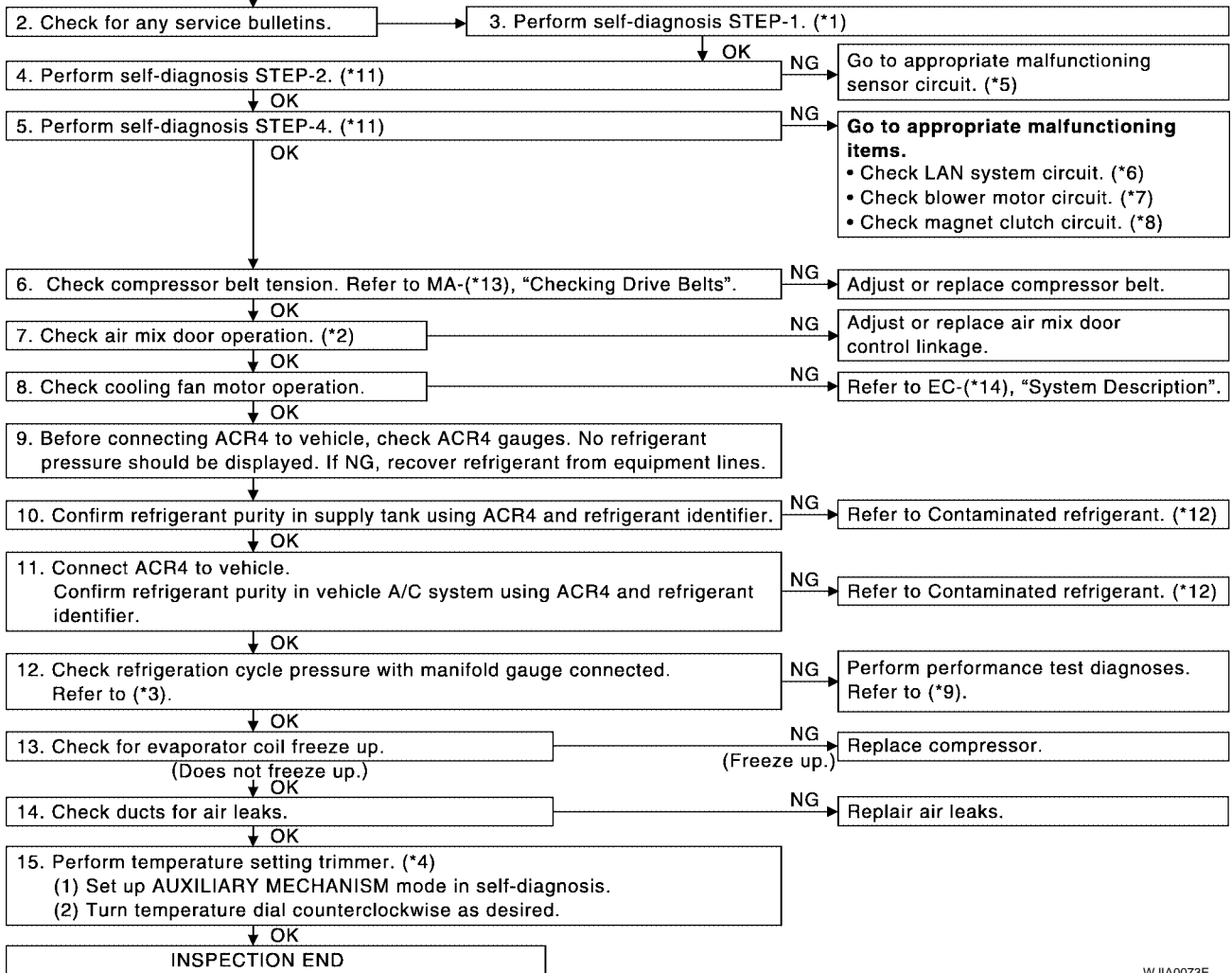

A
B
C
D
E
F
G
H
I
K
L
M

ATC

WJIA0073E

- *1 [ATC-41, "Self-diagnosis"](#), see No.1.
- *2 [ATC-61, "Air Mix Door Motor Circuit"](#)
- *3 [ATC-82, "Test Reading"](#)
- *4 [ATC-41, "Self-diagnosis" STEP6](#), Auxiliary mechanism
- *5 [ATC-41, "Self-diagnosis"](#), see No. 14.
- *6 [ATC-54, "LAN System Circuit"](#)
- *7 [ATC-67, "Blower Motor Circuit"](#)
- *8 [ATC-73, "Magnet Clutch Circuit"](#)
- *9 [ATC-80, "PERFORMANCE TEST ANALYSIS"](#)
- *10 [ATC-49, "Operational Check"](#)
- *11 [ATC-41, "Self-diagnosis"](#), see No.5 or 7.
- *12 [ATC-4, "Contaminated Refrigerant"](#)
- *13 [MA-22, "Checking Drive Belts"](#)
- *14 [EC-1104](#)

TROUBLE DIAGNOSIS

PERFORMANCE TEST ANALYSIS

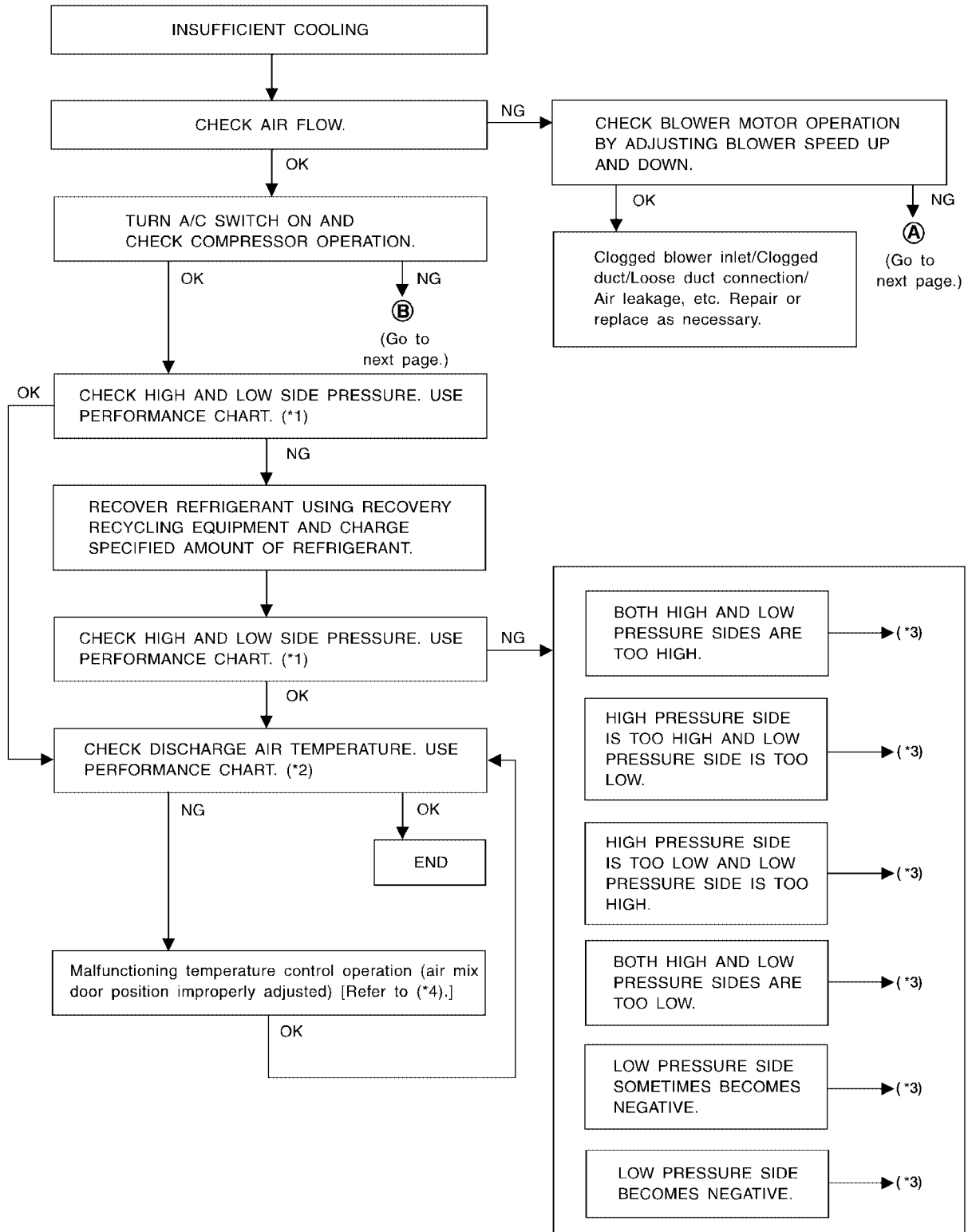

WJIA0198E

*1 [ATC-82, "PERFORMANCE CHART"](#) *3 [ATC-82, "TROUBLE DIAGNOSIS FOR ABNORMAL PRESSURE"](#) *4 [ATC-61, "Air Mix Door Motor Circuit"](#)
 *2 [ATC-82, "PERFORMANCE CHART"](#)

TROUBLE DIAGNOSIS

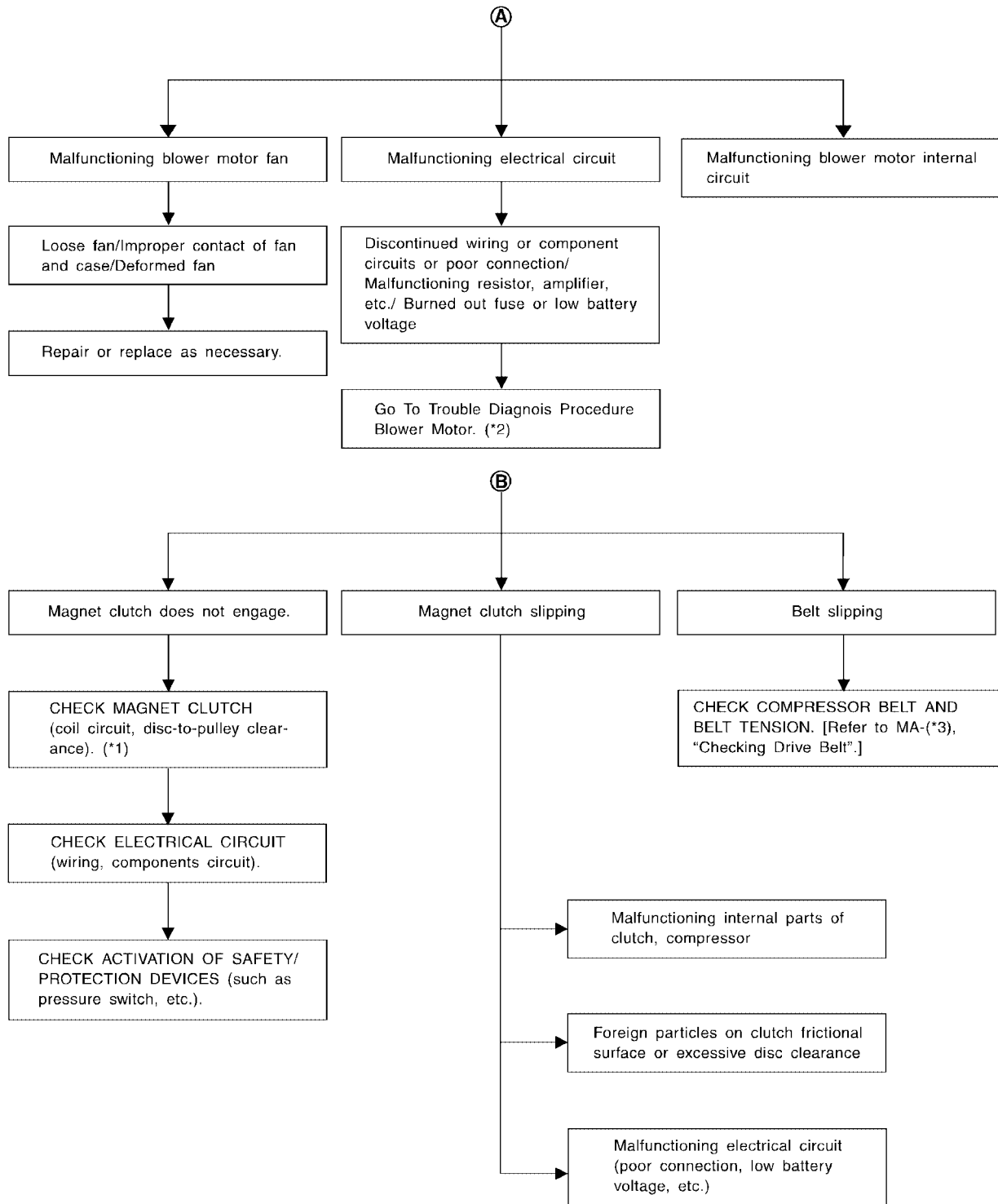

A
B
C
D
E
F
G
H
I
ATC
K
L
M

*1 [ATC-123, "INSTALLATION"](#)

*2 [ATC-67, "Blower Motor Circuit"](#)

*3 [MA-22, "Checking Drive Belts"](#)



SHA329F

TROUBLE DIAGNOSIS

PERFORMANCE CHART

Test Condition

Testing must be performed as follows:

Vehicle location	Indoors or in the shade (in a well-ventilated place)
Doors	Closed
Door windows	Open
Hood	Open
TEMP.	Max. COLD
Mode switch	 (Ventilation) set
Intake switch	 (Recirculation) set
 (blower) speed	Max. speed set
Engine speed	Idle speed

Operate the air conditioning system for 10 minutes before taking measurements.

Test Reading

Recirculating-to-discharge Air Temperature Table

Inside air (Recirculating air) at blower assembly inlet		Discharge air temperature at center ventilator °C (°F)
Relative humidity %	Air temperature °C (°F)	
50 - 60	25 (77)	10.0 - 12.3 (50 - 54)
	30 (86)	13.2 - 15.3 (56 - 60)
	35 (95)	17.2 - 21.0 (63 - 70)
60 - 70	25 (77)	12.3 - 14.9 (54 - 59)
	30 (86)	15.3 - 19.3 (60 - 67)
	35 (95)	21.0 - 24.4 (70 - 76)

Ambient Air Temperature-to-operating Pressure Table

Ambient air		High-pressure (Discharge side) kPa (kg/cm ² , psi)	Low-pressure (Suction side) kPa (kg/cm ² , psi)
Relative humidity %	Air temperature °C (°F)		
50 - 70	30 (86)	1,220 - 1,500 (12.44 - 15.30, 176.9 - 217.5)	240 - 295 (2.45 - 3.01, 34.8 - 42.8)
	35 (95)	1,360 - 1,690 (13.87 - 17.24, 197.2 - 245.1)	275 - 335 (2.81 - 3.42, 39.9 - 48.6)
	40 (104)	1,500 - 1,830 (12.44 - 18.67, 176.9 - 265.4)	310 - 375 (3.16 - 3.83, 45.0 - 54.4)

TROUBLE DIAGNOSIS FOR ABNORMAL PRESSURE

Whenever system's high and/or low side pressure is abnormal, diagnose using a manifold gauge. The marker above the gauge scale in the following tables indicates the standard (normal) pressure range. Since the standard (normal) pressure differs from vehicle to vehicle, refer to Ambient Air Temperature-to-operating Pressure Table above.

TROUBLE DIAGNOSIS

Both High- and Low-pressure Sides are Too High

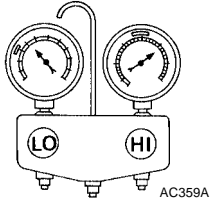
Gauge indication	Refrigerant cycle	Probable cause	Corrective action
<p>Both high and low-pressure sides are too high.</p>  <p style="text-align: right; font-size: small;">AC359A</p>	<p>Pressure is reduced soon after water is splashed on condenser.</p>	<p>Excessive refrigerant charge in refrigeration cycle</p>	<p>Reduce refrigerant until specified pressure is obtained.</p>
	<p>Air suction by cooling fan is insufficient.</p>	<p>Insufficient condenser cooling performance ↓ 1. Condenser fins are clogged. 2. Improper fan rotation of cooling fan</p>	<ul style="list-style-type: none"> ● Clean condenser. ● Check and repair cooling fan as necessary.
	<ul style="list-style-type: none"> ● Low-pressure pipe is not cold. ● When compressor is stopped high-pressure value quickly drops by approximately 196 kPa (2 kg/cm², 28 psi). It then decreases gradually thereafter. 	<p>Poor heat exchange in condenser (After compressor operation stops, high pressure decreases too slowly.) ↓ Air in refrigeration cycle</p>	<p>Evacuate repeatedly and recharge system.</p>
	<p>Engine tends to overheat.</p>	<p>Engine cooling systems malfunction.</p>	<p>Check and repair each engine cooling system.</p>
	<ul style="list-style-type: none"> ● An area of the low-pressure pipe is colder than areas near the evaporator outlet. ● Plates are sometimes covered with frost. 	<ul style="list-style-type: none"> ● Excessive liquid refrigerant on low-pressure side ● Excessive refrigerant discharge flow ● Expansion valve is open a little compared with the specification. <p>↓</p> <p>1. Improper thermal valve installation 2. Improper expansion valve adjustment</p>	<p>Replace expansion valve.</p>

High-pressure Side is Too High and Low-pressure Side is Too Low

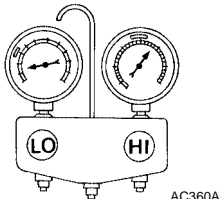
Gauge indication	Refrigerant cycle	Probable cause	Corrective action
<p>High-pressure side is too high and low-pressure side is too low.</p>  <p style="text-align: right; font-size: small;">AC360A</p>	<p>Upper side of condenser and high-pressure side are hot, however, liquid tank is not so hot.</p>	<p>High-pressure tube or parts located between compressor and condenser are clogged or hot.</p>	<ul style="list-style-type: none"> ● Check and repair or replace malfunctioning parts. ● Check lubricant for contamination.

High-pressure Side is Too Low and Low-pressure Side is Too High

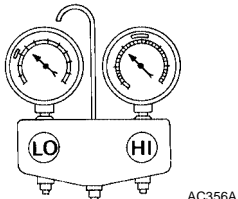
Gauge indication	Refrigerant cycle	Probable cause	Corrective action
<p>High-pressure side is too low and low-pressure side is too high.</p>  <p style="text-align: right; font-size: small;">AC356A</p>	<p>High and low-pressure sides become equal soon after compressor operation stops.</p>	<p>Compressor pressure operation is improper. ↓ Damaged inside compressor packings</p>	<p>Replace compressor.</p>
	<p>No temperature difference between high and low-pressure sides</p>	<p>Compressor pressure operation is improper. ↓ Damaged inside compressor packings.</p>	<p>Replace compressor.</p>

TROUBLE DIAGNOSIS

Both High- and Low-pressure Sides are Too Low

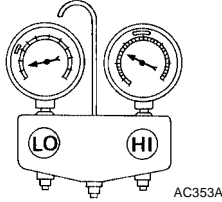
Gauge indication	Refrigerant cycle	Probable cause	Corrective action
<p>Both high- and low-pressure sides are too low.</p> 	<ul style="list-style-type: none"> There is a big temperature difference between receiver drier outlet and inlet. Outlet temperature is extremely low. Liquid tank inlet and expansion valve are frosted. 	Liquid tank inside is slightly clogged.	<ul style="list-style-type: none"> Replace desiccant assy. Check lubricant for contamination.
	<ul style="list-style-type: none"> Temperature of expansion valve inlet is extremely low as compared with areas near liquid tank. Expansion valve inlet may be frosted. Temperature difference occurs somewhere in high-pressure side 	High-pressure pipe located between receiver drier and expansion valve is clogged.	<ul style="list-style-type: none"> Check and repair malfunctioning parts. Check lubricant for contamination.
	Expansion valve and liquid tank are warm or only cool when touched.	Low refrigerant charge ↓ Leaking fittings or components	Check refrigerant for leaks. Refer to Checking Refrigerant Leaks, ATC-128, "Checking for Refrigerant Leaks" and ATC-129, "Electronic Refrigerant Leak Detector" .
	There is a big temperature difference between expansion valve inlet and outlet while the valve itself is frosted.	Expansion valve closes a little compared with the specification. ↓ 1. Improper expansion valve adjustment 2. Malfunctioning thermal valve 3. Outlet and inlet may be clogged.	<ul style="list-style-type: none"> Remove foreign particles by using compressed air. Check lubricant for contamination.
	An area of the low-pressure pipe is colder than areas near the evaporator outlet.	Low-pressure pipe is clogged or crushed.	<ul style="list-style-type: none"> Check and repair malfunctioning parts. Check lubricant for contamination.
	Air flow volume is not enough or is too low.	Evaporator is frozen.	<ul style="list-style-type: none"> Check thermo control amp. operation. Replace compressor.

Low-pressure Side Sometimes Becomes Negative

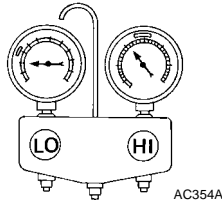
Gauge indication	Refrigerant cycle	Probable cause	Corrective action
<p>Low-pressure side sometimes becomes negative.</p> 	<ul style="list-style-type: none"> Air conditioning system does not function and does not cyclically cool the compartment air. The system constantly functions for a certain period of time after compressor is stopped and restarted. 	Refrigerant does not discharge cyclically. ↓ Moisture is frozen at expansion valve outlet and inlet. ↓ Water is mixed with refrigerant.	<ul style="list-style-type: none"> Drain water from refrigerant or replace refrigerant. Replace desiccant assy.

TROUBLE DIAGNOSIS

Low-pressure Side Becomes Negative

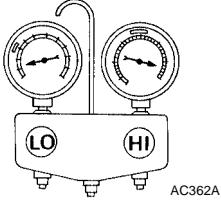
Gauge indication	Refrigerant cycle	Probable cause	Corrective action
<p>Low-pressure side becomes negative.</p> 	<p>Liquid tank or front/rear side of expansion valve's pipe is frosted or dewed.</p>	<p>High-pressure side is closed and refrigerant does not flow. ↓ Expansion valve or liquid tank is frosted.</p>	<p>Leave the system at rest until no frost is present. Start it again to check whether or not the problem is caused by water or foreign particles.</p> <ul style="list-style-type: none"> ● If water is the cause, initially cooling is okay. Then the water freezes causing a blockage. Drain water from refrigerant or replace refrigerant. ● If due to foreign particles, remove expansion valve and remove the particles with dry and compressed air (not shop air). ● If either of the above methods cannot correct the problem, replace expansion valve. ● Replace desiccant assy. ● Check lubricant for contamination.

A
B
C
D
E
F
G
H
I

ATC

K
L
M

TROUBLE DIAGNOSIS

EJS001D2

Insufficient Heating

SYMPTOM: Insufficient heating

INSPECTION FLOW

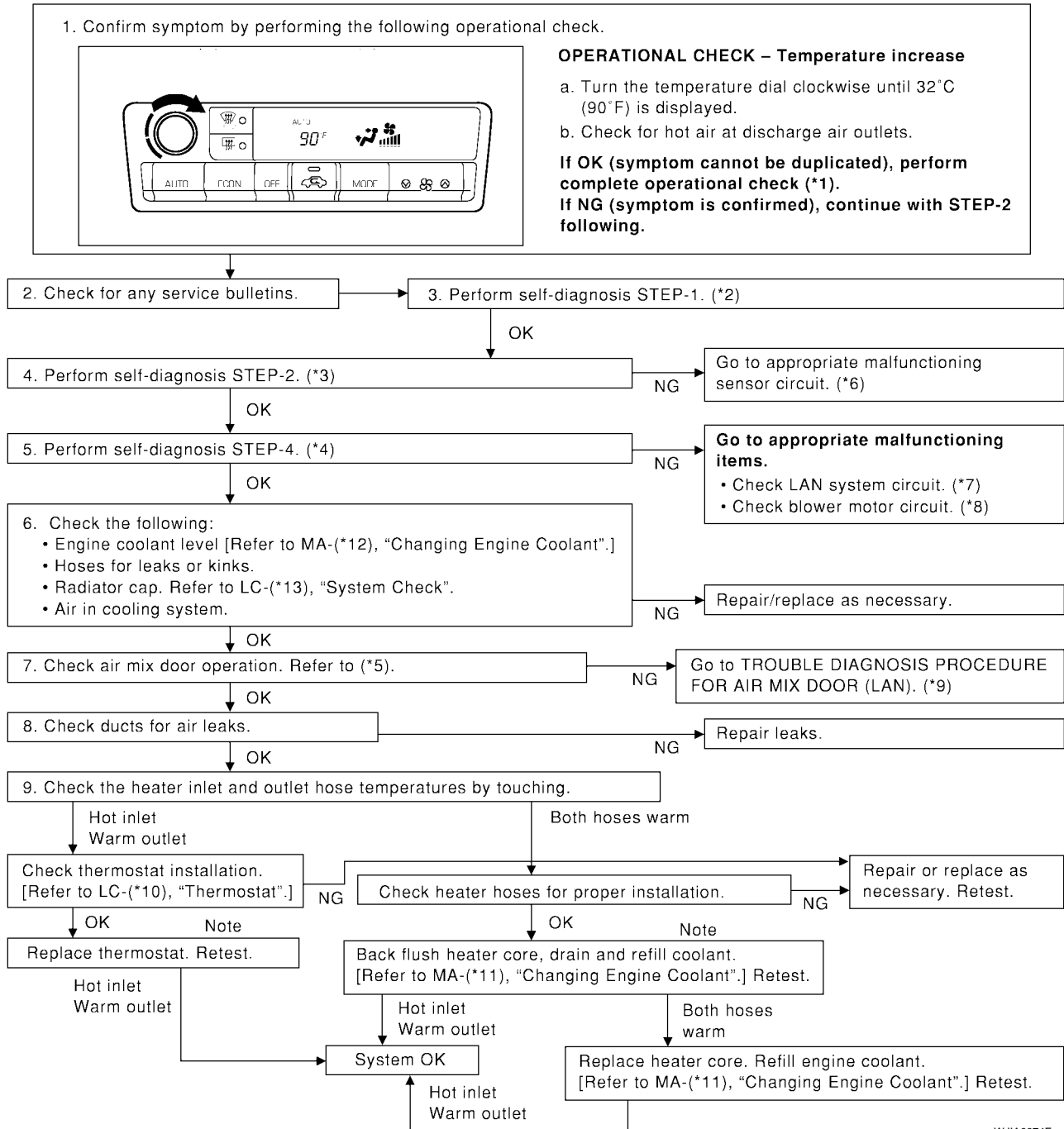

WJIA0074E

*1 [ATC-49. "Operational Check"](#)

*2 [ATC-41. "Self-diagnosis"](#), see No.1.

*3 [ATC-41. "Self-diagnosis"](#), see No.5.

*4 [ATC-41. "Self-diagnosis"](#), see No.7.

*5 [ATC-61. "Air Mix Door Motor Circuit"](#)

*6 [ATC-41. "Self-diagnosis"](#), see No.14.

*7 [ATC-54. "LAN System Circuit"](#)

*8 [ATC-67. "Blower Motor Circuit"](#)

*9 [ATC-61. "Air Mix Door Motor Circuit"](#)

*10 [CO-42. "THERMOSTAT AND THERMOSTAT HOUSING"](#)

*11 [MA-23. "Changing Engine Coolant"](#)

*12 [MA-23. "Changing Engine Coolant"](#)

*13 [CO-29. "CHECKING RADIATOR CAP"](#)

TROUBLE DIAGNOSIS

EJS001D3

Noise

SYMPTOM: Noise

INSPECTION FLOW

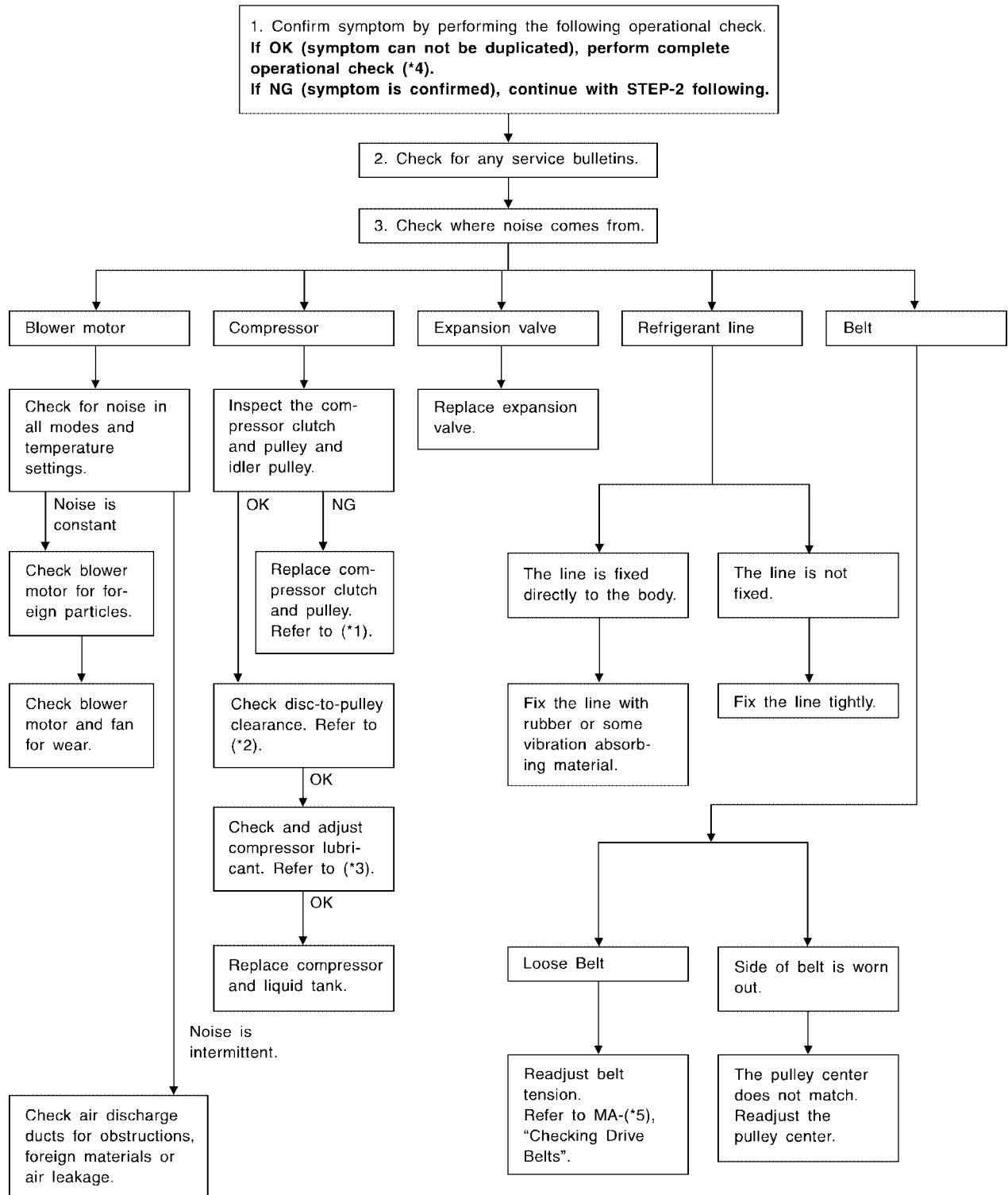

*1 [ATC-122, "Removal and Installation for Compressor Clutch"](#)

*3 [ATC-18, "LUBRICANT"](#)

*5 [MA-22, "Checking Drive Belts"](#)

*2 [ATC-122, "Removal and Installation for Compressor Clutch"](#)

*4 [ATC-49, "Operational Check"](#)

SHA331F

TROUBLE DIAGNOSIS

EJS001D4

Self-diagnosis

SYMPTOM: Self-diagnosis cannot be performed.

INSPECTION FLOW

1. Confirm symptom by performing operational check.

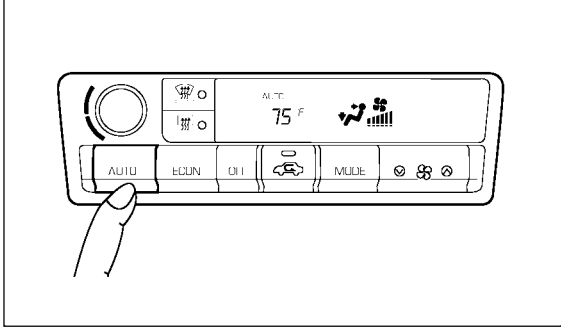

OPERATIONAL CHECK – AUTO mode

- Press AUTO switch.
- Display should indicate AUTO (not ECON). Confirm that the compressor clutch engages (audio or visual inspection). (Discharge air and blower speed will depend on ambient, in-vehicle and set temperatures.)

**If OK (symptom cannot be duplicated), perform complete operational check (*9).
If NG (symptom is confirmed), continue with STEP-2 following.**

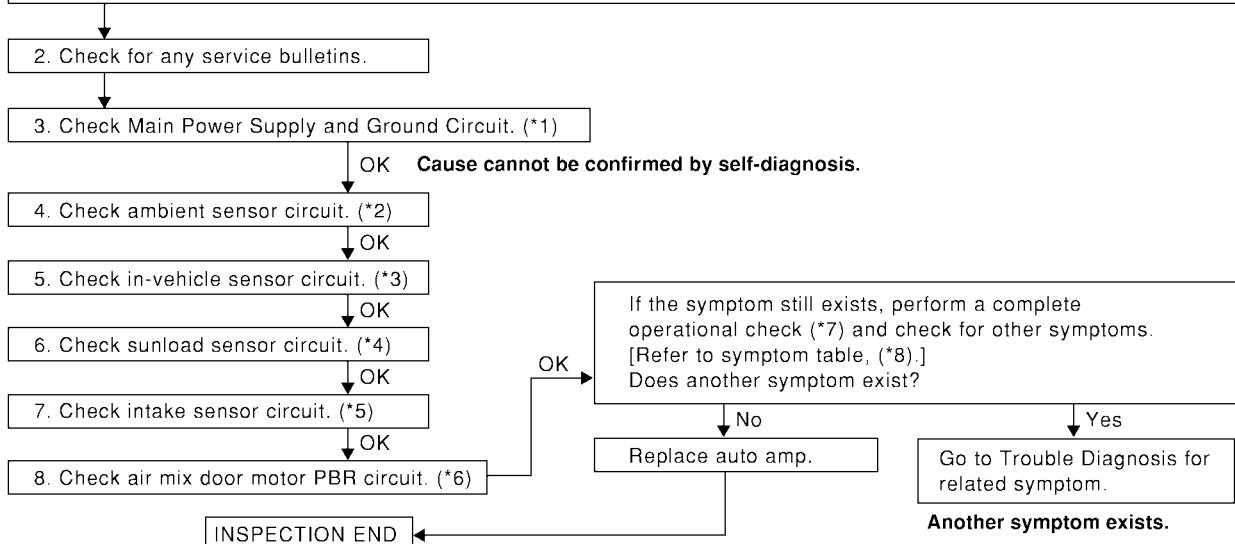

*1 [ATC-52, "Power Supply and Ground Circuit for Auto Amp."](#)

*2 [ATC-90, "Ambient Sensor Circuit"](#)

*3 [ATC-92, "In-vehicle Sensor Circuit"](#)

*4 [ATC-95, "Sunload Sensor Circuit"](#)

*5 [ATC-98, "Intake Sensor Circuit"](#)

*6 [ATC-61, "Air Mix Door Motor Circuit"](#)

*7 [ATC-49, "Operational Check"](#)

*8 [ATC-31, "SYMPTOM TABLE"](#)

*9 [ATC-49, "Operational Check"](#)

WJIA0075E

TROUBLE DIAGNOSIS

EJS001D5

Memory Function

SYMPTOM: Memory function does not operate.

INSPECTION FLOW

1. Confirm symptom by performing the following operational check.

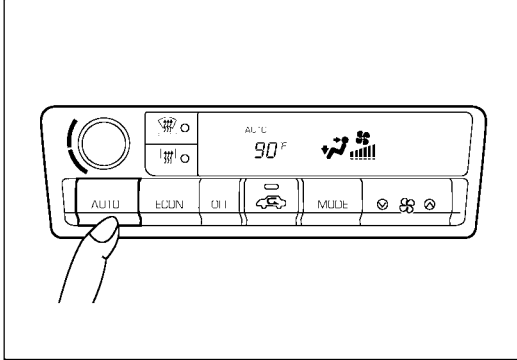

OPERATIONAL CHECK – Memory function

- Set the temperature 90°F or 32°C.
- Press OFF switch.
- Turn the ignition off.
- Turn the ignition on.
- Press the AUTO switch.
- Confirm that the set temperature remains at previous temperature.
- Press OFF switch.

If OK (symptom cannot be duplicated), perform complete operational check (*2).

If NG (symptom is confirmed), continue with STEP-2 following.

2. Check for any service bulletins.

3. Check Main Power Supply and Ground Circuit. (*1)

OK

Go to A/C system circuit. (*4)

OK

4. Replace auto amp.

5. FINAL CHECK

Go to self-diagnosis step-by-step procedure (*3) and perform self-diagnosis STEP-2.
Confirm that code No. 20 is displayed.

A

B

C

D

E

F

G

H

I

ATC

K

L

M

WJIA0076E

*1 [PG-3, "POWER SUPPLY ROUTING CIRCUIT"](#) *3 [ATC-41, "Self-diagnosis"](#)

*4 [ATC-35, "Wiring Diagram — A/C,A —"](#)

*2 [ATC-49, "Operational Check"](#)

TROUBLE DIAGNOSIS

EJS001D6

ECON (ECONOMY) Mode

SYMPTOM: ECON mode does not operate.

INSPECTION FLOW

1. Confirm symptom by performing the following operational check.

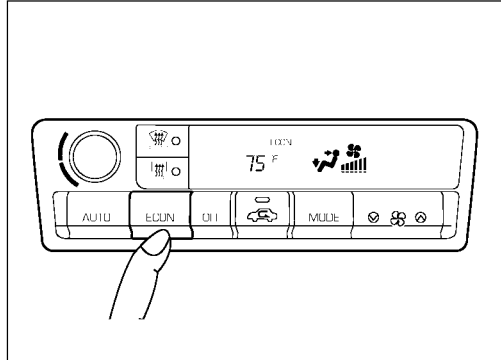

OPERATIONAL CHECK – ECON (ECONOMY) mode

- Set the temperature 75°F or 25°C.
- Press ECON switch.
- Display should indicate ECON (not AUTO).
Confirm that the compressor clutch is not engaged (visual inspection).
(Discharge air and blower speed will depend on ambient, in-vehicle, and set temperatures.)

If OK (symptom cannot be duplicated), perform complete operational check (*2).
If NG (symptom is confirmed), continue with STEP-2 following.

2. Check for any service bulletins.

3. Check Main Power Supply and Ground Circuit. (*1)

OK

Go to A/C system circuit. (*4)

OK

4. Replace auto amp.

5. FINAL CHECK

Go to self-diagnosis step-by-step procedure (*3) and perform self-diagnosis STEP-2.
Confirm that code No. 20 is displayed.

*1 [PG-3, "POWER SUPPLY ROUTING CIRCUIT"](#) *3 [ATC-41, "Self-diagnosis"](#)

*4 [ATC-35, "Wiring Diagram — A/C.A. —"](#)

*2 [ATC-49, "Operational Check"](#)

WJIA0077E

Ambient Sensor Circuit COMPONENT DESCRIPTION

EJS001D7

Ambient Sensor

The ambient sensor is attached to the front bumper reinforcement. It detects ambient temperature and converts it into a resistance value which is then input into the auto amplifier.

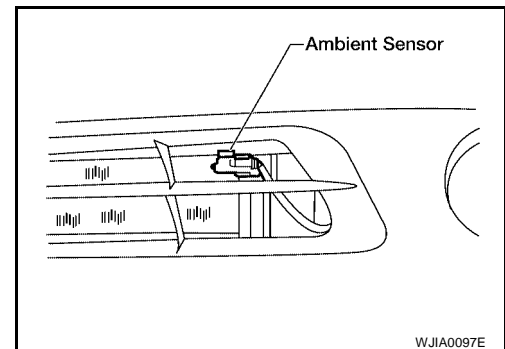

WJIA0097E

AMBIENT TEMPERATURE INPUT PROCESS

The automatic amplifier includes a processing circuit for the ambient sensor input. However, when the temperature detected by the ambient sensor increases quickly, the processing circuit retards the auto amp. function. It only allows the auto amp. to recognize an ambient temperature increase of 0.33°C (0.6°F) per 100 seconds.

TROUBLE DIAGNOSIS

As an example, consider stopping for a cup of coffee after high speed driving. Although the actual ambient temperature has not changed, the temperature detected by the ambient sensor will increase. This is because the heat from the engine compartment can radiate to the front grille area, location of the ambient sensor.

DIAGNOSTIC PROCEDURE

SYMPTOM: Ambient sensor circuit is open or shorted. (21 or -21 is indicated on auto amp. as a result of conducting Self-diagnosis STEP 2.)

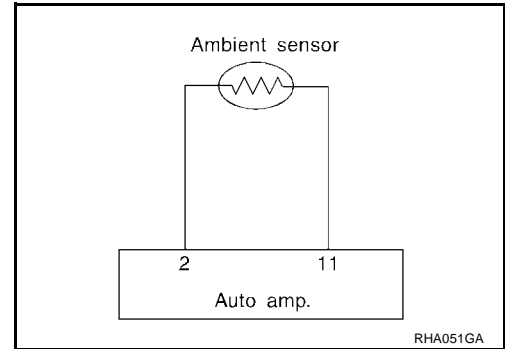

1. CHECK VOLTAGE BETWEEN AMBIENT SENSOR HARNESS CONNECTOR AND BODY GROUND

Disconnect ambient sensor harness connector.

Terminal (+)		Terminal (-)	Voltage (V) (Approx.)
Connector	Wire color	Body ground	
E1-1	OR/B		12V

OK or NG

- OK >> GO TO 2.
- NG >> GO TO 4.

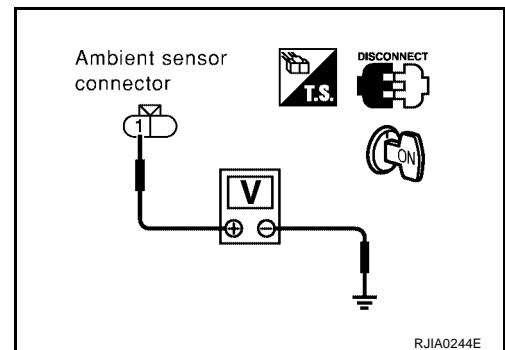

2. CHECK AMBIENT SENSOR GROUND CIRCUIT BETWEEN AMBIENT SENSOR AND AUTO AMP. (LCU)

Disconnect auto amp. (LCU) harness connector.

Terminals				Continuity
Connector	Wire color	Connector	Wire color	Yes
M49-11	B/Y	E1-2	B	

If OK, check harness for short.

OK or NG

- OK >> GO TO 3.
- NG >> Repair harness or connector.

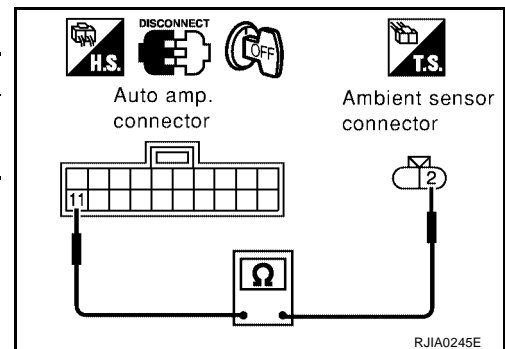

3. CHECK AMBIENT SENSOR

Refer to [ATC-90, "Ambient Sensor Circuit"](#).

OK or NG

- OK >> 1. Replace auto amp. (LCU).
- 2. Go to [ATC-41, "Self-diagnosis"](#) and perform self-diagnosis STEP 2. Confirm that code No. 20 is displayed.
- NG >> Replace ambient sensor.

TROUBLE DIAGNOSIS

4. CHECK AMBIENT SENSOR CIRCUIT BETWEEN AMBIENT SENSOR AND AUTO AMP. (LCU)

Disconnect auto amp. (LCU) harness connector.

Terminals				Continuity
Connector	Wire color	Connector	Wire color	
M49-2	OR/B	E1-1	OR/B	Yes

If OK, check harness for short.

OK or NG

- OK >> 1. Replace auto amp. (LCU).
 2. Go to self-diagnosis step-by-step procedure (Refer to [ATC-41. "Self-diagnosis"](#)) and perform self-diagnosis STEP 2. Confirm that code No. 20 is displayed.

NG >> Repair harness or connector.

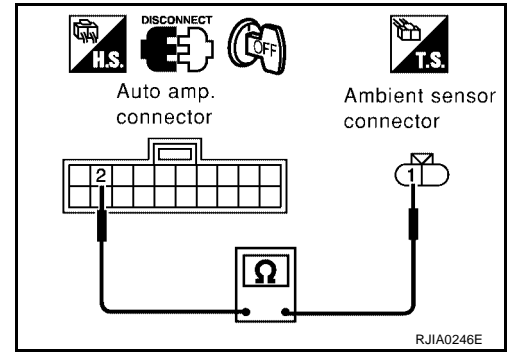

COMPONENT INSPECTION

Ambient Sensor

After disconnecting ambient sensor harness connector, measure resistance between terminals 2 and 1 at sensor harness side, using the table below.

Temperature °C (°F)	Resistance kΩ
-15 (5)	12.73
-10 (14)	9.92
-5 (23)	7.80
0 (32)	6.19
5 (41)	4.95
10 (50)	3.99
15 (59)	3.24
20 (68)	2.65
25 (77)	2.19
30 (86)	1.81
35 (95)	1.51
40 (104)	1.27
45 (113)	1.07

If NG, replace ambient sensor.

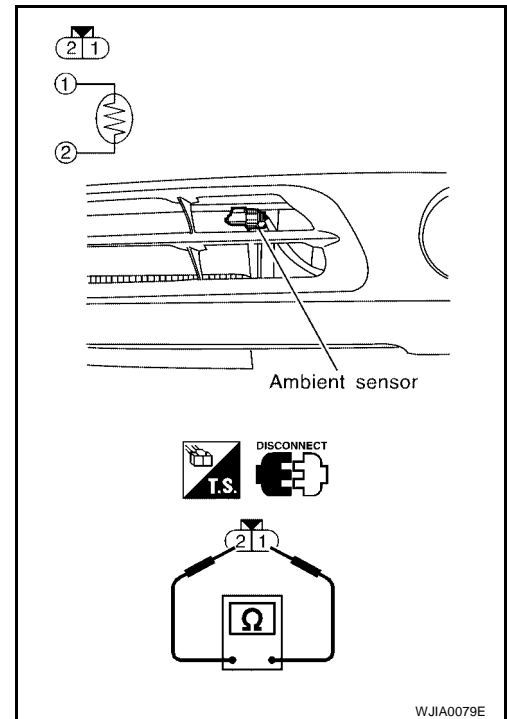

In-vehicle Sensor Circuit COMPONENT DESCRIPTION

In-vehicle sensor

The in-vehicle sensor is located on instrument lower panel. It converts variations in temperature of compartment air drawn from the aspirator into a resistance value. It is then input into the auto amplifier.

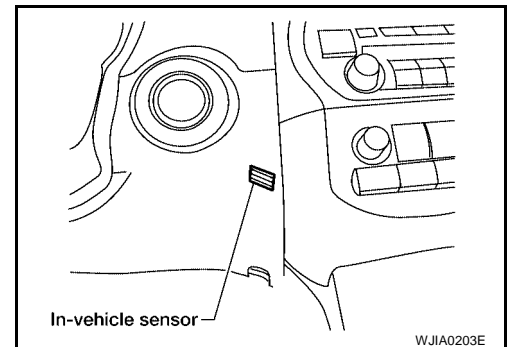

TROUBLE DIAGNOSIS

Aspirator

The aspirator is located on driver's side of heater and cooling unit. It produces vacuum pressure due to air discharged from the heater and cooling unit, continuously taking compartment air in the aspirator.

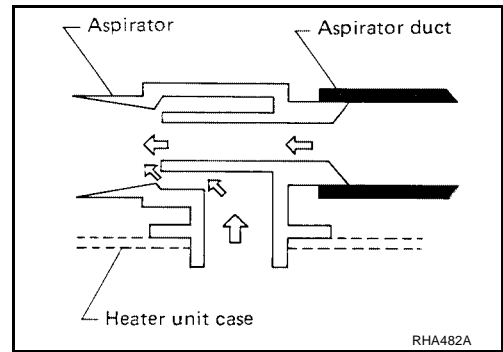
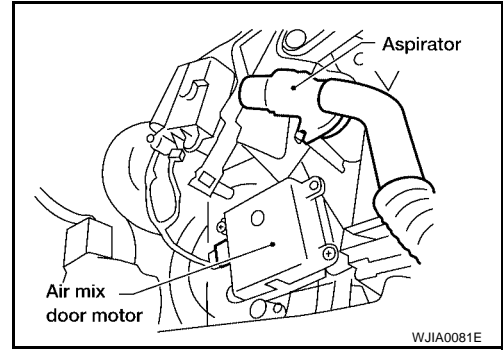

DIAGNOSTIC PROCEDURE

SYMPTOM: In-vehicle sensor circuit is open or shorted. (22 or -22 is indicated on auto amp. as a result of conducting Self-diagnosis STEP 2.)

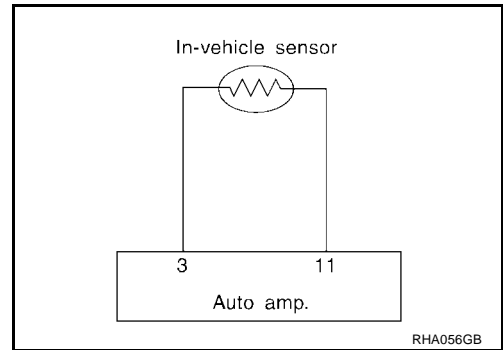

1. CHECK IN-VEHICLE SENSOR CIRCUIT BETWEEN IN-VEHICLE SENSOR AND BODY GROUND

Disconnect in-vehicle sensor harness connector.

Terminals		Voltage (V) (Approx.)
(+)	(-)	
Connector	Wire color	5V
M32-1	B/Y	
		Body ground

OK or NG

- OK >> GO TO 2.
- NG >> GO TO 4.

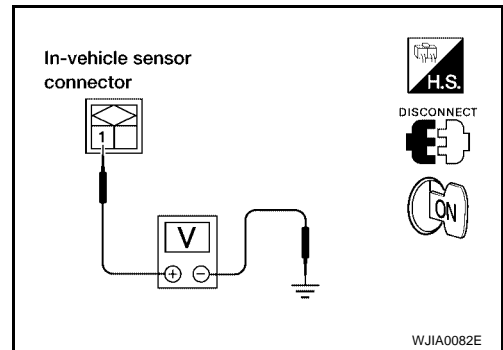

TROUBLE DIAGNOSIS

2. CHECK IN-VEHICLE SENSOR GROUND CIRCUIT BETWEEN IN-VEHICLE SENSOR AND AUTO AMP. (LCU)

Disconnect auto amp. (LCU) harness connector.

Terminals				Continuity
Connector	Wire color	Connector	Wire color	
M49-11	B/Y	M32-2	B/Y	Yes

If OK, check harness for short.

OK or NG

- OK >> GO TO 3.
- NG >> Repair harness or connector.

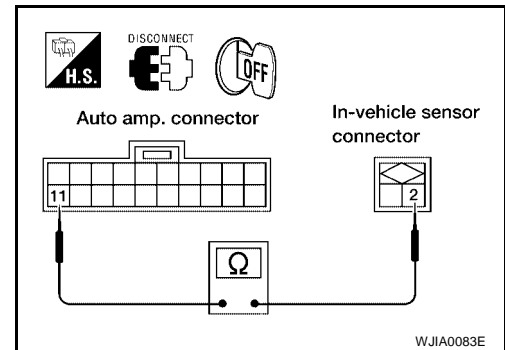

3. CHECK IN-VEHICLE SENSOR

Refer to [ATC-98, "Intake Sensor"](#) .

OK or NG

- OK >> 1. Replace auto amp.
- 2. Go to self-diagnosis step-by-step procedure (Refer to [ATC-41, "Self-diagnosis"](#)) and perform self-diagnosis STEP 2. Confirm that code No. 20 is displayed.
- NG >> 1. Replace in-vehicle sensor.
- 2. Go to self-diagnosis step-by-step procedure (Refer to [ATC-41, "Self-diagnosis"](#)) and perform self-diagnosis STEP 2. Confirm that code No. 20 is displayed.

4. CHECK IN-VEHICLE SENSOR CIRCUIT BETWEEN AMBIENT SENSOR AND AUTO AMP. (LCU)

Disconnect auto amp. (LCU) harness connector.

Terminals				Continuity
Connector	Wire color	Connector	Wire color	
M49-3	LG	M39-1	LG	Yes

If OK, check harness for short.

OK or NG

- OK >> 1. Replace auto amp. (LCU).
- 2. Go to self-diagnosis step-by-step procedure ([ATC-41, "Self-diagnosis"](#)) and perform self-diagnosis STEP 2. Confirm that code No. 20 is displayed.
- NG >> Repair harness or connector.

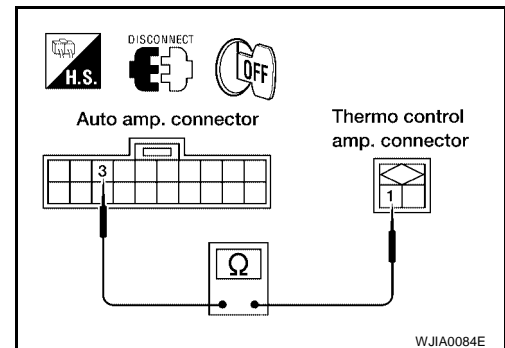

TROUBLE DIAGNOSIS

COMPONENT INSPECTION

In-vehicle Sensor

After disconnecting in-vehicle sensor harness connector, measure resistance between terminals 1 and 2 at sensor harness side, using the table below.

Temperature °C (°F)	Resistance kΩ
-15 (5)	12.73
-10 (14)	9.92
-5 (23)	7.80
0 (32)	6.19
5 (41)	4.95
10 (50)	3.99
15 (59)	3.24
20 (68)	2.65
25 (77)	2.19
30 (86)	1.81
35 (95)	1.51
40 (104)	1.27
45 (113)	1.07

If NG, replace in-vehicle sensor.

Sunload Sensor Circuit COMPONENT DESCRIPTION

The sunload sensor is located on the right defroster grille. It detects sunload entering through windshield by means of a photo diode. The sensor converts the sunload into a current value which is then input into the auto amplifier.

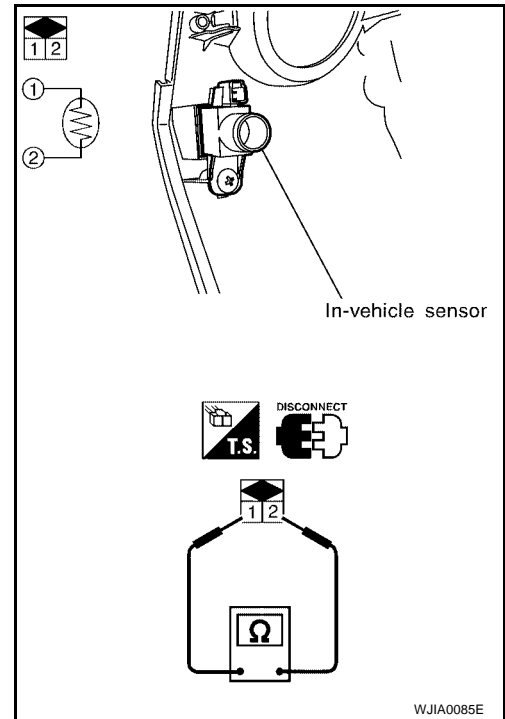

WJIA0085E

EJS001D9

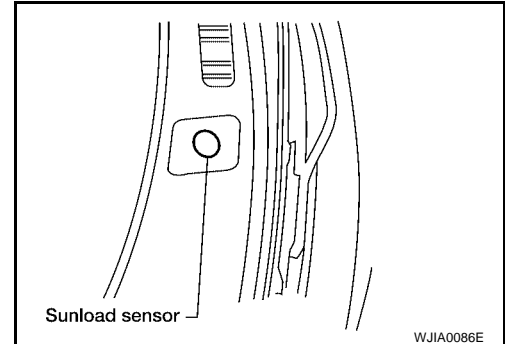

WJIA0086E

SUNLOAD INPUT PROCESS

The auto amp. also includes a processing circuit which average the variations in detected sunload over a period of time. This prevents drastic swings in the ATC system operation due to small or quick variations in detected sunload.

For example, consider driving along a road bordered by an occasional group of large trees. The sunload detected by the sunload sensor will vary whenever the trees obstruct the sunlight. The processing circuit averages the detected sunload over a period of time, so that the (insignificant) effect of the trees momentarily obstructing the sunlight does not cause any change in the ATC system operation. On the other hand, shortly after entering a long tunnel, the system will recognize the change in sunload, and the system will react accordingly.

A
B
C
D
E
F
G
H
I

ATC

K
L
M

TROUBLE DIAGNOSIS

DIAGNOSTIC PROCEDURE

SYMPTOM: Sunload sensor circuit is open or shorted. (25 or -25) is indicated on auto amp. as a result of conducting Self-diagnosis STEP 2.)

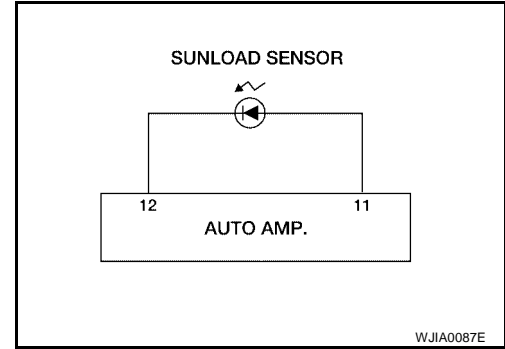

1. CHECK SUNLOAD SENSOR CIRCUIT BETWEEN SUNLOAD SENSOR AND BODY GROUND

Disconnect sunload sensor harness connector.

Terminals		Voltage (V) (Approx.)
(+)	(-)	
Connector	Wire color	Body ground 5V
M65-1	OR	

OK or NG

OK >> GO TO 2.

NG >> GO TO 4.

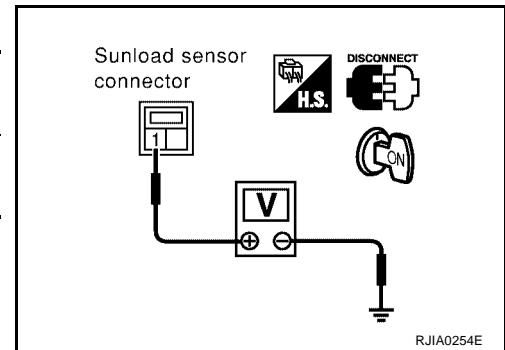

2. CHECK SUNLOAD SENSOR GROUND CIRCUIT BETWEEN SUNLOAD SENSOR AND AUTO AMP. (LCU)

Disconnect auto amp. (LCU) harness connector.

Terminals				Continuity
Connector	Wire color	Connector	Wire color	Yes
M49-12	OR	M65-1	OR	

If OK, check harness for short.

OK or NG

OK >> GO TO 3.

NG >> Repair harness or connector.

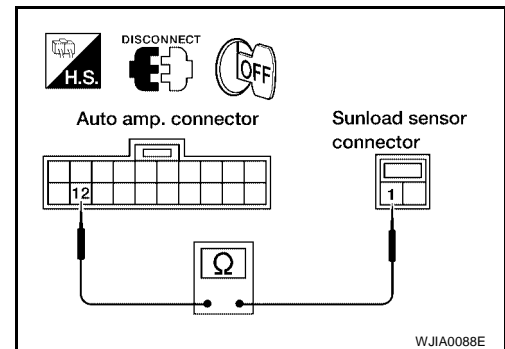

3. CHECK SUNLOAD SENSOR

Refer to [ATC-97, "Sunload Sensor"](#) .

OK or NG

OK >> 1. Replace auto amp. (LCU).

2. Go to self-diagnosis step-by-step procedure (Refer to [ATC-41, "Self-diagnosis"](#)) and perform self-diagnosis STEP 2. Confirm that code No. 20 is displayed.

NG >> 1. Replace sunload sensor.

2. Go to self-diagnosis step-by-step procedure (Refer to [ATC-41, "Self-diagnosis"](#)) and perform self-diagnosis STEP 2. Confirm that code No. 20 is displayed.

TROUBLE DIAGNOSIS

4. CHECK SUNLOAD SENSOR CIRCUIT BETWEEN SUNLOAD SENSOR AND AUTO AMP. (LCU)

Disconnect auto amp. (LCU) harness connector.

Terminals				Continuity
Connector	Wire color	Connector	Wire color	
M49-11	B/Y	M65-2	B/Y	Yes

If OK, check harness for short.

OK or NG

- OK >> 1. Replace auto amp.
 2. Go to self-diagnosis step-by-step procedure (Refer to [ATC-41, "Self-diagnosis"](#)) and perform self-diagnosis STEP 2. Confirm that code No. 20 is displayed.

NG >> Repair harness or connector.

COMPONENT INSPECTION

Sunload Sensor

Measure voltage between auto amp. terminal 12 and body ground.
 If NG, replace auto amp.

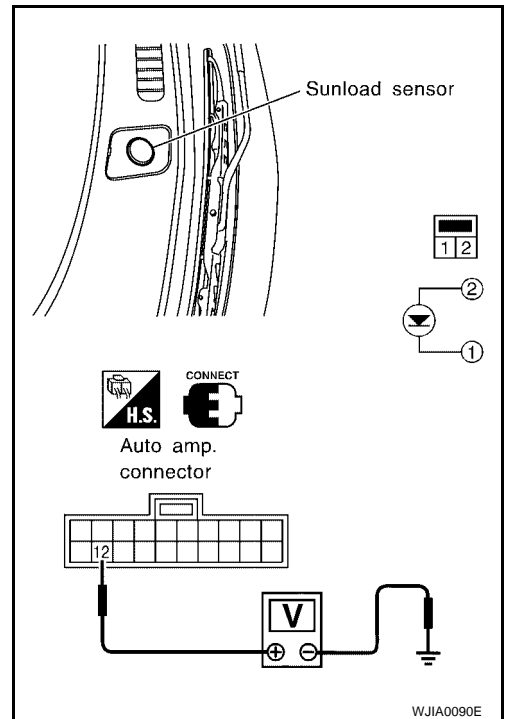
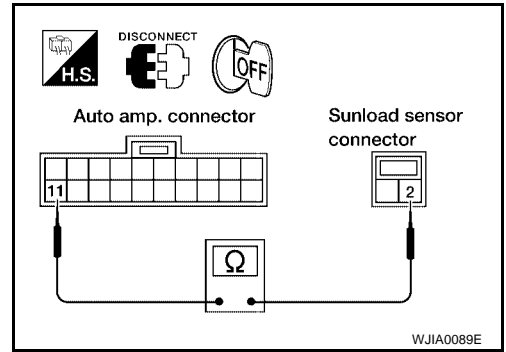

A
B
C
D
E
F
G
H
I
ATC
K
L
M

TROUBLE DIAGNOSIS

- When checking sunload sensor, select a place where sun shines directly on it.

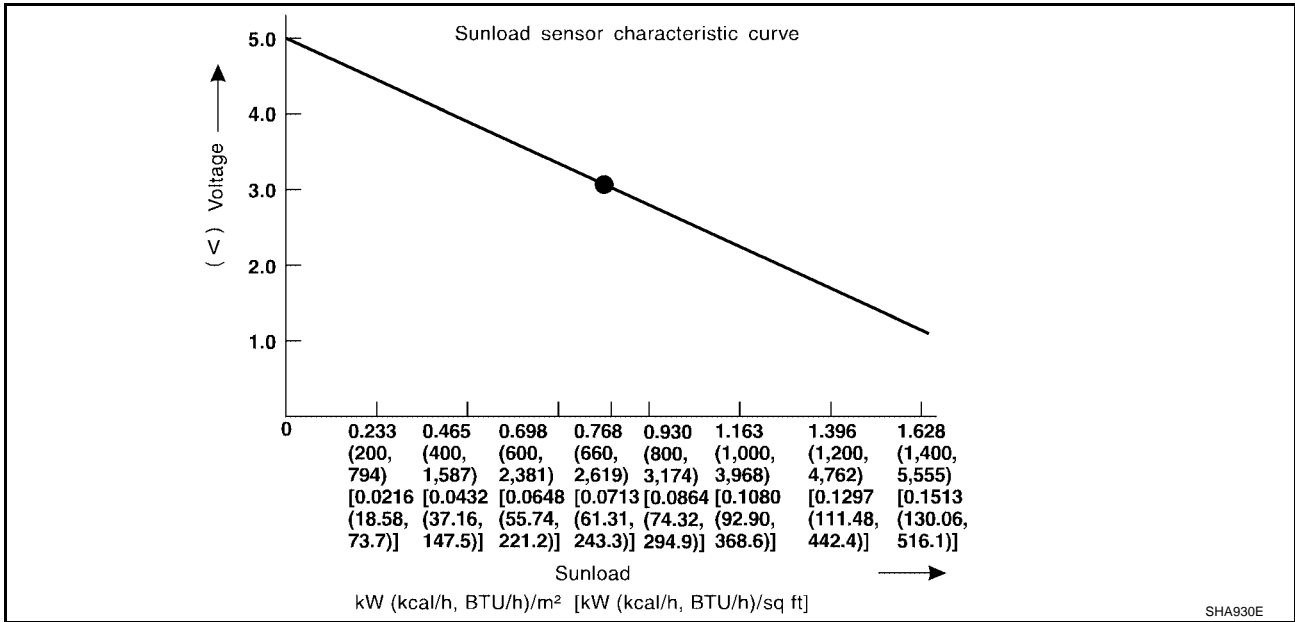

Intake Sensor Circuit COMPONENT DESCRIPTION

EJS001DA

Intake Sensor

The intake sensor is located on the heater and cooling unit. It converts temperature of air after it passes through the evaporator into a resistance value which is then input to the auto amp.

After disconnecting intake sensor harness connector, measure resistance between terminals 1 and 2 at sensor harness side, using the table below.

Temperature °C (°F)	Resistance kΩ
-15 (5)	12.34
-10 (14)	9.62
-5 (23)	7.56
0 (32)	6.00
5 (41)	4.80
10 (50)	3.87
15 (59)	3.15
20 (68)	2.57
25 (77)	2.12
30 (86)	1.76
35 (95)	1.47
40 (104)	1.23
45 (113)	1.04

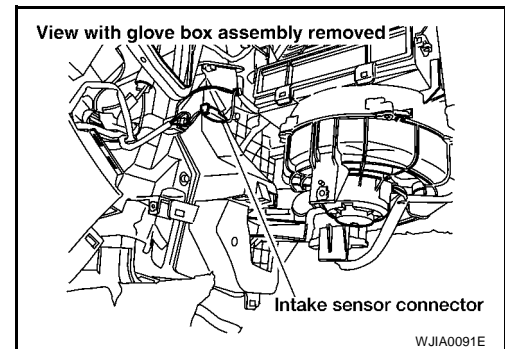

If NG, replace intake sensor.

TROUBLE DIAGNOSIS

DIAGNOSTIC PROCEDURE

SYMPTOM: Intake sensor circuit is open or shorted. (24 or -24 is indicated on auto amp. as a result of conducting Self-diagnosis STEP 2.)

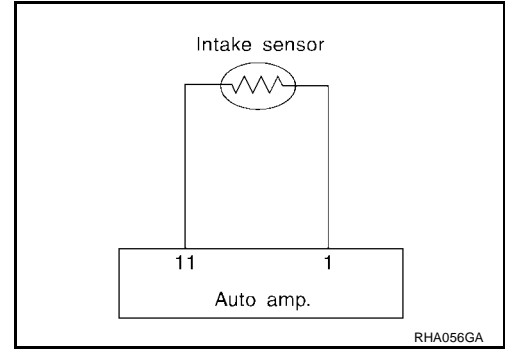

1. CHECK INTAKE SENSOR CIRCUIT BETWEEN INTAKE SENSOR AND BODY GROUND

Disconnect intake sensor harness connector.

Terminals		Voltage (V) (Approx.)
(+)	(-)	
Connector	Wire color	Body ground 5V
M33-2	B/Y	

OK or NG

OK >> GO TO 2.

NG >> GO TO 4.

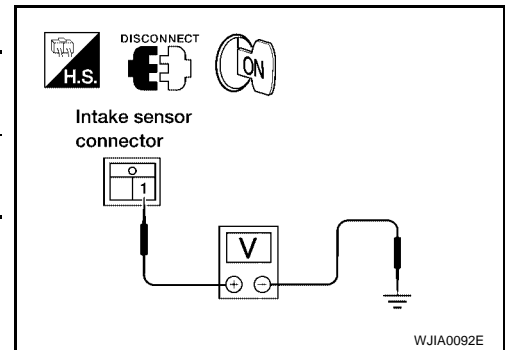

2. CHECK INTAKE SENSOR GROUND CIRCUIT BETWEEN INTAKE SENSOR AND AUTO AMP. (LCU)

Disconnect auto amp. (LCU) harness connector.

Terminals				Continuity
Connector	Wire color	Connector	Wire color	
M49-11	B/Y	M33-2	B/Y	Yes

If OK, check harness for short.

OK or NG

OK >> GO TO 3.

NG >> Repair harness or connector.

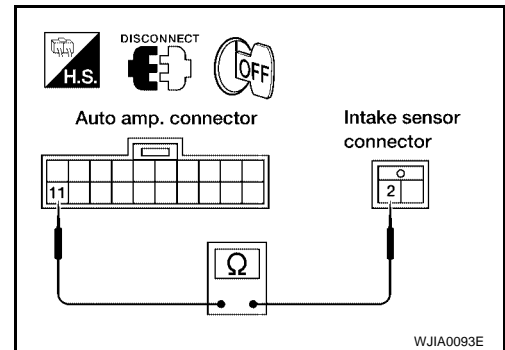

3. CHECK INTAKE SENSOR

Refer to [ATC-98, "Intake Sensor"](#) .

OK or NG

OK >> 1. Replace auto amp.

2. Go to self-diagnosis step-by-step procedure (Refer to [ATC-41, "Self-diagnosis"](#)) and perform self-diagnosis STEP 2. Confirm that code No. 20 is displayed.

NG >> 1. Replace intake sensor.

2. Go to self-diagnosis step-by-step procedure (Refer to [ATC-41, "Self-diagnosis"](#)) and perform self-diagnosis STEP 2. Confirm that code No. 20 is displayed.

TROUBLE DIAGNOSIS

4. CHECK INTAKE SENSOR CIRCUIT BETWEEN AMBIENT SENSOR AND AUTO AMP. (LCU)

Disconnect auto amp. (LCU) harness connector.

Terminals				Continuity
Connector	Wire color	Connector	Wire color	Yes
M33-1	R/W	M49-1	R/W	

If OK, check harness for short.

OK or NG

- OK >> 1. Replace auto amp.
2. Go to self-diagnosis step-by-step procedure (Refer to [ATC-41. "Self-diagnosis"](#)) and perform self-diagnosis STEP 2. Confirm that code No. 20 is displayed.
- NG >> Repair harness or connector.

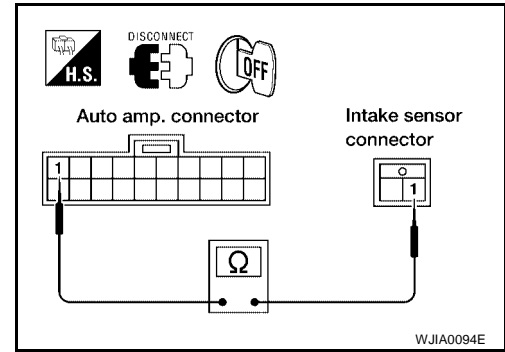

AUTO AMP

AUTO AMP

PF2:27760

Removal and Installation

EJS001DB

1. Remove cluster lid D. Refer to [IP-12, "Cluster Lid D"](#) .
2. Remove the audio unit. Refer to [AV-22, "AUDIO UNIT"](#) .
3. Remove the A/C auto amp. screws and then remove it from the instrument panel.
4. Disconnect the connectors.

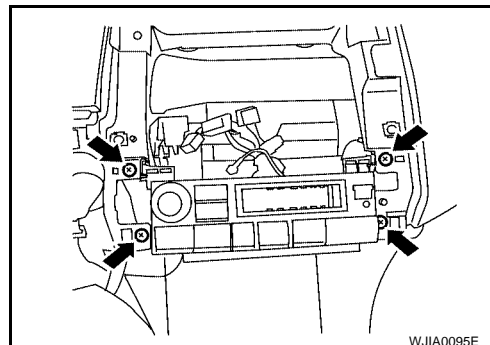

A

B

C

D

E

F

G

H

I

ATC

K

L

M

AMBIENT SENSOR

AMBIENT SENSOR

PF2:27722

Removal and Installation

EJS001DC

1. Disconnect ambient sensor connector.
2. Release the ambient sensor clip and then remove it.

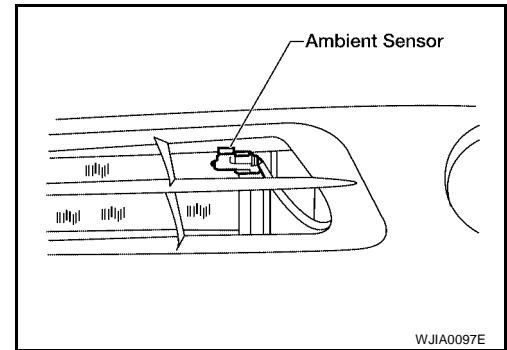

IN-VEHICLE SENSOR

IN-VEHICLE SENSOR

PFP:27720

Removal and Installation

EJS001DD

1. Remove lower driver instrument panel assembly. Refer to [IP-12, "Driver Lower Instrument Panel"](#).
2. Remove the in-vehicle sensor screw and then remove it.

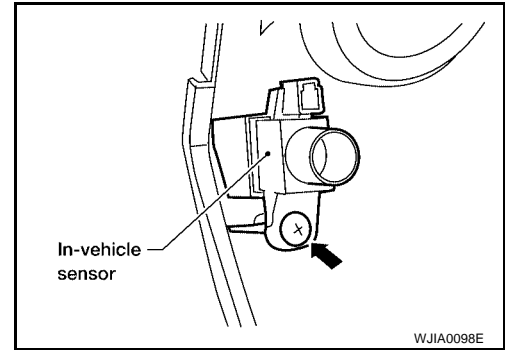

A
B
C
D
E
F
G
H
I

ATC

K
L
M

SUNLOAD SENSOR

SUNLOAD SENSOR

PFP:27721

Removal and Installation

EJS001DE

1. Remove the sunload sensor garnish.
2. Disconnect the connector.
3. Release the sunload sensor tabs and then remove it from the garnish.

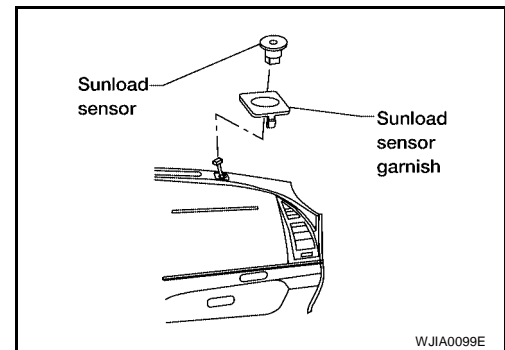

INTAKE SENSOR

PFP:27723

INTAKE SENSOR

Removal and Installation

1. Remove the evaporator. Refer to [ATC-126, "Removal and Installation for Evaporator"](#) .
2. Remove the intake sensor clip and then the sensor.

CAUTION:

Be careful not to damage the core surface.

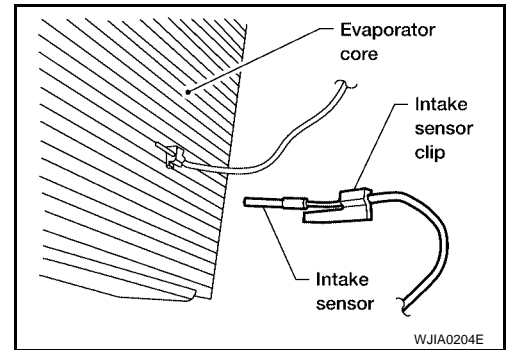

A

B

C

D

E

F

G

H

I

ATC

K

L

M

THERMO CONTROL AMPLIFIER

THERMO CONTROL AMPLIFIER

PFP:27675

Removal and Installation

EJS001DG

1. Remove evaporator. Refer to [ATC-126, "Removal and Installation for Evaporator"](#).
2. Remove thermo control amplifier.

CAUTION:

Be careful not to damage the core surface.

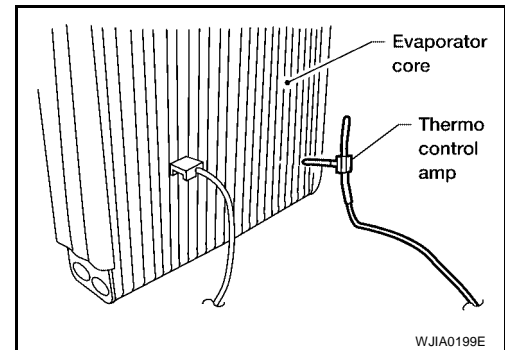

BLOWER UNIT

BLOWER UNIT

PFP:27200

Removal and Installation

EJS001DH

REMOVAL

1. Remove the glove box assembly. Refer to [IP-14, "Glove Box"](#)
2. Remove the ECM.
3. Disconnect the blower motor, intake door motor and fan control amp. connector.
4. Remove the 2 bolts and 1 screw from the blower unit, then remove it.

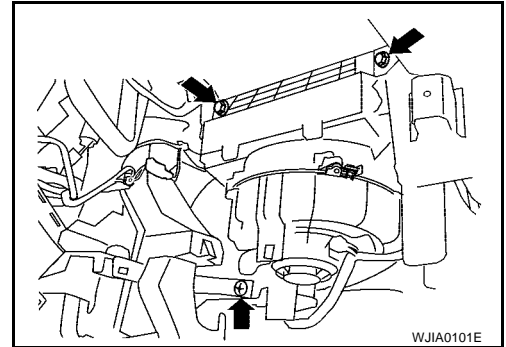

A

B

C

D

E

F

G

H

I

ATC

K

L

M

BLOWER MOTOR

BLOWER MOTOR

PFP:27226

Removal and Installation

EJS001DI

1. Remove the blower unit. Refer to [ATC-107, "Removal and Installation"](#) .
2. Release the 8 tabs attaching blower motor to blower unit case and then remove it.

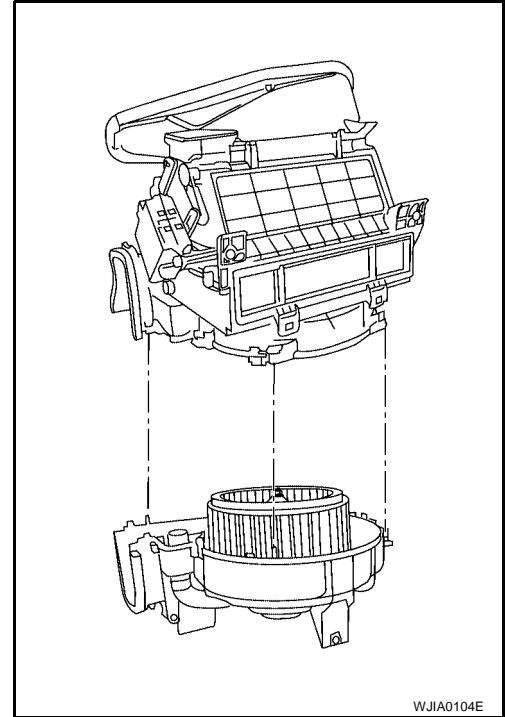

INTAKE DOOR MOTOR

INTAKE DOOR MOTOR

PFP:27730

Removal and Installation

EJS001DJ

1. Remove the blower unit. Refer to [ATC-107, "Removal and Installation"](#) .
2. Remove the screws and then the intake door motor from the blower unit.

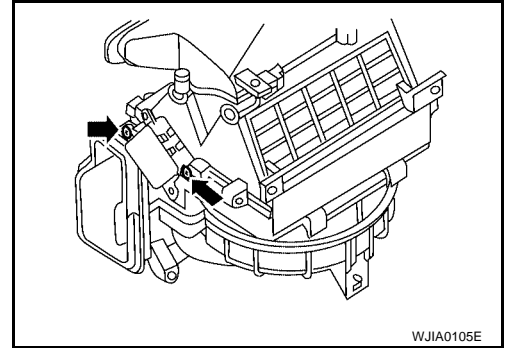

A
B
C
D
E
F
G
H
I

ATC

K
L
M

IN-CABIN MICROFILTER

IN-CABIN MICROFILTER

PF2:27277

Removal and Installation FUNCTION

EJS001GC

Air inside passenger compartment is kept clean at either recirculation or fresh mode by installing in-cabin microfilter into blower unit.

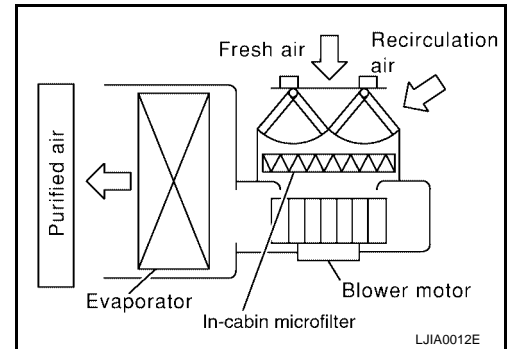

REPLACEMENT TIMING

Replace in-cabin microfilter.
Refer to [MA-7, "SCHEDULE 1"](#) and [MA-10, "SCHEDULE 2"](#).
Caution label is affixed inside the glove box.

REPLACEMENT PROCEDURES

1. Remove glove box assembly. Refer to [IP-14, "Glove Box"](#).
2. Remove in-cabin microfilter cover.
3. Remove the in-cabin microfilter from blower unit.
4. Replace with new in-cabin microfilter and reinstall cover on blower unit.
5. Reinstall glove box assembly.

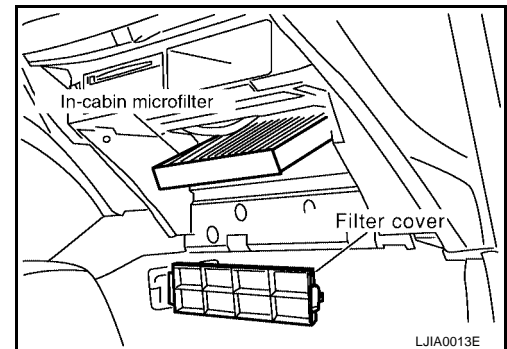

HEATER & COOLING UNIT ASSEMBLY

PF27110

EJS001DK

HEATER & COOLING UNIT ASSEMBLY

Removal and Installation

REMOVAL

1. Discharge refrigerant from A/C system. Refer to [ATC-118, "HFC-134a \(R-134a\) Service Procedure"](#)
2. Drain coolant from cooling system. Refer to [MA-23, "Changing Engine Coolant"](#) .
3. Remove wiper motor and linkage. Refer to [WW-27, "REMOVAL"](#)
4. Remove fasteners and cowl.
5. Disconnect heater hoses from heater core pipes.
6. Disconnect refrigerant lines from evaporator.

CAUTION:

Cap or wrap the joint of the pipe with suitable material such as vinyl tape to avoid entry of contaminants

7. Remove the steering member. Refer to [IP-10, "INSTRUMENT PANEL ASSEMBLY"](#) .
8. Remove the blower unit. Refer to [ATC-107, "BLOWER UNIT"](#) .
9. Disconnect mode door motor and air mix door motor connectors.
10. Remove the heater and cooling unit.

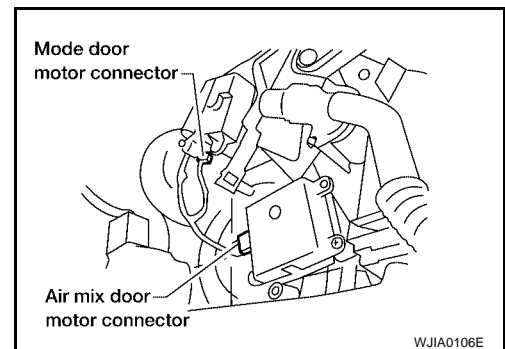

INSTALLATION

Install in the reverse order of removal.

NOTE:

When filling radiator with coolant, refer to [MA-23, "REFILLING ENGINE COOLANT"](#) . Recharge the A/C system. Refer to [ATC-118, "HFC-134a \(R-134a\) Service Procedure"](#) .

A
B
C
D
E
F
G
H
I
K
L
M

ATC

HEATER CORE

HEATER CORE

PFP:27140

Removal and Installation

EJS001DL

1. Remove heater and cooling unit. Refer to [ATC-111, "HEATER & COOLING UNIT ASSEMBLY"](#).
2. Remove heater core pipe support screws and then remove heater core pipe support.

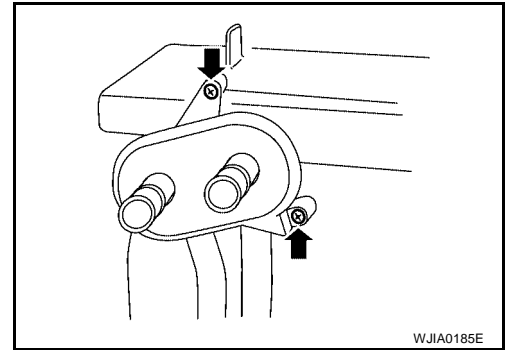

3. Remove heater core cover screws and then remove heater core cover.

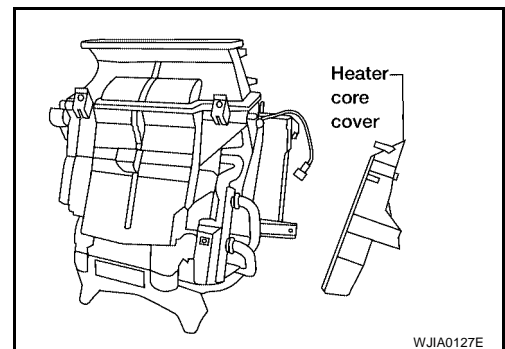

4. Remove heater core.

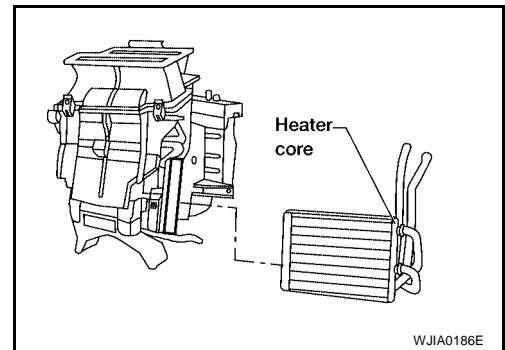

MODE DOOR MOTOR

MODE DOOR MOTOR

PFP:27731

Removal and Installation

EJS001DM

1. Remove the driver lower instrument panel assembly. Refer to [IP-12, "Driver Lower Instrument Panel"](#).
2. Disconnect the mode door motor connector.
3. Remove the mode door motor screws and then remove mode door motor.

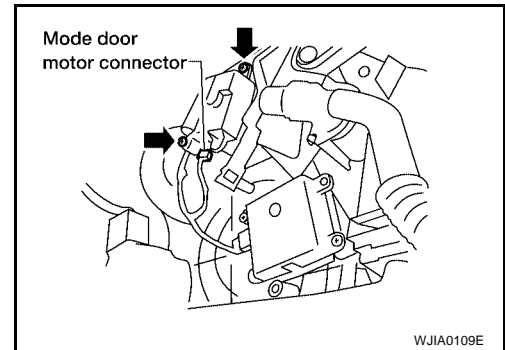

A

B

C

D

E

F

G

H

I

ATC

K

L

M

AIR MIX DOOR MOTOR

AIR MIX DOOR MOTOR

PF2:27732

Removal and Installation

EJS001DN

1. Remove the driver lower instrument panel assembly. Refer to [IP-12, "Driver Lower Instrument Panel"](#).
2. Disconnect the air mix door motor connector.
3. Remove the air mix door motor screws and then remove air mix door motor.

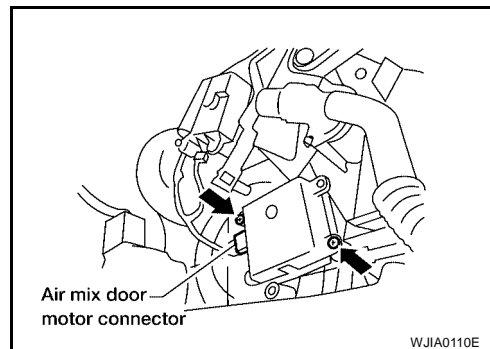

FAN CONTROL AMPLIFIER

FAN CONTROL AMPLIFIER

PF2:27761

Removal and Installation

EJS001DO

1. Disconnect fan control amp. connector
2. Remove screws from the fan control amp. and then remove fan control amp.

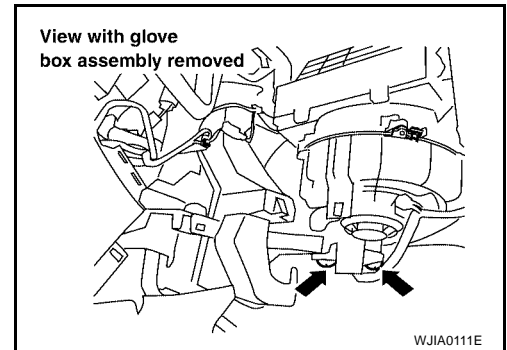

A

B

C

D

E

F

G

H

I

ATC

K

L

M

DUCTS AND GRILLES

DUCTS AND GRILLES

PFP:27860

Removal and Installation

EJS001DP

Ventilator Duct, Defroster Nozzle and Defroster Ducts

EJS001DQ

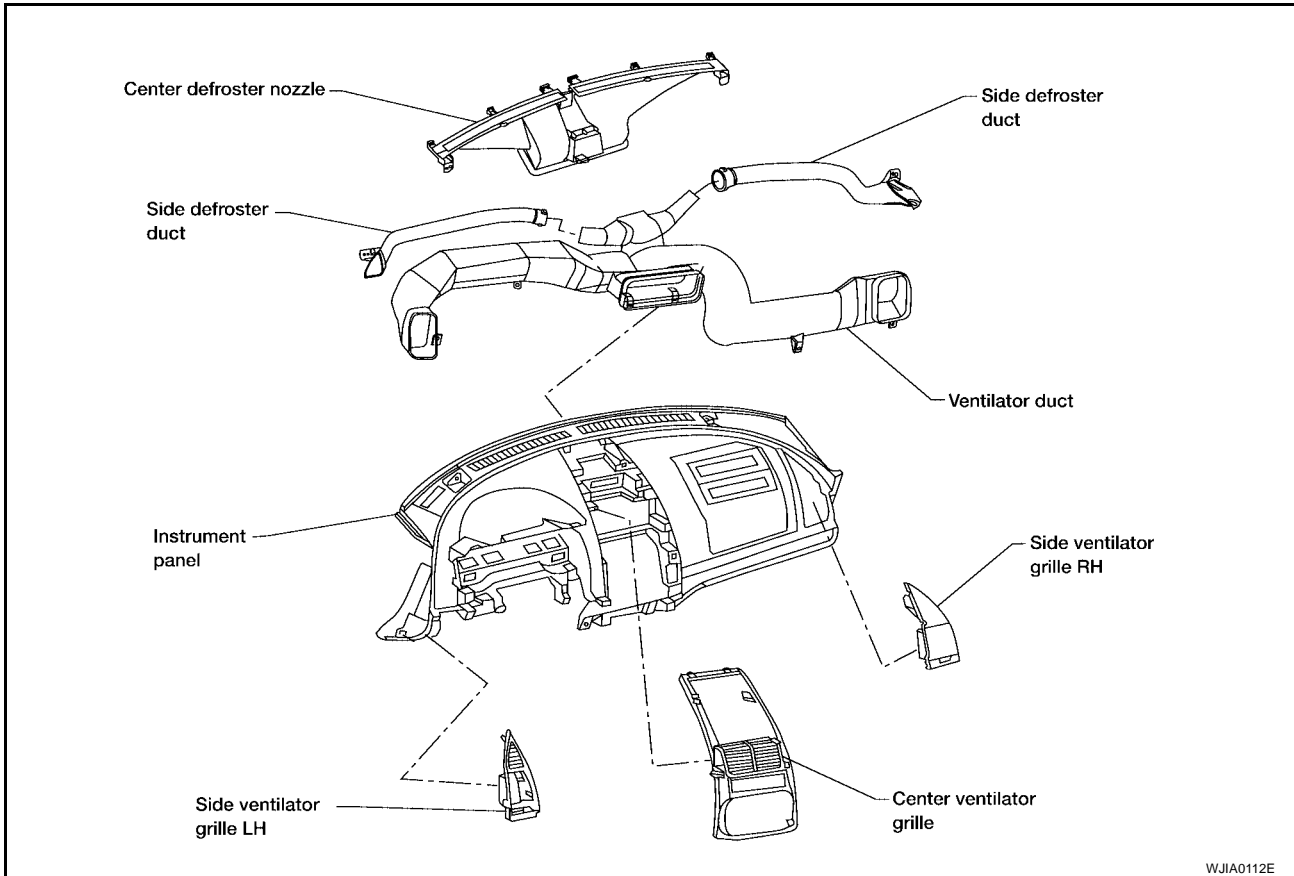

Center Ventilator Grille

EJS001DR

1. Remove cluster lid D. Refer to [IP-12, "Cluster Lid D"](#).
2. Release the tabs to remove center ventilator grille.

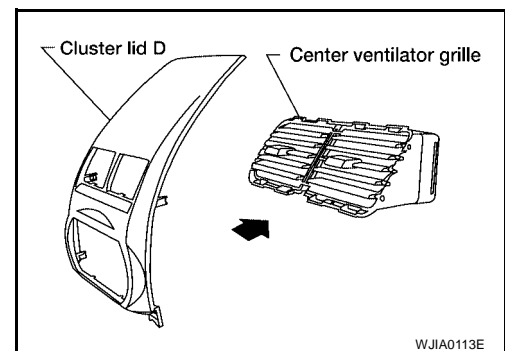

Side Ventilator Grille LH

EJS001DS

1. Remove cluster lid A. Refer to [IP-13, "Cluster Lid A"](#).
2. Remove side ventilator grille LH.

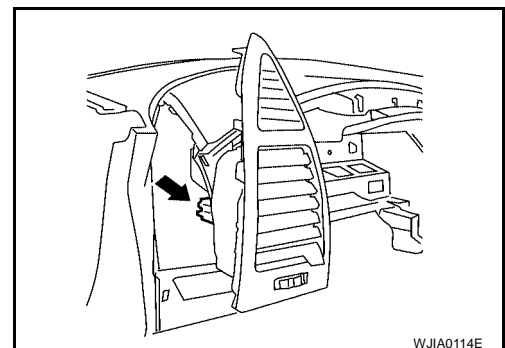

DUCTS AND GRILLES

Side Ventilator Grille RH

EJS001DT

1. Remove glove box assembly. Refer to [IP-14, "Glove Box"](#).
2. Remove side ventilator grille RH screw and then remove side ventilator grille RH.

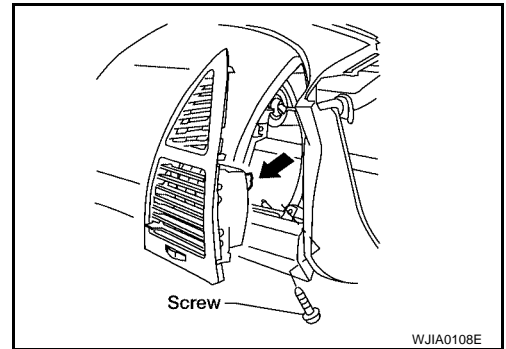

Floor duct

EJS001DU

1. Remove the carpet. Refer to [EI-32, "FLOOR TRIM"](#).
2. Release foam tape and slide floor duct rearward to release from clips.

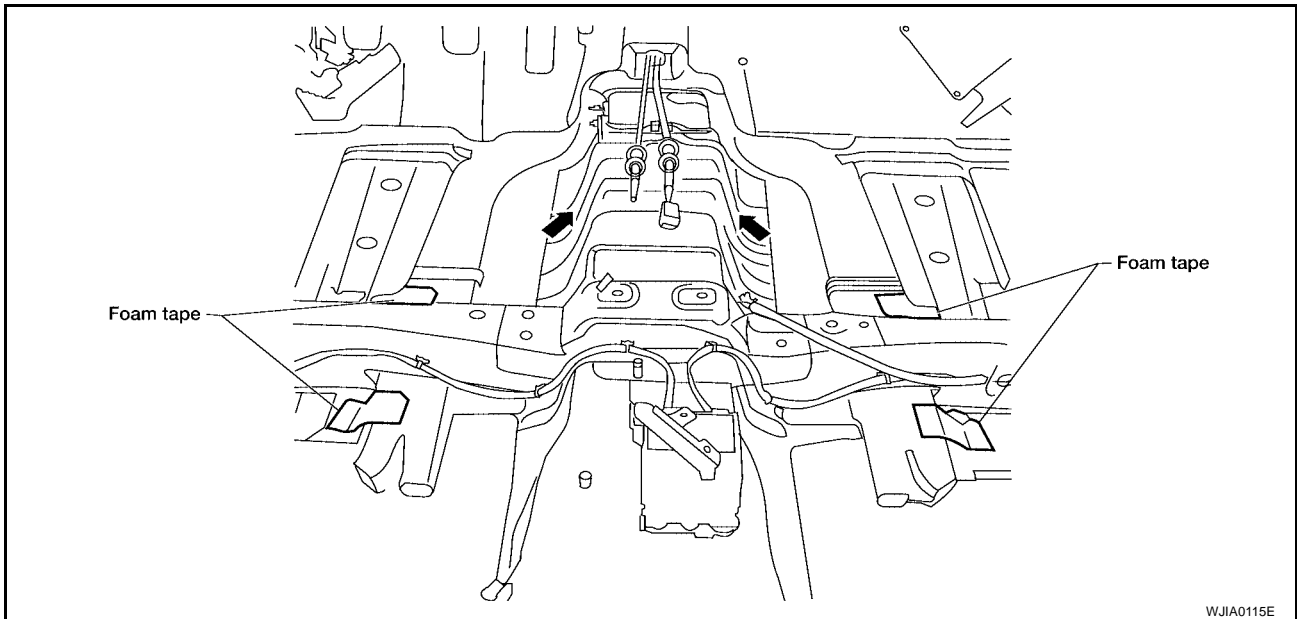

A
B
C
D
E
F
G
H
I
K
L
M

ATC

REFRIGERANT LINES

REFRIGERANT LINES

PF9:92600

HFC-134a (R-134a) Service Procedure SETTING OF SERVICE TOOLS AND EQUIPMENT

EJS001DV

Discharging Refrigerant

WARNING:

Avoid breathing A/C refrigerant and lubricant vapor or mist. Exposure may irritate eyes, nose and throat. Remove HFC-134a (R-134a) from A/C system using certified service equipment meeting requirements of SAE J2210 (R-134a recycling equipment) or J2201 (R-134a recovery equipment). If accidental system discharge occurs, ventilate work area before resuming service. Additional health and safety information may be obtained from refrigerant and lubricant manufacturers.

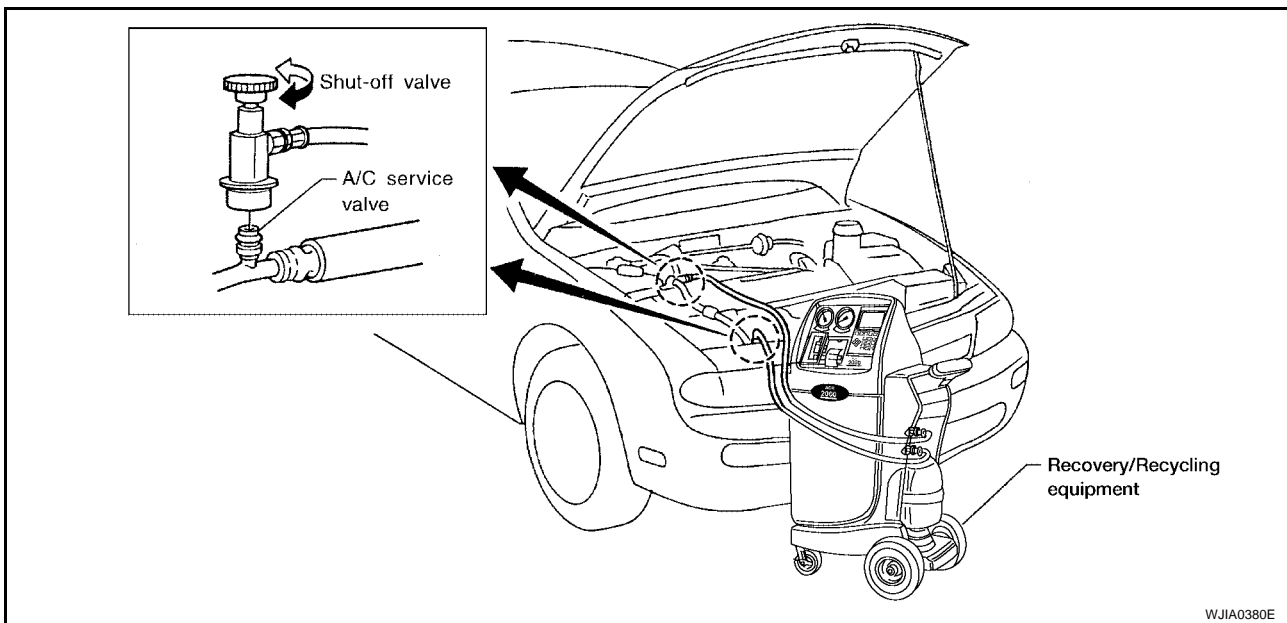

Evacuating System and Charging Refrigerant

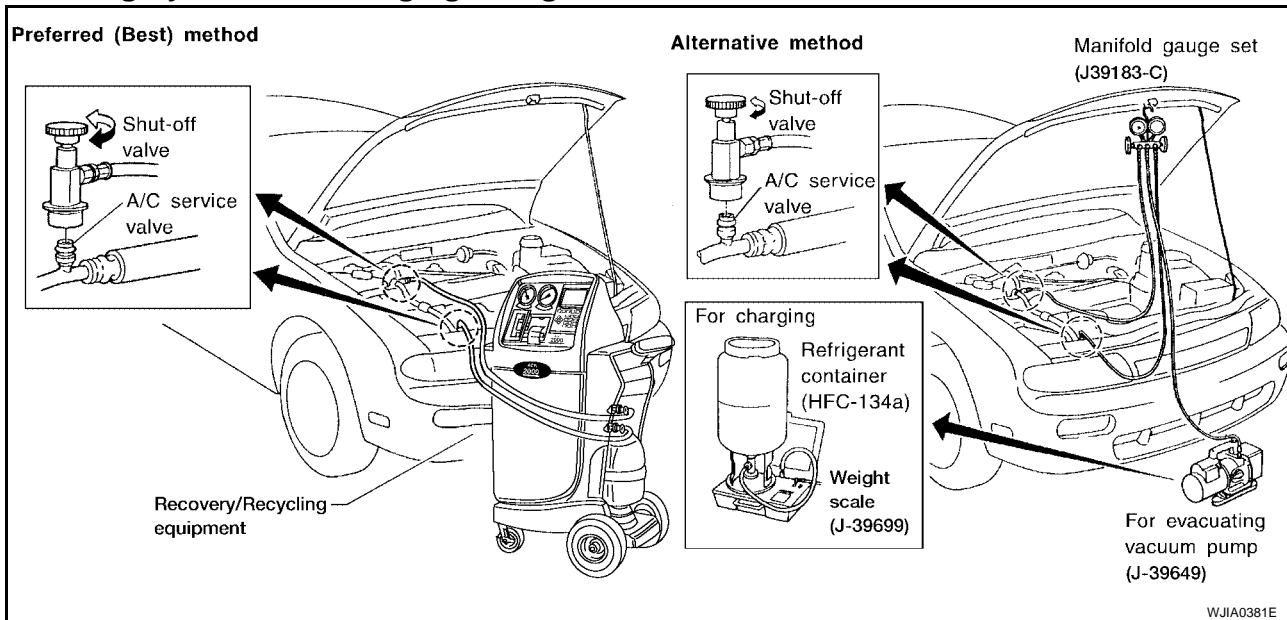

REFRIGERANT LINES

Recovered lubricant. Refer to "CHECKING AND ADJUSTING", *1.

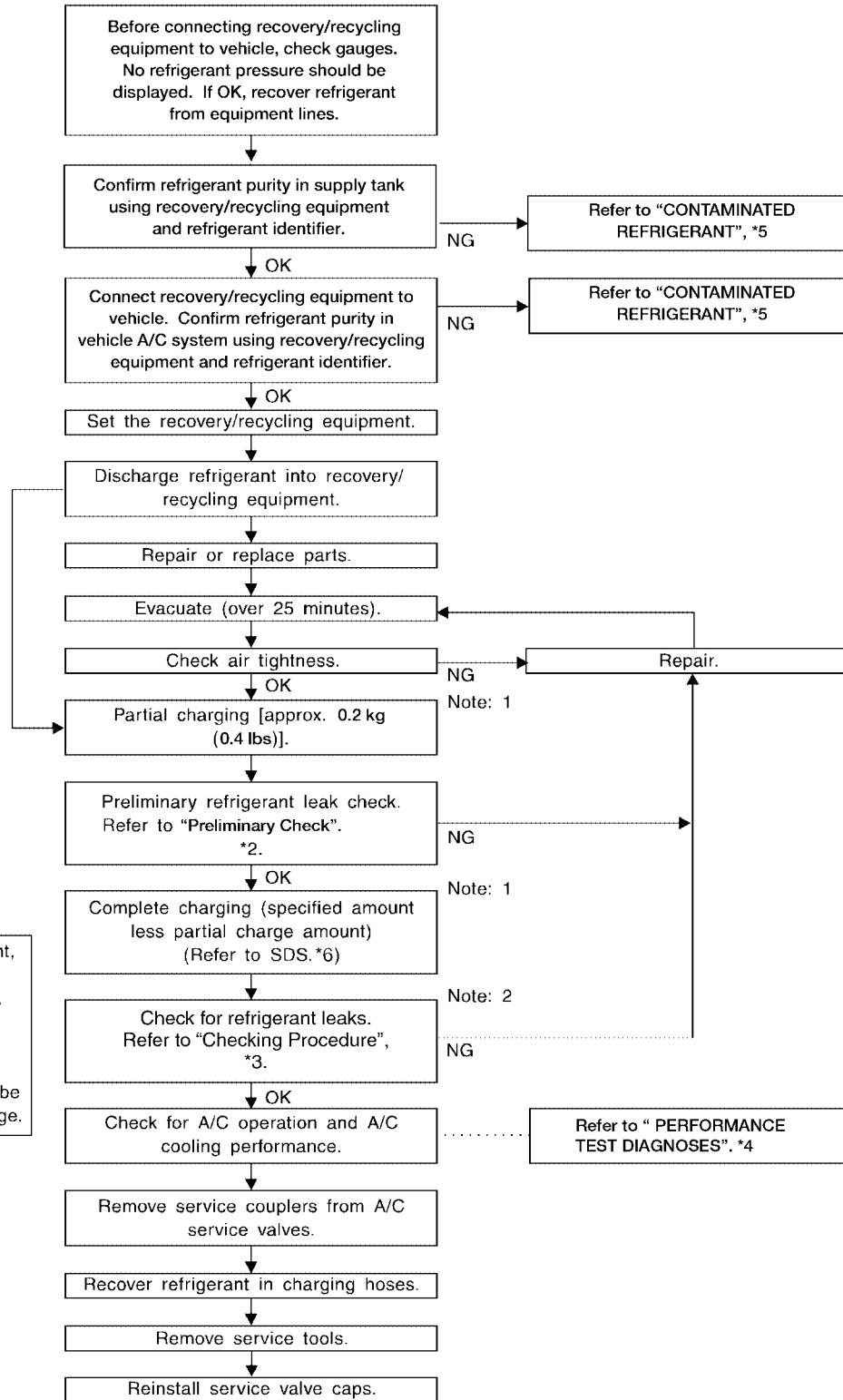

Note: 1 Before charging refrigerant, ensure engine is off.
 Note: 2 Before checking for leaks, start engine to activate air conditioning system then turn engine off. Service valve caps must be installed to prevent leakage.

*1 [ATC-18, "CHECKING AND ADJUSTING"](#)

*2 [ATC-128, "Checking for Refrigerant Leaks"](#)

*3 [ATC-128, "Checking for Refrigerant Leaks"](#)

*4 [ATC-80, "PERFORMANCE TEST ANALYSIS"](#)

*5 [ATC-4, "Contaminated Refrigerant"](#)

WJIA0382E

REFRIGERANT LINES

EJS001DW

Components

Refer to [ATC-6, "Precautions for Refrigerant Connection"](#).

SEC. 214 • 271 • 274 • 276

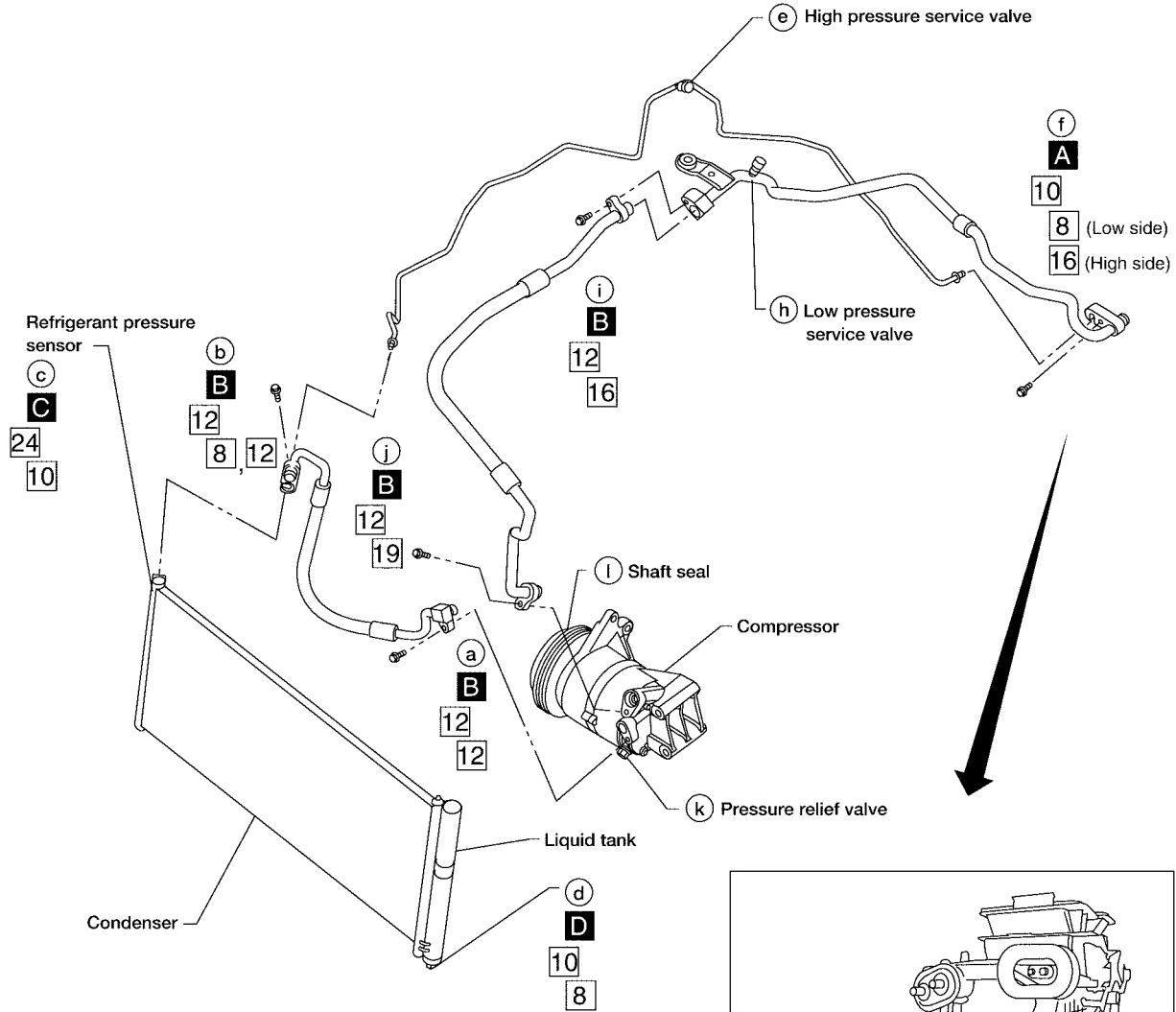

- : Refrigerant leak checking order
- : (Tightening torque)
- □ : (Wrench size)
- : (O-ring size)
- ⊗ : N·m (kg·m, in·lb)
- ⊙ : N·m (kg·m, ft·lb)
- A** : 2.9 – 5.9 (0.29 – 0.60, 26 – 52)
- B** : 7.8 – 19.6 (0.8 – 1.9, 69 – 173)
- C** : 9.8 – 11.7 (1.0 – 1.1, 7.3 – 8.6)
- D** : 5.0 – 6.47 (0.51 – 0.65, 45 – 57)

WJIA0116E

REFRIGERANT LINES

Removal and Installation for Compressor

EJS001DX

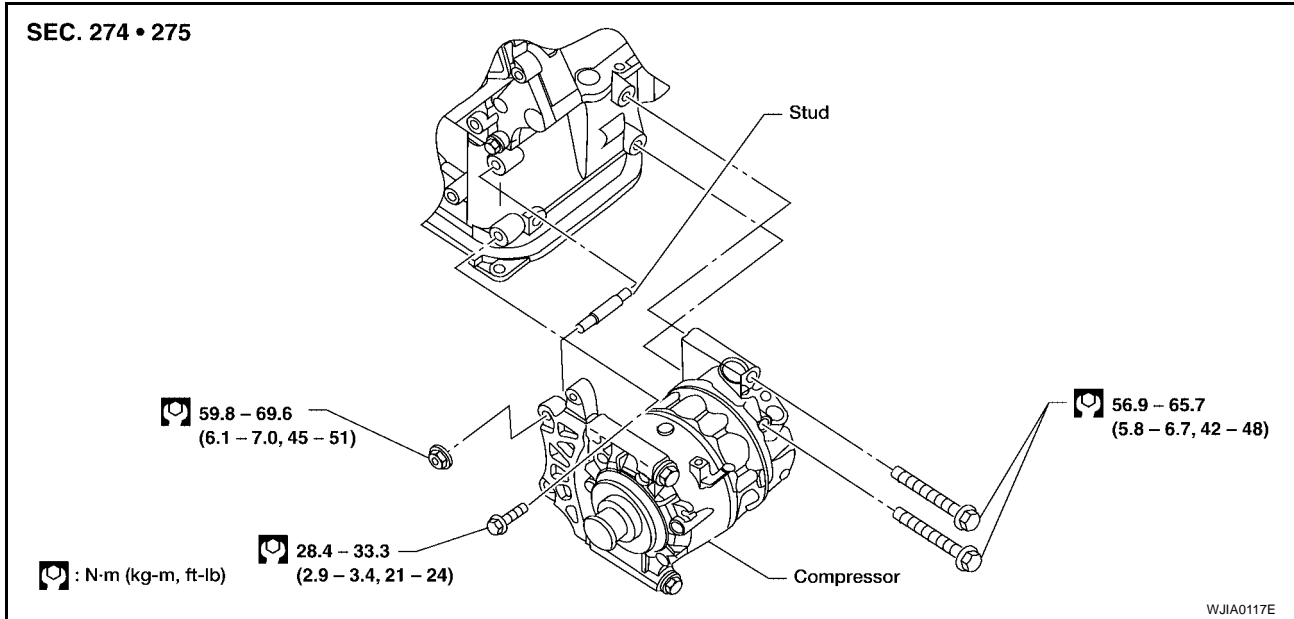

REMOVAL

1. Discharge the refrigerant. Refer to [ATC-118, "HFC-134a \(R-134a\) Service Procedure"](#) .
2. Remove the drive belt.
Refer to [MA-22, "ENGINE MAINTENANCE \(VQ35DE ENGINE\)"](#) .
3. Remove the coolant pipe bracket bolt.
4. Remove compressor mounting stud.
5. Disconnect the compressor connector.
6. Remove the high-pressure flexible hose and low-pressure flexible hose.

CAUTION:

Cap or wrap the joint of the pipe with suitable material such as vinyl tape to avoid the entry of air.

7. Remove the mounting bolts and nut from compressor using power tools.

INSTALLATION

CAUTION:

- Replace the O-ring of the low-pressure flexible hose and high-pressure flexible hose with a new one, then apply compressor oil to it when installing it.
- When charging refrigerant, check for leaks.

Bolts mounting the compressor (rear side)

Tightening torque : 56.9 - 65.7 N-m (5.8 - 6.8 kg-m, 42 - 48 ft-lb)

Bolt mounting the compressor (front side)

Tightening torque : 28.4 - 33.3 N-m (2.9 - 3.4 kg-m, 21 - 24 ft-lb)

Nut mounting the compressor (front side)

Tightening torque : 59.8 - 69.6 N-m (6.1 - 7.0 kg-m, 45 - 51 ft-lb)

Bolt mounting the high- and low-pressure flexible hoses

Tightening torque : 7.8 - 19.6 N-m (0.8 - 1.9 kg-m, 69 - 173 in-lb)

REFRIGERANT LINES

EJS001DY

Removal and Installation for Compressor Clutch REMOVAL

- When removing center bolt, hold clutch disc with clutch disc tool.
- Remove the clutch disc.
Clutch disc holding tool:
(J-44614) Commercial service tool

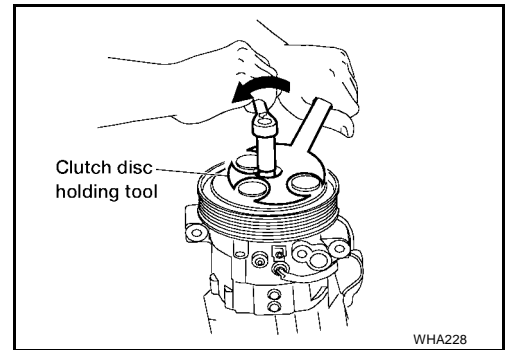

- Remove the snap ring using external snap ring pliers.

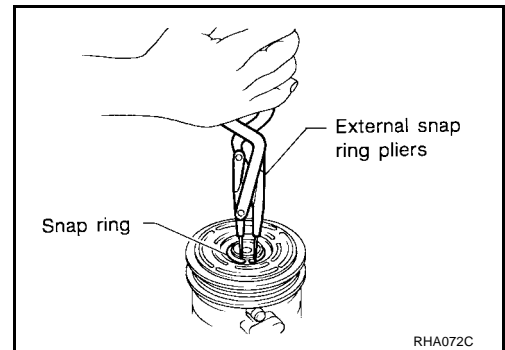

- Pulley removal:

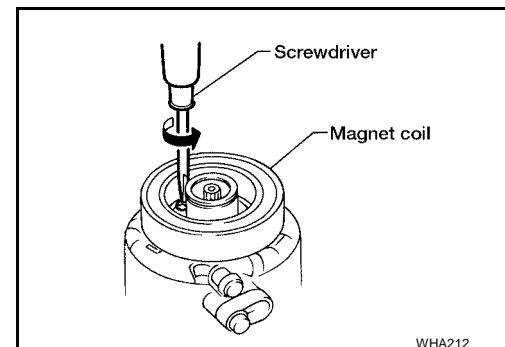
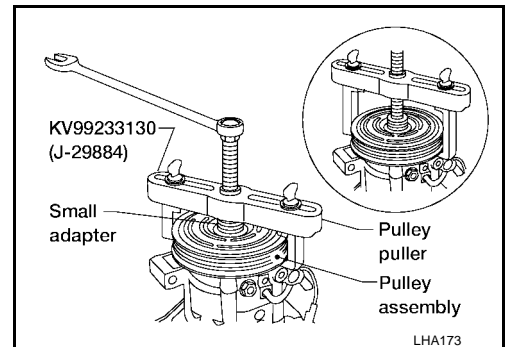

Use a pulley puller with small adapter. Position the small adapter on the end of the drive shaft and the center of the puller on the small adapter. Remove the pulley assembly with the puller.

To prevent deformation of the pulley groove, the puller claws should be hooked under (not into) the pulley groove.

- Remove the snap ring using external snap ring pliers.
- Remove the magnet coil harness clip using a screwdriver, remove the three magnet coil fixing screws and remove the magnet coil.

REFRIGERANT LINES

INSPECTION

Clutch Disc

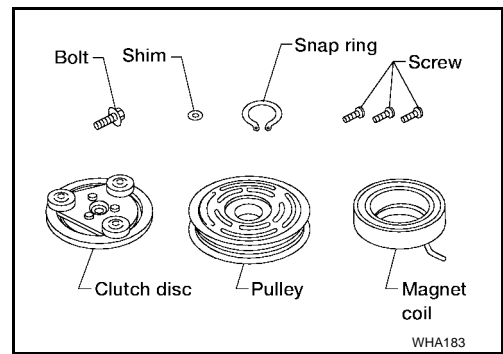

If the contact surface shows signs of damage due to excessive heat, replace clutch disc and pulley.

Pulley

Check the appearance of the pulley assembly. If contact surface of pulley shows signs of excessive grooving, replace clutch disc and pulley. The contact surfaces of the pulley assembly should be cleaned with a suitable solvent before reinstallation.

Coil

Check magnet coil for loose connection or cracked insulation.

INSTALLATION

- Install the magnet coil.
Be sure to align the magnet coil pin with the hole in the compressor front head.
- Install the magnet coil harness clip using a screwdriver.

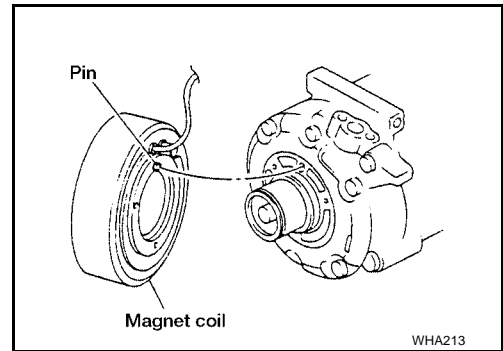

- Install the pulley assembly using the installer and a wrench, and then install the snap ring using snap ring pliers.

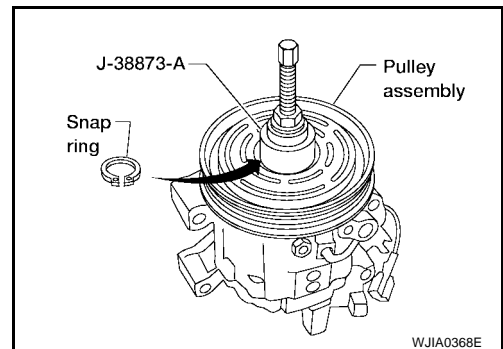

- Install the clutch disc on the drive shaft, together with the original shim(s). Press the clutch disc down using the drive plate installer.

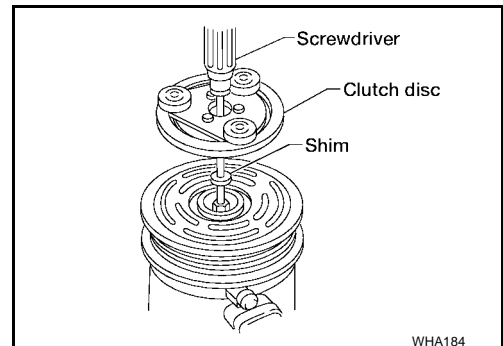

A
B
C
D
E
F
G
H
I
K
L
M

ATC

REFRIGERANT LINES

- Using the clutch disc tool to prevent clutch disc rotation, tighten the bolt to 12 N·m (1.2 kg·m, 9 ft·lb).
- After tightening the bolt, check that the pulley rotates smoothly.

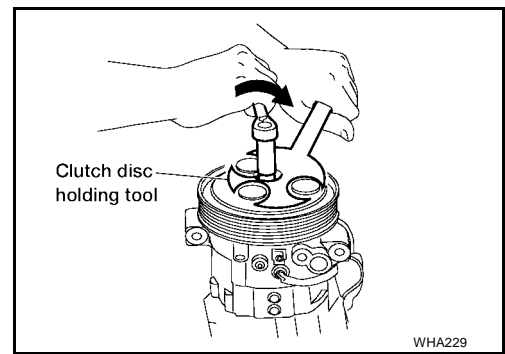

- Check clearance all the way around the clutch disc.

Clutch disc-to-pulley clearance : 0.3 - 0.6 mm (0.012 - 0.024 in)

If the specified clearance is not obtained, replace adjusting spacer and readjust.

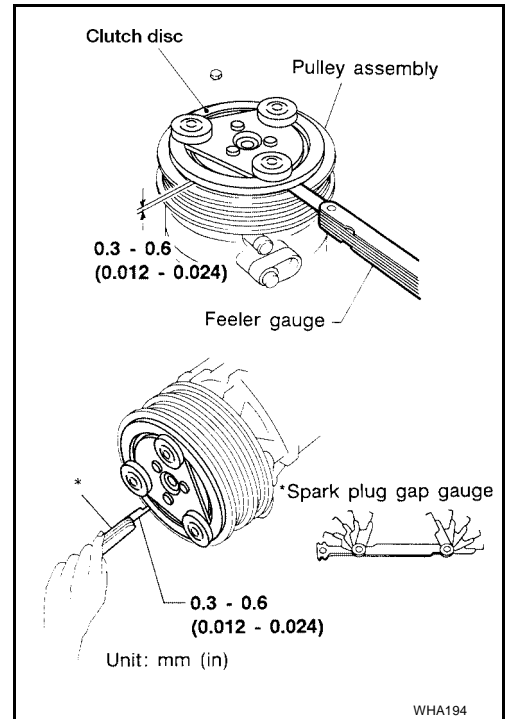

BREAK-IN OPERATION

When replacing compressor clutch assembly, always conduct the break-in operation. This is done by engaging and disengaging the clutch about 30 times. Break-in operation raises the level of transmitted torque.

Removal and Installation for Low-pressure Flexible Hose

EJS001DZ

REMOVAL

1. Discharge the refrigerant. Refer to [ATC-118, "HFC-134a \(R-134a\) Service Procedure"](#).

CAUTION:

Cap or wrap the joint of the pipe with suitable material such as vinyl tape to avoid the entry of air.

2. Remove the low-pressure flexible hose. Refer to [ATC-120, "Components"](#).

INSTALLATION

CAUTION:

- Replace the O-ring of the low-pressure flexible hose with a new one, then apply compressor oil to it when installing it.
- When charging refrigerant, check for leaks.

Bolt mounting the low-pressure flexible hose (evaporator side)

Tightening torque : 2.9 - 5.9 N·m (0.29 - 0.60 kg·m, 26 - 52 in·lb)

Bolt mounting the low-pressure flexible hose (compressor side)

Tightening torque : 7.8 - 19.6 N·m (0.8 - 1.9 kg·m, 69 - 173 in·lb)

REFRIGERANT LINES

Bolt connecting the low-pressure flexible hose in-line connection

Tightening torque : 7.8 - 19.6 N·m (0.8 - 1.9 kg·m, 69 - 173 in·lb)

Removal and Installation for High-pressure Flexible Hose

EJS001E0

REMOVAL

1. Discharge the refrigerant. Refer to [ATC-118, "HFC-134a \(R-134a\) Service Procedure"](#) .
2. Remove the high-pressure flexible hose. Refer to [ATC-120, "Components"](#) .

CAUTION:

Cap or wrap the joint of the pipe with suitable material such as vinyl tape to avoid the entry of air.

INSTALLATION

CAUTION:

- Replace the O-ring of the high-pressure flexible hose with a new one, then apply compressor oil to it when installing it.
- When charging refrigerant, check for leaks.

Bolts mounting the high-pressure flexible hose

Tightening torque : 7.8 - 19.6 N·m (0.8 - 1.9 kg·m, 69 - 173 in·lb)

Removal and Installation for High-pressure Pipe

EJS001E1

REMOVAL

1. Discharge the refrigerant. Refer to [ATC-118, "HFC-134a \(R-134a\) Service Procedure"](#) .
2. Remove the high-pressure pipe. Refer to [ATC-120, "Components"](#) .

CAUTION:

Cap or wrap the joint of the pipe with suitable material such as vinyl tape to avoid the entry of air.

INSTALLATION

CAUTION:

- Replace the O-ring of the high-pressure pipe with a new one, then apply compressor oil to it when installing it.
- When charging refrigerant, check for leaks.

Bolt mounting the high-pressure pipe (evaporator side)

Tightening torque : 2.9 - 5.9 N·m (0.29 - 0.60 kg·m, 26 - 52 in·lb)

Bolt mounting the high-pressure pipe (condenser side)

Tightening torque : 7.8 - 19.6 N·m (0.8 - 1.9 kg·m, 69 - 173 in·lb)

Removal and Installation for Refrigerant Pressure Sensor

EJS001E2

1. Discharge the refrigerant. Refer to [ATC-118, "HFC-134a \(R-134a\) Service Procedure"](#) .
2. Disconnect the refrigerant pressure sensor connector and remove the refrigerant pressure sensor from condenser.

CAUTION:

- Please be careful not to damage the condenser fins.
- Apply compressor oil to the O-ring of the refrigerant pressure sensor when installing it.

Tightening torque : 9.8 - 11.7 N·m (1.0 - 1.2 kg·m, 7.3 - 8.6 ft·lb)

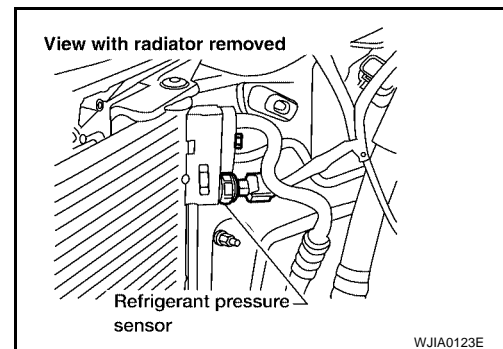

Removal and Installation for Condenser

EJS001E3

REMOVAL

1. Discharge the refrigerant. Refer to [ATC-118, "HFC-134a \(R-134a\) Service Procedure"](#) .
2. Remove the radiator. Refer to [CO-31, "RADIATOR"](#) .

CAUTION:

Be careful not to damage the core surface of the condenser and the radiator.

REFRIGERANT LINES

3. Disconnect the high-pressure flexible hose and the high-pressure pipe from the condenser.

CAUTION:

Cap or wrap the joint of the pipe with suitable material such as vinyl tape to avoid the entry of air.

4. Disconnect the refrigerant pressure sensor connector.
5. Remove the front fascia. Refer to [EI-13, "FRONT BUMPER"](#).

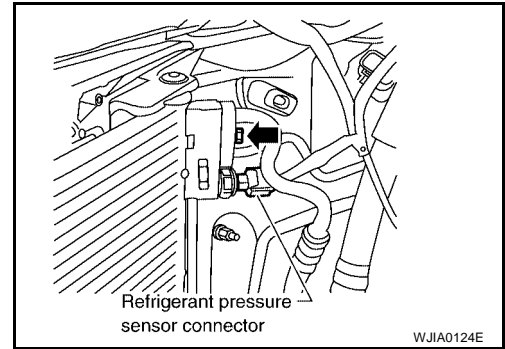

6. Remove the mounting nuts from condenser mounting brackets.

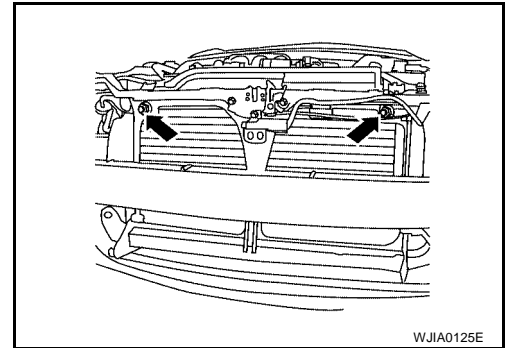

INSTALLATION

CAUTION:

- Replace the O-rings of the high-pressure pipe and the high-pressure flexible hose with new ones, then apply compressor oil to them after installing them.
- When charging refrigerant, check for leaks.

High-pressure flexible hose and pipe mounting bolt

Tightening torque : 7.8 - 19.6 N·m (0.8 - 1.9 kg-m, 69 - 173 in-lb)

Condenser mounting nuts

Tightening torque : 5.0 - 6.79 N·m (0.51 - 0.69 kg-m, 45 - 60 in-lb)

Removal and Installation for Evaporator

EJS00319

REMOVAL

1. Evacuate and recover the A/C system refrigerant. Refer to [ATC-118, "HFC-134a \(R-134a\) Service Procedure"](#).
2. Disconnect the battery negative terminal.
3. Disconnect the air cleaner to electronic throttle control actuator tube. Refer to [EM-16, "AIR CLEANER AND AIR DUCT"](#) (QR25DE), [EM-119, "AIR CLEANER AND AIR DUCT"](#) (VQ35DE).

NOTE:

The tube is located between the air cleaner assembly and the intake manifold and is removed to access the expansion valve.

4. Disconnect the A/C pipe from the expansion valve.

CAUTION:

Cap or wrap the joint of the pipe with suitable material such as vinyl tape to avoid the entry of air.

REFRIGERANT LINES

5. Remove the expansion valve.
6. Remove the center console side finisher RH. Refer to [IP-15, "Center Console"](#) .
7. Remove the glove box assembly. Refer to [IP-14, "Glove Box"](#) .
8. Remove the ECM.
 - Disconnect the ECM connector.
 - Remove the wire harness from the ECM mounting bracket.
 - Remove the two ECM mounting bracket nuts and disconnect the ground wire.
9. Remove the blower unit. Refer to [ATC-107, "BLOWER UNIT"](#) .
10. Remove the heater core cover.

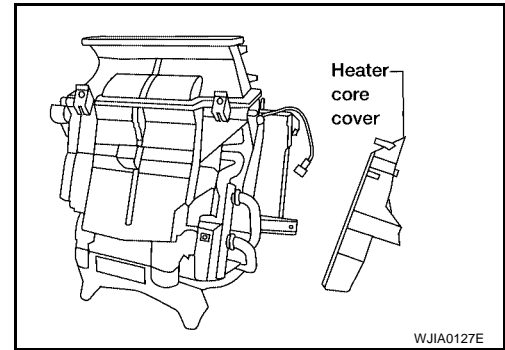
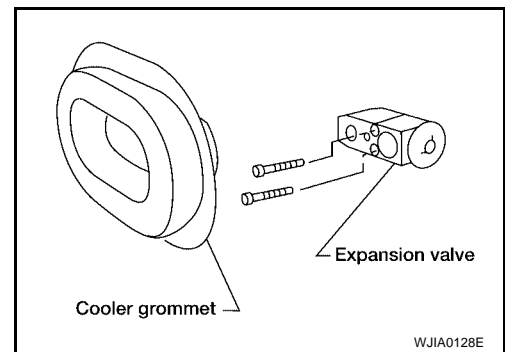

11. Remove the evaporator cover.

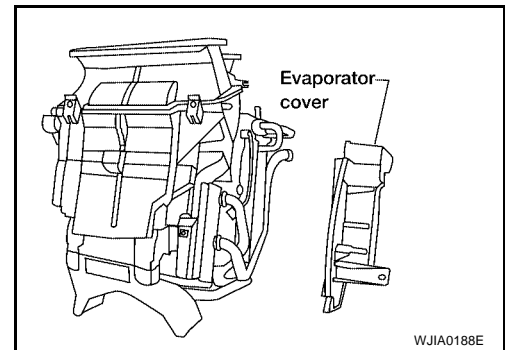

12. Remove the evaporator.
 - Remove the thermo control amplifier.
 - Remove the intake sensor.

CAUTION:

 - Mark the mounting position of the intake sensor and thermo control amplifier.

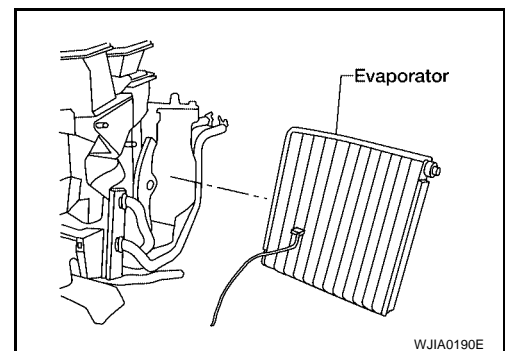

INSTALLATION

Installation is in the reverse order of removal.

Expansion valve mounting bolts : 2.9 - 5.0 N·m (0.29 - 0.51 kg·m, 26 - 44 in·lb)

CAUTION:

- Replace the O-rings with new ones, then apply compressor oil to them when installing them.

Removal and Installation for Expansion Valve REMOVAL

EJS0031A

1. Evacuate and recover the A/C system refrigerant. Refer to [ATC-118, "HFC-134a \(R-134a\) Service Procedure"](#) .

REFRIGERANT LINES

2. Disconnect the air cleaner to electronic throttle control actuator tube. Refer to [EM-16, "AIR CLEANER AND AIR DUCT"](#) (QR25DE), [EM-119, "AIR CLEANER AND AIR DUCT"](#) (VQ35DE).

NOTE:

The tube is located between the air cleaner assembly and the intake manifold and is removed to access the expansion valve.

3. Disconnect the A/C pipe from the expansion valve.

CAUTION:

Cap or wrap the joint of the pipe with suitable material such as vinyl tape to avoid the entry of air.

4. Remove the expansion valve.

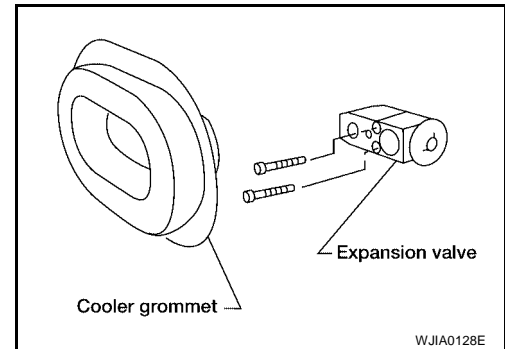

INSTALLATION

Installation is in the reverse order of removal.

Expansion valve mounting bolts : 2.9 - 5.0 N-m (0.29 - 0.51 kg-m, 26 - 44 in-lb)

CAUTION:

- Replace the O-rings with new ones, then apply compressor oil to them when installing them.

Checking for Refrigerant Leaks

EJS001E7

Perform a visual inspection of all refrigeration parts, fittings, hoses and components for signs of A/C lubricant leakage, damage and corrosion. A/C lubricant leakage may indicate an area of refrigerant leakage. Allow extra inspection time in these areas when using either an electronic refrigerant leak detector or fluorescent dye leak detector.

If dye is observed, confirm the leak with an electronic refrigerant leak detector. It is possible a prior leak was repaired and not properly cleaned.

When searching for leaks, do not stop when one leak is found but continue to check for additional leaks at all system components and connections.

When searching for refrigerant leaks using an electronic leak detector, move the probe along the suspected leak area at 25 - 50 mm (1 - 2 in) per second and no further than 6 mm (1/4 in) from the component.

CAUTION:

Moving the electronic leak detector probe slower and closer to the suspected leak area will improve the chances of finding a leak.

Checking System for Leaks Using the Fluorescent Leak Detector

EJS001E8

1. Check A/C system for leaks using the UV lamp and safety glasses (J-42220) in a low sunlight area (area without windows preferable). Illuminate all components, fittings and lines. The dye will appear as a bright green/yellow area at the point of leakage. Fluorescent dye observed at the evaporator drain opening indicates an evaporator core assembly (tubes, core or TXV) leak.
2. If the suspected area is difficult to see, use an adjustable mirror or wipe the area with a clean shop rag or cloth, with the UV lamp for dye residue.
3. After the leak is repaired, remove any residual dye using dye cleaner (J-43872) to prevent future misdiagnosis.
4. Perform a system performance check and verify the leak repair with an approved electronic refrigerant leak detector.

NOTE:

Other gases in the work area or substances on the A/C components, for example, anti-freeze, windshield washer fluid, solvents and lubricants, may falsely trigger the leak detector. Make sure the surfaces to be checked are clean.

Clean with a dry cloth or blow off with shop air.

REFRIGERANT LINES

Do not allow the sensor tip of the detector to contact with any substance. This can also cause false readings and may damage the detector.

Dye Injection

EJS001E9

(This procedure is only necessary when recharging the system or when the compressor has seized and was replaced.)

1. Check A/C system static (at rest) pressure. Pressure must be at least 345 kPa (50 psi).
2. Pour one bottle (1/4 ounce / 7.4 cc) of the A/C refrigerant dye into the injector tool (J-41459).
3. Connect the injector tool to the A/C LOW PRESSURE side service fitting.
4. Start engine and switch A/C ON.
5. When the A/C operating (compressor running), inject one bottle (1/4 ounce / 7.4 cc) of fluorescent dye through the low-pressure service valve using dye injector tool J-41459 (refer to the manufacturer's operating instructions).
6. With the engine still running, disconnect the injector tool from the service fitting.

CAUTION:

If repairing the A/C system or replacing a component, pour the dye directly into the open system connection and proceed with the service procedures.

7. Operate the A/C system for a minimum of 20 minutes to mix the dye with the system oil. Depending on the leak size, operating conditions and location of the leak, it may take from minutes to days for the dye to penetrate a leak and become visible.

Electronic Refrigerant Leak Detector

EJS001EA

PRECAUTIONS FOR HANDLING LEAK DETECTOR

When performing a refrigerant leak check, use a J-41995 A/C leak detector or equivalent. Ensure that the instrument is calibrated and set properly per the operating instructions.

The leak detector is a delicate device. In order to use the leak detector properly, read the operating instructions and perform any specified maintenance.

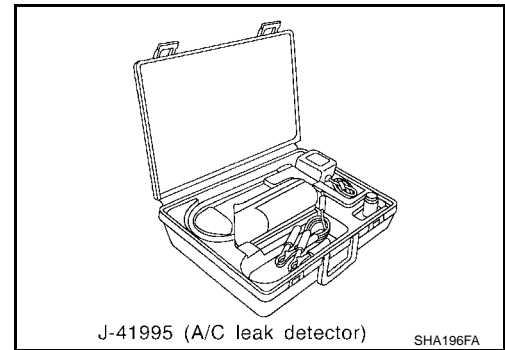

1. Position probe approximately 5 mm (3/16 in) away from point to be checked.

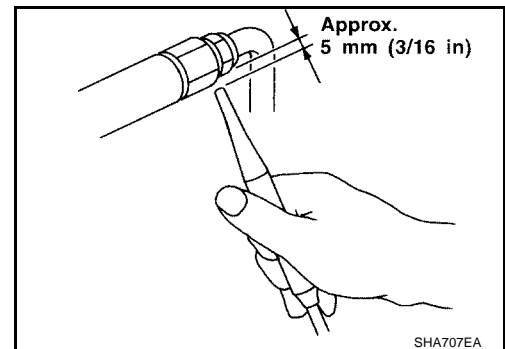

A
B
C
D
E
F
G
H
I
ATC
K
L
M

REFRIGERANT LINES

- When testing, circle each fitting completely with probe.

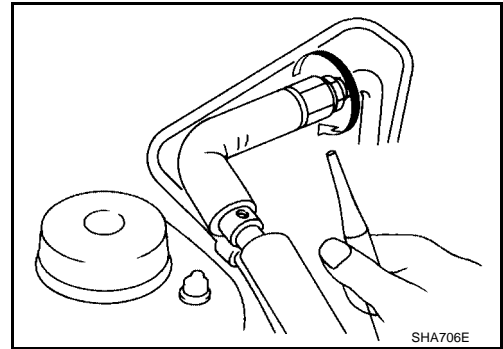

- Move probe along component approximately 25 to 50 mm (1 to 2 in)/sec.

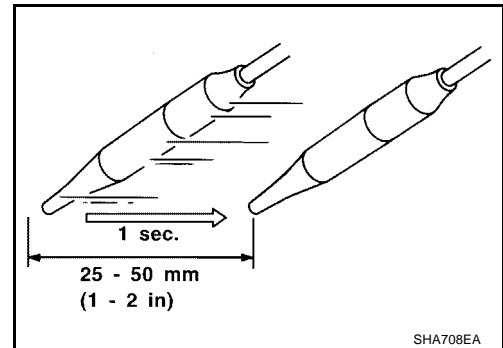

CHECKING PROCEDURE

To prevent inaccurate or false readings, make sure there is no refrigerant vapor, shop chemicals, or cigarette smoke in the vicinity of the vehicle. Perform the leak test in calm area (low air/wind movement) so that the leaking refrigerant is not dispersed.

- Turn engine OFF.
- Connect a suitable A/C manifold gauge set to the A/C service ports.
- Check if the A/C refrigerant pressure is at least 345 kPa (3.52 kg/cm², 50 psi) above 16°C (61°F). If less than specification, recover/evacuate and recharge the system with the specified amount of refrigerant.

NOTE:

At temperatures below 16°C (61°F), leaks may not be detected since the system may not reach 345 kPa (3.54 kg/cm², 50 psi).

- Conduct the leak test from the high side (compressor discharge a to evaporator inlet f) to the low side (evaporator drain hose g to shaft seal l). Refer to [ATC-120](#). Perform a leak check for the following areas carefully. Clean the component to be checked and move the leak detected probe completely around the connection/component.

Compressor

Check the fitting of high- and low-pressure hoses, relief valve and shaft seal.

Liquid tank

Check the refrigerant pressure sensor.

Service valves

Check all around the service valves. Ensure service valve caps are secured on the service valves (to prevent leaks).

NOTE:

After removing A/C manifold gauge set from service valves, wipe any residue from valves to prevent any false readings by leak detector.

Cooling unit (Evaporator)

With engine OFF, turn blower fan on "High" for at least 15 seconds to dissipate any refrigerant trace in the cooling unit. Wait a minimum of 10 minutes accumulation time (refer to the manufacturer's recommended procedure for actual wait time) before inserting the leak detector probe into the drain hose.

Keep the probe inserted for at least 10 seconds. Use caution not to contaminate the probe tip with water or dirt that may be in the drain hose.

REFRIGERANT LINES

5. If a leak detector detects a leak, verify at least once by blowing compressed air into area of suspected leak, then repeat check as outlined above.
6. Do not stop when one leak is found. Continue to check for additional leaks at all system components. If no leaks are found, perform steps 7 - 10.
7. Start engine.
8. Set the heater A/C control as follows;
 - a. A/C switch: ON
 - b. Face mode
 - c. Intake position: Recirculation
 - d. Max cold temperature
 - e. Fan speed: High
9. Run engine at 1,500 rpm for at least 2 minutes.
10. Turn engine off and perform leak check again following steps 4 through 6 above.

Refrigerant leaks should be checked immediately after stopping the engine. Begin with the leak detector at the compressor. The pressure on the high pressure side will gradually drop after refrigerant circulation stops and pressure on the low pressure side will gradually rise, as shown in the graph. Some leaks are more easily detected when pressure is high.

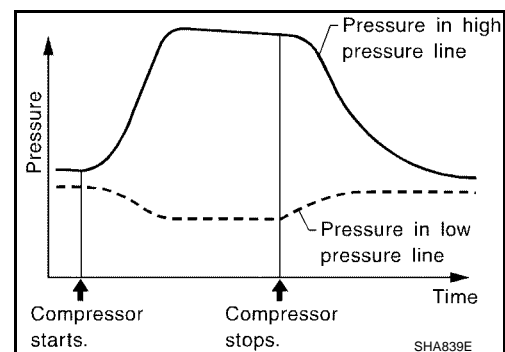

11. Before connecting recovery/recycling equipment to vehicle, check the recovery/recycling equipment gauges. No refrigerant pressure should be displayed. If pressure is displayed, recover refrigerant from equipment lines and then check refrigerant purity.
12. Confirm refrigerant purity in supply tank using recovery/recycling equipment and refrigerant identifier.
13. Confirm refrigerant purity in vehicle A/C system using recovery/recycling equipment and refrigerant identifier.
14. Discharge A/C system using approved recovery/recycling equipment. Repair the leaking fitting or component as necessary.
15. Evacuate and recharge A/C system and perform the leak test to confirm no refrigerant leaks.
16. Conduct A/C performance test to ensure system works properly.

SERVICE DATA AND SPECIFICATIONS (SDS)

SERVICE DATA AND SPECIFICATIONS (SDS)

PFP:00030

Service Data and Specifications (SDS) COMPRESSOR

EJS001EB

Model	CALSONIC KANSEI make
Type	DKS-17D
Displacement cm ³ (cu in)/rev	175.5 (10.7)/rev
Cylinder bore × stroke mm (in)	30.5 (1.201) x 21.4 (0.84)
Direction of rotation	Clockwise (viewed from drive end)
Drive belt	Poly V

LUBRICANT

Model	CALSONIC KANSEI make DKS-17D	
Name	Nissan A/C System Lubricant Type DH-PS or equivalent	
Part number	KLH00-PAGS0	
Capacity mℓ (US fl oz, Imp fl oz)	Total in system	150 (5.03, 5.3)
	Compressor (Service part) charging amount	150 (5.03, 5.3)

REFRIGERANT

Type	HFC-134a (R-134a)
Capacity kg (lb)	0.475 - 0.525 (1.045 - 1.155)

ENGINE IDLING SPEED

Refer to [EC-661, "Idle Speed and Ignition Timing Check"](#) .

BELT TENSION

Refer to [MA-22, "ENGINE MAINTENANCE \(VQ35DE ENGINE\)"](#) .