

SECTION **AV**

AUDIO, VISUAL & TELEPHONE SYSTEM

CONTENTS

PRECAUTIONS	2	(Bose)	20	F
Precautions for Supplemental Restraint System (SRS) "AIR BAG" and "SEAT BELT PRE-TENSIONER"	2	Terminals and Reference Value for Bose Speaker Amp.	21	G
Wiring Diagrams and Trouble Diagnosis	2	Steering Wheel Audio Control Switch Resistance Check	22	H
PREPARATION	3	Removal and Installation	22	I
Commercial Service Tool	3	AUDIO UNIT	22	J
AUDIO	4	DOOR SPEAKER	22	AV
System Description	4	TWEETER SPEAKER	23	L
BASE AND MIDLINE SYSTEM	4	REAR SPEAKER	23	M
BOSE SYSTEM	4	SUBWOOFER SPEAKER	23	
SPEED DEPENDENT VOLUME CONTROL (MIDLINE SYSTEM AND BOSE SYSTEM)	4	BOSE SPEAKER AMP.	23	
Circuit Diagram	5	STEERING WHEEL AUDIO CONTROL SWITCHES	24	
BASE SYSTEM	5	Trouble Diagnoses	24	
MIDLINE SYSTEM	6	AUDIO UNIT	24	
BOSE SYSTEM	7	BASE AND MIDLINE SYSTEM	24	
Wiring Diagram — AUDIO —	8	BOSE SYSTEM	24	
BASE SYSTEM	8	AUDIO ANTENNA	26	
MIDLINE SYSTEM	11	System Description	26	
BOSE SYSTEM	14	Wiring Diagram -W/ANT-	27	
Wiring Diagram - REMOTE -	18	Location of Antenna	28	
Terminals and Reference Value for Audio Unit (Except Bose)	19	Window Antenna Repair	28	
Terminals and Reference Value for Audio Unit (Bose)	20	ELEMENT CHECK	28	
		ELEMENT REPAIR	29	

PRECAUTIONS

PRECAUTIONS

PF0:00001

Precautions for Supplemental Restraint System (SRS) “AIR BAG” and “SEAT BELT PRE-TENSIONER”

EKS00675

The Supplemental Restraint System such as “AIR BAG” and “SEAT BELT PRE-TENSIONER”, used along with a front seat belt, helps to reduce the risk or severity of injury to the driver and front passenger for certain types of collision. This system includes seat belt switch inputs and dual stage front air bag modules. The SRS system uses the seat belt switches to determine the front air bag deployment, and may only deploy one front air bag, depending on the severity of a collision and whether the front occupants are belted or unbelted. Information necessary to service the system safely is included in the SRS and SB section of this Service Manual.

WARNING:

- To avoid rendering the SRS inoperative, which could increase the risk of personal injury or death in the event of a collision which would result in air bag inflation, all maintenance must be performed by an authorized NISSAN/INFINITI dealer.
- Improper maintenance, including incorrect removal and installation of the SRS, can lead to personal injury caused by unintentional activation of the system. For removal of Spiral Cable and Air Bag Module, see the SRS section.
- Do not use electrical test equipment on any circuit related to the SRS unless instructed to in this Service Manual. SRS wiring harnesses can be identified by yellow and/or orange harnesses or harness connectors.

Wiring Diagrams and Trouble Diagnosis

EKS0031U

When you read wiring diagrams, refer to the following:

- Refer to [GI-12, "How to Read Wiring Diagrams"](#) .
Refer to [PG-3, "POWER SUPPLY ROUTING CIRCUIT"](#) .

When you perform trouble diagnosis, refer to the following:

- Refer to [GI-10, "HOW TO FOLLOW TEST GROUPS IN TROUBLE DIAGNOSES"](#) .
Refer to [GI-25, "How to Perform Efficient Diagnosis for an Electrical Incident"](#) .

PREPARATION

PREPARATION

PFP:00002

Commercial Service Tool

EKS003K4

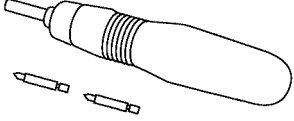
Tool name	Description
<p data-bbox="191 394 305 422">Power tool</p>  <p data-bbox="803 499 878 516">PBIC0191E</p>	<p data-bbox="1003 300 1256 327">Loosening bolts and nuts</p>

A

B

C

D

E

F

G

H

I

J

AV

L

M

AUDIO

System Description BASE AND MIDLINE SYSTEM

Refer to Owner's Manual for audio system operating instructions.

Power is supplied at all times

- through 15A fuse [No. 31, located in the fuse and fusible link box]
- to audio unit terminal 6.

With the ignition switch in the ACC or ON position, power is supplied

- through 10A fuse [No. 6, located in the fuse block (J/B)]
- to audio unit terminal 10.

Ground is supplied through the case of the audio unit.

Audio signals are supplied

- through audio unit terminals 1, 2, 3, 4, 13, 14, 15, and 16
- to terminals + and - of front door speaker LH and RH
- to terminals + and - of rear door speaker LH and RH
- to terminals + and - of tweeter LH and RH.

BOSE SYSTEM

Refer to Owner's Manual for audio system operating instructions.

Power is supplied at all times

- through 15A fuse [No. 31, located in the fuse and fusible link box]
- to audio unit terminal 6, and
- to Bose speaker amp. terminal 1.

With the ignition switch in the ACC or ON position, power is supplied

- through 10A fuse [No. 6, located in the fuse block (J/B)]
- to audio unit terminal 10.

Ground is supplied through the case of the audio unit.

Ground is also supplied

- to speaker amp. terminal 17
- through body ground B117.

Audio signals are supplied

- through audio unit terminals 1, 2, 3, 4, 13, 14, 15, and 16
- to speaker amp. terminals 23, 24, 25, 26, 27, 28, 29, and 30.

Audio signals are amplified by the speaker amp.

The amplified audio signals are supplied

- through speaker amp. terminals 2, 3, 9, 10, 11, 12, 13, 14, 15, 16, 18, and 19
- to terminals + and - of front door speaker LH and RH
- to terminals + and - of rear door speaker LH and RH
- to terminals + and - of tweeter LH and RH
- to terminals + and - of subwoofer LH and RH.

SPEED DEPENDENT VOLUME CONTROL (MIDLINE SYSTEM AND BOSE SYSTEM)

If activated, the radio output volume will be automatically adjusted to compensate for increased driving noises at higher driving speeds.

The radio receives a vehicle speed signal from the combination meter, and selects the output volume.

AUDIO

Circuit Diagram BASE SYSTEM

EKS003JU

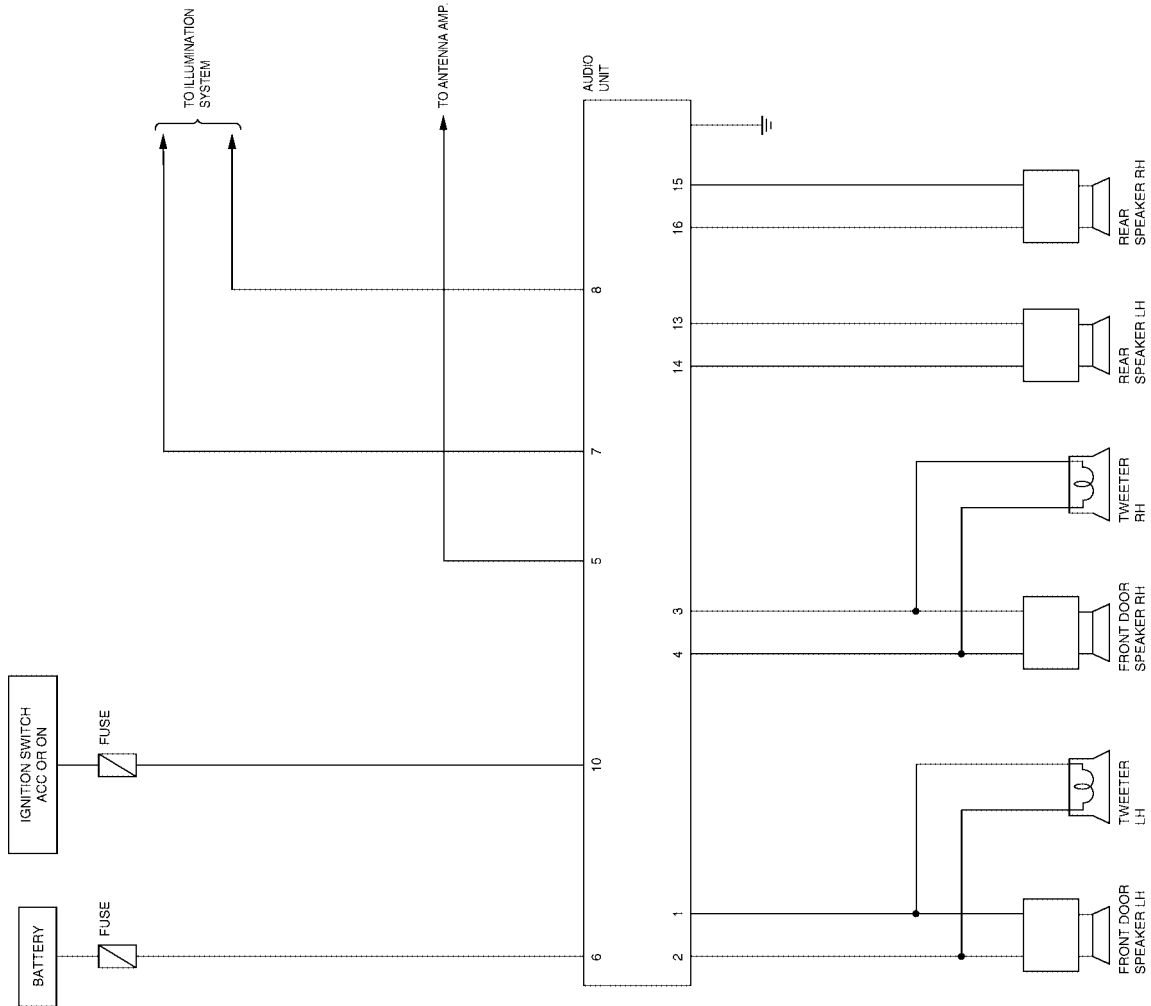

A
B
C
D
E
F
G
H
I
J
L
M

AV

LKWA0001E

AUDIO

MIDLINE SYSTEM

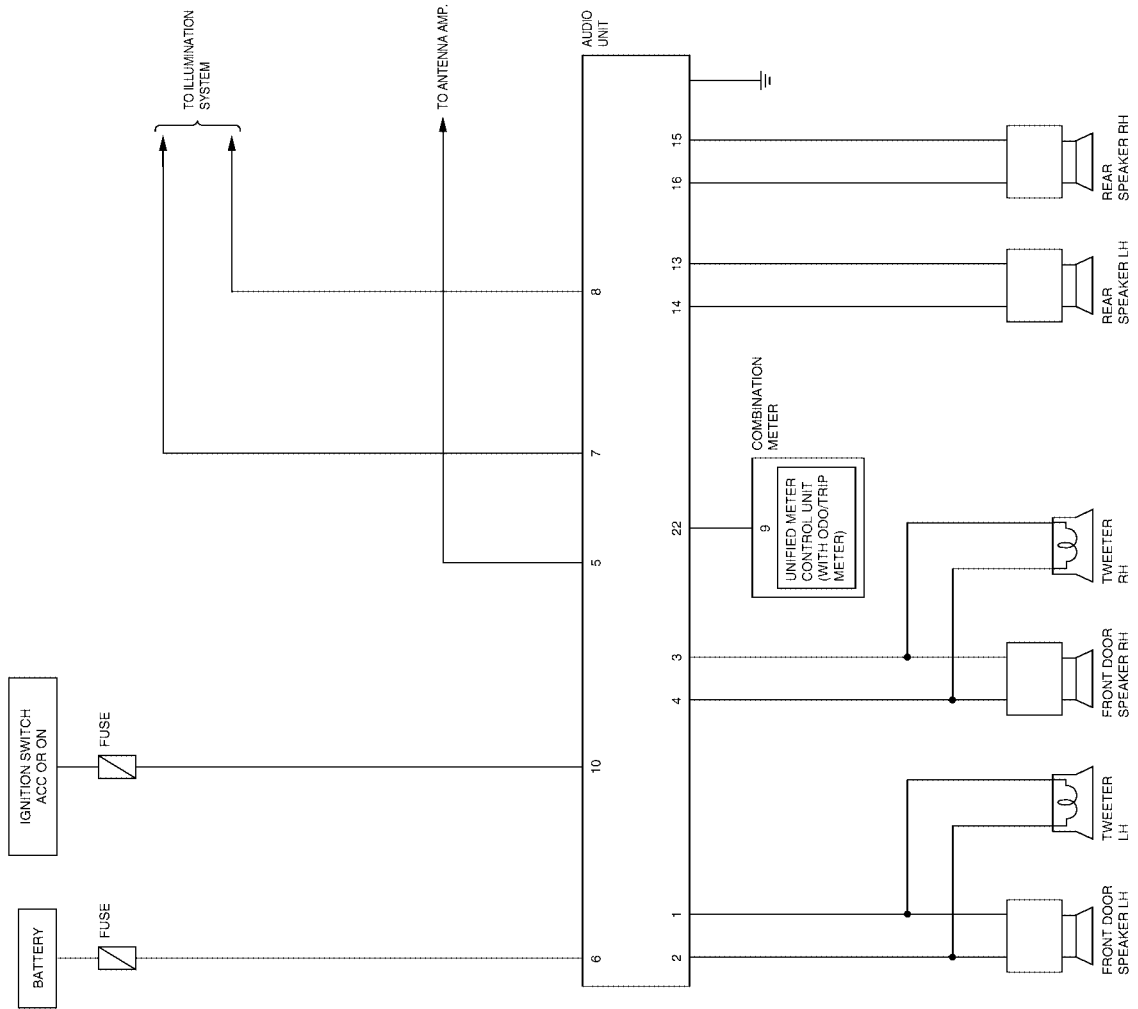

LKWA0002E

AUDIO

BOSE SYSTEM

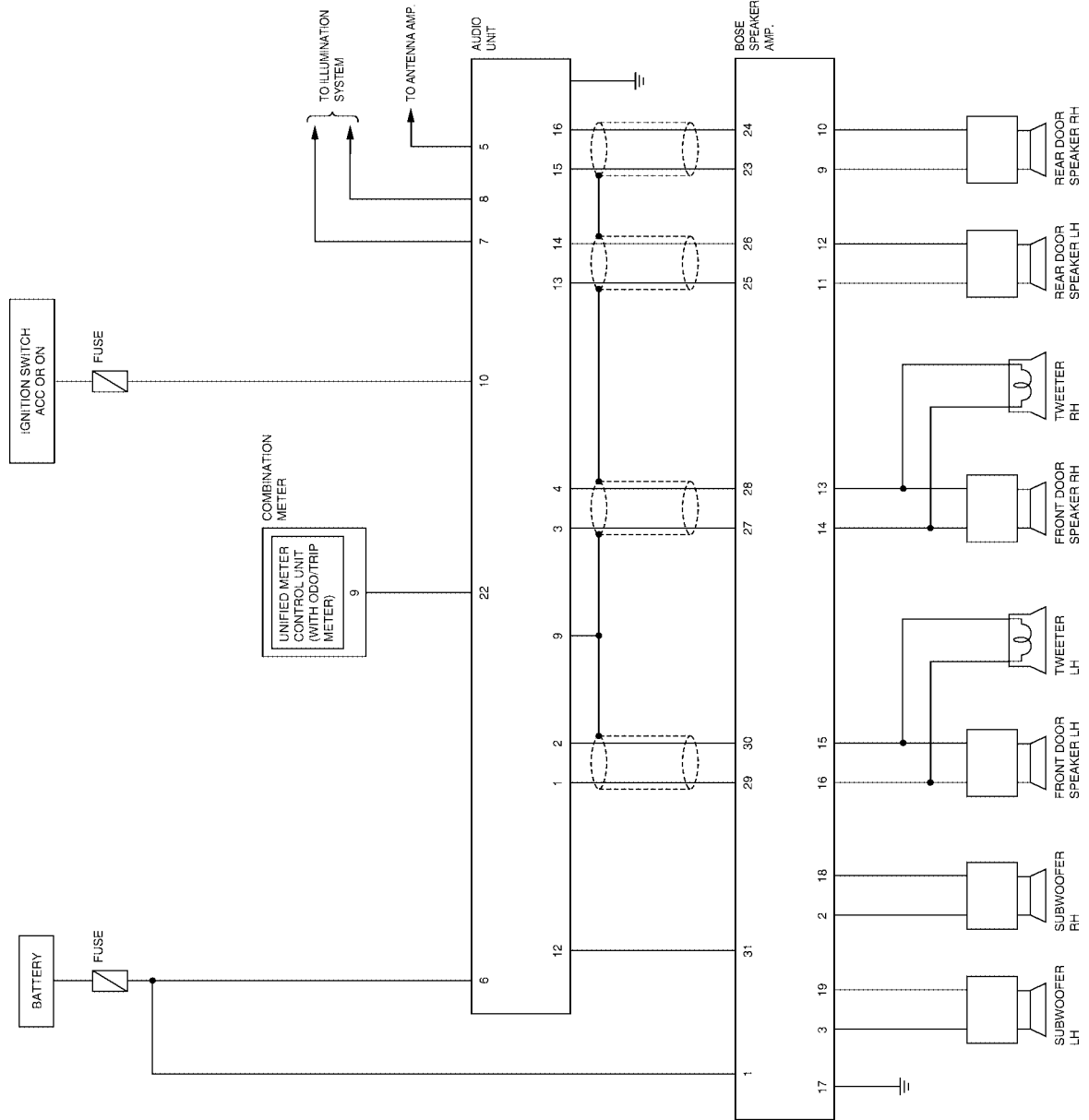

A
B
C
D
E
F
G
H
I
J
AV
L
M

LKWA0003E

AUDIO

Wiring Diagram — AUDIO — BASE SYSTEM

EKS003JV

AV-AUDIO-01

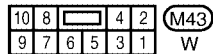
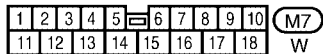
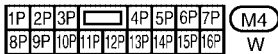
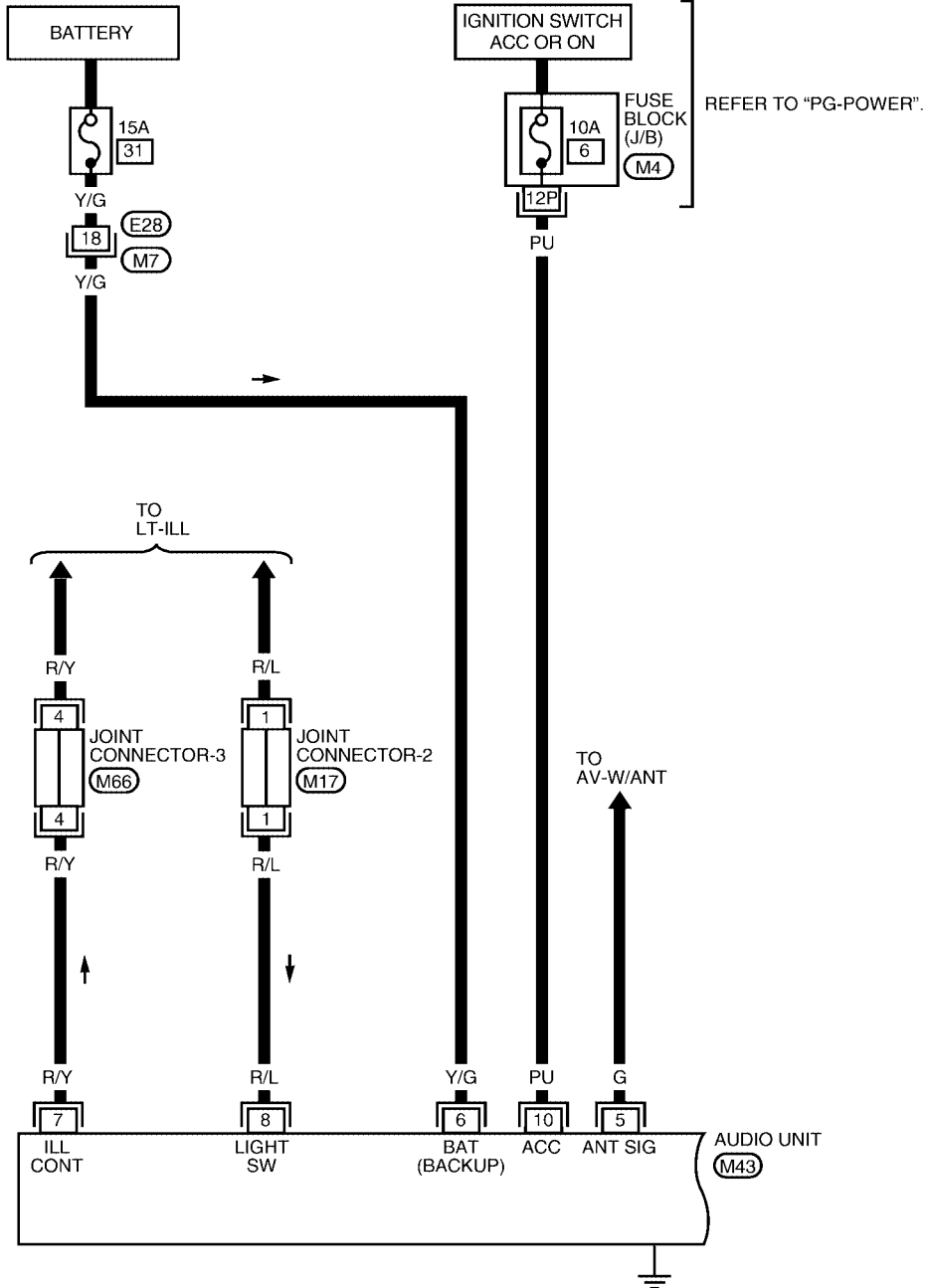

REFER TO THE FOLLOWING.

(M17), (M66) - JOINT CONNECTOR (J/C)

LKWA0004E

AUDIO

AV-AUDIO-02

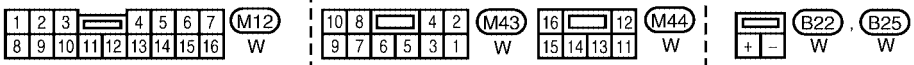
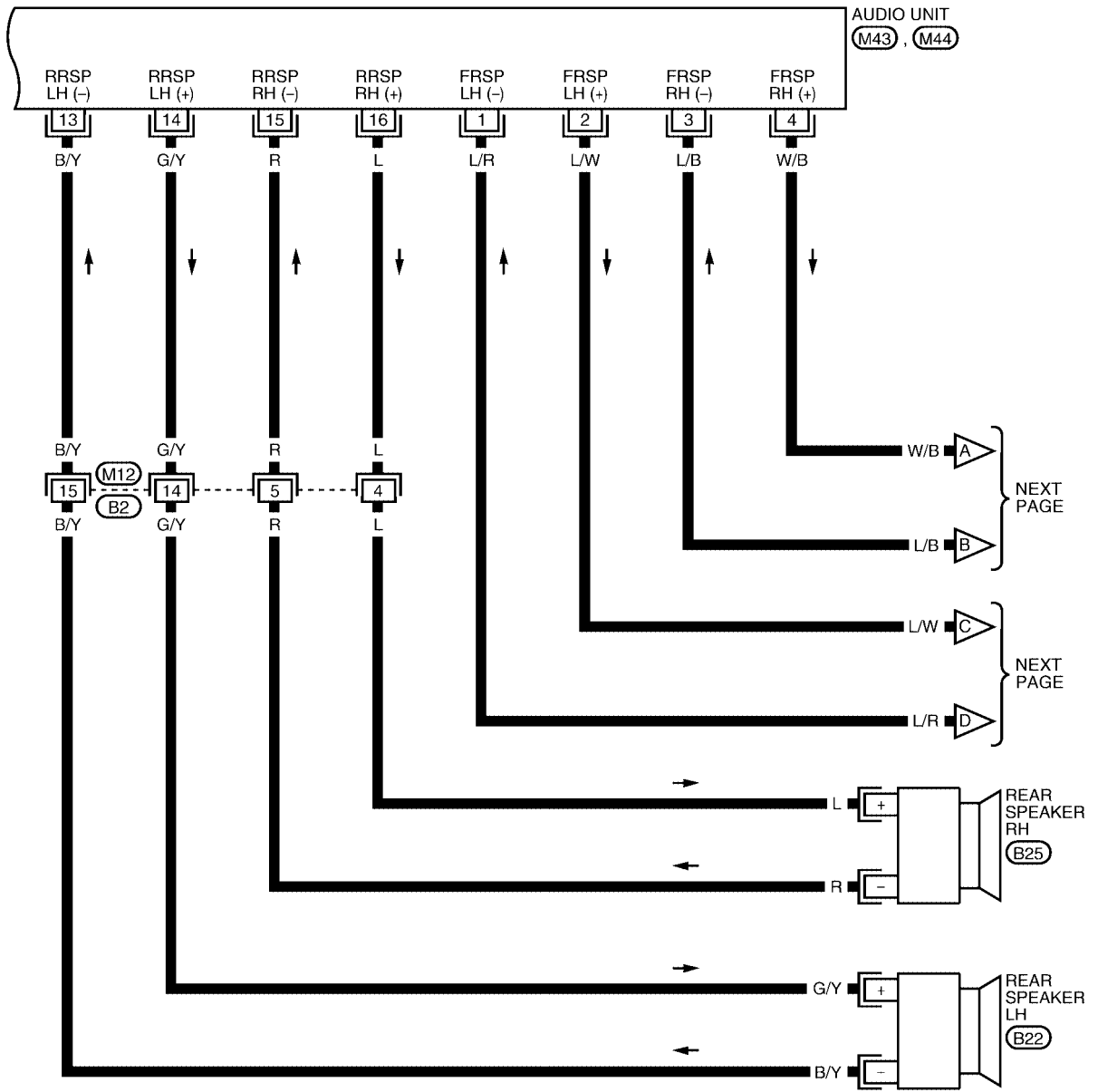

LKWA0093E

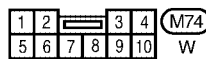
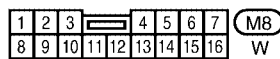
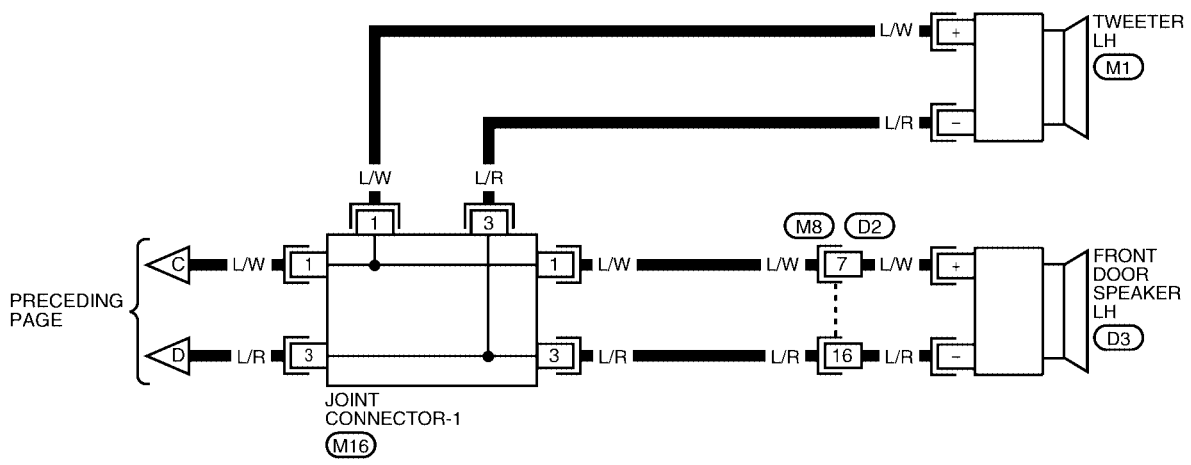
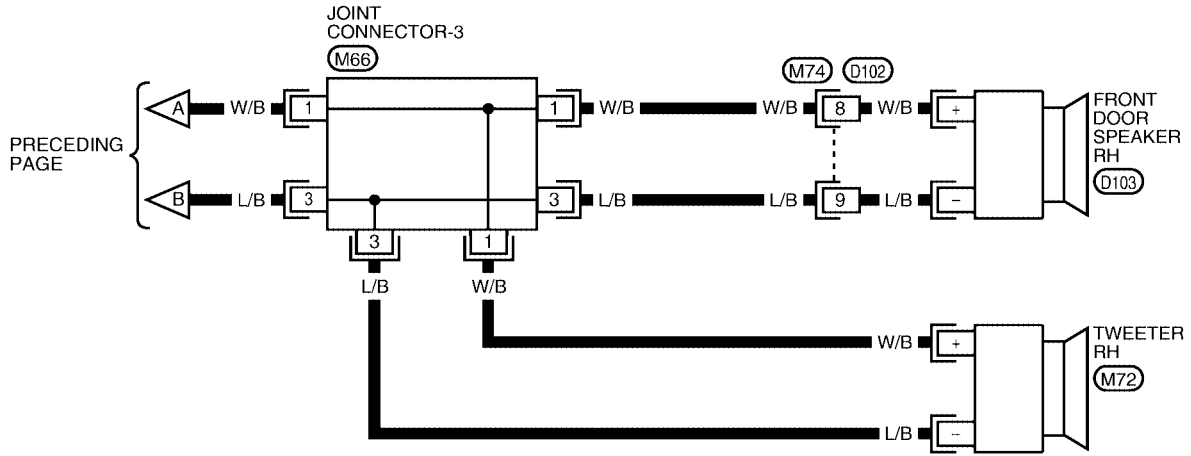

REFER TO THE FOLLOWING.
 (M16), (M66) - JOINT CONNECTOR (J/C)

LKWA0094E

AUDIO

MIDLINE SYSTEM

AV-AUDIO-04

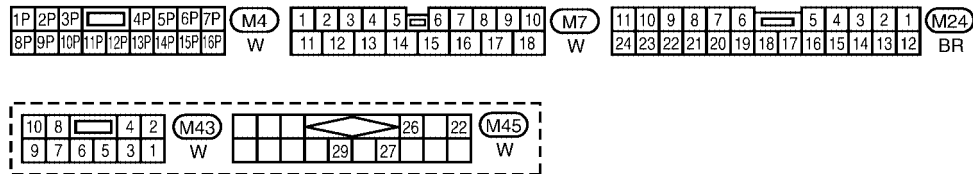
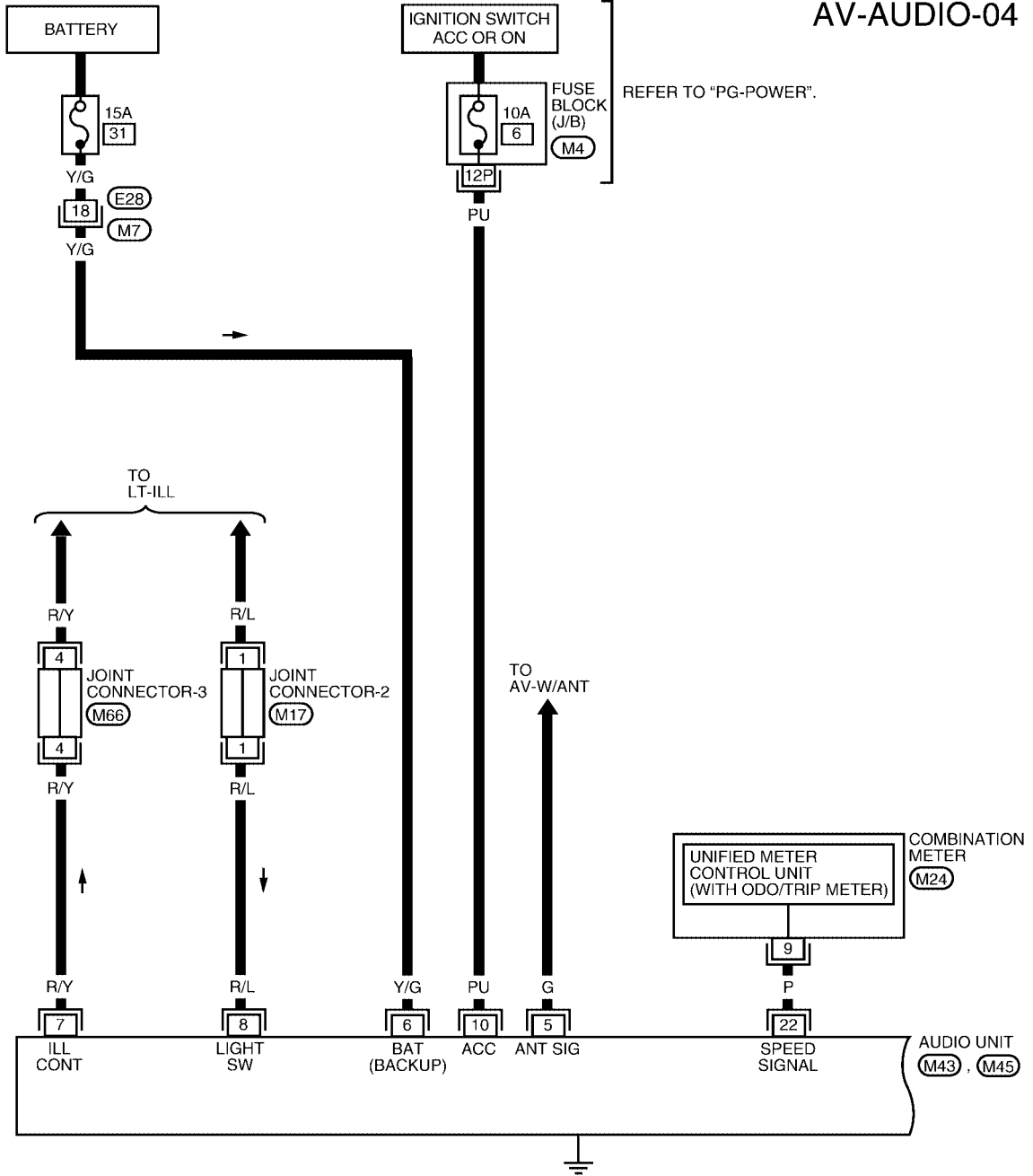

REFER TO THE FOLLOWING.
 (M17), (M66) - JOINT CONNECTOR (J/C)

LKWA0007E

AUDIO

AV-AUDIO-05

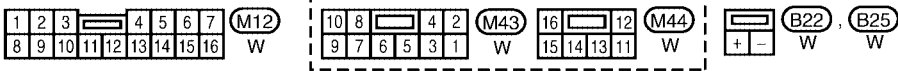
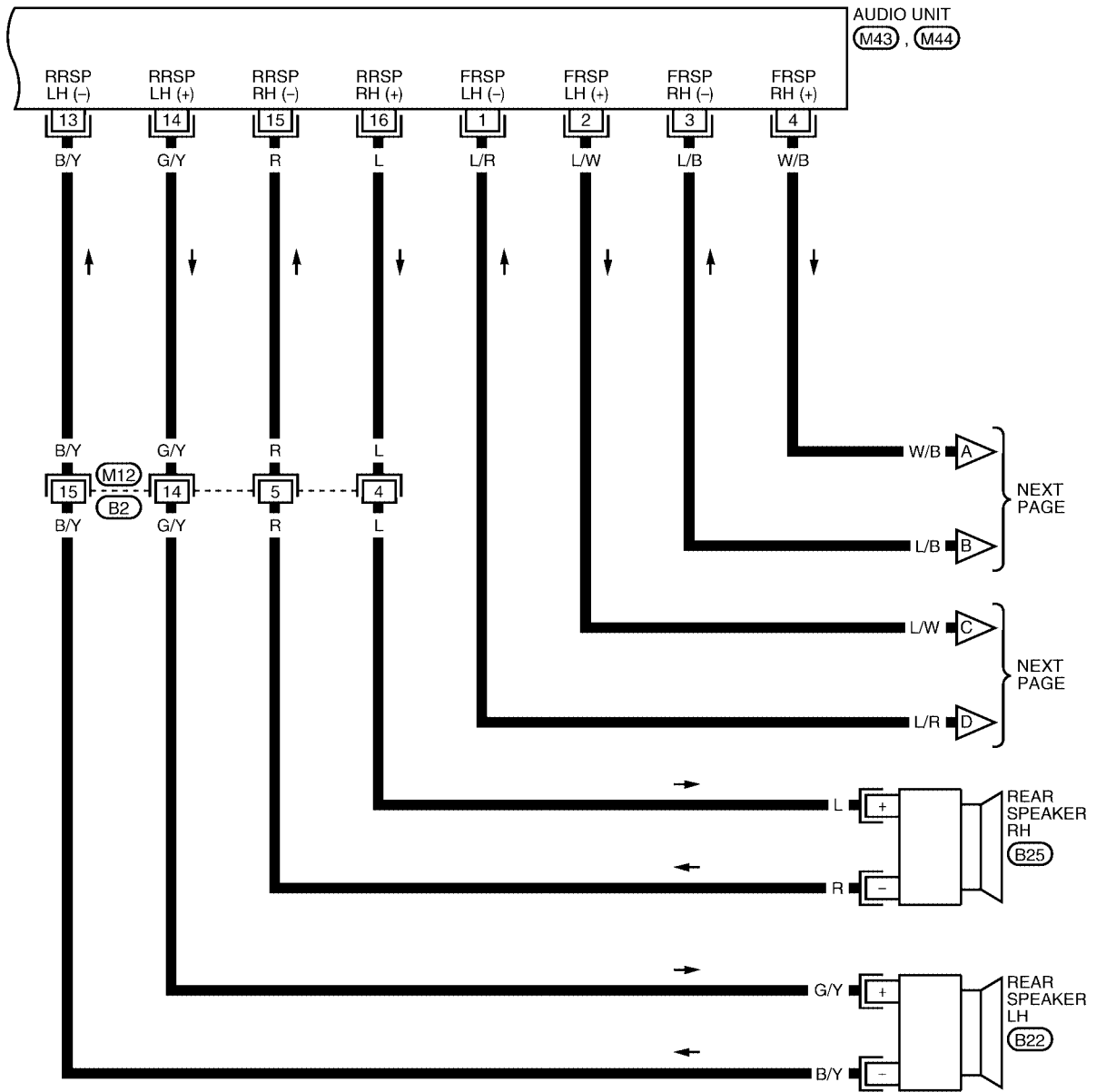

LKWA0095E

AUDIO

AV-AUDIO-06

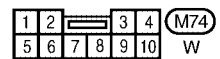
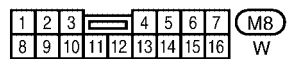
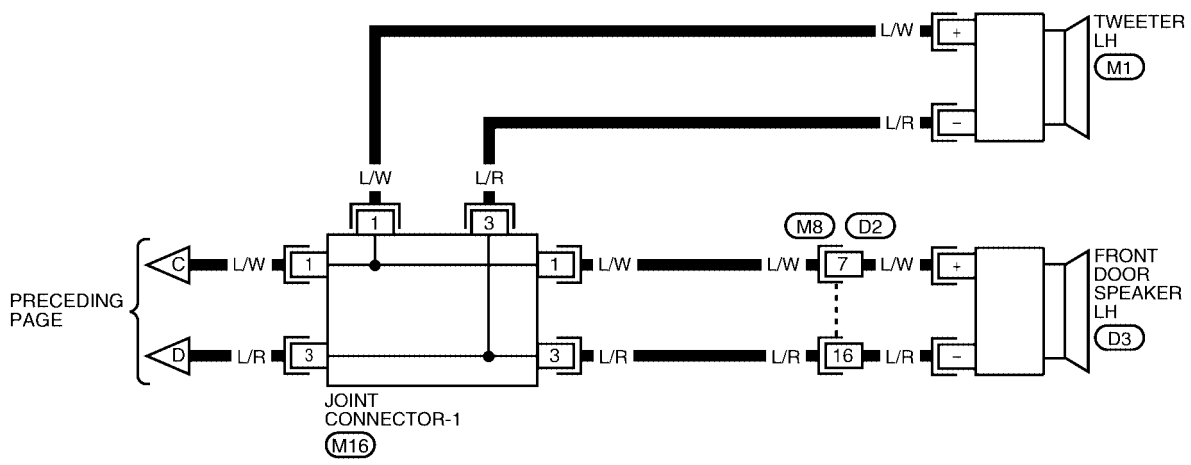
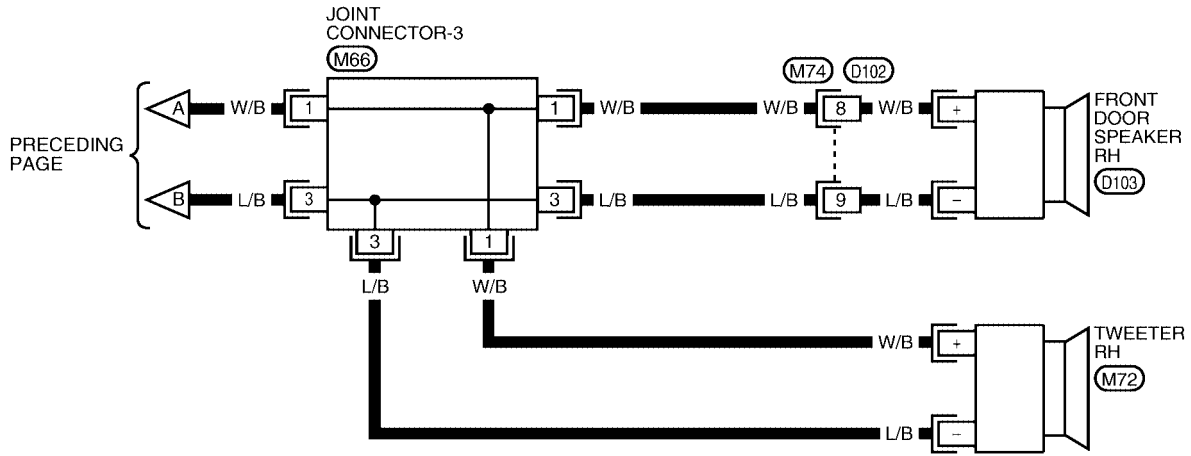

REFER TO THE FOLLOWING.
 (M16), (M66) - JOINT CONNECTOR (J/C)

LKWA0096E

AUDIO

BOSE SYSTEM

AV-AUDIO-07

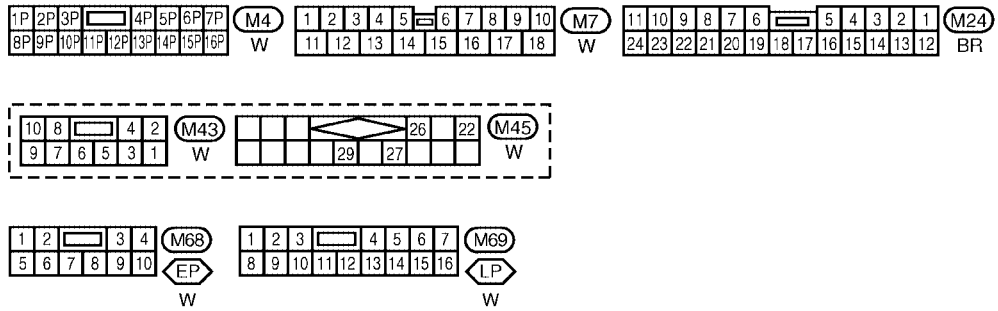
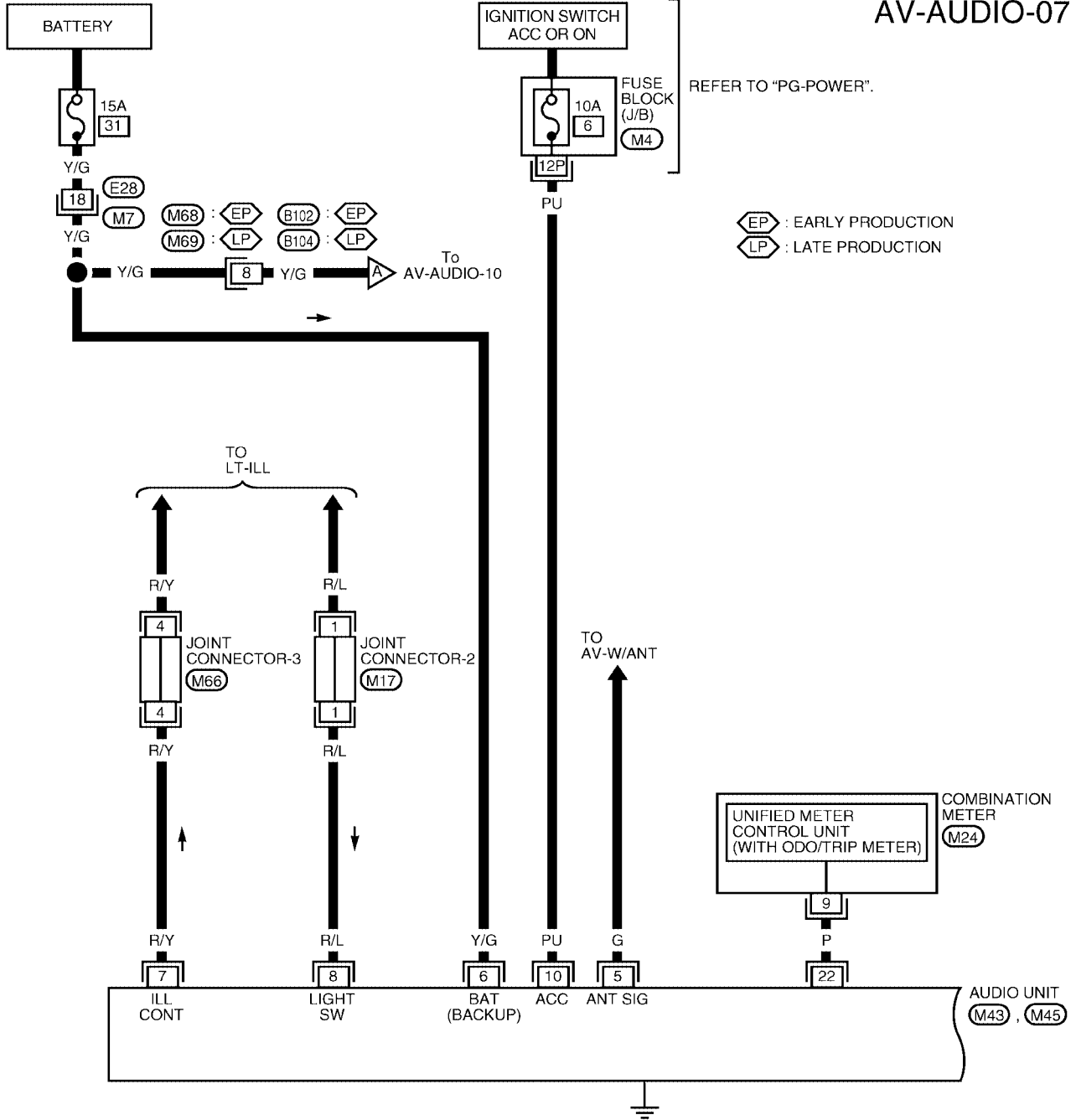

REFER TO THE FOLLOWING.
 (M17), (M66) - JOINT CONNECTOR (J/C)

AUDIO

AV-AUDIO-08

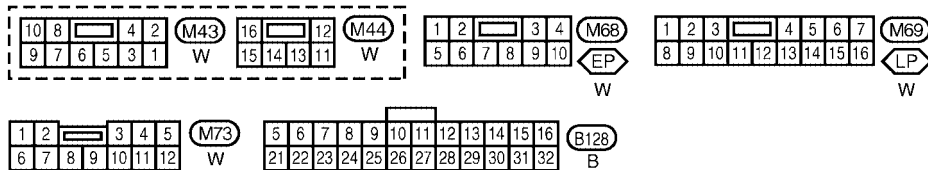
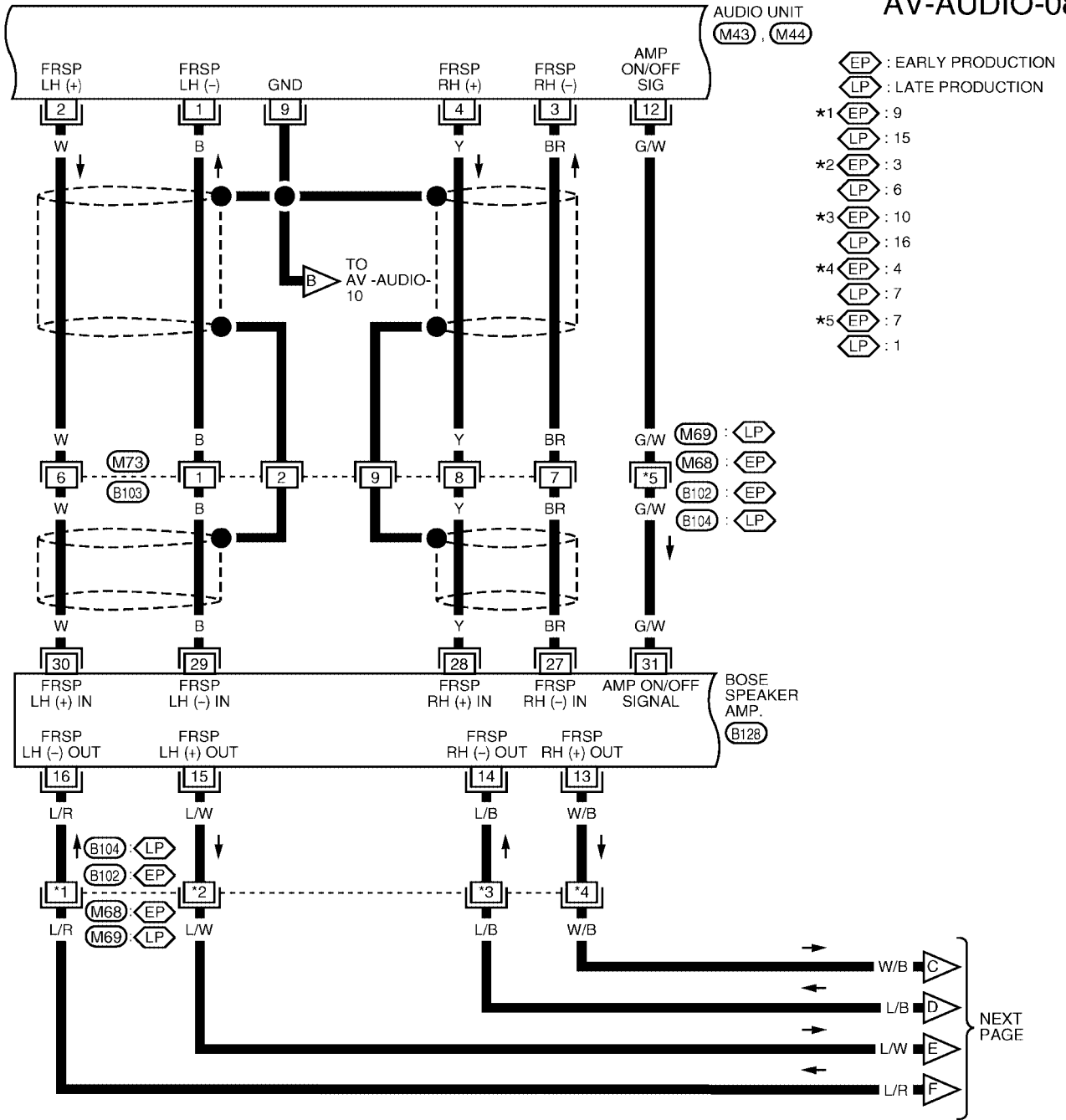

WKWA0498E

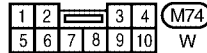
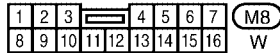
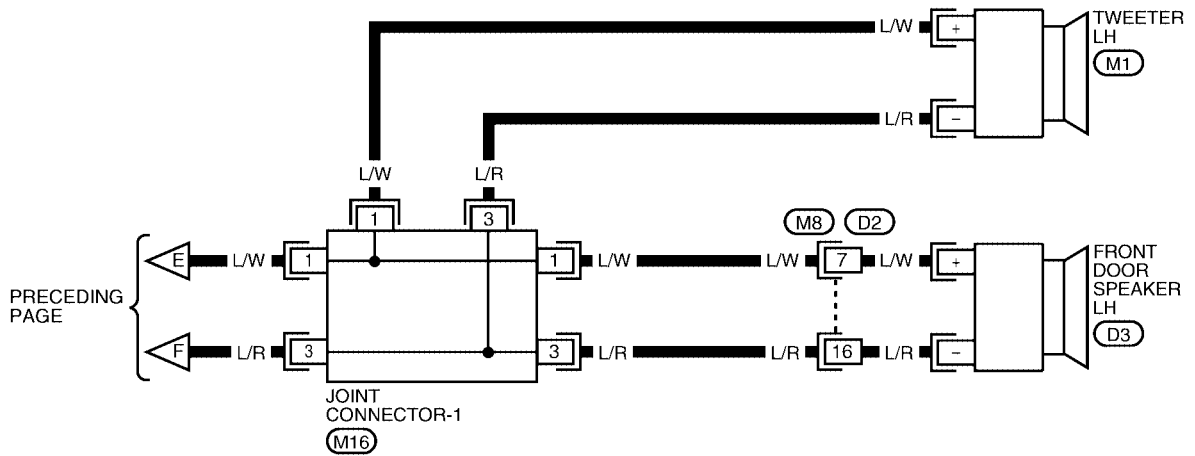
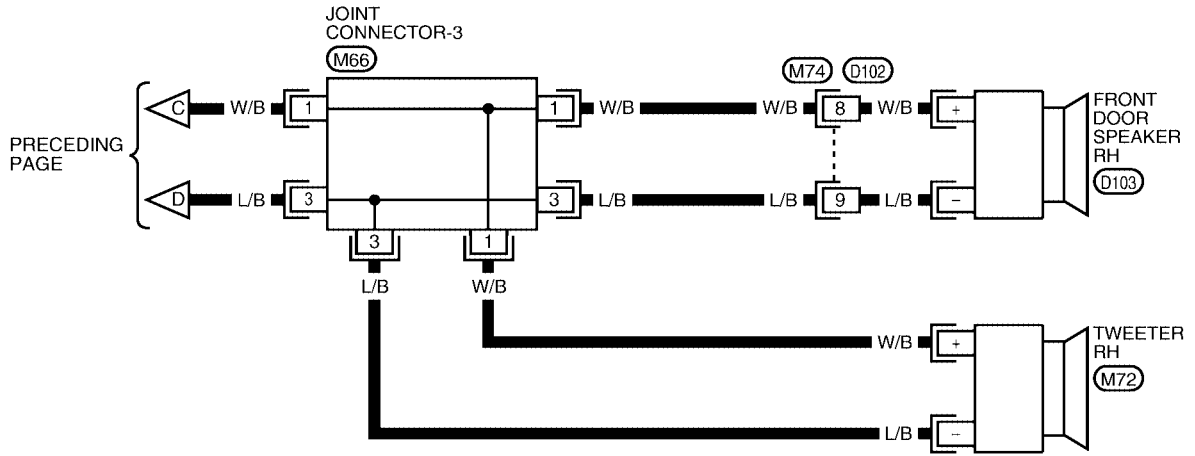

REFER TO THE FOLLOWING.
 (M16), (M66) - JOINT CONNECTOR (J/C)

LKWA0098E

AUDIO

AV-AUDIO-10

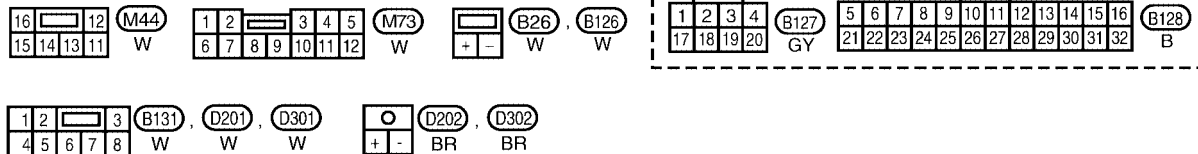
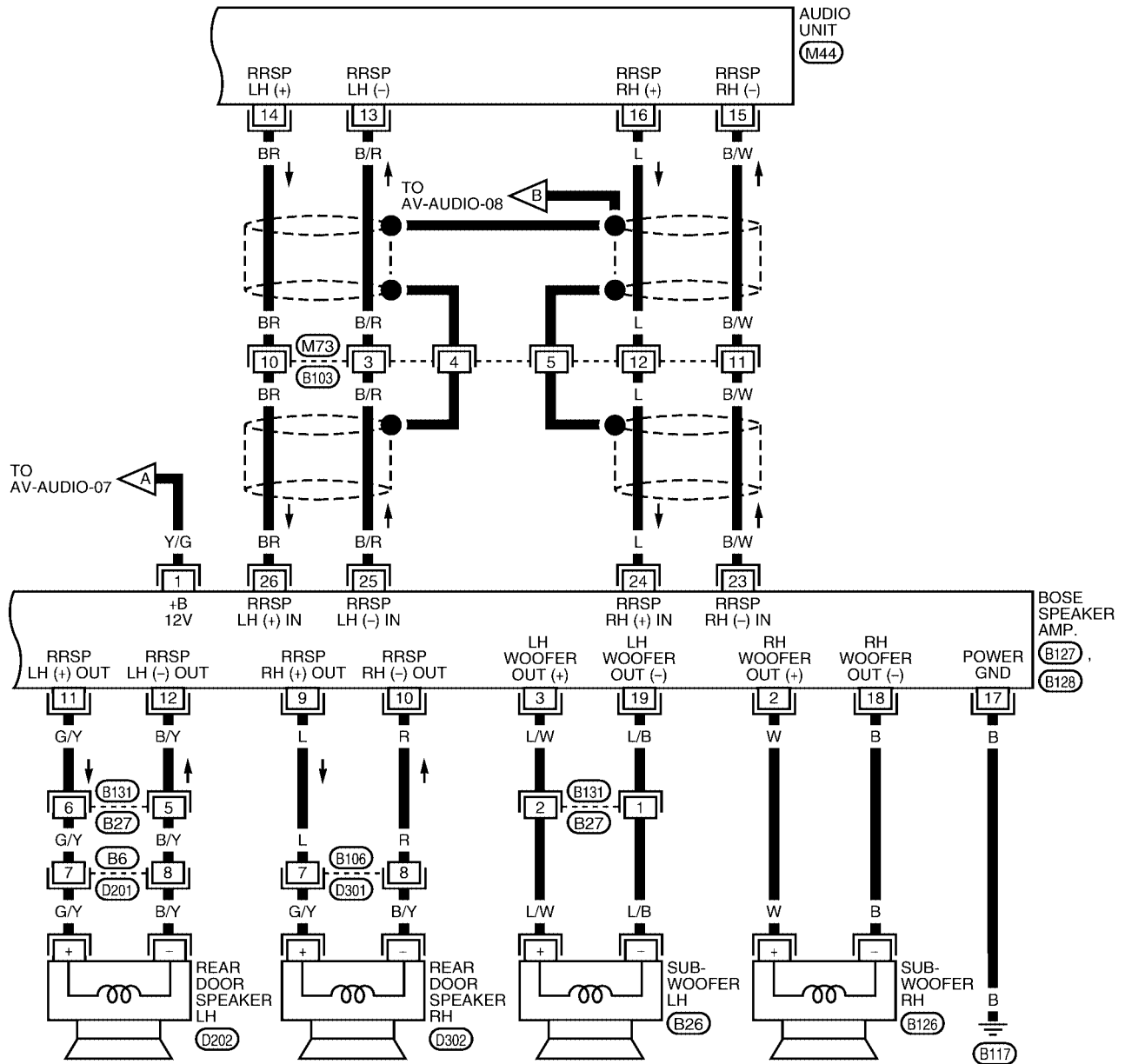

LKWA0099E

AUDIO

Wiring Diagram - REMOTE -

EKS003JW

AV-REMOTE-01

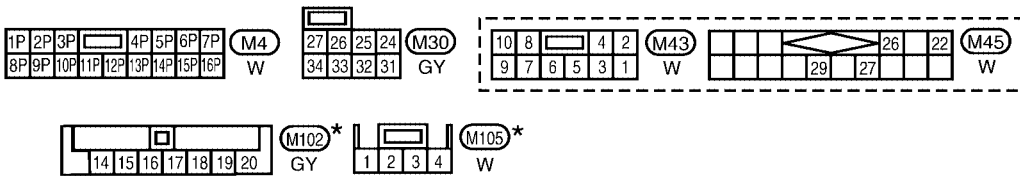
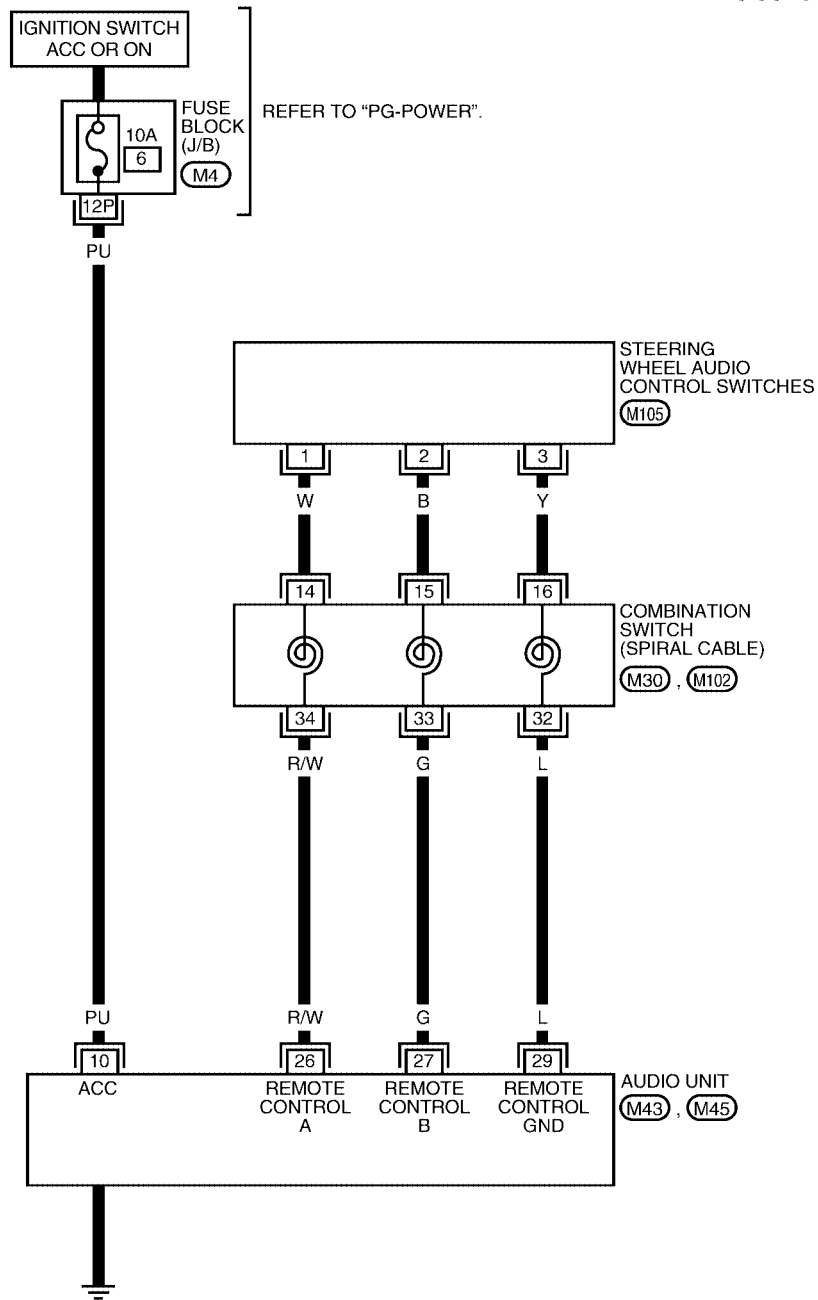

* : This connector is not shown in "HARNESS LAYOUT" of PG section.

LKWA0100E

AUDIO

Terminals and Reference Value for Audio Unit (Except Bose)

EKS003JZ

Terminal No.		Item	Signal input/output	Condition		Voltage (V) (Approx.)	Example of symptom
+	-			Ignition switch	Operation		
1 (L/R)	Ground	Audio sound signal front LH (-)	Output	ON	Receive audio signal	5.5V	No sound from front door speaker LH or tweeter LH.
2 (L/W)	Ground	Audio sound signal front LH (+)	Output	ON	Receive audio signal	5.5V	No sound from front door speaker LH or tweeter LH.
3 (L/B)	Ground	Audio sound signal front RH (-)	Output	ON	Receive audio signal	5.5V	No sound from front door speaker RH or tweeter RH.
4 (W/B)	Ground	Audio sound signal front RH (+)	Output	ON	Receive audio signal	5.5V	No sound from front door speaker RH or tweeter RH.
5 (G)	Ground	Antenna signal	Input	ON	-	5.5V	System does not work properly.
6 (Y/G)	Ground	Battery	Input	-	-	Battery voltage	System does not work properly.
7 (R/Y)	Ground	Illumination control	Input	ON	Lighting switch ON (1st position)	1V → 5V	Audio unit illumination does not function when lighting switch is ON (position 1).
8 (R/L)	Ground	Light switch	Input	ON	Lighting switch ON (1st position)	5.5V	Audio unit illumination does not function when lighting switch is ON (position 1).
10 (PU)	Ground	ACC	Input	ON	Ignition switch ACC or ON	Battery voltage	System does not work properly.
13 (B/Y)	Ground	Audio sound signal rear LH (-)	Output	ON	Receive audio signal	5.5V	No sound from rear speaker LH.
14 (G/Y)	Ground	Audio sound signal rear LH (+)	Output	ON	Receive audio signal	5.5V	No sound from rear speaker LH.
15 (R)	Ground	Audio sound signal rear RH (-)	Output	ON	Receive audio signal	5.5V	No sound from rear speaker RH.
16 (L)	Ground	Audio sound signal rear RH (+)	Output	ON	Receive audio signal	5.5V	No sound from rear speaker RH.
*22 (P)	Ground	Speed signal	Input	ON	Vehicle speed sensor rotating	Voltage increases as vehicle speed sensor rotates faster	Speed dependent volume control does not function.
*26 (R/W)	-	Remote control A	-	-	-	Refer to AV-22. "Steering Wheel Audio Control Switch Resistance Check" .	Steering wheel audio controls do not function.
*27 (G)	-	Remote control B	-	-	-	Refer to AV-22. "Steering Wheel Audio Control Switch Resistance Check" .	Steering wheel audio controls do not function.
*29 (L)	-	Remote control ground	-	-	-	Refer to AV-22. "Steering Wheel Audio Control Switch Resistance Check" .	Steering wheel audio controls do not function.

*: With midline system

AUDIO

Terminals and Reference Value for Audio Unit (Bose)

EKS003K0

Terminal No.		Item	Signal input/output	Condition		Voltage (V) (Approx.)	Example of symptom
+	-			Ignition switch	Operation		
1 (B)	Ground	Audio sound signal front LH (-)	Output	ON	Receive audio signal	5.5V	No sound from front door speaker LH or tweeter LH.
2 (W)	Ground	Audio sound signal front LH (+)	Output	ON	Receive audio signal	5.5V	No sound from front door speaker LH or tweeter LH.
3 (BR)	Ground	Audio sound signal front RH (-)	Output	ON	Receive audio signal	5.5V	No sound from front door speaker RH or tweeter RH.
4 (Y)	Ground	Audio sound signal front RH (+)	Output	ON	Receive audio signal	5.5V	No sound from front door speaker RH or tweeter RH.
5 (G)	Ground	Antenna signal	Input	ON	-	5.5V	System does not work properly.
6 (Y/G)	Ground	Battery	Input	-	-	Battery voltage	System does not work properly.
7 (R/Y)	Ground	Illumination control	Input	ON	Lighting switch ON (1st position)	1V → 5V	Audio unit illumination does not function when lighting switch is ON (position 1).
8 (R/L)	Ground	Light switch	Input	ON	Lighting switch ON (1st position)	5.5V	Audio unit illumination does not function when lighting switch is ON (position 1).
9	-	Ground (Shield drain)	-	-	-	0V	Interference and distortion heard from speakers.
10 (PU)	Ground	ACC	Input	ON	Ignition switch ACC or ON	Battery voltage	System does not work properly.
12 (G/W)	Ground	Amp. ON/OFF signal	Output	ON	Ignition switch ACC or ON	Battery voltage	Amp. does not work properly.
13 (B/R)	Ground	Audio sound signal rear LH (-)	Output	ON	Receive audio signal	5.5V	No sound from rear speaker LH.
14 (BR)	Ground	Audio sound signal rear LH (+)	Output	ON	Receive audio signal	5.5V	No sound from rear speaker LH.
15 (B/W)	Ground	Audio sound signal rear RH (-)	Output	ON	Receive audio signal	5.5V	No sound from rear speaker RH.
16 (L)	Ground	Audio sound signal rear RH (+)	Output	ON	Receive audio signal	5.5V	No sound from rear speaker RH.
22 (P)	Ground	Speed signal	Input	ON	Vehicle speed sensor rotating	Voltage increases as vehicle speed sensor rotates faster	Speed dependent volume control does not function.
26 (R/W)	-	Remote control A	-	-	-	Refer to AV-22, "Steering Wheel Audio Control Switch Resistance Check" .	Steering wheel audio controls do not function.

AUDIO

Terminal No.		Item	Signal input/output	Condition		Voltage (V) (Approx.)	Example of symptom
+	-			Ignition switch	Operation		
27 (G)	-	Remote control B	-	-	-	Refer to AV-22, "Steering Wheel Audio Control Switch Resistance Check" .	Steering wheel audio controls do not function.
29 (L)	-	Remote control ground	-	-	-	Refer to AV-22, "Steering Wheel Audio Control Switch Resistance Check" .	Steering wheel audio controls do not function.

Terminals and Reference Value for Bose Speaker Amp.

EKS003K1

Terminal No.		Item	Signal input/output	Condition		Voltage (V) (Approx.)	Example of symptom
+	-			Ignition switch	Operation		
1 (Y/G)	Ground	Battery	Input	-	-	Battery voltage	System does not work properly.
2 (W)	Ground	Subwoofer RH (+)	Output	ON	Receive audio signal	5 - 7.5V	No sound from subwoofer RH.
3 (L/W)	Ground	Subwoofer LH (+)	Output	ON	Receive audio signal	5 - 7.5V	No sound from subwoofer LH.
9 (L)	Ground	Rear door speaker RH (+)	Output	ON	Receive audio signal	5 - 7.5V	No sound from rear door speaker RH.
10 (R)	Ground	Rear door speaker RH (-)	Output	ON	Receive audio signal	5 - 7.5V	No sound from rear door speaker RH.
11 (G/Y)	Ground	Rear door speaker LH (+)	Output	ON	Receive audio signal	5 - 7.5V	No sound from rear door speaker LH.
12 (B/Y)	Ground	Rear door speaker LH (-)	Output	ON	Receive audio signal	5 - 7.5V	No sound from rear door speaker LH.
13 (W/B)	Ground	Front door speaker RH and tweeter RH (+)	Output	ON	Receive audio signal	5 - 7.5V	No sound from front door speaker RH or tweeter RH.
14 (L/B)	Ground	Front door speaker RH and tweeter RH (-)	Output	ON	Receive audio signal	5 - 7.5V	No sound from front door speaker RH or tweeter RH.
15 (L/W)	Ground	Front door speaker LH and tweeter LH (+)	Output	ON	Receive audio signal	5 - 7.5V	No sound from front door speaker LH or tweeter LH.
16 (L/R)	Ground	Front door speaker LH and tweeter LH (-)	Output	ON	Receive audio signal	5 - 7.5V	No sound from front door speaker LH or tweeter LH.
17 (B)	Ground	Ground	-	-	-	-	-
18 (B)	Ground	Subwoofer RH (-)	Output	ON	Receive audio signal	5 - 7.5V	No sound from subwoofer RH.
19 (L/B)	Ground	Subwoofer LH (-)	Output	ON	Receive audio signal	5 - 7.5V	No sound from subwoofer LH.
23 (B/W)	Ground	Rear speaker RH (-)	Input	ON	Receive audio signal	5 - 7.5V	No sound from RH rear speakers.
24 (L)	Ground	Rear speaker RH (+)	Input	ON	Receive audio signal	5 - 7.5V	No sound from RH rear speakers.
25 (B/R)	Ground	Rear speaker LH (-)	Input	ON	Receive audio signal	5 - 7.5V	No sound from LH rear speakers.

AUDIO

Terminal No.		Item	Signal input/output	Condition		Voltage (V) (Approx.)	Example of symptom
+	-			Ignition switch	Operation		
26 (BR)	Ground	Rear speaker LH (+)	Input	ON	Receive audio signal	5 - 7.5V	No sound from LH rear speakers.
27 (BR)	Ground	Front speaker RH (-)	Input	ON	Receive audio signal	5 - 7.5V	No sound from RH front speakers.
28 (Y)	Ground	Front speaker RH (+)	Input	ON	Receive audio signal	5 - 7.5V	No sound from RH front speakers.
29 (B)	Ground	Front speaker LH (-)	Input	ON	Receive audio signal	5 - 7.5V	No sound from LH front speakers.
30 (W)	Ground	Front speaker LH (+)	Input	ON	Receive audio signal	5 - 7.5V	No sound from LH front speakers.
31 (G/W)	Ground	Amp. ON/OFF signal	Input	ON	-	10V	System does not work properly.

Steering Wheel Audio Control Switch Resistance Check

EKS003K2

*Terminal No. (wire color)		Signal name	Condition	Resistance (Ω) (Approx.)
+	-			
27 (G)	29 (L)	Volume (down)	Depress volume down switch	652 Ω
26 (R/W)	29 (L)	Volume (up)	Depress volume up switch	652 Ω
27 (G)	29 (L)	Mode	Depress (station) down switch	165 Ω
26 (R/W)	29 (L)	Up (next)	Depress (station) up switch	165 Ω
26 (R/W)	29 (L)	Down (previous)	Depress mode switch	1 Ω

*: Audio unit terminals.

Removal and Installation AUDIO UNIT

EKS003K3

1. Remove cluster lid C. Refer to [IP-12, "Cluster Lid C"](#).
2. Remove cluster lid D. Refer to [IP-12, "Cluster Lid D"](#).
3. Remove audio unit screws using power tool and slide audio unit forward.
4. Disconnect connectors and antenna cable and then remove audio unit.

Install in the reverse order of removal.

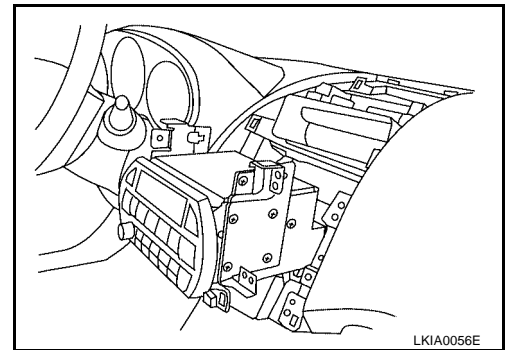

DOOR SPEAKER

1. Remove door finisher. Refer to [EI-27, "Removal and Installation"](#).

AUDIO

2. Remove screws and speaker.
 3. Disconnect speaker connector.
- Install in the reverse order of removal.

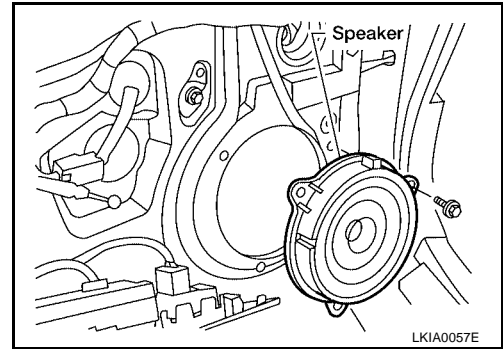

TWEETER SPEAKER

1. Remove windshield garnish molding. Refer to [EI-29, "Removal and Installation"](#).
 2. Remove tweeter speaker by gently prying away from A pillar.
 3. Disconnect tweeter speaker connector.
- Install in the reverse order of removal.

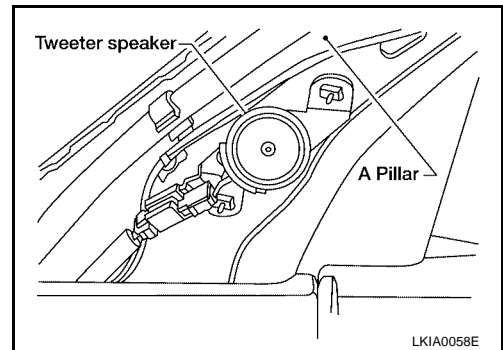

REAR SPEAKER

1. Remove rear parcel shelf finisher. Refer to [EI-31, "Removal and Installation"](#).
2. Remove screws and rear speaker.
3. Disconnect speaker connector.

Install in the reverse order of removal, noting the following:

Rear speaker mounting screws:

 : 2.7 - 3.7 N·m (0.28 - 0.38 kg-m, 24 - 33 in-lb)

SUBWOOFER SPEAKER

1. Remove rear parcel shelf finisher. Refer to [EI-31, "Removal and Installation"](#).
2. Remove screws and subwoofer.
3. Disconnect subwoofer connector.

Install in the reverse order of removal, noting the following:

Subwoofer mounting screws:

 : 2.7 - 3.7 N·m (0.28 - 0.38 kg-m, 24 - 33 in-lb)

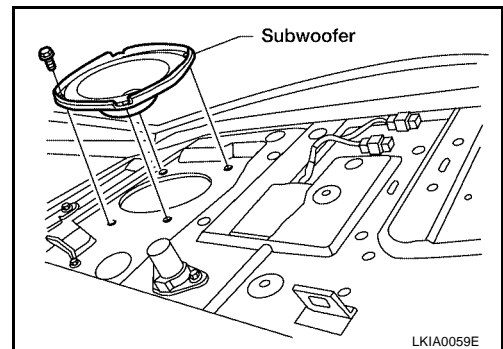

BOSE SPEAKER AMP.

1. Remove rear parcel shelf finisher. Refer to [EI-31, "Removal and Installation"](#).
2. Remove trunk trim and trunk lid finisher. Refer to [EI-35, "Removal and Installation"](#).

AUDIO

3. Remove screws and amp.
4. Disconnect amp. connectors.

Install in the reverse order of removal, noting the following:

Bose speaker amp. mounting screws:

 : 2.7 - 3.7 N·m (0.28 - 0.38 kg·m, 24 - 33 in·lb)

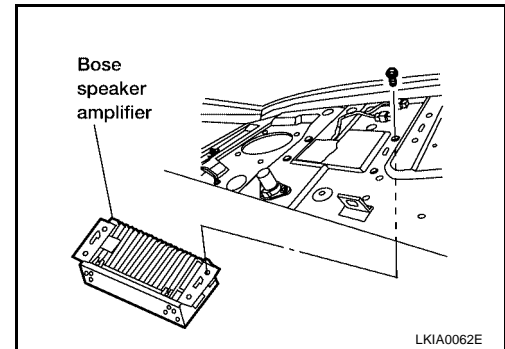

STEERING WHEEL AUDIO CONTROL SWITCHES

1. Remove driver air bag module. Refer to [SRS-39, "REMOVAL"](#).
2. Remove screws and disconnect connector and then remove steering wheel audio control switches.

Install in the reverse order of removal.

Trouble Diagnoses

AUDIO UNIT

EKS003IZ

Symptom	Possible causes	Repair order
Audio unit inoperative (no digital display and no sound from speakers).	<ol style="list-style-type: none"> 1. 10A fuse 2. Poor audio unit case ground 3. Audio unit 	<ol style="list-style-type: none"> 1. Check 10A fuse [No. 6, located in fuse block (J/B)]. Turn ignition switch ON and verify that battery positive voltage is present at terminal 10 of audio unit. 2. Check audio unit case ground. 3. Remove audio unit for repair.
Audio unit presets are lost when ignition switch is turned OFF.	<ol style="list-style-type: none"> 1. 15A fuse 2. Audio unit 	<ol style="list-style-type: none"> 1. Check 15A fuse (No. 31, located in fuse and fusible link box) and verify that battery positive voltage is present at terminal 6 of audio unit. 2. Remove audio unit for repair.
AM/FM stations are weak or noisy.	<ol style="list-style-type: none"> 1. Window antenna or antenna amp. 2. Poor audio unit case ground 3. Audio unit 	<ol style="list-style-type: none"> 1. Check window antenna. 2. Check audio unit case ground. 3. Remove audio unit for repair.
Audio unit generates noise in AM and FM modes with engine running.	<ol style="list-style-type: none"> 1. Poor audio unit case ground 2. Loose or missing ground bonding straps 3. Ignition condenser or rear window defogger noise suppressor condenser 4. Generator 5. Ignition coil(s) 6. Audio unit 	<ol style="list-style-type: none"> 1. Check audio unit case ground. 2. Check ground bonding straps. 3. Replace ignition condenser or rear window defogger noise suppressor condenser. 4. Check generator. 5. Check ignition coil(s). 6. Remove audio unit for repair.
Audio unit generates noise in AM and FM modes with accessories on (switch pops and motor noise).	<ol style="list-style-type: none"> 1. Poor audio unit case ground 2. Antenna 3. Accessory ground 4. Faulty accessory 	<ol style="list-style-type: none"> 1. Check audio unit case ground. 2. Check antenna. 3. Check accessory ground. 4. Replace accessory.

BASE AND MIDLINE SYSTEM

Symptom	Possible causes	Repair order
Individual speaker is noisy or inoperative.	<ol style="list-style-type: none"> 1. Speaker 2. Audio unit output 3. Speaker circuit 4. Audio unit 	<ol style="list-style-type: none"> 1. Check speaker. 2. Check audio unit output voltages. 3. Check wires for open or short between audio unit and speaker. 4. Remove audio unit for repair.

BOSE SYSTEM

AUDIO

Symptom	Possible causes	Repair order
Audio unit controls are operational, but no sound is heard from any speaker.	<ol style="list-style-type: none"> 1. 15A fuse 2. Amp. ON/OFF signal circuit 3. Speaker amp. ground 	<ol style="list-style-type: none"> 1. Check 15A fuse [No. 31, located in the fuse block (J/B)]. Verify battery positive voltage is present at terminal 1 of the speaker amp. 2. Check harness continuity between audio unit terminal 12 and speaker amp. terminal 31. 3. Check harness continuity between speaker amp. terminal 17 and ground.
Individual speaker is noisy or inoperative.	<ol style="list-style-type: none"> 1. Speaker 2. Output circuits to speaker 3. Speaker amp. power supply and ground 	<ol style="list-style-type: none"> 1. Check speaker. 2. Check the output circuits to speaker: <ul style="list-style-type: none"> – between audio unit and speaker amp. – between speaker amp. and speaker 3. Check speaker amp. power supply and ground condition.

A
B
C
D
E
F
G
H
I
J
L
M

AV

AUDIO ANTENNA

PFP:28200

System Description

EKS003J1

With the ignition switch in ACC or ON, power is supplied

- through 10A fuse [No. 6, located in the fuse block (J/B)]
- to audio unit terminal 10.

Ground is supplied through the case of the antenna amp.

When the radio switch is turned ON, antenna signal is supplied

- through audio unit terminal 5
- to the antenna amp. terminal 1.

Then the antenna amp. is activated.

The amplified radio signals are supplied to the audio unit through the antenna amp.

AUDIO ANTENNA

Wiring Diagram -W/ANT-

EKS003J2

AV-W/ANT-01

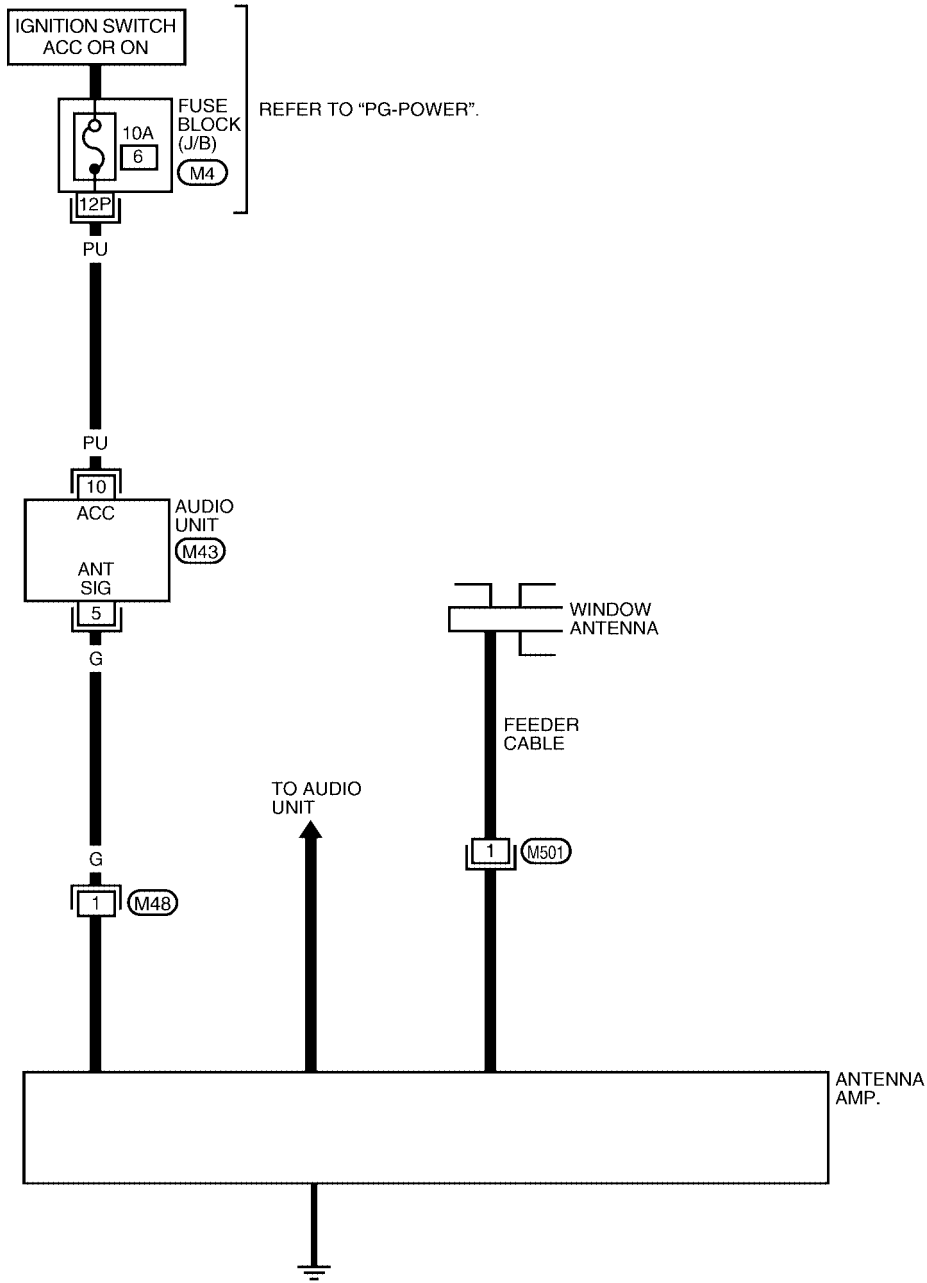

A
B
C
D
E
F
G
H
I
J
AV
L
M

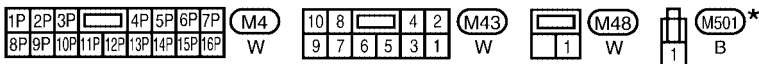

* : This connector is not shown in "HARNESS LAYOUT" of PG section.

LKWA0017E

AUDIO ANTENNA

Location of Antenna

EKS003J3

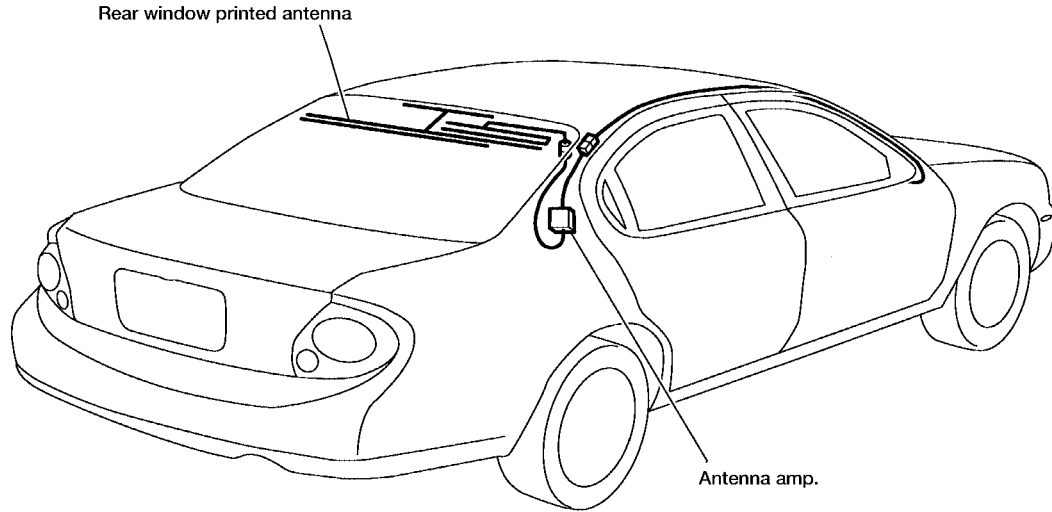

LKIA0012E

Window Antenna Repair ELEMENT CHECK

EKS003J4

1. Attach probe circuit tester (ohm setting) to antenna terminal on each side.

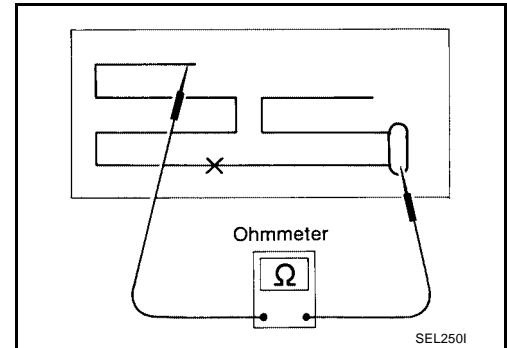

- When measuring continuity, wrap tin foil around the top of probe. Then, press the foil against the wire with your finger.

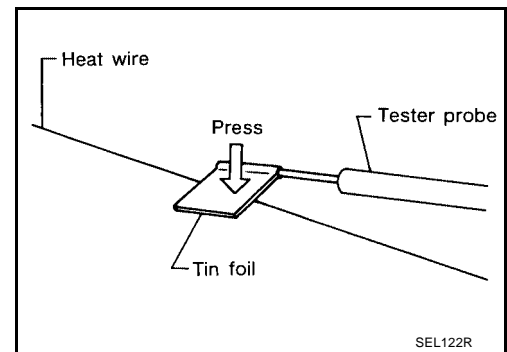

AUDIO ANTENNA

2. If an element is broken, no continuity will exist.

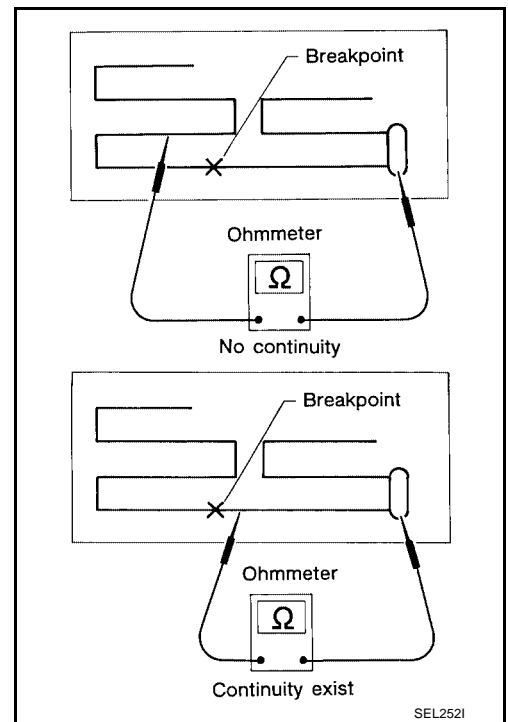

3. To locate a break, move probe along element. Tester needle will swing abruptly when probe passes the broken point.

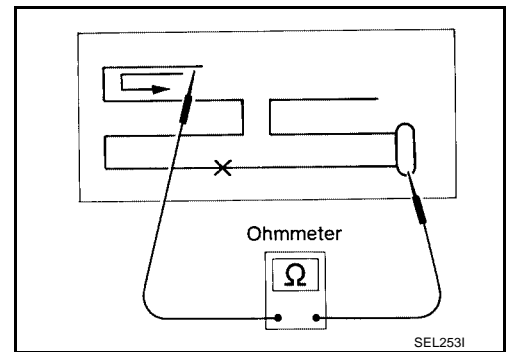

ELEMENT REPAIR

Refer to [GW-58, "Filament Repair"](#) .

A
B
C
D
E
F
G
H
I
J
AV
L
M

AUDIO ANTENNA
