

SECTION **IP**
INSTRUMENT PANEL

A
B
C
D
E
F
G
H
IP
J
K
L
M

CONTENTS

PRECAUTIONS	2	CONFIRM THE REPAIR	6
Precautions for Supplemental Restraint System (SRS) "AIR BAG" and "SEAT BELT PRE-TENSIONER"	2	Generic Squeak and Rattle Troubleshooting	6
PREPARATION	3	INSTRUMENT PANEL	6
Special Service Tools	3	CENTER CONSOLE	6
Commercial Service Tools	3	DOORS	6
SQUEAK AND RATTLE TROUBLE DIAGNOSIS	4	TRUNK	7
Work Flow	4	SUNROOF/HEADLINER	7
CUSTOMER INTERVIEW	4	SEATS	7
DUPLICATE THE NOISE AND TEST DRIVE	5	UNDERHOOD	7
CHECK RELATED SERVICE BULLETINS	5	Diagnostic Worksheet	8
LOCATE THE NOISE AND IDENTIFY THE ROOT CAUSE	5	INSTRUMENT PANEL ASSEMBLY	10
REPAIR THE CAUSE	5	Removal and Installation	10
		REMOVAL AND INSTALLATION	11
		Disassembly and Assembly	15
		CENTER CONSOLE	15

PRECAUTIONS

PRECAUTIONS

PFP:00001

Precautions for Supplemental Restraint System (SRS) “AIR BAG” and “SEAT BELT PRE-TENSIONER”

EIS001F4

The Supplemental Restraint System such as “AIR BAG” and “SEAT BELT PRE-TENSIONER”, used along with a front seat belt, helps to reduce the risk or severity of injury to the driver and front passenger for certain types of collision. This system includes seat belt switch inputs and dual stage front air bag modules. The SRS system uses the seat belt switches to determine the front air bag deployment, and may only deploy one front air bag, depending on the severity of a collision and whether the front occupants are belted or unbelted. Information necessary to service the system safely is included in the SRS and SB section of this Service Manual.

WARNING:

- To avoid rendering the SRS inoperative, which could increase the risk of personal injury or death in the event of a collision which would result in air bag inflation, all maintenance must be performed by an authorized NISSAN/INFINITI dealer.
- Improper maintenance, including incorrect removal and installation of the SRS, can lead to personal injury caused by unintentional activation of the system. For removal of Spiral Cable and Air Bag Module, see the SRS section.
- Do not use electrical test equipment on any circuit related to the SRS unless instructed to in this Service Manual. SRS wiring harnesses can be identified by yellow and/or orange harness connectors.

PREPARATION

PREPARATION

PFP:00002

Special Service Tools

EIS001CS

The actual shapes of Kent-Moore tools may differ from those of special service tools illustrated here.

Tool number (Kent-Moore No.) Tool name	Description
— (J-39570) Chassis ear	Locating the noise
— (J-43980) NISSAN Squeak and Rattle kit	Repairing the cause of noise

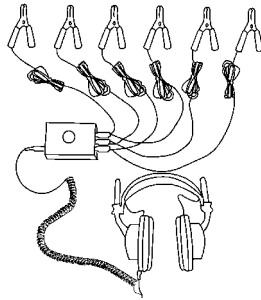

SBT839

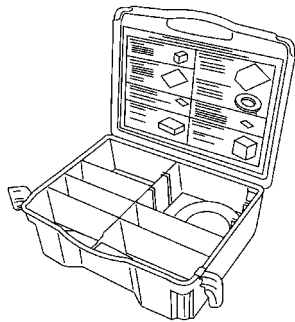

SBT840

Commercial Service Tools

EIS001CT

Tool name	Description
Engine ear (J-39565)	Locating the noise
Power Tool	Loosening bolts and nuts

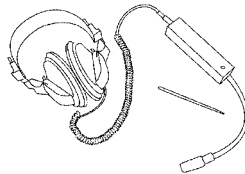

SIIA0995E

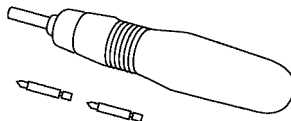

PBIC0191E

A
B
C
D
E
F
G
H
IP
J
K
L
M

SQUEAK AND RATTLE TROUBLE DIAGNOSIS

SQUEAK AND RATTLE TROUBLE DIAGNOSIS

PF0:0000

Work Flow

EIS001CU

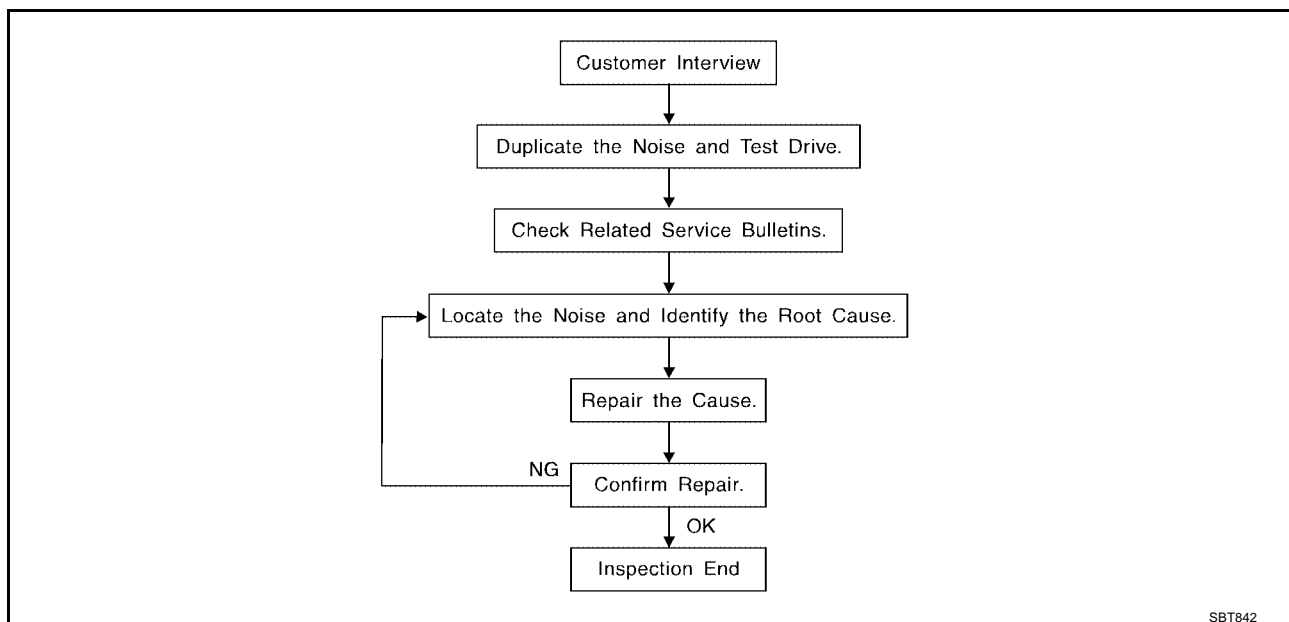

CUSTOMER INTERVIEW

Interview the customer, if possible, to determine the conditions that exist when the noise occurs. Use the Diagnostic Worksheet during the interview to document the facts and conditions when the noise occurs and any customer's comments; refer to [IP-8, "Diagnostic Worksheet"](#). This information is necessary to duplicate the conditions that exist when the noise occurs.

- The customer may not be able to provide a detailed description or the location of the noise. Attempt to obtain all the facts and conditions that exist when the noise occurs (or does not occur).
- If there is more than one noise in the vehicle, be sure to diagnose and repair the noise that the customer is concerned about. This can be accomplished by test driving the vehicle with the customer.
- After identifying the type of noise, isolate the noise in terms of its characteristics. The noise characteristics are provided so the customer, service adviser and technician are all speaking the same language when defining the noise.
- Squeak — (Like tennis shoes on a clean floor)
Squeak characteristics include the light contact/fast movement/brought on by road conditions/hard surfaces = higher pitch noise/softer surfaces = lower pitch noises/edge to surface = chirping.
- Creak — (Like walking on an old wooden floor)
Creak characteristics include firm contact/slow movement/twisting with a rotational movement/pitch dependent on materials/often brought on by activity.
- Rattle — (Like shaking a baby rattle)
Rattle characteristics include the fast repeated contact/vibration or similar movement/loose parts/missing clip or fastener/incorrect clearance.
- Knock — (Like a knock on a door)
Knock characteristics include hollow sounding/sometimes repeating/often brought on by driver action.
- Tick — (Like a clock second hand)
Tick characteristics include gentle contacting of light materials/loose components/can be caused by driver action or road conditions.
- Thump — (Heavy, muffled knock noise)
Thump characteristics include softer knock/dead sound often brought on by activity.
- Buzz — (Like a bumblebee)
Buzz characteristics include high frequency rattle/firm contact.
- Often the degree of acceptable noise level will vary depending upon the person. A noise that you may judge as acceptable may be very irritating to the customer.
- Weather conditions, especially humidity and temperature, may have a great effect on noise level.

SQUEAK AND RATTLE TROUBLE DIAGNOSIS

DUPLICATE THE NOISE AND TEST DRIVE

If possible, drive the vehicle with the customer until the noise is duplicated. Note any additional information on the Diagnostic Worksheet regarding the conditions or location of the noise. This information can be used to duplicate the same conditions when you confirm the repair.

If the noise can be duplicated easily during the test drive, to help identify the source of the noise, try to duplicate the noise with the vehicle stopped by doing one or all of the following:

1. Close a door.
 2. Tap or push/pull around the area where the noise appears to be coming from.
 3. Rev the engine.
 4. Use a floor jack to recreate vehicle "twist".
 5. At idle, apply engine load (electrical load, half-clutch on M/T model, drive position on A/T model).
 6. Raise the vehicle on a hoist and hit a tire with a rubber hammer.
- Drive the vehicle and attempt to duplicate the conditions the customer states exist when the noise occurs.
 - If it is difficult to duplicate the noise, drive the vehicle slowly on an undulating or rough road to stress the vehicle body.

CHECK RELATED SERVICE BULLETINS

After verifying the customer concern or symptom, check ASIST for Technical Service Bulletins (TSBs) related to that concern or symptom.

If a TSB relates to the symptom, follow the procedure to repair the noise.

LOCATE THE NOISE AND IDENTIFY THE ROOT CAUSE

1. Narrow down the noise to a general area. To help pinpoint the source of the noise, use a listening tool (Chassis Ear: J-39570, Engine Ear: J-39565 and mechanics stethoscope).
2. Narrow down the noise to a more specific area and identify the cause of the noise by:
 - Removing the components in the area that you suspect the noise is coming from.
Do not use too much force when removing clips and fasteners, otherwise clips and fasteners can be broken or lost during the repair, resulting in the creation of new noise.
 - Tapping or pushing/pulling the component that you suspect is causing the noise.
Do not tap or push/pull the component with excessive force, otherwise the noise will be eliminated only temporarily.
 - Feeling for a vibration with your hand by touching the component(s) that you suspect is (are) causing the noise.
 - Placing a piece of paper between components that you suspect are causing the noise.
 - Looking for loose components and contact marks.

Refer to [IP-6, "Generic Squeak and Rattle Troubleshooting"](#).

REPAIR THE CAUSE

- If the cause is a loose component, tighten the component securely.
- If the cause is insufficient clearance between components:
 - Separate components by repositioning or loosening and retightening the component, if possible.
 - Insulate components with a suitable insulator such as urethane pads, foam blocks, felt cloth tape or urethane tape. A NISSAN Squeak and Rattle Kit (J-43980) is available through your authorized NISSAN Parts Department.

CAUTION:

Do not use excessive force as many components are constructed of plastic and may be damaged.

Always check with the Parts Department for the latest parts information.

The following materials are contained in the NISSAN Squeak and Rattle Kit (J-43980). Each item can be ordered separately as needed.

URETHANE PADS [1.5 mm (0.059 in) thick]

Insulates connectors, harness, etc.

76268-9E005: 100 x 135 mm (3.94 x 5.31 in)/76884-71L01: 60 x 85 mm (2.36 x 3.35 in)/76884-71L02: 15 x 25 mm (0.59 x 0.98 in)

INSULATOR (Foam blocks)

Insulates components from contact. Can be used to fill space behind a panel.

SQUEAK AND RATTLE TROUBLE DIAGNOSIS

73982-9E000: 45 mm (1.77 in) thick, 50 x 50 mm (1.97 x 1.97 in)/73982-50Y00: 10 mm (0.39 in) thick, 50 x 50 mm (1.97 x 1.97 in)

INSULATOR (Light foam block)

80845-71L00: 30 mm (1.18 in) thick, 30 x 50 mm (1.18 x 1.97 in)

FELT CLOTH TAPE

Used to insulate where movement does not occur. Ideal for instrument panel applications.

68370-4B000: 15 x 25 mm (0.59 x 0.98 in) pad/68239-13E00: 5 mm (0.20 in) wide tape roll

The following materials, not found in the kit, can also be used to repair squeaks and rattles.

UHMW (TEFLON) TAPE

Insulates where slight movement is present. Ideal for instrument panel applications.

SILICONE GREASE

Used in place of UHMW tape that will be visible or not fit.

Note: Will only last a few months.

SILICONE SPRAY

Use when grease cannot be applied.

DUCT TAPE

Use to eliminate movement.

CONFIRM THE REPAIR

Confirm that the cause of a noise is repaired by test driving the vehicle. Operate the vehicle under the same conditions as when the noise originally occurred. Refer to the notes on the Diagnostic Worksheet.

Generic Squeak and Rattle Troubleshooting

EIS001CV

Refer to Table of Contents for specific component removal and installation information.

INSTRUMENT PANEL

Most incidents are caused by contact and movement between:

1. The cluster lid A and instrument panel
2. Acrylic lens and combination meter housing
3. Instrument panel to front pillar garnish
4. Instrument panel to windshield
5. Instrument panel mounting pins
6. Wiring harnesses behind the combination meter
7. A/C defroster duct and duct joint

These incidents can usually be located by tapping or moving the components to duplicate the noise or by pressing on the components while driving to stop the noise. Most of these incidents can be repaired by applying felt cloth tape or silicone spray (in hard to reach areas). Urethane pads can be used to insulate wiring harness.

CAUTION:

Do not use silicone spray to isolate a squeak or rattle. If you saturate the area with silicone, you will not be able to recheck the repair.

CENTER CONSOLE

Components to pay attention to include:

1. Shifter assembly cover to finisher
2. A/C control unit and upper/lower cluster lid C
3. Wiring harnesses behind audio and A/C control unit

The instrument panel repair and isolation procedures also apply to the center console.

DOORS

Pay attention to the:

1. Finisher and inner panel making a slapping noise
2. Inside handle escutcheon to door finisher
3. Wiring harnesses tapping
4. Door striker out of alignment causing a popping noise on starts and stops

SQUEAK AND RATTLE TROUBLE DIAGNOSIS

Tapping or moving the components or pressing on them while driving to duplicate the conditions can isolate many of these incidents. You can usually insulate the areas with felt cloth tape or insulator foam blocks from the NISSAN Squeak and Rattle Kit (J-43980) to repair the noise.

A

TRUNK

Trunk noises are often caused by a loose jack or loose items put into the trunk by the owner. In addition look for:

B

1. Trunk lid bumpers out of adjustment
2. Trunk lid striker out of adjustment
3. The trunk lid torsion bars knocking together
4. A loose license plate or bracket

C

Most of these incidents can be repaired by adjusting, securing or insulating the item(s) or component(s) causing the noise.

D

SUNROOF/HEADLINER

Noises in the sunroof/headliner area can often be traced to one of the following:

E

1. Sunroof lid, rail, linkage or seals making a rattle or light knocking noise
2. Sunvisor shaft shaking in the holder
3. Front or rear windshield touching headliner and squeaking

F

Again, pressing on the components to stop the noise while duplicating the conditions can isolate most of these incidents. Repairs usually consist of insulating with felt cloth tape.

G

SEATS

When isolating seat noises it is important to note the position the seat is in and the load placed on the seat when the noise is present. These conditions should be duplicated when verifying and isolating the cause of the noise.

H

Cause of seat noise include:

1. Headrest rods and holders
2. A squeak between the seat pad cushion and frame
3. The rear seat back lock and bracket

IP

These noises can be isolated by moving or pressing on the suspected components while duplicating the conditions under which the noise occurs. Most of these incidents can be repaired by repositioning the component or applying urethane tape to the contact area.

J

K

UNDERHOOD

Some interior noises may be caused by components under the hood or on the engine wall. The noise is then transmitted into the passenger compartment.

L

Causes of transmitted underhood noises include:

1. Any component mounted to the engine wall
2. Components that pass through the engine wall
3. Engine wall mounts and connectors
4. Loose radiator mounting pins
5. Hood bumpers out of adjustment
6. Hood striker out of adjustment

M

These noises can be difficult to isolate since they cannot be reached from the interior of the vehicle. The best method is to secure, move or insulate one component at a time and test drive the vehicle. Also, engine RPM or load can be changed to isolate the noise. Repairs can usually be made by moving, adjusting, securing, or insulating the component causing the noise.

SQUEAK AND RATTLE TROUBLE DIAGNOSIS

Diagnostic Worksheet

EIS001CW



SQUEAK & RATTLE DIAGNOSTIC WORKSHEET

Dear Nissan Customer:

We are concerned about your satisfaction with your Nissan vehicle. Repairing a squeak or rattle sometimes can be very difficult. To help us fix your Nissan right the first time, please take a moment to note the area of the vehicle where the squeak or rattle occurs and under what conditions. You may be asked to take a test drive with a service advisor or technician to ensure we confirm the noise you are hearing.

I. WHERE DOES THE NOISE COME FROM? (circle the area of the vehicle)

The illustrations are for reference only, and may not reflect the actual configuration of your vehicle.

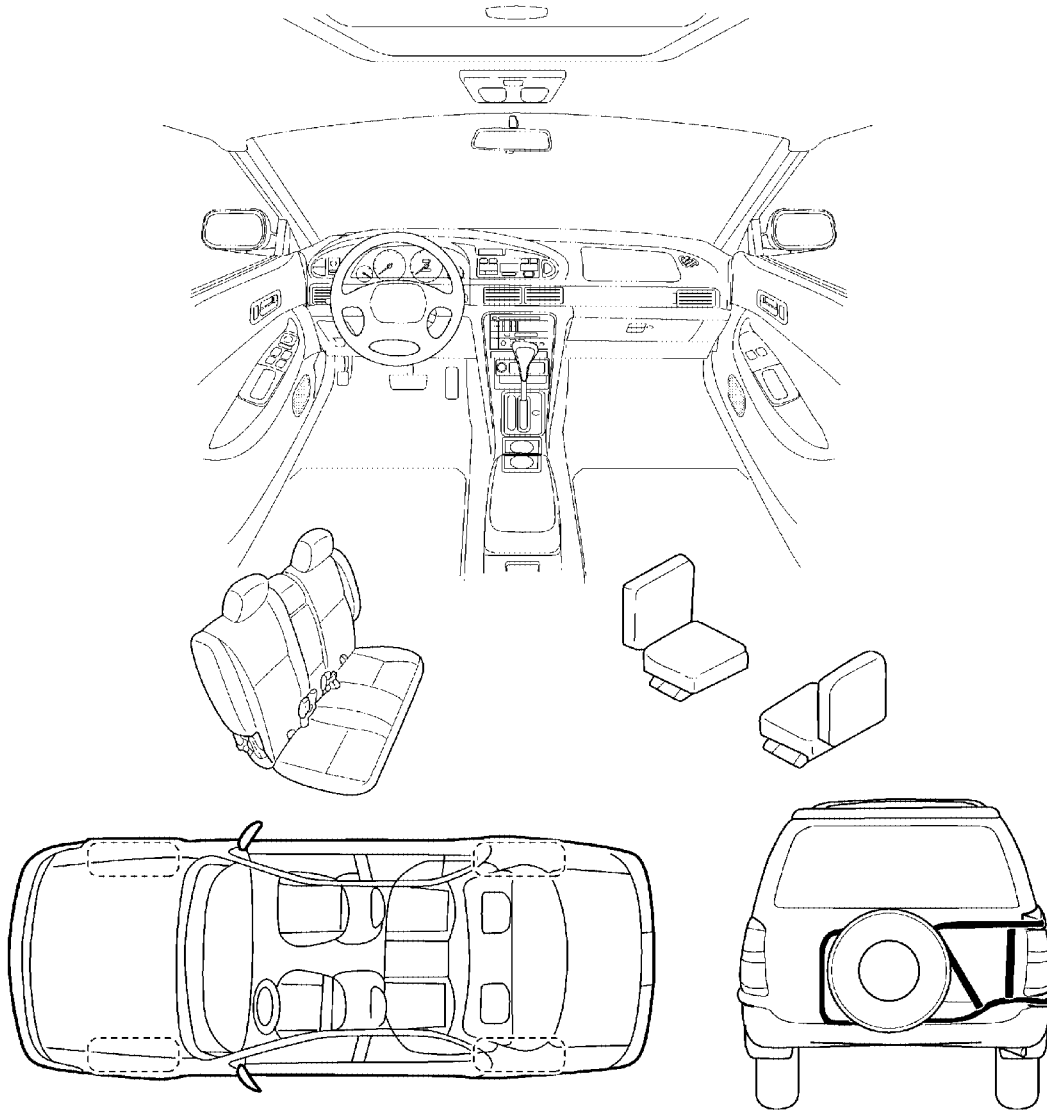

Continue to the back of the worksheet and briefly describe the location of the noise or rattle. In addition, please indicate the conditions which are present when the noise occurs.

SBT843

SQUEAK AND RATTLE TROUBLE DIAGNOSIS

SQUEAK & RATTLE DIAGNOSTIC WORKSHEET- page 2

Briefly describe the location where the noise occurs:

II. WHEN DOES IT OCCUR? (check the boxes that apply)

- | | |
|--|---|
| <input type="checkbox"/> anytime | <input type="checkbox"/> after sitting out in the sun |
| <input type="checkbox"/> 1 st time in the morning | <input type="checkbox"/> when it is raining or wet |
| <input type="checkbox"/> only when it is cold outside | <input type="checkbox"/> dry or dusty conditions |
| <input type="checkbox"/> only when it is hot outside | <input type="checkbox"/> other: _____ |

III. WHEN DRIVING:

- through driveways
- over rough roads
- over speed bumps
- only at about ____ mph
- on acceleration
- coming to a stop
- on turns : left, right or either (circle)
- with passengers or cargo
- other: _____
- after driving ____ miles or ____ minutes

IV. WHAT TYPE OF NOISE?

- squeak (like tennis shoes on a clean floor)
- creak (like walking on an old wooden floor)
- rattle (like shaking a baby rattle)
- knock (like a knock on a door)
- tick (like a clock second hand)
- thump (heavy, muffled knock noise)
- buzz (like a bumble bee)

TO BE COMPLETED BY DEALERSHIP PERSONNEL

Test Drive Notes:

	<u>YES</u>	<u>NO</u>	<u>Initials of person performing</u>
Vehicle test driven with customer	<input type="checkbox"/>	<input type="checkbox"/>	_____
- Noise verified on test drive	<input type="checkbox"/>	<input type="checkbox"/>	_____
- Noise source located and repaired	<input type="checkbox"/>	<input type="checkbox"/>	_____
- Follow up test drive performed to confirm repair	<input type="checkbox"/>	<input type="checkbox"/>	_____

VIN: _____ Customer Name: _____

W.O. #: _____ Date: _____

This form must be attached to Work Order

SBT844

INSTRUMENT PANEL ASSEMBLY

INSTRUMENT PANEL ASSEMBLY

PF6:68200

Removal and Installation

EIS001CX

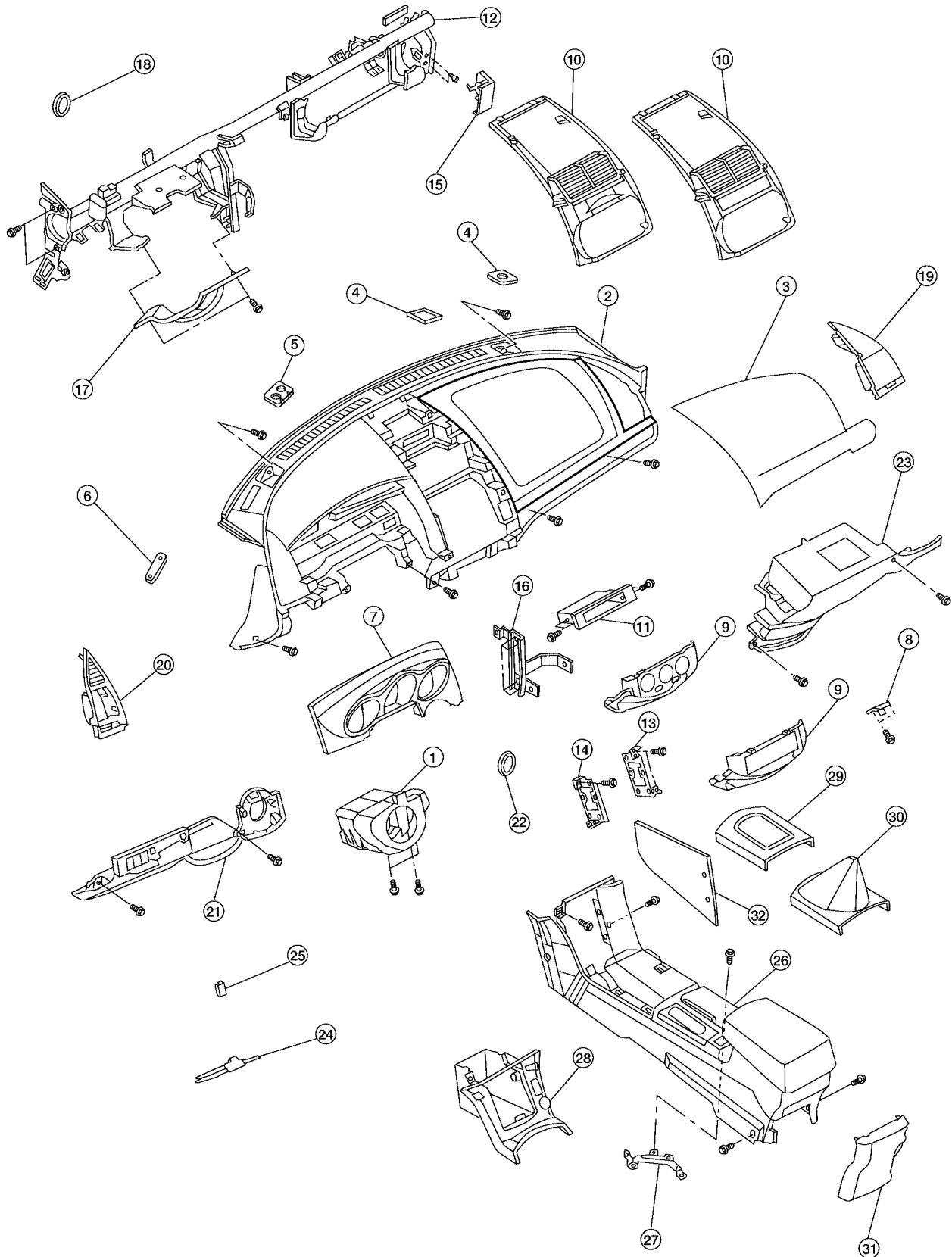

LIA0030E

INSTRUMENT PANEL ASSEMBLY

- | | | |
|--------------------------------|---------------------------------|--------------------------------------|
| 1. Steering column cover | 2. Instrument panel assembly | 3. Passenger side air bag |
| 4. RH instrument mask | 5. LH instrument mask | 6. Vehicle identification plate |
| 7. Cluster lid A | 8. Glove box striker | 9. Cluster lid C |
| 10. Cluster lid D | 11. Deck pocket | 12. Steering member assembly |
| 13. RH audio bracket | 14. LH audio bracket | 15. RH instrument member bracket |
| 16. Driver instrument stay | 17. LH lower knee protector | 18. Bolt cap |
| 19. Side ventilator grille RH | 20. Side ventilator grille LH | 21. Lower driver instrument panel |
| 22. Steering lock escutcheon | 23. Glove box assembly | 24. Fuse block cover |
| 25. Switch mask | 26. Center console assembly | 27. Front console bracket |
| 28. Front console box assembly | 29. A/T console finisher | 30. Console boot manual transmission |
| 31. Console finisher rear | 32. Console front side panel RH | |

REMOVAL AND INSTALLATION

Work Steps

When removing instrument panel and pad, combination meter, console assembly, or steering member take steps in the order shown by the numbers below.

Parts	Instrument panel and pad	Combination meter	Steering member	Console assembly
Cluster lid C	1		1	1
Cluster lid D	2		2	
Glove box assembly	3		3	2
Steering lock escutcheon	4		4	
Cluster lid A	5	1	5	
Combination meter	6	2	6	
Fuse block cover	7		7	
Lower driver instrument panel	8		8	3
Console front side panel RH	9		9	4
Audio unit	10		10	
Climate control unit	11		11	
A/T finisher or M/T boot	12		12	5
Storage bin	13		13	
Front console box assembly	14		14	6
Console finisher	15		15	7
Center console assembly	16		16	8
Driver lower dash side trim	17		17	
Side ventilator grille LH	18		18	
Assistant lower dash side trim	19		19	
Side ventilator grille RH	20		20	
Front passenger air bag module	21		21	
RH and LH instrument masks	22		22	
Instrument panel and pad	23		23	
Steering column covers			24	
Steering column, place aside			25	
RH and LH audio brackets			26	
RH bolt caps			27	
Steering member			28	

Number indicates step in removal procedures

INSTRUMENT PANEL ASSEMBLY

Cluster Lid C

1. Pull lid toward rear of vehicle.
 - Disconnect electrical connectors.

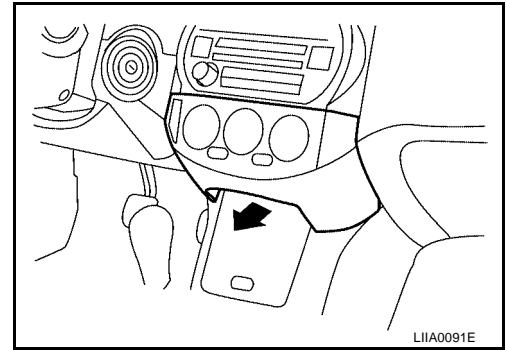

Cluster Lid D

1. Remove cluster lid C. Refer to [IP-12, "Cluster Lid C"](#).
2. Remove cluster lid D.
 - Remove screw using power tool.
 - Pull lid toward rear of vehicle to release clips.

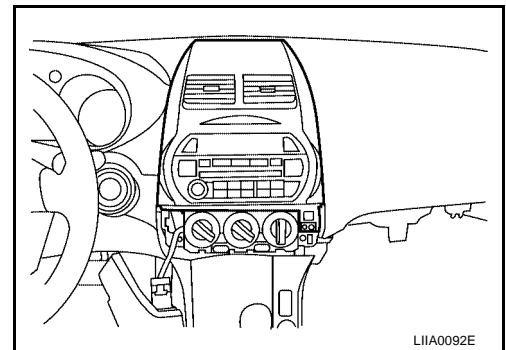

Driver Lower Instrument Panel

1. Remove cluster lid C. Refer to [IP-12, "Cluster Lid C"](#).
2. Remove fuse box cover.

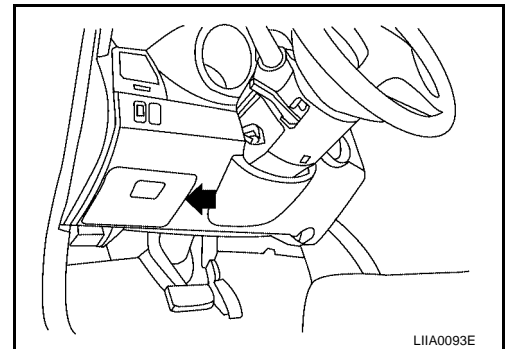

3. Remove screws using power tool, and lower instrument cover.
 - Pull to disconnect clips.

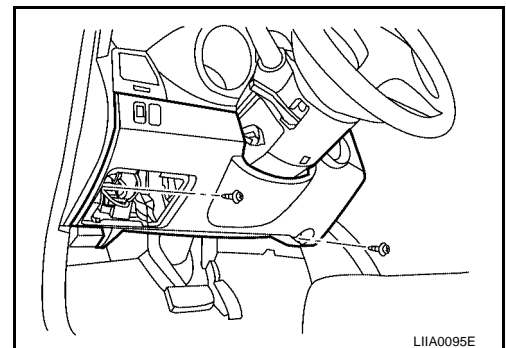

INSTRUMENT PANEL ASSEMBLY

Cluster Lid A

1. Remove driver lower instrument panel. Refer to [IP-12, "Driver Lower Instrument Panel"](#) .
2. Pull toward rear of vehicle to release clips.
 - Disconnect indicator lamp sockets.

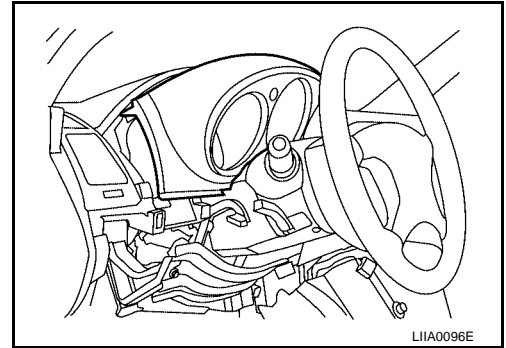

Combination Meter

1. Remove cluster lid A. Refer to [IP-13, "Cluster Lid A"](#) .
2. Remove screws using power tool.
 - Pull cluster lid A from opening.
 - Disconnect electrical connectors.
 - Remove combination meter.

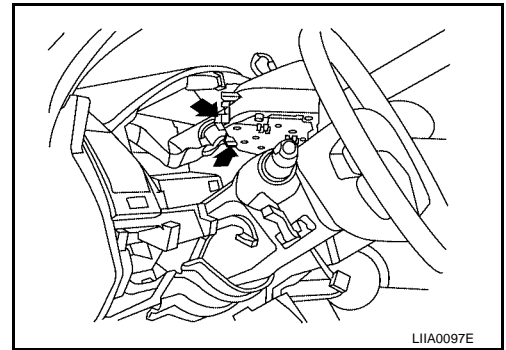

A/T Finisher

1. Pull up to release clips.

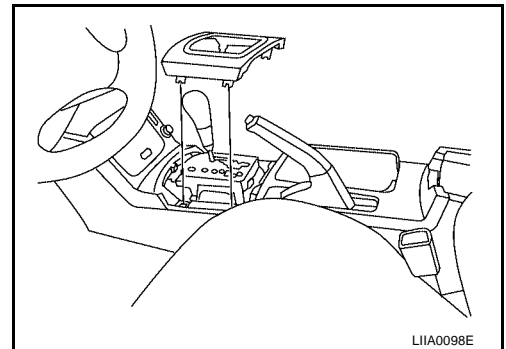

M/T Finisher

1. Remove shifter knob.
2. Pull up to release clips.

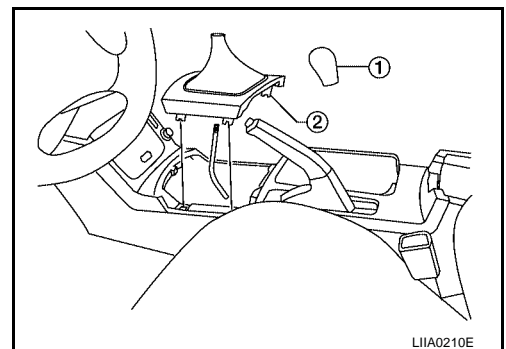

A
B
C
D
E
F
G
H
IP
J
K
L
M

INSTRUMENT PANEL ASSEMBLY

Cup Holder

1. Open storage bin B.
2. Remove console finisher.
3. Remove screw cover and remove screw using power tool.
 - Pull up to release clips on cup holder and remove cup holder.

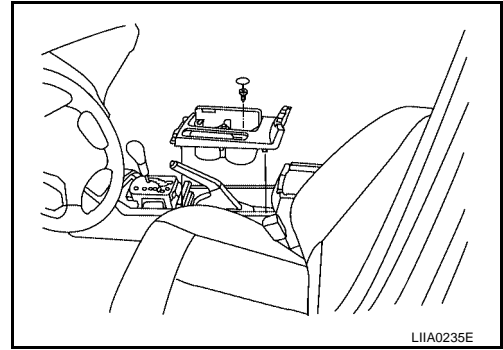

Glove Box

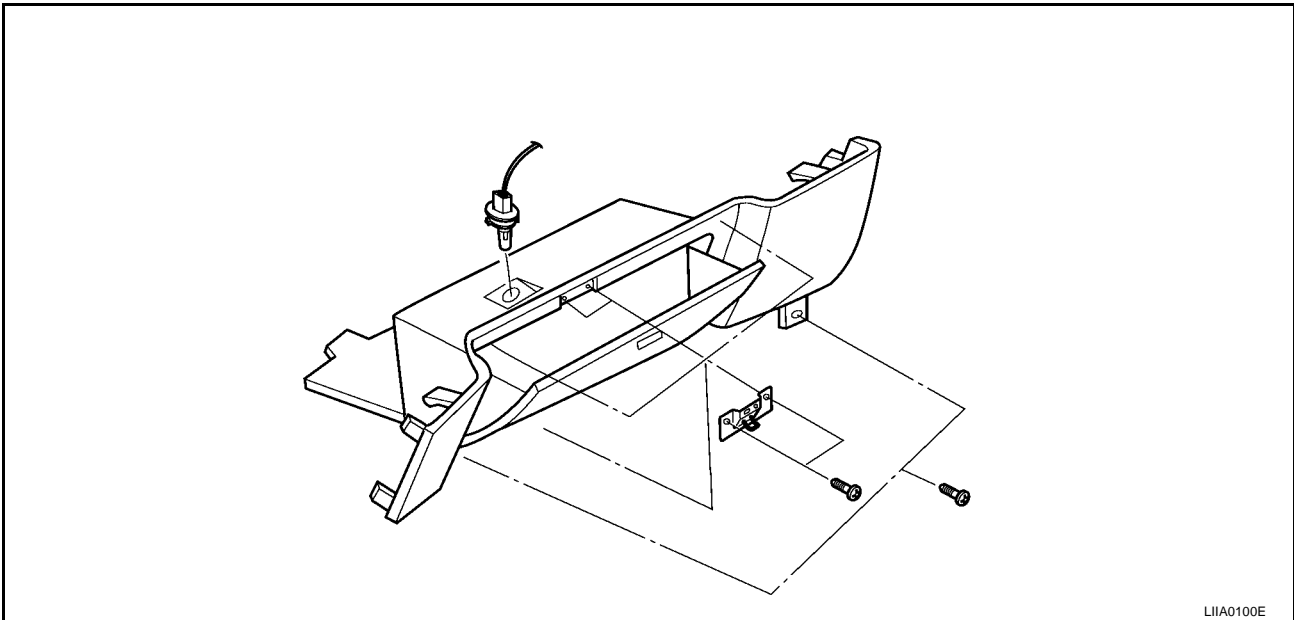

1. Remove screws from glove box striker and glove box using power tool.
2. Pull glove box towards rear of car to release clips.
3. Disconnect lamp socket, and remove glove box.

INSTRUMENT PANEL ASSEMBLY

EIS001CY

Disassembly and Assembly

CENTER CONSOLE

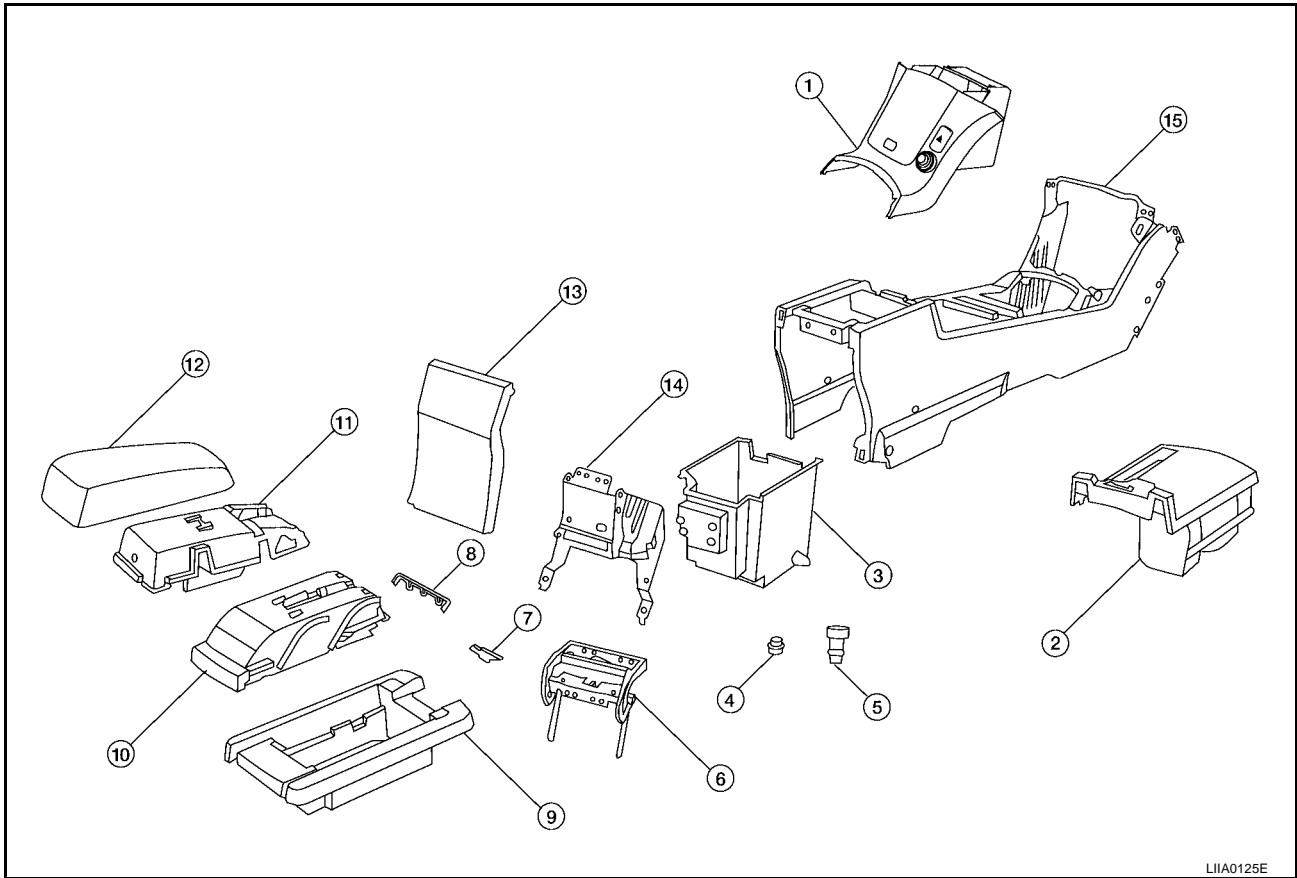

- | | | |
|------------------------------|--|-----------------------------------|
| 1. Console finisher | 2. Cup holder assembly | 3. Storage bin B |
| 4. Power point cover | 5. Power point assembly | 6. Hinge assembly |
| 7. Latch | 8. Adjustable armrest stop reinforcement | 9. Storage bin A |
| 10. Adjustable armrest track | 11. Adjustable armrest slide | 12. Adjustable armrest trim cover |
| 13. Console rear cover | 14. Hinge reinforcement | 15. Console base |

1. Remove center console assembly. Refer to [IP-11, "Work Steps"](#).
2. Remove cup holder.
3. Remove armrest assembly.
4. Remove adjustable armrest track.
5. Separate adjustable armrest slide from adjustable armrest track.
6. Separate adjustable armrest trim cover from adjustable armrest slide.
7. Remove storage bin A.
8. Remove hinge assembly.
9. Remove hinge reinforcement and storage bin B.
10. Separate hinge reinforcement from storage bin B.
11. Remove power point from storage bin B.
12. Assembly is the reverse order of disassembly.

INSTRUMENT PANEL ASSEMBLY
