

SECTION **RF**  
ROOF

A  
B  
C  
D  
E  
F  
G  
H  
J  
K  
L  
M

CONTENTS

<b>PRECAUTIONS</b> .....	<b>2</b>	<b>SUNROOF</b> .....	<b>10</b>
Precautions for Supplemental Restraint System (SRS) "AIR BAG" and "SEAT BELT PRE-TENSIONER" .....	2	Component Parts and Harness Connector Location..	10
Precautions .....	2	System Description .....	10
<b>PREPARATION</b> .....	<b>3</b>	OUTLINE .....	10
Special service tool .....	3	OPERATION .....	10
Commercial Service Tool .....	3	DELAYED POWER OPERATION .....	10
<b>SQUEAK AND RATTLE TROUBLE DIAGNOSES</b> .....	<b>4</b>	MEMORY RESET PROCEDURE .....	10
Work Flow .....	4	Wiring Diagram — SROOF — .....	11
CUSTOMER INTERVIEW .....	4	Terminals and Reference Value for Sunroof Motor..	12
DUPLICATE THE NOISE AND TEST DRIVE .....	5	Trouble Diagnosis Chart by Symptom .....	12
CHECK RELATED SERVICE BULLETINS .....	5	Sunroof Switch Check .....	12
LOCATE THE NOISE AND IDENTIFY THE ROOT CAUSE .....	5	Sunroof Motor Assembly Power Supply and Ground	
REPAIR THE CAUSE .....	5	Circuit Check .....	13
CONFIRM THE REPAIR .....	6	Sunroof Motor Assembly Circuit System Check ....	13
Generic Squeak and Rattle Troubleshooting .....	6	Link and Wire Assembly .....	13
INSTRUMENT PANEL .....	6	Fitting Adjustment .....	14
CENTER CONSOLE .....	6	GAP ADJUSTMENT (A-A, C-C) .....	14
DOORS .....	6	GAP ADJUSTMENT (B-B) .....	14
TRUNK .....	7	HEIGHT DIFFERENCE ADJUSTMENT .....	15
SUNROOF/HEADLINER .....	7	Removal and Installation .....	15
SEATS .....	7	SUNROOF UNIT .....	17
UNDERHOOD .....	7	GLASS LID .....	17
Diagnostic Worksheet .....	8	SUNSHADE .....	18
		SUNROOF MOTOR .....	18

RF

# PRECAUTIONS

## PRECAUTIONS

PF0:00001

### Precautions for Supplemental Restraint System (SRS) “AIR BAG” and “SEAT BELT PRE-TENSIONER”

EIS001BJ

The Supplemental Restraint System such as “AIR BAG” and “SEAT BELT PRE-TENSIONER”, used along with a front seat belt, helps to reduce the risk or severity of injury to the driver and front passenger for certain types of collision. Information necessary to service the system safely is included in the SRS and SB section of this Service Manual.

#### **WARNING:**

- To avoid rendering the SRS inoperative, which could increase the risk of personal injury or death in the event of a collision which would result in air bag inflation, all maintenance must be performed by an authorized NISSAN/INFINITI dealer.
- Improper maintenance, including incorrect removal and installation of the SRS, can lead to personal injury caused by unintentional activation of the system. For removal of Spiral Cable and Air Bag Module, see the SRS section.
- Do not use electrical test equipment on any circuit related to the SRS unless instructed to in this Service Manual. SRS wiring harnesses can be identified by yellow and/or orange harnesses or harness connectors.

#### Precautions

EIS001BK

- Disconnect both battery cables in advance.
- Never tamper with or force air bag lid open, as this may adversely affect air bag performance.
- Be careful not to scratch pad and other parts.
- When removing or disassembling any part, be careful not to damage or deform it. Protect parts which may get in the way with cloth.
- When removing parts with a screwdriver or other tool, protect parts by wrapping them with vinyl or tape.
- Keep removed parts protected with cloth.
- If a clip is deformed or damaged, replace it.
- If an un reusable part is removed, replace it with a new one.
- Tighten bolts and nuts firmly to the specified torque.
- After re-assembly has been completed, make sure each part functions correctly.
- Remove stains in the following way.

Water-soluble stains:

Dip a soft cloth in warm water, and then squeeze it tightly. After wiping the stain, wipe with a soft dry cloth.

Oil stain:

Dissolve a synthetic detergent in warm water (density of 2 to 3% or less), dip the cloth, then clean off the stain with the cloth. Next, dip the cloth in fresh water and squeeze it tightly. Then clean off the detergent completely. Then wipe the area with a soft dry cloth.

- Do not use any organic solvent, such as thinner or benzine.

# PREPARATION



## PREPARATION

PFP:00002

### Special service tool

EIS001BL

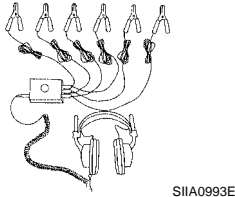
The actual shapes of Kent-Moore tools may differ from those of special service tools illustrated here.

Tool number (Kent-Moore No.) Tool name	Description
<p>(J-39570) Chassis ear</p>  <p style="text-align: right; margin-right: 50px;">SIIA0993E</p>	<p>Locating the noise</p>
<p>(J-43980) NISSAN Squeak and Rattle Kit</p>  <p style="text-align: right; margin-right: 50px;">SIIA0994E</p>	<p>Repairing the cause of noise</p>

## Commercial Service Tool

EIS001BM

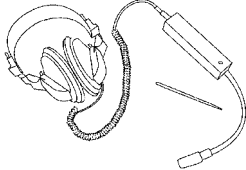
Tool name	Description
<p>(J-39565) Engine ear</p>  <p style="text-align: right; margin-right: 50px;">SIIA0995E</p>	<p>Locating the noise</p>

# SQUEAK AND RATTLE TROUBLE DIAGNOSES

## SQUEAK AND RATTLE TROUBLE DIAGNOSES

PF0:0000

### Work Flow

EIS001BN

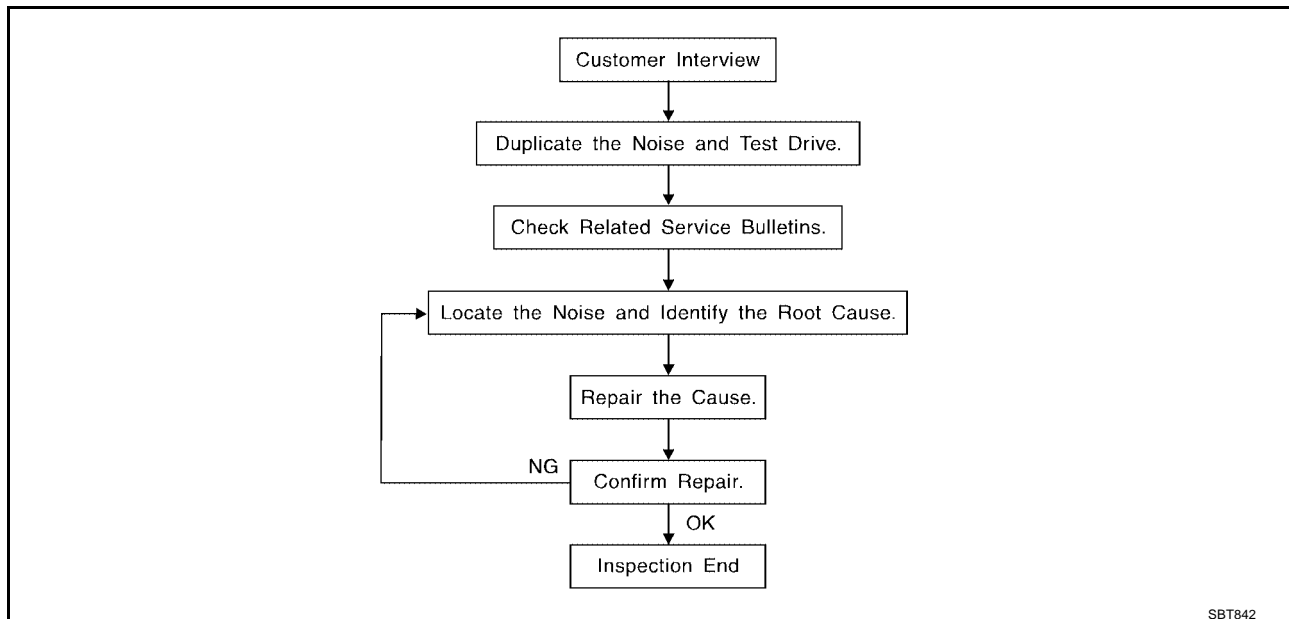

### CUSTOMER INTERVIEW

Interview the customer if possible, to determine the conditions that exist when the noise occurs. Use the Diagnostic Worksheet during the interview to document the facts and conditions when the noise occurs and any customer comments; refer to [RF-8, "Diagnostic Worksheet"](#). This information is necessary to duplicate the conditions that exist when the noise occurs.

- The customer may not be able to provide a detailed description or the location of the noise. Attempt to obtain all the facts and conditions that exist when the noise occurs (or does not occur).
- If there is more than one noise in the vehicle, be sure to diagnose and repair the noise that the customer is concerned about. This can be accomplished by test driving the vehicle with the customer.
- After identifying the type of noise, isolate the noise in terms of its characteristics. The noise characteristics are provided so the customer, service adviser and technician are all speaking the same language when defining the noise.
- Squeak —(Like tennis shoes on a clean floor)  
Squeak characteristics include the light contact/fast movement/brought on by road conditions. Hard surfaces = higher pitch noise/softer surfaces = lower pitch noises/edge to surface = chirping.
- Creak—(Like walking on an old wooden floor)  
Creak characteristics include firm contact/slow movement/twisting with a rotational movement/pitch dependent on materials/often brought on by activity.
- Rattle—(Like shaking a baby rattle)  
Rattle characteristics include the fast repeated contact/vibration or similar movement/loose parts/missing clip or fastener/incorrect clearance.
- Knock —(Like a knock on a door)  
Knock characteristics include hollow sounding/sometimes repeating/often brought on by driver action.
- Tick—(Like a clock second hand)  
Tick characteristics include gentle contacting of light materials/loose components/can be caused by driver action or road conditions.
- Thump—(Heavy, muffled knock noise)  
Thump characteristics include softer knock/dead sound often brought on by activity.
- Buzz—(Like a bumble bee)  
Buzz characteristics include high frequency rattle/firm contact.
- Often the degree of acceptable noise level will vary depending upon the person. A noise that you may judge as acceptable may be irritating to the customer.
- Weather conditions, especially humidity and temperature, may have a great effect on noise level.

# SQUEAK AND RATTLE TROUBLE DIAGNOSES

## DUPLICATE THE NOISE AND TEST DRIVE

If possible, drive the vehicle with the customer until the noise is duplicated. Note any additional information on the Diagnostic Worksheet regarding the conditions or location of the noise. This information can be used to duplicate the same conditions when you confirm the repair.

If the noise can be duplicated easily during the test drive, to help identify the source of the noise, try to duplicate the noise with the vehicle stopped by doing one or all of the following:

- 1) Close a door.
  - 2) Tap or push/pull around the area where the noise appears to be coming from.
  - 3) Rev the engine.
  - 4) Use a floor jack to recreate vehicle "twist".
  - 5) At idle, apply engine load (electrical load, half-clutch on M/T model, drive position on A/T model).
  - 6) Raise the vehicle on a hoist and hit a tire with a rubber hammer.
- Drive the vehicle and attempt to duplicate the conditions the customer states exist when the noise occurs.
  - If it is difficult to duplicate the noise, drive the vehicle slowly on an undulating or rough road to stress the vehicle body.

## CHECK RELATED SERVICE BULLETINS

After verifying the customer concern or symptom, check ASIST for Technical Service Bulletins (TSBs) related to that concern or symptom.

If a TSB relates to the symptom, follow the procedure to repair the noise.

## LOCATE THE NOISE AND IDENTIFY THE ROOT CAUSE

1. Narrow down the noise to a general area. To help pinpoint the source of the noise, use a listening tool (Chassis Ear: J-39570, Engine Ear: J-39565 and mechanics stethoscope).
2. Narrow down the noise to a more specific area and identify the cause of the noise by:
  - removing the components in the area that you suspect the noise is coming from. Do not use too much force when removing clips and fasteners, otherwise clips and fastener can be broken or lost during the repair, resulting in the creation of new noise.
  - tapping or pushing/pulling the component that you suspect is causing the noise. Do not tap or push/pull the component with excessive force, otherwise the noise will be eliminated only temporarily.
  - feeling for a vibration with your hand by touching the component(s) that you suspect is (are) causing the noise.
  - placing a piece of paper between components that you suspect are causing the noise.
  - looking for loose components and contact marks.  
Refer to [RF-6, "Generic Squeak and Rattle Troubleshooting"](#).

## REPAIR THE CAUSE

- If the cause is a loose component, tighten the component securely.
- If the cause is insufficient clearance between components:
  - separate components by repositioning or loosening and retightening the component, if possible.
  - insulate components with a suitable insulator such as urethane pads, foam blocks, felt cloth tape or urethane tape. A Nissan Squeak and Rattle Kit (J-43980) is available through your authorized Nissan Parts Department.

### CAUTION:

**Do not use excessive force as many components are constructed of plastic and may be damaged.**

**Always check with the Parts Department for the latest parts information.**

The following materials are contained in the Nissan Squeak and Rattle Kit (J-43980). Each item can be ordered separately as needed.

URETHANE PADS [1.5 mm (0.059 in) thick]

Insulates connectors, harness, etc.

76268-9E005: 100×135 mm (3.94×5.31 in)

76884-71L01: 60×85 mm (2.36×3.35 in)

76884-71L02: 15×25 mm (0.59×0.98 in)

INSULATOR (Foam blocks)

Insulates components from contact. Can be used to fill space behind a panel.

73982-9E000: 45 mm (1.77 in) thick, 50×50 mm (1.97×1.97 in)

73982-50Y00: 10 mm (0.39 in) thick, 50×50 mm (1.97×1.97 in)

# SQUEAK AND RATTLE TROUBLE DIAGNOSES

---

## INSULATOR (Light foam block)

80845-71L00: 30 mm (1.18 in) thick, 30×50 mm (1.18×1.97 in)

## FELT CLOTH TAPE

Used to insulate where movement does not occur. Ideal for instrument panel applications.

68370-4B000: 15×25 mm (0.59×0.98 in) pad/68239-13E00: 5 mm (0.20 in) wide tape roll.

The following materials, not found in the kit, can also be used to repair squeaks and rattles.

## UHMW (TEFLON) TAPE

Insulates where slight movement is present. Ideal for instrument panel applications.

## SILICONE GREASE

Used in place of UHMW tape that will be visible or not fit.

Note: Will only last a few months.

## SILICONE SPRAY

Use when grease cannot be applied.

## DUCT TAPE

Use to eliminate movement.

## CONFIRM THE REPAIR

Confirm that the cause of a noise is repaired by test driving the vehicle. Operate the vehicle under the same conditions as when the noise originally occurred. Refer to the notes on the Diagnostic Worksheet.

## Generic Squeak and Rattle Troubleshooting

EIS001B0

Refer to Table of Contents for specific component removal and installation information.

## INSTRUMENT PANEL

Most incidents are caused by contact and movement between:

1. The cluster lid A and instrument panel
2. Acrylic lens and combination meter housing
3. Instrument panel to front pillar garnish
4. Instrument panel to windshield
5. Instrument panel mounting pins
6. Wiring harnesses behind the combination meter
7. A/C defroster duct and duct joint

These incidents can usually be located by tapping or moving the components to duplicate the noise or by pressing on the components while driving to stop the noise. Most of these incidents can be repaired by applying felt cloth tape or silicon spray (in hard to reach areas). Urethane pads can be used to insulate wiring harness.

### CAUTION:

**Do not use silicone spray to isolate a squeak or rattle. If you saturate the area with silicone, you will not be able to recheck the repair.**

## CENTER CONSOLE

Components to pay attention to include:

1. Shifter assembly cover to finisher
2. A/C control unit and cluster lid C
3. Wiring harnesses behind audio and A/C control unit

The instrument panel repair and isolation procedures also apply to the center console.

## DOORS

Pay attention to the:

1. Finisher and inner panel making a slapping noise
2. Inside handle escutcheon to door finisher
3. Wiring harnesses tapping
4. Door striker out of alignment causing a popping noise on starts and stops

Tapping or moving the components or pressing on them while driving to duplicate the conditions can isolate many of these incidents. You can usually insulate the areas with felt cloth tape or insulator foam blocks from the Nissan Squeak and Rattle Kit (J-43980) to repair the noise.

# SQUEAK AND RATTLE TROUBLE DIAGNOSES

## TRUNK

Trunk noises are often caused by a loose jack or loose items put into the trunk by the owner. In addition look for:

1. Trunk lid bumpers out of adjustment
2. Trunk lid striker out of adjustment
3. The trunk lid torsion bars knocking together
4. A loose license plate or bracket

Most of these incidents can be repaired by adjusting, securing or insulating the item(s) or component(s) causing the noise.

## SUNROOF/HEADLINER

Noises in the sunroof/headliner area can often be traced to one of the following:

1. Sunroof lid, rail, linkage or seals making a rattle or light knocking noise
2. Sunvisor shaft shaking in the holder
3. Front or rear windshield touching headliner and squeaking

Again, pressing on the components to stop the noise while duplicating the conditions can isolate most of these incidents. Repairs usually consist of insulating with felt cloth tape.

## SEATS

When isolating seat noise it's important to note the position the seat is in and the load placed on the seat when the noise is present. These conditions should be duplicated when verifying and isolating the cause of the noise.

Cause of seat noise include:

1. Headrest rods and holder
2. A squeak between the seat pad cushion and frame
3. The rear seat back lock and bracket

These noises can be isolated by moving or pressing on the suspected components while duplicating the conditions under which the noise occurs. Most of these incidents can be repaired by repositioning the component or applying urethane tape to the contact area.

## UNDERHOOD

Some interior noise may be caused by components under the hood or on the engine wall. The noise is then transmitted into the passenger compartment.

Causes of transmitted underhood noise include:

1. Any component mounted to the engine wall
2. Components that pass through the engine wall
3. Engine wall mounts and connectors
4. Loose radiator mounting pins
5. Hood bumpers out of adjustment
6. Hood striker out of adjustment

These noises can be difficult to isolate since they cannot be reached from the interior of the vehicle. The best method is to secure, move or insulate one component at a time and test drive the vehicle. Also, engine RPM or load can be changed to isolate the noise. Repairs can usually be made by moving, adjusting securing, or insulating the component causing the noise.

A

B

C

D

E

F

G

H

RF

J

K

L

M

# SQUEAK AND RATTLE TROUBLE DIAGNOSES

## Diagnostic Worksheet

EIS001BP



### SQUEAK & RATTLE DIAGNOSTIC WORKSHEET

Dear Nissan Customer:

We are concerned about your satisfaction with your Nissan vehicle. Repairing a squeak or rattle sometimes can be very difficult. To help us fix your Nissan right the first time, please take a moment to note the area of the vehicle where the squeak or rattle occurs and under what conditions. You may be asked to take a test drive with a service advisor or technician to ensure we confirm the noise you are hearing.

#### I. WHERE DOES THE NOISE COME FROM? (circle the area of the vehicle)

The illustrations are for reference only, and may not reflect the actual configuration of your vehicle.

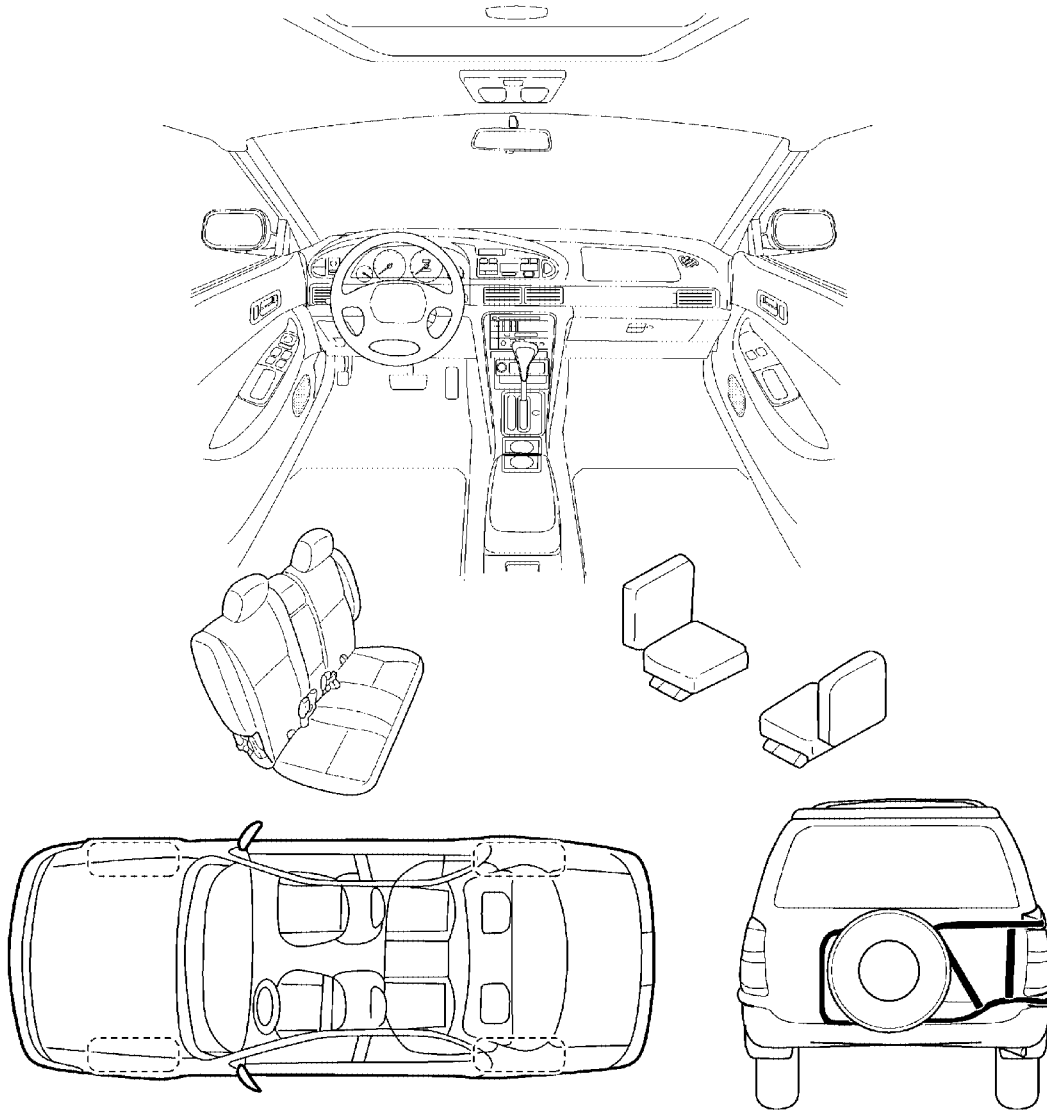

Continue to the back of the worksheet and briefly describe the location of the noise or rattle. In addition, please indicate the conditions which are present when the noise occurs.

SBT843



# SQUEAK AND RATTLE TROUBLE DIAGNOSES

## SQUEAK & RATTLE DIAGNOSTIC WORKSHEET- page 2

Briefly describe the location where the noise occurs:

---

---

---

### II. WHEN DOES IT OCCUR? (check the boxes that apply)

- |  |   |
|--|---|
| <input type="checkbox"/> anytime                             | <input type="checkbox"/> after sitting out in the sun |
| <input type="checkbox"/> 1 <sup>st</sup> time in the morning | <input type="checkbox"/> when it is raining or wet    |
| <input type="checkbox"/> only when it is cold outside        | <input type="checkbox"/> dry or dusty conditions      |
| <input type="checkbox"/> only when it is hot outside         | <input type="checkbox"/> other: _____                 |

### III. WHEN DRIVING:

- through driveways
- over rough roads
- over speed bumps
- only at about \_\_\_\_ mph
- on acceleration
- coming to a stop
- on turns : left, right or either (circle)
- with passengers or cargo
- other: \_\_\_\_\_
- after driving \_\_\_\_ miles or \_\_\_\_ minutes

### IV. WHAT TYPE OF NOISE?

- squeak (like tennis shoes on a clean floor)
- creak (like walking on an old wooden floor)
- rattle (like shaking a baby rattle)
- knock (like a knock on a door)
- tick (like a clock second hand)
- thump (heavy, muffled knock noise)
- buzz (like a bumble bee)

### TO BE COMPLETED BY DEALERSHIP PERSONNEL

#### Test Drive Notes:

---

---

	<u>YES</u>	<u>NO</u>	<u>Initials of person performing</u>
Vehicle test driven with customer	<input type="checkbox"/>	<input type="checkbox"/>	_____
- Noise verified on test drive	<input type="checkbox"/>	<input type="checkbox"/>	_____
- Noise source located and repaired	<input type="checkbox"/>	<input type="checkbox"/>	_____
- Follow up test drive performed to confirm repair	<input type="checkbox"/>	<input type="checkbox"/>	_____

VIN: \_\_\_\_\_ Customer Name: \_\_\_\_\_

W.O. #: \_\_\_\_\_ Date: \_\_\_\_\_

SBT844

**This form must be attached to Work Order**

## SUNROOF

### Component Parts and Harness Connector Location

EIS001BQ

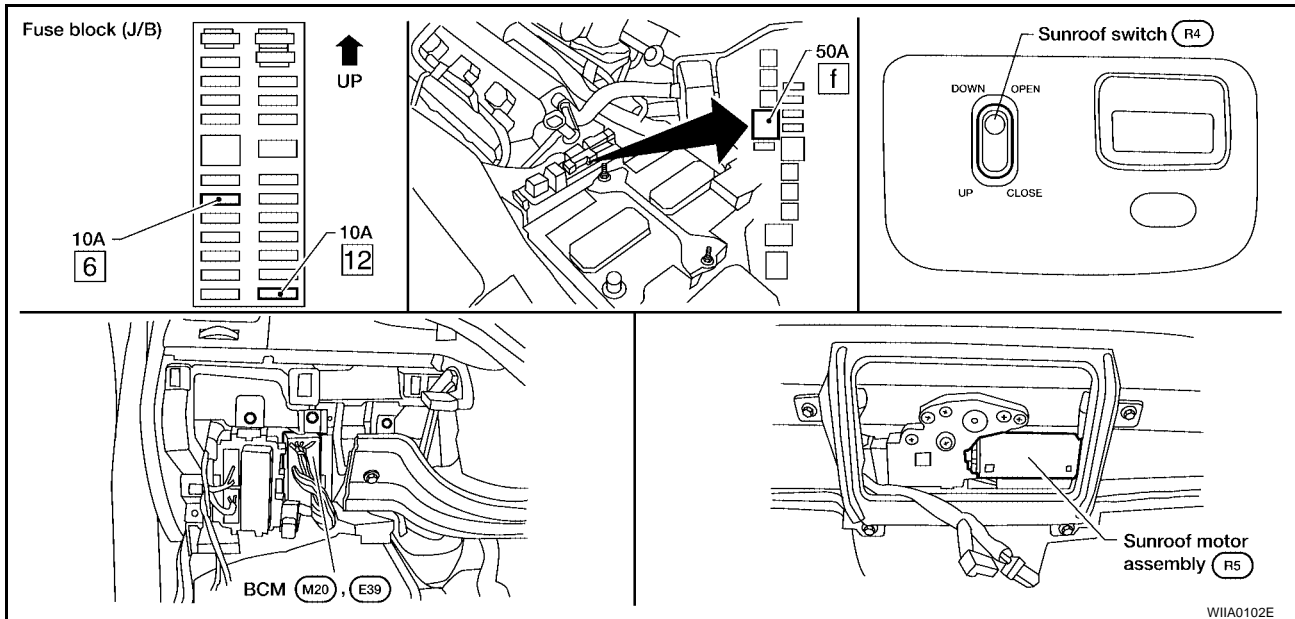

WIIA0102E

### System Description OUTLINE

EIS001BR

Electric sunroof system consists of

- Sunroof switch
- Sunroof motor assembly
- BCM (Body Control Module)

BCM supplies power to the sunroof motor. Sunroof operation depends on sunroof switch condition.

### OPERATION

- Sunroof can be opened or closed and tilted up or down with sunroof switch.

### DELAYED POWER OPERATION

When the ignition switch is turned to the "OFF" position, the sunroof will still operate for up to approximately 45 seconds unless driver or front passenger door is opened.

### MEMORY RESET PROCEDURE

If the battery is disconnected, or the sunroof motor harness connector is disconnected, the sunroof motor memory must be reset. To reset the sunroof motor memory from any sunroof position (full open, partially open, closed, partially vented, and vented), push and hold the sunroof switch in the forward (CLOSE) position until the sunroof vents in the full-up position. This resets the sunroof motor memory and now the sunroof will operate correctly.



# SUNROOF

## Terminals and Reference Value for Sunroof Motor

EIS001BT

TERMI-NAL	WIRE COLOR	ITEM	CONDITION	Voltage
1	L/R	Sunroof tilt up/slide closed switch	Ignition switch ON and sunroof switch in tilt up/slide closed position	Battery voltage → 0V
3	OR	Sunroof tilt down/slide open switch	Ignition switch ON and sunroof switch in tilt down/slide open position	Battery voltage → 0V
5	W/R	Power window power supply (BAT)	Ignition switch ON	Battery voltage
6	B	Ground	—	—

## Trouble Diagnosis Chart by Symptom

EIS001BU

Symptom	Faulty system and reference
Sunroof does not operate.	Sunroof switch system check. Refer to <a href="#">RF-12, "Sunroof Switch Check"</a> .
	Sunroof motor assembly power supply and ground circuit check. Refer to <a href="#">RF-13, "Sunroof Motor Assembly Power Supply and Ground Circuit Check"</a> .
	Sunroof motor assembly circuit system check. Refer to <a href="#">RF-13, "Sunroof Motor Assembly Circuit System Check"</a> .
	If the above systems are normal, replace the sunroof motor assembly.
Sunroof does not open when a foreign material is pinched.	Replace sunroof motor assembly.
Motor does not stop at the sunroof fully open or fully closed position.	

## Sunroof Switch Check

EIS001BV

### 1. CHECK SUNROOF SWITCH

Disconnect sunroof switch connector. Operate sunroof switch, and check continuity between terminals 2 and 3, and terminal 1 on the sunroof switch connector R4 in each of the switch positions.

Tilt up switch operation	
1 – 3	Continuity should exist.
Close switch operation	
1 – 3	Continuity should exist.
Tilt down switch operation	
1 – 2	Continuity should exist.
Open switch operation	
1 – 2	Continuity should exist.

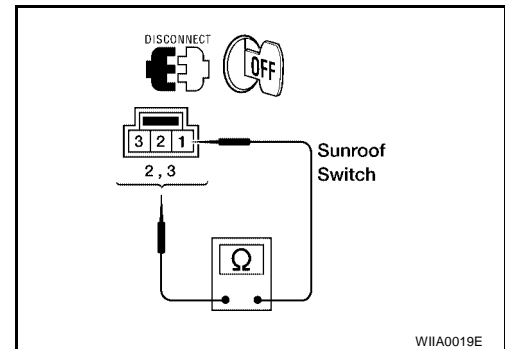

WIIA0019E

### OK or NG

- OK >> Check harness for open or short between BCM and sunroof motor assembly.
- NG >> Replace sunroof switch.

# SUNROOF

## Sunroof Motor Assembly Power Supply and Ground Circuit Check

EIS001BW

### 1. CHECK POWER SUPPLY CIRCUIT

1. Disconnect sunroof motor assembly connector R5.
2. Turn ignition switch ON.
3. Check voltage between sunroof motor assembly connector R5 terminal 5 (W/R) and body ground.

**Battery voltage should exist.**

OK or NG

- OK >> GO TO 2.  
 NG >> Check harness for open or short between sunroof motor assembly and BCM.

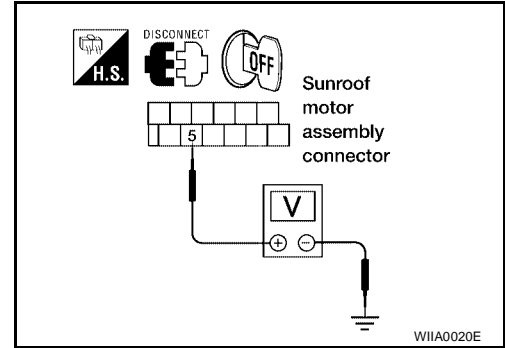

### 2. CHECK GROUND CIRCUIT

Check continuity between sunroof motor assembly connector R5 terminal 6 (B) and body ground.

**Continuity should exist.**

OK or NG

- OK >> Harness connector is OK.  
 NG >> Repair or replace harness.

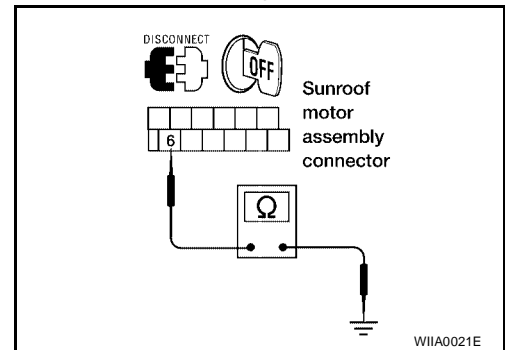

## Sunroof Motor Assembly Circuit System Check

EIS001BX

### 1. CHECK HARNESS CONTINUITY

1. Turn the ignition switch OFF.
2. Disconnect sunroof switch connector R4 and sunroof motor assembly connector R5.
3. Check continuity between sunroof switch connector R4 terminals 2 (OR) and 3 (L/R) and sunroof motor assembly connector R5 terminals 1 (L/R) and 3 (OR).

Terminals				Continuity
(+)		(-)		
Connector	Terminal (wire color)	Connector	Terminal (wire color)	
R4	2 (OR)	R5	3 (OR)	Yes
R4	3 (L/R)	R5	1 (L/R)	Yes

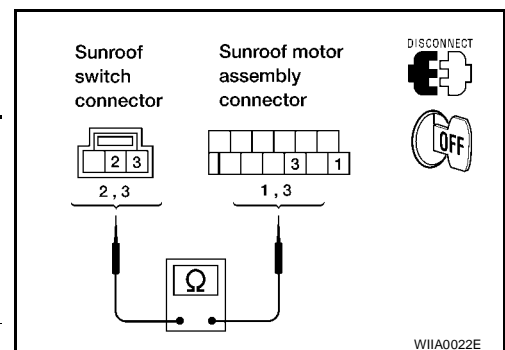

OK or NG

- OK >> Check harness for short between sunroof switch connector and sunroof motor assembly.  
 NG >> Repair or replace harness.

## Link and Wire Assembly

EIS001BY

### NOTE:

Before replacing a suspect part, carefully ensure it is the source of noise being experienced.

# SUNROOF

1. Check link to determine if coating film has peeled off to such an extent that substrate is visible. Check also to determine if link is the source of noise. If it is, replace it.
2. Visually check to determine if a sufficient amount of grease has been applied to wire or rail groove. If not, add grease as required.
3. Check wire for any damage or deterioration. If any damage is found, replace wire.

## Fitting Adjustment

EIS001BZ

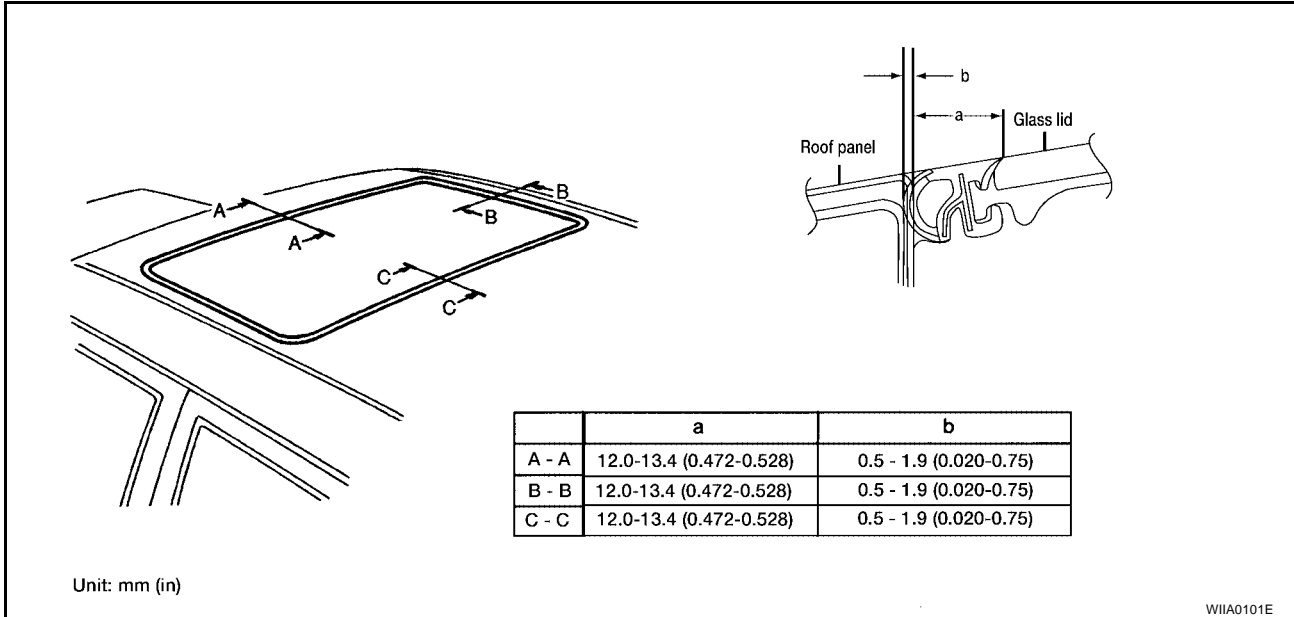

### GAP ADJUSTMENT (A-A, C-C)

1. Open sunshade assembly.
2. Tilt glass lid up then remove side trim.
3. Loosen glass lid securing bolts, then tilt glass lid down.
4. Manually adjust glass lid from outside of vehicle so gap is within specifications, and snug securing bolts.
5. Tilt glass lid up and down several times using sunroof switch to ensure smooth operation.
6. Tilt glass lid up and tighten bolts.

#### NOTE:

First tighten left front bolt, then tighten right rear bolt on glass lid to prevent lid from moving while tightening other bolts.

**Glass lid assembly mounting bolts : 3.0 - 5.0 N·m (0.3 - 0.5 kg·m, 26 - 43 in·lb)**

### GAP ADJUSTMENT (B-B)

1. Remove headlining. Refer to [EI-33, "Removal and Installation"](#).
2. Loosen sunroof assembly front end, side rail, and front and rear bracket attaching bolts.
3. Carefully slide sunroof assembly side to side until gap is within specifications, and snug securing bolts.
4. Tilt glass lid up and down several times using sunroof switch to ensure smooth operation.
5. Tighten sunroof assembly front end, side rail, and front and rear bracket attaching bolts.

#### Sunroof assembly mounting bolts

**Sunroof assembly front end bolts : 5.1 - 6.47 N·m (0.52 - 0.66 kg·m, 46 - 57 in·lb)**

**Sunroof assembly side rail bolts : 5.1 - 6.47 N·m (0.52 - 0.66 kg·m, 46 - 57 in·lb)**

# SUNROOF

Sunroof assembly front : 5.1 - 6.47 N·m (0.52 - 0.66 kg·m,  
bracket bolts 46 - 57 in·lb)  
Sunroof assembly rear : 5.1 - 6.47 N·m (0.52 - 0.66 kg·m,  
bracket bolts 46 - 57 in·lb)

## HEIGHT DIFFERENCE ADJUSTMENT

1. Tilt glass lid up and down.
2. Check height difference between roof panel and glass lid, and compare to "A - A" as shown.

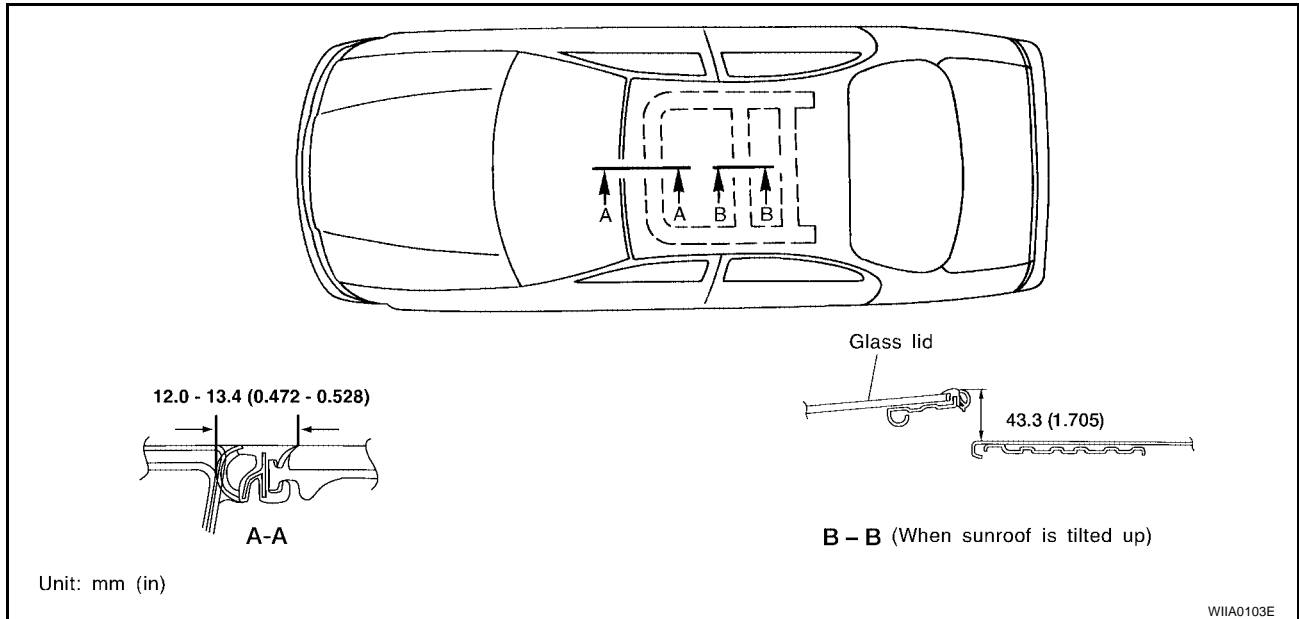

3. If necessary, adjust height difference by using the following procedure.
  - Loosen glass lid securing bolts.
  - Manually raise/lower glass lid until height difference is within specification.
  - Tighten glass lid securing bolts.

Glass lid assembly : 3.0 - 5.0 N·m (0.3 - 0.5 kg·m, 26 - 43 in·lb)  
mounting bolts

## Removal and Installation

EIS001C0

- After any adjustment, check sunroof operation and lid alignment.
- Handle glass lid with care so not to cause damage.
- For easier installation, mark each point before removal.

### CAUTION:

- Always work with a helper.
- Before removal, fully close the glass lid assembly. Then, after removal, do not move the motor assembly.

# SUNROOF

- After installing the sunroof and glass lid, check gap adjustment to ensure there is no malfunction.

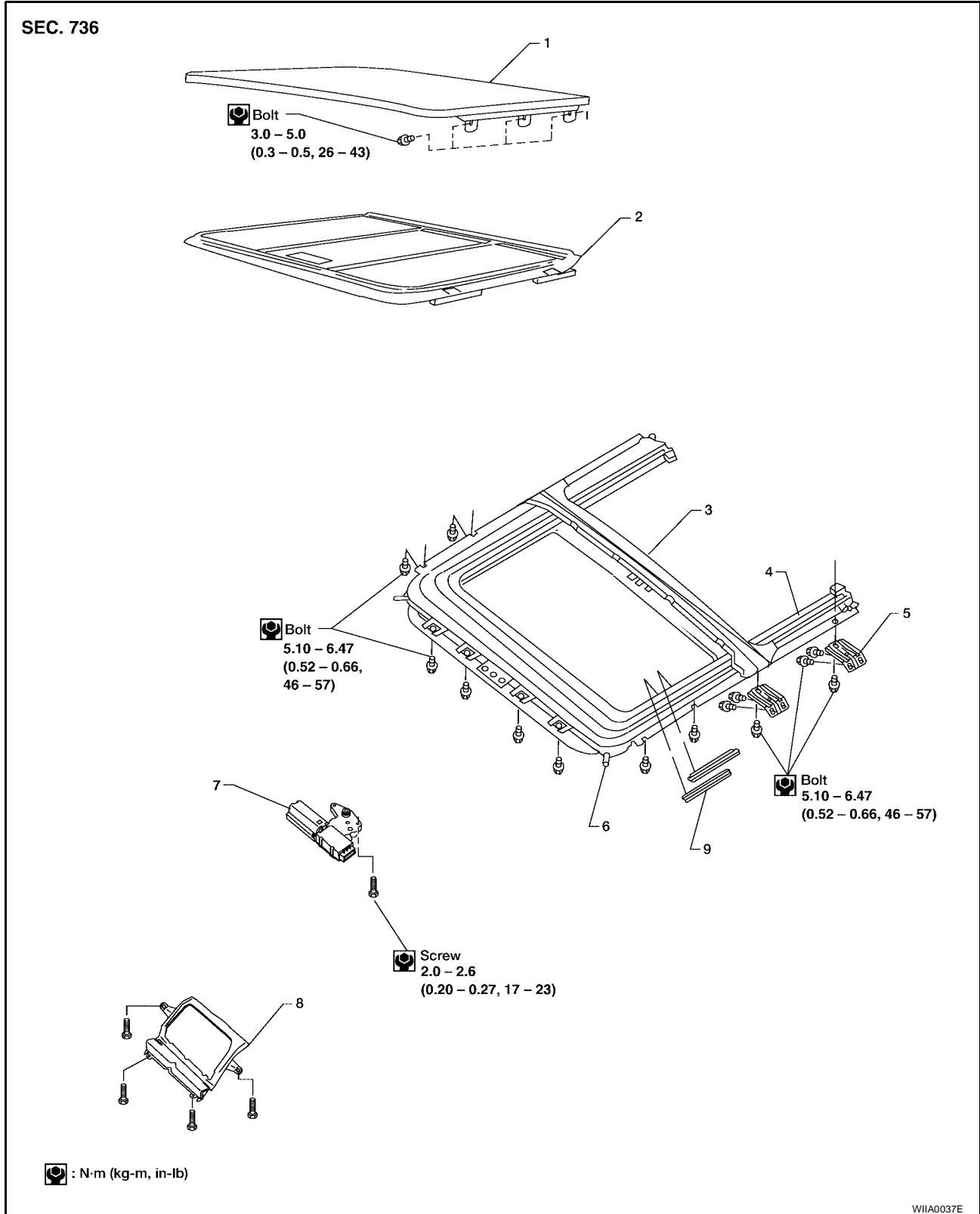

- |                       |                           |                               |
|-----------------------|---------------------------|-------------------------------|
| 1. Glass lid assembly | 2. Sunshade assembly      | 3. Drain channel assembly     |
| 4. Sunroof assembly   | 5. Sunroof bracket        | 6. Drain hose connecting area |
| 7. Sunroof motor      | 8. Sunroof switch bracket | 9. Side trim                  |



# SUNROOF

## SUNROOF UNIT

### Removal

#### CAUTION:

- Always work with a helper.
- When taking sunroof unit out, use shop cloths to protect the seats and trim from damage.
- After installing the sunroof unit and glass lid, be sure to check gap adjustment to ensure there is no malfunction.

1. Remove headlining. Refer to [EI-33, "Removal and Installation"](#).
2. Disconnect drain hoses.
3. Close glass lid.
4. Remove sunroof switch bracket.
5. Disconnect sunroof motor harness electrical connector.

#### CAUTION:

- Before removing sunroof motor, make sure that sunroof is fully closed.
  - After removing sunroof motor, never attempt to rotate sunroof motor as a single unit.
6. Remove bolts on the front end and side rails.
  7. Remove front sunroof bracket bolts.
  8. Remove rear sunroof bracket bolts, and remove sunroof unit from roof panel.
- Remove sunroof unit through the passenger compartment while being careful not to damage the seats and trim.

### Installation

1. Temporarily tighten the mounting bolts on the rear sunroof brackets.
2. Bring sunroof unit into passenger compartment and place the rear end of the rail onto the rear sunroof brackets.
3. Temporarily tighten the mounting bolts on the front end.
4. Tighten the installation point bolts diagonally excluding the installation point of the sunroof bracket around the roof opening.
5. Tighten the bolts on the front sunroof bracket at the vehicle side, and then at the rail side.
6. Tighten the bolts on the rear sunroof bracket at the vehicle side, and then at the rail side.

#### Sunroof assembly mounting bolts

**Sunroof assembly front end bolts** : 5.1 - 6.47 N-m (0.52 - 0.66 kg-m, 46 - 57 in-lb)

**Sunroof assembly side rail bolts** : 5.1 - 6.47 N-m (0.52 - 0.66 kg-m, 46 - 57 in-lb)

**Sunroof assembly front bracket bolts** : 5.1 - 6.47 N-m (0.52 - 0.66 kg-m, 46 - 57 in-lb)

**Sunroof assembly rear bracket bolts** : 5.1 - 6.47 N-m (0.52 - 0.66 kg-m, 46 - 57 in-lb)

7. Install sunroof motor switch bracket.
8. Connect drain hoses.
9. Install headlining. Refer to [EI-33, "Removal and Installation"](#).

## GLASS LID

### Removal

1. Open sunroof shade.
2. Ensure glass lid is closed.
3. Carefully pry away trim to access glass lid securing bolts.
4. Remove bolts securing glass lid assembly to sunroof assembly.

### Installation

1. Position glass lid to sunroof assembly.

A  
B  
C  
D  
E  
F  
G  
H  
J  
K  
L  
M

RF

# SUNROOF

2. Tighten glass lid assembly bolts to specification. (First tighten left front bolt, then tighten right rear bolt on glass lid to prevent lid from moving while tightening other bolts.)

**Glass lid assembly mounting bolts** : 3.0 - 5.0 N-m (0.3 - 0.5 kg-m, 26 - 43 in-lb)

3. Position and push trim into place.
4. After installation, perform fitting adjustment.

## SUNSHADE

### Removal and Installation

#### CAUTION:

Before removing or installing the sunshade, be sure to remove the sunroof unit from the vehicle.

1. Remove glass lid. Refer to [RF-17, "GLASS LID"](#).
2. Carefully pry sunshade from sunroof frame.

Install in the reverse order of removal.

## SUNROOF MOTOR

### Removal

1. Position sunroof assembly in full open position.
2. Remove headlining, refer to [EI-33, "Removal and Installation"](#).
3. Remove motor mounting screws.
4. Disconnect harness connector to remove sunroof motor.

#### CAUTION:

- When removing the sunroof motor, be sure that the sunroof is in the fully open position.
- Never run the removed motor as a single unit.

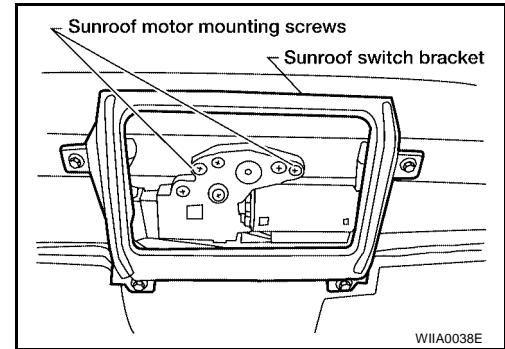

### Installation

1. Move the motor laterally little by little so that the gear is completely engaged into the wire on the sunroof unit and the mounting surface becomes parallel. Then secure the motor with screws.

**Sunroof motor mounting screws** : 2.0 - 2.6 N-m (0.20 - 0.27 kg-m, 17 - 23 in-lb)

#### CAUTION:

Before installing the motor, be sure to place the link and wire assembly in the symmetrical and fully closed position.

Remainder of installation is reverse order of removal.