

SECTION **RSU**
 REAR SUSPENSION

A
B
C
D

RSU

CONTENTS

PRECAUTIONS	2	SUSPENSION ARM	9	F
Precautions	2	RADIUS ROD	9	
PREPARATION	3	FRONT LOWER LINK	9	
Commercial Service Tools	3	REAR LOWER LINK AND COIL SPRING	9	G
NOISE, VIBRATION, AND HARSHNESS (NVH)		STABILIZER BAR	10	
TROUBLESHOOTING	4	Inspection	10	H
NVH Troubleshooting Chart	4	SHOCK ABSORBER ASSEMBLY	10	
REAR SUSPENSION ASSEMBLY	5	SUSPENSION ARM	11	I
Components	5	FRONT LOWER LINK	11	
On-vehicle Service	6	UPPER RUBBER SEAT AND BUSHING	11	
Rear Wheel Alignment	6	REAR LOWER LINK AND COIL SPRING	11	I
PRELIMINARY INSPECTION	6	STABILIZER BAR	11	
CAMBER	7	SERVICE DATA AND SPECIFICATIONS (SDS)	12	J
TOE-IN	7	General Specifications (Rear)	12	
Removal and Installation	8	Rear Wheel Alignment (Unladen*)	12	
REAR SUSPENSION ASSEMBLY	8	Ball Joint	12	K
SHOCK ABSORBER	9	Wheelarch Height (Unladen*)	12	

L
M

PRECAUTIONS

PRECAUTIONS

PFP:00001

Precautions

EES000K0

- When installing each rubber part, final tightening must be carried out under unladen condition* with tires on ground. Oil will shorten the life of rubber bushings. Be sure to wipe off any spilled oil.
*: Fuel, radiator coolant and engine oil full. Spare tire, jack, hand tools and mats in designated positions.
- Use flare nut wrench when removing or installing brake tubes.
- After installing removed suspension parts, check wheel alignment.
- Do not jack up at the trailing arm and lateral link.
- Always torque brake lines when installing.
- Lock nuts are un reusable parts; always use new ones. When replacing, do not wipe the oil off of the new lock nut before tightening.

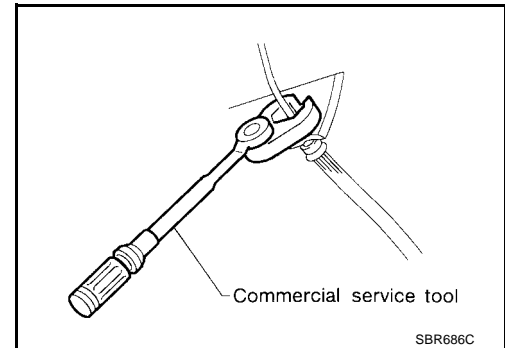

PREPARATION

PREPARATION

PFP:00002

Commercial Service Tools

EES000K1

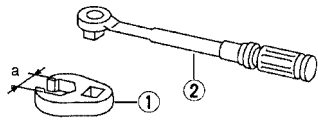
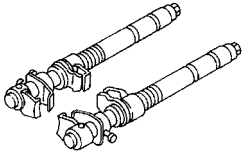
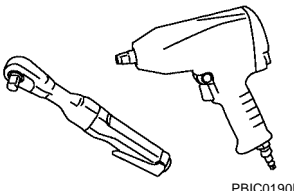
Tool name	Description
<p>Equivalent to GG94310000</p> <ol style="list-style-type: none"> 1. Flare nut crowfoot 2. Torque wrench  <p style="text-align: right;">S-NT360</p>	<p>Removing and installing brake piping a:10 mm (0.39 in)</p>
<p>Spring compressor</p>  <p style="text-align: right;">NT717</p>	<p>Removing and installing coil spring</p>
<p>Power tool</p>  <p style="text-align: right;">PBIC0190E</p>	<p>Loosening bolts and nuts</p>

A
B
C
D
RSU
F
G
H
I
J
K
L
M

NOISE, VIBRATION, AND HARSHNESS (NVH) TROUBLESHOOTING

NOISE, VIBRATION, AND HARSHNESS (NVH) TROUBLESHOOTING

PFP:00003

NVH Troubleshooting Chart

EES000K2

Use the following chart to help you find the cause of the symptom. If necessary, repair or replace these parts.

Symptom		Possible Cause and SUSPECTED PARTS											Reference page										
		Improper installation, looseness	Shock absorber deformation, damage or deflection	Bushing or mounting	Parts interference	Spring fatigue	Suspension looseness	Incorrect wheel alignment	Stabilizer bar fatigue	Out-of-round	Imbalance	Incorrect air pressure	Uneven tire wear	Deformation or damage	Non-uniformity	Incorrect tire size	DRIVE SHAFT	AXLE	SUSPENSION	TIRES	ROAD WHEEL	BRAKES	STEERING
SUSPENSION	Noise	x	x	x	x	x	x									x	x						
	Shake	x	x	x	x		x									x	x						
	Vibration	x	x	x	x	x										x	x						
	Shimmy	x	x	x	x			x									x						
	Judder	x	x	x													x						
	Poor quality ride or handling	x	x	x	x	x		x	x								x						
	TIRES	Noise	x							x	x	x	x	x	x		x	x	x			x	x
		Shake	x							x	x	x	x	x		x	x	x	x			x	x
		Vibration										x				x	x	x	x				
		Shimmy	x							x	x	x	x	x			x	x	x			x	x
		Judder	x							x	x	x	x	x			x	x	x			x	x
		Poor quality ride or handling	x								x	x	x	x			x	x	x			x	
ROAD WHEEL	Noise	x							x	x					x	x	x	x			x	x	
	Shake	x							x	x					x	x	x	x			x	x	
	Shimmy, Judder	x							x	x						x	x	x			x	x	
	Poor quality ride or handling	x								x	x					x	x	x					

x: Applicable

REAR SUSPENSION ASSEMBLY

REAR SUSPENSION ASSEMBLY

Components

PFP:55020

EES000K3

SEC. 430 - 431

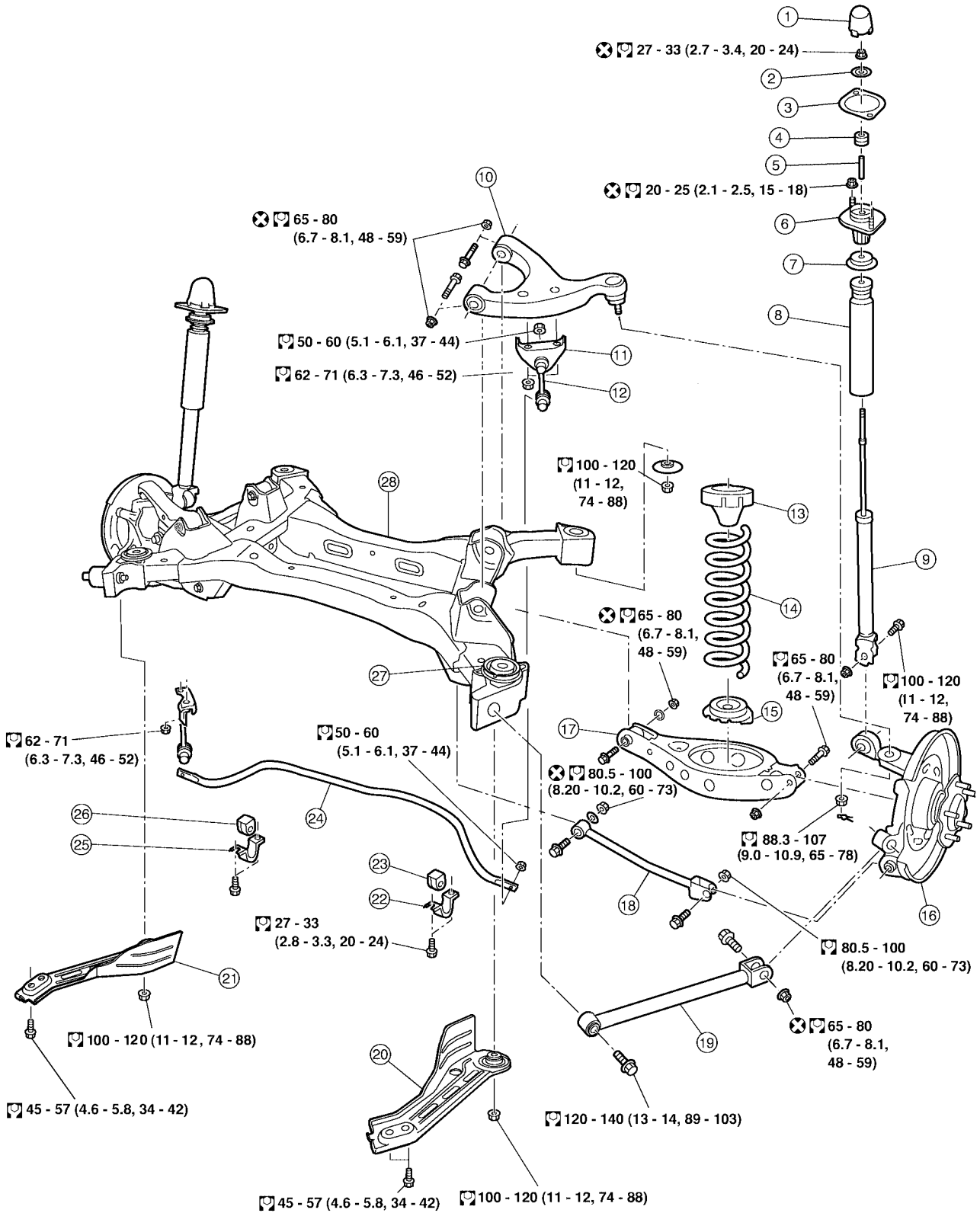

A
B
C
D
RSU
F
G
H
I
J
K
L
M

REAR SUSPENSION ASSEMBLY

- | | | |
|------------------------------------|----------------------------------|---------------------------------|
| 1. Cap | 2. Washer | 3. Gasket |
| 4. Bushing | 5. Distance tube | 6. Shock absorber mount bracket |
| 7. Bound bumper cover | 8. Bound bumper | 9. Shock absorber |
| 10. Suspension arm | 11. Connecting rod mount bracket | 12. Connecting rod |
| 13. Upper rubber seat | 14. Coil spring | 15. Lower rubber seat |
| 16. Wheel hub and spindle assembly | 17. Rear lower link | 18. Front lower link |
| 19. Radius rod | 20. Member stay | 21. Member stay |
| 22. Stabilizer bar clamp | 23. Bushing | 24. Stabilizer bar |
| 25. Stabilizer bar clamp | 26. Bushing | 27. Member stopper |
| 28. Rear suspension member | | |

On-vehicle Service

EES000K4

- Check suspension parts for excessive play, cracks, wear or damage. Shake each rear wheel to check for excessive play.
- Retighten all nuts and bolts to the specified torque.
- Make sure that cotter pin is inserted.
- Check shock absorber for oil leakage or other damage.
- Check wheelarch height. Refer to [RSU-12, "Wheelarch Height \(Unladen*\)"](#).
- Check suspension ball joint for grease leakage and ball joint dust cover for cracks or other damage.

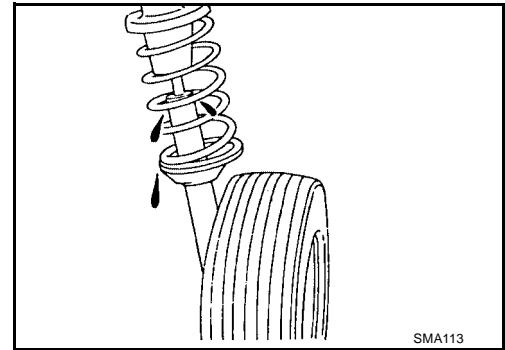

SMA113

Rear Wheel Alignment

EES000K5

Before checking rear wheel alignment, be sure to make a preliminary inspection.

PRELIMINARY INSPECTION

- Check tires for wear and for improper inflation.
- Check wheels for deformation, cracks and other damage. If deformed, remove wheel and check wheel runout. Refer to [WT-3, "Inspection"](#).
- Check rear wheel bearings for looseness.
- Check rear suspension for looseness.
- Check that rear shock absorber works properly.
- Check wheelarch height (Unladen*). Refer to [RSU-12, "Wheelarch Height \(Unladen*\)"](#).

REAR SUSPENSION ASSEMBLY

CAMBER

- Measure camber of both right and left wheels with a suitable alignment gauge and adjust in accordance with the following procedures.

Camber : Refer to [RSU-12, "Rear Wheel Alignment \(Unladen*\)"](#) .

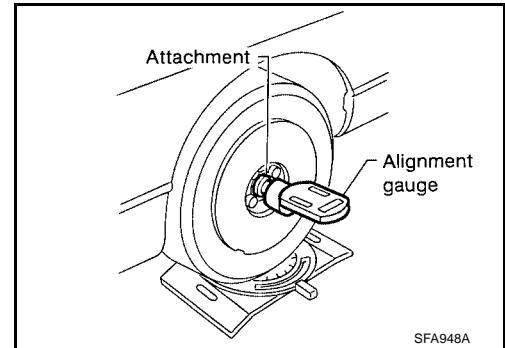

- If camber is not within specification, adjust by turning the adjusting bolts in the same direction.
 1. Turn the adjusting bolts in the same direction to calibrate.

NOTE:

Camber changes about 5° with each graduation of the adjusting bolt.

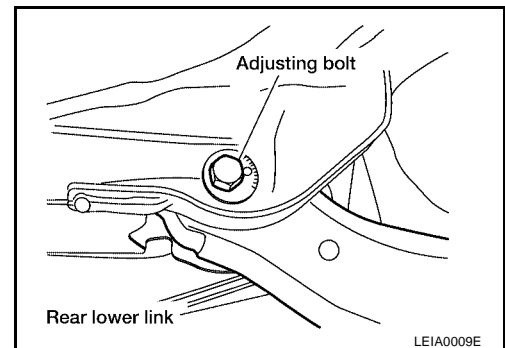
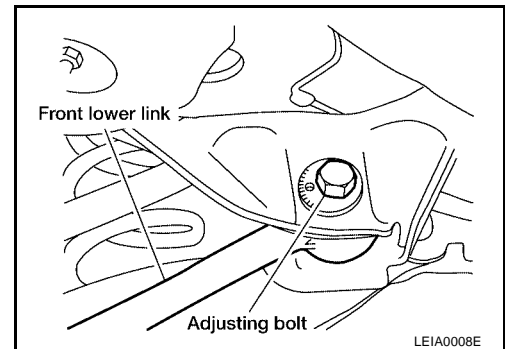

2. Tighten to the specified torque. Refer to [RSU-5, "Components"](#) .

TOE-IN

Measure toe-in using following procedure. If out of specification, inspect and replace any damaged or worn rear suspension parts.

WARNING:

- Always perform the following procedure on a flat surface.
 - Make sure that no person is in front of the vehicle before pushing it.
1. Bounce rear of vehicle up and down to stabilize the posture.
 2. Push the vehicle straight ahead about 5 m (16 ft).
 3. Put a mark on base line of the tread (rear side) of both tires at the same height of hub center. This mark is a measuring point.

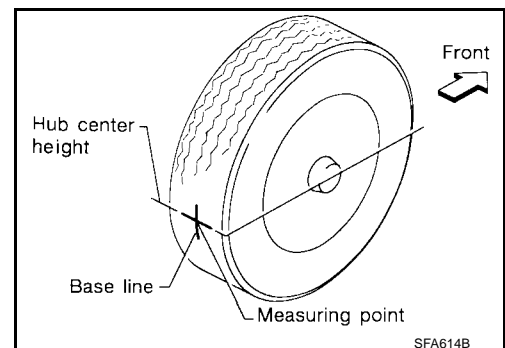

REAR SUSPENSION ASSEMBLY

4. Measure distance "A" (rear side).
5. Push the vehicle slowly ahead to rotate the wheels 180 degrees (1/2 turn).
If the wheels have rotated more than 180 degrees (1/2 turn), try the above procedure again from the beginning. Never push vehicle backward.
6. Measure distance "B" (front side).

Total toe-in : Refer to [RSU-12, "Rear Wheel Alignment \(Unladen*\)"](#) .

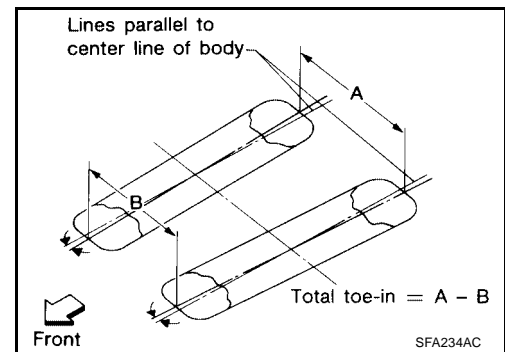

7. Adjust toe-in by turning adjusting bolt.

NOTE:

Toe changes about 1.5 mm (0.059 in) [One side] with each graduation of the adjusting bolt.

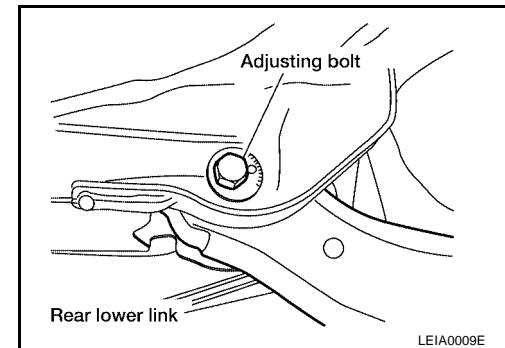
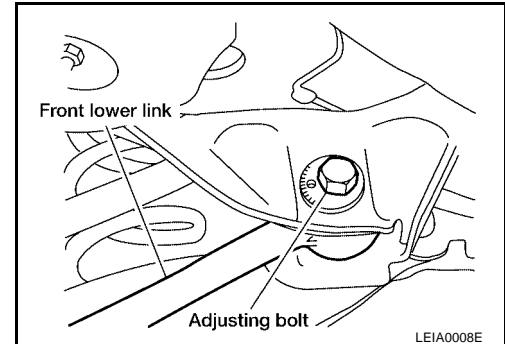

8. Tighten to the specified torque. Refer to [RSU-5, "Components"](#) .

Removal and Installation REAR SUSPENSION ASSEMBLY

EE5000K6

CAUTION:

Before removing the rear suspension assembly, disconnect the ABS wheel sensor from the assembly. Failure to do so may result in damage to the sensor wires and the sensor becoming inoperative.

1. Remove center exhaust tube with muffler(s). Refer to [EX-4, "Removal and Installation"](#) (QR25DE) or [EX-7, "Removal and Installation"](#) (VQ35DE).
2. Disconnect parking brake wire front end.
3. Remove brake caliper assembly, using power tools.
 - Leave brake line connected to brake caliper.
Be careful not to depress brake pedal, or piston will pop out.
Do not pull or twist brake hose.
4. Remove upper end nuts of shock absorber.
5. Remove suspension member mounting nuts. Then draw out rear axle and rear suspension assembly.
6. Installation is in the reverse order of removal.

REAR SUSPENSION ASSEMBLY

SHOCK ABSORBER

1. Set the transmission jack on the rear lower link to remove the fitting bolt and nut in the lower side of shock absorber. A
2. Remove the transmission jack from rear lower link.
3. Remove the fitting nuts in the upper side of shock absorber. B
4. Installation is in the reverse order of removal.

SUSPENSION ARM

1. Remove the connecting rod mounting bracket from suspension arm. C
2. Remove the fixing bolts and nuts in the suspension member side of suspension arm.
3. Remove the cotter pin and lock nut. D
4. Remove the suspension arm from axle housing using puller.

CAUTION:

- Do not damage ball joint with puller.
 - While using puller, temporarily tighten the nut so as not to damage screw part.
5. Installation is in the reverse order of removal.

RADIUS ROD

- Check radius rod for any deformation, cracks, or damage and replace if necessary.
- After installing radius rod, check wheel alignment and adjust if necessary.

FRONT LOWER LINK

1. Jack up front lower link.
2. Remove front lower link, using power tools. H
3. Installation is in the reverse order of removal.
- After installing front lower link, check wheel alignment and adjust if necessary. I

REAR LOWER LINK AND COIL SPRING

Removal

1. Jack up rear lower link. J
2. Loosen the mounting bolt and nut of the rear lower link from the suspension member, using power tool.
3. Remove the mounting bolt and nut from the side of the suspension member.
4. Slowly lower jack, then remove upper rubber seat, coil spring and rubber sheet from rear lower link. K
5. Remove mounting bolt and nut in the side of suspension member to remove rear lower link. L

RSU

REAR SUSPENSION ASSEMBLY

Installation

- Installation is in the reverse order of removal.
- Check that the projecting part inside the upper seat and the flange part of bracket are attached as shown.
- Check that the projection part outside the upper seat directs to vehicle front.
- Position the hollow of the rubber seat with the groove part of rear lower link to install.
- Install coil spring with the side of two paint markers directing to lower side.
- After installing rear lower link and coil spring, check wheel alignment and adjust if necessary.

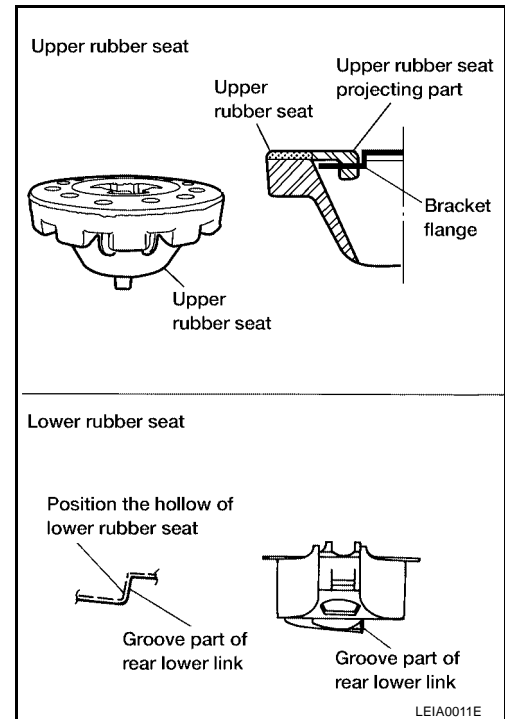

STABILIZER BAR

Removal

1. Remove stabilizer from connecting rod, using power tools.
2. Remove clamps, using power tools, and bushings.
3. Remove the stabilizer bar.

Installation

- Install stabilizer bar with ball joint socket properly placed.
- When the bushing and clamp are installed to stabilizer bar, position the bushing and clamp inside of the sideslip prevention clamp.

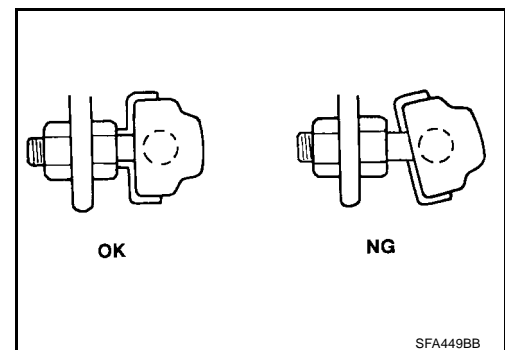

Inspection

SHOCK ABSORBER ASSEMBLY

- Check for smooth operation through a full stroke, both compression and extension.
- Check for oil leakage on welded or gland packing portions.
- Check piston rod for cracks, deformation or other damage and replace if necessary.

EES000K7

REAR SUSPENSION ASSEMBLY

SUSPENSION ARM

- Check suspension arm for damage, cracks, deformation and replace if necessary.
- Check rubber bushing for damage, cracks and deformation. Replace suspension arm assembly if necessary.
- Check ball joint. Replace suspension arm assembly if any of the following exists:
 - a. Ball stud is worn.
 - b. Joint is hard to swing.
 - c. Play in axial direction is excessive.Before checking, turn ball joint at least 10 revolutions so that ball joint is properly broken in.

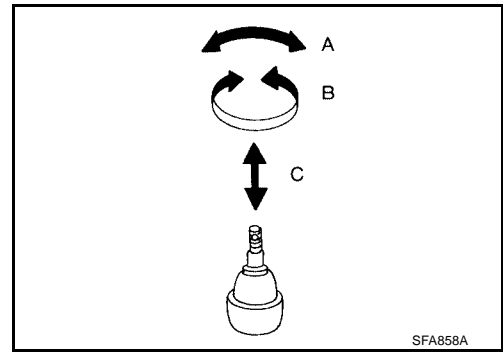

Swinging force: Refer to [RSU-12, "Ball Joint"](#).

Turning force: Refer to [RSU-12, "Ball Joint"](#).

Vertical end play: Refer to [RSU-12, "Ball Joint"](#).

FRONT LOWER LINK

- Check front lower link for any deformation, cracks, or damage and replace if necessary.

UPPER RUBBER SEAT AND BUSHING

- Check rubber parts for deterioration, or cracks and replace if necessary.

REAR LOWER LINK AND COIL SPRING

- Check for deformation, cracks, or other damage and replace if necessary.

STABILIZER BAR

- Check stabilizer bar for any deformation, cracks, or damage and replace if necessary.
- Check rubber bushings for deterioration, or cracks and replace if necessary.

A
B
C
D

RSU

F

G

H

I

J

K

L

M

SERVICE DATA AND SPECIFICATIONS (SDS)

SERVICE DATA AND SPECIFICATIONS (SDS)

PF0:00030

General Specifications (Rear)

EES000K8

Suspension type	Multi-link independent suspension
Shock absorber type	Double-acting hydraulic

Rear Wheel Alignment (Unladen*)

EES000K9

Engine		QR25DE	VQ35DE	
Camber Degree minute (Decimal degree)	Minimum	-0°04' (-0.07°)	-0°10' (-0.17°)	
	Nominal	-0°34' (-0.57°)	-0°40' (-0.67°)	
	Maximum	-0°64' (-1.07°)	-0°70' (-1.17°)	
Total toe-in	Distance (A - B) mm (in)	Minimum	2.4 (0.09)	2.5 (0.10)
		Nominal	3.9 (0.15)	4.0 (0.16)
		Maximum	5.4 (0.21)	5.5 (0.22)
	Angle (left plus right) Degree minute (Decimal degree)	Minimum	6' (0.1°)	
		Nominal	10' (0.167°)	
		Maximum	14' (0.233°)	

*: Fuel, radiator coolant and engine oil full. Spare tire, jack, hand tools and mats in designated positions.

Ball Joint

EES000KA

Swinging force "A" (Measuring point: cotter pin hole of ball stud) N (kg-f, lb-f)	7.8 - 54.9 (0.8 - 5.6, 1.8 - 12.3)
Turning torque "B" N-m (kg-cm, in-lb)	0.49 - 3.43 (5.0 - 35.0, 4.3 - 30.4)
Vertical end play "C" mm (in)	0 (0)

Wheelarch Height (Unladen*)

EES000KB

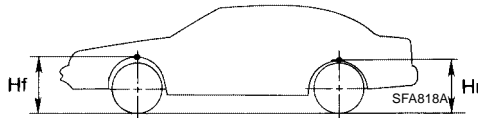

Engine	QR25DE	VQ35DE
Tire	205/65R16	215/55R17
Front (Hf) mm (in)	731 (28.78)	725 (28.54)
Rear (Hr) mm (in)	705 (27.75)	699 (27.52)

*: Fuel, radiator coolant and engine oil full. Spare tire, jack, hand tools and mats in designated positions.