

SECTION **DI**

DRIVER INFORMATION SYSTEM

A
B
C

CONTENTS

<p>PRECAUTION 3</p> <p> Precautions for Supplemental Restraint System (SRS) "AIR BAG" and "SEAT BELT PRE-TENSIONER" 3</p> <p> Wiring Diagrams and Trouble Diagnosis 3</p> <p>COMBINATION METERS 4</p> <p> Component Parts and Harness Connector Location... 4</p> <p> System Description 4</p> <p> UNIFIED CONTROL METER 4</p> <p> HOW TO CHANGE THE DISPLAY FOR ODO/TRIP METER 4</p> <p> POWER SUPPLY AND GROUND CIRCUIT 5</p> <p> WATER TEMPERATURE GAUGE 5</p> <p> TACHOMETER 5</p> <p> FUEL GAUGE 5</p> <p> SPEEDOMETER 5</p> <p> CAN Communication System Description 6</p> <p> Combination Meter 7</p> <p> CHECK 7</p> <p> Schematic 8</p> <p> Wiring Diagram — METER — 9</p> <p> Terminals and Reference Value for Combination Meter 10</p> <p> Meter/Gauges Operation and Odo/Trip Meter 10</p> <p> SELF-DIAGNOSIS FUNCTION 10</p> <p> HOW TO ALTERNATE DIAGNOSIS MODE 10</p> <p> How to Proceed With Trouble Diagnosis 11</p> <p> Diagnosis Flow 11</p> <p> Power Supply and Ground Circuit Check 12</p> <p> Trouble Diagnosis Chart by Symptom 13</p> <p> DIAGNOSIS RESULTS 13</p> <p> Fuel System 13</p> <p> FUEL GAUGE 13</p> <p> LOW-FUEL WARNING LAMP 13</p> <p> Tachometer System 14</p> <p> Engine Coolant Temperature System 15</p> <p> Vehicle Speed System 15</p> <p> The Fuel Gauge Pointer Fluctuates, Indicates Wrong Value or Varies 16</p> <p> The Fuel Gauge Does Not Move to FULL Position.. 16</p>	<p> Electrical Components Inspection 16</p> <p> FUEL LEVEL SENSOR UNIT CHECK 16</p> <p> Removal and Installation of Combination Meter 17</p> <p>WARNING LAMPS 18</p> <p> System Description 18</p> <p> OUTLINE 18</p> <p> MALFUNCTION INDICATOR LAMP (QR25DE MODELS) 18</p> <p> MALFUNCTION INDICATOR LAMP (VQ35DE MODELS) 18</p> <p> LOW WASHER FLUID LEVEL WARNING LAMP.. 18</p> <p> AIR BAG WARNING LAMP 18</p> <p> SEAT BELT WARNING LAMP 18</p> <p> LOW FUEL LEVEL WARNING LAMP 18</p> <p> LOW OIL PRESSURE WARNING LAMP 19</p> <p> CHARGE WARNING LAMP 19</p> <p> BRAKE WARNING LAMP 19</p> <p> TRUNK WARNING LAMP 19</p> <p> DOOR WARNING LAMP 19</p> <p> ASCD SET INDICATOR LAMP 19</p> <p> CRUISE INDICATOR LAMP 19</p> <p> ABS WARNING LAMP 19</p> <p> TCS OFF WARNING LAMP 19</p> <p> SLIP WARNING LAMP 20</p> <p> CAN Communication System Description 20</p> <p> Schematic 21</p> <p> Wiring Diagram — WARN — 22</p> <p> Terminals And Reference Value For BCM 26</p> <p> Work Flow 26</p> <p> Preliminary Check 26</p> <p> INSPECTION FOR POWER SUPPLY AND GROUND CIRCUIT 26</p> <p> CONSULT-II Function 27</p> <p> SELF-DIAGNOSIS PROCEDURE 27</p> <p> DATA MONITOR 28</p> <p> ACTIVE TEST 29</p> <p> Trouble Diagnosis For Door Warning Lamp 29</p> <p> Oil Pressure Warning Lamp Stays Off (Ignition Switch ON) 29</p> <p> Oil Pressure Warning Lamp Does Not Turn Off (Oil</p>
--	---

D
E
F
G
H
I
J
K
DI
L
M

Pressure Is Normal)	30	SELF-DIAGNOSTIC RESULTS	42
Component Inspection	31	All Warnings Are Not Operated	42
OIL PRESSURE SWITCH	31	Key Warning Chime and Light Warning Chime Does Not Operate (Seat Belt Warning Chime Does Oper- ate)	43
A/T INDICATOR	32	Key Warning Chime Does Not Operate	44
Wiring Diagram — AT/IND —	32	Light Warning Chime Does Not Operate	46
A/T Indicator Does Not Illuminate	33	Seat Warning Chime Does Not Operate	47
WARNING CHIME	34	BOARD COMPUTER	49
Component Parts and Harness Connector Location..	34	System Description	49
System Description	34	FUNCTION	49
FUNCTION	34	OUTSIDE AIR TEMPERATURE INDICATION	49
IGNITION KEY WARNING CHIME	34	DTE (DISTANCE TO EMPTY) INDICATION	49
LIGHT WARNING CHIME	35	TRIP DISTANCE	49
SEAT BELT WARNING CHIME	35	TRIP TIME	49
CAN Communication System Description	35	AVERAGE FUEL CONSUMPTION	49
Major Component Parts and Function	35	AVERAGE VEHICLE SPEED	49
Wiring Diagram — CHIME —	36	HOW TO CHANGE/RESET INDICATION	49
Terminals and Reference Value for BCM	38	CAN Communication System Description	50
How to Proceed With Trouble Diagnosis	39	Wiring Diagram — B/COMP —	51
Preliminary Check	39	Trouble Diagnoses	53
INSPECTION FOR POWER SUPPLY AND		SEGMENT CHECK	53
GROUND CIRCUIT	39	PRELIMINARY CHECK	53
CONSULT-II Function	40	DIAGNOSIS PROCEDURE	53
DIAGNOSTIC ITEMS DESCRIPTION	40	Electrical Components Inspection	54
CONSULT-II BASIC OPERATION PROCEDURE		AMBIENT SENSOR	54
... ..	40		
DATA MONITOR	41		
ACTIVE TEST	42		

PRECAUTION

PRECAUTION

PFP:00011

Precautions for Supplemental Restraint System (SRS) “AIR BAG” and “SEAT BELT PRE-TENSIONER”

EKS00673

The Supplemental Restraint System such as “AIR BAG” and “SEAT BELT PRE-TENSIONER”, used along with a front seat belt, helps to reduce the risk or severity of injury to the driver and front passenger for certain types of collision. This system includes seat belt switch inputs and dual stage front air bag modules. The SRS system uses the seat belt switches to determine the front air bag deployment, and may only deploy one front air bag, depending on the severity of a collision and whether the front occupants are belted or unbelted. Information necessary to service the system safely is included in the SRS and SB section of this Service Manual.

WARNING:

- To avoid rendering the SRS inoperative, which could increase the risk of personal injury or death in the event of a collision which would result in air bag inflation, all maintenance must be performed by an authorized NISSAN/INFINITI dealer.
- Improper maintenance, including incorrect removal and installation of the SRS, can lead to personal injury caused by unintentional activation of the system. For removal of Spiral Cable and Air Bag Module, see the SRS section.
- Do not use electrical test equipment on any circuit related to the SRS unless instructed to in this Service Manual. SRS wiring harnesses can be identified by yellow and/or orange harnesses or harness connectors.

Wiring Diagrams and Trouble Diagnosis

EKS003F0

When you read wiring diagrams, refer to the following:

- Refer to [GI-12, "How to Read Wiring Diagrams"](#) .
- Refer to [PG-4, "POWER SUPPLY ROUTING CIRCUIT"](#) for power distribution circuit.

When you perform trouble diagnosis, refer to the following:

- Refer to [GI-10, "HOW TO FOLLOW TEST GROUPS IN TROUBLE DIAGNOSES"](#) .
- Refer to [GI-25, "How to Perform Efficient Diagnosis for an Electrical Incident"](#) .

A
B
C
D
E
F
G
H
I
J
DI
L
M

COMBINATION METERS

COMBINATION METERS

PFP:24814

Component Parts and Harness Connector Location

EKS003F1

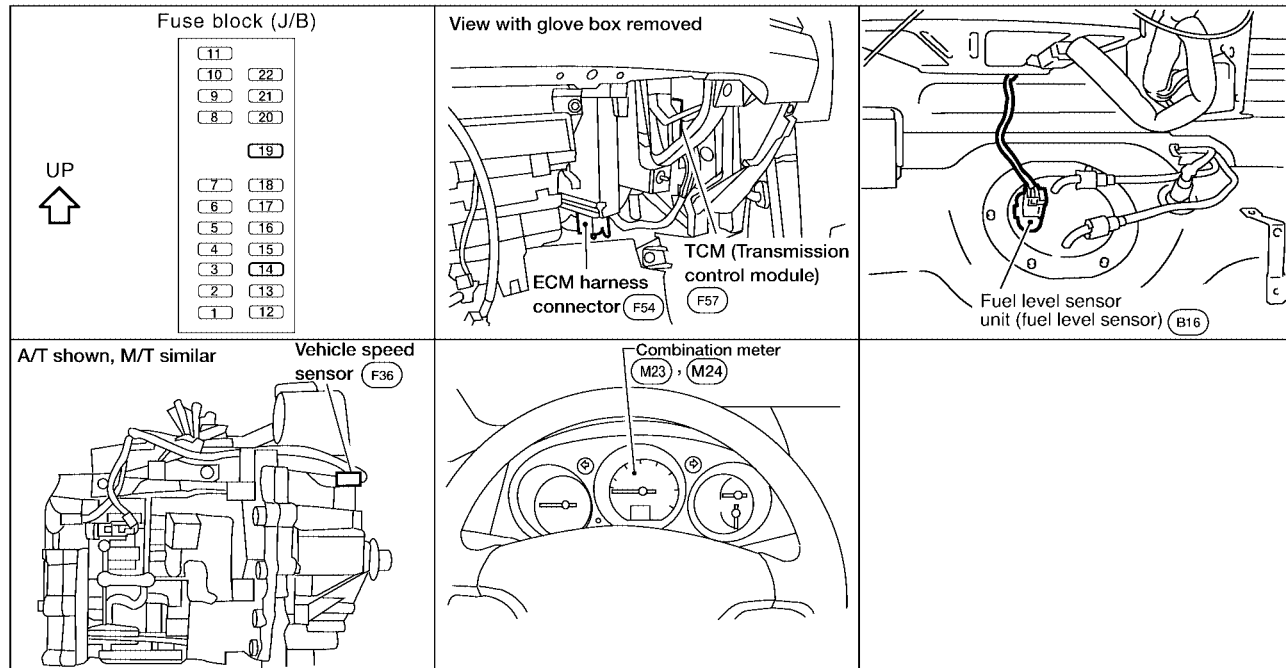

WKIA1776E

EKS003F2

System Description UNIFIED CONTROL METER

- Speedometer, odo/trip meter, tachometer, fuel gauge and water temperature gauge are controlled by the unified meter control unit, which is built into the combination meter.
- Digital meter is adopted for odo/trip meter.*
*The record of the odometer is kept even if the battery cable is disconnected. The record of the trip meter is erased when the battery cable is disconnected.
- Odo/trip meter and A/T indicator segments can be checked in diagnosis mode.
- Meter/gauge can be checked in diagnosis mode.

HOW TO CHANGE THE DISPLAY FOR ODO/TRIP METER

- The vehicle speed signal and the memory signals from the meter memory circuit are processed by the combination meter and the mileage is displayed.

COMBINATION METERS

- Depressing the odometer/trip switch toggles the mode in the following order.

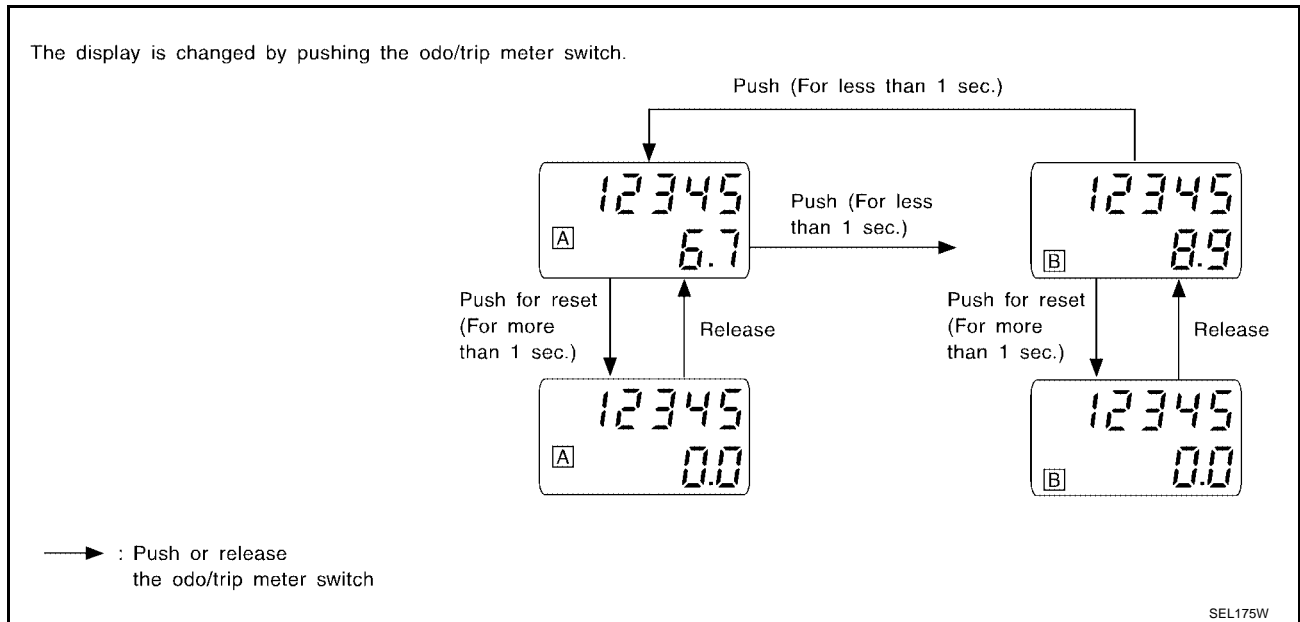

- The odo/trip meter display mode toggling and trip display resetting can be identified by the amount of time that elapses from pressing the odo/trip meter switch to releasing it.
- When resetting with trip A displayed, only trip A display is reset (Trip B operates the same way).

POWER SUPPLY AND GROUND CIRCUIT

Power is supplied at all times

- through 10A fuse [No. 19, located in the fuse block (J/B)]
- to combination meter terminal 5.

With the ignition switch in the ON or START position, power is supplied

- through 10A fuse [No. 14, located in the fuse block (J/B)]
- to combination meter terminals 17 and 18.

Ground is supplied

- to combination meter terminals 6 and 39
- through body grounds F14 (QR25DE models), M57 and M61.

WATER TEMPERATURE GAUGE

The water temperature gauge indicates the engine coolant temperature.

ECM provides an engine coolant temperature signal to combination meter for water temperature gauge with CAN communication line.

TACHOMETER

The tachometer indicates engine speed in revolutions per minute (rpm).

ECM provides an engine speed signal to combination meter for tachometer with CAN communication line.

FUEL GAUGE

The fuel gauge indicates the approximate fuel level in the fuel tank.

The fuel gauge is regulated by a variable ground signal supplied

- to combination meter terminal 12
- from terminal G of the fuel level sensor unit
- through terminal E of the fuel level sensor unit and
- through body grounds F14 (QR25DE models), M57 and M61.

SPEEDOMETER

The vehicle speed sensor provides a vehicle speed signal to the combination meter for speedometer indication.

COMBINATION METERS

CAN Communication System Description

EKS003F3

Refer to [LAN-4, "CAN COMMUNICATION"](#) .

COMBINATION METERS

EKS003F4

Combination Meter CHECK

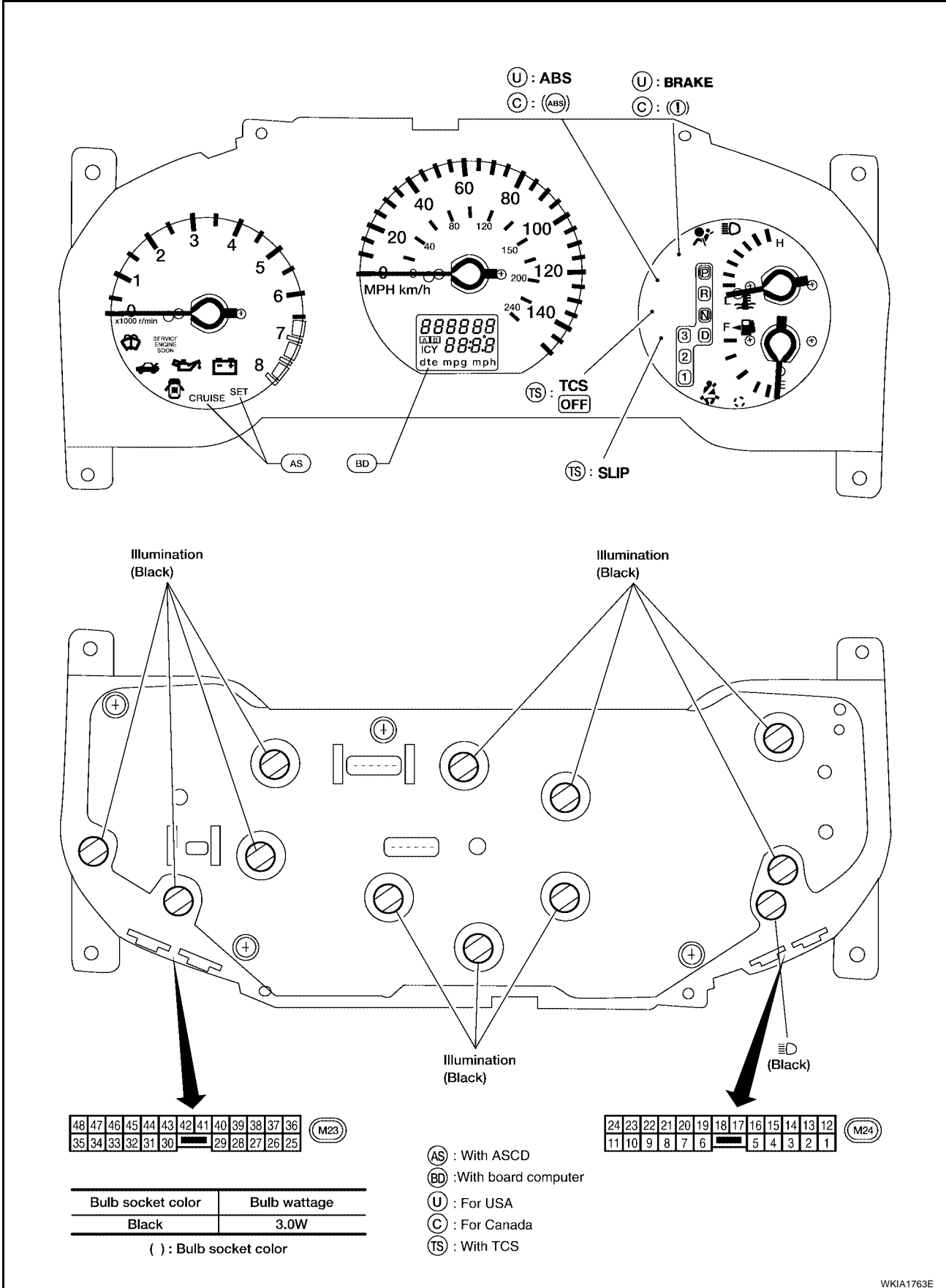

A
B
C
D
E
F
G
H
I
J
DI
L
M

COMBINATION METERS

Schematic

EKS003F5

- (AB) : WITH ABS
- (AS) : WITH ASCD
- (TS) : WITH TCS
- (OR) : WITH OR25DE
- (VQ) : WITH VQ35DE

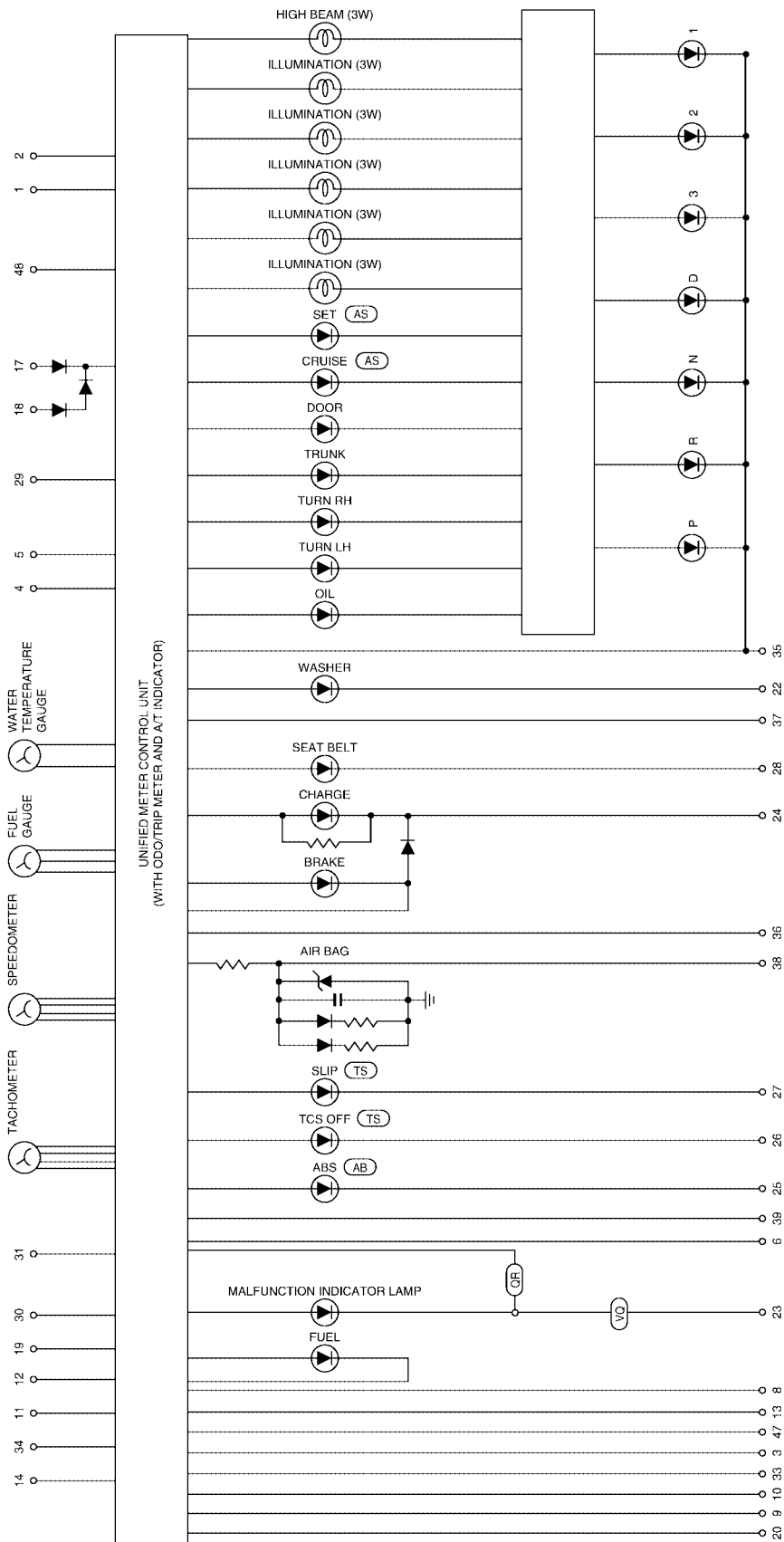

WKWA0991E

COMBINATION METERS

Terminals and Reference Value for Combination Meter

EKS003F7

TERMI- NAL	WIRE COLOR	ITEM	CONDITION		Voltage (V) (Approx.)
			Ignition switch	Operation or condition	
1	L	CAN-H	—	—	—
2	Y	CAN-L	—	—	—
5	Y/R	Battery power supply	—	—	Battery voltage
6	B	Ground	—	—	0
11	L/Y	Vehicle speed signal	ON	Speedometer operated [When vehicle speed is approx. 20 km/h (12 MPH)]	240 Hz
12	G/B	Fuel level sensor signal	ON	—	Refer to DI-16. "FUEL LEVEL SENSOR UNIT CHECK" .
17	GY	Ignition switch ON or START	ON	—	Battery voltage
18	GY	Ignition switch ON or START	ON	—	Battery voltage
39	B	Ground	—	—	0

Meter/Gauges Operation and Odo/Trip Meter SELF-DIAGNOSIS FUNCTION

EKS003F8

- Odo/trip meter (board computer) segment operation can be checked in self-diagnosis mode.
- Meters/gauges can be checked in self-diagnosis mode.

HOW TO ALTERNATE DIAGNOSIS MODE

1. Turn the ignition switch ON, and switch the odometer/trip meter to "trip A" or "trip B".

NOTE:

If the diagnosis function is activated with the trip meter A displayed, the mileage on the trip meter A will indicate 000.0 miles, but the actual trip mileage will be retained. (Trip B operates the same way.)

2. Turn the ignition switch OFF.
3. While pushing the odo/trip meter switch, turn the ignition switch ON again.
4. Check that the trip meter displays "000.0".
5. Push the odo/trip meter switch at least 7 times within 7 seconds after the ignition switch is turned ON.
6. All the segments on the odo/trip meter illuminate, and simultaneously the low-fuel warning lamp indicator illuminates. At this time, the unified meter control unit is turned to diagnosis mode.

NOTE:

If any of the segments is not displayed, replace the combination meter.

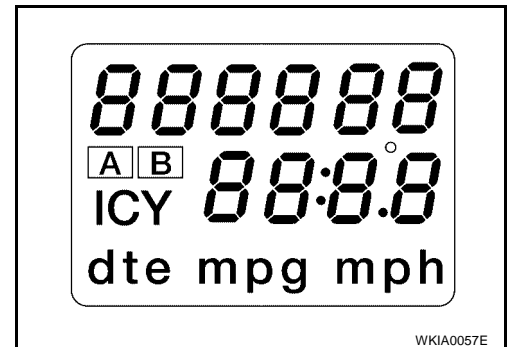

WKIA0057E

COMBINATION METERS

7. Push the odo/trip meter switch. Each meter/gauge should indicate as shown in the figure while pushing odo/trip meter switch. (At this time, the low-fuel warning lamp goes off).

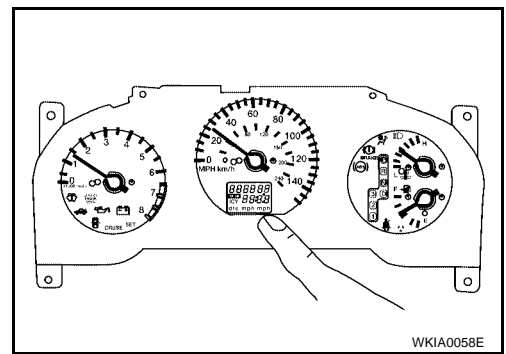

How to Proceed With Trouble Diagnosis

1. Confirm the trouble symptom or customer complaint.
2. Perform diagnosis according to diagnosis flow. Refer to [DI-11, "Diagnosis Flow"](#).
3. According to the trouble diagnosis chart, repair or replace the cause of the trouble symptom. Refer to [DI-13, "Trouble Diagnosis Chart by Symptom"](#).
4. Does the meter operate normally? Yes: Go to 5. No: Go to 2.
5. Inspection End.

Diagnosis Flow

1. WARNING LAMP ILLUMINATION INSPECTION

1. Turn ignition switch ON.
2. Check that warning lamps (such as MIL and oil pressure warning lamp) illuminate.

Do warning lamps illuminate?

YES >> GO TO 2.

NO >> Check ignition power supply system of combination meter. Refer to [DI-12, "Power Supply and Ground Circuit Check"](#).

2. SELF-DIAGNOSIS OPERATION CHECK

Perform combination meter self-diagnosis. Refer to [DI-10, "SELF-DIAGNOSIS FUNCTION"](#).

Does self-diagnosis function operate?

YES >> GO TO 3.

NO >> Check battery power supply of combination meter and ground system. Refer to [DI-12, "Power Supply and Ground Circuit Check"](#).

3. ODO/TRIP METER OPERATION CHECK

Check segment display status of odo/trip meter. Refer to [DI-10, "SELF-DIAGNOSIS FUNCTION"](#).

Is the display normal?

YES >> GO TO 4.

NO >> Replace the combination meter.

4. FUEL WARNING LAMP ILLUMINATION CONFIRMATION

During fuel warning lamp check, confirm illumination of fuel warning lamp. Refer to [DI-10, "SELF-DIAGNOSIS FUNCTION"](#).

Does fuel warning lamp illuminate?

YES >> GO TO 5.

NO >> Replace the combination meter.

COMBINATION METERS

5. METER CIRCUIT CHECK

During meter circuit check, confirm meter illumination. Refer to [DI-10, "SELF-DIAGNOSIS FUNCTION"](#) .
Is the display normal?

- YES >> Go to diagnosis results. Refer to [DI-13, "DIAGNOSIS RESULTS"](#) .
- NO >> Replace the combination meter.

Power Supply and Ground Circuit Check

EKS003FB

1. CHECK FUSES

Check for blown combination meter fuses.

Unit	Power source	Fuse No.
Combination meter	Battery	19
	Ignition switch ON or START	14

OK or NG

- OK >> GO TO 2.
- NG >> If fuse is blown, be sure to eliminate cause of problem before installing new fuse. Refer to [PG-4, "POWER SUPPLY ROUTING CIRCUIT"](#) .

2. POWER SUPPLY CIRCUIT CHECK

1. Disconnect combination meter connector.
2. Check voltage between combination meter harness connector M24 terminals 5 (Y/R), 17 (GY), 18 (GY) and ground.

Terminals			Ignition switch position		
(+)		(-)	OFF	ON	START
Connector	Terminal (Wire color)		OFF	ON	START
M24	5 (Y/R)	Ground	Battery voltage	Battery voltage	Battery voltage
	17 (GY)		0V	Battery voltage	Battery voltage
	18 (GY)		0V	Battery voltage	Battery voltage

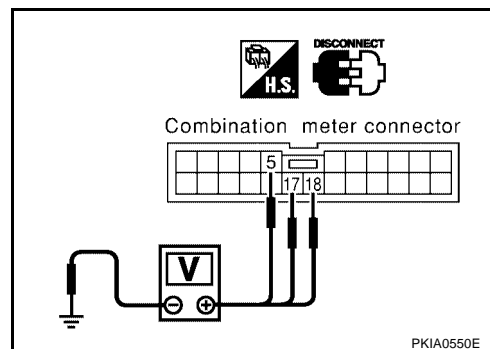

OK or NG

- OK >> GO TO 3.
- NG >> Check harness for open between combination meter and fuse.

3. GROUND CIRCUIT CHECK

Check continuity between combination meter harness connector terminal 6 (B) and 39 (B), and ground.

Terminals			Continuity
(+)		(-)	
Connector	Terminal (Wire color)		Continuity
M24	6 (B)	Ground	Yes
M23	39 (B)		

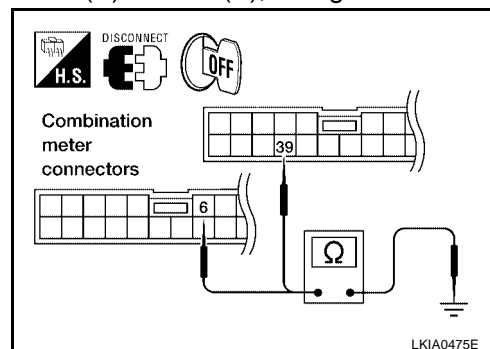

OK or NG

- OK >> Inspection End
- NG >> Check ground harness.

COMBINATION METERS

Trouble Diagnosis Chart by Symptom DIAGNOSIS RESULTS

EKS003FC

Trouble phenomenon	Possible cause
Tachometer indication is irregular.	Refer to DI-14, "Tachometer System" .
Fuel warning lamp indication is irregular.	Refer to DI-16, "FUEL LEVEL SENSOR UNIT CHECK" .
Fuel gauge indication is irregular.	
Water temperature gauge indication is irregular.	Refer to DI-15, "Engine Coolant Temperature System" .
Indication is irregular for the speedometer and odo/trip meter.	Refer to DI-15, "Vehicle Speed System" .
Indications are irregular for more than one gauge.	Replace combination meter.
A/T position indication is irregular.	Refer to DI-32, "A/T INDICATOR" .

Fuel System

EKS003FD

The following symptoms do not indicate a malfunction.

FUEL GAUGE

- Depending on vehicle position or driving circumstance, the fuel in the tank flows and the pointer may fluctuate.
- If the vehicle is fueled with the ignition switch ON, the pointer will move slowly.

LOW-FUEL WARNING LAMP

Depending on vehicle position or driving circumstance, the fuel in the tank flows and the warning lamp ON timing may change.

1. CONNECTOR INSPECTION

- Turn ignition switch OFF.
- Check meter, fuel level sensor unit and terminals (meter-side, unit-side, harness-side) for looseness or bent terminals.

OK or NG

- OK >> GO TO 2.
NG >> Repair terminal or connector.

2. CONTINUITY INSPECTION BETWEEN COMBINATION METER AND FUEL LEVEL SENSOR UNIT

- Disconnect combination meter connector and fuel level sensor unit connector.
- Check continuity between combination meter harness connector M24 terminal 12 (G/B) and fuel level sensor unit harness connector B16 terminal G (G/B).
- Check continuity between combination meter harness connector M24 terminal 12 (G/B) and ground.

Terminals				Continuity
(+)		(-)		
Connector	Terminal (Wire color)	Connector	Terminal (Wire color)	
M24	12 (G/B)	B16	G (G/B)	Yes
M24	12 (G/B)	—	Ground	No

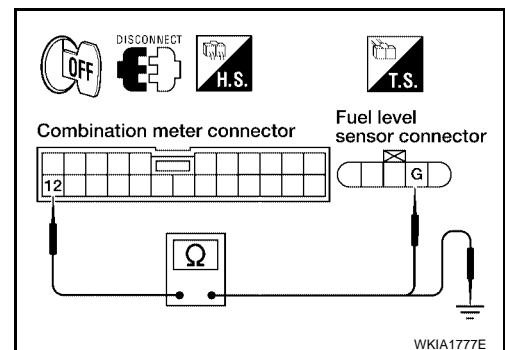

OK or NG

- OK >> GO TO 3.
NG >> Repair harness or connector.

COMBINATION METERS

3. GROUND CIRCUIT INSPECTION OF FUEL LEVEL SENSOR

Check continuity between fuel level sensor unit harness connector B16 terminal E (B) and ground.

Terminals		Continuity
(+)	(-)	
Connector	Terminal (Wire color)	
B16	E (B)	Ground Yes

OK or NG

OK >> GO TO 4.

NG >> Repair harness or connector.

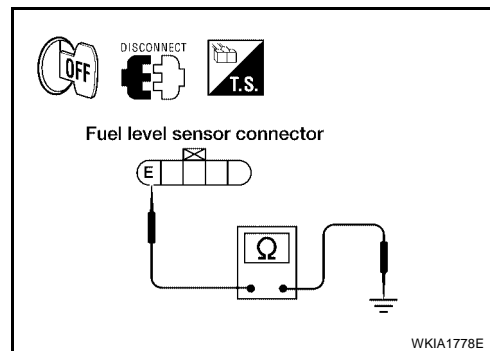

4. FUEL LEVEL SENSOR INSPECTION

Check components. Refer to [DI-16, "FUEL LEVEL SENSOR UNIT CHECK"](#).

OK or NG

OK >> GO TO 5.

NG >> Replace fuel level sensor unit.

5. CHECK INSTALLATION CONDITION

Check fuel level sensor unit installation, and check whether the float arm interferes or binds with any of the internal components in the fuel tank.

OK or NG

OK >> Replace the combination meter.

NG >> Install the fuel level sensor unit properly.

Tachometer System

EKS003FE

1. VISUAL INSPECTION

Check if tachometer fluctuates when the engine starts.

Is the fluctuation acceptable?

YES >> GO TO 2.

NO >> GO TO 3.

2. ENGINE SPEED INSPECTION

Compare the values indicated in the engine speed and tachometer.

Does the engine speed correspond to the speed indicated?

YES >> GO TO 3.

NO >> Replace the combination meter.

3. ECM SYSTEM INSPECTION

Perform ECM self-diagnosis. Refer to [EC-106, "CONSULT-II Function"](#) (QR25DE) or [EC-707, "CONSULT-II Function"](#) (VQ35DE).

OK or NG

OK >> Replace combination meter.

NG >> Go to ECM trouble diagnosis.

COMBINATION METERS

Engine Coolant Temperature System

EKS003FF

1. ECM SYSTEM INSPECTION

Perform ECM self-diagnosis. Refer to [EC-106, "CONSULT-II Function"](#) (QR25DE) or [EC-707, "CONSULT-II Function"](#) (VQ35DE).

OK or NG

- OK >> Replace combination meter.
- NG >> Go to ECM trouble diagnosis.

Vehicle Speed System

EKS003FH

1. CHECK VEHICLE SPEED SENSOR CIRCUITS

1. Remove vehicle speed sensor.
2. Turn ignition switch ON.
3. Rotate vehicle speed sensor while checking voltage between combination meter harness connector M24 terminal 11 (L/Y) and ECM harness connector F54 terminal 58 (B) (VQ35DE models) or 67 (B) (QR25DE models).

Terminals				Voltage value (Approx.)
(+)		(-)		
Connector	Terminal (Wire color)	Connector	Terminal (Wire color)	
M24	11 (L/Y)	F54	58 (B) (VQ35DE)	0.5V
			67 (B) (QR25DE)	

OK or NG

- OK >> Vehicle speed sensor is OK.
- NG >> GO TO 2.

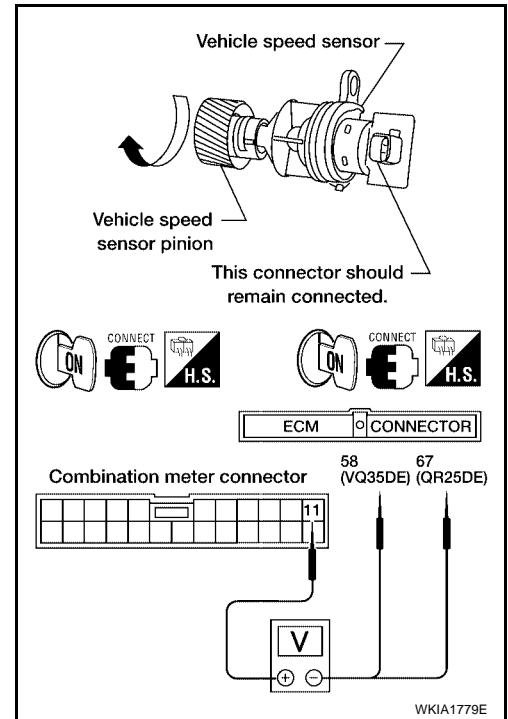

2. CHECK VEHICLE SPEED SENSOR

1. Turn ignition switch OFF.
2. Disconnect speed sensor connector.
3. Check resistance between vehicle speed sensor terminals + and -.

Terminals				Resistance value (Approx.)
(+)		(-)		
Component	Terminal	Component	Terminal	
Vehicle speed sensor	+	Vehicle speed sensor	-	250Ω

OK or NG

- OK >> Check harness or connector between combination meter, vehicle speed sensor and ECM.
- NG >> Replace vehicle speed sensor.

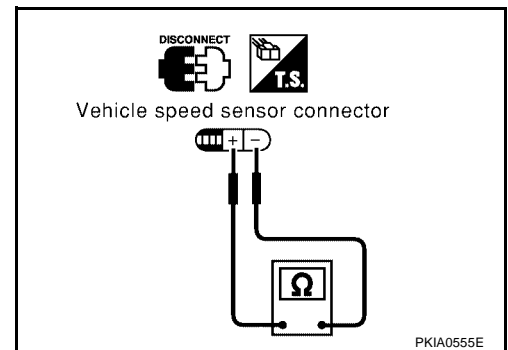

COMBINATION METERS

The Fuel Gauge Pointer Fluctuates, Indicates Wrong Value or Varies

EKS003FJ

1. CHECK FUEL GAUGE FLUCTUATION

Test drive vehicle to see if gauge fluctuates only during driving or before or after stopping.

Does the indication value vary only during driving or before or after stopping?

- Yes >> The pointer fluctuation may be caused by fuel level change in the fuel tank. Condition is normal.
 No >> Ask the customer about the situation when the symptom occurs in detail, and perform the trouble diagnosis.

The Fuel Gauge Does Not Move to FULL Position

EKS003FK

1. OBSERVE FUEL GAUGE

Does it take a long time for the pointer to move to FULL position?

YES or NO

- YES >> GO TO 2.
 NO >> GO TO 3.

2. IDENTIFY FUELING CONDITION

Was the vehicle fueled with the ignition switch ON?

YES or NO

- YES >> Be sure to fuel the vehicle with the ignition switch OFF. Otherwise, it will take a long time to move to FULL position because of the characteristic of the fuel gauge.
 NO >> GO TO 3.

3. OBSERVE VEHICLE POSITION

Is the vehicle parked on an incline?

YES or NO

- YES >> Check the fuel level indication with vehicle on a level surface.
 NO >> GO TO 4.

4. OBSERVE FUEL GAUGE POINTER

During driving, does the fuel gauge pointer move gradually toward EMPTY position?

YES or NO

- YES >> Check the components. Refer to [DI-16, "FUEL LEVEL SENSOR UNIT CHECK"](#).
 NO >> The float arm may interfere or bind with any of the components in the fuel tank.

Electrical Components Inspection

EKS003FN

FUEL LEVEL SENSOR UNIT CHECK

- For removal, refer to [FL-5, "Removal and Installation For All Models Except PZEV"](#) or [FL-8, "Removal and Installation For PZEV Models Only"](#).
- Check the resistance between terminals G and E.

Terminal		Float position mm (in)		Resistance value (Approx.)
G	E	Full (1)	82.7 (3.3)	4.5 – 5.5Ω
		1/2 (2)	200.3 (7.9)	31.5 – 5.5Ω
		Empty (3)	325.0 (12.8)	80.0 – 83.0Ω

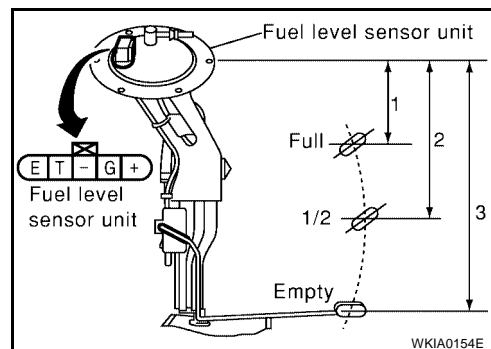

COMBINATION METERS

Removal and Installation of Combination Meter

EKS007RS

For removal and installation procedure, refer to [IP-13, "Combination Meter"](#).

A

B

C

D

E

F

G

H

I

J

DI

L

M

WARNING LAMPS

System Description OUTLINE

With ignition switch in the ON or START position, power is supplied

- through 10A fuse [No. 14, located in the fuse block (J/B)]
- to combination meter terminals 17 and 18.

Ground is supplied

- to combination meter terminals 6 and 39
- through body grounds F14 (QR25DE models), M57 and M61,
- to seat belt buckle switch LH terminal 2
- through body grounds B7 and B19,
- to brake fluid level switch terminal 2, and
- to washer fluid level sensor terminal –
- through body grounds E15 and E24.

MALFUNCTION INDICATOR LAMP (QR25DE MODELS)

The malfunction indicator lamp is controlled by the ECM. During prove out or when an engine control malfunction occurs, the ECM signals the combination meter (unified meter control unit) via the CAN lines and ground is provided to the malfunction indicator lamp.

When power and ground are supplied, the malfunction indicator lamp illuminates.

MALFUNCTION INDICATOR LAMP (VQ35DE MODELS)

During prove out or when an engine control malfunction occurs, ground is supplied

- to combination meter terminal 23
- from ECM terminal 33.

When power and ground are supplied, the malfunction indicator lamp illuminates.

LOW WASHER FLUID LEVEL WARNING LAMP

When the washer fluid level is low, ground is supplied

- to combination meter terminal 22
- from washer fluid level sensor terminal +.

When power and ground are supplied, the low washer level warning lamp illuminates.

AIR BAG WARNING LAMP

During prove out or when an air bag malfunction occurs, the ground path is interrupted

- from the air bag diagnosis sensor unit terminal 15
- to combination meter terminal 38.

Ground is supplied

- to combination meter terminals 6 and 39
- through body grounds F14 (QR25DE models), M57 and M61.

When power and ground are supplied, the air bag warning lamp illuminates.

SEAT BELT WARNING LAMP

When the driver seat belt is unfastened, ground is supplied

- to combination meter terminal 28
- from seat belt buckle switch LH terminal 1.

When power and ground are supplied, the seat belt warning lamp illuminates.

LOW FUEL LEVEL WARNING LAMP

The amount of fuel in the fuel tank is determined by the fuel level sensor in the fuel tank. A signal is sent

- to combination meter terminal 12
- from fuel level sensor unit terminal G.

The fuel level sensor will illuminate the low fuel level warning lamp when the fuel level is low.

When power and ground are supplied, the low fuel level warning lamp illuminates.

WARNING LAMPS

LOW OIL PRESSURE WARNING LAMP

Low oil pressure warning lamp is controlled by the IPDM E/R (Intelligent Power Distribution Module Engine Room).

Low oil pressure causes oil pressure switch terminal + to provide ground to IPDM E/R terminal 57. The IPDM E/R then signals the combination meter (unified meter control unit) via the CAN lines and ground is provided to the low oil pressure warning lamp.

When power and ground are supplied, the low oil pressure warning lamp illuminates.

CHARGE WARNING LAMP

During prove out or when a generator malfunction occurs, ground is supplied

- to combination meter terminal 24
- from generator terminal L.

When power and ground are supplied, the charge warning lamp and brake lamp illuminate.

BRAKE WARNING LAMP

When the parking brake is applied, or if the brake fluid level is low, ground is supplied

- to combination meter terminal 36
- from parking brake switch terminal 1, or
- to combination meter terminal 37
- from brake fluid level switch terminal 1.

When power and ground are supplied, the brake warning lamp illuminates.

TRUNK WARNING LAMP

Trunk warning lamp is controlled by the BCM.

When the trunk is opened, ground is supplied

- to BCM terminal 19
- through body grounds B7 and B19.

The BCM then signals the combination meter (unified meter control unit) via the CAN lines and ground is provided to the trunk warning lamp.

When power and ground are supplied, the trunk warning lamp illuminates.

DOOR WARNING LAMP

Door warning lamp is controlled by the BCM.

When one of the doors is opened, ground is supplied to the BCM terminals 10, 11, 14 or 54. The BCM then signals the combination meter (unified meter control unit) via the CAN lines and ground is provided to the door warning lamp.

When power and ground are supplied, the door warning lamp illuminates.

ASCD SET INDICATOR LAMP

The ASCD set indicator lamp is controlled by the ECM.

When the ASCD system is turned on and the speed is set, the ECM signals the combination meter (unified meter control unit) via the CAN lines and ground is provided to the set indicator lamp.

When power and ground are supplied, the set indicator lamp illuminates.

CRUISE INDICATOR LAMP

The cruise indicator lamp is controlled by the ECM.

When the ASCD system is turned on, the ECM signals the combination meter (unified meter control unit) via the CAN lines and ground is provided to the cruise indicator lamp.

When power and ground are supplied, the cruise indicator lamp illuminates.

ABS WARNING LAMP

When an ABS malfunction occurs, ground is supplied

- to combination meter terminal 25
- from ABS actuator and electric unit (control unit) terminal 21.

When power and ground are supplied, the ABS warning lamp illuminates.

TCS OFF WARNING LAMP

When TCS OFF switch is in OFF position, or a TCS malfunction occurs, ground is supplied

A
B
C
D
E
F
G
H
I
J

DI

L

M

WARNING LAMPS

- to combination meter terminal 26
- from ABS actuator and electric unit (control unit) terminal 26.

When power and ground are supplied, the TCS OFF warning lamp illuminates.

SLIP WARNING LAMP

When TCS is in operation, or a TCS malfunction occurs, ground is supplied

- to combination meter terminal 27
- from ABS actuator and electric unit (control unit) terminal 28.

When power and ground are supplied, the slip warning lamp illuminates.

CAN Communication System Description

EKS003FQ

Refer to [LAN-4, "CAN COMMUNICATION"](#) .

WARNING LAMPS

Schematic

EKS003FR

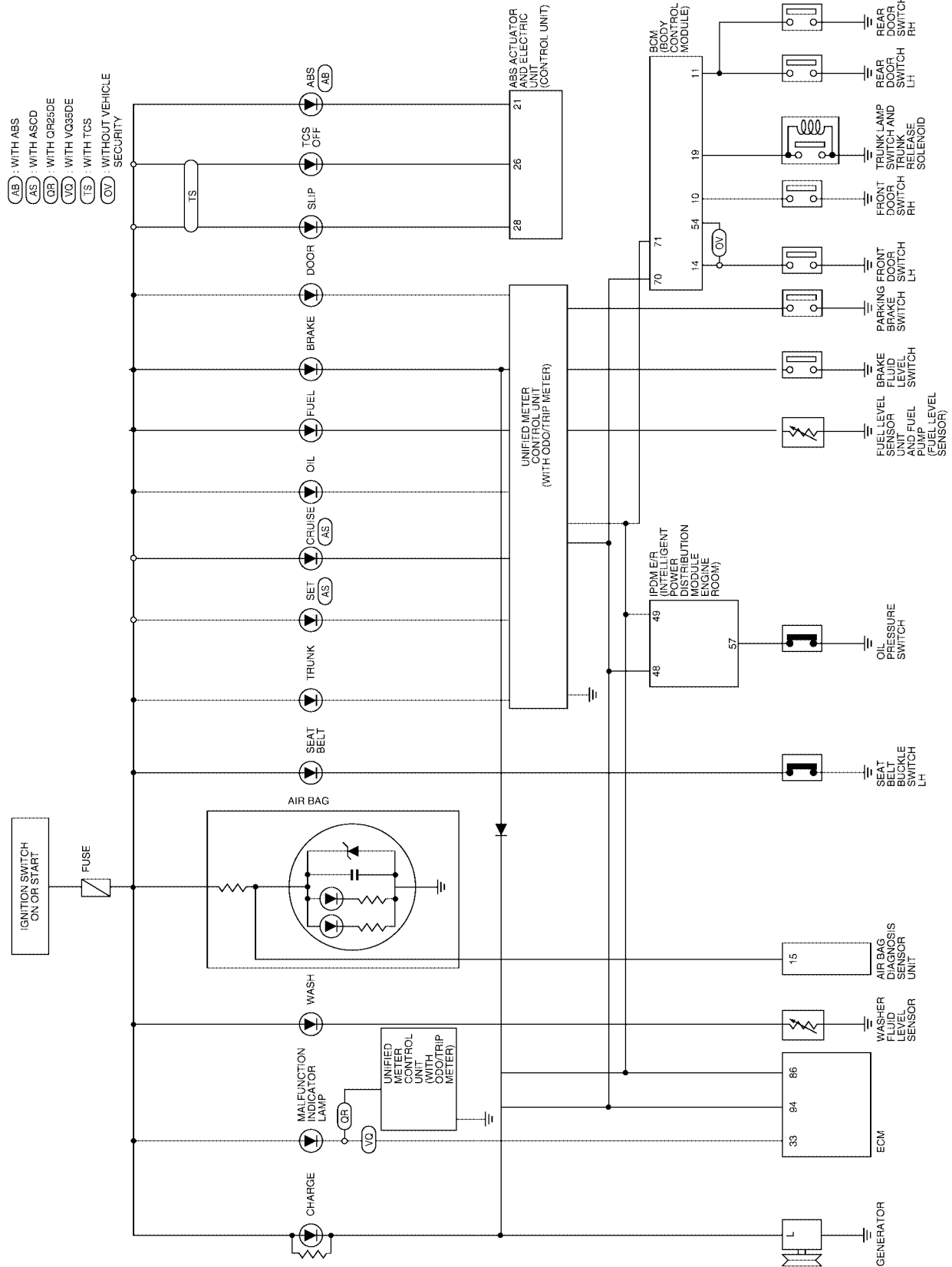

A
B
C
D
E
F
G
H
I
J
DI
L
M

WARNING LAMPS

EKS003FS

Wiring Diagram — WARN —

DI-WARN-01

- : DATA LINE
- QR : WITH QR25DE
- VQ : WITH VQ35DE

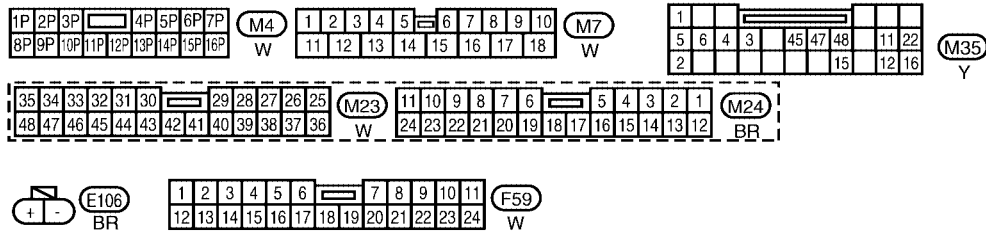
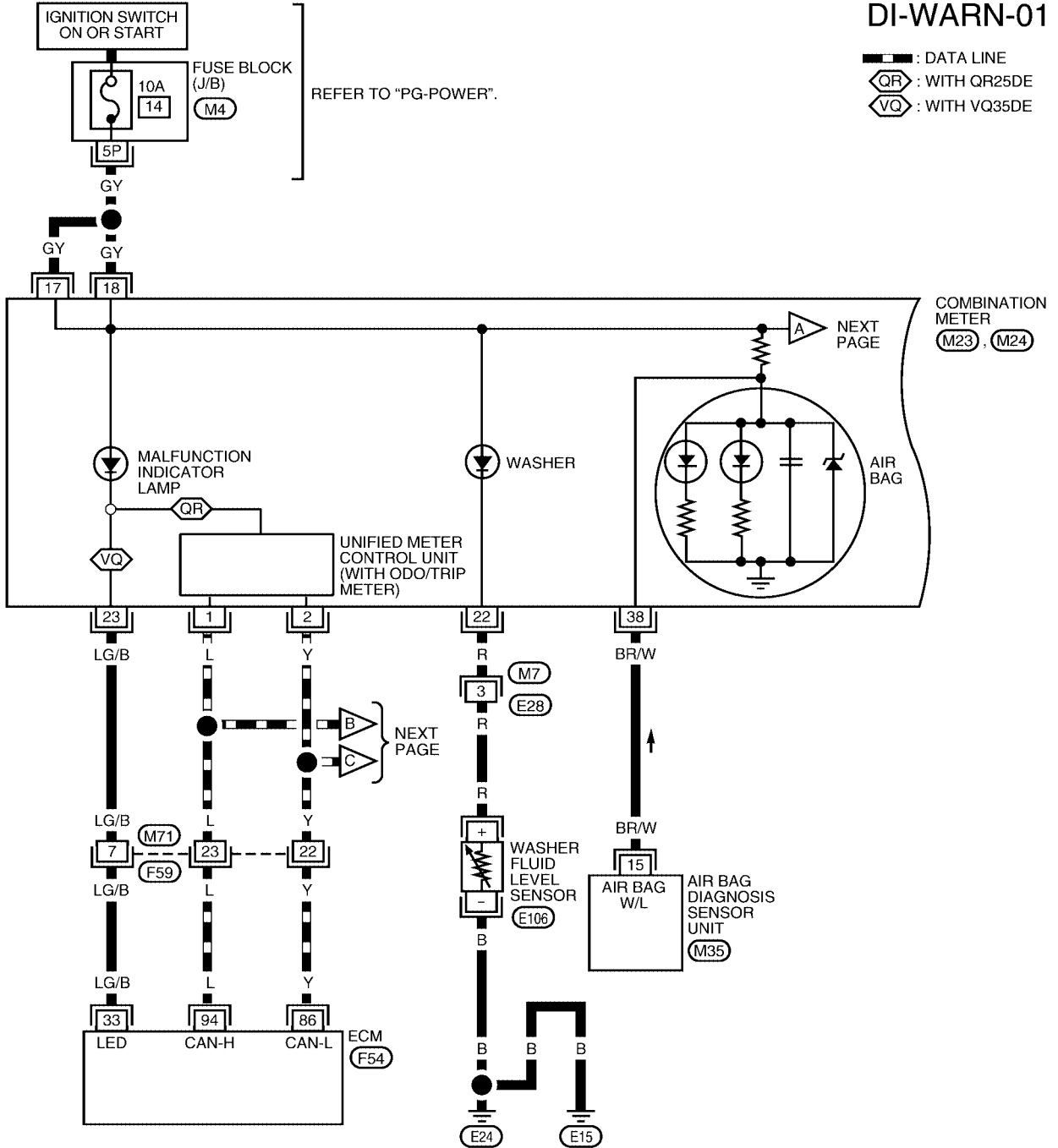

REFER TO THE FOLLOWING.
F54 - ELECTRICAL UNITS

WKWA0994E

WARNING LAMPS

DI-WARN-02

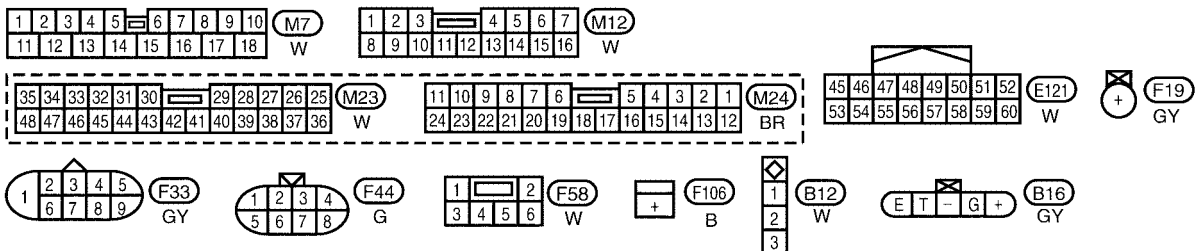
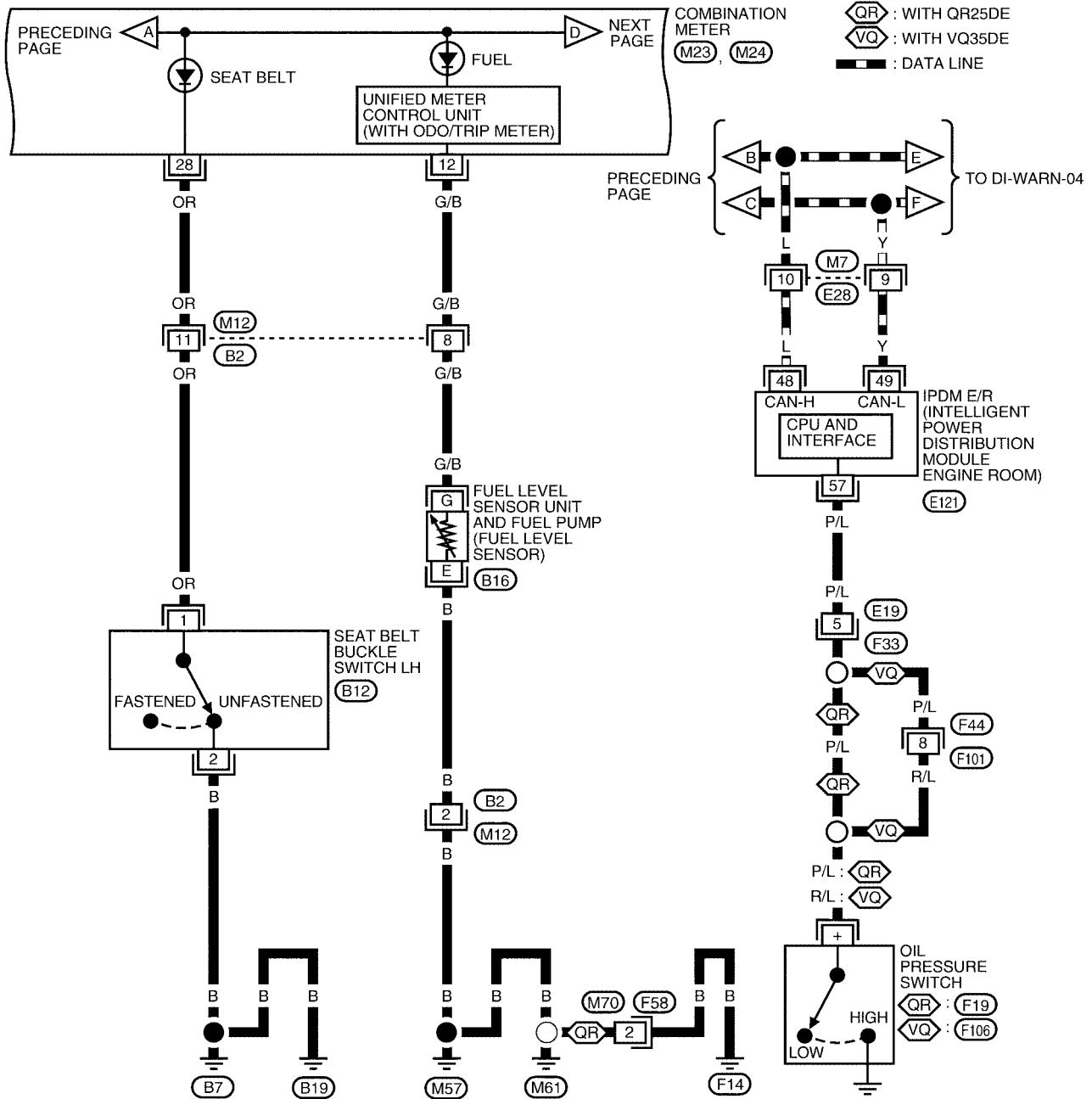

WKWA1190E

WARNING LAMPS

DI-WARN-03

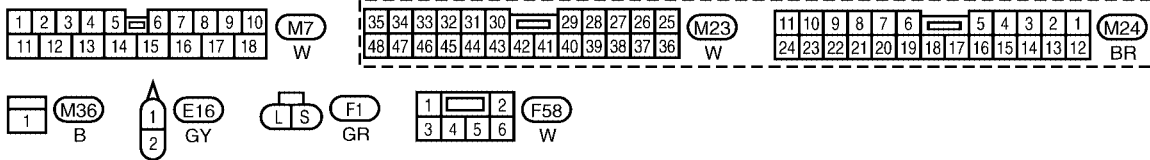
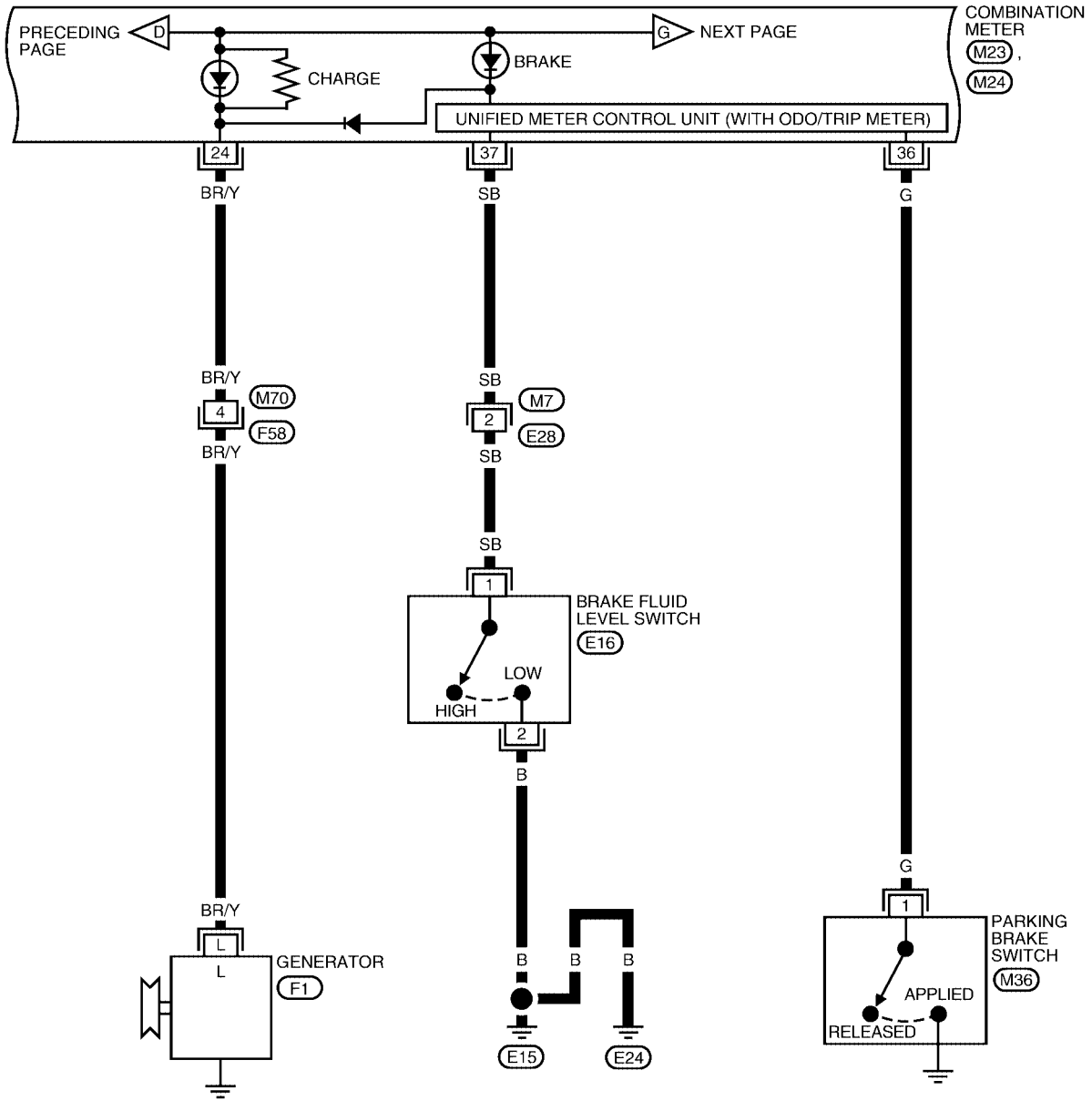

WKWA0996E

WARNING LAMPS

DI-WARN-04

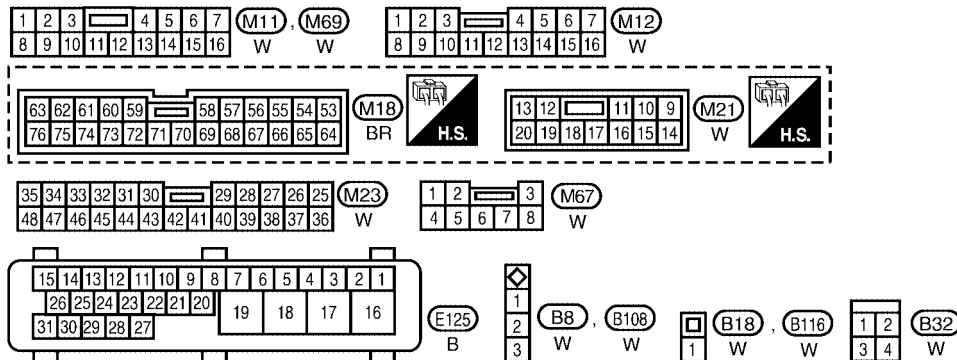
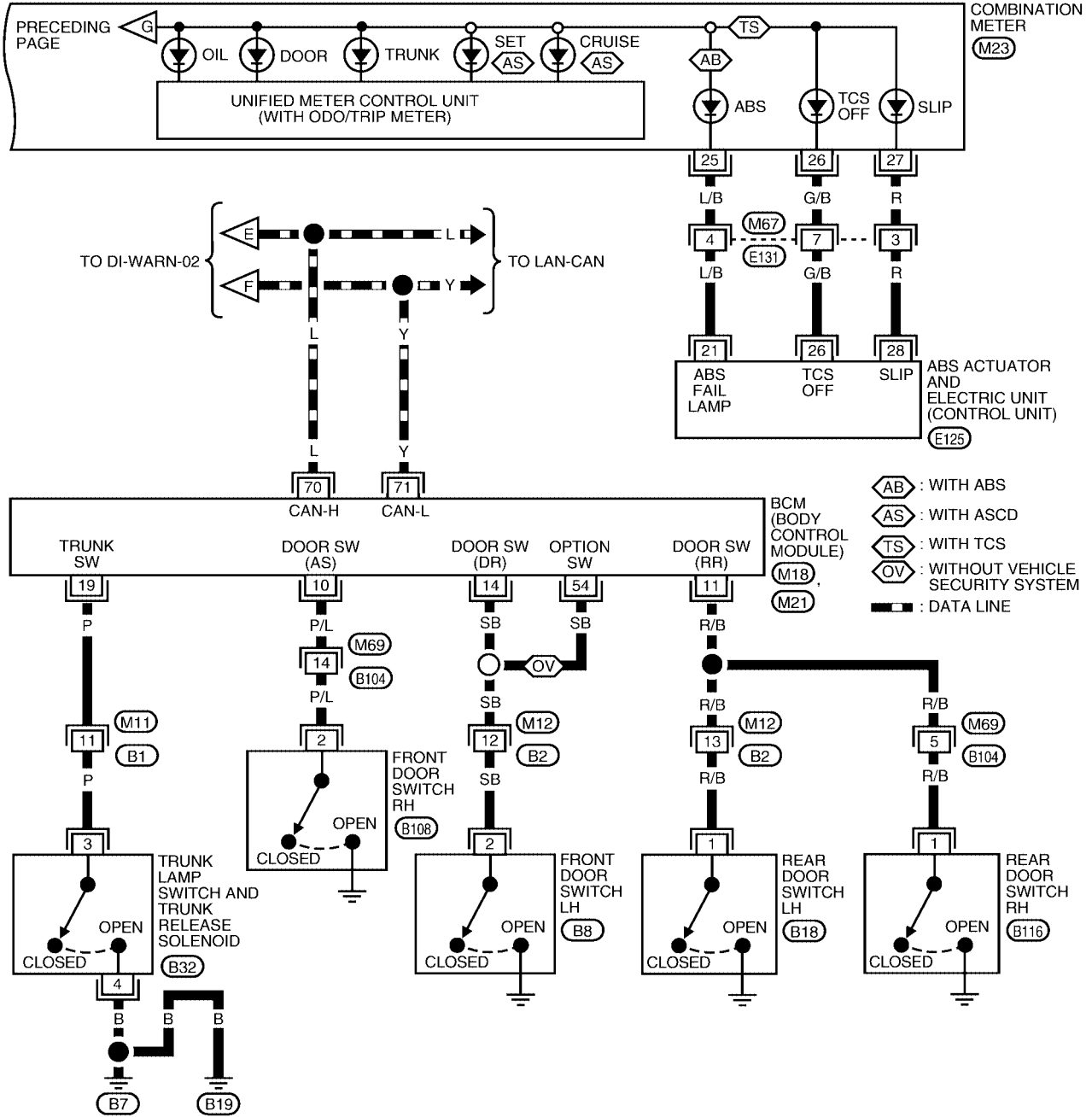

WKWA0997E

WARNING LAMPS

Terminals And Reference Value For BCM

EKS003FT

TERMINAL	WIRE COLOR	ITEM	CONDITION		Voltage (V) (Approx.)
			IGNITION SWITCH	OPERATION	
10	P/L	Front door switch RH	OFF	Front door switch RH	ON (open) 0
					OFF (closed) 12
11	R/B	Rear door switch(es)	OFF	Rear door switch LH or RH	ON (open) 0
					OFF (closed) 12
14	SB	Front door switch LH	OFF	Front door switch LH	ON (open) 0
					OFF (closed) 12
19	P	Trunk lamp switch and trunk release solenoid	OFF	Trunk lamp switch	ON (open) 0
					OFF (closed) 12
54	SB	Front door switch LH (without vehicle security system)	OFF	Front door switch LH	ON (open) 0
					OFF (closed) 12
70	L	CAN-H	—	—	—
71	Y	CAN-L	—	—	—

Work Flow

EKS003FU

1. Check the trouble symptom and customer's requests.
2. Understand the outline of system. Refer to [DI-18, "System Description"](#).
3. Perform the preliminary check. Refer to [DI-26, "Preliminary Check"](#).
4. Referring to Trouble diagnosis chart, repair or replace the cause of the incident. Refer to [DI-29, "Trouble Diagnosis For Door Warning Lamp"](#).
5. Does warning chime system operate normally? If it operates normally, go to step 6. If not, go to step 4.
6. Inspection End.

Preliminary Check

EKS003FV

INSPECTION FOR POWER SUPPLY AND GROUND CIRCUIT

1. CHECK FUSIBLE LINK

Check for blown BCM fusible link.

UNIT	POWER SOURCE	FUSIBLE LINK
BCM	Battery	f

Refer to [DI-36, "Wiring Diagram — CHIME —"](#).

OK or NG

OK >> GO TO 2.

NG >> If fusible link is blown, be sure to eliminate cause of problem before installing new fusible link. Refer to [PG-4, "POWER SUPPLY ROUTING CIRCUIT"](#).

WARNING LAMPS

2. POWER SUPPLY CIRCUIT CHECK

1. Disconnect BCM connector.
2. Check voltage between BCM connector E39 terminal 7 (W/B) and ground. Refer to [PG-4, "POWER SUPPLY ROUTING CIRCUIT"](#)

Terminals		Ignition switch position	
(+)		(-)	OFF
Connector	Terminal (Wire color)		
E39	7 (W/B)	Ground	Battery voltage

OK or NG

- OK >> GO TO 3.
- NG >> Check harness for open between BCM and fuse.

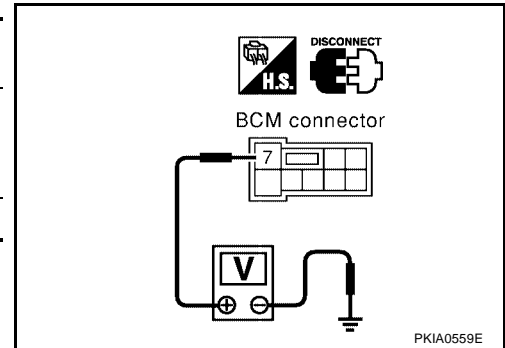

3. GROUND CIRCUIT CHECK

Check continuity between BCM harness connector E39 terminal 8 (B) and body ground. Refer to [PG-28, "GROUND CIRCUIT"](#)

Terminals		Continuity	
(+)			(-)
Connector	Terminal (Wire color)		
E39	8 (B)	Ground	Yes

OK or NG

- OK >> Inspection End.
- NG >> Check harness ground circuit.

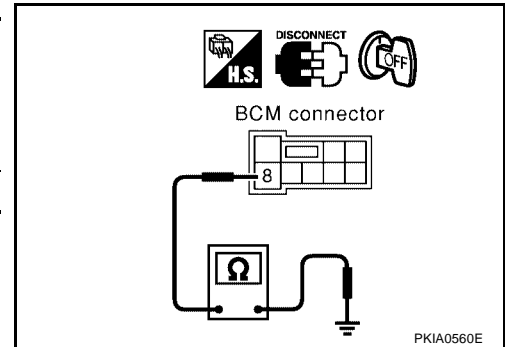

CONSULT-II Function

CONSULT-II executes the following functions by combining data reception and command transmission via the communication line from BCM. CAN system inspection, self-diagnosis, data monitor, and active test display.

SELF-DIAGNOSIS PROCEDURE

CAUTION:

If CONSULT-II is used with no connection of CONSULT-II CONVERTER, malfunctions might be detected in self-diagnosis depending on control unit which carries out CAN communication.

1. With the ignition switch OFF, connect CONSULT-II and CONSULT-II CONVERTER to the data link connector, and turn the ignition switch ON.

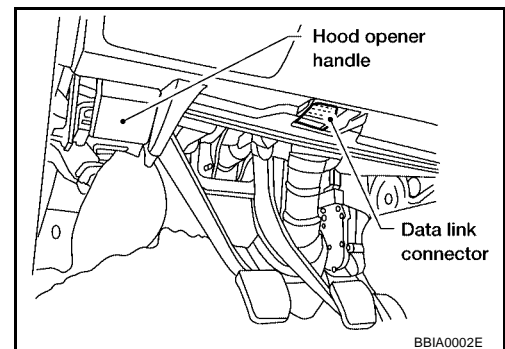

WARNING LAMPS

2. Touch "START".

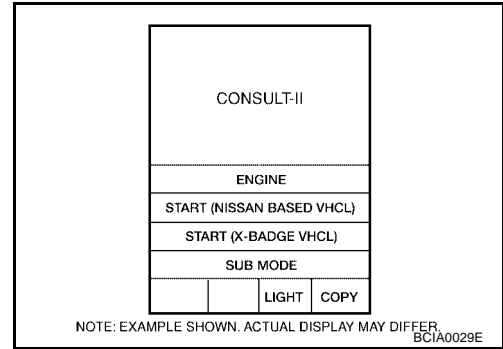

3. Select the desired part to be diagnosed on the "SELECT SYSTEM" screen.

NOTE:

If "BCM" is selected, a further selection of "BCM C/U" must be selected before proceeding with the following step.

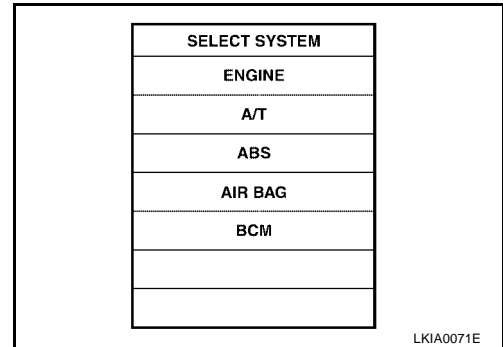

4. Touch "SELF-DIAG RESULTS".

5. Make the necessary repairs following the diagnostic procedures.

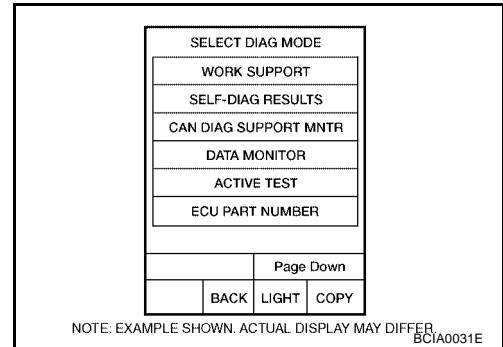

6. After the malfunctions are repaired, erase the self-diagnostic results stored in the control unit by touching "ERASE".

DATA MONITOR

Operation Procedure

1. Touch "SEAT BELT ALM" on "SELECT TEST ITEM" screen.
2. Touch "DATA MONITOR" on "SELECT DIAG MODE" screen.
3. Touch "ALL SIGNALS" or "SELECTION FROM MENU" on "DATA MONITOR" screen.

ALL SIGNALS	Monitors all selected test item related signals.
SELECTION FROM MENU	Selects and monitors the specified item.

4. If "SELECTION FROM MENU" is selected, touch the item desired to monitor. If "ALL SIGNALS" is selected, all selected test item related signals are monitored.
5. Touch "START".
6. During monitoring, touching "COPY" will print the monitored item status.

WARNING LAMPS

Data Monitor Item

Monitored item	Description
IGN ON SW	Indicates [ON/OFF] condition of ignition switch.
SEAT BELT SW	Indicates [ON/OFF] condition of seat belt switch (driver side).

ACTIVE TEST

Operation Procedure

1. Touch "SEAT BELT ALM" on "SELECT TEST ITEM" screen.
2. Touch "ACTIVE TEST" on "SELECT DIAG MODE" screen.
3. Touch the item to be tested ("CHIME"), and check the operation.
4. During the operation check, touching "OFF" deactivates the operation.

Active Test Item

Test item	Malfunction detecting condition
CHIME	This test is able to check chime operation.

Trouble Diagnosis For Door Warning Lamp

EKS003FY

Symptom	Diagnostic procedure and repair order
Door warning lamp does not illuminate with any of doors open.	<ul style="list-style-type: none"> ● Check combination meter circuit. Refer to DI-12, "Power Supply and Ground Circuit Check" . ● Check front door switches. Refer to DI-26, "Terminals And Reference Value For BCM" . ● Check rear door switches. Refer to DI-26, "Terminals And Reference Value For BCM" .
Door warning lamp illuminates constantly.	If the above systems work properly, replace the BCM.

Oil Pressure Warning Lamp Stays Off (Ignition Switch ON)

EKS003FZ

1. CHECK IPDM E/R OUTPUT SIGNAL

Activate IPDM E/R auto active test. Refer to [PG-21, "Auto Active Test"](#) .

Is oil pressure warning lamp blinking?

- YES >> GO TO 4.
NO >> GO TO 2.

2. CHECK SELF-DIAGNOSTIC RESULTS OF IPDM E/R

Select "IPDM E/R" on CONSULT-II, and perform self-diagnosis of IPDM E/R. Refer to [PG-17, "CONSULT-II Function \(IPDM E/R\)"](#) .

Self-diagnostic results content

- No malfunction detected>>GO TO 3.
Malfunction detected>>Go to [PG-18, "SELF-DIAGNOSTIC RESULTS"](#) in "IPDM E/R".

3. CHECK IPDM E/R INPUT SIGNAL

Select "IPDM E/R" on CONSULT-II. Operate ignition switch with "OIL P SW" of "DATA MONITOR" and check operation status.

When ignition switch is in ON : OIL P SW CLOSE position (Engine stopped)

When engine running : OIL P SW OPEN

OK or NG

- OK >> Replace combination meter.
NG >> Replace IPDM E/R. Refer to [PG-27, "Removal and Installation of IPDM E/R"](#) .

DATA MONITOR	
MONITOR	
OIL P SW	CLOSE

LKIA0403E

WARNING LAMPS

4. CHECK OIL PRESSURE SWITCH CIRCUIT

1. Turn ignition switch OFF.
2. Disconnect IPDM E/R connector and oil pressure switch connector.
3. Check the following.

QR Engine

Continuity between IPDM E/R harness connector E121 terminal 57 (P/L) and oil pressure switch harness connector F19 terminal + (P/L).

Continuity should exist.

VQ Engine

Continuity between IPDM E/R harness connector E121 terminal 57 (P/L) and oil pressure switch harness connector F106 terminal + (R/L).

Continuity should exist.

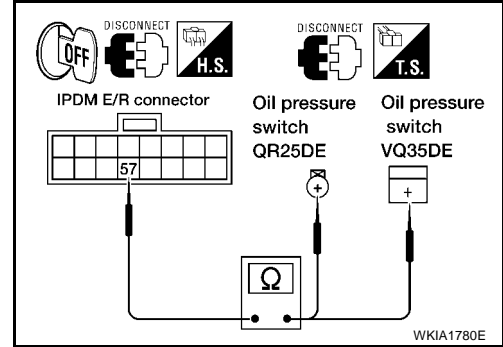

OK or NG

- OK >> GO TO 5.
- NG >> Repair harness or connector.

5. CHECK OIL PRESSURE SWITCH

Check oil pressure switch. Refer to [DI-31, "OIL PRESSURE SWITCH"](#).

OK or NG

- OK >> Replace IPDM E/R. Refer to [PG-27, "Removal and Installation of IPDM E/R"](#).
- NG >> Replace oil pressure switch.

Oil Pressure Warning Lamp Does Not Turn Off (Oil Pressure Is Normal)

EKS003G0

NOTE:

For oil pressure inspection, refer to [LU-6, "OIL PRESSURE CHECK"](#) (QR25DE) or [LU-17, "OIL PRESSURE CHECK"](#) (VQ35DE).

1. CHECK OIL PRESSURE SWITCH CIRCUIT

1. Turn ignition switch OFF.
2. Disconnect IPDM E/R connector and oil pressure switch connector.
3. Check continuity between IPDM E/R harness connector E121 terminal 57 (P/L) and ground.

Continuity should not exist.

OK or NG

- OK >> GO TO 2.
- NG >> Repair harness or connector.

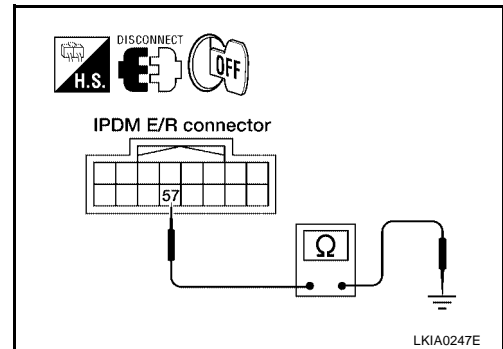

2. CHECK OIL PRESSURE SWITCH

Check oil pressure switch. Refer to [DI-31, "OIL PRESSURE SWITCH"](#).

OK or NG

- OK >> Replace IPDM E/R. Refer to [PG-27, "Removal and Installation of IPDM E/R"](#).
- NG >> Replace oil pressure switch.

WARNING LAMPS

Component Inspection OIL PRESSURE SWITCH

EKS003G1

Check continuity between the oil pressure switch and body ground.

Condition	Oil pressure kPa (kg/cm ² , psi)	Continuity
Engine stopped	Less than 29 (0.3, 4)	Yes
Engine running	More than 29 (0.3, 4)	No

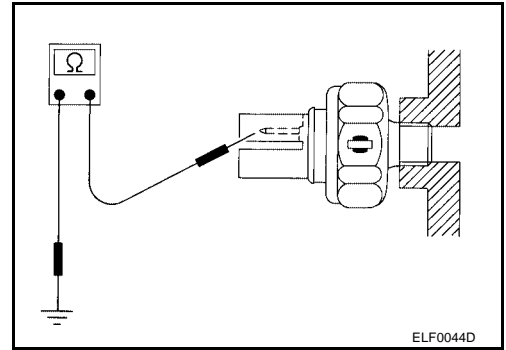

A
B
C
D
E
F
G
H
I
J
DI
L
M

A/T INDICATOR

PF2:24814

A/T INDICATOR

Wiring Diagram — AT/IND —

EKS003G2

DI-AT/IND-01

— : DATA LINE

⬡ : WITH QR25DE

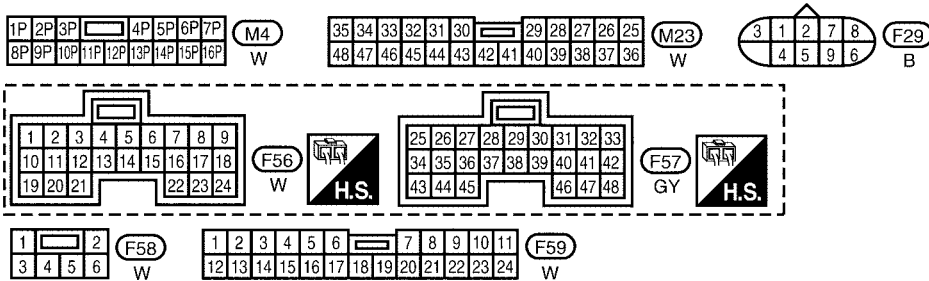
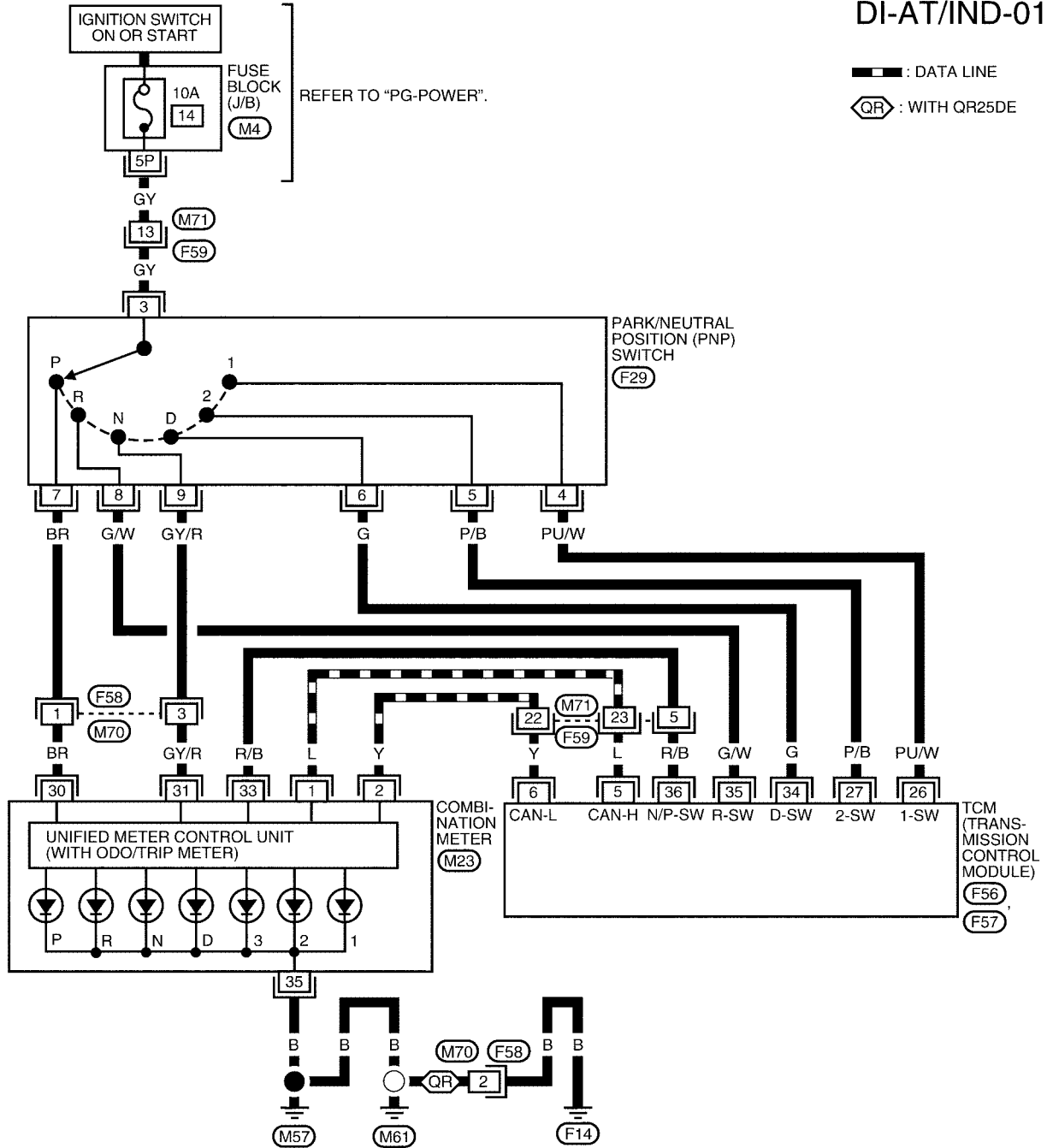

WKWA1191E

A/T INDICATOR

A/T Indicator Does Not Illuminate

EKS003G4

1. TCM CONTROL UNIT SYSTEM INSPECTION

Perform TCM self-diagnosis. Refer to [AT-36, "HOW TO READ DTC AND 1ST TRIP DTC"](#).

OK or NG

OK >> GO TO 2.

NG >> Go to TCM trouble diagnosis.

2. SELF-DIAGNOSIS INSPECTION

Perform combination meter self-diagnosis. Refer to [DI-10, "Meter/Gauges Operation and Odo/Trip Meter"](#).

OK or NG

OK >> A/T indicator is OK.

NG >> Replace combination meter.

A

B

C

D

E

F

G

H

I

J

DI

L

M

WARNING CHIME

PF2:24814

WARNING CHIME

Component Parts and Harness Connector Location

EKS003G5

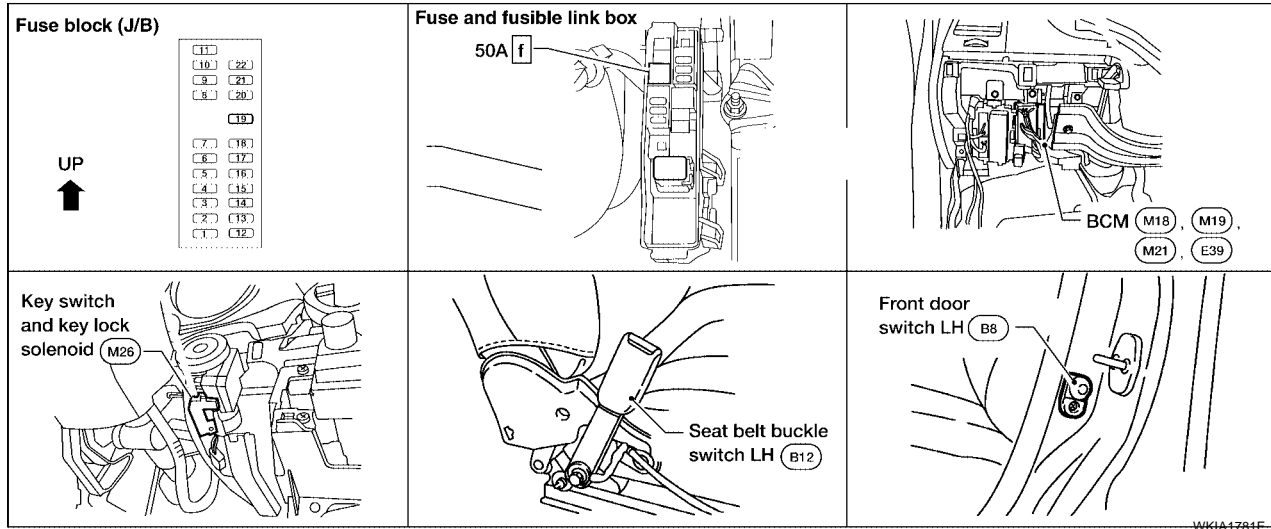

WKIA1784E

System Description

EKS003G6

Item	Description
Ignition key warning chime	Sounds warning chime when driver's door is opened with key in ignition key cylinder and ignition switch "OFF" or "ACC" position.
Light warning chime	Sounds warning chime when driver's door is opened with lighting switch in the 1st or 2nd position and the key removed from the ignition switch.
Seat belt warning chime	Sounds warning chime for approximately 6 seconds after ignition switch is turned "ON" when driver seat belt is unfastened.

NOTE:

When ignition key warning chime, light warning chime, and seat belt warning chime should be performed at the same time, the priorities for each chime are the following.

1. Seat belt warning chime
2. Ignition key warning chime
3. Light warning chime

Power is supplied at all times

- through 50A fuse (letter f, located in the fuse and fusible link box)
- to BCM terminal 7, and
- through 10A fuse [No. 19, located in the fuse block (J/B)]
- to key switch and key lock solenoid terminal 3.

Ground is supplied

- to BCM terminal 8
- through body grounds E15 and E24.

When the proper signal, or combination of signals, is received by the combination meter, the warning chime will sound.

IGNITION KEY WARNING CHIME

Power is supplied

- through key switch and key lock solenoid terminal 4
- to BCM terminal 62.

Ground is supplied

- to BCM terminal 14
- through front door switch LH terminal 2

WARNING CHIME

- through front door switch LH case ground.

With the key inserted in the ignition switch, and the driver door open, the ignition key warning chime will sound.

LIGHT WARNING CHIME

With the key removed from the ignition switch, the driver door open, and the lighting switch in 1ST or 2ND position, the warning chime will sound. [Except when headlamp battery saver control operates (for 5 minutes after ignition switch is turned to OFF or ACC position) and headlamps do not illuminate.]

Signal is supplied

- from combination switch (lighting switch) terminals 1, 2, 3, 4, 5, 6, 7, 8, 9 and 10
- to BCM terminals 40, 41, 42, 43, 47, 48, 49, 50, 51 and 52.

Ground is supplied

- to BCM terminal 14
- through front door switch LH terminal 2
- through front door switch LH case ground.

With these conditions, when power and ground are supplied, the light warning chime sounds.

SEAT BELT WARNING CHIME

With the driver seat belt unfastened (seat belt buckle switch LH ON), warning chime will sound for approximately 6 seconds after the ignition switch is turned ON.

Ground is supplied

- to combination meter terminal 28
- through seat belt buckle switch LH terminal 1
- through seat belt buckle switch LH terminal 2
- through body grounds B7 and B19.

With these conditions, when power and ground are supplied, the seat belt warning chime sounds.

CAN Communication System Description

EKS003G7

Refer to [LAN-4, "CAN COMMUNICATION"](#).

Major Component Parts and Function

EKS003G8

Components	Functions
BCM	Intermittently operates the warning chime by signals from the ignition switch, key switch and key lock solenoid, lighting switch, front door switch LH, and seat belt buckle switch LH.
Warning chime	Generates intermittent sounds by signals from the BCM.

A

B

C

D

E

F

G

H

I

J

DI

L

M

WARNING CHIME

Wiring Diagram — CHIME —

EKS003G9

DI-CHIME-01

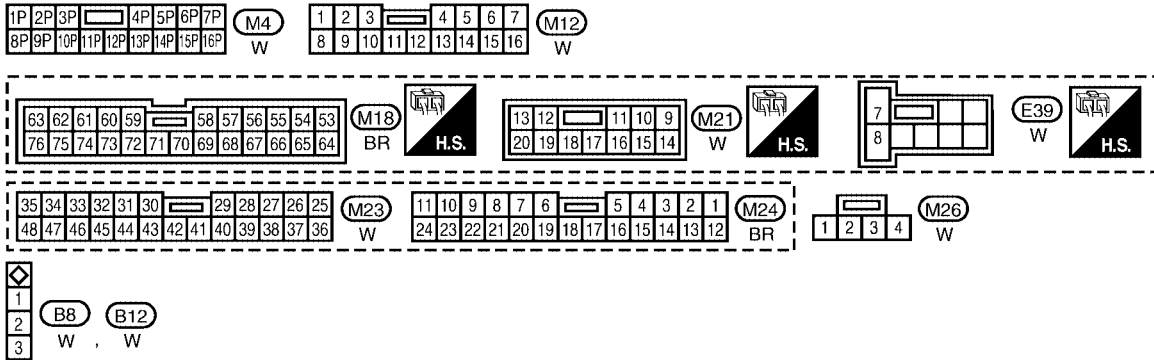
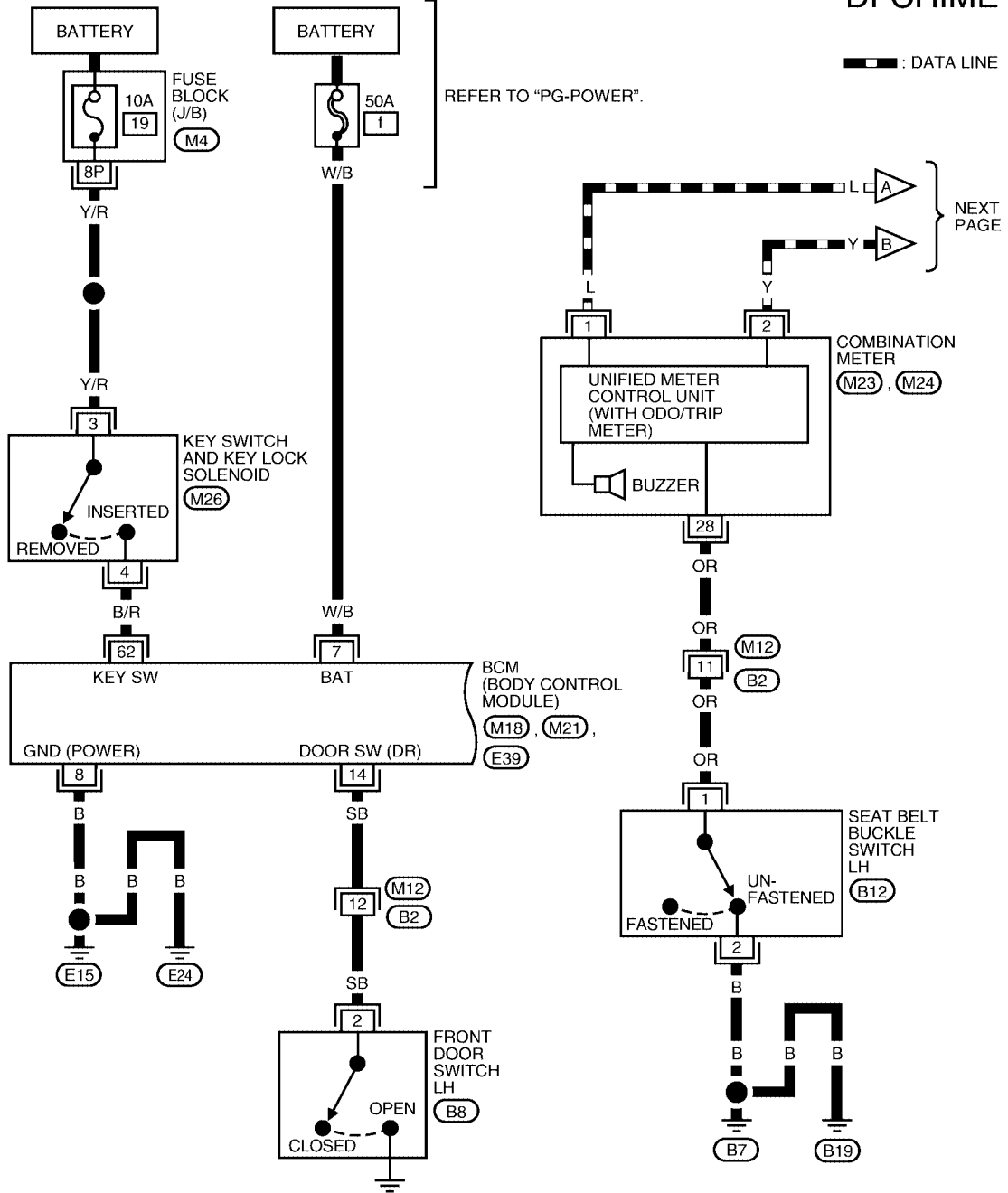

WKWA0999E

WARNING CHIME

DI-CHIME-02

▬ : DATA LINE

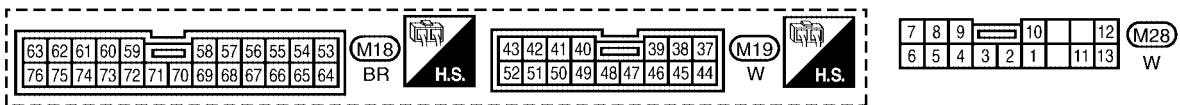
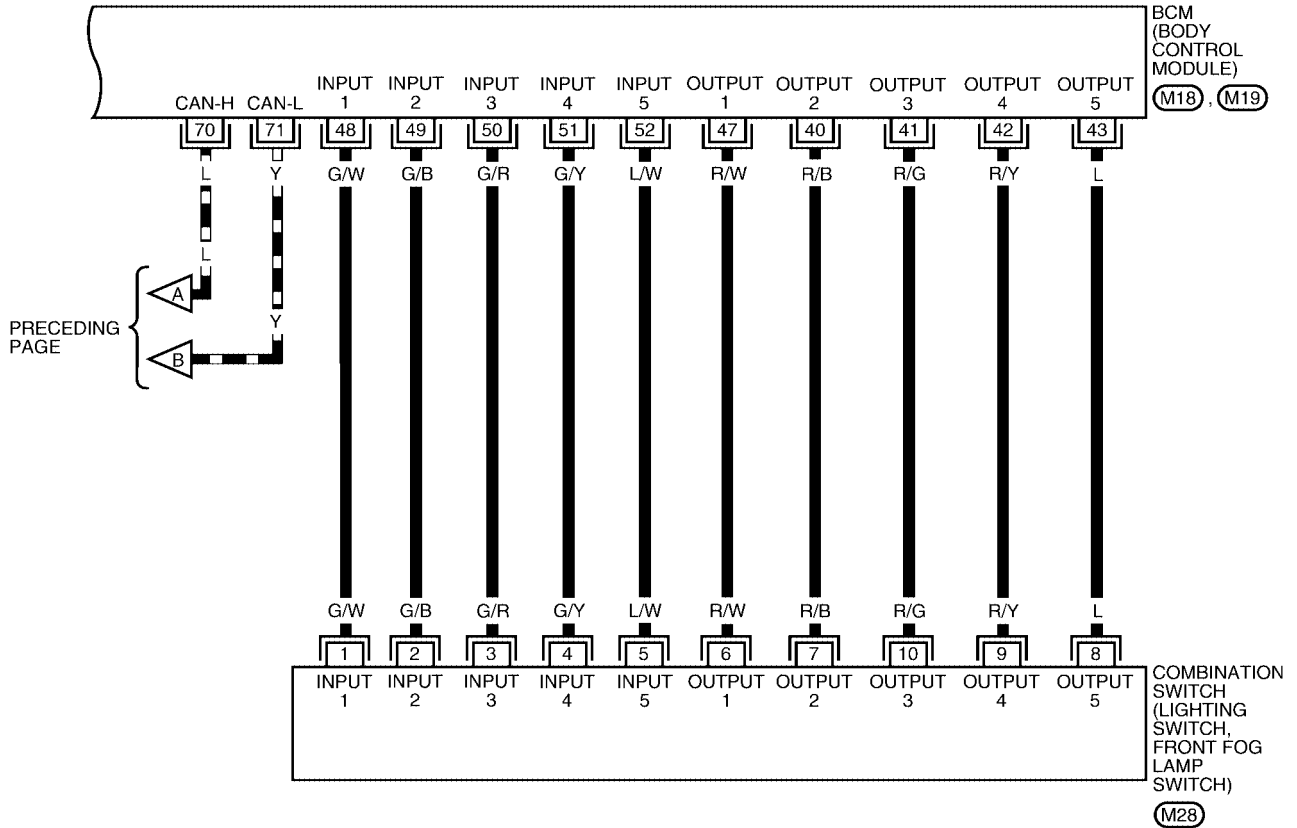

WKWA1000E

WARNING CHIME

Terminals and Reference Value for BCM

EKS003GA

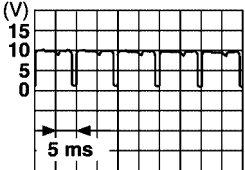
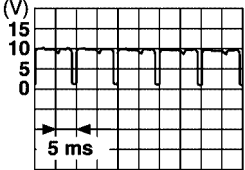
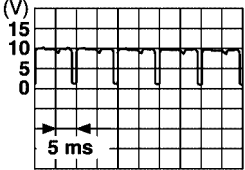
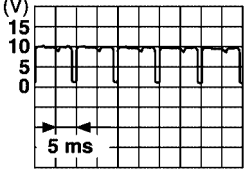
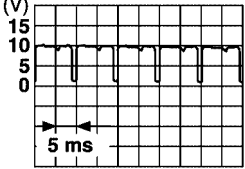
Terminal No.	Wire color	Item	Condition		Voltage (V) (Approx.)	
			Ignition switch	Measurement method		
7	W/B	Battery power supply	OFF	—	Battery voltage	
8	B	Ground	ON	—	0	
14	SB	Front door switch LH signal	OFF	Driver door	ON (open)	0
					OFF (closed)	5
40	R/B	Combination switch output 2	ON	—	 <p style="text-align: right; font-size: small;">SKIA1119J</p>	
41	R/G	Combination switch output 3	ON	—	 <p style="text-align: right; font-size: small;">SKIA1119J</p>	
42	R/Y	Combination switch output 4	ON	—	 <p style="text-align: right; font-size: small;">SKIA1119J</p>	
43	L	Combination switch output 5	ON	—	 <p style="text-align: right; font-size: small;">SKIA1119J</p>	
47	R/W	Combination switch output 1	ON	—	 <p style="text-align: right; font-size: small;">SKIA1119J</p>	
48	G/W	Combination switch input 1	ON	—	5 or more	
49	G/B	Combination switch input 2	ON	—	5 or more	
50	G/R	Combination switch input 3	ON	—	5 or more	
51	G/Y	Combination switch input 4	ON	Lighting switch and wiper switch are OFF.	5 or more	
52	L/W	Combination switch input 5	ON	Lighting switch and wiper switch are OFF.	5 or more	
62	B/R	Key switch signal	OFF	Key is removed.	0	
				Key is inserted.	12	

WARNING CHIME

Terminal No.	Wire color	Item	Condition		Voltage (V) (Approx.)
			Ignition switch	Measurement method	
70	L	CAN H	—	—	—
71	Y	CAN L	—	—	—

How to Proceed With Trouble Diagnosis

EKS003GB

1. Confirm the trouble symptom or customer complaint.
2. Understand operation description and function description. Refer to [DI-34, "System Description"](#) .
3. Carry out the Preliminary Check. Refer to [DI-39, "Preliminary Check"](#) .
4. Check symptom and repair or replace the cause of malfunction.
5. Does the warning chime operate normally? Yes: Go to 6. No: Go to 4.
6. Inspection End.

Preliminary Check

EKS003GC

INSPECTION FOR POWER SUPPLY AND GROUND CIRCUIT

1. CHECK FUSIBLE LINK

Check for blown BCM fusible link.

UNIT	POWER SOURCE	FUSIBLE LINK
BCM	Battery	f

Refer to [DI-36, "Wiring Diagram — CHIME —"](#) .

OK or NG

OK >> GO TO 2.

NG >> If fuse is blown, be sure to eliminate cause of problem before installing new fuse. Refer to [PG-4, "POWER SUPPLY ROUTING CIRCUIT"](#) .

2. POWER SUPPLY CIRCUIT CHECK

1. Disconnect BCM connector.
2. Check voltage between BCM connector E39 terminal 7 (W/B) and ground.

Terminals			Voltage (Approx.)
(+)		(-)	
Connector	Terminal (Wire color)		
E39	7 (W/B)	Ground	Battery voltage

OK or NG

OK >> GO TO 3.

NG >> Check harness for open between BCM and fuse.

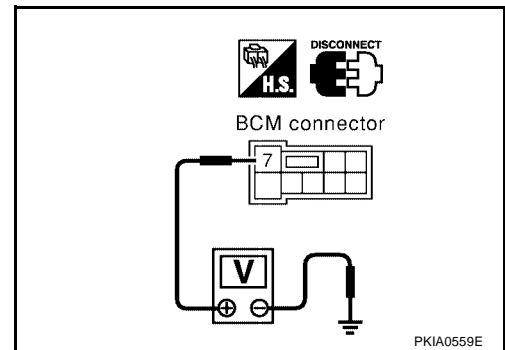

WARNING CHIME

3. GROUND CIRCUIT CHECK

Check continuity between BCM harness connector E39 terminal 8 (B) and ground.

Terminals		(-)	Continuity
(+)			
Connector	Terminal (Wire color)		
E39	8 (B)	Ground	Yes

OK or NG

- OK >> Inspection End.
- NG >> Check harness ground circuit.

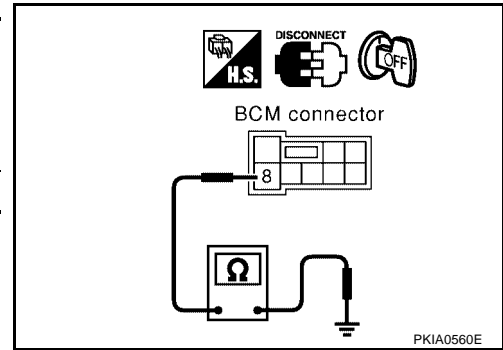

CONSULT-II Function

EKS003GD

CONSULT-II executes the following functions by combining data reception and command transmission via the communication line from BCM: work support, self-diagnosis, data monitor, and active test display.

DIAGNOSTIC ITEMS DESCRIPTION

BCM diagnosis position	Diagnosis mode	Description
KEY WARN ALM	Data monitor	The input data to the BCM control unit is displayed in real time.
	Active test	Operation of electrical loads can be checked by sending driving signal to them.
LIGHT WARN ALM	Data monitor	The input data to the BCM control unit is displayed in real time.
	Active test	Operation of electrical loads can be checked by sending driving signal to them.
SEAT BELT ALM	Data monitor	The input data to the BCM control unit is displayed in real time.
	Active test	Operation of electrical loads can be checked by sending driving signal to them.
BCM C/U	Self-diagnostic	BCM performs self-diagnosis of CAN communication and combination switch.

CONSULT-II BASIC OPERATION PROCEDURE

CAUTION:

If CONSULT-II is used with no connection of CONSULT-II CONVERTER, malfunctions might be detected in self-diagnosis depending on control unit which carries out CAN communication.

1. With the ignition switch OFF, connect CONSULT-II and CONSULT-II CONVERTER to the data link connector, and turn the ignition switch ON.

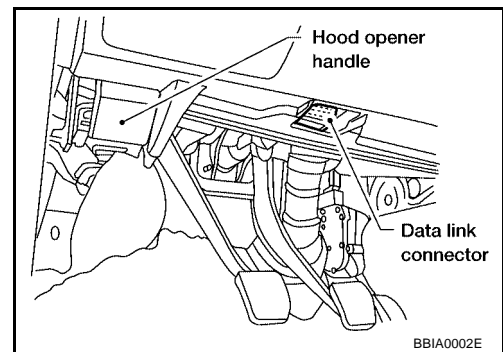

2. Touch "START".

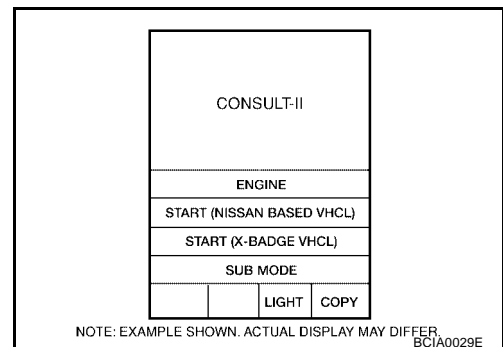

WARNING CHIME

3. Touch "BCM".

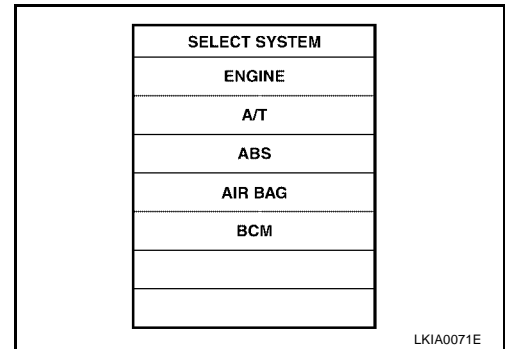

4. Touch "KEY WARN ALM", "LIGHT WARN ALM", "SEAT BELT ALM" or "BCM C/U".
5. Select "DATA MONITOR" "ACTIVE TEST" or "SELF-DIAG RESULTS".

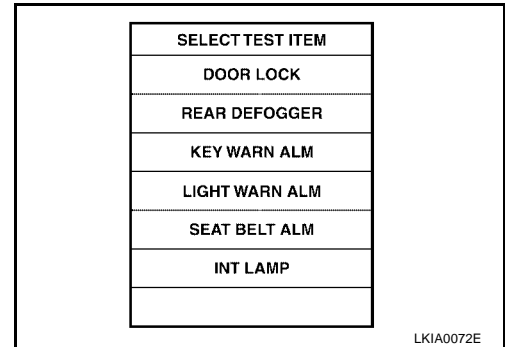

DATA MONITOR

Operation Procedure

1. Touch "KEY WARN ALM", "LIGHT WARN ALM" or "SEAT BELT ALM" on "SELECT TEST ITEM" screen.
2. Touch "DATA MONITOR" on "SELECT DIAG MODE" screen.
3. Touch "ALL SIGNALS" or "SELECTION FROM MENU" on "DATA MONITOR" screen.

ALL SIGNALS	Monitors all selected test item related signals.
SELECTION FROM MENU	Selects and monitors the specified item.

4. If "SELECTION FROM MENU" is selected, touch the item desired to monitor. If "ALL SIGNALS" is selected, all selected test item related signals are monitored.
5. Touch "START".
6. During monitoring, touching "COPY" will print the monitored item status.

Data Monitor Item (KEY WARN ALM)

Monitored item	Description
IGN ON SW	Indicates [ON/OFF] condition of ignition switch.
KEY ON SW	Indicates [ON/OFF] condition of key switch.
DOOR SW-DR	Indicates [ON/OFF] condition of front door switch LH.

Data Monitor Item (LIGHT WARN ALM)

Monitored item	Description
IGN ON SW	Indicates [ON/OFF] condition of ignition switch.
DOOR SW-DR	Indicates [ON/OFF] condition of front door switch LH.
TAIL LAMP SW	Indicates [ON/OFF] condition of lighting switch.
FR FOG SW	Indicates [ON/OFF] condition of front fog lamp switch.

Data Monitor Item (SEAT BELT ALM)

Monitored item	Description
IGN ON SW	Indicates [ON/OFF] condition of ignition switch.
SEAT BELT SW	Indicates [ON/OFF] condition of seat belt buckle switch.

WARNING CHIME

ACTIVE TEST

Operation Procedure

1. Touch "KEY WARN ALM", "LIGHT WARN ALM" or "SEAT BELT ALM" on "SELECT TEST ITEM" screen.
2. Touch "ACTIVE TEST" on "SELECT DIAG MODE" screen.
3. Touch the item to be tested, and check the operation.
4. During the operation check, touching "OFF" deactivates the operation.

Active Test Item (KEY WARN ALM)

Test item	Malfunction detecting condition
CHIME	This test is able to check key warning chime operation. Key warning chime sounds after touching "ON" on CONSULT-II screen.

Active Test Item (LIGHT WARN ALM)

Test item	Malfunction detecting condition
CHIME	This test is able to check light warning chime operation. Light warning chime sounds after touching "ON" on CONSULT-II screen.

Active Test Item (SEAT BELT ALM)

Test item	Malfunction detecting condition
CHIME	This test is able to check seat belt warning chime operation. Seat belt warning chime sounds after touching "ON" on CONSULT-II screen.

SELF-DIAGNOSTIC RESULTS

Operation Procedure

1. Touch "BCM C/U" on "DIAGNOSIS ITEM SELECTION" screen.
2. Touch "SELF-DIAG RESULTS" on "SELECT DIAG MODE" screen.
3. Self-diagnostic results are displayed.

Display Item List

Items to be displayed	CONSULT-II display	Description
CAN communication	CAN communication [U1000]	Malfunction is detected in CAN communication.
Combination switch	Diagnosis 1 - 5 systems open circuit	Malfunction is detected in combination switch system.

NOTE:

If "CAN communication [U1000]" is indicated, after printing the monitor item, go to "CAN System". Refer to [LAN-4, "CAN COMMUNICATION"](#).

All Warnings Are Not Operated

EKS003GE

1. CHIME OPERATION INSPECTION

Select "KEY WARN ALM", "LIGHT WARN ALM" or "SEAT BELT ALM" on CONSULT-II, and perform "CHIME" active test.

Does chime sound?

- YES >> Replace BCM.
NO >> GO TO 2.

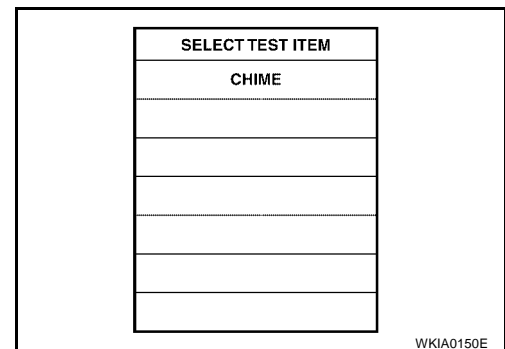

WARNING CHIME

2. BCM SELF-DIAGNOSIS

Select BCM on CONSULT-II, and perform "BCM C/U" self-diagnosis.

Self-diagnostic results content

No malfunction detected>> Replace combination meter.

CAN communication or CAN communication system>> Check BCM CAN communication system. Go to [LAN-4, "CAN COMMUNICATION"](#).

Diagnosis 1 - 5 systems open circuit>> Malfunction in combination switch system. Go to [BCS-12, "Combination Switch Inspection According to Self-Diagnostic Results"](#).

Key Warning Chime and Light Warning Chime Does Not Operate (Seat Belt Warning Chime Does Operate)

EKS007RU

1. CHECK BCM INPUT SIGNAL

Ⓜ With CONSULT-II

With "DATA MONITOR" of "KEY WARN ALM" OR "LIGHT WARN ALM", confirm "DOOR SW-DR" when the front door switch LH is operated.

When front door LH is opened : DOOR SW-DR ON

When front door LH is closed : DOOR SW-DR OFF

DATA MONITOR	
MONITOR	NO DTC
IGN ON SW	ON
KEY ON SW	ON
DOOR SW-DR	OFF

LKIA0335E

⊗ Without CONSULT-II

Check voltage between BCM harness connector M21 terminal 14 (SB) and ground.

When front door LH is opened : Approx. 0V

When front door LH is closed : Approx. 5V

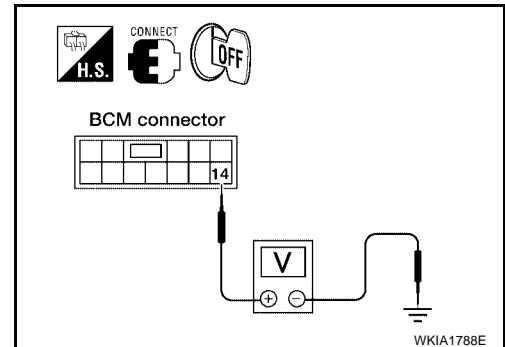

OK or NG

OK >> Replace BCM.

NG >> GO TO 2.

WARNING CHIME

2. CONTINUITY INSPECTION OF DOOR SWITCH CIRCUIT

1. Turn ignition switch OFF.
2. Disconnect BCM connector and front door switch LH connector.
3. Check continuity between BCM harness connector M21 terminal 14 (SB) and front door switch LH harness connector B8 terminal 2 (SB).

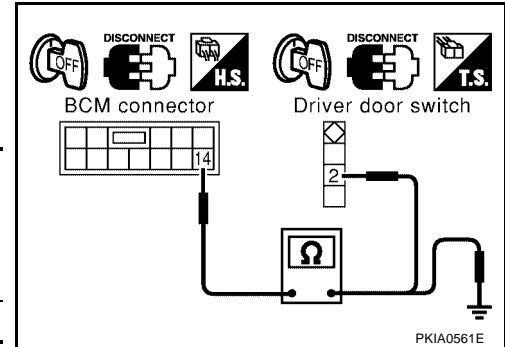

Terminals				Continuity
(+)		(-)		
Connector	Terminal (Wire color)	Connector	Terminal (Wire color)	
M21	14 (SB)	B8	2 (SB)	Yes

4. Check continuity between BCM harness connector M21 terminal 14 (SB) and ground.

Terminals			Continuity
(+)		(-)	
Connector	Terminal (Wire color)	(-)	
M21	14 (SB)	Ground	No

OK or NG

- OK >> GO TO 3.
- NG >> Repair harness or connector.

3. CHECK DOOR SWITCH

Check front door switch LH.

- When front door switch LH is released : Continuity should exist**
- When front door switch LH is pushed : Continuity should not exist**

OK or NG

- OK >> Replace BCM.
- NG >> Replace front door switch LH.

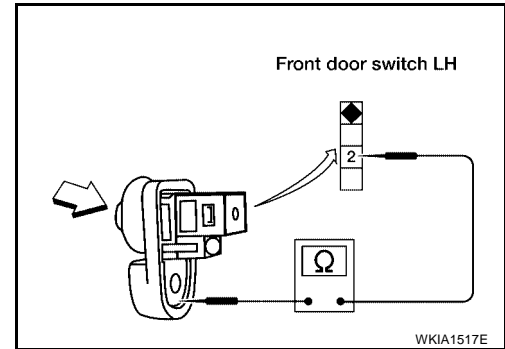

EKS003GF

Key Warning Chime Does Not Operate

1. CHECK FUSE

Check if the key switch and key lock solenoid (key detection) switch fuse is blown. Refer to [DI-36, "Wiring Diagram — CHIME —"](#).

Is the fuse blown?

- YES >> Replace fuse. Be sure to repair the cause of the problem before installing new fuse.
- NO >> GO TO 2.

2. CHECK WARNING CHIME OPERATION

With key removed from the ignition and the front door LH open, turn the lighting switch to 1st or 2nd position.

Does warning chime sound?

- YES >> GO TO 3.
- NO >> Go to [DI-42, "All Warnings Are Not Operated"](#) or [DI-43, "Key Warning Chime and Light Warning Chime Does Not Operate \(Seat Belt Warning Chime Does Operate\)"](#).

WARNING CHIME

3. KEY SWITCH INSPECTION

With CONSULT-II

With "KEY WARN ALM" on the data monitor, insert the key into the ignition cylinder to check ON/OFF operation.

Switch operation	CONSULT-II display	Operation status
Ignition switch (key in switch)	KEY ON SW	ON
Ignition switch (key out of switch)		OFF

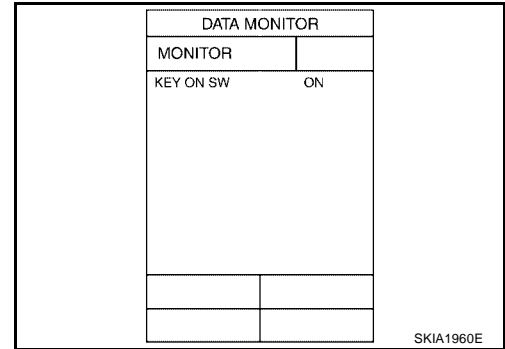

Without CONSULT-II

Check voltage between BCM harness connector M18 terminal 62 (B/R) and ground.

Terminals			Condition	Voltage (V)
(+)		(-)		
Connector	Terminal (Wire color)			
M18	62 (B/R)	Ground	Key is inserted	Battery voltage
			Key is removed	0

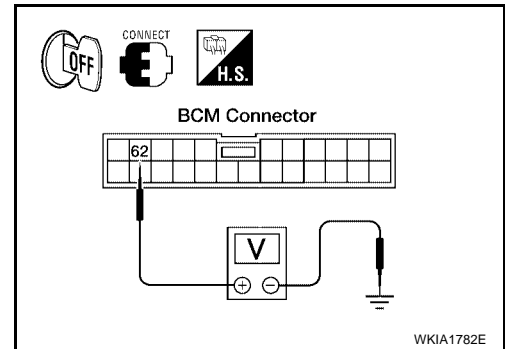

OK or NG

OK >> Replace BCM.

NG >> GO TO 4.

4. CHECK KEY SWITCH (INSERT)

1. Disconnect key switch and key lock solenoid connector.
2. Check continuity between key switch and key lock solenoid terminals 3 and 4.

Terminals		Condition	Continuity
3	4		
		Key is inserted	Yes
		Key is removed	No

OK or NG

OK >> GO TO 5.

NG >> Replace key switch and key lock solenoid.

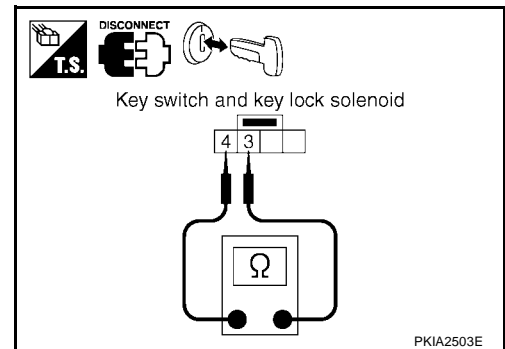

WARNING CHIME

5. BCM AND KEY SWITCH CONTINUITY INSPECTION

1. Disconnect BCM connector.
2. Check continuity between BCM harness connector M18 terminal 62 (B/R) and key switch and key lock solenoid harness connector M26 terminal 4 (B/R).

Continuity should exist.

3. Check continuity between BCM harness connector M18 terminal 62 (B/R) and ground.

Continuity should not exist.

OK or NG

- OK >> GO TO 6.
- NG >> Repair harness or connector.

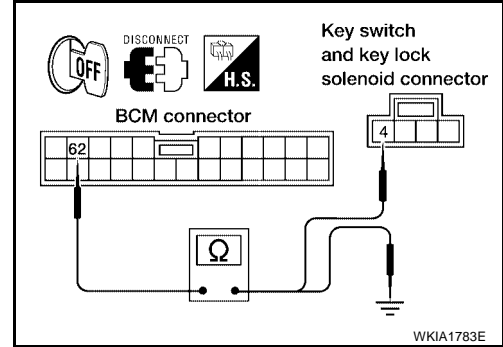

6. KEY SWITCH INPUT SIGNAL INSPECTION

Check voltage between key switch and key lock solenoid harness connector M26 terminal 3 (Y/R) and ground.

Battery voltage should exist.

OK or NG

- OK >> Replace BCM.
- NG >> Check harness for open between key switch and key lock solenoid and fuse.

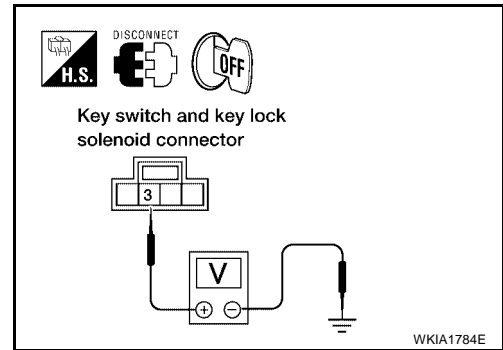

Light Warning Chime Does Not Operate

1. CHECK WARNING CHIME OPERATION

Check key warning chime and seat belt warning chime functions.

Do key warning chime and seat belt warning chime sound?

- YES >> GO TO 2.
- NO >> Go to [DI-42, "All Warnings Are Not Operated"](#) or [DI-43, "Key Warning Chime and Light Warning Chime Does Not Operate \(Seat Belt Warning Chime Does Operate\)"](#).

2. DATA MONITOR INSPECTION

With "LIGHT WARN ALM" on the data monitor, confirm "TAIL LAMP SW" and "FR FOG SW" turn ON/OFF when lighting switch and front fog switch are operated.

Switch operation	CONSULT-II display	Operation status
Headlamp switch (1st position)	TAIL LAMP SW	ON
Headlamp switch (OFF)		OFF
Fog lamp switch (ON)	FR FOG SW	ON
Fog lamp switch (OFF)		OFF

OK or NG

- OK >> Replace BCM.
- NG >> GO TO 3.

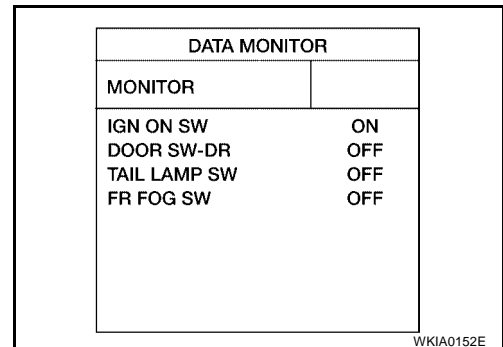

WARNING CHIME

3. INSPECTION BETWEEN COMBINATION SWITCH AND BCM

Select BCM on CONSULT-II, and perform "BCM C/U" self-diagnosis.

Self-diagnostic results content

No malfunction detected>> Replace BCM.

CAN communication or CAN communication system>> Check BCM CAN communication system. Go to [LAN-4, "CAN COMMUNICATION"](#) .

Diagnosis 1 - 5 systems open circuit>> Malfunction in combination switch system. Go to [BCS-12, "Combination Switch Inspection According to Self-Diagnostic Results"](#) .

Seat Warning Chime Does Not Operate

EKS003GH

1. CHECK WARNING CHIME OPERATION

1. With key removed from the ignition and the front door LH open, turn the lighting switch to 1st or 2nd position.
2. Return lighting switch to OFF position, and insert key into ignition.

Does warning chime sound for both steps?

YES >> GO TO 2.

NO >> Go to [DI-42, "All Warnings Are Not Operated"](#) .

2. DATA MONITOR INSPECTION

With "SEAT BELT ALM" on the data monitor, confirm "SEAT BELT SW" when the seat belt buckle switch LH is operated.

Switch operation	CONSULT-II display	Operation status
Seat belt buckle switch LH (unfastened)	SEAT BELT SW	ON
Seat belt buckle switch LH (fastened)		OFF

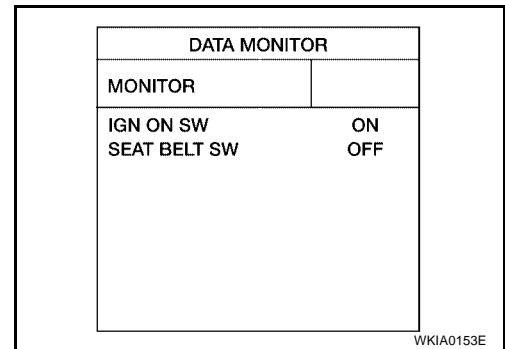

WKIA0153E

OK or NG

OK >> Replace BCM.

NG >> GO TO 3.

3. COMBINATION METER INPUT SIGNAL INSPECTION

1. Turn ignition switch ON.
2. Check voltage between combination meter harness connector M23 terminal 28 (OR) and ground.

Terminals		Condition	Voltage (V) (Approx.)
(+)	(-)		
Connector	Terminal		
M23	28 (OR)	Seat belt is fastened	Battery voltage
		Seat belt is unfastened	0

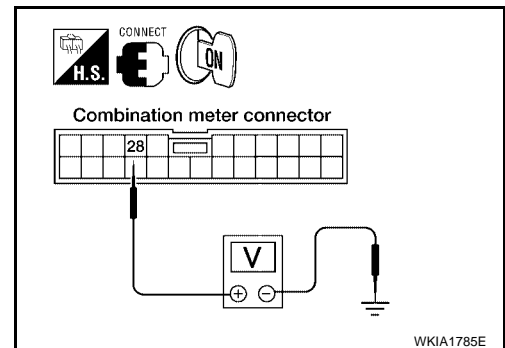

WKIA1785E

OK or NG

OK >> Replace combination meter. Refer to [DI-17, "Removal and Installation of Combination Meter"](#) .

NG >> GO TO 4.

WARNING CHIME

4. SEAT BELT BUCKLE SWITCH INSPECTION

1. Turn ignition switch OFF.
2. Disconnect seat belt buckle switch LH connector.
3. Check continuity between seat belt buckle switch LH terminals 1 and 2.

Terminals		Condition	Continuity
1	2	Seat belt is fastened	No
		Seat belt is unfastened	Yes

OK or NG

- OK >> GO TO 5.
NG >> Replace seat belt buckle switch LH.

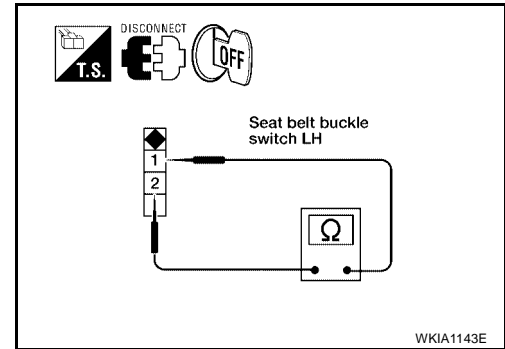

5. SEAT BELT BUCKLE SWITCH CIRCUIT INSPECTION

1. Disconnect combination meter connector.
2. Check continuity between combination meter harness connector M23 terminal 28 (OR) and seat belt buckle switch LH harness connector B12 terminal 1 (OR).

Continuity should exist.

3. Check continuity between combination meter harness connector M23 terminal 28 (OR) and ground.

Continuity should not exist.

OK or NG

- OK >> GO TO 6.
NG >> Repair harness or connector.

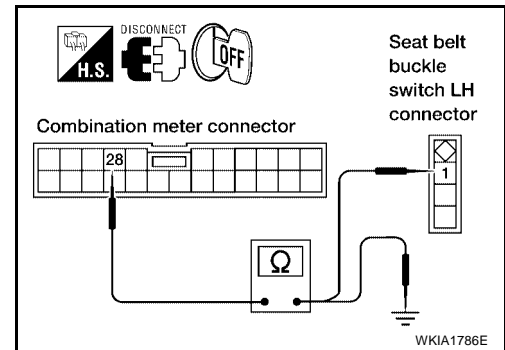

6. SEAT BELT BUCKLE SWITCH GROUND CIRCUIT INSPECTION

1. Disconnect BCM connector.
2. Check continuity between seat belt buckle switch LH harness connector B12 terminal 2 (B) and ground.

Continuity should exist.

OK or NG

- OK >> Replace combination meter.
NG >> Repair harness or connector.

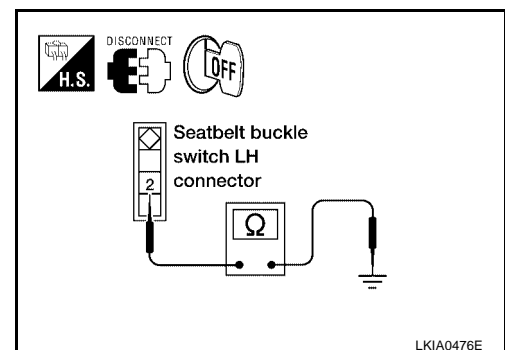

BOARD COMPUTER

System Description FUNCTION

The board computer can indicate the following items.

- Outside air temperature
- DTE (distance to empty)
- Trip distance
- Trip time
- Average fuel consumption
- Average vehicle speed

OUTSIDE AIR TEMPERATURE INDICATION

The outside air temperature indication is displayed while the ignition switch is in the ON position. Signal is supplied

- through ambient sensor terminal 1
- to combination meter (board computer) terminal 13.

Indication range is between -30 and 55°C (-22 and 131°F). When outside temperature is less than -30°C (-22°F), display shows ICY. When outside temperature is more than 55°C (131°F), indication will be blank. When outside temperature is less than 3°C (37°F) continuously, display will blink as a warning. In this case, the display will change to the outside air temperature mode even though the display is showing a different mode. The indicated temperature is not affected by engine heat. It changes only when one of the following conditions exists.

- When vehicle speed is more than 20 km/h (12 MPH).
- The ignition switch has been turned OFF for more than 3.5 hours.
- When outside air temperature is less than the indicated temperature.

DTE (DISTANCE TO EMPTY) INDICATION

The range indication provides the driver with an estimation of the distance that can be driven before refueling. The range is calculated by signals from the fuel level sensor unit (fuel remaining), ECM (fuel consumption) and vehicle speed sensor. The indication will be refreshed every 30 seconds. When fuel remaining is less than approximately 10 ℓ (10 5/8 US quarts, 8 3/4 Imp quarts), the indication will blink as a warning. If the fuel remaining is less than approximately 8 ℓ (8 1/2 US quarts, 7 Imp quarts), the indication will show "---". In this case, the display will change to the DTE mode even though the display is showing a different mode. When the battery is disconnected and reconnected, DTE mode will display "---" until the vehicle is driven 500 miles (804.5 km).

TRIP DISTANCE

Trip distance is calculated by signal from the vehicle speed sensor. If trip distance is reset, trip time will be reset at the same time.

TRIP TIME

Trip time displays cumulative ignition switch ON time. If trip time is reset, trip distance will be reset at the same time.

AVERAGE FUEL CONSUMPTION

Average fuel consumption indication is calculated by signals from the vehicle speed sensor and the ECM (fuel consumption). The indication will be refreshed every 30 seconds.

AVERAGE VEHICLE SPEED

Average vehicle speed indication is calculated by running distance and running time. The indication will be refreshed every 30 seconds. If average vehicle speed is reset, average fuel consumption will be reset at the same time. After resetting, the display will show "---" for 30 seconds.

HOW TO CHANGE/RESET INDICATION

Indication can be changed in the following order by momentarily depressing the board computer switch or the board computer steering switch.

Outside air temperature → dte → Average fuel consumption → Average vehicle speed → Trip time → Trip distance.

A
B
C
D
E
F
G
H
I
J
DI
L
M

BOARD COMPUTER

Holding the switch for more than 0.8 second will reset the indication of the currently displayed mode (trip distance, trip time, average vehicle speed or average fuel consumption).

NOTE:

After the display changes automatically, the indication can be changed to the last mode by pushing the board computer switch or the board computer steering switch.

CAN Communication System Description

EKS003GJ

Refer to [LAN-4, "CAN COMMUNICATION"](#) .

BOARD COMPUTER

Wiring Diagram — B/COMP —

EKS003GK

DI-B/COMP-01

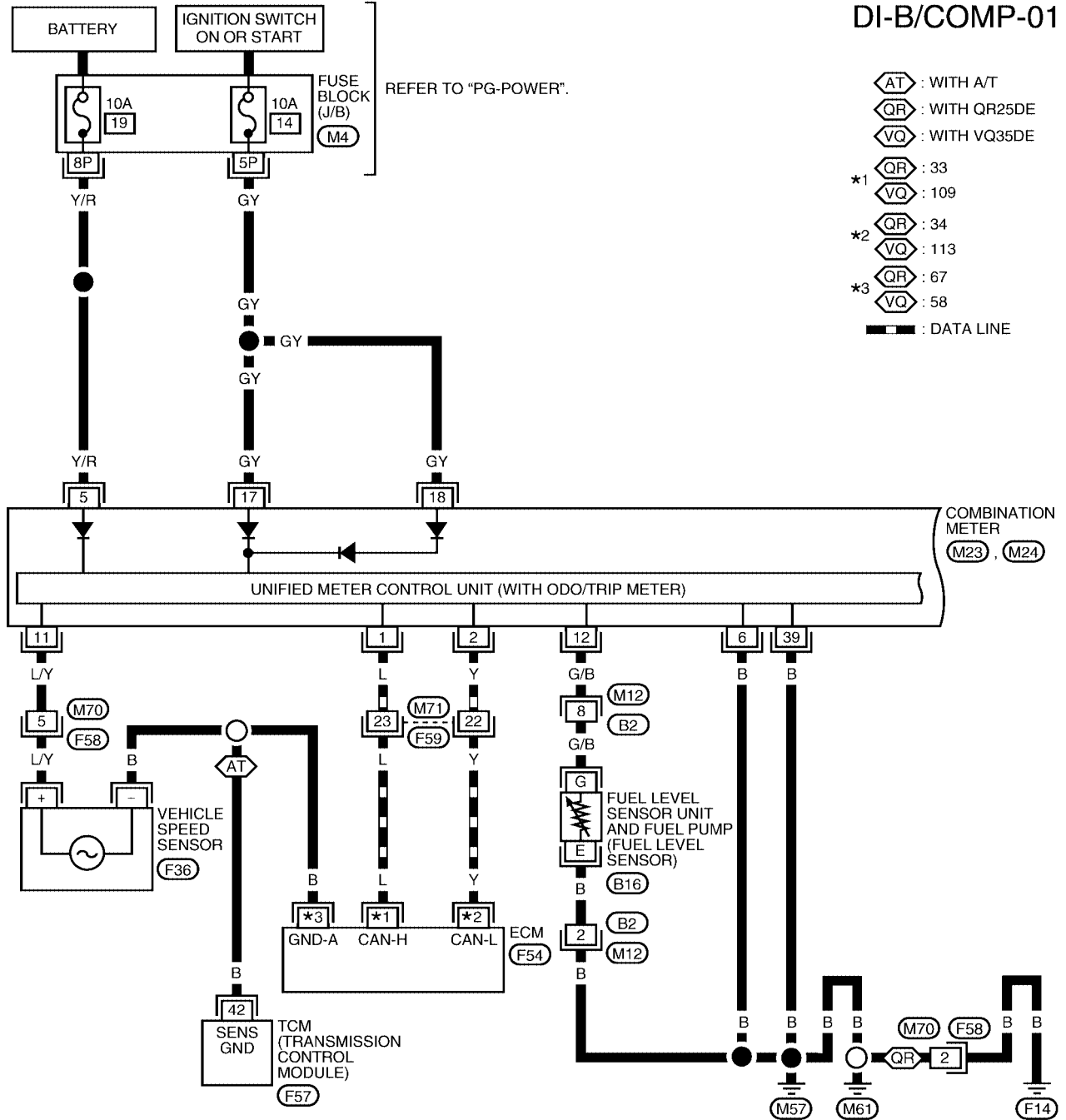

A
B
C
D
E
F
G
H
I
J
DI
L
M

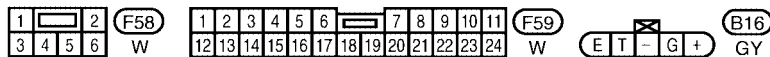
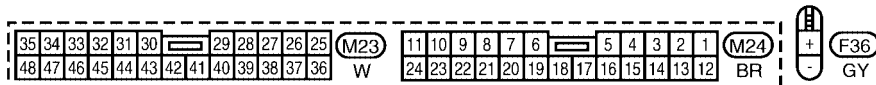
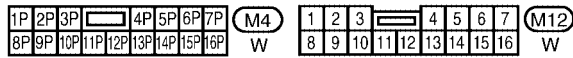

REFER TO THE FOLLOWING.
F54, F57 - ELECTRICAL UNITS

WKWA1001E

BOARD COMPUTER

DI-B/COMP-02

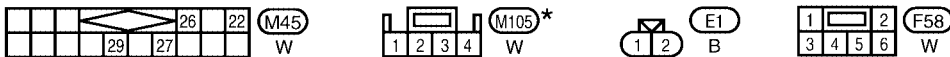
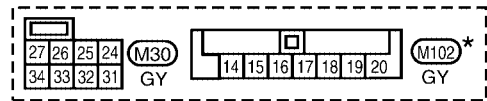
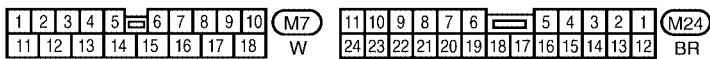
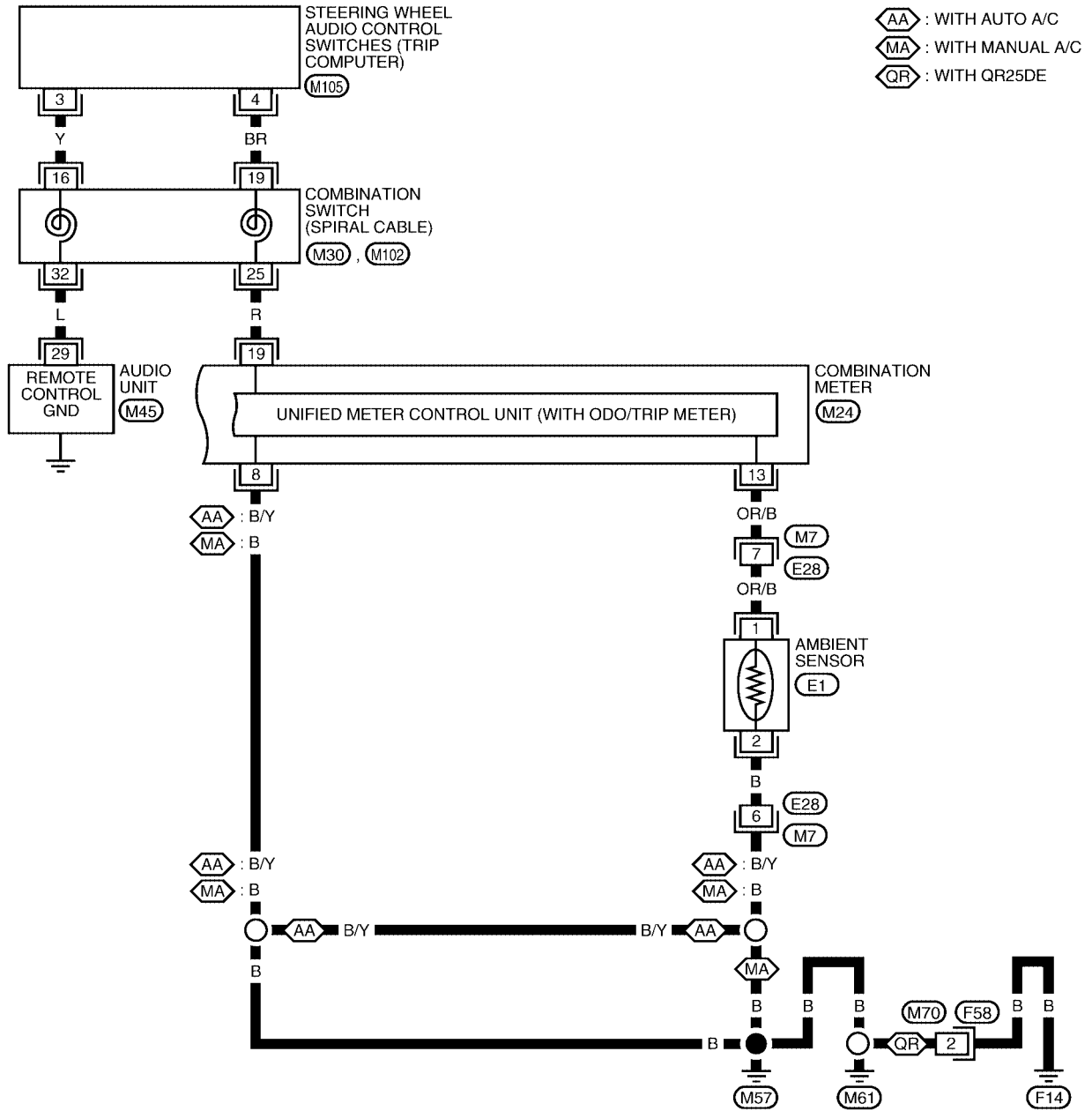

* This connector is not shown in "HARNES LAYOUT" of PG section.

WKWA1002E

BOARD COMPUTER

EKS003GL

Trouble Diagnoses SEGMENT CHECK

The board computer segment display can be checked by entering combination meter self-diagnostic mode. Refer to [DI-10, "SELF-DIAGNOSIS FUNCTION"](#).

PRELIMINARY CHECK

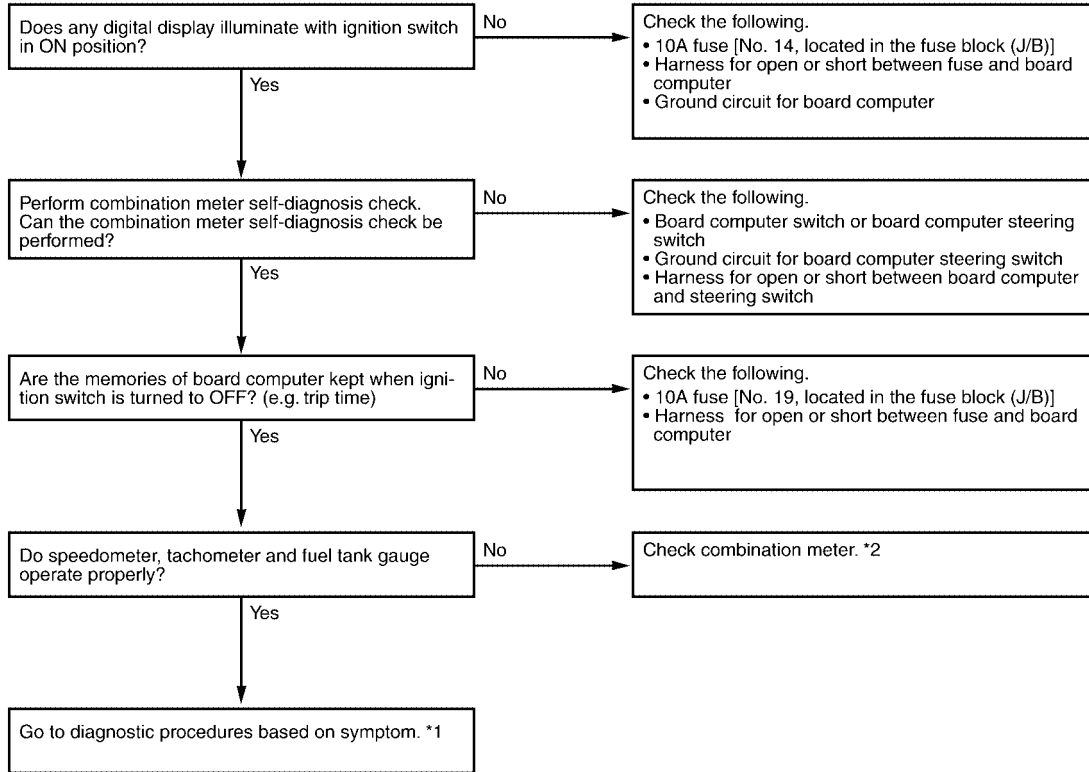

LKIA0061E

*1 [DI-53, "DIAGNOSIS PROCEDURE"](#) *2 [DI-7, "CHECK"](#)

DIAGNOSIS PROCEDURE

Symptom	Possible cause	Repair order
Outside air temperature display is not displayed properly. (It may take a short time to steady the indication after ignition switch is turned ON.) NOTE: If the meter is powered up with the ambient sensor disconnected, outside air temperature display will show "----" even if the sensor is reconnected. In this case, with the sensor connected, disconnect and reconnect the battery, then the correct temperature will be displayed.	1. Ambient sensor 2. Ambient sensor circuit 3. Vehicle speed sensor signal	1. Check ambient sensor. 2. Check harness for open or short between ambient sensor and board computer. 3. Check harness for open or short between combination meter terminal 11 and vehicle speed sensor.
DTE (distance to empty) is not displayed properly.)	1. Average fuel consumption display 2. Fuel tank gauge signal circuit.	1. Make sure fuel consumption is displayed properly. If NG, check fuel consumption display. 2. Make sure fuel gauge operates properly. If NG, check fuel gauge.
Trip distance is not indicated properly.	1. Vehicle speed sensor signal circuit	1. Check harness for open or short between combination meter terminal 11 and vehicle speed sensor.

BOARD COMPUTER

Symptom	Possible cause	Repair order
Trip time is not indicated properly.	1. Fuse	1. 10A fuse [No. 19 (located in fuse block (J/B))]. Verify battery voltage is present at combination meter terminal 5.
Average fuel consumption is not displayed properly.	1. Trip distance display 2. Fuel consumption signal	1. Check harness for open or short between combination meter terminal 11 and vehicle speed sensor. 2. Check CAN lines for open or short between ECM and combination meter.
Average vehicle speed is not indicated properly.	1. Trip distance display 2. Trip time display	1. Check harness for open or short between combination meter terminal 11 and vehicle speed sensor. 2. Make sure trip time is displayed properly. If NG, check trip time display.

Electrical Components Inspection AMBIENT SENSOR

EKS003GM

After disconnecting ambient sensor harness connector, measure resistance between terminals 2 and 1 at sensor harness side, using the table below.

Temperature °C (°F)	Resistance kΩ
-15 (5)	12.73
-10 (14)	9.92
-5 (23)	7.80
0 (32)	6.19
5 (41)	4.95
10 (50)	3.99
15 (59)	3.24
20 (68)	2.65
25 (77)	2.19
30 (86)	1.81
35 (95)	1.51
40 (104)	1.27
45 (113)	1.07

If NG, replace ambient sensor.

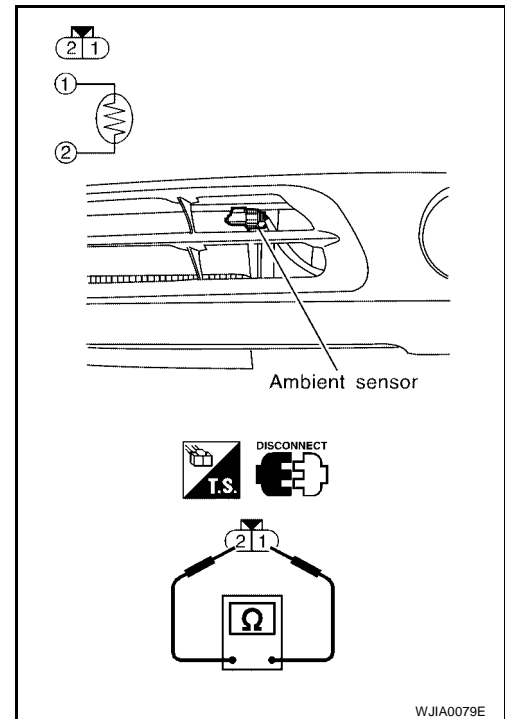

WJIA0079E