

LT
SECTION
LIGHTING SYSTEM

A
B
C
D
E

CONTENTS

<p>PRECAUTIONS 4</p> <p> Precautions for Supplemental Restraint System (SRS) "AIR BAG" and "SEAT BELT PRE-TENSIONER" 4</p> <p> General precautions for service operations 4</p> <p> Wiring Diagrams and Trouble Diagnosis 4</p> <p>HEADLAMP (FOR USA) 6</p> <p> Component Parts and Harness Connector Location... 6</p> <p> System Description 6</p> <p> OUTLINE 6</p> <p> BATTERY SAVER CONTROL 7</p> <p> AUTO LIGHT OPERATION 7</p> <p> VEHICLE SECURITY SYSTEM 7</p> <p> XENON HEADLAMP (IF EQUIPPED) 7</p> <p> CAN Communication System Description 8</p> <p> Wiring Diagram — H/LAMP — 9</p> <p> HALOGEN 9</p> <p> XENON 11</p> <p> Terminals and Reference Value for BCM 13</p> <p> Terminals and Reference Values for IPDM E/R ... 13</p> <p> How to Proceed With Trouble Diagnosis 13</p> <p> Preliminary Check 14</p> <p> CHECK POWER SUPPLY AND GROUND CIRCUIT 14</p> <p> CONSULT-II Function (BCM) 14</p> <p> CONSULT-II BASIC OPERATION 14</p> <p> DATA MONITOR 15</p> <p> ACTIVE TEST 16</p> <p> CONSULT-II Function (IPDM E/R) 17</p> <p> CONSULT-II OPERATION 17</p> <p> DATA MONITOR 18</p> <p> ACTIVE TEST 18</p> <p> Headlamp HI Does Not Illuminate (Both Sides) ... 19</p> <p> Headlamp HI Does Not Illuminate (One Side) 21</p> <p> High-Beam Indicator Lamp Does Not Illuminate ... 22</p> <p> Headlamp LO Does Not Illuminate (Both Sides) ... 22</p> <p> Headlamp LO Does Not Illuminate (One Side) 24</p> <p> Headlamps Do Not Turn OFF 25</p> <p> One Xenon Headlamp Does Not Illuminate At Full Brightness 26</p>	<p> One Xenon Headlamp Flickers 26</p> <p> Aiming Adjustment 27</p> <p> LOW BEAM AND HIGH BEAM 27</p> <p> Bulb Replacement 28</p> <p> HEADLAMP (OUTER SIDE), FOR LOW BEAM (XENON) 28</p> <p> HEADLAMP (OUTER SIDE), FOR LOW BEAM (HALOGEN) 28</p> <p> HEADLAMP (INNER SIDE), FOR HIGH BEAM.. 28</p> <p> FRONT TURN SIGNAL LAMP 29</p> <p> Removal and Installation 29</p> <p> REMOVAL 29</p> <p> INSTALLATION 29</p> <p> Disassembly and Assembly 30</p> <p> DISASSEMBLY 30</p> <p> ASSEMBLY 31</p> <p>HEADLAMP (FOR CANADA) - DAYTIME LIGHT SYSTEM - 32</p> <p> Component Parts and Harness Connector Location.. 32</p> <p> System Description 32</p> <p> HEADLAMP OPERATION 33</p> <p> BATTERY SAVER CONTROL 34</p> <p> AUTO LIGHT OPERATION 34</p> <p> DAYTIME LIGHT OPERATION 34</p> <p> XENON HEADLAMP (IF EQUIPPED) 34</p> <p> OPERATION 34</p> <p> CAN Communication System Description 35</p> <p> Schematic 36</p> <p> HALOGEN 36</p> <p> XENON 37</p> <p> Wiring Diagram — DTRL — 38</p> <p> HALOGEN 38</p> <p> XENON 41</p> <p> Terminals and Reference Value for Daytime Light Control Unit 44</p> <p> Aiming Adjustment 45</p> <p> Bulb Replacement 45</p> <p> Removal and Installation 45</p> <p> Disassembly and Assembly 45</p> <p>AUTO LIGHT SYSTEM 46</p>
---	--

F
G
H
I
J
LT

L
M

Component Parts and Harness Connector Location ..	46	Wiring Diagram — TURN —	80
System Description	46	Terminals and Reference Value for BCM	83
OUTLINE	46	CONSULT-II Function (BCM)	84
BATTERY SAVER CONTROL	47	CONSULT-II BASIC OPERATION	84
SHUT OFF DELAY	47	DATA MONITOR	85
CAN Communication System Description	47	ACTIVE TEST	85
Major Components and Functions	47	Turn Signal Lamp Does Not Operate	86
Schematic	48	Hazard Lamp Does Not Operate	87
HALOGEN (WITH DAYTIME LIGHT SYSTEM)...	48	Turn Signal Indicator Lamp Does Not Operate	88
XENON (WITH DAYTIME LIGHT SYSTEM)	49	Bulb Replacement	88
Wiring Diagram — AUTO/L —	50	FRONT TURN SIGNAL LAMP	88
HALOGEN (USA)	50	REAR TURN SIGNAL LAMP	89
XENON (USA)	52	Removal and Installation	89
HALOGEN (CANADA)	54	FRONT TURN SIGNAL LAMP	89
XENON (CANADA)	57	REAR TURN SIGNAL LAMP	89
Terminals and Reference Value for BCM	60	LIGHTING AND TURN SIGNAL SWITCH	90
Terminals and Reference Values for IPDM E/R	60	Removal and Installation	90
How to Proceed With Trouble Diagnosis	60	Switch Circuit Inspection	90
Preliminary Check	60	HAZARD SWITCH	91
SETTING CHANGE FUNCTIONS	60	Removal and Installation	91
CHECK POWER SUPPLY AND GROUND CIR- CUIT	61	COMBINATION SWITCH	92
CONSULT-II Function (BCM)	62	Combination Switch Reading Function	92
CONSULT-II BASIC OPERATION	62	CONSULT-II Function (BCM)	92
WORK SUPPORT	63	CONSULT-II BASIC OPERATION	92
DATA MONITOR	63	DATA MONITOR	93
ACTIVE TEST	64	Removal and Installation	94
CONSULT-II Function (IPDM E/R)	65	Switch Circuit Inspection	94
CONSULT-II OPERATION	65	STOP LAMP	95
DATA MONITOR	66	Wiring Diagram — STOP/L —	95
ACTIVE TEST	66	Bulb Replacement for High-mounted Stop Lamp ...	97
Trouble Diagnosis Chart by Symptom	67	WITH REAR SPOILER	97
Lighting Switch Inspection	67	WITHOUT REAR SPOILER	97
Auto Light Sensor System Inspection	68	Bulb Replacement for Rear Combination Lamp ...	97
FRONT FOG LAMP	70	Removal and Installation for High-mounted Stop Lamp	97
System Description	70	WITH REAR SPOILER	97
OUTLINE	70	WITHOUT SPOILER	97
BATTERY SAVER CONTROL	70	Removal and Installation for Rear Combination Lamp	97
CAN Communication System Description	70	STEP LAMP	98
Wiring Diagram — F/FOG —	71	System Description	98
Terminals and Reference Value for BCM	72	Wiring Diagram — STEP/L —	99
Terminals and Reference Values for IPDM E/R	72	Terminals and Reference Value for BCM	100
How to Proceed With Trouble Diagnosis	72	Step Lamp Does Not Operate	100
Preliminary Check	73	Bulb Replacement	101
CHECK POWER SUPPLY AND GROUND CIR- CUIT	73	Removal and Installation	101
CONSULT-II Functions	73	BACK-UP LAMP	102
Front Fog Lamps Do Not Illuminate (Both Sides) ...	73	Wiring Diagram — BACK/L —	102
Front Fog Lamp Does Not Illuminate (One Side) ...	74	Bulb Replacement	103
Aiming Adjustment	75	Removal and Installation	103
Removal and Installation	75	PARKING, LICENSE PLATE AND TAIL LAMPS ...	104
TURN SIGNAL AND HAZARD WARNING LAMPS..	77	System Description	104
System Description	77	OPERATION BY LIGHTING SWITCH	104
TURN SIGNAL OPERATION	77	BATTERY SAVER CONTROL	105
HAZARD LAMP OPERATION	77	CAN Communication System Description	105
REMOTE KEYLESS ENTRY SYSTEM OPERA- TION	78	Schematic	106
CAN Communication System Description	78	Wiring Diagram — TAIL/L —	107
Schematic	79	Terminals and Reference Value for BCM	110
		Terminals and Reference Values for IPDM E/R ...	110

How to Proceed With Trouble Diagnosis	110	ACTIVE TEST	122	
Preliminary Check	111	Interior Lamp Control Does Not Operate	122	A
CHECK POWER SUPPLY AND GROUND CIR-		Bulb Replacement	123	
CUIT	111	MAP LAMP	123	
CONSULT-II Functions	111	Removal and Installation	123	B
Parking, License Plate and/or Tail Lamps Do Not		ROOM LAMP	123	
Illuminate	111	IGNITION KEY HOLE ILLUMINATION LAMP ..	124	
Parking, License Plate and Tail Lamps Do Not Turn		ILLUMINATION	125	C
OFF (After Approx. 10 Minutes)	115	System Description	125	
Bulb Replacement	116	ILLUMINATION OPERATION BY LIGHTING		
LICENSE PLATE LAMP	116	SWITCH	125	
FRONT TURN SIGNAL (PARKING) LAMP	116	BATTERY SAVER CONTROL	126	D
TAIL LAMP	116	CAN Communication System Description	126	
Removal and Installation	116	Schematic	127	
LICENSE PLATE LAMP	116	Wiring Diagram — ILL —	128	E
FRONT TURN SIGNAL (PARKING) LAMP	116	Removal and Installation	132	
REAR COMBINATION LAMP	116	ILLUMINATION CONTROL SWITCH	132	
INTERIOR ROOM LAMP	117	GLOVE BOX LAMP	132	F
Component Parts and Harness Connector Location	117	VANITY MIRROR AND TRUNK ROOM LAMPS ...	133	
System Description	118	Wiring Diagram — INT/L —	133	
INTERIOR LAMP TIMER OPERATION	118	Bulb Replacement for Vanity Mirror Lamp	135	G
BATTERY SAVER	118	Bulb Replacement, Removal and Installation for		
Wiring Diagram — ROOM/L —	119	Trunk Room Lamp	135	
Terminals and Reference Value for BCM	120	BULB SPECIFICATIONS	136	H
CONSULT-II Function (BCM)	120	Headlamp	136	
CONSULT-II BASIC OPERATION	120	Exterior Lamp	136	
WORK SUPPORT	121	Interior Lamp/Illumination	136	I
DATA MONITOR	121			J

LT

L

M

PRECAUTIONS

PRECAUTIONS

PF0:00011

Precautions for Supplemental Restraint System (SRS) “AIR BAG” and “SEAT BELT PRE-TENSIONER”

EKS00652

The Supplemental Restraint System such as “AIR BAG” and “SEAT BELT PRE-TENSIONER”, used along with a front seat belt, helps to reduce the risk or severity of injury to the driver and front passenger for certain types of collision. This system includes seat belt switch inputs and dual stage front air bag modules. The SRS system uses the seat belt switches to determine the front air bag deployment, and may only deploy one front air bag, depending on the severity of a collision and whether the front occupants are belted or unbelted. Information necessary to service the system safely is included in the SRS and SB section of this Service Manual.

WARNING:

- To avoid rendering the SRS inoperative, which could increase the risk of personal injury or death in the event of a collision which would result in air bag inflation, all maintenance must be performed by an authorized NISSAN/INFINITI dealer.
- Improper maintenance, including incorrect removal and installation of the SRS, can lead to personal injury caused by unintentional activation of the system. For removal of Spiral Cable and Air Bag Module, see the SRS section.
- Do not use electrical test equipment on any circuit related to the SRS unless instructed to in this Service Manual. SRS wiring harnesses can be identified by yellow and/or orange harnesses or harness connectors.

General precautions for service operations

EKS003C0

- Never work with wet hands.
- The xenon headlamp system includes a high voltage generating part. Be sure to disconnect battery negative cable (negative terminal) or power fuse before removing, installing, or touching the xenon headlamp (including lamp bulb).
- Turn the lighting switch OFF before disconnecting and connecting the connector.
- When turning the xenon headlamp on and while it is illuminated, never touch the harness, bulb, and socket of the headlamp.
- When checking the headlamp on/off operation, check it on vehicle and with the power connected to the vehicle-side connector.
- Do not touch the headlamp bulb glass surface with bare hands or allow oil or grease to get on it. Do not touch the headlamp bulb just after the headlamp is turned off, because it is very hot.
- Install the xenon headlamp bulb socket correctly. If it is installed improperly, high-voltage leak or corona discharge may occur that can melt the bulb, connector, and housing. Do not illuminate the xenon headlamp bulb out of the headlamp housing. Doing so can cause fire and harm your eyes.
- When the bulb has burned out, wrap it in a thick vinyl bag and discard. Do not break the bulb.
- Leaving the bulb removed from the headlamp housing for a long period of time can deteriorate the performance of the lens and reflector (dirt, clouding). Always prepare a new bulb and have it on hand when replacing the bulb.
- When adjusting the headlamp aiming, turn the aiming adjustment screw only in the tightening direction. (If it is necessary to loosen the screw, first fully loosen the screw, and then turn it in the tightening direction.)
- Do not use organic solvent (paint thinner or gasoline) to clean lamps and to remove old sealant.

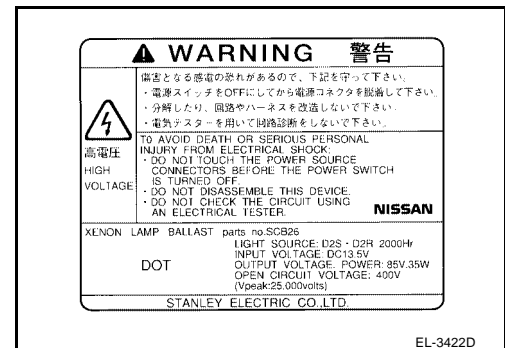
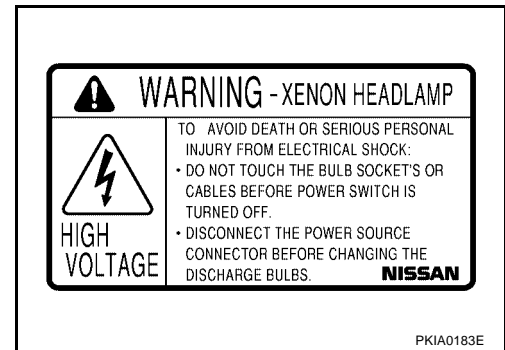

Wiring Diagrams and Trouble Diagnosis

EKS003C1

When you read wiring diagrams, refer to the following:

- [GI-12, "How to Read Wiring Diagrams"](#)
- [PG-4, "POWER SUPPLY ROUTING CIRCUIT"](#)

PRECAUTIONS

When you perform trouble diagnosis, refer to the following:

- [GI-10, "HOW TO FOLLOW TEST GROUPS IN TROUBLE DIAGNOSES"](#)
- [GI-25, "How to Perform Efficient Diagnosis for an Electrical Incident"](#)

A

B

C

D

E

F

G

H

I

J

LT

L

M

HEADLAMP (FOR USA)

HEADLAMP (FOR USA)

PF2:26010

Component Parts and Harness Connector Location

EKS003C2

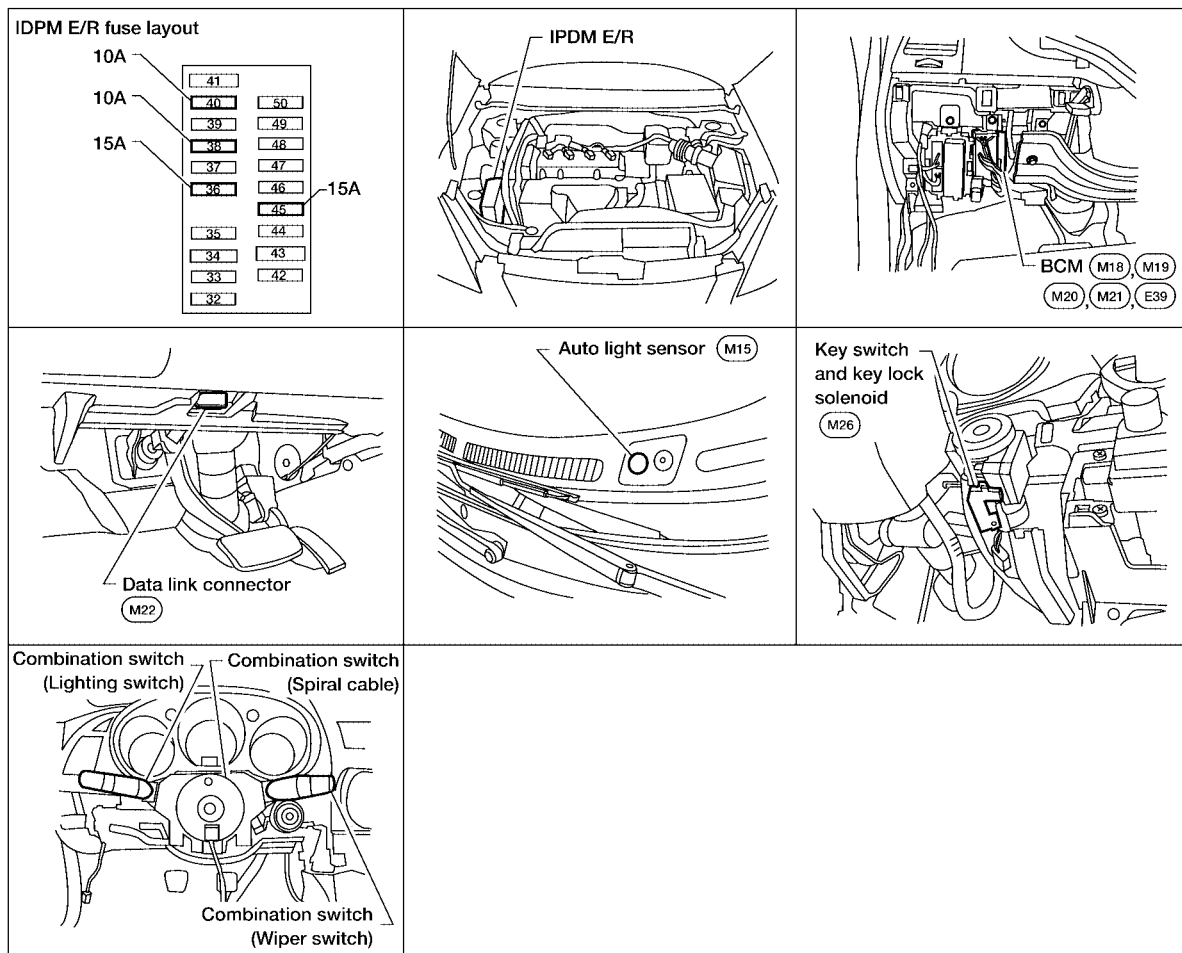

WKIA1577E

System Description

EKS003C3

Control of the headlamp system operation is dependent upon the position of the combination switch (lighting switch). When the lighting switch is placed in the 2ND position, the BCM (body control module) receives input requesting the headlamps (and tail lamps) illuminate. This input is communicated to the IPDM E/R (intelligent power distribution module engine room) across the CAN communication lines. The central processing unit of the IPDM E/R controls the headlamp high and headlamp low relay coils. When energized, these relays direct power to the respective headlamps, which then illuminate.

OUTLINE

Power is supplied at all times

- to headlamp high relay, located in the IPDM E/R, and
- to headlamp low relay, located in the IPDM E/R, and
- to BCM terminal 7
- through 50A fusible link (letter f , located in the fuse and fusible link box).

With the ignition switch in the ON or START position, power is supplied

- to BCM terminal 35
- through 10A fuse [No. 12, located in the fuse block (J/B)].

With the ignition switch in the ACC or ON position, power is supplied

- to BCM terminal 36
- through 10A fuse [No. 6, located in the fuse block (J/B)].

Ground is supplied

HEADLAMP (FOR USA)

- to BCM terminals 8, 27, and 63
- through body grounds F14 (QR25DE models), M57, M61, E15, and E24.

Low Beam Operation

With the lighting switch in 2ND position, the BCM receives input requesting the headlamps to illuminate. This input is communicated to the IPDM E/R across the CAN communication lines. The central processing unit of the IPDM E/R controls the headlamp low relay coil. When energized, this relay directs power

- to 15A fuse (No. 36, located in the IPDM E/R)
- through terminal 20 of the IPDM E/R
- to terminal 1 of headlamp RH, and
- to 15A fuse (No. 45, located in the IPDM E/R)
- through terminal 30 of the IPDM E/R
- to terminal 1 of headlamp LH.

Ground is supplied at all times

- to terminal 2 of headlamp RH
- through body grounds E15 and E24, and
- to terminal 2 of headlamp LH
- through body grounds E15 and E24.

With power and ground supplied, low beam headlamps illuminate.

High Beam Operation/Flash-to-Pass Operation

With the lighting switch in 2ND position and placed in HIGH or PASS position, the BCM receives input requesting the headlamp high beams to illuminate. This input is communicated to the IPDM E/R across the CAN communication lines. The central processing unit of the IPDM E/R controls the headlamp high relay coil. When energized, this relay directs power

- to 10A fuse (No. 40, located in the IPDM E/R)
- through terminal 27 of the IPDM E/R
- to terminal 1 of headlamp RH, and
- to 10A fuse (No. 38, located in the IPDM E/R)
- through terminal 28 of the IPDM E/R
- to terminal 1 of headlamp LH.

Ground is supplied

- to terminal 2 of headlamp RH
- through body grounds E15 and E24, and
- to terminal 2 of headlamp LH
- through body grounds E15 and E24.

With power and ground supplied, the high beam headlamps and the HIGH BEAM indicator illuminate.

BATTERY SAVER CONTROL

When the combination switch (lighting switch) is in the 2ND position (ON), and the ignition switch is turned from ON or ACC to OFF, the battery saver control feature is activated.

Under this condition, the headlamps remain illuminated for 5 minutes, unless the combination switch (lighting switch) position is changed. If the combination switch (lighting switch) position is changed, then the headlamps are turned off.

AUTO LIGHT OPERATION

Refer to [LT-46, "System Description"](#) for auto light operation.

VEHICLE SECURITY SYSTEM

The vehicle security system will flash the high beams if the system is triggered. Refer to [BL-82, "VEHICLE SECURITY \(THEFT WARNING\) SYSTEM"](#).

XENON HEADLAMP (IF EQUIPPED)

The low beam headlamps may be equipped with xenon type bulbs. Xenon bulbs do not use a filament. Instead, they produce light when a high voltage current is passed between two tungsten electrodes through a

A
B
C
D
E
F
G
H
I
J
LT
L
M

HEADLAMP (FOR USA)

mixture of xenon (an inert gas) and certain other metal halides. In addition to added lighting power, electronic control of the power supply gives the headlamps stable quality and tone color. Following are some of the advantages of the xenon type headlamp.

- The light produced by the headlamps is a white color comparable to sunlight that is easy on the eyes.
- Light output is nearly double that of halogen headlamps, affording increased area of illumination.
- The light features a high relative spectral distribution at wavelengths to which the human eye is most sensitive. This means that even in the rain, more light is reflected back from the road surface toward the vehicle for added visibility.
- Power consumption is approximately 25 percent less than halogen headlamps, reducing battery load.

CAN Communication System Description

EKS003C4

Refer to [LAN-4, "CAN COMMUNICATION"](#) .

HEADLAMP (FOR USA)

Wiring Diagram — H/LAMP — HALOGEN

EKS003C5

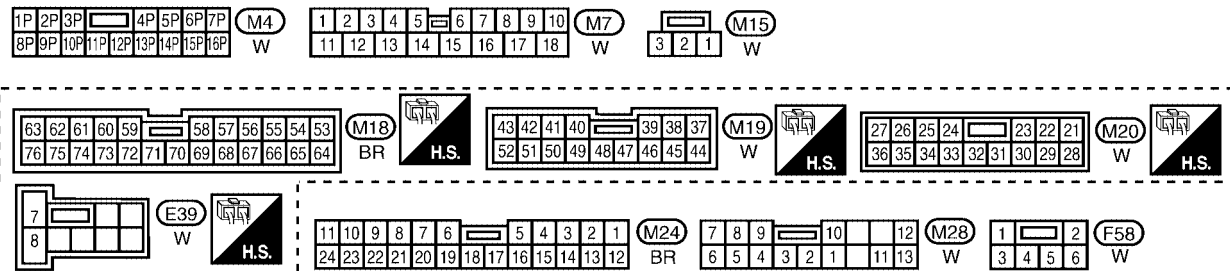
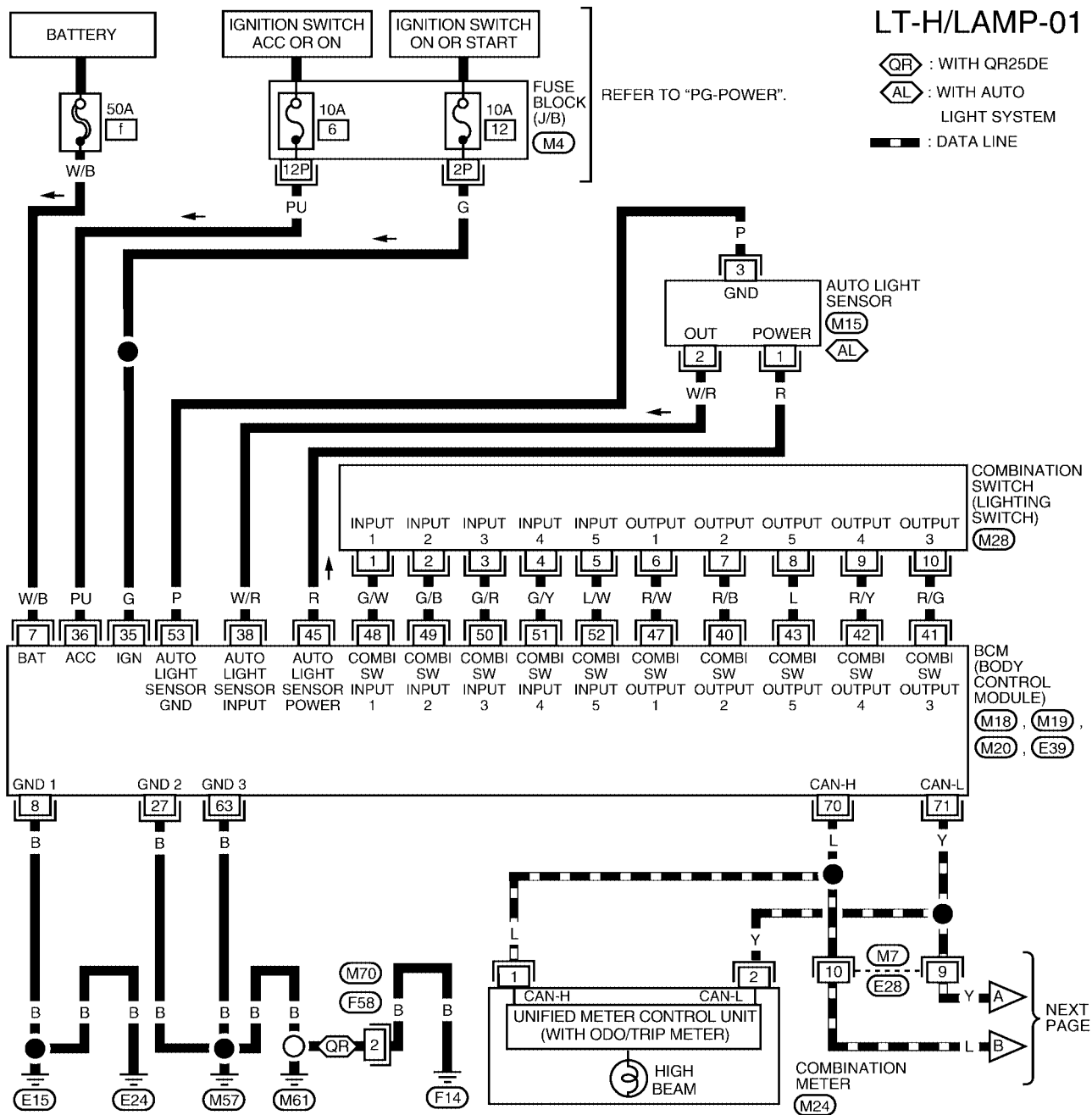

WKWA0870E

HEADLAMP (FOR USA)

LT-H/LAMP-04

— : DATA LINE

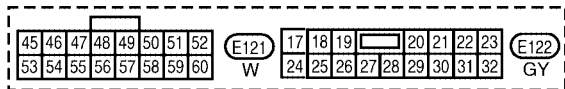
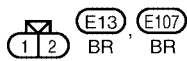
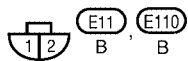
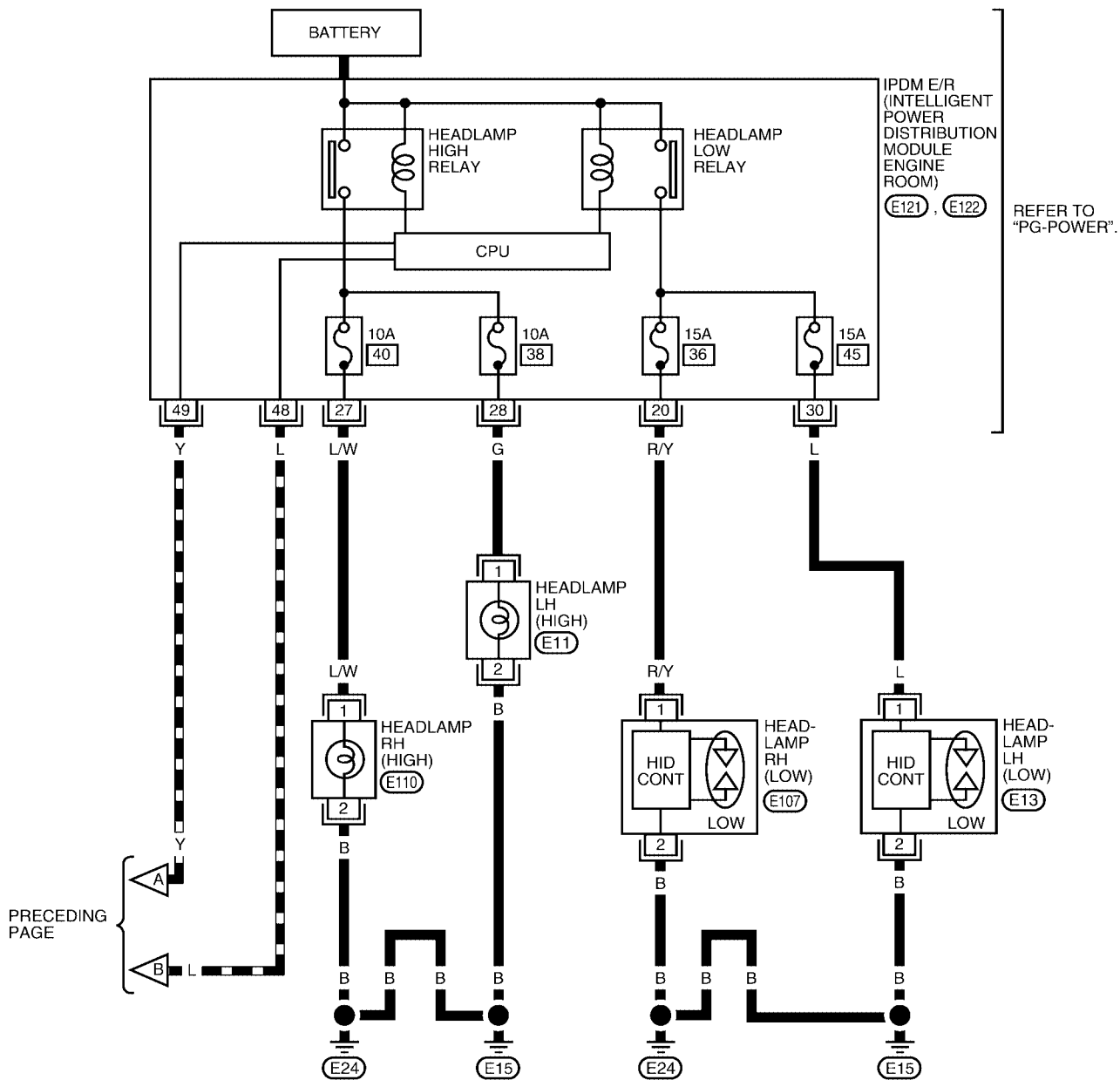

WKWA0873E

HEADLAMP (FOR USA)

Terminals and Reference Value for BCM

EKS003C6

Terminal No.	Wire color	Item	Measuring condition		Voltage (Approx.)
			Ignition switch	Operation or condition	
7	W/B	Battery power supply	OFF	—	Battery voltage
8	B	Ground	—	—	—
27	B	Ground	—	—	—
35	G	Ignition power supply	ON	—	Battery voltage
36	PU	Ignition power supply	ACC	—	Battery voltage
38	W/R	Auto light sensor input	ON	Headlamps illuminate by auto light control	0V → 3V
40	R/B	Combination switch output 2	—	—	2V → 10V
41	R/G	Combination switch output 3	—	—	2V → 10V
42	R/Y	Combination switch output 4	—	—	2V → 10V
43	L	Combination switch output 5	—	—	2V → 10V
45	R	Auto light sensor power	—	Ignition switch OFF → ON	0V → 5V
47	R/W	Combination switch output 1	—	—	2V → 10V
48	G/W	Combination switch input 1	—	—	1.5V → 10V
49	G/B	Combination switch input 2	—	—	1.5V → 10V
50	G/R	Combination switch input 3	—	—	1.5V → 10V
51	G/Y	Combination switch input 4	—	—	1.5V → 10V
52	L/W	Combination switch input 5	—	—	1.5V → 10V
53	P	Auto light sensor ground	—	—	—
63	B	Ground	—	—	—
70	L	CAN - H	—	—	1V → 3V
71	Y	CAN - L	—	—	1V → 3V

Terminals and Reference Values for IPDM E/R

EKS0070B

Terminal No.	Wire color	Signal name	Measuring condition		Reference value (Approx.)	
			Ignition switch	Operation or condition		
20	R/Y	Headlamp low (RH)	ON	Lighting switch 2ND position	OFF	0V
					ON	Battery voltage
27	L/W	Headlamp high (RH)	ON	Lighting switch HIGH or PASS position	OFF	0V
					ON	Battery voltage
28	G	Headlamp high (LH)	ON	Lighting switch HIGH or PASS position	OFF	0V
					ON	Battery voltage
30	L	Headlamp low (LH)	ON	Lighting switch 2ND position	OFF	0V
					ON	Battery voltage
48	L	CAN - H	—	—	—	
49	Y	CAN - L	—	—	—	

How to Proceed With Trouble Diagnosis

EKS0070C

1. Confirm the symptom or customer complaint.
2. Understand operation description and function description. Refer to [LT-6, "System Description"](#).
3. Perform the Preliminary Check. Refer to [LT-14, "Preliminary Check"](#).
4. Check symptom and repair or replace the cause of malfunction.

HEADLAMP (FOR USA)

5. Does the headlamp operate normally? If YES: GO TO 6. If NO: GO TO 4.

6. Inspection End.

Preliminary Check CHECK POWER SUPPLY AND GROUND CIRCUIT

EKS0070D

1. CHECK FUSES OR FUSIBLE LINK

Check for blown fuses or fusible link.

Unit	Power source	Fuse No.
BCM	Battery	f
	Ignition switch ON or START position	12
	Ignition switch ACC or ON position	6
IPDM E/R	Battery	36
		38
		40
		45

Refer to [LT-9, "Wiring Diagram — H/LAMP —"](#) .

OK or NG

OK >> Inspection End.

NG >> If fuse is blown, be sure to eliminate cause of malfunction before installing new fuse. Refer to [PG-4, "POWER SUPPLY ROUTING CIRCUIT"](#) .

CONSULT-II Function (BCM)

EKS003C7

CONSULT-II can display each diagnostic item using the diagnostic test modes shown following.

BCM diagnosis part	Check item, diagnosis mode	Description
HEADLAMP	Work support	Changes the setting for each function.
	Data monitor	Displays BCM input data in real time.
	Active test	Operation of electrical loads can be checked by sending drive signal to them.
BCM	Self-diagnosis	BCM performs self-diagnosis of CAN communication.
	CAN DIAG SUPPORT MNTR	The result of transmit/receive diagnosis of CAN communication can be read.

CONSULT-II BASIC OPERATION

CAUTION:

If CONSULT-II is used with no connection of CONSULT-II CONVERTER, malfunctions might be detected in self-diagnosis depending on control unit which carries out CAN communication.

1. With the ignition switch OFF, connect CONSULT-II and CONSULT-II CONVERTER to the data link connector, then turn ignition switch ON.

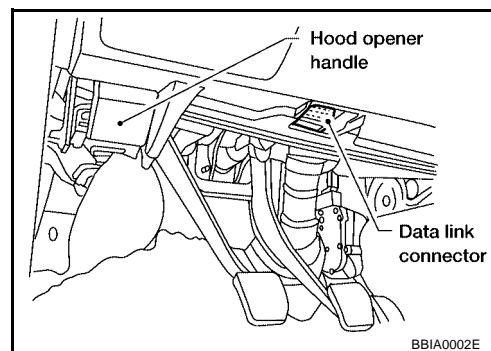

HEADLAMP (FOR USA)

2. Touch "START (NISSAN BASED VEHICLE)".

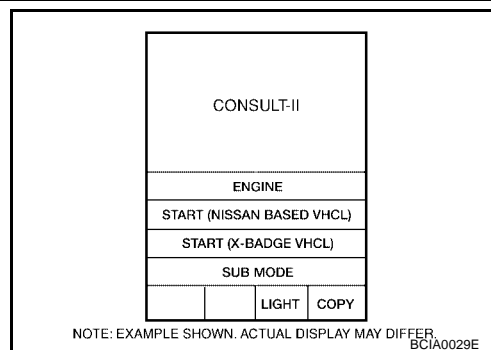

A
B
C
D

3. Touch "BCM" on "SELECT SYSTEM" screen.
If "BCM" is not indicated, go to [GI-37, "CONSULT-II Data Link Connector \(DLC\) Circuit"](#).

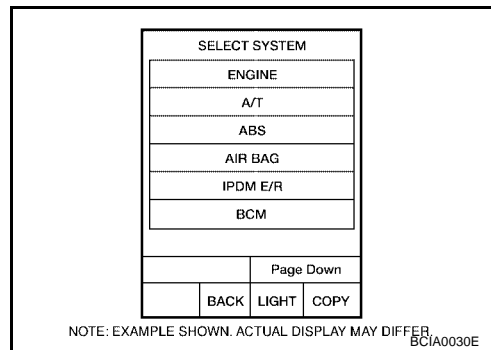

E
F
G

4. Select the desired part to be diagnosed on the "SELECT TEST ITEM" screen.

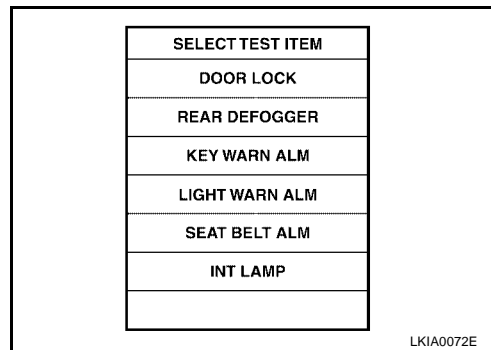

H
I
J
LT

DATA MONITOR

Operation Procedure

1. Touch "HEAD LAMP" on "SELECT TEST ITEM" screen.
2. Touch "DATA MONITOR" on "SELECT DIAG MODE" screen.
3. Touch either "ALL SIGNALS" or "SELECTION FROM MENU" on the "DATA MONITOR" screen.

All signals	Monitors all the signals.
Selection from menu	Selects and monitors individual signal.

L
M

4. Touch "START".
5. When "SELECTION FROM MENU" is selected, touch individual items to be monitored. When "ALL SIGNALS" is selected, all the items will be monitored.
6. Touch "RECORD" while monitoring, then the status of the monitored item can be recorded. To stop recording, touch "STOP".

Display Item List

Monitor item name "OPERATION OR UNIT"	Contents
IGN ON SW "ON/OFF"	"IGN position (ON)/OFF, ACC position (OFF)" judged from the ignition switch signal is displayed.
ACC ON SW "ON/OFF"	Displays "ACC (ON)/OFF, Ignition OFF (OFF)" status judged from ignition switch signal.

HEADLAMP (FOR USA)

Monitor item name "OPERATION OR UNIT"	Contents
AUTO LIGHT SW ^{Note}	"ON/OFF" Displays status of the lighting switch as judged from the lighting switch signal. (AUTO position: ON/Other than AUTO position: OFF)
TAIL LAMP SW	"ON/OFF" Displays status (lighting switch 1st position: ON/Others: OFF) of light switch judged from lighting switch signal.
HEAD LAMP SW 1	"ON/OFF" Displays status (headlamp switch: ON/Others: OFF) of headlamp switch judged from lighting switch signal.
HI BEAM SW	"ON/OFF" Displays status (high beam switch: ON/Others: OFF) of high beam switch judged from lighting switch signal.
PASSING SW	"ON/OFF" Displays status (flash-to-pass switch: ON/Others: OFF) of flash-to-pass switch judged from lighting switch signal.
FR FOG SW	"ON/OFF" Displays status (front fog switch: ON/Others: OFF) of front fog switch judged from lighting switch signal.
DOOR SW - DR	"ON/OFF" Displays status of the driver door as judged from the driver door switch signal. (Door is open: ON/Door is closed: OFF)
DOOR SW - AS	"ON/OFF" Displays status of the passenger door as judged from the passenger door switch signal. (Door is open: ON/Door is closed: OFF)
DOOR SW - RR	"ON/OFF" Displays status of the rear doors as judged from the rear door switch signal. (Door is open: ON/Door is closed: OFF)
HEAD LAMP SW 2	"ON/OFF" Displays status (headlamp switch 2: ON/Others: OFF) of headlamp switch 2 judged from lighting switch signal.
OPTICAL SENSOR	[0 - 5V] Displays "ambient light (close to 5V when light/close to 0V when dark)" judged from auto light sensor signal.

NOTE:

Vehicles without auto light system display this item, but cannot monitor it.

ACTIVE TEST

Operation Procedure

1. Touch "HEAD LAMP" on "SELECT TEST ITEM" screen.
2. Touch "ACTIVE TEST" on "SELECT DIAG MODE" screen.
3. Touch item to be tested and check operation of the selected item.
4. During the operation check, touching "BACK" deactivates the operation.

Display Item List

Test item	Display on CONSULT-II screen	Description
Tail light relay output	TAIL LAMP	Allows tail light relay to operate by switching ON-OFF at your option.
Headlamp relay output	HEAD LAMP (LOW)	Allows headlamp relay to operate by switching ON-OFF at your option.
Headlamp relay output	HEAD LAMP (HI)	Allows headlamp relay to operate by switching ON-OFF at your option.
Front fog lamp relay output	FR FOG LAMP	Allows fog lamp relay to operate by switching ON-OFF at your option.

HEADLAMP (FOR USA)

EKS0070F

CONSULT-II Function (IPDM E/R)

CONSULT-II can display each diagnostic item using the diagnostic test modes shown following.

Inspection Item, Diagnosis Mode	Description
DATA MONITOR	The input/output data of the IPDM E/R is displayed in real time.
CAN DIAG SUPPORT MNTR	The result of transmit/receive diagnosis of CAN communication can be read.
ACTIVE TEST	The IPDM E/R sends a drive signal to electronic components to check their operation.

CONSULT-II OPERATION

CAUTION:

If CONSULT-II is used with no connection of CONSULT-II CONVERTER, malfunctions might be detected in self-diagnosis depending on control unit which carries out CAN communication.

1. With the ignition switch OFF, connect CONSULT-II and CONSULT-II CONVERTER to the data link connector, then turn the ignition switch ON.

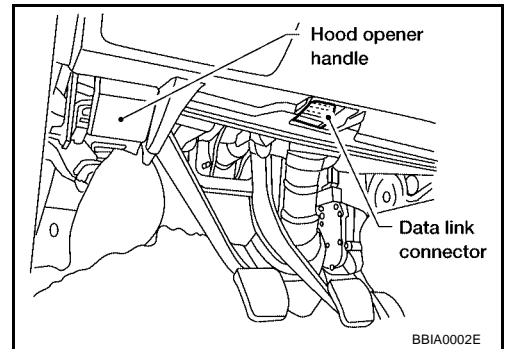

2. Touch "START (NISSAN BASED VHCL)".

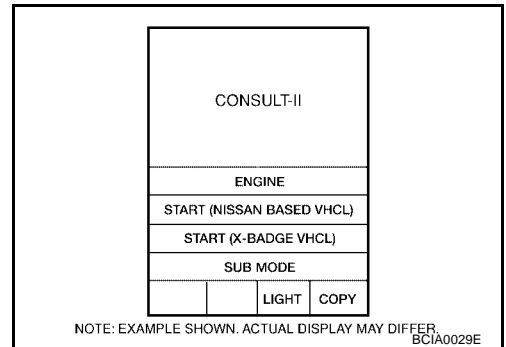

3. Touch "IPDM E/R" on "SELECT SYSTEM" screen. If "IPDM E/R" is not displayed, go to [GI-37, "CONSULT-II Data Link Connector \(DLC\) Circuit"](#).

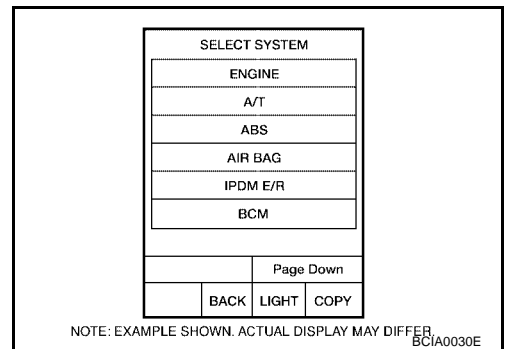

HEADLAMP (FOR USA)

- Select the desired part to be diagnosed on the “SELECT DIAG MODE” screen.

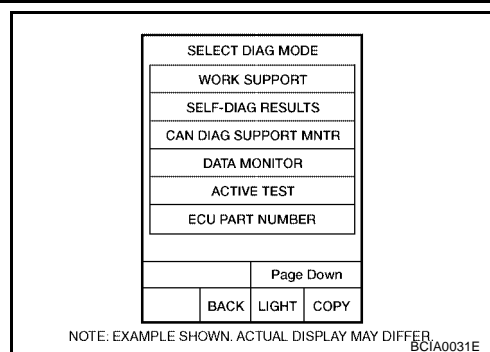

DATA MONITOR

Operation Procedure

- Touch “DATA MONITOR” on “SELECT DIAG MODE ” screen.
- Touch “ALL SIGNALS”, “MAIN SIGNALS” or “SELECT FROM MENU” on the “DATA MONITOR” screen.

ALL SIGNALS	All items will be monitored.
MAIN SIGNALS	Monitor the predetermined item.
SELECT FROM MENU	Select any item for monitoring.

- Touch “START”.
- Touch the required monitoring item on “SELECT ITEM MENU”. In “ALL SIGNALS”, all items are monitored. In “MAIN SIGNALS”, predetermined items are monitored.
- Touch “RECORD” while monitoring to record the status of the item being monitored. To stop recording, touch “STOP”.

All Items, Main Items, Select Item Menu

Item name	CONSULT-II screen display	Display or unit	Monitor item selection			Description
			ALL SIGNALS	MAIN SIGNALS	SELECT FROM MENU	
Position lights request	TAIL&CLR REQ	ON/OFF	×	×	×	Signal status input from BCM
Headlamp low beam request	HL LO REQ	ON/OFF	×	×	×	Signal status input from BCM
Headlamp high beam request	HL HI REQ	ON/OFF	×	×	×	Signal status input from BCM
Front fog lights request	FR FOG REQ	ON/OFF	×	×	×	Signal status input from BCM

NOTE:

Perform monitoring of IPDM E/R data with the ignition switch ON. When the ignition switch is at ACC, the display may not be correct.

ACTIVE TEST

Operation Procedure

- Touch “ACTIVE TEST” on “SELECT DIAG MODE” screen.
- Touch item to be tested, and check operation.
- Touch “START”.
- Touch “STOP” while testing to stop the operation.

HEADLAMP (FOR USA)

Test item	CONSULT-II screen display	Description
Headlamp relay (HI, LO) output	LAMPS	Allows headlamp relay (HI, LO) to operate by switching operation (OFF, HI ON, LO ON) at your option (Head lamp high beam repeats ON-OFF every 1 second).
Front fog lamp relay (FOG) output		Allows fog lamp relay (FOG) to operate by switching operation ON-OFF at your option
Tail lamp relay output	TAIL LAMP	Allows tail lamp relay to operate by switching operation ON-OFF at your option

Headlamp HI Does Not Illuminate (Both Sides)

EKS0070G

1. HEADLAMP ACTIVE TEST

1. Select "IPDM E/R" on CONSULT-II and select "ACTIVE TEST" on "SELECT DIAG MODE" screen.
2. Select "LAMPS" on "SELECT TEST ITEM" screen.
3. Touch "HI" screen.
4. Make sure headlamp high beam operates.

Headlamp high beam should operate.

OK or NG

- OK >> GO TO 2.
 NG >> GO TO 4.

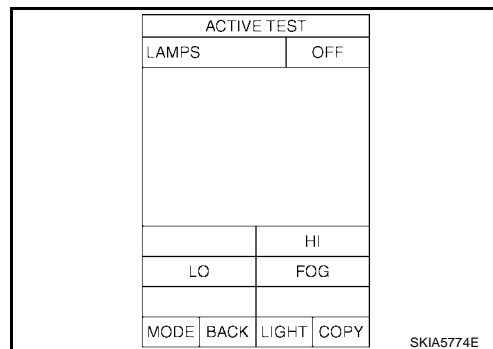

2. INSPECTION 1 BETWEEN COMBINATION SWITCH AND BCM

Carry out "BCM C/U" self-diagnosis.

Displayed results of self-diagnosis

NO MALFUNCTION DETECTED>> GO TO 3.

CAN COMMUNICATION OR CAN SYSTEM>> Inspect the BCM CAN communications system. Refer to [LAN-4, "CAN COMMUNICATION"](#).

OPEN DETECT 1 - 5>> Inspect combination switch system. Refer to [BCS-12, "Combination Switch Inspection According to Self-Diagnostic Results"](#).

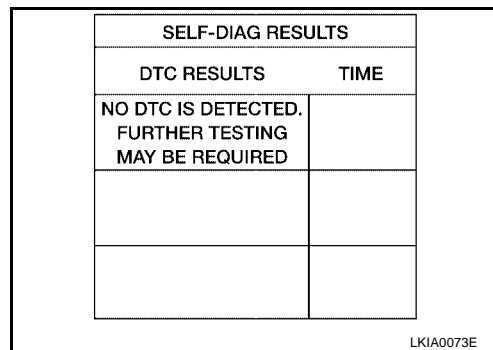

3. INSPECTION 2 BETWEEN COMBINATION SWITCH AND BCM

Select "BCM" on CONSULT-II. With "HEAD LAMP" data monitor, make sure "HI BEAM SW" turns ON-OFF linked with operation of lighting switch.

When lighting switch is in HIGH position : HI BEAM SW ON

OK or NG

- OK >> Replace BCM.
 NG >> Replace lighting switch. Refer to [LT-94, "Removal and Installation"](#).

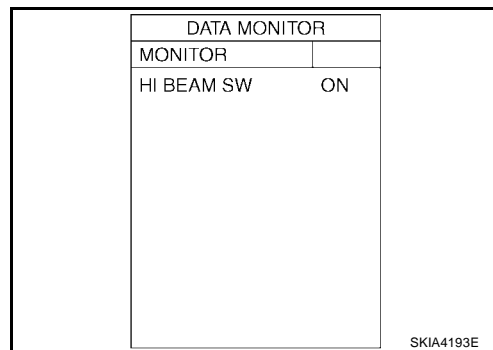

HEADLAMP (FOR USA)

4. CHECK HEADLAMP INPUT SIGNAL

1. Turn ignition switch OFF.
2. Disconnect headlamp RH and LH connector.
3. Select "IPDM E/R" on CONSULT-II and select "ACTIVE TEST" on "SELECT DIAG MODE" screen.
4. Select "LAMPS" on "SELECT TEST ITEM" screen.
5. Touch "HI" screen.
6. When headlamp high beam is operating, check voltage between headlamp RH and LH harness connector and ground.

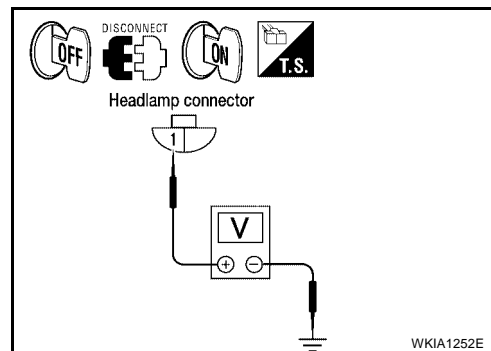

Terminals			Voltage
(+)		(-)	
Connector	Terminal (Wire color)		
RH	E110	1 (L/W)	Ground
LH	E11	1 (G)	
			Battery voltage

OK or NG

- OK >> GO TO 6.
 NG >> GO TO 5.

5. CHECK HEADLAMP CIRCUIT

1. Turn ignition switch OFF.
2. Disconnect IPDM E/R connector.
3. Check continuity between IPDM E/R harness connector E122 terminal 27 (L/W) and headlamp RH harness connector E110 terminal 1 (L/W).

27 (L/W) – 1 (L/W) : Continuity should exist.

4. Check continuity between IPDM E/R harness connector E122 terminal 28 (G) and headlamp LH harness connector E11 terminal 1 (G).

28 (G) – 1 (G) : Continuity should exist.

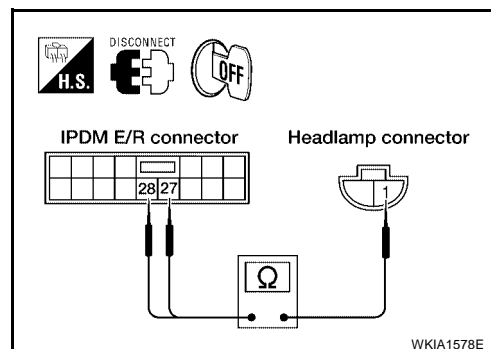

OK or NG

- OK >> Replace IPDM E/R. Refer to [PG-27, "Removal and Installation of IPDM E/R"](#) .
 NG >> Repair harness or connector.

6. CHECK HEADLAMP GROUND

1. Check continuity between headlamp RH harness connector E110 terminal 2 (B) and ground.

2 (B) – Ground : Continuity should exist.

2. Check continuity between headlamp LH harness connector E11 terminal 2 (B) and ground.

2 (B) – Ground : Continuity should exist.

OK or NG

- OK >> Check headlamp connector for damage or poor connection. Repair as necessary.
 NG >> Repair harness or connector.

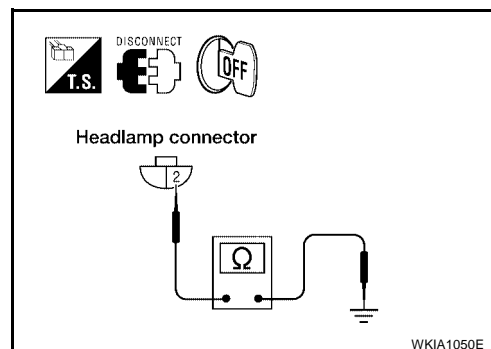

HEADLAMP (FOR USA)

EKS0070H

Headlamp HI Does Not Illuminate (One Side)

1. BULB INSPECTION

Inspect inoperative headlamp bulb.

OK or NG

OK >> GO TO 2.

NG >> Replace headlamp bulb. Refer to [LT-28, "HEADLAMP \(INNER SIDE\), FOR HIGH BEAM"](#) .

2. CHECK POWER TO HEADLAMP

1. Disconnect inoperative headlamp connector.
2. Turn the HI beam headlamps ON.
3. Check voltage between inoperative headlamp terminal and ground.

Terminals			(-)	Voltage (Approx.)
(+)		Terminal (Wire color)		
Connector				Ground
RH	E110	1 (L/W)	Ground	
LH	E11	1 (G)		

OK or NG

OK >> GO TO 3.

NG >> GO TO 4.

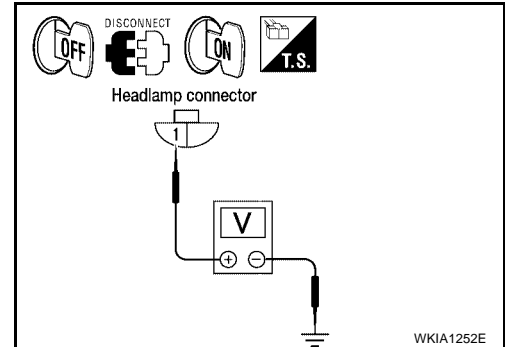

3. CHECK HEADLAMP GROUND

1. Turn the HI beam headlamps OFF.
2. Check continuity between inoperative headlamp connector and ground.

Terminals			(-)	Continuity
(+)		Terminal (Wire color)		
Connector				Ground
RH	E110	2 (B)	Ground	
LH	E11	2 (B)		

OK or NG

OK >> Check headlamp connector for damage or poor connection. Repair as necessary.

NG >> Repair open circuit in harness between inoperative headlamp and ground.

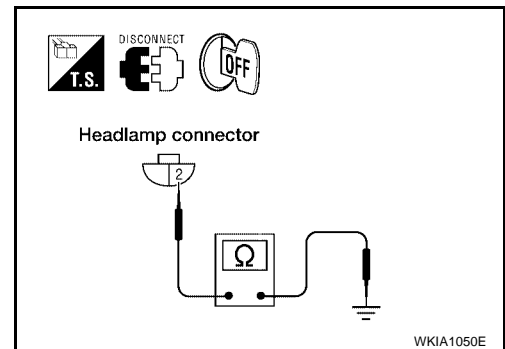

HEADLAMP (FOR USA)

4. INSPECTION BETWEEN IPDM E/R AND HEADLAMPS

1. Disconnect IPDM E/R connector and headlamp connector.
2. Check continuity between harness connector terminals of IPDM E/R and harness connector terminals of inoperative headlamp.

Terminals					Continuity
IPDM E/R		Headlamp			
Connector	Terminal (wire color)	Connector	Terminal (wire color)		
E122	27 (L/W)	Right	E110	1 (L/W)	Yes
	28 (G)	Left	E11	1 (G)	

OK or NG

OK >> Replace IPDM E/R. Refer to [PG-27, "Removal and Installation of IPDM E/R"](#) .

NG >> Check for short circuits and open circuits in harness between IPDM E/R and headlamps. Repair as necessary.

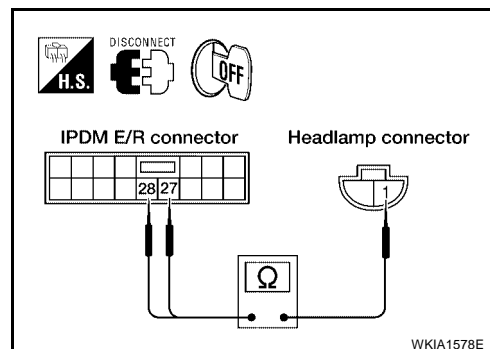

High-Beam Indicator Lamp Does Not Illuminate

EKS0070I

1. BULB INSPECTION

Inspect CAN communication system. Refer to [LAN-4, "CAN COMMUNICATION"](#) .

OK or NG

OK >> Replace combination meter. Refer to [IP-13, "Combination Meter"](#) .

NG >> Repair as necessary.

Headlamp LO Does Not Illuminate (Both Sides)

EKS0070J

1. HEADLAMP ACTIVE TEST

1. Select "IPDM E/R" on CONSULT-II and select "ACTIVE TEST" on "SELECT DIAG MODE" screen.
2. Select "LAMPS" on "SELECT TEST ITEM" screen.
3. Touch "LO" screen.
4. Make sure headlamp low beam operates.

Headlamp low beam should operate.

OK or NG

OK >> GO TO 2.

NG >> GO TO 4.

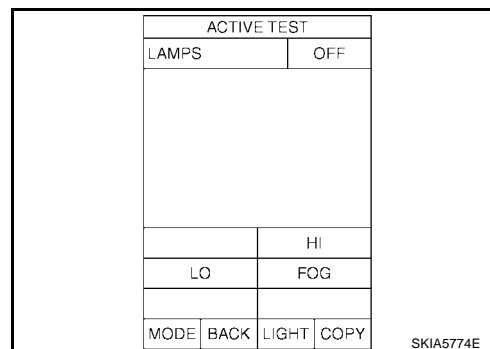

2. INSPECTION 1 BETWEEN COMBINATION SWITCH AND BCM

Carry out "BCM C/U" self-diagnosis.

Displayed results of self-diagnosis

NO MALFUNCTION DETECTED>> GO TO 3.

CAN COMMUNICATION OR CAN SYSTEM>> Inspect the BCM CAN communications system. Refer to [LAN-4, "CAN COMMUNICATION"](#) .

OPEN DETECT 1 - 5>> Inspect combination switch system. Refer to [BCS-12, "Combination Switch Inspection According to Self-Diagnostic Results"](#) .

HEAD LAMP 1 SW or HEAD LAMP 2 SW>> Replace combination switch. Refer to [LT-90, "Removal and Installation"](#) .

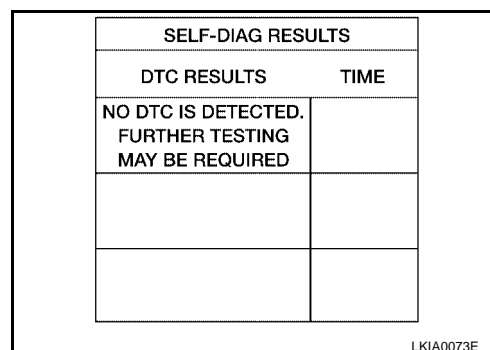

HEADLAMP (FOR USA)

3. INSPECTION 2 BETWEEN COMBINATION SWITCH AND BCM

Select "BCM" on CONSULT-II. With "HEAD LAMP" data monitor, make sure "HEAD LAMP SW1" and "HEAD LAMP SW2" turns ON-OFF linked with operation of lighting switch.

When lighting switch is in 2ND position :
HEAD LAMP SW1 ON
HEAD LAMP SW2 ON

OK or NG

- OK >> Replace BCM.
- NG >> Replace combination switch. Refer to [LT-90, "Removal and Installation"](#).

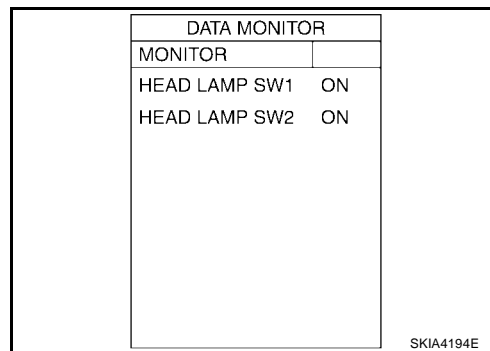

4. CHECK HEADLAMP INPUT SIGNAL

1. Turn ignition switch OFF.
2. Disconnect headlamp RH and LH connector.
3. Select "IPDM E/R" on CONSULT-II and select "ACTIVE TEST" on "SELECT DIAG MODE" screen.
4. Select "LAMPS" on "SELECT TEST ITEM" screen.
5. Touch "LO" screen.
6. When headlamp low beam is operating, check voltage between headlamp RH and LH harness connector and ground.

Terminals			Voltage
(+)		(-)	
Connector	Terminal (Wire color)		
RH	E107	1 (R/Y)	Ground
LH	E13	1 (L)	
			Battery voltage

OK or NG

- OK >> GO TO 6.
- NG >> GO TO 5.

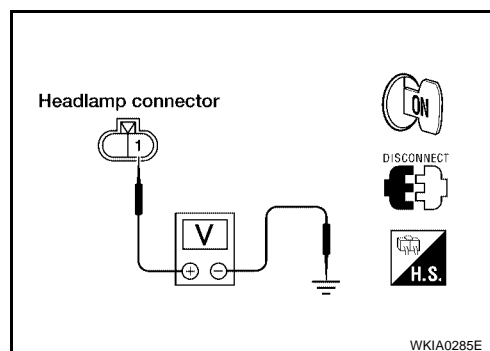

5. CHECK HEADLAMP CIRCUIT

1. Turn ignition switch OFF.
2. Disconnect IPDM E/R connector.
3. Check continuity between IPDM E/R harness connector E122 terminal 20 (R/Y) and headlamp RH harness connector E107 terminal 1 (R/Y).

20 (R/Y) – 1 (R/Y) : Continuity should exist.

4. Check continuity between IPDM E/R harness connector E122 terminal 30 (L) and headlamp LH harness connector E13 terminal 1 (L).

30 (L) – 1 (L) : Continuity should exist.

OK or NG

- OK >> Replace IPDM E/R. Refer to [PG-27, "Removal and Installation of IPDM E/R"](#).
- NG >> Repair harness or connector.

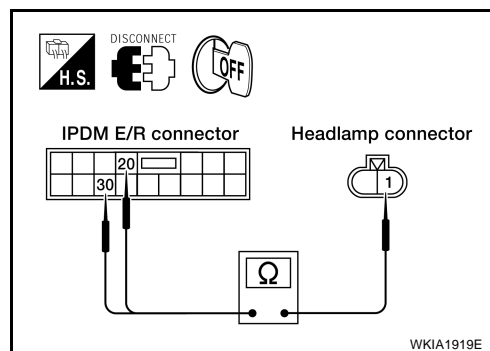

HEADLAMP (FOR USA)

6. CHECK HEADLAMP GROUND

1. Turn ignition switch OFF.
2. Check continuity between headlamp RH harness connector E107 terminal 2 (B) and ground.

2 (B) – Ground : Continuity should exist.

3. Check continuity between headlamp LH harness connector E13 terminal 2 (B) and ground.

2 (B) – Ground : Continuity should exist.

OK or NG

OK >> Check headlamp connector for damage or poor connection. Repair as necessary.

NG >> Repair harness or connector.

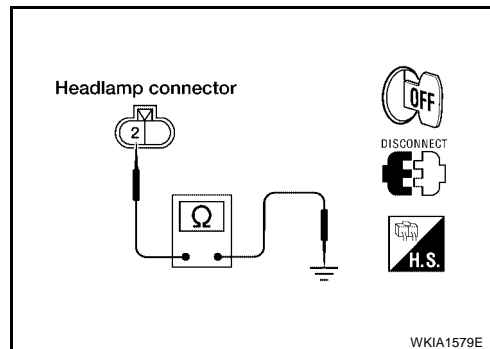

Headlamp LO Does Not Illuminate (One Side)

EKS0070K

1. BULB INSPECTION

Inspect inoperative headlamp bulb.

OK or NG

OK >> GO TO 2.

NG >> Replace headlamp bulb. Refer to [LT-28, "HEADLAMP \(OUTER SIDE\), FOR LOW BEAM \(HALO-GEN\)"](#).

2. CHECK POWER TO HEADLAMP

1. Disconnect inoperative headlamp connector.
2. Turn the low beam headlamps ON.
3. Check voltage between inoperative headlamp connector terminal and ground.

Terminals			Voltage (Approx.)
(+)		(-)	
Connector	Terminal		
Right	E107	1 (R/Y)	12
Left	E13	1 (L)	

OK or NG

OK >> GO TO 3.

NG >> GO TO 4.

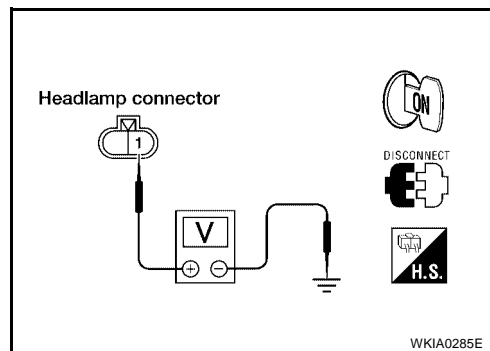

HEADLAMP (FOR USA)

3. CHECK HEADLAMP GROUND

1. Turn the low beam headlamps OFF.
2. Check continuity between inoperative headlamp connector terminal and ground.

Terminals				Continuity
(+)		(-)		
Connector	Terminal (Wire color)			
RH	E107	2 (B)		Yes
LH	E13	2 (B)		

OK or NG

OK >> Check headlamp and IPDM E/R connector. Repair as necessary.

NG >> Repair open circuit in harness between inoperative headlamp and ground.

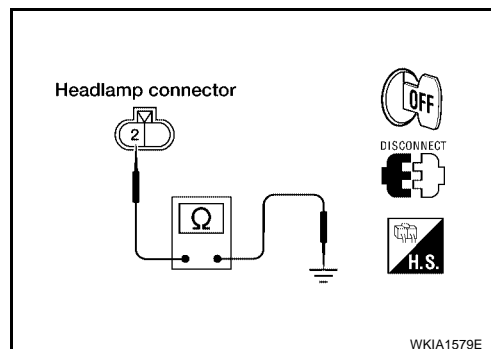

4. INSPECTION BETWEEN IPDM E/R AND HEADLAMPS

1. Disconnect IPDM E/R connector.
2. Check continuity between harness connector terminals of IPDM E/R harness connector terminals of inoperative headlamp.

Terminals					Continuity
IPDM E/R		Front combination lamp			
Connector	Terminal (Wire color)	Connector	Terminal (Wire color)		
E122	20 (R/Y)	RH	E107	1 (R/Y)	Yes
	30 (L)	LH	E13	1 (L)	

OK or NG

OK >> Replace IPDM E/R. Refer to [PG-27, "Removal and Installation of IPDM E/R"](#).

NG >> Check for short circuits and open circuits in harness between IPDM E/R and headlamps. Repair as necessary.

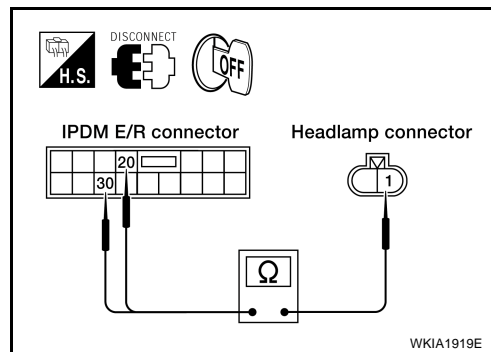

Headlamps Do Not Turn OFF

EKS0070L

1. CHECK COMBINATION SWITCH INPUT SIGNAL

Select "BCM" on CONSULT-II. With "HEAD LAMP" data monitor, make sure "HEAD LAMP SW 1" and "HEAD LAMP SW 2" turns ON-OFF linked with operation of lighting switch.

When lighting switch is OFF : HEAD LAMP SW 1 OFF
position : HEAD LAMP SW 2 OFF

OK or NG

OK >> Replace IPDM E/R. Refer to [PG-27, "Removal and Installation of IPDM E/R"](#).

NG >> GO TO 2.

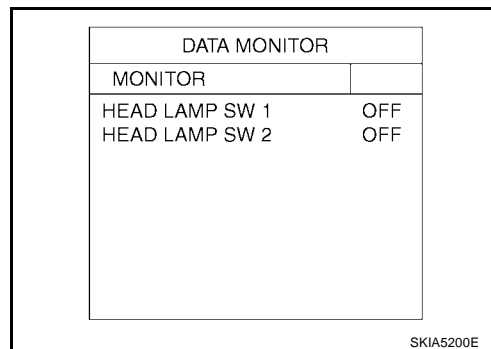

HEADLAMP (FOR USA)

2. CHECK LIGHTING SWITCH

Check lighting switch. Refer to [BCS-12, "Combination Switch Inspection According to Self-Diagnostic Results"](#)

OK or NG

OK >> GO TO 3.

NG >> Replace switch. Refer to [LT-90, "Removal and Installation"](#) .

3. CHECKING CAN COMMUNICATIONS BETWEEN BCM AND IPDM E/R

Select "BCM" by CONSULT-II and perform self-diagnosis for BCM.

Display of self-diagnosis results

NO DTC>>Replace IPDM E/R. Refer to [PG-27, "Removal and Installation of IPDM E/R"](#) .

CAN COMM CIRCUIT>> Refer to [BCS-12, "CAN Communication Inspection Using CONSULT-II \(Self-Diagnosis\)"](#) .

SELF-DIAG RESULTS			
DTC RESULTS		TIME	
CAN COMM CIRCUIT [U1000]		PAST	
ERASE		PRINT	
MODE	BACK	LIGHT	COPY

SKIA1039E

One Xenon Headlamp Does Not Illuminate At Full Brightness

EKS003MG

1. COMPONENT INSPECTION

1. Check the inoperative headlamp subharness for open or short circuits.

OK or NG

OK >> Replace headlamp bulb. Refer to [LT-28, "Bulb Replacement"](#) . Check operation of headlamp. If headlamp still does not illuminate at full brightness, replace ballast and check operation. If headlamp still does not illuminate at full brightness, replace igniter.

NG >> Replace headlamp subharness.

One Xenon Headlamp Flickers

EKS003MH

1. CHECK SYSTEM OPERATION

1. Turn the low beam headlamps ON and check operation.

NOTE:

Xenon headlamps may flicker momentarily when the headlamps are turned ON. This is normal and does not indicate a fault. Diagnosis of flickering headlamps should only be performed if the headlamps continue to flicker for more than 3 seconds after turning headlamps ON.

OK or NG

OK >> System is operating correctly.

NG >> GO TO 2.

2. COMPONENT INSPECTION

1. Check the inoperative headlamp subharness for open or short circuits.

OK or NG

OK >> Replace ballast. Check operation of headlamp. If headlamp still flickers, replace igniter and check operation. If headlamp still flickers, replace headlamp bulb. Refer to [LT-28, "Bulb Replacement"](#) .

NG >> Replace headlamp subharness.

HEADLAMP (FOR USA)

Aiming Adjustment

EKS003CE

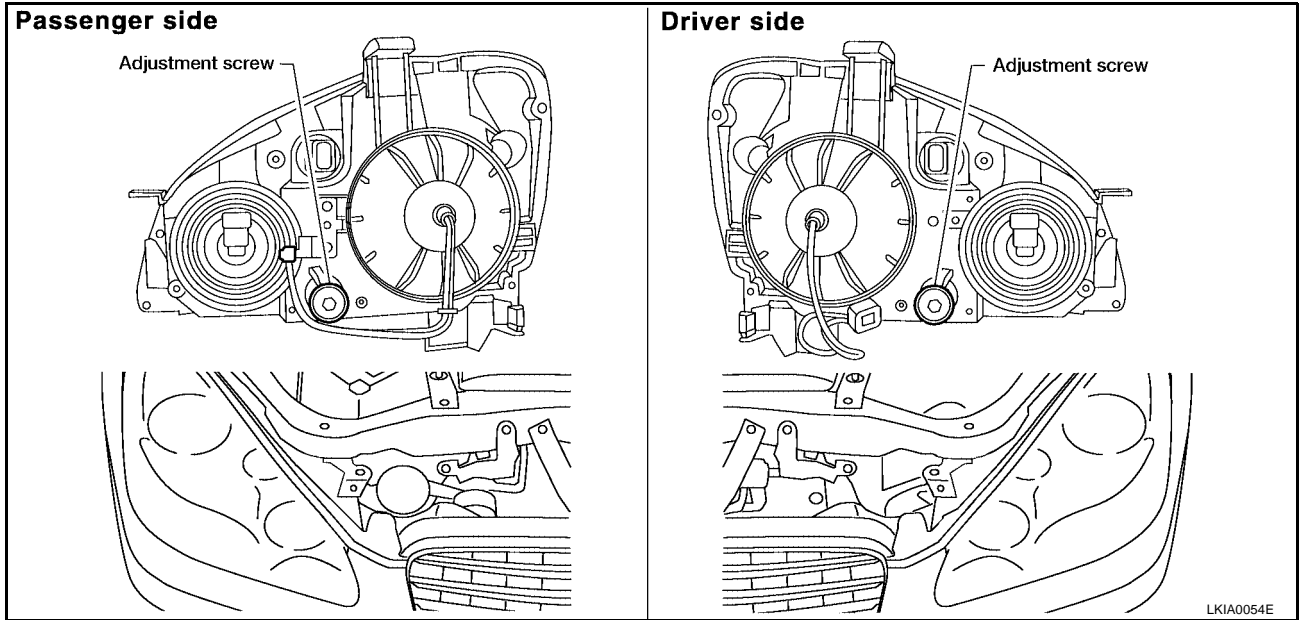

For details, refer to the regulations in your state.

Before performing aiming adjustment, check the following.

1. Ensure all tires are inflated to correct pressure.
2. Place vehicle on flat surface.
3. Ensure there is no load in vehicle other than the driver (or equivalent weight placed in driver's position). Coolant and engine oil filled to correct level, and fuel tank full.

LOW BEAM AND HIGH BEAM

1. Turn headlamp low beam on.
2. Use adjusting screws to perform aiming adjustment.

A
B
C
D
E
F
G
H
I
J
LT
L
M

HEADLAMP (FOR USA)

- First loosen the adjusting screw all the way and then make adjustment by tightening the screw.

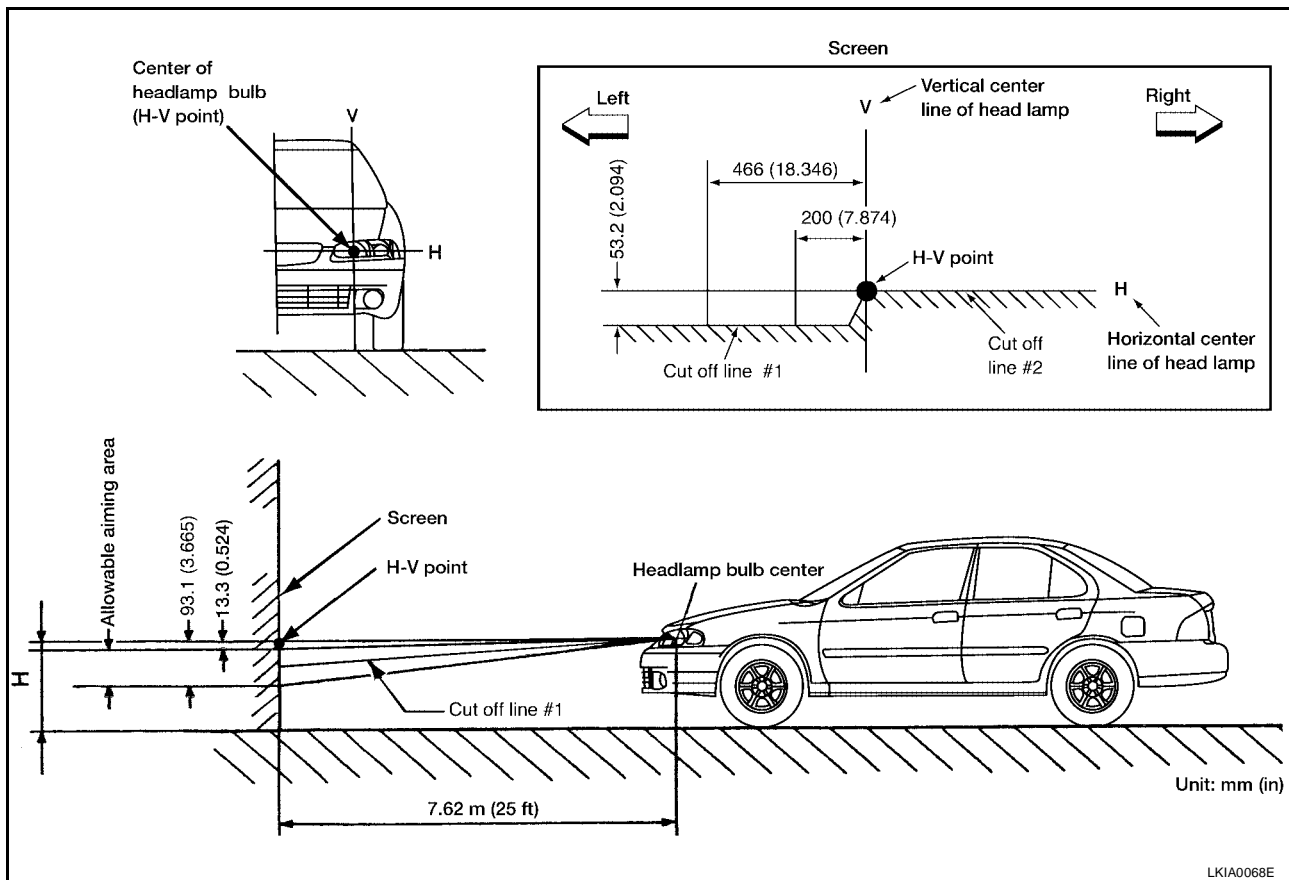

If the vehicle front body has been repaired and/or the headlamp assembly has been replaced, check aiming. Use the aiming chart shown in the figure.

- Basic illuminating area for adjustment should be within the range shown on the aiming chart. Adjust headlamps accordingly.

Bulb Replacement HEADLAMP (OUTER SIDE), FOR LOW BEAM (XENON)

EKS003CF

1. Disconnect negative battery cable.
2. Turn the plastic cap counterclockwise to unlock it from the headlamp.
3. Turn the bulb socket counterclockwise to unlock it.
4. Unlock the retaining spring and remove the bulb from the headlamp.
5. Install in reverse order of removal.

CAUTION:

After installing the bulb, be sure to install the plastic cap securely to ensure watertightness.

HEADLAMP (OUTER SIDE), FOR LOW BEAM (HALOGEN)

1. Disconnect negative battery cable.
2. Turn the plastic cap counterclockwise to unlock it from the headlamp.
3. Disconnect the electrical connectors from the bulb terminals.
4. Unlock the retaining spring and remove the bulb from the headlamp.
5. Install in reverse order of removal.

CAUTION:

After installing the bulb, be sure to install the plastic cap securely to ensure watertightness.

HEADLAMP (INNER SIDE), FOR HIGH BEAM

1. Turn the bulb counterclockwise to remove it.
2. Installation is reverse order of removal.

HEADLAMP (FOR USA)

FRONT TURN SIGNAL LAMP

1. Remove the headlamp. Refer to [LT-29, "Removal and Installation"](#) .
2. Turn the bulb socket counterclockwise to unlock it.
3. Push and turn the bulb counterclockwise to remove it.
4. Installation is reverse order of removal.

Headlamp (outer side), for low beam (Halogen) : 12V 55W (H1)

Headlamp (outer side), for low beam (Xenon) : 12V 35W (D2R)

Headlamp (inner side), for high beam : 12V 60W (HB3)

Front turn signal lamp : 12V 27W/8W (amber)

CAUTION:

After installing the bulb, be sure to install the bulb socket securely to ensure watertightness.

Removal and Installation

REMOVAL

1. Remove the front fascia. Refer to [EI-13, "FRONT BUMPER"](#) .
2. Ensure lighting switch is OFF.
3. Disconnect the negative battery cable.
4. Remove the headlamp mounting bolts.
5. Pull the headlamp toward the front of the vehicle, disconnect connectors, and remove from vehicle.

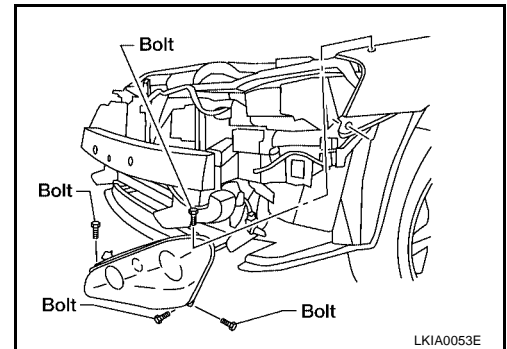

INSTALLATION

Install in the reverse order of removal.

Headlamp mounting bolts:

 **4.4 - 6.4 N·m (0.45 - 0.65 kg-m, 39 - 56 in-lb)**

A
B
C
D
E
F
G
H
I
J
LT
L
M

HEADLAMP (FOR USA)

EKS003CH

Disassembly and Assembly

DISASSEMBLY

Xenon

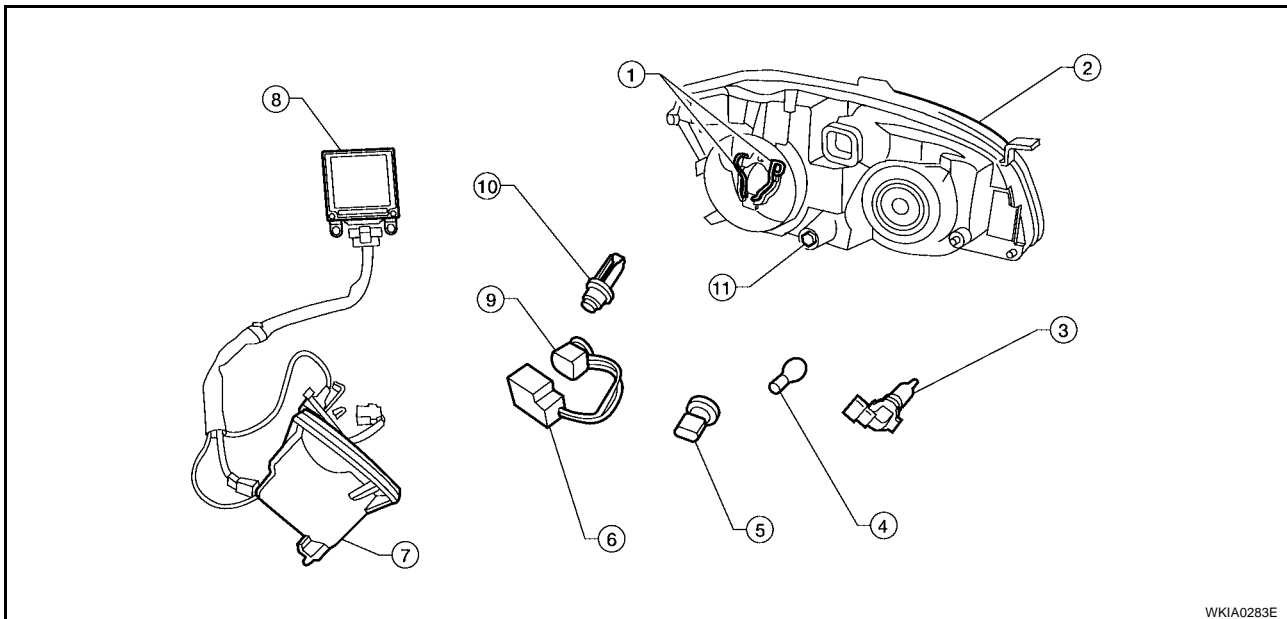

WKIA0283E

- | | | |
|--------------------------------|----------------------------------|-----------------------------|
| 1. Retaining springs | 2. Headlamp assembly | 3. Halogen bulb (high beam) |
| 4. Front turn signal lamp bulb | 5. Front turn signal bulb socket | 6. Ignitor |
| 7. Plastic cap | 8. Ballast | 9. Xenon bulb socket |
| 10. Xenon bulb (low beam) | 11. Aiming adjustment screw | |

Halogen

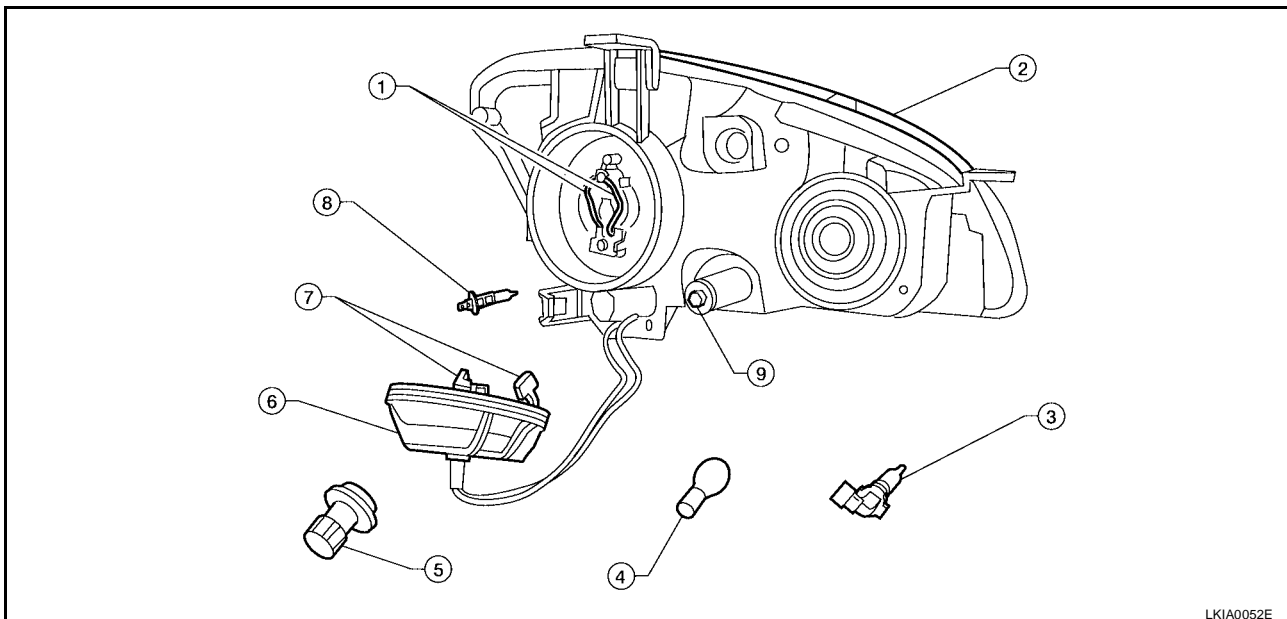

LKIA0052E

- | | | |
|--|----------------------------------|-----------------------------|
| 1. Retaining springs | 2. Headlamp assembly | 3. Halogen bulb (high beam) |
| 4. Front turn signal lamp bulb | 5. Front turn signal bulb socket | 6. Plastic cap |
| 7. Bulb terminal electrical connectors | 8. Halogen bulb (low beam) | 9. Aiming adjustment screw |

1. Turn the low beam plastic cap counterclockwise to unlock and remove it.
2. Turn the bulb socket counterclockwise to unlock and remove it (xenon).
3. Disconnect the electrical connectors from the bulb terminals (halogen).
4. Unlock the retaining springs and remove the low beam bulb.
5. Release the ignitor and remove from the plastic cap (xenon).

HEADLAMP (FOR USA)

6. Turn the high beam lamp socket counterclockwise to unlock and remove it.
7. Turn the front turn signal lamp bulb socket counterclockwise and unlock it.
8. Remove the front turn signal lamp bulb from its socket.

ASSEMBLY

Assemble in the reverse order of disassembly.

CAUTION:

- After installing the xenon bulb, be sure to install the bulb socket and plastic cap securely to ensure watertightness.

A

B

C

D

E

F

G

H

I

J

LT

L

M

HEADLAMP (FOR CANADA) - DAYTIME LIGHT SYSTEM -

HEADLAMP (FOR CANADA) - DAYTIME LIGHT SYSTEM -

PF2:26010

Component Parts and Harness Connector Location

EKS003CI

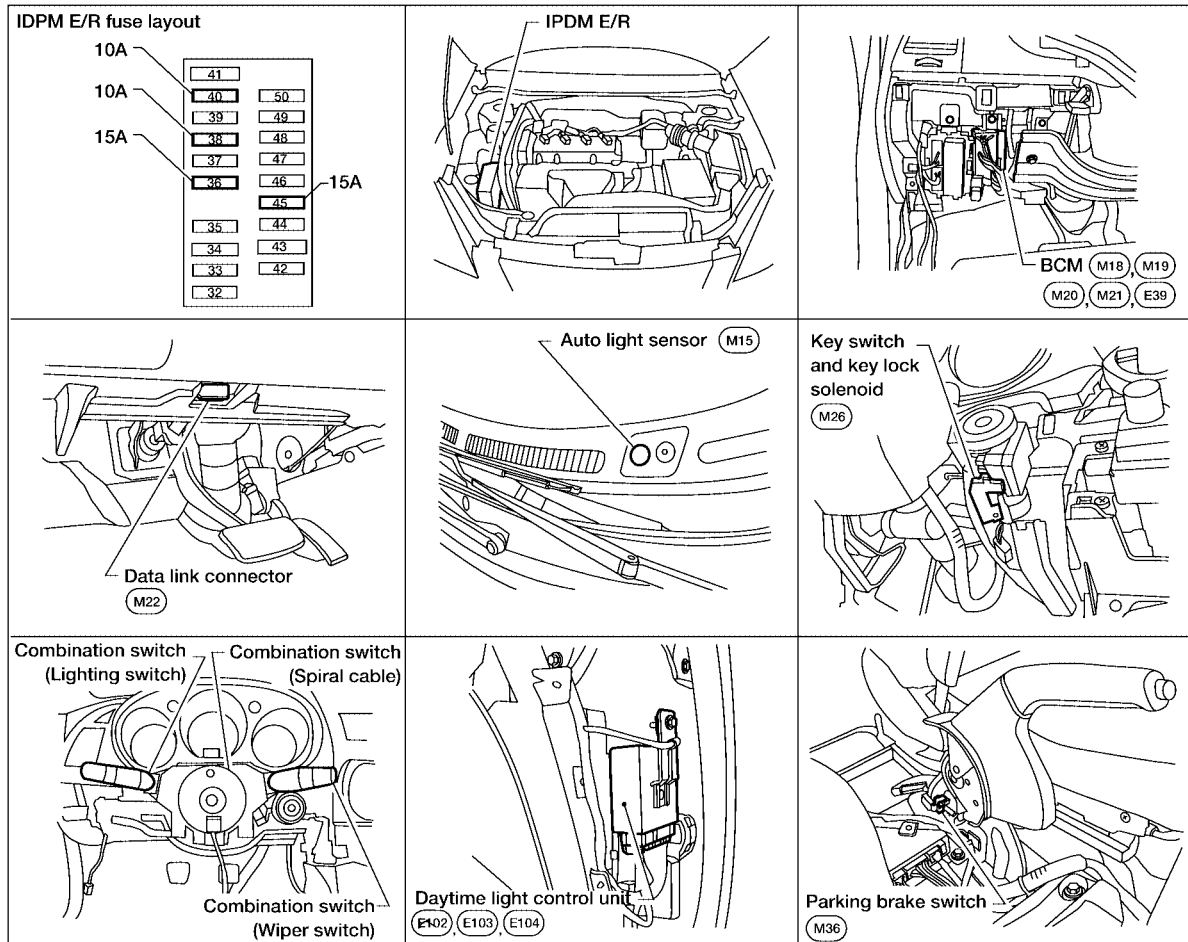

WKIA1581E

System Description

EKS003CJ

The headlamp system for Canada vehicles is equipped with a daytime light control unit that activates the high beam headlamps at approximately half illumination whenever the engine is running. If the parking brake is applied before the engine is started the daytime lights will not be illuminated. The daytime lights will illuminate once the parking brake is released. Thereafter, the daytime lights will continue to operate when the parking brake is applied.

Battery saver system is controlled by the BCM (body control module).

Power is supplied at all times

- to headlamp high relay located in the IPDM E/R (intelligent power distribution module engine room).

Power is also supplied at all times

- to BCM terminal 7
- through 50A fusible link (letter **f**, located in the fuse and fusible link box).

With the ignition switch in the ON or START position, power is supplied

- to daytime light control unit terminal 3 and
- to BCM terminal 35
- through 10A fuse [No. 12, located in the fuse block (J/B)].

With the ignition switch in the ACC or ON position, power is supplied

- to BCM terminal 36
- through 10A fuse [No. 6, located in the fuse block (J/B)].

With the ignition switch in the START position, power is supplied

- to daytime light control unit terminal 2

HEADLAMP (FOR CANADA) - DAYTIME LIGHT SYSTEM -

- through 10A fuse [No. 9, located in the fuse block (J/B)].

Ground is supplied

- to daytime light control unit terminals 13, 14, and 16
- through body grounds E15 and E24, and
- to BCM terminals 8, 27, and 63
- through body grounds F14 (QR25DE models), M57, M61, E15, and E24.

HEADLAMP OPERATION

Low Beam Operation

With the lighting switch in 2ND position, the BCM receives input requesting the headlamps to illuminate. This input is communicated to the IPDM E/R across the CAN communication lines. The central processing unit of the IPDM E/R controls the headlamp low relay coil. When energized, this relay directs power

- to 15A fuse (No. 36, located in the IPDM E/R)
- through terminal 20 of the IPDM E/R
- to terminal 1 of headlamp RH, and
- to 15A fuse (No. 45, located in the IPDM E/R)
- through terminal 30 of the IPDM E/R
- to terminal 1 of headlamp LH.

Ground is supplied at all times

- to terminal 2 of headlamp RH
- through body grounds E15 and E24, and
- to terminal 2 of headlamp LH
- through body grounds E15 and E24.

With power and ground supplied, low beam headlamps illuminate.

High Beam Operation/Flash-to-Pass Operation

With the lighting switch in 2ND position and placed in HIGH or PASS position, the BCM receives input requesting the headlamp high beams to illuminate. This input is communicated to the IPDM E/R across the CAN communication lines. The central processing unit of the IPDM E/R controls the headlamp high relay coil. When energized, this relay directs power

- to 10A fuse (No. 40, located in the IPDM E/R)
- through terminal 27 of the IPDM E/R
- to terminal 4 of the daytime light control unit
- through terminal 7 of the daytime light control unit
- to terminal 1 of headlamp RH, and
- to 10A fuse (No. 38, located in the IPDM E/R)
- through terminal 28 of the IPDM E/R
- to terminal 5 of the daytime light control unit
- through terminal 6 of the daytime light control unit
- to terminal 1 of headlamp LH.

Ground is supplied

- to terminal 2 of headlamp RH
- to terminal 9 of the daytime light control unit
- through terminal 14 of the daytime light control unit
- through body grounds E15 and E24, and
- to terminal 2 of headlamp LH
- to terminal 10 of the daytime light control unit
- through terminal 13 of the daytime light control unit
- through body grounds E15 and E24.

With power and ground supplied, the high beam headlamps and the HIGH BEAM indicator illuminate.

A

B

C

D

E

F

G

H

I

J

LT

L

M

HEADLAMP (FOR CANADA) - DAYTIME LIGHT SYSTEM -

BATTERY SAVER CONTROL

With the combination switch (lighting switch) is in the 2ND position (ON), and the ignition switch is turned from ON or ACC to OFF, the battery saver control feature is activated.

Under this condition, the headlamps remain illuminated for 5 minutes, unless the combination switch (lighting switch) position is changed. If the combination switch (lighting switch) position is changed, then the headlamps are turned off.

AUTO LIGHT OPERATION

For auto light operation, refer to [LT-46, "System Description"](#) .

DAYTIME LIGHT OPERATION

With the engine running, the lighting switch in the OFF or 1ST position and parking brake released, power is supplied

- through daytime light control unit terminal 7
- to terminal 1 of RH headlamp
- through terminal 2 of RH headlamp
- to daytime light control unit terminal 9
- through daytime light control unit terminal 6
- to terminal 1 of LH headlamp
- through terminal 2 of LH headlamp
- to daytime light control unit terminal 10.

Ground is supplied

- to daytime light control unit terminals 13, 14, and 16
- through body grounds E15 and E24.

Because the high beam headlamps are now wired in series, they operate at half illumination.

XENON HEADLAMP (IF EQUIPPED)

The low beam headlamps may be equipped with xenon type bulbs. Xenon bulbs do not use a filament. Instead, they produce light when a high voltage current is passed between two tungsten electrodes through a mixture of xenon (an inert gas) and certain other metal halides. In addition to added lighting power, electronic control of the power supply gives the headlamps stable quality and tone color.

Following are some of the advantages of the xenon type headlamp.

- The light produced by the headlamps is a white color comparable to sunlight that is easy on the eyes.
- Light output is nearly double that of halogen headlamps, affording increased area of illumination.
- The light features a high relative spectral distribution at wavelengths to which the human eye is most sensitive. This means that even in the rain, more light is reflected back from the road surface toward the vehicle, for added visibility.
- Power consumption is approximately 25 percent less than halogen headlamps, reducing battery load.

OPERATION

After starting the engine with the lighting switch in the "OFF" or 1ST position, the headlamp high beam automatically turns on. Lighting switch operations other than the above are the same as conventional light systems.

Engine		With engine stopped									With engine running								
		OFF			1ST			2ND			OFF			1ST			2ND		
Lighting switch		Hi	Lo	P	Hi	Lo	P	Hi	Lo	P	Hi	Lo	P	Hi	Lo	P	Hi	Lo	P
		Headlamp	High beam	-	-	-	-	-	x	x	-	x	●*	●*	x	●*	●*	x	x
Low beam	-		-	-	-	-	x	x	x	x	-	-	x	-	-	x	x	x	x
Tail lamp		-	-	-	x	x	x	x	x	x	-	-	-	x	x	x	x	x	x
License and instrument illumination lamp		-	-	-	x	x	x	x	x	x	-	-	-	x	x	x	x	x	x

- Hi: "HIGH BEAM" position
- Lo: "LOW BEAM" position
- P: "FLASH TO PASS" position

HEADLAMP (FOR CANADA) - DAYTIME LIGHT SYSTEM -

- ×: Lamp "ON"
- -: Lamp "OFF"
- ●: Lamp dims. (Added functions)
- *: When starting the engine with the parking brake released, the daytime lights will operate.
When starting the engine with the parking brake pulled, the daytime lights will not operate.

CAN Communication System Description

EKS003CK

Refer to [LAN-4, "CAN COMMUNICATION"](#).

A

B

C

D

E

F

G

H

I

J

LT

L

M

HEADLAMP (FOR CANADA) - DAYTIME LIGHT SYSTEM -

Schematic HALOGEN

EKS003CL

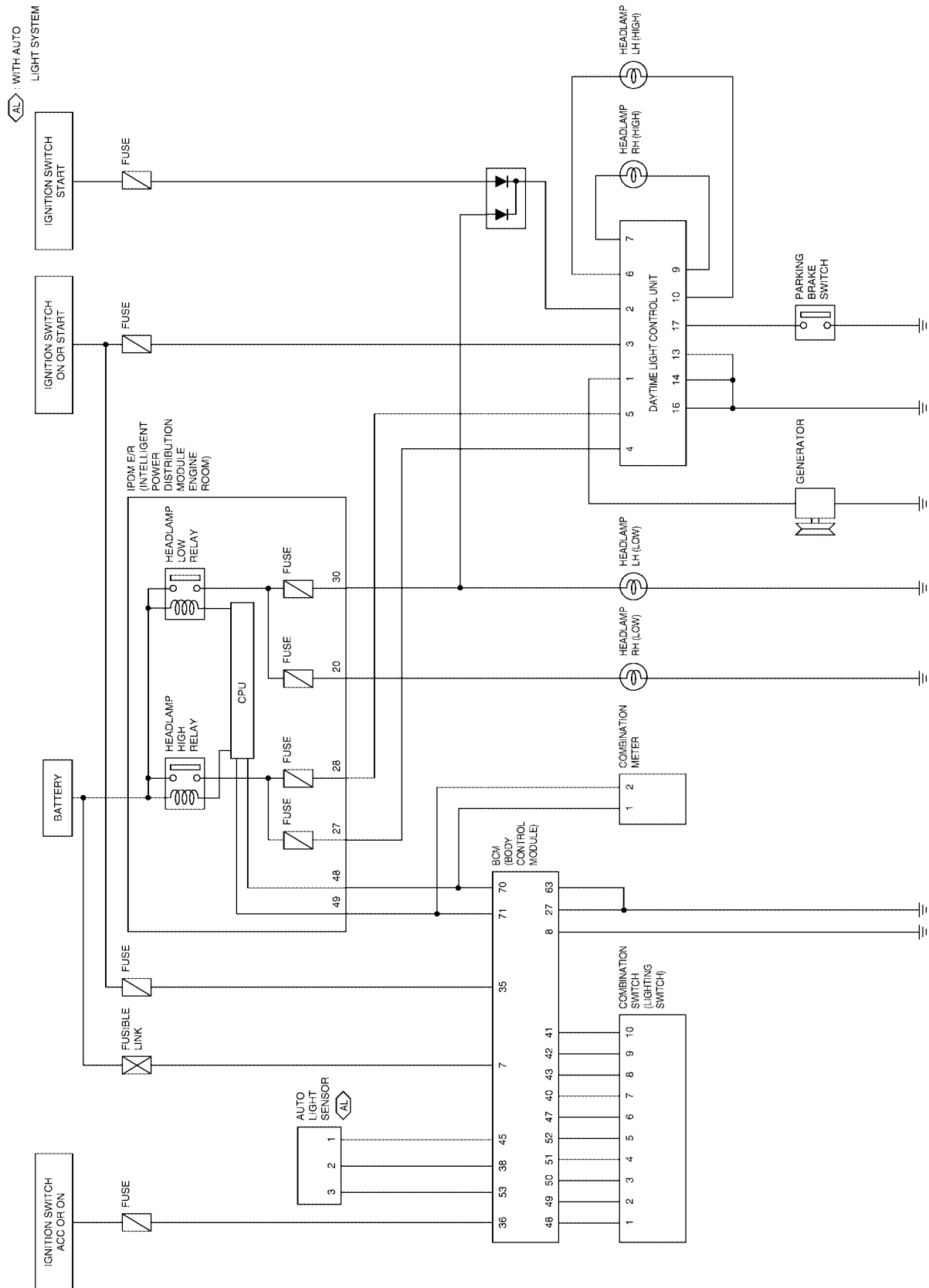

WKWA0874E

HEADLAMP (FOR CANADA) - DAYTIME LIGHT SYSTEM -

XENON

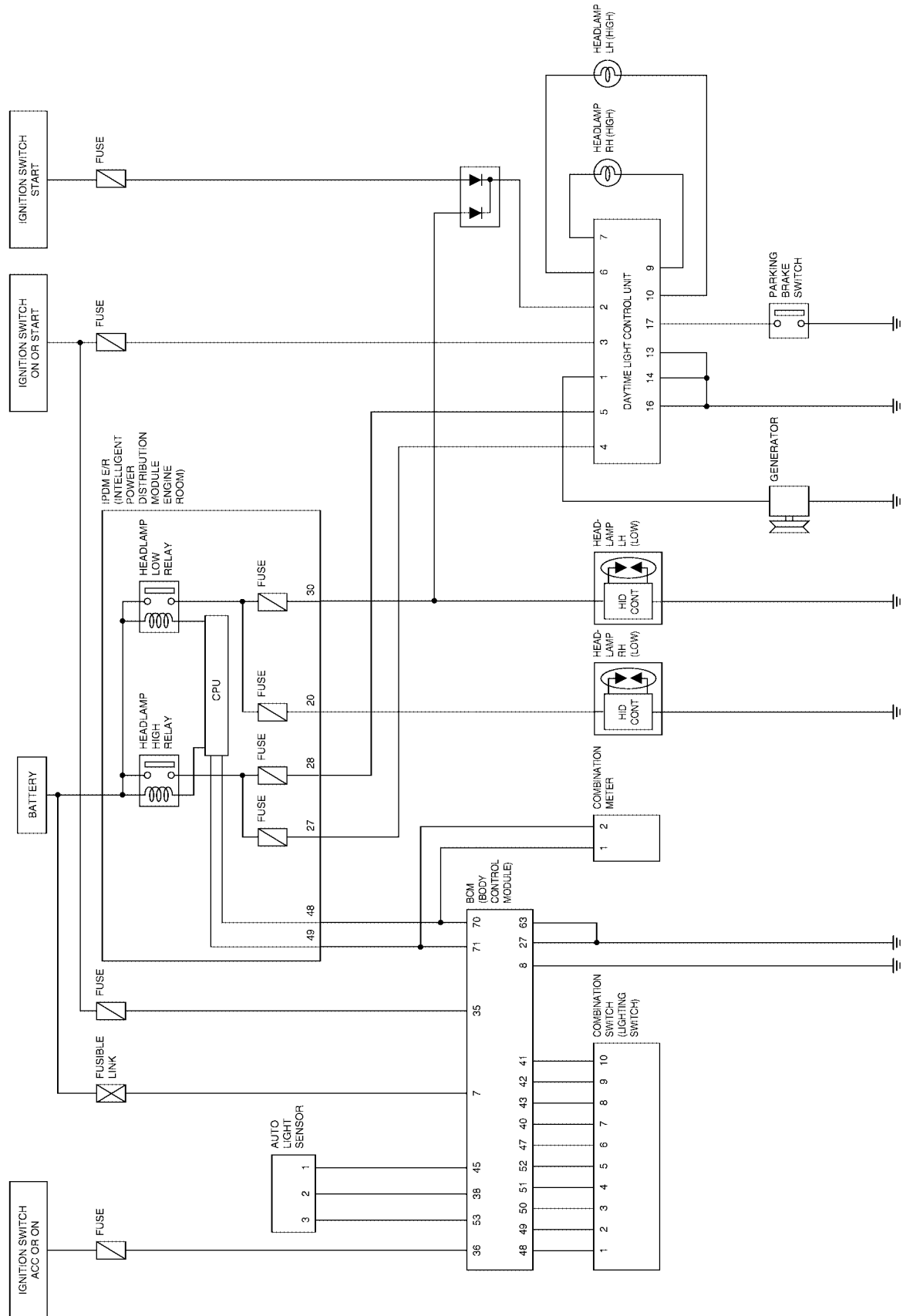

A
B
C
D
E
F
G
H
I
J
LT
L
M

WKWA0875E

HEADLAMP (FOR CANADA) - DAYTIME LIGHT SYSTEM -

EKS003CM

Wiring Diagram — DTRL — HALOGEN

LT-DTRL-01

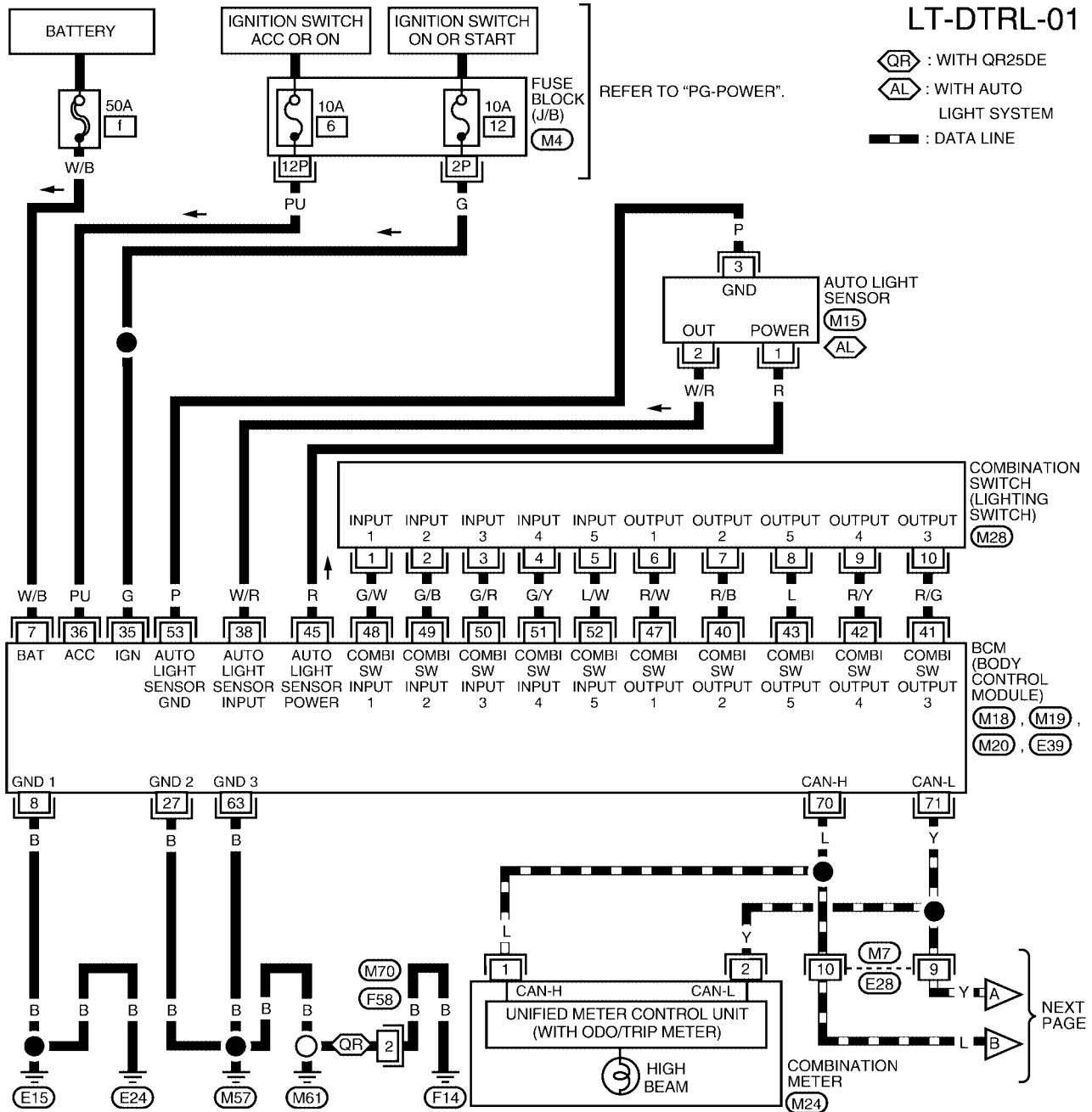

NEXT PAGE

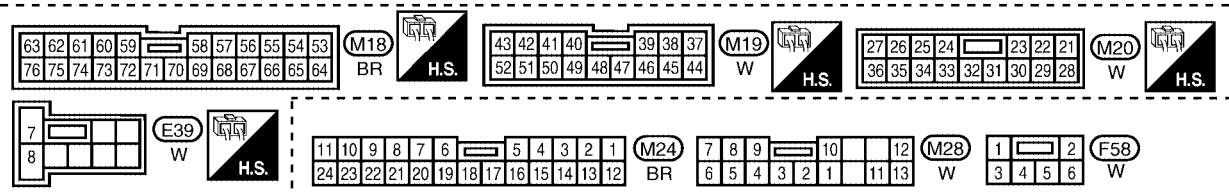
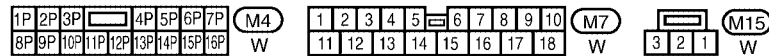

WKWA0876E

HEADLAMP (FOR CANADA) - DAYTIME LIGHT SYSTEM -

LT-DTRL-02

— : DATA LINE

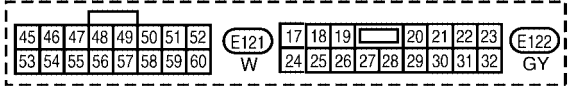
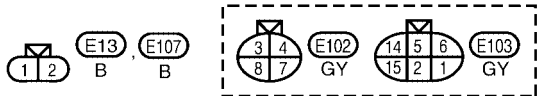
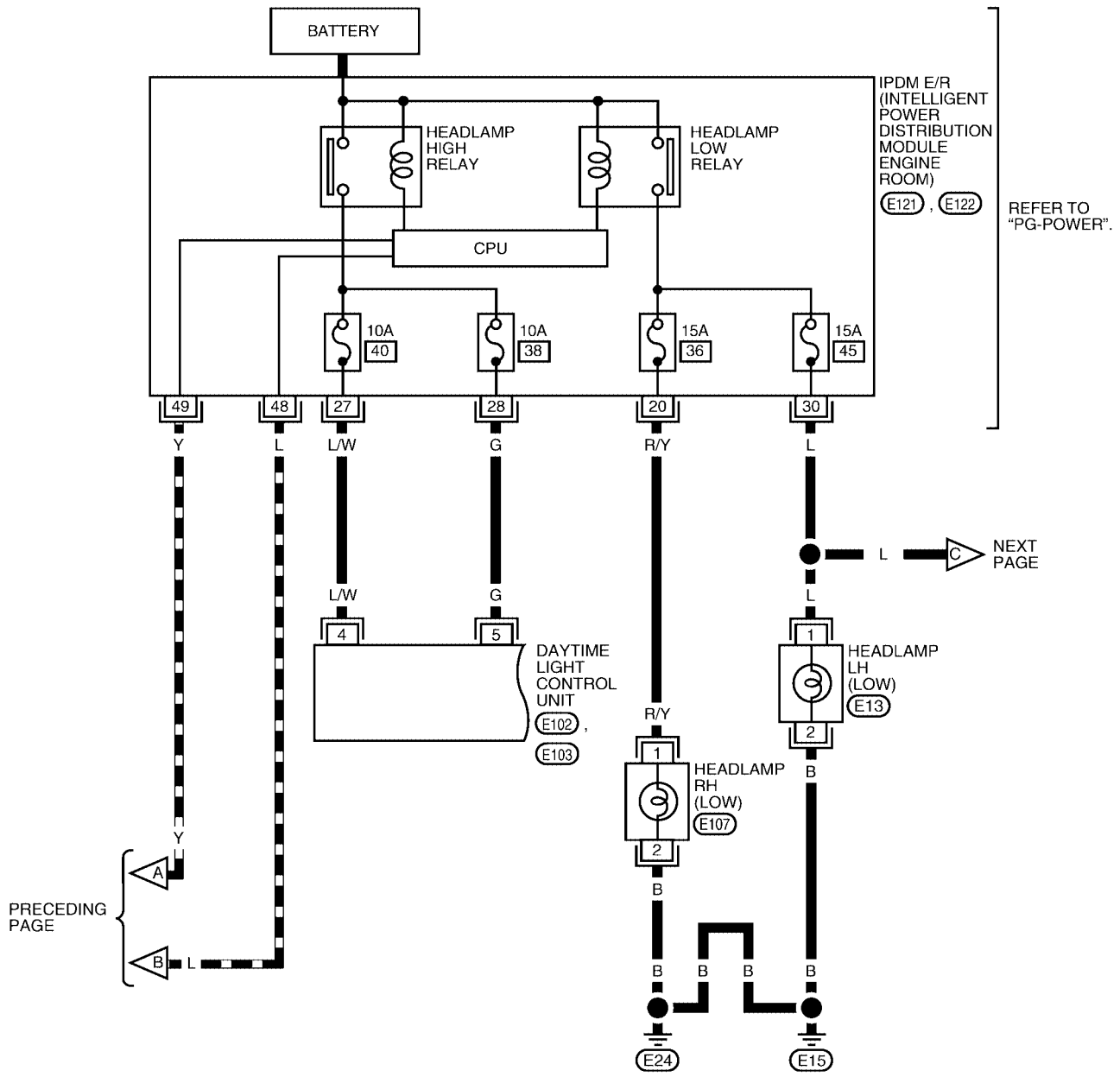

WKWA0877E

HEADLAMP (FOR CANADA) - DAYTIME LIGHT SYSTEM -

LT-DTRL-03

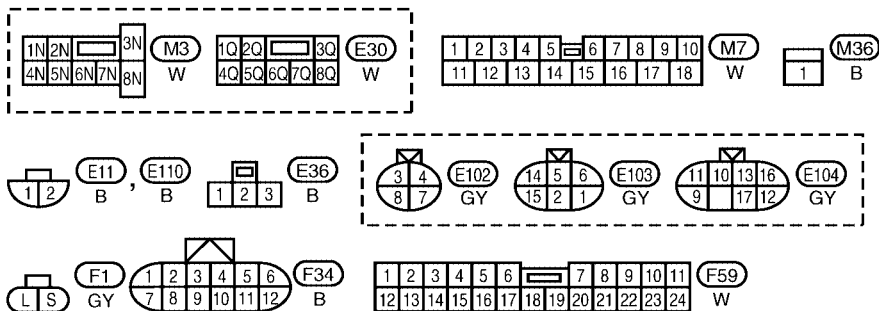
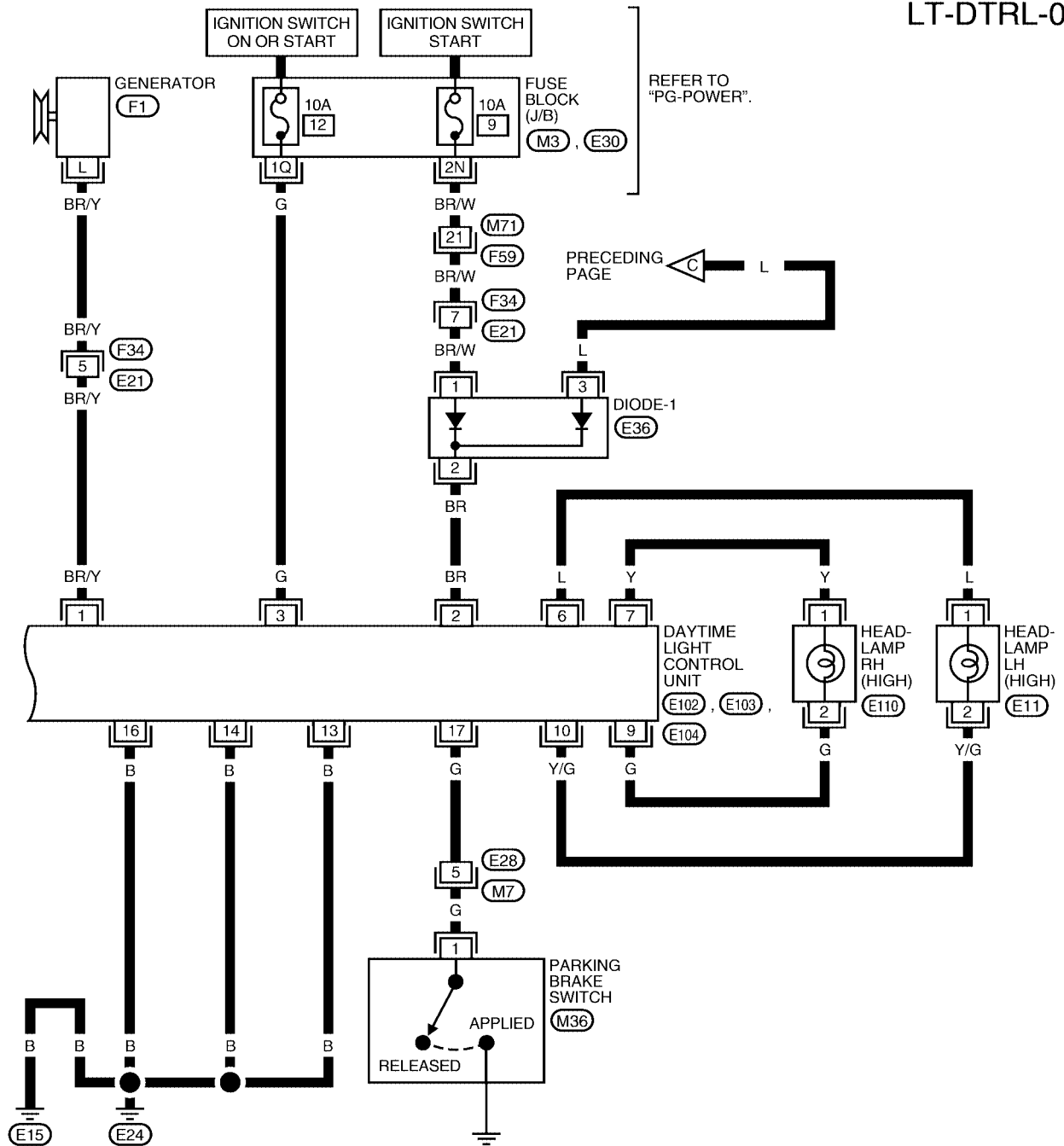

WKWA0878E

HEADLAMP (FOR CANADA) - DAYTIME LIGHT SYSTEM -

XENON

LT-DTRL-04

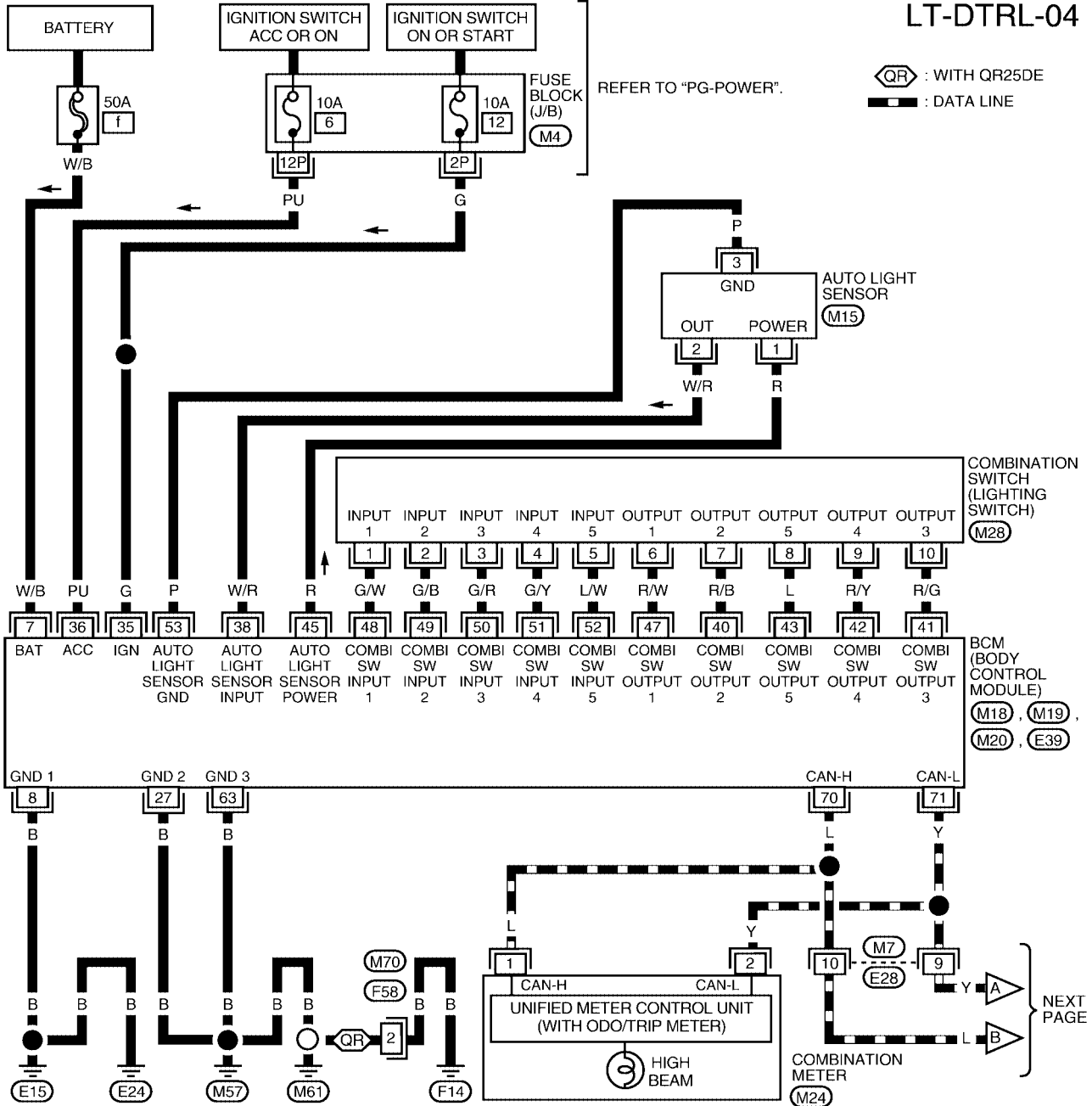

A
B
C
D
E
F
G
H
I
J
LT
L
M

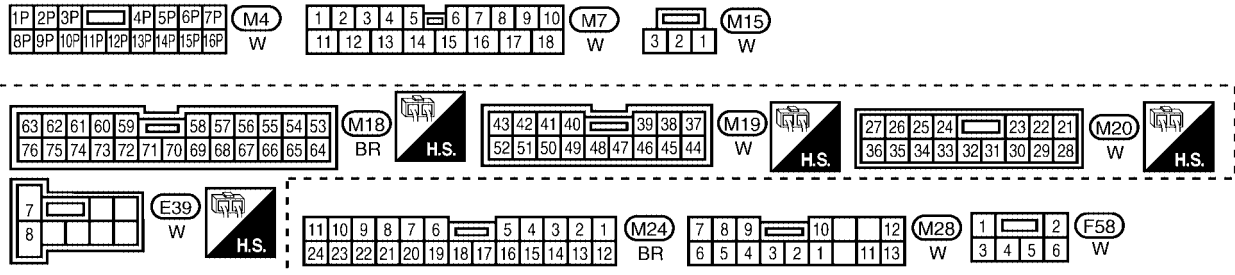

WKWA0879E

HEADLAMP (FOR CANADA) - DAYTIME LIGHT SYSTEM -

LT-DTRL-05

— : DATA LINE

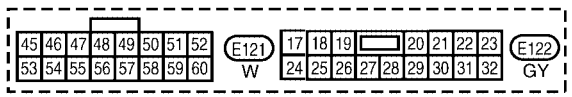
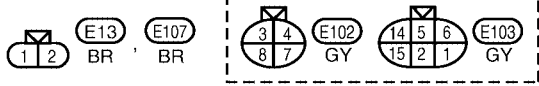
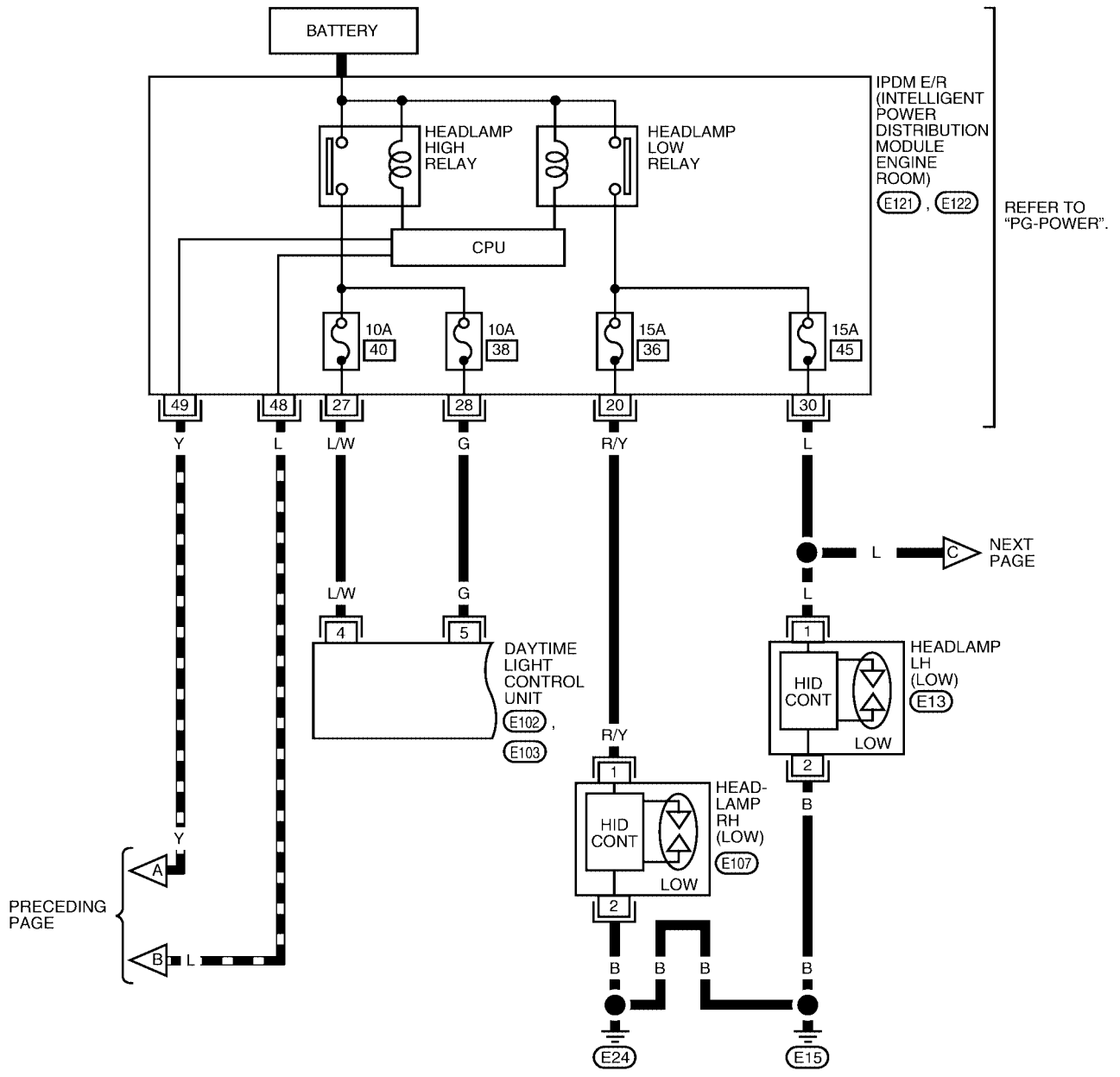

WKWA0880E

HEADLAMP (FOR CANADA) - DAYTIME LIGHT SYSTEM -

LT-DTRL-06

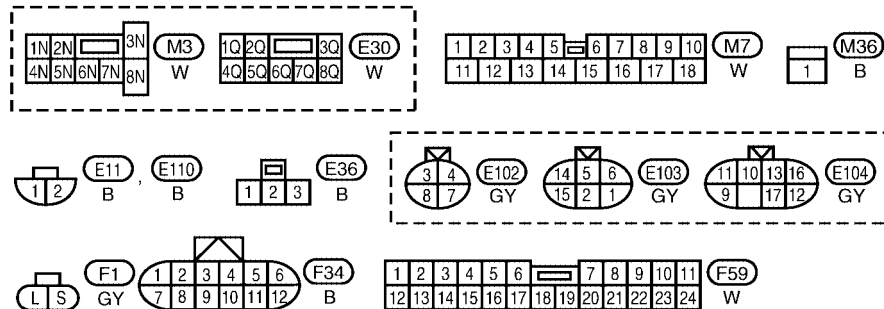
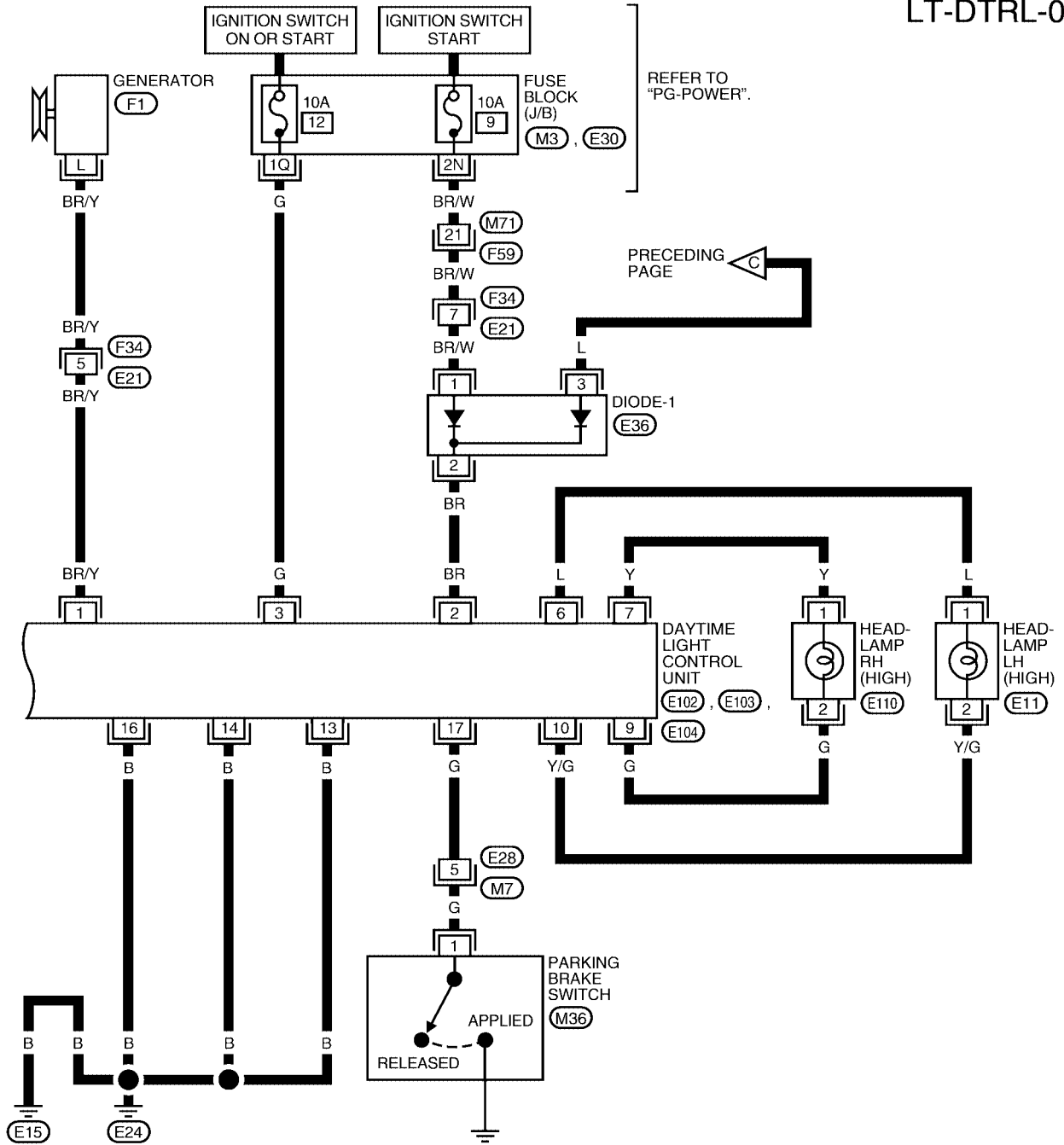

WKWA0881E

HEADLAMP (FOR CANADA) - DAYTIME LIGHT SYSTEM -

Terminals and Reference Value for Daytime Light Control Unit

EKS003CN

Terminal No.	Wire color	Item	Condition	Voltage (Approx.)
1	BR/Y	Generator	When turning ignition switch to "ON"	Less than 1V
			When engine is running	Battery voltage
			When turning ignition switch to "OFF"	Less than 1V
2	BR	Start signal	When turning ignition switch to "START"	Battery voltage
			When turning ignition switch to "ON" from "START"	Less than 1V
			When turning ignition switch to "OFF"	Less than 1V
3	G	Power source	When turning ignition switch to "ON"	Battery voltage
			When turning ignition switch to "START"	Battery voltage
			When turning ignition switch to "OFF"	Less than 1V
4	L/W	LH light fuse	When lighting switch is turned to the 2ND position with "HI BEAM" or "FLASH TO PASS" position	Battery voltage
			When lighting switch is turned to "FLASH TO PASS" position with ignition switch "ON" position	Battery voltage
5	G	RH light fuse	When lighting switch is turned to the 2ND position with "HI BEAM" or "FLASH TO PASS" position	Battery voltage
			When lighting switch is turned to "FLASH TO PASS" position with ignition switch "ON" position	Battery voltage
6	L	LH HI beam	When lighting switch is turned to the 2ND position with "HI BEAM" or "FLASH TO PASS" position	Battery voltage
			When releasing parking brake with engine running and turning lighting switch to "OFF" (daytime light operation) CAUTION: Block wheels and ensure selector lever is in N or P position.	Half battery voltage
7	Y	RH HI beam	When lighting switch is turned to the 2ND position with "HI BEAM" or "FLASH TO PASS" position	Battery voltage
			When releasing parking brake with engine running and turning lighting switch to "OFF" (daytime light operation) CAUTION: Block wheels and ensure selector lever is in N or P position.	Battery voltage
9	G	RH HI beam (ground)	When turning lighting switch to the 2ND position with "HI BEAM" or "FLASH TO PASS" position	Less than 1V
			When releasing parking brake with engine running and turning lighting switch to "OFF" (daytime light operation) CAUTION: Block wheels and ensure selector lever is in N or P position.	Half battery voltage
10	Y/G	LH HI beam (ground)	When turning lighting switch to the 2ND position with "HI BEAM" or "FLASH TO PASS" position	Less than 1V
			When releasing parking brake with engine running and turning lighting switch to "OFF" (daytime light operation) CAUTION: Block wheels and ensure selector lever is in N or P position.	Less than 1V
13	B	Ground	—	—
14	B	Ground	—	—
16	B	Ground	—	—

HEADLAMP (FOR CANADA) - DAYTIME LIGHT SYSTEM -

Terminal No.	Wire color	Item	Condition	Voltage (Approx.)
17	G	Parking brake switch	When parking brake is released	Battery voltage
			When parking brake is set	Less than 1.7V

Aiming Adjustment

EKS003CO

Refer to [LT-27, "Aiming Adjustment"](#) .

Bulb Replacement

EKS003CP

Refer to [LT-28, "Bulb Replacement"](#) .

Removal and Installation

EKS003CQ

Refer to [LT-29, "Removal and Installation"](#) .

Disassembly and Assembly

EKS003CR

Refer to [LT-30, "Disassembly and Assembly"](#) .

A
B
C
D
E
F
G
H
I
J
LT
L
M

LT

AUTO LIGHT SYSTEM

PFP:28491

Component Parts and Harness Connector Location

EKS003CS

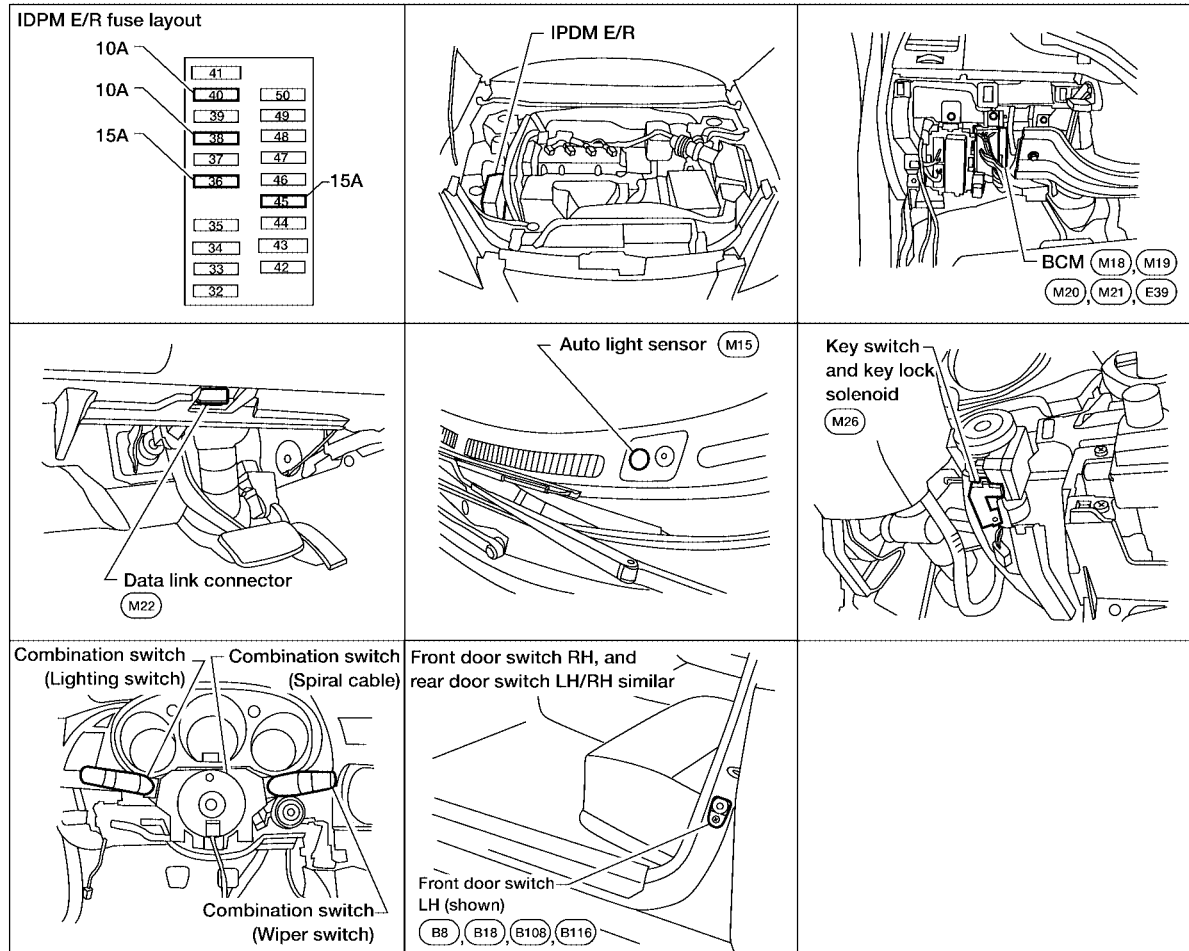

WKIA1582E

System Description

EKS003CT

This system automatically turns the parking lamps and the headlamps on and off in accordance with ambient light.

Timing for when the lamps turn on/off can be selected using four modes.

OUTLINE

The auto light control system uses an optical sensor that detects the brightness of outside light.

When the lighting switch is in AUTO position, it automatically turns on/off the parking lamps and the headlamps (and fog lamps, if equipped) in accordance with the ambient light. Sensitivity can be adjusted in four steps. For the details of the setting, refer to [LT-60, "SETTING CHANGE FUNCTIONS"](#).

When the lighting switch is in "AUTO" position, power is supplied

- from BCM (body control module) terminal 45
- to auto light sensor terminal 1.

When lighting switch is in "AUTO" position, ground is supplied

- from BCM terminal 53
- to auto light sensor terminal 3.

When ignition switch is turned to "ON" or "START" position and when outside brightness is darker than prescribed level, input is supplied

- to BCM terminal 38
- from auto light sensor terminal 2.

The headlamps will then illuminate. For a description of headlamp operation, refer to [LT-6, "System Description"](#) (USA) or [LT-32, "System Description"](#) (Canada).

AUTO LIGHT SYSTEM

BATTERY SAVER CONTROL

When the combination switch (lighting switch) is in the AUTO position, and the ignition switch is turned from ON or ACC to OFF, and one of the doors is opened, the battery saver feature is activated.

Under this condition, the headlamps remain illuminated for 5 minutes, unless the combination switch (lighting switch) position is changed. If the combination switch (lighting switch) position is changed, then the headlamps are turned off.

SHUT OFF DELAY

When the ignition switch is turned from ON to OFF while the auto light system is activated and the headlamps are illuminated, the shut off delay feature is activated. Under this condition, the BCM no longer receives a voltage signal at terminal 35, and this starts the auto light shut off delay timer. The shut off delay timer is active until one of the doors is opened, or the combination switch (lighting switch) position is changed. If one of the doors is opened, the shut off delay feature is deactivated, and the battery saver control feature is activated. If the combination switch (lighting switch) position is changed, the headlamps are turned off.

CAN Communication System Description

EKS003CU

Refer to [LAN-4, "CAN COMMUNICATION"](#) .

Major Components and Functions

EKS003CV

Components	Functions
BCM	<ul style="list-style-type: none">● Turns on/off circuits of tail light and headlamp according to signals from light sensor, lighting switch (AUTO), driver door switch, and ignition switch (ON, OFF), and vehicle signal from combination meter.
Auto light sensor	<ul style="list-style-type: none">● Converts ambient light (lux) to voltage, and sends it to BCM. (Detects light from 50 to 1,300 lux)
Combination meter	<ul style="list-style-type: none">● Sends vehicle signal to BCM via CAN communication line.

A
B
C
D
E
F
G
H
I
J
LT
L
M

LT

AUTO LIGHT SYSTEM

XENON (WITH DAYTIME LIGHT SYSTEM)

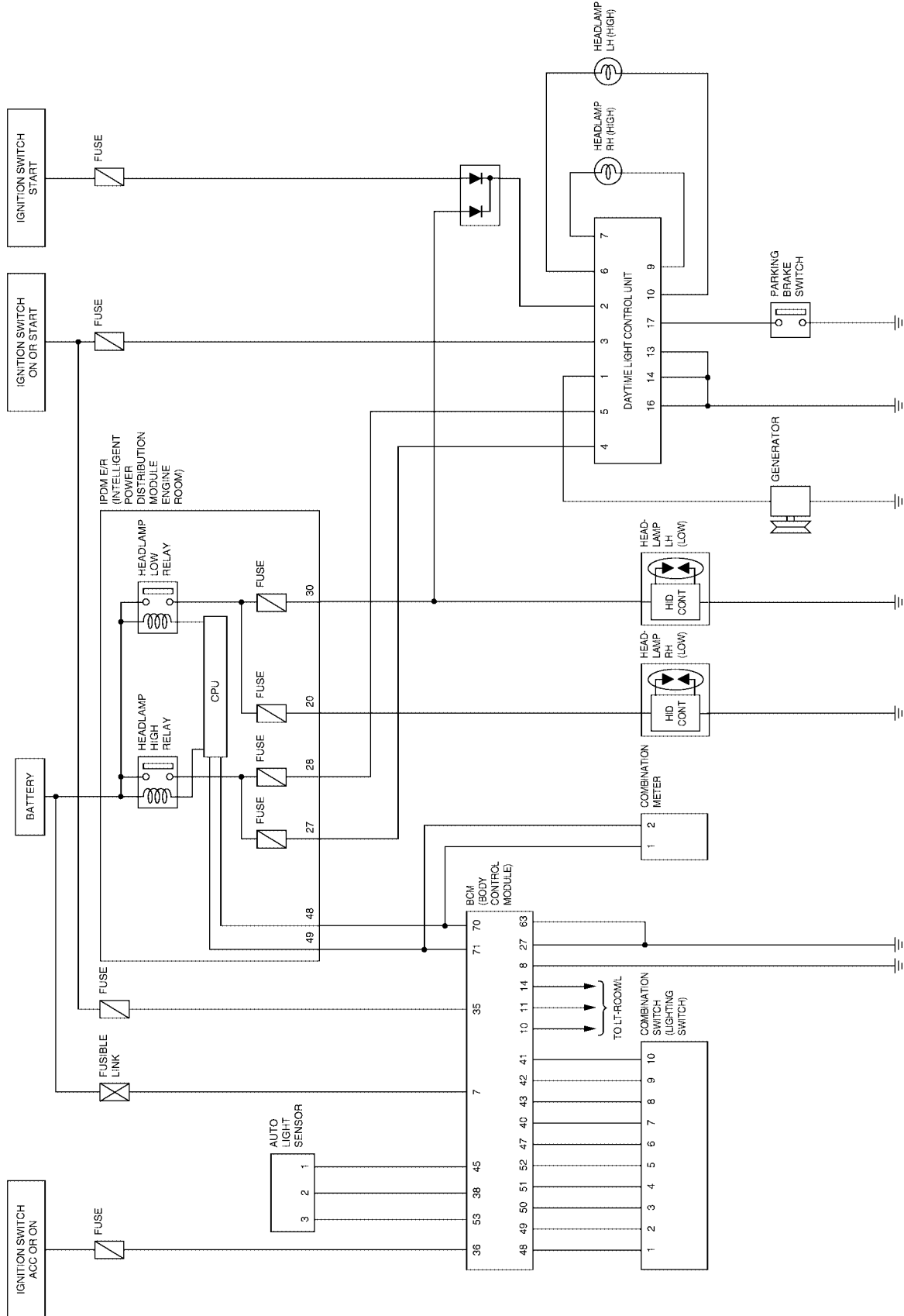

A
B
C
D
E
F
G
H
I
J
LT
L
M

WKWA0883E

AUTO LIGHT SYSTEM

EKS003CX

Wiring Diagram — AUTO/L — HALOGEN (USA)

LT-AUTO/L-01

: WITH QR25DE
 : DATA LINE

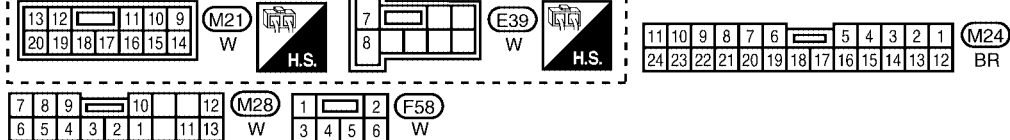
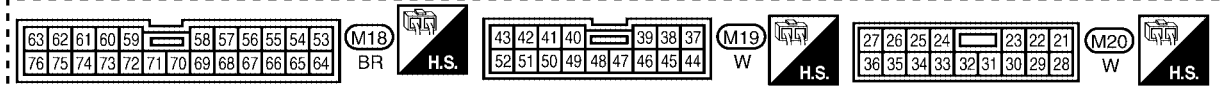
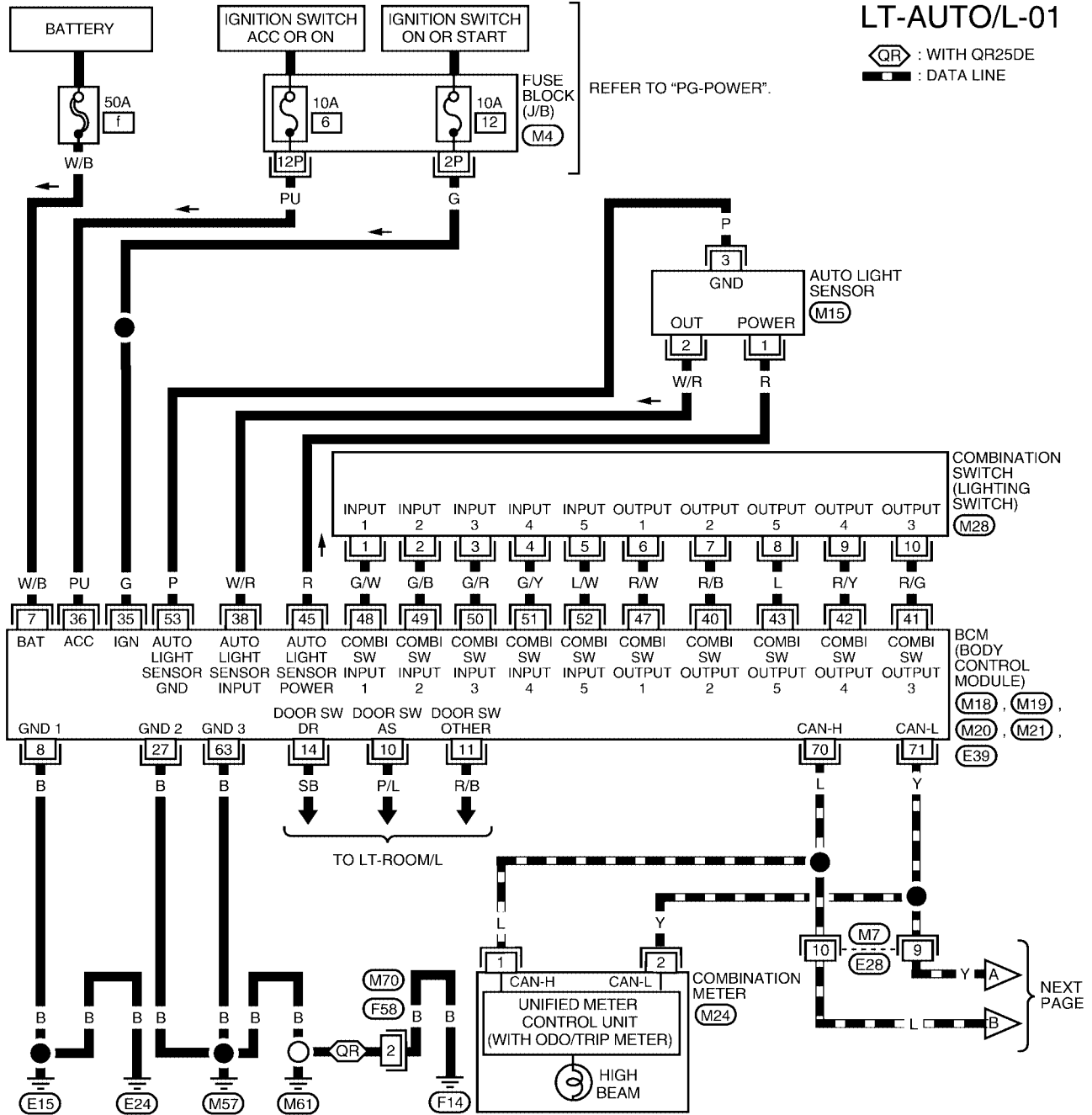

WKWA0884E

AUTO LIGHT SYSTEM

LT-AUTO/L-02

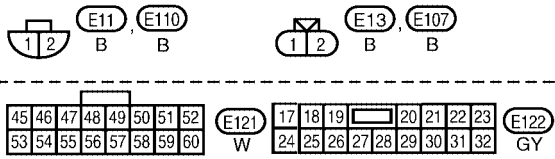
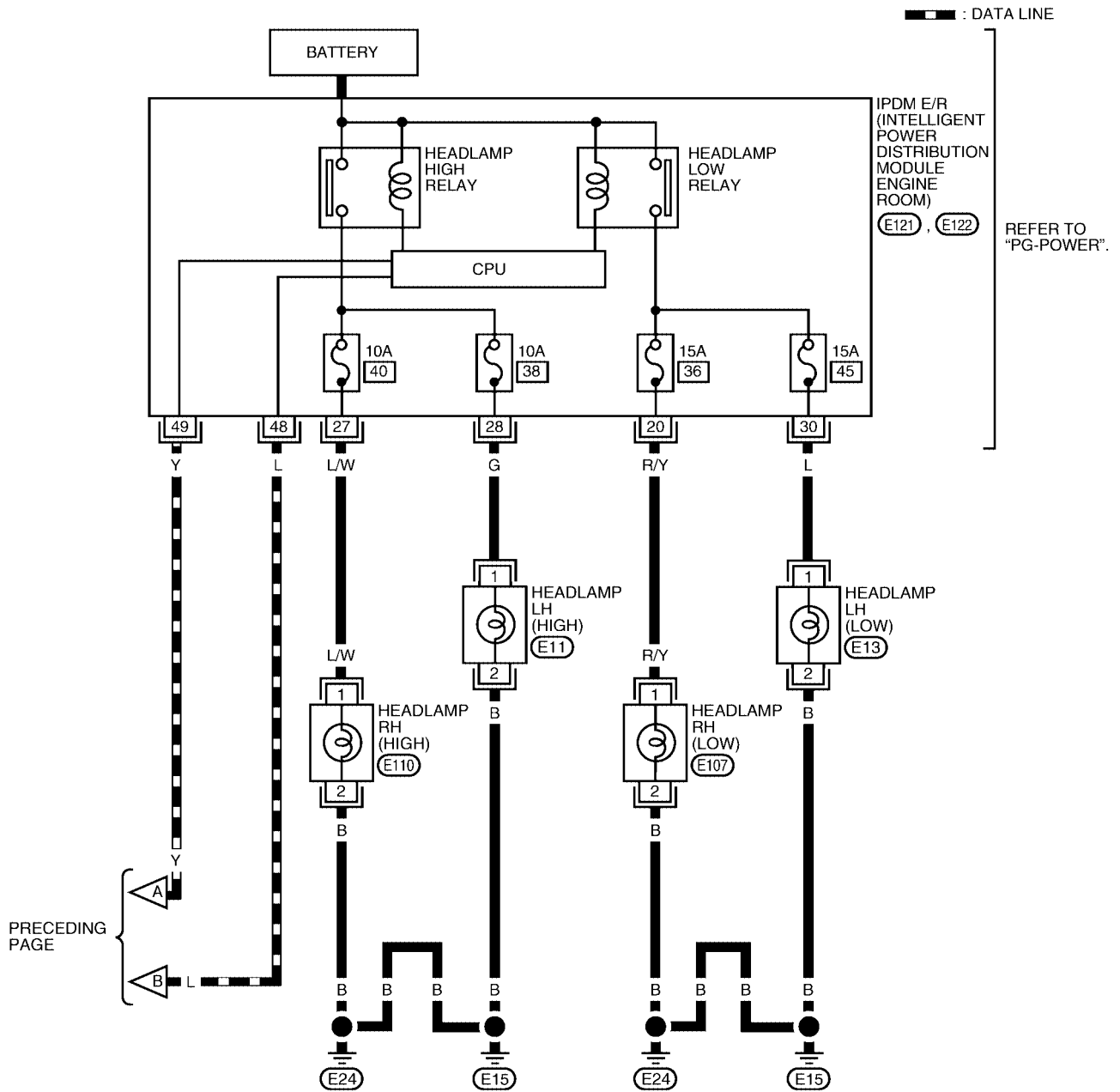

WKWA0885E

AUTO LIGHT SYSTEM

XENON (USA)

LT-AUTO/L-03

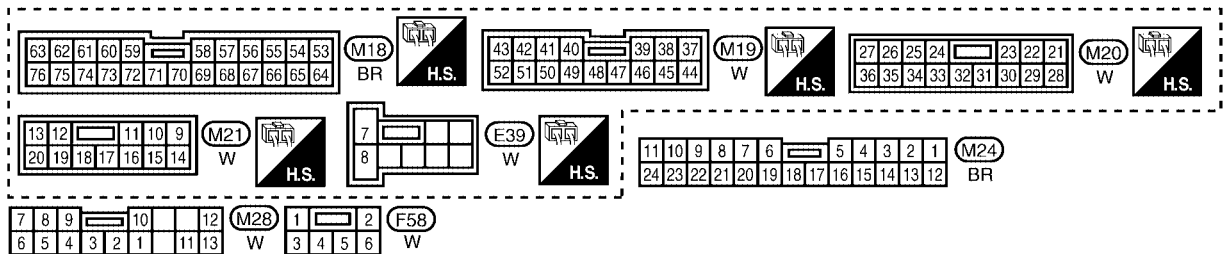
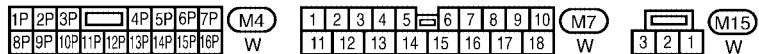
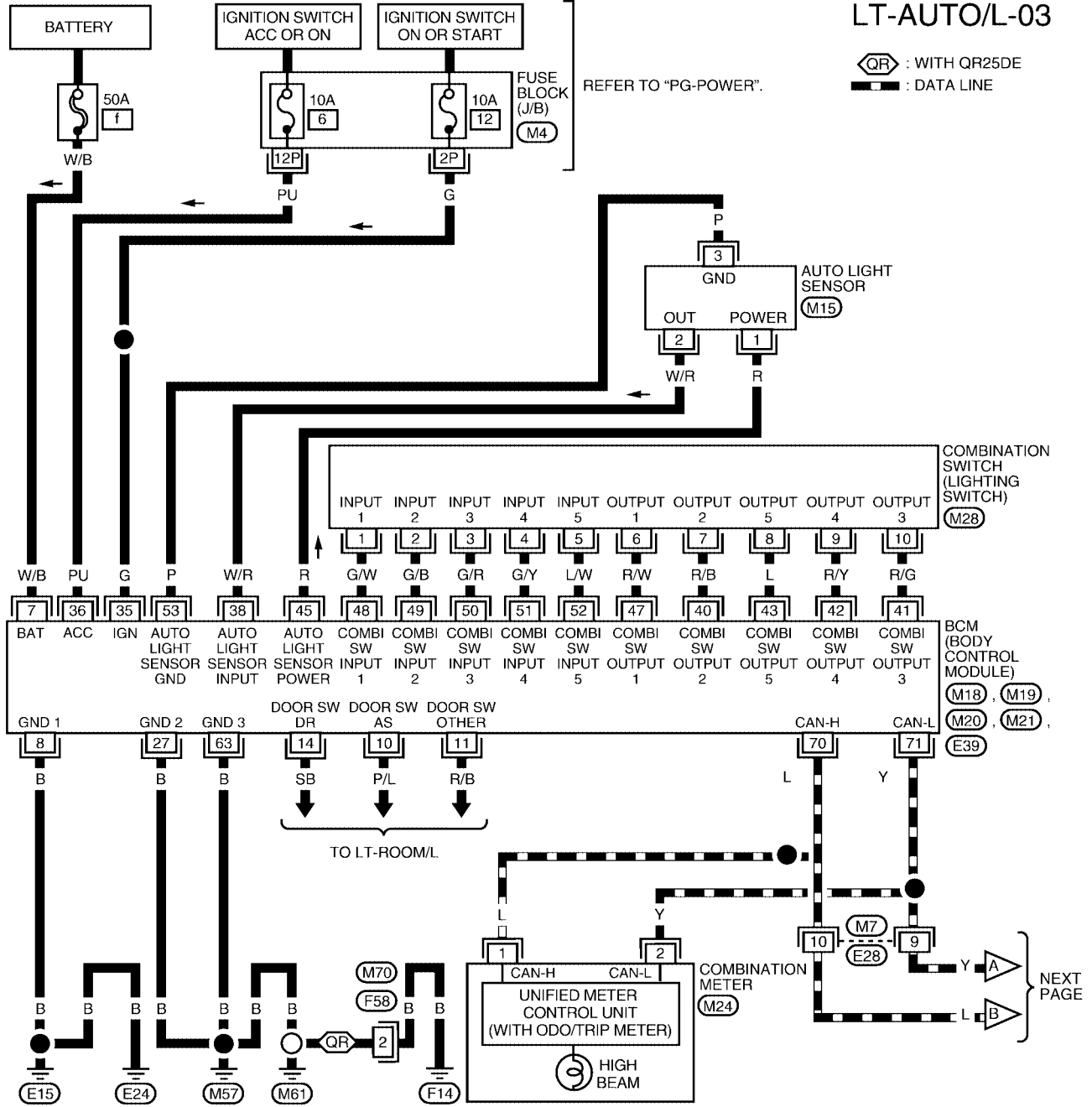

WKWA0886E

AUTO LIGHT SYSTEM

LT-AUTO/L-04

— : DATA LINE

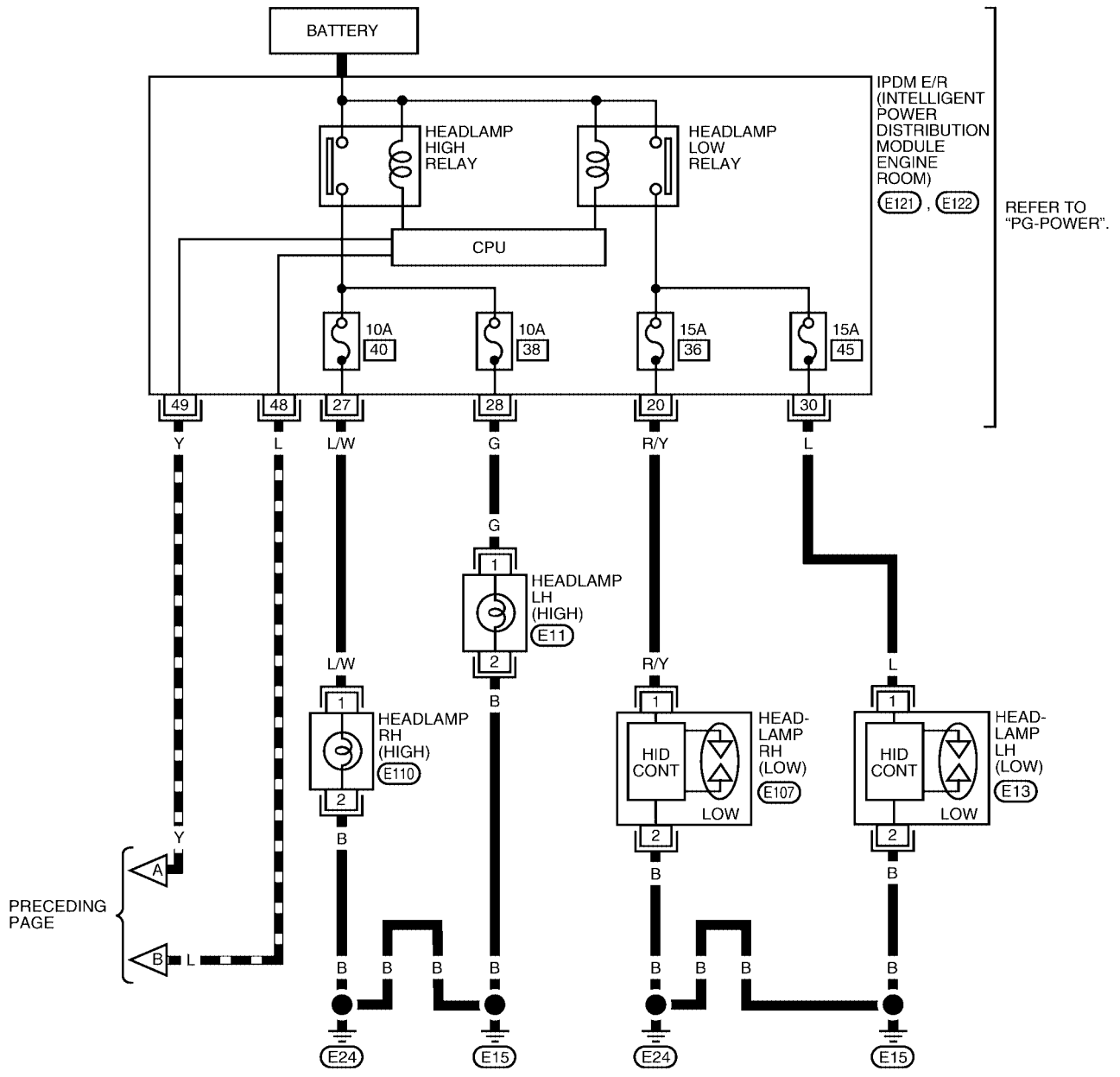

A
B
C
D
E
F
G
H
I
J
LT
L
M

PRECEDING PAGE

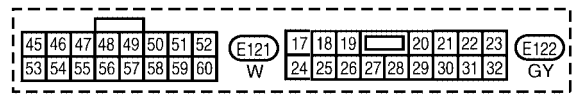

WKWA0887E

AUTO LIGHT SYSTEM

HALOGEN (CANADA)

LT-AUTO/L-05

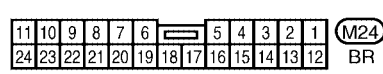
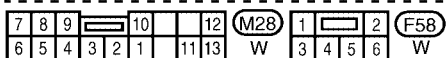
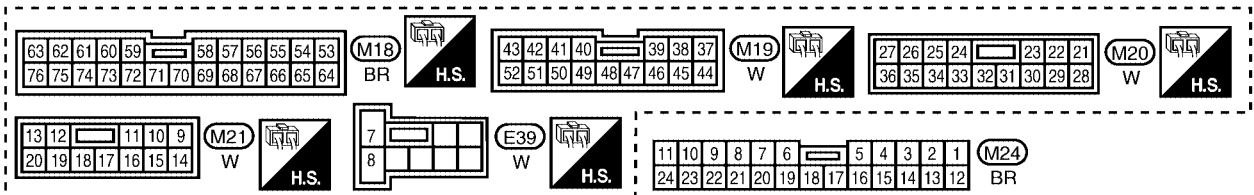
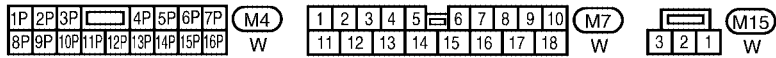
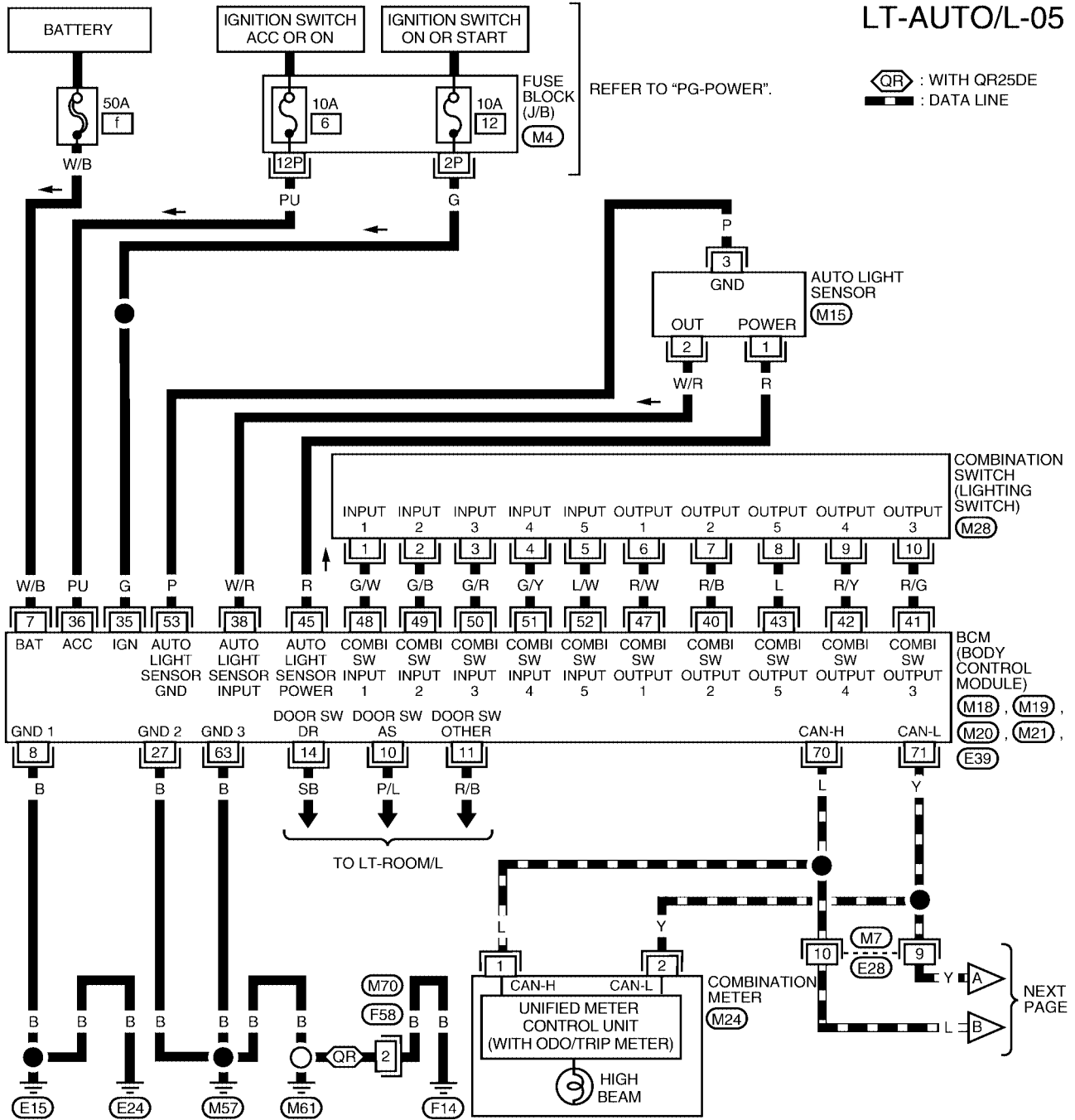

WKWA0888E

AUTO LIGHT SYSTEM

LT-AUTO/L-06

— : DATA LINE

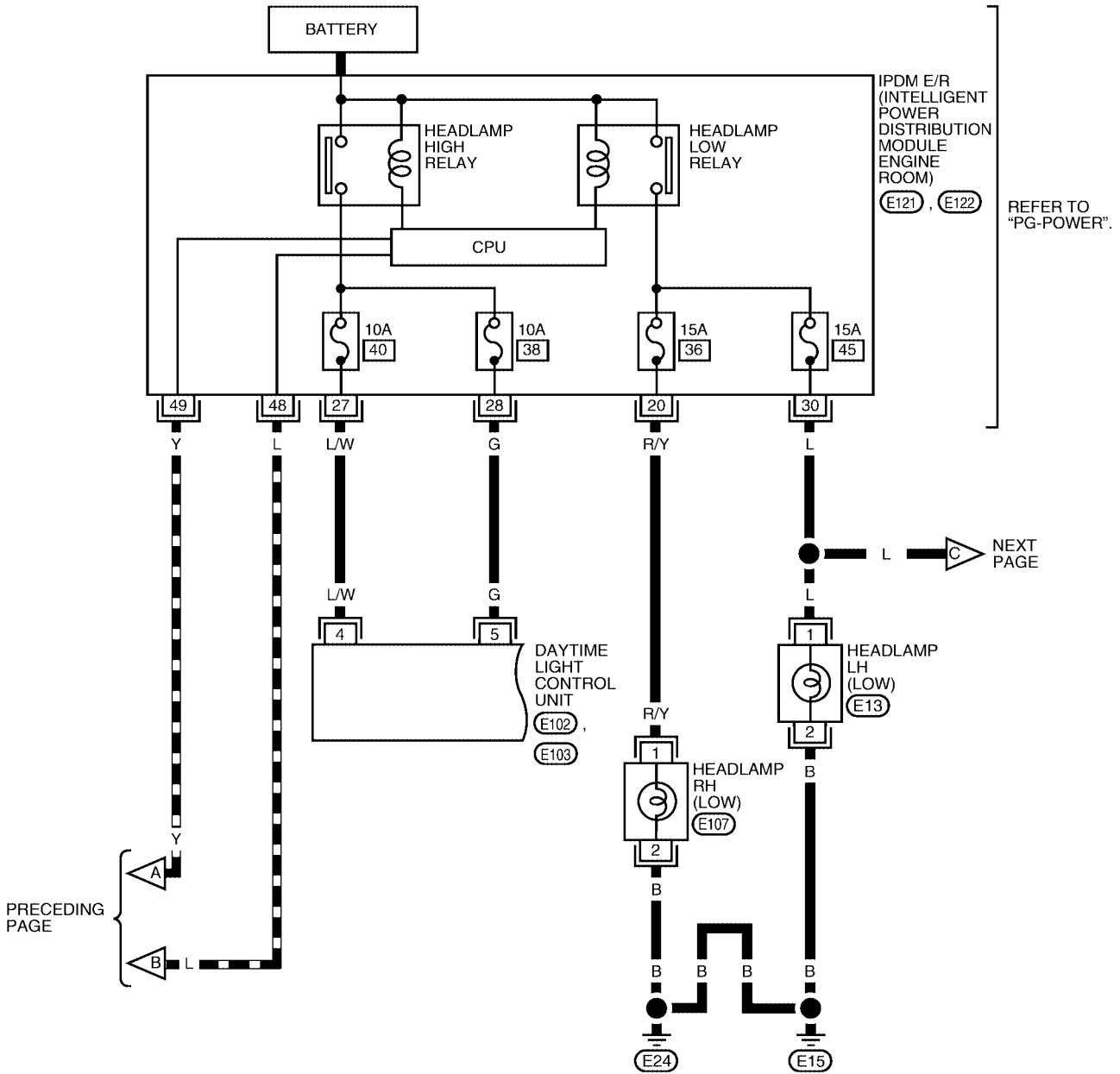

A
B
C
D
E
F
G
H
I
J
LT
L
M

PRECEDING PAGE

NEXT PAGE

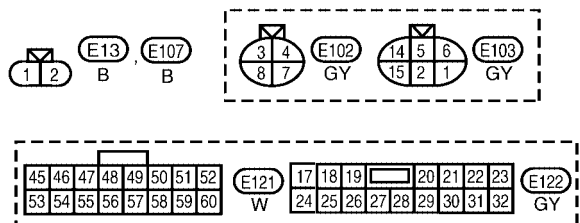

WKWA0889E

AUTO LIGHT SYSTEM

LT-AUTO/L-07

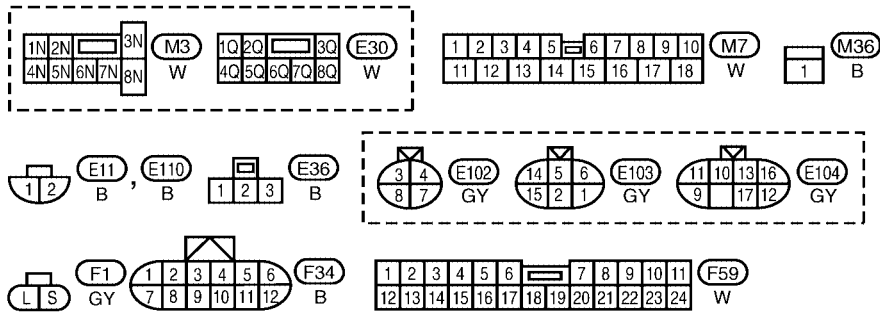
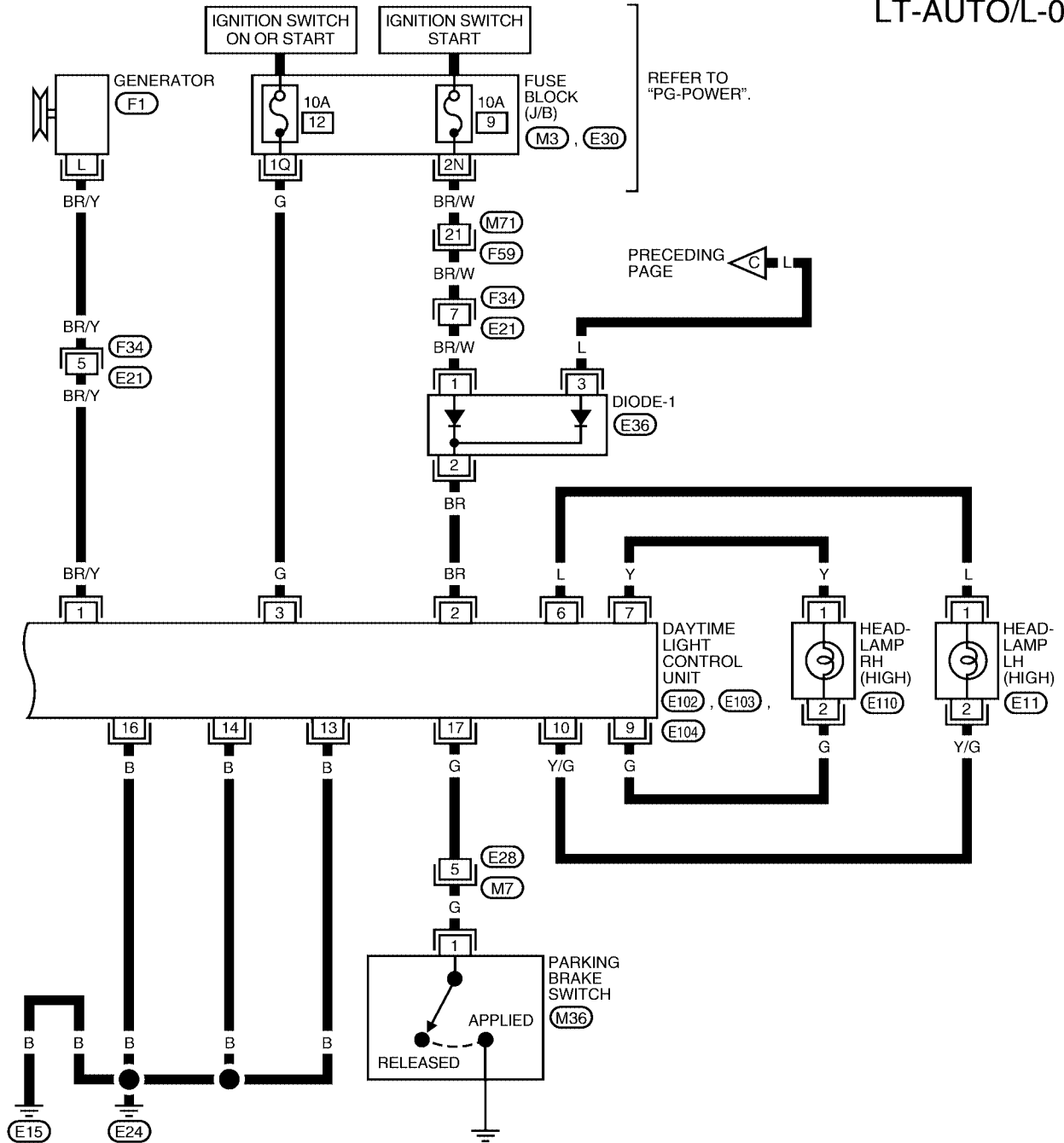

WKWA0890E

AUTO LIGHT SYSTEM

XENON (CANADA)

LT-AUTO/L-08

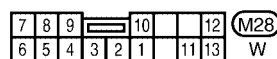
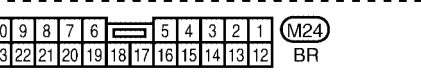
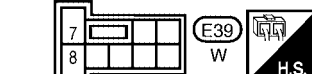
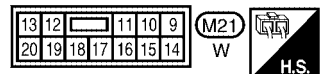
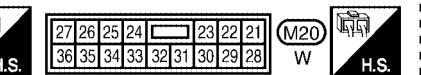
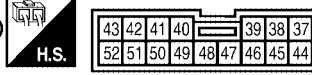
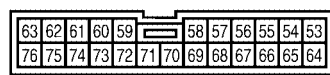
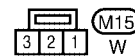
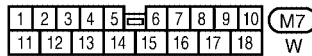
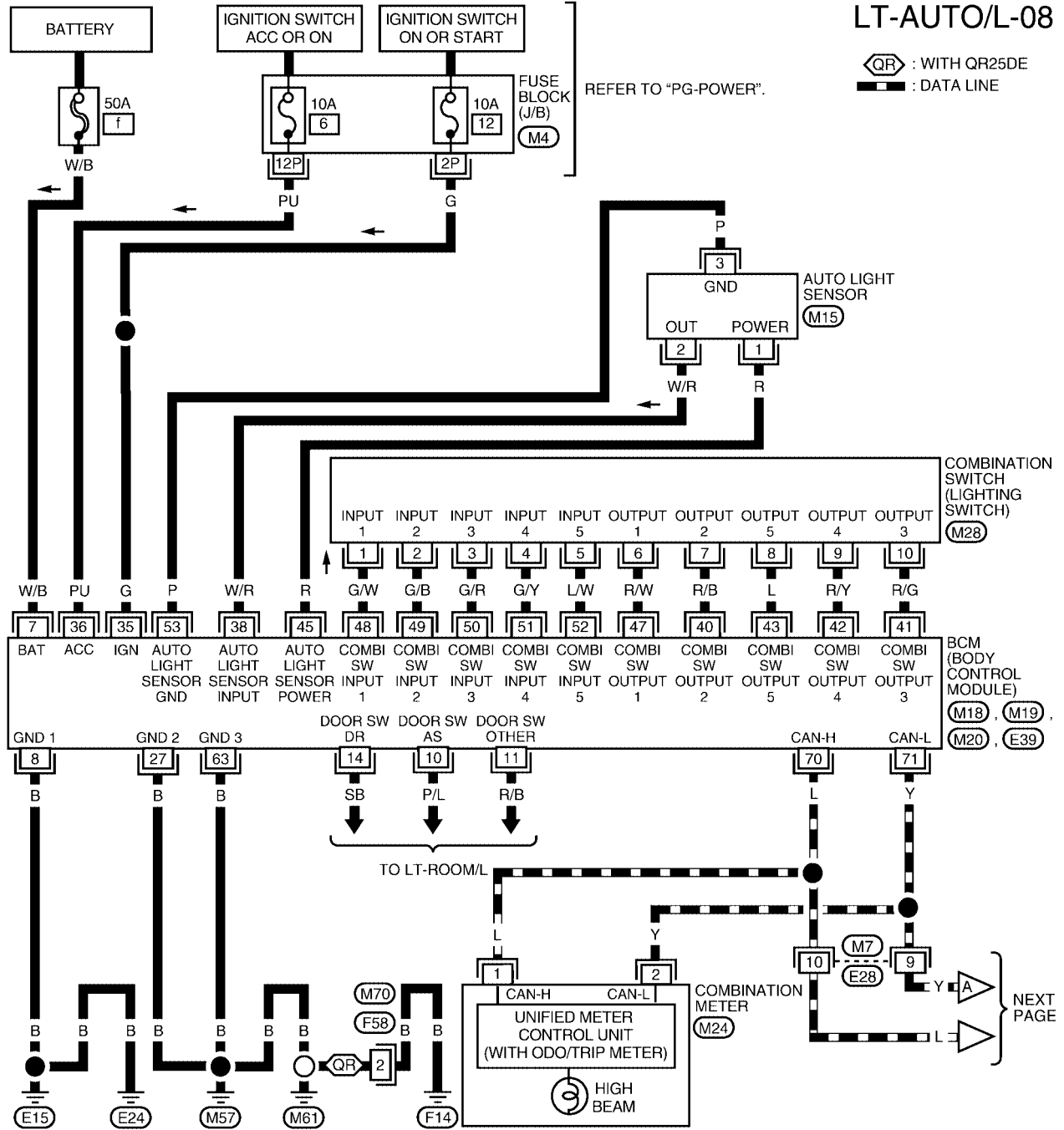

WKWA0891E

AUTO LIGHT SYSTEM

LT-AUTO/L-09

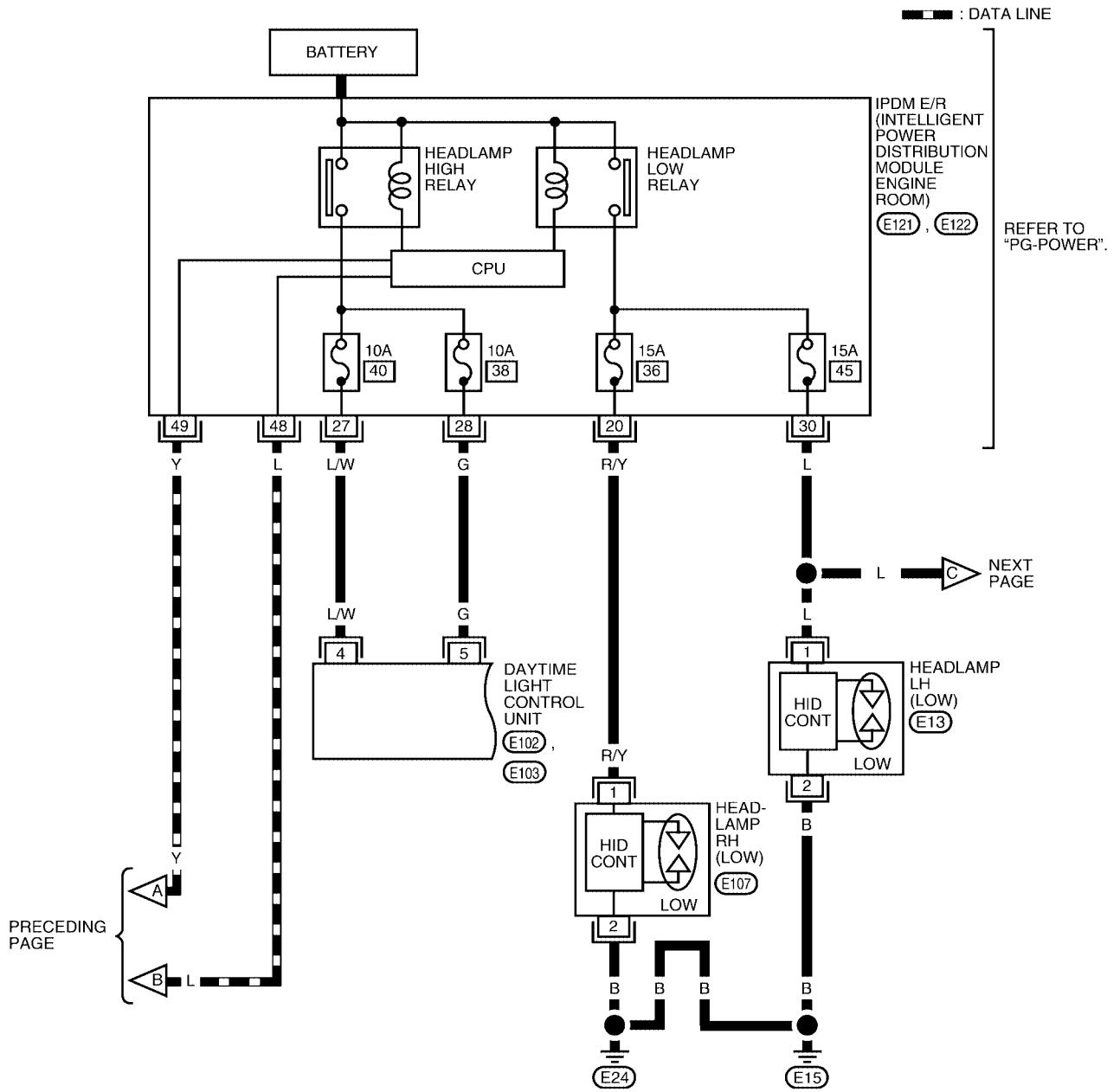

PRECEDING PAGE

NEXT PAGE

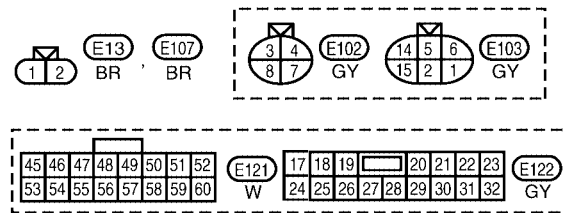

WKWA0892E

AUTO LIGHT SYSTEM

LT-AUTO/L-10

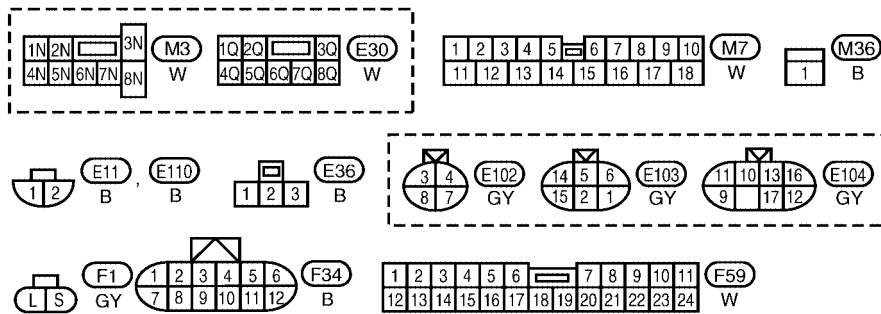
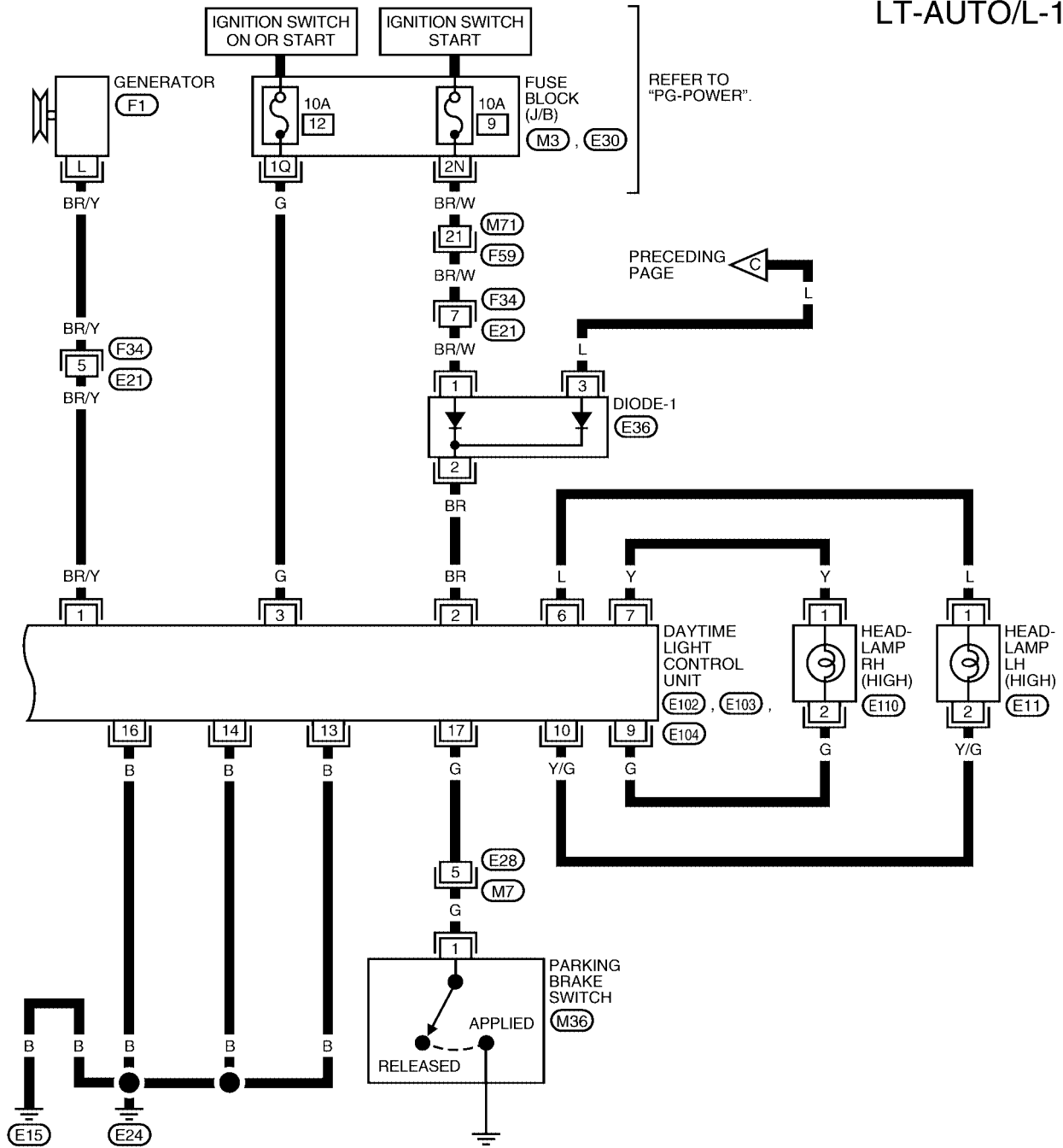

WKWA0893E

AUTO LIGHT SYSTEM

Terminals and Reference Value for BCM

EKS003CY

Terminal No.	Wire color	Signal name	Measuring condition		Standard (V) (Approx.)
			Ignition switch	Operation or condition	
7	W/B	Battery power supply	OFF	—	12V
8	B	Ground	ON	—	0
14	SB	Driver door switch signal	OFF	Driver door switch ON (open)	0
				OFF (closed)	12V
27	B	Ground	ON	—	0
35	G	IGN power	ON	—	12V
36	PU	ACC power	ACC	—	12V
38	W/R	Auto light sensor signal	ON	When auto light sensor is illuminated	3.1V or more ^{Note} (Reference value)
				When auto light sensor is not illuminated	0.6 or less (Reference value)
45	R	Auto light sensor power source	ON	—	5
53	P	Sensor ground	ON	—	0
63	B	Ground	ON	—	0

NOTE:

If the auto light sensor is insufficiently illuminated, the measured value may not satisfy the standard.

Terminals and Reference Values for IPDM E/R

EKS007OM

Terminal No.	Wire color	Signal name	Measuring condition		Reference value (Approx.)	
			Ignition switch	Operation or condition		
20	R/Y	Headlamp low (RH)	ON	Lighting switch 2ND position	OFF	0V
					ON	Battery voltage
27	L/W	Headlamp high (RH)	ON	Lighting switch HIGH or PASS position	OFF	0V
					ON	Battery voltage
28	G	Headlamp high (LH)	ON	Lighting switch HIGH or PASS position	OFF	0V
					ON	Battery voltage
30	L	Headlamp low (LH)	ON	Lighting switch 2ND position	OFF	0V
					ON	Battery voltage
48	L	CAN - H	—	—	—	
49	Y	CAN - L	—	—	—	

How to Proceed With Trouble Diagnosis

EKS007ON

1. Confirm the symptom or customer complaint.
2. Understand operation description and function description. Refer to [LT-46, "System Description"](#).
3. Carry out the Preliminary Check. Refer to [LT-60, "Preliminary Check"](#).
4. Check symptom and repair or replace the cause of malfunction. Refer to [LT-67, "Trouble Diagnosis Chart by Symptom"](#).
5. Does the auto light system operate normally? If YES: GO TO 6. If NO: GO TO 4.
6. Inspection End.

Preliminary Check

EKS007OO

SETTING CHANGE FUNCTIONS

- Sensitivity of auto light system can be adjusted using CONSULT-II. Refer to [LT-63, "WORK SUPPORT"](#).

AUTO LIGHT SYSTEM

CHECK POWER SUPPLY AND GROUND CIRCUIT

1. CHECK FUSES OR FUSIBLE LINK

Check for blown fuses or fusible link.

Unit	Power source	Fuse No.
BCM	Battery	f
	Ignition switch ON or START position	12
	Ignition switch ACC or ON position	6
IPDM E/R	Battery	36
		38
		40
		45

Refer to [LT-50, "Wiring Diagram — AUTO/L —"](#) .

OK or NG

OK >> Inspection End.

NG >> If fuse is blown, be sure to eliminate cause of malfunction before installing new fuse. Refer to [PG-4, "POWER SUPPLY ROUTING CIRCUIT"](#) .

A

B

C

D

E

F

G

H

I

J

LT

L

M

AUTO LIGHT SYSTEM

CONSULT-II Function (BCM)

EKS003D1

CONSULT-II can display each diagnostic item using the diagnostic test modes shown following.

BCM diagnosis part	Check item, diagnosis mode	Description
HEAD LAMP	Work support	Changes the setting for each function.
	Data monitor	Displays BCM input data in real time.
	Active test	Operation of electrical loads can be checked by sending drive signal to them.
BCM	Self-diagnosis	BCM performs self-diagnosis of CAN communication.
	CAN DIAG SUPPORT MNTR	The result of transmit/receive diagnosis of CAN communication can be read.

CONSULT-II BASIC OPERATION

CAUTION:

If CONSULT-II is used with no connection of CONSULT-II CONVERTER, malfunctions might be detected in self-diagnosis depending on control unit which carries out CAN communication.

1. With the ignition switch OFF, connect CONSULT-II and CONSULT-II CONVERTER to the data link connector, then turn ignition switch ON.

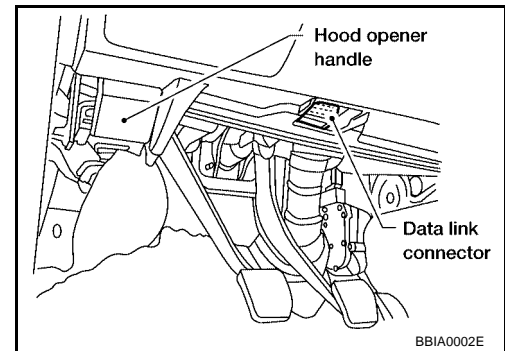

2. Touch "START (NISSAN BASED VEHICLE)".

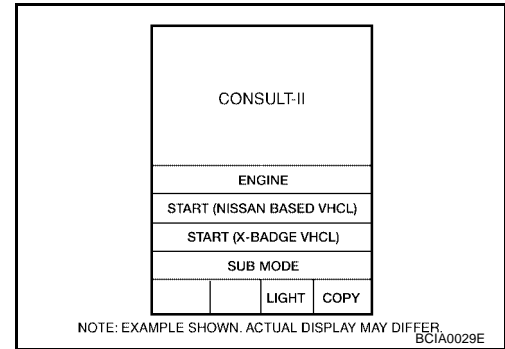

3. Touch "BCM" on "SELECT SYSTEM" screen.
If "BCM" is not indicated, go to [GI-37, "CONSULT-II Data Link Connector \(DLC\) Circuit"](#).

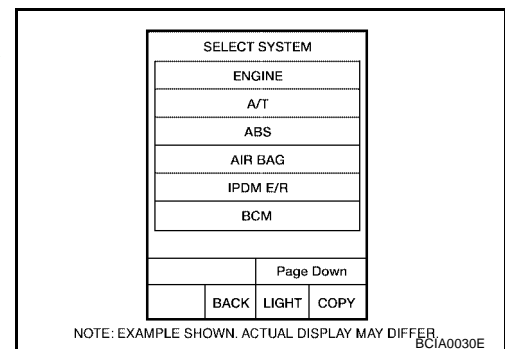

AUTO LIGHT SYSTEM

4. Select the desired part to be diagnosed on the “SELECT TEST ITEM” screen.

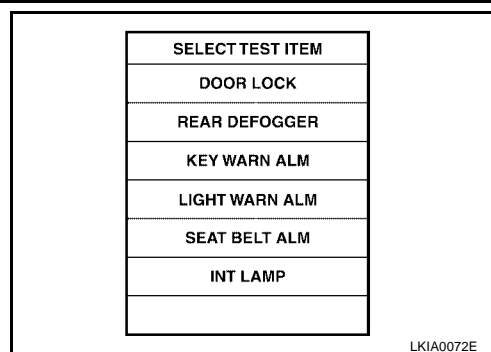

WORK SUPPORT

Operation Procedure

1. Touch “HEAD LAMP” on “SELECT TEST ITEM” screen.
2. Touch “WORK SUPPORT” on “SELECT DIAG MODE” screen.
3. Touch item setting to be changed on “SELECT WORK ITEM” screen.
4. Touch “START”.
5. Touch the item setting desired.
6. Touch “CHANGE SETT”.
7. The setting will be changed and “CUSTOMIZING COMPLETED” will be displayed.
8. Touch “END”.

Work Support Setting Item

Work Support item	Description	Mode	Setting status
CUSTOM A/LIGHT SETTING	Sensitivity of auto light can be selected and set from four modes.	Normal	Factory setting
		Mode 2	More sensitive setting compared to factory setting (The time required for lamp light-up is shorter than “Normal”.)
		Mode 3	Less sensitive setting compared to factory setting (The time required for lamp light-up is longer than “Normal”.)
		Mode 4	Less sensitive setting compared to Mode 3 (The time required for lamp light-up is longer than Mode 3.)
BATTERY SAVER SET	Function is not enabled, battery saver operation cannot be changed.	On	Function is not enabled, battery saver operation cannot be changed.
		Off	
ILL DELAY SET	The timer that turns off the headlamps (and fog lamps, if turned on) after the last door is closed can be selected and set from 8 modes.	Mode 1	45 seconds (Factory setting)
		Mode 2	0 seconds (immediate shutoff)
		Mode 3	30 seconds
		Mode 4	60 seconds
		Mode 5	90 seconds
		Mode 6	120 seconds
		Mode 7	150 seconds
		Mode 8	180 seconds

DATA MONITOR

Operation Procedure

1. Touch “HEADLAMP” on “SELECT TEST ITEM” screen.
2. Touch “DATA MONITOR” on “SELECT DIAG MODE” screen.
3. Touch either “ALL SIGNALS” or “SELECTION FROM MENU”.

All signals	Monitors all the signals.
Selection from menu	Selects and monitors individual signal.

AUTO LIGHT SYSTEM

4. Touch "START".
5. When "SELECTION FROM MENU" is selected, touch items to be monitored. When "ALL SIGNALS" is selected, all the signals will be monitored.
6. Touch "RECORD" while monitoring, then the status of the monitored item can be recorded. To stop recording, touch "STOP".

Display Item List

Monitor item name "OPERATION OR UNIT"	Contents
IGN ON SW "ON/OFF"	"IGN position (ON)/OFF, ACC position (OFF)" judged from the ignition switch signal is displayed.
ACC ON SW "ON/OFF"	Displays "ACC (ON)/OFF, Ignition OFF (OFF)" status judged from ignition switch signal.
AUTO LIGHT SW "ON/OFF"	Displays status of the lighting switch as judged from the lighting switch signal. (AUTO position: ON/Other than AUTO position: OFF)
TAIL LAMP SW "ON/OFF"	Displays status (lighting switch 1st position: ON/Others: OFF) of light switch judged from lighting switch signal.
HEAD LAMP SW 1 "ON/OFF"	Displays status (headlamp switch: ON/Others: OFF) of headlamp switch judged from lighting switch signal.
HI BEAM SW "ON/OFF"	Displays status (high beam switch: ON/Others: OFF) of high beam switch judged from lighting switch signal.
PASSING SW "ON/OFF"	Displays status (flash-to-pass switch: ON/Others: OFF) of flash-to-pass switch judged from lighting switch signal.
FR FOG SW "ON/OFF"	Displays status (front fog switch: ON/Others: OFF) of front fog switch judged from lighting switch signal.
DOOR SW - DR "ON/OFF"	Displays status of the driver door as judged from the driver door switch signal. (Door is open: ON/Door is closed: OFF)
DOOR SW - AS "ON/OFF"	Displays status of the passenger door as judged from the passenger door switch signal. (Door is open: ON/Door is closed: OFF)
DOOR SW - RR "ON/OFF"	Displays status of the rear doors as judged from the rear door switch signal. (Door is open: ON/Door is closed: OFF)
HEAD LAMP SW 2 "ON/OFF"	Displays status (headlamp switch 2: ON/Others: OFF) of headlamp switch 2 judged from lighting switch signal.
OPTICAL SENSOR [0 - 5V]	Displays "ambient light (close to 5V when light/close to 0V when dark)" judged from auto light sensor signal.

ACTIVE TEST

Operation Procedure

1. Touch "HEADLAMP" on "SELECT TEST ITEM" screen.
2. Touch "ACTIVE TEST" on "SELECT DIAG MODE" screen.
3. Touch item to be tested and check operation of the selected item.
4. During the operation check, touching "BACK" deactivates the operation.

Display Item List

Test item	Display on CONSULT-II screen	Description
Tail light relay output	TAIL LAMP	Allows tail light relay to operate by switching ON-OFF at your option.
Headlamp relay output	HEAD LAMP (LOW)	Allows headlamp relay to operate by switching ON-OFF at your option.
Headlamp relay output	HEAD LAMP (HI)	Allows headlamp relay to operate by switching ON-OFF at your option.
Front fog lamp relay output	FR FOG LAMP	Allows fog lamp relay to operate by switching ON-OFF at your option.

AUTO LIGHT SYSTEM

CONSULT-II Function (IPDM E/R)

EKS0070Q

CONSULT-II can display each diagnostic item using the diagnostic test modes shown following.

Inspection Item, Diagnosis Mode	Description
DATA MONITOR	The input/output data of the IPDM E/R is displayed in real time.
CAN DIAG SUPPORT MNTR	The result of transmit/receive diagnosis of CAN communication can be read.
ACTIVE TEST	The IPDM E/R sends a drive signal to electronic components to check their operation.

CONSULT-II OPERATION

CAUTION:

If CONSULT-II is used with no connection of CONSULT-II CONVERTER, malfunctions might be detected in self-diagnosis depending on control unit which carries out CAN communication.

1. With the ignition switch OFF, connect CONSULT-II and CONSULT-II CONVERTER to the data link connector, then turn the ignition switch ON.

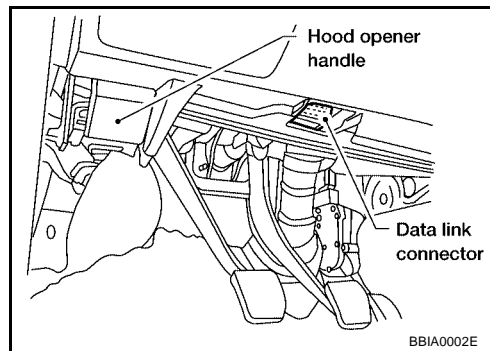

2. Touch "START (NISSAN BASED VHCL)".

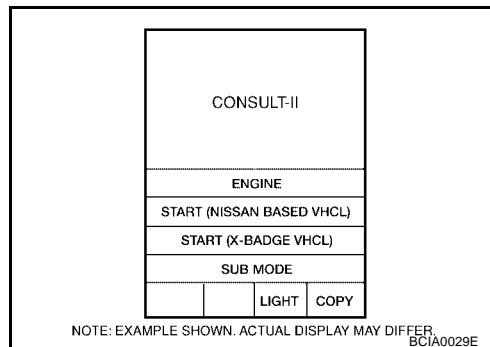

3. Touch "IPDM E/R" on "SELECT SYSTEM" screen. If "IPDM E/R" is not displayed, go to [GI-37, "CONSULT-II Data Link Connector \(DLC\) Circuit"](#).

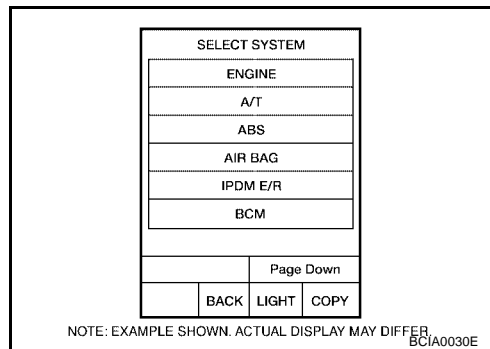

AUTO LIGHT SYSTEM

- Select the desired part to be diagnosed on the "SELECT DIAG MODE" screen.

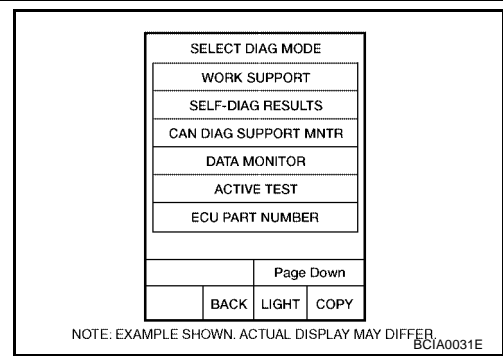

DATA MONITOR

Operation Procedure

- Touch "DATA MONITOR" on "SELECT DIAG MODE" screen.
- Touch "ALL SIGNALS", "MAIN SIGNALS" or "SELECT FROM MENU" on the "DATA MONITOR" screen.

ALL SIGNALS	All items will be monitored.
MAIN SIGNALS	Monitor the predetermined item.
SELECT FROM MENU	Select any item for monitoring.

- Touch "START".
- Touch the required monitoring item on "SELECT ITEM MENU". In "ALL SIGNALS", all items are monitored. In "MAIN SIGNALS", predetermined items are monitored.
- Touch "RECORD" while monitoring to record the status of the item being monitored. To stop recording, touch "STOP".

All Items, Main Items, Select Item Menu

Item name	CONSULT-II screen display	Display or unit	Monitor item selection			Description
			ALL SIGNALS	MAIN SIGNALS	SELECT FROM MENU	
Position lights request	TAIL&CLR REQ	ON/OFF	×	×	×	Signal status input from BCM
Headlamp low beam request	HL LO REQ	ON/OFF	×	×	×	Signal status input from BCM
Headlamp high beam request	HL HI REQ	ON/OFF	×	×	×	Signal status input from BCM
Front fog lights request	FR FOG REQ	ON/OFF	×	×	×	Signal status input from BCM

NOTE:

Perform monitoring of IPDM E/R data with the ignition switch ON. When the ignition switch is at ACC, the display may not be correct.

ACTIVE TEST

Operation Procedure

- Touch "ACTIVE TEST" on "SELECT DIAG MODE" screen.
- Touch item to be tested, and check operation.
- Touch "START".
- Touch "STOP" while testing to stop the operation.

AUTO LIGHT SYSTEM

Test item	CONSULT-II screen display	Description
Headlamp relay (HI, LO) output	LAMPS	Allows headlamp relay (HI, LO) to operate by switching operation (OFF, HI ON, LO ON) at your option (Headlamp high beam repeats ON-OFF every 1 second).
Front fog lamp relay output		Allows fog lamp relay to operate by switching operation ON-OFF at your option.
Tail lamp relay output	TAIL LAMP	Allows tail lamp relay to operate by switching operation ON-OFF at your option.

Trouble Diagnosis Chart by Symptom

EKS003D2

Trouble phenomenon	Malfunction system and reference
<ul style="list-style-type: none"> ● Parking lamps and headlamps will not illuminate when outside of the vehicle becomes dark. (Lighting switch 1st position and 2nd position operate normally.) ● Parking lamps and headlamp will not go out when outside of the vehicle becomes light. (Lighting switch 1st position and 2nd position operate normally.) ● Headlamps go out when outside of the vehicle becomes light, but parking lamps stay on. 	<ul style="list-style-type: none"> ● Refer to LT-63, "WORK SUPPORT" . ● Refer to LT-67, "Lighting Switch Inspection" . ● Refer to LT-68, "Auto Light Sensor System Inspection" . If above systems are normal, replace BCM.
Parking lamps illuminate when outside of the vehicle becomes dark, but headlamps stay off. (Lighting switch 1st position and 2nd position operate normally.)	<ul style="list-style-type: none"> ● Refer to LT-63, "WORK SUPPORT" . ● Refer to LT-68, "Auto Light Sensor System Inspection" . If above systems are normal, replace BCM.
Auto light adjustment system will not operate. (Lighting switch AUTO, 1st position and 2nd position operate normally.)	<ul style="list-style-type: none"> ● Refer to LT-68, "Auto Light Sensor System Inspection" . If above system is normal, replace BCM.
Auto light adjustment system will not operate.	<ul style="list-style-type: none"> ● CAN communication line to BCM inspection. Refer to BCS-12, "CAN Communication Inspection Using CONSULT-II (Self-Diagnosis)" .

Lighting Switch Inspection

EKS007OS

1. CHECK LIGHTING SWITCH INPUT SIGNAL

Ⓜ With CONSULT-II
 Select "BCM" on CONSULT-II. With "HEAD LAMP" data monitor, make sure "AUTO LIGHT SW" turns ON-OFF linked with operation of lighting switch.

When lighting switch is in : AUTO LIGHT SW ON
AUTO position

ⓧ Without CONSULT-II
 Refer to [BCS-12, "Combination Switch Inspection According to Self-Diagnostic Results"](#) .

OK or NG

- OK >> Inspection End.
 NG >> Check lighting switch. Refer to [BCS-12, "Combination Switch Inspection According to Self-Diagnostic Results"](#) .

DATA MONITOR	
MONITOR	
AUTO LIGHT SW	ON

SKIA4196E

AUTO LIGHT SYSTEM

EKS003D4

Auto Light Sensor System Inspection

1. OUTPUT SIGNAL INSPECTION

Select "BCM" in CONSULT-II. Using "OPTICAL SENSOR" data from "DATA MONITOR", check difference in the voltage when the auto light sensor is illuminated and not illuminated.

Illuminated

Light sensor : 3.1V or more

Not illuminated

Light sensor : 0.6V or less

NOTE:

If the auto light sensor is insufficiently illuminated, the measured value may not satisfy the standard.

OK or NG

- OK >> Normal.
- NG >> GO TO 2.

DATA MONITOR	
MONITOR	
OPTICAL SENSOR	XXXV

WKIA0486E

2. POWER SUPPLY CIRCUIT CONTINUITY INSPECTION

1. Disconnect connectors of BCM and auto light sensor.
2. Check harness continuity between BCM vehicle-side connector terminal 45 (R) and vehicle-side connector terminal 1 (R) of auto light sensor.

Continuity should exist.

3. Check continuity between BCM vehicle-side connector terminal 45 (R) and body ground.

Continuity should not exist.

OK or NG

- OK >> GO TO 3.
- NG >> Malfunction in harness between BCM and auto light sensor. Repair or replace as required.

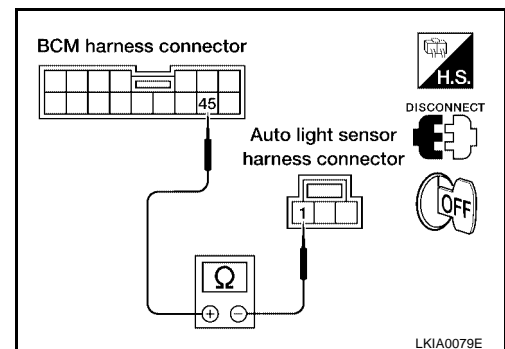

3. OUTPUT CIRCUIT CONTINUITY INSPECTION

1. Check harness continuity between BCM vehicle-side connector terminal 38 (W/R) and vehicle-side connector terminal 2 (W/R) of auto light sensor.

Continuity should exist.

2. Check continuity between BCM vehicle-side connector terminal 38 (W/R) and body ground.

Continuity should not exist.

OK or NG

- OK >> GO TO 4.
- NG >> Malfunction in harness between BCM and auto light sensor. Repair or replace as required.

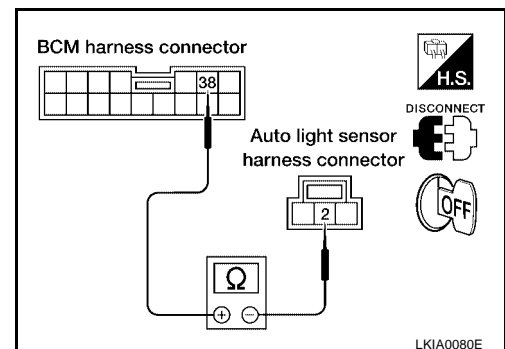

AUTO LIGHT SYSTEM

4. GROUND CIRCUIT CONTINUITY INSPECTION

1. Check harness continuity between BCM vehicle-side connector terminal 53 (P) and vehicle-side connector terminal 3 (P) of auto light sensor.

Continuity should not exist.

2. Check continuity between BCM vehicle-side connector terminal 53 (P) and body ground.

Continuity should not exist.

OK or NG

OK >> GO TO 5.

NG >> Malfunction in harness between BCM and auto light sensor. Repair or replace as required.

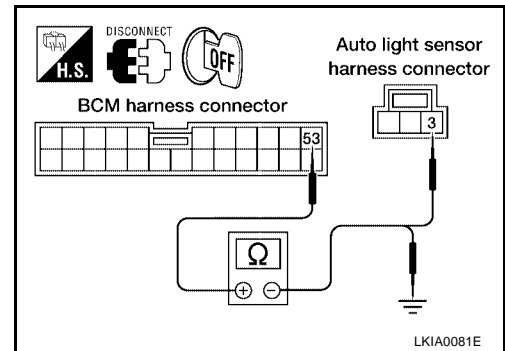

5. SENSOR VOLTAGE INSPECTION

1. Connect BCM connector.
2. Check voltage between BCM terminal 45 (R) and body ground.

Approx. 5V

OK or NG

OK >> Replace the auto light sensor.

NG >> Replace BCM.

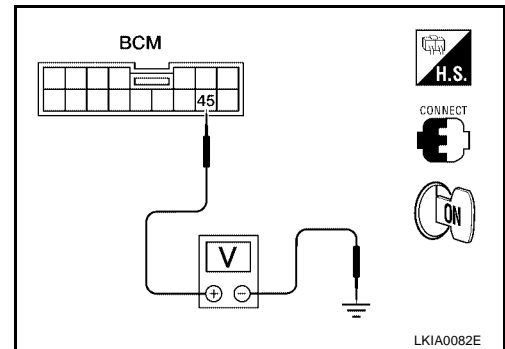

A
B
C
D
E
F
G
H
I
J
LT
L
M

FRONT FOG LAMP

FRONT FOG LAMP

PFP:26150

System Description

EKS003D5

Control of the fog lamps is dependent upon the position of the combination switch (lighting switch). The lighting switch must be in the 2ND position or AUTO position (LOW beam is ON) for front fog lamp operation. When the lighting switch is placed in the fog lamp position, the BCM (body control module) receives input requesting the fog lamps to illuminate. This input is communicated to the IPDM E/R (intelligent power distribution module engine room) across the CAN communication lines. The central processing unit of the IPDM E/R controls the front fog lamp relay coil. When energized, this relay directs power to the front fog lamps.

OUTLINE

Power is supplied at all times

- through 15A fuse (No. 43, located in the IPDM E/R)
- to front fog lamp relay, located in the IPDM E/R, and

Power is also supplied at all times

- to BCM terminal 7
- through 50A fusible link (letter f , located in the fuse and fusible link box).

When the ignition switch is in ON or START position, power is supplied

- to BCM terminal 35
- through 10A fuse [No. 12, located in the fuse block (J/B)].

When the ignition switch is in ACC or ON position, power is supplied

- to BCM terminal 36
- through 10A fuse [No. 6, located in the fuse block (J/B)].

Ground is supplied

- to BCM terminals 8, 27, and 63
- through body grounds F14 (QR25DE models), M57, M61, E15, and E24.

FOG LAMP OPERATION

The fog lamp switch is built into the combination switch. The lighting switch can be in any position (except pass or high beam) and the fog lamp switch must be ON for fog lamp operation.

With the fog lamp switch in the ON position, the central processing unit of the IPDM E/R grounds the coil side of the fog lamp relay. The fog lamp relay then directs power

- to front fog lamp LH terminal 1
- through IPDM E/R terminal 37, and
- to front fog lamp RH terminal 1
- through IPDM E/R terminal 36.

Ground is supplied

- to front fog lamp LH terminal 2
- through body grounds E15 and E24, and
- to front fog lamp RH terminal 2
- through body grounds E15 and E24.

With power and grounds supplied, the front fog lamps illuminate.

BATTERY SAVER CONTROL

When the fog lamp switch is ON and the ignition switch is turned from ON to ACC or OFF, or if the ignition switch is in the OFF position when the fog lamp switch is turned ON, the battery saver control feature is activated.

Under this condition, the fog lamps (and headlamps) remain illuminated for 5 minutes, unless the combination switch (lighting switch) position is changed. If the combination switch (lighting switch) position is changed, then the fog lamps (and headlamps) are turned off.

CAN Communication System Description

EKS003D6

Refer to [LAN-4, "CAN COMMUNICATION"](#) .

FRONT FOG LAMP

Wiring Diagram — F/FOG —

EKS003D7

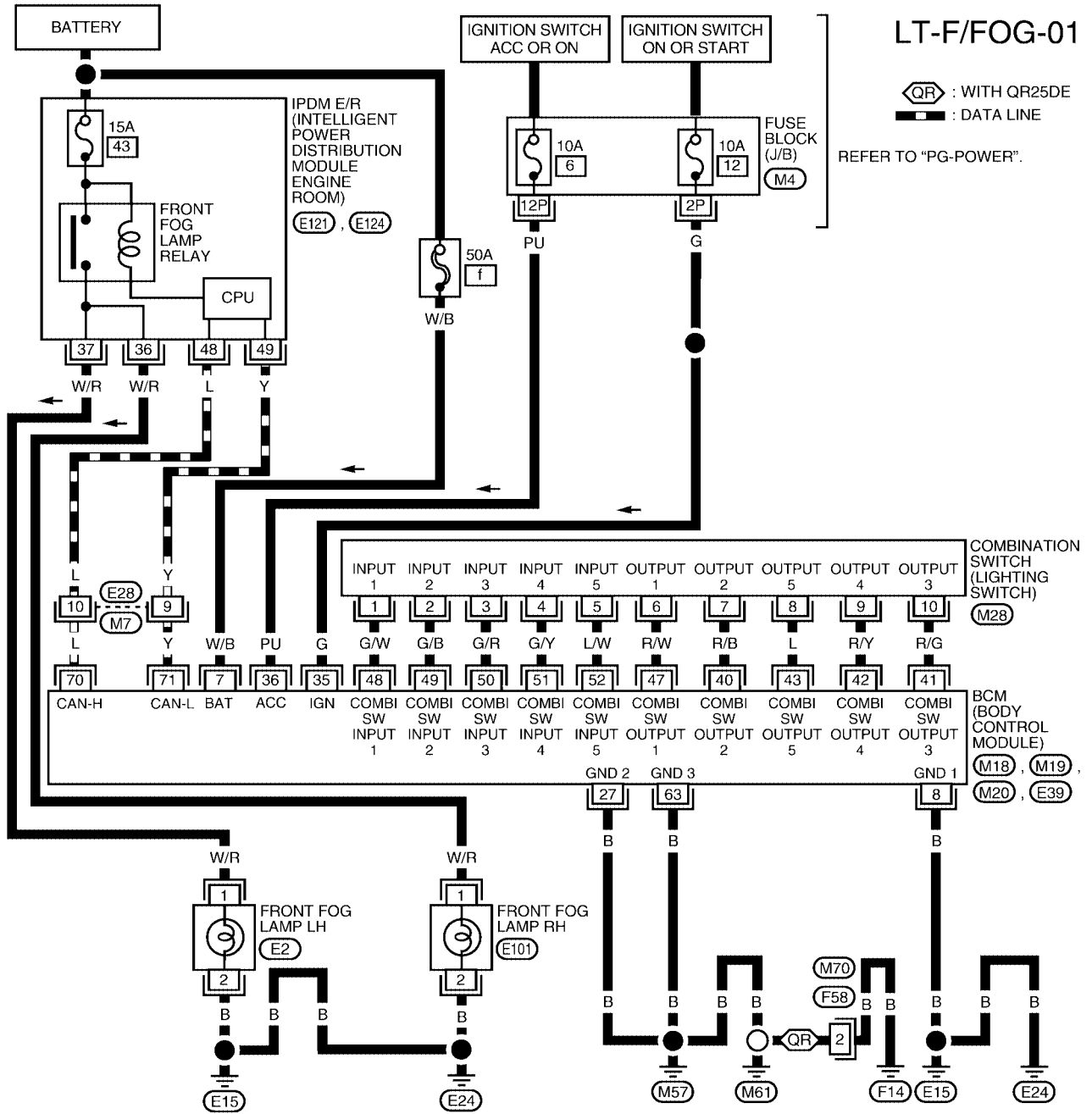

A
B
C
D
E
F
G
H
I
J
LT
L
M

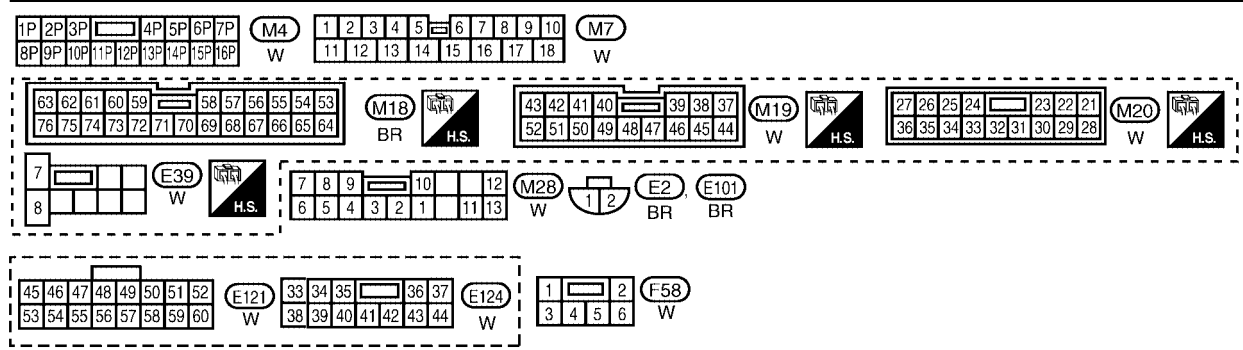

WKWA0894E

FRONT FOG LAMP

Terminals and Reference Value for BCM

EKS007P1

Terminal No.	Wire color	Item	Measuring condition		Voltage (Approx.)
			Ignition switch	Operation or condition	
7	W/B	Battery power supply	OFF	—	Battery voltage
8	B	Ground	—	—	—
27	B	Ground	—	—	—
35	G	Ignition power supply	ON	—	Battery voltage
36	PU	Ignition power supply	ACC	—	Battery voltage
40	R/B	Combination switch output 2	—	—	2V → 10V
41	R/G	Combination switch output 3	—	—	2V → 10V
42	R/Y	Combination switch output 4	—	—	2V → 10V
43	L	Combination switch output 5	—	—	2V → 10V
47	R/W	Combination switch output 1	—	—	2V → 10V
48	G/W	Combination switch input 1	—	—	1.5V → 10V
49	G/B	Combination switch input 2	—	—	1.5V → 10V
50	G/R	Combination switch input 3	—	—	1.5V → 10V
51	G/Y	Combination switch input 4	—	—	1.5V → 10V
52	L/W	Combination switch input 5	—	—	1.5V → 10V
63	B	Ground	—	—	—
70	L	CAN - H	—	—	1V → 3V
71	Y	CAN - L	—	—	1V → 3V

Terminals and Reference Values for IPDM E/R

EKS007OV

Terminal No.	Wire color	Signal name	Measuring condition			Reference value (Approx.)
			Ignition switch	Operation or condition		
36	W/R	Front fog lamp (RH)	ON	Lighting switch must be in the 2ND position or AUTO position (LOW beam is ON) and the front fog lamp switch must be ON	OFF	0V
					ON	Battery voltage
37	W/R	Front fog lamp (LH)	ON	Lighting switch must be in the 2ND position or AUTO position (LOW beam is ON) and the front fog lamp switch must be ON	OFF	0V
					ON	Battery voltage
48	L	CAN - H	—	—	—	
49	Y	CAN - L	—	—	—	

How to Proceed With Trouble Diagnosis

EKS007OW

1. Confirm the symptom or customer complaint.
2. Understand operation description and function description. Refer to [LT-70, "System Description"](#).
3. Perform the Preliminary Check. Refer to [LT-73, "Preliminary Check"](#).
4. Check symptom and repair or replace the cause of malfunction.
5. Does the front fog lamp operate normally? If YES: GO TO 6. If NO: GO TO 4.
6. Inspection End.

FRONT FOG LAMP

Preliminary Check CHECK POWER SUPPLY AND GROUND CIRCUIT

EKS0070X

1. CHECK FUSES OR FUSIBLE LINK

Check for blown fuses or fusible link.

Unit	Power source	Fuse No.
BCM	Battery	f
	Ignition switch ON or START position	12
	Ignition switch ACC or ON position	6
IPDM E/R	Battery	43

Refer to [LT-71, "Wiring Diagram — F/FOG —"](#) .

OK or NG

OK >> Inspection End.

NG >> If fuse is blown, be sure to eliminate cause of malfunction before installing new fuse. Refer to [PG-4, "POWER SUPPLY ROUTING CIRCUIT"](#) .

CONSULT-II Functions

EKS0070Y

Refer to [LT-14, "CONSULT-II Function \(BCM\)"](#) in HEADLAMP (FOR USA).

Refer to [LT-17, "CONSULT-II Function \(IPDM E/R\)"](#) in HEADLAMP (FOR USA).

Front Fog Lamps Do Not Illuminate (Both Sides)

EKS0070Z

1. FOG LAMP ACTIVE TEST

1. Select "IPDM E/R" on CONSULT-II and select "ACTIVE TEST" on "SELECT DIAG MODE" screen.
2. Select "LAMPS" on "SELECT TEST ITEM" screen.
3. Touch "FOG" screen.
4. Make sure fog lamps operate.

Fog lamps should operate.

OK or NG

OK >> GO TO 2.

NG >> GO TO 4.

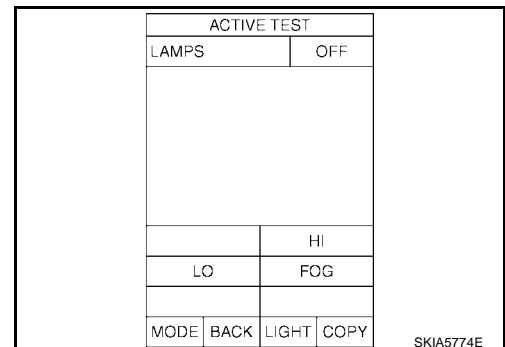

2. INSPECTION 1 BETWEEN COMBINATION SWITCH AND BCM

Carry out BCM C/U self-diagnosis.

Displayed results of self-diagnosis

NO MALFUNCTION DETECTED>> GO TO 3.

CAN COMMUNICATION OR CAN SYSTEM>> Inspect the BCM CAN communications system. Refer to [LAN-4, "CAN COMMUNICATION"](#) .

OPEN DETECT 1 - 5>> Inspect combination switch system. Refer to [BCS-12, "Combination Switch Inspection According to Self-Diagnostic Results"](#) .

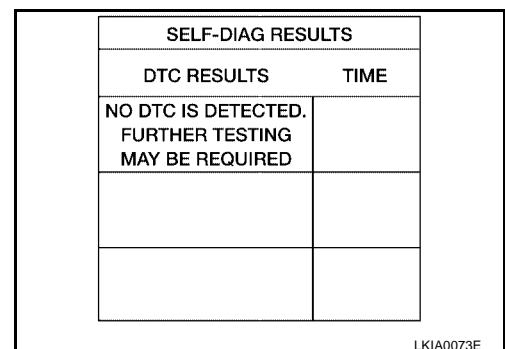

FRONT FOG LAMP

3. INSPECTION 2 BETWEEN COMBINATION SWITCH AND BCM

Select "BCM" on CONSULT-II. With "HEAD LAMP" data monitor, make sure "FR FOG SW" turns ON-OFF linked with operation of lighting switch.

When lighting switch is in FOG position : FR FOG SW ON

OK or NG

- OK >> Replace BCM.
- NG >> Replace lighting switch. Refer to [LT-94, "Removal and Installation"](#).

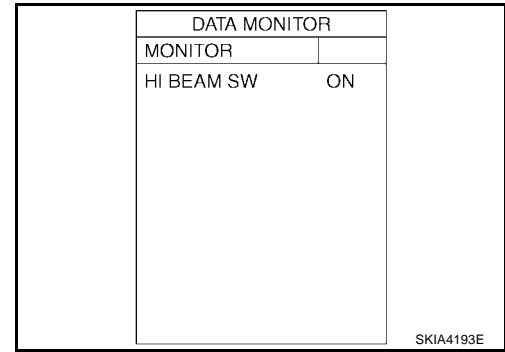

4. IPDM E/R INSPECTION

Start active test. Refer to [PG-21, "Auto Active Test"](#). When front fog lamp relay is operating, check voltage between left/right front fog lamp connector terminals and body ground.

Terminals			Voltage (Approx.)
Front fog lamp			
Connector	Terminal (wire color)		
Right	E101	1 (W/R)	
Left	E2	1 (W/R)	

Body ground (-)

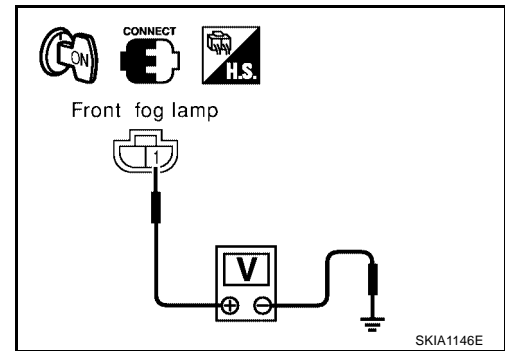

OK or NG

- OK >> Check front fog lamp bulbs and replace as necessary.
- NG >> Replace IPDM E/R. Refer to [PG-27, "Removal and Installation of IPDM E/R"](#).

Front Fog Lamp Does Not Illuminate (One Side)

EKS007P0

1. BULB INSPECTION

Inspect bulbs of lamps which do not illuminate.

OK or NG

- OK >> GO TO 2.
- NG >> Replace lamp bulb.

2. INSPECTION BETWEEN IPDM E/R AND FRONT FOG LAMPS

1. Disconnect IPDM E/R connector and inoperative front fog lamp connector.
2. Check continuity between harness connector terminals of IPDM E/R and harness connector terminal of front fog lamps.

Terminals					Continuity
IPDM E/R		Front fog lamp			
Connector	Terminal (wire color)	Connector	Terminal (wire color)		
E124	36 (W/R)	Right	E101	1 (W/R)	Yes
	37 (W/R)	Left	E2	1 (W/R)	

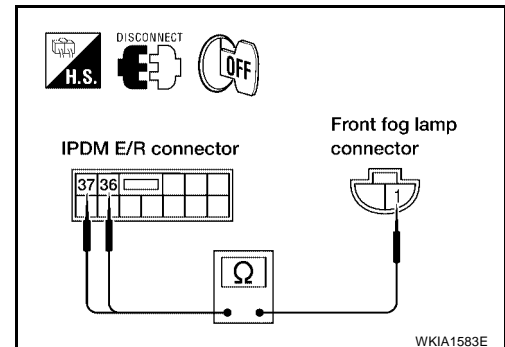

OK or NG

- OK >> Check ground circuit. If OK, replace IPDM E/R. Refer to [PG-27, "Removal and Installation of IPDM E/R"](#). If NG, repair harness or connector.
- NG >> Check for short circuits and open circuits in harness between IPDM E/R and front fog lamps.

FRONT FOG LAMP

EKS003DA

Aiming Adjustment

The fog lamp is a semi-sealed beam type which uses a replaceable halogen bulb. Before performing aiming adjustment, make sure of the following.

- Keep all tires inflated to correct pressure.
- Place vehicle on level ground.
- See that vehicle is unloaded (except for full levels of coolant, engine oil and fuel, and spare tire, jack, and tools). Have the driver or equivalent weight placed in driver seat.

Adjust aiming in the vertical direction by turning the adjusting screw.

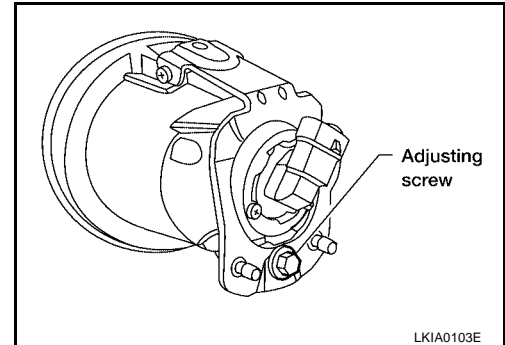

1. Set the distance between the screen and the center of the fog lamp lens as shown.
2. Turn front fog lamps ON.

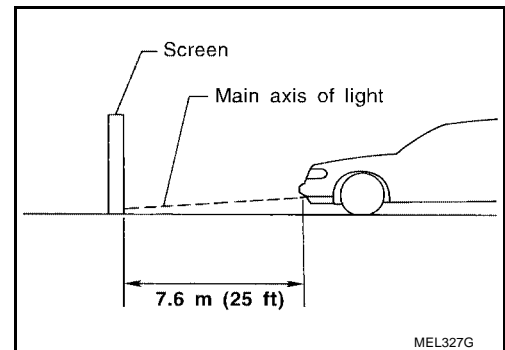

3. Adjust front fog lamps using adjusting screw so that the top edge of the high intensity zone is 100 mm (4 in) below the height of the fog lamp centers as shown.
- When performing adjustment, if necessary, cover the headlamps and opposite fog lamp.

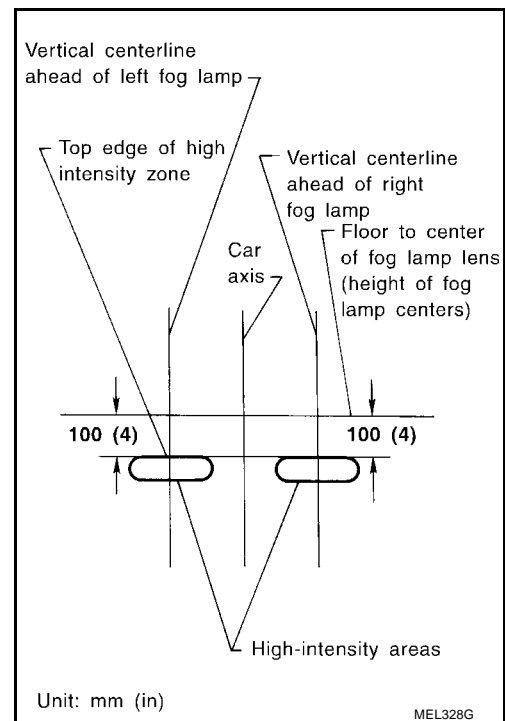

Removal and Installation

EKS003DB

The fog lamp is a semi-sealed beam type which uses a replaceable halogen bulb.

A
B
C
D
E
F
G
H
I
J
LT
L
M

FRONT FOG LAMP

CAUTION:

- Do not leave fog lamp assembly without bulb for a long period of time. Dust, moisture, smoke, etc. entering the fog lamp body may affect the performance. Remove the bulb from the headlamp assembly just before replacement bulb is installed.
 - Grasp only the plastic base when handling the bulb. Never touch the glass envelope. Touching the glass could significantly affect the bulb life and/or fog lamp performance.
1. Remove the fender protector. Refer to [EI-20, "Removal and Installation"](#).
 2. Disconnect electrical connector.
 3. Remove bolt, and slide fog lamp out of front fascia.
- Installation is in the reverse order of removal.

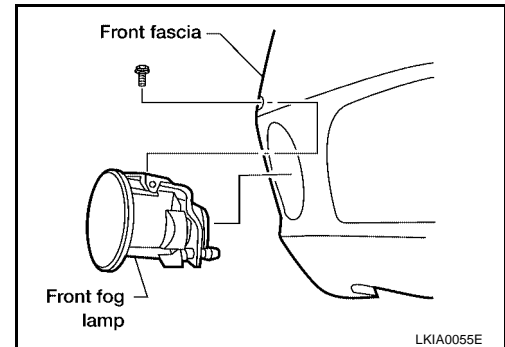

TURN SIGNAL AND HAZARD WARNING LAMPS

TURN SIGNAL AND HAZARD WARNING LAMPS

PF2:26120

System Description

EKS003DC

TURN SIGNAL OPERATION

When the ignition switch is in the ON or START position, power is supplied

- through 10A fuse [No. 12, located in the fuse block (J/B)]
- to BCM (body control module) terminal 35, and
- through 10A fuse [No. 14, located in the fuse block (J/B)]
- to terminals 17 and 18 of the combination meter.

Ground is supplied

- to BCM terminals 8, 27, and 63
- through body grounds F14 (QR25DE models), M57, M61, E15, and E24, and
- to combination meter terminals 6 and 39
- through body grounds F14 (QR25DE models), M57 and M61.

LH Turn

When the turn signal switch (combination switch) is moved to the L position, the BCM receives input requesting the left turn signals to flash. The BCM then supplies power

- to front turn signal lamp LH terminal 3
- to rear turn signal lamp LH (part of the rear combination lamp LH) terminal 3.

Ground is supplied to the front turn signal lamp LH terminal 2 through body grounds E15 and E24.

Ground is supplied to the rear turn signal lamp LH (part of the rear combination lamp) terminal 5 through body grounds B7 and B19.

The BCM also supplies ground to combination meter terminals 1 and 2 across the CAN communication lines. This input is processed by the central processing unit of the combination meter, which in turn supplies ground to the left turn signal indicator lamp.

With power and ground supplied, the BCM controls the flashing of the LH turn signal lamps.

RH Turn

When the turn signal switch (combination switch) is moved to the R position, the BCM (body control module) receives input requesting the right turn signals to flash. The BCM then supplies power

- to front turn signal lamp RH terminal 3
- to rear turn signal lamp RH (part of the rear combination lamp RH) terminal 3.

Ground is supplied to the front turn signal lamp RH terminal 2 through body grounds E15 and E24.

Ground is supplied to the rear turn signal lamp RH (part of the rear combination lamp RH) terminal 5 through body grounds B7 and B19.

The BCM also supplies ground to combination meter terminals 1 and 2 across the CAN communication lines. This input is processed by the central processing unit of the combination meter, which in turn supplies ground to the right turn signal indicator lamp.

With power and ground supplied, the BCM controls the flashing of the RH turn signal lamps.

HAZARD LAMP OPERATION

Power is supplied at all times

- to BCM terminal 7
- through 50A fusible link (letter f , located in the fuse and fusible link box), and
- to combination meter terminal 5
- through 10A fuse [No. 19, located in the fuse block (J/B)].

Ground is supplied

- to hazard switch terminal 3
- through body grounds F14 (QR25DE models), M57 and M61,
- to BCM terminals 8, 27, and 63,
- through body grounds F14 (QR25DE models), M57, M61, E15, and E24, and
- to combination meter terminals 6 and 39
- through body grounds F14 (QR25DE models), M57 and M61.

When the hazard switch is depressed, ground is supplied

A
B
C
D
E
F
G
H
I
J
LT
L
M

TURN SIGNAL AND HAZARD WARNING LAMPS

- to BCM terminal 61
- through hazard lamp switch terminal 1.

The BCM then supplies power

- to front turn signal lamp LH terminal 3
- to front turn signal lamp RH terminal 3
- to rear turn signal lamp LH (part of the rear combination lamp LH) terminal 3
- to rear turn signal lamp RH (part of the rear combination lamp RH) terminal 3.

Ground is supplied

- to the front turn signal lamp LH terminal 2 through body grounds E15 and E24
- to the front turn signal lamp RH terminal 2 through body grounds E15 and E24
- to the rear turn signal lamp LH (part of the rear combination lamp) terminal 5 through body grounds B7 and B19
- to the rear turn signal lamp RH (part of the rear combination lamp RH) terminal 5 through body grounds B7 and B19.

The BCM also supplies input to combination meter terminals 1 and 2 across the CAN communication lines. This input is processed by the central processing unit of the combination meter, which in turn supplies ground to the left and right turn signal indicator lamps.

With power and ground supplied, the BCM controls the flashing of the hazard warning lamps.

REMOTE KEYLESS ENTRY SYSTEM OPERATION

Power is supplied at all times

- to BCM terminal 7
- through 50A fusible link (letter f , located in the fuse and fusible link box), and
- to combination meter terminal 5
- through 10A fuse [No. 19, located in the fuse block (J/B)].

Ground is supplied

- to BCM terminals 8, 27, and 63,
- through body grounds F14 (QR25DE models), M57, M61, E15, and E24, and
- to combination meter terminals 6 and 39
- through body grounds F14 (QR25DE models), M57 and M61.

When the remote keyless entry system is triggered by input from the keyfob, the BCM supplies power

- to front turn signal lamp LH terminal 3
- to front turn signal lamp RH terminal 3
- to rear turn signal lamp LH (part of the rear combination lamp LH) terminal 3
- to rear turn signal lamp RH (part of the rear combination lamp RH) terminal 3.

Ground is supplied

- to the front turn signal lamp LH terminal 2 through body grounds E15 and E24
- to the front turn signal lamp RH terminal 2 through body grounds E15 and E24
- to the rear turn signal lamp LH (part of the rear combination lamp) terminal 5 through body grounds B7 and B19
- to the rear turn signal lamp RH (part of the rear combination lamp RH) terminal 5 through body grounds B7 and B19.

The BCM also supplies input to combination meter terminals 1 and 2 across the CAN communication lines. This input is processed by the central processing unit of the combination meter, which in turn supplies ground to the left and right turn signal indicator lamps.

With power and ground supplied, the BCM controls the flashing of the hazard warning lamps when keyfob is used to activate the remote keyless entry system.

CAN Communication System Description

EKS003DD

Refer to [LAN-4, "CAN COMMUNICATION"](#) .

TURN SIGNAL AND HAZARD WARNING LAMPS

Schematic

EKS003DE

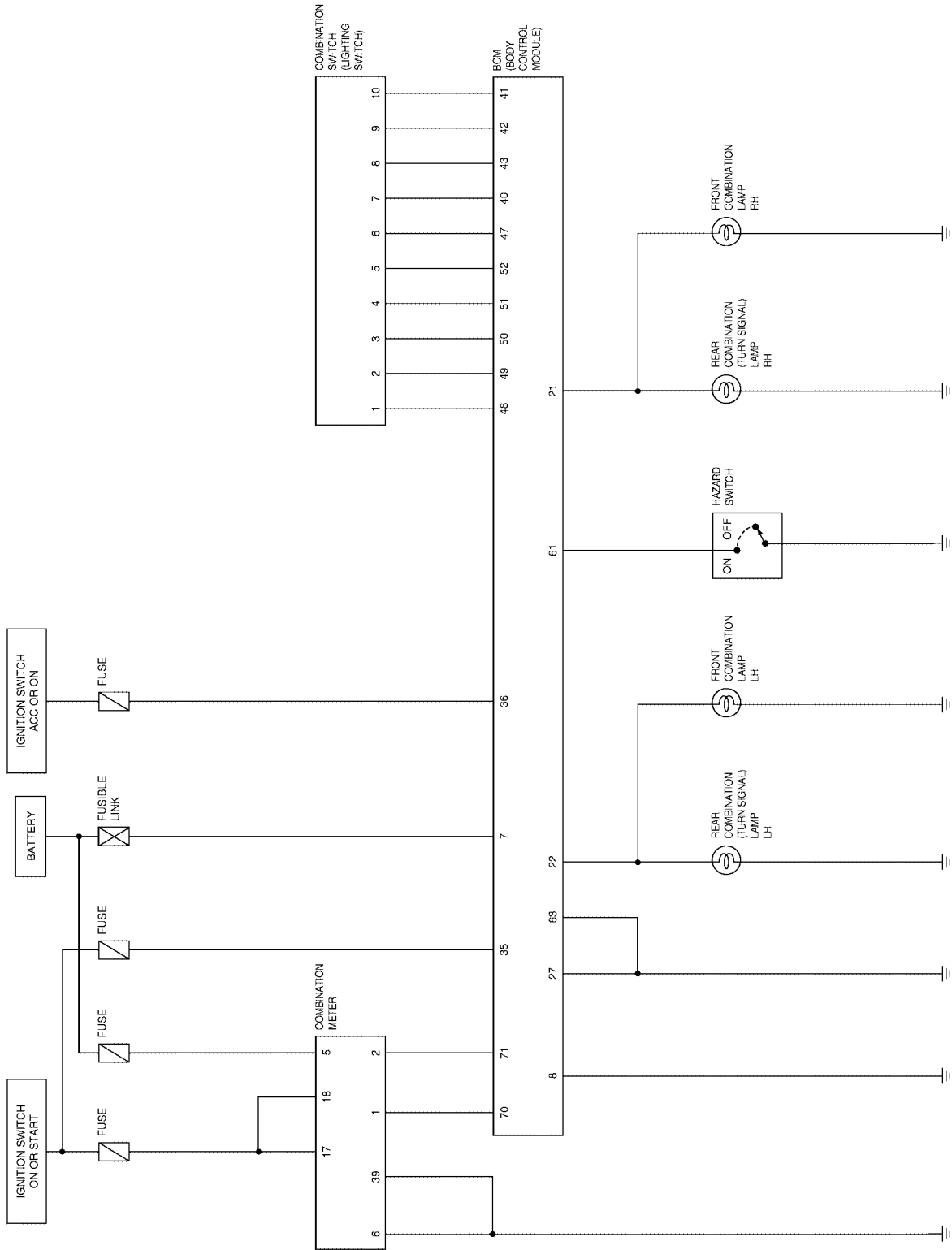

A
B
C
D
E
F
G
H
I
J
LT
L
M

WKWA0186E

TURN SIGNAL AND HAZARD WARNING LAMPS

EKS003DF

Wiring Diagram — TURN —

LT-TURN-01

ⓀR : WITH QR25DE

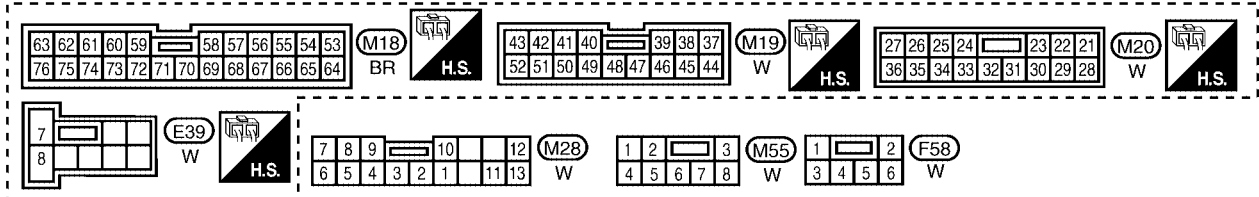
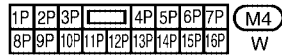
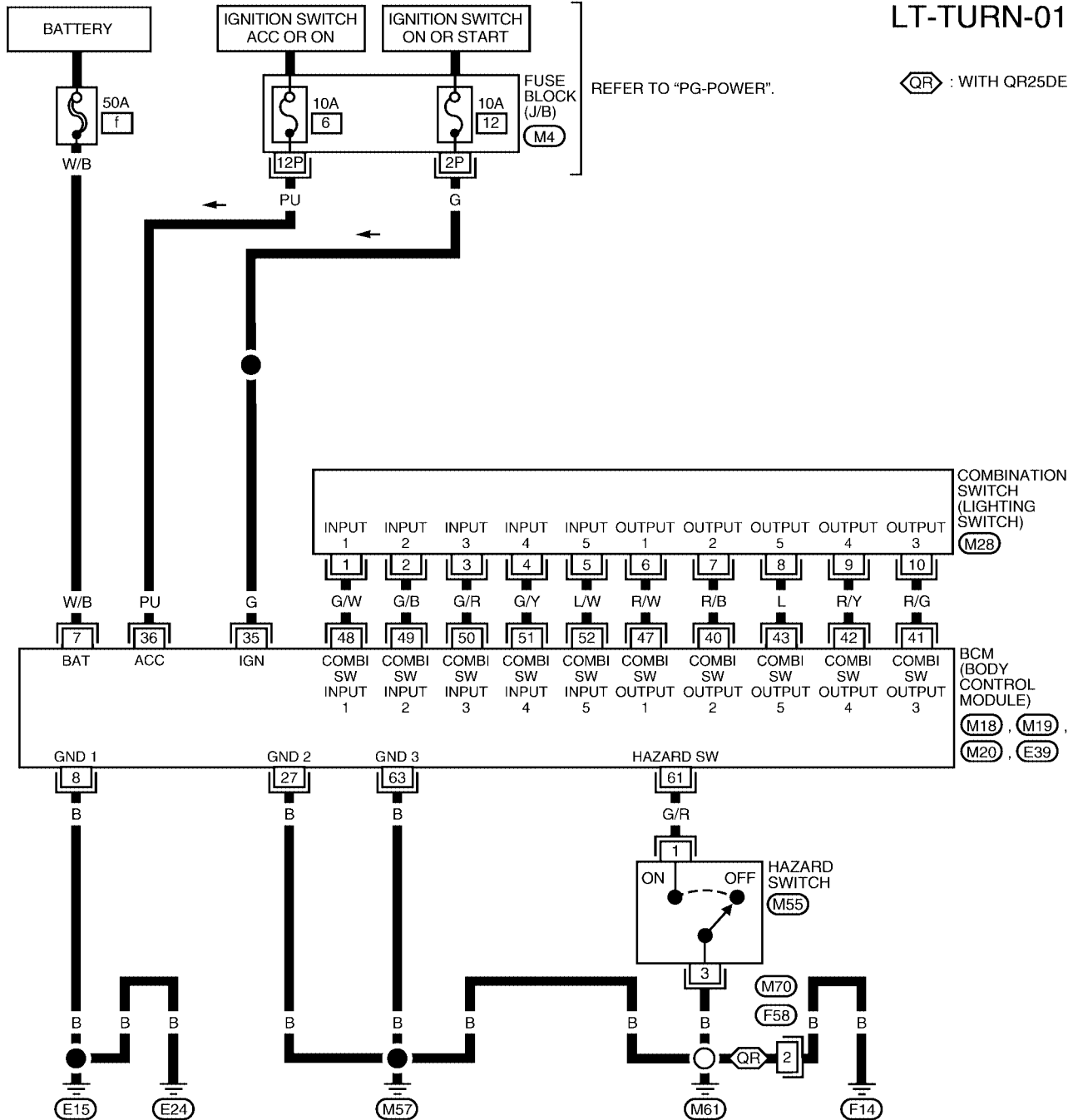

WKWA0895E

TURN SIGNAL AND HAZARD WARNING LAMPS

LT-TURN-02

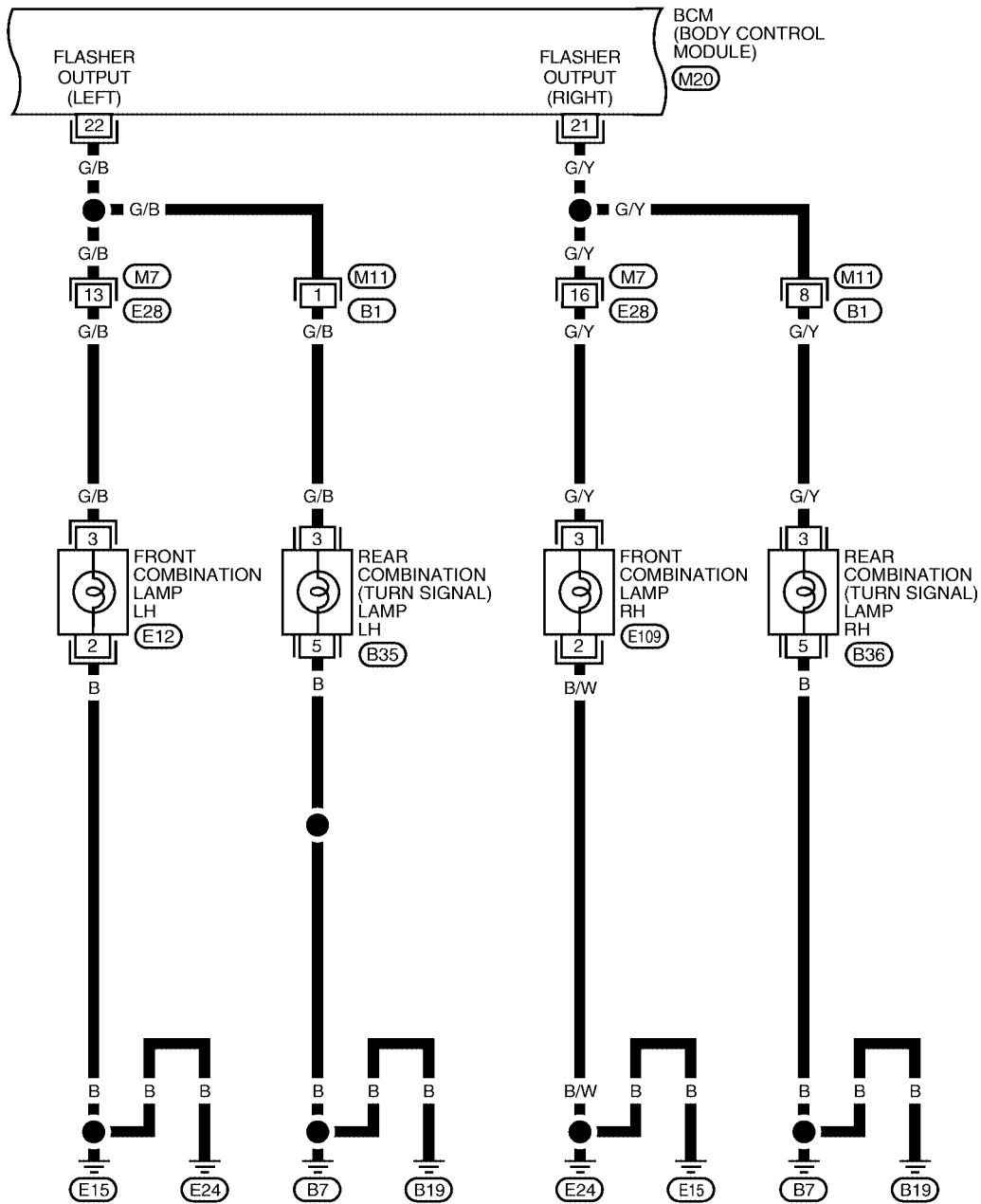

A
B
C
D
E
F
G
H
I
J
LT
L
M

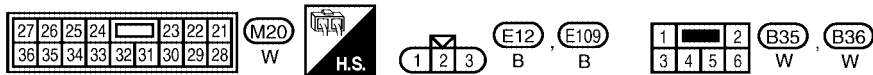
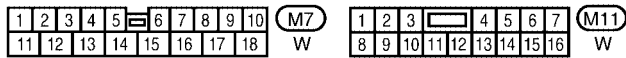

WKWA0896E

TURN SIGNAL AND HAZARD WARNING LAMPS

LT-TURN-03

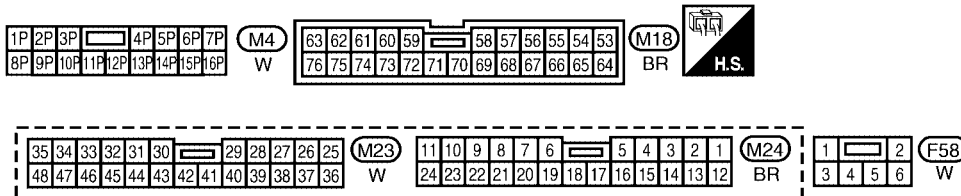
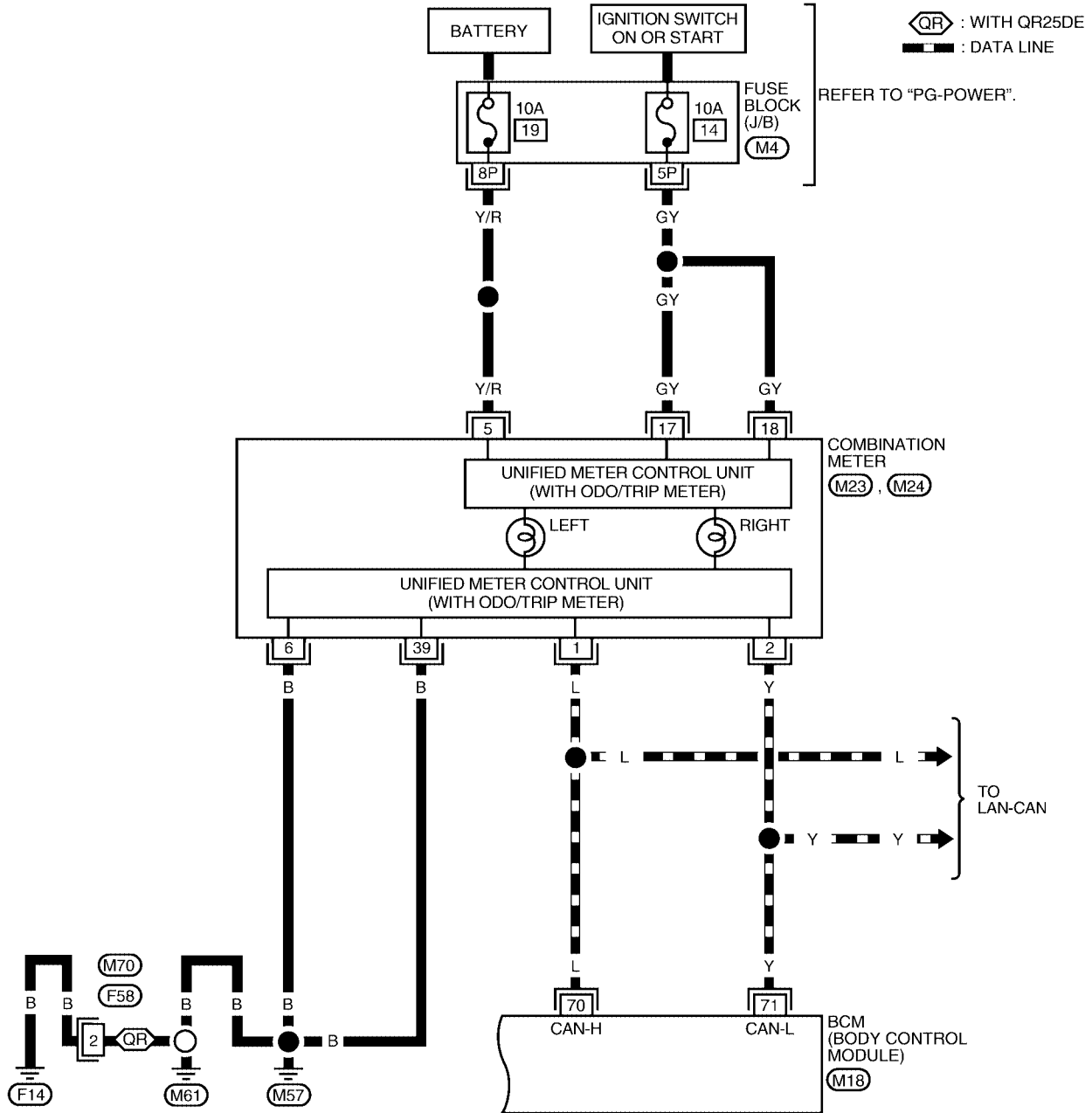

WKWA0897E

TURN SIGNAL AND HAZARD WARNING LAMPS

Terminals and Reference Value for BCM

EKS003DG

Terminal No.	Wire color	Signal name	Measuring condition		Reference value (V) or waveform	
			Ignition switch	Operation or condition		
7	W/B	Battery power supply	OFF	—	Approx. 12V	
8	B	Ground	ON	—	Approx. 0V	
21	G/Y	Turn signal (right)	ON	Combination switch Turn right ON		
22	G/B	Turn signal (left)	ON	Combination switch Turn left ON		
35	G	IGN power	ON	—	Approx. 12V	
42	R/Y	Combination switch OUTPUT 4	ON	Lighting, turn, wiper OFF		
43	L	Combination switch OUTPUT 5	ON	Lighting, turn, wiper OFF		
48	G/W	Combination switch INPUT 1	ON	Lighting, turn, wiper OFF	Approx. 0V	
61	G/R	Hazard	OFF	Hazard switch	ON	Approx. 0V
					OFF	Approx. 5V

A
B
C
D
E
F
G
H
I
J
LT
L
M

TURN SIGNAL AND HAZARD WARNING LAMPS

CONSULT-II Function (BCM)

EKS003DH

CONSULT-II can display each diagnostic item using the diagnostic test modes shown following.

BCM diagnosis part	Check item, diagnosis mode	Description
FLASHER	Data monitor	Displays BCM input data in real time.
	CAN DIAG SUPPORT MNTR	The result of transmit/receive diagnosis of CAN communication can be read.
	Active test	Operation of electrical loads can be checked by sending driving signal to them.

CONSULT-II BASIC OPERATION

CAUTION:

If CONSULT-II is used with no connection of CONSULT-II CONVERTER, malfunctions might be detected in self-diagnosis depending on control unit which carries out CAN communication.

1. With the ignition switch OFF, connect CONSULT-II and CONSULT-II CONVERTER to the data link connector, then turn ignition switch ON.

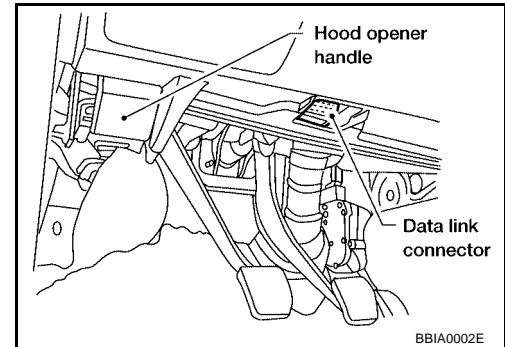

2. Touch "START (NISSAN BASED VEHICLE)".

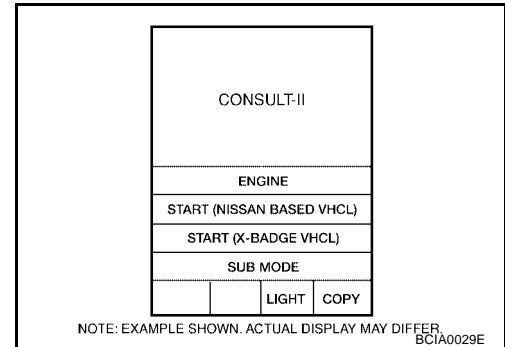

3. Touch "BCM" on "SELECT SYSTEM" screen. If "BCM" is not indicated, go to [GI-37, "CONSULT-II Data Link Connector \(DLC\) Circuit"](#).

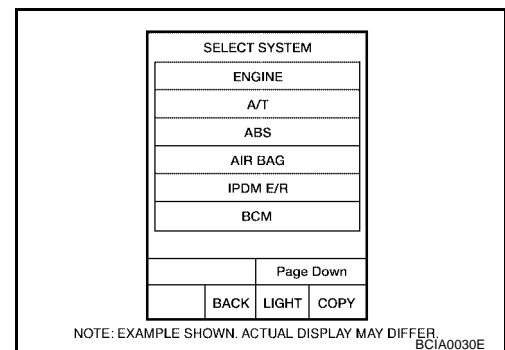

TURN SIGNAL AND HAZARD WARNING LAMPS

- Select the desired part to be diagnosed on the "SELECT TEST ITEM" screen.

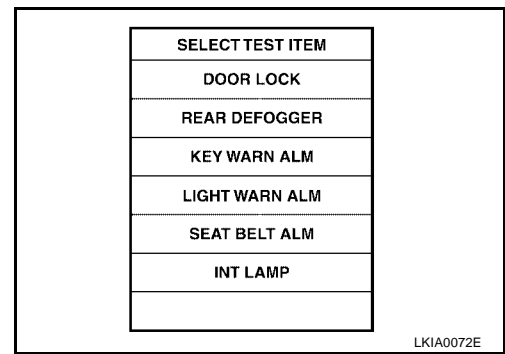

DATA MONITOR

Operation Procedure

- Touch "FLASHER" on "SELECT TEST ITEM" screen.
- Touch "DATA MONITOR" on "SELECT DIAG MODE" screen.
- Touch either "ALL SIGNALS" or "SELECTION FROM MENU" on the "DATA MONITOR" screen.

All signals	Monitors all the signals.
Selection from menu	Selects and monitors the individual signal.

- Touch "START".
- When "SELECTION FROM MENU" is selected, touch items to be monitored. When "ALL SIGNALS" is selected, all the items will be monitored.
- Touch "RECORD" while monitoring, then the status of the monitored item can be recorded. To stop recording, touch "STOP".

Display Item List

Monitor item name "OPERATION OR UNIT"	Contents
IGN ON SW "ON/OFF"	"IGN position (ON)/OFF, ACC position (OFF)" judged from the ignition switch signal is displayed.
HAZARD SW "ON/OFF"	Displays "Hazard ON (ON)/Hazard OFF (OFF)" status, determined from hazard switch signal.
TURN SIGNAL R "ON/OFF"	Displays "Turn right (ON)/Other (OFF)" status, determined from lighting switch signal.
TURN SIGNAL L "ON/OFF"	Displays "Turn left (ON)/Other (OFF)" status, determined from lighting switch signal.

ACTIVE TEST

Operation Procedure

- Touch "FLASHER" on "SELECT TEST ITEM" screen.
- Touch "ACTIVE TEST" on "SELECT DIAG MODE" screen.
- Touch item to be tested and check operation of the selected item.
- During the operation check, touching "BACK" deactivates the operation.

Display Item List

Test item	Display on CONSULT-II screen	Description
Turn signal lamp (right) output	FLASHER (RIGHT)	Turn signal lamp (right) can be operated by any ON-OFF operations.
Turn signal lamp (left) output	FLASHER (LEFT)	Turn signal lamp (left) can be operated by any ON-OFF operations.
Turn signal lamp (right) indicator signal output	FLASHER (RIGHT) (CAN)	Turn signal lamp (right) indicator signal can be output by CAN communication line to gauges by any ON-OFF operations.
Turn signal lamp (left) indicator signal output	FLASHER (LEFT) (CAN)	Turn signal lamp (left) indicator signal can be output by CAN communication line to gauges by any ON-OFF operations.

TURN SIGNAL AND HAZARD WARNING LAMPS

EKS003DI

Turn Signal Lamp Does Not Operate

1. BULB INSPECTION

Check each turn signal lamp bulb to make sure correct bulbs are installed.

OK or NG

- OK >> GO TO 2.
- NG >> Replace bulb.

2. INSPECTION 1 BETWEEN COMBINATION SWITCH AND BCM

Select "BCM" on CONSULT-II. Carry out BCM C/U self-diagnosis.

Displayed results of self-diagnosis

- Diagnosis system 1 - 5>> Combination switch system malfunction.
Refer to [BCS-12, "Combination Switch Inspection According to Self-Diagnostic Results"](#).

No malfunction detected>> GO TO 3.

SELF-DIAG RESULTS	
DTC RESULTS	TIME
NO DTC IS DETECTED. FURTHER TESTING MAY BE REQUIRED	

LKIA0073E

3. INSPECTION 2 BETWEEN COMBINATION SWITCH AND BCM

Select "BCM" on CONSULT-II. With "FLASHER" data monitor, check that "TURN SIGNAL R" and "TURN SIGNAL L" turn ON-OFF according to operation of turn signal switch.

OK or NG

- OK >> GO TO 4.
- NG >> Replace lighting switch. Refer to [LT-90, "Removal and Installation"](#).

DATA MONITOR	
MONITOR	
IGN ON SW	ON
HAZARD SW	ON
TURN SIGNAL R	OFF
TURN SIGNAL L	OFF

LKIA0083E

4. INSPECTION 1 BETWEEN BCM AND TURN SIGNAL LAMPS

1. Select "BCM" on CONSULT-II. Select "FLASHER" active test.
2. Check that "FLASHER RIGHT" and "FLASHER LEFT" operate.

OK or NG

- OK >> Replace BCM.
- NG >> GO TO 5.

ACTIVE TEST	
FLASHER RIGHT	ON
	OFF

LKIA0084E

TURN SIGNAL AND HAZARD WARNING LAMPS

5. INSPECTION 2 BETWEEN BCM AND TURN SIGNAL LAMPS

1. Disconnect BCM connector and all turn signal lamp connectors.
2. Check continuity between harness connectors of BCM and body ground.

Terminals			Continuity
BCM		Body ground	
Connector	Terminal (wire color)		No
Right	M20		21 (G/Y)
Left	M20	22 (G/B)	

OK or NG

OK >> Replace BCM.

NG >> Check for short circuit in harnesses between BCM and each turn signal and repair as necessary.

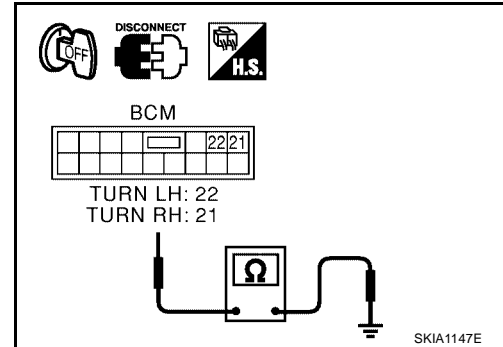

Hazard Lamp Does Not Operate

EKS003DJ

1. BULB INSPECTION

Check each turn signal lamp bulb to make sure correct bulbs are installed.

OK or NG

OK >> GO TO 2.

NG >> Replace bulb.

2. INSPECTION 1 BETWEEN HAZARD SWITCH AND BCM

Select "BCM" on CONSULT-II. Use "FLASHER" data monitor to verify that "HAZARD SW" turns ON-OFF according to operation of hazard switch.

OK or NG

OK >> GO TO 5.

NG >> GO TO 3.

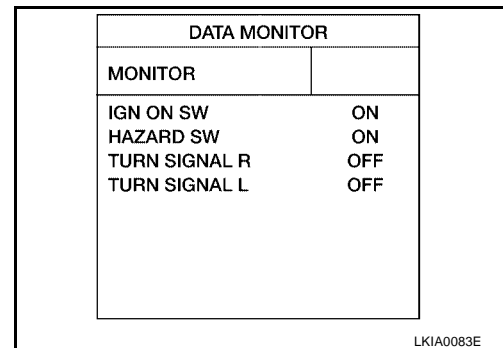

3. INSPECTION 2 BETWEEN HAZARD SWITCH AND BCM

1. Disconnect BCM connector and hazard switch connector.
2. Check continuity between harness connector terminal of BCM and harness connector terminal of hazard switch.

Terminals				Continuity
BCM		Hazard switch		
Connector	Terminal (wire color)	Connector	Terminal (wire color)	
M18	61 (G/R)	M55	1 (G/R)	Yes

OK or NG

OK >> Connect connectors. GO TO 4.

NG >> Check for short circuit or open circuit in harness between BCM and hazard switch. Repair as necessary.

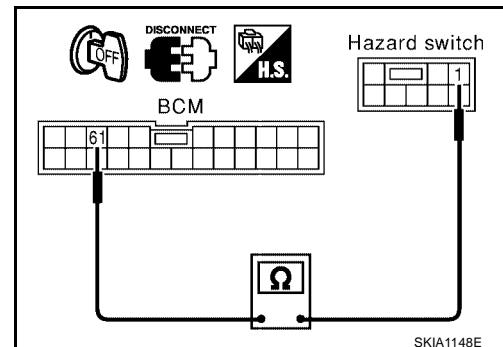

TURN SIGNAL AND HAZARD WARNING LAMPS

4. INSPECTION BCM

Check voltage between BCM terminal and body ground.

Terminals		Body ground (-)	Voltage
BCM (+)			
Connector	Terminal (wire color)		1.6V or more
M18	61 (G/R)		

OK or NG

- OK >> Replace hazard switch. Refer to [LT-91, "Removal and Installation"](#).
- NG >> Replace BCM.

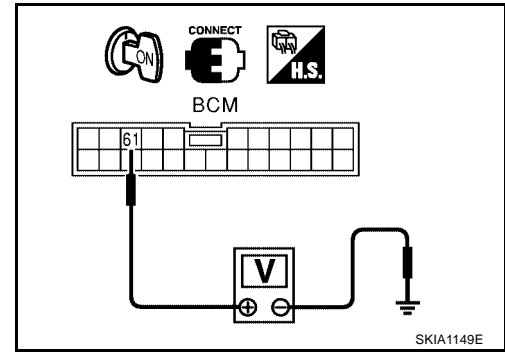

5. INSPECTION 1 BETWEEN BCM AND TURN SIGNAL LAMPS

- Select "BCM" on CONSULT-II. Select "FLASHER" active test.
- Check that "FLASHER RIGHT" and "FLASHER LEFT" operate.

OK or NG

- OK >> Replace BCM.
- NG >> GO TO 6.

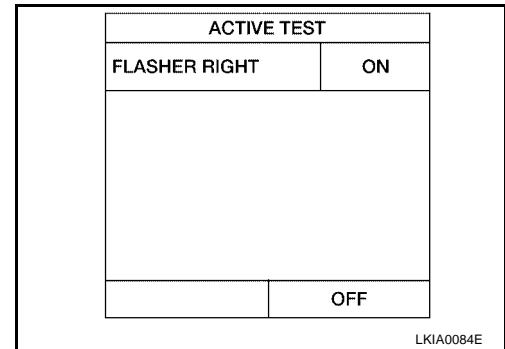

6. INSPECTION 2 BETWEEN BCM AND TURN SIGNAL LAMPS

- Disconnect BCM connector and all turn signal lamp connectors.
- Check continuity between harness connectors of BCM and body ground.

Terminals		Body ground	Continuity
BCM			
Connector	Terminal (wire color)		No
Right	M20 21 (G/Y)		
Left	M20 22 (G/B)		

OK or NG

- OK >> Replace BCM.
- NG >> Check for short circuit in harnesses between BCM and each turn signal. Repair as necessary.

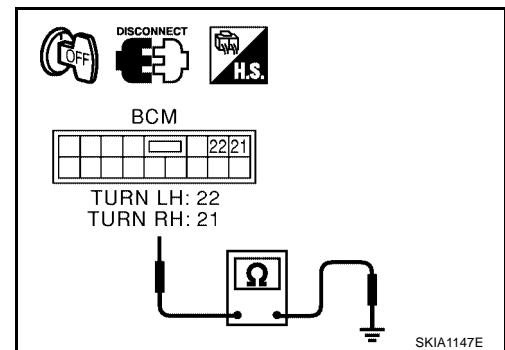

Turn Signal Indicator Lamp Does Not Operate

EKS003DK

1. BULB INSPECTION

Inspect turn signal indicator lamp bulb.

OK or NG

- OK >> Replace combination meter. Refer to [DI-17, "Removal and Installation of Combination Meter"](#).
- NG >> Replace indicator bulb.

Bulb Replacement FRONT TURN SIGNAL LAMP

EKS003DL

Refer to [LT-28, "Bulb Replacement"](#).

TURN SIGNAL AND HAZARD WARNING LAMPS

REAR TURN SIGNAL LAMP

Refer to [LT-116, "TAIL LAMP"](#) .

Removal and Installation

FRONT TURN SIGNAL LAMP

Refer to [LT-29, "Removal and Installation"](#) .

REAR TURN SIGNAL LAMP

Refer to [LT-116, "REAR COMBINATION LAMP"](#) .

A

EKS003DM

B

C

D

E

F

G

H

I

J

LT

L

M

LIGHTING AND TURN SIGNAL SWITCH

LIGHTING AND TURN SIGNAL SWITCH

PFP:25540

Removal and Installation

EKS003DN

1. Remove the steering column cover. Refer to [PS-9, "STEERING COLUMN"](#) .
2. Pinch tabs and slide out lighting and turn signal switch (combination switch).

Installation is in the reverse order of removal.

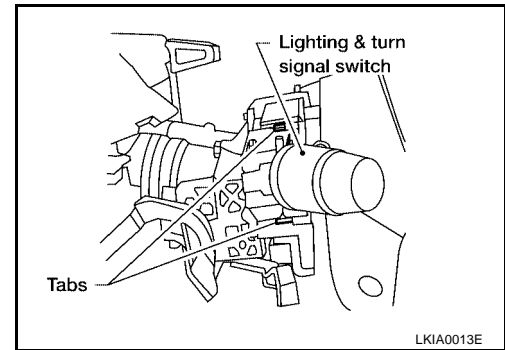

LKIA0013E

Switch Circuit Inspection

EKS003DO

Refer to [BCS-12, "Combination Switch Inspection According to Self-Diagnostic Results"](#) .

HAZARD SWITCH

HAZARD SWITCH

PFP:25290

Removal and Installation

EKS003DP

1. Remove center console storage compartment. Refer to [IP-10](#), ["INSTRUMENT PANEL ASSEMBLY"](#).
 2. Depress hazard switch tab and remove hazard switch.
- Installation is in the reverse order of removal.

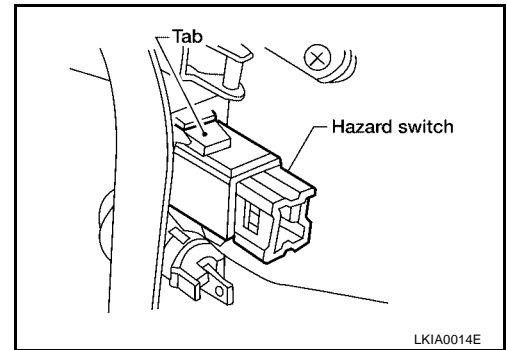

A
B
C
D
E
F
G
H
I
J
LT
L
M

COMBINATION SWITCH

COMBINATION SWITCH

PFP:25567

Combination Switch Reading Function

EKS003DQ

Refer to [BCS-3, "COMBINATION SWITCH READING FUNCTION"](#) .

CONSULT-II Function (BCM)

EKS003DR

CONSULT-II can display each diagnostic item using the diagnostic test modes shown following.

BCM diagnosis part	Check item, diagnosis mode	Description
Combination switch	Data monitor	Displays BCM input data in real time.
	CAN DIAG SUPPORT MNTR	The result of transmit/receive diagnosis of CAN communication can be read.

CONSULT-II BASIC OPERATION

CAUTION:

If CONSULT-II is used with no connection of CONSULT-II CONVERTER, malfunctions might be detected in self-diagnosis depending on control unit which carries out CAN communication.

1. With the ignition switch OFF, connect CONSULT-II and CONSULT-II CONVERTER to the data link connector, then turn ignition switch ON.

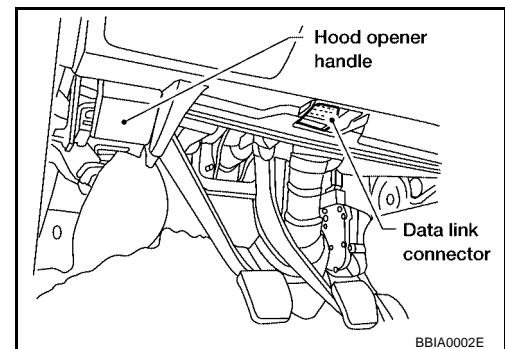

2. Touch "START (NISSAN BASED VEHICLE)".

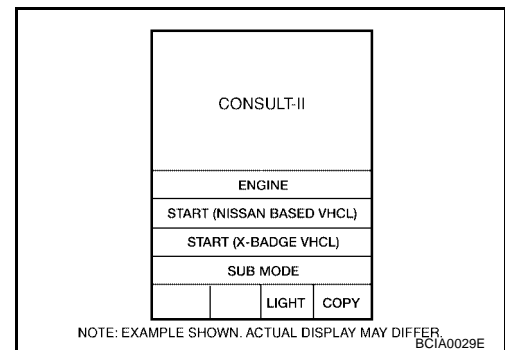

3. Touch "BCM" on "SELECT SYSTEM" screen.
If "BCM" is not indicated, go to [GI-37, "CONSULT-II Data Link Connector \(DLC\) Circuit"](#) .

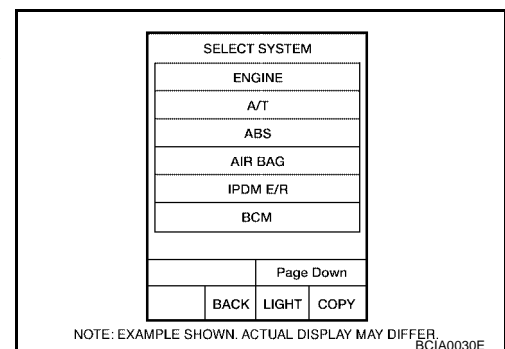

COMBINATION SWITCH

- Select the desired part to be diagnosed on the “SELECT TEST ITEM” screen.

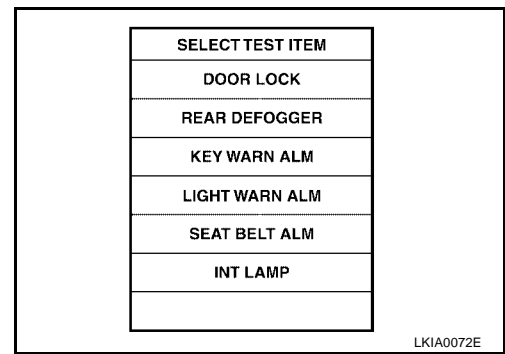

DATA MONITOR

Operation Procedure

- Touch “COMB SW” on “SELECT TEST ITEM” screen.
- Touch “DATA MONITOR” on “SELECT DIAG MODE” screen.
- Touch either “ALL SIGNALS” or “SELECTION FROM MENU” on “DATA MONITOR” screen.

All signals	Monitors all the signals.
Selection from menu	Selects and monitors individual signal.

- Touch “START”.
- When “SELECTION FROM MENU” is selected, touch items to be monitored. When “ALL SIGNALS” is selected, all the signals will be monitored.
- Touch “RECORD” while monitoring, then the status of the monitored item can be recorded. To stop recording, touch “STOP”.

Display Item List

Monitor item name “OPERATION OR UNIT”		Contents
TAIL LAMP SW	“ON/OFF”	Displays status (lighting switch 1st position: ON/Others: OFF) of lighting switch judged from lighting switch signal.
HEAD LAMP SW 1	“ON/OFF”	Displays “Headlamp Switch 1 (ON)/Other (OFF)” status, determined from lighting switch signal.
HEAD LAMP SW 2	“ON/OFF”	Displays status (headlamp switch 2: ON/Others: OFF) of headlamp switch 2 judged from lighting switch signal.
HI BEAM SW	“ON/OFF”	Displays status (high beam switch: ON/Others: OFF) of high beam switch judged from lighting switch signal.
PASSING SW	“ON/OFF”	Displays status (flash-to-pass switch: ON/Others: OFF) of flash-to-pass switch judged from lighting switch signal.
AUTO LIGHT SW ^{Note}	“ON/OFF”	Displays status of the lighting switch as judged from the lighting switch signal. (AUTO position: ON/Other than AUTO position: OFF)
FR FOG SW	“ON/OFF”	Displays status (front fog switch: ON/Others: OFF) of front fog switch judged from lighting switch signal.
FR WIPER HI	“ON/OFF”	Displays “Front Wiper HI (ON)/Other (OFF)” status, determined from wiper switch signal.
FR WIPER LO	“ON/OFF”	Displays “Front Wiper LOW (ON)/Other (OFF)” status, determined from wiper switch signal.
FR WIPER INT	“ON/OFF”	Displays “Front Wiper INT (ON)/Other (OFF)” status, determined from wiper switch signal.
INT VOLUME	[1 - 7]	Displays intermittent operation knob setting (1 - 7), determined from wiper switch signal.
FR WASHER SW	“ON/OFF”	Displays “Front Washer Switch (ON)/Other (OFF)” status, determined from wiper switch signal.
TURN SIGNAL R	“ON/OFF”	Displays “Turn Right (ON)/Other (OFF)” status, determined from lighting switch signal.
TURN SIGNAL L	“ON/OFF”	Displays “Turn Left (ON)/Other (OFF)” status, determined from lighting switch signal.

COMBINATION SWITCH

NOTE:

For vehicles without auto light, item will be displayed but monitoring is not possible.

Removal and Installation

EKS003DS

For details, refer to [LT-90, "Removal and Installation"](#) .

Switch Circuit Inspection

EKS003DT

For details, refer to [BCS-12, "Combination Switch Inspection According to Self-Diagnostic Results"](#) .

STOP LAMP

PF:26550

EKS003DU

STOP LAMP

Wiring Diagram — STOP/L —

LT-STOP/L-01

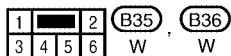
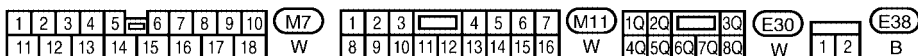
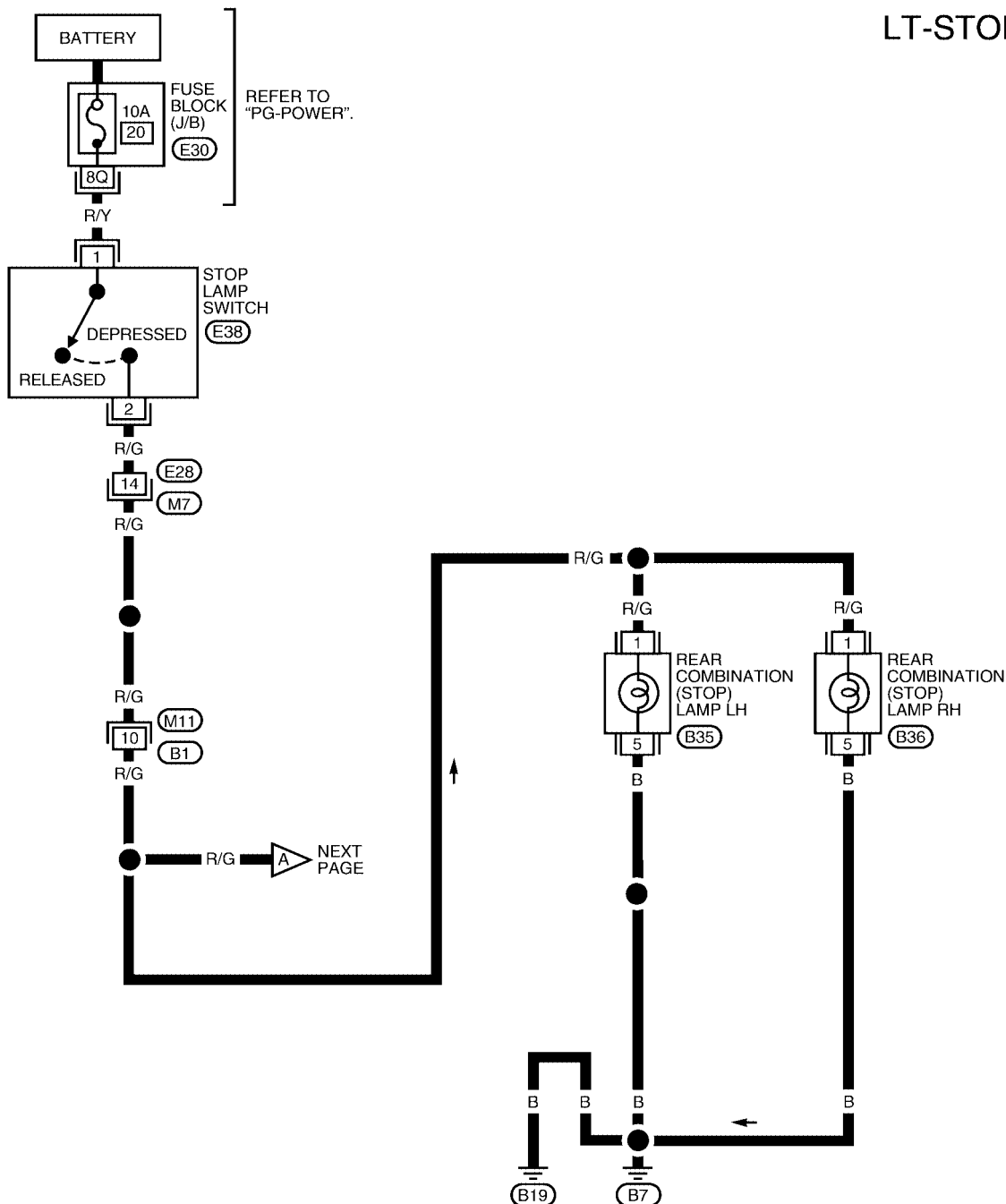

A
B
C
D
E
F
G
H
I
J
LT
L
M

STOP LAMP

LT-STOP/L-02

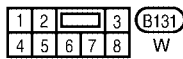
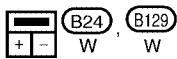
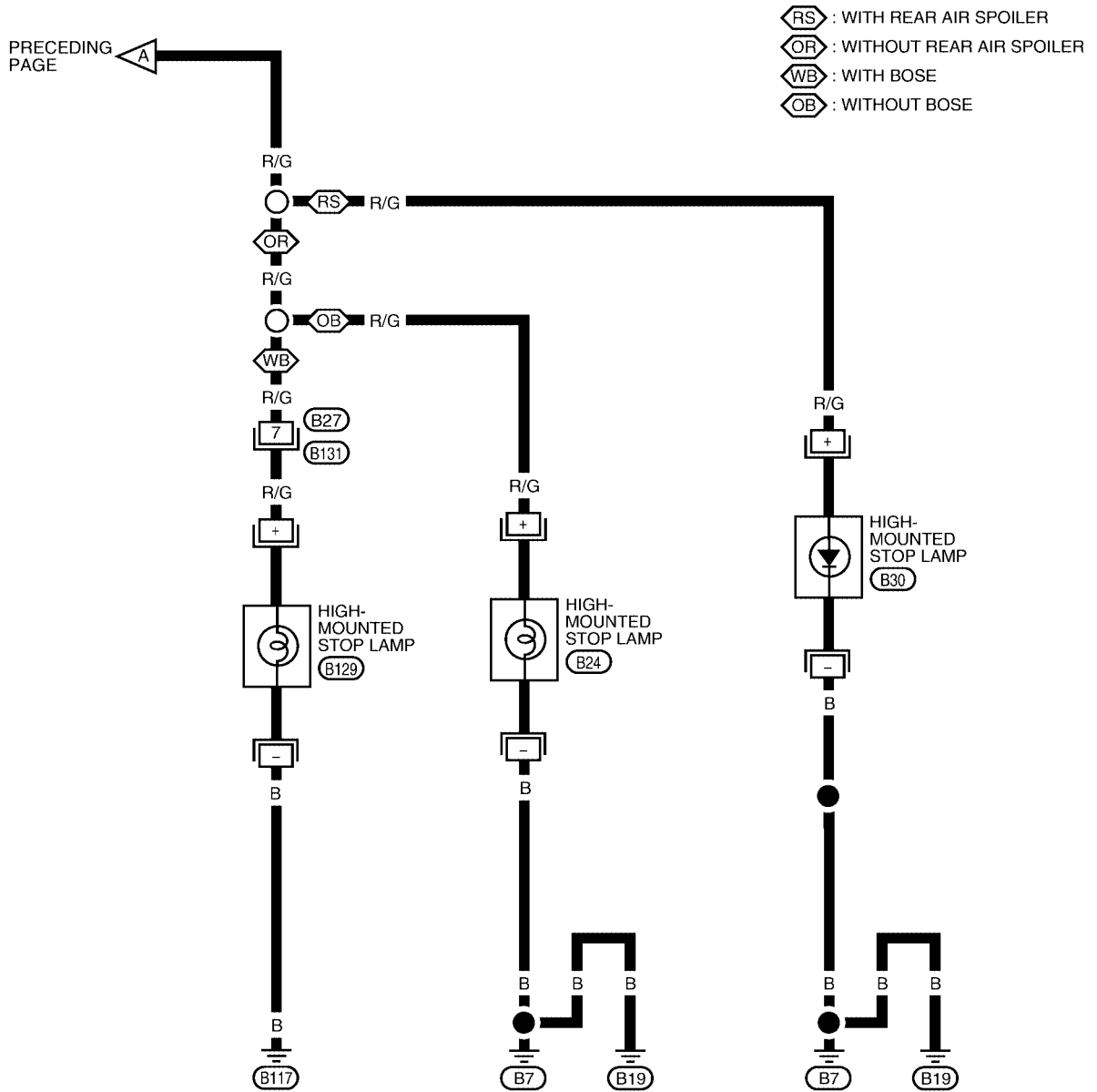

WKWA0899E

STOP LAMP

Bulb Replacement for High-mounted Stop Lamp WITH REAR SPOILER

EKS003DV

When this vehicle is equipped with a rear spoiler, the high-mounted stop lamp uses an LED circuit board instead of a bulb. The LED circuit board is not serviceable and must be replaced as an assembly.

WITHOUT REAR SPOILER

1. Remove high-mounted stop lamp assembly. Refer to [LT-97, "Removal and Installation for High-mounted Stop Lamp"](#).
2. Turn bulb socket counterclockwise to unlock and remove from lamp assembly.
3. Turn bulb counterclockwise to remove from socket.

Installation is in the reverse order of removal.

Bulb Replacement for Rear Combination Lamp

EKS003DW

1. Remove rear combination lamp. Refer to [LT-97, "Removal and Installation for Rear Combination Lamp"](#).
2. Turn bulb socket counterclockwise to unlock and remove from combination lamp assembly.
3. Turn bulb counterclockwise to remove from bulb socket.

Installation is in the reverse order of removal.

Removal and Installation for High-mounted Stop Lamp WITH REAR SPOILER

EKS003DX

When this vehicle is equipped with a rear spoiler, the high-mounted stop lamp uses an LED circuit board instead of a bulb. The LED circuit board is not serviceable and must be replaced as an assembly.

1. From trunk, disconnect electrical connector.
2. Remove screws and high-mounted stop lamp assembly.

Installation is in the reverse order of removal.

WITHOUT SPOILER

1. Slide high-mounted stop lamp assembly rearward on parcel shelf to give clearance to front tabs.
2. Lift front of lamp assembly up and bring forward to give clearance to rear tabs.
3. Disconnect connector, and remove from vehicle.

Installation is in the reverse order of removal.

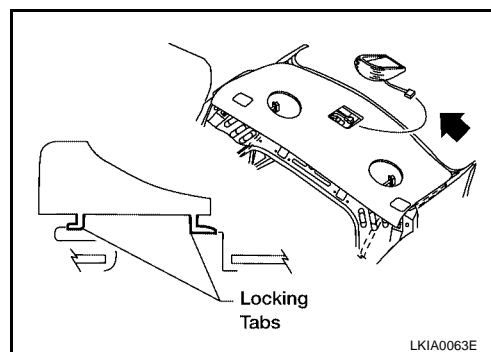

Removal and Installation for Rear Combination Lamp

EKS003DY

1. Displace trunk room trim as needed. Refer to [EI-35, "Removal and Installation"](#).
2. From trunk, remove nuts securing rear combination lamp assembly.
3. Disconnect connectors and remove assembly.

Installation is in the reverse order of removal.

Rear combination lamp mounting nut:

 : 2.5 - 3.7 N·m (0.25 - 0.38 kg·m, 22 - 33 in·lb)

STEP LAMP

STEP LAMP

PF2:26420

System Description

EKS003DZ

Step lamp turns ON at time when driver door, passenger door, RH rear door, or LH rear door is opened (door switch ON). Lamp turns OFF when all doors are closed (all door switches OFF).

STEP LAMP

Wiring Diagram — STEP/L —

EKS003E0

LT-STEP/L-01

OV : WITHOUT VEHICLE SECURITY SYSTEM

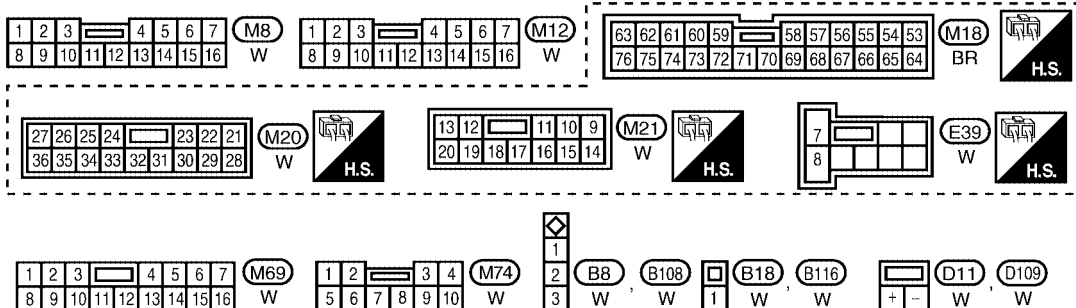
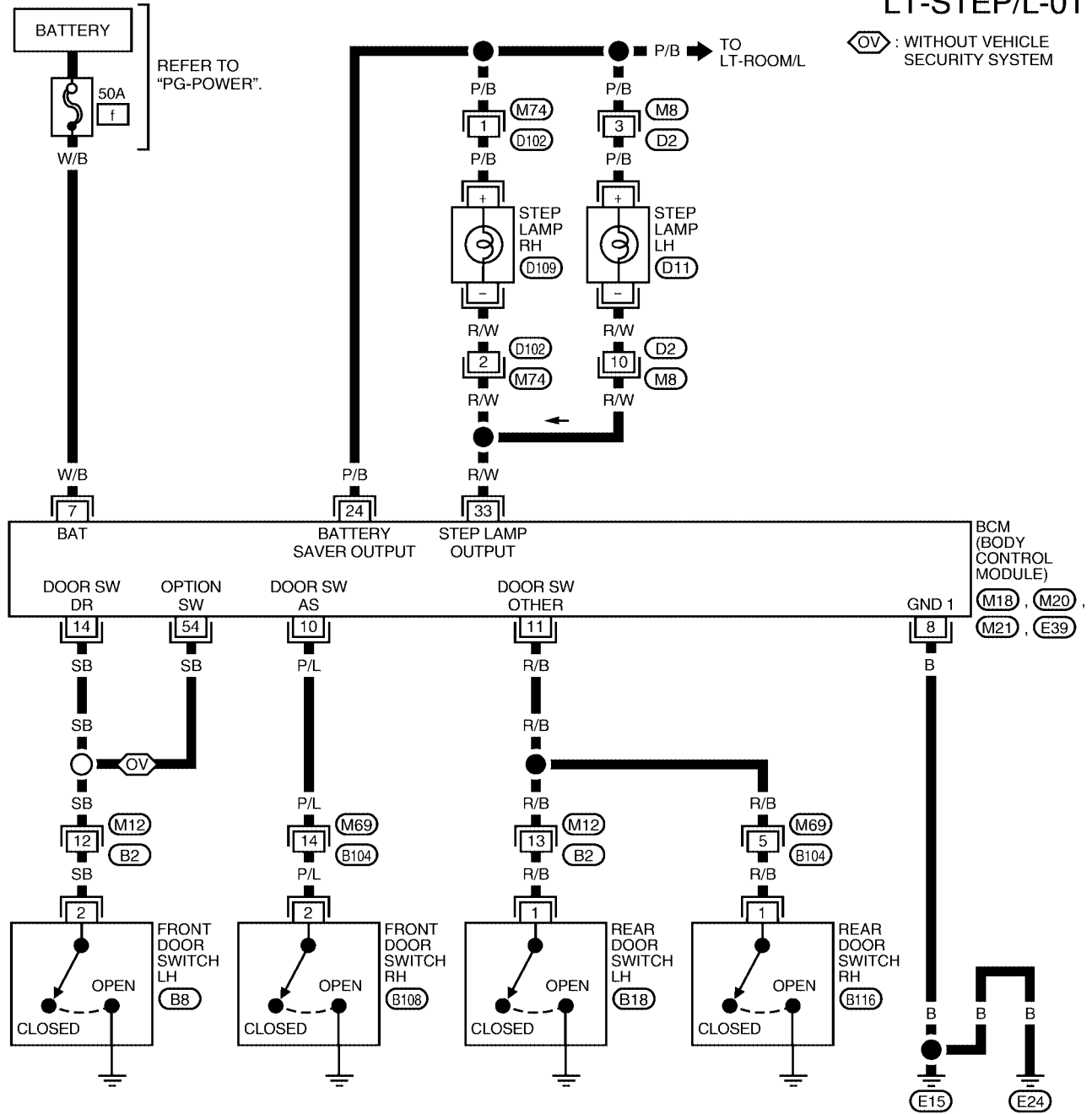

WKWA0900E

STEP LAMP

Terminals and Reference Value for BCM

EKS003E1

Terminal No.	Wire color	Signal name	Measuring condition		Standard (V) (Approx.)	
			Ignition switch	Operation or condition		
7	W/B	Battery power supply	OFF	—	12	
8	B	Ground	ON	—	0	
10	P/L	Front door switch RH signal	OFF	Front door switch RH	ON (open)	0
					OFF (closed)	12
11	R/B	Rear door switch (LH and RH) signal	OFF	Rear door switch (LH and RH)	ON (open)	0
					OFF (closed)	12
14	SB	Front door switch LH signal	OFF	Front door switch LH	ON (open)	0
					OFF (closed)	12V
24	P/B	Battery saver output signal	OFF	Any door switch	ON (open)	0 ^{Note}
					OFF (closed)	12V
33	R/W	Step lamp signal	OFF	Any door is open (ON)	0	
				All doors are closed (OFF)	12	

Note: Becomes battery voltage approximately 30 seconds after any door is opened.

Step Lamp Does Not Operate

EKS003E2

1. CHECK BULBS

Check bulbs.

OK or NG

- OK >> GO TO 2.
- NG >> Replace bulbs.

2. INSPECTION 1 BETWEEN EACH DOOR SWITCH AND BCM

Select "BCM" on CONSULT-II. Use "INT LAMP" data monitor to check that switches listed below turn ON-OFF according to switch operation.

Switch name	CONSULT screen
Driver door switch	DOOR SW - DR
Each door switch	DOOR SW - AS

OK or NG

- OK >> GO TO 3.
- NG >> Inspect malfunctioning switch system. Repair as necessary.

DATA MONITOR	
MONITOR	
IGN ON SW	ON
KEY ON SW	ON
DOOR SW-DR	ON
DOOR SW-AS	OFF
LOCK SW DR/AS	OFF
UNLK SW DR/AS	OFF
KEY CYL LK SW	OFF
KEY CYL UN SW	OFF
LK BUTTON/SIG	OFF

LKIA0085E

STEP LAMP

3. INSPECTION 1 BETWEEN BCM AND STEP LAMP

1. Disconnect BCM connector and left/right step lamp connectors.
2. Check continuity between harness connector terminal of BCM and harness connector terminal of left/right step lamps.

Terminals				Continuity
BCM		Step lamp		
Connector	Terminal (wire color)	Connector	Terminal (wire color)	
M20	24 (P/B)	D109	+ (P/B)	Yes
	24 (P/B)	D11	+ (P/B)	
	33 (R/W)	D109	- (R/W)	
	33 (R/W)	D11	- (R/W)	

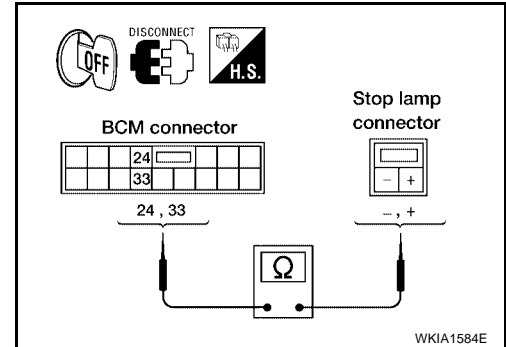

OK or NG

OK >> Replace BCM.

NG >> Repair harness between BCM and step lamp. Repair as necessary.

Bulb Replacement

1. Pry lens cover from lamp assembly.
 2. Push and turn bulb to remove.
- Installation is in the reverse order of removal.

Removal and Installation

1. Carefully pry lens from door finisher.
 2. Disconnect electrical connector.
- Installation is in the reverse order of removal.

EKS003E3

EKS003E4

A
B
C
D
E
F
G
H
I
J
L
M

LT

BACK-UP LAMP

PF:26550

BACK-UP LAMP

Wiring Diagram — BACK/L —

EKS003E5

LT-BACK/L-01

⬡ : WITH A/T
⬡ : WITH M/T

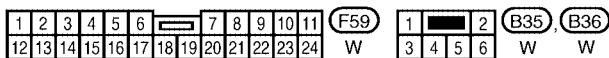
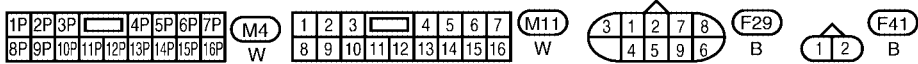
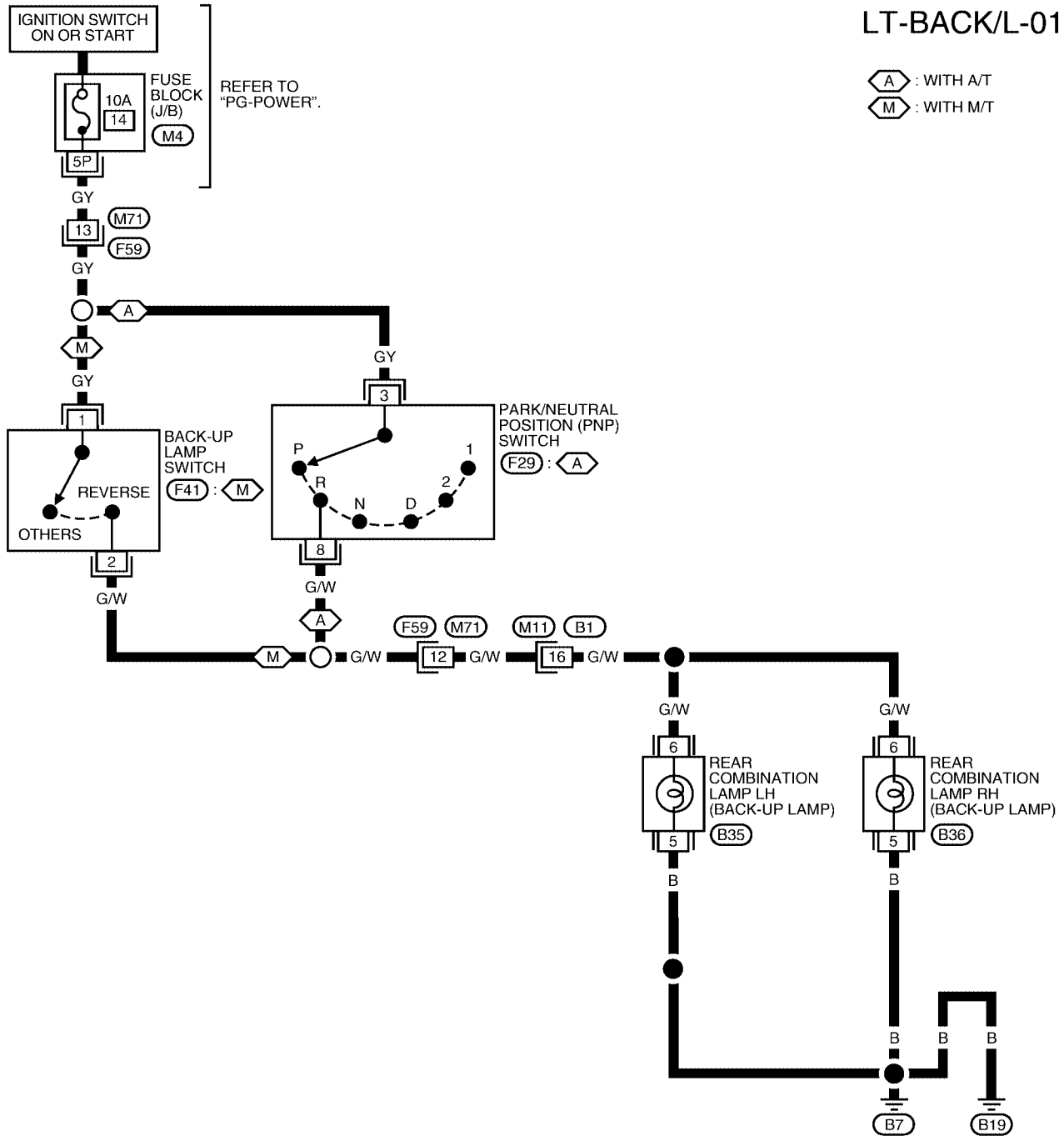

WKWA0901E

BACK-UP LAMP

Bulb Replacement

EKS003E6

1. Remove rear combination lamp. Refer to [LT-97, "Removal and Installation for Rear Combination Lamp"](#) .
2. Turn bulb socket counterclockwise to unlock and remove.
3. Pull bulb from socket to remove.

Installation is in the reverse order of removal.

Removal and Installation

EKS003E7

The back-up lamp is part of the rear combination lamp assembly. For removal and installation, refer to [LT-97, "Removal and Installation for Rear Combination Lamp"](#) .

A

B

C

D

E

F

G

H

I

J

LT

L

M

PARKING, LICENSE PLATE AND TAIL LAMPS

PF2:26550

System Description

EKS003E8

Control of the parking, license plate, and tail lamp operation is dependent upon the position of the lighting switch (combination switch). When the lighting switch is placed in the 1ST position, the BCM (body control module) receives input signal requesting the parking, license plate, and tail lamps to illuminate. This input signal is communicated to the IPDM E/R (intelligent power distribution module engine room) across the CAN communication lines. The central processing unit of the IPDM E/R controls the tail lamp relay coil. When energized, this relay directs power to the parking, license plate, and tail lamps, which then illuminate. Power is supplied at all times

- to tail lamp relay, located in the IPDM E/R
- through 10A fuse (No. 41, located in the IPDM E/R).

Power is also supplied at all times

- to BCM terminal 7
- through 50A fusible link (letter f , located in the fuse and fusible link box).

With the ignition switch in the ON or START position, power is supplied

- to BCM terminal 35
- through 10A fuse [No. 12, located in the fuse block (J/B)].

With the ignition switch in the ACC or ON position, power is supplied

- to BCM terminal 36
- through 10A fuse [No. 6, located in the fuse block (J/B)].

Ground is supplied

- to BCM terminals 8, 27, and 63
- through body grounds F14 (QR25DE models), M57, M61, E15, and E24.

OPERATION BY LIGHTING SWITCH

With the lighting switch in the 1st or 2nd position (or if the auto light system is activated), the BCM receives input signal requesting the parking, license plate, and tail lamps to illuminate. This input signal is communicated to the IPDM E/R across the CAN communication lines. The central processing unit of the IPDM E/R controls the tail lamp relay coil. When energized, this relay directs power

- through terminal 22 of the IPDM E/R
- to front turn signal lamp LH terminal 1,
- to front turn signal lamp RH terminal 1,
- to rear combination lamp LH terminal 2,
- to rear combination lamp RH terminal 2,
- to license lamp LH terminal +, and
- to license lamp RH terminal +.

Ground is supplied at all times

- to front turn signal lamp LH terminal 2,
- through body grounds E15 and E24, and
- to front turn signal lamp RH terminal 2,
- through body grounds E15 and E24, and
- to rear combination lamp LH terminal 5
- through body grounds B7 and B19, and
- to rear combination lamp RH terminal 5
- through body grounds B7 and B19, and
- to license lamp LH terminal –,
- through body grounds B7 and B19, and
- to license lamp RH terminal –
- through body grounds B7 and B19.

With power and ground supplied, the parking, license and tail lamps illuminate.

PARKING, LICENSE PLATE AND TAIL LAMPS

BATTERY SAVER CONTROL

When the combination switch (lighting switch) is in the 1ST (or 2ND) position, and the ignition switch is turned from ON or ACC to OFF, the battery saver control feature is activated.

Under this condition, the parking, license plate, and tail lamps remain illuminated for 5 minutes, unless the combination switch (lighting switch) position is changed. If the combination switch (lighting switch) position is changed, then the parking, license plate and tail lamps are turned off.

CAN Communication System Description

EKS003E9

Refer to [LAN-4, "CAN COMMUNICATION"](#) .

A

B

C

D

E

F

G

H

I

J

LT

L

M

PARKING, LICENSE PLATE AND TAIL LAMPS

Schematic

EKS003EA

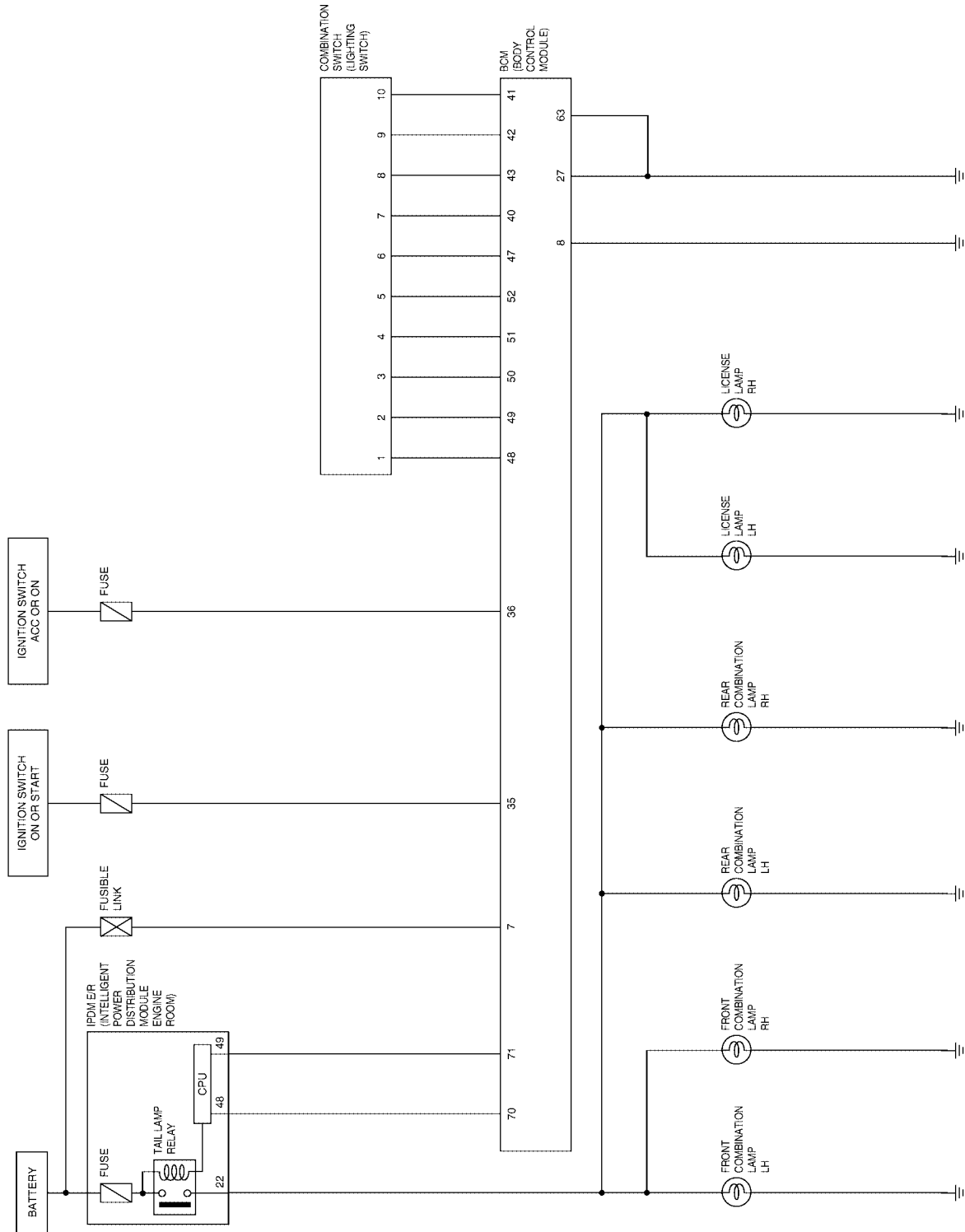

WKWA0902E

PARKING, LICENSE PLATE AND TAIL LAMPS

Wiring Diagram — TAIL/L —

EKS003EB

LT-TAIL/L-01

QR : WITH QR25DE
 ■ : DATA LINE

REFER TO "PG-POWER".

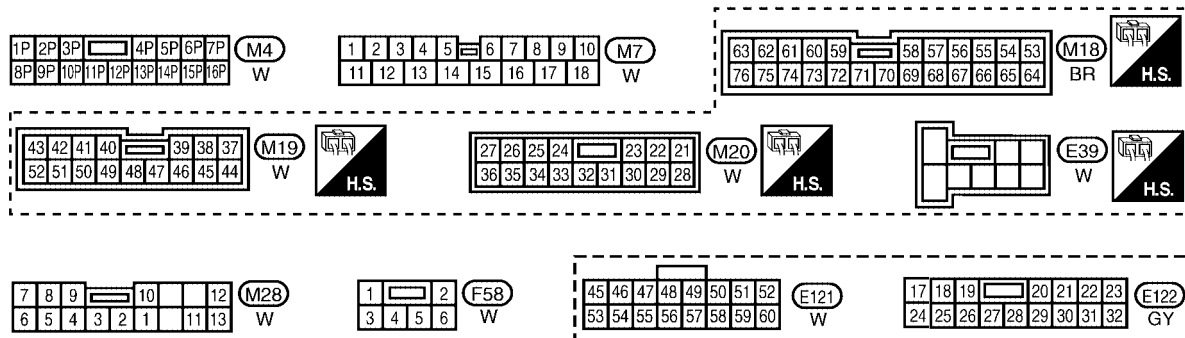
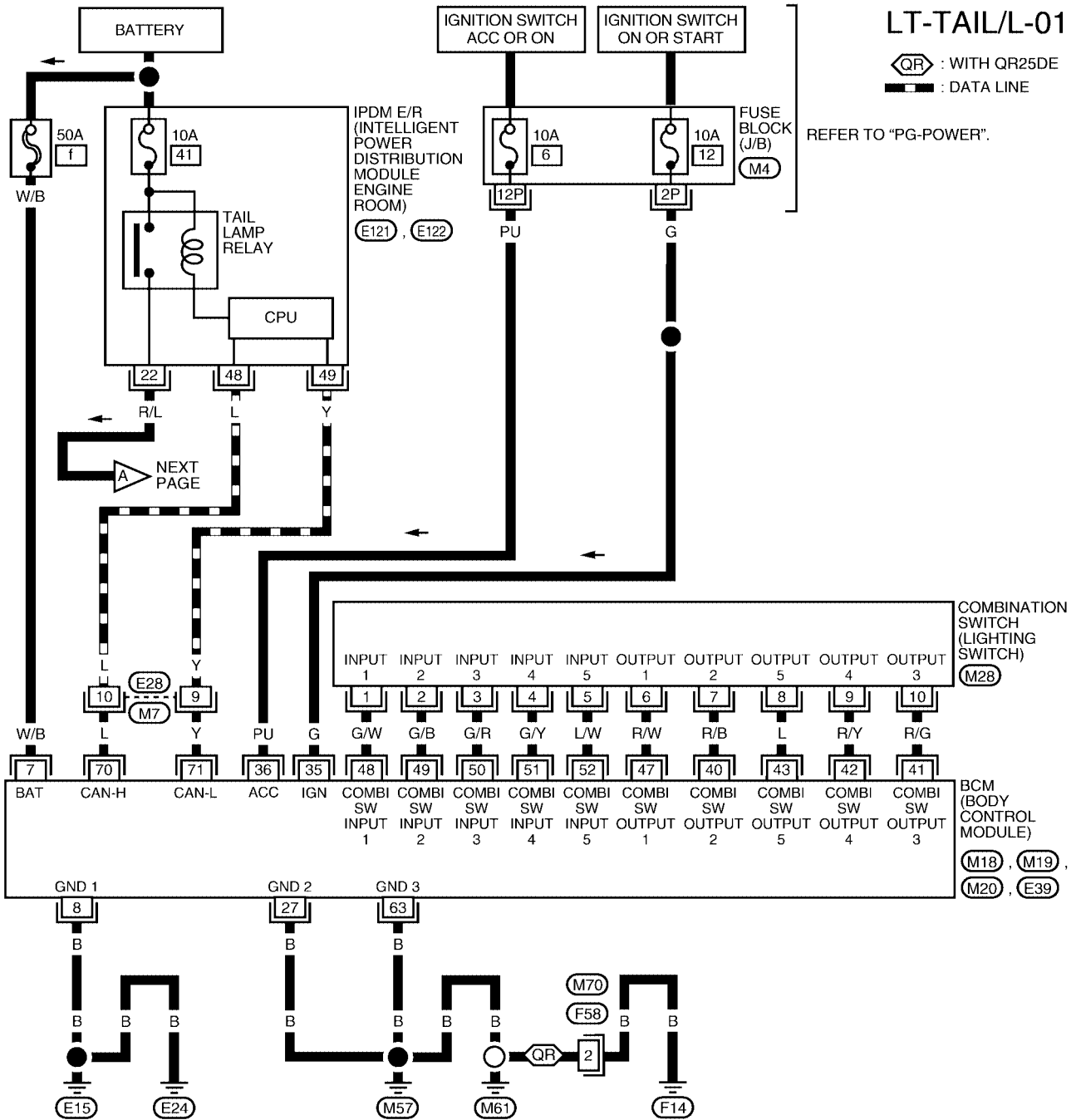

WKWA0903E

PARKING, LICENSE PLATE AND TAIL LAMPS

LT-TAIL/L-02

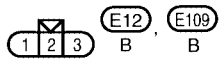
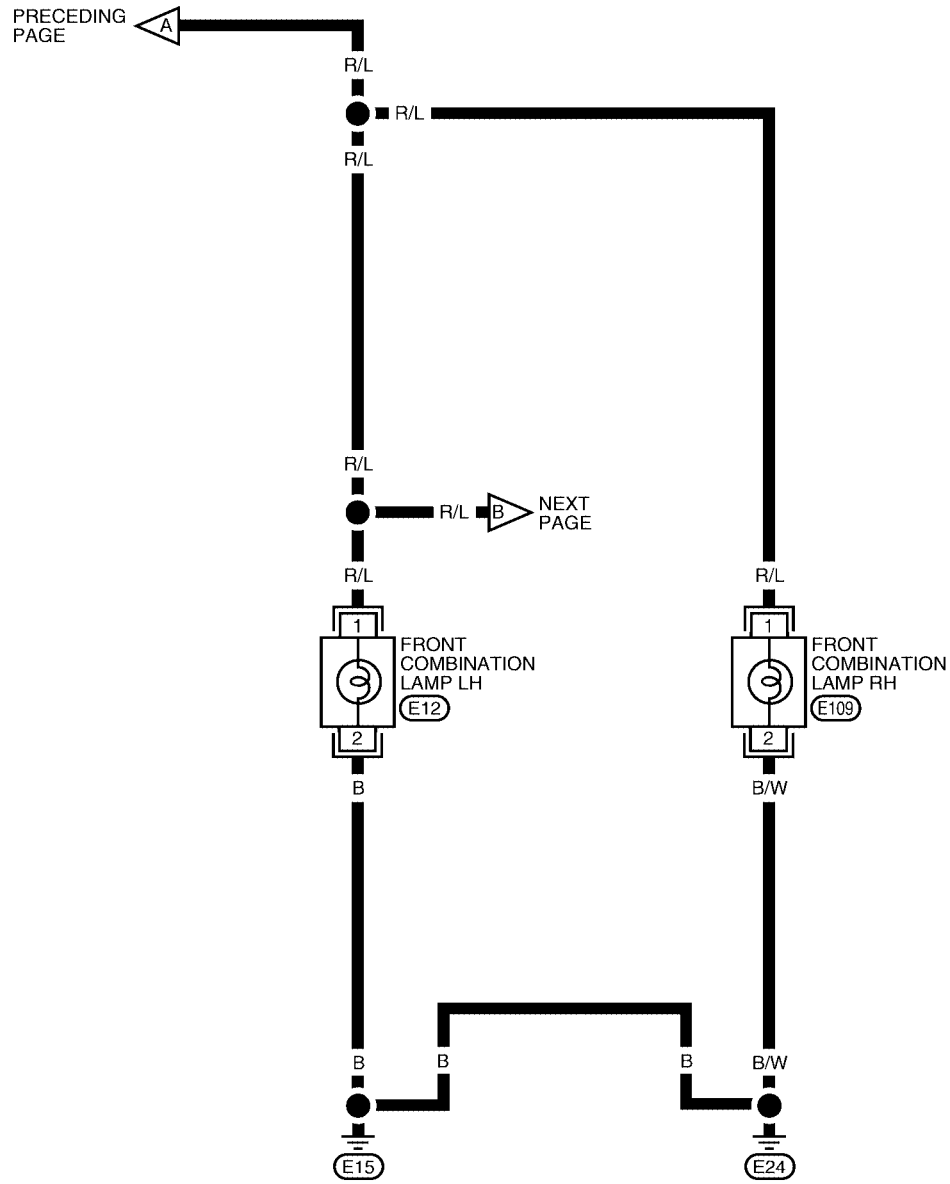

WKWA0193E

PARKING, LICENSE PLATE AND TAIL LAMPS

LT-TAIL/L-03

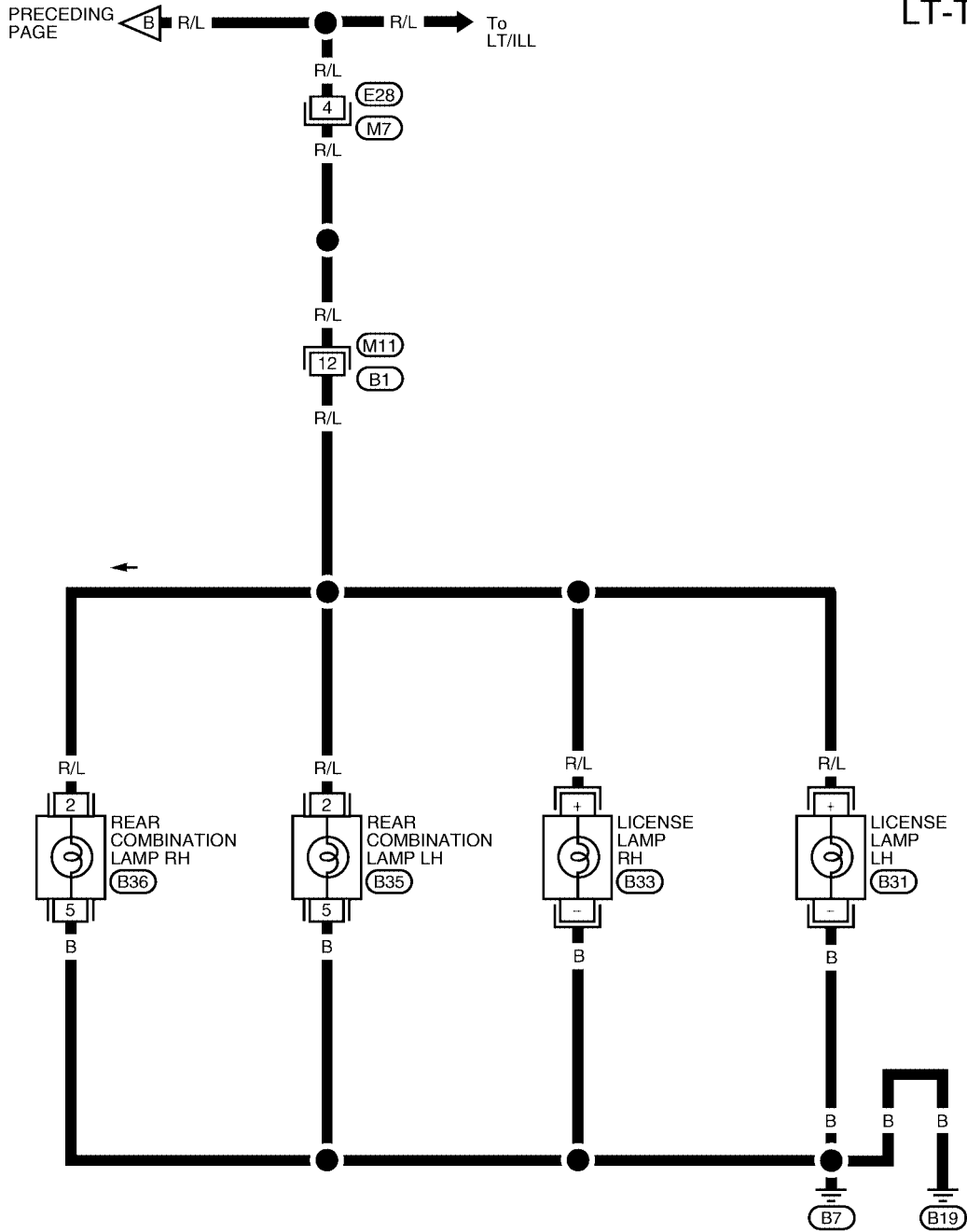

A
B
C
D
E
F
G
H
I
J
LT
L
M

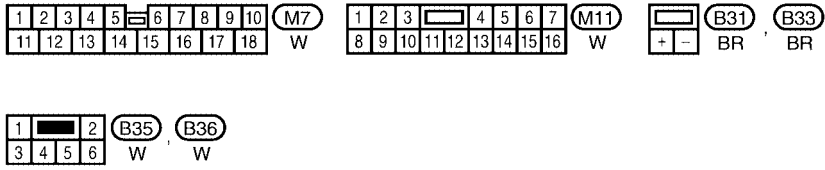

WKWA0904E

PARKING, LICENSE PLATE AND TAIL LAMPS

Terminals and Reference Value for BCM

EKS007P7

Terminal No.	Wire color	Item	Measuring condition		Voltage (Approx.)
			Ignition switch	Operation or condition	
7	W/B	Battery power supply	OFF	—	Battery voltage
8	B	Ground	—	—	—
27	B	Ground	—	—	—
35	G	Ignition power supply	ON	—	Battery voltage
36	PU	Ignition power supply	ACC	—	Battery voltage
40	R/B	Combination switch output 2	—	—	2V → 10V
41	R/G	Combination switch output 3	—	—	2V → 10V
42	R/Y	Combination switch output 4	—	—	2V → 10V
43	L	Combination switch output 5	—	—	2V → 10V
47	R/W	Combination switch output 1	—	—	2V → 10V
48	G/W	Combination switch input 1	—	—	1.5V → 10V
49	G/B	Combination switch input 2	—	—	1.5V → 10V
50	G/R	Combination switch input 3	—	—	1.5V → 10V
51	G/Y	Combination switch input 4	—	—	1.5V → 10V
52	L/W	Combination switch input 5	—	—	1.5V → 10V
63	B	Ground	—	—	—
70	L	CAN - H	—	—	1V → 3V
71	Y	CAN - L	—	—	1V → 3V

Terminals and Reference Values for IPDM E/R

EKS007P8

Terminal No.	Wire color	Signal name	Measuring condition		Reference value (Approx.)	
			Ignition switch	Operation or condition		
22	R/L	Parking, license and tail lamp	ON	Lighting switch 1ST position	OFF	0V
					ON	Battery voltage
48	L	CAN - H	—	—	—	
49	Y	CAN - L	—	—	—	

How to Proceed With Trouble Diagnosis

EKS007P4

1. Confirm the symptom or customer complaint.
2. Understand operation description and function description. Refer to [LT-104, "System Description"](#).
3. Perform the Preliminary Check. Refer to [LT-111, "Preliminary Check"](#).
4. Check symptom and repair or replace the cause of malfunction.
5. Does the front fog lamp operate normally? If YES: GO TO 6. If NO: GO TO 4.
6. Inspection End.

PARKING, LICENSE PLATE AND TAIL LAMPS

Preliminary Check CHECK POWER SUPPLY AND GROUND CIRCUIT

EKS007P5

1. CHECK FUSES OR FUSIBLE LINK

Check for blown fuses or fusible link.

Unit	Power source	Fuse No.
BCM	Battery	f
	Ignition switch ON or START position	12
	Ignition switch ACC or ON position	6
IPDM E/R	Battery	41

Refer to [LT-107, "Wiring Diagram — TAIL/L —"](#).

OK or NG

OK >> Inspection End.

NG >> If fuse is blown, be sure to eliminate cause of malfunction before installing new fuse. Refer to [PG-4, "POWER SUPPLY ROUTING CIRCUIT"](#).

CONSULT-II Functions

EKS007P6

Refer to [LT-14, "CONSULT-II Function \(BCM\)"](#) in HEADLAMP (FOR USA).

Refer to [LT-17, "CONSULT-II Function \(IPDM E/R\)"](#) in HEADLAMP (FOR USA).

Parking, License Plate and/or Tail Lamps Do Not Illuminate

EKS007P9

1. ACTIVE TEST

Ⓜ With CONSULT-II

- Select "IPDM E/R" on CONSULT-II and select "ACTIVE TEST" on "SELECT DIAG MODE" screen.
- Select "TAIL LAMP" on "SELECT TEST ITEM" screen.
- Touch "ON".
- Make sure parking, license plate and tail lamp operate.

Parking, license plate and tail lamp should operate

ⓧ Without CONSULT-II

- Start auto active test. Refer to [PG-21, "Auto Active Test"](#).
- Make sure parking, license plate and tail lamp operate.

Parking, license plate and tail lamp should operate

OK or NG

OK >> GO TO 2.

NG >> GO TO 4.

2. INSPECTION 1 BETWEEN COMBINATION SWITCH AND BCM

Carry out BCM C/U self-diagnosis.

Displayed results of self-diagnosis

NO MALFUNCTION DETECTED>> GO TO 3.

CAN COMMUNICATION OR CAN SYSTEM>> Inspect the BCM CAN communications system. Refer to [LAN-4, "CAN COMMUNICATION"](#).

OPEN DETECT 1 - 5>> Inspect combination switch system. Refer to [BCS-12, "Combination Switch Inspection According to Self-Diagnostic Results"](#).

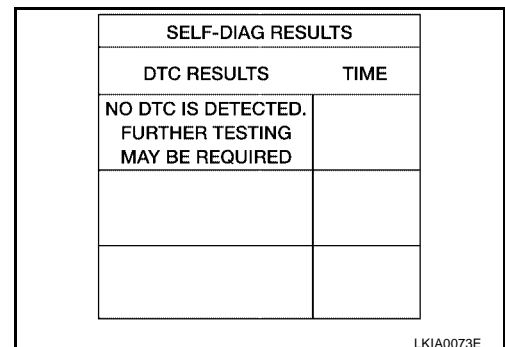
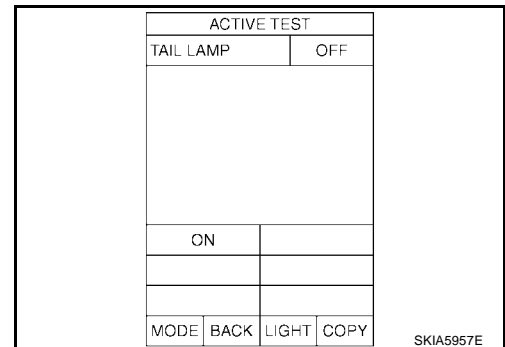

PARKING, LICENSE PLATE AND TAIL LAMPS

3. INSPECTION 2 BETWEEN COMBINATION SWITCH AND BCM

Select "BCM" on CONSULT-II. With "HEAD LAMP" data monitor, make sure "HI BEAM SW" turns ON-OFF linked with operation of lighting switch.

When lighting switch is in 1ST position : TAIL LAMP SW ON

OK or NG

- OK >> Replace BCM.
- NG >> Replace lighting switch. Refer to [LT-94, "Removal and Installation"](#) .

DATA MONITOR	
MONITOR	
HI BEAM SW	ON

SKIA4193E

PARKING, LICENSE PLATE AND TAIL LAMPS

4. CHECK INPUT SIGNAL

Ⓜ With CONSULT-II

1. Turn ignition switch OFF.
2. Disconnect front combination lamp, license plate lamp and rear combination lamp connectors.
3. Select "IPDM E/R" on CONSULT-II and select "ACTIVE TEST" on "SELECT DIAG MODE" screen.
4. Select "TAIL LAMP" on "SELECT TEST ITEM" screen.
5. Touch "ON" screen.
6. When tail lamp is operating, check voltage between front combination lamp, license plate lamp, rear combination lamp harness connector and ground.

ⓧ Without CONSULT-II

1. Turn ignition switch OFF.
2. Start auto active test. Refer to [PG-21, "Auto Active Test"](#).
3. When tail lamp is operating, check voltage between front combination lamp, license plate lamp, rear combination lamp harness connector and ground.

Terminals			(-)	Voltage
Front combination lamp (+)				
Connector		Terminal (Wire color)	Ground	Battery voltage
RH	E109	1 (R/L)		
LH	E12			

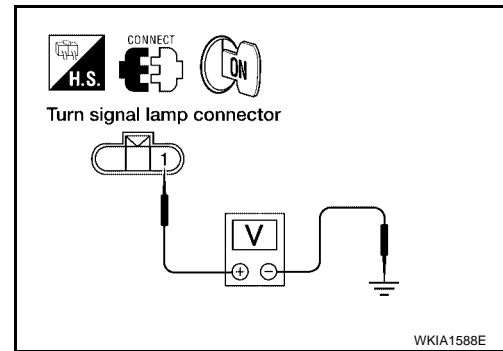

Terminals			(-)	Voltage
License plate lamp (+)				
Connector		Terminal (Wire color)	Ground	Battery voltage
RH	B33	+ (R/L)		
LH	B31			

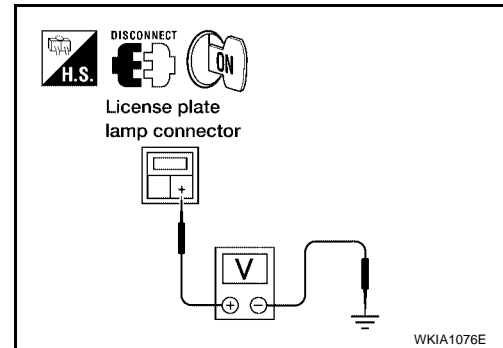

Terminals			(-)	Voltage
Rear combination lamp (+)				
Connector		Terminal (Wire color)	Ground	Battery voltage
RH	B36	2 (R/L)		
LH	B35			

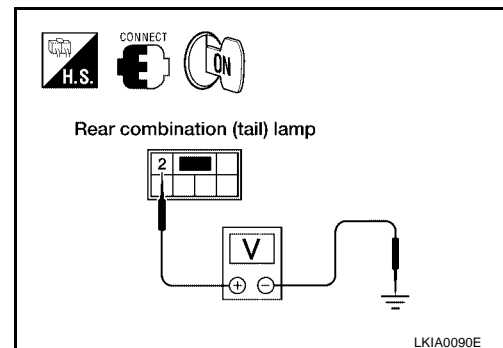

OK or NG

- OK >> GO TO 6.
 NG >> GO TO 5.

PARKING, LICENSE PLATE AND TAIL LAMPS

5. CHECK PARKING, LICENSE PLATE AND TAIL LAMP CIRCUIT

1. Turn ignition switch OFF.
2. Disconnect IPDM E/R connector.
3. Check continuity between IPDM E/R harness connector and front side marker lamp harness connector.

Terminals					Continuity
IPDM E/R		Front combination lamp			
Connector	Terminal (Wire color)	Connector	Terminal (Wire color)		
E122	22 (R/L)	RH	E109	1 (R/L)	Yes
		LH	E12		

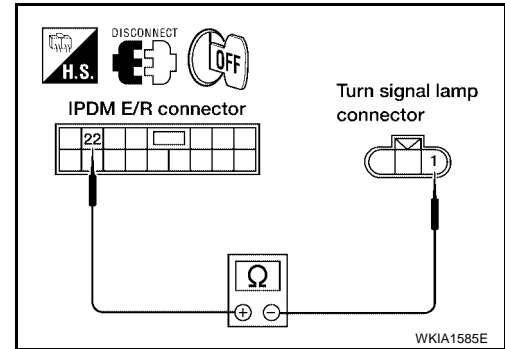

4. Check continuity between IPDM E/R harness connector and license plate lamp harness connector.

Terminals					Continuity
IPDM E/R		License plate lamp			
Connector	Terminal (Wire color)	Connector	Terminal (Wire color)		
E122	22 (R/L)	RH	B33	+ (R/L)	Yes
		LH	B31		

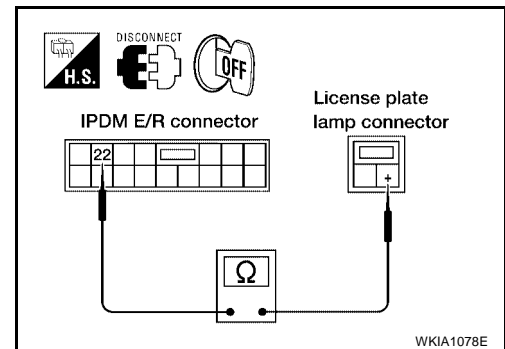

5. Check continuity between IPDM E/R harness connector and rear combination lamp harness connector.

Terminals					Continuity
IPDM E/R		Rear combination lamp			
Connector	Terminal (Wire color)	Connector	Terminal (Wire color)		
E122	22 (R/L)	RH	B36	2 (R/L)	Yes
		LH	B35		

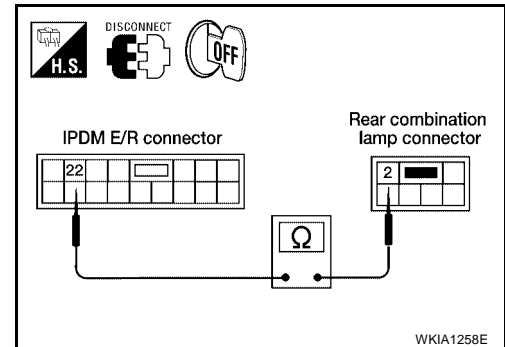

OK or NG

- OK >> Replace IPDM E/R. Refer to [PG-27, "Removal and Installation of IPDM E/R"](#).
- NG >> Repair harness or connector.

PARKING, LICENSE PLATE AND TAIL LAMPS

6. CHECK GROUND

1. Check continuity between front combination lamp harness connector and ground.

Terminals			Ground	Continuity
Front combination lamp				
Connector		Terminal (Wire color)	Ground	Yes
RH	E109	2 (B/W)		
LH	E12	2 (B)		

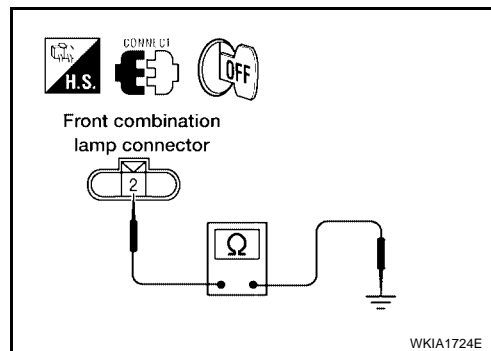

2. Check continuity between license lamp plate harness connector and ground.

Terminals			Ground	Continuity
License plate lamp				
Connector		Terminal (Wire color)	Ground	Yes
RH	B33	- (B)		
LH	B31			

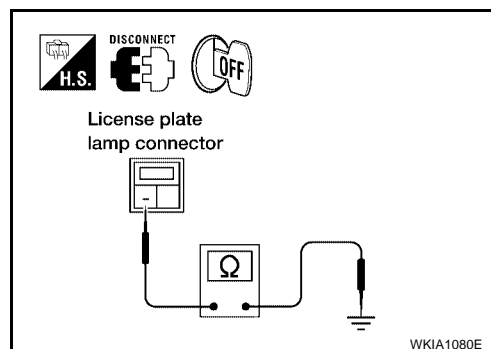

3. Check continuity between rear combination lamp harness connector and ground.

Terminals			Ground	Continuity
Rear combination lamp				
Connector		Terminal (Wire color)	Ground	Yes
RH	B36	5 (B)		
LH	B35			

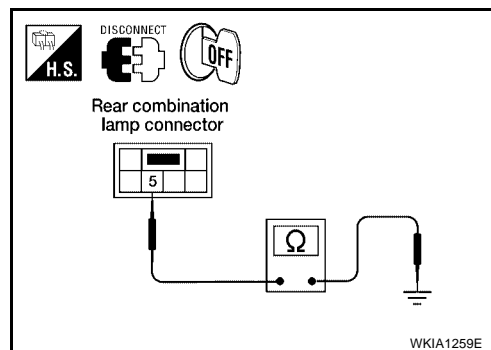

OK or NG

- OK >> Check bulbs.
- NG >> Repair harness or connector.

Parking, License Plate and Tail Lamps Do Not Turn OFF (After Approx. 10 Minutes)

EKS007PA

1. CHECK IPDM E/R

1. Turn ignition switch ON. Turn the combination switch (lighting switch) to the OFF position. Turn ignition switch OFF.
2. Verify that the parking, license plate, and tail lamps turn on and off after approximately 10 minutes.

OK or NG

- OK >> Ignition relay malfunction. Refer to [PG-16, "Function of Detecting Ignition Relay Malfunction"](#).
- NG >> Inspection End.

PARKING, LICENSE PLATE AND TAIL LAMPS

EKS003EE

Bulb Replacement LICENSE PLATE LAMP

1. From trunk, turn bulb socket counterclockwise to unlock and remove.
2. Pull bulb to remove from socket.

License plate lamp : 12V 5W

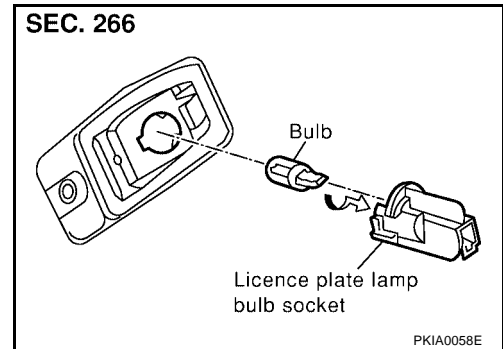

FRONT TURN SIGNAL (PARKING) LAMP

For bulb replacement, refer to [LT-29, "FRONT TURN SIGNAL LAMP"](#).

TAIL LAMP

1. Remove rear combination lamp. Refer to [LT-97, "Removal and Installation for Rear Combination Lamp"](#).
2. Turn bulb socket counterclockwise to unlock and remove.
3. Pull bulb to remove from socket.

Tail lamp : 12V 7W

Removal and Installation LICENSE PLATE LAMP

EKS003EF

Removal

1. Remove the license plate finisher. Refer to [EI-22, "Removal and Installation"](#).
2. Disconnect the license plate lamp connector.
3. Remove the license plate lamp mounting screw and remove the license plate lamp from the vehicle.

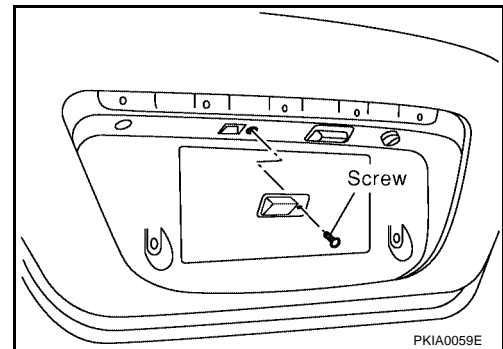

Installation

Install in the reverse order of removal.

License plate lamp mounting screw:

: **1.3 - 1.8 N·m (0.13 - 0.18 kg-m, 11 - 16 in-lb)**

FRONT TURN SIGNAL (PARKING) LAMP

For front turn signal (parking) lamp removal and installation procedures, refer to [LT-29, "Removal and Installation"](#).

REAR COMBINATION LAMP

Removal

For rear combination lamp removal and installation procedures, refer to [LT-97, "Removal and Installation for Rear Combination Lamp"](#).

INTERIOR ROOM LAMP

PFP:26410

EKS003EH

INTERIOR ROOM LAMP

Component Parts and Harness Connector Location

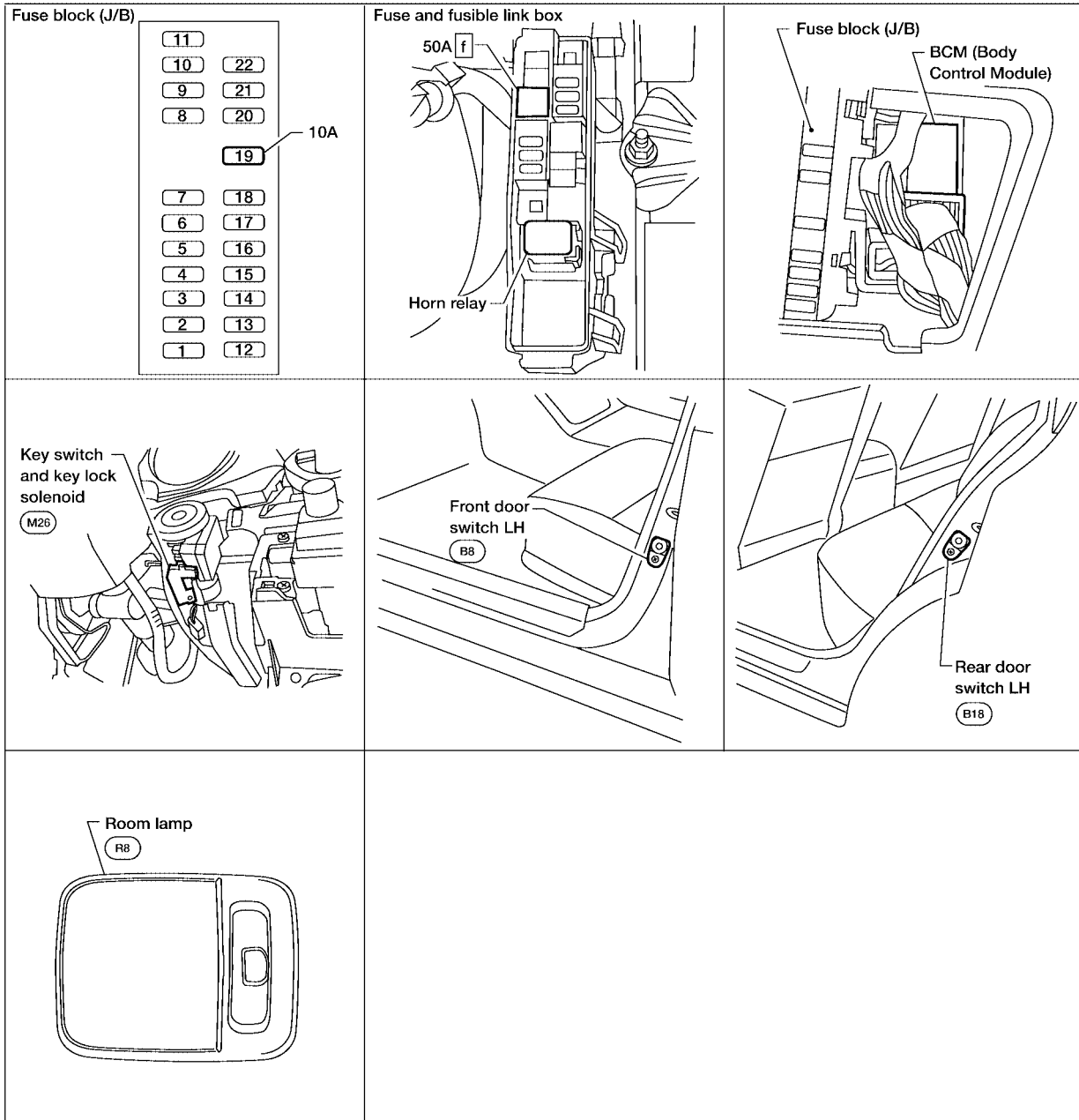

A
B
C
D
E
F
G
H
I
J
LT
L
M

WKIA1589E

INTERIOR ROOM LAMP

EKS003EG

System Description

When room lamp switch is in DOOR position, room lamp ON/OFF is controlled by timer according to signals from switches including key detection switch, driver door switch, driver door lock switch.

When room lamp turns ON, there is a gradual brightening over 1 second. When room lamp turns OFF, there is a gradual dimming over 1 second.

The interior room lamp timer is controlled by the BCM (body control module).

Interior room lamp timer control settings can be changed with CONSULT-II.

INTERIOR LAMP TIMER OPERATION

When room lamp switch is in DOOR position, and when all conditions below are met, BCM performs timer control (maximum 30 seconds) for interior lamp ON/OFF.

In addition, when lamp turns ON or OFF there is gradual brightening or dimming over 1 second.

Power is supplied

- to 10A fuse [No. 19, located in the fuse block (J/B)]
- to key switch and key lock solenoid terminal 3.

When all doors are closed (all door switches OFF) and key is removed from key cylinder (key detection switch OFF), power will not be supplied to BCM terminal 62.

When driver door lock switch is turned ON (unlocked),

Ground is supplied

- from BCM terminal 30
- to front door lock actuator LH terminal 1.

At this time, BCM detects that driver door is unlocked. It determines that interior lamp timer operation conditions are met, and turns the interior lamp ON for 30 seconds.

When all doors are closed (all door switches OFF) and key is in key cylinder (key detection switch ON),

Power is supplied

- through key switch and key lock solenoid terminal 4
- to BCM terminal 62.

When key is removed from key switch and key lock solenoid (key detection switch OFF), power supply to BCM terminal 62 is terminated. BCM detects that key has been removed, determines that interior lamp timer conditions are met, and turns the interior lamp ON for 30 seconds.

When driver door closes, and the key is not inserted in the key switch and key lock solenoid (key detection switch OFF), BCM terminal 14 or 54 changes from 0V (door open) to 12V (door closed). The BCM determines that conditions for interior lamp operation are met and turns the interior lamp ON for 30 seconds.

Timer control is canceled under the following conditions.

- Driver door is locked (driver door lock switch turns OFF)
- Driver door is opened (driver door switch turns ON)
- Ignition switch ON.

BATTERY SAVER

If the interior room lamp remains illuminated by the door switch open signal, or if the room lamp switch is in the ON position for more than 30 minutes after the ignition switch is turned to the OFF position, the BCM will automatically turn off the interior room lamp(s).

INTERIOR ROOM LAMP

Wiring Diagram — ROOM/L —

EKS003EI

LT-ROOM/L-01

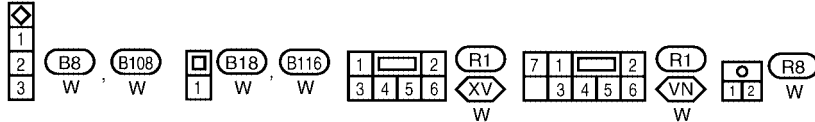
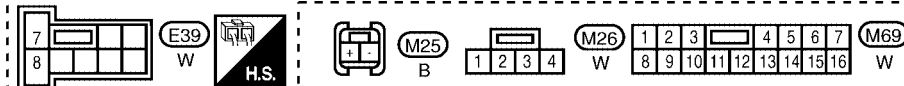
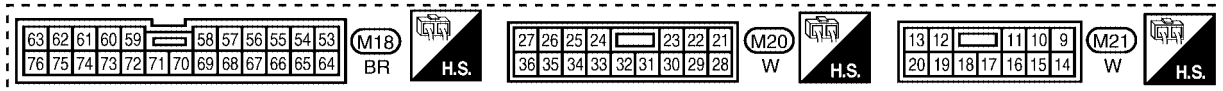
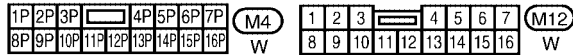
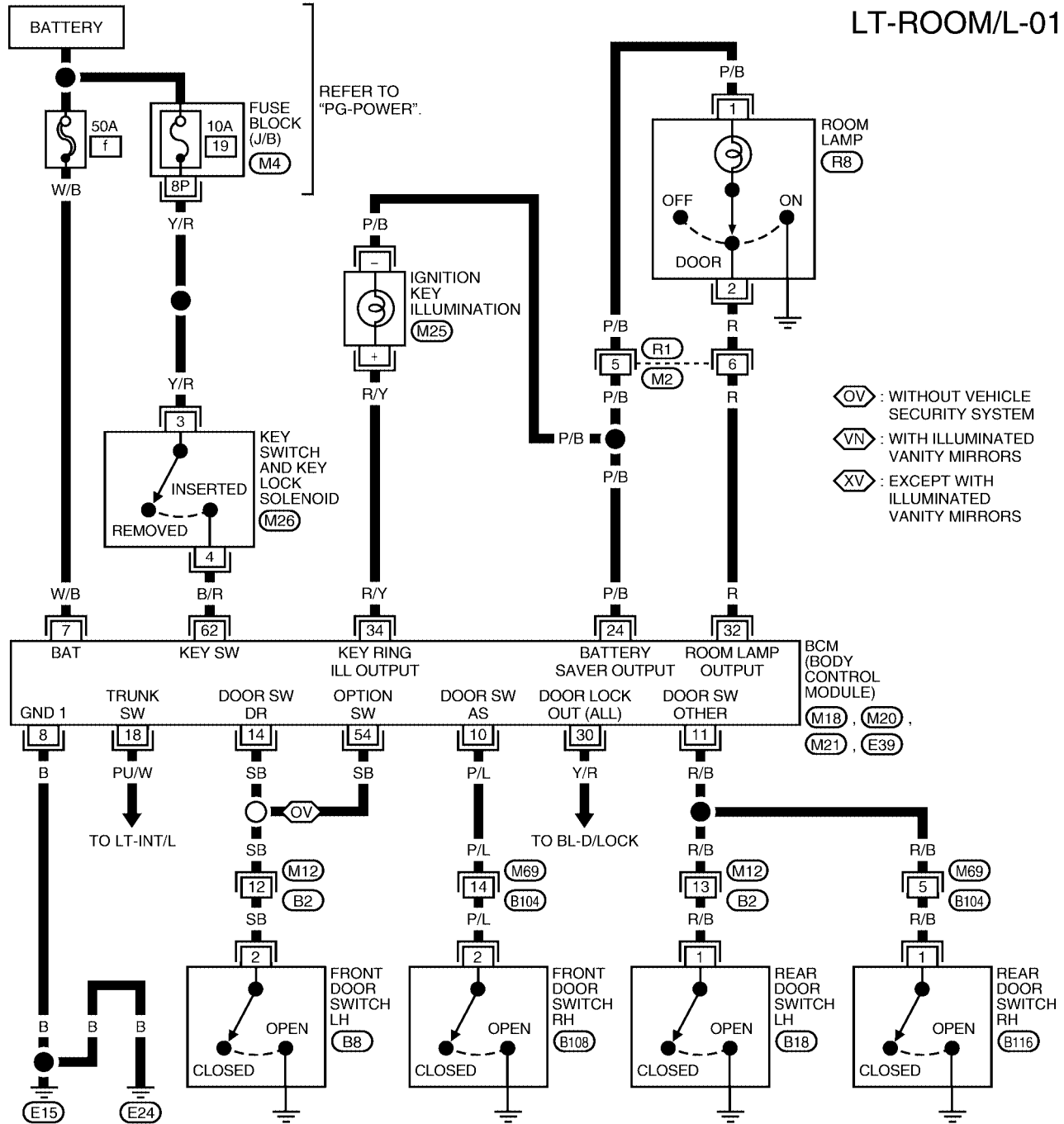

WKWA0905E

INTERIOR ROOM LAMP

Terminals and Reference Value for BCM

EKS003EJ

Terminal No.	Wire color	Signal name	Measuring condition				Standard (V) (Approx.)	
			Ignition switch	Operation or condition				
7	W/B	Battery power supply	OFF	—			12	
8	B	Ground	ON	—			0	
10	P/L	Front door switch RH signal	OFF	Front door switch RH	ON (open)		0	
					OFF (closed)		12	
11	R/B	Rear door switch (LH and RH) signal	OFF	Rear door switch (LH and RH)	ON (open)		0	
					OFF (closed)		12	
14	SB	Front door switch LH signal	OFF	Front door switch LH	ON (open)		0	
					OFF (closed)		12	
32	R	Interior lamp signal	OFF	Interior lamp switch: DOOR position	Key is inserted.	Any door switch	ON (open)	0
						OFF (closed)	12	
			—	Interior lamp switch: DOOR position	All doors are closed.	Vehicle key is removed after being fully inserted.		0 Note
					Turn ignition switch to ON.	12		
30	Y/R	Driver door lock signal	OFF	Door is unlocked. (SW ON)			0	
				Door is locked. (SW OFF)			5	
62	B/R	Key detection switch signal	OFF	Vehicle key is removed.			0	
				Vehicle key is inserted.			12	

Note: Becomes approximately 12V approximately 30 seconds after key is removed.

CONSULT-II Function (BCM)

EKS003EK

CONSULT-II can display each diagnostic item using the diagnostic test modes shown following.

BCM diagnosis part	Check item, diagnosis mode	Description
INTERIOR LAMP	Work support	Changes the setting for each function.
	Data monitor	Displays BCM input data in real time.
	CAN DIAG SUPPORT MNTR	The result of transmit/receive diagnosis of CAN communication can be read.
	Active test	Operation of electrical loads can be checked by sending driving signal to them.

CONSULT-II BASIC OPERATION

CAUTION:

If CONSULT-II is used with no connection of CONSULT-II CONVERTER, malfunctions might be detected in self-diagnosis depending on control unit which carries out CAN communication.

1. With the ignition switch OFF, connect CONSULT-II and CONSULT-II CONVERTER to the data link connector, then turn ignition switch ON.

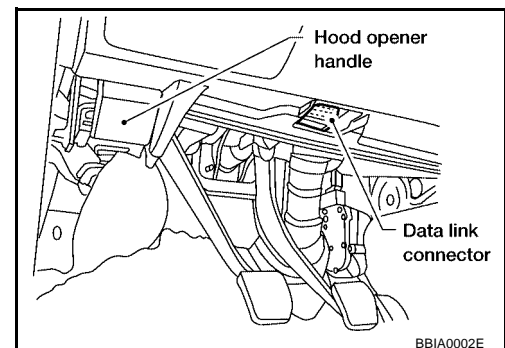

INTERIOR ROOM LAMP

2. Touch "START (NISSAN BASED VEHICLE)".

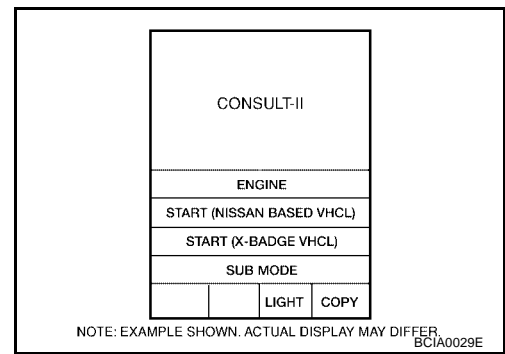

3. Touch "BCM" on "SELECT SYSTEM" screen.
If "BCM" is not indicated, go to [GI-37, "CONSULT-II Data Link Connector \(DLC\) Circuit"](#).

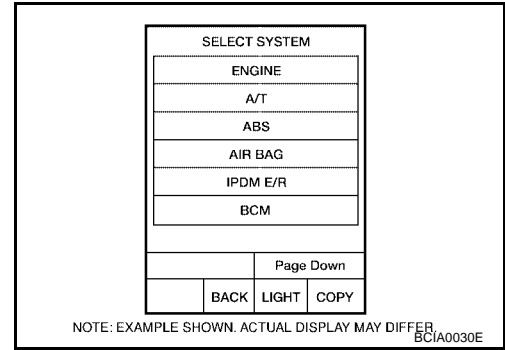

4. Select the desired part to be diagnosed on the "SELECT TEST ITEM" screen.

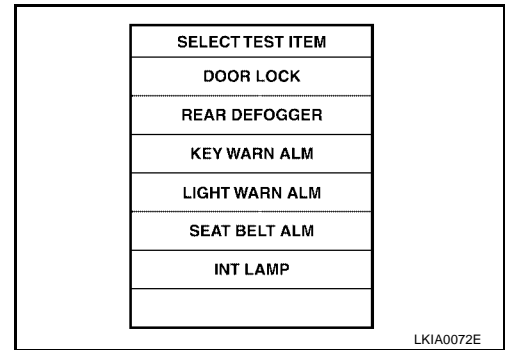

WORK SUPPORT

Operation Procedure

1. Touch "INT LAMP" on "SELECT TEST ITEM" screen.
2. Touch "WORK SUPPORT" on "SELECT DIAG MODE" screen.
3. Touch "ROOM LAMP TIMER SET" on "SELECT WORK ITEM" screen.
4. Touch "START".
5. Touch "CHANGE SETT".
6. The setting will be changed and "CUSTOMIZING COMPLETED" will be displayed.
7. Touch "END".

Display Item List

Item	Description	CONSULT-II	Factory setting
Room lamp timer setting	Interior lamp ON/OFF can be selected for when driver door lock is released (unlocked).	ON	ON
		OFF	—

DATA MONITOR

Operation Procedure

1. Touch "INT LAMP" on "SELECT TEST ITEM" screen.
2. Touch "DATA MONITOR" on "SELECT DIAG MODE" screen.
3. Touch either "ALL SIGNALS" or "SELECTION FROM MENU" on "DATA MONITOR" screen.

A
B
C
D
E
F
G
H
I
J
LT

INTERIOR ROOM LAMP

All signals	Monitors all the signals.
Selection from menu	Selects and monitors the individual signal.

4. Touch "START".
5. When "SELECTION FROM MENU" is selected, touch items to be monitored. When "ALL SIGNALS" is selected, all the items will be monitored.
6. Touch "RECORD" while monitoring, then the status of the monitored item can be recorded. To stop recording, touch "STOP".

Display Item List

Monitor item name "OPERATION OR UNIT"		Contents
IG ON SW	"ON/OFF"	"IGN position (ON)/OFF, ACC position (OFF)" judged from the ignition switch signal is displayed.
KEY ON SW	"ON/OFF"	Displays "Key inserted (ON)/key removed (OFF)" status judged from the key reminder detection switch signal.
DOOR SW - DR	"ON/OFF"	Displays status of the driver door as judged from the driver door switch signal. (Door is open: ON/Door is closed: OFF)
DOOR SW - AS	"ON/OFF"	Displays "Door open (ON)/Door closed (OFF)" status, determined from passenger door switch signal.
LOCK SW DR/AS	"ON/OFF"	Displays "Door locked (ON)/Door unlocked (OFF)" status, determined from locking detection switch in driver door.
KEY CYL LK SW	"ON/OFF"	Displays "Door locked (ON) status, determined from key cylinder lock switch in driver door.
KEY CYL UN SW	"ON/OFF"	Displays "Door unlocked (OFF) status, determined from key cylinder lock switch in driver door.
LK BUTTON/SIG	"ON/OFF"	Displays "Locked (ON)/Other (OFF)" status, determined from lock signal.
UN BUTTON/SIG	"ON/OFF"	Displays "Unlocked (ON)/Other (OFF)" status, determined from unlock signal.
DOOR SW - RR	"ON/OFF"	Displays "Door open (ON)/Door closed (OFF)" status, determined from rear door switch signals.

ACTIVE TEST

Operation Procedure

1. Touch "INT LAMP" on "SELECT TEST ITEM" screen.
2. Touch "ACTIVE TEST" on "SELECT DIAG MODE" screen.
3. Touch item to be tested and check operation of the selected item.
4. During the operation check, touching "BACK" deactivates the operation.

Display Item List

Test item	Display on CONSULT-II screen	Description
Interior lamp output	INT LAMP	Interior lamp can be operated by any ON-OFF operations.

Interior Lamp Control Does Not Operate

EKS003EL

1. CHECK BULBS

Check bulbs.

OK or NG

- OK >> GO TO 2.
 NG >> Replace bulbs.

INTERIOR ROOM LAMP

2. INSPECTION 1 BETWEEN EACH SWITCH AND BCM

Select "BCM" on CONSULT-II. Use "INT LAMP" data monitor to check that switches listed in display item list turn ON-OFF linked with switch operation. Refer to [LT-122, "Display Item List"](#) for switches and their functions.

OK or NG

- OK >> GO TO 3.
- NG >> Inspect malfunctioning switch system and repair as necessary.

DATA MONITOR	
MONITOR	
IGN ON SW	ON
KEY ON SW	ON
DOOR SW-DR	ON
DOOR SW-AS	OFF
LOCK SW DR/AS	OFF
UNLK SW DR/AS	OFF
KEY CYL LK SW	OFF
KEY CYL UN SW	OFF
LK BUTTON/SIG	OFF

LKIA0085E

3. INSPECTION 1 BETWEEN BCM AND ROOM LAMP

- Select "BCM" on CONSULT-II. Select "INT LAMP" active test.
- When room lamp switch is in DOOR position, use active test to verify that room lamp operates.

OK or NG

- OK >> Replace BCM.
- NG >> GO TO 4.

ACTIVE TEST	
INT LAMP	
	ON
	OFF

LKIA0092E

4. INSPECTION 2 BETWEEN BCM AND ROOM LAMP

- Disconnect BCM connector and room lamp connector.
- Check for continuity in wiring harness between BCM and room lamp.

Terminals				Continuity
(+)		(-)		
Connector	Terminal (wire color)	Connector	Terminal (wire color)	
M20	24 (P/B)	R8	1 (P/B)	Yes
	32 (R)	R8	2 (R)	

OK or NG

- OK >> Replace BCM.
- NG >> Check for short circuit or open circuit in harness between BCM and room lamp. Repair as necessary.

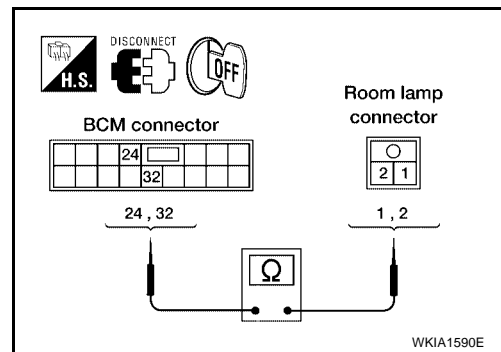

Bulb Replacement MAP LAMP

Map Lamp

- Insert a thin screwdriver in the notch and remove the lens.
- Remove the screw and remove the shade.
- Remove the bulb.

Map lamp : 12V 10W

Removal and Installation ROOM LAMP

- Open the front interior lamp box and remove the screw.

A
B
C
D
E
F
G
H
I
J
L
M

LT

INTERIOR ROOM LAMP

2. Insert a clip driver or a suitable tool and disengage the metal clip fittings of the front interior lamp.
3. Disconnect the connector and remove the front interior lamp.

Room lamp mounting screw:

 : 2.5 - 3.4 N·m (0.25 - 0.35 kg-m, 22 - 30 in-lb)

IGNITION KEY HOLE ILLUMINATION LAMP

1. Remove the lower instrument panel (driver side). Refer to [IP-12, "Instrument Lower Cover LH"](#).
2. Turn the bulb socket counterclockwise and unlock it.

Ignition key hole illumination lamp : 12V 0.74W

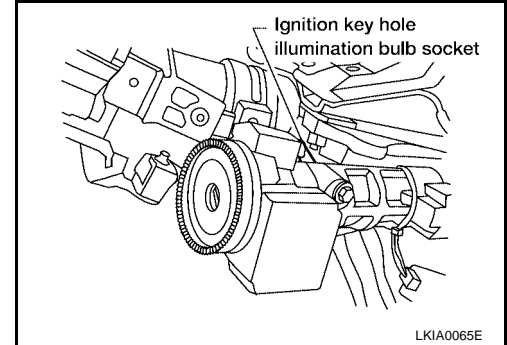

ILLUMINATION**System Description**

EKS003EO

Control of the illumination lamps operation is dependent upon the position of the lighting switch (combination switch). When the lighting switch is placed in the 1ST or 2ND position (or if the auto light system is activated) the BCM (body control module) receives input requesting the illumination lamps to illuminate. This input is communicated to the IPDM E/R (intelligent power distribution module engine room) across the CAN communication lines. The central processing unit of the IPDM E/R controls the tail lamp relay coil. When energized, this relay directs power to the illumination lamps, which then illuminate.

Power is supplied at all times

- to tail lamp relay, located in the IPDM E/R
- through 10A fuse (No. 41, located in the IPDM E/R).

Power is also supplied at all times

- to BCM terminal 7
- through 50A fusible link (letter f , located in the fuse and fusible link box).

With the ignition switch in the ON or START position, power is supplied

- to BCM terminal 35
- through 10A fuse [No. 12, located in the fuse block (J/B)].

With the ignition switch in the ACC or ON position, power is supplied

- to BCM terminal 36
- through 10A fuse [No. 6, located in the fuse block (J/B)].

Ground is supplied

- to BCM terminals 8, 27, and 63
- through body grounds F14 (QR25DE models), M57, M61, E15, and E24.

ILLUMINATION OPERATION BY LIGHTING SWITCH

With the lighting switch in the 1ST or 2ND position (or if the auto light system is activated), the BCM receives input requesting the illumination lamps to illuminate. This input is communicated to the IPDM E/R across the CAN communication lines. The central processing unit of the IPDM E/R controls the tail lamp relay coil, which when energized, directs power

- through terminal 22 of the IPDM E/R
- to illumination control switch terminal 1,
- to A/T device terminal 3,
- to TCS ON/OFF switch terminal 3,
- to audio unit terminal 8,
- to hazard switch terminal 5,
- to rear window defogger switch terminal 5,
- to heated seat switch LH terminal 2,
- to heated seat switch RH terminal 2,
- to A/C control unit terminal 7 (with manual A/C),
- to A/C auto amplifier terminal 24 (with auto A/C),
- to combination meter terminal 48, and
- to glove box lamp terminal +.

With the ignition switch in ON or START, power is supplied

- to auto anti-dazzling inside mirror terminal +,
- through 10A fuse [No. 14, located in the fuse block (J/B)], and
- to BCM terminal 35,
- through 10A fuse [No. 12, located in the fuse block (J/B)].

With the ignition switch in ON or START, power is also supplied

- to main power window and door lock/unlock switch terminal 12 (with left front only power window anti-pinch system) or terminal 17 (with left and right front power window anti-pinch system),

ILLUMINATION

- to front power window switch RH terminal 5 (with left front only power window anti-pinch system) or terminal 13 (with left and right front power window anti-pinch system),
- to rear power window switch RH terminal 5,
- to rear power window switch LH terminal 5,
- through BCM terminal 29.

Ground is supplied at all times

- to illumination control switch terminal 3,
- to glove box lamp terminal –, and
- to auto anti-dazzling inside mirror terminal –
- through body grounds F14 (QR25DE), M57 and M61, and
- to rear power window switch RH terminal 8,
- through body ground B117, and,
- to rear power window switch LH terminal 8,
- through body grounds B7 and B19.

The main power window and door lock/unlock switch and the front power window switch RH illumination circuits are case grounded.

Controlled ground is supplied

- to A/T device terminal 4,
- to TCS ON/OFF switch terminal 4,
- to audio unit terminal 7,
- to hazard switch terminal 4,
- to rear window defogger switch terminal 6,
- to heated seat switch LH terminal 1,
- to heated seat switch RH terminal 1,
- to A/C control unit terminal 8 (with manual A/C),
- to A/C auto amplifier terminal 25 (with auto A/C), and
- to combination meter terminal 47
- from illumination control switch terminal 2.

With power and ground supplied, illumination lamps illuminate.

BATTERY SAVER CONTROL

When the combination switch (lighting switch) is in the 1ST or 2ND position (or if auto light system is activated), and the ignition switch is turned from ON or ACC to OFF, the battery saver control feature is activated. Under this condition, the illumination lamps remain illuminated for 30 minutes, unless the combination switch (lighting switch) position is changed. If the combination switch (lighting switch) position is changed, then the illumination lamps are turned off after a 30 second delay.

When the lighting switch is turned from OFF to 1ST or 2ND position (or if auto light system is activated) after illumination lamps have been turned off by the battery saver control, the illumination lamps illuminate again.

CAN Communication System Description

EKS003EP

Refer to [LAN-4, "CAN COMMUNICATION"](#) .

ILLUMINATION

Schematic

EKS003EQ

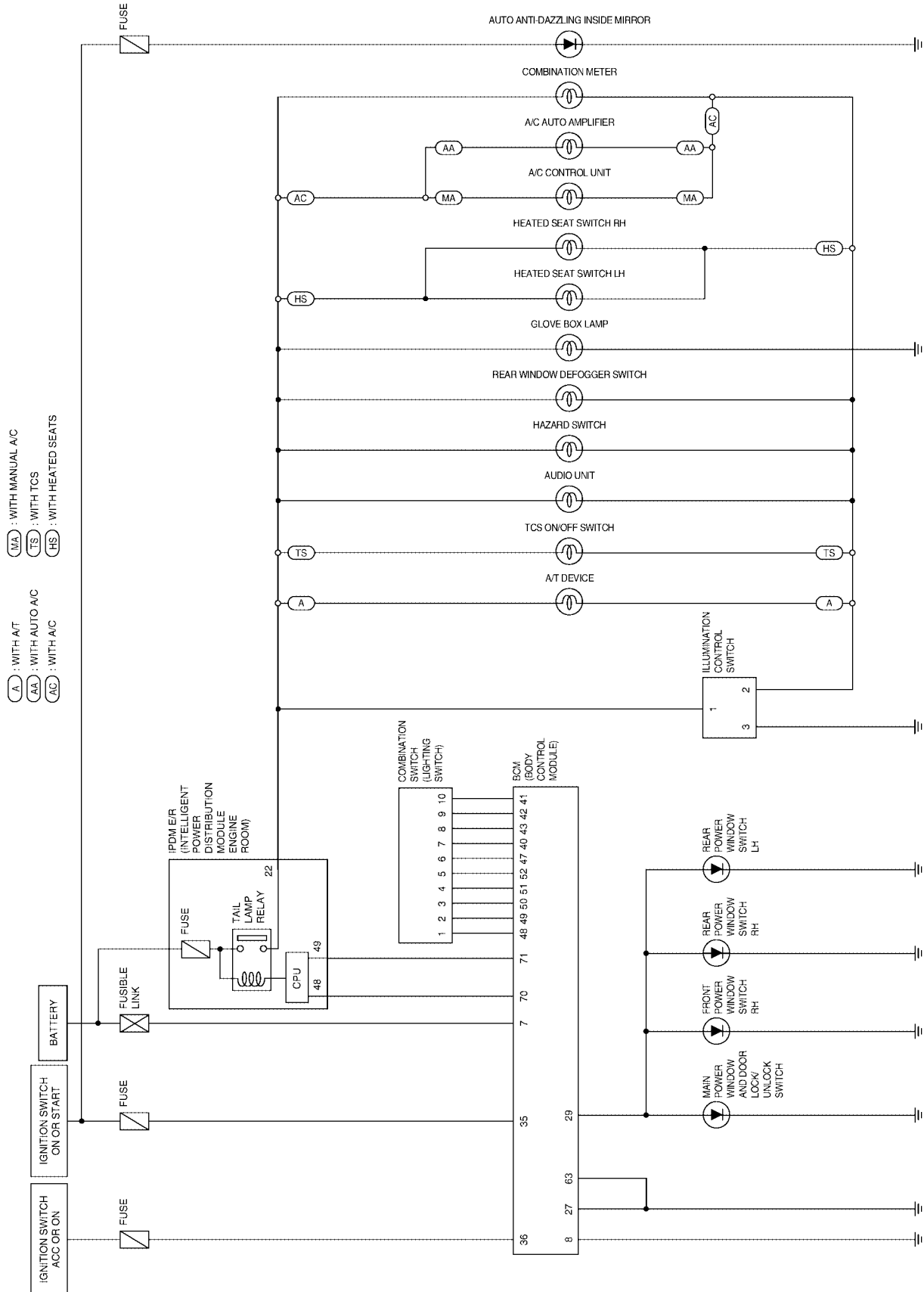

WKWA0906E

A
B
C
D
E
F
G
H
I
J
LT
L
M

ILLUMINATION

Wiring Diagram — ILL —

EKS003ER

LT-ILL-01

: WITH QR25DE
 : DATA LINE

REFER TO "PG-POWER".

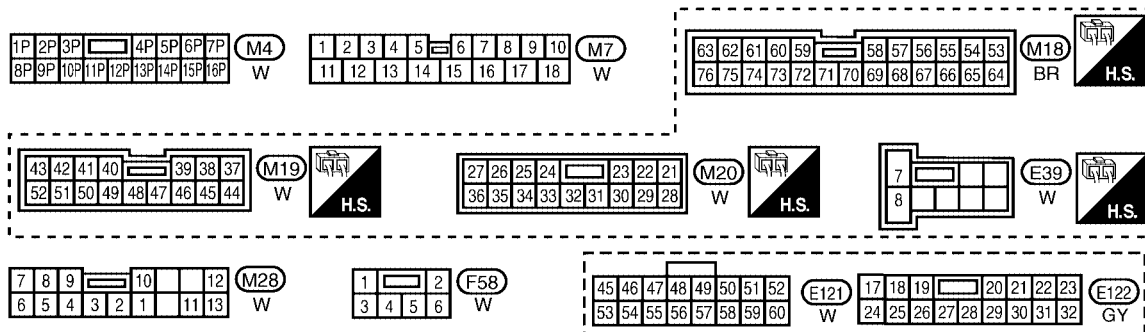
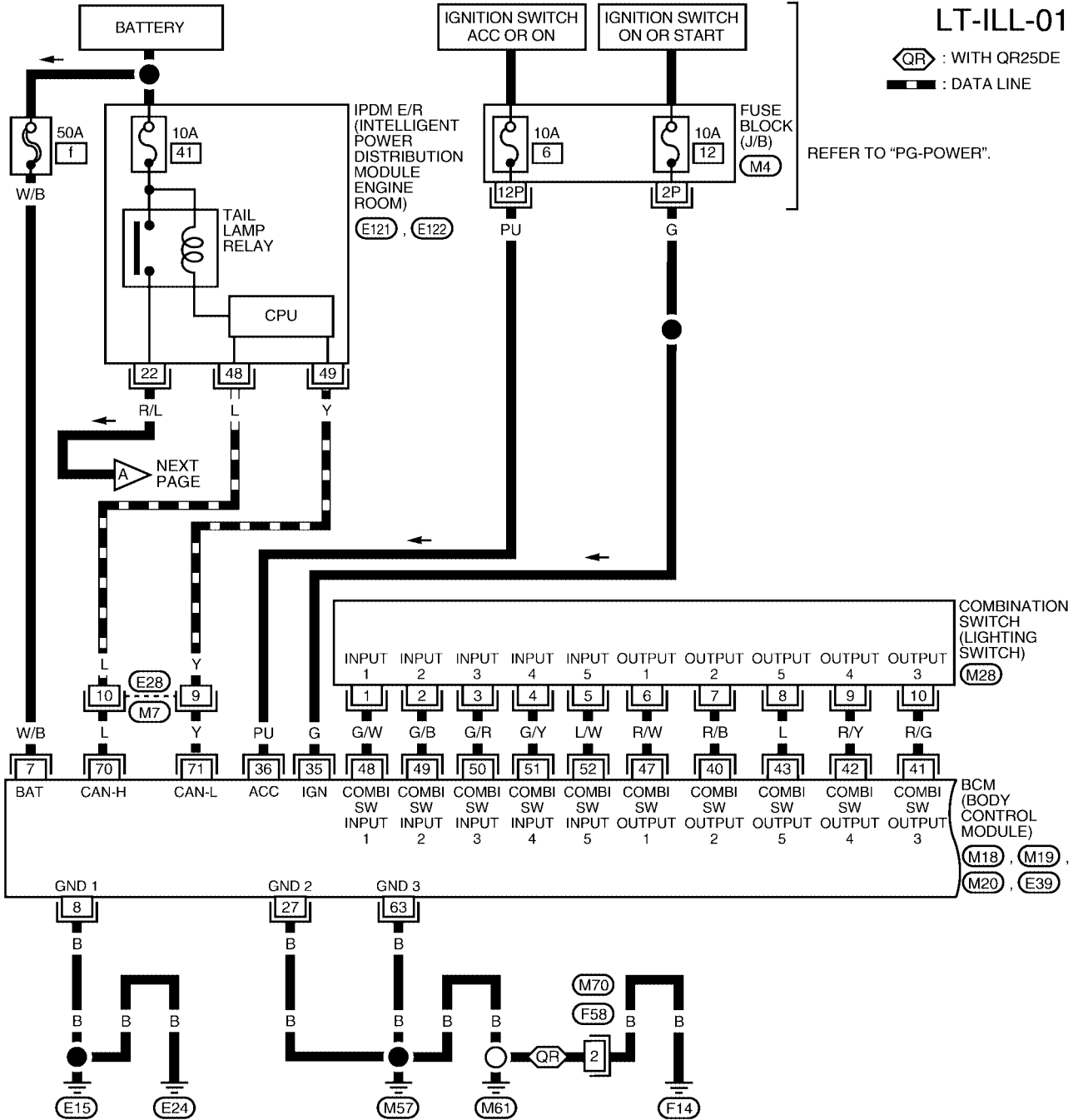

WKWA0907E

ILLUMINATION

LT-ILL-02

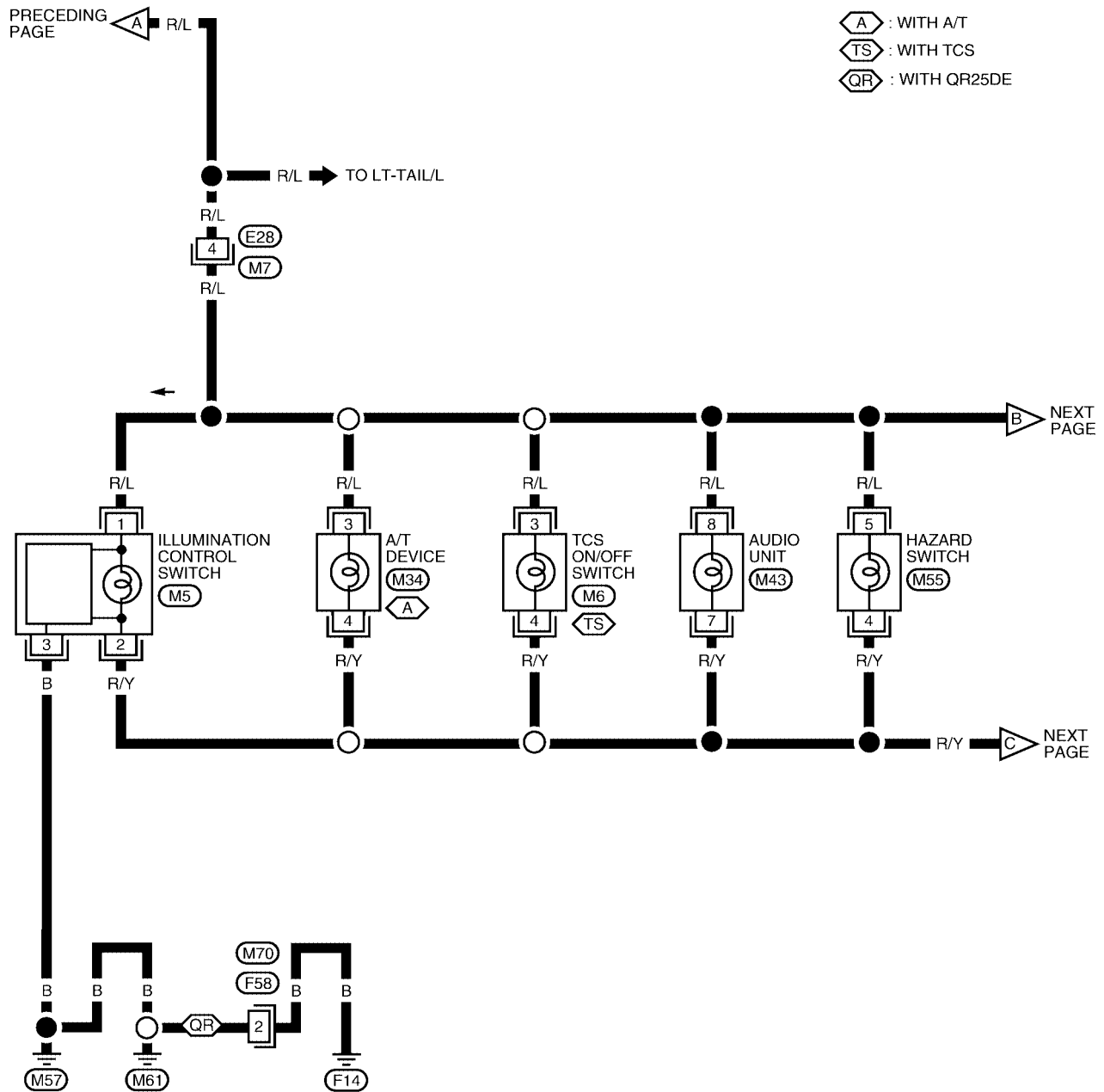

⬠ : WITH A/T
 ⬠ : WITH TCS
 ⬠ : WITH QR25DE



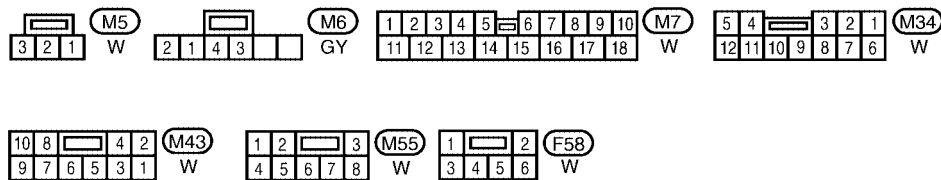

A
 B
 C
 D
 E
 F
 G
 H
 I
 J
 LT
 L
 M



WKWA0908E

ILLUMINATION

LT-ILL-03

-  : WITH A/C
-  : WITH MANUAL A/C
-  : WITH AUTO A/C
-  : WITH HEATED SEATS
-  : WITH QR25DE

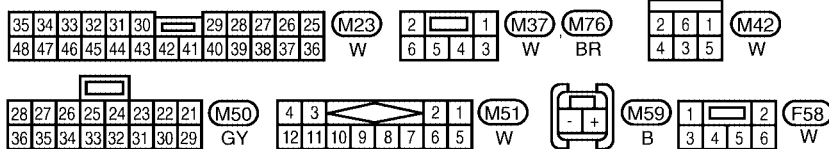
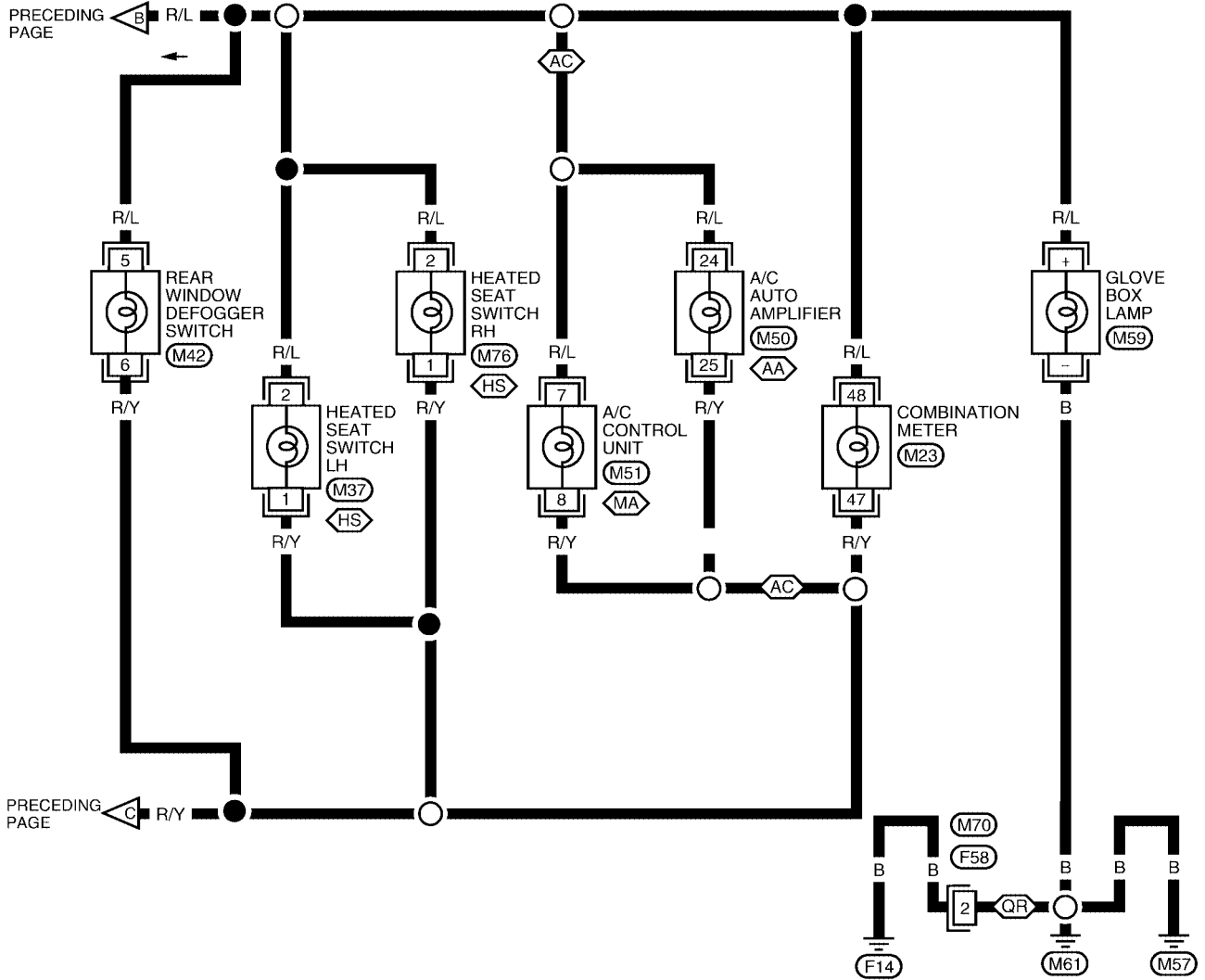

WKWA0909E

ILLUMINATION

LT-ILL-04

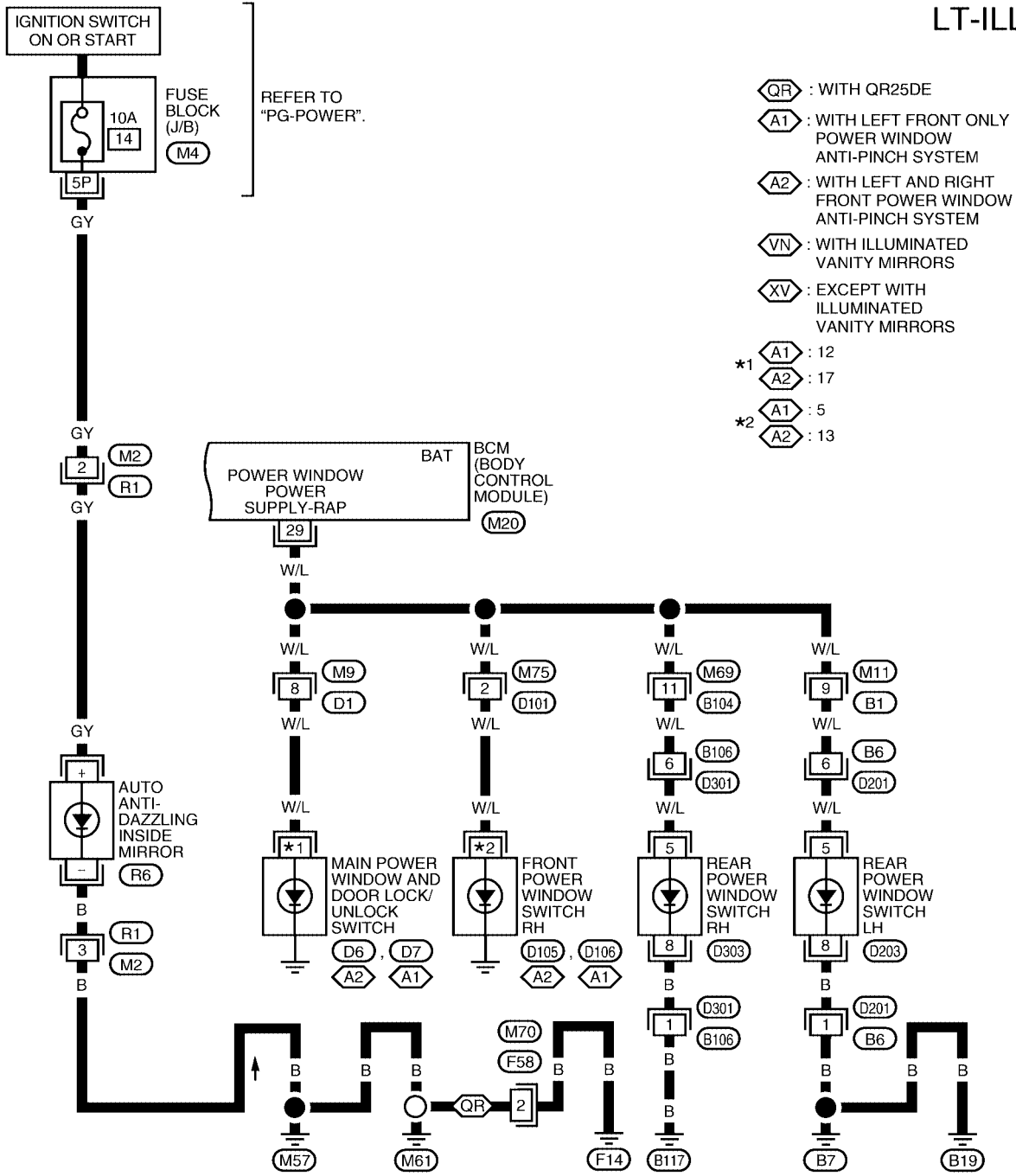

- ⬡QR : WITH QR25DE
- ⬡A1 : WITH LEFT FRONT ONLY POWER WINDOW ANTI-PINCH SYSTEM
- ⬡A2 : WITH LEFT AND RIGHT FRONT POWER WINDOW ANTI-PINCH SYSTEM
- ⬡VN : WITH ILLUMINATED VANITY MIRRORS
- ⬡XV : EXCEPT WITH ILLUMINATED VANITY MIRRORS
- *1 ⬡A1 : 12
⬡A2 : 17
- *2 ⬡A1 : 5
⬡A2 : 13

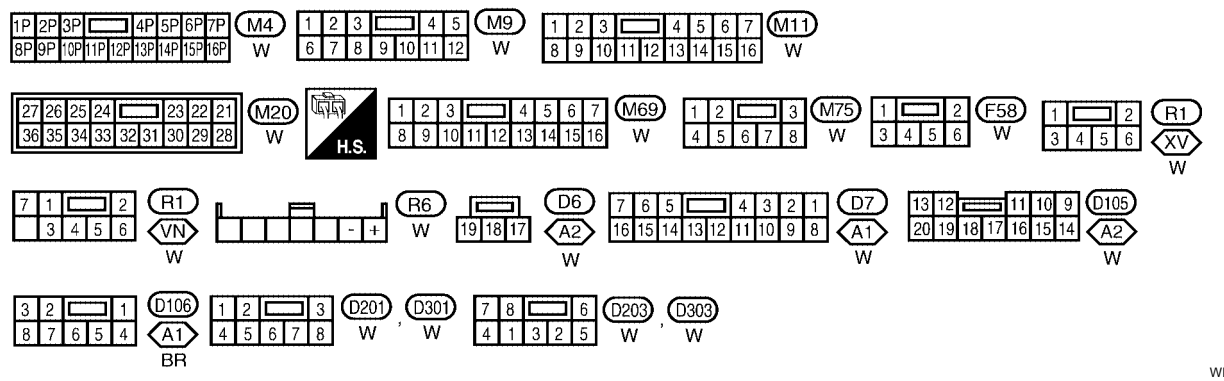

WKWA0910E

ILLUMINATION

EKS003ES

Removal and Installation

ILLUMINATION CONTROL SWITCH

1. Remove driver lower instrument panel. Refer to [IP-12, "Instrument Lower Cover LH"](#) .
2. Press the illumination control switch retaining tabs and remove the unit from the driver lower instrument panel.

Installation is in the reverse order of removal.

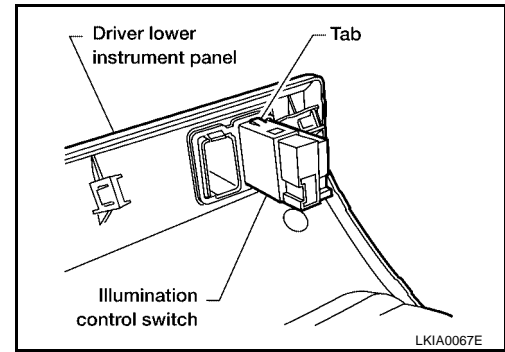

GLOVE BOX LAMP

1. Through the passenger air bag connector access in the top of the glove box, remove bulb socket by turning counterclockwise.
2. Pull the bulb from the socket to remove.

Glove box lamp : 12V 3.4W

Installation is in the reverse order of removal.

VANITY MIRROR AND TRUNK ROOM LAMPS

VANITY MIRROR AND TRUNK ROOM LAMPS

PF26470

Wiring Diagram — INT/L —

EKS003ET

LT-INT/L-01

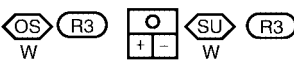
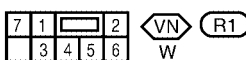
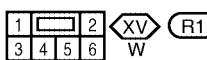
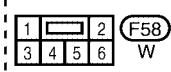
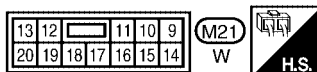
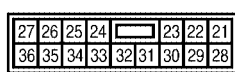
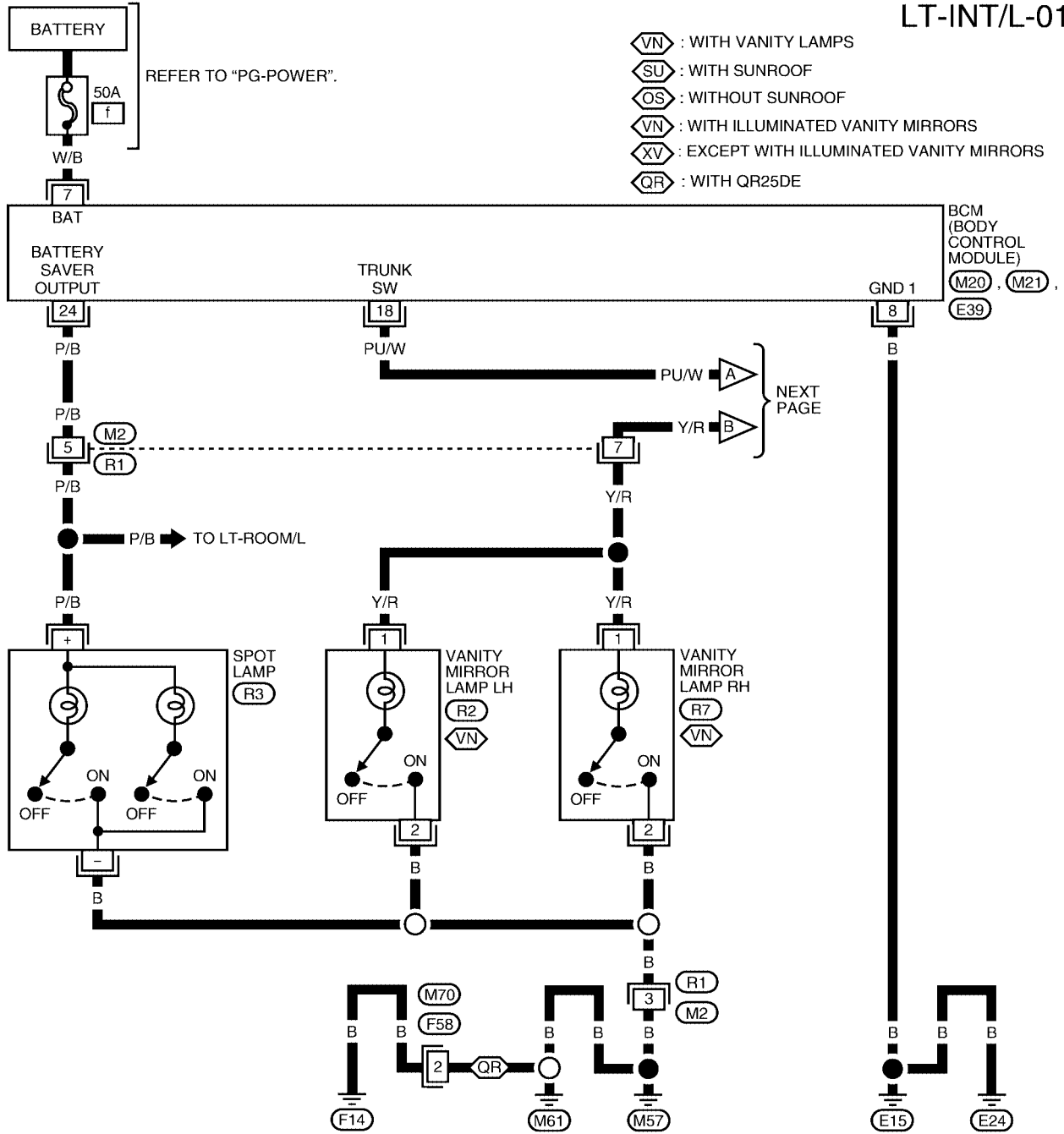

WKWA0911E

VANITY MIRROR AND TRUNK ROOM LAMPS

LT-INT/L-02

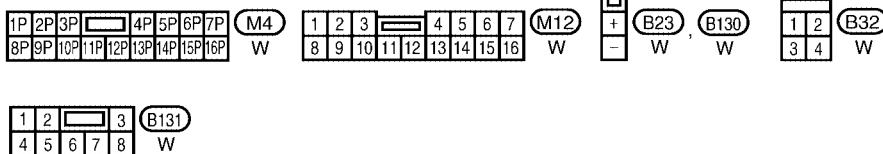
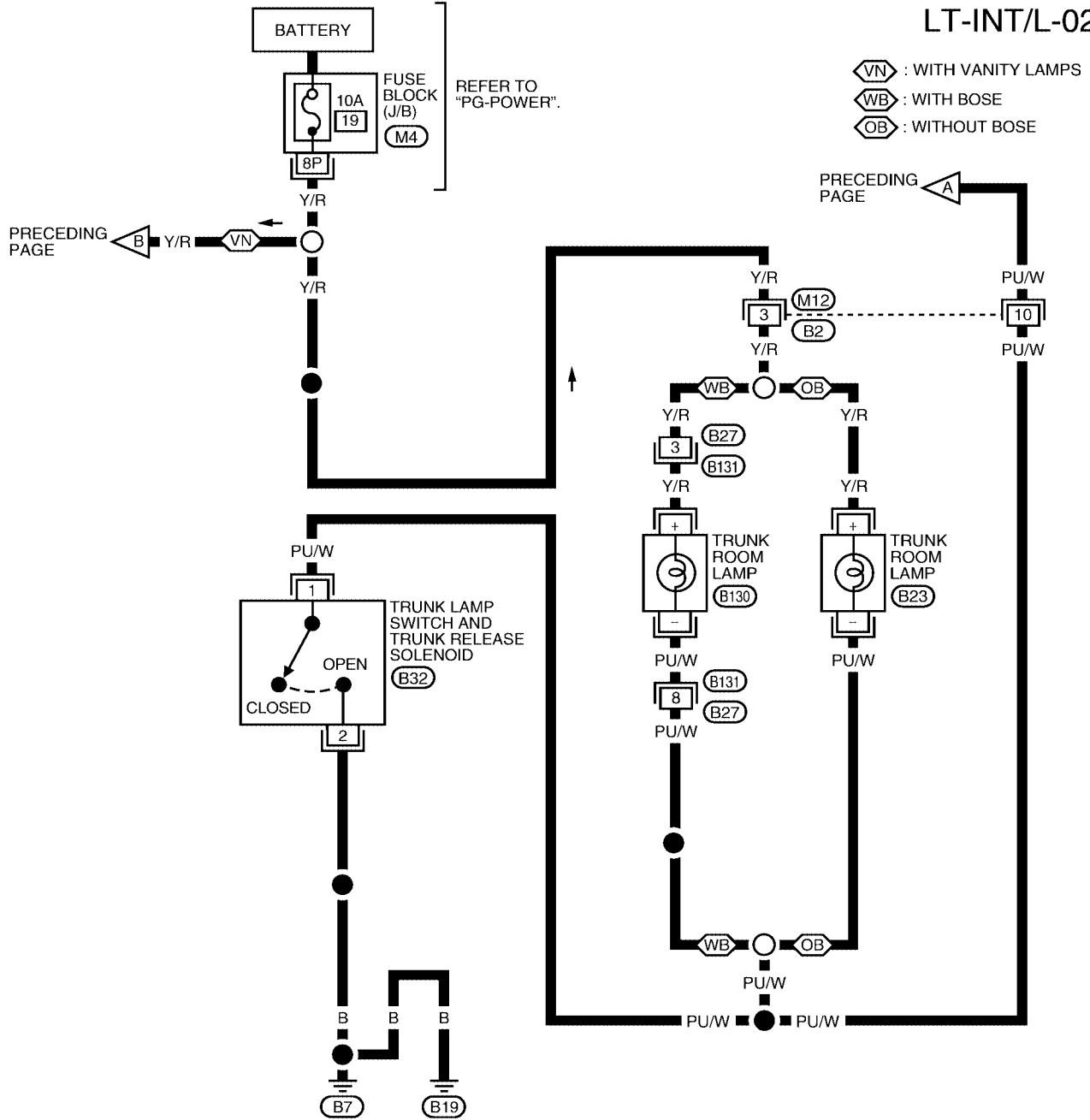

WKWA0912E

VANITY MIRROR AND TRUNK ROOM LAMPS

Bulb Replacement for Vanity Mirror Lamp

EKS003EU

1. Insert a thin screwdriver in the notch and remove the lens.
2. Remove the bulb.

Vanity mirror lamp : 14V 1.4W

Installation is in the reverse order of removal.

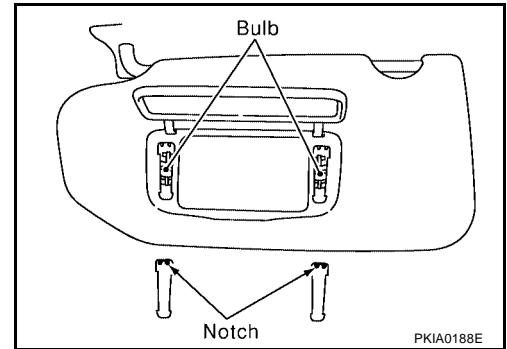

Bulb Replacement, Removal and Installation for Trunk Room Lamp

EKS003EV

1. Unfold tab A and remove the lens.
2. Remove the trunk room lamp while pressing tab B in the direction of the arrow.
3. Disconnect the trunk room lamp connector.
4. Pull bulb from socket to remove.

Trunk room lamp : 12V 3.4W

Installation is in the reverse order of removal.

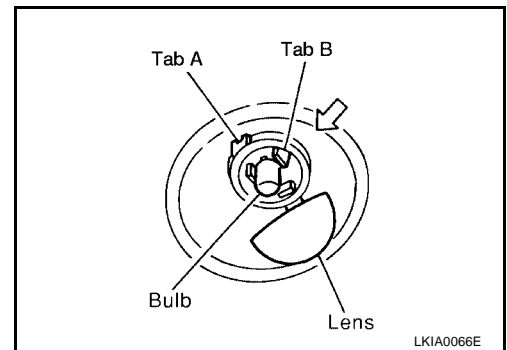

A
B
C
D
E
F
G
H
I
J
LT
L
M

BULB SPECIFICATIONS

BULB SPECIFICATIONS

PFP:26297

Headlamp

EKS003EW

Item	Wattage (W)*
Low (halogen)	55 (H1)
Low (xenon)	35 (D2R)
High	60W (HB3)

*: Always check with the Parts Department for the latest parts information.

Exterior Lamp

EKS003EX

Item	Wattage (W)*
Front combination lamp	Turn signal lamp/parking lamp 27/8 (amber)
Rear combination lamp	Stop/Tail lamp 27/7
	Turn signal lamp 27
	Back-up lamp 13
	Side marker lamp 5
Fog lamp	55
License plate lamp	5
High-mounted stop lamp (parcel shelf mount)	18
High-mounted stop lamp (rear air spoiler mount)	*

*: Always check with the Parts Department for the latest parts information.

Interior Lamp/Illumination

EKS003EY

Item	Wattage (W)*
Glove box lamp	3.4
Ignition key hole illumination lamp	0.74
Map lamp	10
Room lamp	8
Step lamp	3.4
Trunk room lamp	3.4
Vanity mirror lamp	1.4

*: Always check with the Parts Department for the latest parts information.