

SECTION **CL**  
CLUTCH

A  
B  
CL

D

E

CONTENTS

<b>PRECAUTIONS</b> .....	<b>2</b>	INSTALLATION .....	11	F
Precautions .....	2	Disassembly and Assembly .....	11	
<b>PREPARATION</b> .....	<b>3</b>	DISASSEMBLY .....	11	
Special Service Tools .....	3	INSPECTION AFTER DISASSEMBLY .....	12	G
Commercial Service Tools .....	3	ASSEMBLY .....	12	
<b>NOISE, VIBRATION, AND HARSHNESS (NVH)</b>		<b>CLUTCH PIPING</b> .....	<b>13</b>	H
<b>TROUBLESHOOTING</b> .....	<b>4</b>	Removal and Installation .....	13	
NVH TROUBLESHOOTING CHART .....	4	REMOVAL .....	13	
<b>CLUTCH PEDAL</b> .....	<b>5</b>	INSTALLATION .....	13	
Components .....	5	<b>CLUTCH RELEASE MECHANISM</b> .....	<b>14</b>	I
Removal and Installation .....	5	Removal and Installation (5 M/T models) .....	14	
INSPECTION AFTER REMOVAL .....	5	REMOVAL .....	14	
On-vehicle Inspection and Adjustment .....	6	INSPECTION AFTER REMOVAL .....	14	J
<b>CLUTCH FLUID</b> .....	<b>7</b>	INSTALLATION .....	15	
Air Bleeding Procedure .....	7	Removal and Installation (6 M/T models) .....	16	
<b>CLUTCH MASTER CYLINDER</b> .....	<b>8</b>	REMOVAL .....	16	K
Components .....	8	INSPECTION AFTER REMOVAL .....	16	
CLUTCH MASTER CYLINDER .....	8	INSTALLATION .....	17	
REMOVAL .....	8	<b>CLUTCH DISC, CLUTCH COVER AND FLYWHEEL..</b>	<b>18</b>	L
INSTALLATION .....	8	Removal and Installation .....	18	
CLUTCH RESERVOIR TANK .....	9	REMOVAL .....	18	
REMOVAL .....	9	INSTALLATION .....	18	
INSTALLATION .....	9	Inspection and Adjustment after Removal .....	19	M
Disassembly and Assembly .....	9	CLUTCH DISC .....	19	
DISASSEMBLY .....	9	CLUTCH COVER .....	19	
INSPECTION AFTER DISASSEMBLY .....	9	FLYWHEEL .....	19	
ASSEMBLY .....	9	<b>SERVICE DATA AND SPECIFICATIONS (SDS) .....</b>	<b>20</b>	
<b>OPERATING CYLINDER</b> .....	<b>11</b>	Clutch Control System .....	20	
Removal and Installation .....	11	Clutch Master Cylinder .....	20	
REMOVAL .....	11	Clutch Operating Cylinder .....	20	
		Clutch Disc .....	20	
		Clutch Cover .....	20	
		Clutch Pedal .....	20	

# PRECAUTIONS

## PRECAUTIONS

PFP:00001

### Precautions

ECS00939

- Recommended fluid is brake fluid “DOT 3”.
- Never reuse drained brake fluid.
- Be careful not to splash brake fluid on painted areas.
- When removing and installing clutch piping, use Tool.
- Use new brake fluid to clean or wash all parts of master cylinder and operating cylinder.
- Never use mineral oils such as gasoline or kerosene. It will ruin the rubber parts of the hydraulic system.

**WARNING:**

After cleaning clutch disc, wipe it with a dust collector. Do not use compressed air.

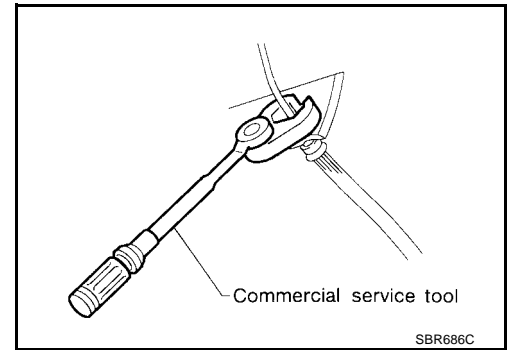

# PREPARATION

## PREPARATION

PFP:00002

### Special Service Tools

ECS0093A

The actual shapes of Kent-Moore tools may differ from those of special service tools illustrated here.

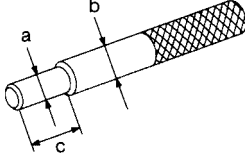
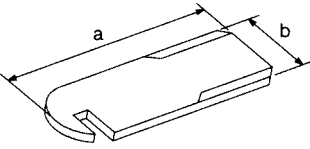
Tool number (Kent-Moore No.) Tool name	Description
ST20630000 (J-26366) Clutch aligning bar	 Installing clutch cover and clutch disc <b>a: 15.8 mm (0.622 in) dia.</b> <b>b: 22.9 mm (0.902 in) dia.</b> <b>c: 45.0 mm (1.772 in)</b>
ST20050240 ( — ) Diaphragm spring adjusting wrench	 Adjusting unevenness of diaphragm spring of clutch cover <b>a: 150 mm (5.91 in)</b> <b>b: 25 mm (0.98 in)</b>

### Commercial Service Tools

ECS0093B

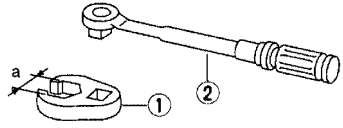
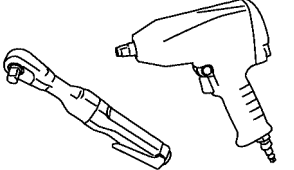
Tool name	Description
1 Flare nut crowfoot 2 Torque wrench	 Removing and installing clutch piping <b>a: 10 mm (0.39 in)</b>
Power tool	 Loosening bolts and nuts



# CLUTCH PEDAL

PF:46540

## CLUTCH PEDAL

### Components

ECS0093D

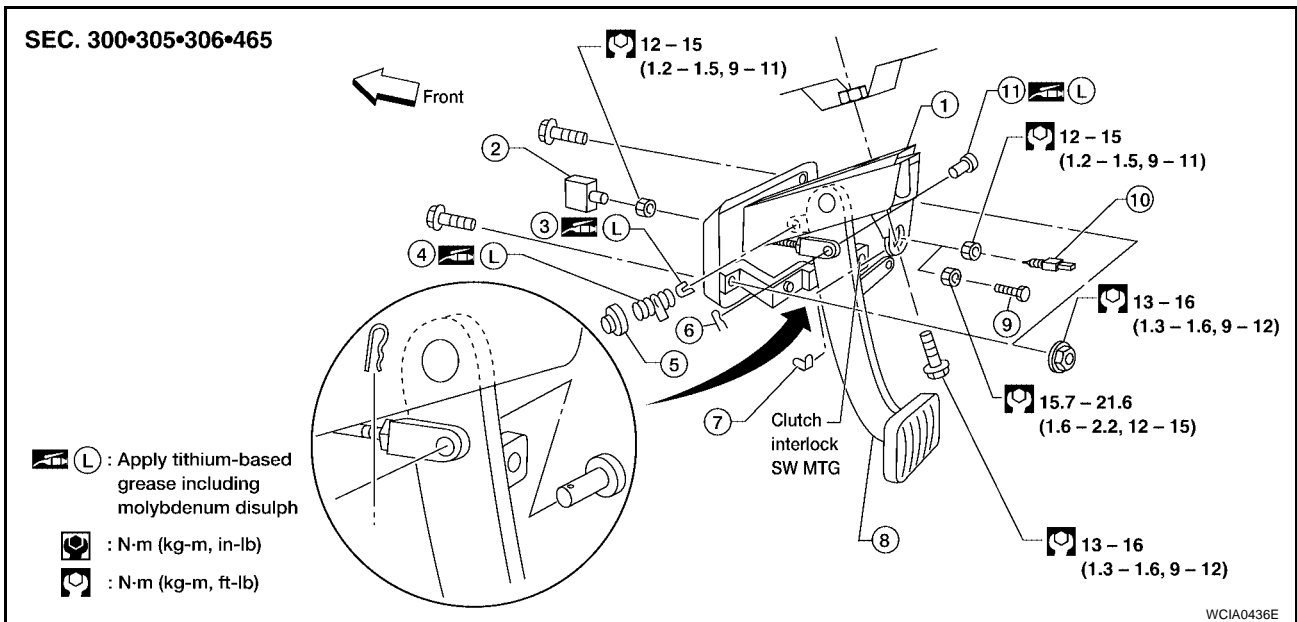

- |                         |                            |                 |
|-------------------------|----------------------------|-----------------|
| 1. Clutch pedal bracket | 2. Clutch interlock switch | 3. Bushing      |
| 4. Assist spring        | 5. Bushing                 | 6. Snap pin     |
| 7. Stopper rubber       | 8. Clutch pedal            | 9. Stopper bolt |
| 10. ASCD clutch switch  | 11. Clevis pin             |                 |

### Removal and Installation

ECS0093E

Refer to [CL-5, "Components"](#) .

#### INSPECTION AFTER REMOVAL

- Inspect clutch for bending, damage and welding cracks. Replace if necessary.
- Make sure that the assist spring and return spring have not lost their spring. Replace if necessary.

# CLUTCH PEDAL

ECS0093F

## On-vehicle Inspection and Adjustment

1. Check to see if the clutch pedal clevis pin floats freely in the bore of the clutch pedal. It should not be bound by the clevis or clutch pedal.
  - a. If the pin is not free, check that the ASCD switch or pedal stopper bolt is not applying pressure to the clutch pedal causing the pin to bind. To adjust, loosen the ASCD switch or pedal stopper bolt lock nut and turn the ASCD switch or pedal stopper bolt.
  - b. Tighten the lock nut.
  - c. Verify that the clutch pedal clevis pin floats freely in the bore of the clutch pedal. It should not be bound by the clevis or clutch pedal.
  - d. If the pin is still not free, remove the pin and check for deformation or damage. Replace the pin if necessary. Leave the pin removed for step 2.
2. Check the clutch pedal stroke for free range of movement.
  - a. With the clutch pedal clevis pin removed, manually move the pedal up and down to determine if it moves freely.
  - b. If any sticking is noted, replace the related parts (clutch pedal, pedal bracket, assist spring and bushing). Reassemble the pedal and re-verify that the clevis pin floats freely in the bore of the pedal.
3. Adjust the clearance "C" while fully depressing the clutch pedal (with the clutch interlock switch) as shown.

**Clearance "C" : 0.1 - 1.0 mm (0.004 - 0.039 in)**

4. Check the clutch hydraulic system components (clutch master cylinder, clutch operating cylinder, Clutch withdrawal lever and clutch release bearing) for sticking or binding.
  - a. If any sticking or binding is noted, repair or replace the related parts as necessary.
  - b. If the hydraulic system was necessary, bleed the clutch hydraulic system. Refer to [CL-7, "Air Bleeding Procedure"](#) .

### NOTE:

Do not use a vacuum assist or any other type of power bleeder on this system. Use of a vacuum assist or power bleeder will not purge all of the air from the system.

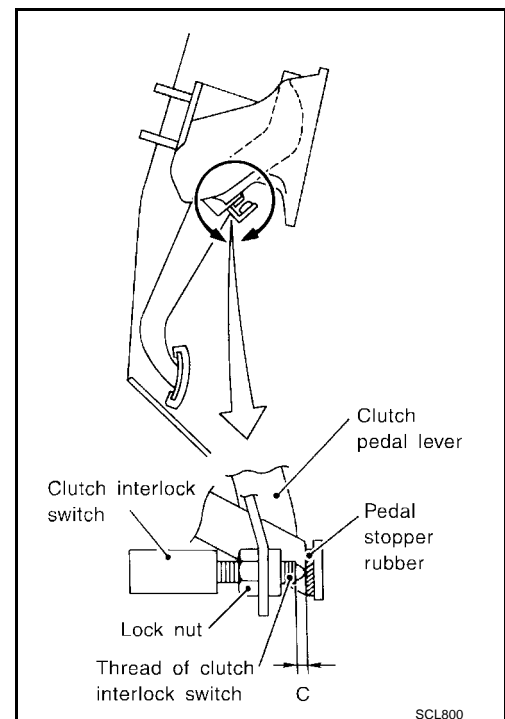
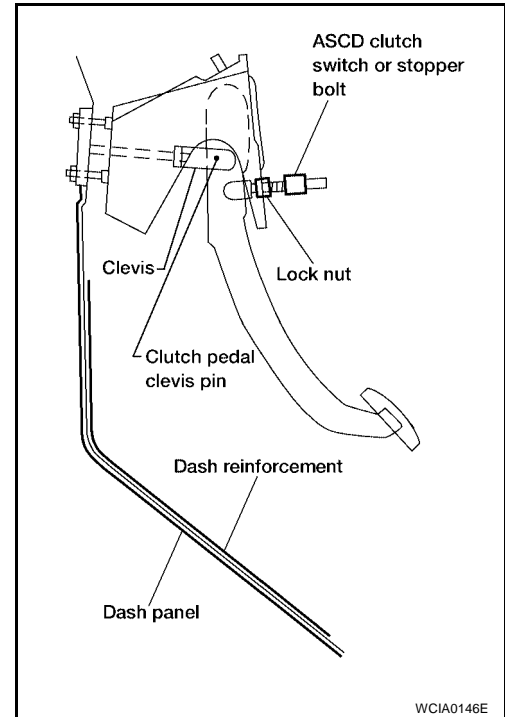

# CLUTCH FLUID

## CLUTCH FLUID

PFP:00017

### Air Bleeding Procedure

ECS0093G

#### NOTE:

Do not use a vacuum assist or any other type of power bleeder on this system. Use of a vacuum assist or power bleeder will not purge all the air from the system.

- Bleed air according to the following procedure.
  - Carefully monitor fluid level at reservoir tank during bleeding operation.
  - When bleeding the air from the clutch fluid, first bleed the air from the operating cylinder air bleed valve and then from the bleed connector air bleed valve.
1. Top off reservoir with new recommended brake fluid.
  2. Connect a transparent vinyl tube to the air bleeder valve on the clutch operating cylinder.

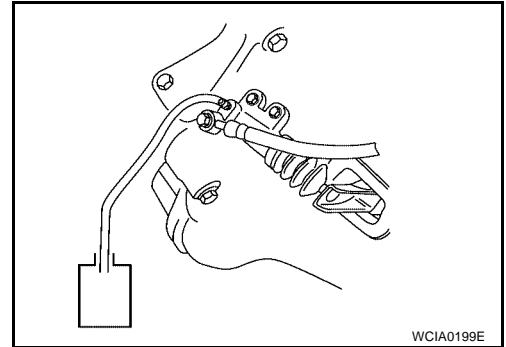

3. Fully depress the clutch pedal several times.
4. With clutch pedal depressed, open the bleeder valve to release air.
5. Close the bleeder valve.
6. Repeat steps 3 through 5 until clear brake fluid comes out of the air bleeder valve.

**Air bleeder valve : 5.9 - 9.8 N·m (0.6 - 1.0 kg·m, 52 - 87 in·lb)**

7. Perform steps 1 through 6 for bleeding air from the air bleeder valve on the bleed connector.

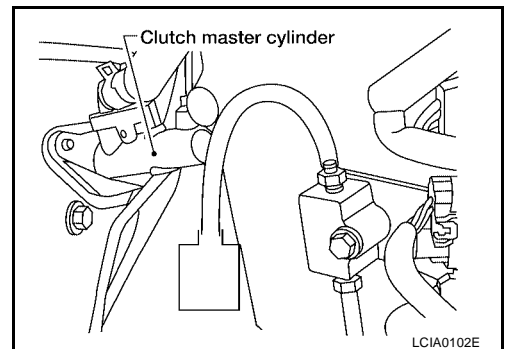

# CLUTCH MASTER CYLINDER

## CLUTCH MASTER CYLINDER

PFP:30610

### Components

ECS0093H

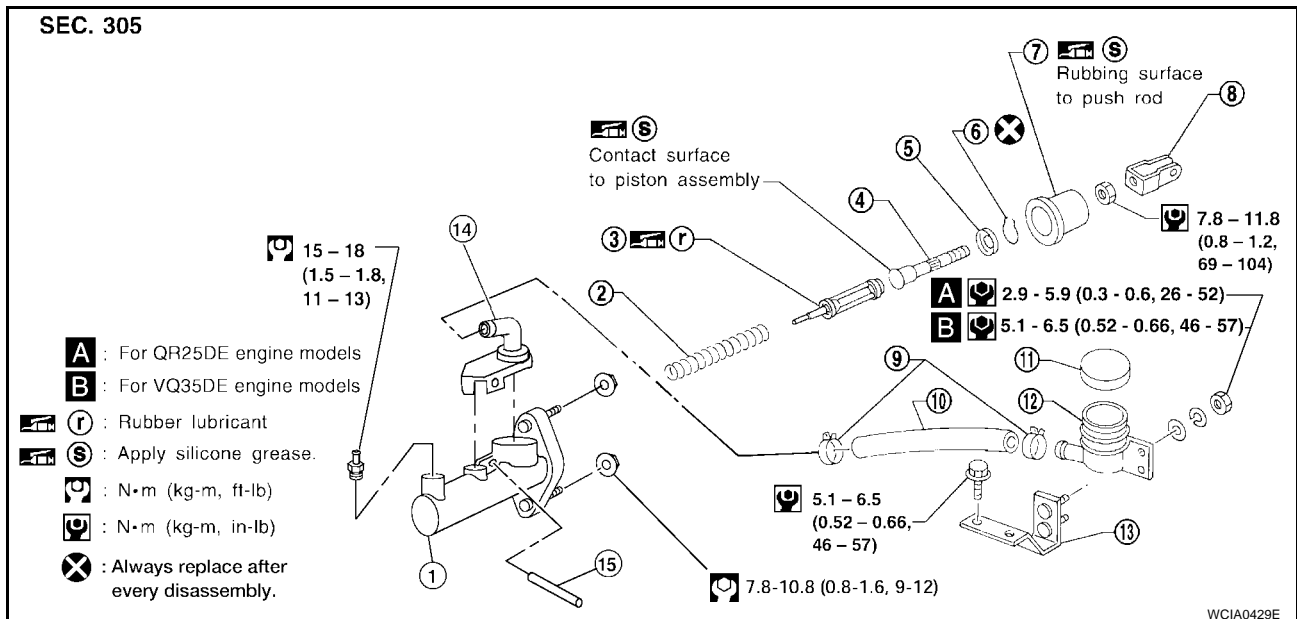

- |                           |                   |                    |
|---------------------------|-------------------|--------------------|
| 1. Clutch master cylinder | 2. Return spring  | 3. Piston assembly |
| 4. Push rod               | 5. Stopper        | 6. Stopper ring    |
| 7. Dust cover             | 8. Clevis         | 9. Hose clamp      |
| 10. Hose                  | 11. Reservoir cap | 12. Reservoir tank |
| 13. Bracket               | 14. Nipple        | 15. Pin            |

## CLUTCH MASTER CYLINDER REMOVAL

ECS0093I

1. Drain the brake fluid from the clutch hydraulic system.

### CAUTION:

**Do not splash brake fluid on painted areas; it may cause paint damage. If brake fluid is splashed on painted areas, wash it away with water immediately.**

2. Remove clutch line using a flare nut wrench.
3. Remove hose clamp and hose from clutch master cylinder.
4. Remove snap pin from clevis pin, then remove clevis pin from push rod and clevis.
5. Remove the clutch master cylinder nuts, then remove the clutch master cylinder from the vehicle.

## INSTALLATION

1. Check position of clevis and push rod. If measurement is outside standard length, adjust position of clevis and push rod.

**Length "L" : 119.5 mm (4.70 in)**

2. Connect the clutch line to the master cylinder assembly, and hand-tighten the flare nut.

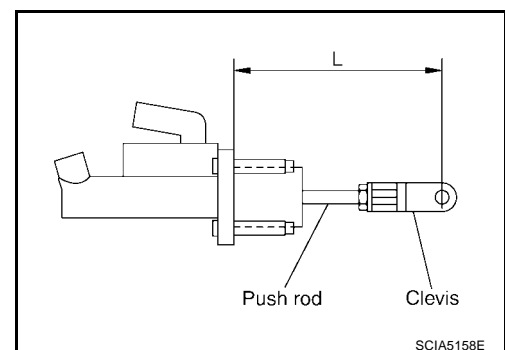

3. Install the master cylinder assembly, tighten the nuts to specification.

**Clutch master cylinder nuts : 7.8 - 10.8 N·m (0.8 - 1.6 kg-m, 9 - 12 ft-lb)**

4. Install clutch reservoir tank hose and hose clamp to the clutch master cylinder assembly.
5. Tighten the clutch line flare nut to specification using a flare nut torque wrench.



# CLUTCH MASTER CYLINDER

**Clutch line flare nut : 15 - 18 N·m (1.5 – 1.8 kg-m, 11 – 13 ft-lb)**

6. Attach clevis and clevis pin to clutch pedal.
7. Attach snap pin to clevis pin.
8. Inspect and adjust the clutch pedal and bleed the air from the clutch hydraulic system. Refer to [CL-6, "On-vehicle Inspection and Adjustment"](#) and [CL-7, "Air Bleeding Procedure"](#).

## CLUTCH RESERVOIR TANK REMOVAL

ECS0093J

CL

1. Drain the brake fluid from the clutch hydraulic system.

### CAUTION:

**Do not splash brake fluid on painted areas; it may cause paint damage. If brake fluid is splashed on painted areas, wash it away with water immediately.**

2. Remove the clamp, then remove the hose from the clutch reservoir tank.
3. Remove the clutch reservoir tank to bracket nuts, then remove the clutch reservoir tank from the vehicle.

## INSTALLATION

1. Install the clutch reservoir tank and nuts to the bracket and hand-tighten.
2. Install the hose and clamp to the clutch reservoir tank.
3. Tighten the clutch reservoir tank nuts to specified torque.

**Reservoir tank bracket bolts : 5.1 – 6.5 N·m (0.52 – 0.66 kg-m, 46 – 57 in-lb)**

**Reservoir tank to bracket nuts**

**(for QR25DE engine models) : 2.9 – 5.9 N·m (0.3 – 0.6 kg-m, 26 – 52 in-lb)**

**(for VQ35DE engine models) : 5.1 – 6.5 N·m (0.52 – 0.66 kg-m, 46 – 57 in-lb)**

## Disassembly and Assembly

### DISASSEMBLY

ECS0093K

1. Loosen the push rod lock nut "A", then remove clevis and lock nut "A" if necessary.

### CAUTION:

**Clutch pedal height is controlled with position of clevis and push rod.**

2. Remove the dust cover.
3. Remove the stopper ring and stopper, and remove the push rod from the cylinder body. During removal, keep the push rod depressed, to prevent the piston inside master cylinder from popping out.
4. Remove the piston assembly from the cylinder body.

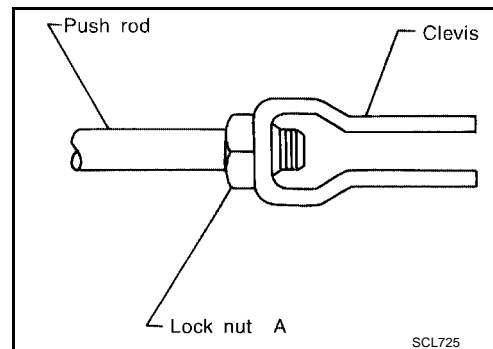

### INSPECTION AFTER DISASSEMBLY

Inspect for the following, and replace parts as necessary.

- Damage, wear, rust, and pinholes on the cylinder inner wall
- Damage and deformation of the reservoir tank
- Weak spring
- Crack and deformation of the dust cover

### ASSEMBLY

1. Apply rubber lubricant to the sliding part of piston assembly, and insert piston assembly.
2. After installing stopper to push rod, install a new stopper ring while keeping piston assembly depressed by hand, so that piston assembly will not pop out.

### CAUTION:

**Stopper ring cannot be reused. Always use a new stopper ring to assemble.**

3. Install dust cover.
4. Install nipple and pin to cylinder body.
5. Install clevis to push rod.

## CLUTCH MASTER CYLINDER

6. Check and adjust position of clevis on push rod. After adjusting "L", tighten lock nut to the specified torque.

**Length "L"** : 119.5 mm (4.70 in)  
**Lock nut "A" tightening torque** : 7.8 - 11.8 N·m (0.8 - 1.2 kg·m, 69 - 104 in-lb)

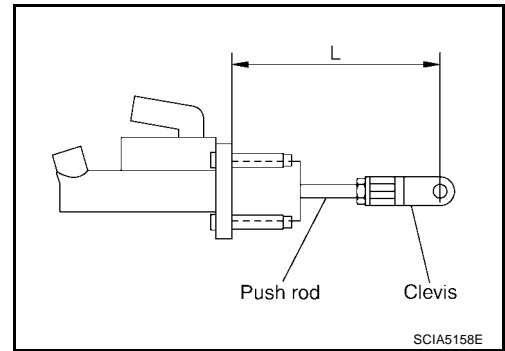

# OPERATING CYLINDER

PFP:30620

ECS0093L

## OPERATING CYLINDER Removal and Installation

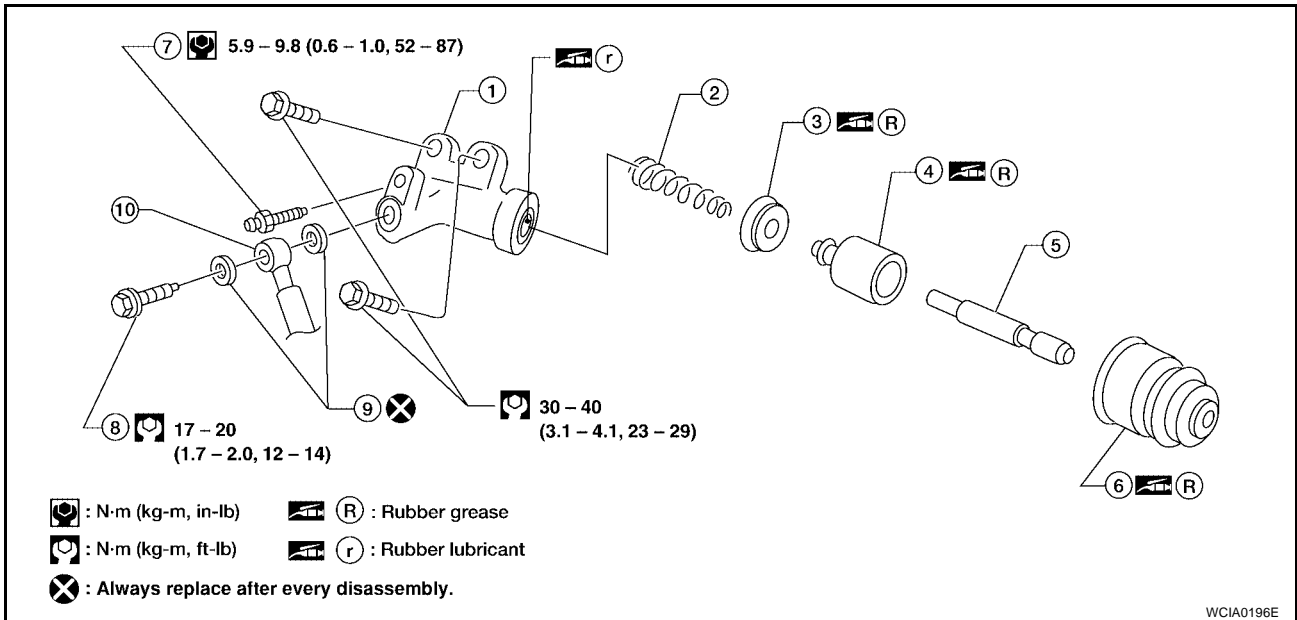

- |                  |                  |                  |
|------------------|------------------|------------------|
| 1. Cylinder body | 2. Piston spring | 3. Piston cup    |
| 4. Piston        | 5. Push rod      | 6. Dust cover    |
| 7. Air bleeder   | 8. Union bolt    | 9. Copper washer |
| 10. Clutch hose  |                  |                  |

### REMOVAL

1. Drain brake fluid from hydraulic clutch system.

#### CAUTION:

**Do not splash brake fluid on painted areas; it may cause paint damage. If brake fluid is splashed on painted areas, wash it away with water immediately.**

2. Remove union bolt and clutch hose from operating cylinder.
3. Remove operating cylinder mounting bolts, and remove cylinder from vehicle.

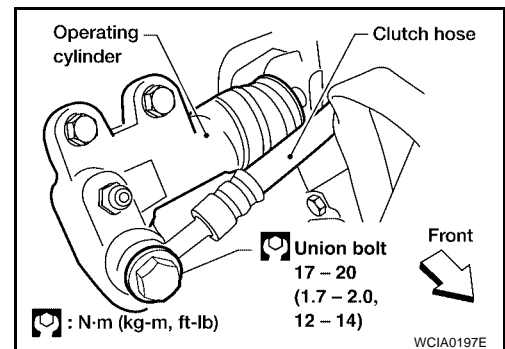

### INSTALLATION

Installation is in the reverse order of removal.

#### CAUTION:

- Install the clutch hose without twisting it.
- The copper washer of the union bolt cannot be reused. Always use a new copper washer when installing the clutch hose.
- After installation, bleed the air from the clutch hydraulic system. Refer to [CL-7. "Air Bleeding Procedure"](#).

### Disassembly and Assembly DISASSEMBLY

ECS0093M

- Remove dust cover, and remove piston assembly from cylinder body.

# OPERATING CYLINDER

---

## **INSPECTION AFTER DISASSEMBLY**

Inspect for following, and replace parts as necessary.

- Damage, foreign material, wear, rust, and pinholes on the cylinder inner surface, piston, and sliding part of piston cup
- Weak spring
- Crack and deformation of dust cover

## **ASSEMBLY**

Assembly is in the reverse order of disassembly.

- Apply recommended rubber grease to piston cup and piston before assembly.

# CLUTCH PIPING

PF3:30650

ECS0093N

## CLUTCH PIPING

### Removal and Installation

#### REMOVAL

1. Remove fuel filter mounting bracket.
2. Remove air cleaner and air duct. Refer to [EM-17, "Removal and Installation"](#) (QR25DE), [EM-120, "Removal and Installation"](#) (VQ35DE).

3. Drain the brake fluid from the hydraulic clutch system.

**CAUTION:**

Do not splash brake fluid on painted areas; it may cause paint damage. If brake fluid is splashed on painted areas, wash it away with water immediately.

4. Remove flare nut using a flare nut wrench.
5. Remove clutch hose and clutch tube.

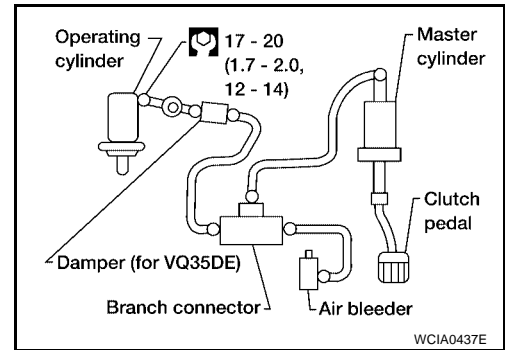

#### INSTALLATION

1. When installing clutch hose to bracket, face lock plate in the correct direction as shown to secure clutch hose.

**CAUTION:**

Install clutch hose without twisting or bending it.

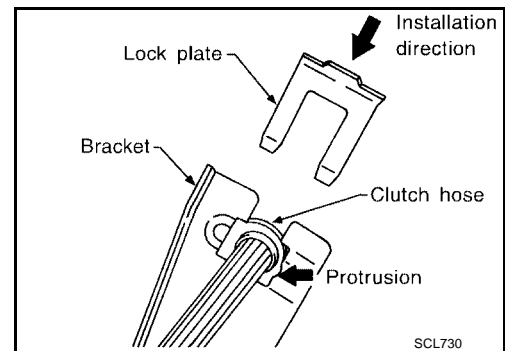

2. Tighten flare nut to the specification, using a flare nut wrench.

**Flare nut : 15 - 18 N·m (1.5 - 1.8 kg·m, 11 - 13 ft·lb)**

**CAUTION:**

Be careful not to damage flare nut and clutch tube.

3. Install clutch hose to operating cylinder, and tighten the union bolt to the specified torque.

**Clutch hose union bolt : 17 - 20 N·m (1.7 - 2.0 kg·m, 12 - 14 ft·lb)**

4. After installation, bleed the air from the clutch hydraulic system. Refer to [CL-7, "Air Bleeding Procedure"](#).

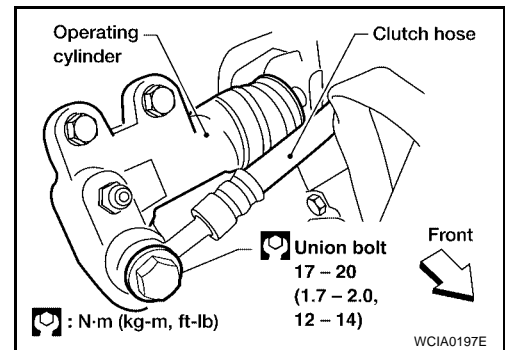

# CLUTCH RELEASE MECHANISM

## CLUTCH RELEASE MECHANISM

PFP:30502

### Removal and Installation (5 M/T models)

ECS00930

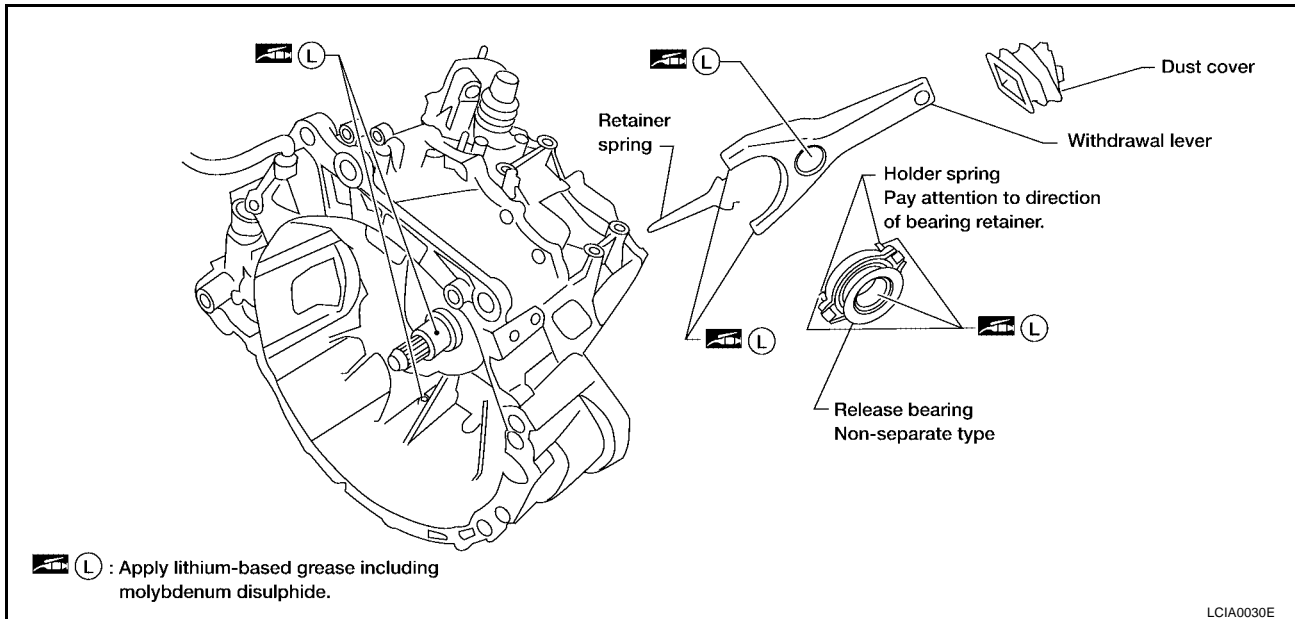

### REMOVAL

1. Remove manual transaxle from vehicle. Refer to [MT-17, "Removal and Installation"](#).
2. Move withdrawal lever enough to remove release bearing, and remove release bearing from withdrawal lever.
3. Remove withdrawal lever retainer spring.
4. Pull out withdrawal lever and remove dust cover.

### INSPECTION AFTER REMOVAL

- Replace the release bearing if it is seized, damaged, faulty in rotation direction, or has poor aligning function.
- Replace the withdrawal lever if its contact surface is worn abnormally.
- Replace the dust seal if it is deformed or cracked.

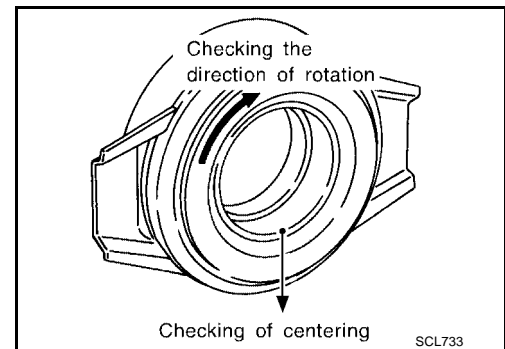

# CLUTCH RELEASE MECHANISM

## INSTALLATION

Installation is in the reverse order of removal.

### NOTE:

- Clean old grease and abrasive materials off the grease application areas.
- Apply grease to the specified points as shown.

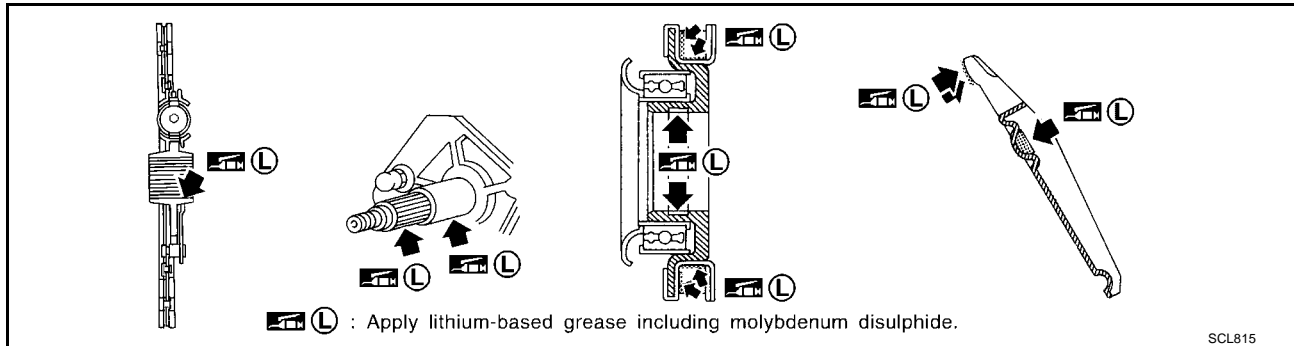

- Apply approximately 1 mm (0.04 in) thick coat of clutch sleeve grease to withdrawal lever and holder spring frictional surfaces.
- Apply a coat of clutch sleeve grease to the grooves on contact surfaces of the withdrawal lever ball pin and inner surface of release bearing; make sure that grease is flush with grooves.
- Apply a thin coat of clutch sleeve grease to release bearing frictional surface. After grease application, install release bearing. Wipe off excess grease forced out during bearing installation.

### CAUTION:

- Before installing the manual transaxle to the vehicle, check that each sliding surface slides smoothly by operating withdrawal lever.
- Be careful with the orientation of the installation.

# CLUTCH RELEASE MECHANISM

## Removal and Installation (6 M/T models)

ECS00BT2

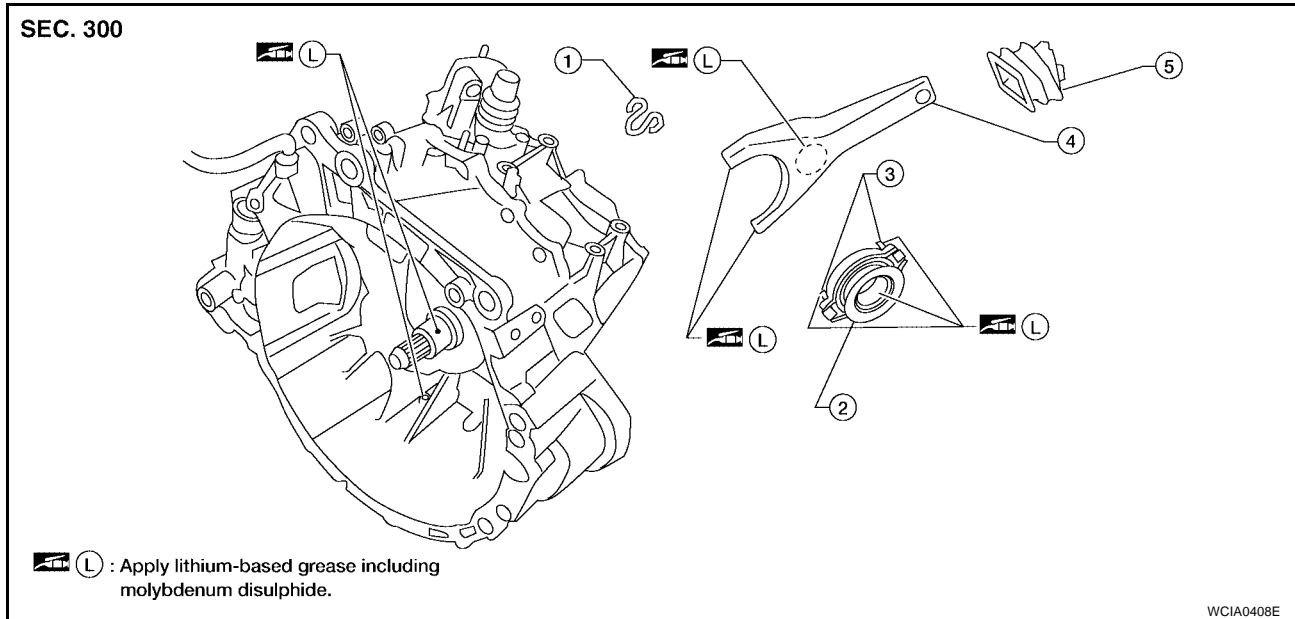

1. Snap spring
2. Release bearing non-separate type
3. Holder spring
4. Withdrawal lever
5. Dust cover

### CAUTION:

When installing the holder spring pay attention to the direction of the bearing retainer.

### REMOVAL

1. Remove manual transaxle from vehicle. Refer to [MT-81, "Removal and Installation"](#).
2. Move withdrawal lever enough to remove release bearing from input shaft, then remove release bearing from withdrawal lever.
3. Remove withdrawal lever snap spring.
4. Pull out withdrawal lever and remove dust cover.

### INSPECTION AFTER REMOVAL

- Replace the release bearing if it is seized, damaged, faulty in rotation direction, or has poor aligning function.
- Replace the withdrawal lever if its contact surface is worn abnormally.
- Replace the dust seal if it is deformed or cracked.

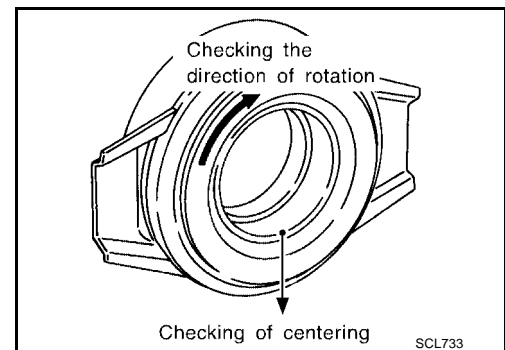



# CLUTCH RELEASE MECHANISM

## INSTALLATION

Installation is in the reverse order of removal.

### NOTE:

- Clean old grease and abrasive materials off the grease application areas.
- Apply grease to the specified points as shown.

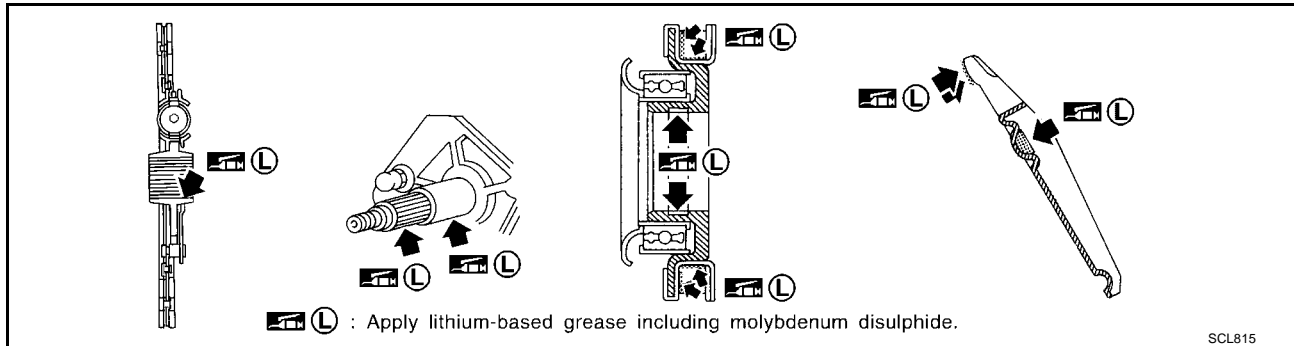

- Apply approximately 1 mm (0.04 in) thick coat of clutch sleeve grease to withdrawal lever and holder spring frictional surfaces.
- Apply a coat of clutch sleeve grease to the grooves on contact surfaces of the withdrawal lever ball pin and inner surface of release bearing; make sure that grease is flush with grooves.
- Apply a thin coat of clutch sleeve grease to release bearing frictional surface. After grease application, install release bearing. Wipe off excess grease forced out during bearing installation.

### CAUTION:

- Before installing the manual transaxle to the vehicle, check that each sliding surface slides smoothly by operating withdrawal lever.
- When assembling, make sure that both ends of the snap spring touch the end face of the withdrawal lever.
- Be careful with the orientation of the installation.

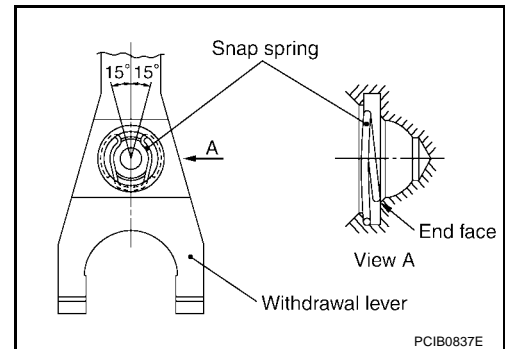

# CLUTCH DISC, CLUTCH COVER AND FLYWHEEL

## CLUTCH DISC, CLUTCH COVER AND FLYWHEEL

PF3:30100

### Removal and Installation

ECS0093P

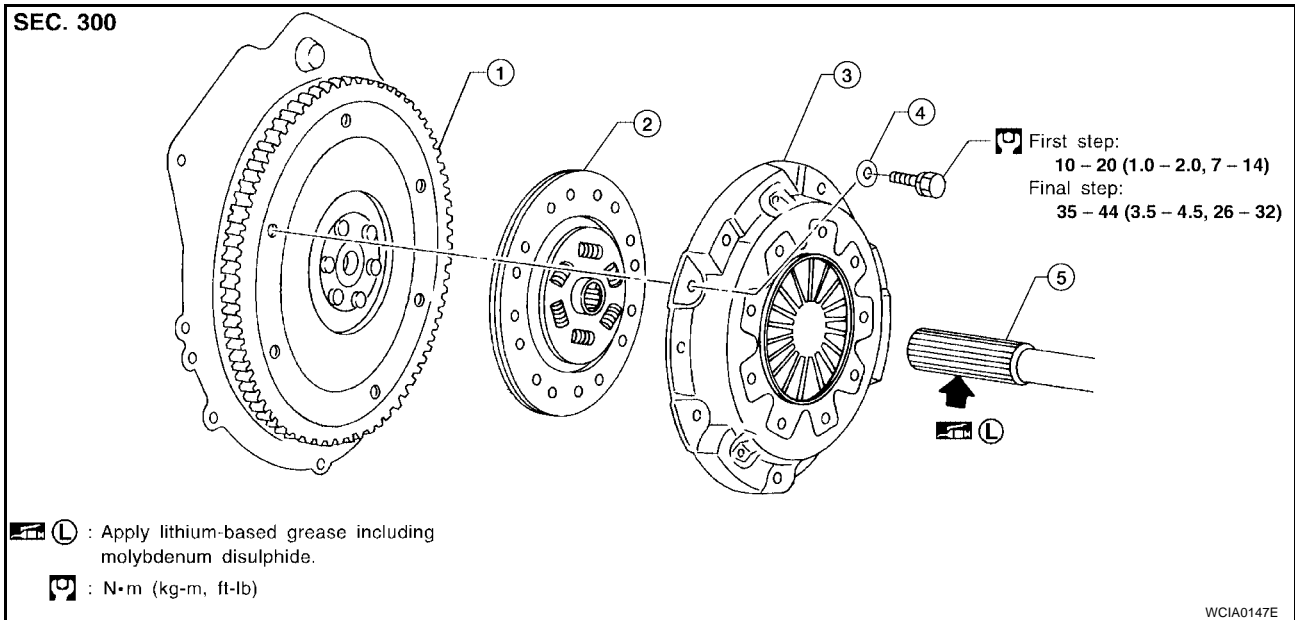

- |             |                     |                 |
|-------------|---------------------|-----------------|
| 1. Flywheel | 2. Clutch disc      | 3. Clutch cover |
| 4. Washer   | 5. Main drive shaft |                 |

#### CAUTION:

- Do not clean the clutch disc with solvent.
- When installing, do not get grease from the main drive shaft onto the clutch disc friction surface.
- If the flywheel needs to be removed, align the dowel pin with the smallest hole of the flywheel. Refer to [EM-78, "ASSEMBLY"](#) in CYLINDER BLOCK (QR25DE), [EM-227, "ASSEMBLY"](#) in CYLINDER BLOCK (VQ35DE).

#### REMOVAL

- Remove the manual transaxle from the vehicle. Refer to [MT-17, "Removal and Installation"](#) (5 M/T), [MT-81, "Removal and Installation"](#) (6 M/T).
- Evenly loosen the bolts holding the clutch cover, using power tool. Then remove the clutch cover and the clutch disc.

#### INSTALLATION

Installation is in the reverse order of removal.

#### CAUTION:

Do not allow grease to contaminate clutch facing.

- Install the clutch cover and disc using Tool.
 

**Tool number : ST20630000 (J-26366)**
- Tighten the clutch cover bolts in two steps using the numerical order as shown.
 

**First step : 10 - 20 N·m (1.0 - 2.0 kg-m, 7 - 14 ft-lb)**  
**Final step : 35 - 44 N·m (3.5 - 4.5 kg-m, 26 - 32 ft-lb)**

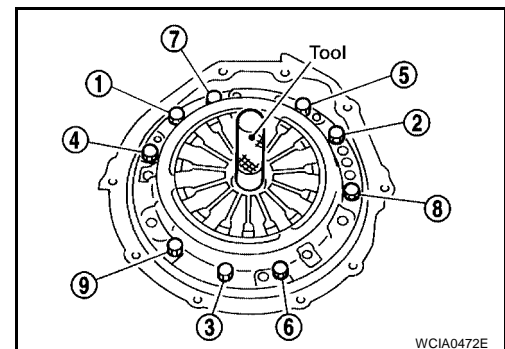

# CLUTCH DISC, CLUTCH COVER AND FLYWHEEL

ECS00930

## Inspection and Adjustment after Removal CLUTCH DISC

- Check clutch disc for wear of facing.  
**Wear limit of facing surface to rivet head : 0.3 mm (0.012 in)**

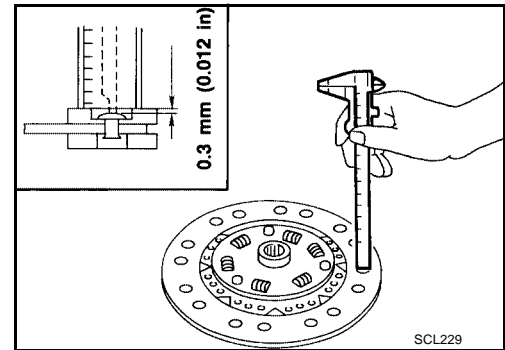

- Check clutch disc for backlash of spline and runout of facing.  
**Maximum backlash of spline : 1.0 mm (0.039 in)**  
**(at outer edge of disc)**  
**Runout limit**  
**QR25DE: 1.0 mm (0.039 in)**  
**VQ35DE: 0.7 mm (0.028 in)**  
**Distance of runout check point (from hub center)**  
**QR25DE: 230 mm (9.06 in)**  
**VQ35DE: 240 mm (9.45 in)**
- Check clutch disc for burns, discoloration or oil or grease leakage. Replace if necessary.

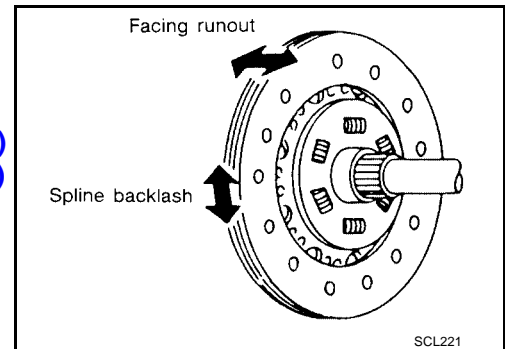

## CLUTCH COVER

- Check clutch cover installed on vehicle for unevenness of diaphragm spring toe height.  
**Uneven limit : 1.0 mm (0.039 in)**
- If out of limit, adjust the height using Tool.  
**Tool number : ST20050240 ( — )**

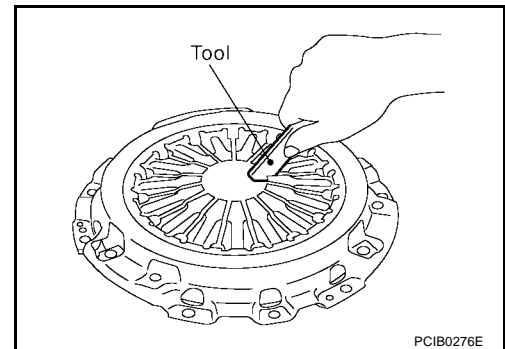

## FLYWHEEL

- Check contact surface of flywheel for slight burns or discoloration. Repair flywheel with emery paper.
- Check the flywheel runout. Refer to [EM-97, "MOVEMENT AMOUNT OF FLYWHEEL \(M/T MODEL\)"](#) (QR25DE), [EM-243, "FLYWHEEL RUNOUT \(M/T\)"](#) (VQ35DE).

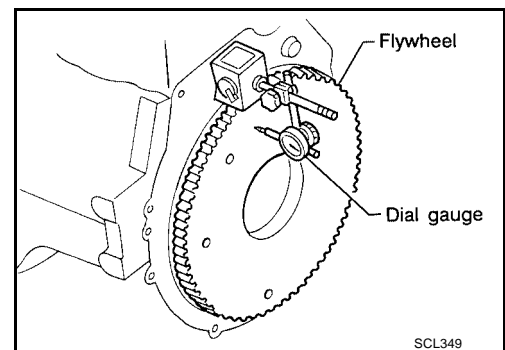

A  
B  
CL  
D  
E  
F  
G  
H  
I  
J  
K  
L  
M

# SERVICE DATA AND SPECIFICATIONS (SDS)

## SERVICE DATA AND SPECIFICATIONS (SDS)

PFP:00100

### Clutch Control System

ECS0093R

Type of clutch control	Hydraulic
------------------------	-----------

### Clutch Master Cylinder

ECS0093S

Unit: mm (in)

Inner diameter	15.87 (5/8)
----------------	-------------

### Clutch Operating Cylinder

ECS0093T

Unit: mm (in)

Engine	QR25DE	VQ35DE
Inner diameter	19.05 (3/4)	17.46 (11/16)

### Clutch Disc

ECS0093U

Engine	QR25DE	VQ35DE
Model	240	250
Facing size (Outer dia. × inner dia. × thickness)	240 mm × 160 mm × 3.5 mm (9.45 in × 6.30 in × 0.138 in)	250 mm × 170 mm × 3.2 mm (9.84 in × 6.69 in × 0.126 in)
Thickness of disc assembly With load	8.1 mm (0.319 in) with 5,884 N (600 kg, 1,323 lb)	7.4 mm (0.291 in) with 8,340 N (850 kg, 1,875 lb)
Wear limit of facing surface to rivet head	0.3 mm (0.012 in)	
Facing runout limit	1.0 mm (0.039 in)	0.7 mm (0.028 in)
Distance of runout check point (from the hub center)	230 mm (9.06 in)	240 mm (9.45 in)
Maximum spline backlash (at outer edge of disc)	1.0 mm (0.039 in)	

### Clutch Cover

ECS0093V

Engine	QR25DE	VQ35DE
Model	240	250
Set load	5,884 N (600 kg, 1,323 lb)	8,340 N (850 kg, 1,875 lb)
Set height	38 mm (1.50 in)	40.5 (1.59 in)
Uneven limit of diaphragm spring toe height	1.0 mm (0.039 in)	

### Clutch Pedal

ECS0093W

Unit: mm (in)

Clearance "C" between pedal stopper rubber and clutch interlock switch threaded end while clutch pedal is fully depressed.	0.1 - 1.0 (0.004 - 0.039)
--	---------------------------